



VITAL!

ESTIRAMIENTO ESPALDA
BACK STRETCHING
ÉTIREMENT DU DOS
ALONGAMIENTO DE COSTAS



EN 16630

DP603D1: 1 x 0,92 x 2,22 m. 45 kg.

Madera laminada tratada en autoclave clase IV y acero pintado al polvo.

Según norma EN 16630: No requiere suelo que amortigüe los impactos según el ensayo HIC de la norma EN 1176.

Autoclave treated class IV laminated wood and powder coated steel.

According to standard EN 16630: Shock-absorbing floor not needed according to HIC test of standard EN 1176.

Bois stratifié traité en autoclave classe IV et acier peint à la poudre.

Selon la norme EN 16630: N'exige pas un sol qui amortit les impacts selon le test HIC de la norme EN 1176.

Madeira laminada tratada em autoclave classe IV e aço pintado a pó.

Em conformidade com a norma EN 16630: Não requer apenas o amortecimento dos impactos em conformidade com o ensaio HIC da norma EN 1176.

-  h > 1,4 m.
-  0 m.
-  45 Kg.
-  2,71 x 0,8 x 0,99 m.
-  4 x 3,92 m.
-  13,76 m².

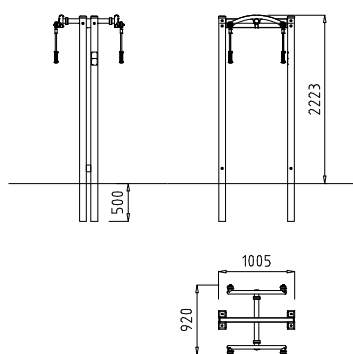

E: 1/100

