

MORE ABOUT THE B.B.C.'s TELEVISION PLANS

TELEVISION

THE FIRST TELEVISION JOURNAL IN THE WORLD

and **SHORT-WAVE WORLD**

MONTHLY 1/-

JANUARY, 1936

No. 95. Vol. IX.

BERNARD JONES PUBLICATIONS LTD.,
CHANSITOR HOUSE, CHANCERY LANE,
LONDON, W.C.2.

EIFFEL TOWER
TELEVISION STATION
FULL DETAILS.

LONDON'S
TELEVISION STAFF.

ELECTRON OPTICS

SHORT WAVE
NEWS & NOTES

AND AN

AMATEUR'S
COMMUNICATION
RECEIVER
FULLY DESCRIBED.

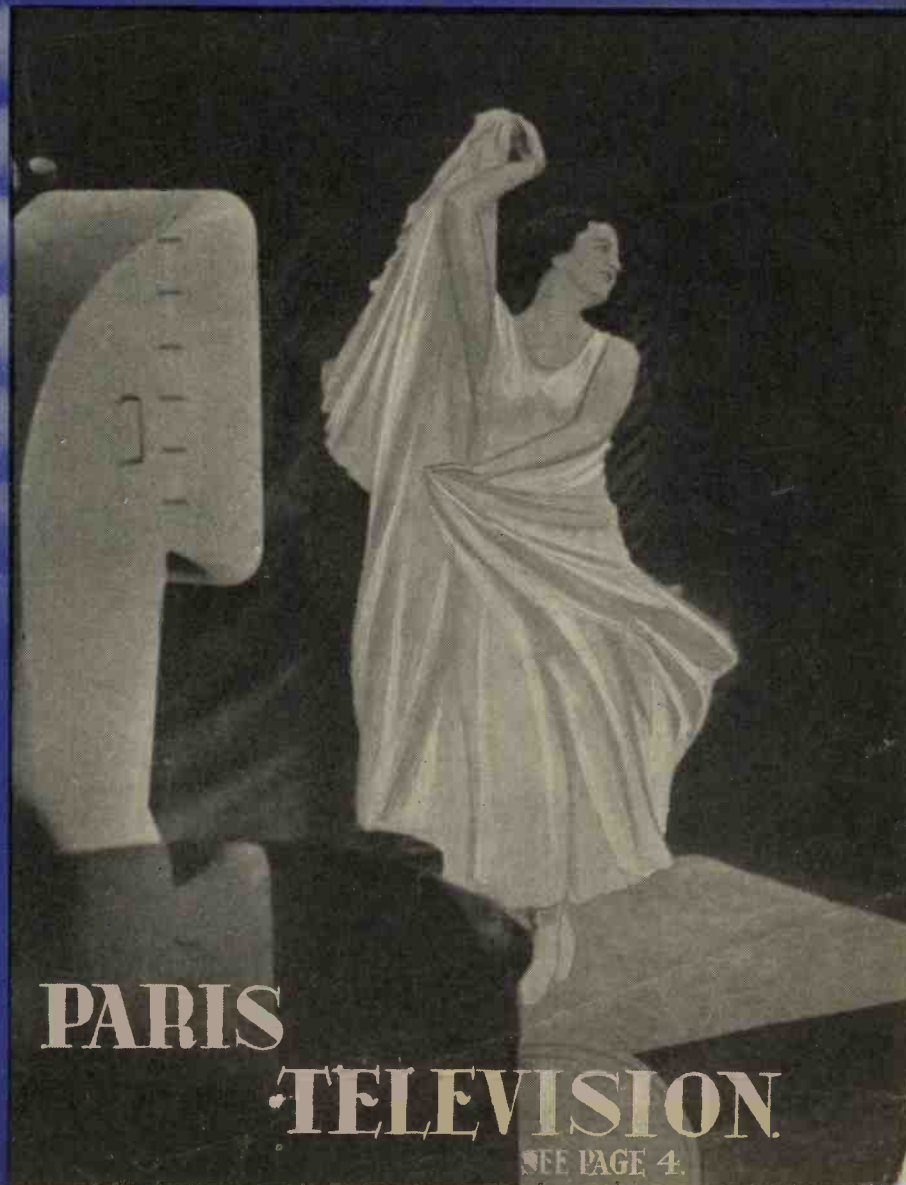

PARIS

TELEVISION

SEE PAGE 4.

"This programme's appalling!"
cried Dunn;
"Dull music, stale news and
no fun;
A good chance to-night
To put the set right . . ."
So he got out the FLUXITE and GUN.



See that FLUXITE is always by you—in the house—garage—workshop—wherever speedy soldering is needed. Used for 30 years in government works and by leading engineers and manufacturers. Of Ironmongers—in tins, 4s., 8d., 1/4 and 2/8. Ask to see the FLUXITE SMALL-SPACE SOLDERING SET—compact but substantial—complete with full instructions, 7/6. Write for Free Book on the art of "soft" soldering and ask for Leaflet on CASE-HARDENING, STEEL and TEMPERING TOOLS with FLUXITE

TO CYCLISTS! Your wheels will NOT keep round and true unless the spokes are tied with fine wire at the crossings and SOLDERED. This makes a much stronger wheel. It's simple—with FLUXITE—but IMPORTANT

THE FLUXITE GUN

is always ready to put fluxite on the soldering job instantly. A little pressure places the right quantity on the right spot and one charging lasts for ages
Price 1/6.



ALL MECHANICS WILL HAVE

FLUXITE

IT SIMPLIFIES ALL SOLDERING

FLUXITE LTD. (Dept. T.V.), DRAGON WORKS, BERMONDSEY ST., S.E.1.

DIODE DETECTION

for freedom from detector distortion
and provision of automatic
volume control



TYPE DN41

- OSRAM D41, Double Diode, Price 5/6
- OSRAM DN41, Double Diode—High Slope Output Pentode. Price 21/-
- OSRAM MHD4, Double Diode—Triode. Price 15/6
- OSRAM WD40, Vari-mu Screen Pentode—Double Diode. Price 20/-

Osram Valves

WRITE FOR FULL PARTICULARS.
MADE IN ENGLAND.

Advt. of The General Electric Co. Ltd., Magnet House, Kingsway, London, W.C.2

Mention of "Television and Short-wave World" will ensure prompt attention.

FOR A GOOD JOB
WELL DONE

BELLING-LEE

FOR EVERY RADIO CONNECTION



No. 1224. 1s. 6d

Low Loss Valve Hood and Connection.



"Wanderfuse,"
Black or Red,
With 150 m/A Fuse.
No. 1028. Complete 1/-

Banana Plugs and Sockets.
No. 1078. Pair, 4/6.
Plug (1021), 2/6.
Metal Socket (1022), 1/6.
Insulated Socket (1071), 2/6.



Cartridge Fuses.
10 distinguishing colours.
All ratings, 6d. each.



Fused Mains Input Connector.
5-amp. (B.S.S.)
No. 1114.
Complete, 3s 6d.

Socket Strips.



Indications available:

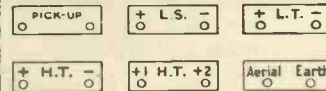

No. 1047. 9d., with plugs.



3-Pin Plug.
No. 1119.
1s. 3d. each.
Plug only,
(No. 1107) 9d. each

USE THE COUPON

BELLING & LEE LTD
CAMBRIDGE ARTERIAL ROAD, ENFIELD, MIDDXX

Please send,
free, your

Complete Catalogue, "Radio Connections."

Name.....

Address.....

[Tel. 1-36]

CONTROLATONE

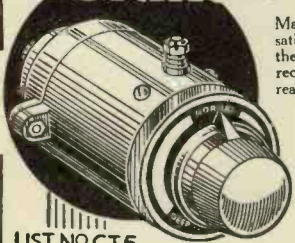

Many people are dissatisfied with the tone they get from their receivers, for various reasons. The Bulgin "Controlatone" can be fitted to any and every set. Types C.T.1 and C.T.2 (at 4/6 each). Type C.T.5 shown here, at 6/6.

LIST NO. CT5
FIT IT TO ANY SET

PILOT BULBS

Pilot bulbs are a very important type of accessory for modern sets. In addition to our "Competa" 12 mm. 60 mA. bulbs, we also offer these 14 mm. M.E.S. types of English make.

2 Volts.	4 Volts.	6 Volts.
B.206, .06A.	B.406, .06A.	B.606, .06A.
B.210, .1A.	B.410, .1A.	B.610, .1A.
B.220, .2A.	B.415, .15A.	B.615, .15A.
B.225, .25A.	B.420, .2A.	B.620, .2A.
B.230, .3A.	B.430, .3A.	B.630, .3A.
B.250, .5A.	B.450, .5A.	B.650, .5A.



ALL PRICE 9d. EACH.

SIGNAL LIGHTS



Described in "Television," for neat, clear indication of switching positions, "aliveness" of apparatus, etc.

Use only 60 mA. bulbs of 12 mm. dia. in this holder. For 2 volts, Competa type "H" at 6d. is suitable. The D.9 holder fits to panels 1/32 in.-3/8 in. thick, with a 3/8 in. dia. hole.

2/- EACH
LIST No. D.9.

TUBULAR CONDENSERS

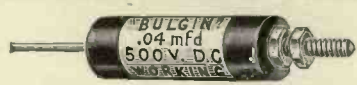

Few constructors nowadays pay high prices for small fixed condensers. Modern types are smaller, more efficient and low-priced. These, for example, will fix to a chassis, and are accurate $\pm 10\%$ (500 v. max.). Types with double wire-ends are also available.

Z.405, .00005, 6d.	Z.305, .0005, 6d.	Z.105, .05, 10d.
Z.301, .0001, 6d.	Z.201, .001, 8d.	Z.P1, .1, 1/-
Z.302, .0002, 6d.	Z.205, .005, 8d.	Z.P25, .25, 1/3
Z.303, .0003, 6d.	Z.101, .01, 10d.	Z.P5, .5, 1/6

RESISTANCES HALF-WATT



Nine times out of ten, a half-watt resistance is quite large enough electrically. A great saving in cost can be effected by their use. Strong wire ends are fitted. Accuracy $\pm 10\%$ 36 types in all.

SPECIFIED IN THIS ISSUE

A SELECTION FROM THE RANGE.

H.W.	mA.	H.W.	mA.
1	250 ohms	45	25,000 ohms
5	2,500 "	16	25 100,000 "
10	5,000 "	10	30 400,000 "
15	10,000 "	7	35 3 Meg. "

PRICE 6^D EACH

RECOMMENDED AGAIN & AGAIN

BULGIN

QUALITY RADIO AND TELEVISION COMPONENTS

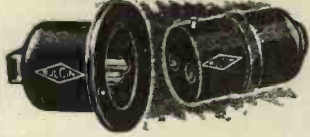

Perfect MAINS Entry

Bulgin Mains Connectors enable the mains to be used for all radio requirements WITH ABSOLUTE SAFETY.

Use a proper Bulgin Mains Connector which is not interchangeable with other fittings, and BE SAFE.

BULGIN MAINS CONNECTORS.

3A. Max.	complete.
List No. P.20 (illustrated)	2/-
P.73, do., 3-pin	2/3
P.76, 2-pin, bracket	2/-
P.18, do., small	2/-

COUPON

To Messrs. A. F. Bulgin & Co., Ltd.,
Abbey Road, Barking, Essex.

Please send me Catalogue No. 155 "M" for which I enclose 3d. stamps

NAME.....

ADDRESS.....

(BLOCK LETTERS PLEASE)

THE BEST AERIAL INSULATORS



For reception, at high frequencies, you must have a suitable aerial system. Use these new Bulgin types with their long always-dry path. As strong as you could want.

List No. L3. 1/6 each.

Thanks to Sound Sales—

Static Shielded Transformers, !
Modulation Hum is overcome !

Note these features :—
Tapped Primary, Ensuring the correct output voltages. An important point especially with A.C. Valve heatings. Standard tapplings suit mains from 210/250 volts at 50 cycles. Combined fuses and supply voltage tapping selector incorporated. High-grade silicon steel core results in very low current consumption. Neat and very effective clamping, resulting in silent operation.

SOUND SALES MAINS TRANSFORMER
Type 500/120 Model

Primary 210, 230, 250 v. at 50 cycles.
H.T. Sec. 500-5-500 v. at 120 m.a.

2-0-2 v. at 3.5 amp.
2-0-2 v. at 2 amp.
2-0-2 v. at 5 amp.

PRICE 55/-

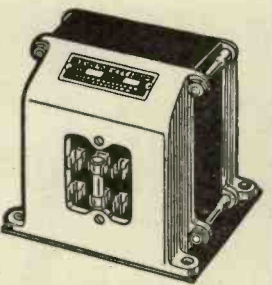

Illustration shows model Type "C" New Monodial pattern at 60/-. For Details, see Catalogue "T.S." Free.

SOUND SALES

SOUND SALES LIMITED

Marlborough Road, Upper Holloway, London, N.19.
Phone: Archway 1661-2-3. (Contr. to G.P.O., etc.)

Sound Sales Type 30 v. 30-Henry Choke, 14/-.
Specified for the "Universal Mains Short-wave Three."



VALVES for your RADIO

(Battery, A.C. Mains and Universal Types)

FOR BROADCAST or SHORT WAVES

FERRANTI CATHODE RAY TUBES

for TELEVISION and INDUSTRIAL USE
FINEST DEFINITION and LONGEST LIFE
Working Voltage 1000/6000. Cathode 1 volt. 3 amps.

FERRANTI LTD.
RADIO WORKS, MOSTON, MANCHESTER, 10

FERRANTI
VALVES



HIGH VOLTAGE METAL RECTIFIERS Type H

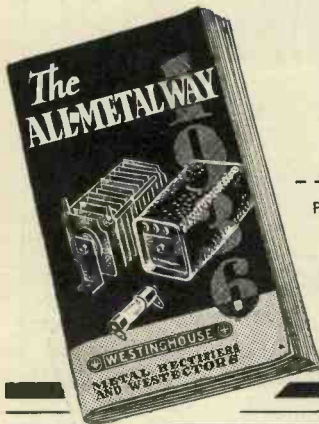

have a maximum current output of 10 milliamps, and have been designed to provide high voltages. They have already been built up into units to give as much as 400,000 volts for X-ray and therapy purposes, and are suitable for cathode ray circuits, anode supplies to small receivers and oscillators, etc.

-----COUPON-----
Please send me "THE ALL METAL WAY, 1936,"
for which I enclose 3d. In stamps

NAME.....
ADDRESS

These rectifiers are made in a wide range of voltage output to suit the various duties and will be found of great use in television. Details of typical units are given in "THE ALL METAL WAY, 1936." Use the coupon and get a copy to-day.

Westinghouse Brake & Signal Co., Ltd.,
82, YORK ROAD, KING'S CROSS, LONDON, N.1

Quick fault-tracing DEMANDS ACCURATE TESTING



British made

- CURRENT**
0-6 milliamps
0-30 "
0-120 "
VOLTAGE
0-6 volts
0-12 "
0-60 "
0-120 "
0-300 "
0-600 "
RESISTANCE
0-10,000 ohms
0-60,000 "
0-1,200,000 "
0-3 megohms

The D.C.
AVOMINOR

40/-

Deferred Terms
if desired.

Even the smallest degree of distortion in television calls for immediate remedy. Slight faults which might pass unnoticed in radio become, in television, glaringly apparent imperfections. More than ever is an accurate testing meter of first importance—vital to perfect reception.

The world-famous D.C.

AVOMINOR

Regd. Trade Mark

Is 13 accurate instruments in one. Circuits, valves, components, batteries and power units can all be tested quickly and easily. In handsome case, with leads, interchangeable crocodile clips, testing prods and instruction booklet.

The UNIVERSAL AVOMINOR

gives 22 different ranges of readings. The best of A.C. and D.C. meters. 3-inch scale. Total resistance 200,000 ohms. Complete with leads, crocodile clips, testing prods and instruction booklet.

**THE AUTOMATIC COIL WINDER &
ELECTRICAL EQUIPMENT CO., LTD.,**

Winder House, Douglas Street, London, S.W.1.
Telephone Victoria 3404-7.

The UNIVERSAL AVOMINOR

- | | |
|-------------------|-------------------|
| D.C. VOLTS | A.C. VOLTS |
| 0-75 millivolts | 0-5 volts |
| 0-5 volts | 0-25 " |
| 0-25 " | 0-100 " |
| 0-100 " | 0-250 " |
| 0-250 " | 0-500 " |
| 0-500 " | |
| MILLIAMPS | RESISTANCE |
| 0-2.5 milliamps | 0-20,000 ohms |
| 0-5 " | 0-100,000 " |
| 0-25 " | 0-500,000 " |
| 0-100 " | 0-2 megohms |
| 0-500 " | 0-5 " |
| | 0-10 " |



£5

Deferred Terms if desired.

● Send for fully descriptive folders, post free.

TELEVISION

and SHORT-WAVE WORLD

Special Features

	PAGE
180-Line Transmissions from the Eiffel Tower	4
London's Television Staff	6
The Farnsworth Multipactor Tube	7
January Short-wave Transmissions	9
The Telepantoscope	14
An Amateur Communication Receiver	15
The Construction of High-frequency Cables	18
The Marconi High-vacuum Cathode-ray Oscillograph	21
First Steps in High-definition Reception	23
What the Short-wave Amateurs are Doing	27
The Principles and Practice of Electron Optics	29
The Development of the Scanning Circuit for Cathode-ray Television	30
The First Kerr Memorial Lecture	33
Further Notes on Frequency Meters	36
A Midget-valve Head Amplifier	37
Nomographs for Kerr Cell Design	39
Cathode-ray Tube Nomenclature	41
Accurate Inductance Measurement	42
The Design of High-definition Amplifiers	43

COMMENT OF THE MONTH

Television and the Amateur Constructor.

HERE is a good deal of discussion at the present time regarding the position of the amateur in television. Chiefly this concerns the ability, or otherwise, of the amateur to build television receivers capable of receiving the new high-definition transmissions, and opinions are sharply divided. Possibly, however, the matter is one of perspective; to assume that amateur television receiver construction will follow on the lines of ordinary wireless receiver construction of a few years ago requires a very big stretch of the imagination. The high voltages necessary, and the many other factors of design definitely preclude any such possibility so far as the novice is concerned. The true amateur, however, may be regarded as being in a very different category.

Constructionally, there is nothing in the high-definition television receiver which is beyond the ability of the reasonably skilled amateur. We have, in fact, seen rough experimental lash-ups which have given quite good results, but such a collection of apparatus is not suitable to put into the hands of a novice; there is very much more in it than mere assembly. Whether this will always be the case we do not care to prophesy, but we have no hesitation in saying that the *real amateur who has a knowledge of what he is doing* will have no difficulty in building his own receiver. It is necessary to stress the point, however, that he will have to be capable of doing more than just blindly following a prepared design, and it is to this end that in preceding issues we have published articles by various experts, which will provide the ground work. These, it will probably have been appreciated, have followed two lines—one for the advanced technician who wishes to concern himself with design, and the other for the amateur who is capable of carrying out a prepared design and attaining a sufficient knowledge of the cathode-ray receiver to construct and operate it. We have at the present time a complete vision and sound receiver in process of construction, and full details of this will be published when we have had an opportunity of testing it upon actual television transmissions from the Alexandra Palace.

Good Progress

IT is gratifying to be able to announce that preparations for the new London television station are being pushed on with all possible speed. Mr. Gerald Cock, the new Director, is certainly not wasting any time—and even the building contractors are working overtime. It is also gratifying to know that now the B.B.C. has set its hand to television it is going into it wholeheartedly. £120,000 is the estimated cost of the institution of the new service, and this should give this country a lead in the new science for many years to come.

TELEVISION AND SHORT-WAVE WORLD

Proprietors :

BERNARD JONES PUBLICATIONS, LTD.

Editor-in-Chief :

BERNARD E. JONES.

Editor :

H. CORBISHLEY.

Editorial, Advertising and Publishing Offices :

Chansitor House, 38, Chancery Lane, London, W.C.2.

Telephones : Holborn 6158, 6159

Telegrams : Beejapee, Holb., London.

Subscription Rates : Post paid to any part of the world—3 months, 3/6; 6 months, 6/9; 12 months, 13/6.

Published Monthly—1/- net.

(Last Wednesday in every month for following month).

Contributions are invited and will be promptly considered. Correspondence should be addressed according to its nature, to the Editor, the Advertisement Manager, or the Publisher, "Television and Short-wave World," Chansitor House, Chancery Lane, London, W.C.2.

IMPORTANT

"Television and Short-wave World" is registered at the General Post Office, London, for transmission to Canada and Newfoundland by Magazine Post.



180-LINE TELEVISION FROM THE EIFFEL TOWER

Details of the French State Trans- missions

Connection to the aerial is made by another concentric type feeder, which consists of a copper tube containing a smaller insulated tube placed concentric with it. This passes up the north leg of the tower to the aerial which, as the photograph shows, is a four-wire arrangement in two planes.

Scanning is accomplished with a disc which revolves at 3,000 revolutions per minute. This disc contains a double spiral of holes so that it makes two turns per image. For synchronising a separate disc is employed, which is positively driven from the scanning disc. Two synchronising pulses are transmitted, one at the end of each line and the other upon the completion of each picture.

Realising that at present very few people will be able to receive these transmissions the authorities are arranging to install receiving apparatus in various parts of Paris, and these viewing rooms will be open to the public.

It appears that it was only in September that this latest installation was planned, and M. George Mandel, who is responsible for it, allowed two months for its completion. Actually in seven weeks everything was complete and ready for the first transmission. Con-

It will be remembered that in April last the French authorities commenced making tentative television experiments by the installation of a low-definition transmitter, and it was announced that the experiments would be progressive towards higher definition. Very little time has been allowed to elapse in attaining this objective for a 180-line television broadcasting station was opened formally on November 17 as a direct result of the experience gained with the low-definition system. The latter, it may be remarked, operated with 60 lines and the transmitter had a power of only 200 watts.

The new station is to work with 180 lines and 25 pictures per second. The power in the first instance is to be 1 kilowatt.

The studio is in the P.T.T. broadcasting station, 103 rue de Grenelle, Paris, and it is really an old radio studio modified for television. Powerful projectors have been installed in a room about thirty-six feet long. There are six of these with a power of 5 kilowatts and twelve of 1 kilowatt, and because of the intense heat generated special arrangements have been made for ventilating and cooling the studios. As will be seen from one of the photographs, ship's type of ventilators have been installed with pipes leading to a chamber where artificial rain is produced, the latter being kept at a very low temperature by means of a refrigerating plant. Fans ensure the constant circulation of air.

The camera room is adjacent to the studio, being separated by a sheet of glass. In this room also are the amplifiers and controls.

An underground cable of the special high-frequency type is used to connect the studio with the transmitter, which is situated in the base of the Eiffel Tower, about two-and-a-half kilometres away.

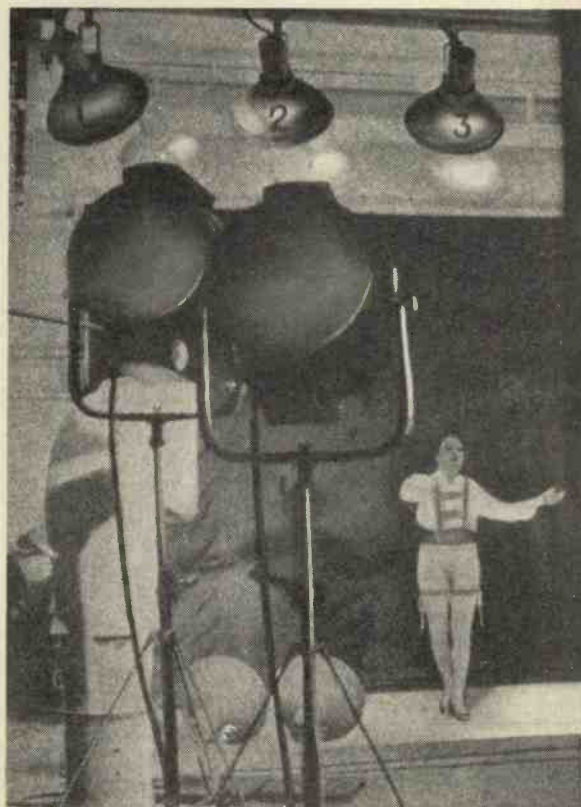

This photograph shows the powerful bank of projectors which are used in the studio.



Left: The amplifier and control room.

Right: The short-wave aerials at the top of the Eiffel Tower.

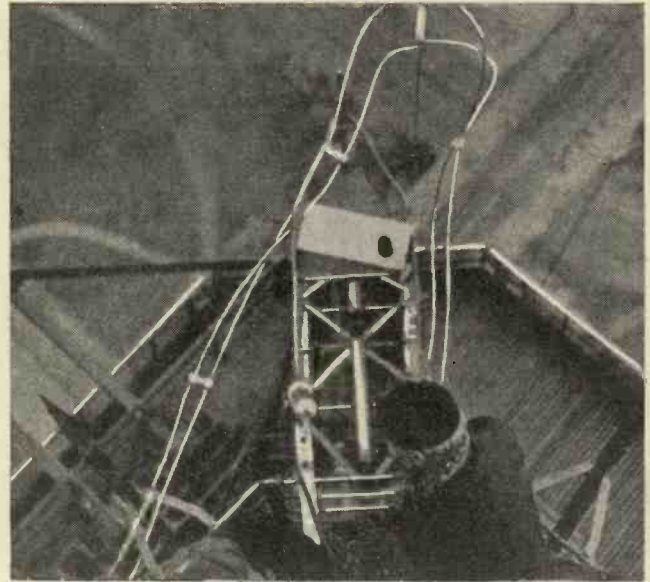

sidering that there was very little previous experience of high-definition work this is remarkable progress.

The transmission created a great deal of interest and the number of applications to witness the first demonstration in the viewing rooms exceeded ten thousand. As this number of persons could not be accommodated other demonstrations were arranged and entrance limited to invitation. At the time of going to press no regular schedule has been arranged.

Apparently some hitch occurred in the reception of the first transmission and only three of the receivers in

the six centres were in operation. The French technical Press, commenting upon the result, observes that the clarity of the pictures was but little better than that obtained with lower definition, and it appears that there was a lack of brightness due to some fault in the receiving apparatus.

In the *Haut Parler*, a journalist describes his experiences. He says: "I was invited to the television reception at the House of Civil Engineers. On the appointed evening I found a theatre and ball in full swing, but no television. A hand-written notice announced 'No television this evening' to a disappointed crowd. From there I went to Chemistry House—in time to see Lys Ganty singing. Two receivers were installed, side by side—the left-hand one showing the picture in black and white, the other in sepia. The latter seems to be taken from closer up. Thus in one case we saw the scenes pleasantly—while in the other the actors continually appeared to come out of the frame, and the canvas at the back of the scene was lighter than the objects. We were assured, however, that both apparatus were worked alike."



Mlle Suzy Vinker, who was the announcer at the first television broadcast.

Ralph Stranger's SCIENCE REVIEW

The first issue of this new publication met with a most gratifying reception and appreciative comments have been received from readers and Press alike. The reason is, no doubt, that it is a first and unique attempt to deal with somewhat abstruse scientific subjects in a manner which, whilst being understandable by the average person, does not become what is loosely termed "popular" and in consequence gloss over the most difficult parts.

The range of subjects which it covers is extremely comprehensive as will be gathered from the following mention of a few of the titles of articles which appear in the January issue: "Stratosphere Flights," "In the Abyss of Space," "Measurements, Calculation and Design," "Colloidal Chemistry," "Electrons in Harness," "Elements of Radio," "The Invisible World," "Chemistry for Beginners," "The Moon and Wireless," "Following the Light Beam," "Wireless Waves," "Splitting the Atom," "Cosmic Radiations," etc., etc. Of no less importance is the fact that the contributions are by the leading authorities on the various special subjects, and in the January issue such names as Professor A. Piccard (of stratosphere fame), Professor M. Grimes, C. Bernard Childs, Ph.D., D.Phil., L. G. H. Huxley, M.A., D.Phil., J. F. McGeheon, D.Sc., appear.

LONDON'S TELEVISION STAFF

SOME PARTICULARS OF THE APPOINTMENTS

DETAILS of the personnel for the chief administrative posts for London's new television station were given last month. These it will be remembered included Gerald Cock, Director of Television, and D. H. Munro, Television Productions Manager.

In addition to members of the Staff named above and to others already appointed by the B.B.C., we are informed that there is a number of vacancies for such posts as Music Director, Stage Managers, Producers, Announcers, etc., and on the assumption that readers would like to have some brief particulars of the posts (although to our knowledge the B.B.C. has already received about four thousand applications, which would appear to leave but little chance for any later applicants) we are giving on this page some indications as to the qualifications in each case.

THE MUSIC DIRECTOR must have a knowledge of theatrical and ballet work and of orchestration, and have had experience as a musical conductor.

STAGE MANAGERS, of whom two will be required, must know stage or film requirements and particularly must have a practical acquaintance

with that difficult subject—lighting. Evidently, too, they must know how to handle men and women and be good disciplinarians.

THE PRODUCERS will include three men who are experienced in theatrical or film production, who will be the more valuable if their experience has been on the light-entertainment sides, and who must certainly have some knowledge of music. In addition, there will be a *Producer of Special Programmes* with all the above qualifications and, additionally, an acquaintance with the outstanding personages of the entertainment, journalistic and political worlds. This Special Producer will need an *Assistant* with similar qualifications.

THE FILM ASSISTANT must have a long acquaintance with film photography, film production and editing and with such practical matters as film cutting, projection, etc., etc. He must be able to manage staff.

THE ANNOUNCERS, one male and one female, must be "super" people whose qualifications have already been referred to in the preceding issue of TELEVISION AND SHORT-WAVE WORLD. Both of them must have a clear and powerful voice, be

of average height, well proportioned, without prominent features, preferably have dark eyes, and they must not have red hair. Of course, they must be of good education, and have a good memory. They must have experience of the theatrical stage and they will be able to do their work all the better if they are able to pronounce foreign words and names correctly. The woman announcer must be all this and more, very much more, and must have a low-pitched voice. Applicants must submit one copy of a recent photograph, and if we were applying for the position we should be much put to it to decide whether to send an honest photograph or one that erred ever so subtly on the side of flattery!

THE HOSTESS, must be—well, nothing short of a paragon, a *rara avis*, a gem of purest ray serene. First of all, she must have all the qualifications necessary in either the male or female announcers as, from time to time, she may be required to assist them and occasionally to do their work. Of course, she will have to submit a photograph and she should see to it that the photograph suggests self-confidence, initiative, tact and equable temperament.

THE ARTISTS' BOOKING ASSISTANT comes at the end of the list, and he will have to know nothing more than everything there is to be known about variety, stage and review artists—who they are, what they are, how to deal with them, and what fees they should get. Evidently artists don't care, as in this case a photograph is not required.

How to Apply for a Post

Fully qualified readers who would like to have the honour of figuring on London's first television staff should write to The General Establishment Officer, Broadcasting House, London, W.1, marking their envelopes "Television Staff." Letters must reach their destination not later than the last post on Friday, January 10, 1936. There is no formal application form; just an ordinary letter will answer the purpose. State your age,

(Continued on page 8).

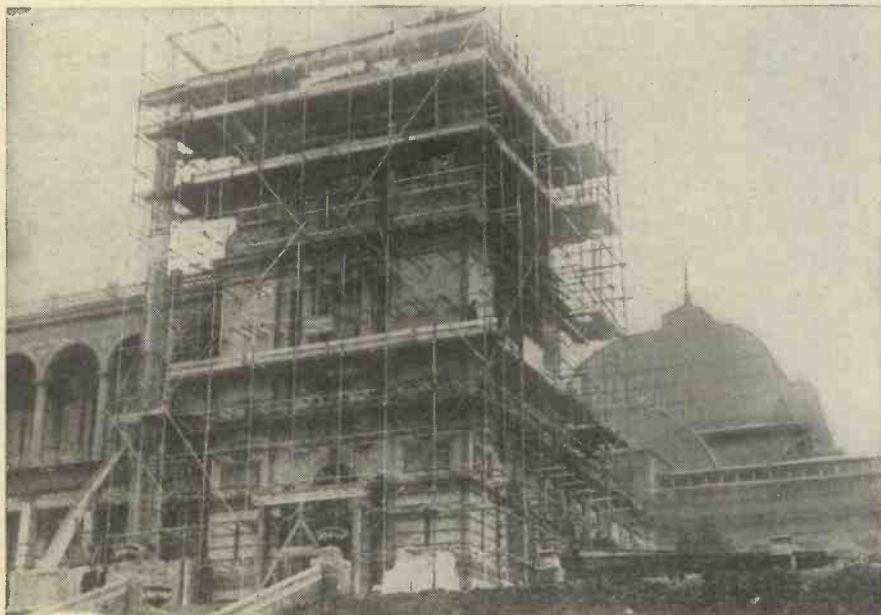

No time is being wasted in the necessary alterations to the Alexandra Palace; this photograph shows the progress made up to the second week of December.

THE FARNSWORTH MULTIPACTOR TUBE

By G. H. Eckhardt

AN ARTICLE APPROVED BY PHILO T. FARNSWORTH.

PHILO T. FARNSWORTH, vice-president of Farnsworth Television Incorporated, U.S.A., has said of the cold cathode multiplier tube, in the development of which he has been the pioneer, "Electron multipliers have been made to perform every function now performed by the thermionic relay. While it is improbable that all of the functions now performed by the thermionic tube will be replaced by the new cold cathode multipactor, nevertheless, it is fully evident to all of us who have worked with secondary multiplication that this new art will have a very revolutionary effect on

the science of radio communications."

In this single tube Mr. Farnsworth has (1) oscillation, (2) current multiplication or amplification, and (3) frequency multiplication. Not only will the development of this tube have a tremendous effect upon television, but it will also have a great bearing upon the entire future of the science of radio communication. The Farnsworth "Multipactor" has the distinct advantage of giving "noiseless" amplification.

As is well known, the science of radio communication has been almost wholly built up because of the availability of devices which will amplify feeble and very rapid electrical variations. These amplifiers are essentially relay devices in which a feeble electric voltage "triggers off" a constant source of power in such a manner as to give a new electrical variation similar in all respects to the original except of much greater magnitude. The process is repeated successively many times until the final variation may be more than a million times greater than the original electrical impulse.

Amplification Factors

The extent to which this amplification may be carried is, however, limited, because electrical charges are not a homogeneous fluid. Two types of variations must be considered (a) one directly due to the "corpuscular" nature or "grain" of the electric fluid. The interference, or "noise," produced by such grain size of the current is called Schotke effect, and may be likened to the noise produced by the pattering of rain upon a tin roof; (b) the other, known as "thermal noise," is due to the fact that the electrons in a substance share the movement of the molecules in the material and thereby produce rapidly varying electric currents in the element of the amplifier itself.

Both these small effects become of great importance in television, and constitute the limit to the amount of amplification that may be employed

in the image pick-up device. This is true for two reasons: (1) the electric currents generated by the transmitting device are extremely feeble, and (2) the duration of certain components in the picture currents is so short that as low as 5 or 10 electrons may represent the total quantity of electron charge involved.



The Farnsworth Multipactor Tube.

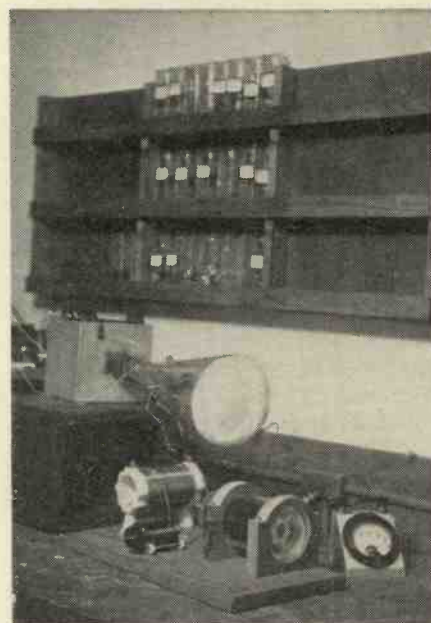

Oscillograph for showing electron motion in Multipactor.

It is a matter of common observation that the amount of noise produced by rain increases as the rainfall becomes heavier. Similarly, the amount of fluctuation noise generated in an amplifier is proportional to the intensity of the electrical current which is used.

In the ordinary hot cathode type of amplifier, widely used in radio today, the total current flowing across the tube may be a million times larger than the component of that current which represents the amplifier signal.

"This, and other considerations," said Mr. Farnsworth, "led me to undertake to develop an amplifier having a much lower fluctuation noise level than could be obtained with the ordinary thermionic relay. After a great many years of research,

there has evolved the so-called electron multiplication system of amplification, and this electron multiplier not only has achieved the results of lower fluctuation noise, making possible approximately two hundred times more amplification of a television picture signal, but has also resulted in many quite unexpected new and valuable applications."

**The Principle of
Electron Multiplication**

The principle of electron multiplication is quite simple. When an electron stream having sufficient velocity is directed against a suitable metal surface, the primary electrons, as they are called, " splash out " other so-called secondary electrons from that surface, and the number of secondary electrons so ejected may be several times greater than the number of primary electrons which produced them. If these electrons, then, in turn, are bombarded against a similar metal target at a sufficient velocity, these will initiate a second set of electrons again several times greater in number. This process may be repeated many times, and the resultant electronic flow finally collected may be many times greater than the original initiating them.

The Farnsworth Multipactor tubes take rather widely varying forms depending upon the uses for which they are designed, but in general two

types have been evolved; the types differing in the methods used to transfer energy to the electrons between impacts: (1) in the first type the electronic impacts progress "spatially," and it is arranged that each successive area of impact is maintained at a higher D.C. potential; (2) in the second type the energy is transferred to electrons between impacts by making use of a suitable radio frequency field across the tube.

**Results from the
Electron Multiplier**

Many surprising results have been accomplished with electron multipliers. Most of these results are achieved because of the possibility of extremely high multiplication ratios. The electron multiplication factor may be anywhere from a few hundred times to over a thousand billion. Because of the extremely high multiplications obtainable in multipactor tubes, the tubes may be used as a source of electrons for purposes other than amplification.

Composite caesium silver oxide surfaces, for example, similar to those used in making photo-electric cells, have an emission of anywhere between 10^{-12} and 10^{-14} amperes per square centimetre at ordinary room temperature. If these currents are multiplied a million million times, an ampere electronic output is obtained from a cold metal surface.

Currents initiated by this process and of this order are now in constant use in the Farnsworth laboratories for many purposes, particularly conversion of direct current voltage to



A photograph showing a trace on the end of the cathode-ray tube obtained with the apparatus shown on the preceding page.

oscillating voltages of from 100,000 cycles to several hundred million cycles per second.

Such oscillators start merely by closing a switch in the battery circuit. Their practical advantages are their simplicity and very high conversion efficiency which may be as great as 95 per cent. The very great advantage to be gained by this high efficiency is that, for a given power output, the tubes may be much smaller than corresponding thermionic tubes.

"London's Television Staff."

(Continued from page 6).

qualifications, give a brief sketch of your career and say the salary you expect, but do not send testimonials or copies, press-cuttings, specimens, etc., etc. If you are having a shot at more than one of these posts, send a separate application for each of them, but you can put the two letters in one envelope. The B.B.C. will acknowledge the receipt of your letter and, if you happen to be one of the chosen few, will invite you to attend for an interview.

By the way, if you are a married woman, do not trouble to apply. Finally, be reminded that if you are applying for the post of Announcer or Hostess, you must send a recent photograph.

And, in every case, mark on your letter, by a heading in block capitals, the post to which your application refers and also mark your envelope "Television Staff."

**The 1936 1.75 mc.
Transoceanic Tests**

By David S. Mitchell (G2II)

FOLLOWING discussions with various 1.75 mc. stations, and the circularising of a letter to all well known British 1.75 mc. operators, the schedules given herewith have been arranged.

In view of the remarkable conditions prevailing on the higher frequency bands these tests should prove particularly interesting, and it is hoped that a greater number of stations will take part this year.

The tests are to be held between 05.00 and 07.00 G.M.T. each Saturday and Sunday commencing January 25, and continuing every week-end until March 15.

In order to avoid unnecessary QRM, separate 15-minute sending and receiving periods have been arranged. W and VE stations are to transmit from the hour to the quarter, and from the half-hour to the three-quarter. These correspond with European listening

periods. European stations transmit from the quarter-hour to the half-hour, and from the three-quarter to the hour, these being W/VE listening periods.

G stations will call "Test USA" and W/VE will call "CQ G."

Participants should sign their calls frequently, and must adhere to their listening periods, even when contact has been established.

All European stations should operate between 1715 and 1800 kcs., as, on the other side of the Atlantic, interference from powerful American and Canadian phone stations usually makes impossible the reception of weak signals between 1800 and 2000 kcs. However, Europeans are advised to listen over the whole band of 1715 to 2000 kcs., as last year the phone band was alive with American amateur signals.

The co-operation of non-transmitters will be appreciated, and these tests should give the B.R.S. an opportunity to provide really useful reports.

As over 130 stations on both sides of the Atlantic have been circularised it is hoped that these will be the best 1.75 mc. tests yet.

January Short-wave Programmes

By A. C. Weston

Any simple short-wave receiver should be capable of bringing in a good variety of programmes from all parts of the world. Conditions show signs of being greatly improved during January.

Ed. Wynne is the well-known American stage and film star who is now being heard over the radio. English listeners with short-wave receivers can hear his broadcasts which are sent out over the Pittsburgh station W8XK.



LISTENERS who study the comprehensive guide to short-wave stations are often very puzzled as to which of the two or three hundred stations on the air they are most likely to hear.

Unfortunately it is not possible to say which are the very best stations except for about half-a-dozen which are receivable no matter how bad the conditions may be. During the past fortnight conditions have shown a decided improvement, so that even raw listeners with one- or two-valve sets have been hearing out-of-the-way stations. It does seem that the conditions will follow the precedent of the last three or four years when short-wave stations have been rolling in for the first few months of the year.

During January some fifty stations at least will be receivable at various times of the day. The American transmitting companies in particular realise how these conditions will change and are putting out particularly good programmes for the benefit of foreign listeners. Of course, most of the commercial firms are booking up famous stars so that their products will be known all the world over. For example, Lily Pons and Nino Martini, who are well known in Europe, will be broadcasting over the Columbia system every Wednesday and Saturday. Freddie Rich, who is well known as an orchestra leader, and radiates over W3XAL on 16 metres at least twice a week, will now be heard on Sunday

afternoons, again over the Columbia system.

Kate Smith, who is perhaps the best known American crooner, is radiating on Tuesdays, Thursdays and Saturdays and will be linked up with Jack Miller's orchestra, which was recently featured during a Five Hours Back programme by the B.B.C.

Burns and Allen, who are known also as stage stars, will be heard through W8XK and the other stations in that group run by the Columbia broadcasting system.

European Programmes

Specially for the benefit of European listeners is a programme radiated at 11.30 most nights over W2XAF on 31.48 metres. This consists of Press news giving details of the current European events. Very often this relay takes the form of a relay from Rome or Addis Ababa.

Jesse Crawford, the well-known organist, has resumed his transmissions from W2XAD on 19.56 metres, and can be heard at 4.15 E.S.T. or 9.15 G.M.T.

South Africa

These few items will give some idea as to the wealth of programme matter available from America alone, but in addition there are other sources of amusement such as programmes radiated from Cape Town via JB on 49.00

metres, which is on the air daily from 2 p.m. until 8.20 p.m., and on Saturdays from 9 p.m. until midnight. The programmes from this station are of a mixed American-English variety, while occasionally English artists on tour in South Africa are allowed to broadcast.

For the day-time short-wave listeners, the best stations at the moment are W8XK on its 13.93-metre channel and W3XAL on its 16.87-metre channel. W8XK can only be heard between 12 and 2 p.m. when it relays the morning session from the medium-wave American station KDKA. When the weather is particularly bad this station will be unsatisfactory; in which case the first American station to be heard will be W3XAL relaying the programmes from WJZ or KDKA. This station is on the air, except Sundays, from 2 p.m. until 4 p.m. and occasionally on Sundays from 3 until 6 p.m.

For many years W3XAL has been very consistent and if the receiver tunes down to about 15 metres it is well worth concentrating on this station to the exclusion of all others.

Programmes from Java

An interesting station is Bandoeng in Java. The call sign is PLE and the wavelength 15.93 metres. It is primarily a commercial station working with Holland, but for the last two or three years has been broadcasting records and native music after lunch until about 3 p.m.

Evening Stations

Evening listeners will be more interested in the 19- and 20-metre bands. Most listeners, even newcomers, know quite well that W2XAD, relaying Schenectady, is one of the most reliable all-the-year-round short-wave stations. It is closely followed, however, by W8XK, when this station is using

the 19.72 channel. During January W8XK will be relaying KDKA from 12 midday until 9.15 p.m.

The Berlin group of Empire stations, which can be found on all of the commercial wavebands, such as 16, 19, 25, 31 and 49 metres, are radiating almost 20 hours a day so that programmes of a Continental type can be heard from one of these channels at almost any time of the day.

Propaganda

Moscow has resumed transmissions on 25 metres using RNE between 1 and 3 p.m. and 8 and 9 p.m. Another transmission from Moscow is made *via* RW59, which radiates from 8 until midnight every day. At 9 p.m. the microphone is taken to Red Square, Moscow, where the chimes of the Kremlin are broadcast.

Not much can be heard of the French transmitters, which are a little too close for satisfactory reception in this country. However, FYA on 25.25 metres can be heard between 4.15 and 7.15 p.m., when conditions are *bad*, and also on 37-33 metres through an experimental station.

The 49-metre waveband is ideal for late listeners between the hours of 10 p.m. and 4 a.m. During these times the North and South American programmes come over with great punch.

COC, in Havana, Cuba, on a wavelength of 49.29 metres, operates regularly between 9 p.m. and midnight. The Marimba bands and typically Latin music come as a welcome relief from English dance music usually radiated at that time of the evening.

Special Stations

Other stations on this waveband include HIX in Santo Domingo on 50.17 metres, XEBT Mexico City radiates from midnight until 6 a.m., HJ4ABE on 50.6 metres from Medellin in Colombia, and many others.

The following fifty stations have been chosen because over a long period of listening and from collating a large number of listeners' letters, it is evident that they are being heard with great consistency.

Wavelength.	Call Sign.	Location and Schedule.
13.93	W8XK	Pittsburgh, Midday—7 p.m.
15.93	PLE	Bandoeng, Midday onwards.
16.87	W3XAL	Boundbrook, N.J., daily ex. Sunday 2-3 p.m. and Tuesday, Thursday and Saturday—8-9 p.m.
16.89	DJE	Berlin, 1-7 p.m.
16.89	IAC	Pisa, 11.30-12.30 a.m.
19.16	JVE	Nazaki, 8 a.m.-1 p.m.
19.2	JVF	Nazaki, 10 a.m.-1 p.m.
19.52	HAS3	Budapest, Sundays 1-2 p.m.
19.56	W2XAD	Schenectady, Weekdays 7-8 p.m., Sundays 2.30-9 p.m.
19.65	W2XE	New York, 4 p.m.-6 p.m.
19.72	W8XK	Pittsburgh, Midday 9.15 p.m.
23.39	CNR	Rabat, Sunday 12.30-2 p.m.
25.00	RNE	Moscow, Sunday 8 a.m., 1 p.m. and 3 p.m.
25.13	FTA	St. Sasse, 8 a.m.-6 p.m.
25.25	FYA	Paris, 4.15-7.15 p.m., 8 p.m.-midnight.
25.26	W8XK	Pittsburgh, 7.20 p.m.-4 a.m.
25.36	W2XE	New York, 8 p.m.-1 a.m.
25.4	I2RO	Rome, 7 p.m. onwards.
25.57	PHI	Huizen, daily except Tuesday and Wednesday, 1.33.
29.04	ORK	Ruysselede, 6.30-9 p.m.
30.43	EAQ	Madrid, daily ex. Saturday 9.15 midnight, Saturday 6-9 p.m.
31.25	CT1AA	Lisbon, Tuesday, Thursday, Saturday, 9.30-midnight.
31.28	VK2ME	Sydney, Sundays 6-9, 10-12 a.m., 7-12 p.m.
31.28	W3XAU	Newtown Square, 5 p.m.-12.50 a.m.
31.32	VK3LR	Melbourne, 8.15 a.m.-12.30 p.m., ex. Sundays.
31.35	W1XAZ	Springfield, 12 midday-6 p.m.
31.38	DJA	Berlin, 1-4.30 p.m., 9.15 p.m.-2.30 a.m.
31.48	W2XAF	Schenectady, 11.25 p.m.-4 a.m., Sundays 11.25 p.m.-6.30 a.m.
37.33	CNR	Rabat, 7.30 p.m.-midnight.
42.02	HJ4ABB	Manizales, Monday-Friday 5.15-6 a.m. Sunday 7.30 p.m.-midnight.
44.41	WOA	Lawrenceville, commercial transmission 7 p.m.-midnight.
45.30	PRADO	Riobamba, Thursday 2-6.30 p.m.
46.53	HJ1ABB	Barranquilla, 4.30-6 p.m., 10 p.m.-3 a.m.
48.86	W8XK	Pittsburgh, 9.30 p.m.-6 a.m.
48.94	LKJ1	Jeloy, 3-9 p.m.
49.02	W2XE	New York, 11 p.m.-4 a.m.
49.18	W3XAL	Boundbrook, Monday, Wednesday, Saturday 11 p.m.-5 a.m., Saturday midnight-6 a.m.
49.3	I2RO	Rome, Monday, Wednesday, Friday 11 p.m.-midnight.
49.41	OER2	Vienna, 2-7 p.m.
49.50	OXY	Skamleboeak, 5-11.30 p.m. Sundays, 4-midnight.
49.50	W8XAL	Cincinnati, 12.30 p.m.-1 a.m., 4-6 a.m.
49.50	VQ7LO	Nairobi, Monday, Wednesday, Friday, 10.45-11.15 a.m., 4-7 p.m. Saturdays 4-8 p.m., Sundays 3.50-7 p.m.
49.50	W3XAU	Newtown Square, 11 p.m.-8 a.m.
49.75	YV6RV	Valencia, 11 p.m.-1 a.m.
49.92	COC	Havana, 9-midnight.
49.96	VE9DN	Montreal, 4.30-6.30 a.m.
50.00	RW59	Moscow, 8 p.m.-2 a.m.
55.96	HAT	Budapest, 9-11 p.m., Sundays only.
85.96	PK1WK	Bandoeng, daily ex. Friday, 9.30-10.30 a.m.
90.22	HCJB	Quito, 12.15-6.15 a.m. daily.

An order placed with your
newsagent will ensure regular
delivery of TELEVISION
AND SHORT-WAVE
WORLD

Scannings and Reflections

By THE LOOKER

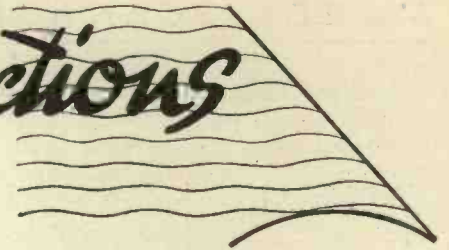

The Cinema's Veto

CINEMA interests are taking time by the forelock. They do not like the potential threat—we should prefer to call it the co-operation—of television to provide cinema news-reels. The exhibitors are organising the cinema industry to veto televised news pictures and I take this to mean both the exhibition of news pictures televised from their source and the supply of cinematograph film for television displays. Presumably, this would affect the supply of news pictures to the B.B.C. for television from their London station, and it may be necessary for the B.B.C. to make their own arrangements for the production of their own films.

The cinema people have an eye to their story and general films as well, and I understand that the new standard contract between the renter and his exhibitors stipulates that films must not be televised until the lapse of three months from the last picture-house booking.

But the Cinema Need Not Worry

Great as my faith is in the future of television I am unable to believe that the televised picture will affect the ordinary cinema for years to come. Even when we are given perfect transmission, reception and projection of the televised image, what then? It is not every cinema-house will wish so to stereotype its programme as to put on exactly the same features and at precisely the same time as every other picture-house in a wide district. I know it is quite idle to prophesy, but if I were in the cinema business I should discount television as a competitor for quite a while.

The cinema is about to give its public pictures in full colour and possibly of stereoscopic quality and can take care of itself quite well; at any rate, for a long time to come. Of course, there has long been talk of television in colours and years ago

we saw Baird's efforts in that direction; but colour television at the moment is nothing more than a hope based upon some crude but interesting laboratory experiments. When television does arrive as a means of public entertainment, it will revolutionise everything. But there is plenty of breathing space yet awhile.

Television Cinema in Berlin

However, Germany appears to believe that the television news theatre is already an attractive proposition, judging by the report that the Reich Film Bureau is proposing to form a television news-reel company in conjunction with some of the leading German news film companies. There is some hope of opening the first theatre of the kind, in Berlin, at an early date.

Red Heads

How the daily Press has been enjoying itself about the B.B.C.'s ban on red heads and married women from the post of television woman announcer! Any amateur photographer will tell you that red is a difficult colour. When you direct a beam of light upon it, so much of the light is absorbed that what you get back, either on your photographic plate or on your bank of photo-electric cells, is scarcely worth having. So the ban on the red head is purely a technical one and has nothing whatever to do with any dislike which the B.B.C. might be supposed to have for irritable people. Aren't red-headed people irritable? The marriage bar has nothing whatever to do with the colour of the woman announcer's hair; "an unmarried woman would be better fitted for the task than one who has home and other ties to take up her time and attention."

That £180,000

The question of finance, as I prophesied in a recent issue of TELEVISION AND SHORT-WAVE WORLD, is causing the B.B.C. concern. Working on an allocation of only £180,000

they find that the installation of the transmitting plant will cost at least £120,000, which will leave of the allocation only £60,000 which has to cover the alteration and reconstruction of part of the building and the provision of the programme until the end of 1936. I prophesy that a bigger allocation will be made and am quite certain that the introductory service will not be spoilt for the lack of a few thousand pounds. Everybody expects that the Ullswater Committee will make a special recommendation in its report, shortly to be published, but whether it does or not, I am quite certain that funds will be found for an adequate experimental service. There is talk of the B.B.C. being unable to finance television and calling for either a special television loan or a separate licence to be issued to "viewers." Neither course is necessary. The B.B.C.'s income has grown amazingly the last year or two and I believe that the Corporation can find the money if it wants to.

U.S.A.

It is difficult to learn exactly what is happening in the United States, the reports are so conflicting. We hear of television transmitters being built at Philadelphia, New York, Boston, Washington, Chicago, San Francisco, Los Angeles and either Seattle or Portland, each designed to serve an area having a 30-mile radius. The snag is finance. There is no opposite number in the States to our B.B.C. There are no licences. Every station is the property of a commercial concern which looks to radio advertising, directly or indirectly, for its means of support. The stations are linked together to form two or three powerful groups which can put through simultaneous broadcasts whenever desirable. It can easily be seen that the running of a television transmitting station in these early days is hardly likely to be a commercial proposition, and the Government of the United States has been asked to consider the financing of the initial stations.

MORE SCANNINGS

A New Help for Air Pilots

The National Physical Laboratory, subsidised by the Air Ministry, is engaged in research into the possibility of using some kind of television transmissions for guiding the pilots of aircraft to their landing grounds in foggy weather or when snow is falling, the *Wireless World* tells us. The scheme under consideration is that, once the position of the aircraft has been fixed by means of the direction-finders, a map of the landing ground and the surrounding country shall be projected on to the viewing screen situated in front of the pilot. His own position can then be indicated to him at any instant by means of a moving spot of light. As he would know the height at which he was flying by means of his altimeter, it should thus be possible for him to land safely in the thickest weather.

Electron Optics

Electron optics, a new branch of the ever-extending field of science made possible by the introduction of the electronic tube, will one day be a big subject. In this issue appears the first of a series of articles written by Dr. Levin, discussing in simple fashion its principles and practice.

A Sign of the Times

An advertisement appears in the daily press of a block of luxury flats in Mayfair which is "the first completed building in London to be equipped with television facilities; each flat is to be fitted immediately with central aerial system, providing unique service for individual reception by tenants' own sets of wireless programmes and television."

Transatlantic 6-metre Work?

Is it possible to hear the 6-metre Berlin television transmitter in New York—3,500 miles away? Somebody claims that the signals were received in New York and gave a recognisable picture, but I doubt it, especially as the chief transmitter used for this 6-metre work was very badly damaged in the fire at the Berlin Radio Exhibition last August. By the time these words are in print the transmitter may again be working.

Television Arrives

"Soft Lights," a film in which the Western Brothers appear, is to be

produced by the British Lion Film Corporation, Ltd., and is to have a television theme.

The Paris Station

The 180-line transmitter at the Eiffel Tower was conceived and completed in the short space of seven weeks and this included the re-designing of the existing broadcasting studios at Rue de Grenelle, Paris, and the installation of a special high-frequency cable between the studio and the Eiffel Tower. Readers will be interested in the illustrated article on the subject in other pages of this issue, in which we give details of the station and system. France is to be congratulated on getting an official television transmitter at work. There is a glamorous touch in the references in the French Press to the programme to be expected from the new station: "Le programme avait été choisi avec soin: des vedettes, des airs populaires, des danses célèbres, l'émotion profonde du grand art, le charme et l'entrain des airs à la mode."

On a Searchlight Beam

President Roosevelt talked from the top of Whiteface Mountain to the Lake Placid airport (New York), a distance of 6 or 7 miles, over a powerful searchlight beam modulated by the voice frequencies, and it is understood that the experiment was highly successful.

Castellani's Scanner

A new cathode-ray scanner is the Telepantoscope, invented by an Italian, Arturo Castellani. It affords, as an article on another page explains, a direct television scanner of very simple form.

Amateur-built Receivers

Mr. Philo T. Farnsworth, vice-president of Farnsworth Television Incorporated, of U.S.A., a company which is exchanging the use of patents with the Baird Company in this country, expresses his belief that it is technically feasible for radio experimenters to build their own television receivers, and he proposes to release information allowing of their doing so immediately there are a few television broadcasting stations transmitting consistent programmes. In his opinion, the cost of parts in the United States for such receivers

will be between £10 and £20. I note with great approval the expression of his opinion that by opening the television art to the amateur experimenter, television will progress much more rapidly towards a commercial service. Readers will see that Mr. Farnsworth has especially approved the article in the present issue of TELEVISION AND SHORT-WAVE WORLD describing his multipactor tube.

Quite a Good Idea

Four R.C.A. radio engineers have been sent from Washington to erect a transmitter at the American Legation at Addis Ababa, the idea being that America shall be first with the news, for the station is being linked up with Riverhead, Long Island, so that "eye-witness reports of the activities in the fighting area can be relayed to all American listeners." And now we must get the Abyssinian authorities to allow the eye-witnesses!

Talking to a Speed Boat

A new use has been found for ultra-short-wave radio. While travelling over Lake George at sixty miles an hour, Bennet Hill, of Detroit, the American speed-boat pilot, broadcast from his boat to the judges' stand. Engineers there were able to hold a two-way conversation with the speed-boat.

A New Dutch Transmitter

The new Philips television transmitter was recently demonstrated before members of the Royal Institute of Dutch inventors at the Philips' laboratories. The transmitter has been designed for a modulation frequency of 3 megacycles and employs an Iconoscope tube. A wavelength of 7 metres was used and outdoor scenes of crowds were transmitted direct and not by the intermediate film method. The Iconoscopes used were made in the Philips' laboratory. It is interesting to see the Philips Company concerning itself in this way. They have always been pioneers in radio and their co-operation must be to the good of television.

Alexandra Palace

Work at the Alexandra Palace proceeds apace, but up to the present it has only amounted to demolition. There is a lot to do to get the building ready by the time stipulated in

AND MORE REFLECTIONS

the contracts for the supply of the Baird and Marconi-E.M.I. transmitters respectively.

Kerr Memorial Lecture

Congratulations to Mr. John L. Baird in being invited to deliver the first Kerr Memorial Lecture under the auspices of the Television Society, at the Royal Institution. Sir Ambrose Fleming honoured the proceedings by presiding. John Kerr was a remarkable man and although in his time television was one of the utter impossibilities, he had more than a glimmering that his plate cell, just one of many clever things which he conceived, would be found a valuable instrument in the days to come. Mr. Baird truly said in the close of his lecture that Dr. Kerr would be delighted if he could see the uses to which his cell has been put.

New Technical Terms

The use of the cathode-ray tube has added new words to the language and elsewhere in this issue in an abstract from the proceedings of the Institute of Radio Engineers, defining a number of them.

High-frequency Cables

Recent notes in TELEVISION AND SHORT-WAVE WORLD have outlined the construction of the special cables now being developed for carrying the high frequencies necessary in television work. This month further details of the construction of one or two such cables are given.

Renewed German Television Activity

The Berlin-Witzleben high-power ultra-short-wave television transmitters were, it will be remembered, destroyed by the fire at the German Radio Exhibition. Shortly after the close of the exhibition the German Post-Office took up television broadcasts with a small auxiliary 20-watt television transmitter. Only sight was broadcast, sound being supplied to various public televiewing rooms in the neighbourhood along special lines. But the range of this 20-watt auxiliary outfit was extremely limited even though it had been placed on the roof of the Berlin Trunk Exchange near the centre of the town.

Speedy Work

The Post-Office which had decided to take up high-power ultra-short-wave television broadcasting at the earliest possible moment again, gave orders to Telefunken to supply twin transmitters similar to those which were destroyed by the fire, with the least possible delay. As it would have taken some months before suitable transmitters for 240 lines and 25 frames-per-second could be ready the Post-Office and Telefunken decided to limit the new outfit to 180 lines and 25 frames. Work on these transmitters has been completed and they have been installed in a temporary transmitter building situated at the foot of the Witzleben radio tower. Operation was planned to start before Christmas (before these lines appear in print). Except for minor improvements the two ultra-short-wave transmitters will be identical with those destroyed.

Programmes will, as before, be supplied by the German Broadcasting Company and will mostly consist of films or scenes taken by the help of the intermediate film reporters' van. Tests carried out with the new transmitters have proved satisfactory.

German Viewing Rooms

The dissolution of the German Listeners' Association which will take place on January 31, 1936, will not affect television as the public televiewing rooms which were operated by this association were additional to public televiewing facilities provided by the Post-Office. The Post-Office will, it is supposed, now supply these localities hitherto served by the Listeners' Association, with suitable public televiewing apparatus. These rooms, it will be remembered, are open during television broadcasting hours, and no charge is made for admittance.

The Brocken Tests

The German Post-Office have decided to leave their mobile television transmitting unit on the summit of the Brocken mountain during the winter in order to determine, by practical test, whether it will be possible to provide an all-the-year-round television service on ultra-short-waves from there. In spite of electrically-heated aerials, a certain amount of

ice formation has been observed, which causes a leakage of energy.

The first official data is now available as to the range of the high-power ultra-short-wave transmitters situated on the Brocken mountain. To the north a service range of about 60 miles has been established, but, curiously enough, the range is only about 30 miles to the south. These tests have proved that it will be possible to supply the towns of Magdeburg, Nordhausen, Hannover, Hildesheim, Braunschweig and Aschersleben with a sight-and-sound television service from there. On the other hand, the large towns of Halle and Leipzig will be outside the range.

Distant Modulation

The hope expressed some time ago, that it might be possible to modulate a television transmitter on the Brocken by wireless link from the Berlin-Witzleben station has not been fulfilled. Reception of the Berlin-Witzleben signals on the summit of the Brocken (this is well beyond the optical range) were registered, but not with sufficient regularity and strength to provide modulation for a transmitter. Experiments with the short length (about 12 miles) of special television cable recently laid in Berlin are therefore being continued and have provided very promising results.

The head of the German Post-Office's television department, Oberpostrat Dr. Banneitz, recently stated at the end of a lecture that in spite of the favourable results and the intensive research work at present being undertaken by all those concerned in the development of German television it will still take some years before every German could become a televiewer like they can now become listeners.

South London and District Radio Transmitters Society

On Wednesday, January 1, 1936, at The Brotherhood Hall, Knight's Hill, W. Norwood, a lecture will be delivered to the members of this Society by Mr. A. T. Mathew, B.Sc., G5AM.

The lecture, entitled "Factors Affecting Radio Propagation," will commence at 8 p.m. A full attendance of members, prospective members and visitors is hoped for.

THE TELEPANTOSCOPE

A NEW CATHODE-RAY SCANNER

First details of a new type of cathode-ray scanning device.

THE Iconoscope of Zworykin and the dissector tube of Farnsworth have been dealt with in detail in previous issues of this journal. Here is a brief description of a new type of apparatus of this kind

In the first cylinder is a cathode-ray electrode system with an indirectly-heated cathode. The beam is focused by the usual Wehnelt cylinder, and electron-optical system on to a rectangular photo-sensitive plate, connected to a terminal on the top of the tube.

In addition to the electron emitting mechanism in the cylindrical portion of the tube, are two parallel deflector plates between which the beam passes. The application of a suitable deflecting potential at high-frequency to these plates causes the beam to sweep across the photo-sensitive surface. This apparatus forms a tele-cine or even direct television scanner in a very simple form.

In the case of tele-cine transmission (Fig. 2), the Telepantoscope is enclosed in a dark box and the cinema film is projected through a

transparent window of the bulb on to the photo-sensitive plate. The projected image of the film is thus passed across the plate at the rate of 25 pictures per second, and if at the same time the beam is caused to traverse the plate in a direction at right angles to the passage of the image, a complete scan of the picture is accomplished.

The variations of current corresponding to variations in luminous intensity on the plate, are transmitted to a pre-amplifier mounted close to the apparatus. The production of the synchronising signal is by means of a motor-driven perforated disc and two photo-cells, on which a small beam of light is thrown through the holes in the disc.

For direct television an analogous system is used (Fig. 3), but it is clearly not sufficient to project the image of the scene direct on to the plate. To provide the necessary transverse component of the scanning movement, the scene is projected on to the plate through a mirror-drum, which is of small diameter and has a large number of mirrors. The drum is usually mounted on the same shaft as the synchronising disc to ensure perfect synchronisation.

It will be noted from the above that only a narrow strip of the photo-sensitive plate is used as an emitter, which ensures stable results. By displacing the spot on the plate by a small amount at regular intervals, it is possible to utilise the whole of the emitting surface.

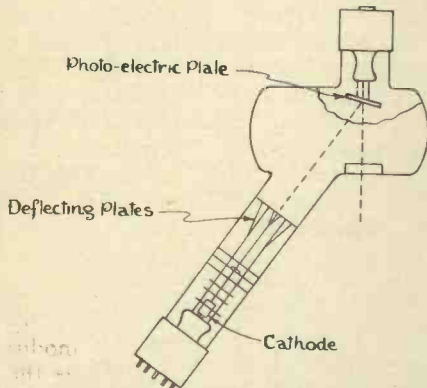

Fig. 1.—Schematic diagram showing the construction of the Telepantoscope.

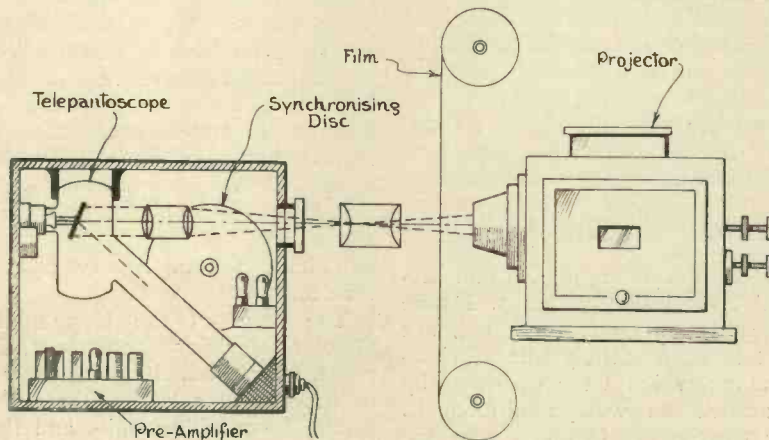

Fig. 2.—Method of employing the Telepantoscope for transmission of film.

developed in Italy for which several novel claims are made.

An Italian inventor, Mr. Arturo Castellani, who is well-known for his numerous researches in television, has recently developed a new cathode-ray scanning device for which several advantages are claimed, including greater relative simplicity, than the apparatus mentioned above.

This interesting apparatus, to which the name Telepantoscope has been given, comprises in principle a long cylinder, terminating in another cylinder of larger diameter, mounted obliquely with respect to the first. This second cylinder is coated internally, and has a single window on its lower portion, as shown in Fig. 1.

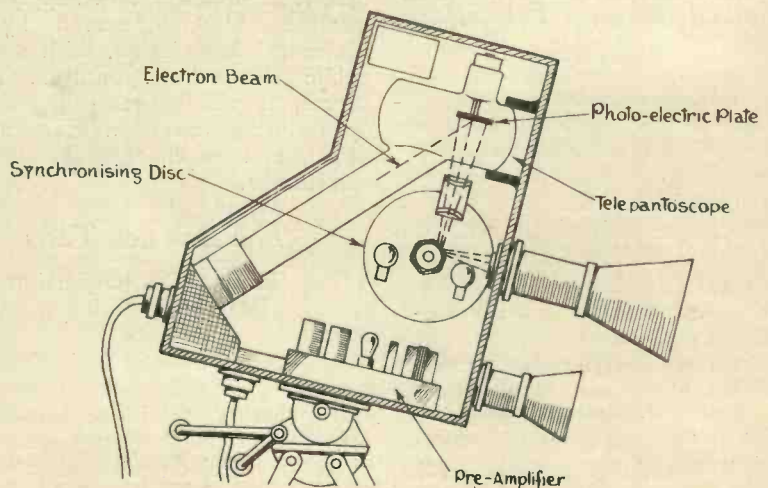

Fig. 3.—The Telepantoscope camera used for direct pick-up.

An Amateur Communication Receiver

By
Kenneth Jowers

This is a battery operated four valve receiver with two high-frequency stages designed to give maximum range with low noise level. One of the main features is permanent band-spread between 30 and 1.5 mc.

A SERIES of tests were arranged between British and American amateurs which took place on Christmas morning and Boxing Day. Stations on both sides of the Atlantic were operating on frequencies of between 1,850 and 1,960 kc., a band which is not normally used for DX work.

In view of the change in conditions during November it was realised that British stations would stand a very good chance of working the Americans on the 160-metre band.

This receiver was designed specially for these tests for although the normal multi-valve receivers were operating satisfactorily something very special had to be used if the signals were to be brought up in strength sufficiently to beat the prevailing noise level.

For that reason a battery-operated two-H.F. set was decided upon, but included many refinements that have in recent years been omitted from large receivers.

The old argument as to whether to use a straight or superhet set did not arise for when noise level is high the straight set is more satisfactory.

There is considerable difficulty in matching up three coils so that they maintain their sensitivity over all wavebands. Although in the A.C. version of the two-H.F. receiver home-made coils with internally-mounted pre-sets were used with complete satisfaction, it generally took at least an hour to wind three coils of the required inductance.

To overcome this difficulty a new system of tuning was decided upon so that standard commercially wound coils could be used without having any trouble in ganging.

Tests were then made to determine whether or not three tuned stages offered any material advantage over two tuned stages. By omitting the intermediate tuned stage the decrease in gain and selectivity was so slight as to be completely ignored.

By this means ganging and coil difficulties were very much simplified for it is a comparatively easy matter to gang up two coils without auxiliary trimmers. In view of the great sensitivity and DX properties of this type of set it is obvious that to use it on one or two bands only would be a

real waste, so that in addition to the 160- and 80-metre bands, it had to be ultra-efficient on all other wavebands. This meant that the band-spread condenser on 160-metres would be too large on 20-metres and *vice versa*.

After making up an experimental chassis the conclusion was formed that a multiplicity of knobs was not a disadvantage, but in fact made the receiver so flexible that in the end it was better than the A.C. version with its advantage of higher voltage and more efficient valves.

Two bandspread condensers were ganged together and arranged so that on 20 metres the amateur channel covered 100 degrees of a 180-degree dial, on 40 metres 150 degrees, and almost the entire scale on 80 metres.

Unfortunately on 160 metres the 15 micromicrofarad condensers would not cover the whole band, but to overcome this the band-setting condensers simply

spreading condensers. Actually all one has to do is to turn the band-setters until each coil is tuning to 40 metres, for example, and then cover the amateur-band with the major band-spread condenser.

The Circuit

The final circuit is shown by the diagram and consists of four valves used in the following way. The aerial is fed into the primary of the first coil through a .00015-mfd. series aerial condenser, this condenser becomes progressively more important and effective as the frequency is increased. On 160 metres, however, it is shorted out of circuit. This is done by simply bending over the edge of the outer rotor plate so that it shorts on to the stator when all the plates are in mesh.

Across the grid of this coil is a .0001-



The tuning dial has a travel of 8 in. when used on the 14 mc. band.

have to be adjusted and the top band band-spread in two sections.

Band-setting condensers at once made the use of special coils quite unnecessary, for coils of different makes can be used as differences in inductance can be taken up by adjustment of the band-

mfd. band-setting condenser and .000015-mfd. band-spread condenser. The band-setter is mounted on the rear screen which can be seen in the plan view. This screen, of course, is at earth potential so that only one wire need be connected to each of the band-

setting condensers, that is to the stator. The first H.F. valve is a four-pin pentode with the suppressor grid connected internally. This valve was no better than a screened-grid on the lower frequencies, but gave a decided boost to weak signals on the higher frequencies when compared with the screened-grid.

more efficient than when using the standard type of condenser.

A little trouble was taken to determine the best value of grid leak. A 2-megohm to L.T. negative was quite satisfactory, but decreased gain somewhat. A potentiometer across the filament supply helped considerably, but

sides being specially picked, is bypassed to earth on both sides. On the anode side is a .0001-mfd. condenser, and on the H.T. side a .001-mfd.

This stops H.F. quite comfortably and at the same time prevents any arc-over in the output pentode.

The volume control decided upon is a $\frac{1}{2}$ -megohm potentiometer across the secondary of the transformer and so as to keep the number of controls as low as is possible and still have flexibility, the on-off switch is embodied in this control. In series with the grid of the output pentode is a 100,000-ohm series resistance, which finally removes all traces of H.F. in the output stage.

Although the auxiliary grid can be run at maximum potential by reducing this slightly, the anode current was materially reduced without decreasing gain so to that end a 5,000-ohms resistance is connected in series with the grid and by-passed by an .01-mfd. condenser.

In the anode circuit of the Pen.220A is a small L.F. choke in parallel with a 100,000-ohm resistance. This, in conjunction with the 2-mfd. condenser, forms the choke-filter output circuit. A .002-mfd. condenser is connected from the anode of the Pen.220A to chassis.

Tone correction although not necessary from a quality point of view is essential when receiving weak signals, which are inclined to be overcome by mush. This tone corrector consists of an .01-mfd. condenser in series with a 50,000-ohm resistance from the anode of the output valve to the chassis. The

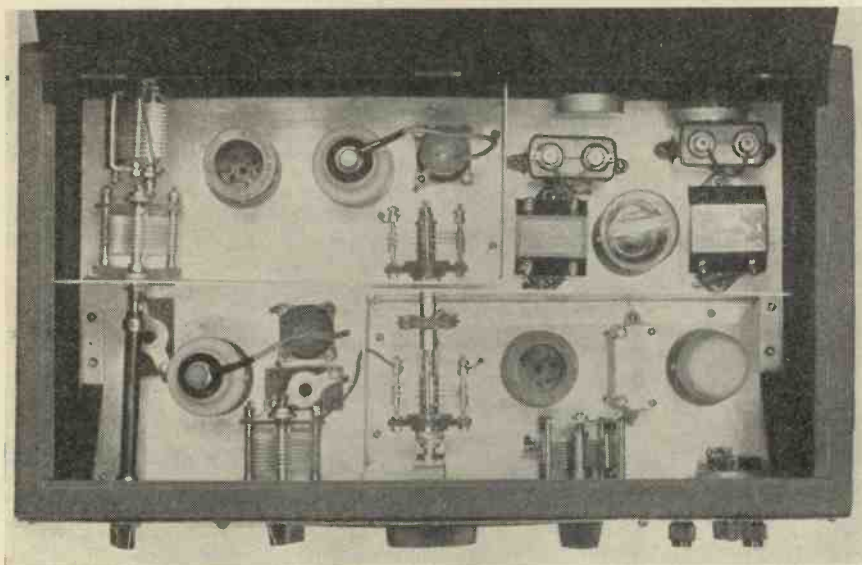

An air spaced grid condenser is another important feature while two independent screens are used.

Between anode and grid of the first and second valve is a .00005-mfd. pre-set condenser, while the grid return is an unscreened choke. The screening grids of the H.F. pentodes are linked together through 10,000-ohm resistance and decoupled with .01-mfd. condensers.

High-tension for the two screens and for the anode of the detector is controlled by means of a 50,000-ohm variable resistance. It was found that the correct screen and anode voltage was round about 60/70 so that the common resistance was entirely suitable.

It is most important to include a resistance of 500 ohms in series with the anode of the first H.F. amplifier and decouple this with another .01-mfd. condenser. The input to the grid of the triode detector is fed through a .00005-mfd. pre-set condenser and to obtain really smooth reaction on all wavebands this should be adjusted for optimum results. The tuning arrangements for the detector circuit are identical with the input circuit to the first valve, except that the band-setting condenser is mounted on the left of the panel as indicated in the front view. Although the rotor of the band-setting condenser is at earth potential the automatic connection to the front panel should not be relied upon.

The grid condenser in the detector stage is an air-spaced .000091, an unusual type and capacity, but the improvement in results can hardly be credited. Noise level is reduced quite appreciably while the detector circuit is

results were equally good when a 5-megohm leak was taken to L.T. positive, so cutting out the potentiometer.

Particular care was taken in the design of the detector and L.F. stages,

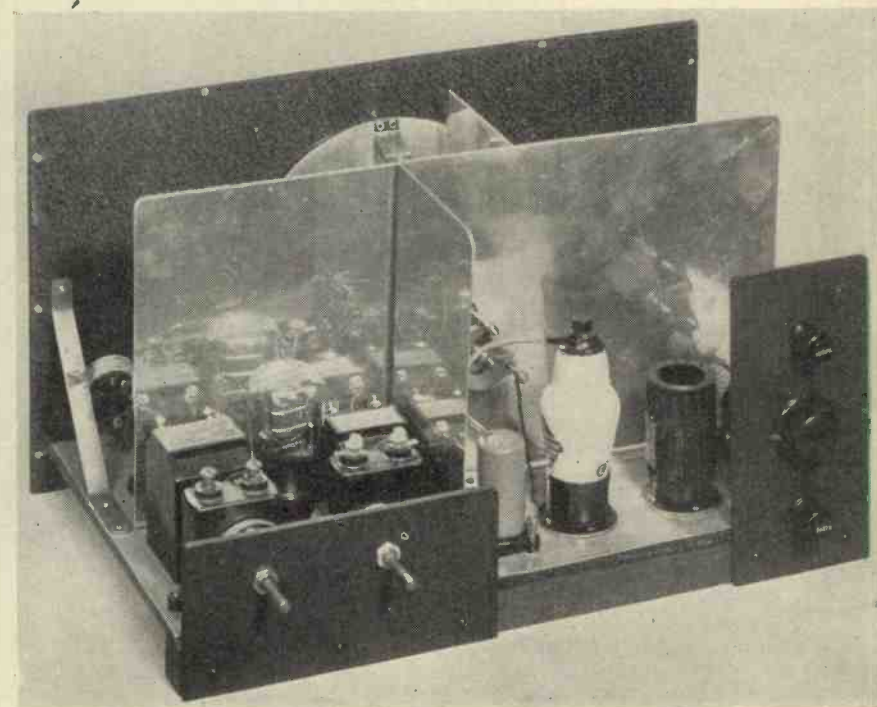

Special ebonite mounting pieces are required for the components at the back of the chassis. This overcomes the use of bushings.

for this end of the receiver can cause a lot of trouble. First of all the H.F. choke in the anode of the detector be-

control knob is actually at the back of the metal case next to the variable voltage control.

Grid bias is obtained automatically for the output pentode by means of a 500-ohm resistance between H. T. negative and L. T. negative, by-passed with a 1-mfd. condenser.

As the entire receiver takes 22-milliamps. a bias of approximately 11 volts is applied to the pentode valve. Those readers who are confined to accumula-

metrical. The high-frequency stage band-setting condenser is actually bolted on to the first screen. Coupling pieces are provided so that the microcondensers can be linked together. As the rotors of both band-spread condensers are at earth potential there is no need to worry about bushing.

The baseboard is 16 ins. by 9½ ins. by

tance and tone control are mounted on small angle brackets at the rear of the chassis and as close up to the edge as possible. In this way a large hole can be drilled at the back of the chassis to take the spindles. Otherwise if the controls are actually bolted to the cabinet the receiver has to be partially unwired before it can be removed from its cabinet.

Another point, make quite sure that the aerial series condenser is carefully bushed, so that the rotor cannot make contact with any earthed part, for this will obviously cause a short-circuit.

A four-way battery cable is provided for the power supply and these are made up of H. T. positive, H. T. negative, L. T. positive and L. T. negative. The connections are taken directly to the components in the receiver so obviating any connecting plugs or terminals.

Operation

Operation is perfectly straightforward on all wavebands and does not need any special comment. A point, however, is that reception down to 28 mc. is perfectly satisfactory, and sensitivity does remain at a high order. During a daylight test the following stations were some of those heard using phone on 28 mc.: VE1GH, W9BHT, CO6OM, W3AUC, W5DDP, 10-metre C.W. included four continents.

On 160 metres night-time reception has been very satisfactory owing to the extremely low noise level, and by careful manipulation of the input condenser stations such as G5VT on 1,916 kc. and G2OV on 1,913 kc. could just be separated.

With a short aerial and a wave-trap in circuit 160-metre duplex working was successfully carried out with stations at the other end of the band.

By overrunning the valves with an anode potential of 170 volts there is an extraordinary increase in gain, and although the valve manufacturers will most probably frown on the idea, it is certainly useful when conditions are bad. Even without special decoupling the receiver is perfectly suitable for mains operation.

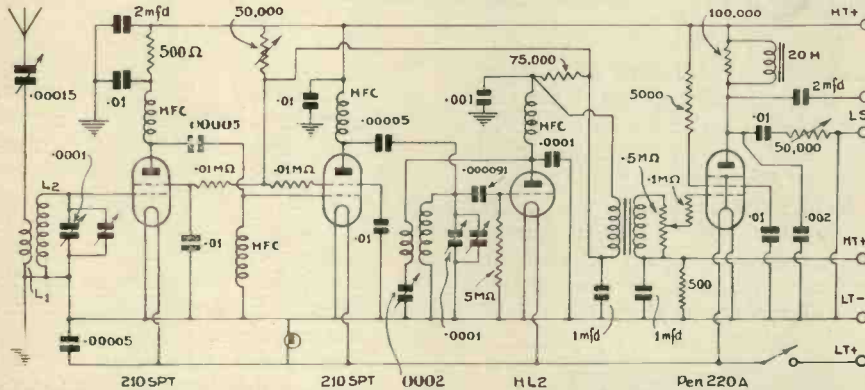

One untuned H.F. stage overcomes the problem of coil matching experienced with three tuned stages.

tors or dry-batteries for high-tension will be advised to use a Pen.220 and a 400-ohm bias resistance, as this will reduce the total consumption to 10 milliamps, a much more reasonable figure.

The metal case supplied by Eddystone is fitted with a metal panel. This is quite light gauge and the tuning drive and escutcheon can be fitted without any trouble. A template is given so that it is almost impossible to make any errors when cutting the holes. Notice that there are five front panel knobs. The first is the aerial band-setter, the second detector grid band-setter, third tuner, fourth reaction, fifth volume and on-off switch.

These controls can be arranged so that the front panel looks quite sym-

metrical, and is covered with a sheet of 20-gauge zinc. Zinc is used because wiring can be soldered directly to it.

Across the underneath of the baseboard at the back is fitted a runner of wood 16 ins. by ¾ in. by 1 in. This is simply to keep the baseboard off the bottom of the cabinet. A 1-in. clearance is required to take the Clix valve holders and the various small condensers and resistances.

Even though the panel is screwed to the cabinet with ten bolts, it is really advisable to use the two angle brackets so as to make quite sure that there is no panel movement which would upset the tuning. This small idea is most important on 10 and 20 metres.

The variable voltage-dropping resis-

BATTERY BAND-SPREAD 2-V-1

BASEPLATE.

- 1—20-gauge zinc 16½ in. by 9½ in. (Peto-Scott).
- 1—¼ in. wood 16½ in. by 9½ in. (Peto-Scott).

CABINET.

- 1—type 1034 (Eddystone).

CONDENSERS, FIXED.

- 6—0.01-mfd. type 411 (Dubilier).
- 1—0.001-mfd. type 665 (Dubilier).
- 1—0.01-mfd. type 4511 (Dubilier).
- 1—0.002-mfd. type 4511 (Dubilier).
- 2—2-mfd. type BB (Dubilier).
- 2—1-mfd. type 4513 (Dubilier).

CONDENSERS, VARIABLE.

- 1—0.0002-mfd. type 957 (Eddystone).
- 2—0.00015-mfd. type 900 with coupling pieces (Eddystone).
- 2—0.001-mfd. type 1054 with quarter spindles (J.B.).
- 2—0.0005-mfd. type 1087 pre-set (J.B.).
- 1—0.0015-mfd. type 1053 with quarter spindle (J.B.).

COILS.

- 2—sets of four-pin type 932 (Eddystone).

CHOKES, HIGH-FREQUENCY.

- 2—type CHN National (Raymart).

- 2—Screened H.F. P.A. with spade tags (Wearite).

CHOKE, LOW-FREQUENCY.

- 1—Ni-choke II (Varley).

DIALS.

- 2—3-inch type 1027 (Eddystone).

- 1—wide-vision 973 (Eddystone).

HOLDERS, VALVE.

- 5—four-pin chassis-type less terminals (Clix).
- 1—five-pin chassis-type less terminals (Clix).

PLUGS, TERMINALS.

- 4—terminals type B marked Aerial, Earth, L.S. pos. L.S. neg. (Beling Lee).
- 2—Wander plugs marked H.T. pos., H.T. neg. (Clix).
- 2—Spade terminals marked L.T. pos., L.T. neg. (Clix).

RESISTANCES, FIXED.

- 2—10,000-ohm type HW15 (Bulgin).
- 1—500-ohm. type HW2 (Bulgin).
- 1—5-megohm type HW36 (Bulgin).
- 2—100,000-ohms. type HW25 (Bulgin).
- 1—75,000-ohm type HW24 (Bulgin).
- 1—5,000-ohm. type HW10 (Bulgin).
- 1—500-ohm type WE10 (Bulgin).

RESISTANCES, VARIABLE.

- 1—50,000-ohm potentiometer (Erie).
- 1—500,000-ohm. potentiometer with switch (Erie).
- 1—50,000-ohm potentiometer (B.T.S.).

SUNDRIES.

- 1—D9 dial light with one B206 bulb (Bulgin).
- 2—Aluminium screens to specification (Peto-Scott).
- 2—Extension control knobs type 1008 (Eddystone).
- 2—large panel brackets (Bulgin).

TRANSFORMER, L.F.

- 1—Nictel type DP22 (Varley).

ACCESSORIES.

ACCUMULATOR.

- 1—2-volt 45-ampere (Exide).

BATTERY.

- 1—super 120-volt (Vidor).

VALVES.

- 2—210SPT met 4-pin (Cossor).
- 1—HL2 met (Ediswan).
- 1—Pen. 220A. (Ediswan).

Slow Morse Transmission for January

	G. M. T.	Kcs.	Station.
Jan. 2	23.00	1990	G6AU
" 4	22.45	1930	G5OD
" 5	09.00	1860	G6QM
" 5	09.30	1785	G5BK
" 5	11.00	7104	G6PJ
" 5	12.00	7149	G5GC
" 9	23.00	1990	G6AU
" 16	23.00	1990	G6AU
" 18	22.45	1930	G5OD
" 19	09.00	1860	G6QM
" 19	09.30	1785	G5BK
" 19	11.00	7104	G6PJ
" 19	12.00	7149	G5GC

THE CONSTRUCTION OF HIGH-FREQUENCY CABLES

By Robert I. Rosenfelder

Here are some particulars of the high-frequency cables which are being developed to carry the enormously high frequencies necessary to interlink television stations.

ULTRA-SHORT waves being quasi-optical with an approximate range of 25 miles, the possibility of transmitting by line the very high frequencies necessary for high-definition television has been under investigation both in Europe and America.

Some details of the construction of such lines are given in British Patent

ported by hard rubber discs spaced at intervals along the inner wire. These individual cable structures have been made in several sizes of the order of $\frac{1}{2}$ in. diameter or less.

While coaxial lines have a relatively high loss at high frequencies, the transmission path is particularly well adapted to the frequent application of repeaters, since the shielding

from 50 to 1,000 kilocycles. They require a supply of about 150 watts.

Theory and experiments carried out show that the width of the transmitted band is controlled by the repeater spacing and line size:

1. For a given size of conductor and given length of line, the band width increases nearly as the square of the number of repeater points.
2. For a given repeater spacing the band width increases approximately as the square of the conductor diameter.

It has been found that for a coaxial circuit with about 0.3 in. inner diameter of the outer conductor a 10-mile spacing will enable a band up to about 1,000,000 cycles to be handled. An interesting condition exists with regard to the relative sizes of the two conductors. There is an optimum ratio of diameters which gives a minimum attenuation and, at high frequencies, is practically independent of frequency. The value of the optimum diameter ratio is about 3 to 6. The high-frequency characteristic impedance of a coaxial circuit depends merely upon the said ratio and not upon the absolute dimensions. For a diameter ratio of 3 to 6, the



Section of a high-frequency cable; insulation consists of a cotton string wound spirally round the inner conductor.

353,020, May 23, 1929, and in the Bell System Technical Journal, October, 1934.

The cable circuit differs from existing types in that it is unbalanced, i.e., one of the conductors is grounded. It consists essentially of an outer conducting tube which envelops concentrically an axial conductor. The high-frequency transmission circuit is formed between the inner surface of the outer conductor and the outer surface of the inner conductor. By virtue of skin effect, the outer tube serves both as conductor and as a shield to the currents to be transmitted.

permits the transmission currents to fall to lower power levels at high frequencies. The repeater is of outstanding importance in this type of system for it must not only transmit the wide band of frequencies with a transmission characteristic inverse to that of the line, and have automatic regulation to take care of temperature changes, but must also have sufficient freedom from inter-modulation effects to permit the use of large numbers of repeaters in tandem without objectionable interference. They

Two Types

Actually, two types of flexible structure have been developed. In one type, the outer conductor is formed of overlapping copper strips held in place with a binding of iron or brass tape. The insulation consists of a cotton string wound spirally around the inner conductor which is a solid copper wire. The outer conductor may be surrounded by a lead sheath, especially when used as an individual cable.

Another type of flexible structure has an outer conductor in the form of a lead sheath which surrounds the inner conductor, the latter being sup-

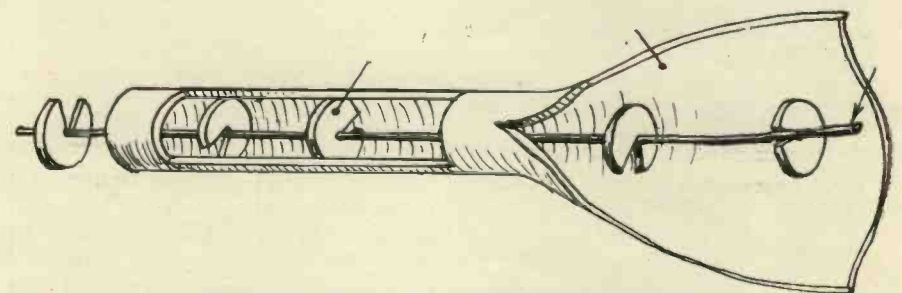

In this type the inner conductor is supported by hard rubber discs.

should be capable of amplifying the entire frequency band *en bloc*. Thus, amplifiers using the reversed feedback principle (see *Electrical Engineering*, January, 1934, p. 114-120) have been extended to higher frequency ranges, and meet the gain requirements for the frequency band

impedance of a coaxial circuit is about 75 ohms.

For a coaxial line the velocity of propagation at high frequencies is substantially constant. It minimises the correction required to bring the delay distortion within the limits re-

(Continued at foot of next page.)

JANUARY, 1936

Amateur Radio W9DXX

W₉DXX, operated by Alice R. Bourke, in Chicago, is one of the few American YL-operated stations which holds its own with other high-power W's. This station is one of the most efficient in the States as is proved by the extraordinary number of countries worked on 40 and 20 metres.

W₉DXX was for many years the crime reporter to the *Chicago Tribune*, and had quite a number of varied experiences before taking up amateur radio a few years back. The G stations who have worked W₉DXX all comment on the excellent and interesting QSO's, which do not consist merely of reports on strength, quality and prevailing weather.

Even though operated by a YL, the QSO's are always of a technical nature, much more so than when European stations work together.

Although half of the gear is commercially built, the original 40-metre C.W. transmitter was built by the operator. This can be seen in the centre of the photograph underneath the aerial ameters.

W₉DXX has just taken the Government examination for a permit to operate phone on 20-metres. She has now obtained a class-A licence so that schedules with 20-metre phone stations in Europe will be welcomed. The equipment is most comprehensive. On the left of the photograph is the new 20-metre phone transmitter with an input of about 300 watts. The crystal control uses a type 53 oscillator at 7 mc., a 53 doubler to 14 mc., a pair of pentode RK23 as buffers, and two of the new Eimac 150T valves in the final stage.



W₉DXX is one of the star American YL operated short-wave stations. Listen for her on the 20-metre band using the new 700-watt transmitter.

The speech amplifier consists of a 57 triode followed by a 56 and two 45's, used with grid bias modulation. The rectifying valves are four heavy-duty 866's, one 83 and a 5Z3. Quality from this line-up is exceptionally good and almost up to broadcast standard. The microphone is one of the new Turner crystal units.

The transmitter was designed primarily for C.W. work with an input of 750 watts, but good reports on phone have been received from all parts of the world.

The original transmitter in the centre of the photograph is for 7 mc., operated with an input of 700 watts. The line-up is a 47 crystal oscillator, a 46, an 801, 2O₃A, and a pair of 203A's in push-pull for the final stage.

BCL's will probably appreciate the equipment on the operating desk. From left to right this is a pre-selector just behind the microphone, while above it is the case for the HRO frequency-changing coils with their tuning curves mounted on the front. The main receiver next to the pre-selector is the National HRO, while next

to that is the National AGSX.

Above this set is the loud-speaker and storage panel for the twelve coils for the AGSX receiver. The C.W. keys, master control and break-in switch can be seen on the operating desk.

W₉DXX is a member of a large number of radio societies including the Wireless Pioneers, American Radio Relay League, Radio Society of Great Britain, Reseau Belge, Reseau Francais and so on. Frequencies used are 7,140, 7,160, 14,238 (for phone), and 14,320.

DX includes all W and VE, CM, D, EA, F, G, HH, K4, K5, K6, LU, LY, NY, OA, ON, TI, VK, VO, VP2, VP4, X, ZL, CE, EZ, GI, HB, HJ, OE, VP5, while B.R.S. reports have been received from EI, HC, K7, PA, SP, U, and ZT.

During January when conditions on 20 metres should be brightening up, these stations are advised to get in touch with W₉DXX for interesting QSO's. Reports should be sent to W₉DXX, Alice R. Bourke, 2560 East Seventy-Second Place, Chicago, Illinois.

"The Construction of High-frequency Cables"

(Continued from preceding page).

quired for a high-quality television band. The attenuation-frequency characteristic is smooth throughout the entire band and obeys a simple law of change with temperature, due to the fact that the dielectric is largely gaseous.

Television signals contain frequency components over nearly the entire range from zero up to a million or more cycles. The amplification

and transmission of these frequencies presents a serious problem. The difficulty can be overcome by translating the entire band upward in frequency to a range which can satisfactorily be transmitted by coaxial line and intermediate repeater.

To effect such a shift, the television band may first be modulated up to a position considerably higher than its highest frequency and then with a second step of modulation be stepped down to a position desired for line transmission. The original television signal of about 500 kilocycles

is first modulated with a relatively high frequency, say, 2,000,000 cycles. The lower sideband, extending to 1,500 kilocycles, is selected and is modulated again with a frequency of 2,100,000 cycles. The lower sideband of 100 to 600 kilocycles is selected with a special filter, so designed that the low-frequency end is accurately reproduced. The television signal then occupies the frequency range of 100 to 600 kilocycles and may be transmitted over a coaxial line. At the receiving end a reverse process is employed.

AN AMERICAN IDEA OF A TELEVISION STUDIO

The Television Research Institute of New York has produced a design for a suite of television studios, particulars of which we give below. The scheme, it is stated, is based upon an extensive study of former television studios, sound broadcasting studios and the technical requirements of television programme production.

Sight and Sound Control Rooms

THE circular construction in the centre of the group is the Visual Control Room. A turntable accommodates part of the equipment

small group dramatics. In addition to this the studio has been designed to accommodate two intermediate-film television cameras for moving-picture transmission. The studio is one story high. The space immediately above the studio on the second

floor is for the main control and switching room.

The Twin Studios

Studios B and C are each two stories high. In the wings on the second floor are balconies for guests. Under these balconies, on the first floor, are "Green Rooms" and quick-change dressing rooms. Both studios can be used in conjunction with studios A and D. The twin studios are designed to carry the bulk of the programme traffic.

The Teletorium

The large studio D is also two stories high. On the second floor in the wings are two balconies for guests. Under the balconies, on the first floor, are supplementary production rooms as in studios B and C. The main features of the design of the Teletorium are a mechanical main stage, and a studio crane for angle and elevated "takes."

Halls, Entrances, etc.

The halls and chambers between studios D and B, and between C and D, are for access to the control rooms and all other studios. These are for use by engineers and production men. Actors and guest entrances are laid out in such a way that access to any of the studios is possible from any wing. These halls also lead to scene docks for reserve sets and costumes, etc.

Construction in General

Studios are fireproof, soundproof, magnetically shielded, air conditioned and built with floating construction. Various outlets for television cameras and microphones are provided in all studios.

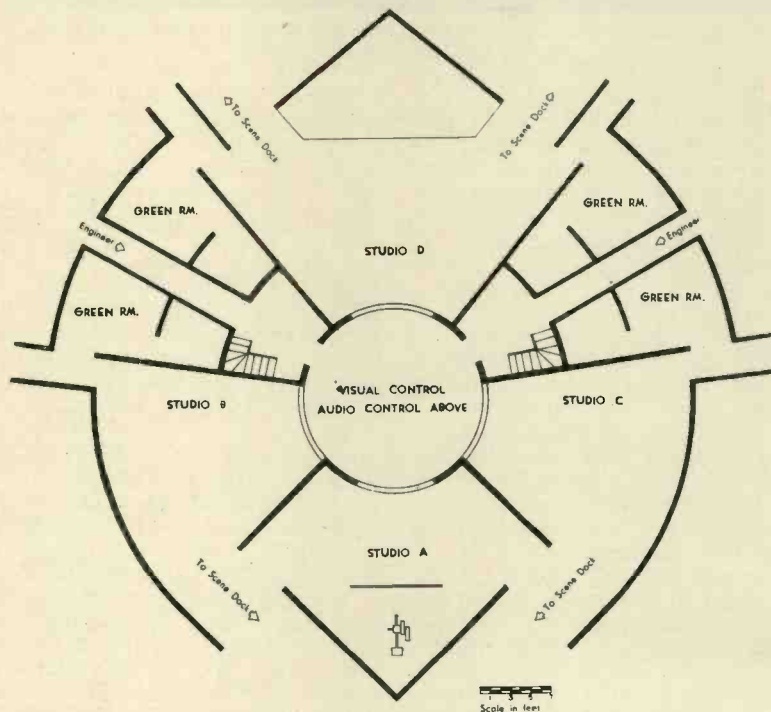

A design for a suite of television studios by the Television Research Institute of New York.

in order that it may be swung into operating position for either of the four studios. On the second floor above the visual control room is the sound control room as is common in radio broadcasting studios to-day.

The Dramatic and Film Studio

Studio A is a small dramatic and intermediate film studio. It is designed and equipped for rear screen projection for moving backgrounds. This assembly is for individual or

BINDING CASES AND INDEXES FOR 1935.

Binding cases and indexes for the 1935 volume of "Television and Short-Wave World" will be available in the second week of January. The binding cases are full brown cloth with stiff boards lettered in gold. The price, including the index, is 2/9 post free. Indexes may be obtained separately and the price is 6d. post free. Orders should be addressed—
BERNARD JONES PUBLICATIONS, LTD.,
CHANSITOR HOUSE,
37/38 CHANCERY LANE, LONDON, W.C.2
and should be accompanied by the remittance.

THE MARCONI HIGH-VACUUM CATHODE-RAY OSCILLOGRAPH

In the following article by A. J. Young which is reprinted from the MARCONI REVIEW the advantages of the high-vacuum type of oscillograph over the gas-focused oscillograph are discussed and a description of the latest type of commercial high-vacuum oscillograph developed by the Marconi Company is given.

THE high-vacuum oscillograph has been developed for use in circumstances where the gas-focused type is ineffective. Two major defects are present in the latter type of oscillograph, origin distortion and a frequency limit. Further, the modulation characteristics of the vacuum oscillograph are considerably better than those of the gas-focused oscillograph; the Wehnelt cylinder of which cannot be used

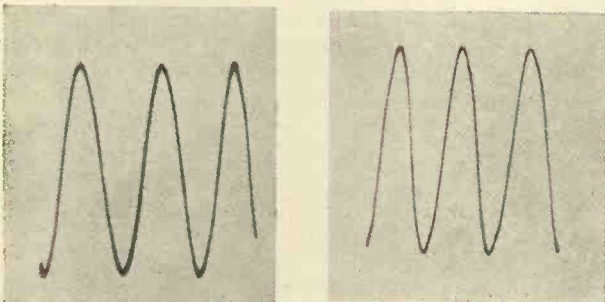

Figs. 1 and 2.—Photographs showing how the trace becomes more clearly defined as the modulation control becomes more negative.

for purposes of modulation without causing a loss of focus of the beam.

The disadvantages of the high-vacuum oscillograph when compared with a gas-focused oscillograph are:—

1. A higher anode voltage is necessary in order to obtain a good focus.
2. More care must be exercised in the deflecting circuit design in order to maintain a good focus over the screen of the oscillograph.
3. The resultant trace is not so well defined.

The normal operating voltage for the oscillograph is between the limits of 1,000 to 2,500 volts, but it is not possible to state the exact photographic recording speed since the modulation control may be adjusted within wide limits. This restriction does not apply in the case of gas-focused oscillographs since only one value of Wehnelt cylinder voltage is possible for a focused spot corresponding to a fixed anode voltage and filament current.

The trace on a vacuum oscillograph becomes more clearly defined as the beam current is decreased, i.e., as the modulation control becomes more negative. This effect is shown in Figs. 1 and 2, for two values of modulation voltage. Provided that the deflectional sensitivity of the oscillograph is not important, the most satisfactory pattern is obtained by using a high anode voltage and restricted beam current, but in many cases some compromise will be found necessary.

The vacuum oscillograph may be deflected either

magnetically or electrostatically without loss of focus provided that suitable precautions are taken. For purposes of general laboratory measurement it is found preferable to use electrostatic deflection, since magnetic deflection becomes impracticable for frequencies in excess of about 10,000 ~ . When electrostatic deflection is used it is preferable to arrange the deflecting circuits so that the instantaneous mean potential of both pairs of deflecting plates is zero with respect to the anode. The photographs shown in Figs. 1 and 2 were taken under these conditions. This condition may be met by connecting the deflecting plates in push-pull, as shown in Fig. 3, in which V_1 and V_2 are the deflecting voltages. Under certain circumstances it may be found difficult in practice to provide a push-pull connection to one pair of plates. It is possible to obtain a moderately focused trace if one pair of plates is connected in the normal manner (i.e., one plate connected to the anode and the other to the voltage to be examined and the other pair of plates being connected in push-pull). Fig. 4 shows the definition obtainable

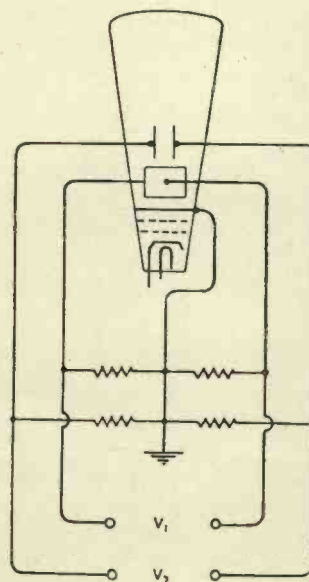
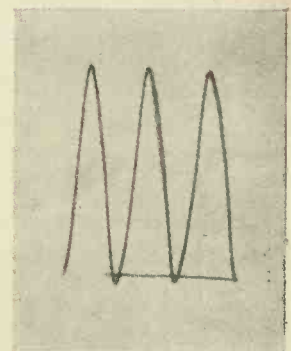

Fig. 3. (Left).—Showing deflecting plates connected in push-pull.

Fig. 4. (Below).—Definition obtainable with one pair of plates connected in push pull.



under these circumstances for which a low beam current was used. If a vacuum oscillograph is used with the standard design of time-base and rack mounted equipment then the oscillograph would be used in this manner. For special purposes, however, push-pull time-bases are available.

The deflectional sensitivity varies slightly according

to the method of deflection. If three of the four deflecting plates are connected to the anode and the remaining plate connected to a variable D.C. supply, a series of deflection deflecting voltage curves are obtained, as shown in Fig. 5. It will be observed that the deflectional sensitivity is different when the deflecting plate is at positive potential to the anode than when it is negative and further that the effect is greater for

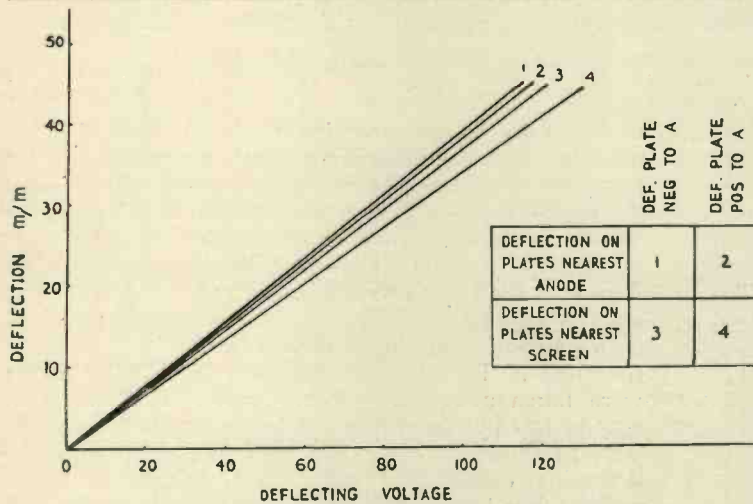

Fig. 5.—Voltage curves obtained with three of the plates connected to the anode and the remaining plate to a variable D.C. supply.

the deflector plates nearest to the screen. This difference of sensitivity causes a distortion of the trace, which for the want of a better name has been called trapezium distortion. If two time-bases are connected to the cathode-ray oscillograph to give a television scan, the effect of this trapezium distortion may be shown (Fig. 6). It will be observed that instead of the scan having a perfectly rectangular shape it is slightly deformed. This distortion is generally less than 2 per cent. for double push-pull deflection. If a push-pull time-base is used in conjunction with a single-phase time-base then a scan approximating to the figure of a trapezium is obtained.

The actual figure obtained may be determined by consideration of the sensitivity curves shown in Fig. 5.

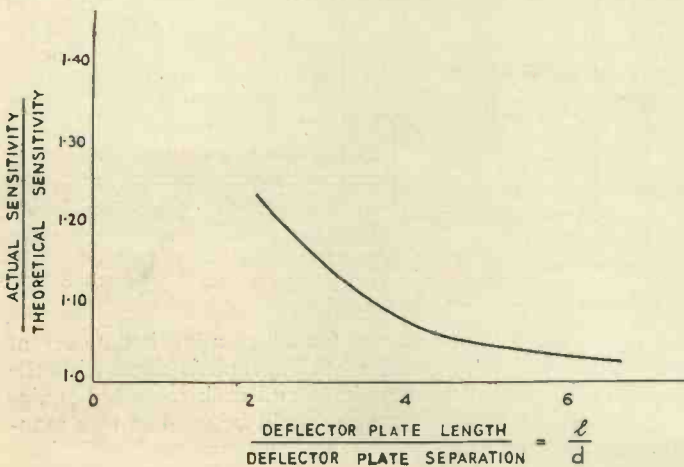

Fig. 7.—The relation between the ratio of actual sensitivity to theoretical sensitivity.

Correcting devices for trapezium distortion are known, but their use is not general since the distortion is usually small.

The trapezium distortion is caused by the fringing field at the edges of the deflector plates. In order to determine the magnitude of this effect measurements were made on the actual sensitivity of the oscillograph compared with the value calculated from simple theory.

If the fringing field at the edges of the deflector plates is neglected, then the following formula for the sensitivity may be used:—

$$S = \frac{L_i}{2dV}$$

where S is the sensitivity in mm/V

L is the effective electron beam length

l is the deflector plate length

d is the separation between the parallel plates

V is the anode voltage.

In practice it is found that due to the fringing field the sensitivity is greater than the value given by this formula. The difference between the actual and theoretical sensitivity therefore gives a measure of the fringing field. Fig. 7 shows the relation between the ratio of actual sensitivity to theoretical sensitivity plotted as a function of the deflector plate length divided by the separation. This curve, however, only applies to the type of construction in use, as the influence of charged elec-

trodes near the deflecting field will change the fringing field.

A further form of distortion experienced with cathode-ray oscillographs is the modulation of one pair of plates by the other. The effect, however, is generally quite small.

A photograph of the complete oscillograph is shown in Fig. 9. The main external dimensions except the length are the same as the gas-focused oscillograph, both are provided with 10 point bayonet caps and sockets.

The focusing of the high-vacuum oscillograph is performed by means of two electron lens combinations, as shown in Fig. 8. The electron beam is brought to an effective focus at F₁ by means of the electron lens combination L₁, and is then allowed to diverge. The paraxial rays are selected by means of the stop S₁ and the electron beam is then brought to a focus on the fluorescent screen at F₂ by means of the electron lens combination L₂. The electron beam is then deflected by means of two pairs of deflector plates placed at right angles to one another, the sensitivity of which is approximately 0.38 and 0.35 mm/V. for the two pairs of plates at an anode voltage of 1,000.

If the cathode-ray beam is not deflected it may be used to demonstrate the properties of an electron microscope. For this purpose the first anode voltage is adjusted not to give the smallest image on the fluorescent

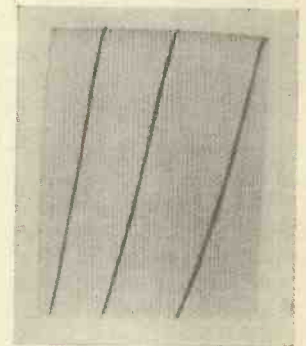

Fig. 6.—An example of trapezium distortion.

(Continued on page 24).

FIRST STEPS IN

By J. H. Reyner, B.Sc., A.M.I.E.E.

HIGH-DEFINITION RECEPTION

The first two articles of this series appeared in the September and October issues. The series relates to experiments which have been conducted over a period of several months.

4.—ADJUSTING THE CATHODE-RAY TUBE (Continued).

As we have seen, an inadequate time-constant results in a tailing off of the black into grey. In cases of serious deficiency a "flare" is produced, the black shading off so rapidly that it gives a sort of shadow effect. This can be seen to some extent in Fig. 5, which was taken under conditions which were theoretically very bad, but actually tolerable, as is explained later. In the top part of the picture the black, which is barely half a line long, is quite good, but at the bottom, where it has to last for several lines, it is only grey. For the reasons given later, however, the transition is so rapid that the flare is not serious.

Over Correction

This flare must not be confused with a somewhat similar effect which can be produced by too much top correction, particularly where this is of the capacity potentiometer type mentioned in the last article. At the actual transition from white to black (and vice versa) there is a sudden change of current which involves a very high frequency component. The top-correcting circuit tends to accentuate this and if the correction is too large an abnormal "black" voltage is set up momentarily.

This is very clearly shown in Fig. 3, which is a photograph of a title taken on my apparatus, the signal being obtained from the transmitter described in the Oct. issue. The top-

correction on the amplifier was deliberately overdone and the marked shadow effect, though rather artistic on a simple title, would clearly ruin a picture containing any fine detail.

Incidentally it will be observed that the L.F. in this example is adequate since the background is a uniform tone, showing no flaring or similar variation. A grey back-



Fig. 3.—Shadow effect produced by too much top correction.

ground was used to show up the shadow to best effect but its consistent character shows that there is no appreciable loss in the amplifier.

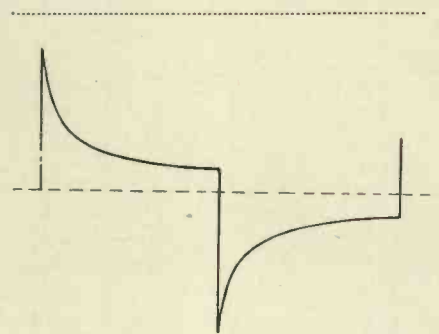

Fig. 4.—Type of waveform obtained with short time constant.

The production of really good L.F. response, however, is apt to be expensive and it is interesting to note that it may be "faked" with some success by various means. One is to allow one of the valves in the chain to run into grid current. The coupling condensers then draw a small charge on each synchronising pulse

which tends to maintain the charge in the condenser for a longer period than would otherwise be possible.

Another and somewhat surprising method which I discovered by accident, is to use a time constant much less than the theoretical value, the figure approximating to the line-frequency period instead of to the much longer picture-frequency period. What happens then is that the waveform takes the shape shown in Fig. 4. The condenser acquires the bulk of its charge almost at once, but the remaining charge takes quite a long time and during this period the current falls off slowly. Therefore, apart from the initial pulse, we have a tolerable approximation to a square-top wave although the amplitude is now less than before. In these circumstances it is possible to use a time constant which is only equivalent to the line frequency. The initial pulse appears not to constitute a serious disadvantage, and may even be helpful since it serves to give an accentuation of the transition or boundary between the white and black. Fig. 5 shows a title taken under these conditions with an actual cut-off occurring at line frequency!

I hesitate to advance this as a suggestion for an actual method of working. It is brutally wrong, but it gives better results than an amplifier which makes only a half-hearted attempt at true L.F. response. In fact the alternatives seem to be either to have thoroughly satisfactory L.F. response or to have none at all!



Fig. 5.—Illustrating possibilities of faked L.F. response. The modulation is correct in this instance.



Fig. 7.—Over-modulation: note the blurring of the whites and loss of detail in the blacks.

Correct Setting

The adjustment of the steady voltage on the shield of the tube is dependent largely upon the amplifier. It would seem that the best results are obtained with a faint background in the black so that the blacks always show some trace of the raster. This is possibly because the tube itself modulates a little better farther up the characteristics. The cathode-ray tube has a characteristic like that of an ordinary valve, as shown in Fig. 6, and the applied modulation must be adjusted relative to the steady voltage on the shield so that the maximum peak is just sufficient to black out the tube when the peak in

the opposite direction should then give a good clear white.

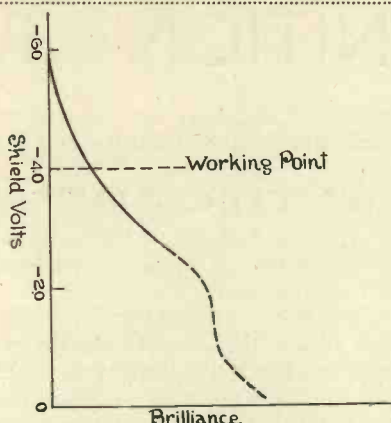

Fig. 6.—Characteristics of cathode-ray tube. The dotted portion of the curve is beyond the range and is not used.

If the whites are made too bright, however, it will usually be found that the tube ceases to focus nicely giving a blurred effect around the high lights which is illustrated in Fig. 7. This is usually due to the use of too strong a signal for the particular setting of shield voltage.

It is to be noted also that while the blacks are quite light in the upper portion they are over intense in the lower portion. This is not due to any amplifier defect but arises merely from the excessive modulation.

As a general rule the tube should be arranged to give a light grey screen when there is no modulation on and the intensity control is then adjusted so that with full modulation the whites are just clear and showing no signs of blurring.

“ The Marconi High-Vacuum Cathode-Ray Oscillograph ”

(Continued from page 22).

screen but an image of the cathode. The range of control provided on the standard rack equipment is usually sufficient for this purpose. An irregular image of the cathode will then be observed on the fluorescent screen.

The electrode G serves to modulate the intensity of the beam and the anode A_1 serves as a focusing control since it changes the effective focal lengths of both L_1 and L_2 .

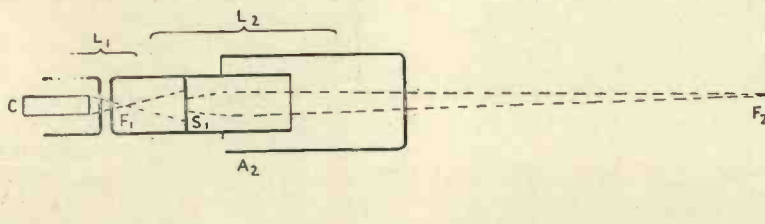
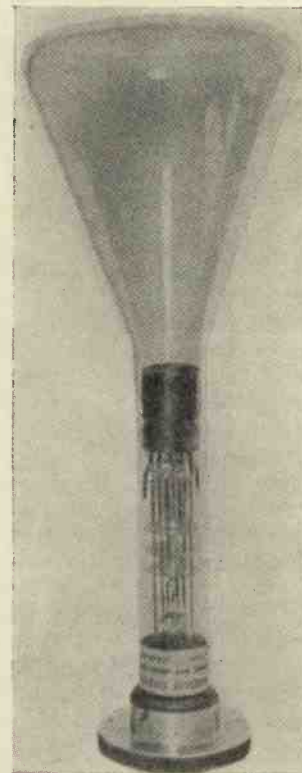

Fig. 8 (Left).—The method of focusing the high-vacuum oscillograph.

Fig. 9 (Right).—A photograph of the Marconi High-vacuum oscillograph.



The mechanical construction of the oscillograph has been improved with the object of providing more uniform characteristics and also ability to withstand the stresses imposed by normal handling in transit. The method adopted is to interlock the electrodes on suitable mica insulators, the whole assembly forming a rigid mount.

A New Zworykin Electron Tube

MOST readers will be aware of the Zworykin Iconoscope used in television. But Dr. Zworykin has now introduced a new radio tube of revolutionary design, which is so sensitive that it can replace six or more normal triode valves.

The electrode assembly is fitted inside a long glass envelope and consists of a double row of electrodes extending the whole length of the tube. The elec-

trodes in one row are coated with caesium and act more or less as “targets” for the electron stream. The electrodes in the second row supply electrostatic fields to guide the electrons in the desired path.

Around the outside of the tube are permanent magnets which also act as guides to the electrons.

A modulated light source, such as a Kerr cell, at one end of the tube, causes electrons to be released which are driven against the first target. As

they hit the target the impact sets free secondary electrons which tend to fly off in all directions, but are guided into the desired path by electrostatic and magnetic fields.

By properly spacing the electrodes the augmented stream jumps from one target to the other and reaches a measurable current flow when it reaches the positive plate at the other end of the tube. Gains of several million times are possible with ten reflections without increase in valve noise.

RECENT TELEVISION DEVELOPMENTS

A RECORD OF PATENTS AND PROGRESS *Specially Compiled for this Journal*

Patentees:—Marconi's Wireless Telegraph Co. Ltd. :: General Electric Co. Ltd. and L. C. Jesty :: J. L. Baird and Baird Television Ltd. :: D. M. Johnstone and Baird Television Ltd. :: Radio Akt. D. S. Loewe

"Talkie" Television Systems (Patent No. 434,882.)

Sound signals are transmitted on the carrier wave during the interval

quick-return of the scanning-spot; and finally picture-signals from the valve V2. The whole produces a continuous talking-picture at the re-

thrown on to a mosaic surface of photo-electric cells A, consisting, say, of a square of 180 in each side or 32,400 in all. The overall dimen-

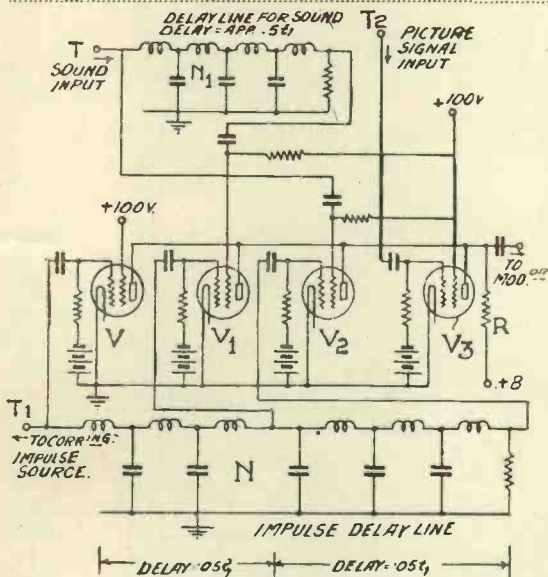

Method of transmitting sound and vision signals on a common wavelength. Patent No. 434,882.

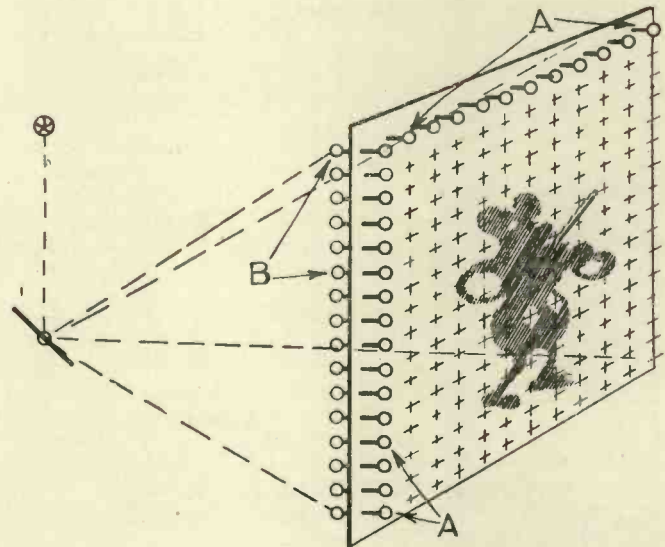

Fig. 1.—Mosaic of photo-electric cells. Patent No. 434,905.

between the scanning of one line of picture signals and the next. They are applied to the terminal T of the circuit shown, whilst the ordinary synchronising-signals are applied to the terminal T1. The latter are fed directly to the first valve V, but pass through a delay network N before reaching the control grid of the next valve V1; whilst the former pass through a delay network N1 on to that valve, but reach the valve V2 directly. Meanwhile the picture-signals from the terminal T2 pass directly to the valve V3.

The sequence of voltages applied to the output resistance R is: first a synchronising-signal from the first valve V; then a signal from valve V1 representing sound applied during the scanning of the previous line; next a signal from the valve V2 corresponding to the sound during the

ceiving end.—(Marconi's Wireless Telegraph Co., Ltd.)

01 3382 Mosaic-cell Screens (Patent No. 434,905.)

The picture to be transmitted is

sions of the screen may be up to 15 feet square, each cell then being one inch square. Connected in series with each A-cell, but screened from it optically is a second cell B, the ar-

Fig. 1a.—Circuit for use with photo-cell mosaic. Patent No. 434,905.

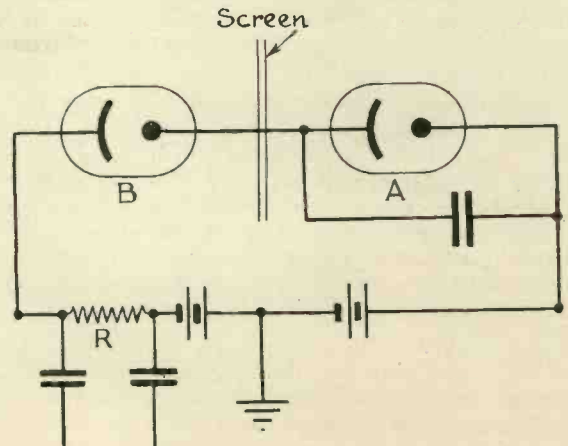

range being such that when a scanning-ray of light is thrown on to a B-cell the corresponding A-cell is discharged through a resistance R or other impedance connected to the transmitter.

The whole assembly is somewhat similar to the known type of mosaic-cell screen which is mounted inside a cathode-ray tube and scanned by the electron stream passing through the tube, but has the advantage that the size of the screen is not limited

a photo-electric cell P, the modulated currents being passed on through amplifiers V to the aerial. The cathode stream is interrupted at the frequency mentioned by a valve generator O which applies cut-off potentials to the control grid of the tube T. The amplifiers are designed to pass only the interruption-frequency and its side-bands, the "tailing-off" effects due to the fluorescent lag thus being cut out.—(Marconi's Wireless Telegraph Co., Ltd.)

drum in which the mirrors are progressively displaced by the required correcting angle. When the arrangement is used for interlaced scanning, additional prisms or mirrors are used to displace or deflect the light-ray by the required amount for successive scans.—(J. L. Baird and Baird Television, Ltd.)

Saw-toothed Oscillators
(Patent No. 435,196.)

The condenser C is slowly charged up by the H.T. source through a bal-

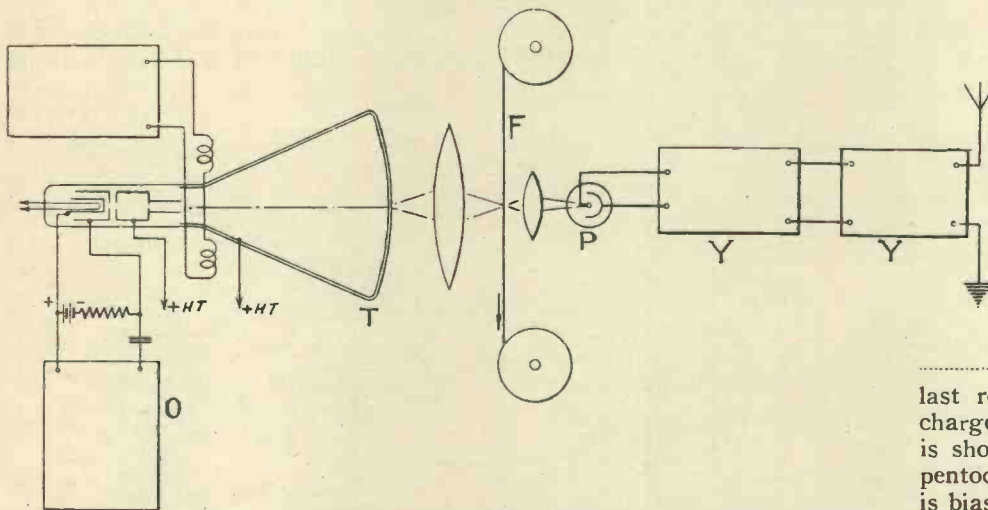

Arrangement for scanning cinema film. Patent No. 434,936.

by that of the cathode-ray tube. Fig. 1A shows how the two series of cells are connected in series and to a common resistance R, on which the signalling voltages are developed.—(General Electric Co., Ltd., and L.)

Cathode-ray Scanning
(Patent No. 434,936.)

The source of light used for scanning consists of the luminous effect produced by the electron stream on the fluorescent screen of a cathode-ray tube. This has certain practical advantages, one being the almost unlimited speed at which the scanning operation can be performed.

On the other hand a difficulty arises owing to the time-lag of the fluorescent material, which does not respond instantaneously to the ray. In order to overcome this defect the cathode-ray stream, according to the invention, is interrupted at a frequency of the order of 100,000 times a second, and this interruption-frequency is also used to generate the carrier-wave.

As shown in the drawing, the cinema film F to be scanned is moved continuously between the fluorescent screen of the cathode-ray tube T and

Film Television
(Patent No. 435,103.)

When a continuously-moving film is scanned in the direction of its movement, a slight distortion occurs owing to the gradual displacement of

last resistance R, and is then discharged through the valve V, which is shown as a triode, but may be a pentode. The grid of the valve V is biased so that no current can pass through it during the charging period. But as soon as the voltage on the condenser C reaches a critical value, the valve starts to discharge and, owing to the back-coupled coils L, L₁, simultaneously generates high-frequency oscillations. Meanwhile

Method of producing saw-toothed oscillations. Patent No. 435,196.

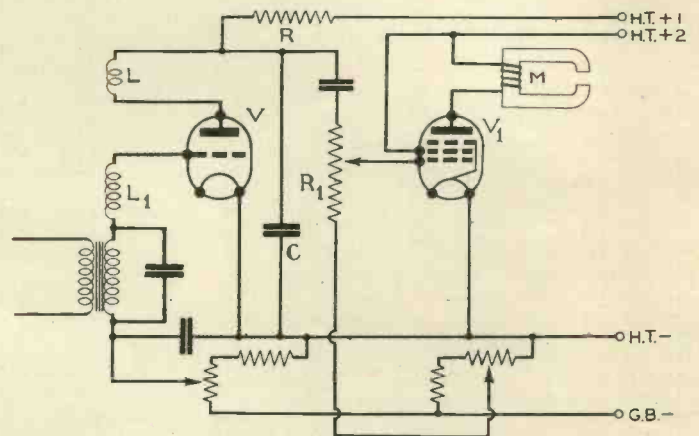

each baseline. Actually the effective scanning area tends to be converted into a parallelogram with inclined top and bottom sides. According to the invention, this tendency is automatically offset by using a scanning-

the voltage swing on the grid serves to discharge the condenser.

The resulting saw-toothed oscillations are applied through a condenser and potentiometer-resistance R₁

(Continued on page 28).

JANUARY, 1936

What the S.W. Amateurs are Doing

Several interesting gadgets and ideas have been discovered by the Short-wave Editor for this issue.
The $2\frac{1}{2}$ -metre transmitter is a very interesting item.

TWO and a half metre working has not gained very much ground in this country due to the lack of active co-operation between amateurs. However, now that Claude Lyons can supply acorn valves there is no reason for simple transmitting circuits not being made up with great success.

Fig. 1 is a good indication of the simplicity of the circuit. A 304A acorn type of triode will oscillate in this circuit down to $1\frac{1}{4}$ metres. The condenser C1 is a .000007 Eddystone midget, while L1 is a single turn coil of 12-

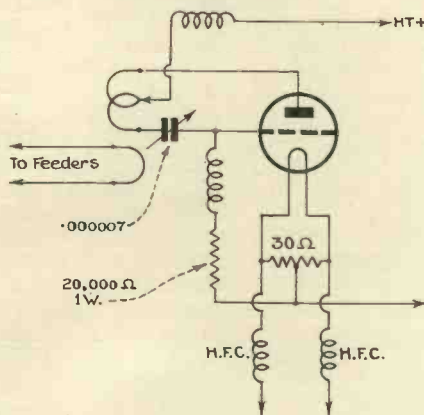

This simple $2\frac{1}{2}$ metre oscillator uses an acorn type of valve now available in this country.

gauge wire. The actual length of conductor is approximately 12 ins. for 112 megacycles and 7 ins. for 224 megacycles. The coil itself is only 1 in. in diameter. R1 is a 20,000-ohm resistor, and R2 a conventional humdinger. The choke in each filament lead is actually the connecting wire wound round a pencil and should be about 15 turns. The choke in the anode circuit should be ten turns again wound on a pencil with a slight space between turns.

The frequency stability of this type of circuit is very poor, but for experimenters will provide a very good start for real ultra-frequency work.

Radiation Angle

The angle of radiation from a transmitter is a very interesting point. When the aerial is suspended above the ground the directional characteristic is changed as some of the energy radiated towards the ground is reflected back

into space. The reflected energy reinforces the original space radiation at certain angles in the plane perpendicular to earth and cancels it in others. The earth, therefore, affects the angle of radiation to a very great extent.

The amount of bearing on the radiation angle depends upon the position of the aerial with respect to earth, the height above ground and the characteristics of the ground itself. If the ground is a good electrical reflector the vertical radiation will be enforced and the horizontal radiation cancelled, when the horizontal aerial is a quarter wavelength above the ground.

As the height is increased, radiation at lower angles is enforced, although purely horizontal radiation is always cancelled with a horizontal aerial. On frequencies where a low angle radiation is required, such as on 14 mc. and higher, the horizontal aerial should always be at least half-wavelength above ground.

The effect of the ground is exactly the same with a vertical aerial and an even number of half-wave long, denoting that horizontal radiation is cancelled. This proves that a vertical aerial should not be full-wave long if very low angle radiation is wanted.

Fig. 2 shows the angle of maximum radiation measured from the line of the aerial or aerials of different lengths in terms of operating wavelength. The

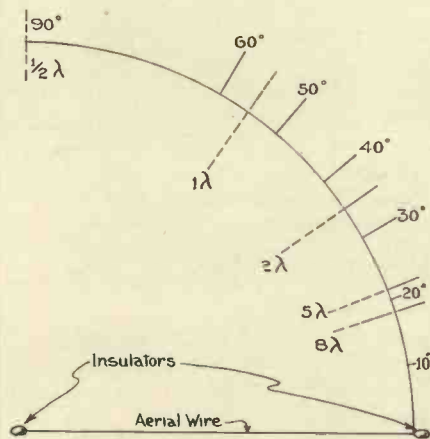

A graph of this kind showing radiation angle should interest every amateur.

angles shown are for one quadrant, but naturally correspond for the other three. The relative length of the extended lines indicating the angle of maximum lobes show power ratios compared with

the maximum for half-wave doublet—90 degrees—assuming the same current at a current loop for each case.

A.C. Meter

An output meter of the simple rectified-current type is a distinct asset for any station. I have seen two or three using crystals and although they are not my idea of extreme efficiency they do provide an easy and cheap means of A.C. measurement. The circuit shown in Fig. 3, is almost self-explanatory.

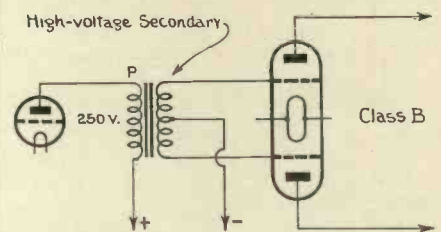

Almost any type of small mains transformer can be used in a class B circuit.

tory, simply an isolating transformer, semi-permanent crystal rectifier and a low-reading milliammeter or galvo.

Still further to save cost the isolating transformer can be omitted in favour of two large capacity blocking condensers. The meter can be calibrated by means of a potentiometer across an A.C. filament transformer, but a standard A.C. voltmeter would have to be borrowed for the purpose of measurement.

Class B

G5BJ has quite an interesting way of obtaining a cheap class B transformer suitable for transmission. As many amateurs know, a transformer of this type either has to be purchased from America or made specially by some English manufacturer.

G5BJ tell me that a standard H.T. transformer with a 250-volt primary and a 500-volt split secondary works excellently to couple a driver to class B valves for modulation purposes. The circuit in Fig. 4 is self-explanatory.

Controlled Carrier

From W1CAA I have received some details of the controlled carrier unit which is finding favour in California.

This unit can be used with nearly any low-power transmitter in order to provide controlled carrier transmission. The advantage of this system is that it reduces heterodyne interference and provides a method for easy reduction of power for local work without having to

triode valve, biased to cut off, acting as a valve voltmeter for later changes of anode current when L.F. voltage is applied across its grid input. The actual valve used in the American circuit is a 2A3 and a power supply with poor regulation should be used if linear

law principle, consequently the doubling of the input voltage would give four times as much anode current unless the anode voltage drops enough only to give twice as much anode current. As only the D.C. current flowing through the variator D.C. winding is import-

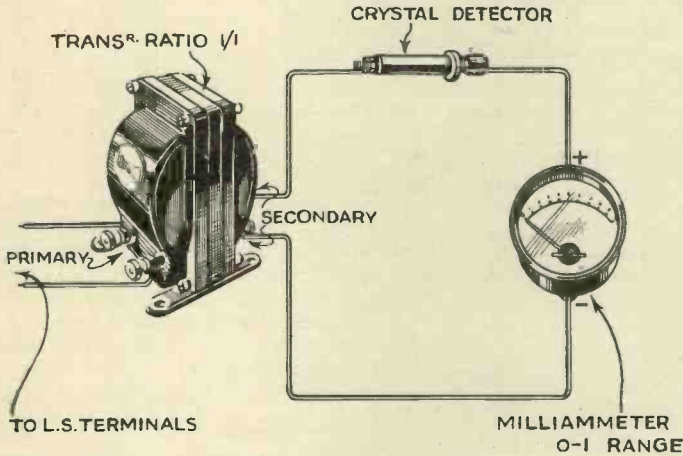

If a transformer is not available two large capacity blocking condensers can be used instead.

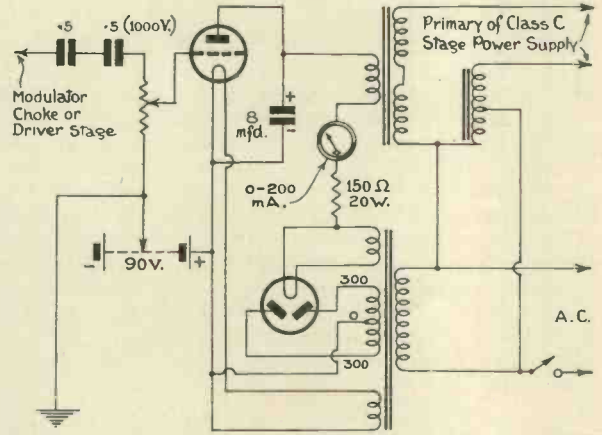

Controlled carrier has not received much attention in this country. This is only one of the many systems that can be used.

resort to very low percentage modulation.

A controlled carrier class C modulated amplifier can be used to drive a high-power radio-frequency linear stage at reasonably high efficiency giving high-power phone operation at low cost.

The circuit (Fig. 5) consists of a

modulation is required. Actually a 20-watt 150-ohm series resistance makes quite sure that the regulation is bad. The idea of this is that it is necessary for the 2A3 anode current which flows through the variator shall vary directly the ratio of input from the modulator.

A valve voltmeter follows the square-

ant in controlling the saturation of iron in this unit it is not necessary to worry about filtering the rectifier. An 8- or 16-mfd. electrolytic condenser across the output of the triode provides a path for the R.F. from plate to filament so allowing the triode valve to act as rectifier or detector.

“Recent Television Developments”

(Continued from page 26).

to the grid of a pentode amplifier V₁, which supplies the coil of the scanning or deflecting magnet M of a cathode-ray tube. Synchronising impulses are applied to the valve V through a transformer T.—(D. M. Johnstone and Baird Television, Ltd.)

Cathode-ray Tubes

(Patent No. 435,203.)

The electrode system consists of the usual cathode, anode, and control and deflecting plates. In addition there is a positively-biased ring-electrode, which is arranged near a negatively-biased funnel connected to the anode. The arrangement is designed to remove the tendency for parts of the picture to become “blurred” owing to the deflecting action of uncontrollable static charges, which collect on the walls of the tube.—(Radio Akt. D. S. Loewe.)

Summary of Other Television Patents

(Patent No. 434,527.)

Interlaced scanning system in

which lines, transmitted as adjacent, are superposed upon each other at the receiver.—(J. L. Baird and Baird Television, Ltd.)

(Patent No. 434,544.)

Television system in which a pair of mirror drums are run at different speeds, both being driven from a shaft running at an intermediate speed.—(J. Guibansky.)

(Patent No. 434,868.)

Television system in which “coloured” effects are produced by using a fluorescent screen composed of different materials, each responsive to one of the primary tints.—(Fernseh Akh.)

(Patent No. 434,873.)

Adapting cinema films to make them more suitable for television.—(Fernseh Akt.)

(Patent No. 434,876.)

Television transmitters of the mosaic-cell type.—(A. D. Blumlein.)

(Patent No. 434,890.)

Transmitting television pictures combined with sound signals.—(Marconi’s Wireless Telegraph Co.)

(Patent No. 434,891.)

Combined sound and picture transmission systems.—(Marconi’s Wireless Telegraph Co., Ltd.)

(Patent No. 434,942.)

Improvements in cathode-ray transmitters of the mosaic-cell type.—(Marconi’s Wireless Telegraph Co., Ltd.)

(Patent No. 434,950.)

Television receiver in which the rectifier stage is coupled to the light-control electrode of a cathode-ray tube, so as to control the D.C. component.—(M. von Ardenne.)

(Patent No. 435,025.)

Metallic-vapour lamps suitable for use in television.—(P. Freedman.)

(Patent No. 435,566.)

Construction and assembly of the electrodes in a cathode-ray tube.—(Marconi’s Wireless Telegraph Co., Ltd., W. E. Benham and A. J. Young.)

THE PRINCIPLES AND PRACTICE OF ELECTRON OPTICS

By N. Levin, Ph.D., A.R.C.S., D.I.C.

This is the first of a series of articles describing in an easily understood manner the principles and practice of electron optics, a new branch of electronics which is becoming of great importance.

TELEVISION has been the dream of inventors since the latter part of the last century, but it has had to wait more than fifty years before it has stepped out of the crude experimental period. The reason is that television is dependent on almost every department of scientific knowledge and, since the idea was in advance of its time, it has had to await the individual development of the component parts.

laws has developed the investigation of the electron in motion from the viewpoint of optics, giving rise to the name "Electron Optics." This has assisted in the rapid development of the cathode-ray tube for television since the principles of optical systems for various purposes can be applied to the electrical system in the tube.

Forming Images

In electrostatic and electromagnetic systems in use in the cathode-ray tube we are concerned with forming on the fluorescent material deposited either on metal or on glass an image, which may be a small spot, such as required in oscillographs or in television tubes, or a large picture of some element in the system, as, for instance, in the electron microscope. The former case means focussing a diminished image of what is in practice the smallest cross section of the beam of electrons. The latter involves an enlarged image of whatever it is desired to examine. This may be the cathode, or emitter of electrons, or a grid which transmits electrons. The electron microscope is still very much in the experimental stage and will therefore be only briefly discussed. The problem of forming a small bright spot is the one which is of the greatest interest at the present time. The ideal system is that which yields a brilliant but diminished image of the electron emitter. Before discussing the various systems, the elementary principles of the design will be considered.

Electronic Laws

Recent progress has had to wait for the commercial development of oscillographs of the cathode-ray type. Once the cathode-ray oscillograph had arrived, the application to television was obviously the next step. As one might expect, the idea had been put forward nearly thirty years ago.

The special requirements of television have led to an intensive study of the influence of electromagnetic and electrostatic fields on the electron in motion. For most practical purposes the electron can be considered as a particle of a certain mass and carrying a definite negative charge of electricity. This is naturally only an approximation, but it is a very good one and will suffice for the great majority of commercial applications. With these conditions, Newton's Laws of Motion can be applied and, moreover, the law that Newton deduced for the refraction of light, on the assumption that light was of a corpuscular nature, that is, that light consisted of small particles or corpuscles, holds exactly for the bending of the direction of electrons in an electrostatic or electromagnetic field. The fact that light is a wave motion does not, in principle, affect the similarity of the two laws of refraction.

From this close analogy of these

intensity to another and different field.

In the case in which the field is uniform but the value of the field strength is zero, both the direction and velocity are unchanged. This occurs, of course, when the electrons pass between two electrodes some distance apart but at the same potential. Since the field strength E is equal to the potential difference V divided by the

distance d , or $E = \frac{V}{d}$, E is zero,

when $V = 0$. For any fixed value of V the field is uniform. If another electrode is placed between these two and is, say, at earth potential, the field is in general no longer uniform.

Now the force acting on an electron at any point is the product of the charge of the electron $-e$ and the field strength E or $F = -eE$. Hence, if the field strength is zero, there is no force on the electron and it will, according to Newton's First Law of Motion, continue in its state of rest or motion unchanged. If the field strength has a constant value and does

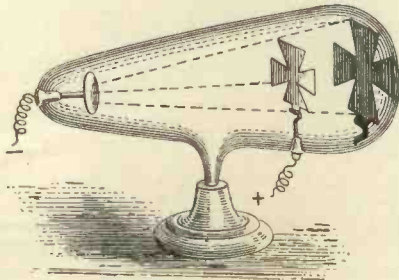
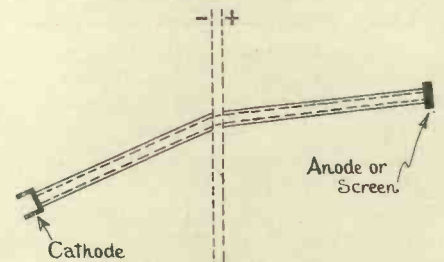

Fig. 1. Crooke's tube showing the rectilinear motion of electrons in a uniform field.



Knoll and Ruska's experiment to illustrate the refraction of a beam of electrons.

not change from point to point, there will then be a constant force acting on the electron. If the electron starts from rest or a certain velocity in such a field, it will acquire an increase in velocity or an acceleration according to Newton's Third Law of Motion. This states that the acceleration is equal to the force divided by the mass. Hence, in the case of the electron

$$a = \frac{F}{m} = \frac{-eE}{m}$$

where a is the acceleration and m is the mass of the electron.

(Continued at foot of page 32.)

THE DEVELOPMENT OF THE SCANNING CIRCUIT FOR CATHODE-RAY TELEVISION—II.

By G. Parr.

CHOOSING A CIRCUIT

THE simple condenser circuit discharged by a gas-filled relay, which was described in last month's article is not satisfactory as it stands for use as a scanning circuit. The reason for this is best under-

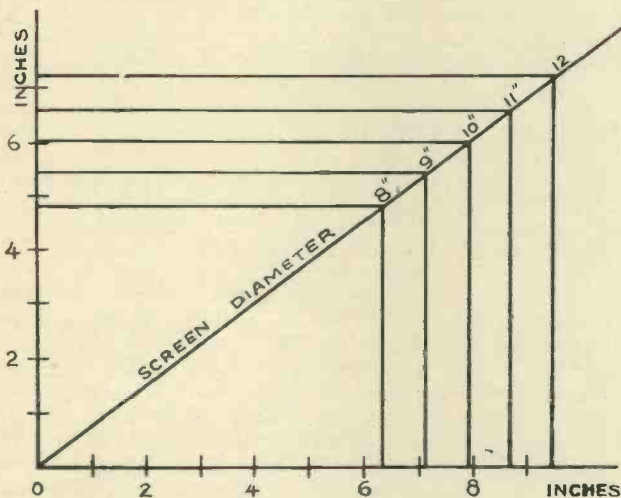

Fig. 1.—The proportion between effective screen diameter and size of picture, assuming a ratio of 4 : 3.

stood by considering the requirements of the line screen as it is to be drawn on the tube.

First the intensity of the line must be high in order that the image can be seen in dull light without the necessity of special screening. This means that the anode voltage of the tube must be as high as possible, since the intensity is roughly proportional to the anode voltage.

A further point is that the trace left on the screen grows weaker as the beam moves faster. With low-definition television the speed of movement of the beam corresponded to a travel of about 7 ins. in $1/375$ th second. Higher definition requires this distance to be covered in $1/6,000$ th second or less, and therefore for the same operating conditions the light given on the end of the screen is much weaker. Tubes for high-definition reproduction must therefore be operated at some 5,000 volts if they are of the large type, and 3,000 volts if of the smaller type.

Tube Sensitivity

Now the sensitivity of the tube, i.e., the distance moved by the beam on the screen for one volt of potential applied to the deflecting plates, varies inversely as the anode voltage. For a given design of tube there is a formula from which the sensitivity can be found. This is usually given in the form Sensitivity = K/V , where K is a figure given by the makers of the tube and V is the anode voltage at which it is operated.

Suppose K is 750, an average figure. Then at 1,500 volts the sensitivity is $750/1,500$ or $\frac{1}{2}$ mm. per volt of deflecting potential. At 3,000 volts the sensitivity will obviously be one half of this or .25 mm. per volt.

Picture Size

Now consider the size of picture required. If the effective tube* diameter is 8 ins. the picture size is approximately $6\frac{1}{2}$ ins. by $4\frac{3}{4}$ ins. (see Fig. 1) for a picture ratio of 4:3. This means that the travel of the beam will be 165 mm. in the horizontal direction and

* The effective diameter of the tube is that diameter of screen which would show an undistorted picture. The size of picture can be increased beyond the effective diameter but the edges will be distorted.

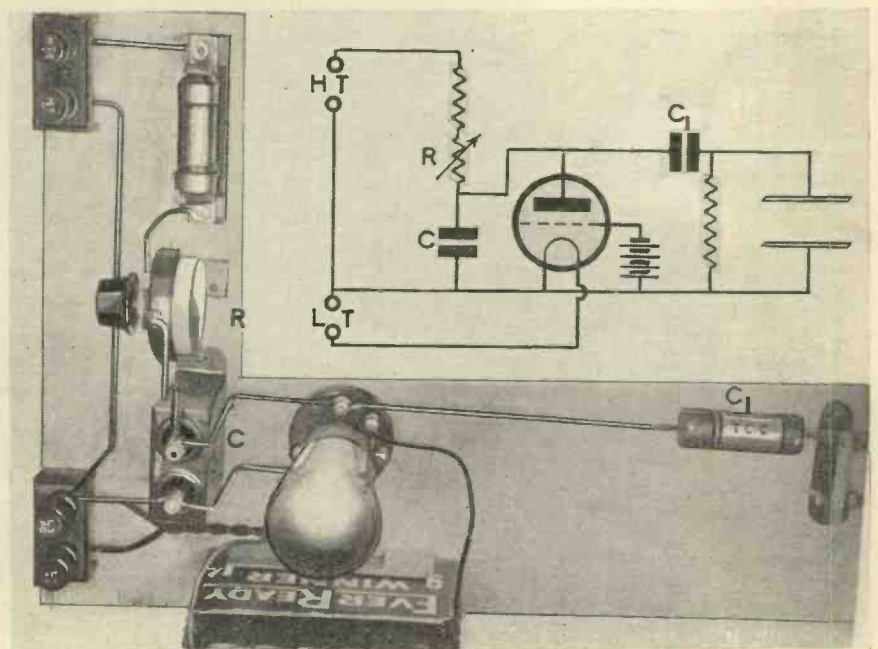

Fig. 2.—A simple scanning circuit shown diagrammatically and as a layout.

the voltage required to deflect it this distance at 3,000 volts on the anode will be 4×165 or 660. It should be understood, of course, that these figures are only typical and the calculation will have to be made accurately for the type of tube used and the conditions under which it is run; but the fact remains that an average figure for the deflecting potential to be applied to the beam is 500 volts or more.

This means that the condenser in the time-base circuit must charge to this potential before the relay strikes. Now assume that we apply a potential of 600 volts to the scanning circuit described in last month's issue. This is reproduced in Fig. 2 for the sake of clearness. The condenser will charge to 500 volts, and the relay will strike at this value if the grid bias is set to a value depending on the characteristics of the relay.

Gas relays have their "control ratio" specified, that is, the relation between the bias on the grid and the

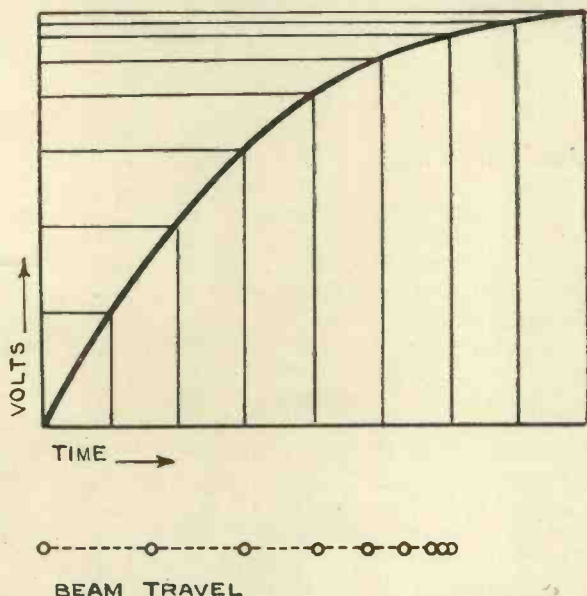

Fig. 3.—Curve of condenser charging through a pure resistance. The dotted line at the bottom shows the path of the beam during equal intervals of time.

anode potential at which the discharge commences. Assuming it is 20:1 the bias of the relay would have to be set at $500/20$ or 25 volts to ensure striking at the correct value.

The most important point to consider now is the behaviour of the condenser. When charged through a simple resistance as in Fig. 2 the growth of potential across the condenser does not follow a linear law, but what is known as an exponential one. This means that the rate of increase of voltage steadily falls off as the condenser charges. If we plot a curve of charging voltage against time we obtain the curve of Fig. 3 in which the voltage increase is shown for equal intervals of time from the commencement. The increments get less and less as the voltage rises to 600, the full H.T. voltage. The deflection of the beam by this voltage will correspond to the rate of increase, and is shown by the dots under the base line.

We have certainly deflected the beam across the screen to the required extent, but the movement is far

from uniform and a hopelessly distorted picture would result if this circuit were used without any modifications.

Improving the Linearity

The next step is to alter the circuit so that the increase of voltage across the condenser is uniform over the range it is desired to work. This can be done in two ways: by altering the circuit or by increasing the charging H.T., and we can now weigh up the advantages and disadvantages of each method.

If we replace the resistance in Fig. 2 with a pentode, the circuit then becomes as Fig. 4. The condenser is connected in series with the anode of the valve and the screen is taken to a potentiometer connected across the H.T. supply. The characteristic of the pentode is familiar to anyone who has studied valve catalogues—the anode current remains practically constant over a very wide range of anode voltage.

When the circuit is switched on the condenser will charge at a rate which is determined by the impedance of the pentode, controlled by the screen volts. As the condenser voltage rises, the voltage across the valve falls, the sum of the two being equal to the applied H.T. But as the pentode anode voltage falls the current flowing through it remains substantially constant, enabling the condenser to charge at a constant rate. The voltage across the condenser will rise uniformly with time and the deflecting potential will give a true linear movement to the beam.

This circuit is therefore a method of overcoming the disadvantage of the one previously described and provided that the characteristic of the valve is as straight as possible there is the minimum of distortion in the scan. On the other hand there is the expense of the extra valve and the associated resistances and this is duplicated in the full scanning circuit.

A High Voltage Circuit

The alternative to this rearrangement of circuit is the increasing of the applied H.T. from 600, our estimated figure, to over 2,000! This seems curious at first sight but the explanation is not difficult. Referring to the curve of Fig. 3 it is seen that the first 150 volts increase takes place at a uniform rate, i.e., the condenser is charging linearly for the first small portion of its charge. If we magnified this small straight portion of about 150 volts three or four times we should get 500 volts of linear portion, which is what is required. At the same time the overall H.T. must be increased in proportion, so it must be made 4×600 or 2,400 volts. Again, these figures must only be taken as approximate, but experience has shown that the curve is sufficiently straight over the initial part if this is made $1/5$ th of the overall H.T. voltage.

On this assumption the figures become 400 and 2,000 and 500 and 2,500. It will be seen that all that has been done is to magnify the whole voltage scale so that the part we wish to use is sufficiently long to give a full linear travel of the beam without distortion.

The only objection to this method is the high voltage used, but in any case we are using a high voltage on the tube itself and the need for care in use and assembly is already present. The components must certainly be

of a better quality than would be serviceable on a lower voltage, but the extra cost of a valve has been saved and the wiring has been kept as simple as possible.

The design will therefore be proceeded with on these lines and it now remains to investigate the tube and see the modifications needed to overcome certain shortcomings inherent in this part of the circuit.

It must not be thought that the above discussion rules out all other types of linear timing circuit. The relay itself has certain disadvantages which have led many experimenters to favour circuits designed to do away with it altogether. If we can design a high-vacuum valve circuit to perform the same job it will be more stable in operation and will in general be more reliable. The cost of these circuits is in general much higher than that of the gas-relay circuit and this usually precludes their use in home-constructed apparatus.

However, there are one or two very good types of valve-scanning circuit, and they can be dealt with before going on with the development of the simple resistance-condenser circuit given above.

Hard-valve Scanning Circuits

The principal difficulty in the design of high-vacuum valve circuits is the imitation of the "snap" discharge action of the gas relay. If an ordinary valve is biased back beyond the point at which anode current starts, an increase in anode voltage will cause a gradual rise in anode current instead of the practically instantaneous rise which we require. To accelerate the growth of current in the valve it is possible to swing the grid momentarily positive which will give a rapid flow of current rising to a high value. If we imagine a condenser charged and connected across a valve which is normally biased to cut-off point, a sudden pulse of potential applied to the grid and swinging it positive will cause a heavy current to flow through the valve from the condenser and will discharge it in much the same way as the gas relay.

Discharge circuits of this type in which the impulse

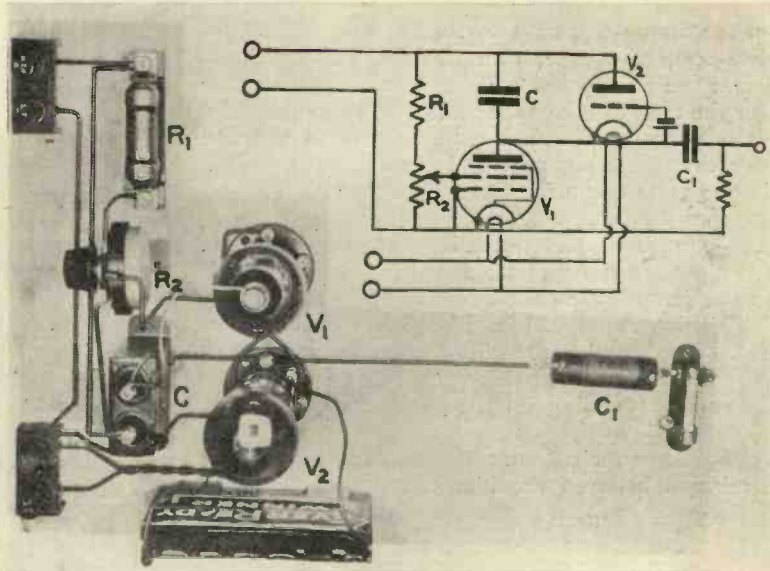

Fig. 4.—The replacing of a resistance by a pentode enables the condenser to charge uniformly at a constant rate.

to the grid is supplied by a separate oscillator have been developed in America* and have the advantage that the frequency of discharge can be kept within very close limits indeed, especially if the oscillator is crystal controlled. They are more complicated at the same time and require time and trouble in getting to work satisfactorily.

A simpler type of circuit is that developed by the Cossor Company in which a triode is used to discharge the condenser, in combination with a pentode. The grid of the triode is normally biased to a high negative value by means of the voltage drop in the anode resistance of the pentode. When the condenser voltage (which is across the anode circuit of the triode) reaches a certain value the valve commences to pass current.

This current in turn produces a change in grid-bias of the pentode and reduces the anode current. The bias applied to the triode is thus reduced in turn and the valve takes more current from the discharging condenser. The action of the two valves is cumulative and the first trickle of current is followed by a rush until the condenser is discharged. One of the advantages of this circuit is the practically unlimited frequency at which it will operate and its stability.

* See this journal for November, 1935. p. 643.

"The Principles and Practice of Electron Optics."

(Continued from page 29).

The mass actually varies with the velocity according to the Theory of Relativity, but at the speeds with which we are concerned the variation is so small as to be negligible. The fact that electrons travel in straight lines in a uniform field was first shown very beautifully by Crookes. He made a tube, see Fig. 1, in which there were only two electrodes, a cathode and an anode, thus conforming to the condition of a uniform electrostatic field. The cathode and anode were at opposite ends of the tube and behind the

anode on the glass end of the bulb he placed some fluorescent material. The cathode was then heated to emit electrons which moved in the direction of the anode. This was cut in the form of a Maltese cross, and when the field was applied a perfect shadow of the cross appeared on the screen.

The change in the direction of the electrons when passing from one field to another has been demonstrated by several experimenters. This change in direction, which is called bending or refraction, must not be confused with the bending produced by the deflector plates in an oscillograph. This action is caused by a field at right angles to the direction of motion, not a change

of field in this direction, called in optical language the principal axis of the system.

Perhaps the best method of illustrating the refraction of electrons is the "net" surfaces employed by Knoll and Ruska. They made two grids very close together (see Fig. 2), one at a negative potential and the other at a positive potential. The electrons travelled from a cathode on the negative side to an anode in the positive field and at the same potential as the positive grid. Fluorescent material either on the anode or on the glass wall at the end of the bulb clearly showed the bending of the beam.

(To be continued.)

THE FIRST KERR MEMORIAL LECTURE

Delivered by John L. Baird, Esq., at the Royal Institution on December 6th, 1935, under the auspices of The Television Society.



THE KERR CELL IN TELEVISION

THE December meeting of the Television Society was held at the Royal Institution, Albermarle Street, London, W., and the lecture, which was the first Kerr Memorial Lecture, was given by John L. Baird, Esq. Sir Ambrose Fleming, M.A., D.Sc., F.R.S., was in the chair.

In opening his lecture Mr. Baird quoted a statement Dr. Kerr made when he gave the first account of his investigations into the relation between electricity and light. Dr. Kerr, Mr. Baird said, made use of

reproduction of television images, and although the trend of developments indicate that the Kerr cell is to be replaced by the cathode-ray tube, its days of usefulness are, I think, by no means at an end.

I feel, as this is the first Kerr Memorial Lecture, that a considerable part of the time should be spent in giving an account of his life, and in describing the actual experiments which he conducted during his researches.

John Kerr was born in Ardrossan, Ayrshire, on December 17, 1824, the second son of Thomas Kerr an owner of a fishing fleet in the district. He began his education at a village

sprang up between teacher and student.

It was under Thomson's guidance that Kerr started his researches into the nature of light, electricity and magnetism, and in the succeeding years gained several special awards for papers on the mathematical theories of magnetism and of electricity. He took his Master of Arts degree in 1849, with highest distinction in Mathematics and Natural Philosophy, and was given the Earl of Eglinton's Prize for the most distinguished student in these two subjects.

In 1857 he was appointed lecturer in mathematics and physical science

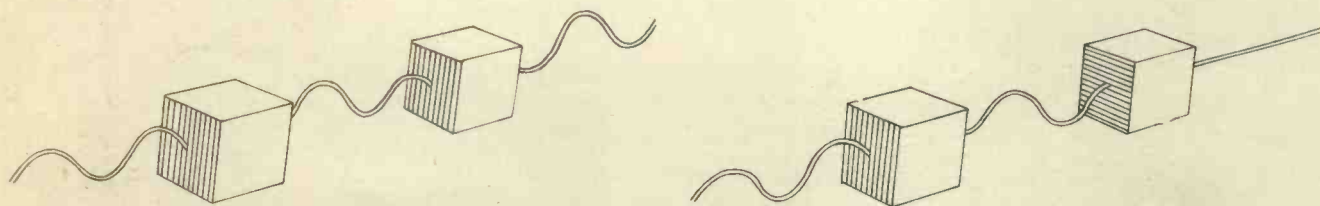

Two diagrams showing the polarisation of waves.

these words. "I cannot conclude without expressing the hope, amounting almost to a belief, that the plate cell will develop from its present rude beginning into a valuable physical instrument." Continuing, Mr. Baird said we are gathered here tonight to show how this hope has been amply fulfilled and to pay tribute to the scientist to whose ability we owe so much in the television world.

In my lecture to-night I hope to show how Dr. Kerr's discovery has been developed and applied to the

school in Skye. In 1841 he entered the University of Glasgow as a divinity student, and attended the usual classes for the degree of Master of Arts.

During the session 1845-46, he attended lectures on Natural Philosophy, and was taught in 1846 by William Thomson, who succeeded Professor Meikleham in the chair of Natural Philosophy. William Thomson, who was later to become famous in the electrical world as Lord Kelvin, was only six months senior to Kerr, and a strong and lasting friendship

at the Free Church Training College for Teachers at Glasgow, and here set up a private laboratory, largely financed out of his own pocket, for carrying out his own investigations. Between this date and 1875, the date of his first great discovery, he published a pamphlet on the metric system and also his book on Rational Mechanics. In 1878 he was recommended by Professors Thomson and Blackburn to receive an honorary degree of Doctor of Laws.

It was not until 1875, however, that the fruits of his researches were

published in the "Philosophical Magazine" under the title of "A New Relation Between Light and Electricity—Die-Electrified Media Bi-refrangent." In his first paper, Dr. Kerr used these words: "The

up waves in a number of planes, but it will be observed that the cord emerging from the first box is vibrating only in one plane. The box having limited the multiple vibrations of the cord to those in the vertical

ised. Nicol produced a prism of Iceland spar so arranged that one of these rays was internally reflected and the other transmitted. If we take one Nicol prism for the polariser and pass through it a beam of light this light is polarised in one direction. We now take a second Nicol prism called the analyser, place it in the path of the polarised beam so that its plane of polarisation is the same as that of the polariser, and the spot of light produced by the beam will still be seen. If now we rotate the second Nicol so that its plane of polarisation is at right angles to that of the first Nicol, the light spot disappears, as one would expect from our cord and box analogy.

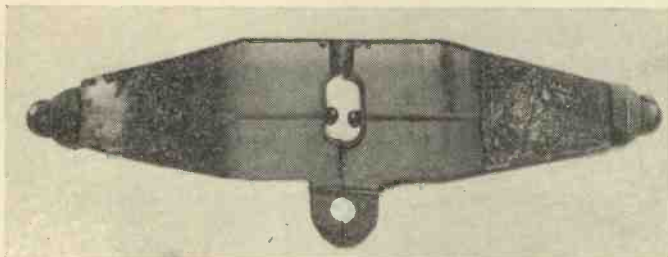

One of the first liquid cells used in 1879.

thought which led me to the following inquiry was briefly this:

That if a transparent and optically isotropic insulator was subjected properly to an intense electrostatic force, it should act no longer as an isotropic body upon light sent through it."

Faraday had already discovered in 1845 the effect of a strong magnetic field on a beam of polarised light and Kerr was urged to investigate whether a similar effect did not exist for the electric field.

Before we continue with Kerr's investigations, I want to pause for a while to explain for the benefit of our non-technical visitors here, the nature of polarised light, in order that we may all fully appreciate the significance of Kerr's work.

We know that light is a form of wave motion—that is, light is emitted from a luminous source in the form of a series of very rapid vibrations, which take place in a plane at right angles to the direction in which the light is travelling. These vibrations are random vibrations, that is to say, they are not all in one plane, but in an infinite number of planes, and in addition, we have in white light a mixture of all kinds of wavelengths. So far as the eye is concerned, we can distinguish nothing of this nature of wavelengths and directions of vibration, but there are substances which have a discriminating effect on the wave trains which pass through them, allowing only those in a certain plane of vibration to pass.

A very good analogy is shown by a simple experiment of a cord passing through two boxes arranged with gratings at either end. These boxes are arranged with their respective gratings in the same plane, in this first case, vertical. The cord is now agitated in all directions, so setting

up waves in a number of planes, but it will be observed that the cord emerging from the first box is vibrating only in one plane. The box having limited the multiple vibrations of the cord to those in the vertical plane, that is to say, the waves are vertically polarised. This vertically polarised wave, you will see, is allowed to pass through the second box as its grating is also arranged vertically.

The two boxes are then arranged so as to have their gratings in a horizontal plane and the same effect is observed, the waves in this case being horizontally polarised. The first box is now arranged with its gratings in a vertical plane, and the second box with its grating in a horizontal plane. The cord is agitated as before and the first box allows only the vertical waves to pass, and the second box allows only the horizontal waves. Therefore, none of the vibrations originally imparted to the cord will pass through, owing to the polaris-

Having found out the nature of polarised light, we are now in a position to appreciate Kerr's discoveries.

Kerr thought that the plane of polarisation of certain substances would be affected by the presence of a strong electric field. In order to investigate this, he conducted experiments with various solid transparent di-electrics, these researches he published in the "Philosophical Magazine" for November, 1875. The first di-electric study consisted of a slab of glass. Here I will quote Kerr's own description of this piece of apparatus: "A piece of good plate glass, $\frac{3}{4}$ -in. thick is formed roughly into a rectangular block 6 ins. long and 2 ins. wide. Two holes, about



Two more liquid cells made from a glass cube (left) and an inkpot (right)

ing planes of the two boxes being opposed to one another.

The Nicol Prism

Certain materials possess the property of polarising light, one of the most common being Iceland spar. This material, however, is doubly refracting, that is, it splits the light into two rays; both of them polar-

$1/10$ th of an inch wide, are drilled into the block from the opposite ends and they lie exactly as in continuation of each other, in a line parallel to the longest edge of the block, and midway between opposite faces; and they terminate in well-rounded bottoms at the centre of the block, with a short extent ($\frac{1}{4}$ in. or less) of clear glass between them." He then goes on to say: "The electricity is obtained

from a Ruhmkorff's induction apparatus, which gives a spark of twenty to twenty-five centimetres. The dielectric just described stands upon the table close to the 'inductorium.' The block was mounted on two rods of glass which acted as insulators, and leads from the so-called "inductorium" were inserted into the holes drilled. The slab was then arranged between two Nicol prisms acting as polariser and analyser crossed, that is to say, so arranged that no light would be passed by them.

A source of light was placed in front of the first Nicol, this source being nowhere near as efficient as we have for experimental work nowadays, consisting of an ordinary flat paraffin flame. But, as Dr. Kerr remarks: "It is exceedingly brilliant," so it doubtless served very well. The induction coil was then switched on, and so arranged that a strong electric field was present between the extremities of the two wires fixed into the glass. The light then re-appeared, showing conclusively that the plane of polarisation had been rotated by the electric field.

In his summary, Dr. Kerr made these remarks:

"Faraday's views as to the constitution and function of dielectrics apply here very aptly."

"Contrary Electrification rapidly succeeding one another exert contrary action of electric polarisation, but conspiring actions of molecular arrangement. They are therefore as effective as a continued electrification in one direction; and a Ruhmkorff's coil is as effective as an electrical machine of equal strength."

This discovery, although important, is not the identical phenomenon that is employed for the control of the light source in television, but paved the way for his next discovery, that a similar effect existed in liquids.

The Kerr Cell

The cell used in this part of his work was similar in construction to the glass slab used in the former experiments, but hollowed in the centre to take liquid. The whole cell was made liquid tight by the addition of two sheets of glass clamped on each side of the slab, the liquid being introduced through the hole shown in the top of the cell. A great variety of liquids were tried by means of this cell besides the volatile liquids such as bi-sulphide of carbon and benzole,

a good many oils were tried, including paraffin and kerosene, olive oil and castor oil, and also turpentine. He found that the presence of an electric field on the liquid caused the same rotation of polarisation as was observed in connection with the experiments on solids, but with one very important difference, namely, the absence of time lag, this being of major importance in adopting the apparatus for the control of a light source for television reception.

Kerr sums up his results in these words: "Compared among themselves with reference to strength of bi-refrigent action, the liquids appear to be very unequal; carbon di-sulphide is strongest, paraffin and kerosene the weakest. Compared with glass, they are much weaker insulators—but if allowances be made for this difference, I think that, for intensity as well as purity of effects, carbon di-sulphide is far superior to glass."

I am now going to endeavour to demonstrate this effect in liquids, but using a modern type of Kerr cell in which a number of plates are arranged with very small spacing in nitro-benzene, and using for the source of electricity a number of batteries. The cell is arranged between two crossed Nicols. The light source is switched on, and you will observe that no light is passed through the Nicols and cell on to the screen—a potential is applied across the cell and it is immediately observed that a light spot appears. Its intensity varies with the amount of potential that is applied to the cell.

It is interesting to notice one more effect, that is, with the increase of potential above a certain critical value a colouration appears in the transmitted light, this phenomenon being known as the Kerr chromatic effect.

Dr. Kerr recognised the necessity for scrupulous cleanliness in these experiments, and he refers several times to the difficulty of keeping cells clean and to the presence of dust in the liquid, which tended to spoil his results, in extreme cases the dust forming a chain between the two conductors.

The two effects so far described in solids and liquids must not be confused with another branch of Dr. Kerr's work which is known as the "Kerr Effect." This is in relation to the effect of a magnetic field on a beam of light and was published by Kerr in May, 1877, two years after

the publication of his researches on the effects already described. He announces it in these words and describes it thus:

A New Fact

"When plane polarised light is reflected regularly from the polished face of an electro-magnet of either polarity, the plane of polarisation is turned through a sensible angle in a direction contrary to the normal direction of the magnetising current; so that the true south-pole of a polished iron electro-magnet turns the plane of polarisation right-handedly."

In 1890, Dr. Kerr was elected to the Fellowship of the Royal Society, and received the Royal Medal for his researches in 1898. In 1901 he retired and lived quietly until his death in 1907, within a few months of his great friend Lord Kelvin.

The Application of the Kerr Cell to Television

I have demonstrated that when a potential is applied across a Kerr cell, mounted between two crossed Nicols, light is allowed to pass through the whole system. The amount of light being variable by varying the potential. Here then, we have a piece of apparatus that will allow different amounts of light to pass at will, in other words, we have a light valve.

Now, if the incoming signal from a television transmission is suitably amplified and the resulting varying potential is fed across a Kerr cell in conjunction with a light source and Nicols, the amount of light allowed to pass will vary proportionally with the strength of the incoming impulses. If now the fluctuating light spot is focused on to a scanning mechanism and from thence thrown on to a screen, a reproduction of the scene at the transmitting end will result.

The Kerr cell has been used for showing pictures on a large screen. Some of the members of this audience, no doubt, were present at the Metropole Cinema in June, 1931, when the Derby was televised and projected on to the screen.

A three-zone method was employed, whereby at the transmitting end the scene was split up into three strips. The impulses from each strip being sent from Epsom to London, utilising three pairs of telephone

(Continued in third column of next page.)

Further Notes on Frequency Meters

By G2DV and G5BJ.

INQUIRIES that have been received regarding the electron-coupled frequency meter, which was described in the July issue, has prompted the following observations.

In operation care should be taken that the coupling between the meter and the receiver is kept quite loose—just sufficient to give a comfortable beat note with an incoming signal. If the receiver is of the straight regenerative

scratch (particularly the filament supply), accuracy as good as that obtained with the mains unit can be attained.

Operation as an electron-coupled oscillator requires that the cathode (or filament) be operated, from a radio-frequency point of view, above baseline. This can be achieved by feeding the source of filament heating supply through two H.F. chokes and taking one end of the filament to the tap on

precludes the use of the coil-centring device, but this cannot be avoided. Other components will remain as in the July issue. Due to the absence of the heavy cathode-heater capacity of a mains valve across the lower portion of the coil, it will be found that each coil will tune to a slightly higher frequency than with the mains version, but the coverage will be substantially the same.

It will be noted that the L.T. supply is switched together with the H.T., but due to the small amount of heat generated from a battery-type valve filament, an accurate calibration may be taken almost immediately after the meter is switched on.

The diagram references are as follows:—

- V₁ Mazda S.G.215.
- L₁ See table in July issue.
- C₁ 100-mfd. microdenser (Eddystone).
- C₂ .0003 mica (T.C.C.).
- C₃₋₆ .01 mica (T.C.C.).
- R₁ 150,000 1-watt (Dubilier).
- R₂ 50,000 1-watt (Dubilier).
- R₃ 30,000 1-watt (Dubilier).
- R₄ 20,000 1-watt (Dubilier).
- S₁ S.P.S.T. on-off switch (Bulgin).

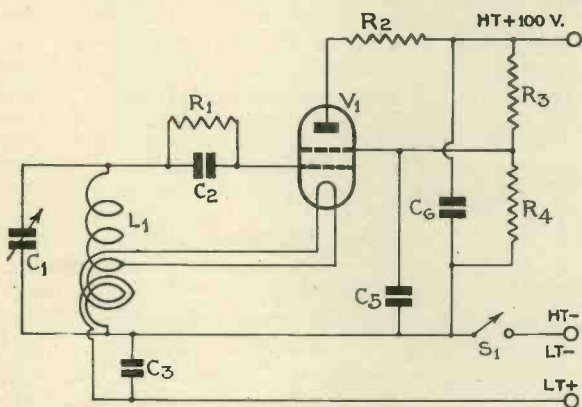

A battery operated screen-grid valve can be used as an oscillator if the circuit constants are carefully worked out.

type, close coupling by means of a condenser will alter the tuning of the receiver appreciably. Disposition some two or three feet from the aerial lead and receiver will normally give a good clean beat.

The receiver must *not* be oscillating when checking frequency, as three different beats can then be obtained—between the signal and receiver, signal and frequency meter, and frequency meter and receiver. With correct operation, when the meter is tuned to zero beat with the transmission being received, the meter must obviously be on the same frequency as the signal—this should be clear to everyone.

Too much stress cannot be placed on using the type of dial specified. This is quite free from backlash, and hand pressure on the driving knob will not affect the calibration by moving the rotor of the condenser in relation to the stator. By the same token, dials with direct drive, admirable for other purposes, are totally unsuited for precision measurement work.

Battery

Operation.

Several inquiries were received as to how the circuit may be adapted to battery operation. This is quite simple, and providing batteries are kept up to

the coil, as in the mains unit. There are, however, two big objections to this procedure. A voltage drop due to the resistance of the H.F. chokes would necessitate the use of a four- or six-volt accumulator and a rheostat, but the most important consideration is the variable efficiency of the H.F. chokes throughout the wide tuning range. No choke, and particularly a pie-wound type, has constant efficiency throughout the wave range covered.

This difficulty can be overcome by feeding the L.T. negative through the tap on L₁ and running a concentric winding of the same gauge wire from the bottom of the coil to the tap, the L.T. positive connecting to this (see diagram). The bypass condenser C₅ must be connected directly across the corresponding pins on the coil holder.

Construction will follow that of the mains version except that 5-pin coil-formers instead of 4-pin will be necessary. The anode pin on the socket will feed the L.T.+ side of the filament, while the L.T.+ feed from the accumulator will connect to the centre pin. This

Our Policy
"The Development of
Television."

"The First Kerr Memorial Lecture."

(Continued from preceding page).

wires. At the "Metropole" the impulses were amplified and passed on to three Kerr cell light valves, which in turn were focused on to a mirror-drum and thence projected on to the screen.

It would seem that for high-definition television generally, the tendency is for mechanical reception to be replaced by cathode-ray. There is, however, still, I believe, a field for the Kerr cell, particularly in large screen reception.

I have traced the progress of Dr. Kerr's discovery, from its publication in 1875 to its present form in 1935, and we will agree that he would be delighted if he could see the uses to which it has been put. The prophecy which he uttered sixty years ago has been fulfilled. In closing I thank Mr. Parr and Mr. Maybank for the great help they have given me in preparing this lecture.

JANUARY, 1936

A Midget-valve Head Amplifier

By Malcolm Harvey

IN the September issue was described a single-valve R.C. coupled microphone amplifier which I have been using with a transverse current type of microphone. Several amateurs have approached me about a design of a pre-amplifier that could be built on similar

multi-purpose primary giving ratios of 30, 40, 50 and 60-1. In series with this primary is a 10-volt wet cell for energising the microphone. In the secondary circuit of this transformer is a high-frequency choke between one end of the winding and the grid of the first

second stage is a 50,000-ohm resistance without decoupling. A .05-mfd. condenser is in the output circuit and is coupled indirectly to the input of the following speech amplifier.

A 1,000-ohm resistance between H.T. negative and L.T. negative is by-passed by a 1-mfd. condenser and provides automatic grid bias for the two valves. As these valves are of identical characteristics the bias required is approximately the same even though the first is operating with the lower anode potential.

The dial light across the L.T. supply is of the 2-volt .06-ampere type, as are the two XD valves, so that the total filament consumption of the entire amplifier is only .18 ampere. As the anode consumption is only 3 milliamps running costs are negligible.

This amplifier used with a very low output microphone increases the gain so much that faint sounds inaudible to the human ear, can be picked up and transmitted. This may sound rather a tall claim, but in actual fact sounds such as birds whistling and clocks ticking which normally could not be heard were transmitted.

Another point which is of great value is the gain control which enables the amplifier to be used with any type of microphone, irrespective whether it is of the low- or high-output type.

Construction

Construction is very easy providing it is done in the proper sequence. First of all the case. This is made of zinc for two reasons. Connections can be

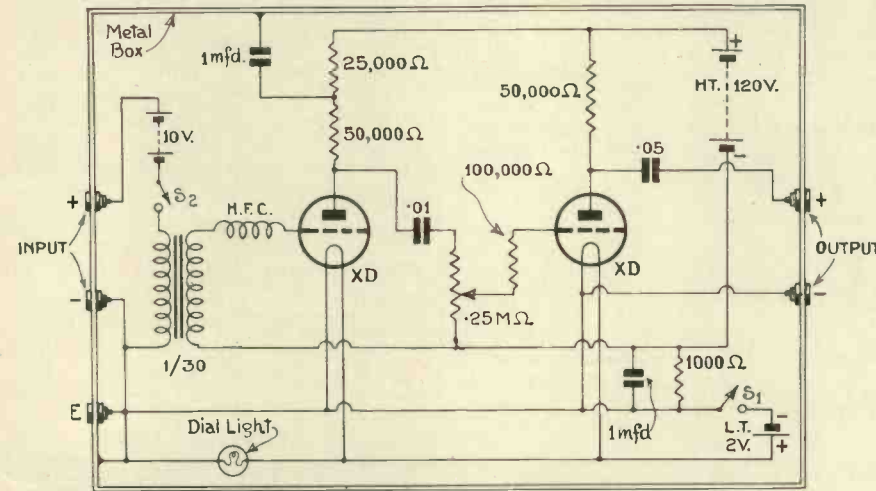

Fig. 2.—The midget valves used in this amplifier are quite free from noise and microphony even at maximum anode potential.

lines so as to boost the output from the low output types of microphone.

Although the unit to be described may appear to be comparatively simple, it has taken some weeks to make it completely trouble-free and suitable for general construction.

Trouble such as hum pick-up from the transmitter, valve microphony, instability, noise-level, etc., are only some of the difficulties that had to be overcome.

The amplifier in its present state is so stable and fool-proof that it can be linked up to almost any type of speech amplifier through either a long line without step-down transformer or close to the actual grid of the amplifier. In the former case no difficulty is experienced due to instability, while in the latter, owing to the special metal used, hum pick-up is negligible.

The external appearance of the amplifier can be seen from Fig. 1, where the left-hand set of terminals are top, grid input, middle, negative input, bottom, common earth. The lever switch in the centre operates on both L.T. and microphone battery simultaneously while the knob beneath the switch is the L.F. gain control. The last two terminals are—top, positive output—and bottom, negative output.

Fig. 2 gives a comprehensive idea as to the circuit arrangements. The input from the microphone is fed into a special Eddystone transformer having a

amplifying valve. Note how the other side of the secondary goes back to H.T. negative and not to the chassis.

R.C. coupling is used between the first and second valves. In the anode circuit of the first XD triode is a 50,000-ohm resistance followed by a 25,000-ohm resistance for decoupling. The coupling condenser is a .01-mfd. which feeds into a .25-megohm potentiometer,

Fig. 1.—In the centre is the master switch which cuts off the two power supplies. The gain control is underneath the switch.

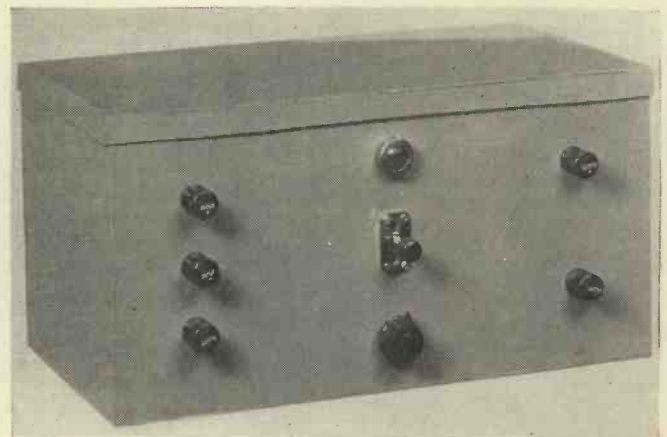

which is used as a combined grid leak and L.F. gain control. A 100,000-ohm grid stopper to prevent leakage of H.F. is in series with the slider of this gain control and the grid of the second triode. The anode impedance in the

soldered directly to it and it is easy to work. The case measures 14 ins. long, 8 ins. deep by 7½ ins. in height and is built up of ten pieces of zinc, all soldered together. The actual box can be obtained ready-made.

A wooden baseboard 11 ins. by 4½ ins. is required to take the components for the actual amplifier, but more about this later. First of all drill the five holes on the front of the panel to take the Belling-Lee terminals, then cut the hole for the lever switch and dial light

is the special input transformer. On the left-hand side of this are four terminals. The first, the one nearest the panel, gives 30-1 ratio, the second 40-1, the third 50-1, and the fourth 60-1. The common tapping for this primary is the centre terminal on the right-hand

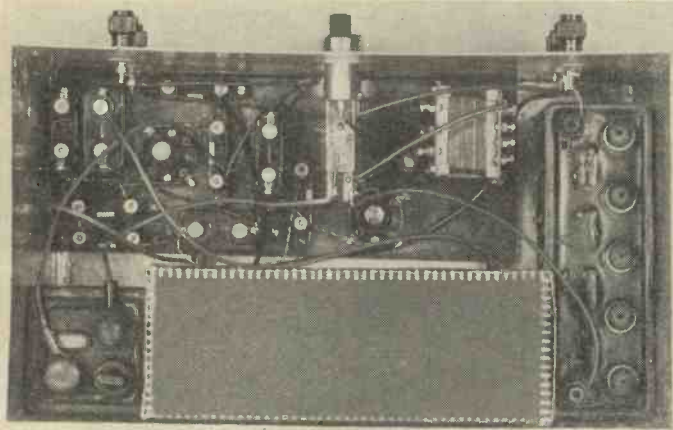

Fig. 4.—This gives a good idea as to the layout of the components and the dry and wet batteries.

and drill another hole for the volume control. Then mount the components on the baseboard as can be seen from Fig. 3.

All resistances are Ferranti synthetic, which are in this instance more satisfactory than the usual wire-wound type for as all the resistances are inter-linked the amplifier would not be too rigid unless some means of anchoring were devised.

Wire up the entire amplifier with the exception of the panel contacts. Then put three wires on to the gain control, one on to the earth terminal, one on to the negative input and one on to the positive input. Join up the five flexible battery leads and then put the amplifier chassis into the case and bolt it to the bottom with two small counter-

side. It is merely a matter of selecting the required ratio to give the cor-

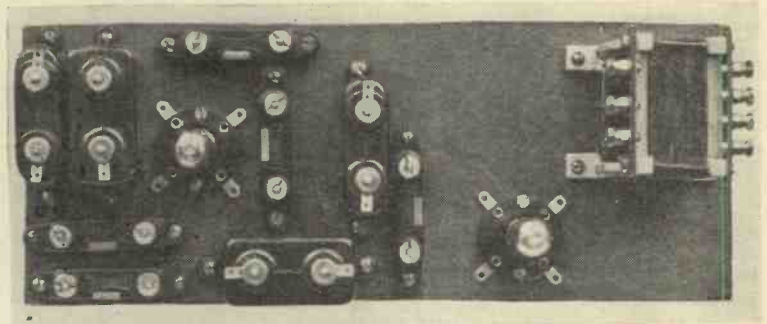

Fig. 3.—Before building these components should be screwed to the wood baseboard.

rect amount of step-up to suit your own microphone.

- COMPONENTS FOR HEAD
AMPLIFIER**
- CABINET AND CHASSIS.**
1—Soft iron to specification (Peto-Scott).
- CONDENSERS, FIXED.**
2—1-mfd. type BB (Dubilier).
1—.05-mfd. type B775 (Dubilier).
1—.01-mfd. type B775 (Dubilier).
- CHOKE, HIGH-FREQUENCY.**
1—Receiving type CHN (Raymart).
- HOLDERS, VALVE.**
2—VH30 (Bulgin).
- PLUGS, TERMINALS, ETC.**
2—Heavy-duty spade terminals, 1 red 1 black (Clix).
4—Wander plugs marked H.T. neg., H.T. pos., 1 red, 1 black (Clix).
5—Insulated terminals type B marked Input neg., Input Pos., Output neg., Output pos. and Earth (Belling Lee).
- RESISTANCES, FIXED.**
2—50,000-ohm. type GH5 (Ferranti).
1—25,000-ohm. type GH5 (Ferranti).
1—100,000-ohm. type GH5 (Ferranti).
1—1,000-ohm. type GH1 (Ferranti).
- RESISTANCE, VARIABLE.**
1—250,000-ohm. (Erie).
- SUNDRIES.**
1—Dial Light type D9 plus B206 bulb (Bulgin).
- SWITCH.**
1—Lever type two-pole 1.1 (Wearite).
- TRANSFORMER.**
1—type 1035 (Eddystone).
- MICROPHONE BATTERY.**
1—10-volt wet cell (Exide).
- VALVES.**
2—type XD (Hivac).

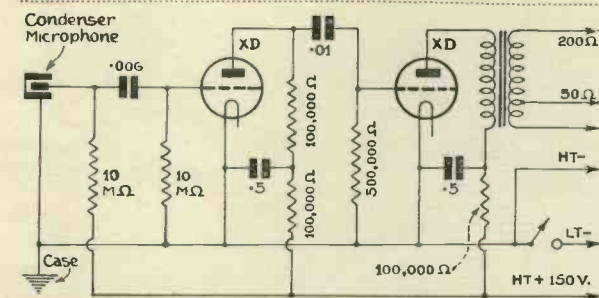

Fig. 5.—When a condenser or crystal microphone is used this is the type of circuit that should be employed. It can be built in the same way.

sunk bolts. The gain control can then be wired up, four connections made to the switch, three to the dial light, and all of the terminals, with the exception of the negative output which automatically makes contact to the case. One special point, the Belling-Lee terminals should all make contact with the case with the exception of positive input and positive output.

On the left-hand side of the amplifier

As regards microphony the Hivac valves chosen are absolutely perfect in this respect. Even with maximum gain and maximum anode potential, there is absolutely no trace of noise or howl. The Ferranti resistances are also quiet in operation so that no background noise will be experienced.

Another point to remember is that the coupling condensers in the R.C. stages

are of the Dubilier mica type and it is important that these condensers be used.

The 10-volt H.T. accumulator used for energising the microphone is a good investment. If two of these are purchased one can always be kept ready charged so that the amplifier will not fail in use. Fig. 4 gives quite a good idea of the layout and the way in which the three sources of supply have been fitted. Constructors should adhere to this component layout.

Readers who wish to use the condenser type of microphone will have to make slight modifications to the input stage of this circuit. Fig. 5 shows what alterations are necessary. The input transformer cannot be used while the first anode resistance has a value of 10 megohms. The remaining resistance values are also unusual, but the circuit does give extremely fine quality with reasonable stage gain. This circuit can be used in place of the one shown in Fig. 2, while the layout can remain fundamentally similar.

THE TELEVISION ENGINEER

NOMOGRAPHS FOR KERR CELL DESIGN

By L. M. Myer

This article is published in response to a number of requests for a permanent record of the information given on Kerr cell design. It explains how the electrode dimensions of cells for various uses can be calculated.

FOR the purpose of rapid calculation of the electrode dimensions for a Kerr cell, whatever the use to which the cell is put, it is very convenient to resort to the nomographic method.

We give here the required nomo-

The electrode gap d is in mms. The electrode length in cms. If it is necessary to use the diverging plate type of electrodes then ab is substituted for d^2 , a is the gap at the centre and b is the gap at the ends of the electrodes, both in mms.

From the curve of Fig. 1 we note that the control voltage V_c is roughly .3 of the maximum voltage; this eliminates working on the initial bend of the characteristic. The bias voltage is $.707 V_{max}$. Therefore, to obtain the control voltage from the maximum voltage it is necessary only to multiply by the factor 0.3.

From the curves of Fig. 2 we obtain the nomograph of Fig. 3. This nomograph gives both the maximum voltage and the control voltage for a given electrode gap or electrode length. To use, simply place a straight edge to intersect the left-hand line at a given electrode gap, which is in mms., and to intersect the right-hand line at a given electrode length, which is in cms. Then the intersection of the straight edge with the centre line gives the required voltage for operation of the cell. On the left-hand side of the centre line we have the maximum voltages and on the right-hand side of this line we are given the control voltages. For example, taking an electrode gap of 1 mm. and an electrode length of 3 cms. we find that the maximum volt-

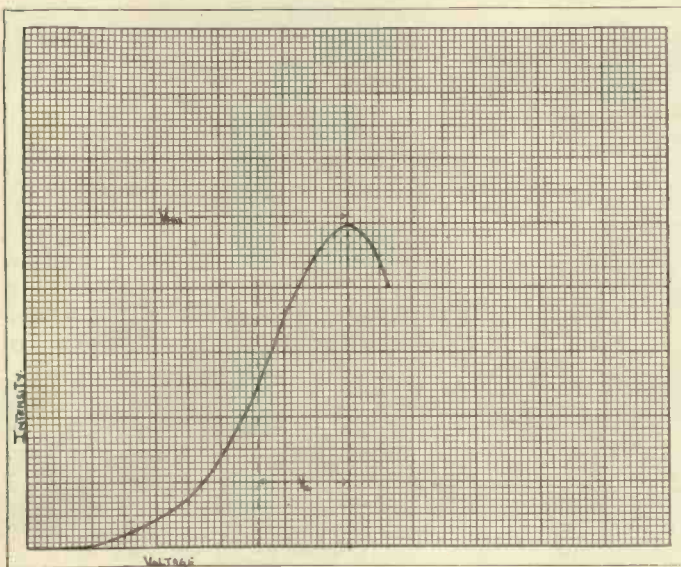

Fig 1.—Intensity curve for first working slope.

graphs for the calculations respecting the operation of the cell on the first slope of the intensity curve and also for the operation of the cell with half-wave electrical bias.

For operation on the first slope we examine the curve of Fig. 1. The maximum voltage, or the peak voltage, is obtained from the Kerr equation.

$$\phi = \frac{BIV^2}{d^2}$$

by putting $\phi = \frac{1}{2}$. If B , the Kerr constant, is put $= 20 \times 10^{-8}$ then the expression yields

$$V_{max} \sqrt{I} = 4750d.$$

If we now take the logs of these terms we have

$\log V + \frac{1}{2} \log I = \log 4750 + \log d$
the graph of which is a straight line as given in Fig. 2. In this graph double log paper is used so that the co-ordinates read off the voltages against the electrode lengths for a number of different electrode gaps.

Fig. 2.—Curves for operation on first slope. The numerals on the right-hand side refer to the electrode gap.

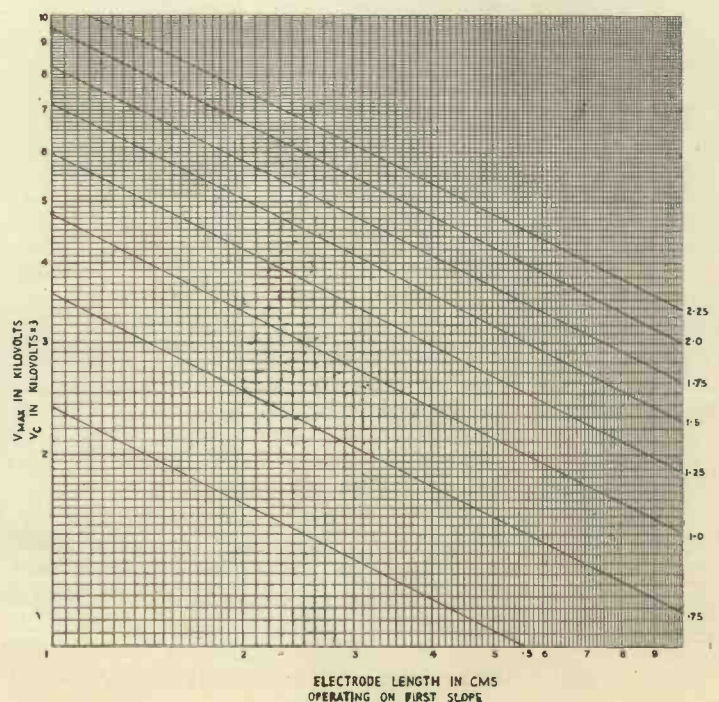

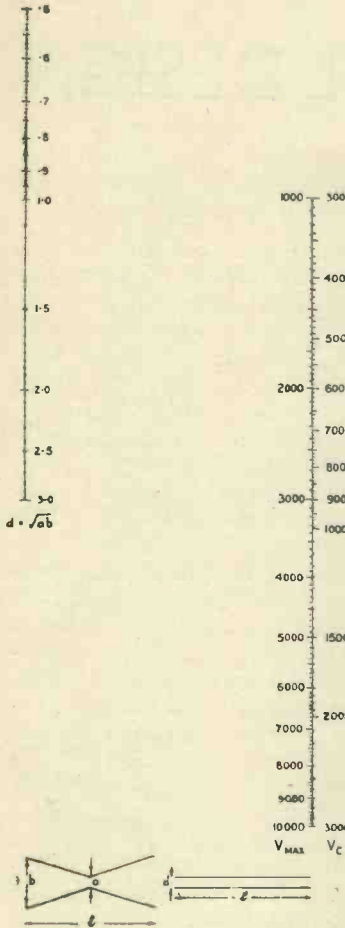

Fig. 3.—Nomograph for operation on first slope. Electrode length on right-hand scale in centimetres. Electrode gap on left-hand scale in millimetres.

age is 2,750 volts, at the same time the control voltage is 825 volts.

It is now the practice to operate the cell with half-wave electrical bias, as shown in the curve of Fig. 3. The maximum voltage is now found by putting $\phi = 3/4$ in the Kerr expression; thus we have

$$V_{\max} \sqrt{I} = 5800d.$$

Taking the logs and plotting the curves as before, we have in Fig. 5 the means of obtaining the maximum voltage for given electrode lengths. As before, each curve corresponds to a particular value of the electrode gap.

To obtain the control volts we examine the difference between the bias volts V_b and the maximum volts V_{\max} ; the former is obtained by putting $\phi = 1/2$ and the latter by putting $\phi = 3/4$, the difference being equal to $0.18 V_{\max}$.

Fig. 6 shows the nomograph for

Fig. 4.—Cell operation with half-wave electrical bias. The cell is given a forward bias of V_b and an optical compensation of quarter wavelength.

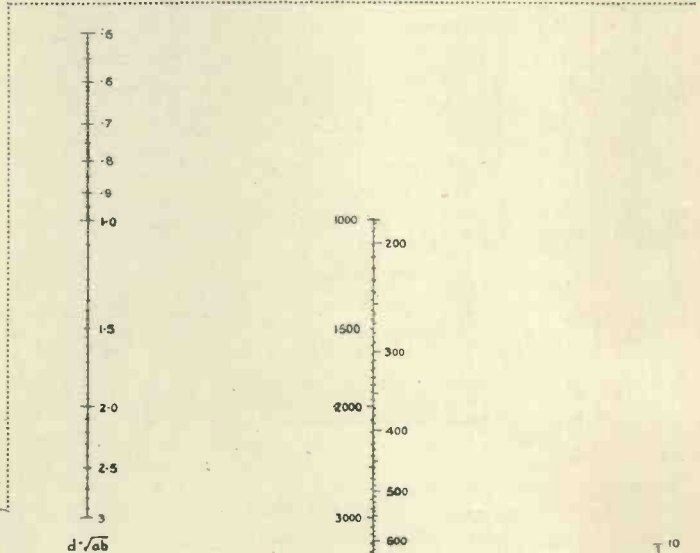
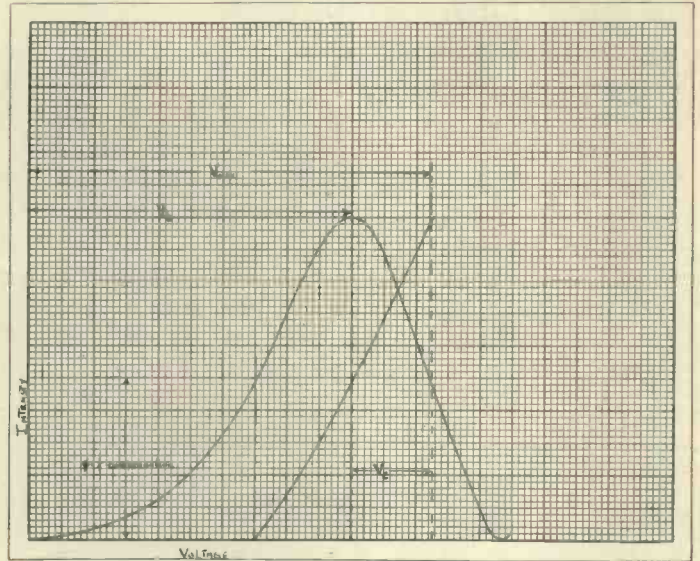
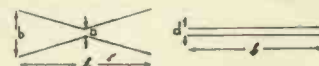

Fig. 6.—Nomograph for operation with half-wave bias. Electrode length on right-hand scale in centimetres. Electrode gap on left-hand scale in millimetres. (Fig. 5 on next page.)



this manner of operation. As before the right-hand scale gives the electrode lengths in cms.; the left-hand scale gives the electrode gap in mms. and the centre scale gives the required voltages. The left-hand side of this scale gives the maximum volt-

age and the right-hand side gives the control voltages.

These nomographs have been drawn well within the scope of electrode dimensions, and it will be obvious on referring to them that the

best method of operating the cell is to do so with half-wave electrical bias. In this case it is, of course, essential to insert a compensating quarter-wave plate.

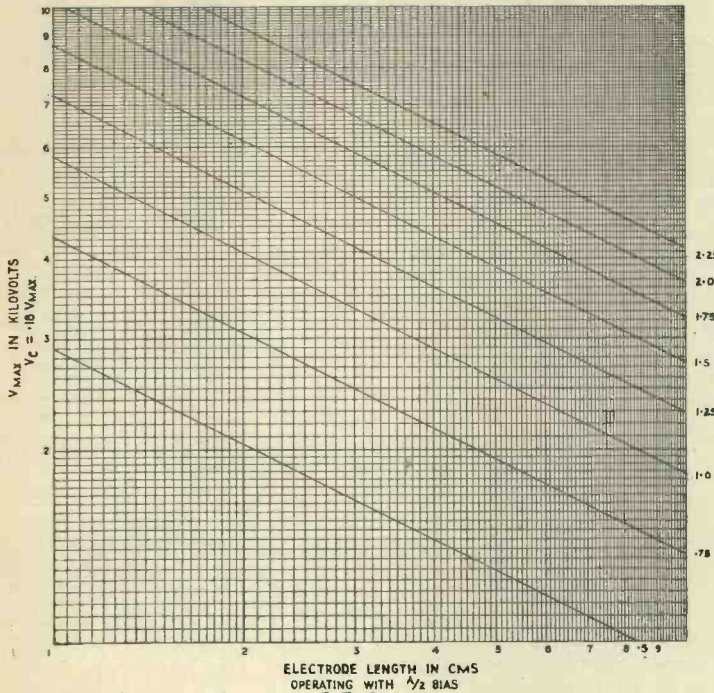

Fig. 5.—Curves for operation with half-wave bias. The numerals on the right-hand side refer to the electrode gap.

CATHODE-RAY TUBE NOMENCLATURE

With the increasing use of cathode-ray tubes a large number of technical terms are being introduced into the literature of the subject. This article, abstracted from the Proceedings of the Institute of Radio Engineers, gives a summary of the various definitions and terms used in America in estimating the performance of a tube. It is probable that similar definitions will be standardised in this country.

THE efficiency of a tube can be considered both with reference to the "gun" and to the fluorescent screen. The term "gun" is understood to comprise all the electrodes which contribute to the production and focusing of the beam. The "gun" is considered perfectly efficient when all the electrodes produced by the cathode reach the fluorescent screen. The "gun" efficiency is therefore the ratio of the electron current leaving the cathode to the electron content of the beam arriving at the screen. This latter is usually referred to as the *beam current*.

The screen efficiency can be expressed in many forms. The most generally used rating is the screen luminous efficiency which is a measure of the ability of the screen to convert electron energy into visible radiation. Since the unit of visible radiation is the *lumen* the efficiency can be expressed in *lumens per watt*. An alternative is candle-power per watt. This unit, however, does not take account of the actinic value of the radiation from the screen, and it is there-

fore desirable for photographic purposes to measure the *actinic efficiency*.

Characteristics

The characteristics of the electrode system approximate closely to those of the ordinary thermionic valve and therefore do not require special consideration. There are also the characteristics of the screen itself such as the *spectral characteristic* which gives the relation between the radiant energy per individual wavelength at each wavelength of the spectrum.

This is generally shown in the form of a curve giving relative radiant energy against wavelength of the spectrum in Angstroms.

Of special importance is the *persistence characteristic* which gives the brilliance of the light emitted by the screen after a given interval from the initial excitation. This is sometimes known as the decay characteristic or curve of *afterglow*. The brilliance is usually expressed as a percentage of the initial brilliance (taken as 100).

Luminescence

It is pointed out that there are various terms to describe luminescence and that it is advisable to distinguish between them to avoid confusion. The terms used are:

Fluorescence.—The luminescence emitted by a fluorescent substance during excitation; in the cathode-ray tube the actual radiation during the time the beam is impinging on the screen.

Phosphorescence.—The luminescence emitted after the stimulus has been removed. In the tube this gives the "afterglow."

Luminescence.—The general term which covers all forms of visible radiation from a substance. The following are the main classes into which luminescence can be divided:

- | | |
|----------------------|---|
| Cando-luminescence | Luminosity of incandescent solids. |
| Photo-luminescence | Created by exposure to radiation. |
| Chemi-luminescence | The luminescence of chemical reactions. |
| Electro-luminescence | The luminosity of ionised gas. |
| Bio-luminescence | Emitted by living organisms. |
| Tribo-luminescence | Created by the disruption of crystals. |
| Radio-luminescence | Excited by radio-activity. |

It is also proposed that the screen material which is excited by the electron beam be called a *phosphor*.

Luminescent Spot

Defocus is any condition of the luminous spot other than optimum in shape and size.

Spot size may be measured under various conditions, and is commonly given in terms of spot diameter or of line width.

Apparent Spot Size. When the spot size is measured from photographic records the resultant spot size is not necessarily the true spot size but is affected by length of exposure, etc.

Distortion

Distortion of the pattern should be expressed in per-
(Continued in third column of next page.)

Accurate Inductance Measurement

Amateurs often find trouble in checking the inductance of low-frequency choke under actual working conditions. This article shows how it can be done in a simple way.

THE inductance of iron-cored low-frequency chokes is largely dependent on the working conditions under which the choke is to be used. It is quite well known that the inductance of a choke can only be given for one specific current flow, not considering, of course, some of the special so-called constant inductance chokes. It is not quite so well known that an

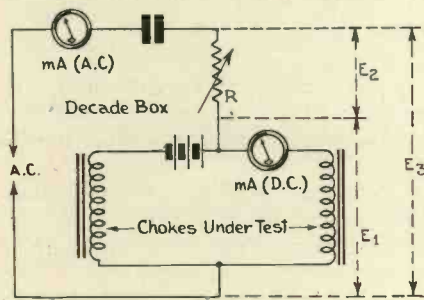

This unit can be made up in a metal container with the power supply in a separate container.

applied A.C. voltage also effects choke inductance.

Copper resistance of a choke is usually small as compared with its inductive reactance so that for most purposes it can be neglected. The core losses, however, are usually large enough to show a marked difference between the current inductance and the actual inductance.

Core losses consist of eddy currents circulating within the molecules of iron and around the paths set up by the magnetic lines of force. Hysteresis losses are due to the tendency of iron when magnetised to hold its magnetic polarity and so reluctantly reverse the polarity as the current reverses in phase.

In well-designed smoothing chokes laminated iron reduces eddy currents and special alloys having the least reluctance magnetically, reduce hysteresis losses, which accounts for the difference in cost between an efficient well-designed choke and some of the cheap ones. Many amateurs have wanted some reasonably simple inductance measuring circuit. Fig. 1 illustrates the method employed to calculate the inductance of iron-cored coils or chokes under conditions which approximate the normal working operations.

Two identical chokes are measured

at once, while batteries are used to give any voltage between 2 and 200 to provide the D.C. current flowing through the choke.

Resistance R is a non-inductive resistance box which can be obtained from many surplus stores. An A.C. component is supplied through a 10-mfd. paper condenser, which, incidentally, should have a power factor of less than one-quarter of one per cent.

Measurements are then made with a conventional valve-voltmeter, such as has been described in previous issues. Of course, the frequency of A.C. supplied is equivalent to the ripple frequency of a full-wave valve rectifier or 100 cycles for the average choke used on a 50-cycle power supply.

The simple method of calculation is with a vector diagram, shown in Fig. 2, where a distance of $\frac{1}{4}$ in. equals 1 volt. With a compass the length equivalent to the three voltages E_1 , E_2 , E_3 are plotted as shown. The acute angle formed by E_1 and an extension of E_2 is measured with a protractor and

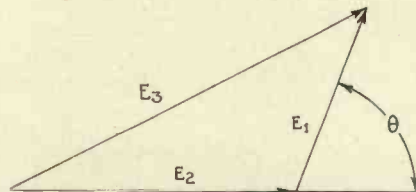

In this vector diagram $\frac{1}{4}$ in. is equal to one volt.

recorded in degrees. From the table of sines the sign of the acute angle is determined. The formula for actual inductance is

$$L = \frac{R(\text{in ohms}) E_1}{\pi f E_2} \sin \theta,$$

where f is the frequency of the alternator and R is the resistance of the standard.

Read

**Television and
Short-Wave World**

Regularly

This method of inductance measurement is very accurate and will suit most interested amateurs, but here is another method more suitable for quick testing measurement. After the actual inductance of the choke is determined it is substituted as the known value K in a Wheatstone Bridge as in Fig. 3, after which subsequent chokes are matched to the standard of the same type on the bridge. According to British makers this is the most accurate method of rapidly testing a large number of inductances of the same type.

It is possible to make comparative measurements of chokes, of unknown or questionable inductance rating with the aid of a Wheatstone Bridge, designed for condenser and capacity leakage. However, results will not be as accurate as the equivalent method shown in Fig. 3.

The difference in air gaps of various chokes makes their performance under

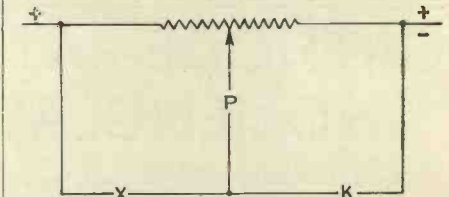

This is the conventional bridge used for capacity tests.

this load quite different from their low-load characteristics, showing that to obtain accurate figures chokes must be tested as they are to be used.

"Cathode-Ray Tube Nomenclature"

(Continued from preceding page.)

centage or the ratio of the actual pattern to the optimum condition. For example, when the amplitude pattern distortion is measured, the amplitude of the trace due to the applied voltage is measured in a given direction over each portion of the screen.

Then the amplitude distortion of the tube is determined by the percentage change in amplitude response of the tube at each portion with respect to the response with the trace in the centre.

THE DESIGN OF HIGH-DEFINITION AMPLIFIERS

By L. E. Q. Walker

The preceding article of this series of which this is the fourth appeared in the November, 1935, issue. The articles are a complete survey of the theory of high-definition amplifier design.

IN the preceding part of this article we have seen how the performance of a resistance-coupled amplifier is modified both at the high-frequency and low-frequency end of the spectrum due to the presence of certain reactive components in the coupling elements between valves. We have considered how the loss of amplification at the low-frequency end of the spectrum can be corrected by means of inserting a condenser in series with the anode feed resistance giving a circuit diagram as shown in Fig. 24, the insertion of the resistance R' being rendered necessary on account of the

Just as in the case of low-frequency correction we raised the low-frequency end of the amplification-frequency characteristic by inserting a condenser in series with either the anode feed resistance or the grid resistance, so we can correct to a certain extent for high-frequency loss by including an inductive element in the same circuits.

In this case, therefore, we have as our revised circuit (in the case of the correcting element being applied in the anode circuit) that shown in Fig. 26.

Where R is the normal anode feed resistance

L is the inductance for high-frequency correction

C is the capacity for low-frequency correction

R_1 is the by-pass resistance.

C_1 is the distributed capacity of the various coupling elements to earth.

From the high-frequency point of view we can neglect C , C_g and R_1 , and, providing $R_g \gg R$, we can also neglect R_g . Our simplified circuit for analysis is, therefore, as shown in Fig. 27.

For this network, in place of Equation (11), we have

$$E'_{g_2} = \frac{\mu E_{g_1}}{1 + \frac{\rho}{R + j\omega L} + j\omega C_1}$$

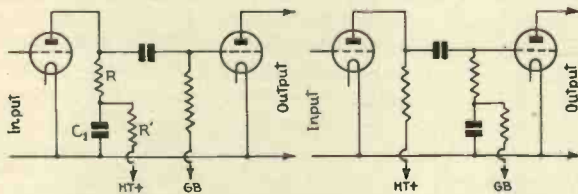

Fig. 24.—Correction at low frequencies by means of condenser in anode circuit.

Fig. 25.—Low frequency correction by means of condenser in grid circuit.

fact that H.T. has to be provided to the anode of the first valve. We have also seen that the effect of the condenser C_1 is to modify the low-frequency performance of the amplifier by raising the stage amplification at the low-frequency end of the spectrum, in accordance with correction factors such as are given in Fig. 22.

The corresponding condenser need not be applied in series with the anode feed resistance; it may be connected in series with the grid coupling resistance as shown in Fig. 25. In either case, the added condenser and its by-passing resistance can be made to fulfil two purposes, that of correction and that of providing a suitable decoupling circuit.

Before proceeding with more practical details we must next investigate the high-frequency performance of the amplifier. It has been shown that high-frequency loss is given theoretically by the relation (11)

$$E_{g_2} = \frac{\mu E_g}{1 + \frac{\rho}{R} + j\omega C_1 \rho} \quad (11)$$

or by its equivalent (11a).

(11) may be put into an analogous form to (10) by suitable factorisation, and we may write

$$E_{g_2} = \frac{\mu E_{g_1}}{\left(1 + \frac{\rho}{R}\right) \left(1 + \frac{j\omega C_1 \rho R}{R + \rho}\right)}$$

where the first bracketed term in the denominator gives the normal stage gain and the second the drop in stage gain with increasing frequency.

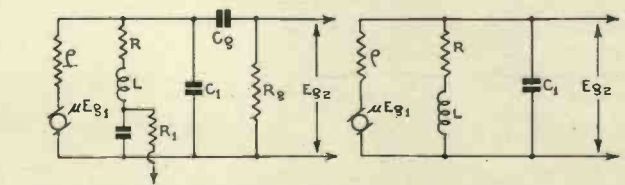

Fig. 26.—High and low frequency correction by means of inductance and capacity in anode circuit.

Fig. 27.—Simplified circuit equivalent to Fig. 26.

and for the ratio of corrected to uncorrected stage gain

$$\sqrt{\frac{R^2 + \omega^2 L^2}{R^2}} \frac{(R + \rho)^2 + \omega^2 C_1^2 \rho^2 R^2}{(R + \rho - \omega^2 C_1 L \rho)^2 + (\omega L + \omega C_1 \rho R)^2} e^{j\phi}$$

which we may write, more simply,

$$\sqrt{\frac{(1 + \omega^2 a^2) ((1 + b)^2 + \omega^2 c^2)}{(1 + b - \omega^2 ca)^2 + (\omega a + \omega c)^2}} e^{j\phi} \quad (13)$$

$$a = \frac{L}{R}$$

$$b = \frac{\rho}{R}$$

$$c = C_1 \rho$$

THE TELEVISION ENGINEER

and where the term under the radical represents the modulus of the ratio, and $e^{j\phi}$ the phase relationship.

This expression is, unfortunately, not very easy to deal with. We may neglect for the moment the phase term and confine ourselves to the expression under the root sign. Plotted against frequency the general shape

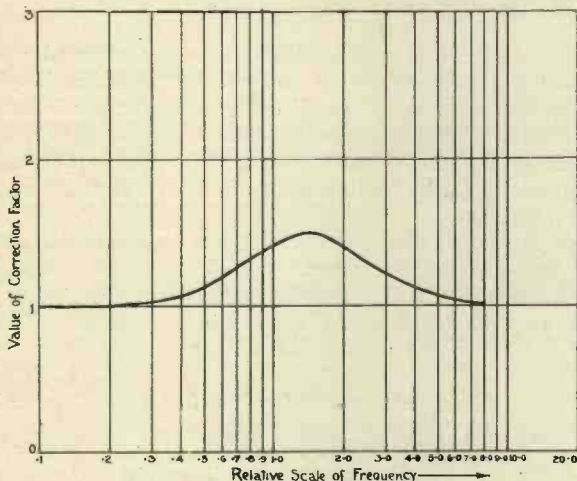

Fig. 28.—Form of correction factor obtained by putting inductance in anode circuit.

of the curve is shown in Fig. 28. It tends to unity for small and large values of ω or frequency, and attains a maximum for

$$\omega_r^2 = \frac{1 + b}{\frac{ca}{R + \rho}}$$

the value of this maximum being

$$\sqrt{\frac{2(1 + b) + c/a + (1 + b)^2 a/c}{c/a + a/c + 2}} \quad (14)$$

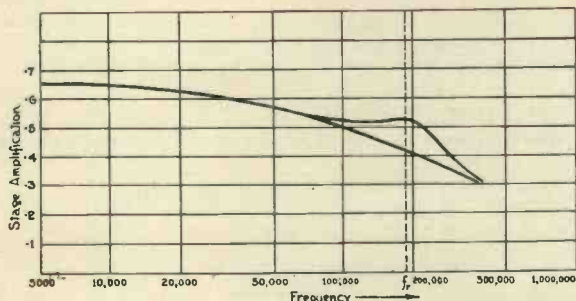

Fig. 29.—Typical corrected and uncorrected frequency characteristic

This last expression then is the maximum factor by which we can multiply our frequency characteristic ordinate, and the frequency of this maximum correc-

tion will be, of course $\frac{\omega_r}{2\pi}$

Taking a numerical example, let $R = 6 \times 10^4$ ohms, $\rho = 3 \times 10^4$ ohms, whence $b = \frac{1}{2}$. Let $c = \frac{C_1 \rho}{L} = 10^{-6}$, whence $C_1 = .00003$ μ fds., and let $a = \frac{L}{R} = 10^{-6}$,

whence $L = 60$ millihenrys.

$$\text{Then } \omega_r^2 = \frac{3/2}{10^{-12}} = 1.33 \times 10^{12}$$

$$\omega_r = 1.16 \times 10^6$$

$$f_r = \frac{\omega_r}{2\pi} = \frac{1.16 \times 10^6}{2\pi} = 185,000 \text{ cycles/sec.}$$

$$(14) \text{ becomes } \sqrt{\frac{6/2 + 1 + 9/4}{1 + 1 + 2}} = 1.23$$

and this is the factor by which we have to multiply the ordinate of the frequency characteristic at the frequency f_r . A typical curve of the results obtained from this method of correction is shown in Fig. 29 where the above figures have been used. It will be observed that the amount of correction obtained is such that, allowing for a drop of 2 dB, sensibly linear amplification is extended from approximately 100,000 cycles/sec. uncorrected to approximately 200,000 cycles/sec. corrected.

Obviously, from the form of (14), we can increase the value of the maximum correction factor by increasing b . This is to be expected as, if we refer to Fig. 27, we see that the smaller R becomes, the higher becomes the Q value of the parallel resonant circuit formed of R and C , and the larger ρ is, the less damping is present in the circuit consisting of ρ and the generator μE_{g1} , which is effectively across the resonant circuit. Incidentally, the higher b is made, the greater will be the value of f_r if the product ca is kept constant.

As an aid in calculating such correcting circuits, the value of the expression (14) is plotted for different values of b assuming $\frac{c}{a} = 1$.

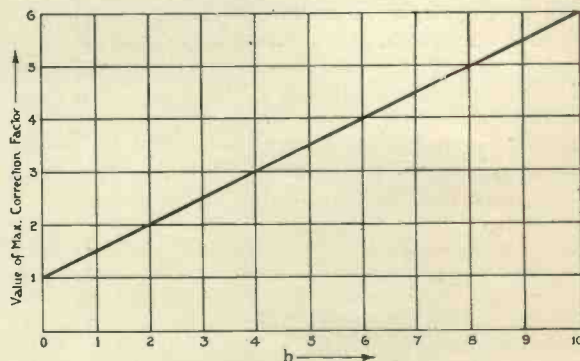

Fig. 30.—Values of (14) for varying b .

Applying the results to a practical case let us suppose that we have our amplification-frequency characteristic which indicates that at a frequency corresponding to $\omega^2 = 10^{12}$ (i.e., $f = 159,000$ cycles per second) we need to apply a correction factor of 2.5. From Fig. 30 we see that for this, b must equal 3.

(Continued at foot of page 46)

The Short-wave Radio World

Push-pull Parallel Final Amplifier

AN economical solution to high-power phone work is to use push-pull parallel output valves as shown below. The radio-frequency amplifier can be driven by either a push-pull or single ended driver with link coupling. According to *Radio*, four 75-watt oscillators can be run at approximately 400 watts while the additional inter-electrode capacity is so small compared with other losses that it can be ignored.

This circuit originally gave trouble in the form of a four-metre parasitic oscillation, when output was increased to optimum value. A small radio-frequency choke consisting of ten turns of 24-gauge wire on a 1/2 in. diameter former and shunted by a 400-ohm resistance completely stopped this effect. This choke and resistance can be seen connected in series with one end of the grid input coil and the top pair of grid insulators. Actually this was done because one grid leak happened to be longer than the other, due to component

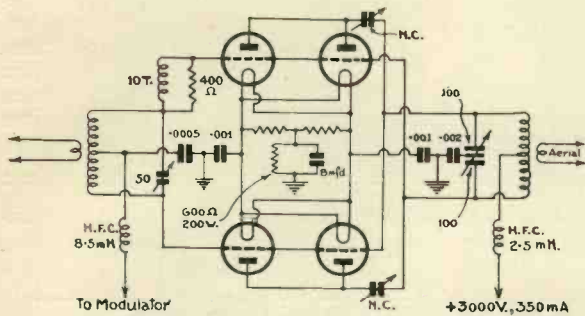

The main advantage of this system is that four small valves can be used up instead of buying two high-power valves. There are no disadvantages up to 7 Mc.

layout, so that a choke was connected in series with a long lead.

Cut-off bias was obtained by means of a high-voltage BCL H.T. mains unit, while cathode bias was obtained by means of a 600-ohm 200-watt resistance in the centre tap lead to the filament. This was shunted with an 8-mfd. capacity.

Since this unit is for phone operation only a small R.F. driver is necessary, actually one that will supply 15 or 20 watts for grid excitation. This circuit is adaptable to English conditions by merely reducing the H.T. and bias feeds and using valves of small wattage. It should be very interesting to low-power stations who may have several small valves of similar types which are not large enough for single ended working.

A Review of the most Important Features of the World's Short-wave Literature.

A Precision Condenser Tester

As an invaluable aid to the service man, experimenter and radio service man, in detecting leaking, shorting, open, off-capacity, and intermittent defects in condensers, this analyser should prove of interest. It will quickly determine the quality of all paper, electrolytic and mica condensers.

The capacity range extends from 20-micro-microfarads to 70 microfarads, and is read directly after visible balance of the bridge circuit which is obtained by the indication of a thermionically controlled neon glow lamp. This is more convenient and much more accurate than the

which improves balance when testing high-power-factor electrolytic condensers.

An A.C. voltage source for the bridge is obtained from a potentiometer across the first secondary. The detecting arms of the bridge are connected to the control grid and cathode of the first valve.

The detector arrangement, including neon lamp N₁, has the advantage over the phone detector often used with bridges in that there is no loss of sensitivity at 50 cycles. With a phone detector the discrimination of ordinary phones and the well known loss of sensitivity of the human ear at low frequencies makes it difficult to obtain a good balance.

The leakage tester consists of a

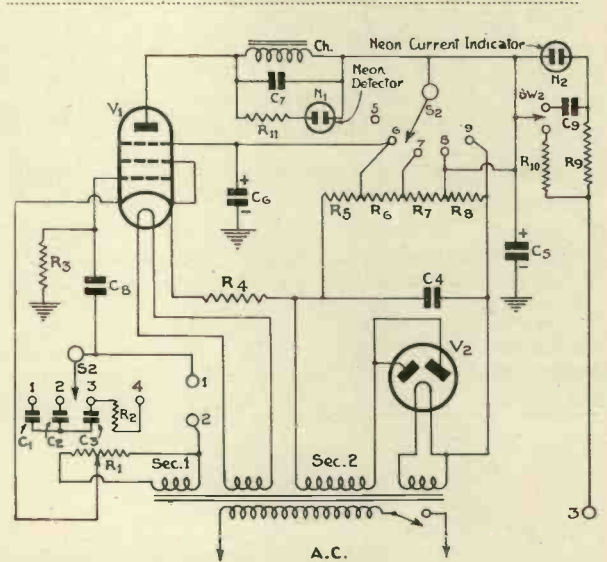

Not every amateur will require a tester of this type but to the serious experimenter it will prove invaluable.

use of headphones for finding the null point.

The use of this analyser for testing the dielectric resistance of cables, insulators, and between transformer windings, in addition to power pack indication should interest the laboratory worker. This tester is a combination of two devices, capacity bridge and direct current leakage tester.

The capacity bridge is made up of the usual four arms; two resistors the ratios of which are varied by adjusting the controls S₁, the other two being condensers, a standard and an unknown. The instrument is provided with three standards selected by the switch S₂ and corresponding to the three calibration scales of the instrument. At position 4 resistance R₂ is in series with a high-capacity standard

source of D.C. voltage provided by No. 2 secondary and the rectifying valve V₂, N₂ being used as a current indicator. The voltage required for condensers of various ratings is obtained by the proper setting of R₂. The full technical data can be obtained from *Radiocraft*.

Light-beam Telephone

The transmissions of signals between two points by means of a light beam has been successfully demonstrated during the past few years. The original low-frequency speech signal is, of course, in the form of air displacement which has to be converted into electrical energy, so that it can be amplified as required. The second stage is the

most difficult one, that is, converting the electrical energy into light energy of varying intensity which must vary exactly as the wave-form of the radio signal. Once this has been accomplished the modulated light beam can be directed by means of lenses and mirrors,

quite satisfactorily. It consists of two type 53 valves, which actually are four valves in two envelopes. First is a class A driver used to operate the second valve as a class B amplifier. The important feature of the circuit, as shown in Fig. 3, is the circuit of the

test purposes a gramophone pick-up of 500-ohm impedance is suitable for use in the primary of J1. As a result of a series of tests with neon and argon lamps ranging from 3 watts to .5 watt, it is noticed that the 1-watt type of neon, sold as indicators, gave good

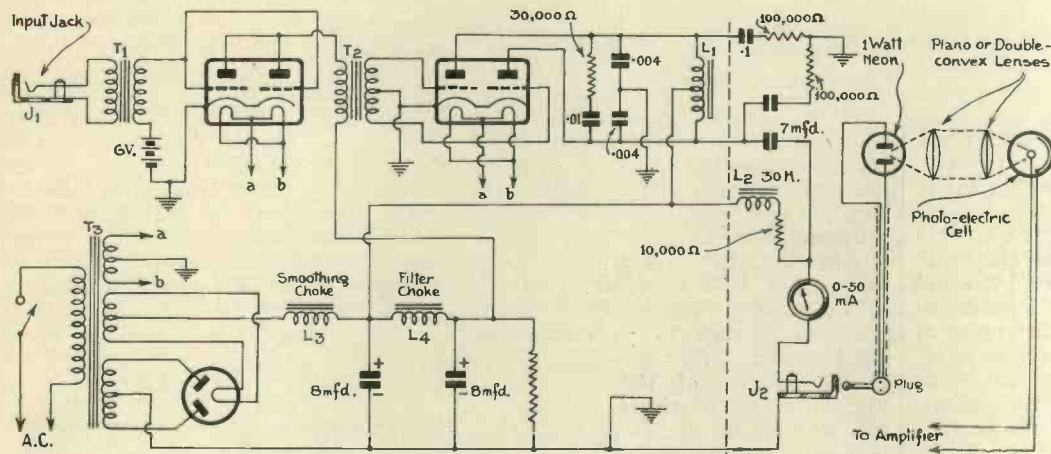

the distance covered only being limited by the optical range.

A photo-electric cell or similar light sensitive device can be placed in the path of the beam, the light energy being converted back into varying values of current.

The major problem in such a series of conversions is to avoid distortion of the original signal. A circuit has been evolved that carries out these operations

output network which couples the receiver to the neon lamp. This network is designed, of course, for driving a discharge tube. Other methods of modulating a light source, such as mechanical light valves, require a different type of circuit.

The transmitter can be built as a single unit providing proper precautions are taken to shield the input transformer from the power supply. For

quality with ample volume. This lamp is mounted horizontally in a small spotlight housing.

The glow discharge when properly connected in this type of lamp is between the outside spiral and the plate. This gives the effect of concentrated light in a circle, which is desirable from an optical point of view. Full data on this apparatus can be obtained from *Radio News*.

"The Design of High-definition Amplifiers"

(Continued from page 44.)

$$\text{Now } \omega^2 = 10^{12} = \frac{i + b}{ca} = \frac{i + b}{C_1 L b} = \frac{i + 3}{3 C_1 L}$$

Hence, $C_1 L = 1.33 \times 10^{-12}$ (15)

$$\frac{c}{a} = i = \frac{C_1 \rho R}{L}$$

Hence, $\frac{C_1}{L} = \frac{i}{\rho R} = \frac{3}{\rho^2}$

since $R = \rho / 3$ (16)

The value of ρ is fixed by the valve we are using. Let us say it is 10^6 ohms.

Then $\frac{C_1}{L} = 3 \times 10^{-10}$ (17)

From (15) and (17) we have at once

$$C_1 = .00002 \mu\text{fd.}$$

$$L = .066 \text{ hy.}$$

and from (16) knowing ρ we have

$$R = 33,000 \omega.$$

We can thus easily design our correcting network. One point, however, must be borne in mind. Our supposition that a correction factor of 2.5 was necessary

was deduced from the shape of the amplification-frequency characteristic, which, in turn, was derived with

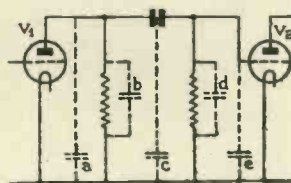

Fig. 31. Bye-pass capacities existing in stage of resistance capacity amplification.

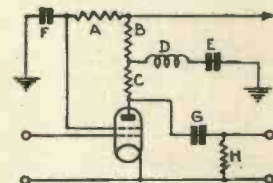

Fig. 33. Diagram of single stage of Marconi television amplifier.

a particular value of C_1 . This value is not, in all probability, the same as the C_1 obtained from (15) and (17).

(To be continued)

TELEVISION SOCIETY : NEXT MEETING

On January 15, at 7 p.m., at University College, Gower Street, W.C., a lecture will be given by R. R. Poole, B.Sc., entitled:—

"Measuring, and Measurement Instruments for Television."

Readers may obtain tickets for admission on application to the Business Secretary, Television Society, 25 Lisburne Road, Hampstead, N.W.3.

AN EXPERIMENTAL TELEVISION TRANSMITTER

AMATEURS who are carrying out transmission experiments will be interested in the gear shown by the accompanying photographs. This, of course, is intended

obvious that the apparatus could be modified without much trouble within the limits of the more simple types of mechanical transmitters.

The construction of the transmit-

new type of Kerr cell produced by the same concern. This cell has been designed for comparatively low-power operation. Two types of cell are made. One is for ordinary use, and requires a polarising voltage of 300, and will modulate fully with a peak swing of - 90 volts. The second type requires a polarising voltage of 400 with peak voltage swing of - 140. Deterioration of the nitro-benzine, resulting in reduced efficiency has largely been overcome in the new B.T.S. cell by a special method of sealing, and the design of the cell is such that a large radiating surface is obtained all around the nitro benzine chamber, which is of special glass, so that the heat is rapidly dissipated. If at any time the efficiency of the cell falls off due to deterioration it can be re-filled for a comparatively small sum. The cell is made to plug into a valve socket for easy removal.

The Nicol prisms are carried in a removable housing which is located in position by a collar on the outside.

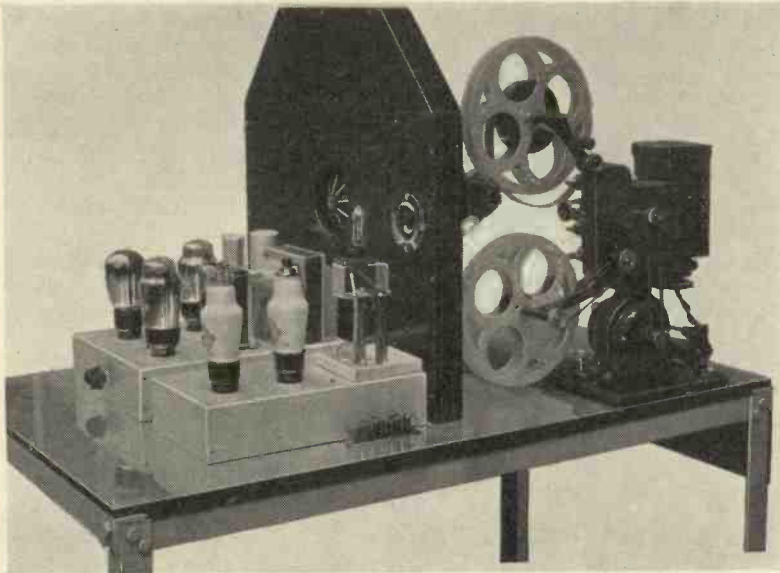

An experimental disc transmitter.

purely for experimental purposes and as constructed will only provide the usual 30-line, 12½-pictures per second of the 7-to-3 ratio. It is, however,

ter will be clear from the photographs and diagram. It employs a standard 16 mm. cinema projector but so arranged as to provide two pictures per frame. Six and a quarter frames therefore pass the aperture per second. The scanner is an ordinary 30-hole disc driven by a motor provided with an 8-pole phonic wheel and the coils of this are fed with current from 50-cycle A.C. mains. The same type of synchronising gear is, of course, used for the receiver and there is absolutely no difficulty in obtaining perfect synchronism.

Two amplifiers are provided, a high-gain battery-operated primary and a high-gain compensated secondary. When it is desired to use the apparatus in conjunction with a mirror drum receiver a third amplifier is necessary for really efficient working. The photo-cell is a Phillips and the source of illumination a 60-volt 150-watt projection lamp.

This apparatus is manufactured by British Television Supplies, Ltd., and as remarked before is intended purely for experimental purposes.

The second photograph shows a

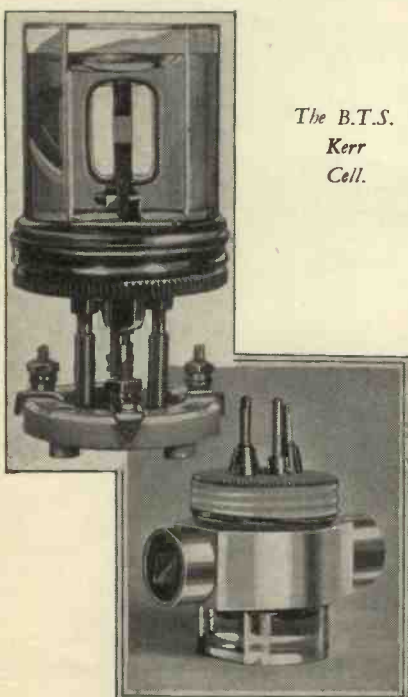

The B.T.S. Kerr Cell.

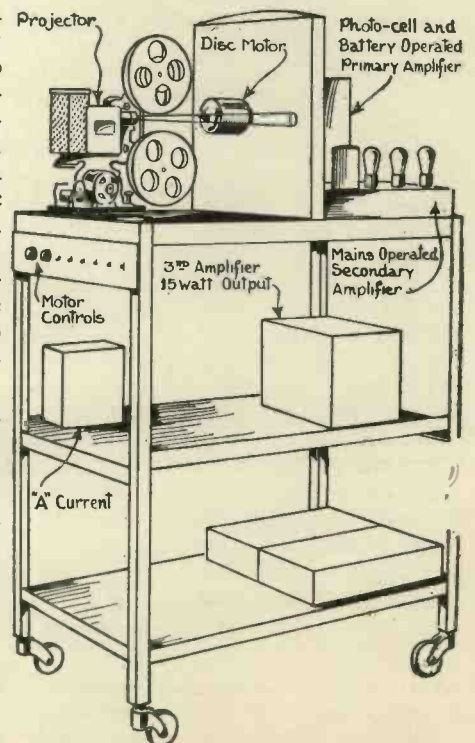

Schematic drawing showing the arrangement of parts.

DECOUPLING SCREEN-GRID CIRCUITS IN TELEVISION AMPLIFIERS

By J. Beardsall

For many reasons it is becoming general practice to employ screen-grid valves in television amplifiers, especially for the new high-definition technique which requires the smallest possible grid-anode self-capacity.

IN respect of small grid-anode capacity screen-grid valves are many hundreds of times superior to triodes, and, as they are at least equal in other respects, it is advantageous to employ them in photo-cell amplifiers, and in receivers, except for the final stage where a triode is

triode, regarding the screen-grid as its anode.

Although the figures are not published by the valve manufacturers, such a triode has its own amplification factor and internal resistance, just like any other, and, if we apply an alternating voltage to the control

small additional variation on the screen-grid, due to what is known as the "second-grid reflex factor." This consists of a change in screen-grid volts divided by a change in anode volts, keeping the screen current constant. This is another factor we need to know, and we will denote it by μ_r . The resultant screen voltage acts on the anode, in opposition to the voltage on it due to the control grid, through yet another unorthodox factor, which we may call the "second-grid amplification factor."

It will be understood that the screen-grid acts as another control grid, in fact we have virtually another triode comprising the cathode, screen-grid and anode, having, of course, the same internal resistance as the usual cathode, control grid, anode part, but a new amplification factor, which is a change in anode volts divided by a change in screen-grid volts (anode current kept constant). The latter can be denoted by μ_2 . Thus, due to the voltage on the screen, a voltage on the anode will be developed, which by the usual formula will be $\frac{\mu_2 R_p}{R_p + \rho_2} \times$ screen-grid voltage, where $R_p =$ anode load resistance, $\rho_2 =$ ordinary internal resistance.

The anode voltage due directly to the control grid is, of course, $\frac{\mu_3 R_p}{R_p + \rho_2}$,

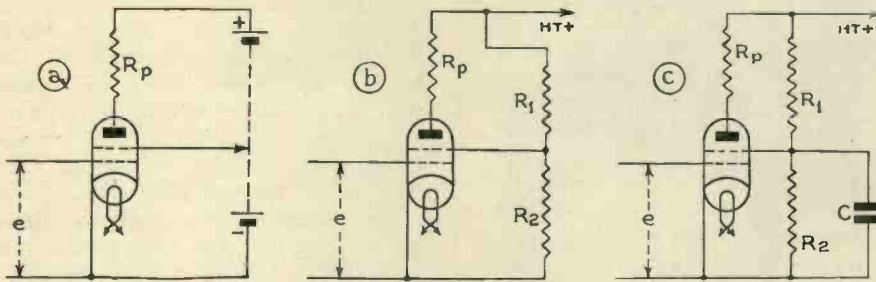

Fig. 1.—Three diagrams showing different methods of supplying screen grid potential.

needed to cope with the high output voltage.

The screen-grid potential has to be anywhere between 50 and 120 volts, and in any case less than the anode voltage. This means that in the case of a battery supply a separate tapping in the battery must be used (Fig. 1a) or, with the high-tension provided by the mains through an eliminator it is necessary to derive the screen-grid voltage by means of a potentiometer. Such a circuit is shown by Fig. 1b. Consider for a moment the circuit consisting of the cathode, control grid and screen-grid. This will behave just like a

grid, we shall get a voltage on the

$$\frac{\mu_3 R_a}{R_a + \rho_1}$$

screen equal to $\frac{\mu_3 R_a}{R_a + \rho_1}$, which is the usual amplification formula, where ρ_1 is the internal resistance between cathode and screen, μ_3 is the amplification factor, and R_a is the parallel resistance of R_1 and R_2 . (As far as alternating conditions are concerned, any voltage on the screen can send current to the cathode through both R_1 and R_2 , so the screen load is regarded as these two resistances in parallel.)

When the anode is connected, the alternating voltage on it causes a

Valve.	ρ_2 (usual)	ρ_1	μ_3 (usual)	μ_1	μ_2	μ_r	Taken at		
							Anode Volts.	Screen Volts.	Grid Bias.
AC/SG	900,000	16,000	1,700	18	130	.057	200	60	1.5
S434N	610,000	13,600	2,100	74.5	63.7	.02	200	100	1.5
AC/SGVM	690,000	31,000	1,350	17	150	.041	200	60	1.5
MM4V	370,000	33,000	890	69	37	.12	200	110	1.5
AG/S2PEN	1,600,000	6,200	8,100	91	83	.02	220	100	1.5

Fig. 2.—Table showing additional characteristics for five types of valves.

where μ_s = ordinary amplification factor, and this is what we want, and would get if the screen potential could not alter, i.e., was connected directly to a battery as in Fig. 1a. Owing, however, to the extra and opposing voltage which we have seen will appear in the anode when we use the circuit of Fig. 1b, the stage amplification will be much diminished. In practice we do not care to put up with such inefficiency, and in order to reduce the opposition voltage on the anode due to the alternating voltages developed on the screen-grid, steps are taken to reduce the screen load. We can make the resistances R_1 and R_2 as small as possible, keeping their ratio correct so as not to disturb the D.C. potential on the screen.

This measure cannot be carried very far because we should otherwise impose an excessive load on the eliminator. The usual and simplest re-

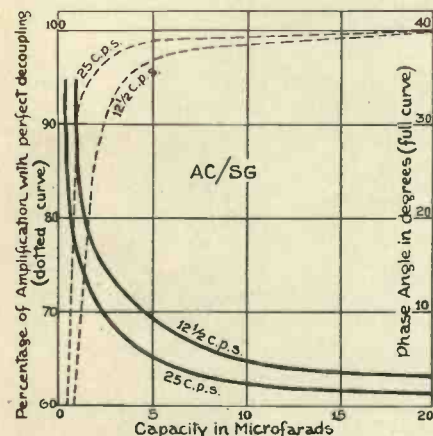

Fig. 3.—Curves showing percentage of maximum amplification and the phase displacement for different values of decoupling capacity of A.C./S.G. valve. $R_p=20,000$ ohms ; $R_s=18,000$ ohms.

medy is to place a condenser between screen-grid and cathode (Fig. 1c). This is known as screen decoupling. It has no effect on the D.C. voltage but will provide an alternative, and, if large enough, lower impedance path for the screen current. The higher television frequencies will pass directly to cathode and no alternating voltage will occur on the screen. At the lower frequencies, however, unless the condenser has a very large capacity, its reactance will be appreciable, and an opposing voltage will reduce the amplification. The tendency, therefore, will be for such a circuit as Fig. 1c to give us phase and frequency distortion of the lower frequencies.

In designing an amplifier, the value of capacity must be so chosen that at the lowest frequency concerned, the reduction in amplification and the phase angle will fall within the limits of tolerance which are to be allowed. In the appendix the theory of the circuit we have been discussing is developed mathematically, and formulæ are derived enabling the correct capacity to be calculated. Such calculation involves the knowledge of the four additional valve constants to which reference has been made, viz., ρ_1, μ_1, μ_2 and μ_r . It is probable that in future these will be quoted with the other valve characteristics. The writer has measured them for several valves which happened to be at hand, and these are tabulated, together with the usually quoted constants, in Fig. 2, and will serve to give some idea of the magnitudes involved. (2 H.F. pentodes are included. The theory for these, when the suppressor grid is connected to the cathode, is just the same as for the ordinary four-electrode valve.)

Figs. 3 and 4 show the results of some calculations which have been made with a view to illustrating the order of capacity likely to be required for minimums of $12\frac{1}{2}$ and 25 cycles per second. (These cover the past low and future high-definition requirements.) Two typical valves are taken: a screen-grid and an H.F. pentode. The same anode resistance is used with each, but owing to their different respective D.C. requirements it has not been possible to keep R_a the same. This, however, makes very little difference, as the controlling factor is the condenser alone. The curves show percentage of maximum amplification (i.e., the amplification obtainable with the cir-

cuit of Fig. 1a) and the phase displacement for different values of decoupling capacity. For example, in the case of Fig. 3, if we require the amplification to be within 5 per cent. at $12\frac{1}{2}$ cycles per second, we must use 4 mfd. Using a pentode (Fig. 4), the same condition implies a capacity of 7 mfd.

Though more de-coupling is seen to be necessary it must be remembered that the pentode in question gives more amplification than the

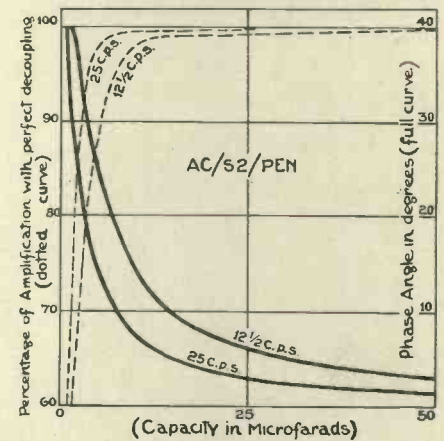

Fig. 4.—Curves of A.C./S2/Pen. $R_p=20,000$ ohms ; $R_s=13,000$ ohms.

other valve. Usually a correct phase angle is considered as more important than the actual amplification at any particular frequency. If, say, the angle must not exceed 5 degrees at $12\frac{1}{2}$ cycles, the curves show that decoupling condensers of 8 and 30 mfd. respectively are necessary.

Probably enough has been said to indicate the importance of adequate screen-grid de-coupling, and it is hoped that readers will be encouraged to design their amplifiers accurately in this respect. Accuracy means efficiency with economy!

The mathematical appendix relating to this article is given on page 64.

BOOK REVIEW

Television Up-to-date, by Robert W. Hutchinson, M.Sc. This handbook, true to its title, is one of the most up-to-date which we have received for review. Obviously it has been written quite recently for much of the information which is given has only lately been disclosed. It is intended for those who have some elementary knowledge of wireless matters but are unacquainted with the newest branch. Broadcasting and elementary ideas of electricity are dealt with briefly as also are low-definition systems of television, but

the major part of the book is devoted to the more recent developments, such apparatus as the Iconoscope and the Farnsworth dissector tube being described in some detail. There has been careful avoidance of terms which might confuse the beginner and the book is easy to understand for practical applications are described concurrent with elementary theory. For the beginner, or even those who have a fair knowledge of modern television development, the book can be thoroughly recommended. The price is 2s. 10d., post free, and it can be obtained from H. E. Sanders & Co., 4 Grays Inn Road, London, W.C.1.

THE MANY USES FOR PHOTO-ELECTRIC CELLS

By R. L. Ashmore

NEW practical applications for the photo-electric cell are being discovered almost every day. The modern cell is so sensitive that



A caesium photo-electric cell of the "plate-cathode" type, suitable for televising films. Commercially produced for talkies.

it can be used for the operation of all sorts of mechanical devices, such as automatic door opening, control of flood-lighting, advertising displays, counting, speed checking, protection of oil burners, and so on.

A caesium cell of the latest gas-filled type has an emission of about 15 microamperes per lumen.

Experience has shown that the only cases where a caesium cell is not very suitable are those involving small quantities of light. There is with these cells a small "dark current" which is independent of the light and which is a very slight thermionic emission from the cathode at ordinary temperatures. Although the caesium cells are most suitable for absolute white light, they are also good at the red end of the spectrum and indispensable for working with infra-red rays. A sensitised potassium cell is used for blue light, although the emission is only in the nature of 0.5 microampere per lumen.

Usually the photo-cell is coupled to a single valve relay. In some cases true measurement of light value is needed, and there is a continuous

variation of the output with the photo-cell current. In other cases, where a relay has to be operated, it is necessary only to determine whether the photo-cell current is above or below a definite limit. Colour matching involves accurate measurement, but most of the commercial uses of photo-cells involve relay applications.

Photo-cell Counting

Two very common applications are counting and recording. A photo-cell counter is particularly useful where the objects to be counted are of all shapes and sizes. In the Nestle chocolate factory, for example, Osram photo-cell relays are fitted to all packing machines. These relays count the gift coupons delivered and (through a make-and-break relay) stop the machine if a coupon is missing, or when the coupon supply is exhausted. These counters will operate at a speed of 300 per minute. A photo-cell smoke detector records the amount of smoke by indirect means. It is not always possible to use the smoke particles for controlling the photo-cell light. This application depends on the particles of smoke absorbing the light that is normally directed from the lamp on to the photo-cell cathode. Where very faint smoke has to be detected, the reflected light scattered by the smoke particles is used instead of a direct interruption of the light beam by the smoke. For measuring the exact smoke density the photo-cell is put in a housing with a variable diaphragm, which is closed until the required sensitivity is obtained. The interruption of a light beam directed on a photo-cell as a burglar alarm is too well known to need detailed observation. It is, however, interesting to note the way in which photo-cells are used in a very similar manner for race timing.

Smoke detection is another frequent use in order to cut down atmosphere pollution in factory districts. Incidentally this means a saving in factory expenses as excessive smoke is one of the signs of incomplete combustion. There are also fire alarms which work on a similar principle.

Race Timing

In the timing of races the photo-cell is invaluable, for those who have made a study of dog-timing by hand can seldom get within one-tenth of a second of the correct time. The human element enters too much into manual timing and it is rare for two time-keepers to record exactly the same readings on their watches; records are often broken by a few hundredths of a second.

For this work the photo-cell relay is arranged to work in conjunction with a clock which records time to one-hundredth of a second. The clock is stopped mechanically within this space of time by the photo-cell relay.

On some dog tracks the door of the trap in which the dogs are enclosed is fitted with a switch. This is normally held open when the trap cover is shut and closes as the trap cover is raised and the dogs come out. Immediately the trap is raised the coil circuit of the clock is closed, and it begins to record. The photo-cell relay is also ready for action at the touch of a switch, but when a race consists of more than one lap the judge does not switch on the photo-

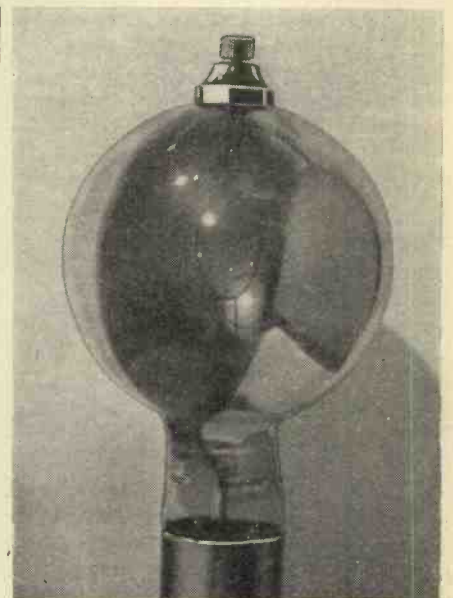

A recent "Oxford" cell; caesium surface specially designed for television used for spotlight scanning of studio subjects.

cell amplifier until the commencement of the last lap. The passing of the first dog across the light beam closes the relay circuit and stops the clock. The printed record of the time can be read at leisure and a push button then enables the judge to reset the clock for the next race. Extension tubes are fitted to trap all extraneous light so that the photo-cell equipment can be used even in strong sunlight.

In paper and printing works, photo-cell relays are being fitted to all the modern machines. A trouble with fast-running paper handling

machines is that breakages which sometimes occur in the web are liable to pass unnoticed. The paper is continuously fed by the other rollers, forming a jamb which, after a few seconds means shutting down the machine until all the waste paper has been removed.

Photo-cell relays also perform a vital job in some steel works which turn out welded steel tubes. The hot strip from which these steel tubes are rolled needs very rapid handling as it comes out of the furnace at well over 1,350 degrees Centigrade. The tubes pass through the sizing rolls

and then run down a trough to cross rolls which pass them on to a cooling tank. These machines work so rapidly that there is only a few seconds gap between the tubes as they are passed from roll to roll. There is roughly three feet distance between each tube, and any error in timing causes a serious collision of the hot steel parts.

In order to prevent this a photo-cell relay is operated by the ray given out by the hot tubes only a few feet away. In the event of a fault red and green lights warn the operator when the line is blocked.

Television
Terms

Photometers

Our Readers' Views

First
Steps in
High-definition
Reception

Correspondence is invited. The Editor does not necessarily agree with views expressed by readers which are published on this page.

The Photo-cell as a Simple Photometer

SIR,

I have read with great interest the article in the December issue of TELEVISION AND SHORT-WAVE WORLD on the "Photo-cell as a Simple Photometer," by Mr. R. L. Ashmore. It is true that the photo-cell is a very useful instrument for photometric measurement but, if the figures in Mr. Ashmore's article are correct, no one who wished for accurate results would think of using a photo-cell for any measurements which had to be even approximately correct.

I will pass over the obvious printer's error in the first table where inches have clearly been put in place of feet and also the remark, just prior to this, where it would seem that observations are considered which are at least equal to the limits of experimental error. The main point is that all other observers agree that, within wide limits, the current from a vacuum photo-cell is directly proportional to the incident light. In other words, as we vary the distance of a source of light from a photo-cell, the current will vary as the inverse square of the distance. Thus the relative currents from a cell illuminated from a source at distances of six inches and two feet should be in the ratio of 16 to 1. The cells tested by Mr. Ashmore, however, would seem to give ratios of 12, 13.3, 6.1 and 11.3 to 1. Either the cells with which he has made his measurements must be most remarkably bad or else Mr. Ashmore must have made

some error. Perhaps he will explain this.

There is another matter which, as I think, is not made clear in the article. It is mentioned that all the tests were made with an anode potential on the cells of 15-18 volts. Apart from the fact that with large illuminations this voltage may not be sufficient to produce saturation in a vacuum or gas-filled cell, it is not made clear that a gas-filled cell may be used to give linear readings over a large range of light intensities. With a good modern photo-cell it is quite possible to obtain a gas amplification of six to eight times while still retaining a linear illumination-current curve over all normal light intensities. The curve of the gas-filled cell only becomes non-linear when the cell is near the glow potential. Although not suitable for experiments where absolute accuracy is necessary, the amplification which is derived from a gas-filled cell can often be put to very great use, especially where the available illumination is small.

May I finally suggest that it would be most interesting if Mr. Ashmore could publish figures to show how readings obtained by him after valve amplification of the photo-cell currents compare with the actual cell currents. If he can show that the

"milliamps.-microamps" curve is linear, he will make it clear that such a system of photometry is of very great use.

PHOTOELECTRICAS (Oxford).

SIR,

In reply to "Photoelectricas," I would suggest that if he reads the article in question again he will find that it is pointed out that the figures in the table appear other than might be expected owing to the fact that at the distances mentioned an ordinary electric light bulb cannot be considered as a point source of light, which is, of course, necessary for the inverse square law to hold good.

With regard to "Photoelectricas's" remarks about a gas-filled cell being more sensitive owing to gas amplification, I quite agree, though unfortunately gas cells are not linear to light intensities and furthermore in the writer's personal experience appear to vary from time to time in their response to a standard light while their gas magnification always falls off in a relatively short time, probably owing to change in gas pressure.

Regarding the query of how the cell current compares with that of the valve's, the writer personally has not a sensitive enough meter to actually measure currents below three microamperes, but it can, of course, be easily calculated from the grid-volt-anode-current curve of the valve and be made linear (within the limits of the valve characteristics) with that of the valve's by working the valve on the straight part of its grid-volt-

READ TELEVISION
& SHORT-WAVE WORLD
REGULARLY

anode-current curve, the standing current being balanced out of the meter by connecting the valve and meters in an ordinary bridge network.

In conclusion, I would point out that the figure of 15-18 volts is not mentioned in connection with the potential applied to the four cells referred to in the table—the actual potential being of the order of 40-30 volts.

R. L. ASHMORE (London, W.1.).

"What a Word!"

SIR,

The appearance of Mr. A. P. Herbert's book under the above title has prompted me to air a grievance which has worried me for some time.

Mr. Herbert condemns the introduction of new words into the English language until they have passed an entrance examination designed to satisfy us that they are useful and essential to the needs of the subject.

Judged by this standard, I am protesting against the growing use of the word "raster" in television literature. I don't know who first introduced it, but I suspect Mr. Bedford or Mr. Puckle. As we may, or may not, know it is used to describe the line screen produced on the end of the cathode-ray tube, and I submit that it is unnecessary and (with deference to our German friends) even ugly when it is pronounced "rahster."

We already have the words "line," "screen," and "frame," so why not stick to them and refer to a "line-screen," or just "frame"?

In any case, I contend that the sponsors of "raster" have not made a good case for its adoption as a brand new indispensable word, and that we would do well to follow Mr. Herbert's example and take up arms against attempts to foist new terms on a science which is already sufficiently burdened with technicalities for the lay reader.

G. PARR (London, N.21).

First Steps in High-definition Reception

SIR,

Regarding the article on page 729 of the December issue of TELEVISION AND SHORT-WAVE WORLD, I am unable to agree with Mr. Reyner's description of the behaviour of the circuit in Fig. 1.

Surely the current in "R" cannot reverse when the switch is opened, but will simply fall to zero?

Further, it is impossible for the

condenser "C" to discharge when the switch is opened. Assuming "C" does not leak, every time the switch is closed, "C" will acquire a further increment of voltage, until ultimately it attains the voltage of the battery. Similarly the current in "R" will be progressively lower at each switching on, eventually becoming zero.

B. C. GALLOWAY (Surbiton).

SIR,

In reply to Mr. Galloway's letter,

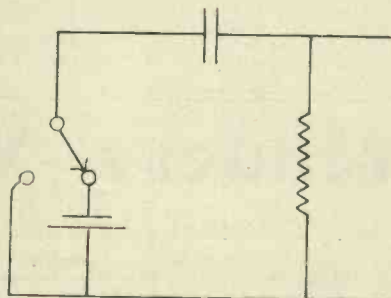

the diagram of Fig. 1c is incorrect. The switch should be shown as plac-

ing a short circuit across the circuit in place of the battery as I have indicated in the accompanying diagram.

With this modification the diagrams of Fig. 1 (a) and (b) are correct. The voltage will be alternately full positive and zero, while the current will either be a charging current of gradually falling intensity or a discharging current in the opposite direction of similarly falling intensity giving the sloping top to what should otherwise be a square-topped wave.

J. H. REYNER (Boreham Wood).

Lectures on Television

At Morley College, Westminster Bridge Road, S.E.1, a more advanced course of twelve lectures will begin on January 10, at 7.30 p.m.

The course is intended for students who already have some knowledge of the subject, but beginners will not find themselves unduly handicapped. Fee for course, 5s.

When to Listen for Short-wave Stations during JANUARY

By C. J. Greenaway—G2LC.

G.M.T.	3.5 mc.	7 mc.	14 mc.
0000		W1, 4	
0300		W1, 2, 3, 4	
0400		W1, 2, 3, 4	
0500	W8	W1, 2, 3, 4	
0600	W1, 2, 3, 4, 8, 9		
0700	W1, 8, 9	CN	
0800		ZL	
1000			ZL
1100			VE2; ZL
1200			SU; VE2; VK; W1; Y1; ZL
1300			FA8; SU; VE2; VK; W1; Y1
1400			FA8; FT4; SU; VE1, 2; VK; W1, 2, 8; Y1
1500			CE; FT4; VE1, 2; W1, 2, 9; Y1
1600		FT4; VK; VS7; VU; ZC1; ZL	CN; VE1, 2; W1, 2, 8, 9; Y1; ZS
1700		FA8; FT4; VK; VQ4; VS7; VU; Y1; ZL; ZS	EA8; VE1, 2; VO; W1, 2, 8; ZS
1800		CN; CT3; SU; VK; VS7; VU; Y1; ZL; ZS	VE1, 3; VO; W9
1900		CN; CT3; SU; VK; VU; Y1; ZD; ZL; ZS	VE3; VO; W8
2000		CN; CT3; FA8; SU; VK; W1, 2; Y1; ZS	
2100		CN; EA8; FA8; SU; W1, 2, 4, 8; Y1	
2200		CN; EA8; SU; W1, 2, 3, 4, 8; Y1	
2300		CN; CM; SU; W2, 4, 8; Y1	
2400		CM	

A Multi-purpose Neon Tester

By

R. C. Horsnell, G2YI

FOR the keen experimenter wishing to know as much as possible about the accuracy of components in use, there exists a big gap in the field of measuring instruments it is possible to construct, particularly when cost is of primary importance.

The limits of an instrument of the moving-coil test meter type are found when any readings of capacity are to be made or if resistances of the order of 50,000 to 5 megohms are to be tested, as with a normal test meter the high resistances can only

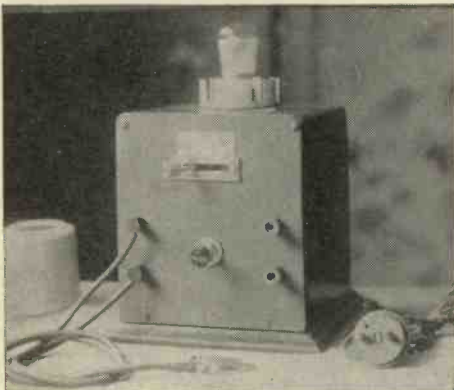

The cover around the neon tube is part of a valve screen; its purpose is to prevent radiation from the neon.

be checked by the addition of an external voltage supply of constant voltage.

With capacity readings nothing can be read except an indication of short-circuits, while no clue to capacity can be obtained. So much for the deficiencies of a moving-coil test meter.

With the meter about to be described tests can be made to limits of accuracy sufficient for all except laboratory experts of any capacity from .00005-mfd. to 4-mfd. and resistances up to 5 megohms. High values in variable resistances can be checked for smooth and correct increase, continuity of rotation, etc. Compression-type variable condensers and pre-set condensers can also be tested under working conditions from zero to maximum capacity. Air-dielectric condensers can be checked for insulation.

The cost of this instrument using normal components should not exceed 15s. to 20s., while, of course, many constructors will have several of the components available. This initial cost will soon be recovered when it comes to checking up doubtful components.

The apparatus is for A.C. mains only, but the illustration and theoretical circuit should make this quite clear. It is desirable to point out that one of the tests leads is live to the mains so should the instrument be used on non-earthed mains, a shock will be obtained between

this lead and direct earth. It will be seen, however, that an on-off switch is provided, but in any case, all who make this apparatus will probably have knowledge of such matters.

It is well known that A.C. current will pass through a condenser and this point is the basis of the tester. It will be seen from the circuit diagram that a neon tube is used lit by either A.C. or D.C. at will by the throw of a switch.

The neon tube is the standard indicator type used on domestic appliances. It has a standard bayonet cap fitting and on 230 to 250 volts takes .5 watt. Of this wattage the actual consumption is 2 milliamps. so that any resistance placed in one lead to the supply to it will cause a change in current, so dimming the light in the tube.

The circuit is self-explanatory so assume the d.p.d.t. switch to be in the A.C. position. Join test clips A and B together and the tube will light with maximum brilliancy as the full-mains voltage is applied to it. Headphones are optional and can be brought into circuit by opening the parallel switch; they provide a means of aural testing as the working of a neon tube on A.C. provides a 50-cycle note.

It is advisable to mount the tube in a position of easy visibility, as shown in the illustration, where the metal cover is shown removed. This can be part of a Colvern valve screen which serves to protect the tube.

Any capacity or resistance connected between A or B is actually placed in one lead of the mains supply to the tube, and due to the small wattage and current taken use of this can be made to provide visible means of change in small capacities and changes in larger resistances which are outside the limits of normal testers.

With capacities it will be found that the tube will light even with .00005-mfd. in circuit. Of course, correspondingly greater light is obtained as the capacity

is increased up to .1-mfd. The variation is still marked, but after checking up a few known values, the unknown can be accurately checked. The resistances produce clearly visible readings up to 5 megohms so that after measuring a few known standards intermediate resistances can be located quite easily.

From the headphone terminals a constant signal is obtained which can be fed directly to a suspected loud-speaker for comparison tests. This 50-cycle note can also be fed into the pick-up terminals of an amplifier via an interval transformer so that it can be utilised for centring and adjusting moving-coil loud-speakers. With a pair of headphones in circuit and a morse key across A and B, the novice can make use of the tester as a practice buzzer.

If D.C. is applied to the terminals of the condenser via A and B, as the condenser charges up a flash is obtained in the tube, the brilliancy of which depends on the value of the condenser. A leaky condenser will immediately be shown up by a rapid series of flashes.

The required D.C. is obtained from a half-wave rectifier using a bell transformer. For filament heating, a five-volt tap is used to light the valve, which should be of the 6-volt power type with grid and anode strapped together. The

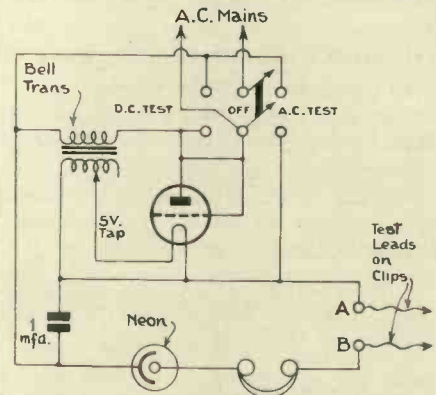

This circuit is only suitable for A.C. mains; the neon tube is of the 1/2-watt indicator type.

half-wave system direct from the mains ensures a steady output of 230 volts as if an isolating transformer were used.

The 1-mfd. condenser shown in the circuit is used to smooth the voltage on the D.C. side. It is important to wire this condenser on the rectifier side of the terminals will have to carry A.C. current passed by this condenser.

The main point is that the light from standard resistances and condensers must be memorised for the amount of brilliancy obtained.

Our Policy

“The Development of
Television.”

MORE EFFECTS AND LAWS USED IN TELEVISION PHYSICS

The first list of these known effects appeared in the December issue.

Lenz's Law

When a circuit is moved in a magnetic field in such a manner that a change takes place in the number of lines passing through the circuit, a current is induced in the circuit, and a mechanical force is set up which tends to oppose the motion of the circuit which gave rise to the current.

Lissajous' Figures

Figures traced by a beam of light on a screen when actuated by two rhythmically varying forces at right angles. The original figures were produced by two tuning forks to which small mirrors were fitted.

Maxwell's Law

Any two circuits carrying current tend so to dispose themselves that they will include the largest possible number of lines of force, common to the two.

Every electromagnetic system tends to change its configuration so that the exciting circuit will embrace the maximum number of lines of force in every possible direction.

Michelson Grating

A diffraction grating made up of glass plates laid together in echelon.

Newton's Laws of Motion

Every body continues in a state of rest or of uniform motion in a straight line unless acted upon by some external force tending to change its state of rest or motion.

Change of motion is proportional to the applied force and takes place in the direction in which the force acts.

Ohm's Law

The current in every circuit is proportional to the applied e.m.f. and inversely proportional to the resistance of the circuit.

Paschen's Law

The sparking potential between electrodes in a gas depends on the length of the gap and the pressure of the gas in such a way that it is directly proportional to the mass of the gas between the two electrodes—or, the sparking potential is a function of the pressure times the density of the gas.

Piezo-electric Effect

When certain crystals are compressed between parallel planes, which are at right angles to particular axes, opposite ends of these axes become oppositely electrified. This is known as piezo-electricity.

Pinch Effect

When a current, either direct or alternating passes through a liquid conductor, the conductor tends to contract in cross section, due to electromagnetic forces. This contracting

force in the case of heavy currents is large enough to separate the conducting liquid altogether.

Planck's Constant

"h." See Quantum Theory.

Poynting's Law

When a conductor carrying a current is in an electrostatic field, the transfer of energy takes place through the dielectric along paths which are the intersections of the equi-potential surfaces of the electrostatic field with the equi-potential surfaces of the electromagnetic field due to the current.

Pyro-electricity

When certain crystals are undergoing changes of temperature, opposite ends of particular axes become oppositely electrified.

Quantum Theory

Postulates the existence of a universal constant whose physical dimensions are (energy x time). If an electron radiates an amount of energy E , the wavelength of the radiation is E/h , h being the constant

Richardson's Equation

A formula giving the electron emission from a heated metal as a function of the temperature.

$$I = a \sqrt{T} e^{-\frac{b}{T}}$$

where I is the electron current in amps./sq.cm.; T the absolute temperature; e the base of Napierian Logarithms; a and b are constants for the metal used.

Secondary Emission

The emission of electrons from a metal surface caused by the impact of electrons arriving from another source.

Schumann's Emulsion

A special silver bromide emulsion which applied thinly to a glass plate, is sensitive to extreme ultra-violet up to = 1,200 tenth metres.

Schottky Effect

The increase in electron emission from a cathode with increasing anode potential due to the lowering of the "work function."

'Schrotteffekt' or Shot Effect

The passage of the electron current in a thermionic tube is non-uniform, the electrons arriving at the anode in an irregular way.

The variation in the number of electrons arriving in successive intervals form in effect an A.C. component of the emission current which gives rise to valve noise.

Heard on the Short Waves

By Kenneth Jowers.



G5FC is situated in Reddish, Cheshire, and operated by F. D. Crawley. He is well heard on the higher frequency bands in most parts of the world.

W₉BHT, from Canton, advised me to pay more attention to 28 mc. work than to 14 mc. as the W stations have been a little tired of the congestion on 20 metres and the colossal number of B.R.S. reports received from Europe. English listening stations have also backed this up by sending me long reports of reception on 10 metres, both with phone and C.W.

On investigating the possibilities of DX for the average listener I find that providing the conditions are reasonably good, really R₉ signals can be brought in from America, Cuba and other parts of the world. It is rather an interesting problem determining just how far these short-waves can penetrate.

B.R.S. 1,847 is perhaps one of the most consistent listeners on 10 metres, which accounts for his log of 99 stations on C.W. and 17 stations on phone, including VE₁GH, W₁GBE, W₂FWK, W₃SI, W₅GDP, W₆FQY, CO6OM, and even G's such as 6LK, 5BY, 5ML. On C.W. he has heard OA, VP₅, ZL₃, VK₂, VK₄, LU₉, X₁, U₈, EI₅, EI₈, VE₂, VE₃, W₁₋₉, and many others, which is surely enough proof that the 10-metre band is really active.

It is not only in America and Europe that this waveband is commanding such attention. Don. B. Knock, well-known as VK₂NO, VK₂NU, and formerly G₆HG is using a Jones exciter unit followed by a 53, 45, 801 buffer, and an Eimac 50T in the final stage. All stages are link-coupled and he is asking for schedules on 10 metres with G stations. VK₂JU, also from Sydney, is active on 10 metres, but is now more interested in 5-metre work. He is using a mobile transmitter and was able to contact with another transmitter in a car travelling at over 80 miles an hour. An interesting point brought to light

by VK₂JU is that with a 5-metre transmitter in the centre of Sydney Harbour bridge, there was no trace of QSB at a distance of five miles.

The Municipal College in Portsmouth, which was responsible for the 5-metre trans-Atlantic tests of December 13 and 14, have now been making fresh records for this wave-band. Their station G₆PU was operating on the 5- and 40-metre bands simultaneously and they were received by G₂PB in London, who reported on the 5-metre signal via the 40-metre band. The first report was R₄ QSA₄₋₅ with a super-het receiver. During the second test 2PB received 6PU, R₄ QSA₄₋₄, with a two-stage super-regenerative receiver *without an aerial*.

Talking about DX on ultra-short wavelengths, it will be remembered that a listener in New York claimed reception of the Berlin television transmitter operating on a wavelength of 6½ metres. This has now been confirmed, but the claim that the signals were good enough for picture reception has not been confirmed.

Battleships in California find no difficulty in contacting Washington, a distance of over 3,000 miles, on a wavelength of 7.5 metres, while the 7-metre harmonic of the first B.B.C. Empire station is quite regularly heard in Buenos Aires, so it remains to be seen just how far these ultra-short waves can travel.

B.R.S. 1,784, in the Channel Islands, is giving daily reports to G₆GO on the top-band stations heard at his QRA. Amongst the stations heard are G₂KT, G₅MM, G₆SR, G₂XC, G₂OV, G₆TL, G₅ZJ, G₂AO, G₆FV and G₅KG. G₆GO is the star station, being heard when the rest of the band is completely dead.

Things on the top-band seem to be waking up. What with the American stations coming over as early as 11.30 p.m. and G₆GO working duplex with Holland and the Irish Free State, it seems that this band really is worth a lot more attention.

A BERS station in Gibraltar has sent a long report to G₂OV giving relative strength of the G station heard out there. This report is being sent fort-

nightly so I will endeavour to persuade 20V to let me have a copy.

District 14 are now becoming much more active since they joined up with the Southend Radio Society. 2BWP, who compiles our listening charts, has decided that he has had his three-letter call quite long enough. He has taken his morse test and been issued with G₂LC.

G₅VP, who has been off the air for some time, is now active with a T.P.T.G. link-coupled transmitter, while 6CT has come back again on 1.7. A new station heard just recently is G₂MY, in Thundersley, who will welcome reports.

The North Manchester Radio Society inaugurated in October, 1935, has now a greatly increased membership. Meetings are held every Friday at the

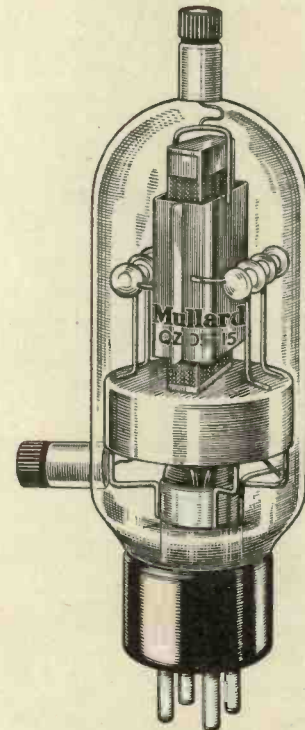

This is the latest Mullard 15 watt transmitting type of S.V. valve. The anode potential is 500 and it will dissipate 10 watts at 15 metres.

TELEVISION AND SHORT-WAVE WORLD

● Month by month *Television and Short-Wave World* is the publication that will keep you abreast of the many developments that are taking place in television and allied subjects.

● Order your copy to be delivered regularly.

British Legion, Elms Street, Bury New Road, Whitefield, near Manchester. Morse instruction is given for intending transmitters, while hints on receiver design are given from time to time. An interesting series of lectures has been arranged for the ensuing year and amateurs should get in touch with Mr. R. Lawton, the secretary, 10 Dalton Avenue, Thatch Leach Lane, Whitefield, Manchester.

G5BL, who arranged the 80-metre tests, tells me that he is trying to arrange a G-VK contest on 3.5 mc. for the latter part of January. Will anybody interested get in touch with G5VL, at Porth House, Porth, St. Columb Minor, Cornwall.

Alice Bourke, W9DXX, in Chicago, seems to be hearing almost everything except G's. The only consistent station heard in Chicago from Europe is G6XN from Welwyn Garden City. Coming a little nearer home, B. McDougall, in Stornoway, complains about QRM on 40 metres. I wonder whether he has heard about the Chinwaggers' Club instituted in Coventry. The idea is to get together two or three dozen 40-metre regulars, and instead of them all coming on together to come on one at a time in a ring, so reducing the effective QRM. McDougall reports

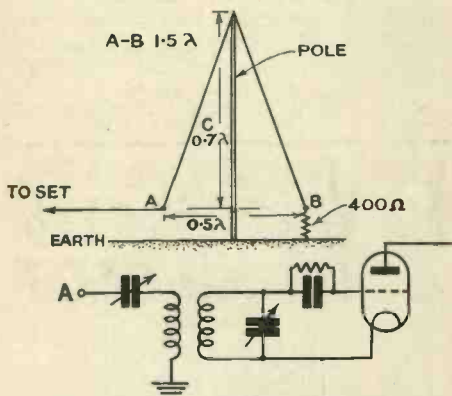

The inverted V aerial is being used with great success by listeners in different parts of the country. This is the way it is erected.

R7-8 reception of G2FC, G2AV, G5PF, G2LD, G5DC, G5VM.

It is surprising how few stations have any reliable means of monitoring phone transmissions. I should feel quite lost simply speaking into a microphone and wondering just how the transmission is going out. For the past twelve months every transmission has been monitored by means of a detector circuit using a metal rectifier.

There is no need even to go to the expense of the metal rectifier, for any old valve can have its grid and anode strapped and will operate most effectively on even high frequencies. In this way a real guide can be kept on over-modulation, hum content of the carrier and quality, while an added advantage is the R.F. meter measuring over-modulation tapped into the P.A. circuit.

Several readers have asked me to give constructional details of the inverted V aerial for reception. The details for this are shown in the diagram, which is almost self-explanatory. In practice the points A and B have to be



Tungram have a very efficient heptode valve for short-wave use. It is battery operated and oscillates quite freely on the 10-metre bands.

anchored to the ground by means of rope and insulators, while the apex has to be insulated where the aerial wire passes over the top of the pole.

I used this aerial myself for some time until space made it necessary for me to change over to something more suitable. However, American receiving stations say that this is the best aerial for all-round reception.

BCL's and other listening stations should make a mental note that conditions on all bands are changing very rapidly at the moment. I was surprised to find that 20-metre stations were coming in as late as midnight, while W8XX, on 1,393 metres is now most consistent after lunch.

Trade Notes of the Month

TUBULAR MICA CONDENSERS.—Complete range of tubular condensers with a mica dielectric can now be obtained from the Franklin Electric Company. They are provided with wire ends and are made in capacities from .00005 to .03 mfd. with tolerances of $\pm 10, 5$ or 1 per cent. A series of electrolytic condensers for midget receivers are also available. Details from Franklin Electric Co., Ltd., 150 Charing Cross Road, London, W.C.2.

ALL-WAVE RECEIVERS.—In addition to the Empire Six all-wave superhet, Philco have now released an A.C./D.C. six-valve superhet priced at 17 guineas. It is model 290 and con-

sists of high-frequency amplifier, heptode frequency changer, pentode intermediate-frequency amplifier, pentode output, rectifier, and barretter. It covers 16.6 to 52 metres, 196 to 550 metres and 860 to 2,000 metres.

A.C./D.C. VALVES.—Mazda have now introduced a PP3521 a triode valve for use in push-pull A.C./D.C. circuits. It has a heater taking 2 amps. at 35 volts and a maximum anode voltage rating of 250.

The amplification factor is 6 with a mutual conductance of 10 milliamps.-per-volt. An SP2220 is an H.F. pentode with 22-volt 2-amp. filament. Both anode and screen require maximum voltage and a slope of 3 milliamps.-per-volt. A third valve designed specially for Murphy receivers is the AC/SP1. It uses 4-volt .1-amp. heater while both anode and screen require 250 volts, the slope being 3 milliamps.-per-volt.

Bulgin Universal A.C. and D.C. Watt Meter,

This new instrument is fully insulated in a moulded bakelite case and gives direct reading of the consumption (in watts) of all mains apparatus. It will not, however, read receiver output.

Actually it is an 0-1 amp.-meter, with a special dial scaling and engraving so that it gives direct reading of watts from A.C. or D.C. mains of between 200 and 250 inclusive. The maximum read-



The Bulgin universal watt meter.

ing for the type UM12 is 250 watts. The instrument is provided with standard two-pin five-amp. sockets to take the apparatus plug and two five-amp. pins to which the supply is connected.

A second model is available, type UM14, for maximum readings of 125 watts, the list price of which is 15s. This instrument is of great service to experimenters and servicemen as it avoids the necessity for using a plate meter for watts calculation. The instrument is housed in a bakelite case, is quite shock proof and, if desired, can be left continuously in circuit.

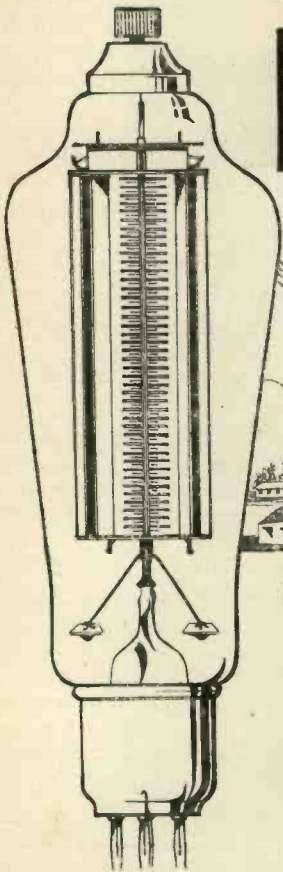

THIS IS NEWS

ENTIRELY BRITISH—SIX MONTHS
GUARANTEE

RFP 362 ... £3
Suppressor Grid Transmitter.
Output 75 watts at 125 watts input, 50 watts dissipation. Pair in P/P 200 watts output at 300 watts input. Mutual Conductance of 8 mA/V requires negligible radio input on short waves.

ACME 4c ... 13/-
Low Frequency Pentode.
Suitable for modulation feed. Screen 250 v. max. Anode 400 v. max. Output at 250 Va. 3½ watts. Output at 400 Va. 4½ watts.

ACPX 4a ... 9/-
Oscillator for Exceptionally Short Waves.
Should be ordered without cap for below 2½ metres 4 volts 1 amp. Directly heated.

UPX ... 13/-
Power Triode for D.C. Mains.
Speech output of 3 watts at only 9½ watts input and 250 volts anode. Indirectly heated, 25 volts .3 amps.

P 2 ... 4/6
Power Triode for Batteries.
Speech output .9 watt. Anode volts 250. Fil. volts 2, .2 amp. Mut. cond. 3 mA/V. Mag. factor 9.

ACFC 4 ... 15/-
Frequency Changer.
For superheterodyne reception of weak signals. Oscillation anode voltage should be increased to 250 for ultra short waves.
Exceptionally low noise level.

RB 42 ... 10/-
Bi-Phase Rectifier.
Output 500 v. 120 mA. at 500-0-500 input.

RB ... 15/-
650/250 Bi-phase Rectifier.
Output 650 volts, 250 mA at 650-0-650 (8 mfd. condensers, 4 volt, 4 amps. filament).

362

RADIO VALVE CO LTD
STONEHAM WORKS E 5 (Lissold 6607)



VARIABLE
SUPPLY

TO STABILISE VOLTAGE OF SUPPLIES

An efficient and convenient method of dispensing with storage batteries or mechanical current supply stabilisers is now available in the Stabilovolt glow gap divider.

Stabilovolt systems capable of stabilising voltages up to 600 with a maximum current drain of 200 milliamperes are available. A fluctuation of only 1 or 2 per cent. at any condition between full and no load is ensured, and only ± 0.1 per cent. on supply voltage variations of ± 10 per cent.

STEADY SUPPLY

STABILOVOLT

Stabilovolt Glow Gap Dividers are available from £1 - 16 - 0 to £6½; and Iron Barretters from 16s. to £1 - 7 - 6. Full particulars from:

MARCONI'S

WIRELESS TELEGRAPH COMPANY LIMITED,
ElectraHouse, Victoria Embankment, London, W.C.2



AGAIN CHOSEN

For the "Amateur Communication Receiver" the unique receiver described in this issue of "Television" the following J.B. Components have been chosen, with no alternative.

- Two of type 1054 (.0001) 4/6 each
- Two of type 1087 (.00005) 1/- each]
- One of type 1053 (.00015) 4/9 each

The consistent "starring" of J.B. Components in famous constructor receivers, is positive proof of the reliability of J.B. Components.

Send now for the 1936 list describing these and other J.B. instruments.

JACKSON BROS. (London), Ltd., 72 St. Thomas Str., S.E.1
TELEPHONE HOP. 1837

A Universal All-wave Superhet

PETO-SCOTT, LTD., who are well known for short-wave apparatus, have now gone a step further and produced an all-wave superhet of advanced design, suitable for A.C. or D.C. mains. This receiver enables the average listener to obtain, by what appears to be a family set, world-wide reception of short-wave stations, normally limited to short-wave enthusiasts.

The circuit comprises six valves in the following sequence. An octode frequency changer, pentode intermediate frequency amplifier, double diode triode which functions as a diode detector, A.V.C. control and low-frequency amplifier, triode muting valve for interstation noise suppression, pentode output and full-wave valve rectifier.

The wave ranges are 17-52, 200-550, 900-2,000 metres, and any of these wavebands can be brought into circuit by means of one multiple switch.

A feature that non-technical listeners will appreciate is the fact that the tuning dial is calibrated not only with the positions of the medium- and long-wave stations but with the approximate positions of short-wave stations.

Aerial equipment is supplied with each set so that the purchase price of 14 guineas is the first and final outlay. The makers are the Peto-Scott Co., Ltd., 77 City Road, and branches

The Radio Physical Television Society

MEETINGS of the above Society are held every Friday at 8 p.m., at 72a North End Road, West Kensington. Lectures and demonstrations on various radio and physical subjects are given, while visits are being arranged to various radio concerns.

A morse class and a course in theory and fundamentals of wireless have been started. Many facilities are available and all kinds of radio and physical apparatus can be tested.

The subscription is 2s. per annum with 3d. payable at each meeting attended, but visitors are under no obligations whatsoever. Readers of TELEVISION AND SHORT-WAVE WORLD are invited. Further details can be obtained from the Hon. Secretary, M. I. Arnold, 12 Nassau Road, Barnes, S.W.13.

The Positron

THE notion of the electron as the unit of negative electricity has been drummed into one's ears for so long that it comes as a bit of a shock to learn that there is also a positive electron, which, it seems, is anchored more or less firmly to every atom of matter. The physicists are rather pleased with this new discovery because it removes the apparent "one-sidedness" of electricity.

One has always been taught to think of an electric current as so many billions of negative electrons in movement, either along a metal conductor, or inside the glass bulb of a valve. But no one seems to have bothered very much about the "positive" side of electricity, except to explain airily that it is all due to a deficiency of negative electrons.

However, we have now succeeded in isolating a positive electric atom, quite distinct from the electron, and known as the Positron. There are, of course other close relatives of the electron, such as the neutron and the proton, but so far none of them seem likely to replace our old friend in doing useful work in an ordinary electric circuit.

READ TELEVISION & SHORT-WAVE WORLD REGULARLY

IT PAYS TO BUY THE BEST



ADJUSTABLE BRACKET.
A strong baseboard bracket for mounting components controlled by an extension rod. Has adjustable (2 1/2" to 3 1/2") slide of DL-9 H.F. insulation. No. 1007. Price 1/6.



EXTENSION CONTROL OUTFIT.
Ample length adjustment is obtainable with the 4" non-warp precision-drawn insulating tube and 3" brass rod provided in this outfit. Complete with panel-bush and nut. No. 1008. Price 1/3.



BAR INSULATOR.
An ultra high frequency insulator for strain or spacer purposes, made from Frequentite. Slotted ends for feeders with 2" spacing. No. 1017. Price 4 1/2d. each.



ULTRA SHORT-WAVE H.F. CHOKES.
These chokes are single layer space wound on DL-9 formers, and have an exceedingly low self-capacity. 2 1/2-10 metres. No. 1011. D.C. Resistance 1.3 ohms. Price 1/3. No. 1021. D.C. Resistance 0.4 ohms. Price 1/3.

INSULATING PILLARS.
Invaluable for mounting components in ultra short-wave receivers. White DL-10 insulations 7/16" diameter. Long 6BA adjustable screw shank at top. N.P. Metal foot. No. 1028. 2 1/2" high 6d. each. No. 1029. 1 1/2" high 4 1/2d. each.



MIDGET INSULATOR.
Made from Frequentite for high frequency work, with N.P. metal parts. 1" overall height. No. 1019. Price 4 1/2d. each.



UNIVERSAL S.W. VALVEHOLDER.
A low loss holder for above or below baseboard use. The valve enters the contacts from either side. There is no measurable increase of self-capacity to that already in the valve base. DL-9. H.F. dielectric, one-piece noiseless contacts. No. 1015. 4-pin, 1/3. No. 1016. 5-pin, 1/5. No. 1024. 7-pin, 1/8.



EDDYSTONE MICRODENSER
(No. 900).
For Ultra Short Waves from 5-10 metres DL-9 insulation. Low series resistance at high frequencies. Noiseless operation. 15 m.mfd. 3/9. 40 m.mfd. 4/3. 100 m.mfd. 5/-.

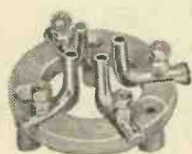

LOW LOSS VALVE HOLDER
Suitable for all high frequency requirements. Frequentite base, one piece metal sockets, lowest self capacity. No. 949. 4 pin 1/5. No. 950. 5 pin 1/8.



FLEXIBLE COUPLER
Free from back-lash but very flexible, this coupler banishes alignment troubles. DL-9 H.F. insulation. For 1/2" spindles. No. 1009. Price 1/6.

ULTRA SHORT-WAVE COILS.
The coils are wound with 14g. copper wire, heavily silver plated. The mean diameter is 1/2". A Frequentite base is used for mounting purposes. No. 1020. 3-turns, 1/6. 4-turns, 1/6. 5-turns, 1/7. 6-turns, 1/8. 8-turns, 1/10.

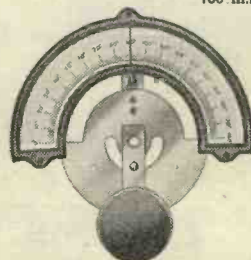

WIDE VISION VERNIER DIAL.
A precision dial for all purposes where accuracy and smoothness of tuning are required. 22:1 ratio entirely free from back-lash. Black bakelite escutcheon, 0-180° dial with travelling pointer. No. 973. Price 10/6.

EDDYSTONE SHORT WAVE COMPONENTS

WHEREVER YOU ARE—WHATEVER YOU DO—

DON'T MISS THIS!

THE FINEST AND MOST COMPLETE
BOOK ON RADIO STARS AND RADIO
ENTERTAINMENT EVER PUBLISHED



HERE'S a splendid opportunity to really know about the brilliant men and women who entertain you over the air—you'll find everything you want to know in the "Radio Pictorial" ANNUAL. Never before has anything like it been offered to listeners—its 84 big pages, printed throughout in beautiful photogravure, reveal in pictures and words all the secrets of the "stars" of the microphone. It tells you of their homes, their private lives, their fads and fancies—told to you by those who know them intimately. Each page abounds in wonderful pictures—of the "stars" whom you hear in your home, but never see—announcers, singers, crooners, dance bands, famous people who talk to you—over 360 lifelike shots of men and women whose names are household words in every town and hamlet of this country.

And that's not all! Famous writers like A. J. Alan and the Reverend Dick Sheppard have contributed some remarkable features to thrill you . . . amuse you . . . hold you.

Look at the list below—it will give you some idea of the remarkable contents of the "Radio Pictorial" ANNUAL.

HERE ARE SOME OF THE AMAZING CONTENTS

- 360 Radio Star Photographs
- A. J. Alan Short Story
- Jane Carr on Fashion
- Rev. Dick Sheppard on Christmas
- Britain's Broadcasting Centre—a pictorial peep into Broadcasting House
- Dance Music's Amazing Story, by Charlie Kunz
- I Look after Harry Roy—by His Brother
- All about B.B.C. Music Halls
- 200 Radio Star Who's Who

Remember, there are nearly 8,000,000 listeners in the country—everyone will be eager to get a copy of this grand ANNUAL—so make sure of your copy quickly—otherwise you'll be told "Sold Out."

It is now on sale price 6d., of all newsagents and bookstalls throughout the country.

Now On Sale

LOOK FOR THE FINE COVER ON THE BOOKSTALLS

Class-B Amplification

By G5ZJ

AMATEURS using C.W. stations and wishing to go over to phone operation often quibble at the cost of good class-A amplifiers of sufficient wattage output. A 50-watt station finds that as 25 watts of audio are required for good modulation, this is likely to prove difficult and expensive. Unfortunately as a general rule the result is either grid modulation or an overloaded amplifier for anode modulation. Which is the worst of these two I am not quite sure.

shillings will do equally as well. A transformer of the low-current variety with a 250-volt primary and a 250-0-250 secondary can be used for class-B work quite satisfactorily. These can be picked up very cheaply just at the moment.

Although I have shown an output transformer, this is not always the most satisfactory method, for unless the transformer is a good one R.F. leakage from primary to secondary is a possibility. In such an event a split choke

uses another 56 followed by a 59 and two 59's in class-B. The output from such an arrangement is about 25 watts, which can be increased to 50 watts or a little over by using parallel class-B, that is four 59's.

To obtain sufficient drive for four 59's it is sometimes an advantage to have push-pull input, so having a split primary transformer with a 59 in each leg.

Class-B Operation

When valves are operated in class-B the grids are driven positive causing grid current to flow. This necessitates using a driver valve having a power output capable of swinging the class-B grids without stopping the signal. The design of the driver transformer is, therefore, rather important, since the secondary must be of a low resistance to prevent distortion due to voltage drop. Also the impedance ratio must be correct so the reflected impedance of the driver valve remains high enough to prevent harmonic distortion even when the grid impedance is low, as on loud musical passages.

These amplifiers will operate directly from a carbon type of microphone or gramophone pick-up, but with quality microphones the head amplifier will be required. A suitable amplifier is described elsewhere in this issue. A very great increase in gain can be obtained by using a Mullard 994V in place of the 56's, but in such circumstances only a single valve head amplifier will be necessary.

By using various combinations of this

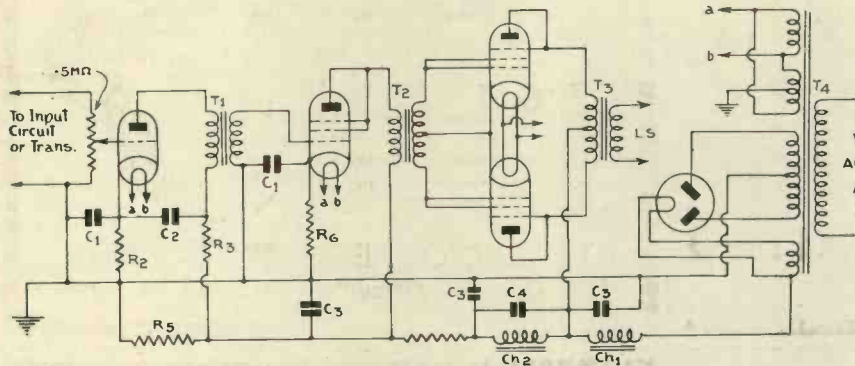

Fig. 1. Most of the components needed for this amplifier are of conventional design and easily obtainable. The inter-valve transformer is described in the text.

Class-B amplifiers for modulation are in a way the next step in the right direction. Two small valves with positive drive will give a very high output with reasonable quality. Some stations actually put out music *via* a class-B amplifier, but this is not recommended. Taking, for example, a 50-watt station requiring 25 watts of audio, it is a very different thing from using ordinary class-A with a high voltage and expensive valves, to using a pair of 46's or 59's which will give between 20 and 25 watts.

Suitable Valves

These valves, suitable for class-B operation, are available in this country at very reasonable cost. Also as the maximum anode potential need not be more than 400 volts, the cost of transformers and smoothing condensers is correspondingly less. Consider for a moment the circuit of Fig. 1. It consists of a type 56 triode, or an AC/HL if you have one, followed by a 46 driving a pair of 46's in class-B. The second transformer with a split secondary, is rather hard to obtain, but a cheap mains transformer costing only a few

can be used, the speech current being taken off from either end through large fixed condensers. There is nothing very extraordinary about the circuit, for

Fig. 2. A slightly higher output can be obtained by using type 59's in class B without increasing the cost to any appreciable extent. The amplifier can be built on either a chassis or bread-board provided the latter is metal covered. This is because so many wires are connected to earth or chassis

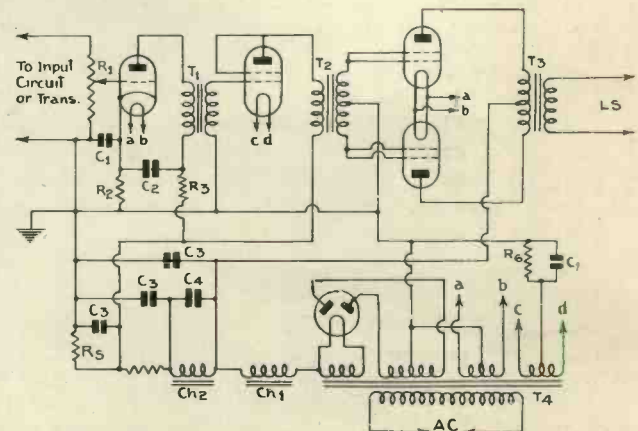

both the arrangement of the amplifier and of the power pack are conventional. Fig. 2 is a variation of Fig. 1. It

valve carriers up to 200 watts can be modulated with comparatively simple apparatus.

APPEARANCE Trouble-free Service

Neatness of appearance, strength of construction, compactness of design, perfection of contact—all these features have resulted in the unassailable popularity of "Clix" Valveholders with set manufacturers, designers of sets described in the technical press and home constructors.

The following Clix perfect contact components are specified for the
"AMATEUR COMMUNICATION RECEIVER"

- Clix Chassis Mounting Valveholders 4-pin 5d.
5-pin 6d.
(Without terminals)
- Clix Wander Plugs (For H.T. & G.B.) 1½d. each.
- Clix Spade Terminals Large 2d.
Small 1½d.

Clix Spade Terminals (Heavy Duty Type) as specified for the "Midget" Valve—Head Amplifier 3d. each



OUR "1936" FOLDER "S.T.S." WILL BE SENT YOU FREE ON REQUEST.

LECTRO LINX LIMITED
79a Rochester Row, London, S.W.1

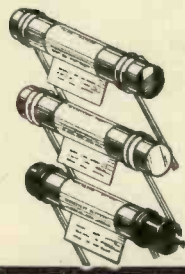

with ERIE RESISTORS

Specified by designers and manufacturers for their unfailing dependability under all conditions. Impregnated to withstand extremes of heat, cold, and damp. Make sure you get genuine Erie resistors. Look for the label—your guarantee of efficiency.

1/- per watt in all values

Each resistor colour coded, labelled and Guaranteed.

ERIE VOLUME CONTROL

Smooth and positive contact, free from hop-off noises. The bone-hard Erie resistance element and Erie precision construction make this variable resistance unique in its permanent efficiency.

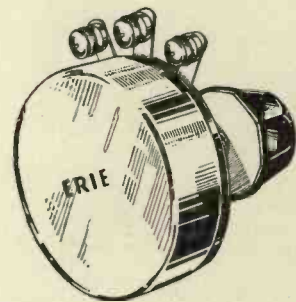

3/6 or with built-in mains switch. 5/-

Follow the technical experts who fit Erie components for trouble-free service.

The RADIO RESISTOR Co., Ltd.,
1, Golden Sq., Piccadilly Circus, London, W.1

MAKE AMATEUR RADIO YOUR HOBBY FOR 1936

But begin right.

Join the R.S.G.B. and keep in touch with Members all over the world.

Co-operate with and secure the advice and help of Fellow Members. Have the Official Monthly Journal "The T. & R. Bulletin" sent you Free and Post-paid every month. Come to the Lectures, Outings and District Meetings and keep in touch with the latest Short-wave Developments.

An Application form for Membership and a copy of the 100 Page Book "A Guide to Amateur Radio" will be sent you for postal-order or stamps to the value of 8d.

Write to the Secretary (Dept. S.W.10).

RADIO SOCIETY OF GREAT BRITAIN
53, Victoria St. London S.W.1.

MIKES and "MIDGETS"



XSG Actual Size.

"On test Hivac 'Midget' Valves proved to be the most satisfactory ones available, and gave a thoroughly satisfactory performance when used in a two-stage Microphone Amplifier."

Specified for the
AMATEUR COMMUNICATION RECEIVER

These Hivac Midget Valves are excellent for short wave work and have made possible true pocket and portable radio.

HERE IS THE HIVAC RANGE OF 2 VOLT MIDGET VALVES:—

XSG Screen Grid	15/6
XL For L.F. Stages	10/6
XD Detector	10/6
XP Power	12/6
XY Pentode type	15/6

Hivac Folder "T.S." gives all details and characteristics of Hivac Midget and Standard Battery and Mains Valves.



THE HIGH VACUUM VALVE CO., LTD.
113-117, Farringdon Road, :: London, E.C.1.

Top Band Frequency Register

THE frequency register published in the December number has caused considerable interest and, in view of numerous requests, we are reprinting it in this issue with the new stations that have come on the air during December.

Will any stations who are not listed please send us details for inclusion in the next issue.

Frequency.	Frequency.	Frequency.	Frequency.
1726 G6GO	1773.1 5BC	1810 2LD	1875 6WF
1735 6BO	1774 6SO	1810 5PP	1881 6FV
1740 5HO	1774.5 6NU	1815 2DQ	1884 5KJ
1740.7 5ZJ	1775 6ZQ	1818.5 2OG	1888 2XC
1742 5WL	1780 6BO	1824.5 2WG	1890 2MI
1752 2KL	1780 5RI	1824.5 6UJ	1893 5RD
1753 6KV	1780 5BK	1830 5KG	1900 2PK
1754 6ZR	1780 6BO	1830 6QB	1905 6QA
1754 6GO	1780 6HD	1836.5 6RQ	1910 2NO
1755 6PY	1781.5 5VS	1840 2JU	1913 2OV
1756 2AO	1785.5 5ZT	1844 6VD	1913.5 2UJ
1757 6YU	1787.5 2XP	1849 5CJ	1916 5VT
1759.5 5JW	1788.5 2GG	1850 2CD	1925 6CT
1760 5AR	1789 6IF	1850 5OC	1925 6UU
1760 5BM	1790 5UM	1850 2HF	1930 5OD
1760.5 2KT	1790 2SN	1850 6SR	1936.6 5IL
1762.5 2ZN	1791 5AK	1850 6UD	1940 6PA
1764 5NW	1794 5JU	1850 6VD	1950 6KD
1766 2WO	1795 2UY	1852 2KV	1950 5SZ
1769 5GC	1801.5 5LL	1857 6TQ	1960 5UK
1769.5 5FI	1802.9 5ZJ	1857 2CF	1961 2UJ
1770 5PR	1806 5MM	1860 6QM	1965.5 5LL
		1861 2KL	1970 6UT
		1862 6WY	1975 6OM
		1869 2PS	1980 6KV
		1870 2PL	1988 5WW
		1870 5RI	1990 6AU
		1874.5 2XP	

Frequency.	Frequency.
1810 2LD	1875 6WF
1810 5PP	1881 6FV
1815 2DQ	1884 5KJ
1818.5 2OG	1888 2XC
1824.5 2WG	1890 2MI
1824.5 6UJ	1893 5RD
1830 5KG	1900 2PK
1830 6QB	1905 6QA
1836.5 6RQ	1910 2NO
1840 2JU	1913 2OV
1844 6VD	1913.5 2UJ
1849 5CJ	1916 5VT
1850 2CD	1925 6CT
1850 5OC	1925 6UU
1850 2HF	1930 5OD
1850 6SR	1936.6 5IL
1850 6UD	1940 6PA
1850 6VD	1950 6KD
1852 2KV	1950 5SZ
1857 6TQ	1960 5UK
1857 2CF	1961 2UJ
1860 6QM	1965.5 5LL
1861 2KL	1970 6UT
1862 6WY	1975 6OM
1869 2PS	1980 6KV
1870 2PL	1988 5WW
1870 5RI	1990 6AU
1874.5 2XP	

RALPH STRANGER'S Science Review

1/-

January Issue Now on Sale.

Calls Heard

B.R.S. 1,784, M. G. Bourke, Channel Islands. (160-metre Phone.)
G6GO, 2KT, 5MM, 6SR, 2XC, 2OV, 6TL, 5ZJ, 2AO, 6FV, 5KG.

(80-metre Phone.)

W1CMD, 1DVQ, 3CSJ, 3DQ, VE1EI, CT1KW, SP1CC.

(40-metre Phone.)

HB9J, VP3MR, EI7G, 1TT, CT1ZH.

(20-metre Phone.)

LU7AZ, SM5WK, SU1SG, K4SA, VP9R, VE1GH.

(10-metre Phone.)

W2HIJ, 2BC, 2BOF, 1KZE, 8PK, *B.R.S. 1,991, Peter Elm, Aylesbury, Bucks. 1-Valve Receiver.*

(80-metre Phone.)

G2DQ, 2LZ, 5RV, 5KG, F3AM, ON4US, 4LV, 4NC.

(40-metre Phone.)

G2AO, 2IL, 2TU, 2DU, 2XU, 2PP, 2YH, 2MI, 2LZ, 5PT, 5SP, 5YW, 5KJ, 5RD, 5PP, 5MW, 5YY, 5LC, 5BF, 6LX, 6PK, 6DL, 6TO, 6LZ, 6PL, 6XX, 6SR, 6LH, GI5AJ, 5MZ, SP1OL, EI7G.

B.R.S. 1,847, J. A. Jagger, Guildford, Surrey. (10-metre Phone.)

VE1GH, VP5AC, W1AJS, 1DZE, 1GBE, 2BCR, 2FWK, 3AUC, 3SI, 5DDP, 6FQY, 8MWL, 9BHT, CO6OM, G6LK, 5BY, 5ML.

(10-metre C.W.)

OA4J, VP5PZ, 5AZ, ZL3AJ, VK2LZ, 4EI, 4BB, LU9BV, 9AX, X1AY, U8VO, EI5F, EI8B, VE2FR, 3AEL, 3DU, 3MS, 3WA, 5HC, W1DF, 1DZE, 1DSH, 1AVV, 1CMX, 1SZ, 1CFD, 1ZHI, 1ASO, 1AUR, 1HDV, 1ARH, 1HGB, 2GOQ, 2DTB, 2BPY, 2DNG, 2PWK, 2HIJ, 2TP, 2AIW, 2BPD, 2DM, 2GJK, 2CAY, 3EBT, 3FED, 3BDX, 3AWH, 3CHH, 4AJY, 4EF, 4CBY, 4BBP, 5QL, 5EEX, 5BEQ, 5DNV, 5EBT, 6DOB, 6GRX, 6JN, 6KIP, 7FLU, 7AMX, 8CRA, 8MWL, 8PK, 8KTW, 8CRX, 8LEA, 9AGS, 9VQD, 9HAQ, 9FQH, 9BMN, 9FQQ, 9GVM.

(Continued on next page.)

B.T.S. SHORT WAVE and TELEVISION COMPONENTS



DESIGNED by experts whose exhaustive experiments and research have produced components unrivalled for reliability, efficiency and quality. B.T.S. are fully confident that they offer components not only technically perfect and absolutely reliable, but reasonably priced and within the means of all. Illustrated here is a small selection only of the range of B.T.S. Components obtainable from all good Dealers.

Send for complete lists of Short Wave and Television Components and Adaptor-Converters.

PRODUCED
by SPECIALISTS.
PREFERRED
by EXPERTS.

B.T.S.

BRITISH TELEVISION SUPPLIES, LTD.
Faraday House, 8-10, Charing Cross Road, London, W.C.2

Read
"Television
and
Short-wave
World"
Regularly

TELEVISION.

A NEW COURSE OF INSTRUCTION.

We have pleasure in announcing that our new "Television" Course has met with remarkable success. The enormous demand for the Course has shown, beyond any shadow of doubt, that it fills that long-felt need which we anticipated when we went to such trouble and expense in its preparation.

We shall be happy to send full details of this special "Television" Course on request. Particulars are also available of other Courses in all branches of Wireless, Television, Talking Picture Engineering, etc., and of the easiest way in which to prepare for the A.M.I.E.E., A.M.I.W.T., A.M.I.R.E., etc., Examinations.

We teach by correspondence, and guarantee "NO PASS—NO FEE." Our Technical Consultant is Professor A. M. Low.

Send for full particulars to-day. Free and without obligation.

THE BRITISH INSTITUTE OF ENGINEERING TECHNOLOGY.
Recently removed to greatly enlarged premises at
337, SHAKESPEARE HOUSE, 17/19, STRATFORD PLACE,
LONDON, W.1.

AMPLION

Specified for apparatus described in this journal because the designers have had full proof of their reliability.

A reliable and constant form of resistance means consistent radio enjoyment. Amplion wire-wound resistances are "entirely dependable"—that's what "Popular Wireless" said after testing 22 different values.

Amplion Resistances.
50 Ohms to 2 Megohms. All colour coded and also have values clearly printed on labels. Price 1/- each (all values).

Don't let that next overflow of current cost you shillings or pounds; fit Amplion fuses at all vital points and protect the life of valuable valves, transformers and other expensive components.

Amplion Cartridge Fuses
from 60 mA to 3 Amp. for Battery or Mains sets cost only 6d. each.

Amplion Speaker and Component Folders "T.S." Free on request.

AMPLION (1932), LTD.
82-84, ROSOMAN STREET, LONDON, E.C.1



SOMETHING NEW in SHORT-WAVE Catalogues
1 1d. Post Free
2

THE VERY LATEST IN SHORT WAVE COMPONENTS

RAYMART, 44, Holloway Head, Birmingham
Retail Services, Radlo Mart, 19, John Bright Street and 22, Summer Row, Birmingham.

OUR POLICY
The Development
of
TELEVISION

"Calls Heard"

(Continued from preceding page.)

W9DXX, Alice R. Bourke, Chicago, Illinois. (20-metre C.W.)

CE2II, 7AA, CM2AF, 2DO, 6DW, 8CK, G2IN, 2UR, 6MJ, 6NJ, HI6O, K4DRW, LU1CA, SM6UA, SM5UR, OA4N, ZS6AL, ZT6Z, YN1AA, X1BA, 1DA, 1CM, 2AH, 2C.

(20-metre Phone.)

CX2HA, 2HP, LU6AP, LU7AZ, X1G.

W9NY, H. F. Wareing, Milwaukee, Wis., U.S.A. (10-metre C.W.)

D4ARR, F8OZ, F8VS, F8WK, FA8CR, FA8IH, G2HG, 2MV, 2YL, 5BY, 5LO.

W3AR, J. J. Michaels, North Wales, Pennsylvania. (10-metre C.W.)

D4ARR, 4AUU, 4KPJ, 5LNM, F8OZ, 8BS, FA8CR, 8IH, G2HG, 2AX.

W7AVV, V. C. Sahnaw, Hillsborough, Oregon. (10-metre C.W.)

X1AY, K5AG, 6AJA, 6EWQ, J3FJ, 2HJ, LU1EP, 2AM, 9BV, ZL1BA, ZSIH.

W3DLB, G. H. McClurg, Washington, D.C. (10-metre C.W.)

D4ARR, 4AUU, 4GWF, 4KPJ, 4ORT, EA4AV, F8EF, 8KJ, 8OZ, 8WK, FA8CR, 8IH, G2HG, 6GS, 6LK, YM4AA.

BERS, 195, E. W. Trebilcock, Moonta, South Australia. (40-metre C.W.)

EA1AM, 3EE, 5CG, 7AK, 7AO, 7BC, G2DL, 2NN, 2OO, 5NU, 5NO, 6DL, 6HJ, 6IY, 6KO, 6QP, 6TR, 6UJ.

W. Cooper, Santa Barbara, California. (10-metre C.W.)

F8BF, G5BO, HI7G, J2HJ, OA4J. CX1CG, W. Figueira, Montevideo, Uruguay. (20-metre C.W.)

FMSCO, G2VD, 6QA, 6XN, OE7JH, LA1G, ON4NIL, OH3NP.

ZL2HR, Arthur Stevens, Hawera, New Zealand. (40-metre C.W.)

EA3EG, 5BS, F8LU, 8NE, 8NY, FM4AA, 8IH, 8WH, G2VQ, 5YH, 5XH, 6WY, HB9AQ.

Norman Brandon, Barnet, Herts. (80-metre Phone.)

W1CBX, 1BBN, 2HFA, 2HYG, 2BOG, 2IJF, 2GHP, 2GYG, W3BFC, 3CWG, 3BHO, 3BQ, 3MZ, 3EFF, 4CS, 8KBJ, 8AOM, VO1I, W1LI, W1QN.

A Receiver for High-definition Signals

In the description of the Receiver for High-definition Signals on page 735, of the December issue, a slight error was made in the text. The makers informed us that the wave-range was 5 to 80 metres, whereas, of course, this should have read 5 to 8 metres. All other details given are correct.

PILOT AUTHOR KITS

are exact in every detail, and are only obtainable from Peto-Scott Co., Ltd.

COMBINATION RECEIVER

BATTERY VERSION

KIT "A" Cash or C.O.D., Carriage paid **£7/10/0**
Or 12 monthly payments of 13/9

Authors Kit of first specified parts, including zinc baseplate and 4 coils, less valves and cabinet.

KIT "B." As for Kit "A" but including specified valves, less cabinet. Cash or C.O.D., carriage paid **£9/16/0** or 12 monthly payments of 18/-.

KIT "C." As for Kit "A" but including valves and cabinet. Cash or C.O.D. Carr. Pd. **£11/1/0** or 12 monthly payments of 20/3.

1 Peto-Scott zinc baseplate (undrilled) ... 3/6

Peto-Scott 6-VALVE All-Wave SUPERHET 12/6

17-2,000 METRES

YOURS FOR
and 18 monthly payments of 18/

Long, medium and short waves . . . stations from every part of the World on this powerful set, the very latest all-wave superhet circuit. B.V.A. Valves, Automatic Volume Control. Energised M.C. Speaker. A.C. Mains 200/250 v. 40/100 cycles. Walnut veneered cabinet.

CASH or C.O.D. Carriage Paid

£14 : 14 : 0

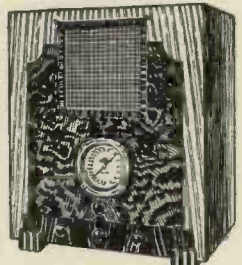

D.C.J.A.C. Model same price and terms.

PETO-SCOTT CO., LTD.

77 (T.7) CITY RD., LONDON, E.C.1 Clerk 9406/7
West End Showrooms; 82 (T.7) High Holborn, W.C.1 EST. 1919

Short Ultra-Short UNIT RADIO CONVERTERS

5 to 100 METRES

This S.U.S. Converter is an entirely new model, original in design and covering both Ultra-Short (5-7 metre band) and Short (13-100 metre band). Special circuits employed give maximum results on all wave-bands. An entirely separate low-loss circuit is brought into operation when working on 5-7 metre band. Enjoy all the advantages of an expensive all-wave set by just attaching the S.U.S. to your present receiver.

UNIT SHORT AND ULTRA-SHORT CONVERTER

Covers 5 to 100 metres. Aeroplane dial. Ratio 100:1. New Type with special scale. Two controls only. Two connections only to set. Also receives 240-line Television sound, in addition to world-wide short-wave broadcasts. All metal non-hand-capacity cabinet. Complete with valve ready for use. **Battery Model 506. £3 5 0.**

A.C. Mains Model 509. £3 12 6.



Cash or C.O.D. Carriage Paid.

The Unit Universal AC/DC. HEPTODE SHORT-WAVE CONVERTER.

This self-contained converter can be added to any mains receiver either superhet or straight type. There are no coils to be changed as a switch controls the three ranges of wave bands which cover 12 to 85 metres. An improved method of tuning is employed, the 100 to 1 tuning dial makes for simple and perfect handling. You do not disconnect when changing to normal broadcast: just switch over. Ready for use after making only two simple connections to your present set.

Complete with self-contained power unit and valve in attractive cabinet. **AC/DC Model £6 15 0**

Battery Model £4 5 0
Cash or C.O.D. Carriage Paid
(List "T.S." Free.) Phone CLE 5340

Unit Radio 347 CITY ROAD LONDON E.C.1

Decoupling of Screen Grid Circuits in Television Amplifiers (see page 48).

APPENDIX.

Let Z_s = impedance of C and R_s in parallel

$$= \frac{1}{j\omega C R_s + 1}$$

i_s = alternating screen current.

i_p = alternating anode current.

Other definitions as in text.

$$e_p = i_p R_p \dots\dots\dots (1)$$

$$e_s = i_s Z_s \dots\dots\dots (2)$$

$$i_s = \frac{\mu_1 e + \mu_r e_p}{\rho_1 + Z_s} \dots\dots\dots (3)$$

$$i_p = \frac{\mu_2 e_s + \mu_3 e}{R_p + \rho_2} \dots\dots\dots (4)$$

Substituting (1) and (2) in (3) and (4) respectively, we have

$$\frac{e_p}{e} = R_p \left[\frac{\mu_3 (\rho_1 + Z_s) + \mu_2 \mu_1 Z_s}{(\rho_2 + R_p) (\rho_1 + Z_s) - \mu_2 \mu_r R_p Z_s} \right] \dots\dots\dots (5)$$

Substituting value of Z_s , multiplying numerator and denominator by $(j\omega C R_s + 1)$ and assuming $\rho_2 \gg R_p$ we have

$$\frac{e_p}{e} = R_p \left[\frac{\mu_3 \rho_1 + \mu_3 R_s + \mu_1 \mu_2 R_s + j\omega C R_s \rho_1 \mu_2}{\rho_1 \rho_2 + R_s \rho_2 - \mu_2 \mu_r R_p R_s + j\omega C R_s \rho_1 \rho_2} \right]$$

Let

$$\mu_3 \rho_1 + \mu_3 R_s + \mu_1 \mu_2 R_s = X$$

$$\rho_1 \rho_2 + R_s \rho_2 - \mu_2 \mu_r R_p R_s = Y$$

$$j\omega C R_s \rho_1 = Z$$

then $\frac{e_p}{e}$ becomes $R_p \left(\frac{X + jZ\mu_2}{Y + jZ\rho_2} \right)$

or, in scalar form,

$$R_p \sqrt{\frac{X^2 + Z^2 \mu_2^2}{Y^2 + Z^2 \rho_2^2}}$$

Phase angle is determined after rationalising denominator. Multiplying numerator by $(Y - jZ\rho_2)$ we have, for numerator,

$$R_p [XY + Z^2 \mu_2 \rho_2 + j(YZ\mu_2 - XZ\rho_2)].$$

whence angle = $\tan^{-1} \frac{Z(Y\mu_2 - XZ\rho_2)}{XY + Z^2 \mu_2 \rho_2}$ degrees.

THE TELEVISION SOCIETY

President: Sir AMBROSE FLEMING, M.A., D.Sc., F.R.S.

Founded in 1927 for the furtherance of Study and Research in Television and allied Photo-electric Problems.

Ordinary Fellows are elected on a Certificate of Recommendation signed by Two Ordinary Fellows, the Proposer certifying his personal knowledge of the Candidate. The Admission Fee for Fellows is half-a-guinea, payable at the time of election, the Annual Subscription is £1, payable on election, and subsequently in advance on January 1st in each year, but the Annual Subscription may be compounded at any time by the payment of Ten Guineas.

Any person over 21, interested in Television, may be eligible for the Associate Membership without technical qualifications, but must give some evidence of interest in the subject as shall satisfy the Committee. For Associate Members the Entrance Fee is 5/-, payable at the time of election, with Annual Subscription 15/-, payable in advance on January 1st in each year.

Student Members.—The Council has arranged for the entrance of persons under the age of 21 as Student Members, with Entrance Fee 2/6 and Annual Subscription 10/-, payable as above.

The Ordinary Meetings are held in London on the second Wednesday of the month (October to May inclusive) at 7 p.m. The business of the meetings includes the reading and discussion of papers. A Summer Meeting is usually held, and affords Members the opportunity of inspecting laboratories, works, etc. A Research Committee and the preparation of An Index of Current Literature are active branches of the Society's work.

The Journal of the Television Society

is published three times a year. All members are entitled to a copy; and it is also sold to Non-Members, at an annual subscription of 15/- post free.

Forms of proposal for Membership, and further information regarding the Society, may be obtained on application to the Business Secretary, J. J. Denton, 25, Lisburne Road, Hampstead, London, N.W.3.

AN ENTIRELY NEW SCIENTIFIC JOURNAL

Ralph Stranger's

SCIENCE REVIEW

OFFICIAL ORGAN OF THE WORLD-WIDE RADIO RESEARCH LEAGUE

A monthly periodical devoted to modern scientific research and progress

THE SECOND ISSUE IS NOW ON SALE

Monthly 1/-

Feb
30442/-

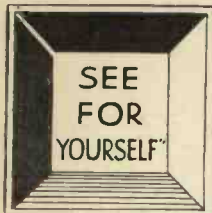

B T C
means
Better Television
Coming
meanwhile
ALL-WAVE
Your Present Set
FROM 30/-
Descriptive leaflet free
BENNETT
TELEVISION CO.
REDHILL

CLASS "B" AMPLIFIERS

We can supply

RAYTHEON RADIO TUBES

of the types required for Class "B" Amplifiers; i.e. types 46, 56, 59 and 83 at 10/- each

We can supply

COMPLETE KIT OF PARTS VALVES AND SPEAKER

for that proved excellent receiver

THE "ADVANCE ALL-WAVER"

£9-10-0 Cash or C.O.D. Carriage Paid

We can supply the KIT of specified components for the

"UNIVERSAL MAINS SHORT-WAVE THREE"

Full details on request.

Complete List T.S. of Radio Apparatus. Free.

CHAS. F. WARD

46 Farringdon Street, London, E.C.4
Telephone: Holborn 9703

Constructor's Circle

Additional Members.

W. Backhouse, 109 Sturgess Avenue, Hendon, N.W.4; W. Dunn, Jnr., 118 Hamilton Road, Rutherglen, Glasgow; R. J. S. Gibbens, "Laundale," Usk Road, Caerleon, Mon.; F. E. Williams, 37 Max Road, West Derby, Liverpool, 12; J. H. Kostromin, Broadway Radio Service, 18 Gower Place, Mumbles, Glam.; J. E. Bryden, Collin, 24 City Way, Rochester, Kent; W. S. Bagley, 17 Hubert Road, Clacton-on-Sea; G. Buttery, 23 Preston Road, Brighton, Sussex; W. Ingram, 5 Bromford Road, Oldbury, Worcs.; H. Fisher, 12 Rawlings Road, Bearwood, Smethwick, Staffs.; C. L. Davies, 78 Rhondda Street, Mount Pleasant, Swansea, S. Wales; F. Smalley, 20 Chatsworth Park Road, Gleadless, Sheffield, 2; W. P. Newling, 88 Salisbury Crescent, Oxford; R. L. Allen, Vision Radio, 43 Lower Marsh, S.E.8; J. Munns, 24 High Street, Wellingborough; C. Abraham, 24 Ravensbury Avenue, Morden, Surrey; C. O. Anderson, Highfield Lawn, Highfield Road, Derby; H. Lundean, 145 Stanhope Road, S. Shields, Co. Durham.

TELEVISION UP TO DATE

Send for the very latest book by Hutchinson, as described in this Journal. Dealing with High-Definition, Cathode-Ray, Time Bases, 240 and 405 line Transmission and Reception, Ultra Short Wave, and INTERLaced Scanning, etc. 125 illustrations. Price 2/6. Post Extra 4d.

H. E. SANDERS & CO., 4, Grays Inn Rd., London, W.C.1. Phone Chancery 8778

THE CONSTRUCTORS' CIRCLE

Application for Membership

To be filled in and sent with a stamped envelope for reply to the Editor, "Television and Short-wave World," Chansitor House, Chancery Lane, London, W.C.2.

- (1) I already subscribe to your journal at the address below.
- (2) I have placed a regular order for TELEVISION and SHORT WAVE WORLD with my book-sellers, Messrs.....

.....
and desire to be enrolled as a member of the TELEVISION and SHORT WAVE WORLD. "Constructors' Circle."

Please send membership badge free of charge to

Name (in block letters)

Address

*Strike out lines not applicable.

"TELEVISION COUPON and SHORT-WAVE WORLD." FOR FREE INQUIRY SERVICE

Name

Address

January, 1936

Read

"TELEVISION AND SHORT-WAVE WORLD"

Regularly

There is news in the "Television and Short-wave World" advertisements.

MISCELLANEOUS ADVERTISEMENTS

The charge for advertisements in these columns is 12 words or less 2/-, and 2d. for every additional word. All advertisements must be accompanied by remittance. Cheques and Postal Orders should be made payable to Bernard Jones Publications Ltd., and crossed, and should reach this office not later than the 15th of the month previous to date of issue.

PATENTS. Trade Marks Advice. Handbook and Consultations free.—B. T. King, Patent Agents, G.B., U.S.A. and Canada, 146a, Queen Victoria Street, London, 50 years' references. City 6161.

RADIO AMATEURS HANDBOOK. 1936 edition (twice as big), 5/3d. First batch over from U.S.A. were completely sold out in two days. Nuff said. Below.

LIGHTNING RADIO CALCULATORS (A.R.R.L.) Type "A." 4/6d. Below.

WINTER CALLBOOKS. Start the New Year well, and have an up to date copy. Price 6/-. All post free. G5KA, 41, Kinfauns Road, Goodmayes, Essex.

PATENT AND TRADE MARK AGENTS

A. MATHISEN, Chartered Patent Agent, F.Tel.S. Patents, Designs and Trade Marks.—First Avenue House, High Holborn, W.C.1. Holborn 8950. Telegrams: "Patam" Holb., London.

PATENTS. Trade Marks Advice. Handbook and Consultations free.—B. T. King, Patent Agents, G.B., U.S.A. and Canada, 146a, Queen Victoria Street, London, 49 years' references. City 6161.

GEE & CO. (Estab. 1905), patents and trade marks throughout the world (H. T. P. Gee, Mem.R.S.G.B., A.M.I.R.E., etc.), 51-52, Chancery Lane, London, W.C.2 (2 doors from Government Patent Office.) 'Phone: Holborn 1525. Handbook free.

INDEX TO ADVERTISERS

Amplion (1932), Ltd.	63
Automatic Coil Winder & Electrical Equipment Co., Ltd.	2
Belling & Lee, Ltd.	Cover ii
Bennett Television Co., Ltd.	Cover iii
British Television Supplies, Ltd.	62
Bulgin, A. F., & Co., Ltd.	1
Edison Swan Electric Co., Ltd.	Cover iv
Ferranti, Ltd.	1
Fluxite, Ltd.	Cover ii
General Electric Co., Ltd.	Cover ii
High Vacuum Valve Co., Ltd.	61
Jackson Bros.	57
Lectro Linx, Ltd.	61
Marconi Co., Ltd.	57
Peto Scott	63
Radio Resistor Co., Ltd.	61
Radio Society of Great Britain	61
Retail Services, Radio Mart	63
Sanders, H. E., & Co.	Cover iii
Science Review	64
Sound Sales, Ltd.	1
Stratton & Co., Ltd.	58
Television Society	64
The Technological Institute of Great Britain	62
Unit Radio, Ltd.	63
Ward, Chas. F.	Cover iii
Westinghouse Brake & Signal Co., Ltd.	2
362 Valves Co., Ltd.	57



Suppliers of
Electric Lamps
By Appointment

EDISWAN



Manufacturers
and Suppliers
of Electric Lamps
By Appointment

Television developments

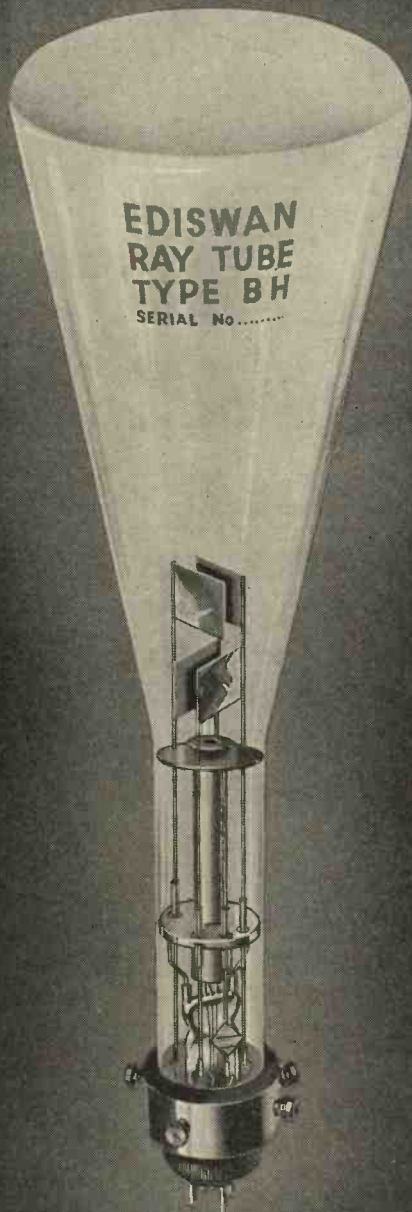

Here is the Cathode Ray Tube specially developed for television reception. Ediswan have been associated with the application of Cathode Ray Tubes to television from the commencement and have kept to the front with the most recent improvements.

Ediswan High Vacuum Cathode Ray Tubes are made in two sizes:

Prices

Type AH - £10.10.0 Type BH - £8.8.0

All have special screens giving a black-and-white image. Green or Blue screens can be supplied without extra charge.

We also manufacture:

- Mercury Vapour Rectifiers
- High Vacuum Diodes
- Transmitting Valves for ultra-short waves
- Grid controlled discharge tubes for time bases

These have been specially developed for line-scanning circuits.

Full information on the tube and its associated circuits can be obtained on application to the Technical Service Department, at the address below.

ENTIRELY BRITISH MADE

EDISWAN RADIO VALVES

THE EDISON SWAN ELECTRIC CO. LTD.



155 CHARING CROSS RD., LONDON, W.C.2

USED BY ALL GOVERNMENT DEPARTMENTS

R.E.245