

# DX News

•Serving DX'ers since 1933•

Volume 59, No. 25 - May 11, 1992 (ISSN 0737-1659)



## Inside...

- 2 .. AM Switch; KDKA, Jamaica
- 4 .. DDXD
- 18 .. IDXD
- 21 .. FM DXD
- 22 .. Professional Sports Nets
- 23 .. SEN
- 24 .. WOSU, CRTG
- 26 .. GYDXA-1490

- 29 .. Formats
- 31 .. Quantum Loop
- 36 .. Answer Man
- 37 .. In the Beginning
- 38 .. Radio Waves / Roundup
- 42 .. Is AM Dying?
- 43 .. Hard Times for Radio
- 44 .. Musings
- 47 .. NRC DXCon '92 - in Omaha!

### From the publisher ...

The big news for this issue is that the NRC Convention for 1992 has shifted a few miles west, to Omaha, NE, and is now under the leadership of Ernie (I thought I retired) Wesolowski. See p. 47 for more details, and p. 46 for a statement from Rick Dau.

Bob Curtis and others have notified us that John D. Bowker's father, John G. Bowker, passed away April 20 in Middlebury, VT, at age 89. He was emeritus professor and Dean of Faculty at Middlebury College. And Eric Bueneman wrote to let us know that Robert F. Hyland, Jr., Regional Vice-President of CBS Radio and General Manager of KMOX-1120 / KLOU-103.3, St. Louis, MO, died on March 5, 1992, at age 71. He was the originator of what became talk radio, when he switched KMOX to that format in February of 1960, while preserving musical offerings. Our sincerest condolences to the two families.

**DX Gathering ...** The Northland Antique Radio Club will meet May 29-30 at the Hotel Seville in Bloomington, MN. For complete details, send a large SASE to Radio Daze '92 - NARC- P. O. Box 18362 - Minneapolis, MN 55418.

And ... thanks for a tip from Jeffrey Less for the information from Parts Express.

The Audiovox radio does replace stock Chrysler units but is not AM stereo. Each unit is \$14.95, plus 6.5% tax to Ohio Residents. Plus, Radio Shack appears to be closing out its 12-625 portable. We reviewed this unit last year; it appears to be a nice second

receiver, especially on FM, but not up to the old TRF (12-655) standards.

**They joined ...** Joe Perge WB8HWF, Newark, OH; Evan R. Newlon NP2EE, St. Thomas, U. S. Virgin Islands; Greg Ledbetter, Purvis, MI (rejoins); Gerald Gibbs, West Palm Beach, FL; Jeff Cohen N1ACQ, Derry, NY; James Cronin, Pittsford, NY; Lloyd Kantor, Elgin, AZ; Tim Kerfoot, Toronto, ON (rejoins); and Olin F. McDivitt, Olean, NY.

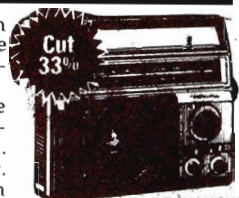

REALISTIC

Portable AM/FM Radio

2688 Reg. 29.95

■ AC/Battery ■ Earphone #12-625

### Remaining DXN Schedule, Volume 59:

#	Deadline	Pub. Date	#	Deadline	Pub. Date
26.	May 29	June 8	28.	July 24	Aug. 3
27.	June 26	July 6	29.	Aug. 21	Aug. 31
			30.	Sept. 18	Sept. 28

### DX Time Machine

Receptions from the DX log of Max Watkins, Tecumseh, NE: 1923: April 21: WHAB, Galveston, TX; WGV, New Orleans, LA.

From the pages of DX News

50 years ago ... from the April 11 and 25, 1942 DXN's: An account was published of the trip by nine Chicago DX'ers to the farm of Fred Borchardt, Milwaukee, to visit the Beer City DX'ers ... Don Meyer, Boxtown, NY, mused that he fell asleep while listening to a DX program from WIAC-580 on Apr. 12 and dreamed that his radio had another tube, remarking, "It could use it".

25 years ago ... from the May 6, 1967 DXN: News of DX GTG's in Santa Barbara, Cincinnati, and the annual NRC convention in Eugene, OR, hosted by Bart Cronin.

10 years ago ... from the May 10, 1982 DXN: The Newark News Radio Club suspended operations, according to Charles George ... Cyril J. Anderson, Mt. Hawthorn, Australia, reported that he heard KOMA-1520 actually mentioning his reception report on the air.

### Audiovox AM/FM ETR BUYOUT



Special purchase Audiovox AM/FM electronically tuned radio will replace stock units in Chrysler automobiles. Features include: Digital time/frequency display, balance, fader, tone control, seek, and 10 station presets (5 AM/5 FM). Dimensions: 2-1/2" (H) x 8-3/8" (W) x 5-1/4" (D). Net weight: 4-1/2 lbs.

#DI-269-350 \$14<sup>95</sup> **\$12<sup>50</sup>**

(1-3) (4-up)  
Parts Express - 340 E. First St. - Dayton,  
OH 45402-1257; (513) 222-0173

# AM Switch

**Jerry Starr**  
c/o WHOT Radio  
4040 Simon Road  
Youngstown, OH 44512-1320  
*Status changes in AM stations, supplied by the FCC and listeners*

## CALL LETTER CHANGES

### Old call:

1410 WZAL GA McDonough  
1460 WMXF NC Laurinburg  
1530 WJGC FL Jacksonville

### New call:

WKKP  
WEWO  
WCRJ\*

Note: WJGC-1530 previously requested WJFL but had that request set aside in favor of WCRJ as noted above.

## APPLICATIONS / GRANTS FOR NEW STATIONS

None

## APPLICATIONS FROM EXISTING FACILITIES

1340 WMID NJ Atlantic City: reduce powers to 870/810 watts  
1400 KTUC AZ Tucson: reduce powers to 757/757 watts, diplex into KJYK-1490 tower  
1430 WOOG SC Ridgeland: reduce power to 714 watts (our records show this station is silent, this may indicate it is due to return to the air)  
1530 WJDM NJ Elizabeth: power to 1000 watts

## GRANTS TO EXISTING FACILITIES

640 WNNZ MA Westfield: powers to 50000/15000 watts  
1160 WPIE NY Trumansburg: powers to 5000/310 watts  
1230 KWSN SD Sioux Falls: relocate transmitter site  
1570 WTRB TN Ripley: powers to 28000, add 534 watts nights

## OTHERNESS

550 WCBM MS Columbus: license for this silent station was CANCELLED 3-11-91, info unearthed while checking FCC files for new NRC Log project.  
640 WROR MI Zeeland: silent station has been sold, new owners expected to return it to the air.  
1010 WXFL FL Baldwin: station was silent for a short period but is back ON THE AIR  
1110 CKTY ON Sarnia: relays programming from CKCY-590 Toronto from midnight to 6:00 AM  
1140 WBXR AL Hazel Green: silent station is ON THE AIR  
1270 WYAK SC Scotland Neck: station is SILENT due to fire at transmitter, will be off "for awhile"  
1450 WUJM SC Charleston: silent station is ON THE AIR  
WKEL SC Myrtle Beach: station is SILENT and a member reports that their studio building was torn down.  
1490 KXRE CO Manitou Springs: this silent station has new ownership, may be returning to the air  
1530 KHPY CA Morena Valley: silent station is ON THE AIR  
1550 WVAB VA Virginia Beach: has been silent since 1987 but newspaper article reports new owners expected to return it to the air "around April 15th"

### The Answer Man

Got a question about radio? Send it to NRC's Answer Man: Russ Edmunds - 753 Valley Rd. - Blue Bell, PA 19422-2052. No question is a dumb question, and Russ will answer all, from basic to highly technical. Watch for the answer in *DX News!*



5853 Sunset Blvd., Los Angeles, CA 90028

## AM FREEZE

The FCC has finally announced the date the "AM Freeze" will end, April 19, 1992, the same day their new AM technical rules go into effect. The lifting of the freeze will once again allow the FCC to accept applications for major technical facility changes and applications for new AM stations. The one exception to this is the expanded AM broadcast band. Requests for a move to the 1600-1705 kHz band will be accepted during a "filing window" to be announced later. We expect this to not take place until much later this year.

## THANKS

Dave Schmidt, Jack Parks, Eric Bueneman and M Street Journal

73 and Good DX, *Jerry & BKF* Jerry Starr & Buffalo K. Fooman

## No more music on pioneer station

■ One of nation's first commercial radio stations drops music format for news

By JIM STRADER  
The Associated Press

PITTSBURGH — The last disc jockey on one of the country's pioneer commercial radio stations ended his final show Friday with the song that refers to "the day the music died."

After Larry Richert played Don McLean's "American Pie," shortly before noon, KDKA-AM dropped music from its regular schedule, completing a gradual shift to a news, talk and information format.

"That song doesn't mean anything to anyone here except today," said John Cigna, host of the morning show.

"KDKA since 1920 has been music-oriented. It's the end of an era."

Other stations, including Detroit's WWJ, also contend for the title of the country's first commercial radio station. But KDKA's November 1920 broadcast of results from the Harding-Cox presidential election is often cited as the inauguration of the radio age.

KDKA was the successor to an amateur operation known as 8XK, which had broadcast radio tests and messages sporadically during World War I.

The station's operator, Dr. Frank Conrad, varied his routine for the first time in October 1919 by broadcasting the song "Old Black Joe." Soon, KDKA had its own orchestra, singers and performers and, over the years, added news reporters, personalities and sports announcers.

The 50,000-watt station has long been Pittsburgh's ratings leader. Its

signal at 1020 AM can be heard throughout the East and Midwest, especially at night when it bounces off the ionosphere.

But management made the change because market research showed listeners were tuning in for news and information, not music.

"While it's a sentimental favorite, it's not a fundamental strength of the radio station," said program manager Chuck Dickemann. "You lead with your strength."

Edward Bliss, author of several books on broadcasting, said he was bothered by a trend that has seen many stations cut back on news.

"I'm pleased the pioneer station is going in the reverse direction," he said.

But KDKA is part of another trend in radio: the switch away from music to other formats on AM. Music is now increasingly limited to the FM band, where there is a clearer signal and no static.

"FM has turned into the music medium and AM is the news and information medium," said Jeff Wakefield, research director of Interop Radio Store, a national radio sales representative based in New York.

Wakefield said KDKA is the one of the last big AM stations to play music and also lead its market. But the station did not need music to draw listeners, he said.

"They probably could have stopped playing music one day and not told anyone and no one would have noticed," Wakefield said.

KDKA is one of a few stations in the East which has call letters beginning with K. The Federal Communications Commission assigns those letters to stations west of the Mississippi River and gives eastern stations call letters starting with W. Early stations were allowed to keep call letters assigned before the distinction was made.



John Cigna, host of the morning show on KDKA-AM radio queues a song on the pioneering station's last day of music programming.

## Religious radio coming

KINGSTON: Plans are underway for the establishment of a religious radio station in Jamaica.

A group called the National Religious Media Company (NRMC) is putting up J\$5.5 million as investment capital for the station.

The company is made up of the Jamaica Council of Churches, Jamaica Association of Evangelicals, Jamaica Pentecostal Union, Jamaica Full Gospel Churches, Jamaica Union of Seventh Day Adventists and the Church of God in Jamaica.

The NRMC received its broadcasting licence at a sign-

ing ceremony attended by Senator Paul Robertson, the Minister of Public Service and Information.

He said that the government was pleased to grant the licence, since there was a need for more channels through which Jamaicans could express their opinions.

Reverend Orville Neil, who is Chairman of NRMC, said the station is expected to be in operation by June of this year.

He said that it is expected to broadcast 24 hours a day, offering a blend of news, music, information, discussion and instruction.

The Toronto Share  
-via Don Trelford

**WCNS AM 1480**

The (Strasburg) Northern Virginia Daily, via Perry Crabill, Jr.; The Tampa Tribune via John D. Bowker; The Topeka Capital-Journal, via Paul Swearingen

# Domestic DX Digest

DX Catches in the Eastern U. S. and Canada, with 24-hr. ELT

## MEDIUM WAVE RAMBLINGS

- A BIG NRC DDXD WELCOME to new reporter Al (Marshall) Dillon of Prichard, WV. Good report, Al. Hope we hear more from your location in just about the furthest point west in West Virginia. Did I have a time locating Prichard . . . and how!
- Wouldn't you know it? Reports from the first six DXers appearing in the "credits" section arrived the day I mailed last issue's column. A Monday! Watch those deadlines!
- Got a splendid report from Mark Hattam of England. Actually two reports from a couple of DXpeditions at Sheigra, Scotland. I've extracted two new Graveyard records from one of the logs, and forwarded the data to HQ.
- DX reports from "East" and "West" DXers have been meticulously separated, for the convenience of those who have indicated they would like it like that. Special stuff and UNID help goes to the area of the original report. Thanks for the idea, John Wilkins . . . and others.
- Deadline reminder time . . . Issue 26 May 23 . . . Issue 27 June 20 . . . Issue 28 July 18.
- . . . and YES, the earth did move a bit here on 4/22!!

**WDCY-AM 1310**

3909 Oak Street • Box 1310  
Fairfax, Virginia 22030-1310

First, The Eastern and Central Time Zones . . . and points East

## SPECIAL

- 570 **WTEM MD Bethesda** - 3/21 1551-1632 Now with these CLS, ex: WGMS. Carrying NCAA BKB tourney. Still with classical music | WGMS-FM 103.5, but understand will become all-sports in April. Will carry Redskins, replacing WMAL, which carried them for 42 years. (HH-MD)
- 640 **CHOG ON Richmond Hill** - recently relocated their studios to a location near Steeles Ave. in North York, Ontario (the northern boundary of Metro Toronto) and consolidated operations with their FM CILQ 107.1 formally located in downtown Toronto. I believe both stations may have changed their city-of-license to North York, but not sure. They have also dropped hard rock in favour of mostly rap and dance music and gives non-ID as AM 640, *The Beat of Toronto*. And have dropped *The Hog* slogan. (MS-ON)
- 730 **WVIC MI East Lansing** - Now carries Sports & Entertainment Network sports talk, and Unistar News on the hour. No local IDs or ads, but this AM (4-8) hrd several KVEG pgm promos and PSAs. (TS-MI)
- 850 **WUTK TN Knoxville** - Has dropped BRN for CNN Headline News. (SF-TN)
- 900 **WMVU NH Nashua** - 4/3 noted on the air with local news/talk and CNN Headline News. Schedule is E:0500-2100. (BC-NH)
- 980 **WKLY GA Hartwell** - Signs off all year 'round at 2100. Format is C&W Mon thru Sat, REL on Sunday. Verie signer is Bryan Hicks, CE. This info from a letter from Hicks, in a reply to a report in which I was in error thinking I had received them. (DT-ON)
- WPGA GA Perry** - According to letter from WKLY, this station is 24 hours. (DT-ON)
- WBZK SC York** - A follow-up with some info (courtesy Curtis Sigman at stn) on the unID IDd in Issue 22 (Part I) . . . is U3 3150 186 para 500. Pattern is a cloverleaf, with main lobes E & W + minor lobes. Affiliated with NBC's

**NRC  
AM RADIO  
LOGBOOK**

1992  
Edition

The NRC AM Radio Logbook, 1992 Edition contains verified heard station information in the U. S. and Canada. Only \$16.95; Canada \$17.95 to U. S./Canadian NRC Subscribers ONLY. \$19.95 to U. S., Non-NRC Subscriber; \$20.95 Canadian Non-NRC Subscriber. Others - please write.

Specify your mailing address and number of Logs ordered. Make out check or money order to: NRC. Mail to: NRC Publications - Box 164 - Mannsville, NY 13661 (NY residents add sales tax).

- The Source and AP Radio. Slogans are *Your Local Source* and starting this fall *Your Clemson Connection* (BKB & FB) (JM-NC)
- 990 **WIVK TN Knoxville** - Knoxville's *News-Sentinel* quotes GM Bobby Denton as saying they're slowly phasing out the C&W simulcast with 107.7, and they should be all talk by 6/1. (SF-TN)
- 1120 **WYZQ TN Maryville** - Went silent again 3/19, less than 12 months after returning. (SF-TN)
- 1170 **KSTT IA Davenport** - per verie and monitoring, is now all sports. (RD-IA)
- 1150 **CKMO ON Hamilton** - hardly DX, but noted here 3/30 with new oldies format and non-ID as *Oldies 1150*. They had been CHR for years and had held the CKOC call sign since 1922! (MS-ON)
- 1200 **WCHB MI Taylor-Detroit** - had been playing more mainstream jazz early in the month, but on 4/8 went all Jazz. Sunday church remotes stay, but midday gospel record show and blues are gone. Promo re new format sez . . . *all the pieces are in place*. OUCH! Had been among the best blues stations on the dial. Possibly, raiding FM sister WJZZ's record library, since JZZ played similar music before going new age/new jazz 2 years ago. (TS-MI)
- WOAI San Antonio** - if WOAI's Sunday 0400-0600 silent period continues, don't forget that WKOX-MA and WNSS-NY will be on their non-directional day rigs prior to 0600 through July (August for WKOX). Ditto WBZY-PA and WAGB-VA after 0545 during June. (SF-TN)
- 1220 **WCPE TN Etowah** - Now signs off in broad daylight, at 1700 daily. (SF-TN)
- 1290 **WNRS MI Saline** - To confirm Jerry Starr's AM Switch item in Issue 22, WNRS is simulcasting WIQB-FM 102.9. No AM ID, just *Rock and Roll Radio 103*, *WQJB, Ann Arbor's Number 1*. Ironically, this is not the first time these stations have simulcasted. Also a rocker in the early 70s, WIQB was WNRS Ann Arbor - WNRS Saline. Over the course of the last 11 years or so, this station has been: C&W; AC; All news; Oldies; BBD. A true success story. (JL-OH) . . . now | 102.9 with CHR/AOR. Legal ID is *WIQB-AM Saline, WIQB-FM Ann Arbor*. (TS-MI)
- WHLI 1000**  
K-JOY 98.3
- 1300 **WNQM TN Nashville** - Monitoring this channel shows they are no longer simulcasting WWCR in the evening hours, plus WWCR moved its night operations to 5935 kHz. (EB-GA)
- 1330 **WFIN OH Findlay** - when not news/talk, they play oldies. Ex: C&W. Still in Stereo. (JL-OH)
- 1350 **CKDO ON Oshawa** - Seems like CKAR is no longer the call here. These were original CLS. No further info at this time. (DT-ON)
- 1360 **WBLC TN Lenoir City** - Now signs off at 1800. (SF-TN)
- 1370 **KFGI TX Rollingwood** - Now simulcasting with and IDing as *KFGI Froggy 94* (94.7 Austin). Oldies off the satellite. (TXConn)
- 1400 **WLTN NH Littleton** - 4/20 Adds *Sports Byline USA* show per announcement on pgm today. Correction: show runs 2200-0100 ELT weeknights). Calls itself *Your North Country Sports Leader* and the GM is Jackie Scott. (DP-HI)
- 1470 **WMDR TN Alcoa** - Don't look for this one at SSS as they sign off daily at 1830. (SF-TN)
- 1480 **CKAN ON Newmarket** - Station has been silent since mid-March as they couldn't afford a massive rent increase on their transmitter site, which is located on prime real estate land for suburban development. They have 90 days to get back on the air or forfeit the license. (MS-ON)
- 1490 **WSTP NC Salisbury** - is carrying Detroit Tigers baseball. Bob Rathburn, who does Tigers commentary, was once a sports director at WSTP. They will broadcast all Tiger games that don't conflict with the local American Legion schedule. (JM-NC)
- 1530 **WCEG MA Middleboro** - per v/l: Signed on Sunday 3/15 0600 with oldies & IDing as *Cool Stereo 1530* with emphasis on local programming. Temporarily operating with 250 watts from its 97' tower in North Middleboro, MA 02346. CP in for over 10 years! (RA-MA)
- 1550 **WVAB VA Virginia Beach** - recent newspaper reports mention recently sold station due to return on or about 4/15. (DS-DE)
- 1560 **WINV FL Inverness** - 4/13 0253-0300 Weak but clear with satellite talk. 0300 AM 1560, *WINV Inverness, the voice of Citrus County* → USA News. Fulltime CP from 1984! is on. (SF-TN)

1600 WSNF

**WTE 640**A Service of Cella Communications  
249 Union Street/P.O. Box 1570  
Westfield, Massachusetts 01086

**MI Muskegon** - 4/13 noted with Unistar's Satellite Sports-Talk format (originating at KVEG-840 Las Vegas). Slogan is *Sports Fan 1600*. Ex: WSNX. (PLB-MI) [A complete list of Sports Entertainment Network stations went in to HQ about a month ago, but may be outdated now - Ed.]

## UNIDS AND UNID HELP

- 600 WCAO MD Baltimore** - Bob Gilfert's unID is definitely this . . . they use *Heaven 600* slogans and is black GOS. They beam their signal down Chesapeake Bay. (EB-GA) . . . is **BG-VA's** unID from 3/16 issue. They're coming in many nights here also (DA messed up?) (JK-VA)
- 690 UNID ??** - 3/25 either 0135-0155 or 0235-0255 (I was sleepy, hi!) CLA music under XETRA. Possibly CBU? (DS-CA)
- 770 WILT? ??** - 3/20 1830 Not clear! (AL-WV) [WILT doesn't match any AM CLs, but may be an FMer out there. No other details given. Any help out there, DXers! - Ed.]
- 780 UNID ??** - 4/5 0429-0437 (while trying for WWOL test) With EE-language female vocals in WBBM null. Title at 0430 was *Come Back to Me*. QSB @ 0437, replaced in WBBM null @ 0438 by unID LA station. Faded back in at 0441-0443 with chatter. Appeared to mention *Q-104*, followed by POP music. Help, anyone? (AR-ON)
- 790 WQXI GA Atlanta** - unID of **REH-ON** in Issue 19 may be this . . . other possibilities: **WWKY** Louisville and **WMC** Memphis. (EB-GA)
- 800 KREI MO Farmington** - **Charles Reh's** unID in Issue 19 may be this one (150 watts at night) if they stay up that late. (EB-GA)
- 950 CFAM MB Altona** - is most likely **RF-OH's** unID. The format fits perfect. (SA-MB)
- 980 UNID ??** - 4/10 0602 Noted SS talk and Latin music over/under possible **KFWB** during **KHVH-990's** Monday morning SP. Het de 981. (DP-HI)
- 1010 UNID ??** - 4/9 0525 Fair with Interstate Radio Network IDs, C&W music. Creamed by **XEHZ** at 0430 [0430 local, I assume - Ed.]. (SA-MB)
- 1080 KOAK IA Red Oak** - is **FM-IL's** unID from Issue 18. That's in Montgomery County! (BS-NE)
- UNID ??** - 3/29 0755 REL music, no ID at :00 but right back into GOS music with a later interlude saying that the services were broadcast on TV channel 32 with an address given which was unintelligible. Then a shouter of a preacher until **WTIC** took over. Looped SW/NE. (LK-ON)
- 1120 WADN MA Concord** - **Russ Edmunds's** unID in Issue 22 is very likely this . . . it's much warmer than that in Destin, Florida! (Oops, I'm thinking of **WBZR!**) (EB-GA) [Hal I've got pictures of it snowing in Fort Walton Beach in February!! Hi Hi - Ed.]
- 1230 HELP** - **Rick Dan's** unID of 2/5 could either be **KCON** Conway or **KFPW** Ft. Smith. (DP-HI)
- 1240 HELP** - **Rick Dan's** unID of 2/5 could be either be **KVRC** Arkadelphia, **KTLO** Mountain Home or **KWAK** Stuttgart per my I of Arkansas Radio Network list . . . sorry, it's the football list from 1985! (DP-HI)
- 1270 HELP** - **Laurence Kearley's** unID of 2/1 could either be **WHYD-GA** or **KGNM-MO** per 1991 IRCA Almanac, but neither Columbus nor St. Joseph has a mountain in sight. (DP-HI) [And the only *Bearskin* anything in my Almanac is a *Bearskin Lake* in Northwest Ontario - Ed.]
- 1390 WGCI IL Chicago** - **Greg Henson's** unID in Issue 22 is this . . . they use *Dusty 1390* slogans (EB-GA) . . . *Dusty Radio* is **WGCI** Chicago. (BF-IL) . . . *Dusty Radio* is **WGCI**. (SA-MB) . . . may be **GH-OH's** unID with *Dusty Radio*. Saw this reported elsewhere with this slogan. (JW-CO) [Reaffirms reports from last issue - Ed.]
- 1400 UNID ??** - 2/165 0325 Good with ad for restaurant named *Luigi's* → wx forecast (high later today 74, low tonight 44) and ID as *95 Kick FM*. DJ gave request line # as 454-3282. I highly suspect TX or LA due to temperatures. Anyone want to take a stab at this? (RD-IA)
- KGBX MO Springfield** - **Rick Dan's** unID in Issue 22 is definitely this . . . **KGBX-FM** is on 105.9 in suburban Nixa, MO. (EB-GA)
- 1430 KQLL OK Tulsa** - Let's clear this all up! (See Issue 20 & 23) **KSKS** is now **KQLL**, which simulcasts with their sister FM, and their slogan is *Kool 106*.

KTLO RADIO, INC.

517 S. Muskogee  
P.O. Box 719  
Tahlequah, OK 74465

- 1440 WGEM IL Quincy** - **Laurence Kearley's** unID in Issue 21 is probably this one . . . **WGEM** is the only 1440/105.1 combo I know about. (EB-GA)
- 1450 KGRE CO Greeley** - **SA-MB's** unID may be this. They used to, and maybe still do, relay some pgms from **KJME-1390** Denver (*La Jota Mexicana*). Don't know exact hours of relay. Seems to me it was only a few hours on weekends. (JW-CO)
- 1480 WYZE GA Atlanta** - **Doug Smith's** unID in Issue 14 may be this . . . 523 is an Atlanta prefix in GA's 404 area code. (EB-GA)
- 1510 UNID ??** - 3/21 0816 Ad for carpet store, then *We play the ?? ??'s best rock, AM 151*, then fade. Looped WSW/ENE. Could have been **CKOT** reported elsewhere, but unsure. (LK-ON)
- 1530 KGBT TX Harlingen** - **Laurence Kearley's** unID in Issue may be this . . . as they run SS fulltime, even though it isn't in the direction it was looped. (EB-GA) [Yeah, and stranger things have happened in this column! -Ed.]
- 1550 UNID ??** - 3/21 2025 Sports Media Network ID on show called *Sports Roundtable*. Looped SE/NW. USA Radio Network News at 2100, but no legal ID before return to pgm. (LK-ON)
- 1600 UNID ??** - 3/25 2236 With **Buffalo Sabres** **HKY** | good **WGR-550** | fair **CJCL**. **CHNR?** (JK-VA)

## DX AND EQUIPMENT TESTS

- 650 KMTI UT Miami** - 3/4 0230-0240 Poor to fair w/numerous CIDs and TTs. Only made out one VID the whole time. Early season t'storm static made things tough. (RD-IA) [I'm surprised you heard this as the test was scheduled for 3/9 according to DXN! - Ed.]
- 760 WVNE MA Worcester** - 2/24 0418-0445 With **IRCA** DX pgm. Usually atop channel. Slight to heavy **WJR** QRM. No CIDs. CE did pgm (most religious pgm ever heard). Announcer who had code cassette slept thru! (HH-MD\*)
- 780 WCKB NC Dunn** - 4/7 0539-0555 Poor on Test, mixing with **WBBM** with 1000 Hz TT and only 2 audible VIDs at 0549 and 0553. (RA-MA) . . . 4/7 0530-0600 Extremely weak under **WBBM** with CIDs and 1 kHz TT at 0539. Heard more between 0545 and 0600, but conditions were so bad that I couldn't tell any difference between the CIDs and the TTs. (JL-OH) . . . 4/7 0539-0600 Very, very weak carrier signal under **WBBM**. (DT-ON) . . . 4/7 0535 Doubtless the one with TT under **WBBM**. (SF-TN)
- WWOL NC Forest City** - 4/5 0430 Nothing but **WBBM**, **WBBM** and more **WBBM**. (SA-MB) . . . 0430-0500 No sign of Test. Just **WBBM** and unID. (RA-MA) . . . Not heard. Sat on channel 0429-0549 (in case of a mixup over changeover to daylight time). Hrd QRM from **WBBM**, **Radio Coro** (Venezuela), unID EE-language mystery station and perhaps a second **LA**. But no sign of **WWOL**. (AR-ON) . . . 0430-0500 Nothing heard as **WBBM** dominates. (JL-OH) . . . Just **WBBM**. (SF-TN)
- 1620 WCIL IL Carbondale** - 3/16 0304 Already hrd and verified from Oakland, but this made a welcome addition to my Iowa City logbook when I caught a very nice VID. (RD-IA) . . . 3/16 0305 Test heard. *Stars and Stripes*, CID, voice anncts, *Stars and Stripes*. (BF-IL) . . . 3/16 Not heard, too much **KDKA**. (WPT-DC)
- 1310 WJLK NJ Asbury Park** - 2/24 Midnight to 0030 Had the recorder rolling for this one in hopes that it would finally arrive, but all the tape revealed was a mix of **WIBA**/**WTIX**/**WDOD**. One of my all-time most-wanted stations remains that way . . . for now. (RD-IA)
- WRIX SC Homeland Park** - 3/2 0200-0302 By far the most listenable AND the most friendly DX test all season. Signal here was good to fair with mostly chatter by two annrs and several selections of GOS music. Only a few CIDs and TTs noted. I called in and put in an on-air plug for this year's NRC convention. (RD-IA)

- 1370 **WZAO** WV **Glen Dale** - 3/8 0537 Fair with several CIDs, TTs, VID. (WPT-DC)  
 1420 **WIMS** IN **Michigan City** - 4/6 0305-0400 Tentative on scheduled Test with possible CIDs only at 0312, 0322, 0333, 0340:30 & 0358. Nothing positive noted . . . no voice or music or TT. Tuff frequency with WBSM only 5 miles south of here. (RA-MA) . . . 4/6 0300-0400 CIDs and 1 kHz TTs at 0303 and 0322 when pattern was SE. Five more tests starting at 0331 occurring in 6-8 minute cycles with East pattern. Signal should have been stronger here during the last 1/2 hour, but wasn't. Whole test was poor to fair, over/under WHK. (JL-OH) . . . 4/6 0330-0400 Code, tone, march music. Disappeared at 0340. Int 0330 WHK. Splash CJCL. (DT-ON) . . . 4/6 0300-0310 Fair under WVJS with code and some partial VIDs. (SF-TN)
- 1520 **WTRI** MD **Brunswick** - 4/20 0200-0210 Gave up after 10 minutes of nothing but t'storm static and a mix of KOMA/WWKB. Test-wise, I'd rate this season fair, at best. (RD-IA) . . . 4/20 0200-0245 No trace. Just WWKB/WVOI. (SF-TN)
- 1530 **KPCR** MO **Bowling Green** - Not heard. (WPT-DC)

### TIS, FORTUNES TOLD, PORTFOLIOS ASSESSED & OTHER STUFF

- 521 **JJH** NY **Johnstown** - this is unID reported by **Bruce Conti**. Power is probably 25 watts and I believe there is a 6-second cycle between their IDs. If any member is interested in longwave communications, they should contact the Longwire Club of America, c/o Bill Oliver, 45 Wildflower Rd., Levittown, PA 19057. (RM-PA)
- 1620 **WNWZ910** IL **Bensenville** - is my own unID from #23 (also reported by **Chuck Reh** in December). I talked to Don Schultz in the Emergency Services and Disaster Assistance Department who told me they have received a good response from the station. Unfortunately, he's aware the station will soon be moving because of the expansion of the broadcast band. Send verie requests to Village of Bensenville, E.S.D.A. Department, 100 N. Church Road, Bensenville, IL 60106. At least 1 mystery has been solved! (BW-MI)

**KRVN**  
 880 Farm Lite 93  
 P.O. Box 880  
 Lexington, Nebraska 68850-0880

### MIDNIGHT TO 0800 HOURS ELT

- 540 **CBBF** ON **Windsor** - 4/18 0310 Fair with instrumental music, *Radio Canada* ID | 1050 CKSB. NRC Log sez D3, but must be U3 as is 24 hrs. (SA-MB)
- 550 **WJMW** PA **Bloomsburg** - 3/22 0750-0755 C&W, ID *Valley's Best Country - WJMW*. (RH-NJ)
- 590 **WOW** NE **Omaha** - 3/23 0130-0205 Wx and traffic reports, C&W, lots *WOWs*. Local ads, top-of-the-hour ID: *From the heart of the greatest country on Earth, WOW, WOW-FM, Omaha-Council Bluffs-Lincoln*. 0150 Like a local in null of Cuban. (AL-WV)
- WMBS** PA **Uniontown** - 3/25 0130 Sign-off announcement. Good with some QRM. (AL-WV)
- 600 **WRBC** TN **Memphis** - 3/25 0159 Topped up over mess with legal ID. (AL-WV)
- 620 **CKCK** SK **Regina** - 4/4 0308 Fair with OLD and 620 *CK Radio* IDs in CKRC partial null. 1st time from Winnipeg. (SA-MB)
- 840 **WVPO** PA **Stroudsburg** - 3/22 0731-0745 NOS music, 840 *WVPO, Voice of the Poconos* ID. Loud & clear over WRYM in SS. (RH-NJ)
- 900 **WBRV** NY **Boonville** - 3/16 0714 Poor in CHML null with local weather, PSA for recycling in Oneida County. 0715 A rundown of school lunches at local schools (eg Irish Stew at Remsen Central School for St. Patrick's Day). (MB-ON)
- 910 **WGBI** PA **Scranton** - 3/29 0638 Up out of nowhere with *WGBI, your music station* and → local ads and fade under CHRL to be heard no more. (LK-ON)
- 920 **KWAD** MN **Wadena** - 4/16 0635 Fair with local news & weather → C&W music. Under CFRY. Not heard since CFRY went NSP. (SA-MB)
- WGHQ** NY **Kingston** - 3/29 0645 NOS and OLD songs with an ID as *Ron Knowles' Weekender with the greatest songs by the stars who made them great on WGHQ*. Strong and clear in CKNX/CFLS null. (LK-ON)

- CKNX** ON **Wingham** - 3/29 0700 A preacher, then an ad for *Enviro-Man* and . . . on *AM 920, serving mid-Ontario, we are CKNX* and → Broadcast News. In CFLS/WGHQ null. (LK-ON)
- 930 **CKNS** ON **Espanola** - 3/29 0705 End of news, then wx for Espanola, Elliot Lake and other northern locales and ID as *North Shore Radio* and → a *Bonnie Raitt* song. In *WBEN* null and fade. (LK-ON)
- 1000 **WLNL** NY **Horseneads** - 3/29 0745 Long string of GOS/REL songs, then ad for a local sandwich shop and programme anncts for *Right here on WLNL*. Fade in null of CKLS-990 splatter. (LK-ON)
- 1070 **KNX** CA **Los Angeles** - 4/2 0200-0215 Heard bits and pieces of a broadcast of news, traffic, weather and sports. Is KNX a CBS affiliate or was the 0200 network news QRM? Also QRM from CHOK and WIBC. (TB-OH) [Yes, KNX is a CBS affiliate and should have been carrying the 0200 net news. In fact, they are owned by CBS. But for a station of their great stature, they sure miss a lot of "legal" IDs!! - Ed.]
- KNX** CA **Los Angeles** - 4/12 0719 Good w/traffic report & *KNX* IDs. (SA-MB)
- 1080 **WMVR** OH **Sidney** - 4/3 0736-0813 A genuine "Cornfield County" radio station with a sports talk pgm, local nx (man arrested for robbery for stealing \$11 worth of meat and cheese from a convenience store.) (TB-OH)
- 1090 **WBAL** MD **Baltimore** - 4/2 0106-0145 With Larry King Show. Jingle calls them the *Spirit of Baltimore - WBAL*. (TB-OH)
- 1120 **WBIS** CT **Bristol** - 3/21 0638 Ad for *Chippinella's Restaurant* in downtown Bristol, a local church, and a BKB game on *WBIS, 1120*. Fairly strong in KMOX null. (LK-ON)
- 1170 **WVZN** VA **Lynchburg** - 4/3 0544 Fair with SSB and sign-on mentioning *Vision 1170* and GOS format. Lost when *WWVA* went to day rig at 0547. (SF-TN)
- 1250 **WMTR** NJ **Morristown** - 3/21 0720 Ad for local store, then *From the WMTR newsroom* followed by local events and an ID as *The new WMTR*. Possible format change as not a business format. Heavy QRM in *CHWO* null. (LK-ON)
- 1270 **WDLA** NY **Walton** - 3/21 0735 Local news and sports with many mentions of Delhi and Walton in items and ads with New York state news and lottery numbers. Heavy QRM and fade. Over/under *CFGT/WTSN*. (LK-ON)
- 1280 **KVOX** MN **Moorhead** - 4/12 0740 Good with *Kisses Sweeter Than Wine, KVOX* ID. In *CIFX* null. (SA-MB)
- 1330 **WFBC** SC **Greenville** - 3/24 0130 ID during Talknet break. Is WORD relaying? (AL-WV) [Aye, says the NRC Log - Ed.]
- 1350 **KCOR** TX **San Antonio** - 4/4 0012 With SS programming, numerous *La Tremenda* IDs. Good ID at 0028 *KCOR La Tremenda, AM estereo con musica Ranchero, Norteña, Romantica . . . Escucho KCOR, La estación de San Antonio, KCOR* (SP-A,C)
- 1360 **WWOW** OH **Conneaut** - 3/23 0532 Strong with vocal SSB and annct, ID and into news. Good signal for 32 watts! (DS-DE)
- 1380 **WACB** PA **Kittanning** - 3/29 0730-0753 In/out with *WTVR* & atop at times with C&W music, community notes, ads (!) & ID as *All American Radio*. Last heard in the mid-60s! (DS-DE)
- 1410 **WELM** NY **Bhmira** - 3/23 0528 Good with wx, ID, oldies. Way over *WPOP/WDOV/etal*. (DS-DE)
- 1440 **WROK** IL **Rockford** - 4/6 0650 Fair with sports, weather, *WROK* ID. In *KKXL* null. (SA-MB)
- KCHE** IA **Cherokee** - 4/6 0659 Fair with sign-on info for *KCHE AM & FM*. No SSB heard. New for IA #60. (SA-MB)
- 1450 **WRJM** CT **Poquonock** - 4/1 Midnight Noted with ID → sign-off w/*GSQ*, SSB & unID Yiddish anthem. Mentioned co-owned with the *Horsechester Wind Sock & Dance Floor Wax Manufacturing Co*. Yessir. We STILL hear ALL the good ones! (DS-DE)
- 1470 **WHUT** IN **Anderson** - 3/5 0623 Fair with promo for HS BKB game *Friday night right here on WHUT*. (RD-IA)
- 1540 **WMYF** NH **Bxeter** - 3/28 0618 *Hooked on Phonics* ad, then *Good morning, this is your favourite radio station, 1540 WMYF*, then a PSA and another ID. Over/under many others including *KXEL*, but strong at times. (LK-ON)

- 1550 **WXVA** **WV Charlestown** - 3/22 0650 Caught the end of the sign-on with *We are WXVA. Good morning.* A PSA, ID and the day's programme lineup later. Clear with fade later back → clutter, emerging again later. (LK-ON)
- 1560 **KCJJ** **IA Iowa City** - 4/8 0650 Good with oldies music, *KCJJ Stereo* ID. Not REL as per Log. (SA-MB)
- 1570 **WFEL** **MD Towson** - 3/22 0705 News and local weather with temperature for downtown Baltimore, then call ID and sports scores. Heavy QRM with fade. (LK-ON)
- 1580 **WPGC** **MD Morningside** - 4/3 0530-0600 Came thundering in just before sunrise. Good reception for 30 minutes and then almost disappeared. *First Light* pgm. BRN News. Financial news. (TB-OH) [City and state correction here - Ed.]
- 1590 **WCBG** **PA Chambersburg** - 3/22 0632 Song *Goodbye Michèle*, then *More gold all the time on 92.1 Gold*. Multiple ID by CLs and city at 6:43. Strong and clear at first, then heavy QRM and fade. (LK-ON)
- WTOQ** **WI Plattsville** - 4/8 0640 Good with *AM 1580* [I hope you meant 1590 - Ed.] *WTOQ and K107 WKPL* ID. C&W music, not AC per Log. (SA-MB)
- 1600 **WINX** **MD Rockville** - 3/22 0001-0100 OLD, ID at 0058 *AM 1600 WINX*. Int WAAM. Poor. (DT-ON)
- WBBD** **WV Wheeling** - 3/22 0010-0015 ID *AM 1600 - WBBD*. Songs by *Sinatra (I've Got You Under My Skin)* and the *Blackbirds (Walking In Rhythm)*. Listed as 33 watts in NRC Log. 1st-timer. (RH-NJ)

### 0800 TO 1600 HOURS ELT

- 660 **WXIC** **OH Waverly** - 3/25 1558-1645 Excellent copy for 1 kw with local ads and IDs. (AL-WV)
- 700 **CHSJ** **NB Saint John** - 4/12 Good with *Country-700 CHSJ* ID. With WCAT nulled. NB #5. (BC-NH)
- 940 **KIOA** **IA Des Moines** - 4/12 0812 Good with *All oldies KIOA* → oldies music. In CJGX null. (SA-MB)
- 1000 **KXRB** **SD Sioux Falls** - 4/12 0808 Good with *Country One Thousand & KXRB* IDs. C&W music. In CBW null. (SA-MB)
- 1010 **WERQ** **MD Baltimore** - 3/22 1211-1235 Ex: WYST. Strong here with *Jewish Star* pgm. (HH-MD)
- 1040 **CKST** **BC Vancouver** - 4/12 0803 Fair with alternative rock music, *Coast-to-Coast* IDs. New for BC #20. (SA-MB)
- 1220 **WKRS** **IL Waukegan** - 3/22 1330 In tight WLPO null with local ads, ID. Only 2nd time heard. (KO-IL)
- 1300 **WJFK** **MD Baltimore** - 3/22 1053-1115 Ex: WLIF. Local, strong with classic rock and ads. (HH-MD\*)
- 1350 **CHAL** **PQ St. Pamphile** - 3/22 0803 News in FF. Occasional pickup. (RH-NJ)
- 1390 **KULP** **TX El Campo** - 3/31 1536 With C&W programming, ad for *Stanley Lawnmower of El Campo*. Good ID at 1549 *1390 KULP El Campo, The Best Of The Country*. (SP-A,D)
- 1420 **KGNB** **TX New Braunfels** - 4/2 1559 With MoYL programming, IDD at 1559 *AM 1420 KGNB New Braunfels*. ABC Radio News at 1600. Ad at 1631 for *Canyon High School Easter Bunny Photos, call 625-6251*. (SP-B,C)
- 1440 **KELG** **TX Elgin** - 4/5 1502 With SS programming, numerous ads for *Joker's in Austin, Texas*, ID at 1513 *En Radio Caliente, Exitos, Exitos Exitos!!* Ad at 1517 for *Pronto Tax, Teléfono 926-1040* (SP-B,C)
- 1460 **WUFI** **IL Rantoul** - 3/22 1350 Fair with local ads, then to CNN Headline News. Dominating over weak WIXN in background. Your old stomping grounds, Bill! (KO-IL) [Yup. Have many fond memories of the old WRTL! Thanks, Ken! - Ed.]
- 1470 **WCFJ** **IL Chicago Heights** - 3/22 1343 Local black GOS pest heard signing off unexpectedly while bandscanning with new Superadio II. Gave good info, leaving WMBD with PIA [Whattzat? - Ed] BKB dominating. In null. Poor unID stn to NW. At 1400 syndicated *American Gold* started (WBKY?). (KO-IL)
- 1480 **WFXW** **IL Geneva** - 3/22 1352 Fair with ROL [Huh? - Ed.] Probable WMAX poor in null. (KO-IL)

- 1490 **WPNA** **IL Oak Park** - 3/22 1354 Local nulled easily. Probable WNDU-IN hrd with ROL and under WPNA. PIA [Wanna explain? - Ed.] BKB on WDAN. Fun frequency to DX in Homewood. (KO-IL)
- 1500 **KBRN** **TX Boerne** - 4/5 1436 With MoYL programming. Good ID at 1500 *This is 1500, KBRN, in Boerne, covering the Hill Country with Great Music*. Ad at 1452 for *All-American Roofing & Construction phone 249-2989*. (SP-B,C)
- 1510 **WNLC** **CT New London** - 3/21 0824 Up, out of the jumble with *Weather every fifteen minutes on WNLC and WNLC newstime is 8:25* → news. Lots of QRM and fade, over/under WSSH/CJRS. (LK-ON)
- CKOT**, **ON Tillonsburg** - 3/21 0833 Tent ID with Canadian and Ontario nx. Loop WSW/ENE. Only other Ontario stn on 1510 is a 40 watter way up north. Over/under WWWH/CJRS. (LK-ON)

**KFJM PUBLIC RADIO**  
Univ. of N.D.  
Box 8116  
Grand Forks, ND 58202

### 1600 TO 2400 HOURS ELT

- 530 **CIAO** **ON Brampton** - 3/14 2306 In EE, for a change. (RH-NJ)
- 560 **CHVO** **NF Carbonara** - 3/21 2205 POP music, Top 20, mention of Newfoundland, DJ named Liz. 1st-timer. (RH-NJ)
- 600 **WCAO** **MD Baltimore** - 3/17 2106 With HKY game. Also, in on 3/18 1958 with *The New Gospel, WCAO Baltimore*, then NBC News. (JK-VA)
- 610 **WDAF**, **MO Kansas City** - 3/17 2110 With C&W. Thought I heard a *WDAF* ID. (JK-VA)
- 620 **WDNC** **NC Durham** - 3/17 2106 Good, with *WDNC, the best of talk radio*, then Talknet. (JK-VA)
- WVMT** **VT Burlington** - 3/14 2300 Talk, news, ads, ID. Thru WSKQ. (RH-NJ)
- WTMJ** **WI Milwaukee** - 4/13 2317 Fair with *AM 620 WTMJ* ID → news. Under/over CKCK in CKRC null. (SA-MB)
- 720 **KSAH** **TX San Antonio** - 3/31 1626 With SS programming, numerous *Radio Festival* IDs. Good ID at 1659, *KSAH, Radio Festival, KSAH Universal City-San Antonio*. (SP-A,D)
- 760 **KSJL** **TX San Antonio** - 4/4 2311 With UC programming, IDs at 2315 & 2332 *76 KSJL . . . Jay Harris . . . call 470-KSJL* both times. Ad at 2324 for the *Starving Artists Sale at La Villita on the Riverwalk*. (SP-A,C)
- 770 **WEW** **MO St. Louis** - 3/20 1753 Out of the mess with clear ID. (AL-WV)
- 850 **WUTK** **TN Knoxville** - 3/22 1820-1830 CNN Headline News, ID as *All-News Voice of University of Tennessee*. 1st-timer. (RH-NJ)
- 860 **WBGR** **MD Baltimore** - 3/17 2050 On very late, stomping out CJBC. Not on 60 watt power at this time. With REL/UC. (JK-VA)
- 880 **WRFD** **OH Columbus-Worthington** - 4/12 2014 Good with GOS music and sign-off mentioning power of 9000 watts. In WCBS null. (BC-NH)
- 910 **CKLY** **ON Lindsay** - 3/16 2015 Good with *910 CKLY - Ontario's favourite oldies*. (JK-VA)
- 920 **CJCH** **NS Halifax** - 3/28 1958 Fair → good with OLD contest promos . . . *Win 1000 dollars at 7:07 Monday morning on 92 CJCH and 92 CJCH, the only station in metro that helps you pay the bills*, then mention of *CJCH Solid Gold Saturday Night*. (MS-ON)
- 970 **WNIV** **GA Atlanta** - 3/1 1955 Fair with lots of *NIV 970* mentions in pgm promos. #2 from Atlanta at this QTH. (RD-IA)
- 980 **CBV** **PQ Quebec City** - 3/16 1917 Loud at an early time over WWRC/WTRY with FF programming. (JK-VA)
- 990 **KXLA** **LA Rayville** - 3/23 2245 C&W with legal ID at 2300. Good signal. Is WEBB an NSPer now? (AL-WV)
- WZZD** **PA Philadelphia** - 3/18 2109 Loud, on day power/pattern with female anner and REL music. (JK-VA)
- WTVK** **TN Knoxville** - 3/18 2055 Under/over WZZD & super-pest WEBB with BKB. *WTVK* mentions. (JK-VA)
- 1040 **WSGH** **NC Lewisville** - 3/14 1755 Several IDs, Greensboro ads, mention of Christian format. Area code 919# noted. 1st-timer. (RH-NJ)
- WSGH** **NC Lewisville** - 3/27 1914 With sign-off, mentioning tower location, etc. No SSB. (JK-VA)

- WSKE** PA Everett - 3/27 3/27 1915 Signing off after WSGH, mentioning that programming would continue on WSKE-FM 104.3, then gone. Also, no SSB. (JK-VA)
- 1060 CJRP** PQ Quebec City - 3/19 2348 Completely wiping out KYW with talk about hockey in FF. Probably on day power/pattern. (JK-VA)
- 1080 WOAP** MI Owosso - 3/22 1806-1810 C&W, ID. Strong in WTIC null, no WEEP. Needed a road atlas to locate (West of Flint). (RH-NJ)
- WKBY** VA Chatham - 3/18 1820 Signing off after REL show. (JK-VA)
- 1090 WAQE** WI Rice Lake - 3/15 1843 Good with Sam Cooke's *Cupid* → ID: *Great oldies all the time . . . WAQE*. (RD-IA)
- 1120 WBIS** CT Bristol - 4/12 1854 Good with talk, local ads for businesses on Route 6 on Bristol. Over local WADN. (BC-NH)
- 1150 CKOC** ON Hamilton - 4/10 2100 Good with *Oldies 1150* jingles and non-IDs, local ads, \$1000 *Oldies* contest promo. In WMAX null. (BC-NH)
- 1160 WPGV** MD Funkstown - 3/1 1846 Good with ad for store on Main Street in Hagarstown. Medical talk show. (WPT-DC)
- WPGV** MD Funkstown - 3/27 1930 Another *1160 GY'er*, with C&W over WJJD with *WPGV* IDs along with CNN News. Also *WPGV Country General Store* promo heard, where listeners phone in and sell things over the air for free. (JK-VA)
- WYNS** PA Lehighton - 4/14 2006 With *Classic Hits - 1160 Wins* ID and Eric Clapton tune. Briefly over WOBM. (BC-NH)
- 1200 CFGO** ON Ottawa - 4/14 (no time given) Xint with CHR, *Energy-1200* ID. With local WKOX nulled out. (BC-NH)
- 1230 WBVP** PA Beaver Falls - 4/7 2256-2309 OLD, nx, female anncr. ID as *24 Hours a day, 1230 WBVP*. Over/under unID with talk. (DT-ON)
- 1240 KICD** IA Spencer - 3/19 2220 Weak with Iowa BKB | WHO. (RD-IA)
- WJTN** NY Jamestown - 3/27 1859 Fair with ads for exhibitors appearing at the *Home and Garden Show* at Chataugua Mall, *WJTN Jamestown* ID and news with Bob? Hart. (MS-ON)
- WATN** NY Watertown - 3/27 2015-2140 *This is Original Hits Station, bringing back great memories*. Finally at 2100 *1240 WATN*. Poor, track of CJCS and unID with BKB. (DT-ON)
- 1270 CFGT** PQ Alma - 3/14 2257 FF talk, ID. Again L&C @ 2337 with FF songs & 0005-0010 with OLD. (RH-NJ)
- 1280 WTTX** VA Appomattox - 3/16 1811 With ad for *Davis Pontiac*, then REL with mentions of Farmville. Daytime semi-local here. (JK-VA)
- WNAM** WI Neenah-Menasha - 3/8 2005 Fair with CLs in weather forecast. (RD-IA)
- 1300 WCLG** WV Morgantown - 3/18 1859 On top of channel with *Pure Gold 1310 AM WCLG, Morgantown*. ROK music, then news. Under/over WJFK. (JK-VA)
- 1310 WXMC** NJ Parsippany-Troy Hills - 3/19 1828 Fair over CIWW etal, with promo for *WXMC Music of Your Life Club* → instrumental MoYL tune. 1830 *WXMC Parsippany-Troy Hills* ID → Associated Press News. (MB-ON)
- WTLB** NY Utica - 3/17 1845 In very briefly with *WTLB* ID, over/under weak WDPN. Utica #1 at this QTH! Now need WIBX and WRUN. (JK-VA)
- CHCB** PQ Ville-Pocatiere - 3/14 2250 FF noted in jumble. (RH-NJ)
- 1320 CKEC** NS New Glasgow - 3/14 2255 POP music, ID, mention of DJ *Shadoc Stevens* coming on later [so they must carry *AT 40*, for you list-keepers - Ed.]. 1st-timer. (RH-NJ)
- 1340 WLOK** TN Memphis - 3/27 1847 A major surprise with UC anncr and programming, Memphis mentions along with *WLOK* IDs. About "666" miles away, I doubt a record however. (JK-VA) [Nope. Actually 698 miles, but far short of the 2138 mile record on the books. Nice catch, anyway - Ed.]
- 1360 WCHL** NC Chapel Hill - 3/17 1828 Good w/Chapel Hill news and sports. (JK-VA)
- 1370 WSPD** OH Toledo - 4/12 2238 Good with *Blues Spectrum* music program, guitar blues by *T-Bone Walker*, *B.B. King*, mention of blues every Friday and Sunday night. Local WFEA nulled out! (BC-NH)
- WPAZ** PA Pottstown - 3/17 1832 In after WVMR sign-off with *Irish Hour* and mentions of WPAZ. (JK-VA)
- 1380 KBOP** TX Pleasanton - 4/2 1648 With C&W programming. ID at 1648 *The First in Country, 1380 KBOP*. Ad at 1712 for *Falcon Cable*. (SP-B,C)
- 1390 WFBL** NY Syracuse - 3/27 2241 On top with *AM Stereo 1390, WFBL*. Over WEED/WCSC. Playing NOS music. (JK-VA)

- WRSC** PA State College - 3/23 1854 Fair with talk on college sports, plug for *W.R. Hanley's, sponsor of Penn State sports on WRSC*. (MS-ON)
- 1410 WPOP** CT Hartford - 3/27 2058 Turning into a semi-regular, with NOS and *Music Radio 14 - WPOP Hartford*. Better than WTIC. DA messed up? (JK-VA)
- WVMR** WV Frost - 3/17 1831 With sign-off, mentions of Frost and C&W *Hillbilly-sounding* sign-off music. West Virginia Mountain Radio. (JK-VA)
- 1420 KXOW** AR Hot Springs - 4/3 2110 Fair and alone on frequency with NOS music, mentions of Hot Springs. Must not have switched power. Thanks for *Wayne* for the tip. AR #11. (SA-MB)
- WCOJ** PA Coatsville - 3/27 2047 With *Right now, it's 40 degrees at WCOJ*, then *Chicago* music. (JK-VA)
- WVJS** KY Owensboro - 4/5 1922 On the first evening of DST, up briefly over WHK with *You're listening to the American Top 30 on WVJS*. Focus year was '66. (JL-OH)
- 1430 WNJR** NJ Newark - 3/17 2053 Briefly over super-powered CJCL with promo for free trip to the Poconos, WNJR mentions. NJ #2 at this QTH, not counting the 50 Kwer NYC'ers! (JK-VA)
- 1440 WLXN** NC Lexington - 3/17 1820 With ad for *Southeast Data Products*, 1-800-888-8588, and mentions of Lexington. (JK-VA)
- 1450 KCTI** TX Gonzales - 4/2 1731 With C&W programming. Ad at 1736 for *Guadalupe Valley Electric Cooperative*. ID at 1754 *1450 KCTI Gonzales, Texas, cradle of Texas independence*. (SP-B,C)
- 1470 WKZN** ME Lewistown - 3/18 2200 Over/under major pain CHOW with NOS music. At 2200, thought I heard a *WLAM* ID. If so, ME #2 here. (JK-VA)
- WTKO** NY Ithaca - 3/17 1815 With . . . *weather for Ithaca and Central New York . . . currently 37 degrees downtown . . . for 1470 WTKO, I'm Gene* (fade). (JK-VA)
- WMDR** TN Alcoa - 3/27 2014 With *It's* (fade) from the *Voice of Alcoa, WMDR*. Over/under CHOW. 105 watts? (JK-VA)
- KSPL** TX San Marcos - 4/2 1625 With AC programming. Ad at 1643 for *H-E-B Food Stores. We've got the power! Say Yes, Texas* at 1644. ID at 1641 *AM 1470 KSPL, Your Central Texas Sports Connection, KSPL*. (SP-B,C) [Now I am homesick!! -Ed.]
- 1480 WLEA** NY Hornell - 3/18 1759 Good with CKAN now silent. Ad for *Nationwide Financial*, no-frills *WLEA* ID (ie no slogan, no jingle) → ABC News at 1800. (MB-ON)
- WZRC** NY New York - 3/25 1850 Good in WHBC null with CKAN still silent. Hard rock music and non-IDs as *1480, New York's Zee-Rock*. (MS-ON)
- WZRC** NY New York - 3/29 2003-2020 ROK ID as *Z-Rock & Z-Rock 50*. Over/under WHBC. (DT-ON)
- WCNS** PA Latrobe - 3/23 1856 Fair w/local CKAN silent. Sports talk re NHL, then *We've got the Pittsburgh Pirates covered on 1480 WCNS*. (MS-ON)
- 1510 WSSH** MA Boston - 3/21 2217-2300 SS mix and talk. (DT-ON)
- 1520 WWBZ** MI Muskegon Heights - 4/4 2005 Poor in KOMA null. Heard after KOLM sign-off at 2000 with EZLZ music. Last heard as *WQWQ*. MI #76. (SA-MB)
- WMLM** MI St. Louis - 4/16 2201 Fair with ABC News, weather. ID as *WMLM St. Louis, Elma, Itacha*. In KOMA null. (SA-MB)
- 1530 WRTP** NC Chapel Hill - 3/17 1757 With . . . *on Christian Radio 1530 WRTP*, then REL music. (JK-VA)
- 1540 WPTR** NY Albany - 3/17 1804 Increasingly rare these days (due to CHIN high power 24 hr NSP), w/*WPTR* IDs and *1540 Traffic Center* mentions. (JK-VA)
- WPGR** PA Philadelphia - 3/17 1755 With sign-off, . . . *from the staff and management of Philly Gold Radio, have a pleasant evening*. (JK-VA)
- KEDA** TX San Antonio - 4/4 2334 With SS programming. Ad at 2336 for *J.C. Penney*. Good ID at 2340 *San Antonio's most imitated radio station, KEDA*. (SP-A,C)
- 1550 WYNX** GA Smyrna - 3/27 1825 With *Coming up next, a look at your Atlanta Metro Traffic* and *WYNX* mentions. (JK-VA)
- 1560 WQXR** NY New York - 4/4 1956 Fair with TC and ID as *WQXR 96.3FM* → classical music. Alone in KKAA null. (SA-MB)

- WAGL SC Lancaster - 3/18 1828 With sign-off, mentions of 10kw power . . . *Inviting you to tune in again tomorrow, then America The Beautiful.* (JK-VA)
- 1570 WHOG FL **Fernandina Beach** - 3/3 1853 Fair with GOS program, mention of St. Augustine. #30 on 1570, my most productive frequency. (WPT-DC)
- WPGM PA **Danville** - 3/23 1858 Fair with instrumental music, then *WPGM weather.* (MS-ON)
- WYTI VA **Rocky Mount** - 3/27 1827 With mentions of **Clinton Tires** and *Franklin County*, then gone at 1830 with power cut. (JK-VA)
- 1580 WAMJ IN **South Bend** - 4/11 2030-2145 PBP BKB **Hornets** and ?. Cluster of ads 2134 including firm on Main Street in Michiwaka. Poor, under/over CBJ. (DT-ON)
- 1590 WQQW CT **Waterbury** - 3/21 2351-2400 OLD or NOS music and sign-off. Under WAKR. (DT-ON)
- WQCH GA **Lafayette** - 3/21 1818 Tent ID with **Alabama** singing *If I Had You*. Then *Good evening, it's 21 minutes past 6 O'Clock. We'll be with you until sign-off at 6:45 here on Q-Country, WQ??.* Weather fit Georgia. Clear and strong, then wiped out by WAKR at 6:41!! (LK-ON)
- WJRO MD **Glen Burnie** - 3/16 1930 With UC/GOS and *WJRO* IDs. (JK-VA)
- 1600 KQRO TX **Cuero** - 4/5 1606 With C&W programming. Good ID at 1606 *Q97, Real Texas Country, KQRO.* Ad at 1614 for the **Carson & Barnes 5-Ring Circus at the Cuero City Park on April 9th.** (SP-B,C)

... Now, We hear from the Mountain, Pacific & Hawaiian Zones

### SPECIAL

- 650 KHNR HI **Honolulu** - 3/24 0030 Noted back on the air for 1st time since 9/22 (when it ended a primitive LMA [Local Marketing Agreement - Ed.] with KLHI-FM) with CNN Headline News | cable, dead air during local breaks except ID at 0059 *This is KHNR Honolulu, conducting ETs. We'll start our programming momentarily. Thank you for listening.* On RS after 0500 w/local newscasts though inaugural date is 3/26. Ex: KORL. Investor group led by former Gov. George Ariyoshi and developer/powerboat racer Tom Gentry bought it from debtor-in-poseessor. CE is Clayton Caughill. QTH is 850 Richards St, Honolulu 96813. (DP-HI)
- 1080 KWAI HI **Honolulu** - 3/8 Noted with CNN Radio News via satellite [is there any other way - Ed.], probably the only talk/ethnic/brokered time station with network news, hi. However, station's Mainland programming is either via tape or phone line [how archaic! - Ed.] and use of CNN conflicts with KULA's (see 1460) (DP-HI)
- 1190 KORG CA **Anahcim** - 4/6 0426 Hrd with satellite-delivered NOS/EZL and 1190 *KORG. AM 1190 KORG* at 0429 and *We are KORG* at 0433. So not all REL/BTH as in Log. [Ed.-CA]
- 1320 KOLT NE **Scottsbluff** - 3/30 2015 Reactivated after about a two-year Silent Period. *The Best Country is Colt Country* and *Western Nebraska is Colt Country, AM 1320* slogans. ID and AP Net News @ 2100. 2105 *Colt Country Weather.* Good signal, mixing with KCPX/KLWN. (JW-CO)
- KCPX UT **Salt Lake City** - 3/31 1900 Back to these CLs again. Ex: KUTR. Oldies format. A regular at this QTH. (JW-CO)
- 1360 KNNS AZ **Glendale** - 3/31 0848 Area news, sports. 1360 *K-News* slogans. 0900 ID: *Newsradio for CNN news, KNNS Glendale-Phoenix* and into CNN Headline News. Fair with KSCJ/KBUY/KNGN QRM. Ex: KLFF. (JW-CO)
- KNNS AZ **Glendale** - 4/6 0945 Heard an anct this AM that they are carrying the L.A. Angels. [Ed.-CA]
- 1460 KULA HI **Honolulu-Kailua** - 3/13 Noted with Unistar's adult standards format for 1st time instead of simulcasting KRTR-FM's light rock with slogans such as *The Memories Station, AM 1460.* Noted later | KCTC. Stn also airs CNN Radio News, making three CNNs in local radio! Newspaper says format switch was 3/2. (DP-HI)

### DX AND EQUIPMENT TESTS

- 640 KFI CA **Los Angeles** - 3/24 0320 Noted off the air completely. Fiji-639 booming in but with an annoying het from 640. Back on at 0702 re/ with network news. (DP-HI)
- 640 KFI CA **Los Angeles** - 4/3 0405 1 kHz Test Tone, which was then tuned down at 0407 (so low only trees could hear it, hi). Back on at 0430 recheck with replay of **Bill Press** from 3/28, complete with time checks and afternoon traffic reports. Fiji-639 het, KHNR-650 splatter. (DP-HI)
- 650 KMTI UT **Manti** - 3/9 0240-0300 Nothing heard except very dominant KYAK (probably for the last time here) with **Dolly Parton** special and CISL lurking beneath. This attempted at Maunaulua Bay. (DP-HI)
- 940 KDEO HI **Waipahu** - Noted testing by flicking its OC on & off, mostly off. (DP-HI)
- 990 KHVH HI **Honolulu** - 3/23 0458 Going out of *Best of King. Irv Beech* with promo . . . *proud to be on Hawai'i's only all-news radio station, KHVH Honolulu. Dave Curtis* with full ID (always played at 11:59 PM daily). Off but back on at 0600 re/. (DP-HI)
- 1090 KTNS CA **Oakhurst** - 3/9 0303 Not heard. Only KING with talk show and possible XEPRS. Last possible test for the season that could be tried from here. Attempted at Maunaulua Bay. (DP-HI)

### TIS AND OTHER STUFF

- 1610 TIS WA **Chief Joseph Dam** - 4/8 0545 Corps of Engineers message talks about the dam, power house and recreation facilities in area. Heard often, poor this time. (JW-OR)

### MIDNIGHT TO 0800 HOURS ELT

- 540 KHKN CA **Carmel Valley** - 4/13 0632 Noted in passing with C&W music from SMN | KCWM-550, KMIX-1390 and KCWW-1580 - talk about overkill, hit By the way, did you know the IRCA Almanac (plug) has a list of stations airing **Lee Arnold?** [Nope - Ed.] Oh, fair with lightning QRN. (DP-HI)
- 550 KBOW MT **Butte** - 4/8 0640 Poor with ID, C&W. Rare here, last logged in 1987. (JW-OR)
- 570 KLAC CA **Los Angeles** - 3/16 0616 Possible concert promo. Female DJ reading PSA for UCLA's *garage sale* at a Santa Monica hangar, then *KLAC weather . . . Country, KLAC. Song 500 Miles.* DJ ID, **Mickey Gilley's True Love Ways.** Poor. KQNG getting louder/softer like a bunji jumper. (DP-HI)
- 620 KINK, OR **Portland** - 3/9 0555 With KTWV-FM-like format (aka NAC) [huh? - Ed.] with children's song by **Olivia Newton-John, Suzanne Ciani**-style piano with vocal, *Chicago's I've Been Searching So Long*, sax-synth. jaz. With possible ID at 0613, more NAC [I give . . . what is NAC? - Ed.] Then seemed to shift format at 0619 for I heard **The Pretenders' Brass in Pocket** and **Springsteen's Human Touch.** Who is this? All under KIPA's *First Light*/NBC Radio news/**Dr. Ruben.** Poor to very poor. (DP-HI)
- 630 KXDC CA **Monterey** - 3/22 0645 Probably this with fusion jazz music. )652 Mellow-sounding talk → ad that mentioned *season tickets*, order by mail for \$19.95 from 800-722-1234 or 800-???-7654. Mellow talk again at 0654, jazz vocals by female. Very poor to poor. Over/under 4QN with 2YZ underneath Increasing white noise QRN. Actually, this station was easier to hear as KIDD. (DP-HI)
- KIDO ID **Boise** - 3/21 0354 With **Larry King Show** | KFRC-610 and KHVH-990, net ads. Distorted ID but did hear a *K?DO* → NBC Radio News. Soon after faded under KXDC. Poor with heavy electrical QRM. (DP-HI)
- 670 KBOI ID **Boise** - 3/20 0628 **Dave Bogart** with ad-free Unistar AC music, with slogans like *More Great Songs From Yesterday and Today on 67 KBOI* and *Depend on Us 24 Hours a Day, KBOI Boise.* ABC-I News at 0700. More satellited music (so when's the morning drive show?) [At 0600 local - Ed.] KPUA apparently off. Did hear weak talk underneath @ 0641 (KWNK or WMAQ?). Fair to poor. KQM-QRM [sic - Ed.], het de 3YA-675. (DP-HI)
- 710 KMPC CA **Los Angeles** - 3/20 0759 Traffic report mentioning San Diego and Golden State Freeway on the *KMPC Airwatch*, weather, jingle → NBC News.



- Lost to KQMQ QRM but briefly up at 0813 AdStan [sic - Ed.] music. Poor to very poor, over/under KIRO. (DP-HI)
- 720 **WGN** IL Chicago - 3/23 0540 Weak with tele-talk show by man and woman team. On a hunch, I called Tribune Radio's "800" phone # and asked the IRN producer who answered to feed me the WGN pgm. So she punched it up and put it thru the phonenumber. Sure enough, I heard Johnnie Putnam over the phone . . . then six seconds later over the air! Second time logged here. Unfortunately, it got buried under 4YZ and heavy QRN. Very poor. (DP-HI)
- 830 **KIKI** HI Honolulu - 4/6 0553 Fair with oldies, ID *Hawaii's Oldies Channel, KIKI*. (JW-OR)
- 840 **KVEG** NV North Las Vegas - 4/6 0545 Fair with sports talk, ID *Your Sports Superstation*. (JW-OR)
- 940 **KFRE** CA Fresno - 3/23 0621 *All-Night Truckers Show* with C&W music (different from KRVN and WWL's shows) and lots of local IDs and PST TCs. *Overdrive Trucking News* at 0631. Either in clear or underneath KDEO's OC. Fair to poor. UnID SS in back (KNST? XEQ?) (DP-HI)
- 1200 **WOAI** TX San Antonio - 3/23 0706 News items about a Major Duncan and involvement in the Heidi Seaman murder, reducing flooding in the Five Points area near San Pedro Park, city's anti-smoking ordinance. Jingle . . . *12 Hundred Newsradio (all You Need To Know)*, ad. Poor to very poor, mixing badly with CKDA (DP-HI)
- 1360 **KKMO** WA Tacoma - 3/22 0520 Playing ranchera and some unfamiliar types of Latin American music. At 0528 mention of *Radio Exitos, La Voz de ???* and conversation with 2nd man. IRCA says KKMO is now ethnic overnights. Poor with KPOP under, local QRM. (DP-HI)
- 1570 **CHUB** BC Nanaimo - 3/22 0532 *Nightshift* show with PSAs from Canadian Red Cross, BC Assn of Broadcasters on drunk driving, AC music. Regional weather at 0539. At 0559 DJ promo for area musicians to audition for live local show on CHUB/CHPQ. Sounder, Vancouver I. traffic advisory, net news. 0606 taxi company ad, pgm note → pgm about the grandparents of Gunnar, Matthew and Tracy, *The Adventures of Ozzie and Harriet* (hi). Fair to poor with SS in back. (DP-HI)
- 1600 **KMNY** CA Pomona - 4/6 0635 Poor with Social Security PSA, ID *We cover Southern California*. First time heard. (JW-OR)

### 0800 TO 1600 HOURS ELT

- 710 **KIRO** WA Seattle - 3/20 0800 CBS News, then lost to noise. Returned at 0811 with talk, *Sports Flashback* with Jack Buck on the 1968 Stanley Cup. News teaser, list of personnel working on the show, weather (*Right now, 42° in Seattle*). Promo for Mariners BB on *Kiro Newsradio 710*. TC, news about assault and kidnapping of a Federal Way kindergarten student. Very poor to fair, over/under KMPC. Het de 711. (DP-HI)
- 1360 **KBUY** NM Ruidoso - 3/31 0905 *Dateline New Mexico* with news, tourist features, local ads, *K-Buy* slogans. Fair w/good peaks over KNGN/KNNS. (JW-CO)
- 1600 **KUBA** CA Yuba City - 4/7 0930 Fair with ID and local news. (JW-OR)

### 1600 TO 2400 HOURS ELT

- 1120 **KPNW** OR Eugene - 3/21 2335 Rerun of *Tom Snyder's Radio Show* from 3/18, when he was in San Francisco. At 2359 promo with line *Paul Harvey and Newstalk Radio 1120, What a Team*. Jingle *KPNW Newstalk Radio 1120*, ABC-I News. Fair to very poor. Usual KAOI-1110 QRM. (DP-HI)
- 1130 **KFAN** MN Minneapolis - 3/21 2103 *Timberwolves Tonight* pregame pgm with Tom Hanlon. Many ads. Fair, o/u XEHN. (JW-CO)
- 1250 **KBRF** MN Fergus Falls - 3/30 1945 Local weather, ID, into lite music. Semi-regular here. (JW-CO)
- KIKZ** TX Seminole - 3/30 2315 C&W music. *Crook & Chase Countdown the Top 40 Saturdays on KIKZ/KSEM Seminole*. Fair, o/u QRM. (JW-CO)
- 1260 **KPOW** WY Powell - 3/29 2209 Very good with C&W music. Female with weather, sponsored by *Yellowstone Regional Airport*. (JW-CO)

### ... all brought to you by these INTERNATIONAL REPORTERS

- RD-IA Richard Dau, Jr. Iowa City, IA; R-1000 + RW Loop (x2)
- JM-NC Jeff Multer Charlotte, NC; (x2)
- AL-WV Al Dillon Prichard, WV; DX-440 and Superadio
- DP-HI Dale Park Honolulu, HI; ATS-803A + Select-A-Tenna [Truly, an environmentalist, or ellipsier, or whatever - Ed.] (x2)
- EB-GA Eric Bueneman Marietta, GA; unID help
- RH-NJ Rich Harrison Hewitt, NJ; Grundig Satellit 3400 + SM-2 Space Magnet
- HH-MD Hank Holbrook (who thinks I still live in TX) Dunkirk, MD; SP-600 with 50' lw or \* with Colegrove Loop
- LK-ON Laurence Kearley Orleans, ON; ICF-SW1 + Select-A-Tenna
- KO-IL Ken Onyschuk Homewood, IL; Superadio II
- BF-IL Barry Finkel Chicago, IL; Yaesu FRG-7700 + McKay-Dymek DA-5
- BS-NE Bob Straube Palmyra, NE;
- JW-CO John Wilkins Wheat Ridge, CO; R-1000 + 4' box loop
- JK-VA Jeff Kitz Dillwyn, VA; Sony FD-555 AM/FM/TV "Mega-Watchman" barefoot
- WPT-DC Bill Townshend Washington, DC; ICF-2010
- JL-OH Jeffrey Less Toledo, OH; RF5000A (x2)
- MB-ON Mike Brooker Toronto, ON; RF-2200 or ICF-7600D
- DS-DE Dave Schmidt New Castle, DE; HQ180A, SM2, R390A, short lw
- SA-MB Snow Almost gone aka Shawn Axelrod Winterpeg, MB; ICR-70 + new 4' box loop (workin' fine) or 100' wire (x2)
- TB-OH Tony Bernhoffer Toledo, OH; ICF-SW7600 + 2' diameter BCB loop that I built by myself in the basement
- DS-CA Duncan Shaw San Rafael, CA;
- RA-MA Ray Arruda Acushnet, MA; SX-122, HQ-180A, Radio West Loop
- TS-MI Tom Sanders Davison, MI; ICF-2010
- AR-ON Andy Rugg Cornwall, ON; Superadio II
- PT-OK Phil Tallman Purcell, OK; Thanks for Bumper Sticker!
- SP-xx Stephen Ponder (C)San Antonio, TX or (D)Houston, TX; (A)Toshiba RP-F11 AM/FM/SW Portable or (B) Toyota Car Radio [Whew! - Ed]
- DT-ON Don Trelford Scarborough, ON; R-2000 or DX-440
- MS-ON Morris Sorensen Scarborough, ON; HQ-150 with McKay-Dymek DA-9 Ferrite Loop or RF-B65 barefoot
- BW-MI Bob Walker Bloomfield Hills, MI;
- TS-MI Tom Sanders Davison, MI; ICF-2010
- BC-NH Bruce Conti Nashua, NH; R70, DX400, MWDX-5, 3 longwires
- PLB-MI is: Philip Boersma Spring Lake, MI;
- JW-OR Jack Woods Waldport, OR; 1946 Philco Table Model 6-tuber with built-in loop antenna
- RM-PA Randy Masure Bushkill, PA;
- SF-TN Steve Francis Alcoa, TN; TRF
- TXConn My Texas Connection
- Ed.-CA Editor, NSSZC/6 Victorville, CA;

### GYDXA UPDATE

1240 kHz:			
CJCD NT	Yellowknife	UK DXpedition#	Sheigra, Scotland 3277
1450 kHz:			
WFRA PA	Franklin	UK DXpedition#	Sheigra, Scotland 3326

### ABBREVIATIONS AND SPECIAL SYMBOLS USED IN DDXD-National Edition

||:parallel with or to - :into :00:on the hour AC:Adult contemporary AP:Associated Press BBD:big band BRN:Business Radio Net C&W:country & western CHR:contemporary hit radio CID:code ID CL:call letter ContChr:contemporary Christian EZL:easy listening EB:English FR:French GOS:gospel IRN:Interstate Radio Net LSR:local sunrise LSS:local sunset MLB:Major League Baseball NBA:National Basketball Assn NPR:National Public Radio OC:open carrier pbp:play-by-play POL:political PSRA:pre-sunrise authority PSSA:post-sunrise authority QRM:man-made interference QRN:natural interference QTH:location REL:religious ROK:rock 'n' roll RS:regular schedule S:stereo SID:singing ID SRS:sunrise skip SS:Spanish SSB:Star Spangled Banner SSS:sunset skip TC:time check TT:test tones UC:urban contemporary UPI:United Press International

73, Bill

# International DX Digest

**Jim Renfrew**

61 Wilcox Street  
Rochester, NY 14607-3832

*Foreign DX Catches. Times are UTC; for ELT, subtract 5 hrs.*

It's nice to see some good logs from Manitoba. The beverages were under up to five feet of snow at the time! Shawn and Larry also report lots of TA hets between 702-1314 kHz during the same time period, and also a number of TP hets, but audio only noted on two of them, and no positive IDs.

Chris Vito checks in with some TA loggings, which is not an easy accomplishment from Florida.

## PAN-AMERICAN

- 540 MEXICO XEWA, San Luis Potosí 3/31 0926 - Good, alone on frequency with lively music and ads most nights after CBK s/off. [SA-MB]  
590 CUBA R. Reloj, Santa Clara 3/22 0431 - Usual format with clock ticks and Spanish news, rare here, fair. [DX\*MB]  
640 CUBA R. Progreso, Guanabacoa 3/22 0440 - Latin music, mentions of Cuba, fair. [DX\*MB]  
650 COLOMBIA RCN, Bogotá 4/13 0348 - Good with "tu música" merengue and salsa hits, characteristic 5 pips at the top of the hour, and RCN jingle, phased in on tight WSM null. [BAC-NH]  
670 CUBA R. Progreso, Arroyo Arenas 3/22 0440 - Fair, // 640. [DX\*MB]  
690 MEXICO XETRA, Tijuana 3/22 1020 - Fair with news and sports, ads for S. California. [DX\*MB]  
700 JAMAICA JBC, Montego Bay 4/10 0209 - Good with Radio One-derful jingle, time announcement 9:09, soul and reggae music, WLW phased out. [BAC-NH]  
730 MEXICO XEX, Mexico DF 4/1 0915 - Strong, in CKDM null with lots of music and talk, XEX ID. [SA-MB]  
770 COLOMBIA HJKL, Bogota 3/22 0330 - Good, dominating frequency with RCN IDs and music, first time heard in 2 years. [DX\*MB]  
830 BELIZE R. Belize 3/31 0430 - Poor in partial WCCO null, man in accented English with reggae music. First time heard, new country. [SA-MB]  
860 DOMINICA The Voice of the Islands, Roseau 3/9 0018 - Woman with VOI News, fair signal. [CV-FL]  
900t BARBADOS CBC Radio 900, Bridgetown 3/9 2354 - Likely them with accented English, UTC-4 time check, "It's six minutes away from 8:00", fair with WSWN and unID SS station. [CV-FL]  
900 CUBA R. Progreso 4/10 0130 - Good with end of news, "bailando" promo, and salsa music, CHML/CKTS phased out. [BAC-NH]  
940 CUBA R. Reloj, Holguín 3/30 0757 - Poor in CJGX null with man and woman doing the news, clock and Morse code ID on the minute. [SA-MB]  
980 MEXICO XEKE, Navajoa 3/27 1055 - Fair with music, then man doing news (I think) and XEKE ID. New for me in CBW null. [SA-MB]  
1000 unID 4/2 1023 - Poor under KTOK/WLUP with slow and fast-paced Mexican music. Heard R. Mil ID who is 24 hours now? [SA-MB]  
1030 MEXICO XEQR, Mexico DF 4/2 1038 - Fair with slow Mexican music, and whistle theme between songs in partial KTWO null. [SA-MB]  
1100 ANTIGUA ZDK 4/13 0100 - Excellent with Master Control REL program, followed by Magic Radio countdown beginning with #50 by Shaba Ranks and KRS-One. [BAC-NH]  
1160 BERMUDA VSB3, Hamilton 4/10 0044 - Good with BBC // 5975, WOBM at al. phased out. [BAC-NH]  
1375 ST. PIERRE ET MIQUELON 3/11 0538 - Up to very good with man in French. [CV-FL] 4/10 0015 - Tentative, fair to poor in WFEA/WSYB slop. [BAC-NH]  
1550 MEXICO XERUV, Jalapa VER 4/9 0346 - With Manhattan Transfer style EE music, promo spot at 0356 "Orchestra Sinfónica de Jalapa en Radio Universidad Veracruzana", good ID at 0400 "Ésta es XERUV, Radio Universidad Veracruzana, 1550 kHz con 10 mil watts de potencia, desde Jalapa, Veracruz, México"; extremely strong signals. [SHP-TX]  
1555 CAYMAN ISLANDS R. Cayman 3/22 0230 - Good clear audio, music, man talking in accented English, in for about one hour. [DX\*MB]  
1560 MEXICO XEFAJ, Mexico DF 3/29 1150 - Poor with lots of music and ID in KCAA null, new for me. [SA-MB]

## TRANS-PACIFIC

- 603 AUSTRALIA 4CH, Charleville 4/8 1417 - Man reading list of celebrity birthdays for April 9 (among them Winona Ryder, Steve Ballesteros, Keshia Knight-Pulliam); into light pop music plus ads for ABC Shoppe; state weather report at 1436 // 855, 630, 540, slightly behind 612 due to satellite delay. Poor, slop from KSSK-590. [DP-HI]  
756 unID 1YA? 3/22 1210 - Poor, good het, some English talk by man, but not Aussie accent, lite pop music. [DX\*MB]  
981 unID 4/13 1032 - Woman doing some sort of dramatic reading; not // R. NZ on shortwave, so a local; o/u tentative KATY-CA; KHVH off on MM SP. Very poor. [DP-HI]  
1008 unID JONR? 3/22 1215 - Very poor, strong het, man talking in possible Japanese (not English and I'm not good at oriental languages). [DX\*MB]  
1224 MARSHALL ISLANDS WXLG, Kwajalein 4/6 1043 - First hour of Westwood One's "Dr. Demento Show" with an all request edition, with song by Robert Q. Lewis; history feature about Jesse Brown, first black Air Force aviator, in lieu of a commercial. Fair to poor. [DP-HI]

## TRANS-ATLANTIC

- 747 unID carrier 3/11 0546 - Too much slop for audio to break through. [CV-FL]  
765 SENEGAL Dakar 3/11 0608 - Good with man in French with possible mentions of Dakar, and at 0700 stronger than any more local splits and still hanging in there at 0730. Also 3/10 0628 with very good signal on SE beverage. [CV-FL]  
774 unID 3/10 0532 - Good carrier in slop. [CV-FL]  
837 unID 3/11 0606 - carrier. [CV-FL]  
819 unID (Rabat?) 4/10 2330 - Strong but wavering het (R-390A, 60' zip cord), Strong but wavering het (stock barebones Superadio), Strong but wavering het (Ray Jefferson Model 680 Radio direction finder). [CCH-RI]  
891 unID 3/11 0530 - Severe het against WLS, probably Algeria. [CV-FL] 4/10 2330 - Very weak het (R-390A 60' zip cord). [CCH-RI]  
1305 unID 3/11 0543 - Weak audio, too weak to note language. [CV-FL]  
1349 unID 3/11 0616 - Good carrier with barely discernable audio at times. Mauretania suspected here. [CV-FL]  
1557 unID 3/11 0504 - Fair signal with man in unidentified language into what sounded like Arabic music. Heard again a few minutes later with what I believe was Koranic recitations. France? Malta? [CV-FL] (WRTH shows France's program for immigrant workers, which could include Arabic, begins at 0530 on weekdays; Malta programs begin at 0600 in English; but summer time shifts may move these to one hour earlier - Jim)  
1575t GERMANY Burg 3/11 0516 - Pretty weak, but little interference made easy copy of man and woman in German; sounded like a news program. [CV-FL]  
1584 unID 3/11 0529 - Poor signal with man in what sounds like Spanish. Spain the only thing that makes sense here. [CV-FL] (Various synchros - Jim)  
1593t GERMANY Langenburg 3/11 0520 - Up to very good peaks with man and woman in German with pop music, including Abba's "Take a Chance On Me", surprisingly good (very listenable) signal. [CV-FL]

## CORRECTIONS

- R. Imperial, Guatemala (see DXN 59-20) should read 925 kHz, not 952 kHz. Thanks to Chris Vito for spotting this error on his logging.

## STATION NEWS

**BULGARIA:** Revised listing of stations from Stoyan Kovatchev in ARC #19 (only high power stations are shown here from his list): 261 Sofia 5 60 kW 24 hrs "Horizont"; 576 Vidin 2 500 kW 0400-2200 "Christo Botev"; 2200-2245 "Horizont"; 594 Plevin 1 250 kW (plus synchros) 0300-0100 "Horizont"; 747 Petrich 500 kW 0300-0400, 0800-1300, 1600-0100 "Horizont"; 828 Shumen 500 kW 0100-0400 "Horizont"; 0400-2200 "Christo Botev"; 1224 Vidin 1 500 kW 0400-0700 (-0900 Su) Foreign Service, 0700-1300 (0900- Su) "Horizont"; 1224 Vidin 1&2 1000 kW 2249-0130 "Horizont"; 1296 Kardzhali 2 150 kW 0100-0400 "Horizont", 0400-2200 "Christo Botev".

**COLOMBIA:** There is a new phenomena in Colombia: a big boom of the "Radio Comunes", that is Community stations. They are now "broadcasting" via loudspeakers. This activity is especially common in the neighborhood of Bogota. These "R. Comunes" are expecting to broadcast on medium waves with low power in the near future. [RRR in Pampas DXing in ARC #18] R. Robledo 1020 (ex-1580) heard 2/17. [MARL in TRN in ARC #19]

**CUBA:** Current information from Luis Jimenez Pina, La Habana via Pampas DXing: R. Progreso, CMBC, 640 kHz (93.0 FM), 50 kW; Apartado Postal 3042 or Calzada de Infanta #105, Vedado, La Habana. R. Rebelde, CMCV, 719 kHz (92.1 FM), 75/150 kW; Calle 23 #258, Vedado, La Habana. R. Reloj, CMCD, 760 kHz (99.0 FM), 5 kW; Calle 23 Esquina P., Vedado La Habana. R. Ciudad Habana, CMCA, 810 kHz (101.0 FM), 10 kW; Calle N #266, Vedado, La Habana. R. Metropolitana, CMBL, 860 kHz (102.9 FM), 1 kW; Avenida 26 #877, Nuevo Vedado, La Habana. R. Musical Nacional, CMBF, 950 kHz (95.0 FM), 5 kW; Calle 23 #258, Vedado, La Habana. R. El Periódico del Aire, CMCK, 980 kHz (100.0 FM), 1 kW; Avenida 15 #210, Vedado, La Habana. R. Taíno, no official call, 1040 kHz (no FM), 75/150 kW; Box 3040, Habana 3 or Calle "O" #216, Vedado, La Habana. This station shares time with: The Voice of Cuba, using call CMCX, 1040 kHz (no FM), 75/150 kW; Infanta #105, 3er piso, Habana 3. Broadcasts are in English language, schedule is unknown as it was not submitted by the station. R. Cadena Habana, CMCH, 1080 kHz (104.0 FM), 10 kW; Avenida 51 e/128 y 130, La Habana. R. Enciclopedia, CMBQ, 1290 kHz (95.0 FM), 1 kW; Calle N #266, Vedado, La Habana. [via ARC #18]

**DOMINICAN REPUBLIC:** HIMG 1360 R. Rutas Musical (ex 1350). [Pampas DXing in ARC #18] **AFRICA:** I heard on the radio that Kenya and other East African countries are experiencing a serious drought, reducing the amount of hydro power available from dams, causing them to reduce electrical use [NPR, 4/2], which might affect radio broadcast schedules. [JR-NY]

**UNITED KINGDOM:** Airport Information Radio 1584 ceased broadcasting on February 7. [MET via BDXC in ARC #18]

**VENEZUELA:** Mundial Perija 540 now uses 100 kW. [JSR in TRN in ARC #19], Super Ondas Gaiteira 1120 is the new slogan used by Ondas del Lago. [A. Contin in TRN in ARC #19]

#### QSL INFORMATION

**BRITISH VIRGIN ISLANDS:** ZBVI 780 Box 78 Roadtown, Tortola, v/s Olin D. Hester, General Sales Manager.

**DOMINICA:** Voice of Life 1060 kHz (ex-740), Box 205, Roseau, v/s Ralph Dik.

**GRENADA:** Harbour Light of the Windwards, v/s Randy Cornelius, Chief Engineer.

**PUERTO RICO:** WOSO 1030 v/s Miss Rosemary Quagan, Traffic Manager. [all from R.G. Sewdien, Suriname, in Play-DX #689]

#### CONTRIBUTORS

[DX\*MB] Shawn Axelrod and Larry Shewchuk, Valhalla Beach MB; R-70, TS-440 and various beverages.

[SA-MB] Shawn Axelrod, Winnipeg MB; ICR-70, new 4' box loop. "The 4' box loop is a definite improvement over the old 3' model, the nulls are very sharp."

[CV-FL] Chris Vito, Plantation FL; Sony ICF-2010, ground beverage with 510 ohm resistor then additional 250' additional wire at 110' for 3/9-10 logs, same antenna at 90' for 3/11 logs.

[JR-NY] Jim Renfrew, Rochester NY; HQ-180, Radio West Loop.

[SHP-TX] Stephen H. Ponder, Houston TX; Toshiba RP-F11 AM/FM/SW Portable.

[CCH-RI] Charles C. Harrison, Lincoln RI; receivers and antennas noted in loggings.

[BAC-NH] Bruce Conti, Nashua NH; R70, MWDX-5 (new), 3 longwires.

[DP-HI] Dale Park, Honolulu HI; Sangean ATS-803A, Selec-A-Tenna

## SACHSEN RADIO - täglich weltweit



New from NRC's DX Audio Service:

### "After Dark #2"

Four C-90 tapes in a holder now available for only \$9.50 postpaid. Listen to accounts about the VOA ... news about radio today ... 45 minutes from WNRC, and more airchecks from special stations ... and many special features. Order from NRC Publications - Box 164 - Mannsville, NY 13661. NY orders, please add sales tax.

# FM DX

## Digest

DX on the FM band, from April through September

Todd Brandenburg, KAØKAN

9720 NW 31st

Silver Lake, KS 66539-9403

Hello again, not much new in the DX front here. Last week though I did hear some southwest Missouri stations on my boombox at work via tropo last week.

E-skip season is upon us, so by next edition I hope to catch a few openings. Also pay attention to meteor scatter. Random meteor activity (between showers) will be increasing dramatically between now and July and taper off through October. 73 for now.

**Rick Dau, 401 Emerald St #9, Iowa City, IA 52246**

I've got a couple of FM catches for your column, which represents the extent of FM 'DXing' that I've done this year:

- 3.16.92  
107.9 KLTE MO Kirksville- ad for Christian programming, then legal ID at 1300. Semi-local powerhouse KFMW off the air for a few hours.
- 4.17.92  
97.1 WCOW WI Sparta- in well with Milwaukee Brewers baseball and ad at 1818 for Western WI Technical College in Viroqua. Only 3rd FM catch from WI here (you're 1 ahead of me- trb) Both of the above are new stations here.

**Eric Bueneman, 4866 Olde Mill Dr., Marietta, GA 30066-1159**

DX from Kennesaw Mountain National Battlefield Park, GA Receiver: Delco ETR in a 1986 Pontiac 6000 at about 1600 feet ASL

- 4.2.92  
87.7 WBRC-TV AL Birmingham - 1432 VHF-TV Channel 6 audio in good with local ads and afternoon soap opera.
- 107.9 WJRX TN East Ridge- 1434 good with CCM, '107.9 FM, RX-107' slogan, PSA, ad for Benny Jackson Ford in Ringgold, GA.
- 107.7 WENN AL Birmingham- 1438 good with ad for the Alabama State Fair, contest promo, 'Win' slogan into UC.
- 102.9 WMJE GA Clarkesville- 1440 good with Braves promo, local ads, 'Magic 103' slogan with mention of 25 kW, into SMN AC.
- 98.1 WBFM SC Seneca- 1444 good with mention of records played, ID with WSNW-1150, PSA, local ad, 'WBFM, your station for CBS news on the hour' slogan, into EZL/NOS. The best place to DX when you're in a mountainous area is on top of one. Whenever you're in the Rockies or the Appalachians, you should try it with your car radio. WMBW-88.9 was some 200 feet from me when I visited Lookout Mountain on 4/17, so make sure your car radio has good ACI (Adjacent Channel Interference- TRB) rejection, and the mountain should have as few FM transmitters as possible. If you were wondering what CCM stands for, it's the industry abbreviation for Contemporary Christian music. Look out for my next report, it may come from familiar ground! 73, KDX0STL/4.

**Mike Hawk NØOSY, 10212 P St, Omaha, NE 68127-2130**

During spring break (5 days off including the weekend), I listen for some tropo-scatter, which was most of my DX. Due to the snowstorm on Tuesday (11"), groundwave and line of sight was much worse than normal. This opened up some frequencies, like 97.9, which usually has Sioux City in here at near local strength. On this day, they were quite a bit weaker than normal, which let me get a complete null on them, letting me get WLUP. This is all for now. I expect my next batch of loggings may include a little E-skip (lets all hope- trb). Equipment: Kenwood KT-815 tuner; Antennacraft FM-10 up about 30'

- 4.4 Tropo-Scatter 1028  
103.3 KILS KS Hays, ads  
4.12 Tropo-Scatter 1224  
93.9 KIAI IA Mason City, ads  
4.17 Tropo 0809  
103.5 KXNP NE North Platte, country KX-104

**ALABAMA  
100**

WHMA-FM 100.5  
P.O. Box 278  
Anniston, Alabama 36202

- 0837
- 107.9 KZXL KS Great Bend, stereo Z-108
- 4.18 Tropo-Scatter 1609
- 102.5 KKUZ MO Joplin, Z-103
- 1620
- 102.5 KKDY MO West Plains, KDY
- 1920
- 107.5 WCCN WI Nielsville, country
- 4.19 Tropo Scatter and Meteor Scatter 1903
- 99.1 WZFX NC Whiteville, '99.1 The Fox'
- 2000
- 99.1 KFUO MO Clayton, 'Classic 99'
- 4.21 Tropo Scatter
- 1000
- 98.9 WPXR IL Rock Island, 'Power 98.9'
- 1403
- 97.9 WLUP IL Chicago, local news
- 1641
- 102.1 KPNY NE Alliance, weather
- 4.22 Tropo Scatter
- 1611
- 101.1 KXIA IA Marshalltown, country 'Kicks 101'
- 2134
- 4.24 Tropo
- 2053
- 99.7 KFMH IA Muscatine, rock in stereo
- 2055
- 97.5 WZOK IL Rockford, '97-ZOK'
- 2121
- 102.3 WRMJ IL Aledo, country.



WLS AM 89 & 7-85 WTTZ  
368 N. Michigan Ave.  
Chicago, IL 60601



190 N. State Street, Chicago, Illinois 60601

WLS Talkradio 890 AM  
190 North State Street Chicago IL 60601

# Professional Sports Networks

**Barry S. Finkel**

10314 S. Oakley  
Chicago, IL 60643-2409

Network listings for team sports stations

Los Angeles Kings (NHL) 1991/92 (per team via Dale Park, IRCA)  
Nick Nickson, Brian Engblom

610 KAVL-CA	1150 KCKY-AZ	1240 KSAC-CA	1320 KHSJ-CA
690 XETRA-BC	1220 KBET-CA	1270 KNWZ-CA	1400 KTUC-AZ
970 KIAK-AZ	1230 KPRL-CA	KPLY-NV	1430 KAMP-CA

Continental Basketball Association (via Dale Park, IRCA - "The Sporting News Pro Basketball 1991-92 Yearbook")

- NY Albany Patroons
- CA Bakersfield Jammers
- 690 WVOL-AL Birmingham Bandits
- OH Columbus Horizon
- 1380 WQHK-IN Fort Wayne Fury
- 99.9 WGRD-MI Grand Rapids Hoops
- 1410 QIZM-WI La Crosse Catbirds
- 1340 KXXY-OK Oklahoma City Cavalry
- 1290 KOIL-NE Omaha Racers
- 1230 WLLR-IL Quad City Thunder
- 1380 KOTA-SD Rapid City Thrillers
- IL Rockford Lightning
- 1140 KSOO-SD Sioux Falls Skyforce
- 106.5 KOTY-WA Tri-City Chinook
- TX Wichita Falls Texans
- OK Tulsa Zone
- 980 KUTI-WA Yakima Sun Kings



1065 S. Range • Box 27 • Colby, KS 67701



## SPORTS ENTERTAINMENT NETWORK

by Bill Hale

In the Fall of 1991, a new, 24-hour, 7-day-a-week sports network made its debut, giving the sports junkie an endless dose of interviews, scores, odds, talk and the chance to participate via an 800 number. It's the **Sports Entertainment Network (SEN)**. And what could be a better location to flagship from, but the twenty-four hour town, Las Vegas, Nevada on KVEG-840?

Some of the personalities and programs to listen for as you DX are (all times Eastern): **Larry Cotlar**, formerly of WHO Des Moines, and his show *Sports and More* from 0500-0900 M-F. **Rod Stowell** with the *Morning Sports Page* (0900-1200 M-F).

**Tim Neverett**, who was previously heard on the Sports Final network is on from 1200-1500 Monday through Friday.

**Joe Chevalier**, ex: Pittsburg sports show host, reporter for Mutual and writer for UPI. (no times provided).

**Rick Talley** (yes, that Rick Talley), a top sports reporter at WGN and KABC hosts two shows. *Rick Talley's Sports Panel* (no times given) and *Sports Spotlight on America*, which airs from 1800-2000 on Sundays.

Award-winning **Ken Silverstein**, formerly of KTRH Houston brings listeners *The Sports Almanac* 2300-0100 Monday through Friday.

*Bally's Sports Central* (0100-0300) is hosted by **Larry Ness** and originates from **Bally's Casino and Resort** features, among other sports insights, the earliest betting lines offered.

*Wrestling Insiders* airs from 2100-2300 Saturdays and is hosted by **Rodd Wm Stowell** and **Mike Tenay**. Naturally, this show is about "professional" wrestling.

Other names and show titles you may hear on weekends are:  
**TC Martin** on *Sports Nite-Flight* (0300-0500); **Kevin Olson** hosts *Sports Overview* (0500-0900 Sat and Sun plus 0200-0300 Mon); **Marty Rodick** talks hoops *On The Boards With The NBA* (0900-1100), **Chris Lubner** looks at the *Collegiate Circuit* (1100-1400 Sat) and hosts *Sports Talk* (2300-0100 Sun), **Mike Rice** brings you *The International Arena of Sports* (1400-1500 Sat and 1100-1200 Sun), *Saturday Sports Review* (1500-1800 Sat) is hosted by **Jay Richards**, **Rob Lee** presents *Weekend Sports Beat* (1800-2100 Sat and 1200-1500 Sun), *The Week in Sports That Was* is hosted by **Scott Higgins** (1500-1800 Sun), *The Classic Card Exchange* is on from 2000-2200 Sundays with **Ricciardo Brothers** in charge. **Jay Richards** scores with *Hockey Central* (2300-0100 Sat) and **Pat Rogerson** is in the driver's seat of *Rogerson on Racing* (0100-0200 Mon).

Stations can carry any or all of the programs. When DXing, and you hear sports, chances are you're hearing the **Sports Entertainment Network** on:

580	WCHS	WV	Charleston	1330	KTOD	AR	Conway
620	WTRP	GA	LaGrange	1340	WHPI	IL	Herrin
640	WWLS	OK	Moore	1360	KSCJ	IA	Sioux City
690	WVOK	AL	Birmingham		WKMI	MI	Kalamazoo
	WTIX	LA	New Orleans	1380	KASP	MO	St. Louis
810	KCMO	MO	Kansas City		WCQL	NH	Portsmouth
840	KVEG	NV	Las Vegas	1400	WJHO	AL	Opelika
870	WHCU	NY	Ithaca		WBIZ	WI	Eau Claire
910	WFNS	FL	Plant City	1410	WLAQ	GA	Rome
930	WNZS	FL	Jacksonville	1450	KGIW	CO	Alamosa
	KSEI	ID	Pocatello		WFXX	PA	South Williamsport
1010	WCSI	IN	Columbus	1470	KNTS	TX	Abilene
1130	KFAN	MN	Minneapolis	1480	WABB	AL	Mobile
1150	KDEF	NM	Albuquerque	1490	WMGW	PA	Meadville
1170	KSTT	IA	Davenport		WJOC	TN	Chattanooga
1230	WGGG	FL	Gainesville	1520	KFXX	OR	Oregon City
	KWAS	MO	Joplin	1530	KXTD	OK	Wagoner
	KWYZ	WA	Everett	1600	WSNX	MI	Muskegon
1240	KSAC	CA	Sacramento				
1270	KPLY	NV	Sparks				
1280	WQUE	LA	New Orleans				
1290	KMEN	CA	San Bernardino				
	KGVO	MT	Missoula				
1300	WIBR	LA	Baton Rouge				
1320	KXOL	OK	Clinton				

My thanks to **Joe Speck**, SEN's Director of Programming, for providing a promotion brochure and station list. Good DX!



# Graveyard Achievements

**William Hale**  
15366 La Paz Avenue, #110  
Victorville, CA 92392

*Distance records for stations logged on graveyard frequencies*

**1490 kHz**

**WMRF FM MUSIC 96  
WIEZ AM EZ 1490**

Logged from Jan 1, 1960 to Present

Date of Last Update: Jan 27, 1992



WAJF	AL	Decatur	Neil Wolfish	Toronto, ON	745
WRLD		Lanett	Charles Reh	Leamington, ON	648
WHBB		Selma	Frank Merrill	Milan, MI	687
AFRN	AK	Campion	Esa Hänninen	Lemmenjoki, Finland	3209
AFRN		Eleison AFB	Frank Merrill	Nenana, AK	52
KBAS	AZ	Bullhead City	John Wilkins	Wheat Ridge, CO	599
KCUZ		Clifton	Rick Carr	Bloomington, IL	1168
KYCA		Prescott	Jeff Tynan	Parker, CO	543
KAIR		Tucson	Laurie Boyer	Invercargill, NZ	7386
KZAO	AR	Dardanelle	Stephen Ponder	Harrison, AR	74
KDRS		Paragould	Shawn Axelrod	Winnipeg, MB	1033
KOTN		Pine Bluff	Carl Dabelstein	Lincoln, NE	510
KARV		Russellville	Steve Francis	Alcoa, TN	519
KWAC	CA	Bakersfield	Olle Alm	Abisko, Sweden	4947
KGUD		Banning	Tim Hall	Chula Vista, CA	90
KOWL		Bjou	Pete Taylor	San Francisco, CA	160
KICO		Calexico	Jlm Hilliker	Anaheim, CA	153
KRKC		King City	Frank Merrill	Nenana	2266
KTOB		Petaluma	Frank Merrill	Nenana	2107
KBLF		Red Bluff	Jlm Hilliker	Anaheim	498
KDB		Santa Barbara	Richard E. Wood	Hilo, HI	2393
KOWL		South Lake Tahoe	Esa Hänninen	Lemmenjoki	4791
KSYC		Yreka	Esa Hänninen	Lemmenjoki	4834
KBOL	CO	Boulder	Esa Hänninen	Lemmenjoki	4519
KGUC		Gunnison	Jeff Tynan	Parker	133
KIUC		Manitou Springs	John Wilkins	West Des Moines	612
WGCH	CT	Greenwich	Rodney Valdron	Petit Rocher, NB	610
WNLC		New London	Russ Edmunds	Little Silver, NJ	122
WTOR		Torrington	Russ Edmunds	Little Silver	114
WTRL	FL	Bradenton	Frank Merrill	Milan	1013
WXVQ		Deland	Karl Jeter	Stone Mountain, GA	375
WKEM		Immokalee	Emie Cooper	Provincetown, MA	1253
WMBM		Miami Beach	Mike Csorbay	Canfield, ON	1191
WCKC		Milton	Steve Francis	Alcoa	399
WTTB		Vero Beach	Steve Francis	Alcoa	600
WSIR		Winter Haven	Shawn Axelrod	Orlando, FL	34
WMOG	GA	Brunswick	Don Lynch	Willbraham, MA	907
WMJM		Cordele	Don Davis	Warner Robins, GA	50
WAJF		Decatur	Bruce Winkleman	Man, WV	355
WMLS		Monroe	Jason Hustedt	Lexington, SC	144
WSFB		Quitman	Don Lynch	Lynn, MA	1063
WSNT		Sandersville	Emie Cooper	Provincetown	990
WSYL		Sylvania	Mike Csorbay	Canfield	715
KCID	ID	Caldwell	Esa Hänninen	Lemmenjoki	4435
KKLB		Chubbuck	Esa Hänninen	Lemmenjoki	4431
WKRO	IL	Cairo	Russ Edmunds	Glen Rock, NJ	851
WDAN		Danville	Niel Wolfish	Winnipeg, MB	848
			Shawn Axelrod	Winnipeg	(Tie) 848
WESL		East St. Louis	John Malky	Pittsburgh, PA	546
WOPA		Oak Park	Wayne Heinen	Buffalo, NY	480
WZOE		Princeton	Niel Wolfish	Willowdale, ON	541
WKBV	IN	Richmond	Niel Wolfish	Winnipeg	981
WNDU		South Bend	Steve Francis	Alcoa	427
KBUR	IA	Burlington	Esa Hänninen	Lemmenjoki	4220
WDBQ		Dubuque	Wayne Heinen	Colorado Springs, CO	778
KXLQ		Indianola	John Wilkins	Wheat Ridge	617

KRIB		Mason City	Esa Hänninen	Lemmenjoki	4110
KKAN	KS	Phillipsburg	Olle Alm	Abisko, Sweden	4318
KTOP		Topeka	Esa Hänninen	Lemmenjoki	4417
WKAY	KY	Frankfort	Tim Kerfoot	Weston, ON	472
WFXY		Glasgow	Frank Merrill	Milan	352
WFXY		Middlesboro	Robert Kramer	Chicago, IL	418
WOMI		Owensboro	Niel Wolfish	Toronto	573
WSIP		Paintsville	Andy Rugg	Waterloo, ON	407
WIKC	LA	Bogalusa	Charles Reh	Leamington	867
KJIN		Houma	Steve Francis	Alcoa	584
KRUS		Ruston	Charles Reh	Leamington	859
WTVL	ME	Lewiston	Dave Yocis	Fairfield, CT	250
WPOR		Portland	Esa Hänninen	Lemmenjoki	3600
WTVL		Waterville	Charles Reh	Leamington	671
WARK	MD	Hagerstown	Andy Rugg	Montreal, PQ	455
WHAV	MA	Haverhill	Jerry Starr	Youngstown, OH	516
WMRC		Milford	Christian DeHaes	Chicoutimi, PQ	436
WTXL		West Springfield	Jerry Starr	Youngstown	420
WABJ	MI	Adrian	Esa Hänninen	Lemmenjoki	4009
WAND		Manistique	Rodney Valdron	Petit Rocher	975
WMPX		Midland	Niel Wolfish	Winnipeg	791
			Shawn Axelrod	Winnipeg	(Tie) 791
WPBK		Whitehall	Don Voorhies	Oswego, NY	489
KXRA	MN	Alexandria	Russ Edmunds	Parsippany	1111
KQDS		Duluth	Shawn Axelrod	Winnipeg	309
KLGR		Redwood Falls	Roy Millar	Marysville, WA	1322
WLOX	MS	Biloxi	Frank Merrill	Milan	855
WCLE		Cleveland	Charles Reh	Leamington	718
WHOC		Philadelphia	Jery Starr	Youngstown	731
WTUP		Tupelo	Ralph Sperry	Fairfield, CT	1180
WJFL		Vicksburg	Sreva Francis	Alcoa	462
KDMO	MO	Carthage	Frank Merrill	Milan	661
KTRR		Rolla	Shawn Axelrod	Winnipeg	874
KDRO		Sedalia	Shawn Axelrod	Winnipeg	813
KDBM	MT	Dillon	Esa Hänninen	Lemmenjoki	4279
KXGF		Great Falls	Shawn Axelrod	Winnipeg	621
KLYN		Laurel	Esa Hänninen	Lemmenjoki	4199
KEZO	NE	Omaha	Esa Hänninen	Lemmenjoki	4282
WEMJ	NH	Laconia	Jerry Starr	Youngstown	511
WLGW		Lancaster	Andy Rugg	Nuns' Island, PQ	125
WIKE		Newport	Charles Reh	Leamington	582
WUSS	NJ	Atlantic City	Debra Hdden	Orlando, FL	860
KRSN	NM	Los Alamos	John Wilkins	Wheat Ridge	277
KRTN		Raton	Tim Hall	Rancho Bernardo, CA	767
KOAW		Ruidoso Downs	Tim Hall	Rancho Bernardo	668
WCSS	NY	Amsterdam	Morris Sorensen	Port Carling, ON	304
WBTA		Batavia	Russ Edmunds	Little Silver	286
WKNY		Kingston	Frank Merrill	Milan	496
WICY		Malone	Charles Reh	Leamington	446
WDLC		Port Jervis	Mike Csorbay	Canfield	276
WCDO		Sidney	Mike Csorbay	Canfield	188
WOLF		Schenectady	Laurie Boyer	Invercargill	9348
WSSB	NC	Durham	Andy Rugg	Montreal	705
WLOE		Eden	Russ Edmunds	Kinnelon, NJ	430
WFLB		Fayetteville	Tim Kerfoot	Weston	599
WRNB		New Bern	Dave Fox	Reading, PA	370
WRMT		Rocky Mount	Andy Rugg	Montreal	705
WSTP		Salisbury	Charles Reh	Leamington	455
WSVM		Valdese	Frank Merrill	Milan	449
WHSL		Wilmington	Tim Kerfoot	Toronto, ON	655
KNDK	ND	Hettinger	Olle Alm	Abisko, Sweden	3982
KOVC		Valley City	Roy Millar	Marysville	1137
WBEX	OH	Chillicothe	Bill Ailsauskas	Douglasville, GA	378
WJMO		Cleveland Heights	Chris Lucas	Fairfield	430
WOHI		East Liverpool	Robert Kramer	Chicago	377
WMOA		Marletta	Steve Francis	Alcoa	284
WMRN		Marion	Niel Wolfish	Winnipeg	978
			Shawn Axelrod	Winnipeg	(Tie) 978
KOKC	OK	Guthrie	Esa Hänninen	Lemmenjoki	4820
KBIX		Muskogee	Niel Wolfish	Winnipeg	1000
KBKR	OR	Baker	Esa Hänninen	Lemmenjoki	4374

KRNR		Roseburg	Esa Hänninen	Lemmenjoki	4541
KBZY		Salem	Esa Hänninen	Lemmenjoki	4420
WESB	PA	Bradford	Esa Hänninen	Lemmenjoki	3894
WAZL		Hazleton	Andy Rugg	Montreal	330
WARD		Johnstown	Don Lynch	Lynn	435
WGAL		Lancaster	Charles Reh	Leamington	356
WBCB		Lewistown	Morris Sorensen	Kirkland Lake, ON	671
WMRF		Lewistown	Niel Wolfish	Toronto	228
WMGW		Meadville	Esa Hänninen	Lemmenjoki	3945
WAGO		Reading	Don Trelford	Scarborough, ON	290
WNBT		Wellsboro	Charles Reh	Leamington	273
WSIB	SC	Beaufort	Steve Francis	Alcoa	416
WGCD		Chester	Steve Francis	Alcoa	174
WMRB		Greenville	Robert Kramer	Chicago	570
WSDC		Hartsville	Russ Edmunds	Little Silver	515
KORN	SD	Mitchell	Charles Reh	Leamington	786
WOPI	TN	Bristol	Andy Rugg	Montreal	750
WDXB		Chattanooga	Carl Dabelstein	Lincoln, NE	730
WCSV		Crossville	Charles Reh	Leamington	442
WITA		Knoxville	Charles Reh	Leamington	430
WJIM		Lewisburg	Mike Corbay	Canfield	641
WDXL		Lexington	Tom Sundstrom	Willingboro, NJ	825
KNOW	TX	Austin	Roy Millar	Marysville	1779
KBST		Big Spring	John Wilkins	Wheat Ridge	548
KQTY		Borger	Shawn Axelrod	Winnipeg	988
KZZN		Littlefield	Shawn Axelrod	Winnipeg	1125
KDOK		Tyler	Steve Francis	Alcoa	690
KJQN	UT	Ogden	Olle Alm	Abisko	4449
WKVT	VT	Brattleboro	Rodney Valdron	Pettit Rocher	480
WFD		Middlebury	Mike Corbay	Canfield	339
WIKE		Newport	Don Trelford	Scarborough	438
WYKR		Wells River	Rodney Valdron	Pettit Rocher	395
WCVA	VA	Culpepper	Andy Rugg	Montreal	525
WPAK		Farmville	Mike Corbay	Canfield	397
WVEC		Hampton	UK DXPedition*	Sheffield, Scotland	3445
WAYB		Waynesboro	Don Lynch	Lynn	514
KBRO	WA	Bremerton	Esa Hänninen	Lemmenjoki	4239
KVAC		Forks	Esa Hänninen	Lemmenjoki	4229
KEYG		Grand Coulee	Esa Hänninen	Lemmenjoki	4180
KGHO		Hoquiam	Tim Hall	Vancouver, BC	161
KLOG		Kelso	Esa Hänninen	Lemmenjoki	4324
KENE		Toppenish	Esa Hänninen	Lemmenjoki	4294
KTEL	WV	Walla Walla	Esa Hänninen	Lemmenjoki	4295
WXIT		Charleston	Rodney Valdron	Pettit Rocher	1030
WTCS		Fairmont	Frank Merrill	Milan	257
WLOH		Princeton	Frank Merrill	Milan	347
WSGB		Sutton	Stephen McIntire	Des Moines, IA	675
WGEZ	WI	Beloit	Shawn Axelrod	Winnipeg	680
WLX		LaCrosse	Jerry Starr	Youngstown	580
WIGM		Medford	Steve Francis	Alcoa	728
WOSH		Oshkosh	Esa Hänninen	Lemmenjoki	3968
KIML	WY	Gillette	Gene Allen	Vallejo	985
KUGR		Green River	Olle Alm	Abisko	4390
KOJO		Laramie	Niel Wolfish	Winnipeg	708
KGOS		Torrington	Shawn Axelrod	Winnipeg	614
WMDD	PR	Fajardo	Hank Holbrook	Chevy Chase	1600
CJPR	AB	Crowsnest Pass	Esa Hänninen	Lemmenjoki	4053
CBXY		Fahler	Esa Hänninen	Lemmenjoki	3631
CFWB	BC	Campbell River	Esa Hänninen	Lemmenjoki	4102
CKGO		Hope	Roy Millar	Marysville	135
CBXN		Natal	Roy Millar	Marysville	375
CKOO1		Oliver	Tim Hall	Banff, AB	227
CKMV	NB	Grand Sault	Christian DeHaes	Chicoutimi	182
VOHF	NF	Harmon Field	Rodney Valdron	Pettit Rocher	410
CBDQ		Labrador City	Esa Hänninen	Lemmenjoki	2968
CBDJ	NT	Hay River	Esa Hänninen	Lemmenjoki	3281
CKEN	NS	Kentville	Frank Merrill	St. Johns, NF	587
CKAD		Middleton	Chris Lucas	Troy, NY	495
CHVR	ON	Amprior	Shawn Axelrod	Orleans, ON	210
CKEF		Ear Falls	Niel Wolfish	Winnipeg	227
CHYM		Kitchener	John Wilkins	West Des Moines	691

CFRC		Kingston	Don Voorhies	Oswego	54
CFPS		Port Elgin	Shawn Axelrod	Winnipeg	871
CKLR	PQ	L'Annonciation	Charles Reh	Leamington	490
CKBM		Montmagny	Russ Edmunds	Little Silver	493
CJMC		St-Anne-des-Monts	Esa Hänninen	Espoo, Finland	3810
CJSN	SK	Shaunavon	Esa Hänninen	Lemmenjoki	3930
XERO	AGUA	Aguascalientes	Tim Hall	40ml W of Puerto Vallarta	226
XEGT	MICH	Zamora	Tim Hall	10ml W of Mazatlan, SIN	381
XEDR	SON	Guaymas	Tim Hall	Poway, CA	503
XEMS	TAM	Matamoros	Esa Hänninen	Lemmenjoki	5321
R. Favoritas del Sol					
	VEN	Maracaibo	César Objfo	Santo Domingo	551

\* UK DXPedition [Steve Whitt, Mark Hattam, Clive Rooms]

# Formats

**Tony Fitzherbert**

356 Jackman Avenue  
Fairfield, CT 06430-1728

## Changes in programming status; reported by listeners

Tom Bryant, who works there, advises that WSM - 650, has altered its format to "Hot Country", and the on air slogan is "All Hit 650 - WSM". The Grand Old Opry, Ernest Tubbs Record Shop, and the Sunday night religious block all remain. WSM no longer has a silent period.

Jeff Tomasin has written that KBLA - 1580, Santa Monica, dropped its business - talk format on 2/2/92 in favor of all Asian radio. Korean is aired during AM drive, and KBLA simulcasts KWIZ - 96.7, of Santa Anna. KWIZ cannot reach Los Angeles' substantial Korean community, and KBLA's very directional night signal rolls right into west central L.A., where most of the city's Korean population lives. Here is an unusual example where the AM contributes a lot of listeners.

Here in Connecticut, WQQW - 1590, Waterbury, has dropped its long standing live assisted nostalgia format for an all talk offering.

This column comes courtesy of Kermit Geary, Dave Schmidt, The M Street Journal, and Eric Bueneman, who provides a unique dial scan - for all of the clear channel stations in the USA! Here we go!

560	WQAM	FL	Miami	- Talk, sports (M).
560	WHBQ	TN	Memphis	- New wave evenings, "56-WHBQ", otherwise CWM // FM "Kicks 106" (EB).
590	KCST	CO	Pueblo	- News, talk, Sun talk (M).
730	KBSU	ID	Boise	- Ethnic (M).
760	KSJL	TX	San Antonio	- SMN Urban AC (M).
790	WKY	KY	Louisville	- Talk, AC//FM 0100 - 1000 (M).
790	WAEB	PA	Allentown	- News/talk/info/sports (KG).
800	WDSO	SC	Dillon	- Adult rock/MOR/some CBN feed (DS).
810	WBYY	MI	Rockford	- Gold based AC (M).
880	WBKZ	GA	Jefferson	- UC/oldies (EB).
960	CHNS	NS	Halifax	- Oldies "Oldies 96"//CHNX 6130 Short wave (EB).
960	KFMY	UT	Provo	- Variety, "K-Family" (M).
970	WBLF	PA	Bellefonte	- SMN CWM (M).
980	WMEK	VA	Chase City	- CWM weekdays, rock oldies on WE (DS).
1000	WRNJ	NJ	Hackettstown	- AC (KG).
1010	CFRB	ON	Toronto	- News/talk/variety//CFRX 6070 short wave (EB).
1080	WDJX	KY	Louisville	- CHR//WDJX-FM and WZKS-FM (EB).
1090	KTNS	CA	Oakhurst	- JSA CWM (M).
1110	WKEG	PA	Washington	- News/talk/Sun talk (M).
1150	WNAT	IL	Rockford	- News/talk (M).
1160	WYNS	PA	Lehighton	- Oldies (KG).
1170	KSTT	IA	Davenport	- SEN Sports (M).
1230	WODE	PA	Easton	- Oldies, mostly 1966 to 1973 (KG).
1240	KFBC	WI	Cheyenne	- News/talk (M).
1260	WNRK	DE	Newark	- Adult standards (DS).
1290	WBZT	FL	West Palm Beach	- News/talk (M).
1290	KLLF	TX	Wichita Falls	- Variety, Sun talk (M).



1300	WNQM	TN	Nashville	- Paid religion (EB).
1310	KGMT	NE	Fairburg	- Sun talk, news (M).
1310	WJLK	NJ	Asbury Park	- SMN CWM (M).
1320	WKAP	PA	Allentown	- Now "Unforgatable" nostalgia, 1940's through 1960's (KG).
1360	KZIQ	CA	Ridgecrest	- CWM days, AC//FM nights (M).
1360	KSPG	KS	El Dorado	- Contemporary Christian (M).
1400	WSGA	GA	Savannah	- Unis CNN Headline News (M).
1400	WQYO	MI	Munising	- SMN Adult standards (M).
1400	WSAM	MI	Saginaw	- Unis Adult Standards (M).
1400	WEST	PA	Easton	- MOR Music (KG).
1410	WLSH	PA	Lansford	- MOR (KG).
1430	WNWZ	TN	Germantown	- Urban AC//FM (M).
1440	WBBC	VA	Blackstone	- Now gospel (DS).
1470	WXKW	PA	Allentown	- Country music (KG).
1480	WISN	PA	Shamokin	- Oldies (M).
1490	WPAK	VA	Farmville	- Gospel (DS).
1490	WXLS	MS	Biloxi	- Travel info (M).
1500	KCLF	LA	New Roads	- SMN Urban AC (M).
1600	WHOL	PA	Contemporary	- Christian (KG).



P.O. Box 710  
Covington, Virginia 24426

And on to Eric Bueneman's Clear Channel Dial Scan....

640	KFI	CA	Los Angeles	- News/talk "64 KFI".
650	WSM	TN	Nashville	- CWM "All Hit 650"
660	WFAN	NY	New York	- All sports "Sportsradio 66-the Fan".
670	WMAQ	IL	Chicago	- All news "MAQ All News 67".
680	KNBR	CA	San Francisco	- News/talk "68 KNBR".
700	WLW	OH	Cincinnati	- AC/Oldies/Sports/CWM overnights.
710	WOR	NY	New York	- News/talk.
720	WGN	IL	Chicago	- News/talk/variety.
750	WSB	GA	Atlanta	- News/talk. "News-Talk Radio AM 750".
760	WJR	MI	Detroit	- News/talk.
770	WABC	NY	New York	- News/talk "77 WABC".
780	WBBM	IL	Chicago	- News, old time radio. "Newsradio 78".
810	WGY	NY	Schnectady	- AC/Talk "81 WGY".
820	WBAP	TX	Forth Worth	- CWM.
830	WCCO	MN	Minneapolis	- News/talk/easy listening music.
840	WHAS	KY	Louisville	- AC/Oldies/talk "84 WHAS".
850	KOA	CO	Denver	- News/talk "85 KOA".
870	WWL	LA	New Orleans	- News/talk/CWM overnights.
880	WCBS	NY	New York	- All news "Newsradio 88".
890	WLS	IL	Chicago	- News/talk//FM.
1010	WINS	NY	New York	- All news "1010 WINS".
1020	KDKA	PA	Pittsburgh	- News/talk/AC "The K-team".
1030	WBZ	MA	Boston	- News/talk "The Spirit of New England".
1040	WHO	IA	Des Moines	- News/talk/CWM.
1060	KYW	PA	Philadelphia	- All News "KYW Newsradio 1060".
1070	KNX	CA	Los Angeles	- All News "KnX Newsradio 1070".
1100	WWWE	OH	Cleveland	- News/talk "3WE".
1120	KMOX	MO	St Louis	- News/talk/EZL, BBD some Saturdays.
1140	WRVA	VA	Richmond	- AC/Oldies/talk/CWM overnights.
1160	KSL	UT	Salt Lake City	- News/talk/some AC.
1180	WHAM	NY	Rochester	- News/talk/AC jammed by Radio Tiano.
1200	WOAI	TX	San Antonio	- News/talk/sports/variety.
1210	WGL	PA	Philadelphia	- Oldies//FM 0000-1000, Sports talk 2200 to 2400 "Oldies 1210".

**KMOX**  
CBS Radio  
A Division of CBS Inc.  
One Memorial Drive  
St. Louis, Missouri 63102-2486

Another good column. Thank you very much, folks for your contributions. And for everyone else, when your favorite station goes to a new format, do let everyone know through your formats column.

735 72

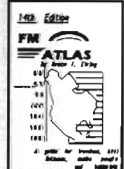

## Bruce Elving's FM Atlas ... 14th Edition

The world-famous guide which has served FM DX'ers for over 20 years is now available from NRC Publications at the special price of \$12.00. NY orders, please add sales tax.

## THE QUANTUM LOOP

### A COMPACT, HIGH-GAIN FERRITE ROD ANTENNA

Gerry Thomas

With the price of ferrite rods going through the roof, I decided to see if I could design a loop antenna using a minimum of ferrite and a maximum of amplifier. The result of this experimentation is a loop I call the *Quantum Loop* ("quantum" -- a small packet of energy; "loop" -- well, you know loop).

Whereas most loop amplifiers for antennas using 10"-16" rods put out between 15 dB and 25 dB of gain, my more modest 8" rod antenna would require an additional 6-12 dB of gain. So, I was shooting for amplification in the 30-35 dB range. As it turned out, I was able to design an amp that delivers between 42-48 dB of gain across its tuning range. Of course, this degree of amplification would be of little benefit if you had 20 dB of amplifier hiss to go along with it. So, low-noise components were chosen and the result is quite satisfying. Also, because this level of gain is not always desirable (overloading problems can occur in receivers with lesser front-ends/mixers), a gain control was included in the design.

In addition to the preceding requirements, I also have a few preferences of my own regarding loop operation: (1) I prefer the tuning knob to be on the stationary loop base and not on the revolving loop head; (2) I like a loop head which rotates continuously (without stops) and, of course, tilts; (3) I also wanted a loop head that was removable so that the antenna could easily be placed in a suitcase; and (4) for the sake of domestic tranquility, I desired a finished loop which looked sufficiently attractive to spare me from the critical comments which loops usually evoke from my wife.

#### BRIEF DESCRIPTION

The *Quantum Loop* measures approximately 10"(H) x 7"(D) x 8-1/2"(W) at its maximum points (see Figure 1). The loop head housing is constructed of black plexiglas and is connected to the black, sloped-front amplifier base by a chromed tube pedestal. The amplifier is a two-stage, balanced input/unbalanced output design with low-noise JFETs in the first stage and a low-noise MOSFET in the second; both stages are arranged in a common-source configuration.

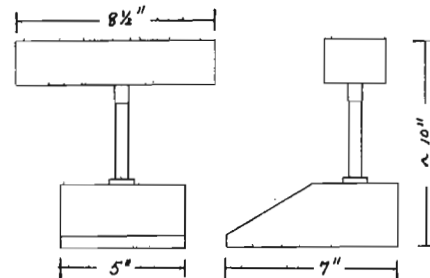

Figure 1. *Quantum Loop* dimensions.

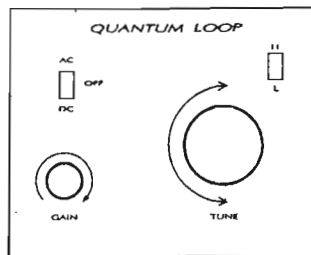

Figure 2. Front panel controls.

The loop tunes from 530 kHz to 2000 kHz in two ranges and has a variable gain control and on/off switch. Power is supplied by either a 9VDC battery or an AC wall adapter (switch selectable). Figure 2 shows the front panel lay-out.



Sociedade Pitangui de Comunicação Ltda.

**RADIO PITANGUI**  
A VOZ DE PONTA GROSSA FAZENDO ECO NO PARANÁ

ZYJ 278  
AM  
1300 KHZ



## CONSTRUCTION DETAILS

Be aware that the construction of the *Quantum Loop* is LABOR INTENSIVE! If this project is beyond your available time or abilities, see the last paragraph of this article.

### A. Loop Head Housing --

The overall dimensions of the housing are 8-1/2"(L) x 1-3/4"(H) x 2-1/2"(D). The *Quantum Loop's* ferrite housing is constructed of black plexiglas; all panels are 1/8" thick with the exception of the base panel which is a sturdier 3/16" in thickness. The pieces are cut to the dimensions illustrated in Figure 3.

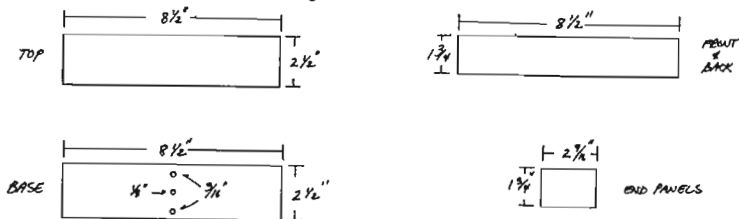

Figure 3. Loop housing panel dimensions.

One hole (1/8" diameter) is drilled in the base panel to allow the passage of the loop coil's wires down to the amplifier base and two 3/16" holes are drilled to permit the fastening of the tilting assembly. The paneling is glued together to form the box-like housing with the front panel left off until the rod/coil assembly is installed.

### B. Tilt Assembly --

The tilt assembly is constructed of the stationary part of a Radio Shack microphone holder (#33-371). Remove the screws holding the two parts of the holder together and discard the upper part and the screws. Drill out the center of the holder to allow the passage of the coil wires to the 1/4" phone plug (to be installed later). Tap the holes which held the pivoting portion of the holder with the 5/16" x 3/8" cap screws. Use two 1/2" angle brackets to form the platform upon which the base of housing will be attached and fasten to the tapped mike holder with the tap screws (nylon washers can be added to make tilting smoother, if you wish). The holes in the angle brackets will have to be enlarged and the right angles of one end rounded to permit unobstructed tilting. Figure 4 illustrates the tilt assembly, the chromed tube pedestal, and phone plug bearing.

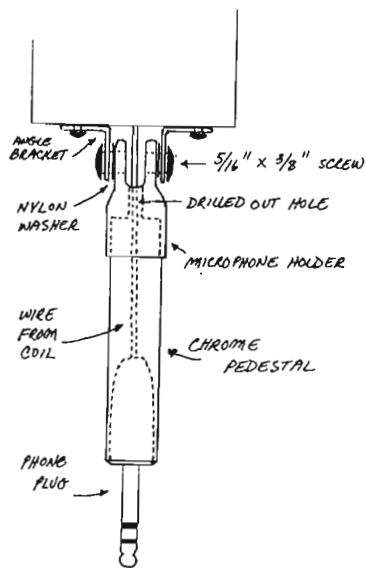

Figure 4. Tilt, pedestal, and plug assembly.

### C. Chrome Pedestal and Base --

The chrome tube pedestal is a threaded microphone tube and screws into the

microphone holder (preceding section). I bought the 6" model (Atlas Sound AD-8B) and cut it in half to provide a 3" pedestal. I also used a chrome base collar (Atlas Sound AD-11B) to add lateral stability. Unfortunately, these collars have an interior thread which must be removed by filing or reaming before the pedestal tube can rotate freely. Because the chrome tube is grounded and because it shares ground with loop coil and electronic circuitry, it is noticeably "RF hot" in some situations (e.g., deep nulls). To remedy this, I slid a 1-1/2" length of 5/8" (ID) clear vinyl tubing onto the tube to insulate it and provide a comfortable grip for loop head rotation.

### D. Phone Plug Bearing --

The loop head rotates on a standard 1/4" phone jack which has been epoxied into the interior of the chrome tube (see Figure 4). Wires from the loop coil are routed down through the microphone holder and chrome tube and are soldered to the plug's terminals. Don't waste your time with the Taiwanese/Korean/Japanese phone plugs and jacks; they are generally constructed of inferior materials and will break or wear out in relatively short order. Use only American-made Switchcraft components (#12B and #297); they are heavy, nickel-plated brass and are still going strong after six years in my loops.

### E. Loop Amplifier Base --

I chose a sloped-front aluminum cabinet (which allows more comfortable tuning) to house the loop's amplifier. The LMB752 (from Mouser) fits the bill nicely but comes in a beige/tan color scheme which I changed to satin black. First, mount the Switchcraft 1/4" phone jack in the center of the top of the cabinet, then mount the chrome collar (which reinforces the chrome pedestal) so that it too is centered (sheet metal screws are fine). Drill holes in the rear of the cabinet to accommodate the battery holder, patch cord connection, and AC adapter jack and install these components. The other holes in the cabinet depend on your lay-out of the electronic circuitry, so I won't give specific dimensions for those. I have found the sloped front of the cabinet to be ergonomically effective in permitting fine tuning knob adjustments and reducing arm/wrist fatigue so a sloped front cabinet is definitely recommended.

### F. Amplifier Details --

Figure 5 provides the schematic of the loop amplifier. Parts lay-out is not particularly critical as long as straight-line design and minimal lead length principles are followed.

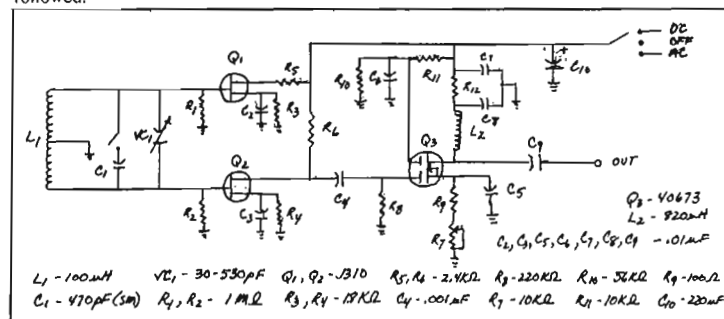

Figure 5. Loop amplifier schematic.

VC1 is a dual-ganged, 15-266 pF polyvaricon variable capacitor (Mouser # 24WC001) with the two gangs connected to provide a capacitance range of about 30-530 pF. (This capacitor requires a shaft extension -- a .625" x .25" nylon spacer glued and held in place by a 2.5mm x .75" machine screw; VC1 must be mounted on a plastic base). C1 is a 470 pF silver mica capacitor which is switched across VC1 to allow low-end tuning. The signals from the rotor and stator tabs of the VC1 are routed to the gates of Q1 and Q2. Transistors Q1 and Q2 are J310 JFETs. These are extremely low noise devices and provide approximately 20 dB of gain across the tuning range. They are arranged in a common source configuration with source by-pass capacitance (C2 and C3). The signal is taken off

the drain of one transistor and capacitively coupled (C4) to Gate 1 of Q3. Transistor Q3 is a dual-gate, diode protected, low-noise MOSFET (40673); it, too, is in the common source configuration with gain being controlled at the source by R7. [NOTE: After designing and testing this circuit, I learned that Motorola and RCA were ceasing production of the 40673 MOSFET; the recommended substitute is the 3N201, but I have not yet tried it]. L2 is an inductor measuring 820 uH which resonates with the stray capacitance of the components and circuit to provide an amplification peak at the low end of the tuning range. Actually any choke in the 800 - 1200 uH range should be suitable because the stray capacitances can vary a bit depending on a number of factors. The output of Q3 is taken off the drain and is capacitively coupled to the output jack for connection to the receiver. You may notice that there is no impedance matching network or low impedance emitter-follower circuitry in this amplifier design. The gain of the amplifier is such that I decided to design for a medium impedance output to adequately match either high (500-1000 Ohm) or low (50 Ohm) receiver inputs. The gain of the *Quantum Loop* is sufficiently high that I didn't feel it was worth it to perfectly match impedances to gain a couple of dB.

#### G. Coil Winding/Ferrite Rod --

The ferrite rod I used has a permeability of 125 mu and is 8" in length and 3/8" in diameter. The coil is of litz wire (64") resulting in 31 turns (with a center tap at turn 16) on a 1/2" polystyrene coil form (this tubing is available from aquarium supply houses). If you are using the more popular Amidon 7-1/2" rod, you will need 66-68" of litz and 33 turns to cover the tuning range. The overall inductance of the coil is 100 uH when centered on the ferrite rod. It is extremely important that both legs (to ground) be exactly equal in inductance in order to attain perfect loop balance. (An inductance meter is invaluable here and is well worth the \$125-\$150 outlay to the inveterate experimenter.) The coil's center tap and ends are soldered to a three-lug terminal strip mounted in the loop housing and RG-174U coax continues the signal path out of the housing, down the chrome tube to terminate on the lugs of the 1/4" phone jack. RG-174U coax then routes the signal from the jack to the circuit board and the rotor and stator of VC1. Equal lengths of coax from each side of the coil must be used throughout this routing to preserve the balance of the coil.

The ferrite rod/coil assembly is shock-mounted in a length of pipe insulating foam (available from hardware stores) which fits snugly in the loop housing. At this point, you can wrap a width of conductive tape (aluminum or copper) 3/4ths of the way around the foam which, when connected to the terminal strip's ground lug, will provide shielding for the loop. Quite frankly, I've found that shielded loops work only in certain situations and generally reduce the coil's Q (and therefore, loop gain) so, there's a trade-off.

H. Power Supply -- The *Quantum Loop* requires 9VDC which can be supplied by either a 9-volt battery or a 9-volt AC adapter and can be selected by a front panel-mounted switch. The *Quantum Loop* draws between 10 and 15 mA which is about 2X-3X the current requirements of some of my earlier amplifiers but, nonetheless, a 9-volt battery should last a fair length of time.

I. Signal Output -- The output of the JFET/MOSFET amplifier is routed to a cabinet-mounted jack and ultimately fed via cable to the receiver. Over the years I must have tried about two dozen different kinds of patch cables. It's been my experience that in loop applications the impedance of these cables is irrelevant. I've used everything from 50 Ohm coax to high impedance microphone cable and have never been able to discern any difference at all. What is important, however, is the amount of shielding the cable possesses. Coax cable shielding runs from about 70% to 100%; choose 100% shielded cable and your site/night/vertical effects will be minimized. The best cable I've found is computer Local Area Network trunk cable such as "Ethernet." Unfortunately, this stuff is really expensive and hard to find in short lengths. There exists 100% shield RG-8/M, RG-58, and various microphone cables; use one of these.

### LOOP OPERATION

A. Set-up -- Plug the loop head fully into the amplifier base and connect the patch cable to both the loop base and receiver. Install a 9-volt battery or plug in the AC adapter and

turn the loop and receiver on. Position the loop away from the radio's digital display (if it has one) and as far away from electrical wiring and other antennas as is practical. Positioning the *Quantum Loop* too near radios with poorly shielded cabinets (e.g., portables) could result in antenna/circuitry interactions and a resulting oscillation.

B. Tuning -- The *Quantum Loop* tunes in two ranges: 530-700 kHz in the "L" position; and 700-2000 kHz in the "H" position. In lieu of a vernier tuning dial, I opted for a dual diameter tuning knob. This is nothing more than a skirted knob measuring 1-1/2" at the skirt and about 7/8" at the grip. The smaller diameter grip allows for fast tuning while tuning by using the wider skirt permits easier fine tuning. Tuning of the *Quantum Loop* is very sharp and should be done carefully.

C. Gain Setting -- The *Quantum Loop* possesses more than adequate gain for most of my DXing situations. I've found that most radios (at least those I own) tend to perform best if the station of interest is producing no higher than an S-9 on the S-meter. Running the *Quantum Loop* so that most signals are in this ball park will take a load off your radio's front-end and mixer. As you are adjusting the gain, you will notice that the range of adjustment does not allow you to completely eliminate moderately strong and strong stations. This was a design decision on my part because I've never had the need to completely eliminate the signal (via gain setting) of a desired station. A brouhaha by users, however, would cause me to change the design. On a related topic, the dynamic range of the front-end J310 JFETs is in excess of 100 dB (according to the manufacturer and my own tests). I've not measured the present JFET/MOSFET amplifier for dynamic range because I've only used it in loop applications where signal levels are pitifully low.

D. Nulling -- I usually position the loop so that my elbow rests on the desktop and my fingers grip and rotate either the insulated vinyl tube or the microphone holder; I don't use the loop housing to rotate the antenna because the height is a little less comfortable and because the added leverage could strain the plug/jack.

To null weak to moderately strong stations, simply rotate the antenna for a minimum signal. As the null approaches, slow down, the null is very sharp and the deepest null is at a single point in the semi-circular rotation. On strong stations, especially locals in the daytime, it will probably be necessary to both rotate and tilt the loop. For this, I usually grip the loop housing to simultaneously tilt and rotate the loop. Here too, the deepest null will occur at a precise combination of tilt and rotation. I have no problem completely eliminating all of my locals but the strongest is only 10 kW; it is possible that a station producing unusual signal polarization will resist all attempts at nulling. Luckily, these stations are fairly rare.

On a related note: If the *Quantum Loop* is constructed as described, i.e., ensuring identical inductances in each leg of the coil path, you will end up with a nearly perfectly balanced loop (except for the fact that I've found a very slight measureable difference in the rotor's and stator's capacitances to ground). If you were to operate this loop far from antennas, housing wiring, metal cabinets, etc., the two opposite nulls would be virtually identical in depth and exactly 180 degrees apart. However, this ideal DXing location is not the typical one. Consequently, depending upon your location, you may find one null to be slightly deeper than the other and one null to be slightly skewed by a few degrees. In practical DXing terms, there's little you can do about this.

E. Routine Maintenance -- I've been using this basic design since about 1986 with no major failures. About the only thing I do to maintain the loop is occasionally remove the loop head from the amplifier base and clean and lubricate the phone plug with WD-40. I similarly clean and lubricate the stabilizing collar on the top of the base periodically.

All in all, I'm quite satisfied with the overall design and performance of the *Quantum Loop* but am open to suggestions for improvement. As I mentioned earlier, this is a very labor intensive construction project which requires tools and test equipment that may not be available to everyone. For this reason, I've assembled the components to make about 20 *Quantum Loops*. The price for one of these initial 20 is \$125 (plus \$4 UPS). This includes the AC adapter, patch cord, and connector of your choice (specify standard UHF, BNC, RCA, or alligator clips). You can contact me at 3635 Chastain Way, Pensacola, FL 32504. 73's....GT

# The Answer Man

"No Question Is A Dumb Question"

Answers to members' questions, from the basic to the technical

Hello, again! We have an interesting array of questions this time, so we'll get right to it!

**QUESTION:** I have noticed that it is almost impossible to buy a consumer portable AM-FM radio and tune the dial without hearing shortwave broadcast, code, and the like. Why is this?

**ANSWER:** There are all sorts of reasons for this, many of which are covered in the article "How to Live With a Budget Receiver" contained in the NRC Receiver Reference Manual, Volume I, and still more of which are discussed in the article "Spurious Signals" by the late Gordon Nelson (NRC Reprint # R-1). Receiver design compromises are the largest single cause. In order to make receivers lighter and smaller, such DX necessities as multiple conversion stages and filtration are reduced or omitted. Another cause is the relaxation of regulation and the resultant proliferation of stations, more having higher power, and more with directional arrays which concentrate the signal in such a way as to be more likely to cause receiver overload when listening nearby in the main pattern. The combination of these factors which frequently occurs is quite devastating.

**QUESTION:** What's the deal with "scratchy" volume controls? Frequently these become unusable after the radio hasn't been used in a while. Could I pack a simple portable radio away for a hundred years and expect it would work whenever someone opened it?

**ANSWER:** If you can get by the probability that appropriate batteries wouldn't be available after that time, and that batteries generally won't last over time, the answer is only a "maybe". If stored under optimum conditions of temperature, humidity and dust elimination, it might be possible. Generally, however, we know that many of the components used in the first tube radios which were manufactured in the 1920's and 1930's (capacitors and transformers in particular) did not stand the test of time. Since we have no way of knowing about current components, it's really a toss-up.

**QUESTION:** Why do some stations have pre-sunrise authority at lower powers than their normal night power? **ANSWER:** Although this subject is discussed in detail in my article "What is a Pre-Sunrise Authorization?" (NRC Reprint # D4), the short answer is that either they are using their daytime antenna authorization or an antenna configuration more favorable than their

R. J. Edmunds

753 Valley Road  
Blue Bell, PA 19422-2052

night pattern. The night power is relative to the pattern used, and the critical issue is the combination of the two, not just the power.

**QUESTION:** Why do some stations apply to lower their power? You would think that they would want to have the greatest power possible to reach the most listeners.

**ANSWER:** The answer is similar to that for the prior question. It's all a matter of the combination of power and pattern. A lower power with a less severe pattern may net them more listeners than a simple power increase, and it may also cause less interference to co-channel or adjacent channel stations. In some cases, it may become technically impossible or expensive to achieve or maintain a power/pattern combination which may have looked good "on paper" or in test.

**QUESTION:** Why are stations spaced every 10 kHz. in North America, every 9 kHz. in Europe, Asia and Africa, and every 5 or 10 kHz. in Central and South America?

**ANSWER:** The quick answer is that in most cases it's a matter of politics in the creation of the particular international broadcast treaty or agreement which is negotiated in that part of the world. Another factor in that is that in most European, African and Asiatic countries there are fewer AM stations than in North America, and pretty much always have been. For whatever reason, adjacent channel interference tends to be more of a problem here.

**QUESTION:** How should I determine what receiver to buy? What antenna to use?

**ANSWER:** This is probably the most frequently-asked question and yet the hardest to answer, because everything is subjective, and the individual DX'er's interests, physical space limitations, local environment and financial considerations are all highly variable. I would suggest several articles: "How to Live with a Budget Receiver" in the "NRC Receiver Reference Manual - Volume I"; any receiver review in reprints which may seem appropriate. As to antennas, there are numerous variables, some of which are dictated by what the receiver will accommodate. A balanced, amplified loop, for example, requires three terminals. Most other loops require two. A wire and ground require two. Many receivers only have an antenna terminal. Both volumes of the NRC Antenna Reference Manual contain articles for loop construction -- from simple to complex. A loop is

a directional, generally indoor antenna. A wire can be indoors or outdoors, and, at short distances (under 100 feet) is pretty much nondirectional. Longer wires (up to Beverage size -- 1000' plus at minimum) display varying directional characteristics, becoming more pronounced with increasing length. Good BCB results can be achieved with a wire of as little as 30 or 40 feet in length, if it is straight, insulated from its mounting points and from objects touching it in midspan, if it's not near any known electrical noise sources, and if the feed wire is situated and shielded properly (see Dallas Lankford's DXN articles last fall). Finally, don't overlook the DX value of many of today's digital AM/FM car radios. I do about 70% of my DX on one, and have since I became active again 3 years ago. I realize that this isn't a specific answer, and that it may not be of immediate help, but I would suggest holding off on buying a receiver right away, and perhaps to experiment with a very basic loop and/or wire antenna to get started.

Most of us started that way until we grew more accustomed to the available options. Watch DDXD and IDXD for names and model numbers or receivers which you may have seen in prior shopping, and remember them for the future.

**FINALE:** The prior question raises a point that perhaps someone with the time and experience to do so might want to consider researching and writing an up-to-date article summarizing what types of budget receivers are available, and what their features are. Perhaps a basic survey of BCB DX antennas might be another article topic.

Okay, that does it for this time. I'd like to get in one more column this season, and my target date would be late April or early May. That means a deadline in early April. Let's see what we can get in here by then!

73's RJE

## In the Beginning

John D. Bowker

The complete list of U. S. broadcast stations on the indicated frequency as published by the Federal Radio Commission in 1934. "S" = shared; "SH" = Specified hours; "T" = Transmitter location; "D" = Daytime operation only; "U" = Unlimited time

Frequency (kc)	Call letters	Main studio and transmitter location	Power	Time designation
1380, regional.	WSMK	Dayton, Ohio-----	200 w-----	Simultaneous D-KQV. S.H. night.
	KQV	Pittsburgh, Pa-----	500 w-----	
	WKBH	LaCrosse, Wis-----	1 kw-----	U.
	KOH	Reno, Nev-----	500 w-----	
1390, regional.	WHK	Cleveland, Ohio-----	{1 kw-----	U.
		T—Seven Hills.	{2½ kw LS }	
	KLRA	Little Rock, Ark-----	1 kw-----	U.
	KOY	Phoenix, Ariz-----	{500 w-----	
		{1 kw LS }		

### Need more information about Medium Wave DX'ing?

Mail \$1.00 to NRC Publications - P. O. Box 164 -  
Mannsville, NY 13661-0164, and ask for the Reprints Catalog.

### Music Grade audio cassettes

C-90 tapes: retail value ... \$4.00 each; now at a special price of \$9.00 per 10, \$22.00 per 25, or \$42.00 per 50.

C-60 tapes: Hurry, quantities limited: 10 for \$8.00.

C-12 tapes, while they last, 10 for \$7.50.

Order from NRC Publications - Box 164 - Mannsville, NY  
13661. NY orders, please add sales tax.

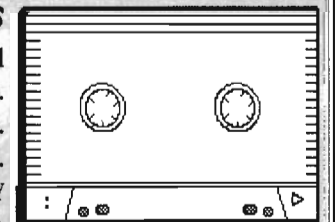

# Radio Waves

*News of the industry, of interest to DX'ers*

Greetings and salutations, all static fans! Time again for more news of the industry, of interest to DXers ... In light of the demise of the Birch radio ratings service, Willhight Research has decided to make its service available nationwide. Willhight is a 10-year-old Seattle-based ratings firm which regularly surveys many Northwestern markets. Willhight says it has no plans to provide a nationwide service such as that provided by Birch; rather, it will survey a market only if there is station support for its service. Willhight uses a 24-hour telephone recall method with larger-than-normal sample sizes. For example, in Yakima County, WA, Arbitron bases its ratings survey on a 350-day sample, while Willhight's in-tab sample size there is 1,000. The company's research is also rather detailed, asking respondents for call letters, band and dial position, city, format, slogans, special programs, and DJ names ... On a related note, Arbitron has listed WPLJ-FM NYC below the line in the fall '91 ratings. Though no ratings distortion occurred, Arbitron stated that "radiothon" promotions which blend discussion of ratings from prior surveys with requests for listener support and/or statements emphasizing the importance of ratings, have the potential to create bias in current or future surveys." I see WPLJ has finally dropped the "Mojo" moniker. Guess they figured out nobody knows (or cares) what it's supposed to mean ... Mom and Pop radio stations could become separate entities as a result of an FCC ruling late in February. The Commission abolished its policy that the media holdings of one marriage partner are automatically attributable to the other, unless the spouses prove that they maintain separate careers and don't exert control over each other's media

## Laura McCusker

Oakbrook Manor #23E  
Ravena, NY 12143-1017

holdings. Spousal relationships will now be treated the same as other family relationships, the bottom line being that Mom and Pop may now compete within the same market! ... An update on WJDM-1530, Elizabeth, NJ's bid for going full-time: The NJ congressional delegation recently tacked a rider onto telemarketing legislation which requires the FCC to find a way to get larger-market daytimers on the air at night. The daytimer must be the only station in a city of more than 100,000, and the city must be within the FCC-recognized service contours of a protected clear-channel AM on an U. S.-controlled frequency, to qualify for the legislation.

According to research by *Radio Business Report* and the *M Street Journal*, only two other stations might benefit: KIDZ-1510 Independence, MO, and WUFL-1030, Sterling Heights, MI. WJDM owner John Quinn says he doesn't expect to get nighttime authorization in the current AM band. Instead, "I want to be the first station authorized in the new, expanded AM band." ... And lastly, the FCC has been asked to reconsider some provisions of the recently-introduced AM rule change package. A major problem, according to the Association of Fed. Comm. Consulting Engineers, is the "10% Rule", requiring any AM station that wants to increase power or move its tower to cut its signal radiation by 10% in the direction of all stations within a few hundred miles, even if it is not presently required to protect such stations. AFCCE says this new rule "will discourage facilities changes that could be beneficial to the AM industry." .....

Information from *Radio Business Report*  
*Radio & Records*

## Radio Roundup

*News of radio personalities, of interest to DX'ers*

Greetings all ... April Fool's Day brought many jokes to the airwaves. When WABC's Curtis and Lisa Silwa passed the mike over to the Metro Traffic reporter the listeners were

treated to the Spanish version, aired on Latin stations in the market ... CBS's long running newscast, "The World Tonight," is about to undergo a little fine tuning. Many of the

affiliated stations indicated that they wanted a shorter version of this daily 15 minute broadcast. Currently stations are fed the full fifteen segment with a cutaway at the nine minute mark, with stations having the option of airing the last segment. The broadcast is currently being hosted by Christopher Glenn, who took over from the late Douglas Edwards. Others who have held the chair include Ned Calmer, Blair Clark, Dallas Townsend, Robert Trout and Doug Polling. The show made its network debut in 1947 and is currently aired on some 300 stations. Trivia nuts take note that the morning version, "The CBS World News Round-Up", went on the air in 1938.

If you're a Bob & Ray fan and will be in New York City, between now and September, be sure to stop by the Museum of Television and Radio to take part in the Bob and Ray Retrospective. Join the likes of Wally Ballou, Harry Backstayge, Mary McGoan, the MaBee Twin as well as Bert and Harry Piel, of beer fame. The Museum is located on 25 West 52nd Street. For more details given them a call at (212) 621-6800 ... The Christian Science Monitor has ceased operating its cable television channel. They had been losing an estimated four million dollars a month ... Sharp eyed NRCer Jeff Mutter along, via the Charlotte Observer, that WBT-1110, in Charlotte, NC, has decided not to sell any air time for political ads. The station says they don't have to accept advertising. The bottom line appears to be money as the F.C.C. regulations say that stations must offer political advertisers the lowest unit rate available. According to an F.C.C. ruling, January 4th, stations are not obligated to accept political ads. This ruling doesn't affect Federal races ... After a brief stay in the BIG APPLE, Garrison Keillor is taking his cast back home to its roots, "the little town that time forgot and that decades can not improve (Lake Wobegon)." The American Radio Company is going back to the World Theater in St Paul, where its original show, the Prairie Home Companion got its start in 1974. Keillor will keep his apartment in New York City and produce 8 to 10 shows from there next season. He likes New York but laments that he still feels like a tourist there. His show currently is aired from the Brooklyn Academy of Music on nearly 275 stations ... A new book has appeared on the shelves exploring the life of legendary Disk Jockey, Alan Freed. Check out *Big Beat Heat* by John Jackson, published by Schirmer. The book has recently won the 1991 Ralph J. Gleason Award for music books.

On the subject of DJs, does anyone have an air check of Mad Daddy, a.k.a. Pete Meyers? He was one of the most creative talents in New York. When WINS went all-news he

went over to WNEW. If so, let me know ... If you enjoyed listening to New York Radio in the '50's and '60's then be sure to purchase a copy of the videotape "Sweet Talkin' Guys," available from Rhino Home Video, the video arm of the famed Rock and Roll record label. Hosted by Cousin Bruce Morrow, this video has interviews with many of the top jocks of that era, as well as a variety of historical clips and airchecks. You won't want to miss out on this tape, and you'll watch it time and again.

Ernie Harwell, the King of Detroit baseball broadcasters, has a new team to play with, the CBS Radio Sports Team. He will be teamed with Johnny Bench, Jerry Coleman and Vin Scully to cover the Game of the Week ... WNEW-1130 has dropped Geri Latchford from its news staff for budgetary reasons. That leaves this 50,000-watt, one-time programming powerhouse with a news staff of ONE, that's right. This will leave Shelli Sonstein to do double duty, doing the news on FM-sister station WYNY too. What a sad state of programming ... Jim Lampley has hired on as the afternoon sports show host at KMPC, when they go all-sports April 27th. He had recently lost his TV News Anchor job at KCBS-TV. He has also signed a separate contract with NBC Sports. He'll be covering the Summer Olympics, NFL play-by-play and a six-game Norte Dame football deal. All this and HBO Sports too! Guess he thinks he's Marv Alpert ...

Morton Downey, Jr, TV's BIG MOUTH, has returned to the airwaves, this time on AM radio in our nation's capitol. He has just signed on for a mid-morning talk show on WWDC. Downey has penned a two-year contract and hopes to syndicate the show ... NRCer Perry Crabill, Jr. reports, via the (Strasburg) *Northern Virginia Daily*, that supermodel Christy Brinkley is about to become the voice of a ten-ton concrete duck that rests along side a roadway in Flanders, New York. Brinkley recorded a 120-second tape, to be aired on low powered radio transmitters, including special events and bits of Long Island history. The famous duck has just celebrated its 60th birthday ... Leida Snow, a 13 year veteran, as a theater critic at WINS-1010, has signed on to WNEW-1130 in a similar capacity. She will be heard on Fridays ... Scott Shannon's Rockin' America syndicated countdown show has been shelved by Westwood One, by mutual agreement, after an eight year run ... Westwood One has just signed on MTV's Downtown Julie Brown to host America Dance Traxx, replacing Jeff Whyatt ... Thanks to NRC'ers Perry Crabill, Jr and Bill Hale for their newspaper clipping reviewing PBS's "Empire of the Air: The Men Who Made Radio." This documentary, based upon the

book by Skidmore College professor, Tom Lewis, has been well received by the critics and radiophiles everywhere ... Phil Boersma reports, via the *Grand Rapids Press*, that listeners were either entertained or not too pleased by WCUZ's reporting of hunters going into the Wisconsin woods to hunt a werewolf. Nighttime DJ Ron Bailey, together with the help of the Grand Rapid Radio Players, took listeners across the Big Lake. At the conclusion of this theater of the mind, the following disclaimer was aired "You have experienced the power of radio. No other medium can match it, can touch it, can even see it. Radio is alive and thank fully so are we." ... Dave Schmidt reports that WPCR-1540, the home of Jerry Blavat, has been sold to All Star Radio. Blavat will remain on the air and become Operations Manager ... John Bowker reports, via the *Chicago Sun-Times*, that WSCR-820 is now on the air as an all-sports station. Trivia nuts take note that the station signed on at 7:15 AM CST, with sports-talk show host Tom Shaer. He remains on the air as a sports anchor for WMAQ-TV. He had worked previously on the AM band at WGN and WBBM ... WLS-890 has signed on to the ESPN Radio Network on weekends ... WRBQ-1380, in Tampa, has gone the satellite fed route, carrying the Touch, an urban adult contemporary format from the Satellite Music Network in Dallas. SMN reports that it has over 1,000 affiliates across the United States and the Caribbean ... Despite pretty good ratings, the Ron Reagan Show has been dropped by KSDO-1130 after a two-year run. He will be replaced by Rush Limbaugh, who recently found himself without a home in the market when XTRA-690 announced its plans to go All-Sports ... Carl Dabelstein reports, via the *St. Paul Pioneer Press*, that WCCO's Boone and Erickson Duo is splitting up after a 30 year run. Charlie Boone will be replaced by Dave Lee. Boone will remain with the station in a number of on-air capacities. The famous Boone-Erickson skits will remain on the air for at least another year, with a possibility of an extension if they can come to a contractual agreement ... From the What Ever Happened To- Department, Claudia Lamb, Mary Hartman's TV daughter Heather, is now the morning talkshow host on mighty KCMO-810, as reported by NRC'er Todd Brandenburg from an article in *The Kansas City Star*. A lifetime in the business, at the young age of 28, she was once the poster child for a line of Mattel toys that didn't do too well and appeared in over 50 national commercials as a child ... Jack Horner sent in a Dear Abby column of November 23, 1991, where a reader bemoans the fact that while traveling she couldn't figure out the call letters

of any of the radio stations she heard on a recent long-distance trip. Another article on the subject appeared in the February 24, 1992 column of Hints From Heloise. It seems like Dear Abby/Heloise readers and Broadcast Band DXers share the same problems when trying to identify certain stations ...

WLUP isn't winning any friends in Washington, D.C. They have refused to pay the \$6,000 fine assessed by the F.C.C. The Department of Justice has been brought into the case. The F.C.C. had issued fines upon hearing excerpts from the Steve (Dahl) & Garry (Meier) Show which were judged "indecent." An attorney for Evergreen Media Corporation claims "free speech" issues are at stake ... WCBS-AM, the flagship station of the Columbia Broadcasting System, has avoided stiff fines, having gotten off with a written reprimand, for failure to properly carry out its alerting responsibilities as part of the EBS system. WCBS played a pre-recorded alerting tape, not the live tones required (part 73.94). The tape system did not transmit a pure tone, thus the dedicated alerting receivers, employed by stations down the line, were not activated during Hurricane Bob's arrival on the east coast last summer. The F.C.C. said the WCBS avoided fines due to their past record of EBS support. Reaction was quick from WDOE in Dunkirk, NY, as they were fined \$1,250 for failure to follow EBS rules. On the surface, an F.C.C. spokesman said, it looks unfair, but it really isn't. This column editor doesn't think that the last word has been heard on this subject. CBS management has requested changes to the New York State EBS procedures ... Ron Nessen, Vice President (News) of Westwood One's Mutual Broadcasting and NBC Radio, will be the host of "The Media Inside", a new daily feature to appear on the NBC Radio side on their operation. On the Mutual side of things, "The Entertainment Report" will be added to their line-up, with Chuck Rich as host ... WSCR has become the first All Sports station in Chicago. WSCR has a limited broadcast day, as the BIG Texas voice of WBAP shares the same frequency ... The Business Radio Network has begun a new programming service to be called "The American Forum." AF will feature interactive talk programming and incorporate Star Communications "Sports Extra" and "Sports Final" ... NRC'er Eric Bueneman checks in with some interesting tidbits...WFOM-1230 in Marietta, GA has been sold to Toccoa Falls College and is expected to change programming to a light Contemporary Christian format ... Michael Dixon has replaced Bruce Bradley on KMOX-1120, in Saint Louis ... The Business Radio Network has a new affiliate in St Lou having signed on WRYT-1080 ... KGIR-1220 has signed on to satellite fed programming picking up SMR's Stardust package ... WSJP-1130, in Murry, Kentucky has started

programming Rock on Friday and Saturday nights, departing from their usual Country & Western offering ... KGLD-1380 has changed its calls to KASP and is now programming All-Sports ... WQXI-790, in Atlanta, has affiliated with the NBC radio Network ... Atlanta's long-time talker Ludlow Porch has an interesting on-air arrangement. He is live on WGUN-1010 and can be heard overnight, on a tape delayed basis, on WSB-750. Ludlow's show also airs on WNEX-1400, in Dublin, and WMLT-1330, in Milton, Georgia ... WDGR-1210, Dahlonga, GA has gone off the air for financial reasons ... NRC'er Barbara Lombardi checks in with information on WADS in Ansonia, CT. WADS's impending sale has been put on hold, as former employees have filed suit contesting the sale. The station's management and engineering practices have also come under close scrutiny. The station programs heavily in Portuguese, despite the fact that only 2 to 3 percent of the area's population is Portuguese. One of the station's owners also owns WACM in West Springfield, MA which programs a similar format. The station has "no overhead" as it canned all its on-air and support staff, now relying exclusively on independent programmers, who sell advertising on their own shows and pay the management a share of the revenues ... Tampa's WFLA didn't look too good on a recent 20/20 segment, on ABC. The station's defacto conditions of employment came under quite an attack. Interesting to note that the station settled out of court with the primary party involved ...

G. Gordon Liddy, of Watergate fame, has surfaced as a mid-day talk show host on WJFK, from 10 a.m. to 2 p.m. weekdays. Interesting to note that WABC, in New York City, also was in the bidding war for his services ... WAVA, in our nation's capitol, has been sold to Salem Communications. Look for a programming change to Religion, just as the company did with WMCA in New York a few years ago ... Ken and Daria Dolan, who host a 1-3 p.m. money show on WOR will be adding business reports to their schedule on the morning Rambling with Gambling Show ... The National Association of Broadcasters (NAB) has formally endorsed a plan to encourage In-Band development of Digital Audio Broadcasting (DAB) technology. Other parties in this action have proposed additional frequency allocations for this new technology. As this battle continues the World Administrative Radio Conference (WARC) is taking place in Torremolinos, Spain ... In response to the recent rash of hoaxes perpetrated by on-air personalities, the F.C.C. is looking to re-evaluate its regulations on the subject to tighten things up a bit. The NAB has voiced objections, as the current rules are too vague ... In the new budget submitted by

President Bush holds, the F.C.C. will see an improvement in its bottom line from \$126.9 million to \$153.3 million in 1993 ... CNN Radio programming will be beamed to Africa via satellite's AfriStar 1 when it commences broadcasting in early 1993. They will be using S-band DAB technology ... Here are some of the new frequency assignments for the expanded AM band: KJLA, Kansas City to 1660, WLKF, Lakeland, Florida to 1680, WKCM, Hawesville, Kentucky to 1640, WAOK, Atlanta, Georgia to 1670, KHVN, Fort Worth, Texas to 1660, WDNB, Daytona Beach, Florida to 1640, and WONE, Dayton, Ohio will be moving upward, but is currently awaiting its new allocation ... Radio Broadcasting Data Systems (RBDS) will start to take a foothold here in the United States, once the F.C.C. establishes standards, expected in mid-1992. This system, which has been employed in Europe for many years, allows radio listeners to receive data via a scrolling screen on a standard AM radio. These systems are popular in Europe. Stations transmit their call signs, slogans, general and emergency information to listeners via a sub-carrier. General Motors already has a car unit with decoder ready to go ... Bill Mazer, one of the best sportscasters in New York, has surfaced on WEVD-1050, as the new morning man 5:30 to 10 a.m. weekdays. It is interesting to note that Mr. Mazer has been on 1050 before, as he had worked for WMGN, WHN and WFAN. His new bosses say he can talk about anything he wants, not just sports ... *Empire of the Air: The Men Who Made Radio*, by Skidmore College professor Tom Lewis, has been a BIG hit with radiophiles. This PBS documentary traces the roots of radio broadcasting and was most enlightening. For those who missed this program, a companion book is available from Burlingame Books ... Westwood One Radio News has expanded its overseas operations to provide additional international news to its NBC and Mutual Radio networks ... Howard Stern's on-air reporter "Stuttering" John Melendez now has his own show on WZRC-1480, Friday nights ... Bob Costa's weekend Coast to Coast has switched from WFAN to WABC in New York ... *Billboard* Magazine has listed KLOS's Mark Thompson and Britan Phelps as top radio personalities of the year ... Jack Buck has been replaced by Sean McDonough, to team with Tim McCarver, for CBS Baseball coverage ...

Your contributions to this column are welcome. I may be reached at the address above, via CompuServe 72376,2557, GENIE P.Kemp3, SWL/Ham/Broadcasting echoes on Fido, or amateur radio packet KZ1Z @ KIUOL.CT.U.S.A.N.A ... So much for now.

## Is AM Dying? ... via César Objío

What you are about to read is the translation of one article published in a Santo Domingo newspaper related to radio, more exactly to Medium Wave, or AM as it is named now, even though it does not say so directly, with its importance being diminished by television and FM, and its becoming more and more outdated or obsolete, as it has been mentioned in other clippings from U. S. newspapers I have read in DX News.

### Who Pays Attention to the Radio?

by José Luis Sáez, S. J.  
(from *El Siglo*, March 10, 1992  
Santo Domingo, Dominican Republic)

Perhaps This is a bad selection for a title to this little article. To the reader, if there is anyone who might read it, perhaps he would have liked to ask: "Who listens to the radio?" or "Who hears the radio while doing something else?" That expression, "pays attention", is the same as saying that nobody pays attention to the radio at all, because listeners have lost the faith they had in it. Maybe the reader is right, although if that is his reasoning, he reveals himself as a nominalist, and, for that reason, he would like to start useless arguments.

It is of no importance what is the meaning or where that expression "pays attention" leads to. In a vulgar language we have always said that we should not hear what is being said, but just that: "nobody pays attention to it."

The world radio, and, in the same way, our radio, have entered since some years ago into a new stage in its commercial history, which is already seventy years old. Television, and in some cases, the same flat press, have been forced to renew itself or just adopt a new style and, probably, a new objective.

When I was a child, and I hope I am not the only one who has had that experience, radio was a household instrument which completed the winter evenings around the heater, and to many it was the beginning of sleeping. When there were still readers, and the soap operas had already started, based on second-hand literature, radio challenged but it did not reject the community reading. At least in my home, after listening to the radio versions of three or four novels, we used to read those same novels in groups, perhaps with the intention of checking if the radio novel was as exact as the original. So, that way we read, for instance, "Sinfonía Pastoral" by Armando Palacio Valdes, "Marianela" by Benito Pérez Galsós, and "Cristina Guzmán",

one of those big books as we used to call them today, by Carmen de Icaza. [Those are famous Spanish novels -C. O.]

Interview programs had not yet been introduced, and we did not know what a panel was, except for that thing that separates once space from another one. "The round table" was not yet conceived, and the newsreels, in spite of being entitled as "the spoken daily news", did not go beyond the government opinion. That is the reason why for a long time people denominated these newsreels as "the part" (or the report), remind you that something like this used to be broadcast during the war, any war.

As radio wanted to be everywhere, some dramas were broadcast directly from the stage. I think that all those interested in it, and I was one of them, had to develop their imagination, as the only thing that the speaker did was to read the cast, and, then in a low voice, describe the setting before saying goodbye until the intermission.

A long time later, radio defined its social role, its finality and style. No doubt that the newspapers must have been one of the decisive factors for the new stage of radio. The same had happened with documental films; the Second World War made radio a very fast and more trusted source of information and a lot more when it came from a foreign radio station.

Since then, and still more when several countries lived in a stage of political freedom or just tolerance, radio ratified its role of a trusted communicator. Due to the lack, then, of portable recording equipment, and, with a great deal of imagination, radio information won its place with rapidity and even with dynamism. When the speaker said: "Now we connect with our microphones installed at the place of the action," the family seated at the table ordered the forks to be quiet, and we all looked toward the receiver, as if in this way the news could be heard much better. We don't know why but the ear required the eye in order to catch much better what was being said.

When television entered in a real competence with radio - and much more now when we have other resources of simultaneous transmissions - the second one had to question itself seriously what was its real work. And one of its salvation boards was to become a "background music station", because it could do this better than anybody else. Because of that, radio, during the sixties and seventies, starts to change its face and becomes a simple broadcaster of music for all tastes, only interrupted by the announcer who

speaks at the same volume of that music and then the unavoidable set of commercials.

With that kind of radio, the traveling companion, or just as a work complement, who is going to pay any attention to it? Who is going to stop and listen as we did during the forties? And finally, who is going to care for that?

*In our country, in order to stay alive, our radio (meaning AM radio) has dedicated its time to several well-defined programs: newsreels, world and local news during the day and at special times: in the morning before going to work and while you are preparing yourself to leave for work, later after six o'clock when you are supposed to arrive home. In the afternoons and evenings, presentation of major league baseball*

## A New Tune For Radio: Hard Times

By EDMUND L. ANDREWS

**T**HOUGH a dedicated optimist, Randall Harris looks out from his tiny AM radio station in Sarasota, Fla., and periodically wonders whether survival is possible. When his father bought WSPB two years ago to air classical music, the station was so unprofitable that its former owner had turned off the transmitter. Since then, at least two other stations in the city have "gone dark," in industry jargon, and two more broadcast on and off as their owners search for successful formats.

Mr. Harris says he doesn't expect to see his first annual profit until 1993, and he is working feverishly to persuade advertisers that classical music has an audience and that his station's ability to broadcast in stereo makes it possible to overcome the notorious inferiority of AM sound. But the competition is brutal: broadcast and cable television, daily and weekly newspapers, free shopping flyers and direct mail. "The future of radio is bright," Mr. Harris contended. "But it's 10 years from now. Right now, it's incredibly difficult."

WSPB's story is relatively positive in today's radio industry. Once the principal medium by which people received their news and entertainment, radio has become a sick industry where small stations are falling in droves, forced to slash newsgathering and original programming. The problems are much deeper than the current recession. Over the last decade, the Federal Communications Commission has licensed 2,000 new stations, bringing the total to 10,800. Meanwhile, the growth of cable television, telephone marketing and other forms of advertising have spurred intense competition for ad dollars.

In financial terms, the result has been a bloodbath. The National Association of Broadcasters estimates that most stations are losing money. Like the population of a troubled third world country, the radio industry has become divided into two groups: the wealthy few and the impoverished many. According to N. A. B., the nation's 50 biggest stations generate about 11 percent of the industry's revenues and about 50 percent of its profits.

Once, broadcasters who had fallen on hard times would have been able to find an eager buyer for their licenses. No more. The F. C. C. reports that 287 stations have simply shut down operations, 155 in the last year alone, because their licenses had become worthless.

Hoping to stem the financial decline of commercial radio, the F. C. C. last week eased regulations limiting a single company from owning more than one AM and one FM station in one city and more than 12 of each nationwide. The new rules, a boon to big broadcasting companies, will enable a company to acquire as many as six stations in a single city and as many as 60 stations nationwide.

Most broadcasters argue that consolidation will help the industry become more efficient, allowing it to cut costs and invest in expensive programming that reaches a bigger audience, while critics say it will enable a few big corporations to dominate. But even those who say the old rules have become outdated admit that radio's ills will not be solved just by changing ownership rules.

games during the U. S. season or in our winter season; local basketball games or NBA or old romantic music, nostalgia-wise, for the older people who still dream with they bygone times, remembering those beautiful songs they used to sing or listen to during their youth, avoiding the actual rock or disco music which makes no sense for them. Because of this, many local stations have been sold to religious groups, as the owners have seen themselves in bankruptcy and no longer able to support the stations, all advertisements going to TV or stereophonic FM. And these religious groups, as they collect a steady quota from their members, they always have enough money to support a radio station and spend the whole day and night with their talks and religious services.

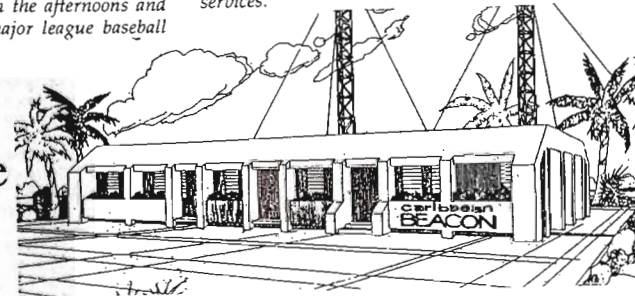

Small stations that remain have cut back or dropped active newsgathering. "It is unassailable that stations have been cutting back dramatically on old-fashioned newsgathering, enterprise reporting, where reporters go out and cover stories," said Richard Bartlett, president of the Radio-Television News Directors Association.

### Robot Stations

Many small stations have virtually stopped airing any original programming at all. In the last year, a growing number of stations have essentially been transformed into robot transmitters that broadcast material of more powerful stations elsewhere.

Broadcasters and the F. C. C. deserve part of the blame for their plight. AM stereo has been technically feasible for years, and many car radios are equipped to receive it. But the Government refused to order the industry to adopt a particular standard in the early 1980's, and broadcasters became split between two rival technical approaches. As a result, AM stereo was largely stillborn and failed to help stem the decline relative to FM radio.

Meanwhile, social changes have compounded the problem. The phenomenal rise of nationwide mass-merchandise stores like Wal-Mart has displaced small-town retailers that once advertised heavily on radio. Big mass merchandisers rely more on national advertising than local radio.

What may be the biggest challenge yet is still on the horizon: digital radio, which proponents say can offer the clarity of compact disks and may be broadcast from satellites within the next several years.

Yet, just as the advent of television failed to stop the growth of radio, and just as videocassette recorders hardly spelled the end of movie theaters, radio continues to have certain unique advantages. It is cheap, local and, at least for now, the only form of broadcasting most people can receive in their cars.

### The New York Times - via Peter Weeks



HCBJ

UN MILLON DE VOTOS  
LA VOZ DE LOS ANDES  
14 idiomas  
HOSPITALES VOZANDES  
Quito - Shell  
LIBRERIA VOZANDES  
Literatura - Música  
CENTRO DE EVANGELISMO  
Y DISCIPULADO  
Cursos Bíblicos  
Consjería - Películas  
PRODUCCIONES VOZANDES  
TV  
IMPRENTA VOZANDES  
Villalengua 278

CONMUTADORES:  
241550 - 433512  
433603

Hospital Vozandes  
Telfs.: 241540  
241541 - 241542  
Noticias: 241565



# Musings

## of the Members

*Thoughts from NRC members ... the opinions expressed in this column are those of the individual writer and do not necessarily reflect those of the editors, publishers, or the National Radio Club, Inc.*

### Dave Schmidt

P. O. Box 11502

Wilmington, DE 19850-1502

*Times are local per Muse; submit double-spaced only.*

MARK CONNELLY - 30 WILLIAMS ROAD - BILLERICA, MA 01821-6079

Local stuff first - WMVU "News 900" is on from Nashua, NH w/a news/sports/talk format. It is probably using the facilities of long silent WOTW, the signal is about the same as that from WOTW's old 1 kw rig. They clearly dominate the channel here days, way c/WCLZ (ME). WCLZ can only be brought in clearly by phasing or looping WMVU. WKPE-1170 has been off for a while now, I'm not sure if this is permanent. I miss them as I liked their rock and because they were useful here for judging performance of antenna systems on signal paths to the eastern Caribbean and Brazil. If they were loud compared to stations in the "pest" direction (eg: west), a given Antenna-Under-Test would clean up during an aurora. With both WKPE & WJCC gone, 1170 is now fairly empty here days (line noise is heard). Maybe pre-sunset 1170 TA's will be more likely now. I'll have to check out 1170 throughout the day from a good beach/saltmarsh location such as Salisbury, MA. WNSH-1570 is still off - maybe forever! WUDK (ex-WOCB) has been on with CNN News format for a while, it dominates 1240 w/WOON/WFTN in the background. For the last few months, local WUNR-1600 seems to have dropped power considerably (perhaps to 1 kw or less from former 5 kw). WUNR used to be within 3 db of WNTN-1550 but now it is at least 10 db weaker. WLNG can be heard days more easily in a loop or phaser null. At night, even within 15 miles of the Newton WUNR transmitter, interference from WRWL can be bad. Recent activities: I've been more active at DX-project building/testing than dial twisting. Conditions haven't been too impressive, just a few of the highest-powered 'routine' TA's have been showing. Of course, after having DX'ed with phased beverages from NFLD, little that can be heard here is likely to be impressive. On another matter, I think all DX columns should use GMT/UTC rather than a mix of local times. That's what the ham & SW clubs do. Also, because number style dates (eg: 4/2/92) aren't universally consistent, a date w/a 3 letter month abbreviation is preferable (eg: Apr 2 or 2 Apr). Language abbreviations still differ between MW & SW clubs, is there any real justification for this? SW clubs typically deal with more different languages, so their abbreviation scheme is more advanced. MW types should adopt it. Comments? As we move from the DX season to the spring/summer antenna construction/test/repair season, don't forget to send in your antenna tips. 73

KARL V. JETER - 2115 SCARBROUGH ROAD - STONE MOUNTAIN, GA 30088

The ups & downs of self employment, during JAN & FEB, during prime DX times, I was incredibly busy. And now that spring has arrived with it's lousy conditions, guess what? The workload has diminished-hi! Oh well, I did at least get to attempt most of the scheduled tests, but the results were mixed. The down side is that out of somewhere between 50-60 tests published in both clubs, I only heard 10 total. The upside is that I was able to hear some rare states (though no new ones), such as UT #2 (KMTI-650), First UT logging since 1969's KSL! Ditto for DE, w/the WDOV-1410 test, first since 1970's WDEL-1150. Also got NM #3, KHAC-880 and other infrequently heard states like NJ (WJIC-1510) & NY (WIQT-820). Other tests heard & verified are WVWV-630, WSKE-1040, WQTW-1570 (actually unnn., turns out!), KMYZ-1570 & WGEE-1360. So far, only WIQT-820 has failed to reply and a followup has been sent to them. The next verie milestone of 1500 is already within striking distance, as the total is currently at 1478. I would like to hit that lofty goal by years' end. The local AM dial continues to "shake out" a little more (or should I say, semi-local) as now W06R-1210 has been noted silent for the past few weeks. That can be added to the list of others that have bitten the dust, such as WLBA-1100, W2AL-1410, WFOM-1230 & WMLS-1490. The other trend in local radio is to SS programming, now heard on 1400, 1450 & 1600 (the latter 2 being in that grand Cuban broadcasting tradition, parallel). A few highlights of recent DX: 3/21 JBC-1 700 in rock solid during auroral conditions which knocked out WLW completely from 8:26-9 PM, with a popular music program. With them recently verifying a report, I may try (yet) again. On 3/19 a log taken on on XEAR-660 Tampico w/"La Mexicana" slogan, 6:10-6:30 AM in also somewhat auroral conditions. 3/9 WHOG-1120 logged w/UC music and "The Power Pig" slogan (no kidding) at 6:44 PM before the signal disappeared. It looks pretty good for me to make Des Moines this year as I can tie that trip to St. Louis to see my folks (and drop off the son so he can stay with his grandparents). I did this with the Topeka convention and it worked well. 73

ERIC BUENEMAN - 4856 OLDE MILL DRIVE - MARIETTA, GA 30066-1159

Corrections from my MUSE V59#23, KGLO (now KASP) had no news at the top of the hour. Also, WCHK is on 1290, not 1260. From BILL ALISAUSKAS comes word that WDCY-1520 is now silent on Saturdays (except when Bill does a Saturday show) & is up for sale. WSOC-930 has been sold to the Bible Broadcasting Network and will have changed calls to WYFQ soon, if not already. Also, I made my debut on the SW

band on 3/22 when I filled in for Big Steve Cole on the CROSSBAND program on Radio NewYork International (RNI) via WWCR. I was heard on 7435 which was switched the following Sunday to 5920 khz! CROSSBAND is heard at 0200 UTC on RNI. An aircheck is available, please send a C60 cassette. Dave, your WCIE-1450 feed may have been fed via satellite. (Or perhaps a T1 digital phone circuit such as that being used at WJFK-1300). Rumors running around Atlanta market that long silent WFOM-1230 has been sold to Toccoa Falls College, despite the station being \$5 million in debt! WSB-750 is now airing repeats overnights of their various talk programs, including The Worst of David Paul & the Best of Clark Howard, among others. 73 & good DX.

KEN ONYSCHUK - 13602 WENTWORTH APT. 3 - RIVERDALE, IL 60627

My phone # here is 708-841-7982 & I welcome calls (prepaid!). Well, I finally did it, I was able to save some money & buy my second GE Superadio. The first was in the mid 70's when it first came out (I think). The other was given to me by a close friend in 1981, who was not a DXer and this one was on sale for \$47.95 at Montgomery Ward. I'm happy. The weather turned real nice on 3/1 & I drove to quiet Wampum Lake, about 8 miles S to do a band scan. I logged 109 stations on 92 frequencies. WCFJ-1470 was on OC, I managed to hear unnn. WKAM 1st time in day light. I did loop WLS on 870 but failed to hear WKAR and I was about 13 miles E of the WLS xmtr. A week later, it warmed up enough to go to the park at local sunset. Of interest, at 6:30 PM, KSOO-1140 noted w/WRVA w/state news, then to 1130 & a nice signal of KBMR 6:35-6:45 PM, several promos. Trying for KFAN but no luck. It's been too cold in March to test the Superadio II. I have increased my FM DXing though, mainly educational stations. One final note, I am hoping to attend the convention on Labor Day, I'm trying to figure out a reasonable budget. If anyone may need some company, please contact me. Go BULLS!

RICHARD A. D'ANGELO - 2216 BURKEY DRIVE - WYOMISSING, PA 19610

The 5th annual Winter SWL Festival is now history. Well c/2000 hobbyists attended what has become the premier hobby gathering in NA. Hosts Bob Brown, Harold Cones & Kris Field did a superb job arranging yet another FEST. This year's FEST added forums on MW & Scanner DXing to the usual array of SW broadcast & utility DXing. It's good to see the FEST grow into other areas of interest turning this into an all wave convention. The old ANARC Conventions never seemed to address the needs of all hobby modes of DXing. Fortunately, the Winter SWL Festival seems to be filling that void nicely. I hope the FEST continues to grow in that direction and that more MW DXers will attend next years FEST which has been tentatively set for the 3rd week in February. It was good seeing HARRY MAYO manning the NRC booth, the loop antenna made the table easy to find! DAVE SCHMIDT did a Forum on MW DXing. It was good to see ANDY RUGG once again. Andy, as do many other Canadians, come S to Philadelphia for the warm weather during the winter-hi! Perhaps next year additional NRCers from around the country will be in attendance! Life as ANARC's Interim Coordinator has been interesting. The clubs have been very enthusiastic which has made the job a pleasure. I would like to briefly address some of PAUL'S remarks in the 3/2 V59#21 issue of DX NEWS. I have received numerous letters from Club Representatives about ANARC matters since last December, I not only read each one but I respond to each and every letter. Items that need broader review are placed before the appropriate body such as Executive Council. While Paul was concerned about Executive Council being dominated by SW oriented clubs, I was concerned about not having qualified candidates running for this position. Perhaps those asked will consider running in Octobers' elections for Council. It's up to each club to participate accordingly. Talented individuals with a desire to make the organization succeed are needed! 73

BOB MCCOY - 4618 COOPER AVENUE #6 - LINCOLN, NE 68506

After many false starts, I think I'm actually going to write a MUSE! My life has been somewhat chaotic this past year w/sporadic & partial employment, taking Library Science courses at NE Wesleyan & studying for a ham license. Yes, NEIL ZANK & I decided to go through with something we had been talking about for some 20 years. This January, we started classes for Novice & Technician licenses with the idea of picking up at least a no-code Tech. Within the last 2 weeks of this writing, we have both passed the exams for Tech and are awaiting the bureaucracy's pleasure. I got so carried away, even, that I studied the questions for a few days and then passed the written test (38) for the General. Now it looks like I'm going to learn some code after all, as I have a year to pass the 13 WPM test. My next step is find some way to get some equipment. MY DXing activities have been mostly SW oriented this season but I did make an effort to try for some of the DX TESTS from the assortment made available. I found that relying solely on summary on the front page of DX NEWS without checking the details elsewhere was not always a good idea. This happened with a couple of frequencies & mailing addresses. Most of my BCB DX for the tests was done while working, so I took my WALKMAN with me on my rounds and listened (weather permitting) from some strange places. I didn't take my log with me but tried to take DX NEWS. Of the tests I remembered to try for, actually heard & don't consider a semi-local, I heard the test from WR1X, KXDL, KBBS, WTMA, WJIC, & WGEE. 3 of these are new stations and NJ a new state (#47), the first new one in a very long time! This season, virtually all my DX was done on on my SONY SRFM30 Walkman, my only problem with its reception capability is the noise on 530, interfering w/CIAC. Enjoyed meeting with

MIKE HAWK, CURN CHADWICK, BOB STRAUBE & ERNEST WESOLOWSKI at NEIL ZANK's place in late January. I am looking forward to making it to Des Moines for the convention, seeing as how its an easy (but boring) trip from here. Everybody have fun, now. 73

RAY ARRUDA - 47 BURT STREET - ACUSHNET, MA 02743

At long last, WCEG-1530 Middleboro was noted on the air Sunday afternoon 3/22 programming oldies and IDing frequently as "Cool Stereo 1530". Address is 66 Cambridge Street, Middleboro, MA 02346. The signal is weak but clear here during the day, approx. 18 miles NE of Acushnet. Veries...WZNN-930, WK2E-1020 & TEST varies from WR1X-1020, WCIL-1020, WMTR-1250, WZAO-1370 & KPCR-1530, WMTR & KPCR were unnn but reverified. In SE MA, more snow has fallen the last 2 weeks of March than the entire winter, 14+ inches! I thought springtime was here but I guess not. 73

DICK TRUAX - 3018 GUS EMMETT TRAIL - SELLERSBURG, IN 47172

Greetings once again from the Hoosier State. Still nothing of note to report due to a constant line noise here on the BCB. However, I did trace it down to its source, my next door neighbors kitchen microwave! We turned off all his power circuits and when we did, I could hear perfectly for the very first time. The power company was most co-operative in tracing the noise to his house but of course could not fix the problem source. So maybe soon I'll be able to listen again. Did anyone beside me notice the John R. article in the 2/24 DX NEWS? I first got interested in DXing the BOB band in the mid-50's when I stumbled across WLAC. I ordered one of the cassettes mentioned at the end of the article - most interesting. If anyone else ordered one, or plans on ordering one, please order #2 or #3 as I have #1 and would be willing to dub a copy in exchange for a copy of #2 or #3. Or perhaps someone has some off-the-air tapes of him from the late 50's/early 60's? If so, I'd be interested in hearing from you. Lastly, I'll make my annual offer to go shopping at the wrolds greatest Fleamarket at Dayton on 4/24, let me know your wants, price range & arrangements for getting funds to me no later than 4/20. (Well, that's come and gone but, knowing Dick, he attends additional Hamfests so I'm sure the offer still stands through the Hamfest season-DWS). That's it from here for now - more as it happens.

RICK DAU - 401 EMERALD ST. - IOWA CITY, IA 52246

Hello again to all in DX-land. It was a painful decision, but I have decided to put off plans to host an NRC convention in Des Moines, IA until next year. There where several factors that weighed in this decision, but the main one was the departure of Mike Knitter as the NRC's general manager (especially coming at the time that it did). As a first-time host, I felt that I just wouldn't have been able to get the assistance from the NRC this year that has been provided to other rookie convention hosts in the past. Rather than trying to shoulder all of the burdens myself, perhaps resulting in a sub-par event, I decided to save face and postpone a Des Moines-hosted convention until Labor Day weekend 1993. By next January, the club's new leadership should be settled into place, and will then be able to assist me with what needs to be done. A second, less significant, factor was that one of my targeted guest speakers, WHO Sports Director and "Voice of the Hawkeyes" Jim Zabel, was unavailable this Labor Day weekend. That's because the University of Iowa, in its infinite wisdom, moved its gridiron tangle with the mighty Miami Hurricanes from Sept. 19 to Sept. 5 and made it a night game, thus the convention would have been taking place at the same time as the game. I view this as a on-time only occurrence, so I should be able to snare one of the Midwest's brightest sports play-by-play personalities for Labor Day weekend next year. In the meantime, I still have definite plans to host a get-together in Davenport, IA the weekend of Oct. 17-18, 1992. There will be more info on this as the time for that GTG approaches. In closing, I apologize for any inconvenience this may have caused for those who have already made reservations with Hotel Fort Des Moines. I hope that you understand the situation. The Good Lord willin', everything should run a lot smoother next year. 73 for now.

DAVE SCHMIDT - P O BOX 11502 - WILMINGTON, DE 19850-1502

Like KARL JETER noted in his report, we also got caught up in a busy spell/work crunch. This column going out 4/28 with a couple of things/reports/et al for next months column. And that's it for this trip, see you in 4 weeks!

### The NRC is growing - and you can help.

More members in the NRC means a larger *DX News* ... and more features and services for all members. You can help your club grow: just send the names and addresses of potential club members to the NRC - P. O. Box 5711 - Topeka, KS 66605 and we'll send them a current copy of *DX News*. Spread the word - the National Radio Club is on the grow!

## NRC DXCon - '92 in Omaha

This year's convention, on September 4-6, will be held in the "Big O", Omaha, Nebraska, at Days Inn - 3001 Chicago Street - 61831, on the edge of the downtown. Room rates are a flat \$46 plus \$7.52 in tax per room. This is for one to four people per room with two double beds. Rooms for the disabled are available. Each room has a refrigerator. A Deluxe Continental breakfast is included each morning in the Friendship Room. If you miss your favorite DX the night before, work off your frustrations in the fitness center and enjoy the sauna and whirlpool. The Nebraska Room is ours for the entire three days. The "Big O Team" is joining forces to present to you a joyous time. a shopping spree will be provided for the ladies. Tours and two main meals are in the works along with a guest speaker. For reservations at the six-story hotel, call direct: (402) 345-2222, and be sure to tell them you want the NRC Convention Rate of \$46.00 If you are even considering "Big O" this year, write for a free convention packet to Ernie J. Wesolowski - 13312 Westwood Lane - Omaha, NE 68144-3543. Send auction items to Ernie after 8-1, postpaid. The registration fee will be announced next issue. BYOB; beer and pop provided. Good Amtrak service from Chicago and Denver. Same for airlines with a free shuttle (7:00 am to 10:30 pm to Days Inn). See you over Labor Day weekend in Omaha!

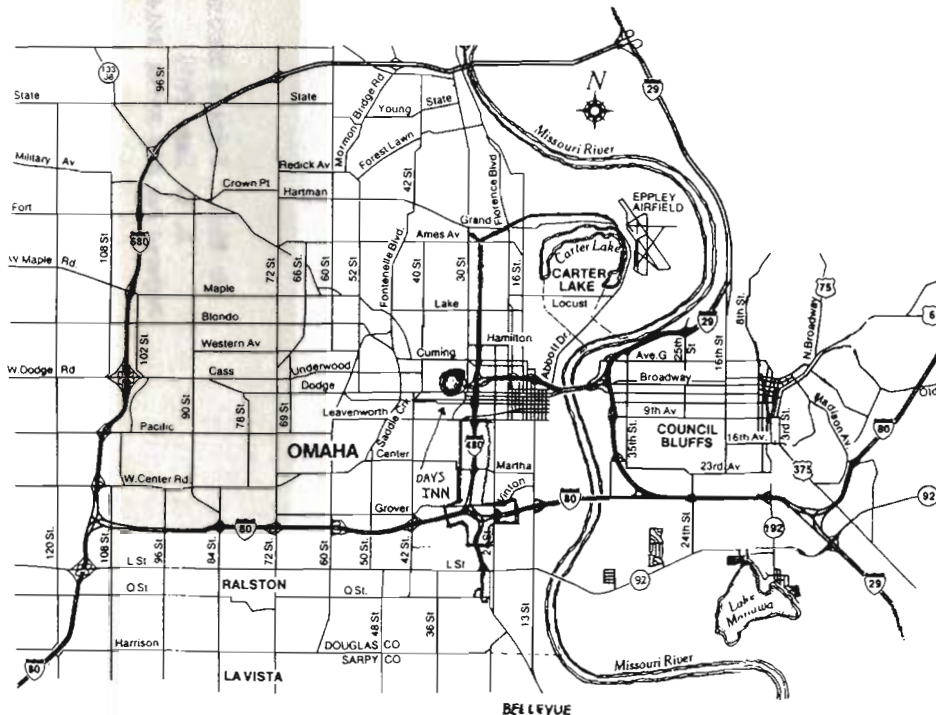

### Not sure about renewing?

Consider these benefits of a membership in the National Radio Club: 720+ pages per year of easy-to-read, comprehensive DX and radio information ... reduced prices for publications ... responsive editors ... and the friendliest bunch of DX'ers in the world! Why not send that renewal check to Ron today!