

QUALITY ASSURANCE MANUAL GINNA STATION	TITLE: APPENDIX B R.E. GINNA NUCLEAR POWER PLANT INSERVICE INSPECTION PROGRAM FOR THE 1990-1999 INTERVAL	DATE 12/31/93
		PAGE 1 of 5

TABLE OF CONTENTS

Section 1.0	Inservice Inspection Program: 1.0 Introduction 1.1 General 1.2 Applicable Documents 1.3 Inspection Intervals 1.4 Classification of Components 1.5 Responsibility 1.6 Records 1.7 Examination Methods and Requirements 1.8 Repair Requirements 1.9 Replacement Requirements 1.10 System Pressure Testing 2.0 Class 1 Program Plan 2.1 Basis for Preparation 2.2 Components Subject to Examination 2.3 Extent and Frequency of Examinations 2.4 Exemption Criteria 2.5 Examination of Reactor Coolant Pump Flywheels 2.6 Inservice Inspection Program Plan 3.0 Class 2 Program Plan 3.1 Basis for Preparation 3.2 Components Subject to Examination 3.3 Extent and Frequency of Examinations 3.4 Exemption Criteria 3.5 Inservice Inspection Program Plan 4.0 Class 3 Program Plan 4.1 Basis for Preparation 4.2 Components Subject to Examination 4.3 Extent and Frequency of Examinations 4.4 Exemption Criteria 4.5 Inservice Inspection Program Plan 5.0 Class 1, 2 & 3 Component Supports 5.1 Basis for Preparation 5.2 Components Subject to Examination 5.3 Extent and Frequency of Examinations 5.4 Exemption Criteria 5.5 Inservice Inspection Program Plan
-------------	---

QUALITY ASSURANCE MANUAL GINNA STATION	TITLE: APPENDIX B R.E. GINNA NUCLEAR POWER PLANT INSERVICE INSPECTION PROGRAM FOR THE 1990-1999 INTERVAL	DATE 12/31/93
		PAGE 2 of 5

Section 2.0 Relief Requests:

- 1.0 Introduction
- 1.1 General

Section 3.0 P&ID Boundary Drawings:

- 1.0 General
P&ID Boundary Drawings

Section 4.0 Code Tables:

- 1.0 General
Table 1, Class 1
Table 2, Class 2
Table 3, Class 3
Table 4, Class 1, 2, & 3 IWF Component
Supports

Section 5.0 Line List:

- 1.0 General
Line List

Section 6.0 Allocation Tables:

- 1.0 General
- ASME Code Requirements
- Class 1
- Class 2
- Class 3
- Class 1,2, & 3 Supports
- Augmented Reactor Coolant Pump Flywheel
Program
- Reactor Vessel Augmented Program,
Category B-A
- High Energy Program
- Snubber Program
- Seismic Support Program

QUALITY ASSURANCE MANUAL GINNA STATION	TITLE: APPENDIX B R.E. GINNA NUCLEAR POWER PLANT INSERVICE INSPECTION PROGRAM FOR THE 1990-1999 INTERVAL	DATE 12/31/93
		PAGE 3 of 5

Section 7.0 UT Calibration Blocks:

- 1.0 General
UT Calibration Blocks

Section 8.0 High Energy Program:

- 1.0 General
- 2.0 Examination Requirements
- 3.0 Examination Methods
- 4.0 Frequency of Examination
- 5.0 Examination Evaluation
- 6.0 Repair & Testing Requirements
- 7.0 Replacement & Testing Requirements
- 8.0 Scheduling
- 9.0 Reports & Records

Table 1 - High Energy Welds & Component Support Identification.

Section 9.0 Snubber Program:

- 1.0 General
- 2.0 Examination, Testing & Monitoring Requirements
- 3.0 Examination & Testing Methods
- 4.0 Examination & Testing Frequency
- 5.0 Examination, Testing & Monitoring Evaluation
- 6.0 Repair, Replacement & Modification Requirements
- 7.0 Scheduling
- 8.0 Reports & Records

Section 10.0 Seismic Support Program:

- 1.0 General
- 2.0 Examination Requirements
- 3.0 Examination Methods
- 4.0 Frequency of Examination
- 5.0 Examination Evaluation
- 6.0 Repair & Testing Requirements
- 7.0 Replacement & Testing Requirements
- 7.0 Scheduling
- 8.0 Reports & Records

QUALITY ASSURANCE MANUAL GINNA STATION	TITLE: APPENDIX B R.E. GINNA NUCLEAR POWER PLANT INSERVICE INSPECTION PROGRAM FOR THE 1990-1999 INTERVAL	DATE 12/31/93
		PAGE 4 of 5

Section 11.0

Additional Programs:

- 1.0 General
- 2.0 Steam Generator Tube Inspection Program
 - 2.1 General
 - 2.2 Examination Requirements
 - 2.3 Examination Methods
 - 2.4 Frequency of Examination
 - 2.5 Examination Evaluation
 - 2.6 Repair, Replacement & Testing Requirements
 - 2.7 Scheduling
 - 2.8 Reports & Records
- 3.0 Reactor Coolant Pump Flywheel Program
 - 3.1 General
 - 3.2 Examination Requirements
 - 3.3 Examination Methods
 - 3.4 Frequency of Examination
 - 3.5 Examination Evaluation
 - 3.6 Repair, Replacement & Testing Requirements
 - 3.7 Scheduling
 - 3.8 Reports & Records
- 4.0 Class 1 Bolting Program (IEB 82-02)
 - 4.1 General
 - 4.2 Examination Requirements
 - 4.3 Examination Methods
 - 4.4 Frequency of Examination
 - 4.5 Examination Evaluation
 - 4.6 Repair, Replacement & Testing Requirements
 - 4.7 Scheduling
 - 4.8 Reports & Records
- 5.0 Reactor Vessel Augmented Program, Category B-A
 - 5.1 General
 - 5.2 Examination Requirements
 - 5.3 Examination Methods
 - 5.4 Frequency of Examination
 - 5.5 Examination Evaluation
 - 5.6 Repair, Replacement & Testing Requirements
 - 5.7 Scheduling
 - 5.8 Reports & Records

QUALITY ASSURANCE MANUAL GINNA STATION	TITLE:	APPENDIX B R.E. GINNA NUCLEAR POWER PLANT INSERVICE INSPECTION PROGRAM FOR THE 1990-1999 INTERVAL	DATE 12/31/93
			PAGE 5 of 5

SUPPLEMENT 1 TO APPENDIX B

"Inservice Inspection Program Plan"

(Separate Document controlled by Materials Engineering
& Inspection Services.)

SUPPLEMENT 2 TO APPENDIX B

"The Repair, Replacement and Modification Program"

QUALITY ASSURANCE MANUAL GINNA STATION ROCHESTER GAS & ELECTRIC CORPORATION	Section 1	REV. 3	PAGE 1 of 34
	EFFECTIVE DATE: December 31, 1993		
TITLE: APPENDIX B R. E. GINNA NUCLEAR POWER PLANT INSERVICE INSPECTION PROGRAM FOR THE 1990-1999 INTERVAL	SIGNATURE		DATE
	PREPARED BY:	<i>Frank A. Lepore</i>	12-1-93
	QUALITY ASSURANCE REVIEW:	<i>W. M. Jones</i>	12-2-93
	APPROVED BY:	<i>Michael J. Spurr</i>	12-6-93

1.0 INTRODUCTION

1.1 General

This Appendix "B" to the Quality Assurance Manual outlines the third interval inservice inspection examination (ISI) requirements for Class 1, Class 2, and Class 3 systems, and components for Rochester Gas & Electric Corporation's (RG&E) R. E. Ginna Nuclear Power Plant (Ginna Station). The third inspection interval begins on January 1, 1990, as permitted by Paragraph IWA-2400 of ASME Code Section XI, the second interval concluded December 31, 1989.

1.1.1 This program is based on the requirements of the 1986 Edition of the American Society for Mechanical Engineers (ASME) Boiler and Pressure Vessel Code, Section XI, "Inservice Inspection of Nuclear Power Plant Components" as adopted by the Code of the Federal Regulations, 10 CFR Part 50, (Federal Register 53FR16051) May 5, 1988.

1.1.2 This program excludes the controls of the Enforcement Authority, and N-Stamp, in addition to IWE of ASME Section XI, since it is not endorsed by the Regulation.

1.1.3 Inservice Testing of pumps (IWP) and valves (IWV) is performed in accordance with Appendix C of the Ginna Station Quality Assurance Manual.

QUALITY ASSURANCE MANUAL GINNA STATION	TITLE:	Section 1	REV. 3
	APPENDIX B R.E. GINNA NUCLEAR POWER PLANT INSERVICE INSPECTION PROGRAM FOR THE 1990-1999 INTERVAL	PAGE 2 of 34	

1.2 **Applicable Documents**

RG&E has adopted the following documents as the basis for the third inspection interval and is committed to satisfying their requirements. Specific exceptions to the requirements of ASME Section XI are identified and located in the "Relief Requests", Section 2.0 of this document. This program was developed in accordance with these documents:

1.2.1 ASME Boiler and Pressure Vessel Code Section XI, "Rules for Inservice Inspection of Nuclear Power Plant Components," 1986 Edition, no Addenda.

1.2.1.1 ASME Boiler & Pressure Vessel Code, Section XI, 1986 Edition, no Addenda, Appendix IV.

1.2.2 U.S. Nuclear Regulatory Commission (USNRC) Regulatory Guides:

- a. 1.14, Rev. 1, "Reactor Coolant Pump Flywheel Integrity"
- b. 1.147, Latest Revision, "Inservice Inspection Code Case Acceptability - ASME Section XI, Division 1"
- c. 1.150, Rev. 1, "Ultrasonic Testing of Reactor Vessel Welds During Preservice and Inservice Examinations"
- d. 1.83, Rev. 1, "Inservice Inspection of Pressurized Water Reactor Steam Generator Tubes"
- e. 1.26, Rev. 3 "Quality Group Classifications and Standards for Water, Steam, and Radioactive Waste Containing Components of Nuclear Power Plants.
- f. 1.29, Rev. 3, "Seismic Design Classification".
- g. 1.121, Rev. 0, "Bases for Plugging Degraded PWR Steam Generator Tubes".

QUALITY ASSURANCE MANUAL GINNA STATION	TITLE:	Section 1	REV. 3
	APPENDIX B R.E. GINNA NUCLEAR POWER PLANT INSERVICE INSPECTION PROGRAM FOR THE 1990-1999 INTERVAL	PAGE 3 of 34	

h. 1.65, Rev. 0, "Materials and Inspections for Reactor Vessel Closure Studs".

1.2.3

ASME Code Cases

In accordance with 10CFR50.55a, Footnote 6, ASME Section XI Code Cases referenced in Regulatory Guide 1.147, "Inservice Inspection Code Case Acceptability- ASME Section XI, Division 1," may be incorporated into the Ginna Station ISI Program. Those Code Cases included in Regulatory Guide 1.147 that will be implemented at Ginna Station are identified in this section. Each Code Case is preceded by information on the applicable component/area, ASME requirements, and how the Code Case will be implemented.

Paragraph 1.2.3.1 lists those code cases that have been technically reviewed and endorsed, with or without conditions by the NRC in Regulatory Guide 1.147 and will be implemented during the 3rd ten year Inspection Interval.

Use of any subsequent NRC endorsed code cases that are identified in revisions to the Regulatory Guide 1.147 may be incorporated in the program and used during the 3rd ten year Inspection Interval.

1.2.3.1

USNRC Regulatory Guide 1.147 - Approved ASME Section XI Code Cases

<u>Code Case No.</u>	<u>Sect. XI References</u>	<u>Component/Area</u>
N 307-1	IWB-2500-1	Studs and Bolts with Heater Holes
N-416	IWA-4400	Any repaired or replaced Class 2 piping component that cannot be isolated by valves or requires securing safety/relief valves.
N-401	IWA-2233	Eddy Current Examinations

QUALITY ASSURANCE MANUAL GINNA STATION	TITLE: APPENDIX B R.E. GINNA NUCLEAR POWER PLANT INSERVICE INSPECTION PROGRAM FOR THE 1990-1999 INTERVAL	Section 1	REV. 3
		PAGE 4 of 34	

N-402	IWA-2233	Eddy Current Calibration Standard Material
N-427*	Code Cases	Code Cases in Inspection Plans
N-437	IWA-5260	Use of digital readout and digital measurement devices for performing Pressure Tests.
N-446	IWA-2300	Recertification of Visual Examination Personnel.
N-460	IWA-2000/3000	Alternative examination coverage for Class 1 and Class 2 welds.
N-481	B-L-1, Item B12.10	Alternative examination requirements for Cast Austenitic Pump Casings.
N-491	IWF-1000/2000/3000	Alternative rules for examination of Class 1, 2, 3, and MC Component Supports of Light Water Cooled Power Plants.
N-498	IWX-5000	Alternative rules for 10-year Hydrostatic Pressure Testing for Class 1 and 2 systems.
* As amended by USNRC Regulatory Guide 1.147, April, 1992.		
1.2.4	R.E. Ginna Updated Final Safety Analysis Report (UFSAR):	
	Section 5.4 - For Class 1	
	Section 6.6 - For Class 2 and 3	

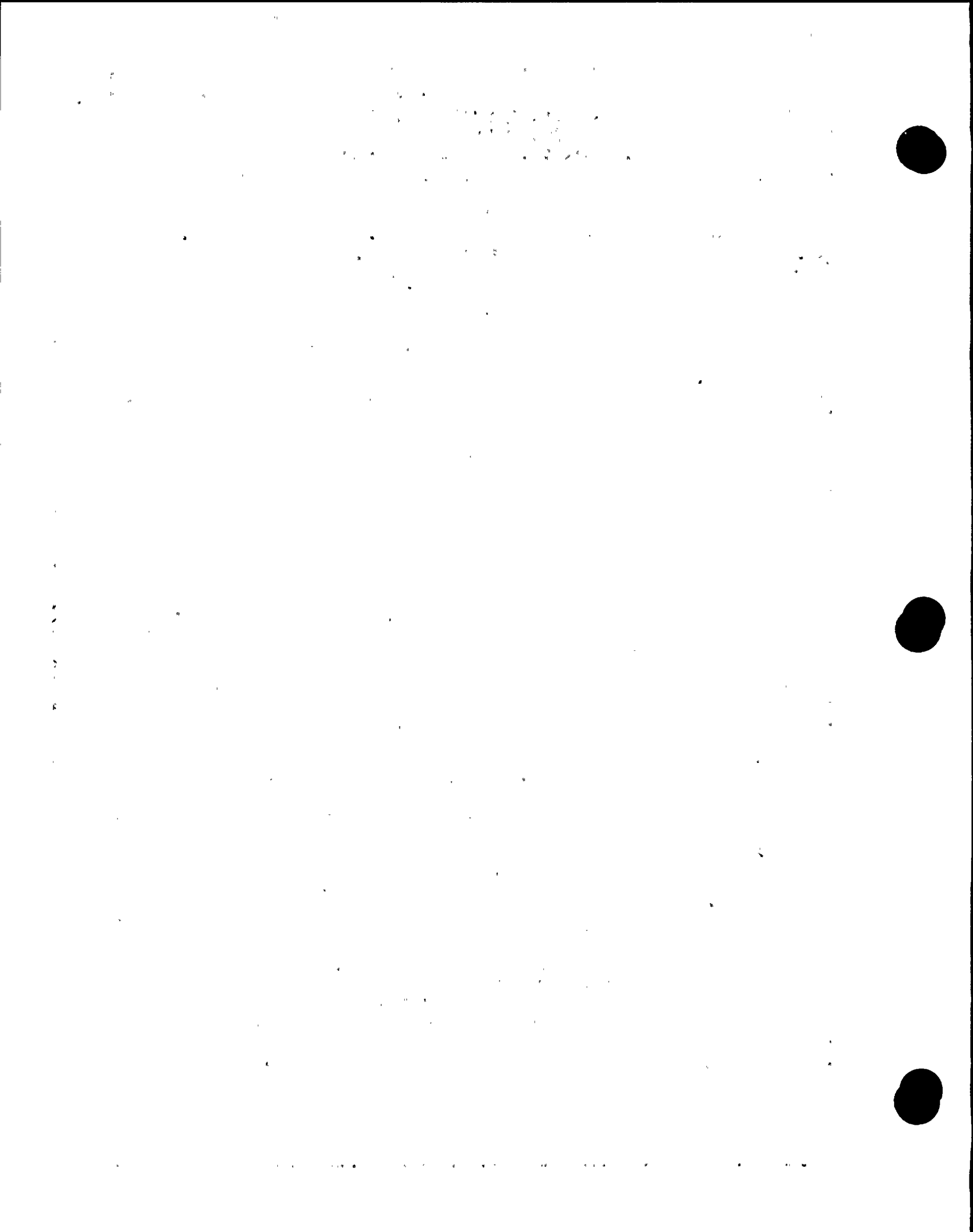

QUALITY ASSURANCE MANUAL GINNA STATION	TITLE:	Section 1	REV. 3
	APPENDIX B R.E. GINNA NUCLEAR POWER PLANT INSERVICE INSPECTION PROGRAM FOR THE 1990-1999 INTERVAL	PAGE 5 of 34	

1.2.5	Letter dated March 23, 1981, from Darrell G. Eisenhut, Director, Division of Licensing, USNRC, regarding Technical Specification Revisions for Snubber Surveillance
1.2.5.1	First Addenda to ASME/ANSI OM-1987, Part 4 Published in 1988.
1.2.6	USAS B31.1.0-1967, "Power Piping" for High Energy Systems
1.2.7	R. E. Ginna, Technical Specification 4.2. "Inservice Inspection".
1.2.8	R. E. Ginna Technical Specification 3.13 and 4.14 "Snubbers".
1.2.9	Letter dated February 16, 1989, to Mr. Carl Stahle, USNRC, PWR Project Directorate No. 1, regarding proposed changes to Snubber Technical Specification R. E. Ginna Nuclear Power Plant, Docket No. 50-244.
1.2.10	Rochester Gas and Electric Corporation Mechanical Engineering Specification, ME-256, Titled - "Snubber Inspection and Test Program".
1.2.11	Electric Power Research Institute PWR Steam Generator Inspection Guidelines, Rev. 2.
1.2.12	Code of the Federal Regulations, 10CFR Part 50.
1.2.13	USNRC, NRC Region I Inspection Report 50-244/90-12, Section 3.4 regarding repair program "Service Induced" and "Code Rejectable" repairs.
1.3	Inspection Intervals
1.3.1	The inservice inspection intervals for Class 1 components started on January 1, 1970, with the second interval starting on January 1, 1980. The third inspection interval shall start on January 1, 1990.

QUALITY ASSURANCE MANUAL GINNA STATION	TITLE:	Section 1	REV. 3
	APPENDIX B R.E. GINNA NUCLEAR POWER PLANT INSERVICE INSPECTION PROGRAM FOR THE 1990-1999 INTERVAL	PAGE 6 of 34	

1.3.2 For Class 2 and Class 3, the first inspection interval started on May 1, 1973; the second on January 1, 1980; and the third on January 1, 1990.

1.3.3 The third inspection interval for Class 1, 2 and 3 is scheduled to end December 31, 1999. However, this date is subject to change as allowed by IWA-2400, which states that each inspection interval may be decreased or extended (but not cumulatively) by as much as one year. If R. E. Ginna Nuclear Power Plant is out of service continuously for 6 months or more, the inspection interval and associated period during which the outage occurred may be extended for a period of time equivalent to the outage.

1.3.4 A 10-year examination Program Plan (Supplement 1 to Appendix B), will describe the distribution of examinations for Class 1, Class 2, and Class 3 components in accordance with Inspection Program B, the IWB-2400, IWC-2400, IWD-2400 and IWF-2400 of Section XI, "Rules for Inservice Inspection of Nuclear Power Plant Components", 1986 Edition, no Addenda.

1.4 Classification of Components

The Program Plan components and piping have been classified by RG&E for purposes of inservice inspection based on Section XI, Article IWA-1320, and definitions contained in 10CFR50.2.

1.5 Responsibility

As specified in Paragraph IWA-1400 of ASME Section XI, RG&E bears the overall responsibility for implementation of an ISI program. Administrative Procedures, NDE Procedures, ISI Plans and Schedules are in place to control and implement these Inservice Inspection requirements.

QUALITY ASSURANCE MANUAL GINNA STATION	TITLE:	APPENDIX B R.E. GINNA NUCLEAR POWER PLANT INSERVICE INSPECTION PROGRAM FOR THE 1990-1999 INTERVAL	Section 1	REV. 3
			PAGE 7 of 34	

1.6 Records

Examination records and documentation of results provide the basis for evaluation and facilitate comparison with previous results and subsequent inspections. In accordance with Section XI, IWA-6000, these records will be maintained for the plant life.

- 1.6.1 An Inservice Inspection Report shall be generated to document applicable Inservice Inspection and associated Repair, Replacement and Modification activities. ASME NIS-1 and NIS-2 Forms shall be generated and included within the Inservice Inspection Report.

1.7 Examination Methods and Requirements

Examination methods which will be used to satisfy Code examination requirements have been listed for nonexempt Class 1, Class 2, and Class 3 components, as applicable.

Provided in the following is a brief explanation of the examination methods which will be performed to satisfy the Code requirements.

Personnel performing nondestructive examinations will be qualified in accordance with written procedures prepared as required by Paragraph IWA-2300 of Section XI. Methods of examination are also described in the applicable sections of this Inservice Inspection Program.

1.7.1 Visual Examination Method

Visual examinations (VT) will be performed in accordance with IWA-2210 of ASME Section XI. IWA-2210 defines the three types of VT examinations as follows:

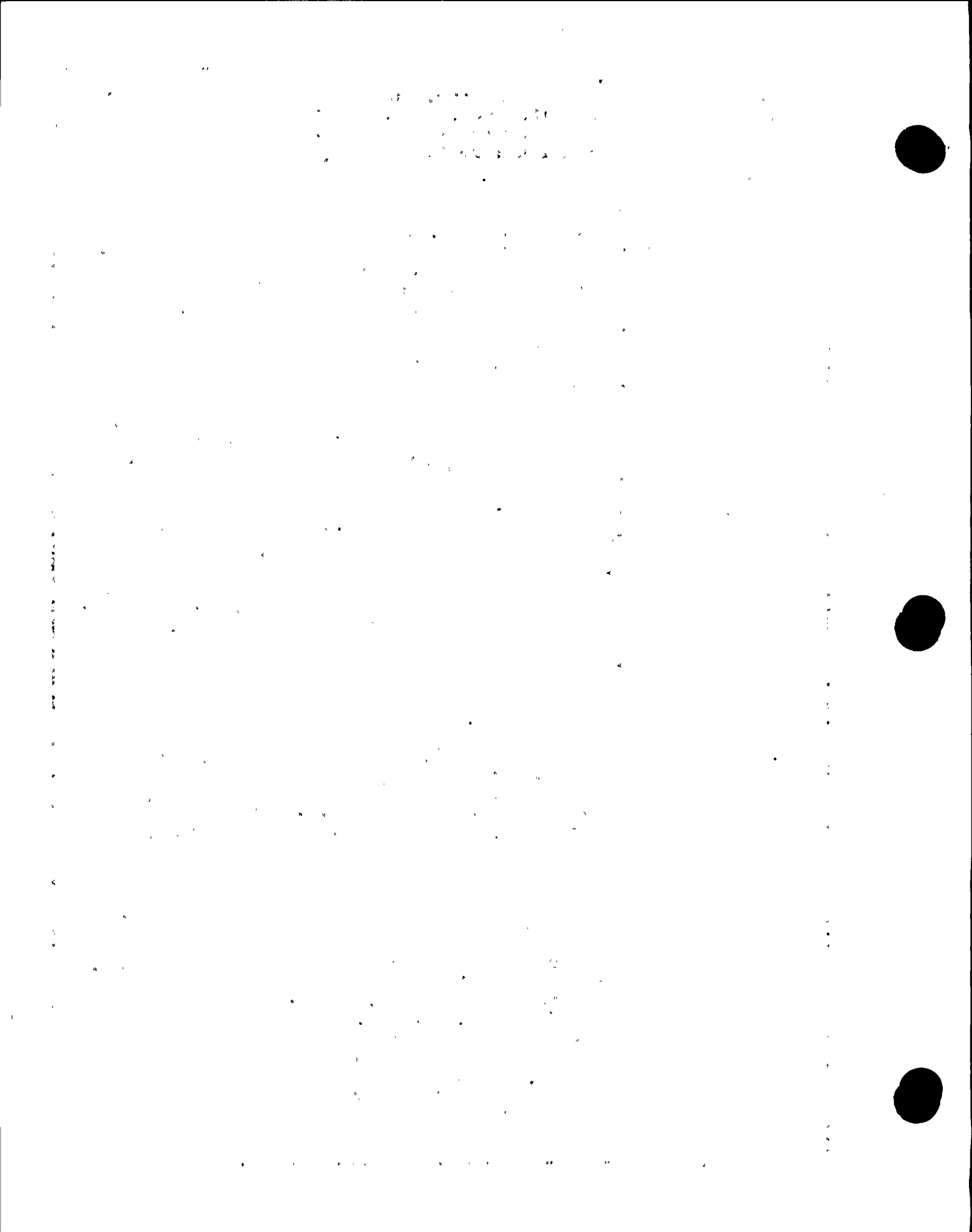

QUALITY ASSURANCE MANUAL GINNA STATION	TITLE:	APPENDIX B R.E. GINNA NUCLEAR POWER PLANT INSERVICE INSPECTION PROGRAM FOR THE 1990-1999 INTERVAL	Section 1	REV. 3
			PAGE 8 of 34	

- 1.7.1.1 VT-1 examinations are conducted to determine the condition of the part, component or surface examined. The examination shall determine conditions such as cracks, wear, corrosion, erosion, or physical damage on the surfaces of the part or components. This type of examination may be performed by direct or remote methods as defined in IWA-2211.
- 1.7.1.2 VT-2 examinations are conducted to detect leakage (or abnormal leakage) from pressure-retaining components during system pressure or functional tests as defined in IWA-2212.
- 1.7.1.3 VT-3 examinations are conducted to determine general mechanical and structural conditions of components and their supports such as the presence of loose parts, debris, or abnormal corrosion products, wear, erosion, corrosion, and the loss of integrity at bolted or welded connections. VT-3 Examinations are also conducted to determine conditions related to operability of mechanical and hydraulic snubbers, and spring devices.
- 1.7.2 **Surface Examination Method**
- 1.7.2.1 A surface examination is performed to detect the presence of discontinuities open to the surface of a material. Techniques for surface examination include either magnetic particle (MT) or liquid penetrant (PT) methods. Surface examinations will be conducted as defined in IWA-2220.
- 1.7.3 **Volumetric Examination Method**
- 1.7.3.1 A volumetric examination is performed to detect the presence of discontinuities in the volume of a material. Such volumetric examinations include radiographic (RT), ultrasonic (UT), and eddy current (ET). Volumetric examinations will be conducted as defined in IWA-2230.
- 1.7.3.2 Radiography may be performed by utilizing either x-ray or gamma ray techniques.

QUALITY ASSURANCE MANUAL GINNA STATION	TITLE:	APPENDIX B R.E. GINNA NUCLEAR POWER PLANT INSERVICE INSPECTION PROGRAM FOR THE 1990-1999 INTERVAL	Section 1	REV. 3
			PAGE 9 of 34	

1.7.3.3 The UT examinations may be performed by utilizing either manual or mechanized UT (Mech UT) techniques in accordance with Appendix I of Section XI and Regulatory Guide 1.150, Rev. 1 for the Reactor Vessel Examination only.

1.7.3.4 The ET Method will be utilized in the examination of heat exchanger tubing in accordance with Appendix IV of ASME Section XI and USNRC Regulatory Guide 1.83.

1.7.4 Alternative Examination Methods

1.7.4.1 Alternative examination methods may be performed to those described in 1.7.1, 1.7.2 and 1.7.3 as allowed in IWA-2240. These may include such things as newly developed techniques, provided that these alternative methods are shown by practical demonstration to be equivalent or superior to those of the specific method to the satisfaction of the Level III NDE Examiner & Authorized Nuclear Inservice Inspector (ANII).

1.7.4.2 Examinations that detect flaws which require evaluation may be supplemented by other examination methods and techniques to determine the character of the flaw.

1.7.5 Evaluation of Examination Results and Successive Inspections

1.7.5.1 The evaluation of nondestructive examination results shall be in accordance with Article IWA-3000 of Section XI. All reportable indications will be subject to comparison with previous data to aid in characterization and determination of origin.

Class 1 and Class 3 components containing relevant service induced conditions will be considered acceptable for continued service providing an analytical evaluation performed demonstrates the component's acceptability and is subsequently examined in accordance with the requirements of IWB-3132.4, IWB-3142.4 and IWB-3144(b). Acceptance by Repair or Replacement can also be performed. Successive inspections for Class 1 relevant service induced conditions shall comply with the

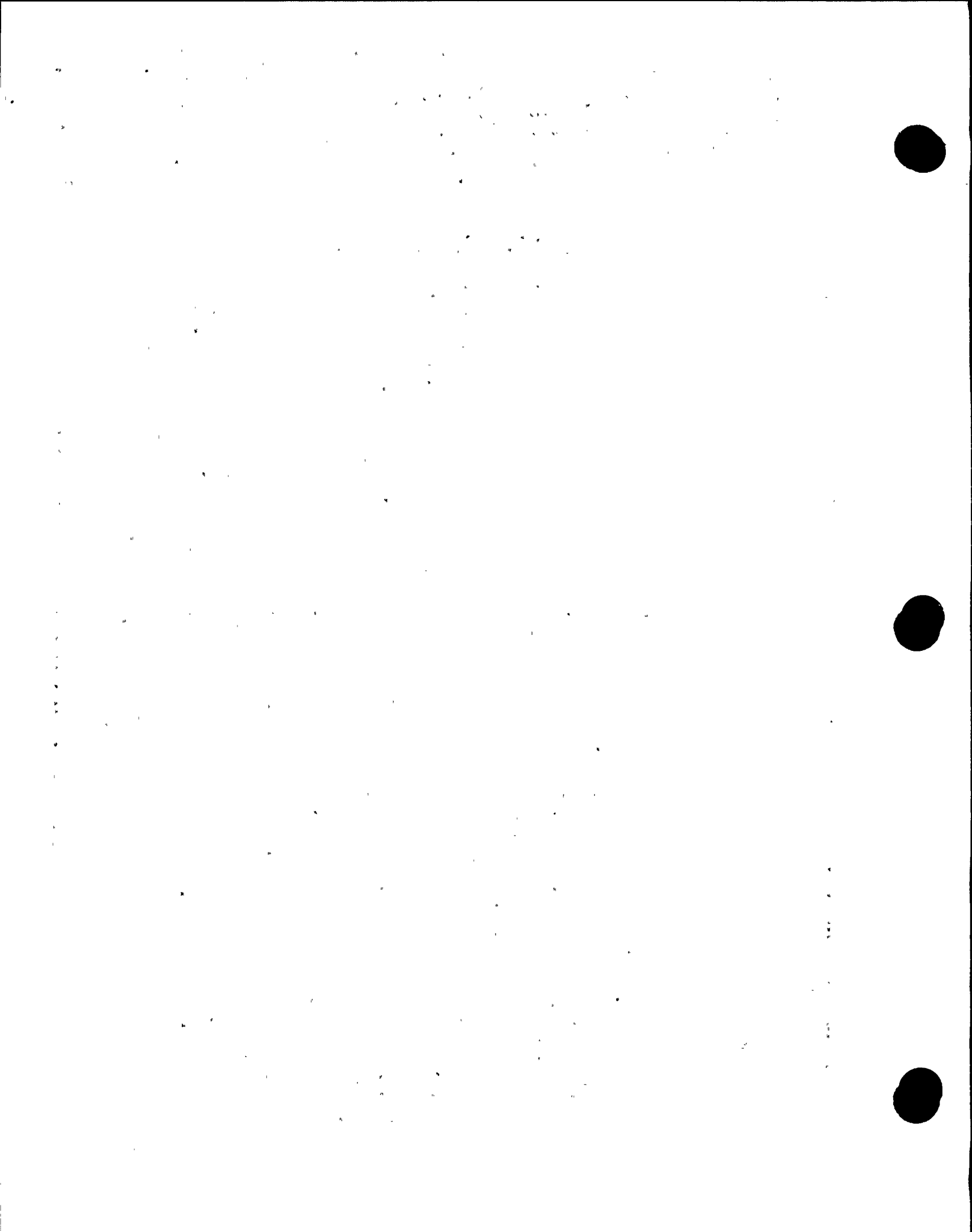

QUALITY ASSURANCE MANUAL GINNA STATION	TITLE:	APPENDIX B R.E. GINNA NUCLEAR POWER PLANT INSERVICE INSPECTION PROGRAM FOR THE 1990-1999 INTERVAL	Section 1	REV. 3
			PAGE 10 of 34	

requirements of IWB-2420(b) and (c). For Class 3 relevant service induced conditions, successive inspections shall comply with the requirements of IWC-2420(b) and (c).

Class 2 components containing relevant service induced conditions will be considered acceptable for continued service providing an evaluation performed demonstrates the component's acceptability and is subsequently examined in accordance with the requirements of IWC-3122.4, IWC-3132.3 and IWC-3134(b). Acceptance by Repair or Replacement can also be performed. For Class 2 relevant service induced conditions, successive inspections shall comply with the requirements of IWC-2420(b) and (c).

Period 1 and up to the '94 Outage ('86 Code):
Class 1, Class 2, and Class 3 Supports containing relevant service induced conditions will be considered acceptable for continued service providing an evaluation or test is performed that demonstrates the component's acceptability. Acceptance by Repair or Replacement can also be performed. Successive inspections on supports containing relevant service induced conditions shall comply with the requirements of IWF-2420(b) and (c).

Periods 2 (Starting '94 Outage) and 3:
Class 1, Class 2, and Class 3 Supports whose visual examination does not reveal conditions as described in the acceptance standards (-3400 of Code Case N-491), shall be acceptable for service.

Visual examinations which detect relevant service induced conditions as described in the acceptance standards shall be unacceptable for service unless accepted or corrected by one of the following methods;

- Corrective measures (adjustment, repair, or replacement), and subsequent reexamination including the requirements of -2220(b) (Note: Successive examination requirements of -2420 must be applied to supports containing relevant service induced conditions in which corrective measures were utilized for acceptance.)

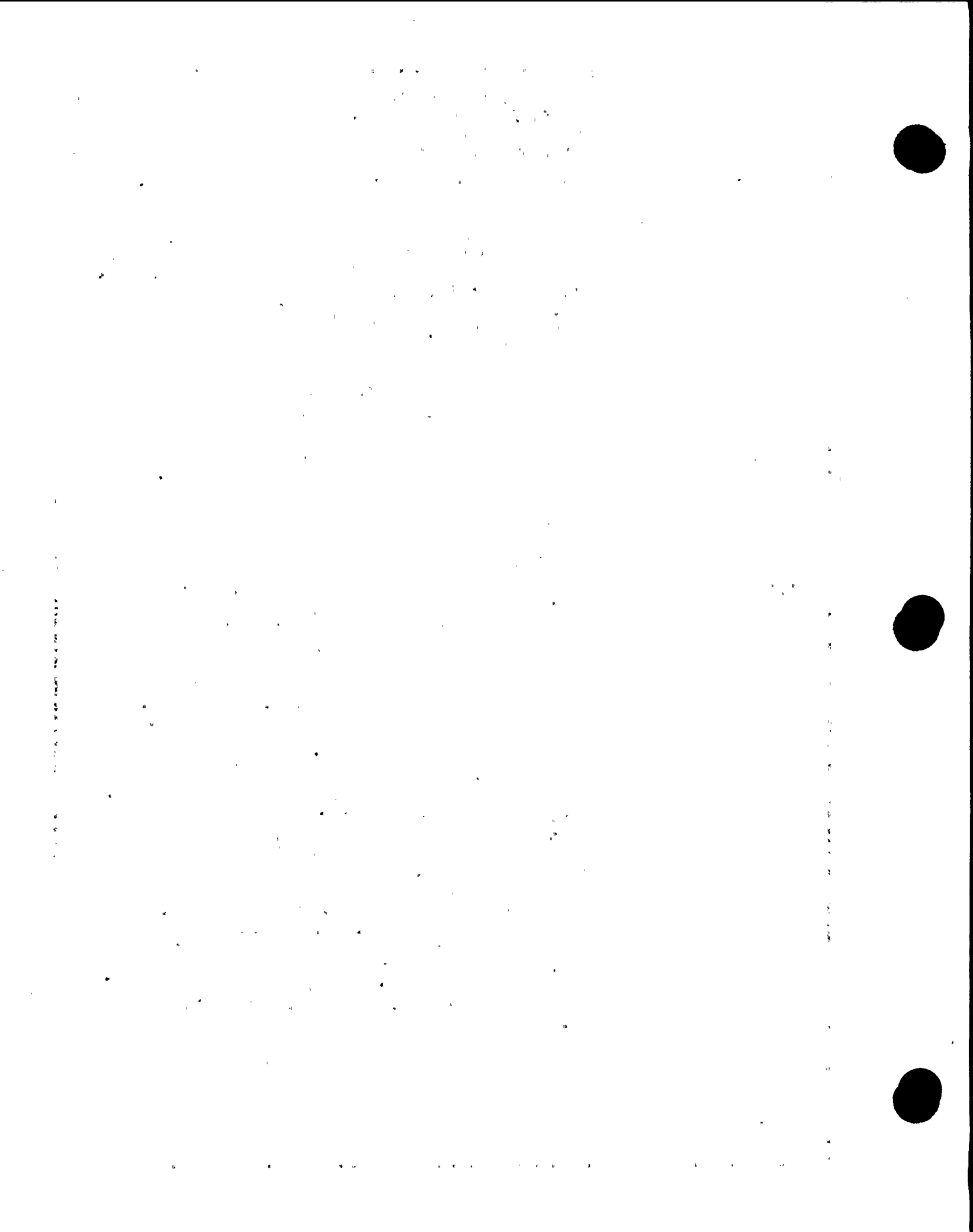

QUALITY ASSURANCE MANUAL GINNA STATION	TITLE:	Section 1	REV. 3
	APPENDIX B R.E. GINNA NUCLEAR POWER PLANT INSERVICE INSPECTION PROGRAM FOR THE 1990-1999 INTERVAL	PAGE 11 of 34	

- Evaluation ¹ or Test to the extent necessary to substantiate its integrity for its intended service (Note: Visual examinations that detect surface flaws that exceed -3400 criteria shall be supplemented by either surface or volumetric examinations).

Note 1: Flaws or relevant conditions in which analytical evaluations are being performed to determine acceptance, may be considered acceptable for continued service during this evaluation process.

1.7.6

Additional Examinations

1.7.6.1

Inservice examinations performed that revealed service induced flaws that exceeds the acceptance standards shall have additional examinations performed.

1.7.6.2

Additional examinations shall be performed to the extent required by IWB-2430 whenever a service induced rejectable flaw is identified during the performance of ISI examinations in accordance with the requirements specified within IWB and IWD.

1.7.6.3

Additional examinations shall be performed to the extent required by IWC-2430 whenever a service induced rejectable flaw is identified during the performance of ISI examinations in accordance with the requirements specified within IWC.

1.7.6.4

Additional examinations shall be performed, starting the '94 outage, to the extent required by -2430 (Code Case N-491) whenever a service induced rejectable flaw is identified during the performance of ISI examinations in accordance with the requirements specified within Code Case N-491 and IWF.

QUALITY ASSURANCE MANUAL GINNA STATION	TITLE:	APPENDIX B R.E. GINNA NUCLEAR POWER PLANT INSERVICE INSPECTION PROGRAM FOR THE 1990-1999 INTERVAL	Section 1	REV. 3
			PAGE 12 of 34	

1.8 Repair Requirements

Repairs shall be performed to the requirements specified within Supplement 2 to Appendix B, The Repair, Replacement & Modification (RR&M) Program. This RR&M Program shall apply to ASME Class 1, 2 & 3 pressure boundary piping, components & supports.

1.8.1 Performance of Repair

Repairs on ASME Class 1, 2 or 3 components shall be performed in accordance with the requirements of IWA/B/C/D/F-4000 of ASME Section XI, 1986 Edition or later Edition/Addenda that is approved via 10CFR50.55a. Alternatively, repairs may be performed either to the requirements of the original Construction Code, which the component or system was fabricated to, or to later approved editions of the Construction Code, or later approved editions of ASME Section III along with any Code Cases approved via Regulatory Guide 1.147.

1.8.2 Examination/Test for Repairs

1.8.2.1 Applicable examination requirements of the Construction Code shall be met. If the repair is performed on an existing weld that requires the complete removal of the original weld metal within that joint before rewelding, the following additional NDE requirements are required:

(a) Pressure retaining components greater than 2 inches in diameter shall require both surface and 100% volumetric examinations to be performed on the new weld.

Or

(b) Pressure retaining components 2 inches or less in diameter shall require a surface examination to be performed on the new weld.

Examinations and testing of snubbers and supports that have been repaired shall be performed in accordance with 5.0 below and Section 9 of this program.

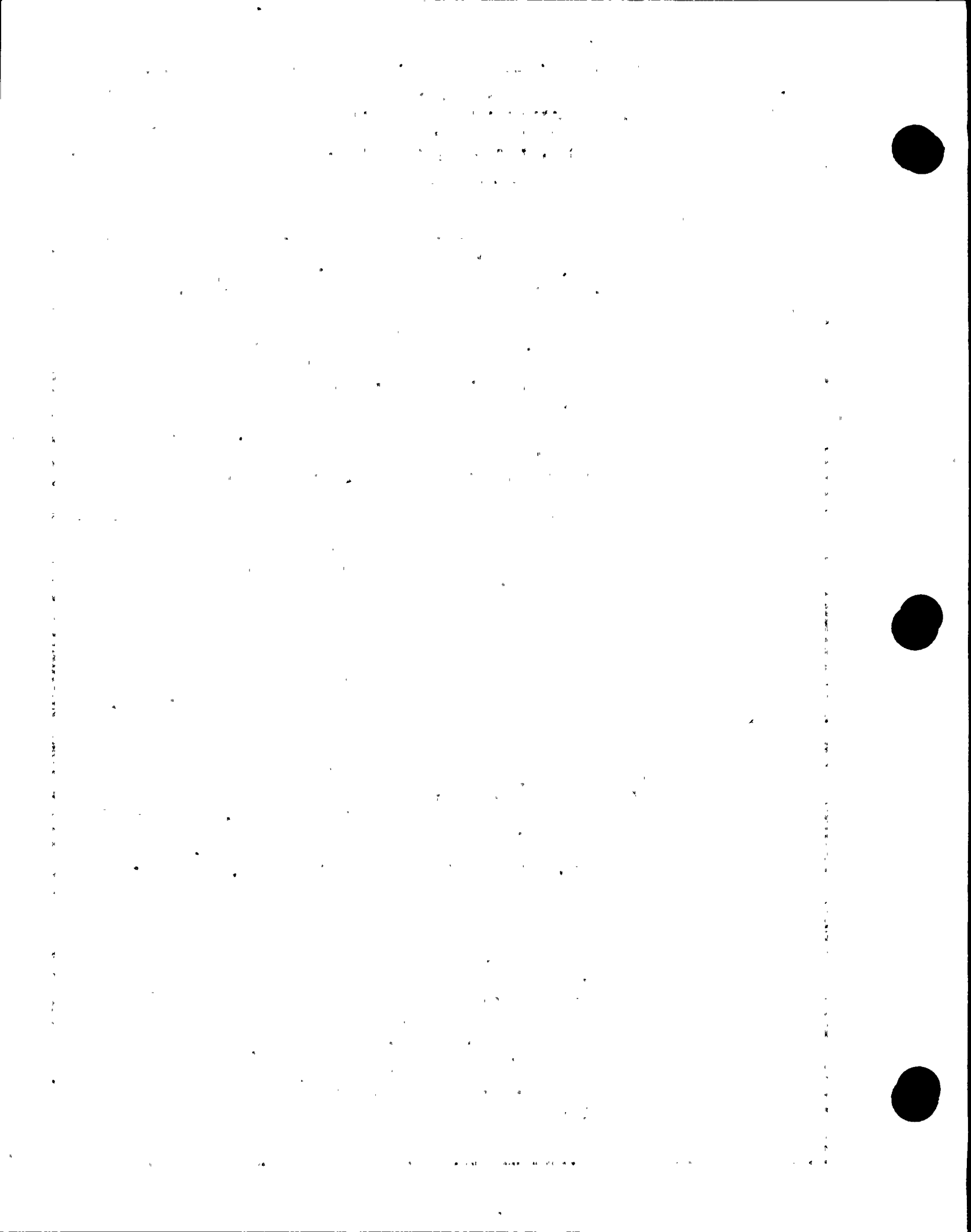

QUALITY ASSURANCE MANUAL GINNA STATION	TITLE:	Section 1	REV. 3
	APPENDIX B R.E. GINNA NUCLEAR POWER PLANT INSERVICE INSPECTION PROGRAM FOR THE 1990-1999 INTERVAL	PAGE 13 of 34	

- 1.8.2.2 The examination shall include the original examination method that detected the flaw, if applicable.
- 1.8.2.3 Applicable examination requirements of ASME section XI, 1986 Edition shall also be met to serve as a new PSI baseline for future ISI examinations, unless the examination performed under paragraph 1.8.2.1 was conducted under conditions and with equipment and techniques equivalent to those required by Section XI.
- 1.8.2.4 A hydrostatic test shall be performed in accordance with ASME Section XI, 1986 Edition, unless specifically exempted by Section XI Article IWA-4400, or the Alternate Rules of Incorporated Code Cases or Relief Requests, as applicable..
- 1.8.3 Surface flaws in Class 1, 2, or 3, bolts, studs, nuts and ligaments may be removed by mechanical means provided the removal of that flaw does not alter the basic configuration of the item. Bolts, studs, and nuts that have flaws that cannot be removed by mechanical means shall be replaced or reported for evaluation as indicated by Section XI, Article IWA-3100.
- 1.9 Replacement Requirements
- Replacement requirements, which includes modifications, are applicable to ASME Class 1, 2 and 3 pressure retaining components and piping systems and their supports, unless specifically exempted by ASME Section XI, 1986 Edition, Article IWA-7400.
- 1.9.1 Replacement Performance
- Replacements shall meet the requirements of ASME Section XI, 1986 Edition or a later Edition/Addenda approved via 10CFR50.55a. In addition, replacement items shall meet the requirements of the original Construction Code to which the original part was constructed. The R. E. Ginna Nuclear Power Plant Replacement Program is defined within Supplement 2 to Appendix B.

QUALITY ASSURANCE MANUAL GINNA STATION	TITLE:	Section 1	REV. 3
	APPENDIX B R.E. GINNA NUCLEAR POWER PLANT INSERVICE INSPECTION PROGRAM FOR THE 1990-1999 INTERVAL	PAGE 14 of 34	

- 1.9.1.1 A "Like for Like" replacement is an item that meets the original requirements of the design and procurement documents for the item being replaced and does not require reconciliation, reanalysis or changes to the item's design and technical requirements.
- 1.9.1.2 An approved equivalent is a replacement that will result in a design or technical change to the original requirements based on reconciliation, re-analysis and/or testing per Paragraph 1.9.2.1.
- 1.9.2 Alternatively items used for replacement may meet all or portions of the requirements later additions of the Construction Code or Section III, when the construction code was not Section III. In order to use this alternate approach, the following additional requirements apply.
- 1.9.2.1 Reconcile the requirements affecting the design, fabrication and examination of the replacement with the Design Analysis or Design Criteria or other methods of analysis that demonstrates the item is satisfactory for the specified design and operating conditions.
- 1.9.2.2 Mechanical interfaces, fits and tolerances that provide satisfactory performance are compatible with the system and component requirements.
- 1.9.2.3 Materials used are compatible with installation and system requirements.
- 1.9.2.4 If a replacement is because of a failure of the item being replaced, a design evaluation or analysis shall consider the cause of the failure and its impact on other similar items, and the necessary actions to be taken to preclude recurrence.
- 1.9.2.5 When welding is to be performed as part of the replacement, the rules of Section IX shall be followed to satisfy the requirements of IWA-7320 and IWF-7000.
- 1.9.2.6 Items identified in IWA-7400 will be exempt from the requirements of the replacement program.

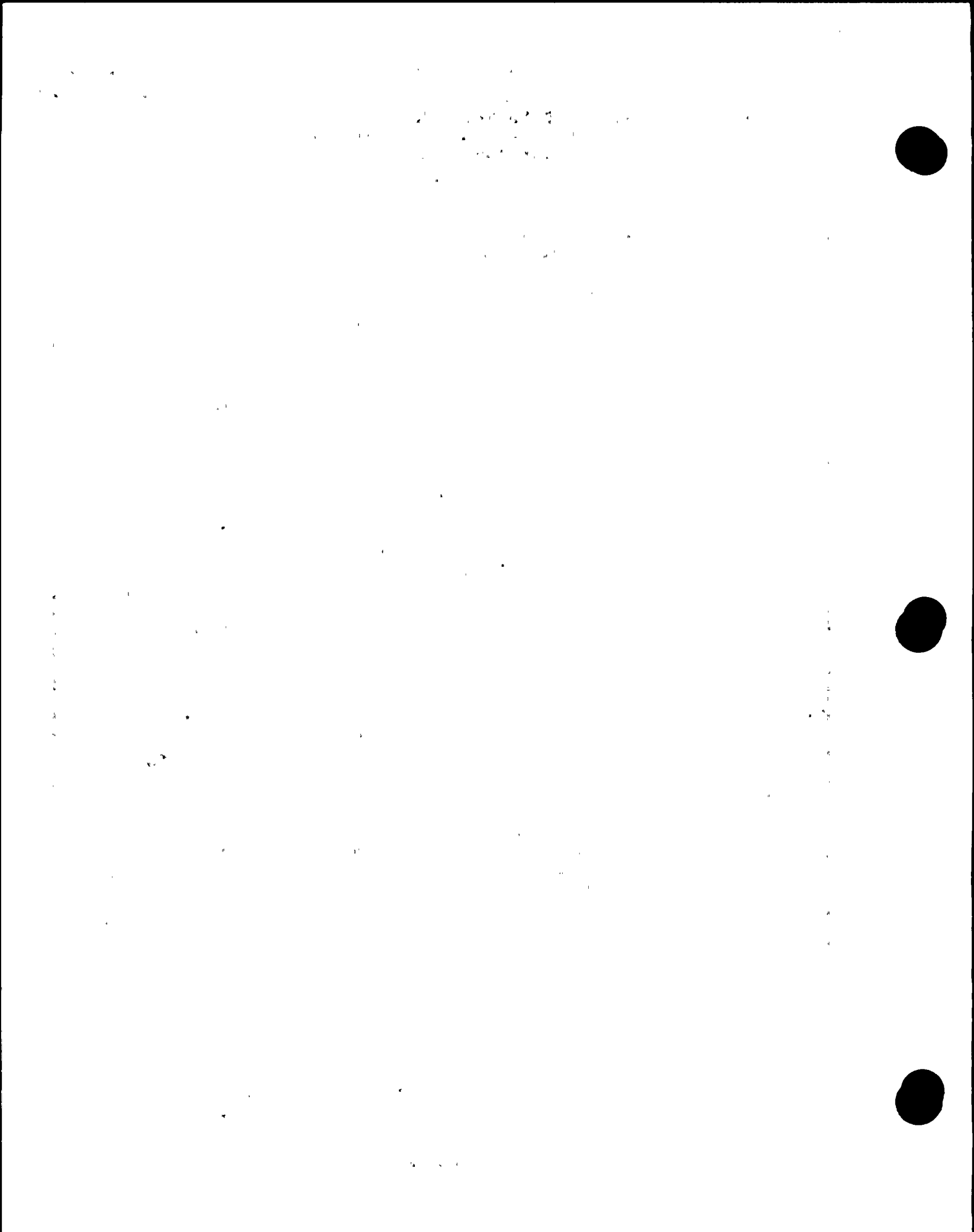

QUALITY ASSURANCE MANUAL GINNA STATION	TITLE:	APPENDIX B R.E. GINNA NUCLEAR POWER PLANT INSERVICE INSPECTION PROGRAM FOR THE 1990-1999 INTERVAL	Section 1	REV. 3
			PAGE 15 of 34	

1.9.3 Examination/Test

1.9.3.1 The replacement item shall be examined and pressure tested in accordance with the Construction Code or later Code provided it meets the requirements of 1.9.1 above.

Snubbers shall be examined and tested in accordance with Section 9 of this program.

1.9.3.2 Where the attachment of the non-pressure-retaining item is welded to a pressure boundary, the weld shall be examined in accordance with the requirements of 1.8.2.

1.9.3.3 Applicable examination requirements of ASME Section XI, 1986 Edition, shall also be met to serve as a new PSI baseline for future ISI examinations, unless the examination performed under 1.9.3.1 was conducted under conditions and with equipment and techniques equivalent to those required by ASME Section XI.

1.9.3.4 Replacements installed by mechanical methods shall be pressure tested at nominal operating pressure, or for Class 1 systems, the pressure associated with 100% rated reactor power.

1.9.4 Reports and Records

Reports and records to the extent required by the construction code and IWA-7520, as applicable for the replacement, shall be completed for all replacements.

QUALITY ASSURANCE MANUAL GINNA STATION	TITLE:	Section 1	REV. 3
	APPENDIX B R.E. GINNA NUCLEAR POWER PLANT INSERVICE INSPECTION PROGRAM FOR THE 1990-1999 INTERVAL	PAGE 16 of 34	

1.10 System Pressure Testing

1.10.1 General Requirements

1.10.1.1 Pressure testing shall be conducted on all Class 1, 2, and 3 pressure retaining components in accordance with the requirements of Section XI Articles IWA-5000, IWB-5000, IWC-5000, IWD-5000; and Section XI Table IWB-2500-1 - Examination Category B-P, Table IWC-2500-1 - Examination Category C-H, and Table IWD-2500-1 - Examination Category D-A, D-B and D-C.

In addition, "High Energy" Main Steam and Feedwater Piping shall also be pressure tested on these non-class systems in accordance with the rules of IWC-5000.

1.10.1.2 Pressure tests are conducted from normal operating pressure, to a pressure up to 25% over design pressure. The degree of pressurization and the test boundary depends upon the type of pressure test being performed. A visual examination (VT-2 method) is performed in concert with the pressure test on pressure retaining components under test pressure. Specific exceptions from achieving Section XI requirements are detailed in the Relief Request Section of this document.

1.10.2 Type of Pressure Tests

The various types of pressure tests which are required during the inspection interval are described in the following:

1.10.2.1 LEAKAGE PRESSURE TEST

This test is performed subsequent to refueling outages. The boundary subject to test pressurization and the associated VT-2 examination during a leakage pressure test will extend to the pressure retaining components within the system boundary containing pressurized reactor coolant under the plant mode of normal reactor startup.

QUALITY ASSURANCE MANUAL GINNA STATION	TITLE:	Section 1	REV. 3
	APPENDIX B R.E. GINNA NUCLEAR POWER PLANT INSERVICE INSPECTION PROGRAM FOR THE 1990-1999 INTERVAL	PAGE 17 of 34	

1.10.2.2

FUNCTIONAL PRESSURE TEST

This test is performed once each inspection period. The boundary subject to test pressurization and the associated VT-2 examination during a system functional pressure test will include only those pressure retaining components within the system boundary pressurized under the test mode required during the performance or a periodic system/component surveillance test.

1.10.2.3

INSERVICE PRESSURE TEST

This test is performed once each inspection period. The boundary subject to a test pressurization and the associated VT-2 examination during a system inservice pressure test will include only those pressure retaining components under operating pressure during normal system service.

1.10.2.4

HYDROSTATIC PRESSURE TEST

This test is performed once each inspection interval. The boundary subject to test pressurization and the associated VT-2 examination during a system hydrostatic pressure test includes all Class 1, 2, and 3 components and piping.

1.10.2.5

PNEUMATIC PRESSURE TEST

This test is limited to Class 2 and 3 systems. The boundary limits subject to test pressurization and the associated VT-2 examination during a system pneumatic pressure test are the same as a hydrostatic pressure test.

QUALITY ASSURANCE MANUAL GINNA STATION	TITLE:	APPENDIX B R.E. GINNA NUCLEAR POWER PLANT INSERVICE INSPECTION PROGRAM FOR THE 1990-1999 INTERVAL	Section 1 ⁷	REV. 3
			PAGE 18	of 34

1.10.2.6

REPAIR/REPLACEMENT PRESSURE TESTS

The boundary subject to test pressurization and the associated VT-2 examination is limited to the portion repaired or replaced, within the Class 1, 2 or 3 boundary. The specific type of pressure test is either a hydrostatic, pneumatic or a test at operating pressure such as the Leakage, Inservice or Functional. The specific type of test to be performed and the exemptions which apply to repair/replacement pressure testing are described in Supplement 2 to Appendix B, the Repair, Replacement & Modification Program. Code Case N-498 does not apply to Repairs, Replacements or Modifications.

1.10.3

Examination Requirements

1.10.3.1

During the conduct of pressure tests, certified VT-2 examination personnel, using RG&E approved NDE VT-2 examination procedure and the associated recording form, will examine the portions of piping under pressurization. The examination and test boundaries are depicted on controlled color-coded P&ID's. In some cases, the test boundary extends beyond the examination boundary due to valve location and/or check valve flow direction. In general, personnel will examine for evidence of leakage, inoperative leakage collection systems and evidence of corrosion.

1.10.4

Test Requirements

1.10.4.1

GENERAL

The contained fluid in the system or fluid added to the system shall serve as the pressurizing or test medium. In steam systems either water or air may be used. Where air is used, the test procedures shall permit the detection and location of through wall leakages in components of the system tested. The temperature of the test medium will be that of the available source unless otherwise specified by the implementing test procedure/document. The test medium will be of a quality which is equal to or better than the system operating medium.

QUALITY ASSURANCE MANUAL GINNA STATION	TITLE:	Section 1	REV. 3
	APPENDIX B R.E. GINNA NUCLEAR POWER PLANT INSERVICE INSPECTION PROGRAM FOR THE 1990-1999 INTERVAL	PAGE 19 of 34	

- 1.10.4.1.1 During conduct of hydrostatic tests, all entrained air will be vented from the system except in the following cases:
- a. Atmospheric Storage Tanks
 - b. 0-15 psi Storage Tanks
 - c. Class 1 systems where a mixture of steam, water and noncondensable gases are present in a proportion typical of normal startup conditions.
 - d. Normal Steam Systems
- 1.10.4.1.2 For Leakage, Functional, Inservice and Hydrostatic tests, the level of system pressure and temperature indicated or recorded by normal operating system instrumentation, or alternatively by test instrumentation is acceptable. For hydrostatic tests, the instrument requirements of IWA-5260 and applicable Code Case N-437 must be met.
- 1.10.4.2 **LEAKAGE PRESSURE TEST REQUIREMENTS**
- The system leakage pressure test shall be conducted at a pressure not less than nominal operating pressure associated with 100% Rated Reactor Power.
- The pressure and temperature will be attained at a rate in accordance with the heat-up limitations specified in the Ginna Technical Specifications for the component/piping system being tested.
- 1.10.4.3 **FUNCTIONAL PRESSURE TEST REQUIREMENTS**
- The system functional pressure test is normally performed during performance or a Periodic Surveillance Test. The test is used to establish the test conditions associated with normal system operating pressure and temperature for performance of the system functional pressure test.
- 1.10.4.4 **INSERVICE PRESSURE TEST REQUIREMENTS**
- The operating pressure and temperature during normal system operation is used during performance of this test.

QUALITY ASSURANCE MANUAL GINNA STATION	TITLE:	Section 1	REV. 3
	APPENDIX B R.E. GINNA NUCLEAR POWER PLANT INSERVICE INSPECTION PROGRAM FOR THE 1990-1999 INTERVAL	PAGE 20 of 34	

1.10.4.5 HYDROSTATIC PRESSURE TEST REQUIREMENTS

1.10.4.5.1 General

Code Case N-498 stipulations may be employed on Class 1 and 2 Required Systems in lieu of the 10 year Hydrostatic Test. Hydrostatic test pressure requirements vary among each of the classifications. The minimum test pressure will be maintained for the entire duration of the test, with the exception of tests performed at temperatures greater than 200°F, where the examination phase may be performed at a lower pressure corresponding to 200°F. The test pressure shall not exceed the maximum allowable test pressure of any component within the test boundary.

1.10.4.5.2 The hydrostatic test pressure, including static head, will not exceed 106% of the specified test pressure for the system anywhere within the test boundary.

1.10.4.5.2.1 In cases where the highest and lowest elevations cannot be isolated, and the test pressure including static head, would exceed 106% of the specified test pressure at the lowest point, the test pressure will be reduced.

1.10.4.5.2.2 In cases where the high and low elevations result in unreasonably small differences between the test pressure including static head, and 106% of the specified test pressure, the test pressure will be reduced to accommodate the precision of the test instrument.

1.10.4.5.2.3 The test pressure, as identified in sections 1.10.4.5.2.1 and 1.10.4.5.2.2, will be adjusted such that the test pressure, including static head, does not exceed 106% of the specified test pressure at the lowest point. The resulting pressure at the highest point will be considered acceptable.

QUALITY ASSURANCE MANUAL GINNA STATION	TITLE:	Section 1	REV. 3
	APPENDIX B R.E. GINNA NUCLEAR POWER PLANT INSERVICE INSPECTION PROGRAM FOR THE 1990-1999 INTERVAL	PAGE 21 of 34	

1.10.4.5.3 The hydrostatic test boundary will end at the transition between system piping and instrumentation tubing shown on P&ID drawings. When this transition does not occur at an isolation valve, the boundary will be extended to the first isolation valve after the transition.

1.10.4.6 The following sections list the hydrostatic test pressure requirements which will be met for each Code classification:

1.10.4.6.1 Class 1

The system hydrostatic pressure test is conducted at the pressure calculated from the following table based on the test temperature:

<u>Test Temperature, Deg. F.</u>	<u>Test Pressure</u>
100 or less	1.10 P _o
200	1.08 P _o
300	1.06 P _o
400	1.04 P _o
500 or greater	1.02 P _o

"P" is the nominal operating pressure corresponding with 100% rated reactor power. Linear interpolation will be used at intermediate test temperatures. Technical Specification heat-up/cool-down limits will be observed.

1.10.4.6.2 Class 2, 3, and High Energy:

- a. The test pressure will be at least 1.10 times the system pressure for systems with a design temperature of 200°F or less, and at least 1.25 times the system pressure for systems with a design temperature above 200°F. The system pressure will be the lowest pressure setting among the number of safety or relief valves provided for overpressure protection within the boundary of the system to be tested. For systems (or portions of systems) not provided with safety or relief valves, the system design pressure will be substituted for the system pressure.

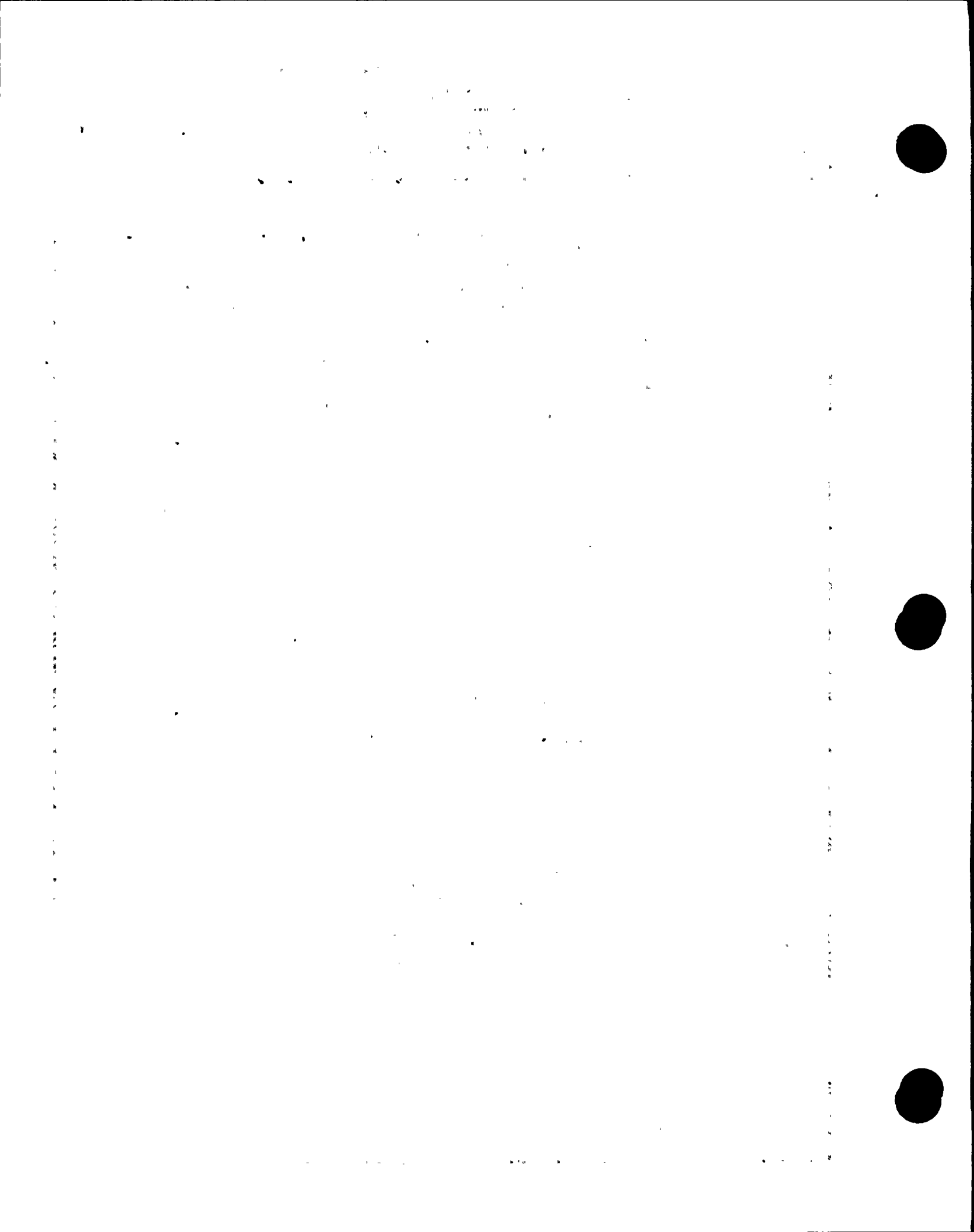

QUALITY ASSURANCE MANUAL GINNA STATION	TITLE:	Section 1	REV. 3
	APPENDIX B R.E. GINNA NUCLEAR POWER PLANT INSERVICE INSPECTION PROGRAM FOR THE 1990-1999 INTERVAL	PAGE 22 of 34	

- b. In the case of atmospheric storage tanks, the nominal hydrostatic pressure developed with the tank filled to its design capacity will be acceptable as the test pressure.
- c. For 0 to 15 psi storage tanks, the test pressure will be 1.1 times the design pressure of vapor or gas space above liquid level for which overpressure protection is provided by the relief valves. If relief valves are not installed, the test pressure will be equal to 1.1 times the normal operating pressure.
- d. For the purpose of the test, open-ended portions of a suction or drain line from a storage tank extending to the first shutoff valve are considered as an extension of the storage tank.
- e. For open ended portions of discharge lines beyond the last shutoff valve in nonclosed systems, a test that demonstrates unimpaired flow will be performed in lieu of a system hydrostatic pressure test. Unimpaired flow for Class 2 is defined as an "open flow path" and for Class 3 as "adequate flow during system operation".

1.10.5 Test Implementation

1.10.5.1 All pressure testing is implemented using both the VT-2 examination procedure and the specific test procedure for the type of test and portion of system being tested.

1.10.5.2 Applicable Required System Pressure Test Boundaries shall be confirmed prior to examination performance.

QUALITY ASSURANCE MANUAL GINNA STATION	TITLE:	APPENDIX B R.E. GINNA NUCLEAR POWER PLANT INSERVICE INSPECTION PROGRAM FOR THE 1990-1999 INTERVAL	Section 1	REV. 3
			PAGE 23 of 34	

1.10.6 Scheduling

When using the inspection plan, it should be noted that during a period or refueling outage in which a hydrostatic test is performed on a system or portion(s) of a system, the leakage test (Functional or Inservice) required for that period on the same system or portion of the system, may be deleted from that period or outage.

The hydrostatic test will satisfy the requirements for that leakage test.

2.0 CLASS 1 PROGRAM PLAN

2.1 Basis for Preparation

2.1.1 Preparation of the Class 1 ISI program plan was based on the requirements of Articles IWB-1000 and IWB-2000 of Section XI. These articles provide rules and guidelines for exemptions, inspection schedules, and examination requirements for Class 1 pressure retaining components and their integral attachments.

2.1.2 As allowed by 10CFR50.55a (b)(2)(ii), the extent and frequency requirements for Class 1 Category B-J weld examinations may be based on the 1974 Edition of ASME Section XI with Addenda through Summer, 1975. This earlier Code does not have any criteria established for the selection of specific welds to be examined, and therefore, stress level criteria, and terminal end criteria is not required for the selection process. Instead of utilizing the earlier Code rules for Category B-J welds (which has no selection guidance), the 1986 Code rules will be utilized to the extent practical. In lieu of the stress level selection criteria Table IWB-2500-1, Note 1(b), all accessible terminal end welds (including terminal ends to vessel per Note 1(a) of Table IWB-2500-1) shall be selected. Refer to Code Table 1 in Section 4 for selection criteria.

QUALITY ASSURANCE MANUAL GINNA STATION	TITLE:	Section 1	REV. 3
	APPENDIX B R.E. GINNA NUCLEAR POWER PLANT INSERVICE INSPECTION PROGRAM FOR THE 1990-1999 INTERVAL	PAGE 24 of 34	

2.2	Components Subject to Examination						
2.2.1	Based on the requirements of Section XI, Class 1 nonexempt pressure-retaining components and their integral attachments will be subject to examination during the third inspection interval.						
2.3	Extent and Frequency of Examinations						
2.3.1	Class 1 components, as listed in Section 4, Table 1 shall be examined to the extent and frequency required in Table IWB-2500-1 and Figures IWB 2500 through IWB 2500-20 of Section XI.						
2.4	Exemption Criteria						
2.4.1	In accordance with IWB-1220, certain Class 1 components are exempt from examination. The following criteria were applied to exempt components from surface and volumetric examinations in accordance with Section XI :						
	<table border="0"> <thead> <tr> <th><u>Exemption Criteria</u></th> <th><u>Code Reference</u></th> </tr> </thead> <tbody> <tr> <td>Piping of 1 inch nominal pipe size (NPS) and smaller, except for steam generator tubing</td> <td>IWB-1220(b) (1)</td> </tr> <tr> <td>Components and their connections in piping of 1 inch NPS and smaller</td> <td>IWB-1220(b) (2)</td> </tr> </tbody> </table>	<u>Exemption Criteria</u>	<u>Code Reference</u>	Piping of 1 inch nominal pipe size (NPS) and smaller, except for steam generator tubing	IWB-1220(b) (1)	Components and their connections in piping of 1 inch NPS and smaller	IWB-1220(b) (2)
<u>Exemption Criteria</u>	<u>Code Reference</u>						
Piping of 1 inch nominal pipe size (NPS) and smaller, except for steam generator tubing	IWB-1220(b) (1)						
Components and their connections in piping of 1 inch NPS and smaller	IWB-1220(b) (2)						
2.5	Examination of Reactor Coolant Pump Flywheels						
	The Reactor Coolant Pump Flywheels shall be examined as specified in Section 11 of this program. These examinations shall be scheduled in the Class 1 section of the ISI program plan.						
2.6	Inservice Inspection Program Plan (Supplement 1 to Appendix B)						
	This plan provides the examination requirements for Class 1 components per the 1986 Edition of Section XI. These requirements shall be satisfied during the third inspection interval. The plan also shows the results of examinations performed in the previous two intervals.						

QUALITY ASSURANCE MANUAL GINNA STATION	TITLE:	APPENDIX B R.E. GINNA NUCLEAR POWER PLANT INSERVICE INSPECTION PROGRAM FOR THE 1990-1999 INTERVAL	Section 1	REV. 3
			PAGE 25 of 34	

A detailed description of the contents of the Class 1 Examination Plan can be found in the "Introduction". This immediately precedes the tables and the isometric and component drawings, in the plan. From this plan, an examination schedule is extracted for implementation of the examinations for each outage of the third interval.

3.0 CLASS 2 PROGRAM PLAN

3.1 Basis for Preparation

3.1.1 Preparation of the Class 2 ISI program plan is based on the requirements of Articles IWC-1000 and IWC-2000 of Section XI. These articles provide rules and guidelines for exemptions, inspection schedule, and examination requirements for Class 2 pressure retaining components and their integral attachments.

3.2 Components Subject to Examination

3.2.1 Based on the requirements of Section XI, Class 2, nonexempt pressure-retaining components and their integral attachments will be subject to examination during the third inspection interval.

3.3 Extent and Frequency of Examinations

3.3.1 Class 2 components, as listed in Section 4, Table 2, shall be examined to the extent and frequency required in Table IWC 2500-1 and Figures IWC 2500-1 through IWC 2500-13 of Section XI.

3.4 Exemption Criteria

IWC-1220 of Section XI provides the exemption criteria for Class 2 components. The following criteria were used to exempt Class 2 components from surface and volumetric examinations in accordance with IWC-1220.

QUALITY ASSURANCE MANUAL GINNA STATION	TITLE:	Section 1	REV. 3
	APPENDIX B R. E. GINNA NUCLEAR POWER PLANT INSERVICE INSPECTION PROGRAM FOR THE 1990-1999 INTERVAL	PAGE 26 of 34	

3.4.1

The following components (or parts of components) of Residual Heat Removal (RHR), Emergency Core Cooling (ECC), and Containment Heat Removal (CHR), systems (or portions of systems) are exempt from the volumetric and surface examination requirements of IWC-2500:

- (a) vessels, piping, pumps, valves and other components 4 inches NPS and smaller in all systems except in high pressure safety injection systems of pressurized water reactor plants;
- (b) vessels, piping, pumps, valves, and other components 1-1/2 inches NPS and smaller in high pressure safety injection systems of pressurized water reactor plants;
- (c) component connections 4 inches NPS and smaller (including nozzles, socket fittings, and other connections) in vessels, piping, pumps, valves, and other components of any size in all systems except in high pressure safety injection systems of pressurized water reactor plants;
- (d) component connections 1-1/2 inches NPS and smaller (including nozzles, socket fittings and other connections) in vessels, piping, pumps, valves and other components of any size in high pressure safety injection systems of pressurized water reactor plants;
- (e) vessels, piping, pumps, valves, other components, and component connections of any size in statically pressurized, passive (i.e., no pumps) safety injection systems of pressurized water reactor plants; and
- (f) piping and other components of any size beyond the last shutoff valve in open- ended portions of systems that do not contain water during normal plant operating conditions.

QUALITY ASSURANCE MANUAL GINNA STATION	TITLE:	Section 1	REV. 3
	APPENDIX B R.E. GINNA NUCLEAR POWER PLANT INSERVICE INSPECTION PROGRAM FOR THE 1990-1999 INTERVAL	PAGE 27 of 34	

3.4.2

The following components (or parts of components) of systems (or portions of systems) other than RHR, ECC and CHR systems are exempt from the volumetric and surface examination requirements of IWC-2500:

- (a) vessels, piping, pumps, valves and other components 4 inches NPS and smaller;
- (b) component connections 4 inches NPS and smaller (including nozzles, socket fittings and other connections) in vessels, piping, pumps, valves and other components of any size;
- (c) vessels, piping, pumps, valves, other components and component connections of any size in systems or portions of systems that operate (when the system function is required) at a pressure equal to or less than 275 psig and at a temperature equal to or less than 200°F; and
- (d) piping and other components of any size beyond the last shutoff valve in open ended portions of systems that do not contain water during normal plant operating conditions.

3.4.3

In addition to the exemptions of IWC-1220, non-piping component size exemptions shall be as follows: Nonpiping components having a cumulative inlet and a cumulative outlet nominal cross section area, neither of which exceeds the nominal cross section area of the applicable exemption size, shall be exempted from the surface, volumetric, and visual VT-1 and VT-3 examination requirements of IWC-2500. The applicable exemption size shall be 4" NPS for all systems except the Class 2 High Pressure Safety Injection System, which shall be 1 1/2" NPS. This position is based on the interpretation of the clarification made by footnote 1 of IWC-1220 of the 1989 Addenda to ASME Section XI. For the purpose of applying this criteria, it is assumed that the intention of the Code is not to accumulate the cross-section areas of piping from different fluid systems entering a given component (e.g., heat exchanger shell &

QUALITY ASSURANCE MANUAL GINNA STATION	TITLE:	APPENDIX B R.E. GINNA NUCLEAR POWER PLANT INSERVICE INSPECTION PROGRAM FOR THE 1990-1999 INTERVAL	Section 1	REV. 3
			PAGE 28 of 34	

tube sides), nor the non-process piping (e.g., vents, drains and instrumentation).

3.5 Inservice Inspection Program Plan (Supplement 1 to Appendix B)

This plan provides the examination requirements for Class 2 components per ASME Section XI, 1986 Edition, no Addenda. These requirements shall be satisfied during the third inspection interval. The plan also shows the results of examinations performed during the previous two intervals.

A detailed description of the contents of the Class 2 Examination Plan can be found in the "Introduction". This immediately precedes the tables and the isometric and components drawings in the plan. From the plan an examination schedule is extracted for implementation of the examinations for each outage of the third interval.

4.0 CLASS 3 PROGRAM

4.1 Basis for Preparation

4.1.1 Preparation of the Class 3 ISI program was based on the requirements of Articles IWD-1000 and IWD-2000 of Section XI. These articles provide rules and guidelines for exemptions, inspection schedules, and examination requirements for Class 3 pressure retaining components and their integral attachments.

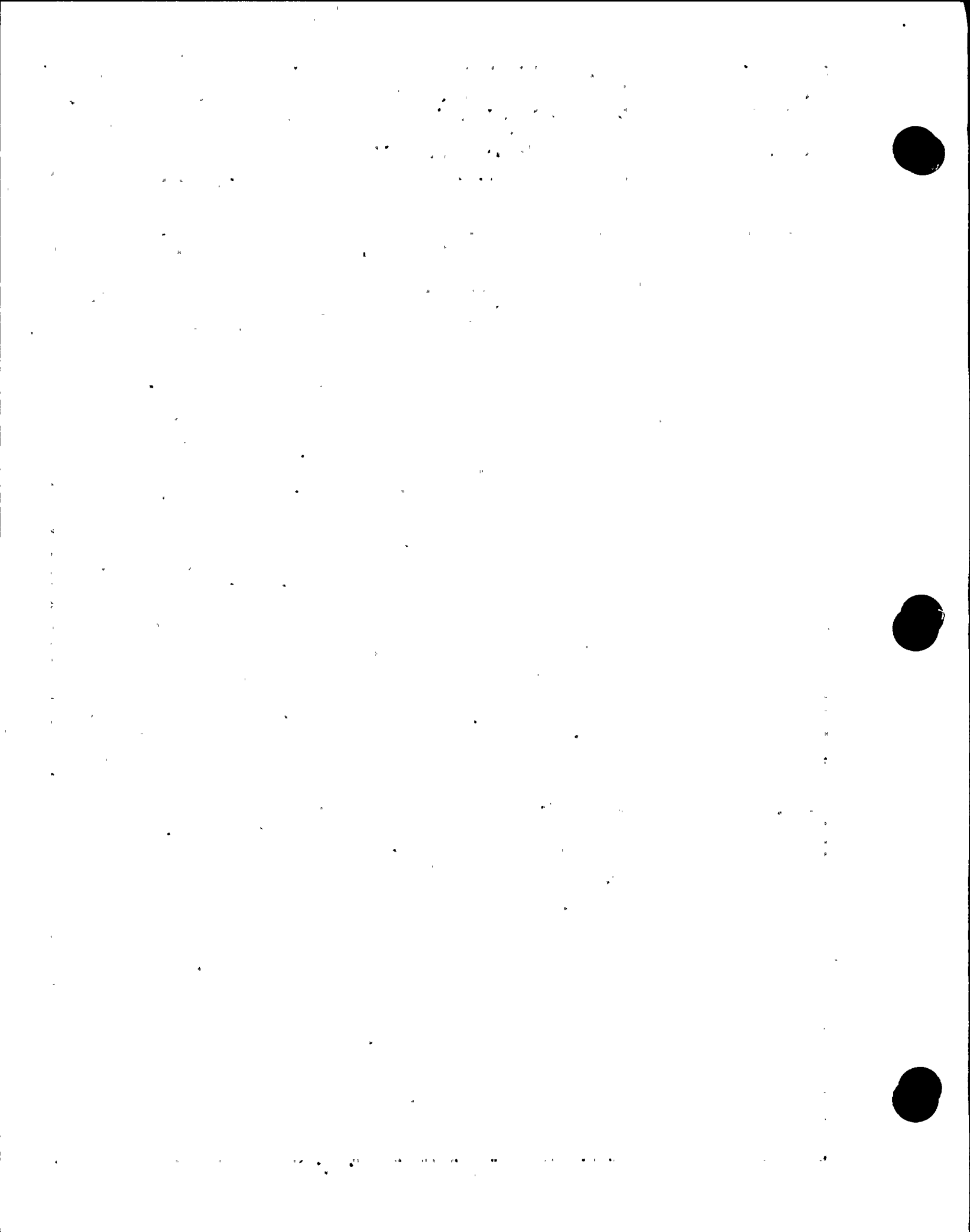

QUALITY ASSURANCE MANUAL GINNA STATION	TITLE:	APPENDIX B R.E. GINNA NUCLEAR POWER PLANT INSERVICE INSPECTION PROGRAM FOR THE 1990-1999 INTERVAL	Section 1	REV. 3
			PAGE 29	of 34

4.2 Components Subject to Examination

4.2.1 Based on the requirements of Section XI, Class 3 nonexempt pressure-retaining components integral attachments will be subject to examination during the third inspection interval:

4.2.1.1 Other Class 3 systems are not subject to the examination or System Pressure Testing requirements of ASME Section XI because they do not meet the system function requirements of Examination Categories D-A, D-B and D-C, where:

D-A Systems in support of Reactor Shutdown Function

D-B Systems in support of Emergency Core Cooling, Containment Heat Removal, Atmosphere Clean-up and Reactor Residual Heat Removal.

D-C Systems in support of Residual Heat Removal From Spent Fuel Storage Pool.

4.3 Extent and Frequency of Examinations

4.3.1 Class 3 components, as listed in Table 3 shall be examined to the extent and frequency required in Table IWD 2500-1 and Figure IWD 2500-1 of Section XI.

4.3.2 Integrally welded attachments shall be examined, utilizing the VT-3 method, once during the Interval on all Class 3 Component Supports. The associated Class 3 Categories have been grouped since the methods of examination and their Requirements are identical.

QUALITY ASSURANCE MANUAL GINNA STATION	TITLE: APPENDIX B R.E. GINNA NUCLEAR POWER PLANT INSERVICE INSPECTION PROGRAM FOR THE 1990-1999 INTERVAL	Section 1	REV. 3
		PAGE 30 of 34	

4.4 Exemption Criteria

4.4.1 In accordance with IWD-1220, certain Class 3 components are exempt from examination. The following exemption criteria was applied to Class 3 systems as specified in IWD-1220:

<u>Exemption Criteria</u>	<u>Section XI Reference</u>
Integral attachments of supports and restraints to components that are 4 inches NPS and smaller within the system boundaries of Examination Categories D-A, D-B, and D-C shall be exempt from the VT-3 examination, except for Auxiliary Feedwater. Exemption for the Auxiliary Feedwater System is 1 inch and less.	IWD-1220.1
Integral attachments of supports and restraints to components exceeding 4" nominal pipe size may be exempted from the visual examination VT-3 of Table IWD-2500-1 provided:	IWD-1220.2
(a) the components are located in systems (or portions of systems) whose function is not required in support of reactor residual heat removal, containment heat removal, and emergency core cooling; and	
(b) The components operate at a pressure of 275 psig or less and at a temperature or 200 degrees F or less.	

QUALITY ASSURANCE MANUAL GINNA STATION	TITLE:	APPENDIX B R.E. GINNA NUCLEAR POWER PLANT INSERVICE INSPECTION PROGRAM FOR THE 1990-1999 INTERVAL	Section 1	REV. 3
			PAGE 31	of 34

4.4.2

In addition to the exemptions of IWD-1220, non-piping component size exemptions shall be as follows: Nonpiping components having a cumulative inlet and a cumulative outlet nominal cross section area, neither of which exceeds the nominal cross section area of the applicable exemption size, shall be exempted from the surface, volumetric, and visual VT-1 and VT-3 examination requirements of IWD-2500. The applicable exemption size shall be 4" NPS for all systems except the Class 3 Auxiliary Feedwater System, which shall be 1" NPS. This position is based on the interpretation of the clarification made by footnote 1 of IWD-1220 of the 1989 Addenda to ASME Section XI. For the purpose of applying this criteria, it is assumed that the intention of the Code is not to accumulate the cross-section areas of piping from different fluid systems entering a given component (e.g., heat exchanger shell & tube sides), nor the non-process piping (e.g., vents, drains and instrumentation).

4.5

Inservice Inspection Program Plan (Supplement 1 to Appendix B)

This plan provides the examination requirements for Class 3 IWD components per the 1986 Edition of Section XI. These requirements shall be satisfied during the third inspection interval. The plan also shows the results of examinations performed during the previous two intervals.

A detailed description of the contents of the Class 3 Examination Plan can be found in the "Introduction". This immediately precedes the tables and the isometric and component drawings in the plan. From the plan an examination schedule is extracted for implementation of the examinations for each outage of the third interval.

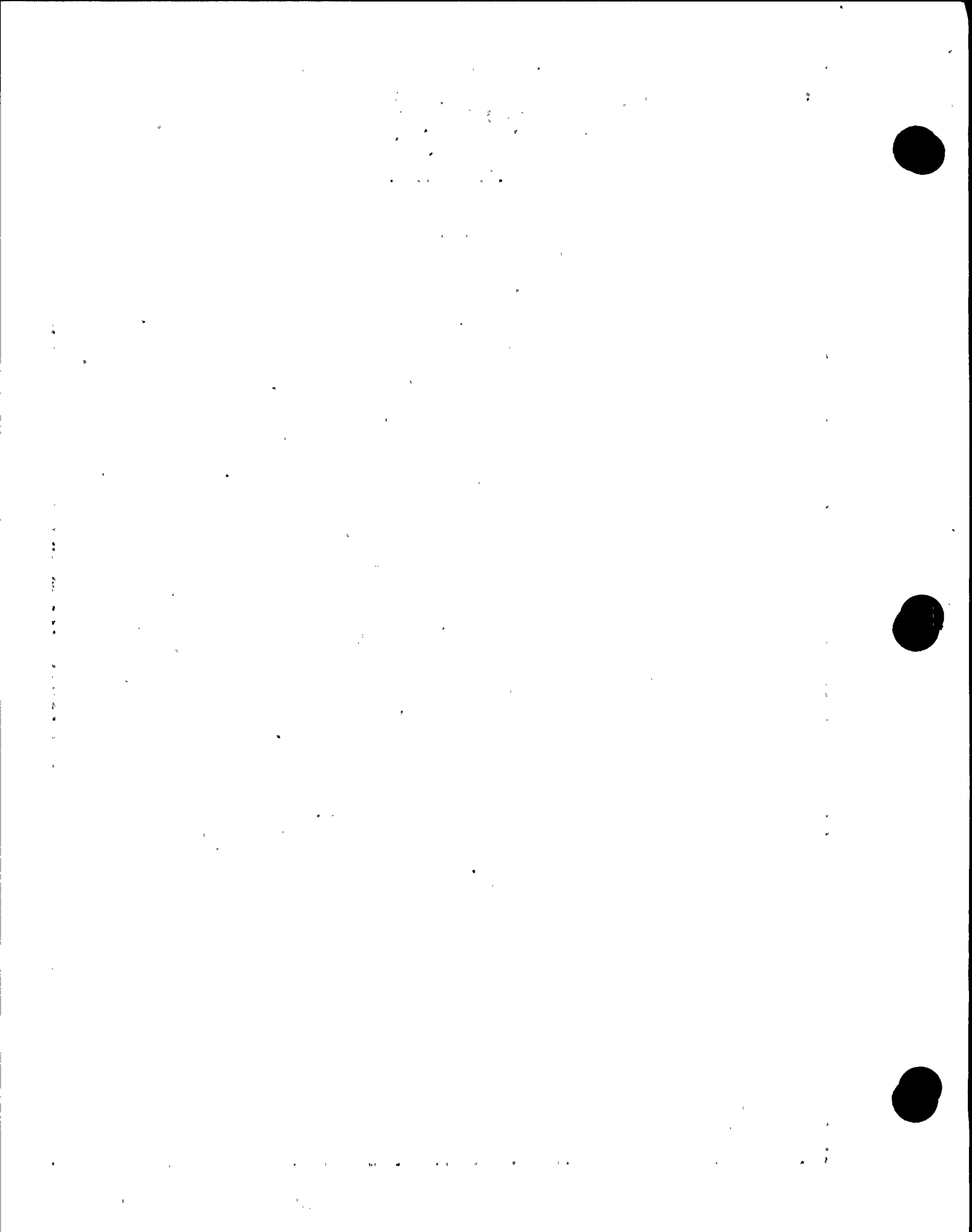

QUALITY ASSURANCE MANUAL GINNA STATION	TITLE:	Section 1	REV. 3
	APPENDIX B R.E. GINNA NUCLEAR POWER PLANT INSERVICE INSPECTION PROGRAM FOR THE 1990-1999 INTERVAL	PAGE 32 of 34	

5.0 CLASS 1, CLASS 2, AND CLASS 3 COMPONENT SUPPORTS

5.1 Basis for Preparation

The following paragraphs (5.1 through 5.4) describe the Inservice Inspection Program for Class 1, 2, and 3 component supports for the First and Second Periods, up to and including the first outage ('93). The remainder of the Second and Third Periods shall be in accordance with Code Case N-491 (for IWF-1000, -2000 and -3000) and IWF of the '86 Section XI Code.

5.1.1 Preparation of the component support ISI Program was based on the requirements of Articles IWF-1000 and IWF-2000 of Section XI. These articles provide rules and guidelines for exemptions, inspection schedules, and examination requirements for Class 1, Class 2, and Class 3 component supports. Inservice test requirements and VT-3 inspection requirements for snubbers shall be conducted in accordance with Section 9 of this program which implements the requirements of Article IWF-2000.

5.2 Component Supports Subject to Examination

5.2.1 Based on the requirements of Section XI, nonexempt component supports for the Class 1, Class 2 and Class 3 systems identified in paragraphs 2.2, 3.2 and 4.2 of this section shall be subject to examination during the third inspection interval. The component supports requiring examination shall be as follows:

5.2.1.1 Plate and Shell-Type Supports

Supports which are fabricated from plate and shell elements, such as vessel skirts and saddles, and are normally subjected to a biaxial stress.

QUALITY ASSURANCE MANUAL GINNA STATION	TITLE:	APPENDIX B R.E. GINNA NUCLEAR POWER PLANT INSERVICE INSPECTION PROGRAM FOR THE 1990-1999 INTERVAL	Section 1	REV. 3
			PAGE 33 of 34	

5.2.1.2 Linear-Type Supports

Supports acting under essentially a single component or direct stress. Such elements may also be subjected to shear stress. Examples of such structural elements are: tension and compression struts; beams and columns subjected to bending; trusses; frames; arches; rings; and cables.

5.2.1.3 Component Standard Supports

A support assembly consisting of one or more generally mass-produced units usually referred to as catalog items. Examples of such items are shown in Figure IWF-1210-1 of Section XI.

5.3 Extent and Frequency of Examination

5.3.1 Component supports selected for examination shall be those components required to be examined under the requirements of 2.3, 3.3 and 4.3, IWF-2500. The inservice test requirements of Article IWF-5000 shall be satisfied by the requirements of Section 9 of this program.

5.3.1.1 Class 3 component supports containing integrally welded attachments shall be examined, utilizing the VT-3 method, once during the Interval. The associated IWF categories have been grouped since the methods of examination and associated Requirements are identical.

5.3.2 In addition, snubbers shall be functionally tested at the frequency required by Section 9 of this program.

5.3.3 On piping systems where a piping seismic analysis boundary is beyond the safety class boundary, the component supports within the portion between those two boundaries shall be examined. The extent of these examinations shall be consistent with the examination requirements of that safety class system.

QUALITY ASSURANCE MANUAL GINNA STATION	TITLE:	APPENDIX B R.E. GINNA NUCLEAR POWER PLANT INSERVICE INSPECTION PROGRAM FOR THE 1990-1999 INTERVAL	Section 1	REV. 3
			PAGE 34 of 34	

- 5.3.4 High Energy Piping Component Supports shall be examined to IWC-2500 Category C-C and to IWF-2500 in an Augmented Program.
- 5.4 Exemptions
- 5.4.1 ASME Section XI, 1986 Edition, no Addenda, does not contain defined exemption criteria for component supports.
- 5.4.2 Exemption criteria specified in IWB, IWC and IWD have been used.
- 5.5 Inservice Inspection Program Plan (Supplement 1 to Appendix B)
- This plan identifies and incorporates the appropriate component supports into the Class 1, 2, and 3 sections of the examination plan. These requirements shall be satisfied during the third inspection interval. The plan also shows the results of examinations performed in the previous two intervals.

QUALITY ASSURANCE MANUAL GINNA STATION	Section 2	REV. 3	PAGE 1 of 39
	EFFECTIVE DATE: December 31, 1993		
ROCHESTER GAS & ELECTRIC CORPORATION	SIGNATURE		DATE
	TITLE:	PREPARED BY: <i>Frank A. Klypedt</i>	12-1-93
APPENDIX B R. E. GINNA NUCLEAR POWER PLANT INSERVICE INSPECTION PROGRAM FOR THE 1990-1999 INTERVAL ISI RELIEF REQUESTS	QUALITY ASSURANCE REVIEW:	<i>[Signature]</i>	12-2-93
	APPROVED BY:	<i>Michael J. Squit</i>	12-6-93

1.0 Introduction:

1.1 General:

In accordance with 10CFR50.55a(g) (5) (iv), Rochester Gas & Electric has requested relief from those ASME Section XI requirements that have been determined impractical for certain areas. This section identifies each active and owner withdrawn Relief Request submitted to the Nuclear Regulatory Commission for their consideration and acceptance.

Table 1 provides information in a summary format for both active and withdrawn relief requests applicable to R. E. Ginna Nuclear Power Plant.

Following Table 1, detailed Relief Requests are listed. These provide information on the component for which relief is requested, ASME requirements, proposed alternate method, and other pertinent information, as needed. Existing active relief requests can be withdrawn by the owner at any time. Additional relief requests will be submitted to the Nuclear Regulatory Commission, as appropriate.

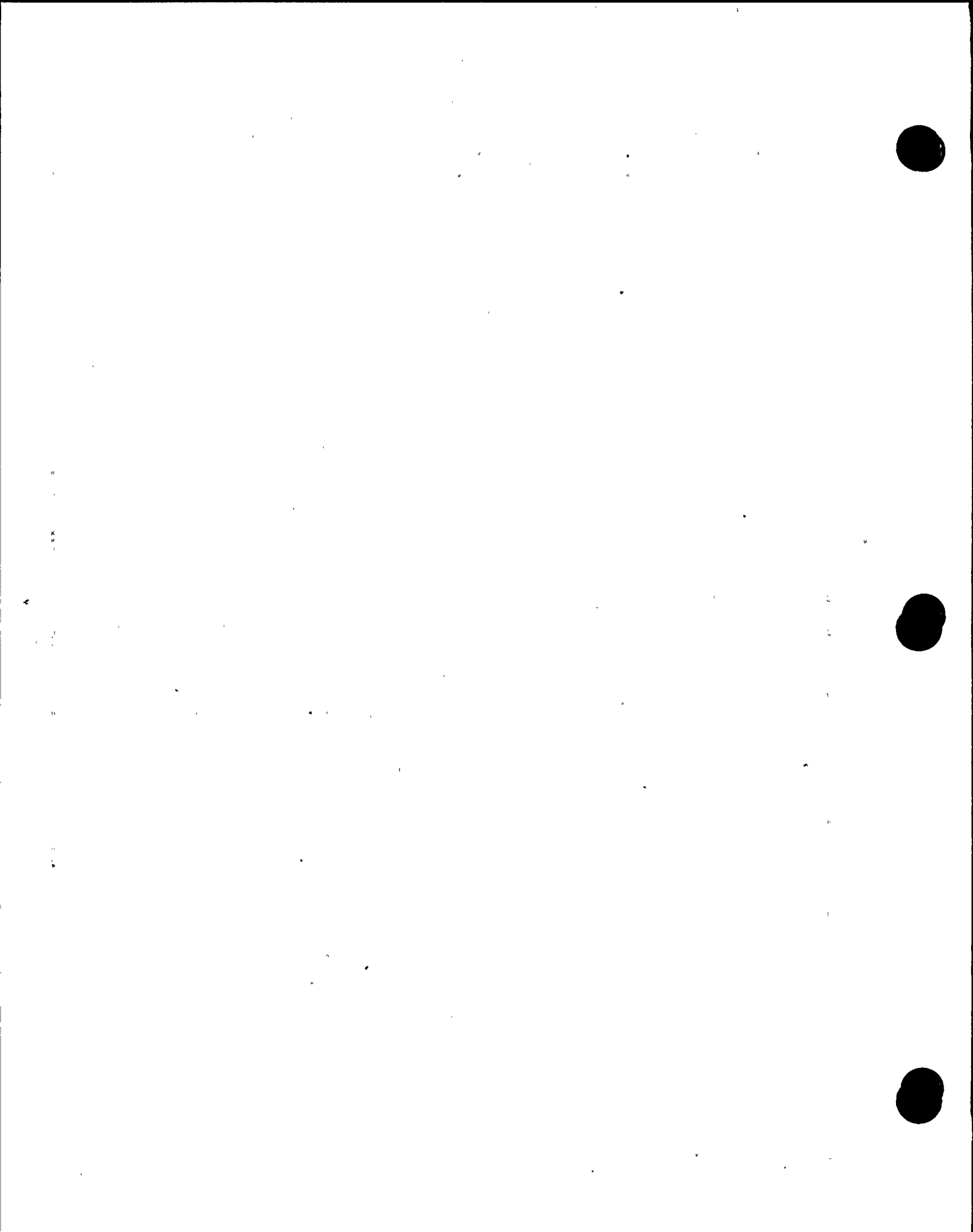

QUALITY ASSURANCE MANUAL GINNA STATION	TITLE: APPENDIX B R. E. GINNA NUCLEAR POWER PLANT INSERVICE INSPECTION PROGRAM FOR THE 1990-1999 INTERVAL ISI RELIEF REQUESTS	Section 2	REV. 3
		PAGE 2 of 39	

TABLE 1
SUMMARY OF RELIEF REQUESTS

Relief Request Number	Section XI Reference	Component	ASME Requirement for Which Relief is Requested	Reason for Relief Request	Proposed Alternate Examination
1	IWB-2500-1 Cat. B-A	RPV Shell to Flange Weld	Volumetric Examination during two different periods.	To perform all examinations associated with the Shell-to-Flange during the same period.	Perform all examinations associated with the Shell-to-Flange at or near the end of the interval.
2	IWB-2500-1 Cat. B-D	RPV Nozzle-to-Vessel Welds	Volumetric Examination during two different periods.	To perform all examinations associated with the Nozzle-to-Vessel welds during the same period.	Perform all examinations associated with the Nozzle-to-Vessel welds at or near the end of the interval.
3 (*)	IWA-1400 Inspection	Authorized Inspection Agency.	Use of "Authorized Agency"	New York State has not endorsed ASME Codes and does not have an Authorized Inspection Agency.	Use R. E. Ginna Quality Assurance Program.
4 (*)	IWB-2500-1 Cat. B-L-1 B-L-2	Reactor Coolant Pump Case Welds and Intervals.	Volumetric Examination of case welds and visual of internals.	Pump material and configuration.	Hydrostatic test, surface and visual exams of outside surfaces.
5	IWB-2500-1 Cat. B-M-2	Class 1 Valves Greater than NPS 4.	Visual Examination of valve internals.	Excessive radiation exposure and historical reliability of valves.	Examine valve internals when disassembled for maintenance.
6 (*)	IWD-2500-1 Cat. D-B	Radioactive Waste Holdup Tank.	Visual Examination at hydrostatic pressure.	Tank will be rendered inoperative during tests.	Perform visual examination each period at normal operating pressure.
7	IWC-5222(a)	Charging Pumps	Visual Examination at 3420 psig Hydrostatic Pressure.	Pumps have maximum pressure limit on the seals.	Perform Hydro Test and visual at 2400 psig.
8	IWC-5222(a)	Valves PCV 430 and PCV 431C.	Visual Examination at Hydrostatic Pressure.	Valve diaphragms cannot withstand Test Pressure.	Hydrostatic Test to Flex Connection operate diaphragm per valve test requirements and perform Inservice visual examination once per period.
9	IWC-5222(a)	Secondary Side of steam generator and associated main steam piping.	Visual Examination at Hydrostatic Pressure.	RG&E adopted pressure differential limitation of 800 psig to prevent primary side tube sheet cladding separation.	Hydrostatic Test at 1.10 times instead of 1.25 Psv setting and perform visual examination.
10 (*)	IWD-5223(a)	Standby Auxiliary Pump Recircul. Line from AOV 9710A, AOV 9710B and their associated downstream flow orifices.	Visual Examination at Hydrostatic Pressure.	Pressure Reduction Flow Orifice requires removal and blank-off. System piping does not provide isolation to condensate supply tank. Significant tank reduction would be required for removal and is considered impractical.	Perform Inservice Visual Examination once per period.
11 (*)	IWD-5223(a)	Boric Acid Filter and associated piping between Valves 347, 348A and 349A.	Visual Examination at Hydrostatic Pressure.	Test Pressure required will exceed limits for safe working pressure on Boric Acid Filter Housing Flange Gaskets.	Perform Inservice Visual Examination once per period.

(*) - WITHDRAWN

QUALITY ASSURANCE MANUAL GINNA STATION	TITLE:	APPENDIX B R.E. GINNA NUCLEAR POWER PLANT INSERVICE INSPECTION PROGRAM FOR THE 1990-1999 INTERVAL ISI RELIEF REQUESTS	Section 2	REV. 3
			PAGE	3 of 39

TABLE 1
SUMMARY OF RELIEF REQUESTS

Relief Request Number	Section XI Reference	Component	ASME Requirement for Which Relief is Requested	Reason for Relief Request	Proposed Alternate Examination
12.1	IWD-5223(a)	Air Start for Diesel Generator including Receiver Tanks and Piping.	Visual Examination at Hydrostatic Pressure.	Air Start Pressure Test would require termination prior to reaching engine skid to preclude air to air start motors, leaving portion of piping untestable.	Perform Inservice Examination once per period and once each quarter a pressure decay test performed on air receiver.
12.2	IWD-5223(a)	Fuel Oil Transfer Pumps and associated piping to terminals at Oil Storage Tank.	Visual Examination at Hydrostatic Pressure.	Requires isolation of Diesel Oil Storage and Dry Tank where no means of isolation is provided at Transfer pump discharge piping with tanks vented to atmosphere.	Perform system Functional Testing with associated Visual Examination once per period.
12.3	IWD-5223(a)	Jacket Cooling Water System and associated piping to terminals at Water Expansion Tanks.	Visual Examination at Hydrostatic Pressure.	Cooling Water Expansion Tank vented to atmosphere requiring isolation with vast piping involved will be unable to pressurize.	Perform System Functional Testing with associated Visual Examination once per period.
13 (***)	Table IWC-2500-1, Category C-H	Class 2 Piping penetrating containment vessel with balance of piping system outside Section XI scope.	Under Revision.		
14	IWD-5223(a)	Class 3 Portion of the service water system	Visual Examination at Hydrostatic Pressure.	Hydrostatic Testing is impractical due to system design that is open-ended and employing butterfly valves that were not designed to provide a leaktight boundary.	Perform Inservice Visual Examination once per period.
15 (*)	IWC-2500 Cat. C-F-1 & C-F-2 Items C5.10 and C5.50 resp.	Class 2 Piping Welds < 3/8" nominal wall thickness for piping > NPS4.	Piping Welds < 3/8" nominal wall thickness do not require surface and volumetric examinations.	At a minimum terminal connection welds of identified exempted welds per Items C5.10 and C5.50 of Table IWC-2500 should be examined.	Surface and Volumetric Examinations on terminal connection welds of identified exempted welds shall be performed to the requirements of IWC-2500-1.
16 (*)	IWB-2500 Cat. B-K-1 Item B10.10 and IWC-2500, Cat. C-C, Item C3.20	Class 1 & 2 Integral Attachment on piping specifically support Attachments.	Volumetric or surface examination on Class 1 Integral Attachments is required on Base Attachment $\geq 5/8"$. Class 2 requires a surface examination on Base Attachments $\geq 3/4"$.	Integral Attachments on Class 1 & 2 support attachments should have a surface examination to insure safety and system integrity.	On Class 1 & 2 Integral Attachments, a surface examination shall be performed on support attachments to IWB and IWC-2500 requirements.
19	IWC-2500 Category C-B, Items C2.21 & C2.22	Pulsation Dampener, Nozzle Weld & Inside Radius.	Applicable Surface and/or Volumetric Examinations.	Physical configuration not conducive for full Examination coverage.	Perform Surface and/or Volumetric Examination to Maximum extent practical.
(*) =	WITHDRAWN				
(***) =	UNDER REVISION				

1
2
3
4
5
6
7
8
9
10
11
12
13
14
15
16
17
18
19
20
21
22
23
24
25
26
27
28
29
30
31
32
33
34
35
36
37
38
39
40
41
42
43
44
45
46
47
48
49
50
51
52
53
54
55
56
57
58
59
60
61
62
63
64
65
66
67
68
69
70
71
72
73
74
75
76
77
78
79
80
81
82
83
84
85
86
87
88
89
90
91
92
93
94
95
96
97
98
99
100

QUALITY ASSURANCE MANUAL GINNA STATION	TITLE:	APPENDIX B R.E. GINNA NUCLEAR POWER PLANT INSERVICE INSPECTION PROGRAM FOR THE 1990-1999 INTERVAL ISI RELIEF REQUESTS	Section 2	REV. 3
			PAGE 4 of 39	

TABLE 1					
<u>SUMMARY OF RELIEF REQUESTS</u>					
Relief Request Number	Section XI Reference	Component	ASME Requirement for Which Relief is Requested	Reason for Relief Request	Proposed Alternate Examination
23 (**)	IWA-4400	Class 3 Valves: V-4023 V-4611 V-4613 V-4626 V-4669 V-4738 V-4739 V-4760	Hydrostatic Testing of Code Replacement Activities.	Impracticality	ASME Section III NDE with PT of Root Pass. Perform a VT-2 Leak Test. This Relief is a "one-time" use only.
24 (**)	IWA-4400	Class 3 Valves: V-4013 V-4027 V-4028 V-4663	Hydrostatic Testing of Code Replacement Activities.	Impracticality	ASME Section III NDE with PT of Root Pass. Perform a VT-2 Leak Test. This Relief is a "one-time" use only.

(**) - ONE TIME USE ONLY.

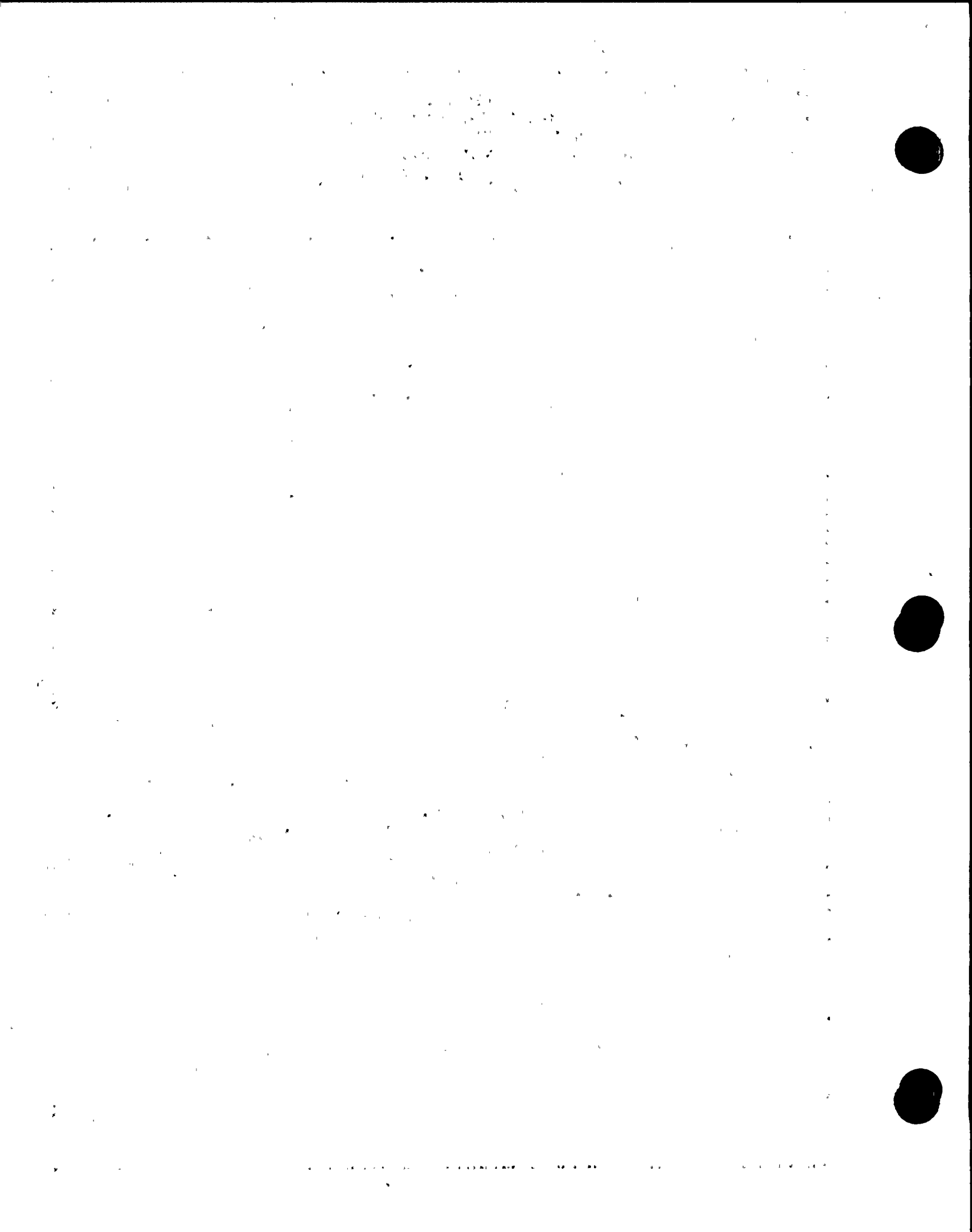

QUALITY ASSURANCE MANUAL GINNA STATION	TITLE:	Section 2	REV. 3
	APPENDIX B R.E. GINNA NUCLEAR POWER PLANT INSERVICE INSPECTION PROGRAM FOR THE 1990-1999 INTERVAL ISI RELIEF REQUESTS	PAGE 5 of 39	

RELIEF REQUEST NO. 1

DEFER RPV EXAMINATIONS TO END OF INTERVAL

I. Components for Which Relief is Requested:

The component for which relief is requested is the Reactor Pressure Vessel (RPV) Shell-to-Flange Weld.

II. ASME Requirement from Which Relief is Requested:

Table IWB-2500-1, Examination Category B-A, requires that the RPV Shell-to-Flange weld be examined during the first and third periods in conjunction with the nozzle examinations, with at least 50 percent examined during the first period and the remainder by the end of the third period. The required Shell-to-Flange examination is impractical if performed during the periods specified as it can only be accomplished from the flange surface.

III. Proposed Alternate Method:

During the first two inspection intervals, 100 percent of the accessible length of the RPV welds including the Shell-to-Flange weld were examined at or near the end of the interval when the entire examination could be performed from both the flange surface and the vessel wall. This is a more practical approach in that the required examinations from both surfaces can be performed at the same time. During the third interval, 100 percent of the accessible length of all RPV welds including the shell-to-flange weld will be performed at or near the end of the interval when all the required examinations can be performed at the same time.



QUALITY ASSURANCE MANUAL GINNA STATION	TITLE:	Section 2	REV. 3
	APPENDIX B R.E. GINNA NUCLEAR POWER PLANT INSERVICE INSPECTION PROGRAM FOR THE 1990-1999 INTERVAL ISI RELIEF REQUESTS	PAGE 6 of 39	

**RELIEF REQUEST NO. 2
DEFER RPV NOZZLE EXAMINATIONS TO END OF INTERVAL**

I. Components for Which Relief is Requested:

The components for which relief is requested are the RPV Nozzle-to-Vessel welds and Nozzle Inside Radius Sections.

II. ASME Requirements for Which Relief is Requested:

Table IWB-2500-1, Examination Category B-D, Item B3.90, Nozzle-to-Vessel welds allows partial deferral. "If examinations are conducted from inside the component and the nozzle weld is examined by straight beam ultrasonic method from the nozzle bore, the remaining examinations required to be conducted from the shell inside diameter may be performed at or near the end of each interval."

Examination Category B-D, Item 3.100 Nozzle Inside Radius Sections, does not allow deferral to the end of the interval, and requires (footnote 2) 25 percent to 50 percent of the nozzles to be examined during the first period, with the remainder to be examined at the end of the interval.

Examinations from the nozzle bore and nozzle inside radius examinations can only be performed on two (outlets) of the six major nozzles without removal of the core barrel. The mechanized examination of the two accessible nozzle and inside radius sections is quite expensive, and the nozzle-to-vessel examination is only a partial examination from the nozzle bore. From a technical position considering the progress which is being made in ultrasonic examination equipment and techniques and for the correlation of data obtained from the bore with that obtained from the shell, it is highly desirable to perform both examinations at the same time.

III. Proposed Alternate Method:

Rochester Gas & Electric (RG&E) proposes to perform both nozzle-to-vessel examinations (from the nozzle bore and from the shell inside diameter) at or near the end of the interval. The nozzle inside radius examinations will also be performed at this time. This more practical approach will allow all the required examinations to be performed at the same time on all the nozzles and nozzle inside radii.

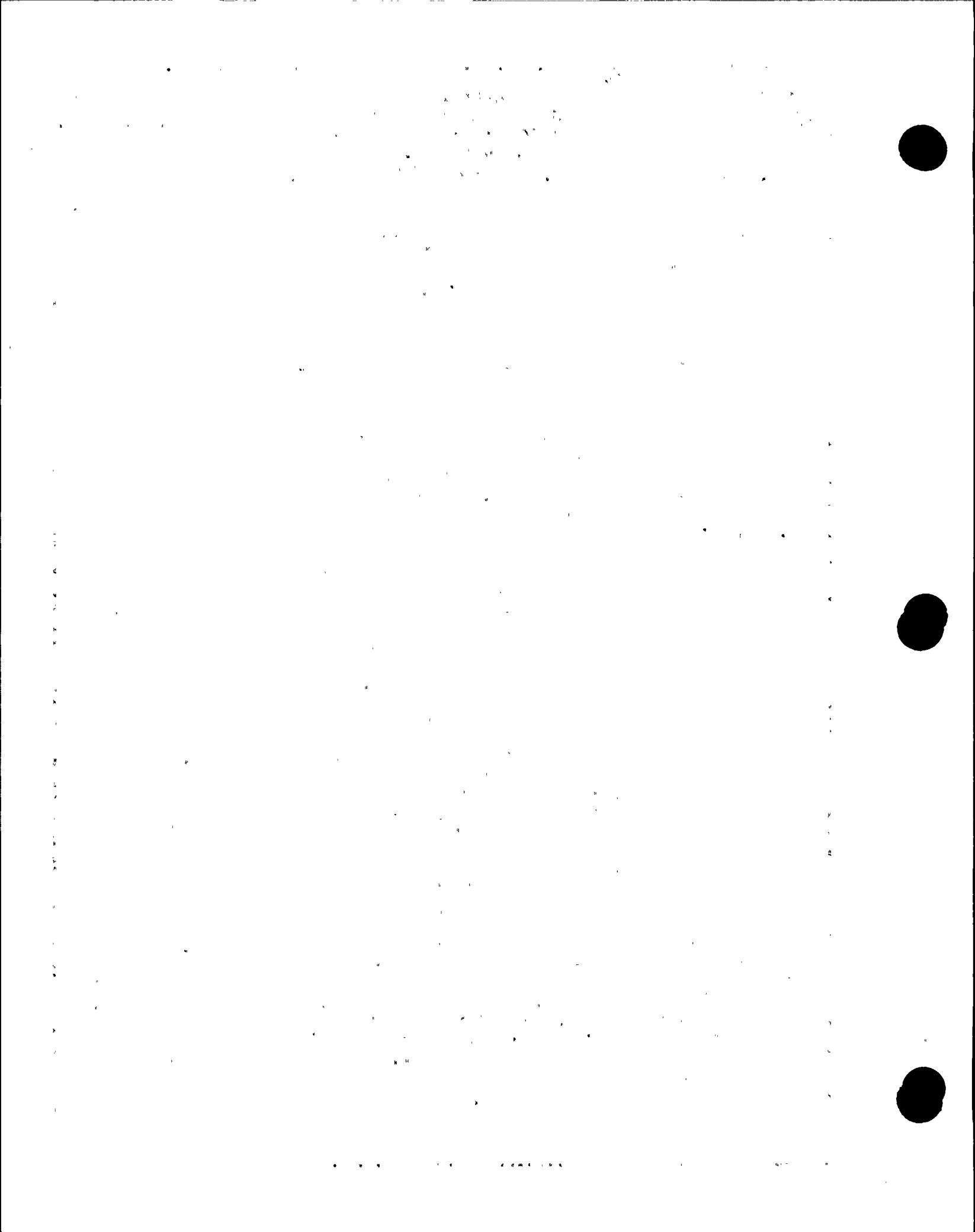

QUALITY ASSURANCE MANUAL GINNA STATION	TITLE:	APPENDIX B R.E. GINNA NUCLEAR POWER PLANT INSERVICE INSPECTION PROGRAM FOR THE 1990-1999 INTERVAL ISI RELIEF REQUESTS	Section 2	REV. 3
			PAGE 7 of 39	

(WITHDRAWN)

RELIEF REQUEST NO. 3

USE OF AUTHORIZED INSPECTION AGENCY

I. Examination Requirement for Which Relief is Requested:

The ASME Boiler and Pressure Vessel Code, Section XI, 1986 Edition, IWA-1400(f), requires an arrangement with an Authorized Inspection Agency to provide inspection services. In addition, the Code requires that certain administrative functions be performed by the "Enforcement Authority" and "Authorized Nuclear Inservice Inspector".

II. Proposed Alternative:

Ginna Station is located in the state of New York. This state has not endorsed ASME Codes and therefore does not provide administrative organization and controls such as "Enforcement Authority", "Authorized Nuclear Inservice Inspector" and "Reporting Systems". However, Ginna Station's Quality Assurance Program does provide equivalent administrative control. Therefore, RG&E requests that Ginna's Station Quality Assurance Program be used in lieu of Code administrative functions.

Rochester Gas & Electric's program for the inservice inspection, governed by the R. E. Ginna Station Quality Assurance Manual, contains the requirements and responsibilities for implementation of the program and procedures. The procedures have been prepared and approved by the responsible organizations within Rochester Gas & Electric (e.g., Ginna Station, Engineering, Materials Engineering and Inspection Services, Electric Meter and Laboratory and Purchasing).

Approved procedures will be implemented to control the standards for examination evaluation. These procedures include the identifications of the organization performing the inspection, description of the method of inspection to be used, acceptance and rejection criteria, and requirements for providing evidence of completion and certification of the inspection activity.

QUALITY ASSURANCE MANUAL GINNA STATION	TITLE:	Section 2	REV. 3
	R.E. GINNA NUCLEAR POWER PLANT INSERVICE INSPECTION PROGRAM FOR THE 1990-1999 INTERVAL ISI RELIEF REQUESTS	PAGE 8 of 39	

(WITHDRAWN)

RELIEF REQUEST NO. 3 (Con't)

In addition, procedures are developed by Ginna Station to prescribe the disposition of nonconformances. The procedures implemented for the repairs, the retest procedures and the test results will be reviewed by the Plant Operating Review Committee. The members of this committee include technically qualified staff personnel.

Examination techniques have been established in accordance with written requirements and incorporated into written procedures. qualifications for nondestructive test personnel are in compliance with Regulatory Guide 1.58, "Qualification of Nuclear Power Plant Inspection, Examination and Testing Personnel."

Records and reports of the inservice inspection will be developed and maintained by Rochester Gas and Electric and include such items as examination plans and schedules, examination of results and corrective actions.

The functions of the authorized nuclear inservice inspector, namely their review and verification of inservice examinations, personnel qualification and equipment certification during the annual outages at Ginna Station will be performed by personnel of the Hartford Steam Boiler Inspection and Insurance Company. The qualifications of the inspectors, inspections specialists and inspection agency are in compliance with the Code.

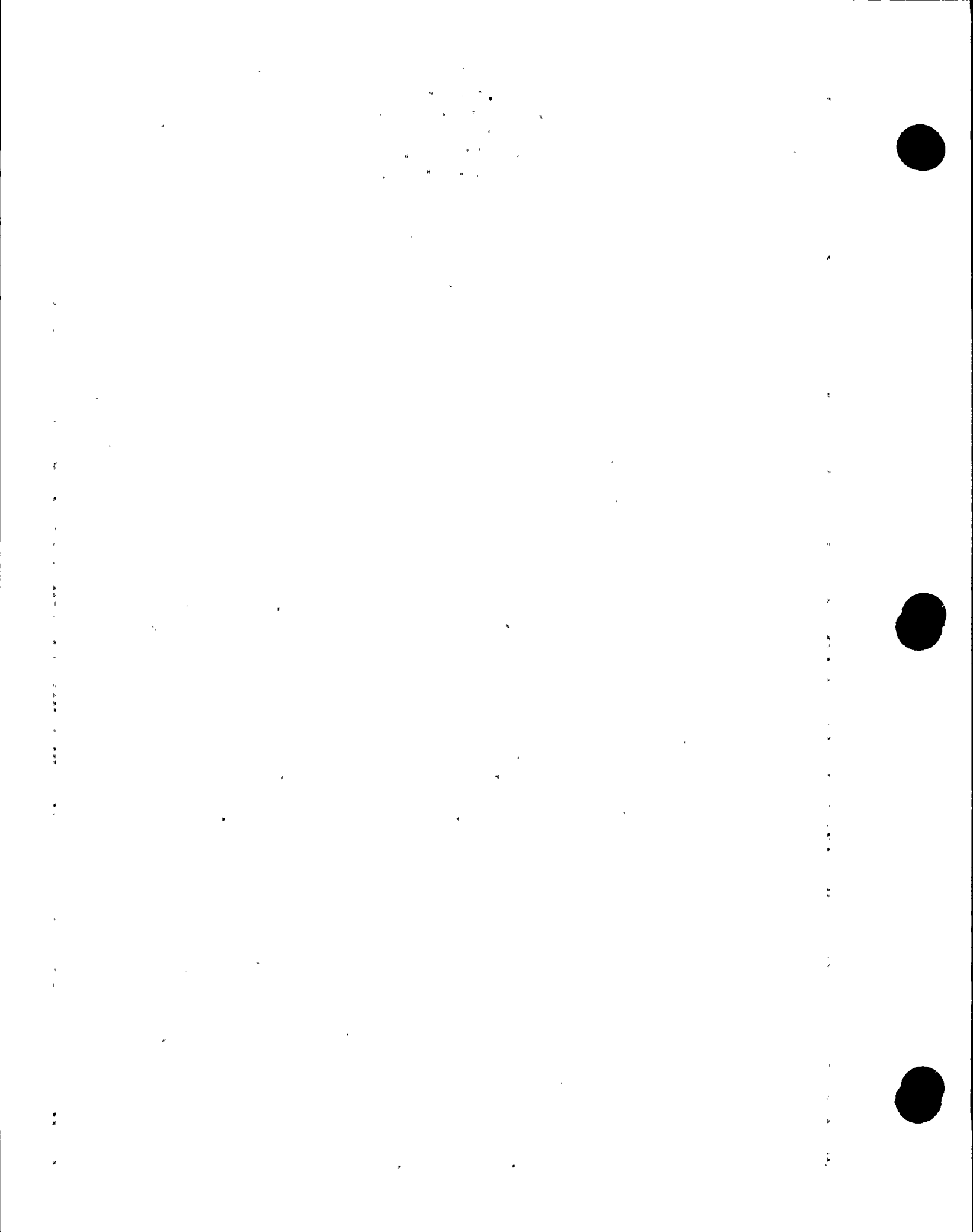

QUALITY ASSURANCE MANUAL GINNA STATION	TITLE:	Section 2	REV. 3
	APPENDIX B R.E. GINNA NUCLEAR POWER PLANT INSERVICE INSPECTION PROGRAM FOR THE 1990-1999 INTERVAL ISI RELIEF REQUESTS	PAGE 9 of 39	

(WITHDRAWN)

RELIEF REQUEST NO. 4

RCP CASING WELDS VOLUMETRIC AND INTERNAL EXAMINATION

I. Components for Which Relief is Requested:

Each of the 27.5 inch diameter recirculation loops at R.E. Ginna has a Class 1 Reactor Coolant Pump. The function of these two pumps is to provide forced circulation through the RPV core during normal reactor operation.

II. Code Requirement for Which Relief is Requested:

Table IWB-2500-1, Examination Categories B-L-1 and B-L-2 require volumetric examination of casing welds and visual examination of internal pressure boundary surfaces of one pump case in each of the pump groups performing similar system functions each inspection interval. These examinations are impractical for the reactor coolant pumps at Ginna Station and relief is, therefore, requested.

A. Supporting Information

1. The two reactor coolant pumps (RCP) for R.E. Ginna are Westinghouse Model 93 pumps. Each pump casing is fabricated by welding four stainless steel (SA351 CF8) castings together. Thus, there are 3 circumferential pressure-retaining welds that are to be volumetrically inspected in accordance with Category B-L-1.
2. The unsuitability of ultrasonic examination was demonstrated during the "A" reactor coolant pump examination in 1980. An attempt was made to determine the wall thicknesses using ultrasonic examination; the casing welds must be inspected using the miniature linear accelerator (MINAC).
3. Radiographic examination using the MINAC was performed on the R. E. Ginna "A" RCP during the Spring 1981 refueling outage. In addition, the same type of examination has been performed at several other sites.

QUALITY ASSURANCE MANUAL GINNA STATION	TITLE:	APPENDIX B R.E. GINNA NUCLEAR POWER PLANT INSERVICE INSPECTION PROGRAM FOR THE 1990-1999 INTERVAL ISI RELIEF REQUESTS	Section 2	REV. 3
			PAGE 10 of 39	

(WITHDRAWN)

RELIEF REQUEST NO. 4 (Con't)

This examination was performed by placing the MINAC inside the pump casing and placing the film on the outside of the pump. To perform the examination, the pump was completely disassembled.

Disassembly to this extent is far beyond any disassembly expected for this examination. Also, insulation on the casing exterior was removed for film placement.

Additionally, the pump bowl must be dry for installation of the MINAC. Therefore, all fuel assemblies were removed from the reactor vessel and the vessel water level lowered to below the nozzles. Complete disassembly of the pump was also required to conduct the VT-1 examination in accordance with Category B-L-2.

4. No problems have been found with the welds at R. E. Ginna or other sites. Additionally, no problems have been found during the Category B-L-2 visual examination. The visual examination was conducted at R. E. Ginna by using the video camera on the MINAC.

The whole body exposure to personnel during the Spring 1981 directly attributable to the RCP "A" examinations 93,067 millirem. This does not include the dose received during the complete core unload to get the plant in condition for the RCP disassembly.

5. The nuclear industry has been successfully applying leak-before-break concepts to primary loop and Class 1 auxiliary piping systems of commercial nuclear power plants. Currently, the analyses supporting such concepts comes under the review of the Nuclear Regulatory Commission by General Design Criteria-4 (GDC-4).

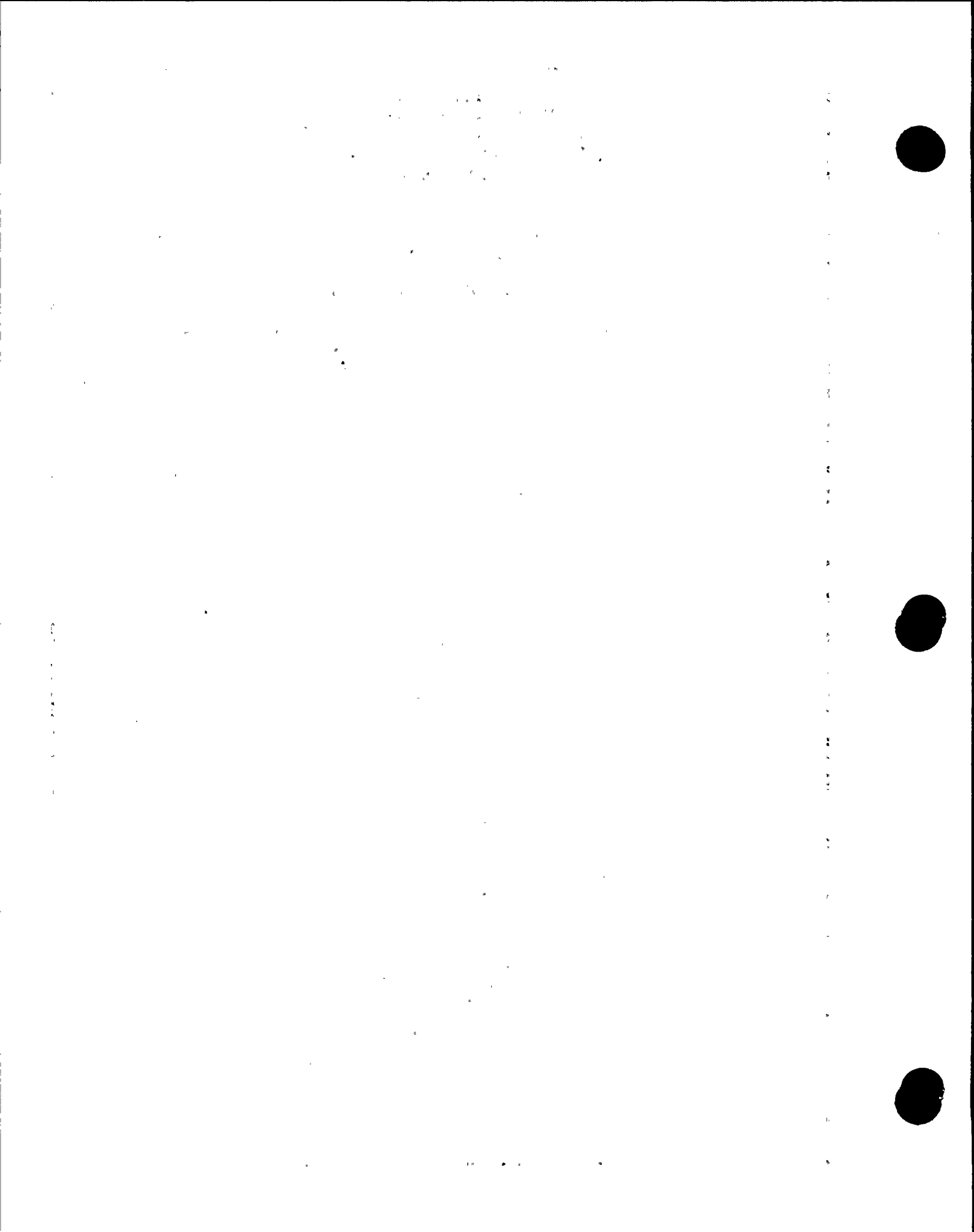

QUALITY ASSURANCE MANUAL GINNA STATION	TITLE:	APPENDIX B R.E. GINNA NUCLEAR POWER PLANT INSERVICE INSPECTION PROGRAM FOR THE 1990-1999 INTERVAL ISI RELIEF REQUESTS	Section 2	REV. 3
			PAGE 11 of 39	

(WITHDRAWN)

RELIEF REQUEST NO. 4 (Con't)

There are eight different models of RCP's in Westinghouse-type PWRs. Model 93 methodology used in the analyses is consistent with that recommended in NUREG 1061, Vol. 3 and GDC-4. A finite element stress analysis model for the Model 93 pump was developed.

The RCP casings are cast stainless steel. The chemistries of each heat of material used in the pumps were used to determine the fracture toughness. The phenomenon of thermal aging was addressed.

The program successfully demonstrates that leak-before-break analyses are applicable to all primary pump casings of all Westinghouse design PWRs for which the screening loads are reasonably applicable and the fracture toughness are known.

6. We believe that performing a volumetric examination of the Ginna Station Unit 1 RCP casing welds and a visual examination of the interior pressure retaining surface of one pump during the third 10-year inspection period does not provide an increase in safety and expected radiation exposure. The following items have been considered:
 - a. Visual examination (VT-2) of the exterior of all pumps during the hydrostatic pressure test required by Table IWB 2500-1 Category B-P.
 - b. Perform a Visual examination (VT-1) of the external surfaces of the welds of one pump casing.
 - c. Perform a visual examination (VT-3) of the internal surfaces each time pump disassembly is required for maintenance.

QUALITY ASSURANCE MANUAL GINNA STATION	TITLE:	APPENDIX B R.E. GINNA NUCLEAR POWER PLANT INSERVICE INSPECTION PROGRAM FOR THE 1990-1999 INTERVAL ISI RELIEF REQUESTS	Section 2	REV. 3
			PAGE 12 of 39	

(WITHDRAWN)

RELIEF REQUEST NO. 4 (Con't)

- d. Perform an evaluation to demonstrate the safety and serviceability of the pump casing. The evaluation will include:
- (i) Establishing material properties including fracture toughness values.
 - (ii) Performing a stress analysis of the structure.
 - (iii) Reviewing of the operating history of the structure.
 - (iv) Selection of locations for postulating flaws.
 - (v) Determination of a flaw size resulting in the detectable leak rate
 - (vi) Establishing the stability of the selected flaw.
 - (vii) Demonstration that a postulated through-wall flaw which yields detectable leakage remains stable for all design loadings, with a margin of 2 on flaw size.

NOTE: In making this assessment, thermal aging embrittlement and any other processes which may degrade the properties of the pump casing during service will be considered.

1954



QUALITY ASSURANCE MANUAL GINNA STATION	TITLE:	Section 2	REV. 3
	APPENDIX B R.E. GINNA NUCLEAR POWER PLANT INSERVICE INSPECTION PROGRAM FOR THE 1990-1999 INTERVAL ISI RELIEF REQUESTS	PAGE 13 of 39	

RELIEF REQUEST NO. 5

VISUAL INTERNAL EXAMINATION OF CLASS 1 VALVES

I. Components for Which Relief is Requested:

Class 1 valves requiring valve body internal VT examination.

<u>Size (In.)</u>	<u>Valve No.</u>	<u>MFG/Type</u>	<u>Line No.</u>
10	842A	Darling/Check	10A-SI2-1502-A
10	842B	Darling/Check	10A-SI2-2501-B
10	867A	Darling/Check	10A-SI2-2501-A
10	867B	Darling/Check	10A-SI2-2501-B
10	700	Velan/Gate	10A-RC02501-A
10	701	Velan/Gate	10A-RC0-2501-A
10	720	Velan/Gate	10A-RC0-2501-B
10	721	Velan/Gate	10A-RC0-2501-B
6	853A	Velan/Check	6A-RC-2501-A
6	853B	Velan/Check	6A-RC-2501-B
6	852A	Velan/Gate	6A-RC-2501-A
6	852B	Velan/Gate	6A-RC-2501-B

II. ASME Requirement for Which Relief is Requested

Table IWB-2500-1, Examination Category B-M-2, requires an internal VT-3 examination on at least one valve within each group of valves that are of the same size, constructional design (such as globe, gate or check valves) and manufacturing method, that perform similar functions in the system. This relief request is based on the following points:

1. to complete the subject examination, unnecessary expenditures of man-hours and manrem are required with essentially no compensating increase in plant safety, and

QUALITY ASSURANCE MANUAL GINNA STATION	TITLE:	APPENDIX B R.E. GINNA NUCLEAR POWER PLANT INSERVICE INSPECTION PROGRAM FOR THE 1990-1999 INTERVAL ISI RELIEF REQUESTS	Section 2	REV. 3
			PAGE 14 of 39	

RELIEF REQUEST NO. 5 (Con't)

2. the structural integrity afforded by valve casing material utilized will not significantly degrade over the lifetime of the valve.

Based on data compiled from a plant similar in age and design to Ginna Station, it is expected that approximately 100 manhours and 5 manrem exposure would be required to disassemble, inspect, and reassemble these valves. Performing this visual examination under such adverse conditions, high doses rate (30-40 R/hr), and poor as-cast surface conditions, realistically provides little additional information as to the valve's casing integrity.

The valves material, a high-strength cast stainless steel (ASTM A351-CF8), is widely used in the nuclear industry and has performed extremely well. The presence of some delta ferrite (typically 5% or more) substantially increases resistance to intergranular stress corrosion cracking. The delta ferrite also helps the material to resist pitting corrosion in chloride containing environments.

RG&E feels that adequate safety margins are inherent in the basic valve design and that the public's health and safety will not be adversely affected by not performing a visual examination of the valve internal pressure boundary surfaces. Additionally, this visual examination adds little or no value to the overall safety of the plant and subjects plant personnel to unnecessary radiation exposure. Therefore, a request for relief from this requirement is sought.

III. Proposed Alternative Method:

As stated above, RG&E does not believe that the visual examination required each ten-year interval is warranted. However, as standard maintenance practice dictates, when these valves are disassembled for maintenance purposes, a visual examination of the internals and internal pressure boundary surfaces will be performed, to the extent practical.

QUALITY ASSURANCE MANUAL GINNA STATION	TITLE:	APPENDIX B R.E. GINNA NUCLEAR POWER PLANT INSERVICE INSPECTION PROGRAM FOR THE 1990-1999 INTERVAL ISI RELIEF REQUESTS	Section 2	REV. 3
			PAGE 15 of 39	

(WITHDRAWN)

RELIEF REQUEST NO. 6

HYDROSTATIC TESTING OF RADIOACTIVE WASTE HOLDUP TANK

I. Component for Which Relief is Requested:

The radioactive waste hold-up tank in the waste disposal system provides a means of storing contaminated water that has been used in the operation of the nuclear power plant. The waste disposal system and waste hold-up tank may be required to function in all modes of reactor operation including cold shutdown and refueling.

II. ASME Requirement for Which Relief is Requested:

Table IWD 2500-1, Examination Category D-B, Item No. D2.10, requires VT-2 examination of the waste hold-up tank at hydrostatic testing levels (at least 1.10 system pressure) during each interval as well as VT-2 examinations at nominal operating pressure during each period.

The design of the waste disposal system is such that contaminated water is stored in the waste holdup tank until such time as the level of contamination is below the limits for discharge. At this time the holdup tanks may be unavailable for use by emptying the stored liquid.

Several important systems within the chemical volume and control system drain into the waste disposal system hold-up tanks. These are the volume and control tank drains, reactor coolant letdown system, reactor coolant drain tank discharge, and the demineralizer system drains.

If the tank was to be hydrostatically tested by filling it with water and pressurizing to 1.10 system pressure, the hold-up tank would be rendered useless. The plant would then be potentially put into an unsafe condition for any abnormal plant function and if startup occurred without a holdup tank being available.



QUALITY ASSURANCE MANUAL GINNA STATION	TITLE:	APPENDIX B R.E. GINNA NUCLEAR POWER PLANT INSERVICE INSPECTION PROGRAM FOR THE 1990-1999 INTERVAL ISI RELIEF REQUESTS	Section 2	REV. 3
			PAGE 16 of 39	

(WITHDRAWN)

RELIEF REQUEST NO. 6 (Con't)

Since this hold-up tank constantly stores liquid, any degradation of the tank material would show up prior to it becoming a problem. RG&E believes that hydrostatically testing the rad-waste hold-up tank puts Ginna's plant in an unsafe condition and therefore a request for relief from this requirement is sought.

III. Proposed Alternative Method:

A Visual VT-2 examination shall be performed once every period with the system at normal operating pressure to verify continued structural integrity.



QUALITY ASSURANCE MANUAL GINNA STATION	TITLE:	APPENDIX B R.E. GINNA NUCLEAR POWER PLANT INSERVICE INSPECTION PROGRAM FOR THE 1990-1999 INTERVAL ISI RELIEF REQUESTS	Section 2	REV. 3
			PAGE 17 of 39	

RELIEF REQUEST NO.7

REDUCED HYDROSTATIC PRESSURE TESTING OF CHARGING PUMPS &
DISCHARGE PIPING

I. Components for which Relief is Requested:

CVCS, Three Charging Pumps and Discharge Piping to
Discharge Isolation Valves.

II. ASME Requirements for which Relief is Requested:

IWC-5222(a) System Hydrostatic Test; The system hydrostatic test pressure shall be at least 1.10 times the system pressure Psv for systems with Design Temperature of 200°F (93C) or less, and at least 1.25 times the system pressure Psv for systems with Design Temperature above 200°F (93C). The system pressure Psv shall be the lowest pressure setting among the number of safety or relief valves provided for overpressure protection within the boundary of the system to be tested. This corresponds to a test pressure of 3420 psig.

The charging pumps have a minimum hydrostatic test pressure limitation on the seals of 2400 psig, as specified by the pump manufacturer. As a result, the pumps and associated discharge piping to the first isolation valves cannot be tested to the required Code Test Pressure.

III. Proposed Alternate Method:

During the hydrostatic test and associated VT-2 examination, the charging pumps and associated discharge piping to the first isolation valves will be tested at a pressure of 2400 psig.

QUALITY ASSURANCE MANUAL GINNA STATION	TITLE:	APPENDIX B R.E. GINNA NUCLEAR POWER PLANT INSERVICE INSPECTION PROGRAM FOR THE 1990-1999 INTERVAL ISI RELIEF REQUESTS	Section 2	REV. 3
			PAGE 18 of 39	

RELIEF REQUEST NO. 8

ALTERNATIVE TESTING OF RCS OVERPRESSURE PROTECTION, NITROGEN
ACCUMULATOR SYSTEM OF VALVES PCV 430 & PCV 431C

I. Components for Which Relief is Requested:

RCS Overpressure Protection Nitrogen Accumulator System
Valves PCV 430 and PCV 431C

II. ASME Requirements for Which Relief is Requested:

IWC-5222(a) System Hydrostatic Test; The system hydrostatic test pressure shall be at least 1.10 times the system pressure Psv for systems with Design Temperature of 200°F (93C) or less, and at least 1.25 times the system pressure Psv for systems with Design Temperature above 200°F (93C). The system pressure Psv shall be the lowest pressure setting among the number of safety or relief valves provided for overpressure protection within the boundary of the system to be tested. This corresponds to a test pressure of 137.5 psig.

The diaphragms in the operators of the subject valves are only designed to withstand a maximum pressure of 105 psig, and therefore cannot be tested to the required Code test pressure.

III. Proposed Alternate Method:

The RCS overpressure nitrogen accumulator system will be tested to the Code requirements up to the flex connection to the valve operator. Operability of the diaphragm and operator is verified by valve testing requirements. In addition, an inservice pressure test at operating pressure will be performed once each inspection period on the piping, including the diaphragm.

QUALITY ASSURANCE MANUAL GINNA STATION	TITLE:	APPENDIX B R.E. GINNA NUCLEAR POWER PLANT INSERVICE INSPECTION PROGRAM FOR THE 1990-1999 INTERVAL ISI RELIEF REQUESTS	Section 2	REV. 3
			PAGE 19 of 39	

RELIEF REQUEST NO. 9

REDUCED HYDROSTATIC TEST OF THE STEAM GENERATOR SECONDARY SIDE

I. Components for Which Relief is Requested:

Main Steam Secondary Side of Steam Generator and
Downstream Piping to Class Boundary.

ASME Requirement from Which Relief is Requested:

IWC-5222(a) System Hydrostatic Test; The system hydrostatic test pressure shall be at least 1.10 times the system pressure Psv for systems with Design Temperature of 200°F (93C) or less, and at least 1.25 times the system pressure Psv for systems with Design Temperature above 200°F (93C). The system pressure Psv shall be the lowest pressure setting among the number of safety or relief valves provided for overpressure protection within the boundary of the system to be tested. Since the design temperature of the Main Steam system is greater than 200°F, the test pressure is required to be 1.25 times Psv, or 1356 psig.

A pressure differential limitation of 800 psig between the primary and secondary side of the Steam Generator has been adopted. This was established early in plant life due to the experiences of some plants with primary side tube sheet cladding separation. To maintain this 800 psig differential, and the required pressure on the secondary side, the primary system must be heated up to a minimum of 160°F which would result in a problem with heat balance and a potential operational problem during implementation of the test procedure. The administrative controls necessary to assure a proper and safe test and the complexity required for the test procedure result in a situation that should be minimized.

In addition to the Section XI volumetric and surfaces examination requirements, the piping is part of the augmented inspection program since it falls within the high energy break criteria.

QUALITY ASSURANCE MANUAL GINNA STATION	TITLE:	Section 2	REV. 3
	APPENDIX B R.E. GINNA NUCLEAR POWER PLANT INSERVICE INSPECTION PROGRAM FOR THE 1990-1999 INTERVAL ISI RELIEF REQUESTS	PAGE 20 of 39	

RELIEF REQUEST NO. 9 (con't)

A letter was submitted to Dennis L. Ziemann, Chief Operating Reactor Branch #2, USNRC, Dated: November 8, 1979, requesting relief.

Subject: System Pressure Test Restriction for Steam Generator and associated Feedwater and Main Steam piping, R.E. Ginna Nuclear Power Plant #1, Docket No. 50-244.

III. Proposed Alternate Method:

Test the secondary side of the Steam Generator and associated Main Steam piping at a pressure of 1194 psig, which corresponds to 1.10 times the Psv setting.

These components are inside containment and any significant leakage would be detected by various leakage monitoring systems during plant operation.



QUALITY ASSURANCE MANUAL GINNA STATION	TITLE:	APPENDIX B R.E. GINNA NUCLEAR POWER PLANT INSERVICE INSPECTION PROGRAM FOR THE 1990-1999 INTERVAL ISI RELIEF REQUESTS	Section 2	REV. 3
			PAGE 21 of 39	

(WITHDRAWN)

RELIEF REQUEST NO. 10

ALTERNATIVE HYDROSTATIC TESTING OF STANDBY AUXILIARY PUMP
RECIRCULATION LINE

I. Component for Which Relief is Requested:

Feedwater, Standby Auxiliary Pump recirculation line between AOV 9710A, AOV 9710B and their associated downstream flow orifices.

I. ASME Requirement from Which Relief is Requested:

IWD-5223(a) System Hydrostatic Test; The system hydrostatic test pressure shall be at least 1.10 times the system pressure Psv for systems with Design Temperature of 200°F (93C) or less, and at least 1.25 times the system pressure Psv for systems with Design Temperature above 200°F (93C). The system pressure Psv shall be the lowest pressure setting among the number of safety or relief valves provided for overpressure protection within the boundary of the system to be tested. For systems (or portions of systems) not provided with safety or relief valves, the system design pressure Pd shall be substituted for Psv.

In order to hydrotest this piping to Section XI requirements, the pressure reducing flow orifices downstream of AOV 9710A & B would require removal and blank flanges installed. System piping does not provide an isolation valve between the orifices and the Condensate Supply Tank. A significant reduction in tank level would be required to facilitate orifice removal, which is considered to be impractical.

II. Proposed Alternate Method:

The Class 3 portion of this piping shall be VT-2 examined at operational discharge pressure during functional testing which is performed once each period.

1948



QUALITY ASSURANCE MANUAL GINNA STATION	TITLE:	Section 2	REV. 3
	APPENDIX B R.E. GINNA NUCLEAR POWER PLANT INSERVICE INSPECTION PROGRAM FOR THE 1990-1999 INTERVAL ISI RELIEF REQUESTS	PAGE 22 of 39	

(WITHDRAWN)

RELIEF REQUEST NO. 11

ALTERNATIVE HYDROSTATIC TESTING OF BORIC ACID FILTER &
ASSOCIATED PIPING

I. Component for Which Relief is Requested:

CVCS, Boric Acid Filter (CSFLBA) and all piping between valves 347, 348A and 349A.

I. ASME Requirement from Which Relief is Requested:

IWD-5223 (a) System Hydrostatic Test: The system hydrostatic test pressure shall be at least 1.10 times the system pressure Psv for systems with Design Temperature of 200°F (93C) or less, and at least 1.25 times the system pressure Psv for systems with Design Temperature above 200°F (93C). The system pressure Psv shall be the lowest pressure setting among the number of safety or relief valves provided for overpressure protection within the boundary of the system to be tested. For systems (or portions of systems) not provided with safety or relief valves, the system design pressure Pd shall be substituted for Psv.

The hydrostatic test pressure necessary to satisfy Section XI requirements will exceed the limits for the safe working pressure on the Boric Acid Filter housing flange gaskets.

II. Proposed Alternate Method:

The Boric Acid Filter and associated piping shall be VT-2 examined, at full operational pressure during inservice testing which shall be performed once each period.

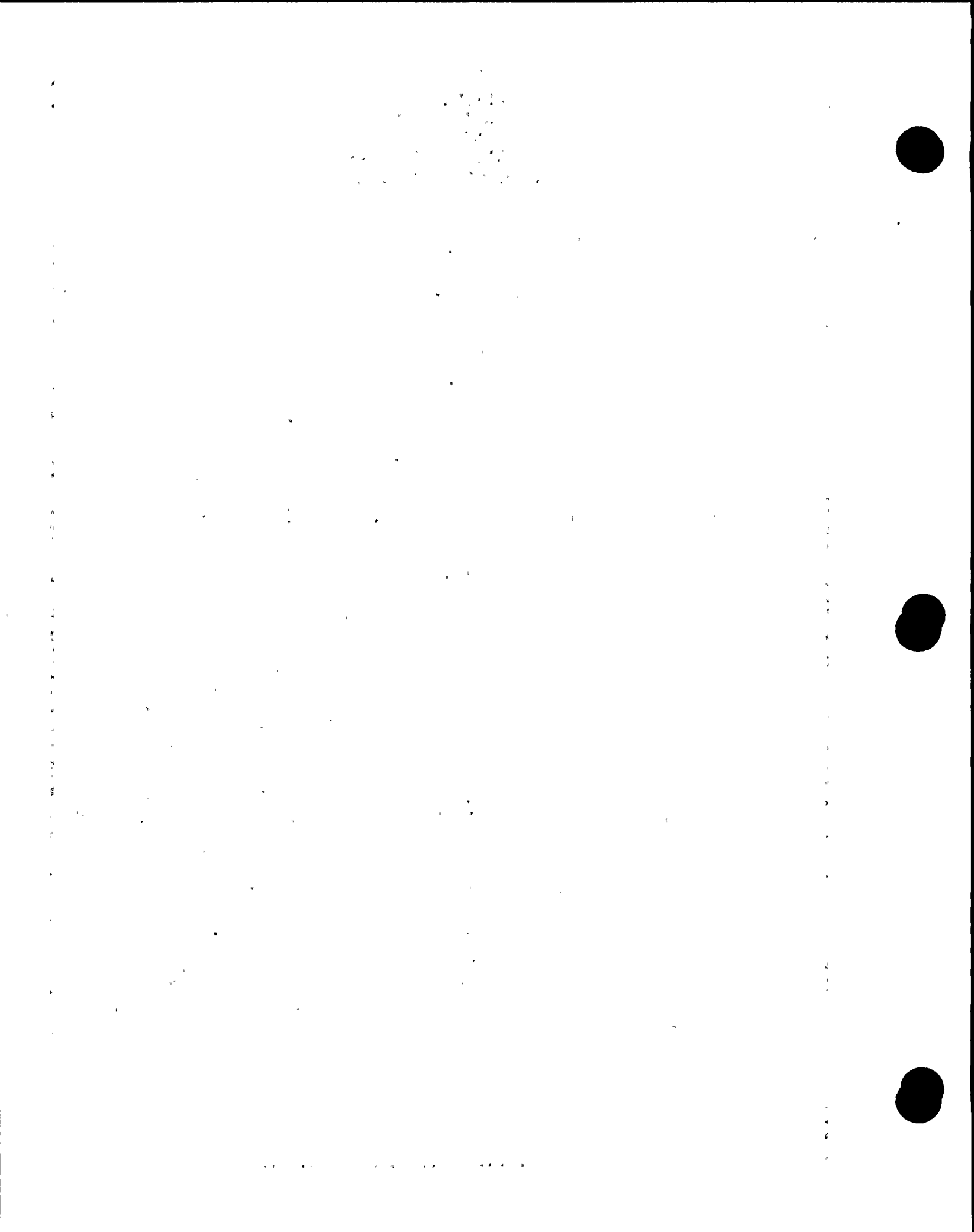

QUALITY ASSURANCE MANUAL GINNA STATION	TITLE:	Section 2	REV. 3
	APPENDIX B R.E. GINNA NUCLEAR POWER PLANT INSERVICE INSPECTION PROGRAM FOR THE 1990-1999 INTERVAL ISI RELIEF REQUESTS	PAGE 23 of 39	

RELIEF REQUEST NO. 12

ALTERNATIVE HYDROSTATIC TESTING OF THE EMERGENCY DIESEL
GENERATOR COMPONENTS & ASSOCIATED PIPING

I. Component for Which Relief is Requested;

Emergency Diesel Generation:

1. Starting Air including receiver tanks and associated piping.
2. Fuel Oil Transfer pumps, suction and discharge including miscellaneous lines terminating at oil storage tanks.
3. Jacket Cooling Water system including miscellaneous line terminating at cooling water expansion tanks.

II. ASME Requirement from Which Relief is Requested:

IWD-5223(a) System Hydrostatic Test; The system hydrostatic test pressure shall be at least 1.10 times the system pressure Psv for systems with Design Temperature of 200°F (93C) or less, and at least 1.25 times the system pressure Psv for systems with Design Temperature above 200°F (93C). The system pressure Psv shall be the lowest pressure setting among the number of safety or relief valves provided for overpressure protection within the boundary of the system to be tested. For systems (or portions of systems) not provided with safety or relief valves, the system design pressure Pd shall be substituted for Psv.

Only portions of the piping associated with the components identified above are capable of being pressure tested.

The Air Start System pressure test would require termination prior to reaching the engine skid to preclude administrating air to the Air Start Motors. This would leave that portion of piping between the Air Start Motors to the first isolation, prior to reaching the engine skid, untestable.

[Faint, illegible text scattered across the page, possibly bleed-through from the reverse side.]



QUALITY ASSURANCE MANUAL GINNA STATION	TITLE:	Section 2	REV. 3
	APPENDIX B R.E. GINNA NUCLEAR POWER PLANT INSERVICE INSPECTION PROGRAM FOR THE 1990-1999 INTERVAL ISI RELIEF REQUESTS	PAGE 24 of 39	

RELIEF REQUEST NO. 12 (Con't)

The Diesel Fuel Oil Transfer system would require flange connection disassembly and the installation of blind flanges to isolate the Diesel Oil Storage Tank, which is vented to atmosphere, and the Day Tank where no means is provided to isolate the transfer pump discharge piping at a point close to the day tank. Additionally, the overflow piping from the day tank to the storage tank, which is identified as Class 3, has no isolation valves installed and is vented to the atmosphere.

The Jacket Cooling Water System would require isolating the Cooling Water Expansion Tank, due to vents to the atmosphere, which would include most of the piping subject to pressure testing. Due to the amount of piping within the class boundary which is unable to be pressurized, testing in accordance with Section XI requirements would not prove system integrity over and above the existing Surveillance Inservice and Functional Testing.

II. Proposed Alternate Method:

Inservice Testing shall be performed on the Air Start System at least once each period in accordance with the requirements of Section XI. Additionally, once each quarter a pressure decay test shall be performed on the air receiver to verify check valve operability in the reverse direction for the air receiver inlet check.

System Functional Testing shall be performed at least once each period on the Diesel Fuel Oil Transfer and Jacket Cooling Water Systems in accordance with the requirements of Section XI.

In addition to the testing discussed above, Technical Specifications 6.4.1 requires surveillance testing to be performed on a monthly basis. Such as, verifying operability of the fuel oil transfer pumps and verifying that the diesel starts from normal standby conditions.

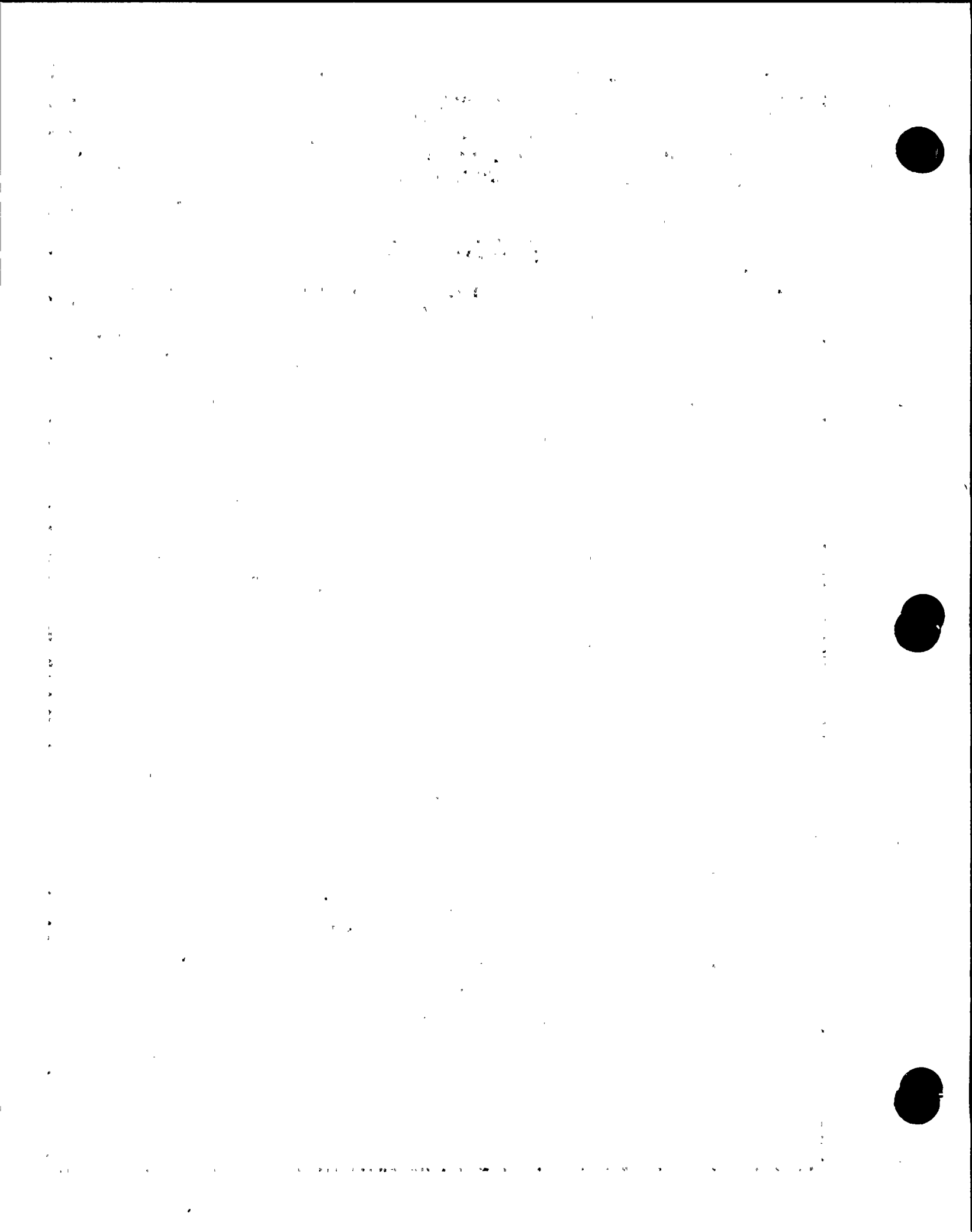

QUALITY ASSURANCE MANUAL GINNA STATION	TITLE: APPENDIX B R.E. GINNA NUCLEAR POWER PLANT INSERVICE INSPECTION PROGRAM FOR THE 1990-1999 INTERVAL ISI RELIEF REQUESTS	Section 2	REV. 3
		PAGE 25 of 39	

RELIEF REQUEST NO. 13

ALTERNATIVE PRESSURE TESTING OF CONTAINMENT PENETRATION PIPING

Under Revision.

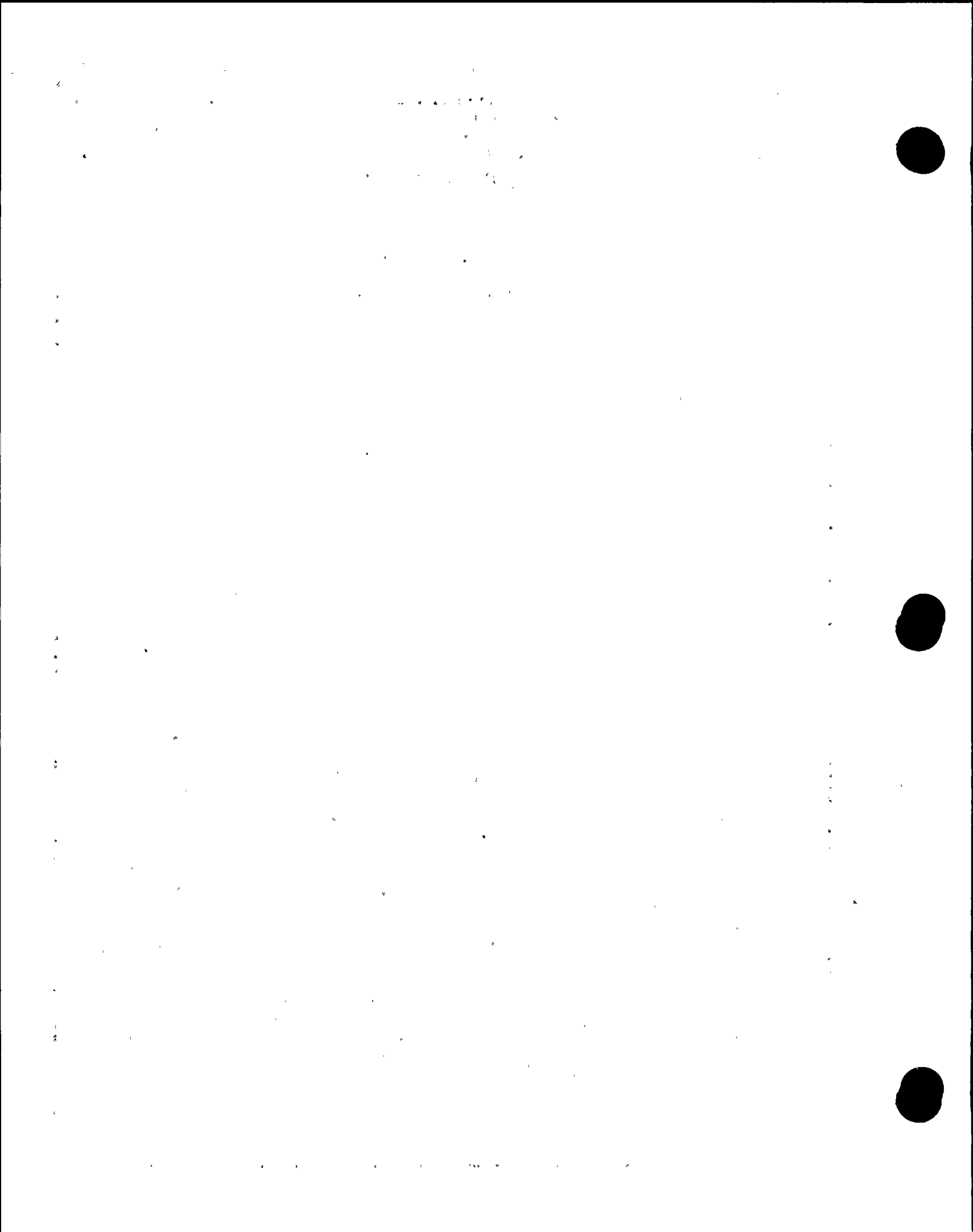

QUALITY ASSURANCE MANUAL GINNA STATION	TITLE:	Section 2	REV. 3
	APPENDIX B R.E. GINNA NUCLEAR POWER PLANT INSERVICE INSPECTION PROGRAM FOR THE 1990-1999 INTERVAL ISI RELIEF REQUESTS	PAGE 26 of 39	

RELIEF REQUEST NO. 14

ALTERNATIVE HYDROSTATIC TESTING OF THE CLASS 3 SERVICE WATER SYSTEM

I. Component for Which, Relief is Requested:

Service Water, All pressure retaining components within the Class 3 portion of the Service Water System.

II. ASME Requirement for Which Relief is Requested:

IWD-5223(a) System Hydrostatic Test; The system hydrostatic test pressure shall be at least 1.10 times the system pressure Psv for systems with Design Temperature of 200°F (93C) or less, and at least 1.25 times the system pressure Psv for systems with Design Temperature above 200°F (93C). The system pressure Psv shall be the lowest pressure setting among the number of safety or relief valves provided for overpressure protection within the boundary of the system to be tested. For systems (or portions of systems) not provided with safety or relief valves, the system design pressure Pd shall be substituted for Psv.

Rochester Gas and Electric believes that the hydrostatic test requirement for the service water system is impractical due to system design which dictates the use of an open-ended test. The portion of the system downstream of the heat exchanger is also open-ended and cannot be hydrostatically tested. The remaining section of the system is only isolatable by means of butterfly valves which were not designed to provide a leak-tight boundary. With the system as such it would be impractical to expect the leakages other than at the valves could be detected.

The ample margin in cooling capacity inherently provided by system design does not dictate the need for an essentially leak-tight boundary. Since the system is in constant operation, its integrity is continually monitored. Thorough inspection of the system each period at the full operating pressure is adequate to detect any gross failures in the system without degrading system safety or availability.



QUALITY ASSURANCE MANUAL GINNA STATION	TITLE: APPENDIX B R.E. GINNA NUCLEAR POWER PLANT INSERVICE INSPECTION PROGRAM FOR THE 1990-1999 INTERVAL ISI RELIEF REQUESTS	Section 2	REV. 3
		PAGE 27 of 39	

RELIEF REQUEST NO. 14 (Con't)

III. Proposed Alternate Method:

Pressure retaining components within the operational boundary will receive an inservice test at operating pressure and an associated VT-2 examination each period during the interval.

QUALITY ASSURANCE MANUAL GINNA STATION	TITLE:	Section 2	REV. 3
	APPENDIX B R.E. GINNA NUCLEAR POWER PLANT INSERVICE INSPECTION PROGRAM FOR THE 1990-1999 INTERVAL ISI RELIEF REQUESTS	PAGE 28 of 39	

(WITHDRAWN)

RELIEF REQUEST NO. 15

CLASS 2 PIPING < 3/8", AUGMENTED EXAMINATION

I. Component for Which Relief is Requested:

Class 2, IWC 2500-1 Table Examination Category C-F-1 and C-F-2, Items C5.10 and C5.50.

II. ASME Requirements for Which Relief is Requested:

Category C-F-1 and C-F-2 (Items C5.10 and C5.50, respectively) for piping welds > 3/8 inches nominal wall thickness for piping > NPS4, a surface and volumetric examination is required on 100% of each weld requiring examination at each inspection interval.

III. Proposed Alternate Method:

Rochester Gas and Electric believes as a minimum that the terminal connection welds of identified exempted welds (< 3/8" nominal wall) should be examined to the requirements of IWC 2500-1 Table, Category C-F-1 and C-F-2, Items C5.10 and C5.50 respectively. These examinations are identified in the Class 2 Allocation Tables as Augmented Examinations and also are included under the category C-F-1 and C-F-2. In the Program Plan Tables (Supplement 1 to Appendix B). These are identified as C-F-1 or C-F-2 followed by "----". These components are also noted in the instruction field.

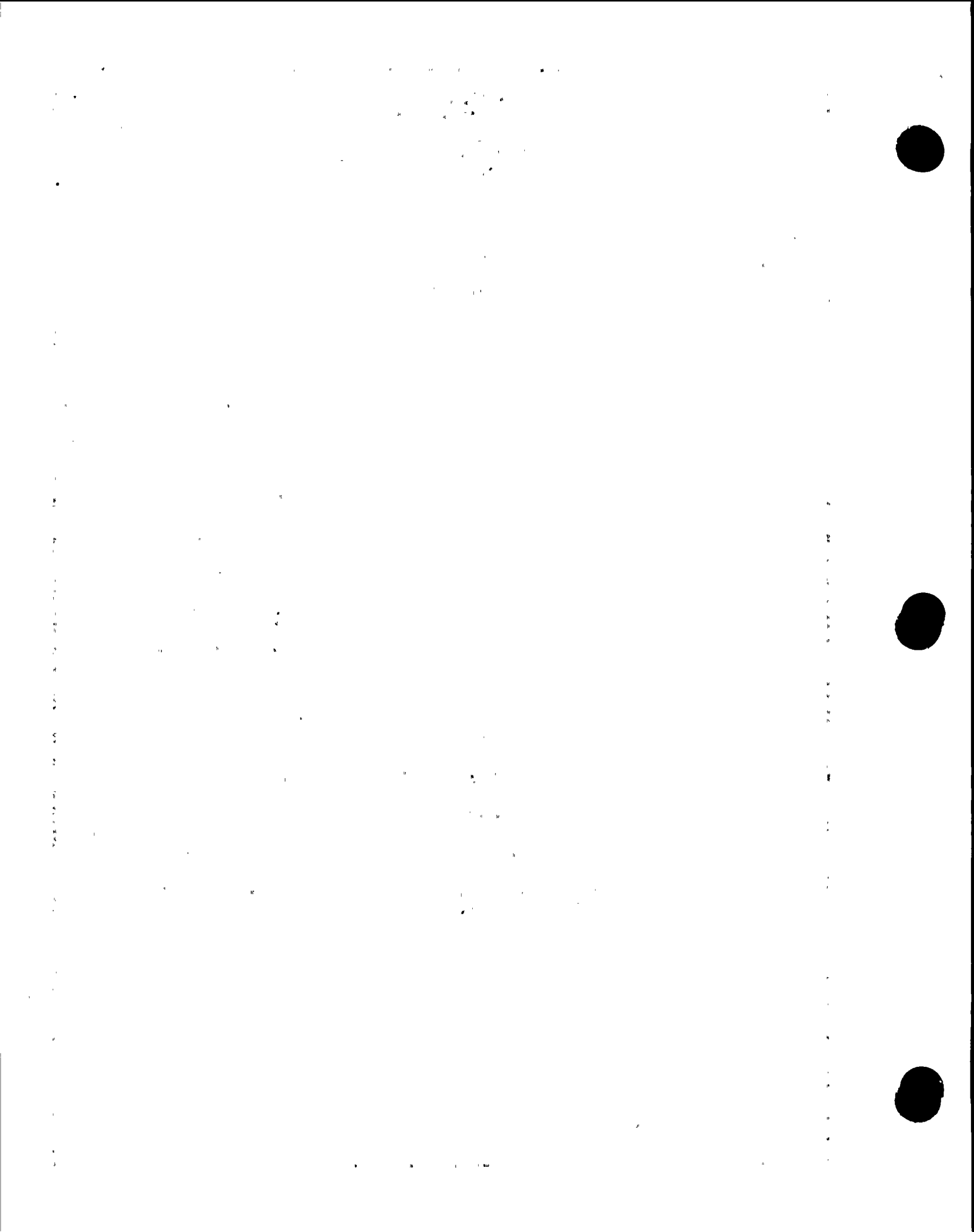

QUALITY ASSURANCE MANUAL GINNA STATION	TITLE:	APPENDIX B R.E. GINNA NUCLEAR POWER PLANT INSERVICE INSPECTION PROGRAM FOR THE 1990-1999 INTERVAL ISI RELIEF REQUESTS	Section 2	REV. 3
			PAGE 29 of 39	

(WITHDRAWN)

RELIEF REQUEST NO. 16

CLASS 1 & 2 INTEGRAL ATTACHMENTS, AUGMENTED EXAMINATIONS

I. Components for Which Relief is Requested:

Class 1 and Class 2 Integral Attachments on Piping specifically to Support Attachments.

II. ASME Requirements for Which Relief is Requested:

For Class 1, Integral Attachments on piping as indicated in IWB-2500-1, Category B-K-1, Item B10.10, requires volumetric or surface examination be performed on Base Attachment Thickness $\geq 5/8$ ". For Class 2, Integral Attachments on piping as indicated in IWC-2500-1, Category C-C, Item C3.20, requires a surface examination be performed on Base Attachments $\geq 3/4$ ".

It has been felt that support attachments to the pressure boundary such as gussets and stanchions should have a surface examination performed to insure the safety and integrity of the Class 1 and Class 2 Systems.

III. Proposed Alternate Method:

Surface examinations shall be performed on Integral Attachments on piping specifically support attachments once per interval in accordance with IWB-2500-1 and IWC-2500-1, B-K-1 and C-C, respectively.

[The page contains extremely faint and illegible text, likely bleed-through from the reverse side of the document. The text is scattered across the page and cannot be transcribed accurately.]



QUALITY ASSURANCE MANUAL GINNA STATION	TITLE:	APPENDIX B R.E. GINNA NUCLEAR POWER PLANT INSERVICE INSPECTION PROGRAM FOR THE 1990-1999 INTERVAL ISI RELIEF REQUESTS	Section 2	REV. 3
			PAGE 30 of 39	

RELIEF REQUEST NO. 19

PULSATION DAMPENER, ALTERNATIVE EXAMINATIONS FOR NOZZLE WELDS &
INSIDE RADIUS

I. Components for Which Relief is Requested:

Charging System, Class 2 Pulse Dampener nozzle inside radius and nozzle welds examination volumes per Category C-B, Items C2.21 and C2.22.

II. ASME Requirements for Which Relief is Requested:

Within Table IWC-2500-1, Category C-B provides examination requirements for Class 2 pressure retaining nozzle welds in vessels. The Pulse Dampener contains three (3) nozzles, in line, located at the bottom of the unit. These nozzles require both surface and volumetric examinations as specified by Item C2.21 for nozzle-to-shell welds. The same three (3) nozzles also require volumetric examination as identified by Item C2.22 for the nozzle inside radius sections. ASME Section XI requires "essentially 100% of the weld length" as specified within the Notes within the IWC-2500-1 tables. ASME Section XI Code Case N-460 states that if the entire examination volume or area cannot be examined due to interference by another component or part geometry, a reduction in coverage is acceptable provided that the coverage is less than 10%.

R. E. Ginna Nuclear Power Plant was constructed to B31.1, 1955 edition. This code did not contain requirements to ensure that items be accessible for future examinations. The Pulse Dampener was constructed and installed in the early 1970's, the construction code utilized did not provide provisions for accessibility for ISI NDE.

The Pulse Dampener contains three (3) nozzles that require examination under ASME Section XI, 1986 Edition, no addenda per Category C-B. These nozzles are identified as CF-N1, CF-N2 and CF-N3. The three (3) Nozzle-to-Shell welds require both surface and volumetric examinations as specified by Item C2.21. The same nozzles are also examined volumetrically for the Nozzle Inside Radius Section per Item C2.22. The design of the Pulse Dampener is not conducive for examination of the nozzles as identified within the above item numbers. The outboard

[The page contains extremely faint and illegible text, likely bleed-through from the reverse side of the document. The text is scattered across the page and cannot be transcribed accurately.]



QUALITY ASSURANCE MANUAL GINNA STATION	TITLE:	Section 2	REV. 3
	APPENDIX B R.E. GINNA NUCLEAR POWER PLANT INSERVICE INSPECTION PROGRAM FOR THE 1990-1999 INTERVAL ISI RELIEF REQUESTS	PAGE 31 of 39	

RELIEF REQUEST NO. 19 (Con't)

nozzle is identified as CF-N1. Between this nozzle and the middle nozzle (identified as CF-N2) is a support that covers the edge of one nozzle weld heat affected zone. From the middle nozzle to the third nozzle (identified as CF-N3) is a space of only 7/8" from the edge of one nozzle weld heat affected zone to the edge of the other nozzle heat affected zone. Due to the identified interferences of the nozzles and vessel support, the associated volumetric and surface volume coverage acceptance criteria is below the stated value within Code Case N-460. The following table summarizes the coverage obtained using the indicated examination methods.

<u>Nozzle Weld</u>	<u>NDE Method</u>	<u>% of Coverage</u>
CF-N1	PT	66%
	UT	65%
CF-N2	PT	66%
	UT	65%
CF-N3	PT	>90%
	UT	80%

Since ASME Section XI Code requires examination of this component and since it is the only one of its type, style and function; the above identified surface and volume coverage should be acceptable in meeting code requirements.

II. Proposed Alternate Method:

Rochester Gas and Electric (RG&E) proposes that the NDE surface and volume coverage identified within the table above be acceptable in fulfilling the code required examinations. The actual physical configuration of the component being examined is not conducive in obtaining the requirements specified within Code Case N-460.

In addition, RG&E proposes to perform a VT-2 visual examination on the entire Pulse Dampener during a leakage test and hydrostatic pressure test in accordance with IWA-5000 and Table IWC-2500-1, as applicable.

[The page contains extremely faint and illegible text, likely bleed-through from the reverse side of the document. The text is scattered across the page and cannot be transcribed accurately.]



QUALITY ASSURANCE MANUAL GINNA STATION	TITLE:	Section 2	REV. 3
	APPENDIX B R.E. GINNA NUCLEAR POWER PLANT INSERVICE INSPECTION PROGRAM FOR THE 1990-1999 INTERVAL ISI RELIEF REQUESTS	PAGE 32 of 39	

(ONE-TIME USE ONLY)

RELIEF REQUEST NO. 23

ALTERNATIVE CLASS 3 HYDROSTATIC TESTING FOR CODE REPLACEMENTS

I. Components for Which Relief is Requested:

A. Service Water System, Rules for Hydrostatic Testing of Repairs, Replacements or Modifications to pressure retaining Class 3 components.

1. Installation of isolation valves

- a. V-4611
- b. V-4613
- c. V-4626
- d. V-4669
- e. V-4738
- f. V-4739
- g. V-4760

B. Turbine Driven Auxiliary Feedwater System, Rules for Hydrostatic Testing of Repairs, Replacements or Modifications to pressure retaining Class 3 components.

1. Installation of valve V-4023

II. ASME Requirements for Which Relief is Requested:

Hydrostatic testing of Repairs, Replacements or Modifications on Class 3 systems is required by IWA-4400 which specifies that hydrostatic testing shall be performed to IWD-5223(a). The system hydrostatic test pressure shall be at least 1.10 times the system pressure P_{sv} for systems with Design Temperature of 200°F or less, and at least 1.25 times the system pressure P_{sv} for systems with Design Temperature above 200°F. The system pressure P_{sv} shall be the lowest pressure setting among the number of safety or relief valves provided for overpressure protection within the boundary of the system to be tested. For systems (or portions of systems) not provided with safety or relief valves, the system design pressure P_d shall be substituted for P_{sv} .



QUALITY ASSURANCE MANUAL GINNA STATION	TITLE:	Section 2	REV. 3
	R.E. GINNA NUCLEAR POWER PLANT INSERVICE INSPECTION PROGRAM FOR THE 1990-1999 INTERVAL ISI RELIEF REQUESTS	PAGE 33 of 39	

(ONE-TIME USE ONLY)

RELIEF REQUEST NO. 23 (Con't)

III. Basis:

The first activity to be performed is the replacement of seven (7) valves in the Class 3 Service Water System. The second activity is the replacement of a check valve in the Class 3 Turbine Driven Auxiliary Feedwater System.

Service Water System:

Seven (7) valves within the service water system are currently being replaced: valve numbers 4611, 4613, 4626, 4669, 4738, 4739, and 4760. The replacement of the valves is being performed to the 1986 edition of ASME B&PV Code, Section III.

An evaluation to establish the work area test boundaries for the valve replacements was performed as discussed below (refer to drawings 33013-1250 sheets 1-3):

V-4626:

The replacement valve is a gate valve. Both the upstream and downstream isolations would require the use of butterfly type isolation valves, thus making an elevated (hydrostatic) pressure test impractical. (see Relief Request #14)

V-4611, V-4669, V-4738, V-4739, V-4760, V-4613:

The first five replacement valves are gate valves and serve as loop cross-connects. V-4613 is a butterfly type design and serves as a loop isolation valve. In order to isolate the selected areas for replacement, freeze seals would be required to maintain some systems supplied by the Service Water System operational. The use of freeze seals as isolation boundaries is not feasible. In order to establish test boundaries, complete service water loops would be required to be isolated, thus creating an operational hardship resulting in a reduction in plant safety due to rendering certain critical operational and safety related equipment unavailable.

Faint, illegible text scattered across the page, possibly bleed-through from the reverse side. The text is too light to transcribe accurately.



QUALITY ASSURANCE MANUAL GINNA STATION	TITLE:	APPENDIX B R.E. GINNA NUCLEAR POWER PLANT INSERVICE INSPECTION PROGRAM FOR THE 1990-1999 INTERVAL ISI RELIEF REQUESTS	Section 2	REV. 3
			PAGE 34 of 39	

(ONE-TIME USE ONLY)

RELIEF REQUEST NO. 23 (Con't)

Turbine Driven Auxiliary Feedwater System:

The work activity being performed is the replacement of check valve 4023 in the recirculation test line. The Code used for this work is the 1989 edition of ANSI B31.1. Once the valve is installed, the pipe section cannot be isolated to perform the elevated (hydrostatic) pressure test.

Referring to drawing 33013-1237, boundaries for the work area would be the pump suction valves (V-4024 & 4098), the pump discharge valve (V-3996) and downstream flow control valve V-4291. Both V-3996 and V-4291 are not designed for isolation applications, and would require the installation of test blocks. Installation of these blocks was found to be impractical.

Part of the work area would incorporate piping having a design pressure of 150 psi, with a required test pressure of 2304 psi, therefore, an unacceptable condition would exist. Installation of a test block at the discharge of the pump was reviewed and found to be impractical because disassembly of the pump would be required.

IV. Proposed Alternate Method:

Alternative Pressure Test Requirements for Welded Repairs or Installation of Replacement Items by Welding:

Class 3:

Using ANSI B31.1 and ASME B&PV Code Case N-416 as a basis for relief, Rochester Gas & Electric considers the following alternative requirements to be acceptable:

1. NDE shall be performed in accordance with the methods and acceptance criteria of Subsection ND of the 1986 Edition of Section III. Additional NDE also is performed by dye penetrant testing of the root pass weld for the service water valves. For V-4023, a surface examination will be performed.

QUALITY ASSURANCE MANUAL GINNA STATION	TITLE:	APPENDIX B R.E. GINNA NUCLEAR POWER PLANT INSERVICE INSPECTION PROGRAM FOR THE 1990-1999 INTERVAL ISI RELIEF REQUESTS	Section 2	REV. 3
			PAGE 35 of 39	

(ONE-TIME USE ONLY)

RELIEF REQUEST NO. 23 (Con't)

2. Prior to, or immediately upon return to service, a VT-2 visual examination shall be performed in conjunction with an inservice or functional leakage test, using the 1986 Edition of Section XI, in accordance with IWA-5000, at nominal operating pressure and temperature.

This code required test pressure and the nominal system pressure at which a leak test will be performed as proposed are shown in the table below:

<u>SWS Valves</u>	<u>Code Required Test Pressure</u>	<u>Test Pressure to be Performed⁽¹⁾</u>
V-4611	165 psig	75 psig (Nom.)
V-4613	165 psig	75 psig (Nom.)
V-4626	165 psig	75 psig (Nom.)
V-4669	165 psig	75 psig (Nom.)
V-4738	165 psig	75 psig (Nom.)
V-4739	165 psig	75 psig (Nom.)
V-4760	165 psig	75 psig (Nom.)

(1) Test pressure reflects system operating pressure of nominal 75 psig.

The test pressure (and nominal operating pressure) is considered adequate to detect potential leakage after performing the replacement.

1
2
3
4
5
6
7
8
9
10
11
12
13
14
15
16
17
18
19
20
21
22
23
24
25
26
27
28
29
30
31
32
33
34
35
36
37
38
39
40
41
42
43
44
45
46
47
48
49
50
51
52
53
54
55
56
57
58
59
60
61
62
63
64
65
66
67
68
69
70
71
72
73
74
75
76
77
78
79
80
81
82
83
84
85
86
87
88
89
90
91
92
93
94
95
96
97
98
99
100

1
2
3
4
5
6
7
8
9
10
11
12
13
14
15
16
17
18
19
20
21
22
23
24
25
26
27
28
29
30
31
32
33
34
35
36
37
38
39
40
41
42
43
44
45
46
47
48
49
50
51
52
53
54
55
56
57
58
59
60
61
62
63
64
65
66
67
68
69
70
71
72
73
74
75
76
77
78
79
80
81
82
83
84
85
86
87
88
89
90
91
92
93
94
95
96
97
98
99
100



QUALITY ASSURANCE MANUAL GINNA STATION	TITLE:	APPENDIX B R.E. GINNA NUCLEAR POWER PLANT INSERVICE INSPECTION PROGRAM FOR THE 1990-1999 INTERVAL ISI RELIEF REQUESTS	Section 2	REV. 3
			PAGE 36 of 39	

(ONE-TIME USE ONLY)

RELIEF REQUEST NO. 23 (Con't)

<u>AFW Valve</u>	<u>Code Required Test Pressure</u>	<u>Test Pressure to be Performed⁽²⁾</u>
V-4023	2304 psig	1100 psig (Nom.)

(2) Test pressure reflects system operating pressure of nominal 1100 psig.

3. Use of this Relief Request will be documented on the NIS-2 Form for the Replacement.

1
2
3
4
5
6
7
8
9
10
11
12
13
14
15
16
17
18
19
20
21
22
23
24
25
26
27
28
29
30
31
32
33
34
35
36
37
38
39
40
41
42
43
44
45
46
47
48
49
50
51
52
53
54
55
56
57
58
59
60
61
62
63
64
65
66
67
68
69
70
71
72
73
74
75
76
77
78
79
80
81
82
83
84
85
86
87
88
89
90
91
92
93
94
95
96
97
98
99
100



QUALITY ASSURANCE MANUAL GINNA STATION	TITLE:	APPENDIX B R.E. GINNA NUCLEAR POWER PLANT INSERVICE INSPECTION PROGRAM FOR THE 1990-1999 INTERVAL ISI RELIEF REQUESTS	Section 2	REV. 3
			PAGE 37 of 39	

(ONE-TIME USE ONLY)

RELIEF REQUEST NO. 24

ALTERNATIVE CLASS 3 HYDROSTATIC TESTING FOR CODE REPLACEMENTS

I. Components for Which Relief is Requested:

Service Water System, Rules for Hydrostatic Testing of Repairs, Replacements or Modifications to pressure retaining Class 3 components.

1. Installation of isolation valves

- a. V-4663
- b. V-4013
- c. V-4027
- d. V-4028

II. ASME Requirements for Which Relief is Requested:

Hydrostatic testing of Repairs, Replacements or Modifications on Class 3 systems is required by IWA-4400 which specifies that hydrostatic testing shall be performed to IWD-5223(a). The system hydrostatic test pressure shall be at least 1.10 times the system pressure P_{sv} for systems with Design Temperature of 200°F or less, and at least 1.25 times the system pressure P_{sv} for systems with Design Temperature above 200°F. The system pressure P_{sv} shall be the lowest pressure setting among the number of safety or relief valves provided for overpressure protection within the boundary of the system to be tested. For systems (or portions of systems) not provided with safety or relief valves, the system design pressure P_d shall be substituted for P_{sv} .

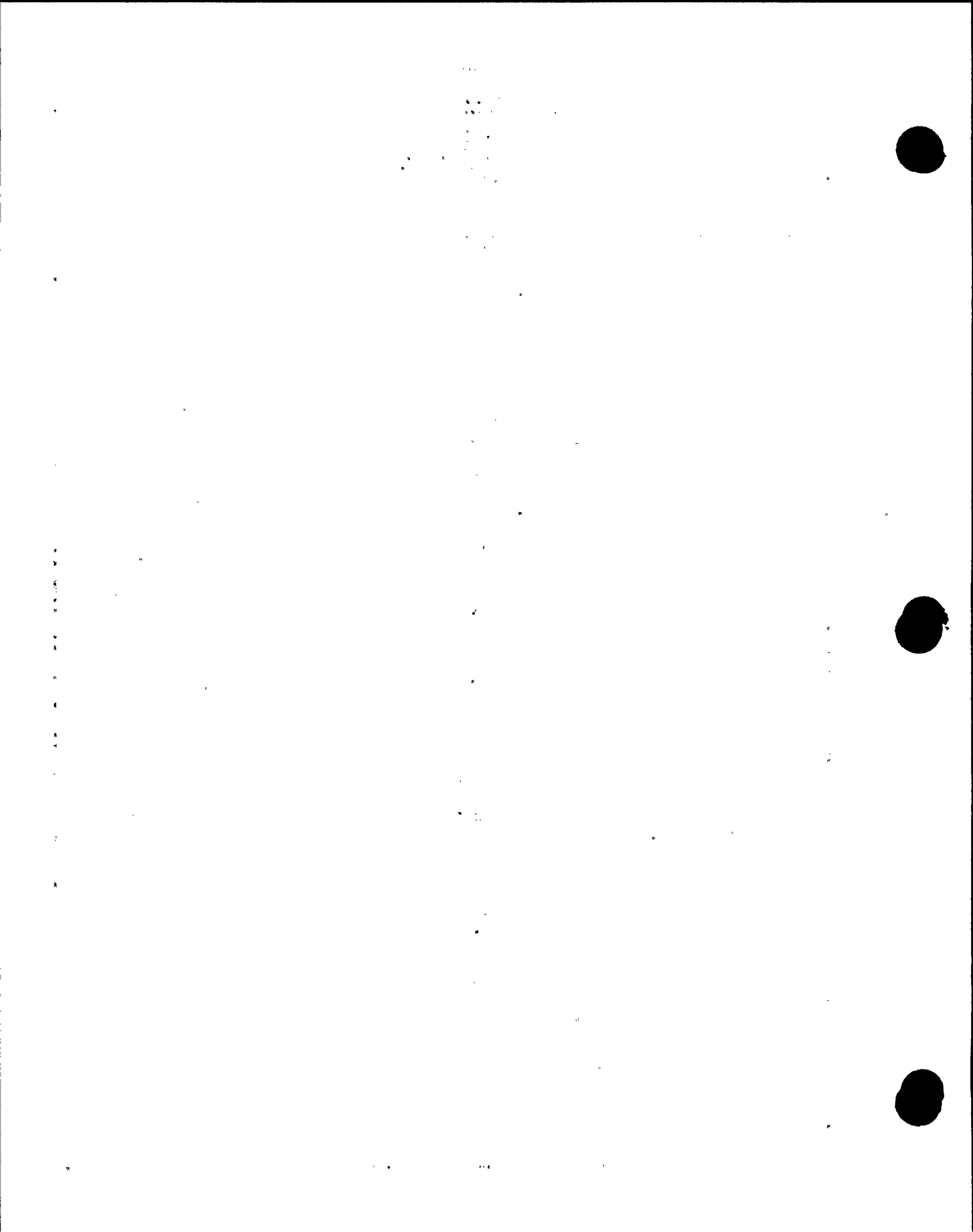

QUALITY ASSURANCE MANUAL GINNA STATION	TITLE:	APPENDIX B R.E. GINNA NUCLEAR POWER PLANT INSERVICE INSPECTION PROGRAM FOR THE 1990-1999 INTERVAL ISI RELIEF REQUESTS	Section 2	REV. 3
			PAGE 38 of 39	

(ONE-TIME USE ONLY)

RELIEF REQUEST NO. 24 (Con't)

III. Basis:

This request for relief is for a "one-time" use for the replacement of four (4) Class 3 service water valves. The four valves being replaced are valve numbers 4663, 4013, 4027, and 4028. The replacement represents a previously unscheduled activity attributable to defects encountered during a refurbishment program. The replacement of the valves is being performed to the 1986 edition of ASME B&PV Code, Section III.

An evaluation to establish the work area test boundaries for the valve replacements was performed as discussed below (refer to drawings 33013-1250 sheet 3 for V-4663 and 33013-1237 for V-4013, V-4027, and V-4028)

All replacement valves are gate valves. Isolation boundaries for the valves would require the use of butterfly valves, making an elevated (hydrostatic) pressure test impractical. (see Relief Request # 14)

IV. Proposed Alternate Method:

Alternative Pressure Test Requirements for Welded Repairs or Installation of Replacement Items by Welding:

Class 3:

Using ANSI B31.1 and ASME B&PV Code Case N-416 as a basis for relief, Rochester Gas & Electric considers the following alternative requirements to be acceptable:

1. NDE shall be performed in accordance with the methods and acceptance criteria of Subsection ND of the 1986 Edition of Section III. Additional NDE also is performed by dye penetrant testing of the root pass weld.



QUALITY ASSURANCE MANUAL GINNA STATION	TITLE:	APPENDIX B R.E. GINNA NUCLEAR POWER PLANT INSERVICE INSPECTION PROGRAM FOR THE 1990-1999 INTERVAL ISI RELIEF REQUESTS	Section 2	REV. 3
			PAGE 39 of 39	

(ONE-TIME USE ONLY)

RELIEF REQUEST NO. 24 (Con't)

2. Prior to, or immediately upon return to service, a VT-2 visual examination shall be performed in conjunction with an inservice or functional leakage test, using the 1986 Edition of Section XI, in accordance with IWA-5000, at nominal operating pressure and temperature.

This code required test pressure and the nominal system pressure at which a leak test will be performed as proposed are shown in the table below:

<u>SWS Valves</u>	<u>Code Required Test Pressure</u>	<u>Test Pressure to be Performed⁽¹⁾</u>
V-4663	165 psig	75 psig (Nom.)
V-4013	165 psig	75 psig (Nom.)
V-4027	165 psig	75 psig (Nom.)
V-4028	165 psig	75 psig (Nom.)

(1) Test pressure reflects system operating pressure of nominal 75 psig.

The test pressure (and nominal operating pressure) is considered adequate to detect potential leakage after performing the replacement.

3. Use of this Relief Request will be documented on the NIS-2 Form for the Replacement.

QUALITY ASSURANCE MANUAL GINNA STATION ROCHESTER GAS & ELECTRIC CORPORATION	Section 3	REV. 2	PAGE 1 of 3
	EFFECTIVE DATE: December 31, 1993		
TITLE: APPENDIX B R. E. GINNA NUCLEAR POWER PLANT INSERVICE INSPECTION PROGRAM FOR THE 1990-1999 INTERVAL P&ID BOUNDARY DRAWINGS		SIGNATURE	DATE
	PREPARED BY:	<i>Frank A. Klepac</i>	12-1-93
	QUALITY ASSURANCE REVIEW:	<i>[Signature]</i>	12-2-93
	APPROVED BY:	<i>Michael J. Depina</i>	12-6-93

1.0 General:

The P&ID drawings included within this section identify drawings containing lines classified as ASME Class 1, 2, 3 and High Energy pressure boundary. A unique line identifier has been established for each class line and high energy pressure boundary line. The line identifier was used in the preparation of the "Line List" to identify the pressure boundary as well as document the line on the applicable P&ID drawing.

The rules of ASME Section XI were applied to both class and high energy pressure boundaries as specified by IWB/C/D/F-1200. The color coded lines appearing on the applicable drawings identify those lines requiring Inservice Inspection and are not exempt under ASME Section XI for volumetric, surface and/or visual examinations. Leakage examination boundaries and accompanying visual examinations for leakage is not addressed on these drawings.

Pressure boundaries that are not color coded reflect lines that are exempt from volumetric, surface and/or visual examinations.

The following color codes were applied to Class 1, 2, 3, and High Energy pressure boundaries;

Class 1	=	Blue
Class 2 & High Energy	=	Red
Class 3	=	Green

QUALITY ASSURANCE MANUAL GINNA STATION	TITLE:	Section 3	REV. 2
	APPENDIX B R. E. GINNA NUCLEAR POWER PLANT INSERVICE INSPECTION PROGRAM FOR THE 1990-1999 INTERVAL P&ID BOUNDARY DRAWINGS	PAGE 2 of 3	

The following list identifies the P&ID drawings that contain ASME Class 1, 2, 3, or High Energy pressure boundaries.

<u>Drawing Number</u>	<u>Revision</u>
33013-1231	Rev. 22
33013-1232	Rev. 9
33013-1236 Sheet 1	Rev. 8
33013-1236 Sheet 2	Rev. 6
33013-1237	Rev. 27
33013-1238	Rev. 9
33013-1239 Sheet 1	Rev. 11
33013-1239 Sheet 2	Rev. 9
33013-1245	Rev. 18
33013-1246 Sheet 1	Rev. 7
33013-1246 Sheet 2	Rev. 6
33013-1247	Rev. 20
33013-1248	Rev. 17
33013-1250 Sheet 1	Rev. 13
33013-1250 Sheet 2	Rev. 14
33013-1250 Sheet 3	Rev. 9
33013-1258	Rev. 14
33013-1260	Rev. 15
33013-1261	Rev. 21
33013-1262 Sheet 1	Rev. 10
33013-1262 Sheet 2	Rev. 5
(*) 33013-1263	Rev. 7
33013-1264	Rev. 14
33013-1265 Sheet 1	Rev. 6
33013-1265 Sheet 2	Rev. 5
33013-1266	Rev. 16
33013-1270 Sheet 1	Rev. 5
33013-1272 Sheet 1	Rev. 6
33013-1272 Sheet 2	Rev. 5
(*) 33013-1275 Sheet 1	Rev. 2
33013-1275 Sheet 2	Rev. 2
33013-1277 Sheet 1	Rev. 6
(*) 33013-1278 Sheet 1	Rev. 8
(*) 33013-1278 Sheet 2	Rev. 9
33013-1279	Rev. 9
33013-1863	Rev. 11
33013-1865	Rev. 8
33013-1866	Rev. 13
33013-1870	Rev. 8

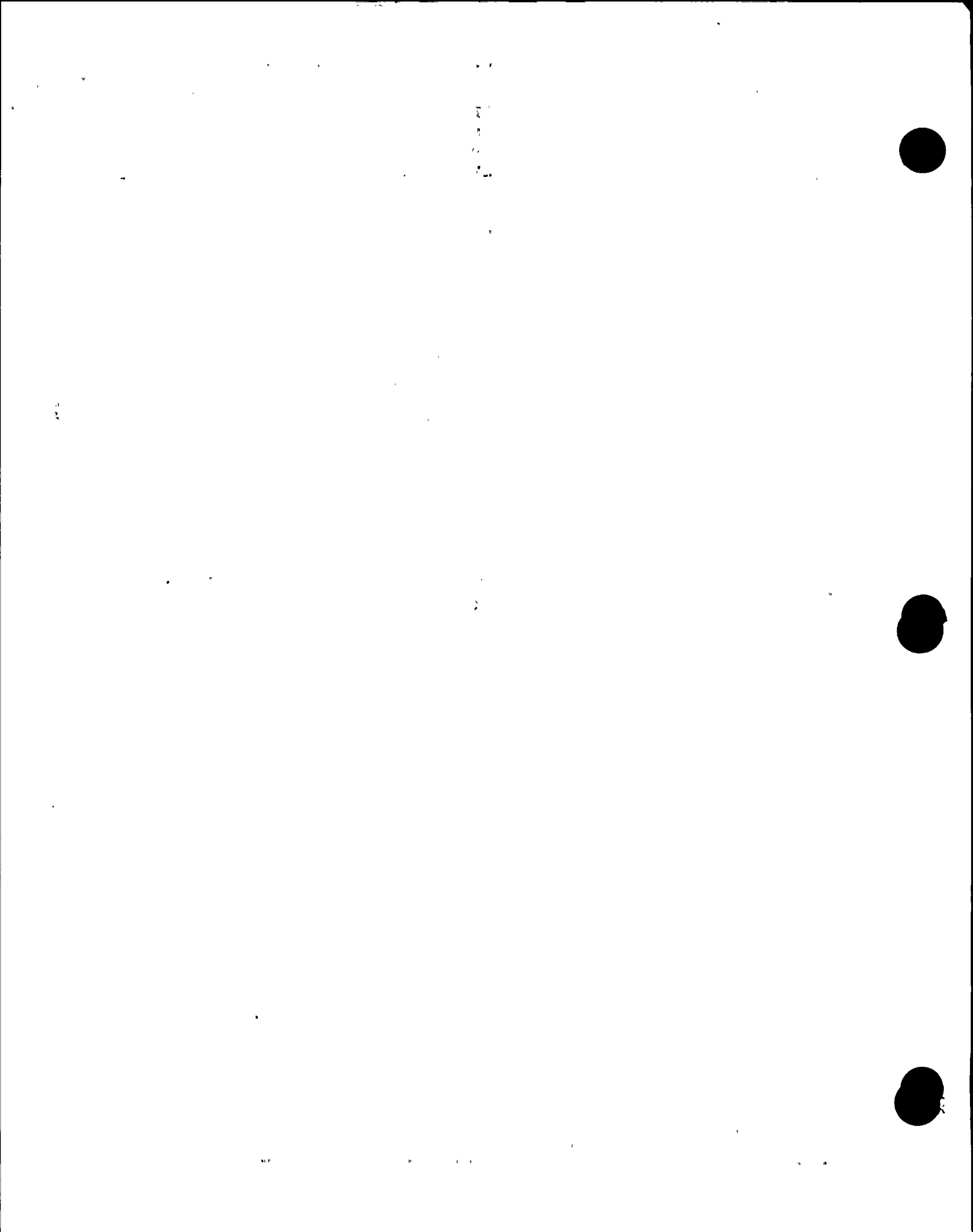

QUALITY ASSURANCE MANUAL GINNA STATION	TITLE:	APPENDIX B R.E. GINNA NUCLEAR POWER PLANT INSERVICE INSPECTION PROGRAM FOR THE 1990-1999 INTERVAL P&ID BOUNDARY DRAWINGS	Section 3	REV. 2
			PAGE 3 of 3	

<u>Drawing Number</u>	<u>Revision</u>
33013-1882	Rev. 9
33013-1886 Sheet 2	Rev. 5
33013-1887	Rev. 5
(*) 33013-1893	Rev. 10
33013-1908 Sheet 3	Rev. 3
33013-1915	Rev. 9
33013-1991	Rev. 8
(*) 33013-2278	Rev. 0
33013-2279 Sheet 1	Rev. 0

Note: (*) = Identifies P&IDs containing ASME Class piping NPS 1" and below. These identified drawings are not included within this section.

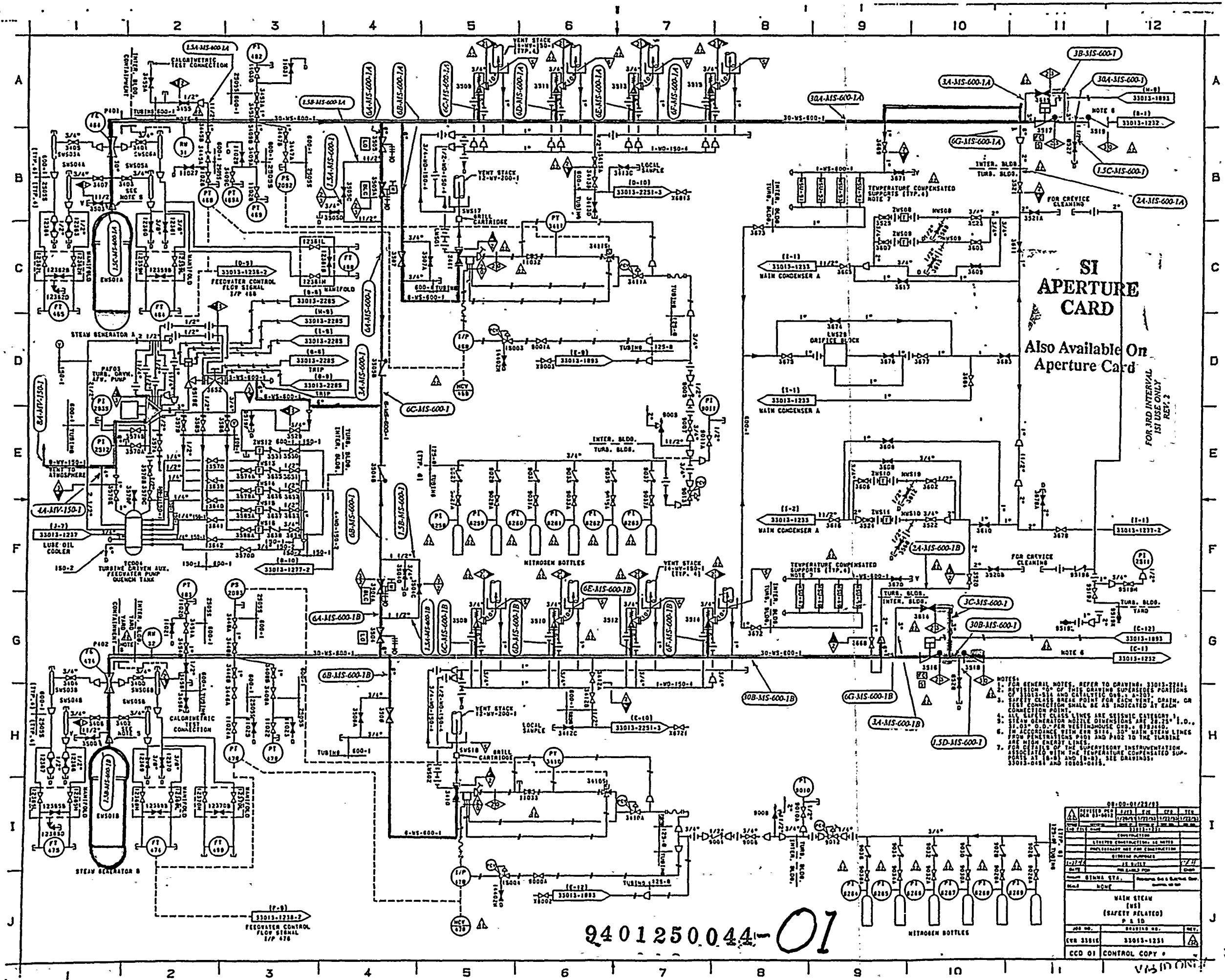

SI APERTURE CARD
 Also Available On Aperture Card

FOR 3RD INTERVAL
 1ST USE ONLY
 REV. 2

- NOTES:
1. FOR GENERAL NOTES, REFER TO DRAWING 33013-2231.
 2. REVISION NO. OF THE DRAWING SUPERSEDES PREVIOUS EDITIONS.
 3. ALL INSTRUMENTS ARE TO BE INSTALLED IN ACCORDANCE WITH THE INSTRUMENTATION SPECIFICATIONS.
 4. ALL INSTRUMENTS ARE TO BE INSTALLED IN ACCORDANCE WITH THE INSTRUMENTATION SPECIFICATIONS.
 5. ALL INSTRUMENTS ARE TO BE INSTALLED IN ACCORDANCE WITH THE INSTRUMENTATION SPECIFICATIONS.
 6. ALL INSTRUMENTS ARE TO BE INSTALLED IN ACCORDANCE WITH THE INSTRUMENTATION SPECIFICATIONS.
 7. ALL INSTRUMENTS ARE TO BE INSTALLED IN ACCORDANCE WITH THE INSTRUMENTATION SPECIFICATIONS.

REV.	DATE	BY	CHKD.	APP.
1	08-00-01/23/68			
2				
3				
4				
5				
6				
7				
8				
9				
10				
11				
12				

WARM STEAM (MS)	
(SAFETY RELATED)	
P. 10	
JOB NO.	33013-1231
REV. NO.	01
REV. 1	08-00-01/23/68
REV. 2	
REV. 3	
REV. 4	
REV. 5	
REV. 6	
REV. 7	
REV. 8	
REV. 9	
REV. 10	
REV. 11	
REV. 12	

9401250.044-01

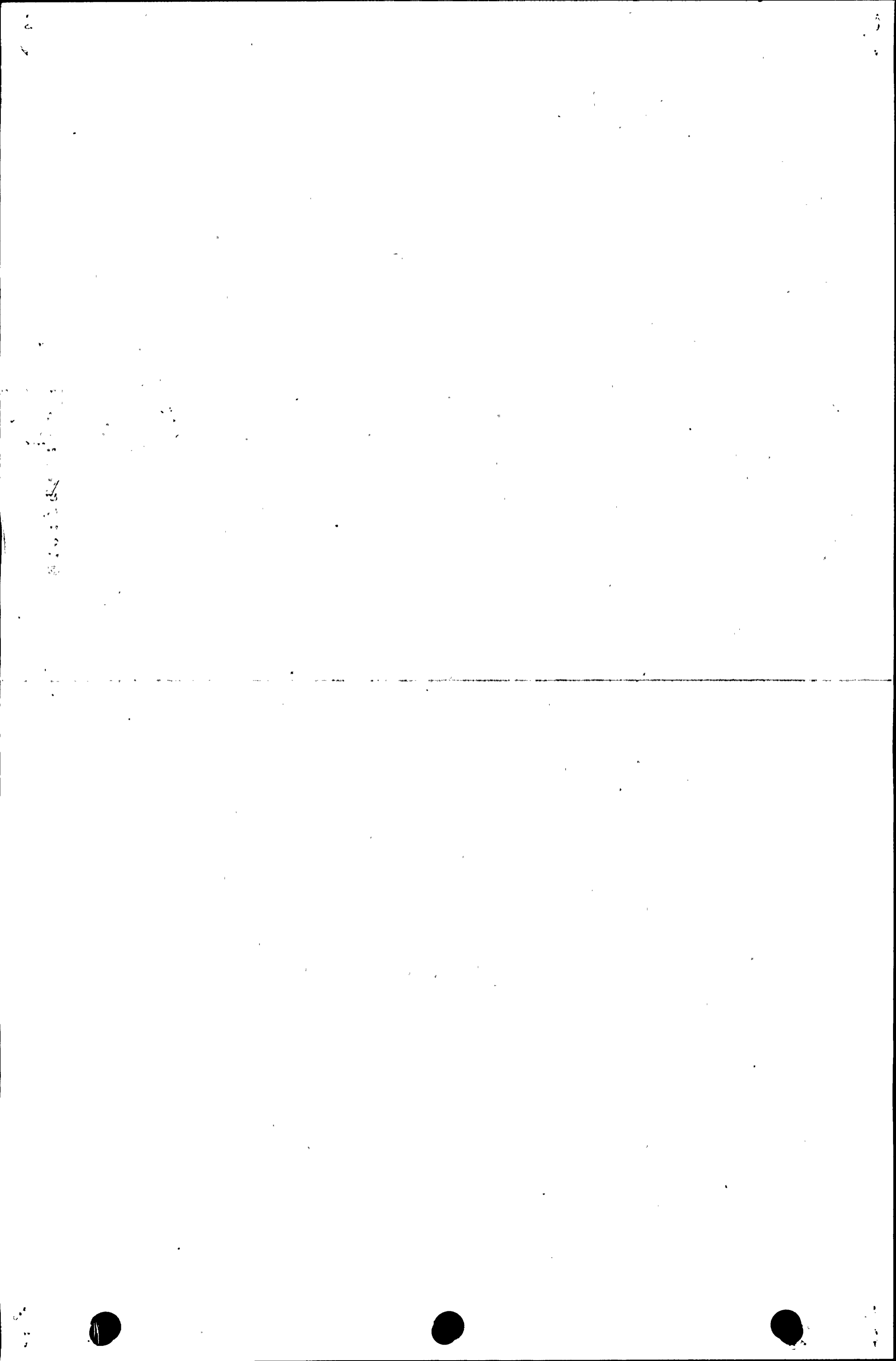

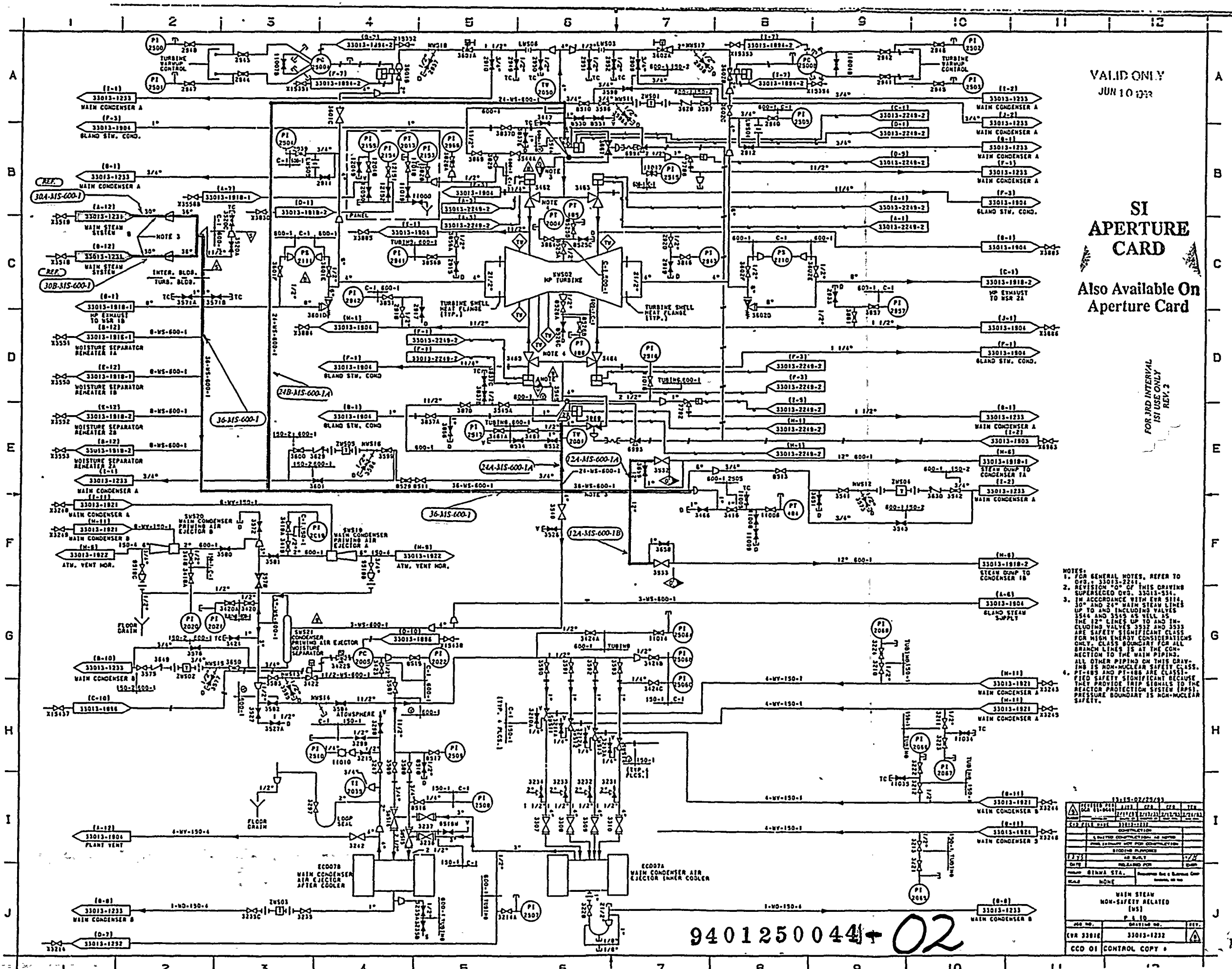

VALID ONLY
JUN 10 1973

**SI
APERTURE
CARD**

Also Available On
Aperture Card

FOR P&ID INTERNAL
SI USE ONLY
REV. 2

- NOTES:
- FOR GENERAL NOTES, REFER TO DGS 33013-2241.
 - REVISION 02 OF THIS DRAWING SUPERSEDES DGS 33013-534.
 - IN ACCORDANCE WITH EIA 514, 30" AND 24" MAIN STEAM LINES UP TO AND INCLUDING VALVES 3544 AND 3545 AS WELL AS THE 12" LINES UP TO AND INCLUDING VALVES 3532 AND 3533 ARE SAFETY SIGNIFICANT CLASS FOR HIGH ENERGY CONSIDERATIONS ONLY. CLASS BOUNDARY FOR ALL BRANCH LINES IS AT THE CONNECTION TO THE MAIN PIPING. ALL OTHER PIPING ON THIS DRAWING IS NON-NUCLEAR SAFETY CLASS.
 - PT-485 AND PT-486 ARE CLASSIFIED SAFETY SIGNIFICANT BECAUSE THEY PROVIDE TRIP SIGNALS TO THE REACTOR PROTECTION SYSTEM (RPS). PRESSURE BOUNDARY IS NON-NUCLEAR SAFETY.

NO.	DATE	BY	CHKD.	APP.	REV.
1	12/15/72
2	02/23/73

NO.	DATE	BY	CHKD.	APP.	REV.
1	12/15/72
2	02/23/73

9401250044-02

1901

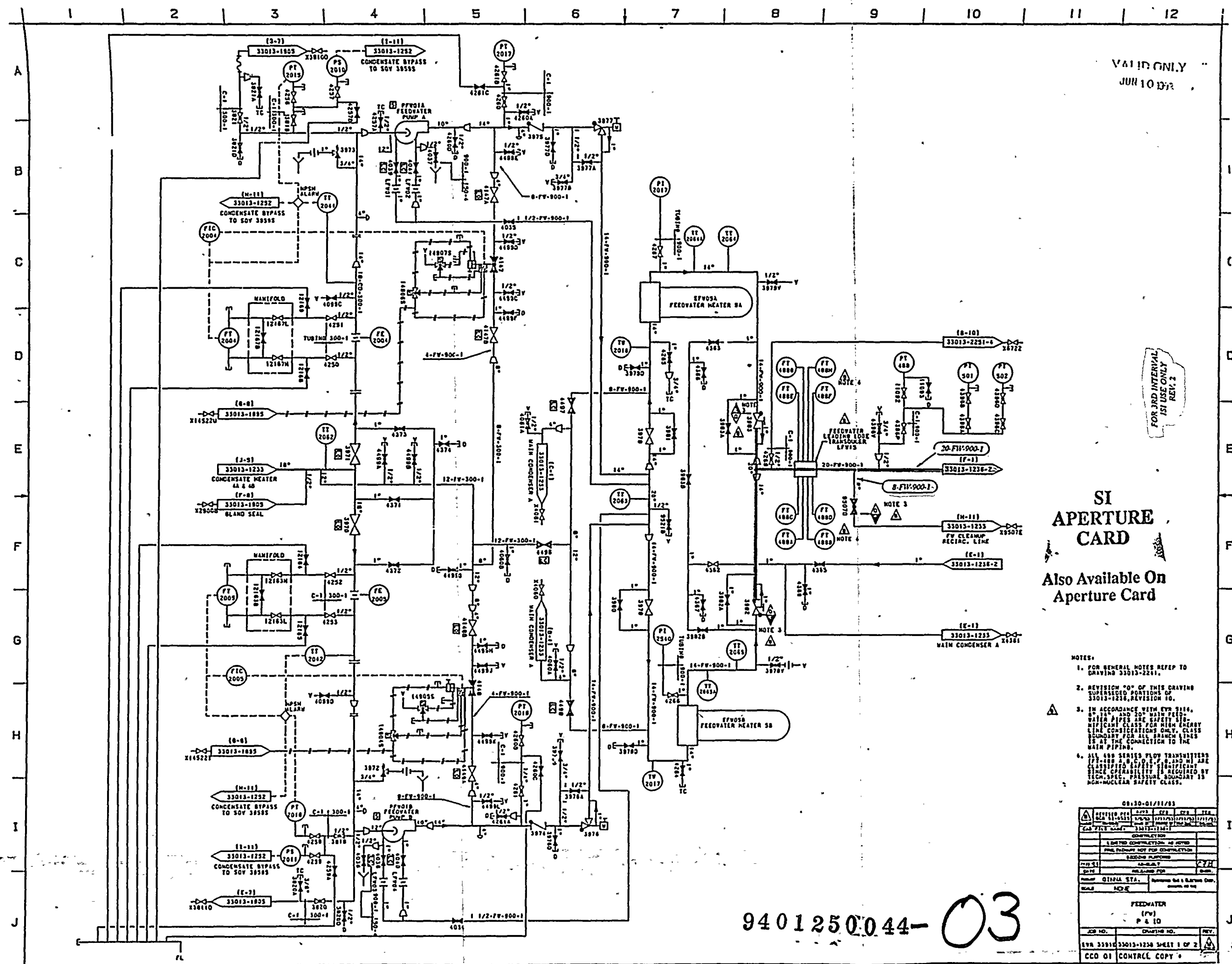

VALID ONLY
JUN 10 1973

FOR JRD INTERNAL
SI USE ONLY
REV. 2

**SI
APERTURE
CARD**

Also Available On
Aperture Card

- NOTES:
- FOR GENERAL NOTES REFER TO DRAWING 33013-2231.
 - REVISION "0" OF THIS DRAWING SUPERSEDES PORTIONS OF 33013-1233, REVISION 10.
 - IN ACCORDANCE WITH EPR 3014, 14" AND 20" MAIN FEEDWATER PIPES ARE SAFETY SIGNIFICANT CLASS FOR HIGH ENERGY LINE CONSIDERATIONS ONLY. CLASS BOUNDARY FOR ALL BRANCH LINES IS AT THE CONNECTION TO THE MAIN PIPING.
 - ALL 400 SERIES FLOW TRANSMITTERS (PT-100 A, B, C, D, E, F, G, H, I, J) ARE CLASSIFIED AS SIGNIFICANT SINCE OPERABILITY IS REQUIRED BY TECH. SPEC. PRESSURE BOUNDARY IS NON-NUCLEAR SAFETY CLASS.

09:30-01/11/83

REV	DATE	BY	CHK	APP
01	01/11/83			
02	01/11/83			
03	01/11/83			
04	01/11/83			
05	01/11/83			
06	01/11/83			
07	01/11/83			
08	01/11/83			
09	01/11/83			
10	01/11/83			

DESIGNED BY	QIN/AL
CHECKED BY	QIN/AL
APPROVED BY	QIN/AL
DATE	01/11/83
SCALE	NONE
PROJECT	FEEDWATER
DRAWING NO.	33013-1233
SHEET NO.	1 OF 2
CONTRACT NO.	CCO 01

9401250044-03

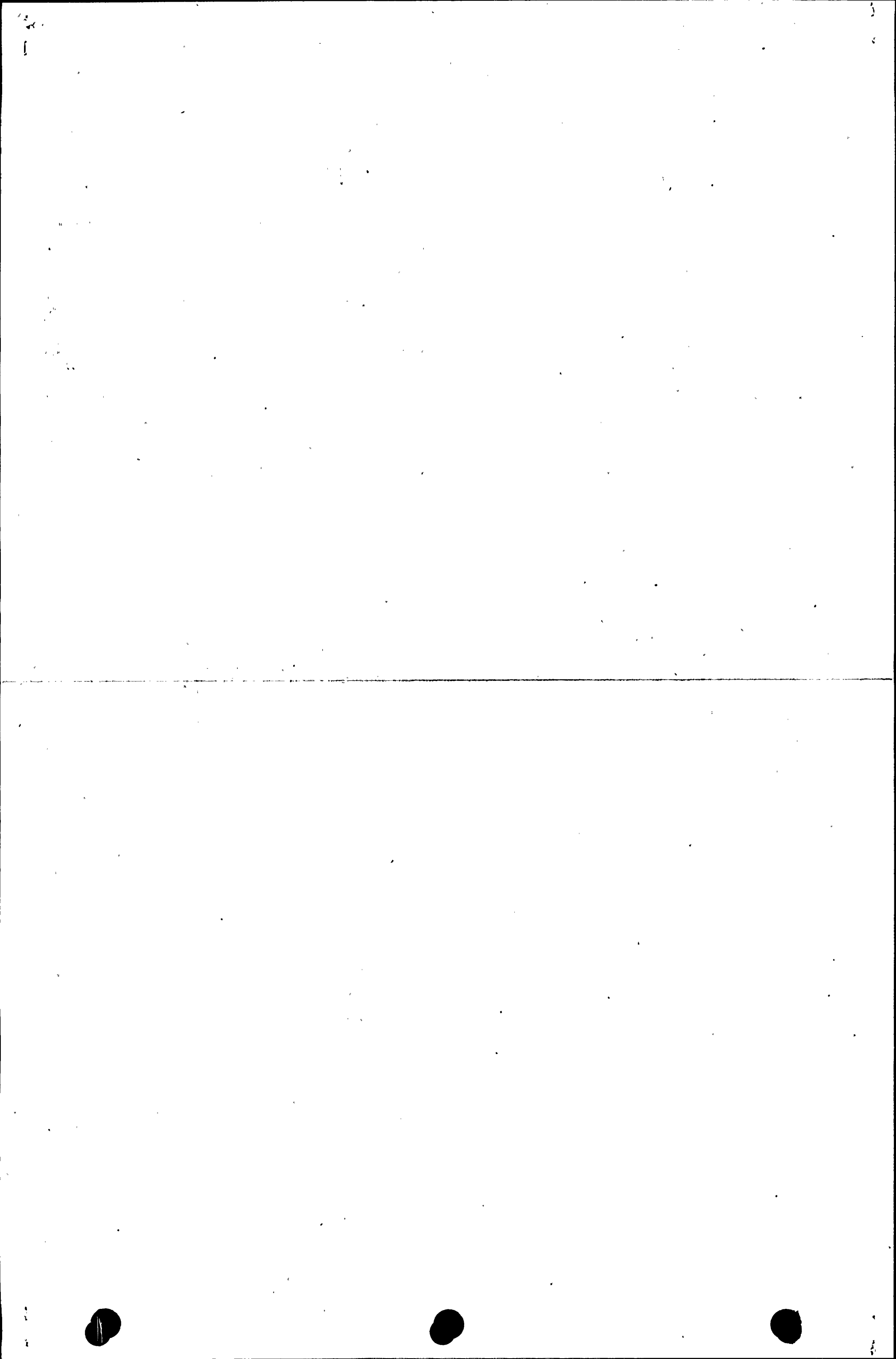

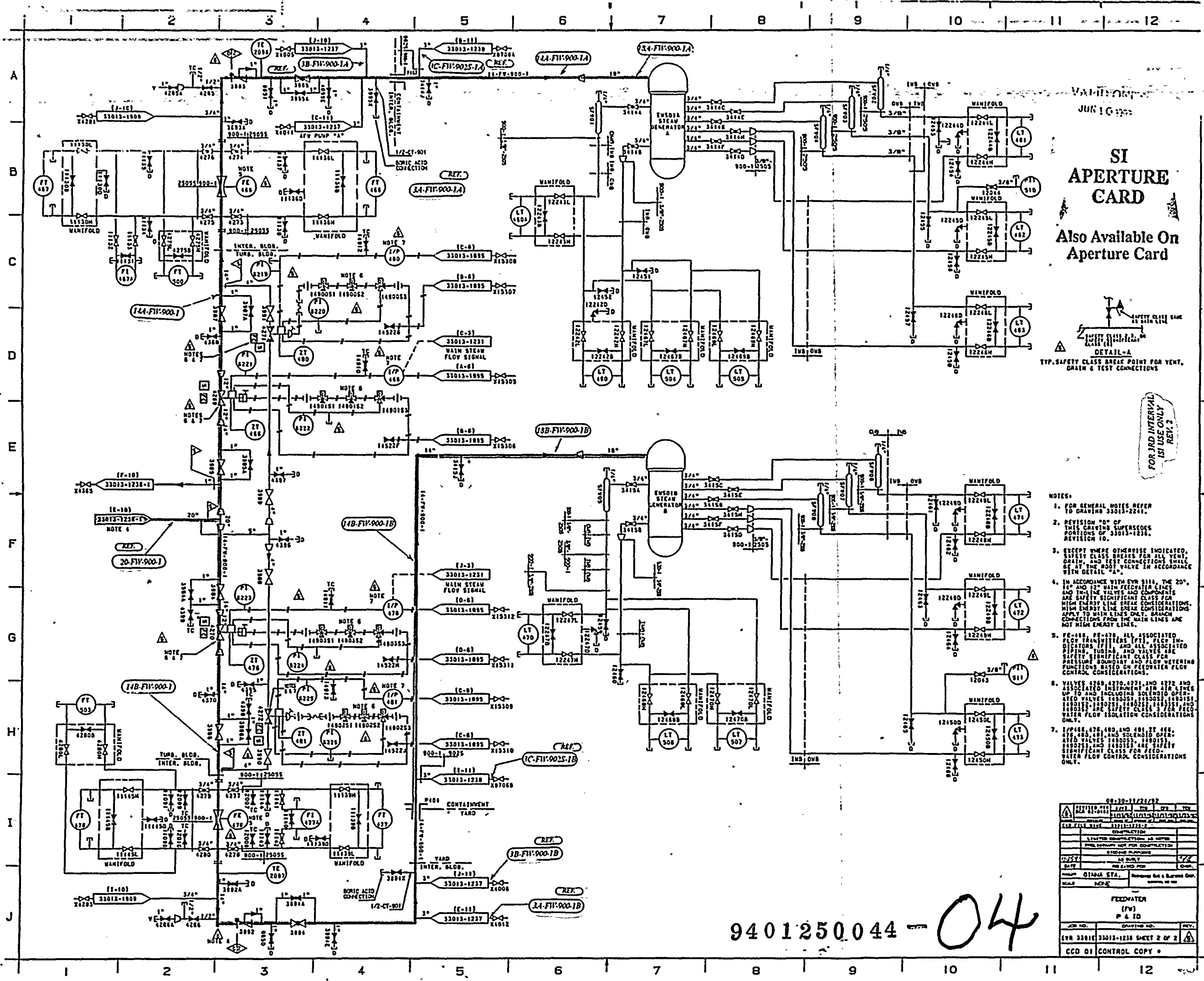

JUN 10 1966

SI APERTURE CARD

Also Available On Aperture Card

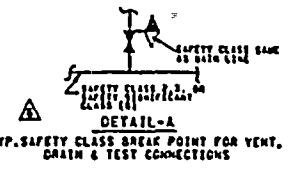

FOR 3RD INTERVAL
1ST USE ONLY
REV. 2

- NOTES:
1. FOR GENERAL NOTES REFER TO DRAWING 33013-2211.
 2. REVISION "0" OF THIS DRAWING SUPERSEDES PORTIONS OF 33013-1238, REVISION 10.
 3. EXCEPT WHERE OTHERWISE INDICATED, SAFETY CLASS BREAKS FOR ALL VENT, DRAIN, AND TEST CONNECTIONS SHALL BE AT THE ROOT VALVE IN ACCORDANCE WITH DETAIL "A".
 4. IN ACCORDANCE WITH ENR 9111, THE 20", 18" AND 12" MAIN FEEDER LINES AND IN-LINE VALVES AND COMPONENTS ARE SAFETY SIGNIFICANT CLASS FOR HIGH ENERGY LINE BREAK CONSIDERATIONS. HIGH ENERGY LINE BREAK CONSIDERATIONS APPLY TO MAIN LINES ONLY. SAFETY CONNECTIONS FROM THE MAIN LINES ARE NOT HIGH ENERGY LINES.
 5. PE-188, PE-678, ALL ASSOCIATED FLOW TRANSMITTERS (FT), FLEP IN-STRUMENTS (FI) AND ALL ASSOCIATED PIPING, FUSING, AND VALVES ARE SAFETY SIGNIFICANT CLASS FOR PRESSURE DROUGHT AND FLOW MEASUREMENT FUNCTIONS BASED ON FEEDWATER FLOW CONTROL CONSIDERATIONS.
 6. VALVES 4269, 4270, 4271, AND 4272 AND ASSOCIATED INSTRUMENT AIR LINES UP TO AND INCLUDING SOLENOID OPERATED VALVES 1890501, 1890502, 1890503, 1890504, 1890505, 1890506, 1890507, AND 1890508 ARE SAFETY SIGNIFICANT CLASS FOR FEEDWATER FLOW ISOLATION CONSIDERATIONS ONLY.
 7. 1890509, 476, 480, AND 481 FT ARE 18" AND 12" MAIN FEEDER LINES AND ASSOCIATED INSTRUMENT AIR LINES UP TO AND INCLUDING SOLENOID OPERATED VALVES 1890503, 1890504, 1890505, 1890506, 1890507, AND 1890508 ARE SAFETY SIGNIFICANT CLASS FOR FEEDWATER FLOW CONTROL CONSIDERATIONS ONLY.

9401250.044			
NO.	DATE	BY	CHKD.
1	06/10/66	JUN	JUN
CONSTRUCTION			
OPERATION			
MAINTENANCE			
REVISIONS			
REV.	DATE	BY	CHKD.
0/2/77			
PROJECT: QINMA STA.			
DRAWN BY: [Name]			
CHECKED BY: [Name]			
SCALE: NONE			
FEEDWATER (FW) P & ID			
JOB NO.	DRAWING NO.	REV.	
(ENR 33013)	33013-1238	SHEET 2 OF 2	
CCD 01 CONTROL COPY			

9401250.044 - 04

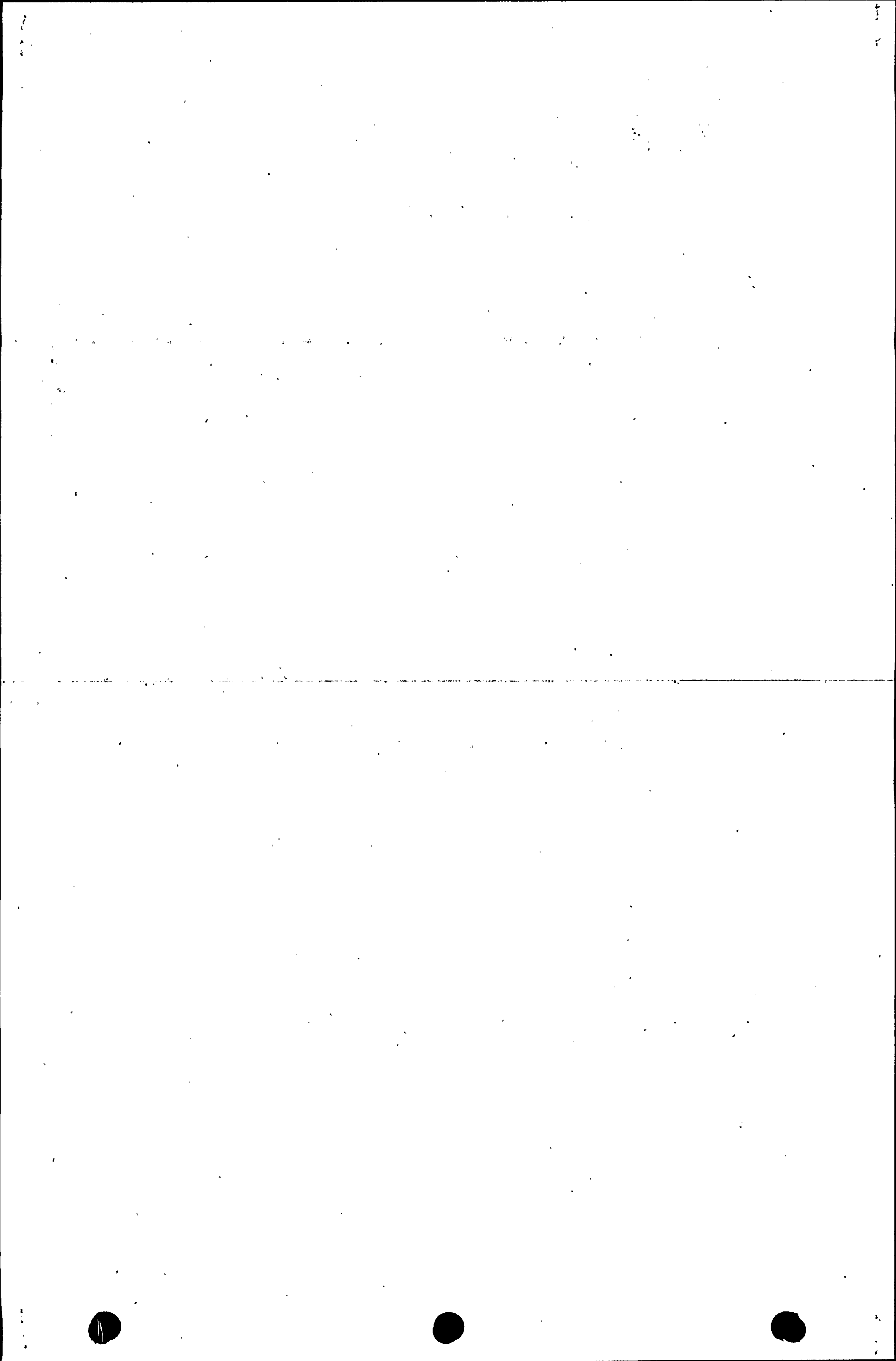

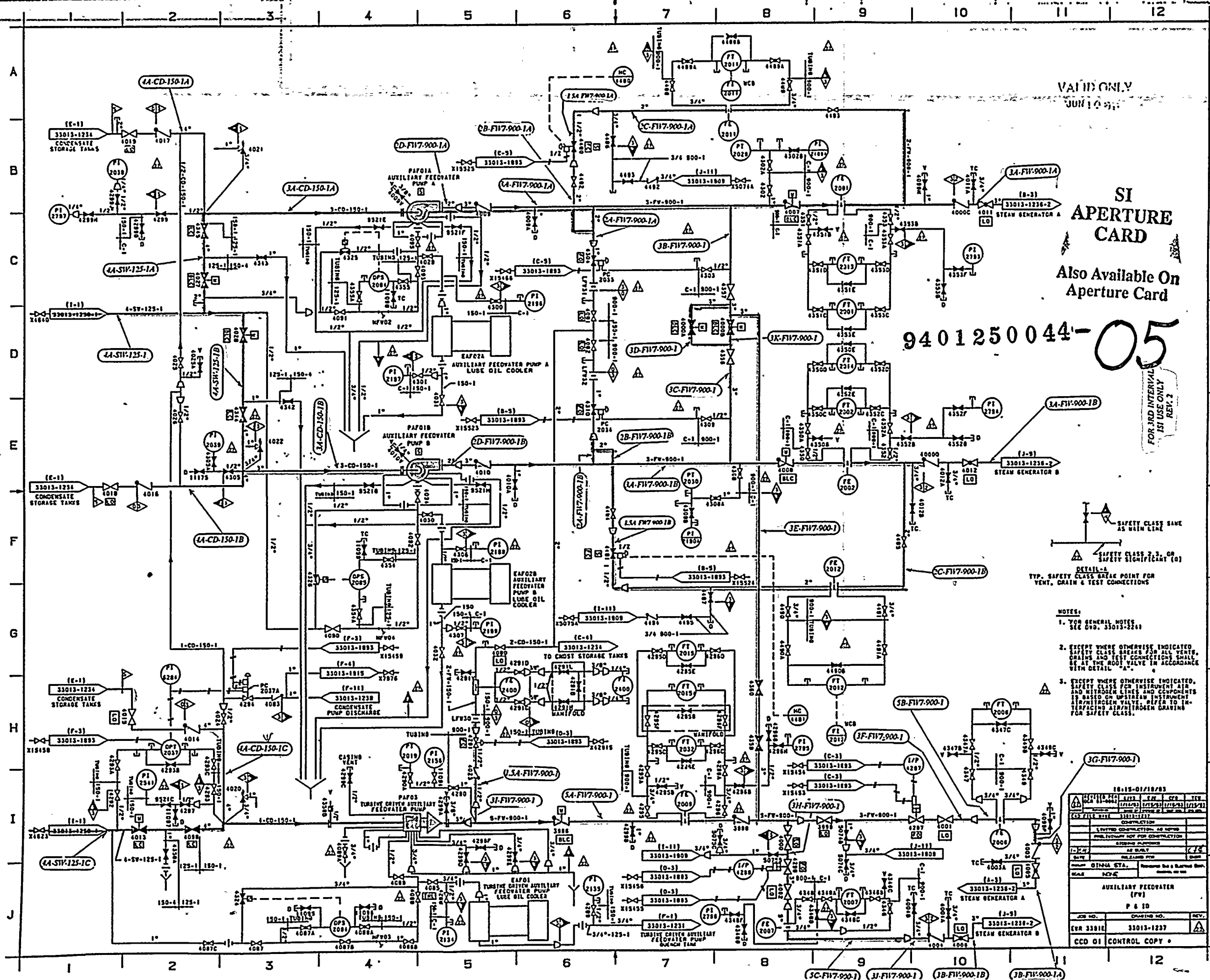

VALID ONLY
JUN 10 1973

SI
APERTURE
CARD

Also Available On
Aperture Card

9401250044-05

FOR 3RD INTERVAL
AS USE ONLY
REV. 2

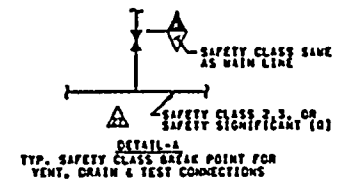

- NOTES:
1. FOR GENERAL NOTES SEE DTD. 33013-12311
 2. EXCEPT WHERE OTHERWISE INDICATED SAFETY CLASS BREAKS FOR ALL VENTS, DRAINS AND TEST CONNECTIONS SHALL BE AT THE ROOT VALVE IN ACCORDANCE WITH DETAIL "A".
 3. EXCEPT WHERE OTHERWISE INDICATED, SAFETY CLASS FOR INSTRUMENTATION AND MEASUREMENT LINES AND EQUIPMENT IS BASED ON UPSTREAM INSTRUMENT AND MEASUREMENT VALVE. REFER TO INSTRUMENTATION/MEASUREMENT DRAWINGS FOR SAFETY CLASS.

NO.	DATE	BY	CHK	APP	REV.
1	18-15-01/18/73	[Signature]	[Signature]	[Signature]	1
2					2
3					3
4					4
5					5
6					6
7					7
8					8
9					9
10					10
11					11
12					12

18-15-01/18/73		
AUXILIARY FEEDWATER (FW)		
P & ID		
JOB NO.	DRAWING NO.	REV.
33013-1237	33013-1237	1
CCD OF CONTROL COPY		

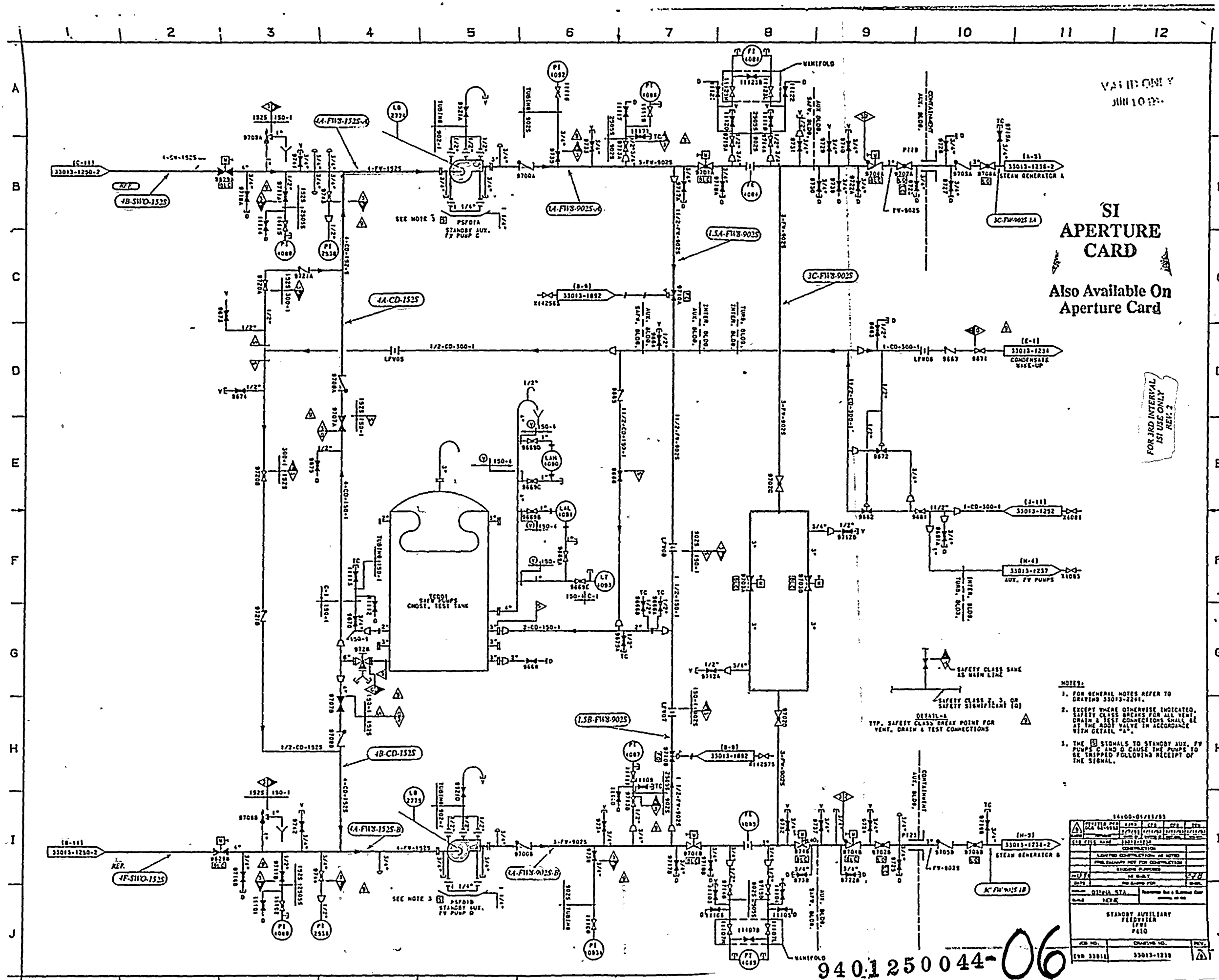

VERSION 4
JUN 1978

**SI
APERTURE
CARD**
Also Available On
Aperture Card

FOR 3RD INTERVAL
SI USE ONLY
REV. 2

- NOTES:**
- FOR GENERAL NOTES REFER TO DRAWING 33013-2261.
 - EXCEPT WHERE OTHERWISE INDICATED, SAFETY CLASS BREAKS FOR ALL VENT, DRAIN & TEST CONNECTIONS SHALL BE AT THE ROOT VALVE IN ACCORDANCE WITH DETAIL "A".
 - THE \square SIGNALS TO STANDBY AUX. FW PUMPS C AND D CAUSE THE PUMPS TO BE TRIPPED FOLLOWING RECEIPT OF THE SIGNAL.

SAFETY CLASS SAME AS MAIN LINE
SAFETY CLASS 2, 3, OR SAFETY SIGNIFICANT (S)
DETAIL "A"
TYP. SAFETY CLASS BREAK POINT FOR VENT, DRAIN & TEST CONNECTIONS

14-00-01/11/93				
DESIGNED BY	CHKD BY	APP'D BY	DATE	REV.
33013-1228-2				
CONSTRUCTION				
LIMITED COMPLETION AS NOTED				
FINAL SIGNATURE NOT FOR CONSTRUCTION				
SIGNATURE & DATE				
DATE				
BY				
FOR				
STANDBY AUXILIARY FEEDWATER (SAFW) P&ID				
REV. NO.	CHANGING NO.	REV.		
EVN 33013	33013-1228			

9401250044-06

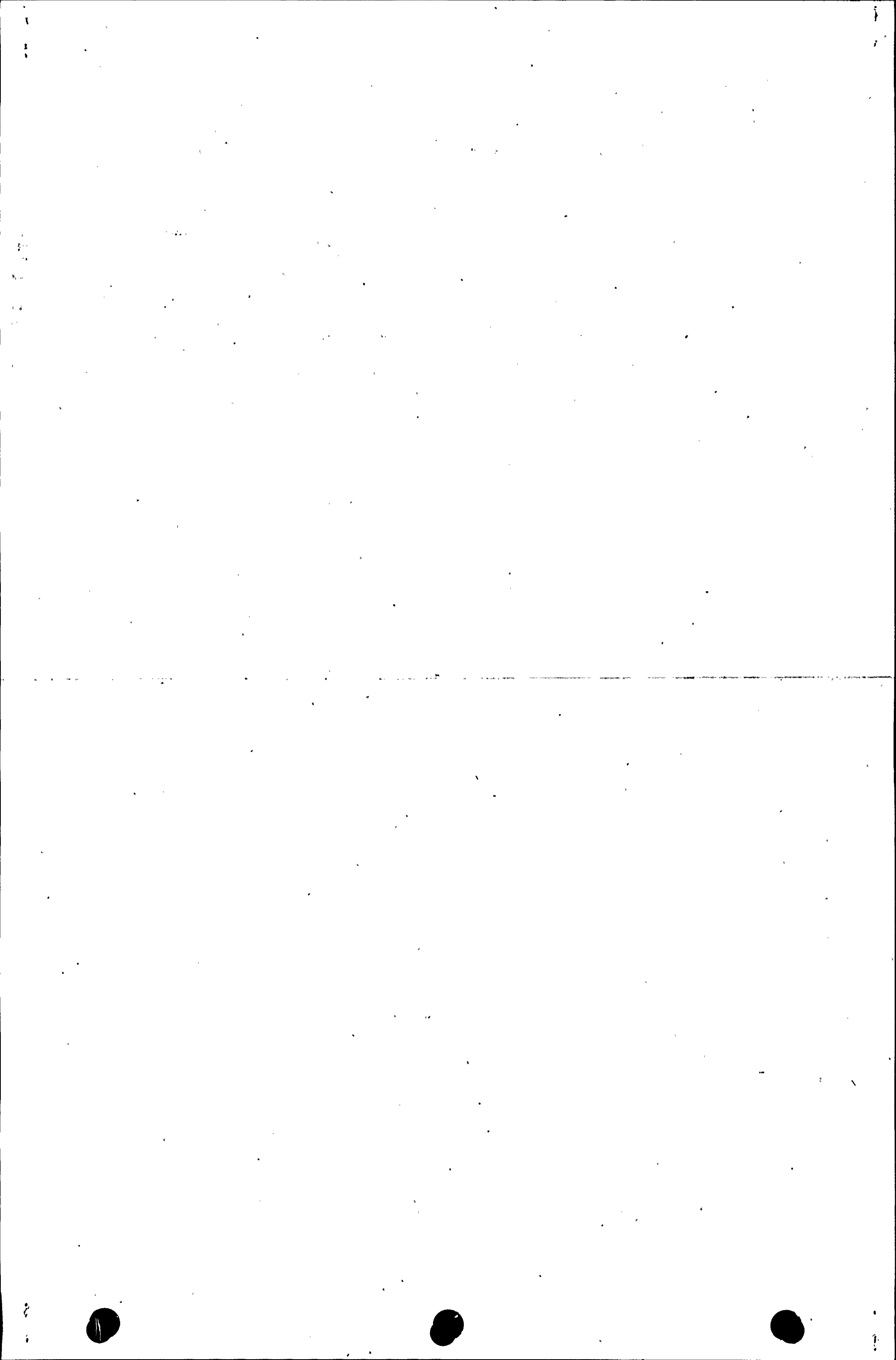

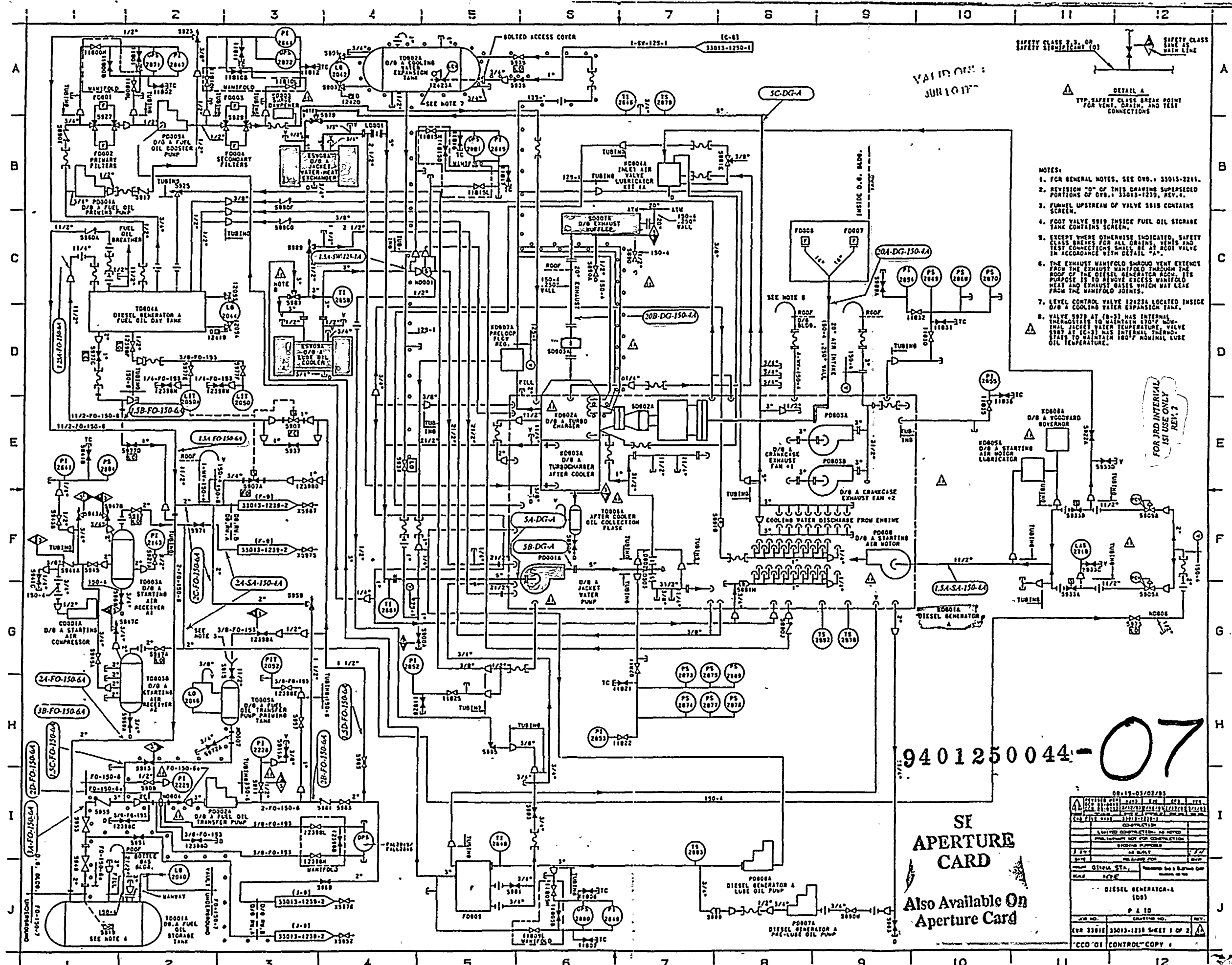

VALVING: JUN 10 1977

SAFETY CLASS 2, 3, OR SAFETY SIGNIFICANT (O)
DETAIL A
TYP. SAFETY CLASS BREAK POINT FOR VENT, DRAIN, AND TEST CONNECTIONS

- NOTES:
- 1. FOR GENERAL NOTES, SEE DWG. 33013-2230-1.
- 2. REVISION '06' OF THIS DRAWING SUPERSEDES PORTIONS OF DWG. 33013-2230-1, REV. 1.
- 3. FUNNEL UPSTREAM OF VALVE 5815 CONTAINS SCREEN.
- 4. FOOT VALVE 5818 INSIDE FUEL OIL STORAGE TANK CONTAINS SCREEN.
- 5. EXCEPT WHERE OTHERWISE INDICATED, SAFETY CLASS BREAKS FOR ALL DRAINS, VENTS AND TEST CONNECTIONS SHALL BE AT FOOT VALVE IN ACCORDANCE WITH DETAIL 'A'.
- 6. THE EXHAUST MANIFOLD SHOULD HAVE EXTENSE FACED THE EXHAUST MANIFOLD THROUGH THE ROOF OF THE DIESEL GENERATOR ROOM. ITS PURPOSE IS TO REMOVE EXCESS MANIFOLD HEAT AND EXHAUST GASES WHICH MAY LEAK FROM THE MANIFOLD JOINTS.
- 7. LEVEL CONTROL VALVE 12423A LOCATED INSIDE D/B A COOLING WATER EXPANSION TANK.
- 8. VALVE 5828 AT (E-3) HAS INTERNAL THERMOSTAT TO MAINTAIN 150°F MINIMUM SETPOINT WATER TEMPERATURE. VALVE 5827 AT (E-3) HAS INTERNAL THERMOSTAT TO MAINTAIN 100°F NOMINAL LUBE OIL TEMPERATURE.

FOR 3RD INTERVAL TEST USE ONLY REV. 3

9401250044-07

SI APERTURE CARD
Also Available On Aperture Card

33013-2230-1	
REV. 1	1977
REV. 2	1977
REV. 3	1977
REV. 4	1977
REV. 5	1977
REV. 6	1977
REV. 7	1977
REV. 8	1977
REV. 9	1977
REV. 10	1977
REV. 11	1977
REV. 12	1977
REV. 13	1977
REV. 14	1977
REV. 15	1977
REV. 16	1977
REV. 17	1977
REV. 18	1977
REV. 19	1977
REV. 20	1977
REV. 21	1977
REV. 22	1977
REV. 23	1977
REV. 24	1977
REV. 25	1977
REV. 26	1977
REV. 27	1977
REV. 28	1977
REV. 29	1977
REV. 30	1977
REV. 31	1977
REV. 32	1977
REV. 33	1977
REV. 34	1977
REV. 35	1977
REV. 36	1977
REV. 37	1977
REV. 38	1977
REV. 39	1977
REV. 40	1977
REV. 41	1977
REV. 42	1977
REV. 43	1977
REV. 44	1977
REV. 45	1977
REV. 46	1977
REV. 47	1977
REV. 48	1977
REV. 49	1977
REV. 50	1977
REV. 51	1977
REV. 52	1977
REV. 53	1977
REV. 54	1977
REV. 55	1977
REV. 56	1977
REV. 57	1977
REV. 58	1977
REV. 59	1977
REV. 60	1977
REV. 61	1977
REV. 62	1977
REV. 63	1977
REV. 64	1977
REV. 65	1977
REV. 66	1977
REV. 67	1977
REV. 68	1977
REV. 69	1977
REV. 70	1977
REV. 71	1977
REV. 72	1977
REV. 73	1977
REV. 74	1977
REV. 75	1977
REV. 76	1977
REV. 77	1977
REV. 78	1977
REV. 79	1977
REV. 80	1977
REV. 81	1977
REV. 82	1977
REV. 83	1977
REV. 84	1977
REV. 85	1977
REV. 86	1977
REV. 87	1977
REV. 88	1977
REV. 89	1977
REV. 90	1977
REV. 91	1977
REV. 92	1977
REV. 93	1977
REV. 94	1977
REV. 95	1977
REV. 96	1977
REV. 97	1977
REV. 98	1977
REV. 99	1977
REV. 100	1977

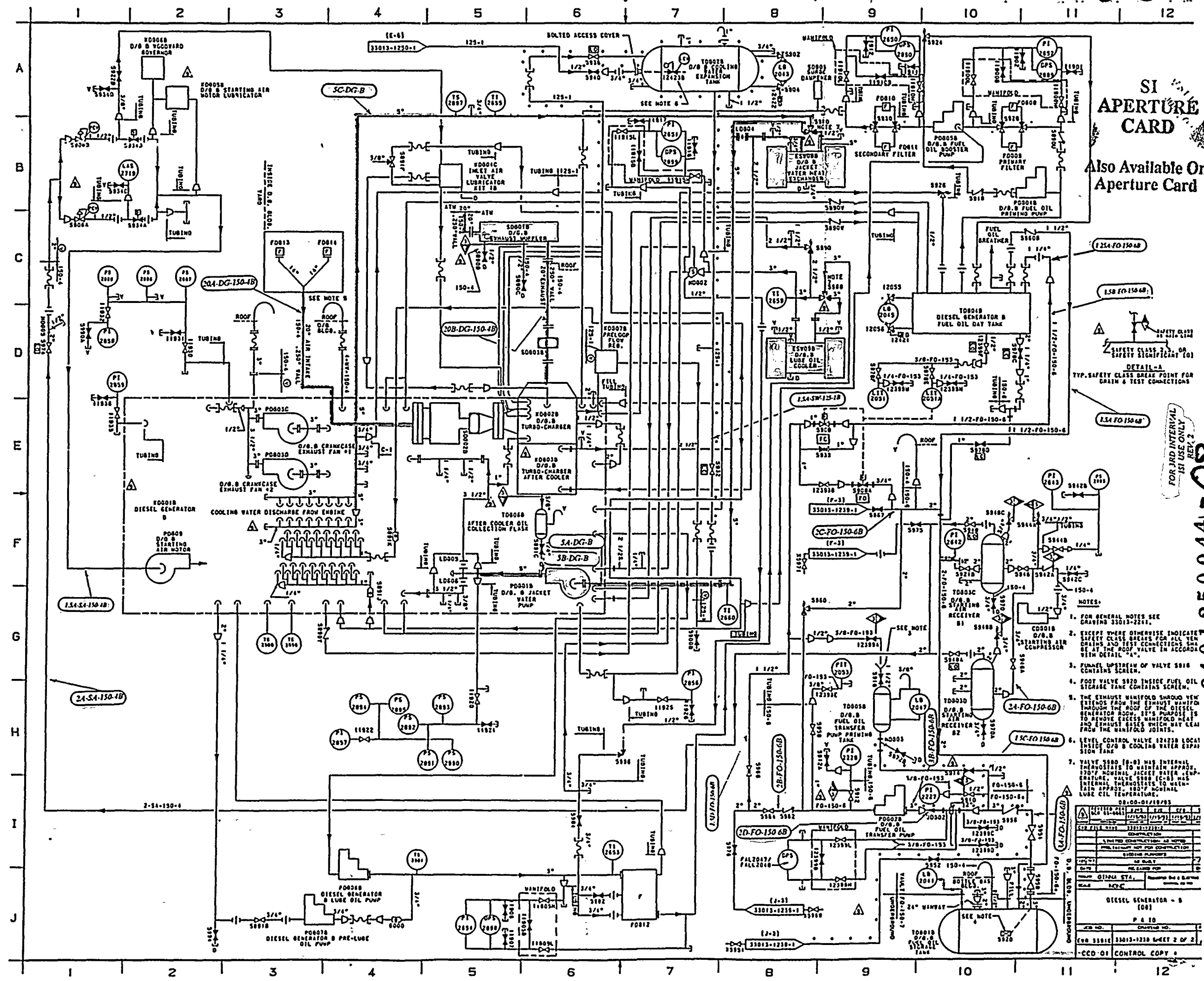

SI APERTURE CARD

Also Available On Aperture Card

SAFETY CLASS 2 OR SAFETY SIGNIFICANT (S) DETAIL - A TYP. SAFETY CLASS BREAK POINT FOR DRAIN & TEST CONNECTIONS

FOR JRD INTERVAL USE ONLY REV. 2

- NOTES:
1. FOR GENERAL NOTES SEE DRAWING 33013-2211.
 2. EXCEPT WHERE OTHERWISE INDICATED SAFETY CLASS BREAKS FOR ALL VENT DRAINS AND TEST CONNECTIONS SHALL BE AT THE ROOF VALVE IN ACCORDANCE WITH DETAIL "A".
 3. FUNNEL UPSTREAM OF VALVE 5818 CONTAINS SCREEN.
 4. ROOF VALVE 5820 INSIDE FUEL OIL STORAGE TANK CONTAINS SCREEN.
 5. THE EXHAUST MANIFOLD SURROUND VENT FITTINGS FROM THE EXHAUST MANIFOLD THROUGH THE ROOF OF THE DIESEL GENERATOR ROOM. ITS PURPOSE IS TO REMOVE EXCESS MANIFOLD HEAT AND EXHAUST GASES WHICH MAY LEAK FROM THE MANIFOLD JOINTS.
 6. LEVEL CONTROL VALVE 12238 LOCAL INSIDE D/O B COOLING WATER ESPAI SIDE TANK.
 7. VALVE 5880 (E-8) HAS INTERNAL THERMOSTATS TO MAINTAIN APPROX. 120°F NOMINAL JACKET WATER. EXHAUST VALVE 5818 (E-8) HAS INTERNAL THERMOSTATS TO MAINTAIN APPROX. 120°F NOMINAL JACKET WATER TEMPERATURE.

REV.	DATE	BY	CHKD.	DESCRIPTION
1	08-00-01/18/75			ISSUED FOR CONSTRUCTION
2				REVISION
3				REVISION
4				REVISION
5				REVISION
6				REVISION
7				REVISION
8				REVISION
9				REVISION
10				REVISION
11				REVISION
12				REVISION

08-00-01/18/75
 DIESEL GENERATOR - B (08)
 P & ID NO.
 JOB NO. 33013-2210 SHEET 2 OF 2
 CONSTRUCTION 33013-2210-2
 CONTROL COPY

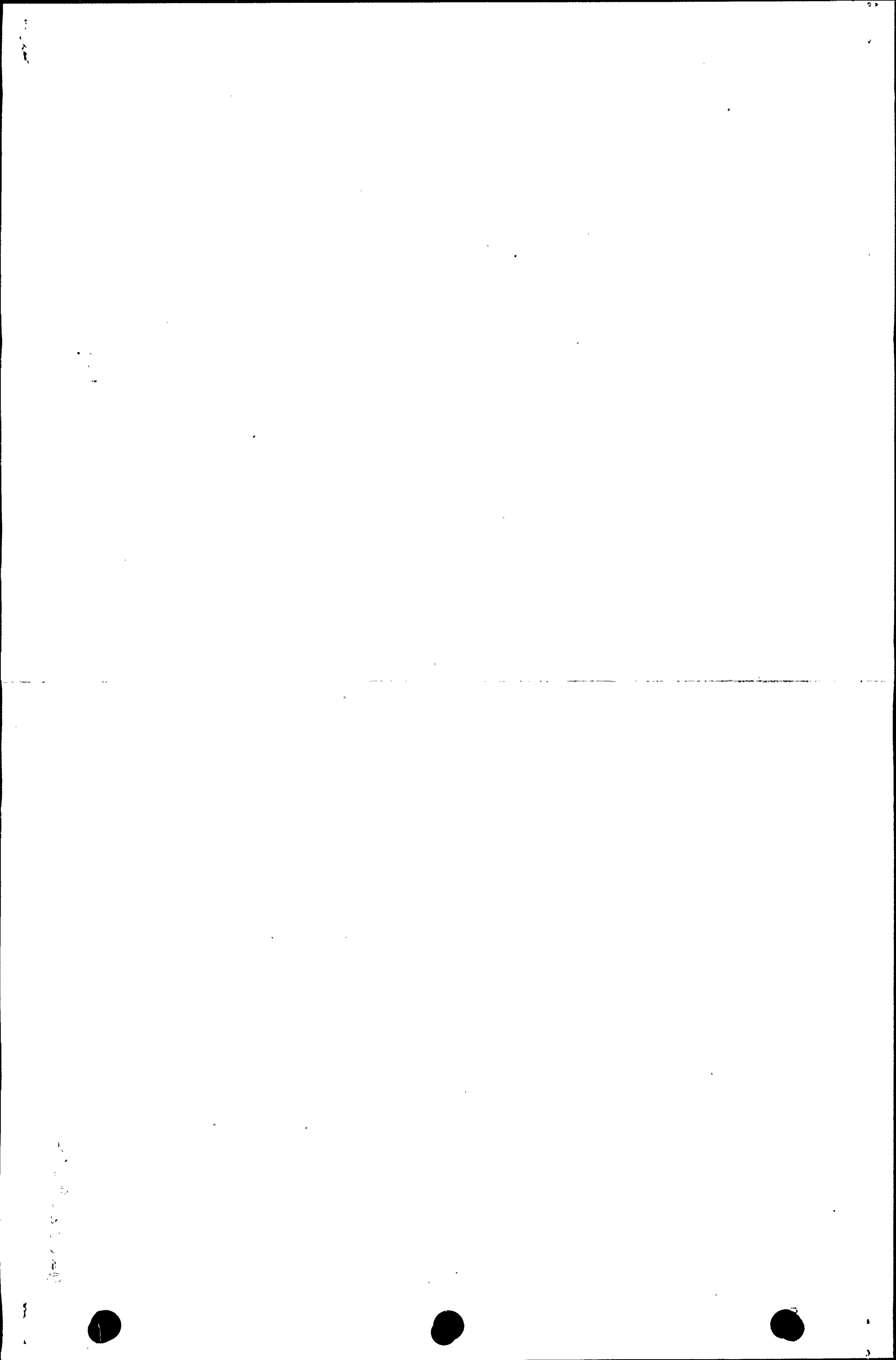

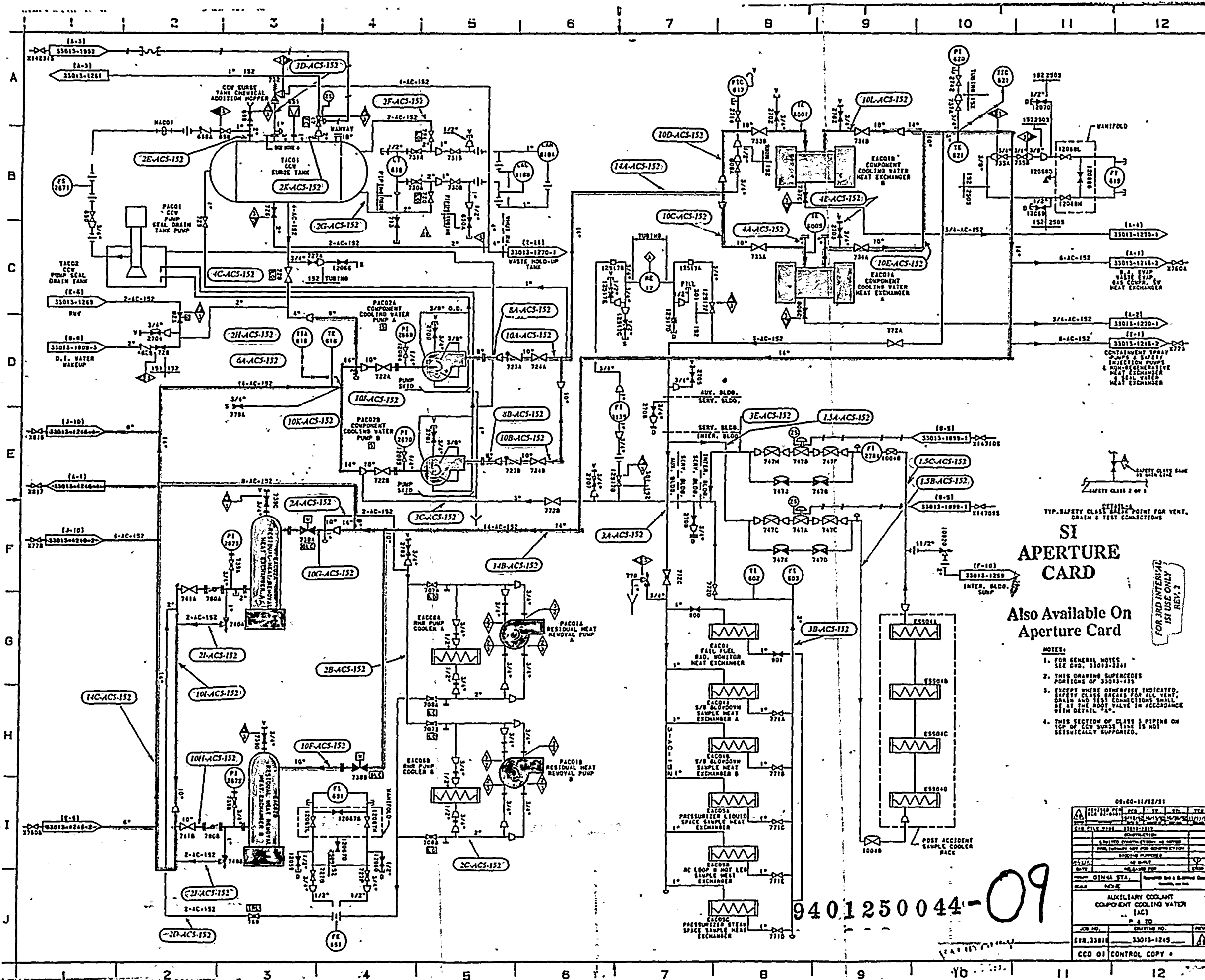

**SI
APERTURE
CARD**

Also Available On
Aperture Card

- NOTES:
1. FOR GENERAL NOTES SEE DTD. 33013-3241
 2. THIS DRAWING SUPERCEDES PORTIONS OF 33013-435
 3. EXCEPT WHERE OTHERWISE INDICATED, SAFETY CLASS BREAKS FOR ALL VENT, DRAIN AND TEST CONNECTIONS SHALL BE AT THE ROOT VALVE IN ACCORDANCE WITH DETAIL "A".
 4. THIS SECTION OF CLASS 3 PIPING ON TOP OF CCV SURGE TANK IS NOT SEISMICALLY SUPPORTED.

09-00-11/12/81			
REV.	DATE	BY	CHK.
1	01/11/81
2
3
4
5
6
7
8
9
10
11
12

AUXILIARY COOLANT
COMPONENT COOLING WATER
.. (AC)
4 TO

JOB NO. DRAWING NO. REV.
EVR.33013 33013-1215

CCD OF CONTROL COPY

9401250044-09

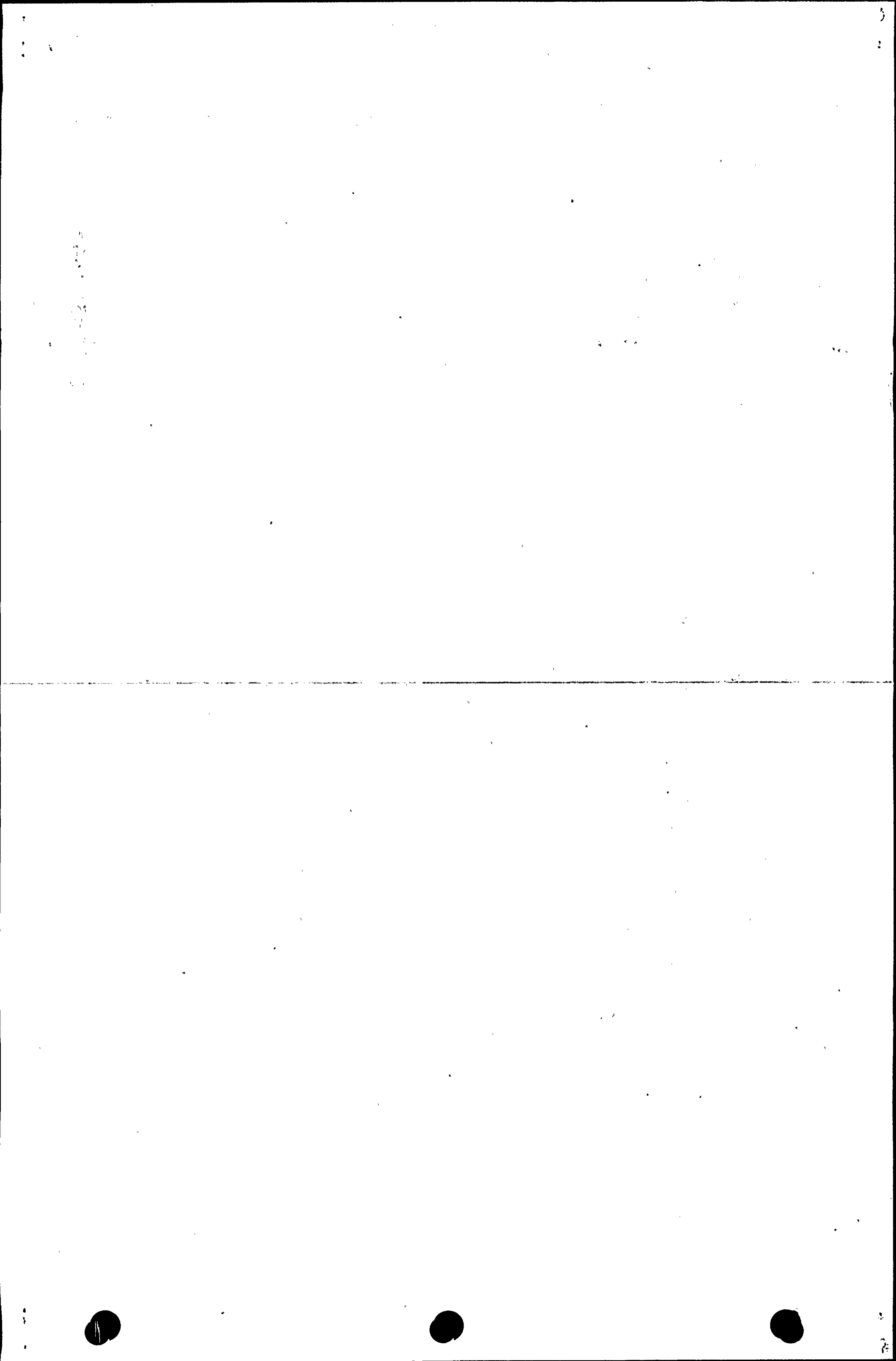

APERTURE CARD

Also Available On Aperture Card

9401250044-10

- NOTES:
1. FOR GENERAL NOTES REFER TO DRAWING 33013-2211
 2. REVISION "0" OF THIS DRAWING SUPERSEDES PORTIONS OF 33013-1218 REV. 9.
 3. EXCEPT WHERE OTHERWISE INDICATED, SAFETY CLASS BREAKS FOR ALL VALVE, DRAIN AND TEST CONNECTIONS SHALL BE AT THE HOSE VALVE IN ACCORDANCE WITH DETAIL "A".
 4. EXCEPT WHERE OTHERWISE INDICATED, SAFETY CLASS FOR INSTRUMENT AIR AND HYDROGEN LINES AND COMPONENTS IS BASED ON UPSTREAM INSTRUMENT AIR/HYDROGEN VALVE. REFER TO INTERFACING HYDROGEN DRAWING FOR SAFETY CLASS.
 5. CHECK VALVE 743A INTERNALS PERMANENTLY REMOVED.
 6. RCP UPPER BEARING COOLERS ARE SUPPLIED WITH MOTORS. 50-150 PSI PRESSURE BOUNDARY IS NON-CLASS, TUBE SIDE CLASS IS THE SAME AS CONDENSER PIPING.
 7. COMPONENT COOLING WATER FOR MOTORS, CLASS 1 AND EXTENS THROUGHOUT CLOSED COOLING COIL.
 8. COMPONENT COOLING WATER FOR PUMPS, COOLING COIL AND THERMAL BARRIER ARE CLASS 1. CLASS BREAK FROM CLASS 1 TO CLASS 2 OCCURS AT CCW PIPE INTERFACE WITH COOLING COIL.

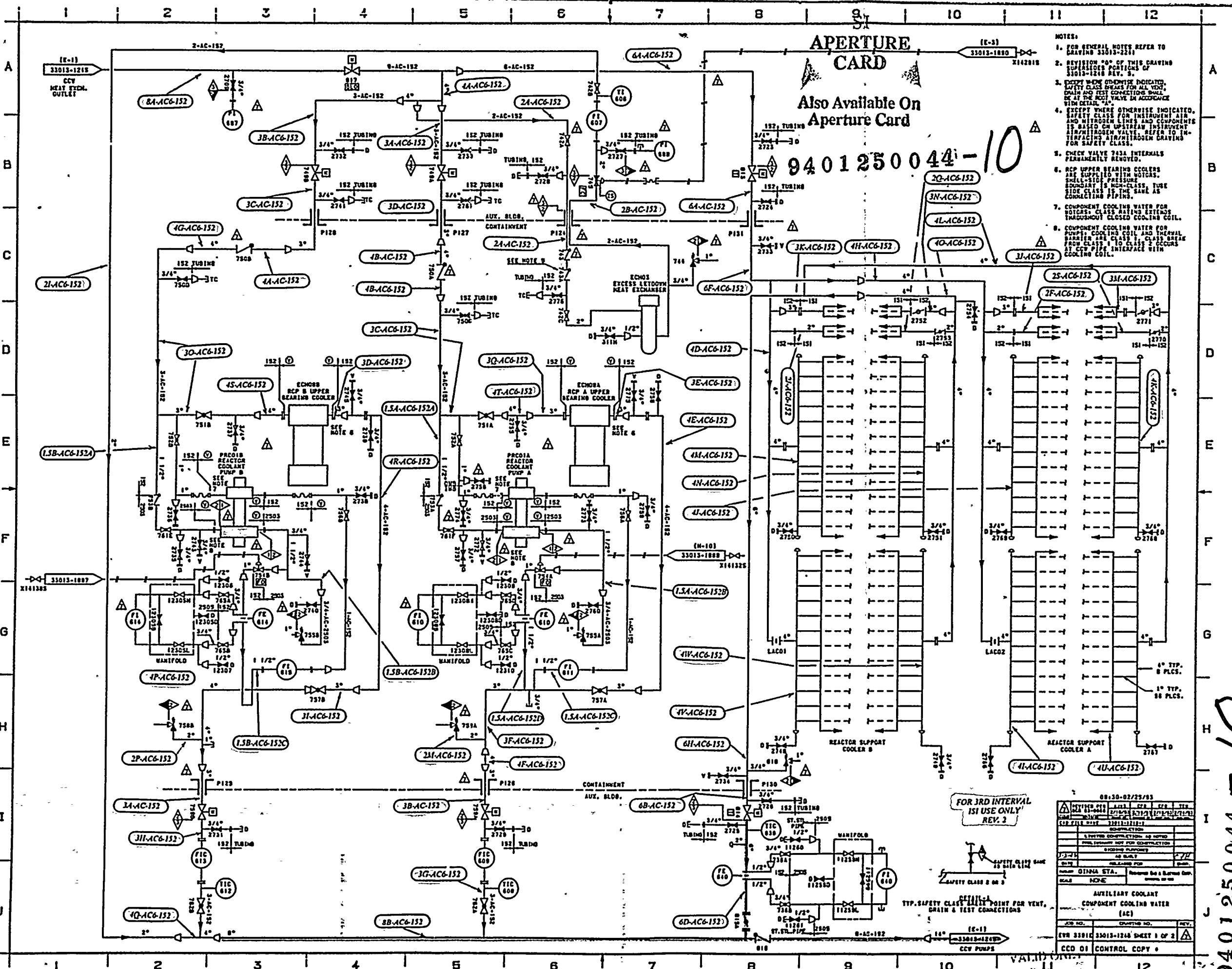

08-30-02/25/83

SYMBOL	QTY	UNIT	DATE	BY	CHKD
APERTURE CARD	1	PLCS.	08-30-02	[Signature]	[Signature]
REACTOR SUPPORT COOLER A	1	PLCS.	08-30-02	[Signature]	[Signature]
REACTOR SUPPORT COOLER B	1	PLCS.	08-30-02	[Signature]	[Signature]
COMPONENT COOLING WATER (CCW) PUMPS	1	PLCS.	08-30-02	[Signature]	[Signature]

APERTURE CARD
COMPONENT COOLING WATER (CCW) PUMPS

REV	NO.	DATE	DESCRIPTION
01	01	08-30-02	ISSUED FOR CONSTRUCTION
02	01	08-30-02	REVISED FOR CONSTRUCTION

APERTURE CARD
COMPONENT COOLING WATER (CCW) PUMPS
SHEET 1 OF 2
CCW CONTROL COPY

9401250044-10

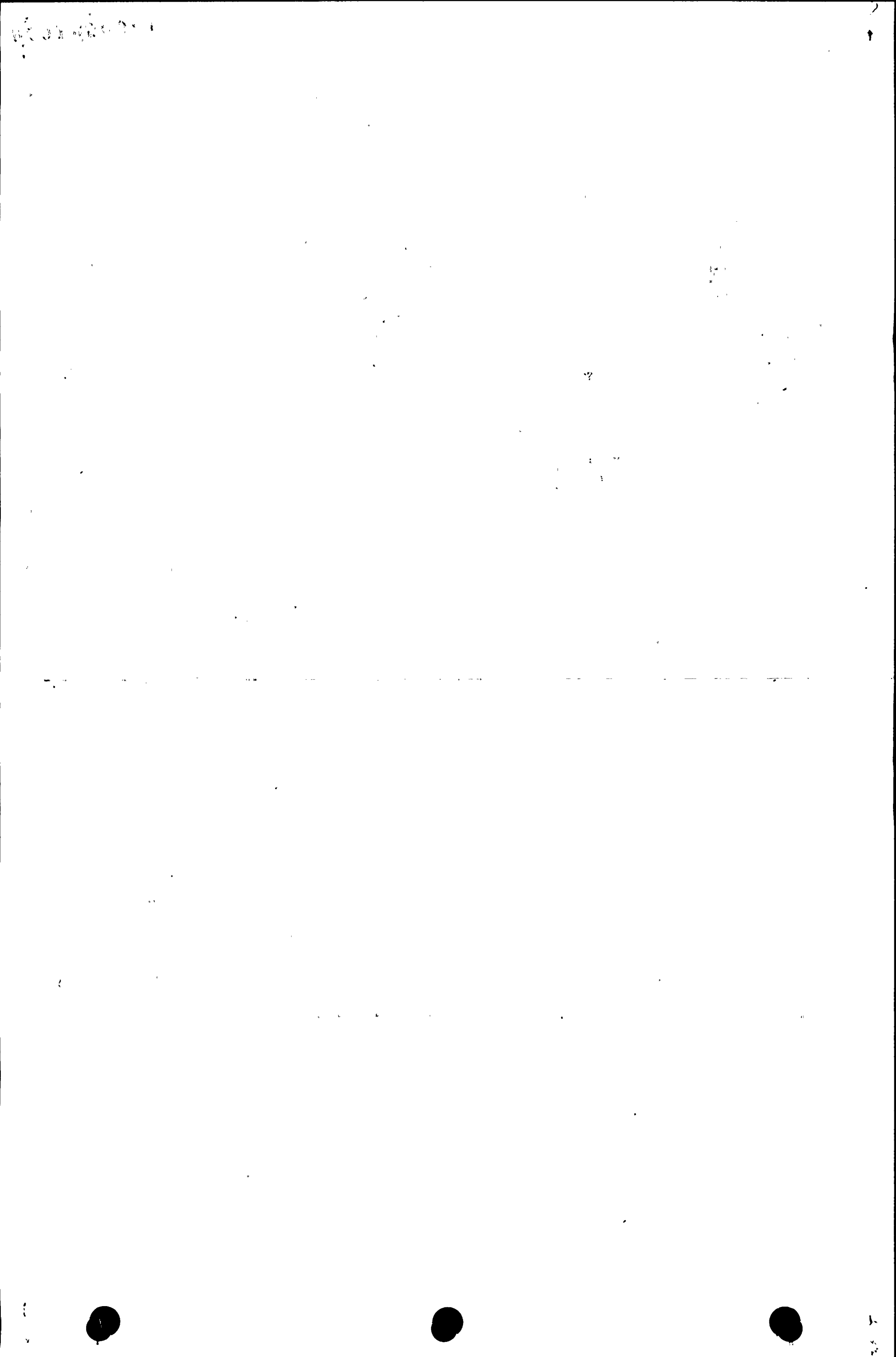

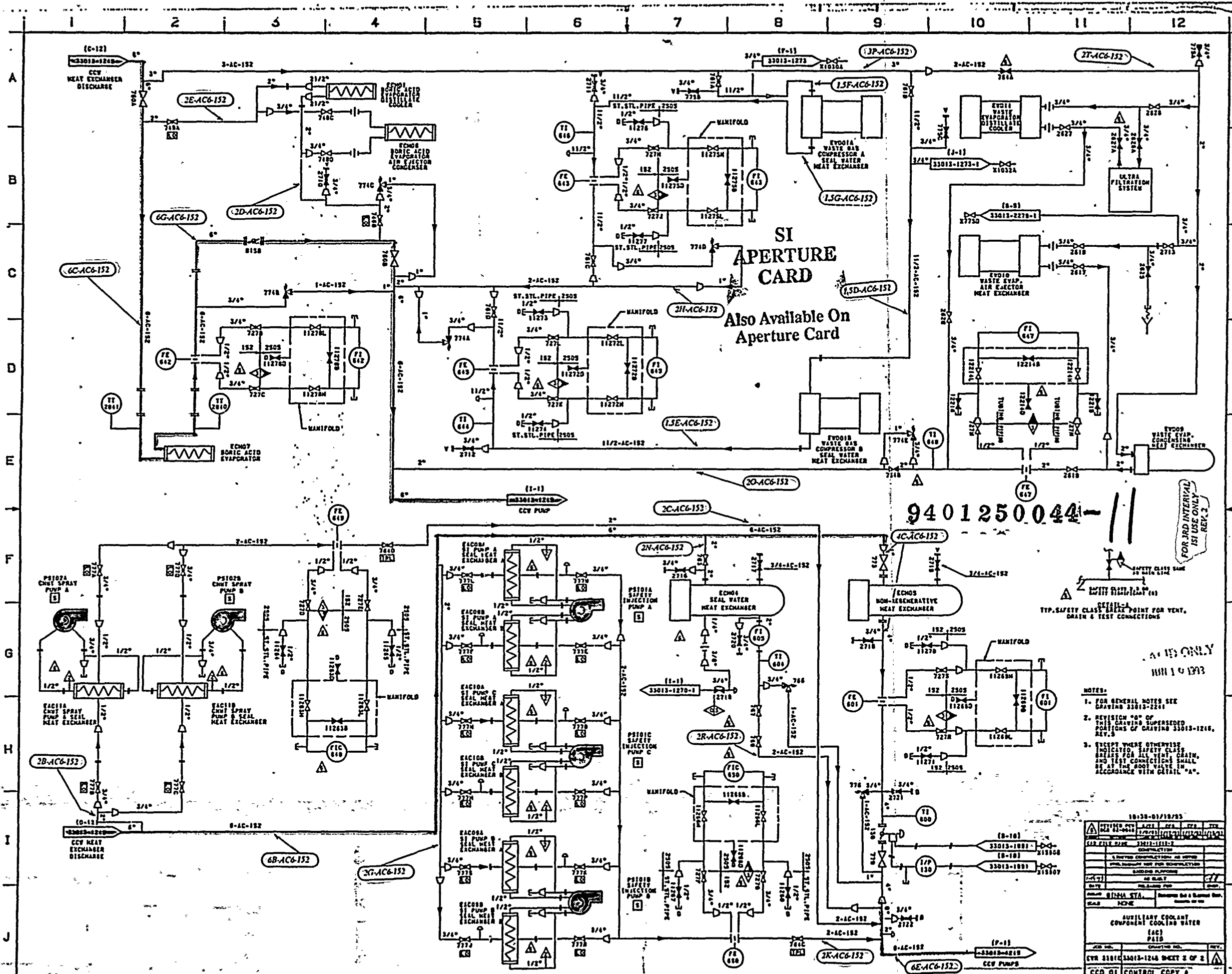

SI APERTURE CARD
Also Available On Aperture Card

9401250044-11

SAFETY CLASS 101
TYP. SAFETY CLASS 101 POINT FOR VENT, DRAIN & TEST CONNECTIONS

- NOTES:
1. FOR GENERAL NOTES SEE DRAWING 33013-2201
 2. REVISION 000 OF THIS DRAWING SUPERSEDES PORTIONS OF DRAWING 33013-1216, REV. 3
 3. EXCEPT WHERE OTHERWISE INDICATED, SAFETY CLASS 101 SHALL BE USED FOR ALL VENT, DRAIN, AND TEST CONNECTIONS SHALL BE AS SHOWN IN THIS DRAWING IN ACCORDANCE WITH DETAIL "A".

REV.	DATE	BY	CHKD.	APP'D.	DESCRIPTION
001	10/18/73				ISSUED FOR CONSTRUCTION
002	11/15/73				REVISION 000 OF THIS DRAWING SUPERSEDES PORTIONS OF DRAWING 33013-1216, REV. 3
003	11/15/73				REVISION 000 OF THIS DRAWING SUPERSEDES PORTIONS OF DRAWING 33013-1216, REV. 3
004	11/15/73				REVISION 000 OF THIS DRAWING SUPERSEDES PORTIONS OF DRAWING 33013-1216, REV. 3
005	11/15/73				REVISION 000 OF THIS DRAWING SUPERSEDES PORTIONS OF DRAWING 33013-1216, REV. 3
006	11/15/73				REVISION 000 OF THIS DRAWING SUPERSEDES PORTIONS OF DRAWING 33013-1216, REV. 3
007	11/15/73				REVISION 000 OF THIS DRAWING SUPERSEDES PORTIONS OF DRAWING 33013-1216, REV. 3
008	11/15/73				REVISION 000 OF THIS DRAWING SUPERSEDES PORTIONS OF DRAWING 33013-1216, REV. 3
009	11/15/73				REVISION 000 OF THIS DRAWING SUPERSEDES PORTIONS OF DRAWING 33013-1216, REV. 3
010	11/15/73				REVISION 000 OF THIS DRAWING SUPERSEDES PORTIONS OF DRAWING 33013-1216, REV. 3

10/18-01/10/73
10/18-01/10/73
10/18-01/10/73
10/18-01/10/73
10/18-01/10/73
10/18-01/10/73
10/18-01/10/73
10/18-01/10/73
10/18-01/10/73
10/18-01/10/73

AUXILIARY COOLANT COMPONENT COOLING WATER (AC) P&ID

REV 33013-1216-1246 SHEET 2 OF 2
CCO OF CONTROL COPY 6

9401250044-11

1901

1901

1901



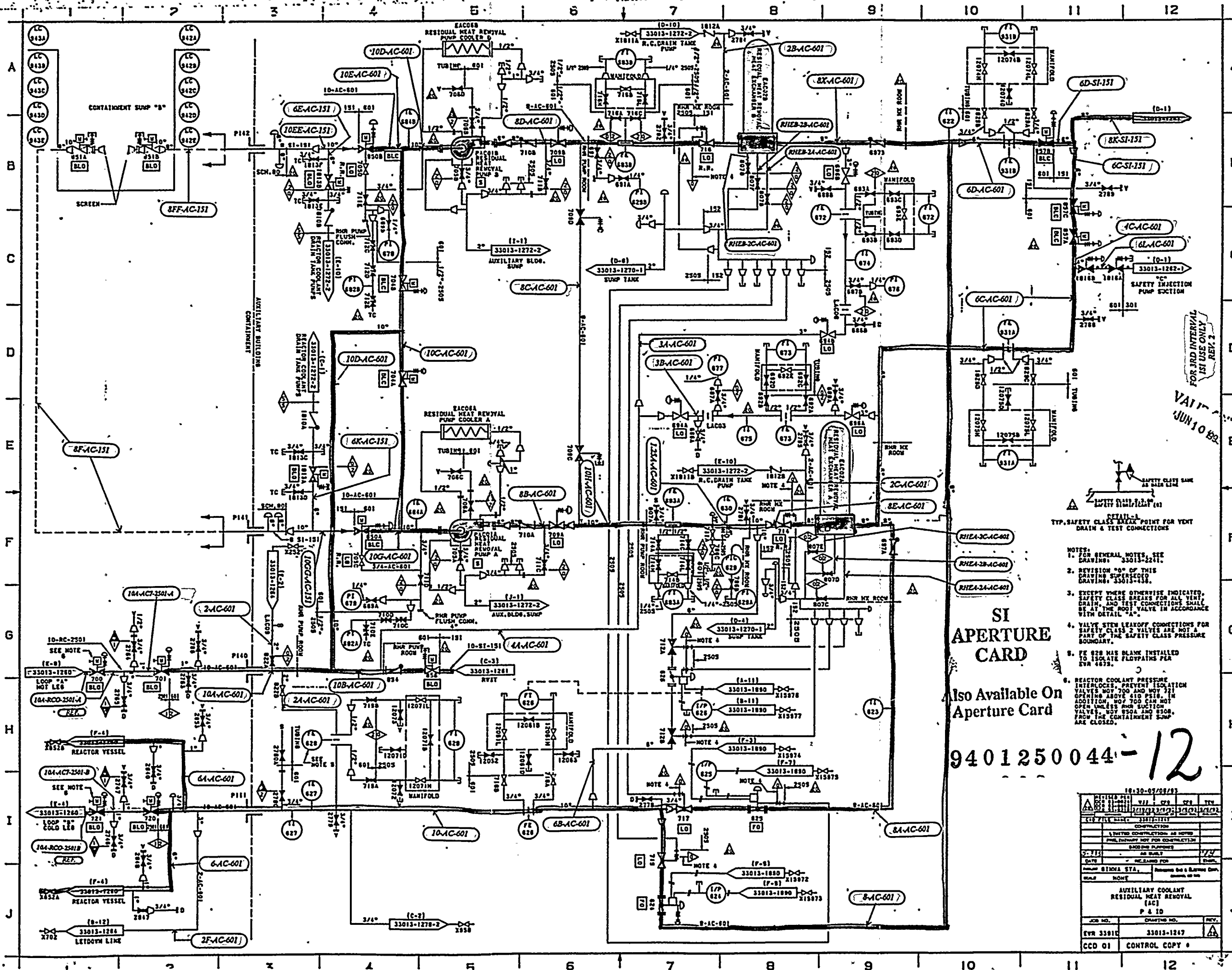

- NOTES:
- FOR GENERAL NOTES, SEE DRAWING 33013-1271.
 - REVISION "B" OF THIS DRAWING SUPERSEDES DRAWING 33013-1272.
 - EXCEPT WHERE OTHERWISE INDICATED, SAFETY CLASS BREAKS FOR ALL VENT, DRAIN, AND TEST CONNECTIONS SHALL BE AT THE ROOF VALVE IN ACCORDANCE WITH DETAIL "A".
 - VALVE STEM LEAKOFF CONNECTIONS FOR SAFETY CLASS 2 VALVES ARE NOT A PART OF THE SAFETY CLASS PRESSURE BOUNDARY.
 - FE 828 WAS BLANK INSTALLED TO ISOLATE FLOPPATHS PIA EVR 4872.
 - REACTOR COOLANT PRESSURE INTERLOCKS, PREVENT ISOLATION VALVES 700 AND 800 FROM OPENING ABOVE 410 PSIG. IN ADDITION, 800 CAN NOT OPEN UNLESS ROOF SUCTION VALVES, 800A AND 800B, FROM THE CONTAINMENT SUMP ARE CLOSED.

SI APERTURE CARD
 Also Available On Aperture Card

9401250044-12

REV	DATE	BY	CHKD	APP'D
1	10/10/88
2
3
4
5
6
7
8
9
10
11
12

18130-87/08/83

AUXILIARY COOLANT RESIDUAL HEAT REMOVAL (ACR) P & ID

JOB NO. DRAWING NO. REV.

EVR 33013 33013-1267

CCD 01 CONTROL COPY 6

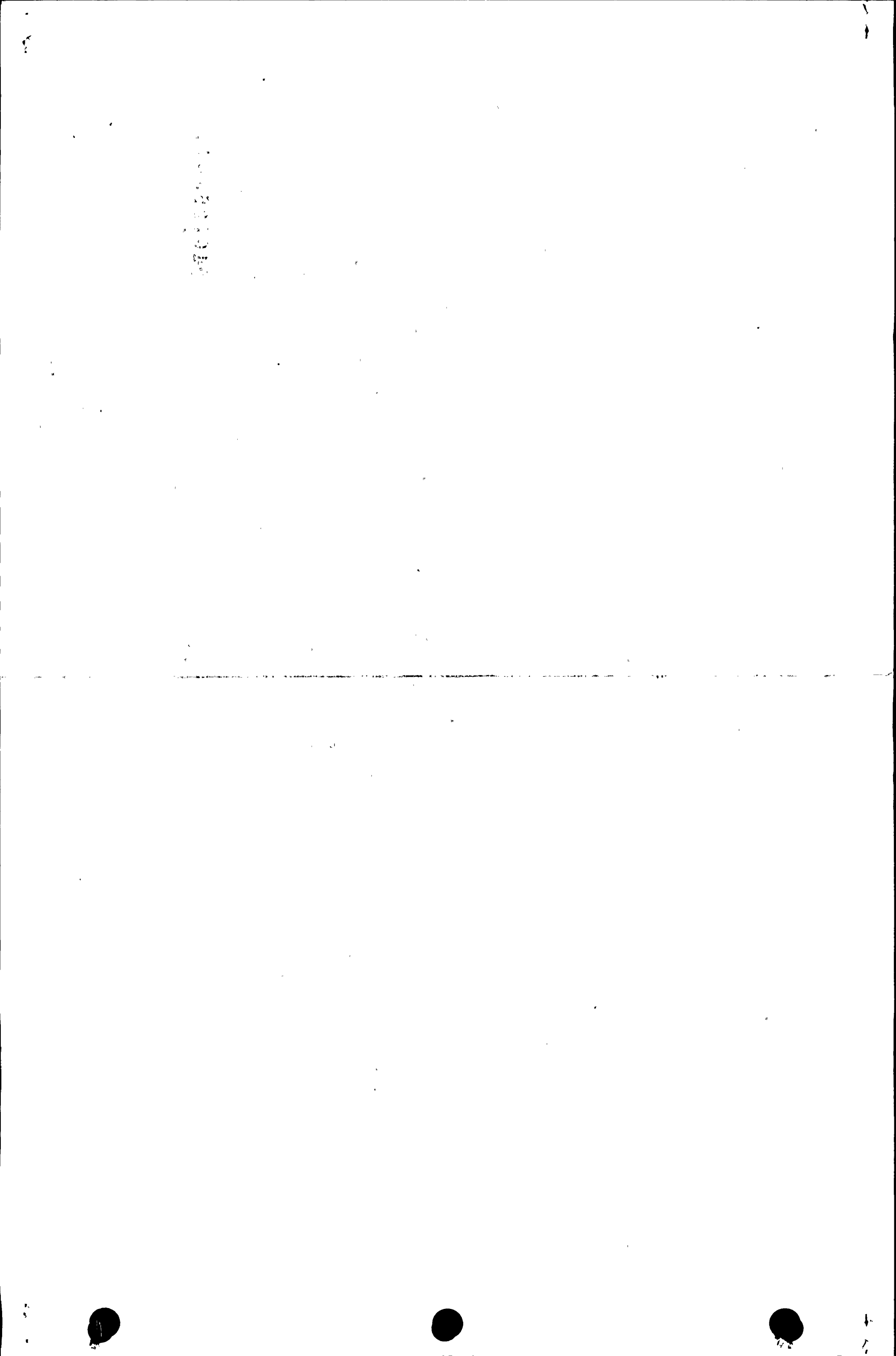

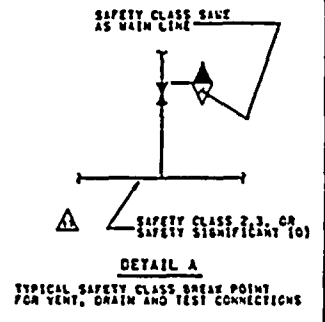
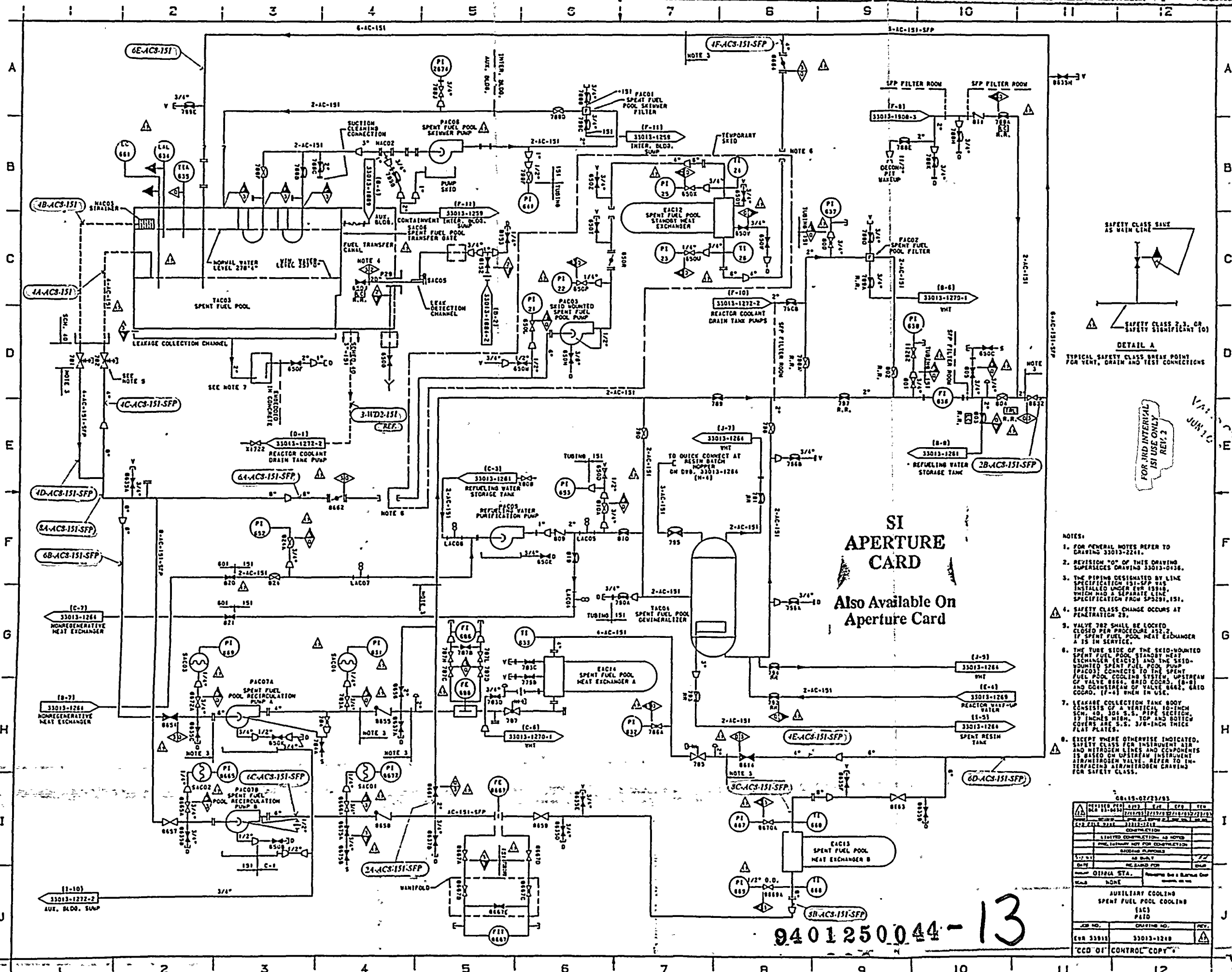

- NOTES:
- FOR GENERAL NOTES REFER TO DRAWING 33013-2218.
 - REVISION 20 OF THIS DRAWING, SUPERSEDES DRAWING 33013-238.
 - THE PIPING DESIGNATED BY LINE SPECIFICATION 151-SFP IS INSTALLED UNDER EFR 1514B, WHICH HAS A SEPARATE LINE SPECIFICATION FROM SP5151, 151.
 - SAFETY CLASS CHANGE OCCURS AT PENETRATION 25.
 - VALVE 782 SHALL BE LOCKED CLOSED PER PROCEDURE 152.2 IF SPENT FUEL POOL HEAT EXCHANGER A IS IN SERVICE.
 - THE TUBE SIDE OF THE SEID-MOUNTED SPENT FUEL POOL STANDBY HEAT EXCHANGER (EAC12) AND THE SEID-MOUNTED SPENT FUEL POOL PUMP (PAC03) CONNECTS TO THE SPENT FUEL POOL COOLING SYSTEM UPSTREAM OF VALVE 864. SEID CODES: (8-8) AND DOWNSTREAM OF VALVE 864. SEID CODES: (7-6) WHEN IN USE.
 - LEAKAGE COLLECTION TANK BODY CONSISTS OF A VERTICAL 10-INCH SCH. 40, 304 S.S. PIPE SECTION, 17 INCHES HIGH. TOP AND BOTTOM COVERS ARE 8-S. 3/8-INCH THICK FLAT PLATES.
 - EXCEPT WHERE OTHERWISE INDICATED, SAFETY CLASS FOR INSTRUMENT AIR AND HYDROGEN LINES AND COMPONENTS IS BASED ON UPSTREAM INSTRUMENT AIR/NITROGEN VALVE. REFER TO INSTRUMENT AIR/NITROGEN DRAWING FOR SAFETY CLASS.

68-15-07/21/93			
REVISION	DATE	BY	CHK
12	01/15/93	12/15/93	12/15/93
EAC12 FUEL TANK			
LIMITED COMPLETION, AS NOTED			
PNE. INST. NOT FOR CONSTRUCTION			
DRAWING PURPOSES			
DATE	BY	CHK	APP
01/15/93	12/15/93	12/15/93	12/15/93
SCALE NONE			
AUXILIARY COOLING SPENT FUEL POOL COOLING (AC) P110			
JOB NO.	DRAWING NO.	REV.	
68-15-07	33013-1210	1	
"GOLD OI" CONTROL COPY			

9401250044-13

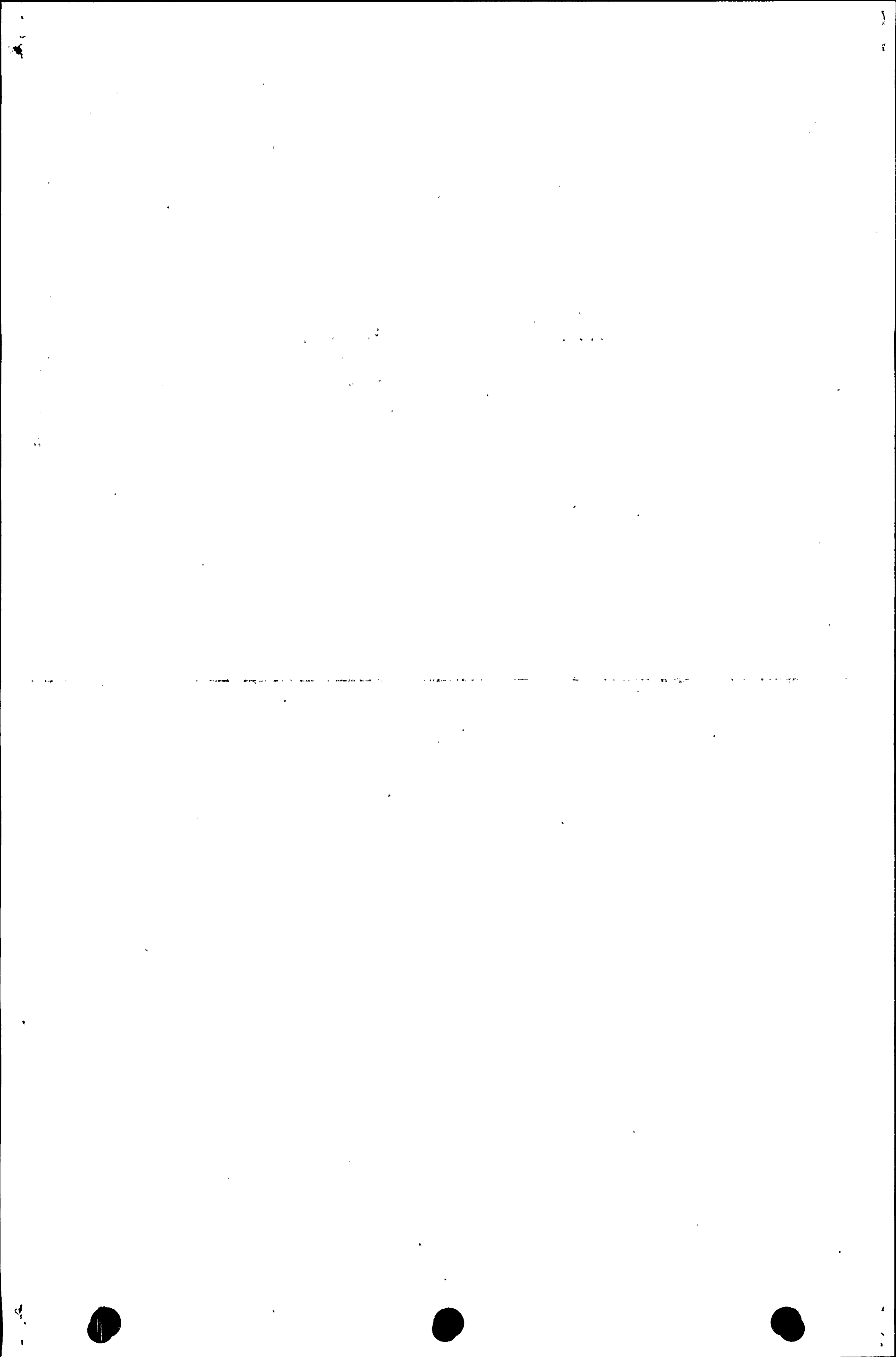

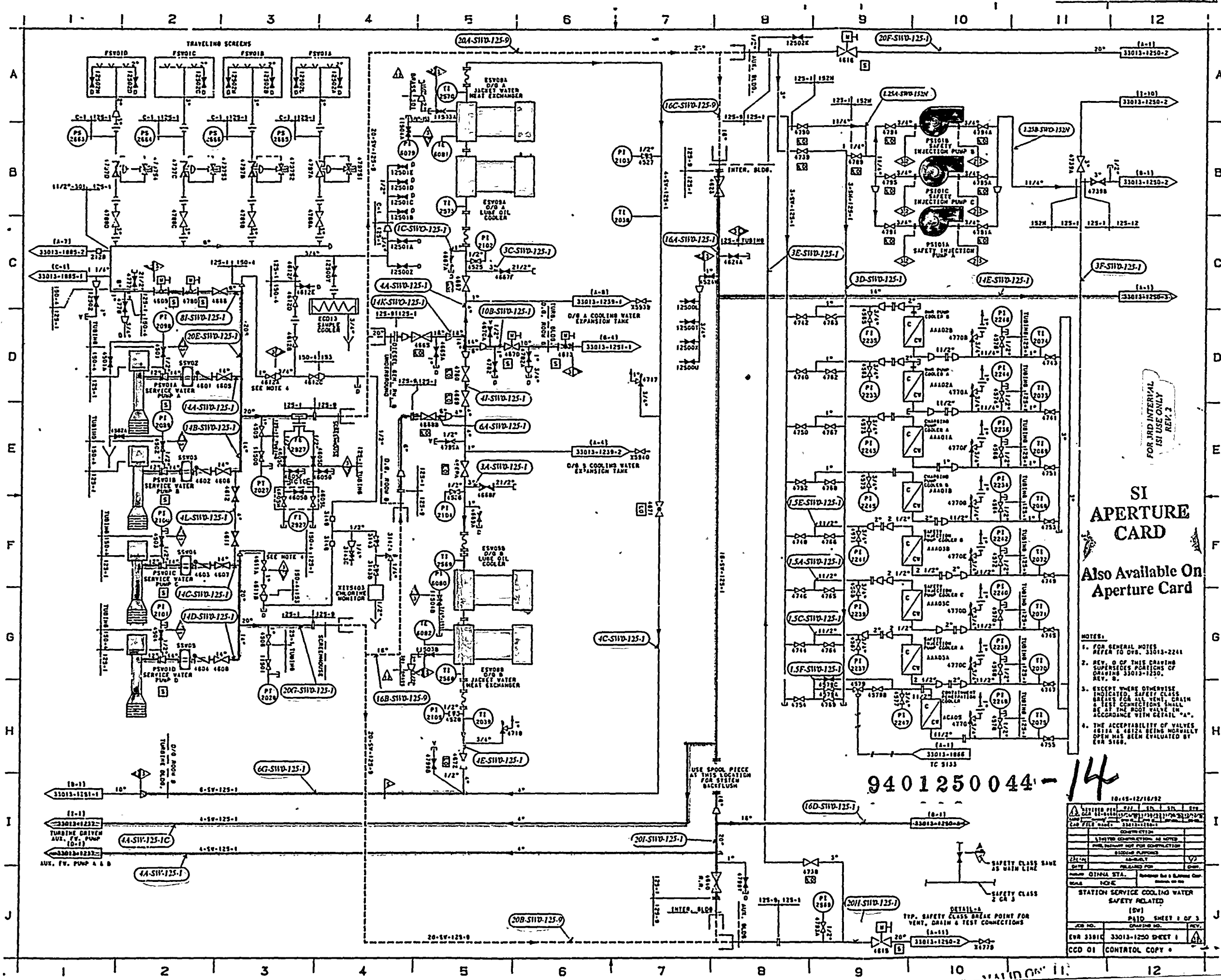

FOR 3RD INTERVAL
ISI USE ONLY
REV. 2

**SI
APERTURE
CARD**

Also Available On
Aperture Card

- NOTES:
- FOR GENERAL NOTES REFER TO DWS 33013-2241
 - REV. 0 OF THIS DRAWING SUPERSEDES PORTIONS OF DRAWING 33013-1250, REV. 0.
 - EXCEPT WHERE OTHERWISE INDICATED, SAFETY CLASS BASIS FOR ALL VENT, DRAIN & TEST CONNECTIONS SHALL BE THE BEST VALUE IN ACCORDANCE WITH DETAIL "A".
 - THE ACCEPTABILITY OF VALVES 4614 & 4612A BEING NORMALLY OPEN HAS BEEN EVALUATED BY ESR 5169.

9401250044-14

DATE	10/15-12/16/92
BY	...
CHECKED BY	...
DESIGNED BY	...
SCALE	AS SHOWN
STATION SERVICE COOLING WATER SAFETY RELATED (SW)	
PAID SHEET 1 OF 3	
CDR NO.	...
FOR 33013	33013-1250 SHEET 1
CCD 01	CONTROL COPY

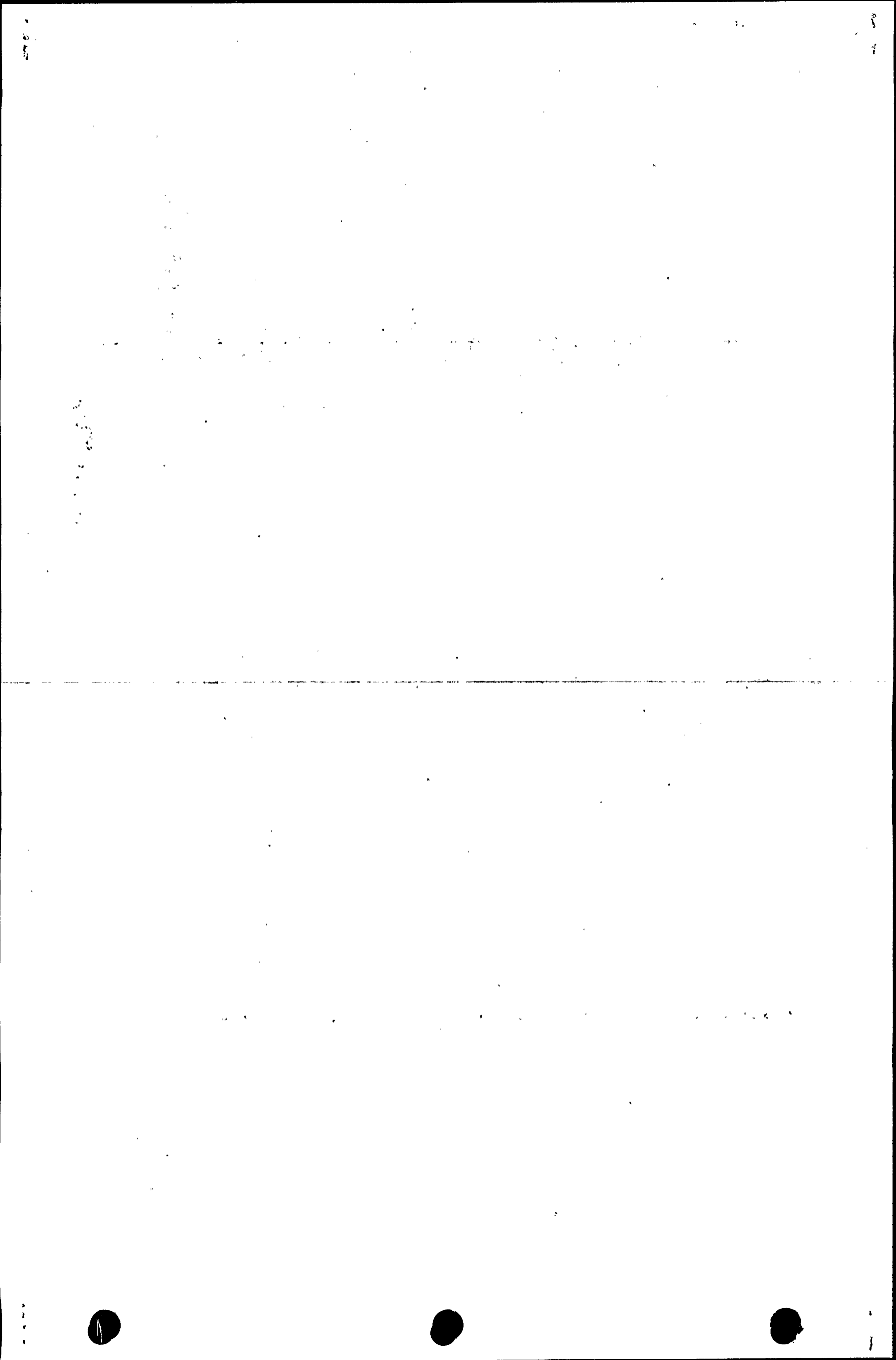

VALID ONLY
JUN 10 1973

SI
APERTURE
CARD

Also Available On
Aperture Card

FOR 3RD INTERVAL
ISI USE ONLY
REV. 2

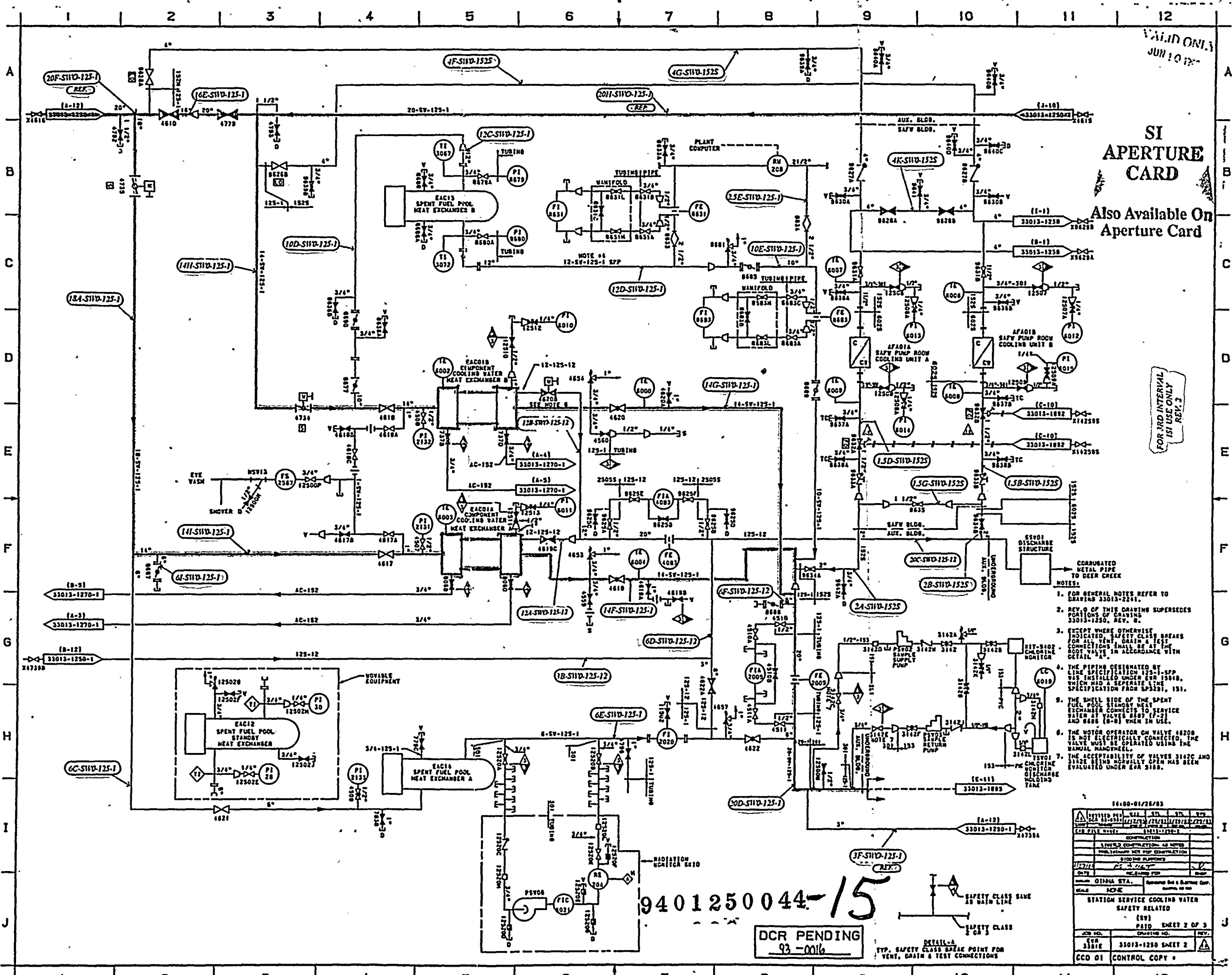

- NOTES:
1. FOR GENERAL NOTES REFER TO DRAWING 33013-2241.
 2. REV. 0 OF THIS DRAWING SUPERSEDES PORTIONS OF DRAWING 33013-1250, REV. 0.
 3. EXCEPT WHERE OTHERWISE INDICATED, SAFETY CLASS BREAKS FOR ALL VENT, DRAIN & TEST CONNECTIONS SHALL BE AT THE ROOT VALVE IN ACCORDANCE WITH DETAIL 'A'.
 4. THE PIPING DESIGNATED BY LINE SPECIFICATION 125-1 SFP WAS INSTALLED UNDER ESR 1581B, WHICH HAD A SEPARATE LINE SPECIFICATION FROM ESR 1581, 1591.
 5. THE SHELL SIDE OF THE SPENT FUEL POOL STANDBY HEAT EXCHANGER CONNECTS TO SERVICE MAIN AT Y-6-01 WHEN IN USE.
 6. THE MOTOR OPERATOR ON VALVE 4820B IS NOT ELECTRICALLY CONNECTED. THE VALVE MUST BE OPERATED USING THE MANUAL HANDWHEEL.
 7. THE ACCEPTABILITY OF VALVES 3147C AND 3122C BEING NORMALLY OPEN HAS BEEN EVALUATED UNDER ESR 3160.

9401250044-15

DCR PENDING
93-0016

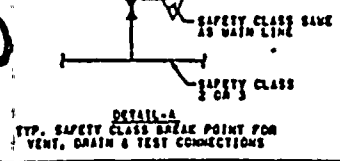

14-00-01/26/83

DESIGNER	DATE	BY	NO.
33013-1250-1	01/22/73	33013-1250-1	01
CHK'D BY	DATE	BY	NO.
33013-1250-1	01/22/73	33013-1250-1	01
DATE	BY	NO.	
01/22/73	33013-1250-1	01	
SCALE	NOTE	DATE	BY
STATION SERVICE COOLING WATER SAFETY RELATED			
SHEET 2 OF 3			
JOB NO.	DRAWING NO.	REV.	
33013	33013-1250 SHEET 2		
CCD 01 CONTROL COPY			

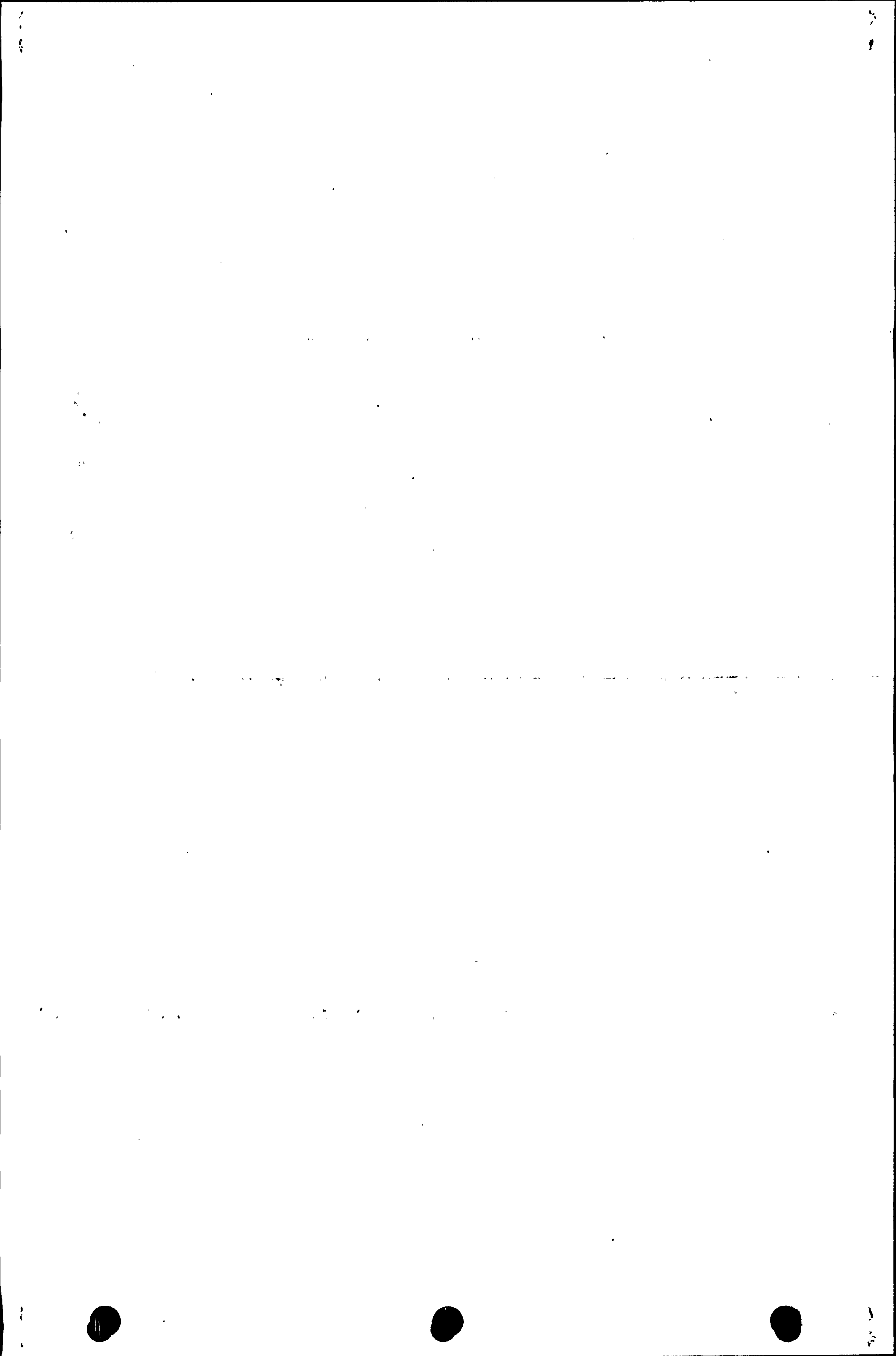

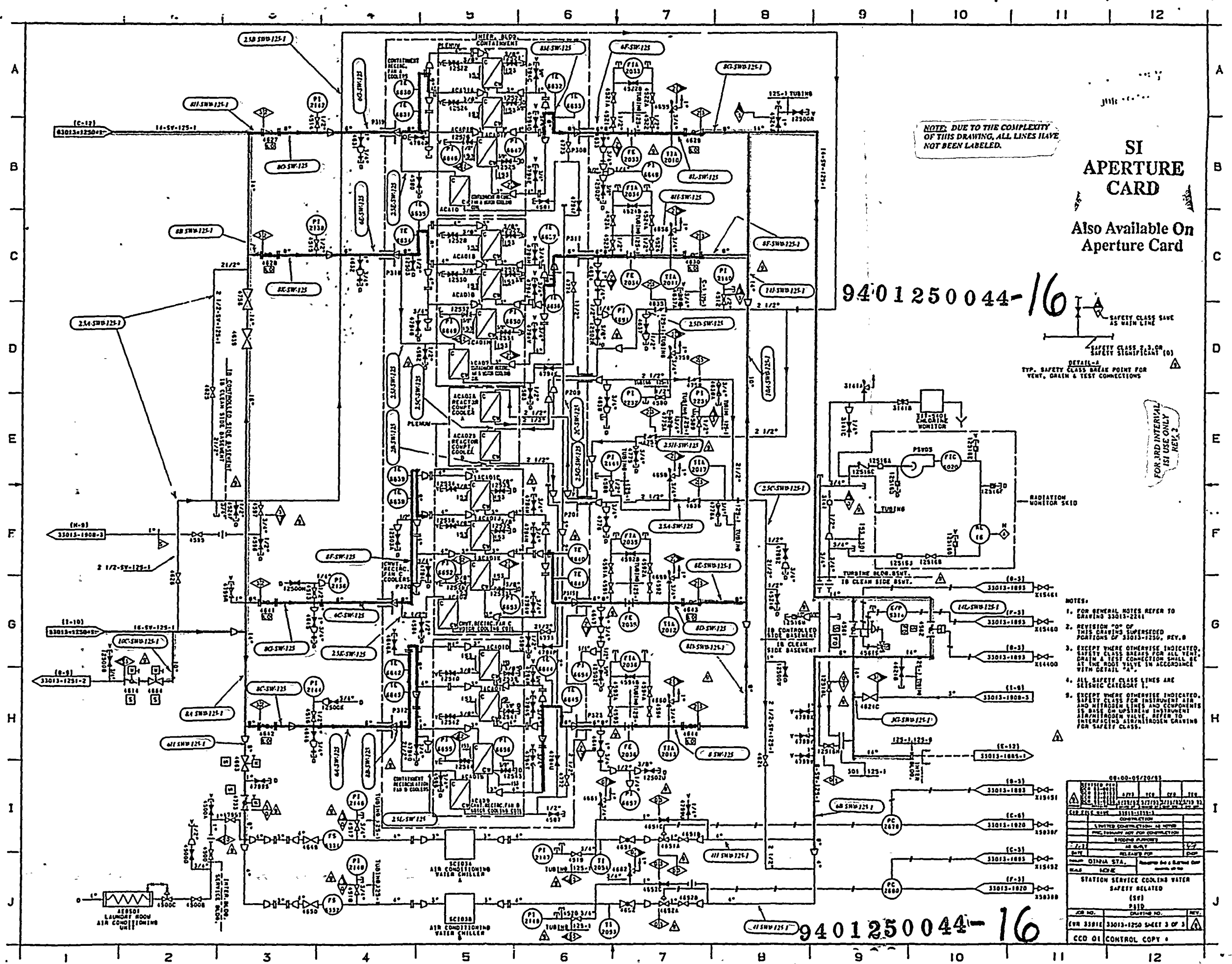

SI APERTURE CARD

Also Available On Aperture Card

9401250044-16

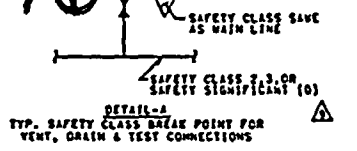

FOR JND INTERNAL USE ONLY
REV. 3

- NOTES:
- FOR GENERAL NOTES REFER TO DRAWING 33013-2284
 - REVISION "00" OF THIS DRAWING SUPERSEDES PORTIONS OF 33013-1250, REV. 0
 - EXCEPT WHERE OTHERWISE INDICATED, SAFETY CLASS BREAKS FOR ALL VENT, DRAIN & TEST CONNECTIONS SHALL BE AT THE ROOT VALVE IN ACCORDANCE WITH DETAIL "A".
 - ALL SAFETY CLASS LINES ARE SEISMIC CATEGORY 1.
 - EXCEPT WHERE OTHERWISE INDICATED, SAFETY CLASS FOR INSTRUMENT AIR AND NITROGEN LINES AND COMPONENTS IS BASED ON UPSHAFT INSTRUMENT AIR/NITROGEN SYSTEMS. REFER TO INTERFACING AIR/NITROGEN DRAWING FOR SAFETY CLASS.

REVISED	DATE	BY	CHK	REV
1	09-00-05/20/83			
33013-1893				
CONNECTION				
LIMITED CONNECTIONS AS NOTED				
PAC. DRAWING NOT FOR CONSTRUCTION				
SHOWN PURPOSE				
AS SHOWN				
RELAYS FOR				
DIP				
STATION SERVICE COOLING WATER SAFETY RELATED (SSC)				
P&ID				
DRAWING NO.				
REV.				
ENR 33013	33013-1250 SHEET 3 OF 3			
CCD OF CONTROL COPY				

9401250044-16

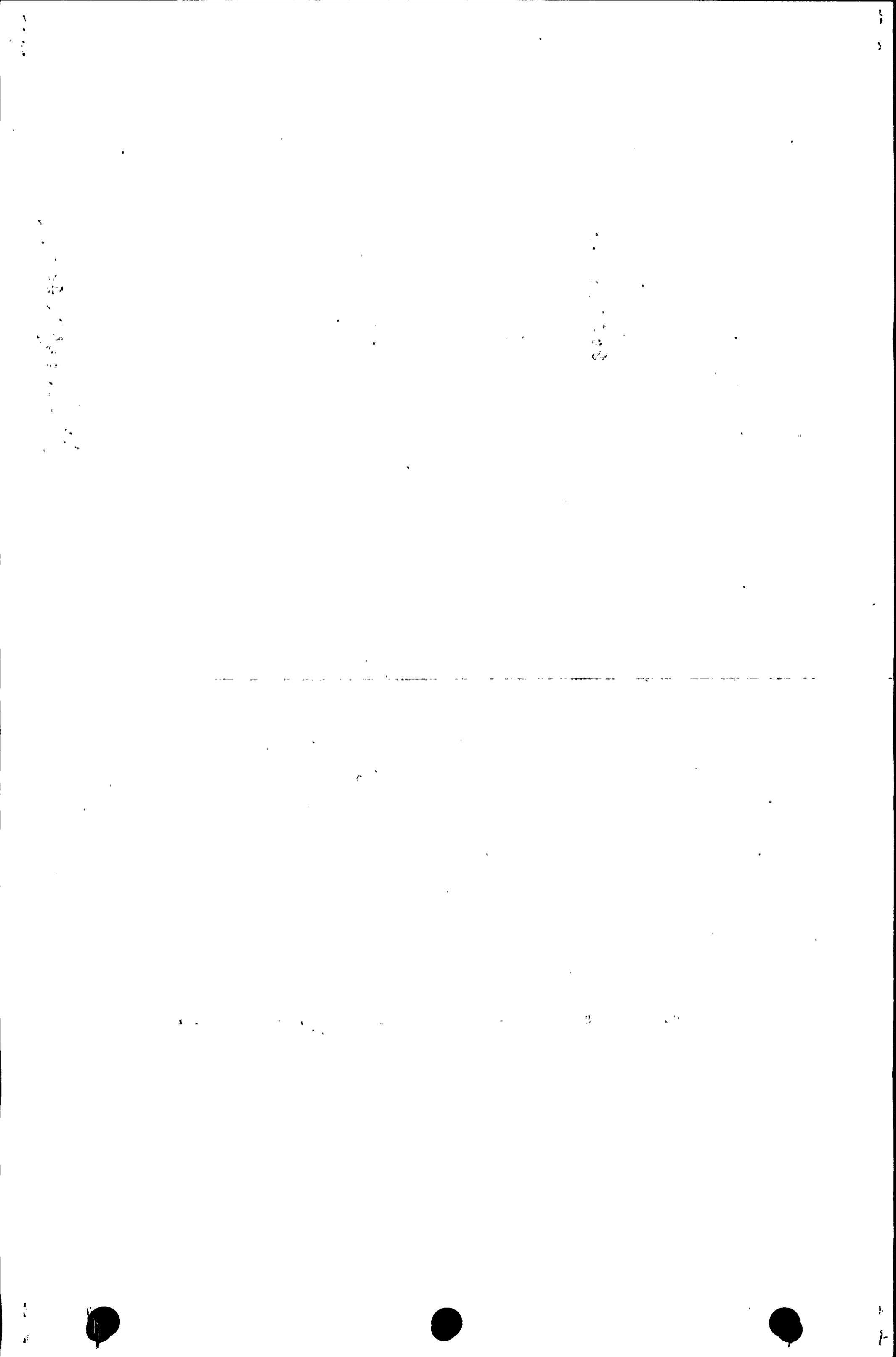

VAL IN... JUN 10 1983

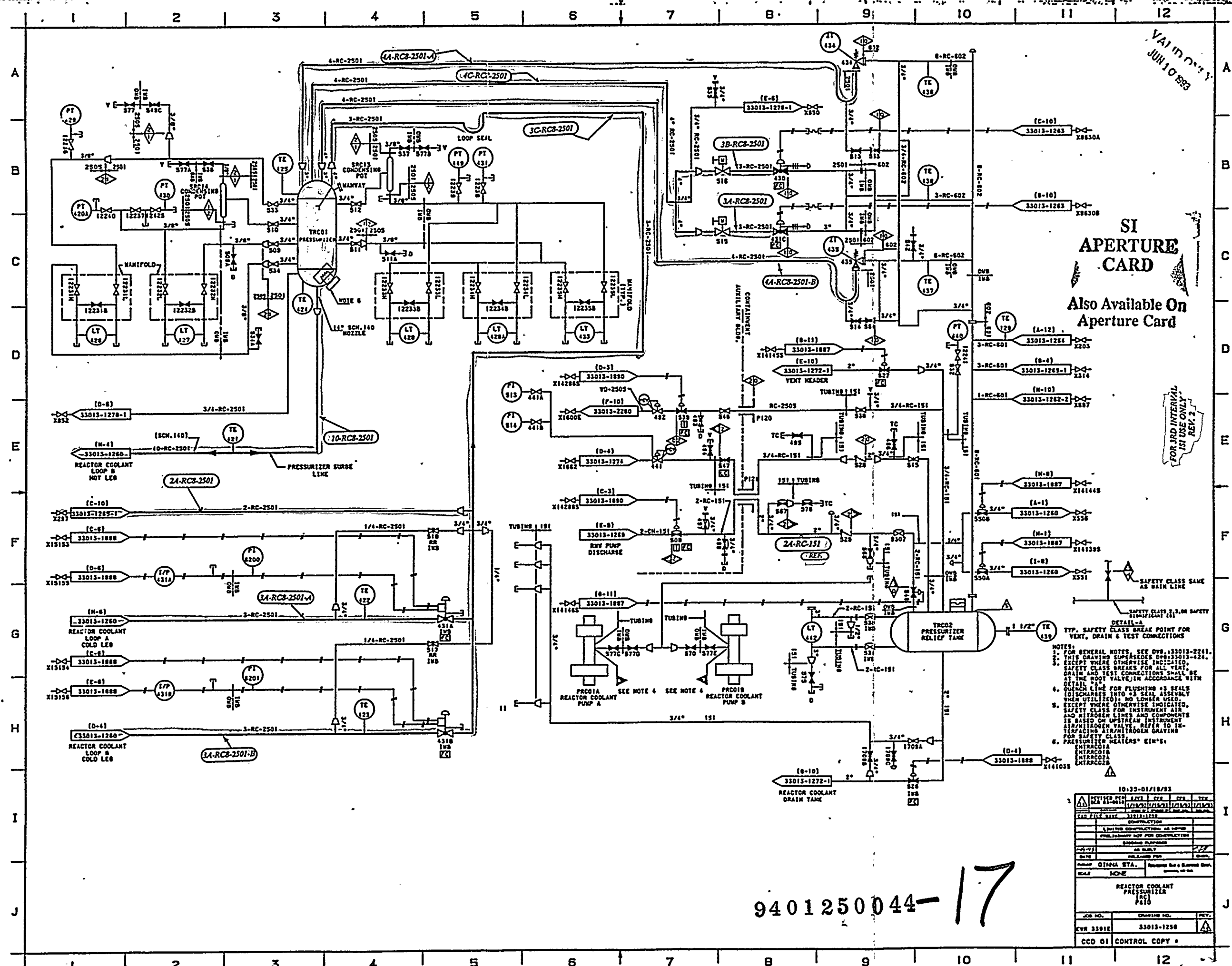

SI APERTURE CARD
 Also Available On Aperture Card

FOR 3RD INTERVAL
 1ST USE ONLY

- NOTES:
- FOR GENERAL NOTES, SEE DWS 33013-2261.
 - THIS DRAWING SUPERSEDES DWS 33013-424.
 - EXCEPT WHERE OTHERWISE INDICATED, SAFETY CLASS BREAKS FOR ALL VENT, DRAIN AND TEST CONNECTIONS SHALL BE AT THE ROOT VALVE IN ACCORDANCE WITH DETAIL "A".
 - CONNECTION LINE FOR PLUSHING (3 SEALS DISCHARGES INTO 3 SEAL ASSEMBLY WHEN UTILIZED); NO LONGER USED.
 - EXCEPT WHERE OTHERWISE INDICATED, SAFETY CLASS FOR INSTRUMENT AIR AND NITROGEN LINES AND COMPONENTS IS BASED ON UPSTREAM INSTRUMENT AIR/NITROGEN VALVE. REFER TO INTERFACING AIR/NITROGEN DRAWING FOR SAFETY CLASS.
 - PRESSURIZER HEATERS' KEIN'S: ENTRAC02A, ENTRAC02B, ENTRAC02C.

10:33-01/15/83

REV	DATE	BY	CHK	APP	APP
1	10/33-01/15/83

CONSTRUCTION

LIMITED CONSTRUCTION - AS SHOWN

PROHIBITIVE FOR CONSTRUCTION

STANDARD PLUMBING

NO SCALE

DATE: 10/33-01/15/83

BY: QINDA STA.

SCALE: NONE

REACTOR COOLANT PRESSURIZER (RC) P&ID

JOB NO.	DRAWING NO.	REV.
33013	33013-1250	1

CCD 01 CONTROL COPY

9401250044-17

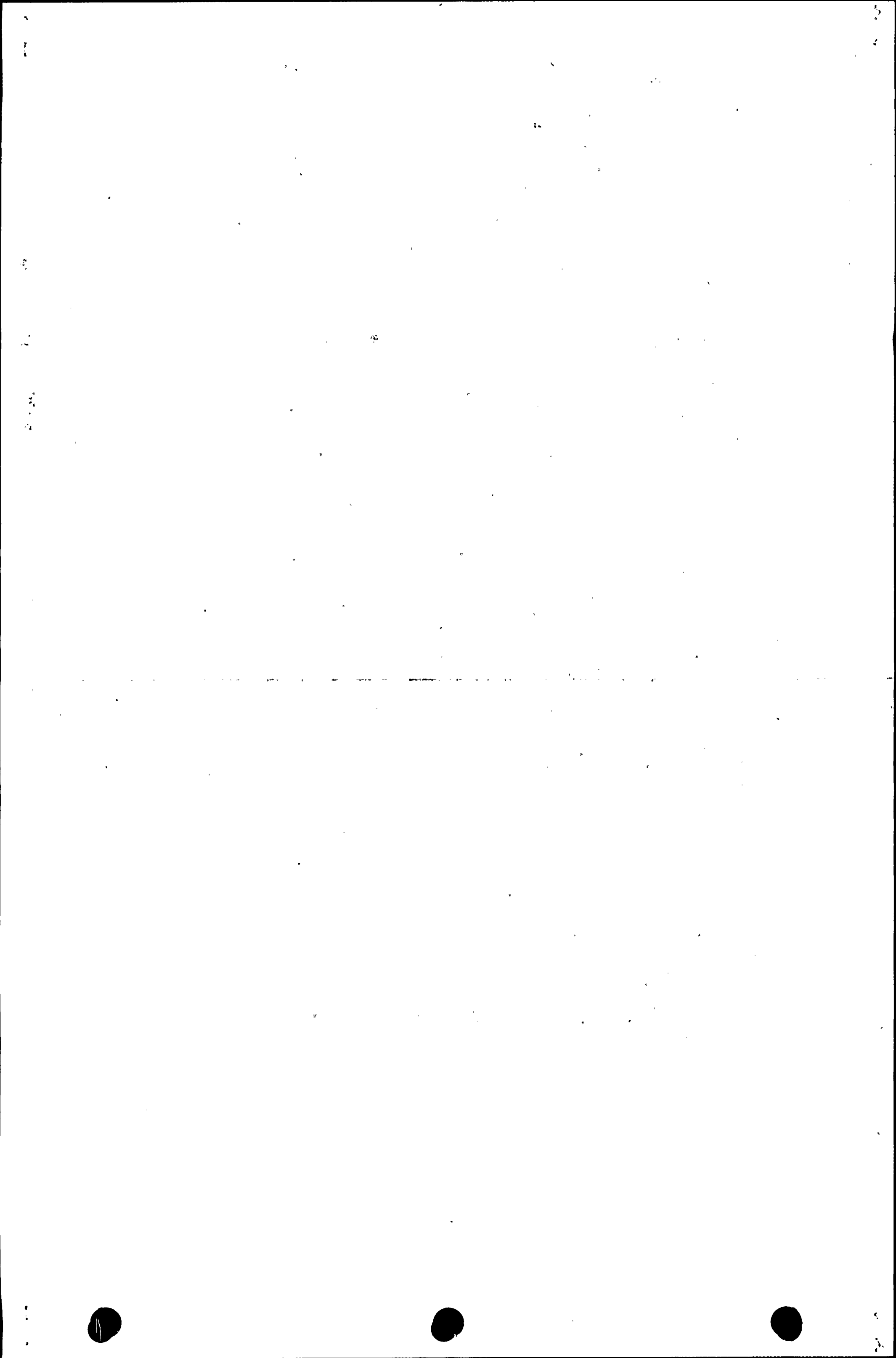

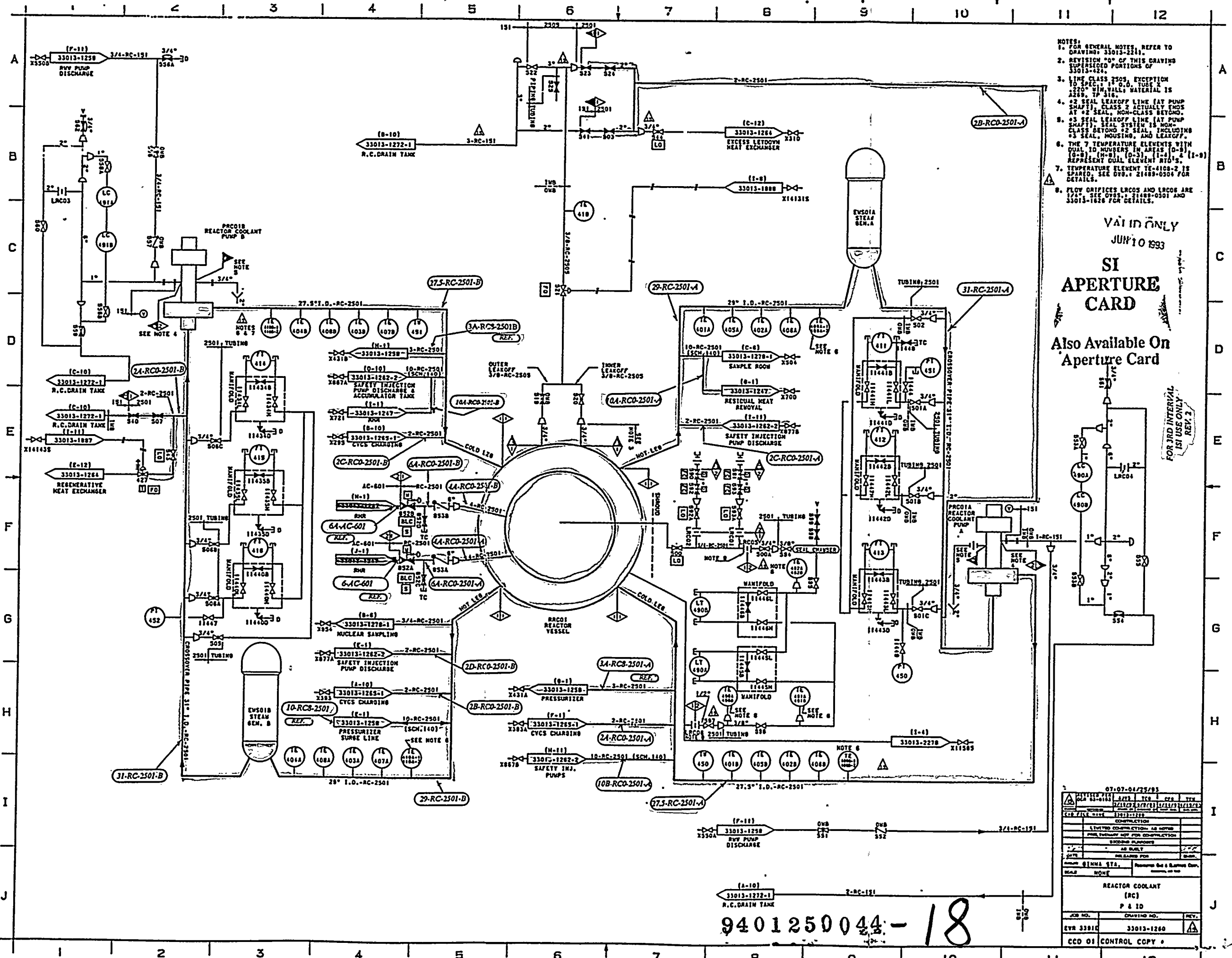

- NOTES:**
- FOR GENERAL NOTES, REFER TO DRAWING 33013-2211.
 - REVISION 00 OF THIS DRAWING SUPERSEDES PORTIONS OF 33013-1224.
 - LINE CLASS 2505, EXCEPTION TO SPEC. 1: O.D. TUBE 2" 250" MIN. WALL; MATERIAL IS 304L, TP 316.
 - 02 SEAL LEAKOFF LINE (AT PUMP SHAFT); CLASS 2 ACTUALLY ENDS AT 02 SEAL, NON-CLASS BEYOND.
 - 03 SEAL LEAKOFF LINE (AT PUMP SHAFT); SEAL SYSTEM IS NON-CLASS BEYOND 02 SEAL, INCLUDING 03 SEAL, HOUSING, AND LEAKOFF.
 - THE 7 TEMPERATURE ELEMENTS WITH DUAL ID NUMBERS IN AREAS (0-8) (0-9) (1-8) (1-9) REPRESENT DUAL ELEMENT RTDS.
 - TEMPERATURE ELEMENT TE-410B-2 IS SPARE; SEE DWG. 21489-0304 FOR DETAILS.
 - FLOW ORIFICES LRC05 AND LRC06 ARE 33013-1226 FOR DETAILS.

VALID ONLY
JUN 10 1993
SI APERTURE CARD

Also Available On Aperture Card

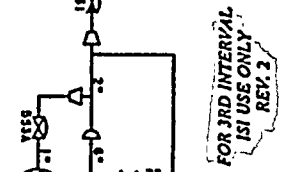

FOR 3RD INTERVAL
SI USE ONLY
REV. 2

REV.	DATE	BY	CHK	APP	TRN
01	07-01/79/93				
02	03-01/83				
03	03-01/83				
04	03-01/83				
05	03-01/83				
06	03-01/83				
07	03-01/83				
08	03-01/83				
09	03-01/83				
10	03-01/83				
11	03-01/83				
12	03-01/83				

REACTOR COOLANT (RC) P & ID		
JOB NO.	DRAWING NO.	REV.
EVR 33013	33013-1260	
CCD 01	CONTROL COPY	

9401250044-18

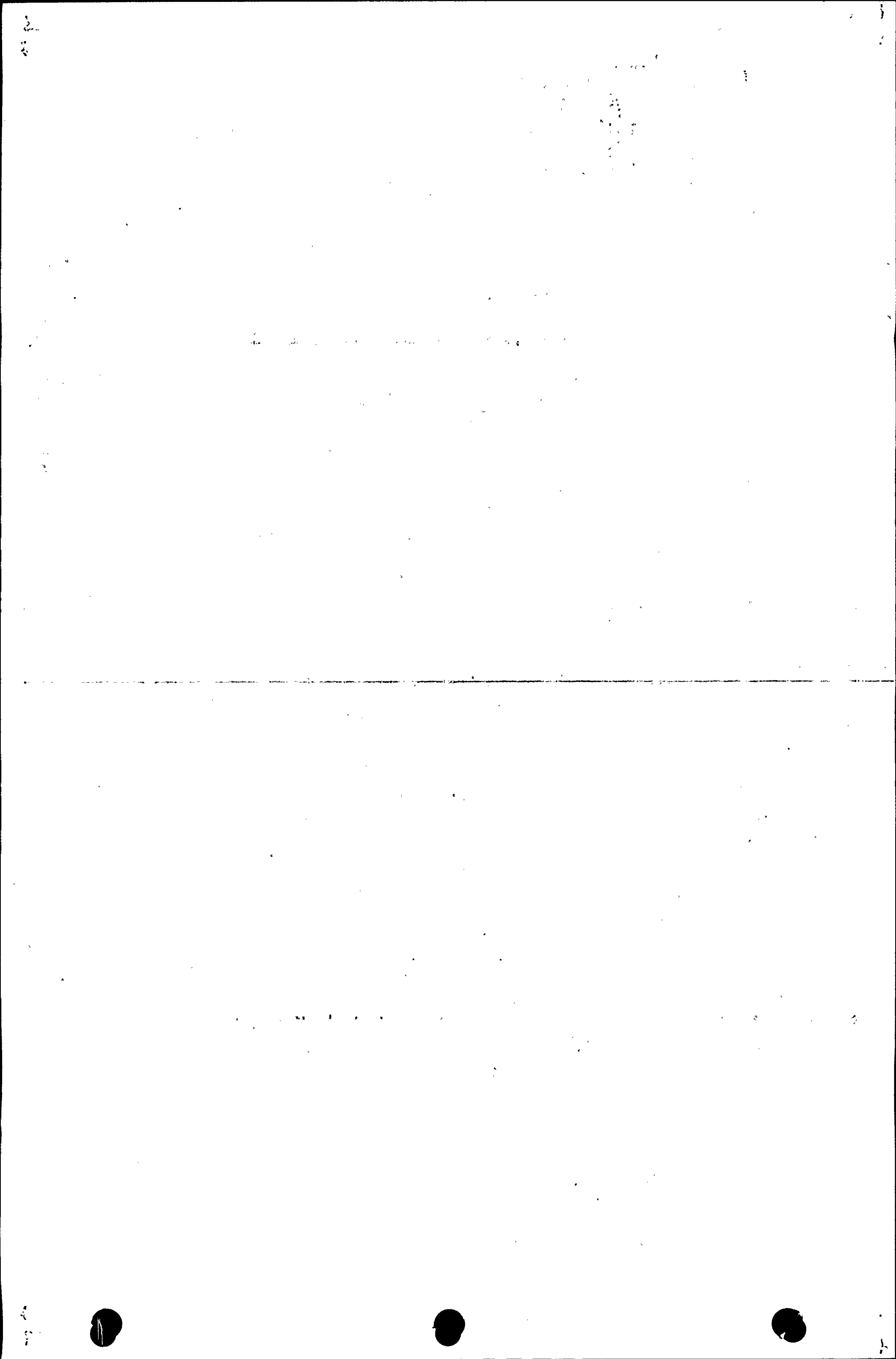

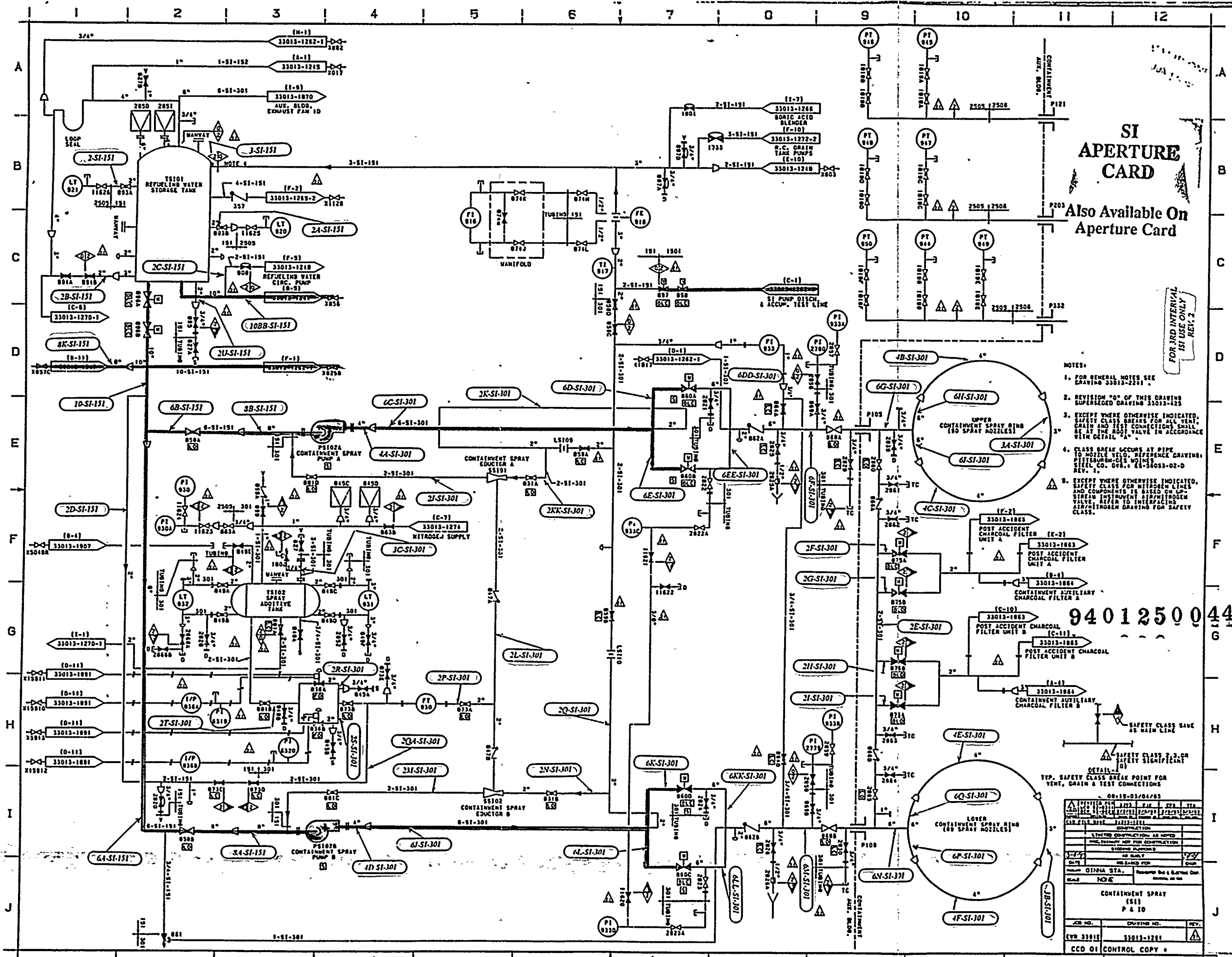

SI APERTURE CARD

Also Available On Aperture Card

FOR 3RD INTERNAL USE ONLY
REV. 2

- NOTES:
- FOR GENERAL NOTES SEE DRAWING 33013-2251.
 - REVISION "A" OF THIS DRAWING SUPERSEDES DRAWING 33013-423.
 - EXCEPT WHERE OTHERWISE INDICATED, SAFETY CLASS BREAKS FOR ALL VENT, DRAIN AND TEST CONNECTIONS SHALL BE AT THE BODY VALVE IN ACCORDANCE WITH DETAIL "A".
 - CLASS BREAK OCCURS AT PIPE TO NOZZLE T.E.D. REFERENCE DRAWING: PITTSBURGH-CIS MOINES STEEL CO. 08.1 26-38053-02-D REV. 1.
 - EXCEPT WHERE OTHERWISE INDICATED, SAFETY CLASS FOR NITROGEN LINES AND COMPONENTS IS BASED ON UP-STREAM INSTRUMENT AIR INTRINSICALLY SAFE VALVE REFER TO INTERFACING AIRBROKEN DRAWING FOR SAFETY CLASS.

9401250044-19

SAFETY CLASS SAVE AS DRAIN LINE
SAFETY CLASS P. 2 OR SAFETY SIGNIFICANT

DETAIL: TYP. SAFETY CLASS BREAK POINT FOR VENT, DRAIN & TEST CONNECTIONS

DESIGNED BY	DATE	SCALE	REV.
CONSTRUCTION			
LIMITED CONNECTIONS AS SHOWN			
INCL. DIMENSIONS FOR CONSTRUCTION			
SHOWN PURPOSES			
NO SCALE			
DATE	REVISED FOR	BY	CHKD.
01/24/81	REVISED FOR		
NOTE	REVISIONS TO BE MADE BY THE USER.		
CONTAINMENT SPRAY (SI) P & ID			
JOB NO.	DRAWING NO.	REV.	
979 33013	33013-1251		
CCD 01 CONTROL COPY			

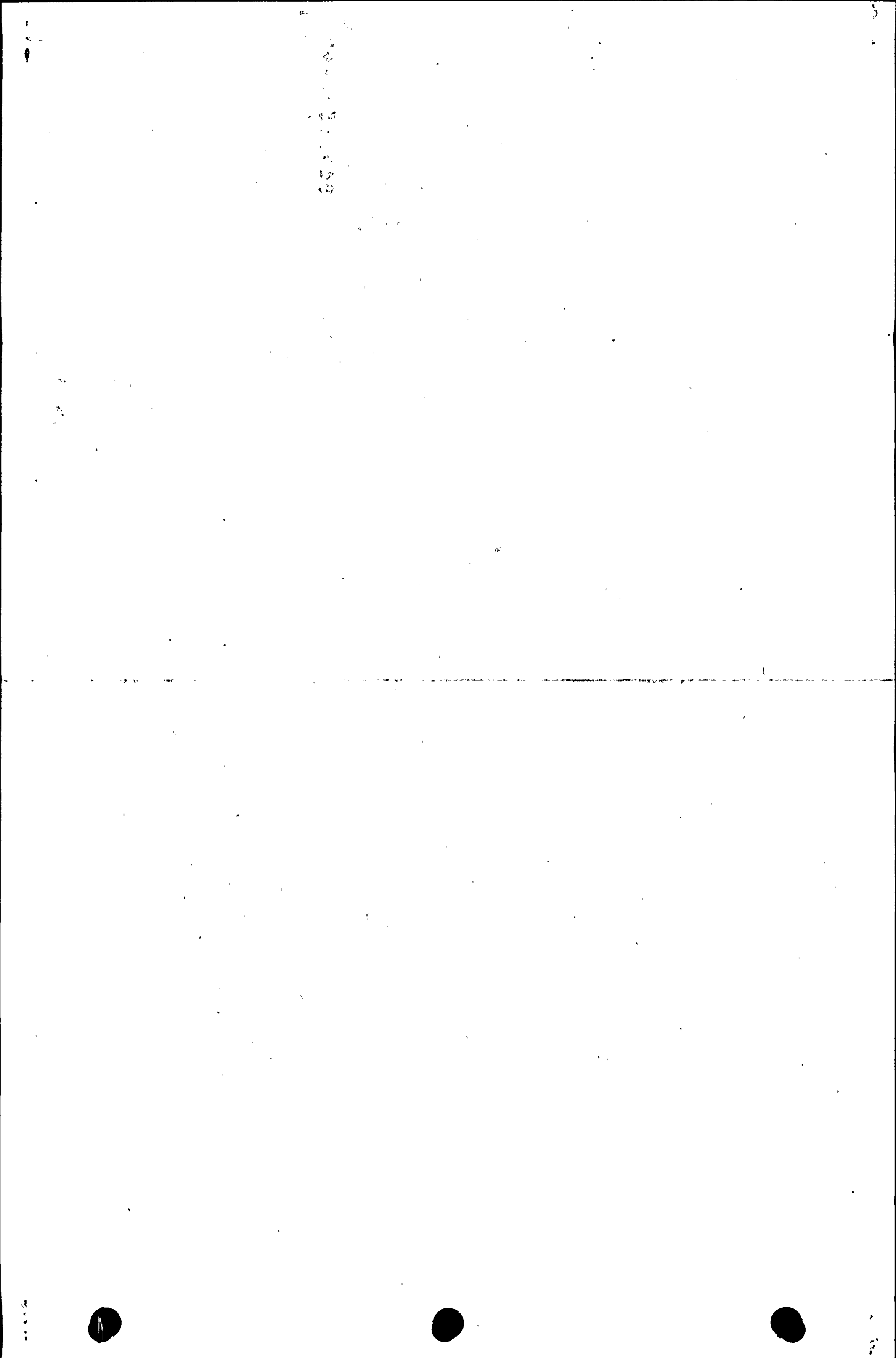

VAI IT ONLY
JUN 10 1993

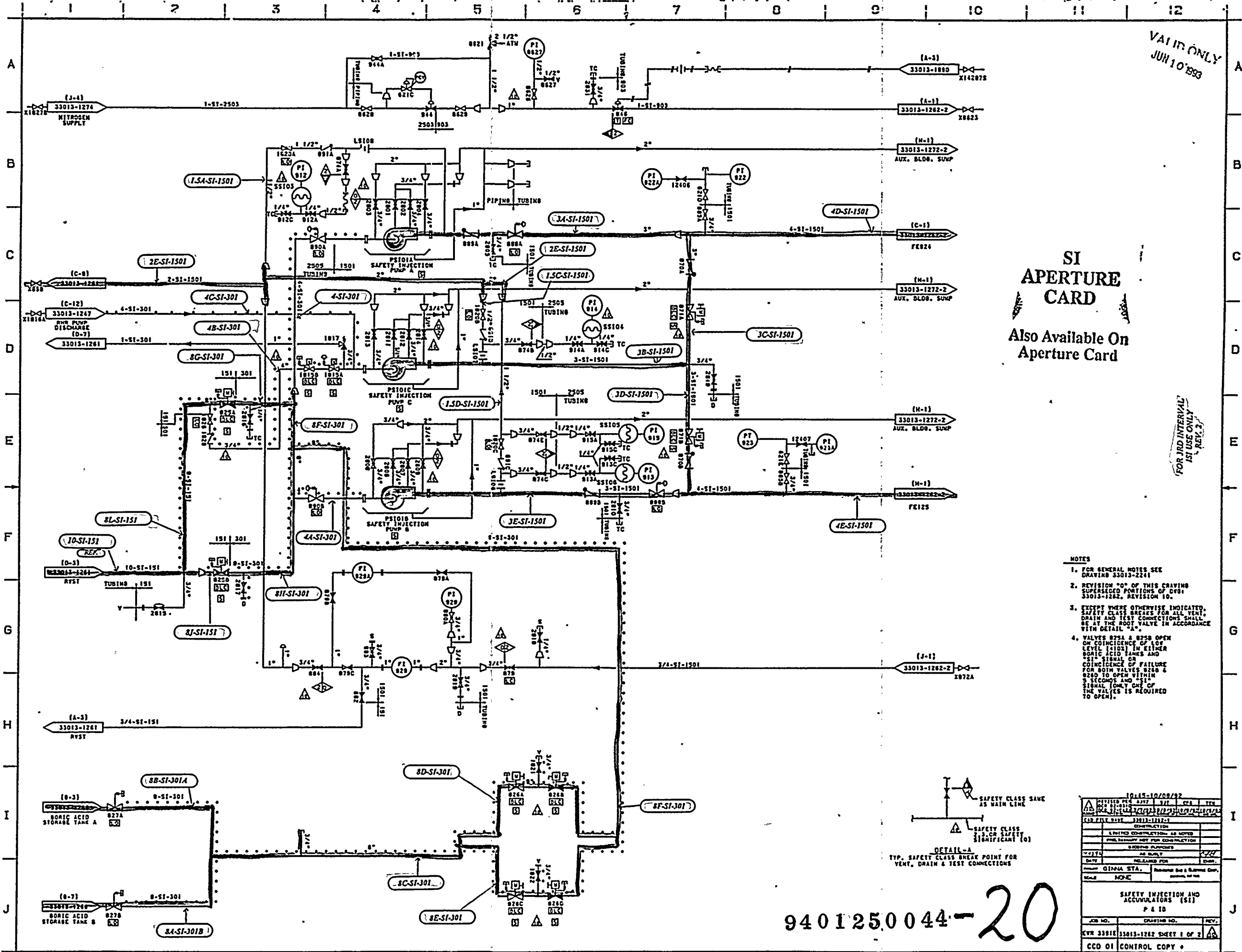

SI APERTURE CARD
Also Available On Aperture Card

FOR JRD INTERVAL
ISI USE ONLY
REV. 2

- NOTES**
- FOR GENERAL NOTES SEE DRAWING 33013-2241
 - REVISION "0" OF THIS DRAWING SUPERSEDES PORTIONS OF DTSI 33013-1262, REVISION 10.
 - EXCEPT WHERE OTHERWISE INDICATED, SAFETY CLASS BREAKS FOR ALL TENDS, DRAIN AND TEST CONNECTIONS SHALL BE AT THE ROOT VALVE IN ACCORDANCE WITH DETAIL "A".
 - VALVES 825A & 825B OPEN ON COINCIDENCE OF LOW LEVEL (LID) IN EITHER BORIC ACID TANKS AND "SI" SIGNAL OR COINCIDENCE OF FAILURE FOR BOTH VALVES 825A & 825B TO OPEN WITHIN 3 SECONDS AND "SI" SIGNAL (ONLY ONE OF THE VALVES IS REQUIRED TO OPEN).

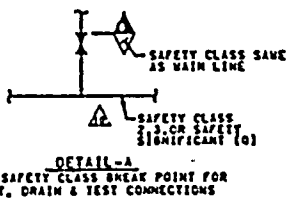

9401250044-20

DATE	10/25-10/28/92
DESIGNED BY	SAJ
CHECKED BY	SAJ
APPROVED BY	SAJ
CONSTRUCTION	AS NOTED
PHYS. SUPPORT NOT FOR CONSTRUCTION	
ISSUING PURPOSES	
AS BUILT	
DATE	RELEASED FOR
BY	GINNA STA.
SCALE	NONE
SAFETY INJECTION AND ACCUMULATORS (SI)	
P & ID	
JOB NO.	DRAWING NO.
CVR 33013	33013-1262 SHEET 1 OF 2
CCD 01	CONTROL COPY

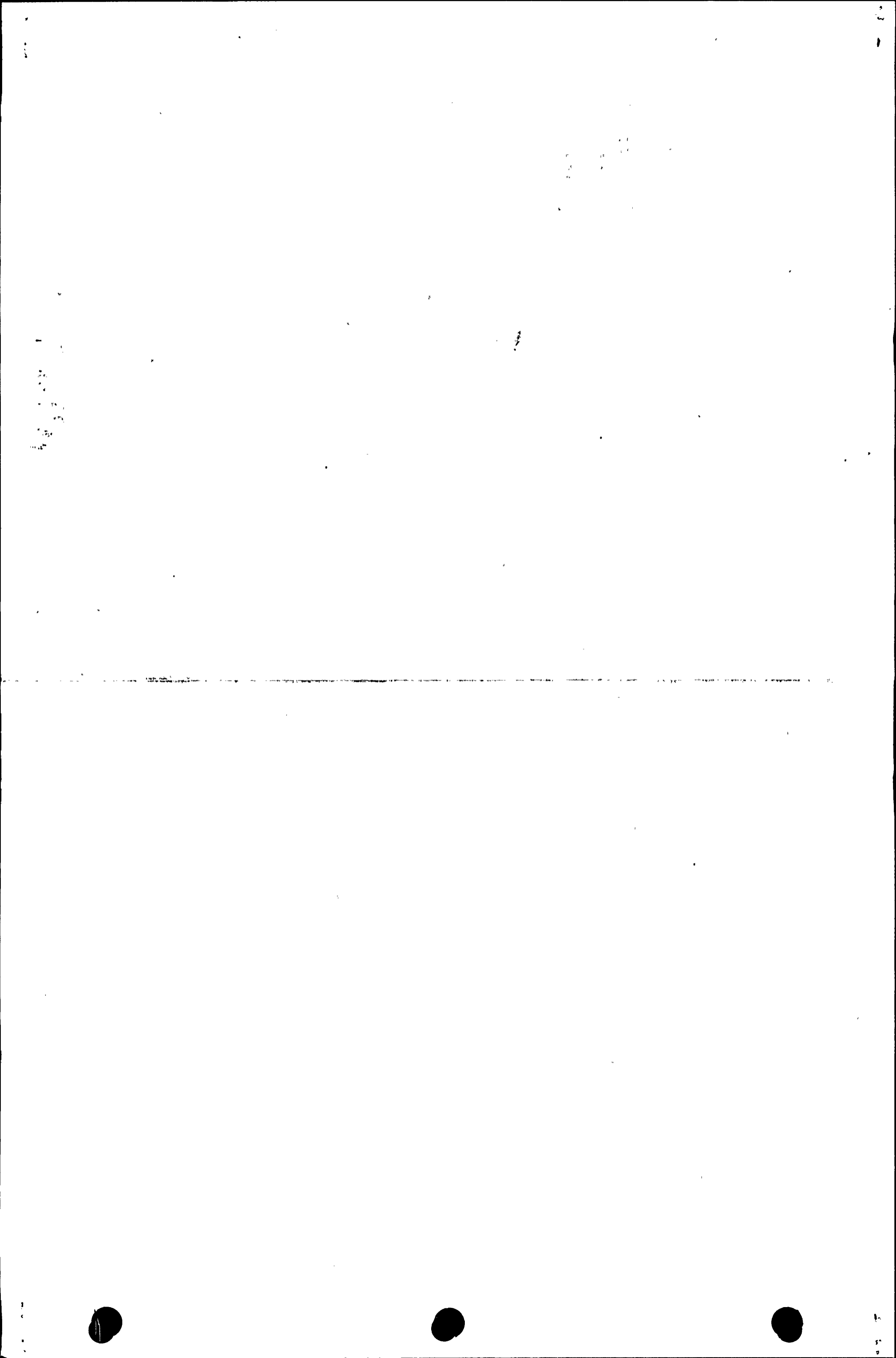

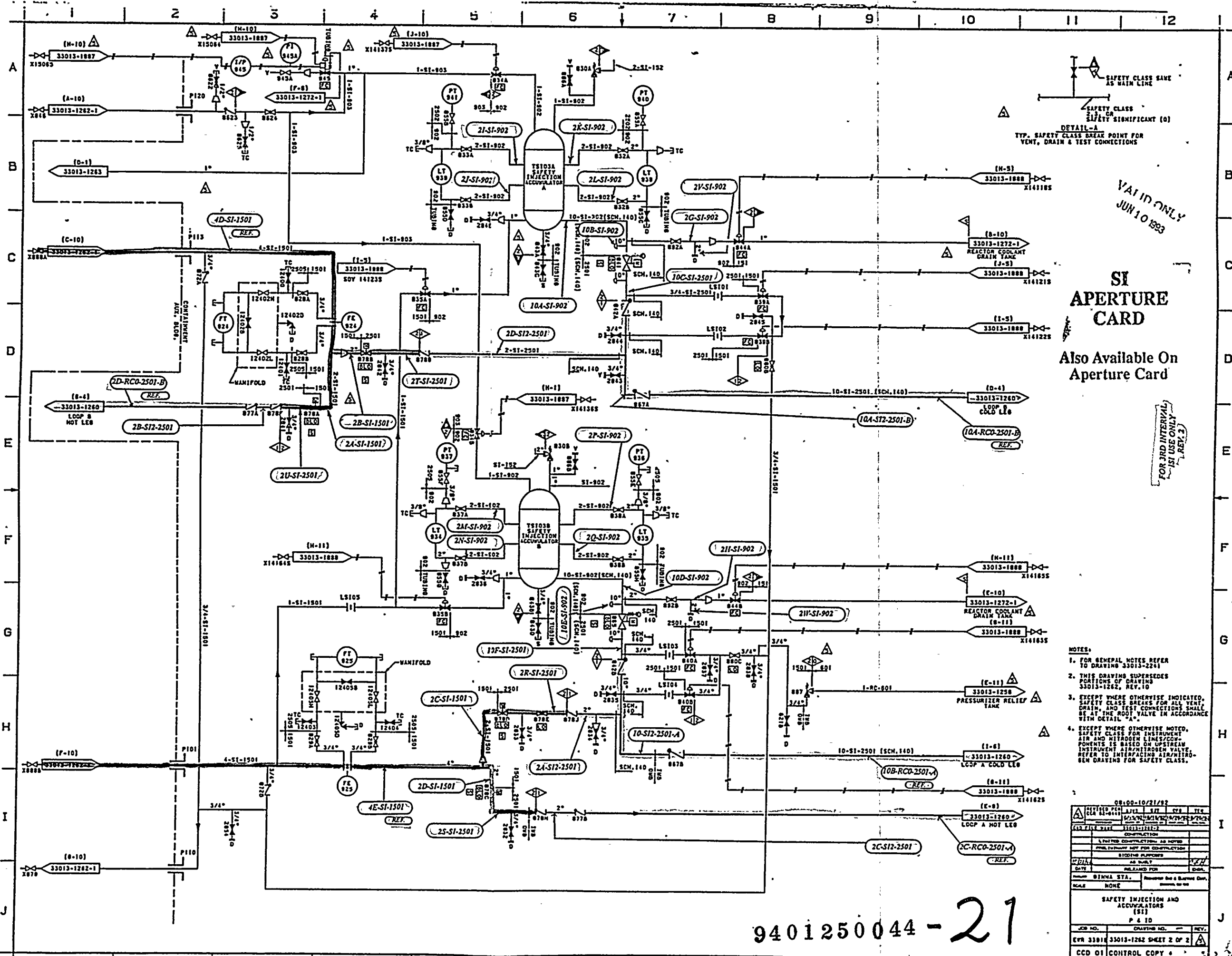

- NOTES:
1. FOR GENERAL NOTES REFER TO DRAWING 33013-2241
 2. THIS DRAWING SUPERSEDES PORTIONS OF DRAWING 33013-1242, REV. 10
 3. EXCEPT WHERE OTHERWISE INDICATED, SAFETY CLASS BREAKS FOR ALL VENT, DRAIN, AND TEST CONNECTIONS SHALL BE AT THE ROOT VALVE IN ACCORDANCE WITH DETAIL "A"
 4. EXCEPT WHERE OTHERWISE NOTED, SAFETY CLASS FOR INSTRUMENT AIR AND NITROGEN LINES/COMPONENTS IS BASED ON UPSTREAM INSTRUMENT AIR/NITROGEN VALVE. REFER TO INTERFACING AIR/NITROGEN DRAWING FOR SAFETY CLASS.

DESIGNED BY	DATE	REV.	BY
33013-1242	05/00-10/21/92	1	...
CHECKED BY	DATE	REV.	BY
...
DATE	RELEASED FOR	SCALE	SCALE
...	...	NONE	NONE
SAFETY INJECTION AND ACCUMULATORS (SI)			
P. 4 10			
JOB NO.	DRAWING NO.	REV.	
...
CCD 01	CONTROL COPY	4	

9401250044-21

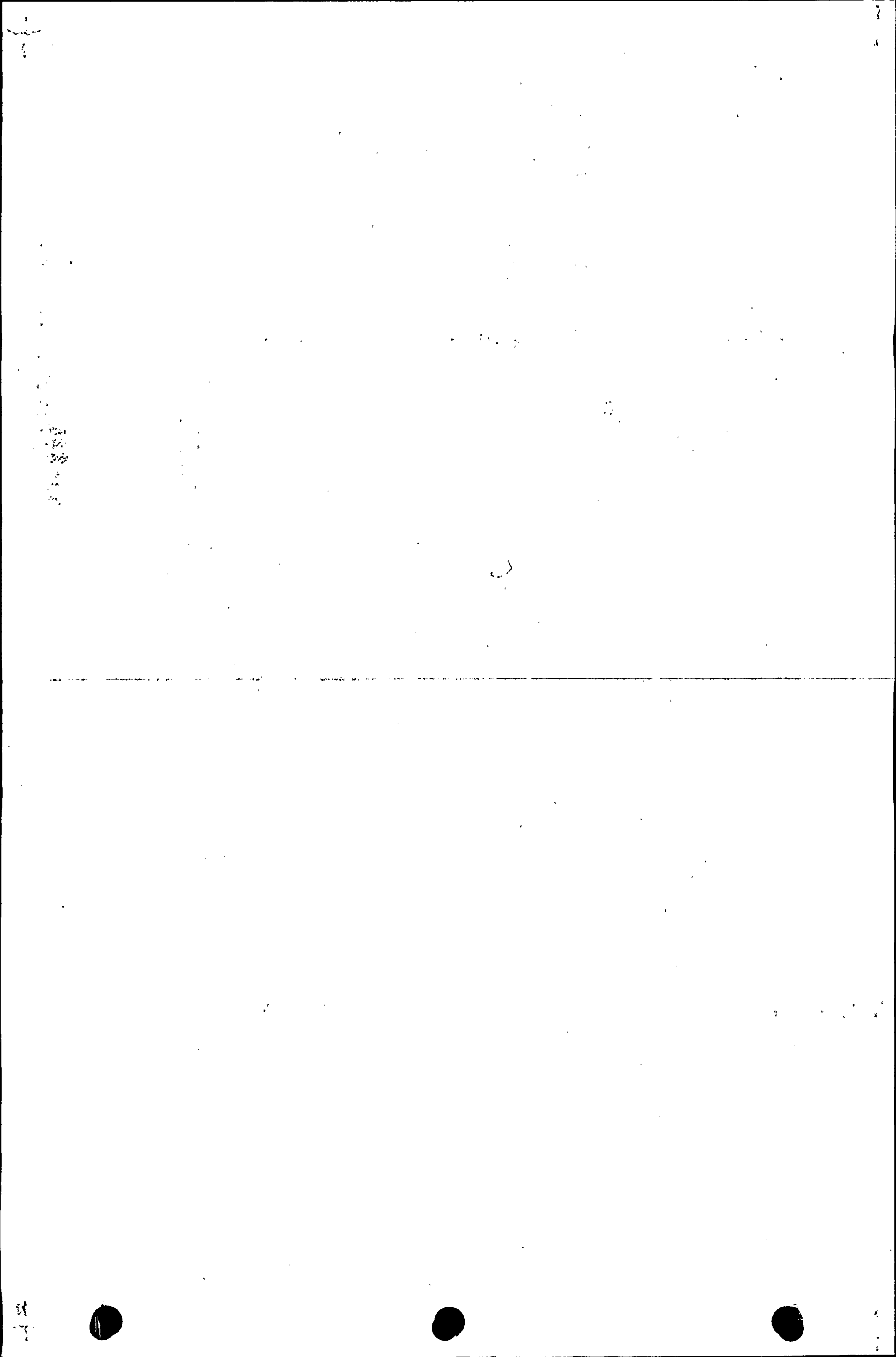

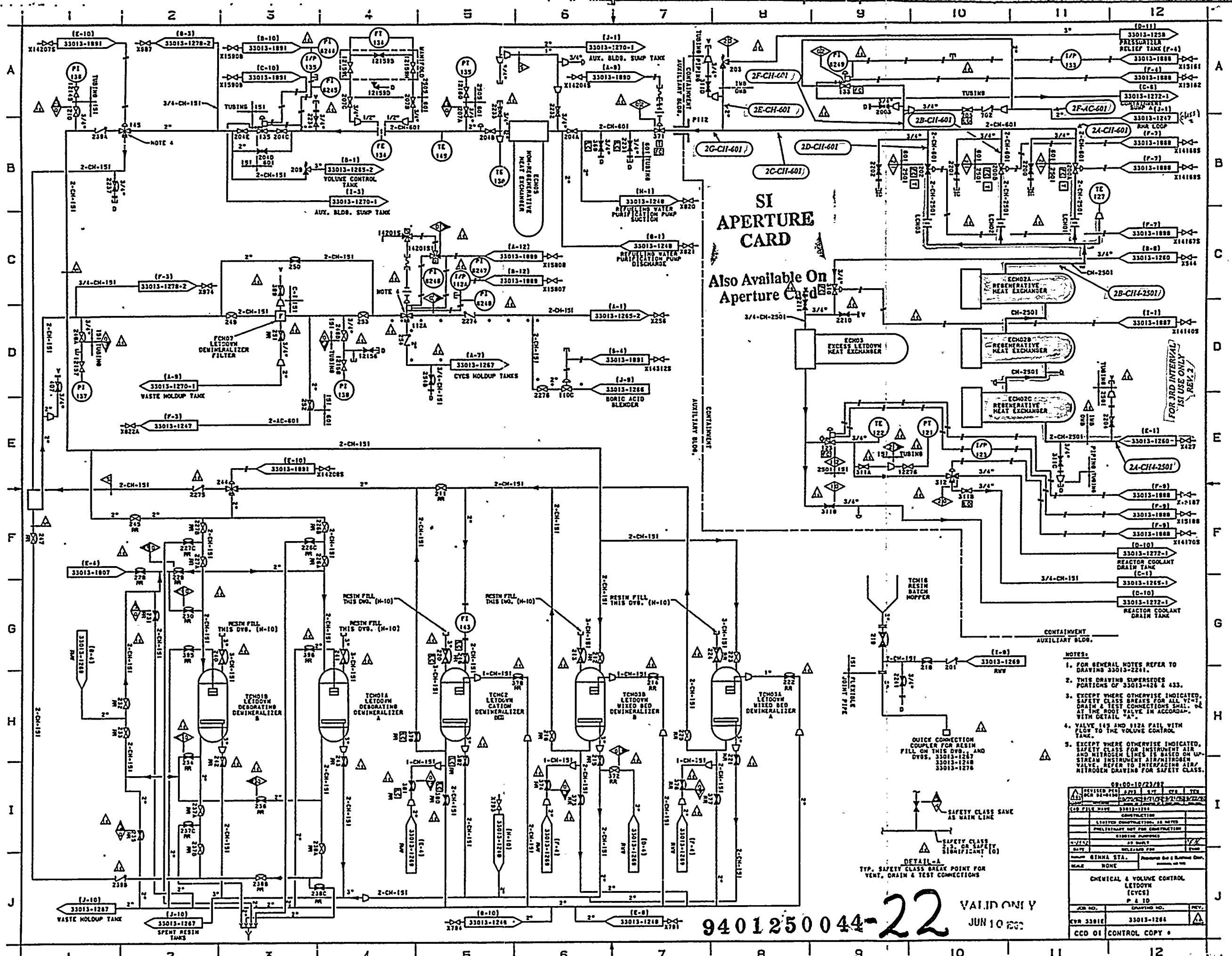

SI APERTURE CARD
Also Available On Aperture Card

- NOTES:
- FOR GENERAL NOTES REFER TO DRAWING 33013-2241.
 - THIS DRAWING SUPERSEDES PARTS OF 33013-426 & 433.
 - EXCEPT WHERE OTHERWISE INDICATED, SAFETY CLASS BREAKS FOR ALL VENT, DRAIN & TEST CONNECTIONS SHALL BE AT THE ROOT VALVE IN ACCORDANCE WITH DETAIL "A".
 - VALVE 145 AND 152A FAIL WITH FLOW TO THE VOLUME CONTROL TANK.
 - EXCEPT WHERE OTHERWISE INDICATED, SAFETY CLASS FOR INSTRUMENT AIR AND NITROGEN LINES IS BASED ON UP-STREAM INSTRUMENT AIR/NITROGEN VALVE. REFER TO INSTRUMENT AIR/NITROGEN DRAWING FOR SAFETY CLASS.

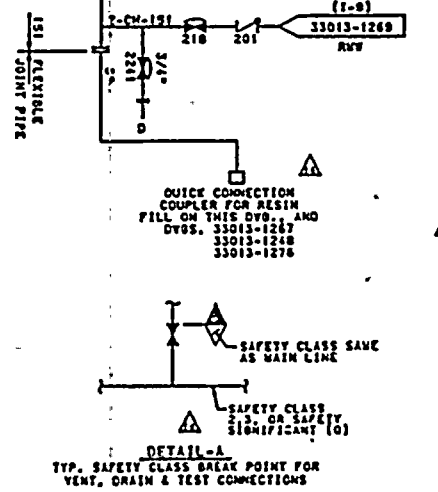

89-00-10/23/87

REV	DATE	BY	CHK	APP
1	12/11/87
2
3
4
5
6
7
8
9
10
11
12

SAFETY CLASS SAME AS MAIN LINE

DETAIL-A
TYP. SAFETY CLASS BREAK POINT FOR VENT, DRAIN & TEST CONNECTIONS

CHEMICAL & VOLUME CONTROL LETDOWN (CYCS) P. & ID	
JOB NO.	DRAWING NO.
33013-1248	33013-1248
REV 3301E	33013-1248
CCD 01	CONTROL COPY

9401250044-22 VALID ONLY JUN 10 2001

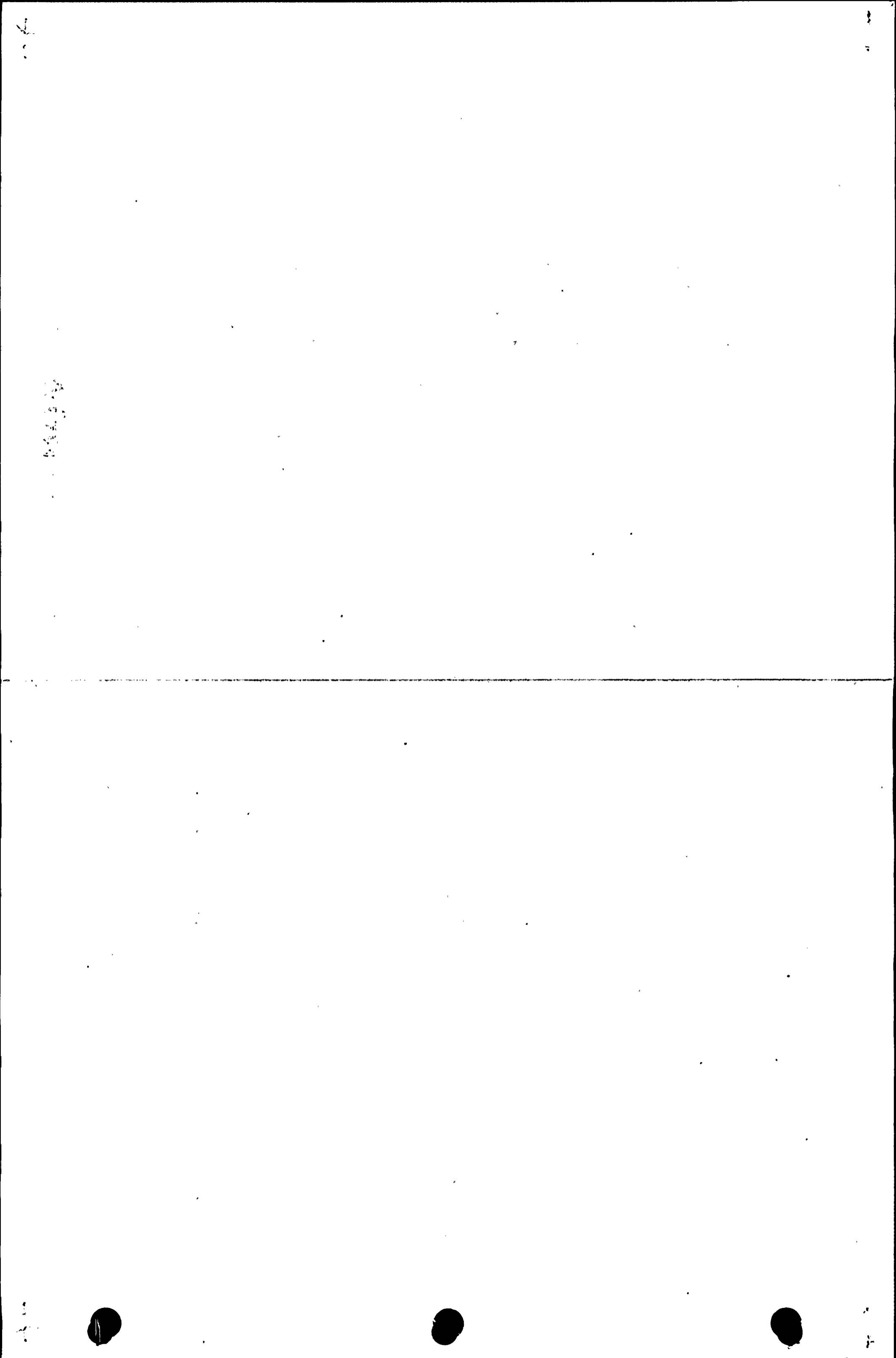

VALID ONLY
JUN 10 1953

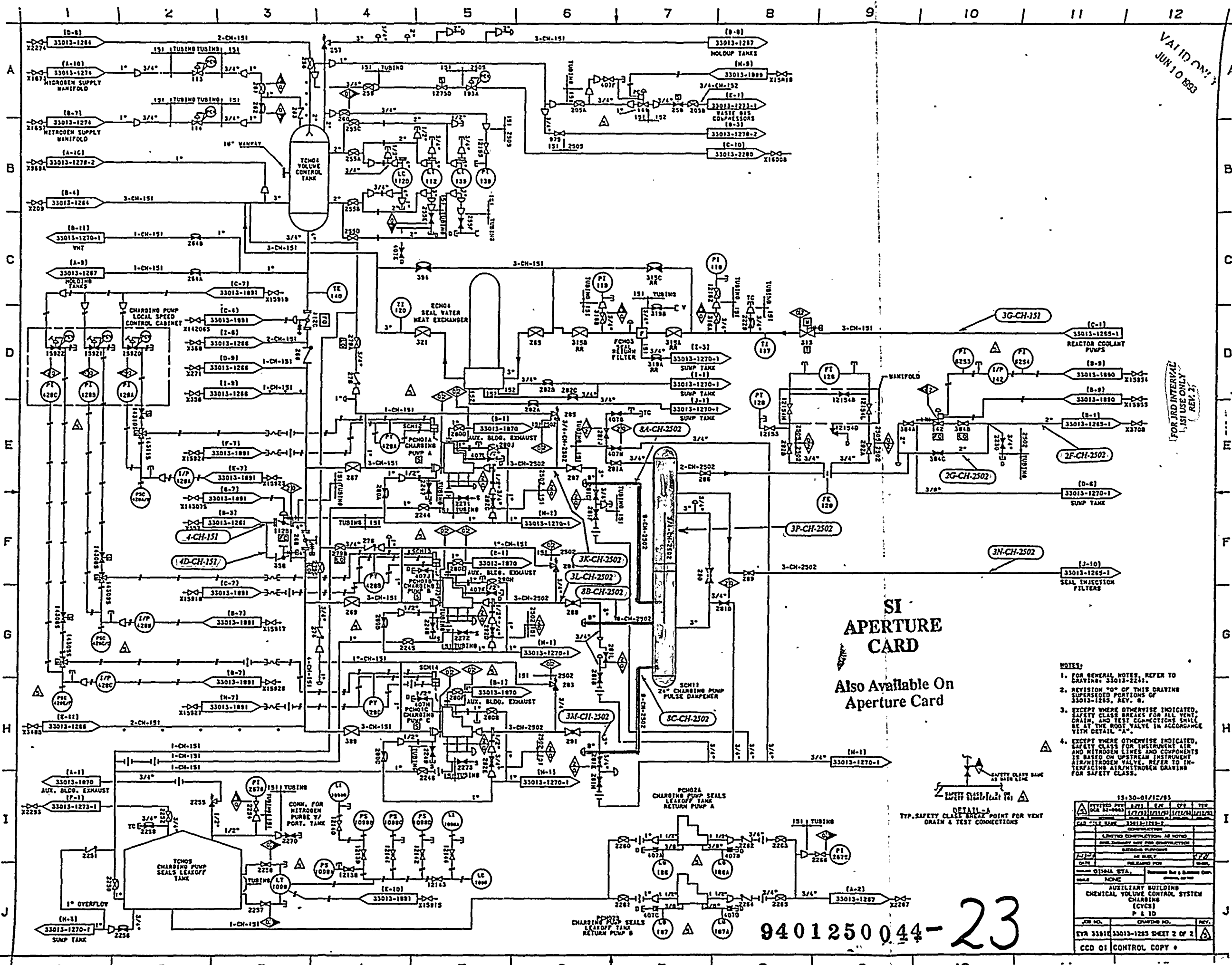

SI APERTURE CARD
Also Available On Aperture Card

- NOTES:**
- FOR GENERAL NOTES, REFER TO DRAWING 33013-2211.
 - REVISION "0" OF THIS DRAWING SUPERSEDES PORTIONS OF 33013-1265, REV. B.
 - EXCEPT WHERE OTHERWISE INDICATED, SAFETY CLASS BREAKS FOR ALL VENT, DRAIN, AND TEST CONNECTIONS SHALL BE AT THE ROOT VALVE IN ACCORDANCE WITH DETAIL "A".
 - EXCEPT WHERE OTHERWISE INDICATED, SAFETY CLASS FOR INSTRUMENT AIR AND NITROGEN LINES AND COMPONENTS IS BASED ON UPSTREAM INSTRUMENT AIR/NITROGEN VALVE. REFER TO INTERFACING AIR/NITROGEN DRAWING FOR SAFETY CLASS.

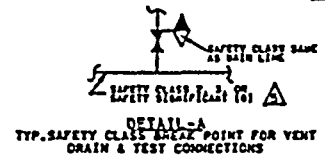

9401250044-23

15-30-01/15/53			
APPROVED FOR	DATE	BY	REV.
33013-1265-1	12/23/52	WJL	1
LIMITED CONSTRUCTION AS SHOWN			
DESIGNED BY: WJL			
CHECKED BY: WJL			
DATE: 12/23/52			
SCALE: NONE			
PROJECT: OILFIELD STA.,			
SHEET: NONE			
AUXILIARY BUILDING			
CHEMICAL VOLUME CONTROL SYSTEM			
CHARGING (CVCS)			
P & ID			
JOB NO.	DRAWING NO.	REV.	
SVR 33013	33013-1265 SHEET 2 OF 2		
CCD 01 CONTROL COPY			

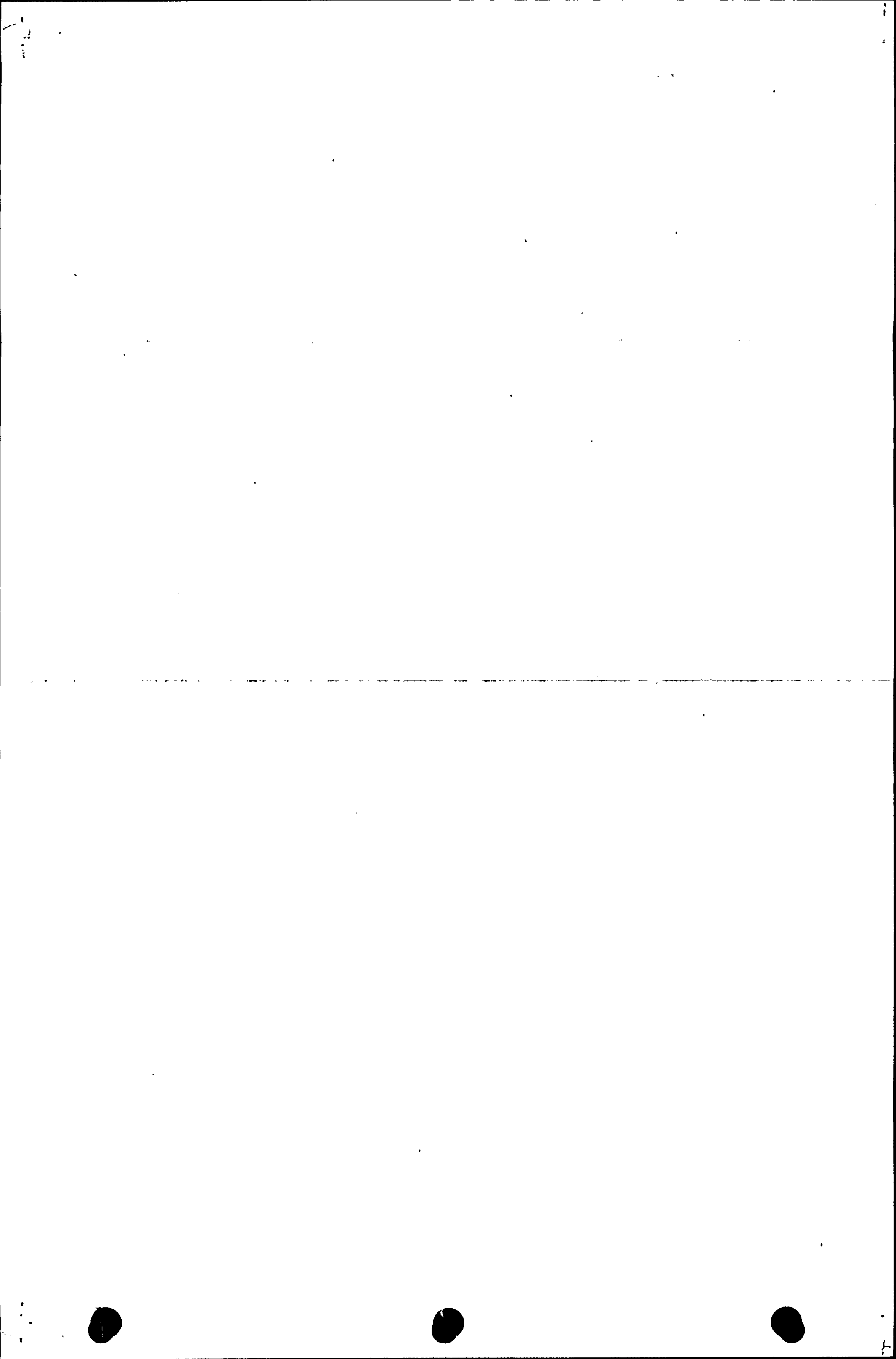

VALID ONLY
JUN 10 1993

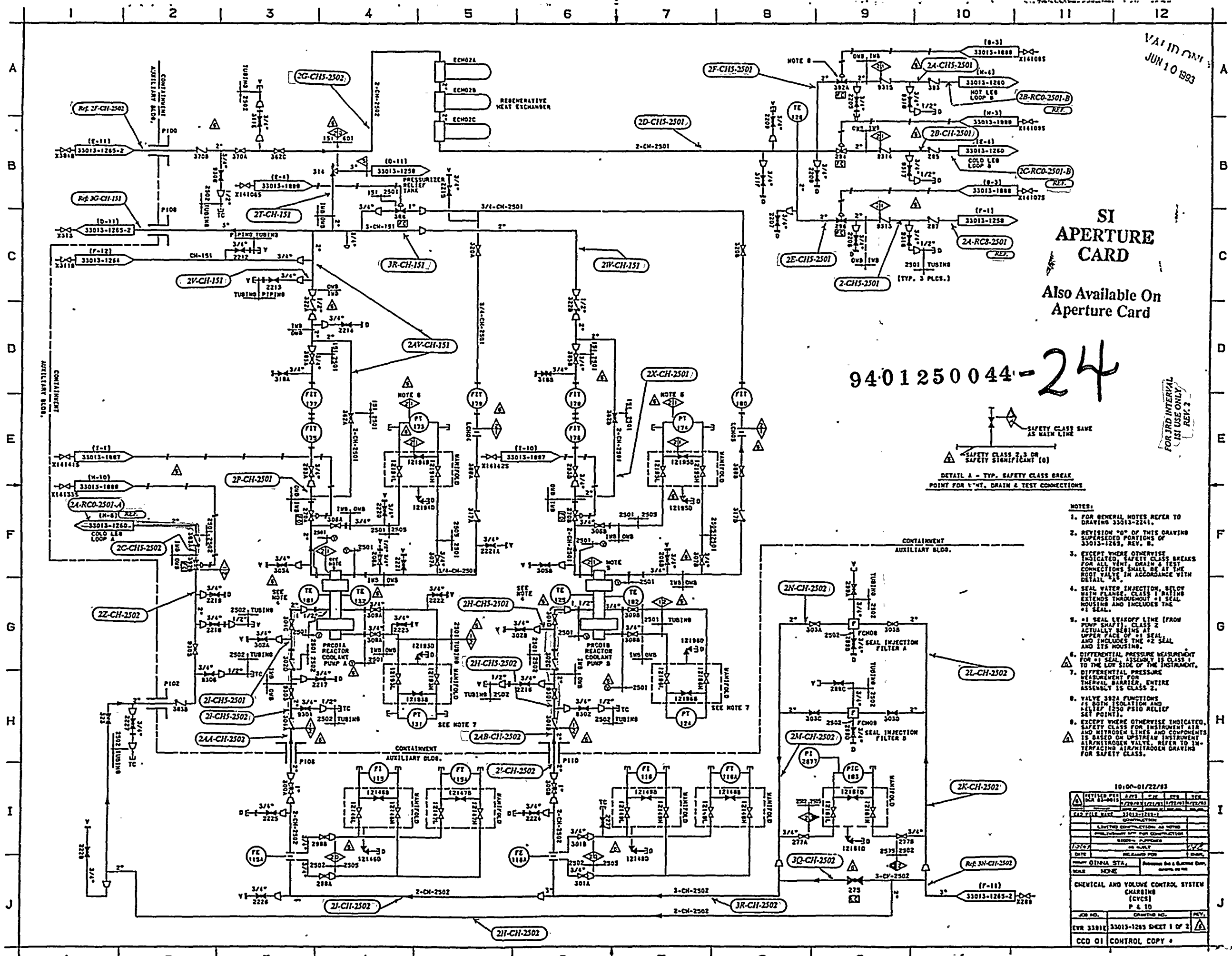

SI APERTURE CARD
Also Available On Aperture Card

9401250044-24

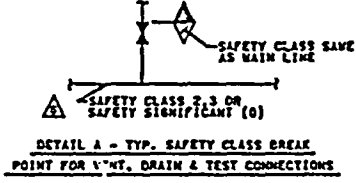

- NOTES:
1. FOR GENERAL NOTES REFER TO DRAWING 33013-2241.
 2. REVISION "00" OF THIS DRAWING SUPERSEDES PORTIONS OF 33013-1263, REV. 0.
 3. EXCEPT WHERE OTHERWISE INDICATED, SAFETY CLASS BREAKS FOR ALL VENT, DRAIN & TEST CONNECTIONS SHALL BE AT THE ROOT VALVE IN ACCORDANCE WITH DETAIL "A".
 4. SEAL WATER INJECTION, BELOW WITH FLANGE, CLASS 1 RATING EXTENDS THROUGHOUT OF SEAL HOUSING AND INCLUDES THE #1 SEAL.
 5. #1 SEAL SHROFF LINE (FROM PUMP SHAFT), CLASS 2 ACTUALLY BEGINS AT UPPER FACE OF #1 SEAL AND INCLUDES THE #2 SEAL AND ITS HOUSING.
 6. DIFFERENTIAL PRESSURE MEASUREMENT FOR #1 SEAL ASSEMBLY IS CLASS 1 TO THE LEFT SIDE OF THE INSTRUMENT.
 7. DIFFERENTIAL PRESSURE MEASUREMENT FOR THERMAL BARRIER, ENTIRE ASSEMBLY IS CLASS 2.
 8. VALVE 302A FUNCTIONS AS ROOM ISOLATION AND RELIEF (250 PSID RELIEF SET POINT).
 9. EXCEPT WHERE OTHERWISE INDICATED, SAFETY CLASS FOR INSTRUMENT AIR AND NITROGEN LINES AND COMPONENTS IS BASED ON UPSTREAM INSTRUMENT AIR/NITROGEN VALVE. REFER TO INSTRUMENT AIR/NITROGEN DRAWING FOR SAFETY CLASS.

10/06-01/22/83

REVISED	DATE	BY	CHK	APP	TRK
01	10/06/83
02	01/22/83

CONSTRUCTION

DESIGNED	BY	DATE
CHECKED	BY	DATE
APPROVED	BY	DATE

SCALE: NONE

CHEMICAL AND VOLUME CONTROL SYSTEM CHARGING (CVCS) P. 4 OF 10

JOB NO.	DRAWING NO.	REV.
EVR 33812	33013-1263 SHEET 1 OF 2	1

CCD 01 CONTROL COPY

FOR 3RD INTERVAL ISI USE ONLY
REV. 2

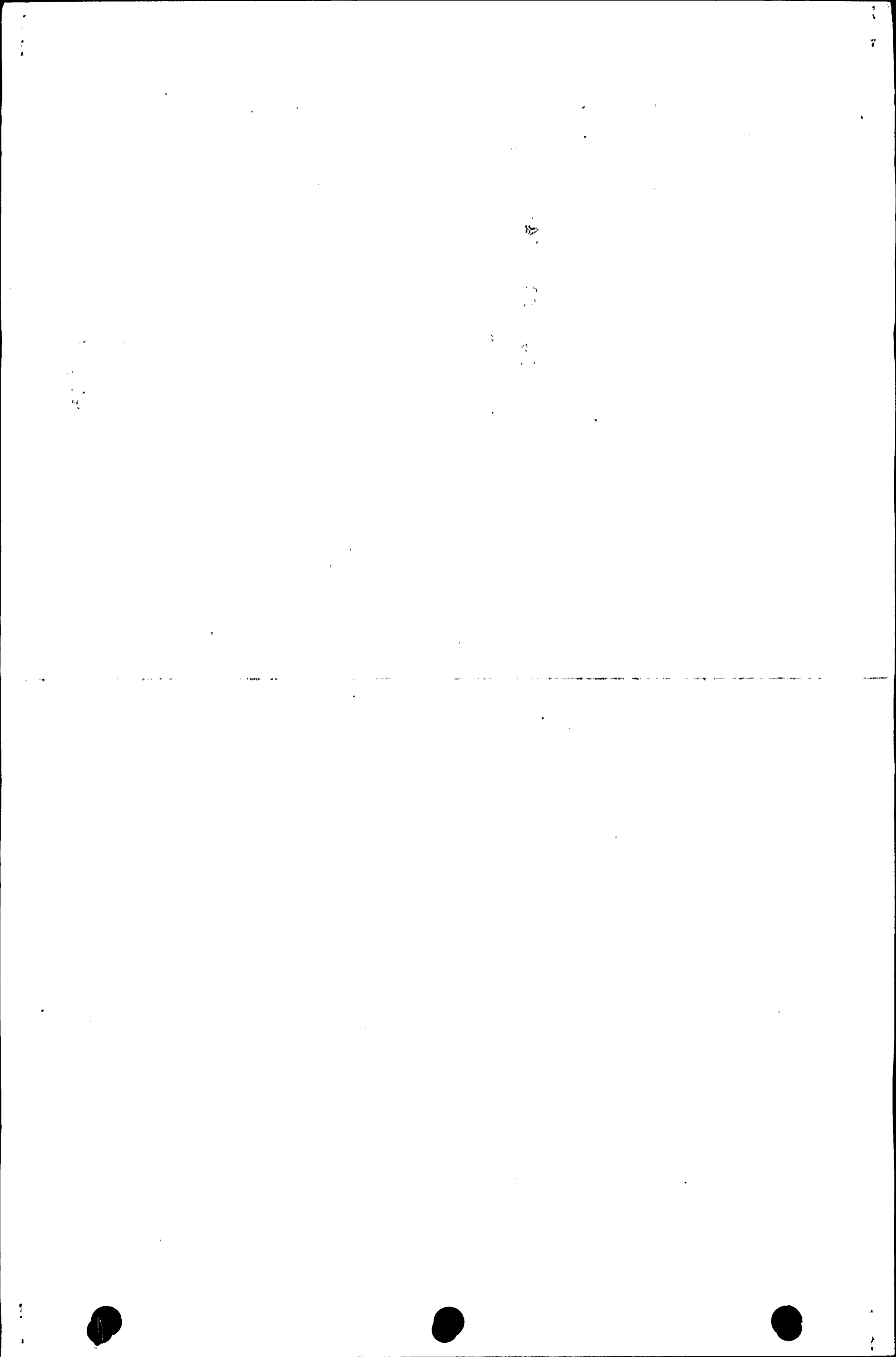

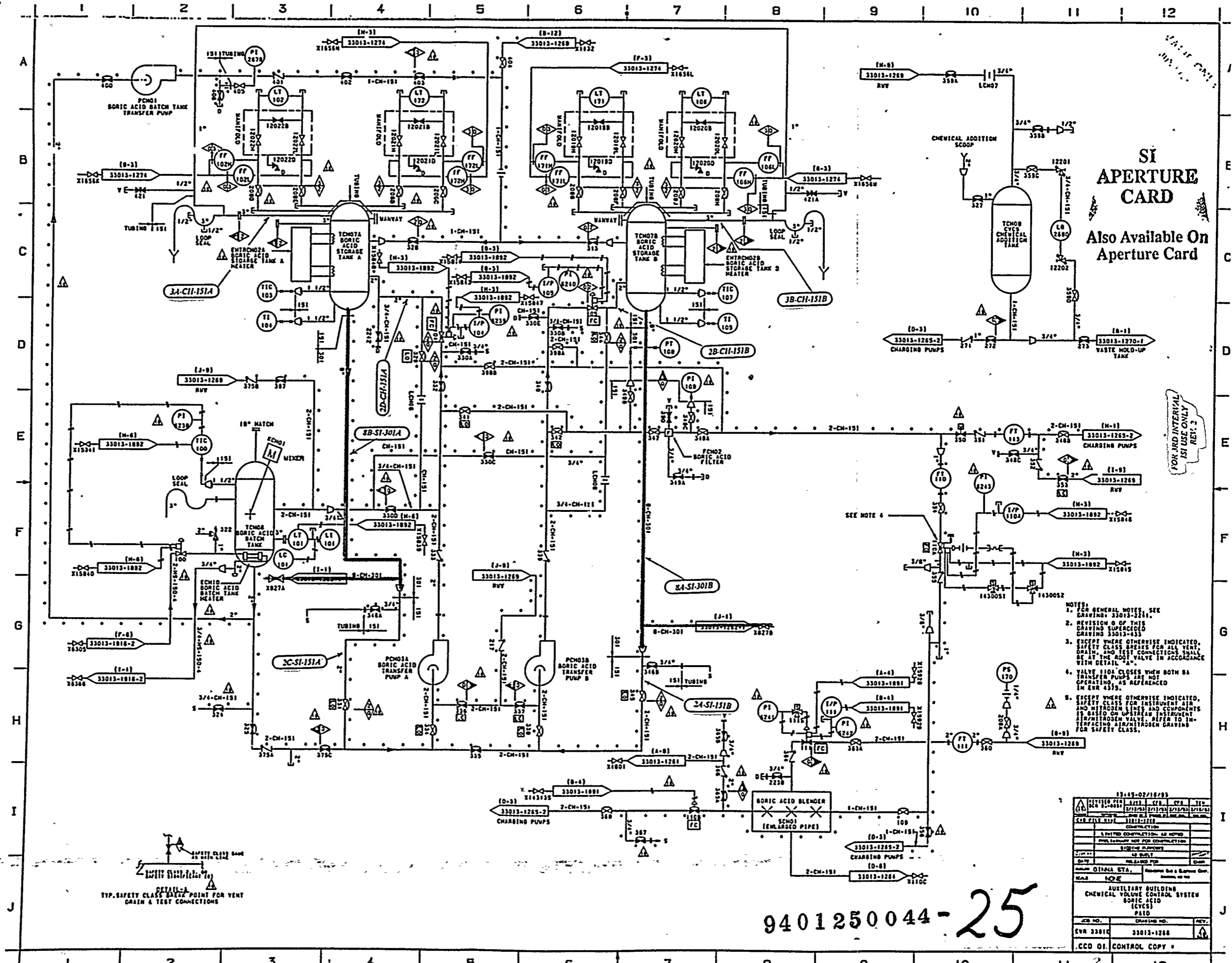

SI
APERTURE
CARD
Also Available On
Aperture Card

FOR AND INTERNAL
USE ONLY
REV. 2

- NOTES:
- FOR GENERAL NOTES, SEE DRAWING 33013-2211.
 - REVISION 0 OF THIS DRAWING SUPERCEDES DRAWING 33013-433.
 - EXCEPT WHERE OTHERWISE INDICATED, SAFETY CLASS BREAKS FOR ALL VENT, DRAIN, AND TEST CONNECTIONS SHALL BE AT THE ROOT VALVE IN ACCORDANCE WITH DETAIL "A".
 - VALVE 110A CLOSING WHEN BOTH BA TRANSFER PUMPS ARE NOT OPERATING AS REFERENCED IN EWR 4333.
 - EXCEPT WHERE OTHERWISE INDICATED, SAFETY CLASS FOR INSTRUMENT AIR AND NITROGEN LINES AND COMPONENTS IS BASED ON UPSTREAM INSTRUMENT AIR/NITROGEN VALVE. REFER TO INSTRUMENT AIR/NITROGEN DRAWING FOR SAFETY CLASS.

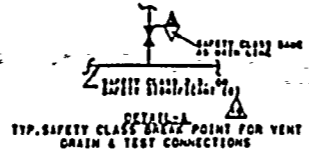

9401250044-25

83-69-02/18/83

NO.	DATE	BY	CHKD.	APP'D.	REV.
1	08/11/83	J. J. [unclear]	[unclear]	[unclear]	1
2	08/11/83	[unclear]	[unclear]	[unclear]	2
3	08/11/83	[unclear]	[unclear]	[unclear]	3
4	08/11/83	[unclear]	[unclear]	[unclear]	4
5	08/11/83	[unclear]	[unclear]	[unclear]	5
6	08/11/83	[unclear]	[unclear]	[unclear]	6
7	08/11/83	[unclear]	[unclear]	[unclear]	7
8	08/11/83	[unclear]	[unclear]	[unclear]	8
9	08/11/83	[unclear]	[unclear]	[unclear]	9
10	08/11/83	[unclear]	[unclear]	[unclear]	10
11	08/11/83	[unclear]	[unclear]	[unclear]	11
12	08/11/83	[unclear]	[unclear]	[unclear]	12

AUXILIARY BUILDING
CHEMICAL VOLUME CONTROL SYSTEM
BORIC ACID
LEVELS
PIED

NO.	DATE	BY	CHKD.	APP'D.	REV.
1	08/11/83	[unclear]	[unclear]	[unclear]	1
2	08/11/83	[unclear]	[unclear]	[unclear]	2

CCD OF CONTROL COPY

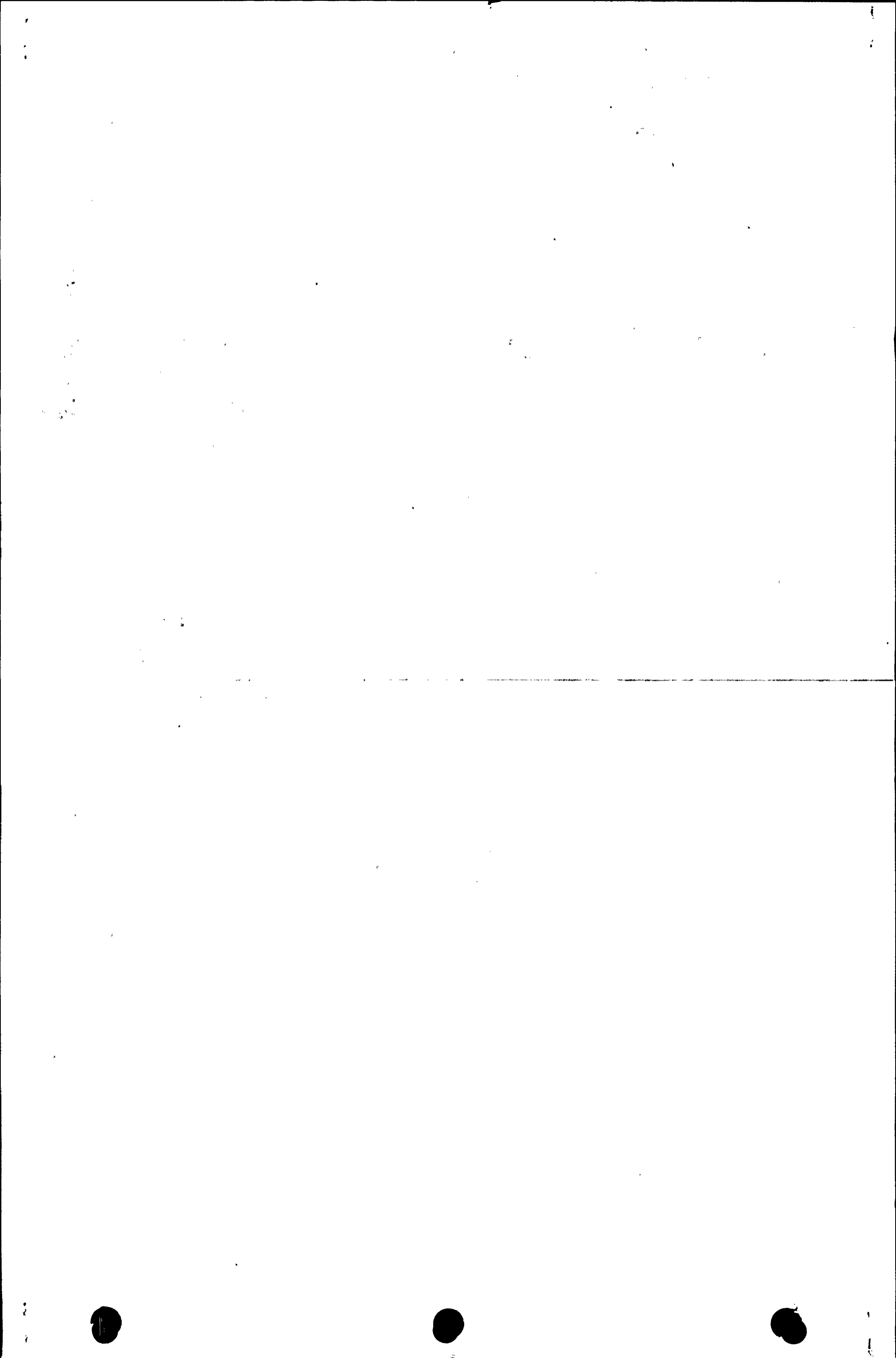

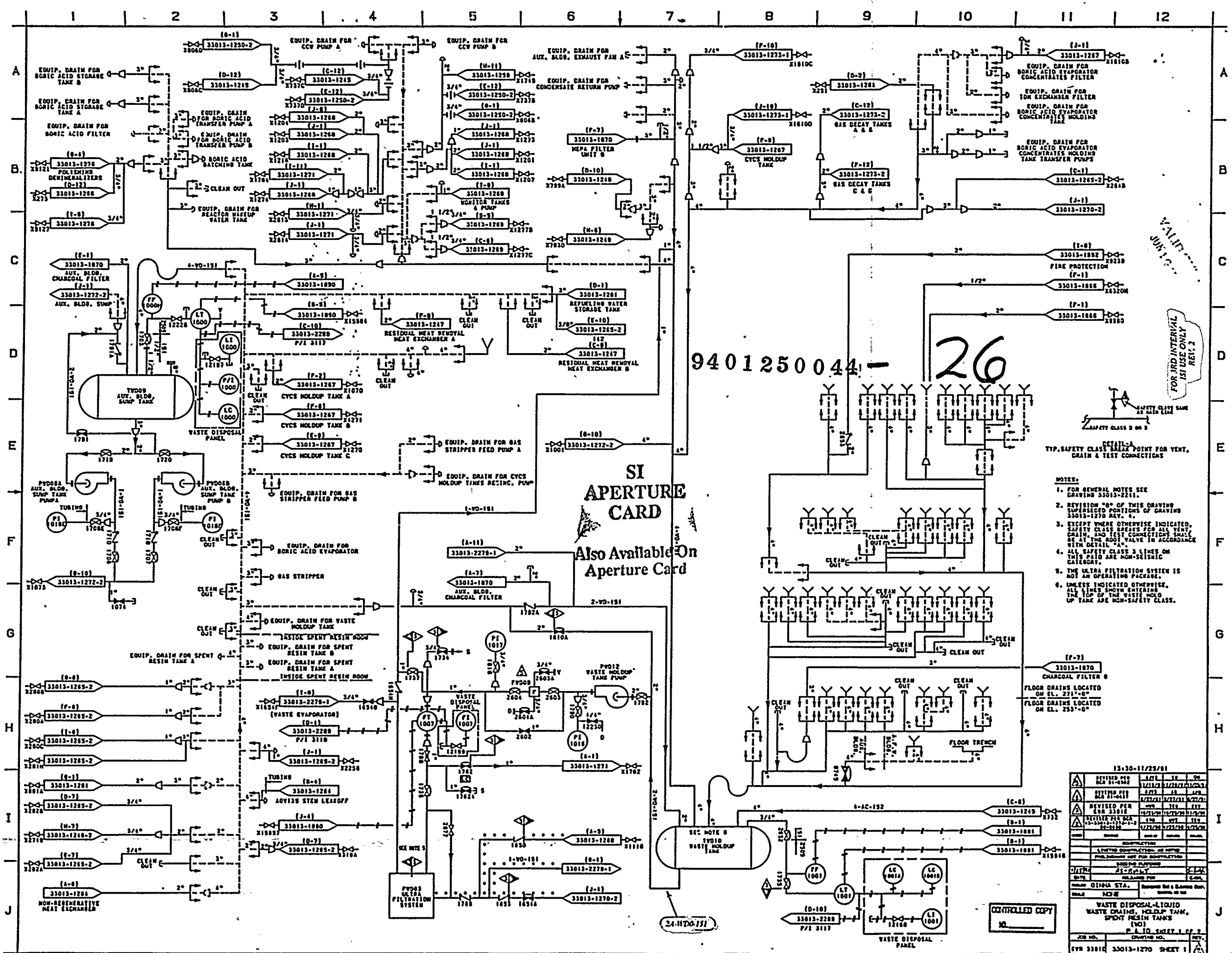

9401250044 - 26

SI
APERTURE
CARD

Also Available On
Aperture Card

- NOTES:
- 1. FOR GENERAL NOTES SEE DRAWING 33013-2261.
 - 2. REVISION "00" OF THIS DRAWING SUPERSEDES PORTIONS OF DRAWING 33013-1270 REV. 4.
 - 3. EXCEPT WHERE OTHERWISE INDICATED, SAFETY CLASS BEARS PER ALL VENT DRAIN, AND TEST CONNECTIONS SHALL BE AT THE ROOT VALVE IN ACCORDANCE WITH DETAIL "A".
 - 4. ALL SAFETY CLASS 3 LINES ON THIS PLD ARE NON-SEISMIC CATEGORY.
 - 5. THE ULTRA FILTRATION SYSTEM IS NOT AN OPERATING PACKAGE.
 - 6. UNLESS INDICATED OTHERWISE, ALL LINES SHOW ENTERING THE TOP OF THE WASTE HOLD UP TANK ARE NON-SAFETY CLASS.

REVISED BY	DATE	REVISION	DESCRIPTION
...
...
...
...
13-30-11/25/81 WASTE DISPOSAL-LIQUID WASTE DRAINING, HOLDUP TANK, SPENT RESIN TANKS (NO) P. 10 SHEET 1 OF 2 DRAWING NO.			

CONTROLLED COPY
NO.

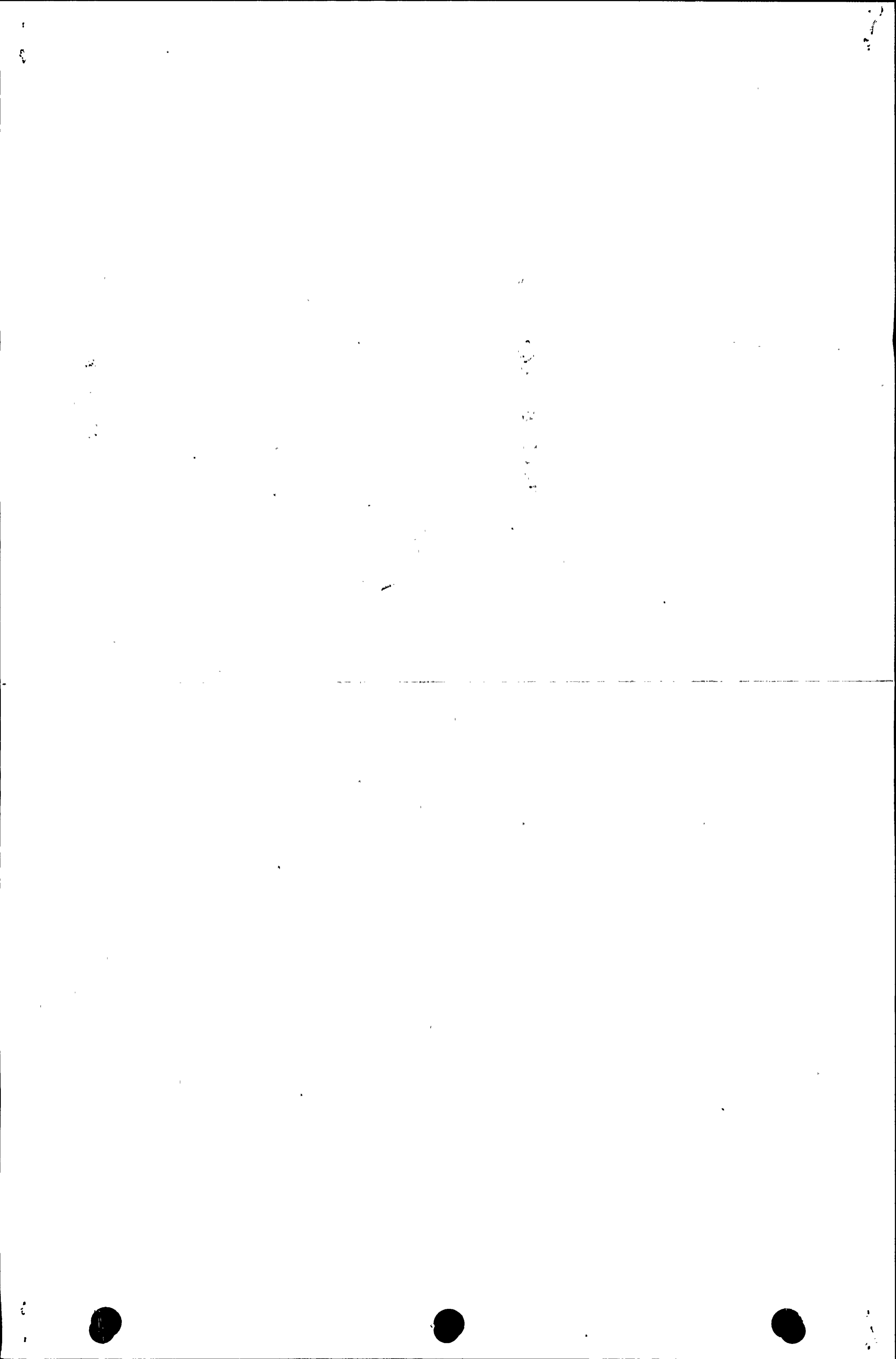

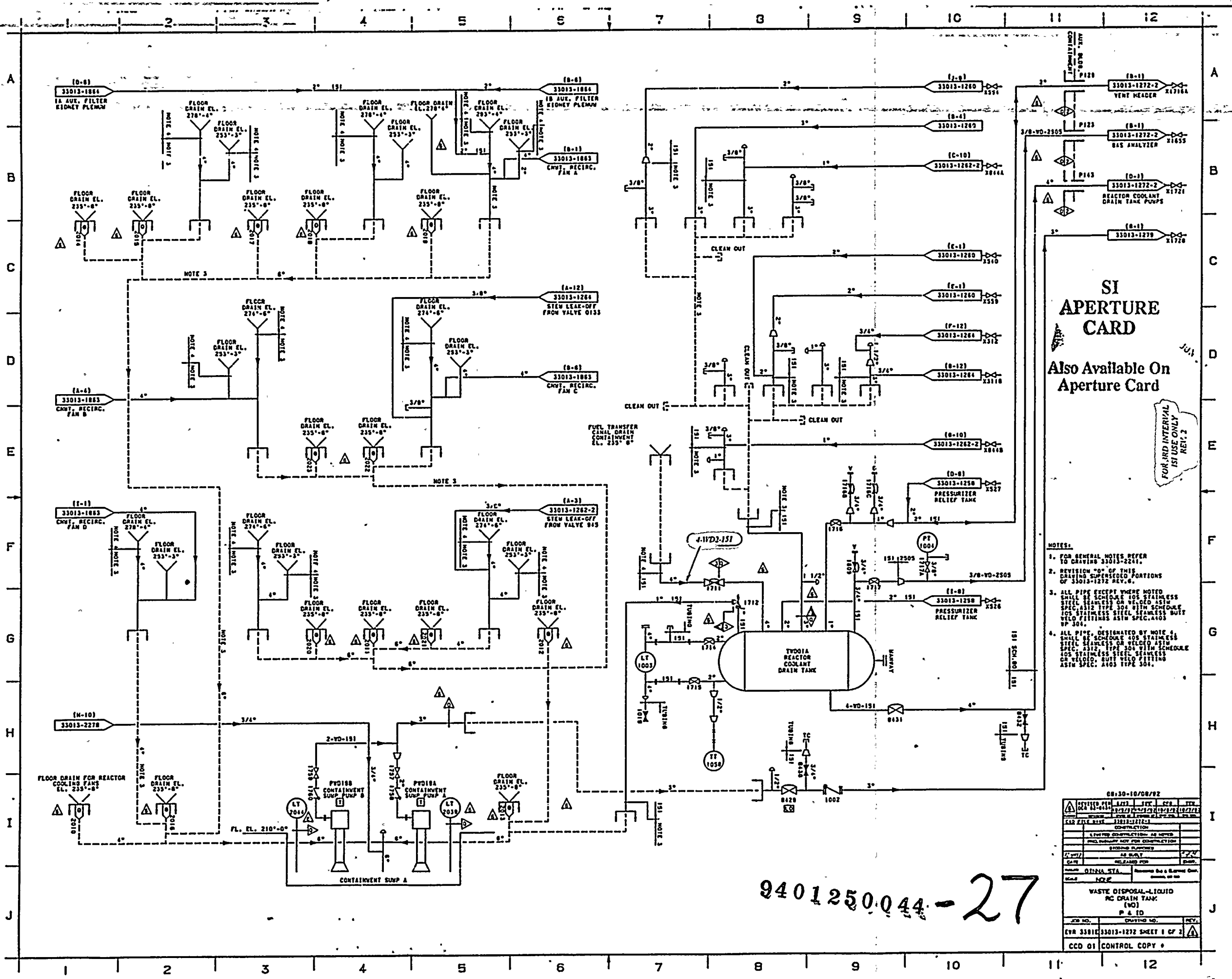

SI APERTURE CARD
 Also Available On Aperture Card

FOR IRD INTERVAL
 1ST USE ONLY
 REV. 2

- NOTES:**
1. FOR GENERAL NOTES REFER TO DRAWING 33013-2241.
 2. REVISION "00" OF THIS DRAWING SUSPENDED PORTIONS OF 33013-1272 REV. 0.
 3. ALL PIPE EXCEPT WHERE NOTED SHALL BE SCHEDULE 10S STAINLESS STEEL SEAMLESS OR WELDED ASTM SPEC. A312 TYPE 304 OR 316 SCHEDULE 10S STAINLESS STEEL SEAMLESS BUT WELD FITTINGS ASTM SPEC. A307 WP 304.
 4. ALL PIPE, DESIGNATED BY NOTE 3, SHALL BE SCHEDULE 10S STAINLESS STEEL SEAMLESS OR WELDED ASTM SPEC. A312 TYPE 304 OR 316 SCHEDULE 10S STAINLESS STEEL SEAMLESS OR WELDED, BUT WELD FITTING ASTM SPEC. A307 TYPE 304.

68-30-10/08/82			
DESIGNED BY	DATE	REV.	APP.
33013-1272	10/10/79	01	
EVR 33013-1272 SHEET 1 OF 2			
CCD 01 CONTROL COPY			

9401250.044-27

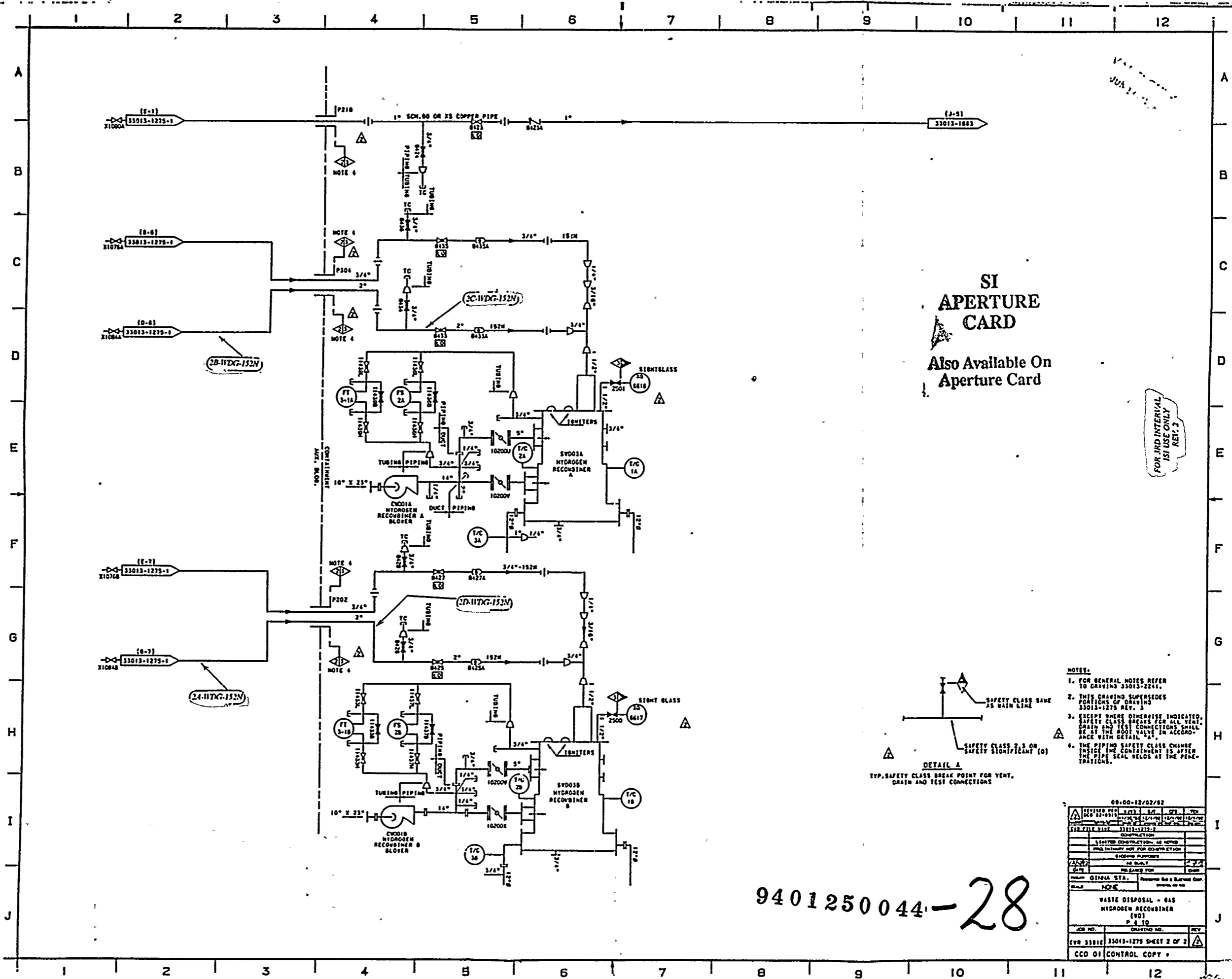

SI APERTURE CARD
 Also Available On Aperture Card

FOR JND INTERNAL USE ONLY REV. 3

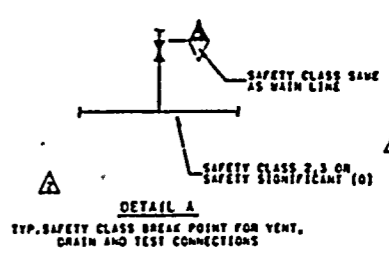

- NOTES:
1. FOR GENERAL NOTES REFER TO DRAWING 33013-2211.
 2. THIS DRAWING SUPERSEDES PORTIONS OF DRAWING 33013-1275 REV. 3.
 3. EXCEPT WHERE OTHERWISE INDICATED, SAFETY CLASS BREAKS FOR ALL VENT, DRAIN AND TEST CONNECTIONS SHALL BE AT THE ROOT VALVE IN ACCORDANCE WITH DETAIL "A".
 4. THE PIPING SAFETY CLASS CHANGES INSIDE THE CONTAINMENT IS AFTER THE PIPE SEAL BELOWS AT THE PENETRATIONS.

9401250044-28

08:00-12/02/82	
DESIGNED BY	DATE
DRAWN BY	DATE
CHECKED BY	DATE
APPROVED BY	DATE
CONSTRUCTION	
LIMITED CONSTRUCTION - AS SHOWN	
AND 100% INSPECTION FOR CONSTRUCTION	
SHOWN PURPOSE	
AS SHOWN	
RELEASING FOR	
DATE	
WASTE DISPOSAL - GAS HYDROGEN RECYCLER (VD)	
P. 4 TO	
JOB NO.	DRAWING NO.
REV	REV
08 33013	33013-1275 SHEET 2 OF 2
CCD 01	CONTROL COPY

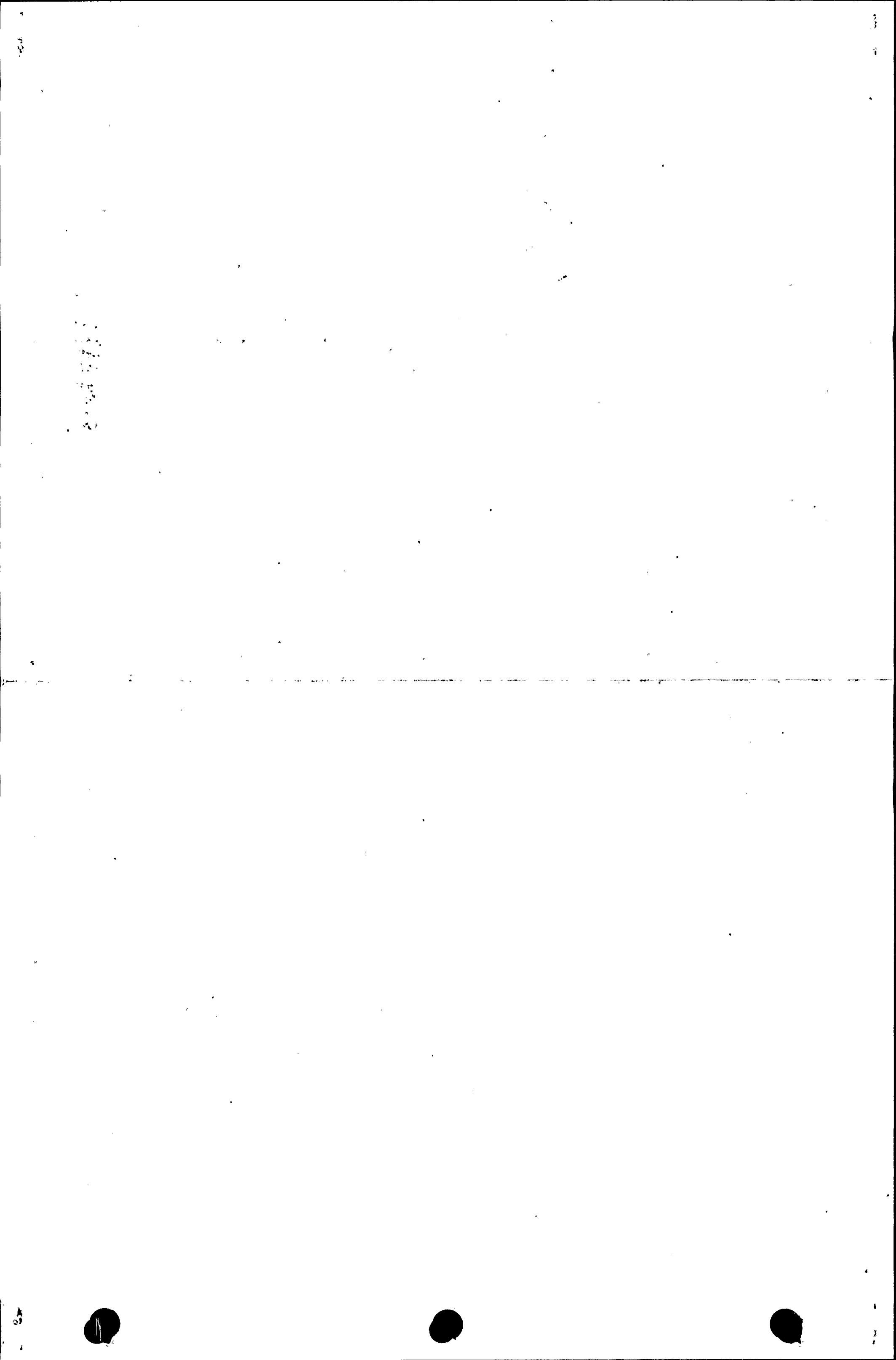

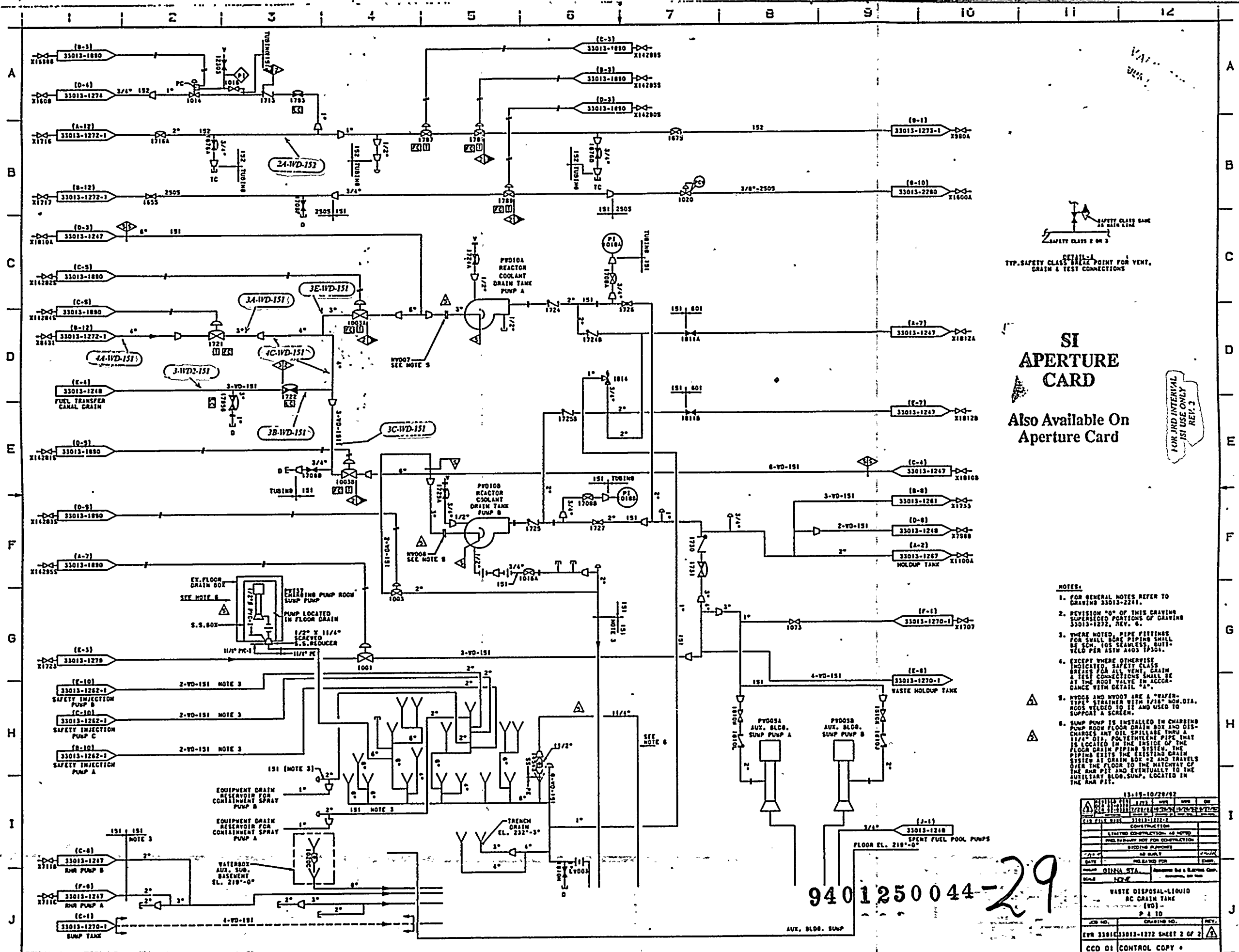

SAFETY CLASS 2 OR 3
 SAFETY CLASS 2 OR 3
 TYP. SAFETY CLASS 2 POINT FOR VENT, DRAIN & TEST CONNECTIONS

SI APERTURE CARD

Also Available On
Aperture Card

FOR I&D INTERNAL
 USE ONLY
 REV. 3

- NOTES:**
- FOR GENERAL NOTES REFER TO DRAWING 33013-2244.
 - REVISION "0" OF THIS DRAWING SUPERSEDES PORTIONS OF DRAWING 33013-1272, REV. 6.
 - WHERE NOTED, PIPE FITTINGS FOR SMALL BORE PIPING SHALL BE SCH. 10S SEAMLESS, BUT WELD PER ASTM A403 TP301.
 - EXCEPT WHERE OTHERWISE INDICATED, SAFETY CLASS BRESS FOR ALL VENT, DRAIN & TEST CONNECTIONS SHALL BE AT THE ROOT VALVE IN ACCORDANCE WITH DETAIL "A".
 - WY007 AND WY007 ARE A "WAFER-TYPE" STRAINER WITH 1/16" NOM. DIA. HOLES WELDED TO IT AND USED TO SUPPORT A SCREEN.
 - SUMP PUMP IS INSTALLED IN CHARGING PUMP ROOM FLOOR DRAIN BOX AND DISCHARGES ANY OIL SPILLAGE THRU 1/2" DIA. POLYETHYLENE PIPE THAT IS LOCATED IN THE INSIDE OF THE FLOOR DRAIN PIPING SYSTEM. THE PIPE ENITS THE EXISTING DRAIN SYSTEM AT DRAIN BOX 22 AND TRAVELS OVER THE FLOOR TO THE MATCHWAT OF THE RAN PIT AND EVENTUALLY TO THE AUXILIARY BLDG. SUMP, LOCATED IN THE RAN PIT.

13-12-10/28/82	
DATE	12/22/82
BY	WJL
CHKD	WJL
APP'D	WJL
REV	0
CONSTRUCTION	
LIMITED CONSTRUCTION AS NOTED	
FIELD TO BE USED FOR CONSTRUCTION	
STUDYING PURPOSES	
SCALE	AS SHOWN
DATE	13-12-10/28/82
BY	WJL
CHKD	WJL
APP'D	WJL
WASTE DISPOSAL-LIQUID AC DRAIN TANK (VD) P & ID	
CDR NO.	DRAWING NO.
REV	REV
FOR 33013-1272 SHEET 2 OF 2	
CCD 01 CONTROL COPY	

9401250044-29

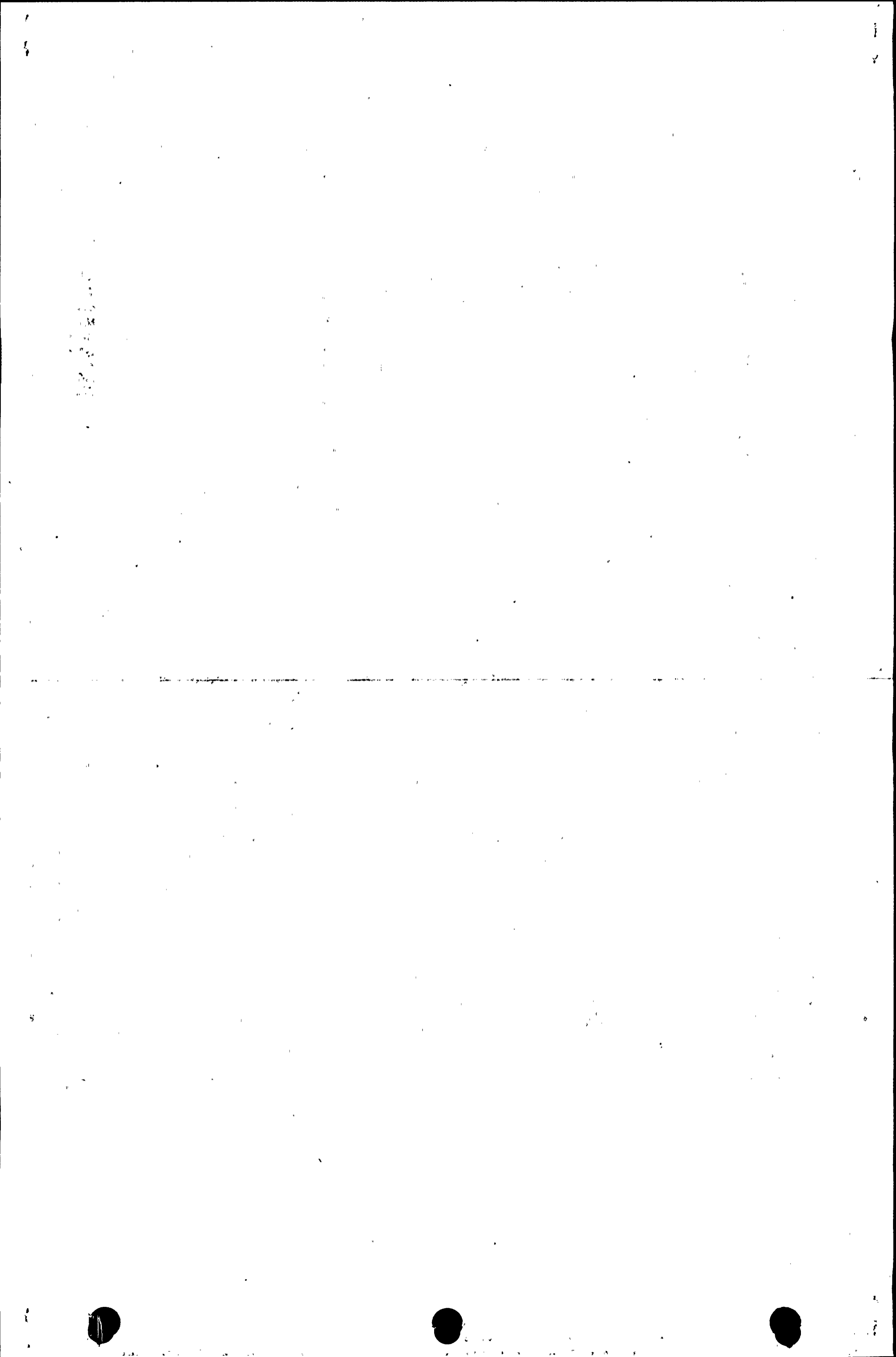

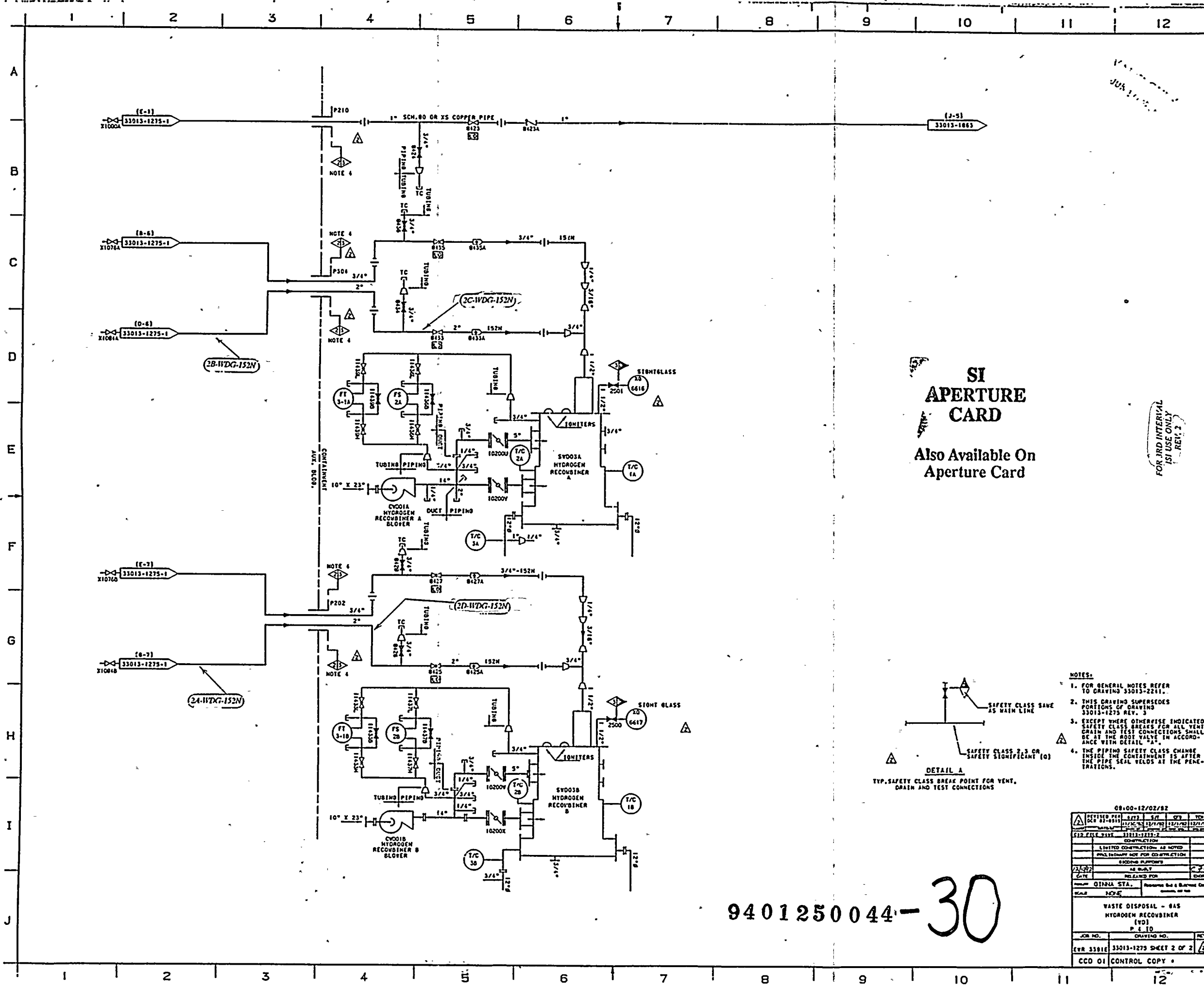

JUN 1 1983

SI APERTURE CARD

Also Available On Aperture Card

FOR 3RD INTERVAL
SI USE ONLY
REV. 2

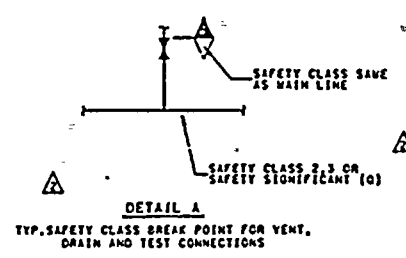

- NOTES:
1. FOR GENERAL NOTES REFER TO DRAWING 33013-2211.
 2. THIS DRAWING SUPERSEDES PORTIONS OF DRAWING 33013-1275 REV. 3
 3. EXCEPT WHERE OTHERWISE INDICATED, SAFETY CLASS BREAKS FOR ALL VENT, DRAIN AND TEST CONNECTIONS SHALL BE AT THE ROSE VALVE IN ACCORDANCE WITH DETAIL "A".
 4. THE PIPING SAFETY CLASS CHANGE INSIDE THE CONTAINMENT IS AFTER THE PIPE SEAL WELDS AT THE PENETRATIONS.

9401250044-30

REVISED PER	DATE	BY	CHKD	APP'D
BY 48-4518	11/16/78	SM	SM	12/1/78
FILED BY	DATE	BY	CHKD	APP'D
3113-1213-2	11/16/78	SM	SM	12/1/78
CONSTRUCTION				
LIMITED CONSTRUCTION AS NOTED				
P&ID INVENTORY NOT FOR CONSTRUCTION				
EXCISE PLUMBING				
AS BUILT				
DATE				
RELEASED FOR				
CONTR.				
QTR4 STA. Approved by 4 Electrical Dept.				
SCALE: NONE				
WASTE DISPOSAL - GAS				
HYDROGEN RECOMBINER				
P-1-10				
JOB NO.	DRAWING NO.	REV.		
EVR 3301E	33013-1275 SHEET 2 OF 2			
CCO 01 CONTROL COPY				

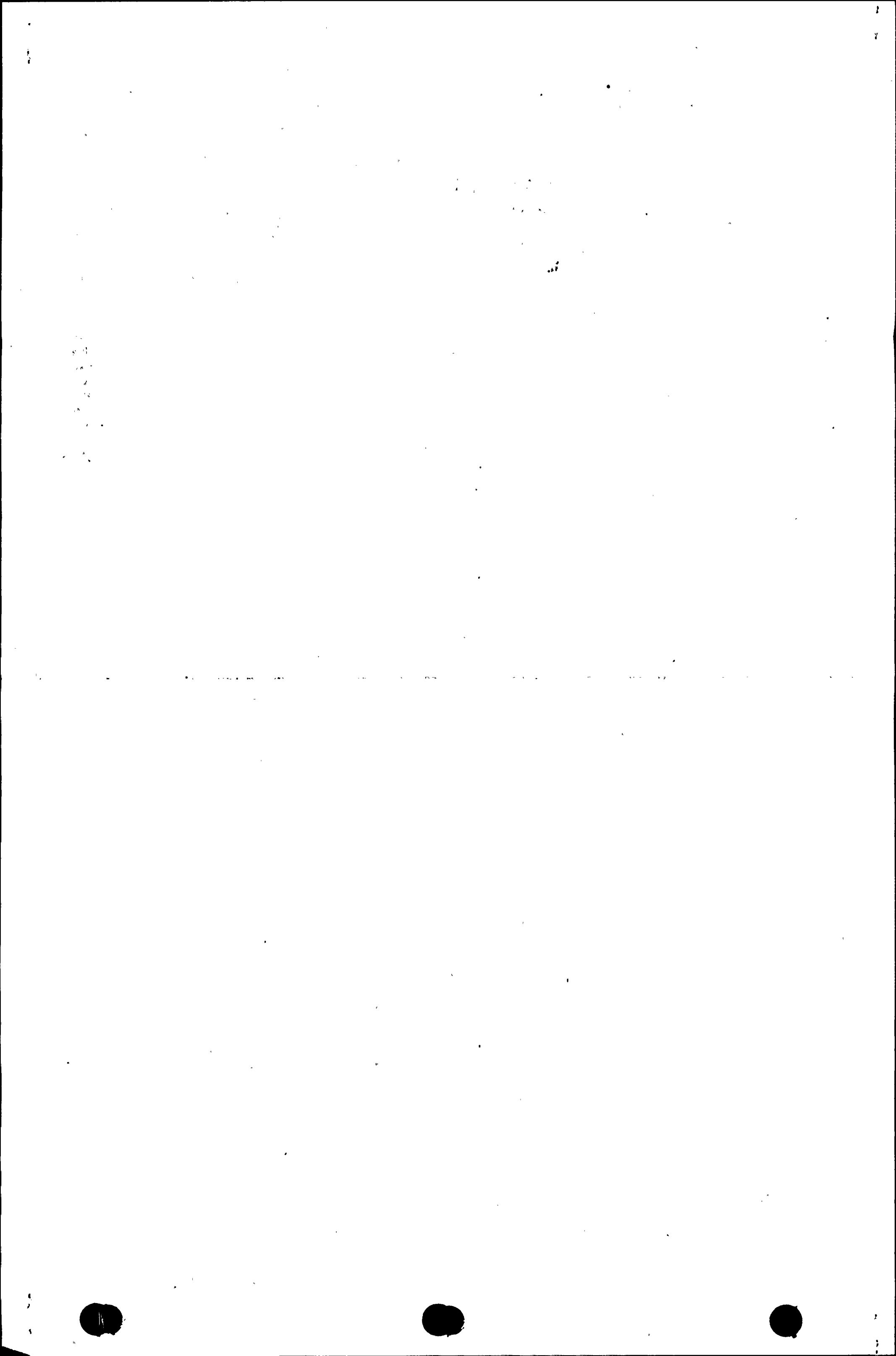

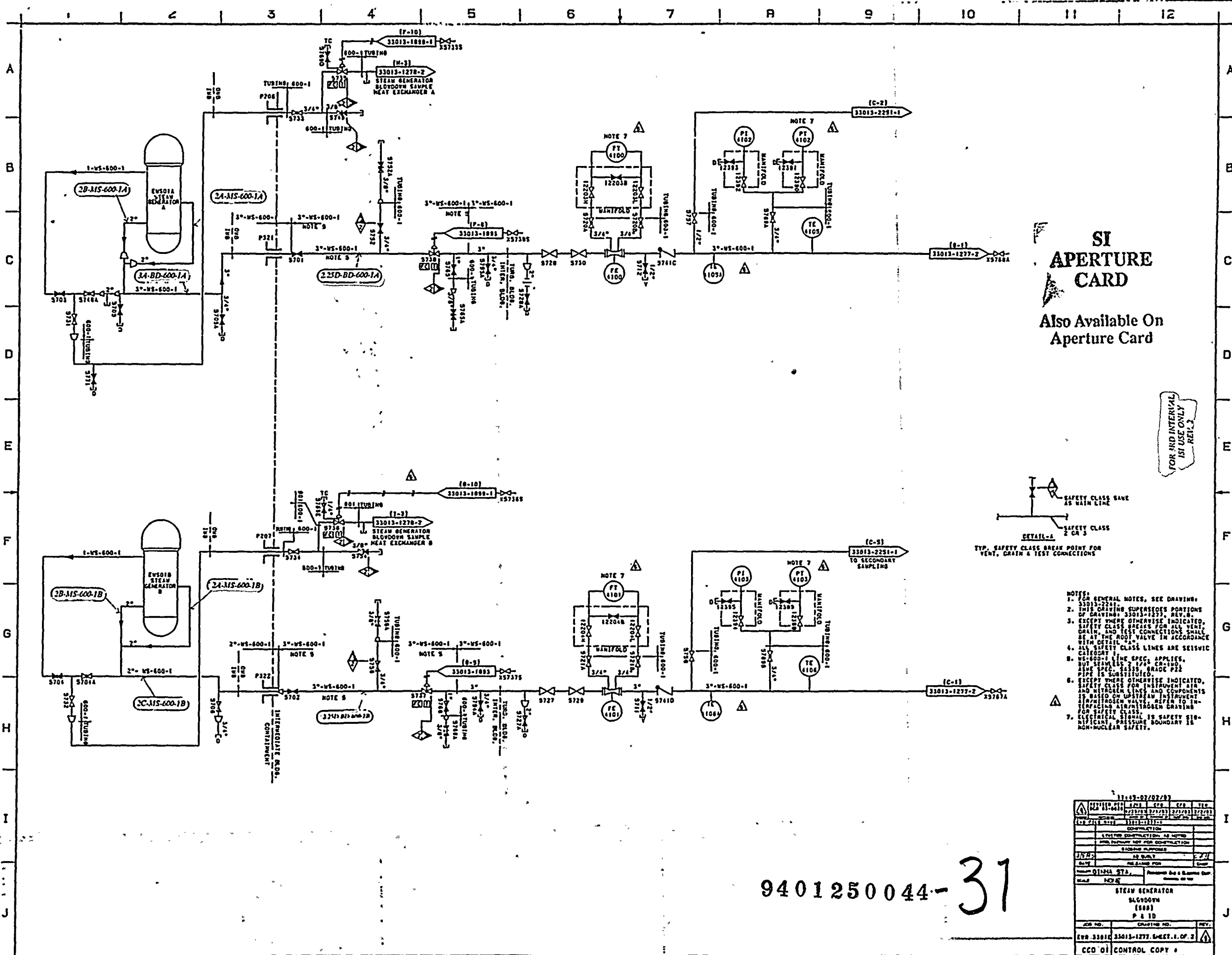

SI APERTURE CARD
 Also Available On Aperture Card

FOR IND INTERVAL
 1ST USE ONLY
 REL. 3

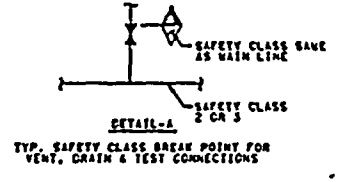

- NOTES:**
- FOR GENERAL NOTES, SEE DRAWING.
 - THIS DRAWING SUPPLEMENTS PORTIONS OF DRAWING 33013-1277, REV. B.
 - EXCEPT WHERE OTHERWISE INDICATED, SAFETY CLASS AREAS FOR ALL VENT, DRAIN, AND TEST CONNECTIONS SHALL BE AT THE ROOT VALVE IN ACCORDANCE WITH DETAIL "A".
 - ALL SAFETY CLASS LINES ARE SEISMIC CATEGORY 1 LINE SPEC. APPLIES, BUT SEISMIC 2 / 44 CR-100, SEE SEC. 11.1.1 GRADE P22 AND IS SUBSTITUTED.
 - EXCEPT WHERE OTHERWISE INDICATED, SAFETY CLASS FOR INSTRUMENTS IN INSTRUMENT LINES AND COMPONENTS IS BASED ON UPSTREAM INSTRUMENT AND ROOT VALVE. REFER TO INSTRUMENTING AIR/NITROGEN DRAWING FOR SAFETY CLASS.
 - ELECTRICAL PRESSURE BOUNDARY IS NON-NUCLEAR SAFETY.

9401250044-31

11-27-07/07/07				
REV	DATE	BY	CHK	APP
1	11/27/07
DESCRIPTION				
STEAM GENERATOR BLOWDOWN (S&S) P & ID				
JOB NO.	DRAWING NO.	REV.		
33013-1277	33013-1277-S&S-1.0P.2			
CCD OF CONTROL COPY				

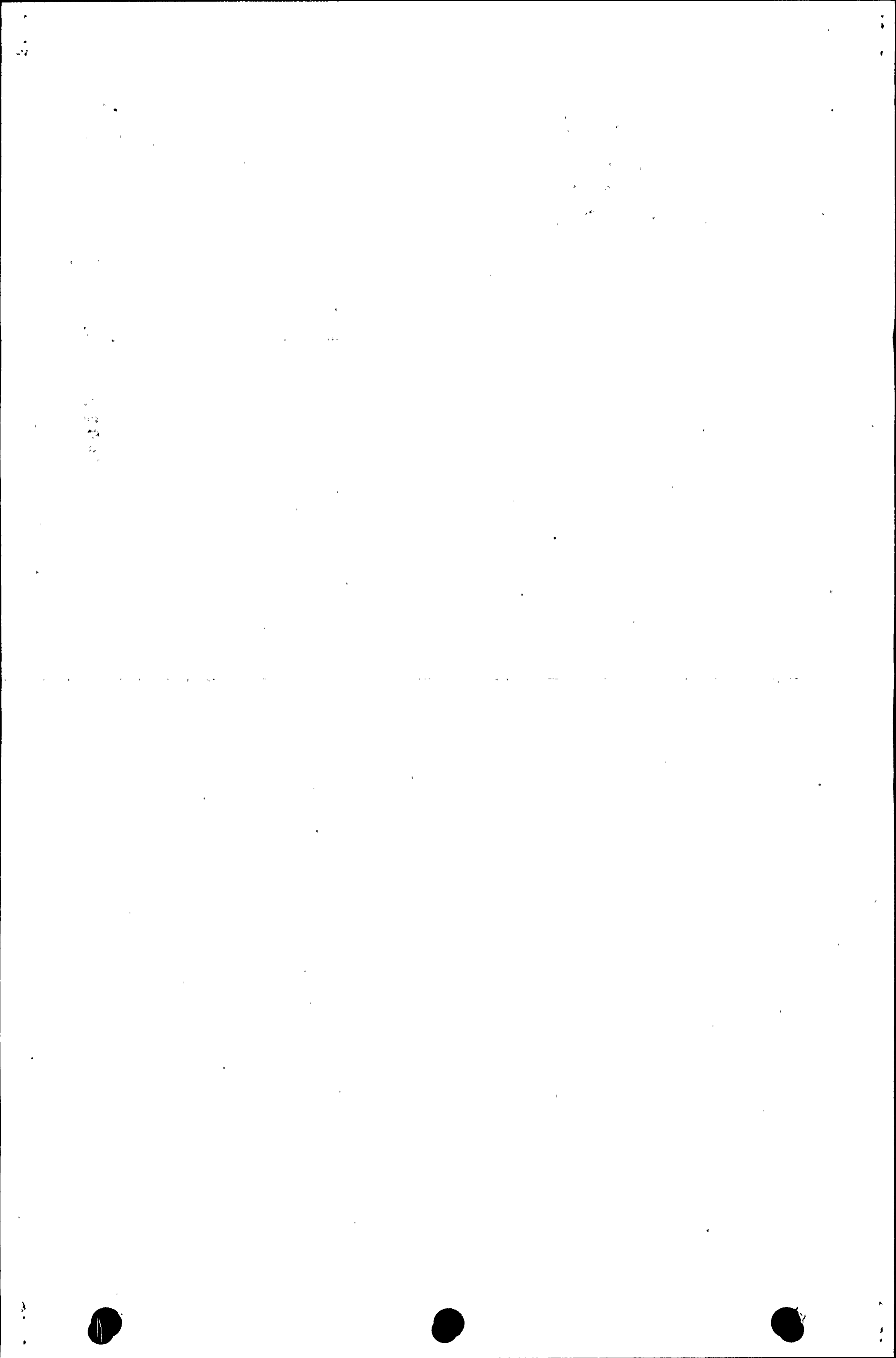

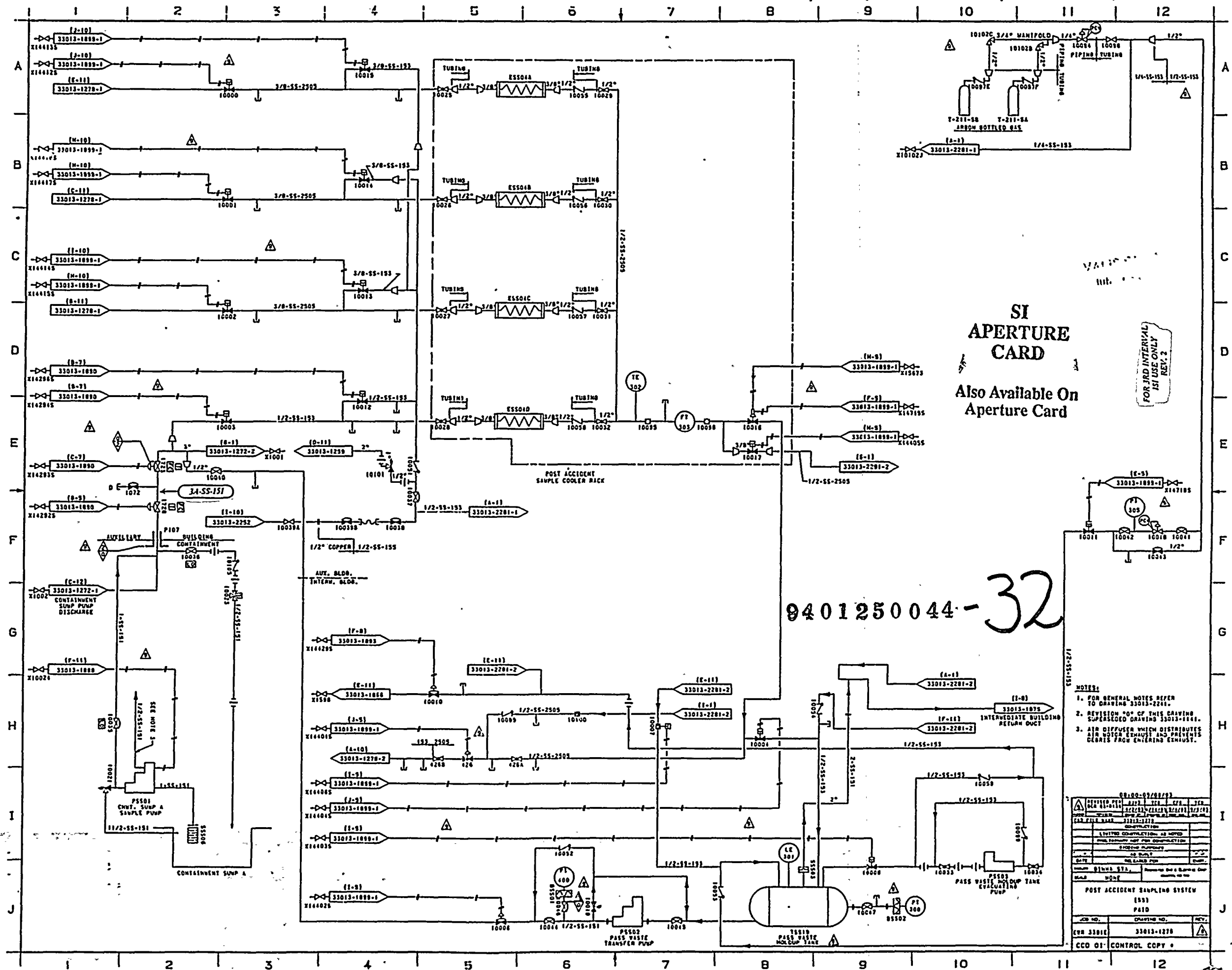

SI
APERTURE
CARD

Also Available On
Aperture Card

FOR 3RD INTERNAL
SI USE ONLY
REV. 2

9401250044-32

- NOTES:
- FOR GENERAL NOTES REFER TO DRAWING 33013-2201.
 - REVISION "0" OF THIS DRAWING SUPERSEDES DRAWING 33013-1801.
 - AIR DIFFUSER WHICH DISTRIBUTES AIR WATER EXHAUST AND PREVENTS GERMS FROM ENTERING EXHAUST.

DESIGNED BY	DATE	SCALE	APP. NO.
DRAWN BY	DATE	SCALE	APP. NO.
CHECKED BY	DATE	SCALE	APP. NO.
APPROVED BY	DATE	SCALE	APP. NO.
POST ACCIDENT SAMPLING SYSTEM			
JOB NO.	DRAWING NO.	REV.	
CVR 33013	33013-1270		
CCD 01: CONTROL COPY			

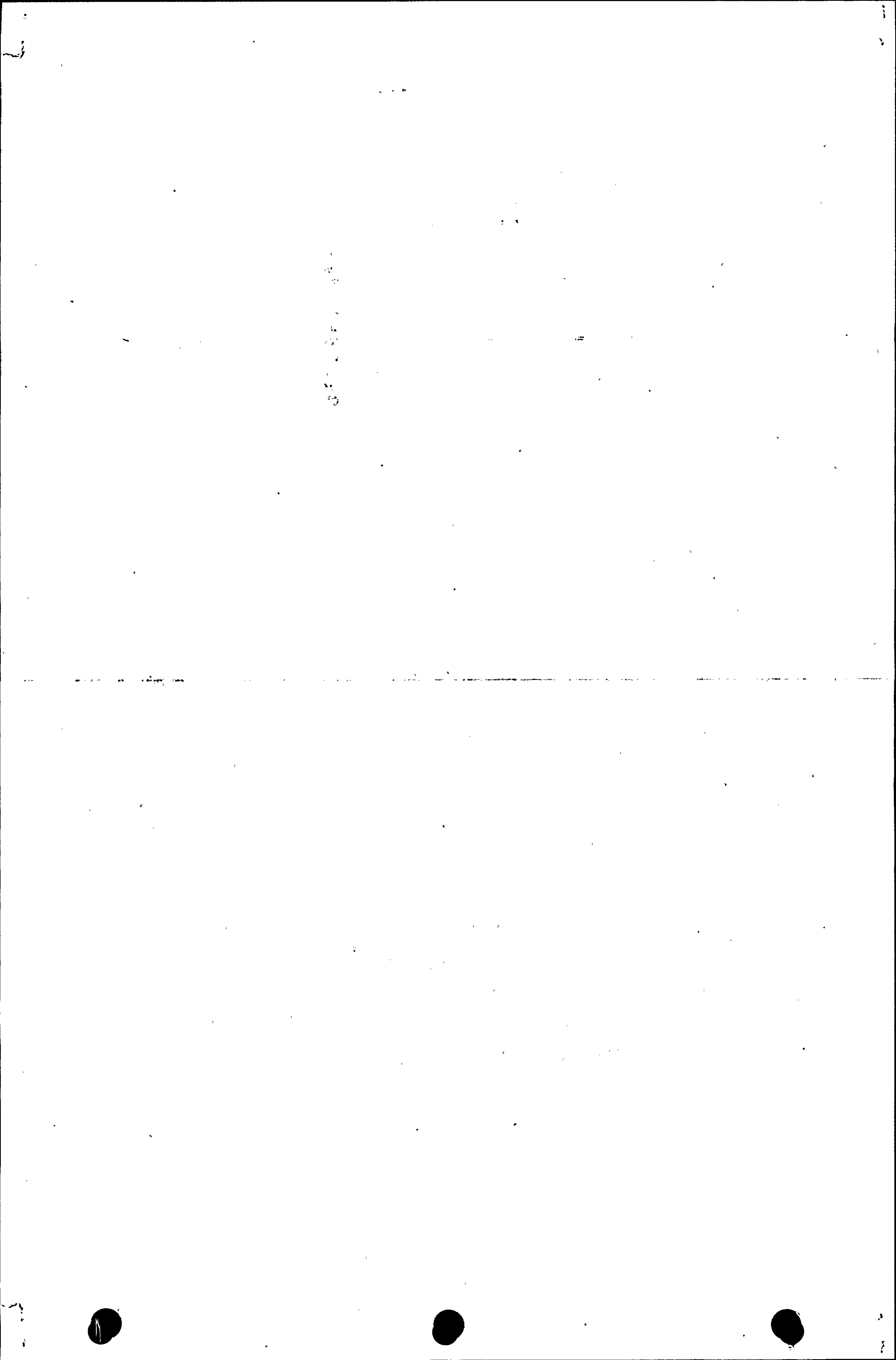

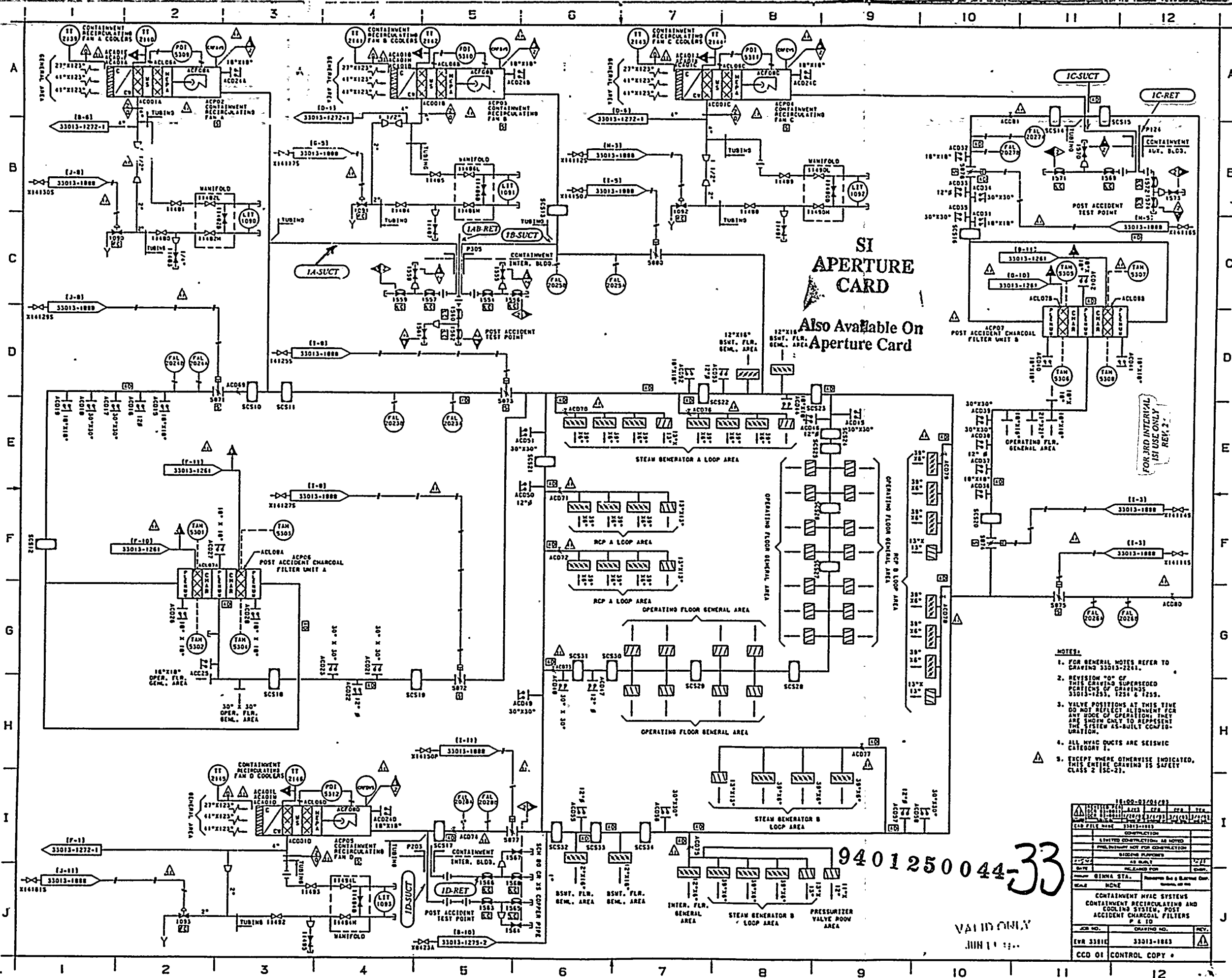

SI APERTURE CARD

Also Available On Aperture Card

- NOTES:**
- FOR GENERAL NOTES REFER TO DRAWING 33013-2281.
 - REVISION "00" OF THIS DRAWING SUPERSEDES PREVIOUS EDITIONS OF DRAWINGS 33013-1251, 1254 & 1255.
 - VALVE POSITIONS AT THIS TIME DO NOT REFLECT ALIGNMENT FOR ANY MODE OF OPERATION. THEY ARE SHOWN ONLY TO REPRESENT THE SYSTEM AS-BUILT CONFIGURATION.
 - ALL HVAC DEVICES ARE SEISMIC CATEGORY I.
 - EXCEPT WHERE OTHERWISE INDICATED, THIS ENTIRE DRAWING IS SAFETY CLASS 2 (SC-2).

15-02-83/04/03		
REV	DESCRIPTION	DATE
1	LIMITED MODIFICATIONS AS NOTED	
2	PRELIMINARY NOT FOR CONSTRUCTION	
3	ISSUING DRAWINGS	
4	AS BUILT	12/81
5	RE-DESIGNED FOR COMP.	
6	SCALE	NONE
DRAWN BY: GIMHA, STA. CHECKED BY: GIMHA, STA. SCALE: NONE		
CONTAINMENT HVAC SYSTEMS CONTAINMENT RECIRCULATING AND COOLING SYSTEM, POST ACCIDENT CHARCOAL FILTERS P & ID		
JOB NO.	DRAWING NO.	REV.
EVF 33013	33013-1863	1
CCD 01 CONTROL COPY		

9401250044-33

VALID ONLY
JUN 11 1981

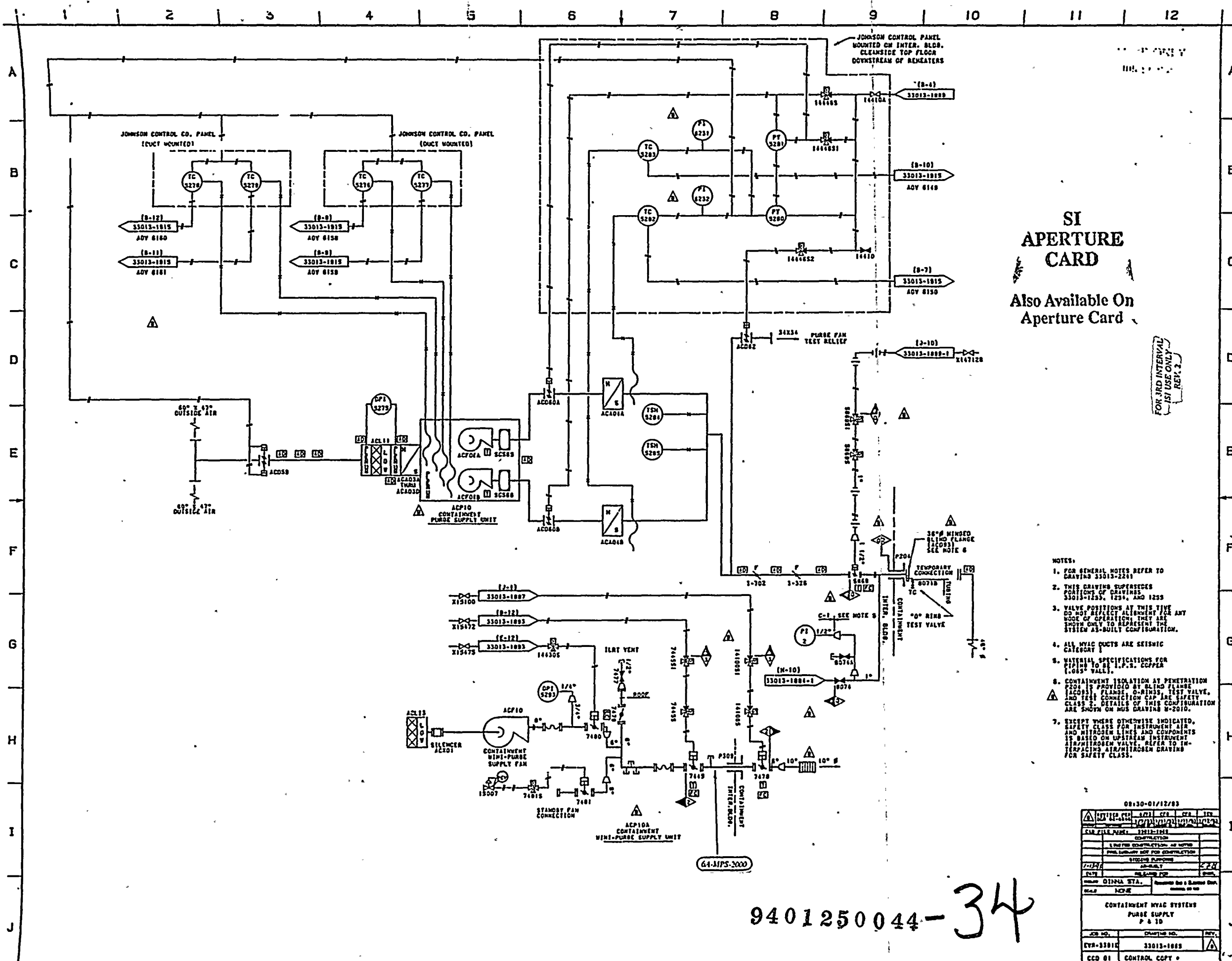

SI APERTURE CARD
 Also Available On Aperture Card

FOR JRD INTERVAL
 ISI USE ONLY
 REV. 2

- NOTES:
- FOR GENERAL NOTES REFER TO DRAWING 33013-2241
 - THIS DRAWING SUPERSEDES PORTIONS OF DRAWINGS 33013-1233, 1234, AND 1235
 - VALVE POSITIONS AT THIS TIME DO NOT REFLECT ALIGNMENT FOR ANY MODE OF OPERATION; THEY ARE SHOWN ONLY TO REPRESENT THE SYSTEM AS-BUILT CONFIGURATION.
 - ALL HVAC DUCTS ARE SEISMIC CATEGORY 1
 - MATERIAL SPECIFICATIONS FOR PIPING TO BE I.P.S. COPPER (1.062" WALL).
 - CONTAINMENT ISOLATION AT PENETRATION POINT IS PROVIDED BY BLIND FLANGE (AC203) FLANGE O-RINGS, TEST VALVE, AND TEST CONNECTION CAP ARE SAFETY CLASS 2. DETAILS OF THIS CONFIGURATION ARE SHOWN ON HIS DRAWING M-2010.
 - EXCEPT WHERE OTHERWISE INDICATED, SAFETY CLASS FOR INSTRUMENT AIR AND NITROGEN LINES AND COMPONENTS IS BASED ON UPSTREAM INSTRUMENT AIR/NITROGEN VALVE. REFER TO INTERFACING AIR/NITROGEN DRAWING FOR SAFETY CLASS.

09:30-01/12/83

REV.	DATE	BY	CHKD	APP'D
1	01/12/83
2
3
4
5
6
7
8
9
10
11
12

CONTAINMENT HVAC SYSTEMS
 PURGE SUPPLY
 P & ID

REV.	DATE	BY	CHKD	APP'D
01	01/12/83
02
03
04
05
06
07
08
09
10
11
12

9401250044-34

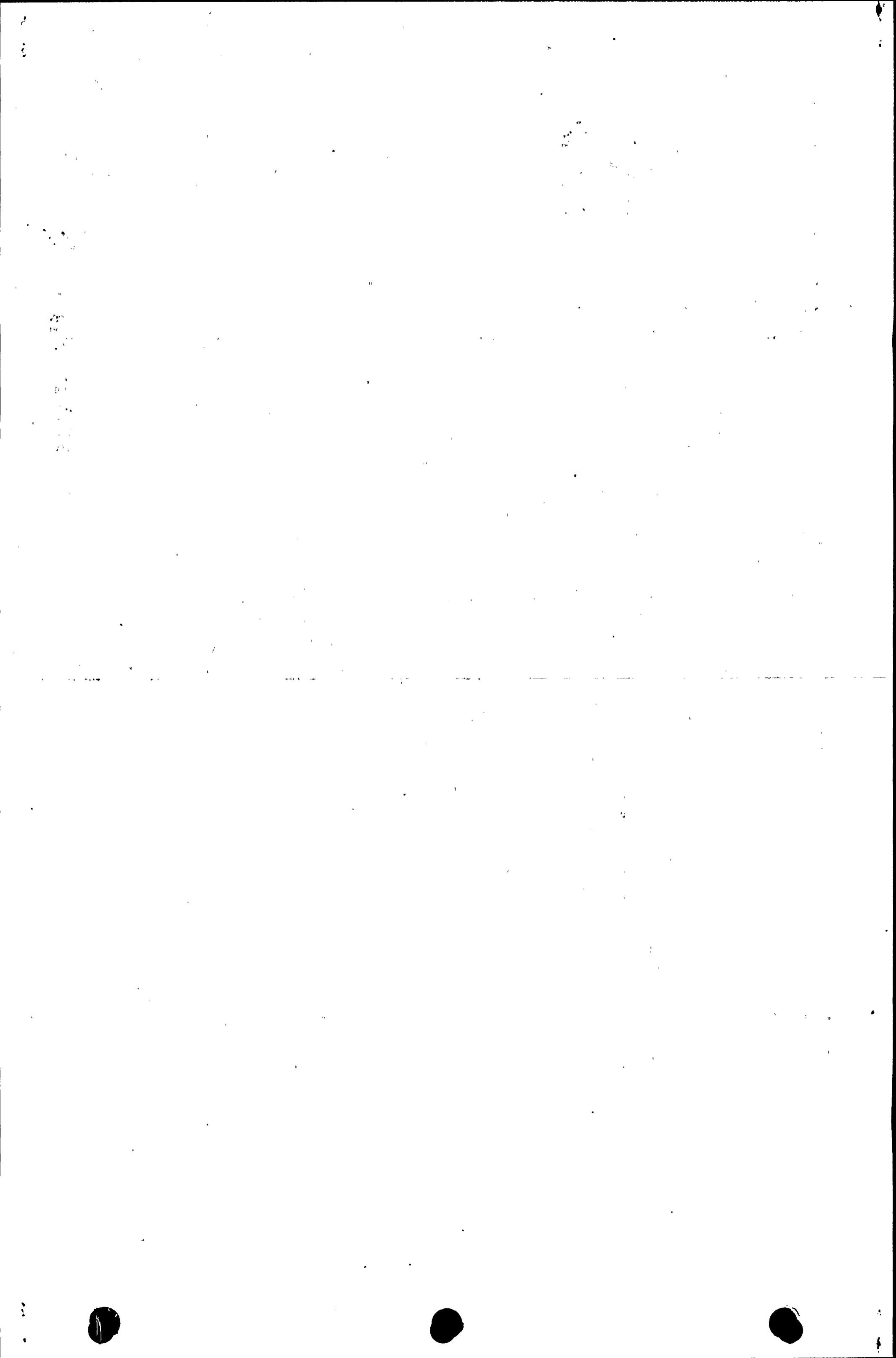

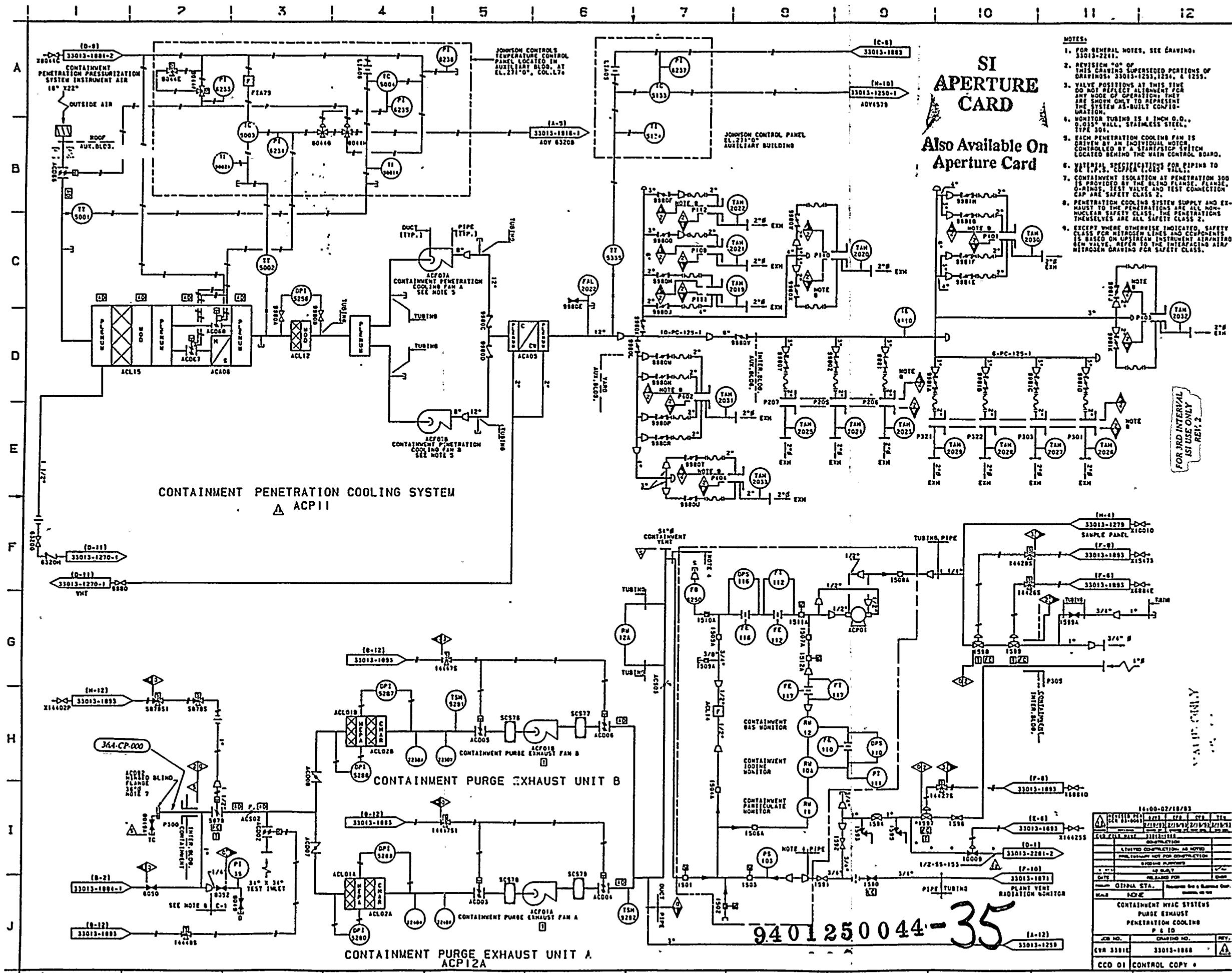

- NOTES:**
1. FOR GENERAL NOTES, SEE DRAWING: 33013-2201.
 2. REVISION NO. OF THIS DRAWING SUPERSEDES PREVIOUS OF DRAWINGS: 33013-1250-1, 1250-2, & 1250-3.
 3. VALVE POSITIONS AT THIS TIME DO NOT REFLECT ALIGNMENT FOR ANY MODE OF OPERATION. THEY ARE SHOWN ONLY TO REPRESENT THE SYSTEM AS-BUILT CONFIGURATION.
 4. MONITOR TUBING IS 1 INCH O.D., 0.015" WALL, STAINLESS STEEL, TYPE 304.
 5. EACH PENETRATION COOLING FAN IS DRIVEN BY AN INDIVIDUAL MOTOR CONTROLLED BY A START/STOP SWITCH LOCATED BEHIND THE MAIN CONTROL BOARD.
 6. MATERIAL SPECIFICATIONS FOR PIPING TO BE USED IN THIS SYSTEM ARE LISTED IN THE APPROPRIATE SAFETY CLASS.
 7. CONTAINMENT ISOLATION AT PENETRATION 300 IS PROVIDED BY THE BLIND FLANGE, FLANGE, G-RINGS, TEST VALVE AND TEST CONNECTION CAP ARE SAFETY CLASS 2.
 8. PENETRATION COOLING SYSTEM SUPPLY AND EXHAUST TO THE PENETRATIONS ARE ALL NON-NUCLEAR SAFETY CLASS. THE PENETRATIONS THEMSELVES ARE ALL SAFETY CLASS 2.
 9. EXCEPT WHERE OTHERWISE INDICATED, SAFETY CLASS FOR NITROGEN LINES AND COMPONENTS IS BASED ON OPTIMUM INSTRUMENT AIR/PURGE GAS VALVE. REFER TO THE INTERFACING AIR/NITROGEN DRAWING FOR SAFETY CLASS.

SI APERTURE CARD
 Also Available On Aperture Card

FOR 3RD INTERVAL
 ISI USE ONLY
 REV. 2

9401250044-35

DATE	11-00-02/18/73
BY	11-00-02/18/73
CHKD	11-00-02/18/73
APP'D	11-00-02/18/73
REV	11-00-02/18/73
DESCRIPTION	CONTAINMENT HVAC SYSTEMS PURGE EXHAUST PENETRATION COOLING P & ID
JOB NO.	33013-1888
DRAWING NO.	33013-1250
REV.	
CCO 01 CONTROL COPY	

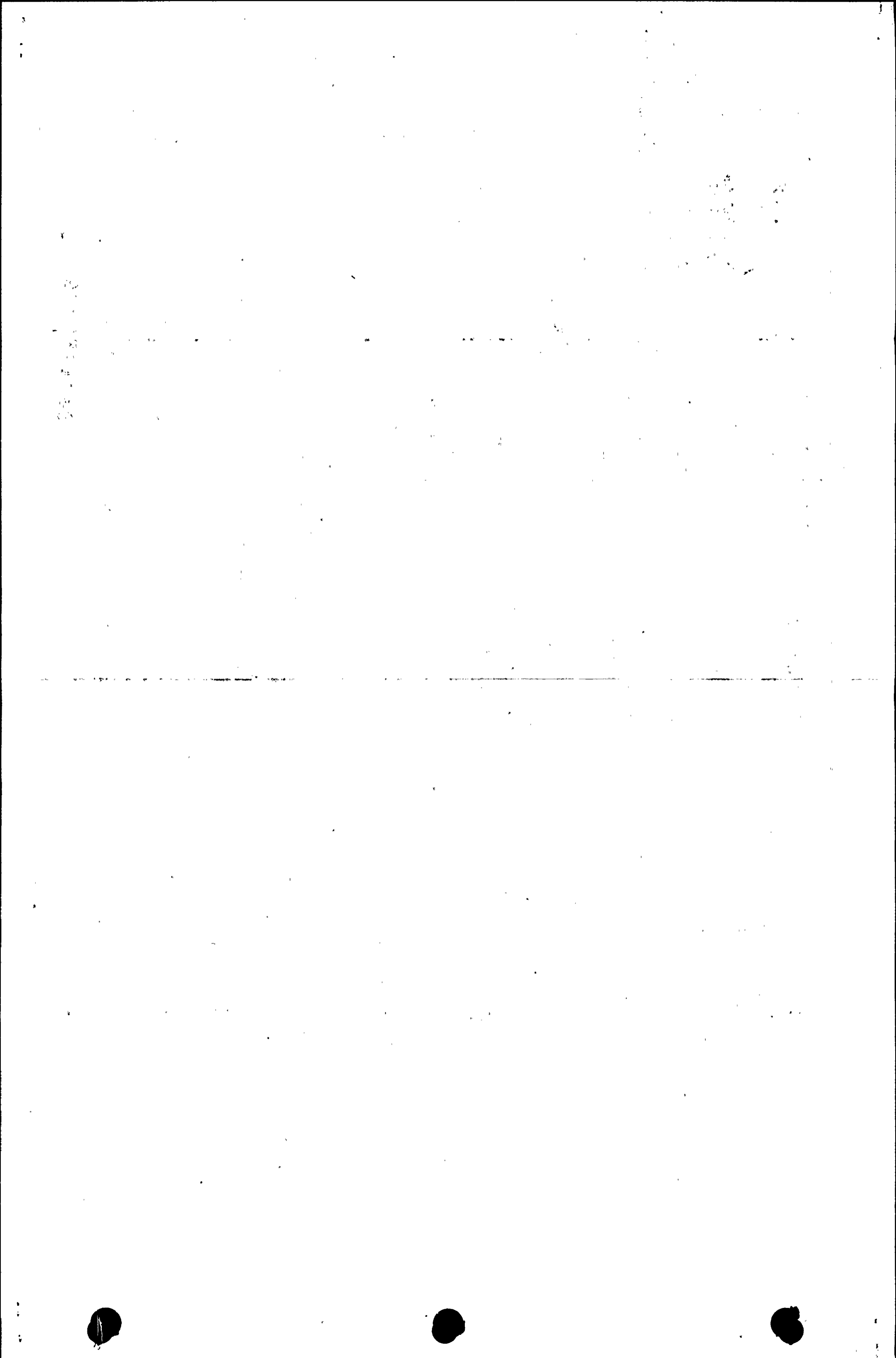

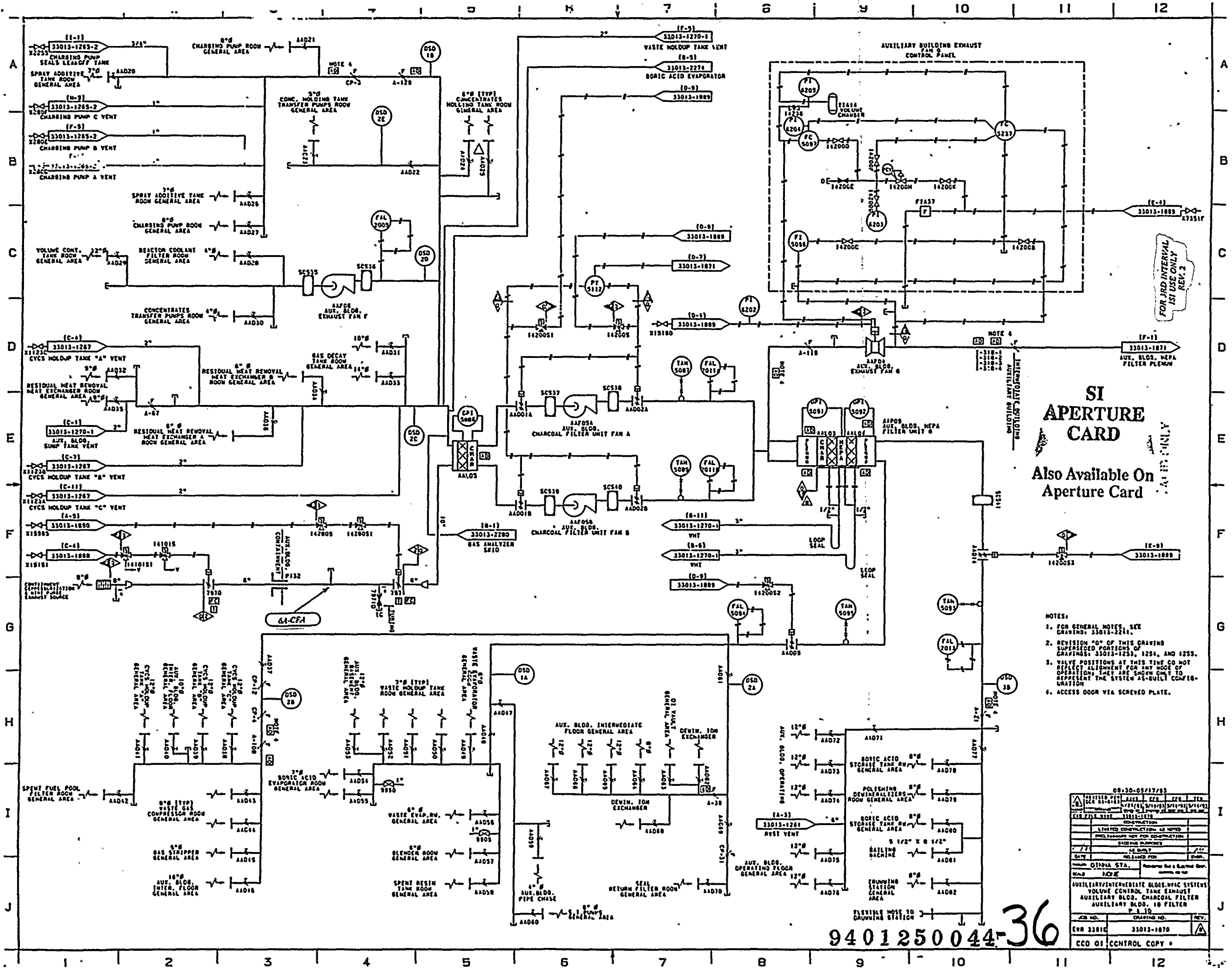

FOR 1RD INTERVAL
1ST USE ONLY
REV. 2

SI APERTURE CARD
Also Available On Aperture Card

- NOTES:
1. FOR GENERAL NOTES, SEE DRAWING: 33013-2211.
 2. REVISION "00" OF THIS DRAWING SUPERSEDES PORTIONS OF DRAWINGS: 33013-1253, 1254, AND 1255.
 3. VALVE POSITIONS AT THIS TIME DO NOT REFLECT ALIGNMENT FOR ANY MODE OF OPERATION; THEY ARE SHOWN ONLY TO REPRESENT THE SYSTEM AS-BUILT CONFIGURATION.
 4. ACCESS DOOR VIA SCREWED PLATE.

DATE	DESCRIPTION	BY	CHK
08-30-65/17/83	ISSUED FOR CONSTRUCTION
...
...
LIMITED CONSTRUCTION AS NOTED			
AND TOLERANCE NOT FOR CONSTRUCTION			
SHEET NO. 11			
TOTAL SHEETS 11			
SHEET TITLE: 33013-1870			
PROJECT: OTHRA STA.			
NOTE: REFER TO 33013-1870			
AUXILIARY/INTERMEDIATE BLDG. EXHAUST SYSTEM VOLUME CONTROL TANK EXHAUST AUXILIARY BLDG. CHARCOAL FILTER AUXILIARY BLDG. 10 FILTER			
JOB NO.	DRAWING NO.	REV.	
33013	33013-1870		
CCD 01	CONTROL COPY		

FLEXIBLE WORK TO DRAWING STATION
9401250044-36

0000000000

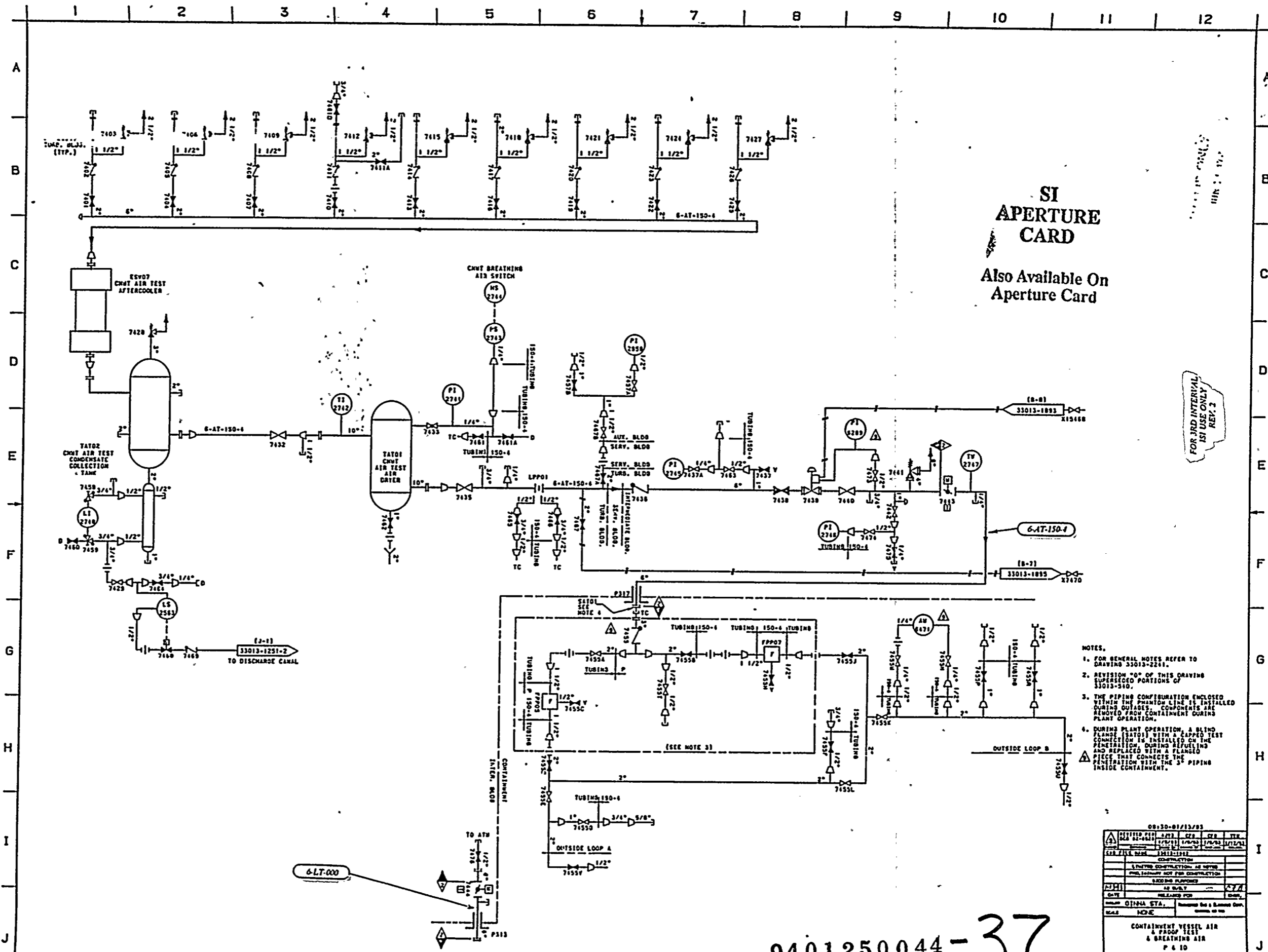

SI
APERTURE
CARD

Also Available On
Aperture Card

FOR 3RD INTERVAL
ISI USE ONLY
REV. 2

- NOTES.
1. FOR GENERAL NOTES REFER TO DRAWING 33013-2241.
 2. REVISION "0" OF THIS DRAWING SUPERSEDES PORTIONS OF 33013-500.
 3. THE PIPING CONFIGURATION ENCLOSED WITHIN THE PHANTOM LINE IS INSTALLED DURING OUTAGES. COMPONENTS ARE REMOVED FROM CONTAINMENT DURING PLANT OPERATION.
 4. DURING PLANT OPERATION A BLIND FLANGE (T401) WITH A LAPPED TEST CONNECTION IS INSTALLED ON THE PENERATION. DURING REPAIRS AND REPLACED WITH A FLANGED PIECE THAT CONNECTS THE PENERATION WITH THE 3" PIPING INSIDE CONTAINMENT.

08-30-01/13/83			
DESIGNED BY	CHKD BY	APP'D BY	REV.
12/81	12/81	12/81	1/1/82
FILE NAME	FILE NO.	FILE DATE	FILE TIME
33013-1883	1883-102	12/12/81	10:00
CONSTRUCTION			
1. PIPING CONSTRUCTION AS NOTED			
AND IN ACCORDANCE WITH THE CONSTRUCTION			
SPECIFICATIONS			
DATE	AS SHOWN	BY	CHKD
12/12/81	12/12/81	12/12/81	12/12/81
SCALE	RELEASED FOR	DATE	BY
NONE			
CONTAINMENT VESSEL AIR & PURGE AIR			
A BREATHING AIR			
P & ID			
JOB NO.	DRAWING NO.	REV.	
33013-1883	33013-1883	1	
CCD 01	CONTROL COPY		

9401250044-37

6-LT-000

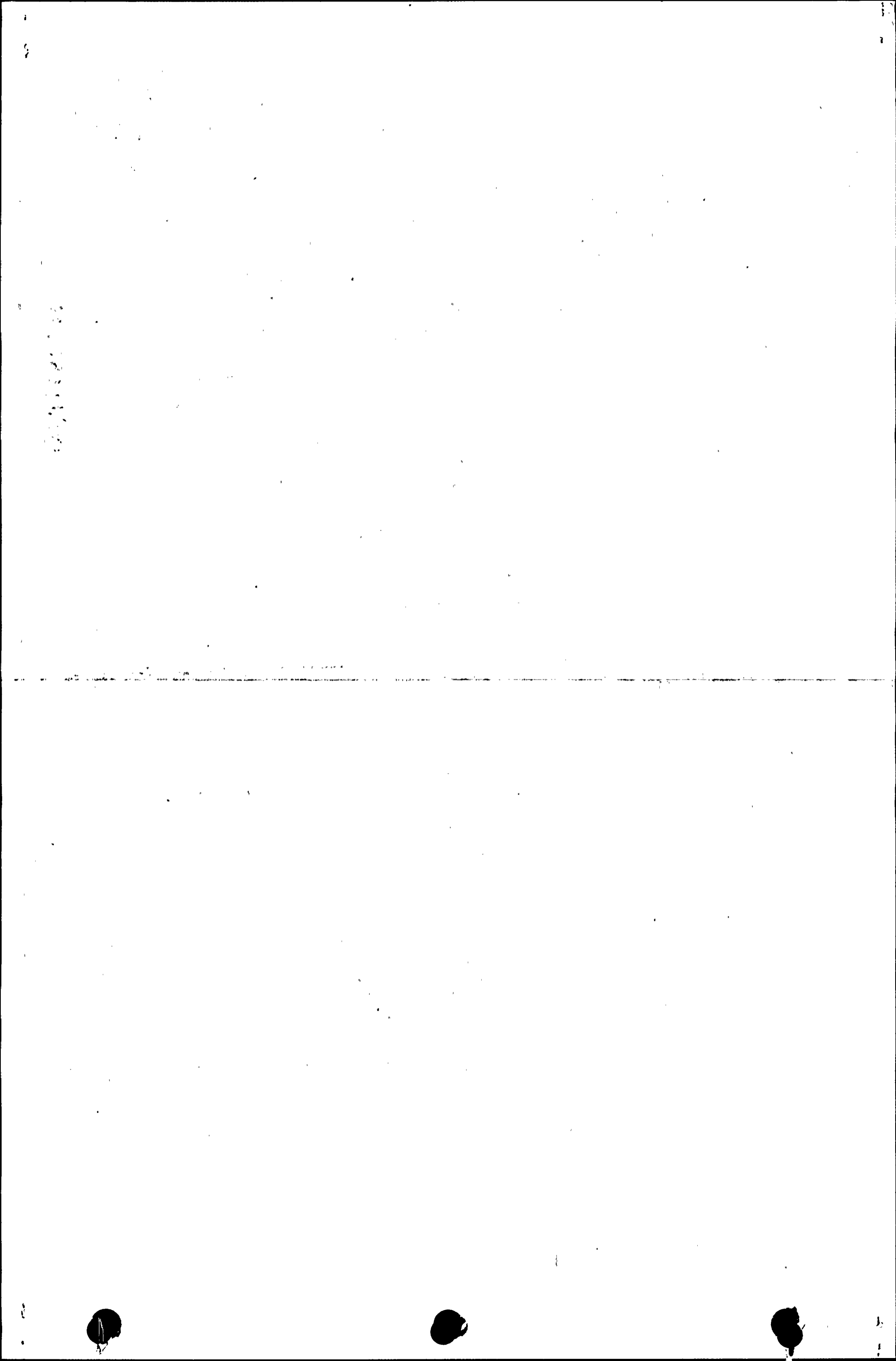

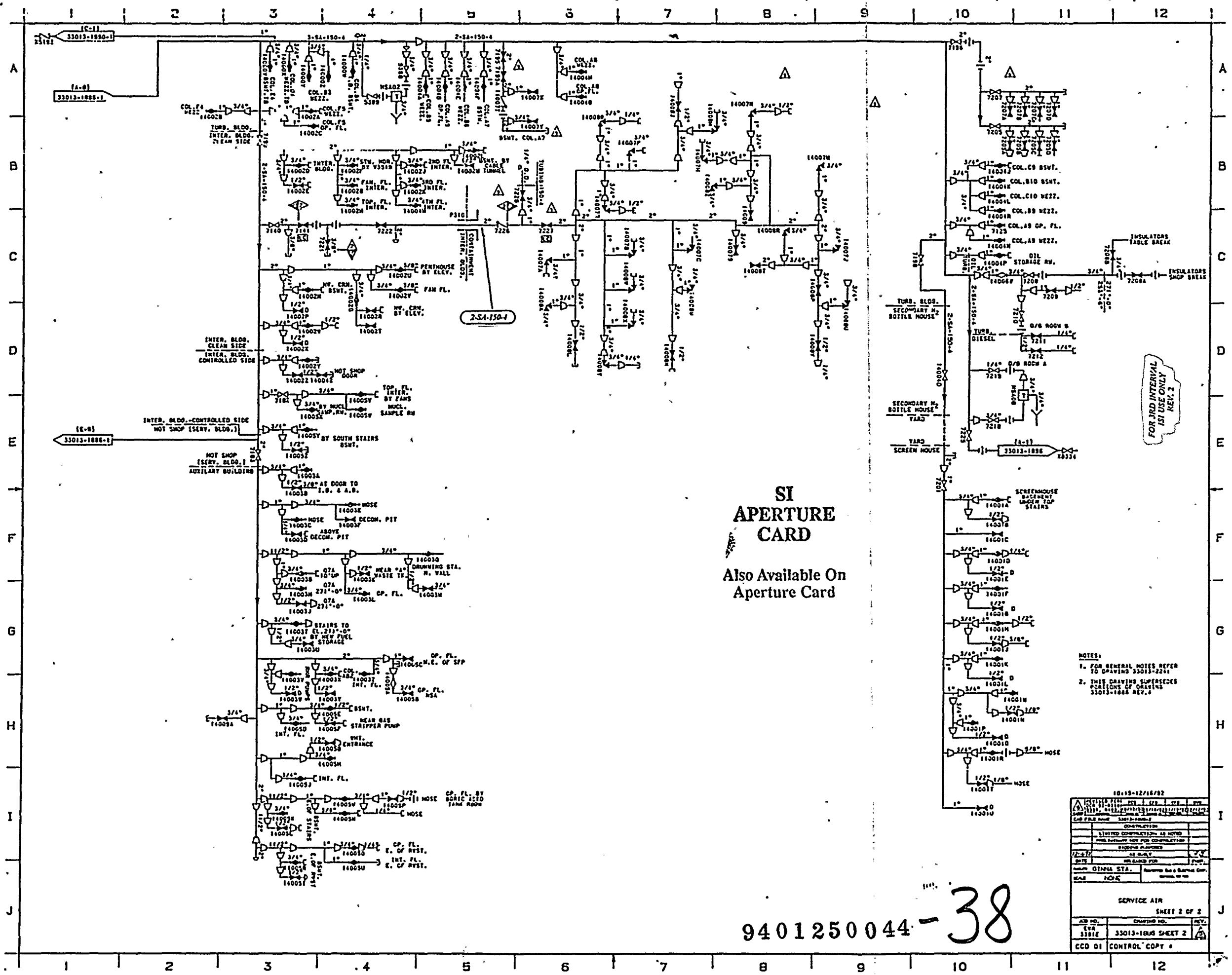

**SI
APERTURE
CARD**
Also Available On
Aperture Card

- NOTES:
1. FOR GENERAL NOTES REFER TO DRAWING 33013-1886-1
2. THIS DRAWING SUPERSEDES PORTIONS OF DRAWING 33013-1886 REV. 1

10155-12/16/82			
DESIGNED BY	CHKD BY	APP'D BY	DATE
10155-12/16/82			
LIMITED CONTRACTOR - AS NOTED			
SMALL EQUIPMENT NOT FOR CONSTRUCTION			
BUILDING IN PARTS			
DATE	AS SHOWN	BY	
DATE	ON BOARD FOR	DATE	
SCALE	NOTE	REVISIONS	
SERVICE AIR			
SHEET 2 OF 2			
JOB NO.	DRAWING NO.	REV.	
3318	33013-1886 SHEET 2	1	
CCD 01	CONTROL COPY		

9401250044-38

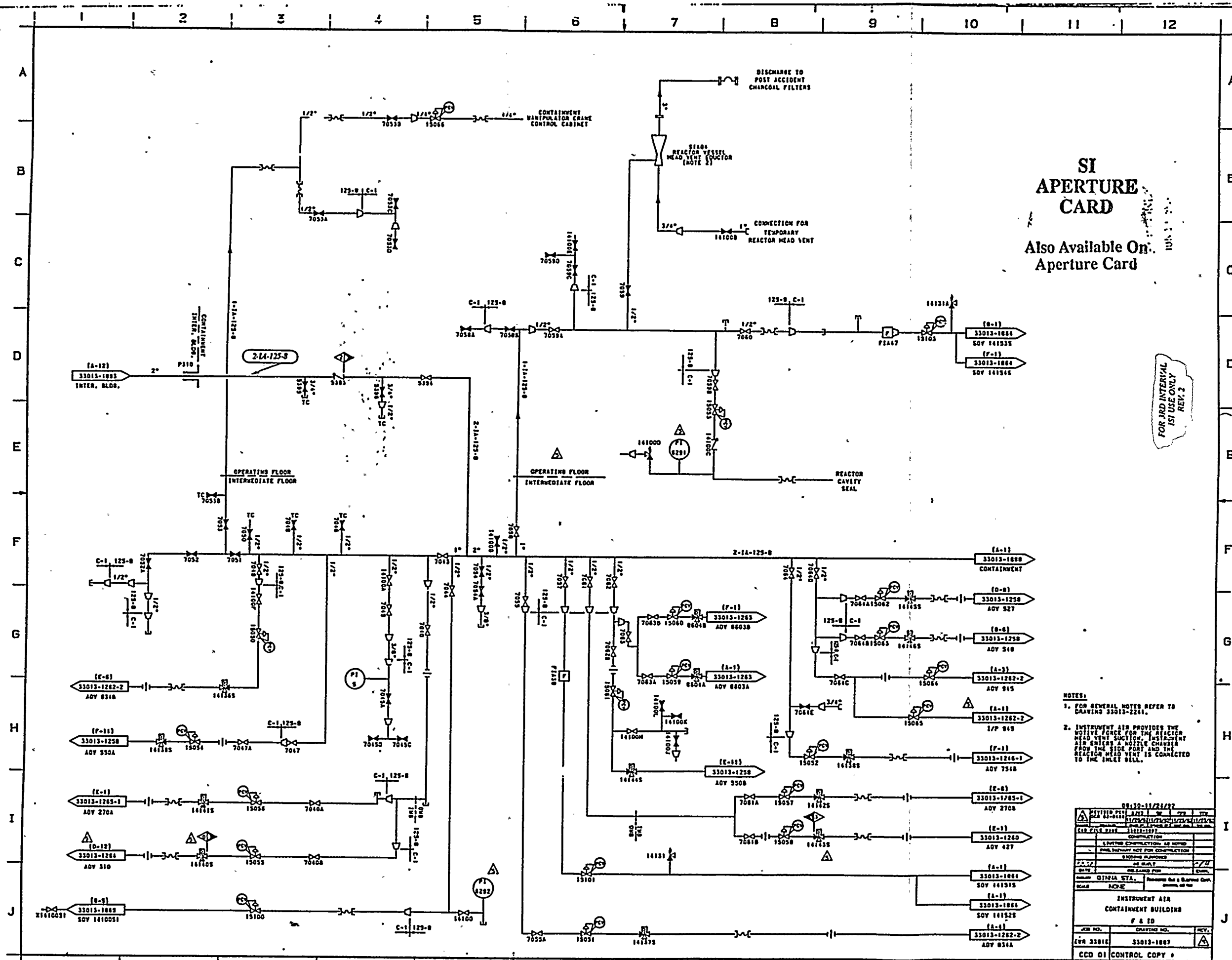

**SI
APERTURE
CARD**

Also Available On
Aperture Card

FOR JRD INTERVAL
1ST USE ONLY
REV. 2

- NOTES:**
- FOR GENERAL NOTES REFER TO DRAWING 33013-2261.
 - INSTRUMENT AIR PROVIDES THE MOTIVE FORCE FOR THE REACTOR HEAD VENT SUCTION. INSTRUMENT AIR ENTERS A NOZZLE CHAMBER FROM THE SIDE PORT AND THE REACTOR HEAD VENT IS CONNECTED TO THE INLET BELL.

09-10-11/21/72		
DESIGNED BY	CHKD BY	APP'D BY
DRN	W	W
FILE FILE DATE	11/11/72	
CONSTRUCTION		
LIMITED CONSTRUCTION AS NOTED		
FINAL DRAWING NOT FOR CONSTRUCTION		
SHOWN OTHERWISE		
DATE	AS SHOWN	7/0
BY	FOR AS SHOWN FOR	CHKD
NAME	GIZELA STA.	REVISIONS
SCALE	NONE	DATE
INSTRUMENT AIR		
CONTAINMENT BUILDING		
F & ID		
JOB NO.	DRAWING NO.	REV.
EVR 33013	33013-1887	1
CCD 01	CONTROL COPY	

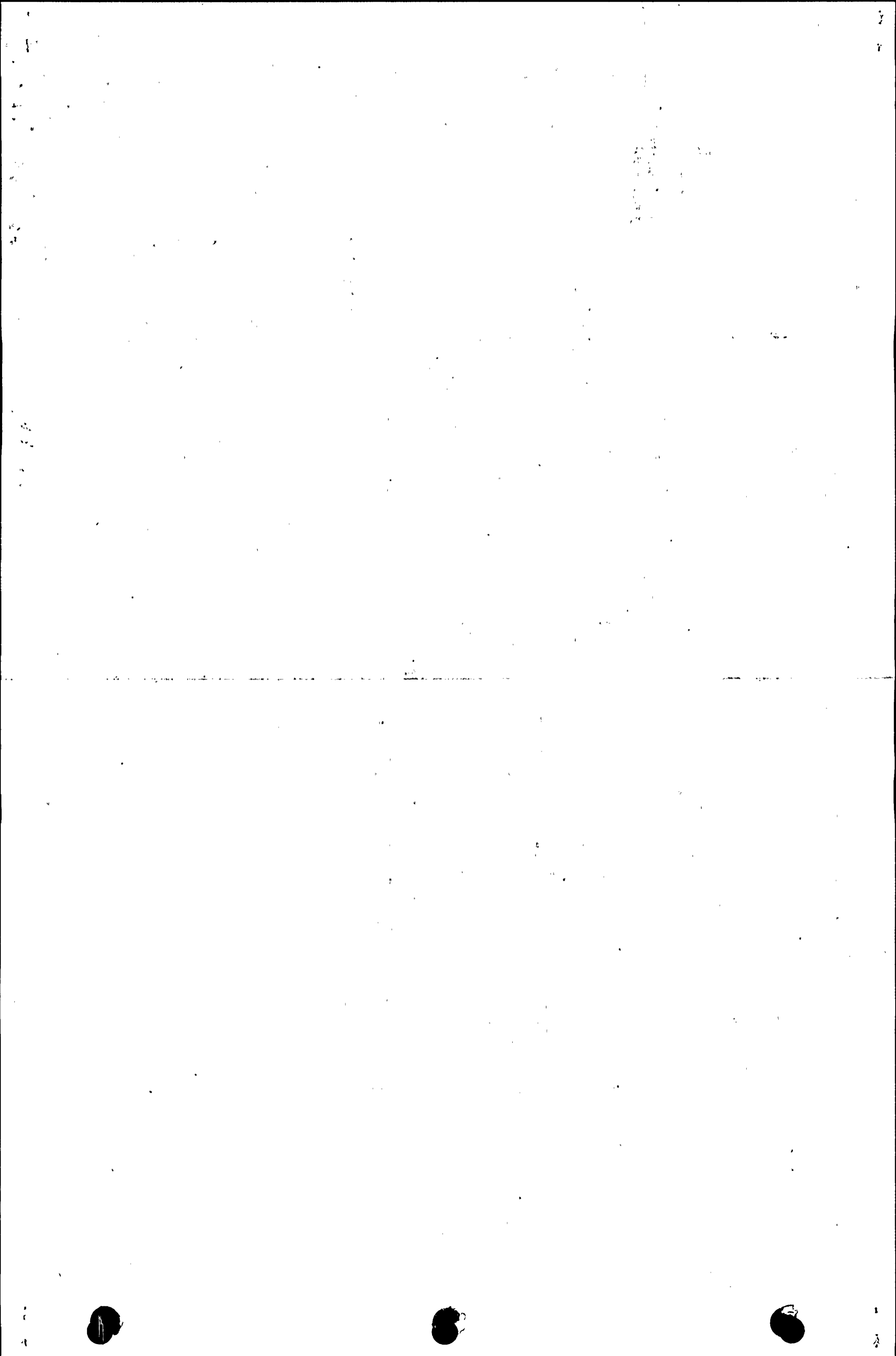

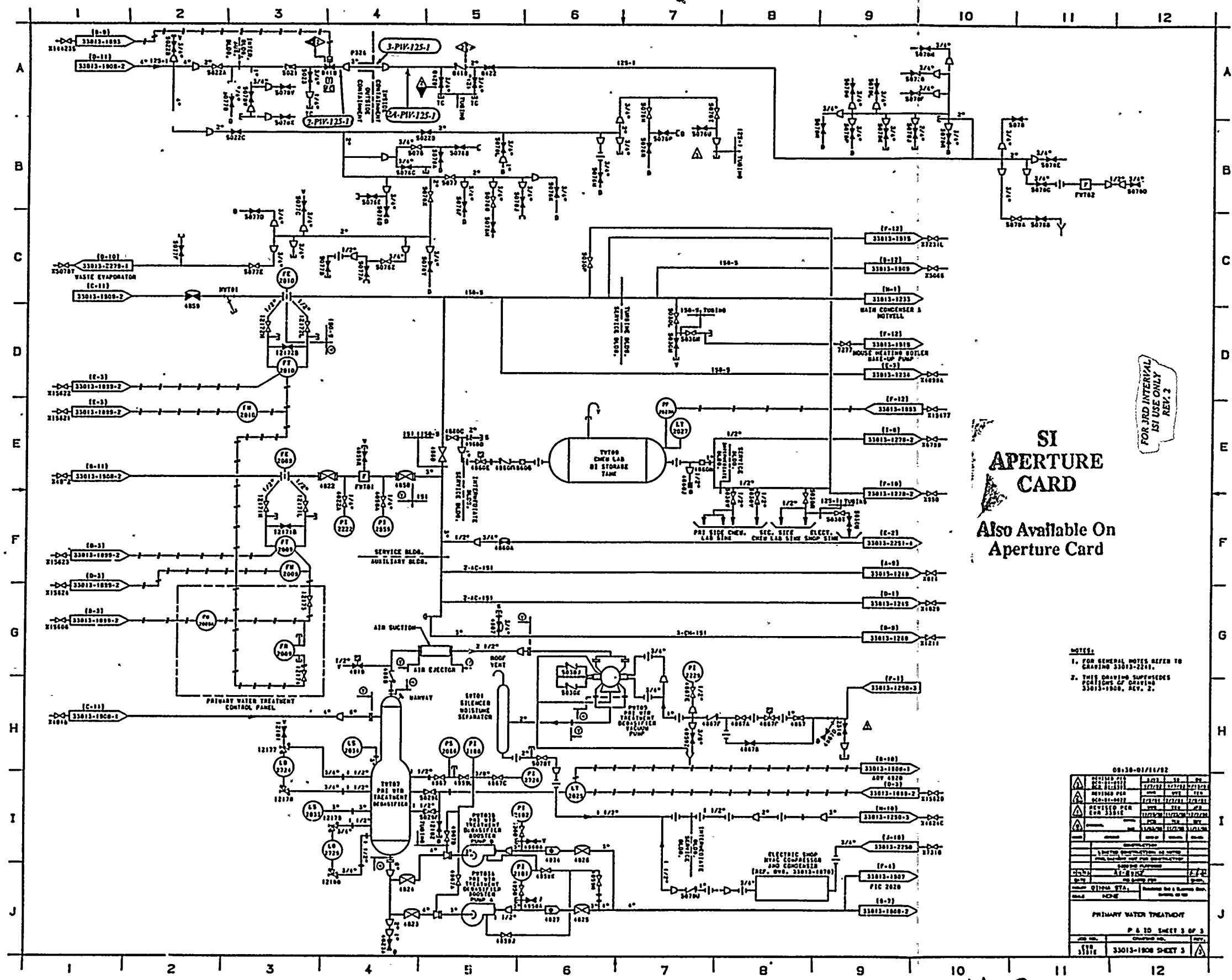

FOR JRD INTERVAL
ISI USE ONLY
REV. 2

**SI
APERTURE
CARD**
Also Available On
Aperture Card

- NOTES:
1. FOR GENERAL NOTES REFER TO DRAWING 33013-2301.
2. THIS DRAWING SUPERSEDES REVISIONS OF DRAWING 33013-1900, REV. 2.

NO.	DATE	BY	CHKD.	APP'D.	REVISION
1	08/20/72	JRD	JRD	JRD	REVISED PER ERM 5351E
2	08/20/72	JRD	JRD	JRD	REVISED PER ERM 5351E
3	08/20/72	JRD	JRD	JRD	REVISED PER ERM 5351E
4	08/20/72	JRD	JRD	JRD	REVISED PER ERM 5351E
5	08/20/72	JRD	JRD	JRD	REVISED PER ERM 5351E
6	08/20/72	JRD	JRD	JRD	REVISED PER ERM 5351E
7	08/20/72	JRD	JRD	JRD	REVISED PER ERM 5351E
8	08/20/72	JRD	JRD	JRD	REVISED PER ERM 5351E
9	08/20/72	JRD	JRD	JRD	REVISED PER ERM 5351E
10	08/20/72	JRD	JRD	JRD	REVISED PER ERM 5351E
11	08/20/72	JRD	JRD	JRD	REVISED PER ERM 5351E
12	08/20/72	JRD	JRD	JRD	REVISED PER ERM 5351E

PRIMARY WATER TREATMENT
P & ID SHEET 3 OF 3
33013-1900 SHEET 3

9401250044-40

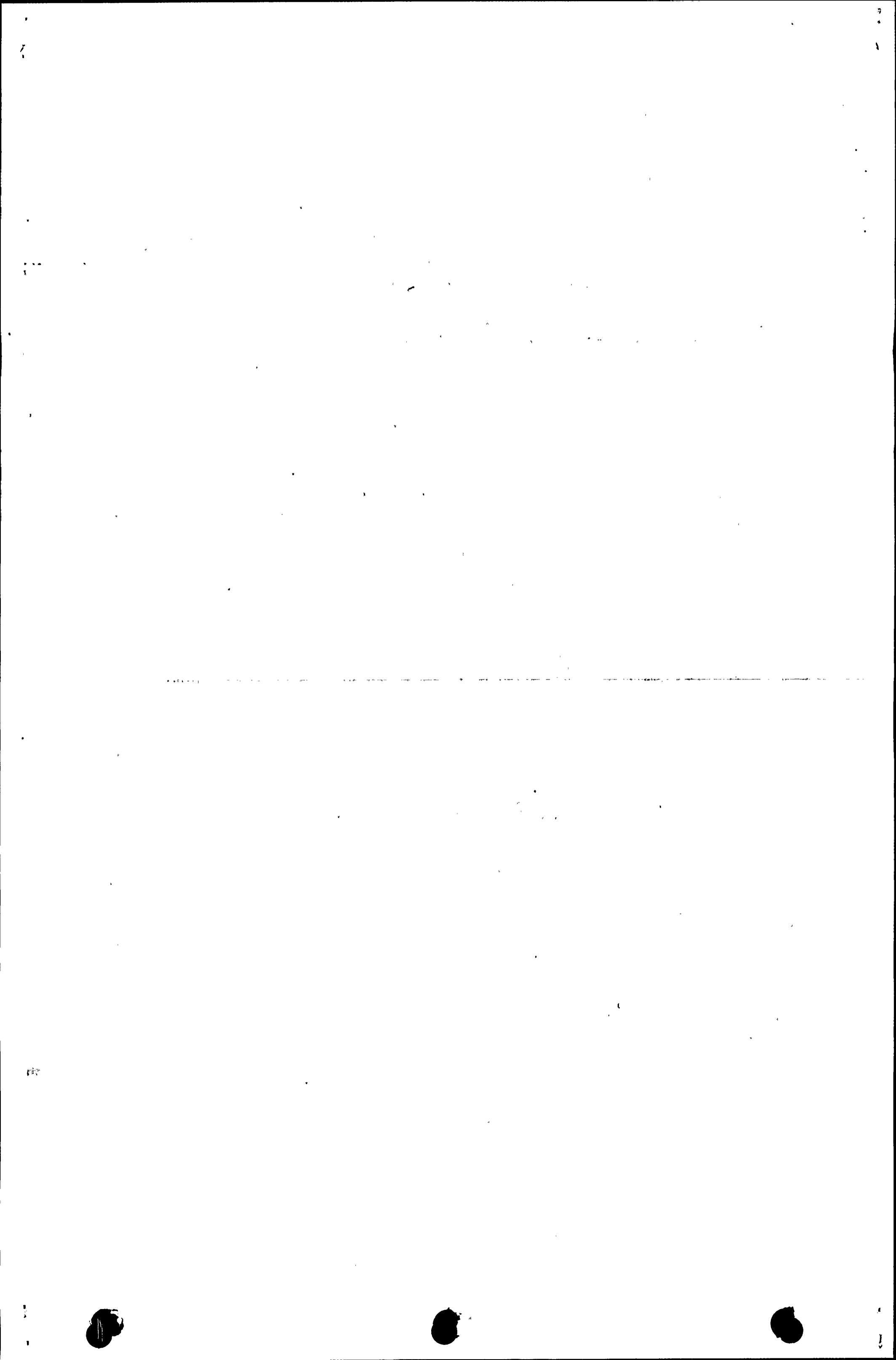

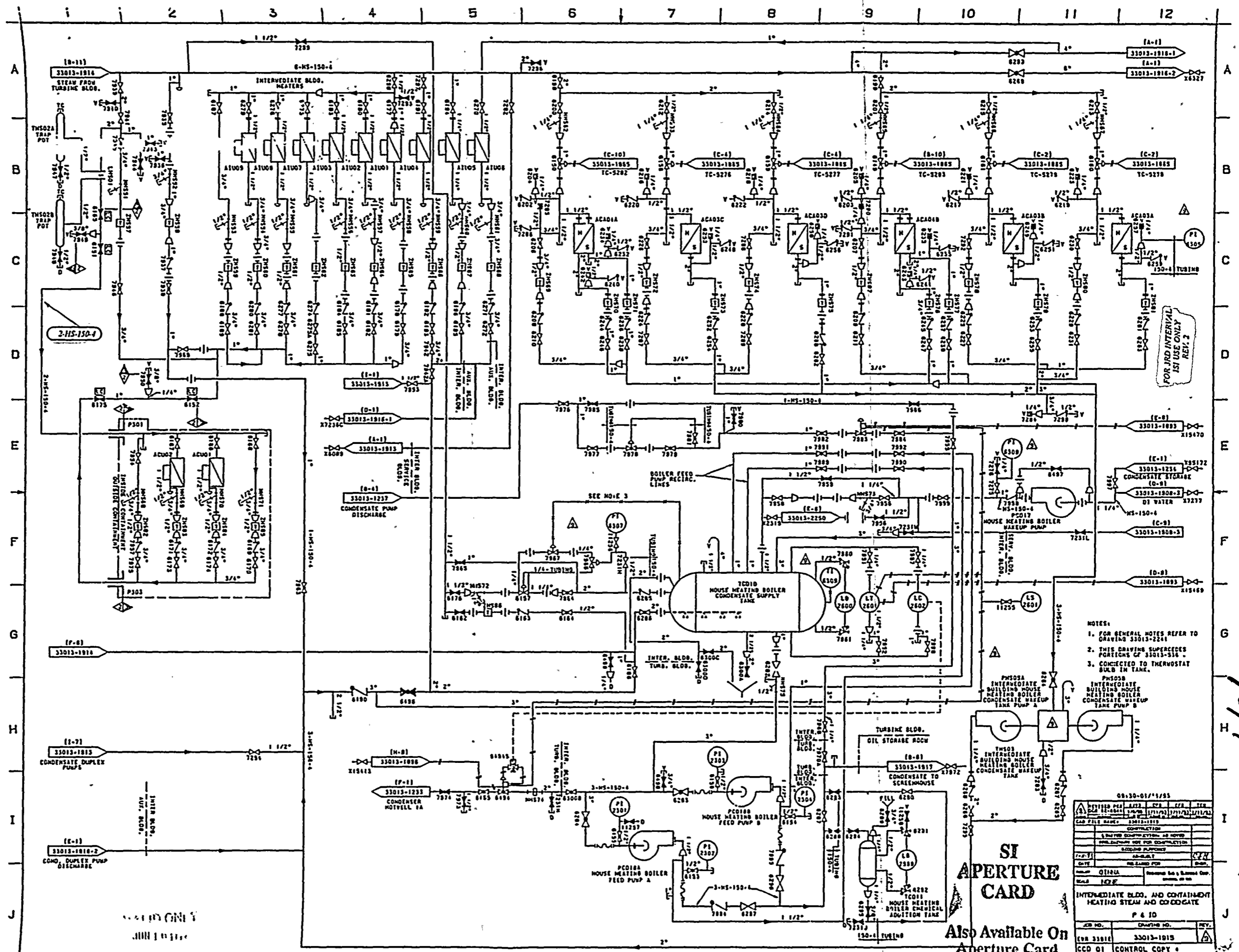

FOR JRD INTERVAL
ISI USE ONLY
REV. 2

- NOTES:
1. FOR GENERAL NOTES REFER TO DRAWING 33013-2241
 2. THIS DRAWING SUPERCEDES PORTIONS OF 33013-516.
 3. CONNECTED TO THERMOSTAT BULB IN TANK.

SI
APERTURE
CARD

Also Available On
Aperture Card

REV	DATE	BY	CHK	APP
1	08-30-61
2
3
4
5
6
7
8
9
10
11
12

CONSTRUCTION

INTERMEDIATE BLDG. AND CONTAINMENT HEATING STEAM AND CONDENSATE

P & ID

CD 01 CONTROL COPY

Handwritten text at the top left corner, possibly a page number or date.



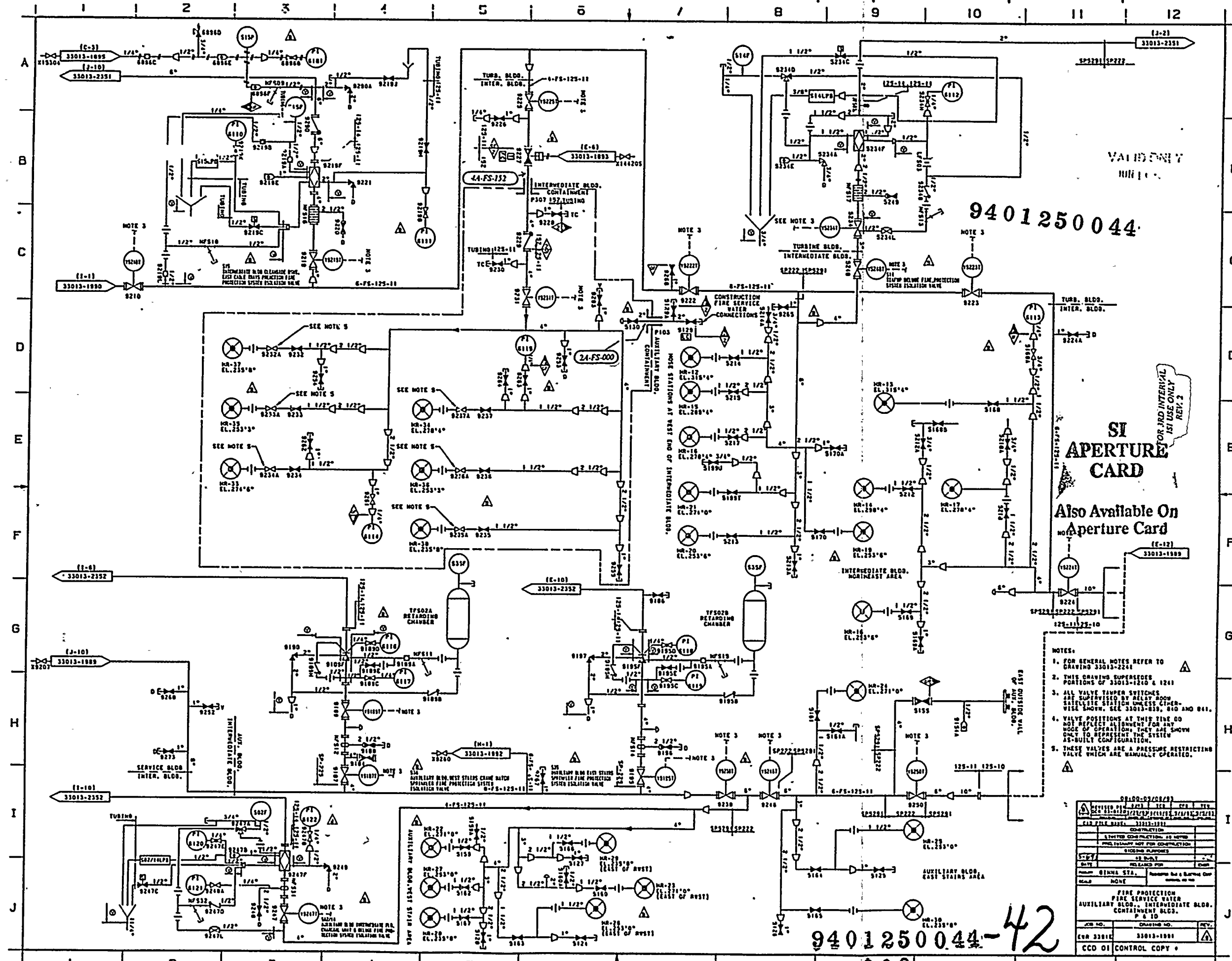

9401250044

SI APERTURE CARD

Also Available On Aperture Card

- NOTES:
1. FOR GENERAL NOTES REFER TO DRAWING 33013-244
 2. THIS DRAWING SUPERSEDES PORTIONS OF 33013-1210 & 1241
 3. ALL VALVE TAMPER SWITCHES ARE SUPERVISED BY RELAY ROOM SAFETY STATION UNLESS OTHERWISE SHOWN. SEE 33013-818, 810 AND 861.
 4. VALVE POSITIONS AT THIS TIME DO NOT REFLECT ALIGNMENT FOR ANY MODE OF OPERATION THEY ARE SHOWN ONLY TO REPRESENT THE SYSTEM AS-BUILT CONFIGURATION
 5. THESE VALVES ARE A PRESSURE RESTRICTING VALVE WHICH ARE MANUALLY OPERATED.

REVISED BY		DATE	ISSUED	BY	APP'D.
1
2
CIVIL FILE LABEL: 33013-1311		CONTINUATION			
A LIMITED CONSTRUCTION AS SHOWN					
PREFERENTIAL FOR CONSTRUCTION:					
EXISTING ALPHABET:					
AS SHOWN					
NO LAYOUT FOR					
NAME: OMINA STA. Purpose: See 4-Barrel Cop					
BLOCK: NONE					
FIRE PROTECTION					
FIRE SERVICE WATER					
AUXILIARY BLDG., INTERMEDIATE BLDG.,					
CONTAINMENT BLDG.					
P & 10					
JOB NO.	33013-1301	DRAWING NO.			
CVR 33013	33013-1301	REV.			
CCD 01	CONTROL COPY				

9401250044-42

1950

1950

1950



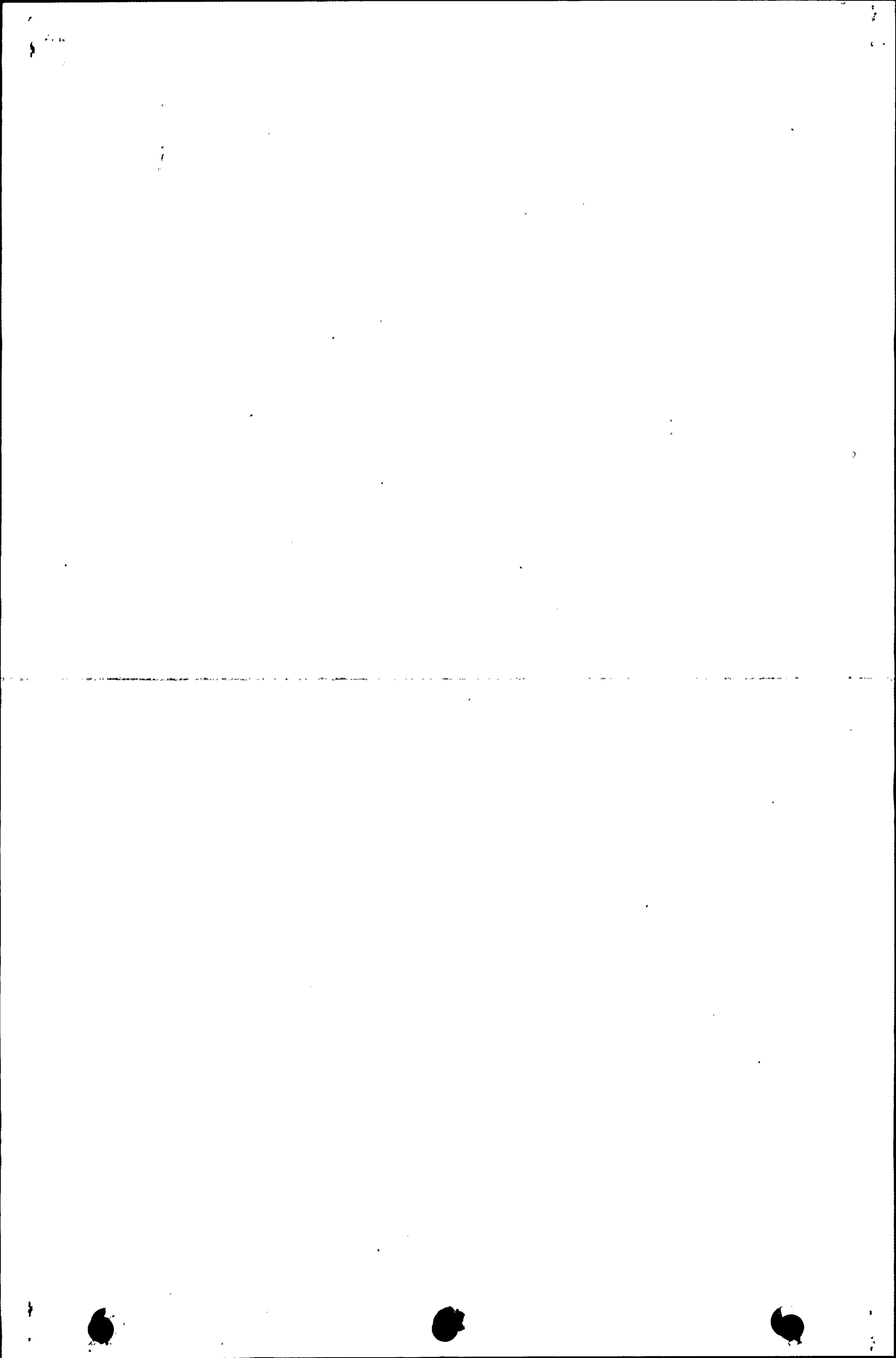

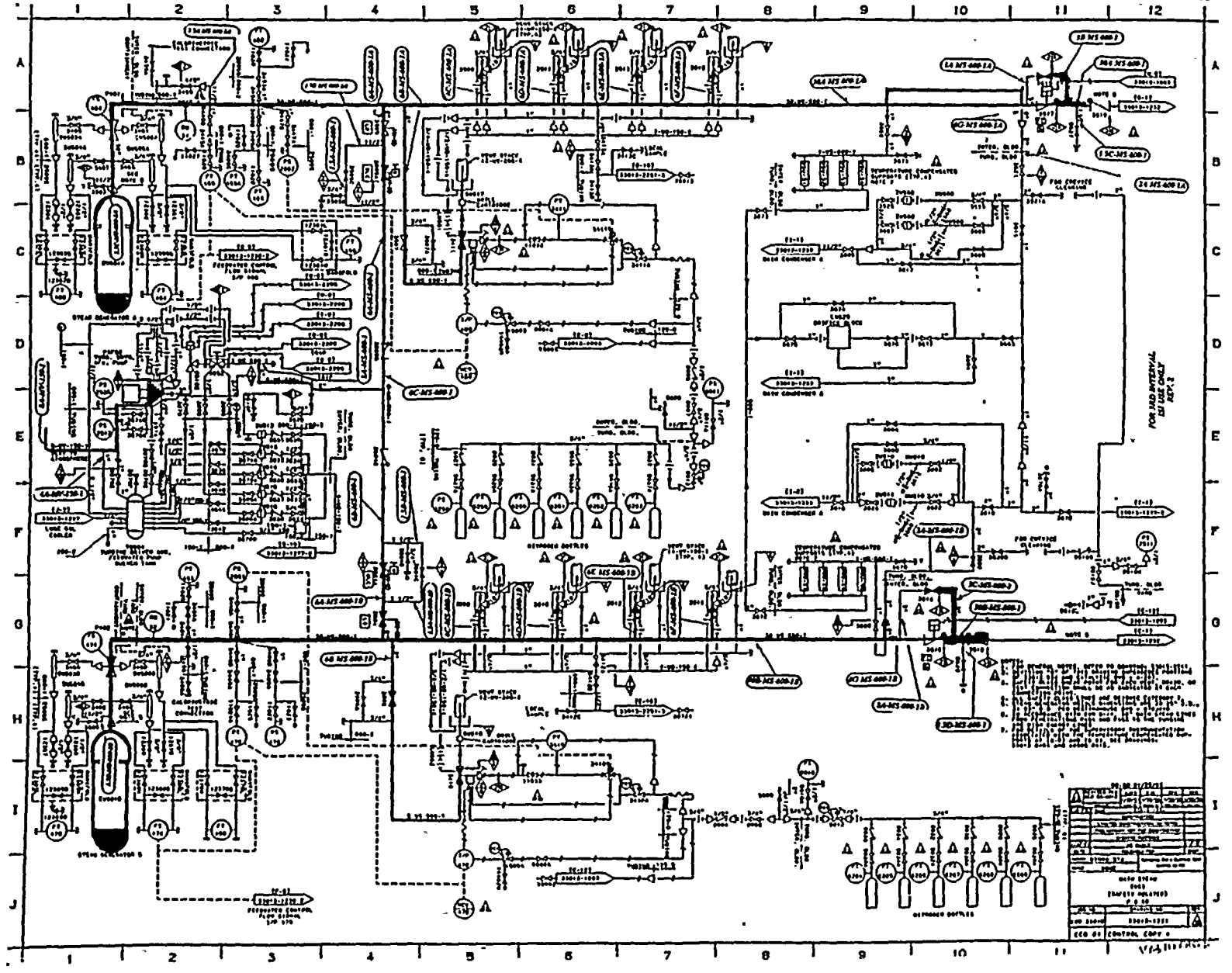

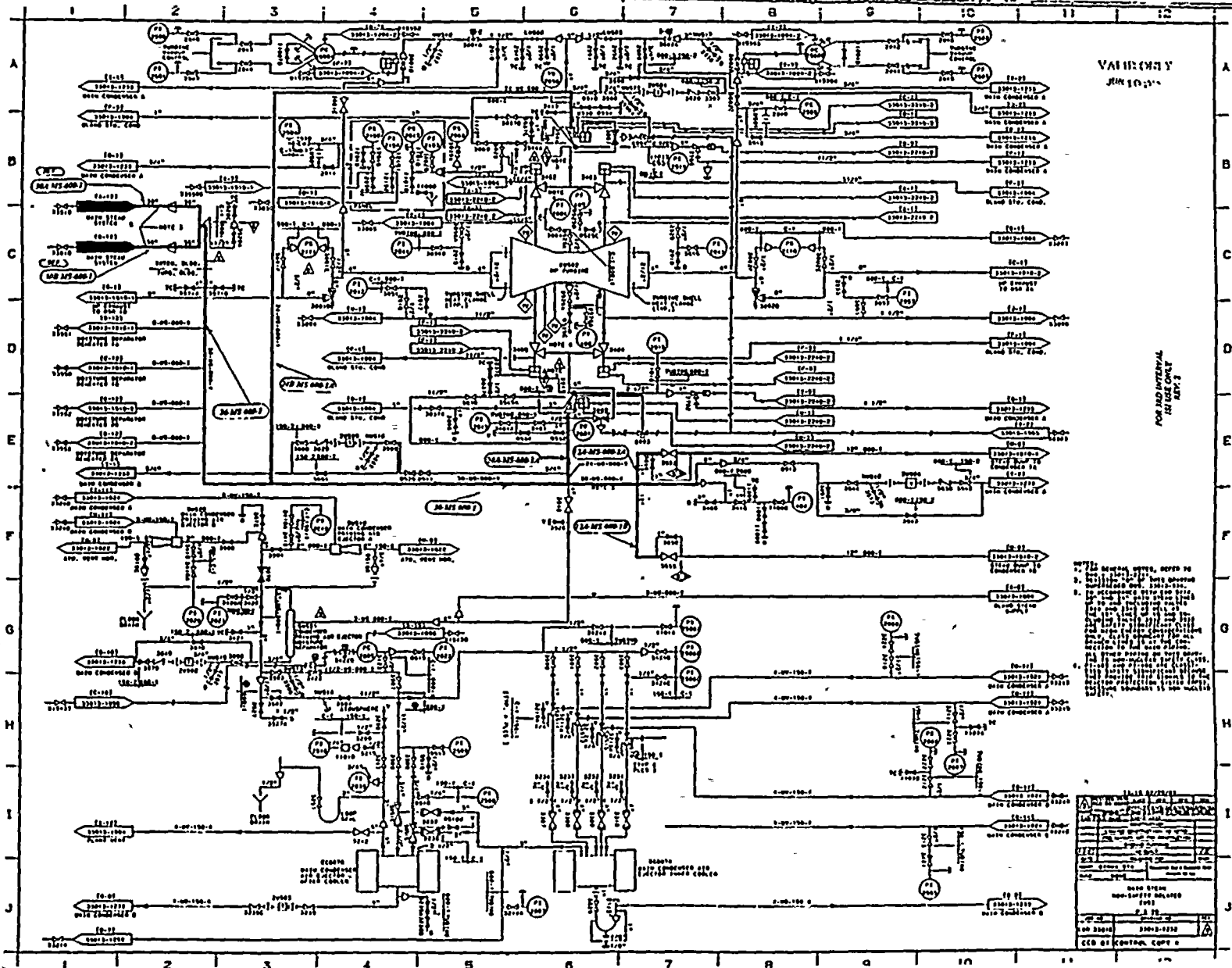

VARIATION
JUN 10 1954

FOR INFO INTERNAL
USE ONLY
REF: 1

1. This assembly shall be used to
compress data received from
the microphone system into
a compressed form suitable
for transmission over a radio
frequency channel. The
compression shall be performed
in accordance with the
specifications given in the
instructions to this assembly
drawing. The assembly shall
be capable of handling a
maximum input rate of
4800 bits per second and
shall compress the data to
a rate of 1200 bits per
second. The assembly shall
be capable of operating from
a 150-240 VAC, 60 Hz power
supply. The assembly shall
be capable of operating from
a 28 VDC power supply.
The assembly shall be capable
of operating at a temperature
range of -55°C to +125°C.
The assembly shall be capable
of operating at a relative
humidity of 5% to 95% non-
condensing.

ASSEMBLY DATA SHEET		
PARTS LIST		
QTY	DESCRIPTION	REF. NO.
1	DATA COMPRESSOR A	20-11
1	DATA COMPRESSOR B	20-12
1	ANALOG AMPLIFIER	20-13
1	30 MS AMP	20-14
1	30 MS AMP	20-15
1	30 MS AMP	20-16
1	30 MS AMP	20-17
1	30 MS AMP	20-18
1	30 MS AMP	20-19
1	30 MS AMP	20-20
1	30 MS AMP	20-21
1	30 MS AMP	20-22
1	30 MS AMP	20-23
1	30 MS AMP	20-24
1	30 MS AMP	20-25
1	30 MS AMP	20-26
1	30 MS AMP	20-27
1	30 MS AMP	20-28
1	30 MS AMP	20-29
1	30 MS AMP	20-30
1	30 MS AMP	20-31
1	30 MS AMP	20-32
1	30 MS AMP	20-33
1	30 MS AMP	20-34
1	30 MS AMP	20-35
1	30 MS AMP	20-36
1	30 MS AMP	20-37
1	30 MS AMP	20-38
1	30 MS AMP	20-39
1	30 MS AMP	20-40
1	30 MS AMP	20-41
1	30 MS AMP	20-42
1	30 MS AMP	20-43
1	30 MS AMP	20-44
1	30 MS AMP	20-45
1	30 MS AMP	20-46
1	30 MS AMP	20-47
1	30 MS AMP	20-48
1	30 MS AMP	20-49
1	30 MS AMP	20-50
1	30 MS AMP	20-51
1	30 MS AMP	20-52
1	30 MS AMP	20-53
1	30 MS AMP	20-54
1	30 MS AMP	20-55
1	30 MS AMP	20-56
1	30 MS AMP	20-57
1	30 MS AMP	20-58
1	30 MS AMP	20-59
1	30 MS AMP	20-60

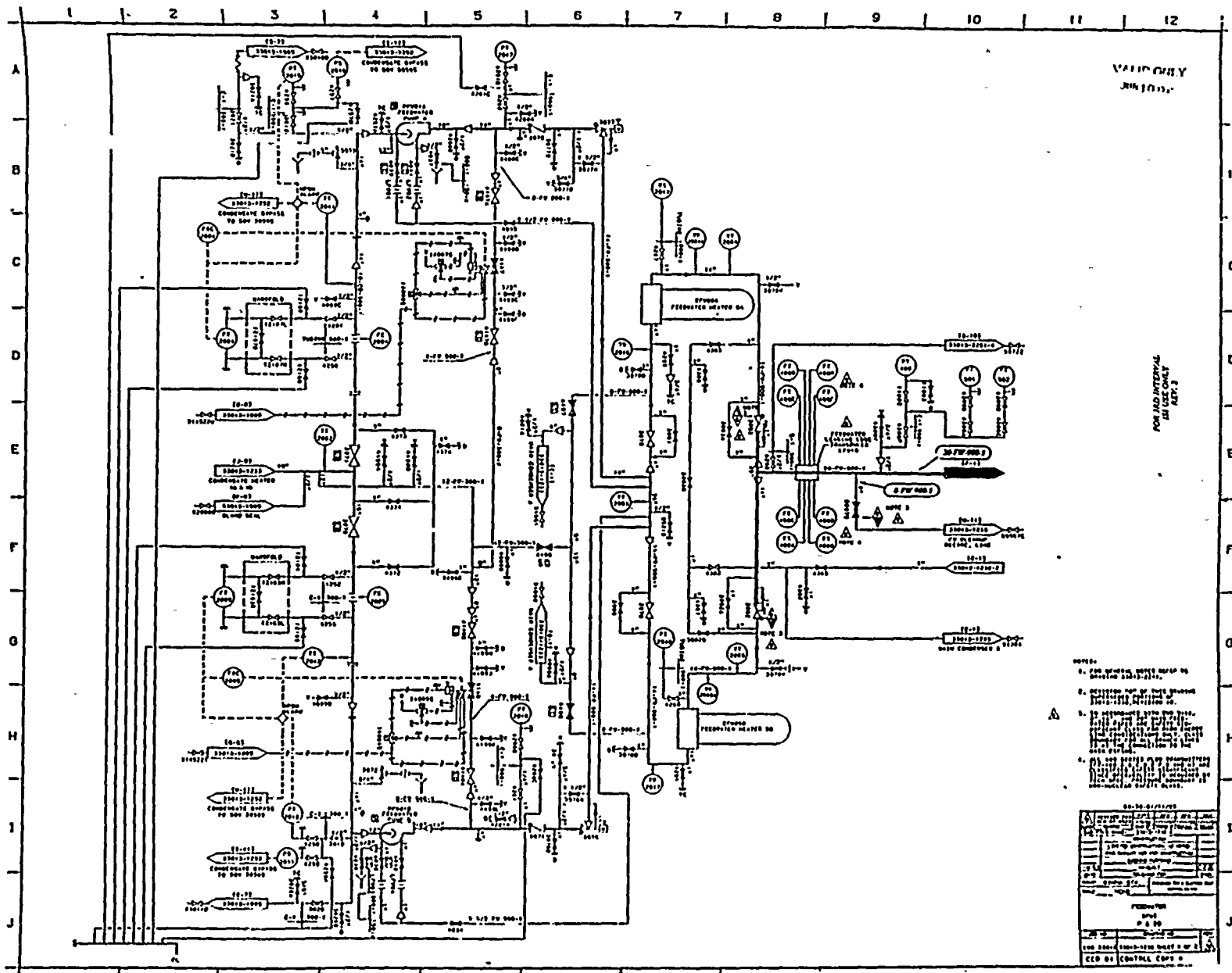

VALID ONLY
REV. 103

FOR INFO INTERVAL
USE ONLY
REV. 1

- NOTES:
1. FOR WIRING, REFER TO THE DRAWING 103-1-101.
 2. ALL WIRING TO BE DONE IN ACCORDANCE WITH THE WIRING REGULATIONS.
 3. ALL WIRING TO BE DONE IN ACCORDANCE WITH THE WIRING REGULATIONS.
 4. ALL WIRING TO BE DONE IN ACCORDANCE WITH THE WIRING REGULATIONS.

REVISIONS	
NO.	DESCRIPTION
1	ISSUED FOR INFORMATION
2	ISSUED FOR INFORMATION
3	ISSUED FOR INFORMATION
4	ISSUED FOR INFORMATION
5	ISSUED FOR INFORMATION
6	ISSUED FOR INFORMATION
7	ISSUED FOR INFORMATION
8	ISSUED FOR INFORMATION
9	ISSUED FOR INFORMATION
10	ISSUED FOR INFORMATION
11	ISSUED FOR INFORMATION
12	ISSUED FOR INFORMATION
13	ISSUED FOR INFORMATION
14	ISSUED FOR INFORMATION
15	ISSUED FOR INFORMATION
16	ISSUED FOR INFORMATION
17	ISSUED FOR INFORMATION
18	ISSUED FOR INFORMATION
19	ISSUED FOR INFORMATION
20	ISSUED FOR INFORMATION

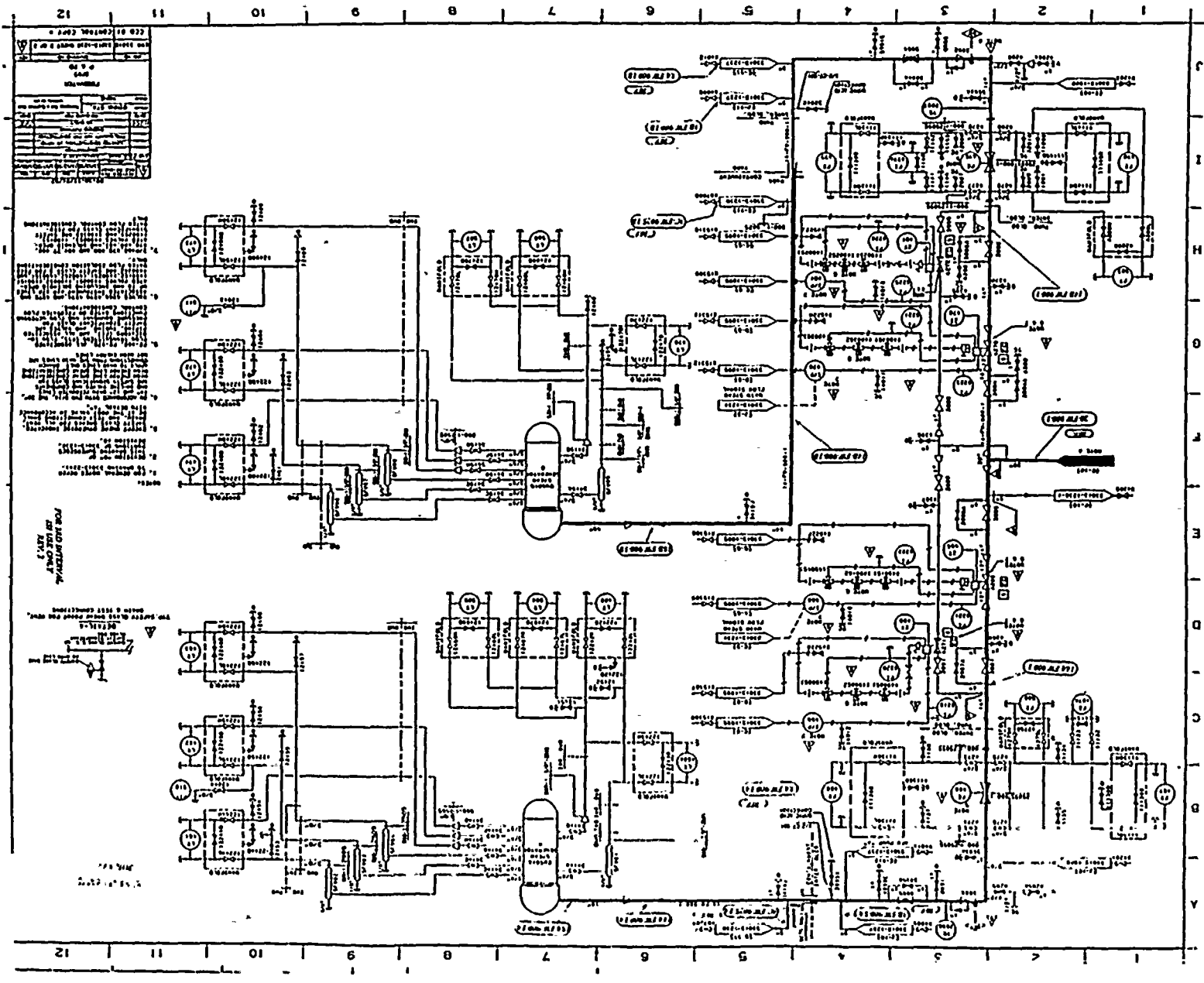

FOR USE ONLY

NO.	DESCRIPTION	DATE
1
2
3
4
5
6
7
8
9
10
11
12

FOR USE ONLY

...

FOR USE ONLY

...

...

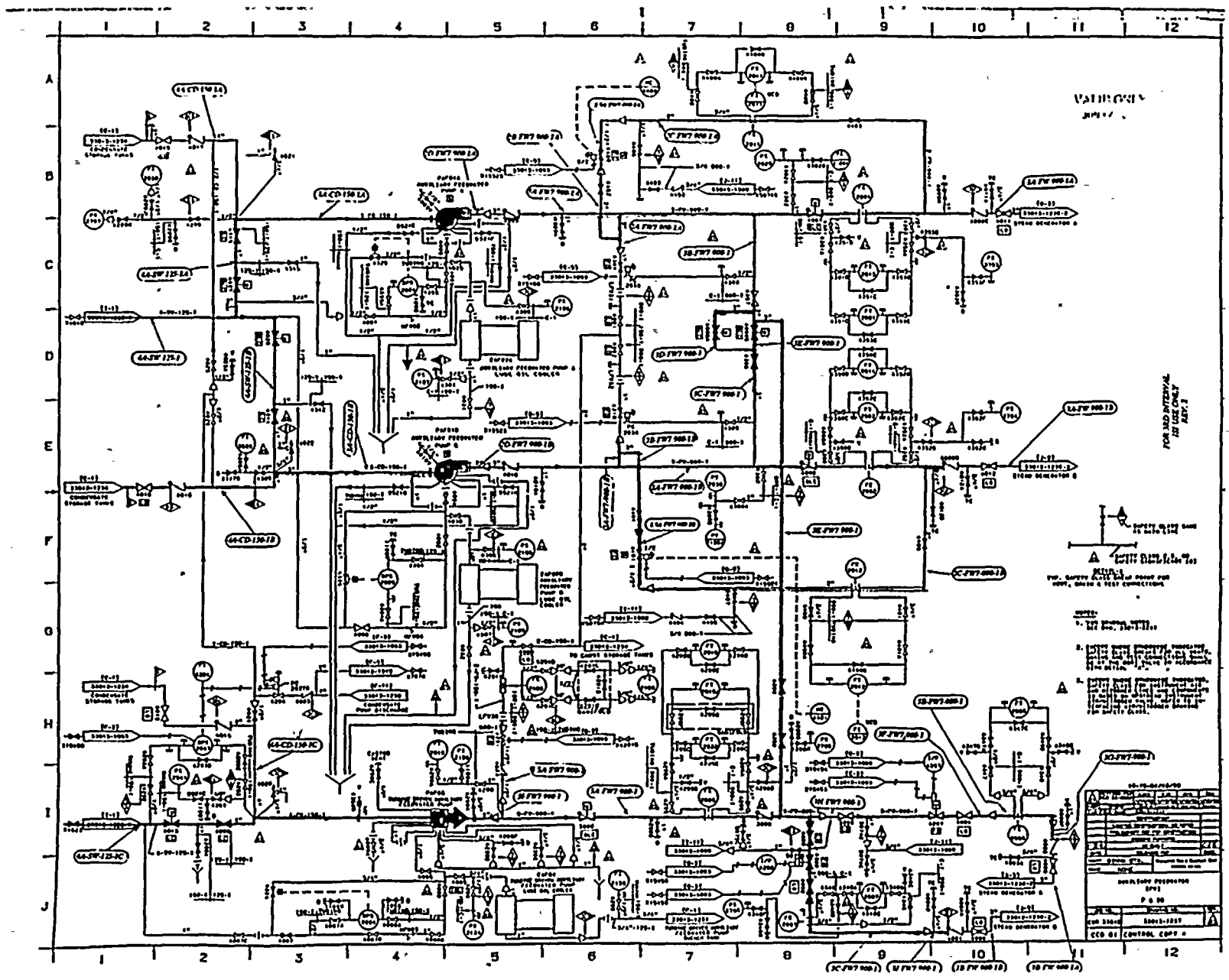

VALVE ONLY
REV. 12

FOR NO. 1000
REV. 12

FOR NO. 1000
REV. 12

FOR NO. 1000
REV. 12

WORKSHOP OPERATOR	3000-1001
P & B	
FORM 3300	3000-1001
CCO OF CONTROL CPT #	

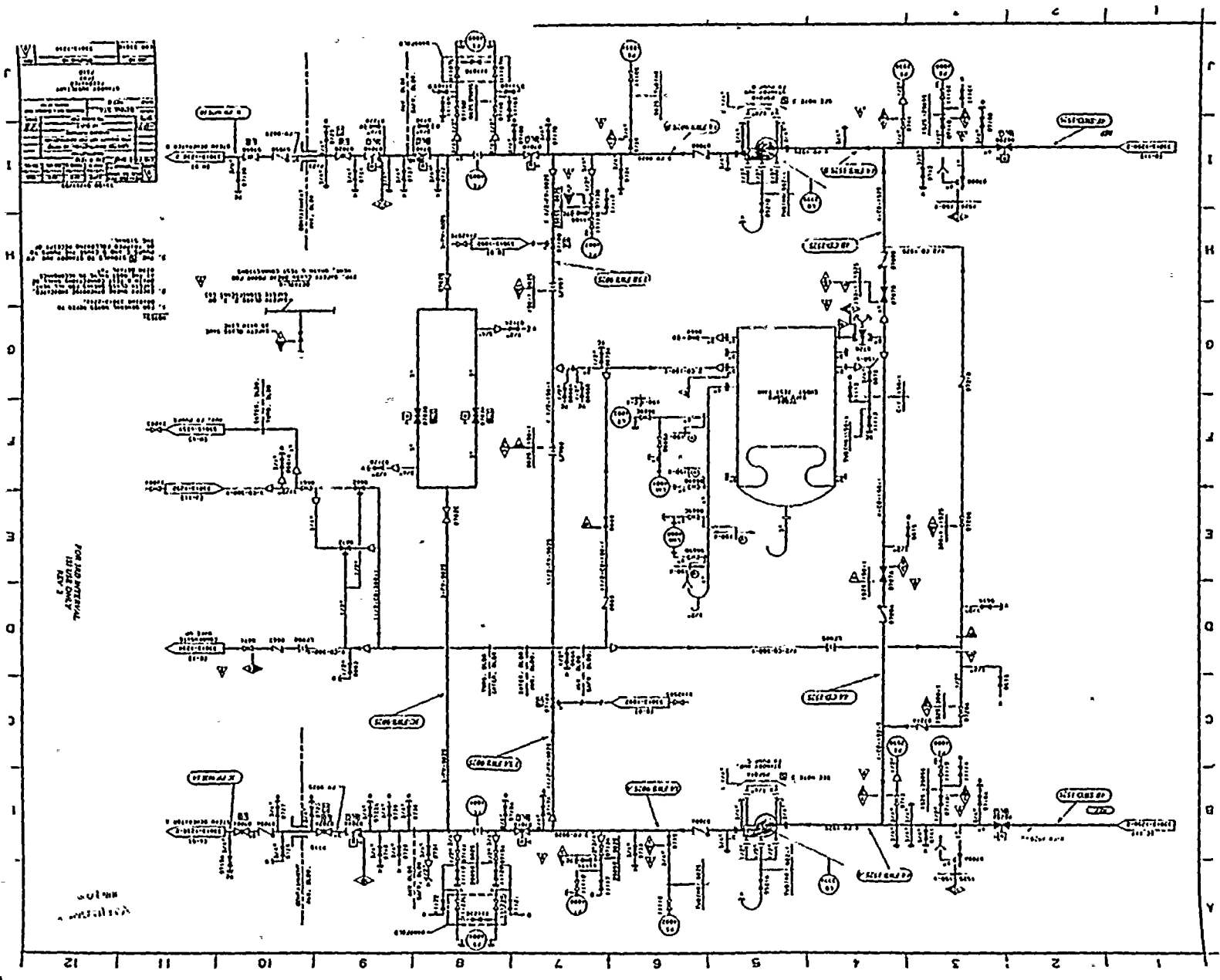

FOR THE INTERNAL WIRING ONLY

FOR THE INTERNAL WIRING ONLY

WIRE NO.	WIRE SIZE	WIRE COLOR	WIRE TYPE
1	14	RED	14 AWG
2	14	RED	14 AWG
3	14	RED	14 AWG
4	14	RED	14 AWG
5	14	RED	14 AWG
6	14	RED	14 AWG
7	14	RED	14 AWG
8	14	RED	14 AWG
9	14	RED	14 AWG
10	14	RED	14 AWG
11	14	RED	14 AWG
12	14	RED	14 AWG
13	14	RED	14 AWG
14	14	RED	14 AWG
15	14	RED	14 AWG
16	14	RED	14 AWG
17	14	RED	14 AWG
18	14	RED	14 AWG
19	14	RED	14 AWG
20	14	RED	14 AWG
21	14	RED	14 AWG
22	14	RED	14 AWG
23	14	RED	14 AWG
24	14	RED	14 AWG
25	14	RED	14 AWG
26	14	RED	14 AWG
27	14	RED	14 AWG
28	14	RED	14 AWG
29	14	RED	14 AWG
30	14	RED	14 AWG
31	14	RED	14 AWG
32	14	RED	14 AWG
33	14	RED	14 AWG
34	14	RED	14 AWG
35	14	RED	14 AWG
36	14	RED	14 AWG
37	14	RED	14 AWG
38	14	RED	14 AWG
39	14	RED	14 AWG
40	14	RED	14 AWG
41	14	RED	14 AWG
42	14	RED	14 AWG
43	14	RED	14 AWG
44	14	RED	14 AWG
45	14	RED	14 AWG
46	14	RED	14 AWG
47	14	RED	14 AWG
48	14	RED	14 AWG
49	14	RED	14 AWG
50	14	RED	14 AWG
51	14	RED	14 AWG
52	14	RED	14 AWG
53	14	RED	14 AWG
54	14	RED	14 AWG
55	14	RED	14 AWG
56	14	RED	14 AWG
57	14	RED	14 AWG
58	14	RED	14 AWG
59	14	RED	14 AWG
60	14	RED	14 AWG
61	14	RED	14 AWG
62	14	RED	14 AWG
63	14	RED	14 AWG
64	14	RED	14 AWG
65	14	RED	14 AWG
66	14	RED	14 AWG
67	14	RED	14 AWG
68	14	RED	14 AWG
69	14	RED	14 AWG
70	14	RED	14 AWG
71	14	RED	14 AWG
72	14	RED	14 AWG
73	14	RED	14 AWG
74	14	RED	14 AWG
75	14	RED	14 AWG
76	14	RED	14 AWG
77	14	RED	14 AWG
78	14	RED	14 AWG
79	14	RED	14 AWG
80	14	RED	14 AWG
81	14	RED	14 AWG
82	14	RED	14 AWG
83	14	RED	14 AWG
84	14	RED	14 AWG
85	14	RED	14 AWG
86	14	RED	14 AWG
87	14	RED	14 AWG
88	14	RED	14 AWG
89	14	RED	14 AWG
90	14	RED	14 AWG
91	14	RED	14 AWG
92	14	RED	14 AWG
93	14	RED	14 AWG
94	14	RED	14 AWG
95	14	RED	14 AWG
96	14	RED	14 AWG
97	14	RED	14 AWG
98	14	RED	14 AWG
99	14	RED	14 AWG
100	14	RED	14 AWG

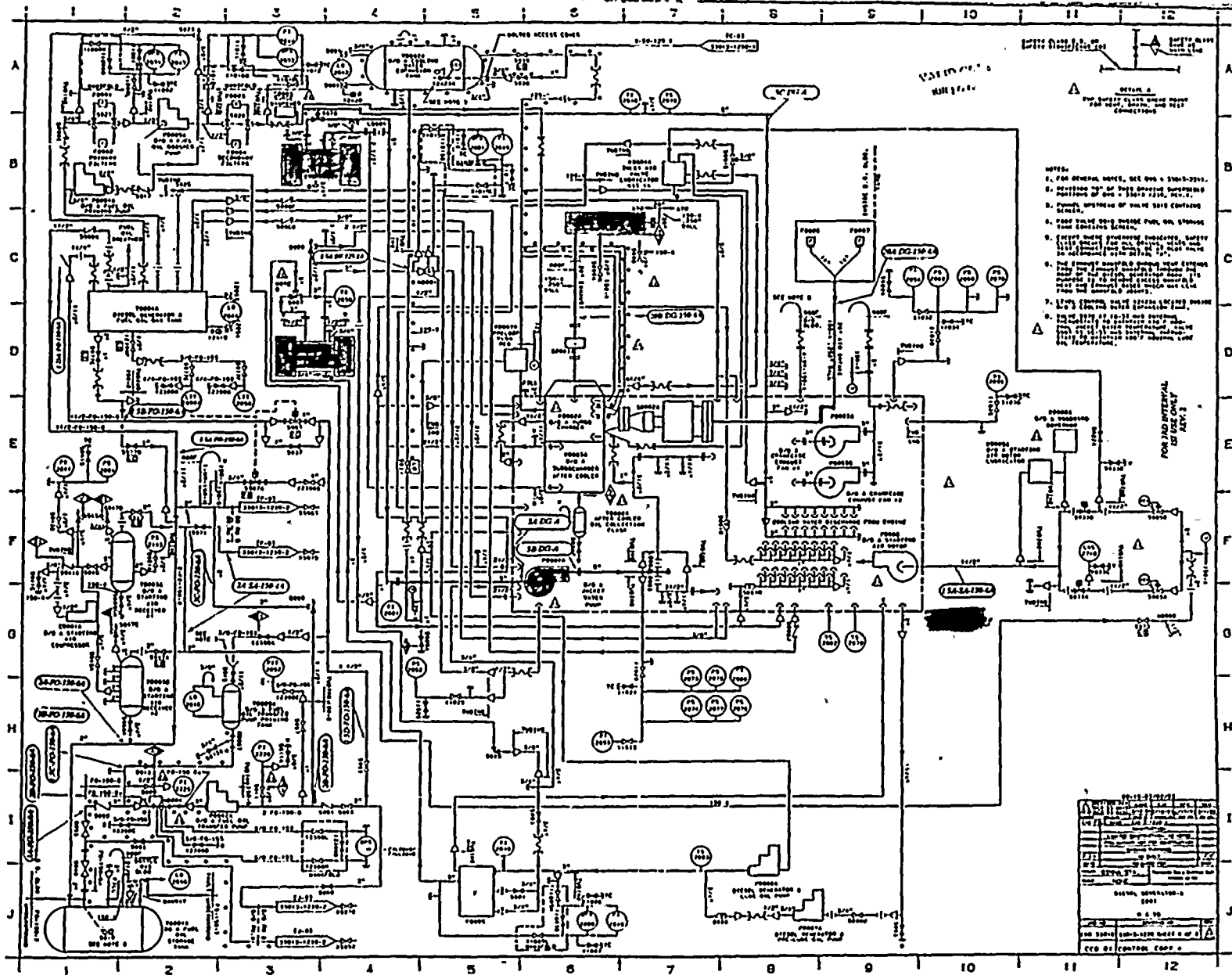

- NOTES:
1. FOR GENERAL NOTES, SEE DWG. 3-100-130-1.
 2. SECTION 50 OF THIS DRAWING SHOWN IN POSITION OF DWG. 3-100-130-1.
 3. CHECK SYSTEMS OF THIS DRAWING AGAINST THE DRAWING SHEETS.
 4. THIS DRAWING IS TO BE USED FOR THE PURPOSE OF THE DRAWING SHEETS.
 5. THIS DRAWING IS TO BE USED FOR THE PURPOSE OF THE DRAWING SHEETS.
 6. THIS DRAWING IS TO BE USED FOR THE PURPOSE OF THE DRAWING SHEETS.
 7. THIS DRAWING IS TO BE USED FOR THE PURPOSE OF THE DRAWING SHEETS.

REV.	DATE	BY	CHKD.	APP.
1				
2				
3				
4				
5				
6				
7				
8				
9				
10				
11				
12				

DATE: 10-1-59
 DESIGNED BY: [Name]
 CHECKED BY: [Name]
 APPROVED BY: [Name]
 TITLE: CONTROL CONSOLE
 DWG. NO.: 3-100-130-1
 SHEET NO.: 1 OF 1

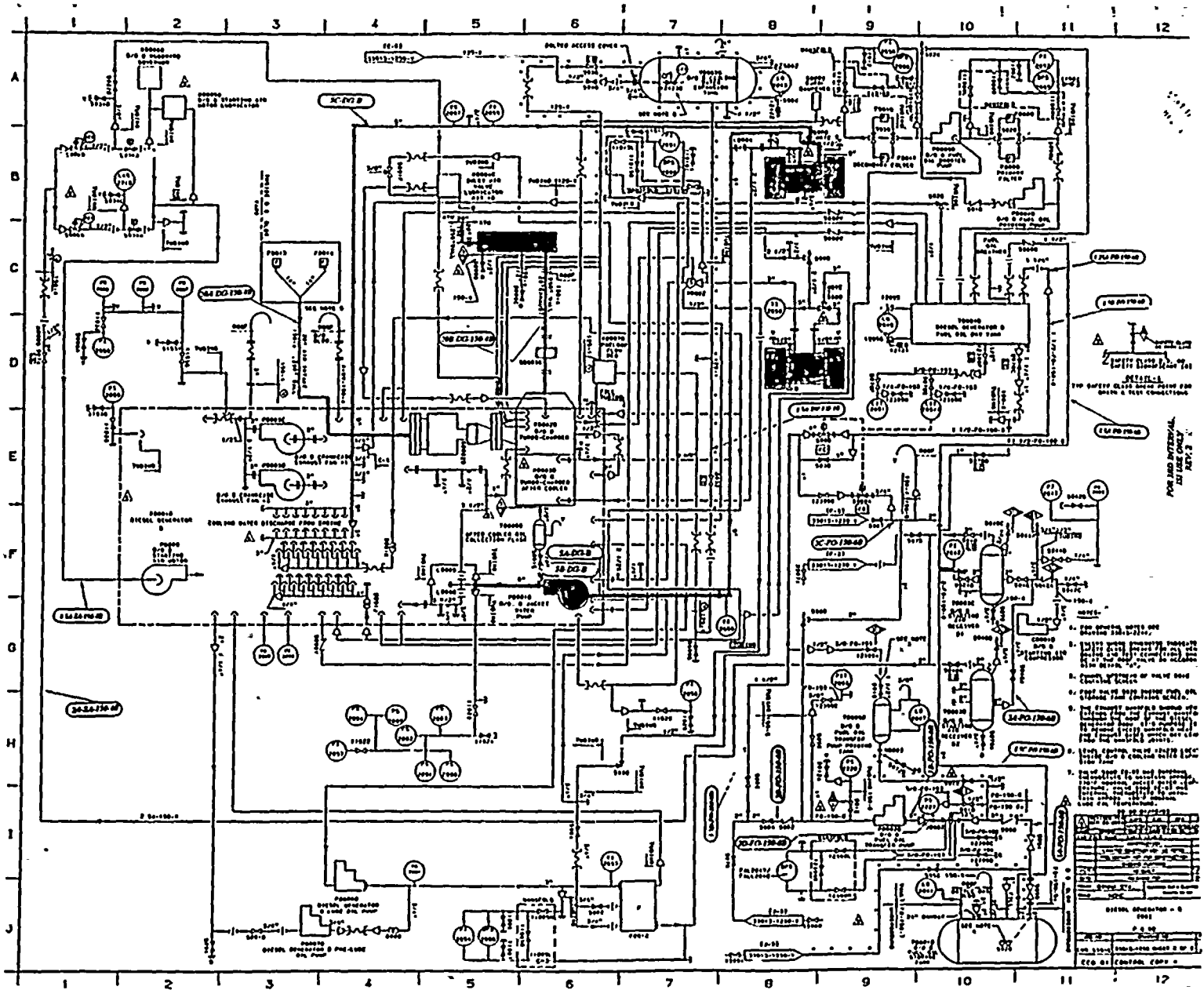

WARNING
 THE SAFETY OF THE SYSTEM DEPENDS ON
 CORRECT AND COMPLETE
 WIRING CONNECTIONS.
 FOR INFO REFER TO
 DRAWING
 REF. 1

1. THIS DRAWING IS THE PROPERTY OF THE COMPANY AND IS NOT TO BE REPRODUCED OR COPIED WITHOUT THE WRITTEN PERMISSION OF THE COMPANY.
2. THIS DRAWING IS THE PROPERTY OF THE COMPANY AND IS NOT TO BE REPRODUCED OR COPIED WITHOUT THE WRITTEN PERMISSION OF THE COMPANY.
3. THIS DRAWING IS THE PROPERTY OF THE COMPANY AND IS NOT TO BE REPRODUCED OR COPIED WITHOUT THE WRITTEN PERMISSION OF THE COMPANY.
4. THIS DRAWING IS THE PROPERTY OF THE COMPANY AND IS NOT TO BE REPRODUCED OR COPIED WITHOUT THE WRITTEN PERMISSION OF THE COMPANY.
5. THIS DRAWING IS THE PROPERTY OF THE COMPANY AND IS NOT TO BE REPRODUCED OR COPIED WITHOUT THE WRITTEN PERMISSION OF THE COMPANY.
6. THIS DRAWING IS THE PROPERTY OF THE COMPANY AND IS NOT TO BE REPRODUCED OR COPIED WITHOUT THE WRITTEN PERMISSION OF THE COMPANY.
7. THIS DRAWING IS THE PROPERTY OF THE COMPANY AND IS NOT TO BE REPRODUCED OR COPIED WITHOUT THE WRITTEN PERMISSION OF THE COMPANY.
8. THIS DRAWING IS THE PROPERTY OF THE COMPANY AND IS NOT TO BE REPRODUCED OR COPIED WITHOUT THE WRITTEN PERMISSION OF THE COMPANY.
9. THIS DRAWING IS THE PROPERTY OF THE COMPANY AND IS NOT TO BE REPRODUCED OR COPIED WITHOUT THE WRITTEN PERMISSION OF THE COMPANY.
10. THIS DRAWING IS THE PROPERTY OF THE COMPANY AND IS NOT TO BE REPRODUCED OR COPIED WITHOUT THE WRITTEN PERMISSION OF THE COMPANY.
11. THIS DRAWING IS THE PROPERTY OF THE COMPANY AND IS NOT TO BE REPRODUCED OR COPIED WITHOUT THE WRITTEN PERMISSION OF THE COMPANY.
12. THIS DRAWING IS THE PROPERTY OF THE COMPANY AND IS NOT TO BE REPRODUCED OR COPIED WITHOUT THE WRITTEN PERMISSION OF THE COMPANY.
13. THIS DRAWING IS THE PROPERTY OF THE COMPANY AND IS NOT TO BE REPRODUCED OR COPIED WITHOUT THE WRITTEN PERMISSION OF THE COMPANY.
14. THIS DRAWING IS THE PROPERTY OF THE COMPANY AND IS NOT TO BE REPRODUCED OR COPIED WITHOUT THE WRITTEN PERMISSION OF THE COMPANY.
15. THIS DRAWING IS THE PROPERTY OF THE COMPANY AND IS NOT TO BE REPRODUCED OR COPIED WITHOUT THE WRITTEN PERMISSION OF THE COMPANY.
16. THIS DRAWING IS THE PROPERTY OF THE COMPANY AND IS NOT TO BE REPRODUCED OR COPIED WITHOUT THE WRITTEN PERMISSION OF THE COMPANY.
17. THIS DRAWING IS THE PROPERTY OF THE COMPANY AND IS NOT TO BE REPRODUCED OR COPIED WITHOUT THE WRITTEN PERMISSION OF THE COMPANY.
18. THIS DRAWING IS THE PROPERTY OF THE COMPANY AND IS NOT TO BE REPRODUCED OR COPIED WITHOUT THE WRITTEN PERMISSION OF THE COMPANY.
19. THIS DRAWING IS THE PROPERTY OF THE COMPANY AND IS NOT TO BE REPRODUCED OR COPIED WITHOUT THE WRITTEN PERMISSION OF THE COMPANY.
20. THIS DRAWING IS THE PROPERTY OF THE COMPANY AND IS NOT TO BE REPRODUCED OR COPIED WITHOUT THE WRITTEN PERMISSION OF THE COMPANY.

DRAWING NUMBER = 0
 0001
 FOR INFO REFER TO
 DRAWING
 REF. 1

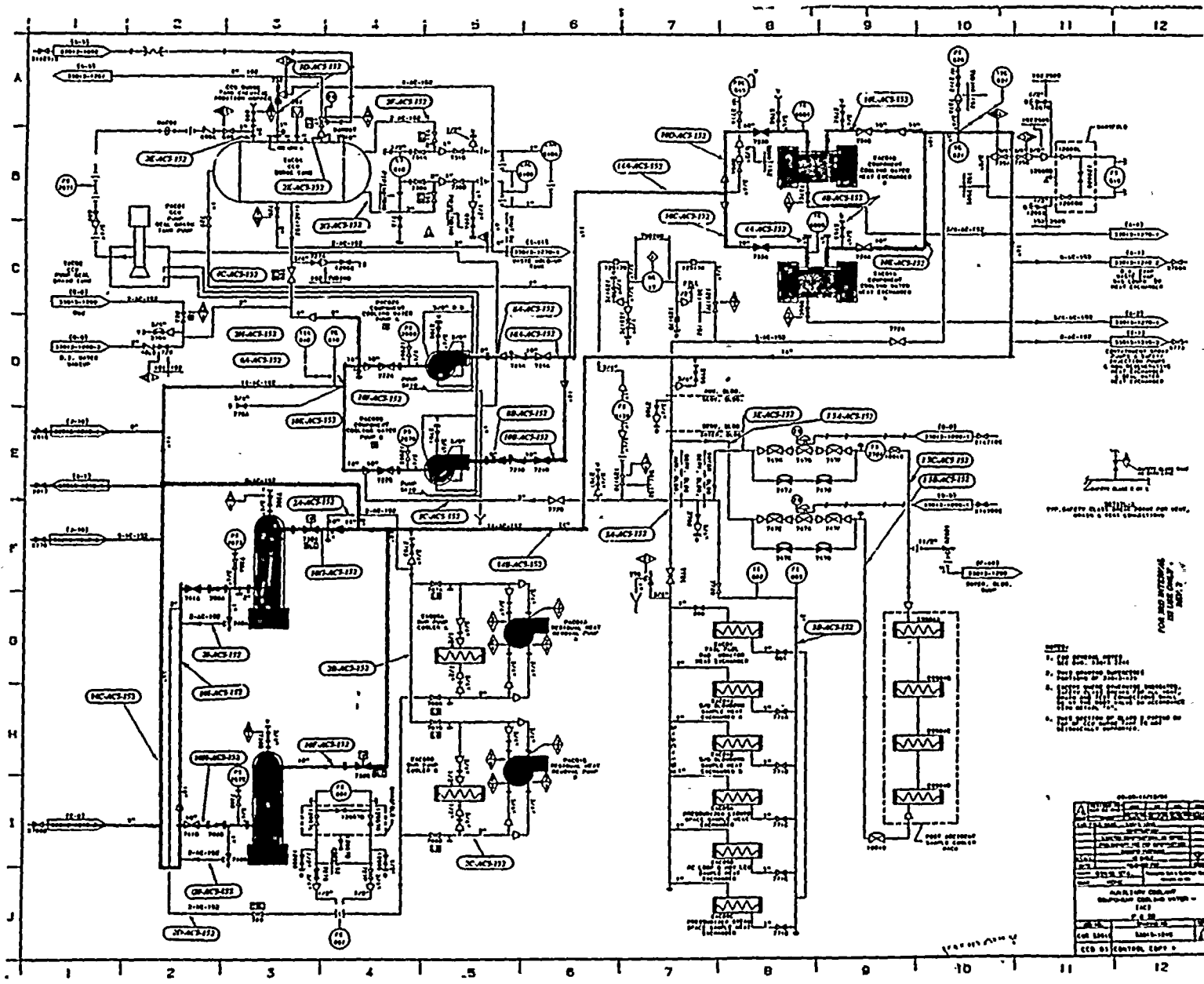

FOR THE ENGINE CONTROL UNIT, SEE THE NEXT DRAWING.

FOR THE PROPULSION CONTROL UNIT, SEE THE NEXT DRAWING.

- 1. ENGINE CONTROL UNIT
- 2. PROPULSION CONTROL UNIT
- 3. ENGINE CONTROL UNIT
- 4. PROPULSION CONTROL UNIT
- 5. ENGINE CONTROL UNIT
- 6. PROPULSION CONTROL UNIT
- 7. ENGINE CONTROL UNIT
- 8. PROPULSION CONTROL UNIT
- 9. ENGINE CONTROL UNIT
- 10. PROPULSION CONTROL UNIT
- 11. ENGINE CONTROL UNIT
- 12. PROPULSION CONTROL UNIT

NO.	DESCRIPTION	QTY	UNIT
1	ENGINE CONTROL UNIT	1	UNIT
2	PROPULSION CONTROL UNIT	1	UNIT
3	ENGINE CONTROL UNIT	1	UNIT
4	PROPULSION CONTROL UNIT	1	UNIT
5	ENGINE CONTROL UNIT	1	UNIT
6	PROPULSION CONTROL UNIT	1	UNIT
7	ENGINE CONTROL UNIT	1	UNIT
8	PROPULSION CONTROL UNIT	1	UNIT
9	ENGINE CONTROL UNIT	1	UNIT
10	PROPULSION CONTROL UNIT	1	UNIT
11	ENGINE CONTROL UNIT	1	UNIT
12	PROPULSION CONTROL UNIT	1	UNIT

DATE: 1964-10-10
 DRAWN BY: J. L. B. (JLB)
 CHECKED BY: J. L. B. (JLB)
 APPROVED BY: J. L. B. (JLB)
 CONTROL UNIT

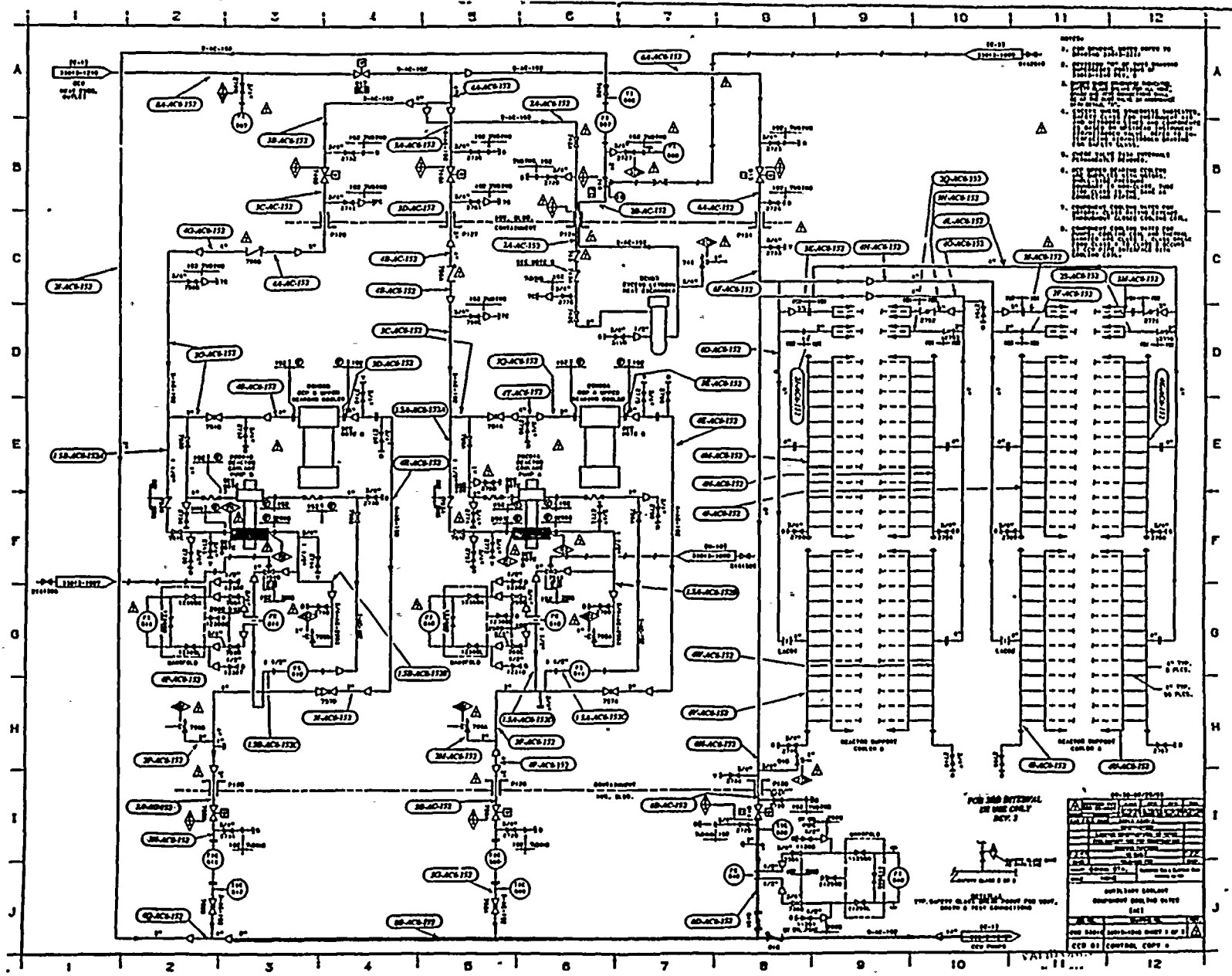

NOTES:

1. THIS SYSTEM IS DESIGNED TO PROVIDE HEATED AIR TO THE CABIN AND WING/ENGINE COMPARTMENTS.
2. THE SYSTEM IS OPERATED BY THE CABIN HEATING CONTROLLER (CHC) AND THE ENGINE HEATING CONTROLLER (EHC).
3. THE SYSTEM IS DESIGNED TO OPERATE AT A PRESSURE OF 100 PSIA.
4. THE SYSTEM IS DESIGNED TO OPERATE AT A TEMPERATURE OF 100°F.
5. THE SYSTEM IS DESIGNED TO OPERATE AT A FLOW RATE OF 100 GPM.
6. THE SYSTEM IS DESIGNED TO OPERATE AT A PRESSURE DROP OF 100 PSI.
7. THE SYSTEM IS DESIGNED TO OPERATE AT A FLOW RATE OF 100 GPM.
8. THE SYSTEM IS DESIGNED TO OPERATE AT A PRESSURE DROP OF 100 PSI.
9. THE SYSTEM IS DESIGNED TO OPERATE AT A FLOW RATE OF 100 GPM.
10. THE SYSTEM IS DESIGNED TO OPERATE AT A PRESSURE DROP OF 100 PSI.

PCB 100 INTERNAL USE ONLY REV. 2

REV.	DATE	DESCRIPTION
1	10/10/70	INITIAL DESIGN
2	11/10/70	REVISED FOR MANUFACTURING
3	12/10/70	REVISED FOR TESTING
4	01/10/71	REVISED FOR PRODUCTION
5	02/10/71	REVISED FOR ASSEMBLY
6	03/10/71	REVISED FOR MAINTENANCE
7	04/10/71	REVISED FOR SAFETY
8	05/10/71	REVISED FOR COMPLIANCE
9	06/10/71	REVISED FOR IMPROVEMENT
10	07/10/71	REVISED FOR FINAL CHECK
11	08/10/71	REVISED FOR CLOSURE
12	09/10/71	REVISED FOR ARCHIVE

CCO 01 CONTROL COPY 2

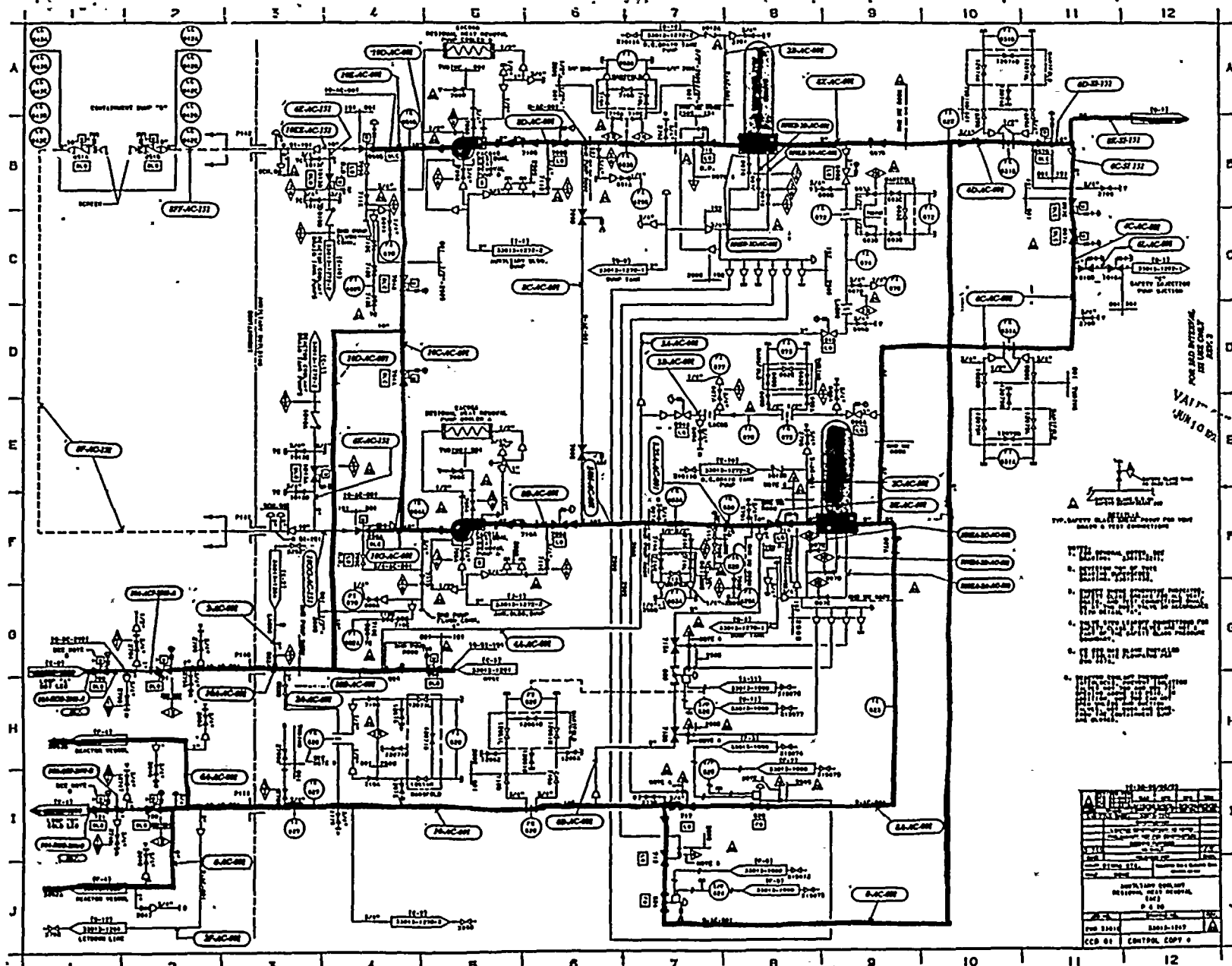

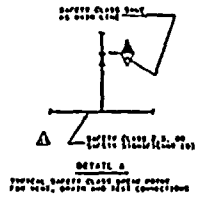
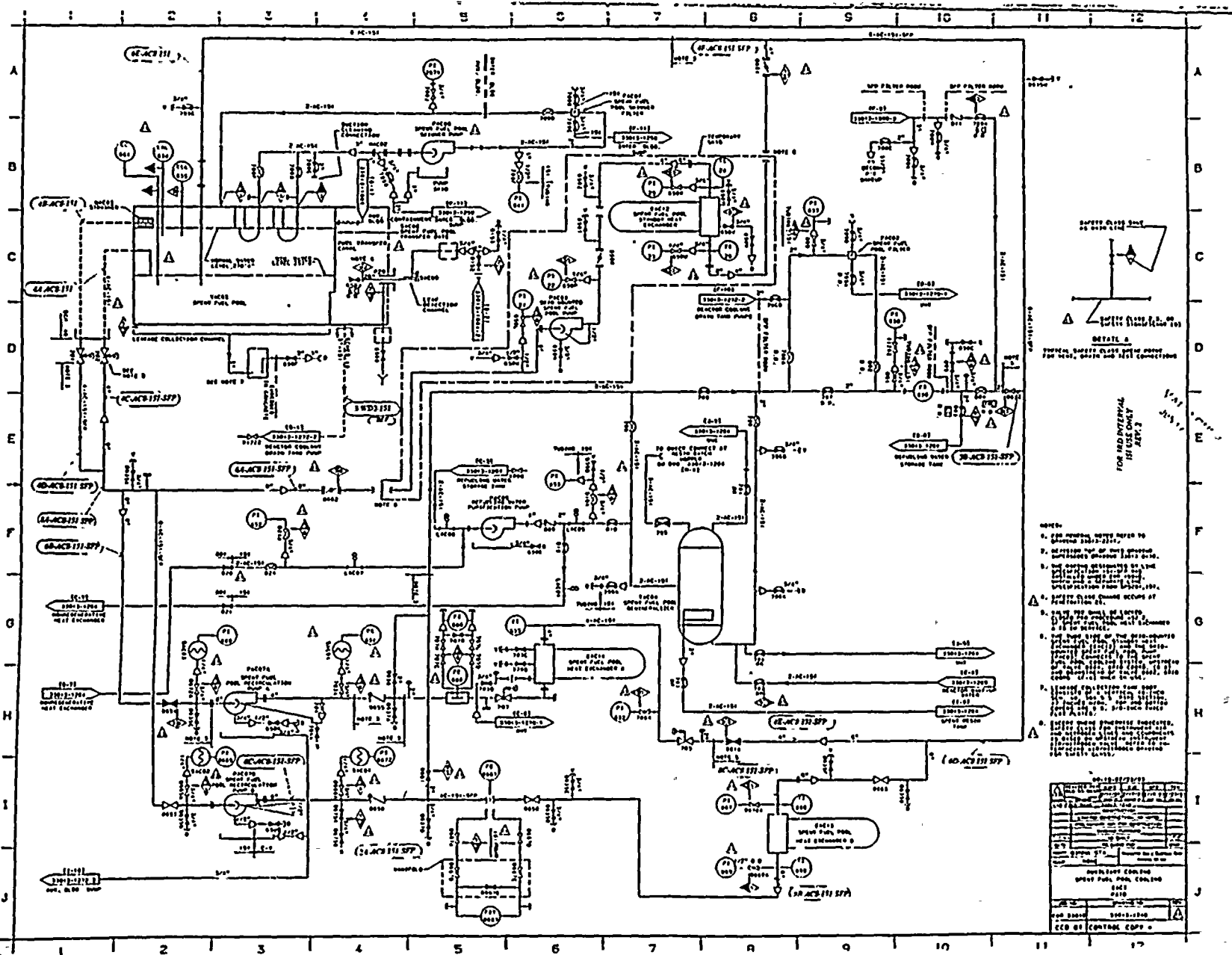

FOR INDUSTRIAL USE ONLY
REV. 2

- NOTES:
1. See drawing notes refer to...
 2. See drawing notes refer to...
 3. See drawing notes refer to...
 4. See drawing notes refer to...
 5. See drawing notes refer to...
 6. See drawing notes refer to...
 7. See drawing notes refer to...
 8. See drawing notes refer to...

TITLE	
NO. 111-111-111	SEWAGE PUMP-OUT SYSTEM
REV. 1	11/11/11
REV. 2	11/11/11
REV. 3	11/11/11
REV. 4	11/11/11
REV. 5	11/11/11
REV. 6	11/11/11
REV. 7	11/11/11
REV. 8	11/11/11
REV. 9	11/11/11
REV. 10	11/11/11
REV. 11	11/11/11
REV. 12	11/11/11
REV. 13	11/11/11
REV. 14	11/11/11
REV. 15	11/11/11
REV. 16	11/11/11
REV. 17	11/11/11
REV. 18	11/11/11
REV. 19	11/11/11
REV. 20	11/11/11
REV. 21	11/11/11
REV. 22	11/11/11
REV. 23	11/11/11
REV. 24	11/11/11
REV. 25	11/11/11
REV. 26	11/11/11
REV. 27	11/11/11
REV. 28	11/11/11
REV. 29	11/11/11
REV. 30	11/11/11
REV. 31	11/11/11
REV. 32	11/11/11
REV. 33	11/11/11
REV. 34	11/11/11
REV. 35	11/11/11
REV. 36	11/11/11
REV. 37	11/11/11
REV. 38	11/11/11
REV. 39	11/11/11
REV. 40	11/11/11
REV. 41	11/11/11
REV. 42	11/11/11
REV. 43	11/11/11
REV. 44	11/11/11
REV. 45	11/11/11
REV. 46	11/11/11
REV. 47	11/11/11
REV. 48	11/11/11
REV. 49	11/11/11
REV. 50	11/11/11

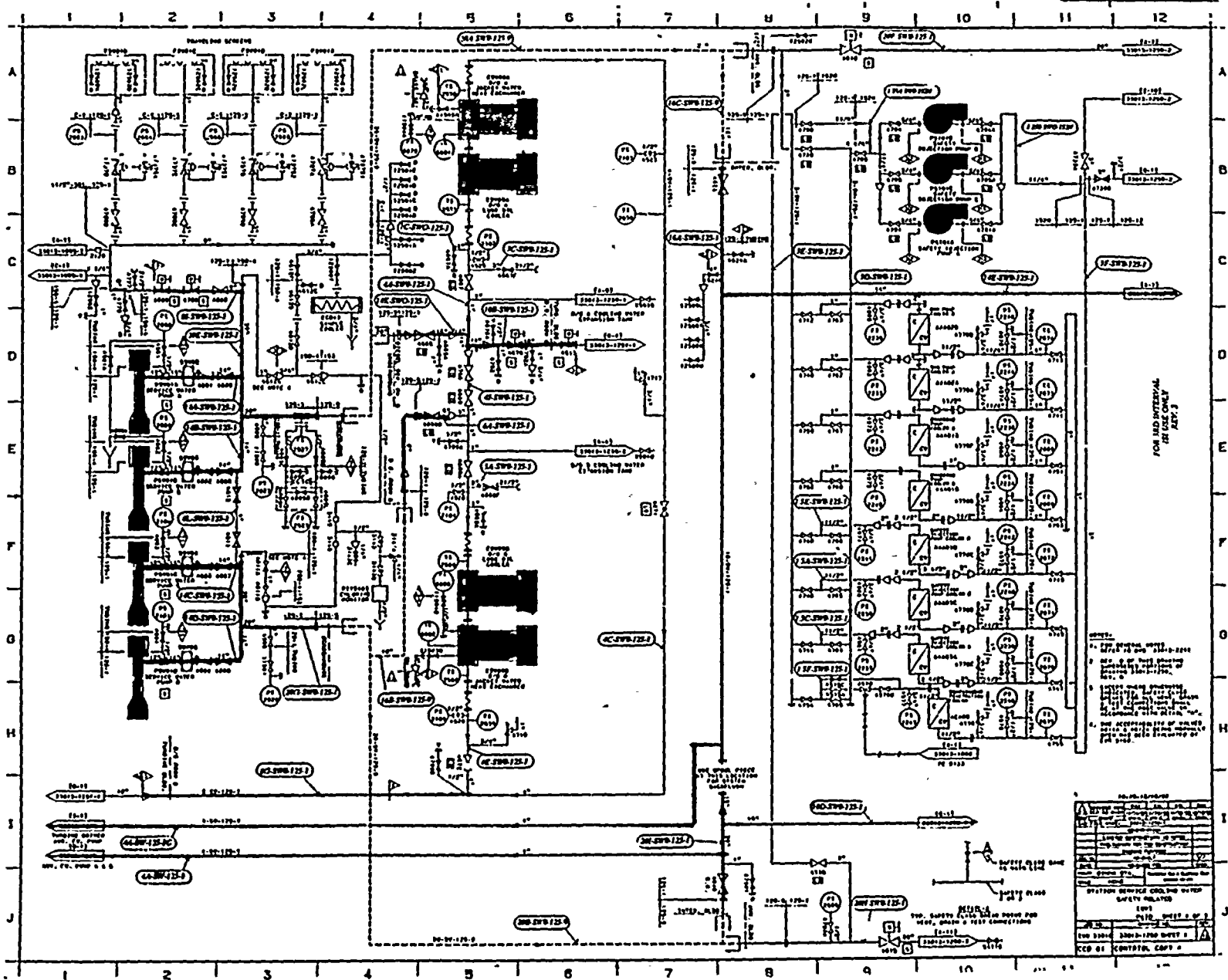

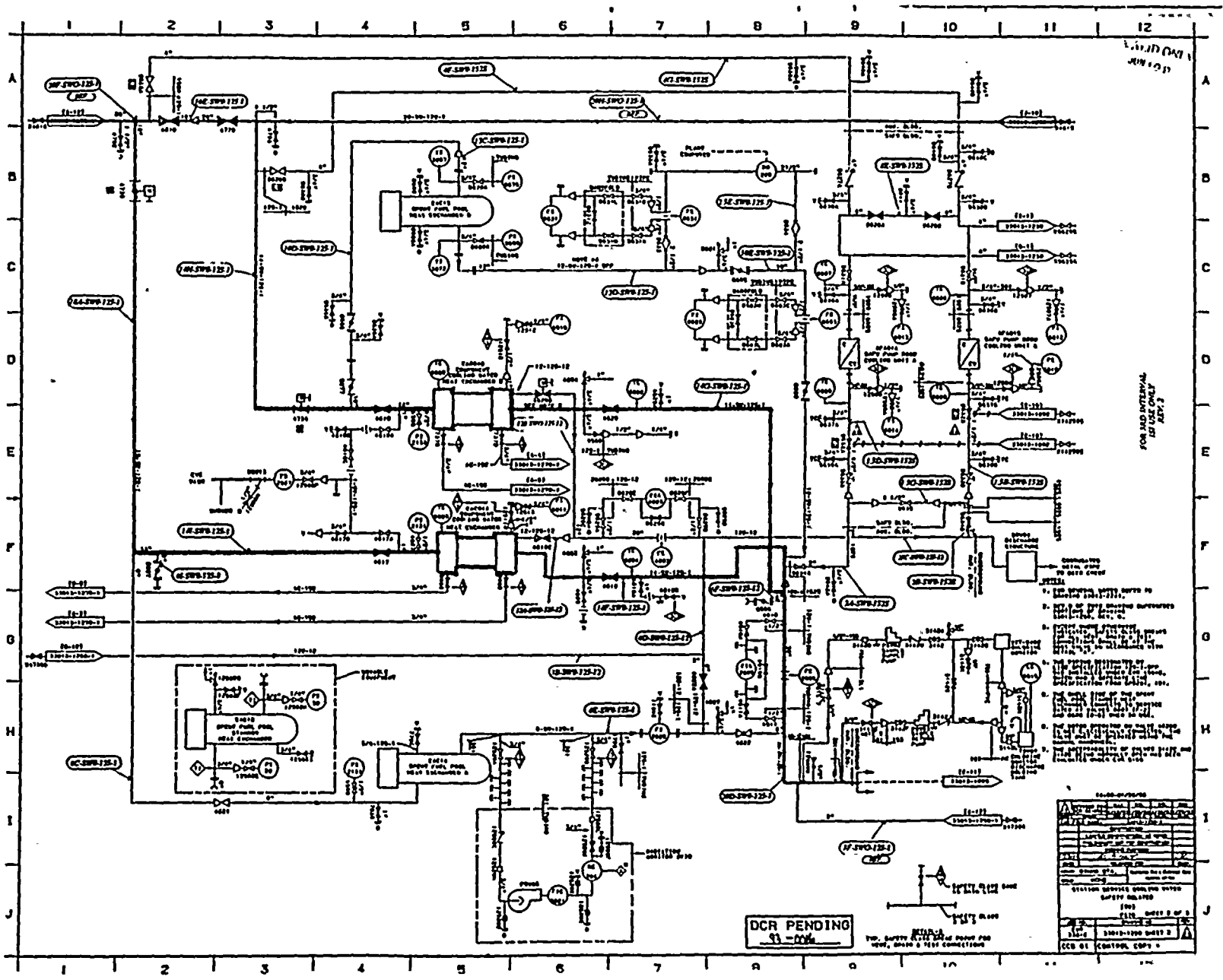

FOR AND INTERNAL USE ONLY

FOR AND INTERNAL USE ONLY

- 1. CHECK THE STATUS OF THE SYSTEM...
- 2. CHECK THE STATUS OF THE SYSTEM...
- 3. CHECK THE STATUS OF THE SYSTEM...
- 4. CHECK THE STATUS OF THE SYSTEM...
- 5. CHECK THE STATUS OF THE SYSTEM...
- 6. CHECK THE STATUS OF THE SYSTEM...
- 7. CHECK THE STATUS OF THE SYSTEM...
- 8. CHECK THE STATUS OF THE SYSTEM...
- 9. CHECK THE STATUS OF THE SYSTEM...
- 10. CHECK THE STATUS OF THE SYSTEM...
- 11. CHECK THE STATUS OF THE SYSTEM...
- 12. CHECK THE STATUS OF THE SYSTEM...

DCR PENDING
93-000

TOP SAFETY...
... AND TEST CONNECTIONS

NO.	DESCRIPTION	DATE	BY

STATION SERVICE QUALITY CHECKED
DATE: _____
BY: _____

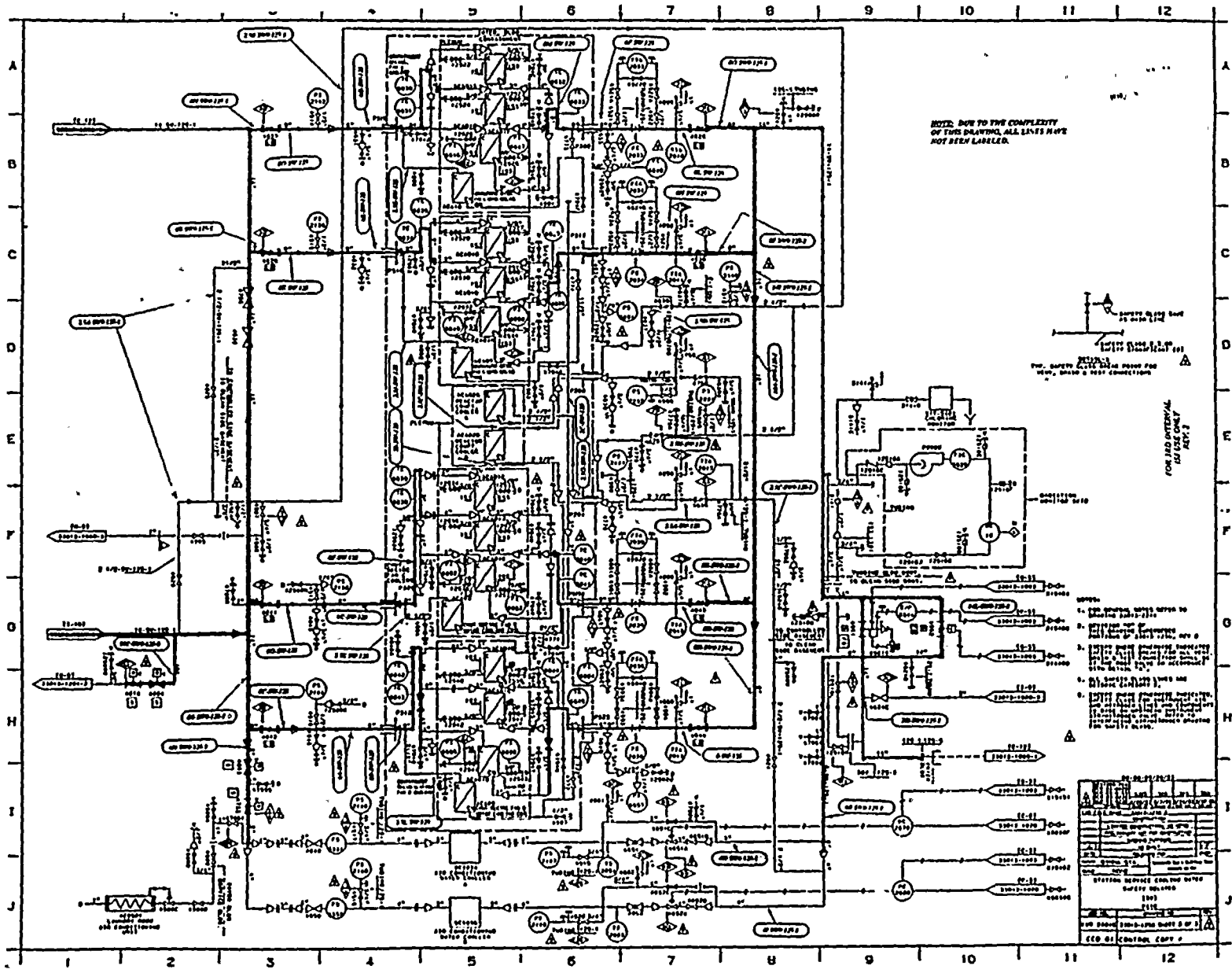

NOTE: DUE TO THE COMPLEXITY OF THIS DRAWING, ALL LINES HAVE NOT BEEN LABELLED.



FOR AND INTERNAL USE ONLY

1. THE ENGINE ROOM CONTROL SYSTEM IS A COMPLEX SYSTEM AND SHOULD BE OPERATED BY PERSONNEL WHO ARE TRAINED AND QUALIFIED TO DO SO.
2. THE SYSTEM IS DESIGNED TO OPERATE UNDER NORMAL CONDITIONS AND SHOULD NOT BE OPERATED UNDER UNUSUAL CONDITIONS.
3. THE SYSTEM IS DESIGNED TO OPERATE AT A SPEED OF 1500 RPM AND SHOULD NOT BE OPERATED AT OTHER SPEEDS.
4. THE SYSTEM IS DESIGNED TO OPERATE AT A PRESSURE OF 150 PSI AND SHOULD NOT BE OPERATED AT OTHER PRESSURES.
5. THE SYSTEM IS DESIGNED TO OPERATE AT A TEMPERATURE OF 150°F AND SHOULD NOT BE OPERATED AT OTHER TEMPERATURES.

COMPONENT	FUNCTION	WIRING	TESTING
11-11	RELAY	11-11	11-11
11-12	RELAY	11-12	11-12
11-13	RELAY	11-13	11-13
11-14	RELAY	11-14	11-14
11-15	RELAY	11-15	11-15
11-16	RELAY	11-16	11-16
11-17	RELAY	11-17	11-17
11-18	RELAY	11-18	11-18
11-19	RELAY	11-19	11-19
11-20	RELAY	11-20	11-20
11-21	RELAY	11-21	11-21
11-22	RELAY	11-22	11-22
11-23	RELAY	11-23	11-23
11-24	RELAY	11-24	11-24
11-25	RELAY	11-25	11-25
11-26	RELAY	11-26	11-26
11-27	RELAY	11-27	11-27
11-28	RELAY	11-28	11-28
11-29	RELAY	11-29	11-29
11-30	RELAY	11-30	11-30

CCO of Control Copy

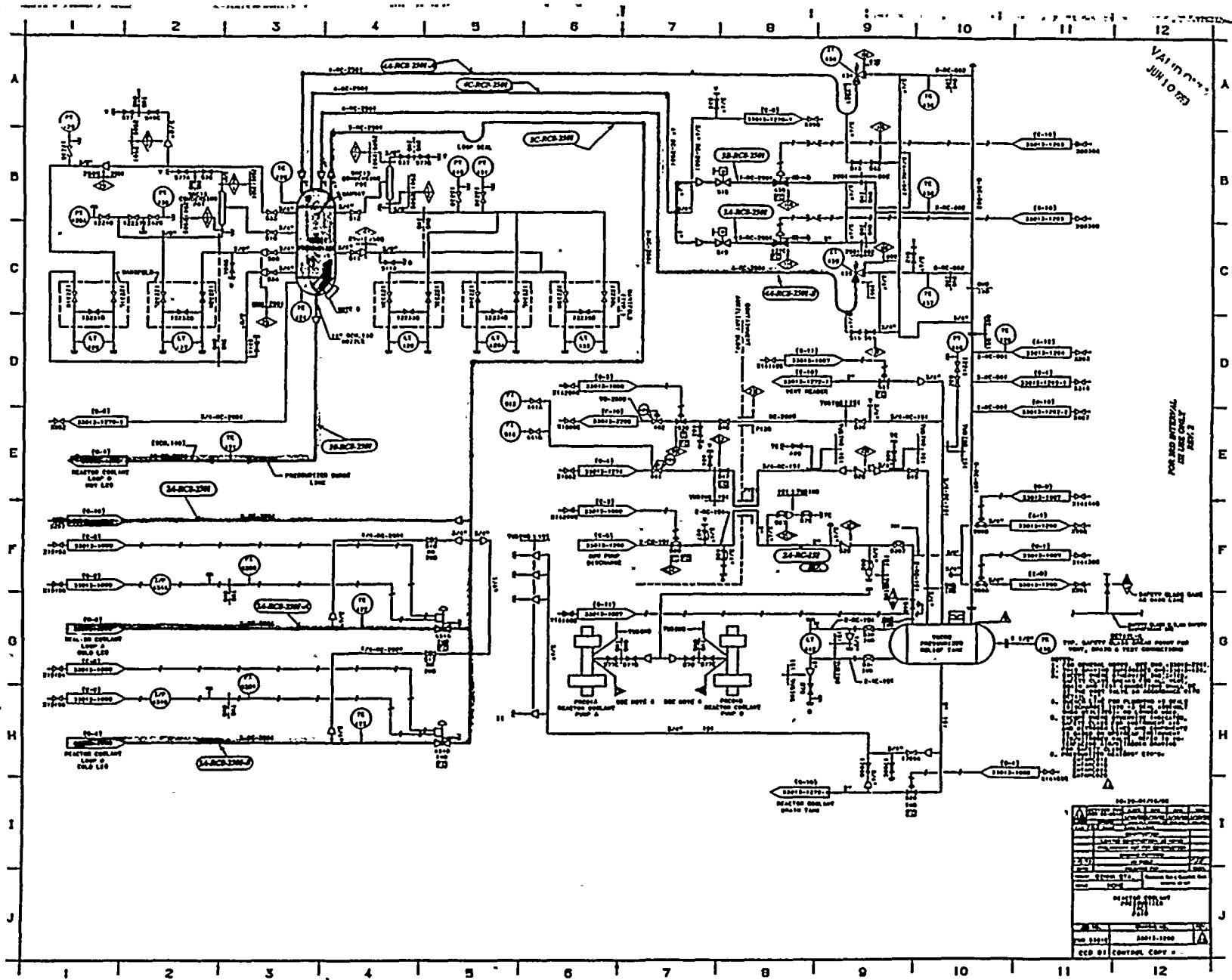

REVISIONS	
NO.	DESCRIPTION
1	INITIAL DESIGN
2	REVISED FOR MANUFACTURING
3	REVISED FOR TESTING
4	REVISED FOR ASSEMBLY
5	REVISED FOR OPERATION
6	REVISED FOR MAINTENANCE
7	REVISED FOR REPAIR
8	REVISED FOR MODIFICATION
9	REVISED FOR IMPROVEMENT
10	REVISED FOR SAFETY
11	REVISED FOR SECURITY
12	REVISED FOR COMPLIANCE

PARTS LIST		
QTY	PART NO.	DESCRIPTION
1	1A-RCR-25W	REACTOR COOLANT PUMP A
1	1B-RCR-25W	REACTOR COOLANT PUMP B
1	1C-RCR-25W	REACTOR COOLANT PUMP C
1	1D-RCR-25W	REACTOR COOLANT PUMP D
1	1E-RCR-25W	REACTOR COOLANT PUMP E
1	1F-RCR-25W	REACTOR COOLANT PUMP F
1	1G-RCR-25W	REACTOR COOLANT PUMP G
1	1H-RCR-25W	REACTOR COOLANT PUMP H
1	1I-RCR-25W	REACTOR COOLANT PUMP I
1	1J-RCR-25W	REACTOR COOLANT PUMP J
1	1K-RCR-25W	REACTOR COOLANT PUMP K
1	1L-RCR-25W	REACTOR COOLANT PUMP L
1	1M-RCR-25W	REACTOR COOLANT PUMP M
1	1N-RCR-25W	REACTOR COOLANT PUMP N
1	1O-RCR-25W	REACTOR COOLANT PUMP O
1	1P-RCR-25W	REACTOR COOLANT PUMP P
1	1Q-RCR-25W	REACTOR COOLANT PUMP Q
1	1R-RCR-25W	REACTOR COOLANT PUMP R
1	1S-RCR-25W	REACTOR COOLANT PUMP S
1	1T-RCR-25W	REACTOR COOLANT PUMP T
1	1U-RCR-25W	REACTOR COOLANT PUMP U
1	1V-RCR-25W	REACTOR COOLANT PUMP V
1	1W-RCR-25W	REACTOR COOLANT PUMP W
1	1X-RCR-25W	REACTOR COOLANT PUMP X
1	1Y-RCR-25W	REACTOR COOLANT PUMP Y
1	1Z-RCR-25W	REACTOR COOLANT PUMP Z

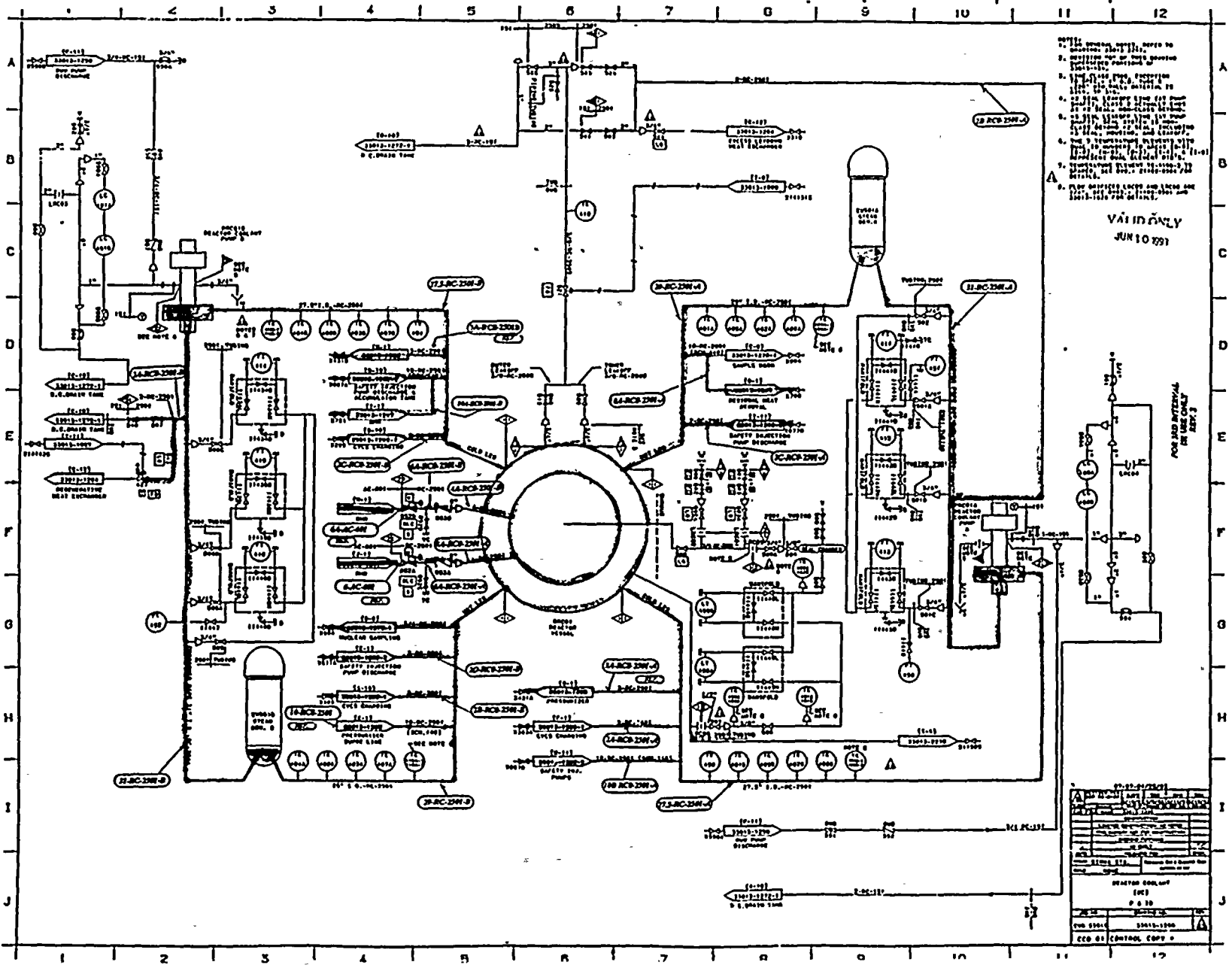

1. This schematic, when used with the reactor schematic, shall be used to determine the status of the reactor control system.
2. This schematic shall be used to determine the status of the reactor control system.
3. This schematic shall be used to determine the status of the reactor control system.
4. This schematic shall be used to determine the status of the reactor control system.
5. This schematic shall be used to determine the status of the reactor control system.
6. This schematic shall be used to determine the status of the reactor control system.
7. This schematic shall be used to determine the status of the reactor control system.
8. This schematic shall be used to determine the status of the reactor control system.
9. This schematic shall be used to determine the status of the reactor control system.
10. This schematic shall be used to determine the status of the reactor control system.

VALID ONLY
JUN 10 1951

NO.	DESCRIPTION	REVISIONS
1	ASSEMBLED	
2		
3		
4		
5		
6		
7		
8		
9		
10		
11		
12		
13		
14		
15		
16		
17		
18		
19		
20		
21		
22		
23		
24		
25		
26		
27		
28		
29		
30		

REACTOR SCHEMATIC
 P 8 30
 JUN 10 1951
 EWD 5304 5304-1-1500
 CCD BY CONTROL COPY

FOR INFO INTENTIONAL
FOR USE ONLY
REV. 2

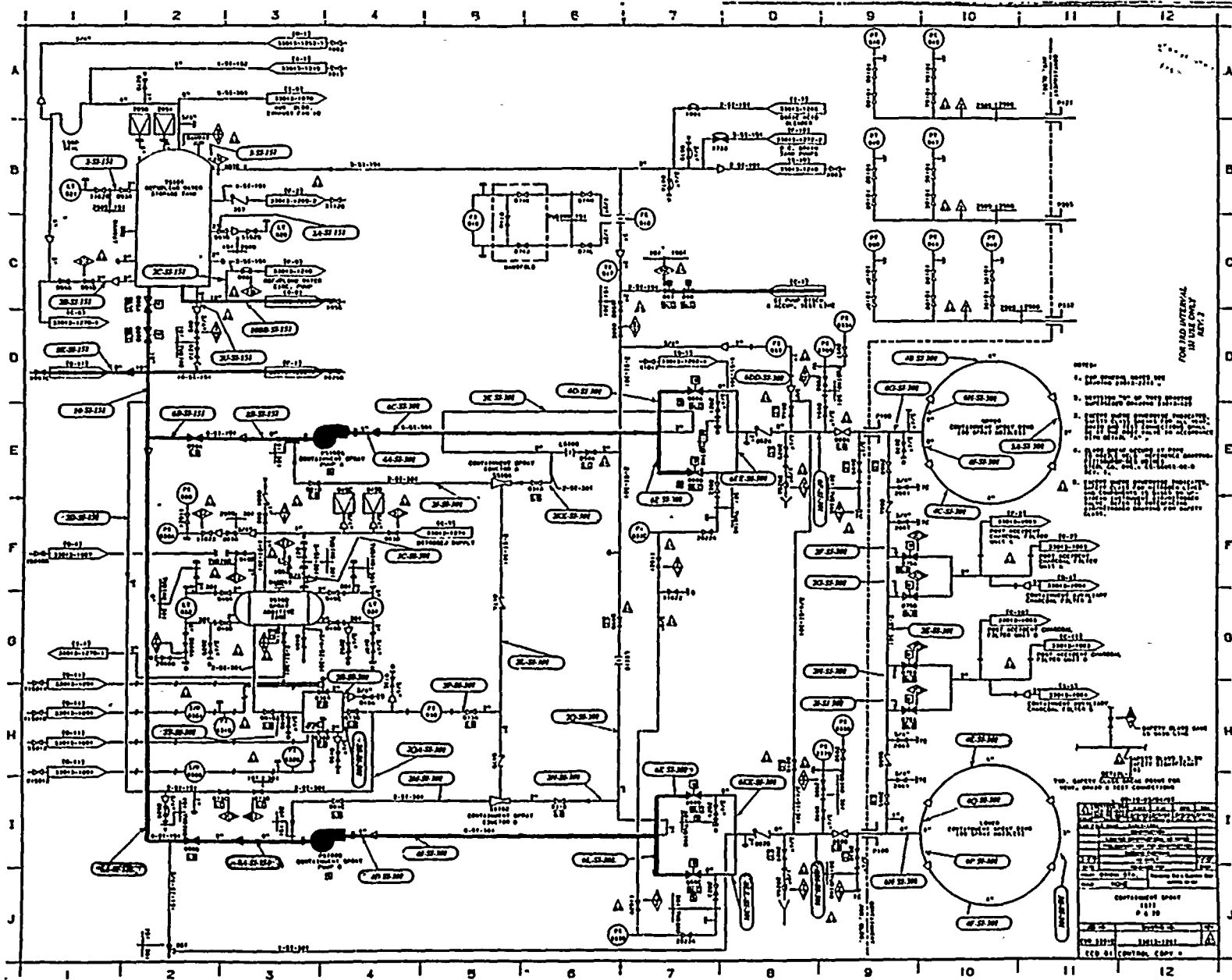

NOTES:
 1. THE OPERATOR MUST BE
 PRESENT AT ALL TIMES.
 2. THE SYSTEM SHALL BE
 TESTED PRIOR TO STARTUP.
 3. THE SYSTEM SHALL BE
 TESTED AFTER STOPPAGE.
 4. THE SYSTEM SHALL BE
 TESTED AFTER MAINTENANCE.
 5. THE SYSTEM SHALL BE
 TESTED AFTER REPAIRS.
 6. THE SYSTEM SHALL BE
 TESTED AFTER OIL CHANGE.
 7. THE SYSTEM SHALL BE
 TESTED AFTER FILTER CHANGE.
 8. THE SYSTEM SHALL BE
 TESTED AFTER VALVE CHANGE.
 9. THE SYSTEM SHALL BE
 TESTED AFTER PUMP CHANGE.
 10. THE SYSTEM SHALL BE
 TESTED AFTER MOTOR CHANGE.
 11. THE SYSTEM SHALL BE
 TESTED AFTER WIRE CHANGE.
 12. THE SYSTEM SHALL BE
 TESTED AFTER PART CHANGE.

THE ABOVE DATA IS FOR USE ONLY
 IN THE ONLY IN THE ONLY IN THE ONLY

NO. 111	NO. 111	NO. 111
REV. 111	REV. 111	REV. 111
DATE 111	DATE 111	DATE 111
BY 111	BY 111	BY 111
CHECKED 111	CHECKED 111	CHECKED 111
APPROVED 111	APPROVED 111	APPROVED 111

CONFINED SPACE
 # 111
 P. 10

FOR TAD INTERNAL IN USE ONLY IN REV. 1

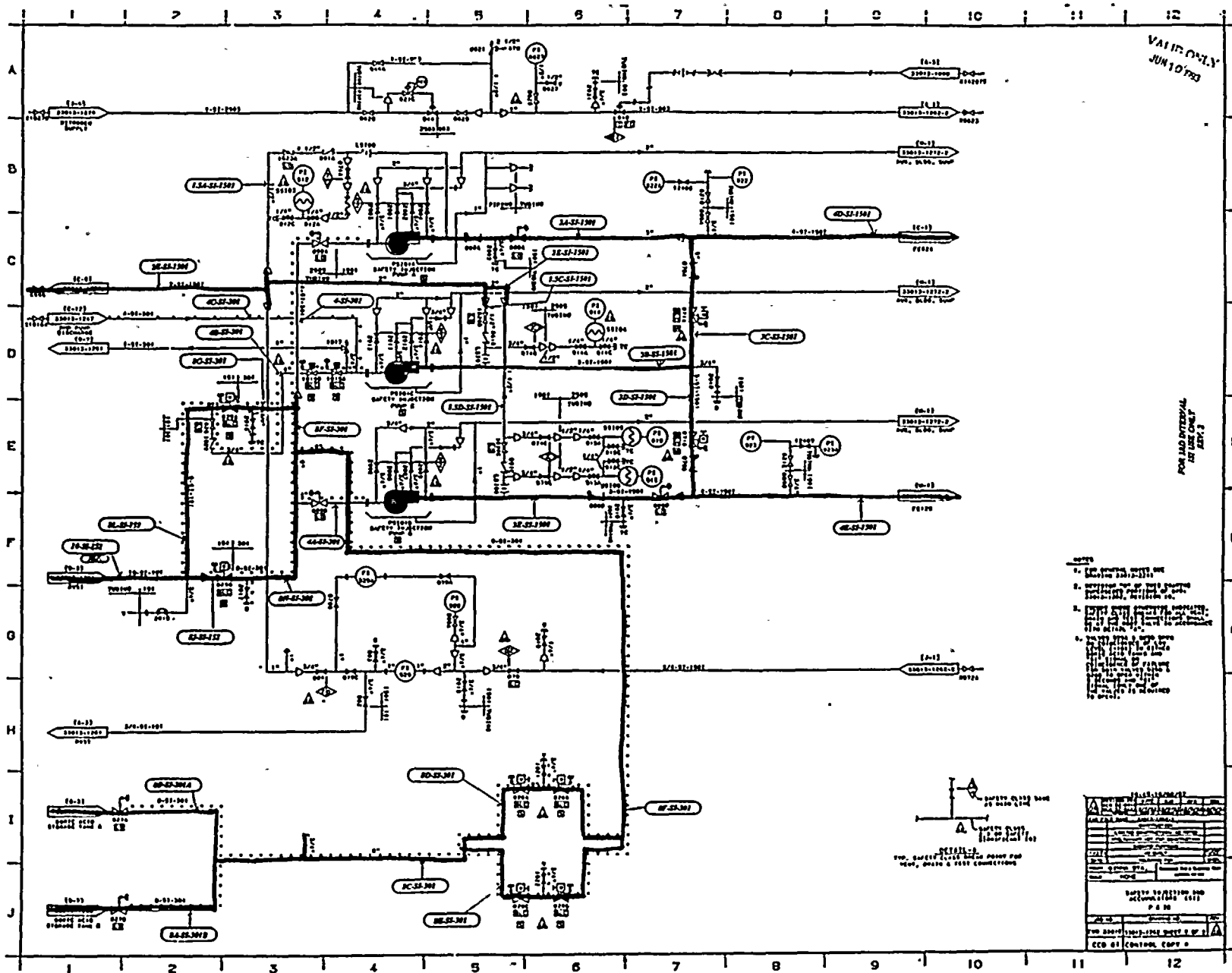

VAL IN ONLY
JUN 10 1963

FOR LOAD INTERFERENCE
USE ONLY
REV. 3

1. THE SAFETY STOP SYSTEM IS A SAFETY SYSTEM WHICH IS DESIGNED TO STOP THE ENGINE IN THE EVENT OF A SAFETY STOP SYSTEM FAILURE. THE SAFETY STOP SYSTEM IS A SAFETY SYSTEM WHICH IS DESIGNED TO STOP THE ENGINE IN THE EVENT OF A SAFETY STOP SYSTEM FAILURE. THE SAFETY STOP SYSTEM IS A SAFETY SYSTEM WHICH IS DESIGNED TO STOP THE ENGINE IN THE EVENT OF A SAFETY STOP SYSTEM FAILURE.

DETAILS:
FOR SAFETY STOP SYSTEM
STOP, STOP & STOP CONNECTIONS

NO.	DESCRIPTION	LOCATION
1	SAFETY STOP SYSTEM	1A-21
2	SAFETY STOP SYSTEM	1B-21
3	SAFETY STOP SYSTEM	1C-21
4	SAFETY STOP SYSTEM	1D-21
5	SAFETY STOP SYSTEM	1E-21
6	SAFETY STOP SYSTEM	1F-21
7	SAFETY STOP SYSTEM	1G-21
8	SAFETY STOP SYSTEM	1H-21
9	SAFETY STOP SYSTEM	1I-21
10	SAFETY STOP SYSTEM	1J-21
11	SAFETY STOP SYSTEM	1K-21
12	SAFETY STOP SYSTEM	1L-21

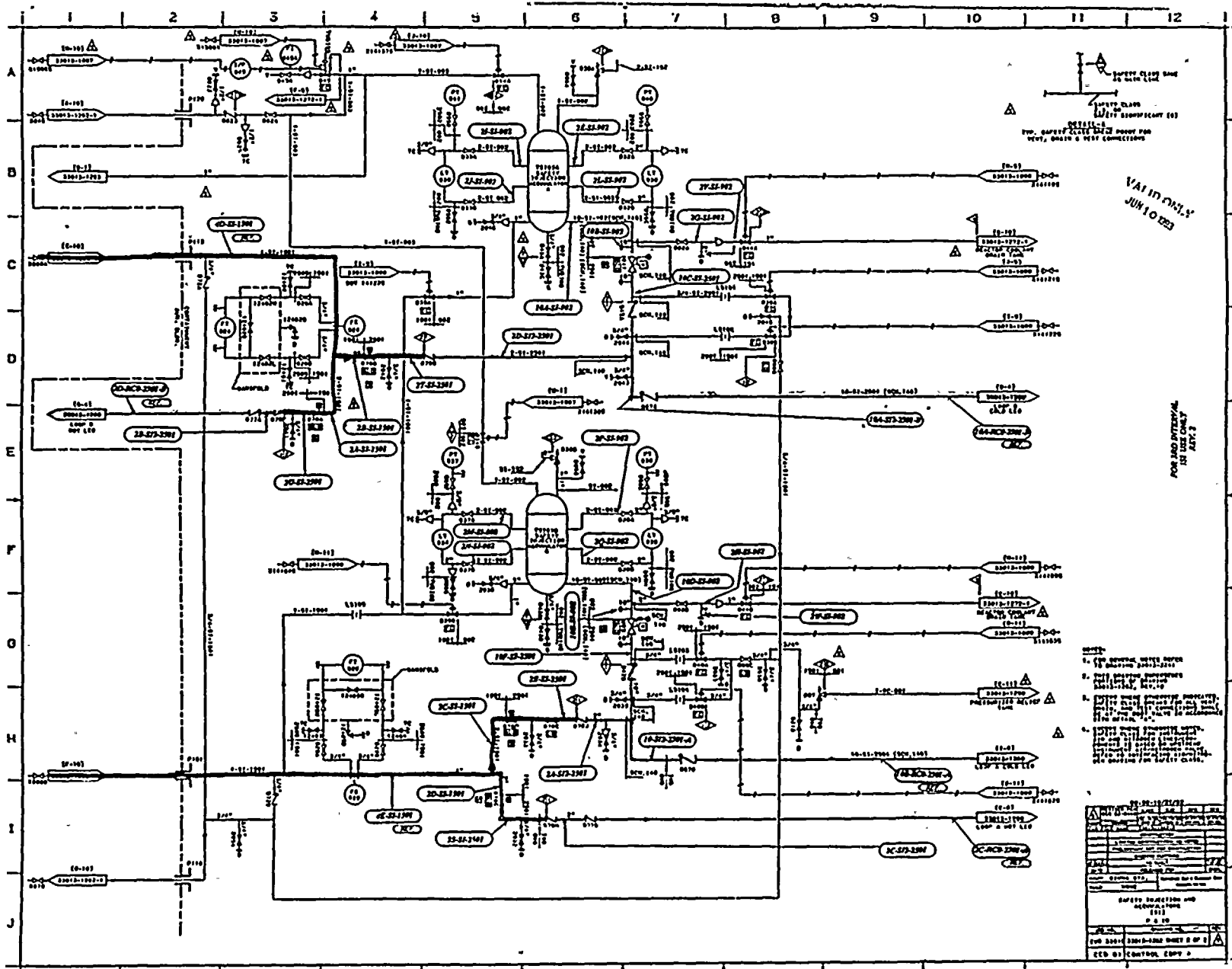

NORTH
 SOUTH
 EAST
 WEST
 100% SAFETY
 100% CONTROL

VALID ONLY
 JUN 10 1953

FOR AND INTERVAL
 IN USE ONLY
 ART. 7

1. FOR GENERAL WIRE REFER TO DRAWING 2001-2001
2. THIS DRAWING SHOWS THE WIRING FOR THE ENGINE ROOM CONTROL SYSTEM
3. THE WIRING IS IDENTIFIED BY THE LETTERS AND NUMBERS IN THE CIRCLES AND TRIANGLES
4. THE WIRING IS IDENTIFIED BY THE LETTERS AND NUMBERS IN THE CIRCLES AND TRIANGLES

NO.	DESCRIPTION	DATE	BY
1	REVISION		
2	REVISION		
3	REVISION		
4	REVISION		
5	REVISION		
6	REVISION		
7	REVISION		
8	REVISION		
9	REVISION		
10	REVISION		
11	REVISION		
12	REVISION		
13	REVISION		
14	REVISION		
15	REVISION		
16	REVISION		
17	REVISION		
18	REVISION		
19	REVISION		
20	REVISION		

SAFETY CONNECTIONS AND
 ADJUSTMENTS
 1111
 P. 8 TO
 FOR 2001-2001 SHEET 2 OF 2
 CDD BY CONTROL COPY 2

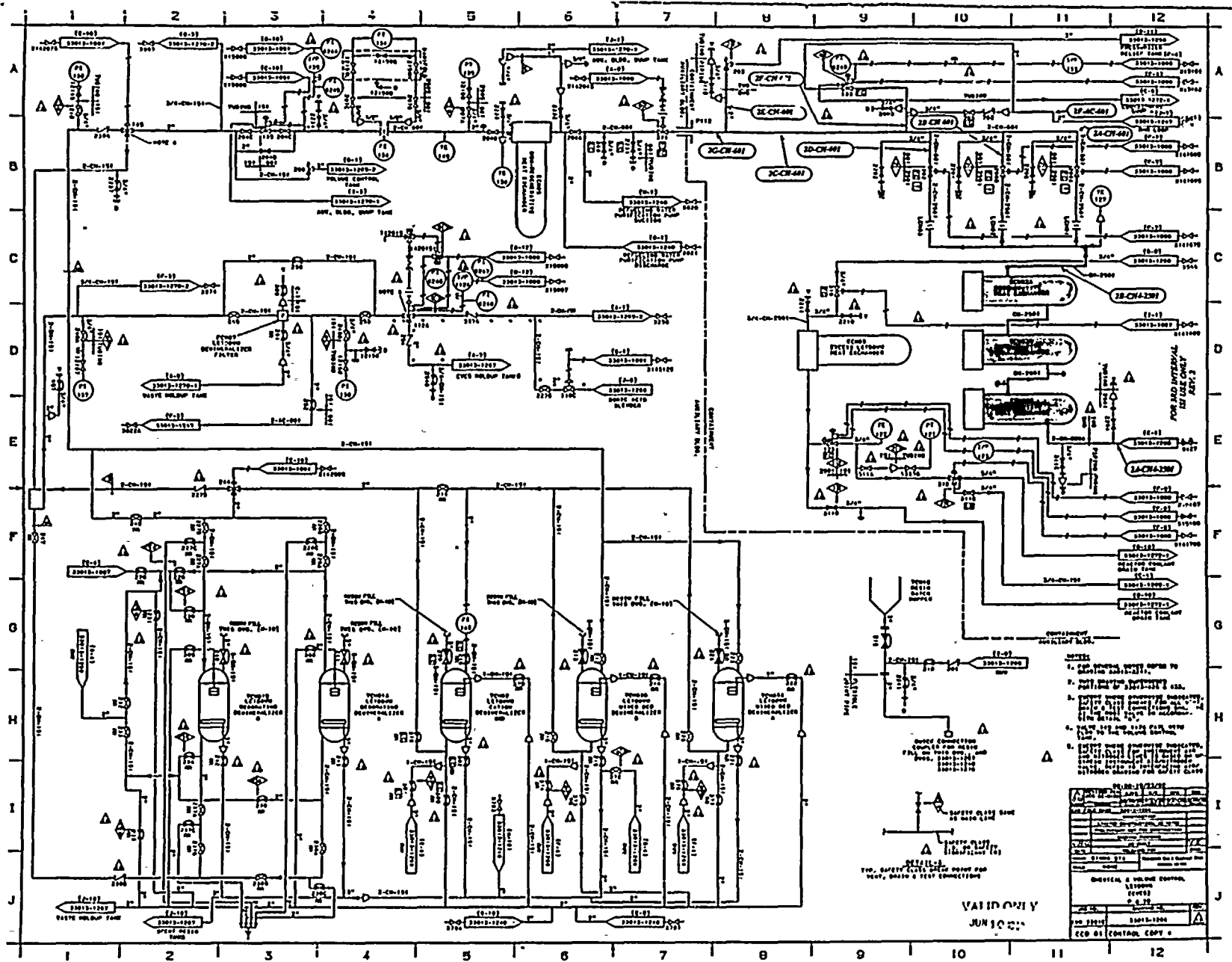

1. THE GENERAL WASTE HOLDUP TIME
 FOR THE SYSTEM IS 10 SECONDS.
 2. THE WASTE HOLDUP TIME IS
 CONTROLLED BY THE WASTE HOLDUP
 TIME RELAY.
 3. THE WASTE HOLDUP TIME IS
 CONTROLLED BY THE WASTE HOLDUP
 TIME RELAY.
 4. THE WASTE HOLDUP TIME IS
 CONTROLLED BY THE WASTE HOLDUP
 TIME RELAY.
 5. THE WASTE HOLDUP TIME IS
 CONTROLLED BY THE WASTE HOLDUP
 TIME RELAY.

THE WASTE HOLDUP TIME IS
 CONTROLLED BY THE WASTE HOLDUP
 TIME RELAY.

VALID ONLY
 JUN 1964

REVISIONS	
NO.	DESCRIPTION
1	INITIAL DESIGN
2	REVISIONS
3	REVISIONS
4	REVISIONS
5	REVISIONS
6	REVISIONS
7	REVISIONS
8	REVISIONS
9	REVISIONS
10	REVISIONS
11	REVISIONS
12	REVISIONS

APPROVED FOR RELEASE
 AUTHORITY: 3010-108
 DATE: 06-1964
 CONTROL COPY 1

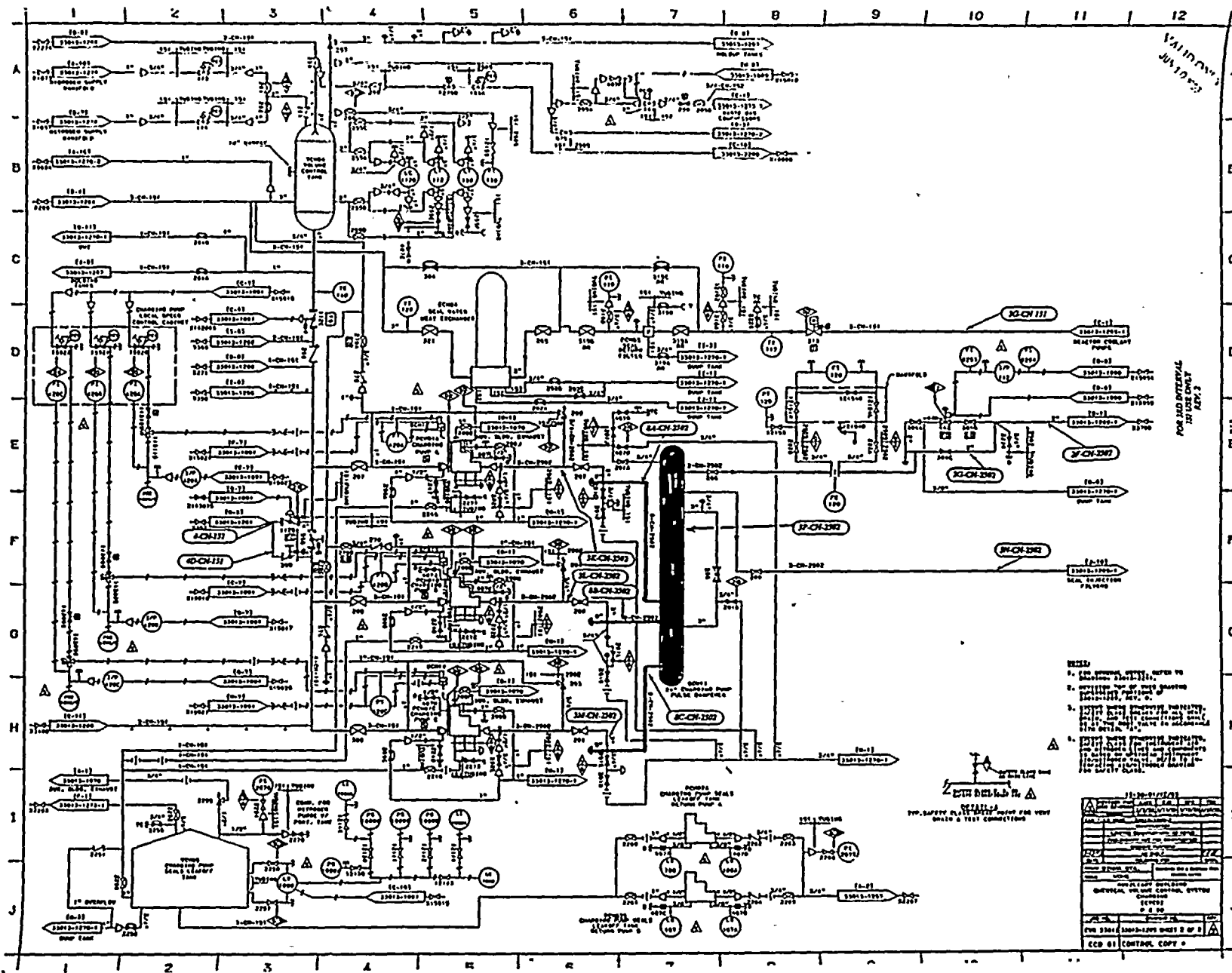

VALID ONLY
JUN 19 1953

FOR INFO REFERENCE
SEE DRAWING
APP-2

- NOTES:
1. See drawing APP-2 for details of reactor control system.
 2. See drawing APP-3 for details of reactor control system.
 3. See drawing APP-4 for details of reactor control system.
 4. See drawing APP-5 for details of reactor control system.

WITH DELTA R
FOR SAFETY PLANT CONTROL SYSTEM
DURING TEST OPERATIONS

APP-2	REACTOR CONTROL SYSTEM	1
APP-3	REACTOR CONTROL SYSTEM	1
APP-4	REACTOR CONTROL SYSTEM	1
APP-5	REACTOR CONTROL SYSTEM	1
APP-6	REACTOR CONTROL SYSTEM	1
APP-7	REACTOR CONTROL SYSTEM	1
APP-8	REACTOR CONTROL SYSTEM	1
APP-9	REACTOR CONTROL SYSTEM	1
APP-10	REACTOR CONTROL SYSTEM	1
APP-11	REACTOR CONTROL SYSTEM	1
APP-12	REACTOR CONTROL SYSTEM	1
APP-13	REACTOR CONTROL SYSTEM	1
APP-14	REACTOR CONTROL SYSTEM	1
APP-15	REACTOR CONTROL SYSTEM	1
APP-16	REACTOR CONTROL SYSTEM	1
APP-17	REACTOR CONTROL SYSTEM	1
APP-18	REACTOR CONTROL SYSTEM	1
APP-19	REACTOR CONTROL SYSTEM	1
APP-20	REACTOR CONTROL SYSTEM	1
APP-21	REACTOR CONTROL SYSTEM	1
APP-22	REACTOR CONTROL SYSTEM	1
APP-23	REACTOR CONTROL SYSTEM	1
APP-24	REACTOR CONTROL SYSTEM	1
APP-25	REACTOR CONTROL SYSTEM	1
APP-26	REACTOR CONTROL SYSTEM	1
APP-27	REACTOR CONTROL SYSTEM	1
APP-28	REACTOR CONTROL SYSTEM	1
APP-29	REACTOR CONTROL SYSTEM	1
APP-30	REACTOR CONTROL SYSTEM	1
APP-31	REACTOR CONTROL SYSTEM	1
APP-32	REACTOR CONTROL SYSTEM	1
APP-33	REACTOR CONTROL SYSTEM	1
APP-34	REACTOR CONTROL SYSTEM	1
APP-35	REACTOR CONTROL SYSTEM	1
APP-36	REACTOR CONTROL SYSTEM	1
APP-37	REACTOR CONTROL SYSTEM	1
APP-38	REACTOR CONTROL SYSTEM	1
APP-39	REACTOR CONTROL SYSTEM	1
APP-40	REACTOR CONTROL SYSTEM	1
APP-41	REACTOR CONTROL SYSTEM	1
APP-42	REACTOR CONTROL SYSTEM	1
APP-43	REACTOR CONTROL SYSTEM	1
APP-44	REACTOR CONTROL SYSTEM	1
APP-45	REACTOR CONTROL SYSTEM	1
APP-46	REACTOR CONTROL SYSTEM	1
APP-47	REACTOR CONTROL SYSTEM	1
APP-48	REACTOR CONTROL SYSTEM	1
APP-49	REACTOR CONTROL SYSTEM	1
APP-50	REACTOR CONTROL SYSTEM	1

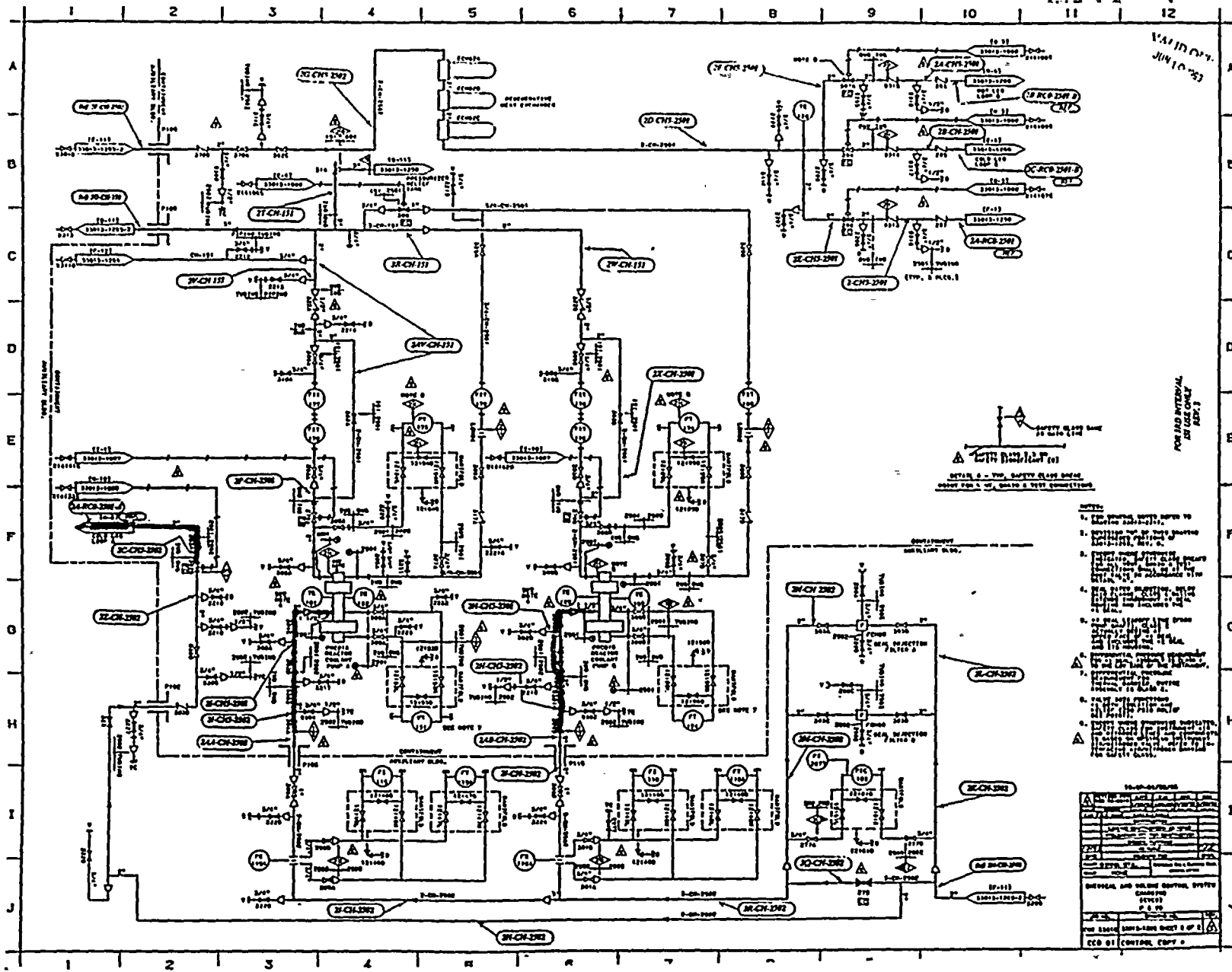

VALINOV
JUN 10 '53

FOR AND INTERNAL
USE ONLY
REV. 2

RELAY PANEL
 SWITCH PANEL
 DETAIL A - THE SAFETY RELAY PANEL
 SHOWS THE WIRING CONNECTIONS

1. This panel is used to control the operation of the system.
2. The panel is divided into three sections: Relay Panel, Switch Panel, and Control Panel.
3. The Relay Panel contains the relays that control the system's operation.
4. The Switch Panel contains the switches that are used to start and stop the system.
5. The Control Panel contains the control units that manage the system's operation.
6. The panel is designed to be used in a control room.
7. The panel is made of metal and is painted black.
8. The panel is mounted on a wall or a rack.
9. The panel is used to control the system's operation.
10. The panel is used to control the system's operation.

NO.	DESCRIPTION	QTY	REMARKS
1	RELAY PANEL	1	
2	SWITCH PANEL	1	
3	CONTROL PANEL	1	
4	RELAY PANEL	1	
5	SWITCH PANEL	1	
6	CONTROL PANEL	1	
7	RELAY PANEL	1	
8	SWITCH PANEL	1	
9	CONTROL PANEL	1	
10	RELAY PANEL	1	
11	SWITCH PANEL	1	
12	CONTROL PANEL	1	

ORIGINAL AND ONLINE DRAWING SYSTEM
 CONTROL SYSTEM
 P. 10
 FOR 10000 SHEET SHEET 8 OF 8
 ECD OF CONTROL COPY



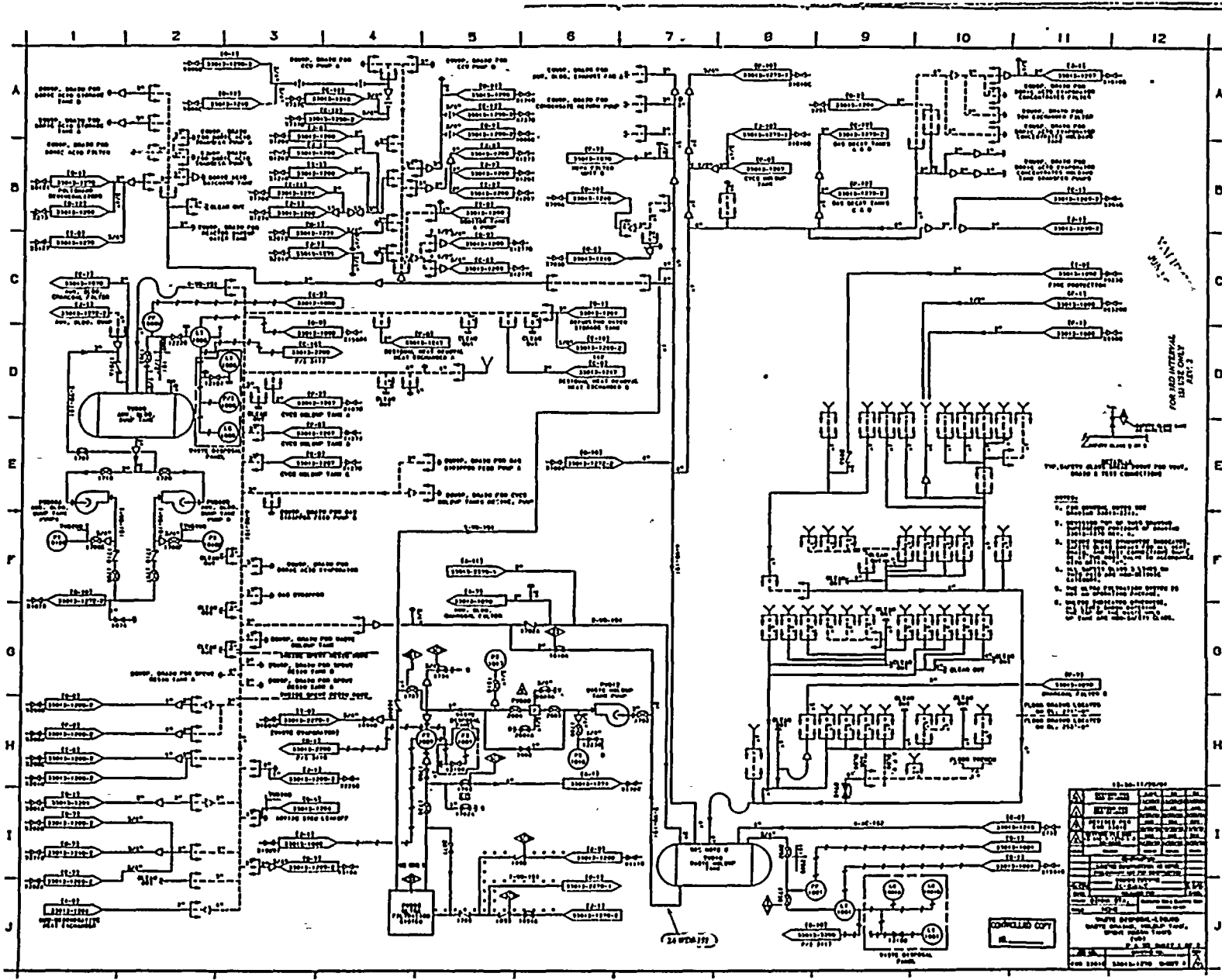

FOR ADDITIONAL USE ONLY

FOR ADDITIONAL USE ONLY

FOR ADDITIONAL USE ONLY

FOR ADDITIONAL USE ONLY

FOR ADDITIONAL USE ONLY

FOR ADDITIONAL USE ONLY

FOR ADDITIONAL USE ONLY

FOR ADDITIONAL USE ONLY

FOR ADDITIONAL USE ONLY

FOR ADDITIONAL USE ONLY

FOR ADDITIONAL USE ONLY

FOR ADDITIONAL USE ONLY

FOR ADDITIONAL USE ONLY

FOR ADDITIONAL USE ONLY

FOR ADDITIONAL USE ONLY

FOR ADDITIONAL USE ONLY

10-11-1170-00	
(10-11)	11000-11000-00
(11-11)	11000-11000-00
(12-11)	11000-11000-00
(13-11)	11000-11000-00
(14-11)	11000-11000-00
(15-11)	11000-11000-00
(16-11)	11000-11000-00
(17-11)	11000-11000-00
(18-11)	11000-11000-00
(19-11)	11000-11000-00
(20-11)	11000-11000-00
(21-11)	11000-11000-00
(22-11)	11000-11000-00
(23-11)	11000-11000-00
(24-11)	11000-11000-00
(25-11)	11000-11000-00
(26-11)	11000-11000-00
(27-11)	11000-11000-00
(28-11)	11000-11000-00
(29-11)	11000-11000-00
(30-11)	11000-11000-00
(31-11)	11000-11000-00
(32-11)	11000-11000-00
(33-11)	11000-11000-00
(34-11)	11000-11000-00
(35-11)	11000-11000-00
(36-11)	11000-11000-00
(37-11)	11000-11000-00
(38-11)	11000-11000-00
(39-11)	11000-11000-00
(40-11)	11000-11000-00
(41-11)	11000-11000-00
(42-11)	11000-11000-00
(43-11)	11000-11000-00
(44-11)	11000-11000-00
(45-11)	11000-11000-00
(46-11)	11000-11000-00
(47-11)	11000-11000-00
(48-11)	11000-11000-00
(49-11)	11000-11000-00
(50-11)	11000-11000-00
(51-11)	11000-11000-00
(52-11)	11000-11000-00
(53-11)	11000-11000-00
(54-11)	11000-11000-00
(55-11)	11000-11000-00
(56-11)	11000-11000-00
(57-11)	11000-11000-00
(58-11)	11000-11000-00
(59-11)	11000-11000-00
(60-11)	11000-11000-00
(61-11)	11000-11000-00
(62-11)	11000-11000-00
(63-11)	11000-11000-00
(64-11)	11000-11000-00
(65-11)	11000-11000-00
(66-11)	11000-11000-00
(67-11)	11000-11000-00
(68-11)	11000-11000-00
(69-11)	11000-11000-00
(70-11)	11000-11000-00
(71-11)	11000-11000-00
(72-11)	11000-11000-00
(73-11)	11000-11000-00
(74-11)	11000-11000-00
(75-11)	11000-11000-00
(76-11)	11000-11000-00
(77-11)	11000-11000-00
(78-11)	11000-11000-00
(79-11)	11000-11000-00
(80-11)	11000-11000-00
(81-11)	11000-11000-00
(82-11)	11000-11000-00
(83-11)	11000-11000-00
(84-11)	11000-11000-00
(85-11)	11000-11000-00
(86-11)	11000-11000-00
(87-11)	11000-11000-00
(88-11)	11000-11000-00
(89-11)	11000-11000-00
(90-11)	11000-11000-00
(91-11)	11000-11000-00
(92-11)	11000-11000-00
(93-11)	11000-11000-00
(94-11)	11000-11000-00
(95-11)	11000-11000-00
(96-11)	11000-11000-00
(97-11)	11000-11000-00
(98-11)	11000-11000-00
(99-11)	11000-11000-00
(100-11)	11000-11000-00

CONTROLLED COPY

CONTROLLED COPY

CONTROLLED COPY

CONTROLLED COPY

CONTROLLED COPY

CONTROLLED COPY

CONTROLLED COPY

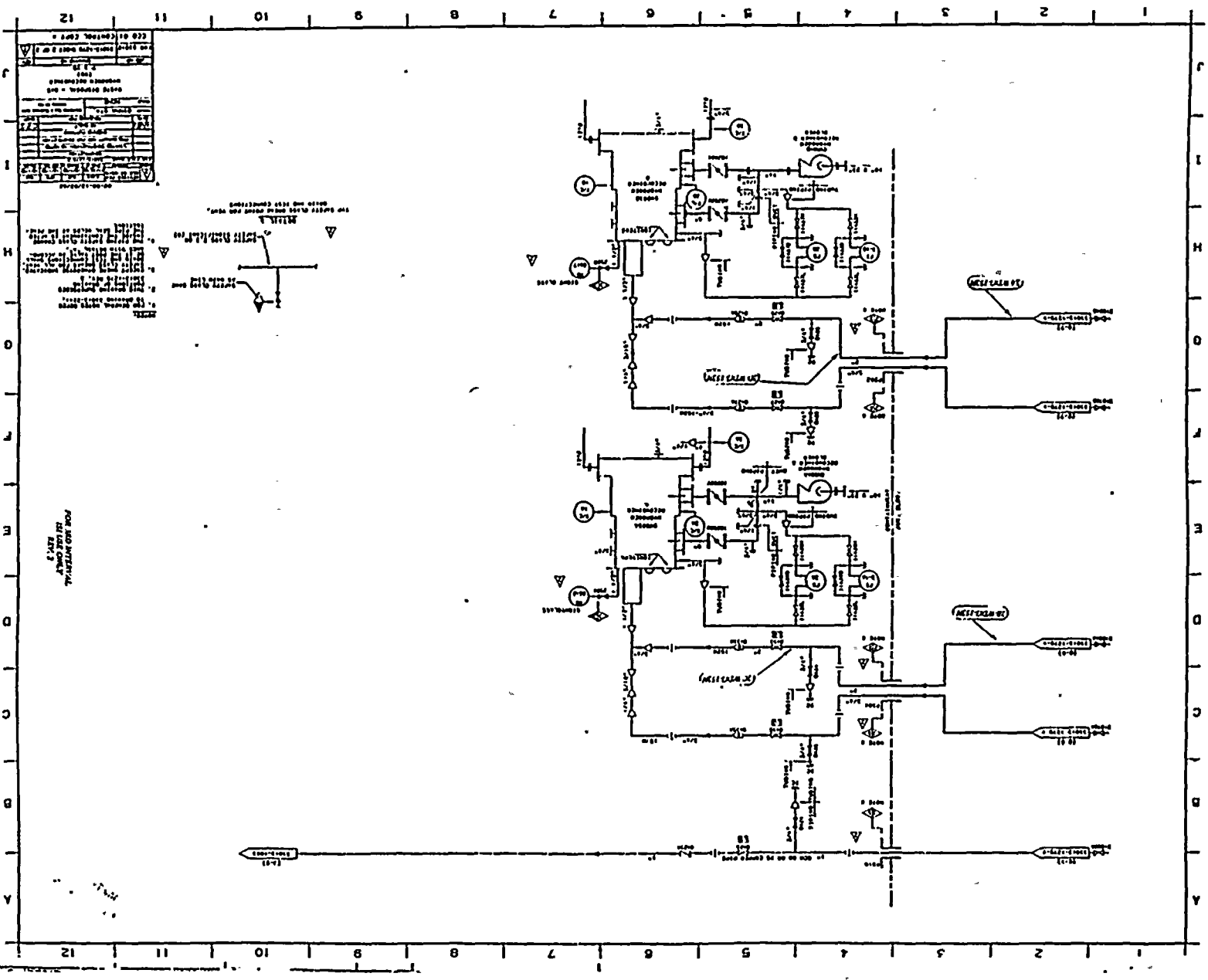

REVISIONS	
NO.	DESCRIPTION
1	...
2	...
3	...
4	...
5	...
6	...
7	...
8	...
9	...
10	...
11	...
12	...

WITH A
 THE SAFETY OF THE SYSTEM IS DEPENDENT ON THE CORRECTNESS OF THE DATA AND TEST CONNECTIONS.
 THE SAFETY OF THE SYSTEM IS DEPENDENT ON THE CORRECTNESS OF THE DATA AND TEST CONNECTIONS.
 THE SAFETY OF THE SYSTEM IS DEPENDENT ON THE CORRECTNESS OF THE DATA AND TEST CONNECTIONS.
 THE SAFETY OF THE SYSTEM IS DEPENDENT ON THE CORRECTNESS OF THE DATA AND TEST CONNECTIONS.

FOR INFORMATION SEE DRAWING 100-100000-100

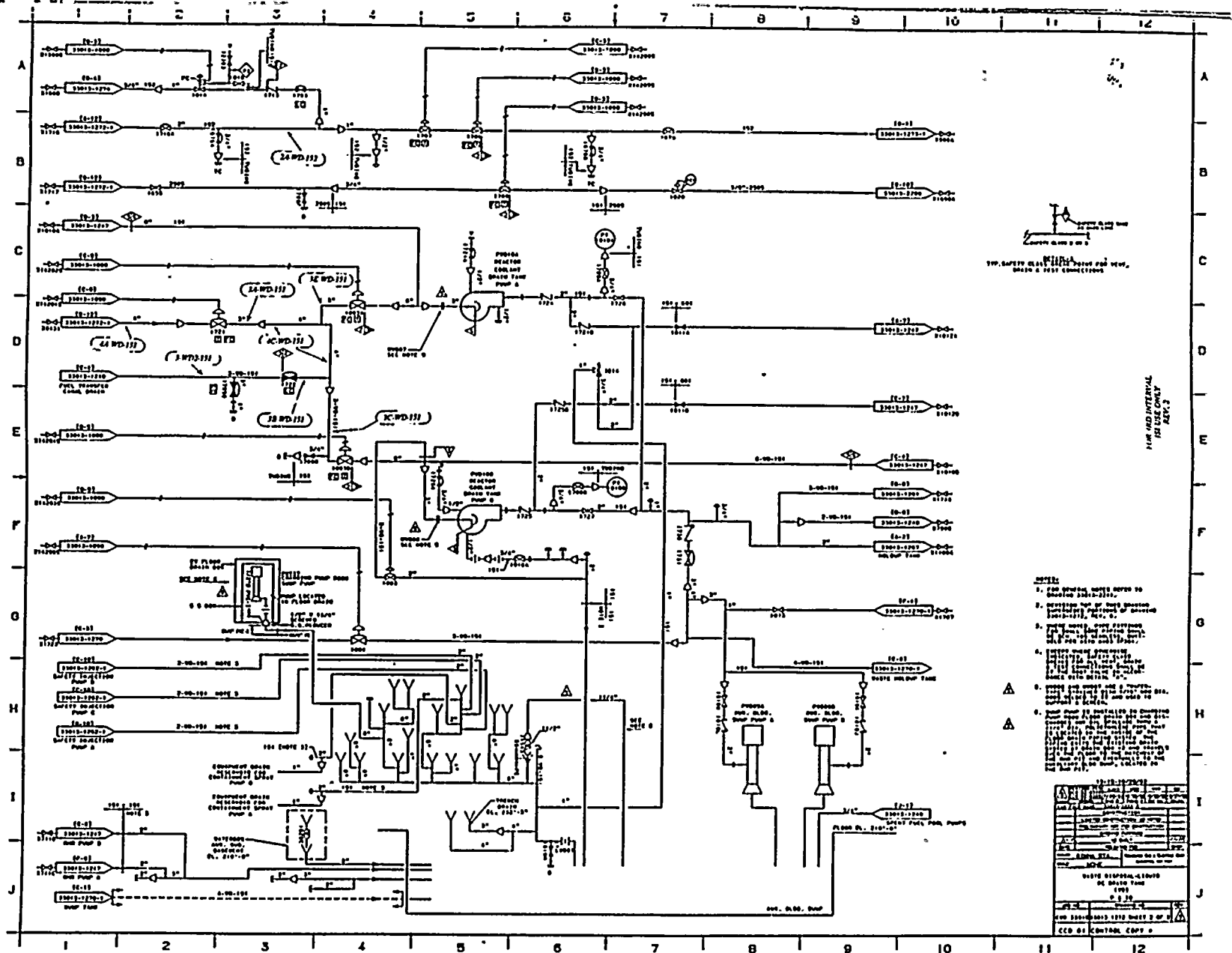

WASTE HOLDUP TANK AND VIEW, SHOWS TEST CONNECTIONS

FOR AND INTERVAL USE ONLY REV. 3

- NOTES:
1. See drawing notes refer to drawing 3100-1-1210.
 2. SECTION TOP OF THIS DRAWING INDICATING METHOD OF GROUNDING.
 3. THIS DRAWING SHOWS PIPING FOR THE WASTE DISPOSAL SYSTEM. THE WASTE DISPOSAL SYSTEM IS DESCRIBED IN THE DRAWING 3100-1-1210.
 4. LISTED PARTS ARE IDENTIFIED BY PART NUMBER AND QUANTITY IN THE DRAWING 3100-1-1210.
 5. THIS DRAWING IS A PART OF THE WASTE DISPOSAL SYSTEM. THE WASTE DISPOSAL SYSTEM IS DESCRIBED IN THE DRAWING 3100-1-1210.
 6. THIS DRAWING IS A PART OF THE WASTE DISPOSAL SYSTEM. THE WASTE DISPOSAL SYSTEM IS DESCRIBED IN THE DRAWING 3100-1-1210.

REVISIONS	
NO.	DESCRIPTION
1	ISSUED FOR CONSTRUCTION
2	REVISED TO SHOW WASTE HOLDUP TANK
3	REVISED TO SHOW WASTE HOLDUP TANK
4	REVISED TO SHOW WASTE HOLDUP TANK
5	REVISED TO SHOW WASTE HOLDUP TANK
6	REVISED TO SHOW WASTE HOLDUP TANK
7	REVISED TO SHOW WASTE HOLDUP TANK
8	REVISED TO SHOW WASTE HOLDUP TANK
9	REVISED TO SHOW WASTE HOLDUP TANK
10	REVISED TO SHOW WASTE HOLDUP TANK
11	REVISED TO SHOW WASTE HOLDUP TANK
12	REVISED TO SHOW WASTE HOLDUP TANK

DATE DISPOSED: 11/10/70
 BY: [Signature]
 FOR: [Signature]
 APPROVED: [Signature]
 TITLE: [Signature]
 WASTE DISPOSAL SYSTEM
 DC 3100-1-1210
 0 3 70
 FOR AND INTERVAL USE ONLY REV. 3
 CCD 01 CONTROL COPY 0

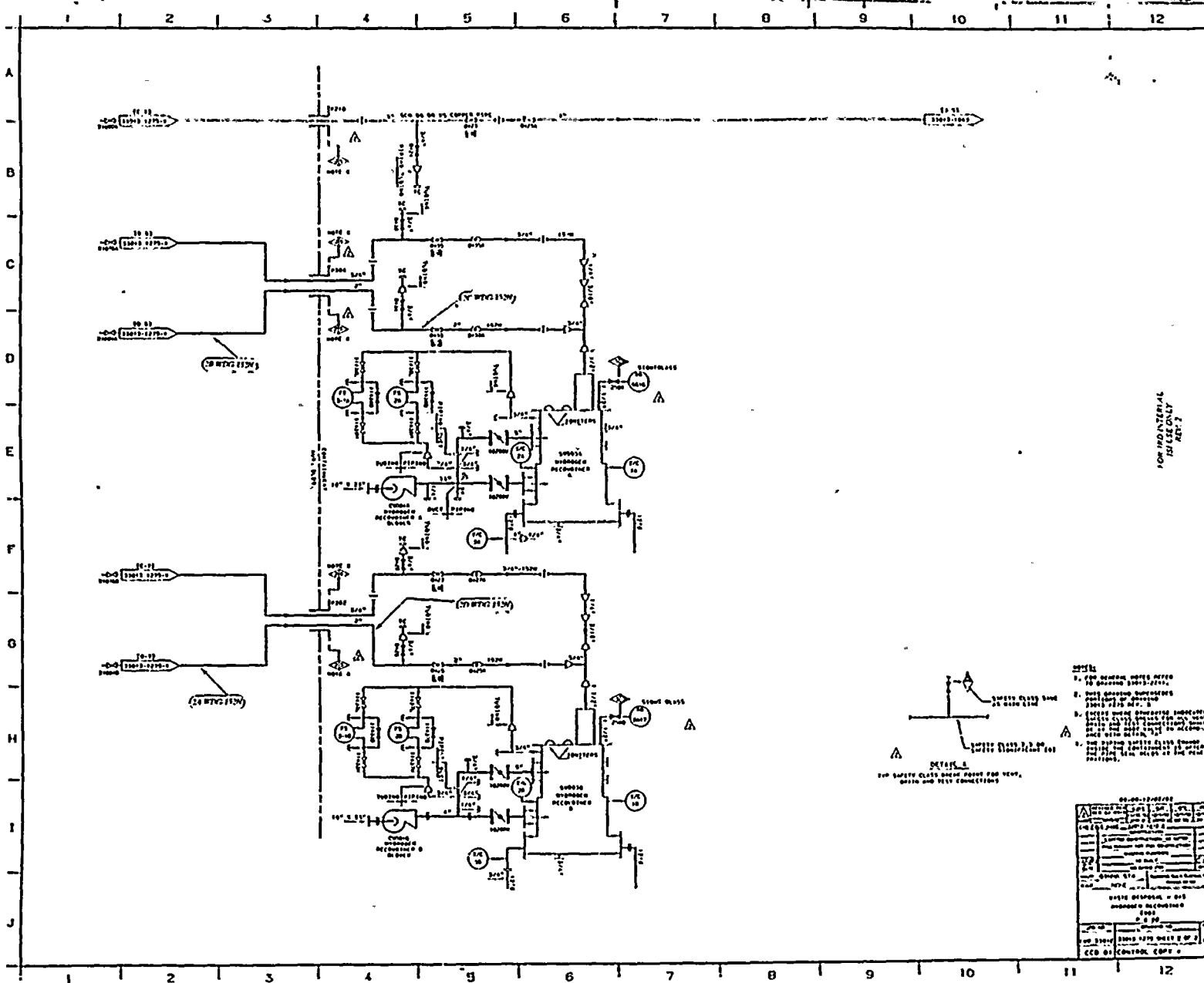

FOR INFORMATION ONLY
REV. 7

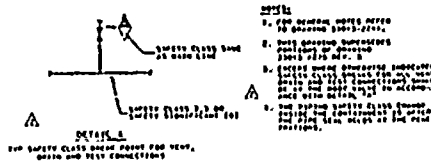

REVISIONS	
NO.	DESCRIPTION
1	ISSUED FOR PRODUCTION
2	REVISION
3	REVISION
4	REVISION
5	REVISION
6	REVISION
7	REVISION
8	REVISION
9	REVISION
10	REVISION
11	REVISION
12	REVISION

DATE DESIGNED = 01/10/77
 DRAWN BY = [Name]
 CHECKED BY = [Name]
 APPROVED BY = [Name]
 TITLE = [Title]
 SHEET NO. = [Number]
 OF [Total] SHEETS

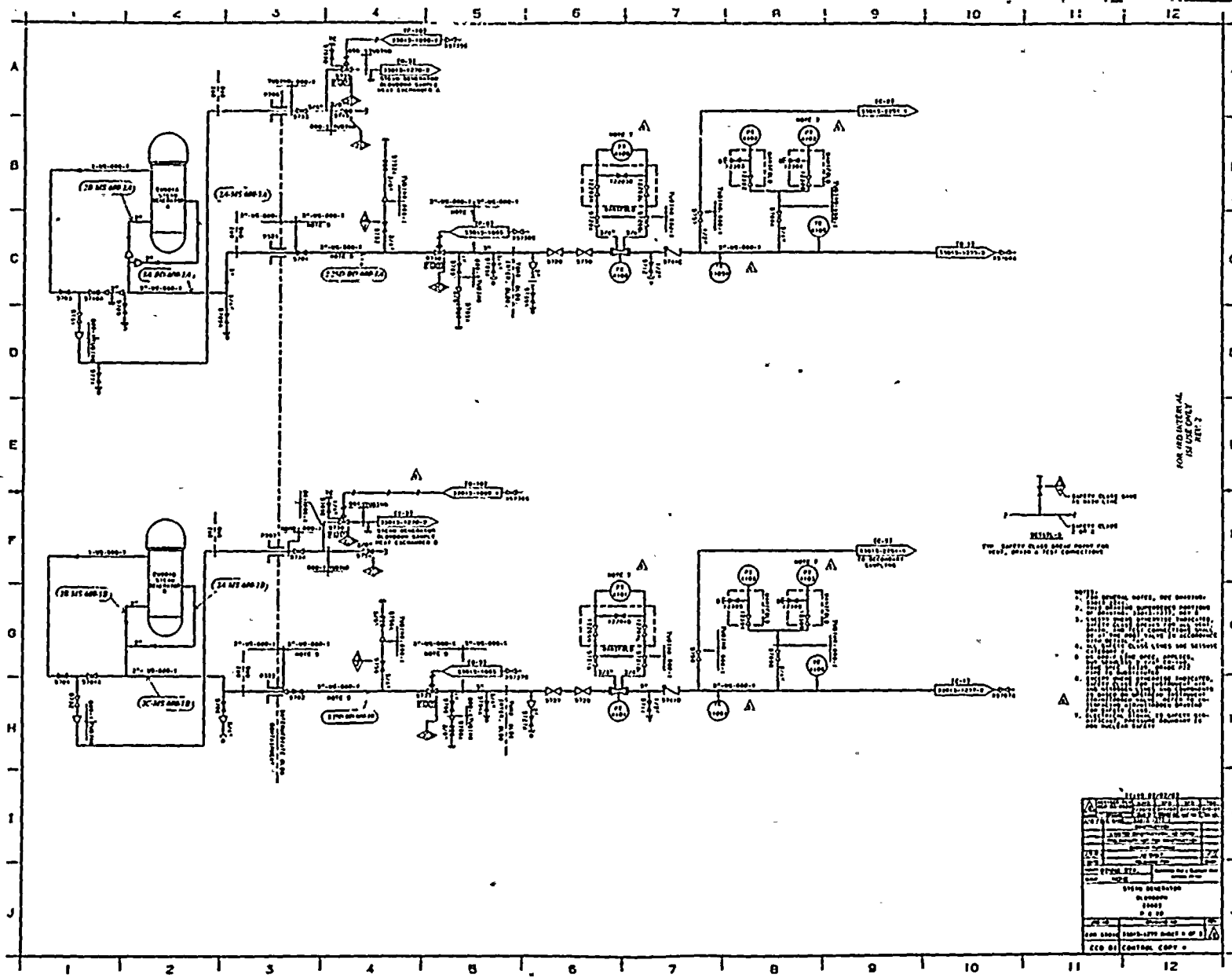

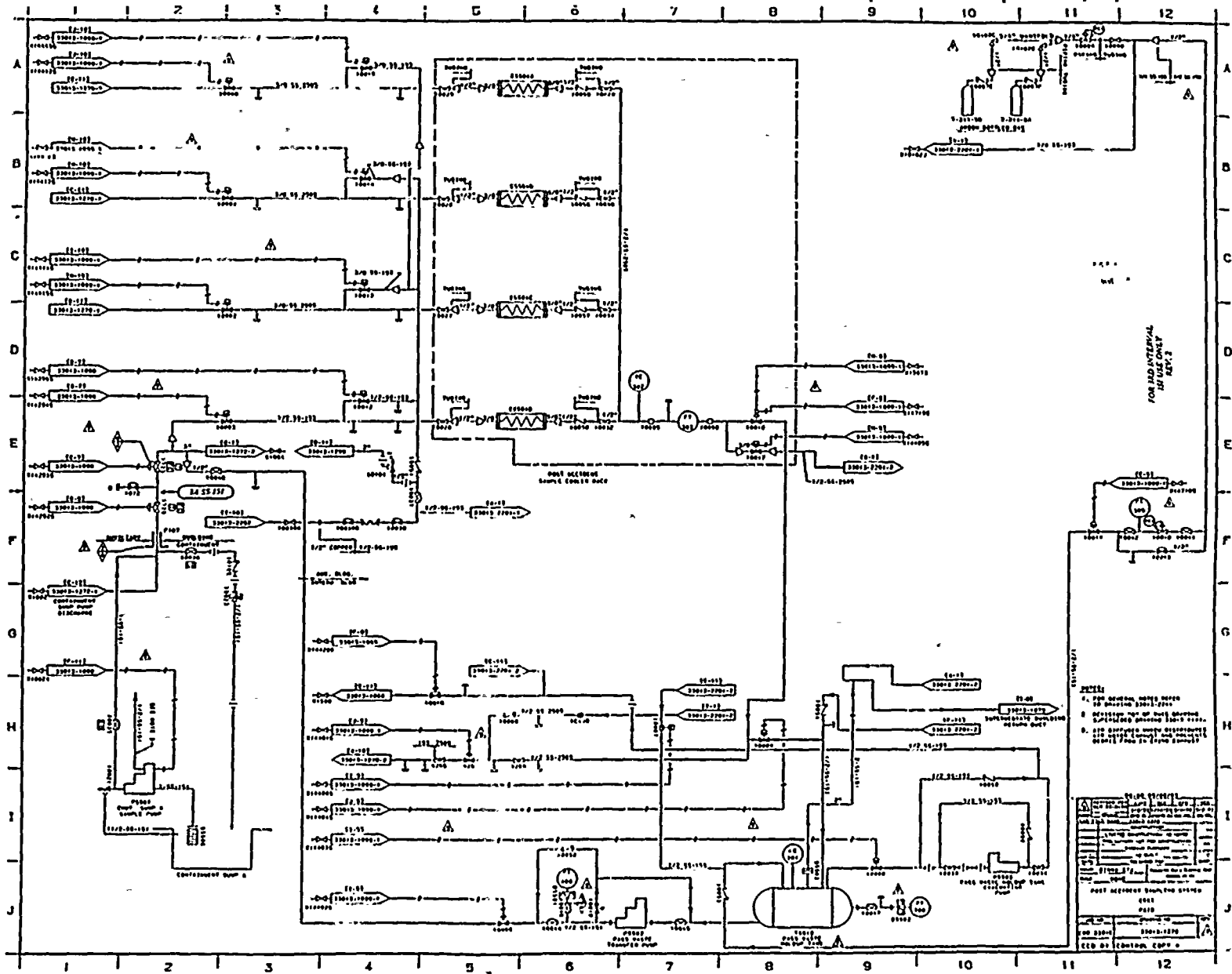

1. FOR SECTION, WERE WERE
 2. SECTION, WERE WERE
 3. SECTION, WERE WERE

POST REPORTED DOWN THE STATES

DATE	0618
NO. 2304	2304-1270
BY	ED BY CONTROL COPY 0

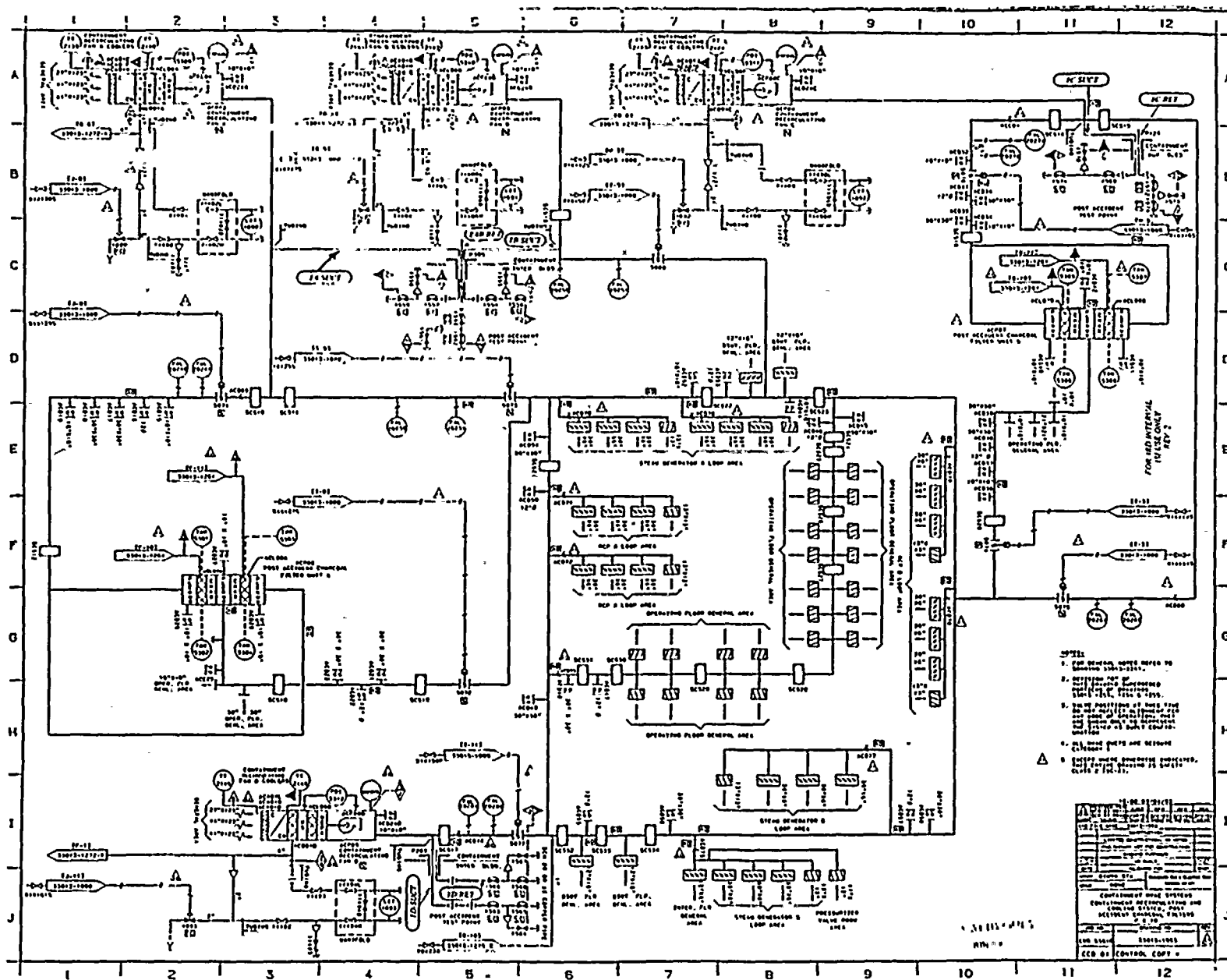



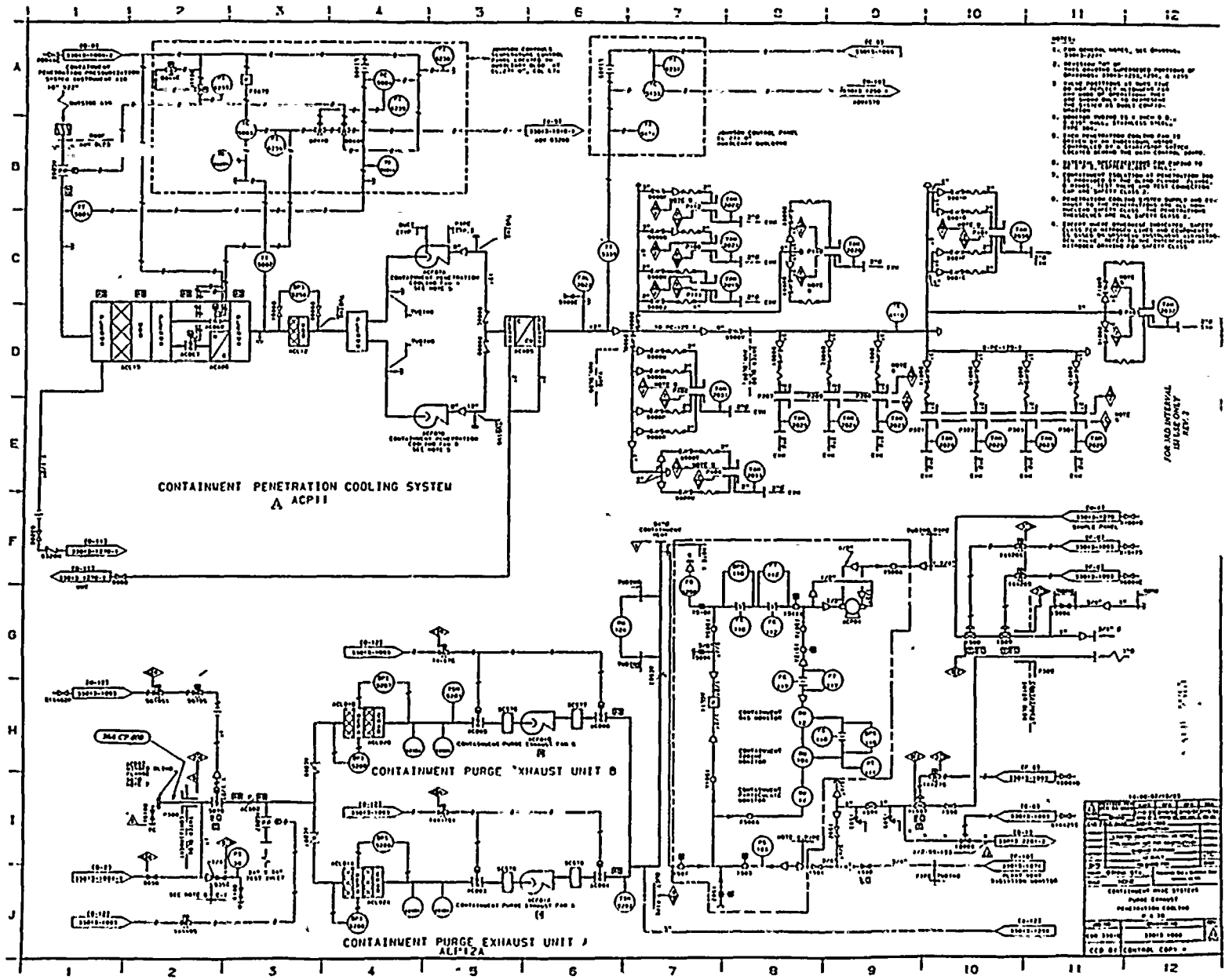

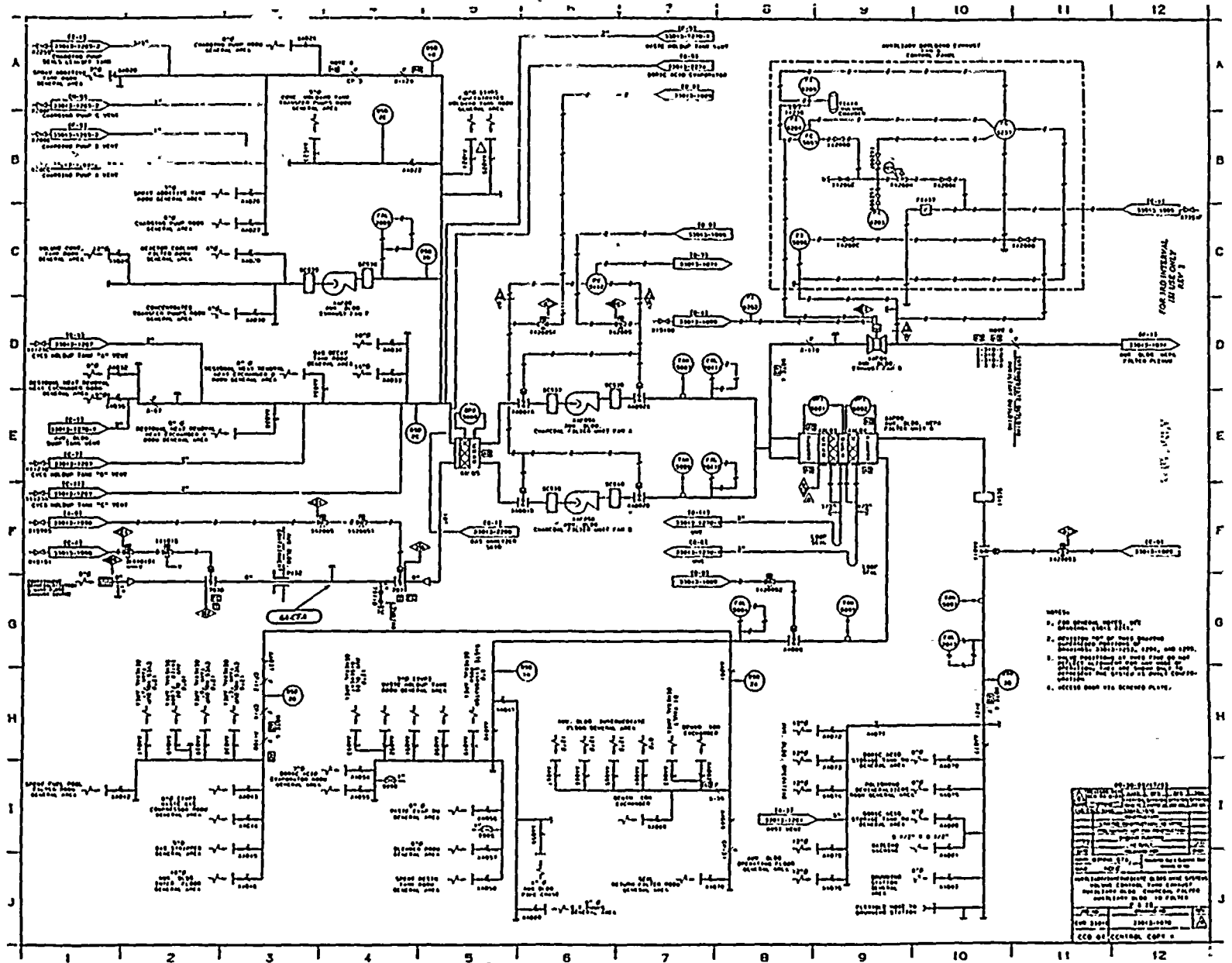

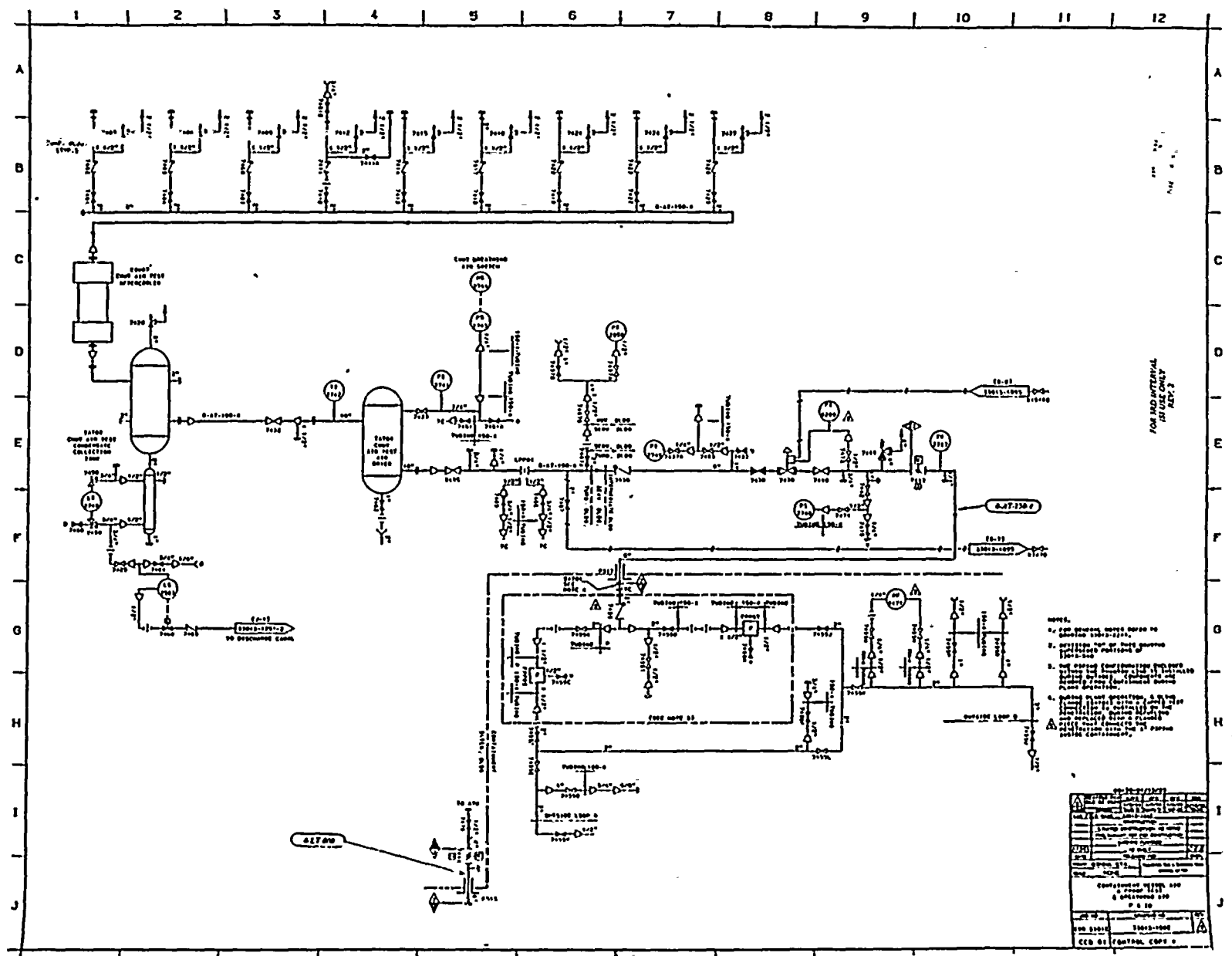

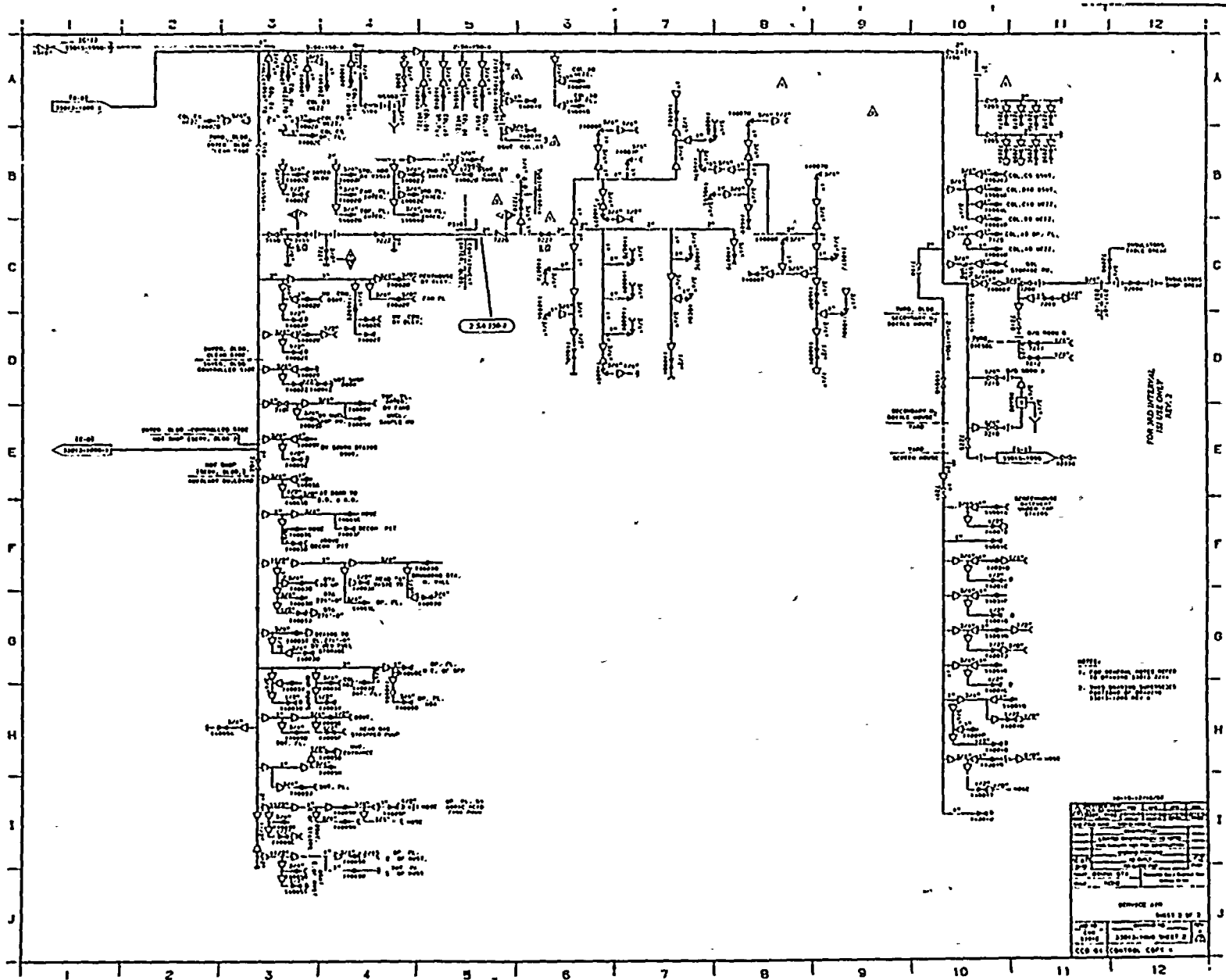

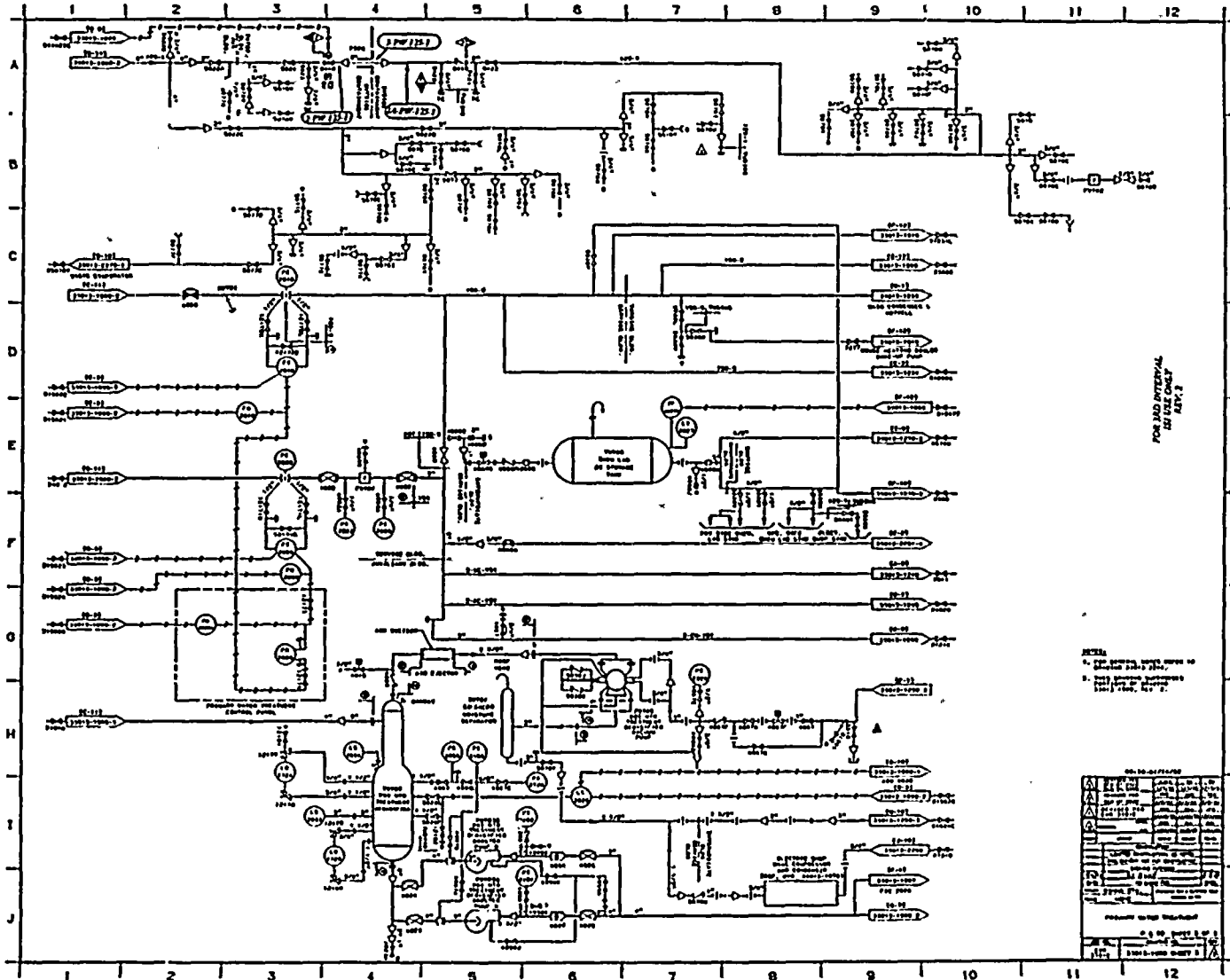

FOR PAD INTERVAL
IN USE ONLY
REV. 2

- NOTES
1. See page 2 for details of the control system.
 2. See page 3 for details of the control system.

REVISIONS	
NO.	DESCRIPTION
1	Initial design
2	Revised design
3	Final design

PARTS LIST		
QTY	PART NO.	DESCRIPTION
1	M-100	Control Unit
2	R-101	Relay
3	S-101	Switch
4	G-101	Gate
5	L-101	Lamp
6	M-102	Motor
7	R-102	Relay
8	S-102	Switch
9	G-102	Gate
10	L-102	Lamp
11	M-103	Motor
12	R-103	Relay
13	S-103	Switch
14	G-103	Gate
15	L-103	Lamp

100
101
102

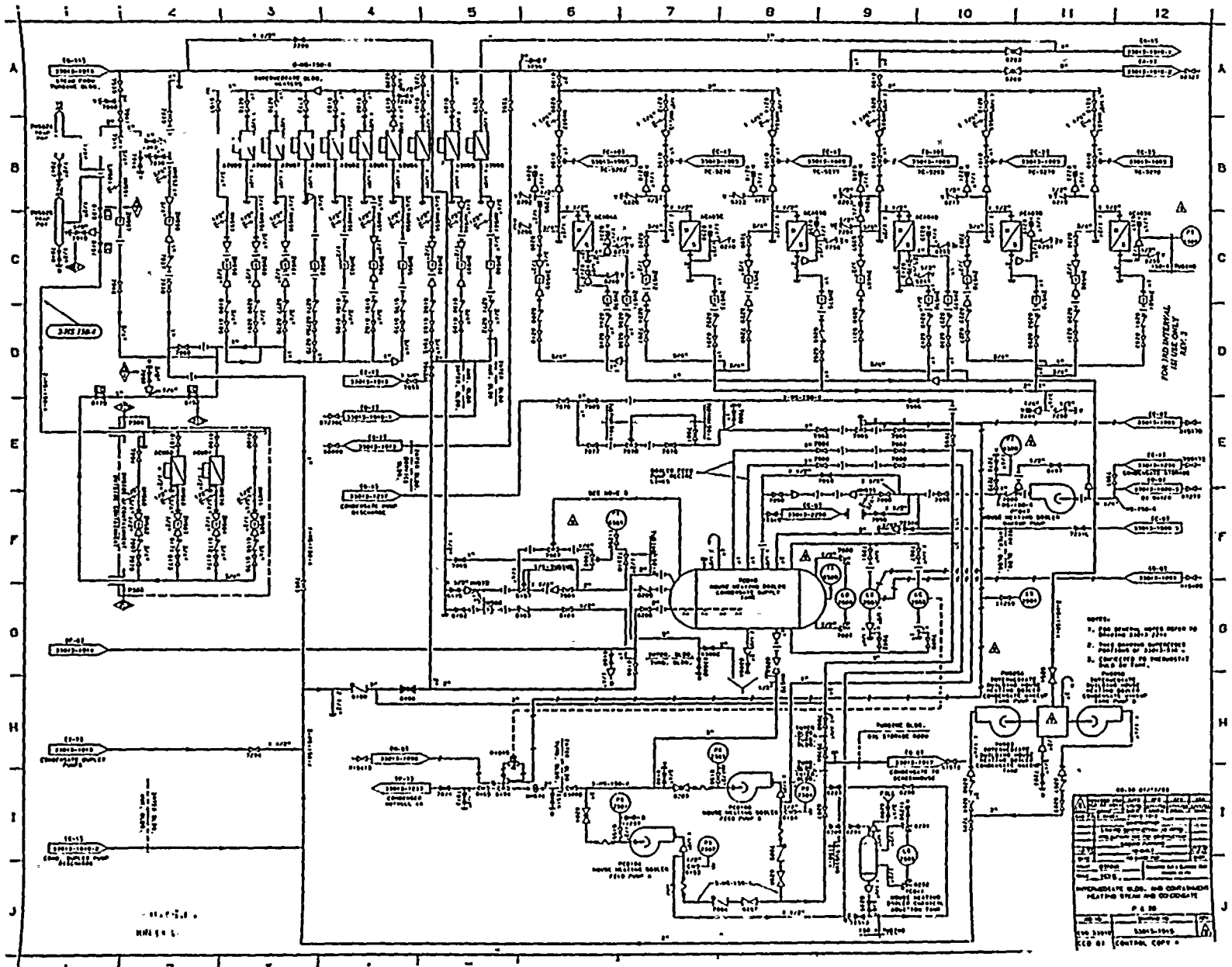

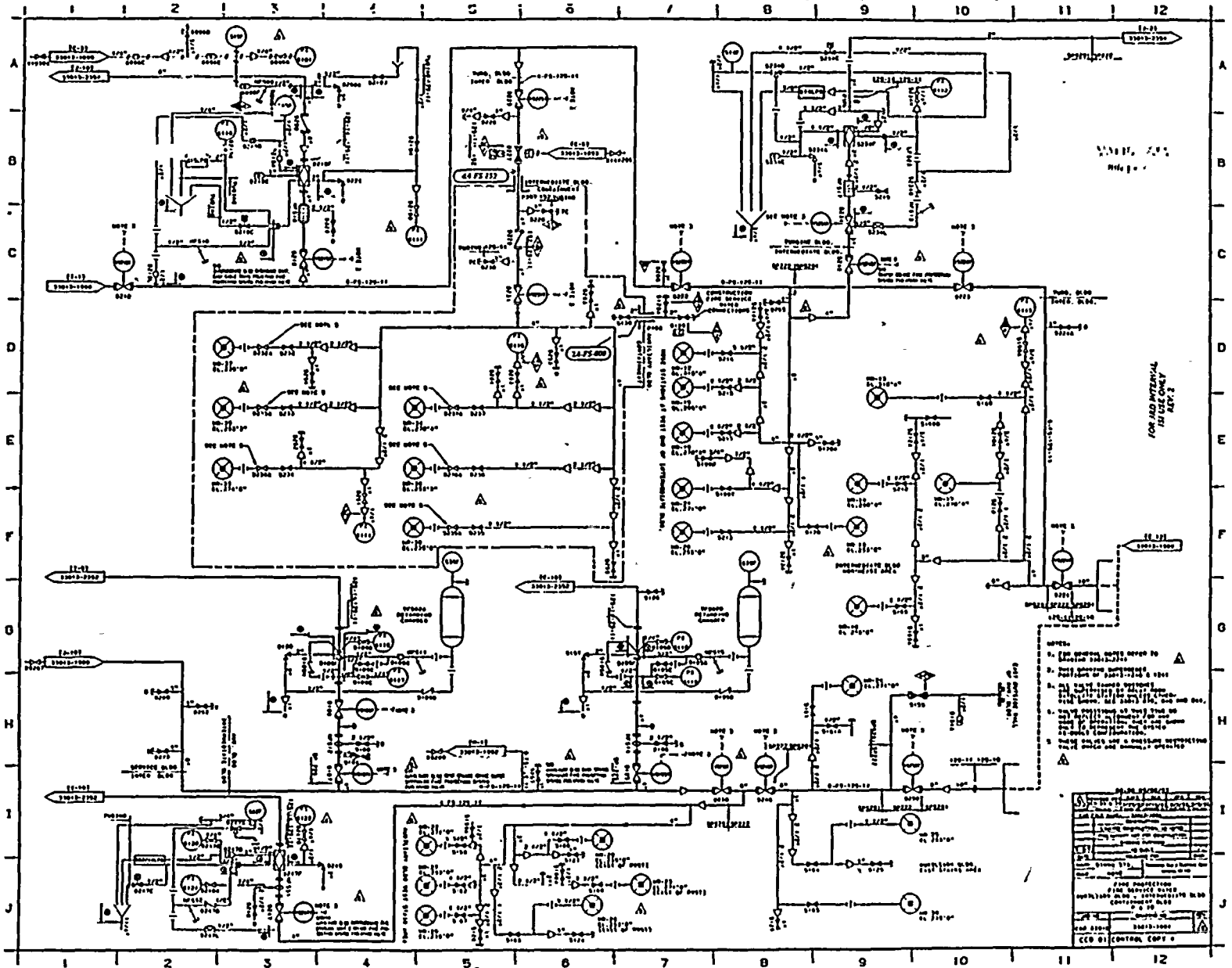

- NOTES:
1. SEE SECTION 1001-1000 FOR...
 2. SEE SECTION 1001-1000 FOR...
 3. SEE SECTION 1001-1000 FOR...
 4. SEE SECTION 1001-1000 FOR...
 5. SEE SECTION 1001-1000 FOR...

NO.	DESCRIPTION	QTY.	REMARKS
1
2
3
4
5
6
7
8
9
10
11
12

FOR ALL INTERNAL USE ONLY
REV. 2

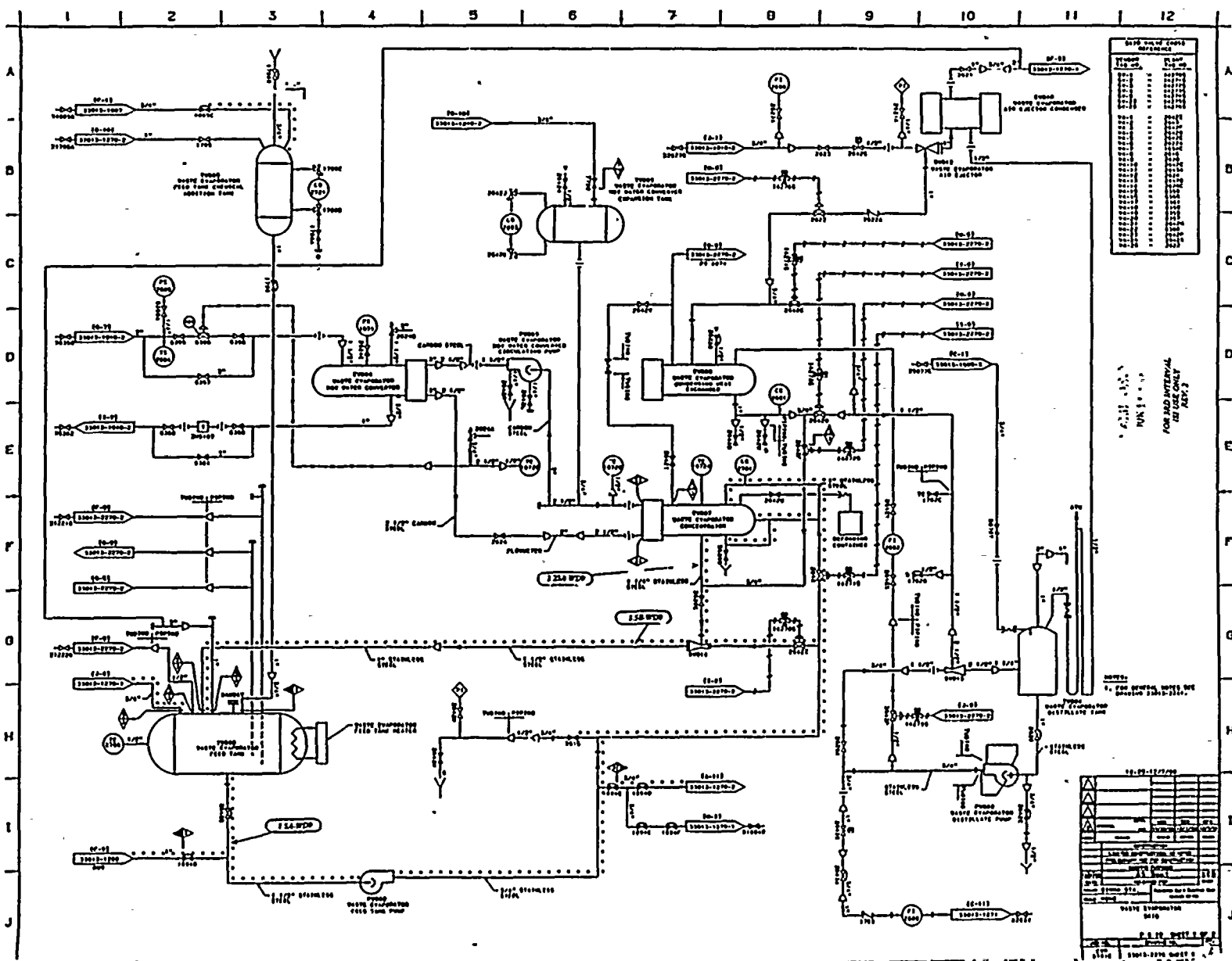

DATE AND TIME OF ANALYSIS

ITEM NO.	DATE	TIME	ANALYST
1			
2			
3			
4			
5			
6			
7			
8			
9			
10			
11			
12			

FOR USE ONLY
 USE ONLY
 REV. 2

NOTE: 1. See drawing sheet 100-101.

10-01-12700

NO.	DATE	TIME	ANALYST
1			
2			
3			
4			
5			
6			
7			
8			
9			
10			
11			
12			

DATE SYNTHESIZED
 10-01-12700

P. E. SHEET 1 OF 2

QUALITY ASSURANCE MANUAL GINNA STATION ROCHESTER GAS & ELECTRIC CORPORATION	Section 4	REV. 3	PAGE 1 of 27
	EFFECTIVE DATE: December 31, 1993		
TITLE: APPENDIX B R. E. GINNA NUCLEAR POWER PLANT INSERVICE INSPECTION PROGRAM FOR THE 1990-1999 INTERVAL CODE TABLES		SIGNATURE	DATE
	PREPARED BY:	<i>Frank A. Klyedli</i>	12-1-93
	QUALITY ASSURANCE REVIEW:	<i>[Signature]</i>	12-2-93
	APPROVED BY:	<i>Michael J. Depina</i>	12-6-93

1.0 General

The following Code Tables were developed to address applicable ASME Section XI Requirements specifically to R. E. Ginna Nuclear Power Plant. The Format of each Table is identical and a definition appears before the start of each text. ASME Section XI Code, 1986 Edition, no Addenda, and 10CFR50 specify that this program conforms to Articles IWB, C, D and F of ASME Section XI, if not altered by a Relief Request and/or Code Case.

The following list identified the Code Table applicability.

<u>Code Table #</u>	<u>Component Jurisdiction</u>
1	Class 1
2	Class 2
3	Class 3
4	Class 1, 2 and 3 IWF Component Supports

Table 1

INSERVICE INSPECTION PROGRAM
CODE CLASS

Item No.	Examination Category	Components and Parts To be Examined	Examination Methods	Examination Requirements for Third Inspection Interval	Examination Technique/Examination Area Comments
The ASME Section XI Item No. and Category of the component are listed in these columns.	Each type of examination area is listed in this column.	The NDE method required to satisfy Code requirements is listed in this column.	This column provides information regarding the number and/or percent of examinations required to be performed for the inspection interval.	This column provides information specific to examination techniques, examination areas, or comments.	

QUALITY ASSURANCE MANUAL GINNA STATION

TITLE:
APPENDIX B
R. E. GINNA NUCLEAR POWER PLANT
INSERVICE INSPECTION PROGRAM
FOR THE 1990-1999 INTERVAL
CODE TABLES

Section 4	REV. 3
PAGE	2 of 27

Table 1

INSERVICE INSPECTION PROGRAM
CLASS 1 COMPONENTS

Item No.	Examination Category	Components and Parts To be Examined	Examination Methods	Examination Requirements for Third Inspection Interval	Examination Technique/Examination Area Comments
REACTOR PRESSURE VESSEL					
B1.10 B1.11 B1.12	B-A	Circumferential and Longitudinal Shell Welds	Volumetric	100% of one circumferential weld to be examined at structural discontinuity in the beltline region. The three other circumferential welds shall be performed as a Augmented Program as specified by 10 CFR Part 50. Examinations may be performed at or near the end of the inspection interval.	Examination of circumferential shell welds will be performed with UT techniques. There are no longitudinal welds at R. E. Ginna.
B1.20 B1.21 B1.22	B-A	Circumferential and Meridional Head Welds	N/A		There are no meridional or circumferential head welds at R. E. Ginna.
B1.30	B-A	Shell-to-Flange Weld	Volumetric	100% of the weld to be examined. At least 50% of the weld shall be examined from the flange face by the end of the first inspection period and the remainder by the end of the third inspection period.	The shell-to-flange weld will be examined from the vessel seal surface and from the vessel wall inside surface with UT. NOTE: Relief Request # 1.
B1.40	B-A	Head-to-Flange Weld	Volumetric and Surface	100% of the weld to be examined.	The head-to-flange weld will be examined with UT and surface examination techniques when the head is removed.
B1.50 B1.51	B-A	Repair Welds	N/A		No repair welds at R. E. Ginna.
B3.90 B3.100	B-D B-D	Nozzle-to-Vessel Welds and Nozzle Inside Radius Section	Volumetric	100% of nozzles. At least 25% but not more than 50% of the nozzles shall be examined by the end of the first period and the remainder by the end of the interval.	The nozzle-to-vessel welds and nozzle inside radius sections will be examined with UT.
B4.10 B4.11 B4.12 B4.13	B-E	Partial Penetration Welds: Vessel Nozzles Control Rod Drive Nozzles Instrumentation Nozzles	Visual (VT-2)	At least 25% of each group of welds of comparable size and function to be examined.	Examination will be performed during the system hydrostatic test or alternatively to Code Case N-498. VT examinations will be performed in accordance with IWA-5240.
B5.10	B-F	Pressure-Retaining Dissimilar Metal Welds	Volumetric & Surface	All Nozzle-to-safe end butt welds NPS 4 or larger.	Exams may be performed coincident with the vessel nozzle exams required by Category B-D.
B5.20 B5.30	B-F	Pressure-Retaining Dissimilar Metal Welds	N/A		No dissimilar metal welds on RPV at R. E. Ginna.
B6.10	B-G-1	Closure Head Nuts >2 Inches in Diameter	Surface	100% of nuts to be examined. Examination may be performed at or near the end of the inspection interval.	Nuts will be examined with MT when removed for refueling.

QUALITY
ASSURANCE
MANUAL
GINNA STATION

TITLE:
APPENDIX B
R. E. GINNA NUCLEAR POWER PLANT
INSERVICE INSPECTION PROGRAM
FOR THE 1990-1999 INTERVAL
CODE TABLES

Section 4
PAGE
3 of 27

REV.
3

Table 1

INSERVICE INSPECTION PROGRAM
CLASS 1 (Cont'd)

Item No.	Examination Category	Components and Parts To be Examined	Examination Methods	Examination Requirements for Third Inspection Interval	Examination Technique/Examination Area Comments
<u>REACTOR PRESSURE VESSEL (cont'd)</u>					
B6.20	B-G-1	Closure Head Studs, In Place, >2 Inches in Diameter	Volumetric	100% of studs to be examined. Examination may be performed at or near the end of the inspection interval.	Closure stud examinations may be performed "in place." Examinations should be scheduled when studs are removed to reduce radiation exposure and allow the most thorough examination. Code Case N-307-1 shall apply.
B6.30	B-G-1	Closure Head Studs, When Removed, >2 Inches in Diameter	Volumetric and Surface	100% of studs to be examined. Examination may be performed at or near the end of the inspection interval.	The studs will be examined with UT and MT. Code Case N-307-1 shall apply.
B6.40	B-G-1	Threads in Flange >2 Inches in Diameter	Volumetric	100% of threaded holes to be examined. Examination may be performed at or near the end of the inspection interval.	The threads in flange will be examined from the flange face with UT.
B6.50	B-G-1	Pressure-Retaining Closure Washers and Bushings >2 Inches in Diameter	Visual (VT-1)	All washers and bushings to be examined upon stud removal. Examination may be performed at or near the end of the inspection interval.	
B7.10	B-G-2	Pressure-Retaining Bolting ≥ 2 Inches in Diameter			No pressure-retaining bolting ≤ 2 " in diameter on RPV at R. E. Ginna.
B7.80	B-G-2	CRD Housings Bolts, Studs, and Nuts	Visual (VT-1)	All bolts, studs, and nuts to be examined.	Pressure-retaining CRD housing bolting will be examined when disassembled.
B8.10	B-H	Integral Attachments for RPV	N/A		No integrally welded attachments on RPV at R. E. Ginna that meet the requirements of Category B-H.
B13.10	B-N-1	Vessel Interior	Visual (VT-3)	Accessible areas to be examined during each inspection period.	
B13.50	B-N-2	Interior Attachments Within Beltline Region	Visual (VT-1)	Accessible attachment welds to be examined. Examinations may be completed at or near the end of the inspection interval.	
B13.60	B-N-2	Interior Attachments Beyond Beltline Region	Visual (VT-3)	Accessible attachment welds to be examined. Examinations may be completed at or near the end of the inspection interval.	
B13.70	B-N-3	Core-Support Structure	Visual (VT-3)	With core-support structure removed, all accessible surfaces to be examined. Examinations may be completed at or near the end of the inspection interval.	
B14.10	B-O	Control Rod Drive Housing Welds	Volumetric or Surface	Welds in 10% of the peripheral CRD housings to be examined. Examinations may be performed at or near the end of the inspection interval.	The CRD housing welds will be examined with PT.

QUALITY
ASSURANCE
MANUAL
GINNA STATIONTITLE:
APPENDIX B
R. E. GINNA NUCLEAR POWER PLANT
INSERVICE INSPECTION PROGRAM
FOR THE 1990-1999 INTERVAL
CODE TABLESSection 4
PAGE
4 of 27REV.
3

Table 1
INSERVICE INSPECTION PROGRAM
CLASS 1 COMPONENTS (Cont'd)

Item No.	Examination Category	Components and Parts To be Examined	Examination Methods	Examination Requirements for Third Inspection Interval	Examination Technique/Examination Area Comments
<u>REACTOR PRESSURE VESSEL (cont'd)</u>					
B15.10	B-P	All Pressure-Retaining Boundaries for Vessel Components	Visual (VT-2)	All components to be examined during system leakage test. Examinations to be performed in accordance with IWB-5221 prior to plant startup after each refueling outage.	VT examinations will be performed in accordance with IWA-5240.
B15.11	B-P	All Pressure-Retaining Boundaries for Vessel Components	Visual (VT-2)	All components to be examined during system hydrostatic test or alternatively to Code Case N-498. Examinations to be performed in accordance with IWB-5221/5222 at or near the end of the inspection interval.	VT examinations will be performed in accordance with IWA-5240.

QUALITY
ASSURANCE
MANUAL
GINNA STATION

TITLE:
APPENDIX B
R. E. GINNA NUCLEAR POWER PLANT
INSERVICE INSPECTION PROGRAM
FOR THE 1990-1999 INTERVAL
CODE TABLES

Section 4
PAGE 5 of 27

REV.
3

Table 1
INSERVICE INSPECTION PROGRAM
CLASS 1 COMPONENTS (Cont'd)

Item No.	Examination Category	Components and Parts To be Examined	Examination Methods	Examination Requirements for Third Inspection Interval	Examination Technique/Examination Area Comments
<u>PRESSURIZER</u>					
B2.10 B2.11 B2.12	B-B	Circumferential and Longitudinal Shell-to-Head Welds	Volumetric	The upper and lower head-to-shell welds to be examined. One foot of one longitudinal weld intersecting each head-to-shell weld to be examined.	Examination will be performed with UT techniques.
B2.20 B2.21 B2.22	B-B	Circumferential and Meridional Head Welds	Volumetric	There are no pressurizer head welds at R. E. Ginna.	
B3.110	B-D	Nozzle-to-Vessel Welds	N/A		No nozzle-to-vessel welds. Nozzles are integrally cast into the head of pressurizer at R. E. Ginna.
B3.120	B-D	Nozzle Inside Radius Sections	Volumetric	All inside radius sections to be examined. At least 25% but not more than 50% of the nozzles shall be examined by the end of the first period and the remainder by the end of the inspection interval.	Examinations will be performed with UT techniques.
B4.20	B-E	Heater Penetration Welds	Visual (VT-2)	All pressurizer heater penetration welds shall be examined during system hydrostatic test or alternatively to Code Case N-498 in accordance with IWB-5222 at or near the end of the inspection interval.	VT examination will be performed in accordance with IWA-5240.
B5.40	B-F	Nozzle-to-Safe End Dissimilar Metal Welds ≥ 4 Inches NPS	Surface and Volumetric	All butt welds to be examined.	Examinations will be performed with PT and UT techniques.
B5.50	B-F	Nozzle-to-Safe End Dissimilar Metal Welds < 4 Inches NPS	N/A		No nozzle-to-safe end dissimilar metal welds on pressurizer at R. E. Ginna.
B5.60	B-F	Nozzle-to-Safe End Socket Welds	N/A		No dissimilar metal socket welds on pressurizer at R. E. Ginna.
B6.60 B6.70 B6.80	B-G-1	Pressure-Retaining Bolting > 2 Inches in Diameter	N/A		No bolting on pressurizer > 2 inches in diameter at R. E. Ginna.
B7.20	B-G-2	Bolts, Studs, and Nuts ≥ 2 Inches in Diameter	Visual (VT-1)	All bolts, studs, and nuts to be examined.	Bolting examinations may be performed in place under tension or when disassembled or removed.
B8.20	B-H	Integrally Welded Attachments	N/A		Pressurizer support skirt not required for examination for 3rd and 4th intervals by Code.

QUALITY
ASSURANCE
MANUAL
GINNA STATION

TITLE:
APPENDIX B
R. E. GINNA NUCLEAR POWER PLANT
INSERVICE INSPECTION PROGRAM
FOR THE 1990-1999 INTERVAL
CODE TABLES

Section 4
REV. 3
PAGE 6 of 27



Table 1
INSERVICE INSPECTION PROGRAM
CLASS 1 COMPONENTS (Cont'd)

Item No.	Examination Category	Components and Parts To be Examined	Examination Methods	Examination Requirements for Third Inspection Interval	Examination Technique/Examination Area Comments
<u>PRESSURIZER (Cont'd)</u>					
B15.20	B-P	Pressure-Retaining Boundaries for Vessel Components	Visual (VT-2)	All pressurizer components to be examined during system leakage test. Examination to be performed in accordance with IWB-5221 prior to plant startup after each refueling outage.	VT examination will be performed in accordance with IWB-5240.
B15.21	B-P	Pressure-Retaining Boundaries for Vessel Components	Visual (VT-2)	All pressurizer components to be examined during system hydrostatic test or alternatively to Code Case N-498. Examination to be performed in accordance with IWB-5221/5222 at or near the end of the inspection interval.	VT examination will be performed in accordance with IWA-5240.

QUALITY
 ASSURANCE
 MANUAL
 GINNA STATION

TITLE:
 APPENDIX B
 R.E. GINNA NUCLEAR POWER PLANT
 INSERVICE INSPECTION PROGRAM
 FOR THE 1990-1999 INTERVAL
 CODE TABLES

Section 4
 PAGE 7 of 27

REV.
 3

Table 1
INSERVICE INSPECTION PROGRAM
CLASS 1 COMPONENTS (Cont'd)

Item No.	Examination Category	Components and Parts To be Examined	Examination Methods	Examination Requirements for Third Inspection Interval	Examination Technique/Examination Area Comments
STEAM GENERATORS					
B2.30 B2.31 B2.32	B-B	Circumferential and Meridional Welds in the Lower Head	N/A		There are no steam generator lower head circumferential or meridional welds.
B2.40	B-B	Tubesheet-to-Head Weld	Volumetric	The tubesheet-to-head weld will be examined. The examination will be limited to one of the two steam generators.	Examination will be performed with UT techniques.
B3.130	B-D	Nozzle-to-Vessel Welds	N/A		There are no steam generator nozzle-to-vessel welds. Nozzles are integrally cast into heads.
B3.140	B-D	Nozzle Inside Radius Sections	Volumetric	All nozzle inside radius sections will be examined. At least 25% but not more than 50% of the nozzles shall be examined by the end of the first inspection period and the remainder by the end of the inspection interval.	Examinations will be performed with UT techniques. There are no steam generator nozzle-to-vessel welds.
B5.70	B-F	NPS 4 or Larger Nozzle-to-Safe End Dissimilar Metal Welds	Surface and Volumetric	All nozzle safe-end dissimilar metal welds shall be examined.	Examinations will be performed with PT and UT techniques at R. E. Ginna.
B5.80	B-F	Less than NPS4, Nozzle-to-Safe End Dissimilar Metal Welds	N/A		There are no steam generator welds of this type.
B5.90	B-F	Nozzle-to-Safe End Dissimilar Metal Welds	N/A		There are no steam generator welds of this type.
B6.90 B6.100 B6.110	B-G-1	Pressure-Retaining Bolting >2 Inches in Diameter	N/A	No bolting on steam generators >2 inches in diameter at R. E. Ginna.	
B7.30	B-G-2	Bolts, Studs, and Nuts ≥ 2 Inches in Diameter	Visual (VT-1)	All bolts, studs, and nuts will be examined. The examination will be limited to one of the two steam generators.	Examinations may be performed in place under tension or when removed.
B8.30	B-H	Integrally Welded Attachments	N/A		There are no steam generator integrally welded attachments. IWB-2500-13.
B15.30	B-P	Pressure-Retaining Boundaries	Visual (VT-2)	All steam generator components to be examined during system leakage test. Examinations to be performed in accordance with IWB-5221 prior to plant startup after each refueling outage.	VT examinations will be performed in accordance with IWA-5240.

QUALITY
ASSURANCE
MANUAL
GINNA STATION

TITLE:
APPENDIX B
R. E. GINNA NUCLEAR POWER PLANT
INSERVICE INSPECTION PROGRAM
FOR THE 1990-1999 INTERVAL
CODE TABLES

Section 4	REV. 3
PAGE 8 of 27	

Table 1
INSERVICE INSPECTION PROGRAM
CLASS 1 COMPONENTS (Cont'd)

Item No.	Examination Category	Components and Parts To be Examined	Examination Methods	Examination Requirements for Third Inspection Interval	Examination Technique/Examination Area Comments
STEAM GENERATORS (Cont'd)					
B15.31	B-P	Pressure-Retaining Boundaries	Visual (VT-2)	All steam generator components to be examined during system hydrostatic test or alternatively to Code Case N-498. Examinations to be performed in accordance with IWB-S221/5222 at or near the end of the inspection interval.	VT examinations will be performed in accordance with IWA-5240.
B16.20	B-Q	Steam Generator Tubing	Volumetric	The tubing in the hot leg side, U-bend portion, and optionally cold leg side will be examined.	Examination requirements, examination method, and the extent and frequency of examination shall be in accordance with plant Technical Specifications.

QUALITY
ASSURANCE
MANUAL
GINNA STATION

TITLE:
APPENDIX B
R. E. GINNA NUCLEAR POWER PLANT
INSERVICE INSPECTION PROGRAM
FOR THE 1990-1999 INTERVAL
CODE TABLES

Section 4

REV.
3

PAGE

9 of 27

SECRET

CONFIDENTIAL

SECRET

CONFIDENTIAL

SECRET



Table 1
INSERVICE INSPECTION PROGRAM
CLASS 1 COMPONENTS (Cont'd)

Item No.	Examination Category	Components and Parts To be Examined	Examination Methods	Examination Requirements for Third Inspection Interval	Examination Technique/Examination Area Comments
HEAT EXCHANGERS					
B2.50 B2.51 B2.52	B-B	Head Welds	N/A		No meridional or circumferential head welds in heat exchanger at R. E. Ginna.
B2.60	B-B	Tubesheet-to-Head Welds	Volumetric	Each tubesheet-to-head weld will be examined.	Examination will be performed with UT techniques.
B2.70	B-B	Longitudinal Welds	N/A		There are no RHE longitudinal welds at R. E. Ginna.
B2.80	B-B	Tubesheet-to-Shell Welds	Volumetric	Each tubesheet-to-shell weld will be examined.	Examination will be performed with UT techniques.
B3.150 B3.160	B-D B-D	Nozzle-to-Vessel Welds and Nozzle Inside Radius Section	Volumetric	All nozzle-to-shell and nozzle inside radius sections will be examined. At least 25% but not more than 50% of the nozzles shall be examined by the end of the first inspection period and the remainder by the end of the interval.	Examination will be performed with UT techniques.
B5.100 B5.110 B5.120	B-F	Pressure-Retaining Dissimilar Metal Welds	N/A		No heat exchanger dissimilar welds at R. E. Ginna.
B6.120 B6.130 B6.140	B-G-1	Pressure-Retaining Bolting >2 Inches in Diameter	N/A		No heat exchanger bolting at R. E. Ginna.
B7.40	B-G-2	Bolts, Studs, and Nuts ≥ 2 Inches in Diameter	N/A		No heat exchanger bolting at R. E. Ginna.
B8.40	B-H	Integrally Welded Attachments	N/A		Integrally welded attachments not required for examination for 3rd and 4th intervals by code.
B15.40	B-P	Pressure-Retaining Boundaries	Visual (VT-2)	All RHE components will be examined during system leakage test. Examinations to be performed in accordance with IWB-5221 prior to plant startup after each refueling outage.	VT examinations will be performed in accordance with IWA-5240
B15.41	B-P	Pressure-Retaining Boundaries	Visual (VT-2)	All RHE components will be examined during system hydrostatic test or alternatively to Code Case N-498. Examinations to be performed in accordance with IWB-5221/5222 at or near the end of the inspection interval.	VT examinations will be performed in accordance with IWA-5240.

QUALITY
ASSURANCE
MANUAL
GINNA STATION

TITLE:
APPENDIX B
R. E. GINNA NUCLEAR POWER PLANT
INSERVICE INSPECTION PROGRAM
FOR THE 1990-1999 INTERVAL
CODE TABLES

Section 4	REV. 3
PAGE 10 of 27	

1954



Table 1
INSERVICE INSPECTION PROGRAM
CLASS 1 COMPONENTS (Cont'd)

Item No.	Examination Category	Components and Parts To be Examined	Examination Methods	Examination Requirements for Third Inspection Interval	Examination Technique/Examination Area Comments
<u>PIPING</u>					
B5.130	B-F	Dissimilar Metal Welds ≥ 4 Inches NPS	Volumetric and Surface	All butt welds to be examined.	The welds will be examined with UT and PT.
B5.140	B-F	Dissimilar Metal Welds < 4 Inches NPS	N/A		No dissimilar metal welds < 4 inches NPS at R. E. Ginna.
B5.150	B-F	Dissimilar Metal Socket Welds	N/A		No dissimilar metal socket welds at R. E. Ginna.
B6.150 B6.160 B6.170	B-G-1	Pressure-Retaining Bolting > 2 Inches in Diameter	N/A		No pressure-retaining bolting > 2 inches in diameter at R. E. Ginna.
B7.50	B-G-2	Pressure-Retaining Bolting ≤ 2 Inches in Diameter	N/A		No pressure-retaining bolting ≤ 2 inches on piping at R. E. Ginna.
B9.10 B9.11	B-J	Circumferential Pipe Welds ≥ 4 Inches NPS	Volumetric and Surface	25% of the required circumferential butt welds to be examined. See Note 1 at end of Table 1 for selection criteria.	The piping welds will be examined with UT and PT.
B9.12	B-J	Longitudinal Pipe Welds ≥ 4 Inches NPS	Volumetric and Surface	Longitudinal welds that adjoin scheduled circumferential welds are to be examined. One pipe diameter not to exceed 12 inches of each longitudinal weld length required.	The piping welds will be examined with UT and PT.
B9.20 B9.21	B-J	Circumferential Welds < 4 Inches NPS	Surface	25% of the required circumferential butt welds to be examined. See Note 1 at end of Table 1 for selection criteria.	The piping welds will be examined with PT.
B9.22	B-J	Longitudinal Pipe Welds < 4 Inches NPS	N/A		No pressure-retaining longitudinal pipe welds ≤ 4 inches NPS at R. E. Ginna.
B9.30 B9.31	B-J	Branch Pipe Connection Welds ≥ 4 Inches NPS	Volumetric and Surface	25% of the required branch connection joints to be examined. See Note 1 at end of Table 1 for selection criteria.	The branch connection welds will be examined with UT and PT.
B9.32	B-J	Branch Pipe Connection Welds < 4 Inches NPS	Surface	25% of the required branch connection joints to be examined. See Note 1 at end of Table 1 for selection criteria.	The branch connection welds will be examined with PT.
B9.40	B-J	Socket Welds	Surface	25% of the required socket welds to be examined. See Note 1 at end of Table 1 for selection criteria.	The socket welds will be examined with PT.
B10.10	B-K-1	Integrally Welded Attachments	N/A		Integrally welded attachments not required for examination for 3rd and 4th intervals by code.

QUALITY
ASSURANCE
MANUAL
GINNA STATION

TITLE:
APPENDIX B
R. E. GINNA NUCLEAR POWER PLANT
INSERVICE INSPECTION PROGRAM
FOR THE 1990-1999 INTERVAL
CODE TABLES

Section 4	REV. 3
PAGE 11 of 27	

1
2
3
4
5
6
7
8
9
10
11
12
13
14
15
16
17
18
19
20
21
22
23
24
25
26
27
28
29
30
31
32
33
34
35
36
37
38
39
40
41
42
43
44
45
46
47
48
49
50
51
52
53
54
55
56
57
58
59
60
61
62
63
64
65
66
67
68
69
70
71
72
73
74
75
76
77
78
79
80
81
82
83
84
85
86
87
88
89
90
91
92
93
94
95
96
97
98
99
100



Table 1
INSERVICE INSPECTION PROGRAM
CLASS 1 COMPONENTS (Cont'd)

Item No.	Examination Category	Components and Parts To be Examined	Examination Methods	Examination Requirements for Third Inspection Interval	Examination Technique/Examination Area Comments
<u>PIPING (Cont'd)</u>					
B15.50	B-P	All Pressure-Retaining Boundaries for Piping Components	Visual (VT-2)	All components to be examined during system leakage test. Examination to be performed in accordance with IWB-5221 prior to plant startup after each refueling outage.	VT examination will be performed in accordance with IWA-5240.
B15.51	B-P	All Pressure-Retaining Boundaries for Piping Components	Visual (VT-2)	All components to be examined during system hydrostatic test or alternatively to Code Case N-498. Examination to be performed in accordance with IWB-5221/5222 at or near the end of the inspection interval.	VT examination will be performed in accordance with IWA-5240.

QUALITY
ASSURANCE
MANUAL
GINNA STATION

TITLE:
APPENDIX B
R. E. GINNA NUCLEAR POWER PLANT
INSERVICE INSPECTION PROGRAM
FOR THE 1990-1999 INTERVAL
CODE TABLES

Section 4	REV. 3
PAGE 12 of 27	

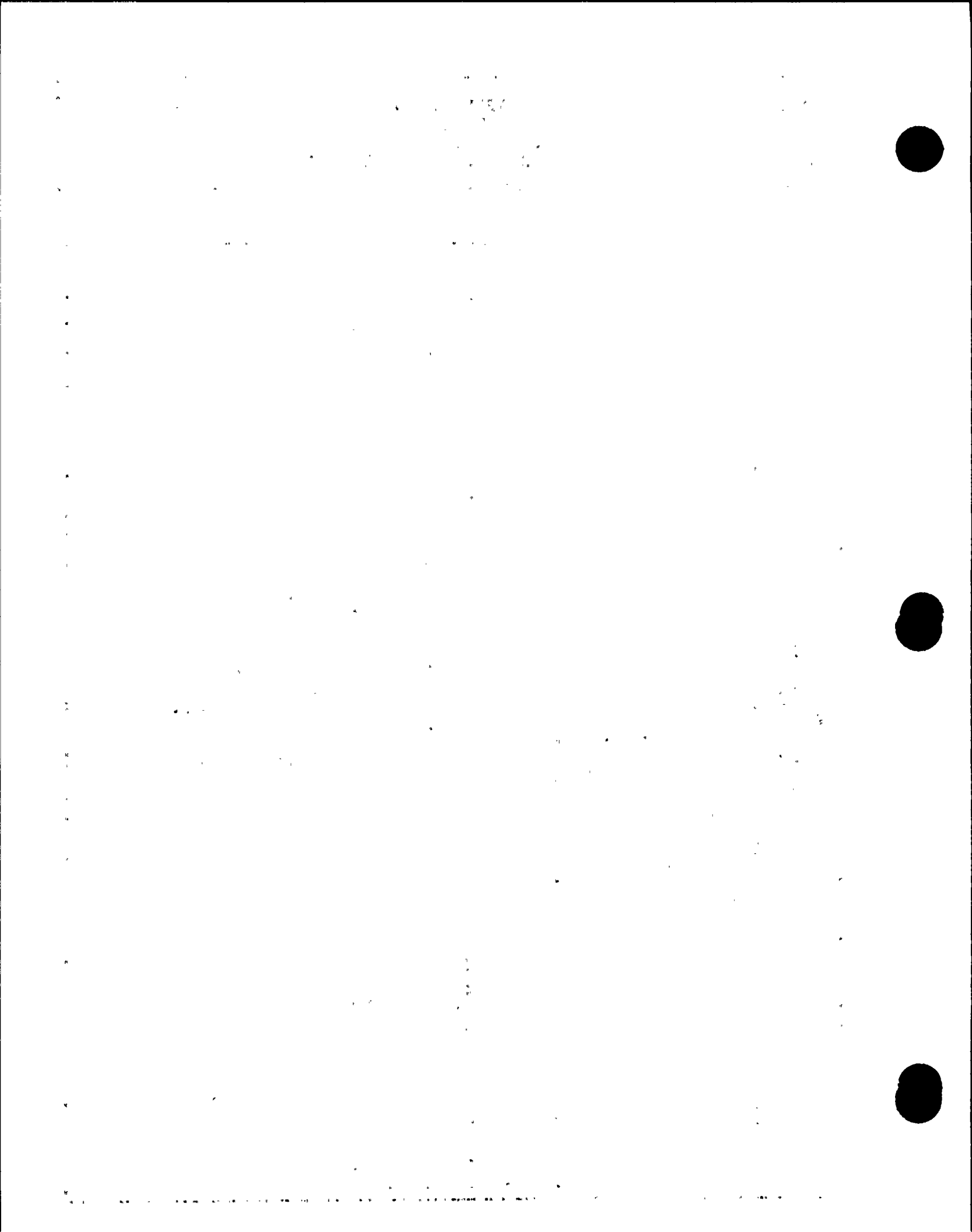

Table 1
INSERVICE INSPECTION PROGRAM
CLASS 1 COMPONENTS (Cont'd)

Item No.	Examination Category	Components and Parts To be Examined	Examination Methods	Examination Requirements for Third Inspection Interval	Examination Technique/Examination Area Comments
PUMPS					
B6.180	B-G-1	Bolts and Studs, >2 Inches in Diameter	Volumetric	All bolts and studs to be examined for items associated with one component in a multicomponent group.	The bolting will be examined with UT. Code Case N-307-1 shall apply. The bolting may be examined in place under tension or when disassembled or removed.
B6.190	B-G-1	Flange Surface for Bolting >2 Inches in Diameter When Connection Is Disassembled	Visual (VT-1)	Examination includes 1 inch annular surface of flange around each stud hole surface when disassembled.	VT examination will be performed when disassembled.
B6.200	B-G-1	Nuts, Bushings, and Washers >2 Inches in Diameter	Visual (VT-1)	All nuts, bushings, and washers to be examined when disassembled on one component in a multicomponent group.	VT examination will be performed when disassembled.
B7.60	B-G-2	Pressure-Retaining Bolting \leq 2 Inches in Diameter	N/A		No pressure-retaining bolting \leq 2 inches in diameter on pumps at R. E. Ginna.
B10.20	B-K-1	Integrally Welded Attachments	N/A		Integrally welded attachments not required for examination for 3rd and 4th intervals by code.
B12.10	B-L-1	Pump Casing Welds	Visual (VT-1)	Reactor coolant pump casing welds on one pump to be examined.	Examination performed in accordance with Code Case N-481.
B12.20	B-L-2	Internal Surfaces of Pump Casings	Visual (VT-3)	One reactor coolant pump to be examined when disassembled.	Pump casing internal surface will be examined with visual techniques when disassembled.
B15.60	B-P	Pressure-Retaining Boundaries for Pump Components	Visual (VT-2)	All components to be examined during system leakage test. Examination to be performed in accordance with IWB-5221 prior to plant startup after each refueling outage.	VT examinations will be performed in accordance with IWA-5240.
B15.61	B-P	Pressure-Retaining Boundaries for Pump Components	Visual (VT-2)	All components to be examined during system hydrostatic test or alternatively to Code Case N-498. Examination to be performed in accordance with IWB-5221/5222 at or near the end of the inspection interval.	VT examinations will be performed in accordance with IWA-5240.
RG1.14	Flywheel	Pump Flywheels	Surface and Volumetric	Each reactor coolant pump flywheel to be examined per Reg. Guide 1.14. High-stress areas to be examined each period with full examination at the end of interval.	Examinations will be performed with MT and UT techniques on the 2 active components as a minimum on an Augmented Program.

QUALITY
ASSURANCE
MANUAL
GINNA STATION

TITLE:
R. E. GINNA NUCLEAR POWER PLANT
INSERVICE INSPECTION PROGRAM
FOR THE 1990-1999 INTERVAL
APPENDIX B
CODE TABLES

Section 4
PAGE 13 of 27
REV. 3

[Faint, illegible text covering the majority of the page, possibly bleed-through from the reverse side.]



Table 1
INSERVICE INSPECTION PROGRAM
CLASS 1 COMPONENTS (Cont'd)

Item No.	Examination Category	Components and Parts To be Examined	Examination Methods	Examination Requirements for Third Inspection Interval	Examination Technique/Examination Area Comments
<u>VALVES</u>					
B6.210 B6.220 B6.230	B-G-1	Bolting >2 Inches in Diameter	N/A		No valve bolting >2 inches in diameter at R. E. Ginna.
B7.70	B-G-2	Bolting \geq 2 Inches in Diameter	Visual (VT-1)	All bolts, studs, and nuts to be examined on 1 component per group.	The bolting may be examined in place under tension or when disassembled or removed.
B10.30	B-K-1	Integrally Welded Attachments	N/A		Integrally welded attachments not required for examination for 3rd and 4th intervals by code.
B12.30	B-M-1	Pressure-Retaining Welds in Valve Bodies <4 Inches NPS	N/A		No pressure-retaining welds in valve bodies <4 inches NPS at R. E. Ginna.
B12.40	B-M-1	Pressure-Retaining Welds in Valve Bodies \geq 4 Inches NPS	Volumetric	All welds on one valve in each group of valves that is of the same construction and similar function to be examined.	Valve welds will be examined with UT.
B12.50	B-M-2	Internal Surfaces of Valve Bodies on Valves >4 Inches NPS	Visual (VT-3)	One valve in each group of valves that is of the same construction and similar function to be examined.	Internal surfaces of valve bodies to be examined with VT-3.
B15.70	B-P	All Pressure-Retaining Boundaries for Valve Components	Visual (VT-2)	All components to be examined during system leakage test. Examination to be performed in accordance with IWB-5221 prior to plant startup after each refueling outage.	VT examinations will be performed in accordance with IWB-5240.
B15.71	B-P	All Pressure-Retaining Boundaries for Valve Components	Visual (VT-2)	All components to be examined during system hydrostatic test or alternatively to Code Case N-498. Examination to be performed in accordance with IWB-5221/5222 at or near the end of the inspection interval.	VT examinations will be performed in accordance with IWA-5240.

QUALITY
ASSURANCE
MANUAL
GINNA STATION

TITLE:
APPENDIX B
R. E. GINNA NUCLEAR POWER PLANT
INSERVICE INSPECTION PROGRAM
FOR THE 1990-1999 INTERVAL
CODE TABLES

Section 4	REV. 3
PAGE 14	of 27

Table 1

NOTES

(1) As allowed by 10CFR50.55(a)(b)(2)(ii), ASME Section XI 1974 Edition with addenda through 1975 is permitted for Category B-J weld selection and does not utilize stress level criteria. Category B-J weld selection shall be performed to ASME Section XI, 1986 Edition, no addenda and shall not utilize stress level criteria. Examinations selected shall be distributed in such a manner to include:

- (a) All accessible Terminal Ends in each pipe or branch run connected to vessels.
- (b) All accessible Terminal Ends and joints in each pipe or branch run connected to other components such as pumps, branches and anchors.
- (c) All dissimilar metal welds.
- (d) Additional piping welds (structural discontinuity welds) so that the total number of circumferential butt welds (or branch connection or socket welds) selected for examination equals 25% of the circumferential butt welds (or branch connection or socket welds) in the Reactor Coolant piping system. This total does not include welds excluded by IWB-1220. These additional welds may be located in one loop and shall be selected among the Class 1 systems, prorated, to the degree practical.

Note: 1. Terminal End (TE) Welds are defined as the extremities of piping runs that connect to structures, components, or pipe anchors, each of which acts as a rigid restraint or provides at least two degrees of restraint to piping thermal expansion. This definition (ref. IWA-9000) is interpreted to include the following:

- (a) Circumferential welds within 3 pipe diameters of the centerline of rigid pipe anchors or anchors at penetrations of the primary reactor containment.
- (b) Piping connection welds in which the main process piping is at least 3 times larger than the Branch Run.
- (c) Piping connections to rigidly mounted components, such as vessels, pumps, etc.

Terminal Ends at component or branch connections are considered to be the piping weld connection to the safe-end, nozzle, reducer, weldolet, sockolet or flange.

2. Structural Discontinuity (SD) Welds includes circumferential weld joints at pipe-to-nozzle, pipe-to-valve, pipe-to-pump or pipe-to-fitting. Fitting-to-Fitting connections and all socket-welded connections shall be considered Structural Discontinuities.

3. The following weld types are identified in Supplement I to Appendix B, the Program Plan.

- TE-A Terminal End at a Piping Anchor
- TE-B Terminal End at a Branch Connection
- TE-P Terminal End at a Pump Connection
- TE-V Terminal End at a Vessel Connection
- SD Structural Discontinuity
- PP Pipe to Pipe Butt Weld
- SEAM Longitudinal Seam Weld

 Note: When more than one weld type is applicable, the more restrictive (i.e. TE) is utilized.

(2) Examination is limited to those integrally welded attachments that meet the following conditions:

- (a) the attachment is on the outside surface of the pressure-retaining component;
- (b) the attachment provides component support as defined in NF-1110;
- (c) the attachment base material design thickness is 5/8 inch or greater; and
- (d) the attachment weld joins the attachment either directly to the surface of the component or to an integrally cast or forged attachment to the component.

Examinations include the welded attachments of piping required to be examined by Examination Category B-J and the welded attachments to associated pumps and valves integral to such piping.

QUALITY ASSURANCE MANUAL GINNA STATION		TITLE: APPENDIX B R. E. GINNA NUCLEAR POWER PLANT INSERVICE INSPECTION PROGRAM FOR THE 1990-1999 INTERVAL CODE TABLES
PAGE 15	Section 4	REV. 3
		of 27

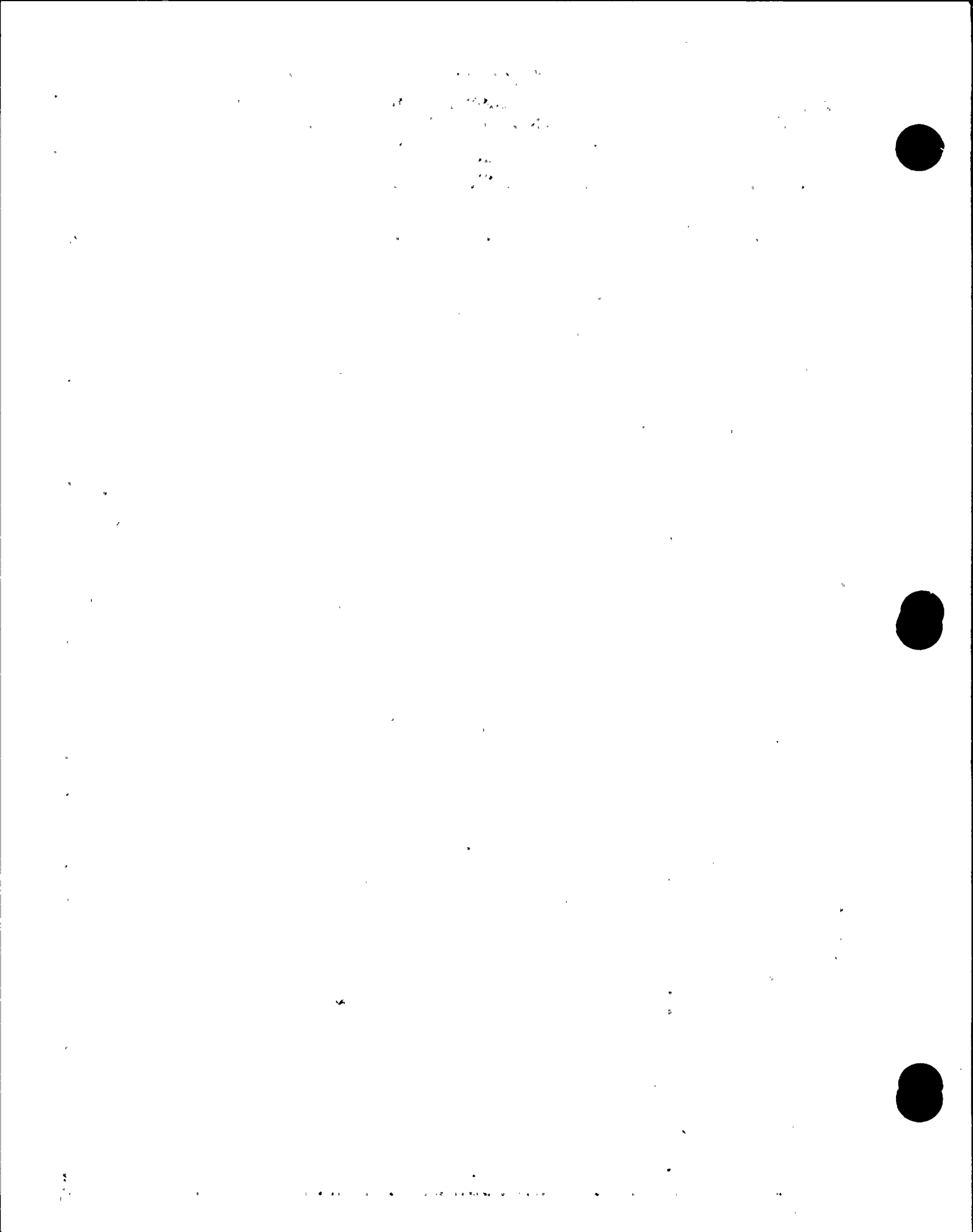

Table 2

INSERVICE INSPECTION PROGRAM
CODE CLASS

Item No.	Examination Category	Components and Parts To be Examined	Examination Methods	Examination Requirements for Third Inspection Interval	Examination Technique/Examination Area Comments
The ASME Section XI Item No. and Category of the component are listed in these columns.	Each type of examination area is listed in this column.	The NDE method required to satisfy Code requirements is listed in this column.	This column provides information regarding the number and/or percent of examinations required to be performed for the inspection interval.	This column provides information specific to examination techniques, examination areas, or comments.	

QUALITY
ASSURANCE
MANUAL
GINNA STATION

TITLE:
APPENDIX B
R. E. GINNA NUCLEAR POWER PLANT
INSERVICE INSPECTION PROGRAM
FOR THE 1990-1999 INTERVAL
CODE TABLES

Section 4	REV. 3
PAGE 16 of 27	



Table 2

INSERVICE INSPECTION PROGRAM
CLASS 2 COMPONENTS

Item No.	Examination Category	Components and Parts To be Examined	Examination Methods	Examination Requirements for Third Inspection Interval	Examination Technique/Examination Area Comments
<u>PRESSURE VESSELS</u>					
C1.10	C-A	Shell Circumferential Welds	Volumetric	100% of each weld to be examined (applies only to welds at gross structural discontinuities). For multiple vessels of similar design size and service, examinations may be limited to one vessel.	The welds will be examined with UT.
C1.20	C-A	Head Circumferential Welds	Volumetric	100% of each head-to-shell weld to be examined. For multiple vessels of similar design size and service, examinations may be limited to one vessel.	The welds will be examined with UT.
C1.30	C-A	Tubesheet-to-Shell Weld	Volumetric	100% of each weld to be examined. For multiple vessels of similar design size and service, examinations may be limited to one vessel.	The welds will be examined with UT.
C2.10	C-B	Nozzles in Vessels $\leq 1/2$ -Inch Nominal Thickness Nozzle-to-Shell (or Head) Weld	N/A		No Code required Nozzles in Vessels $\leq 1/2$ -Inch Nominal Thickness Nozzle-to-Shell (or Head) Weld at R. E. Ginna.
C2.20	C-B	Nozzles Without Reinforcing Plate in Vessels $> 1/2$ -Inch Nominal Thickness Nozzle-to-Shell (or Head) Weld	Surface and Volumetric	All nozzles to be selected at terminal ends of piping runs selected for examination under Categories C-F-1 and C-F-2. 100% of each weld to be examined. Manways and hand holes excluded. For multiple vessels of similar design, size, and service, examinations may be limited to one vessel.	The welds will be examined with UT and MT or PT as applicable.
C2.21					
C2.22	C-B	Nozzle Inside Radius Section	Volumetric	100% of each area to be examined. Manways and hand holes are excluded. For multiple vessels of similar design, size, and service, examinations may be limited to one vessel.	The nozzle inside radius section will be examined with UT.
C2.30	C-B	Nozzles with Reinforcing Plate in Vessels $> 1/2$ inch Nominal Thickness			See C2.31, C2.32, C2.33
C2.31	C-B	Reinforcing Plate Welds Surface to Nozzle & Vessel	Surface	All nozzles at terminal ends of piping runs. For multiple vessels of similar design, size, and service, examinations may be limited to one vessel.	The reinforcing plate welds will be examined with PT or MT as applicable.

QUALITY
ASSURANCE
MANUAL
GINNA STATIONTITLE:
APPENDIX B
R. E. GINNA NUCLEAR POWER PLANT
INSERVICE INSPECTION PROGRAM
FOR THE 1990-1999 INTERVAL.
CODE TABLESSection 4
REV. 3
PAGE 17 of 27

1. The first part of the document discusses the importance of maintaining accurate records of all transactions.



Table 2
INSERVICE INSPECTION PROGRAM
CLASS 2 COMPONENTS (Cont'd)

Item No.	Examination Category	Components and Parts To be Examined	Examination Methods	Examination Requirements for Third Inspection Interval	Examination Technique/Examination Area Comments
<u>PRESSURE VESSELS (Cont'd)</u>					
C2.32	C-B	Nozzle-To-Shell (or Head) Welds When Inside of Vessel is Accessible	N/A	All nozzles at terminal ends of piping runs. For multiple vessels of similar design, size, and service, examinations may be limited to one vessel.	The inside of vessel is not accessible, performing C2.33 instead.
C2.33	C-B	Nozzle-To-Shell (or Head) Welds When Inside of Vessel is Inaccessible	Visual (VT-2)	All nozzles at terminal ends of piping runs. For multiple vessels of similar design, size, and service, examinations may be limited to one vessel.	VT examinations will be performed in accordance with IWB-5240. The required components to be examined during system leakage test.
C3.10	C-C	Integrally Welded Attachments	Surface	100% of each weld to be examined. Attachments whose base material is 3/4 inch or greater to be selected. Where multiple vessels are provided with a number of similar attachments, the attachments may be distributed among the vessels. For multiple vessels of similar design and service, examinations may be limited to one vessel.	The welded attachments will be examined with MT or PT as applicable.
C4.10	C-D	Pressure-Retaining Bolting >2 Inches in Diameter	N/A		No pressure-retaining vessel bolting >2 inches in diameter at R. E. Ginna.
C7.10	C-H	Pressure-Retaining Components	Visual (VT-2)	All pressure-retaining boundaries for vessels to be examined during system pressure test. Examinations to be performed in accordance with IWC-5221 for each inspection period.	VT examinations will be performed in accordance with IWA-5240.
C7.20	C-H	Pressure-Retaining Components	Visual (VT-2)	All pressure-retaining boundaries for vessels to be examined during system hydrostatic test or alternatively to Code Case N-498. Examinations to be performed in accordance with IWC-5221/5222 at or near the end of each inspection interval or during same inspection periods of each interval.	VT examinations will be performed in accordance with IWA-5240.

QUALITY
ASSURANCE
MANUAL
GINNA STATION

TITLE:
APPENDIX B
R. E. GINNA NUCLEAR POWER PLANT
INSERVICE INSPECTION PROGRAM
FOR THE 1990-1999 INTERVAL
CODE TABLES

Section 4	REV. 3
PAGE 18 of 27	

1947



Table 2
INSERVICE INSPECTION PROGRAM
CLASS 2 COMPONENTS (Cont'd)

Item No.	Examination Category	Components and Parts To be Examined	Examination Methods	Examination Requirements for Third Inspection Interval	Examination Technique/Examination Area Comments
PIPING					
C3.20	C-C	Integrally Welded Attachments	Surface	100% of each weld to be examined. Attachments whose base material is 3/4 inch or greater to be selected. Selection limited to those components selected under Examination Categories C-F-1 and C-F-2.	The welds will be examined with MT or PT as applicable.
C4.20	C-D	Pressure-Retaining Bolting >2 Inches in Diameter	N/A		No pressure-retaining bolting >2 inches in diameter at R. E. Ginna.
CS.10 CS.11	C-F-1	Piping Welds in Austenitic Stainless Steel or High-Alloy Piping $\geq 3/8$ -Inch Nominal Wall Thickness for Piping >4 NPS, Circumferential.	Surface and Volumetric	100% of each circumferential weld requiring examination. See Note 1 at end of Table 2 for selection criteria.	The welds will be examined with UT and PT.
CS.12	C-F-1	Piping Welds in Austenitic Stainless Steel or High-Alloy Piping $\geq 3/8$ -Inch Nominal Wall Thickness for Piping >4 NPS, Longitudinal	N/A		No longitudinal welds of this item number at R. E. Ginna.
CS.20 CS.21	C-F-1	Piping Welds in Austenitic Stainless Steel or High-Alloy Piping $\geq 1/5$ -Inch Nominal Wall Thickness for Piping ≥ 2 NPS and ≤ 4 NPS, Circumferential	Surface and Volumetric	100% of each circumferential weld requiring examination. See Note 1 at end of Table 2 for selection criteria.	The welds will be examined with UT and PT.
CS.22	C-F-1	Piping Welds in Austenitic Stainless Steel or High-Alloy Piping $\geq 1/5$ -Inch Nominal Wall Thickness for Piping ≥ 2 NPS and ≤ 4 NPS, Longitudinal	N/A		No longitudinal welds of this item number at R. E. Ginna.
CS.30	C-F-1	Socket Welds in Austenitic Stainless Steel or High-Alloy Piping	Surface	100% of each weld requiring examination. See Note 1 at end of Table 2 for selection criteria.	The welds will be examined with PT.
CS.40 CS.41	C-F-1	Pipe Branch Connections in Austenitic Stainless Steel or High-Alloy Piping ≥ 2 NPS, Circumferential	Surface	100% of each circumferential weld requiring examination. See Note 1 at end of Table 2 for selection criteria.	The welds will be examined with PT.

QUALITY
ASSURANCE
MANUAL
GINNA STATION

TITLE:
APPENDIX B
R. E. GINNA NUCLEAR POWER PLANT
INSERVICE INSPECTION PROGRAM
FOR THE 1990-1999 INTERVAL
CODE TABLES

Section 4	REV. 3
PAGE 19 of 27	

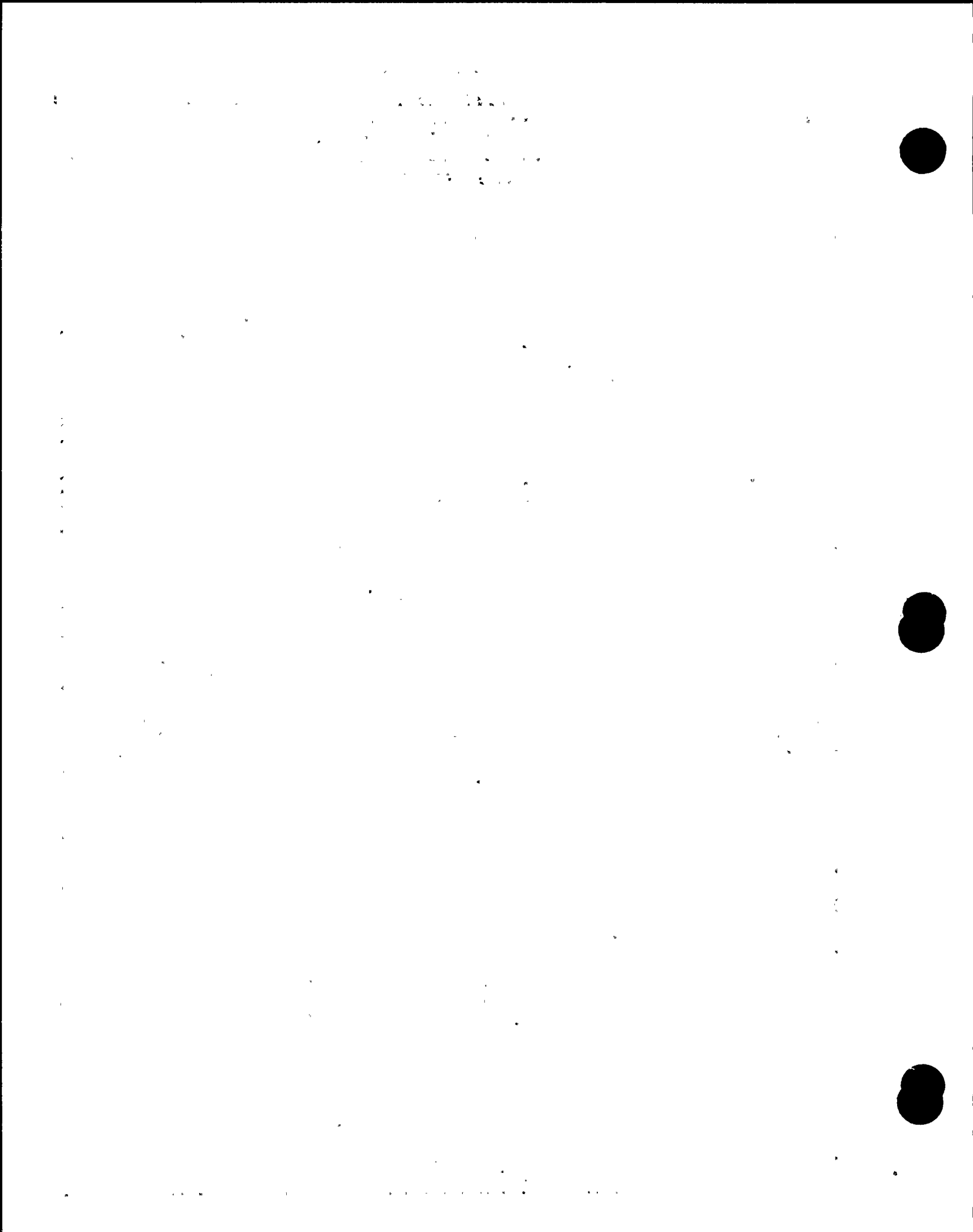

Table 2
INSERVICE INSPECTION PROGRAM
CLASS 2 COMPONENTS (Cont'd)

Item No.	Examination Category	Components and Parts To be Examined	Examination Methods	Examination Requirements for Third Inspection Interval	Examination Technique/Examination Area Comments
PIPING (cont'd)					
CS.42	C-F-1	Pipe Branch Connections in Austenitic Stainless Steel or High-Alloy Piping ≥ 2 NPS, Longitudinal	N/A		No longitudinal welds of this item number at R. E. Ginna.
CS.50 CS.51 CS.52	C-F-2	Piping Welds in Carbon or Low-Alloy Steel $\geq 3/8$ -Inch Nominal Wall Thickness for Piping > 4 NPS, Circumferential and Longitudinal	Surface and Volumetric	100% of each circumferential and 2.5t of each longitudinal weld requiring examination. See Note 2 at end of Table 2 for selection criteria. In addition, 100% of the main steam and main feedwater welds located outside containment and traversing safety areas shall be examined per Technical Specifications.	The welds will be examined with UT and MT.
CS.60 CS.61 CS.62	C-F-2	Piping Welds in Carbon or Low-Alloy Steel $> 1/5$ -Inch Nominal Wall Thickness for Piping ≥ 2 NPS and ≥ 4 NPS, Circumferential and Longitudinal	N/A		No carbon or low-alloy steel nonexempt welds in this category at R. E. Ginna.
CS.70	C-F-2	Socket Welds in Carbon or Low-Alloy Steel	N/A		No carbon or low-alloy steel nonexempt welds in this category at R. E. Ginna.
CS.80 CS.81	C-F-2	Pipe Branch Connections in Carbon or Low-Alloy Steel ≥ 2 NPS, Circumferential	Surface	100% of each circumferential weld requiring examination. See Note 2 at end of Table 2 for selection criteria.	The welds will be examined with MT.
CS.82	C-F-1	Pipe Branch Connections in Carbon or Low-Alloy Steel ≥ 2 NPS, Longitudinal	N/A		No longitudinal welds of this item number at R. E. Ginna.
C7.30	C-H	Pressure-Retaining Components	Visual (VT-2)	All pressure-retaining boundaries for piping to be examined during system pressure test. Examination to be performed in accordance with IWC-5221 for each inspection period.	VT examinations will be performed in accordance with IWA-5240.
C7.40	C-H	Pressure-Retaining Components	Visual (VT-2)	All pressure-retaining boundaries for piping to be examined during system hydrostatic test or alternatively to Code Case N-498. Examination to be performed in accordance with IWC-5221/5222 at or near the end of each inspection interval or during same inspection periods of each interval.	VT examinations will be performed in accordance with IWA-5240.

QUALITY
ASSURANCE
MANUAL
GINNA STATION

TITLE:
R. E. GINNA NUCLEAR POWER PLANT
INSERVICE INSPECTION PROGRAM
FOR THE 1990-1999 INTERVAL
CODE TABLES

Section 4	REV. 3
PAGE 20 of 27	

Table 2
INSERVICE INSPECTION PROGRAM
CLASS 2 COMPONENTS (Cont'd)

Item No.	Examination Category	Components and Parts To be Examined	Examination Methods	Examination Requirements for Third Inspection Interval	Examination Technique/Examination Area Comments
<u>PUMPS</u>					
C3.30	C-C	Integrally Welded Attachments	N/A		100% of each weld to be examined. Attachments whose base material is 3/4 inch or greater to be selected. Selection limited to those components selected under Examination Category C-G. No pumps meet this criteria at R. E. Ginna.
C4.30	C-D	Pressure-Retaining Bolting >2 Inches in Diameter	N/A		No pressure-retaining pump bolting >2 inches in diameter at R. E. Ginna.
C6.10	C-G	Pressure-Retaining Welds in Pump Casings	N/A		No pressure-retaining pump welds at R. E. Ginna.
C7.50	C-H	Pressure-Retaining Components	Visual (VT-2)	All pressure-retaining boundaries for pumps to be examined during pressure test. Examination to be performed in accordance with IWC-5221 for each inspection period.	VT examinations will be performed in accordance with IWA-S240.
C7.60	C-H	Pressure-Retaining Components	Visual (VT-2)	All pressure-retaining boundaries for pumps to be examined during system hydrostatic test or alternatively to Code Case N-498. Examination to be performed in accordance with IWC-5221/5222 at or near the end of each inspection interval or during same inspection periods of each interval.	VT examinations will be performed in accordance with IWA-S240.

QUALITY ASSURANCE MANUAL GINNA STATION

TITLE:
APPENDIX B
R. E. GINNA NUCLEAR POWER PLANT
INSERVICE INSPECTION PROGRAM
FOR THE 1990-1999 INTERVAL
CODE TABLES

Section 4
REV. 3

PAGE 21 of 27

Table 2
INSERVICE INSPECTION PROGRAM
CLASS 2 COMPONENTS (Cont'd)

Item No.	Examination Category	Components and Parts To be Examined	Examination Methods	Examination Requirements for Third Inspection Interval	Examination Technique/Examination Area Comments
VALVES					
C3.40	C-C	Integrally Welded Attachments	Surface	100% of each weld to be examined. Attachments whose base material is 3/4 inch or greater to be selected. Selection limited to those components selected under Examination Category C-G.	The welds will be examined with MT or PT as applicable.
C4.40	C-D	Pressure-Retaining Bolting >2 Inches in Diameter	N/A		No pressure-retaining bolting >2 inches in diameter at R. E. Ginna.
C6.20	C-G	Pressure-Retaining Welds in Valve Bodies	N/A		No pressure-retaining welds in valve bodies at R. E. Ginna.
C7.70	C-H	Pressure-Retaining Components	Visual (VT-2)	All pressure-retaining boundaries for valves to be examined during system pressure test. Examination to be performed in accordance with IWC-5221 for each inspection period.	VT examinations will be performed in accordance with IWA-5240.
C7.80	C-H	Pressure-Retaining Components	Visual (VT-2)	All pressure-retaining boundaries for valves to be examined during system hydrostatic test or alternatively to Code Case N-498. Examination to be performed in accordance with IWC-5221/5222 at or near the end of each inspection interval or during same inspection periods of each interval.	VT examinations will be performed in accordance with IWA-5240.

QUALITY
ASSURANCE
MANUAL
GINNA STATION

TITLE:
APPENDIX B
R. E. GINNA NUCLEAR POWER PLANT
INSERVICE INSPECTION PROGRAM
FOR THE 1990-1999 INTERVAL
CODE TABLES

Section 4
PAGE 22 of 27

REV.
3



Table 2

NOTES

- (1) The welds selected for examination shall include 7.5%, but not less than 28 welds, of all austenitic stainless steel or high-alloy welds not exempted by IWC-1220. (Some welds not exempted by this Case are not required to be nondestructively examined per Examination Category C-F-1. These welds, however, shall be included in the total weld count to which the 7.5% sampling rate is applied.) The examinations shall be distributed as follows:
- (a) the examinations shall be distributed among the Class 2 systems prorated, to the degree practicable, on the number of nonexempt austenitic stainless steel or high-alloy welds in each system (i.e., if a system contains 30% of the nonexempt welds, then 30% of the nondestructive examinations required by Examination Category C-F-1 should be performed on that system);
 - (b) within a system, the examinations shall be distributed among terminal ends [see Note (3)] and structural discontinuities [see Note (4)] prorated, to the degree practicable, on the number of nonexempt terminal ends and structural discontinuities in that system; and
 - (c) within each system, examinations shall be distributed between line sizes prorated to the degree practicable.
- (2) The welds selected for examination shall include 7.5%, but not less than 28 welds, of all carbon or low-alloy welds not exempted by IWC-1220. (Some welds not exempted by this Case are not required to be nondestructively examined per Examination Category C-F-2. These welds, however, shall be included in the total weld count to which the 7.5% sampling rate is applied.) The examinations shall be distributed as follows:
- (a) the examinations shall be distributed among the Class 2 systems prorated, to the degree practicable, on the number of nonexempt carbon or low-alloy welds in each system (i.e., if a system contains 30% of the nonexempt welds, then 30% of the nondestructive examinations required by Examination Category C-F-2 should be performed on that system);
 - (b) within a system, the examinations shall be distributed among terminal ends [see Note (3)] and structural discontinuities [see Note (4)] prorated, to the degree practicable, on the number of nonexempt terminal ends and structural discontinuities in that system; and
 - (c) within each system, examinations shall be distributed between line sizes prorated to the degree practicable.
 - (d) Only those welds showing reportable preservice transverse indications need to be examined for transverse reflectors.
- (3) Terminal Ends (TE) are defined in Table 1 Notes, note number 1.
- (4) Structural Discontinuities (SD) are defined in Table 1 Notes, note number 2.

The following weld types are identified in Supplement I to Appendix B, the Program Plan.

- * TE-A Terminal End at a Piping Anchor
- * TE-B Terminal End at a Branch Connection
- * TE-P Terminal End at a Pump Connection
- * TE-V Terminal End at a Vessel Connection
- * SD Structural Discontinuity
- * PP Pipe to Pipe Butt Weld
- * SEAM Longitudinal Seam Weld

Note: When more than one weld type is applicable, the more restrictive (i.e. TE) is utilized.

QUALITY ASSURANCE MANUAL GINNA STATION	TITLE: APPENDIX B R. E. GINNA NUCLEAR POWER PLANT INSERVICE INSPECTION PROGRAM FOR THE 1990-1999 INTERVAL CODE TABLES	Section 4	REV. 3
		PAGE 23	of 27

1952



QUALITY
ASSURANCE
MANUAL
GINNA STATION

TITLE:
APPENDIX B
R.E. GINNA NUCLEAR POWER PLANT
INSERVICE INSPECTION PROGRAM
FOR THE 1990-1999 INTERVAL
CODE TABLES

Section 4	REV. 3
PAGE 24	of 27

Table 3

INSERVICE INSPECTION PROGRAM
CODE CLASS

Item No.	Examination Category	Components and Parts To be Examined	Examination Methods	Examination Requirements for Third Inspection Interval	Examination Technique/Examination Area Comments
	The ASME Section XI Item No. and Category of the component are listed in these columns.	Each type of examination area is listed in this column.	The NDE method required to satisfy Code requirements is listed in this column.	This column provides information regarding the number and/or percent of examinations required to be performed for the inspection interval.	This column provides information specific to examination techniques, examination areas, or comments.

1950
1951
1952
1953
1954
1955
1956
1957
1958
1959
1960
1961
1962
1963
1964
1965
1966
1967
1968
1969
1970
1971
1972
1973
1974
1975
1976
1977
1978
1979
1980
1981
1982
1983
1984
1985
1986
1987
1988
1989
1990
1991
1992
1993
1994
1995
1996
1997
1998
1999
2000
2001
2002
2003
2004
2005
2006
2007
2008
2009
2010
2011
2012
2013
2014
2015
2016
2017
2018
2019
2020
2021
2022
2023
2024
2025



Table 3

INSERVICE INSPECTION PROGRAM
CLASS 3 COMPONENTS

Item No.	Examination Category	Components and Parts To be Examined	Examination Methods	Examination Requirements for Third Inspection Interval	Examination Technique/Examination Area Comments
CLASS 3 COMPONENTS					
D1.10 D2.10 D3.10	D-A D-B D-C	Pressure-Retaining Components	Visual (VT-2)	All components to be examined during system pressure or system hydrostatic test as defined by IWD-2500-1 Table Descriptions. Examination to be performed in accordance with IWD-5221 for each inspection period and performed once each interval in accordance with IWD-5223.	VT examinations will be performed in accordance with IWA-5240.
D1.20 through D1.60 D2.20 through D2.60 D3.20 through D3.60	D-A D-B D-C	Integral Attachments of Supports and Restraints, Hydraulic Snubbers, Spring, Constant Load, and Shock Absorbers	Visual (VT-3)	All required attachments to be examined during each inspection interval as defined by IWD-2500-1 Table Descriptions. For multiple components in a system of similar design, function, and service, the integral attachment of only one of the multiple components shall be examined. The integral attachments selected shall correspond to those support components selected for examination in accordance with IWF-2510(b).	The integral attachments will be examined.

QUALITY
ASSURANCE
MANUAL
GINNA STATION

TITLE:
R. E. GINNA NUCLEAR POWER PLANT
INSERVICE INSPECTION PROGRAM
FOR THE 1990-1999 INTERVAL
CODE TABLES

Section 4
PAGE 25 of 27
REV. 3

1952



QUALITY
ASSURANCE
MANUAL
GINNA STATION

TITLE:
APPENDIX B
R. E. GINNA NUCLEAR POWER PLANT
INSERVICE INSPECTION PROGRAM
FOR THE 1990-1999 INTERVAL
CODE TABLES

Section 4
REV. 3

PAGE 26 of 27

Table 4

INSERVICE INSPECTION PROGRAM

CODE CLASS

Item No.	Examination Category	Components and Parts To be Examined	Examination Methods	Examination Requirements for Third Inspection Interval	Examination Technique/Examination Area Comments
The ASME Section XI Item No. and Category of the component are listed in these columns.	Each type of examination area is listed in this column.	The NDE method required to satisfy Code requirements is listed in this column.	This column provides information regarding the number and/or percent of examinations required to be performed for the inspection interval.	This column provides information specific to examination techniques, examination areas, or comments.	

Table 4

INSERVICE INSPECTION PROGRAM
CLASS 1, CLASS 2, AND CLASS 3 COMPONENT SUPPORTS

Item No.	Examination Category	Components and Parts To be Examined	Examination Methods	Examination Requirements for Third Inspection Interval	Examination Technique/Examination Area Comments
----------	----------------------	-------------------------------------	---------------------	--	---

CLASS 1, 2, AND 3 IWF COMPONENTS SUPPORTS FROM 1990 TO 1993 OUTAGE USING IWF 1986 Code

PLATE AND SHELL TYPE SUPPORTS, LINEAR TYPE SUPPORTS, AND COMPONENT STANDARD SUPPORTS

F1.10 through F1.40	F-A	Mechanical Connections to Pressure-Retaining Components and Building Structure; Weld Connections to Building Structure; Weld and Mechanical Connections at Intermediate Joints in Multi-connected Integral and Nonintegral Supports; and Component Displacement Settings of Guides and Stops, Misalignment of Supports, Assembly of Support Items; Spring Type Supports; Constant Load Type Supports; Shock Absorbers; Hydraulic Type Snubbers	Visual (VT-3)	Component supports to be selected for examination are the supports of the nonexempt Class 1, 2, and 3 components scheduled to be examined. Examination boundaries established in accordance with IWF-1300. Examinations may be performed during normal system operation or plant outages.	Functional testing of snubber type support components shall be performed in accordance with Technical Specifications and in accordance with requirements of this program.
F2.10 through F2.40	F-B				
F3.10 through F3.50	F-C				

CLASS 1, 2, AND 3 IWF COMPONENT SUPPORTS FROM 1994 TO 1999, USING CODE CASE N-491 AND IWF 1986 CODE

Item No.	Exam. Category	Components & Parts to be Examined	Examination Method	Examination Requirement for the Third Interval	Examination Technique/Examination Area Comments
F1.10	F-A	Class 1 piping supports	Visual (VT-3)	25% of Class 1 supports	Functional testing of snubber type support components shall be performed in accordance with Technical Specifications and in accordance with requirements of this program.
F1.20	F-A	Class 2 piping supports	Visual (VT-3)	15% of Class 2 supports	.
F1.30	F-A	Class 3 piping supports	Visual (VT-3)	10% of Class 3 supports	.
F1.40	F-A	Class 1, 2, & 3 supports other than piping supports	Visual (VT-3)	100% except for multiple components.	.

QUALITY ASSURANCE MANUAL GINNA STATION

TITLE:
R. E. GINNA NUCLEAR POWER PLANT
INSERVICE INSPECTION PROGRAM
FOR THE 1990-1999 INTERVAL
APPENDIX B
CODE TABLES

Section 4
PAGE 27 of 27

REV.
3

QUALITY ASSURANCE MANUAL GINNA STATION	Section 5	REV. 3	PAGE 1 of 96
	EFFECTIVE DATE: December 31, 1993		
ROCHESTER GAS & ELECTRIC CORPORATION	SIGNATURE		DATE
	PREPARED BY: <i>Frank A. Klepach</i>		12-1-93
TITLE: APPENDIX B R. E. GINNA NUCLEAR POWER PLANT INSERVICE INSPECTION PROGRAM FOR THE 1990-1999 INTERVAL LINE LIST	QUALITY ASSURANCE REVIEW: <i>[Signature]</i>		12-2-93
	APPROVED BY: <i>Michael J. Spunt</i>		12-6-93

1.0 General

The following line list was developed utilizing ASME Section XI Rules and Criteria to identify all Class 1, 2 & 3 exempt and non-exempt items. This list further identifies non-exempt piping lines and components, type of nondestructive examination requirements as well as providing a line description. Visual examination for leakage (VT-2) boundaries are not addressed in this Section, but shall be administratively confirmed by the responsible Rochester Gas & Electric organization before implementation.

The line list is grouped by P&ID Drawing Number, Class, System, and Component Type. This information appears on each page of the Line List on the upper left hand corner. The Component Type description defines the information as either components or piping.

On the individual pages, unique line numbers were identified that correspond to a description of a particular segment. Other relative information listed within each page of the line list includes ISI Figure Numbers, material type, pipe size, wall thickness, applicable code exemption basis, typical examination (NDE) methods, applicable operating pressure and temperature, as well as component insulation information. The revision status of "R" shall indicate that a change has occurred anywhere horizontally for the line number in question. A Revision Status of "A" indicates a new entry was made.

A visual representation of the line number can be seen on the corresponding P&ID contained within Section 3. Lines 1" and under are not shown. However, they are identified in the line list data base.

R. E. GINNA NUCLEAR POWER PLANT
 Inservice Examination Boundary Line List
 Third Inspection Interval

P&ID No.: 33013-1231
 Class.: 2
 System.: MAIN STEAM
 Comp Type: COMPONENTS

<u>RG&E Line No.</u>	<u>Gilbert Line No.</u>	<u>SWRI Line No.</u>	<u>ISI Fig.</u>	<u>Matrl.</u>	<u>Size (in.)</u>	<u>Thkns (in.)</u>	<u>Exemption Basis</u>	<u>NDE Method</u>	<u>Po</u>	<u>Temp</u>	<u>In?</u>	<u>Line description/remarks</u>	<u>Revised</u>
EMS01A			B-1		0.00	0.000		SUR/VOL	715	505	-	STEAM GENERATOR A.	R 11/91
EMS01B			B-1		0.00	0.000		SUR/VOL	715	505	-	STEAM GENERATOR B.	R 11/91

QUALITY
 ASSURANCE
 MANUAL
 GINNA STATION

TITLE:
 R. E. GINNA NUCLEAR POWER PLANT
 INSERVICE INSPECTION PROGRAM
 FOR THE 1990-1999 INTERVAL
 LINE LIST

Section 5
 PAGE 2 of 96

REV.
 3

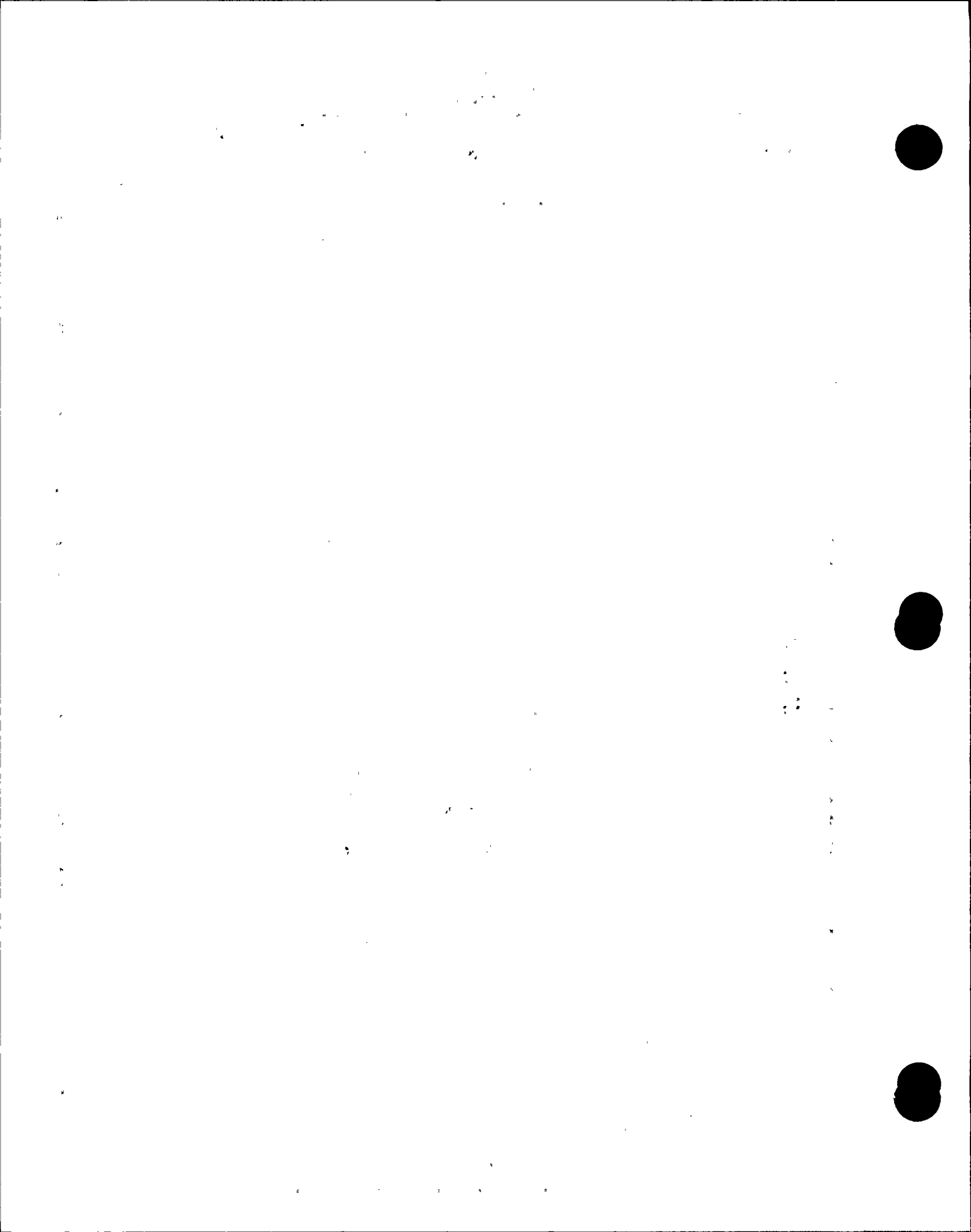

R. E. GINNA NUCLEAR POWER PLANT
Inservice Examination Boundary Line List
Third Inspection Interval

P&ID No.: 33013-1231
Class.: 2
System.: MAIN STEAM
Comp Type: PIPING

RG&E Line No.	Gilbert Line No.	SWRI Line No.	ISI Fig.	Matl. Matr.	Size (in.)	Thkns (in.)	Exemption Basis	NDE Method	Po	Temp	In?	Line description/remarks	Revised
30A-MS-600-1A	MS-100	MS-1000	B-8	A115	30.00	1.250		SUR/VOL	715	505	Y	S/G 1A TO VALVE 3517.	
30B-MS-600-1B	MS-200	SMS-1001	B-8	A115	30.00	1.250		SUR/VOL	715	505	Y	S/G 1B TO VALVE 3516.	
6A-MS-600-1A	MS-100	MS-1000	B-9A	A106	6.00	0.432		SUR/VOL	715	505	Y	30" MS PIPE TO VALVE 3505A.	R 11/91
6A-MS-600-1B	MS-300	SMS-1001	B-10	A106	6.00	0.432		SUR/VOL	715	505	Y	30" MS PIPE TO VALVE 3504A.	
6B-MS-600-1A	MS-300	MS-1000	B-9A	A106	6.00	0.432		SUR/VOL	715	505	Y	30" MS PIPE TO VALVE 3411.	R 11/91
6B-MS-600-1B	MS-120	SMS-1001	B-10	A106	6.00	0.432		SUR/VOL	715	505	Y	30" MS PIPE TO VALVE 3410.	
6C-MS-600-1A	MS-300	MS-1000	B-9A	A106	6.00	0.432		SUR/VOL	715	505	Y	30" MS PIPE TO VALVE 3509.	R 11/91
6C-MS-600-1B	MS-300	SMS-1001	B-10	A106	6.00	0.432		SUR/VOL	715	505	Y	30" MS PIPE TO VALVE 3508.	
6D-MS-600-1A	MS-300	MS-1000	B-9A	A106	6.00	0.432		SUR/VOL	715	505	Y	30" MS PIPE TO VALVE 3511.	R 11/91
6D-MS-600-1B	MS-300	SMS-1001	B-10	A106	6.00	0.432		SUR/VOL	715	505	Y	30" MS PIPE TO VALVE 3510.	
6E-MS-600-1A	MS-300	MS-1000	B-9A	A106	6.00	0.432		SUR/VOL	715	505	Y	30" MS PIPE TO VALVE 3513.	R 11/91
6E-MS-600-1B	MS-300	SMS-1001	B-10	A106	6.00	0.432		SUR/VOL	715	505	Y	30" MS PIPE TO VALVE 3512.	
6F-MS-600-1A	MS-300	MS-1000	B-9A	A106	6.00	0.432		SUR/VOL	715	505	Y	30" MS PIPE TO VALVE 3515.	R 11/91
6F-MS-600-1B	MS-300	SMS-1001	B-10	A106	6.00	0.432		SUR/VOL	715	505	Y	30" MS PIPE TO VALVE 3514.	
6G-MS-600-1A	MS-300	MS-1000	B-9A	A106	6.00	0.432		SUR/VOL	715	505	Y	30" MS PIPE TO 6 X 2 REDUCER.	R 11/91
6G-MS-600-1B	MS-300	SMS-1001	B-10	A106	6.00	0.432		SUR/VOL	715	505	Y	30" MS PIPE TO 6 X 2 REDUCER.	R 11/91
3A-MS-600-1A	MS-300	MS-1000	B-9A	A106	3.00	0.300	IWC-1222(A)	SUR/VOL	715	505	Y	30" MS PIPE TO VALVE 3615 (3517 BYPASS).	R 11/91
3A-MS-600-1B	MS-300	SMS-1001	B-10	A106	3.00	0.300	IWC-1222(A)	SUR/VOL	715	505	Y	30" MS PIPE TO VALVE 3614 (3516 BYPASS).	R 11/91
2A-MS-600-1A			B-9A		2.00	0.000	IWC-1222(A)					6G-MS-600-1A TO VALVE 3521.	A 11/91
2A-MS-600-1B			B-10		2.00	0.000	IWC-1222(A)					6G-MS-600-1B TO VALVE 3520.	A 11/91
1.5A-MS-600-1A	MS-300	MS-1000	B-9	A106	1.50	0.145	IWC-1222(A)		715	505	Y	30" MS PIPE TO VALVE 3455.	
1.5A-MS-600-1B	MS-300	SMS-1001	B-10	A106	1.50	0.145	IWC-1222(A)		715	505	Y	6A-MS-600-1B TO VALVE 3504C.	
1.5B-MS-600-1A	MS-300	MS-1000	B-9A	A106	1.50	0.147	IWC-1222(A)		715	505	Y	6A-MS-600-1A TO VALVE 3505C.	R 11/91
1.5B-MS-600-1B			B-8		1.50	0.000	IWC-1222(A)					30" MS PIPE TO VALVE 3500.	R 06/93
1.5C-MS-600-1A			B-8		1.50	0.000	IWC-1222(A)					30" MS PIPE TO VALVE 3503.	R 06/93

QUALITY
ASSURANCE
MANUAL
GINNA STATION

TITLE:
R. E. GINNA NUCLEAR POWER PLANT
INSERVICE INSPECTION PROGRAM
FOR THE 1990-1999 INTERVAL
LINE LIST

Section 5
PAGE 3 of 96
REV. 3

Faint, illegible text scattered across the page, possibly bleed-through from the reverse side. Some faint words like "THE" and "AND" are visible.



R. E. GINNA NUCLEAR POWER PLANT
 Inservice Examination Boundary Line List
 Third Inspection Interval

P&ID No.: 33013-1231
 Class.: 3
 System.: MAIN STEAM
 Comp Type: COMPONENTS

<u>RG&E Line No.</u>	<u>Gilbert Line No.</u>	<u>SWRI Line No.</u>	<u>ISI Fig.</u>	<u>Matl.</u>	<u>Size (in.)</u>	<u>Thkns (in.)</u>	<u>Exemption Basis</u>	<u>NDE Method</u>	<u>Po</u>	<u>Temp</u>	<u>In?</u>	<u>Line description/remarks</u>	<u>Revised</u>
PFW04			N/A		0.00	0.000	NO IWA	VT-3				TURBINE DRIVEN AFW PUMP TURBINE.	A 11/91

QUALITY
 ASSURANCE
 MANUAL
 GINNA STATION

TITLE:
 APPENDIX B
 R.E. GINNA NUCLEAR POWER PLANT
 INSERVICE INSPECTION PROGRAM
 FOR THE 1990-1999 INTERVAL
 LINE LIST

Section 5
 PAGE 4 of 96
 REV. 3

R. E. GINNA NUCLEAR POWER PLANT
Inservice Examination Boundary Line List
Third Inspection Interval

P&ID No.: 33013-1231
Class.: 3
System.: MAIN STEAM
Comp Type: PIPING

RG&E Line No.	Gilbert Line No.	SWRI Line No.	ISI Fig.	Matl.	Size (in.)	Thkns (in.)	Exemption Basis	NDE Method	Po	Temp	In?	Line description/remarks	Revised
30A-MS-600-1			B-9A	A115	30.00	1.250	NO IWA	VT-3	715	505	Y	VALVE 3517 TO REDUCER AT VALVE 3519.	A 06/93
30B-MS-600-1			B-10	A115	30.00	1.250	NO IWA	VT-3	715	505	Y	VALVE 3516 TO REDUCER AT VALVE 3518.	A 06/93
8A-MV-150-1			N/A		8.00	0.000	NO IWA	VT-3				AFW PUMP TURBINE EXH TO ATMOS.	A 11/91
6A-MS-600-1	MS-120		C-32	A106	6.00	0.432		VT-3	1085	508	Y	3505A TO 3505B.	
6B-MS-600-1	MS-120		C-32	A106	6.00	0.432		VT-3	1085	508	Y	3504A TO 3504B.	
6C-MS-600-1	MS-120		C-32	A106	6.00	0.432		VT-3	1085	508	Y	6A & 6B TO 3A.	R 11/91
4A-MV-150-1			N/A		4.00	0.000	IWD-1220.1					AUX FW PUMP TURBINE QUENCH TANK TO 8A.	A 11/91
3A-MS-600-1	MS-120		C-32	A106	3.00	0.216	IWD-1220.1		1085	508	Y	6C TO AUX FW PUMP TURBINE.	R 11/91
3B-MS-600-1			B-9A	A115	3.00	0.216	IWD-1220.1		715	505	Y	VALVE 3615 TO 30A-MS-600-1.	A 06/93
3C-MS-600-1			B-10	A115	3.00	0.216	IWD-1220.1		715	505	Y	VALVE 3614 TO 30B-MS-600-1.	A 06/93
1.5A-MS-600-1	MS-120		C-32	A106	1.50	0.145	IWD-1220.1		1085	508	Y	3505C TO 6A.	R 11/91
1.5B-MS-600-1	MS-120		C-32	A106	1.50	0.145	IWD-1220.1		1085	508	Y	3504C TO 6B.	R 11/91
1.5C-MS-600-1			B-9A	A115	1.50	0.145	IWD-1220.1		715	505	Y	30A-MS-600-1 TO VALVE 8527.	A 06/93
1.5D-MS-600-1			B-10	A115	1.50	0.145	IWD-1220.1		715	505	Y	30B-MS-600-1 TO VALVE 8528.	A 06/93

QUALITY
ASSURANCE
MANUAL
GINNA STATION

TITLE:
APPENDIX B
R. E. GINNA NUCLEAR POWER PLANT
INSERVICE INSPECTION PROGRAM
FOR THE 1990-1999 INTERVAL
LINE LIST

Section 5
PAGE 5 of 96

REV.
3



R. E. GINNA NUCLEAR POWER PLANT
 Inservice Examination Boundary Line List
 Third Inspection Interval

P&ID No.: 33013-1231
 Class.: HE-2
 System.: MAIN STEAM
 Comp Type: HE-PIPING: APP-B

RG&E Line No.	Gilbert Line No.	SWRI Line No.	ISI Fig.	Mtrl.	Size (in.)	Thkns (in.)	Exemption Basis	NDE Method	Po	Temp	In?	Line description/remarks	Revised
30A-MS-600-1A	MS-100	MS-1000	HE-1	A115	30.00	1.250		SUR/VOL	715	505	Y	S/G 1A TO VALVE 3517.	R 06/93
30B-MS-600-1B	MS-200	SMS-1001	HE-2A	A115	30.00	1.250		SUR/VOL	715	505	Y	S/G 1B TO VALVE 3516.	R 06/93
6A-MS-600-1A	MS-100	MS-1000	HE-1A	A106	6.00	0.432		SUR/VOL	715	505	Y	30" MS PIPE TO VALVE 3505A.	R 06/93
6A-MS-600-1B	MS-300	SMS-1001	HE-2	A106	6.00	0.432		SUR/VOL	715	505	Y	30" MS PIPE TO VALVE 3504A.	R 06/93
6B-MS-600-1A	MS-300	MS-1000	HE-1A	A106	6.00	0.432		SUR/VOL	715	505	Y	30" MS PIPE TO VALVE 3411.	R 06/93
6B-MS-600-1B	MS-200	SMS-1001	HE-2	A106	6.00	0.432		SUR/VOL	715	505	Y	30" MS PIPE TO VALVE 3410.	R 06/93
6C-MS-600-1A	MS-300	MS-1000	HE-1A	A106	6.00	0.432		SUR/VOL	715	505	Y	30" MS PIPE TO VALVE 3509.	R 06/93
6C-MS-600-1B	MS-300	SMS-1001	HE-2	A106	6.00	0.432		SUR/VOL	715	505	Y	30" MS PIPE TO VALVE 3508.	R 06/93
6D-MS-600-1A	MS-300	MS-1000	HE-1A	A106	6.00	0.432		SUR/VOL	715	505	Y	30" MS PIPE TO VALVE 3511.	R 06/93
6D-MS-600-1B	MS-300	SMS-1001	HE-2	A106	6.00	0.432		SUR/VOL	715	505	Y	30" MS PIPE TO VALVE 3510.	R 06/93
6E-MS-600-1A	MS-300	MS-1000	HE-1A	A106	6.00	0.432		SUR/VOL	715	505	Y	30" MS PIPE TO VALVE 3513.	R 06/93
6E-MS-600-1B	MS-300	SMS-1001	HE-2	A106	6.00	0.432		SUR/VOL	715	505	Y	30" MS PIPE TO VALVE 3512.	R 06/93
6F-MS-600-1A	MS-300	MS-1000	HE-1A	A106	6.00	0.432		SUR/VOL	715	505	Y	30" MS PIPE TO VALVE 3515.	R 06/93
6F-MS-600-1B	MS-300	SMS-1001	HE-2	A106	6.00	0.432		SUR/VOL	715	505	Y	30" MS PIPE TO VALVE 3514.	R 06/93
6G-MS-600-1A			HE-1A	A106	6.00	0.432		SUR/VOL	715	505	Y	30" MS PIPE TO VALVE 3521.	R 06/93
6G-MS-600-1B	MS-300	SMS-1001	HE-2	A106	6.00	0.432		SUR/VOL	715	505	Y	30" MS PIPE TO VALVE 3520.	R 06/93

QUALITY
 ASSURANCE
 MANUAL
 GINNA STATION

TITLE:
 R. E. GINNA NUCLEAR POWER PLANT
 INSERVICE INSPECTION PROGRAM
 FOR THE 1990-1999 INTERVAL
 APPENDIX B
 LINE LIST

Section 5
 PAGE 6 of 96
 REV. 3

11
12
13
14
15
16
17
18
19
20
21
22
23
24
25
26
27
28
29
30
31
32
33
34
35
36
37
38
39
40
41
42
43
44
45
46
47
48
49
50
51
52
53
54
55
56
57
58
59
60
61
62
63
64
65
66
67
68
69
70
71
72
73
74
75
76
77
78
79
80
81
82
83
84
85
86
87
88
89
90
91
92
93
94
95
96
97
98
99
100



R. E. GINNA NUCLEAR POWER PLANT
 Inservice Examination Boundary Line List
 Third Inspection Interval

P&ID No.: 33013-1231
 Class.: HE-3
 System.: MAIN STEAM
 Comp Type: HE-PIPING: APP-B

<u>RG&E Line No.</u>	<u>Gilbert Line No.</u>	<u>SWRI Line No.</u>	<u>ISI Fig.</u>	<u>Matl.</u>	<u>Size (in.)</u>	<u>Thkns (in.)</u>	<u>Exemption Basis</u>	<u>NDE Method</u>	<u>Ps</u>	<u>Temp</u>	<u>In?</u>	<u>Line description/remarks</u>	<u>Revised</u>
30A-MS-600-1			HE-1A	A115	30.00	1.250	.	SUR/VOL	715	505	Y	VALVE 3517 TO REDUCER AT VALVE 3519.	A 06/93
30B-MS-600-1			HE-2	A115	30.00	1.250		SUR/VOL	715	505	Y	VALVE 3516 TO REDUCER AT VALVE 3518.	A 06/93

QUALITY
 ASSURANCE
 MANUAL
 GINNA STATION

TITLE:
 APPENDIX B
 R. E. GINNA NUCLEAR POWER PLANT
 INSERVICE INSPECTION PROGRAM
 FOR THE 1990-1999 INTERVAL
 LINE LIST

Section 5
 PAGE 7 of 96

REV.
 3



R. E. GINNA NUCLEAR POWER PLANT
 Inservice Examination Boundary Line List
 Third Inspection Interval

P&ID No.: 33013-1232
 Class.: HE-Q
 System.: MAIN STEAM
 Comp Type: HE-PIPING: APP-B

<u>RG&E Line No.</u>	<u>Gilbert Line No.</u>	<u>SWRI Line No.</u>	<u>ISI Fig.</u>	<u>Matl.</u>	<u>Size (in.)</u>	<u>Thkns (in.)</u>	<u>Exemption Basis</u>	<u>NDE Method</u>	<u>Po</u>	<u>Temp</u>	<u>In?</u>	<u>Line description/remarks</u>	<u>Revised</u>
36-MS-600-1		MS -1000	HE-7		36.00	0.000	.	SUR/VOL				30" X 36" REDUCERS TO END CAP.	R 06/93
24A-MS-600-1A		MS -1002	HE-7A		24.00	0.000		SUR/VOL	715	505	Y	36" MS PIPE TO VALVE 3544.	R 11/91
24B-MS-600-1A		MS -1003	HE-7A		24.00	0.000		SUR/VOL	715	505	Y	36" MS PIPE TO VALVE 3545.	R 11/91
12A-MS-600-1A			HE-7		12.00	0.000		SUR/VOL				36" MS PIPE TO VALVE 3532.	A 11/91
12A-MS-600-1B			HE-7		12.00	0.000		SUR/VOL				36" MS PIPE TO VALVE 3533.	A 11/91

QUALITY
 ASSURANCE
 MANUAL
 GINNA STATION

TITLE:
 APPENDIX B
 R.E. GINNA NUCLEAR POWER PLANT
 INSERVICE INSPECTION PROGRAM
 FOR THE 1990-1999 INTERVAL
 LINE LIST

Section 5
 PAGE 8 of 96

REV.
 3

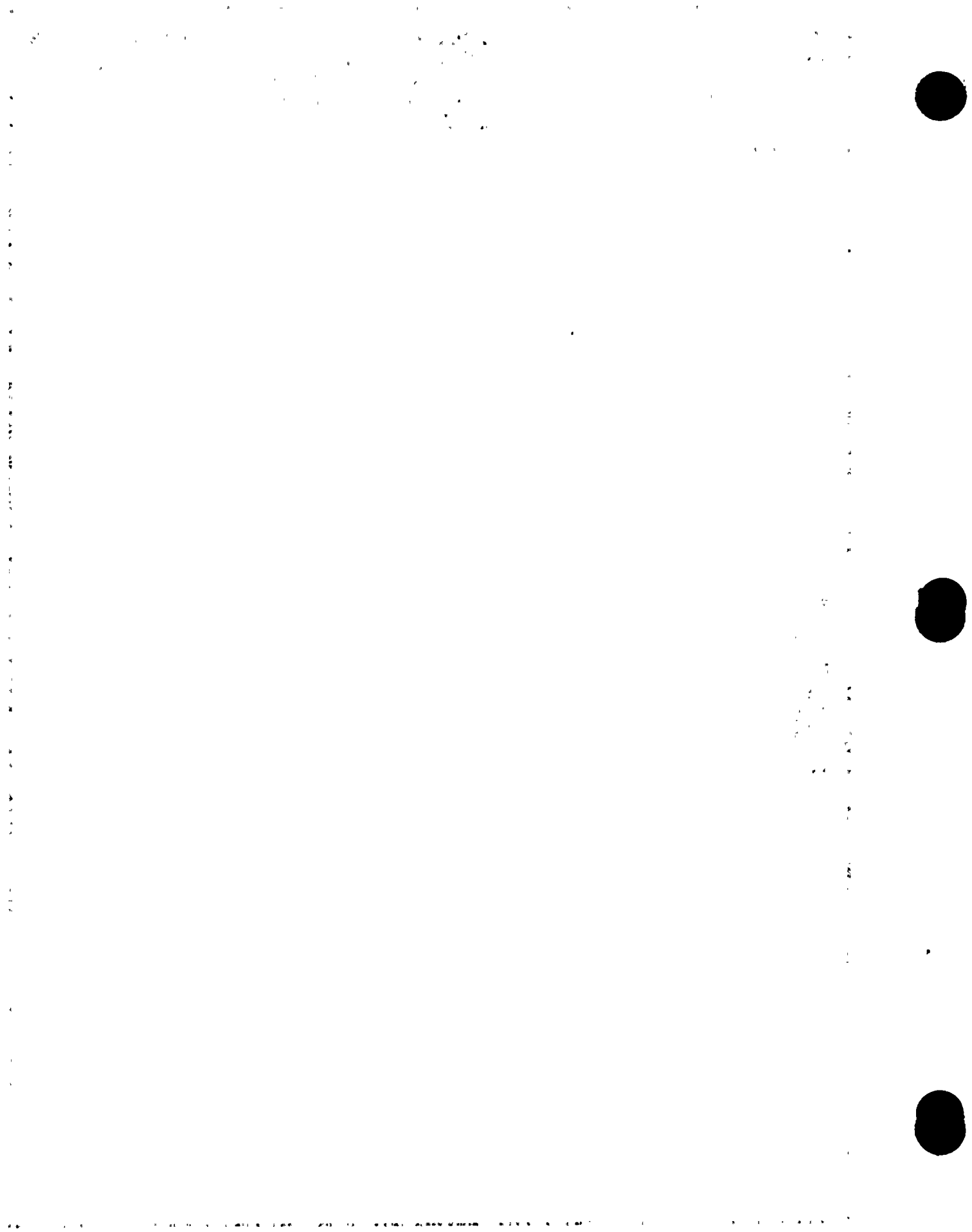

R. E. GINNA NUCLEAR POWER PLANT
 Inservice Examination Boundary Line List
 Third Inspection Interval

P&ID No.: 33013-1236-1
 Class: HE-Q
 System: FEEDWATER
 Comp Type: HE-PIPING: APP-B

<u>RG&E Line No.</u>	<u>Gilbert Line No.</u>	<u>SWRI Line No.</u>	<u>ISI Fig.</u>	<u>Matl.</u>	<u>Size (in.)</u>	<u>Thkns (in.)</u>	<u>Exemption Basis</u>	<u>NDE Method</u>	<u>Ps</u>	<u>Temp</u>	<u>In?</u>	<u>Line description/remarks</u>	<u>Revised</u>
20-FW-900-1		FW-1001	HE-6		20.00	0.000		SUR/VOL	715	505	Y	TEE AT 3984 & 3985 TO TEE AT 3982 & 3983	R 06/93
8-FW-900-1		FW-1081	HE-6		8.00	0.000		SUR/VOL	715	505	Y	20-FW-900-1 TO VALVE 9507D.	R 06/93

QUALITY
 ASSURANCE
 MANUAL
 GINNA STATION

TITLE:
 APPENDIX B
 R. E. GINNA NUCLEAR POWER PLANT
 INSERVICE INSPECTION PROGRAM
 FOR THE 1990-1999 INTERVAL
 LINE LIST

Section 5
 PAGE 9 of 96
 REV. 3



R. E. GINNA NUCLEAR POWER PLANT
 Inservice Examination Boundary Line List
 Third Inspection Interval

P&ID No.: 33013-1236-2
 Class.: 2
 System.: FEEDWATER
 Comp Type: COMPONENTS

<u>RG&E Line No.</u>	<u>Gilbert Line No.</u>	<u>SWRI Line No.</u>	<u>ISI Fig.</u>	<u>Matl.</u>	<u>Size (in.)</u>	<u>Thkns (in.)</u>	<u>Exemption Basis</u>	<u>NDE Method</u>	<u>Ps</u>	<u>Temp</u>	<u>In?</u>	<u>Line description/remarks</u>	<u>Revised</u>
EMS 01A			B-1		0.00	0.000		SUR/VOL	715	505		THIS COMP ACCOUNTED FOR ON 33013-1231.	R 06/93
EMS 01B			B-1		0.00	0.000		SUR/VOL	715	505		THIS COMP ACCOUNTED FOR ON 33013-1231.	R 06/93

QUALITY
 ASSURANCE
 MANUAL
 GINNA STATION

TITLE:
 APPENDIX B
 R. E. GINNA NUCLEAR POWER PLANT
 INSERVICE INSPECTION PROGRAM
 FOR THE 1990-1999 INTERVAL
 LINE LIST

Section 5	REV. 3
PAGE 10 of 96	

Faint, illegible text scattered across the page, possibly bleed-through from the reverse side. Some faint words like "THE" and "AND" are visible.



R. E. GINNA NUCLEAR POWER PLANT
 Inservice Examination Boundary Line List
 Third Inspection Interval

P&ID No.: 33013-1236-2
 Class.: 2
 System.: FEEDWATER
 Comp Type: PIPING

RG&E Line No.	Gilbert Line No.	SWRI Line No.	ISI Fig.	Matl.	Size (in.)	Thkns (in.)	Exemption Basis	NDE Method	Po	Temp	In?	Line description/remarks	Revised
18A-FW-900-1A			B-12		18.00	0.000		SUR/VOL				S/G-A TO 18 X 14 REDUCER.	R 06/93
18B-FW-900-1B			B-13		18.00	0.000		SUR/VOL				S/G-B TO 18 X 14 REDUCER.	R 06/93
14A-FW-900-1A	FW-100	FW-1001	B-11	A106	14.00	0.938		SUR/VOL	715	505	Y	18 X 14 REDUCER TO VALVE 3993.	R 06/93
14B-FW-900-1B	FW-200	FW-1005	B-13	A106	14.00	0.938		SUR/VOL	715	505	Y	18 X 14 REDUCER TO VALVE 3992.	R 06/93

QUALITY
 ASSURANCE
 MANUAL
 GINNA STATION

TITLE:
 APPENDIX B
 R. E. GINNA NUCLEAR POWER PLANT
 INSERVICE INSPECTION PROGRAM
 FOR THE 1990-1999 INTERVAL
 LINE LIST

Section 5	REV. 3
PAGE 11 of 96	



R. E. GINNA NUCLEAR POWER PLANT
 Inservice Examination Boundary Line List
 Third Inspection Interval

P&ID No.: 33013-1236-2
 Class: HE-2
 System: FEEDWATER
 Comp Type: HE-PIPING: APP-B

<u>RG&E Line No.</u>	<u>Gilbert Line No.</u>	<u>SWRI Line No.</u>	<u>ISI Fig.</u>	<u>Mtrl.</u>	<u>Size (in.)</u>	<u>Thkns (in.)</u>	<u>Exemption Basis</u>	<u>NDE Method</u>	<u>Ps</u>	<u>Temp</u>	<u>In?</u>	<u>Line description/remarks</u>	<u>Revised</u>
14A-FW-900-1A	FW-100	FW-1001	HE-3	A106	14.00	0.938	.	SUR/VOL	715	505	Y	18 X 14 REDUCER TO VALVE 3993.	R 06/93
14B-FW-900-1B	FW-200	FW-1005	HE-4	A106	14.00	0.938		SUR/VOL	715	505	Y	18 X 14 REDUCER TO VALVE 3992.	R 06/93

QUALITY
 ASSURANCE
 MANUAL
 GINNA STATION

TITLE:
 R. E. GINNA NUCLEAR POWER PLANT
 INSERVICE INSPECTION PROGRAM
 FOR THE 1990-1999 INTERVAL
 LINE LIST

Section 5
 REV. 3

PAGE 12 of 96

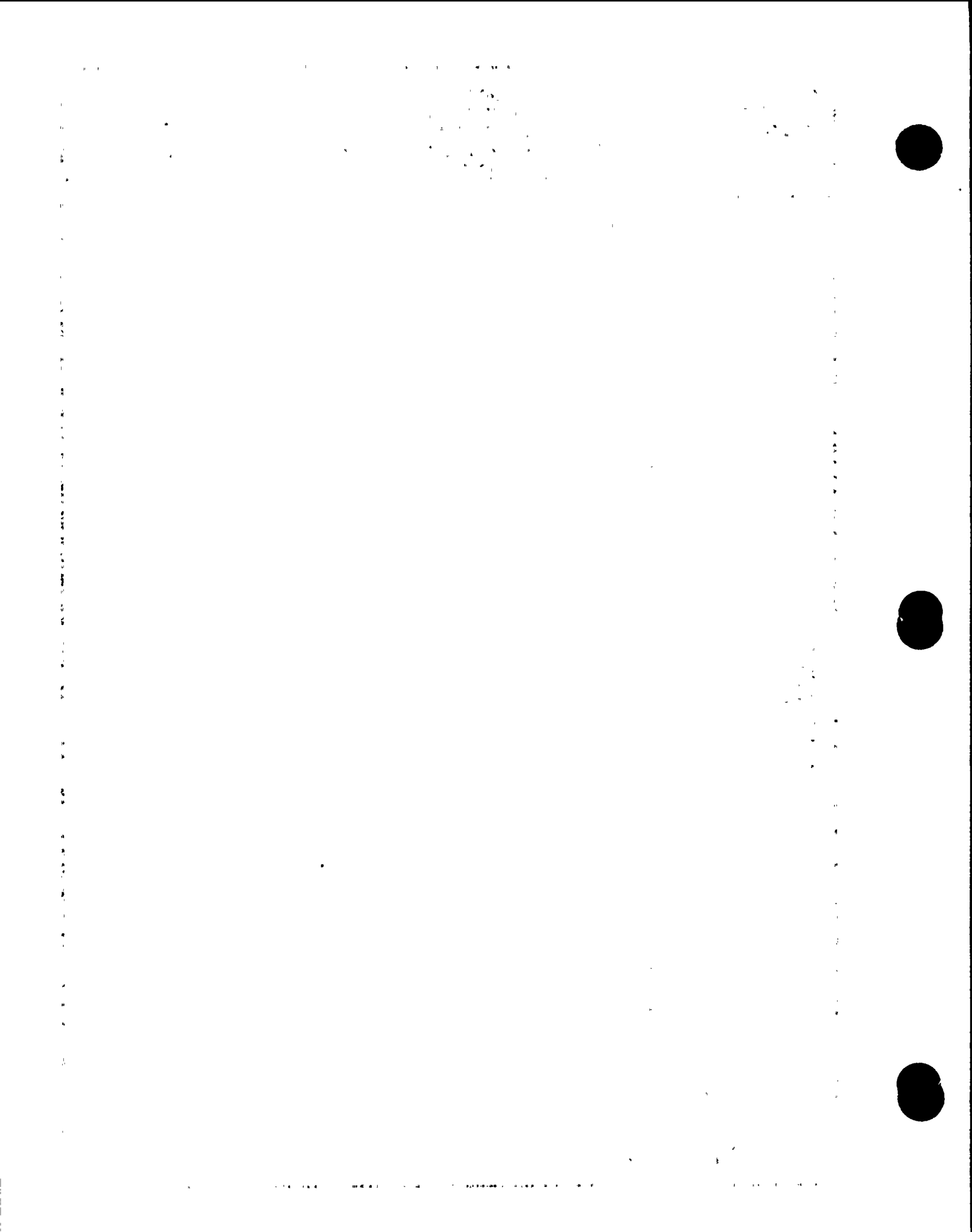

R. E. GINNA NUCLEAR POWER PLANT
 Inservice Examination Boundary Line List
 Third Inspection Interval

P&ID No.: 33013-1236-2
 Class: HE-Q
 System: FEEDWATER
 Comp Type: HE-PIPING: APP-B

<u>RG&E Line No.</u>	<u>Gilbert Line No.</u>	<u>SWRI Line No.</u>	<u>ISI Fig.</u>	<u>Mtrl.</u>	<u>Size (in.)</u>	<u>Thkns (in.)</u>	<u>Exemption Basis</u>	<u>NDE Method</u>	<u>Po</u>	<u>Temp</u>	<u>In?</u>	<u>Line description/remarks</u>	<u>Revised</u>
14A-FW-900-1			HE-3	A106	14.00	0.938		SUR/VOL	715	505	Y	VALVE 3993 TO 20-FW-900-1.	A 06/93
14B-FW-900-1			HE-4	A106	14.00	0.938		SUR/VOL	715	505	Y	VALVE 3992 TO 20-FW-900-1.	A 06/93

QUALITY
 ASSURANCE
 MANUAL
 GINNA STATION

TITLE:
 APPENDIX B
 R. E. GINNA NUCLEAR POWER PLANT
 INSERVICE INSPECTION PROGRAM
 FOR THE 1990-1999 INTERVAL
 LINE LIST

Section 5	REV. 3
PAGE 13 of 96	



R. E. GINNA NUCLEAR POWER PLANT
Inservice Examination Boundary Line List
Third Inspection Interval

P&ID No.: 33013-1237
Class.: 2
System.: AUXILIARY FEEDWATER
Comp Type: PIPING

<u>RG&E Line No.</u>	<u>Gilbert Line No.</u>	<u>SWRI Line No.</u>	<u>ISI Fig.</u>	<u>Matl.</u>	<u>Size (in.)</u>	<u>Thkns (in.)</u>	<u>Exemption Basis</u>	<u>NDE Method</u>	<u>Po.</u>	<u>Temp</u>	<u>In?</u>	<u>Line description/remarks</u>	<u>Revised</u>
3A-FW-900-1A	AFW-500	FW-1001	C-1A	A106	3.00	0.300	IWC-1222(A)		715	505	Y	4000C TO 4011, 14A-FW-900-1A.	R 06/93
3A-FW-900-1B	AFW-400	FW-1005	C-1C	A106	3.00	0.300	IWC-1222(A)		715	505	Y	4000D TO 4012, 14B-FW-900-1B.	R 06/93
3B-FW-900-1A	AFW-500	FW-1001	C-1A	A106	3.00	0.300	IWC-1222(A)		715	505	Y	4003 TO 4005, 14A-FW-900-1A.	R 06/93
3B-FW-900-1B	AFW-400	FW-1005	C-1B	A106	3.00	0.300	IWC-1222(A)		715	505	Y	4004 TO 4006, 14B-FW-900-1B.	R 06/93

QUALITY
ASSURANCE
MANUAL
GINNA STATION

TITLE:
APPENDIX B
R. E. GINNA NUCLEAR POWER PLANT
INSERVICE INSPECTION PROGRAM
FOR THE 1990-1999 INTERVAL
LINE LIST

Section 5	REV. 3
PAGE 14 of 96	

Faint, illegible text covering the majority of the page, possibly bleed-through from the reverse side.

Vertical text on the right side of the page, possibly a date or reference number.



R. E. GINNA NUCLEAR POWER PLANT
 Inservice Examination Boundary Line List
 Third Inspection Interval

P&ID No.: 33013-1237
 Class.: 3
 System.: AUXILIARY FEEDWATER
 Comp Type: COMPONENTS

<u>RG&E Line No.</u>	<u>Gilbert Line No.</u>	<u>SWRI Line No.</u>	<u>ISI Fig.</u>	<u>Matl.</u>	<u>Size (in.)</u>	<u>Thkns (in.)</u>	<u>Exemption Basis</u>	<u>NDE Method</u>	<u>Po</u>	<u>Temp</u>	<u>In?</u>	<u>Line description/remarks</u>	<u>Revised</u>
EAF01			N/A		0.00	0.000	IWD-1220.1		75	80		TURBIN DRIVEN AFW PUMP LUBE OIL COOLER.	A 11/91
EAF02A			N/A		0.00	0.000	IWD-1220.1		75	80		AFW PUMP A LUBE OIL COOLER.	A 11/91
EAF02B			N/A		0.00	0.000	IWD-1220.1		75	80		AFW PUMP B LUBE OIL COOLER.	A 11/91
PAF01A			N/A		0.00	0.000	NO IWA	VT-3	1250	100		AUXILIARY FEEDWATER PUMP A.	A 11/91
PAF01B			N/A		0.00	0.000	NO IWA	VT-3	1250	100		AUXILIARY FEEDWATER PUMP B.	A 11/91
PAF03			N/A		0.00	0.000	NO IWA	VT-3	1250	100		TURBIN DRIVEN AFW PUMP.	A 11/91

QUALITY
 ASSURANCE
 MANUAL
 GINNA STATION

TITLE:
 APPENDIX B
 R. E. GINNA NUCLEAR POWER PLANT
 INSERVICE INSPECTION PROGRAM
 FOR THE 1990-1999 INTERVAL
 LINE LIST

Section 5
 REV. 3

PAGE
 15 of 96

1950-1951

THE UNIVERSITY OF CHICAGO
DEPARTMENT OF CHEMISTRY
RESEARCH REPORT NO. 100
BY
J. H. GOLDSTEIN AND
R. A. FESSenden
PUBLISHED BY THE UNIVERSITY OF CHICAGO PRESS
CHICAGO, ILLINOIS, U.S.A.
1951



R. E. GINNA NUCLEAR POWER PLANT
Inservice Examination Boundary Line List
Third Inspection Interval

P&ID No.: 33013-1237
Class.: 3
System.: AUXILIARY FEEDWATER
Comp Type: PIPING

RG&E Line No.	Gilbert Line No.	SWRI Line No.	ISI Fig.	Matl.	Size (in.)	Thkns (in.)	Exemption Basis	NDE Method	Po	Temp	In?	Line description/remarks	Revised
5A-FW7-900-1	AFW-200		C-1	A106	5.00	0.375		VT-3	1250	100	?	3I-FW7-900-1 TO VALVE 3998, 3F-FW7-900-1	R 11/91
5B-FW7-900-1	AFW-200		C-1A	A106	5.00	0.375	NO SUPPORTS	VT-3	1250	100	?	3F-FW7-900-1 TO RDCR BEFORE 4003.	R 11/91
5C-FW7-900-1	AFW-400,200		C-1B	A106	5.00	0.375	NO SUPPORTS	VT-3	1250	100	?	3H-FW7-900-1 TO 3J-FW7-900-1.	R 11/91
4A-CD-150-1A	SW-1520		C-33	A53	4.00	0.237	NO SUPPORTS	VT-3	12	80	?	VALVE 4017 TO 4345.	R 06/93
4A-CD-150-1B	SW-1520		C-33	A53	4.00	0.237	NO SUPPORTS	VT-3	12	80	?	VALVE 4016 TO 4344.	R 06/93
4A-CD-150-1C	SW-1520		C-16	A53	4.00	0.237		VT-3	12	80	?	4014 TO 4098, TURB AUX FW PUMP SUCTION.	R 11/91
4A-SW-125-1			C-33	A53	4.00	0.237	NO SUPPORTS	VT-3	75	80	?	20I-SW0-125-1, 4640 TO & INCL TEE.	R 11/91
4A-SW-125-1A			C-33		4.00	0.237		VT-3			?	4A-SW-125-1 TO VALVES 4027, 4345.	R 11/91
4A-SW-125-1B			C-33		4.00	0.237		VT-3			?	4A-SW-125-1 TO VALVES 4028, 4344.	R 11/91
4A-SW-125-1C			C-16		4.00	0.237		VT-3			?	16A-SW0-125-1, 4623 TO 4098.	A 11/91
3A-CD-150-1A			C-33	A53	3.00	0.000	NO SUPPORTS	VT-3	12	80	?	4A-CD-150-1A TO AFW PUMP A SUCTION.	A 06/93
3A-CD-150-1B			C-33	A53	3.00	0.000	NO SUPPORTS	VT-3	12	80	?	4A-CD-150-1B TO AFW PUMP B SUCTION.	A 06/93
3A-FW7-900-1A	AFW-100,500		C-1A	A106	3.00	0.300		VT-3	1250	100	?	2D-FW7-900-1A TO VALVE 4000C.	R 11/91
3A-FW7-900-1B	AFW-100,400		C-1F	A106	3.00	0.300		VT-3	1250	100	?	2D-FW7-900-1B TO VALVE 4000D.	R 11/91
3B-FW7-900-1			C-1D	A106	3.00	0.300	NO SUPPORTS	VT-3	1250	100	?	3A-FW7-900-1A TO 4357.	A 11/91
3C-FW7-900-1	AFW-100		C-1E	A106	3.00	0.300	NO SUPPORTS	VT-3	1250	100	?	3A-FW7-900-1B TO 4356.	R 11/91
3D-FW7-900-1			C-1E		3.00	0.438		VT-3	1250	100	?	BYPASS FROM 4357 TO 4356 THRU 4000A.	A 11/91
3E-FW7-900-1	AFW-100		C-1D	A106	3.00	0.438		VT-3	1250	100	?	3K-FW7-900-1 TO 4360, 4359, 5A-FW7-900-1.	R 11/91
3F-FW7-900-1	AFW-200		C-1	A106	3.00	0.300		VT-3	1250	100	?	5A-FW7-900-1 TO 4001, 5B-FW7-900-1.	R 11/91
3G-FW7-900-1	AFW-200,500		C-1A	A106	3.00	0.300		VT-3	1250	100	?	5B-FW7-900-1 TO 4003.	R 11/91
3H-FW7-900-1	AFW-200		C-1	A106	3.00	0.300		VT-3	1250	100	?	5A-FW7-900-1 TO 4000, 4002, 5C-FW7-900-1.	R 11/91
3I-FW7-900-1			C-1		3.00	0.300	NO SUPPORTS	VT-3			?	TURB AFW PUMP DISCHG TO 5A-FW7-900-1.	A 11/91
3J-FW7-900-1	AFW-200		C-1B	A106	3.00	0.438		VT-3	1250	100	?	5C-FW7-900-1 TO 4004.	R 11/91
3K-FW7-900-1	AFW-100		C-1E		3.00	0.438		VT-3	1250	100	?	BYPASS FROM 4357 TO 4356 THRU 4000B.	R 11/91
2A-FW7-900-1A	AFW-100		C-1G	A106	2.00	0.145		VT-3	1250	100	?	3A-FW7-900-1A TO 1A-FW7-900-1A.	R 11/91
2A-FW7-900-1B	AFW-100		C-1H	A106	2.00	0.154		VT-3	1250	100	?	3A-FW7-900-1B TO 4310.	R 11/91
2B-FW7-900-1A	AFW-100		C-1G	A106	2.00	0.145		VT-3	1250	100	?	2A-FW7-900-1A TO 4482, 1.5A-FW7-900-1A.	R 11/91
2B-FW7-900-1B			C-1H		2.00	0.145		VT-3	1250	100	?	2A-FW7-900-1B TO 4484, 1.5A-FW7-900-1B.	R 11/91
2C-FW7-900-1A			C-1G		2.00	0.145		VT-3			?	1.5A-FW7-900-1A TO 4483, 3A-FW7-900-1A.	A 11/91
2C-FW7-900-1B			C-1H		2.00	0.145		VT-3			?	1.5A-FW7-900-1B TO 4485, 3A-FW7-900-1B.	A 11/91
2D-FW7-900-1A			C-1A		2.00	0.145	NO SUPPORTS	VT-3	1250	100	?	AFW PUMP A DISCHG TO 3A-FW7-900-1A.	A 11/91
2D-FW7-900-1B			C-1F		2.00	0.145	NO SUPPORTS	VT-3	1250	100	?	AFW PUMP B DISCHG TO 3A-FW7-900-1B.	A 11/91
1.5A-FW7-900-1			C-1		1.50	0.145	NO IWA	VT-3			?	5A-FW7-900-1 TO 4023, 4291, LFW30.	A 11/91
1.5A-FW7-900-1A			C-1G		1.50	0.145	NO SUPPORTS	VT-3			?	2B-FW7-900-1A TO 4480, 2C-FW7-900-1A.	A 11/91
1.5A-FW7-900-1B			C-1H		1.50	0.145	NO SUPPORTS	VT-3			?	2B-FW7-900-1B TO 4481, 2C-FW7-900-1B.	A 11/91

QUALITY
ASSURANCE
MANUAL
GINNA STATION

TITLE:
R. E. GINNA NUCLEAR POWER PLANT
INSERVICE INSPECTION PROGRAM
FOR THE 1990-1999 INTERVAL
LINE LIST

Section 5
REV. 3
PAGE 16 of 96

R. E. GINNA NUCLEAR POWER PLANT
 Inservice Examination Boundary Line List
 Third Inspection Interval

P&ID No.: 33013-1238
 Class.: 2
 System.: STANDBY AUXILIARY FEEDWATER
 Comp Type: PIPING

<u>RG&E Line No.</u>	<u>Gilbert Line No.</u>	<u>SWRI Line No.</u>	<u>ISI Fig.</u>	<u>Mtrl.</u>	<u>Size (in.)</u>	<u>Thkns (in.)</u>	<u>Exemption Basis</u>	<u>NDE Method</u>	<u>Ps</u>	<u>Temp</u>	<u>In?</u>	<u>Line description/remarks</u>	<u>Revised</u>
3C-FW-902S-1A	AFW-500	FW-1001	C-20	A106	3.00	0.300	IWC-1222(A)		715	505	Y	14A-FW-900-1A TO 9706A, 9704A.	R 06/93
3C-FW-902S-1B	AFW-400	FW-1005	C-24	A106	3.00	0.300	IWC-1222(A)		715	505	Y	14B-FW-900-1B TO 9706B, 9704A.	R 06/93

QUALITY
 ASSURANCE
 MANUAL
 GINNA STATION

TITLE:
 APPENDIX B
 R. E. GINNA NUCLEAR POWER PLANT
 INSERVICE INSPECTION PROGRAM
 FOR THE 1990-1999 INTERVAL
 LINE LIST

Section 5	REV. 3
PAGE 17 of 96	



R. E. GINNA NUCLEAR POWER PLANT
 Inservice Examination Boundary Line List
 Third Inspection Interval

P&ID No.: 33013-1238
 Class.: 3
 System.: STANDBY AUXILIARY FEEDWATER
 Comp Type: COMPONENTS

<u>RG&E Line No.</u>	<u>Gilbert Line No.</u>	<u>SWRI Line No.</u>	<u>ISI Fig.</u>	<u>Matl.</u>	<u>Size (in.)</u>	<u>Thkns (in.)</u>	<u>Exemption Basis</u>	<u>NDE Method</u>	<u>Po</u>	<u>Temp</u>	<u>In?</u>	<u>Line description/remarks</u>	<u>Revised</u>
PSF01A			N/A		0.00	0.000	NO IWA-	VT-3				STANDBY AFW PUMP C.	A 11/91
PSF01B			N/A		0.00	0.000	NO IWA	VT-3				STANDBY AFW PUMP D.	A 11/91

QUALITY
 ASSURANCE
 MANUAL
 GINNA STATION

TITLE:
 APPENDIX B
 R. E. GINNA NUCLEAR POWER PLANT
 INSERVICE INSPECTION PROGRAM
 FOR THE 1990-1999 INTERVAL
 LINE LIST

Section 5	REV. 3
PAGE 18 of 96	

[Faint, illegible text covering the majority of the page, possibly bleed-through from the reverse side.]

1954
1955
1956
1957
1958
1959
1960
1961
1962
1963
1964
1965
1966
1967
1968
1969
1970
1971
1972
1973
1974
1975
1976
1977
1978
1979
1980
1981
1982
1983
1984
1985
1986
1987
1988
1989
1990
1991
1992
1993
1994
1995
1996
1997
1998
1999
2000
2001
2002
2003
2004
2005
2006
2007
2008
2009
2010
2011
2012
2013
2014
2015
2016
2017
2018
2019
2020
2021
2022
2023
2024
2025



R. E. GINNA NUCLEAR POWER PLANT
 Inservice Examination Boundary Line List
 Third Inspection Interval

P&ID No.: 33013-1238
 Class.: 3
 System.: STANDBY AUXILIARY FEEDWATER
 Comp Type: PIPING

<u>RG&E Line No.</u>	<u>Gilbert Line No.</u>	<u>SWRI Line No.</u>	<u>ISI Fig.</u>	<u>Matl</u>	<u>Size (in.)</u>	<u>Thkns (in.)</u>	<u>Exemption Basis</u>	<u>NDE Method</u>	<u>Po</u>	<u>Temp</u>	<u>In?</u>	<u>Line description/remarks</u>	<u>Revised</u>
4A-CD-152S			C-28A	A106	4.00	0.300	NO SUPPORTS	VT-3			?	9707A TO 4A-FW8-152S-A.	R 06/93
4A-FW8-152S-A			C-28	A106	4.00	0.300		VT-3			?	9629A TO STBY AUX FW PUMP C SUCTION.	R 11/91
4A-FW8-152S-B			C-28	A106	4.00	0.300		VT-3			?	9629B TO STBY AUX FW PUMP D SUCTION.	R 11/91
4B-CD-152S			C-28A	A106	4.00	0.300	NO SUPPORTS	VT-3			?	9707B TO 4A-FW8-152S-B.	R 06/93
3A-FW8-902S-A			C-22	A106	3.00	0.300		VT-3			?	STBY AUX FW PUMP C DISCHARGE TO 9704A.	R 11/91
3A-FW8-902S-B			C-22	A106	3.00	0.300		VT-3			?	STBY AUX FW PUMP D DISCHARGE TO 9704B.	R 11/91
3C-FW8-902S			C-23	A106	3.00	0.300		VT-3			?	3A-FW8-902S-A TO 3A-FW8-902S-B.	R 11/91
1.5A-FW8-902S			C-22	A106	1.50	0.200		VT-3			?	3A-FW8-902S-A TO LFW08.	R 11/91
1.5B-FW8-902S			C-22A	A106	1.50	0.200		VT-3			?	3A-FW8-902S-B TO LFW07.	R 11/91

QUALITY
 ASSURANCE
 MANUAL
 GINNA STATION

TITLE:
 APPENDIX B
 R. E. GINNA NUCLEAR POWER PLANT
 INSERVICE INSPECTION PROGRAM
 FOR THE 1990-1999 INTERVAL
 LINE LIST

Section 5
 PAGE 19 of 96

REV.
 3

[Faint, illegible text covering the majority of the page]

1950
1951
1952

[Vertical text along the right edge of the page]



R. E. GINNA NUCLEAR POWER PLANT
 Inservice Examination Boundary Line List
 Third Inspection Interval

P&ID No.: 33013-1239-1
 Class.: 3
 System.: DIESEL GENERATORS
 Comp Type: COMPONENTS

RG&E Line No.	Gilbert Line No.	SWRI Line No.	ISI Fig.	Matl.	Size (in.)	Thkns (in.)	Exemption Basis	NDE Method	Po	Temp	In?	Line description/remarks	Revised
ESW08A			C-37		0.00	0.000		VT-3				DIESEL GEN A JACKET WATER HEAT EXCHGR.	R 06/93
ESW09A			N/A		0.00	0.000	IWD-1220.1					DIESEL GEN A LUBE OIL COOLER.	R 06/93
FDG01			N/A		0.00	0.000	IWD-1220.1					DIESEL GEN A PRIMARY FILTER.	R 06/93
FDG02			N/A		0.00	0.000	IWD-1220.1					DIESEL GEN A PRIMARY FILTER.	R 06/93
FDG03			N/A		0.00	0.000	IWD-1220.1					DIESEL GEN A SECONDARY FILTER.	R 06/93
FDG04			N/A		0.00	0.000	IWD-1220.1					DIESEL GEN A SECONDARY FILTER.	R 06/93
FDG05			N/A		0.00	0.000	IWD-1220.1					DIESEL GEN A LUBE OIL FILTER.	R 06/93
FDG06			N/A		0.00	0.000	IWD-1220.1					DIESEL GEN A INTAKE FILTER.	R 06/93
FDG07			N/A		0.00	0.000	IWD-1220.1					DIESEL GEN A INTAKE FILTER.	R 06/93
KDG01A			N/A		0.00	0.000	NO IWA	VT-3				DIESEL GENERATOR A.	R 06/93
PDG01A			N/A		0.00	0.000	NO IWA	VT-3				DIESEL GEN A JACKET WATER PUMP.	R 06/93
PDG02A			N/A		0.00	0.000	IWD-1220.1					DIESEL GEN A FUEL OIL TRANSFER PUMP.	R 06/93
PDG04A			N/A		0.00	0.000	IWD-1220.1					DIESEL GEN A FUEL OIL PRIMING PUMP.	R 06/93
PDG05A			N/A		0.00	0.000	IWD-1220.1					DIESEL GEN A FUEL OIL BOOSTER PUMP.	R 06/93
PDG06A			N/A		0.00	0.000	IWD-1220.1					DIESEL GEN A LUBE OIL PUMP.	R 06/93
PDG07A			N/A		0.00	0.000	IWD-1220.1					DIESEL GEN A PRE-LUBE OIL PUMP.	R 06/93
PDG08			N/A		0.00	0.000	IWD-1220.1					DIESEL GEN A AIR STARTING MOTOR.	R 06/93
SDG01A			N/A		0.00	0.000	NO IWA	VT-3				DIESEL GEN A EXHAUST MUFFLER.	R 06/93
TDG01A			N/A		0.00	0.000	IWD-1220.1					DIESEL GEN A FUEL OIL STORAGE TANK.	R 06/93
TDG02A			N/A		0.00	0.000	IWD-1220.1					DIESEL GEN A COOLING WATER EXPANSION TK.	R 06/93
TDG03A			N/A		0.00	0.000	IWD-1220.1					DIESEL GEN A STARTING AIR RECEIVER A1.	R 06/93
TDG03B			N/A		0.00	0.000	IWD-1220.1					DIESEL GEN A STARTING AIR RECEIVER A2.	R 06/93
TDG04A			N/A		0.00	0.000	IWD-1220.1					DIESEL GEN A FUEL OIL DAY TANK.	R 06/93

QUALITY
 ASSURANCE
 MANUAL
 GINNA STATION

TITLE:
 R. E. GINNA NUCLEAR POWER PLANT
 INSERVICE INSPECTION PROGRAM
 FOR THE 1990-1999 INTERVAL
 LINE LIST

Section 5
 REV. 3

PAGE
 20 of 96

THE UNIVERSITY OF CHICAGO LIBRARY

THE UNIVERSITY OF CHICAGO LIBRARY
1215 EAST 58TH STREET
CHICAGO, ILLINOIS 60637
TEL: 773-936-3200
WWW.CHICAGO.LIBRARY.EDU



R. E. GINNA NUCLEAR POWER PLANT
Inservice Examination Boundary Line List
Third Inspection Interval

P&ID No.: 33013-1239-1
Class.: 3
System.: DIESEL GENERATORS
Comp Type: PIPING

<u>RG&E Line No.</u>	<u>Gilbert Line No.</u>	<u>SWRI Line No.</u>	<u>ISI Fig.</u>	<u>Matrl.</u>	<u>Size (in.)</u>	<u>Thkns (in.)</u>	<u>Exemption Basis</u>	<u>NDE Method</u>	<u>Po</u>	<u>Temp</u>	<u>In?</u>	<u>Line description/remarks</u>	<u>Revised</u>
20A-DG-150-4A			N/A	A53	20.00	0.250	NO SUPPORTS	VT-3			?	AIR INTAKE DG 1A.	R 06/93
20B-DG-150-4A			C-39	A53	20.00	0.250		VT-3			?	AIR EXHAUST DG 1A.	R 06/93
5A-DG-A			C-35		5.00	0.000	NO SUPPORTS	VT-3			?	JW-HX-A TO JW PUMP A SUCT.	R 06/93
5B-DG-A			C-35		5.00	0.000	NO SUPPORTS	VT-3			?	JW PUMP A DISCHG TO DG-A.	R 06/93
5C-DG-A			C-35		5.00	0.000		VT-3			?	DG-A RETURN LINE TO JW-HX-A.	R 06/93
3A-FO-150-6A			N/A	A53	3.00	0.216	IWD-1220.1				?	DIESEL OIL STORAGE TANK TO 5955, 2" RED.	R 06/93
3B-FO-150-6A			N/A	A53	3.00	0.216	IWD-1220.1				?	2D TO OIL TRANSFER PUMP.	R 06/93
2A-FO-150-6A			N/A	A53	2.00	0.145	IWD-1220.1				?	1.5A TO DIESEL OIL STORAGE TANK A.	R 06/93
2A-SA-150-4A			N/A	A53	2.00	0.145	IWD-1220.1				?	AIR RECEIVERS A1 & A2 TO 5905A & B, 5975	R 06/93
2B-FO-150-6A			N/A	A53	2.00	0.145	IWD-1220.1				?	OIL TRANSFER PUMP TO 5965 & 5976.	R 06/93
2C-FO-150-6A			N/A	A53	2.00	0.145	IWD-1220.1				?	1.5A TO 5967 & 5959.	R 06/93
2D-FO-150-6A			N/A	A53	2.00	0.145	IWD-1220.1				?	3A TO 3B.	R 06/93
1.5A-FO-150-6A			N/A	A53	1.50	0.133	IWD-1220.1				?	DAY TANK A TO 5960A, 2A.	R 06/93
1.5A-SA-150-4A			N/A	A53	1.50	0.133	IWD-1220.1				?	2A TO DG-A AIR STARTING MOTOR.	R 06/93
1.5A-SW-125-1A			N/A	A53	1.50	0.133	IWD-1220.1				?	5900A TO COOLING WATER EXPANSION TANK.	R 06/93
1.5B-FO-150-6A			N/A	A53	1.50	0.133	IWD-1220.1				?	1.25A TO 1A.	R 06/93
1.5C-FO-150-6A			N/A	A53	1.50	0.133	IWD-1220.1				?	5913 TO 5909 & 3A.	R 06/93
1.5D-FO-150-6A			N/A		1.50	0.133	IWD-1220.1				?	5965 TO 1A.	R 06/93
1.25A-FO-150-6A			N/A		1.25	0.133	IWD-1220.1				?	1.5B TO DAY TANK A.	R 06/93

QUALITY
ASSURANCE
MANUAL
GINNA STATION

TITLE:
APPENDIX B
R. E. GINNA NUCLEAR POWER PLANT
INSERVICE INSPECTION PROGRAM
FOR THE 1990-1999 INTERVAL
LINE LIST

Section 5
PAGE 21 of 96

REV.
3

1 2 3 4 5 6 7 8 9 10 11 12 13 14 15 16 17 18 19 20 21 22 23 24 25 26 27 28 29 30 31 32 33 34 35 36 37 38 39 40 41 42 43 44 45 46 47 48 49 50 51 52 53 54 55 56 57 58 59 60 61 62 63 64 65 66 67 68 69 70 71 72 73 74 75 76 77 78 79 80 81 82 83 84 85 86 87 88 89 90 91 92 93 94 95 96 97 98 99 100



R. E. GINNA NUCLEAR POWER PLANT
 Inservice Examination Boundary Line List
 Third Inspection Interval

P&ID No.: 33013-1239-2
 Class.: 3
 System.: DIESEL GENERATORS
 Comp Type: COMPONENTS

RG&E Line No.	Gilbert Line No.	SWRI Line No.	ISI Fig.	Matl	Size (in.)	Thkns (in.)	Exemption Basis	NDE Method	Po	Temp	In?	Line description/remarks	Revised
ESW08B			C-38		0.00	0.000		VT-3				DIESEL GEN B JACKET WATER HEAT EXCHGR.	R 06/93
ESW09B			N/A		0.00	0.000	IWD-1220.1					DIESEL GEN B LUBE OIL COOLER.	R 06/93
FDG08			N/A		0.00	0.000	IWD-1220.1					DIESEL GEN B PRIMARY FILTER.	R 06/93
FDG09			N/A		0.00	0.000	IWD-1220.1					DIESEL GEN B PRIMARY FILTER.	R 06/93
FDG10			N/A		0.00	0.000	IWD-1220.1					DIESEL GEN B SECONDARY FILTER.	R 06/93
FDG11			N/A		0.00	0.000	IWD-1220.1					DIESEL GEN B SECONDARY FILTER.	R 06/93
FDG12			N/A		0.00	0.000	IWD-1220.1					DIESEL GEN B LUBE OIL FILTER.	R 06/93
FDG13			N/A		0.00	0.000	IWD-1220.1					DIESEL GEN B INTAKE FILTER.	R 06/93
FDG14			N/A		0.00	0.000	IWD-1220.1					DIESEL GEN B INTAKE FILTER.	R 06/93
KDG01B			N/A		0.00	0.000	NO IWA	VT-3				DIESEL GENERATOR B.	R 06/93
PDG01B			N/A		0.00	0.000	NO IWA	VT-3				DIESEL GEN B JACKET WATER PUMP.	R 06/93
PDG02B			N/A		0.00	0.000	IWD-1220.1					DIESEL GEN B FUEL OIL TRANSFER PUMP.	R 06/93
PDG04B			N/A		0.00	0.000	IWD-1220.1					DIESEL GEN B FUEL OIL PRIMING PUMP.	R 06/93
PDG05B			N/A		0.00	0.000	IWD-1220.1					DIESEL GEN B FUEL OIL BOOSTER PUMP.	R 06/93
PDG06B			N/A		0.00	0.000	IWD-1220.1					DIESEL GEN B LUBE OIL PUMP.	R 06/93
PDG07B			N/A		0.00	0.000	IWD-1220.1					DIESEL GEN B PRE-LUBE OIL PUMP.	R 06/93
PDG09			N/A		0.00	0.000	IWD-1220.1					DIESEL GEN B AIR STARTING MOTOR.	R 06/93
SDG01B			N/A		0.00	0.000	NO IWA	VT-3				DIESEL GEN B EXHAUST MUFFLER.	R 06/93
TDG01B			N/A		0.00	0.000	IWD-1220.1					DIESEL GEN B FUEL OIL STORAGE TANK.	R 06/93
TDG02B			N/A		0.00	0.000	IWD-1220.1					DIESEL GEN B COOLING WATER EXPANSION TK.	R 06/93
TDG03C			N/A		0.00	0.000	IWD-1220.1					DIESEL GEN B STARTING AIR RECEIVER A1.	R 06/93
TDG03D			N/A		0.00	0.000	IWD-1220.1					DIESEL GEN B STARTING AIR RECEIVER A2.	R 06/93
TDG04B			N/A		0.00	0.000	IWD-1220.1					DIESEL GEN B FUEL OIL DAY TANK.	R 06/93

QUALITY
 ASSURANCE
 MANUAL
 GINNA STATION

TITLE:
 R. E. GINNA NUCLEAR POWER PLANT
 INSERVICE INSPECTION PROGRAM
 FOR THE 1990-1999 INTERVAL
 LINE LIST

Section 5

REV.
 3

PAGE

22 of 96



R. E. GINNA NUCLEAR POWER PLANT
Inservice Examination Boundary Line List
Third Inspection Interval

P&ID No.: 33013-1239-2
Class: 3
System: DIESEL GENERATORS
Comp Type: PIPING

<u>RG&E Line No.</u>	<u>Gilbert Line No.</u>	<u>SWRI Line No.</u>	<u>ISI Fig.</u>	<u>Matl.</u>	<u>Size (in.)</u>	<u>Thkns (in.)</u>	<u>Exemption Basis</u>	<u>NDE Method</u>	<u>Po</u>	<u>Temp</u>	<u>In?</u>	<u>Line description/remarks</u>	<u>Revised</u>
20A-DG-150-4B			N/A	A53	20.00	0.250	NO SUPPORTS	VT-3			?	AIR INTAKE DG 1B.	R 06/93
20B-DG-150-4B			C-40	A53	20.00	0.250		VT-3			?	AIR EXHAUST DG 1B.	R 06/93
5A-DG-B			C-36		5.00	0.000	NO SUPPORTS	VT-3			?	JW-HX-B TO JW PUMP SUCT.	R 06/93
5B-DG-B			C-36		5.00	0.000	NO SUPPORTS	VT-3			?	JW PUMP B DISCHG TO DG-B.	R 06/93
5C-DG-B			C-36		5.00	0.000		VT-3			?	DG-B RETURN LINE TO JW-HX-B.	R 06/93
3A-FO-150-6B			N/A	A53	3.00	0.216	IWD-1220.1				?	DIESEL OIL STORAGE TANK TO 5956, 2" RED.	R 06/93
3B-FO-150-6B			N/A	A53	3.00	0.438	IWD-1220.1				?	2D TO OIL TRANSFER PUMP.	R 06/93
2A-FO-150-6B			N/A	A53	2.00	0.145	IWD-1220.1				?	1.5A TO DIESEL OIL STORAGE TANK B.	R 06/93
2A-SA-150-4B			N/A	A53	2.00	0.145	IWD-1220.1				?	AIR RECEIVERS B1 & B2 TO 5906A & B, 5975	R 06/93
2B-FO-150-6B			N/A	A53	2.00	0.145	IWD-1220.1				?	OIL TRANSFER PUMP TO 5966 & 5976.	R 06/93
2C-FO-150-6B			N/A	A53	2.00	0.145	IWD-1220.1				?	1.5A TO 5967 & 5960.	R 06/93
2D-FO-150-6B			N/A	A53	2.00	0.145	IWD-1220.1				?	3A TO 3B.	R 06/93
1.5A-FO-150-6B			N/A	A53	1.50	0.133	IWD-1220.1				?	DAY TANK B TO 5960B, 2A.	R 06/93
1.5A-SA-150-4B			N/A	A53	1.50	0.133	IWD-1220.1				?	2A TO DG-B AIR STARTING MOTOR.	R 06/93
1.5A-SW-125-1B			N/A	A53	1.50	0.133	IWD-1220.1				?	5900B TO COOLING WATER EXPANSION TANK.	R 06/93
1.5B-FO-150-6B			N/A	A53	1.50	0.133	IWD-1220.1				?	1.25A TO 1A.	R 06/93
1.5C-FO-150-6B			N/A	A53	1.50	0.133	IWD-1220.1				?	5914 TO 5910 & 3A.	R 06/93
1.5D-FO-150-6B			N/A		1.50	0.133	IWD-1220.1				?	5966 TO 1A.	R 06/93
1.25A-FO-150-6B			N/A		1.25	0.133	IWD-1220.1				?	1.5B TODAY TANK B.	R 06/93

QUALITY
ASSURANCE
MANUAL
GINNA STATION

TITLE:
R. E. GINNA NUCLEAR POWER PLANT
INSERVICE INSPECTION PROGRAM
FOR THE 1990-1999 INTERVAL
LINE LIST

Section 5
PAGE 23 of 96

REV.
3

1 2 3 4 5 6 7 8 9 10 11 12 13 14 15 16 17 18 19 20 21 22 23 24 25 26 27 28 29 30 31 32 33 34 35 36 37 38 39 40 41 42 43 44 45 46 47 48 49 50 51 52 53 54 55 56 57 58 59 60 61 62 63 64 65 66 67 68 69 70 71 72 73 74 75 76 77 78 79 80 81 82 83 84 85 86 87 88 89 90 91 92 93 94 95 96 97 98 99 100

101 102 103 104 105 106 107 108 109 110 111 112 113 114 115 116 117 118 119 120 121 122 123 124 125 126 127 128 129 130 131 132 133 134 135 136 137 138 139 140 141 142 143 144 145 146 147 148 149 150 151 152 153 154 155 156 157 158 159 160 161 162 163 164 165 166 167 168 169 170 171 172 173 174 175 176 177 178 179 180 181 182 183 184 185 186 187 188 189 190 191 192 193 194 195 196 197 198 199 200



R. E. GINNA NUCLEAR POWER PLANT
 Inservice Examination Boundary Line List
 Third Inspection Interval

P&ID No.: 33013-1245
 Class.: 2
 System.: AUXILIARY COOLANT-CCW
 Comp Type: COMPONENTS

<u>RG&E Line No.</u>	<u>Gilbert Line No.</u>	<u>SWRI Line No.</u>	<u>ISI Fig.</u>	<u>Matrl.</u>	<u>Size (in.)</u>	<u>Thkns (in.)</u>	<u>Exemption Basis</u>	<u>NDE Method</u>	<u>Po</u>	<u>Temp</u>	<u>In?</u>	<u>Line description/remarks</u>	<u>Revised</u>
PAC01A	1247		B-28		0.00	0.000	.	VT-3	410	350	.	THIS COMP ACCOUNTED FOR ON 33013-1247.	A 11/91
PAC01B	1247		B-28		0.00	0.000		VT-3	410	350	.	THIS PUMP ACCOUNTED FOR ON 33013-1247.	A 11/91

QUALITY
 ASSURANCE
 MANUAL
 GINNA STATION

TITLE:
 APPENDIX B
 R. E. GINNA NUCLEAR POWER PLANT
 INSERVICE INSPECTION PROGRAM
 FOR THE 1990-1999 INTERVAL
 LINE LIST

Section 5
 REV. 3

PAGE 24 of 96

[Faint, illegible text covering the majority of the page, possibly bleed-through from the reverse side.]



R. E. GINNA NUCLEAR POWER PLANT
Inservice Examination Boundary Line List
Third Inspection Interval

P&ID No.: 33013-1245
Class.: 3
System.: AUXILIARY COOLANT-CCW
Comp Type: COMPONENTS

RG&E Line No.	Gilbert Line No.	SWRI Line No.	ISI Fig.	Matl.	Size (in.)	Thkns (in.)	Exemption Basis	NDE Method	Po	Temp	In?	Line description/remarks	Revised
EAC01			N/A		0.00	0.000	IWD-1220.1		<275	<200		FAILED FUEL RAD MONITOR HEAT EXCHGR.	A 11/91
EAC01A			C-41		0.00	0.000		VT-3				COMPONENT COOLING WATER HEAT EXCHGR A.	A 11/91
EAC01B			C-41		0.00	0.000		VT-3				COMPONENT COOLING WATER HEAT EXCHGR B.	A 11/91
EAC02A			B-109		0.00	0.000		N/A				RHR-HX-A ACCOUNTED FOR ON 33013-1247.	A 11/91
EAC02B			B-109		0.00	0.000		N/A				RHR-HX-B ACCOUNTED FOR ON 33013-1247.	A 11/91
EAC04A			N/A		0.00	0.000	IWD-1220.1		<275	<200		S/G BLOWDOWN SAMPLE HEAT EXCHGR A.	A 11/91
EAC04B			N/A		0.00	0.000	IWD-1220.1		<275	<200		S/G BLOWDOWN SAMPLE HEAT EXCHGR B.	A 11/91
EAC05A			N/A		0.00	0.000	IWD-1220.1		<275	<200		PRESSURIZER LIQUID SPACE SAMPLE HE.	A 11/91
EAC05B			N/A		0.00	0.000	IWD-1220.1		<275	<200		RC LOOP B HOT LEG SAMPLE HEAT EXCHGR.	A 11/91
EAC05C			N/A		0.00	0.000	IWD-1220.1		<275	<200		PRESSURIZER STEAM SPACE SAMPLE HE.	A 11/91
EAC06A			N/A		0.00	0.000	IWD-1220.1					RHR PUMP COOLER A.	A 11/91
EAC06B			N/A		0.00	0.000	IWD-1220.1					RHR PUMP COOLER B.	A 11/91
ESS04A			N/A		0.00	0.000	IWD-1220.1		<275	<200		POST ACCIDENT SAMPLE COOLER A.	A 11/91
ESS04B			N/A		0.00	0.000	IWD-1220.1		<275	<200		POST ACCIDENT SAMPLE COOLER B.	A 11/91
ESS04C			N/A		0.00	0.000	IWD-1220.1		<275	<200		POST ACCIDENT SAMPLE COOLER C.	A 11/91
ESS04D			N/A		0.00	0.000	IWD-1220.1		<275	<200		POST ACCIDENT SAMPLE COOLER D.	A 11/91
PAC02A					0.00	0.000	NO IWA	VT-3				COMPONENT COOLING WATER PUMP A.	R 01/92
PAC02B					0.00	0.000	NO IWA	VT-3				COMPONENT COOLING WATER PUMP B.	R 01/92
TAC01					0.00	0.000		VT-3				COMPONENT COOLING WATER SURGE TANK.	A 11/91

QUALITY
ASSURANCE
MANUAL
GINNA STATION

TITLE:
APPENDIX B
R. E. GINNA NUCLEAR POWER PLANT
INSERVICE INSPECTION PROGRAM
FOR THE 1990-1999 INTERVAL
LINE LIST

Section 5	REV. 3
PAGE 25 of 96	

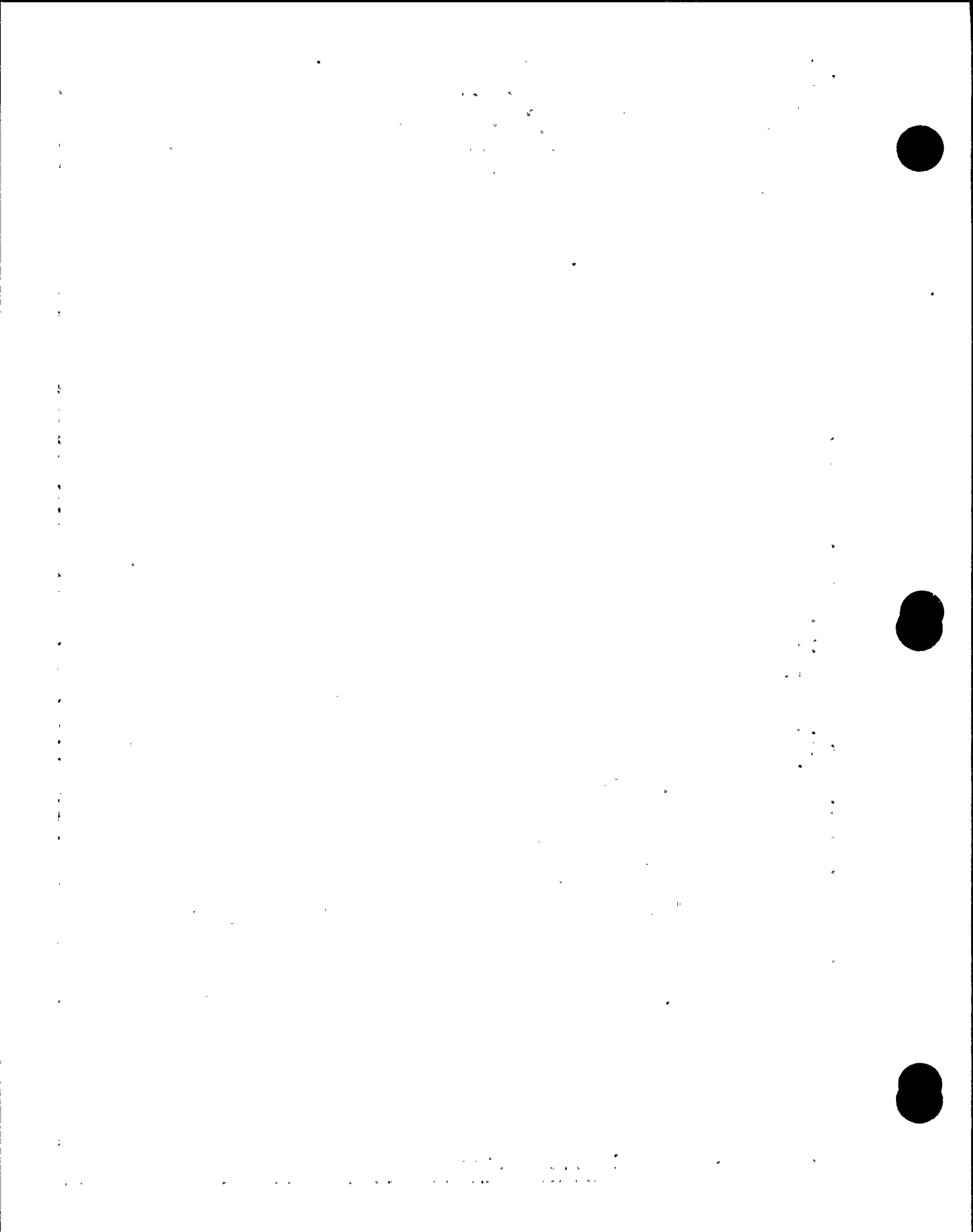

R. E. GINNA NUCLEAR POWER PLANT
Inservice Examination Boundary Line List
Third Inspection Interval

P&ID No.: 33013-1245
Class.: 3
System.: AUXILIARY COOLANT-CCW
Comp Type: PIPING

RG&E Line No.	Gilbert Line No.	SWRI Line No.	ISI Fig.	Matl.	Size (in.)	Thkns (in.)	Exemption Basis	NDE Method	Po	Temp	In?	Line description/remarks	Revised
14A-ACS-152	CC-100	N/A	C-2	A53	14.00	0.375		VT-3	<150	<200	?	10 X 14 RDCR FROM B CC PUMP TO 10" RDCRS.	R 11/91
14B-ACS-152	CC-200	N/A	C-4	A53	14.00	0.375		VT-3	<150	<200	?	734B TO 10" REDUCING ELL BEFORE 738A.	R 11/91
14C-ACS-152	CC-300	N/A	C-6	A53	14.00	0.375		VT-3	<150	<200	?	14" TEE AT RHRHE OUTLETS TO CC PUMPS.	R 11/91
10A-ACS-152	CC-100	N/A	C-2	A53	10.00	0.365		VT-3	<150	<200	?	VALVE 723A TO 14" TEE, 14A.	R 11/91
10B-ACS-152	CC-100	N/A	C-2	A53	10.00	0.365	NO SUPPORTS	VT-3	<150	<200	?	VALVE 723B TO 14 X 10" REDUCER.	R 11/91
10C-ACS-152	CC-100	N/A	C-2	A53	10.00	0.365	NO SUPPORTS	VT-3	<150	<200	?	14" REDUCER TO VALVE 733A, CCHE A.	R 11/91
10D-ACS-152	CC-100	N/A	C-2	A53	10.00	0.365		VT-3	<150	<200	?	14" REDUCER TO VALVE 733B, CCHE B.	R 11/91
10E-ACS-152	CC-200	N/A	C-4	A53	10.00	0.365		VT-3	<150	<200	?	CCHE A TO VALVE 734A, 14B.	R 11/91
10F-ACS-152	CC-200	N/A	C-4	A53	10.00	0.365		VT-3	<150	<200	?	14B TO RHRHE B.	R 11/91
10G-ACS-152	CC-200	N/A	C-4	A53	10.00	0.365		VT-3	<150	<200	?	14B TO RHRHE A.	R 11/91
10H-ACS-152	CC-300	N/A	C-6	A53	10.00	0.365		VT-3	<150	<200	?	RHRHE B OUTLET TO 14" TEE.	R 11/91
10I-ACS-152	CC-300	N/A	C-6	A53	10.00	0.365		VT-3	<150	<200	?	RHRHE A OUTLET TO 14" REDUCER.	R 11/91
10J-ACS-152	CC-300	N/A	C-6	A53	10.00	0.365	NO SUPPORTS	VT-3	<150	<200	?	14C TO CC PUMP A SUCTION.	R 11/91
10K-ACS-152	CC-300	N/A	C-6	A53	10.00	0.365	NO SUPPORTS	VT-3	<150	<200	?	14C TO CC PUMP B SUCTION.	R 11/91
10L-ACS-152	CC-200	N/A	C-4	A53	10.00	0.365		VT-3	<150	<200	?	CCHE B TO 734B, 14B.	R 11/91
8A-ACS-152	CC-100	N/A	C-2	A53	8.00	0.365		VT-3	<150	<200	?	CC PUMP A TO VALVE 723A.	R 11/91
8B-ACS-152	CC-100	N/A	C-2	A53	8.00	0.365		VT-3	<150	<200	?	CC PUMP B TO VALVE 723B.	R 11/91
6A-ACS-152			C-6		6.00	0.280	NO SUPPORTS	VT-3	<150	<200	?	14C TO 4C.	R 01/92
4A-ACS-152	CC-200	N/A	C-2	A53	4.00	0.237	IWD-1220.1		<150	<200	?	10C TO ACAHDX.	R 11/91
4B-ACS-152	CC-200	N/A	C-4	A53	4.00	0.237	IWD-1220.1		<150	<200	?	10E TO ACAPCP.	R 11/91
4C-ACS-152	CC-300	N/A	C-6	A53	4.00	0.237	IWD-1220.1		<150	<200	?	CC SURGE TANK TO 728, 6A.	R 11/91
3A-ACS-152	CC-340	N/A	C-4	A53	3.00	0.216	IWD-1220.1		<150	<200	?	DRAIN FROM 14B TO SAMPLE HES.	
3B-ACS-152	CC-350	N/A	N/A	A53	3.00	0.216	IWD-1220.1		<150	<200	?	SAMPLE HES TO 772D.	R 11/91
3C-ACS-152	CC-350	N/A	C-6	A53	3.00	0.216	IWD-1220.1		<150	<200	?	772D TO CC PUMPS SUCTION.	R 11/91
3D-ACS-152		N/A	N/A		3.00	0.216	IWD-1220.1		<150	<200	?	CC SURGE TANK TO 732.	
3E-ACS-152			N/A		3.00	0.216	IWD-1220.1		<150	<200	?	747H TO 3C.	A 11/91
2A-ACS-152	CC-240,120	N/A	C-4	A53	2.00	0.154	IWD-1220.1		<150	<200	?	10G TO 707A, RHR PUMP A.	R 11/91
2B-ACS-152	CC-240,120	N/A	N/A	A53	2.00	0.154	IWD-1220.1		<150	<200	?	2A TO 707B, RHR PUMP B.	R 11/91
2C-ACS-152	CC-140,180	N/A	N/A	A53	2.00	0.154	IWD-1220.1		<150	<200	?	RHR PUMP B TO 708B, 2D.	R 11/91
2D-ACS-152	CC-170,180	N/A	C-6	A53	2.00	0.154	IWD-1220.1		<150	<200	?	RHR PUMP A TO 741A, 769, 10I.	R 11/91
2E-ACS-152		N/A	N/A		2.00	0.154	IWD-1220.1		<150	<200	?	699 TO CC SURGE TANK.	R 11/91
2F-ACS-152		N/A	N/A		2.00	0.154	IWD-1220.1		<150	<200	?	CC SURGE TANK TO 731A.	R 11/91
2G-ACS-152		N/A	N/A		2.00	0.154	IWD-1220.1		<150	<200	?	CC SURGE TANK TO 713.	R 11/91
2H-ACS-152	CC-170	N/A	N/A	A53	2.00	0.154	IWD-1220.1		<150	<200	?	4C TO 823, 729.	R 11/91
2I-ACS-152			C-6		2.00	0.154	IWD-1220.1		<150	<200	?	740A TO 10I.	A 11/91
2J-ACS-152			C-6		2.00	0.154	IWD-1220.1		<150	<200	?	740B TO 14C.	A 11/91
2K-ACS-152			N/A		2.00	0.154	IWD-1220.1		<150	<200	?	CC SURGE TANK TO RCV017.	A 11/91
1.5A-ACS-152			N/A		1.50	0.145	IWD-1220.1		<150	<200	?	3A TO VALVE 747C.	A 11/91
1.5B-ACS-152			N/A		1.50	0.145	IWD-1220.1		<150	<200	?	VALVE 747E TO 1S, PAS COOLER.	A 11/91
1.5C-ACS-152			N/A		1.50	0.145	IWD-1220.1		<150	<200	?	1S, PAS COOLERS TO VALVE 747F.	A 11/91

QUALITY
ASSURANCE
MANUAL
GINNA STATION

TITLE:
R. E. GINNA NUCLEAR POWER PLANT
INSERVICE INSPECTION PROGRAM
FOR THE 1990-1999 INTERVAL
APPENDIX B
LINE LIST

PAGE

26 of 96

Section 5

REV.
3

Faint, illegible text scattered across the page, possibly bleed-through from the reverse side.



R. E. GINNA NUCLEAR POWER PLANT
 Inservice Examination Boundary Line List
 Third Inspection Interval

P&ID No.: 33013-1246-1
 Class: 1
 System: AUXILIARY COOLANT-CCW
 Comp Type: COMPONENTS

<u>RG&E Line No.</u>	<u>Gilbert Line No.</u>	<u>SWRI Line No.</u>	<u>ISI Fig.</u>	<u>Matl.</u>	<u>Size (in.)</u>	<u>Thkns (in.)</u>	<u>Exemption Basis</u>	<u>NDE Method</u>	<u>Pa</u>	<u>Temp</u>	<u>In?</u>	<u>Line description/remarks</u>	<u>Revised</u>
PRC01A			A-7		0.00	0.000		SUR/VOL				THIS PUMP ACCOUNTED FOR ON 33013-1250.	R 06/93
PRC01B			A-7		0.00	0.000		SUR/VOL				THIS PUMP ACCOUNTED FOR ON 33013-1250.	R 06/93

QUALITY
 ASSURANCE
 MANUAL
 GINNA STATION

TITLE:
 APPENDIX B
 R. E. GINNA NUCLEAR POWER PLANT
 INSERVICE INSPECTION PROGRAM
 FOR THE 1990-1999 INTERVAL
 LINE LIST

Section 5	REV. 3
PAGE 27	of 96

THE UNIVERSITY OF MICHIGAN LIBRARY



R. E. GINNA NUCLEAR POWER PLANT
 Inservice Examination Boundary Line List
 Third Inspection Interval

P&ID No.: 33013-1246-1
 Class.: 2
 System.: AUXILIARY COOLANT-CCW
 Comp Type: COMPONENTS

<u>RG&E Line No.</u>	<u>Gilbert Line No.</u>	<u>SWRI Line No.</u>	<u>ISI Fig.</u>	<u>Matl.</u>	<u>Size (in.)</u>	<u>Thkns (in.)</u>	<u>Exemption Basis</u>	<u>NDE Method</u>	<u>Po</u>	<u>Temp</u>	<u>In?</u>	<u>Line description/remarks</u>	<u>Revised</u>
ECH03			N/A		0.00	0.000	IWC-1222(A)		<275	<200		EXCESS LETDOWN HEAT EXCHANGER.	R 06/93
ECH08A			N/A		0.00	0.000	IWC-1222(A)		<275	<200		RCP A UPPER BEARING COOLER.	R 06/93
ECH08B			N/A		0.00	0.000	IWC-1222(A)		<275	<200		RCP B UPPER BEARING COOLER.	R 06/93
RX SUPT COOL A			N/A		0.00	0.000	IWC-1222(A)		<275	<200		REACTOR SUPPORT COOLER A.	R 06/93
RX SUPT COOL B			N/A		0.00	0.000	IWC-1222(A)		<275	<200		REACTOR SUPPORT COOLER B.	R 06/93

QUALITY
 ASSURANCE
 MANUAL
 GINNA STATION

TITLE:
 APPENDIX B
 R. E. GINNA NUCLEAR POWER PLANT
 INSERVICE INSPECTION PROGRAM
 FOR THE 1990-1999 INTERVAL
 LINE LIST

Section 5
 PAGE 28 of 96
 REV. 3

Faint, illegible text, possibly bleed-through from the reverse side of the page.



R. E. GINNA NUCLEAR POWER PLANT
Inservice Examination Boundary Line List
Third Inspection Interval

P&ID No.: 33013-1246-1
Class: 2
System: AUXILIARY COOLANT-OCW
Comp Type: PIPING

RG&E Line No.	Gilbert Line No.	SWRI Line No.	ISI Fig.	Matl.	Size (in.)	Thkns (in.)	Exemption Basis	NDE Method	Po	Temp	In?	Line description/remarks	Revised
6A-AC-152	CC-200		C-5	A53	6.00	0.280	IWC-1222(C)		90	70	N	VALVE 813 TO PEN 131.	R 06/93
6B-AC-152	CC-220		C-5	A53	6.00	0.280	IWC-1222(C)		90	70	N	PEN 130 TO VALVE 814.	R 06/93
6F-AC6-152	CC-500,525	N/A	C-9	A53	6.00	0.280	IWC-1222(C)		<150	<200	?	PEN 131 TO 4D, 4H.	R 06/93
6H-AC6-152	CC-575	N/A	C-9	A53	6.00	0.280	IWC-1222(C)		<150	<200	?	REACTOR SUPPORT COOLERS, 4O TO PEN 130.	R 06/93
4A-AC-152	CC-450		B-29	A53	4.00	0.237	IWC-1222(A)		90	70	N	VALVE 750B IN CONT TO RDCR PEN 128.	R 06/93
4B-AC-152	CC-625		B-30	A53	4.00	0.237	IWC-1222(A)		90	70	N	VALVE 750A TO RDCR BEFORE PEN 127 IN CON	R 06/93
4B-AC6-152	CC-625,CC-600	N/A	N/A	A53	4.00	0.237	IWC-1222(A)		<150	<200	?	750A AT PEN 127 TO 3C.	R 06/93
4D-AC6-152	CC-525	N/A	C-9	A53	4.00	0.237	IWC-1222(A)		<150	<200	?	6F TO RX SUPT COOLER B HEADERS 4M & 4V.	R 06/93
4E-AC6-152	CC-700	N/A	N/A	A53	4.00	0.237	IWC-1222(A)		<150	<200	?	3E AT RPC A TO 3F.	R 06/93
4F-AC6-152	CC-700,-725	N/A	N/A	A53	4.00	0.237	IWC-1222(A)		<150	<200	?	3F TO PEN 126.	R 06/93
4G-AC6-152	CC-450	N/A	B-29	A53	4.00	0.237	IWC-1222(A)		<150	<200	?	750B AT PEN 128 TO 3" RDCR (30).	R 06/93
4H-AC6-152	CC-525	N/A	C-9	A53	4.00	0.237	IWC-1222(A)		<150	<200	?	6F TO RX SUPT COOLER A HEADERS 4J & 4I.	R 06/93
4I-AC6-152	CC-525	N/A	N/A	A53	4.00	0.237	IWC-1222(A)		<150	<200	?	4H TO RX SUPT COOLER A.	R 06/93
4J-AC6-152	CC-525	N/A	N/A	A53	4.00	0.237	IWC-1222(A)		<150	<200	?	4H TO RX SUPT COOLER A.	R 06/93
4K-AC6-152	CC-525	N/A	N/A	A53	4.00	0.237	IWC-1222(A)		<150	<200	?	RX SUPT COOLER A TO 4L.	R 06/93
4L-AC6-152	CC-525	N/A	C-9	A53	4.00	0.237	IWC-1222(A)		<150	<200	?	RX SUPT COOLER A DSCHG HDRS 4K, 4U TO 6H	R 06/93
4M-AC6-152	CC-525	N/A	N/A	A53	4.00	0.237	IWC-1222(A)		<150	<200	?	4D TO RX SUPT COOLER B.	R 06/93
4N-AC6-152	CC-525	N/A	N/A	A53	4.00	0.237	IWC-1222(A)		<150	<200	?	RX SUPT COOLER B TO 4O.	R 06/93
4O-AC6-152	CC-525	N/A	C-9	A53	4.00	0.237	IWC-1222(A)		<150	<200	?	RX SUPT COOLER B DSCHG HDRS 4N, 4W TO 6H	R 06/93
4P-AC6-152	CC-400	N/A	N/A	A53	4.00	0.237	IWC-1222(A)		<150	<200	?	757B TO P125.	R 06/93
4R-AC6-152			N/A		4.00	0.237	IWC-1222(A)		<150	<200	?	3D AT RCP B TO 3I, 757B.	R 06/93
4S-AC6-152			B-29		4.00	0.237	IWC-1222(A)		<150	<200	?	3O TO RCP B.	R 06/93
4T-AC6-152			B-30		4.00	0.237	IWC-1222(A)		<150	<200	?	3C TO 3Q AT RCP A.	R 06/93
4U-AC6-152			N/A		4.00	0.237	IWC-1222(A)		<150	<200	?	RX SUPT COOLER A TO 4L.	R 06/93
4V-AC6-152			N/A		4.00	0.237	IWC-1222(A)		<150	<200	?	4D TO RX SUPT COOLER B.	R 06/93
4W-AC6-152			N/A		4.00	0.237	IWC-1222(A)		<150	<200	?	RX SUPT COOLER B TO 4O.	R 06/93
3A-AC-152	CC-220		N/A	A58	3.00	0.216	IWC-1222(A)		90	70	N	PEN 125 TO VALVE 759B.	R 06/93
3B-AC-152	CC-220		N/A	A58	3.00	0.216	IWC-1222(A)		90	70	N	PEN 126 TO VALVE 759A.	R 06/93
3C-AC-152	CC-330&CC-450		B-29	A53	3.00	0.216	IWC-1222(A)		90	70	N	RDCR BEFORE PEN 128 IN CONT TO VAL 749B.	R 06/93
3C-AC6-152	CC-600	N/A	B-30	A53	3.00	0.216	IWC-1222(A)		<150	<200	?	4B TO 751A, 4T.	R 06/93
3D-AC-152	CC-525&CC-330		B-30	A53	3.00	0.216	IWC-1222(A)		90	70	N	RDCR BEFORE PEN 127 IN CONT TO VAL 749A.	R 06/93
3D-AC6-152	CC-600	N/A	N/A	A53	3.00	0.216	IWC-1222(A)		<150	<200	?	RCP B TO REDUCER AT 4R.	R 06/93
3E-AC6-152	CC-700	N/A	C-34	A53	3.00	0.216	IWC-1222(A)		<150	<200	?	RCP A TO REDUCER AT 4E.	R 06/93
3F-AC6-152	CC-700	N/A	N/A	A53	3.00	0.216	IWC-1222(A)		<150	<200	?	4E TO 757A, 4F.	R 06/93
3I-AC6-152	CC-400	N/A	N/A	A53	3.00	0.216	IWC-1222(A)		<150	<200	?	4R TO 757B, 4P.	R 06/93
3J-AC6-152	CC-525	N/A	N/A	A53	3.00	0.216	IWC-1222(A)		<150	<200	?	4H TO RX SUPT COOLER A.	R 06/93
3K-AC6-152	CC-525	N/A	N/A	A53	3.00	0.216	IWC-1222(A)		<150	<200	?	4D TO RX SUPT COOLER B.	R 06/93
3M-AC6-152	CC-525	N/A	N/A	A53	3.00	0.216	IWC-1222(A)		<150	<200	?	RX SUPT COOLER A TO 4L.	R 06/93
3N-AC6-152	CC-525	N/A	N/A	A53	3.00	0.216	IWC-1222(A)		<150	<200	?	RX SUPT COOLER B TO 4O.	R 06/93
3O-AC6-152	CC-450	N/A	B-29	A53	3.00	0.216	IWC-1222(A)		<150	<200	?	4G TO 751B, 4S.	R 06/93
3Q-AC6-152			B-30		3.00	0.216	IWC-1222(A)		<150	<200	?	4T TO RCP A.	R 06/93
2A-AC-152			N/A	A53	2.00	0.154	IWC-1222(A)		90	70	N	PEN 124 TO VALVE 743.	R 06/93
2B-AC-152	CC-220		N/A	A53	2.00	0.154	IWC-1222(A)		90	70	N	PEN 124 TO VALVE 745.	R 06/93

QUALITY
ASSURANCE
MANUAL
GINNA STATION

TITLE:
R. E. GINNA NUCLEAR POWER PLANT
INSERVICE INSPECTION PROGRAM
FOR THE 1990-1999 INTERVAL
APPENDIX B
LINE LIST

Section 5
PAGE 29 of 96
REV. 3

[Faint, illegible text covering the majority of the page]



R. E. GINNA NUCLEAR POWER PLANT
 Inservice Examination Boundary Line List
 Third Inspection Interval

P&ID No.: 33013-1246-1 (Cont'd)
 Class.: 2
 System.: AUXILIARY COOLANT-CCW
 Comp Type: PIPING

RG&E Line No.	Gilbert Line No.	SWRI Line No.	ISI Fig.	Matl.	Size (in.)	Thkns (in.)	Exemption Basis	NDE Method	Po	Temp	In?	Line description/remarks	Revised
2F-AC6-152	CC-525	N/A	N/A	A53	2.00	0.109	IWC-1222(A)		<150	<200	?	4H TO RX SUPT COOLER A.	R 06/93
2J-AC6-152	CC-525	N/A	N/A	A53	2.00	0.109	IWC-1222(A)		<150	<200	?	4D TO RX SUPT COOLER B.	R 06/93
2M-AC6-152	CC-700	N/A	N/A	A53	2.00	0.154	IWC-1222(A)		<150	<200	?	3F TO 758A.	R 06/93
2P-AC6-152	CC-400	N/A	N/A	A53	2.00	0.154	IWC-1222(A)		<150	<200	?	4P TO 758B.	R 06/93
2Q-AC6-152	CC-525	N/A	N/A	A53	2.00	0.109	IWC-1222(A)		<150	<200	?	RX SUPT COOLER B TO 4O.	R 06/93
2S-AC6-152			N/A		2.00	0.154	IWC-1222(A)		<150	<200	?	RX SUPT COOLER A TO 4L.	R 06/93
1.5A-AC6-152A	CC-700	N/A	B-30	A53	1.50	0.145	IWC-1222(A)		<150	<200	?	3C TO RCP A.	R 06/93
1.5A-AC6-152B			N/A		1.50	0.145	IWC-1222(A)		<150	<200	?	RCP A TO .75H, 1M.	R 06/93
1.5A-AC6-152C			N/A		1.50	0.145	IWC-1222(A)		<150	<200	?	1A, FI-611 TO 3F.	R 06/93
1.5A-AC6-152D			N/A		1.50	0.145	IWC-1222(A)		<150	<200	?	1M TO 3F.	R 06/93
1.5B-AC6-152A	CC-400	N/A	B-29	A53	1.50	0.145	IWC-1222(A)		<150	<200	?	3O TO RCP B.	R 06/93
1.5B-AC6-152B			N/A		1.50	0.145	IWC-1222(A)		<150	<200	?	RCP B TO .75O.	R 06/93
1.5B-AC6-152C			N/A		1.50	0.145	IWC-1222(A)		<150	<200	?	1G-AC6-152A TO 1G-AC6-152B.	R 06/93

QUALITY
 ASSURANCE
 MANUAL
 GINNA STATION

TITLE:
 APPENDIX B
 R. E. GINNA NUCLEAR POWER PLANT
 INSERVICE INSPECTION PROGRAM
 FOR THE 1990-1999 INTERVAL
 LINE LIST

Section 5
 PAGE 30 of 96

REV.
 3

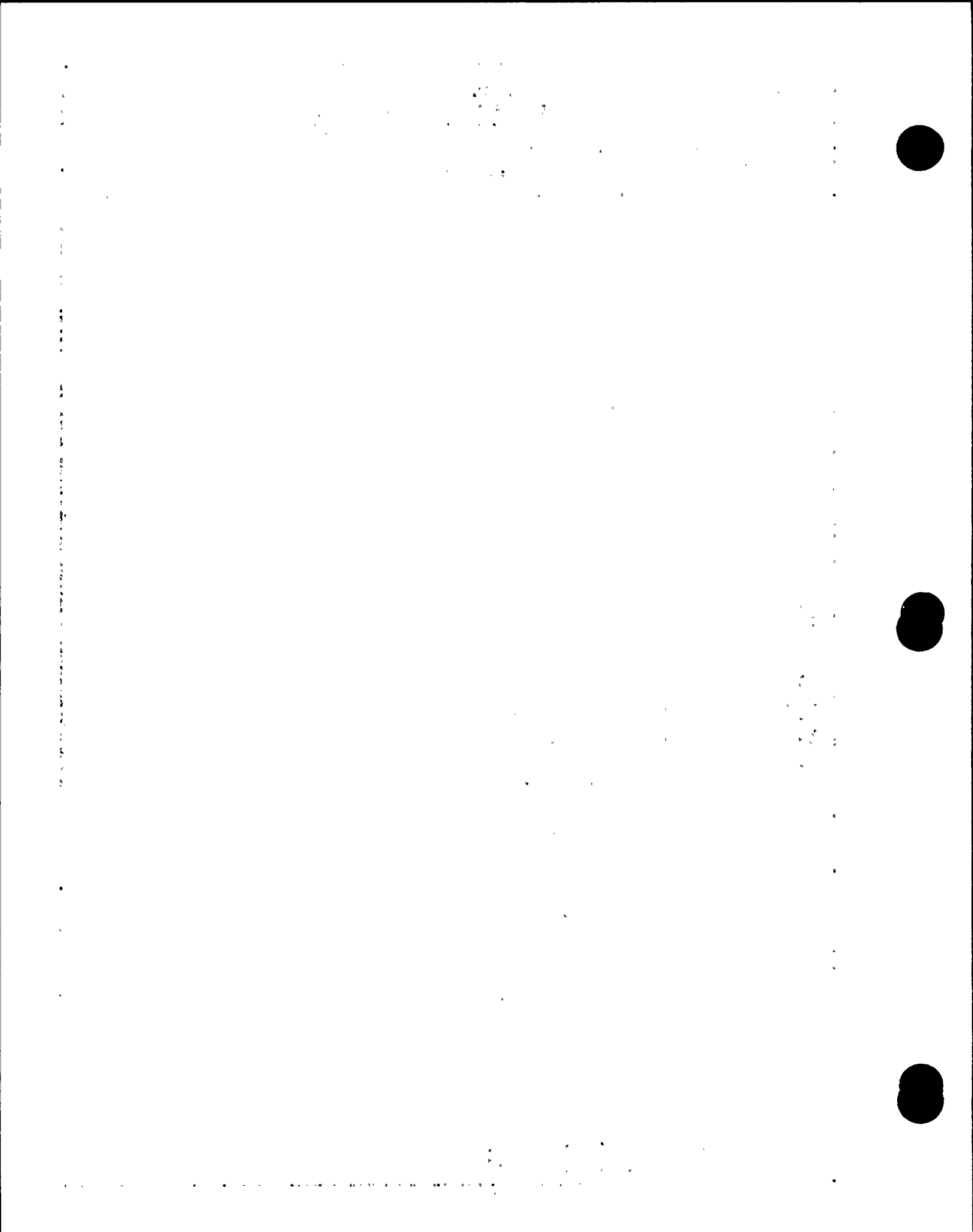

R. E. GINNA NUCLEAR POWER PLANT
 Inservice Examination Boundary Line List
 Third Inspection Interval

P&ID No.: 33013-1246-1
 Class.: 3
 System.: AUXILIARY COOLANT-CCW
 Comp Type: PIPING

RG&E Line No.	Gilbert Line No.	SWRI Line No.	ISI Fig.	Mtrl.	Size (in.)	Thkns (in.)	Exemption Basis	NDE Method	Po	Temp	In?	Line description/remarks	Revised
8A-AC6-152	CC-200	N/A	C-5	A53	8.00	0.322	.	VT-3	<150	<200	?	COMPONENT COOLING HE TO 817, 6" REDUCER.	R 06/93
8B-AC6-152	CC-220	N/A	C-5	A53	8.00	0.322		VT-3	<150	<200	?	4Q TO 816, 14" REDUCER.	R 06/93
6A-AC6-152	CC-200	N/A	C-5	A53	6.00	0.280	NO SUPPORTS	VT-3	<150	<200	?	8A TO 813.	R 06/93
6D-AC6-152	CC-220	N/A	C-5	A53	6.00	0.280		VT-3	<150	<200	?	814 TO 815A, 8B.	R 06/93
4A-AC6-152	CC-330	N/A	C-5	A53	4.00	0.237	IWD-1220.1		<150	<200	?	8A TO REDUCER BEFORE 749A.	R 06/93
4Q-AC6-152	CC-220	N/A	C-5	A53	4.00	0.237	IWD-1220.1		<150	<200	?	CONNECTS 8B, 3H, & 2L.	R 06/93
3A-AC6-152	CC-330	N/A	N/A	A53	3.00	0.216	IWD-1220.1		<150	<200	?	4A TO 749A.	R 06/93
3B-AC6-152	CC-330	N/A	N/A	A53	3.00	0.216	IWD-1220.1		<150	<200	?	4A TO 749B.	R 06/93
3G-AC6-152	CC-220	N/A	C-5	A53	3.00	0.216	IWD-1220.1		<150	<200	?	759A TO 762A, 8B.	R 06/93
3H-AC6-152	CC-220	N/A	N/A	A53	3.00	0.216	IWD-1220.1		<150	<200	?	759B TO 762B, 4Q.	R 06/93
2A-AC6-152	CC-330	N/A	N/A	A53	2.00	0.154	IWD-1220.1		<150	<200	?	4A TO 742A, & 743 TO EXCESS LETDN HE.	R 06/93
2I-AC6-152	CC-220	N/A	N/A	A53	2.00	0.154	IWD-1220.1		<150	<200	?	EXCESS LETDN HE TOP 124 & 745 TO 742B, 4Q	R 06/93

QUALITY
 ASSURANCE
 MANUAL
 GINNA STATION

TITLE:
 R. E. GINNA NUCLEAR POWER PLANT
 INSERVICE INSPECTION PROGRAM
 FOR THE 1990-1999 INTERVAL
 APPENDIX B
 LINE LIST

Section 5
 REV. 3

PAGE
 31 of 96

[The page contains extremely faint and illegible text, likely bleed-through from the reverse side of the document. The text is scattered across the page and is not readable.]



R. E. GINNA NUCLEAR POWER PLANT
Inservice Examination Boundary Line List
Third Inspection Interval

P&ID No.: 33013-1246-2

Class.: 2

System.: AUXILIARY COOLANT-CCW

Comp Type: COMPONENTS

<u>RG&E Line No.</u>	<u>Gilbert Line No.</u>	<u>SWRI Line No.</u>	<u>ISI Fig.</u>	<u>Matl.</u>	<u>Size (in.)</u>	<u>Thkns (in.)</u>	<u>Exemption Basis</u>	<u>NDE Method</u>	<u>Po.</u>	<u>Temp</u>	<u>In?</u>	<u>Line description/remarks</u>	<u>Revised</u>
EAC08A			N/A		0.00	0.000	IWC-1222(A)					SAFETY INJECTION PUMP A COOLER A.	R 06/93
EAC08B			N/A		0.00	0.000	IWC-1222(A)					SAFETY INJECTION PUMP A COOLER B.	R 06/93
EAC09A			N/A		0.00	0.000	IWC-1222(A)					SAFETY INJECTION PUMP B COOLER A.	R 06/93
EAC09B			N/A		0.00	0.000	IWC-1222(A)					SAFETY INJECTION PUMP B COOLER B.	R 06/93
EAC10A			N/A		0.00	0.000	IWC-1222(A)					SAFETY INJECTION PUMP C COOLER A.	R 06/93
EAC10B			N/A		0.00	0.000	IWC-1222(A)					SAFETY INJECTION PUMP C COOLER B.	R 06/93
EAC11A			N/A		0.00	0.000	IWC-1222(A)					CONTAINMENT SPRAY PUMP A COOLER.	R 06/93
EAC11B			N/A		0.00	0.000	IWC-1222(A)					CONTAINMENT SPRAY PUMP B COOLER.	R 06/93
PSIO1A	1262		N/A		0.00	0.000	NO IWA	VT	1550	200	-	THIS PUMP ACCOUNTED FOR ON 33013-1262.	R 06/93
PSIO1B	1262		N/A		0.00	0.000	NO IWA	VT	1550	200	-	THIS PUMP ACCOUNTED FOR ON 33013-1262.	R 06/93
PSIO1C	1262		N/A		0.00	0.000	NO IWA	VT	1550	200	-	THIS PUMP ACCOUNTED FOR ON 33013-1262.	R 06/93
PSIO2A	1261		N/A		0.00	0.000	NO IWA	VT	205	70	-	THIS PUMP ACCOUNTED FOR ON 33013-1261.	R 06/93
PSIO2B	1261		N/A		0.00	0.000	NO IWA	VT	205	70	-	THIS PUMP ACCOUNTED FOR ON 33013-1261.	R 06/93

QUALITY ASSURANCE MANUAL
GINNA STATION

TITLE:
R. E. GINNA NUCLEAR POWER PLANT
INSERVICE INSPECTION PROGRAM
FOR THE 1990-1999 INTERVAL
LINE LIST

Section 5
PAGE 32 of 96
REV. 3

[Faint, illegible text covering the majority of the page, possibly bleed-through from the reverse side.]



R. E. GINNA NUCLEAR POWER PLANT
 Inservice Examination Boundary Line List
 Thrd Inspection Interval

P&ID No.: 33013-1246-2
 Class.: 3
 System.: AUXILIARY COOLANT-CCW
 Comp Type: COMPONENTS

<u>RG&E Line No.</u>	<u>Gilbert Line No.</u>	<u>SWRI Line No.</u>	<u>ISI Fig.</u>	<u>Matrl.</u>	<u>Size (in.)</u>	<u>Thkns (in.)</u>	<u>Exemption Basis</u>	<u>NDE Method</u>	<u>Po</u>	<u>Temp</u>	<u>In?</u>	<u>Line description/remarks</u>	<u>Revised</u>
EAC08A			N/A		0.00	0.000	IWD-1220.1					SAFETY INJECTION PUMP A COOLER A.	R 06/93
EAC08B			N/A		0.00	0.000	IWD-1220.1					SAFETY INJECTION PUMP A COOLER B.	R 06/93
EAC09A			N/A		0.00	0.000	IWD-1220.1					SAFETY INJECTION PUMP B COOLER A.	R 06/93
EAC09B			N/A		0.00	0.000	IWD-1220.1					SAFETY INJECTION PUMP B COOLER B.	R 06/93
EAC10A			N/A		0.00	0.000	IWD-1220.1					SAFETY INJECTION PUMP C COOLER A.	R 06/93
EAC10B			N/A		0.00	0.000	IWD-1220.1					SAFETY INJECTION PUMP C COOLER B.	R 06/93
EAC11A			N/A		0.00	0.000	IWD-1220.1					CONTAINMENT SPRAY PUMP A COOLER.	R 06/93
EAC11B			N/A		0.00	0.000	IWD-1220.1					CONTAINMENT SPRAY PUMP B COOLER.	R 06/93
ECH01			N/A		0.00	0.000	IWD-1220.1		<275	<200		BORIC ACID EVAP DISTILATE COOLER.	R 06/93
ECH04			N/A		0.00	0.000	IWD-1220.1		<275	<200		SEAL WATER HEAT EXCHANGER.	R 06/93
ECH05			N/A		0.00	0.000	IWD-1220.1					NON-REGENERATIVE HEAT EXCHANGER.	R 06/93
ECH06			N/A		0.00	0.000	IWD-1220.1		<275	<200		BORIC ACID EVAP AIR EJECTOR CONDENSOR.	R 06/93
ECH07			N/A		0.00	0.000	IWD-1220.2		<275	<200		BORIC ACID EVAPORATOR.	R 06/93
EWD01A			N/A		0.00	0.000	IWD-1220.2		<275	<200		WASTE GAS COMPRESSOR A SEAL WATER HE.	R 06/93
EWD01B			N/A		0.00	0.000	IWD-1220.2		<275	<200		WASTE GAS COMPRESSOR B SEAL WATER HE.	R 06/93
EWD09			N/A		0.00	0.000	IWD-1220.1		<275	<200		WASTE EVAP CONDENSING HEAT EXCHGR.	R 06/93
EWD10			N/A		0.00	0.000	IWD-1220.1		<275	<200		WASTE EVAP AIR EJECTOR HEAT EXCHGR.	R 06/93
EWD11			N/A		0.00	0.000	IWD-1220.1		<275	<200		WASTE EVAPORATOR DISTILATE COOLER.	R 06/93

QUALITY
 ASSURANCE
 MANUAL
 GINNA STATION

TITLE:
 R. E. GINNA NUCLEAR POWER PLANT
 INSERVICE INSPECTION PROGRAM
 FOR THE 1990-1999 INTERVAL
 LINE LIST

Section 5
 REV. 3

PAGE 33 of 96

R. E. GINNA NUCLEAR POWER PLANT
Inservice Examination Boundary Line List
Third Inspection Interval

P&ID No.: 33013-1246-2
Class.: 3
System.: AUXILIARY COOLANT-CCW
Comp Type: PIPING

RG&E Line No.	Gilbert Line No.	SWRI Line No.	ISI Fig.	Matl.	Size (in.)	Thkns (in.)	Exemption Basis	NDE Method	Po	Temp	In?	Line description/remarks	Revised
6B-AC6-152	CC-310	N/A	C-3	A53	6.00	0.280		VT-3	<150	<200	?	COMPONENT COOLING HE TO 4C, 773.	R 06/93
6C-AC6-152	CC-230	N/A	C-7	A53	6.00	0.280		VT-3	<150	<200	?	COMP CLG HE TO 760A & BORIC ACID EVAP.	R 06/93
6E-AC6-152	CC-160	N/A	C-3	A53	6.00	0.280		VT-3	<150	<200	?	4C TO COMPONENT COOLING PUMPS .	R 06/93
6G-AC6-152	CC-190,CC-300	N/A	C-7	A53	6.00	0.280		VT-3	<150	<200	?	BORIC ACID EVAP TO COMP COOLING PUMPS .	R 06/93
4C-AC6-152	CC-160	N/A	C-3	A53	4.00	0.237	IWD-1220.1		<150	<200	?	6B TO 773, NON REGEN HE, 778, 6E.	R 06/93
3P-AC6-152	CC-230	N/A	C-7	A53	3.00	0.216	IWD-1220.1		<150	<200	?	6C TO 2" REDUCER BEFORE 764A, 2T.	R 06/93
2B-AC6-152	CC-250	N/A	C-3	A53	2.00	0.154	IWD-1220.1		<150	<200	?	6B TO 777B, 777C.	R 06/93
2C-AC6-152	CC-260	N/A	C-3	A53	2.00	0.154	IWD-1220.1		<150	<200	?	CS PUMPS A & B TO 6E.	R 06/93
2D-AC6-152	CC-300	N/A	C-7	A53	2.00	0.154	IWD-1220.1		<150	<200	?	DISTILLATE COOLER TO 748B, 6G.	R 06/93
2E-AC6-152	CC-230	N/A	C-7	A53	2.00	0.154	IWD-1220.1		<150	<200	?	6C TO DISTILLATE COOLER.	R 06/93
2G-AC6-152	CC-270	N/A	C-3	A53	2.00	0.154	IWD-1220.1		<150	<200	?	6B TO SI PUMP COOLERS.	R 06/93
2H-AC6-152	CC-230	N/A	C-7	A53	2.00	0.154	IWD-1220.1		<150	<200	?	1I TO 6G.	R 06/93
2K-AC6-152	CC-320	N/A	C-3	A53	2.00	0.154	IWD-1220.1		<150	<200	?	SI PUMP COOLERS TO 764C,6E.	R 06/93
2N-AC6-152	CC-310	N/A	C-3	A53	2.00	0.154	IWD-1220.1		<150	<200	?	6B TO 763, SEAL WATER HE.	R 06/93
2O-AC6-152	CC-230	N/A	C-7	A53	2.00	0.154	IWD-1220.1		<150	<200	?	WASTE EVAP CONDENSING HE TO 764B,6G.	R 06/93
2R-AC6-152	CC-160	N/A	C-3	A53	2.00	0.154	IWD-1220.1		<150	<200	?	SEAL WATER HX TO 6E.	R 06/93
2T-AC6-152			N/A		2.00	0.154	IWD-1220.1		<150	<200	?	3P TO 764A, EWD09.	R 06/93
1.5D-AC6-152	CC-230	N/A	N/A	A53	1.50	0.145	IWD-1220.1		<150	<200	?	3P TO GAS COMPRESSOR HE B.	R 06/93
1.5E-AC6-152	CC-230	N/A	N/A	A53	1.50	0.145	IWD-1220.1		<150	<200	?	GAS COMPRESSOR HE B TO 2H.	R 06/93
1.5F-AC6-152	CC-230	N/A	N/A	A53	1.50	0.145	IWD-1220.1		<150	<200	?	3P TO GAS COMPRESSOR HE A.	R 06/93
1.5G-AC6-152			N/A		1.50	0.145	IWD-1220.1		<150	<200	?	GAS COMPRESSOR HE A TO 2H.	R 06/93

QUALITY
ASSURANCE
MANUAL
GINNA STATION

TITLE:
R. E. GINNA NUCLEAR POWER PLANT
INSERVICE INSPECTION PROGRAM
FOR THE 1990-1999 INTERVAL
APPENDIX B
LINE LIST

Section 5
PAGE
34 of 96

REV.
3

[Faint, illegible text scattered across the page, possibly bleed-through from the reverse side.]



R. E. GINNA NUCLEAR POWER PLANT
 Inservice Examination Boundary Line List
 Third Inspection Interval

P&ID No.: 33013-1247
 Class.: 1
 System.: AUXILIARY COOLANT-RHR
 Comp Type: PIPING

<u>RG&E Line No.</u>	<u>Gilbert Line No.</u>	<u>SWRI Line No.</u>	<u>ISI Fig.</u>	<u>Matri.</u>	<u>Size (in.)</u>	<u>Thkns (in.)</u>	<u>Exemption Basis</u>	<u>NDE Method</u>	<u>Pa</u>	<u>Temp</u>	<u>In?</u>	<u>Line description/remarks</u>	<u>Revised</u>
10A-AC7-2501-A			A-15	A376	10.00	1.000	.	SUR/VOL			Y	RHR FROM VALVE 700 TO 701.	A 06/93
10A-AC7-2501-B			A-14	A376	10.00	1.000		SUR/VOL			Y	RHR FROM VALVE 720 TO 721.	A 06/93

QUALITY
 ASSURANCE
 MANUAL,
 GINNA STATION

TITLE:
 APPENDIX B
 R. E. GINNA NUCLEAR POWER PLANT
 INSERVICE INSPECTION PROGRAM
 FOR THE 1990-1999 INTERVAL
 LINE LIST

Section 5	REV. 3
PAGE 35	of 96

R. E. GINNA NUCLEAR POWER PLANT
Inservice Examination Boundary Line List
Third Inspection Interval

P&ID No.: 33013-1247
Class.: 2
System.: AUXILIARY COOLANT-RHR
Comp Type: COMPONENTS

<u>RG&E Line No.</u>	<u>Gilbert Line No.</u>	<u>SWRI Line No.</u>	<u>ISI Fig.</u>	<u>Matl.</u>	<u>Size (in.)</u>	<u>Thkns (in.)</u>	<u>Exemption Basis</u>	<u>NDE Method</u>	<u>Po</u>	<u>Temp</u>	<u>In?</u>	<u>Line description/remarks</u>	<u>Revised</u>
CONTAIN SUMP B	RHR-300		N/A		0.00	0.000	IWC-1221(F)		ATM.	<200	-	CONCRETE SUMP EXEMPT FROM EXAMINATION.	R 11/91
EAC02A	1247		B-109		0.00	0.000		VOL	410	350	-	RESIDUAL HEAT REMOVAL HEAT EXCHGR A.	R 11/91
EAC02B	1247		B-109		0.00	0.000		VOL	410	350	-	RESIDUAL HEAT REMOVAL HEAT EXCHGR B.	R 11/91
EAC06A			N/A		0.00	0.000	IWC-1221(A)					RHR PUMP COOLER A.	A 11/91
EAC06B			N/A		0.00	0.000	IWC-1221(A)					RHR PUMP COOLER B.	A 11/91
PAC01A	1247		B-28		0.00	0.000		VT-3	410	350	-	RHR PUMP A, MFG-PACIFIC.	R 11/91
PAC01B	1247		B-28		0.00	0.000		VT-3	410	350	-	RHR PUMP B, MFG-PACIFIC.	R 11/91

QUALITY
ASSURANCE
MANUAL
GINNA STATION

TITLE:
APPENDIX B
R. E. GINNA NUCLEAR POWER PLANT
INSERVICE INSPECTION PROGRAM
FOR THE 1990-1999 INTERVAL
LINE LIST

Section 5	REV. 3
PAGE 36 of 96	

[The page contains extremely faint and illegible text, likely bleed-through from the reverse side of the document. The text is scattered across the page and cannot be transcribed accurately.]



R. E. GINNA NUCLEAR POWER PLANT
Inservice Examination Boundary Line List
Third Inspection Interval

P&ID No.: 33013-1247
Class.: 2
System.: AUXILIARY COOLANT-RHR
Comp Type: PIPING

RG&E Line No.	Gilbert Line No.	SWRI Line No.	ISI Fig.	Matl.	Size (In.)	Thkns (In.)	Exemption Basis	NDE Method	Po	Temp	In?	Line description/remarks	Revised
10-AC-601	RHR-100	10-RH-2013	B-17	A312	10.00	0.365		SUR/VOL	350	350	Y	V720 TO REDUCER 10 X 6 BEFORE VALVE 717.	R 11/91
10A-AC-601	RHR-300	10-RH-2001	B-22	A312	10.00	0.365		SUR/VOL	410	350	Y	VALVE 701 THRU PEN P140 TO 1ST TEE.	R 11/91
10B-AC-601	RHR-300	10-RH-2001	B-20	A312	10.00	0.365		SUR/VOL	410	350	Y	10" TEE FROM 10A-AC-601 TO VALVE 856.	R 11/91
10C-AC-601	RHR-300	10-RH-2004	B-20A	A312	10.00	0.365		SUR/VOL	350	350	Y	TEE ON 10D-AC-601 TO RHR PUMP A.	R 11/91
10D-AC-601	RHR-300	10-RH-2004	B-20	A312	10.00	0.365		SUR/VOL	350	350	Y	TEE ON 10A-AC-601 TO RHR PUMP B.	R 11/91
10E-AC-601	RHR-300	10-RH-2003	B-20	A312	10.00	0.365		SUR/VOL	350	350	Y	TEE ON 10D-AC-601 TO VALVE 850B.	
10EE-AC-151	RHR-300	10-RH-2003	B-20	A312	10.00	0.365	IWC-1221(F)		350	350	Y	VALVE 850B TO 1ST REDUCING ELBOW.	R 11/91
10G-AC-601	RHR-300	10-SI-2010	B-20A	A312	10.00	0.365		SUR/VOL	350	350	Y	VALVE 850A PAST TEE TO 10C-AC-601.	R 11/91
10GG-AC-151	RHR-300	10-SI-2010	B-20A	A312	10.00	0.365	IWC-1221(F)		350	350	Y	VALVE 850A TO 1ST REDUCING ELBOW.	R 11/91
10H-AC-601	RHR-350,RHR-400	10-RH-2007	B-24	A312	10.00	0.365		SUR/VOL	410	350	N	CONT. OF 8B-AC-601 RED ELBOW TO TEE.	
8-AC-601	RHR-400	8-RH-2010	B-26	A312	8.00	0.322		SUR/VOL	350	350	Y	10-AC-601 TEE-RED TO TEE PAST HVC-624.	
8A-AC-601	RHR-400	8-RH-2010	B-26	A312	8.00	0.322		SUR/VOL	350	350	Y	10 X 8 REDUCER TO RESIDUAL HEAT EXCHA.	
8B-AC-601	RHR-350		B-23	A312	8.00	0.322		SUR/VOL	410	350	N	DISCHG RHR PMP A TO 1ST REDUCING ELBOW.	
8C-AC-601	RHR-350	8-RH-2008	B-23	A312	8.00	0.322		SUR/VOL	410	350	N	10" TEE ON 10H-AC-601 TO RH EX B.	
8D-AC-601	RHR-350	8-RH-2008	B-23	A312	8.00	0.322		SUR/VOL	410	350	N	DISCHG RHR PMP B TO 1ST TEE AFTER V710B	
8E-AC-601	RHR-400	8-RH-2017	B-24	A312	8.00	0.322		SUR/VOL	410	350	Y	REDUCER BEFORE VALVE 714 TO RH HT EXA.	
8F-AC-151	RHR-300	8-SI-2012	B-20A	A312	8.00	0.500	IWC-1221(F)		350	350	Y	VALVE 851A TO RED ELBOW BY VALVE 850A.	R 11/91
8FF-AC-151	RHR-300	8-SI-2009	B-20	A312	8.00	0.500	IWC-1221(F)		350	350	Y	VALVE 851B TO RED ELBOW BY VALVE 850B.	R 11/91
8K-SI-151	SI-151		B-19	A312	8.00	0.148		SUR/VOL			Y	6 X 8 REDUCER ON 6C-SI-151 TO 8 X 10 REDUCER.	R 06/93
8X-AC-601	RHR-400	8-RH-2018	B-26	A312	8.00	0.322		SUR/VOL	410	350	-	RES HEAT EX B TO 8 X 8 X 6 REDUCER TEE.	
6-AC-601	RHR-100	6-RH-2015	B-17	A312	6.00	0.280		SUR/VOL	350	350	Y	VALVE 852A TO 10-AC-601 IN CONT.	
6A-AC-601	RHR-100	6-RH-2016	B-18	A312	6.00	0.280		SUR/VOL	350	350	Y	VALVE 852B TO 10-AC-601 IN CONT.	
6B-AC-601	RHR-400	6-RH-2012	B-25	A312	6.00	0.280		SUR/VOL	350	350	Y	10-AC-601 TO 10H-AC-601.	R 11/91
6C-AC-601	RHR-400,RHR-450	6-RH-2014	B-27	A304	6.00	0.280		SUR/VOL	410	350	Y	8A-AC-601 TO VALVE 857C.	R 11/91
6CSI-151			B-19		6.00	0.000		SUR/VOL				VALVE 857C TO 6 X 8 REDUCER .	R 06/93
6D-AC-601	RHR-450	6-RH-2011	B-26	A312	6.00	0.280		SUR/VOL	410	350	Y	8X-AC-601 TO VALVE 857B.	R 11/91
6D-SI-151			B-19		6.00	0.000		SUR/VOL				VALVE 857B TO 6 X 8 TEE .	R 06/93
6E-AC-151	RHR-300	6-SI-2011	B-21	A312	6.00	0.134	IWC-1221(F)		350	350	N	10" TEE ON 10EE-AC-151 TO VALVE 1813B.	R 11/91
6K-AC-151	RHR-300	6-SI-2014	B-21	A312	6.00	0.134	IWC-1221(F)		350	350	N	10" TEE ON 10GG-AC-151 TO VALVE 1813A.	R 06/93
6L-AC-601			B-16B		6.00	0.280		SUR/VOL				4C-AC-601, 1816B TO 1816A, 4C-SI-301	R 06/93
4A-AC-601			B-20		4.00	0.000	IWC-1221(A)					10B-AC-601 TO 4 X 3 RDCR ON 3A-AC-601.	A 11/91
4C-AC-601			B-16B		4.00	0.000	IWC-1221(A)		410	350	-	6C-AC-601 TO VALVE 1816B.	R 06/93
3A-AC-601			B-26		3.00	0.000	IWC-1221(A)					8X-AC-601 TO 4 X 3 RDCR ON 4A-AC-601.	A 11/91
3B-AC-601			B-27		3.00	0.000	IWC-1221(A)					6C-AC-601 TO 4A-AC-601.	A 11/91
2-AC-601			B-20A	A312	2.00	0.109	IWC-1221(A)		410	350	-	10A-AC-601 TO VALVE 252.	R 11/91
2A-AC-601	RHR-300,RHR-400		B-25	A312	2.00	0.154	IWC-1221(A)		350	350	Y	10-AC-601 TO 10B-AC-601.	
2B-AC-601	RHR-350		B-24	A312	2.00	0.154	IWC-1221(A)		410	350	N	8C-AC-601 TO VALVE 1812A.	
2C-AC-601	RHR-400		B-24	A312	2.00	0.154	IWC-1221(A)		410	350	N	8E-AC-601 TO VALVE 1812B.	
2F-AC-601	CVC-100		B-17	A312	2.00	0.154	IWC-1221(A)		350	350	Y	10-AC-601 TO VALVE 702, 2F-CH-601.	R 11/91
RHEA-2A-AC-601			B-109	A312	2.00	0.154	IWC-1221(A)		410	350	-	RESIDUAL HEAT EXCH. A TO VALVE 807C.	R 11/91
RHEA-2B-AC-601			B-109	A312	2.00	0.154	IWC-1221(A)		410	350	-	RESIDUAL HEAT EXCH. A TO VALVE 807D.	R 11/91
RHEA-2C-AC-601			B-109	A312	2.00	0.154	IWC-1221(A)		410	350	-	RESIDUAL HEAT EXCH. A TO VALVE 807E.	R 11/91
RHEB-2A-AC-601			B-109	A312	2.00	0.154	IWC-1221(A)		410	350	-	RESIDUAL HEAT EXCH. B TO VALVE 807B.	R 11/91

QUALITY
ASSURANCE
MANUAL
GINNA STATION

TITLE:
R. E. GINNA NUCLEAR POWER PLANT
INSERVICE INSPECTION PROGRAM
FOR THE 1990-1999 INTERVAL
LINE LIST

Section 5
PAGE 37 of 96
REV. 3

R. E. GINNA NUCLEAR POWER PLANT
Inservice Examination Boundary Line List
Third Inspection Interval

P&ID No.: 33013-1247 (Cont'd)
Class: 2
System: AUXILIARY COOLANT-RHR
Comp Type: PIPING

<u>RG&E Line No.</u>	<u>Gilbert Line No.</u>	<u>SWRI Line No.</u>	<u>ISI Fig.</u>	<u>Matl. Matr.</u>	<u>Size (in.)</u>	<u>Thkns (in.)</u>	<u>Exemption Basis</u>	<u>NDE Method</u>	<u>Po</u>	<u>Temp</u>	<u>In?</u>	<u>Line description/remarks</u>	<u>Revised</u>
RHEB-2B-AC-601			B-109	A312	2.00	0.154	IWC-1221(A)		410	350	.	RESIDUAL HEAT EXCH. B TO VALVE 807F.	R 11/91
RHEB-2C-AC-601			B-109	A312	2.00	0.154	IWC-1221(A)		410	350	.	RESIDUAL HEAT EXCH. B TO VALVE 807G.	R 11/91
1.25A-AC-601			B-24		1.25	0.000	IWC-1221(A)					10H-AC-601 TO CAP.	A 11/91

QUALITY
ASSURANCE
MANUAL
GINNA STATION

TITLE:
APPENDIX B
R. E. GINNA NUCLEAR POWER PLANT
INSERVICE INSPECTION PROGRAM
FOR THE 1990-1999 INTERVAL
LINE LIST

Section 5
PAGE 38 of 96
REV. 3

Faint, illegible text scattered across the page, possibly bleed-through from the reverse side. Some fragments are visible along the left and right margins.



R. E. GINNA NUCLEAR POWER PLANT
 Inservice Examination Boundary Line List
 Third Inspection Interval

P&ID No.: 33013-1248
 Class.: 3
 System.: AUXILIARY COOLING-SPENT FUEL
 Comp Type: COMPONENTS

<u>RG&E Line No.</u>	<u>Gilbert Line No.</u>	<u>SWRI Line No.</u>	<u>ISI Fig.</u>	<u>Matl.</u>	<u>Size (in.)</u>	<u>Thkns (in.)</u>	<u>Exemption Basis</u>	<u>NDE Method</u>	<u>Po</u>	<u>Temp</u>	<u>In?</u>	<u>Line description/remarks</u>	<u>Revised</u>
EAC13			N/A		0.00	0.000	IWD-1220.2		<275	<200		SPENT FUEL POOL HEAT EXCHGR B.	A 11/91
PAC07B			N/A		0.00	0.000	IWD-1220.2		<275	<200		SPENT FUEL POOL RECIRC PUMP B.	A 11/91
TAC03			N/A		0.00	0.000	IWD-1220.2		<275	<200		SPENT FUEL POOL.	A 11/91

QUALITY
 ASSURANCE
 MANUAL
 GINNA STATION

TITLE:
 APPENDIX B
 R. E. GINNA NUCLEAR POWER PLANT
 INSERVICE INSPECTION PROGRAM
 FOR THE 1990-1999 INTERVAL
 LINE LIST

Section 5
 REV. 3
 PAGE 39 of 96

Faint, illegible text covering the majority of the page, possibly bleed-through from the reverse side.



R. E. GINNA NUCLEAR POWER PLANT
Inservice Examination Boundary Line List
Third Inspection Interval

P&ID No.: 33013-1248
Class.: 3
System.: AUXILIARY COOLING-SPENT FUEL
Comp Type: PIPING

RG&E Line No.	Gilbert Line No.	SWRI Line No.	ISI Fig.	Matl.	Size (in.)	Thkns (in.)	Exemption Basis	NDE Method	Po	Temp	In?	Line description/remarks	Revised
8A-AC8-151-SFP			N/A		8.00	0.000	IWD-1220.2		<275	<200		4C & 4D TO 6A & 6B & 8657, SFP PUMP B.	A 11/91
8B-AC8-151-SFP			N/A		8.00	0.000	IWD-1220.2		<275	<200		6C TO SPENT FUEL POOL HE B.	A 11/91
8C-AC8-151-SFP			N/A		8.00	0.000	IWD-1220.2		<275	<200		SPENT FUEL POOL HE B TO 6D.	A 11/91
6A-AC8-151-SFP			N/A		6.00	0.000	IWD-1220.2		<275	<200		8A TO VALVE 8662.	A 11/91
6B-AC8-151-SFP			N/A		6.00	0.000	IWD-1220.2		<275	<200		8A TO VALVE 8654.	A 11/91
6C-AC8-151-SFP			N/A		6.00	0.000	IWD-1220.2		<275	<200		SPENT FUEL POOL RECIRC PUMP B TO 8B.	A 11/91
6D-AC8-151-SFP			N/A		6.00	0.000	IWD-1220.2		<275	<200		8C TO VALVE 8663, 6E.	A 11/91
6E-AC8-151			N/A		6.00	0.000	IWD-1220.2		<275	<200		6D TO SPENT FUEL POOL.	A 11/91
4A-AC8-151			N/A		4.00	0.000	IWD-1220.1					SPENT FUEL POOL TO 4C, VALVE 782.	A 11/91
4B-AC8-151			N/A		4.00	0.000	IWD-1220.1					SPENT FUEL POOL TO 4D, VALVE 781.	A 11/91
4C-AC8-151-SFP			N/A		4.00	0.000	IWD-1220.1					VALVE 782 TO 8A.	A 11/91
4D-AC8-151-SFP			N/A		4.00	0.000	IWD-1220.1					VALVE 781 TO 8A.	A 11/91
4E-AC8-151-SFP			N/A		4.00	0.000	IWD-1220.1					6D TO VALVE 8614.	A 11/91
4F-AC8-151-SFP			N/A		4.00	0.000	IWD-1220.1					6D TO VALVE 8664.	A 11/91
2A-AC8-151-SFP			N/A		2.00	0.000	IWD-1220.1					6C TO VALVE 8661.	A 11/91
2B-AC8-151-SFP			N/A		2.00	0.000	IWD-1220.1					6D TO VALVE 8632.	A 11/91

QUALITY
ASSURANCE
MANUAL
GINNA STATION

TITLE:
R. E. GINNA NUCLEAR POWER PLANT
INSERVICE INSPECTION PROGRAM
FOR THE 1990-1999 INTERVAL
LINE LIST

Section 5

PAGE
40 of 96

REV.
3

Faint, illegible text scattered across the page, possibly bleed-through from the reverse side. Some faint words like "THE" and "AND" are visible.



R. E. GINNA NUCLEAR POWER PLANT
 Inservice Examination Boundary Line List
 Third Inspection Interval

P&ID No.: 33013-1250-1
 Class.: 2
 System.: SERVICE WATER
 Comp Type: COMPONENTS

<u>RG&E Line No.</u>	<u>Gilbert Line No.</u>	<u>SWRI Line No.</u>	<u>ISI Fig.</u>	<u>Matl.</u>	<u>Size (in.)</u>	<u>Thkns (in.)</u>	<u>Exemption Basis</u>	<u>NDE Method</u>	<u>Po</u>	<u>Temp</u>	<u>In?</u>	<u>Line description/remarks</u>	<u>Revised</u>
PSI01A	1262		N/A		0.00	0.000	NO IWA...	VT	1550	200	-	THIS PUMP ACCOUNTED FOR ON 33013-1262.	R 06/93
PSI01B	1262		N/A		0.00	0.000	NO IWA	VT	1550	200	-	THIS PUMP ACCOUNTED FOR ON 33013-1262.	R 06/93
PSI01C	1262		N/A		0.00	0.000	NO IWA	VT	1550	200	-	THIS PUMP ACCOUNTED FOR ON 33013-1262.	R 06/93

QUALITY
 ASSURANCE
 MANUAL
 GINNA STATION

TITLE:
 APPENDIX B
 R. E. GINNA NUCLEAR POWER PLANT
 INSERVICE INSPECTION PROGRAM
 FOR THE 1990-1999 INTERVAL
 LINE LIST

Section 5
 REV. 3

PAGE
 41 of 96

[Faint, illegible text covering the majority of the page, possibly bleed-through from the reverse side.]



R. E. GINNA NUCLEAR POWER PLANT
Inservice Examination Boundary Line List
Third Inspection Interval

PRID No.: 33013-1250-1
Class.: 3
System.: SERVICE WATER
Comp Type: COMPONENTS

<u>RG&E Line No.</u>	<u>Gilbert Line No.</u>	<u>SWRI Line No.</u>	<u>ISI Fig.</u>	<u>Matl.</u>	<u>Size (in.)</u>	<u>Thkns (in.)</u>	<u>Exemption Basis</u>	<u>NDE Method</u>	<u>Po</u>	<u>Temp</u>	<u>In?</u>	<u>Line description/remarks</u>	<u>Revised</u>
AAA01A			N/A		0.00	0.000	IWD-1220.1					CHARGING PUMP A AIR COOLER.	R 06/93
AAA01B			N/A		0.00	0.000	IWD-1220.1					CHARGING PUMP B AIR COOLER.	R 06/93
AAA02A			N/A		0.00	0.000	IWD-1220.1					RHR PUMP A AIR COOLER.	R 06/93
AAA02B			N/A		0.00	0.000	IWD-1220.1					RHR PUMP B AIR COOLER.	R 06/93
AAA03A			N/A		0.00	0.000	IWD-1220.1					SAFETY INJECTION PUMP A AIR COOLER.	R 06/93
AAA03B			N/A		0.00	0.000	IWD-1220.1					SAFETY INJECTION PUMP B AIR COOLER.	R 06/93
AAA03C			N/A		0.00	0.000	IWD-1220.1					SAFETY INJECTION PUMP C AIR COOLER.	R 06/93
AAA05			N/A		0.00	0.000	IWD-1220.1					PENETRATION AIR COOLER.	R 06/93
ESW08A			C-37		0.00	0.000		VT-3				THIS COMP ACCOUNTED FOR ON 33013-1239.	R 06/93
ESW08B			C-38		0.00	0.000		VT-3				THIS COMP ACCOUNTED FOR ON 33013-1239.	R 06/93
ESW09A			N/A		0.00	0.000	NO IWA	VT-3				THIS COMP ACCOUNTED FOR ON 33013-1239.	R 06/93
ESW09B			N/A		0.00	0.000	NO IWA	VT-3				THIS COMP ACCOUNTED FOR ON 33013-1239.	R 06/93
PSW01A					0.00	0.000	NO IWA	VT-3				SERVICE WATER PUMP A.	R 06/93
PSW01B					0.00	0.000	NO IWA	VT-3				SERVICE WATER PUMP B.	R 06/93
PSW01C					0.00	0.000	NO IWA	VT-3				SERVICE WATER PUMP C.	R 06/93
PSW01D					0.00	0.000	NO IWA	VT-3				SERVICE WATER PUMP D.	R 06/93

QUALITY
ASSURANCE
MANUAL
GINNA STATION

TITLE:
APPENDIX B
R. E. GINNA NUCLEAR POWER PLANT
INSERVICE INSPECTION PROGRAM
FOR THE 1990-1999 INTERVAL
LINE LIST

Section 5
PAGE 42 of 96

REV.
3

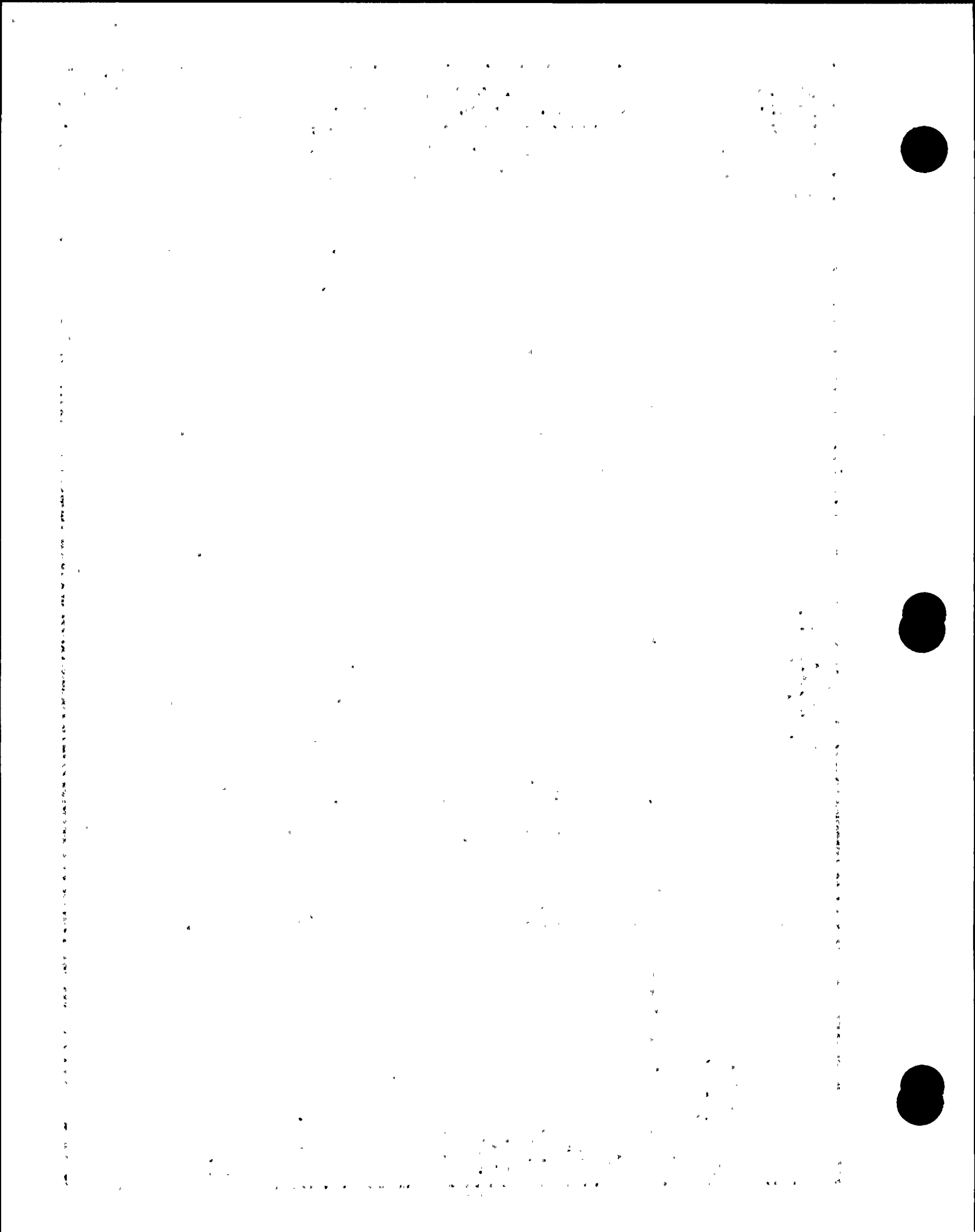

R. E. GINNA NUCLEAR POWER PLANT
Inservice Examination Boundary Line List
Third Inspection Interval

P&ID No.: 33013-1250-1
Class: 3
System: SERVICE WATER
Comp Type: PIPING

RG&E Line No.	Gilbert Line No.	SWRI Line No.	ISI Fig.	Matl.	Size (in.)	Thkns (in.)	Exemption Basis	NDE Method	Po	Temp	In?	Line description/remarks	Revised
20A-SWO-125-9			C-17	AS3	20.00	0.375	IWF-1230		75	80	?	20E TO 20F, 4665 (BURRIED).	R 06/93
20B-SWO-125-9	SW-1500		C-17	AS3	20.00	0.375	IWF-1230		75	80	?	20G TO 20H (BURRIED).	R 06/93
20E-SWO-125-1			C-17		20.00	0.375		VT-3			?	14A, 14B TO 20A.	R 06/93
20F-SWO-125-1			C-12		20.00	0.375		VT-3			?	20A TO 4616, 4610.	R 06/93
20G-SWO-125-1			C-17		20.00	0.375		VT-3			?	14C, 14D TO 20B.	R 06/93
20H-SWO-125-1			C-12		20.00	0.375		VT-3			?	20B TO 4615, 4779.	R 06/93
20I-SWO-125-1			C-16		20.00	0.375		VT-3			?	20B TO 4640, 16A.	R 06/93
16A-SWO-125-1	SW-1850		C-16	AS3	16.00	0.375		VT-3	75	80	?	16C TO 4623, 20I.	R 06/93
16B-SWO-125-9	SW-1850		C-13	AS3	16.00	0.375	IWF-1230		75	80	?	20B TO 6A (BURRIED).	R 06/93
16C-SWO-125-9	SW-1500		C-16	AS3	16.00	0.375	IWF-1230		75	80	?	20A TO 16A (BURRIED).	R 06/93
16D-SWO-125-1	SW-1500		C-16	AS3	16.00	0.375		VT-3	75	80	?	20I TO 14E.	R 06/93
14A-SWO-125-1			C-17	AS3	14.00	0.375		VT-3	75	80	?	SERVICE WATER PUMP A TO 20E.	R 06/93
14B-SWO-125-1			C-17	AS3	14.00	0.375		VT-3	75	80	?	SERVICE WATER PUMP B TO 20E.	R 06/93
14C-SWO-125-1			C-17	AS3	14.00	0.375		VT-3	75	80	?	SERVICE WATER PUMP C TO 20G.	R 06/93
14D-SWO-125-1			C-17	AS3	14.00	0.375		VT-3	75	80	?	SERVICE WATER PUMP D TO 20G.	R 06/93
14E-SWO-125-1	SW-1500		C-16B	AS3	14.00	0.375		VT-3	75	80	?	16A TO 4627, 6H.	R 06/93
14K-SWO-125-1	SW-1400		C-13	AS3	14.00	0.375	NO SUPPORTS	VT-3	75	80	?	4665 TO 4A, 10B.	R 06/93
10B-SWO-125-1			C-13	AS3	10.00	0.375		VT-3	75	80	?	14K TO 4613.	R 06/93
8I-SWO-125-1			C-17	AS3	8.00	0.327		VT-3	75	80	?	20E TO 4609.	R 06/93
6A-SWO-125-1	SW-1850		C-13	AS3	6.00	0.280	NO SUPPORTS	VT-3	75	80	?	16B TO 4668B, 4J.	R 06/93
6G-SWO-125-1			C-13	AS3	6.00	0.280		VT-3	75	80	?	4C, 4E TO 10" REDUCER .	R 06/93
4A-SWO-125-1	SW-1850		C-13	AS3	4.00	0.237	IWD-1220.1		75	80	?	14K TO DIESEL GENERATOR A COOLERS.	R 06/93
4C-SWO-125-1			C-13	AS3	4.00	0.237	IWD-1220.1		75	80	?	DIESEL GENERATOR A COOLERS TO 4671, 6G.	R 06/93
4E-SWO-125-1			C-13	AS3	4.00	0.237	IWD-1220.1		75	80	?	DIESEL GENERATOR B COOLERS TO 4672, 6G.	R 06/93
4J-SWO-125-1			C-13		4.00	0.237	IWD-1220.1				?	14K TO DIESEL GENERATOR B COOLERS, 4668B	R 06/93
4L-SWO-125-1			C-17		4.00	0.237	IWD-1220.1				?	14B THRU 4612, 4611 TO 14C.	R 06/93
3A-SWO-125-1	SW-1850		N/A	AS3	3.00	0.216	IWD-1220.1		75	80	?	4J TO 4668F.	R 06/93
3C-SWO-125-1			N/A	AS3	3.00	0.216	IWD-1220.1		75	80	?	4A TO 4667F.	R 06/93
3D-SWO-125-1			C-12	AS3	3.00	0.216	IWD-1220.1		75	80	?	20F TO 4739, 4769.	R 06/93
3E-SWO-125-1			C-12	AS3	3.00	0.216	IWD-1220.1		75	80	?	20H TO 4738, 4754.	R 06/93
3F-SWO-125-1			C-11	AS3	3.00	0.216	IWD-1220.1		75	80	?	4753 TO 4739A, 4739B, DISCHARGE CANAL.	R 06/93
1.5A-SWO-125-1			N/A	AS3	1.50	0.145	IWD-1220.1		75	80	?	3D TO SI COOLER 3, 3F.	R 06/93
1.5C-SWO-125-1			N/A	AS3	1.50	0.145	IWD-1220.1		75	80	?	3D TO SI COOLER 1, 3F.	R 06/93
1.5E-SWO-125-1			N/A	AS3	1.50	0.145	IWD-1220.1		75	80	?	3D TO SI COOLER 2, 3F.	R 06/93
1.5F-SWO-125-1			N/A	AS3	1.50	0.145	IWD-1220.1		75	80	?	3D TO PEN COOLER , 3F.	R 06/93
1.25A-SWO-152N			N/A		1.25	0.000	IWD-1220.1				?	4789, 4790 TO .75A, SI PUMPS.	R 06/93
1.25B-SWO-152N			N/A		1.25	0.000	IWD-1220.1				?	SI PUMPS, .75A TO 3F.	R 06/93

QUALITY
ASSURANCE
MANUAL
GINNA STATION

TITLE:
R. E. GINNA NUCLEAR POWER PLANT
INSERVICE INSPECTION PROGRAM
FOR THE 1990-1999 INTERVAL
LINE LIST

Section 5

REV.
3

PAGE

43 of 96

[The page contains extremely faint and illegible text, likely bleed-through from the reverse side of the document. The text is scattered across the page and is not readable.]



R. E. GINNA NUCLEAR POWER PLANT
 Inservice Examination Boundary Line List
 Third Inspection Interval

P&ID No.: 33013-1250-2
 Class: 3
 System: SERVICE WATER
 Comp Type: COMPONENTS

<u>RG&E Line No.</u>	<u>Gilbert Line No.</u>	<u>SWRI Line No.</u>	<u>ISI Fig.</u>	<u>Matl.</u>	<u>Size (in.)</u>	<u>Thkns (in.)</u>	<u>Exemption Basis</u>	<u>NDE Method</u>	<u>Po</u>	<u>Temp</u>	<u>In?</u>	<u>Line description/remarks</u>	<u>Revised</u>
AFA01A			N/A		0.00	0.000	IWD-1220.1					STANDBY AFW PUMP ROOM COOLING UNIT A.	R 06/93
AFA01B			N/A		0.00	0.000	IWD-1220.1					STANDBY AFW PUMP ROOM COOLING UNIT B.	R 06/93
EAC01A			C-41		0.00	0.000		VT-3				THIS COMP ACCOUNTED FOR ON 33013-1245.	R 06/93
EAC01B			C-41		0.00	0.000		VT-3				THIS COMP ACCOUNTED FOR ON 33013-1245.	R 06/93
EAC12			N/A		0.00	0.000	IWD-1220.2		<275	<200		STANDBY SPENT FUEL POOL HEAT EXCHGR.	R 06/93
EAC13			N/A		0.00	0.000	IWD-1220.2		<275	<200		THIS COMP ACCOUNTED FOR ON 33013-1248.	R 06/93
EAC14					0.00	0.000	IWD-1220.2		<275	<200		SPENT FUEL POOL HEAT EXCHGR A.	R 06/93

QUALITY
 ASSURANCE
 MANUAL
 GINNA STATION

TITLE:
 R. E. GINNA NUCLEAR POWER PLANT
 INSERVICE INSPECTION PROGRAM
 FOR THE 1990-1999 INTERVAL
 LINE LIST
 APPENDIX B

Section 5
 REV. 3

PAGE
 44 of 96

Faint, illegible text covering the majority of the page, possibly bleed-through from the reverse side.



R. E. GINNA NUCLEAR POWER PLANT
Inservice Examination Boundary Line List
Third Inspection Interval

P&ID No.: 33013-1250-2
Class.: 3
System.: SERVICE WATER
Comp Type: PIPING

RG&E Line No.	Gilbert Line No.	SWRI Line No.	ISI Fig.	Matrl.	Size (in.)	Thkns (in.)	Exemption Basis	NDE Method	Po	Temp	In?	Line description/remarks	Revised
20C-SWO-125-12	SW-1120		N/A	A53	20.00	0.375	IWD-1220.2		75	80	?	12A, 12B TO BURRIED DISCHG STRUC SSW01.	R 06/93
20D-SWO-125-1	SW-1100		C-11	A53	20.00	0.375		VT-3	75	80	?	14F, 14G TO BURRIED DISCHARGE.	R 06/93
18A-SWO-125-1	SW-1000		C-12	A53	18.00	0.000		VT-3	75	80	?	20F TO 14I, 6C.	R 06/93
16E-SWO-125-1			C-12		16.00	0.375	NO SUPPORTS	VT-3			?	4610 TO 20H.	R 06/93
14F-SWO-125-1	SW-1100		C-11	A53	14.00	0.375		VT-3	75	80	?	OCHE A TO 20D.	R 06/93
14G-SWO-125-1	SW-1100		C-11	A53	14.00	0.375		VT-3	75	80	?	OCHE B TO 20D.	R 06/93
14H-SWO-125-1	SW-1000		C-12	A53	14.00	0.375		VT-3	75	80	?	20H TO OCHE B.	R 06/93
14I-SWO-125-1	SW-1000		C-12	A53	14.00	0.375		VT-3	75	80	?	18A TO OCHE A.	R 06/93
12A-SWO-125-12			N/A		12.00	0.375	IWD-1220.2				?	OCHE A TO 20C.	R 06/93
12B-SWO-125-12			N/A		12.00	0.375	IWD-1220.2				?	OCHE B TO 20C.	R 06/93
12C-SWO-125-1			N/A		12.00	0.375	IWD-1220.2				?	10D TO SFPHE B.	R 06/93
12D-SWO-125-1			N/A		12.00	0.375	IWD-1220.2				?	SFPHE B TO 10E.	R 06/93
10D-SWO-125-1			C-12		10.00	0.375	IWD-1220.2				?	14H TO 12C.	R 06/93
10E-SWO-125-1			C-11		10.00	0.375	IWD-1220.2				?	12D TO 14F.	R 06/93
6C-SWO-125-1	SW-1020		C-12	A53	6.00	0.280	IWD-1220.2		75	80	?	18A TO SFPHE A.	R 06/93
6D-SWO-125-12	SW-1120		C-11	A53	6.00	0.280	IWD-1220.2		75	80	?	6E TO 20C.	R 06/93
6E-SWO-125-1	SW-1120		C-11	A53	6.00	0.280	IWD-1220.2		75	80	?	SFPHE A TO 20D (DISCHARGE).	R 06/93
6F-SWO-125-12			C-11	A53	6.00	0.280	IWD-1220.2		75	80	?	20D TO 8686.	R 06/93
6I-SWO-125-1			C-12		6.00	0.280	IWD-1220.2				?	14I TO 8687.	R 06/93
4F-SWO-152S			C-27	A53	4.00	0.237	IWD-1220.1		75	80	?	14H TO 9626B, 9627B, & 9629B.	R 06/93
4G-SWO-152S			C-26	A53	4.00	0.237	IWD-1220.1		75	80	?	20F TO 9626A, 9627A, & 9629A.	R 06/93
4K-SWO-152S			C-29	A53	4.00	0.237	IWD-1220.1		75	80	?	4F TO 9628A, 9628B, 4G.	R 06/93
3B-SWO-125-12			C-11	A53	3.00	0.216	IWD-1220.1		75	80	?	3F TO 6D.	R 06/93
2.5E-SWO-125-1			N/A		2.50	0.203	IWD-1220.1				?	12D TO 8633, 8634, 10E.	R 06/93
2A-SWO-152S			C-11	A53	2.00	0.154	IWD-1220.1		75	80	?	14F TO 1.5D.	R 06/93
2B-SWO-152S			N/A	A53	2.00	0.154	IWD-1220.1		75	80	?	20C TO 1.5B.	R 06/93
1.5B-SWO-152S			C-29	A53	1.50	0.145	IWD-1220.1		75	80	?	2B TO ROOM COOLING UNIT B, 4F.	R 06/93
1.5D-SWO-152S			C-29	A53	1.50	0.145	IWD-1220.1		75	80	?	2A TO ROOM COOLING UNIT A, 4G.	R 06/93
1.5G-SWO-152S			N/A		1.50	0.145	IWD-1220.1				?	2A TO 9635, 2B.	R 06/93

QUALITY
ASSURANCE
MANUAL
GINNA STATION

TITLE:
R. E. GINNA NUCLEAR POWER PLANT
INSERVICE INSPECTION PROGRAM
FOR THE 1990-1999 INTERVAL
APPENDIX B
LINE LIST

Section 5
REV. 3

PAGE
45 of 96

[The page contains extremely faint and illegible text, likely bleed-through from the reverse side of the document. The text is scattered across the page and is not readable.]



R. E. GINNA NUCLEAR POWER PLANT
 Inservice Examination Boundary Line List
 Third Inspection Interval

P&ID No.: 33013-1250-3
 Class.: 2
 System.: SERVICE WATER
 Comp Type: COMPONENTS

RG&E Line No.	Gilbert Line No.	SWRI Line No.	ISI Fig.	Matri	Size (in.)	Thkns (in.)	Exemption Basis	NDE Method	Po	Temp	In?	Line description/remarks	Revised
ACA01A			N/A		0.00	0.000	IWC-1221(C)					CONTAINMENT RECIRC FAN A COOLER .	R 06/93
ACA01B			N/A		0.00	0.000	IWC-1221(C)					CONTAINMENT RECIRC FAN B COOLER .	R 06/93
ACA01C			N/A		0.00	0.000	IWC-1221(C)					CONTAINMENT RECIRC FAN C COOLER .	R 06/93
ACA01D			N/A		0.00	0.000	IWC-1221(C)					CONTAINMENT RECIRC FAN D COOLER .	R 06/93
ACA01E			N/A		0.00	0.000	IWC-1221(C)					CONTAINMENT RECIRC FAN A COOLER .	R 06/93
ACA01F			N/A		0.00	0.000	IWC-1221(C)					CONTAINMENT RECIRC FAN A COOLER .	R 06/93
ACA01G			N/A		0.00	0.000	IWC-1221(C)					CONTAINMENT RECIRC FAN B COOLER .	R 06/93
ACA01H			N/A		0.00	0.000	IWC-1221(C)					CONTAINMENT RECIRC FAN B COOLER .	R 06/93
ACA01J			N/A		0.00	0.000	IWC-1221(C)					CONTAINMENT RECIRC FAN C COOLER .	R 06/93
ACA01K			N/A		0.00	0.000	IWC-1221(C)					CONTAINMENT RECIRC FAN C COOLER .	R 06/93
ACA01L			N/A		0.00	0.000	IWC-1221(C)					CONTAINMENT RECIRC FAN D COOLER .	R 06/93
ACA01M			N/A		0.00	0.000	IWC-1221(C)					CONTAINMENT RECIRC FAN D COOLER .	R 06/93
ACA02A			N/A		0.00	0.000	IWC-1221(C)					REAC TO R COMPARTMENT COOLER A.	R 06/93
ACA02B			N/A		0.00	0.000	IWC-1221(C)					REAC TO R COMPARTMENT COOLER B.	R 06/93
ACA07			N/A		0.00	0.000	IWC-1221(C)					CONTAINMENT RECIRC FAN B COOLER .	R 06/93
ACA08			N/A		0.00	0.000	IWC-1221(C)					CONTAINMENT RECIRC FAN C COOLER .	R 06/93
ACA09			N/A		0.00	0.000	IWC-1221(C)					CONTAINMENT RECIRC FAN D COOLER .	R 06/93
ACA10			N/A		0.00	0.000	IWC-1221(C)					CONTAINMENT RECIRC FAN A COOLER .	R 06/93

QUALITY
 ASSURANCE
 MANUAL
 GINNA STATION

TITLE:
 R. E. GINNA NUCLEAR POWER PLANT
 INSERVICE INSPECTION PROGRAM
 FOR THE 1990-1999 INTERVAL
 LINE LIST

Section 5

REV.
 3

PAGE

46 of 96

Faint, illegible text covering the majority of the page, possibly bleed-through from the reverse side.



R. E. GINNA NUCLEAR POWER PLANT
Inservice Examination Boundary Line List
Third Inspection Interval

P&ID No.: 33013-1250-3
Class.: 2
System.: SERVICE WATER
Comp Type: PIPING

RG&E Line No.	Gilbert Line No.	SWRI Line No.	ISI Fig.	Matrl.	Size (in.)	Thkns (in.)	Exemption Basis	NDE Method	Po	Temp	In?	Line description/remarks	Revised
8-SW-125	SW-1400		B-53A	AS3	8.00	0.322		SUR/VOL	60	80	Y	VALVE 4644 TO 8" TEE BY PEN 323 OUT CONT	R 06/93
8A-SW-125	SW-1400		B-53A	AS3	8.00	0.322		SUR/VOL	60	80	Y	PEN 323 TO D RECIRC FAN COOLER.	R 06/93
8B-SW-125	SW-700		B-53	AS3	8.00	0.322		SUR/VOL	60	80	Y	D RECIRC FAN COOLER TO PEN 312.	R 06/93
8C-SW-125	SW-1500		B-53	AS3	8.00	0.322		SUR/VOL	60	80	Y	RED ELBOW AFTER PEN 312 TO VALVE 4642.	R 06/93
8D-SW-125	SW-1400		B-52B	AS3	8.00	0.322		SUR/VOL	60	80	Y	VALVE 4643 TO 8" TEE BEFORE PEN 315.	R 06/93
8E-SW-125	SW-100		B-52B	AS3	8.00	0.322		SUR/VOL	60	80	Y	RED EL PAST P315 TO C RECIRC FAN COOLER.	R 06/93
8F-SW-125	SW-200		B-52	AS3	8.00	0.322		SUR/VOL	60	80	Y	RED EL PAST P320 TO C RECIRC FAN COOLER.	R 06/93
8G-SW-125	SW-1500		B-52	AS3	8.00	0.322		SUR/VOL	60	80	Y	VALVE 4641 TO RED ELBOW PAST PEN 320.	R 06/93
8H-SW-125	SW-1400		B-51C	AS3	8.00	0.322		SUR/VOL	60	80	Y	VALVE 4630 TO 1ST 8" TEE BY PEN 311.	R 06/93
8I-SW-125	SW-150		B-51B	AS3	8.00	0.322		SUR/VOL	60	80	Y	RED EL BY P311 TO B RECIRC FAN COOLER.	R 06/93
8J-SW-125	SW-600		B-51	AS3	8.00	0.322		SUR/VOL	60	80	Y	B RECIRC FAN COOLER TO PEN 316.	R 06/93
8K-SW-125	SW-1500		B-51	AS3	8.00	0.322		SUR/VOL	60	80	Y	RED ELBOW AFTER PEN 316 TO VALVE 4628.	R 06/93
8L-SW-125	SW-1400		B-50A	AS3	8.00	0.322		SUR/VOL	60	80	Y	VALVE 4629 TO 8" TEE BY PEN 308.	R 06/93
8M-SW-125	SW-200		B-50A	AS3	8.00	0.322		SUR/VOL	60	80	Y	RED EL BY P308 TO A RECIRC FAN COOLER.	R 06/93
8N-SW-125	SW-500		B-50	AS3	8.00	0.322		SUR/VOL	60	80	Y	A RECIRC FAN COOLR TO RED EL BEFORE P319	R 06/93
8O-SW-125	SW-1500		B-50	AS3	8.00	0.322		SUR/VOL	60	80	Y	RED ELBOW BY PEN 319 TO VALVE 4627.	R 06/93
6-SW-125	SW-1400		B-53A	AS3	6.00	0.280		SUR/VOL	60	80	Y	8" TEE BY PEN 323 TO 1ST RED ELBOW.	R 06/93
6A-SW-125	SW-700,SW-1500		B-53	AS3	6.00	0.280		SUR/VOL	60	80	Y	RED ELBOW BEFORE & AFTER PEN 312.	R 06/93
6B-SW-125	SW-1400		B-52B	AS3	6.00	0.280		SUR/VOL	60	80	Y	8" TEE ON 8D-SW-125 TO PEN 315.	R 06/93
6C-SW-125	SW-200,SW-1500		B-52	AS3	6.00	0.280		SUR/VOL	60	80	Y	RED ELBOW IN CONT & OUT CONT AT PEN 320.	R 06/93
6D-SW-125	SW-1400,SW-150		B-51C	AS3	6.00	0.280		SUR/VOL	60	80	Y	8" TEE BY PEN 311 TO RED ELBOW PEN 311.	R 06/93
6E-SW-125	SW-600,SW-1500		B-51	AS3	6.00	0.280		SUR/VOL	60	80	Y	RED ELBOW BEFORE & AFTER PEN 316.	R 06/93
6F-SW-125	SW-1400,SW-200		B-50A	AS3	6.00	0.280		SUR/VOL	60	80	Y	8" TEE BY PEN 308 TO 1ST RED ELBOW 308.	R 06/93
6G-SW-125	SW-500,SW-1500		B-50	AS3	6.00	0.280		SUR/VOL	60	80	Y	RED ELBOW PEN 319 IN CONT TO 319 OUT CON	R 06/93
4A-SW-125			B-50	AS3	4.00	0.237	IWC-1221(A)		60	80		8 X 4 RDOG ELL TO RDCR ON FCU 1-A SUPPLY.	R 06/93
4B-SW-125			B-50	AS3	4.00	0.237	IWC-1221(A)		60	80		8 X 8 X 4 TEE TO RDCR ON FCU 1-A SUPPLY.	R 06/93
4C-SW-125			B-50	AS3	4.00	0.237	IWC-1221(A)		60	80		8 X 4 RDCR TO FCU 1-A SUPPLY.	R 06/93
4D-SW-125			B-50A	AS3	4.00	0.237	IWC-1221(A)		60	80		8 X 4 RDCR TO RDOG ELL ON FCU 1-A RETURN.	R 06/93
4E-SW-125			B-50A	AS3	4.00	0.237	IWC-1221(A)		60	80		8 X 8 X 4 TEE TO RDOG ELL ON FCU 1-A RETURN.	R 06/93
4F-SW-125			B-50A	AS3	4.00	0.237	IWC-1221(A)		60	80		8 X 4 RDCR TO RDOG ELL ON FCU 1-A RETURN.	R 06/93
4G-SW-125			B-51A	AS3	4.00	0.237	IWC-1221(A)		60	80		8 X 8 X 4 TEE TO RDOG ELL ON FCU 1-B SUPPLY.	R 06/93
4H-SW-125			B-51A	AS3	4.00	0.237	IWC-1221(A)		60	80		8 X 8 X 4 TEE TO RDOG ELL ON FCU 1-B SUPPLY.	R 06/93
4I-SW-125			B-51A	AS3	4.00	0.237	IWC-1221(A)		60	80		8 X 4 RDCR TO RDOG ELL ON FCU 1-B SUPPLY.	R 06/93
4J-SW-125			B-51B	AS3	4.00	0.237	IWC-1221(A)		60	80		8 X 4 RDCR TO RDOG ELL ON FCU 1-B RETURN.	R 06/93
4K-SW-125			B-51B	AS3	4.00	0.237	IWC-1221(A)		60	80		8 X 8 X 4 TEE TO RDOG ELL ON FCU 1-B RETURN.	R 06/93
4L-SW-125			B-51B	AS3	4.00	0.237	IWC-1221(A)		60	80		8 X 4 RDCR TO RDOG ELL ON FCU 1-B RETURN.	R 06/93
4M-SW-125			B-52A	AS3	4.00	0.237	IWC-1221(A)		60	80		8 X 8 X 4 TEE TO RDOG ELL ON FCU 1-C SUPPLY.	R 06/93
4N-SW-125			B-52A	AS3	4.00	0.237	IWC-1221(A)		60	80		8 X 8 X 4 TEE TO RDOG ELL ON FCU 1-C SUPPLY.	R 06/93
4O-SW-125			B-52A	AS3	4.00	0.237	IWC-1221(A)		60	80		8 X 4 RDCR TO RDOG ELL ON FCU 1-C SUPPLY.	R 06/93
4P-SW-125			B-52B	AS3	4.00	0.237	IWC-1221(A)		60	80		8 X 4 RDCR TO RDOG ELL ON FCU 1-C RETURN.	R 06/93
4Q-SW-125			B-52B	AS3	4.00	0.237	IWC-1221(A)		60	80		8 X 4 RDCR TO RDOG ELL ON FCU 1-C RETURN.	R 06/93
4R-SW-125			B-53	AS3	4.00	0.237	IWC-1221(A)		60	80		8 X 8 X 4 TEE TO RDCR ON FCU 1-D SUPPLY.	R 06/93
4S-SW-125			B-53	AS3	4.00	0.237	IWC-1221(A)		60	80		8 X 8 X 4 TEE TO RDCR ON FCU 1-D SUPPLY.	R 06/93

QUALITY
ASSURANCE
MANUAL
GINNA STATION

TITLE:
APPENDIX B
R. E. GINNA NUCLEAR POWER PLANT
INSERVICE INSPECTION PROGRAM
FOR THE 1990-1999 INTERVAL
LINE LIST

Section 5
PAGE 47 of 96
REV. 3

Faint, illegible text covering the majority of the page, possibly bleed-through from the reverse side.

Handwritten notes or a signature in the right margin.



R. E. GINNA NUCLEAR POWER PLANT
 Inservice Examination Boundary Line List
 Third Inspection Interval

P&ID No.: 33013-1250-3 (Cont'd)
 Class.: 2
 System.: SERVICE WATER
 Comp Type: PIPING

RG&E Line No.	Gilbert Line No.	SWRI Line No.	ISI Fig.	Matl.	Size (in.)	Thkns (in.)	Exemption Basis	NDE Method	Po	Temp	In?	Line description/remarks	Revised
4T-SW-125			B-53	A53	4.00	0.237	IWC-1221(A)		60	80		8 X 4 RDCR TO 4 X 3 RDCR ON FCU 1-D SUPPLY.	R 06/93
4U-SW-125			B-53A	A53	4.00	0.237	IWC-1221(A)		60	80		8 X 4 RDCR TO RDCG ELL ON FCU 1-D RETURN.	R 06/93
4V-SW-125			B-53A	A53	4.00	0.237	IWC-1221(A)		60	80		8 X 8 X 4 TEE TO RDCG ELL ON FCU 1-D RETURN.	R 06/93
4W-SW-125			B-53A	A53	4.00	0.237	IWC-1221(A)		60	80		8 X 4 RDCR TO RDCG ELL ON FCU 1-D RETURN.	R 06/93
3A-SW-125			N/A		3.00	0.216	IWC-1221(A)		60	80		CROSS CONNECT FOR ACA07, 08, & 10.	R 06/93
3B-SW-125			B-52B	A53	3.00	0.000	IWC-1221(A)		60	80		FCU 1-C RETURN TO 8" TEE.	R 06/93
2.5A-SW-125	SW-1410		N/A	A53	2.50	0.203	IWC-1221(A)		60	80	Y	VALVE 4636 TO 2.5 X 2.5 X 2 TEE PAST PEN 201.	R 06/93
2.5B-SW-125	SW-800		N/A	A53	2.50	0.203	IWC-1221(A)		60	80	Y	1ST ELBOW PAST PEN 201 TO ACA02B.	R 06/93
2.5C-SW-125	SW-450		N/A	A53	2.50	0.203	IWC-1221(A)		60	80	Y	REAC TO R COOLER ACA02B TO PEN 209.	R 06/93
2.5D-SW-125	SW-1550		N/A	A53	2.50	0.203	IWC-1221(A)		60	80	Y	2.5 X 2.5 X 2 TEE BY PEN 209 TO VALVE 4635.	R 06/93
2.5E-SW-125	SW-1410		N/A	A53	2.50	0.203	IWC-1221(A)		60	80	Y	VALVE 4758 TO 2.5 X 2.5 X 2 TEE BY PEN 209.	R 06/93
2.5F-SW-125	SW-300		N/A	A53	2.50	0.203	IWC-1221(A)		60	80	Y	1ST RED ELBOW BY PEN IN CONT TO ACA02A.	R 06/93
2.5G-SW-125	SW-800		N/A	A53	2.50	0.203	IWC-1221(A)		60	80	Y	REAC TO R COOLER ACA02A TO PEN 201.	R 06/93
2.5H-SW-125	SW-1550		N/A	A53	2.50	0.203	IWC-1221(A)		60	80	Y	2.5 X 2.5 X 2 TEE BY PEN 201 TO VALVE 4757.	R 06/93
2.5I-SW-125			B-50		2.50	0.000	IWC-1221(A)		60	80		8N THRU ACA10, TO 8M.	R 06/93
2.5J-SW-125			B-51		2.50	0.000	IWC-1221(A)		60	80		8J THRU ACA07, TO 8I.	R 06/93
2.5K-SW-125			B-52A		2.50	0.000	IWC-1221(A)		60	80		8F THRU ACA08, TO 8E.	R 06/93
2.5L-SW-125			B-53		2.50	0.000	IWC-1221(A)		60	80		8B THRU ACA09, TO 8A.	R 06/93
2A-SW-125	SW-1410,SW-800		N/A	A53	2.00	0.154	IWC-1221(A)		60	80	Y	2.5 X 2.5 X 2 TEE AT PEN 201 1ST RED ELBOW.	R 06/93
2B-SW-125	SW-450,SW-1550		N/A	A53	2.00	0.154	IWC-1221(A)		60	80	Y	RED ELBOW BY PEN 209 TO 1ST 2" TEE.	R 06/93
2C-SW-125	SW-1410,SW-300		N/A	A53	2.00	0.154	IWC-1221(A)		60	80	Y	2.5 X 2.5 X 2 TEE BY PEN 209 1ST RED ELBOW.	R 06/93
2D-SW-125	SW-800,SW-1550		N/A	A53	2.00	0.154	IWC-1221(A)		60	80	Y	1ST RED ELBOW BY PEN 201 TO 2" TEE.	R 06/93
2E-SW-125			N/A		2.00	0.000	IWC-1221(A)		60	80		2.5I-SW-125 PAST VALVE 4794F.	R 06/93
2F-SW-125			N/A		2.00	0.000	IWC-1221(A)		60	80		2.5J-SW-125 PAST VALVE 4794K.	R 06/93
2G-SW-125			N/A		2.00	0.000	IWC-1221(A)		60	80		VALVE 4794U TO 2.5F-SW-125.	R 06/93
1.5A-SW-125			B-50A		1.50	0.000	IWC-1221(A)		60	80		8M THRU VALVE 4773 TO 2E.	R 06/93

QUALITY
 ASSURANCE
 MANUAL
 GINNA STATION

TITLE:
 R. E. GINNA NUCLEAR POWER PLANT
 INSERVICE INSPECTION PROGRAM
 FOR THE 1990-1999 INTERVAL
 LINE LIST

Section 5
 REV. 3
 PAGE 48 of 96

[The page contains extremely faint and illegible text, likely bleed-through from the reverse side of the document. The text is scattered across the page and cannot be transcribed.]



R. E. GINNA NUCLEAR POWER PLANT
Inservice Examination Boundary Line List
Third Inspection Interval

P&ID No.: 33013-1250-3
Class.: 3
System.: SERVICE WATER
Comp Type: PIPING

RG&E Line No.	Gilbert Line No.	SWRI Line No.	ISI Fig.	Matl.	Size (in.)	Thkns (in.)	Exemption Basis	NDE Method	Po	Temp	In?	Line description/remarks	Revised
14J-SWO-125-1	SW-1400		C-14	A53	14.00	0.375		VT-3	75	80	?	10A TO 4561, DISCHARGE CANAL.	R 06/93
14L-SWO-125-1			C-14		14.00	0.375	NO SUPPORTS	VT-3			?	BYPASS FOR 4561 FROM 14J THRU 4562.	R 06/93
10A-SWO-125-1	SW-1400		C-14	A53	10.00	0.375		VT-3	75	80	?	8D, 8E TO 14" REDUCER, 14L.	R 06/93
10C-SWO-125-1			C-16		10.00	0.375		VT-3			?	16D TO 4614.	R 06/93
8A-SWO-125-1	SW-1500		C-16B	A53	8.00	0.322		VT-3	75	80	?	14E TO 4642.	R 06/93
8B-SWO-125-1	SW-1500		C-16B	A53	8.00	0.322	NO SUPPORTS	VT-3	75	80	?	14E TO 4628.	R 06/93
8C-SWO-125-1	SW-1500		C-16B	A53	8.00	0.322		VT-3	75	80	?	14E TO 4641.	R 06/93
8D-SWO-125-1	SW-1400		C-14	A53	8.00	0.322		VT-3	75	80	?	4644 TO 10A.	R 06/93
8E-SWO-125-1			C-14	A53	8.00	0.327		VT-3	75	80	?	4643 TO 10A.	R 06/93
8F-SWO-125-1			C-14	A53	8.00	0.327		VT-3	75	80	?	4630 TO 14J.	R 06/93
8G-SWO-125-1			C-14	A53	8.00	0.327		VT-3	75	80	?	4629 TO 14 X 14 X 8 TEE, 14J.	R 06/93
8H-SWO-125-1			C-16B	A53	8.00	0.327	NO SUPPORTS	VT-3	75	80	?	14E TO 4627.	R 06/93
6B-SWO-125-1	SW-1410		C-18	A53	6.00	0.280		VT-3	75	80	?	4H,4I TO 14J.	R 06/93
4H-SWO-125-1			C-18	A53	4.00	0.237	IWD-1220.1		75	80	?	4651A TO 6B-SWO-125-1.	R 06/93
4I-SWO-125-1			C-18	A53	4.00	0.237	IWD-1220.1		75	80	?	4652A TO 6B-SWO-125-1.	R 06/93
3G-SWO-125-1			C-14		3.00	0.216	IWD-1220.1				?	4624C TO 14J.	R 06/93
2.5A-SWO-125-1			C-16	A53	2.50	0.203	IWD-1220.1		75	80	?	14E TO 4625, 4626, 16D.	R 06/93
2.5B-SWO-125-1			N/A	A53	2.50	0.203	IWD-1220.1		75	80	?	2.5A TO 4635, 4757.	R 06/93
2.5C-SWO-125-1			N/A	A53	2.50	0.203	IWD-1220.1		75	80	?	4636 TO 4L.	R 06/93
2.5D-SWO-125-1			N/A	A53	2.50	0.203	IWD-1220.1		75	80	?	4758 TO 2.5C.	R 06/93

QUALITY
ASSURANCE
MANUAL
GINNA STATION

TITLE:
APPENDIX B
R. E. GINNA NUCLEAR POWER PLANT
INSERVICE INSPECTION PROGRAM
FOR THE 1990-1999 INTERVAL
LINE LIST

Section 5
PAGE
49 of 96

REV.
3

Faint, illegible text scattered across the page, possibly bleed-through from the reverse side.



R. E. GINNA NUCLEAR POWER PLANT
 Inservice Examination Boundary Line List
 Third Inspection Interval

P&ID No.: 33013-1258
 Class.: 1
 System.: REACTOR COOLANT-PRESSURIZER
 Comp Type: COMPONENTS

<u>RG&E</u> <u>Line No.</u>	<u>Gilbert</u> <u>Line No.</u>	<u>SWRI</u> <u>Line No.</u>	<u>ISI</u> <u>Fig.</u>	<u>Matl.</u>	<u>Size</u> <u>(in.)</u>	<u>Thkns</u> <u>(in.)</u>	<u>Exemption</u> <u>Basis</u>	<u>NDE</u> <u>Method</u>	<u>Po</u>	<u>Temp</u>	<u>In?</u>	<u>Line description/remarks</u>	<u>Revised</u>
TRC01			A-4		0.00	0.000	.	VOL				PRESSURIZER.	A 11/91

QUALITY
 ASSURANCE
 MANUAL
 GINNA STATION

TITLE:
 APPENDIX B
 R. E. GINNA NUCLEAR POWER PLANT
 INSERVICE INSPECTION PROGRAM
 FOR THE 1990-1999 INTERVAL
 LINE LIST

Section 5
 PAGE 50 of 96

REV.
 3

Faint, illegible text covering the majority of the page, likely bleed-through from the reverse side of the document. The text is too light to transcribe accurately.



R. E. GINNA NUCLEAR POWER PLANT
 Inservice Examination Boundary Line List
 Third Inspection Interval

P&ID No.: 33013-1258
 Class: 1
 System: REACTOR COOLANT-PRESSURIZER
 Comp Type: PIPING

RG&E Line No.	Gilbert Line No.	SWRI Line No.	ISI Fig.	Matri	Size (in.)	Thkns (in.)	Exemption Basis	NDE Method	Po	Temp	In?	Line description/remarks	Revised
10-RC8-2501	RC-200	10 PRZ SURGE	A-3D	A376	10.00	1.000		SUR/VOL			Y	PRZ SURGE LINE TO B HOT LEG.	R 11/91
4A-RC8-2501-A		4-RC-273	A-13	A376	4.00	0.531		SUR/VOL			Y	PRZ RELIEF PRZ TO PCV 434.	
4A-RC8-2501-B		4-RC-273	A-13	A376	4.00	0.531		SUR/VOL			Y	PRZ RELIEF PRZ TO PCV 435.	
4C-RC8-2501		4-RC-1005	A-12	A376	4.00	0.531		SUR/VOL			Y	PRZ RELIEF PRZ TO RELIEF MANIFOLD.	
3A-RC8-2501		3-RC-1005	A-12	A376	3.00	0.438		SUR			Y	PRZ RELIEF MANIFOLD TO VALVE S515 & 431C	
3A-RC8-2501-A	RC-300	3-RC-1000	A-10	A376	3.00	0.438		SUR			Y	PRZ SPRAY FROM LOOP A TO 431A.	R 11/91
3A-RC8-2501-B	RC-300	3-RC-1001	A-10	A376	3.00	0.438		SUR			Y	PRZ SPRAY FROM LOOP B TO 431B.	R 11/91
3B-RC8-2501		3-RC-1006	A-12	A376	3.00	0.438		SUR			Y	PRZ RELIEF MANIFOLD TO VALVE S516 & 430.	
3C-RC8-2501	RC-300	3-RC-1000	A-9	A376	3.00	0.438		SUR			Y	PRZ SPRAY FROM 431A & B TO PRZ HEAD.	
2A-RC8-2501			A-11		2.00	0.000		SUR			?	VALVE 297 TO REDUCER AT 3C-RC8-2501.	A 06/93

QUALITY
 ASSURANCE
 MANUAL
 GINNA STATION

TITLE:
 R. E. GINNA NUCLEAR POWER PLANT
 INSERVICE INSPECTION PROGRAM
 FOR THE 1990-1999 INTERVAL
 LINE LIST

Section 5
 REV. 3
 PAGE 51 of 96

[The page contains extremely faint and illegible text, likely bleed-through from the reverse side of the document. The text is scattered across the page and is not readable.]



R. E. GINNA NUCLEAR POWER PLANT
 Inservice Examination Boundary Line List
 Third Inspection Interval

P&ID No.: 33013-1258
 Class.: 2
 System.: REACTOR COOLANT-PRESSURIZER
 Comp Type: PIPING

<u>RG&E Line No.</u>	<u>Gilbert Line No.</u>	<u>SWRI Line No.</u>	<u>ISI Fig.</u>	<u>Matri.</u>	<u>Size (in.)</u>	<u>Thkns (in.)</u>	<u>Exemption Basis</u>	<u>NDE Method</u>	<u>Ps</u>	<u>Temp</u>	<u>In?</u>	<u>Line description/remarks</u>	<u>Revised</u>
2A-RC-151			N/A		2.00	0.000	TWC-1222(A)		60	70	-	VALVE 529 BY PEN 121 TO VALVE 508.	

QUALITY
 ASSURANCE
 MANUAL
 GINNA STATION

TITLE:
 APPENDIX B
 R. E. GINNA NUCLEAR POWER PLANT
 INSERVICE INSPECTION PROGRAM
 FOR THE 1990-1999 INTERVAL
 LINE LIST

Section 5	REV. 3
PAGE 52 of 96	

Faint, illegible text scattered across the page, possibly bleed-through from the reverse side.



R. E. GINNA NUCLEAR POWER PLANT
 Inservice Examination Boundary Line List
 Third Inspection Interval

P&ID No.: 33013-1260
 Class.: 1
 System.: REACTOR COOLANT
 Comp Type: COMPONENTS

<u>RG&E Line No.</u>	<u>Gilbert Line No.</u>	<u>SWRI Line No.</u>	<u>ISI Fig.</u>	<u>Matl.</u>	<u>Size (in.)</u>	<u>Thkns (in.)</u>	<u>Exemption Basis</u>	<u>NDE Method</u>	<u>Po</u>	<u>Temp</u>	<u>In?</u>	<u>Line description/remarks</u>	<u>Revised</u>
EMS 01A			A-5		0.00	0.000	.	SUR/VOL				STEAM GENERATOR A.	A 11/91
EMS 01B			A-5		0.00	0.000		SUR/VOL				STEAM GENERATOR B.	A 11/91
PRC01A			A-7		0.00	0.000		SUR/VOL				REACTOR COOLANT PUMP A.	A 11/91
PRC01B			A-7		0.00	0.000		SUR/VOL				REACTOR COOLANT PUMP B.	A 11/91
RRC01			A-1		0.00	0.000		SUR/VOL				REACTOR VESSEL.	A 11/91

QUALITY ASSURANCE MANUAL GINNA STATION		TITLE:
APPENDIX B		R. E. GINNA NUCLEAR POWER PLANT INSERVICE INSPECTION PROGRAM FOR THE 1990-1999 INTERVAL
Section 5	REV. 3	
PAGE 53	of 96	

[Faint, illegible text covering the majority of the page, possibly bleed-through from the reverse side.]



R. E. GINNA NUCLEAR POWER PLANT
 Inservice Examination Boundary Line List
 Third Inspection Interval

P&ID No.: 33013-1260
 Class.: 1
 System.: REACTOR COOLANT
 Comp Type: PIPING

RG&E Line No.	Gilbert Line No.	SWRI Line No.	ISI Fig.	Matl.	Size (in.)	Thkns (in.)	Exemption Basis	NDE Method	Po	Temp	In?	Line description/remarks	Revised
31-RC-2501-A		LINE A	A-3	CCSS	31.00	2.500	.	SUR/VOL			Y	CROSS OVER FROM SG-A TO RCP A.	
31-RC-2501-B		LINE B	A-3B	CCSS	31.00	2.500		SUR/VOL			Y	CROSS OVER FROM SG-B TO RCP B.	
29-RC-2501-A		LINE A	A-3	CCSS	29.00	2.500		SUR/VOL			Y	HOT LEG FROM RPV TO SG-A.	
29-RC-2501-B		LINE B	A-3B	CCSS	29.00	2.500		SUR/VOL			Y	HOT LEG FROM RPV TO SGB.	
27.5-RC-2501-A		LINE A	A-3	CCSS	27.50	2.400		SUR/VOL			Y	COLD LEG FROM RCP A TO RPV.	
27.5-RC-2501-B		LINE B	A-3B	CCSS	27.50	2.400		SUR/VOL			Y	COLD LEG FROM RCP B TO RPV.	
10A-RCO-2501-A	RHR-2500	10-AC-1004	A-15	A376	10.00	1.000		SUR/VOL			Y	RHR FROM HOT LEG A TO VALVE 700.	R 11/91
10A-RCO-2501-B	SI-200	10-AC-1001	A-14	A376	10.00	1.000		SUR/VOL			Y	RHR/SI FROM 721, 867A TO COLD LEG B.	R 06/93
10B-RCO-2501-A			A-17	A376	10.00	1.000		SUR/VOL			Y	SI FROM 867B TO LOOP A COLD LEG.	A 06/93
6A-RCO-2501-A	RHR-100	6-AC-1003	A-14	A376	6.00	0.718		SUR/VOL			Y	RHR FROM VALVE 852A TO 6X4 REDUCER .	R 11/91
6A-RCO-2501-B	RHR-100	6-AC-1002	A-18	A376	6.00	0.718		SUR/VOL			Y	RHR FROM VALVE 852B TO 6X4 REDUCER .	R 11/91
4A-RCO-2501-A	RHR-100	4-AC-1003	A-14	A376	4.00	0.531		SUR/VOL			Y	RHR FROM 6X4 REDUCER TO RPV.	R 11/91
4A-RCO-2501-B	RHR-100	4-AC-1002	A-18	A376	4.00	0.531		SUR/VOL			Y	RHR FROM 6X4 REDUCER TO RPV.	R 11/91
2A-RCO-2501-A			A-26	A376	2.00	0.344		SUR			Y	CHARGING VALVE 383A TO LOOP A COLD LEG.	A 06/93
2A-RCO-2501-B		2-DR-1002	A-23A	A376	2.00	0.344		SUR			Y	LETDOWN FROM CROSSOVER LEG TO 427, 540.	R 06/93
2B-RCO-2501-A		2-LD-1001	A-22	A376	2.00	0.000		SUR			Y	DRAIN FROM CROSS OVER LEG TO 541, 523.	R 06/93
2B-RCO-2501-B			A-27	A376	2.00	0.344		SUR			Y	CHARGING VALVE 393 TO LOOP B HOT LEG.	A 06/93
2C-RCO-2501-A			A-20	A376	2.00	0.000		SUR			Y	SI FROM VALVE 877B TO LOOP A HOT LEG.	A 06/93
2C-RCO-2501-B			A-25	A376	2.00	0.344		SUR			Y	CHARGING VALVE 295 TO LOOP B COLD LEG.	A 06/93
2D-RCO-2501-B			A-21	A376	2.00	0.000		SUR			Y	SI FROM VALVE 877A TO LOOP B HOT LEG.	A 06/93

QUALITY
 ASSURANCE
 MANUAL
 GINNA STATION

TITLE:
 R. E. GINNA NUCLEAR POWER PLANT
 INSERVICE INSPECTION PROGRAM
 FOR THE 1990-1999 INTERVAL
 LINE LIST

Section 5

REV.
 3

PAGE

54 of 96

R. E. GINNA NUCLEAR POWER PLANT
Inservice Examination Boundary Line List
Third Inspection Interval

P&ID No.: 33013-1261
Class.: 2
System.: CONTAINMENT SPRAY
Comp Type: COMPONENTS

<u>RG&E Line No.</u>	<u>Gilbert Line No.</u>	<u>SWRI Line No.</u>	<u>ISI Fig.</u>	<u>Matl.</u>	<u>Size (in.)</u>	<u>Thkns (in.)</u>	<u>Exemption Basis</u>	<u>NDE Method</u>	<u>Ps</u>	<u>Temp</u>	<u>In?</u>	<u>Line description/remarks</u>	<u>Revised</u>
PSIO2A	1261		N/A		0.00	0.000	NO IWA ₂	VT	205	70	-	CONTAINMNT SPRAY PMP A, MFG=INGERSOL RAND	R 01/92
PSIO2B	1261		N/A		0.00	0.000	NO IWA	VT	205	70	-	CONTAINMNT SPRAY PMP B, MFG=INGERSOL RAND	R 01/92
SSI01	1261		N/A		0.00	0.000	IWC-1221(A)				-	CONTAINMNT SPRAY EDUCTOR.	R 11/91
SSI02	1261		N/A		0.00	0.000	IWC-1221(A)				-	CONTAINMENT SPRAY EDUCTOR B.	R 11/91
TSI01	1261		N/A		0.00	0.000	NOT SECT XI		30	70	-	REFUELING WATER STORAGE TANK.	R 11/91
TSI02	1261		N/A		0.00	0.000	IWC-1221(A)				-	SPRAY ADDITIVE TANK.	R 06/93

QUALITY
ASSURANCE
MANUAL
GINNA STATION

TITLE:
APPENDIX B
R. E. GINNA NUCLEAR POWER PLANT
INSERVICE INSPECTION PROGRAM
FOR THE 1990-1999 INTERVAL
LINE LIST

Section 5
PAGE 55 of 96

REV.
3

R. E. GINNA NUCLEAR POWER PLANT
Inservice Examination Boundary Line List
Third Inspection Interval

P&ID No.: 33013-1261
Class.: 2
System.: CONTAINMENT SPRAY
Comp Type: PIPING

RG&E Line No.	Gilbert Line No.	SWRI Line No.	ISI Fig.	Matl.	Size (in.)	Thkns (in.)	Exemption Basis	NDE Method	Po	Temp	In?	Line description/remarks	Revised
10-SI-151	RHR-450	10-SI-2004	B-19	A312	10.00	0.165	.	SUR/VOL	30	70	-	RWST TO 1ST 10 X 8 & 10 X 6 RDCRS, 825B.	R 06/93
10BB-SI-151			B-20		10.00	0.000		SUR/VOL	410	350	-	RWST TO VALVE 856.	R 11/91
8A-SI-151	RHR-450		B-19	A312	8.00	0.148		SUR/VOL	30	70	-	6A-SI-151 TO CS PUMP B.	R 11/91
8B-SI-151	RHR-450	10-SI-151R	B-19	A312	8.00	0.148		SUR/VOL	30	70	-	6B-SI-151 TO CS PUMP A.	R 11/91
6A-SI-151	RHR-450	6-SI-151R	B-19	A312	6.00	0.148		SUR/VOL	30	70	-	10-SI-151 TO RDCR PAST VALVE 858B.	R 11/91
6B-SI-151	RHR-450	10-SI-151R	B-19	A312	6.00	0.148		SUR/VOL	30	70	-	10-SI-151 TO RDCR PAST VALVE 858A.	R 11/91
6C-SI-301	CS-500		B-46	A403	6.00	0.280		SUR/VOL	205	70	-	4A-SI-301 TO 1ST 6 X 6 X 6 TEE.	R 11/91
6D-SI-301	CS-500		B-46	A403	6.00	0.280		SUR/VOL	205	70	-	6C-SI-301 TO VALVE 860A.	
6DD-SI-301	CS-500		B-46	A403	6.00	0.280	IWC-1221(F)		205	70	-	VALVE 860A TO 1ST 6" TEE BEFORE V 862A.	
6E-SI-301	CS-500		B-46	A403	6.00	0.280		SUR/VOL	205	70	-	1ST TEE ON LINE 6C-SI-301 TO VALVE 860B.	
6EE-SI-301	CS-500		B-46	A403	6.00	0.280	IWC-1221(F)		205	70	-	VALVE 860B TO VALVE 862A.	
6F-SI-301	CS-500		B-46	A403	6.00	0.280	IWC-1221(F)		205	70	-	VALVE 862A TO PEN 105.	R 11/91
6G-SI-301	CS-100,CS-150		B-48	A312	6.00	0.281	IWC-1221(F)		205	70	N	PEN 105 TO CS SPRAY RING.	
6H-SI-301	CS-150		N/A	A312	6.00	0.281	IWC-1221(F)		205	70	N	6G-SI-301 TO 4B-SI-301.	
6I-SI-301	CS-150		N/A	A312	6.00	0.281	IWC-1221(F)		205	70	N	4C-SI-301 TO 6C-SI-301.	
6J-SI-301	CS-800		B-47	A403	6.00	0.280		SUR/VOL	205	70	-	4D-SI-301 TO 1ST 6 X 6 X 6 TEE.	
6K-SI-301	CS-800		B-47	A403	6.00	0.280		SUR/VOL	205	70	-	6 X 6 X 6 TEE ON 6J-SI-301 TO VALVE 860D.	
6KK-SI-301	CS-800		B-47	A403	6.00	0.280	IWC-1221(F)		205	70	-	VALVE 860D TO 6" TEE BEFORE VALVE 862B.	
6L-SI-301	CS-800		B-47	A403	6.00	0.280		SUR/VOL	205	70	-	6 X 6 X 6 TEE ON 6I-SI-301 TO VALVE 860C.	
6LL-SI-301	CS-800		B-47	A403	6.00	0.280	IWC-1221(F)		205	70	-	VALVE 860C TO 6" TEE BEFORE VALVE 862B.	
6M-SI-301	CS-800		B-47	A403	6.00	0.280	IWC-1221(F)		205	70	-	6 X 6 X 6 TEE BEFORE VALVE 862B TO PEN 109.	
6N-SI-301	CS-200,CS-250		N/A	A312	6.00	0.280	IWC-1221(F)		205	70	N	PEN 109 TO 6" TEE ON LOWER CS RING.	
6P-SI-301	CS-250		N/A	A312	6.00	0.281	IWC-1221(F)		205	70	N	4F-SI-301 TO 6N-SI-301.	
6Q-SI-301	CS-250		N/A	A312	6.00	0.281	IWC-1221(F)		205	70	N	6N-SI-301 TO 4E-SI-301.	
4A-SI-301	CS-500		B-46	A312	4.00	0.000	IWC-1221(A)		205	70	-	A CS PUMP TO REDUCER.	R 11/91
4B-SI-301	CS-150		N/A	A312	4.00	0.237	IWC-1221(A)		205	70	N	6H-SI-301 TO 3A-SI-301.	R 11/91
4C-SI-301	CS-150		N/A	A312	4.00	0.237	IWC-1221(A)		205	70	N	3A-SI-301 TO 6I-SI-301.	R 11/91
4D-SI-301	CS-800		B-47	A403	4.00	0.000	IWC-1221(A)		205	70	-	B CS PUMP TO REDUCER.	R 11/91
4E-SI-301	CS-250		N/A	A312	4.00	0.237	IWC-1221(A)		205	70	N	6 X 4 RDCR TO 3B-SI-301.	R 11/91
4F-SI-301	CS-250		N/A	A312	4.00	0.237	IWC-1221(A)		205	70	N	4 X 3 RDCR TO 6 X 4 RDCR ON 6P-SI-301.	R 11/91
3-SI-151			N/A		3.00	0.000	IWC-1221(A)		30	70	-	RWST TO NOZZLE WELD.	R 11/91
3A-SI-301	CS-150		N/A	A312	3.00	0.216	IWC-1221(A)		205	70	N	4B-SI-301 TO 4C-SI-301.	R 11/91
3B-SI-301	CS-250		N/A	A312	3.00	0.216	IWC-1221(A)		205	70	N	4 X 3 RDCR ON 4E-SI-301 TO 4 X 3 RDCR.	R 11/91
3C-SI-301			N/A		3.00	0.000	IWC-1221(A)				-	SPRAY ADDITIVE TANK TO VALVE 627.	R 11/91
2-SI-151			N/A		2.00	0.154	IWC-1221(A)		30	70	-	RWST TO VALVE 893A.	R 11/91
2A-SI-151			N/A		2.00	0.154	IWC-1221(A)		30	70	-	RWST TO VALVE 893B.	R 11/91
2B-SI-151			N/A		2.00	0.154	IWC-1221(A)		30	70	-	RWST TO VALVE 894B.	R 11/91
2C-SI-151			B-20		2.00	0.154	IWC-1221(A)		30	70	-	RWST TO VALVE 808.	R 11/91
2D-SI-151	CS-520		B-19	A312	2.00	0.154	IWC-1221(A)		30	70	-	10-SI-151 TO VALVE 873C.	R 11/91
2E-SI-301	CS-100		N/A	A312	2.00	0.154	IWC-1221(A)		205	70	N	6G-SI-301 TO 6N-SI-301.	R 11/91
2F-SI-301	CS-100		N/A	A312	2.00	0.154	IWC-1221(A)		205	70	N	2E-SI-301 TO VALVE 875A.	R 11/91
2G-SI-301	CS-100		N/A	A312	2.00	0.154	IWC-1221(A)		205	70	N	2E-SI-301 TO VALVE 875B.	R 11/91
2H-SI-301	CS-100		N/A	A312	2.00	0.154	IWC-1221(A)		205	70	N	2E-SI-301 TO VALVE 876B.	R 11/91

QUALITY
ASSURANCE
MANUAL
GINNA STATION

TITLE:
R. E. GINNA NUCLEAR POWER PLANT
INSERVICE INSPECTION PROGRAM
FOR THE 1990-1999 INTERVAL
APPENDIX B
LINE LIST

Section 5
PAGE 56 of 96
REV. 3

[The page contains extremely faint and illegible text, likely bleed-through from the reverse side of the document. The text is scattered across the page and is not readable.]



R. E. GINNA NUCLEAR POWER PLANT
 Inservice Examination Boundary Line List
 Third Inspection Interval

P&ID No.: 33013-1261 (Cont'd)
 Class.: 2
 System.: CONTAINMENT SPRAY
 Comp Type: PIPING

RG&E Line No.	Gilbert Line No.	SWRI Line No.	ISI Fig.	Matl.	Size (in.)	Thkns (in.)	Exemption Basis	NDE Method	Po	Temp	In?	Line description/remarks	Revised
2I-SI-301	CS-100		N/A	A312	2.00	0.154	IWC-1221(A)		205	70	N	2E-SI-301 TO VALVE 876A.	
2J-SI-301	CS-510		B-19	A312	2.00	0.154	IWC-1221(A)		205	70	-	8B-SI-151 TO CS EDUCTOR.	R 11/91
2K-SI-301	CS-510		B-46	A312	2.00	0.154	IWC-1221(A)		205	70	-	6C-SI-301 TO VALVE 859A.	R 11/91
2KK-SI-301	CS-510		N/A	A312	2.00	0.154	IWC-1221(A)		205	70	-	CS EDUCTOR A TO 2K-SI-301.	
2L-SI-301	CS-510		N/A	A312	2.00	0.154	IWC-1221(A)		205	70	-	CS EDUCTOR 1 TO CS EDUCTOR 2.	R 11/91
2M-SI-301	CS-510		B-19	A312	2.00	0.154	IWC-1221(A)		205	70	-	8A-SI-151 TO CS EDUCTOR.	
2N-SI-301	CS-510		N/A	A312	2.00	0.154	IWC-1221(A)		205	70	-	CS EDUCTOR 2 TO 2Q-SI-301.	R 11/91
2P-SI-301	CS-510,CS-520		N/A	A312	2.00	0.154	IWC-1221(A)				-	2L-SI-301 TO VALVE 873A.	R 11/91
2Q-SI-301	CS-510		B-47	A312	2.00	0.154	IWC-1221(A)				-	6J-SI-301 TO VALVE 859A, 859C.	R 06/93
2QA-SI-301	CS-520		N/A	A312	2.00	0.154	IWC-1221(A)				-	2P-SI-301 BY VALVE 873B TO VALVE 873D.	R 11/91
2R-SI-301	CS-520		N/A	A312	2.00	0.154	IWC-1221(A)				-	2" TEE ON P-SI-151 PAST VALVE .	R 11/91
2S-SI-301	CS-520		N/A	A312	2.00	0.154	IWC-1221(A)				-	2P-SI-301 PAST VALVE 836B TO 1ST 2" TEE .	R 11/91
2T-SI-301	CS-520		N/A	A312	2.00	0.154	IWC-1221(A)				-	VALVE 881B TO SPRAY ADDITIVE TANK.	R 11/91
2U-SI-151			N/A		2.00	0.000	IWC-1222(A)				-	RWST TO VALVE 895.	A 11/91

QUALITY
 ASSURANCE
 MANUAL
 GINNA STATION

TITLE:
 R. E. GINNA NUCLEAR POWER PLANT
 INSERVICE INSPECTION PROGRAM
 FOR THE 1990-1999 INTERVAL
 APPENDIX B
 LINE LIST

Section 5
 PAGE 57 of 96
 REV. 3



R. E. GINNA NUCLEAR POWER PLANT
 Inservice Examination Boundary Line List
 Third Inspection Interval

P&ID No.: 33013-1262-1
 Class.: 2
 System.: SAFETY INJECTION
 Comp Type: COMPONENTS

RG&E Line No.	Gilbert Line No.	SWRI Line No.	ISI Fig.	Matri	Size (in.)	Thkns (in.)	Exemption Basis	NDE Method	Po	Temp	In?	Line description/remarks	Revised
PSI01A	1262		N/A		0.00	0.000	NO IWA	VT	1550	200	-	SAFETY INJECTION PUMP A, MFG-WORTHINGTON	R 06/93
PSI01B	1262		N/A		0.00	0.000	NO IWA	VT	1550	200	-	SAFETY INJECTION PUMP B, MFG-WORTHINGTON	R 06/93
PSI01C	1262		N/A		0.00	0.000	NO IWA	VT	1550	200	-	SAFETY INJECTION PUMP C, MFG-WORTHINGTON	R 06/93

QUALITY
 ASSURANCE
 MANUAL
 GINNA STATION

TITLE:
 APPENDIX B
 R. E. GINNA NUCLEAR POWER PLANT
 INSERVICE INSPECTION PROGRAM
 FOR THE 1990-1999 INTERVAL
 LINE LIST

Section 5	REV. 3
PAGE 58	of 96



R. E. GINNA NUCLEAR POWER PLANT
 Inservice Examination Boundary Line List
 Third Inspection Interval

P&ID No.: 33013-1262-1
 Class.: 2
 System.: SAFETY INJECTION
 Comp Type: PIPING

RG&E Line No.	Gübert Line No.	SWRI Line No.	ISI Fig.	Matl.	Size (in.)	Thkns (in.)	Exemption Basis	NDE Method	Po	Temp	In?	Line description/remarks	Revised
8C-SI-301	SI-400,8-SI-301	8-SI-2001	B-15	A312	8.00	0.322		SUR/VOL	200	200	Y	8A/8B-SI-301 TO 1ST 8" TEE.	R 06/93
8D-SI-301	SI-400,SI-301	8-SI-2003	B-16	A312	8.00	0.322		SUR/VOL	200	200	Y	8C-SI-301 TO TEE PAST VALVE 826B.	R 06/93
8E-SI-301	SI-400,8-SI-301	8-SI-2002	B-16	A312	8.00	0.322		SUR/VOL	200	200	Y	8C-SI-301 TO 1ST TEE PAST VALVE 826D.	R 06/93
8F-SI-301	SI-400,RHR-450	8-SI-2003	B-16A	A312	8.00	0.322		SUR/VOL	200	200	Y	8D/8E-SI-301 TO 1ST 8 X 4 RDGR.	R 06/93
8G-SI-301	RHR-450		B-19	A312	8.00	0.322		SUR/VOL	200	200	Y	8F-SI-301 TO VALVE 825A.	R 06/93
8H-SI-301	RHR-450		B-16	A312	8.00	0.322		SUR/VOL	200	200	-	8F-SI-301 TO VALVE 825B.	R 06/93
8J-SI-151			B-19		8.00	0.000		SUR/VOL				VALVE 825B TO 10-SI-151.	R 06/93
8L-SI-151			B-19		8.00	0.000		SUR/VOL				VALVE 825A TO 10-SI-151.	R 06/93
4-SI-301	RHR-450		B-16B	A312	4.00	0.237	IWC-1221(A)		200	200	Y	8F-SI-301 TO SI PUMP SUCTION A.	R 06/93
4A-SI-301	RHR-450		B-16B	A312	4.00	0.237	IWC-1221(A)		200	200	Y	8H-SI-301 TO SI PUMP SUCTION B.	R 06/93
4B-SI-301	RHR-450		B-16B	A312	4.00	0.237	IWC-1221(A)		200	200	Y	8G-SI-301 TO SI PUMP SUCTION C.	R 06/93
4C-SI-301	RHR-450		B-16B	A312	4.00	0.237	IWC-1221(A)		200	200	Y	4B-SI-301 TO 1816A.	R 06/93
4D-SI-1501	SI-300,SI-210		B-37	A312	4.00	0.337		SUR/VOL	1550	200	N	3A-SI-1501 THRU PEN 113 TO 4 X 4 X 3 TEE.	R 06/93
4E-SI-1501	SI-300,SI-110		B-42	A312	4.00	0.337		SUR/VOL	1550	200	-	3E-SI-1501 THRU PEN 101 TO 4 X 4 X 3 TEE.	R 06/93
3A-SI-1501	SI-300		B-37	A312	3.00	0.300		SUR/VOL	1550	200	-	SI PUMP A TO 4 X 3 RDGR AFTER VALVE 888A.	R 06/93
3B-SI-1501	SI-300		B-40	A312	3.00	0.300		SUR/VOL	1550	200	-	SI PUMP C PAST FLANGE TO 3" TEE.	R 06/93
3C-SI-1501	SI-300		B-41	A312	3.00	0.300		SUR/VOL	1550	200	-	3" TEE FROM 3B TO 871A, 870A, & 4D.	R 06/93
3D-SI-1501	SI-300		B-41	A312	3.00	0.300		SUR/VOL	1550	200	-	3" TEE FROM 3B TO 871B, 870B, & 4E.	R 06/93
3E-SI-1501	SI-300		B-42	A312	3.00	0.300		SUR/VOL	1550	200	-	SI PUMP B TO 4 X 3 RDGR AFTER VALVE 888B.	R 06/93
2E-SI-1501			B-54		2.00	0.000		SUR				SI PUMPS DISG RDGRS TO VALVE 8898 & 897.	R 06/93
1.5A-SI-1501	SI-300		B-37	A312	1.50	0.000	IWC-1221(B)		1550	200	-	2E-SI-1501 TO 3A-SI-1501.	R 06/93
1.5C-SI-1501	SI-300		B-54	A312	1.50	0.000	IWC-1221(B)		1550	200	-	3B-SI-1501 TO 2E-SI-1501.	R 06/93
1.5D-SI-1501	SI-300		B-42	A312	1.50	0.000	IWC-1221(B)		1550	200	-	3E-SI-1501 TO 2E-SI-1501.	R 06/93

QUALITY
 ASSURANCE
 MANUAL,
 GINNA STATION

TITLE:
 R. E. GINNA NUCLEAR POWER PLANT
 INSERVICE INSPECTION PROGRAM
 FOR THE 1990-1999 INTERVAL
 LINE LIST

Section 5
 REV. 3
 PAGE 59 of 96

[Faint, illegible text covering the majority of the page]



R. E. GINNA NUCLEAR POWER PLANT
 Inservice Examination Boundary Line List
 Third Inspection Interval

P&ID No.: 33013-1262-2
 Class.: 1
 System.: SAFETY INJECTION
 Comp Type: PIPING

<u>RG&E Line No.</u>	<u>Gilbert Line No.</u>	<u>SWRI Line No.</u>	<u>ISI Fig.</u>	<u>Matri.</u>	<u>Size (in.)</u>	<u>Thkns (in.)</u>	<u>Exemption Basis</u>	<u>NDE Method</u>	<u>Po</u>	<u>Temp</u>	<u>In?</u>	<u>Line description/remarks</u>	<u>Revised</u>
10A-SI2-2501-A	SI-100	10-SI-1005	A-17	A376	10.00	1.000	.	SUR/VOL			Y	CHECK VALVE 842B TO 867B.	R 06/93
10A-SI2-2501-B	SI-200	10-SI-1004	A-16	A376	10.00	1.000		SUR/VOL			Y	CHECK VALVE 842A TO 867A.	R 06/93
2A-SI2-2501	SI-110	2-SI-1001	A-19	A376	2.00	0.344		SUR			Y	878J TO 10" SI ACCUM B DUMP.	R 06/93
2B-SI2-2501	SI-210	2-SI-1002	A-21	A376	2.00	0.344		SUR			Y	VALVE 878F TO 877A.	R 06/93
2C-SI2-2501	SI-110,-111	2-SI-1001	A-20	A376	2.00	0.344		SUR			Y	VALVE 878H TO 877B.	R 06/93
2D-SI2-2501	SI-210	2-SI-1002	A-16	A376	2.00	0.344		SUR			Y	878G TO 10" SI ACCUM A DUMP.	R 06/93

QUALITY
 ASSURANCE
 MANUAL
 GINNA STATION

TITLE:
 APPENDIX B
 R. E. GINNA NUCLEAR POWER PLANT
 INSERVICE INSPECTION PROGRAM
 FOR THE 1990-1999 INTERVAL
 LINE LIST

Section 5	REV. 3
PAGE 60 of 96	

[Faint, illegible text scattered across the page, possibly bleed-through from the reverse side.]



R. E. GINNA NUCLEAR POWER PLANT
 Inservice Examination Boundary Line List
 Third Inspection Interval

P&ID No.: 33013-1262-2
 Class.: 2
 System.: SAFETY INJECTION
 Comp Type: COMPONENTS

<u>RG&E Line No.</u>	<u>Gilbert Line No.</u>	<u>SWRI Line No.</u>	<u>ISI Fig.</u>	<u>Matrl.</u>	<u>Size (in.)</u>	<u>Thkns (in.)</u>	<u>Exemption Basis</u>	<u>NDE Method</u>	<u>Po</u>	<u>Temp</u>	<u>In?</u>	<u>Line description/remarks</u>	<u>Revised</u>
TS103A	1262		N/A		0.00	0.000	IWC-1221(E)		740	80	-	SAFETY INJECTION ACCUMULATOR A.	R 06/93
TS103B	1262		N/A		0.00	0.000	IWC-1221(E)		740	80	-	SAFETY INJECTION ACCUMULATOR B.	R 06/93

QUALITY
 ASSURANCE
 MANUAL
 GINNA STATION

TITLE:
 APPENDIX B
 R. E. GINNA NUCLEAR POWER PLANT
 INSERVICE INSPECTION PROGRAM
 FOR THE 1990-1999 INTERVAL
 LINE LIST

Section 5	REV. 3
PAGE 61 of 96	

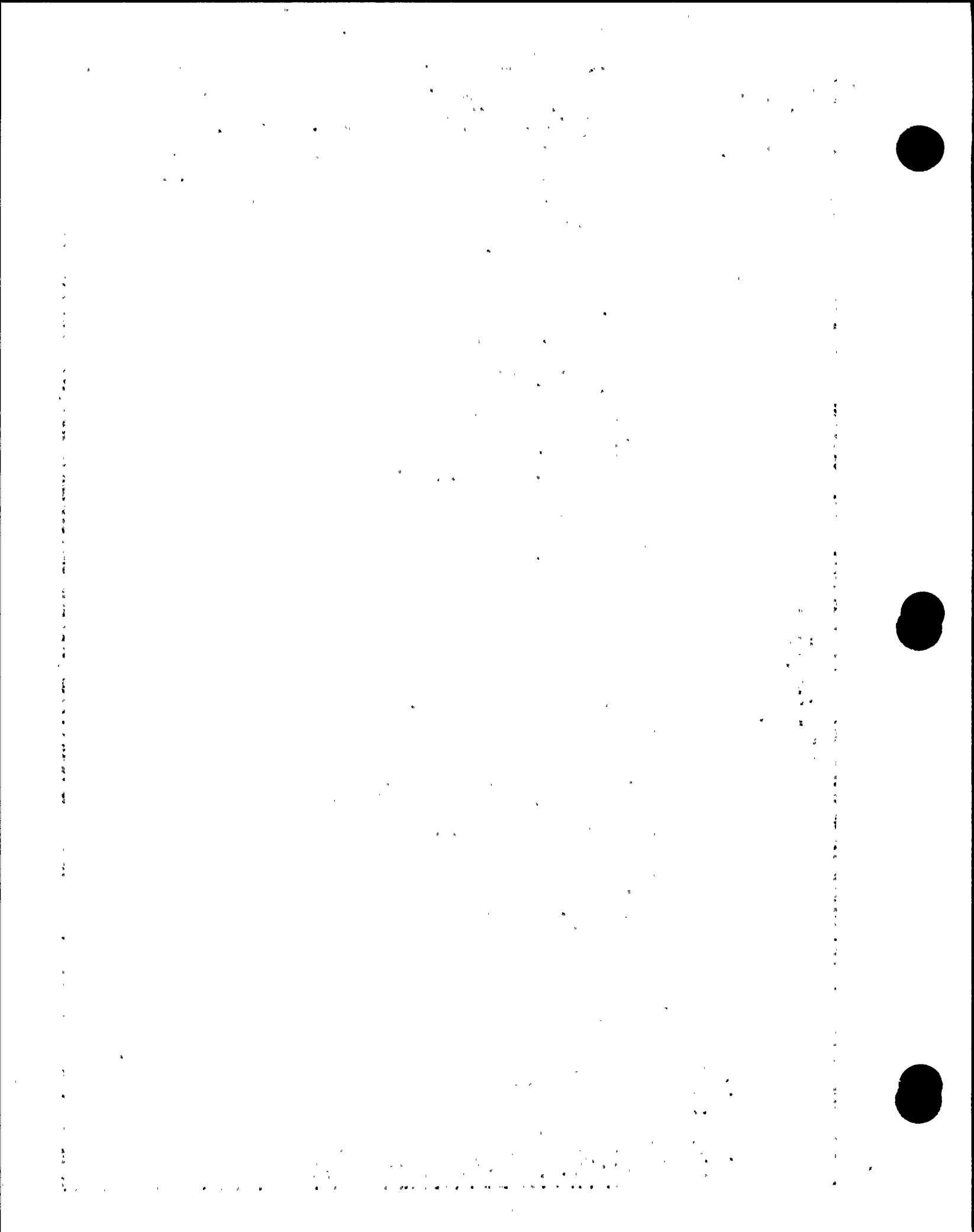

R. E. GINNA NUCLEAR POWER PLANT
Inservice Examination Boundary Line List
Third Inspection Interval

P&ID No.: 33013-1262-2
Class.: 2
System.: SAFETY INJECTION
Comp Type: PIPING

RG&E Line No.	Gilbert Line No.	SWRI Line No.	ISI Fig.	Matl.	Size (in.)	Thkns (in.)	Exemption Basis	NDE Method	Po	Temp	In?	Line description/remarks	Revised
10A-SI-902	SIS-200		N/A	A376	10.00	1.000	IWC-1221(E)		740	80	.	ACCUMULATOR 1 TO VALVE 841.	R 06/93
10B-SI-902	SIS-200		N/A	A376	10.00	1.000	IWC-1221(E)		740	80	.	10A-SI-902 TO CAP ON TEE .	R 06/93
10C-SI-2501	SIS-200		N/A	A376	10.00	1.000	IWC-1221(E)		740	80	.	VALVE 841 TO 842A INCLD CAP ON TEE .	R 06/93
10D-SI-902	SI-100		N/A	A376	10.00	1.000	IWC-1221(E)		740	80	Y	ACCUMULATOR 2 TO VALVE 865.	R 06/93
10E-SI-902	SI-100		N/A	A376	10.00	1.000	IWC-1221(E)		740	80	.	10D-SI-902 TO TEE CAP.	R 06/93
10F-SI-2501	SI-100		N/A	A376	10.00	1.000	IWC-1221(E)		740	80	.	VALVE 865 TO 842B INCLD CAP ON TEE .	R 06/93
2A-SI-1501	SI-210		B-39	A312	2.00	0.218		SUR	1550	200	N	4D-SI-1501 TO VALVE 878A.	R 06/93
2B-SI-1501	SI-210		B-39	A376	2.00	0.218		SUR	1550	200	N	4D-SI-1501 TO VALVE 878B.	R 06/93
2C-SI-1501	SI-110		B-45	A376	2.00	0.343		SUR	1550	200	Y	4" TEE ON 4E-SI-1501 TO VALVE 878D.	R 06/93
2D-SI-1501	SI-110		B-44	A312	2.00	0.218		SUR	1550	200	Y	4" TEE ON 4E-SI-1501 TO VALVE 878C.	R 06/93
2G-SI-902	SIS-200		N/A	A312	2.00	0.343	IWC-1221(E)		740	80	.	10A-SI-902 TO VALVE 844A.	R 06/93
2H-SI-902	SI-101		N/A	A312	2.00	0.154	IWC-1221(E)		740	80	.	10D-SI-902 TO VALVE 844B.	R 06/93
2I-SI-902			N/A	A312	2.00	0.154	IWC-1221(E)		740	80	.	ACCUMULATOR 1 PAST V 833A TO LT 939.	R 06/93
2J-SI-902			N/A	A312	2.00	0.154	IWC-1221(E)		740	80	.	LT 939 PAST V 833B TO ACCUMULATOR 1.	R 06/93
2K-SI-902			N/A	A312	2.00	0.154	IWC-1221(E)		740	80	.	ACCUMULATOR 1 PAST V 832A TO LT 938.	R 06/93
2L-SI-902			N/A	A312	2.00	0.154	IWC-1221(E)		740	80	.	LT 938 PAST V 832B TO ACCUMULATOR 1.	R 06/93
2M-SI-902			N/A	A312	2.00	0.154	IWC-1221(E)		740	80	.	ACCUMULATOR 2 PAST V 837A TO LT 934.	R 06/93
2N-SI-902			N/A	A312	2.00	0.154	IWC-1221(E)		740	80	.	LT 934 PAST V 837B TO ACCUMULATOR 2.	R 06/93
2P-SI-902			N/A	A312	2.00	0.154	IWC-1221(E)		740	80	.	ACCUMULATOR 2 PAST V 838A TO LT 935.	R 06/93
2Q-SI-902			N/A	A312	2.00	0.154	IWC-1221(E)		740	80	.	LT 935 PAST V 838B TO ACCUMULATOR 2.	R 06/93
2R-SI-2501			B-45		2.00	0.000		SUR				VALVE 878D TO VALVE 878J.	R 06/93
2S-SI-2501			B-44		2.00	0.000		SUR				VALVE 878C TO VALVE 878H.	R 06/93
2T-SI-2501			B-39		2.00	0.000		SUR				VALVE 878B TO VALVE 878G.	R 06/93
2U-SI-2501			B-39		2.00	0.000		SUR				VALVE 878A TO VALVE 878E.	R 06/93
2V-SI-902			N/A		2.00	0.000	IWC-1221(E)					DRAIN OFF 2G-SI-902.	R 06/93
2W-SI-902			N/A		2.00	0.000	IWC-1221(E)					DRAIN OFF 2H-SI-902.	R 06/93

QUALITY
ASSURANCE
MANUAL
GINNA STATION

TITLE:
APPENDIX B
R. E. GINNA NUCLEAR POWER PLANT
INSERVICE INSPECTION PROGRAM
FOR THE 1990-1999 INTERVAL
LINE LIST

Section 5
REV. 3

PAGE
62 of 96

[Faint, illegible text covering the majority of the page, possibly bleed-through from the reverse side.]



R. E. GINNA NUCLEAR POWER PLANT
Inservice Examination Boundary Line List
Third Inspection Interval

P&ID No.: 33013-1263
Class.: 3
System.: RCS OVERPRESS. PROT. N2 ACCUM.
Comp Type: COMPONENTS

<u>RG&E Line No.</u>	<u>Gilbert Line No.</u>	<u>SWRI Line No.</u>	<u>ISI Fig.</u>	<u>Matl.</u>	<u>Size (in.)</u>	<u>Thkns (in.)</u>	<u>Exemption Basis</u>	<u>NDE Method</u>	<u>Ps</u>	<u>Temp</u>	<u>In?</u>	<u>Line description/remarks</u>	<u>Revised</u>
TRC03A			N/A		0.00	0.000	IWD-1220.1					OVERPRESSURE PROTECTION ACCUMULATOR A.	R 06/93
TRC03B			N/A		0.00	0.000	IWD-1220.1					OVERPRESSURE PROTECTION ACCUMULATOR B.	R 06/93
TRC04A			N/A		0.00	0.000	IWD-1220.1					OVERPRESSURE PROTECTION N2 SURGE TANK A.	R 06/93
TRC04B			N/A		0.00	0.000	IWD-1220.1					OVERPRESSURE PROTECTION N2 SURGE TANK B.	R 06/93

QUALITY
ASSURANCE
MANUAL
GINNA STATION

TITLE:
APPENDIX B
R. E. GINNA NUCLEAR POWER PLANT
INSERVICE INSPECTION PROGRAM
FOR THE 1990-1999 INTERVAL
LINE LIST

Section 5	REV. 3
PAGE 63 of 96	

[Faint, illegible text covering the majority of the page, possibly bleed-through from the reverse side.]



R. E. GINNA NUCLEAR POWER PLANT
 Inservice Examination Boundary Line List
 Third Inspection Interval

P&ID No.: 33013-1264
 Class.: 1
 System.: CVCS-LETDOWN
 Comp Type: COMPONENTS

<u>RG&E Line No.</u>	<u>Gilbert Line No.</u>	<u>SWRI Line No.</u>	<u>ISI Fig.</u>	<u>Matl.</u>	<u>Size (in.)</u>	<u>Thkns (in.)</u>	<u>Exemption Basis</u>	<u>NDE Method</u>	<u>Pa</u>	<u>Temp</u>	<u>In?</u>	<u>Line description/remarks</u>	<u>Revised</u>
ECH02A			A-8		0.00	0.000		VOL			.	THIS COMP ACCOUNTED FOR ON 33013-1265.	R 01/92
ECH02B			A-8		0.00	0.000		VOL			.	THIS COMP ACCOUNTED FOR ON 33013-1265.	R 01/92
ECH02C			A-8		0.00	0.000		VOL			.	THIS COMP ACCOUNTED FOR ON 33013-1265	R 01/92
ECH03			N/A		0.00	0.000	IWB-1220(B)					EXCESS LETDOWN HEAT EXCHANGER.	A 11/91

QUALITY
 ASSURANCE
 MANUAL
 GINNA STATION

TITLE:
 APPENDIX B
 R. E. GINNA NUCLEAR POWER PLANT
 INSERVICE INSPECTION PROGRAM
 FOR THE 1990-1999 INTERVAL
 LINE LIST

Section 5	REV. 3
PAGE 64 of 96	

[Faint, illegible text covering the majority of the page, possibly bleed-through from the reverse side.]



R. E. GINNA NUCLEAR POWER PLANT
 Inservice Examination Boundary Line List
 Third Inspection Interval

PAID No.: 33013-1264
 Class.: 1
 System.: CVCS-LETDOWN
 Comp Type: PIPING

<u>RG&E Line No.</u>	<u>Gilbert Line No.</u>	<u>SWRI Line No.</u>	<u>ISI Fig.</u>	<u>Matl.</u>	<u>Size (in.)</u>	<u>Thkns (in.)</u>	<u>Exemption Basis</u>	<u>NDE Method</u>	<u>Po</u>	<u>Temp</u>	<u>In?</u>	<u>Line description/remarks</u>	<u>Revised</u>
2A-CH4-2501	CVC-730	2-LD-1002	A-23	A376	2.00	0.344	.	SUR			Y	CVCSV LETDOWN FROM 427 TO 2204, THRU RHES	R 11/91
2B-CH4-2501		2-LD-1003	A-24	A376	2.00	0.344		SUR			Y	RHES TO 200A, 200B, 202.	R 11/91

QUALITY
 ASSURANCE
 MANUAL
 GINNA STATION

TITLE:
 APPENDIX B
 R. E. GINNA NUCLEAR POWER PLANT
 INSERVICE INSPECTION PROGRAM
 FOR THE 1990-1999 INTERVAL
 LINE LIST

Section 5	REV. 3
PAGE 65 of 96	

R. E. GINNA NUCLEAR POWER PLANT
 Inservice Examination Boundary Line List
 Third Inspection Interval

PAID No.: 33013-1264
 Class.: 2
 System.: CVCS-LETDOWN
 Comp Type: PIPING

<u>RG&E Line No.</u>	<u>Gilbert Line No.</u>	<u>SWRI Line No.</u>	<u>ISI Fig.</u>	<u>Matl.</u>	<u>Size (in.)</u>	<u>Thkns (in.)</u>	<u>Exemption Basis</u>	<u>NDE Method</u>	<u>Po</u>	<u>Temp</u>	<u>In?</u>	<u>Line description/remarks</u>	<u>Revised</u>
2A-CH-601	CVC-105		N/A	A312	2.00	0.154	IWC-1222(A)		250	350	Y	VALVE 200A TO 1ST 2 X 2 X 2 TEE.	
2B-CH-601	CVC-105		N/A	A312	2.00	0.154	IWC-1222(A)		250	350	Y	VALVE 200B TO 1ST 2" TEE ON 2A-CH-601.	
2C-CH-601	CVC-105		B-32	A312	2.00	0.154	IWC-1222(A)		250	350	Y	2" TEE ON 2A-CH-601 TO 2G-CH-601.	R 06/93
2D-CH-601	CVC-105		N/A	A312	2.00	0.154	IWC-1222(A)		250	350	Y	VALVE 202 TO LINE 2C-CH-601.	
2E-CH-601	CVC-105		B-32	A312	2.00	0.154	IWC-1222(A)		250	350	Y	2C-CH-601 TO VALVE 203.	
2F-CH-601	CVC-100		N/A	A312	2.00	0.154	IWC-1222(A)		250	350	Y	2F-AC-601 TO 2" TEE PAST VALVE HCV-133.	R 11/91
2G-CH-601	CVC-100		B-32	A312	2.00	0.154	IWC-1222(A)		250	350	Y	2" TEE ON 2C-CH-601 TO PEN 112, VLV 371.	R 06/93

QUALITY
 ASSURANCE
 MANUAL
 GINNA STATION

TITLE:
 R. E. GINNA NUCLEAR POWER PLANT
 INSERVICE INSPECTION PROGRAM
 FOR THE 1990-1999 INTERVAL
 LINE LIST

Section 5

REV.
3

PAGE

66 of 96

1950

1950



R. E. GINNA NUCLEAR POWER PLANT
 Inservice Examination Boundary Line List
 Third Inspection Interval

P&ID No.: 33013-1265-1
 Class.: 1
 System.: CVCS-CHARGING
 Comp Type: COMPONENTS

<u>RG&E Line No.</u>	<u>Gilbert Line No.</u>	<u>SWRI Line No.</u>	<u>ISI Fig.</u>	<u>Matl.</u>	<u>Size (in.)</u>	<u>Thkns (in.)</u>	<u>Exemption Basis</u>	<u>NDE Method</u>	<u>Po</u>	<u>Temp</u>	<u>In?</u>	<u>Line description/remarks</u>	<u>Revised</u>
PRC01A			A-7		0.00	0.000		SUR/VOL				THIS PUMP ACCOUNTED FOR ON 33013-1260.	R 06/93
PRC01B			A-7		0.00	0.000		SUR/VOL				THIS PUMP ACCOUNTED FOR ON 33013-1260.	R 06/93

QUALITY
 ASSURANCE
 MANUAL
 GINNA STATION

TITLE:
 APPENDIX B
 R. E. GINNA NUCLEAR POWER PLANT
 INSERVICE INSPECTION PROGRAM
 FOR THE 1990-1999 INTERVAL
 LINE LIST

Section 5
 PAGE 67 of 96
 REV. 3

R. E. GINNA NUCLEAR POWER PLANT
 Inservice Examination Boundary Line List
 Third Inspection Interval

P&ID No.: 33013-1265-1
 Class.: 1
 System.: CVCS-CHARGING
 Comp Type: PIPING

<u>RG&E Line No.</u>	<u>Gilbert Line No.</u>	<u>SWRI Line No.</u>	<u>ISI Fig.</u>	<u>Matrl.</u>	<u>Size (in.)</u>	<u>Thkns (in.)</u>	<u>Exemption Basis</u>	<u>NDE Method</u>	<u>Po</u>	<u>Temp</u>	<u>In?</u>	<u>Line description/remarks</u>	<u>Revised</u>
2-CHS-2501	RC-300;CVC-700	2-AS-1001	A-11	A376	2.00	0.344		SUR			Y	CVCS AUX SPRAY FROM 9313 TO 297.	R 06/93
2A-CHS-2501	CVC-700;701	2-ACH-1002	A-27	A376	2.00	0.344		SUR			Y	CVCS ALT CHARGING FROM 9315 TO 393.	R 06/93
2B-CHS-2501			A-25	A376	2.00	0.344		SUR			Y	CVCS CHARGING FROM 9314 TO 295.	R 06/93
2C-CHS-2502	CVC-400;401	2-ACH-1001	A-26	A376	2.00	0.344		SUR			Y	CVCS ALT CHARG FROM 392B TO 383A.	R 06/93
2H-CHS-2501			A-32		2.00	0.344		SUR				VALVE 302C TO RCP-B.	A 06/93
2H-CHS-2502			A-32A		2.00	0.344		SUR				VALVE 304B TO VALVE 302C.	A 06/93
2I-CHS-2501			A-31		2.00	0.344		SUR				VALVE 302D TO RCP-A.	A 06/93
2I-CHS-2502			A-31A		2.00	0.344		SUR				VALVE 304A TO VALVE 302D.	A 06/93

QUALITY
 ASSURANCE
 MANUAL
 GINNA STATION

TITLE:
 APPENDIX B
 R. E. GINNA NUCLEAR POWER PLANT
 INSERVICE INSPECTION PROGRAM
 FOR THE 1990-1999 INTERVAL
 LINE LIST

Section 5
 PAGE 68 of 96

REV.
 3

1950

1951

1952

1953

1954

1955

1956

1957

1958

1959

1960

1961

1962



R. E. GINNA NUCLEAR POWER PLANT
Inservice Examination Boundary Line List
Third Inspection Interval

P&ID No.: 33013-1265-1
Class.: 2
System.: CVCS-CHARGING
Comp Type: COMPONENTS

<u>RG&E Line No.</u>	<u>Gilbert Line No.</u>	<u>SWRI Line No.</u>	<u>ISI Fig.</u>	<u>Matl.</u>	<u>Size (in.)</u>	<u>Thkns (in.)</u>	<u>Exemption Basis</u>	<u>NDE Method</u>	<u>Po</u>	<u>Temp</u>	<u>In?</u>	<u>Line description/remarks</u>	<u>Revised</u>
ECH02A			A-8		0.00	0.000	IWC-1222(A)		2300	525	-	REGENERATIVE HEAT EXCHANGER A.	R 06/93
ECH02B			A-8		0.00	0.000	IWC-1222(A)		2300	525	-	REGENERATIVE HEAT EXCHANGER B.	R 06/93
ECH02C			A-8		0.00	0.000	IWC-1222(A)		2300	525	-	REGENERATIVE HEAT EXCHANGER C.	R 06/93
FCH08	1265		B-7		0.00	0.000	IWC-1222(A)		2450	100	-	SEAL INJECTION FILTER A.	R 06/93
FCH09	1265		B-7		0.00	0.000	IWC-1222(A)		2450	1007	-	SEAL INJECTION FILTER B.	R 06/93

QUALITY
ASSURANCE
MANUAL
GINNA STATION

TITLE:
APPENDIX B
R. E. GINNA NUCLEAR POWER PLANT
INSERVICE INSPECTION PROGRAM
FOR THE 1990-1999 INTERVAL
LINE LIST

Section 5
PAGE 69 of 96
REV. 3

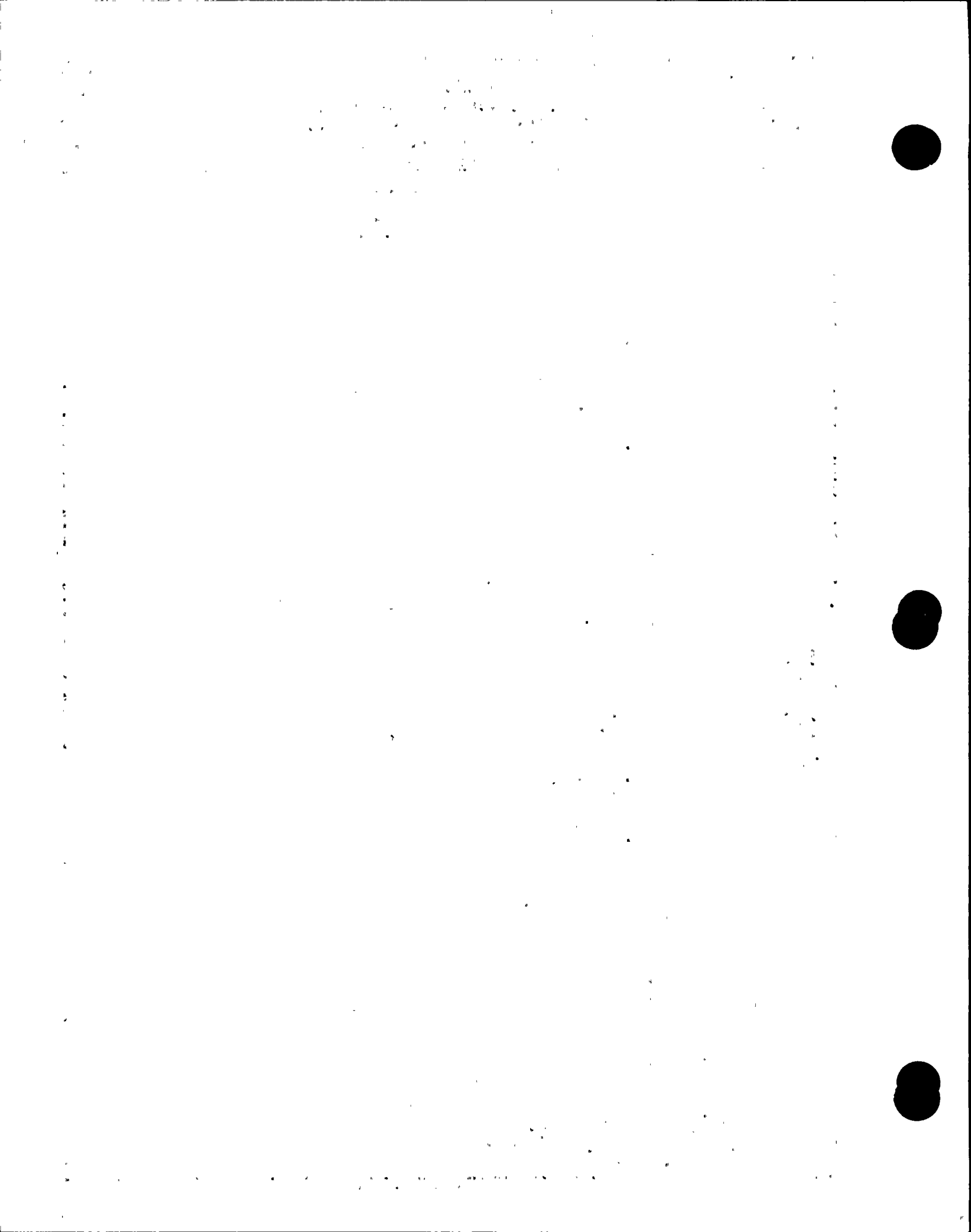

R. E. GINNA NUCLEAR POWER PLANT
Inservce Examination Boundary Line List
Third Inspection Interval

P&ID No.: 33013-1265-1
Class.: 2
System.: CVCS-CHARGING
Comp Type: PIPING

RG&E Line No.	Gilbert Line No.	SWRI Line No.	ISI Fig.	Matrl Matrl	Size (in.)	Thkns (in.)	Exemption Basis	NDE Method	Po	Temp	In?	Line description/remarks	Revised
3Q-CH-2502	CVC-1100		N/A	A312	3.00	0.438	IWC-1222(A)		2450	100	Y	2" TEE ON 3N-CH-2502 PAST VALVE 275.	R 06/93
3R-CH-151	CVC-200		N/A	A312	3.00	0.120	IWC-1222(A)		140	40	Y	PEN 108 TO 3 X 2 REDUCER.	R 06/93
3R-CH-2502	CVC-1100		N/A	A312	3.00	0.438	IWC-1222(A)		2450	100	Y	2" TEE ON 3Q-CH-2502 TO 1ST 2" RDCR TEE .	R 06/93
2AA-CH-2502	CVC-600,CVC-601		A-31A	A312	2.00	0.344	IWC-1222(A)		2450	100	Y	PEN 106 TO VALVE 304A.	R 06/93
2AB-CH-2502	CVC-500,CVC-501		A-32A	A312	2.00	0.344	IWC-1222(A)		2450	100	Y	PEN 110 TO VALVE 304B.	R 06/93
2AV-CH-151	CVC-200		N/A	A312	2.00	0.109	IWC-1222(A)		140	40	Y	3R-CH-151 TO VALVES 362A & 385A.	R 06/93
2D-CHS-2501			A-29		2.00	0.000	IWC-1222(A)					REGEN HEAT EXCHANGER TO VALVE 9314.	R 06/93
2E-CHS-2501			A-11		2.00	0.000	IWC-1222(A)					2D-CHS-2501 TO VALVE 9313.	R 06/93
2F-CHS-2501			A-27		2.00	0.000	IWC-1222(A)					2D-CHS-2501 TO VALVE 9315.	R 06/93
2G-CHS-2502			A-30		2.00	0.000	IWC-1222(A)					REGEN HES TO VALVE 370B.	R 06/93
2H-CH-2502	CVC-1100		N/A	A312	2.00	0.343	IWC-1222(A)		2450	100	Y	3Q-CH-2502 PAST VALVE 323 TO PEN 102.	R 06/93
2I-CH-2502	CVC-1100		N/A	A312	2.00	0.344	IWC-1222(A)		2450	100	Y	2" RDCR TEE ON 3R-CH-2502 TO PEN 110.	R 06/93
2J-CH-2502	CVC-1100		N/A	A312	2.00	0.344	IWC-1222(A)		2450	100	Y	2" RDCR TEE 3R-CH-2502 TO PEN 106.	R 06/93
2K-CH-2502	CVC-1100		N/A	A312	2.00	0.344	IWC-1222(A)		2450	100	Y	2" TEE ON 3N-CH-2502 TO FCH09.	R 06/93
2L-CH-2502	CVC-1100		N/A	A312	2.00	0.344	IWC-1222(A)		2450	100	Y	2K-CH-2502 PAST VALVE 303B TO SW FIL 2.	R 06/93
2M-CH-2502	CVC-1100		N/A	A312	2.00	0.344	IWC-1222(A)		2450	100	Y	2" TEE ON 3Q-CH-2502 TO FCH09.	R 06/93
2N-CH-2502	CVC-1100		N/A	A312	2.00	0.344	IWC-1222(A)		2450	100	Y	2M-CH-2502 PAST VALVE 303A TO FCH08.	R 06/93
2P-CH-2501			B-34		2.00	0.000	IWC-1222(A)					2AV-CH-151 TO RC PUMP A.	R 06/93
2T-CH-151	CVC-200		SS-1	A312	2.00	0.109	IWC-1222(A)		140	40	Y	3R-CH-151 TO VALVE 314.	R 06/93
2V-CH-151	CVC-200		N/A	A312	2.00	0.109	IWC-1222(A)		140	40	Y	2AV-CH-151 TO 2 X .75 RDCR.	R 06/93
2W-CH-151	CVC-200		SS-1	A312	2.00	0.109	IWC-1222(A)		140	40	Y	3" RDCR ON 3R-CH-151 TO VALVE 362B.	R 06/93
2X-CH-2501	CVC-700		S-3	A376	2.00	0.344	IWC-1222(A)		140	40	Y	VALVE 362B PAST VALVE 270B TO RC PMP 1B.	R 06/93
2Z-CH-2502	CVC-400,CVC-402		N/A	A312	2.00	0.344	IWC-1222(A)		2450	100	Y	PEN 102 TO VALVE 392B.	R 06/93

QUALITY
ASSURANCE
MANUAL
GINNA STATION

TITLE:
APPENDIX B
R. E. GINNA NUCLEAR POWER PLANT
INSERVICE INSPECTION PROGRAM
FOR THE 1990-1999 INTERVAL
LINE LIST

Section 5

PAGE
70 of 96

REV.
3



R. E. GENNA NUCLEAR POWER PLANT
 Inservice Examination Boundary Line List
 Third Inspection Interval

P&ID No.: 33013-1265-2
 Class.: 2
 System.: CVCS-CHARGING
 Comp Type: COMPONENTS

<u>RG&E Line No.</u>	<u>Gilbert Line No.</u>	<u>SWRI Line No.</u>	<u>ISI Fig.</u>	<u>Matl.</u>	<u>Size (In.)</u>	<u>Thkns (In.)</u>	<u>Exemption Basis</u>	<u>NDE Method</u>	<u>Po</u>	<u>Temp</u>	<u>In?</u>	<u>Line description/remarks</u>	<u>Revised</u>
PCH01A	1265		N/A		0.00	0.000	IWC-1222(A)		2450	100	-	CHARGING PUMP A, MFG-AJAX.	R 06/93
PCH01B	1265		N/A		0.00	0.000	IWC-1222(A)		2450	100	-	CHARGING PUMP B, MFG-AJAX.	R 06/93
PCH01C	1265		N/A		0.00	0.000	IWC-1222(A)		2450	100	-	CHARGING PUMP C, MFG-AJAX.	R 06/93
SCH11	1265		B-6		0.00	0.000		SUR/VOL	2450	100	-	24" CHARGING PUMP PULSE DAMPENER.	R 06/93

QUALITY
 ASSURANCE
 MANUAL
 GINNA STATION

TITLE:
 APPENDIX B
 R. E. GENNA NUCLEAR POWER PLANT
 INSERVICE INSPECTION PROGRAM
 FOR THE 1990-1999 INTERVAL
 LINE LIST

Section 5	REV. 3
PAGE 71	of 96

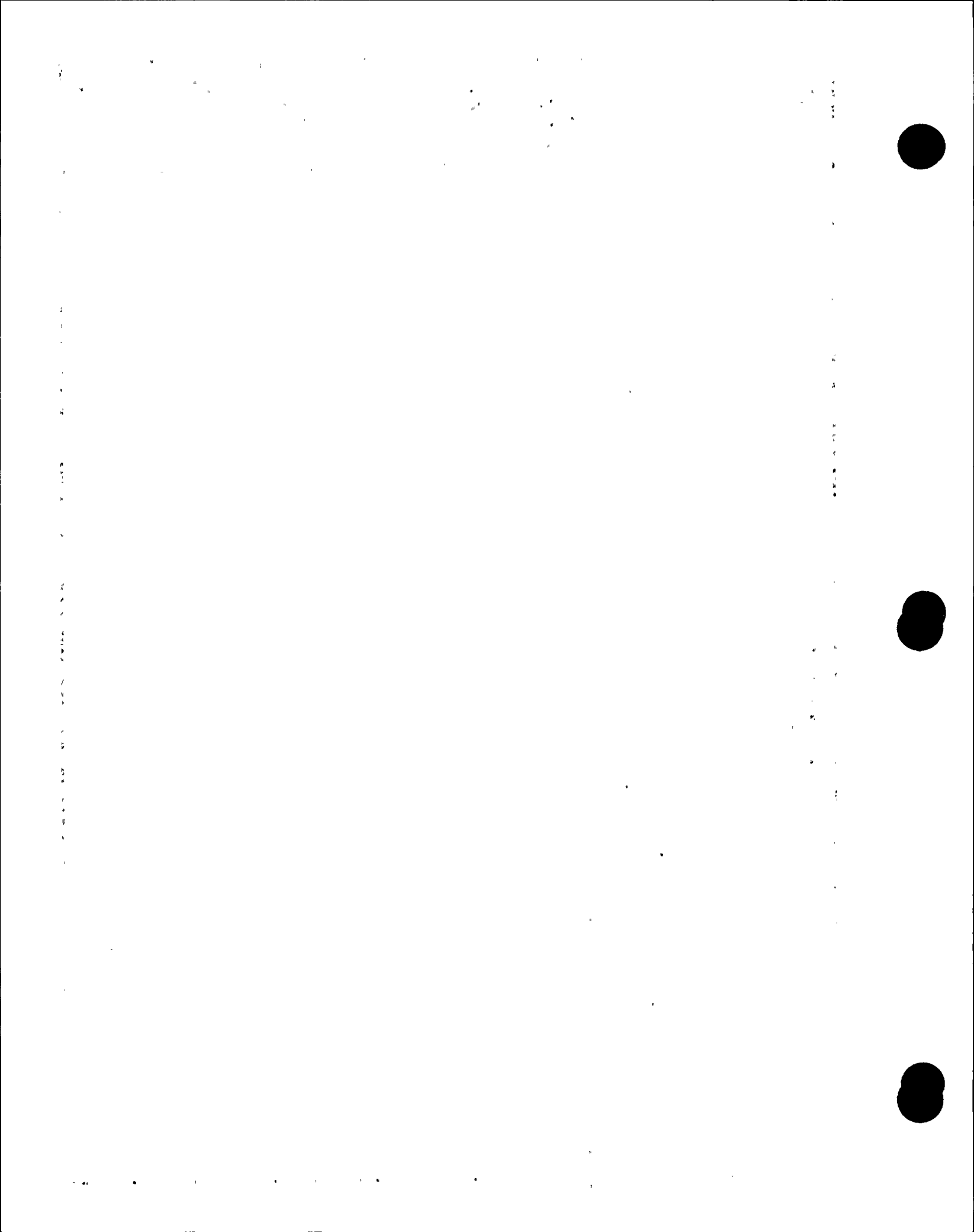

R. E. GINNA NUCLEAR POWER PLANT
Inservice Examination Boundary Line List
Third Inspection Interval

P&ID No.: 33013-1265-2
Class.: 2
System.: CVCS-CHARGING
Comp Type: PIPING

RG&E Line No.	Gilbert Line No.	SWRI Line No.	ISI Fig.	Matri. Matri.	Size (in.)	Thkns (in.)	Exemption Basis	NDE Method	Po	Temp	In?	Line description/remarks	Revised
8A-CH-2502	CVC-851	PULSE DAMPENER	B-6	A312	8.00	0.906		SUR/VOL	2450	100	Y	3" TEE ON 3K-CH-2502 TO PULSE DAMPENER.	R 06/93
8B-CH-2502	CVC-852	PULSE DAMPENER	B-6	A312	8.00	0.906		SUR/VOL	2450	100	Y	3" TEE ON 3L-CH-2502 TO PULSE DAMPENER.	R 06/93
8C-CH-2502	CVC-853	PULSE DAMPENER	B-6	A312	8.00	0.906		SUR/VOL	2450	100	Y	3" TEE ON 3M-CH-2502 TO PULSE DAMPENER.	R 06/93
4-CH-151	CVC-1200		N/A	A312	4.00	0.120	IWC-1221(A)		30	100	-	4B-CH-151 PAST VALVE 357 TO RWST.	R 06/93
4D-CH-151			N/A		4.00	0.000	IWC-1222(A)					4C-CH-151 THRU 358 TO 4-CH-151.	R 06/93
3G-CH-151	CVC-1000		N/A	A312	3.00	0.120	IWC-1222(A)		40	140	-	VALVE 313 TO PEN 108.	R 06/93
3K-CH-2502	CVC-851		B-6	A312	3.00	0.437	IWC-1222(A)		2450	100	-	CHG PUMP 1 DISCHG PAST VALVE 287 TO TEE .	R 06/93
3L-CH-2502	CVC-852		B-6	A312	3.00	0.437	IWC-1222(A)		2450	100	-	CHG PUMP 2 DISCHG PAST VALVE 288 TO TEE .	R 06/93
3M-CH-2502	CVC-853		B-6	A312	3.00	0.437	IWC-1222(A)		2450	100	-	CHG PUMP 3 DISCHG PAST VALVE 291 TO TEE .	R 06/93
3N-CH-2502	CVC-1000		N/A	A312	3.00	0.438	IWC-1222(A)		2450	100	Y	PULSE DAMPENER PAST VALVE 289 TO 1ST TEE	R 06/93
3P-CH-2502			N/A	A312	3.00	0.438	IWC-1222(A)		2450	100	Y	PULSE DAMPENER PAST VALVE 290 PUL DAMP.	R 06/93
2F-CH-2502	CVC-800		N/A	A312	2.00	0.344	IWC-1222(A)		2450	100	Y	PULSE DAMPER TO CHECK VALVE 370B.	R 06/93
2G-CH-2502	CVC-800		N/A	A312	2.00	0.344	IWC-1222(A)		2450	100	Y	2F-CH-2502 THRU 384C TO DAMPER.	R 06/93

QUALITY
ASSURANCE
MANUAL
GINNA STATION

TITLE:
R. E. GINNA NUCLEAR POWER PLANT
INSERVICE INSPECTION PROGRAM
FOR THE 1990-1999 INTERVAL
LINE LIST

Section 5	REV. 3
PAGE 72 of 96	

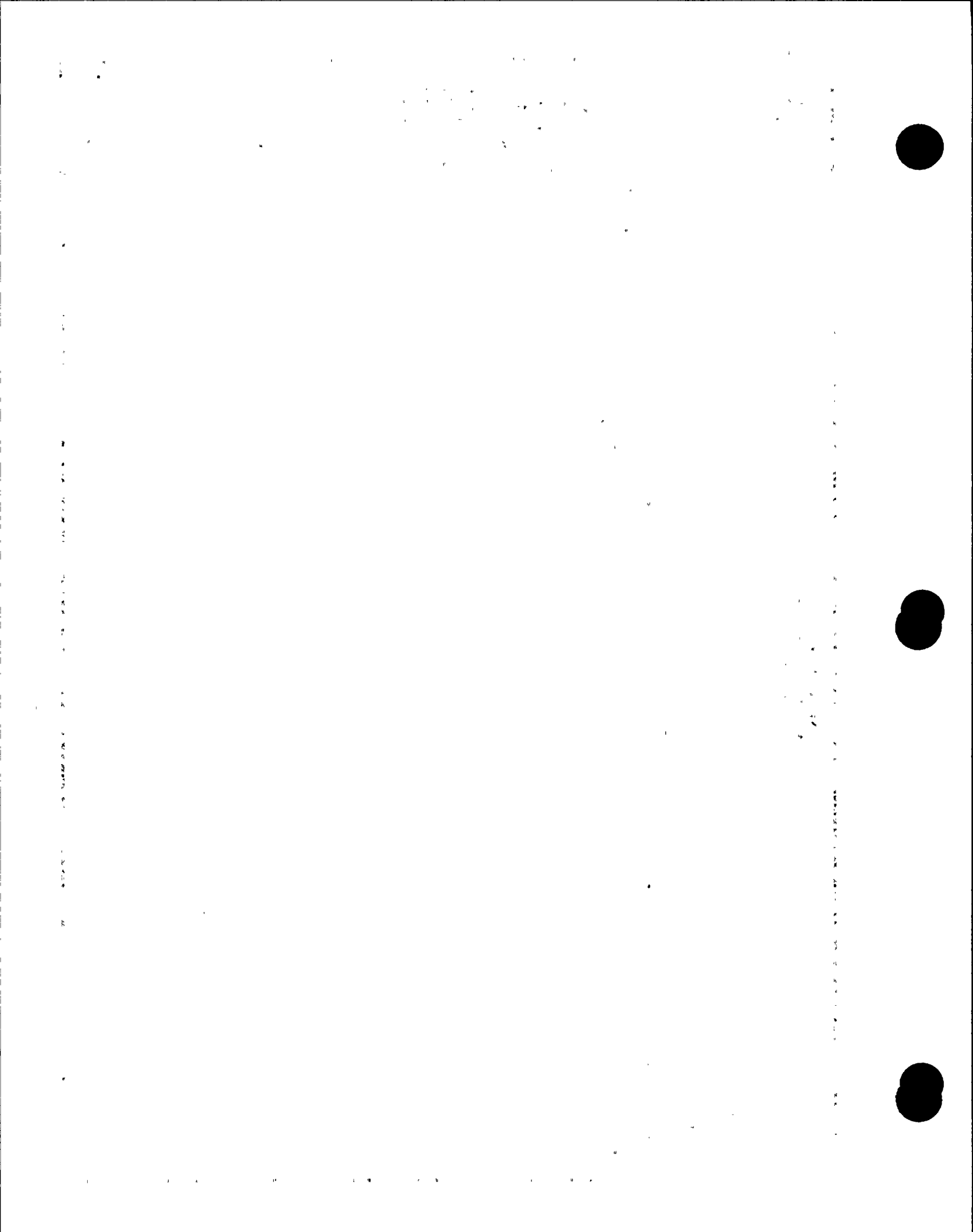

R. E. GINNA NUCLEAR POWER PLANT
 Inservice Examination Boundary Line List
 Third Inspection Interval

P&ID No.: 33013-1266
 Class.: 2
 System.: CVCS-BORIC ACID
 Comp Type: COMPONENTS

<u>RG&E Line No.</u>	<u>Gilbert Line No.</u>	<u>SWRI Line No.</u>	<u>ISI Fig.</u>	<u>Matl.</u>	<u>Size (in.)</u>	<u>Thkns (in.)</u>	<u>Exemption Basis</u>	<u>NDE Method</u>	<u>Po</u>	<u>Temp</u>	<u>In?</u>	<u>Line description/remarks</u>	<u>Revised</u>
TCH07A	1266		N/A		0.00	0.000	NOT SECT XI		5	210	-	BORIC ACID STORAGE TANK A.	R 11/91
TCH07B	1266		N/A		0.00	0.000	NOT SECT XI		5	210	-	BORIC ACID STORAGE TANK B.	R 11/91

QUALITY
 ASSURANCE
 MANUAL
 GINNA STATION

TITLE:
 APPENDIX B
 R. E. GINNA NUCLEAR POWER PLANT
 INSERVICE INSPECTION PROGRAM
 FOR THE 1990-1999 INTERVAL
 LINE LIST

Section 5
 PAGE 73 of 96

REV.
 3

R. E. GINNA NUCLEAR POWER PLANT
Inservice Examination Boundary Line List
Third Inspection Interval

P&ID No.: 33013-1266
Class.: 2
System.: CVCS-BORIC ACID
Comp Type: PIPING

RG&E Line No.	Gilbert Line No.	SWRI Line No.	ISI Fig.	Mtrl.	Size (in.)	Thkns (in.)	Exemption Basis	NDE Method	Po	Temp	In?	Line description/remarks	Revised
8A-SI-301B	SI-400	8-SI-2001	B-15	A312	8.00	0.322		SUR/VOL	5	210	Y	BORIC ACID TANK B TO 8 X 8 X 8 TEE .	R 11/91
8B-SI-301A	SI-400	8-SI-2001	B-15	A312	8.00	0.322		SUR/VOL	5	210	Y	BORIC ACID TANK A TO 8 X 8 X 8 TEE .	R 11/91
3A-CH-151A	SI-400		N/A		3.00	0.000	IWC-1221(A)		5	210	Y	BORIC ACID TANK A TO LOOP SEAL FLANGE.	R 11/91
3B-CH-151B	SI-400		N/A	A312	3.00	0.120	IWC-1221(A)		5	210	Y	BORIC ACID TANK B TO LOOP SEAL FLANGE.	R 11/91
2A-SI-151B	SI-400		B-15	A312	2.00	0.154	IWC-1221(A)		5	210	Y	8 X 8 X 2 TEE ON 8A-SI-301B TO VALVE 345.	R 11/91
2B-CH-151B	SI-400		N/A	A312	2.00	0.154	IWC-1221(A)		5	210	Y	BORIC ACID TANK B TO HCV 105.	
2C-SI-151A	SI-400		B-15	A312	2.00	0.154	IWC-1221(A)		5	210	Y	8 X 8 X 2 TEE ON 8B-SI-301A TO VALVE 331.	R 11/91
2D-CH-151A	SI-400		N/A	A312	2.00	0.154	IWC-1221(A)		5	210	Y	BORIC ACID TANK A TO HCV 104.	

QUALITY
ASSURANCE
MANUAL
GINNA STATION

TITLE:
APPENDIX B
R. E. GINNA NUCLEAR POWER PLANT
INSERVICE INSPECTION PROGRAM
FOR THE 1990-1999 INTERVAL
LINE LIST

Section 5
PAGE

74 of 96

REV.
3



R. E. GINNA NUCLEAR POWER PLANT
 Inservice Examination Boundary Line List
 Third Inspection Interval

P&ID No.: 33013-1270-1
 Class.: 3
 System.: WASTE DISPOSAL-LIQUID DRAINS
 Comp Type: COMPONENTS

<u>RG&E Line No.</u>	<u>Gilbert Line No.</u>	<u>SWRI Line No.</u>	<u>ISI Fig.</u>	<u>Matri.</u>	<u>Size (in.)</u>	<u>Thkns (in.)</u>	<u>Exemption Basis</u>	<u>NDE Method</u>	<u>Ps</u>	<u>Temp</u>	<u>In?</u>	<u>Line description/remarks</u>	<u>Revised</u>
FWD03			N/A		0.00	0.000	IWD-1220.2		<275	<200		ULTRA FILTRATION SYSTEM.	R 06/93
FWD09			N/A		0.00	0.000	IWD-1220.2		<275	<200		WASTE FILTER.	R 06/93
PWD12			N/A		0.00	0.000	IWD-1220.2		<275	<200		WASTE HOLDUP TANK PUMP.	R 06/93
TWD10			N/A		0.00	0.000	IWD-1220.2		<275	<200		WASTE HOLDUP TANK.	R 06/93

QUALITY
 ASSURANCE
 MANUAL.
 GINNA STATION

TITLE:
 APPENDIX B
 R. E. GINNA NUCLEAR POWER PLANT
 INSERVICE INSPECTION PROGRAM
 FOR THE 1990-1999 INTERVAL
 LINE LIST

Section 5	REV. 3
PAGE 75 of 96	

[Faint, illegible text covering the majority of the page, possibly bleed-through from the reverse side.]



R. E. GINNA NUCLEAR POWER PLANT
 Inservice Examination Boundary Line List
 Third Inspection Interval

P&ID No.: 33013-1270-1
 Class: 3
 System: WASTE DISPOSAL-LIQUID DRAINS
 Comp Type: PIPING

<u>RG&E Line No.</u>	<u>Gilbert Line No.</u>	<u>SWRI Line No.</u>	<u>ISI Fig.</u>	<u>Matrl.</u>	<u>Size (in.)</u>	<u>Thkns (in.)</u>	<u>Exemption Basis</u>	<u>NDE Method</u>	<u>Po</u>	<u>Temp</u>	<u>In?</u>	<u>Line description/remarks</u>	<u>Revised</u>
2A-WDO-151			N/A		2.00	0.145	IWD-1220.1				?	WST HOLDUP TK TO 1792, WHT PUMP, & 1610A	R 06/93

QUALITY
 ASSURANCE
 MANUAL
 GINNA STATION

TITLE:
 APPENDIX B
 R. E. GINNA NUCLEAR POWER PLANT
 INSERVICE INSPECTION PROGRAM
 FOR THE 1990-1999 INTERVAL
 LINE LIST

Section 5
 PAGE 76 of 96
 REV. 3

Faint, illegible text scattered across the page, possibly bleed-through from the reverse side.



R. E. GINNA NUCLEAR POWER PLANT
 Inservice Examination Boundary Line List
 Third Inspection Interval

P&ID No.: 33013-1272-1
 Class.: 3
 System.: WASTE DISPOSAL-LIQ-RC DRAIN TK
 Comp Type: PIPING

<u>RG&E Line No.</u>	<u>Gilbert Line No.</u>	<u>SWRI Line No.</u>	<u>ISI Fig.</u>	<u>Matrl.</u>	<u>Size (in.)</u>	<u>Thkns (in.)</u>	<u>Exemption Basis</u>	<u>NDE Method</u>	<u>Pa</u>	<u>Temp</u>	<u>In?</u>	<u>Line description/remarks</u>	<u>Revised</u>
4-WD2-151			N/A		4.00	0.000	IWD-1220.1				?	FUEL TRANSFER CANAL TO VALVE 1711.	R 06/93

QUALITY
 ASSURANCE
 MANUAL
 GINNA STATION

TITLE:
 APPENDIX B
 R.E. GINNA NUCLEAR POWER PLANT
 INSERVICE INSPECTION PROGRAM
 FOR THE 1990-1999 INTERVAL
 LINE LIST

Section 5	REV. 3
PAGE 77	of 96

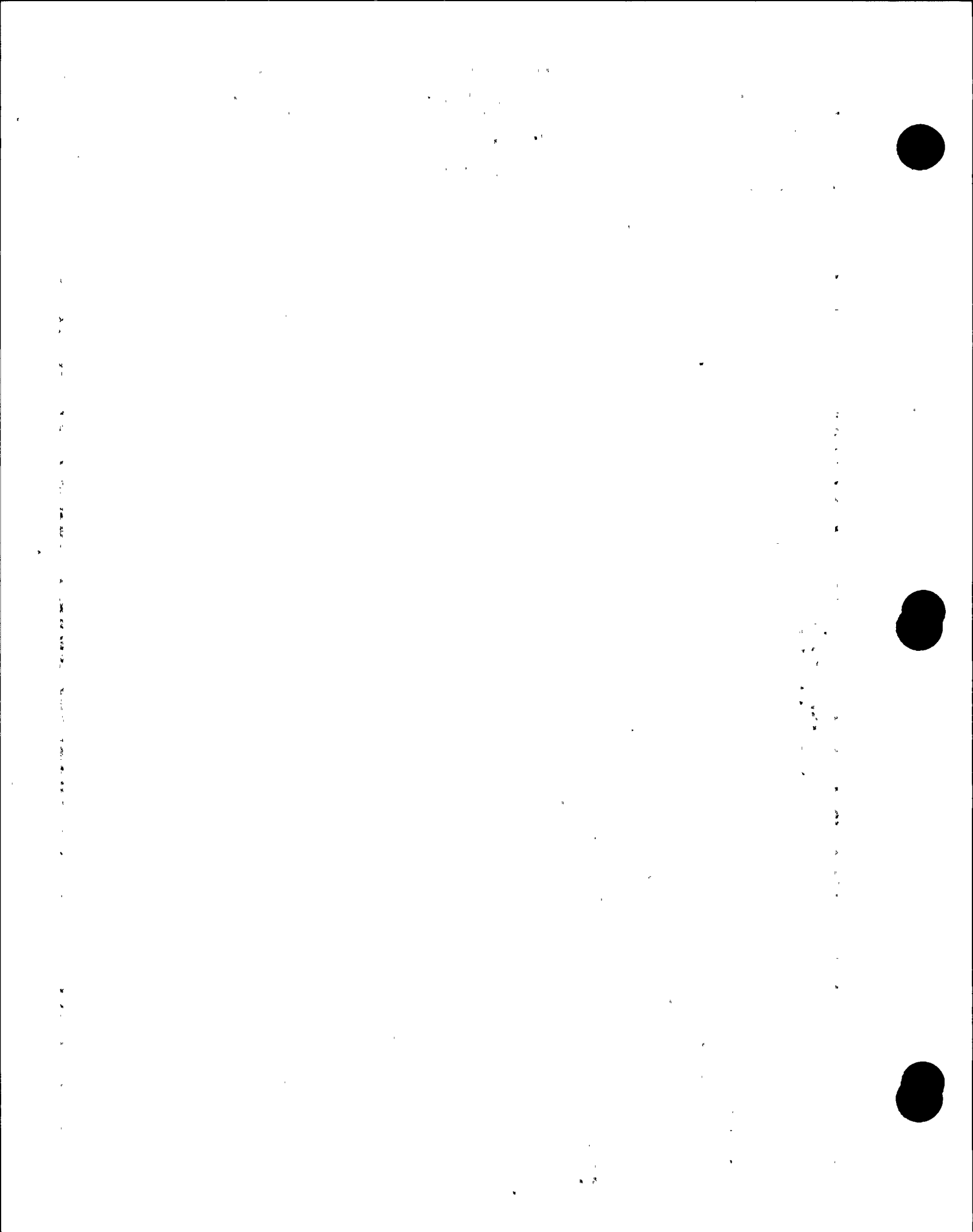

R. E. GINNA NUCLEAR POWER PLANT
Inservice Examination Boundary Line List
Third Inspection Interval

P&ID No.: 33013-1272-2
Class.: 2
System.: WASTE DISPOSAL-LIQ-RC DRAIN TK
Comp Type: PIPING

<u>RG&E Line No.</u>	<u>Gilbert Line No.</u>	<u>SWRI Line No.</u>	<u>ISI Fig.</u>	<u>Matl.</u>	<u>Size (in.)</u>	<u>Thkns (in.)</u>	<u>Exemption Basis</u>	<u>NDE Method</u>	<u>Po</u>	<u>Temp</u>	<u>In?</u>	<u>Line description/remarks</u>	<u>Revised</u>
4A-WD-151	RHR-300		N/A	A312	4.00	0.120	IWC-1222(A)		2	80	-	PEN 143, TO 8431, 4 X 3 RDCR BEFORE 1721.	R 06/93
4C-WD-151	RHR-300		N/A	A312	4.00	0.120	IWC-1222(A)		2	80	-	3A TO 3C.	R 06/93
3A-WD-151	RHR-300		N/A	A312	3.00	0.120	IWC-1222(A)		2	80	-	4A TO VALVE 1721, 4C.	R 06/93
3B-WD-151	RHR-300		N/A	A312	3.00	0.120	IWC-1222(A)		2	80	-	VALVE 1722 TO 4C.	R 06/93
3C-WD-151	RHR-300		N/A	A312	3.00	0.120	IWC-1222(A)		2	80	-	4C TO VALVE 1003B.	R 06/93
3E-WD-151			N/A		3.00	0.120	IWC-1222(A)					4 X 4 X 3 TEE ON 4C TO VALVE 1003A.	R 06/93
2A-WD-152			N/A		2.00	0.000	IWC-1222(A)		3	80	-	PEN 129 TO 1716A, 1ST TEE W/RDCRS.	R 06/93

QUALITY
ASSURANCE
MANUAL
GINNA STATION

TITLE:
APPENDIX B
R. E. GINNA NUCLEAR POWER PLANT
INSERVICE INSPECTION PROGRAM
FOR THE 1990-1999 INTERVAL
LINE LIST

Section 5
PAGE 78 of 96

REV.
3

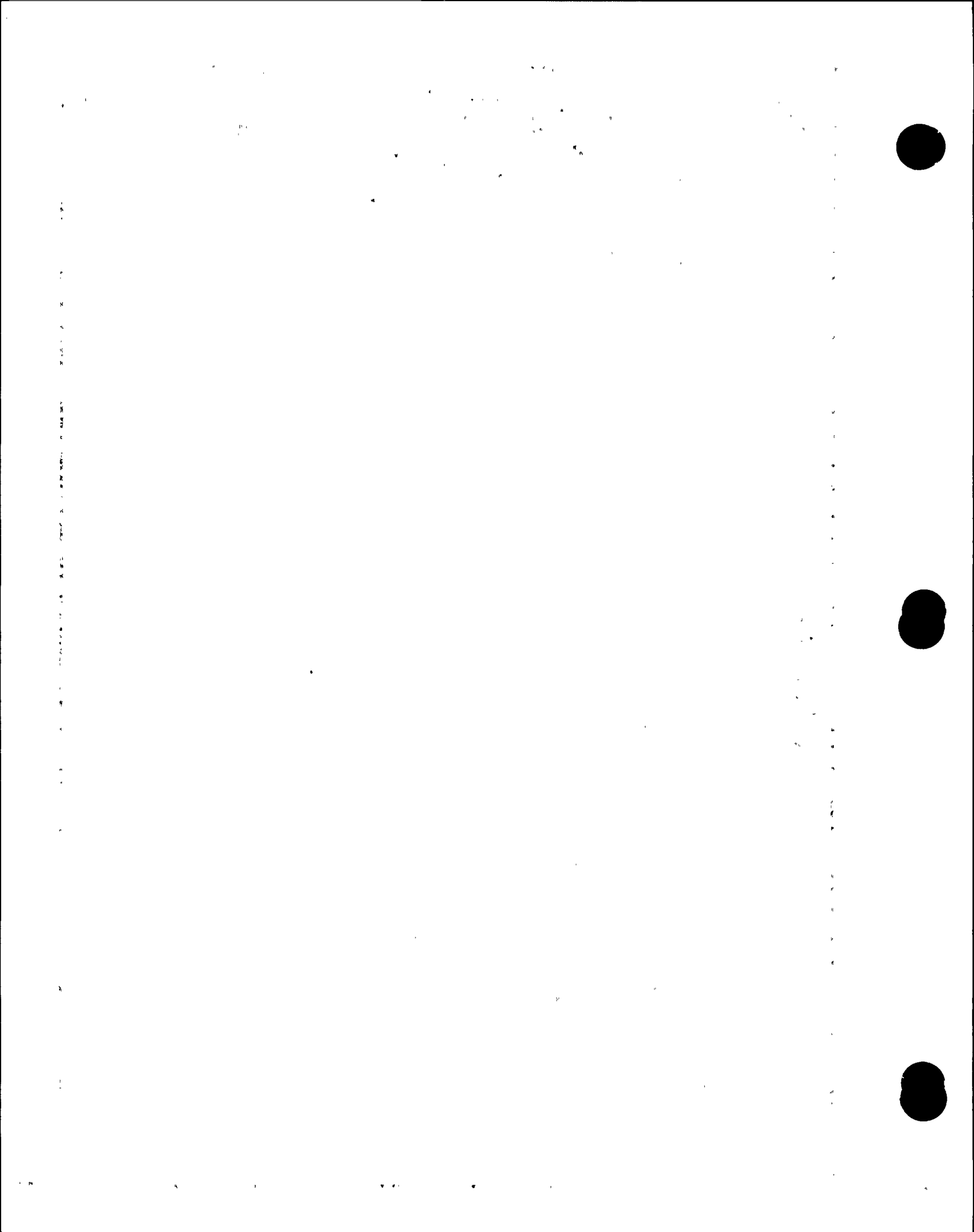

R. E. GINNA NUCLEAR POWER PLANT
 Inservice Examination Boundary Line List
 Third Inspection Interval

P&ID No.: 33013-1272-2
 Class: 3
 System: WASTE DISPOSAL-LIQ-RC DRAIN TK
 Comp Type: PIPING

<u>RG&E Line No.</u>	<u>Gilbert Line No.</u>	<u>SWRI Line No.</u>	<u>ISI Fig.</u>	<u>Mtrl</u>	<u>Size (in.)</u>	<u>Thkns (in.)</u>	<u>Exemption Basis</u>	<u>NDE Method</u>	<u>Po</u>	<u>Temp</u>	<u>In?</u>	<u>Line description/remarks</u>	<u>Revised</u>
3-WD2-151			N/A		3.00	0.216	IWD-1220.1				?	FUEL TRANSFER DRAIN TO 1795G, 1722.	R 06/93

QUALITY
 ASSURANCE
 MANUAL
 GINNA STATION

TITLE:
 APPENDIX B
 R. E. GINNA NUCLEAR POWER PLANT
 INSERVICE INSPECTION PROGRAM
 FOR THE 1990-1999 INTERVAL
 LINE LIST

Section 5
 PAGE 79 of 96

REV.
 3

R. E. GINNA NUCLEAR POWER PLANT
 Inservice Examination Boundary Line List
 Third Inspection Interval

P&ID No.: 33013-1275-2
 Class.: 2
 System.: WASTE DISPOSAL-GAS H2 RECOMBIN
 Comp Type: PIPING

<u>RG&E Line No.</u>	<u>Gilbert Line No.</u>	<u>SWRI Line No.</u>	<u>ISI Fig.</u>	<u>Matrl.</u>	<u>Size (in.)</u>	<u>Thkns (in.)</u>	<u>Exemption Basis</u>	<u>NDE Method</u>	<u>Po</u>	<u>Temp</u>	<u>In?</u>	<u>Line description/remarks</u>	<u>Revised</u>
2A-WDG-152N			N/A		2.00	0.000	IWC-1222(A)		<275	<200	-	PEN 202 TO RDGR BEFORE VALVE 1084B.	R 06/93
2B-WDG-152N			N/A		2.00	0.000	IWC-1222(A)					PEN P304 TO VALVE 1084A.	R 06/93

QUALITY
 ASSURANCE
 MANUAL
 GINNA STATION

TITLE:
 APPENDIX B
 R. E. GINNA NUCLEAR POWER PLANT
 INSERVICE INSPECTION PROGRAM
 FOR THE 1990-1999 INTERVAL
 LINE LIST

Section 5
 PAGE 80 of 96

REV.
 3

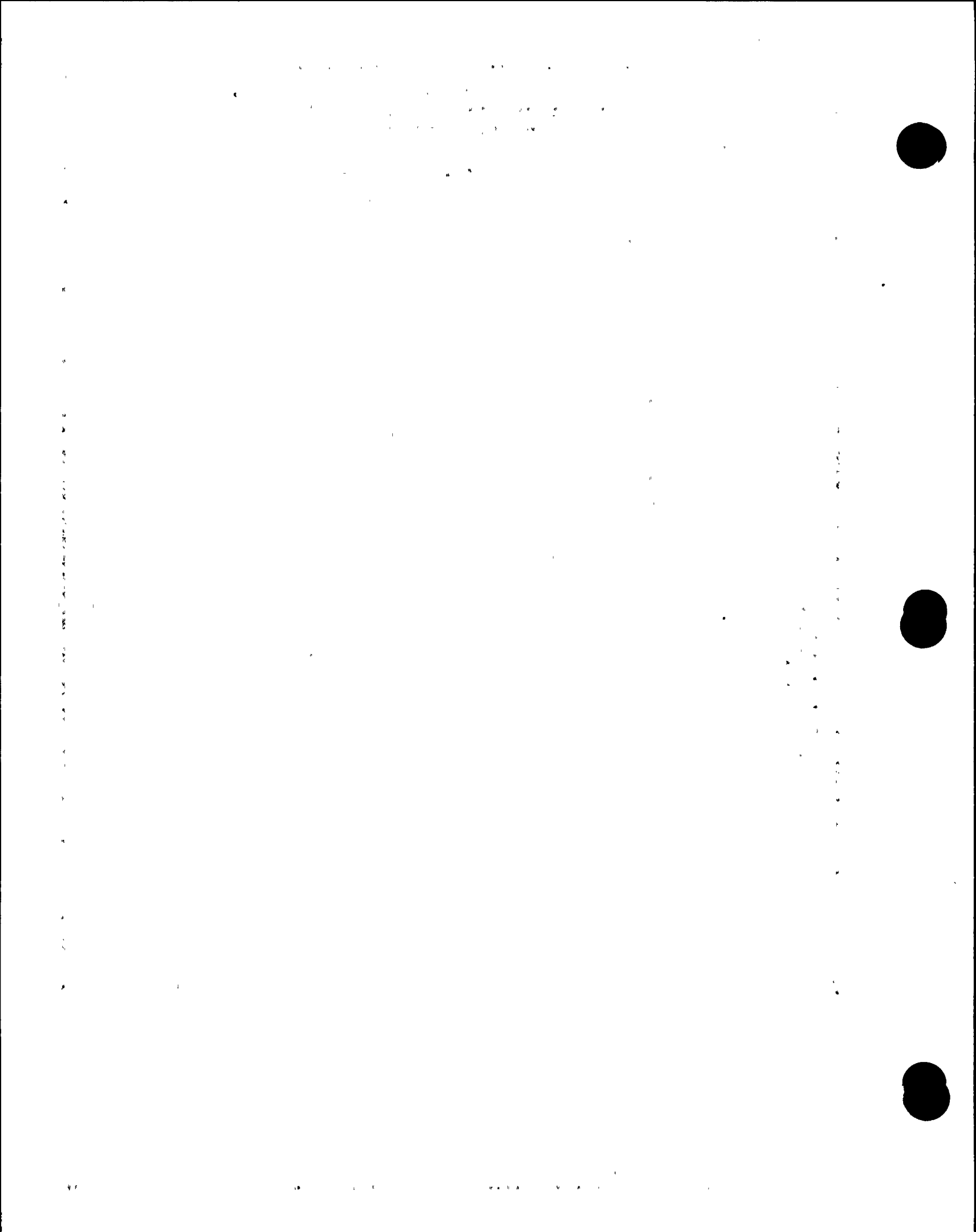

R. E. GINNA NUCLEAR POWER PLANT
Inservice Examination Boundary Line List
Third Inspection Interval

P&ID No.: 33013-1275-2
Class.: 3
System.: WASTE DISPOSAL-GAS H2 RECOMBIN
Comp Type: PIPING

<u>RG&E Line No.</u>	<u>Gilbert Line No.</u>	<u>SWRI Line No.</u>	<u>ISI Fig.</u>	<u>Matl.</u>	<u>Size (in.)</u>	<u>Thkns (in.)</u>	<u>Exemption Basis</u>	<u>NDE Method</u>	<u>Po</u>	<u>Temp</u>	<u>In?</u>	<u>Line description/remarks</u>	<u>Revised</u>
2C-WDG-152N			N/A		2.00	0.000	IWD-1220.1		<275	<200	-	PEN 202 TO 8425, 8425A, 3/4" REDCR.	A 06/93
2D-WDG-152N			N/A		2.00	0.000	IWD-1220.1		<275	<200	-	PEN 304 TO 8433, 8433A, 3/4" REDCR.	A 06/93

QUALITY
ASSURANCE
MANUAL
GINNA STATION

TITLE:
APPENDIX B
R. E. GINNA NUCLEAR POWER PLANT
INSERVICE INSPECTION PROGRAM
FOR THE 1990-1999 INTERVAL
LINE LIST

Section 5	REV. 3
PAGE 81 of 96	

R. E. GINNA NUCLEAR POWER PLANT
 Inservice Examination Boundary Line List
 Third Inspection Interval

P&ID No.: 33013-1277-1
 Class: 2
 System: STEAM GENERATOR BLOWDOWN
 Comp Type: COMPONENTS

<u>RG&E Line No.</u>	<u>Gilbert Line No.</u>	<u>SWRI Line No.</u>	<u>ISI Fig.</u>	<u>Matl.</u>	<u>Size (in.)</u>	<u>Thkns (in.)</u>	<u>Exemption Basis</u>	<u>NDE Method</u>	<u>Ps</u>	<u>Temp</u>	<u>In?</u>	<u>Line description/remarks</u>	<u>Revised</u>
EMS01A			B-1		0.00	0.000		SUR/VOL	715	505		THIS COMP ACCOUNTED FOR ON 33013-1231.	R 06/93
EMS01B			B-1		0.00	0.000		SUR/VOL	715	505		THIS COMP ACCOUNTED FOR ON 33013-1231.	R 06/93

QUALITY
 ASSURANCE
 MANUAL
 GINNA STATION

TITLE:
 APPENDIX B
 R. E. GINNA NUCLEAR POWER PLANT
 INSERVICE INSPECTION PROGRAM
 FOR THE 1990-1999 INTERVAL
 LINE LIST

Section 5
 PAGE 82 of 96

REV.
 3

R. E. GINNA NUCLEAR POWER PLANT
Inservice Examination Boundary Line List
Third Inspection Interval

P&ID No.: 33013-1277-1
Class.: 2
System.: STEAM GENERATOR BLOWDOWN
Comp Type: PIPING

<u>RG&E Line No.</u>	<u>Gilbert Line No.</u>	<u>SWRI Line No.</u>	<u>ISI Fig.</u>	<u>Matl.</u>	<u>Size (in.)</u>	<u>Thkns (in.)</u>	<u>Exemption Basis</u>	<u>NDE Method</u>	<u>Po</u>	<u>Temp</u>	<u>In?</u>	<u>Line description/remarks</u>	<u>Revised</u>
3A-BD-600-1A	SGB-100		N/A	A106	3.00	0.000	IWC-1222(A)		1005	547	Y	TEE 2A-MS-600-1A & 2B TO 5701.	R 06/93
2.25D-BD-600-1A			N/A		2.25	0.000	IWC-1222(A)					VALVE 5701 TO VALVE 5738.	R 06/93
2.25D-BD-600-1B			N/A		2.25	0.000	IWC-1222(A)					VALVE 5702 TO VALVE 5737.	R 06/93
2A-MS-600-1A	SGB-100		N/A	A106	2.00	0.218	IWC-1222(A)		1005	547	Y	N. NOZZLE TO FIRST TEE GIRTH WELD.	R 06/93
2A-MS-600-1B	SGB-200		B-31	A106	2.00	0.218	IWC-1222(A)		1005	547	Y	N. NOZZLE TO FIRST TEE GIRTH WELD.	R 06/93
2B-MS-600-1A	SGB-100		N/A	A106	2.00	0.218	IWC-1222(A)		1005	547	Y	S. NOZZLE TO FIRST TEE GIRTH WELD.	R 06/93
2B-MS-600-1B	SGB-200		B-31	A106	2.00	0.218	IWC-1222(A)		1005	547	Y	S. NOZZLE TO FIRST TEE GIRTH WELD.	R 06/93
2C-MS-600-1B	SGB-200,SGB-400		B-31	A106	2.00	0.218	IWC-1222(A)		1005	547	Y	2A-MS-600-1B & 2B TO VALVE 5702.	R 06/93

QUALITY
ASSURANCE
MANUAL
GINNA STATION

TITLE:
APPENDIX B
R.E. GINNA NUCLEAR POWER PLANT
INSERVICE INSPECTION PROGRAM
FOR THE 1990-1999 INTERVAL
LINE LIST

Section 5	REV. 3
PAGE 83 of 96	

R. E. GINNA NUCLEAR POWER PLANT
 Inservice Examination Boundary Line List
 Third Inspection Interval

P&ID No.: 33013-1279
 Class: 2
 System: POST ACCIDENT SAMPLING
 Comp Type: PIPING

<u>RG&E Line No.</u>	<u>Gilbert Line No.</u>	<u>SWRI Line No.</u>	<u>ISI Fig.</u>	<u>Matl.</u>	<u>Size (in.)</u>	<u>Thkns (in.)</u>	<u>Exemption Basis</u>	<u>NDE Method</u>	<u>Po</u>	<u>Temp</u>	<u>In?</u>	<u>Line description/remarks</u>	<u>Revised</u>
3A-SS-151			N/A		3.00	0.000	IWC-1222(A)					PEN P107 TO VALVE 1723.	A 11/91

QUALITY
 ASSURANCE
 MANUAL
 GINNA STATION

TITLE:
 APPENDIX B
 R. E. GINNA NUCLEAR POWER PLANT
 INSERVICE INSPECTION PROGRAM
 FOR THE 1990-1999 INTERVAL
 LINE LIST

Section 5
 PAGE 84 of 96
 REV. 3

R. E. GINNA NUCLEAR POWER PLANT
 Inservice Examination Boundary Line List
 Third Inspection Interval

P&ID No.: 33013-1863

Class.: 2

System.: CONTAINMENT HVAC SYSTEMS

Comp Type: PIPING

<u>RG&E Line No.</u>	<u>Gilbert Line No.</u>	<u>SWRI Line No.</u>	<u>ISI Fig.</u>	<u>Mtrl.</u>	<u>Size (in.)</u>	<u>Thkns (in.)</u>	<u>Exemption Basis</u>	<u>NDE Method</u>	<u>Po</u>	<u>Temp</u>	<u>In?</u>	<u>Line description/remarks</u>	<u>Revised</u>
1A-SUCT			N/A		0.00	0.000	IWC-1222(B)		60	120		VLV 1559 TO "A" CONT RECIRC FAN A SYS.	A 01/92
1AB-RET			N/A		0.00	0.000	IWC-1222(B)		60	120		VLV 1562 THRU PEN 305 TO CONTINMENT.	R 06/93
1B-SUCT			N/A		0.00	0.000	IWC-1222(B)		60	120		VLV 1556 TO "B" CONT RECIRC FAN B SYS.	A 01/92
1C-RET			N/A		0.00	0.000	IWC-1222(B)		60	120		VLV 1574 THRU PEN 124 TO CONTINMENT.	A 01/92
1C-SUCT			N/A		0.00	0.000	IWC-1222(B)		60	120		VLV 1571 TO "C" CONT RECIRC FAN C SYS.	A 01/92
1D-RET			N/A		0.00	0.000	IWC-1222(B)		60	120		VLV 1568 THRU PEN 203 TO CONTINMENT.	A 01/92
1D-SUCT			N/A		0.00	0.000	IWC-1222(B)		60	120		VLV 1563 TO "D" CONT RECIRC FAN D SYS.	A 01/92

QUALITY
 ASSURANCE
 MANUAL
 GINNA STATION

TITLE:
 R. E. GINNA NUCLEAR POWER PLANT
 INSERVICE INSPECTION PROGRAM
 FOR THE 1990-1999 INTERVAL
 APPENDIX B
 LINE LIST

Section 5
 PAGE 85 of 96
 REV. 3

R. E. GINNA NUCLEAR POWER PLANT
 Inservice Examination Boundary Line List
 Third Inspection Interval

P&ID No.: 33013-1865
 Class.: 2
 System.: CONTAINMENT HVAC SYSTEMS
 Comp Type: PIPING

<u>RG&E</u> <u>Line No.</u>	<u>Gilbert</u> <u>Line No.</u>	<u>SWRI</u> <u>Line No.</u>	<u>ISI</u> <u>Fig.</u>	<u>Matrl</u>	<u>Size</u> <u>(in.)</u>	<u>Thkns</u> <u>(in.)</u>	<u>Exemption</u> <u>Basis</u>	<u>NDE</u> <u>Method</u>	<u>Po</u>	<u>Temp</u>	<u>In?</u>	<u>Line description/remarks</u>	<u>Revised</u>
6A-MPS-2000			N/A		6.00	0.000	IWC-1222(C)		125	80	-	V 7445 OUT CONT PAST PEN 309 TO V 7478.	R 06/93

QUALITY
 ASSURANCE
 MANUAL
 GINNA STATION

TITLE:
 R. E. GINNA NUCLEAR POWER PLANT
 INSERVICE INSPECTION PROGRAM
 FOR THE 1990-1999 INTERVAL
 LINE LIST

Section 5	REV. 3
PAGE 86 of 96	

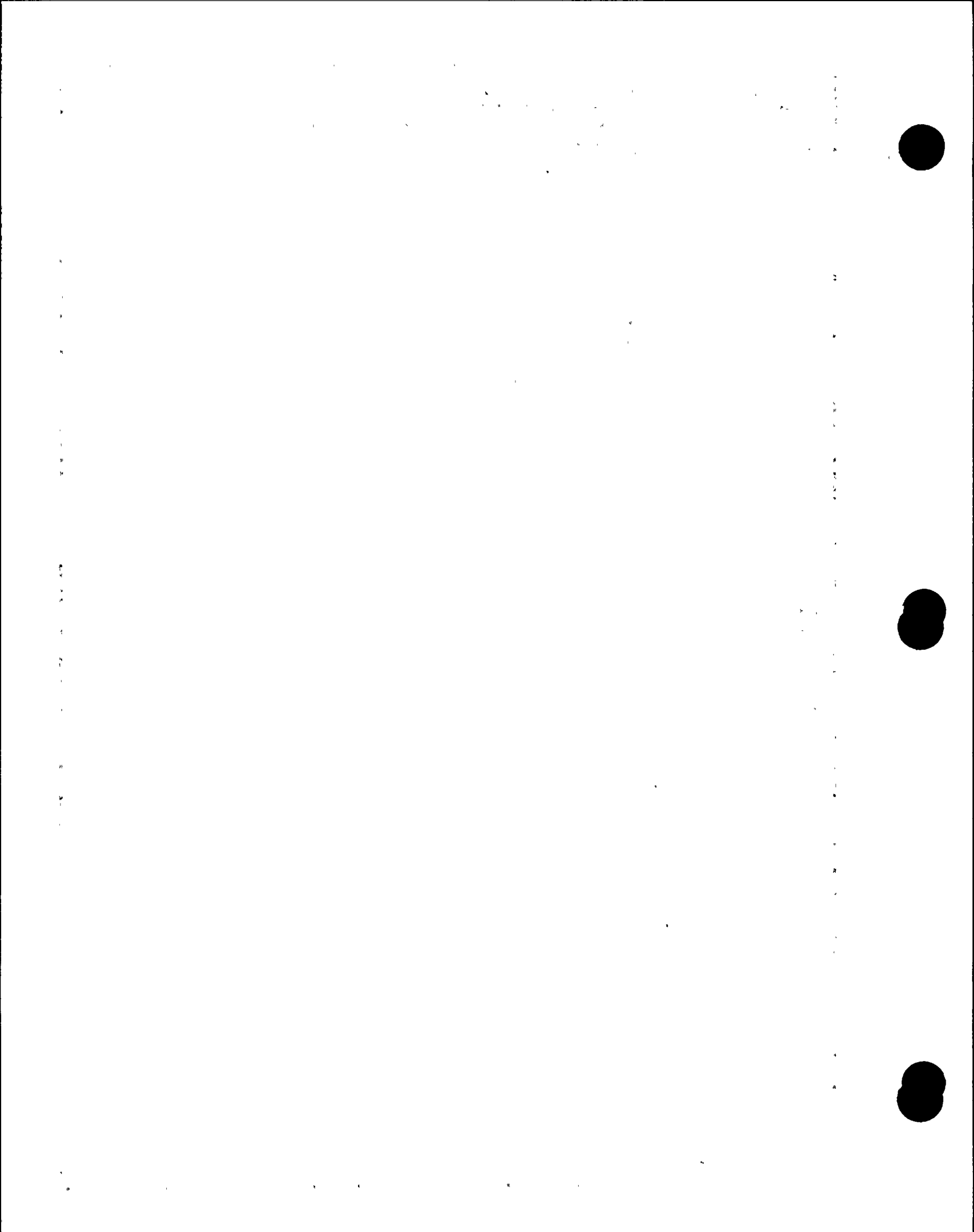

R. E. GINNA NUCLEAR POWER PLANT
 Inservice Examination Boundary Line List
 Third Inspection Interval

P&ID No.: 33013-1866
 Class: 2
 System: CONTAINMENT PURGE EXH & MONIT
 Comp Type: PIPING

<u>RG&E</u> <u>Line No.</u>	<u>Gilbert</u> <u>Line No.</u>	<u>SWRI</u> <u>Line No.</u>	<u>ISI</u> <u>Fig.</u>	<u>Matl.</u>	<u>Size</u> <u>(in.)</u>	<u>Thkns</u> <u>(in.)</u>	<u>Exemption</u> <u>Basis</u>	<u>NDE</u> <u>Method</u>	<u>Po</u>	<u>Temp</u>	<u>In?</u>	<u>Line description/remarks</u>	<u>Revised</u>
36A-CP-000			N/A		36.00	0.000	IWC-1222(B)					36" PURGE EXHAUST THRU PEN 300.	A 06/93

QUALITY
 ASSURANCE
 MANUAL
 GINNA STATION

TITLE:
 R. E. GINNA NUCLEAR POWER PLANT
 INSERVICE INSPECTION PROGRAM
 FOR THE 1990-1999 INTERVAL
 LINE LIST

Section 5
 REV. 3

PAGE 87 of 96

R. E. GINNA NUCLEAR POWER PLANT
 Inservice Examination Boundary Line List
 Third Inspection Interval

PAID No.: 33013-1870
 Class.: 2
 System.: HVAC-AUXILIARY & INTERM. BLDG.
 Comp Type: PIPING

<u>RG&E Line No.</u>	<u>Gilbert Line No.</u>	<u>SWRI Line No.</u>	<u>ISI Fig.</u>	<u>Mtrl.</u>	<u>Size (in.)</u>	<u>Thkns (in.)</u>	<u>Exemption Basis</u>	<u>NDE Method</u>	<u>Po</u>	<u>Temp</u>	<u>In?</u>	<u>Line description/remarks</u>	<u>Revised</u>
6A-CFA			N/A		6.00	0.000	IWC-1222(C)		S	110	.	VALVE 7970 PAST PEN P132 TO VALVE 7971.	R 06/93

QUALITY
 ASSURANCE
 MANUAL
 GINNA STATION

TITLE:
 R. E. GINNA NUCLEAR POWER PLANT
 INSERVICE INSPECTION PROGRAM
 FOR THE 1990-1999 INTERVAL
 LINE LIST

Section 5
 REV. 3

PAGE 88 of 96

[Faint, illegible text covering the majority of the page, possibly bleed-through from the reverse side.]



R. E. GINNA NUCLEAR POWER PLANT
Inservice Examination Boundary Line List
Third Inspection Interval

P&ID No.: 33013-1882

Class.: 2

System.: CONTAINMENT BREATHING AIR

Comp Type: PIPING

<u>RG&E Line No.</u>	<u>Gilbert Line No.</u>	<u>SWRI Line No.</u>	<u>ISI Fig.</u>	<u>Matl.</u>	<u>Size (in.)</u>	<u>Thkns (in.)</u>	<u>Exemption Basis</u>	<u>NDE Method</u>	<u>Ps</u>	<u>Temp</u>	<u>In?</u>	<u>Line description/remarks</u>	<u>Revised</u>
6-AT-150-4			N/A		6.00	0.000	IWC-1222(C)		<275	<200		VALVE 7443 THRU PEN P317 TO FLANGE.	A 11/91
6-LT-000			N/A		6.00	0.000	IWC-1222(C)		<275	<200		VALVE 7444 THRU PEN P313 TO FLANGE.	R 06/93

QUALITY
ASSURANCE
MANUAL
GINNA STATION

TITLE:
APPENDIX B
R. E. GINNA NUCLEAR POWER PLANT
INSERVICE INSPECTION PROGRAM
FOR THE 1990-1999 INTERVAL
LINE LIST

Section 5
PAGE 89 of 96

REV.
3

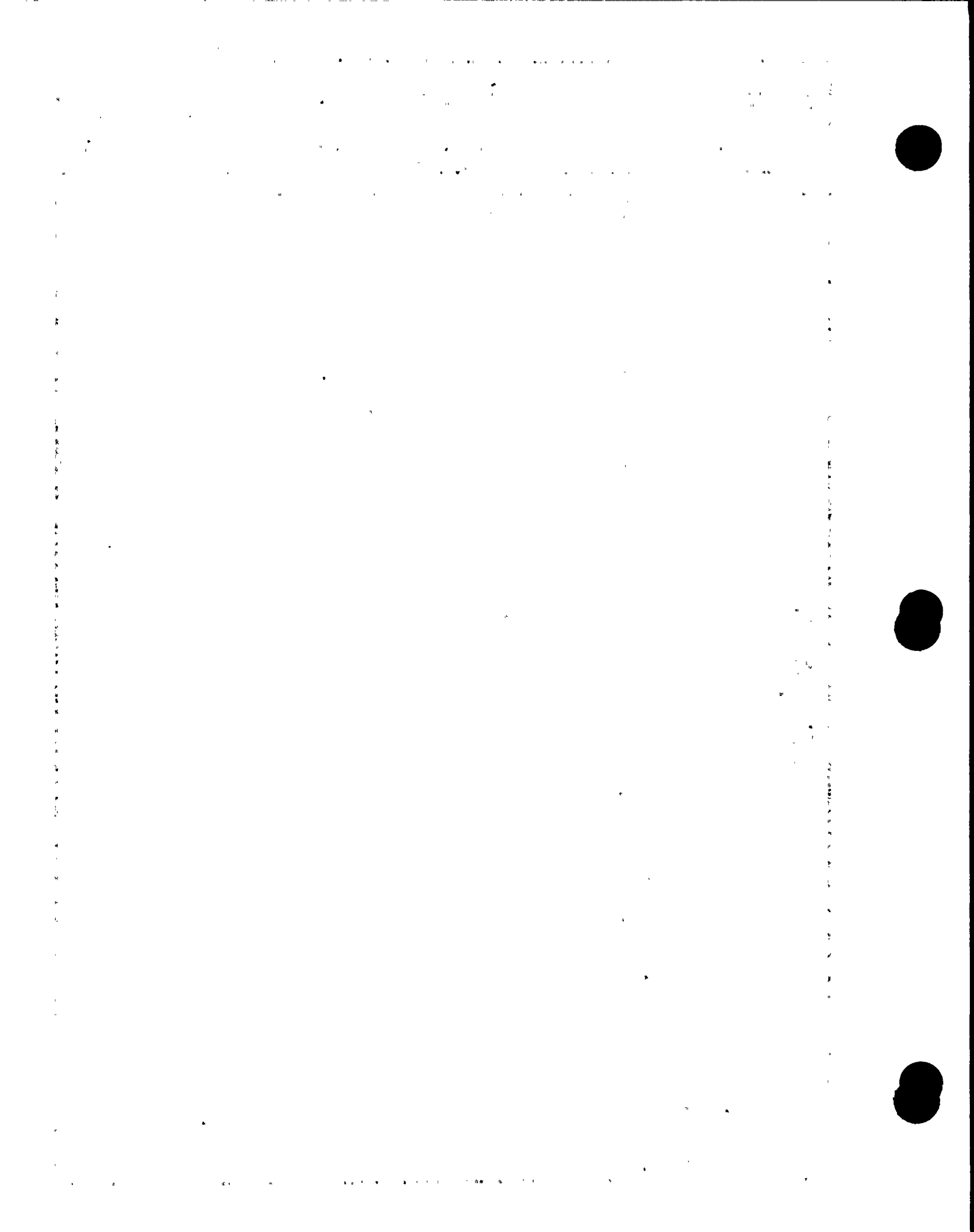

R. E. GINNA NUCLEAR POWER PLANT
 Inservice Examination Boundary Line List
 Third Inspection Interval

P&ID No.: 33013-1886-2
 Class.: 2
 System.: SERVICE AIR
 Comp Type: PIPING

<u>RG&E Line No.</u>	<u>Gilbert Line No.</u>	<u>SWRI Line No.</u>	<u>ISI Fig.</u>	<u>Matl.</u>	<u>Size (in.)</u>	<u>Thkns (in.)</u>	<u>Exemption Basis</u>	<u>NDE Method</u>	<u>Po</u>	<u>Temp</u>	<u>In?</u>	<u>Line description/remarks</u>	<u>Revised</u>
2-SA-150-4			N/A		2.00	0.000	IWC-1222(A)					VALVE 7141 THRU PEN P310 TO VALVE 7226.	R 06/93

QUALITY
 ASSURANCE
 MANUAL
 GINNA STATION

TITLE:
 R. E. GINNA NUCLEAR POWER PLANT
 INSERVICE INSPECTION PROGRAM
 FOR THE 1990-1999 INTERVAL
 LINE LIST

Section 5	REV. 3
PAGE 90 of 96	

R. E. GINNA NUCLEAR POWER PLANT
 Inservice Examination Boundary Line List
 Third Inspection Interval

P&ID No.: 33013-1887
 Class.: 2
 System.: INSTRUMENT AIR - CONTNMT BLDG
 Comp Type: PIPING

<u>RG&E Line No.</u>	<u>Gilbert Line No.</u>	<u>SWRI Line No.</u>	<u>ISI Fig.</u>	<u>Mtrl.</u>	<u>Size (in.)</u>	<u>Thkns (in.)</u>	<u>Exemption Basis</u>	<u>NDE Method</u>	<u>Po</u>	<u>Temp</u>	<u>In?</u>	<u>Line description/remarks</u>	<u>Revised</u>
2-1A-125-8			N/A		2.00	0.000	IWC-1222(A)					VALVE 5392 THRU PEN P310 TO VALVE 5393.	A 11/91

QUALITY
 ASSURANCE
 MANUAL
 GINNA STATION

TITLE:
 R. E. GINNA NUCLEAR POWER PLANT
 INSERVICE INSPECTION PROGRAM
 FOR THE 1990-1999 INTERVAL
 LINE LIST

Section 5	REV. 3
PAGE 91	of 96



R. E. GINNA NUCLEAR POWER PLANT
 Inservice Examination Boundary Line List
 Third Inspection Interval

P&ID No.: 33013-1908-3
 Class.: 2
 System.: PRIMARY WATER TREATMENT
 Comp Type: PIPING

<u>RG&E Line No.</u>	<u>Gilbert Line No.</u>	<u>SWRI Line No.</u>	<u>ISI Fig.</u>	<u>Matl.</u>	<u>Size (in.)</u>	<u>Thkns (in.)</u>	<u>Exemption Basis</u>	<u>NDE Method</u>	<u>Po</u>	<u>Temp</u>	<u>In?</u>	<u>Line description/remarks</u>	<u>Revised</u>
3-PW-125-1			N/A		3.00	0.000	IWC-1222(A)					3 X 2 RDCR OUTSIDE TO 3 X 2 RDCR INSIDE.	R 06/93
2-PW-125-1			N/A		2.00	0.000	IWC-1222(A)					VALVE 8418 TO 3 X 2 RDCR OUTSIDE CONTNMT.	R 06/93
2A-PW-125-1			N/A		2.00	0.000	IWC-1222(A)					3 X 2 RDCR INSIDE CONTNMT TO VALVE 8419.	R 06/93

QUALITY
 ASSURANCE
 MANUAL
 GINNA STATION

TITLE:
 APPENDIX B
 R. E. GINNA NUCLEAR POWER PLANT
 INSERVICE INSPECTION PROGRAM
 FOR THE 1990-1999 INTERVAL
 LINE LIST

Section 5
 PAGE 92 of 96

REV.
 3

R. E. GINNA NUCLEAR POWER PLANT
 Inservice Examination Boundary Line List
 Third Inspection Interval

P&ID No.: 33013-1915
 Class: 2
 System: HEATING STEAM & CONDENSATE
 Comp Type: PIPING

<u>RG&E Line No.</u>	<u>Gilbert Line No.</u>	<u>SWRI Line No.</u>	<u>ISI Fig.</u>	<u>Matl.</u>	<u>Size (in.)</u>	<u>Thkns (in.)</u>	<u>Exemption Basis</u>	<u>NDE Method</u>	<u>Po</u>	<u>Temp</u>	<u>In?</u>	<u>Line description/remarks</u>	<u>Revised</u>
2-HS-150-4			N/A		2.00	0.000	IWC-1222(A)					PENETRATION 301 TO VALVE 616S.	A 11/91

QUALITY
 ASSURANCE
 MANUAL
 GINNA STATION

TITLE:
 APPENDIX B
 R. E. GINNA NUCLEAR POWER PLANT
 INSERVICE INSPECTION PROGRAM
 FOR THE 1990-1999 INTERVAL
 LINE LIST

Section 5	REV. 3
PAGE 93 of 96	



R. E. GINNA NUCLEAR POWER PLANT
 Inservice Examination Boundary Line List
 Third Inspection Interval

P&ID No.: 33013-1991
 Class.: 2
 System.: FIRE PROTECTION IN CONTAINMENT
 Comp Type: PIPING

<u>RG&E Line No.</u>	<u>Gilbert Line No.</u>	<u>SWRI Line No.</u>	<u>ISI Fig.</u>	<u>Matl.</u>	<u>Size (in.)</u>	<u>Thkns (in.)</u>	<u>Exemption Basis</u>	<u>NDE Method</u>	<u>Po</u>	<u>Temp</u>	<u>In?</u>	<u>Line description/remarks</u>	<u>Revised</u>
4A-FS-152			N/A		4.00	0.000	IWC-1222(A)		135	80	-	VALVE 9227 TO VALVE 9229 IN CONTAINMENT.	R 11/91
2A-FS-000			N/A		2.00	0.000	IWC-1221(A)					VALVE 5129 AT PEN P103 TO 5130.	A 11/91

QUALITY
 ASSURANCE
 MANUAL
 GINNA STATION

TITLE:
 APPENDIX B
 R. E. GINNA NUCLEAR POWER PLANT
 INSERVICE INSPECTION PROGRAM
 FOR THE 1990-1999 INTERVAL
 LINE LIST

Section 5
 PAGE 94 of 96

REV.
 3



R. E. GINNA NUCLEAR POWER PLANT
 Inservice Examination Boundary Line List
 Third Inspection Interval

P&ID No.: 33013-2279-1
 Class.: 3
 System.: WASTE EVAPORATOR SKID
 Comp Type: COMPONENTS

<u>RG&E Line No.</u>	<u>Gilbert Line No.</u>	<u>SWRI Line No.</u>	<u>ISI Fig.</u>	<u>Matl.</u>	<u>Size (in.)</u>	<u>Thkns (in.)</u>	<u>Exemption Basis</u>	<u>NDE Method</u>	<u>Po</u>	<u>Temp</u>	<u>In?</u>	<u>Line description/remarks</u>	<u>Revised</u>
EWD07			N/A		0.00	0.000	IWD-1220.1					WASTE EVAPORATOR CONCENTRATOR.	R 06/93
PWD08			N/A		0.00	0.000	IWD-1220.1					WASTE EVAPORATOR FEED TANK PUMP.	R 06/93
TWD08			N/A		0.00	0.000	IWD-1220.1					WASTE EVAPORATOR FEED TANK.	R 06/93

QUALITY
 ASSURANCE
 MANUAL
 GINNA STATION

TITLE:
 APPENDIX B
 R. E. GINNA NUCLEAR POWER PLANT
 INSERVICE INSPECTION PROGRAM
 FOR THE 1990-1999 INTERVAL
 LINE LIST

Section 5	REV. 3
PAGE 95 of 96	

Faint, illegible text scattered across the page, possibly bleed-through from the reverse side.



R. E. GINNA NUCLEAR POWER PLANT
Inservice Examination Boundary Line List
Third Inspection Interval

P&ID No.: 33013-2279-1
Class: 3
System: WASTE EVAPORATOR SKID
Comp Type: PIPING

<u>RG&E Line No.</u>	<u>Gilbert Line No.</u>	<u>SWRI Line No.</u>	<u>ISI Fig.</u>	<u>Mtrl.</u>	<u>Size (in.)</u>	<u>Thkns (in.)</u>	<u>Exemption Basis</u>	<u>NDE Method</u>	<u>Ps</u>	<u>Temp</u>	<u>In?</u>	<u>Line description/remarks</u>	<u>Revised</u>
1.5A-WD9			N/A		1.50	0.000	IWD-1220.1				?	WEFT TWD08 TO 2642D, WEFT PUMP.	R 06/93
1.5B-WD9			N/A		1.50	0.000	IWD-1220.1				?	1A TO SWD14, 2642Z, .75A.	R 06/93
1.25A-WD9			N/A		1.25	0.000	IWD-1220.1				?	WE CONCENTRATOR EWD07 TO 2620C, SWD14.	R 06/93

QUALITY
ASSURANCE
MANUAL
GINNA STATION

TITLE:
APPENDIX B
R. E. GINNA NUCLEAR POWER PLANT
INSERVICE INSPECTION PROGRAM
FOR THE 1990-1999 INTERVAL
LINE LIST

Section 5	REV. 3
PAGE 96 of 96	

QUALITY ASSURANCE MANUAL GINNA STATION ROCHESTER GAS & ELECTRIC CORPORATION	Section 6	REV. 2	PAGE 1 of 6
	EFFECTIVE DATE: December 31, 1993		
TITLE: APPENDIX B R. E. GINNA NUCLEAR POWER PLANT INSERVICE INSPECTION PROGRAM FOR THE 1990-1999 INTERVAL ALLOCATION TABLES		SIGNATURE	DATE
	PREPARED BY:	<i>Frank H. Kypaci</i>	12-1-93
	QUALITY ASSURANCE REVIEW:	<i>[Signature]</i>	12-2-93
	APPROVED BY:	<i>Michael J. Sparto</i>	12-6-93

1.0 General

This section identifies program examination allocations for "ASME Code Required" and "Augmented Required" groups that will be performed during the third interval at R. E. Ginna Nuclear Power Plant. The tables identify the total number of components, the required number and the distribution of the required number within one of the three periods.

The "ASME Code Required" group addresses the program requirements with respect to ASME Section XI. This group is divided into the following allocations.

- Class 1
- Class 2
- Class 3
- Class 1, 2, & 3 Supports

The "Augmented Required" group addresses Rochester Gas & Electric commitments that were added to the Inservice Inspection Program to ensure compliance to the commitments and performance. This group is divided into the following allocations.

- Reactor Coolant Pump Flywheel Program
- Reactor Vessel Augmented Program, Category B-A
- High Energy Program
- Snubber Program
- Steam Generator Tubing Program
- Seismic Support Program

Other additional "Owner Elected" examinations are performed by Rochester Gas & Electric. These additional examinations are not mandatory and are determined by the owner to ensure additional safety and reliability of the plant. These additional "Owner Elected" examinations are not identified within the following allocation tables.

QUALITY ASSURANCE MANUAL GINNA STATION	TITLE:	APPENDIX B R.E. GINNA NUCLEAR POWER PLANT INSERVICE INSPECTION PROGRAM FOR THE 1990-1999 INTERVAL ALLOCATION TABLES	Section 6	REV. 2
			PAGE 2 of 6	

ASME CODE REQUIRED

Class 1

Category	Total	Required	Third Interval Scheduled/Percent		
			Period 1	Period 2	Period 3
B-A	10	7	2/28.5%	2/57.1%	3/100%
B-B	12	7	4/57.1%	1/71.4%	2/100%
B-D	30	24	5/20.8%	6/45.8%	13/100%
B-F	15	15	5/33.3%	3/53.3%	7/100%
B-G-1	245	195	49/25.1%	49/50.2%	97/100%
B-G-2	22	9	3/33.3%	3/66.6%	3/100%
B-J	536	132	28/21.2%	51/59.8%	53/100%
B-L-1	6	3	3/100%	0/100%	0/100%
B-L-2	2	1	0/0%	0/0%	1/100%
B-M-1	8	2	2/100%	0/100%	0/100%
B-M-2	12	4(*)	1/100%	(3 remaining, only if disassembled, Per RR #5.)	
(*) = if disassembled.					
B-N-1	3	3	1/33.3%	1/66.6%	1/100%
B-N-2	2	2	0/0%	0/0%	2/100%
B-N-3	1	1	0/0%	0/0%	1/100%
B-O	20	3	0/0%	0/0%	3/100%
B-P	11	11	3/27.2%	4/63.6%	4/100%
B-Q	6	54	18/30%	24/70	18/100%
Total	950	479			



QUALITY ASSURANCE MANUAL GINNA STATION	TITLE:	APPENDIX B R.E. GINNA NUCLEAR POWER PLANT INSERVICE INSPECTION PROGRAM FOR THE 1990-1999 INTERVAL ALLOCATION TABLES	Section 6	REV. 2
			PAGE 3 of 6	

Class 2

<u>Category</u>	<u>Total</u>	<u>Required</u>	Third Interval Scheduled/Percent		
			<u>Period 1</u>	<u>Period 2</u>	<u>Period 3</u>
C-A	22	13	3/23.0%	4/53.8%	6/100%
C-B	30	18	6/33.3%	6/66.6%	6/100%
C-C	131	124	29/23.4%	52/65.3%	43/100%
C-F-1	677	53	17/32.1%	19/67.9%	17/100%
C-F-2	387	30	10/33.3%	10/66.6%	10/100%
C-H	72	124	39/31.4%	43/66.1%	42/100%
Total	1319	362			

Class 3

<u>Category</u>	<u>Total</u>	<u>Required</u>	Third Interval Scheduled/Percent		
			<u>Period 1</u>	<u>Period 2</u>	<u>Period 3</u>
D-A, D-B & D-C	145	141	38/26.9%	54/65.2%	49/100%
D-A, D-B & D-C Hydro/Leakage	30	164	53/32.3%	51/64.3%	60/100%
Total	175	305			



QUALITY ASSURANCE MANUAL GINNA STATION	TITLE:	APPENDIX B R.E. GINNA NUCLEAR POWER PLANT INSERVICE INSPECTION PROGRAM FOR THE 1990-1999 INTERVAL ALLOCATION TABLES	Section 6	REV. 2
			PAGE 4 of 6	

Class 1, 2, & 3 Supports

Original Distribution to 1986 Code

Class Group	Total	Required	Third Interval Scheduled/Percent		
			Period 1	Period 2	Period 3
Class 1	159	142	19/13.4%	55/52.1%	68/100%
Class 2	377	368	93/25.3%	134/61.6%	141/100%
Class 3	477	141	38/26.9%	54/65.2%	49/100%
Total	1013	651	150/23.0%	243/59.6%	258/100%

Incorporation of Code Case N-491 with 1986 Code, Revised Distribution

Program Reference	Category Item	Total Supports	Required	Period 1 Completed /Credited	Period 2 Completed /Credited /Scheduled	Period 3 Scheduled
1986 Code Req. for Period 1 and '93 Outage	F-A,B,C All Items	1013	651	150 Completed (23.0%)	44 Completed 199 Scheduled	253 Scheduled
Code Case N-491 for Period 2 (Starting '94 Outage) and Period 3	F-A Fl.10	114	32	10 Credit	6 Credit 5 Sched.	11 Sched.
	F-A Fl.20	358	58	19 Credit	17 Credit 2 Sched.	20 Sched.
	F-A Fl.30	467	50	17 Credit	12 Credit 4 Sched.	17 Sched.
	F-A Fl.40	74	44	10 Credit	0 Credit 3 Sched.	31 Sched.
	Totals	1013	184	56(30.4%)	49 (57.0%)	79 (100%)

Augmented Required

RCP Flywheel Program:

Category	Total	Required	Third Interval Scheduled/Percent		
			Period 1	Period 2	Period 3
Flywheel	2	6	2/33.3%	2/66.6%	2/100%

QUALITY ASSURANCE MANUAL GINNA STATION	TITLE:	APPENDIX B R.E. GINNA NUCLEAR POWER PLANT INSERVICE INSPECTION PROGRAM FOR THE 1990-1999 INTERVAL ALLOCATION TABLES	Section 6	REV. 2
			PAGE 5 of 6	

Reactor Vessel Augmented Program, Category B-A:

<u>Category</u>	<u>Total</u>	<u>Required</u>	Third Interval Scheduled/Percent		
			<u>Period 1</u>	<u>Period 2</u>	<u>Period 3</u>
B-A	3	3	0/0%	0/0%	3/100%

High Energy, Program:

<u>Category</u>	<u>Total</u>	<u>Required</u>	Third Interval Scheduled/Percent		
			<u>Period 1</u>	<u>Period 2</u>	<u>Period 3</u>
HE-CB	97	97	34/35%	30/65.9%	33/100%
HE-CC (*)	17	17	9/52.9%	3/70.6%	5/100%
HE-DB	18	54	18/33.3%	18/66.6%	18/100%
HE-LK	2	6	2/28.5%	2/57.1%	2/100%
Total	134	174			

(*) = Denotes Integral Attachment

Code Case N-491, Class 2 Criteria, Non-Class High Energy Support Distribution

<u>Program Reference</u>	<u>Category Item</u>	<u>Total Supports</u>	<u>Required</u>	<u>Period 1 Completed /Credited</u>	<u>Period 2 Completed /Credited /Scheduled</u>	<u>Period 3 Scheduled</u>
Requirement for Period 1 and '93 Outage.	N/A	62	62	20 Comp. (31.7%)	6 Comp. 18 Sched.	-- 19 Sched.
Code Case N-491 for Period 2 (Starting '94 Outage) and Period 3	N/A (F-A F1.20)	62	11	3 Credit (27.3%)	4 Credit 0 Sched. (63.6%)	-- 4 Sched. (100%)

QUALITY ASSURANCE MANUAL GINNA STATION	TITLE: APPENDIX B R.E. GINNA NUCLEAR POWER PLANT INSERVICE INSPECTION PROGRAM FOR THE 1990-1999 INTERVAL ALLOCATION TABLES	Section 6	REV. 2
		PAGE 6 of 6	

Snubber Program:

Category	Total	Required	Third Interval Scheduled/Percent		
			Period 1	Period 2	Period 3
SN-VT (*)	149	1039	443/43.0%	447/86.4%	149/100%
SN-FT	149	149	48/32.2%	57/70.4%	44/100%
Total	298	1188			

(*) = Note: Generic Letter 90-09 will be implemented during the '94 Outage of the Second Period.

Seismic Support Program Outside ASME Class Boundary:

Code Case N-491, Class 2 Criteria, Seismic Support Distribution

Program Reference	Category Item	Total Supports	Required	Period 1 Completed /Credited	Period 2 Credited /Scheduled	Period 3 Scheduled
Code Case N-491 for Period 2 (Starting '94 Outage) and Period 3	N/A (F-A F1.20)	93	19	0 Comp. 0 Credit	-- -- 9 Sched. (47.3%)	-- -- 10 Sched. (100%)

QUALITY ASSURANCE MANUAL GINNA STATION ROCHESTER GAS & ELECTRIC CORPORATION	Section 7	REV. 1	PAGE 1 of 3
	EFFECTIVE DATE: December 31, 1993		
TITLE: APPENDIX B R. E. GINNA NUCLEAR POWER PLANT ULTRASONIC CALIBRATION BLOCK LISTING	PREPARED BY:	<i>Frank A. Klapach</i>	12-1-93
	QUALITY ASSURANCE REVIEW:	<i>[Signature]</i>	12-2-93
	APPROVED BY:	<i>Michael J. Syrett</i>	12-6-93
		SIGNATURE	DATE

1.0 General:

The list below identifies Ultrasonic Calibration Blocks that are owned by Rochester Gas & Electric and utilized at R. E. Ginna Nuclear Power Plant. Other calibration blocks not owned by Rochester Gas & Electric may be employed only if they meet the applicable requirements specified within ASME Section XI, 1986 Edition, no Addenda.

<u>IDENTIFICATION NUMBER</u>	<u>DESCRIPTION</u>	<u>MATERIAL SPEC.</u>
6-SS-10S-.134-1A-REG	6" D-SCHEDULE 10-SS-PIPE	SA 312
6-SS-40S-.280-2-REG	6" D-SCHEDULE 40-SS-PIPE	SA 312
8-SS-10S-.148-3-REG	8" D-SCHEDULE 10-SS-PIPE	SA 312
8-SS-40S-.322-4-REG	8" D-SCHEDULE 40-SS-PIPE	SA 312
8-SS-160-.906-5-REG	8" D-SCHEDULE 160-SS-PIPE	SA 312
10-SS-10S-.165-6-REG	10" D-SCHEDULE 10-SS-PIPE	SA 312
10-SS-40S-.365-7-REG	10" D-SCHEDULE 40-SS-PIPE	SA 312
10-SS-140-1.0-8-REG	10" D-SCHEDULE 140-SS-PIPE	SA 376
12-SS-5S-.156-9-REG	12" D-SCHEDULE 5-SS-PIPE	SA 312
14-SS-10-.250-10-REG	14" D-SCHEDULE 10-SS-PIPE	SA 312
14-CS-30-.375-11-REG	14" D-SCHEDULE 30-CS-PIPE	SA 106
PL-1.187-SS-12-REG	1.187 THICK-SS-PLATE	SA 240
PL-.30-SS-13-REG	.30 THICK-SS-PLATE	SA 240
PL-3.5-CS-14-REG	3.5 THICK-CS-PLATE	SA 533
9-CSCL-15-REG	9" THICK-CS-CLAD-VESSEL BLOCK	SA 508
7-CSCL-16-REG	7" THICK-CS-CLAD-VESSEL BLOCK	SA 508
5-CSCL-17-REG	5" THICK-CS-CLAD-VESSEL BLOCK	SA 508
PL-3.0-SS-18-REG	3" THICK-SS-PLATE	SA 479

QUALITY ASSURANCE MANUAL GINNA STATION	TITLE:	APPENDIX B R.E. GINNA NUCLEAR POWER PLANT ULTRASONIC CALIBRATION BLOCK LISTING	Section 7	REV. 1
			PAGE 2 of 3	

<u>IDENTIFICATION NUMBER</u>	<u>DESCRIPTION</u>	<u>MATERIAL SPEC.</u>
6-SS-160-.719-19-REG	6" D-SCHEDULE 160-SS-PIPE	SA 312
4-SS-160-.531-20-REG	4" D-SCHEDULE 160-SS-PIPE	SA 376
3-SS-160-.438-21-REG	3" D-SCHEDULE 160-SS-PIPE	SA 376
8.5-6-8-CS-22-REG	REACTOR PRESSURE VESSEL NUT	SA 320-L43
6-1-8-CS-23-REG	REACTOR PRESSURE VESSEL STUD	SA 320-L43
IR-CSCL-24-REG	O.D. INNER RADIUS BLOCK	SA 533
6-SS-120-.562-25-REG	6" D-SCHEDULE 120-SS-PIPE	SA 312
FS/NS-CSCL-26-REG	FLANGE AND NOZZLE SHELL BLOCK	SA 533
IR-CSCL-27-REG	NOZZLE INNER RADIUS BLOCK	SA 553
CRD-SS/IN-.656-28-REG	SS-CONTROL ROD DRIVE BLOCK	SA 182
10-SS-140-1.0-29-REG	10" D-SCHEDULE 140-SS-PIPE	SA 312
3.5-.625-8-CS-30-REG	REACTOR COOLANT PUMP STUD	ACTUAL STUD
5.375-3.5-8-CS-31-REG	REACTOR COOLANT PUMP NUT	ACTUAL NUT
1.187-S-7-CS-32-REG	1.187" DIA. X 7 THREADS/IN-CS-STUD	SA 193
1.187-N-7-CS-33-REG	1.187" DIA. X 7 THREADS/IN-CS-NUT	SA 194
1.125-S-12-CS-34-REG	1.125" DIA. X 12 THREADS/IN-CS-STUD	SA 193
1.125-N-12-CS-35-REG	1.125" DIA. X 12 THREADS/IN-CS-NUT	SA 194
1.250-S-7-CS-36-REG	1.250" DIA. X 7 THREADS/IN-CS-STUD	SA 193
1.250-N-7-CS-37-REG	1.250" DIA. X 7 THREADS/IN-CS-NUT	SA 194
10-SS-160-1.147-70	10" D-SCHEDULE 160-SS-PIPE	SA 312
6-SS-X-1.1-38-REG	6" D-1.1" WALL-SS-PIPE	SA 182
29-SS-X-2.5-39-REG	29" ID-SS-PIPE	SA 182
SI/N-CSCL-40-REG	SAFETY INJECTION NOZZLE BLOCK	SA 508
27.5-CSS-X-2.4-41-REG	27.5" ID-CS-PIPE	SA 351
29-CSCL-X-2.5-42-REG	29" ID-CLAD-CS-PIPE	SA 508
5.437-SS-X-1.0-43-REG	5.437" D-1" WALL-SS-PIPE	SA 182
PL-1.5-CS-44-REG	1.5" THICK-CS-PLATE	SA 285
14-CS-100-.938-45-REG	14" D-SCHEDULE 100-CS-PIPE	SA 106



QUALITY ASSURANCE MANUAL GINNA STATION	TITLE: APPENDIX B R.E. GINNA NUCLEAR POWER PLANT ULTRASONIC CALIBRATION BLOCK LISTING	Section 7	REV. 1
		PAGE 3 of 3	

<u>IDENTIFICATION NUMBER</u>	<u>DESCRIPTION</u>	<u>MATERIAL SPEC.</u>
18-CS-100-1.156-46-REG	18" D-SCHEDULE 100-CS-PIPE	SA 106
4-SS-80-.337-47-REG	4" D-SCHEDULE 80-SS-PIPE	SA 312
3-SS-80-.300-48-REG	3" D-SCHEDULE 80-SS-PIPE	SA 312
4.25-R-CS-N/RB-49-REG	REACTOR PRESSURE VESSEL NUT REFERENCE BLOCK	SA 516
1.250-B-6-A490-50-REG	S/G SECONDARY MANWAY BOLT	ASTM A 490
1.375-S-17-A490-51-REG	1.375 DIA. X 17" LONG-STEEL-STUD	ASTM A 490
1.375-S-24-A490-52-REG	1.375 DIA. X 24" LONG-STEEL-STUD	ASTM A 490
1.375-S-33-A490-53-REG	1.375 DIA. X 33" LONG-STEEL-STUD	ASTM A 490
3-SP-14-A514-GRF-54-REG	COLUMN PIN	ASTM A 514
2-IC600-80-J-NOZ-55-REG	S/G "J" NOZZLE	INCONEL 600
1.875-9-8N-CS-56-REG	S/G AND PRESSURIZER MANWAY BOLT	SA 193
1.0-4-8N-CS-57-REG	S/G HAND HOLD BOLT	SA 193
1.875-S-8-CS-58-REG	S/G PRIMARY MANWAY STUD	SA 193
2.89-1.87-8-CS-59-REG	S/G PRIMARY MANWAY CLOSURE NUT	SA 193
2-CS-40-.218-60-REG	2" BLOWDOWN	SA 335
8-CS-100-.594-63-REG	8" FW BLOCK	SAW6-GR B
15.0-SS-X-1.60-61-REG	15" PZR BLOCK	SA182-F316
20-CS-X-1.281-64-REG	20" FW BLOCK	SA333-GR 6
24-CS-80-1.218-65-REG	24" MS BLOCK	SA106-GR B
30-CS-X-1.250-66-REG	30" MS BLOCK	SA517-GR 70
36-CS-X-1.47-67-REG	30" MS BLOCK	SA517-GR 70
3.0-CS-80-.218-68-REG	3" BLOWDOWN	SA335-

QUALITY ASSURANCE MANUAL GINNA STATION	Section 8	REV. 3	PAGE 1 of 8
	EFFECTIVE DATE: December 31, 1993		
ROCHESTER GAS & ELECTRIC CORPORATION	SIGNATURE		DATE
TITLE: APPENDIX B R. E. GINNA NUCLEAR POWER PLANT INSERVICE INSPECTION PROGRAM FOR THE 1990-1999 INTERVAL HIGH ENERGY PROGRAM	PREPARED BY: <i>Frank J. Lepore</i>	12-1-93	
	QUALITY ASSURANCE REVIEW: <i>[Signature]</i>	12-2-93	
	APPROVED BY: <i>Michael J. Depina</i>	12-6-93	

1.0 **General:**

1.1 The augmented inservice inspection program for High Energy (Class & Non-Class) Piping, outside of containment, as established in Rochester Gas and Electric Corporation's Report "Effect of Postulated Pipe Breaks Outside the Containment Building", dated October 29, 1973, provides for the examination of all identified circumferential butt welds at design break locations and at discontinuity (Consequential) locations where a failure would result in unacceptable consequences. This program also establishes a Non-Class High Energy Piping component support examination requirements. The required examinations are used to detect any change in condition or development of service induced flaws in advance of a potential failure. Surveillance of these components by the inspection program provides assurance that the design basis or consequential Main Steam or Feedwater breaks will not occur.

2.0 **Examination Requirements:**

2.1 Identified High Energy Piping circumferential butt welds at design break locations and discontinuity (consequential) locations shall be examined utilizing volumetric, surface and visual examination techniques.



QUALITY ASSURANCE MANUAL GINNA STATION	TITLE:	APPENDIX B R.E. GINNA NUCLEAR POWER PLANT INSERVICE INSPECTION REPORT FOR THE 1990-1999 INTERVAL HIGH ENERGY PROGRAM	Section 8	REV. 3
			PAGE 2 of 8	

- 2.2 Identified Non-Class High Energy Piping component supports shall be examined utilizing visual examination techniques. For periods 2 and 3, a reduced selection shall be utilized based on the requirements of Code Case N-491 for Class 2 piping supports. This sampling scheme requires a 15% sample distribution among the systems and support types within each system. All integral attachments associated with High Energy component supports shall receive a surface examination, based on the Code requirements for Class 2 piping integrally welded attachments.
- 2.3 Examinations on High Energy Piping circumferential butt welds at design break locations and consequential break locations, as well as component supports and integrally welded attachments, are identified within Table 1 of this section.
- 2.4 System Pressure Testing and associated visual examination for leakage, shall be performed on the main run of the High Energy Piping.
- 2.4.1 The 10-year Hydrostatic testing requirements for High Energy Piping was derived from ASME Section XI Code, IWC-5000, as a continuation of the Class 2 boundary. With the implementation of Code Case N-498 within the ISI Program, the code case requirements may be performed in lieu of hydrostatic test requirements for High Energy Piping.
- 2.4.2 Leakage testing requirements for High Energy Piping was derived from ASME Section XI Code, IWC-5000, as a continuation of the Class 2 boundary.
- 3.0 Examination Methods:
- 3.1 Applicable examinations shall be performed in accordance with 1.7.1, 1.7.2, 1.7.3 and 1.7.4 of Section 1.

QUALITY ASSURANCE MANUAL GINNA STATION	TITLE:	Section 8	REV. 3
	R.E. GINNA NUCLEAR POWER PLANT INSERVICE INSPECTION REPORT FOR THE 1990-1999 INTERVAL HIGH ENERGY PROGRAM	PAGE 3 of 8	

- 4.0 Frequency of Examination
- 4.1 Identified High Energy Piping circumferential butt welds at design break locations shall be examined once each period. Circumferential butt welds at discontinuity (consequential) locations shall be examined once per interval.
- 4.2 Selected Non-Class High Energy Piping component supports shall be examined once per interval.
- 4.3 Identified High Energy Piping Integrally welded attachments shall be examined once per interval.
- 4.4 On the main run of High Energy Piping pressure boundary, a Leakage examination shall be performed once per period.
- 4.5 In lieu of a Hydrostatic Test once per interval on the main run of High Energy Piping pressure boundary, a Leakage examination may be performed once per interval to Code Case N-498 criteria.
- 5.0 Examination Evaluation:
- 5.1 The evaluation of examinations of the High-Energy piping welds outside of containment will be in accordance with Section XI IWC-3130 for visual examinations and IWC-3120 for volumetric and surface examinations. Evaluations of radiographic results shall be in accordance with the acceptance criteria for radiographic examinations referenced in USAS B31.1.0-1967, "Power Piping" and "ASME Section XI." Ultrasonic Examinations performed in accordance with the requirements of Appendix I and III and the acceptance criteria in USAS B31.1.0 - 1967 (Radiography).
- Visual examinations of identified High Energy Piping Supports will be evaluated in accordance with IWF-3000 for Period 1, and -3000 of Code Case N-491 for Periods 2 and 3.

QUALITY ASSURANCE MANUAL GINNA STATION	TITLE:	APPENDIX B R.E. GINNA NUCLEAR POWER PLANT INSERVICE INSPECTION REPORT FOR THE 1990-1999 INTERVAL HIGH ENERGY PROGRAM	Section 8	REV. 3
			PAGE 4 of 8	

6.0 Repair & Testing Requirements:

6.1 Repairs and applicable system pressure tests performed on ASME Class 2 and 3 High Energy pressure retaining piping and associated component supports and integral attachments shall conform to the requirements specified within Supplement 2 to Appendix B, the Repair, Replacement and Modification Program. Code Case N-498 does not apply to Repairs.

7.0 Replacement & Testing Requirements:

7.1 Replacements, including Modifications, and applicable system pressure tests performed on ASME Class 2 and 3 High Energy pressure retaining piping and associated component supports and integral attachments shall conform to the requirements specified within Supplement 2 to Appendix B, the Repair, Replacement and Modification Program. Code Case N-498 does not apply to Replacements and Modifications.

8.0 Scheduling:

8.1 Scheduling of the High Energy Program piping welds, component supports and integral attachments shall be performed and controlled within Supplement 1 to Appendix B, the Program Plan.

8.2 Table 1 identifies welds, component supports and integral attachments that are within the High Energy Program.

9.0 Reports and Records:

9.1 Reports and Records generated on High Energy pressure retaining components, integral attachments and component supports shall conform, as applicable, to the requirements of Section 1 and Supplement 2 to Appendix B, the Repair, Replacement and Modification Program.

QUALITY ASSURANCE MANUAL GINNA STATION	TITLE:	APPENDIX B R.E. GINNA NUCLEAR POWER PLANT INSERVICE INSPECTION REPORT FOR THE 1990-1999 INTERVAL HIGH ENERGY PROGRAM	Section 8	REV. 3
			PAGE 5 of 8	

TABLE 1

HIGH ENERGY PROGRAM

MAIN STEAM LOOP A - WELDS:

Design Basis Break

30A-MS-600-1A	D	30A-MS-600-1A	D1
30A-MS-600-1A	F1	36-MS-600-1	L1

Consequential Break

30A-MS-600-1A	D2	30A-MS-600-1A	D3
30A-MS-600-1A	E	30A-MS-600-1A	E1
30A-MS-600-1A	E2	30A-MS-600-1A	F
30A-MS-600-1A	G	30A-MS-600-1A	G1
30A-MS-600-1A	G2	30A-MS-600-1A	H
30A-MS-600-1	J	30A-MS-600-1	K
30A-MS-600-1	L		

MAIN STEAM LOOP B - WELDS:

Design Basis Break

30B-MS-600-1B	D	30B-MS-600-1B	H1
30B-MS-600-1B	J1	36-MS-600-1	P1

Consequential Break

30B-MS-600-1B	D1	30B-MS-600-1B	D2
30B-MS-600-1B	E	30B-MS-600-1B	J
30B-MS-600-1B	K	30B-MS-600-1B	L
30B-MS-600-1B	L1	30B-MS-600-1B	L2
30B-MS-600-1B	M	30B-MS-600-1	N
30B-MS-600-1	O	30B-MS-600-1	P

QUALITY ASSURANCE MANUAL GINNA STATION	TITLE:	APPENDIX B R.E. GINNA NUCLEAR POWER PLANT INSERVICE INSPECTION REPORT FOR THE 1990-1999 INTERVAL HIGH ENERGY PROGRAM	Section 8	REV. 3
			PAGE 6 of 8	

TABLE 1 (Cont.)

MAIN STEAM - TURBINE BUILDING - WELDS:

Design Basis Break

36-MS-600-1 L2

Consequential Break

36-MS-600-1	L4	24A-MS-600-1A	A
24A-MS-600-1A	B	24A-MS-600-1A	B1
24A-MS-600-1A	C1	24A-MS-600-1A	D
24A-MS-600-1A	D1	24B-MS-600-1A	A
24B-MS-600-1A	B	24B-MS-600-1A	B1
24B-MS-600-1A	C	24B-MS-600-1A	C1
24B-MS-600-1A	D		

FEEDWATER - TURBINE BUILDING - WELDS:

Design Basis Break

20-FW-900-1 M3

Consequential Break

20-FW-900-1	J	20-FW-900-1	K1
20-FW-900-1	L	20-FW-900-1	L1
20-FW-900-1	M	20-FW-900-1	M1
20-FW-900-1	M2	8-FW-900-1	A
8-FW-900-1	B	8-FW-900-1	C
8-FW-900-1	D	8-FW-900-1	E
8-FW-900-1	F	8-FW-900-1	G
8-FW-900-1	H		

THE UNIVERSITY OF CHICAGO LIBRARY

UNIVERSITY OF CHICAGO LIBRARY



QUALITY ASSURANCE MANUAL GINNA STATION	TITLE:	APPENDIX B R.E. GINNA NUCLEAR POWER PLANT INSERVICE INSPECTION REPORT FOR THE 1990-1999 INTERVAL HIGH ENERGY PROGRAM	Section 8	REV. 3
			PAGE 7 of 8	

TABLE 1 (Cont.)

FEEDWATER LOOP A - WELDS:

Design Basis Break

20-FW-900-1	M4	20-FW-900-1	U1
20-FW-900-1	U2	14A-FW-900-1A	AA

Consequential Break

14A-FW-900-1	T2	14A-FW-900-1	T3
14A-FW-900-1	U7	14A-FW-900-1	U5
14A-FW-900-1	U6	14A-FW-900-1	V
14A-FW-900-1	VA	14A-FW-900-1	VB
14A-FW-900-1	V1	14A-FW-900-1	V2
14A-FW-900-1	V2A	14A-FW-900-1	V2B
14A-FW-900-1	W	14A-FW-900-1A	X
14A-FW-900-1A	Y	14A-FW-900-1A	Z
14A-FW-900-1A	Z1	14A-FW-900-1A	Z2
14A-FW-900-1A	Z3	14A-FW-900-1A	Z4

FEEDWATER LOOP B - WELDS:

Design Basis Break

20-FW-900-1	A1	20-FW-900-1	F4
14B-FW-900-1B	N	14B-FW-900-1B	V

Consequential Break

14B-FW-900-1	F3	14B-FW-900-1	F5
14B-FW-900-1	F1	14B-FW-900-1	F2
14B-FW-900-1	G	14B-FW-900-1	G2
14B-FW-900-1	G1	14B-FW-900-1	G3
14B-FW-900-1	G4	14B-FW-900-1	H
14B-FW-900-1	HA	14B-FW-900-1	HB
14B-FW-900-1	H1	14B-FW-900-1	H2
14B-FW-900-1	H2A	14B-FW-900-1	H2B
14B-FW-900-1	J	14B-FW-900-1	K
14B-FW-900-1B	L	14B-FW-900-1B	M
14B-FW-900-1B	N1	14B-FW-900-1B	O
14B-FW-900-1B	O1	14B-FW-900-1B	P

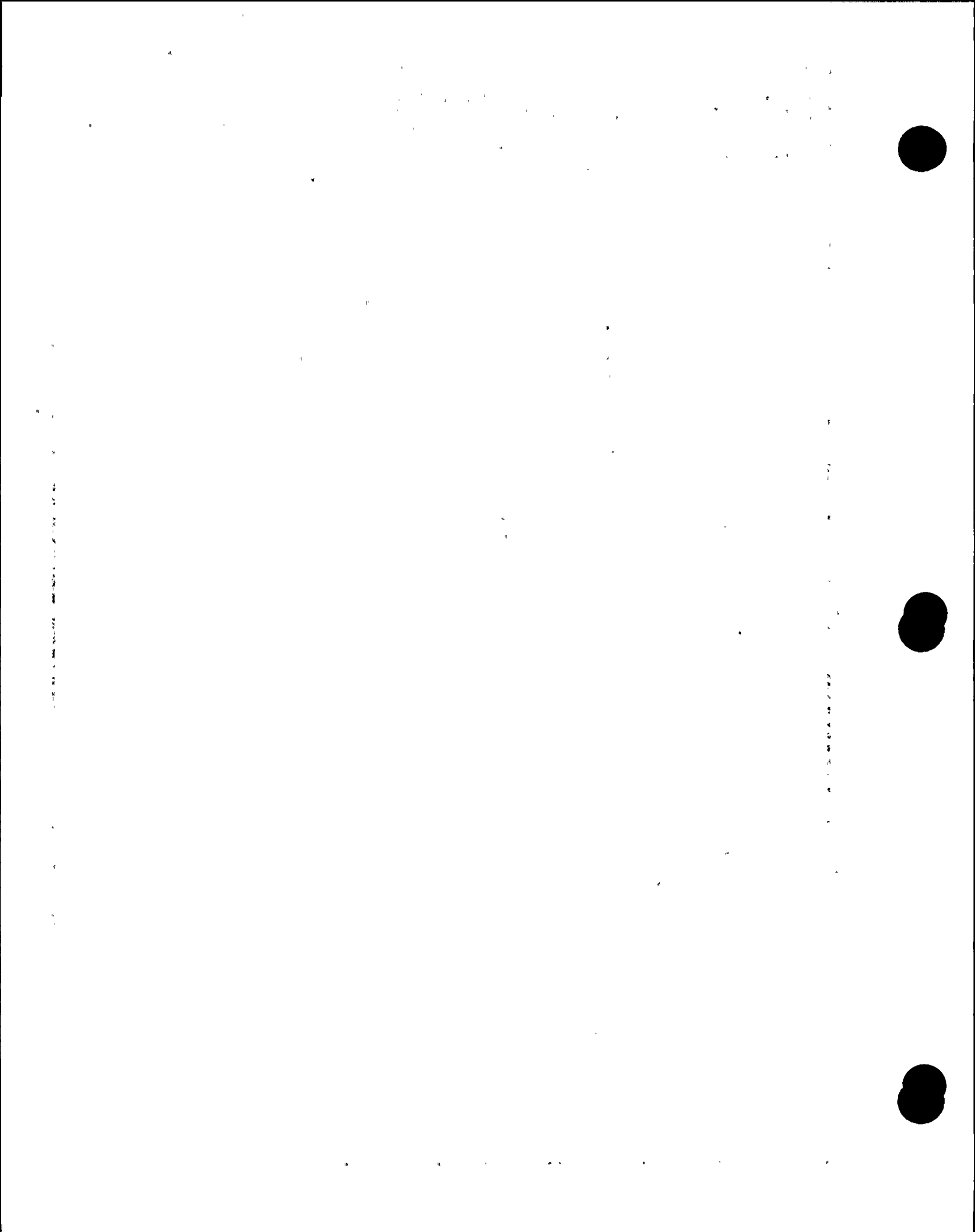

QUALITY ASSURANCE MANUAL GINNA STATION	TITLE:	Section 8	REV. 3
	APPENDIX B R. E. GINNA NUCLEAR POWER PLANT INSERVICE INSPECTION REPORT FOR THE 1990-1999 INTERVAL HIGH ENERGY PROGRAM	PAGE 8 of 8	

TABLE 1 (Cont.)

MAINSTEAM - COMPONENT SUPPORTS:

(*) MSU-35	MS-39	MS-167
(*) MS-34	MS-151	MS-153
(*) MS-35	MS-40	MS-44
(*) MS-47	(*) MS-41	(*) MS-149
MS-59	S13A	MS-45
MS-36	S13B	(*) MS-46
MS-37	MS-42	S23A
(*) MS-150	MS-43	S23B
MS-38		

FEEDWATER - LOOP A - COMPONENT SUPPORTS:

FWU-16	(*) FWU-21	FWU-25
FWU-17	FWU-22	(*) FWU-26
(*) FWU-18	FWU-23	(*) FWU-27
FWU-19	FWU-24	(*) FWU-28
FWU-20		

FEEDWATER - LOOP B - COMPONENT SUPPORTS:

FWU-36	FWU-33	FWU-40
FWU-35	FWU-31	(*) FWU-39
FWU-34	FWU-30	FWU-38
FWU-32	(*) FWU-29	FWU-37

FEEDWATER - MAIN - COMPONENT SUPPORTS:

FW-37	FW-40	FW-43
FW-38	FW-41	(*) FW-45
FW-39	FW-42	

FEEDWATER - RECIRCULATION LINE - COMPONENT SUPPORTS:

CD-167	CD-169
CD-168	(*) CD-170

NOTE: * = Integral Attachments

QUALITY ASSURANCE MANUAL GINNA STATION ROCHESTER GAS & ELECTRIC CORPORATION	Section 9	REV. 3	PAGE 1 of 4
	EFFECTIVE DATE: December 31, 1993		
TITLE: APPENDIX B R.E. GINNA NUCLEAR POWER PLANT INSERVICE INSPECTION PROGRAM FOR THE 1990-1999 INTERVAL SNUBBER PROGRAM	PREPARED BY:	<i>Frank A. Klepac</i>	12-1-93
	QUALITY ASSURANCE REVIEW:	<i>[Signature]</i>	12-3-93
	APPROVED BY:	<i>Michael J. Sypert</i>	12-6-93
		SIGNATURE	DATE

- 1.0 **General:**
- 1.1 The inspection and testing of all safety related snubbers shall be implemented and performed in accordance with Mechanical Engineering Specification ME-256, "Snubber Inspection & Test Program", to ensure the required operability of these snubbers during a seismic or other event, initiating dynamic loads.
- 1.2 The snubber program, as defined within ME-256, establishes both visual examination and functional testing requirements.
- 1.2.1 This program pertains to mechanical and hydraulic snubbers.
- 1.2.2 The snubber program includes:
- a. Visual Inspection Requirements
 - b. Visual Inspection Failure Evaluation
 - c. Visual Inspection Corrective Action and Impact on Examination Frequency
 - d. Functional Testing Requirements
 - e. Functional Test Sample
 - f. Functional Test Failure Analysis
 - g. Functional Testing Corrective Action
 - h. Functional Testing Methods
 - i. Inspection and Testing Documentation
- 1.3 The Snubber Program adheres to the requirements of ASME Section XI, 1986 Edition Article IWF and includes guidance provided by ASME/ANSI OMc-1990, Part 4.
- 1.4 R.E. Ginna Nuclear Power Plant Technical Specifications establishes a Snubber Seal Service Life Monitoring for Hydraulic Snubbers that is controlled by R.E. Ginna Station Procedures.

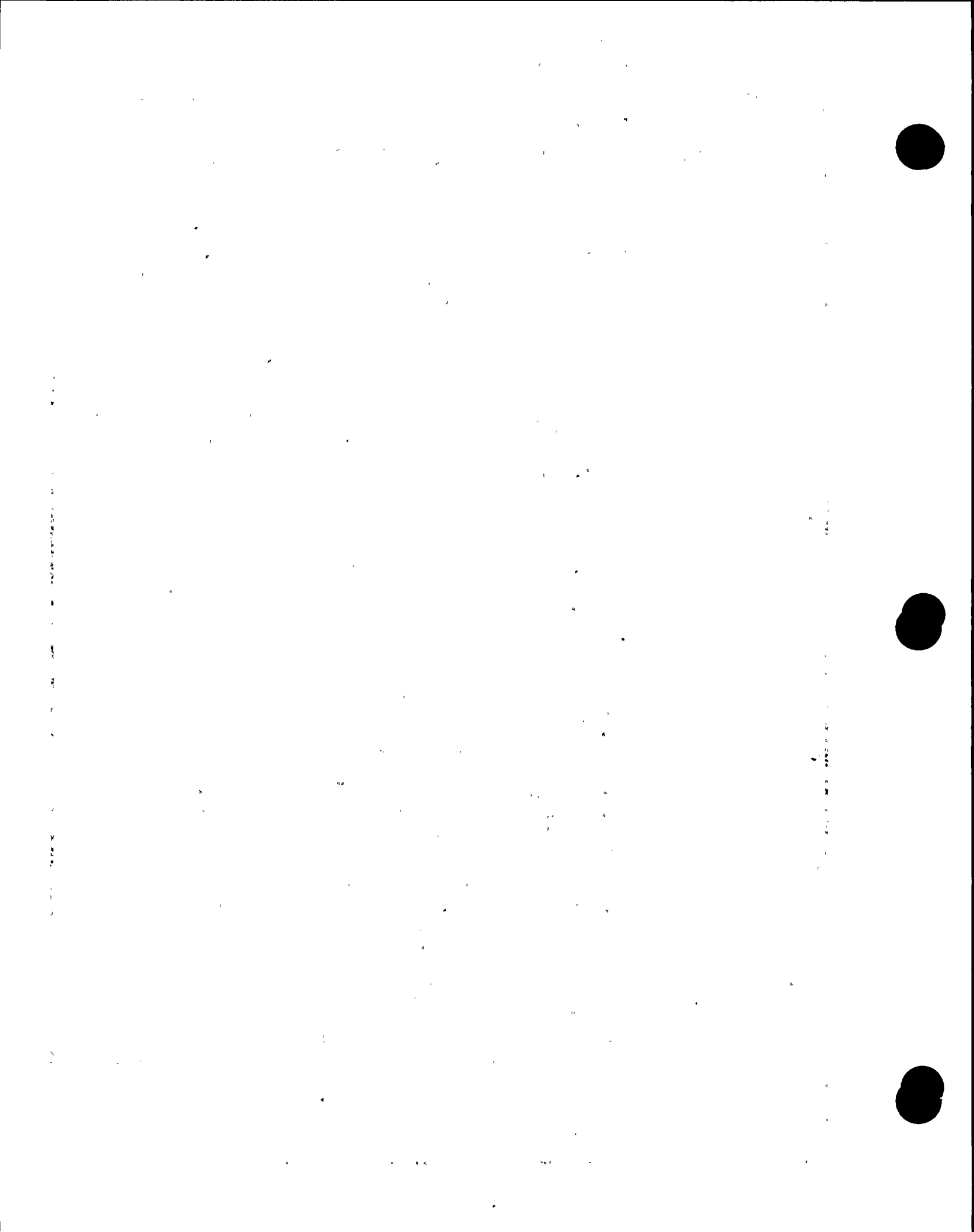

QUALITY ASSURANCE MANUAL GINNA STATION	TITLE:	APPENDIX B R.E. GINNA NUCLEAR POWER PLANT INSERVICE INSPECTION PROGRAM FOR THE 1990-1999 INTERVAL SNUBBER PROGRAM	Section 9	REV. 3
			PAGE 2 of 4	

2.0 Examination, Testing and Monitoring Requirements:

2.1 Visual (VT-3) Examinations and Functional (FT) Testing shall be performed to the extent specified within ME-256.

2.2 The seal service life of hydraulic snubbers shall be monitored and seals replaced as required to ensure that the service life is not exceeded between surveillance inspections during a period when the snubber is required to be operable. The seal replacement shall be documented and retained in accordance with Technical Specification.

3.0 Examination and Testing Methods:

3.1 Visual (VT-3) Examinations and Functional (FT) Testing shall be performed to verify the requirements specified within ME-256, as a minimum.

4.0 Examination and Testing Frequency:

4.1 Visual (VT-3) Examinations and Functional (FT) Testing shall be performed at the frequency specified within ME-256.

4.2 Visual (VT-3) Baseline Examinations shall be performed whenever new snubbers are installed, reinstallation of existing or swapped snubbers that were functionally tested, or after repairs, replacements or modifications.

4.3 Functional testing requirements for new installations or spares shall be equal to or more stringent than that specified within ME-256.

5.0 Examination, Testing and Monitoring Evaluation:

5.1 Snubbers that do not appear to conform with the Visual (VT-3) Examination requirements of Mechanical Engineering Specification ME-256, shall be reported for evaluation and appropriate corrective action. Visual examination failure evaluation shall be performed when necessary and required by ME-256. Corrective action may include repair, replacement or modification of the snubber.



QUALITY ASSURANCE MANUAL GINNA STATION	TITLE:	APPENDIX B R.E. GINNA NUCLEAR POWER PLANT INSERVICE INSPECTION PROGRAM FOR THE 1990-1999 INTERVAL SNUBBER PROGRAM	Section 9	REV. 3
			PAGE 3 of 4	

5.2 Snubbers that do not appear to conform with the visual examination acceptance requirements and are later confirmed as failures and appears inoperable may be declared operable for the purpose of establishing the next visual inspection interval, providing that:

(1) the cause of the rejection is clearly established and remedied for that particular snubber and for other snubbers that may be generically susceptible;

and

(2) the affected snubber is functionally tested in the "as found" condition and determined operable.

All snubbers found connected to an inoperable common hydraulic fluid reservoir shall be counted as inoperable for determining the next inspection interval.

Snubbers that do not appear to conform with the visual examination acceptance requirements and are later confirmed as failures but does not appear inoperable shall not be declared inoperable and the cause of the rejection shall be remedied.

5.3 Snubbers that do not meet the operability testing acceptance criteria in ME-256 shall be evaluated to determine the cause of the failure and appropriate corrective action taken.

5.4 The service life of a snubber is evaluated via manufacturing input and engineering information through consideration of the snubber service conditions and functional design requirements. The only snubber components with service lives not expected to exceed plant life are seal and o-rings fabricated from certain seal materials. Therefore, a seal replacement program is required to monitor snubber seal and o-ring service life and to assure snubber operability is not degraded due to exceeding component service life.

1 2 3 4 5 6 7 8 9 10 11 12 13 14 15 16 17 18 19 20 21 22 23 24 25 26 27 28 29 30 31 32 33 34 35 36 37 38 39 40 41 42 43 44 45 46 47 48 49 50 51 52 53 54 55 56 57 58 59 60 61 62 63 64 65 66 67 68 69 70 71 72 73 74 75 76 77 78 79 80 81 82 83 84 85 86 87 88 89 90 91 92 93 94 95 96 97 98 99 100



QUALITY ASSURANCE MANUAL GINNA STATION	TITLE:	APPENDIX B R.E. GINNA NUCLEAR POWER PLANT INSERVICE INSPECTION PROGRAM FOR THE 1990-1999 INTERVAL SNUBBER PROGRAM	Section 9	REV. 3
			PAGE 4 of 4	

6.0 Repair, Replacement and Modification Requirements:

6.1 Repairs, Replacements and Modifications performed on snubbers under this program shall conform, as applicable, to the requirements specified within Supplement 2 to Appendix B, the Repair, Replacement and Modification Program.

7.0 Scheduling:

7.1 The Visual Examinations and Functional Testing schedules shall be established, tracked and maintained within Supplement 1 to this Appendix.

7.2 The Inservice Inspection Program Plan shall identify and track expanded or additional testing and/or examinations as specified and required by ME-256.

8.0 Reports and Records:

8.1 Reports and records for the Visual (VT-3) Examinations and Functional (FT) Testing shall be maintained on all snubbers listed within ME-256.

8.2 Applicable records and reports, as required by Supplement 2 for Repairs, Replacements or Modifications, shall be maintained for snubbers.

8.3 Records of the service lives of all hydraulic and mechanical snubbers listed in this program, including the date at which the service life commences, and associated installation and maintenance records will be maintained.



QUALITY ASSURANCE MANUAL GINNA STATION ROCHESTER GAS & ELECTRIC CORPORATION	Section 10	REV. 1	PAGE 1 of 6
	EFFECTIVE DATE: December 31, 1993		
TITLE: APPENDIX B R.E. GINNA NUCLEAR POWER PLANT INSERVICE INSPECTION PROGRAM FOR THE 1990-1999 INTERVAL SEISMIC SUPPORT PROGRAM		SIGNATURE	DATE
	PREPARED BY:	<i>Frank J. Klepac</i>	12-1-93
	QUALITY ASSURANCE REVIEW:	<i>[Signature]</i>	12-2-93
	APPROVED BY:	<i>Michael J. Depina</i>	12-6-93

1.0 **General:**

1.1 The augmented inservice inspection program for Seismic Category I supports outside of the ASME Class boundary was developed to provide greater assurance that identified component supports will operate when and if needed during a seismic event.

1.2 Seismic Category I supports outside of the ASME Class boundary are identified in Table 1.

2.0 **Examination Requirements:**

2.1 Selected Seismic Category I supports shall be examined utilizing visual (VT-3) examination techniques. Support selection shall be based on Code Case N-491 for Class 2 piping supports. This sampling scheme requires a 15% sample distributed among the systems and support types within each system.

3.0 **Examination Methods:**

3.1 The visual (VT-3) examination shall be performed in accordance with Section 1.

4.0 **Frequency of Examination:**

4.1 The selected sample shall be examined at least once during the inspection interval.

5.0 **Examination Evaluation:**

5.1 The visual (VT-3) examination results shall be evaluated in accordance with IWF-3000 for Period 1, and -3000 of Code Case N-491 for Periods 2 and 3.

QUALITY ASSURANCE MANUAL GINNA STATION	TITLE:	APPENDIX B R.E. GINNA NUCLEAR POWER PLANT INSERVICE INSPECTION PROGRAM FOR THE 1990-1999 INTERVAL SEISMIC SUPPORT PROGRAM	Section 10	REV. 1
			PAGE 2 of 6	

5.2	Supports which do not meet the visual (VT-3) examination requirements shall be reported for evaluation and appropriate corrective action.
6.0	Repair & Testing Requirements:
6.1	Applicable repairs and testing shall be performed to the requirements of Supplement 2 to Appendix B, the Repair, Replacement and Modification Program. Code Case N-498 does not apply to Repairs.
7.0	Replacement & Modification, and Testing Requirements:
7.1	Replacements and Modifications, and applicable testing shall be performed to the requirements of Supplement 2 to Appendix B, the Repair, Replacement and Modification Program. Code Case N-498 does not apply to Replacements and Modifications.
8.0	Scheduling:
8.1	Scheduling of identified Seismic Category I supports shall be performed and controlled within Supplement 1 to Appendix B, the program plan.
9.0	Reports and Records:
9.1	Reports and records generated on identified Seismic Category I supports shall conform to applicable requirements specified within Section 1 and Supplement 2 to Appendix B.



QUALITY ASSURANCE MANUAL GINNA STATION	TITLE: APPENDIX B R.E. GINNA NUCLEAR POWER PLANT INSERVICE INSPECTION PROGRAM FOR THE 1990-1999 INTERVAL SEISMIC SUPPORT PROGRAM	Section 10	REV. 1
		PAGE 3 of 6	

Table 1

Seismic Category I Supports

Line Segment: AFW100

<u>Support Number</u>	<u>Support Number</u>	<u>Support Number</u>	<u>Support Number</u>
AFU-130	AFU-132	AFU-137	AFU-138
AFU-139			

Line Segment: AFW200

Support
Number
AFU-88

Line Segment: AFW300

<u>Support Number</u>	<u>Support Number</u>	<u>Support Number</u>	<u>Support Number</u>
AFU-4	AFU-5	AFU-6	AFU-7

Line Segment: CVC100

Support
Number
CVU-84

Line Segment: CVC200

<u>Support Number</u>	<u>Support Number</u>	<u>Support Number</u>	<u>Support Number</u>
CVU-125	CVU-126	CVU-129	CVU-130

Line Segment: CVC700

<u>Support Number</u>	<u>Support Number</u>
CVC-56	CVC-58

QUALITY ASSURANCE MANUAL GINNA STATION	TITLE: APPENDIX B R.E. GINNA NUCLEAR POWER PLANT INSERVICE INSPECTION PROGRAM FOR THE 1990-1999 INTERVAL SEISMIC SUPPORT PROGRAM	Section 10	REV. 1
		PAGE 4 of 6	

Table 1 (Cont.)

Seismic Category I Supports

Line Segment: CVC730

<u>Support Number</u> CVC-39	<u>Support Number</u> CVC-40
-------------------------------------	-------------------------------------

Line Segment: FW300

<u>Support Number</u> FWU-40 FWU-36 FWU-32 FWU-28	<u>Support Number</u> FWU-39 FWU-35 FWU-31	<u>Support Number</u> FWU-38 FWU-34 FWU-30	<u>Support Number</u> FWU-37 FWU-33 FWU-29
---	---	---	---

Line Segment: FW301

<u>Support Number</u> FWU-16 FWU-20 FWU-24	<u>Support Number</u> FWU-17 FWU-21 FWU-25	<u>Support Number</u> FWU-18 FWU-22 FWU-26	<u>Support Number</u> FWU-19 FWU-23 FWU-27
---	---	---	---

Line Segment: MS300

<u>Support Number</u> MSU-35 MSU-52 MSU-48 MSU-57	<u>Support Number</u> MSU-59 MSU-53 MSU-49	<u>Support Number</u> MSU-60 MSU-54 MSU-50	<u>Support Number</u> MSU-51 MSU-47 MSU-56
---	---	---	---

Line Segment: RHR300

<u>Support Number</u> RHU-86	<u>Support Number</u> RHR-87	<u>Support Number</u> RHU-90	<u>Support Number</u> RHR-91
-------------------------------------	-------------------------------------	-------------------------------------	-------------------------------------

QUALITY ASSURANCE MANUAL GINNA STATION	TITLE:	APPENDIX B R.E. GINNA NUCLEAR POWER PLANT INSERVICE INSPECTION PROGRAM FOR THE 1990-1999 INTERVAL SEISMIC SUPPORT PROGRAM	Section 10	REV. 1
			PAGE 5 of 6	

Table 1 (Cont.)

Seismic Category I Supports

Line Segment: SAFW450

<u>Support Number</u>	<u>Support Number</u>	<u>Support Number</u>	<u>Support Number</u>
AFU-169	AFU-170	AFU-175	AFU-176
AFU-177			

Line Segment: SGB-300

<u>Support Number</u>	<u>Support Number</u>
BDU-21	BDU-23

Line Segment: SGB-400

<u>Support Number</u>	<u>Support Number</u>
BDU-26	BDU-27

Line Segment: SI100

<u>Support Number</u>
SIU-8

Line Segment: SI200

<u>Support Number</u>
SIU-55

Line Segment: SW1500

<u>Support Number</u>	<u>Support Number</u>	<u>Support Number</u>	<u>Support Number</u>
SWU-363	SWU-364	SWU-365	SWU-366



QUALITY ASSURANCE MANUAL GINNA STATION	TITLE:	APPENDIX B R.E. GINNA NUCLEAR POWER PLANT INSERVICE INSPECTION PROGRAM FOR THE 1990-1999 INTERVAL SEISMIC SUPPORT PROGRAM	Section 10	REV. 1
			PAGE 6 of 6	

Table 1 (Cont.)

Seismic Category I Supports

Line Segment: SW2100

<u>Support Number</u>	<u>Support Number</u>	<u>Support Number</u>	<u>Support Number</u>
SWU-523	SWU-524	SWU-525	SWU-526
SWU-533	SWU-534		

Line Segment: SW2300

<u>Support Number</u>	<u>Support Number</u>	<u>Support Number</u>	<u>Support Number</u>
SWU-602	SWU-603	SWU-604	SWU-605
SWU-606	SWU-607		

Line Segment: SW2500

<u>Support Number</u>	<u>Support Number</u>	<u>Support Number</u>	<u>Support Number</u>
SWU-637	SWU-642	SWU-639	SWU-640
SWU-638			

QUALITY ASSURANCE MANUAL GINNA STATION	Section 11	REV. 3	PAGE 1 of 9
	EFFECTIVE DATE: December 31, 1993		
ROCHESTER GAS & ELECTRIC CORPORATION	SIGNATURE		DATE
	TITLE:	PREPARED BY: <i>Frank A Klepacki</i>	12-1-93
APPENDIX B R. E. GINNA NUCLEAR POWER PLANT INSERVICE INSPECTION PROGRAM FOR THE 1990-1999 INTERVAL ADDITIONAL PROGRAMS	QUALITY ASSURANCE REVIEW:	<i>[Signature]</i>	12-2-93
	APPROVED BY: <i>Michael J. Synet</i>		12-6-93

1.0 **General:**

1.1 The purpose of this section is to provide information and clarification on additional inspection programs being performed at R. E. Ginna Nuclear Power Plant. These inspection programs may be due in part to ASME Section XI program requirements or to other commitments made by Rochester Gas and Electric.

The following list identifies additional inspection programs being performed at R. E. Ginna Nuclear Power Plant:

- * Steam Generator Tube Inspection Program
- * Reactor Coolant Pump Flywheel Program
- * Class 1 Bolting Program (IEB 82-02)
- * Reactor Vessel Augmented Program, Category B-A

2.0 **Steam Generator Tube Inspection Program:**

2.1 **General:**

2.1.1 The Steam Generator Tube Inspection Program incorporates the requirements of ASME Section XI Code, under Category B-Q, Item Number B16.20. The Code requires that Steam Generator tubing in U-Tube Design be volumetrically (Eddy Current) examined to the extent and frequency governed by the plant Technical Specifications. In accordance with this Code requirement and R. E. Ginna Station Technical Specifications, eddy current examinations shall be performed. Steam Generator Tubing shall be examined their full length, at least once every five years.



QUALITY ASSURANCE MANUAL GINNA STATION	TITLE:	APPENDIX B R.E. GINNA NUCLEAR POWER PLANT INSERVICE INSPECTION PROGRAM FOR THE 1990-1999 INTERVAL ADDITIONAL PROGRAMS	Section 11	REV. 3
			PAGE 2 of 9	

2.1.2 The Steam Generator Tube Inspection Program also incorporates the requirements of USNRC Regulatory Guide 1.83, Revision 1, dated July, 1975, "Inservice Inspection of Pressurized Water Reactor Steam Generator Tubes" and the recommendations of the Electric Power Research (EPRI) PWR Steam Generator Inspection Guidelines, Revision 2.

2.2 Examination Requirements:

2.2.1 The program for each year of the five years shall include, as a minimum, the following requirements:

1. A rotating random sampling of 20% of all operational tubes for their full length.
2. A rotating random sample of 20% of each type of sleeved inlet tube for their full length, including the sleeve from the upper end through the expanded transition of the lower end.
3. All operational tubes that had a previously identified degradation of greater than 20% through wall to the extent of previously identified degradation. However, if after two (2) consecutive inspections these tubes have not had greater than 10% further penetration, the inspection frequency on these tubes may be extended to 40 months.

2.2.2 Other tubes may be added to the program each year as necessary to meet other concerns and are classified as "owner elected". "Owner Elected" examinations are not mandatory and may be performed as determined by the owner.

2.2.3 The Ginna Steam Generator Reliability Committee may change the aforementioned plan to meet outage schedules, provided that the changes meet the requirement of Regulatory Guide 1.83 and Supplement 1 to this Appendix.

2.3 Examination Method:

2.3.1 Eddy Current (Volumetric) Examination techniques shall be employed to perform the required examinations on Steam Generator tubes.

QUALITY ASSURANCE MANUAL GINNA STATION	TITLE:	APPENDIX B R.E. GINNA NUCLEAR POWER PLANT INSERVICE INSPECTION PROGRAM FOR THE 1990-1999 INTERVAL ADDITIONAL PROGRAMS	Section 11	REV. 3
			PAGE 3 of 9	

- 2.4 Frequency of Examinations:
- 2.4.1 Examinations shall be performed every refueling outage to the extent required and specified within 2.2, as a minimum.
- 2.5 Examination Evaluation:
- 2.5.1 Eddy Current evaluation shall be performed in accordance with R. E. Ginna Station Technical Specifications.
- 2.6 Repair, Replacement and Testing Requirements
- 2.6.1 Repair criteria for steam generator tubes is based on the requirements of Regulatory Guide 1.121, "Bases for Plugging Degraded PWR Steam Generator Tubes".
- 2.6.1.1 Steam generator tubes that have imperfections greater than 40 percent through-wall as indicated by eddy current, shall be repaired by plugging or sleeving.
- 2.6.1.2 Steam generator sleeves that have imperfections greater than 30 percent through wall as indicated by eddy current shall be repaired by plugging.
- 2.6.2 Repairs by welded plugs and sleeves shall be performed in accordance with Supplement 2 to this Appendix.
- 2.7 Scheduling:
- 2.7.1 Eddy Current examination schedules of Steam Generator Tubes shall be established within Supplement 1 to this Appendix.
- 2.8 Reports and Records:
- 2.8.1 Applicable records shall be maintained as specified within Section 1 of this program and as applicable and required within Supplement 2 to this Appendix.

QUALITY ASSURANCE MANUAL GINNA STATION	TITLE:	Section 11	REV. 3
	APPENDIX B R.E. GINNA NUCLEAR POWER PLANT INSERVICE INSPECTION PROGRAM FOR THE 1990-1999 INTERVAL ADDITIONAL PROGRAMS	PAGE 4 of 9	

- 2.8.2 Within 15 days following the completion of the evaluation of each inservice inspection of steam generator tubes, the number of tubes required by Paragraph 2.6.1 above to be plugged or sleeved in each steam generator shall be reported to the USNCR in a Special Report.
- 2.8.3 The complete results of the steam generator tube inservice inspection shall be submitted to the USNRC in a Special Report within 12 months following the completion of the inspection. This Special Report shall include:
- (a) Number of tubes inspected and extent to which inspected.
 - (b) Location and percent of wall-thickness penetration for each indication of an imperfection, and
 - (c) Identification of tubes plugged or sleeved.
- 2.8.4 If the number of tubes in a generator falling into categories (a) or (b) below exceeds the criteria, then results of the inspection shall be considered a Reportable Event pursuant to 10 CFR 50.73. Oral notification to the NRC Staff shall be accomplished within 48 hours, but no sooner than the next normal working day after the final review of the eddy current results. A written follow-up report shall provide a description of investigations conducted to determine the cause of the tube degradation and corrective measures taken to preclude recurrence. Categories (a) and (b) are:
- (a) More than 10 percent of the total tubes inspected are degraded (imperfections greater than 20 percent of the nominal wall thickness). However, previously degraded tubes must exhibit at least 10 percent further wall penetration to be included in this calculation.
 - (b) More than 1 percent of the total tubes inspected are degraded (imperfections greater than the repair limit).

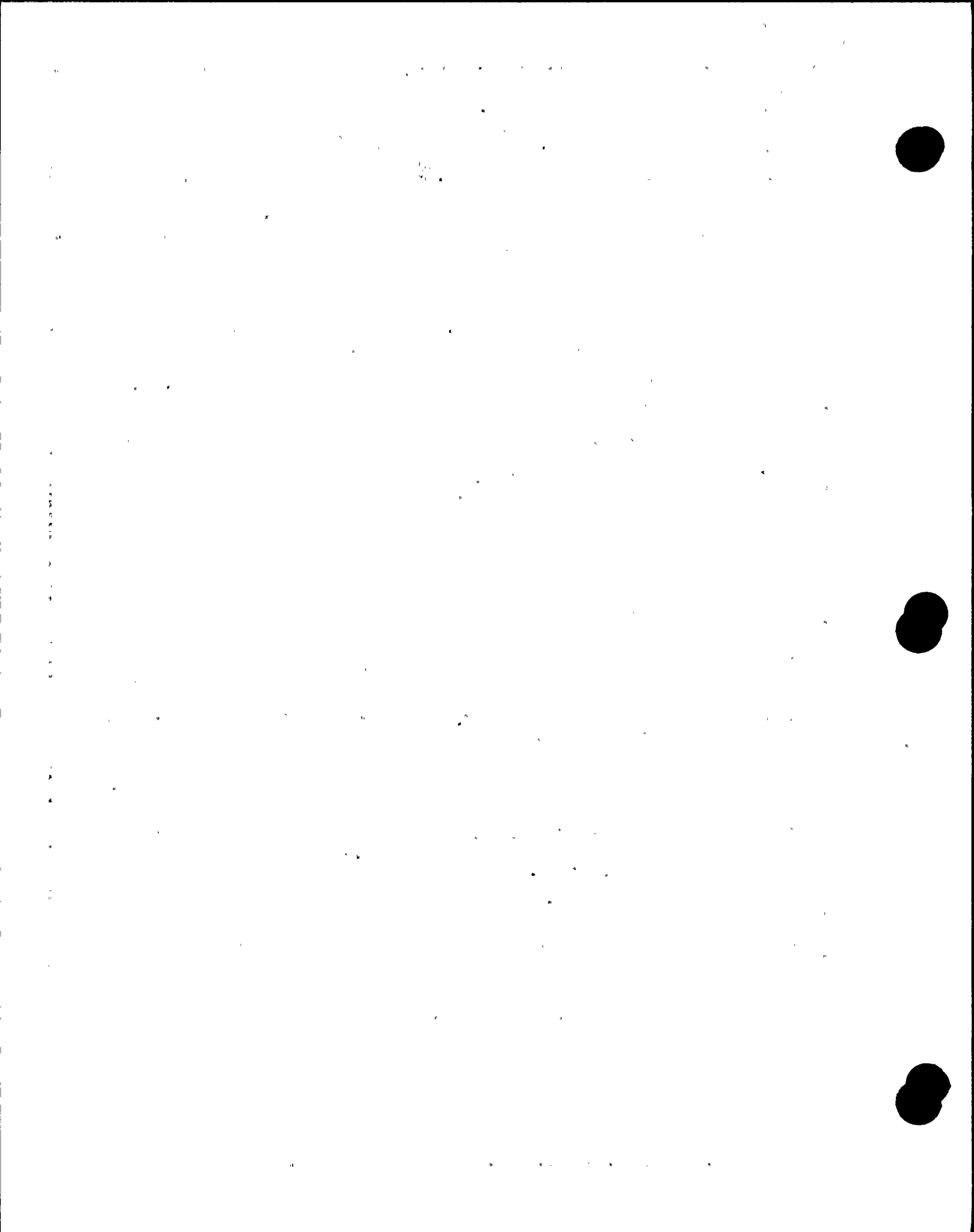

QUALITY ASSURANCE MANUAL GINNA STATION	TITLE:	APPENDIX B R.E. GINNA NUCLEAR POWER PLANT INSERVICE INSPECTION PROGRAM FOR THE 1990-1999 INTERVAL ADDITIONAL PROGRAMS	Section 11	REV. 3
			PAGE 5 of 9	

3.0	<u>Reactor Coolant Pump Flywheel Program:</u>
3.1	General: The augmented inservice inspection program for Reactor Coolant Pump Flywheels incorporates the requirements of the USNRC Regulatory Guide 1.14, Revision 1, dated August 1975, entitled "Reactor Coolant Pump Flywheel Integrity".
3.2	Examination Requirements:
3.2.1	Examinations shall be performed on all active Reactor Coolant Pump Flywheels and Anti-Rotation Pawls.
3.3	Examination Method:
3.3.1	Reactor Coolant Pump Flywheels shall be examined using Ultrasonic and Surface examination techniques.
3.3.2	Reactor Coolant Pump Anti-Rotation Pawls shall be examined using Surface examination techniques.
3.3.1	Ultrasonic and Surface examinations shall conform to and be performed in accordance with Section 1 of this program.
3.4	Frequency of Examinations:
3.4.1	Examinations shall be performed on all operating Reactor Coolant Pump Flywheel and Anti-Rotation Pawls once each period.
3.5	Examination Evaluation:
3.5.1	Examination evaluations shall be performed in accordance with Section 1 of this program.
3.5.2	Unacceptable examinations shall be reported for evaluation and appropriate corrective action.

QUALITY ASSURANCE MANUAL GINNA STATION	TITLE:	APPENDIX B R.E. GINNA NUCLEAR POWER PLANT INSERVICE INSPECTION PROGRAM FOR THE 1990-1999 INTERVAL ADDITIONAL PROGRAMS	Section 11	REV. 3
			PAGE 6 of 9	

- 3.6 Repair, Replacement and Testing Requirements
- 3.6.1 Repairs and Replacements shall be performed in accordance with Supplement 2 to this Appendix, as applicable.
- 3.7 Scheduling:
- 3.7.1 Examination schedules shall be established within Supplement 1 to this Appendix.
- 3.8 Reports and Records:
- 3.8.1 Applicable records shall be maintained as specified in Section 1 of this program and when required within Supplement 2 to this Appendix.
- 4.0 Class 1 Bolting Program (IEB 82-02):
- 4.1 General:
- This augmented inspection program was established to address IE Bulletin 82-02, "Degradation of Threaded Fasteners in the Reactor Coolant Pressure Boundary of PWR Plants" dated June 2, 1982.
- 4.2 Examination Requirements:
- 4.2.1 Examinations shall be performed on threaded fasteners of closure connections when opened for component inspection or maintenance for the following, as applicable:
1. Steam generator and pressurizer manway closures.
 2. Valve bonnets and pump flange connections installed on lines having a nominal diameter of 6 inches or greater.
 3. Control rod drive (CDR) flange and pressurizer heater connections that do not have seal welds to provide leak-tight integrity.



QUALITY ASSURANCE MANUAL GINNA STATION	TITLE:	APPENDIX B R.E. GINNA NUCLEAR POWER PLANT INSERVICE INSPECTION PROGRAM FOR THE 1990-1999 INTERVAL ADDITIONAL PROGRAMS	Section 11	REV. 3
			PAGE 7 of 9	

- 4.3 Examination Method:
- 4.3.1 Applicable threaded fasteners of closure connections shall be examined utilizing both Surface and Visual techniques.
- 4.4 Frequency of Examinations:
- 4.4.1 Applicable components containing threaded fasteners of closure connections shall be examined when opened for component inspection or maintenance.
- 4.5 Examination Evaluation:
- 4.5.1 Examination evaluations shall be performed in accordance with Section 1 of this program.
- 4.5.2 Unacceptable examinations shall be reported for evaluation and appropriate corrective action.
- 4.6 Repair, Replacement and Testing Requirements
- 4.6.1 Repairs and Replacements shall be performed in accordance with Supplement 2 to this Appendix, as applicable.
- 4.7 Scheduling:
- 4.7.1 Examination schedules shall be established, as applicable and required, within Supplement 1 to this Appendix or the Maintenance Inservice Inspection Program (MISIP).
- 4.8 Reports and Records:
- 4.8.1 Applicable records shall be maintained as specified within Section 1 of this program and as applicable when required within Supplement 2 to this Appendix.



QUALITY ASSURANCE MANUAL GINNA STATION	TITLE:	APPENDIX B R.E. GINNA NUCLEAR POWER PLANT INSERVICE INSPECTION PROGRAM FOR THE 1990-1999 INTERVAL ADDITIONAL PROGRAMS	Section 11	REV. 3
			PAGE 8 of 9	

5.0 Reactor Vessel Augmented Program, Category B-A:

5.1 General:

As specified within the Federal Register, 10 CFR Part 50, Vol. 57, No. 152 dated August 6, 1992, a specific augmented examination program is required for ASME Section XI Category B-A, Shell Welds of "Pressure Retaining Welds in Reactor Vessel".

5.2 Examination Requirements:

5.2.1 Examinations shall be performed on all ASME Section XI Category B-A, Item B1.0, Shell Welds of "Pressure Retaining Welds in Reactor Vessel" that are not required by the Code.

5.3 Examination Method:

5.3.1 Ultrasonic examinations shall conform and be performed in accordance with Section 1 of this program.

5.4 Frequency of Examinations:

5.4.1 Examinations shall be performed once during the Inspection Interval.

5.5 Examination Evaluation:

5.5.1 Examination Evaluations shall be performed in accordance with Section 1 of this program.

5.5.2 Unacceptable examinations shall be reported for evaluation and appropriate corrective action.

5.6 Repair, Replacement and Testing Requirements

5.6.1 Repairs and Replacements shall be performed in accordance with Supplement 2 to this Appendix, as applicable.

Faint, illegible text covering the majority of the page, possibly bleed-through from the reverse side.



QUALITY ASSURANCE MANUAL GINNA STATION	TITLE:	APPENDIX B R.E. GINNA NUCLEAR POWER PLANT INSERVICE INSPECTION PROGRAM FOR THE 1990-1999 INTERVAL ADDITIONAL PROGRAMS	Section 11	REV. 3
			PAGE 9 of 9	

- 5.7 **Scheduling:**
- 5.7.1 Examination schedules shall be established within Supplement 1 to this Appendix.
- 5.8 **Reports and Records:**
- 5.8.1 Applicable records shall be maintained as specified within Section 1 of this program and when required within Supplement 2 to this Appendix.

