



Bentley K. Jones
Director, Organizational Effectiveness
Harris Nuclear Plant
5413 Shearon Harris Rd
New Hill, NC 27562-9300

919.362.2305

NOV 03 2016

10 CFR 50.47(b)(10)
10 CFR 50, Appendix E

Serial: HNP-16-106

ATTN: Document Control Desk
U.S. Nuclear Regulatory Commission
Washington, DC 20555-0001

Shearon Harris Nuclear Power Plant, Unit 1
Docket No. 50-400/Renewed License No. NPF-63

Subject: Development of Evacuation Time Estimates

Ladies and Gentlemen:

As required by 10 CFR 50.47(b)(10) and 10 CFR 50, Appendix E, Section IV, Paragraph 4, Duke Energy, LLC, is providing an updated evacuation time estimate (ETE) analysis for the Harris Nuclear Plant (HNP). Enclosure 1 contains the updated ETE analysis.

This submittal contains no regulatory commitments.

Please refer any questions regarding this submittal to Jeffrey Robertson, Manager, Regulatory Affairs, at (919) 362-3137.

Sincerely,

Bentley K. Jones

Enclosure 1 – Development of Evacuation Time Estimates

cc: M. Riches, NRC Resident Inspector, HNP
M. Barillas, NRC Project Manager, HNP
NRC Regional Administrator, Region II



Bentley K. Jones
Director, Organizational Effectiveness
Harris Nuclear Plant
5413 Shearon Harris Rd
New Hill, NC 27562-9300

919.362.2305

10 CFR 50.47(b)(10)
10 CFR 50, Appendix E

Serial: HNP-16-106

ATTN: Document Control Desk
U.S. Nuclear Regulatory Commission
Washington, DC 20555-0001

Shearon Harris Nuclear Power Plant, Unit 1
Docket No. 50-400/Renewed License No. NPF-63

Subject: Development of Evacuation Time Estimates

Ladies and Gentlemen:

As required by 10 CFR 50.47(b)(10) and 10 CFR 50, Appendix E, Section IV, Paragraph 4, Duke Energy, LLC, is providing an updated evacuation time estimate (ETE) analysis for the Harris Nuclear Plant (HNP). Enclosure 1 contains the updated ETE analysis.

This submittal contains no regulatory commitments.

Please refer any questions regarding this submittal to Jeffrey Robertson, Manager, Regulatory Affairs, at (919) 362-3137.

Sincerely,

Bentley K. Jones

Enclosure 1 – Development of Evacuation Time Estimates

cc: M. Riches, NRC Resident Inspector, HNP
M. Barillas, NRC Project Manager, HNP
NRC Regional Administrator, Region II

Document Control Desk
Serial: HNP-16-106
Enclosure 1

Enclosure 1

Harris Nuclear Plant
Development of Evacuation Time Estimates

556 pages, including cover

Harris Nuclear Plant

Development of Evacuation Time Estimates

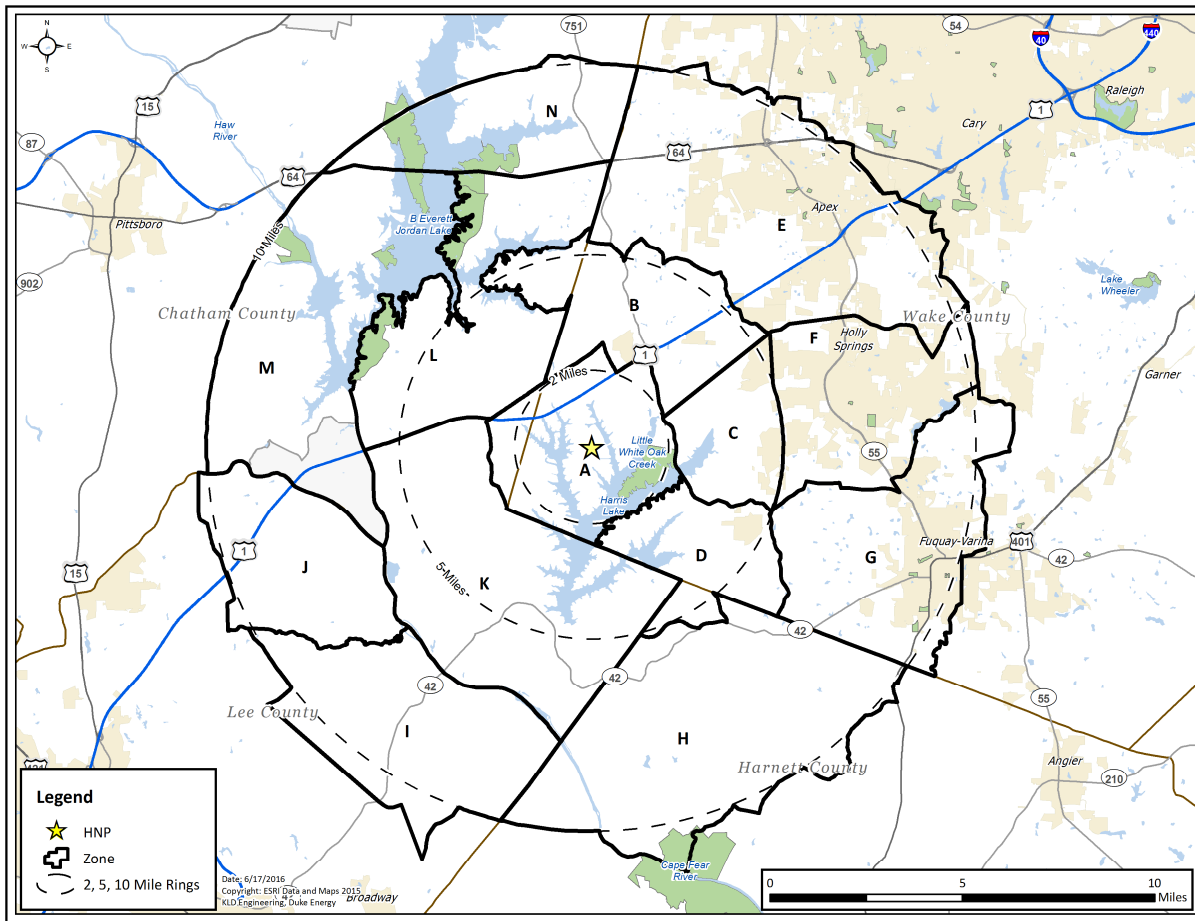

Work performed for Duke Energy, by:

KLD Engineering, P.C.
1601 Veterans Memorial Highway, Suite 340
Islandia, NY 11749
E-mail: kweinisch@kldcompanies.com

SIGNATURE LIST

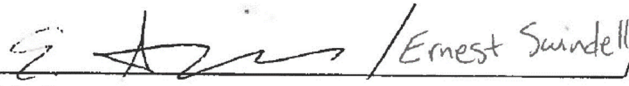
 Ernest Swindell, 10/31/16
Duke Energy Date
Project Lead, Emergency Preparedness

 , 10/25/16
KLD Engineering, P.C. – Lead Analyst Date

 , 10/25/16
KLD Engineering, P.C. – Senior Project Manager Date

Table of Contents

1	INTRODUCTION.....	1-1
1.1	Overview of the ETE Process.....	1-2
1.2	The Harris Nuclear Plant Location.....	1-4
1.3	Preliminary Activities	1-6
1.4	Comparison with Prior ETE Study	1-10
2	STUDY ESTIMATES AND ASSUMPTIONS.....	2-1
2.1	Data Estimates	2-1
2.2	Study Methodological Assumptions	2-2
2.3	Study Assumptions.....	2-5
3	DEMAND ESTIMATION.....	3-1
3.1	Permanent Residents	3-2
3.2	Shadow Population	3-11
3.3	Transient Population.....	3-14
3.4	Employees.....	3-18
3.5	Medical Facilities.....	3-22
3.6	External Traffic	3-22
3.7	Background Traffic	3-22
3.8	Special Event	3-23
3.9	Summary of Demand	3-25
4	ESTIMATION OF HIGHWAY CAPACITY.....	4-1
4.1	Capacity Estimations on Approaches to Intersections	4-2
4.2	Capacity Estimation along Sections of Highway	4-4
4.3	Application to the Harris Nuclear Plant Study Area.....	4-6
4.3.1	Two-Lane Roads	4-6
4.3.2	Multi-Lane Highway	4-6
4.3.3	Freeways	4-7
4.3.4	Intersections	4-8
4.4	Simulation and Capacity Estimation	4-8
4.5	Boundary Conditions.....	4-9
5	ESTIMATION OF TRIP GENERATION TIME.....	5-1
5.1	Background	5-1
5.2	Fundamental Considerations	5-3
5.3	Estimated Time Distributions of Activities Preceding Event 5.....	5-6
5.4	Calculation of Trip Generation Time Distribution.....	5-11
5.4.1	Statistical Outliers	5-12
5.4.2	Staged Evacuation Trip Generation	5-15
5.4.3	Trip Generation for Waterways and Recreational Areas.....	5-16
6	DEMAND ESTIMATION FOR EVACUATION SCENARIOS	6-1
7	GENERAL POPULATION EVACUATION TIME ESTIMATES (ETE).....	7-1
7.1	Voluntary Evacuation and Shadow Evacuation	7-1

7.2	Staged Evacuation.....	7-1
7.3	Patterns of Traffic Congestion during Evacuation	7-2
7.4	Evacuation Rates.....	7-4
7.5	Evacuation Time Estimate (ETE) Results	7-5
7.6	Staged Evacuation Results	7-6
7.7	Guidance on Using ETE Tables	7-7
8	TRANSIT-DEPENDENT AND SPECIAL FACILITY EVACUATION TIME ESTIMATES	8-1
8.1	Transit Dependent People Demand Estimate.....	8-2
8.2	School Population – Transit Demand.....	8-4
8.3	Medical Facility Demand.....	8-4
8.4	Evacuation Time Estimates for Transit Dependent People	8-5
8.5	Special Needs Population.....	8-11
9	TRAFFIC MANAGEMENT STRATEGY	9-1
10	EVACUATION ROUTES.....	10-1
A.	GLOSSARY OF TRAFFIC ENGINEERING TERMS	A-1
B.	DYNAMIC TRAFFIC ASSIGNMENT AND DISTRIBUTION MODEL	B-1
C.	DYNEV TRAFFIC SIMULATION MODEL	C-1
C.1	Methodology.....	C-5
C.1.1	The Fundamental Diagram.....	C-5
C.1.2	The Simulation Model	C-5
C.1.3	Lane Assignment	C-13
C.2	Implementation	C-13
C.2.1	Computational Procedure.....	C-13
C.2.2	Interfacing with Dynamic Traffic Assignment (DTRAD)	C-16
D.	DETAILED DESCRIPTION OF STUDY PROCEDURE	D-1
E.	FACILITY DATA.....	E-1
F.	TELEPHONE SURVEY.....	F-1
F.1	Introduction	F-1
F.2	Survey Instrument and Sampling Plan	F-2
F.3	Survey Results	F-3
F.3.2	Household Demographic Results	F-4
F.3.3	Evacuation Response	F-9
F.3.4	Time Distribution Results.....	F-11
F.4	Conclusions	F-13
G.	TRAFFIC MANAGEMENT PLAN.....	G-1
G.1	Traffic Control Points	G-1
G.2	Security Road Blocks	G-2
H	EVACUATION REGIONS	H-1
J.	REPRESENTATIVE INPUTS TO AND OUTPUTS FROM THE DYNEV II SYSTEM	J-1

K.	EVACUATION ROADWAY NETWORK.....	K-1
L.	ZONE BOUNDARIES.....	L-1
M.	EVACUATION SENSITIVITY STUDIES.....	M-1
M.1	Effect of Changes in Trip Generation Times.....	M-1
M.2	Effect of Changes in the Number of People in the Shadow Region Who Relocate.....	M-2
M.3	Effect of Changes in EPZ Resident Population.....	M-3
M.4	Effect of 50% Reduction in Capacity and Free Flow Speed for Ice Scenarios.....	M-5
M.5	Enhancements in Evacuation Time.....	M-6
N.	ETE CRITERIA CHECKLIST.....	N-1

Note: Appendix I intentionally skipped

List of Figures

Figure 1-1. HNP Location.....	1-5
Figure 1-2. HNP Link-Node Analysis Network.....	1-8
Figure 2-1. Voluntary Evacuation Methodology	2-4
Figure 3-1. HNP EPZ	3-5
Figure 3-2. Census Boundaries within the HNP Study Area.....	3-7
Figure 3-3. Permanent Resident Population by Sector.....	3-9
Figure 3-4. Permanent Resident Vehicles by Sector	3-10
Figure 3-5. Shadow Population by Sector	3-12
Figure 3-6. Shadow Vehicles by Sector	3-13
Figure 3-7. Transient Population by Sector.....	3-16
Figure 3-8. Transient Vehicles by Sector	3-17
Figure 3-9. Employee Population by Sector.....	3-20
Figure 3-10. Employee Vehicles by Sector	3-21
Figure 4-1. Fundamental Diagrams.....	4-9
Figure 5-1. Events and Activities Preceding the Evacuation Trip.....	5-5
Figure 5-2. Evacuation Mobilization Activities.....	5-10
Figure 5-3. Comparison of Data Distribution and Normal Distribution.....	5-13
Figure 5-4. Comparison of Trip Generation Distributions.....	5-19
Figure 5-5. Comparison of Staged and Un-staged Trip Generation Distributions in the 2 to 5 Mile Region	5-21
Figure 6-1. HNP EPZ Zones	6-7
Figure 7-1. Voluntary Evacuation Methodology	7-17
Figure 7-2. HNP Shadow Region	7-18
Figure 7-3. Congestion Patterns at 30 Minutes after the Advisory to Evacuate	7-19
Figure 7-4. Congestion Patterns at 1 Hour after the Advisory to Evacuate.....	7-20
Figure 7-5. Congestion Patterns at 1 Hour 30 Minutes after the Advisory to Evacuate.....	7-21
Figure 7-6. Congestion Patterns at 2 Hours 30 Minutes after the Advisory to Evacuate	7-22
Figure 7-7. Congestion Patterns at 4 Hours after the Advisory to Evacuate	7-23
Figure 7-8. Congestion Patterns at 4 Hours 30 Minutes after the Advisory to Evacuate	7-24
Figure 7-9. Congestion Patterns at 5 Hours after the Advisory to Evacuate	7-25
Figure 7-10. Congestion Patterns at 5 Hours 45 Minutes after the Advisory to Evacuate	7-26
Figure 7-11. Evacuation Time Estimates - Scenario 1 for Region R03	7-27
Figure 7-12. Evacuation Time Estimates - Scenario 2 for Region R03	7-27
Figure 7-13. Evacuation Time Estimates - Scenario 3 for Region R03	7-28
Figure 7-14. Evacuation Time Estimates - Scenario 4 for Region R03	7-28
Figure 7-15. Evacuation Time Estimates - Scenario 5 for Region R03	7-29
Figure 7-16. Evacuation Time Estimates - Scenario 6 for Region R03	7-29
Figure 7-17. Evacuation Time Estimates - Scenario 7 for Region R03	7-30
Figure 7-18. Evacuation Time Estimates - Scenario 8 for Region R03	7-30
Figure 7-19. Evacuation Time Estimates - Scenario 9 for Region R03	7-31
Figure 7-20. Evacuation Time Estimates - Scenario 10 for Region R03	7-31
Figure 7-21. Evacuation Time Estimates - Scenario 11 for Region R03	7-32
Figure 7-22. Evacuation Time Estimates - Scenario 12 for Region R03	7-32
Figure 7-23. Evacuation Time Estimates - Scenario 13 for Region R03	7-33
Figure 7-24. Evacuation Time Estimates - Scenario 14 for Region R03	7-33

Figure 8-1. Chronology of Transit Evacuation Operations	8-13
Figure 8-2. Transit-Dependent Bus Routes	8-14
Figure 10-1. General Population Reception Centers and Relocation Schools	10-2
Figure 10-2. Evacuation Routes	10-3
Figure B-1. Flow Diagram of Simulation-DTRAD Interface.....	B-4
Figure C-1. Representative Analysis Network.....	C-4
Figure C-2. Fundamental Diagrams.....	C-6
Figure C-3. A UNIT Problem Configuration with $t_1 > 0$	C-7
Figure C-4. Flow of Simulation Processing (See Glossary: Table C-3)	C-15
Figure D-1. Flow Diagram of Activities.....	D-5
Figure E-1. Schools within the EPZ.....	E-12
Figure E-2. Overview of Child Care Centers within the EPZ.....	E-13
Figure E-3. Child Care Centers within Zones E and F	E-14
Figure E-4. Child Care Centers within Zones F and G.....	E-15
Figure E-5. Medical Facilities within the EPZ	E-16
Figure E-6. Non-EPZ Employee Locations within the EPZ	E-17
Figure E-7. Recreational Areas within the EPZ.....	E-18
Figure E-8. Recreational Areas within Zones E, F and G	E-19
Figure E-9. Lodging Facilities within the EPZ.....	E-20
Figure F-1. Household Size in the EPZ.....	F-4
Figure F-2. Household Vehicle Availability.....	F-5
Figure F-3. Vehicle Availability - 1 to 5 Person Households.....	F-6
Figure F-4. Vehicle Availability - 6 to 9+ Person Households.....	F-6
Figure F-5. Household Ridesharing Preference.....	F-7
Figure F-6. Commuters in Households in the EPZ.....	F-8
Figure F-7. Modes of Travel in the EPZ	F-9
Figure F-8. Number of Vehicles Used for Evacuation	F-10
Figure F-9. Percent of Households that Await Returning Commuter Before Leaving	F-10
Figure F-10. Households Evacuating with Pets	F-11
Figure F-11. Time Required to Prepare to Leave Work/College	F-12
Figure F-12. Time to Travel Home from Work/College.....	F-12
Figure F-13. Time to Prepare Home for Evacuation.....	F-13
Figure G-1. Overview of Traffic Control Points and Security Road Blocks for the HNP Site	G-3
Figure G-2. Traffic Control Points and Security Road Blocks within Zone E.....	G-4
Figure G-3. Traffic Control Points and Security Road Blocks within Zones F and G.....	G-5
Figure G-4. Modified Traffic Control Point at US-1 North Access Ramps & Hawkins Avenue.....	G-6
Figure G-5. Modified Traffic Control Point at SR-55 & Lufkin Road.....	G-7
Figure G-6. Modified Traffic Control Point at SR-55 Bypass & Holly Springs Road.....	G-8
Figure G-7. Modified Traffic Control Point at US-64 & Lake Pine Drive.....	G-9
Figure G-8. Modified Traffic Control Point at US-64 & Edinburgh Drive	G-10
Figure H-1. Region R01.....	H-4
Figure H-2. Region R02.....	H-5
Figure H-3. Region R03.....	H-6
Figure H-4. Region R04.....	H-7
Figure H-5. Region R05.....	H-8
Figure H-6. Region R06.....	H-9
Figure H-7. Region R07.....	H-10

Figure H-8. Region R08.....	H-11
Figure H-9. Region R09.....	H-12
Figure H-10. Region R10.....	H-13
Figure H-11. Region R11.....	H-14
Figure H-12. Region R12.....	H-15
Figure H-13. Region R13.....	H-16
Figure H-14. Region R14.....	H-17
Figure H-15. Region R15.....	H-18
Figure H-16. Region R16.....	H-19
Figure H-17. Region R17.....	H-20
Figure H-18. Region R18.....	H-21
Figure H-19. Region R19.....	H-22
Figure H-20. Region R20.....	H-23
Figure H-21. Region R21.....	H-24
Figure H-22. Region R22.....	H-25
Figure H-23. Region R23.....	H-26
Figure H-24. Region R24.....	H-27
Figure H-25. Region R25.....	H-28
Figure H-26. Region R26.....	H-29
Figure H-27. Region R27.....	H-30
Figure H-28. Region R28.....	H-31
Figure H-29. Region R29.....	H-32
Figure H-30. Region R30.....	H-33
Figure H-31. Region R31.....	H-34
Figure H-32. Region R32.....	H-35
Figure H-33. Region R33.....	H-36
Figure H-34. Region R34.....	H-37
Figure H-35. Region R35.....	H-38
Figure H-36. Region R36.....	H-39
Figure H-37. Region R37.....	H-40
Figure J-1. ETE and Trip Generation: Summer, Midweek, Midday, Good Weather (Scenario 1)	J-9
Figure J-2. ETE and Trip Generation: Summer, Midweek, Midday, Rain (Scenario 2)	J-9
Figure J-3. ETE and Trip Generation: Summer, Weekend, Midday, Good Weather (Scenario 3).....	J-10
Figure J-4. ETE and Trip Generation: Summer, Weekend, Midday, Rain (Scenario 4)	J-10
Figure J-5. ETE and Trip Generation: Summer, Midweek, Weekend, Evening, Good Weather (Scenario 5)	J-11
Figure J-6. ETE and Trip Generation: Winter, Midweek, Midday, Good Weather (Scenario 6)	J-11
Figure J-7. ETE and Trip Generation: Winter, Midweek, Midday, Rain (Scenario 7)	J-12
Figure J-8. ETE and Trip Generation: Winter, Midweek, Midday, Ice (Scenario 8).....	J-12
Figure J-9. ETE and Trip Generation: Winter, Weekend, Midday, Good Weather (Scenario 9).....	J-13
Figure J-10. ETE and Trip Generation: Winter, Weekend, Midday, Rain (Scenario 10).....	J-13
Figure J-11. ETE and Trip Generation: Winter, Weekend, Midday, Ice (Scenario 11)	J-14
Figure J-12. ETE and Trip Generation: Winter, Midweek, Weekend, Evening, Good Weather (Scenario 12)	J-14
Figure J-13. ETE and Trip Generation: Summer, Weekend, Evening, Good Weather, Special Event (Scenario 13)	J-15

Figure J-14. ETE and Trip Generation: Summer, Midweek, Midday, Good Weather, Roadway Impact (Scenario 14)	J-15
Figure K-1. Harris Link-Node Analysis Network	K-2
Figure K-2. Link-Node Analysis Network – Grid 1	K-3
Figure K-3. Link-Node Analysis Network – Grid 2	K-4
Figure K-4. Link-Node Analysis Network – Grid 3	K-5
Figure K-5. Link-Node Analysis Network – Grid 4	K-6
Figure K-6. Link-Node Analysis Network – Grid 5	K-7
Figure K-7. Link-Node Analysis Network – Grid 6	K-8
Figure K-8. Link-Node Analysis Network – Grid 7	K-9
Figure K-9. Link-Node Analysis Network – Grid 8	K-10
Figure K-10. Link-Node Analysis Network – Grid 9	K-11
Figure K-11. Link-Node Analysis Network – Grid 10	K-12
Figure K-12. Link-Node Analysis Network – Grid 11	K-13
Figure K-13. Link-Node Analysis Network – Grid 12	K-14
Figure K-14. Link-Node Analysis Network – Grid 13	K-15
Figure K-15. Link-Node Analysis Network – Grid 14	K-16
Figure K-16. Link-Node Analysis Network – Grid 15	K-17
Figure K-17. Link-Node Analysis Network – Grid 16	K-18
Figure K-18. Link-Node Analysis Network – Grid 17	K-19
Figure K-19. Link-Node Analysis Network – Grid 18	K-20
Figure K-20. Link-Node Analysis Network – Grid 19	K-21
Figure K-21. Link-Node Analysis Network – Grid 20	K-22
Figure K-22. Link-Node Analysis Network – Grid 21	K-23
Figure K-23. Link-Node Analysis Network – Grid 22	K-24
Figure K-24. Link-Node Analysis Network – Grid 23	K-25
Figure K-25. Link-Node Analysis Network – Grid 24	K-26
Figure K-26. Link-Node Analysis Network – Grid 25	K-27
Figure K-27. Link-Node Analysis Network – Grid 26	K-28
Figure K-28. Link-Node Analysis Network – Grid 27	K-29
Figure K-29. Link-Node Analysis Network – Grid 28	K-30
Figure K-30. Link-Node Analysis Network – Grid 29	K-31
Figure K-31. Link-Node Analysis Network – Grid 30	K-32
Figure K-32. Link-Node Analysis Network – Grid 31	K-33
Figure K-33. Link-Node Analysis Network – Grid 32	K-34
Figure K-34. Link-Node Analysis Network – Grid 33	K-35
Figure K-35. Link-Node Analysis Network – Grid 34	K-36
Figure K-36. Link-Node Analysis Network – Grid 35	K-37
Figure K-37. Link-Node Analysis Network – Grid 36	K-38
Figure K-38. Link-Node Analysis Network – Grid 37	K-39
Figure K-39. Link-Node Analysis Network – Grid 38	K-40
Figure K-40. Link-Node Analysis Network – Grid 39	K-41
Figure K-41. Link-Node Analysis Network – Grid 40	K-42
Figure K-42. Link-Node Analysis Network – Grid 41	K-43
Figure K-43. Link-Node Analysis Network – Grid 42	K-44
Figure K-44. Link-Node Analysis Network – Grid 43	K-45

List of Tables

Table 1-1. Stakeholder Interaction	1-1
Table 1-2. Highway Characteristics	1-6
Table 1-3. ETE Study Comparisons.....	1-11
Table 2-1. Evacuation Scenario Definitions.....	2-3
Table 2-2. Model Adjustment for Adverse Weather.....	2-8
Table 3-1. County Population Change and Annual Growth Rate from April 1, 2010 to July 1, 2015	3-6
Table 3-2. Municipality Population Change and Annual Growth Rate from April 1, 2010 to July 1, 2015	3-6
Table 3-3. EPZ Permanent Resident Population	3-8
Table 3-4. Permanent Resident Population and Vehicles by Zone	3-8
Table 3-5. Shadow Population and Vehicles by Sector	3-11
Table 3-6. Summary of Transients and Transient Vehicles	3-15
Table 3-7. Summary of Non-EPZ Resident Employees and Employee Vehicles.....	3-19
Table 3-8. HNP EPZ External Traffic	3-24
Table 3-9. Summary of Population Demand.....	3-26
Table 3-10. Summary of Vehicle Demand.....	3-27
Table 5-1. Event Sequence for Evacuation Activities.....	5-3
Table 5-2. Time Distribution for Notifying the Public	5-6
Table 5-3. Time Distribution for Employees to Prepare to Leave Work	5-7
Table 5-4. Time Distribution for Commuters to Travel Home	5-8
Table 5-5. Time Distribution for Population to Prepare to Leave Home	5-9
Table 5-6. Mapping Distributions to Events.....	5-11
Table 5-7. Description of the Distributions.....	5-11
Table 5-8. Trip Generation Histograms for the EPZ Population for Un-staged Evacuation	5-18
Table 5-9. Trip Generation Histograms for the EPZ Population for Staged Evacuation	5-20
Table 6-1. Description of Evacuation Regions.....	6-6
Table 6-2. Evacuation Scenario Definitions.....	6-8
Table 6-3. Percent of Population Groups Evacuating for Various Scenarios	6-9
Table 6-4. Vehicle Estimates by Scenario.....	6-10
Table 7-1. Time to Clear the Indicated Area of <u>90</u> Percent of the Affected Population	7-10
Table 7-2. Time to Clear the Indicated Area of <u>100</u> Percent of the Affected Population	7-12
Table 7-3. Time to Clear <u>90</u> Percent of the 2-Mile Region within the Indicated Region	7-14
Table 7-4. Time to Clear <u>100</u> Percent of the 2-Mile Region within the Indicated Region	7-15
Table 7-5. Description of Evacuation Regions.....	7-16
Table 8-1. Transit-Dependent Population Estimates	8-15
Table 8-2. School Population Demand Estimates	8-16
Table 8-3. Relocation Schools for Schools and Child Care Centers.....	8-18
Table 8-4. Medical Facility Transit Demand.....	8-20
Table 8-5. Summary of Transportation Resources	8-22
Table 8-6. Bus Route Descriptions	8-24
Table 8-7. School and Child Care Center Evacuation Time Estimates - Good Weather.....	8-28
Table 8-8. School and Child Care Center Evacuation Time Estimates - Rain	8-31
Table 8-9. School and Child Care Center Evacuation Time Estimates – Ice	8-34
Table 8-10. Summary of Transit-Dependent Bus Routes.....	8-37
Table 8-11. Transit-Dependent Evacuation Time Estimates - Good Weather	8-38
Table 8-12. Transit-Dependent Evacuation Time Estimates - Rain.....	8-40

Table 8-13. Transit Dependent Evacuation Time Estimates – Ice	8-42
Table 8-14. Medical Facility Evacuation Time Estimates – Good Weather.....	8-44
Table 8-15. Medical Facility Evacuation Time Estimates - Rain	8-46
Table 8-16. Medical Facility Evacuation Time Estimates - Ice.....	8-48
Table 8-17. Homebound Special Needs Population Evacuation Time Estimates	8-50
Table A-1. Glossary of Traffic Engineering Terms	A-1
Table C-1. Selected Measures of Effectiveness Output by DYNEV II	C-2
Table C-2. Input Requirements for the DYNEV II Model	C-3
Table C-3. Glossary.....	C-8
Table E-1. Schools within the EPZ	E-2
Table E-2. Child Care Centers within the EPZ.....	E-3
Table E-3. Medical Facilities within the EPZ.....	E-5
Table E-4. Major Employers within the EPZ.....	E-7
Table E-5. Campgrounds within the EPZ	E-8
Table E-6. Parks and Community Centers within the EPZ.....	E-9
Table E-7. Golf Courses within the EPZ	E-11
Table E-8. Lodging Facilities within the EPZ.....	E-11
Table F-1. Harris Telephone Survey Sampling Plan.....	F-3
Table G-1. Proposed Modifications to Existing Traffic Control Points	G-2
Table H-1. Percent of Zone Population Evacuating for Each Region	H-2
Table J-1. Characteristics of the Ten Highest Volume Signalized Intersections.....	J-2
Table J-2. Sample Simulation Model Input	J-4
Table J-3. Selected Model Outputs for the Evacuation of the Entire EPZ (Region R03)	J-5
Table J-4. Average Speed (mph) and Travel Time (min) for Major Evacuation Routes (Region R03, Scenario 1)	J-6
Table J-5. Simulation Model Outputs at Network Exit Links for Region R03, Scenario 1	J-7
Table K-1. Evacuation Roadway Network Characteristics	K-46
Table K-2. Nodes in the Link-Node Analysis Network which are Controlled	K-152
Table M-1. Evacuation Time Estimates for Trip Generation Sensitivity Study	M-1
Table M-2. Evacuation Time Estimates for Shadow Sensitivity Study	M-2
Table M-3. ETE Variation with Population Change	M-4
Table M-4. ETE Variation for 50% Ice Reduction – Scenario 8.....	M-5
Table M-5. ETE Variation for 50% Ice Reduction – Scenario 11.....	M-5
Table N-1. ETE Review Criteria Checklist	N-1

EXECUTIVE SUMMARY

This report describes the analyses undertaken and the results obtained by a study to develop Evacuation Time Estimates (ETE) for the Harris Nuclear Plant (HNP) located in Wake County, North Carolina. ETE are part of the required planning basis and provide Duke Energy and State and local governments with site-specific information needed for Protective Action decision-making.

In the performance of this effort, guidance is provided by documents published by Federal Governmental agencies. Most important of these are:

- Emergency Planning and Preparedness for Production and Utilization Facilities, 10CFR50, Appendix E.
- Criteria for Development of Evacuation Time Estimate Studies, NUREG/CR-7002, December 2011.
- Criteria for Preparation and Evaluation of Radiological Emergency Response Plans and Preparedness in Support of Nuclear Power Plants, NUREG-0654/FEMA-REP-1, Rev. 1, November 1980.
- Development of Evacuation Time Estimates for Nuclear Power Plants, NUREG/CR-6863, January 2005.

Overview of Project Activities

This project began in March, 2016 and extended over a period of 7 months. The major activities performed are briefly described in chronological sequence:

- Attended a “kick-off” meeting with Duke Energy personnel and emergency management personnel representing state and county governments.
- Accessed 2010 U.S. Census Bureau data files and projected permanent resident population to 2016 using annual growth rates computed by comparing 2010 data with 2015¹ population estimates published by the Census Bureau.
- Studied Geographic Information Systems (GIS) maps of the area in the vicinity of the HNP, then conducted a detailed field survey of the highway network to observe any roadway changes relative to the previous ETE study done in 2012.
- Updated the analysis network representing the highway system topology and capacities within the Emergency Planning Zone (EPZ), plus a Shadow Region covering the region between the EPZ boundary and approximately 15 miles radially from the plant.
- Utilized the results of the 2012 telephone survey of residents within the EPZ, to gather

¹ The annual population estimates prepared by the Census Bureau for the entire U.S. involve an extensive data gathering process. As such, population estimates are a year behind – 2015 data are released in 2016. The schedule for release of Census data is provided on the Census website: <http://www.census.gov/popest/schedule.html>

focused data needed for this ETE study that were not contained within the census database. The U.S Census Bureau's American Community Survey (ACS)² household income and household size data for the counties within the EPZ for 2012 and 2014³ were analyzed to validate that EPZ demographics are similar and justify the use of the 2012 telephone survey results in this ETE study.

- The data gathered for the 2012 ETE study were reviewed and updated accordingly by the offsite response organizations (OROs). Special facility data was requested from the OROs at the kickoff meeting. If updated information was not provided, the data gathered in the 2012 ETE study was utilized.
- The traffic demand and trip-generation rates of evacuating vehicles were estimated from the gathered data. The trip generation rates reflect the estimated mobilization time (i.e., the time required by evacuees to prepare for the evacuation trip) computed using the results of the telephone survey of EPZ residents.
- Following federal guidelines, the existing 14 Zones, within the EPZ, are grouped within circular areas or "keyhole" configurations (circles plus radial sectors) that define a total of 37 Evacuation Regions.
- The time-varying external circumstances are represented as Evacuation Scenarios, each described in terms of the following factors: (1) Season (Summer, Winter); (2) Day of Week (Midweek, Weekend); (3) Time of Day (Midday, Evening); and (4) Weather (Good, Rain, Ice). One special event scenario for Fourth of July on Jordan Lake was considered. One roadway impact scenario was considered wherein a single lane was closed on US-1 northbound (from New Hill Holleman Rd to I-40) and US-64 eastbound (from NC-751 to US-1) for the duration of the evacuation.
- Staged evacuation was considered for those regions wherein the 2 mile radius and sectors downwind to 5 miles are evacuated.
- As per NUREG/CR-7002, the Planning Basis for the calculation of ETE is:
 - A rapidly escalating accident at the HNP that quickly assumes the status of a general emergency wherein evacuation is ordered promptly and no early protective actions have been implemented such that the Advisory to Evacuate (ATE) is virtually coincident with the siren alert.
 - While an unlikely accident scenario, this planning basis will yield ETE, measured as the elapsed time from the ATE until the stated percentage of the population exits the impacted Region that represent "upper bound" estimates. This conservative Planning Basis is applicable for all initiating events.
- If the emergency occurs while schools are in session, the ETE study assumes that the children will be evacuated by bus directly to relocation schools located outside the EPZ.

² <http://factfinder.census.gov/faces/nav/jsf/pages/searchresults.xhtml?refresh=t>

³ Information for 2015 or 2016 was unavailable.

Parents, relatives, and neighbors are advised to not pick up their children at school prior to the arrival of the buses dispatched for that purpose. The ETE for schoolchildren are calculated separately.

- Evacuees who do not have access to a private vehicle will either ride-share with relatives, friends or neighbors, or be evacuated by buses provided as specified in the county evacuation plans. Those in special facilities will likewise be evacuated with public transit, as needed: bus, minivan, passenger car, wheelchair transport or ambulance, as required. Separate ETE are calculated for the transit-dependent evacuees, for homebound special needs population, and for those evacuated from special facilities.
- Attended “final” meeting with Duke Energy personnel and emergency management personnel representing state and county governments to present results from the study.

Computation of ETE

A total of 518 ETE were computed for the evacuation of the general public. Each ETE quantifies the aggregate evacuation time estimated for the population within one of the 37 Evacuation Regions to evacuate from that Region, under the circumstances defined for one of the 14 Evacuation Scenarios (37 x 14 = 518). Separate ETE are calculated for transit-dependent evacuees, including schoolchildren for applicable scenarios.

Except for Region R03, which is the evacuation of the entire EPZ, only a portion of the people within the EPZ would be advised to evacuate. That is, the Advisory to Evacuate applies only to those people occupying the specified impacted region. It is assumed that 100 percent of the people within the impacted region will evacuate in response to this Advisory. The people occupying the remainder of the EPZ outside the impacted region may be advised to take shelter.

The computation of ETE assumes that 20 percent of the population within the EPZ, but outside the impacted region, will elect to “voluntarily” evacuate. In addition, 20 percent of the population in the Shadow Region will also elect to evacuate. These voluntary evacuees could impede those who are evacuating from within the impacted region. The impedance that could be caused by voluntary evacuees is considered in the computation of ETE for the impacted region.

Staged evacuation is considered wherein those people within the 2-mile region evacuate immediately, while those beyond 2 miles, but within the EPZ, shelter-in-place. Once 90 percent of the 2-mile region is evacuated, those people beyond 2 miles begin to evacuate. As per federal guidance, 20 percent of people beyond 2 miles will evacuate (non-compliance) even though they are advised to shelter-in-place.

The computational procedure is outlined as follows:

- A link-node representation of the highway network is coded. Each link represents a unidirectional length of highway; each node usually represents an intersection or merge point. The capacity of each link is estimated based on the field survey observations and

on established traffic engineering procedures.

- The evacuation trips are generated at locations called “zonal centroids” located within the EPZ and Shadow Region. The trip generation rates vary over time reflecting the mobilization process, and from one location (centroid) to another depending on population density and on whether a centroid is within, or outside, the impacted area.
- The evacuation model computes the routing patterns for evacuating vehicles that are compliant with federal guidelines (outbound relative to HNP) and then simulates the traffic flow movements over space and time. This simulation process estimates the rate that traffic flow exits the impacted region.

The ETE statistics provide the elapsed times for 90 percent and 100 percent, respectively, of the population within the impacted region, to evacuate from within the impacted region. These statistics are presented in tabular and graphical formats. The 90th percentile ETE have been identified as the values that should be considered when making protective action decisions because the 100th percentile ETE are prolonged by those relatively few people who take longer to mobilize. This is referred to as the “evacuation tail” in Section 4.0 of NUREG/CR-7002.

Traffic Management

This study used the comprehensive existing traffic management plans provided by Chatham, Harnett, Lee and Wake Counties. Based on ETE simulations, one Traffic Control Point (TCP) was eliminated, and 5 TCPs were modified to expedite the evacuation. Refer to Section 9 and Appendix G.

Selected Results

A compilation of selected information is presented on the following pages in the form of figures and tables extracted from the body of the report; these are described below.

- Figure 6-1 displays a map of the HNP EPZ showing the layout of the 14 Zones that comprise, in aggregate, the EPZ.
- Table 3-3 presents the estimates of permanent resident population in each Zone based on the 2010 Census data extrapolated to 2016.
- Table 6-1 defines each of the 37 Evacuation Regions in terms of their respective groups of Zones.
- Table 6-2 defines the 14 Evacuation Scenarios.
- Tables 7-1 and 7-2 are compilations of ETE. These data are the times needed to clear the indicated regions of 90 and 100 percent of the population occupying these regions, respectively. These computed ETE include consideration of mobilization time and of estimated voluntary evacuations from other regions within the EPZ and from the Shadow Region.
- Tables 7-3 and 7-4 present ETE for the 2-mile region for un-staged and staged evacuations for the 90th and 100th percentiles, respectively.
- Table 8-7, Table 8-8 and Table 8-9 present ETE for the schools and child care centers in good weather, rain and ice.

- Table 8-11, Table 8-12, Table 8-13 present ETE for the transit-dependent population in good weather, rain and ice.
- Figure H-8 presents an example of an Evacuation Region (Region R08) to be evacuated under the circumstances defined in Table 6-1. Maps of all Regions are provided in Appendix H.

Conclusions

- General population ETE were computed for 518 unique cases. Table 7-1 and Table 7-2 document these ETE for the 90th and 100th percentiles. The 90th percentile ETE range from 45 minutes to 4:00 (hr:min). The 100th percentile ETE range from 4:30 to 6:10.
- Inspection of Table 7-1 and Table 7-2 indicates that the ETE for the 100th percentile are significantly longer than those for the 90th percentile. This is the result of the pronounced congestion within the major population centers (Apex, Holly Springs and Fuquay-Varina) within the EPZ. When the system becomes congested, traffic exits the EPZ at rates somewhat below capacity until some evacuation routes have cleared. As more routes clear, the aggregate rate of egress slows since many vehicles have already left the EPZ. Towards the end of the process, relatively few evacuation routes service the remaining demand. See Sections 7.3 and 7.4, and Figures 7-3 through 7-24.
- Inspection of Table 7-3 and Table 7-4 indicates that a staged evacuation provides no benefits to evacuees from within the 2-mile region and unnecessarily delays the evacuation of those beyond 2 miles (compare Regions R02 and R04 through R12 with Regions R28 through R37, respectively, in Table 7-1). See Section 7.6 for additional discussion.
- Comparison of Scenarios 5 (summer, midweek/weekend, evening) and 13 (summer, weekend, evening) in Table 7-1 and Table 7-2 indicates that the special event, Fourth of July on Jordan Lake, does not affect the ETE. See Section 7.5 for additional discussion.
- Comparison of Scenarios 1 and 14 in Table 7-1 and Table 7-2 indicates that the roadway closure – one lane northbound on US-1 and one lane eastbound on US-64 – causes at most a 10 minute increase for the 90th percentile ETE and 15 minutes for the 100th percentile ETE. . See Section 7.5 for additional discussion.
- The population centers of Apex, Holly Springs and Fuquay-Varina are the most congested areas throughout the evacuation. The last location in the EPZ to exhibit traffic congestion is Fuquay-Varina; this is the result of two major evacuation routes, NC-55 and US-401 coming together in the city center of Fuquay-Varina as evacuees make their way out of the EPZ. All congestion within the EPZ clears by 5 hours after the Advisory to Evacuate. See Section 7.3 and Figures 7-3 through 7-10.
- Separate ETE were computed for schools and child care centers, medical facilities, transit-dependent persons and homebound special needs persons. The average single-wave ETE for schools, child care centers and medical facilities are comparable (within 5 minutes) to the 90th percentile ETE for the general population; average single-wave ETE for transit dependent persons are greater than the 90th percentile for the general population. The average single-wave ETE for homebound special needs persons are

comparable (15 minutes longer) to the general population ETE at the 90th percentile. See Section 8.

- Table 8-5 indicates that there are enough buses, wheelchair transport vehicles, passenger cars and ambulances available to evacuate everyone in a single wave; however, there are not enough minivans to evacuate medical facilities in a single wave. There are surplus buses and passenger cars available to supplement the shortage in minivans such that all people can evacuate in a single wave. See Sections 8.4 and 8.5.
- The general population ETE at the 90th percentile is insensitive to reductions in the base trip generation time of 4½ hours due to the traffic congestion within the EPZ. An increase in mobilization time by 1 hour increases the 90th percentile ETE by 20 minutes. See Table M-1.
- The general population ETE is significantly impacted by the increase in voluntary evacuation of vehicles in the Shadow Region (60% and 100% shadow evacuation percentages increase 90th percentile ETE by 20 minutes and 50 minutes, respectively). See Table M-2.
- An increase in permanent resident population (EPZ plus Shadow Region) of 17% or greater results in an increase in the 90th percentile ETE of 30 minutes, which meets the federal criterion for performing a fully updated ETE study between decennial Censuses. See Section M.3.
- A severe ice storm resulting in a 50% reduction in link capacity and free flow speed has minimal impact on ETE for the 2-Mile and 5-Mile Regions; however, the 90th percentile ETE for the entire EPZ increases by up to 1 hour and 55 minutes. See Section M-4.

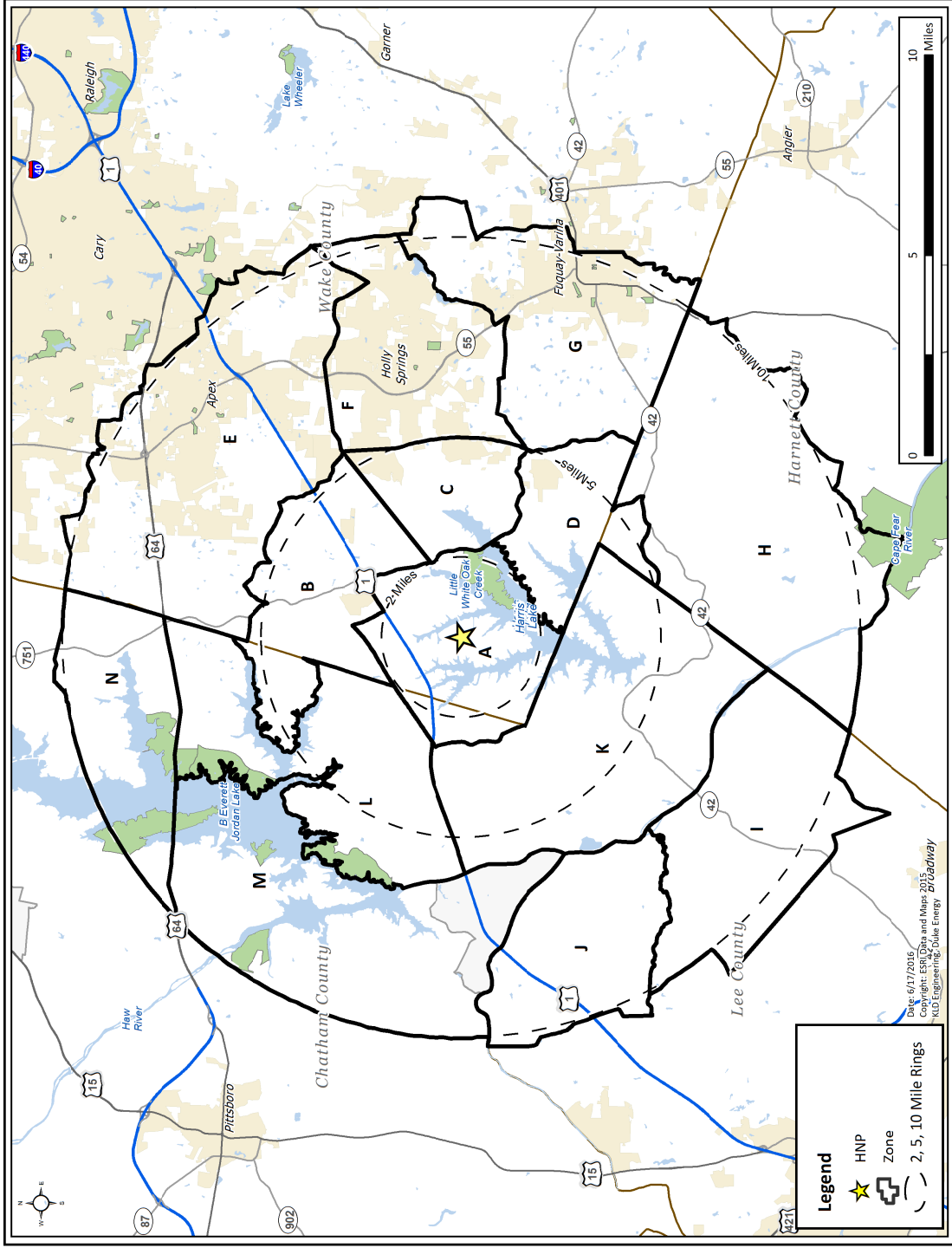

Figure 6-1. HNP EPZ Zones

Table 3-3. EPZ Permanent Resident Population

Zone	2010 Population	2016 Extrapolated Population
A	134	157
B	1,257	1,472
C	2,086	2,788
D	346	401
E	45,269	57,048
F	22,342	29,945
G	21,463	28,379
H	3,868	4,444
I	963	1,001
J	1,126	1,168
K	688	791
L	815	939
M	1,753	2,011
N	851	976
TOTAL	102,961	131,520
EPZ Population Growth (2010-2016):		27.74%

Table 6-1. Description of Evacuation Regions

Region	Description	Site PAR Description	Zone													
			A	B	C	D	E	F	G	H	I	J	K	L	M	N
R01	2-Mile Radius	2-Mile Radius	X													
R02	5-Mile Radius	5-Mile Radius	X	X	X	X						X	X			
R03	Full EPZ	10-Mile Radius	X	X	X	X	X	X	X	X	X	X	X	X	X	X
Evacuate 2-Mile Radius and Downwind to 5 Miles																
Region	Wind Direction From:	Site PAR Description	Zone													
			A	B	C	D	E	F	G	H	I	J	K	L	M	N
R04	NNW, N	327° - 010°	X			X						X				
R05	NNE, NE	011° - 056°	X									X				
R06	ENE, E, ESE	057° - 124°	X									X	X			
R07	SE, SSE, S	125° - 191°	X	X									X			
R08	SSW	192° - 214°	X	X												
R09	SW, WSW	215° - 259°	X	X	X											
R10	Site Specific Region*		X		X											
R11	W, WNW	260° - 304°	X		X	X										
R12	NW	305° - 326°	X			X										
Evacuate 2-Mile Radius and Downwind to the EPZ Boundary																
Region	Wind Direction From:	Site PAR Description	Zone													
			A	B	C	D	E	F	G	H	I	J	K	L	M	N
R13	N	348° - 010°	X			X				X	X	X				
R14	NNE	011° - 034°	X							X	X	X	X			
R15	NE	035° - 056°	X								X	X	X		X	
R16	ENE	057° - 079°	X								X	X	X	X	X	
R17	E	080° - 101°	X									X	X	X	X	
R18	ESE	102° - 124°	X									X	X	X	X	X
R19	SE	125° - 146°	X	X										X	X	X
R20	SSE, S	147° - 191°	X	X			X							X	X	X
R21	SSW	192° - 214°	X	X			X							X		X
R22	SW	215° - 236°	X	X	X		X	X								
R23	WSW	237° - 259°	X	X	X		X	X	X							
R24	W	260° - 281°	X	X	X	X	X	X	X							
R25	WNW	282° - 304°	X		X	X		X	X	X						
R26	NW	305° - 326°	X		X	X			X	X			X			
R27	NNW	327° - 347°	X			X			X	X			X			
Staged Evacuation - 2-Mile Radius Evacuates, then Evacuate Downwind to 5 Miles																
Region	Wind Direction From:	Site PAR Description	Zone													
			A	B	C	D	E	F	G	H	I	J	K	L	M	N
R28	-	5-Mile Radius	X	X	X	X							X	X		
R29	NNW, N	327° - 010°	X			X							X			
R30	NNE, NE	011° - 056°	X										X			
R31	ENE, E, ESE	057° - 124°	X										X	X		
R32	SE, SSE, S	125° - 191°	X	X										X		
R33	SSW	192° - 214°	X	X												
R34	SW, WSW	215° - 259°	X	X	X											
R35	Site Specific Region*		X		X											
R36	W, WNW	260° - 304°	X		X	X										
R37	NW	305° - 326°	X			X										
Shelter-in-Place until 90% ETE for R01, then Evacuate			Zone(s) Shelter-in-Place							Zone(s) Evacuate						

*Region does not follow three-sector keyhole approach and is not used in PAR.

Table 6-2. Evacuation Scenario Definitions

Scenario	Season ⁴	Day of Week	Time of Day	Weather	Special
1	Summer	Midweek	Midday	Good	None
2	Summer	Midweek	Midday	Rain	None
3	Summer	Weekend	Midday	Good	None
4	Summer	Weekend	Midday	Rain	None
5	Summer	Midweek, Weekend	Evening	Good	None
6	Winter	Midweek	Midday	Good	None
7	Winter	Midweek	Midday	Rain	None
8	Winter	Midweek	Midday	Ice	None
9	Winter	Weekend	Midday	Good	None
10	Winter	Weekend	Midday	Rain	None
11	Winter	Weekend	Midday	Ice	None
12	Winter	Midweek, Weekend	Evening	Good	None
13	Summer	Weekend	Evening	Good	Fourth of July on Jordan Lake
14	Summer	Midweek	Midday	Good	Roadway Impact – Lane Closures on US-1 and US-64

⁴ Winter means that school is in session at normal enrollment levels (also applies to spring and autumn). Summer means that school is in session at summer school enrollment levels (lower than normal enrollment).

Table 7-1. Time to Clear the Indicated Area of 90 Percent of the Affected Population

	Summer		Summer		Summer	Winter			Winter			Winter	Summer	Summer
	Midweek		Weekend		Midweek Weekend	Midweek			Weekend			Midweek Weekend	Weekend	Midweek
Scenario:	(1)	(2)	(3)	(4)	(5)	(6)	(7)	(8)	(9)	(10)	(11)	(12)	(13)	(14)
Region	Midday		Midday		Evening	Midday			Midday			Evening	Evening	Midday
	Good Weather	Rain	Good Weather	Rain	Good Weather	Good Weather	Rain	Ice	Good Weather	Rain	Ice	Good Weather	Special Event	Roadway Impact
Entire 2-Mile Region, 5-Mile Region, and EPZ														
R01	0:55	0:55	0:50	0:50	1:00	0:55	0:55	0:55	0:45	0:45	0:50	1:00	1:00	0:55
R02	1:50	1:50	1:35	1:35	1:50	1:50	1:50	1:50	1:40	1:40	1:40	2:00	1:50	1:50
R03	3:05	3:15	2:50	3:05	2:50	3:00	3:15	3:35	2:50	3:00	3:20	2:50	2:50	3:15
2-Mile Region and Keyhole to 5 Miles														
R04	1:25	1:25	1:20	1:20	1:35	1:25	1:25	1:25	1:25	1:25	1:25	1:40	1:35	1:25
R05	1:20	1:20	1:15	1:15	1:35	1:20	1:20	1:20	1:20	1:20	1:20	1:40	1:35	1:20
R06	1:25	1:25	1:20	1:20	1:35	1:30	1:30	1:30	1:25	1:25	1:25	1:45	1:35	1:25
R07	1:35	1:35	1:25	1:25	1:40	1:40	1:40	1:40	1:30	1:30	1:30	1:45	1:40	1:35
R08	1:35	1:35	1:25	1:25	1:40	1:40	1:40	1:40	1:25	1:25	1:25	1:40	1:40	1:35
R09	1:55	1:55	1:40	1:40	1:50	1:55	1:55	1:55	1:40	1:40	1:40	1:55	1:50	1:55
R10	1:45	1:45	1:30	1:30	1:45	1:45	1:45	1:45	1:35	1:35	1:35	1:50	1:45	1:45
R11	1:50	1:50	1:35	1:35	1:50	1:50	1:50	1:50	1:35	1:35	1:35	1:50	1:50	1:50
R12	1:10	1:10	1:00	1:00	1:20	1:10	1:10	1:10	1:00	1:00	1:00	1:25	1:20	1:10
2-Mile Region and Keyhole to EPZ Boundary														
R13	2:05	2:05	1:50	1:50	2:00	2:05	2:05	2:05	1:55	1:55	1:55	2:05	2:00	2:05
R14	2:05	2:05	1:55	1:55	2:05	2:05	2:05	2:05	1:55	1:55	1:55	2:05	2:05	2:05
R15	1:45	1:45	1:35	1:35	1:50	1:50	1:50	1:50	1:40	1:40	1:40	2:00	1:50	1:45
R16	1:45	1:45	1:35	1:35	1:50	1:50	1:50	1:50	1:45	1:45	1:45	2:00	1:50	1:45
R17	1:45	1:45	1:35	1:35	1:50	1:50	1:50	1:50	1:40	1:40	1:40	2:00	1:50	1:45
R18	1:45	1:45	1:35	1:35	1:50	1:50	1:50	1:50	1:40	1:40	1:40	2:00	1:50	1:45
R19	1:45	1:45	1:30	1:30	1:45	1:50	1:50	1:50	1:40	1:40	1:40	1:55	1:45	1:45
R20	2:25	2:30	2:20	2:25	2:20	2:25	2:30	2:40	2:20	2:20	2:30	2:20	2:20	2:30
R21	2:25	2:30	2:20	2:20	2:25	2:30	2:30	2:40	2:20	2:25	2:30	2:25	2:25	2:30
R22	2:40	2:50	2:35	2:45	2:35	2:40	2:50	3:05	2:35	2:40	2:55	2:35	2:35	2:50
R23	3:05	3:15	2:50	3:05	2:50	3:05	3:15	3:40	2:55	3:05	3:15	2:50	2:50	3:15
R24	3:05	3:15	2:55	3:10	2:50	3:05	3:20	3:45	2:50	3:05	3:20	2:55	2:50	3:15
R25	3:35	3:35	3:15	3:15	3:10	3:25	3:50	4:00	3:00	3:10	3:35	3:10	3:10	3:35

	Summer		Summer		Summer	Winter			Winter			Winter	Summer	Summer
	Midweek		Weekend		Midweek Weekend	Midweek			Weekend			Midweek Weekend	Weekend	Midweek
Scenario:	(1)	(2)	(3)	(4)	(5)	(6)	(7)	(8)	(9)	(10)	(11)	(12)	(13)	(14)
Region	Midday		Midday		Evening	Midday			Midday			Evening	Evening	Midday
	Good Weather	Rain	Good Weather	Rain	Good Weather	Good Weather	Rain	Ice	Good Weather	Rain	Ice	Good Weather	Special Event	Roadway Impact
R26	3:15	3:25	2:45	3:00	2:50	3:10	3:25	3:50	2:45	3:00	3:15	2:45	2:50	3:15
R27	3:10	3:25	2:45	3:00	2:45	3:15	3:30	3:50	2:45	3:00	3:15	2:40	2:45	3:10
Staged Evacuation - 2-Mile Region and Keyhole to 5 Miles														
R28	1:50	1:50	1:40	1:40	1:50	1:50	1:50	1:50	1:40	1:45	1:50	2:00	1:50	1:50
R29	1:25	1:25	1:20	1:20	1:35	1:25	1:25	1:25	1:25	1:25	1:25	1:40	1:35	1:25
R30	1:20	1:20	1:20	1:20	1:35	1:20	1:20	1:20	1:20	1:20	1:20	1:40	1:35	1:20
R31	1:25	1:25	1:20	1:20	1:35	1:30	1:30	1:30	1:25	1:25	1:25	1:45	1:35	1:25
R32	1:35	1:35	1:25	1:25	1:40	1:40	1:40	1:40	1:30	1:30	1:30	1:45	1:40	1:35
R33	1:35	1:35	1:25	1:25	1:40	1:40	1:40	1:40	1:25	1:25	1:25	1:40	1:40	1:35
R34	1:55	1:55	1:40	1:40	1:50	1:55	1:55	1:55	1:40	1:40	1:45	1:55	1:50	1:55
R35	1:45	1:45	1:40	1:40	1:45	1:45	1:45	1:45	1:40	1:40	1:45	1:50	1:45	1:45
R36	1:50	1:50	1:40	1:40	1:50	1:50	1:50	1:50	1:40	1:40	1:45	1:50	1:50	1:50
R37	1:15	1:15	1:10	1:10	1:20	1:15	1:15	1:15	1:10	1:10	1:10	1:25	1:20	1:15

Table 7-2. Time to Clear the Indicated Area of 100 Percent of the Affected Population

	Summer		Summer		Summer	Winter			Winter			Winter	Summer	Summer
	Midweek		Weekend		Midweek Weekend	Midweek			Weekend			Midweek Weekend	Weekend	Midweek
Scenario:	(1)	(2)	(3)	(4)	(5)	(6)	(7)	(8)	(9)	(10)	(11)	(12)	(13)	(14)
Region	Midday		Midday		Evening	Midday			Midday			Evening	Evening	Midday
	Good Weather	Rain	Good Weather	Rain	Good Weather	Good Weather	Rain	Ice	Good Weather	Rain	Ice	Good Weather	Special Event	Roadway Impact
Entire 2-Mile Region, 5-Mile Region, and EPZ														
R01	4:30	4:30	4:30	4:30	4:30	4:30	4:30	4:30	4:30	4:30	4:30	4:30	4:30	4:30
R02	4:35	4:35	4:35	4:35	4:35	4:35	4:35	4:35	4:35	4:35	4:35	4:35	4:35	4:35
R03	5:00	5:25	4:40	4:45	4:40	5:00	5:30	6:10	4:40	4:45	5:05	4:40	4:40	5:15
2-Mile Region and Keyhole to 5 Miles														
R04	4:35	4:35	4:35	4:35	4:35	4:35	4:35	4:35	4:35	4:35	4:35	4:35	4:35	4:35
R05	4:35	4:35	4:35	4:35	4:35	4:35	4:35	4:35	4:35	4:35	4:35	4:35	4:35	4:35
R06	4:35	4:35	4:35	4:35	4:35	4:35	4:35	4:35	4:35	4:35	4:35	4:35	4:35	4:35
R07	4:35	4:35	4:35	4:35	4:35	4:35	4:35	4:35	4:35	4:35	4:35	4:35	4:35	4:35
R08	4:35	4:35	4:35	4:35	4:35	4:35	4:35	4:35	4:35	4:35	4:35	4:35	4:35	4:35
R09	4:35	4:35	4:35	4:35	4:35	4:35	4:35	4:35	4:35	4:35	4:35	4:35	4:35	4:35
R10	4:35	4:35	4:35	4:35	4:35	4:35	4:35	4:35	4:35	4:35	4:35	4:35	4:35	4:35
R11	4:35	4:35	4:35	4:35	4:35	4:35	4:35	4:35	4:35	4:35	4:35	4:35	4:35	4:35
R12	4:35	4:35	4:35	4:35	4:35	4:35	4:35	4:35	4:35	4:35	4:35	4:35	4:35	4:35
2-Mile Region and Keyhole to EPZ Boundary														
R13	4:40	4:40	4:40	4:40	4:40	4:40	4:40	4:40	4:40	4:40	4:40	4:40	4:40	4:40
R14	4:40	4:40	4:40	4:40	4:40	4:40	4:40	4:40	4:40	4:40	4:40	4:40	4:40	4:40
R15	4:40	4:40	4:40	4:40	4:40	4:40	4:40	4:40	4:40	4:40	4:40	4:40	4:40	4:40
R16	4:40	4:40	4:40	4:40	4:40	4:40	4:40	4:40	4:40	4:40	4:40	4:40	4:40	4:40
R17	4:40	4:40	4:40	4:40	4:40	4:40	4:40	4:40	4:40	4:40	4:40	4:40	4:40	4:40
R18	4:40	4:40	4:40	4:40	4:40	4:40	4:40	4:40	4:40	4:40	4:40	4:40	4:40	4:40
R19	4:40	4:40	4:40	4:40	4:40	4:40	4:40	4:40	4:40	4:40	4:40	4:40	4:40	4:40
R20	4:40	4:40	4:40	4:40	4:40	4:40	4:40	4:40	4:40	4:40	4:40	4:40	4:40	4:40
R21	4:40	4:40	4:40	4:40	4:40	4:40	4:40	4:40	4:40	4:40	4:40	4:40	4:40	4:40
R22	4:40	4:40	4:40	4:40	4:40	4:40	4:40	5:35	4:40	4:40	4:50	4:40	4:40	4:40
R23	4:50	5:20	4:40	4:45	4:40	4:50	5:20	6:10	4:40	4:40	4:50	4:40	4:40	5:05
R24	4:55	5:20	4:40	4:45	4:40	4:55	5:30	6:10	4:40	4:40	5:05	4:40	4:40	5:05
R25	4:55	5:20	4:40	4:40	4:40	5:00	5:30	6:05	4:40	4:40	4:55	4:40	4:40	5:10

	Summer		Summer		Summer	Winter			Winter			Winter	Summer	Summer
	Midweek		Weekend		Midweek Weekend	Midweek			Weekend			Midweek Weekend	Weekend	Midweek
Scenario:	(1)	(2)	(3)	(4)	(5)	(6)	(7)	(8)	(9)	(10)	(11)	(12)	(13)	(14)
Region	Midday		Midday		Evening	Midday			Midday			Evening	Evening	Midday
	Good Weather	Rain	Good Weather	Rain	Good Weather	Good Weather	Rain	Ice	Good Weather	Rain	Ice	Good Weather	Special Event	Roadway Impact
R26	4:40	4:55	4:40	4:40	4:40	4:40	5:00	5:35	4:40	4:40	4:40	4:40	4:40	4:40
R27	4:40	4:50	4:40	4:40	4:40	4:40	4:55	5:35	4:40	4:40	4:40	4:40	4:40	4:40
Staged Evacuation - 2-Mile Region and Keyhole to 5 Miles														
R28	4:35	4:35	4:35	4:35	4:35	4:35	4:35	4:35	4:35	4:35	4:35	4:35	4:35	4:35
R29	4:35	4:35	4:35	4:35	4:35	4:35	4:35	4:35	4:35	4:35	4:35	4:35	4:35	4:35
R30	4:35	4:35	4:35	4:35	4:35	4:35	4:35	4:35	4:35	4:35	4:35	4:35	4:35	4:35
R31	4:35	4:35	4:35	4:35	4:35	4:35	4:35	4:35	4:35	4:35	4:35	4:35	4:35	4:35
R32	4:35	4:35	4:35	4:35	4:35	4:35	4:35	4:35	4:35	4:35	4:35	4:35	4:35	4:35
R33	4:35	4:35	4:35	4:35	4:35	4:35	4:35	4:35	4:35	4:35	4:35	4:35	4:35	4:35
R34	4:35	4:35	4:35	4:35	4:35	4:35	4:35	4:35	4:35	4:35	4:35	4:35	4:35	4:35
R35	4:35	4:35	4:35	4:35	4:35	4:35	4:35	4:35	4:35	4:35	4:35	4:35	4:35	4:35
R36	4:35	4:35	4:35	4:35	4:35	4:35	4:35	4:35	4:35	4:35	4:35	4:35	4:35	4:35
R37	4:35	4:35	4:35	4:35	4:35	4:35	4:35	4:35	4:35	4:35	4:35	4:35	4:35	4:35

Table 7-3. Time to Clear 90 Percent of the 2-Mile Region within the Indicated Region

	Summer		Summer		Summer	Winter			Winter			Winter	Summer	Summer
	Midweek		Weekend		Midweek Weekend	Midweek			Weekend			Midweek Weekend	Weekend	Midweek
Scenario:	(1)	(2)	(3)	(4)	(5)	(6)	(7)	(8)	(9)	(10)	(11)	(12)	(13)	(14)
Region	Midday		Midday		Evening	Midday			Midday			Evening	Evening	Midday
	Good Weather	Rain	Good Weather	Rain	Good Weather	Good Weather	Rain	Ice	Good Weather	Rain	Ice	Good Weather	Special Event	Roadway Impact
Entire 2-Mile Region and 5-Mile Region														
R01	0:55	0:55	0:50	0:50	1:00	0:55	0:55	0:55	0:45	0:45	0:50	1:00	1:00	0:55
R02	0:55	0:55	0:50	0:50	1:00	0:55	0:55	0:55	0:45	0:45	0:50	1:00	1:00	0:55
Un-staged Evacuation - 2-Mile Region and Keyhole to 5-Miles														
R04	0:55	0:55	0:50	0:50	1:00	0:55	0:55	0:55	0:45	0:45	0:50	1:00	1:00	0:55
R05	0:55	0:55	0:50	0:50	1:00	0:55	0:55	0:55	0:45	0:45	0:50	1:00	1:00	0:55
R06	0:55	0:55	0:50	0:50	1:00	0:55	0:55	0:55	0:45	0:45	0:50	1:00	1:00	0:55
R07	0:55	0:55	0:50	0:50	1:00	0:55	0:55	0:55	0:45	0:45	0:50	1:00	1:00	0:55
R08	0:55	0:55	0:50	0:50	1:00	0:55	0:55	0:55	0:45	0:45	0:50	1:00	1:00	0:55
R09	0:55	0:55	0:50	0:50	1:00	0:55	0:55	0:55	0:45	0:45	0:50	1:00	1:00	0:55
R10	0:55	0:55	0:50	0:50	1:00	0:55	0:55	0:55	0:45	0:45	0:50	1:00	1:00	0:55
R11	0:55	0:55	0:50	0:50	1:00	0:55	0:55	0:55	0:45	0:45	0:50	1:00	1:00	0:55
R12	0:55	0:55	0:50	0:50	1:00	0:55	0:55	0:55	0:45	0:45	0:50	1:00	1:00	0:55
Staged Evacuation - 2-Mile Region and Keyhole to 5-Miles														
R28	0:55	0:55	0:50	0:50	1:00	0:55	0:55	0:55	0:45	0:45	0:50	1:00	1:00	0:55
R29	0:55	0:55	0:50	0:50	1:00	0:55	0:55	0:55	0:45	0:45	0:50	1:00	1:00	0:55
R30	0:55	0:55	0:50	0:50	1:00	0:55	0:55	0:55	0:45	0:45	0:50	1:00	1:00	0:55
R31	0:55	0:55	0:50	0:50	1:00	0:55	0:55	0:55	0:45	0:45	0:50	1:00	1:00	0:55
R32	0:55	0:55	0:50	0:50	1:00	0:55	0:55	0:55	0:45	0:45	0:50	1:00	1:00	0:55
R33	0:55	0:55	0:50	0:50	1:00	0:55	0:55	0:55	0:45	0:45	0:50	1:00	1:00	0:55
R34	0:55	0:55	0:50	0:50	1:00	0:55	0:55	0:55	0:45	0:45	0:50	1:00	1:00	0:55
R35	0:55	0:55	0:50	0:50	1:00	0:55	0:55	0:55	0:45	0:45	0:50	1:00	1:00	0:55
R36	0:55	0:55	0:50	0:50	1:00	0:55	0:55	0:55	0:45	0:45	0:50	1:00	1:00	0:55
R37	0:55	0:55	0:50	0:50	1:00	0:55	0:55	0:55	0:45	0:45	0:50	1:00	1:00	0:55

Table 7-4. Time to Clear 100 Percent of the 2-Mile Region within the Indicated Region

	Summer		Summer		Summer	Winter			Winter			Winter	Summer	Summer
	Midweek		Weekend		Midweek Weekend	Midweek			Weekend			Midweek Weekend	Weekend	Midweek
Scenario:	(1)	(2)	(3)	(4)	(5)	(6)	(7)	(8)	(9)	(10)	(11)	(12)	(13)	(14)
Region	Midday		Midday		Evening	Midday			Midday			Evening	Evening	Midday
	Good Weather	Rain	Good Weather	Rain	Good Weather	Good Weather	Rain	Ice	Good Weather	Rain	Ice	Good Weather	Special Event	Roadway Impact
Entire 2-Mile Region and 5-Mile Region														
R01	4:30	4:30	4:30	4:30	4:30	4:30	4:30	4:30	4:30	4:30	4:30	4:30	4:30	4:30
R02	4:30	4:30	4:30	4:30	4:30	4:30	4:30	4:30	4:30	4:30	4:30	4:30	4:30	4:30
Un-staged Evacuation - 2-Mile Region and Keyhole to 5-Miles														
R04	4:30	4:30	4:30	4:30	4:30	4:30	4:30	4:30	4:30	4:30	4:30	4:30	4:30	4:30
R05	4:30	4:30	4:30	4:30	4:30	4:30	4:30	4:30	4:30	4:30	4:30	4:30	4:30	4:30
R06	4:30	4:30	4:30	4:30	4:30	4:30	4:30	4:30	4:30	4:30	4:30	4:30	4:30	4:30
R07	4:30	4:30	4:30	4:30	4:30	4:30	4:30	4:30	4:30	4:30	4:30	4:30	4:30	4:30
R08	4:30	4:30	4:30	4:30	4:30	4:30	4:30	4:30	4:30	4:30	4:30	4:30	4:30	4:30
R09	4:30	4:30	4:30	4:30	4:30	4:30	4:30	4:30	4:30	4:30	4:30	4:30	4:30	4:30
R10	4:30	4:30	4:30	4:30	4:30	4:30	4:30	4:30	4:30	4:30	4:30	4:30	4:30	4:30
R11	4:30	4:30	4:30	4:30	4:30	4:30	4:30	4:30	4:30	4:30	4:30	4:30	4:30	4:30
R12	4:30	4:30	4:30	4:30	4:30	4:30	4:30	4:30	4:30	4:30	4:30	4:30	4:30	4:30
Staged Evacuation - 2-Mile Region and Keyhole to 5-Miles														
R28	4:30	4:30	4:30	4:30	4:30	4:30	4:30	4:30	4:30	4:30	4:30	4:30	4:30	4:30
R29	4:30	4:30	4:30	4:30	4:30	4:30	4:30	4:30	4:30	4:30	4:30	4:30	4:30	4:30
R30	4:30	4:30	4:30	4:30	4:30	4:30	4:30	4:30	4:30	4:30	4:30	4:30	4:30	4:30
R31	4:30	4:30	4:30	4:30	4:30	4:30	4:30	4:30	4:30	4:30	4:30	4:30	4:30	4:30
R32	4:30	4:30	4:30	4:30	4:30	4:30	4:30	4:30	4:30	4:30	4:30	4:30	4:30	4:30
R33	4:30	4:30	4:30	4:30	4:30	4:30	4:30	4:30	4:30	4:30	4:30	4:30	4:30	4:30
R34	4:30	4:30	4:30	4:30	4:30	4:30	4:30	4:30	4:30	4:30	4:30	4:30	4:30	4:30
R35	4:30	4:30	4:30	4:30	4:30	4:30	4:30	4:30	4:30	4:30	4:30	4:30	4:30	4:30
R36	4:30	4:30	4:30	4:30	4:30	4:30	4:30	4:30	4:30	4:30	4:30	4:30	4:30	4:30
R37	4:30	4:30	4:30	4:30	4:30	4:30	4:30	4:30	4:30	4:30	4:30	4:30	4:30	4:30

Table 8-7. School and Child Care Center Evacuation Time Estimates - Good Weather

School	Driver Mobilization Time (min)	Loading Time (min)	Dist. To EPZ Bdry (mi)	Average Speed (mph)	Travel Time to EPZ Bdry (min)	ETE (hr:min)	Dist. EPZ Bdry to R.S. (mi.)	Travel Time from EPZ Bdry to R.S. (min)	ETE to R.S. (hr:min)
CHATHAM COUNTY SCHOOLS									
Moncure Elementary School	90	15	4.7	45.0	7	1:55	8.4	12	2:10
HARNETT COUNTY SCHOOLS									
Lafayette Elementary School ¹	90	15	0.0	0.0	0	1:45	3.9	6	1:55
LEE COUNTY SCHOOLS									
Deep River Elementary School ¹	90	15	0.0	0.0	0	1:45	8.8	12	2:00
WAKE COUNTY SCHOOLS									
A.V. Baucom Elementary School	90	15	3.0	30.6	6	1:55	17.3	24	2:20
Apex Elementary School	90	15	3.3	8.9	23	2:10	14.7	20	2:30
Apex Friendship High School ²	90	15	7.4	5.6	80	3:05	25.3	34	3:40
Apex Middle School	90	15	2.9	8.4	21	2:10	17.1	23	2:35
Apex Senior High School	90	15	0.8	10.9	5	1:50	15.9	22	2:15
Lufkin Road Middle School	90	15	1.2	5.9	13	2:00	17.1	23	2:25
Olive Chapel Elementary School	90	15	3.3	10.6	19	2:05	17.4	24	2:30
St. Mary Magdalene Catholic School	90	15	4.9	10.1	29	2:15	10.6	15	2:30
Scotts Ridge Elementary School	90	15	4.9	10.1	29	2:15	10.6	15	2:30
Thales Academy	90	15	2.9	20.4	9	1:55	14.7	20	2:15
Holly Grove Elementary School	90	15	8.3	14.9	34	2:20	13.5	19	2:40
Holly Grove Middle School	90	15	8.2	14.9	34	2:20	25.3	34	2:55
Holly Ridge Elementary School	90	15	3.2	10.5	19	2:05	24.7	33	2:40
Holly Ridge Middle School	90	15	3.2	10.5	19	2:05	24.7	33	2:40
Holly Springs Elementary School	90	15	3.7	9.0	25	2:10	24.7	33	2:45
Holly Springs High School	90	15	8.7	14.9	35	2:20	13.5	19	2:40
New School, Inc. Montessori	90	15	2.7	17.8	10	1:55	13.4	18	2:15
Fuquay-Varina Middle School	90	15	0.9	5.7	10	1:55	28.4	38	2:35
Fuquay-Varina Senior High School ²	90	15	1.1	6.0	12	2:00	29.3	40	2:40
Herbert Akins Road Elementary School	90	15	3.3	37.9	6	1:55	27.0	37	2:35
Lincoln Heights Elementary School	90	15	1.7	7.9	13	2:00	28.4	38	2:40
Oakview Elementary School	90	15	7.6	11.2	41	2:50	25.3	34	3:30
Southern Wake Academy High School ²	90	15	3.8	3.1	74	3:00	27.5	37	3:40

School	Driver Mobilization Time (min)	Loading Time (min)	Dist. To EPZ Bdry (mi)	Average Speed (mph)	Travel Time to EPZ Bdry (min)	ETE (hr:min)	Dist. EPZ Bdry to R.S. (mi.)	Travel Time from EPZ Bdry to R.S. (min)	ETE to R.S. (hr:min)
WAKE COUNTY CHILD CARE CENTERS									
All About Kids	90	15	1.5	21.2	5	1:50	16.1	22	2:15
Angels Garden Day Care	90	15	2.5	15.8	10	1:55	14.7	20	2:15
Apex Baptist Church Preschool	90	15	2.7	16.1	11	2:00	14.7	20	2:20
Apex Child Care with Debbie	90	15	3.0	20.4	9	1:55	14.7	20	2:15
Apex Peak Schools, Inc.	90	15	2.9	7.8	23	2:10	17.1	23	2:35
Apex United Methodist Church Preschool	90	15	2.7	16.1	11	2:00	14.7	20	2:20
Children's Choice	90	15	1.8	31.1	4	1:50	14.7	20	2:10
Earth Angel's Day Care Home	90	15	1.8	31.1	4	1:50	16.1	22	2:15
Edith Franklin Day Care Home	90	15	2.7	16.1	11	2:00	14.7	20	2:20
Eileen's Day Care	90	15	1.0	0.0	0	1:45	15.9	22	2:10
Goddard School Apex	90	15	2.7	16.1	11	2:00	14.7	20	2:20
Grace Church Preschool	90	15	1.5	21.2	5	1:50	16.1	22	2:15
Growing Years Learning Center	90	15	2.7	16.1	11	2:00	14.7	20	2:20
Hope Chapel Preschool	90	15	1.4	7.2	13	2:00	15.9	22	2:25
Judy's Home Care	90	15	0.8	10.9	5	1:50	15.9	22	2:15
Karen's Kids Home Child Care	90	15	6.6	12.8	31	2:20	10.1	14	2:35
Karin'-4-Kidz	90	15	4.4	10.6	26	2:15	14.7	20	2:35
Lori's Family Day Care	90	15	1.0	10.8	6	1:55	14.7	20	2:15
Moravic Family Day Care	90	15	1.0	10.8	6	1:55	14.7	20	2:15
Peace Montessori	90	15	2.8	20.4	9	1:55	13.5	19	2:15
Play Care	90	15	3.2	8.6	23	2:10	15.9	22	2:35
Primose School of Apex	90	15	0.1	10.9	1	1:50	15.9	22	2:15
Rainbow Child Care Center	90	15	4.6	9.5	30	2:15	10.1	14	2:30
The Learning Experience in Apex	90	15	4.6	9.5	30	2:15	10.1	14	2:30
Tracey's House	90	15	2.7	20.7	8	1:55	13.5	19	2:15
Vickie's Day Care Home	90	15	2.7	16.1	11	2:00	14.7	20	2:20
Woodhaven Baptist Pre-school	90	15	1.5	21.2	5	1:50	16.1	22	2:15
Holly Springs Learning Center	90	15	4.4	13.3	20	2:05	15.0	20	2:25
Holly Springs School For Early Education	90	15	4.5	10.4	26	2:15	13.5	19	2:35
Home Away From Home Childcare	90	15	8.3	14.9	34	2:20	13.5	19	2:40

School	Driver Mobilization Time (min)	Loading Time (min)	Dist. To EPZ Bdry (mi)	Average Speed (mph)	Travel Time to EPZ Bdry (min)	ETE (hr:min)	Dist. EPZ Bdry to R.S. (mi.)	Travel Time from EPZ Bdry to R.S. (min)	ETE to R.S. (hr:min)
Kiddie Academy of Holly Springs	90	15	4.5	10.4	26	2:15	13.5	19	2:35
Kris' Home Sweet Home Daycare	90	15	4.4	13.3	20	2:05	15.0	20	2:25
Little Dreamers Preschool	90	15	4.5	10.4	26	2:15	13.5	19	2:35
Sisters' Child Care Services	90	15	4.4	13.3	20	2:05	15.0	20	2:25
Stella Lowery Small Day Care	90	15	1.5	17.2	6	1:55	13.4	18	2:15
Sunrise United Methodist Church Preschool	90	15	2.7	17.8	10	1:55	13.4	18	2:15
The Carolina School	90	15	4.4	13.3	20	2:05	15.0	20	2:25
A Mother's Love ²	90	15	2.1	3.7	35	2:20	29.4	40	3:00
Childcare Network - Fuquay Varina ²	90	15	1.1	5.9	12	2:00	29.4	40	2:40
Fuquay-Varina Baptist Wee Care ²	90	15	0.8	5.7	9	1:55	29.4	40	2:35
Fuquay-Varina UMC Preschool Seeds of Faith ²	90	15	0.8	5.7	9	1:55	28.6	39	2:35
Little Angels Preparatory ²	90	15	1.1	45.0	2	1:50	31.1	42	2:35
Little Miracles ²	90	15	1.1	45.0	2	1:50	31.1	42	2:35
Ready Or Not Here I Grow ²	90	15	1.1	6.0	12	2:00	25.9	35	2:35
Shining Star Child Care Home ²	90	15	1.1	45.0	2	1:50	31.1	42	2:35
South Wake Preschool & Academy ²	90	15	3.1	2.9	63	2:50	29.4	40	3:30
Spinning Wheels Learning Center ²	90	15	1.4	5.1	17	2:05	27.9	38	2:45
Vanessa Bland's Small Day Care Home ²	90	15	1.1	6.0	12	2:00	25.9	35	2:35
Maximum for EPZ:						3:05	Maximum:		3:40
Average for EPZ:						2:05	Average:		2:30

Notes: 1 – Not included in calculation for Maximum and Average ETE values since school is in the Shadow Region.

2 – Knightdale High School will serve as a temporary relocation school during the renovation of Garner High School.

Table 8-8. School and Child Care Center Evacuation Time Estimates - Rain

School	Driver Mobilization Time (min)	Loading Time (min)	Dist. To EPZ Bdry (mi)	Average Speed (mph)	Travel Time to EPZ Bdry (min)	ETE (hr:min)	Dist. EPZ Bdry to R.S. (mi.)	Travel Time from EPZ Bdry to R.S. (min)	ETE to R.S. (hr:min)
CHATHAM COUNTY SCHOOLS									
Moncure Elementary School	100	20	4.7	41.0	7	2:10	8.4	13	2:25
HARNETT COUNTY SCHOOLS									
Lafayette Elementary School ¹	100	20	0.0	0.0	0	2:00	3.9	6	2:10
LEE COUNTY SCHOOLS									
Deep River Elementary School ¹	100	20	0.0	0.0	0	2:00	8.8	13	2:15
WAKE COUNTY SCHOOLS									
A.V. Baucom Elementary School	100	20	3.0	40.7	5	2:05	17.3	26	2:35
Apex Elementary School	100	20	3.3	14.1	15	2:15	14.7	22	2:40
Apex Friendship High School ²	100	20	7.4	5.4	82	3:25	25.3	38	4:05
Apex Middle School	100	20	2.9	15.4	12	2:15	17.1	26	2:45
Apex Senior High School	100	20	0.8	8.3	6	2:10	15.9	24	2:35
Lufkin Road Middle School	100	20	1.2	5.2	14	2:15	17.1	26	2:45
Olive Chapel Elementary School	100	20	3.3	11.6	18	2:20	17.4	26	2:50
St. Mary Magdalene Catholic School	100	20	4.9	12.9	23	2:25	10.6	16	2:45
Scotts Ridge Elementary School	100	20	4.9	12.9	23	2:25	10.6	16	2:45
Thales Academy	100	20	2.9	17.1	11	2:15	14.7	22	2:40
Holly Grove Elementary School	100	20	8.3	24.0	21	2:25	13.5	20	2:45
Holly Grove Middle School	100	20	8.2	24.0	21	2:25	25.3	38	3:05
Holly Ridge Elementary School	100	20	3.2	10.0	20	2:20	24.7	37	3:00
Holly Ridge Middle School	100	20	3.2	10.0	20	2:20	24.7	37	3:00
Holly Springs Elementary School	100	20	3.7	8.4	27	2:30	24.7	37	3:10
Holly Springs High School	100	20	8.7	24.0	22	2:25	13.5	20	2:45
New School, Inc. Montessori	100	20	2.7	21.8	8	2:10	13.4	20	2:30
Fuquay-Varina Middle School	100	20	0.9	3.6	15	2:15	28.4	42	3:00
Fuquay-Varina Senior High School ²	100	20	1.1	5.4	13	2:15	29.3	43	3:00
Herbert Akins Road Elementary School	100	20	3.3	35.1	6	2:10	27.0	40	2:50
Lincoln Heights Elementary School	100	20	1.7	6.9	15	2:15	28.4	42	3:00
Oakview Elementary School	100	20	7.6	10.7	43	2:45	25.3	38	3:25
Southern Wake Academy High School ²	100	20	3.8	3.1	74	3:15	27.5	41	4:00

School	Driver Mobilization Time (min)	Loading Time (min)	Dist. To EPZ Bdry (mi)	Average Speed (mph)	Travel Time to EPZ Bdry (min)	ETE (hr:min)	Dist. EPZ Bdry to R.S. (mi.)	Travel Time from EPZ Bdry to R.S. (min)	ETE to R.S. (hr:min)
WAKE COUNTY CHILD CARE CENTERS									
All About Kids	100	20	1.5	19.0	5	2:05	16.1	24	2:30
Angels Garden Day Care	100	20	2.5	13.1	12	2:15	14.7	22	2:40
Apex Baptist Church Preschool	100	20	2.7	13.1	13	2:15	14.7	22	2:40
Apex Child Care with Debbie	100	20	3.0	16.0	12	2:15	14.7	22	2:40
Apex Peak Schools, Inc.	100	20	2.9	13.6	13	2:15	17.1	26	2:45
Apex United Methodist Church Preschool	100	20	2.7	30.6	6	2:10	14.7	22	2:35
Children's Choice	100	20	1.8	28.6	4	2:05	14.7	22	2:30
Earth Angel's Day Care Home	100	20	1.8	28.6	4	2:05	16.1	24	2:30
Edith Franklin Day Care Home	100	20	2.7	13.1	13	2:15	14.7	22	2:40
Eileen's Day Care	100	20	1.0	8.3	8	2:10	15.9	24	2:35
Goddard School Apex	100	20	2.7	13.1	13	2:15	14.7	22	2:40
Grace Church Preschool	100	20	1.5	19.0	5	2:05	16.1	24	2:30
Growing Years Learning Center	100	20	2.7	13.1	13	2:15	14.7	22	2:40
Hope Chapel Preschool	100	20	1.4	4.4	20	2:20	15.9	24	2:45
Judy's Home Care	100	20	0.8	8.3	6	2:10	15.9	24	2:35
Karen's Kids Home Child Care	100	20	6.6	16.9	24	2:25	10.1	15	2:40
Karin'-4-Kidz	100	20	4.4	24.9	11	2:15	14.7	22	2:40
Lori's Family Day Care	100	20	1.0	8.8	7	2:10	14.7	22	2:35
Moravic Family Day Care	100	20	1.0	8.8	7	2:10	14.7	22	2:35
Peace Montessori	100	20	2.8	17.1	10	2:10	13.5	20	2:30
Play Care	100	20	3.2	9.4	21	2:25	15.9	24	2:50
Primose School of Apex	100	20	0.1	8.6	1	2:05	15.9	24	2:30
Rainbow Child Care Center	100	20	4.6	9.9	28	2:30	10.1	15	2:45
The Learning Experience in Apex	100	20	4.6	9.9	28	2:30	10.1	15	2:45
Tracey's House	100	20	2.7	17.3	10	2:10	13.5	20	2:30
Vickie's Day Care Home	100	20	2.7	13.1	13	2:15	14.7	22	2:40
Woodhaven Baptist Pre-school	100	20	1.5	19.0	5	2:05	16.1	24	2:30
Holly Springs Learning Center	100	20	4.4	10.6	26	2:30	15.0	22	2:55
Holly Springs School For Early Education	100	20	4.5	21.4	13	2:15	13.5	20	2:35
Home Away From Home Childcare	100	20	8.3	24.0	21	2:25	13.5	20	2:45

School	Driver Mobilization Time (min)	Loading Time (min)	Dist. To EPZ Bdry (mi)	Average Speed (mph)	Travel Time to EPZ Bdry (min)	ETE (hr:min)	Dist. EPZ Bdry to R.S. (mi.)	Travel Time from EPZ Bdry to R.S. (min)	ETE to R.S. (hr:min)
Kiddie Academy of Holly Springs	100	20	4.5	21.4	13	2:15	13.5	20	2:35
Kris' Home Sweet Home Daycare	100	20	4.4	10.6	26	2:30	15.0	22	2:55
Little Dreamers Preschool	100	20	4.5	21.4	13	2:15	13.5	20	2:35
Sisters' Child Care Services	100	20	4.4	10.6	26	2:30	15.0	22	2:55
Stella Lowery Small Day Care	100	20	1.5	20.3	5	2:05	13.4	20	2:25
Sunrise United Methodist Church Preschool	100	20	2.7	21.8	8	2:10	13.4	20	2:30
The Carolina School	100	20	4.4	10.6	26	2:30	15.0	22	2:55
A Mother's Love ²	100	20	2.1	3.9	32	2:35	29.4	44	3:20
Childcare Network - Fuquay Varina ²	100	20	1.1	5.3	14	2:15	29.4	44	3:00
Fuquay-Varina Baptist Wee Care ²	100	20	0.8	3.6	14	2:15	29.4	44	3:00
Fuquay-Varina UMC Preschool Seeds of Faith ²	100	20	0.8	3.6	14	2:15	28.6	42	3:00
Little Angels Preparatory ²	100	20	1.1	41.0	2	2:05	31.1	46	2:55
Little Miracles ²	100	20	1.1	41.0	2	2:05	31.1	46	2:55
Ready Or Not Here I Grow ²	100	20	1.1	5.4	13	2:15	25.9	38	2:55
Shining Star Child Care Home ²	100	20	1.1	41.0	2	2:05	31.1	46	2:55
South Wake Preschool & Academy ²	100	20	3.1	2.9	64	3:05	29.4	44	3:50
Spinning Wheels Learning Center ²	100	20	1.4	4.8	18	2:20	27.9	41	3:05
Vanessa Bland's Small Day Care Home ²	100	20	1.1	5.4	13	2:15	25.9	38	2:55
Maximum for EPZ:						3:25	Maximum:		4:05
Average for EPZ:						2:20	Average:		2:50

Notes: 1 – Not included in calculation for Maximum and Average ETE values since school is in the Shadow Region.

2 – Knightdale High School will serve as a temporary relocation school during the renovation of Garner High School.

Table 8-9. School and Child Care Center Evacuation Time Estimates – Ice

School	Driver Mobilization Time (min)	Loading Time (min)	Dist. To EPZ Bdry (mi)	Average Speed (mph)	Travel Time to EPZ Bdry (min)	ETE (hr:min)	Dist. EPZ Bdry to R.S. (mi.)	Travel Time from EPZ Bdry to R.S. (min)	ETE to R.S. (hr:min)
CHATHAM COUNTY SCHOOLS									
Moncure Elementary School	110	25	4.7	36.0	8	2:25	8.4	14	2:40
HARNETT COUNTY SCHOOLS									
Lafayette Elementary School ¹	110	25	0.0	0.0	0	2:15	3.9	7	2:25
LEE COUNTY SCHOOLS									
Deep River Elementary School ¹	110	25	0.0	0.0	0	2:15	8.8	15	2:30
WAKE COUNTY SCHOOLS									
A.V. Baucom Elementary School	110	25	3.0	32.6	6	2:25	17.3	29	2:55
Apex Elementary School	110	25	3.3	11.2	18	2:35	14.7	25	3:00
Apex Friendship High School ²	110	25	7.4	5.2	86	3:45	25.3	43	4:30
Apex Middle School	110	25	2.9	11.4	16	2:35	17.1	29	3:05
Apex Senior High School	110	25	0.8	9.2	6	2:25	15.9	27	2:55
Lufkin Road Middle School	110	25	1.2	3.4	22	2:40	17.1	29	3:10
Olive Chapel Elementary School	110	25	3.3	8.8	23	2:40	17.4	29	3:10
St. Mary Magdalene Catholic School	110	25	4.9	11.1	27	2:45	10.6	18	3:05
Scotts Ridge Elementary School	110	25	4.9	11.1	27	2:45	10.6	18	3:05
Thales Academy	110	25	2.9	15.3	12	2:30	14.7	25	2:55
Holly Grove Elementary School	110	25	8.3	20.0	25	2:40	13.5	23	3:05
Holly Grove Middle School	110	25	8.2	20.0	25	2:40	25.3	43	3:25
Holly Ridge Elementary School	110	25	3.2	6.6	30	2:45	24.7	42	3:30
Holly Ridge Middle School	110	25	3.2	6.6	30	2:45	24.7	42	3:30
Holly Springs Elementary School	110	25	3.7	6.0	38	2:55	24.7	42	3:40
Holly Springs High School	110	25	8.7	20.4	26	2:45	13.5	23	3:10
New School, Inc. Montessori	110	25	2.7	11.0	15	2:30	13.4	23	2:55
Fuquay-Varina Middle School	110	25	0.9	3.4	16	2:35	28.4	48	3:25
Fuquay-Varina Senior High School ²	110	25	1.1	3.6	19	2:35	29.3	49	3:25
Herbert Akins Road Elementary School	110	25	3.3	30.0	7	2:25	27.0	46	3:15
Lincoln Heights Elementary School	110	25	1.7	4.9	22	2:40	28.4	48	3:30
Oakview Elementary School	110	25	7.6	9.6	48	3:05	25.3	43	3:50
Southern Wake Academy High School ²	110	25	3.8	2.8	81	3:40	27.5	46	4:30

School	Driver Mobilization Time (min)	Loading Time (min)	Dist. To EPZ Bdry (mi)	Average Speed (mph)	Travel Time to EPZ Bdry (min)	ETE (hr:min)	Dist. EPZ Bdry to R.S. (mi.)	Travel Time from EPZ Bdry to R.S. (min)	ETE to R.S. (hr:min)
WAKE COUNTY CHILD CARE CENTERS									
All About Kids	110	25	1.5	16.8	6	2:25	16.1	27	2:55
Angels Garden Day Care	110	25	2.5	11.7	13	2:30	14.7	25	2:55
Apex Baptist Church Preschool	110	25	2.7	11.7	14	2:30	14.7	25	2:55
Apex Child Care with Debbie	110	25	3.0	15.3	12	2:30	14.7	25	2:55
Apex Peak Schools, Inc.	110	25	2.9	11.4	16	2:35	17.1	29	3:05
Apex United Methodist Church Preschool	110	25	2.7	11.7	14	2:30	14.7	25	2:55
Children's Choice	110	25	1.8	25.7	5	2:20	14.7	25	2:45
Earth Angel's Day Care Home	110	25	1.8	25.7	5	2:20	16.1	27	2:50
Edith Franklin Day Care Home	110	25	2.7	11.7	14	2:30	14.7	25	2:55
Eileen's Day Care	110	25	1.0	9.2	7	2:25	15.9	27	2:55
Goddard School Apex	110	25	2.7	11.7	14	2:30	14.7	25	2:55
Grace Church Preschool	110	25	1.5	16.8	6	2:25	16.1	27	2:55
Growing Years Learning Center	110	25	2.7	11.7	14	2:30	14.7	25	2:55
Hope Chapel Preschool	110	25	1.4	7.2	13	2:30	15.9	27	3:00
Judy's Home Care	110	25	0.8	9.2	6	2:25	15.9	27	2:55
Karen's Kids Home Child Care	110	25	6.6	14.1	29	2:45	10.1	17	3:05
Karin'-4-Kidz	110	25	4.4	19.0	14	2:30	14.7	25	2:55
Lori's Family Day Care	110	25	1.0	8.3	8	2:25	14.7	25	2:50
Moravic Family Day Care	110	25	1.0	8.3	8	2:25	14.7	25	2:50
Peace Montessori	110	25	2.8	15.3	11	2:30	13.5	23	2:55
Play Care	110	25	3.2	14.4	14	2:30	15.9	27	3:00
Primose School of Apex	110	25	0.1	8.8	1	2:20	15.9	27	2:50
Rainbow Child Care Center	110	25	4.6	10.5	27	2:45	10.1	17	3:05
The Learning Experience in Apex	110	25	4.6	10.5	27	2:45	10.1	17	3:05
Tracey's House	110	25	2.7	15.5	11	2:30	13.5	23	2:55
Vickie's Day Care Home	110	25	2.7	11.7	14	2:30	14.7	25	2:55
Woodhaven Baptist Pre-school	110	25	1.5	16.8	6	2:25	16.1	27	2:55
Holly Springs Learning Center	110	25	4.4	8.5	32	2:50	15.0	25	3:15
Holly Springs School For Early Education	110	25	4.5	17.5	16	2:35	13.5	23	3:00
Home Away From Home Childcare	110	25	8.3	20.0	25	2:40	13.5	23	3:05

School	Driver Mobilization Time (min)	Loading Time (min)	Dist. To EPZ Bdry (mi)	Average Speed (mph)	Travel Time to EPZ Bdry (min)	ETE (hr:min)	Dist. EPZ Bdry to R.S. (mi.)	Travel Time from EPZ Bdry to R.S. (min)	ETE to R.S. (hr:min)
Kiddie Academy of Holly Springs	110	25	4.5	17.5	16	2:35	13.5	23	3:00
Kris' Home Sweet Home Daycare	110	25	4.4	8.5	32	2:50	15.0	25	3:15
Little Dreamers Preschool	110	25	4.5	17.5	16	2:35	13.5	23	3:00
Sisters' Child Care Services	110	25	4.4	8.5	32	2:50	15.0	25	3:15
Stella Lowery Small Day Care	110	25	1.5	10.9	9	2:25	13.4	23	2:50
Sunrise United Methodist Church Preschool	110	25	2.7	11.0	15	2:30	13.4	23	2:55
The Carolina School	110	25	4.4	8.5	32	2:50	15.0	25	3:15
A Mother's Love ²	110	25	2.1	3.7	35	2:50	29.4	49	3:40
Childcare Network - Fuquay Varina ²	110	25	1.1	3.5	20	2:35	29.4	49	3:40
Fuquay-Varina Baptist Wee Care ²	110	25	0.8	3.4	15	2:30	29.4	49	3:25
Fuquay-Varina UMC Preschool Seeds of Faith ²	110	25	0.8	3.4	15	2:30	29.4	49	3:20
Little Angels Preparatory ²	110	25	1.1	20.3	4	2:20	28.6	48	3:20
Little Miracles ²	110	25	1.1	20.3	4	2:20	31.1	52	3:15
Ready Or Not Here I Grow ²	110	25	1.1	3.6	19	2:35	31.1	52	3:15
Shining Star Child Care Home ²	110	25	1.1	20.3	4	2:20	25.9	44	3:20
South Wake Preschool & Academy ²	110	25	3.1	2.7	69	3:25	31.1	52	3:15
Spinning Wheels Learning Center ²	110	25	1.4	3.9	22	2:40	29.4	49	4:15
Vanessa Bland's Small Day Care Home ²	110	25	1.1	3.6	19	2:35	27.9	47	3:30
Maximum for EPZ:						3:45	Maximum:		4:30
Average for EPZ:						2:40	Average:		3:10

Notes: 1 – Not included in calculation for Maximum and Average ETE values since school is in the Shadow Region.

2 – Knightdale High School will serve as a temporary relocation school during the renovation of Garner High School.

Table 8-11. Transit-Dependent Evacuation Time Estimates - Good Weather

Route Number	Bus Number	One-Wave						Distance to R. C. (miles)	Two-Wave					
		Mobilization (min)	Route Length (miles)	Speed (mph)	Route Travel Time (min)	Pickup Time (min)	ETE (hr:min)		Travel Time to R. C. (min)	Unload (min)	Driver Rest (min)	Route Travel Time (min)	Pickup Time (min)	ETE (hr:min)
40	1-3	120	20.2	45.0	27	30	3:00	10.0	13	5	10	67	30	5:05
	4-6	135	20.2	45.0	27	30	3:15	10.0	13	5	10	67	30	5:20
	6-10	150	20.2	45.0	27	30	3:30	10.0	13	5	10	67	30	5:35
41 ¹	1-4	120	14.7	5.8	153	30	5:05	30.4	41	5	10	80	30	7:55
	5-8	130	14.7	6.0	147	30	5:10	30.4	41	5	10	80	30	8:00
	9-12	140	14.7	6.6	133	30	5:05	30.4	41	5	10	80	30	7:55
	13-16	150	14.7	7.0	127	30	5:10	30.4	41	5	10	80	30	8:00
42	1-4	120	13.0	45.0	17	30	2:50	6.5	9	5	10	44	30	4:30
	5-8	130	13.0	45.0	17	30	3:00	6.5	9	5	10	44	30	4:40
	9-12	140	13.0	45.0	17	30	3:10	6.5	9	5	10	44	30	4:50
	12-14	150	13.0	45.0	17	30	3:20	6.5	9	5	10	44	30	5:00
43	1-6	120	17.2	18.5	56	30	3:30	14.7	20	5	10	66	30	5:45
	7-12	125	17.2	19.1	54	30	3:30	14.7	20	5	10	66	30	5:45
	13-18	130	17.2	19.7	53	30	3:35	14.7	20	5	10	66	30	5:50
	19-24	135	17.2	22.1	47	30	3:35	14.7	20	5	10	66	30	5:50
	25-30	140	17.2	23.0	45	30	3:35	14.7	20	5	10	66	30	5:50
	31-36	145	17.2	24.0	43	30	3:40	14.7	20	5	10	66	30	5:55
	37-41	150	17.2	27.2	38	30	3:40	14.7	20	5	10	66	30	5:55
44	1-4	120	20.5	15.6	79	30	3:50	13.4	18	5	10	73	30	6:10
	5-8	125	20.5	16.1	76	30	3:55	13.4	18	5	10	73	30	6:15
	9-11	130	20.5	16.7	74	30	3:55	13.4	18	5	10	73	30	6:15
	12-15	135	20.5	17.3	71	30	4:00	13.4	18	5	10	73	30	6:20
	16-19	140	20.5	17.9	69	30	4:00	13.4	18	5	10	73	30	6:20
	20-24	145	20.5	19.9	62	30	4:00	13.4	18	5	10	73	30	6:20
	25-30	150	20.5	20.9	59	30	4:00	13.4	18	5	10	73	30	6:20

Route Number	Bus Number	One-Wave						Two-Wave						
		Mobilization (min)	Route Length (miles)	Speed (mph)	Route Travel Time (min)	Pickup Time (min)	ETE (hr:min)	Distance to R. C. (miles)	Travel Time to R. C. (min)	Unload (min)	Driver Rest (min)	Route Travel Time (min)	Pickup Time (min)	ETE (hr:min)
45 ¹	1-4	120	8.3	19.7	25	30	2:55	30.4	41	5	10	66	30	5:30
	5-8	130	8.3	24.6	20	30	3:00	30.4	41	5	10	66	30	5:35
	9-11	135	8.3	25.2	20	30	3:05	30.4	41	5	10	66	30	5:40
	12-14	140	8.3	28.6	17	30	3:10	30.4	41	5	10	66	30	5:45
	15-19	145	8.3	30.5	16	30	3:15	30.4	41	5	10	66	30	5:50
	20-25	150	8.3	31.8	16	30	3:20	30.4	41	5	10	66	30	5:55
46	1	120	14.3	45.0	19	30	2:50	24.2	32	5	10	70	30	5:20
	2-3	150	14.3	45.0	19	30	3:20	24.2	32	5	10	70	30	5:50
47	1	120	17.3	19.4	54	30	3:25	18.8	25	5	10	72	30	5:50
	2	135	17.3	23.1	45	30	3:30	18.8	25	5	10	71	30	5:55
	3-4	150	17.3	29.9	35	30	3:35	18.8	25	5	10	71	30	6:00
48	1	120	6.0	45.0	8	30	2:40	10.5	14	5	10	30	30	4:10
49	1	120	9.9	45.0	13	30	2:45	7.4	10	5	10	36	30	4:20
	2	150	9.9	45.0	13	30	3:15	7.4	10	5	10	37	30	4:50
Maximum ETE:							5:10	Maximum ETE:						8:00
Average ETE:							3:35	Average ETE:						5:55

Note 1 - Knightdale High School will serve as a temporary reception center during the renovation of Garner High School

Table 8-12. Transit-Dependent Evacuation Time Estimates - Rain

Route Number	Bus Number	One-Wave						Two-Wave						
		Mobilization (min)	Route Length (miles)	Speed (mph)	Route Travel Time (min)	Pickup Time (min)	ETE (hr:min)	Distance to R. C. (miles)	Travel Time to R. C. (min)	Unload (min)	Driver Rest (min)	Route Travel Time (min)	Pickup Time (min)	ETE (hr:min)
40	1-3	130	20.2	41.0	30	40	3:20	10.0	15	5	10	74	40	5:45
	4-6	145	20.2	41.0	30	40	3:35	10.0	15	5	10	74	40	6:00
	6-10	160	20.2	41.0	30	40	3:50	10.0	15	5	10	74	40	6:15
41 ¹	1-4	130	14.7	5.4	165	40	5:35	30.4	44	5	10	87	40	8:45
	5-8	140	14.7	5.5	159	40	5:40	30.4	44	5	10	87	40	8:50
	9-12	150	14.7	5.8	153	40	5:45	30.4	44	5	10	87	40	8:55
	13-16	160	14.7	6.3	141	40	5:45	30.4	44	5	10	87	40	8:55
42	1-4	130	13.0	41.0	19	40	3:10	6.5	9	5	10	47	40	5:05
	5-8	140	13.0	41.0	19	40	3:20	6.5	9	5	10	47	40	5:15
	9-12	150	13.0	41.0	19	40	3:30	6.5	9	5	10	47	40	5:25
	12-14	160	13.0	41.0	19	40	3:40	6.5	9	5	10	47	40	5:35
43	1-6	130	17.2	18.9	55	40	3:45	14.7	21	5	10	71	40	6:15
	7-12	135	17.2	19.6	53	40	3:50	14.7	21	5	10	71	40	6:20
	13-18	140	17.2	21.0	49	40	3:50	14.7	21	5	10	71	40	6:20
	19-24	145	17.2	21.6	48	40	3:55	14.7	21	5	10	71	40	6:25
	25-30	150	17.2	22.9	45	40	4:00	14.7	21	5	10	71	40	6:30
	31-36	155	17.2	23.3	44	40	4:00	14.7	21	5	10	71	40	6:30
	37-41	160	17.2	24.2	43	40	4:05	14.7	21	5	10	71	40	6:35
44	1-4	130	20.5	13.2	93	40	4:25	13.4	20	5	10	80	40	7:00
	5-8	135	20.5	13.5	91	40	4:30	13.4	20	5	10	80	40	7:05
	9-11	140	20.5	14.0	88	40	4:30	13.4	20	5	10	80	40	7:05
	12-15	145	20.5	15.4	80	40	4:30	13.4	20	5	10	80	40	7:05
	16-19	150	20.5	15.8	78	40	4:30	13.4	20	5	10	80	40	7:05
	20-24	155	20.5	16.4	75	40	4:30	13.4	20	5	10	80	40	7:05
	25-30	160	20.5	17.1	72	40	4:35	13.4	20	5	10	80	40	7:10

Route Number	Bus Number	One-Wave						Two-Wave						
		Mobilization (min)	Route Length (miles)	Speed (mph)	Route Travel Time (min)	Pickup Time (min)	ETE (hr:min)	Distance to R. C. (miles)	Travel Time to R. C. (min)	Unload (min)	Driver Rest (min)	Route Travel Time (min)	Pickup Time (min)	ETE (hr:min)
45 ¹	1-4	130	8.3	15.1	33	40	3:25	30.4	44	5	10	71	40	6:15
	5-8	140	8.3	20.3	25	40	3:25	30.4	44	5	10	71	40	6:15
	9-11	145	8.3	22.2	22	40	3:30	30.4	44	5	10	71	40	6:20
	12-14	150	8.3	24.6	20	40	3:35	30.4	44	5	10	71	40	6:25
	15-19	155	8.3	26.4	19	40	3:35	30.4	44	5	10	71	40	6:25
	20-25	160	8.3	28.2	18	40	3:40	30.4	44	5	10	71	40	6:30
46	1	130	14.3	41.0	21	40	3:15	24.2	35	5	10	77	40	6:05
	2-3	160	14.3	41.0	21	40	3:45	24.2	35	5	10	77	40	6:35
47	1	130	17.3	16.8	62	40	3:55	18.8	27	5	10	78	40	6:35
	2	145	17.3	20.7	50	40	4:00	18.8	27	5	10	78	40	6:40
	3-4	160	17.3	25.7	40	40	4:05	18.8	27	5	10	78	40	6:45
48	1	130	6.0	41.0	9	40	3:00	10.5	15	5	10	33	40	4:45
49	1	130	9.9	40.8	15	40	3:05	7.4	11	5	10	40	40	4:55
	2	160	9.9	41.0	14	40	3:35	7.4	11	5	10	40	40	5:25
Maximum ETE:							5:45	Maximum ETE:						8:55
Average ETE:							4:00	Average ETE:						6:35

Note 1 - Knightdale High School will serve as a temporary reception center during the renovation of Garner High School

Table 8-13. Transit Dependent Evacuation Time Estimates – Ice

Route Number	Bus Number	One-Wave						Two-Wave						
		Mobilization (min)	Route Length (miles)	Speed (mph)	Route Travel Time (min)	Pickup Time (min)	ETE (hr:min)	Distance to R. C. (miles)	Travel Time to R. C. (min)	Unload (min)	Driver Rest (min)	Route Travel Time (min)	Pickup Time (min)	ETE (hr:min)
40	1-3	140	20.2	36.0	34	50	3:45	10.0	17	5	10	84	50	6:35
	4-6	155	20.2	36.0	34	50	4:00	10.0	17	5	10	84	50	6:50
	6-10	170	20.2	36.0	34	50	4:15	10.0	17	5	10	84	50	7:05
41 ¹	1-4	140	14.7	4.6	193	50	6:25	30.4	51	5	10	100	50	10:05
	5-8	150	14.7	4.7	188	50	6:30	30.4	51	5	10	100	50	10:10
	9-12	160	14.7	5.0	176	50	6:30	30.4	51	5	10	100	50	10:10
	13-16	170	14.7	5.2	171	50	6:35	30.4	51	5	10	100	50	10:15
42	1-4	140	13.0	36.0	22	50	3:35	6.5	11	5	10	54	50	5:45
	5-8	150	13.0	36.0	22	50	3:45	6.5	11	5	10	54	50	5:55
	9-12	160	13.0	36.0	22	50	3:55	6.5	11	5	10	54	50	6:05
	12-14	170	13.0	36.0	22	50	4:05	6.5	11	5	10	54	50	6:15
43	1-6	140	17.2	14.4	72	50	4:25	14.7	24	5	10	81	50	7:15
	7-12	145	17.2	14.9	69	50	4:25	14.7	24	5	10	81	50	7:15
	13-18	150	17.2	15.5	66	50	4:30	14.7	24	5	10	81	50	7:20
	19-24	155	17.2	16.1	64	50	4:30	14.7	24	5	10	81	50	7:20
	25-30	160	17.2	17.3	60	50	4:30	14.7	24	5	10	81	50	7:20
	31-36	165	17.2	17.8	58	50	4:35	14.7	24	5	10	81	50	7:25
	37-41	170	17.2	19.4	53	50	4:35	14.7	24	5	10	81	50	7:25
44	1-4	140	20.5	10.7	114	50	5:05	13.4	22	5	10	90	50	8:05
	5-8	145	20.5	11.9	103	50	5:00	13.4	22	5	10	90	50	8:00
	9-11	150	20.5	12.2	101	50	5:05	13.4	22	5	10	90	50	8:05
	12-15	155	20.5	12.5	98	50	5:05	13.4	22	5	10	90	50	8:05
	16-19	160	20.5	12.9	95	50	5:10	13.4	22	5	10	90	50	8:10
	20-24	165	20.5	13.3	92	50	5:10	13.4	22	5	10	90	50	8:10
	25-30	170	20.5	13.8	89	50	5:10	13.4	22	5	10	90	50	8:10

Route Number	Bus Number	One-Wave						Two-Wave							
		Mobilization (min)	Route Length (miles)	Speed (mph)	Route Travel Time (min)	Pickup Time (min)	ETE (hr:min)	Distance to R. C. (miles)	Travel Time to R. C. (min)	Unload (min)	Driver Rest (min)	Route Travel Time (min)	Pickup Time (min)	ETE (hr:min)	
45 ¹	1-4	140	8.3	9.6	52	50	4:05	30.4	51	5	10	82	50	7:25	
	5-8	150	8.3	12.2	41	50	4:05	30.4	51	5	10	82	50	7:25	
	9-11	155	8.3	13.0	38	50	4:05	30.4	51	5	10	82	50	7:25	
	12-14	160	8.3	13.9	36	50	4:10	30.4	51	5	10	82	50	7:30	
	15-19	165	8.3	15.2	33	50	4:10	30.4	51	5	10	82	50	7:30	
	20-25	170	8.3	16.8	30	50	4:10	30.4	51	5	10	82	50	7:30	
46	1	140	14.3	36.0	24	50	3:35	24.2	40	5	10	88	50	6:50	
	2-3	170	14.3	36.0	24	50	4:05	24.2	40	5	10	88	50	7:20	
47	1	140	17.3	14.9	70	50	4:20	18.8	31	5	10	89	50	7:25	
	2	155	17.3	17.9	58	50	4:25	18.8	31	5	10	89	50	7:30	
	3-4	170	17.3	21.6	48	50	4:30	18.8	31	5	10	89	50	7:35	
48	1	140	6.0	36.0	10	50	3:20	10.5	17	5	10	37	50	5:20	
49	1	140	9.9	35.9	17	50	3:30	7.4	12	5	10	45	50	5:35	
	2	170	9.9	36.0	17	50	4:00	7.4	12	5	10	45	50	6:05	
Maximum ETE:							6:35	Maximum ETE:							10:15
Average ETE:							4:35	Average ETE:							7:30

Note 1 - Knightdale High School will serve as a temporary reception center during the renovation of Garner High School

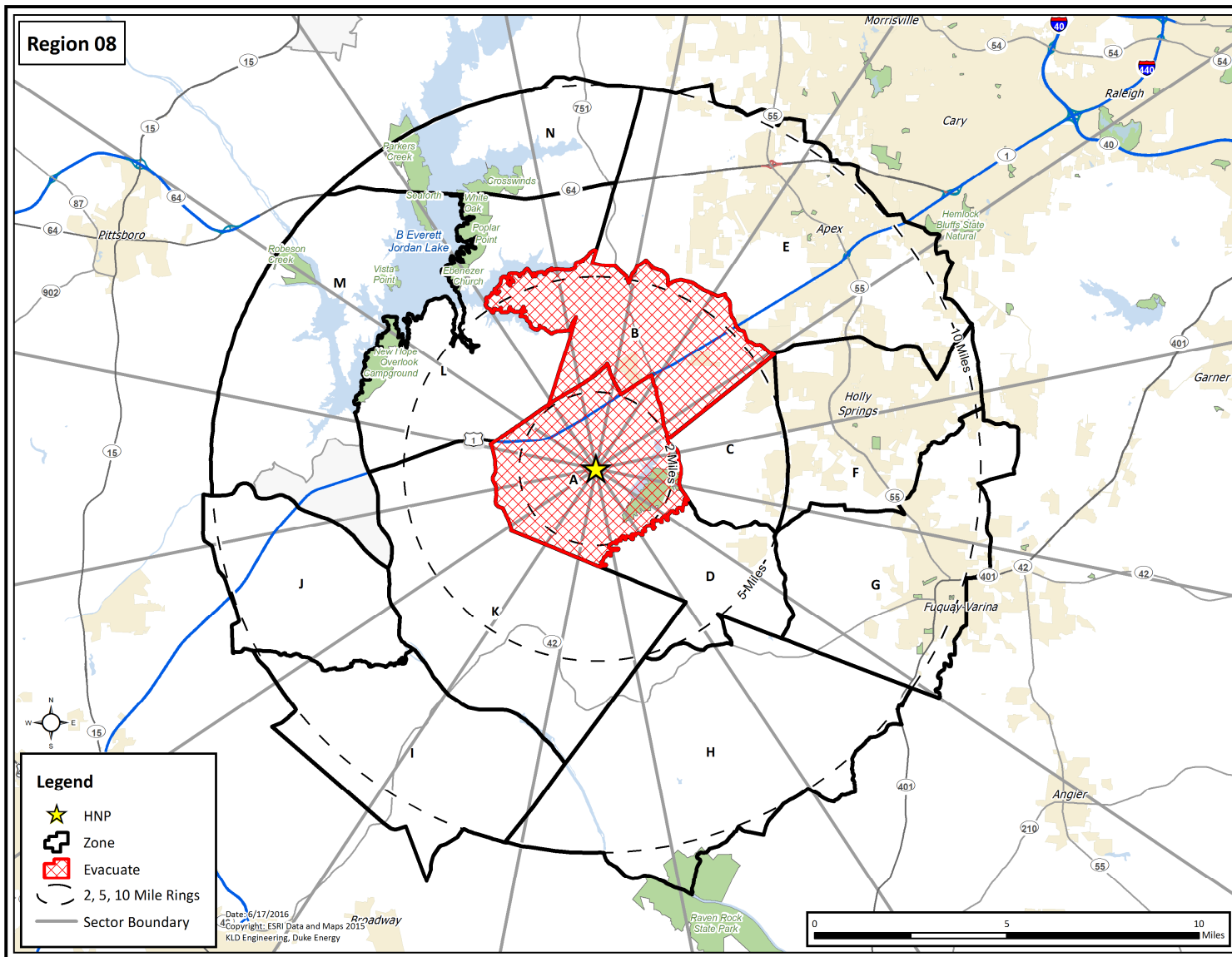

Figure H-8. Region R08

1 INTRODUCTION

This report describes the analyses undertaken and the results obtained by a study to develop Evacuation Time Estimates (ETE) for the Harris Nuclear Plant (HNP), located in Wake County, North Carolina. This ETE study provides Duke Energy and state and local governments with site-specific information needed for Protective Action decision-making.

In the performance of this effort, guidance is provided by documents published by Federal Governmental agencies. Most important of these are:

- Title 10, Code of Federal Regulations, Appendix E to Part 50 (10CFR50), Emergency Planning and Preparedness for Production and Utilization Facilities, NRC, 2011.
- Criteria for Development of Evacuation Time Estimate Studies, NUREG/CR-7002, November 2011.
- Criteria for Preparation and Evaluation of Radiological Emergency Response Plans and Preparedness in Support of Nuclear Power Plants, NUREG-0654/FEMA REP 1, Rev. 1, November 1980.
- Analysis of Techniques for Estimating Evacuation Times for Emergency Planning Zones, NUREG/CR-1745, November 1980.
- Development of Evacuation Time Estimates for Nuclear Power Plants, NUREG/CR-6863, January 2005.

The work effort reported herein was supported and guided by local stakeholders who contributed suggestions, critiques, and the local knowledge base required. Table 1-1 presents a summary of stakeholders and interactions.

Table 1-1. Stakeholder Interaction

Stakeholder	Nature of Stakeholder Interaction
Duke Energy	Attended meetings to define data requirements and set up contacts with local government agencies. Reviewed and approved all project assumptions. Attended final meeting where the ETE study results were presented.
Chatham County Emergency Management	Met to discuss project methodology, key project assumptions and to define data needs. Provided county emergency plans, special facility data and existing traffic management plans through e-mail and phone calls. Reviewed and approved all project assumptions. Attended final meeting where the ETE study results were presented.

Stakeholder	Nature of Stakeholder Interaction
Harnett County Emergency Management	Met to discuss project methodology, key project assumptions and to define data needs. Provided county emergency plans, special facility data and existing traffic management plans through e-mail and phone calls. Reviewed and approved all project assumptions. Attended final meeting where the ETE study results were presented.
Lee County Office of Emergency Services	Met to discuss project methodology, key project assumptions and to define data needs. Provided county emergency plans, special facility data and existing traffic management plans through e-mail and phone calls. Reviewed and approved all project assumptions. Attended final meeting where the ETE study results were presented.
Wake County Emergency Management	Met to discuss project methodology, key project assumptions and to define data needs. Provided county emergency plans, special facility data and existing traffic management plans through e-mail and phone calls. Reviewed and approved all project assumptions. Attended final meeting where the ETE study results were presented.
North Carolina Emergency Management	Met to discuss project methodology, key project assumptions and to define data needs. Provided county emergency plans, special facility data and existing traffic management plans through e-mail and phone calls. Reviewed and approved all project assumptions. Attended final meeting where the ETE study results were presented.
Offices of Jordan Lake State Recreation Area (SRA)	Provided current transient data and information for Jordan Lake.

1.1 Overview of the ETE Process

The following outline presents a brief description of the work effort in chronological sequence:

1. Information Gathering:
 - a. Defined the scope of work in discussions with representatives from Duke Energy.
 - b. Attended meetings with emergency planners from Chatham County Emergency Management, Harnett County Emergency Management, Lee County Office of Emergency Services, Wake County Emergency Management and North Carolina Emergency Management to identify issues to be addressed and resources available.

- c. Conducted a detailed field survey of the highway system and of area traffic conditions within the Emergency Planning Zone (EPZ)¹ and Shadow Region.
 - d. Obtained demographic data from the 2010 census. Projected 2010 Census data to the year 2016 (see Section 3.1).
 - e. Utilized data from the 2012 random sample telephone survey of EPZ residents.
 - f. Obtained data (to the extent available) to update the database of schools and child care centers, medical facilities, transient attractions, major employers, transportation resources available, and other important information gathered in support of the 2012 ETE study.
2. Reviewed the 2012 distributions of trip generation times representing the time required by various population groups (permanent residents, employees, and transients) to prepare (mobilize) for the evacuation trip and updated where necessary. These estimates are primarily based upon the 2012 random sample telephone survey.
 3. Defined Evacuation Scenarios. These scenarios reflect the variation in demand, in trip generation distribution and in highway capacities, associated with different seasons, day of week, time of day and weather conditions.
 4. Reviewed the existing traffic management plan to be implemented by local and state police in the event of an incident at the plant. Traffic control is applied at specified Traffic Control Points (TCPs) and Security Road Blocks (SRBs) located within the study area.
 5. Used existing Zones to define evacuation regions. The EPZ is partitioned into 14 Zones along jurisdictional and geographic boundaries. "Regions" are groups of contiguous Zones for which ETE are calculated. The configurations of these Regions reflect wind direction and the radial extent of the impacted area. Each Region, other than those that approximate circular areas, approximates a "key-hole section" within the EPZ as recommended by NUREG/CR-7002.
 6. Estimated demand for transit services for persons at special facilities and for transit-dependent persons at home.
 7. Prepared the input streams for the DYNEV II.
 - a. Estimated the evacuation traffic demand, based on the available information derived from Census data, and from data provided by local and state agencies, Duke Energy and from the 2012 telephone survey.
 - b. Applied the procedures specified in the 2010 Highway Capacity Manual (HCM²) to the data acquired during the field survey, to estimate the capacity of all highway segments comprising the evacuation routes.

¹ All references to Emergency Planning Zone or EPZ refer to the plume exposure pathway EPZ.

² Highway Capacity Manual (HCM 2010), Transportation Research Board, National Research Council, 2010.

- c. Updated the link-node representation of the evacuation network, which is used as the basis for the computer analysis that calculates the ETE.
 - d. Calculated the evacuating traffic demand for each Region and for each Scenario.
 - e. Specified selected candidate destinations for each “origin” (location of each “source” where evacuation trips are generated over the mobilization time) to support evacuation travel consistent with outbound movement relative to the location of the HNP.
8. Executed the DYNEV II model to determine optimal evacuation routing and compute ETE for all residents, transients and employees (“general population”) with access to private vehicles. Generated a complete set of ETE for all specified Regions and Scenarios.
 9. Documented ETE in formats in accordance with NUREG/CR-7002.
 10. Calculated the ETE for all transit activities including those for special facilities (schools, child care centers, and medical facilities), for the transit-dependent population and for homebound special needs population.

1.2 The Harris Nuclear Plant Location

The HNP is located on Lake Harris in New Hill (within Wake County), North Carolina. It is approximately 20 miles southwest of Raleigh, North Carolina. The EPZ consists of parts of Chatham, Harnett, Lee and Wake Counties. A majority of the northwestern portion of the EPZ is made up of B Everett Jordan Lake. Figure 1-1 displays the area surrounding the HNP. This map identifies the communities in the area and the major roads.

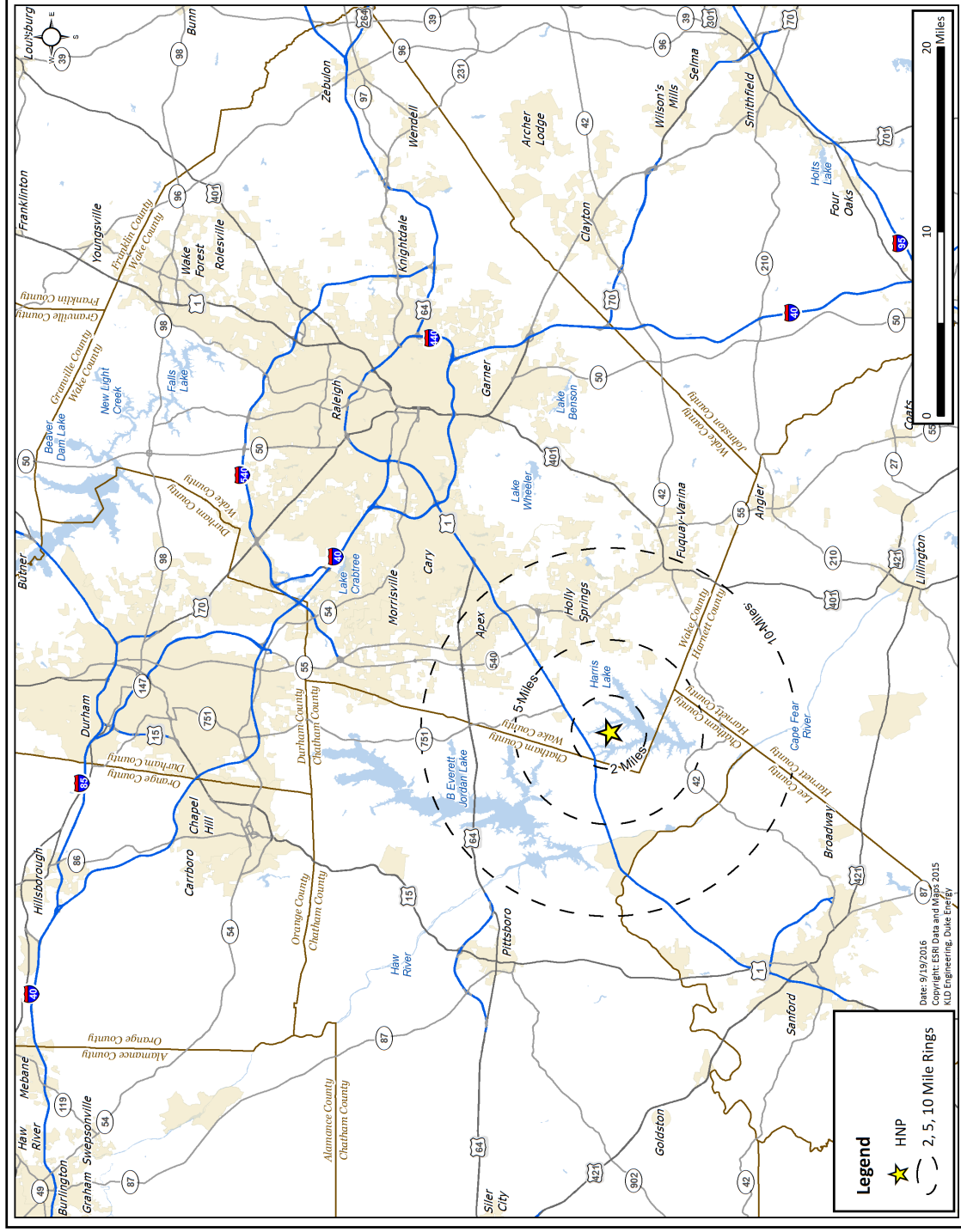

Figure 1-1. HNP Location

1.3 Preliminary Activities

These activities are described below.

Field Surveys of the Highway Network

In 2012, KLD personnel drove the entire highway system within the EPZ and the Shadow Region which consists of the area between the EPZ boundary and approximately 15 miles radially from the plant. The characteristics of each section of highway were recorded. In March 2016, KLD personnel drove roads within population centers and along newly constructed highways to update the 2012 highway network. These characteristics are shown in Table 1-2:

Table 1-2. Highway Characteristics

- | | |
|---|---|
| • Number of lanes | • Posted speed |
| • Lane width | • Actual free speed |
| • Shoulder type & width | • Abutting land use |
| • Interchange geometries | • Control devices |
| • Lane channelization & queuing capacity (including turn bays/lanes) | • Intersection configuration (including roundabouts where applicable) |
| • Geometrics: curves, grades (>4%) | • Traffic signal type |
| • Unusual characteristics: Narrow bridges, sharp curves, poor pavement, flood warning signs, inadequate delineations, toll booths, etc. | |

Video and audio recording equipment were used to capture a permanent record of the highway infrastructure. No attempt was made to meticulously measure such attributes as lane width and shoulder width; estimates of these measures based on visual observation and recorded images were considered appropriate for the purpose of estimating the capacity of highway sections. For example, Exhibit 15-7 in the HCM 2010 indicates that a reduction in lane width from 12 feet (the “base” value) to 10 feet can reduce free flow speed (FFS) by 1.1 mph – not a material difference – for two-lane highways. Exhibit 15-30 in the HCM 2010 shows little sensitivity for the estimates of Service Volumes at Level of Service (LOS) E (near capacity), with respect to FFS, for two-lane highways.

The data from the audio and video recordings were used to create detailed geographic information systems (GIS) shapefiles and databases of the roadway characteristics and of the traffic control devices observed during the road survey; this information was referenced while preparing the input stream for the DYNEV II System.

As documented on page 15-5 of the HCM 2010, the capacity of a two-lane highway is 1,700 passenger cars per hour in one direction. For freeway sections, a value of 2,250 vehicles per hour per lane is assigned, as per Exhibit 11-17 of the HCM 2010. The road survey has identified several segments which are characterized by adverse geometrics on two-lane highways which are reflected in reduced values for both capacity and speed. These estimates are consistent

with the service volumes for LOS E presented in HCM Exhibit 15-30. These links may be identified by reviewing Appendix K. Link capacity is an input to DYNEV II which computes the ETE. Further discussion of roadway capacity is provided in Section 4 of this report.

Traffic signals are either pre-timed (signal timings are fixed over time and do not change with the traffic volume on competing approaches), or are actuated (signal timings vary over time based on the changing traffic volumes on competing approaches). Actuated signals require detectors to provide the traffic data used by the signal controller to adjust the signal timings. These detectors are typically magnetic loops in the roadway, or video cameras mounted on the signal masts and pointed toward the intersection approaches. If detectors were observed on the approaches to a signalized intersection during the road survey, detailed signal timings were not collected as the timings vary with traffic volume. TCPs at locations which have control devices are represented as actuated signals in the DYNEV II system.

If no detectors were observed, the signal control at the intersection was considered pre-timed, and detailed signal timings were gathered for several signal cycles. These signal timings were input to the DYNEV II system used to compute ETE, as per NUREG/CR-7002 guidance.

Figure 1-2 presents the link-node analysis network that was constructed to model the evacuation roadway network in the EPZ and Shadow Region. The directional arrows on the links and the node numbers have been removed from Figure 1-2 to clarify the figure. The detailed figures provided in Appendix K depict the analysis network with directional arrows shown and node numbers provided. The observations made during the field survey were used to calibrate the analysis network.

Telephone Survey

A telephone survey was performed in 2012 to gather information needed for the previous ETE study. Appendix F presents the survey instrument, the procedures used and tabulations of data compiled from the survey returns along with discussion validating the use of the 2012 survey results in this study.

These data were utilized to develop estimates of vehicle occupancy to estimate the number of evacuating vehicles during an evacuation and to estimate elements of the mobilization process. This database was also referenced to estimate the number of transit-dependent residents.

Computing the Evacuation Time Estimates

The overall study procedure is outlined in Appendix D. Demographic data were obtained from several sources, as detailed later in this report. These data were analyzed and converted into vehicle demand data. The vehicle demand was loaded onto appropriate "source" links of the analysis network using GIS mapping software. The DYNEV II system was then used to compute ETE for all Regions and Scenarios.

Analytical Tools

The DYNEV II System that was employed for this study is comprised of several integrated computer models. One of these is the DYNEV (Dynamic Network Evacuation) macroscopic simulation model, a new version of the IDYNEV model that was developed by KLD under contract with the Federal Emergency Management Agency (FEMA).

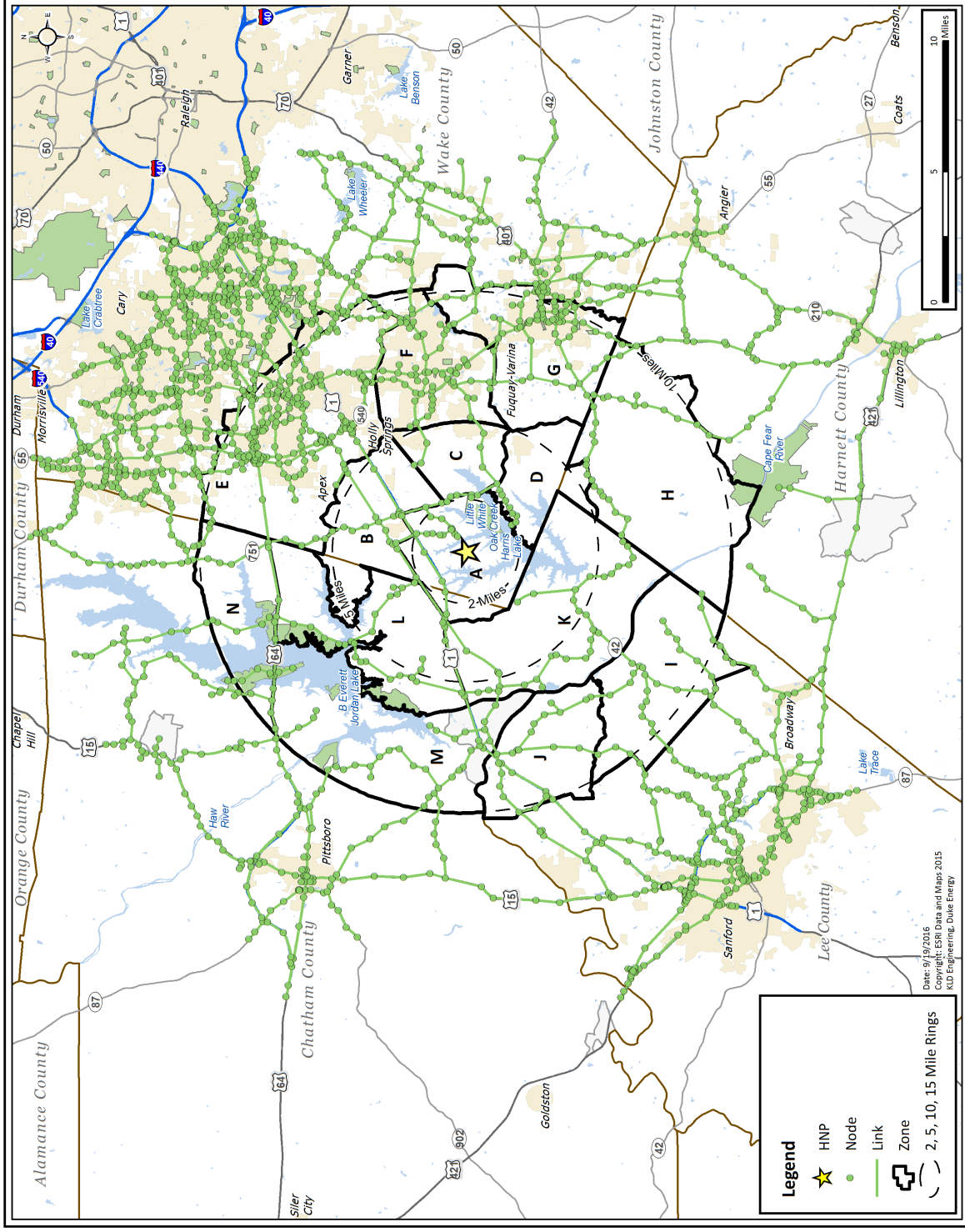

Figure 1-2. HNP Link-Node Analysis Network

DYNEV II consists of four sub-models:

- A macroscopic traffic simulation model (for details, see Appendix C).
- A Trip Distribution (TD), model that assigns a set of candidate destination (D) nodes for each “origin” (O) located within the analysis network, where evacuation trips are “generated” over time. This establishes a set of O-D tables.
- A Dynamic Traffic Assignment (DTA), model which assigns trips to paths of travel (routes) which satisfy the O-D tables, over time. The TD and DTA models are integrated to form the DTRAD (Dynamic Traffic Assignment and Distribution) model, as described in Appendix B.
- A Myopic Traffic Diversion model which diverts traffic to avoid intense, local congestion, if possible.

Another software product developed by KLD, named UNITES (UNified Transportation Engineering System) was used to expedite data entry and to automate the production of output tables.

The dynamics of traffic flow over the network are graphically animated using the software product, EVAN (Evacuation Animator), developed by KLD. EVAN is GIS based, and displays statistics such as LOS, vehicles discharged, average speed, and percent of vehicles evacuated, output by the DYNEV II System. The use of a GIS framework enables the user to zoom in on areas of congestion and query road name, town name and other geographical information.

The procedure for applying the DYNEV II System within the framework of developing ETE is outlined in Appendix D. Appendix A is a glossary of terms.

For the reader interested in an evaluation of the original model, I-DYNEV, the following references are suggested:

- NUREG/CR-4873 – Benchmark Study of the I-DYNEV Evacuation Time Estimate Computer Code
- NUREG/CR-4874 – The Sensitivity of Evacuation Time Estimates to Changes in Input Parameters for the I-DYNEV Computer Code

The evacuation analysis procedures are based upon the need to:

- Route traffic along paths of travel that will expedite their travel from their respective points of origin to points outside the EPZ.
- Restrict movement toward the plant to the extent practicable, and disperse traffic demand so as to avoid focusing demand on a limited number of highways.
- Move traffic in directions that are generally outbound, relative to the location of the plant.

DYNEV II provides a detailed description of traffic operations on the evacuation network. This description enables the analyst to identify bottlenecks and to develop countermeasures that are designed to represent the behavioral responses of evacuees. The effects of these countermeasures may then be tested with the model.

1.4 Comparison with Prior ETE Study

Table 1-3 presents a comparison of the present ETE study with the 2012 ETE study. The 90th percentile ETE for the full EPZ in this study increases by as much as 25 minutes when compared with the 2012 study, while the 100th percentile ETE for the full EPZ increases by as much as 1 hour and 30 minutes. The major factors contributing to the differences between the ETE values obtained in this study and those of the previous study are:

- The permanent resident population was projected to 2016, which resulted in a significant increase in permanent resident population (27.74%) within the EPZ. The increase in permanent resident population results in significantly more evacuating vehicles, which can increase ETE.
- The permanent resident population in the Shadow Region was also projected to 2016, which resulted in a 22.43% increase in shadow population. This population increase results in significantly more vehicles evacuating in the Shadow Region, which reduces the available roadway capacity for EPZ evacuees and can increase ETE.
- More reliable data for computing the number of employees commuting into the EPZ resulted in a significant increase (approximately 350%) in the number of employees and employee vehicles commuting into the EPZ. This increase in vehicular demand can increase the ETE.
- External traffic on major roads (US-1/I-440, US-401, US-421, I-40) traversing the EPZ increased by approximately 10%. The increase in external traffic on these roads reduces the available capacity to evacuees, increasing congestion, and prolonging ETE.
- Several significant roadway improvements were completed since the 2012 study was done, including NC-540 Toll, US-421 Bypass (near Sanford) and Morrisville Parkway. This is to be expected – as population increases, infrastructure improves, albeit slowly at times. These roadway improvements can reduce ETE.
- TCPs were updated based on the latest simulations and resulting congestion patterns, which can reduce ETE.

The various factors that can increase ETE outweigh those that can reduce ETE, thereby explaining why the 90th and 100th percentile ETE have significantly increased in this study relative to the 2012 ETE study.

Table 1-3. ETE Study Comparisons

Topic	Previous ETE Study	Current ETE Study
Resident Population Basis	ArcGIS Software using 2010 US Census blocks; area ratio method used. Population = 102,961	ArcGIS software using 2010 US Census blocks and projecting out to 2016 using 2015 population changes published by the US Census; area ratio method used. Population = 131,520
Resident Population Vehicle Occupancy	2.82 persons/household, 1.39 evacuating vehicles/household yielding: 2.03 persons/vehicle.	2.82 persons/household, 1.39 evacuating vehicles/household yielding: 2.03 persons/vehicle.
Employee Population	Employee estimates based on information provided about major employers in EPZ. 1.07 employees per vehicle based on telephone survey results. Employees = 3,467	Employee estimates based on census work area profile and GIS inflow/outflow analysis. 1.07 employees per vehicle based on telephone survey results. Employees = 15,516
Transit-Dependent Population	Estimates based upon U.S. Census data and the results of the telephone survey. Includes households with 0 vehicles and households with 1 or 2 vehicles which are used by a commuter who would not return home. A total of 3,419 people who do not have access to a vehicle, requiring 114 buses to evacuate. An additional 103 homebound special needs persons need special transportation to evacuate (75 require a bus, 19 require a wheelchair-accessible vehicle, and 9 require an ambulance).	Estimates based upon U.S. Census data and the results of the 2012 telephone survey. Includes households with 0 vehicles and households with 1 or 2 vehicles which are used by a commuter who would not return home. A total of 4,349 people who do not have access to a vehicle, requiring 147 buses to evacuate. An additional 116 homebound special needs persons need special transportation to evacuate (85 require a bus, 21 require a wheelchair-accessible vehicle, and 10 require an ambulance).
Transient Population	Transient estimates based on information provided by each county within the EPZ. Transients = 11,442	Transient estimates based on information provided by each county within the EPZ. Transients = 11,442
Medical Facility Population	Medical facility population based on information provided by each county within the EPZ. Medical Facility Population = 896 Vehicles originating at special facilities = 143	Medical facility population based on information provided by each county within the EPZ. Medical Facility Population = 884 Vehicles originating at special facilities = 140

Topic	Previous ETE Study	Current ETE Study
School and Child Care Center Population	School population based on information provided by each county within the EPZ. Child Care Centers included in these estimates. Total enrollment = 23,530 Buses required = 445	School population based on information provided by each county within the EPZ. Child Care Centers included in these estimates. Total enrollment = 28,601 Buses required = 540
Shadow Population	ArcGIS Software using 2010 US Census blocks; area ratio method used. Population = 198,090	ArcGIS software using 2010 US Census blocks and projecting out to 2016 using 2015 population changes published by the US Census; area ratio method used. Population = 242,526
Voluntary evacuation from within EPZ in areas outside region to be evacuated	20% of the population within the EPZ, but not within the Evacuation Region.	20% of the population within the EPZ, but not within the Evacuation Region (see Figure 2-1)
Shadow Evacuation	20% of people outside of the EPZ within the Shadow Region.	20% of people outside of the EPZ within the Shadow Region (see Figure 7-2)
Network Size	2,311 links; 1,613 nodes	2,860 links; 1,988 nodes
Roadway Geometric Data	Field surveys conducted in March 2012. Roads and intersections were video archived. Road capacities based on 2010 HCM.	Field surveys conducted in March 2016. Roads and intersections were video archived. Road capacities based on 2010 HCM.
School Evacuation	Direct evacuation to designated Relocation School.	Direct evacuation to designated Relocation School.
Ridesharing	50 percent of transit dependent persons will evacuate with a neighbor or friend.	50 percent of transit dependent persons will evacuate with a neighbor or friend.
Trip Generation for Evacuation	Based on residential telephone survey of specific pre-trip mobilization activities: Residents with commuters returning leave between 30 and 270 minutes. Residents without commuters returning leave between 15 and 225 minutes. Employees and transients leave between 15 and 105 minutes. All times measured from the Advisory to Evacuate.	Based on residential telephone survey of specific pre-trip mobilization activities: Residents with commuters returning leave between 30 and 270 minutes. Residents without commuters returning leave between 15 and 225 minutes. Employees and transients leave between 15 and 105 minutes. All times measured from the Advisory to Evacuate.

Topic	Previous ETE Study	Current ETE Study
Weather	Normal, Rain, or Ice. The capacity and free flow speed of all links in the network are reduced by 10% in the event of rain and 20% for ice.	Normal, Rain, or Ice. The capacity and free flow speed of all links in the network are reduced by 10% in the event of rain and 20% for ice.
Modeling	DYNEV II System – Version 4.0.10.0	DYNEV II System – Version 4.0.19.2
Special Events	Fourth of July on Jordan Lake Special Event Population = 7,112 additional transients	Fourth of July on Jordan Lake Special Event Population = 8,962 additional transients
Evacuation Cases	36 Regions (central sector wind direction and each adjacent sector technique used) and 14 Scenarios producing 504 unique cases.	37 Regions (central sector wind direction and each adjacent sector technique used) and 14 Scenarios producing 518 unique cases.
Evacuation Time Estimates Reporting	ETE reported for 90 th and 100 th percentile population. Results presented by Region and Scenario.	ETE reported for 90 th and 100 th percentile population. Results presented by Region and Scenario.
Evacuation Time Estimates for the entire EPZ, 90th percentile	Winter Weekday Midday, Ice (longest 90 th percentile ETE) = 3:10 Winter Weekday Midday, Good Weather = 2:50 Summer Weekend, Midday, Good Weather = 2:40	Winter Weekday Midday, Ice (longest 90 th percentile ETE) = 3:35 Winter Weekday Midday, Good Weather = 3:00 Summer Weekend, Midday, Good Weather = 2:50
Evacuation Time Estimates for the entire EPZ, 100th percentile	Winter Weekday Midday, Ice = 4:40 Winter Weekday Midday, Good Weather = 4:40 Summer Weekend, Midday, Good Weather = 4:40	Winter Weekday Midday, Ice = 6:10 Winter Weekday Midday, Good Weather = 5:00 Summer Weekend, Midday, Good Weather = 4:40

2 STUDY ESTIMATES AND ASSUMPTIONS

This section presents the estimates and assumptions utilized in the development of the evacuation time estimates.

2.1 Data Estimates

1. Permanent resident population estimates are based upon 2010 US Census data projected to 2016, using annual growth rates computed by comparing 2010 data with 2015¹ population estimates published by the US Census (see Section 3.1).
2. Estimates of employees who reside outside the EPZ and commute to work within the EPZ are based upon data obtained from the US Census Longitudinal Employer-Household Dynamics from the OnTheMap Census analysis tool². The number of Non-EPZ Employees was calculated within the EPZ by Census block using the work area profile and GIS inflow/outflow analysis (see Section 3.4).
3. Population estimates at special facilities are based upon data provided by county emergency management agencies and supplemented by phone calls to individual facilities.
4. Population mobilization times are based on a statistical analysis of data acquired from a random sample telephone survey of EPZ residents conducted in 2012 (see Section 5 and Appendix F).
5. The relationship between resident population and evacuating vehicles is developed from the U.S. Census and the telephone survey conducted in 2012 (See Appendix F). Average values of 2.82 people per household and 1.39 evacuating vehicles per household are used. The relationship between persons and vehicles for employees, transients and the special event is as follows:
 - a. Employees: 1.07 employees per vehicle (2012 telephone survey results) for all major employers. See Figure F-7.
 - b. Campgrounds, parks, community centers, golf courses and lodging facilities: Vehicle occupancy varies by facility, but is 2.61 persons per vehicle, on average. See Section 3.3 and Appendix E.
 - c. Special Event: The Fourth of July on Jordan Lake – 3.5 transients per vehicle based on data provided by the offices of the Jordan Lake State Recreation Area. See Section 3.8.
6. Roadway capacity estimates are based on field surveys performed in 2012 (verified by aerial imagery), 2016 field surveys and the application of the Highway Capacity Manual 2010.

¹ The annual population estimates prepared by the Census Bureau for the entire U.S. involve an extensive data gathering process. As such, population estimates are a year behind – 2015 data are released in 2016. The schedule for release of Census data is provided on the Census website: <http://www.census.gov/popest/schedule.html>

² <http://onthemap.ces.census.gov/>

2.2 Study Methodological Assumptions

1. The center-point of the plant will be located at the center of the containment building, 35° 38' 2" N, 77° 0' 32" W.
2. As indicated in Figure 2-2 of NUREG/CR-7002, 100% of people within the impacted "keyhole" will evacuate. Twenty percent (20%) of those people within the EPZ, not within the impacted keyhole, will voluntarily evacuate. Also, twenty percent (20%) of those people within the Shadow Region beyond the EPZ will voluntarily evacuate. See Figure 2-1 for a graphical representation of these evacuation percentages. Sensitivity studies explore the effect on ETE of increasing the percentage of voluntary evacuees in the Shadow Region (see Appendix M).
3. The ETE are computed and presented in tabular format and graphically, in a format compliant with NUREG/CR-7002.
4. ETE are presented for the evacuation of the 90th and 100th percentiles of population for each Region and for each Scenario. The percentile ETE is defined as the elapsed time from the Advisory to Evacuate issued to a specific Region of the EPZ, to the time that Region is clear of the indicated percentile of evacuees. A Region is defined as a group of Zones that is issued an Advisory to Evacuate. A Scenario is a combination of circumstances, including time of day, day of week, season, and weather conditions.
5. Staged evacuation will be considered as defined in NUREG/CR-7002 – those people beyond 2 miles will shelter-in-place until 90 percent of the 2-mile region has evacuated, and then they will evacuate.
6. The models of the I-DYNEV System were recognized as state of the art by the Atomic Safety & Licensing Board (ASLB) in past hearings. (Sources: Atomic Safety & Licensing Board Hearings on Seabrook and Shoreham; Urbanik³). The models have continuously been refined and extended since those hearings and were independently validated by a consultant retained by the NRC. The new DYNEV II model incorporates the latest technology in traffic simulation and in dynamic traffic assignment. The DYNEV II System is used to compute ETE in this study.
7. Evacuation movements (paths of travel) are generally outbound relative to the plant to the extent permitted by the highway network. All major evacuation routes are used in the analysis.
8. Regions are defined by the underlying "keyhole" or circular configurations as specified in Section 1.4 of NUREG/CR-7002. These Regions, as defined, display irregular boundaries reflecting the geography of the Zones included within these underlying configurations. All 16 cardinal and intercardinal wind direction keyhole configurations are considered.
9. The Shadow Region extends to 15 miles radially from the plant, or approximately 5 miles radially beyond the EPZ boundary, as per NRC guidance.
10. A total of 14 "Scenarios" representing different temporal variations (season, time of day, day of week) and weather conditions are considered. These Scenarios are outlined

³ Urbanik, T., et. al. Benchmark Study of the I-DYNEV Evacuation Time Estimate Computer Code, NUREG/CR-4873, Nuclear Regulatory Commission, June, 1988.

in Table 2-1.

11. Scenario 14 considers the closure of one lane northbound on US-1 from just east of the interchange with New Hill Holleman Rd (Exit 89) to the interchange with I-40 (Exit 1A) and one lane eastbound on US-64 from New Hill Olive Chapel Rd/NC-751 to the interchange with US-1 (exit 404A/B).

Table 2-1. Evacuation Scenario Definitions

Scenario	Season ⁴	Day of Week	Time of Day	Weather	Special
1	Summer	Midweek	Midday	Good	None
2	Summer	Midweek	Midday	Rain	None
3	Summer	Weekend	Midday	Good	None
4	Summer	Weekend	Midday	Rain	None
5	Summer	Midweek, Weekend	Evening	Good	None
6	Winter	Midweek	Midday	Good	None
7	Winter	Midweek	Midday	Rain	None
8	Winter	Midweek	Midday	Ice	None
9	Winter	Weekend	Midday	Good	None
10	Winter	Weekend	Midday	Rain	None
11	Winter	Weekend	Midday	Ice	None
12	Winter	Midweek, Weekend	Evening	Good	None
13	Summer	Weekend	Evening	Good	Fourth of July on Jordan Lake
14	Summer	Midweek	Midday	Good	Roadway Impact – Lane Closures on US-1 and US-64

⁴ Winter means that school is in session, at normal enrollment levels (also applies to spring and autumn). Summer means that school is in session at summer school enrollment levels (lower than normal enrollment).

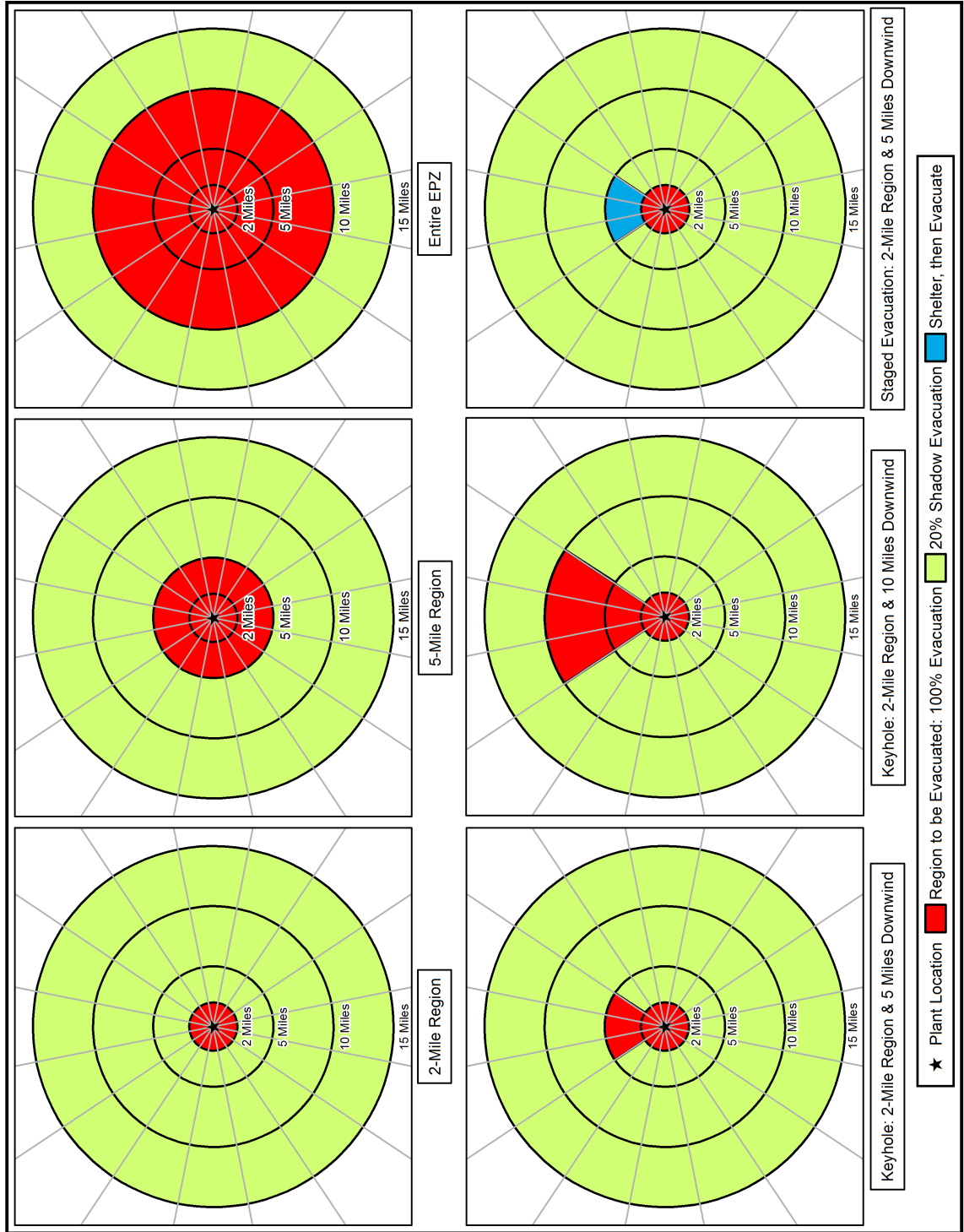

Figure 2-1. Voluntary Evacuation Methodology

2.3 Study Assumptions

1. The Planning Basis Assumption for the calculation of ETE is a rapidly escalating event at the plant wherein evacuation is ordered promptly and no early protective actions have been implemented that requires evacuation, and includes the following⁵:
 - a. Advisory to Evacuate is announced coincident with the siren notification.
 - b. Mobilization of the general population will commence within 15 minutes after siren notification.
 - c. ETE are measured relative to the Advisory to Evacuate.
2. It is assumed that 100 percent of the EPZ population can be notified within 45 minutes, in accordance with the 2016 Federal Emergency Management Agency (FEMA) Radiological Emergency Preparedness Program Manual.
3. It is assumed that everyone within the group of Zones forming a Region that is issued an Advisory to Evacuate will, in fact, respond and evacuate in general accord with the planned routes.
4. In calculating ETE, it is assumed that evacuees will drive safely, travel in directions identified in the plan, and obey all control devices and traffic guides.
5. Buses, vans, ambulances, wheelchair transport vehicles, passenger cars and minivans will be used to transport those without access to private vehicles:
 - a. If schools are in session, transport (buses) will evacuate students directly to the designated relocation schools.
 - b. Students at private schools and child care centers will evacuate directly to the designated relocation schools.
 - c. Buses will evacuate children at child care centers within the EPZ, as needed.
 - d. Buses, minivans, passenger cars, wheelchair buses, wheelchair vans and ambulances will evacuate patients at medical facilities and at any senior facilities within the EPZ, as needed.
 - e. Transit-dependent general population will be evacuated to reception centers.
 - f. Schoolchildren, if schools and child care centers are in session, are given priority in assigning transit vehicles.
 - g. Bus mobilization time is considered in ETE calculations.
 - h. Analysis of the number of required round-trips ("waves") of evacuating transit vehicles is presented.
 - i. Transport of transit-dependent evacuees from reception centers to congregate care centers is not considered in this study.

⁵ It is emphasized that the adoption of this planning basis is not a representation that these events will occur within the indicated time frame. Rather, these assumptions are necessary in order to:

1. Establish a temporal framework for estimating the Trip Generation distribution in the format recommended in Section 2.13 of NUREG/CR-6863.
2. Identify temporal points of reference that uniquely define "Clear Time" and ETE.

See Section 5.1 for more detail.

6. Transit vehicles mobilization times:
 - a. Transit dependent buses are mobilized within 120 minutes, the time it takes approximately 90 percent of residents with no commuters to complete their mobilization.
 - b. School buses will arrive at schools to be evacuated within 90 minutes of the ATE.
 - c. Vehicles will arrive at medical facilities to be evacuated within 90 minutes of the ATE.
7. Vehicle loading times:
 - a. School buses will be loaded in 15 minutes
 - b. Transit Dependent buses will require 1 minute of loading time per passenger
 - c. Ambulances will require 15 minutes of loading time per passenger
 - d. Vehicles used in the evacuation of ambulatory patients from medical facilities and senior facilities will require 2 minutes of loading time per passenger
 - e. Wheelchair transport vehicles will require 7 minutes of loading time per passenger
8. Transit vehicle capacities :
 - a. School buses = 70 students per bus for primary schools/child care centers and 50 students per bus for middle/high schools
 - b. Transit buses, ambulatory transit-dependent persons and medical facility patients = 30 persons per bus
 - c. Minivans used for medical facilities = 5 persons
 - d. Passenger cars used for medical facilities = 4 persons
 - e. Ambulances = 2 persons
 - f. Wheelchair vans = 4 persons
 - g. Wheelchair buses = 15 persons
9. It is assumed that drivers for all transit vehicles identified in Table 8-5 are available.
10. Provisions are made for evacuating the transit-dependent portion of the general population to reception centers by bus, based on the assumption that some of these people will ride-share with family, neighbors, and friends, thus reducing the demand for buses. We assume that the percentage of people who rideshare is 50 percent. This assumption is based upon reported experience for other emergencies⁶, and on guidance in Section 2.2 of NUREG/CR-7002.
11. The ETE will also include consideration of “through” (External-External) trips during the time that such traffic is permitted to enter the evacuated Region. “Normal” traffic flow is assumed to be present within the EPZ at the start of the emergency.
12. Security Road Blocks (SRB) will be staffed within approximately 30 minutes following the siren notifications (based upon data provided by emergency management agencies), to divert traffic attempting to enter the EPZ. Earlier activation of SRB locations could delay returning commuters. It is assumed that no through traffic will enter the EPZ after this

⁶ Institute for Environmental Studies, University of Toronto, THE MISSISSAUGA EVACUATION FINAL REPORT, June 1981. The report indicates that 6,600 people of a transit-dependent population of 8,600 people shared rides with other residents; a ride share rate of 76% (Page 5-10).

30 minute time period.

13. Traffic Control Points (TCP) within the EPZ will be staffed over time, beginning at the Advisory to Evacuate. Their number and location will depend on the Region to be evacuated and resources available. The objectives of these TCP are:
 - a. Facilitate the movements of all (mostly evacuating) vehicles at the location.
 - b. Discourage inadvertent vehicle movements towards the plant.
 - c. Provide assurance and guidance to any traveler who is unsure of the appropriate actions or routing.
 - d. Act as local surveillance and communications center.
 - e. Provide information to the emergency operations center (EOC) as needed, based on direct observation or on information provided by travelers.
14. Based on discussions with local law enforcement and county emergency management agencies, Priority 1 TCP will be manned within 30 minutes and all other TCP will be manned within 120 minutes.
15. Two types of adverse weather scenarios are considered. Rain may occur for either winter or summer scenarios; ice occurs in winter scenarios only. It is assumed that the rain or ice begins earlier or at about the same time the evacuation advisory is issued. No weather-related reduction in the number of transients who may be present in the EPZ is assumed. It is assumed that roads are passable and that the appropriate agencies are clearing the roads as they would normally when icy conditions are present.
16. Adverse weather scenarios affect roadway capacity and the free flow highway speeds. The factors applied for the ETE study are based on research on the effects of weather on roadway operations⁷; the factors are shown in Table 2-2.
17. Trip generation time (time to prepare for and begin evacuation) will be based upon the results of the 2012 telephone survey, as per NRC guidance.
18. The telephone survey, conducted in 2012, indicated that 68% of the households in the EPZ have at least 1 commuter (see Figure F-6 in Appendix F); 41% of those households with commuters will await the return of a commuter (see Figure F-9 in Appendix F) before beginning their evacuation trip. Therefore 28% ($68\% \times 41\% = 28\%$) of EPZ households will await the return of a commuter, prior to beginning their evacuation trip.

⁷ Agarwal, M. et. al. Impacts of Weather on Urban Freeway Traffic Flow Characteristics and Facility Capacity, Proceedings of the 2005 Mid-Continent Transportation Research Symposium, August, 2005. The results of this paper are included as Exhibit 10-15 in the HCM 2010.

Table 2-2. Model Adjustment for Adverse Weather

Scenario	Highway Capacity*	Free Flow Speed*	Mobilization Time for General Population	Mobilization Time for Transit Vehicles
Rain	90%	90%	No Effect	10 minute increase
Ice	80%	80%	No Effect	20 minute increase
Ice (Sensitivity) ⁸	50%	50%	No Effect	Not applicable Transit-dependent ETE not considered for this sensitivity study

*Adverse weather capacity and speed values are given as a percentage of good weather conditions. Roads are assumed to be passable.

⁸ A sensitivity study was considered for a major ice storm with a 50% reduction in roadway capacity and free flow speed for Scenario 8 and Scenario 11. See Appendix M.

3 DEMAND ESTIMATION

The estimates of demand, expressed in terms of people and vehicles, constitute a critical element in developing an evacuation plan. These estimates consist of three components:

1. An estimate of population within the EPZ, stratified into groups (resident, employee, transient).
2. An estimate, for each population group, of mean occupancy per evacuating vehicle. This estimate is used to determine the number of evacuating vehicles.
3. An estimate of potential double-counting of vehicles.

Appendix E presents much of the source material for the population estimates. Our primary source of population data, the 2010 Census, however, is not adequate for directly estimating some transient groups.

Throughout the year, vacationers and tourists enter the EPZ. These non-residents may dwell within the EPZ for a short period (e.g., a few days or one or two weeks), or may enter and leave within one day. Estimates of the size of these population components must be obtained, so that the associated number of evacuating vehicles can be ascertained.

The potential for double-counting people and vehicles must be addressed. For example:

- A resident who works and shops within the EPZ could be counted as a resident, again as an employee and once again as a shopper.
- A visitor who stays at a hotel and spends time at a park, then goes shopping could be counted three times.

Furthermore, the number of vehicles at a location depends on time of day. For example, motel parking lots may be full at dawn and empty at noon. Similarly, parking lots at area parks, which are full at noon, may be almost empty at dawn. Estimating counts of vehicles by simply adding up the capacities of different types of parking facilities will tend to overestimate the number of transients and can lead to ETE that are too conservative.

Analysis of the population characteristics of the HNP EPZ indicates the need to identify three distinct groups:

- Permanent residents – people who are year round residents of the EPZ.
- Transients – people who reside outside of the EPZ who enter the area for a specific purpose (shopping, recreation) and then leave the area.
- Employees – people who reside outside of the EPZ and commute to work within the EPZ on a daily basis.

Estimates of the population and number of evacuating vehicles for each of the population groups are presented for each Zone and by polar coordinate representation (population rose). The HNP EPZ is subdivided into 14 Zones. The EPZ is shown in Figure 3-1.

3.1 Permanent Residents

The U.S. Census Bureau conducts a physical census of the permanent resident population in the U.S. every ten years. The last census began on April 1, 2010 with data from the census being published on April 1, 2011. In the years between the decennial censuses, the Census Bureau works with state and local agencies to provide annual population estimates at the state and local levels. These estimates are done using data on deaths, births and migration. This annual data gathering process and analysis is extensive. As such, population estimates are a year behind – 2015 data are released in 2016.

This study is based on 2010 Census population data from the Census Bureau website¹ extrapolated to 2016 using annual growth rates computed from the 2015 Census population estimates as outlined in the methodology below.

The Census Bureau QuickFacts² website provides annual population estimates for each state, county, and municipality³ in the United States. As discussed above, Census population estimates are a year behind. Thus, the most recent population estimates available for the counties and municipalities are for the time period from April 1, 2010 to July 1, 2015⁴. The population change and annual growth rate for each county and municipality in the study area (EPZ plus Shadow Region) are provided in Table 3-1 and Table 3-2, respectively. Figure 3-2 shows the county and municipality boundaries identified by the Census Bureau.

The permanent resident population, as per the 2010 Census, for the EPZ and the Shadow Region was projected to 2016 using the compound growth formula (Equation 1). In the compound growth formula, g is the annual growth rate and X is the number of years projected forward from Year 2010. The compound growth formula can be solved for g as shown in Equation 2.

Equation 1

$$(Compound\ Growth\ for\ X\ years):\ Population\ 201X = Population\ 2010 (1 + g)^x$$

Equation 2

$$(Solving\ for\ the\ annual\ growth\ rate):\ g = (Population\ 201X \div Population\ 2010)^{1/x} - 1$$

¹ www.census.gov

² <http://quickfacts.census.gov/qfd/index.html>

³ <http://www.census.gov/popest/data/cities/totals/2015/SUB-EST2015-3.html>

⁴ The schedule for release of Census data is provided on the Census website: <http://www.census.gov/popest/schedule.html>

The 2010 and 2015 population data provided in Table 3-1 and Table 3-2 were used in Equation 2 to compute the annual growth rate for each county and municipality in the study area using $X = 5.25$ (5 years and 3 months from April 1, 2010 to July 1, 2015). The computed annual growth rate for each county and municipality is summarized in the final column of Table 3-1 and Table 3-2, respectively.

The most detailed data should always be used when forecasting population. In terms of detailed data, municipal data is the finest level of detail, then county data, and state data. The municipality growth rate was used first and if that was not available or applicable within the study area, then the county growth rate was used. County growth rates are available for the entire study area and were used (in the absence of municipal data) as they are the finest level of detail available for the entire study area. Thus, state data was not used.

The Census Bureau does not provide population data specific to the boundaries of the study area. As such, the entire county or municipality population was used to compute the annual growth rate. Then, the appropriate municipality or county growth rate was applied only to those Census blocks located within the study area. All other blocks outside of the study area were not considered as part of the EPZ or Shadow Region population, even if they are located within one of the municipalities or counties that intersect the study area. The appropriate annual growth rate was applied to each Census block in the study area depending on which county or municipality the block is located within. The population was extrapolated, using Equation 1, to November 1, 2016 as the base year for this ETE study.

The permanent resident population is estimated by cutting the census block polygons by the Zone and EPZ boundaries. A ratio of the original area of each census block and the updated area (after cutting) is multiplied by the total block population to estimate what the population is within the EPZ. This methodology (referred to as the “area ratio method”) assumes that the population is evenly distributed across a census block.

Table 3-3 provides the permanent resident population within the EPZ, by Zone, for 2010 (based on the most recent U.S. Census) and for 2016 (based on the methodology above). As indicated, the permanent resident population within the EPZ has increased by 27.74% since the 2010 Census.

The average household size (2.82 persons/household) was estimated using U.S. Census data – see Appendix F, sub-section F.3.1). The number of evacuating vehicles per household (1.39 vehicles/household – See Appendix F, sub-section F.3.2) was adapted from the telephone survey results.

The year 2016 permanent resident population is divided by the average household size and then multiplied by the average number of evacuating vehicles per household in order to estimate number of vehicles. Permanent resident population and vehicle estimates are presented in Table 3-4. Figure 3-3 and Figure 3-4 present the permanent resident population and permanent resident vehicle estimates by sector and distance from HNP. This population “rose” was constructed using GIS software.

It can be argued that this estimate of permanent residents overstates, somewhat, the number of evacuating vehicles, especially during the summer. It is certainly reasonable to assert that some portion of the population would be on vacation during the summer and would travel elsewhere. A rough estimate of this reduction can be obtained as follows:

- Assume 50 percent of all households vacation for a period over the summer.
- Assume these vacations, in aggregate, are uniformly dispersed over 10 weeks, i.e. 10 percent of the population is on vacation during each two-week interval.
- Assume half of these vacationers leave the area.

On this basis, the permanent resident population would be reduced by 5 percent in the summer and by a lesser amount in the off-season. Given the uncertainty in this estimate, we elected to apply no reductions in permanent resident population for the summer scenarios to account for residents who may be out of the area.

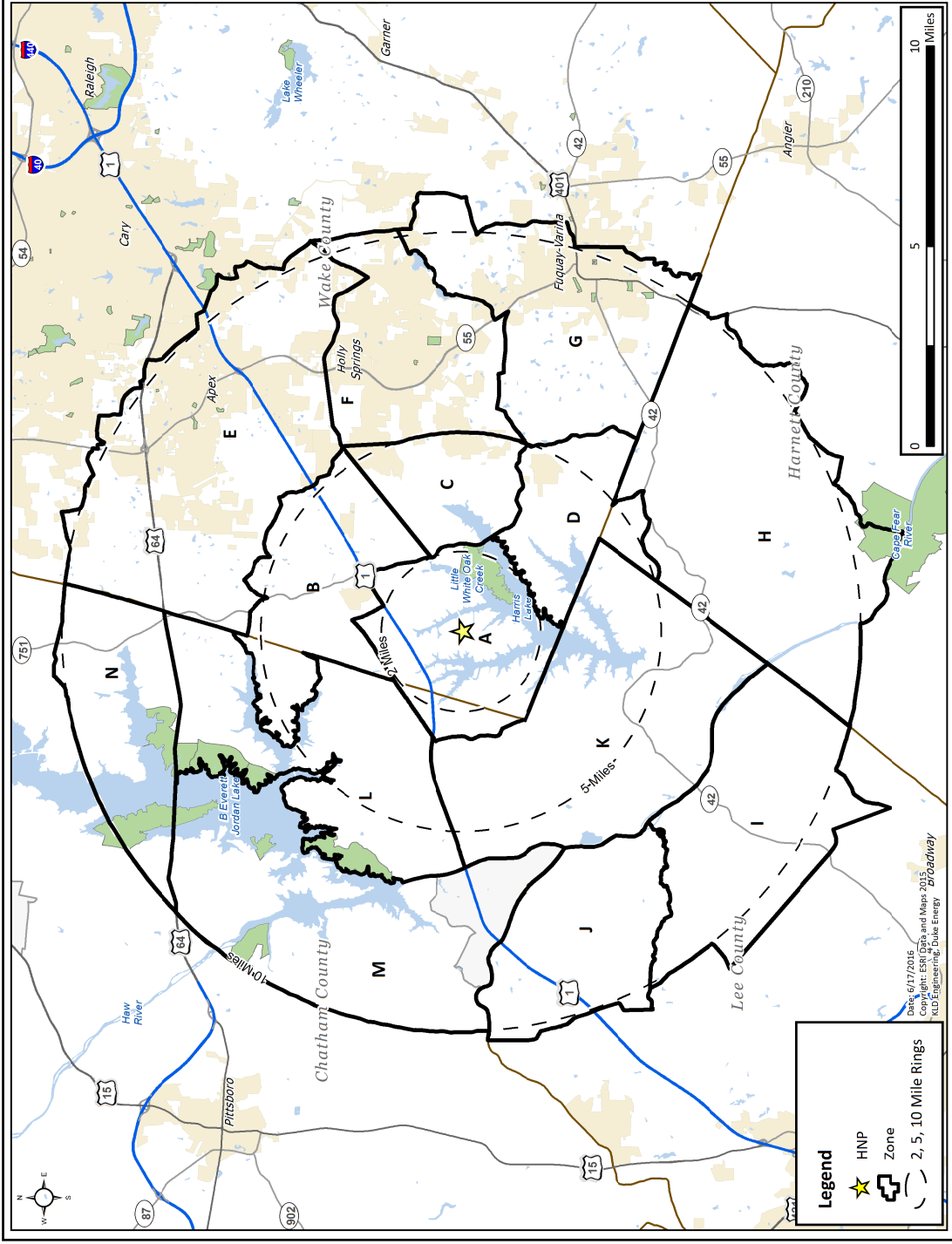

Figure 3-1. HNP EPZ

Table 3-1. County Population Change and Annual Growth Rate from April 1, 2010 to July 1, 2015

County	2010 Population	2015 Population	Percent Change	Annual Growth Rate
Chatham	63,491	70,928	11.71%	2.13%
Harnett	114,678	128,140	11.74%	2.14%
Lee	57,866	59,660	3.10%	0.58%
Wake	901,021	1,024,198	13.67%	2.47%

Table 3-2. Municipality Population Change and Annual Growth Rate from April 1, 2010 to July 1, 2015

Municipality ⁵	2010 Population	2015 Population	Percent Change	Annual Growth Rate
Chatham County, NC				
<i>Shadow Region</i>				
Cary	1,425	1,700	19.30%	3.42%
Pittsboro	3,766	4,198	11.47%	2.09%
Harnett County, NC				
<i>Shadow Region</i>				
Angier	4,245	4,858	14.44%	2.60%
Broadway	25	26	4.00%	0.75%
Lee County, NC				
<i>Shadow Region</i>				
Broadway	1,204	1,238	2.82%	0.53%
Sanford	28,132	29,144	3.60%	0.68%
Wake County, NC				
<i>EPZ</i>				
Apex	37,540	45,585	21.43%	3.77%
Cary	133,935	158,069	18.02%	3.21%
Fuquay-Varina	17,994	23,907	32.86%	5.56%
Holly Springs	24,687	31,377	27.10%	4.67%
<i>Shadow Region</i>				
Angier	103	112	8.74%	1.61%
Garner	25,765	28,053	8.88%	1.63%
Morrisville	18,576	23,820	28.23%	4.85%
Raleigh	402,934	449,894	11.65%	2.12%

⁵ The city boundaries of Angier, Broadway, Cary, and Raleigh extend across multiple counties. Only the portion of population within each respective county is reported in Table 3-2.

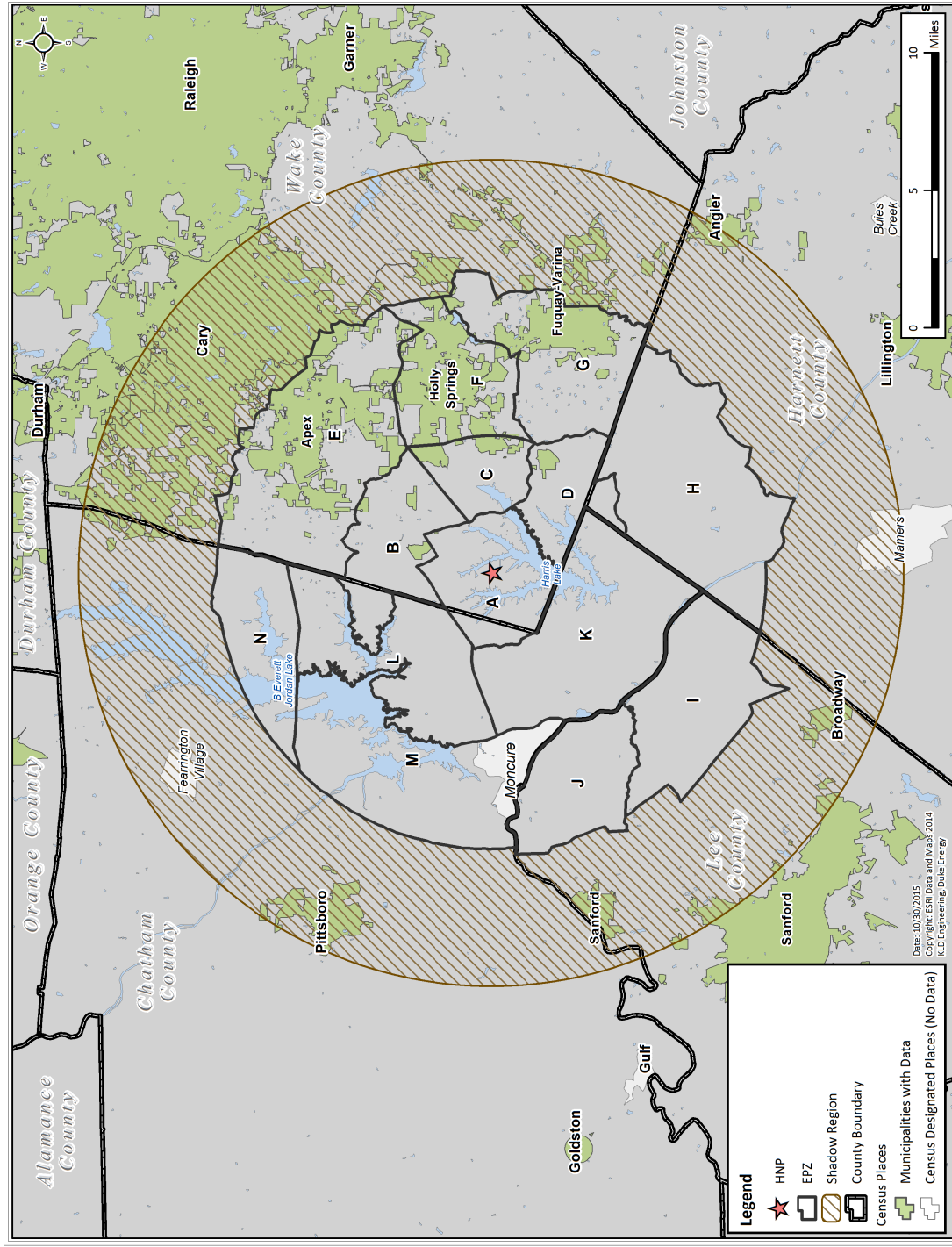

Figure 3-2. Census Boundaries within the HNP Study Area

Table 3-3. EPZ Permanent Resident Population

Zone	2010 Population	2016 Extrapolated Population
A	134	157
B	1,257	1,472
C	2,086	2,788
D	346	401
E	45,269	57,048
F	22,342	29,945
G	21,463	28,379
H	3,868	4,444
I	963	1,001
J	1,126	1,168
K	688	791
L	815	939
M	1,753	2,011
N	851	976
TOTAL	102,961	131,520
EPZ Population Growth (2010-2016):		27.74%

Table 3-4. Permanent Resident Population and Vehicles by Zone

Zone	2016 Extrapolated Population	2016 Resident Vehicles
A	157	76
B	1,472	722
C	2,788	1,371
D	401	197
E	57,048	28,085
F	29,945	14,752
G	28,379	13,968
H	4,444	2,186
I	1,001	488
J	1,168	574
K	791	383
L	939	459
M	2,011	988
N	976	480
TOTAL	131,520	64,729

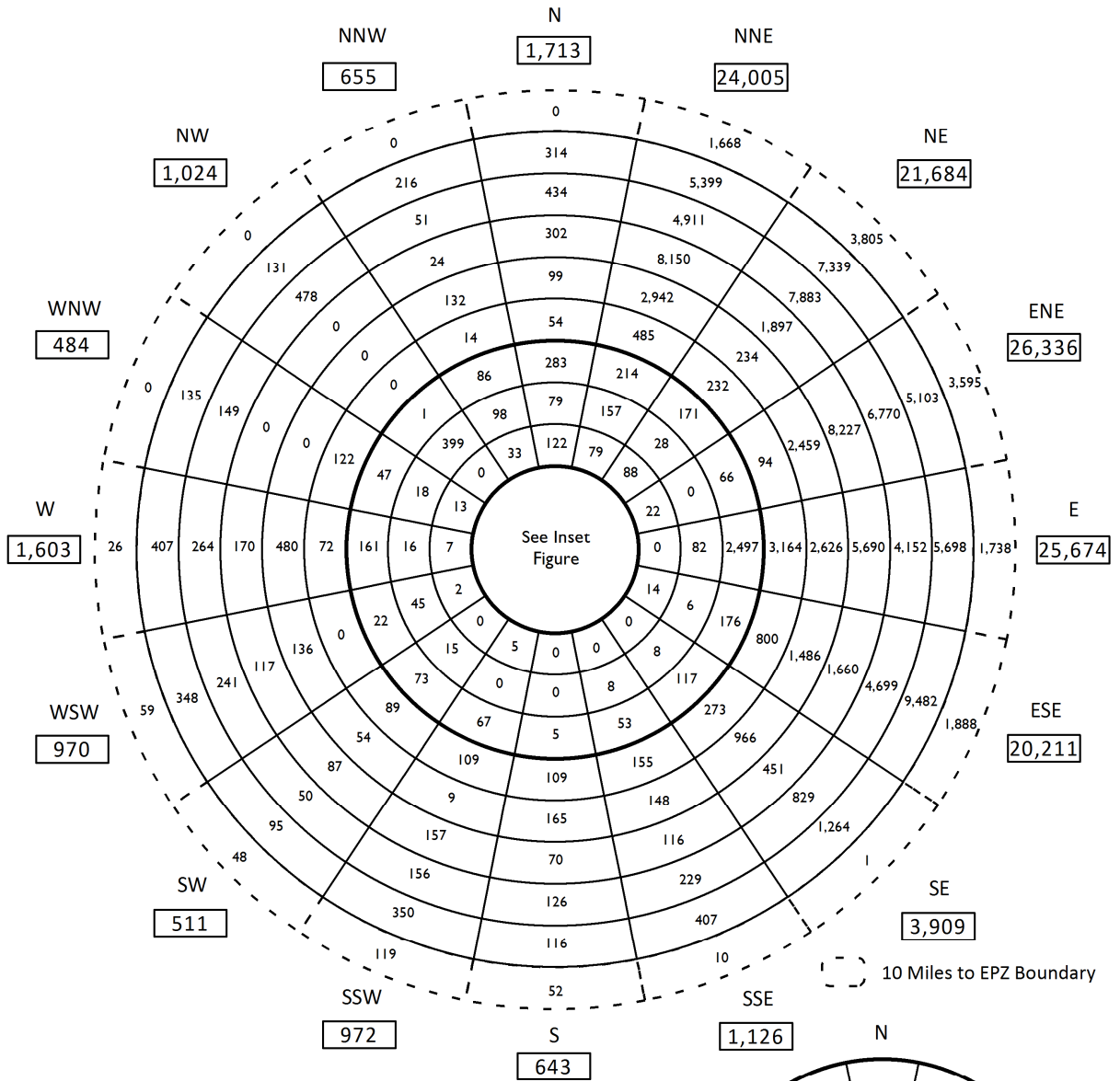

Resident Population

Miles	Subtotal by Ring	Cumulative Total
0 - 1	0	0
1 - 2	76	76
2 - 3	385	461
3 - 4	959	1,420
4 - 5	4,039	5,459
5 - 6	5,772	11,231
6 - 7	11,936	23,167
7 - 8	27,118	50,285
8 - 9	31,422	81,707
9 - 10	36,804	118,511
10 - EPZ	13,009	131,520
Total:		131,520

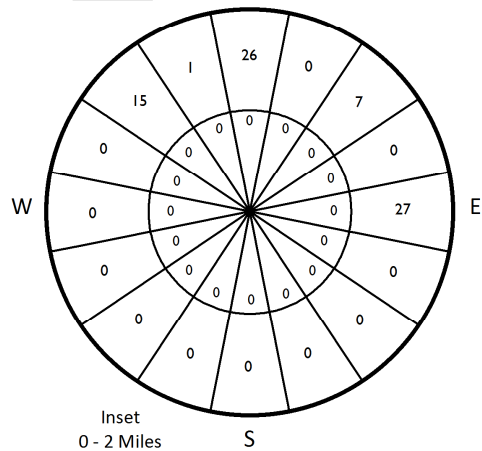
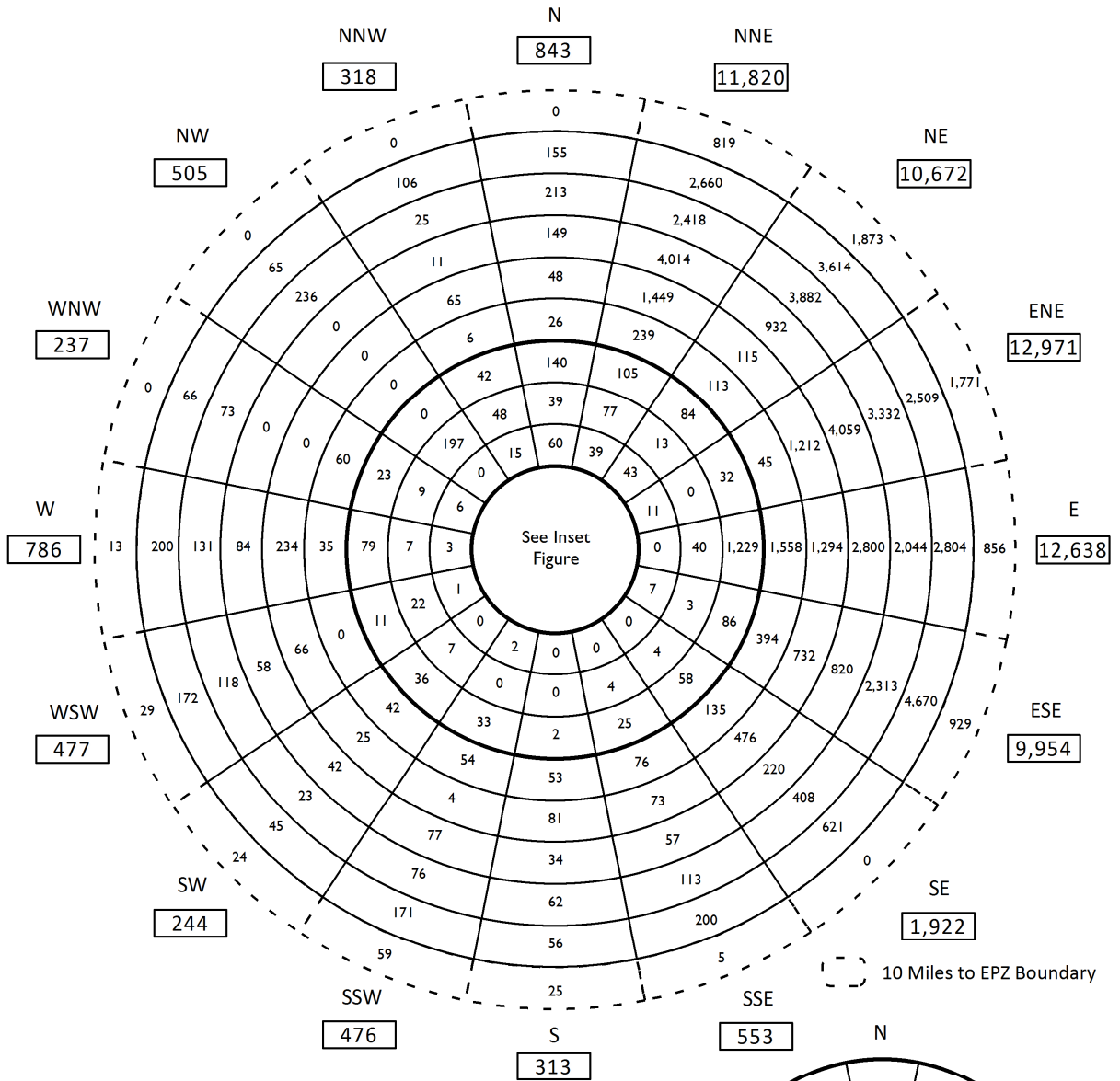

Figure 3-3. Permanent Resident Population by Sector



Resident Vehicles

Miles	Subtotal by Ring	Cumulative Total
0 - 1	0	0
1 - 2	36	36
2 - 3	187	223
3 - 4	470	693
4 - 5	1,985	2,678
5 - 6	2,836	5,514
6 - 7	5,874	11,388
7 - 8	13,357	24,745
8 - 9	15,467	40,212
9 - 10	18,114	58,326
10 - EPZ	6,403	64,729
Total:		64,729

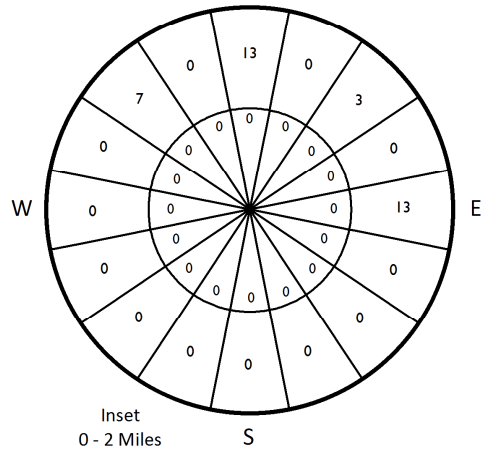

Figure 3-4. Permanent Resident Vehicles by Sector

3.2 Shadow Population

A portion of the population living outside the evacuation area extending to 15 miles radially from the HNP (in the Shadow Region) may elect to evacuate without having been instructed to do so. Based upon NUREG/CR-7002 guidance, it is assumed that 20 percent of the permanent resident population, based on U.S. Census Bureau data, in the Shadow Region will elect to evacuate.

Shadow population characteristics (household size, evacuating vehicles per household, mobilization time) are assumed to be the same as those for the EPZ permanent resident population. Table 3-5, Figure 3-5, and Figure 3-6 present estimates of the shadow population and vehicles, by sector.

The 2010 Census permanent resident population within the Shadow Region was also extrapolated to November 1, 2016 using the methodology discussed in Section 3.1 for the permanent resident population within the EPZ.

Table 3-5. Shadow Population and Vehicles by Sector

Sector	2016 Extrapolated Population	Evacuating Vehicles
N	7,811	3,843
NNE	63,090	31,072
NE	71,584	35,275
ENE	26,943	13,278
E	20,851	10,270
ESE	14,186	6,980
SE	6,962	3,419
SSE	2,259	1,111
S	2,044	1,003
SSW	3,739	1,832
SW	3,032	1,485
WSW	3,043	1,500
W	1,400	685
WNW	5,707	2,795
NW	3,344	1,642
NNW	6,531	3,213
TOTAL	242,526	119,403

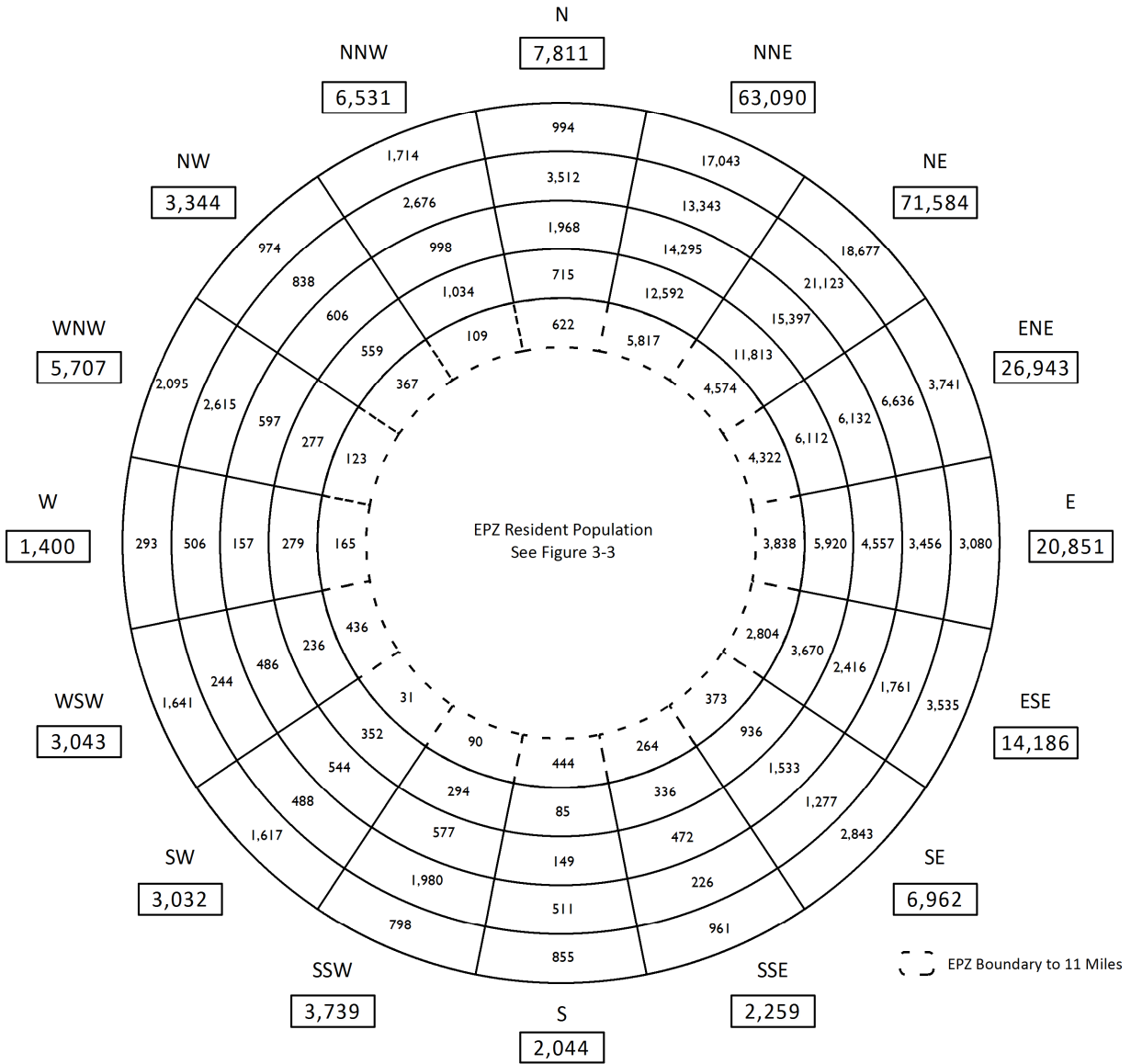

Shadow Population

Miles	Subtotal by Ring	Cumulative Total
EPZ - 11	24,379	24,379
11 - 12	45,210	69,589
12 - 13	50,884	120,473
13 - 14	61,192	181,665
14 - 15	60,861	242,526
Total:		242,526

Figure 3-5. Shadow Population by Sector

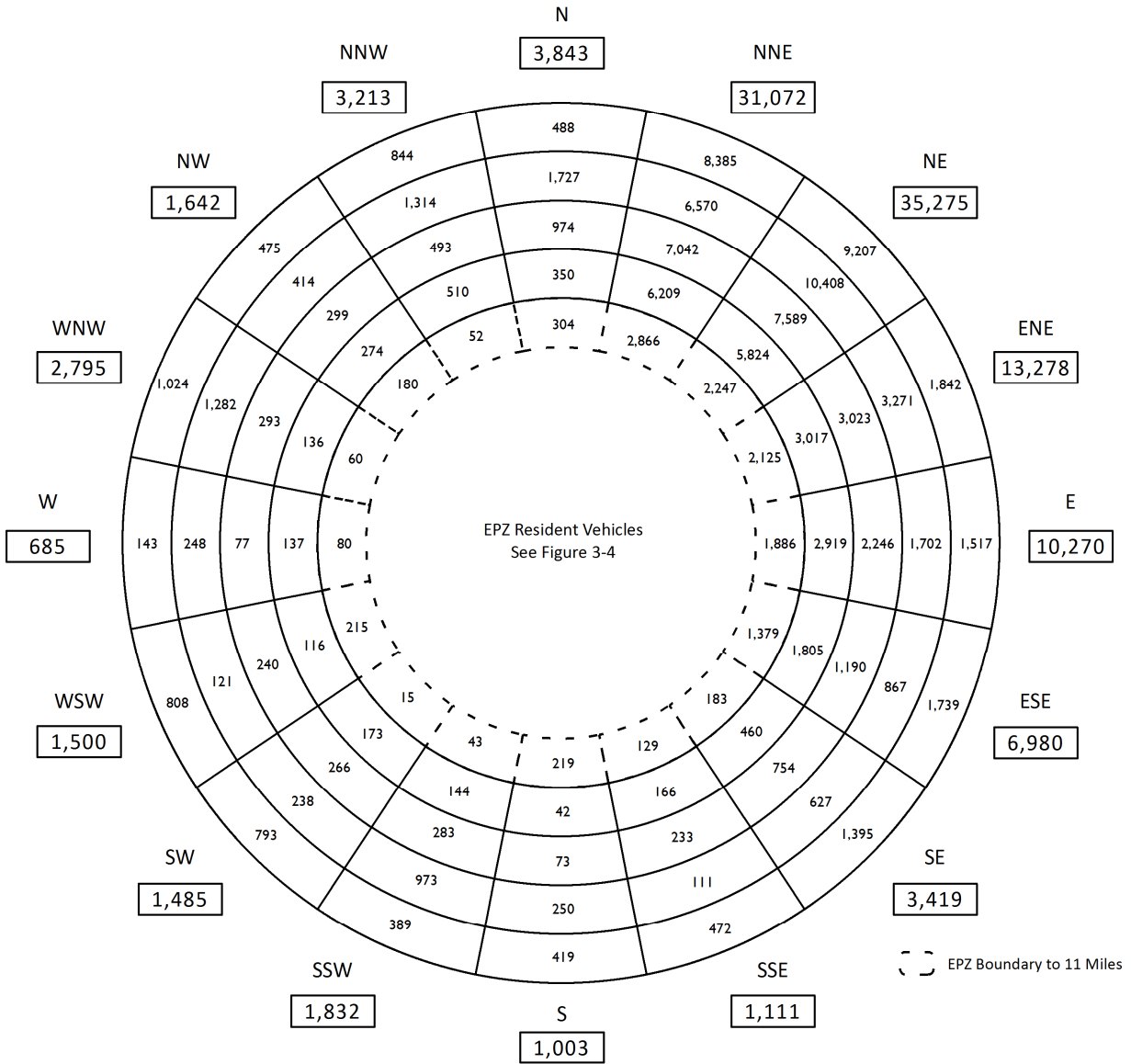

Shadow Vehicles

Miles	Subtotal by Ring	Cumulative Total
EPZ - 11	11,983	11,983
11 - 12	22,282	34,265
12 - 13	25,075	59,340
13 - 14	30,123	89,463
14 - 15	29,940	119,403
Total:		119,403

Figure 3-6. Shadow Vehicles by Sector

3.3 Transient Population

Transient population groups are defined as those people (who are not permanent residents, nor commuting employees) who enter the EPZ for a specific purpose (shopping, recreation). Transients may spend less than one day or stay overnight at camping facilities, hotels and motels. The HNP EPZ has a number of areas and facilities that attract transients, including:

- Campgrounds
- Parks
- Community Centers
- Golf Courses
- Lodging Facilities

Jordan Lake State Recreation Area is the primary transient attraction within the EPZ. Jordan Lake is a 46,768 acre lake located in the northwestern portion of the EPZ, occupying parts of Zones L, M, and N. The Jordan Lake State Recreation Area (SRA) consists of 12 separate facilities (11 of which are in the EPZ with Crosswinds Campground and Marina accounting for 2 facilities) that offer camping, fishing, swimming, and boating.

There are eight campgrounds within the EPZ. Data provided by Chatham County and the offices of the Jordan Lake SRA included the number of campsites, peak occupancy and the number of vehicles and people per campsite for each facility. These data were used to estimate the number of evacuating vehicles for transients at each of these facilities. A total of 4,060 transients and 1,338 vehicles have been assigned to campgrounds within the EPZ. The majority, 3,775 transients and 1,161 vehicles, are attributed to the five different Jordan Lake campground facilities (New Hope Overlook, Poplar Point, Vista Point, Crosswinds Campground and Marina, and Parker's Creek).

There are numerous parks and community centers within the EPZ. Five of the facilities are Jordan Lake SRA facilities (Ebenezer Church, Poe's Ridge, Robeson Creek, Seaforth and White Oak). Data provided by Chatham, Harnett and Wake Counties and the offices of the Jordan Lake SRA included the number of transients and vehicles visiting each facility on a peak day. A total of 6,296 transients and 2,234 vehicles have been assigned to parks and community centers within the EPZ. 3,337 transients and 873 vehicles are attributed to the five different Jordan Lake park facilities.

There are three golf courses within the EPZ. Data provided by Wake County included the number of golfers and vehicles at each facility on a peak day, and the number of golfers that travel from outside the area. A total of 620 transients and 410 vehicles are assigned to golf courses within the EPZ.

There are nine lodging facilities within the EPZ. Data provided by Wake County included the number of rooms, percentage of occupied rooms at peak times, and the number of people and vehicles per room for each facility. These data were used to estimate the number of transients and evacuating vehicles at each of these facilities. A total of 466 transients in 402 vehicles are assigned to lodging facilities in the EPZ.

Appendix E summarizes the transient data that was estimated for the EPZ. Table E-5 presents the number of transients visiting campgrounds, Table E-6 presents the number of transients at parks and community centers, Table E-7 presents the number of transients at golf courses and Table E-8 presents the number of transients at lodging facilities within the EPZ.

Table 3-6 presents transient population and transient vehicle estimates by Zone. Figure 3-7 and Figure 3-8 present these data by sector and distance from the plant. There are a total of 11,442 transients in the EPZ at peak times, evacuating in 4,384 vehicles – an average vehicle occupancy of 2.61 transients per vehicle.

Table 3-6. Summary of Transients and Transient Vehicles

Zone	Transients	Transient Vehicles
A	401	182
B	289	131
C	70	30
D	224	102
E	1,230	771
F	703	428
G	824	375
H	80	52
I	0	0
J	0	0
K	440	210
L	2,767	909
M	2,306	667
N	2,108	527
TOTAL	11,442	4,384

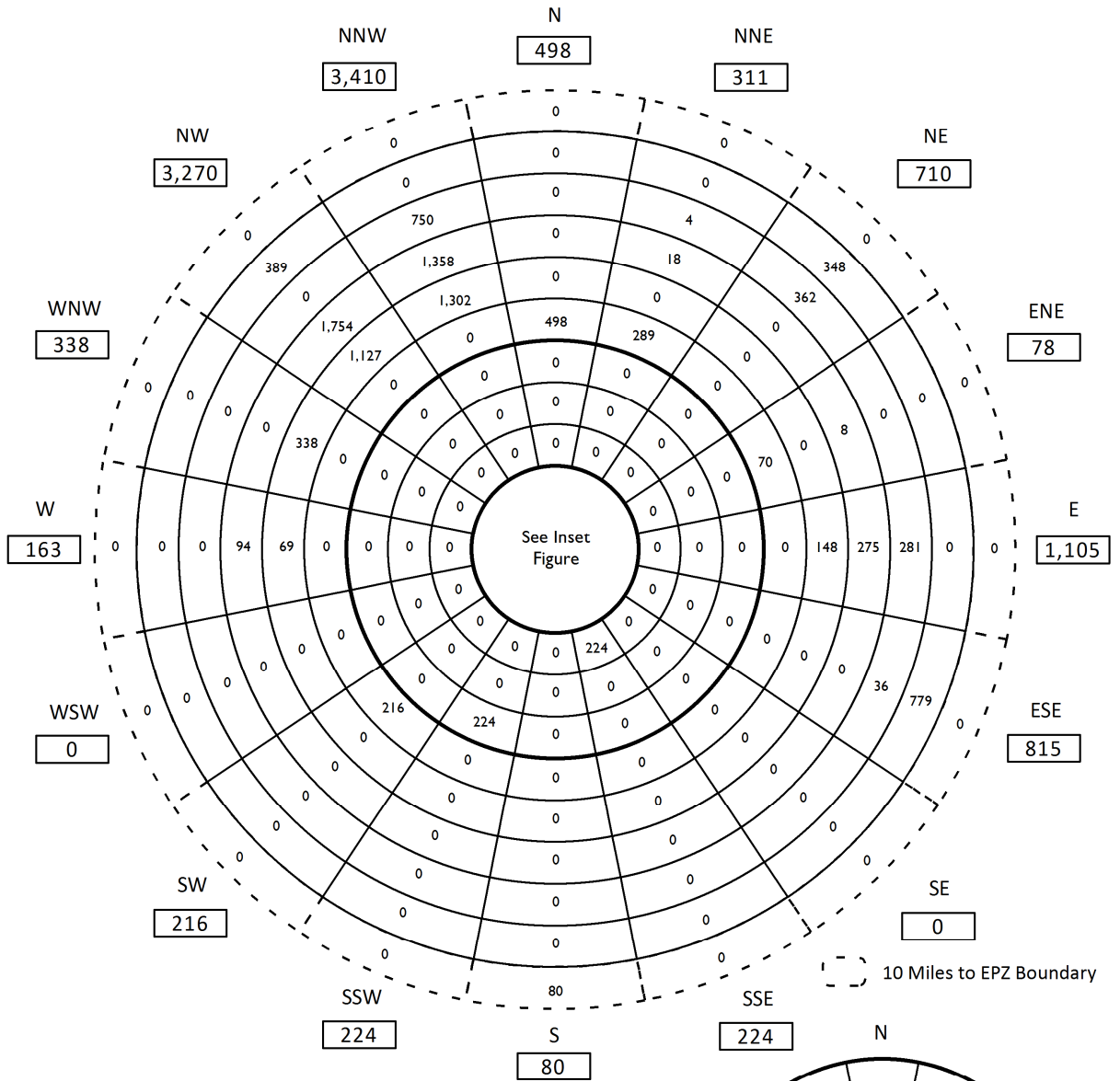

Transients

Miles	Subtotal by Ring	Cumulative Total
0 - 1	0	0
1 - 2	401	401
2 - 3	224	625
3 - 4	0	625
4 - 5	224	849
5 - 6	1,073	1,922
6 - 7	2,984	4,906
7 - 8	3,507	8,413
8 - 9	1,433	9,846
9 - 10	1,516	11,362
10 - EPZ	80	11,442
Total:		11,442

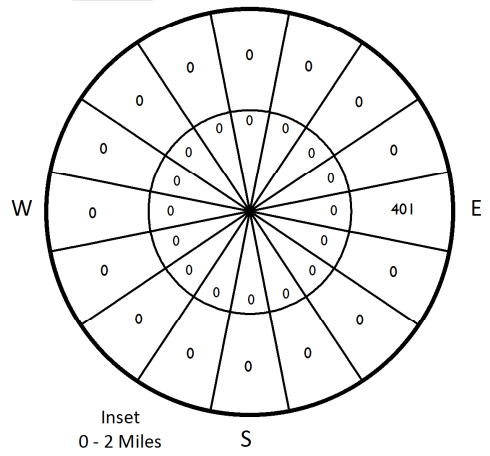
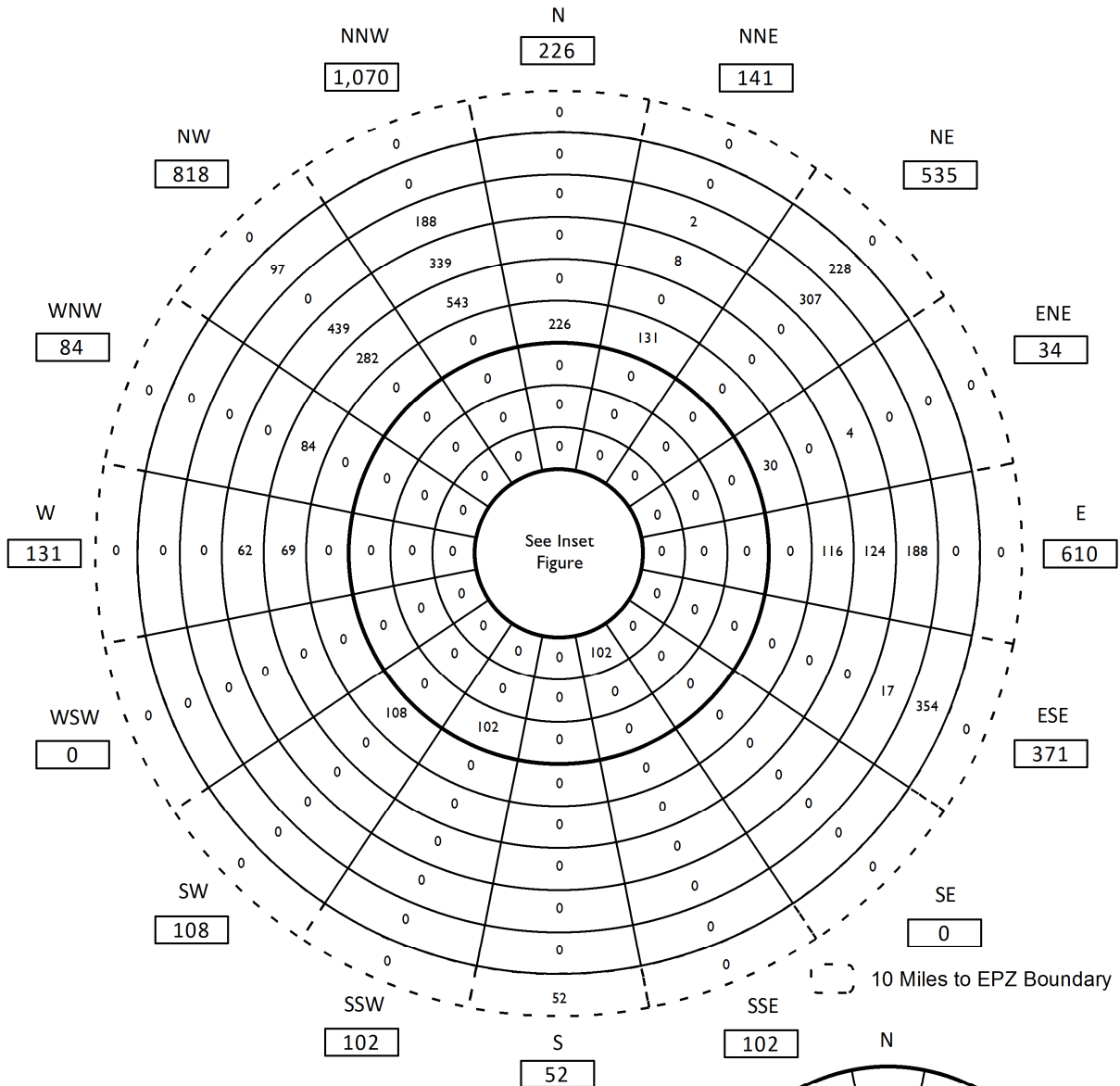

Figure 3-7. Transient Population by Sector



Transient Vehicles

Miles	Subtotal by Ring	Cumulative Total
0 - 1	0	0
1 - 2	182	182
2 - 3	102	284
3 - 4	0	284
4 - 5	102	386
5 - 6	495	881
6 - 7	1,094	1,975
7 - 8	976	2,951
8 - 9	702	3,653
9 - 10	679	4,332
10 - EPZ	52	4,384
Total:		4,384

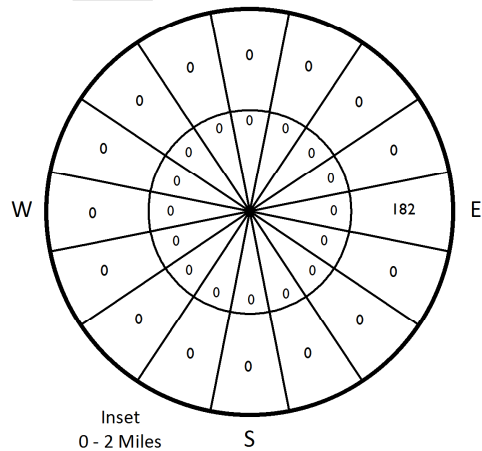

Figure 3-8. Transient Vehicles by Sector

3.4 Employees

Employees who work within the EPZ fall into two categories:

- Those who live and work in the EPZ
- Those who live outside of the EPZ and commute to jobs within the EPZ.

Those of the first category are already counted as part of the permanent resident population. To avoid double counting, we focus only on those employees commuting from outside the EPZ who will evacuate along with the permanent resident population.

Data obtained from the US Census Longitudinal Employer-Household Dynamics from the OnTheMap Census analysis tool⁶ were used to estimate the number of employees commuting into the EPZ. The 2014 Workplace Area Characteristic data was also obtained from this website and was used to determine the number of employees by Census Block within the HNP EPZ.

Since not all employees are working at facilities within the EPZ at one time, a maximum shift reduction was applied. The Work Area Profile Report, also output by the OnTheMap Application, breaks down jobs within the EPZ by industry sector. Assuming maximum shift employment occurs Monday through Friday between 9 AM and 5 PM, the following jobs take place outside the typical 9-5 work day:

- Manufacturing – 11.0% of jobs; takes place in shifts over 24 hours
- Arts, Entertainment, and Recreation – 1.3% of jobs; takes place in evenings and on weekends
- Accommodations and Food Services – 8.5% of jobs; peaks in the evenings

The maximum shift in the EPZ is about 79.2% ($100\% - 11.0\% - 1.3\% - 8.5\% = 79.2\%$). This value was applied to the total employment for 2014 to represent the maximum number of employees present in the EPZ at any one time. The Inflow/Outflow Report for the HNP EPZ was then used to calculate the percent of employees that work within the EPZ but live outside. This value, 79.8%, was applied to the maximum shift employee values to compute the number of people commuting into the EPZ to work at peak times.

Employees (Max Shift) are multiplied by the percent non-EPZ factor to determine the number of employees who are not residents of the EPZ. A vehicle occupancy of 1.07 employees per vehicle obtained from the telephone survey (See Figure F-7) was used to determine the number of evacuating employee vehicles for all major employers.

Table 3-7 presents non-EPZ Resident employee and vehicle estimates by Zone. Figure 3-9 and Figure 3-10 present these data by sector.

⁶ <http://onthemap.ces.census.gov/>

The latest data available using the OnTheMap census tool is for the year 2014.

Table 3-7. Summary of Non-EPZ Resident Employees and Employee Vehicles

Zone	Employees	Employee Vehicles
A	499	466
B	5	5
C	6	6
D	8	8
E	8,668	8,113
F	2,295	2,147
G	2,777	2,598
H	17	17
I	3	3
J	141	132
K	608	568
L	342	319
M	47	44
N	100	94
TOTAL	15,516	14,520

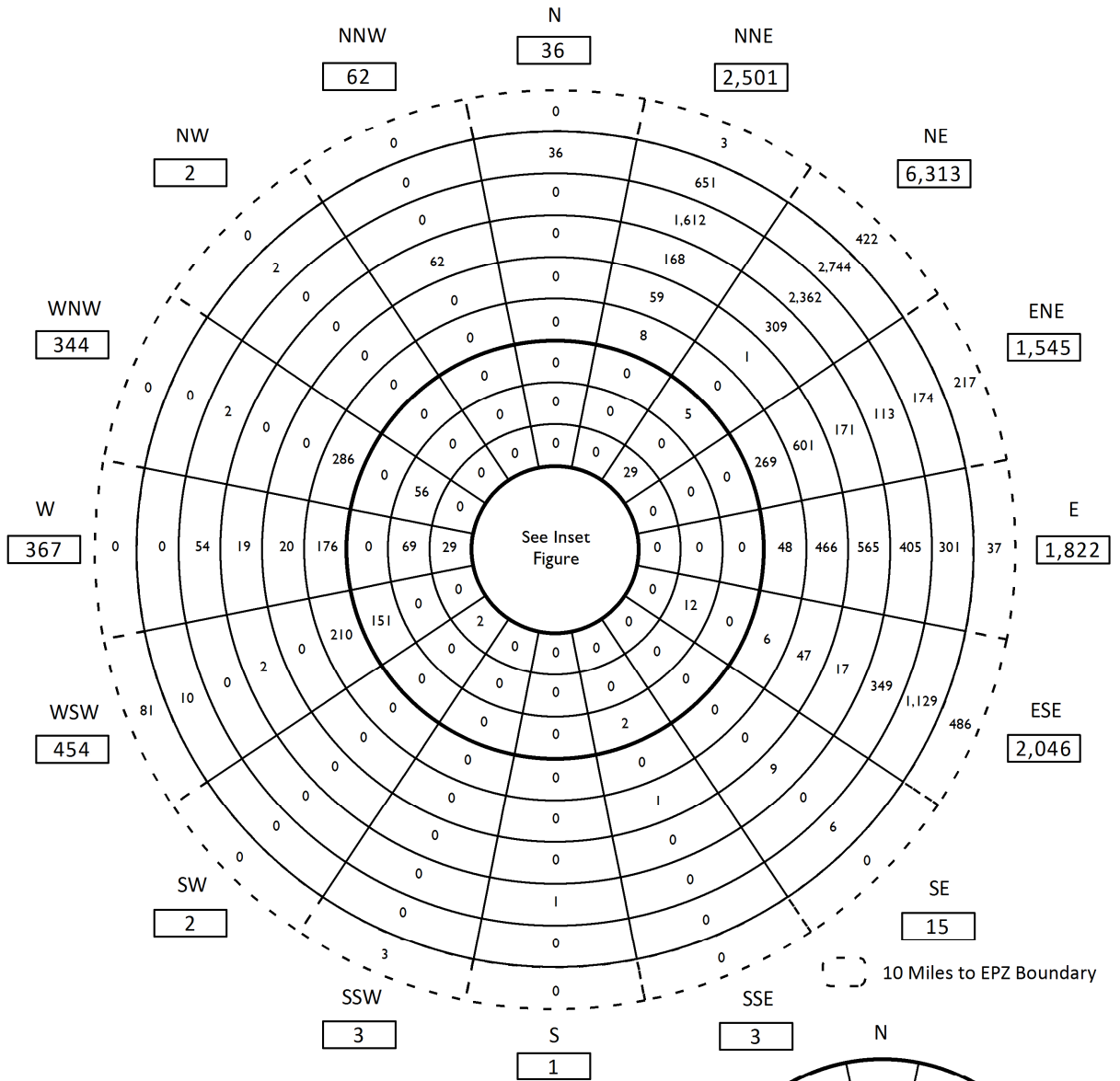

Employees

Miles	Subtotal by Ring	Cumulative Total
0 - 1	441	441
1 - 2	0	441
2 - 3	60	501
3 - 4	137	638
4 - 5	158	796
5 - 6	1,003	1,799
6 - 7	1,195	2,994
7 - 8	1,322	4,316
8 - 9	4,898	9,214
9 - 10	5,053	14,267
10 - EPZ	1,249	15,516
Total:		15,516

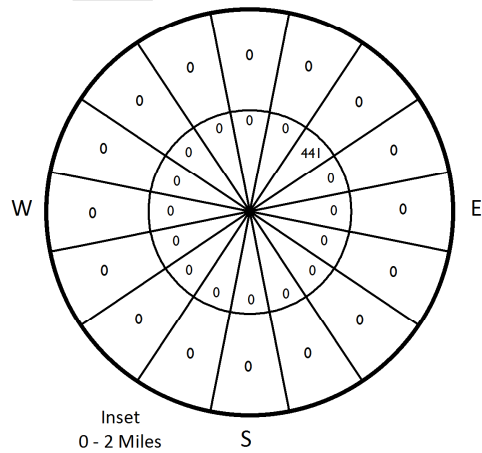
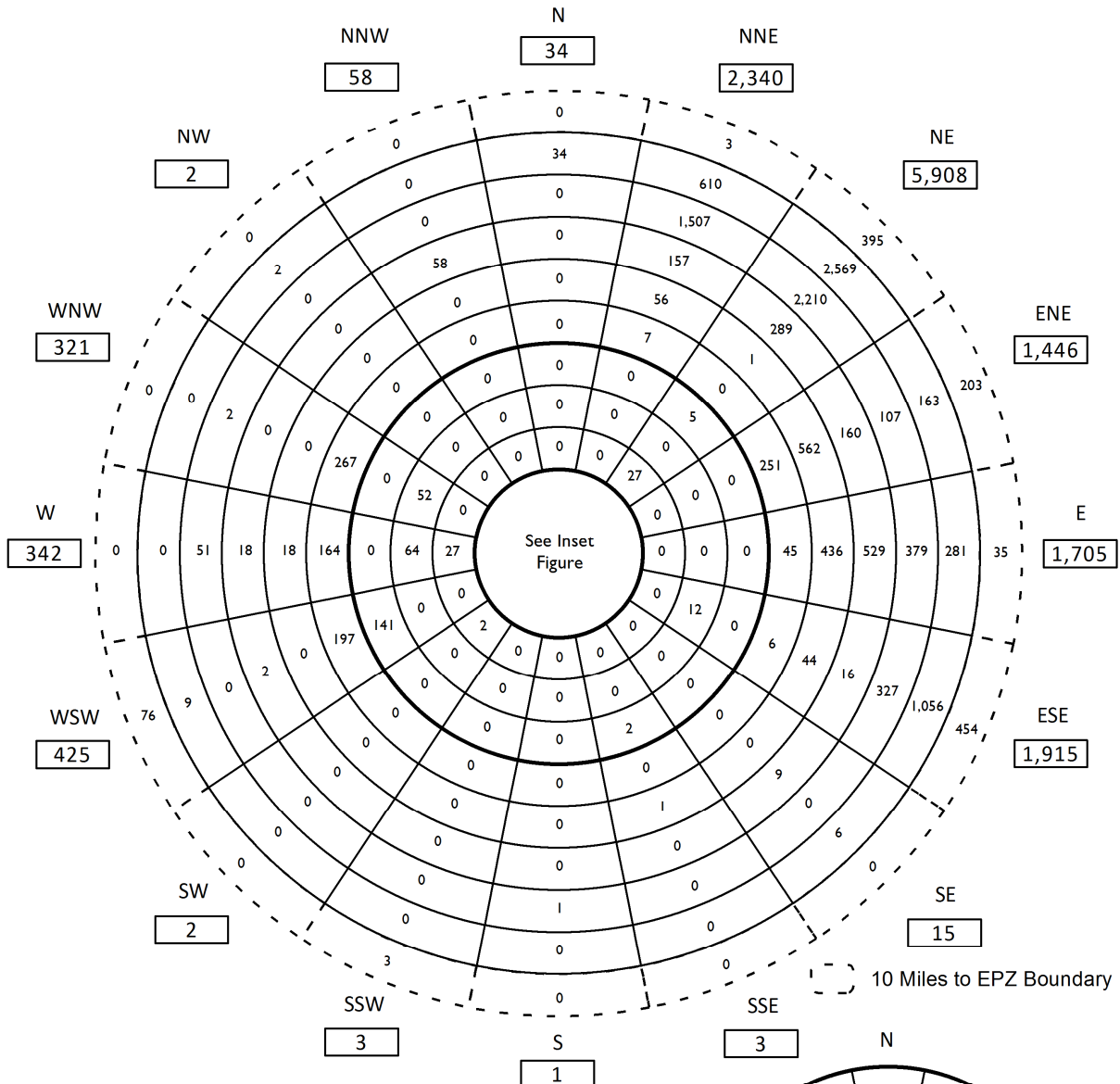

Figure 3-9. Employee Population by Sector



Employee Vehicles

Miles	Subtotal by Ring	Cumulative Total
0 - 1	412	412
1 - 2	0	412
2 - 3	56	468
3 - 4	128	596
4 - 5	148	744
5 - 6	937	1,681
6 - 7	1,118	2,799
7 - 8	1,238	4,037
8 - 9	4,584	8,621
9 - 10	4,730	13,351
10 - EPZ	1,169	14,520
Total:		14,520

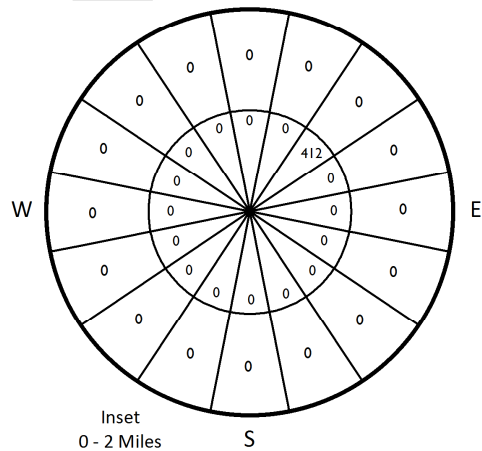

Figure 3-10. Employee Vehicles by Sector

3.5 Medical Facilities

Data were provided by the counties for each of the medical facilities within the EPZ. Table E-3 in Appendix E summarizes the data gathered. Section 8 details the evacuation of medical facilities and their patients. The number and type of evacuating vehicles that need to be provided depend on the patients' state of health. It is estimated that buses can transport up to 30 people; wheelchair vans, up to 4 people; wheelchair buses up to 15 people; minivans up to 5 people; passenger cars up to 4 people; and ambulances, up to 2 people.

3.6 External Traffic

Vehicles will be traveling through the EPZ (external-external trips) at the time of an emergency event. After the Advisory to Evacuate is announced, these through-travelers will also evacuate. These through vehicles are assumed to travel on the major routes traversing the study area – US-1, US-401, US-421, I-440 and I-40). Emergency management agencies indicated that this traffic will continue to enter the study during the first 30 minutes following the Advisory to Evacuate.

Average Annual Daily Traffic (AADT) data was obtained from the North Carolina Department of Transportation to estimate the number of vehicles per hour on the aforementioned routes. The AADT was multiplied by the K-Factor, which is the proportion of the AADT on a roadway segment or link during the design hour, resulting in the design hour volume (DHV). The design hour is usually the 30th highest hourly traffic volume of the year, measured in vehicles per hour (vph). The DHV is then multiplied by the D-Factor, which is the proportion of the DHV occurring in the peak direction of travel (also known as the directional split). The resulting values are the directional design hourly volumes (DDHV), and are presented in Table 3-8, for each of the routes considered. The DDHV is then multiplied by ½ hour (Security Road Blocks – SRB – are assumed to be activated at 30 minutes after the advisory to evacuate based upon information provided by emergency management agencies) to estimate the total number of external vehicles loaded on the analysis network. As indicated, there are 7,622 vehicles entering the study area as external-external trips prior to the activation of the SRB and the diversion of this traffic. This number is reduced by 60% for evening scenarios (Scenarios 5 and 12) as discussed in Section 6.

3.7 Background Traffic

Section 5 discusses the time needed for the people in the EPZ to mobilize and begin their evacuation trips. As shown in Table 5-8, there are 14 time periods during which traffic is loaded on to roadways in the study area to model the mobilization time of people in the EPZ. Note, there is no traffic generated during the 15th time period, as this time period is intended to allow traffic that has already begun evacuating to clear the study area boundaries.

This study does not assume that roadways are empty at the start of Time Period 1. Rather, there is a 50 minute initialization time period (often referred to as “fill time” in traffic simulation) wherein the traffic volumes from Time Period 1 are loaded onto roadways in the

study area. The amount of initialization/fill traffic that is on the roadways in the study area at the start of Time Period 1 depends on the scenario and the region being evacuated (see Section 6). There are 4,952 vehicles on the roadways in the study area at the end of fill time for an evacuation of the entire EPZ (Region R03) under Scenario 1 (summer, midweek, midday, good weather) conditions.

3.8 Special Event

During the project kickoff meeting in 2012, the offsite agencies discussed two special events in the study area. Events at the Koka Booth Amphitheatre (located in Cary just outside the EPZ) can attract at most 31,000 people, 15% of whom are transients for a total of 4,650 transients (data provided by Wake County). Data provided by the Offices of Jordan Lake SRA in 2012 indicated that 75% of individuals visiting Jordan Lake facilities are transients, with EPZ permanent residents making up the remaining 25%. The fireworks display during Fourth of July on Jordan Lake attracted 14,224 transients in 2012, which does not include permanent residents who may attend.

Fourth of July was chosen as the special event (Scenario 13) in accordance with NUREG/CR-7002, because it has the largest transient population. People attending the fireworks show are dispersed between the 11 different Jordan Lake facilities within the EPZ. In discussions with the office of Jordan Lake SRA, it was stated that visitation to Jordan Lake has increased by 26%. Based on this information, the 2012 special event data⁷ was increased by 26%, resulting in 17,923 transients attending the fireworks who travel in approximately 5,124 vehicles (3.5 persons per vehicle based on information provided by the office of Jordan Lake SRA). Fifty percent (50%) of these transients are already present on Jordan Lake during an average summer weekend. Thus, there are an additional 8,962 transients traveling in approximately 2,562 vehicles for the special event. These additional vehicles were loaded onto appropriate roadways in the analysis network at each of the different Jordan Lake facilities. The special event vehicle trips were generated utilizing the same mobilization distributions for transients. Public transportation is not provided for this event and was not considered in the special event analysis.

⁷ Note that the transients at Jordan Lake for non-special event cases were not increased by 26% as the facilities were already considered at capacity.

Table 3-8. HNP EPZ External Traffic

Upstream Node	Downstream Node	Road Name	Direction	NCDOT ¹ AADT	K-Factor ²	D-Factor ²	Hourly Volume	External Traffic
8590	1680	US-1	NB	20,000	0.116	0.5	1,160	580
8375	1700	US-1/I-440	SB	20,000	0.116	0.5	1,160	580
8222	1817	US-401	NB	12,000	0.116	0.5	696	348
8224	224	US-401	SB	12,000	0.116	0.5	696	348
8160	1800	US-421	NB	16,000	0.116	0.5	928	464
8230	1815	US-421	SB	16,00	0.116	0.5	928	464
8020	20	I-40	EB	118,000	0.082	0.5	4,838	2,419
8359	359	I-40	WB	118,000	0.082	0.5	4,838	2,419
							TOTAL	7,622

¹NCDOT 2014 AADT and Class Event Data

²HCM 2010

3.9 Summary of Demand

A summary of population and vehicle demand is provided in Table 3-9 and Table 3-10, respectively. This summary includes all population groups described in this section and Section 8. Additional population groups – transit-dependent, special facility and school population – are described in greater detail in Section 8. A total of 240,817 people and 116,681 vehicles are considered in this study.

Table 3-9. Summary of Population Demand

Zone	Residents	Transit-Dependent	Transients	Employees	Medical Facilities	Schools	Shadow Population	External Traffic	Total
A	157	5	401	499	44	0	0	0	1,106
B	1,472	49	289	5	0	1,000	0	0	2,815
C	2,788	92	70	6	3	0	0	0	2,959
D	401	13	224	8	0	0	0	0	646
E	57,048	1,887	1,230	8,668	249	10,391	0	0	79,473
F	29,945	991	703	2,295	44	9,999	0	0	43,977
G	28,379	938	824	2,777	407	5,534	0	0	38,859
H	4,444	147	80	17	0	0	0	0	4,688
I	1,001	33	0	3	0	0	0	0	1,037
J	1,168	39	0	141	137	0	0	0	1,485
K	791	26	440	608	0	0	0	0	1,865
L	939	31	2,767	342	0	0	0	0	4,079
M	2,011	66	2,306	47	0	291	0	0	4,721
N	976	32	2,108	100	0	0	0	0	3,216
Shadow	0	0	0	0	0	1,386	48,505	0	49,891
Total	131,520	4,349	11,442	15,516	884	28,601	48,505	0	240,817

NOTE: Shadow Population has been reduced to 20%. Refer to Figure 2-1 for additional information.

Table 3-10. Summary of Vehicle Demand

Zone	Residents	Transit-Dependent	Transients	Employees	Medical Facilities	Schools	Shadow Population	External Traffic	Total
A	76	2	182	466	7	0	0	0	733
B	722	4	131	5	0	40	0	0	902
C	1,371	6	30	6	1	0	0	0	1,414
D	197	2	102	8	0	0	0	0	309
E	28,085	126	771	8,113	52	414	0	0	37,561
F	14,752	66	428	2,147	13	362	0	0	17,768
G	13,968	62	375	2,598	70	214	0	0	17,287
H	2,186	10	52	17	0	0	0	0	2,265
I	488	2	0	3	0	0	0	0	493
J	574	4	0	132	28	0	0	0	738
K	383	2	210	568	0	0	0	0	1,163
L	459	2	909	319	0	0	0	0	1,689
M	988	4	667	44	0	10	0	0	1,713
N	480	2	527	94	0	0	0	0	1,103
Shadow	0	0	0	0	0	40	23,881	7,622	31,543
Total	64,729	294	4,384	14,520	171	1,080	23,881	7,622	116,681

NOTE: Buses (including wheelchair buses) represented as two passenger vehicles. Refer to Section 8 for additional information.

NOTE: Shadow Population has been reduced to 20%. Refer to Figure 2-1 for additional information.

4 ESTIMATION OF HIGHWAY CAPACITY

The ability of the road network to service vehicle demand is a major factor in determining how rapidly an evacuation can be completed. The capacity of a road is defined as the maximum hourly rate at which persons or vehicles can reasonably be expected to traverse a point or uniform section of a lane of roadway during a given time period under prevailing roadway, traffic and control conditions, as stated in the 2010 Highway Capacity Manual (HCM 2010).

In discussing capacity, different operating conditions have been assigned alphabetical designations, A through F, to reflect the range of traffic operational characteristics. These designations have been termed "Levels of Service" (LOS). For example, LOS A connotes free-flow and high-speed operating conditions; LOS F represents a forced flow condition. LOS E describes traffic operating at or near capacity.

Another concept, closely associated with capacity, is "Service Volume" (SV). Service volume is defined as "The maximum hourly rate at which vehicles, bicycles or persons reasonably can be expected to traverse a point or uniform section of a roadway during an hour under specific assumed conditions while maintaining a designated level of service." This definition is similar to that for capacity. The major distinction is that values of SV vary from one LOS to another, while capacity is the service volume at the upper bound of LOS E, only.

This distinction is illustrated in Exhibit 11-17 of the HCM 2010. As indicated there, the SV varies with Free Flow Speed (FFS), and LOS. The SV is calculated by the DYNEV II simulation model, based on the specified link attributes, FFS, capacity, control device and traffic demand.

Other factors also influence capacity. These include, but are not limited to:

- Lane width
- Shoulder width
- Pavement condition
- Horizontal and vertical alignment (curvature and grade)
- Percent truck traffic
- Control device (and timing, if it is a signal)
- Weather conditions (rain, fog, wind speed, ice)

These factors are considered during the road survey and in the capacity estimation process; some factors have greater influence on capacity than others. For example, lane and shoulder width have only a limited influence on Base Free Flow Speed (BFFS¹) according to Exhibit 15-7 of the HCM. Consequently, lane and shoulder widths at the narrowest points were observed during the road survey and these observations were recorded, but no detailed measurements of lane or shoulder width were taken. Horizontal and vertical alignment can influence both FFS and capacity. The estimated FFS were measured using the survey vehicle's speedometer and observing local traffic, under free flow conditions. Capacity is estimated from the procedures of

¹ A very rough estimate of BFFS might be taken as the posted speed limit plus 10 mph (HCM 2010 Page 15-15)

the 2010 HCM. For example, HCM Exhibit 7-1(b) shows the sensitivity of Service Volume at the upper bound of LOS D to grade (capacity is the Service Volume at the upper bound of LOS E).

As discussed in Section 2.3, it is necessary to adjust capacity figures to represent the prevailing conditions during inclement weather. Based on limited empirical data, weather conditions such as rain reduce the values of free speed and of highway capacity by approximately 10 percent. Over the last decade new studies have been made on the effects of rain on traffic capacity. These studies indicate a range of effects between 5 and 20 percent depending on wind speed and precipitation rates. As indicated in Section 2.3, we employ a reduction in free speed and in highway capacity of 10 percent and 20 percent for rain and ice, respectively.

Since congestion arising from evacuation may be significant, estimates of roadway capacity must be determined with great care. Because of its importance, a brief discussion of the major factors that influence highway capacity is presented in this section.

Rural highways generally consist of: (1) one or more uniform sections with limited access (driveways, parking areas) characterized by “uninterrupted” flow; and (2) approaches to at-grade intersections where flow can be “interrupted” by a control device or by turning or crossing traffic at the intersection. Due to these differences, separate estimates of capacity must be made for each section. Often, the approach to the intersection is widened by the addition of one or more lanes (turn pockets or turn bays), to compensate for the lower capacity of the approach due to the factors there that can interrupt the flow of traffic. These additional lanes are recorded during the field survey and later entered as input to the DYNEV II system.

4.1 Capacity Estimations on Approaches to Intersections

At-grade intersections are apt to become the first bottleneck locations under local heavy traffic volume conditions. This characteristic reflects the need to allocate access time to the respective competing traffic streams by exerting some form of control. During evacuation, control at critical intersections will often be provided by traffic control personnel assigned for that purpose, whose directions may supersede traffic control devices. The existing traffic management plans documented in the county emergency plans are extensive and were updated based upon construction of NC-540 Toll and the completion of Judd Pkwy in Fuquay-Varina. See Appendix G for more information.

The per-lane capacity of an approach to a signalized intersection can be expressed (simplistically) in the following form:

$$Q_{cap,m} = \left(\frac{3600}{h_m} \right) \times \left(\frac{G - L}{C} \right)_m = \left(\frac{3600}{h_m} \right) \times P_m$$

where:

$Q_{cap,m}$	=	Capacity of a single lane of traffic on an approach, which executes movement, m , upon entering the intersection; vehicles per hour (vph)
h_m	=	Mean queue discharge headway of vehicles on this lane that are executing movement, m ; seconds per vehicle
G	=	Mean duration of GREEN time servicing vehicles that are executing movement, m , for each signal cycle; seconds
L	=	Mean "lost time" for each signal phase servicing movement, m ; seconds
C	=	Duration of each signal cycle; seconds
P_m	=	Proportion of GREEN time allocated for vehicles executing movement, m , from this lane. This value is specified as part of the control treatment.
m	=	The movement executed by vehicles after they enter the intersection: through, left-turn, right-turn, and diagonal.

The turn-movement-specific mean discharge headway h_m , depends in a complex way upon many factors: roadway geometrics, turn percentages, the extent of conflicting traffic streams, the control treatment, and others. A primary factor is the value of "saturation queue discharge headway", h_{sat} , which applies to through vehicles that are not impeded by other conflicting traffic streams. This value, itself, depends upon many factors including motorist behavior. Formally, we can write,

$$h_m = f_m(h_{sat}, F_1, F_2, \dots)$$

where:

h_{sat}	=	Saturation discharge headway for through vehicles; seconds per vehicle
F_1, F_2	=	The various known factors influencing h_m
$f_m()$	=	Complex function relating h_m to the known (or estimated) values of h_{sat} , F_1, F_2, \dots

The estimation of h_m for specified values of h_{sat} , F_1, F_2, \dots is undertaken within the DYNEV II simulation model by a mathematical model². The resulting values for h_m always satisfy the condition:

$$h_m \geq h_{sat}$$

²Lieberman, E., "Determining Lateral Deployment of Traffic on an Approach to an Intersection", McShane, W. & Lieberman, E., "Service Rates of Mixed Traffic on the far Left Lane of an Approach". Both papers appear in Transportation Research Record 772, 1980. Lieberman, E., Xin, W., "Macroscopic Traffic Modeling For Large-Scale Evacuation Planning", presented at the TRB 2012 Annual Meeting, January 22-26, 2012

That is, the turn-movement-specific discharge headways are always greater than, or equal to the saturation discharge headway for through vehicles. These headways (or its inverse equivalent, “saturation flow rate”), may be determined by observation or using the procedures of the HCM 2010.

The above discussion is necessarily brief given the scope of this ETE report and the complexity of the subject of intersection capacity. In fact, Chapters 18, 19 and 20 in the HCM 2010 address this topic. The factors, F_1, F_2, \dots , influencing saturation flow rate are identified in equation (18-5) of the HCM 2010.

The traffic signals within the EPZ and Shadow Region are modeled using representative phasing plans and phase durations obtained as part of the field data collection. Traffic responsive signal installations allow the proportion of green time allocated (P_m) for each approach to each intersection to be determined by the expected traffic volumes on each approach during evacuation circumstances. The amount of green time (G) allocated is subject to maximum and minimum phase duration constraints; 2 seconds of yellow time are indicated for each signal phase and 1 second of all-red time is assigned between signal phases, typically. If a signal is pre-timed, the yellow and all-red times observed during the road survey are used. A lost time (L) of 2.0 seconds is used for each signal phase in the analysis.

4.2 Capacity Estimation along Sections of Highway

The capacity of highway sections -- as distinct from approaches to intersections -- is a function of roadway geometrics, traffic composition (e.g. percent heavy trucks and buses in the traffic stream) and, of course, motorist behavior. There is a fundamental relationship which relates service volume (i.e. the number of vehicles serviced within a uniform highway section in a given time period) to traffic density. The top curve in Figure 4-1 illustrates this relationship.

As indicated, there are two flow regimes: (1) Free Flow (left side of curve); and (2) Forced Flow (right side). In the Free Flow regime, the traffic demand is fully serviced; the service volume increases as demand volume and density increase, until the service volume attains its maximum value, which is the capacity of the highway section. As traffic demand and the resulting highway density increase beyond this "critical" value, the rate at which traffic can be serviced (i.e. the service volume) can actually decline below capacity (“capacity drop”). Therefore, in order to realistically represent traffic performance during congested conditions (i.e. when demand exceeds capacity), it is necessary to estimate the service volume, V_F , under congested conditions.

The value of V_F can be expressed as:

$$V_F = R \times Capacity$$

where:

R = Reduction factor which is less than unity

We have employed a value of $R=0.90$. The advisability of such a capacity reduction factor is based upon empirical studies that identified a fall-off in the service flow rate when congestion occurs at “bottlenecks” or “choke points” on a freeway system. Zhang and Levinson³ describe a research program that collected data from a computer-based surveillance system (loop detectors) installed on the Interstate Highway System, at 27 active bottlenecks in the twin cities metro area in Minnesota over a 7-week period. When flow breakdown occurs, queues are formed which discharge at lower flow rates than the maximum capacity prior to observed breakdown. These queue discharge flow (QDF) rates vary from one location to the next and also vary by day of week and time of day based upon local circumstances. The cited reference presents a mean QDF of 2,016 passenger cars per hour per lane (pcphpl). This figure compares with the nominal capacity estimate of 2,250 pcphpl estimated for the ETE and indicated in Appendix K for freeway links. The ratio of these two numbers is 0.896 which translates into a capacity reduction factor of 0.90.

Since the principal objective of evacuation time estimate analyses is to develop a “realistic” estimate of evacuation times, use of the representative value for this capacity reduction factor ($R=0.90$) is justified. This factor is applied only when flow breaks down, as determined by the simulation model.

Rural roads, like freeways, are classified as “uninterrupted flow” facilities. (This is in contrast with urban street systems which have closely spaced signalized intersections and are classified as “interrupted flow” facilities.) As such, traffic flow along rural roads is subject to the same effects as freeways in the event traffic demand exceeds the nominal capacity, resulting in queuing and lower QDF rates. As a practical matter, rural roads rarely break down at locations away from intersections. Any breakdowns on rural roads are generally experienced at intersections where other model logic applies, or at lane drops which reduce capacity there. Therefore, the application of a factor of 0.90 is appropriate on rural roads, but rarely, if ever, activated.

The estimated value of capacity is based primarily upon the type of facility and on roadway geometrics. Sections of roadway with adverse geometrics are characterized by lower free-flow speeds and lane capacity. Exhibit 15-30 in the Highway Capacity Manual was referenced to estimate saturation flow rates. The impact of narrow lanes and shoulders on free-flow speed and on capacity is not material, particularly when flow is predominantly in one direction as is the case during an evacuation.

The procedure used here was to estimate “section” capacity, V_E , based on observations made traveling over each section of the evacuation network, based on the posted speed limits and travel behavior of other motorists and by reference to the 2010 HCM. The DYNEV II simulation model determines for each highway section, represented as a network link, whether its capacity would be limited by the “section-specific” service volume, V_E , or by the intersection-specific capacity. For each link, the model selects the lower value of capacity.

³Lei Zhang and David Levinson, “Some Properties of Flows at Freeway Bottlenecks,” Transportation Research Record 1883, 2004.

4.3 Application to the Harris Nuclear Plant Study Area

As part of the development of the link-node analysis network for the study area, an estimate of roadway capacity is required. The source material for the capacity estimates presented herein is contained in:

2010 Highway Capacity Manual (HCM)
Transportation Research Board
National Research Council
Washington, D.C.

The highway system in the study area consists primarily of three categories of roads and, of course, intersections:

- Two-Lane roads: Local, State
- Multi-Lane Highways (at-grade)
- Freeways

Each of these classifications will be discussed.

4.3.1 Two-Lane Roads

Ref: HCM Chapter 15

Two lane roads comprise the majority of highways within the EPZ. The per-lane capacity of a two-lane highway is estimated at 1,700 passenger cars per hour (pc/h). This estimate is essentially independent of the directional distribution of traffic volume except that, for extended distances, the two-way capacity will not exceed 3,200 pc/h. The HCM procedures then estimate LOS and Average Travel Speed. The DYNEV II simulation model accepts the specified value of capacity as input and computes average speed based on the time-varying demand: capacity relations.

Based on the field survey and on expected traffic operations associated with evacuation scenarios:

- Most sections of two-lane roads within the EPZ are classified as "Class I", with "level terrain"; some are "rolling terrain".
- "Class II" highways are mostly those within urban and suburban centers.

4.3.2 Multi-Lane Highway

Ref: HCM Chapter 14

Exhibit 14-2 of the HCM 2010 presents a set of curves that indicate a per-lane capacity ranging from approximately 1,900 to 2,200 pc/h, for free-speeds of 45 to 60 mph, respectively. Based on observation, the multi-lane highways outside of urban areas within the EPZ service traffic with free-speeds in this range. The actual time-varying speeds computed by the simulation model reflect the demand: capacity relationship and the impact of control at intersections. A

conservative estimate of per-lane capacity of 1,900 pc/h is adopted for this study for multi-lane highways outside of urban areas, as shown in Appendix K.

4.3.3 Freeways

Ref: HCM Chapters 10, 11, 12, 13

Chapter 10 of the HCM 2010 describes a procedure for integrating the results obtained in Chapters 11, 12 and 13, which compute capacity and LOS for freeway components. Chapter 10 also presents a discussion of simulation models. The DYNEV II simulation model automatically performs this integration process.

Chapter 11 of the HCM 2010 presents procedures for estimating capacity and LOS for "Basic Freeway Segments". Exhibit 11-17 of the HCM 2010 presents capacity vs. free speed estimates, which are provided below.

Free Speed (mph):	55	60	65	70+
Per-Lane Capacity (pc/h):	2,250	2,300	2,350	2,400

The inputs to the simulation model are highway geometrics, free-speeds and capacity based on field observations. The simulation logic calculates actual time-varying speeds based on demand: capacity relationships. A conservative estimate of per-lane capacity of 2,250 pc/h is adopted for this study for freeways, as shown in Appendix K.

Chapter 12 of the HCM 2010 presents procedures for estimating capacity, speed, density and LOS for freeway weaving sections. The simulation model contains logic that relates speed to demand volume: capacity ratio. The value of capacity obtained from the computational procedures detailed in Chapter 12 depends on the "Type" and geometrics of the weaving segment and on the "Volume Ratio" (ratio of weaving volume to total volume).

Chapter 13 of the HCM 2010 presents procedures for estimating capacities of ramps and "merge" areas. There are three significant factors to the determination of capacity of a ramp-freeway junction: The capacity of the freeway immediately downstream of an on-ramp or immediately upstream of an off-ramp; the capacity of the ramp roadway; and the maximum flow rate entering the ramp influence area. In most cases, the freeway capacity is the controlling factor. Values of this merge area capacity are presented in Exhibit 13-8 of the HCM 2010, and depend on the number of freeway lanes and on the freeway free speed. Ramp capacity is presented in Exhibit 13-10 and is a function of the ramp free flow speed. The DYNEV II simulation model logic simulates the merging operations of the ramp and freeway traffic in accord with the procedures in Chapter 13 of the HCM 2010. If congestion results from an excess of demand relative to capacity, then the model allocates service appropriately to the two entering traffic streams and produces LOS F conditions (The HCM does not address LOS F explicitly).

4.3.4 Intersections

Ref: HCM Chapters 18, 19, 20, 21

Procedures for estimating capacity and LOS for approaches to intersections are presented in Chapter 18 (signalized intersections), Chapters 19, 20 (un-signalized intersections) and Chapter 21 (roundabouts). The complexity of these computations is indicated by the aggregate length of these chapters. The DYNEV II simulation logic is likewise complex.

The simulation model explicitly models intersections: Stop/yield controlled intersections (both 2-way and all-way) and traffic signal controlled intersections. Where intersections are controlled by fixed time controllers, traffic signal timings are set to reflect average (non-evacuation) traffic conditions. Actuated traffic signal settings respond to the time-varying demands of evacuation traffic to adjust the relative capacities of the competing intersection approaches.

The model is also capable of modeling the presence of manned traffic control. At specific locations where it is advisable or where existing plans call for overriding existing traffic control to implement manned control, the model will use actuated signal timings that reflect the presence of traffic guides. At locations where a special traffic control strategy (continuous left-turns, contra-flow lanes) is used, the strategy is modeled explicitly. Where applicable, the location and type of traffic control for nodes in the evacuation network are noted in Appendix K. The characteristics of the ten highest volume signalized intersections are detailed in Appendix J.

4.4 Simulation and Capacity Estimation

Chapter 6 of the HCM is entitled, “HCM and Alternative Analysis Tools.” The chapter discusses the use of alternative tools such as simulation modeling to evaluate the operational performance of highway networks. Among the reasons cited in Chapter 6 to consider using simulation as an alternative analysis tool is:

“The system under study involves a group of different facilities or travel modes with mutual interactions invoking several procedural chapters of the HCM. Alternative tools are able to analyze these facilities as a single system.”

This statement succinctly describes the analyses required to determine traffic operations across an area encompassing an EPZ operating under evacuation conditions. The model utilized for this study, DYNEV II, is further described in Appendix C. It is essential to recognize that simulation models do not replicate the methodology and procedures of the HCM – they *replace* these procedures by describing the complex interactions of traffic flow and computing Measures of Effectiveness (MOE) detailing the operational performance of traffic over time and by location. The DYNEV II simulation model includes some HCM 2010 procedures only for the purpose of estimating capacity.

All simulation models must be calibrated properly with field observations that quantify the performance parameters applicable to the analysis network. Two of the most important of

these are: (1) Free flow speed (FFS); and (2) saturation headway, h_{sat} . The first of these is estimated by direct observation during the road survey; the second is estimated using the concepts of the HCM 2010, as described earlier. These parameters are listed in Appendix K, for each network link.

4.5 Boundary Conditions

As illustrated in Figure 1-2 and in Appendix K, the link-node analysis network used for this study is finite. The analysis network does extend well beyond the 15-mile radial study area in some locations in order to model intersections with other major evacuation routes beyond the study area. However, the network does have an end at the destination (exit) nodes as discussed in Appendix C. Beyond these destination nodes, there may be signalized intersections or merge points that impact the capacity of the evacuation routes leaving the study area. Rather than neglect these “boundary conditions,” this study assumes a 25% reduction in capacity on two-lane roads (Section 4.3.1 above) and multi-lane highways (Section 4.3.2 above). There is no reduction in capacity for freeways due to boundary conditions. The 25% reduction in capacity is based on the prevalence of actuated traffic signals in the study area (see Table K-2) and the fact that the evacuating traffic volume will be more significant than the competing traffic volume at any downstream signalized intersections, thereby warranting a more significant percentage (75% in this case) of the signal green time.

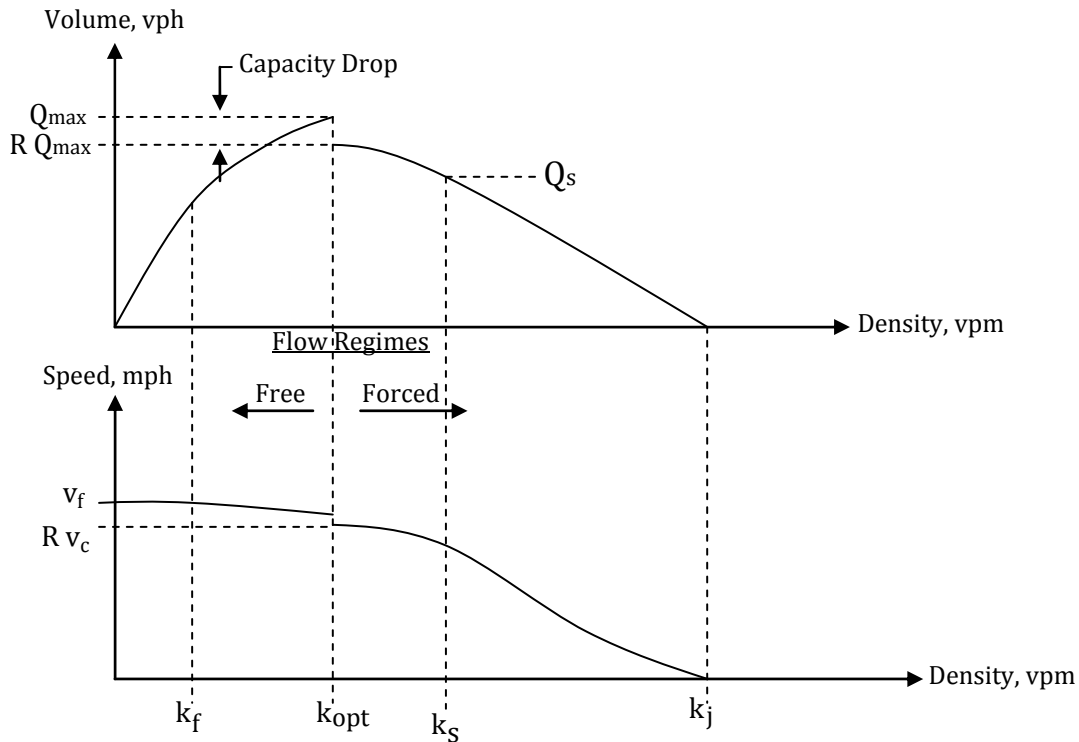

Figure 4-1. Fundamental Diagrams

5 ESTIMATION OF TRIP GENERATION TIME

Federal Government guidelines (see NUREG/CR-7002) specify that the planner estimate the distributions of elapsed times associated with mobilization activities undertaken by the public to prepare for the evacuation trip. The elapsed time associated with each activity is represented as a statistical distribution reflecting differences between members of the public. The quantification of these activity-based distributions relies largely on the results of the telephone survey. We define the sum of these distributions of elapsed times as the Trip Generation Time Distribution.

5.1 Background

In general, an accident at a nuclear power plant is characterized by the following Emergency Classification Levels (see Appendix 1 of NUREG-0654 for details):

1. Unusual Event
2. Alert
3. Site Area Emergency
4. General Emergency

At each level, the Federal guidelines specify a set of Actions to be undertaken by the Licensee and by the State and Local offsite authorities. As a Planning Basis, we will adopt a conservative posture, in accordance with Section 1.2 of NUREG/CR-7002, that a rapidly escalating accident at the plant wherein evacuation is ordered promptly and no early protective actions have been implemented will be considered in calculating the Trip Generation Time. We will assume:

1. The Advisory to Evacuate will be announced coincident with the siren notification.
2. Mobilization of the general population will commence within 15 minutes after the siren notification.
3. ETE are measured relative to the Advisory to Evacuate.

We emphasize that the adoption of this planning basis is not a representation that these events will occur within the indicated time frame. Rather, these assumptions are necessary in order to:

1. Establish a temporal framework for estimating the Trip Generation distribution in the format recommended in Section 2.13 of NUREG/CR-6863.
2. Identify temporal points of reference that uniquely define "Clear Time" and ETE.

It is likely that a longer time will elapse between the various classes of an emergency. For example, suppose one hour elapses from the siren alert to the Advisory to Evacuate. In this case, it is reasonable to expect some degree of spontaneous evacuation by the public during this one-hour period. As a result, the population within the EPZ will be lower when the Advisory to Evacuate is announced, than at the time of the siren alert. In addition, many will engage in preparation activities to evacuate, in anticipation that an Advisory will be broadcast. Thus, the time needed to complete the mobilization activities and the number of people

remaining to evacuate the EPZ after the Advisory to Evacuate, will both be somewhat less than the estimates presented in this report. Consequently, the ETE presented in this report are higher than the actual evacuation time, if this hypothetical situation were to take place.

The notification process consists of two events:

1. Transmitting information using the alert and notification systems (ANS) available within the EPZ (e.g. sirens, tone alerts, EAS broadcasts, loud speakers).
2. Receiving and correctly interpreting the information that is transmitted.

The population within the EPZ is dispersed over an area of 330 square miles and is engaged in a wide variety of activities. It must be anticipated that some time will elapse between the transmission and receipt of the information advising the public of an accident.

The amount of elapsed time will vary from one individual to the next depending on where that person is, what that person is doing, and related factors. Furthermore, some persons who will be directly involved with the evacuation process may be outside the EPZ at the time the emergency is declared. These people may be commuters, shoppers and other travelers who reside within the EPZ and who will return to join the other household members upon receiving notification of an emergency.

As indicated in Section 2.13 of NUREG/CR-6863, the estimated elapsed times for the receipt of notification can be expressed as a distribution reflecting the different notification times for different people within, and outside, the EPZ. By using time distributions, it is also possible to distinguish between different population groups and different day-of-week and time-of-day scenarios, so that accurate ETE may be computed.

For example, people at home or at work within the EPZ will be notified by siren, and/or tone alert and/or radio (if available). Those well outside the EPZ will be notified by telephone, radio, TV and word-of-mouth, with potentially longer time lags. Furthermore, the spatial distribution of the EPZ population will differ with time of day – families will be united in the evenings, but dispersed during the day. In this respect, weekends will differ from weekdays.

As indicated in Section 4.1 of NUREG/CR-7002, the information required to compute trip generation times is typically obtained from a telephone survey of EPZ residents. Such a survey was conducted in 2012 in support of a previous ETE study for this site. Appendix F discusses the survey sampling plan, documents the survey instrument utilized, and provides the survey results. The remaining discussion will focus on the application of the trip generation data obtained from the 2012 telephone survey to the development of the ETE documented in this report.

5.2 Fundamental Considerations

The environment leading up to the time that people begin their evacuation trips consists of a sequence of events and activities. Each event (other than the first) occurs at an instant in time and is the outcome of an activity.

Activities are undertaken over a period of time. Activities may be in "series" (i.e., to undertake an activity implies the completion of all preceding events) or may be in parallel (two or more activities may take place over the same period of time). Activities conducted in series are functionally dependent on the completion of prior activities; activities conducted in parallel are functionally independent of one another. The relevant events associated with the public's preparation for evacuation are:

<u>Event Number</u>	<u>Event Description</u>
1	Notification
2	Awareness of Situation
3	Depart Work
4	Arrive Home
5	Depart on Evacuation Trip

Associated with each sequence of events are one or more activities, as outlined below:

Table 5-1. Event Sequence for Evacuation Activities

Event Sequence	Activity	Distribution
1 → 2	Receive Notification	1
2 → 3	Prepare to Leave Work	2
2,3 → 4	Travel Home	3
2,4 → 5	Prepare to Leave to Evacuate	4

These relationships are shown graphically in Figure 5-1.

- An Event is a 'state' that exists at a point in time (e.g., depart work, arrive home)
- An Activity is a 'process' that takes place over some elapsed time (e.g., prepare to leave work, travel home)

As such, a completed Activity changes the 'state' of an individual (i.e., the activity, 'travel home' changes the state from 'depart work' to 'arrive home'). Therefore, an Activity can be described as an 'Event Sequence'; the elapsed times to perform an event sequence vary from one person to the next and are described as statistical distributions on the following pages.

An employee who lives outside the EPZ will follow sequence (c) of Figure 5-1. A household within the EPZ that has one or more commuters at work, and will await their return before beginning the evacuation trip will follow the first sequence of Figure 5-1(a). A household within the EPZ that has no commuters at work, or that will not await the return of any commuters, will follow the second sequence of Figure 5-1(a), regardless of day of week or time of day.

Households with no commuters on weekends or in the evening/night-time will follow the applicable sequence in Figure 5-1(b). Transients will always follow one of the sequences of Figure 5-1(b). Some transients away from their residence could elect to evacuate immediately without returning to the residence, as indicated in the second sequence.

It is seen from Figure 5-1, that the Trip Generation time (the total elapsed time from Event 1 to Event 5) depends on the scenario and will vary from one household to the next. Furthermore, Event 5 depends, in a complicated way, on the time distributions of all activities preceding that event. That is, to estimate the time distribution of Event 5, we must obtain estimates of the time distributions of all preceding events. For this study, we adopt the conservative posture that all activities will occur in sequence.

In some cases, assuming certain events occur strictly sequential (for instance, commuter returning home before beginning preparation to leave) can result in rather conservative (that is, longer) estimates of mobilization times. It is reasonable to expect that at least some parts of these events will overlap for many households, but that assumption is not made in this study.

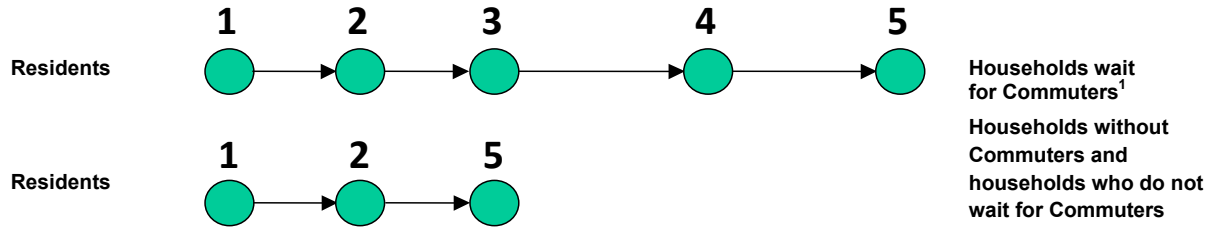

(a) Accident occurs during midweek, at midday; year round

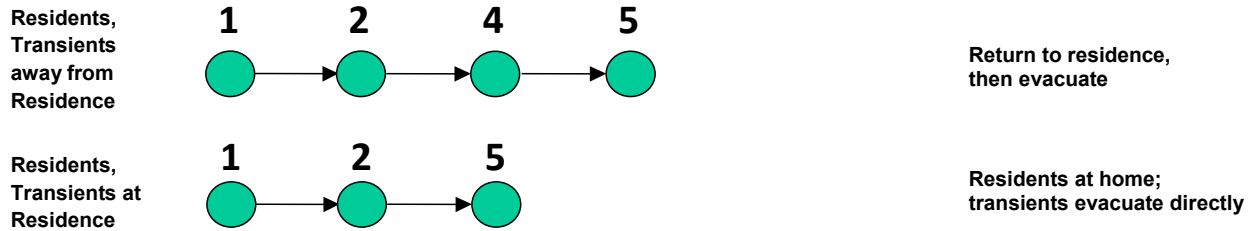

(b) Accident occurs during weekend or during the evening²

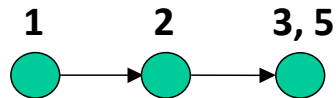

(c) Employees who live outside the EPZ

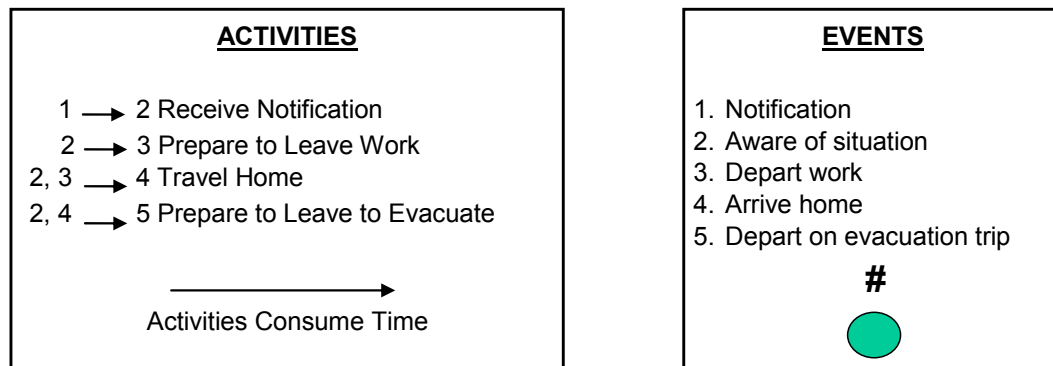

¹ Applies for evening and weekends also if commuters are at work.

² Applies throughout the year for transients.

Figure 5-1. Events and Activities Preceding the Evacuation Trip

5.3 Estimated Time Distributions of Activities Preceding Event 5

The time distribution of an event is obtained by "summing" the time distributions of all prior contributing activities. (This "summing" process is quite different than an algebraic sum since it is performed on distributions – not scalar numbers).

Time Distribution No. 1, Notification Process: Activity 1 → 2

Federal regulations (10CFR50 Appendix E, Item IV.D.3) stipulate, "[t]he design objective of the prompt public alert and notification system shall be to have the capability to essentially complete the initial alerting and initiate notification of the public within the plume exposure pathway EPZ within about 15 minutes". Furthermore, Item 2 of Section B in Appendix 3 of NUREG-0654/FEMA-REP-1 states that "special arrangements will be made to assure 100 percent coverage within 45 minutes of the population who may not have received the initial notification within the entire plume exposure EPZ".

Given the federal regulations and guidance, and the presence of sirens within the EPZ, it is assumed that 100 percent of the population in the EPZ can be notified within 45 minutes. The assumed distribution for notifying the EPZ population is provided in Table 5-2.

Table 5-2. Time Distribution for Notifying the Public

Elapsed Time (Minutes)	Percent of Population Notified
0	0.0%
5	7.1%
10	13.3%
15	26.5%
20	46.9%
25	66.3%
30	86.7%
35	91.8%
40	96.9%
45	100.0%

Distribution No. 2, Prepare to Leave Work: Activity 2 → 3

It is reasonable to expect that the vast majority of business enterprises within the EPZ will elect to shut down following notification and most employees would leave work quickly. Commuters, who work outside the EPZ could, in all probability, also leave quickly since facilities outside the EPZ would remain open and other personnel would remain. Personnel or farmers responsible for equipment/livestock would require additional time to secure their facility. The distribution of Activity 2 → 3 shown in Table 5-3 reflects data obtained by the telephone survey. This distribution is also applicable for residents to leave stores, restaurants, parks and other locations within the EPZ. This distribution is plotted in Figure 5-2.

Table 5-3. Time Distribution for Employees to Prepare to Leave Work

Elapsed Time (Minutes)	Cumulative Percent Employees Leaving Work
0	0.0%
5	42.9%
10	63.7%
15	75.4%
20	79.8%
25	80.6%
30	88.6%
35	89.2%
40	90.0%
45	92.2%
50	92.6%
55	92.6%
60	98.8%
75	99.2%
90	100.0%

NOTE: The survey data was normalized to distribute the "Don't know" response. That is, the sample was reduced in size to include only those households who responded to this question. The underlying assumption is that the distribution of this activity for the "Don't know" responders, if the event takes place, would be the same as those responders who provided estimates.

Distribution No. 3, Travel Home: Activity 3 → 4

These data are provided directly by those households which responded to the telephone survey. This distribution is plotted in Figure 5-2 and listed in Table 5-4.

Table 5-4. Time Distribution for Commuters to Travel Home

Elapsed Time (Minutes)	Cumulative Percent Returning Home
0	0.0%
5	9.0%
10	22.4%
15	34.6%
20	50.8%
25	57.4%
30	78.5%
35	80.9%
40	87.3%
45	94.0%
50	94.8%
55	94.8%
60	98.7%
75	99.8%
90	100.0%

NOTE: The survey data was normalized to distribute the "Don't know" response.

Distribution No. 4, Prepare to Leave Home: Activity 2, 4 → 5

These data are provided directly by those households which responded to the telephone survey. This distribution is plotted in Figure 5-2 and listed in Table 5-5.

Table 5-5. Time Distribution for Population to Prepare to Leave Home

Elapsed Time (Minutes)	Cumulative Percent Ready to Evacuate
0	0.0%
15	15.8%
30	56.4%
45	65.3%
60	79.8%
75	87.2%
90	88.7%
105	89.2%
120	93.7%
135	97.6%
150	98.0%
165	98.0%
180	98.7%
195	100.0%

NOTE: The survey data was normalized to distribute the "Don't know" response

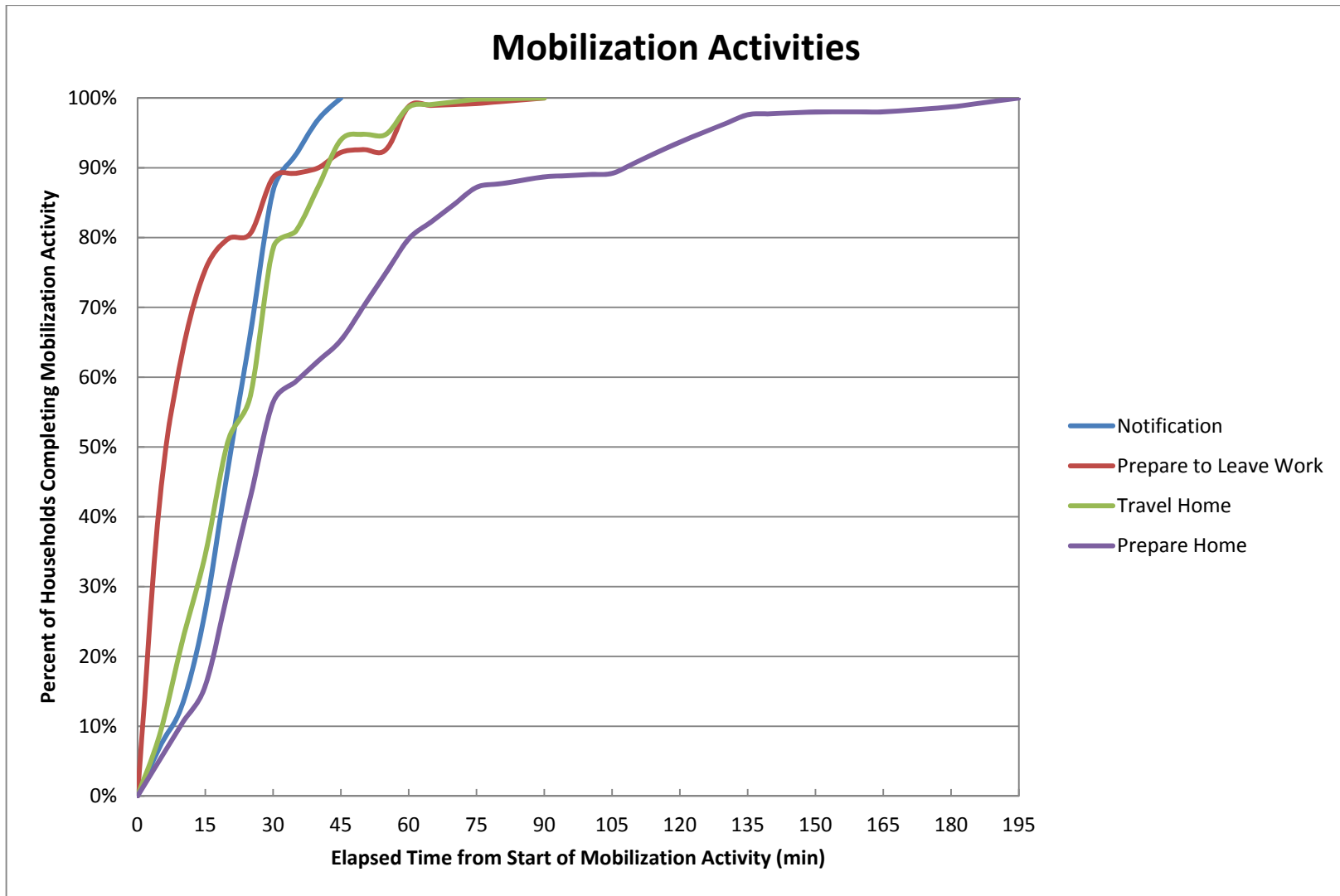

Figure 5-2. Evacuation Mobilization Activities

5.4 Calculation of Trip Generation Time Distribution

The time distributions for each of the mobilization activities presented herein must be combined to form the appropriate Trip Generation Distributions. As discussed above, this study assumes that the stated events take place in sequence such that all preceding events must be completed before the current event can occur. For example, if a household awaits the return of a commuter, the work-to-home trip (Activity 3 → 4) must precede Activity 4 → 5.

To calculate the time distribution of an event that is dependent on two sequential activities, it is necessary to “sum” the distributions associated with these prior activities. The distribution summing algorithm is applied repeatedly as shown to form the required distribution. As an outcome of this procedure, new time distributions are formed; we assign “letter” designations to these intermediate distributions to describe the procedure. Table 5-6 presents the summing procedure to arrive at each designated distribution.

Table 5-6. Mapping Distributions to Events

Apply “Summing” Algorithm To:	Distribution Obtained	Event Defined
Distributions 1 and 2	Distribution A	Event 3
Distributions A and 3	Distribution B	Event 4
Distributions B and 4	Distribution C	Event 5
Distributions 1 and 4	Distribution D	Event 5

Table 5-7 presents a description of each of the final trip generation distributions achieved after the summing process is completed.

Table 5-7. Description of the Distributions

Distribution	Description
A	Time distribution of commuters departing place of work (Event 3). Also applies to employees who work within the EPZ who live outside, and to Transients within the EPZ.
B	Time distribution of commuters arriving home (Event 4).
C	Time distribution of residents with commuters who return home, leaving home to begin the evacuation trip (Event 5).
D	Time distribution of residents without commuters returning home, leaving home to begin the evacuation trip (Event 5).

5.4.1 Statistical Outliers

As already mentioned, some portion of the survey respondents answer “don’t know” to some questions or choose to not respond to a question. The mobilization activity distributions are based upon actual responses. But, it is the nature of surveys that a few numeric responses are inconsistent with the overall pattern of results. An example would be a case in which for 500 responses, almost all of them estimate less than two hours for a given answer, but 3 say “four hours” and 4 say “six or more hours”.

These “outliers” must be considered: are they valid responses, or so atypical that they should be dropped from the sample?

In assessing outliers, there are three alternatives to consider:

- 1) Some responses with very long times may be valid, but reflect the reality that the respondent really needs to be classified in a different population subgroup, based upon special needs;
- 2) Other responses may be unrealistic (6 hours to return home from commuting distance, or 2 days to prepare the home for departure);
- 3) Some high values are representative and plausible, and one must not cut them as part of the consideration of outliers.

The issue of course is how to make the decision that a given response or set of responses are to be considered “outliers” for the component mobilization activities, using a method that objectively quantifies the process.

There is considerable statistical literature on the identification and treatment of outliers singly or in groups, much of which assumes the data is normally distributed and some of which uses non-parametric methods to avoid that assumption. The literature cites that limited work has been done directly on outliers in sample survey responses.

In establishing the overall mobilization time/trip generation distributions, the following principles are used:

- 1) It is recognized that the overall trip generation distributions are conservative estimates, because they assume a household will do the mobilization activities sequentially, with no overlap of activities;
- 2) The individual mobilization activities (prepare to leave work, travel home, prepare home) are reviewed for outliers, and then the overall trip generation distributions are created (see Figure 5-1, Table 5-6, Table 5-7);
- 3) Outliers can be eliminated either because the response reflects a special population (e.g. special needs, transit dependent) or lack of realism, because the purpose is to estimate trip generation patterns for personal vehicles;

- 4) To eliminate outliers,
 - a) the mean and standard deviation of the specific activity are estimated from the responses,
 - b) the median of the same data is estimated, with its position relative to the mean noted,
 - c) the histogram of the data is inspected, and
 - d) all values greater than 3.5 standard deviations are flagged for attention, taking special note of whether there are gaps (categories with zero entries) in the histogram display.

In general, only flagged values more than 4 standard deviations from the mean are allowed to be considered outliers, with gaps in the histogram expected.

When flagged values are classified as outliers and dropped, steps “a” to “d” are repeated.

- 5) As a practical matter, even with outliers eliminated by the above, the resultant histogram, viewed as a cumulative distribution, is not a normal distribution. A typical situation that results is shown below in Figure 5-3.

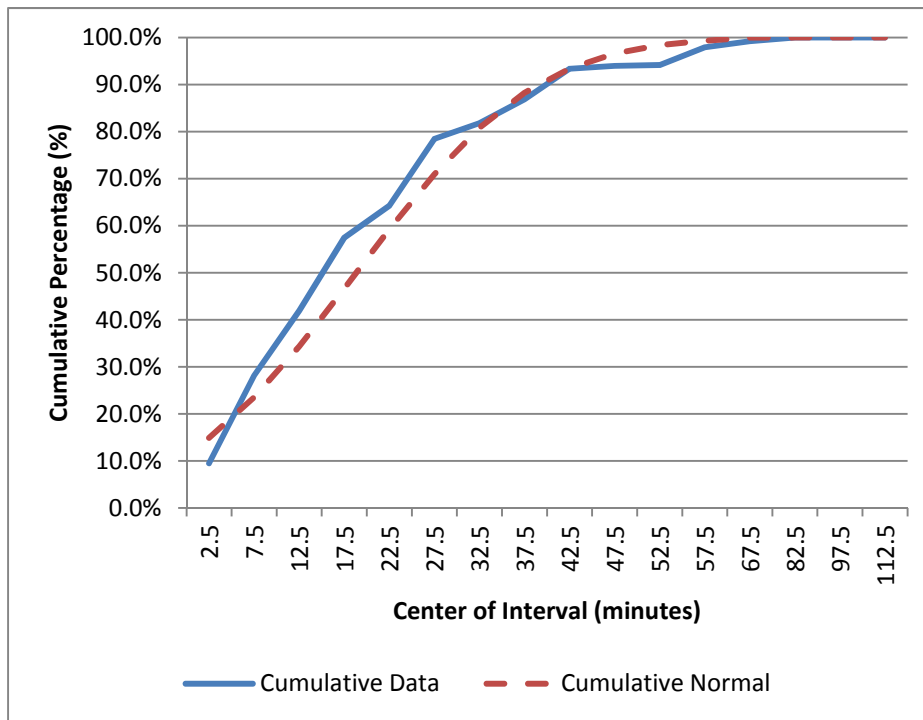

Figure 5-3. Comparison of Data Distribution and Normal Distribution

- 6) In particular, the cumulative distribution differs from the normal distribution in two key aspects, both very important in loading a network to estimate evacuation times:
- Most of the real data is to the left of the “normal” curve above, indicating that the network loads faster for the first 80-85 percent of the vehicles, potentially causing more (and earlier) congestion than otherwise modeled;
 - The last 10-15 percent of the real data “tails off” slower than the comparable “normal” curve, indicating that there is significant traffic still loading at later times.

Because these two features are important to preserve, it is the histogram of the data that is used to describe the mobilization activities, not a “normal” curve fit to the data. One could consider other distributions, but using the shape of the *actual* data curve is unambiguous and preserves these important features;

- 7) With the mobilization activities each modeled according to Steps 1-6, including preserving the features cited in Step 6, the overall (or total) mobilization times are constructed.

This is done by using the data sets and distributions under different scenarios (e.g., commuter returning, no commuter returning in each). In general, these are additive, using weighting based upon the probability distributions of each element; Figure 5-4 presents the combined trip generation distributions for each population group considered. These distributions are presented on the same time scale. (As discussed earlier, the use of strictly additive activities is a conservative approach, because it makes all activities sequential – preparation for departure follows the return of the commuter, and so forth. In practice, it is reasonable that some of these activities are done in parallel, at least to some extent – for instance, preparation to depart begins by a household member at home while the commuter is still on the road.)

The mobilization distributions that result are used in their tabular/graphical form as direct inputs to later computations that lead to the ETE.

The DYNEV II simulation model is designed to accept varying rates of vehicle trip generation for each origin centroid, expressed in the form of histograms. These histograms, which represent Distributions A, C and D, properly displaced with respect to one another, are tabulated in Table 5-8 (Distribution B, Arrive Home, omitted for clarity).

The final time period (15) is 600 minutes long. This time period is added to allow the analysis network to clear, in the event congestion persists beyond the trip generation period. Note that there are no trips generated during this final time period.

5.4.2 Staged Evacuation Trip Generation

As defined in NUREG/CR-7002, staged evacuation consists of the following:

1. Zones comprising the 2 mile region are advised to evacuate immediately
2. Zones comprising regions extending from 2 to 5 miles downwind are advised to shelter in-place while the 2 mile region is cleared
3. As vehicles evacuate the 2 mile region, sheltered people from 2 to 5 miles downwind continue preparation for evacuation
4. The population sheltering in the 2 to 5 mile region are advised to begin evacuating when approximately 90 percent of those originally within the 2 mile region evacuate across the 2 mile region boundary
5. Non-compliance with the shelter recommendation is the same as the shadow evacuation percentage of 20 percent

Assumptions

1. The EPZ population in Zones beyond 5 miles will shelter in place, with the exception of the 20 percent non-compliance.
2. The population in the Shadow Region beyond the EPZ boundary, extending to approximately 15 miles radially from the plant, will react as they do for all non-staged evacuation scenarios. That is 20 percent of these households will elect to evacuate with no shelter delay.
3. The transient population will not be expected to stage their evacuation because of the limited sheltering options available to people who may be at parks, on a beach, or at other venues. Also, notifying the transient population of a staged evacuation would prove difficult.
4. Employees will also be assumed to evacuate without first sheltering.

Procedure

1. Trip generation for population groups in the 2 mile region will be as computed based upon the results of the telephone survey and analysis.
2. Trip generation for the population subject to staged evacuation will be formulated as follows:
 - a. Identify the 90th percentile evacuation time for the Zones comprising the 2 mile region. This value, T_{Scen}^* , is obtained from simulation results. It will become the time at which the region being sheltered will be told to evacuate for each scenario.
 - b. The resultant trip generation curves for staging are then formed as follows:
 - i. The non-shelter trip generation curve is followed until a maximum of 20 percent of the total trips are generated (to account for shelter non-compliance).

- ii. No additional trips are generated until time T_{Scen}^*
 - iii. Following time T_{Scen}^* , the balance of trips are generated:
 - 1. by stepping up and then following the non-shelter trip generation curve (if T_{Scen}^* is \leq max trip generation time) or
 - 2. by stepping up to 100 percent (if T_{Scen}^* is $>$ max trip generation time)
 - c. Note: This procedure implies that there may be different staged trip generation distributions for different scenarios, however, that was not the case for this site. NUREG/CR-7002 uses the statement “approximately 90th percentile” as the time to end staging and begin evacuating. The value of T_{Scen}^* is about 1:00 for all scenarios (see Region R01 in Table 7-1).
 - d. Note: Since approximately 90 percent of the 2 mile region (Zone A) is comprised of employees and transients, the T_{Scen}^* value of 1:00 is dictated by the trip generation of these population groups as opposed to the trip generation of residents.
3. Staged trip generation distributions are created for the following population groups:
- a. Residents with returning commuters
 - b. Residents without returning commuters

Table 5-8 presents the staged trip generation distributions for both residents with and without returning commuters and employees/transients. At T_{Scen}^* , 20 percent of the resident population (who normally would have completed their mobilization activities for an un-staged evacuation) advised to shelter has nevertheless departed the area. These people do not comply with the shelter advisory. Also included on the plot are the trip generation distributions for these groups as applied to the regions advised to evacuate immediately.

Since the 90th percentile evacuation time occurs before the end of the trip generation time, after the sheltered region is advised to evacuate, the shelter trip generation distribution rises to meet the balance of the non-staged trip generation distribution. Following time T_{Scen}^* , the balance of staged evacuation trips that are ready to depart are released within 15 minutes. After $T_{Scen}^* + 15$, the remainder of evacuation trips are generated in accordance with the un-staged trip generation distribution.

Table 5-9 provides the trip generation histograms for staged evacuation.

5.4.3 Trip Generation for Waterways and Recreational Areas

Appendix 2 to Annex G of the North Carolina Radiological Emergency Response Plan (September 2015) establishes the basic procedures and organizational responsibilities for the emergency alert and notification on Harris and Jordan Lakes, the Haw, Deep and Cape Fear Rivers in addition to associated recreational sites, surrounding areas and other facilities within the 10-mile EPZ. Individuals on Jordan Lake, Upper Cape Fear, Deep and Haw Rivers will be notified by the Chatham County Emergency Management Office, assisted by the following organizations:

- 1. Moncure Fire Department

2. NC Wildlife Resources Commission
3. NC Department of Environment and Natural Resources (DENR), from the Division of Parks and Recreation & Division of Forest Resources
4. United States Army Corps of Engineers (USACE) from the B. Everett Jordan Lake and Dam field office
5. NC Highway Patrol from the Communications and Logistics Section and Special Operations/Aviation Unit.

Individuals on Harris Lake will be notified by the Wake County Department of Public Safety, Division of Emergency Management, assisted by the following organizations:

1. Wake County Sheriff's Department
2. NC Highway Patrol, from the Communications and Logistics Section and Special Operations/Aviation Unit of the
3. Chatham County Emergency Management Office
4. NC Wildlife Resources Commission, from the Division of Enforcement.

Individuals on the Lower Cape Fear River will be notified by Harnett County Emergency Management, assisted by the following organizations¹:

1. NC Highway Patrol, from the Communications and Logistics Section and Special Operations/Aviation Unit of the
2. NC DENR, Division of Parks and Recreation & Division of Forest Resources
3. Northwest Harnett Volunteer Fire Department
4. Summerville Volunteer Fire Department.

As indicated in Table 5-2, this study assumes 100 percent notification in 45 minutes which is consistent with the FEMA REP Manual. Table 5-8 indicates that all transients will have mobilized within 1 hour 45 minutes. It is assumed that this timeframe is sufficient time for boaters, campers and other transients to return to their vehicles or lodging facilities and begin their evacuation trip.

¹ DENR, Northwest Harnett Volunteer Department and Summerville Volunteer Fire Department are backup alert and notification agencies to be activated for this area if State Highway Patrol (SHP) Aviation assets are unavailable or individuals identified by SHP do not leave the area when advised.

Table 5-8. Trip Generation Histograms for the EPZ Population for Un-staged Evacuation

Time Period	Duration (Min)	Percent of Total Trips Generated Within Indicated Time Period			
		Employees (Distribution A)	Transients (Distribution A)	Residents with Commuters (Distribution C)	Residents Without Commuters (Distribution D)
1	15	7%	7%	0%	1%
2	15	35%	35%	0%	9%
3	15	34%	34%	2%	24%
4	15	13%	13%	8%	24%
5	15	5%	5%	15%	14%
6	15	4%	4%	18%	10%
7	15	2%	2%	15%	5%
8	15	0%	0%	13%	2%
9	15	0%	0%	8%	3%
10	30	0%	0%	10%	5%
11	30	0%	0%	6%	1%
12	30	0%	0%	3%	2%
13	15	0%	0%	1%	0%
14	30	0%	0%	1%	0%
15	600	0%	0%	0%	0%

NOTE:

- Shadow vehicles are loaded onto the analysis network (Figure 1-2) using Distribution C for good weather.
- Special event vehicles are loaded using Distribution A.

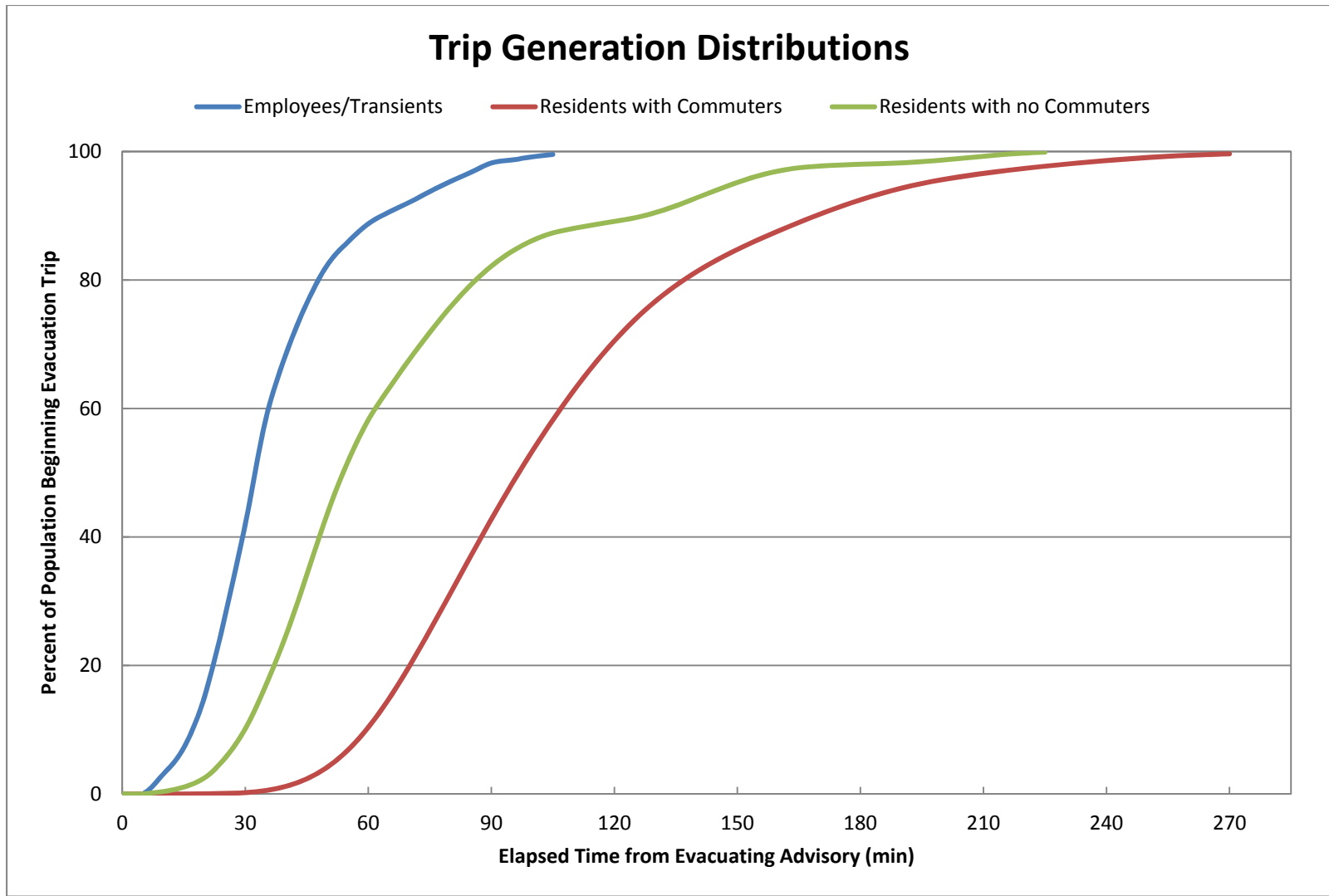

Figure 5-4. Comparison of Trip Generation Distributions

Table 5-9. Trip Generation Histograms for the EPZ Population for Staged Evacuation

Time Period	Duration (Min)	Percent of Total Trips Generated Within Indicated Time Period*	
		Residents with Commuters (Distribution C)	Residents Without Commuters (Distribution D)
1	15	0%	0%
2	15	0%	2%
3	15	0%	5%
4	15	2%	5%
5	15	23%	60%
6	15	18%	10%
7	15	15%	5%
8	15	13%	2%
9	15	8%	3%
10	30	10%	5%
11	30	6%	1%
12	30	3%	2%
13	15	1%	0%
14	30	1%	0%
15	600	0%	0%

*Trip Generation for Employees and Transients (see Table 5-8) is the same for Un-staged and Staged Evacuation.

Staged and Un-staged Evacuation Trip Generation

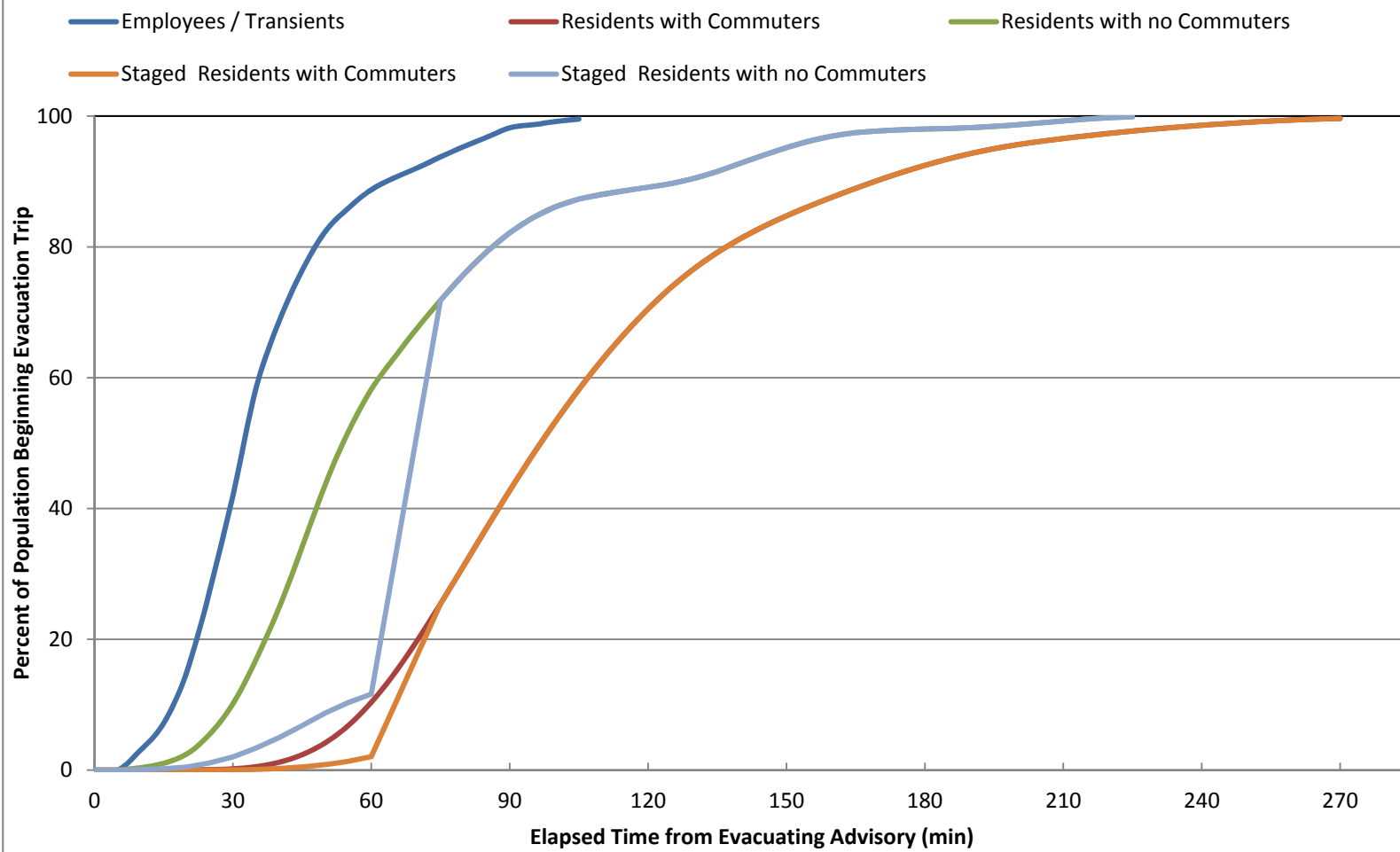

Figure 5-5. Comparison of Staged and Un-staged Trip Generation Distributions in the 2 to 5 Mile Region

6 DEMAND ESTIMATION FOR EVACUATION SCENARIOS

An evacuation “case” defines a combination of Evacuation Region and Evacuation Scenario. The definitions of “Region” and “Scenario” are as follows:

- Region** A grouping of contiguous evacuating Zones that forms either a “keyhole” sector-based area, or a circular area within the EPZ, that must be evacuated in response to a radiological emergency.
- Scenario** A combination of circumstances, including time of day, day of week, season, and weather conditions. Scenarios define the number of people in each of the affected population groups and their respective mobilization time distributions.

A description of each scenario is provided below:

1. **Summer Midweek Midday (normal):** This scenario represents a typical normal weather daytime period when permanent residents are generally dispersed within the EPZ performing daily activities and major work places are at typical daytime levels. This scenario includes assumptions that permanent residents will evacuate from their place of residence; summer school is in session; hotel and motel facilities are occupied at average summer levels; and recreational facilities are at average summer daytime levels.
2. **Summer Midweek Midday (adverse):** This scenario represents an adverse weather daytime period when permanent residents are generally dispersed within the EPZ performing daily activities and major work places are at typical daytime levels. This scenario includes assumptions that permanent residents will evacuate from their place of residence; summer schools are in session; hotel and motel facilities are occupied at average summer levels; and recreational facilities are at average summer daytime levels.
3. **Summer Weekend Midday (normal):** This scenario represents a typical normal weather weekend period when permanent residents are both at home and dispersed within the EPZ performing typical summer weekend activities. This scenario includes assumptions that permanent residents will evacuate from their place of residence; schools are closed and students are at home or with their families; work places are staffed at typical weekend levels; hotel and motel facilities are occupied at average summer weekend levels; and recreational facilities are at average summer weekend levels.
4. **Summer Weekend Midday (adverse):** This scenario represents an adverse (rain) weather weekend period when permanent residents are both at home and dispersed within the EPZ performing typical summer weekend activities. This scenario includes assumptions that permanent residents will evacuate from their place of residence; schools are closed and students are at home or with their families; work places are staffed at typical weekend levels; hotel and motel facilities are occupied at average

summer weekend levels; and recreational facilities are at average summer weekend levels.

5. **Summer Midweek and Weekend Evening (normal):** This scenario represents a typical normal weather midweek and weekend evening period when permanent residents are generally at home with fewer dispersed within the EPZ performing evening activities. This scenario includes assumptions that permanent residents will evacuate from their place of residence; schools are closed and students are at home; work places are staffed at typical evening levels; hotel and motel facilities are occupied at average summer levels; and recreational facilities are at average summer evening levels. External traffic is reduced.
6. **Winter Midweek Midday (normal):** This scenario represents a typical normal weather weekday period during the winter when school is in session and the work force is at a full daytime level. This scenario includes assumptions that permanent residents will evacuate from their place of residence; students will evacuate directly from the schools; work places are fully staffed at typical daytime levels; hotel and motel facilities are occupied at average winter levels; and recreational facilities are at winter daytime levels.
7. **Winter Midweek Midday (adverse):** This scenario represents an adverse (rain) weather weekday period during the winter when school is in session and the work force is at a full daytime level. This scenario includes assumptions that permanent residents will evacuate from their place of residence; students will evacuate directly from the schools; work places are fully staffed at typical daytime levels; hotel and motel facilities are occupied at average winter levels; and recreational facilities are at winter daytime levels.
8. **Winter Midweek Midday (adverse):** This scenario represents an adverse (ice) weather weekday period during the winter when school is in session and the work force is at a full daytime level. This scenario includes assumptions that permanent residents will evacuate from their place of residence; students will evacuate directly from the schools; work places are fully staffed at typical daytime levels; hotel and motel facilities are occupied at average winter levels; and recreational facilities are at winter daytime levels.
9. **Winter Weekend Midday (normal):** This scenario reflects a typical normal weather winter weekend period when permanent residents are both at home and dispersed within the EPZ, and the work force is at a weekend level. This scenario includes assumptions that permanent residents will evacuate from their place of residence; schools are closed and students are at home; work places are staffed at typical weekend levels; hotel and motel facilities are occupied at average winter weekend levels and recreational facilities are at winter weekend levels.
10. **Winter Weekend Midday (adverse):** This scenario reflects an adverse (rain) weather winter weekend period when permanent residents are both at home and dispersed within the EPZ, and the work force is at a weekend level. This scenario includes assumptions that permanent residents will evacuate from their place of residence;

schools are closed and students are at home; work places are staffed at typical weekend levels; hotel and motel facilities are occupied at average winter weekend levels and recreational facilities are at winter weekend levels.

11. **Winter Weekend Midday (adverse):** This scenario reflects an adverse (ice) weather winter weekend period when permanent residents are both at home and dispersed within the EPZ, and the work force is at a weekend level. This scenario includes assumptions that permanent residents will evacuate from their place of residence; schools are closed and students are at home; work places are staffed at typical weekend levels; hotel and motel facilities are occupied at average winter weekend levels and recreational facilities are at winter weekend levels.
12. **Winter Midweek and Weekend Evening (normal):** This scenario reflects a typical normal midweek and weekend evening period when permanent residents are home and the work force is at a nighttime level. This scenario includes assumptions that permanent residents will evacuate from their place of residence; schools are closed and students are at home; work places are staffed at typical nighttime levels; hotel and motel facilities are occupied at average winter levels; and recreational facilities are at winter evening levels.
13. **Special Event, Summer Weekend Evening (normal):** This scenario reflects a special event activity where peak tourist populations are present within the EPZ. Assumptions made are indicated in Section 3.7. The population attending the event is developed considering both transients and permanent EPZ residents who are in attendance to avoid double-counting residents. The remaining permanent resident percentage, those not attending the event, will be assumed to evacuate from their residence. Work places will be staffed at typical levels; hotel and motel facilities are occupied at peak special event levels; and recreational facilities are at appropriate levels based on the event and time of year.
14. **Roadway Impact, Summer Midweek Midday (normal):** The intent of this scenario is to represent a variety of conditions that may impact a roadway segment such as construction, flooding, vehicle accidents, etc. The roadway impact scenario assumed that during a summer midweek normal weather daytime scenario, one lane was closed on US-1 northbound from just east of the interchange with New Hill Holleman Rd (Exit 89) to the interchange with I-40 (Exit 1A) and one lane was closed eastbound on US-64 from New Hill Olive Chapel Rd/NC-751 to the interchange with US-1(exit 404A/B).

A total of 37 Regions were defined which encompass all the groupings of Zones considered. These Regions are defined in Table 6-1. The Zone configurations are identified in Figure 6-1. Each keyhole sector-based area consists of a central circle centered at the power plant, and three adjoining sectors, each with a central angle of 22.5 degrees, as per NUREG/CR-7002 guidance. The central sector coincides with the wind direction. These sectors extend to 5 miles from the plant (Regions R04 through R12) or to the EPZ boundary (Regions R13 through R27). Regions R01, R02 and R03 represent evacuations of circular areas with radii of 2, 5 and 10 miles,

respectively. Regions R28 through R36 are identical to Regions R02 and R04 through R12, respectively; however, those Zones between 2 miles and 5 miles are staged until 90% of the 2-mile region (Region R01) has evacuated.

Each Zone that intersects the keyhole is included in the Region; however, there are instances when a small portion (a “sliver”) of a Zone is within the keyhole and the population within that small portion is low (500 people or 10% of the Zone population, whichever is less). Under those circumstances, the Zone would not be included in the Region so as to not evacuate large numbers of people outside of the keyhole for a small number of people that are actually in the keyhole. For example, in Region R26, there is a very small area (0.2 square miles) of Zone F within the keyhole. There are 10 homes and approximately 30 people within the small area of Zone F within the keyhole, versus approximately 30,000 residents living in all of Zone F. Zone F is not included in Region R26 because there are 30 people, or 0.1% of the Zone population, within the keyhole. It would not be prudent to evacuate 29,970 people that are not within the keyhole because 30 people are within the keyhole. Similarly, in Region R12, there are small areas of Zones C and K within the keyhole that do not meet the aforementioned population criteria, and these Zones are not included in the Region. Also, the small area of Zone I in Region R27 does not meet the population criteria and is not included in the Region.

A total of 14 Scenarios were evaluated for all Regions. Thus, there are a total of $37 \times 14 = 518$ evacuation cases. Table 6-2 provides a description of all Scenarios.

Each combination of region and scenario implies a specific population to be evacuated. The population and vehicle estimates presented in Section 3 and in Appendix E are peak values. These peak values are adjusted depending on the scenario and region being considered, using scenario and region specific percentages, such that the average population is considered for each evacuation case. The scenario percentages are presented in Table 6-3, while the regional percentages are provided in Table H-1. The percentages presented in Table 6-3 were determined as follows:

The number of residents with commuters during the week (when workforce is at its peak) is equal to 28%, which is the product of 68% (the number of households with at least one commuter) and 41% (the number of households with a commuter that would await the return of the commuter prior to evacuating). See assumption 18 in Section 2.3. It is estimated for weekend and evening scenarios that 10% of households with returning commuters will have a commuter at work during those times.

Employment is assumed to be at its peak (100%) during the winter, midweek, midday scenarios. Employment is reduced slightly (96%) for summer, midweek, midday scenarios. This is based on the estimation that 50% of the employees commuting into the EPZ will be on vacation for a week during the approximate 12 weeks of summer. It is further estimated that those taking vacation will be uniformly dispersed throughout the summer with approximately 4% of employees vacationing each week. It is further estimated that only 10% of the employees are working in the evenings and during the weekends.

Transient activity is estimated to be at its peak (100%) during summer weekends and less (65%) during the week. As shown in Appendix E, there are many campgrounds and lodging facilities offering overnight accommodations in the EPZ, offset by other transient facilities in which evening use is minimal (parks and community centers); thus, evening transient activity is estimated to be 50% for summer and 20% for winter. Transient activity on winter weekends is estimated to be 40% and less (25%) during the week.

As noted in the shadow footnote to Table 6-3, the shadow percentages are computed using a base of 20% (see assumption 2 in Section 2.2); to include the employees within the Shadow Region who may choose to evacuate, the voluntary evacuation is multiplied by a scenario-specific proportion of employees to permanent residents in the Shadow Region. For example, using the values provided in Table 6-4 for Scenario 6, the shadow percentage is computed as follows:

$$20\% \times \left(1 + \frac{14,520}{18,044 + 46,685} \right) = 24\%$$

One special event – Fourth of July on Jordan Lake – was considered as Scenario 13. Thus, the special event traffic is 100% evacuated for Scenario 13, and 0% for all other scenarios.

Based on 2012 data provided by county emergency management agencies, summer school enrollment is approximately 28% of enrollment during the regular school year for midweek, midday scenarios. School is not in session during weekends and evenings, thus no buses for school children are needed under those circumstances. As discussed in Section 7, schools are in session during the winter season, midweek, midday and 100% of buses will be needed under those circumstances.

Transit buses for the transit-dependent population are set to 100% for all scenarios as it is assumed that the transit-dependent population is present in the EPZ at all times.

External traffic is estimated to be reduced by 60% during evening scenarios and is 100% for all other scenarios.

Table 6-1. Description of Evacuation Regions

Region	Description	Site PAR Description	Zone													
			A	B	C	D	E	F	G	H	I	J	K	L	M	N
R01	2-Mile Radius	2-Mile Radius	X													
R02	5-Mile Radius	5-Mile Radius	X	X	X	X						X	X			
R03	Full EPZ	10-Mile Radius	X	X	X	X	X	X	X	X	X	X	X	X	X	X
Evacuate 2-Mile Radius and Downwind to 5 Miles																
Region	Wind Direction From:	Site PAR Description	Zone													
			A	B	C	D	E	F	G	H	I	J	K	L	M	N
R04	NNW, N	327° - 010°	X			X							X			
R05	NNE, NE	011° - 056°	X										X			
R06	ENE, E, ESE	057° - 124°	X										X	X		
R07	SE, SSE, S	125° - 191°	X	X										X		
R08	SSW	192° - 214°	X	X												
R09	SW, WSW	215° - 259°	X	X	X											
R10	Site Specific Region*		X		X											
R11	W, WNW	260° - 304°	X		X	X										
R12	NW	305° - 326°	X			X										
Evacuate 2-Mile Radius and Downwind to the EPZ Boundary																
Region	Wind Direction From:	Site PAR Description	Zone													
			A	B	C	D	E	F	G	H	I	J	K	L	M	N
R13	N	348° - 010°	X			X				X	X		X			
R14	NNE	011° - 034°	X							X	X	X	X			
R15	NE	035° - 056°	X								X	X	X		X	
R16	ENE	057° - 079°	X								X	X	X	X	X	
R17	E	080° - 101°	X									X	X	X	X	
R18	ESE	102° - 124°	X									X	X	X	X	X
R19	SE	125° - 146°	X	X										X	X	X
R20	SSE, S	147° - 191°	X	X			X							X	X	X
R21	SSW	192° - 214°	X	X			X							X		X
R22	SW	215° - 236°	X	X	X		X	X								
R23	WSW	237° - 259°	X	X	X		X	X	X							
R24	W	260° - 281°	X	X	X	X	X	X	X							
R25	WNW	282° - 304°	X		X	X		X	X	X						
R26	NW	305° - 326°	X		X	X			X	X			X			
R27	NNW	327° - 347°	X			X			X	X			X			
Staged Evacuation - 2-Mile Radius Evacuates, then Evacuate Downwind to 5 Miles																
Region	Wind Direction From:	Site PAR Description	Zone													
			A	B	C	D	E	F	G	H	I	J	K	L	M	N
R28	-	5-Mile Radius	X	X	X	X							X	X		
R29	NNW, N	327° - 010°	X			X							X			
R30	NNE, NE	011° - 056°	X										X			
R31	ENE, E, ESE	057° - 124°	X										X	X		
R32	SE, SSE, S	125° - 191°	X	X										X		
R33	SSW	192° - 214°	X	X												
R34	SW, WSW	215° - 259°	X	X	X											
R35	Site Specific Region*		X		X											
R36	W, WNW	260° - 304°	X		X	X										
R37	NW	305° - 326°	X			X										
Shelter-in-Place until 90% ETE for R01, then Evacuate			Zone(s) Shelter-in-Place							Zone(s) Evacuate						

*Region does not follow three-sector keyhole approach and is not used in PAR.

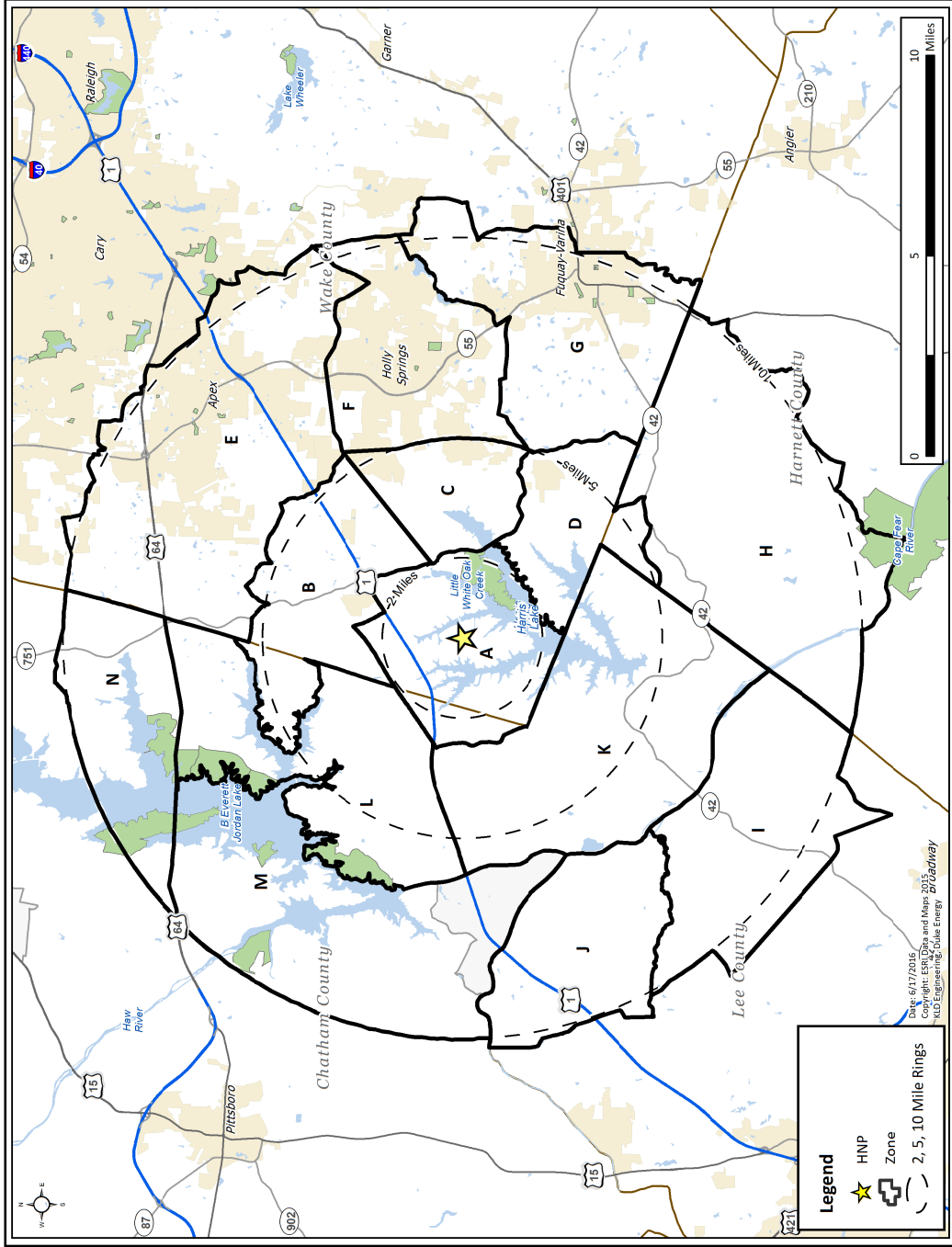

Figure 6-1. HNP EPZ Zones

Table 6-2. Evacuation Scenario Definitions

Scenario	Season ¹	Day of Week	Time of Day	Weather	Special
1	Summer	Midweek	Midday	Good	None
2	Summer	Midweek	Midday	Rain	None
3	Summer	Weekend	Midday	Good	None
4	Summer	Weekend	Midday	Rain	None
5	Summer	Midweek, Weekend	Evening	Good	None
6	Winter	Midweek	Midday	Good	None
7	Winter	Midweek	Midday	Rain	None
8	Winter	Midweek	Midday	Ice	None
9	Winter	Weekend	Midday	Good	None
10	Winter	Weekend	Midday	Rain	None
11	Winter	Weekend	Midday	Ice	None
12	Winter	Midweek, Weekend	Evening	Good	None
13	Summer	Weekend	Evening	Good	Fourth of July on Jordan Lake
14	Summer	Midweek	Midday	Good	Roadway Impact – Lane Closures on US-1 and US-64

¹ Winter means that school is in session at normal enrollment levels (also applies to spring and autumn). Summer means that school is in session at summer school enrollment levels (lower than normal enrollment).

Table 6-3. Percent of Population Groups Evacuating for Various Scenarios

Scenario	Households With Returning Commuters	Households Without Returning Commuters	Employees	Transients	Shadow	Special Event	School Buses	Transit Buses	External Through Traffic
1	28%	72%	96%	65%	24%	0%	28%	100%	100%
2	28%	72%	96%	65%	24%	0%	28%	100%	100%
3	3%	97%	10%	100%	20%	0%	0%	100%	100%
4	3%	97%	10%	100%	20%	0%	0%	100%	100%
5	3%	97%	10%	50%	20%	0%	0%	100%	40%
6	28%	72%	100%	25%	24%	0%	100%	100%	100%
7	28%	72%	100%	25%	24%	0%	100%	100%	100%
8	28%	72%	100%	25%	24%	0%	100%	100%	100%
9	3%	97%	10%	40%	20%	0%	0%	100%	100%
10	3%	97%	10%	40%	20%	0%	0%	100%	100%
11	3%	97%	10%	40%	20%	0%	0%	100%	100%
12	3%	97%	10%	20%	20%	0%	0%	100%	40%
13	3%	97%	10%	50%	20%	100%	0%	100%	40%
14	28%	72%	96%	65%	24%	0%	28%	100%	100%

Resident Households with CommutersHouseholds of EPZ residents who await the return of commuters prior to beginning the evacuation trip.

Resident Households with No Commuters ..Households of EPZ residents who do not have commuters or will not await the return of commuters prior to beginning the evacuation trip.

EmployeesEPZ employees who live outside the EPZ

TransientsPeople who are in the EPZ at the time of an accident for recreational or other (non-employment) purposes.

Shadow.....Residents and employees in the shadow region (outside of the EPZ) who will spontaneously decide to relocate during the evacuation. The basis for the values shown is a 20% relocation of shadow residents along with a proportional percentage of shadow employees.

Special Event.....Additional vehicles in the EPZ due to the identified special event.

School and Transit BusesVehicle-equivalents present on the road during evacuation servicing schools and transit-dependent people (1 bus is equivalent to 2 passenger vehicles).

External Through TrafficTraffic on interstates/freeways and major arterial roads at the start of the evacuation. This traffic is stopped by security road blocks 30 minutes after the evacuation begins.

Table 6-4. Vehicle Estimates by Scenario

Scenario	Households With Returning Commuters	Households Without Returning Commuters	Employees	Transients	Shadow	Special Event	School Buses	Transit Buses	External Through Traffic	Total Scenario Vehicles
1	18,044	46,685	13,939	2,850	29,023	-	302	294	7,622	118,759
2	18,044	46,685	13,939	2,850	29,023	-	302	294	7,622	118,759
3	1,804	62,925	1,452	4,384	24,416	-	-	294	7,622	102,897
4	1,804	62,925	1,452	4,384	24,416	-	-	294	7,622	102,897
5	1,804	62,925	1,452	2,192	24,416	-	-	294	3,049	96,132
6	18,044	46,685	14,520	1,096	29,237	-	1,080	294	7,622	118,578
7	18,044	46,685	14,520	1,096	29,237	-	1,080	294	7,622	118,578
8	18,044	46,685	14,520	1,096	29,237	-	1,080	294	7,622	118,578
9	1,804	62,925	1,452	1,754	24,416	-	-	294	7,622	100,267
10	1,804	62,925	1,452	1,754	24,416	-	-	294	7,622	100,267
11	1,804	62,925	1,452	1,754	24,416	-	-	294	7,622	100,267
12	1,804	62,925	1,452	877	24,416	-	-	294	3,049	94,817
13	1,804	62,925	1,452	2,192	24,416	2,562	-	294	3,049	98,694
14	18,044	46,685	13,939	2,850	29,023	-	302	294	7,622	118,759

Note: Vehicle estimates are for an evacuation of the entire EPZ (Region R03)

7 GENERAL POPULATION EVACUATION TIME ESTIMATES (ETE)

This section presents the ETE results of the computer analyses using the DYNEV II System described in Appendices B, C and D. These results cover 37 regions within the HNP EPZ and the 14 Evacuation Scenarios discussed in Section 6.

The ETE for all Evacuation Cases are presented in Table 7-1 and Table 7-2. These tables present the estimated times to clear the indicated population percentages from the Evacuation Regions for all Evacuation Scenarios. The ETE of the 2-Mile region in both staged and un-staged regions are presented in Table 7-3 and Table 7-4. Table 7-5 defines the Evacuation Regions considered. The tabulated values of ETE are obtained from the DYNEV II System outputs which are generated at 5-minute intervals.

7.1 Voluntary Evacuation and Shadow Evacuation

“Voluntary evacuees” are people within the EPZ in Zones for which an Advisory to Evacuate (ATE) has not been issued, yet who elect to evacuate. “Shadow evacuation” is the voluntary outward movement of some people from the Shadow Region (outside the EPZ) for whom no protective action recommendation has been issued. Both voluntary and shadow evacuations are assumed to take place over the same time frame as the evacuation from within the impacted Evacuation Region.

The ETE for the HNP EPZ addresses the issue of voluntary evacuees in the manner shown in Figure 7-1. Within the EPZ, 20 percent of permanent residents located in Zones outside of the evacuation region who are not advised to evacuate, are assumed to elect to evacuate. Similarly, it is assumed that 20 percent of those permanent residents in the Shadow Region will choose to leave the area.

Figure 7-2 presents the area identified as the Shadow Region. This region extends radially from the plant to cover a region between the EPZ boundary and approximately 15 miles. The population and number of evacuating vehicles in the Shadow Region were estimated using the same methodology that was used for permanent residents within the EPZ (see Section 3.1). As discussed in Section 3.2, it is estimated that a total of 119,403 people reside in the Shadow Region; 20 percent of them would evacuate. See Table 6-4 for the number of evacuating vehicles from the Shadow Region.

Traffic generated within this Shadow Region (including external-external traffic), traveling away from the HNP location, has the potential for impeding evacuating vehicles from within the Evacuation Region. All ETE calculations include this shadow traffic movement.

7.2 Staged Evacuation

As defined in NUREG/CR-7002, staged evacuation consists of the following:

1. Zones comprising the 2 mile region are advised to evacuate immediately.

2. Zones comprising regions extending from 2 to 5 miles downwind are advised to shelter in-place while the 2 mile region is cleared.
3. As vehicles evacuate the 2 mile region, people from 2 to 5 miles downwind continue preparation for evacuation while they shelter.
4. The populations sheltering in the 2 to 5 mile region are advised to begin evacuating when approximately 90 percent of those originally within the 2 mile region evacuate across the 2 mile region boundary.
5. Non-compliance with the shelter recommendation is the same as the shadow evacuation percentage of 20 percent.

See Section 5.4.2 for additional information on staged evacuation.

7.3 Patterns of Traffic Congestion during Evacuation

Figure 7-3 through Figure 7-10 illustrate the patterns of traffic congestion that arise for the case when the entire EPZ (Region R03) is advised to evacuate during the summer, midweek, midday period under good weather conditions (Scenario 1).

Traffic congestion, as the term is used here, is defined as Level of Service (LOS) F. LOS F is defined as follows (HCM 2010, page 5-5):

The HCM uses LOS F to define operations that have either broken down (i.e., demand exceeds capacity) or have exceeded a specified service measure value, or combination of service measure values, that most users would consider unsatisfactory. However, particularly for planning applications where different alternatives may be compared, analysts may be interested in knowing just how bad the LOS F condition is. Several measures are available to describe individually, or in combination, the severity of a LOS F condition:

- *Demand-to-capacity ratios* describe the extent to which capacity is exceeded during the analysis period (e.g., by 1%, 15%, etc.);
- *Duration of LOS F* describes how long the condition persists (e.g., 15 min, 1 h, 3 h); and
- *Spatial extent measures* describe the areas affected by LOS F conditions. These include measures such as the back of queue, and the identification of the specific intersection approaches or system elements experiencing LOS F conditions.

All highway "links" which experience LOS F are delineated in these figures by a thick red line; all others are lightly indicated. Congestion develops rapidly around concentrations of population and traffic bottlenecks.

Figure 7-3 displays congestion patterns within the study area at 30 minutes after the ATE. At this point, external traffic can no longer enter the EPZ. There is significant traffic volume in each of the three major population centers (Apex, Holly Springs, and Fuquay-Varina) in the EPZ, as indicated by the prevalence of colored links. This is to be expected as the population density

in these areas is high and there are many vehicles beginning their evacuation trips from these cities. Within the Apex area, there is pronounced traffic congestion (LOS F) on SR-55/W Williams Street, Ten-Ten Road, Olive Chapel Road and Laura Duncan Road. Holly Springs Road eastbound and SR-55 northbound are operating at LOS F within Holly Springs. James Slaughter Rd southbound and Judd Parkway are operating at LOS F within Fuquay-Varina. The only roadways outside of the population centers experiencing pronounced traffic congestion (LOS F) at this time are Seaforth Recreation Area northbound (transients evacuating from Jordan Lake State Recreation Area) and US 401 between Judd Parkway and Sunset Lake Road/Purfoy Road due to the large number of vehicles exiting the EPZ along Sunset Lake Road and Judd Parkway. Several roads in the Shadow Region are also operating at LOS F.

At 1 hour after the ATE, Figure 7-4 indicates that traffic congestion within the study area has intensified. At this time, approximately 90 percent of employees and transients have mobilized and approximately 32 percent of vehicles have evacuated the EPZ. All of the major evacuation routes servicing the three population centers are experiencing LOS F conditions. Several roads in the Shadow Region are also operating at LOS F, including US-401 southbound leaving Fuquay-Varina, Ten-Ten Rd eastbound, and US-64 eastbound leaving Apex. Note that all roadways in the 2-Mile Region and the 5-Mile Region (except for a small portion of Avent Ferry Road) are not congested (LOS A) at this time.

At 1 hour and 30 minutes after the ATE, as displayed in Figure 7-5, traffic congestion in the study area peaks within Apex, Holly Springs, Fuquay-Varina and within the Shadow Region directly north, south and east of the population centers. All routes leaving the three population centers are heavily congested. Many roads in the Shadow Region are operating at LOS F, including NC-55 northbound, Holly Springs Road eastbound, Ten-Ten Rd eastbound, Lake Wheeler Road northbound, Optimist Farm Road eastbound, East Williams Street eastbound and US-401 southbound. These congestion patterns reflect the large number of evacuating vehicles emanating from the three population centers trying to access the major evacuation routes – US-1, US-64, US-401, I-40, I-440 and I-540 – leaving the area. There is no congestion in the 2-Mile Region, or in the Chatham and Lee County portions of the study area.

Figure 7-6 displays the congestion patterns at 2 hours and 30 minutes after the ATE. At this point, approximately 96 percent of vehicles have mobilized and 81 percent of vehicles have evacuated the EPZ. Traffic congestion in Apex is dissipating, with only a few routes operating at LOS F. All major evacuation routes in the City of Holly Springs and Fuquay-Varina are still operating at LOS F. It should be noted that all roadways west of Apex, Holly Springs and Fuquay-Varina are operating at LOS A.

Figure 7-7 displays the congestion patterns at 4 hours after the ATE. Traffic congestion has cleared in Holly Springs. Congestion, within the EPZ, remains in Apex (along James Street) and in Fuquay-Varina (along SR 55 southbound and Judd Parkway). In the Shadow Region, Ten-Ten Rd, W. Lake Rd, Optimist Farm Rd (to gain access to US 401), Lake Wheeler Road, East Williams Street, Purfoy Road and Angier Road (to gain access to SR-55 and SR-210) are still operating at LOS F. Pronounced congestion persists within Fuquay-Varina due to the limited capacity of the signalized intersections along US-401 and the pronounced traffic volume on competing

approaches to the intersections. The congestion exhibited within Harnett County is largely due to vehicles evacuating southbound from Wake County. At this time, 99 percent of vehicles have mobilized and approximately 98 percent of vehicles have evacuated the study area.

Figure 7-8 displays the congestion patterns at 4 hours and 30 minutes after the ATE. Apex is now clear of congestion. The last area in the EPZ to exhibit LOS F conditions is within Fuquay-Varina along Judd Parkway eastbound to gain access to US-401. Congestion still exists along Angier Road and East Williams Street, within the Shadow Region, to gain access to SR-210 and SR-55. All vehicles have mobilized and 99 percent of vehicles have successfully evacuated the area at this time.

At 5 hours after the ATE, Fuquay-Varina and the EPZ is completely clear of congestion, as shown in Figure 7-9. Congestion continues to remain within the Shadow Region along Angier Road and East Williams Street.

Finally, Figure 7-10 displays the last remnants of traffic congestion within the Shadow Region at 5 hours and 45 minutes after the ATE. This is 1 hour and 5 minutes after the completion of the trip-generation (mobilization) time.

7.4 Evacuation Rates

Evacuation is a continuous process, as implied by Figure 7-11 through Figure 7-24. These figures display the rate at which traffic flows out of the indicated areas for the case of an evacuation of the full EPZ (Region R03) under the indicated conditions. One figure is presented for each scenario considered.

As indicated in Figure 7-11, there is typically a long "tail" to these distributions. Vehicles begin to evacuate an area slowly at first, as people respond to the ATE at different rates. Then traffic demand builds rapidly (slopes of curves increase). When the system becomes congested, traffic exits the EPZ at rates somewhat below capacity until some evacuation routes have cleared. As more routes clear, the aggregate rate of egress slows since many vehicles have already left the EPZ. Towards the end of the process, relatively few evacuation routes service the remaining demand.

This decline in aggregate flow rate, towards the end of the process, is characterized by these curves flattening and gradually becoming horizontal. Ideally, it would be desirable to fully saturate all evacuation routes equally so that all will service traffic near capacity levels and all will clear at the same time. For this ideal situation, all curves would retain the same slope until the end – thus minimizing evacuation time. In reality, this ideal is generally unattainable reflecting the spatial variation in population density, mobilization rates and in highway capacity over the EPZ.

7.5 Evacuation Time Estimate (ETE) Results

Table 7-1 through Table 7-2 present the ETE values for all 37 Evacuation Regions and all 14 Evacuation Scenarios. Table 7-3 through Table 7-4 present the ETE values for the 2-Mile region for both staged and un-staged keyhole regions downwind to 5 miles. They are organized as follows:

Table	Contents
7-1	ETE represents the elapsed time required for 90 percent of the population within a Region, to evacuate from that Region. All Scenarios are considered, as well as Staged Evacuation scenarios.
7-2	ETE represents the elapsed time required for 100 percent of the population within a Region, to evacuate from that Region. All Scenarios are considered, as well as Staged Evacuation scenarios.
7-3	ETE represents the elapsed time required for 90 percent of the population within the 2-Mile Region, to evacuate from the 2-Mile Region with both Concurrent and Staged Evacuations of additional Zones downwind in the keyhole Region.
7-4	ETE represents the elapsed time required for 100 percent of the population within the 2-Mile Region, to evacuate from the 2-Mile Region with both Concurrent and Staged Evacuations of additional Zones downwind in the keyhole Region.

The animation snapshots described above reflect the ETE statistics for the concurrent (un-staged) evacuation scenarios and regions, which are displayed in Figure 7-3 through Figure 7-10. Nearly all of the traffic congestion is located beyond the 5-Mile radius; this is reflected in the ETE statistics:

- The 2-Mile Region (R01) consists of mostly external traffic along US-1 in both directions, plant employees and transients. There is no congestion within this region, which means that ETE is dictated by mobilization time. As such, the 90th percentile ETE for this region is between 45 minutes and 1 hour which mimics the rapidly mobilizing external traffic, employees and transients.
- The 5-Mile Region (R02) has no congestion except for Avent Ferry Road as it approaches Cass Holt Road. R02 has many more resident vehicles than R01, which increases the mobilization time (see Figure 5-4 – mobilization time is longer for residents than for employees and transients). The 90th percentile ETE for Region R02 ranges between 1:35 (hr:min) and 2:00.
- The 90th percentile ETE for Region R03 (full EPZ) is at most are 1 hour and 35 minutes longer than the R02, due to the congestion beyond the 5-Mile radius. The 90th percentile ETE range between 2:50 and 3:35.
- The 100th percentile ETE for the full EPZ is greater than mobilization time for midweek scenarios due to the prevalence of traffic congestion in the large population centers within Apex (Zone E), Holly Springs (Zone F) and Fuquay-Varina (Zone G). The ETE for

many of the weekend and evening scenarios mimic mobilization time as residents are united at home and employees in the EPZ are minimal. The 100th percentile ETE range from 4:40 (mobilization time plus 10 minutes to travel out of the EPZ) to 6:10.

Comparison of Scenarios 5 and 13 in Table 7-1 indicates that the Special Event – Fourth of July fireworks on Jordan Lake – does not impact the 90th or 100th percentile ETE. As shown in Figure 7-3 through Figure 7-10 and discussed in Section 7.3, the congestion within the EPZ is predominantly to the east of the plant near the major population centers. The additional 2,562 vehicles present for the special event are located west of the plant and predominantly travel north on Beaver Creek Road and west on US-64 to evacuate the EPZ. There is sufficient capacity on US-64 to service these additional vehicles, which explains why ETE are not affected.

Comparison of Scenarios 1 and 14 in Table 7-1 indicates that the roadway closure – one lane northbound on US-1 from just east of the interchange with New Hill Holleman Rd (Exit 89) to the interchange with I-40 (Exit 1A) and one lane eastbound on US-64 from New Hill Olive Chapel Rd/NC-751 to the interchange with US-1 (Exit 404A/B) – causes at most a 10 minute increase for the 90th percentile ETE and 15 minutes for the 100th percentile ETE for the full EPZ or any regions that contain any of the Zones E, F or G. As shown in Figure 7-3 through Figure 7-10, US-1 northbound is mostly operating below capacity (LOS A through D). Most of US-64 eastbound is also operating below capacity (LOS F at some signalized intersections). The ramps to US-1 have limited capacity and thus meter the traffic entering the main thoroughfare of US-1. As a result, there is unused capacity on US-1 for all non-roadway impact scenarios. Thus, closing a lane does not have an impact. In addition, there are other alternate routes – most notably NC-55 northbound and NC-540 Toll eastbound which have available capacity to compensate for the loss of capacity on US-64. Some vehicles reroute onto these roadways as a result of the lane closures on US-1 and US-64, offsetting any substantial increase in ETE. Also, the bottlenecks in the major population centers dictate the ETE for the EPZ, not traffic congestion along US-1 or US-64.

7.6 Staged Evacuation Results

Table 7-3 and Table 7-4 present a comparison of the ETE compiled for the concurrent (unstaged) and staged evacuation studies. Note that Regions R28 through R37 are the same geographic areas as Regions R02 and R04 through R12, respectively. The times shown in Table 7-3 and Table 7-4 are when the 2-mile region is 90 percent clear and 100 percent clear, respectively.

The objective of a staged evacuation is to show that the ETE for the 2-mile region can be reduced without significantly impacting the region between 2 miles and 5 miles. In all cases, as shown in these tables, the ETE for the 2-mile region is unchanged in the 90th and 100th percentile ETE when a staged evacuation is implemented for all scenarios.

As discussed in Section 7.3, there is no congestion within the 2-mile region and minimal congestion (small portion of Avent Ferry Road) in the 5-Mile region. In addition, the congestion beyond 5 miles does not extend upstream to the extent that it penetrates within 2 miles of HNP, so evacuees from within the 2-mile region are not impeded. Therefore, staging the

evacuation provides no benefits to evacuees from within the 2-mile region.

To determine the effect of staged evacuation on residents beyond the 2-mile region, the ETE for Regions R02 and R04 through R12 are compared to Regions R28 through R37, respectively, in Table 7-1 and Table 7-2. A comparison of ETE between these similar regions reveals that staging increases the 90th percentile ETE for those in the 2 to 5-mile area by at most 10 minutes (see Table 7-1) and has no impact on 100th percentile ETE.

The increase in the 90th percentile ETE is due to evacuating vehicles, beyond the 2-mile region, sheltering and delaying the start of their evacuation. As shown in Figure 5-5, staging the evacuation causes a significant “spike” (sharp increase) in mobilization (trip-generation rate) of evacuating vehicles.

In summary, the staged evacuation option provides no benefits to evacuees from within the 2-mile region, and adversely impacts some evacuees located beyond 2 miles from the plant.

7.7 Guidance on Using ETE Tables

The user first determines the percentile of population for which the ETE is sought (The NRC guidance calls for the 90th percentile). The applicable value of ETE within the chosen table may then be identified using the following procedure:

1. Identify the applicable **Scenario**:
 - Season
 - Summer
 - Winter (also Autumn and Spring)
 - Day of Week
 - Midweek
 - Weekend
 - Time of Day
 - Midday
 - Evening
 - Weather Condition
 - Good Weather
 - Rain
 - Ice
 - Special Event
 - Fourth of July on Jordan Lake
 - Roadway Impact – Lane Closure on US-1 and US-64
 - Evacuation Staging
 - No, Staged Evacuation is not considered
 - Yes, Staged Evacuation is considered

While these Scenarios are designed, in aggregate, to represent conditions throughout the year, some further clarification is warranted:

- The conditions of a summer evening (either midweek or weekend) and rain are not explicitly identified in the Tables. For these conditions, Scenarios (2) and (4) apply.

- The conditions of a winter evening (either midweek or weekend) and rain are not explicitly identified in the Tables. For these conditions, Scenarios (7) and (10) for rain apply.
 - The conditions of a winter evening (either midweek or weekend) and ice are not explicitly identified in the Tables. For these conditions, Scenarios (8) and (11) for ice apply.
 - The seasons are defined as follows:
 - Summer assumes school is in session at summer school enrollment levels (lower than normal enrollment).
 - Winter (includes Spring and Autumn) considers that public schools are in session at normal enrollment levels.
 - Time of Day: Midday implies the time over which most commuters are at work or are travelling to/from work.
2. With the desired percentile ETE and Scenario identified, now identify **the Evacuation Region**:
- Determine the projected azimuth direction of the plume (coincident with the wind direction). This direction is expressed in terms of compass orientation – from N, NNE, NE – or in degrees.
 - Determine the distance that the Evacuation Region will extend from the nuclear power plant. The applicable distances and their associated candidate Regions are given below:
 - 2 Miles (Region R01)
 - To 5 Miles (Region R02, R04 through R12)
 - To EPZ Boundary (Regions R03, R13 through R27)
 - Enter Table 7-5 and identify the applicable group of candidate Regions based on the distance that the selected Region extends from the HNP. Select the Evacuation Region identifier in that row, based on the azimuth direction of the plume, from the first column of the Table.
3. Determine the ETE Table based on the percentile selected. Then, for the Scenario identified in Step 1 and the Region identified in Step 2, proceed as follows:
- The columns of Table 7-1 through Table 7-4 are labeled with the Scenario numbers. Identify the proper column in the selected Table using the Scenario number defined in Step 1.
 - Identify the row in this table that provides ETE values for the Region identified in Step 2.
 - The unique data cell defined by the column and row so determined contains the desired value of ETE expressed in Hours:Minutes.

Example

It is desired to identify the ETE for the following conditions:

- Sunday, August 10th at 4:00 AM.
- It is raining.
- Wind direction is from the SE.
- Wind speed is such that the distance to be evacuated is judged to be a 2-Mile radius and downwind to 10 miles (to EPZ boundary).
- The desired ETE is that value needed to evacuate 90 percent of the population from within the impacted Region.
- A staged evacuation is not desired.

Table 7-1 is applicable because the 90th percentile ETE is desired. Proceed as follows:

1. Identify the Scenario as summer, weekend, evening and raining. Entering Table 7-1, it is seen that there is no match for these descriptors. However, the clarification given above assigns this combination of circumstances to Scenario 4.
2. Enter Table 7-5 and locate the Region described as “Evacuate 2-Mile Radius and Downwind to the EPZ Boundary” for wind direction from SE and read Region R19 in the first column of that row.
3. Enter Table 7-1 to locate the data cell containing the value of ETE for Scenario 4 and Region R19. This data cell is in column (4) and in the row for Region R19; it contains the ETE value of 1:30.

Table 7-1. Time to Clear the Indicated Area of 90 Percent of the Affected Population

	Summer		Summer		Summer	Winter			Winter			Winter	Summer	Summer
	Midweek		Weekend		Midweek Weekend	Midweek			Weekend			Midweek Weekend	Weekend	Midweek
Scenario:	(1)	(2)	(3)	(4)	(5)	(6)	(7)	(8)	(9)	(10)	(11)	(12)	(13)	(14)
Region	Midday		Midday		Evening	Midday			Midday			Evening	Evening	Midday
	Good Weather	Rain	Good Weather	Rain	Good Weather	Good Weather	Rain	Ice	Good Weather	Rain	Ice	Good Weather	Special Event	Roadway Impact
Entire 2-Mile Region, 5-Mile Region, and EPZ														
R01	0:55	0:55	0:50	0:50	1:00	0:55	0:55	0:55	0:45	0:45	0:50	1:00	1:00	0:55
R02	1:50	1:50	1:35	1:35	1:50	1:50	1:50	1:50	1:40	1:40	1:40	2:00	1:50	1:50
R03	3:05	3:15	2:50	3:05	2:50	3:00	3:15	3:35	2:50	3:00	3:20	2:50	2:50	3:15
2-Mile Region and Keyhole to 5 Miles														
R04	1:25	1:25	1:20	1:20	1:35	1:25	1:25	1:25	1:25	1:25	1:25	1:40	1:35	1:25
R05	1:20	1:20	1:15	1:15	1:35	1:20	1:20	1:20	1:20	1:20	1:20	1:40	1:35	1:20
R06	1:25	1:25	1:20	1:20	1:35	1:30	1:30	1:30	1:25	1:25	1:25	1:45	1:35	1:25
R07	1:35	1:35	1:25	1:25	1:40	1:40	1:40	1:40	1:30	1:30	1:30	1:45	1:40	1:35
R08	1:35	1:35	1:25	1:25	1:40	1:40	1:40	1:40	1:25	1:25	1:25	1:40	1:40	1:35
R09	1:55	1:55	1:40	1:40	1:50	1:55	1:55	1:55	1:40	1:40	1:40	1:55	1:50	1:55
R10	1:45	1:45	1:30	1:30	1:45	1:45	1:45	1:45	1:35	1:35	1:35	1:50	1:45	1:45
R11	1:50	1:50	1:35	1:35	1:50	1:50	1:50	1:50	1:35	1:35	1:35	1:50	1:50	1:50
R12	1:10	1:10	1:00	1:00	1:20	1:10	1:10	1:10	1:00	1:00	1:00	1:25	1:20	1:10
2-Mile Region and Keyhole to EPZ Boundary														
R13	2:05	2:05	1:50	1:50	2:00	2:05	2:05	2:05	1:55	1:55	1:55	2:05	2:00	2:05
R14	2:05	2:05	1:55	1:55	2:05	2:05	2:05	2:05	1:55	1:55	1:55	2:05	2:05	2:05
R15	1:45	1:45	1:35	1:35	1:50	1:50	1:50	1:50	1:40	1:40	1:40	2:00	1:50	1:45
R16	1:45	1:45	1:35	1:35	1:50	1:50	1:50	1:50	1:45	1:45	1:45	2:00	1:50	1:45
R17	1:45	1:45	1:35	1:35	1:50	1:50	1:50	1:50	1:40	1:40	1:40	2:00	1:50	1:45
R18	1:45	1:45	1:35	1:35	1:50	1:50	1:50	1:50	1:40	1:40	1:40	2:00	1:50	1:45
R19	1:45	1:45	1:30	1:30	1:45	1:50	1:50	1:50	1:40	1:40	1:40	1:55	1:45	1:45
R20	2:25	2:30	2:20	2:25	2:20	2:25	2:30	2:40	2:20	2:20	2:30	2:20	2:20	2:30
R21	2:25	2:30	2:20	2:20	2:25	2:30	2:30	2:40	2:20	2:25	2:30	2:25	2:25	2:30
R22	2:40	2:50	2:35	2:45	2:35	2:40	2:50	3:05	2:35	2:40	2:55	2:35	2:35	2:50
R23	3:05	3:15	2:50	3:05	2:50	3:05	3:15	3:40	2:55	3:05	3:15	2:50	2:50	3:15
R24	3:05	3:15	2:55	3:10	2:50	3:05	3:20	3:45	2:50	3:05	3:20	2:55	2:50	3:15
R25	3:35	3:35	3:15	3:15	3:10	3:25	3:50	4:00	3:00	3:10	3:35	3:10	3:10	3:35

	Summer		Summer		Summer	Winter			Winter			Winter	Summer	Summer
	Midweek		Weekend		Midweek Weekend	Midweek			Weekend			Midweek Weekend	Weekend	Midweek
Scenario:	(1)	(2)	(3)	(4)	(5)	(6)	(7)	(8)	(9)	(10)	(11)	(12)	(13)	(14)
Region	Midday		Midday		Evening	Midday			Midday			Evening	Evening	Midday
	Good Weather	Rain	Good Weather	Rain	Good Weather	Good Weather	Rain	Ice	Good Weather	Rain	Ice	Good Weather	Special Event	Roadway Impact
R26	3:15	3:25	2:45	3:00	2:50	3:10	3:25	3:50	2:45	3:00	3:15	2:45	2:50	3:15
R27	3:10	3:25	2:45	3:00	2:45	3:15	3:30	3:50	2:45	3:00	3:15	2:40	2:45	3:10
Staged Evacuation - 2-Mile Region and Keyhole to 5 Miles														
R28	1:50	1:50	1:40	1:40	1:50	1:50	1:50	1:50	1:40	1:45	1:50	2:00	1:50	1:50
R29	1:25	1:25	1:20	1:20	1:35	1:25	1:25	1:25	1:25	1:25	1:25	1:40	1:35	1:25
R30	1:20	1:20	1:20	1:20	1:35	1:20	1:20	1:20	1:20	1:20	1:20	1:40	1:35	1:20
R31	1:25	1:25	1:20	1:20	1:35	1:30	1:30	1:30	1:25	1:25	1:25	1:45	1:35	1:25
R32	1:35	1:35	1:25	1:25	1:40	1:40	1:40	1:40	1:30	1:30	1:30	1:45	1:40	1:35
R33	1:35	1:35	1:25	1:25	1:40	1:40	1:40	1:40	1:25	1:25	1:25	1:40	1:40	1:35
R34	1:55	1:55	1:40	1:40	1:50	1:55	1:55	1:55	1:40	1:40	1:45	1:55	1:50	1:55
R35	1:45	1:45	1:40	1:40	1:45	1:45	1:45	1:45	1:40	1:40	1:45	1:50	1:45	1:45
R36	1:50	1:50	1:40	1:40	1:50	1:50	1:50	1:50	1:40	1:40	1:45	1:50	1:50	1:50
R37	1:15	1:15	1:10	1:10	1:20	1:15	1:15	1:15	1:10	1:10	1:10	1:25	1:20	1:15

Table 7-2. Time to Clear the Indicated Area of 100 Percent of the Affected Population

	Summer		Summer		Summer	Winter			Winter			Winter	Summer	Summer
	Midweek		Weekend		Midweek Weekend	Midweek			Weekend			Midweek Weekend	Weekend	Midweek
Scenario:	(1)	(2)	(3)	(4)	(5)	(6)	(7)	(8)	(9)	(10)	(11)	(12)	(13)	(14)
Region	Midday		Midday		Evening	Midday			Midday			Evening	Evening	Midday
	Good Weather	Rain	Good Weather	Rain	Good Weather	Good Weather	Rain	Ice	Good Weather	Rain	Ice	Good Weather	Special Event	Roadway Impact
Entire 2-Mile Region, 5-Mile Region, and EPZ														
R01	4:30	4:30	4:30	4:30	4:30	4:30	4:30	4:30	4:30	4:30	4:30	4:30	4:30	4:30
R02	4:35	4:35	4:35	4:35	4:35	4:35	4:35	4:35	4:35	4:35	4:35	4:35	4:35	4:35
R03	5:00	5:25	4:40	4:45	4:40	5:00	5:30	6:10	4:40	4:45	5:05	4:40	4:40	5:15
2-Mile Region and Keyhole to 5 Miles														
R04	4:35	4:35	4:35	4:35	4:35	4:35	4:35	4:35	4:35	4:35	4:35	4:35	4:35	4:35
R05	4:35	4:35	4:35	4:35	4:35	4:35	4:35	4:35	4:35	4:35	4:35	4:35	4:35	4:35
R06	4:35	4:35	4:35	4:35	4:35	4:35	4:35	4:35	4:35	4:35	4:35	4:35	4:35	4:35
R07	4:35	4:35	4:35	4:35	4:35	4:35	4:35	4:35	4:35	4:35	4:35	4:35	4:35	4:35
R08	4:35	4:35	4:35	4:35	4:35	4:35	4:35	4:35	4:35	4:35	4:35	4:35	4:35	4:35
R09	4:35	4:35	4:35	4:35	4:35	4:35	4:35	4:35	4:35	4:35	4:35	4:35	4:35	4:35
R10	4:35	4:35	4:35	4:35	4:35	4:35	4:35	4:35	4:35	4:35	4:35	4:35	4:35	4:35
R11	4:35	4:35	4:35	4:35	4:35	4:35	4:35	4:35	4:35	4:35	4:35	4:35	4:35	4:35
R12	4:35	4:35	4:35	4:35	4:35	4:35	4:35	4:35	4:35	4:35	4:35	4:35	4:35	4:35
2-Mile Region and Keyhole to EPZ Boundary														
R13	4:40	4:40	4:40	4:40	4:40	4:40	4:40	4:40	4:40	4:40	4:40	4:40	4:40	4:40
R14	4:40	4:40	4:40	4:40	4:40	4:40	4:40	4:40	4:40	4:40	4:40	4:40	4:40	4:40
R15	4:40	4:40	4:40	4:40	4:40	4:40	4:40	4:40	4:40	4:40	4:40	4:40	4:40	4:40
R16	4:40	4:40	4:40	4:40	4:40	4:40	4:40	4:40	4:40	4:40	4:40	4:40	4:40	4:40
R17	4:40	4:40	4:40	4:40	4:40	4:40	4:40	4:40	4:40	4:40	4:40	4:40	4:40	4:40
R18	4:40	4:40	4:40	4:40	4:40	4:40	4:40	4:40	4:40	4:40	4:40	4:40	4:40	4:40
R19	4:40	4:40	4:40	4:40	4:40	4:40	4:40	4:40	4:40	4:40	4:40	4:40	4:40	4:40
R20	4:40	4:40	4:40	4:40	4:40	4:40	4:40	4:40	4:40	4:40	4:40	4:40	4:40	4:40
R21	4:40	4:40	4:40	4:40	4:40	4:40	4:40	4:40	4:40	4:40	4:40	4:40	4:40	4:40
R22	4:40	4:40	4:40	4:40	4:40	4:40	4:40	5:35	4:40	4:40	4:50	4:40	4:40	4:40
R23	4:50	5:20	4:40	4:45	4:40	4:50	5:20	6:10	4:40	4:40	4:50	4:40	4:40	5:05
R24	4:55	5:20	4:40	4:45	4:40	4:55	5:30	6:10	4:40	4:40	5:05	4:40	4:40	5:05
R25	4:55	5:20	4:40	4:40	4:40	5:00	5:30	6:05	4:40	4:40	4:55	4:40	4:40	5:10

	Summer		Summer		Summer	Winter			Winter			Winter	Summer	Summer
	Midweek		Weekend		Midweek Weekend	Midweek			Weekend			Midweek Weekend	Weekend	Midweek
Scenario:	(1)	(2)	(3)	(4)	(5)	(6)	(7)	(8)	(9)	(10)	(11)	(12)	(13)	(14)
Region	Midday		Midday		Evening	Midday			Midday			Evening	Evening	Midday
	Good Weather	Rain	Good Weather	Rain	Good Weather	Good Weather	Rain	Ice	Good Weather	Rain	Ice	Good Weather	Special Event	Roadway Impact
R26	4:40	4:55	4:40	4:40	4:40	4:40	5:00	5:35	4:40	4:40	4:40	4:40	4:40	4:40
R27	4:40	4:50	4:40	4:40	4:40	4:40	4:55	5:35	4:40	4:40	4:40	4:40	4:40	4:40
Staged Evacuation - 2-Mile Region and Keyhole to 5 Miles														
R28	4:35	4:35	4:35	4:35	4:35	4:35	4:35	4:35	4:35	4:35	4:35	4:35	4:35	4:35
R29	4:35	4:35	4:35	4:35	4:35	4:35	4:35	4:35	4:35	4:35	4:35	4:35	4:35	4:35
R30	4:35	4:35	4:35	4:35	4:35	4:35	4:35	4:35	4:35	4:35	4:35	4:35	4:35	4:35
R31	4:35	4:35	4:35	4:35	4:35	4:35	4:35	4:35	4:35	4:35	4:35	4:35	4:35	4:35
R32	4:35	4:35	4:35	4:35	4:35	4:35	4:35	4:35	4:35	4:35	4:35	4:35	4:35	4:35
R33	4:35	4:35	4:35	4:35	4:35	4:35	4:35	4:35	4:35	4:35	4:35	4:35	4:35	4:35
R34	4:35	4:35	4:35	4:35	4:35	4:35	4:35	4:35	4:35	4:35	4:35	4:35	4:35	4:35
R35	4:35	4:35	4:35	4:35	4:35	4:35	4:35	4:35	4:35	4:35	4:35	4:35	4:35	4:35
R36	4:35	4:35	4:35	4:35	4:35	4:35	4:35	4:35	4:35	4:35	4:35	4:35	4:35	4:35
R37	4:35	4:35	4:35	4:35	4:35	4:35	4:35	4:35	4:35	4:35	4:35	4:35	4:35	4:35

Table 7-3. Time to Clear 90 Percent of the 2-Mile Region within the Indicated Region

	Summer		Summer		Summer	Winter			Winter			Winter	Summer	Summer
	Midweek		Weekend		Midweek Weekend	Midweek			Weekend			Midweek Weekend	Weekend	Midweek
Scenario:	(1)	(2)	(3)	(4)	(5)	(6)	(7)	(8)	(9)	(10)	(11)	(12)	(13)	(14)
Region	Midday		Midday		Evening	Midday			Midday			Evening	Evening	Midday
	Good Weather	Rain	Good Weather	Rain	Good Weather	Good Weather	Rain	Ice	Good Weather	Rain	Ice	Good Weather	Special Event	Roadway Impact
Entire 2-Mile Region and 5-Mile Region														
R01	0:55	0:55	0:50	0:50	1:00	0:55	0:55	0:55	0:45	0:45	0:50	1:00	1:00	0:55
R02	0:55	0:55	0:50	0:50	1:00	0:55	0:55	0:55	0:45	0:45	0:50	1:00	1:00	0:55
Un-staged Evacuation - 2-Mile Region and Keyhole to 5-Miles														
R04	0:55	0:55	0:50	0:50	1:00	0:55	0:55	0:55	0:45	0:45	0:50	1:00	1:00	0:55
R05	0:55	0:55	0:50	0:50	1:00	0:55	0:55	0:55	0:45	0:45	0:50	1:00	1:00	0:55
R06	0:55	0:55	0:50	0:50	1:00	0:55	0:55	0:55	0:45	0:45	0:50	1:00	1:00	0:55
R07	0:55	0:55	0:50	0:50	1:00	0:55	0:55	0:55	0:45	0:45	0:50	1:00	1:00	0:55
R08	0:55	0:55	0:50	0:50	1:00	0:55	0:55	0:55	0:45	0:45	0:50	1:00	1:00	0:55
R09	0:55	0:55	0:50	0:50	1:00	0:55	0:55	0:55	0:45	0:45	0:50	1:00	1:00	0:55
R10	0:55	0:55	0:50	0:50	1:00	0:55	0:55	0:55	0:45	0:45	0:50	1:00	1:00	0:55
R11	0:55	0:55	0:50	0:50	1:00	0:55	0:55	0:55	0:45	0:45	0:50	1:00	1:00	0:55
R12	0:55	0:55	0:50	0:50	1:00	0:55	0:55	0:55	0:45	0:45	0:50	1:00	1:00	0:55
Staged Evacuation - 2-Mile Region and Keyhole to 5-Miles														
R28	0:55	0:55	0:50	0:50	1:00	0:55	0:55	0:55	0:45	0:45	0:50	1:00	1:00	0:55
R29	0:55	0:55	0:50	0:50	1:00	0:55	0:55	0:55	0:45	0:45	0:50	1:00	1:00	0:55
R30	0:55	0:55	0:50	0:50	1:00	0:55	0:55	0:55	0:45	0:45	0:50	1:00	1:00	0:55
R31	0:55	0:55	0:50	0:50	1:00	0:55	0:55	0:55	0:45	0:45	0:50	1:00	1:00	0:55
R32	0:55	0:55	0:50	0:50	1:00	0:55	0:55	0:55	0:45	0:45	0:50	1:00	1:00	0:55
R33	0:55	0:55	0:50	0:50	1:00	0:55	0:55	0:55	0:45	0:45	0:50	1:00	1:00	0:55
R34	0:55	0:55	0:50	0:50	1:00	0:55	0:55	0:55	0:45	0:45	0:50	1:00	1:00	0:55
R35	0:55	0:55	0:50	0:50	1:00	0:55	0:55	0:55	0:45	0:45	0:50	1:00	1:00	0:55
R36	0:55	0:55	0:50	0:50	1:00	0:55	0:55	0:55	0:45	0:45	0:50	1:00	1:00	0:55
R37	0:55	0:55	0:50	0:50	1:00	0:55	0:55	0:55	0:45	0:45	0:50	1:00	1:00	0:55

Table 7-4. Time to Clear 100 Percent of the 2-Mile Region within the Indicated Region

	Summer		Summer		Summer	Winter			Winter			Winter	Summer	Summer
	Midweek		Weekend		Midweek Weekend	Midweek			Weekend			Midweek Weekend	Weekend	Midweek
Scenario:	(1)	(2)	(3)	(4)	(5)	(6)	(7)	(8)	(9)	(10)	(11)	(12)	(13)	(14)
Region	Midday		Midday		Evening	Midday			Midday			Evening	Evening	Midday
	Good Weather	Rain	Good Weather	Rain	Good Weather	Good Weather	Rain	Ice	Good Weather	Rain	Ice	Good Weather	Special Event	Roadway Impact
Entire 2-Mile Region and 5-Mile Region														
R01	4:30	4:30	4:30	4:30	4:30	4:30	4:30	4:30	4:30	4:30	4:30	4:30	4:30	4:30
R02	4:30	4:30	4:30	4:30	4:30	4:30	4:30	4:30	4:30	4:30	4:30	4:30	4:30	4:30
Un-staged Evacuation - 2-Mile Region and Keyhole to 5-Miles														
R04	4:30	4:30	4:30	4:30	4:30	4:30	4:30	4:30	4:30	4:30	4:30	4:30	4:30	4:30
R05	4:30	4:30	4:30	4:30	4:30	4:30	4:30	4:30	4:30	4:30	4:30	4:30	4:30	4:30
R06	4:30	4:30	4:30	4:30	4:30	4:30	4:30	4:30	4:30	4:30	4:30	4:30	4:30	4:30
R07	4:30	4:30	4:30	4:30	4:30	4:30	4:30	4:30	4:30	4:30	4:30	4:30	4:30	4:30
R08	4:30	4:30	4:30	4:30	4:30	4:30	4:30	4:30	4:30	4:30	4:30	4:30	4:30	4:30
R09	4:30	4:30	4:30	4:30	4:30	4:30	4:30	4:30	4:30	4:30	4:30	4:30	4:30	4:30
R10	4:30	4:30	4:30	4:30	4:30	4:30	4:30	4:30	4:30	4:30	4:30	4:30	4:30	4:30
R11	4:30	4:30	4:30	4:30	4:30	4:30	4:30	4:30	4:30	4:30	4:30	4:30	4:30	4:30
R12	4:30	4:30	4:30	4:30	4:30	4:30	4:30	4:30	4:30	4:30	4:30	4:30	4:30	4:30
Staged Evacuation - 2-Mile Region and Keyhole to 5-Miles														
R28	4:30	4:30	4:30	4:30	4:30	4:30	4:30	4:30	4:30	4:30	4:30	4:30	4:30	4:30
R29	4:30	4:30	4:30	4:30	4:30	4:30	4:30	4:30	4:30	4:30	4:30	4:30	4:30	4:30
R30	4:30	4:30	4:30	4:30	4:30	4:30	4:30	4:30	4:30	4:30	4:30	4:30	4:30	4:30
R31	4:30	4:30	4:30	4:30	4:30	4:30	4:30	4:30	4:30	4:30	4:30	4:30	4:30	4:30
R32	4:30	4:30	4:30	4:30	4:30	4:30	4:30	4:30	4:30	4:30	4:30	4:30	4:30	4:30
R33	4:30	4:30	4:30	4:30	4:30	4:30	4:30	4:30	4:30	4:30	4:30	4:30	4:30	4:30
R34	4:30	4:30	4:30	4:30	4:30	4:30	4:30	4:30	4:30	4:30	4:30	4:30	4:30	4:30
R35	4:30	4:30	4:30	4:30	4:30	4:30	4:30	4:30	4:30	4:30	4:30	4:30	4:30	4:30
R36	4:30	4:30	4:30	4:30	4:30	4:30	4:30	4:30	4:30	4:30	4:30	4:30	4:30	4:30
R37	4:30	4:30	4:30	4:30	4:30	4:30	4:30	4:30	4:30	4:30	4:30	4:30	4:30	4:30

Table 7-5. Description of Evacuation Regions

Region	Description	Site PAR Description	Zone														
			A	B	C	D	E	F	G	H	I	J	K	L	M	N	
R01	2-Mile Radius	2-Mile Radius	X														
R02	5-Mile Radius	5-Mile Radius	X	X	X	X							X	X			
R03	Full EPZ	10-Mile Radius	X	X	X	X	X	X	X	X	X	X	X	X	X	X	X
Evacuate 2-Mile Radius and Downwind to 5 Miles																	
Region	Wind Direction From:	Site PAR Description	Zone														
			A	B	C	D	E	F	G	H	I	J	K	L	M	N	
R04	NNW, N	327° - 010°	X			X							X				
R05	NNE, NE	011° - 056°	X										X				
R06	ENE, E, ESE	057° - 124°	X										X	X			
R07	SE, SSE, S	125° - 191°	X	X											X		
R08	SSW	192° - 214°	X	X													
R09	SW, WSW	215° - 259°	X	X	X												
R10	Site Specific Region*		X		X												
R11	W, WNW	260° - 304°	X		X	X											
R12	NW	305° - 326°	X			X											
Evacuate 2-Mile Radius and Downwind to the EPZ Boundary																	
Region	Wind Direction From:	Site PAR Description	Zone														
			A	B	C	D	E	F	G	H	I	J	K	L	M	N	
R13	N	348° - 010°	X			X				X	X		X				
R14	NNE	011° - 034°	X							X	X	X	X				
R15	NE	035° - 056°	X							X	X	X			X		
R16	ENE	057° - 079°	X							X	X	X	X	X	X		
R17	E	080° - 101°	X								X	X	X	X	X		
R18	ESE	102° - 124°	X								X	X	X	X	X	X	
R19	SE	125° - 146°	X	X										X	X	X	
R20	SSE, S	147° - 191°	X	X			X							X	X	X	
R21	SSW	192° - 214°	X	X			X							X		X	
R22	SW	215° - 236°	X	X	X		X	X									
R23	WSW	237° - 259°	X	X	X		X	X	X								
R24	W	260° - 281°	X	X	X	X	X	X	X								
R25	WNW	282° - 304°	X		X	X		X	X	X							
R26	NW	305° - 326°	X		X	X			X	X			X				
R27	NNW	327° - 347°	X			X			X	X			X				
Staged Evacuation - 2-Mile Radius Evacuates, then Evacuate Downwind to 5 Miles																	
Region	Wind Direction From:	Site PAR Description	Zone														
			A	B	C	D	E	F	G	H	I	J	K	L	M	N	
R28	-	5-Mile Radius	X	X	X	X							X	X			
R29	NNW, N	327° - 010°	X			X							X				
R30	NNE, NE	011° - 056°	X										X				
R31	ENE, E, ESE	057° - 124°	X										X	X			
R32	SE, SSE, S	125° - 191°	X	X											X		
R33	SSW	192° - 214°	X	X													
R34	SW, WSW	215° - 259°	X	X	X												
R35	Site Specific Region*		X		X												
R36	W, WNW	260° - 304°	X		X	X											
R37	NW	305° - 326°	X			X											
Shelter-in-Place until 90% ETE for R01, then Evacuate			Zone(s) Shelter-in-Place							Zone(s) Evacuate							

*Region does not follow three-sector keyhole approach and is not used in PAR.

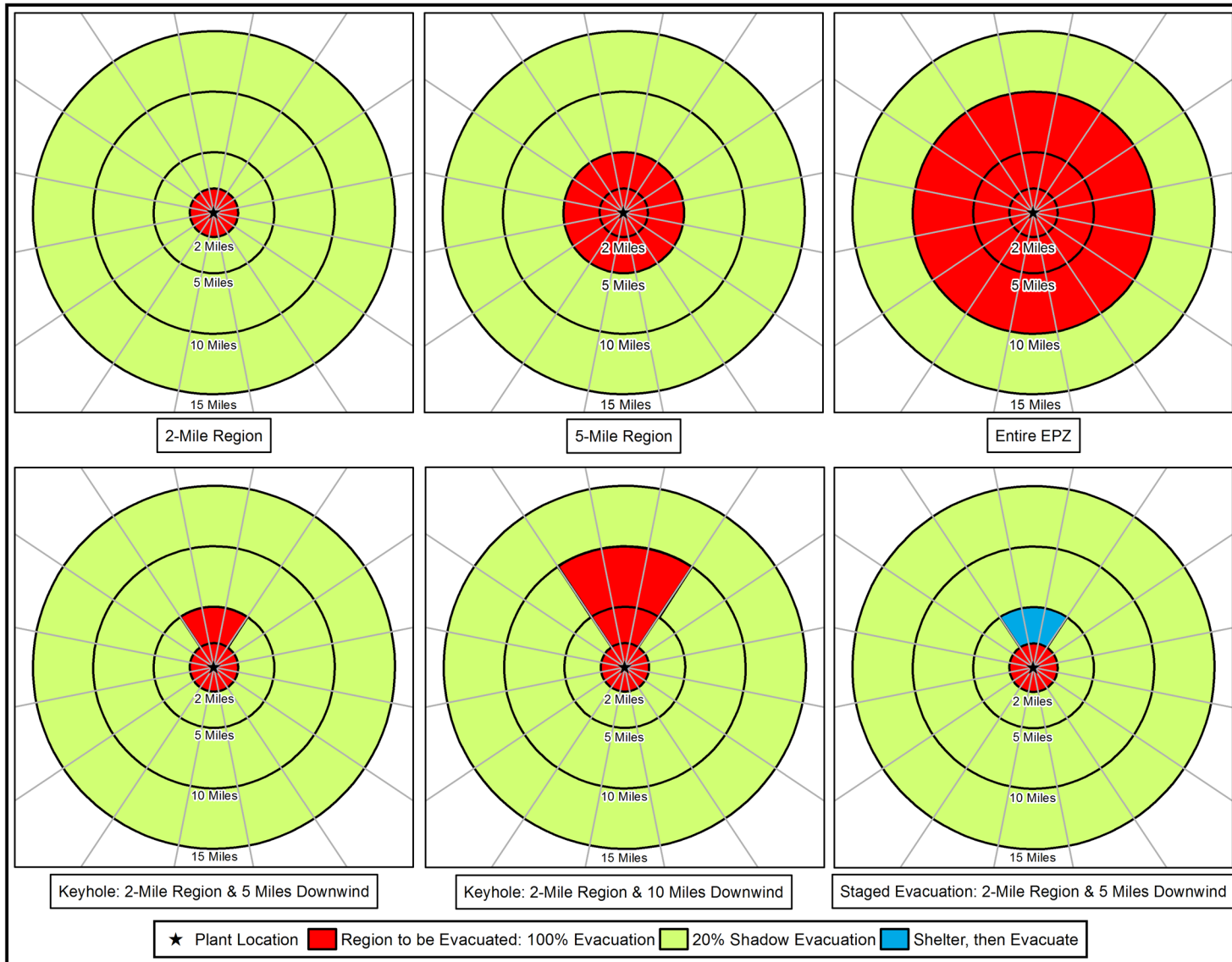

Figure 7-1. Voluntary Evacuation Methodology

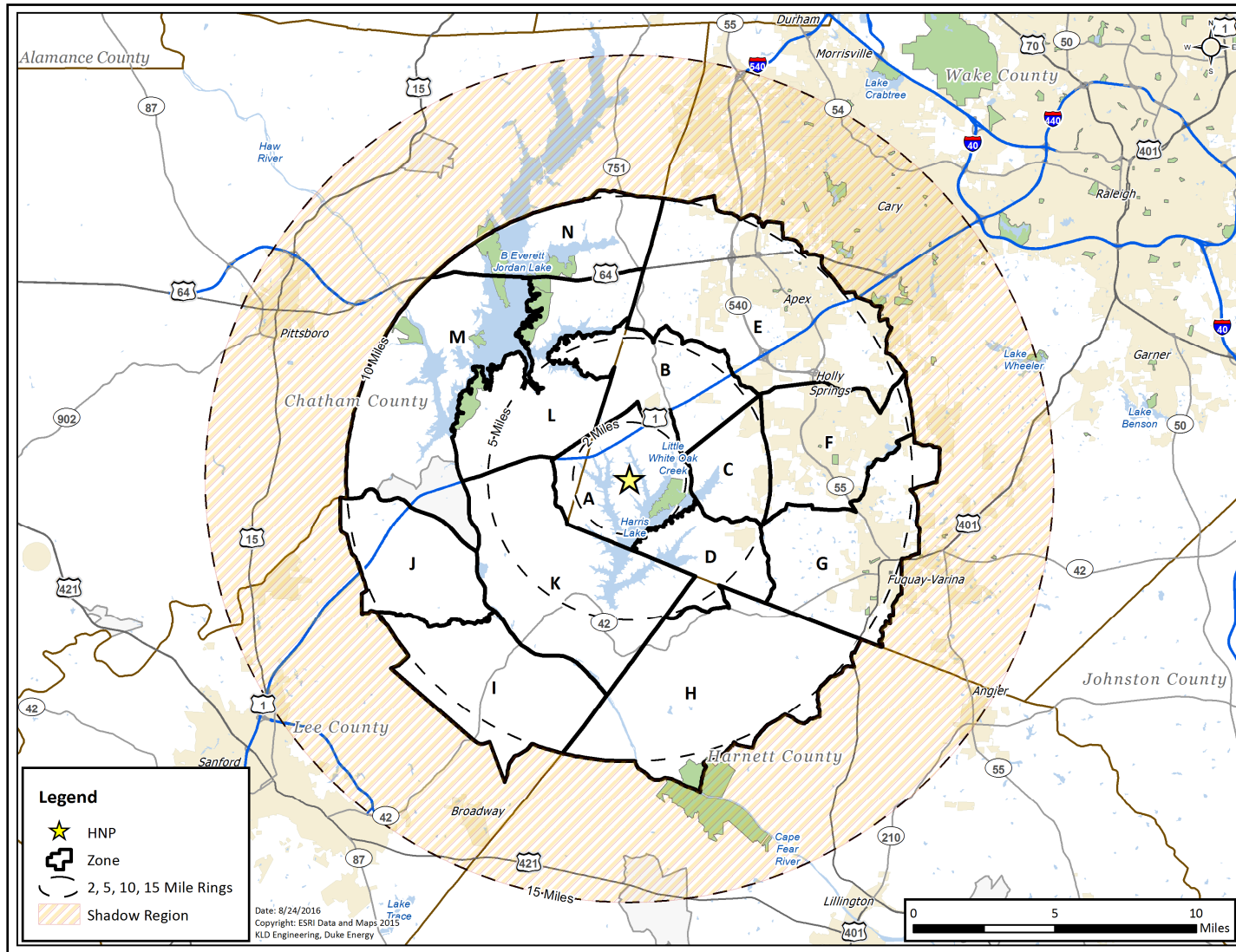

Figure 7-2. HNP Shadow Region

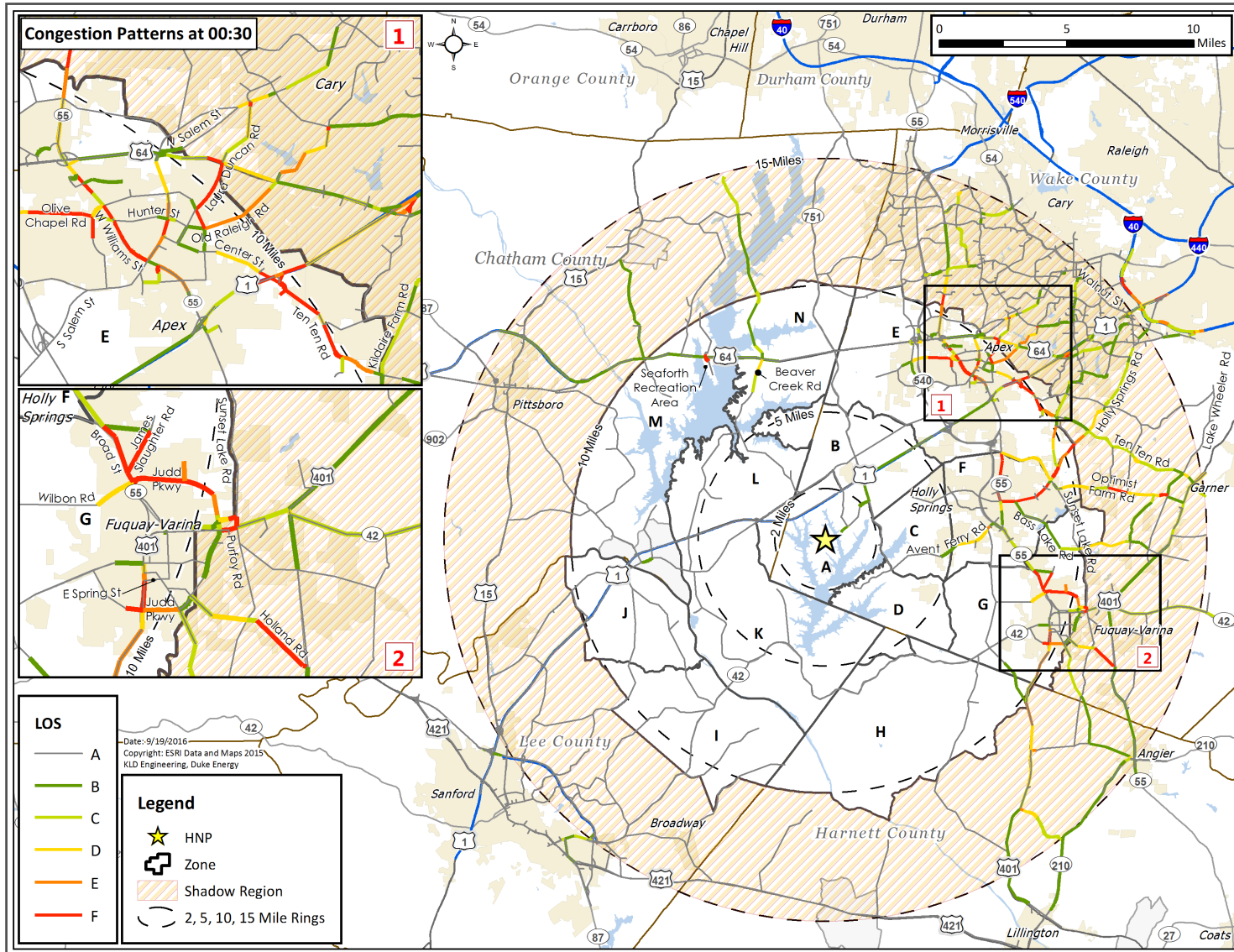

Figure 7-3. Congestion Patterns at 30 Minutes after the Advisory to Evacuate

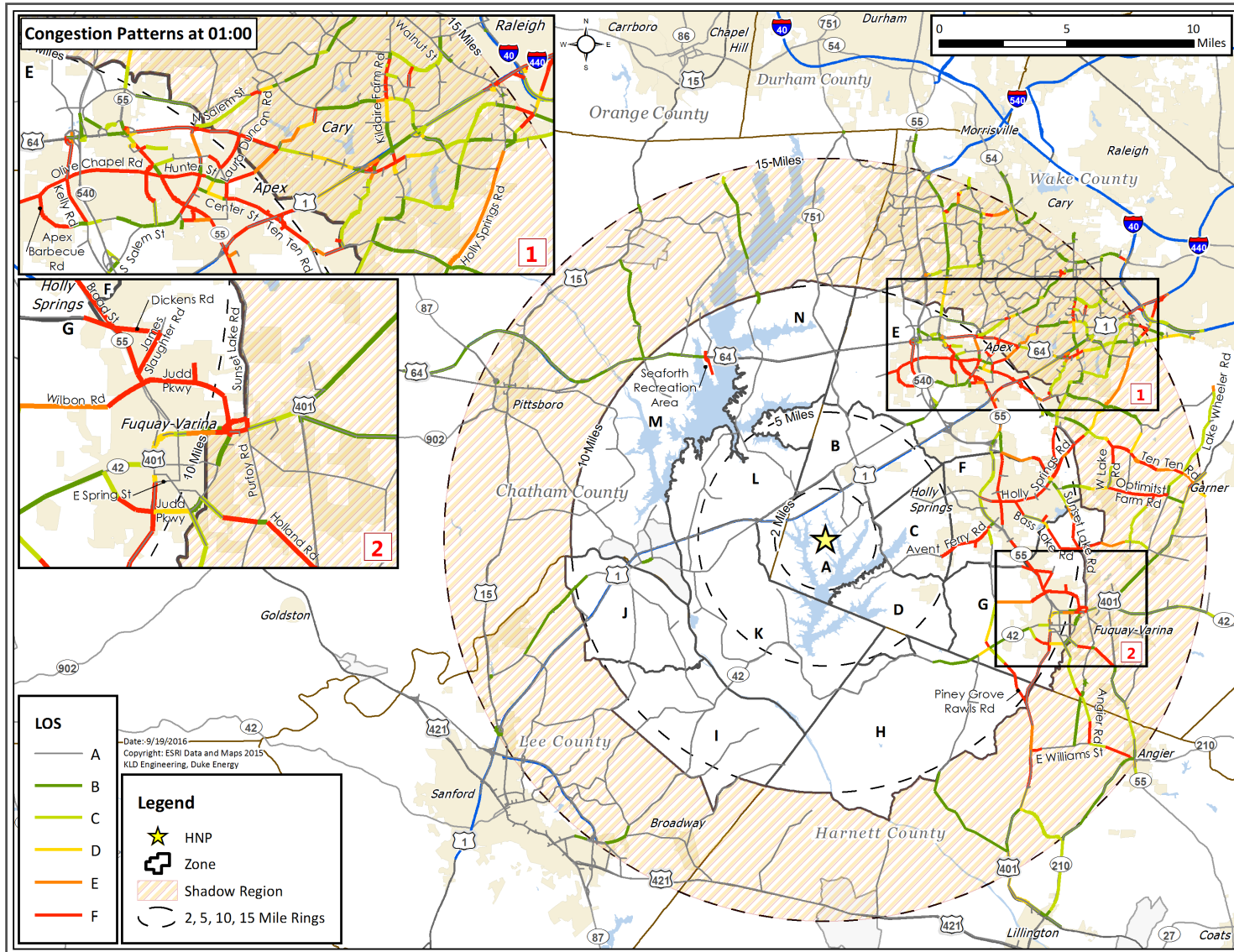

Figure 7-4. Congestion Patterns at 1 Hour after the Advisory to Evacuate

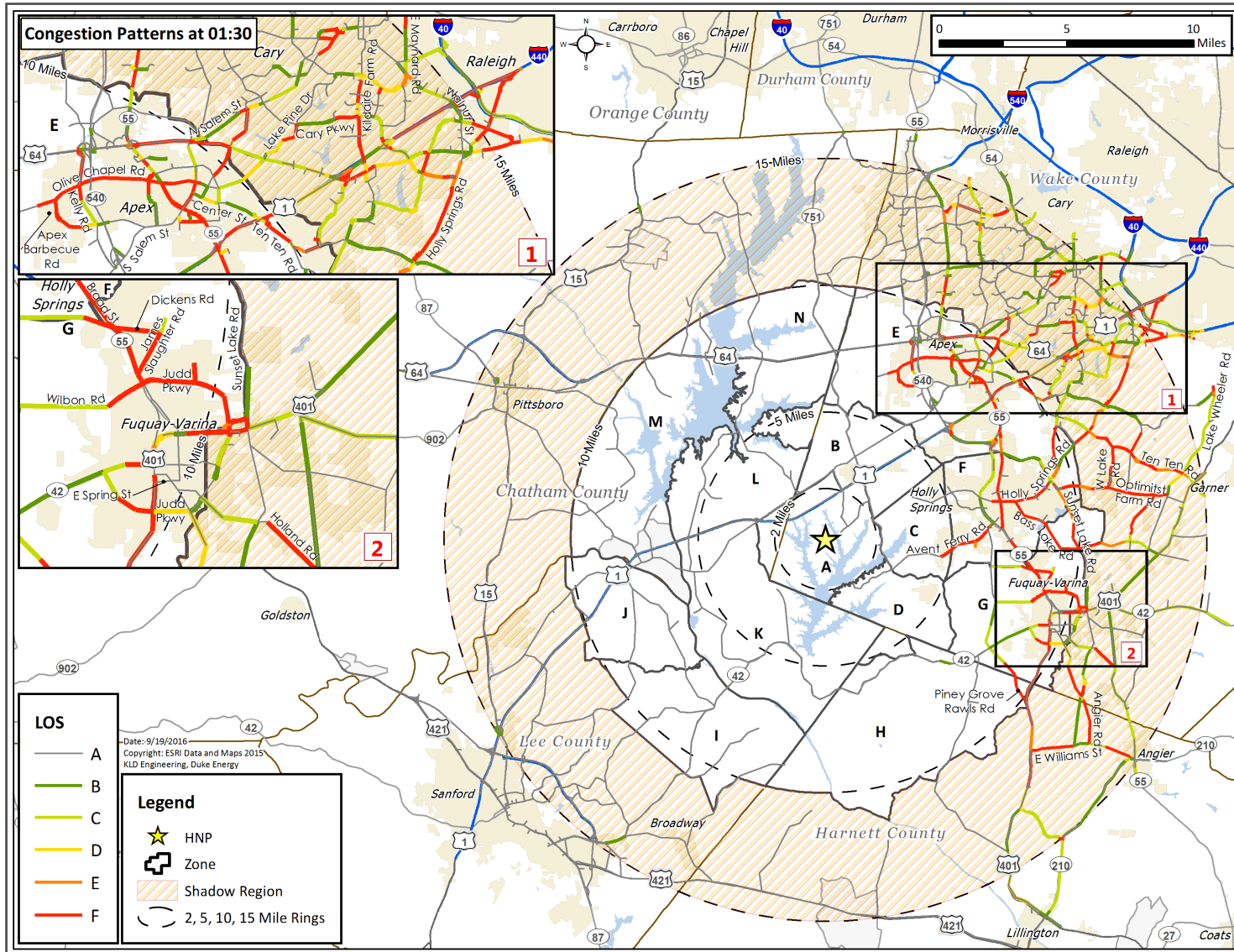

Figure 7-5. Congestion Patterns at 1 Hour 30 Minutes after the Advisory to Evacuate

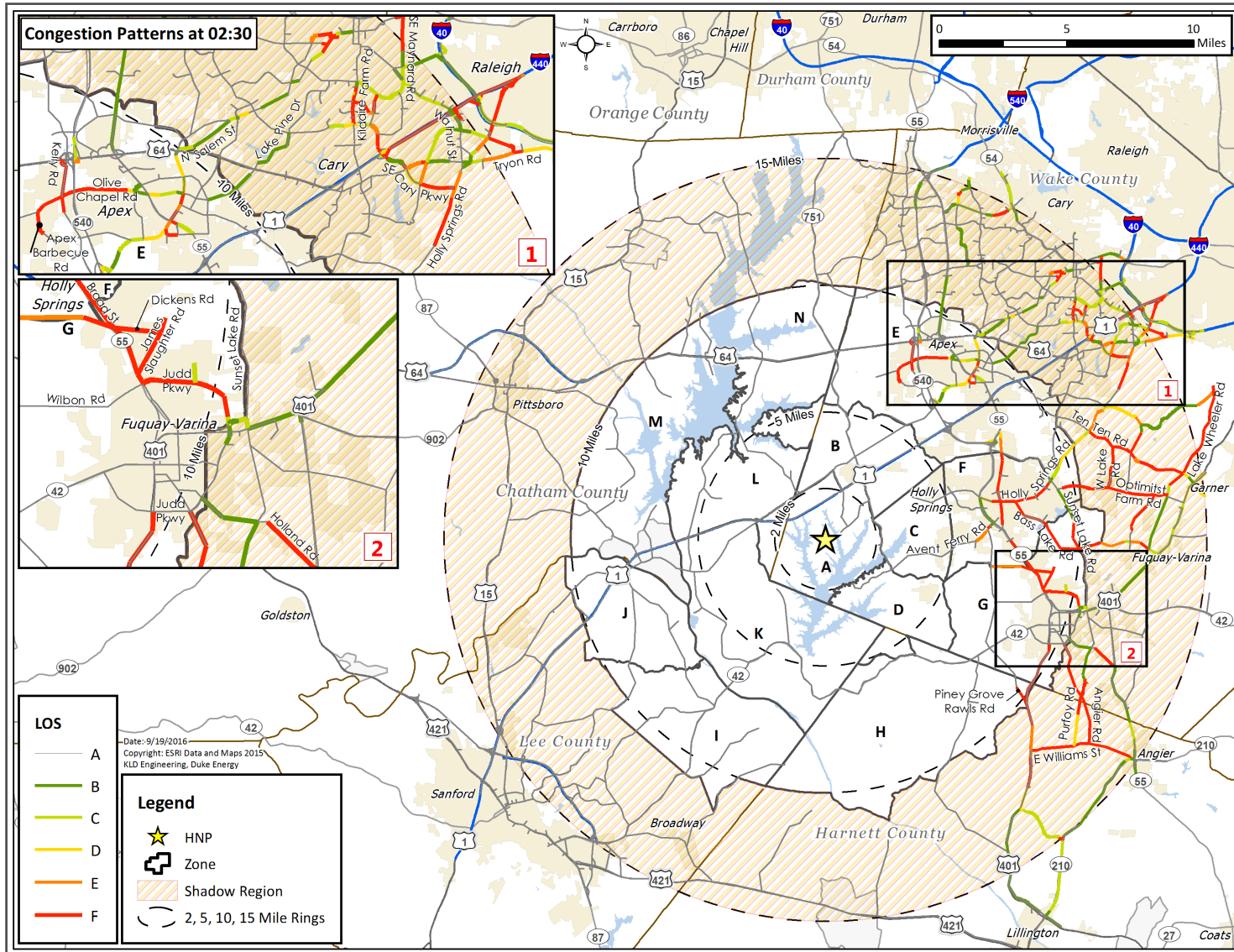

Figure 7-6. Congestion Patterns at 2 Hours 30 Minutes after the Advisory to Evacuate

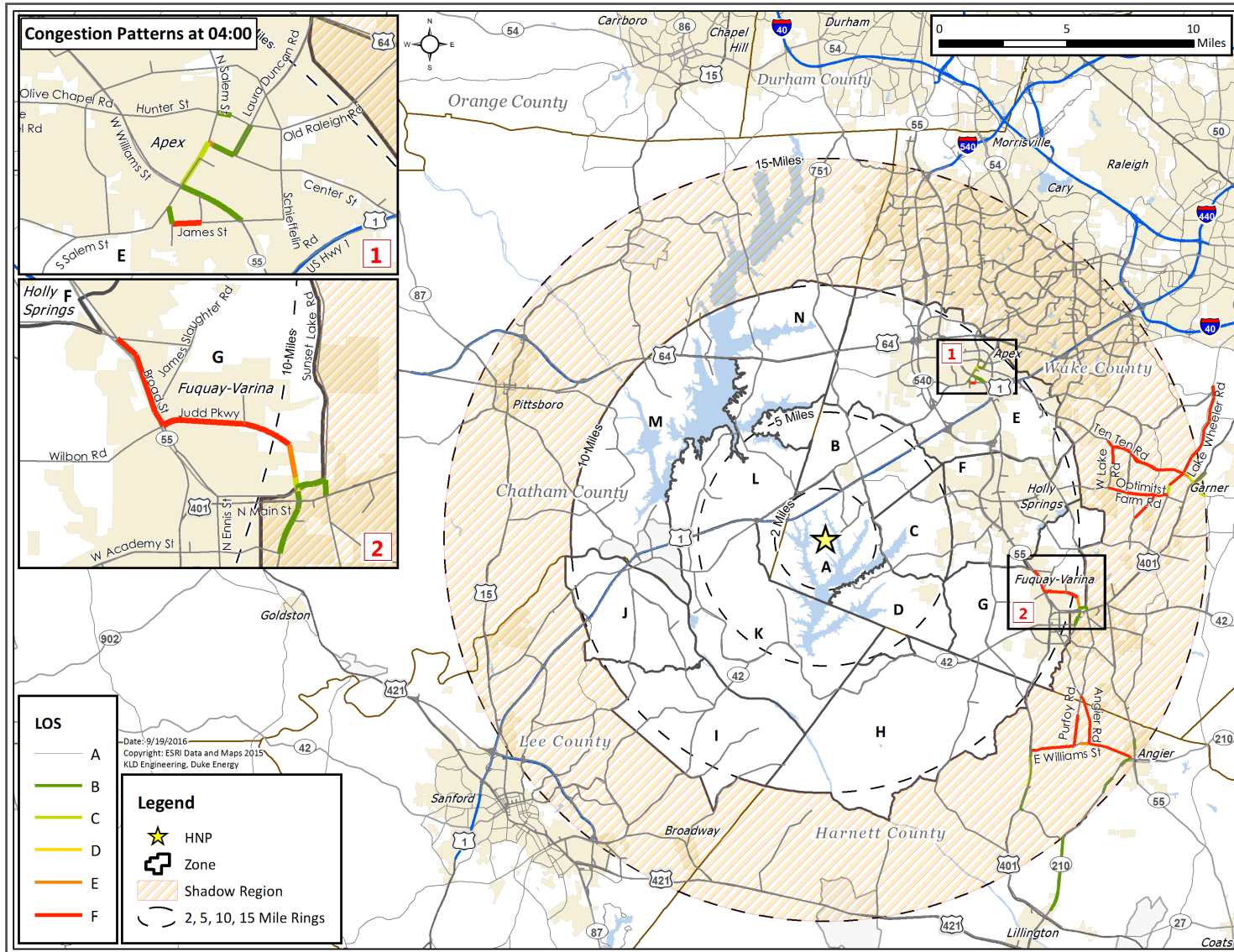

Figure 7-7. Congestion Patterns at 4 Hours after the Advisory to Evacuate

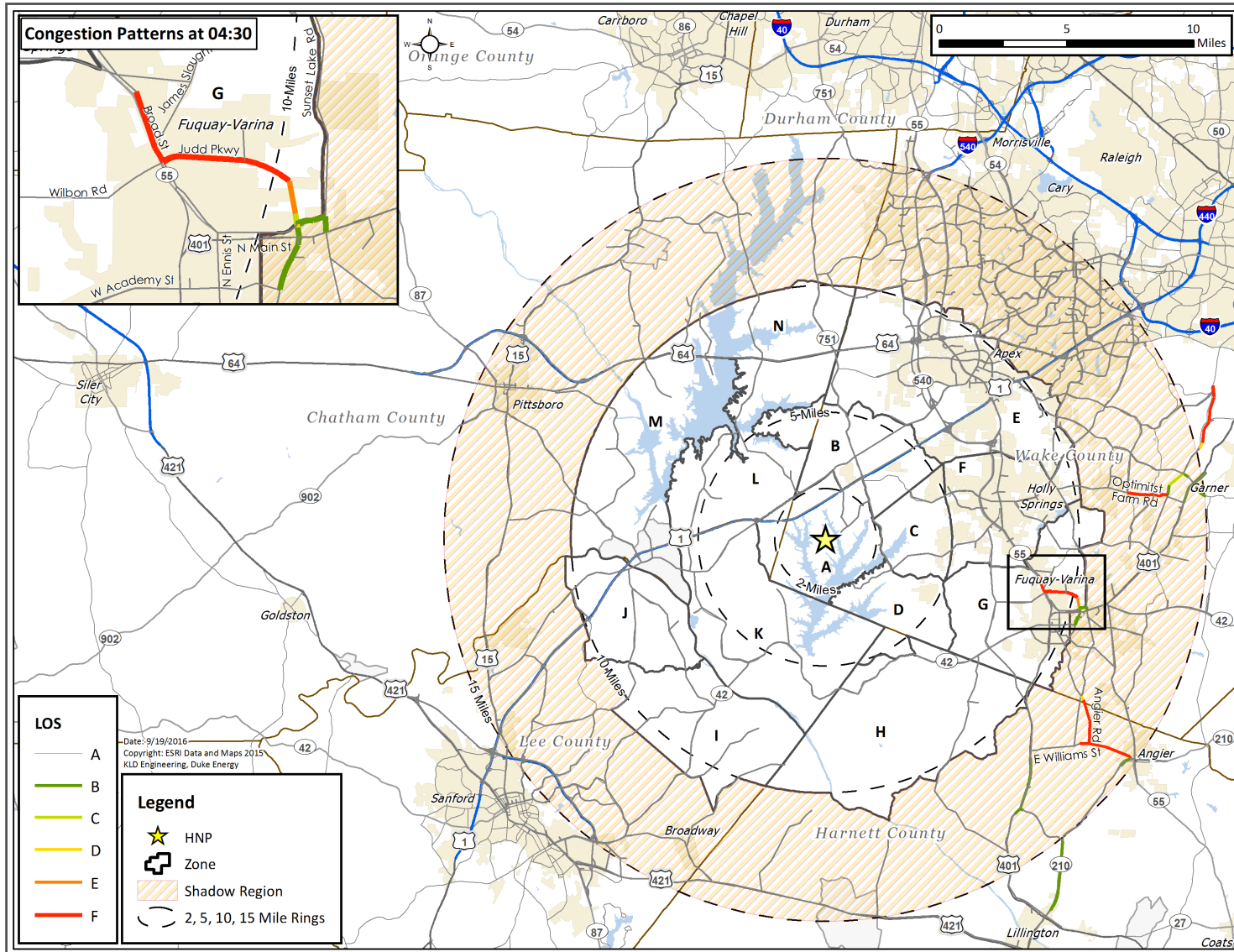

Figure 7-8. Congestion Patterns at 4 Hours 30 Minutes after the Advisory to Evacuate

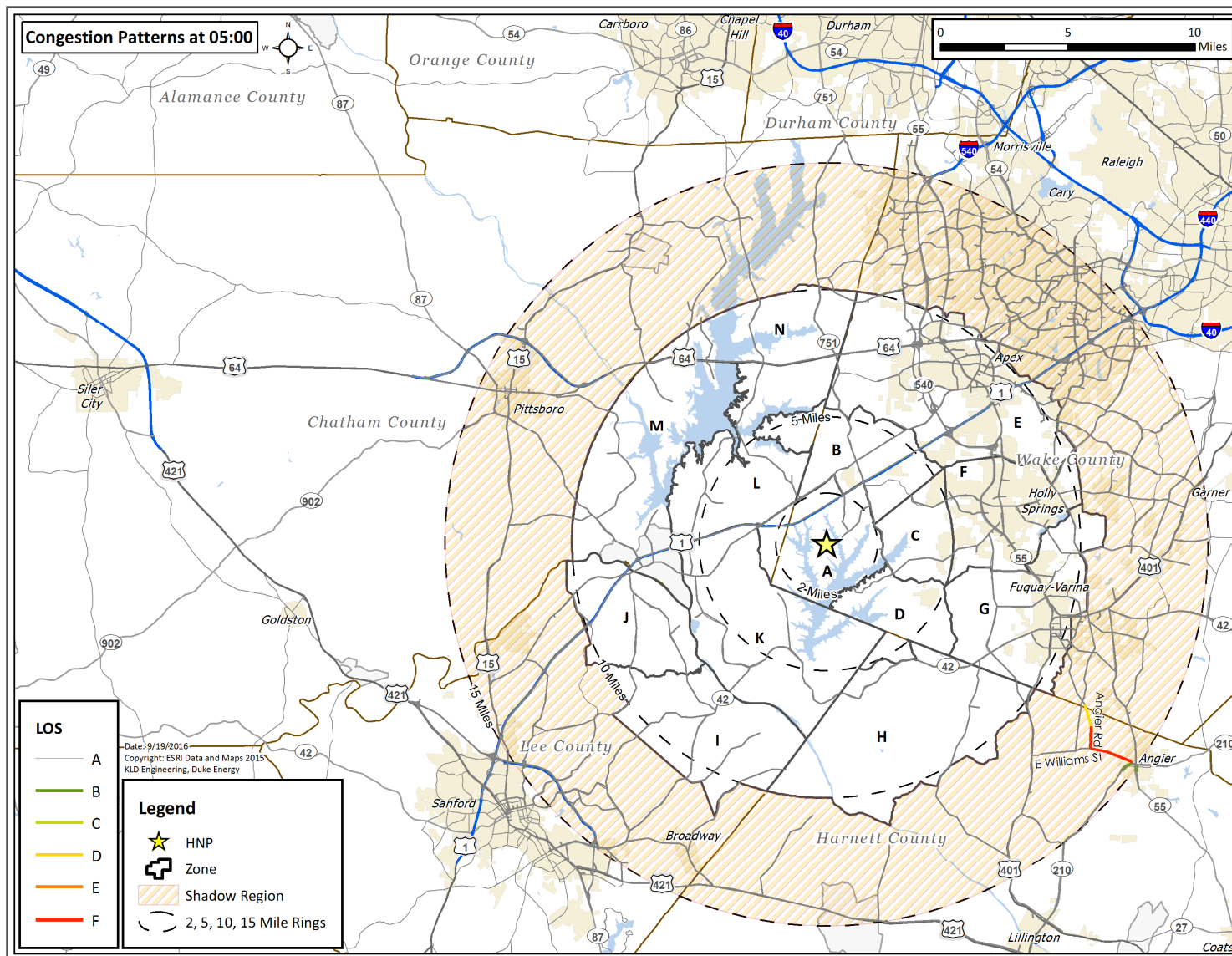

Figure 7-9. Congestion Patterns at 5 Hours after the Advisory to Evacuate

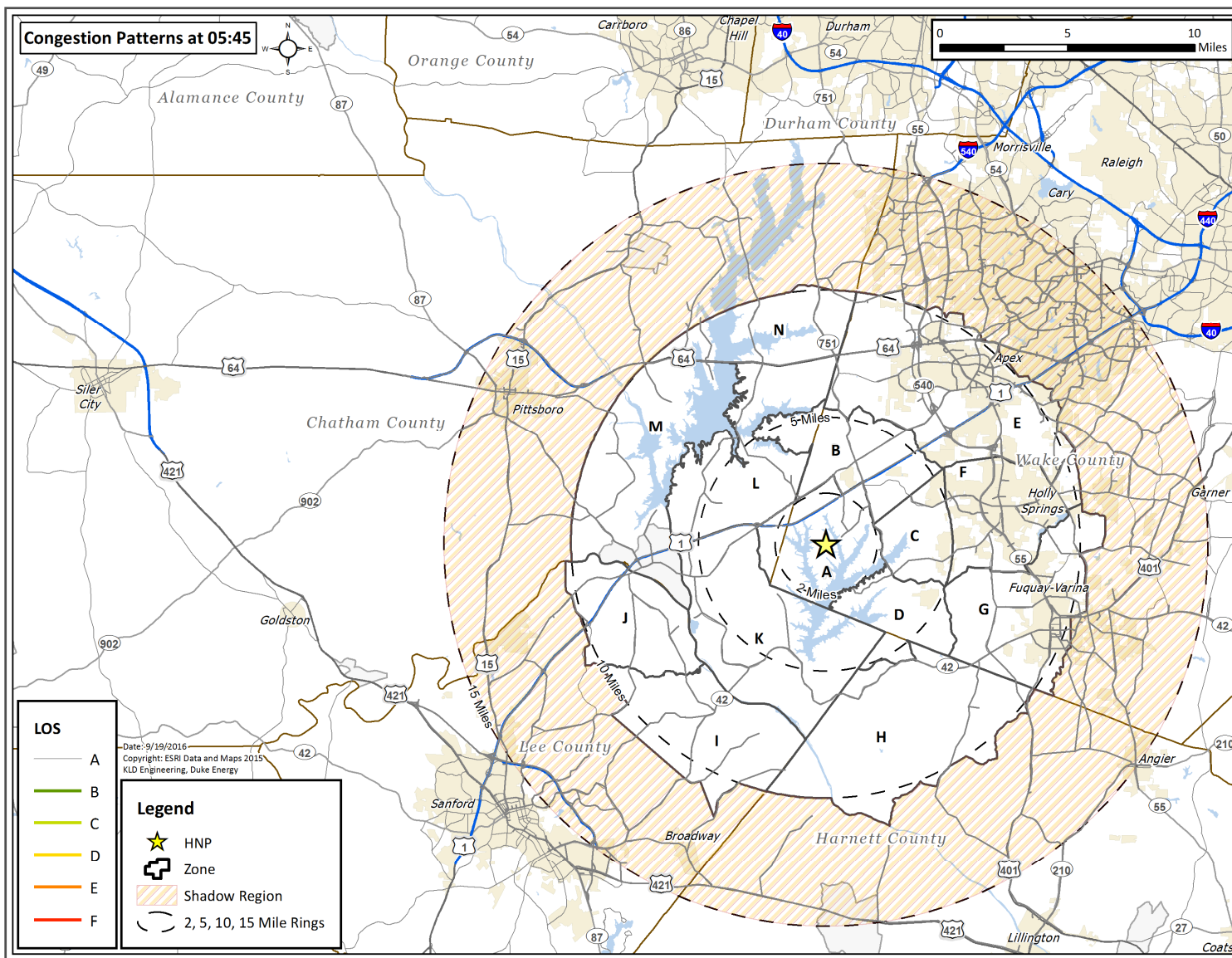

Figure 7-10. Congestion Patterns at 5 Hours 45 Minutes after the Advisory to Evacuate

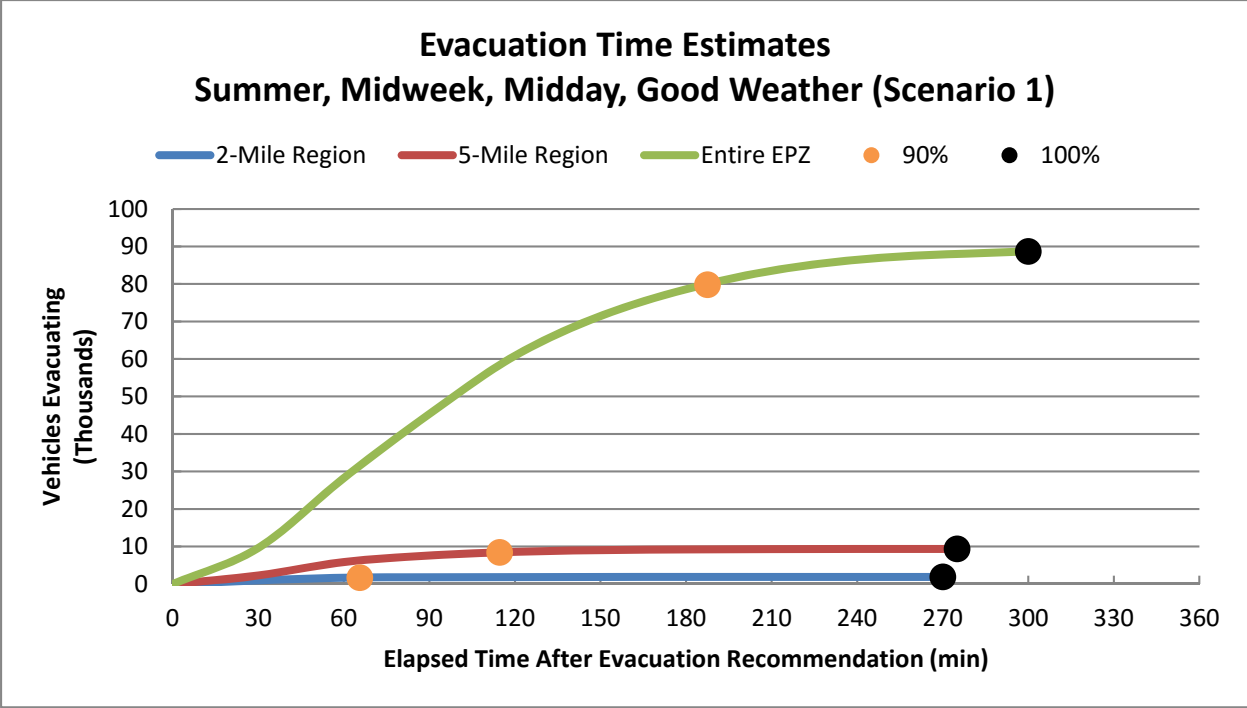

Figure 7-11. Evacuation Time Estimates - Scenario 1 for Region R03

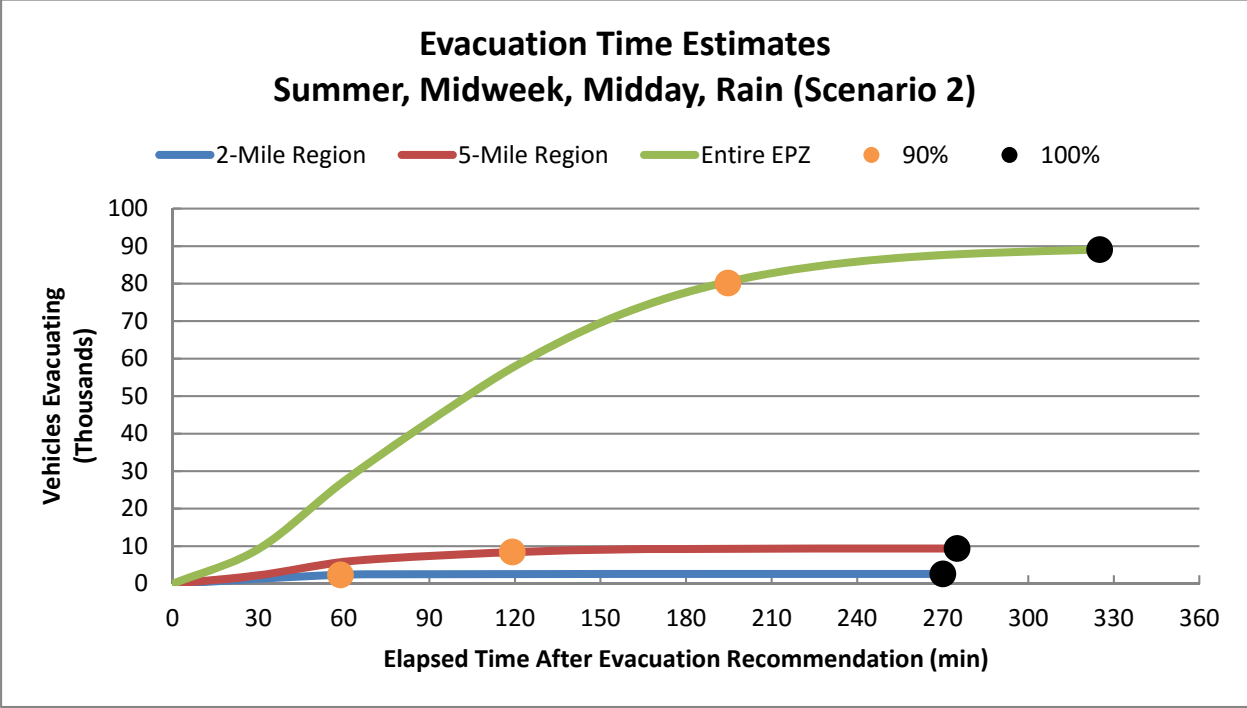

Figure 7-12. Evacuation Time Estimates - Scenario 2 for Region R03

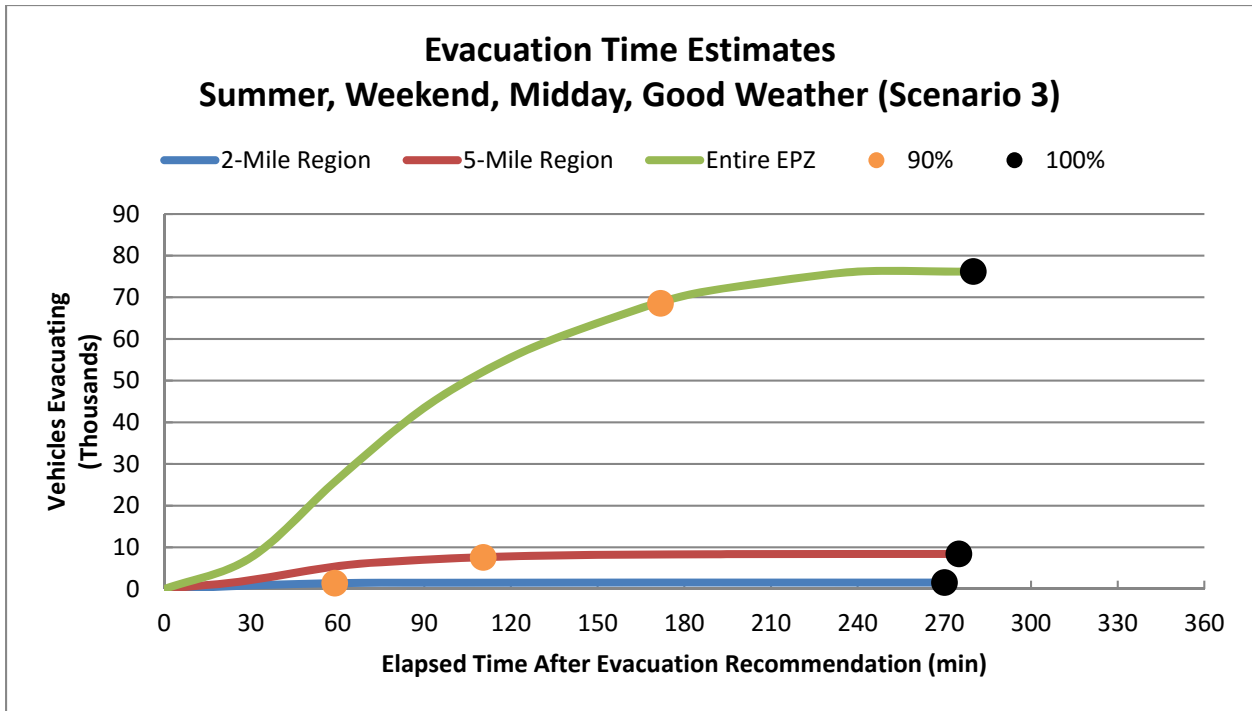

Figure 7-13. Evacuation Time Estimates - Scenario 3 for Region R03

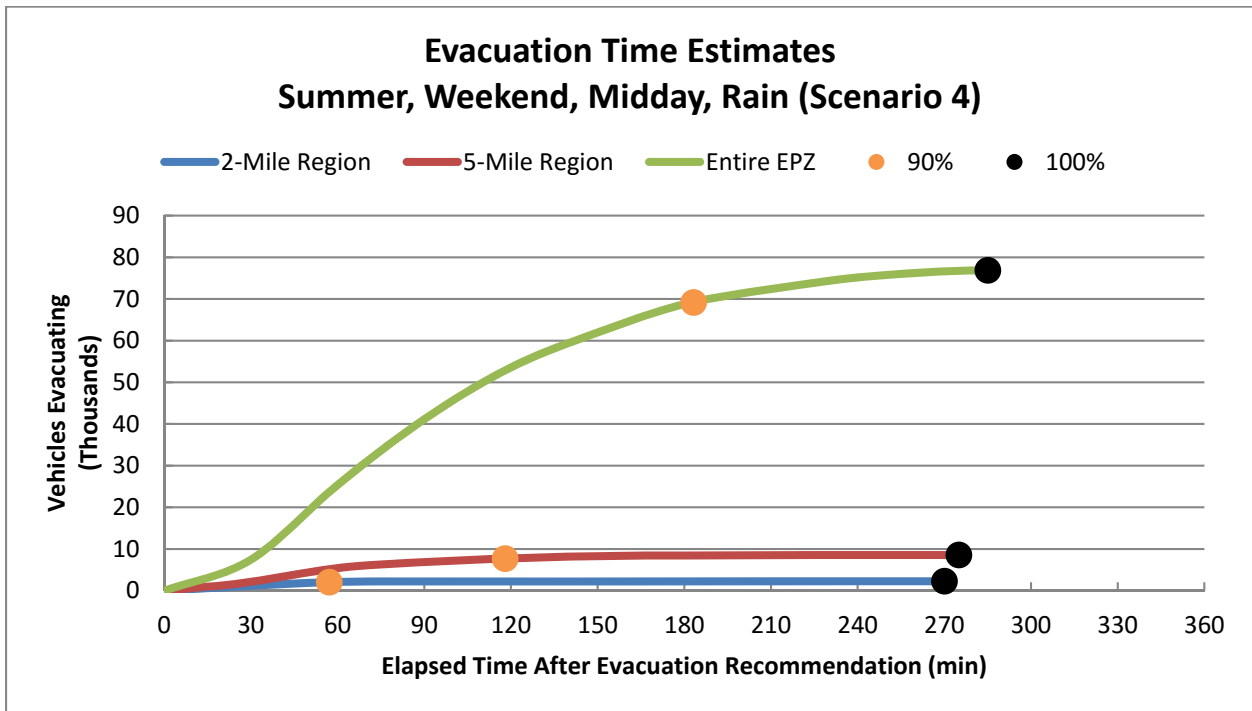

Figure 7-14. Evacuation Time Estimates - Scenario 4 for Region R03

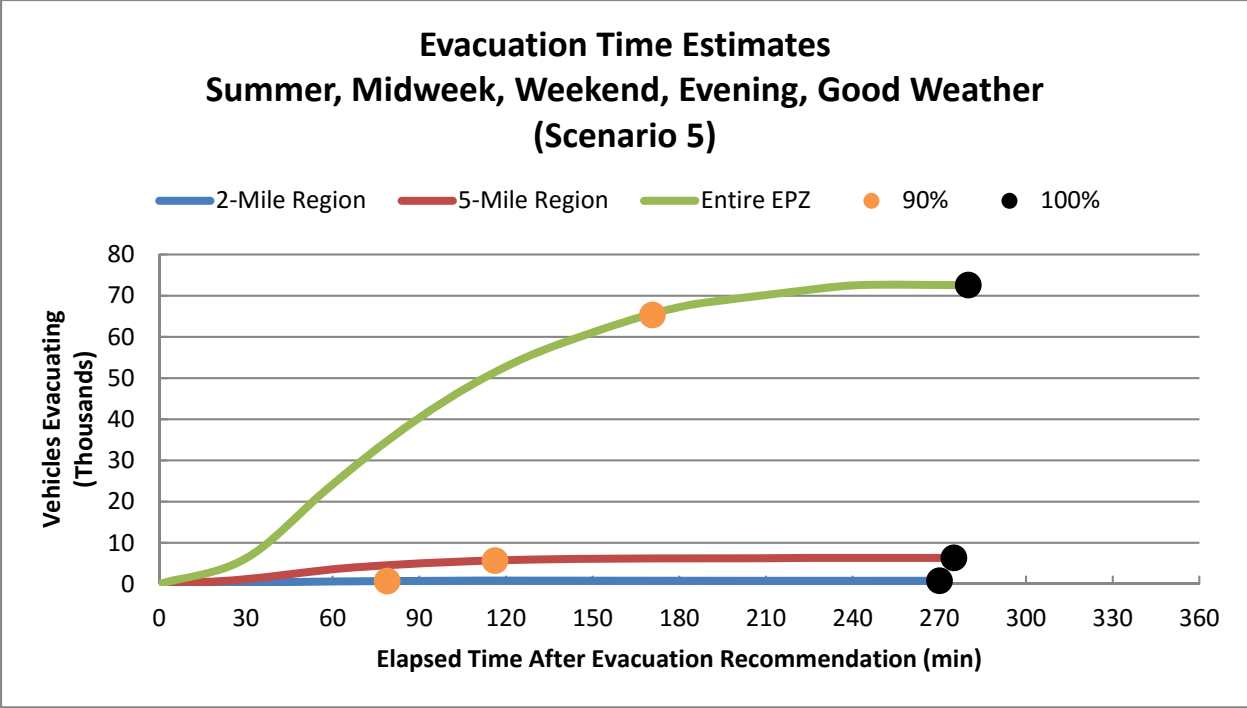

Figure 7-15. Evacuation Time Estimates - Scenario 5 for Region R03

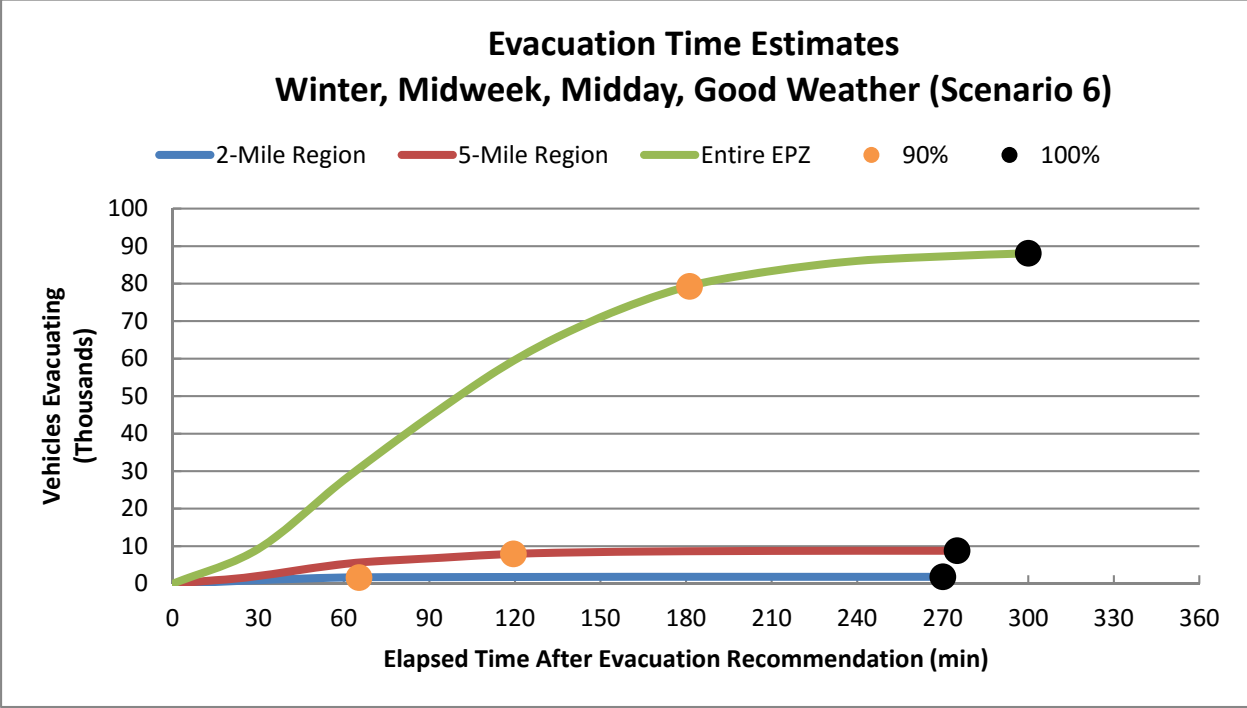

Figure 7-16. Evacuation Time Estimates - Scenario 6 for Region R03

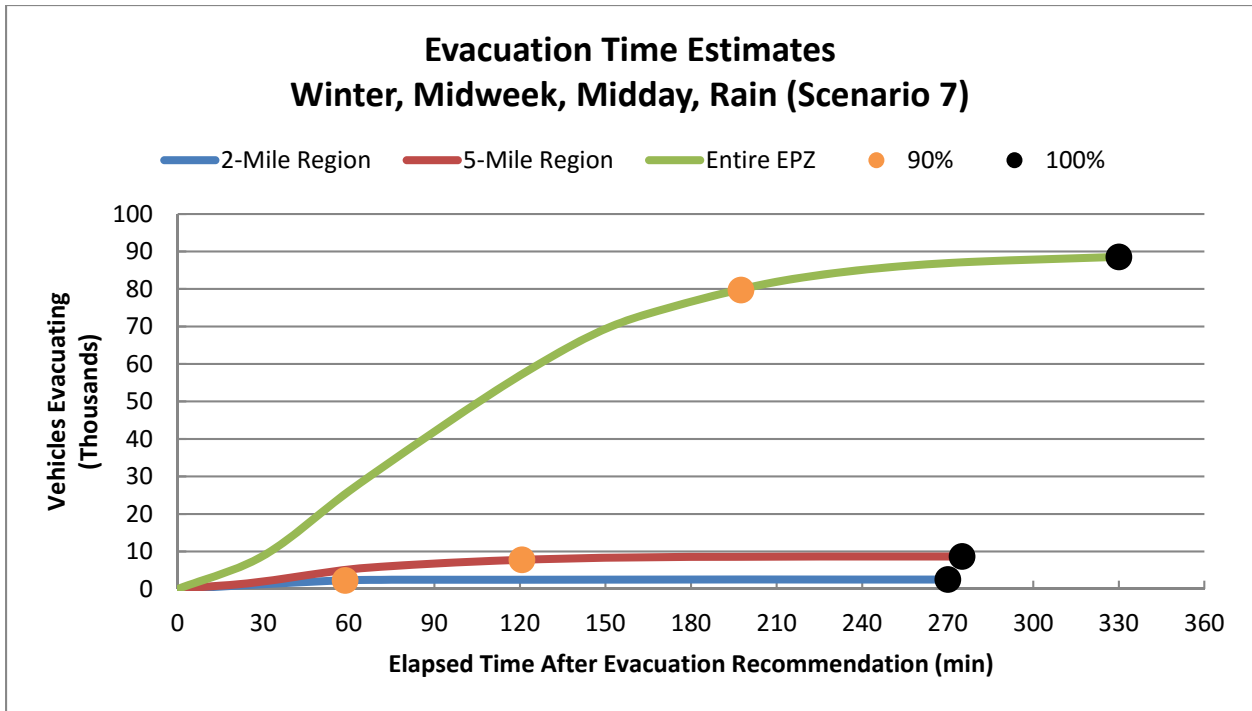

Figure 7-17. Evacuation Time Estimates - Scenario 7 for Region R03

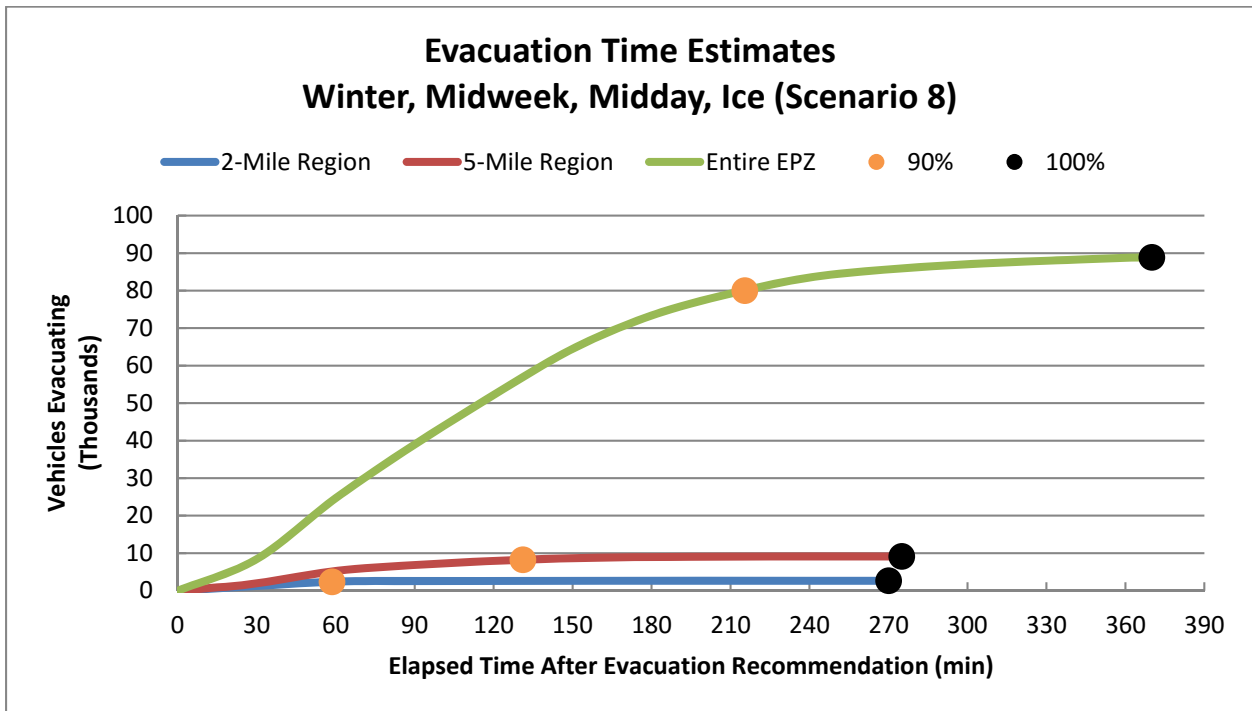

Figure 7-18. Evacuation Time Estimates - Scenario 8 for Region R03

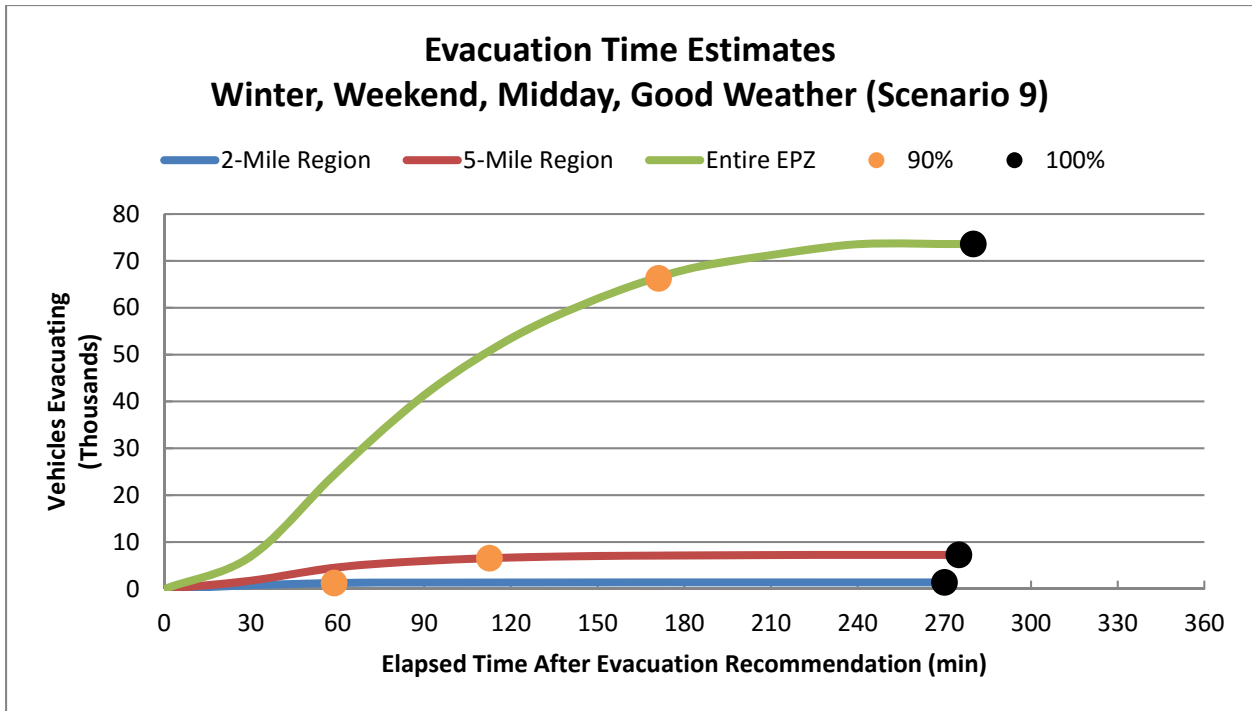

Figure 7-19. Evacuation Time Estimates - Scenario 9 for Region R03

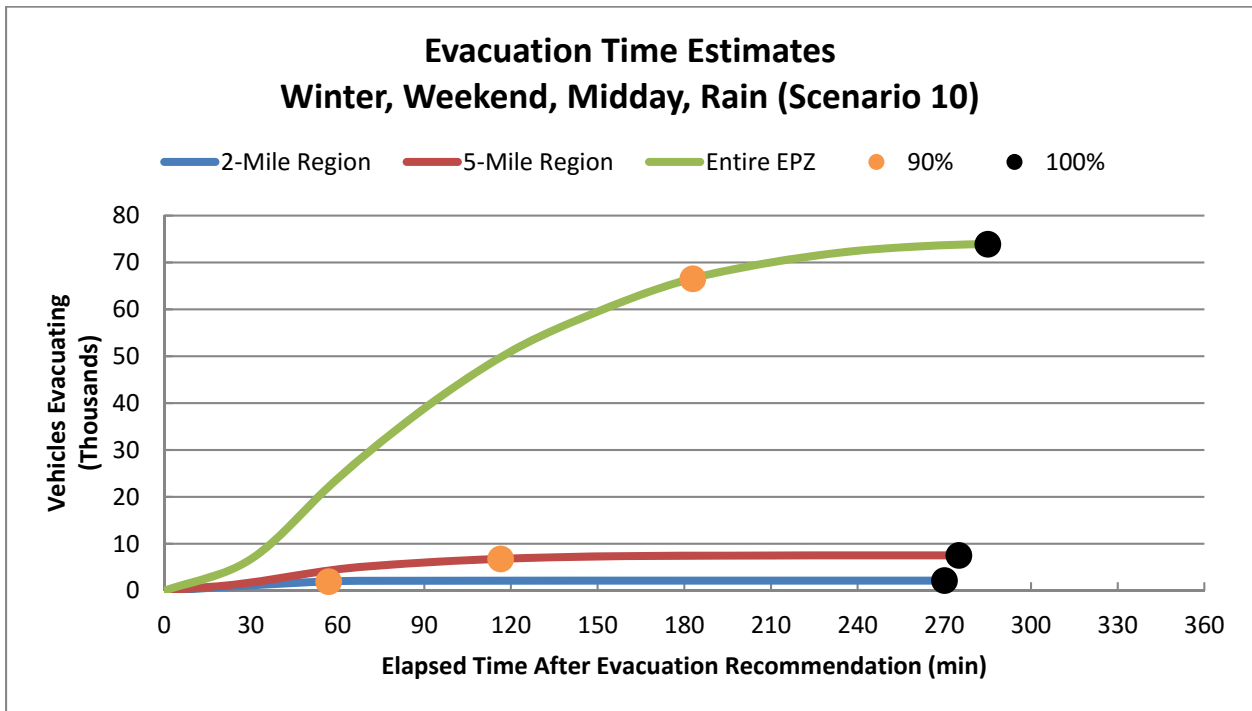

Figure 7-20. Evacuation Time Estimates - Scenario 10 for Region R03

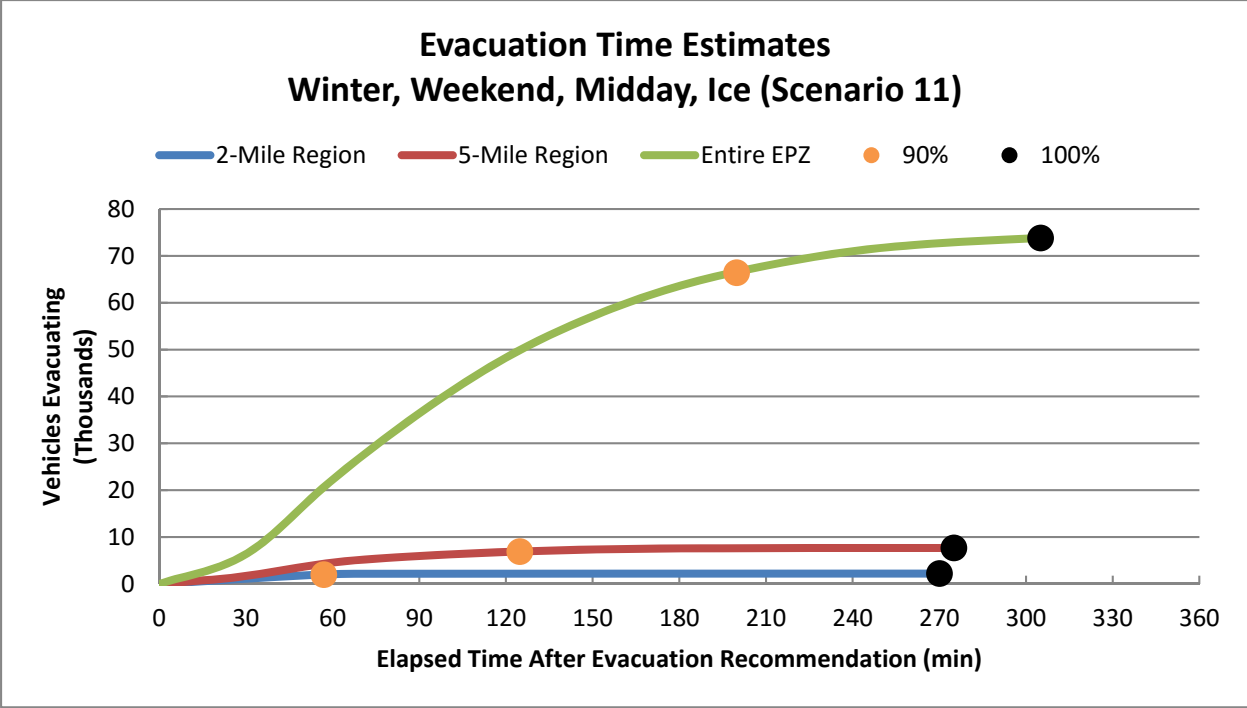

Figure 7-21. Evacuation Time Estimates - Scenario 11 for Region R03

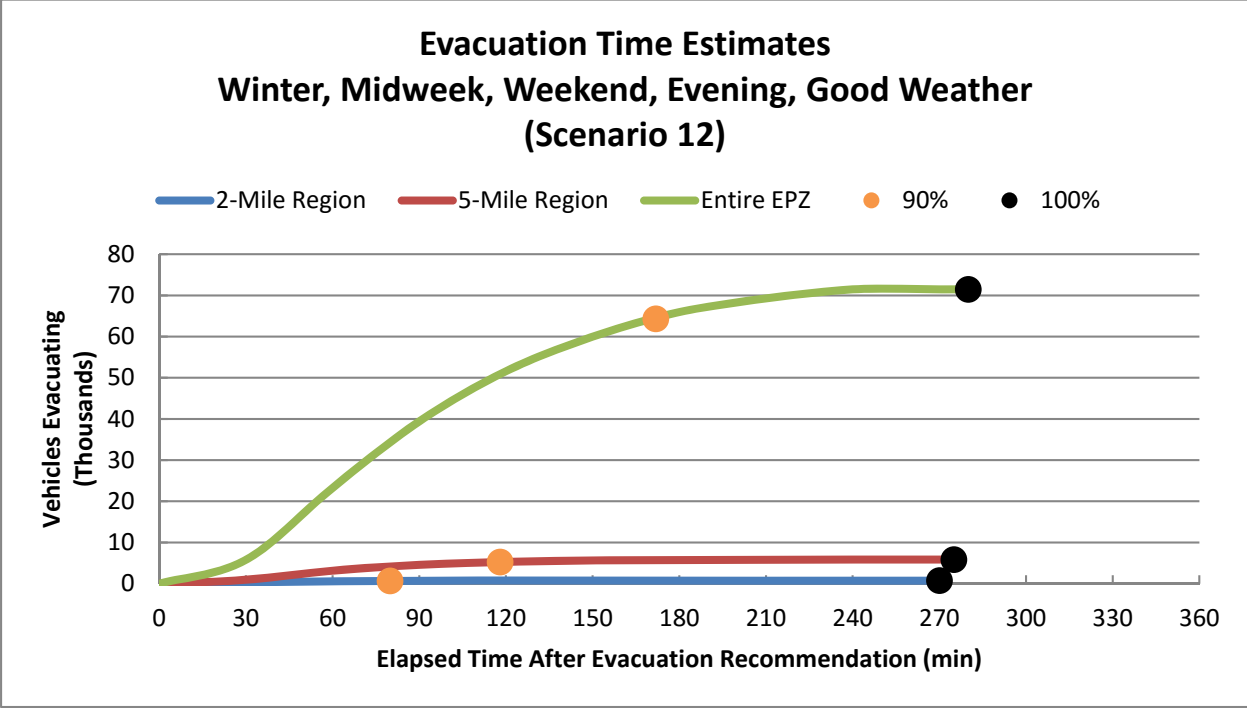

Figure 7-22. Evacuation Time Estimates - Scenario 12 for Region R03

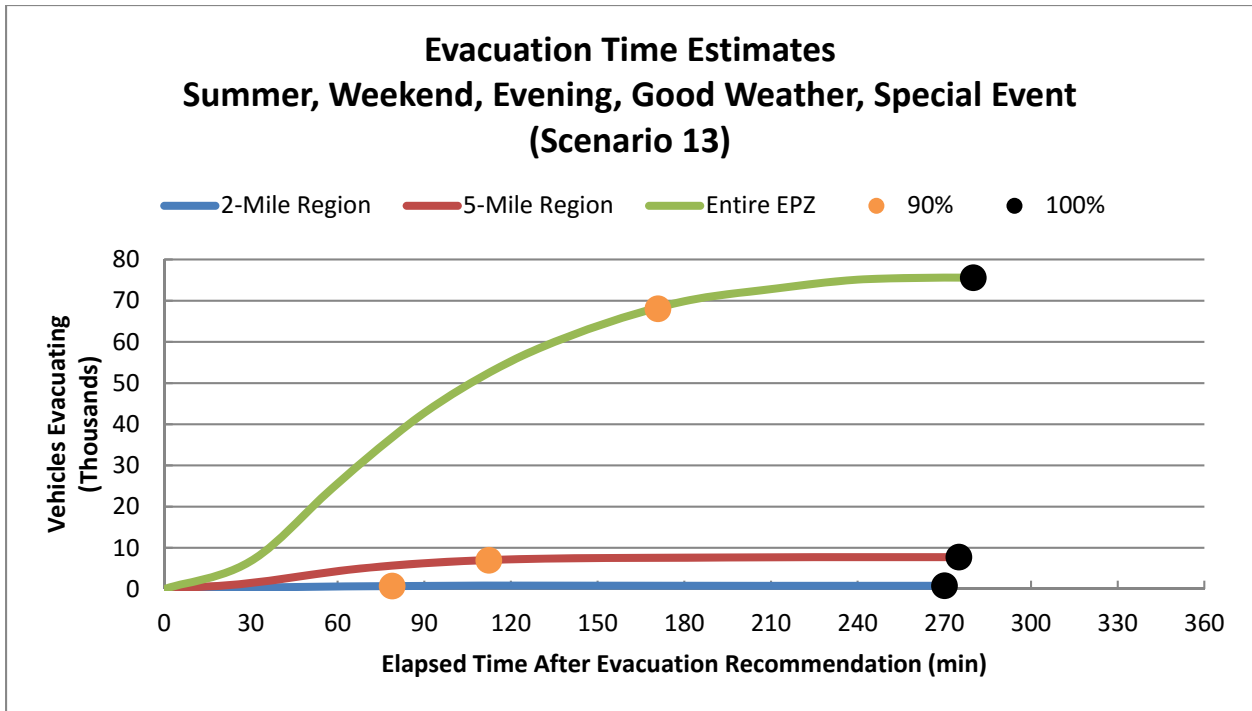

Figure 7-23. Evacuation Time Estimates - Scenario 13 for Region R03

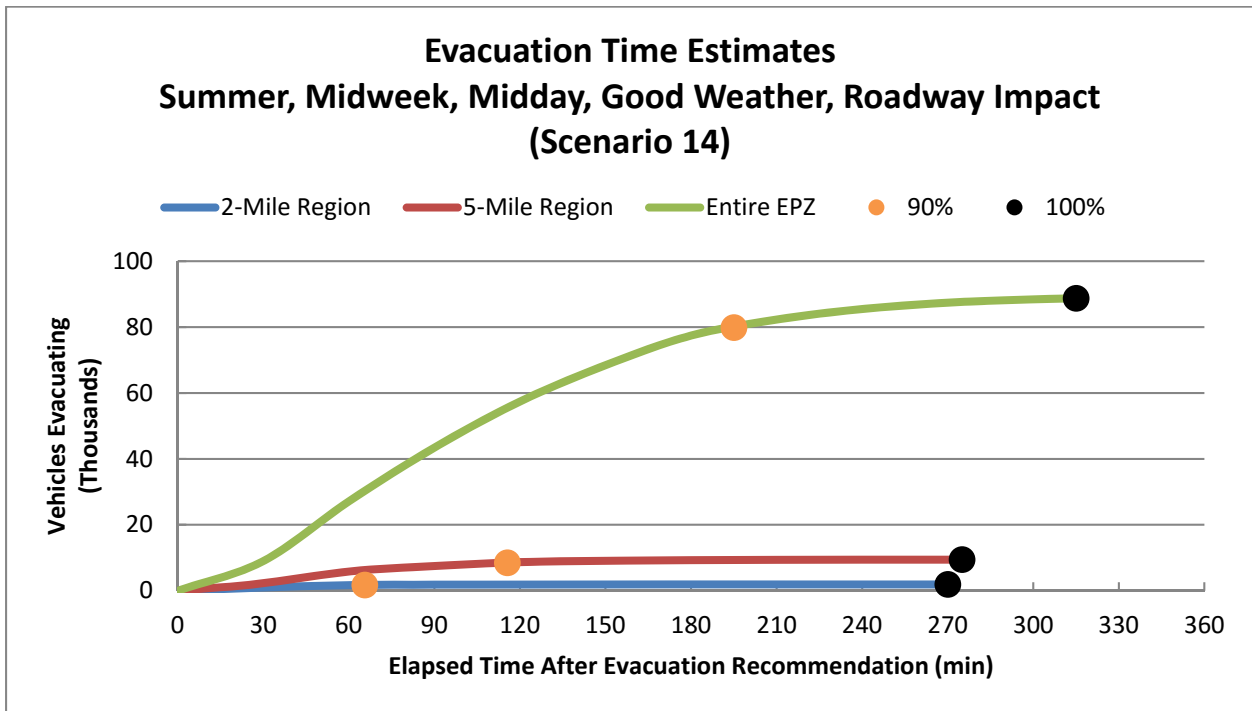

Figure 7-24. Evacuation Time Estimates - Scenario 14 for Region R03

8 TRANSIT-DEPENDENT AND SPECIAL FACILITY EVACUATION TIME ESTIMATES

This section details the analyses applied and the results obtained in the form of evacuation time estimates for transit vehicles (buses, ambulances, and wheelchair transport vehicles). The demand for transit service reflects the needs of three population groups: (1) residents with no vehicles available; (2) residents of special facilities such as schools, child care centers, and medical facilities; and (3) homebound special needs population.

These transit vehicles mix with the general evacuation traffic that is comprised mostly of “passenger cars” (pc’s). The presence of each transit vehicle in the evacuating traffic stream is represented within the modeling paradigm described in Appendix D as equivalent to two pc’s. This equivalence factor represents the longer size and more sluggish operating characteristics of a transit vehicle, relative to those of a pc.

Transit vehicles must be mobilized in preparation for their respective evacuation missions. Specifically:

- Bus drivers must be alerted
- They must travel to the bus depot
- They must be briefed there and assigned to a route or facility

These activities consume time. Based on discussion with the offsite agencies, it is estimated that bus mobilization time will average approximately 90 minutes extending from the Advisory to Evacuate, to the time when buses first arrive at the facility to be evacuated. The location of bus depots impacts the time to travel from the bus depots to the facilities being evacuated. Locations of bus depots were not identified in this study. Rather, the offsite agencies were asked to factor the location of the depots and the distance to the EPZ into the estimate of mobilization time.

During this mobilization period, other mobilization activities are taking place. One of these is the action taken by parents, neighbors, relatives and friends to pick up children from school prior to the arrival of buses, so that they may join their families. Virtually all studies of evacuations have concluded that this “bonding” process of uniting families is universally prevalent during emergencies and should be anticipated in the planning process. The current public information disseminated to residents of the HNP EPZ indicates that schoolchildren (includes private schools and child care centers) will be evacuated to relocation schools where they can be picked up by their parents.

As discussed in Section 2, this study assumes a rapidly escalating event at the plant wherein evacuation is ordered promptly and no early protective actions have been implemented. Therefore, children are evacuated to relocation schools. Picking up children at school could add to traffic congestion at the schools, delaying the departure of the buses evacuating schoolchildren, which may have to return in a subsequent “wave” to the EPZ to evacuate the transit-dependent population. This report provides estimates of buses under the assumption that no children will be picked up by their parents (in accordance with NUREG/CR-7002), to present an upper bound estimate of buses required.

The procedure for computing transit-dependent ETE is to:

- Estimate demand for transit service
- Estimate time to perform all transit functions
- Estimate route travel times to the EPZ boundary and to the relocation schools and reception centers

8.1 Transit Dependent People Demand Estimate

The 2012 telephone survey (see Appendix F) results were used to estimate the portion of the population requiring transit service:

- Those persons in households that do not have a vehicle available.
- Those persons in households that do have vehicle(s) that would not be available at the time the evacuation is advised.

In the latter group, the vehicle(s) may be used by a commuter(s) who does not return (or is not expected to return) home to evacuate the household.

Table 8-1 presents estimates of transit-dependent people. Note:

- Estimates of persons requiring transit vehicles include schoolchildren. For those evacuation scenarios where children are at school when an evacuation is ordered, separate transportation is provided for the schoolchildren. The actual need for transit vehicles by residents is thereby less than the given estimates. However, estimates of transit vehicles are not reduced when schools are in session.
- It is reasonable and appropriate to consider that many transit-dependent persons will evacuate by ride-sharing with neighbors, friends or family. For example, nearly 80 percent of those who evacuated from Mississauga, Ontario who did not use their own cars, shared a ride with neighbors or friends. Other documents report that approximately 70 percent of transit dependent persons were evacuated via ride sharing. **We will adopt a conservative estimate that 50 percent of transit dependent persons will ride share, in accordance with NUREG/CR-7002.**

The estimated number of bus trips needed to service transit-dependent persons is based on an estimate of average bus occupancy of 30 persons at the conclusion of the bus run. Transit vehicle seating capacities typically equal or exceed 60 children on average (roughly equivalent to 40 adults). If transit vehicle evacuees are two thirds adults and one third children, then the number of “adult seats” taken by 30 persons is $20 + (2/3 \times 10) = 27$. On this basis, the average load factor anticipated is $(27/40) \times 100 = 68$ percent. Thus, if the actual demand for service exceeds the estimates of Table 8-1 by 50 percent, the demand for service can still be accommodated by the available bus seating capacity.

$$\left[20 + \left(\frac{2}{3} \times 10 \right) \right] \div 40 \times 1.5 = 1.00$$

Table 8-1 indicates that transportation must be provided for 4,349 people. Therefore, a total of

145 bus runs are required from a capacity standpoint. As discussed below in Section 8.4, in order to service all of the transit dependent population, and have at least one bus drive through each of the Zones picking up transit dependent people, **147 bus runs** are used in the ETE calculations.

To illustrate this estimation procedure, we calculate the number of persons, P, requiring public transit or ride-share, and the number of buses, B, required for the HNP EPZ:

$$P = \text{No. of HH} \times \sum_{i=0}^n \{(\% \text{ HH with } i \text{ vehicles}) \times [(Average \text{ HH Size}) - i]\} \times A^i C^i$$

Where,

A = Percent of households with commuters

C = Percent of households who will not await the return of a commuter

$$P = 46,638 \times [0.0186 \times 2.00 + 0.190 \times (1.86 - 1) \times 0.68 \times 0.59 + 0.515 \times (3.01 - 2) \times (0.68 \times 0.59)^2] = 8,697$$

$$B = (0.5 \times P) \div 30 = (0.5 \times 8,697) \div 30 = 145$$

These calculations, based on the 2012 telephone survey results, are explained as follows:

- All members (2.00 avg.) of households (HH) with no vehicles (1.86%) will evacuate by public transit or ride-share. The term 46,638 (number of households) x 0.0186 x 2.00, accounts for these people.
- The members of HH with 1 vehicle away (19.0%), who are at home, equal (1.86-1). The number of HH where the commuter will not return home is equal to (46,638 x 0.190 x 0.68 x 0.59), as 68% of EPZ households have a commuter, 59% of which would not return home in the event of an emergency. The number of persons who will evacuate by public transit or ride-share is equal to the product of these two terms.
- The members of HH with 2 vehicles that are away (51.5%), who are at home, equal (3.01 - 2). The number of HH where neither commuter will return home is equal to 46,638 x 0.515 x (0.68 x 0.59)². The number of persons who will evacuate by public transit or ride-share is equal to the product of these two terms (the last term is squared to represent the probability that neither commuter will return).
- Households with 3 or more vehicles are assumed to have no need for transit vehicles.
- The total number of persons requiring public transit is the sum of such people in HH with no vehicles, or with 1 or 2 vehicles that are away from home.

The estimate of transit-dependent population in Table 8-1 far exceeds the number of registered transit-dependent persons in the EPZ as provided by the counties in 2012 and projected to 2016, utilizing the County annual growth rates (discussed below in Section 8.5). This is consistent with the findings of NUREG/CR-6953, Volume 2, in that a large majority of the

transit-dependent population within the EPZs of U.S. nuclear plants does not register with their local emergency response agency.

8.2 School Population – Transit Demand

Table 8-2 presents the school population and transportation requirements for the direct evacuation of all schools and child care centers within the EPZ for the 2015 to 2016 school year. The column in Table 8-2 entitled “Buses Required” specifies the number of buses required for each school under the following set of assumptions and estimates:

- No students will be picked up by their parents prior to the arrival of the buses.
- While many high school students commute to school using private automobiles (as discussed in Section 2.4 of NUREG/CR-7002), the estimate of buses required for school evacuation does not consider the use of these private vehicles.
- Bus capacity, expressed in students per bus, is set to 70 for primary schools and child care centers and 50 for middle and high schools.
- Those staff members who do not accompany the students will evacuate in their private vehicles.
- No allowance is made for student absenteeism, typically 3 percent daily.

Implementation of a process to confirm individual school transportation needs prior to bus dispatch may improve bus utilization. In this way, the number of buses dispatched to the schools will reflect the actual number needed. The need for buses would be reduced by any high school students who have evacuated using private automobiles (if permitted by school authorities). Those buses originally allocated to evacuate schoolchildren that are not needed due to children being picked up by their parents, can be gainfully assigned to service other facilities or those persons who do not have access to private vehicles or to ride-sharing.

Table 8-3 presents a list of the relocation schools for each evacuating school and child care center in the EPZ. Children will be transported to these relocation schools where they will be subsequently retrieved by their respective families.

8.3 Medical Facility Demand

Table 8-4 presents the census of medical facilities in the EPZ. A total of 884 people have been identified as living in, or being treated in, these facilities. Since the average number of patients at these facilities fluctuates often, the capacity, current census and breakdown of ambulatory, wheelchair bound and bedridden patients for each facility were provided by the county emergency management agencies.

The transportation requirements for the medical facility population are also presented in Table 8-4. The number of ambulance runs is determined by assuming that 2 patients can be accommodated per ambulance trip; the number of wheelchair bus runs assumes 15 wheelchairs per trip; the number of wheelchair van runs assumes 4 wheelchairs per trip; the number of minivan runs assumes 5 patients per trip; the number of passenger car runs assumes

4 patients per trip, and the number of bus runs estimated assumes 30 ambulatory patients per trip.

8.4 Evacuation Time Estimates for Transit Dependent People

EPZ bus resources are assigned to evacuating schoolchildren (if school is in session at the time of the ATE) as the first priority in the event of an emergency. In the event that the allocation of buses dispatched from the depots to the various facilities and to the bus routes is somewhat inefficient, or if there is a shortfall of available drivers, then there may be a need for some buses to return to the EPZ from the reception center or relocation school after completing their first evacuation trip, to complete a “second wave” of providing transport service to evacuees. For this reason, the ETE for the transit-dependent population will be calculated for both a one wave transit evacuation and for two waves. Of course, if the impacted Evacuation Region is other than R03 (the entire EPZ), then there will likely be ample transit resources relative to demand in the impacted Region and this discussion of a second wave would likely not apply. It is assumed that there are enough drivers available to man all resources listed in Table 8-5.

When school evacuation needs are satisfied, subsequent assignments of buses to service the transit-dependent should be sensitive to their mobilization time. Clearly, the buses should be dispatched after people have completed their mobilization activities and are in a position to board the buses when they arrive at the various routes described below.

Evacuation Time Estimates for transit trips were developed using both good weather and adverse weather conditions. Figure 8-1 presents the chronology of events relevant to transit operations. The elapsed time for each activity will now be discussed with reference to Figure 8-1.

Activity: Mobilize Drivers (A→B→C)

Mobilization is the elapsed time from the Advisory to Evacuate until the time the buses arrive at the facility to be evacuated. Based on discussions with the county emergency management agencies, drivers would require 90 minutes to be contacted, to travel to the depot, be briefed, and to travel to the transit-dependent facilities for a rapidly escalating radiological emergency with no observable indication before the fact. Mobilization time is slightly longer in adverse weather – 100 minutes when raining, 110 minutes with ice.

Activity: Board Passengers (C→D)

Based on discussions with the offsite agencies, a loading time of 15 minutes (20 minutes for rain and 25 minutes for ice) for school buses is used.

For multiple stops along a pick-up route (transit-dependent bus routes) estimation of travel time must allow for the delay associated with stopping and starting at each pick-up point. The time, t , required for a bus to decelerate at a rate, “ a ”, expressed in ft/sec/sec, from a speed, “ v ”, expressed in ft/sec, to a stop, is $t = v/a$. Assuming the same acceleration rate and final speed following the stop yields a total time, T , to service boarding passengers:

$$T = t + B + t = B + 2t = B + \frac{2v}{a},$$

Where B = Dwell time to service passengers. The total distance, “s” in feet, travelled during the deceleration and acceleration activities is: $s = v^2/a$. If the bus had not stopped to service passengers, but had continued to travel at speed, v, then its travel time over the distance, s, would be: $s/v = v/a$. Then the total delay (i.e. pickup time, P) to service passengers is:

$$P = T - \frac{v}{a} = B + \frac{v}{a}$$

Assigning reasonable estimates:

- B = 50 seconds: a generous value for a single passenger, carrying personal items, to board per stop
- v = 25 mph = 37 ft/sec
- a = 4 ft/sec/sec, a moderate average rate

Then, $P \approx 1$ minute per stop. Allowing 30 minutes pick-up time per bus run implies 30 stops per run, for good weather. It is assumed that bus acceleration and speed will be less in rain; total loading time is 40 minutes per bus in rain, 50 minutes in ice.

Activity: Travel to EPZ Boundary (D→E)

School and Child Care Center Evacuation

The transportation resources available were provided by the EPZ county emergency management agencies and are summarized in Table 8-5. Also included in the table are the number of buses needed to evacuate schools and child care centers, medical facilities, transit-dependent population and homebound special needs persons (discussed below in Section 8.5). These numbers indicate there are sufficient bus, wheelchair transport, passenger car, and ambulance resources available to evacuate everyone in a single wave. There are not enough minivans to evacuate in a single wave. There are surplus buses and passenger cars available to supplement the shortage in minivans such that all people can evacuate in a single wave.

The buses servicing the schools and child care centers are ready to begin their evacuation trips at 105 minutes after the advisory to evacuate – 90 minutes mobilization time plus 15 minutes loading time – in good weather. The UNITES software discussed in Section 1.3 was used to define bus routes along the most likely path from a school being evacuated to the EPZ boundary, traveling toward the appropriate relocation school. This is done in UNITES by interactively selecting the series of nodes from the school to the EPZ boundary. Each bus route is given an identification number and is written to the DYNEV II input stream. DYNEV computes the route length and outputs the average speed for each 5 minute interval, for each bus route. The specified bus routes are documented in Table 8-6 (refer to the maps of the link-node analysis network in Appendix K for node locations). Data provided by DYNEV during the appropriate timeframe depending on the mobilization and loading times (i.e., 100 to 105 minutes after the advisory to evacuate for good weather) were used to compute the average speed for each route, as follows:

$$\begin{aligned}
 & \text{Average Speed } \left(\frac{\text{mi.}}{\text{hr}} \right) \\
 & = \left[\frac{\sum_{i=1}^n \text{length of link } i \text{ (mi)}}{\sum_{i=1}^n \left\{ \text{Delay on link } i \text{ (min.)} + \frac{\text{length of link } i \text{ (mi.)}}{\text{current speed on link } i \left(\frac{\text{mi.}}{\text{hr.}} \right)} \times \frac{60 \text{ min.}}{1 \text{ hr.}} \right\}} \right] \times \frac{60 \text{ min.}}{1 \text{ hr.}}
 \end{aligned}$$

The average speed computed (using this methodology) for the buses servicing each of the schools and child care centers in the EPZ is shown in Table 8-7 through Table 8-9, and in Table 8-11 through Table 8-13 for the transit vehicles evacuating transit-dependent persons, which are discussed later. The travel time to the EPZ boundary was computed for each bus using the computed average speed and the distance to the EPZ boundary along the most likely route out of the EPZ. The travel time from the EPZ boundary to the relocation school was computed assuming an average speed of 45 mph, 41 mph, and 36 mph for good weather, rain and ice, respectively. Speeds were reduced in Table 8-7 through Table 8-9 and in Table 8-11 through Table 8-13 to 45 mph (41 mph for rain – 10% decrease – and 36 mph for ice – 20% decrease) for those calculated bus speeds which exceeded 45 mph, as the school bus speed limit in North Carolina is 45 mph.

Table 8-7 (good weather), Table 8-8 (rain) and Table 8-9 (ice) present the following evacuation time estimates (rounded up to the nearest 5 minutes) for schools and child care centers in the EPZ: (1) The elapsed time from the Advisory to Evacuate until the bus exits the EPZ; and (2) The elapsed time until the bus reaches the relocation school.

The evacuation time out of the EPZ can be computed as the sum of times associated with Activities A→B→C, C→D, and D→E (For example: 90 min. + 15 + 7 = 1:55, for Moncure Elementary School, in good weather, rounded up to the nearest 5 minutes). The average single wave ETE for schools and child care centers is comparable (within 5 minutes) to the 90th percentile ETE for Region R03 for the general population during Scenario 6 conditions.

The evacuation time to the relocation school is determined by adding the time associated with Activity E→F (discussed below), to this EPZ evacuation time.

Evacuation of Transit-Dependent Population

The buses dispatched from the depots to service the transit-dependent evacuees will be scheduled so that they arrive at their respective routes after their passengers have completed their mobilization. As shown in Figure 5-4 (Residents with no Commuters), approximately 90 percent of the evacuees will complete their mobilization by the time buses will begin their routes, approximately 120 minutes after the Advisory to Evacuate.

In the 2007 ETE study done for HNP in support of the Combined License Application (COLA) for Units 2 and 3 to be built at the HNP site, a detailed computation of transit buses needed (based on population) for each Zone was done. Table 8-10 summarizes this computation and identifies

the routes that will service each Zone. The same routes and distribution of buses were also used in the 2012 ETE study for HNP. Zones E, F and G have the highest population and require more buses than any other Zones in Table 8-10.

Although Section 8.1 indicates that only 145 buses are needed from a capacity standpoint to service the transit dependent population, Table 8-10 indicates a total of 147 buses based on round-off error with the computations, and the need to have at least one bus service each Zone in the EPZ.

Those routes with multiple buses have been designed such that individual buses or groups of buses are dispatched using varying headways (5 to 30 minutes), as shown in Table 8-11 through Table 8-13. The use of bus headways ensures that those people who take longer to mobilize will be picked up. Mobilization time for the first buses to arrive at each route will be 120 minutes during good weather, 130 minutes in rain and 140 minutes in ice, to account for slower travel speeds and reduced roadway capacity in adverse weather.

Those buses servicing the transit-dependent evacuees will travel along their pick-up routes and then proceed out of the EPZ to their respective Reception Center. The county emergency plans do not identify pre-defined bus routes or pick-up points to service the transit-dependent population in the EPZ. The 10 bus routes shown graphically in Figure 8-2 and described in Table 8-10 were designed by KLD during the 2007 COLA ETE study to service the major routes through each Zone. It is assumed that residents will walk to the nearest major roadway and flag down a passing bus, and that they can arrive at the roadway within the 120 minute bus mobilization time (good weather).

As previously discussed, a pickup time of 30 minutes (good weather) is estimated for 30 individual stops to pick up passengers, with an average of one minute of delay associated with each stop. Longer pickup times of 40 minutes and 50 minutes are used for rain and ice, respectively.

The travel distance along the respective pick-up routes within the EPZ is estimated using the UNITES software. Bus travel times within the EPZ are computed using average speeds computed by DYNEV, using the aforementioned methodology that was used for school and child care center evacuation.

Table 8-11 through Table 8-13 present the transit-dependent population evacuation time estimates for each bus route calculated using the above procedures for good weather, rain and ice, respectively.

For example, the ETE for the first group of 3 buses servicing the southern portion of the EPZ (Route 40 – NC-42 spanning Zones G, H, I and K) is computed as $120 + 27 + 30 = 3:00$ for good weather (rounded up to nearest 5 minutes). Here, 27 minutes is the time to travel 20.2 miles at 45.0 mph, the average speed output by the model for this route starting at 120 minutes. The ETE for a second wave (discussed below) is presented in the event there is a shortfall of available buses or bus drivers; however, this is unlikely given the ample transportation resources spread between the four counties as shown in Table 8-5.

Activity: Travel to Relocation Schools and Reception Centers (E→F)

The distances from the EPZ boundary to the relocation schools and reception centers are measured using GIS software along the most likely route from the EPZ exit point to the reception center or relocation school. The relocation schools and reception centers are mapped in Figure 10-1. For a one-wave evacuation, this travel time outside the EPZ does not contribute to the ETE. For a two-wave evacuation, the ETE for buses must be considered separately, since it could exceed the ETE for the general population. Assumed bus speeds of 45 mph, 41 mph, and 36 mph for good weather, rain, and ice, respectively, will be applied for this activity for buses servicing the transit-dependent population.

Activity: Passengers Leave Bus (F→G)

A bus can empty within 5 minutes. The driver takes a 10 minute break.

Activity: Bus Returns to Route for Second Wave Evacuation (G→C)

The buses assigned to return to the EPZ to perform a “second wave” evacuation of transit-dependent evacuees will be those that have already evacuated transit-dependent people who mobilized more quickly. The first wave of transit-dependent people depart the bus, and the bus then returns to the EPZ, travels to its route and proceeds to pick up more transit-dependent evacuees along the route. The travel time back to the EPZ is equal to the travel time to the reception center.

The second-wave ETE for Route 40 (NC-42 spanning Zones G, H, I and K) is computed as follows for good weather:

- Bus arrives at reception center at 3:13 in good weather (3:00 to exit EPZ + 13 minute travel time to reception center).
- Bus discharges passengers (5 minutes) and driver takes a 10-minute rest: 15 minutes.
- Bus returns to EPZ, drives to the start of the route and completes second route: 13 minutes (equal to travel time to reception center) + 27 minutes (equal to travel time to start of route, i.e., 20.2 miles @ 45mph) + 27 minutes (equal to travel time for second route) = 67 minutes
- Bus completes pick-ups along route: 30 minutes.
- Bus exits EPZ at time 3:00 + 0:13 + 0:15 + 1:07 + 0:30 = 5:05 (rounded to nearest 5 minutes) after the Advisory to Evacuate.

The ETE for the completion of the second wave for all transit-dependent bus routes are provided in Table 8-11 through Table 8-13.

The average single wave ETE for the transit-dependent population is 35 minutes longer than the 90th percentile ETE for the evacuation of the general population in the entire EPZ (Region R03) during Scenario 6 conditions. Therefore, the evacuation of transit-dependents could impact protective action decision making. The average ETE for a two-wave evacuation of transit-dependent people also exceeds the ETE for the general population at the 90th percentile and could also impact protect action decision making.

The relocation of transit-dependent evacuees from the reception centers to congregate care centers, if the counties decide to do so, is not considered in this study.

Evacuation of Medical Facilities

The evacuation of these facilities is similar to school evacuation except:

- Buses are assigned on the basis of 30 patients to allow for staff to accompany the patients.
- Wheelchair buses can accommodate 15 patients.
- Wheelchair vans can accommodate 4 patients.
- Ambulances can accommodate 2 patients.
- Minivans can accommodate 5 patients
- Passenger cars can accommodate 4 patients.
- Based on feedback from the county emergency management agencies, loading times of 2 minutes, 7 minutes, and 15 minutes per patient are used for ambulatory, wheelchair bound, and bedridden patients, respectively.

The vehicles owned by/available to each medical facility were provided by the county emergency management agencies. It is assumed that facilities with a high wheelchair-bound population will evacuate using a wheelchair bus and that wheelchair vans will evacuate those facilities with a smaller wheelchair-bound population. It is assumed that Wake County medical facilities with a low ambulatory census will evacuate via minivans and passenger cars, since those are the transportation assets those facilities have on-site. Using the data provided, these assumptions, and the aforementioned vehicle capacities, Table 8-4 indicates that 16 bus runs, 15 wheelchair bus runs, 17 wheelchair van runs, 27 minivan runs, 10 passenger car runs and 55 ambulance runs are needed to service all of the medical facilities in the EPZ. As previously discussed the shortfall in minivans can be supplemented by the surplus bus and passenger car resources available.

As is done for the schools, it is estimated that mobilization time averages 90 minutes in good weather (100 in rain, 110 in ice). Specially trained medical support staff (working their regular shift) will be on site to assist in the evacuation of patients. Additional staff (if needed) could be mobilized over this same 90 minute timeframe.

Table 8-14 through Table 8-16 summarize the ETE for medical facilities within the EPZ for good weather, rain, and ice. The distances from the medical facilities to the EPZ boundary were estimated using GIS software. Average speeds output by the model for Scenario 6 (Scenario 7 for rain and Scenario 8 for ice) Region 3, capped at 45 mph (41 mph for rain and 36 mph for ice), are used to compute travel time to EPZ boundary. The travel time to the EPZ boundary is computed by dividing the distance to the EPZ boundary by the average travel speed. The ETE is the sum of the mobilization time, total passenger loading time, and travel time out of the EPZ. Concurrent loading on multiple buses, wheelchair buses/vans, minivans, passenger cars and ambulances at capacity is assumed such that the maximum loading times for buses (maximum capacity of 30 times 2 minutes per passenger), minivans (5 times 2), passenger cars (4 times 2), wheelchair buses (15 times 7), wheelchair vans (4 times 7), and ambulances (2 times 15) are 60,

10, 8, 105, 28 and 30 minutes, respectively. All ETE are rounded to the nearest 5 minutes.

For example, the calculation of ETE for Sanford Health & Rehabilitation with 41 ambulatory residents during good weather is:

$$\text{ETE: } 90 + 30 \times 2 + 3 = 153 \text{ minutes or } 2:35 \text{ (rounded up to the nearest 5 minutes.)}$$

It is assumed that the medical facility population is directly evacuated to appropriate host medical facilities outside of the EPZ. Relocation of this population to permanent facilities and/or passing through the reception center before arriving at the host facility are not considered in this analysis.

Average ETE for medical facilities are less than the 90th percentile ETE for the evacuation of the general population from Region R03 during Scenario 6 conditions, and will not impact protective action decision making.

8.5 Special Needs Population

The county emergency management agencies have a combined registration for transit-dependent and homebound special needs persons. Utilizing the same methodology as discussed in Section 3.1 for permanent residents, the annual growth rate by County (see Table 3-1), the 2012 special needs population provided by the counties was projected to 2016. Based on these projections, there are an estimated 21 homebound special needs people (16 ambulatory, 4 wheelchair-bound and 1 bedridden) within the Chatham County portion of the EPZ; 13 homebound special needs people (9 ambulatory, 3 wheelchair-bound and 1 bedridden) within the Harnett County portion of the EPZ; 3 homebound special needs people (all ambulatory) within the Lee County portion of the EPZ; and, 79 homebound special needs people (57 ambulatory, 14 wheelchair-bound and 8 bedridden) within the Wake County portion of the EPZ. This results in 85 ambulatory persons, 21 wheelchair-bound persons and 10 bedridden persons for a total special needs population of 116 people.

Parents are encouraged to register their children with the county if they would need a ride at any time to evacuate. As such, it is assumed that latchkey children, children who are at home while both parents are at work, are included in this data.

ETE for Homebound Special Needs Persons

Table 8-17 summarizes the ETE for homebound special needs people. The table is categorized by type of vehicle required and then broken down by weather condition. The table takes into consideration the deployment of multiple vehicles (not filled to capacity) to reduce the number of stops per vehicle. Due to the limitations on driving for Homebound Special Needs Persons, it is assumed they will be picked up from their homes. Furthermore, it is conservatively assumed that ambulatory and wheelchair bound special needs households are spaced 3 miles apart and bedridden households are spaced 5 miles apart. Van and bus speeds approximate 20 mph between households and ambulance speeds approximate 30 mph in good weather (10% slower in rain, 20% slower in ice). Mobilization times of 90 minutes were used (100 minutes for rain, and 110 minutes for ice). Loading times of 5 minutes per person are assumed for ambulatory

people, 7 minutes for wheelchair bound people and 15 minutes per person are assumed for bedridden people. The last HH is assumed to be 5 miles from the EPZ boundary, and the network-wide average speed, capped at 45 mph (41 mph for rain and 36 mph for ice), after the last pickup is used to compute travel time. ETE is computed by summing mobilization time, loading time at first household, travel to subsequent households, loading time at subsequent households, and travel time to EPZ boundary. All ETE are rounded to the nearest 5 minutes.

For example, assuming no more than one special needs person per HH implies that 85 ambulatory households need to be serviced. While only 3 buses are needed from a capacity perspective, if 10 buses are deployed to service these special needs HH, then each would require at most 9 stops. The following outlines the ETE calculations:

1. Assume 10 buses are deployed, each with at most 9 stops, to service a total of 85 HH.
2. The ETE is calculated as follows:
 - a. Buses arrive at the first pickup location: 90 minutes
 - b. Load HH members at first pickup: 5 minutes
 - c. Travel to subsequent pickup locations: 8 @ 9 minutes (3 miles @ 20 mph) = 72 minutes
 - d. Load HH members at subsequent pickup locations: 8 @ 5 minutes = 40 minutes
 - e. Travel to EPZ boundary: 19 minutes (5 miles @ 15.7 mph – network wide average speed at this time).

ETE: $90 + 5 + 72 + 40 + 17 = 3:45$ rounded to the nearest 5 minutes

The average ETE for a single wave evacuation of the homebound special needs population is approximately 15 minutes longer than the general population ETE at the 90th percentile for an evacuation of the entire EPZ (Region R03), during Scenario 6 conditions. Therefore, the evacuation of transit-dependents could potentially impact protective action decision making.

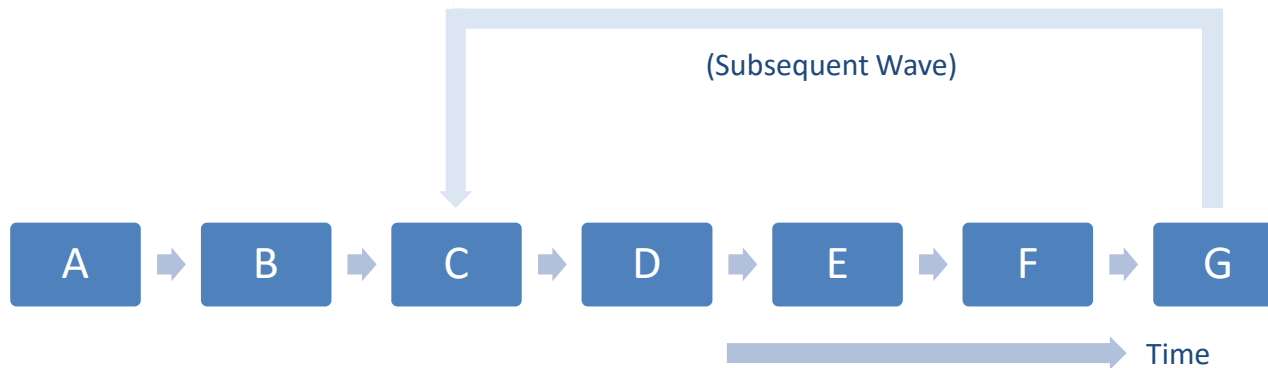

Event	
A	Advisory to Evacuate
B	Bus Dispatched from Depot
C	Bus Arrives at Facility/Pick-up Route
D	Bus Departs for Reception Center/Relocation School
E	Bus Exits Region
F	Bus Arrives at Reception Center/Relocation School
G	Bus Available for "Second Wave" Evacuation Service
Activity	
A→B	Driver Mobilization
B→C	Travel to Facility or to Pick-up Route
C→D	Passengers Board the Bus
D→E	Bus Travels Towards Region Boundary
E→F	Bus Travels Towards Reception Center/Relocation School Outside the EPZ
F→G	Passengers Leave Bus; Driver Takes a Break

Figure 8-1. Chronology of Transit Evacuation Operations

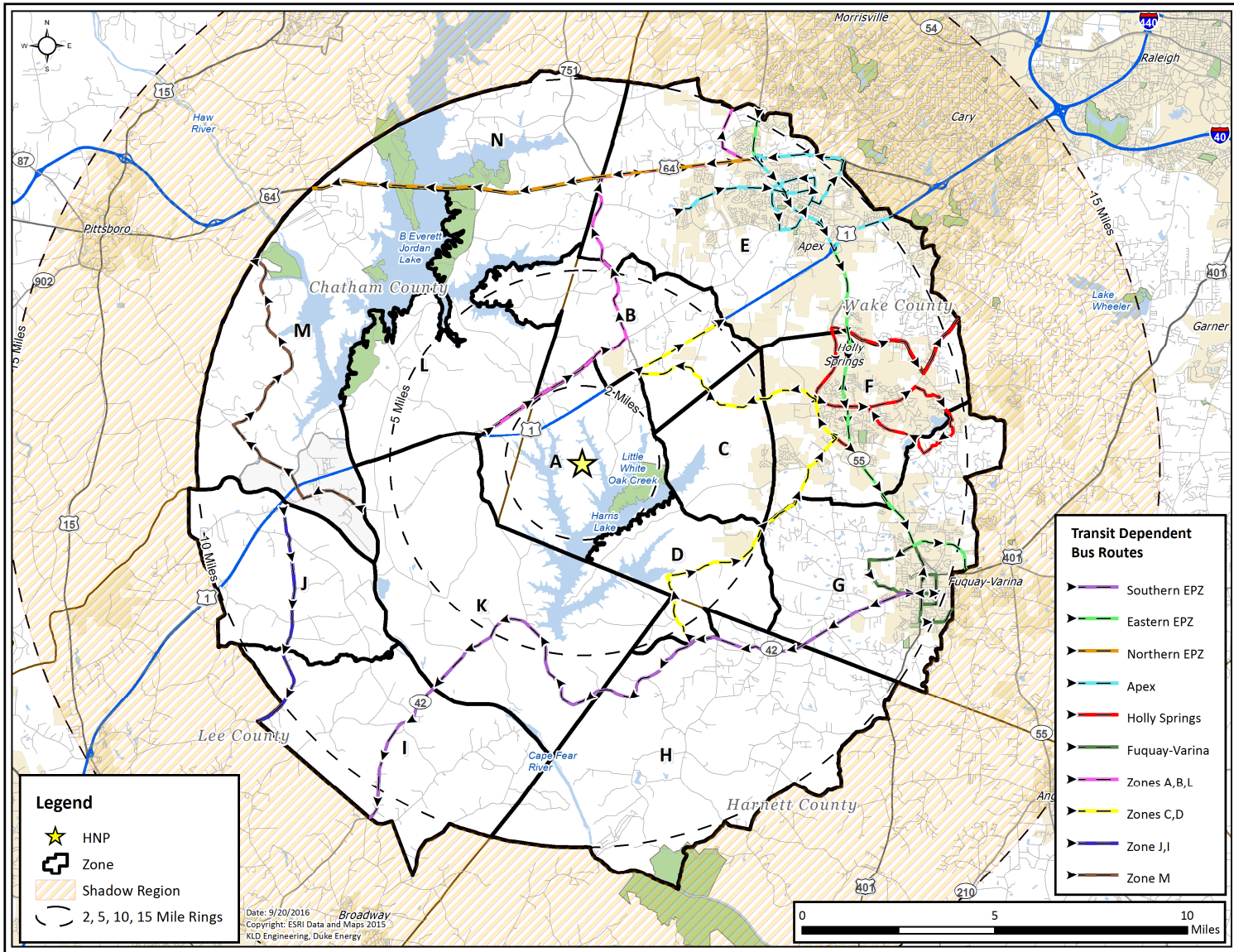

Figure 8-2. Transit-Dependent Bus Routes

Table 8-1. Transit-Dependent Population Estimates

2010 EPZ Population	Survey Average HH Size with Indicated No. of Vehicles			Estimated No. of Households	Survey Percent HH with Indicated No. of Vehicles			Survey Percent HH with Commuters	Survey Percent HH with Non-Returning Commuters	Total People Requiring Transport	Estimated Ridesharing Percentage	People Requiring Public Transit	Percent Population Requiring Public Transit
	0	1	2		0	1	2						
131,520	2.00	1.86	3.01	46,638	1.86%	19.0%	51.5%	68%	59%	8,697	50%	4,349	3.3%

Table 8-2. School Population Demand Estimates

Zone	School Name	Enrollment	Buses Required
B	Apex Friendship High School	1,000	20
E	A.V. Baucom Elementary School	790	16
E	Apex Elementary School	675	10
E	Apex Middle School	1,355	28
E	Apex Senior High School	2,400	48
E	Lufkin Road Middle School	1,090	22
E	Olive Chapel Elementary School	920	14
E	Scotts Ridge Elementary School	770	11
E	St. Mary Magdalene Catholic School	704	11
E	Thales Academy	319	7
F	Holly Grove Elementary School	1,150	23
F	Holly Grove Middle School	1,600	32
F	Holly Ridge Elementary School	1,000	15
F	Holly Ridge Middle School	1,330	19
F	Holly Springs Elementary School	1,180	17
F	Holly Springs High School	2,255	46
F	New School, Inc. Montessori	180	3
F	Oakview Elementary School	650	10
G	Fuquay-Varina Middle School	875	18
G	Fuquay-Varina Senior High School	2,300	46
G	Herbert Akins Road Elementary School	1,120	16
G	Lincoln Heights Elementary School	505	8
G	Southern Wake Academy High School	119	3
M	Moncure Elementary School	291	5
Shadow	Deep River Elementary School	638	9
Shadow	Lafayette Elementary School	748	11
<i>School Subtotal</i>		25,964	468
Zone	Child Care Center Name	Enrollment	Buses Required
E	All About Kids	125	2
E	Angels Garden Home Daycare	5	1
E	Apex Baptist Church Preschool	174	3
E	Apex Child Care with Debbie	5	1
E	Apex Peak Schools, Inc.	7	1
E	Apex United Methodist Church Preschool	78	2
E	Childrens Choice	8	1
E	Earth Angel's Day Care Home	8	1
E	Edith Franklin Day Care Home	5	1
E	Eileen's Day Care	8	1
E	Goddard School Apex	120	2
E	Grace Church Preschool	82	2
E	Growing Years Learning Center	100	2
E	Hope Chapel Preschool	75	2
E	Judy's Home Care	5	1
E	Karen's Kids Home Child Care	5	1
E	Karin'-4-Kidz	8	1
E	Lori's Family Day Care	2	1
E	Moravic Family Day Care	5	1

Zone	Child Care Center Name	Enrollment	Buses Required
E	Peace Montessori	85	2
E	Play Care	6	1
E	Primose School of Apex	185	3
E	Rainbow Child Care Center	62	1
E	The Learning Experience in Apex	95	2
E	Tracey's House	3	1
E	Vickie's Day Care Home	5	1
E	Woodhaven Baptist Pre-school	102	2
F	Holly Springs Learning Center	159	3
F	Holly Springs School For Early Education	88	2
F	Home Away From Home Childcare	5	1
F	Kiddie Academy of Holly Springs	145	3
F	Kris' Home Sweet Home Daycare	5	1
F	Little Dreamers Preschool	111	2
F	Sisters' Child Care Services	20	1
F	Stella Lowery Small Day Care Home	5	1
F	Sunrise United Methodist Church Preschool	66	1
F	The Carolina School	50	1
G	A Mother's Love	5	1
G	Childcare Network - Fuquay Varina	113	2
G	Fuquay-Varina Baptist Wee Care	98	2
G	Fuquay-Varina UMC Preschool Seeds of Faith	180	3
G	Little Angels Preparatory	50	1
G	Little Miracles	4	1
G	Ready Or Not Here I Grow	92	2
G	Shining Star Child Care Home	5	1
G	South Wake Preschool & Academy	37	1
G	Spinning Wheels Learning Center	24	1
G	Vanessa Bland's Small Day Care Home	7	1
<i>Child Care Center Subtotal</i>		<i>2,637</i>	<i>72</i>
EPZ TOTAL:		28,601	540

Table 8-3. Relocation Schools for Schools and Child Care Centers

School/Child Care Center	Relocation School ¹
Deep River Elementary School ²	Benjamin T. Bullock Elementary School
St. Mary Magdalene Catholic School	Cardinal Gibbons High School
Apex Friendship High School	Knightdale High School ³
Fuquay-Varina Senior High School	
A Mother's Love	
Childcare Network - Fuquay Varina	
Fuquay-Varina Baptist Wee Care	
Fuquay-Varina UMC Preschool Seeds of Faith	
Little Angels Preparatory	
Little Miracles	
Ready Or Not Here I Grow	
Shining Star Child Care Home	
South Wake Preschool & Academy	
Southern Wake Academy High School	
Spinning Wheels Learning Center	
Vanessa Bland's Small Day Care Home	
Lafayette Elementary School ²	Harnett Central Middle School
Holly Grove Middle School	Knightdale High School
Holly Ridge Elementary School	
Holly Ridge Middle School	
Holly Springs Elementary School	
Oakview Elementary School	
A.V. Baucom Elementary School	Leesville High School
Apex Middle School	
Lufkin Road Middle School	
Olive Chapel Elementary School	
Fuquay-Varina Middle School	Millbrook High School
Scotts Ridge Elementary School	
Herbert Akins Road Elementary School	
Lincoln Heights Elementary School	
Moncure Elementary School	Northwood High School
Apex Elementary School	Sanderson High School
All About Kids	
Apex Baptist Church Preschool	
Apex Child Care with Debbie	
Apex Senior High School	
Apex United Methodist Church Preschool	
Earth Angel's Day Care Home	
Edith Franklin Day Care Home	
Angels Garden Home Daycare	
Apex Peak Schools, Inc.	
Childrens Choice	
Eileen's Day Care	

¹ Child care facilities will move children to the relocation school for the Zone where the child care facility is located.

² School is in Shadow Region, but is evacuated according to county plans due to close proximity to the EPZ.

³ Knightdale High School will serve as a temporary relocation school for these schools over the next 2 years rather than their normal relocation school (Garner High School) which is undergoing extensive renovations and construction; see Section 10.

School/Child Care Center	Relocation School ¹
Goddard School Apex	Sanderson High School
Grace Church Preschool	
Growing Years Learning Center	
Hope Chapel Preschool	
Judy's Home Care	
Karen's Kids Home Child Care	
Karin'-4-Kidz	
Lori's Family Day Care	
Moravic Family Day Care	
Peace Montessori	
Play Care	
Primose School of Apex	
Rainbow Child Care Center	
Thales Academy	
The Learning Experience in Apex	
Tracey's House	
Vickie's Day Care Home	
Woodhaven Baptist Pre-school	
Holly Grove Elementary School	
Holly Springs High School	
Holly Springs Learning Center	
Holly Springs School For Early Education	
Home Away From Home Childcare	
Kiddie Academy of Holly Springs	
Kris' Home Sweet Home Daycare	
Little Dreamers Preschool	
New School, Inc. Montessori	
Sisters' Child Care Services	
Stella Lowery Small Day Care Home	
Sunrise United Methodist Church Preschool	
The Carolina School	

Table 8-4. Medical Facility Transit Demand

Zone	Facility Name	Capacity	Current Census	Ambulatory	Wheel-chair Bound	Bed-ridden	Bus Runs	Wheel-chair Bus Runs	Wheel-chair Van Runs	Minivan Runs	Car Runs	Ambulance
LEE COUNTY MEDICAL FACILITIES												
J	Sanford Health and Rehabilitation	137	137	41	69	27	2	5	0	0	0	14
Lee County Subtotal:		137	137	41	69	27	2	5	0	0	0	14
WAKE COUNTY MEDICAL FACILITIES												
A	Brown's Family Care Home	6	6	6	0	0	1	0	0	0	0	0
A	James Rest Home	40	38	28	10	0	1	0	3	0	0	0
C	Murchison Residential Corp Home	3	3	3	0	0	0	0	0	0	1	0
E	Azalea Gardens Mental Health	6	6	6	0	0	0	0	0	2	0	0
E	Brookridge Assisted Living	55	52	40	12	0	2	0	3	0	0	0
E	Favour Home	6	6	6	0	0	0	0	0	0	2	0
E	Kings Group Home for Children	4	4	4	0	0	0	0	0	0	1	0
E	Lockley Road Home	6	6	6	0	0	0	0	0	2	0	0
E	Mason Street Group Home	6	6	6	0	0	0	0	0	2	0	0
E	Olive Home	6	6	6	0	0	0	0	0	2	0	0
E	Rex Rehab & Nursing Center of Apex	107	90	20	40	30	1	3	0	0	0	15
E	Seagraves Family Care Home	6	4	4	0	0	0	0	0	1	0	0
E	Shackleton Home	3	3	3	0	0	0	0	0	0	1	0
E	Spring Arbor of Apex	76	66	47	19	0	2	0	5	0	0	0
F	Avent Ferry Home	6	6	6	0	0	0	0	0	2	0	0
F	Bass Lake Home	6	6	6	0	0	0	0	0	0	2	0

Zone	Facility Name	Capacity	Current Census	Ambulatory	Wheel-chair Bound	Bed-ridden	Bus Runs	Wheel-chair Bus Runs	Wheel-chair Van Runs	Minivan Runs	Car Runs	Ambulance
F	Country Lane Group Home	6	6	6	0	0	0	0	0	2	0	0
F	Herbert Reid Home	5	5	5	0	0	0	0	0	1	0	0
F	Hickory Avenue Home	6	6	6	0	0	0	0	0	2	0	0
F	St. Mark's Manor	9	9	9	0	0	0	0	0	2	0	0
F	Trotter's Bluff	6	6	6	0	0	0	0	0	2	0	0
G	Creekway Home	6	6	6	0	0	0	0	0	2	0	0
G	Evans-Walston Home	3	3	3	0	0	0	0	0	0	1	0
G	Fuquay-Varina Homes for the Elderly	80	62	60	2	0	2	0	1	0	0	0
G	Hope House	4	4	4	0	0	0	0	0	0	1	0
G	Kinton Court Home	16	16	16	0	0	0	0	0	4	0	0
G	Life Skills Independent Care #1	4	4	4	0	0	0	0	0	1	0	0
G	Mim's Family Care Home	6	2	2	0	0	0	0	0	0	1	0
G	WakeMed Fuquay Skilled Nursing Facility	36	35	0	20	15	0	0	5	0	0	8
G	Windsor Point Continuing Care	300	275	140	100	35	5	7	0	0	0	18
Wake County Subtotal:		829	747	464	203	80	14	10	17	27	10	41
EPZ TOTAL:		966	884	505	272	107	16	15	17	27	10	55

Table 8-5. Summary of Transportation Resources

Transportation Resource	Buses	Wheelchair Buses	Wheelchair Vans	Minivans	Passenger Cars	Ambulances	Medevac Helicopter
Resources Available							
Wake County Public School System	883	0	0	0	0	0	0
Wake County EMS - Apex	0	0	0	0	0	3	0
Wake County EMS - Fuquay-Varina	0	0	0	0	0	2	0
Wake County EMS - Holly Springs	0	0	0	0	0	2	0
Eastern Wake and Cary Area EMS	0	1	0	0	0	39	0
WakeMed Critical Care	0	0	0	0	0	20	1
Rex Healthcare	0	0	0	0	0	4	0
Avent Ferry Home	0	0	0	1	0	0	0
Azalea Gardens Mental Health	0	0	0	1	0	0	0
Bass Lake Home	0	0	0	0	1	0	0
Brookridge Assisted Living	0	0	0	2	0	0	0
Country Lane Group Home	0	0	0	1	0	0	0
Creekway Home	0	0	0	1	0	0	0
Evans-Walston Home	0	0	0	0	1	0	0
Favour Home	0	0	0	0	4	0	0
Fuquay Varina Homes for the Elderly	0	0	0	0	1	0	0
Herbert Reid Home	0	0	0	1	0	0	0
Hickory Avenue Home	0	0	0	1	0	0	0
Hope House	0	0	0	0	1	0	0
Kings Group Home for Children	0	0	0	0	4	0	0
Kinton Court Home	0	0	0	2	0	0	0
Life Skills Independent Care #1	0	0	0	1	0	0	0
Lockley Road Home	0	0	0	1	0	0	0
Mason Street Group Home	0	0	0	1	0	0	0
Mim's Family Care Home	0	0	0	0	1	0	0
Murchison Residential Corp Home	0	0	0	0	1	0	0
Olive Home	0	0	0	1	0	0	0
Seagraves Family Care Home	0	0	0	1	0	0	0
Shackleton Home	0	0	0	0	1	0	0
Spring Arbor of Apex	0	0	1	0	0	0	0
St. Mark's Manor	0	0	0	1	0	0	0

Transportation Resource	Buses	Wheelchair Buses	Wheelchair Vans	Minivans	Passenger Cars	Ambulances	Medevac Helicopter
Resources Available							
Trotter's Bluff	0	0	0	1	0	0	0
Windsor Point Continuing Care	1	0	0	0	0	0	0
Chatham Transit	1	3	11	2	2	0	0
Chatham County EMS Stations	0	0	0	0	0	0	0
FirstHealth	0	0	0	0	0	8	0
Moncure Elementary School	5	0	0	0	0	0	0
Lee County	130	0	0	0	0	8	0
Central Carolina Hospital (CCH)	0	0	1	0	0	0	0
County of Lee Transit System (COLTS)	0	15	18	0	0	0	0
Sanford Health & Rehab	0	0	1	0	0	0	0
Harnett County	257	0	2	0	0	0	0
Harnett Area Transit System	0	0	1	0	0	0	0
Anderson Creek Emergency Services	0	0	0	0	0	3	0
Erwin Fire Rescue	0	0	0	0	0	2	0
Coats Grove Fire Department	0	0	0	0	0	2	0
TOTAL:	1,277	19	35	19	17	93	1
Resources Needed							
Schools and Child Care Centers (Table 8-2):	540	0	0	0	0	0	0
Medical Facilities (Table 8-4):	16	15	17	27	10	55	0
Transit-Dependent Population (Table 8-10):	147	0	0	0	0	0	0
Homebound Special Needs (Table 8-17):	10	0	6	0	0	5	0
TOTAL TRANSPORTATION NEEDS:	713	15	23	27	10	60	0

Table 8-6. Bus Route Descriptions

Bus Route Number	Description	Nodes Traversed from Route Start to EPZ Boundary
1	Apex Elementary School	1276, 1275, 757, 320, 734, 1274, 1271, 1273, 758, 68, 690, 759, 691, 1583, 692, 601
2	Apex Senior HS, Judy's Home Care, Eileen's Day Care, Primose School of Apex	1018, 1450, 120
3	Apex Middle School, Apex Peak Schools, Inc.	319, 320, 734, 1274, 1271, 1273, 758, 68, 690, 759, 691, 1583, 692
4	A.V. Baucom Elementary School	694, 1282, 710, 669, 665, 660, 325, 326, 327, 396, 1578
5	Apex Friendship High School	1695, 1696, 1697, 287, 290, 1549, 1698, 1699, 1347, 1554, 1715, 1561, 1716, 1719, 1348, 1562, 1563, 1529, 1567, 1530, 1709, 1708, 25, 26, 24, 30, 31, 32, 33, 21, 35, 435, 1264, 615, 431, 1032, 1573, 1033, 425, 1031, 1253, 424, 226, 1574, 202
6	Lufkin Road Middle School	447, 60, 692, 601
7	Olive Chapel Elementary School	296, 299, 1541, 1542, 1539, 1544, 1726, 434, 1737, 1739, 1543, 1343, 1532, 1531
8	St. Mary Magdalene Catholic School, Scotts Ridge Elementary School	1010, 291, 1277, 292, 1276, 294, 319, 320, 734, 1274, 1271, 1273, 758, 68, 690, 759, 691, 1583, 692, 601
9	Deep River Elementary School	516, 521, 526, 530, 531, 533
10	Holly Grove Elementary School, Holly Grove Middle School, Holly Springs High School, Home Away From Home Childcare	156, 140, 1319, 21, 33, 32, 31, 30, 24, 26, 25, 1566, 1707, 1564, 28, 27, 762, 445, 68, 690, 759, 691, 1583, 692, 601
11	Holly Ridge Middle School, Holly Ridge Elementary School	555, 715, 1629, 716, 52, 790, 520, 522, 524, 525, 511
12	Holly Springs Elementary School	439, 555, 715, 1629, 716, 52, 790, 520, 522, 524, 525, 511
13	Southern Wake Academy High School, South Wake Preschool & Academy	431, 1032, 1573, 1033, 1257, 1254, 1256, 1255, 1258
14	New School, Inc. Montessori Sunrise United Methodist Church Preschool, Stella Lowery Small Day Care Home	50, 1463, 51, 52, 790, 520, 522, 524, 525, 511
15	Fuquay-Varina Senior High School, Ready Or Not Here I Grow, Vanessa Bland's Small Day Care Home	1031, 1253, 424, 226, 1574, 202
16	Fuquay-Varina Middle School	957, 226, 1574, 202
17	Lincoln Heights Elementary School	894, 228, 959, 204, 203, 1030, 226, 1574, 202
18	Moncure Elementary School	74, 261, 770, 771, 772
19	Herbert Akins Road Elementary School	789, 47, 1462, 1461, 46, 44, 43, 1261
20	Thales Academy, Apex Child Care with Debbie, Peace Montessori	1450, 1018, 585, 1019, 1376, 704, 581, 1220, 60, 692, 601
21	Lafayette Elementary School	212, 735, 1240, 1241, 1242
22	Oakview Elementary School	1128, 1267, 1268, 1269, 1270, 1266, 33, 21, 35, 438, 1320, 1321, 439, 775, 32, 31, 30, 24, 26, 25, 1566, 1707, 1564, 28, 27, 762, 445, 68, 690, 759, 691, 1583, 692, 601, 693, 598, 45, 1401, 34, 597, 1111, 40, 355, 1336, 357

Bus Route Number	Description	Nodes Traversed from Route Start to EPZ Boundary
23	Karen's Kids Home Child Care	1798, 293, 295, 1322, 1613, 1614, 291, 1277, 292, 1276, 294, 319, 320, 734, 1274, 1271, 1273, 758, 68, 690, 759, 691, 1583, 692, 601
24	Tracey's House	799, 297, 703, 1378, 585, 1019, 1376, 704, 581, 1220, 60, 692, 601
40	Transit Dependent Bus Route - Southern EPZ	872, 873, 874, 875, 807, 866, 809, 808, 810, 811, 839, 840, 841, 842
41	Transit Dependent - Eastern EPZ	31, 32, 33, 21, 35, 435, 1264, 615, 431, 1032, 1573, 1033, 1257, 1254, 1256, 1255, 1258, 1263
42	Transit Dependent - Northern EPZ	128, 641, 129, 130, 466, 1024, 1598, 1025, 135, 620, 655
43	Transit Dependent - Apex	315, 314, 306, 299, 303, 304, 1280, 694, 1799, 297, 703, 1378, 585, 1018, 1450, 120, 587, 122, 123, 1582, 672, 126, 326, 325, 660, 665, 669, 710, 1282, 694, 702, 294, 319, 320, 734, 1274, 1271, 1273, 758, 68, 690, 759, 691, 1583, 692, 601
44	Transit Dependent - Holly Springs	439, 441, 1036, 1627, 443, 444, 25, 26, 24, 30, 31, 32, 33, 21, 35, 438, 1320, 1321, 439, 555, 715, 1629, 716, 52, 790, 520, 522, 524, 525, 511
45	Transit Dependent - Fuquay-Varina	957, 958, 229, 1250, 228, 1504, 957, 226, 1030, 203, 204, 959, 228, 1250, 229, 1100, 1099, 1499, 1249, 1501, 1502, 1575, 202
46	Transit Dependent - Zones A,B, L	278, 632, 436, 282, 283, 235, 239, 241, 243, 244, 245, 246, 249, 251, 128, 433, 1539, 1544, 1726, 434, 1737, 1739, 1543, 1343, 1532, 1531
47	Transit Dependent - Zones C,D	1318, 156, 140, 1319, 21, 33, 32
48	Transit Dependent - Zones I, J	1580, 913, 915, 914, 916, 918, 917, 919
49	Transit Dependent - Zone M	281, 280, 279, 277, 275
59	Mim's Family Care Home	893, 894, 228, 959, 204, 203, 1030, 226, 1574
60	Brown's Family/James Rest Home	452, 75, 73, 72, 1557, 1555, 1560, 582, 1552, 71, 690, 759, 691, 1583, 692, 601
62	Rex Rehab & Nursing Center of Apex	734, 1274, 1271, 1273, 758, 68, 690, 759, 691, 1583, 692, 601
63	Spring Arbor of Apex	304, 1280, 694, 1799, 297, 298, 1281, 670, 671, 123, 122, 587, 120
71	Fuquay-Varina Homes for the Elderly	206, 1100, 1099, 1499, 1249, 1501, 1502, 1575, 202
72	Windsor Point Continuing Care	1033, 425, 1031, 1253, 424, 226, 1574, 202
73	Sanford Health and Rehabilitation	83, 84, 87, 89
74	WakeMed Apex Healthplex	665, 660, 325, 126, 672, 1582, 123, 122, 587, 120
75	Avent Ferry Home, Country Lane Group Home, Trotter's Bluff	1319, 21, 33, 32, 31, 30, 24, 26, 25, 1566, 1707, 1564, 28, 27, 762, 445, 68, 690, 759, 691, 1583, 692, 601
76	Bass Lake Home	439, 555, 715, 1629, 716, 52, 790, 520, 522, 524, 525
77	Brookridge Assisted Living	1276, 294, 319, 320, 734, 1274, 1271, 1273, 758, 68, 690, 759, 691, 1583, 692, 601
79	Creekway Home	1499, 1249, 1501
80	Evans-Walston Home	44, 43, 1261, 42

Bus Route Number	Description	Nodes Traversed from Route Start to EPZ Boundary
81	Favour Home	444, 29, 28, 27, 762, 445, 68, 690, 759, 691, 1583, 692, 601
82	Herbert Reid Home, St. Mark's Manor	54, 53, 791, 52, 790, 520, 522, 524, 525
83	Hickory Avenue Home	438, 1320, 1321, 439, 441, 1036, 1627, 443, 444, 29, 28, 27, 762, 445, 68, 690, 759, 691, 1583, 692, 601
84	Kinton Court Home	229, 1250, 228, 959, 204, 203, 1030, 226, 1574, 202
85	Mason Street Group Home	378, 585, 1019, 1376, 704, 581, 1220, 60, 692, 601
87	Seagraves Family Care Home	294, 1451, 703, 297, 1454, 1018, 1450, 120
88	St. Mark's Manor Home	449, 447, 60, 692, 601
90	WakeMed Fuquay Skilled Nursing Facility	1100, 229, 1250, 228, 959, 204, 203, 1030, 226, 1574, 202
91	Azalea Gardens Mental Health, Olive Home	1019, 1376, 704, 581, 1220, 60, 692, 601
92	Hope House	1254, 1256, 1255, 1258, 1263, 202
93	Kings Group Home for Children, Rainbow Child Care Center, The Learning Experience in Apex	299, 1541, 1542, 1539, 1544, 1726, 434, 127, 1584, 1593, 126, 672, 1582, 123, 122, 587, 120
94	Life Skills Independent Care #1	1262, 1259, 1258, 1263, 202, 1576, 42
95	Lockley Road Home	790, 520, 522, 524, 525
96	Murchison Residential Corp Home	158, 156, 140, 1319, 21, 33, 32, 31, 30, 24, 26, 25, 1566, 1707, 1564, 28, 27, 762, 445, 68, 690, 759, 691, 1583, 692, 601, 693
97	Shackleton Home	1272, 1271, 1273, 758, 68, 690, 759, 691, 1583, 692, 601, 693
110	Fuquay-Varina Baptist Wee Care, Fuquay-Varina UMC Preschool Seeds of Faith	957, 226, 1574, 202
111	Little Angels Preparatory, Little Miracles, Shining Star Child Care Home	1100, 1099, 1499, 1249
112	Childcare Network - Fuquay-Varina	959, 204, 203, 1030, 226, 1574, 202
113	A Mother's Love	1032, 1573, 1033, 1257, 1254, 1256, 1255, 1258
114	Spinning Wheels Learning Center	48, 47, 56
115	Holly Springs Learning Center, Kris' Home Sweet Home Daycare, Sisters' Child Care Services, The Carolina School	555, 715, 1629, 716, 52, 790, 520, 519, 518, 517, 1436, 454, 717, 459
116	Holly Springs School For Early Education, Kiddie Academy of Holly Springs, Little Dreamers Preschool	443, 444, 29, 28, 27, 762, 445, 68, 690, 759, 691, 1583, 692, 601
117	Karin'-4-Kidz	444, 29, 28, 27, 762, 445, 68, 690, 759, 691, 1583, 692, 601
118	All About Kids, Grace Church Preschool, Woodhaven Baptist Pre-school	517, 1436, 454, 717, 459
119	Earth Angel's Day Care Home, Children's Choice	1211, 1063, 728, 727, 1374, 454, 717, 459
120	Apex Baptist Church Preschool, Apex United Methodist Church Preschool, Edith Franklin Day Care Home, Goddard School Apex, Growing Years Learning Center, Vickie's Day Care Home, Angels Garden Day Care	294, 1451, 703, 1378, 585, 1019, 1376, 704, 581, 1220, 60, 692, 601

Bus Route Number	Description	Nodes Traversed from Route Start to EPZ Boundary
121	Play Care	682, 1283, 684, 660, 325, 126, 672, 1582, 123, 122, 587, 120
122	Lori's Family Day Care, Moravic Family Day Care	1221, 1220, 60, 692, 601
123	Hope Chapel Preschool	301, 1009, 673, 671, 123, 122, 587, 120

Table 8-7. School and Child Care Center Evacuation Time Estimates - Good Weather

School	Driver Mobilization Time (min)	Loading Time (min)	Dist. To EPZ Bdry (mi)	Average Speed (mph)	Travel Time to EPZ Bdry (min)	ETE (hr:min)	Dist. EPZ Bdry to R.S. (mi.)	Travel Time from EPZ Bdry to R.S. (min)	ETE to R.S. (hr:min)
CHATHAM COUNTY SCHOOLS									
Moncure Elementary School	90	15	4.7	45.0	7	1:55	8.4	12	2:10
HARNETT COUNTY SCHOOLS									
Lafayette Elementary School ¹	90	15	0.0	0.0	0	1:45	3.9	6	1:55
LEE COUNTY SCHOOLS									
Deep River Elementary School ¹	90	15	0.0	0.0	0	1:45	8.8	12	2:00
WAKE COUNTY SCHOOLS									
A.V. Baucom Elementary School	90	15	3.0	30.6	6	1:55	17.3	24	2:20
Apex Elementary School	90	15	3.3	8.9	23	2:10	14.7	20	2:30
Apex Friendship High School ²	90	15	7.4	5.6	80	3:05	25.3	34	3:40
Apex Middle School	90	15	2.9	8.4	21	2:10	17.1	23	2:35
Apex Senior High School	90	15	0.8	10.9	5	1:50	15.9	22	2:15
Lufkin Road Middle School	90	15	1.2	5.9	13	2:00	17.1	23	2:25
Olive Chapel Elementary School	90	15	3.3	10.6	19	2:05	17.4	24	2:30
St. Mary Magdalene Catholic School	90	15	4.9	10.1	29	2:15	10.6	15	2:30
Scotts Ridge Elementary School	90	15	4.9	10.1	29	2:15	10.6	15	2:30
Thales Academy	90	15	2.9	20.4	9	1:55	14.7	20	2:15
Holly Grove Elementary School	90	15	8.3	14.9	34	2:20	13.5	19	2:40
Holly Grove Middle School	90	15	8.2	14.9	34	2:20	25.3	34	2:55
Holly Ridge Elementary School	90	15	3.2	10.5	19	2:05	24.7	33	2:40
Holly Ridge Middle School	90	15	3.2	10.5	19	2:05	24.7	33	2:40
Holly Springs Elementary School	90	15	3.7	9.0	25	2:10	24.7	33	2:45
Holly Springs High School	90	15	8.7	14.9	35	2:20	13.5	19	2:40
New School, Inc. Montessori	90	15	2.7	17.8	10	1:55	13.4	18	2:15
Fuquay-Varina Middle School	90	15	0.9	5.7	10	1:55	28.4	38	2:35
Fuquay-Varina Senior High School ²	90	15	1.1	6.0	12	2:00	29.3	40	2:40
Herbert Akins Road Elementary School	90	15	3.3	37.9	6	1:55	27.0	37	2:35
Lincoln Heights Elementary School	90	15	1.7	7.9	13	2:00	28.4	38	2:40
Oakview Elementary School	90	15	7.6	11.2	41	2:50	25.3	34	3:30
Southern Wake Academy High School ²	90	15	3.8	3.1	74	3:00	27.5	37	3:40

School	Driver Mobilization Time (min)	Loading Time (min)	Dist. To EPZ Bdry (mi)	Average Speed (mph)	Travel Time to EPZ Bdry (min)	ETE (hr:min)	Dist. EPZ Bdry to R.S. (mi.)	Travel Time from EPZ Bdry to R.S. (min)	ETE to R.S. (hr:min)
WAKE COUNTY CHILD CARE CENTERS									
All About Kids	90	15	1.5	21.2	5	1:50	16.1	22	2:15
Angels Garden Day Care	90	15	2.5	15.8	10	1:55	14.7	20	2:15
Apex Baptist Church Preschool	90	15	2.7	16.1	11	2:00	14.7	20	2:20
Apex Child Care with Debbie	90	15	3.0	20.4	9	1:55	14.7	20	2:15
Apex Peak Schools, Inc.	90	15	2.9	7.8	23	2:10	17.1	23	2:35
Apex United Methodist Church Preschool	90	15	2.7	16.1	11	2:00	14.7	20	2:20
Children's Choice	90	15	1.8	31.1	4	1:50	14.7	20	2:10
Earth Angel's Day Care Home	90	15	1.8	31.1	4	1:50	16.1	22	2:15
Edith Franklin Day Care Home	90	15	2.7	16.1	11	2:00	14.7	20	2:20
Eileen's Day Care	90	15	1.0	0.0	0	1:45	15.9	22	2:10
Goddard School Apex	90	15	2.7	16.1	11	2:00	14.7	20	2:20
Grace Church Preschool	90	15	1.5	21.2	5	1:50	16.1	22	2:15
Growing Years Learning Center	90	15	2.7	16.1	11	2:00	14.7	20	2:20
Hope Chapel Preschool	90	15	1.4	7.2	13	2:00	15.9	22	2:25
Judy's Home Care	90	15	0.8	10.9	5	1:50	15.9	22	2:15
Karen's Kids Home Child Care	90	15	6.6	12.8	31	2:20	10.1	14	2:35
Karin'-4-Kidz	90	15	4.4	10.6	26	2:15	14.7	20	2:35
Lori's Family Day Care	90	15	1.0	10.8	6	1:55	14.7	20	2:15
Moravic Family Day Care	90	15	1.0	10.8	6	1:55	14.7	20	2:15
Peace Montessori	90	15	2.8	20.4	9	1:55	13.5	19	2:15
Play Care	90	15	3.2	8.6	23	2:10	15.9	22	2:35
Primose School of Apex	90	15	0.1	10.9	1	1:50	15.9	22	2:15
Rainbow Child Care Center	90	15	4.6	9.5	30	2:15	10.1	14	2:30
The Learning Experience in Apex	90	15	4.6	9.5	30	2:15	10.1	14	2:30
Tracey's House	90	15	2.7	20.7	8	1:55	13.5	19	2:15
Vickie's Day Care Home	90	15	2.7	16.1	11	2:00	14.7	20	2:20
Woodhaven Baptist Pre-school	90	15	1.5	21.2	5	1:50	16.1	22	2:15
Holly Springs Learning Center	90	15	4.4	13.3	20	2:05	15.0	20	2:25
Holly Springs School For Early Education	90	15	4.5	10.4	26	2:15	13.5	19	2:35
Home Away From Home Childcare	90	15	8.3	14.9	34	2:20	13.5	19	2:40

School	Driver Mobilization Time (min)	Loading Time (min)	Dist. To EPZ Bdry (mi)	Average Speed (mph)	Travel Time to EPZ Bdry (min)	ETE (hr:min)	Dist. EPZ Bdry to R.S. (mi.)	Travel Time from EPZ Bdry to R.S. (min)	ETE to R.S. (hr:min)
Kiddie Academy of Holly Springs	90	15	4.5	10.4	26	2:15	13.5	19	2:35
Kris' Home Sweet Home Daycare	90	15	4.4	13.3	20	2:05	15.0	20	2:25
Little Dreamers Preschool	90	15	4.5	10.4	26	2:15	13.5	19	2:35
Sisters' Child Care Services	90	15	4.4	13.3	20	2:05	15.0	20	2:25
Stella Lowery Small Day Care	90	15	1.5	17.2	6	1:55	13.4	18	2:15
Sunrise United Methodist Church Preschool	90	15	2.7	17.8	10	1:55	13.4	18	2:15
The Carolina School	90	15	4.4	13.3	20	2:05	15.0	20	2:25
A Mother's Love ²	90	15	2.1	3.7	35	2:20	29.4	40	3:00
Childcare Network - Fuquay Varina ²	90	15	1.1	5.9	12	2:00	29.4	40	2:40
Fuquay-Varina Baptist Wee Care ²	90	15	0.8	5.7	9	1:55	29.4	40	2:35
Fuquay-Varina UMC Preschool Seeds of Faith ²	90	15	0.8	5.7	9	1:55	28.6	39	2:35
Little Angels Preparatory ²	90	15	1.1	45.0	2	1:50	31.1	42	2:35
Little Miracles ²	90	15	1.1	45.0	2	1:50	31.1	42	2:35
Ready Or Not Here I Grow ²	90	15	1.1	6.0	12	2:00	25.9	35	2:35
Shining Star Child Care Home ²	90	15	1.1	45.0	2	1:50	31.1	42	2:35
South Wake Preschool & Academy ²	90	15	3.1	2.9	63	2:50	29.4	40	3:30
Spinning Wheels Learning Center ²	90	15	1.4	5.1	17	2:05	27.9	38	2:45
Vanessa Bland's Small Day Care Home ²	90	15	1.1	6.0	12	2:00	25.9	35	2:35
Maximum for EPZ:						3:05	Maximum:		3:40
Average for EPZ:						2:05	Average:		2:30

Notes: 1 – Not included in calculation for Maximum and Average ETE values since school is in the Shadow Region.

2 – Knightdale High School will serve as a temporary relocation school during the renovation of Garner High School.

Table 8-8. School and Child Care Center Evacuation Time Estimates - Rain

School	Driver Mobilization Time (min)	Loading Time (min)	Dist. To EPZ Bdry (mi)	Average Speed (mph)	Travel Time to EPZ Bdry (min)	ETE (hr:min)	Dist. EPZ Bdry to R.S. (mi.)	Travel Time from EPZ Bdry to R.S. (min)	ETE to R.S. (hr:min)
CHATHAM COUNTY SCHOOLS									
Moncure Elementary School	100	20	4.7	41.0	7	2:10	8.4	13	2:25
HARNETT COUNTY SCHOOLS									
Lafayette Elementary School ¹	100	20	0.0	0.0	0	2:00	3.9	6	2:10
LEE COUNTY SCHOOLS									
Deep River Elementary School ¹	100	20	0.0	0.0	0	2:00	8.8	13	2:15
WAKE COUNTY SCHOOLS									
A.V. Baucom Elementary School	100	20	3.0	40.7	5	2:05	17.3	26	2:35
Apex Elementary School	100	20	3.3	14.1	15	2:15	14.7	22	2:40
Apex Friendship High School ²	100	20	7.4	5.4	82	3:25	25.3	38	4:05
Apex Middle School	100	20	2.9	15.4	12	2:15	17.1	26	2:45
Apex Senior High School	100	20	0.8	8.3	6	2:10	15.9	24	2:35
Lufkin Road Middle School	100	20	1.2	5.2	14	2:15	17.1	26	2:45
Olive Chapel Elementary School	100	20	3.3	11.6	18	2:20	17.4	26	2:50
St. Mary Magdalene Catholic School	100	20	4.9	12.9	23	2:25	10.6	16	2:45
Scotts Ridge Elementary School	100	20	4.9	12.9	23	2:25	10.6	16	2:45
Thales Academy	100	20	2.9	17.1	11	2:15	14.7	22	2:40
Holly Grove Elementary School	100	20	8.3	24.0	21	2:25	13.5	20	2:45
Holly Grove Middle School	100	20	8.2	24.0	21	2:25	25.3	38	3:05
Holly Ridge Elementary School	100	20	3.2	10.0	20	2:20	24.7	37	3:00
Holly Ridge Middle School	100	20	3.2	10.0	20	2:20	24.7	37	3:00
Holly Springs Elementary School	100	20	3.7	8.4	27	2:30	24.7	37	3:10
Holly Springs High School	100	20	8.7	24.0	22	2:25	13.5	20	2:45
New School, Inc. Montessori	100	20	2.7	21.8	8	2:10	13.4	20	2:30
Fuquay-Varina Middle School	100	20	0.9	3.6	15	2:15	28.4	42	3:00
Fuquay-Varina Senior High School ²	100	20	1.1	5.4	13	2:15	29.3	43	3:00
Herbert Akins Road Elementary School	100	20	3.3	35.1	6	2:10	27.0	40	2:50
Lincoln Heights Elementary School	100	20	1.7	6.9	15	2:15	28.4	42	3:00
Oakview Elementary School	100	20	7.6	10.7	43	2:45	25.3	38	3:25
Southern Wake Academy High School ²	100	20	3.8	3.1	74	3:15	27.5	41	4:00

School	Driver Mobilization Time (min)	Loading Time (min)	Dist. To EPZ Bdry (mi)	Average Speed (mph)	Travel Time to EPZ Bdry (min)	ETE (hr:min)	Dist. EPZ Bdry to R.S. (mi.)	Travel Time from EPZ Bdry to R.S. (min)	ETE to R.S. (hr:min)
WAKE COUNTY CHILD CARE CENTERS									
All About Kids	100	20	1.5	19.0	5	2:05	16.1	24	2:30
Angels Garden Day Care	100	20	2.5	13.1	12	2:15	14.7	22	2:40
Apex Baptist Church Preschool	100	20	2.7	13.1	13	2:15	14.7	22	2:40
Apex Child Care with Debbie	100	20	3.0	16.0	12	2:15	14.7	22	2:40
Apex Peak Schools, Inc.	100	20	2.9	13.6	13	2:15	17.1	26	2:45
Apex United Methodist Church Preschool	100	20	2.7	30.6	6	2:10	14.7	22	2:35
Children's Choice	100	20	1.8	28.6	4	2:05	14.7	22	2:30
Earth Angel's Day Care Home	100	20	1.8	28.6	4	2:05	16.1	24	2:30
Edith Franklin Day Care Home	100	20	2.7	13.1	13	2:15	14.7	22	2:40
Eileen's Day Care	100	20	1.0	8.3	8	2:10	15.9	24	2:35
Goddard School Apex	100	20	2.7	13.1	13	2:15	14.7	22	2:40
Grace Church Preschool	100	20	1.5	19.0	5	2:05	16.1	24	2:30
Growing Years Learning Center	100	20	2.7	13.1	13	2:15	14.7	22	2:40
Hope Chapel Preschool	100	20	1.4	4.4	20	2:20	15.9	24	2:45
Judy's Home Care	100	20	0.8	8.3	6	2:10	15.9	24	2:35
Karen's Kids Home Child Care	100	20	6.6	16.9	24	2:25	10.1	15	2:40
Karin'-4-Kidz	100	20	4.4	24.9	11	2:15	14.7	22	2:40
Lori's Family Day Care	100	20	1.0	8.8	7	2:10	14.7	22	2:35
Moravic Family Day Care	100	20	1.0	8.8	7	2:10	14.7	22	2:35
Peace Montessori	100	20	2.8	17.1	10	2:10	13.5	20	2:30
Play Care	100	20	3.2	9.4	21	2:25	15.9	24	2:50
Primose School of Apex	100	20	0.1	8.6	1	2:05	15.9	24	2:30
Rainbow Child Care Center	100	20	4.6	9.9	28	2:30	10.1	15	2:45
The Learning Experience in Apex	100	20	4.6	9.9	28	2:30	10.1	15	2:45
Tracey's House	100	20	2.7	17.3	10	2:10	13.5	20	2:30
Vickie's Day Care Home	100	20	2.7	13.1	13	2:15	14.7	22	2:40
Woodhaven Baptist Pre-school	100	20	1.5	19.0	5	2:05	16.1	24	2:30
Holly Springs Learning Center	100	20	4.4	10.6	26	2:30	15.0	22	2:55
Holly Springs School For Early Education	100	20	4.5	21.4	13	2:15	13.5	20	2:35
Home Away From Home Childcare	100	20	8.3	24.0	21	2:25	13.5	20	2:45

School	Driver Mobilization Time (min)	Loading Time (min)	Dist. To EPZ Bdry (mi)	Average Speed (mph)	Travel Time to EPZ Bdry (min)	ETE (hr:min)	Dist. EPZ Bdry to R.S. (mi.)	Travel Time from EPZ Bdry to R.S. (min)	ETE to R.S. (hr:min)
Kiddie Academy of Holly Springs	100	20	4.5	21.4	13	2:15	13.5	20	2:35
Kris' Home Sweet Home Daycare	100	20	4.4	10.6	26	2:30	15.0	22	2:55
Little Dreamers Preschool	100	20	4.5	21.4	13	2:15	13.5	20	2:35
Sisters' Child Care Services	100	20	4.4	10.6	26	2:30	15.0	22	2:55
Stella Lowery Small Day Care	100	20	1.5	20.3	5	2:05	13.4	20	2:25
Sunrise United Methodist Church Preschool	100	20	2.7	21.8	8	2:10	13.4	20	2:30
The Carolina School	100	20	4.4	10.6	26	2:30	15.0	22	2:55
A Mother's Love ²	100	20	2.1	3.9	32	2:35	29.4	44	3:20
Childcare Network - Fuquay Varina ²	100	20	1.1	5.3	14	2:15	29.4	44	3:00
Fuquay-Varina Baptist Wee Care ²	100	20	0.8	3.6	14	2:15	29.4	44	3:00
Fuquay-Varina UMC Preschool Seeds of Faith ²	100	20	0.8	3.6	14	2:15	28.6	42	3:00
Little Angels Preparatory ²	100	20	1.1	41.0	2	2:05	31.1	46	2:55
Little Miracles ²	100	20	1.1	41.0	2	2:05	31.1	46	2:55
Ready Or Not Here I Grow ²	100	20	1.1	5.4	13	2:15	25.9	38	2:55
Shining Star Child Care Home ²	100	20	1.1	41.0	2	2:05	31.1	46	2:55
South Wake Preschool & Academy ²	100	20	3.1	2.9	64	3:05	29.4	44	3:50
Spinning Wheels Learning Center ²	100	20	1.4	4.8	18	2:20	27.9	41	3:05
Vanessa Bland's Small Day Care Home ²	100	20	1.1	5.4	13	2:15	25.9	38	2:55
Maximum for EPZ:						3:25	Maximum:		4:05
Average for EPZ:						2:20	Average:		2:50

Notes: 1 – Not included in calculation for Maximum and Average ETE values since school is in the Shadow Region.

2 – Knightdale High School will serve as a temporary relocation school during the renovation of Garner High School.

Table 8-9. School and Child Care Center Evacuation Time Estimates – Ice

School	Driver Mobilization Time (min)	Loading Time (min)	Dist. To EPZ Bdry (mi)	Average Speed (mph)	Travel Time to EPZ Bdry (min)	ETE (hr:min)	Dist. EPZ Bdry to R.S. (mi.)	Travel Time from EPZ Bdry to R.S. (min)	ETE to R.S. (hr:min)
CHATHAM COUNTY SCHOOLS									
Moncure Elementary School	110	25	4.7	36.0	8	2:25	8.4	14	2:40
HARNETT COUNTY SCHOOLS									
Lafayette Elementary School ¹	110	25	0.0	0.0	0	2:15	3.9	7	2:25
LEE COUNTY SCHOOLS									
Deep River Elementary School ¹	110	25	0.0	0.0	0	2:15	8.8	15	2:30
WAKE COUNTY SCHOOLS									
A.V. Baucom Elementary School	110	25	3.0	32.6	6	2:25	17.3	29	2:55
Apex Elementary School	110	25	3.3	11.2	18	2:35	14.7	25	3:00
Apex Friendship High School ²	110	25	7.4	5.2	86	3:45	25.3	43	4:30
Apex Middle School	110	25	2.9	11.4	16	2:35	17.1	29	3:05
Apex Senior High School	110	25	0.8	9.2	6	2:25	15.9	27	2:55
Lufkin Road Middle School	110	25	1.2	3.4	22	2:40	17.1	29	3:10
Olive Chapel Elementary School	110	25	3.3	8.8	23	2:40	17.4	29	3:10
St. Mary Magdalene Catholic School	110	25	4.9	11.1	27	2:45	10.6	18	3:05
Scotts Ridge Elementary School	110	25	4.9	11.1	27	2:45	10.6	18	3:05
Thales Academy	110	25	2.9	15.3	12	2:30	14.7	25	2:55
Holly Grove Elementary School	110	25	8.3	20.0	25	2:40	13.5	23	3:05
Holly Grove Middle School	110	25	8.2	20.0	25	2:40	25.3	43	3:25
Holly Ridge Elementary School	110	25	3.2	6.6	30	2:45	24.7	42	3:30
Holly Ridge Middle School	110	25	3.2	6.6	30	2:45	24.7	42	3:30
Holly Springs Elementary School	110	25	3.7	6.0	38	2:55	24.7	42	3:40
Holly Springs High School	110	25	8.7	20.4	26	2:45	13.5	23	3:10
New School, Inc. Montessori	110	25	2.7	11.0	15	2:30	13.4	23	2:55
Fuquay-Varina Middle School	110	25	0.9	3.4	16	2:35	28.4	48	3:25
Fuquay-Varina Senior High School ²	110	25	1.1	3.6	19	2:35	29.3	49	3:25
Herbert Akins Road Elementary School	110	25	3.3	30.0	7	2:25	27.0	46	3:15
Lincoln Heights Elementary School	110	25	1.7	4.9	22	2:40	28.4	48	3:30
Oakview Elementary School	110	25	7.6	9.6	48	3:05	25.3	43	3:50
Southern Wake Academy High School ²	110	25	3.8	2.8	81	3:40	27.5	46	4:30

School	Driver Mobilization Time (min)	Loading Time (min)	Dist. To EPZ Bdry (mi)	Average Speed (mph)	Travel Time to EPZ Bdry (min)	ETE (hr:min)	Dist. EPZ Bdry to R.S. (mi.)	Travel Time from EPZ Bdry to R.S. (min)	ETE to R.S. (hr:min)
WAKE COUNTY CHILD CARE CENTERS									
All About Kids	110	25	1.5	16.8	6	2:25	16.1	27	2:55
Angels Garden Day Care	110	25	2.5	11.7	13	2:30	14.7	25	2:55
Apex Baptist Church Preschool	110	25	2.7	11.7	14	2:30	14.7	25	2:55
Apex Child Care with Debbie	110	25	3.0	15.3	12	2:30	14.7	25	2:55
Apex Peak Schools, Inc.	110	25	2.9	11.4	16	2:35	17.1	29	3:05
Apex United Methodist Church Preschool	110	25	2.7	11.7	14	2:30	14.7	25	2:55
Children's Choice	110	25	1.8	25.7	5	2:20	14.7	25	2:45
Earth Angel's Day Care Home	110	25	1.8	25.7	5	2:20	16.1	27	2:50
Edith Franklin Day Care Home	110	25	2.7	11.7	14	2:30	14.7	25	2:55
Eileen's Day Care	110	25	1.0	9.2	7	2:25	15.9	27	2:55
Goddard School Apex	110	25	2.7	11.7	14	2:30	14.7	25	2:55
Grace Church Preschool	110	25	1.5	16.8	6	2:25	16.1	27	2:55
Growing Years Learning Center	110	25	2.7	11.7	14	2:30	14.7	25	2:55
Hope Chapel Preschool	110	25	1.4	7.2	13	2:30	15.9	27	3:00
Judy's Home Care	110	25	0.8	9.2	6	2:25	15.9	27	2:55
Karen's Kids Home Child Care	110	25	6.6	14.1	29	2:45	10.1	17	3:05
Karin'-4-Kidz	110	25	4.4	19.0	14	2:30	14.7	25	2:55
Lori's Family Day Care	110	25	1.0	8.3	8	2:25	14.7	25	2:50
Moravic Family Day Care	110	25	1.0	8.3	8	2:25	14.7	25	2:50
Peace Montessori	110	25	2.8	15.3	11	2:30	13.5	23	2:55
Play Care	110	25	3.2	14.4	14	2:30	15.9	27	3:00
Primose School of Apex	110	25	0.1	8.8	1	2:20	15.9	27	2:50
Rainbow Child Care Center	110	25	4.6	10.5	27	2:45	10.1	17	3:05
The Learning Experience in Apex	110	25	4.6	10.5	27	2:45	10.1	17	3:05
Tracey's House	110	25	2.7	15.5	11	2:30	13.5	23	2:55
Vickie's Day Care Home	110	25	2.7	11.7	14	2:30	14.7	25	2:55
Woodhaven Baptist Pre-school	110	25	1.5	16.8	6	2:25	16.1	27	2:55
Holly Springs Learning Center	110	25	4.4	8.5	32	2:50	15.0	25	3:15
Holly Springs School For Early Education	110	25	4.5	17.5	16	2:35	13.5	23	3:00
Home Away From Home Childcare	110	25	8.3	20.0	25	2:40	13.5	23	3:05

School	Driver Mobilization Time (min)	Loading Time (min)	Dist. To EPZ Bdry (mi)	Average Speed (mph)	Travel Time to EPZ Bdry (min)	ETE (hr:min)	Dist. EPZ Bdry to R.S. (mi.)	Travel Time from EPZ Bdry to R.S. (min)	ETE to R.S. (hr:min)
Kiddie Academy of Holly Springs	110	25	4.5	17.5	16	2:35	13.5	23	3:00
Kris' Home Sweet Home Daycare	110	25	4.4	8.5	32	2:50	15.0	25	3:15
Little Dreamers Preschool	110	25	4.5	17.5	16	2:35	13.5	23	3:00
Sisters' Child Care Services	110	25	4.4	8.5	32	2:50	15.0	25	3:15
Stella Lowery Small Day Care	110	25	1.5	10.9	9	2:25	13.4	23	2:50
Sunrise United Methodist Church Preschool	110	25	2.7	11.0	15	2:30	13.4	23	2:55
The Carolina School	110	25	4.4	8.5	32	2:50	15.0	25	3:15
A Mother's Love ²	110	25	2.1	3.7	35	2:50	29.4	49	3:40
Childcare Network - Fuquay Varina ²	110	25	1.1	3.5	20	2:35	29.4	49	3:40
Fuquay-Varina Baptist Wee Care ²	110	25	0.8	3.4	15	2:30	29.4	49	3:25
Fuquay-Varina UMC Preschool Seeds of Faith ²	110	25	0.8	3.4	15	2:30	29.4	49	3:20
Little Angels Preparatory ²	110	25	1.1	20.3	4	2:20	28.6	48	3:20
Little Miracles ²	110	25	1.1	20.3	4	2:20	31.1	52	3:15
Ready Or Not Here I Grow ²	110	25	1.1	3.6	19	2:35	31.1	52	3:15
Shining Star Child Care Home ²	110	25	1.1	20.3	4	2:20	25.9	44	3:20
South Wake Preschool & Academy ²	110	25	3.1	2.7	69	3:25	31.1	52	3:15
Spinning Wheels Learning Center ²	110	25	1.4	3.9	22	2:40	29.4	49	4:15
Vanessa Bland's Small Day Care Home ²	110	25	1.1	3.6	19	2:35	27.9	47	3:30
Maximum for EPZ:						3:45	Maximum:		4:30
Average for EPZ:						2:40	Average:		3:10

Notes: 1 – Not included in calculation for Maximum and Average ETE values since school is in the Shadow Region.

2 – Knightdale High School will serve as a temporary relocation school during the renovation of Garner High School.

Table 8-10. Summary of Transit-Dependent Bus Routes

Route	No. of Buses	Route Description	Zones Served	Length (mi.)
40	10	Southern EPZ: NC-42 from Fuquay-Varina west out of the EPZ toward Sanford	G(10%) + H + I + K	20.2
41	16	Eastern EPZ: NC-55 southbound from entrance into EPZ through Holly Springs and Fuquay-Varina	E(15%) + F(10%) + G(10%)	14.7
42	14	Northern EPZ: US-64 westbound from intersection with Salem St (SR 1011) out of EPZ towards Pittsboro	E(20%) + N	13.0
43	41	Circulate through Apex, then east out of EPZ to Reception Centers	E(65%)	17.2
44	30	Circulate through Holly Springs, then northeast out of EPZ to Reception Centers	F(90%)	20.5
45	25	Circulate through Fuquay-Varina, then south out of EPZ to Reception Centers	G(80%)	8.3
46	3	Zones A, B, L: Old US-1 eastbound to New Hill Olive Rd northbound, then out of the EPZ along US-64 WB to NC-540 Toll	A + B + L	14.3
47	4	Zones C, D: Cass Holt Rd eastbound towards Holly Springs, then along Holly Springs New Hill Rd westbound. Exits EPZ along US-1 eastbound to Reception Centers	C + D	17.3
48	2	Zones J and portion of M : Picks up evacuees along Lower Moncure Rd southbound, then out of EPZ towards Sanford	J + M(10%)	6.0
49	2	Portion of Zone M: Old US-1 in Moncure to Moncure Pittsboro Rd northbound, to Gum Springs Church Rd out of the EPZ towards Pittsboro	M(90%)	9.9
Total:	147			

Table 8-11. Transit-Dependent Evacuation Time Estimates - Good Weather

Route Number	Bus Number	One-Wave						Distance to R. C. (miles)	Two-Wave					
		Mobilization (min)	Route Length (miles)	Speed (mph)	Route Travel Time (min)	Pickup Time (min)	ETE (hr:min)		Travel Time to R. C. (min)	Unload (min)	Driver Rest (min)	Route Travel Time (min)	Pickup Time (min)	ETE (hr:min)
40	1-3	120	20.2	45.0	27	30	3:00	10.0	13	5	10	67	30	5:05
	4-6	135	20.2	45.0	27	30	3:15	10.0	13	5	10	67	30	5:20
	6-10	150	20.2	45.0	27	30	3:30	10.0	13	5	10	67	30	5:35
41 ¹	1-4	120	14.7	5.8	153	30	5:05	30.4	41	5	10	80	30	7:55
	5-8	130	14.7	6.0	147	30	5:10	30.4	41	5	10	80	30	8:00
	9-12	140	14.7	6.6	133	30	5:05	30.4	41	5	10	80	30	7:55
	13-16	150	14.7	7.0	127	30	5:10	30.4	41	5	10	80	30	8:00
42	1-4	120	13.0	45.0	17	30	2:50	6.5	9	5	10	44	30	4:30
	5-8	130	13.0	45.0	17	30	3:00	6.5	9	5	10	44	30	4:40
	9-12	140	13.0	45.0	17	30	3:10	6.5	9	5	10	44	30	4:50
	12-14	150	13.0	45.0	17	30	3:20	6.5	9	5	10	44	30	5:00
43	1-6	120	17.2	18.5	56	30	3:30	14.7	20	5	10	66	30	5:45
	7-12	125	17.2	19.1	54	30	3:30	14.7	20	5	10	66	30	5:45
	13-18	130	17.2	19.7	53	30	3:35	14.7	20	5	10	66	30	5:50
	19-24	135	17.2	22.1	47	30	3:35	14.7	20	5	10	66	30	5:50
	25-30	140	17.2	23.0	45	30	3:35	14.7	20	5	10	66	30	5:50
	31-36	145	17.2	24.0	43	30	3:40	14.7	20	5	10	66	30	5:55
	37-41	150	17.2	27.2	38	30	3:40	14.7	20	5	10	66	30	5:55
44	1-4	120	20.5	15.6	79	30	3:50	13.4	18	5	10	73	30	6:10
	5-8	125	20.5	16.1	76	30	3:55	13.4	18	5	10	73	30	6:15
	9-11	130	20.5	16.7	74	30	3:55	13.4	18	5	10	73	30	6:15
	12-15	135	20.5	17.3	71	30	4:00	13.4	18	5	10	73	30	6:20
	16-19	140	20.5	17.9	69	30	4:00	13.4	18	5	10	73	30	6:20
	20-24	145	20.5	19.9	62	30	4:00	13.4	18	5	10	73	30	6:20
	25-30	150	20.5	20.9	59	30	4:00	13.4	18	5	10	73	30	6:20

Route Number	Bus Number	One-Wave						Two-Wave						
		Mobilization (min)	Route Length (miles)	Speed (mph)	Route Travel Time (min)	Pickup Time (min)	ETE (hr:min)	Distance to R. C. (miles)	Travel Time to R. C. (min)	Unload (min)	Driver Rest (min)	Route Travel Time (min)	Pickup Time (min)	ETE (hr:min)
45 ¹	1-4	120	8.3	19.7	25	30	2:55	30.4	41	5	10	66	30	5:30
	5-8	130	8.3	24.6	20	30	3:00	30.4	41	5	10	66	30	5:35
	9-11	135	8.3	25.2	20	30	3:05	30.4	41	5	10	66	30	5:40
	12-14	140	8.3	28.6	17	30	3:10	30.4	41	5	10	66	30	5:45
	15-19	145	8.3	30.5	16	30	3:15	30.4	41	5	10	66	30	5:50
	20-25	150	8.3	31.8	16	30	3:20	30.4	41	5	10	66	30	5:55
46	1	120	14.3	45.0	19	30	2:50	24.2	32	5	10	70	30	5:20
	2-3	150	14.3	45.0	19	30	3:20	24.2	32	5	10	70	30	5:50
47	1	120	17.3	19.4	54	30	3:25	18.8	25	5	10	72	30	5:50
	2	135	17.3	23.1	45	30	3:30	18.8	25	5	10	71	30	5:55
	3-4	150	17.3	29.9	35	30	3:35	18.8	25	5	10	71	30	6:00
48	1	120	6.0	45.0	8	30	2:40	10.5	14	5	10	30	30	4:10
49	1	120	9.9	45.0	13	30	2:45	7.4	10	5	10	36	30	4:20
	2	150	9.9	45.0	13	30	3:15	7.4	10	5	10	37	30	4:50
Maximum ETE:							5:10	Maximum ETE:						8:00
Average ETE:							3:35	Average ETE:						5:55

Note 1 - Knightdale High School will serve as a temporary reception center during the renovation of Garner High School

Table 8-12. Transit-Dependent Evacuation Time Estimates - Rain

Route Number	Bus Number	One-Wave						Two-Wave						
		Mobilization (min)	Route Length (miles)	Speed (mph)	Route Travel Time (min)	Pickup Time (min)	ETE (hr:min)	Distance to R. C. (miles)	Travel Time to R. C. (min)	Unload (min)	Driver Rest (min)	Route Travel Time (min)	Pickup Time (min)	ETE (hr:min)
40	1-3	130	20.2	41.0	30	40	3:20	10.0	15	5	10	74	40	5:45
	4-6	145	20.2	41.0	30	40	3:35	10.0	15	5	10	74	40	6:00
	6-10	160	20.2	41.0	30	40	3:50	10.0	15	5	10	74	40	6:15
41 ¹	1-4	130	14.7	5.4	165	40	5:35	30.4	44	5	10	87	40	8:45
	5-8	140	14.7	5.5	159	40	5:40	30.4	44	5	10	87	40	8:50
	9-12	150	14.7	5.8	153	40	5:45	30.4	44	5	10	87	40	8:55
	13-16	160	14.7	6.3	141	40	5:45	30.4	44	5	10	87	40	8:55
42	1-4	130	13.0	41.0	19	40	3:10	6.5	9	5	10	47	40	5:05
	5-8	140	13.0	41.0	19	40	3:20	6.5	9	5	10	47	40	5:15
	9-12	150	13.0	41.0	19	40	3:30	6.5	9	5	10	47	40	5:25
	12-14	160	13.0	41.0	19	40	3:40	6.5	9	5	10	47	40	5:35
43	1-6	130	17.2	18.9	55	40	3:45	14.7	21	5	10	71	40	6:15
	7-12	135	17.2	19.6	53	40	3:50	14.7	21	5	10	71	40	6:20
	13-18	140	17.2	21.0	49	40	3:50	14.7	21	5	10	71	40	6:20
	19-24	145	17.2	21.6	48	40	3:55	14.7	21	5	10	71	40	6:25
	25-30	150	17.2	22.9	45	40	4:00	14.7	21	5	10	71	40	6:30
	31-36	155	17.2	23.3	44	40	4:00	14.7	21	5	10	71	40	6:30
	37-41	160	17.2	24.2	43	40	4:05	14.7	21	5	10	71	40	6:35
44	1-4	130	20.5	13.2	93	40	4:25	13.4	20	5	10	80	40	7:00
	5-8	135	20.5	13.5	91	40	4:30	13.4	20	5	10	80	40	7:05
	9-11	140	20.5	14.0	88	40	4:30	13.4	20	5	10	80	40	7:05
	12-15	145	20.5	15.4	80	40	4:30	13.4	20	5	10	80	40	7:05
	16-19	150	20.5	15.8	78	40	4:30	13.4	20	5	10	80	40	7:05
	20-24	155	20.5	16.4	75	40	4:30	13.4	20	5	10	80	40	7:05
	25-30	160	20.5	17.1	72	40	4:35	13.4	20	5	10	80	40	7:10

Route Number	Bus Number	One-Wave						Distance to R. C. (miles)	Two-Wave					
		Mobilization (min)	Route Length (miles)	Speed (mph)	Route Travel Time (min)	Pickup Time (min)	ETE (hr:min)		Travel Time to R. C. (min)	Unload (min)	Driver Rest (min)	Route Travel Time (min)	Pickup Time (min)	ETE (hr:min)
45 ¹	1-4	130	8.3	15.1	33	40	3:25	30.4	44	5	10	71	40	6:15
	5-8	140	8.3	20.3	25	40	3:25	30.4	44	5	10	71	40	6:15
	9-11	145	8.3	22.2	22	40	3:30	30.4	44	5	10	71	40	6:20
	12-14	150	8.3	24.6	20	40	3:35	30.4	44	5	10	71	40	6:25
	15-19	155	8.3	26.4	19	40	3:35	30.4	44	5	10	71	40	6:25
	20-25	160	8.3	28.2	18	40	3:40	30.4	44	5	10	71	40	6:30
46	1	130	14.3	41.0	21	40	3:15	24.2	35	5	10	77	40	6:05
	2-3	160	14.3	41.0	21	40	3:45	24.2	35	5	10	77	40	6:35
47	1	130	17.3	16.8	62	40	3:55	18.8	27	5	10	78	40	6:35
	2	145	17.3	20.7	50	40	4:00	18.8	27	5	10	78	40	6:40
	3-4	160	17.3	25.7	40	40	4:05	18.8	27	5	10	78	40	6:45
48	1	130	6.0	41.0	9	40	3:00	10.5	15	5	10	33	40	4:45
49	1	130	9.9	40.8	15	40	3:05	7.4	11	5	10	40	40	4:55
	2	160	9.9	41.0	14	40	3:35	7.4	11	5	10	40	40	5:25
Maximum ETE:							5:45	Maximum ETE:						8:55
Average ETE:							4:00	Average ETE:						6:35

Note 1 - Knightdale High School will serve as a temporary reception center during the renovation of Garner High School

Table 8-13. Transit Dependent Evacuation Time Estimates – Ice

Route Number	Bus Number	One-Wave						Two-Wave						
		Mobilization (min)	Route Length (miles)	Speed (mph)	Route Travel Time (min)	Pickup Time (min)	ETE (hr:min)	Distance to R. C. (miles)	Travel Time to R. C. (min)	Unload (min)	Driver Rest (min)	Route Travel Time (min)	Pickup Time (min)	ETE (hr:min)
40	1-3	140	20.2	36.0	34	50	3:45	10.0	17	5	10	84	50	6:35
	4-6	155	20.2	36.0	34	50	4:00	10.0	17	5	10	84	50	6:50
	6-10	170	20.2	36.0	34	50	4:15	10.0	17	5	10	84	50	7:05
41 ¹	1-4	140	14.7	4.6	193	50	6:25	30.4	51	5	10	100	50	10:05
	5-8	150	14.7	4.7	188	50	6:30	30.4	51	5	10	100	50	10:10
	9-12	160	14.7	5.0	176	50	6:30	30.4	51	5	10	100	50	10:10
	13-16	170	14.7	5.2	171	50	6:35	30.4	51	5	10	100	50	10:15
42	1-4	140	13.0	36.0	22	50	3:35	6.5	11	5	10	54	50	5:45
	5-8	150	13.0	36.0	22	50	3:45	6.5	11	5	10	54	50	5:55
	9-12	160	13.0	36.0	22	50	3:55	6.5	11	5	10	54	50	6:05
	12-14	170	13.0	36.0	22	50	4:05	6.5	11	5	10	54	50	6:15
43	1-6	140	17.2	14.4	72	50	4:25	14.7	24	5	10	81	50	7:15
	7-12	145	17.2	14.9	69	50	4:25	14.7	24	5	10	81	50	7:15
	13-18	150	17.2	15.5	66	50	4:30	14.7	24	5	10	81	50	7:20
	19-24	155	17.2	16.1	64	50	4:30	14.7	24	5	10	81	50	7:20
	25-30	160	17.2	17.3	60	50	4:30	14.7	24	5	10	81	50	7:20
	31-36	165	17.2	17.8	58	50	4:35	14.7	24	5	10	81	50	7:25
	37-41	170	17.2	19.4	53	50	4:35	14.7	24	5	10	81	50	7:25
44	1-4	140	20.5	10.7	114	50	5:05	13.4	22	5	10	90	50	8:05
	5-8	145	20.5	11.9	103	50	5:00	13.4	22	5	10	90	50	8:00
	9-11	150	20.5	12.2	101	50	5:05	13.4	22	5	10	90	50	8:05
	12-15	155	20.5	12.5	98	50	5:05	13.4	22	5	10	90	50	8:05
	16-19	160	20.5	12.9	95	50	5:10	13.4	22	5	10	90	50	8:10
	20-24	165	20.5	13.3	92	50	5:10	13.4	22	5	10	90	50	8:10
	25-30	170	20.5	13.8	89	50	5:10	13.4	22	5	10	90	50	8:10

Route Number	Bus Number	One-Wave						Two-Wave							
		Mobilization (min)	Route Length (miles)	Speed (mph)	Route Travel Time (min)	Pickup Time (min)	ETE (hr:min)	Distance to R. C. (miles)	Travel Time to R. C. (min)	Unload (min)	Driver Rest (min)	Route Travel Time (min)	Pickup Time (min)	ETE (hr:min)	
45 ¹	1-4	140	8.3	9.6	52	50	4:05	30.4	51	5	10	82	50	7:25	
	5-8	150	8.3	12.2	41	50	4:05	30.4	51	5	10	82	50	7:25	
	9-11	155	8.3	13.0	38	50	4:05	30.4	51	5	10	82	50	7:25	
	12-14	160	8.3	13.9	36	50	4:10	30.4	51	5	10	82	50	7:30	
	15-19	165	8.3	15.2	33	50	4:10	30.4	51	5	10	82	50	7:30	
	20-25	170	8.3	16.8	30	50	4:10	30.4	51	5	10	82	50	7:30	
46	1	140	14.3	36.0	24	50	3:35	24.2	40	5	10	88	50	6:50	
	2-3	170	14.3	36.0	24	50	4:05	24.2	40	5	10	88	50	7:20	
47	1	140	17.3	14.9	70	50	4:20	18.8	31	5	10	89	50	7:25	
	2	155	17.3	17.9	58	50	4:25	18.8	31	5	10	89	50	7:30	
	3-4	170	17.3	21.6	48	50	4:30	18.8	31	5	10	89	50	7:35	
48	1	140	6.0	36.0	10	50	3:20	10.5	17	5	10	37	50	5:20	
49	1	140	9.9	35.9	17	50	3:30	7.4	12	5	10	45	50	5:35	
	2	170	9.9	36.0	17	50	4:00	7.4	12	5	10	45	50	6:05	
Maximum ETE:							6:35	Maximum ETE:							10:15
Average ETE:							4:35	Average ETE:							7:30

Note 1 - Knightdale High School will serve as a temporary reception center during the renovation of Garner High School

Table 8-14. Medical Facility Evacuation Time Estimates – Good Weather

Medical Facility	Patient	Mobilization (min)	Loading Rate (min per person)	People	Total Loading Time (min)	Dist. To EPZ Bdry (mi)	Travel Time to EPZ Boundary (min)	ETE (hr:min)
Sanford Health and Rehabilitation	Ambulatory	90	2	41	60	1.9	3	2:35
	Wheelchair bound	90	7	69	105	1.9	3	3:20
	Bedridden	90	15	27	30	1.9	3	2:05
Brown's Family Care Home	Ambulatory	90	2	6	12	3.3	8	1:50
James Rest Home	Ambulatory	90	2	28	56	3.3	6	2:35
	Wheelchair bound	90	7	10	28	3.3	7	2:05
Murchison Residential Corp Home	Ambulatory	90	2	3	6	9.7	40	2:20
Azalea Gardens Mental Health	Ambulatory	90	2	6	10	2.1	8	1:50
Brookridge Assisted Living	Ambulatory	90	2	40	60	3.6	14	2:45
	Wheelchair bound	90	7	12	28	3.6	21	2:20
Favour Home	Ambulatory	90	2	6	8	4.6	29	2:10
Kings Group Home for Children	Ambulatory	90	2	4	8	4.6	33	2:15
Lockley Road Home	Ambulatory	90	2	6	10	1.7	5	1:45
Mason Street Group Home	Ambulatory	90	2	6	10	2.1	7	1:50
Olive Home	Ambulatory	90	2	6	10	2.1	8	1:50
Rex Rehab & Nursing Center of Apex	Ambulatory	90	2	20	40	2.6	15	2:25
	Wheelchair bound	90	7	40	105	2.6	4	3:20
	Bedridden	90	15	30	30	2.6	14	2:15
Seagraves Family Care Home	Ambulatory	90	2	4	8	3.5	19	2:00
Shackleton Home	Ambulatory	90	2	3	6	3.0	16	1:55
Spring Arbor of Apex	Ambulatory	90	2	47	60	2.9	8	2:40
	Wheelchair bound	90	7	19	28	2.9	18	2:20
Avent Ferry Home	Ambulatory	90	2	6	10	7.4	30	2:10
Bass Lake Home	Ambulatory	90	2	6	8	4.1	27	2:05

Medical Facility	Patient	Mobilization (min)	Loading Rate (min per person)	People	Total Loading Time (min)	Dist. To EPZ Bdry (mi)	Travel Time to EPZ Boundary (min)	ETE (hr:min)
Country Lane Group Home	Ambulatory	90	2	6	10	7.4	30	2:10
Herbert Reid Home	Ambulatory	90	2	5	10	3.3	8	1:50
Hickory Avenue Home	Ambulatory	90	2	6	10	6.8	69	2:50
St. Mark's Manor	Ambulatory	90	2	9	10	3.3	8	1:50
Trotter's Bluff	Ambulatory	90	2	6	10	7.4	30	2:10
Creekway Home	Ambulatory	90	2	6	10	0.4	1	1:45
Evans-Walston Home	Ambulatory	90	2	3	6	2.5	11	1:50
Fuquay-Varina Homes for the Elderly	Ambulatory	90	2	60	60	1.4	2	2:35
	Wheelchair bound	90	7	2	14	1.4	10	1:55
Hope House	Ambulatory	90	2	4	8	1.7	18	2:00
Kinton Court Home	Ambulatory	90	2	16	10	1.7	13	1:55
Life Skills Independent Care #1	Ambulatory	90	2	4	8	0.8	7	1:45
Mim's Family Care Home	Ambulatory	90	2	2	4	5.1	17	1:55
WakeMed Fuquay Skilled Nursing Facility	Wheelchair bound	90	7	20	140	1.9	4	2:05
	Bedridden	90	15	15	60	1.9	4	2:35
Windsor Point Continuing Care	Ambulatory	90	2	140	60	1.3	3	2:35
	Wheelchair bound	90	7	100	105	1.3	3	3:20
	Bedridden	90	15	35	30	1.3	5	2:05
Maximum ETE:								3:20
Average ETE:								2:15

Table 8-15. Medical Facility Evacuation Time Estimates - Rain

Medical Facility	Patient	Mobilization (min)	Loading Rate (min per person)	People	Total Loading Time (min)	Dist. To EPZ Bdry (mi)	Travel Time to EPZ Boundary (min)	ETE (hr:min)
Sanford Health and Rehabilitation	Ambulatory	100	2	41	60	1.9	3	2:45
	Wheelchair bound	100	7	69	105	1.9	3	3:30
	Bedridden	100	15	27	30	1.9	3	2:15
Brown's Family Care Home	Ambulatory	100	2	6	12	3.3	6	2:00
James Rest Home	Ambulatory	100	2	28	56	3.3	5	2:45
	Wheelchair bound	100	7	10	28	3.3	5	2:15
Murchison Residential Corp Home	Ambulatory	100	2	3	6	9.7	29	2:15
Azalea Gardens Mental Health	Ambulatory	100	2	6	10	2.1	12	2:05
Brookridge Assisted Living	Ambulatory	100	2	40	60	3.6	7	2:50
	Wheelchair bound	100	7	12	28	3.6	14	2:25
Favour Home	Ambulatory	100	2	6	8	4.6	15	2:05
Kings Group Home for Children	Ambulatory	100	2	4	8	4.6	39	2:30
Lockley Road Home	Ambulatory	100	2	6	10	1.7	6	2:00
Mason Street Group Home	Ambulatory	100	2	6	10	2.1	10	2:00
Olive Home	Ambulatory	100	2	6	10	2.1	13	2:05
Rex Rehab & Nursing Center of Apex	Ambulatory	100	2	20	40	2.6	4	2:25
	Wheelchair bound	100	7	40	105	2.6	4	3:30
	Bedridden	100	15	30	30	2.6	5	2:15
Seagraves Family Care Home	Ambulatory	100	2	4	8	3.5	24	2:15
Shackleton Home	Ambulatory	100	2	3	6	3.0	10	2:00
Spring Arbor of Apex	Ambulatory	100	2	47	60	2.9	6	2:50
	Wheelchair bound	100	7	19	28	2.9	19	2:30
Avent Ferry Home	Ambulatory	100	2	6	10	7.4	15	2:05

Medical Facility	Patient	Mobilization (min)	Loading Rate (min per person)	People	Total Loading Time (min)	Dist. To EPZ Bdry (mi)	Travel Time to EPZ Boundary (min)	ETE (hr:min)
Bass Lake Home	Ambulatory	100	2	6	8	4.1	31	2:20
Country Lane Group Home	Ambulatory	100	2	6	10	7.4	15	2:05
Herbert Reid Home	Ambulatory	100	2	5	10	3.3	9	2:00
Hickory Avenue Home	Ambulatory	100	2	6	10	6.8	74	3:05
St. Mark's Manor	Ambulatory	100	2	9	10	3.3	9	2:00
Trotter's Bluff	Ambulatory	100	2	6	10	7.4	16	2:10
Creekway Home	Ambulatory	100	2	6	10	0.4	2	1:55
Evans-Walston Home	Ambulatory	100	2	3	6	2.5	12	2:00
Fuquay-Varina Homes for the Elderly	Ambulatory	100	2	60	60	1.4	2	2:45
	Wheelchair bound	100	7	2	14	1.4	19	2:15
Hope House	Ambulatory	100	2	4	8	1.7	19	2:10
Kinton Court Home	Ambulatory	100	2	16	10	1.7	22	2:15
Life Skills Independent Care #1	Ambulatory	100	2	4	8	0.8	8	2:00
Mim's Family Care Home	Ambulatory	100	2	2	4	5.1	26	2:10
WakeMed Fuquay Skilled Nursing Facility	Wheelchair bound	100	7	20	140	1.9	4	2:15
	Bedridden	100	15	15	60	1.9	4	2:45
Windsor Point Continuing Care	Ambulatory	100	2	140	60	1.3	3	2:45
	Wheelchair bound	100	7	100	105	1.3	3	3:30
	Bedridden	100	15	35	30	1.3	8	2:20
Maximum ETE:								3:30
Average ETE:								2:25

Table 8-16. Medical Facility Evacuation Time Estimates - Ice

Medical Facility	Patient	Mobilization (min)	Loading Rate (min per person)	People	Total Loading Time (min)	Dist. To EPZ Bdry (mi)	Travel Time to EPZ Boundary (min)	ETE (hr:min)
Sanford Health and Rehabilitation	Ambulatory	110	2	41	60	1.9	3	2:55
	Wheelchair bound	110	7	69	105	1.9	3	3:40
	Bedridden	110	15	27	30	1.9	3	2:25
Brown's Family Care Home	Ambulatory	110	2	6	12	3.3	7	2:10
James Rest Home	Ambulatory	110	2	28	56	3.3	5	2:55
	Wheelchair bound	110	7	10	28	3.3	6	2:25
Murchison Residential Corp Home	Ambulatory	110	2	3	6	9.7	34	2:30
Azalea Gardens Mental Health	Ambulatory	110	2	6	10	2.1	12	2:15
Brookridge Assisted Living	Ambulatory	110	2	40	60	3.6	7	3:00
	Wheelchair bound	110	7	12	28	3.6	22	2:40
Favour Home	Ambulatory	110	2	6	8	4.6	19	2:20
Kings Group Home for Children	Ambulatory	110	2	4	8	4.6	40	2:40
Lockley Road Home	Ambulatory	110	2	6	10	1.7	10	2:10
Mason Street Group Home	Ambulatory	110	2	6	10	2.1	10	2:10
Olive Home	Ambulatory	110	2	6	10	2.1	12	2:15
Rex Rehab & Nursing Center of Apex	Ambulatory	110	2	20	40	2.6	9	2:40
	Wheelchair bound	110	7	40	105	2.6	4	3:40
	Bedridden	110	15	30	30	2.6	9	2:30
Seagraves Family Care Home	Ambulatory	110	2	4	8	3.5	29	2:30
Shackleton Home	Ambulatory	110	2	3	6	3.0	13	2:10
Spring Arbor of Apex	Ambulatory	110	2	47	60	2.9	10	3:00
	Wheelchair bound	110	7	19	28	2.9	22	2:40
Avent Ferry Home	Ambulatory	110	2	6	10	7.4	20	2:20
Bass Lake Home	Ambulatory	110	2	6	8	4.1	42	2:40
Country Lane Group Home	Ambulatory	110	2	6	10	7.4	20	2:20
Herbert Reid Home	Ambulatory	110	2	5	10	3.3	14	2:15

Medical Facility	Patient	Mobilization (min)	Loading Rate (min per person)	People	Total Loading Time (min)	Dist. To EPZ Bdry (mi)	Travel Time to EPZ Boundary (min)	ETE (hr:min)
Hickory Avenue Home	Ambulatory	110	2	6	10	6.8	82	3:25
St. Mark's Manor	Ambulatory	110	2	9	10	3.3	14	2:15
Trotter's Bluff	Ambulatory	110	2	6	10	7.4	20	2:20
Creekway Home	Ambulatory	110	2	6	10	0.4	16	2:20
Evans-Walston Home	Ambulatory	110	2	3	6	2.5	14	2:10
Fuquay-Varina Homes for the Elderly	Ambulatory	110	2	60	60	1.4	5	2:55
	Wheelchair bound	110	7	2	14	1.4	27	2:35
Hope House	Ambulatory	110	2	4	8	1.7	19	2:20
Kinton Court Home	Ambulatory	110	2	16	10	1.7	28	2:30
Life Skills Independent Care #1	Ambulatory	110	2	4	8	0.8	8	2:10
Mim's Family Care Home	Ambulatory	110	2	2	4	5.1	39	2:35
WakeMed Fuquay Skilled Nursing Facility	Wheelchair bound	110	7	20	140	1.9	4	2:25
	Bedridden	110	15	15	60	1.9	5	2:55
Windsor Point Continuing Care	Ambulatory	110	2	140	60	1.3	3	2:55
	Wheelchair bound	110	7	100	105	1.3	3	3:40
	Bedridden	110	15	35	30	1.3	17	2:40
Maximum ETE:								3:40
Average ETE:								2:40

Table 8-17. Homebound Special Needs Population Evacuation Time Estimates

Vehicle Type	People Requiring Vehicle	Vehicles deployed	Stops	Weather Conditions	Mobilization Time (min)	Loading Time at 1 st Stop (min)	Travel to Subsequent Stops (min)	Total Loading Time at Subsequent Stops (min)	Travel Time to EPZ Boundary (min)	ETE (hr:min)
Buses	85	10	9	Good	90	5	72	40	17	3:45
				Rain	100		80		19	4:05
				Ice	110		88		22	4:25
Wheelchair Vans	21	6	4	Good	90	7	27	21	16	2:45
				Rain	100		30		18	3:00
				Ice	110		33		21	3:15
Ambulances	10	5	2	Good	90	15	10	15	16	2:30
				Rain	100		11		18	2:40
				Ice	110		13		21	2:55
Maximum ETE:									4:25	
Average ETE:									3:15	

9 TRAFFIC MANAGEMENT STRATEGY

This section discusses the suggested traffic control and management strategy that is designed to expedite the movement of evacuating traffic. The resources required to implement this strategy include:

- Personnel with the capabilities of performing the planned control functions of traffic guides (preferably, not necessarily, law enforcement officers).
- The Manual of Uniform Traffic Control Devices (MUTCD) published by the Federal Highway Administration (FHWA) of the U.S.D.O.T. provides guidance for Traffic Control Devices to assist these personnel in the performance of their tasks. All state and most county transportation agencies have access to the MUTCD, which is available on-line: <http://mutcd.fhwa.dot.gov> which provides access to the official PDF version.
- A plan, that defines all locations, provides necessary details and is documented in a format that is readily understood by those assigned to perform traffic control.

The functions to be performed in the field are:

1. Facilitate evacuating traffic movements that safely expedite travel out of the EPZ.
2. Discourage traffic movements that move evacuating vehicles in a direction which takes them significantly closer to the power plant, or which interferes with the efficient flow of other evacuees.

The terms "facilitate" and "discourage" are employed rather than "enforce" and "prohibit" to indicate the need for flexibility in performing the traffic control function. There are always legitimate reasons for a driver to prefer a direction other than that indicated. For example:

- A driver may be traveling home from work or from another location, to join other family members prior to evacuating.
- An evacuating driver may be travelling to pick up a relative, or other evacuees.
- The driver may be an emergency worker en route to perform an important activity.

The implementation of a plan must also be flexible enough for the application of sound judgment by the traffic guide.

The traffic management plan is the outcome of the following process:

1. The detailed traffic control tactics discussed in the All County "Standard Operating Guideline (SOG) for Traffic Control Point and Security Road Block Operations in Support of the Harris Nuclear Plant", dated January 1, 2016 serve as the basis of the traffic management plan, as per NUREG/CR-7002. Recommendations were made in areas where modified TCPs and removal of a TCP would benefit ETE. See Appendix G for more detail.
2. Computer analysis of the evacuation traffic flow environment (See Figures 7-3 through 7-10).

This analysis identifies the best routing and those critical intersections that experience pronounced congestion. Any critical intersections that would not

benefit from traffic or access control which are identified in the existing offsite plans are suggested as removed TCPs and SRBs.

3. The existing TCPs and SRBs and the recommended modified TCPs and how they were applied in this study, are discussed in Appendix G.

4. Consultation with emergency management and law enforcement personnel.

Trained personnel who are experienced in controlling traffic and are aware of the likely evacuation traffic patterns have reviewed the control tactics at the suggested additional TCPs and SRBs.

5. Prioritization of TCPs and SRBs.

Application of traffic and access control at some TCPs and SRBs will have a more pronounced influence on expediting traffic movements than at other TCPs and SRBs. For example, TCPs controlling traffic originating from areas in close proximity to the power plant could have a more beneficial effect on minimizing potential exposure to radioactivity than those TCPs located far from the power plant. These priorities have been reviewed and approved by state/county emergency management representatives and by law enforcement personnel.

Based on the computer analysis, revisions to five existing TCPs and the removal of one TCP are recommended – see Appendix G. It is recommended that the control tactics identified in Appendix G be reviewed by the state and county emergency planners, and local and state law enforcement. Specifically, the locations of the modified TCPs and removed TCP should be reviewed in detail.

As discussed in Section 7.5, the roadway impact scenario resulted in at most a 10-minute and 15-minute increase in the 90th percentile ETE and 100th percentile ETE, respectively. This is not a significant change in ETE, thus, no additional traffic management tactics are necessary to mitigate the impacts of a potential roadway closure along US-1 northbound or US-64 eastbound.

The ETE analysis treated all controlled intersections that are existing SRB or TCP locations in the offsite agency plans as being controlled by actuated signals. Appendix K, Table K-2 identifies those intersections that were modeled as TCPs.

The ETE calculations reflect the assumption that all “external-external” trips are interdicted and diverted after 30 minutes have elapsed from the ATE.

All transit vehicles and other responders entering the EPZ to support the evacuation are assumed to be unhindered by personnel manning SRBs and TCPs.

Study Assumptions 12, 13 and 14 in Section 2.3 discuss SRB and TCP staffing schedules and operations.

10 EVACUATION ROUTES

Evacuation routes are comprised of two distinct components:

- Routing from a Zone being evacuated to the boundary of the Evacuation Region and thence out of the EPZ.
- Routing of transit-dependent evacuees from the EPZ boundary to reception centers.

Evacuees will select routes within the EPZ in such a way as to minimize their exposure to risk. This expectation is met by the DYNEV II model routing traffic away from the location of the plant, to the extent practicable. The DTRAD model satisfies this behavior by routing traffic so as to balance traffic demand relative to the available highway capacity to the extent possible. See Appendices B through D for further discussion.

The routing of transit-dependent evacuees from the EPZ boundary to reception centers is designed to minimize the amount of travel outside the EPZ, from the points where these routes cross the EPZ boundary.

Figure 10-1 maps the general population reception centers and relocation schools for evacuees. The major evacuation routes for the EPZ are presented in Figure 10-2.

Based on discussions with the county and state emergency management personnel, Garner High School, which normally serves as a reception center and relocation school, will be closed for the next 2 years due to renovations and construction. Evacuees normally assigned to Garner High School will be assigned to the temporary reception center/relocation school at Knightdale High School instead.

It is assumed that all school evacuees will be taken to the appropriate relocation school and subsequently be picked up by parents or guardians. Transit-dependent evacuees are transported to the nearest reception center for each county. This study does not consider the transport of evacuees from reception centers to congregate care centers, if the counties do make the decision to relocate evacuees.

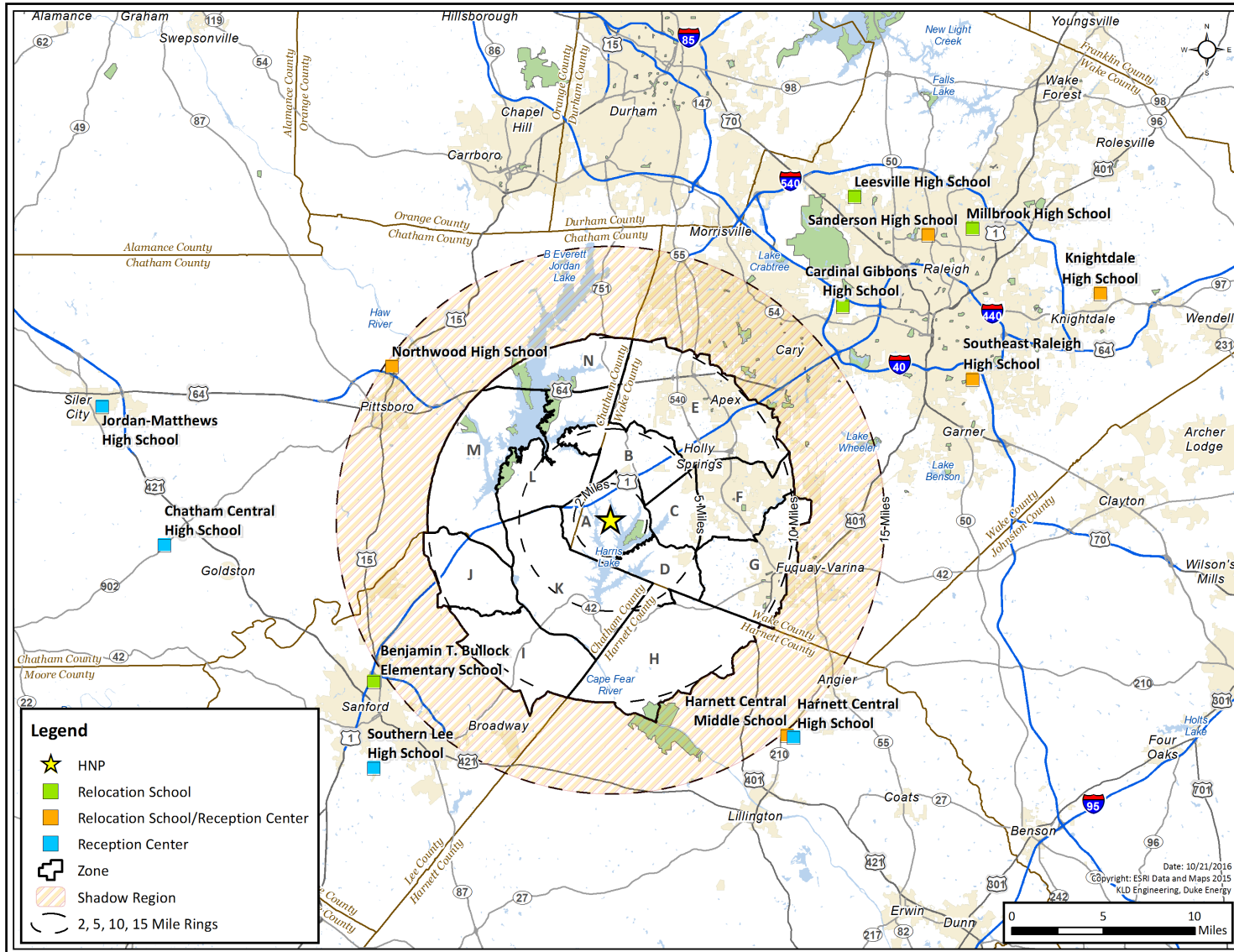

Figure 10-1. General Population Reception Centers and Relocation Schools

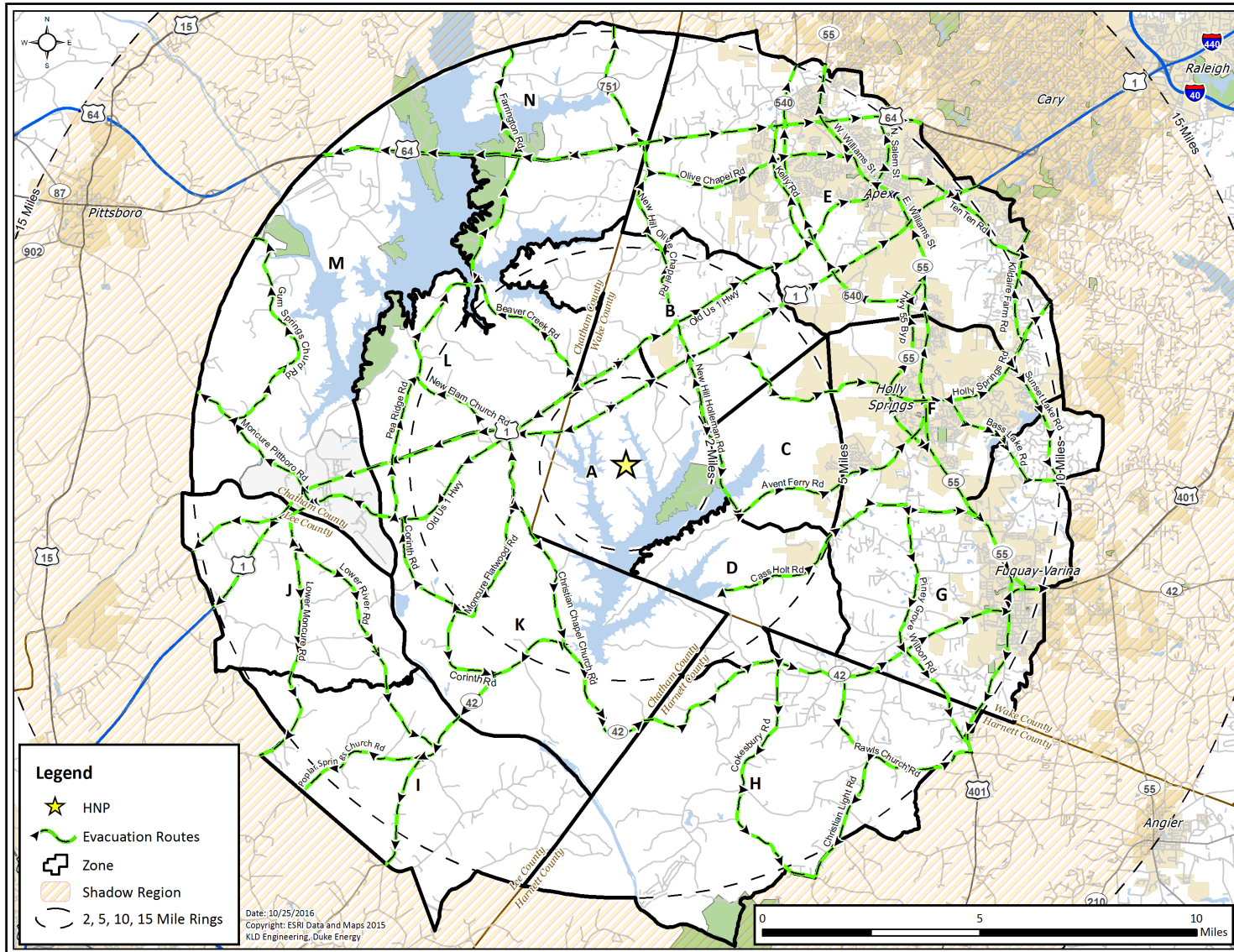

Figure 10-2. Evacuation Routes

APPENDIX A

Glossary of Traffic Engineering Terms

A. GLOSSARY OF TRAFFIC ENGINEERING TERMS

Table A-1. Glossary of Traffic Engineering Terms

Term	Definition
Analysis Network	A graphical representation of the geometric topology of a physical roadway system, which is comprised of directional links and nodes.
Link	A network link represents a specific, one-directional section of roadway. A link has both physical (length, number of lanes, topology, etc.) and operational (turn movement percentages, service rate, free-flow speed) characteristics.
Measures of Effectiveness	Statistics describing traffic operations on a roadway network.
Node	A network node generally represents an intersection of network links. A node has control characteristics, i.e., the allocation of service time to each approach link.
Origin	A location attached to a network link, within the EPZ or Shadow Region, where trips are generated at a specified rate in vehicles per hour (vph). These trips enter the roadway system to travel to their respective destinations.
Prevailing Roadway and Traffic Conditions	Relates to the physical features of the roadway, the nature (e.g., composition) of traffic on the roadway and the ambient conditions (weather, visibility, pavement conditions, etc.).
Service Rate	Maximum rate at which vehicles, executing a specific turn maneuver, can be discharged from a section of roadway at the prevailing conditions, expressed in vehicles per second (vps) or vehicles per hour (vph).
Service Volume	Maximum number of vehicles which can pass over a section of roadway in one direction during a specified time period with operating conditions at a specified Level of Service (The Service Volume at the upper bound of Level of Service, E, equals Capacity). Service Volume is usually expressed as vehicles per hour (vph).
Signal Cycle Length	The total elapsed time to display all signal indications, in sequence. The cycle length is expressed in seconds.
Signal Interval	A single combination of signal indications. The interval duration is expressed in seconds. A signal phase is comprised of a sequence of signal intervals, usually green, yellow, red.

Term	Definition
Signal Phase	A set of signal indications (and intervals) which services a particular combination of traffic movements on selected approaches to the intersection. The phase duration is expressed in seconds.
Traffic (Trip) Assignment	A process of assigning traffic to paths of travel in such a way as to satisfy all trip objectives (i.e., the desire of each vehicle to travel from a specified origin in the network to a specified destination) and to optimize some stated objective or combination of objectives. In general, the objective is stated in terms of minimizing a generalized "cost". For example, "cost" may be expressed in terms of travel time.
Traffic Density	The number of vehicles that occupy one lane of a roadway section of specified length at a point in time, expressed as vehicles per mile (vpm).
Traffic (Trip) Distribution	A process for determining the destinations of all traffic generated at the origins. The result often takes the form of a Trip Table, which is a matrix of origin-destination traffic volumes.
Traffic Simulation	A computer model designed to replicate the real-world operation of vehicles on a roadway network, so as to provide statistics describing traffic performance. These statistics are called Measures of Effectiveness.
Traffic Volume	The number of vehicles that pass over a section of roadway in one direction, expressed in vehicles per hour (vph). Where applicable, traffic volume may be stratified by turn movement.
Travel Mode	Distinguishes between private auto, bus, rail, pedestrian and air travel modes.
Trip Table or Origin-Destination Matrix	A rectangular matrix or table, whose entries contain the number of trips generated at each specified origin, during a specified time period, that are attracted to (and travel toward) each of its specified destinations. These values are expressed in vehicles per hour (vph) or in vehicles.
Turning Capacity	The capacity associated with that component of the traffic stream which executes a specified turn maneuver from an approach at an intersection.

APPENDIX B

DTRAD: Dynamic Traffic Assignment and Distribution Model

B. DYNAMIC TRAFFIC ASSIGNMENT AND DISTRIBUTION MODEL

This section describes the integrated dynamic trip assignment and distribution model named DTRAD (Dynamic Traffic Assignment and Distribution) that is expressly designed for use in analyzing evacuation scenarios. DTRAD employs logit-based path-choice principles and is one of the models of the DYNEV II System. The DTRAD module implements path-based *Dynamic Traffic Assignment* (DTA) so that time dependent Origin-Destination (OD) trips are “assigned” to routes over the network based on prevailing traffic conditions.

To apply the DYNEV II System, the analyst must specify the highway network, link capacity information, the time-varying volume of traffic generated at all origin centroids and, optionally, a set of accessible candidate destination nodes on the periphery of the EPZ for selected origins. DTRAD calculates the optimal dynamic trip distribution (i.e., trip destinations) and the optimal dynamic trip assignment (i.e., trip routing) of the traffic generated at each origin node traveling to its set of candidate destination nodes, so as to minimize evacuee travel “cost.”

Overview of Integrated Distribution and Assignment Model

The underlying premise is that the selection of destinations and routes is intrinsically coupled in an evacuation scenario. That is, people in vehicles seek to travel out of an area of potential risk as rapidly as possible by selecting the “best” routes. The model is designed to identify these “best” routes in a manner that realistically distributes vehicles from origins to destinations and routes them over the highway network, in a consistent and optimal manner, reflecting evacuee behavior.

For each origin, a set of “candidate destination nodes” is selected by the software logic and by the analyst to reflect the desire by evacuees to travel away from the power plant and to access major highways. The specific destination nodes within this set that are selected by travelers and the selection of the connecting paths of travel, are both determined by DTRAD. This determination is made by a logit-based path choice model in DTRAD, so as to minimize the trip “cost”, as discussed later.

The traffic loading on the network and the consequent operational traffic environment of the network (density, speed, throughput on each link) vary over time as the evacuation takes place. The DTRAD model, which is interfaced with the DYNEV simulation model, executes a succession of “sessions” wherein it computes the optimal routing and selection of destination nodes for the conditions that exist at that time.

Interfacing the DYNEV Simulation Model with DTRAD

The DYNEV II system reflects NRC guidance that evacuees will seek to travel in a general direction away from the location of the hazardous event. An algorithm was developed to support the DTRAD model in dynamically varying the Trip Table (O-D matrix) over time from one DTRAD session to the next. Another algorithm executes a “mapping” from the specified “geometric” network (link-node analysis network) that represents the physical highway system, to a “path” network that represents the vehicle [turn] movements. DTRAD computations are performed on the “path” network: DYNEV simulation model, on the “geometric” network.

DTRAD Description

DTRAD is the DTA module for the DYNEV II System.

When the road network under study is large, multiple routing options are usually available between trip origins and destinations. The problem of loading traffic demands and propagating them over the network links is called Network Loading and is addressed by DYNEV II using macroscopic traffic simulation modeling. Traffic assignment deals with computing the distribution of the traffic over the road network for given O-D demands and is a model of the route choice of the drivers. Travel demand changes significantly over time, and the road network may have time dependent characteristics, e.g., time-varying signal timing or reduced road capacity because of lane closure, or traffic congestion. To consider these time dependencies, DTA procedures are required.

The DTRAD DTA module represents the dynamic route choice behavior of drivers, using the specification of dynamic origin-destination matrices as flow input. Drivers choose their routes through the network based on the travel cost they experience (as determined by the simulation model). This allows traffic to be distributed over the network according to the time-dependent conditions. The modeling principles of DTRAD include:

- It is assumed that drivers not only select the best route (i.e., lowest cost path) but some also select less attractive routes. The algorithm implemented by DTRAD archives several “efficient” routes for each O-D pair from which the drivers choose.
- The choice of one route out of a set of possible routes is an outcome of “discrete choice modeling”. Given a set of routes and their generalized costs, the percentages of drivers that choose each route is computed. The most prevalent model for discrete choice modeling is the logit model. DTRAD uses a variant of Path-Size-Logit model (PSL). PSL overcomes the drawback of the traditional multinomial logit model by incorporating an additional deterministic path size correction term to address path overlapping in the random utility expression.
- DTRAD executes the traffic assignment algorithm on an abstract network representation called “the path network” which is built from the actual physical link-node analysis network. This execution continues until a stable situation is reached: the volumes and travel times on the edges of the path network do not change significantly from one iteration to the next. The criteria for this convergence are defined by the user.
- Travel “cost” plays a crucial role in route choice. In DTRAD, path cost is a linear summation of the generalized cost of each link that comprises the path. The generalized cost for a link, a , is expressed as

$$c_a = \alpha t_a + \beta l_a + \gamma s_a ,$$

where c_a is the generalized cost for link a , and α , β , and γ are cost coefficients for link travel time, distance, and supplemental cost, respectively. Distance and supplemental costs are defined as invariant properties of the network model, while travel time is a dynamic property dictated by prevailing traffic conditions. The DYNEV simulation model

computes travel times on all edges in the network and DTRAD uses that information to constantly update the costs of paths. The route choice decision model in the next simulation iteration uses these updated values to adjust the route choice behavior. This way, traffic demands are dynamically re-assigned based on time dependent conditions. The interaction between the DTRAD traffic assignment and DYNEV II simulation models is depicted in Figure B-1. Each round of interaction is called a Traffic Assignment Session (TA session). A TA session is composed of multiple iterations, marked as loop B in the figure.

- The supplemental cost is based on the “survival distribution” (a variation of the exponential distribution). The Inverse Survival Function is a “cost” term in DTRAD to represent the potential risk of travel toward the plant:

$$s_a = -\beta \ln(p), 0 \leq p \leq 1; \beta > 0$$

$$p = \frac{d_n}{d_0}$$

d_n = Distance of node, n, from the plant

d_0 = Distance from the plant where there is zero risk

β = Scaling factor

The value of $d_0 = 15$ miles, the outer distance of the Shadow Region. Note that the supplemental cost, s_a , of link, a, is (high, low), if its downstream node, n, is (near, far from) the power plant.

Network Equilibrium

In 1952, John Wardrop wrote:

Under equilibrium conditions traffic arranges itself in congested networks in such a way that no individual trip-maker can reduce his path costs by switching routes.

The above statement describes the “User Equilibrium” definition, also called the “Selfish Driver Equilibrium”. It is a hypothesis that represents a [hopeful] condition that evolves over time as drivers search out alternative routes to identify those routes that minimize their respective “costs”. It has been found that this “equilibrium” objective to minimize costs is largely realized by most drivers who routinely take the same trip over the same network at the same time (i.e., commuters). Effectively, such drivers “learn” which routes are best for them over time. Thus, the traffic environment “settles down” to a near-equilibrium state.

Clearly, since an emergency evacuation is a sudden, unique event, it does not constitute a long-term learning experience which can achieve an equilibrium state. Consequently, DTRAD was not designed as an equilibrium solution, but to represent drivers in a new and unfamiliar situation, who respond in a flexible manner to real-time information (either broadcast or observed) in such a way as to minimize their respective costs of travel.

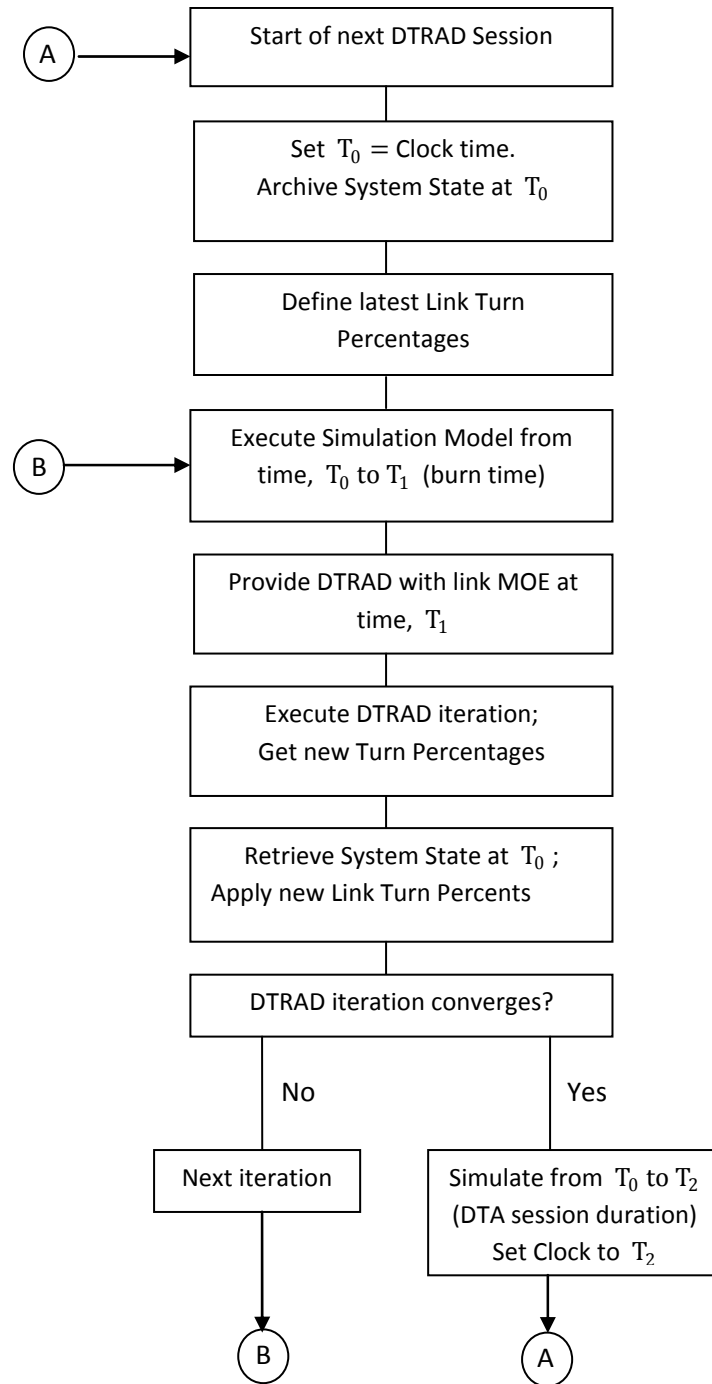

Figure B-1. Flow Diagram of Simulation-DTRAD Interface

APPENDIX C

DYNEV Traffic Simulation Model

C. DYNEV TRAFFIC SIMULATION MODEL

The DYNEV traffic simulation model is a *macroscopic* model that describes the operations of traffic flow in terms of aggregate variables: vehicles, flow rate, mean speed, volume, density, queue length, *on each link*, for each turn movement, during each Time Interval (simulation time step). The model generates trips from “sources” and from Entry Links and introduces them onto the analysis network at rates specified by the analyst based on the mobilization time distributions. The model simulates the movements of all vehicles on all network links over time until the network is empty. At intervals, the model outputs Measures of Effectiveness (MOE) such as those listed in Table C-1.

Model Features Include:

- Explicit consideration is taken of the variation in density over the time step; an iterative procedure is employed to calculate an average density over the simulation time step for the purpose of computing a mean speed for moving vehicles.
- Multiple turn movements can be serviced on one link; a separate algorithm is used to estimate the number of (fractional) lanes assigned to the vehicles performing each turn movement, based, in part, on the turn percentages provided by the DTRAD model.
- At any point in time, traffic flow on a link is subdivided into two classifications: queued and moving vehicles. The number of vehicles in each classification is computed. Vehicle spillback, stratified by turn movement for each network link, is explicitly considered and quantified. The propagation of stopping waves from link to link is computed within each time step of the simulation. There is no “vertical stacking” of queues on a link.
- Any link can accommodate “source flow” from zones via side streets and parking facilities that are not explicitly represented. This flow represents the evacuating trips that are generated at the source.
- The relation between the number of vehicles occupying the link and its storage capacity is monitored every time step for every link and for every turn movement. If the available storage capacity on a link is exceeded by the demand for service, then the simulator applies a “metering” rate to the entering traffic from both the upstream feeders and source node to ensure that the available storage capacity is not exceeded.
- A “path network” that represents the specified traffic movements from each network link is constructed by the model; this path network is utilized by the DTRAD model.
- A two-way interface with DTRAD: (1) provides link travel times; (2) receives data that translates into link turn percentages.
- Provides MOE to animation software, EVAN
- Calculates ETE statistics

All traffic simulation models are data-intensive. Table C-2 outlines the necessary input data elements.

To provide an efficient framework for defining these specifications, the physical highway environment is represented as a network. The unidirectional links of the network represent roadway sections: rural, multi-lane, urban streets or freeways. The nodes of the network generally represent intersections or points along a section where a geometric property changes (e.g. a lane drop, change in grade or free flow speed).

Figure C-1 is an example of a small network representation. The freeway is defined by the sequence of links, (20,21), (21,22), and (22,23). Links (8001, 19) and (3, 8011) are Entry and Exit links, respectively. An arterial extends from node 3 to node 19 and is partially subsumed within a grid network. Note that links (21,22) and (17,19) are grade-separated.

Table C-1. Selected Measures of Effectiveness Output by DYNEV II

Measure	Units	Applies To
Vehicles Discharged	Vehicles	Link, Network, Exit Link
Speed	Miles/Hours (mph)	Link, Network
Density	Vehicles/Mile/Lane	Link
Level of Service	LOS	Link
Content	Vehicles	Network
Travel Time	Vehicle-hours	Network
Evacuated Vehicles	Vehicles	Network, Exit Link
Trip Travel Time	Vehicle-minutes/trip	Network
Capacity Utilization	Percent	Exit Link
Attraction	Percent of total evacuating vehicles	Exit Link
Max Queue	Vehicles	Node, Approach
Time of Max Queue	Hours:minutes	Node, Approach
Route Statistics	Length (mi); Mean Speed (mph); Travel Time (min)	Route
Mean Travel Time	Minutes	Evacuation Trips; Network

Table C-2. Input Requirements for the DYNEV II Model

HIGHWAY NETWORK

- Links defined by upstream and downstream node numbers
- Link lengths
- Number of lanes (up to 9) and channelization
- Turn bays (1 to 3 lanes)
- Destination (exit) nodes
- Network topology defined in terms of downstream nodes for each receiving link
- Node Coordinates (X,Y)
- Nuclear Power Plant Coordinates (X,Y)

GENERATED TRAFFIC VOLUMES

- On all entry links and source nodes (origins), by Time Period

TRAFFIC CONTROL SPECIFICATIONS

- Traffic signals: link-specific, turn movement specific
- Signal control treated as fixed time or actuated
- Location of traffic control points (these are represented as actuated signals)
- Stop and Yield signs
- Right-turn-on-red (RTOR)
- Route diversion specifications
- Turn restrictions
- Lane control (e.g. lane closure, movement-specific)

DRIVER'S AND OPERATIONAL CHARACTERISTICS

- Driver's (vehicle-specific) response mechanisms: free-flow speed, discharge headway
- Bus route designation.

DYNAMIC TRAFFIC ASSIGNMENT

- Candidate destination nodes for each origin (optional)
- Duration of DTA sessions
- Duration of simulation "burn time"
- Desired number of destination nodes per origin

INCIDENTS

- Identify and Schedule of closed lanes
- Identify and Schedule of closed links

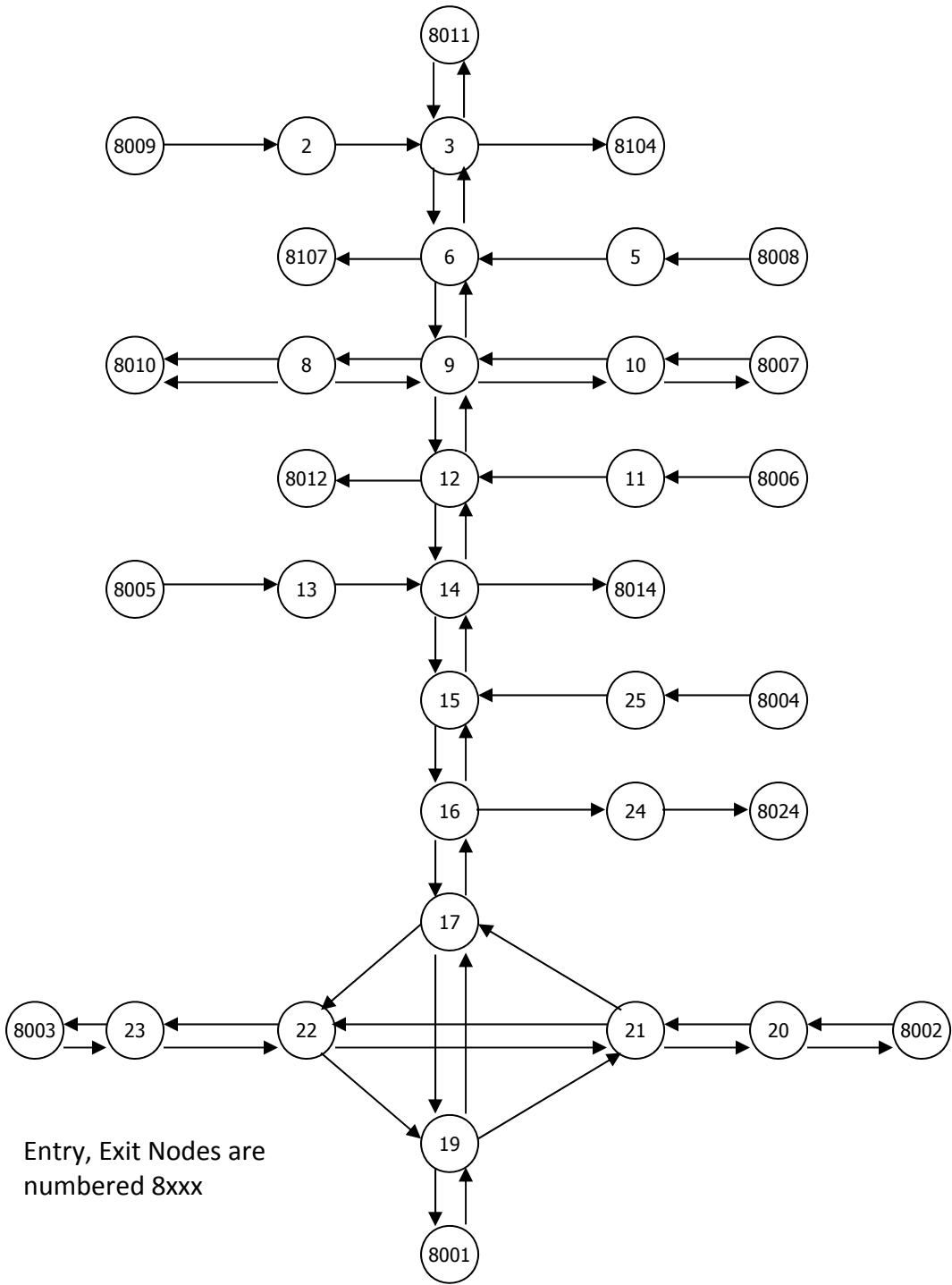

Figure C-1. Representative Analysis Network

C.1 Methodology

C.1.1 The Fundamental Diagram

It is necessary to define the fundamental diagram describing flow-density and speed-density relationships. Rather than “settling for” a triangular representation, a more realistic representation that includes a “capacity drop”, $(1-R)Q_{\max}$, at the critical density when flow conditions enter the forced flow regime, is developed and calibrated for each link. This representation, shown in Figure C-2, asserts a constant free speed up to a density, k_f , and then a linear reduction in speed in the range, $k_f \leq k \leq k_c = 45$ vpm, the density at capacity. In the flow-density plane, a quadratic relationship is prescribed in the range, $k_c < k \leq k_s = 95$ vpm which roughly represents the “stop-and-go” condition of severe congestion. The value of flow rate, Q_s , corresponding to k_s , is approximated at $0.7 RQ_{\max}$. A linear relationship between k_s and k_j completes the diagram shown in Figure C-2. Table C-3 is a glossary of terms.

The fundamental diagram is applied to moving traffic on every link. The specified calibration values for each link are: (1) Free speed, v_f ; (2) Capacity, Q_{\max} ; (3) Critical density, $k_c = 45$ vpm; (4) Capacity Drop Factor, $R = 0.9$; (5) Jam density, k_j . Then, $v_c = \frac{Q_{\max}}{k_c}$, $k_f = k_c - \frac{(v_f - v_c) k_c^2}{Q_{\max}}$. Setting $\bar{k} = k - k_c$, then $Q = RQ_{\max} - \frac{RQ_{\max}}{8333} \bar{k}^2$ for $0 \leq \bar{k} \leq \bar{k}_s = 50$. It can be shown that $Q = (0.98 - 0.0056 \bar{k}) RQ_{\max}$ for $\bar{k}_s \leq \bar{k} \leq \bar{k}_j$, where $\bar{k}_s = 50$ and $\bar{k}_j = 175$.

C.1.2 The Simulation Model

The simulation model solves a sequence of “unit problems.” Each unit problem computes the movement of traffic on a link, for each specified turn movement, over a specified time interval (TI) which serves as the simulation time step for all links. Figure C-3 is a representation of the unit problem in the time-distance plane. Table C-3 is a glossary of terms that are referenced in the following description of the unit problem procedure.

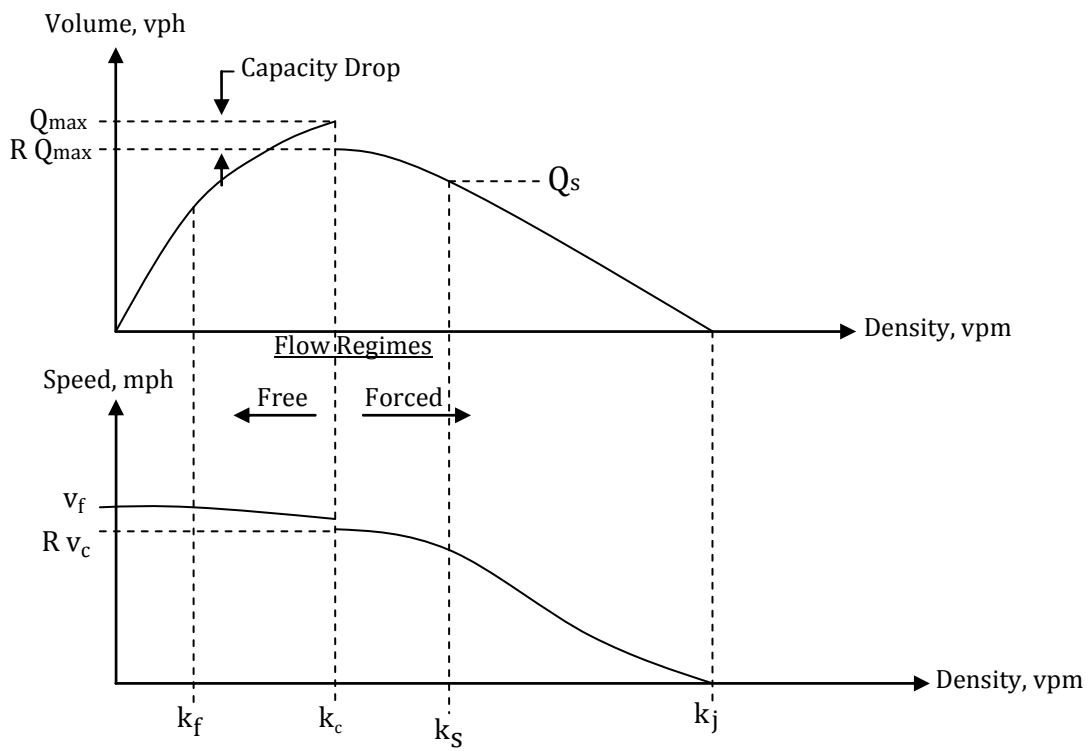

Figure C-2. Fundamental Diagrams

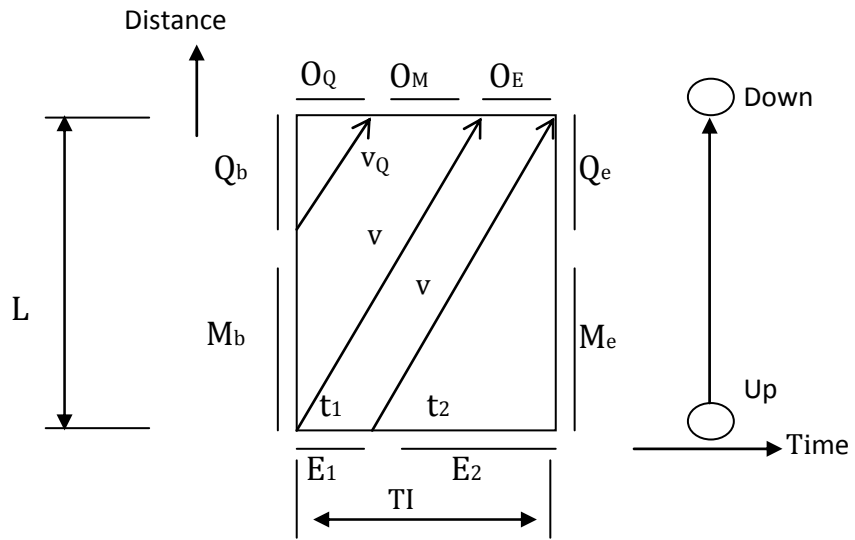

Figure C-3. A UNIT Problem Configuration with $t_1 > 0$

Table C-3. Glossary

Cap	The maximum number of vehicles, of a particular movement, that can discharge from a link within a time interval.
E	The number of vehicles, of a particular movement, that enter the link over the time interval. The portion, E_{TI} , can reach the stop-bar within the TI.
G/C	The green time: cycle time ratio that services the vehicles of a particular turn movement on a link.
h	The mean queue discharge headway, seconds.
k	Density in vehicles per lane per mile.
\bar{k}	The average density of <u>moving</u> vehicles of a particular movement over a TI, on a link.
L	The length of the link in feet.
L_b, L_e	The queue length in feet of a particular movement, at the [beginning, end] of a time interval.
LN	The number of lanes, expressed as a floating point number, allocated to service a particular movement on a link.
L_v	The mean effective length of a queued vehicle including the vehicle spacing, feet.
M	Metering factor (Multiplier): 1.
M_b, M_e	The number of moving vehicles on the link, of a particular movement, that are moving at the [beginning, end] of the time interval. These vehicles are assumed to be of equal spacing, over the length of link upstream of the queue.
O	The total number of vehicles of a particular movement that are discharged from a link over a time interval.
O_Q, O_M, O_E	The components of the vehicles of a particular movement that are discharged from a link within a time interval: vehicles that were Queued at the beginning of the TI; vehicles that were Moving within the link at the beginning of the TI; vehicles that Entered the link during the TI.
P_x	The percentage, expressed as a fraction, of the total flow on the link that executes a particular turn movement, x.

Q_b, Q_e	The number of queued vehicles on the link, of a particular turn movement, at the [beginning, end] of the time interval.
Q_{max}	The maximum flow rate that can be serviced by a link for a particular movement in the absence of a control device. It is specified by the analyst as an estimate of link capacity, based upon a field survey, with reference to the HCM.
R	The factor that is applied to the capacity of a link to represent the “capacity drop” when the flow condition moves into the forced flow regime. The lower capacity at that point is equal to RQ_{max} .
RCap	The remaining capacity available to service vehicles of a particular movement after that queue has been completely serviced, within a time interval, expressed as vehicles.
S_x	Service rate for movement x, vehicles per hour (vph).
t_1	Vehicles of a particular turn movement that enter a link over the first t_1 seconds of a time interval, can reach the stop-bar (in the absence of a queue downstream) within the same time interval.
TI	The time interval, in seconds, which is used as the simulation time step.
v	The mean speed of travel, in feet per second (fps) or miles per hour (mph), of <u>moving</u> vehicles on the link.
v_Q	The mean speed of the last vehicle in a queue that discharges from the link within the TI. This speed differs from the mean speed of moving vehicles, v.
W	The width of the intersection in feet. This is the difference between the link length which extends from stop-bar to stop-bar and the block length.

The formulation and the associated logic presented below are designed to solve the unit problem for each sweep over the network (discussed below), for each turn movement serviced on each link that comprises the evacuation network, and for each TI over the duration of the evacuation.

Given = $Q_b, M_b, L, TI, E_0, LN, G/C, h, L_v, R_0, L_c, E, M$

Compute = O, Q_e, M_e

Define $O = O_Q + O_M + O_E$; $E = E_1 + E_2$

1. For the first sweep, $s = 1$, of this TI, get initial estimates of mean density, k_0 , the R – factor, R_0 and entering traffic, E_0 , using the values computed for the final sweep of the prior TI. For each subsequent sweep, $s > 1$, calculate $E = \sum_i P_i O_i + S$ where P_i, O_i are the relevant turn percentages from feeder link, i , and its total outflow (possibly metered) over this TI; S is the total source flow (possibly metered) during the current TI. Set iteration counter, $n = 0$, $k = k_0$, and $E = E_0$.

2. Calculate $v(k)$ such that $k \leq 130$ using the analytical representations of the fundamental diagram.

Calculate $Cap = \frac{Q_{max}(TI)}{3600} (G/C) LN$, in vehicles, this value may be reduced due to metering

Set $R = 1.0$ if $G/C < 1$ or if $k \leq k_c$; Set $R = 0.9$ only if $G/C = 1$ and $k > k_c$

Calculate queue length, $L_b = Q_b \frac{L_v}{LN}$

3. Calculate $t_1 = TI - \frac{L}{v}$. If $t_1 < 0$, set $t_1 = E_1 = O_E = 0$; Else, $E_1 = E \frac{t_1}{TI}$.

4. Then $E_2 = E - E_1$; $t_2 = TI - t_1$

5. If $Q_b \geq Cap$, then

$O_Q = Cap, O_M = O_E = 0$

If $t_1 > 0$, then

$Q'_e = Q_b + M_b + E_1 - Cap$

Else

$Q'_e = Q_b - Cap$

End if

Calculate Q_e and M_e using Algorithm A (below)

6. Else ($Q_b < Cap$)

$O_Q = Q_b, RCap = Cap - O_Q$

7. If $M_b \leq RCap$, then

8. If $t_1 > 0$, $O_M = M_b, O_E = \min\left(RCap - M_b, \frac{t_1 \text{ Cap}}{TI}\right) \geq 0$
 $Q'_e = E_1 - O_E$
 If $Q'_e > 0$, then
 Calculate Q_e, M_e with Algorithm A
 Else
 $Q_e = 0, M_e = E_2$
 End if
 Else ($t_1 = 0$)
 $O_M = \left(\frac{v(TI) - L_b}{L - L_b}\right) M_b$ and $O_E = 0$
 $M_e = M_b - O_M + E; Q_e = 0$
 End if

9. Else ($M_b > RCap$)
 $O_E = 0$
 If $t_1 > 0$, then
 $O_M = RCap, Q'_e = M_b - O_M + E_1$
 Calculate Q_e and M_e using Algorithm A

10. Else ($t_1 = 0$)
 $M_d = \left[\left(\frac{v(TI) - L_b}{L - L_b}\right) M_b\right]$
 If $M_d > RCap$, then
 $O_M = RCap$
 $Q'_e = M_d - O_M$
 Apply Algorithm A to calculate Q_e and M_e
 Else
 $O_M = M_d$
 $M_e = M_b - O_M + E$ and $Q_e = 0$
 End if
 End if

End if
 End if

11. Calculate a new estimate of average density, $\bar{k}_n = \frac{1}{4} [k_b + 2 k_m + k_e]$,
 where k_b = density at the beginning of the TI
 k_e = density at the end of the TI
 k_m = density at the mid-point of the TI
 All values of density apply only to the moving vehicles.

If $|\bar{k}_n - \bar{k}_{n-1}| > \epsilon$ and $n < N$
 where N = max number of iterations, and ϵ is a convergence criterion, then

12. set $n = n + 1$, and return to step 2 to perform iteration, n, using $k = \bar{k}_n$.
End if

Computation of unit problem is now complete. Check for excessive inflow causing spillback.

13. If $Q_e + M_e > \frac{(L-W) LN}{L_v}$, then

The number of excess vehicles that cause spillback is: $SB = Q_e + M_e - \frac{(L-W) \cdot LN}{L_v}$,
where W is the width of the upstream intersection. To prevent spillback, meter the outflow from the feeder approaches and from the source flow, S, during this TI by the amount, SB. That is, set

$$M = 1 - \frac{SB}{(E + S)} \geq 0 , \text{ where } M \text{ is the metering factor (over all movements).}$$

This metering factor is assigned appropriately to all feeder links and to the source flow, to be applied during the next network sweep, discussed later.

Algorithm A

This analysis addresses the flow environment over a TI during which moving vehicles can

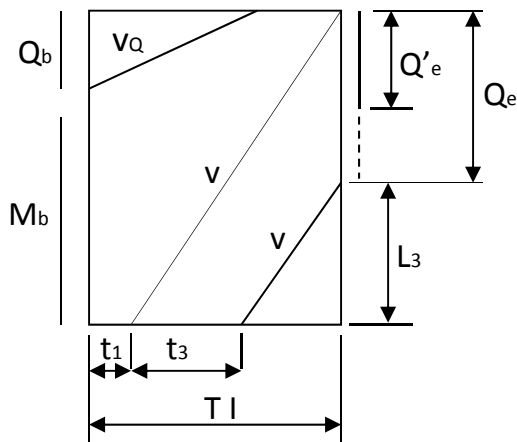

join a standing or discharging queue. For the case shown, $Q_b \leq Cap$, with $t_1 > 0$ and a queue of length, Q'_e , formed by that portion of M_b and E that reaches the stop-bar within the TI, but could not discharge due to inadequate capacity. That is, $Q_b + M_b + E_1 > Cap$. This queue length, $Q'_e = Q_b + M_b + E_1 - Cap$ can be extended to Q_e by traffic entering the approach during the current TI, traveling at speed, v , and reaching the rear of the queue within the TI. A portion of the entering vehicles, $E_3 = E \frac{t_3}{TI}$, will likely join the queue. This analysis calculates t_3, Q_e and M_e for the input

values of $L, TI, v, E, t, L_v, LN, Q'_e$.

When $t_1 > 0$ and $Q_b \leq Cap$:

Define: $L'_e = Q'_e \frac{L_v}{LN}$. From the sketch, $L_3 = v(TI - t_1 - t_3) = L - (Q'_e + E_3) \frac{L_v}{LN}$.

Substituting $E_3 = \frac{t_3}{TI} E$ yields: $-vt_3 + \frac{t_3}{TI} E \frac{L_v}{LN} = L - v(TI - t_1) - L'_e$. Recognizing that the first two terms on the right hand side cancel, solve for t_3 to obtain:

$$t_3 = \frac{L'_e}{\left[v - \frac{E}{TI} \frac{L_v}{LN} \right]} \quad \text{such that } 0 \leq t_3 \leq TI - t_1$$

If the denominator, $\left[v - \frac{E}{TI} \frac{L_v}{LN} \right] \leq 0$, set $t_3 = TI - t_1$.

$$\text{Then, } Q_e = Q'_e + E \frac{t_3}{TI}, \quad M_e = E \left(1 - \frac{t_1 + t_3}{TI} \right)$$

The complete Algorithm A considers all flow scenarios; space limitation precludes its inclusion, here.

C.1.3 Lane Assignment

The “unit problem” is solved for each turn movement on each link. Therefore it is necessary to calculate a value, LN_x , of allocated lanes for each movement, x. If in fact all lanes are specified by, say, arrows painted on the pavement, either as full lanes or as lanes within a turn bay, then the problem is fully defined. If however there remain un-channelized lanes on a link, then an analysis is undertaken to subdivide the number of these physical lanes into turn movement specific virtual lanes, LN_x .

C.2 Implementation

C.2.1 Computational Procedure

The computational procedure for this model is shown in the form of a flow diagram as Figure C-4. As discussed earlier, the simulation model processes traffic flow for each link independently over TI that the analyst specifies; it is usually 60 seconds or longer. The first step is to execute an algorithm to define the sequence in which the network links are processed so that as many links as possible are processed after their feeder links are processed, within the same network sweep. Since a general network will have many closed loops, it is not possible to guarantee that every link processed will have all of its feeder links processed earlier.

The processing then continues as a succession of time steps of duration, TI, until the simulation is completed. Within each time step, the processing performs a series of “sweeps” over all network links; this is necessary to ensure that the traffic flow is synchronous over the entire network. Specifically, the sweep ensures continuity of flow among all the network links; in the context of this model, this means that the values of E, M, and S are all defined for each link such that they represent the synchronous movement of traffic from each link to all of its outbound links. These sweeps also serve to compute the metering rates that control spillback.

Within each sweep, processing solves the “unit problem” for each turn movement on each link. With the turn movement percentages for each link provided by the DTRAD model, an algorithm

allocates the number of lanes to each movement serviced on each link. The timing at a signal, if any, applied at the downstream end of the link, is expressed as a G/C ratio, the signal timing needed to define this ratio is an input requirement for the model. The model also has the capability of representing, with macroscopic fidelity, the actions of actuated signals responding to the time-varying competing demands on the approaches to the intersection.

The solution of the unit problem yields the values of the number of vehicles, O , that discharge from the link over the time interval and the number of vehicles that remain on the link at the end of the time interval as stratified by queued and moving vehicles: Q_e and M_e . The procedure considers each movement separately (multi-piping). After all network links are processed for a given network sweep, the updated consistent values of entering flows, E ; metering rates, M ; and source flows, S are defined so as to satisfy the “no spillback” condition. The procedure then performs the unit problem solutions for all network links during the following sweep.

Experience has shown that the system converges (i.e. the values of E , M and S “settle down” for all network links) in just two sweeps if the network is entirely under-saturated or in four sweeps in the presence of extensive congestion with link spillback. (The initial sweep over each link uses the final values of E and M , of the prior TI). At the completion of the final sweep for a TI, the procedure computes and stores all measures of effectiveness for each link and turn movement for output purposes. It then prepares for the following time interval by defining the values of Q_b and M_b for the start of the next TI as being those values of Q_e and M_e at the end of the prior TI. In this manner, the simulation model processes the traffic flow over time until the end of the run. Note that there is no space-discretization other than the specification of network links.

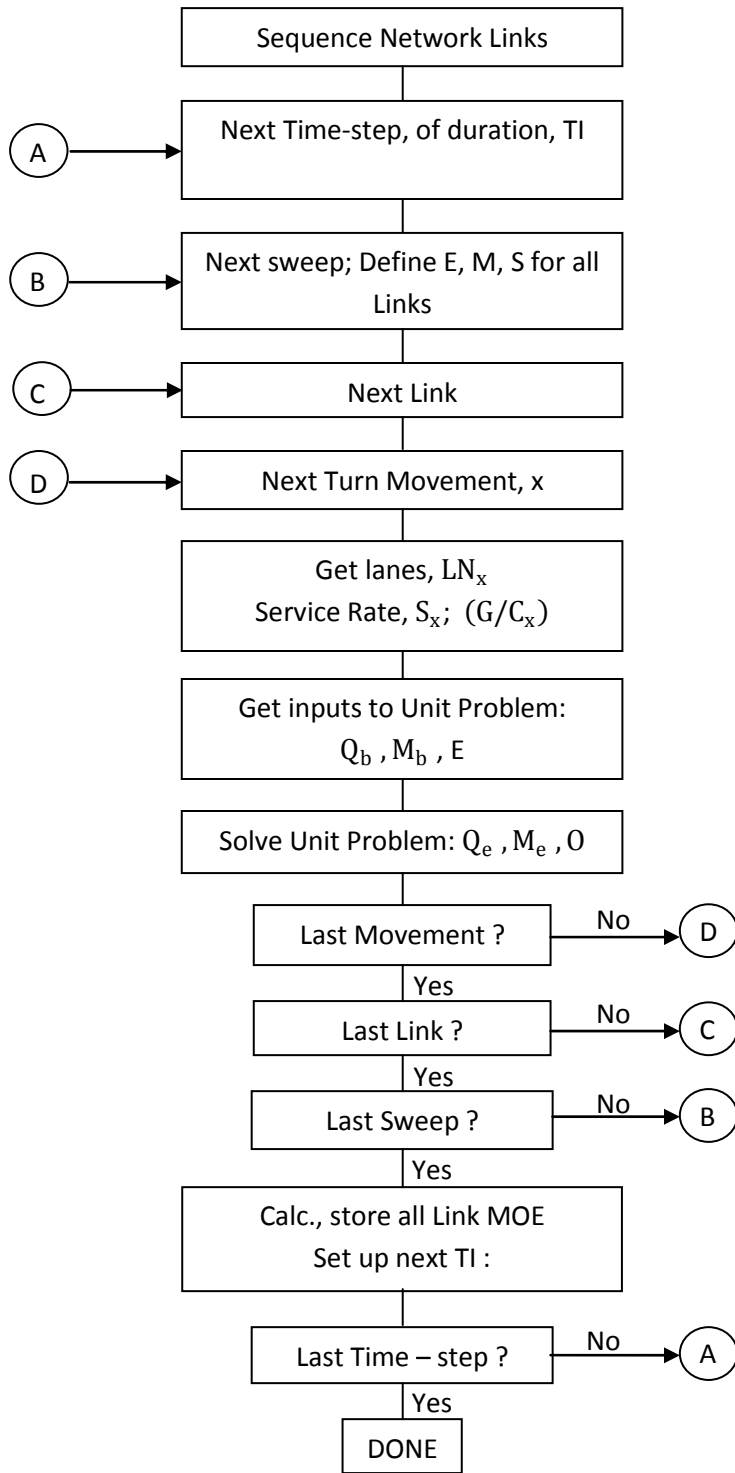

Figure C-4. Flow of Simulation Processing (See Glossary: Table C-3)

C.2.2 Interfacing with Dynamic Traffic Assignment (DTRAD)

The DYNEV II system reflects NRC guidance that evacuees will seek to travel in a general direction away from the location of the hazardous event. Thus, an algorithm was developed to identify an appropriate set of destination nodes for each origin based on its location and on the expected direction of travel. This algorithm also supports the DTRAD model in dynamically varying the Trip Table (O-D matrix) over time from one DTRAD session to the next.

Figure B-1 depicts the interaction of the simulation model with the DTRAD model in the DYNEV II system. As indicated, DYNEV II performs a succession of DTRAD “sessions”; each such session computes the turn link percentages for each link that remain constant for the session duration, $[T_0, T_2]$, specified by the analyst. The end product is the assignment of traffic volumes from each origin to paths connecting it with its destinations in such a way as to minimize the network-wide cost function. The output of the DTRAD model is a set of updated link turn percentages which represent this assignment of traffic.

As indicated in Figure B-1, the simulation model supports the DTRAD session by providing it with operational link MOE that are needed by the path choice model and included in the DTRAD cost function. These MOE represent the operational state of the network at a time, $T_1 \leq T_2$, which lies within the session duration, $[T_0, T_2]$. This “burn time”, $T_1 - T_0$, is selected by the analyst. For each DTRAD iteration, the simulation model computes the change in network operations over this burn time using the latest set of link turn percentages computed by the DTRAD model. Upon convergence of the DTRAD iterative procedure, the simulation model accepts the latest turn percentages provided by the DTA model, returns to the origin time, T_0 , and executes until it arrives at the end of the DTRAD session duration at time, T_2 . At this time the next DTA session is launched and the whole process repeats until the end of the DYNEV II run.

Additional details are presented in Appendix B.

APPENDIX D

Detailed Description of Study Procedure

D. DETAILED DESCRIPTION OF STUDY PROCEDURE

This appendix describes the activities that were performed to compute Evacuation Time Estimates. The individual steps of this effort are represented as a flow diagram in Figure D-1. Each numbered step in the description that follows corresponds to the numbered element in the flow diagram.

Step 1

The first activity was to verify that the EPZ boundary information, created in 2012, is still accurate. A GIS base map was created with the EPZ and Zone boundaries clearly identified. The base map extends beyond the Shadow Region which extends approximately 15 miles (radially) from the power plant location. The base map incorporates the local roadway topology, a suitable topographic background and the EPZ boundary.

Step 2

2010 Census block population and Census population growth (using 2015¹ population estimates published by the US Census) information was obtained in GIS format. This information was used to project the resident population within the EPZ and Shadow Region to the year 2016 and to define the spatial distribution and demographic characteristics of the population within the study area. In 2012, the data for employees, transients, schools, and other facilities were obtained from the county emergency management departments. The database of all facilities from the 2012 study was reviewed with Duke Energy and the county emergency management agencies. The majority of the data from the 2012 study was maintained except for the addition of several schools and childcare facilities that have opened since the 2012 study, and the removal of one medical facility that has closed since the 2012 study.

Step 3

A kickoff meeting was conducted with major stakeholders (state and local emergency managers, on-site and off-site utility emergency managers, local and state law enforcement agencies). The purpose of the kickoff meeting was to present an overview of the work effort, identify key agency personnel, and indicate the data requirements for the study. Specific requests for information were presented to county emergency managers. Unique features of the study area were discussed to identify the local concerns that should be addressed by the ETE study.

Step 4

Next, a physical survey of the roadway system in the study area was conducted to determine any changes to the roadway network since the 2012 study. This survey included consideration of the geometric properties of the highway sections, the channelization of lanes on each

¹ The annual population estimates prepared by the Census Bureau for the entire U.S. involve an extensive data gathering process. As such, population estimates are a year behind – 2015 data are released in 2016. The schedule for release of Census data is provided on the Census website: <http://www.census.gov/popest/schedule.html>

section of roadway, whether there are any turn restrictions or special treatment of traffic at intersections, the type and functioning of traffic control devices, gathering signal timings for pre-timed traffic signals, and to make the necessary observations needed to estimate realistic values of roadway capacity.

Step 5

The data from the 2012 telephone survey of households within the EPZ was used to identify household dynamics, trip generation characteristics, and evacuation-related demographic information of the EPZ population. This information was used to determine important study factors including the average number of evacuating vehicles used by each household, and the time required to perform pre-evacuation mobilization activities.

Step 6

A computerized representation of the physical roadway system, called a link-node analysis network, was updated using the most recent UNITES software (see Section 1.3) developed by KLD. Once the updated geometry of the network was completed, the network was calibrated using the information gathered during the road survey (Step 4). Estimates of highway capacity for each link and other link-specific characteristics were introduced to the network description. Traffic signal timings were input accordingly. The link-node analysis network was imported into a GIS map. 2010 Census data (extrapolated to 2016 using annual growth rates based on 2015 Census population estimates) were overlaid in the map, and origin centroids where trips would be generated during the evacuation process were assigned to appropriate links.

Step 7

The EPZ is subdivided into 14 Zones. Based on wind direction and speed, Regions (groupings of Zones) that may be advised to evacuate, were developed.

The need for evacuation can occur over a range of time-of-day, day-of-week, seasonal and weather-related conditions. Scenarios were developed to capture the variation in evacuation demand, highway capacity and mobilization time, for different time of day, day of the week, time of year, and weather conditions.

Step 8

The input stream for the DYNEV II model, which integrates the dynamic traffic assignment and distribution model, DTRAD, with the evacuation simulation model, was created for a prototype evacuation case – the evacuation of the entire EPZ for a representative scenario.

Step 9

After creating this input stream, the DYNEV II System was executed on the prototype evacuation case to compute evacuating traffic routing patterns consistent with the appropriate NRC guidelines. DYNEV II contains an extensive suite of data diagnostics which check the completeness and consistency of the input data specified. The analyst reviews all warning and error messages produced by the model and then corrects the database to create an input stream that properly executes to completion.

The model assigns destinations to all origin centroids consistent with a (general) radial evacuation of the EPZ and Shadow Region. The analyst may optionally supplement and/or replace these model-assigned destinations, based on professional judgment, after studying the topology of the analysis highway network. The model produces link and network-wide measures of effectiveness as well as estimates of evacuation time.

Step 10

The results generated by the prototype evacuation case are critically examined. The examination includes observing the animated graphics (using the EVAN software which operates on data produced by DYNEV II) and reviewing the statistics output by the model. This is a labor-intensive activity, requiring the direct participation of skilled engineers who possess the necessary practical experience to interpret the results and to determine the causes of any problems reflected in the results.

Essentially, the approach is to identify those bottlenecks in the network that represent locations where congested conditions are pronounced and to identify the cause of this congestion. This cause can take many forms, either as excess demand due to high rates of trip generation, improper routing, a shortfall of capacity, or as a quantitative flaw in the way the physical system was represented in the input stream. This examination leads to one of two conclusions:

- The results are satisfactory; or
- The input stream must be modified accordingly.

This decision requires, of course, the application of the user's judgment and experience based upon the results obtained in previous applications of the model and a comparison of the results of the latest prototype evacuation case iteration with the previous ones. If the results are satisfactory in the opinion of the user, then the process continues with Step 13. Otherwise, proceed to Step 11.

Step 11

There are many "treatments" available to the user in resolving apparent problems. These treatments range from decisions to reroute the traffic by assigning additional evacuation destinations for one or more sources, imposing turn restrictions where they can produce significant improvements in capacity, changing the control treatment at critical intersections so as to provide improved service for one or more movements, or in prescribing specific treatments for channelizing the flow so as to expedite the movement of traffic along major roadway systems. Such "treatments" take the form of modifications to the original prototype evacuation case input stream. All treatments are designed to improve the representation of evacuation behavior.

Step 12

As noted above, the changes to the input stream must be implemented to reflect the modifications undertaken in Step 11. At the completion of this activity, the process returns to Step 9 where the DYNEV II System is again executed.

Step 13

Evacuation of transit-dependent evacuees and special facilities are included in the evacuation analysis. Fixed routing for transit buses and for school buses, ambulances, and other transit vehicles are introduced into the final prototype evacuation case data set. DYNEV II generates route-specific speeds over time for use in the estimation of evacuation times for the transit dependent and special facility population groups.

Step 14

The prototype evacuation case was used as the basis for generating all region and scenario-specific evacuation cases to be simulated. This process was automated through the UNITES user interface. For each specific case, the population to be evacuated, the trip generation distributions, the highway capacity and speeds, and other factors are adjusted to produce a customized case-specific data set.

Step 15

All evacuation cases are executed using the DYNEV II System to compute ETE. Once results are available, quality control procedures are used to assure the results are consistent, dynamic routing is reasonable, and traffic congestion/bottlenecks are addressed properly.

Step 16

Once vehicular evacuation results are accepted, average travel speeds for transit and special facility routes are used to compute evacuation time estimates for transit-dependent permanent residents, schools, hospitals, and other special facilities.

Step 17

The simulation results are analyzed, tabulated and graphed. The results are then documented, as required by NUREG/CR-7002.

Step 18

Following the completion of documentation activities, the ETE criteria checklist (see Appendix N) is completed. An appropriate report reference is provided for each criterion provided in the checklist.

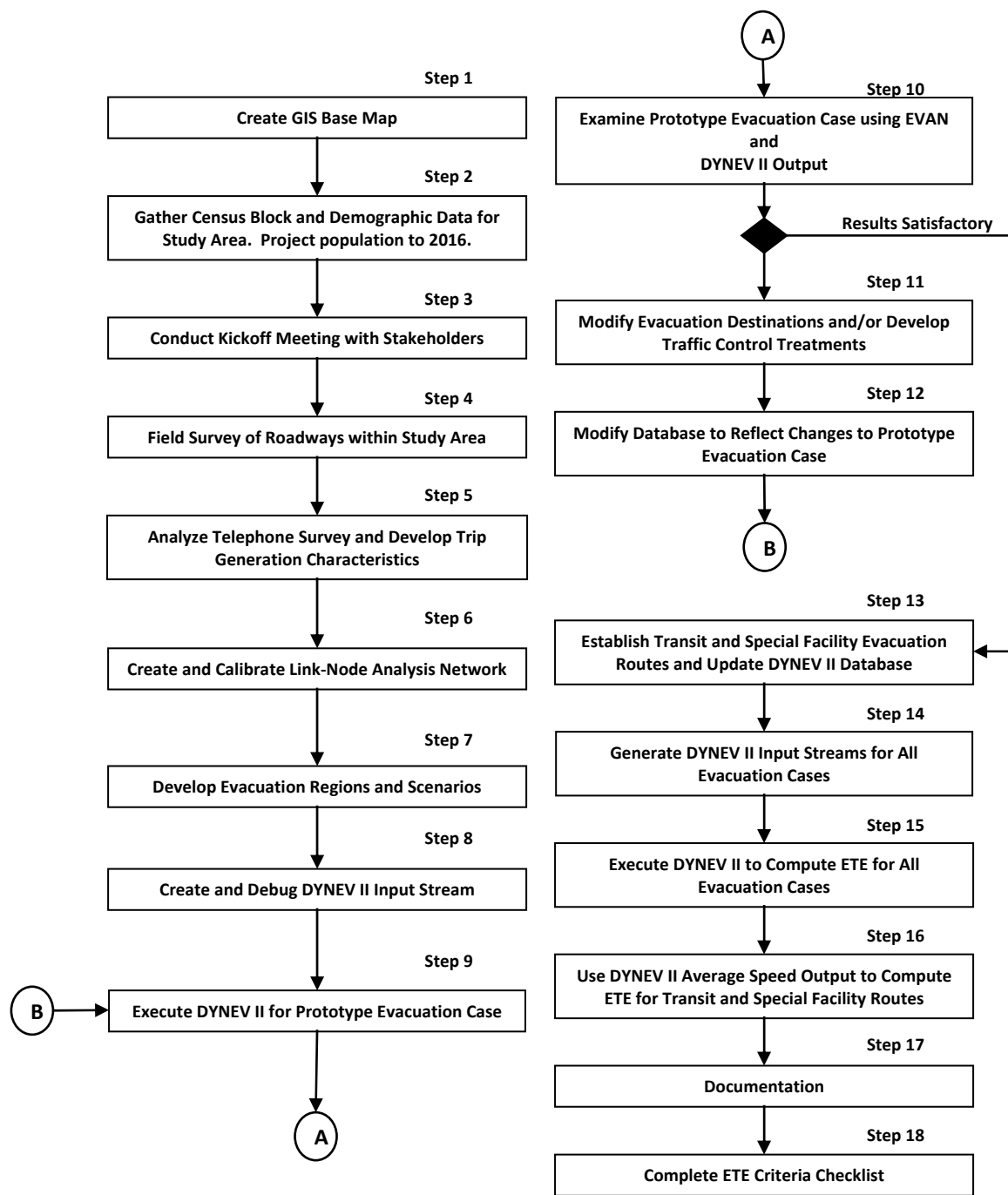

Figure D-1. Flow Diagram of Activities

APPENDIX E

Facility Data

E. FACILITY DATA

The following tables list population information, as of June 2016, for special facilities and transient attractions that are located within the HNP EPZ. Special facilities are defined as schools, child care centers, and medical care facilities. Transient population data is included in the tables for campgrounds, parks and community centers, golf courses and lodging facilities. OnTheMap employment data (see Section 3, sub-section 3.4) is summarized in the table for major employers.

Each table is grouped by county. The location of the facility is defined by its straight-line distance (miles) and direction (magnetic bearing) from the center point of the plant. Maps of each school, child care center, medical facility, campground, park, community center, golf course and lodging facility are also provided.

Table E-1. Schools within the EPZ

Zone	Distance (miles)	Direction	School Name	Street Address	Municipality	Enrollment	Staff
CHATHAM COUNTY							
M	6.8	W	Moncure Elementary School	600 Moncure School Rd	Moncure	291	45
<i>Chatham County Subtotal:</i>						291	45
HARNETT COUNTY							
S.R. ¹	12.5	SE	Lafayette Elementary School	108 Lafayette School Rd	Fuquay-Varina	748	80
<i>Harnett County Subtotal:</i>						748	80
LEE COUNTY							
S.R. ¹	11.1	WSW	Deep River Elementary School	4000 Deep River Rd	Sanford	638	100
<i>Lee County Subtotal:</i>						638	100
WAKE COUNTY							
B	5.4	NNE	Apex Friendship High School ²	7801 Humie Olive Rd	Apex	1,000	85
E	9.2	NE	A.V. Baucom Elementary School	400 Hunter St	Apex	790	100
E	8.3	NE	Apex Elementary School	700 Tingen Rd	Apex	675	80
E	8.8	NE	Apex Middle School	400 E Moore St	Apex	1,355	150
E	10.1	NE	Apex Senior High School	1501 Laura Duncan Rd	Apex	2,400	200
E	9.3	NE	Lufkin Road Middle School	1002 Lufkin Rd	Apex	1,090	115
E	7.8	NNE	Olive Chapel Elementary School	1751 Olive Chapel Rd	Apex	920	130
E	7.3	NNE	Scotts Ridge Elementary School ²	6601 Apex Barbecue Rd	Apex	770	95
E	7.7	NE	St. Mary Magdalene Catholic School	625 Magdala Pl	Apex	704	65
E	9.6	NE	Thales Academy	1177 Ambergate St	Apex	319	30
F	5.9	E	Holly Grove Elementary School	1451 Avent Ferry Rd	Holly Springs	1,150	115
F	6.1	E	Holly Grove Middle School	1401 Avent Ferry Rd	Holly Springs	1,600	115
F	8.0	E	Holly Ridge Elementary School	900 Holly Springs Rd	Holly Springs	1,000	105
F	8.0	E	Holly Ridge Middle School	950 Holly Springs Rd	Holly Springs	1,330	115
F	7.4	E	Holly Springs Elementary School	401 Holly Springs Rd	Holly Springs	1,180	120
F	6.0	E	Holly Springs High School	5329 Cass Holt Rd	Holly Springs	2,255	155
F	9.6	E	New School, Inc. Montessori	5617 Sunset Lake Rd	Holly Springs	180	35
F	5.4	ENE	Oakview Elementary School ²	11500 Holly Springs New Hill Rd	Apex	650	65
G	9.7	ESE	Fuquay-Varina Middle School	109 N Ennis St	Fuquay-Varina	875	100

¹ S.R. is Shadow Region. As per county plans these two facilities evacuate due to their close proximity to the EPZ boundary.

² Three schools, Apex Friendship High School, Oakview Elementary and Scotts Ridge Elementary School, have been built since the previous 2012 ETE study.

Zone	Distance (miles)	Direction	School Name	Street Address	Municipality	Enrollment	Staff
G	9.2	ESE	Fuquay-Varina Senior High School	201 Bengal Dr	Fuquay-Varina	2,300	170
G	8.7	E	Herbert Akins Road Elementary School	2255 Herbert Akins Rd	Fuquay-Varina	1,120	120
G	8.8	ESE	Lincoln Heights Elementary School	307 Bridge St	Fuquay-Varina	505	90
G	7.8	E	Southern Wake Academy High School	5108 Old Powell Rd	Holly Springs	119	15
<i>Wake County Subtotal:</i>						24,287	2,370
EPZ TOTAL:						25,964	2,595

Table E-2. Child Care Centers within the EPZ

Zone	Distance (miles)	Direction	School Name	Street Address	Municipality	Enrollment	Staff
WAKE COUNTY							
E	9.9	ENE	All About Kids	3901 Kildaire Farm Rd	Cary	125	30
E	9.6	ENE	Children's Choice	7960 Smith Rd	Apex	8	2
E	9.5	ENE	Earth Angel's Day Care Home	2909 Earth Drive	Apex	8	1
E	8.7	ENE	Goddard School Apex	903 Olive Chapel Rd	Apex	120	26
E	10.1	ENE	Grace Church Preschool	3725 Kildare Farm Rd	Apex	82	13
E	7.9	ENE	Karin'-4-Kidz	201 Ridge Lake Road	Apex	8	2
E	9.7	ENE	Woodhaven Baptist Pre-school	4000 Kildare Farm Rd	Apex	102	15
E	8.9	NE	Apex Baptist Church Preschool	110 South Salem St	Apex	174	24
E	9.4	NE	Apex Child Care with Debbie	102 Beech Hollow Pl	Apex	5	2
E	8.7	NE	Apex Peak Schools, Inc.	432 E Williams St	Apex	7	2
E	8.9	NE	Apex United Methodist Church Preschool	100 S. Hughes St	Apex	78	25
E	9.0	NE	Edith Franklin Day Care Home	501 E Chatham St	Apex	5	1
E	10.1	NE	Eileen's Day Care	902 Wellstone Cir	Apex	8	1
E	8.7	NE	Growing Years Learning Center	470 West Williams St	Apex	100	14
E	10.2	NE	Hope Chapel Preschool	6175 Old Jenks Rd	Apex	75	15
E	10.0	NE	Judy's Home Care	1300 Laura Duncan Rd	Apex	5	1
E	10.3	NE	Lori's Family Day Care	2610 Haventree Ct	Apex	2	1
E	9.7	NE	Moravic Family Day Care	1814 Misty Hollow Ln	Apex	5	1
E	9.5	NE	Peace Montessori	2190 N Salem Suite 103	Apex	85	10
E	10.3	NE	Primose School of Apex	1710 Laura Duncan Rd	Apex	185	35

Zone	Distance (miles)	Direction	School Name	Street Address	Municipality	Enrollment	Staff
E	9.1	NE	Tracey's House	310 Pate St	Apex	3	1
E	8.8	NE	Vickie's Day Care Home	410 E Chatham St	Apex	5	1
E	9.5	NNE	Angels Garden Home Daycare	2204 Walden Creek Dr	Apex	5	1
E	6.7	NNE	Karen's Kids Home Child Care	1014 Edinburgh Downs Ln	Apex	5	1
E	8.7	NNE	Play Care	1422 Fairfax Woods Dr	Apex	6	1
E	7.7	NNE	Rainbow Child Care Center	1815 Olive Chapel Rd	Apex	62	15
E	7.8	NNE	The Learning Experience in Apex	560 Evening Star	Apex	95	18
F	6.2	E	Home Away From Home Childcare	416 Cline Falls Dr	Holly Springs	5	1
F	7.3	E	Sisters' Child Care Services	400 Earp Street	Holly Springs	20	4
F	8.3	ENE	Holly Springs Learning Center	1180 Holly Springs Rd	Holly Springs	159	30
F	7.5	ENE	Holly Springs School For Early Education	101 Arbor Creek Dr	Holly Springs	88	23
F	7.5	ENE	Kiddie Academy of Holly Springs	150 Rosewood Centre Dr	Holly Springs	145	25
F	7.3	ENE	Kris' Home Sweet Home Daycare	420 Cayman Ave	Holly Springs	5	1
F	7.5	ENE	Little Dreamers Preschool	114 Hyannis Drive	Holly Springs	111	10
F	9.7	ENE	Stella Lowery Small Day Care Home	102 Oakland Dr	Apex	5	1
F	9.3	ENE	Sunrise United Methodist Church Preschool	5420 Sunset Lake Rd	Holly Springs	66	16
F	8.0	ENE	The Carolina School	10308 Holly Springs Road	Holly Springs	50	10
G	9.3	E	A Mother's Love	524 Dogwood Creek Pl	Fuquay-Varina	5	1
G	8.3	E	South Wake Preschool & Academy	2275 N Grassland Dr	Fuquay-Varina	37	7
G	9.8	E	Spinning Wheels Learning Center	6225 Sunset Lake Road	Fuquay-Varina	24	7
G	9.1	ESE	Childcare Network – Fuquay-Varina	350 W. Jones St	Fuquay-Varina	113	19
G	9.6	ESE	Fuquay-Varina Baptist Wee Care	301 N Woodrow Street	Fuquay-Varina	98	23
G	9.7	ESE	Fuquay-Varina UMC Preschool Seeds of Faith	100 S Judd Pkwy SE	Fuquay-Varina	180	27
G	9.6	ESE	Little Angels Preparatory	724 S Main St	Fuquay-Varina	50	10
G	10.2	ESE	Little Miracles	428 Barn View Ct	Fuquay-Varina	4	1
G	9.0	ESE	Ready Or Not Here I Grow	201 Powhatan Drive	Fuquay-Varina	92	15
G	9.0	ESE	Shining Star Child Care Home	516 Nature Walk Road	Fuquay-Varina	5	1
G	9.0	ESE	Vanessa Bland's Small Day Care Home	829 Alderleaf Dr	Fuquay-Varina	7	1
<i>Wake County Subtotal:</i>						2,637	492
EPZ TOTAL:						2,637	492

Table E-3. Medical Facilities within the EPZ

Zone	Distance (miles)	Direction	Facility Name	Street Address	Municipality	Capacity	Current Census	Ambulatory Patients	Wheel-chair Patients	Bed-ridden Patients
LEE COUNTY										
J	10.4	WSW	Sanford Health & Rehab	2702 Farrell Rd	Sanford	137	137	41	69	27
<i>Lee County Subtotals:</i>						<i>137</i>	<i>137</i>	<i>41</i>	<i>69</i>	<i>27</i>
WAKE COUNTY										
A	2.4	NE	Brown's Family Care Home	8416 James Rest Home Rd	New Hill	6	6	6	0	0
A	2.3	NE	James Rest Home	8420 James Rest Home Rd	New Hill	40	38	28	10	0
C	4.7	E	Murchison Residential Corp Home	533 Texanna Way	Holly Springs	3	3	3	0	0
E	9.1	NE	Azalea Gardens Mental Health	413 Culvert St	Apex	6	6	6	0	0
E	8.4	NE	Brookridge Assisted Living	312 Lynch St	Apex	55	52	40	12	0
E	8.0	ENE	Favour Home	202 Lindell Dr	Apex	6	6	6	0	0
E	7.6	NNE	Kings Group Home for Children	109 Evening Star Dr	Apex	4	4	4	0	0
E	9.2	ENE	Lockley Road Home	4617 Lockley Rd	Holly Springs	6	6	6	0	0
E	9.1	NE	Mason Street Group Home	306 N. Mason St	Apex	6	6	6	0	0
E	9.0	NE	Olive Home	707 Olive St	Apex	6	6	6	0	0
E	8.4	NE	Rex Rehab & Nursing Center of Apex	911 S. Hughes St	Apex	107	90	20	40	30
E	7.4	NE	Seagraves Family Care Home	1052 Irongate Dr	Apex	6	4	4	0	0
E	8.0	NE	Shackleton Home	1105 Shackleton Rd	Apex	3	3	3	0	0
E	8.7	NE	Spring Arbor of Apex	901 Spring Arbor Ct	Apex	76	66	47	19	0
F	6.5	E	Avent Ferry Home	904 Avent Ferry Rd	Holly Springs	6	6	6	0	0
F	7.8	E	Bass Lake Home	408 Bass Lake Rd	Holly Springs	6	6	6	0	0
F	6.6	E	Country Lane Group Home	534 Country Ln	Holly Springs	6	6	6	0	0
F	8.5	ENE	Herbert Reid Home	3733 Heritage Meadows Ln	Holly Springs	5	5	5	0	0
F	7.0	E	Hickory Avenue Home	112 Hickory Ave	Holly Springs	6	6	6	0	0

Zone	Distance (miles)	Direction	Facility Name	Street Address	Municipality	Capacity	Current Census	Ambulatory Patients	Wheel-chair Patients	Bed-ridden Patients
F	8.6	ENE	St. Mark's Manor	3735 Heritage Meadows Ln	Holly Springs	9	9	9	0	0
F	6.5	E	Trotter's Bluff	912 Avent Ferry Rd	Holly Springs	6	6	6	0	0
G	10.2	ESE	Creekway Home	424 Creekway Dr	Fuquay-Varina	6	6	6	0	0
G	9.5	E	Evans-Walston Home	808 Hawks View Ct	Fuquay-Varina	3	3	3	0	0
G	9.8	ESE	Fuquay-Varina Homes for the Elderly	1012 S Main St	Fuquay-Varina	80	62	60	2	0
G	9.8	E	Hope House	821 Brookhannah Ct	Fuquay-Varina	4	4	4	0	0
G	9.4	ESE	Kinton Court Home	301 Sunset Dr	Fuquay-Varina	16	16	16	0	0
G	9.9	ESE	Life Skills Independent Care #1	800 Perry Howard Rd	Fuquay-Varina	4	4	4	0	0
G	6.9	SE	Mim's Family Care Home	6337 Mims Rd	Holly Springs	6	2	2	0	0
G	9.4	ESE	WakeMed Fuquay Skilled Nursing Facility	400 Ransom St	Fuquay-Varina	36	35	0	20	15
G	9.0	ESE	Windsor Point Continuing Care	1221 Broad St	Fuquay-Varina	300	275	140	100	35
<i>Wake County Subtotal:</i>						<i>829</i>	<i>747</i>	<i>464</i>	<i>203</i>	<i>80</i>
EPZ TOTAL:						966	884	505	272	107

Table E-4. Major Employers within the EPZ

Zone	Distance (miles)	Direction	Facility Name	Street Address	Municipality	Employees (Max Shift)	Employees (Non-EPZ)	Employee Vehicles
CHATHAM COUNTY								
Various locations throughout the EPZ						1,310	1,126	1,052
<i>Chatham County Subtotal:</i>						1,310	1,126	1,052
HARNETT COUNTY								
Various locations throughout the EPZ						21	17	17
<i>Harnett County Subtotal:</i>						21	17	17
LEE COUNTY								
Various locations throughout the EPZ						161	144	135
<i>Lee County Subtotal:</i>						161	144	135
WAKE COUNTY								
Various locations throughout the EPZ						17,325	14,229	13,316
<i>Wake County Subtotal:</i>						17,325	14,229	13,316
EPZ TOTAL³:						18,817	15,516	14,520

³ The major employer locations identified by the Census Bureau are shown in Figure E-6. The locations are represented by circles which increase in size proportional to the number of non-EPZ Employees present in each Census Block. Note that most of the major employer locations are concentrated in Wake County.

Table E-5. Campgrounds within the EPZ

Zone	Distance (miles)	Direction	Facility Name	Street Address	Municipality	Transients	Vehicles
CHATHAM COUNTY							
K	5.0	SW	Dickens RV Park	2501 Corinth Rd	Moncure	216	108
L	6.2	WNW	New Hope Overlook Campground (Jordan Lake)	Hidden Field Ln	NC State Parks	338	84
L	6.7	NNW	Poplar Point Campground (Jordan Lake)	558 Beaver Creek Rd	NC State Parks	1,302	543
M	6.9	W	Cotten's RV Campground	390 Cotten Acres	Moncure	25	25
M	6.9	W	Jordan Dam RV Park & Campground	284 Moncure School Rd	Moncure	44	44
M	7.3	NW	Vista Point Campground (Jordan Lake)	N Pea Ridge Rd	NC State Parks	420	105
N	7.9	NNW	Crosswinds Campground and Marina (Jordan Lake)	389 Farrington Rd	NC State Parks	965	241
N	8.9	NNW	Parker's Creek Campground (Jordan Lake)	Big Woods Rd	NC State Parks	750	188
<i>Chatham County Subtotals:</i>						4,060	1,338
EPZ TOTAL:						4,060	1,338

Table E-6. Parks and Community Centers within the EPZ

Zone	Distance (miles)	Direction	Facility Name	Street Address	Municipality	Transients	Vehicles
CHATHAM COUNTY							
K	4.2	SSW	Harris Lake Boat Launch (Chatham County)	384 Cross Point Rd	New Hill	224	102
L	6.3	NW	Ebenezer Church Recreation Area (Jordan Lake)	Ebenezer Rd	NC State Parks	1,127	282
M	7.3	W	Poe's Ridge Recreation Area (Jordan Lake) ⁴	Moncure School Rd	U.S. Army Corps of Eng	94	62
M	9.6	NW	Robeson Creek Recreation Area (Jordan Lake)	Hanks Chapel Rd	NC State Parks	389	97
M	7.7	NW	Seaforth Recreation Area (Jordan Lake)	U.S. Highway 64	NC State Parks	1,334	334
N	8.0	NNW	White Oak Recreation Area (Jordan Lake)	U.S. Highway 64	NC State Parks	393	98
<i>Chatham County Subtotal:</i>						<i>3,561</i>	<i>975</i>
HARNETT COUNTY							
H	11.0	S	Raven Rock State Park ⁵	309 Raven Rock Rd	Lillington	80	52
<i>Harnett County Subtotal:</i>						<i>80</i>	<i>52</i>
WAKE COUNTY							
A	2.0	E	Harris Lake County Park	2112 County Park Dr	New Hill	401	182
B	5.1	NNE	Goldstar Soccer Complex	2513 Old US Hwy 1	Apex	289	131
D	2.0	SSE	Harris Lake Boat Launch	4420 Bartley Holleman Rd	New Hill	224	102
E	5.6	N	American Tobacco Trail	1309 New Hill-Olive Chapel Rd	Apex	498	226
E	9.3	NE	Apex Community Center	53 Hunter St	Apex	26	12
E	8.2	NE	Apex Elementary School Park	700 Tingen Rd	Apex	6	3
E	9.1	NE	Claremont Park	801 East Chatham St	Apex	2	1
E	9.1	NE	Halle Cultural Arts Center	237 N Salem St	Apex	32	15
E	8.5	NE	Jaycee Park	451 NC Hwy 55	Apex	13	6
E	7.5	NNE	Kelly Glen Park	1701 Kelly Glen Dr	Apex	2	1
E	7.6	NNE	Kelly Road Park	1609 Kelly Rd	Apex	16	7

⁴ Data obtained from Revision 4 of 2007 COLA

⁵ Only a portion of the Park resides in the EPZ, however, the entire facility evacuates as a precautionary measure

Zone	Distance (miles)	Direction	Facility Name	Street Address	Municipality	Transients	Vehicles
E	8.5	NE	Sue Helton Park	Matney Ln	Apex	2	1
E	8.5	NE	West Street Park	108 West St	Apex	2	1
F	8.6	E	Bass Lake Park & Retreat Center	900 Bass Lake Rd	Holly Springs	10	4
F	6.8	E	Holly Springs Library & Cultural Center	300 W Ballentine St	Holly Springs	32	15
F	7.3	ENE	Jones Memorial Park	405 School Days Ln	Holly Springs	6	3
F	7.3	E	Parrish Womble Park	1201 Grigsby Ave	Holly Springs	240	109
F	7.5	ENE	Veterans Park	600 Bikram Dr	Holly Springs	2	1
F	7.2	E	W.E. Hunt Community Center & Gym	301 Stinson Ave	Holly Springs	35	15
G	9.2	ESE	Action Park	609 Wake Chapel Rd	Fuquay-Varina	296	135
G	9.6	ESE	Carroll Howard Johnson EE Park	301 Wagstaff Rd	Fuquay-Varina	11	5
G	9.9	ESE	Falcon Park	611 E Academy St	Fuquay-Varina	32	15
G	8.6	ESE	Fleming Loop Soccer Complex	301 Fleming Loop Rd	Fuquay-Varina	32	15
G	9.5	ESE	Fuquay Mineral Spring Park	105 Spring St	Fuquay-Varina	2	1
G	8.6	E	Herbert Akins School Park	2255 Herbert Akins Rd	Fuquay-Varina	9	4
G	9.5	ESE	Kinton Soccer Field	300 W Ransom St	Fuquay-Varina	16	7
G	9.0	ESE	Lawrence Street Park	215 Lawrence St	Fuquay-Varina	8	4
G	9.6	ESE	Library Park	116 South Aiken St	Fuquay-Varina	6	2
G	8.9	ESE	Pine Acres Community Center & Park	402 Mclean St	Fuquay-Varina	4	2
G	9.6	ESE	South Park	900 S Main St	Fuquay-Varina	401	182
<i>Wake County Subtotal:</i>						2,655	1,207
EPZ TOTAL:						6,296	2,234

Table E-7. Golf Courses within the EPZ

Zone	Distance (miles)	Direction	Facility Name	Street Address	Municipality	Transients	Vehicles
WAKE COUNTY							
C	5.1	ENE	12 Oaks	1001 Green Oaks Pkwy	Holly Springs	70	30
E	9.8	NE	Knights Play Golf Center	2512 Ten-Ten Rd	Apex	288	200
F	8.6	E	Devils Ridge Golf Club	5107 Linksland Dr	Holly Springs	262	180
<i>Wake County Subtotal:</i>						620	410
EPZ TOTAL:						620	410

Table E-8. Lodging Facilities within the EPZ

Zone	Distance (miles)	Direction	Facility Name	Street Address	Municipality	Transients	Vehicles
WAKE COUNTY							
E	8.5	NE	America's Best Value Inn	1400 E Williams St	Apex	60	52
E	8.8	NNE	B & B Country Garden Inn	1041 Kelly Rd	Apex	4	2
E	8.3	NE	Candlewood Suites	1005 Marco Dr	Apex	76	66
E	8.6	NE	Comfort Inn Apex	1411 E Williams St	Apex	64	56
E	8.6	NE	Holiday Inn Express	1006 Marco Dr	Apex	26	23
E	8.8	NE	Value Place Hotel	901 Lufkin Rd	Apex	113	99
F	6.7	E	Hampton Inn & Suites Holly Springs	1516 Ralph Stephens Rd	Holly Springs	116	101
G	9.5	ESE	Fuquay Mineral Spring Inn and Garden B & B	333 South Main St	Fuquay-Varina	4	2
G	9.8	ESE	Chateau Bellevie	1605 South Main St	Fuquay-Varina	3	1
<i>Wake County Subtotal:</i>						466	402
EPZ TOTAL:						466	402

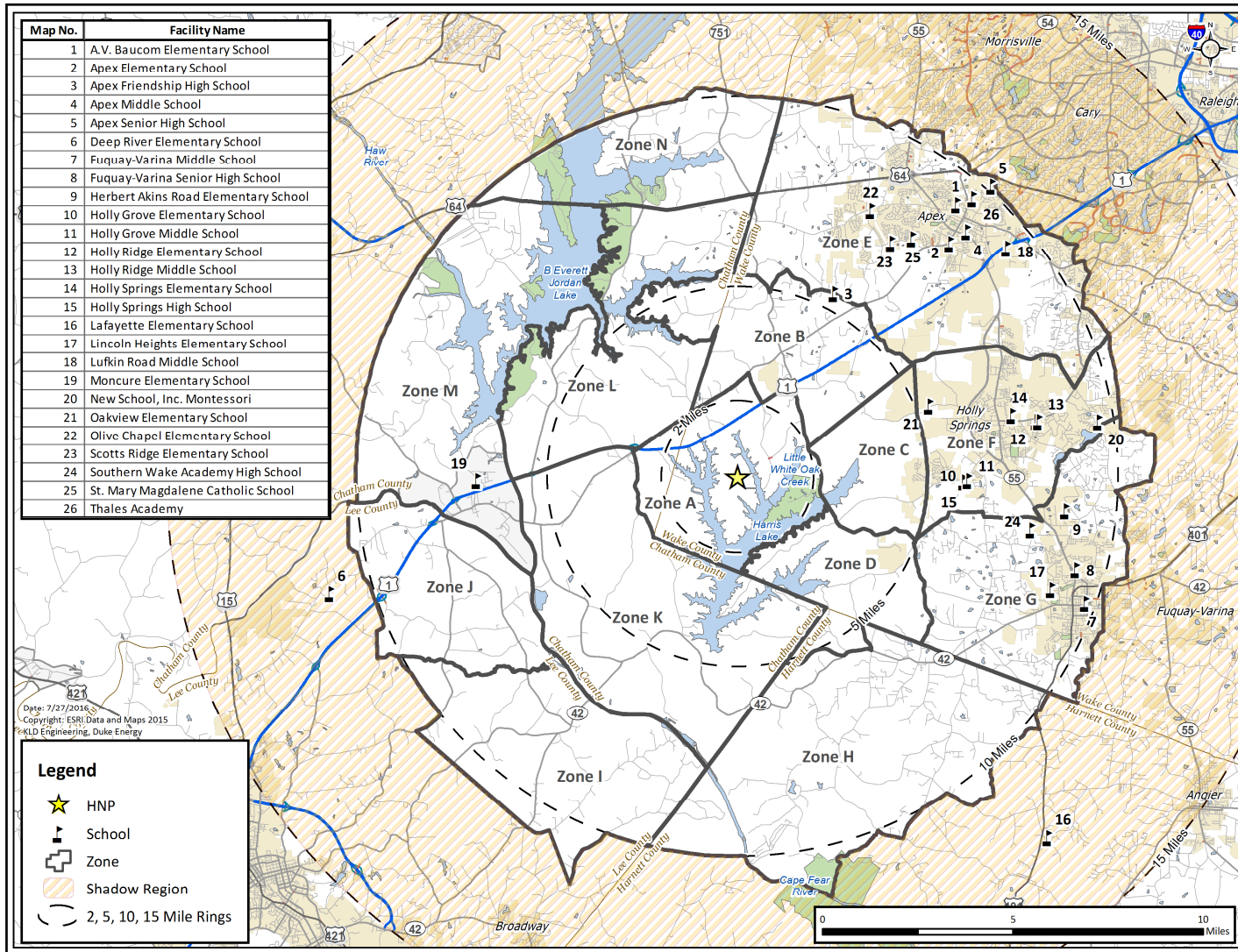

Figure E-1. Schools within the EPZ

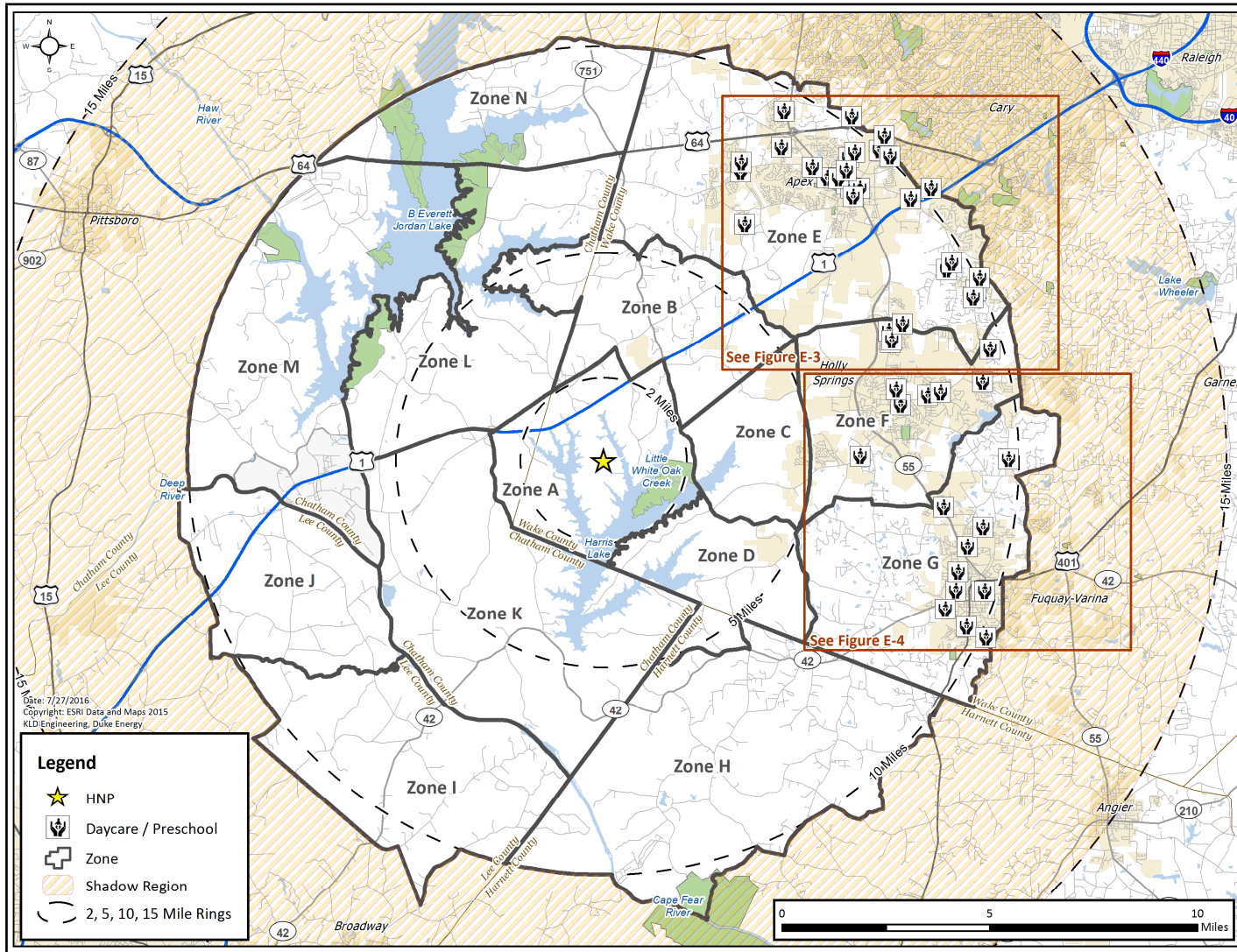

Figure E-2. Overview of Child Care Centers within the EPZ

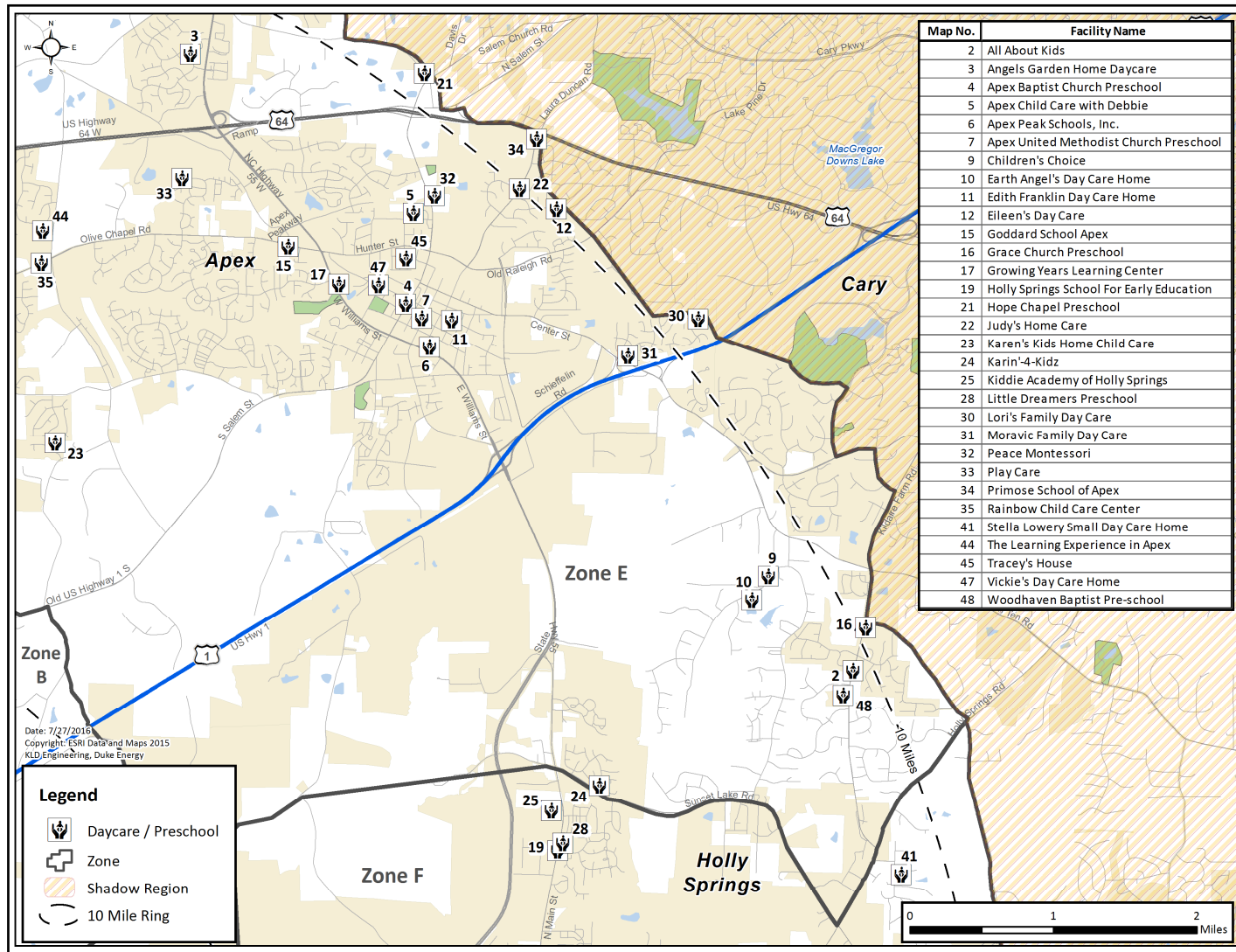

Figure E-3. Child Care Centers within Zones E and F

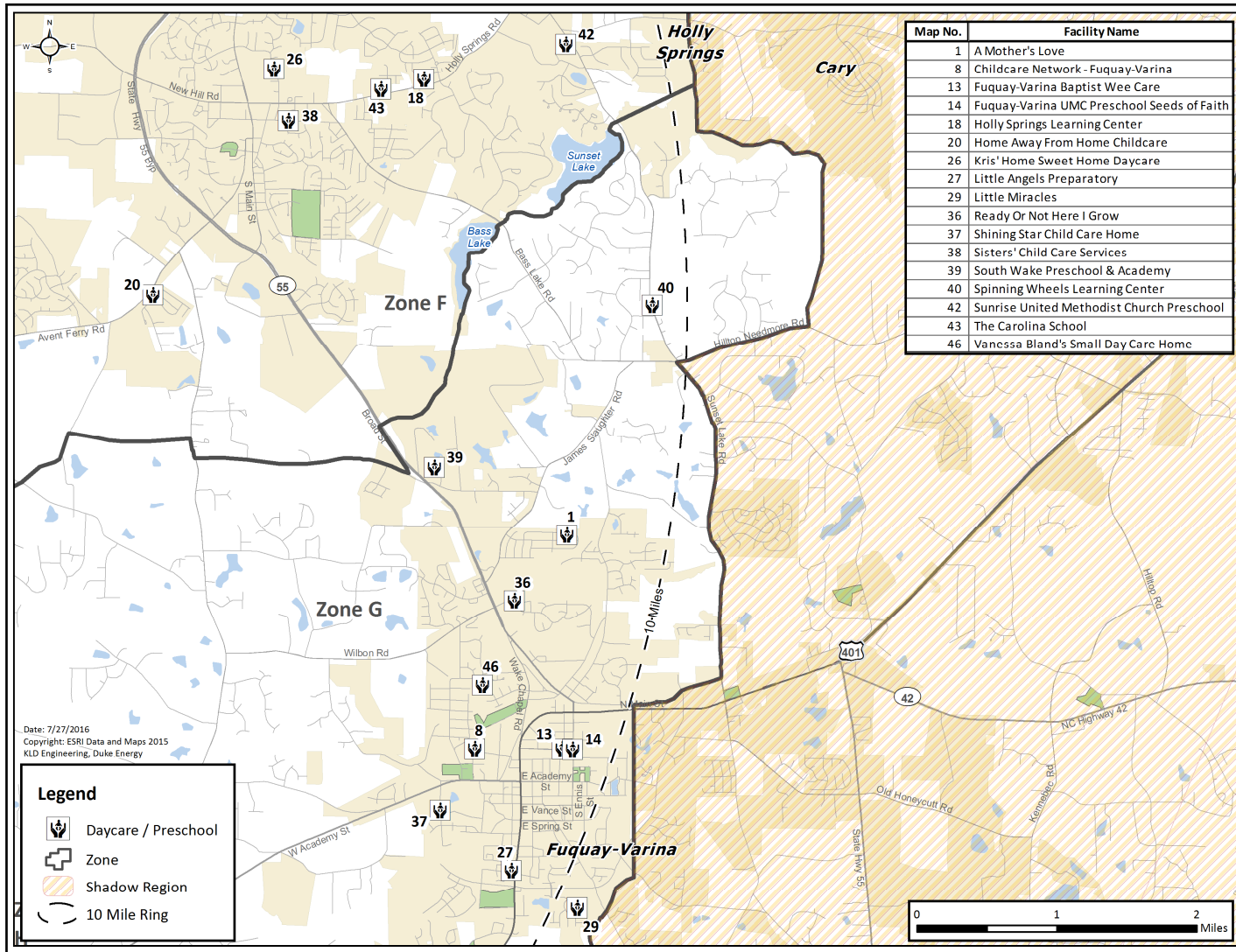

Figure E-4. Child Care Centers within Zones F and G

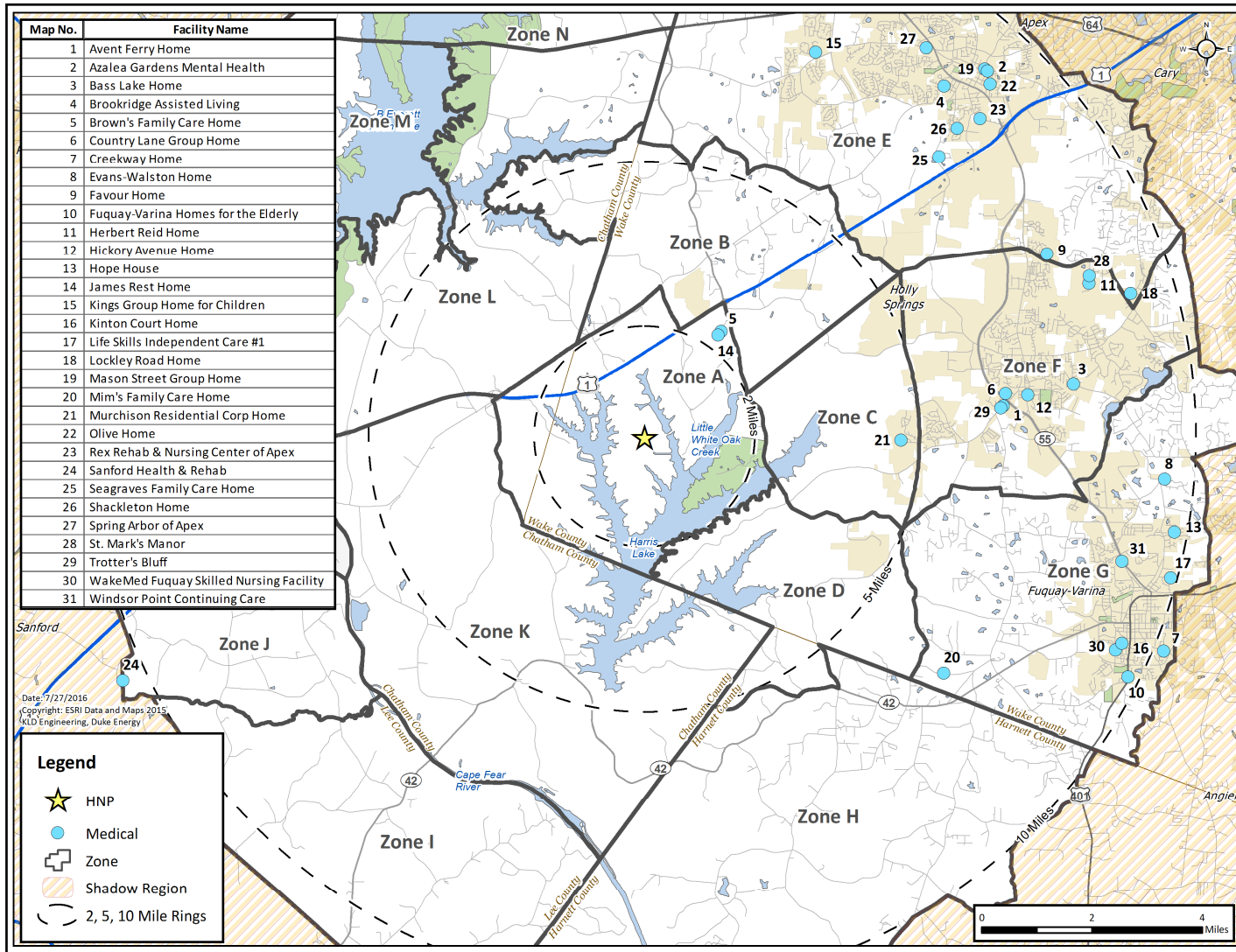

Figure E-5. Medical Facilities within the EPZ

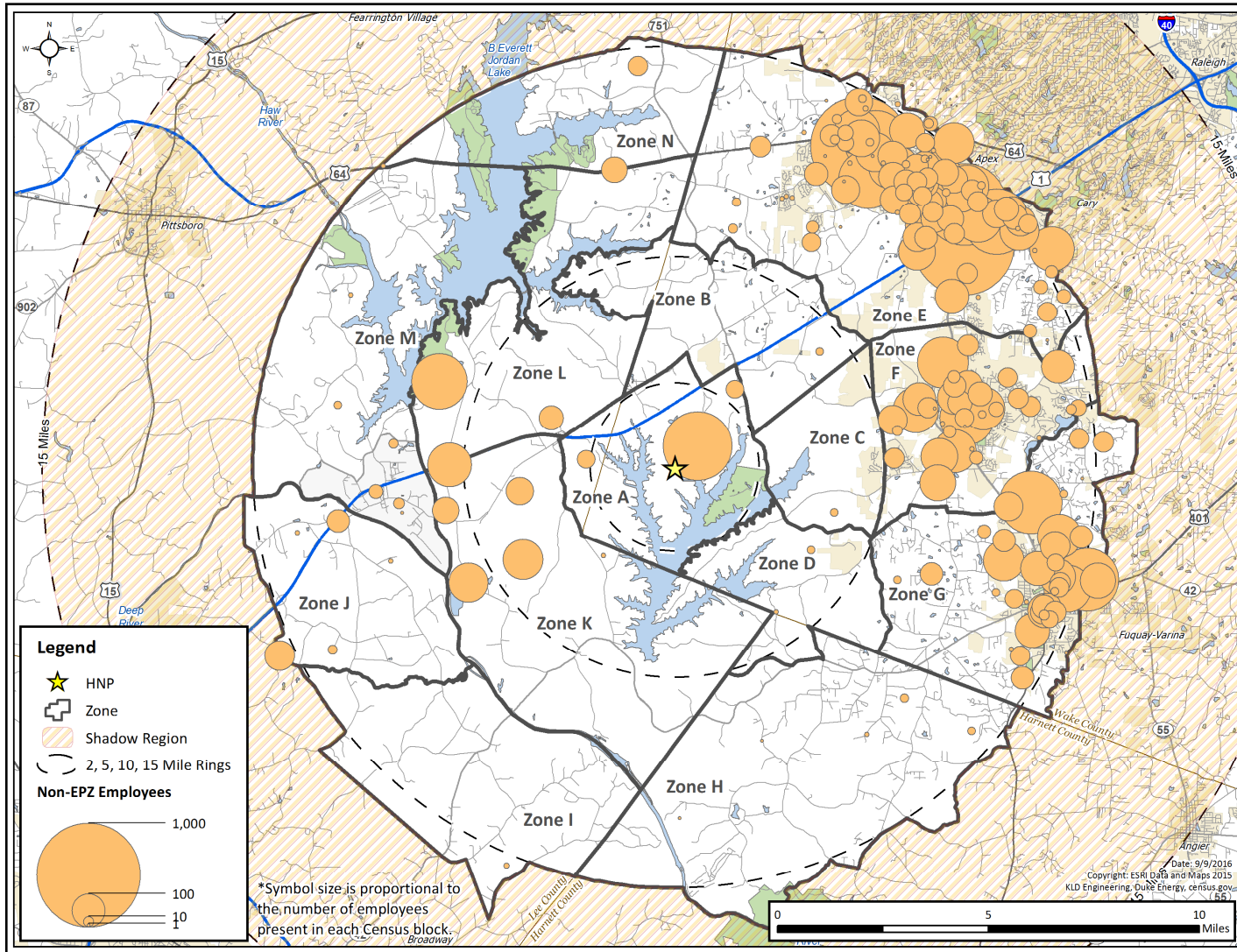

Figure E-6. Non-EPZ Employee Locations within the EPZ

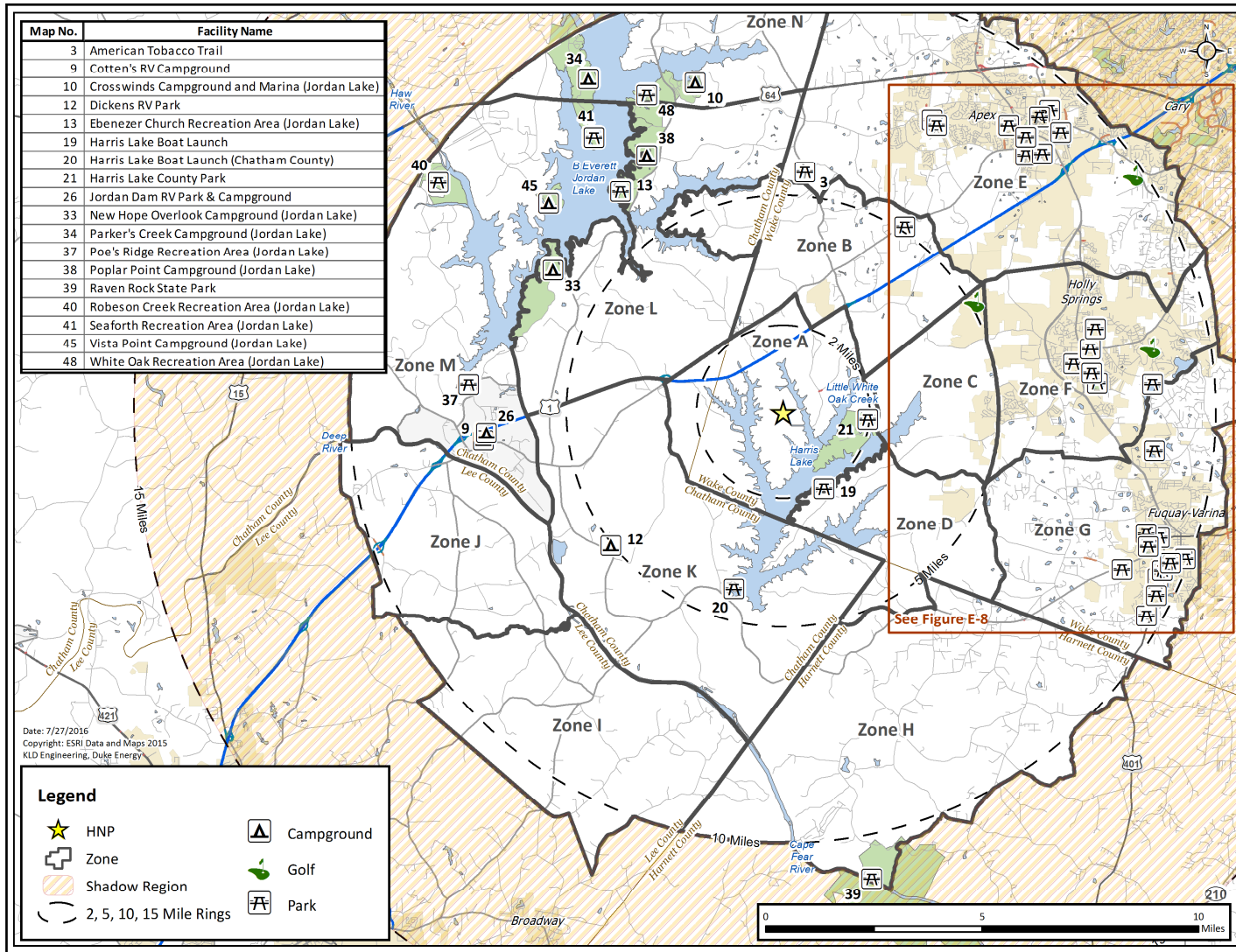

Figure E-7. Recreational Areas within the EPZ

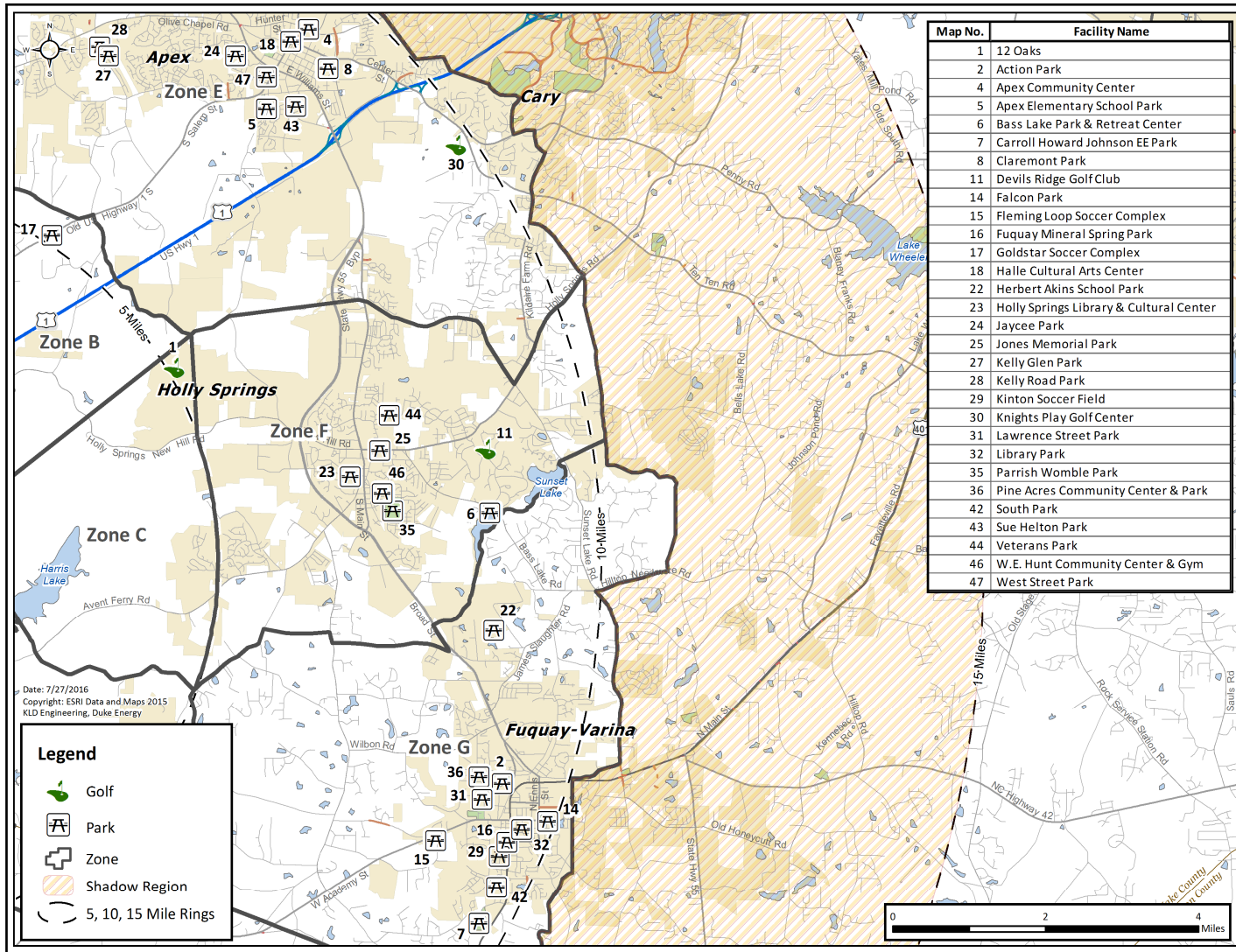

Figure E-8. Recreational Areas within Zones E, F and G

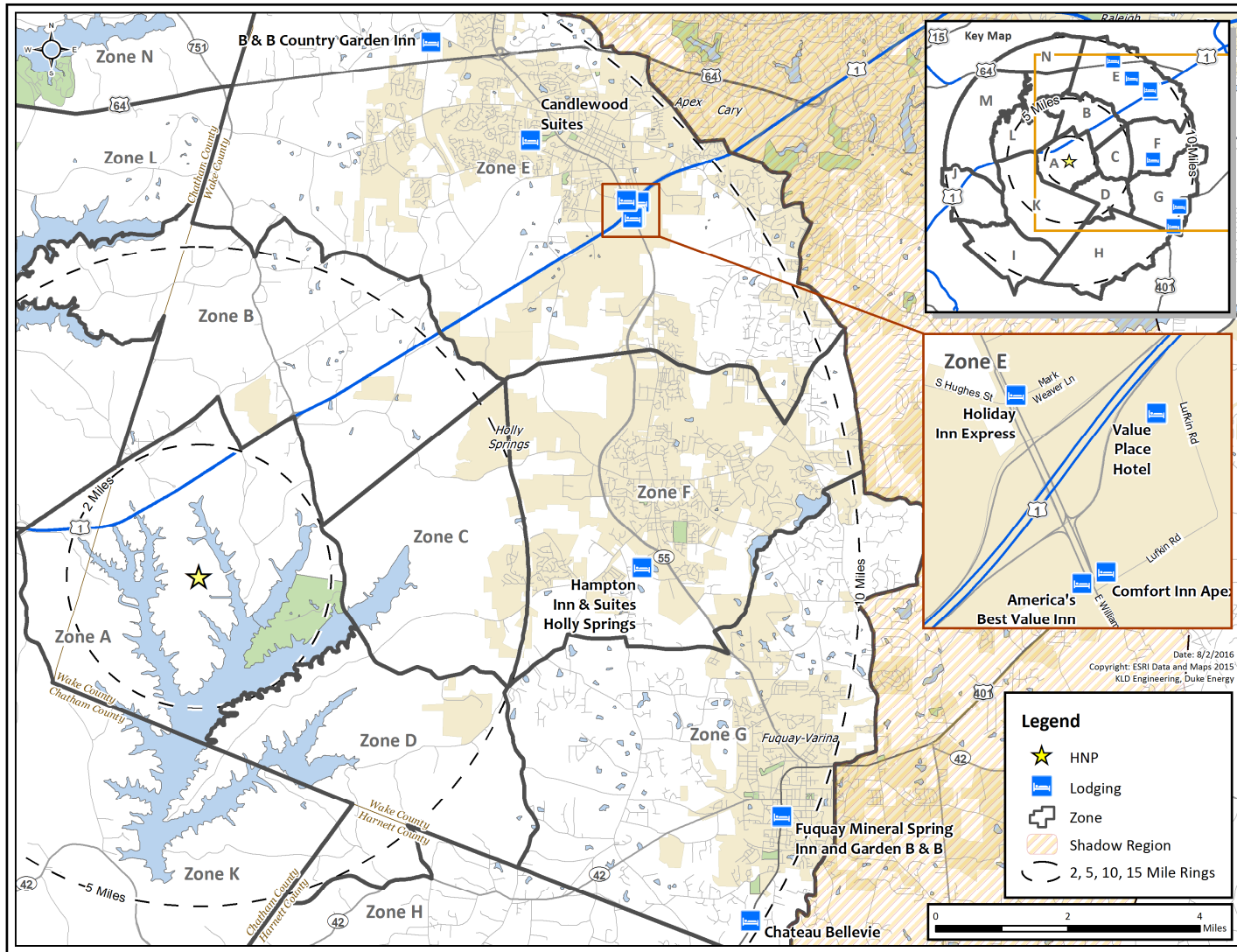

Figure E-9. Lodging Facilities within the EPZ

APPENDIX F

Telephone Survey

F. TELEPHONE SURVEY

F.1 Introduction

The development of evacuation time estimates for the HNP EPZ requires the identification of travel patterns, car ownership and household size of the population within the EPZ. Demographic information can be obtained from Census data. The use of this data has several limitations when applied to emergency planning. First, the Census data do not encompass the range of information needed to identify the time required for preliminary activities (mobilization) that must be undertaken prior to evacuating the area. Secondly, Census data do not contain attitudinal responses needed from the population of the EPZ and consequently may not accurately represent the anticipated behavioral characteristics of the evacuating populace.

These concerns are addressed by conducting a telephone survey of a representative sample of the EPZ population. The survey is designed to elicit information from the public concerning family demographics and estimates of response times to well defined events. The design of the survey includes a limited number of questions of the form “What would you do if ...?” and other questions regarding activities with which the respondent is familiar (“How long does it take you to ...?”)

F.2 Survey Instrument and Sampling Plan

The telephone survey discussed herein was performed in 2012 for the Harris Nuclear Plant Development of Evacuation Time Estimates Technical Report (TR) – 506, dated December 2012. The EPZ population has increased approximately 28% (an increase of 28,559 people) between the 2010 Census and 2016.

Although the population has significantly increased, the population demographics have not significantly changed. According to the U.S Census Bureau’s American Community Survey (ACS)¹ for Chatham, Harnett, Lee and Wake Counties, the average median household income for all four counties was \$51,695 in 2012 versus \$53,611 in 2014², which is a difference of approximately 4 percent. The average household size for all four counties was 2.63 in 2012 versus 2.66 in 2014²; a difference of approximately 1 percent. Given the insignificant changes in demographics, the behavioral responses to the survey questions are not likely to change significantly. Thus, the use of the 2012 telephone survey results is justified.

Attachment A presents the final survey instrument used for the 2012 survey. A draft of the instrument was submitted to stakeholders for comment. Comments were received and the survey instrument was modified accordingly, prior to conducting the survey.

Following the completion of the instrument, a sampling plan was developed. A sample size of approximately 500 **completed** survey forms yields results with a sampling error of $\pm 4.4\%$ at the 95% confidence level. The sample must be drawn from the EPZ population. Consequently, a list of zip codes in the EPZ was developed using GIS software. This list is shown in Table F-1. Along with each zip code, an estimate of the population and number of households in each area was determined by overlaying Census data and the EPZ boundary, again using GIS software. The proportional number of desired completed survey interviews for each area was identified, as shown in Table F-1.

The completed survey adhered to the sampling plan.

¹ <http://factfinder.census.gov/faces/nav/jsf/pages/searchresults.xhtml?refresh=t>

² 2014 data is the latest ACS data currently available from the United States Census Bureau.

Table F-1. Harris Telephone Survey Sampling Plan

Zip Code	Population within EPZ (2010)	Households	Required Sample
27312	821	314	4
27330	2,089	815	11
27502	29,062	10,064	139
27505	70	21	0
27517	49	17	0
27518	3,513	1,182	16
27519	126	46	1
27523	6,178	2,291	31
27526	20,528	7,715	106
27539	9,769	3,464	47
27540	27,467	9,227	127
27559	1,399	562	8
27562	1,890	751	10
Total	102,961	36,469	500
Average Household Size:			2.82
Total Sample Required:			500

F.3 Survey Results

The results of the survey fall into two categories. First, the household demographics of the area can be identified. Demographic information includes such factors as household size, automobile ownership, and automobile availability. The distributions of the time to perform certain pre-evacuation activities are the second category of survey results. These data are processed to develop the trip generation distributions used in the evacuation modeling effort, as discussed in Section 5.

A review of the survey instrument reveals that several questions have a “don’t know” (DK) or “refused” entry for a response. It is accepted practice in conducting surveys of this type to accept the answers of a respondent who offers a DK response for a few questions or who refuses to answer a few questions. To address the issue of occasional DK/refused responses from a large sample, the practice is to assume that the distribution of these responses is the same as the underlying distribution of the positive responses. In effect, the DK/refused responses are ignored and the distributions are based upon the positive data that is acquired.

F.3.2 Household Demographic Results

Household Size

Figure F-1 presents the distribution of household size within the EPZ based on the responses to the telephone survey. The average household contains 2.95 people. The estimated household size (2.82 people) used to determine the survey sample (Table F-1) was drawn from 2010 Census data. The difference between the Census data and survey data is 4.6%, which exceeds the sampling error of 4.4%. This issue was discussed with Duke Energy and the county emergency management agencies during the 2012 ETE study, and it was decided that the U.S. Census estimate of 2.82 people per household should be used for this study. This results in a more conservative estimate when determining the number of households and evacuating vehicles.

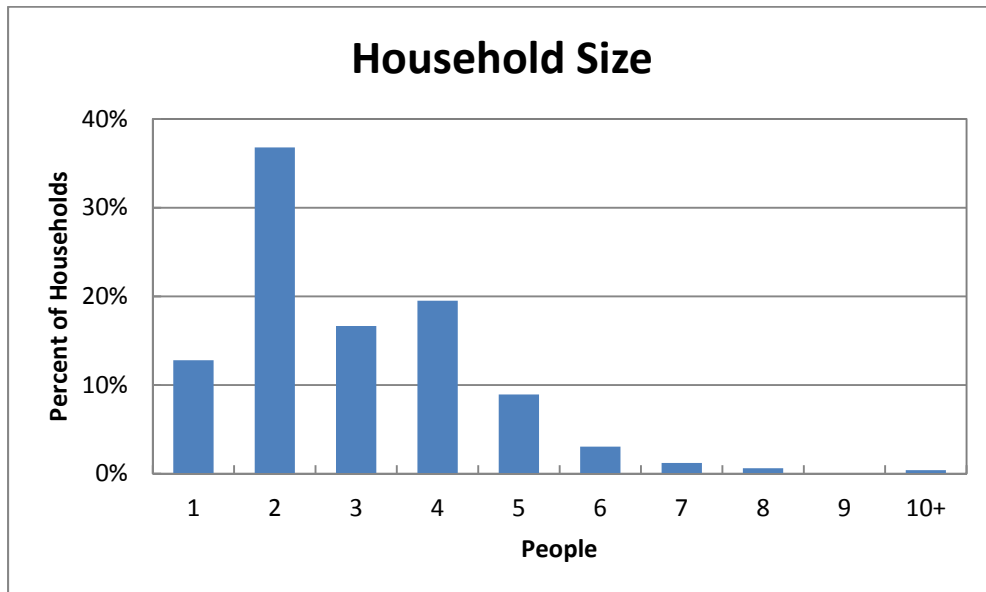

Figure F-1. Household Size in the EPZ

Automobile Ownership

The average number of automobiles available per household in the EPZ is 2.16. It should be noted that 1.8 percent of households do not have access to an automobile. The distribution of automobile ownership is presented in Figure F-2. Figure F-3 and Figure F-4 present the automobile availability by household size. Note that the majority of households without access to a car are single person households. As expected, nearly all households of 2 or more people have access to at least one vehicle.

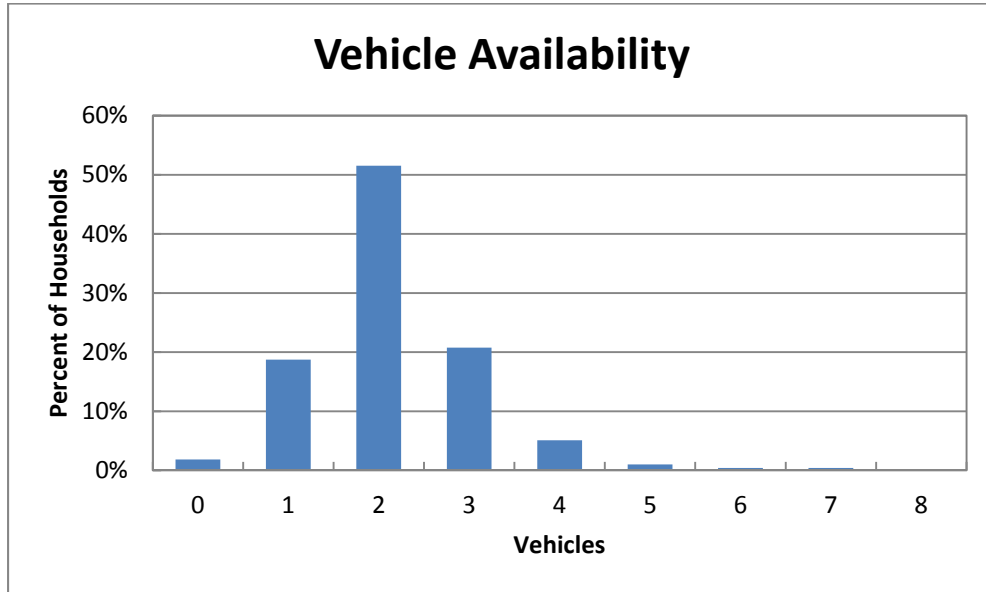

Figure F-2. Household Vehicle Availability

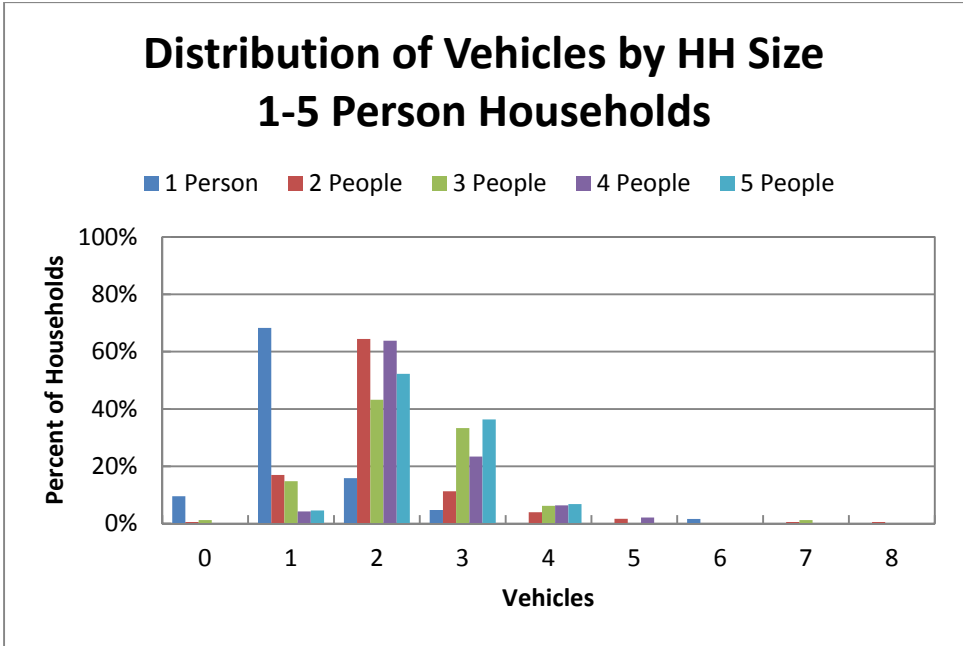

Figure F-3. Vehicle Availability - 1 to 5 Person Households

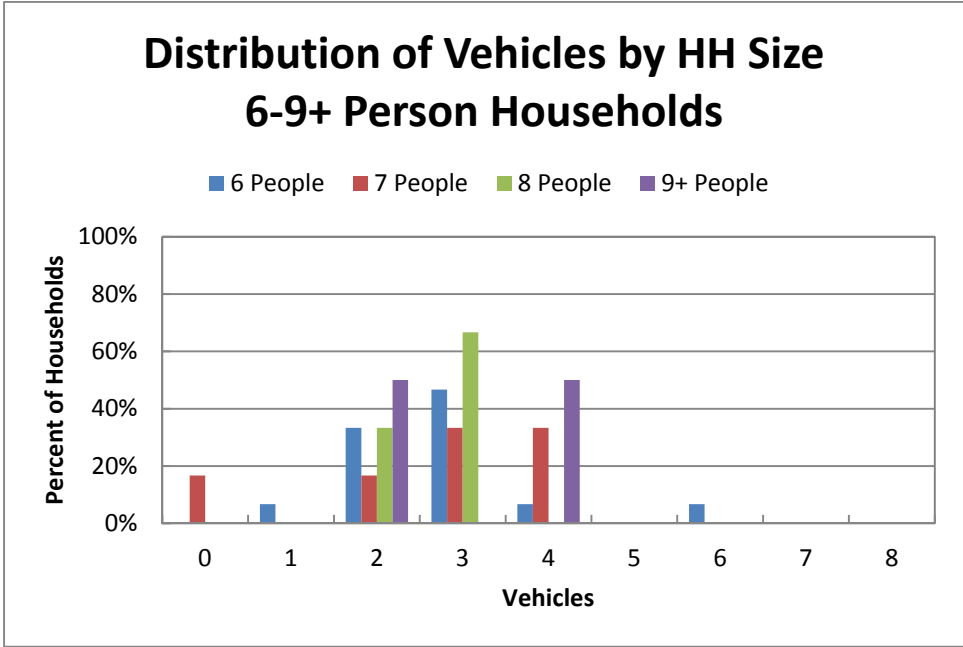

Figure F-4. Vehicle Availability - 6 to 9+ Person Households

Ridesharing

The overwhelming proportion (89%) of the households surveyed (who do not own a vehicle) responded that they would share a ride with a neighbor, relative, or friend if a car was not available to them when advised to evacuate in the event of an emergency. Note, however, that only those households that responded they have no access to a vehicle, or they don't know how many vehicles are available, or refused to answer the question regarding vehicle availability – a total of 18 households out of the sample size of 500 – answered this question. Thus, the results are not statistically significant. As such, the NRC recommendation of 50% ridesharing is used throughout this study. Figure F-5 presents this response.

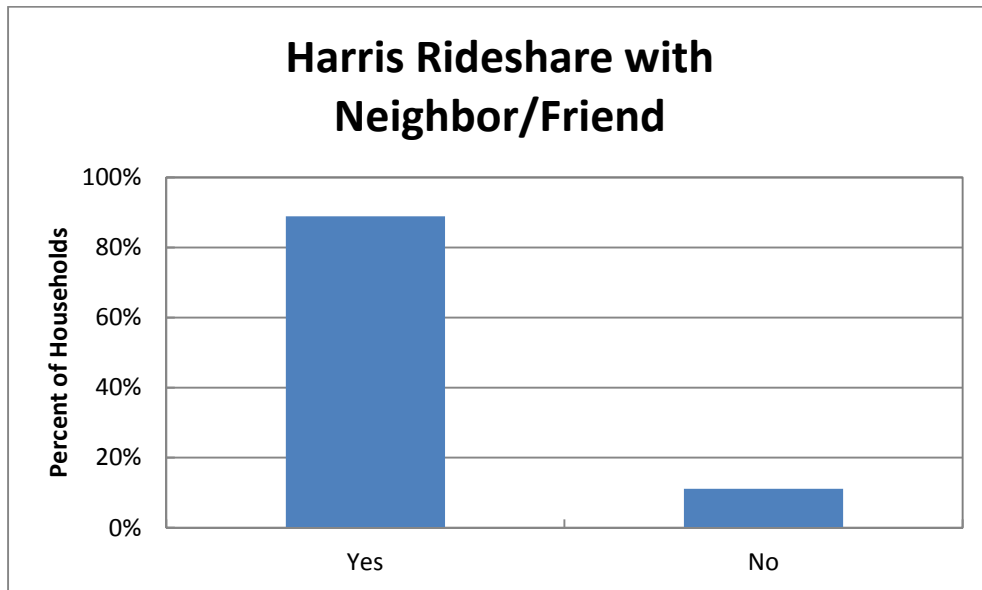

Figure F-5. Household Ridesharing Preference

Commuters

Figure F-6 presents the distribution of the number of commuters in each household. Commuters are defined as household members who travel to work or college on a daily basis. The data shows an average of 1.14 commuters in each household in the EPZ, and 68% of households have at least one commuter.

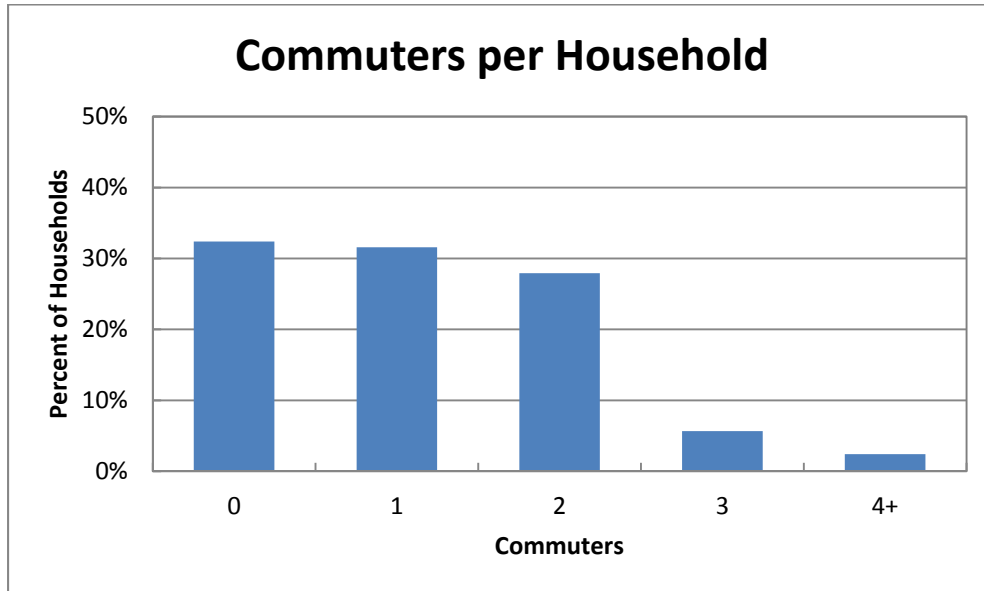

Figure F-6. Commuters in Households in the EPZ

Commuter Travel Modes

Figure F-7 presents the mode of travel that commuters use on a daily basis. The vast majority of commuters use their private automobiles to travel to work or college. The data shows an average of 1.07 commuters per vehicle, assuming 2 people per vehicle – on average – for carpools.

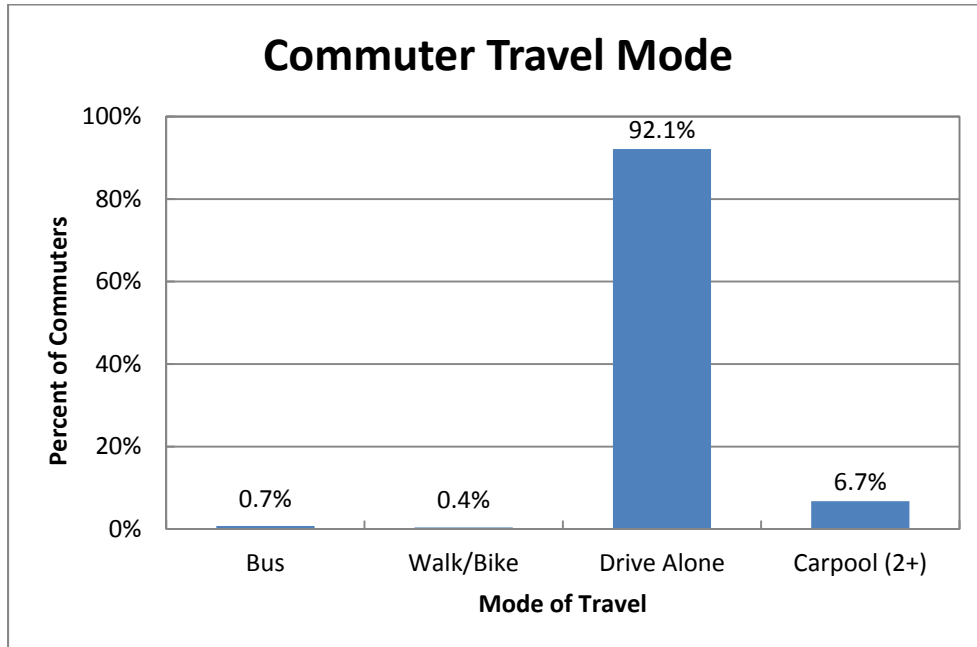

Figure F-7. Modes of Travel in the EPZ

F.3.3 Evacuation Response

Several questions were asked to gauge the population's response to an emergency. These are now discussed:

"How many of the vehicles would your household use during an evacuation?" The response is shown in Figure F-8. On average, evacuating households would use 1.39 vehicles.

"Would your family await the return of other family members prior to evacuating the area?" Of the survey participants who responded, 41 percent said they would await the return of other family members before evacuating and 59 percent indicated that they would not await the return of other family members, as shown in Figure F-9.

"If you had a household pet, would you take your pet with you if you were asked to evacuate the area?" Based on responses from the survey, 76 percent of households do have a family pet. Of the households with pets, 94 percent of them indicated that they would take their pets, as shown in Figure F-10.

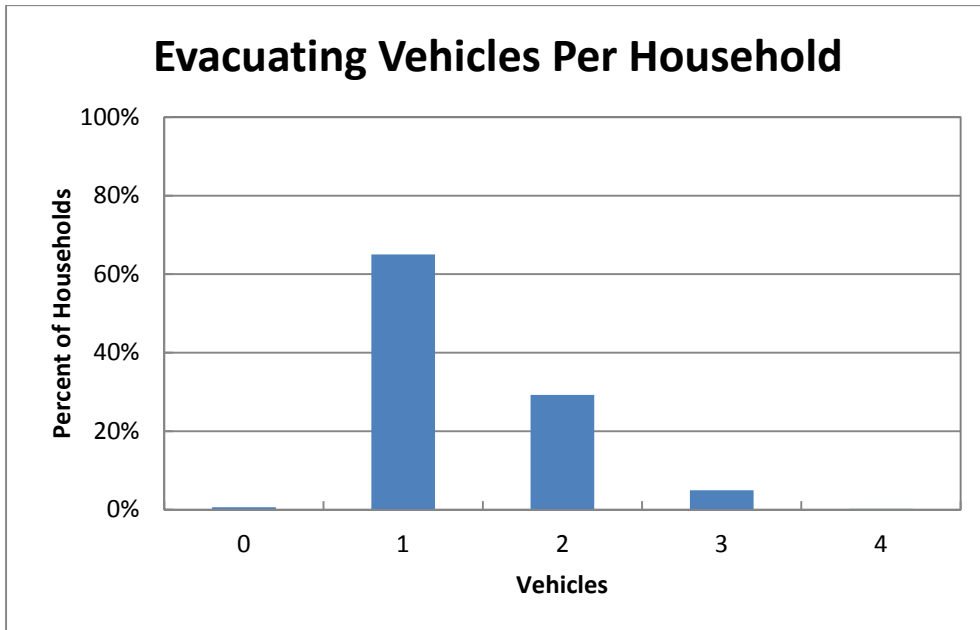

Figure F-8. Number of Vehicles Used for Evacuation

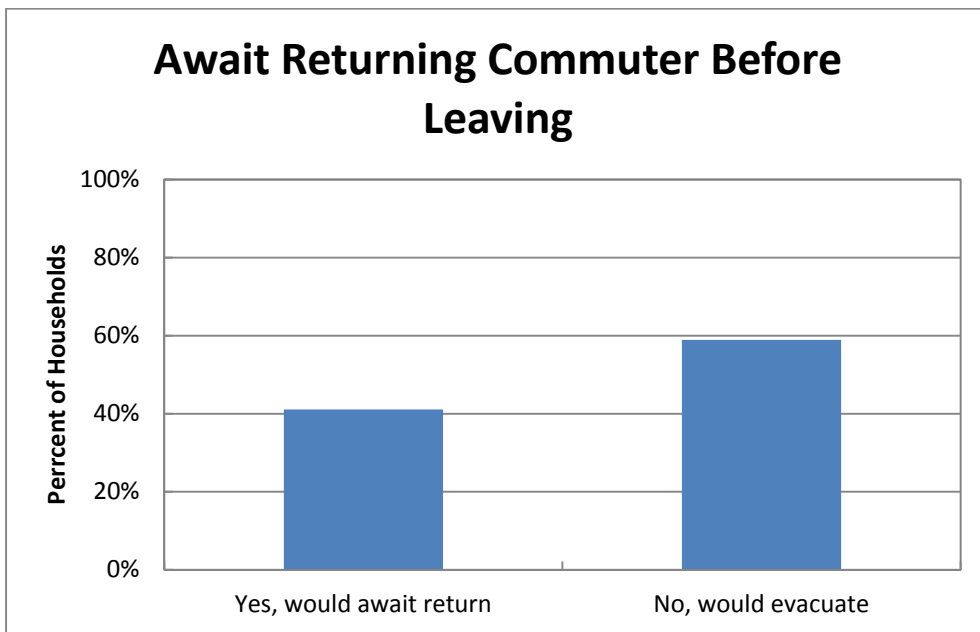

Figure F-9. Percent of Households that Await Returning Commuter Before Leaving

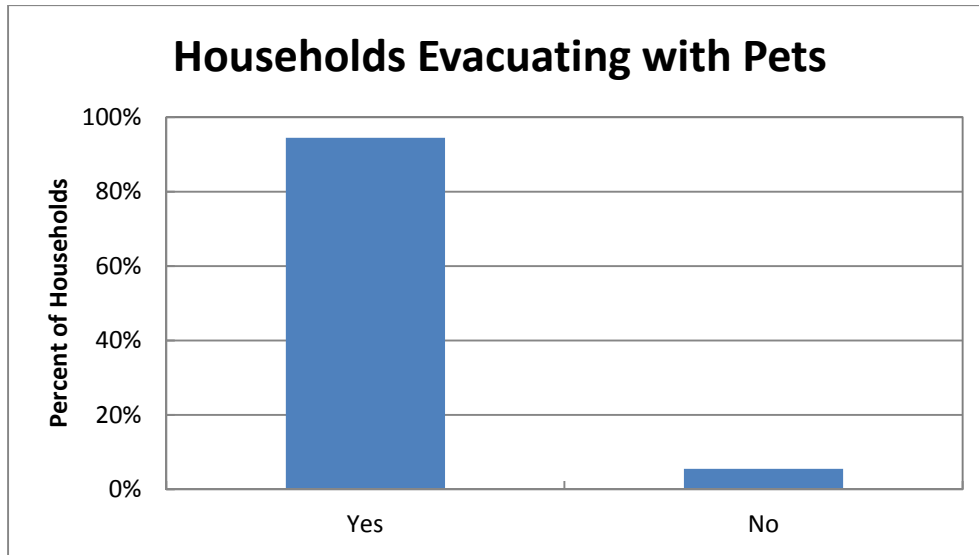

Figure F-10. Households Evacuating with Pets

“Emergency officials advise you to take shelter at home in an emergency. Would you?” This question is designed to elicit information regarding compliance with instructions to shelter in place. The results indicate that 84 percent of households who are advised to shelter in place would do so; the remaining 16 percent would choose to evacuate the area. Note the baseline ETE study assumes 20 percent of households will not comply with the shelter advisory, as per Section 2.5.2 of NUREG/CR-7002. Thus, the data obtained above is slightly less than the federal guidance. Appendix M (Table M-2) includes a sensitivity study to estimate the impact on ETE of using the lesser (16%) shadow evacuation (non-compliance of shelter advisory) based on the telephone survey results.

“Emergency officials advise you to take shelter at home now in an emergency and possibly evacuate later while people in other areas are advised to evacuate now. Would you?” This question is designed to elicit information specifically related to the possibility of a staged evacuation. That is, asking a population to shelter in place now and then to evacuate after a specified period of time. Results indicate that 74 percent of households would follow instructions and delay the start of evacuation until so advised, while the balance of 26 percent would choose to begin evacuating immediately.

F.3.4 Time Distribution Results

The survey asked several questions about the amount of time it takes to perform certain pre-evacuation activities. These activities involve actions taken by residents during the course of their day-to-day lives. Thus, the answers fall within the realm of the responder’s experience.

The mobilization distributions provided below are the result of having applied the analysis described in Section 5.4.1 on the component activities of the mobilization.

“How long does it take the commuter to complete preparation for leaving work/college?” Figure F-11 presents the cumulative distribution; in all cases, the activity is completed within 90 minutes. Approximately 90% can leave within 30 minutes.

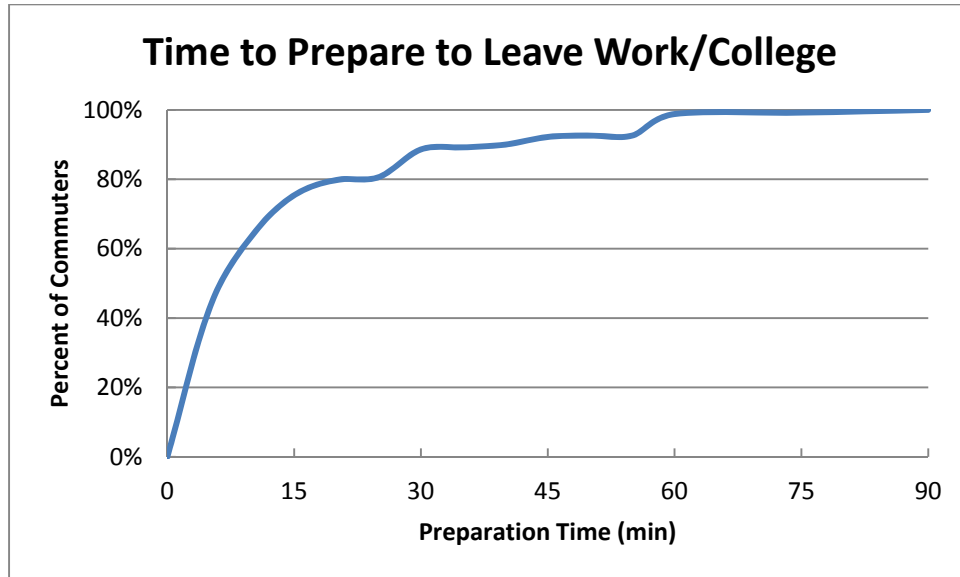

Figure F-11. Time Required to Prepare to Leave Work/College

“How long would it take the commuter to travel home?” Figure F-12 presents the work to home travel time for the EPZ. Approximately 80 percent of commuters can arrive home within 30 minutes of leaving work; all within 90 minutes.

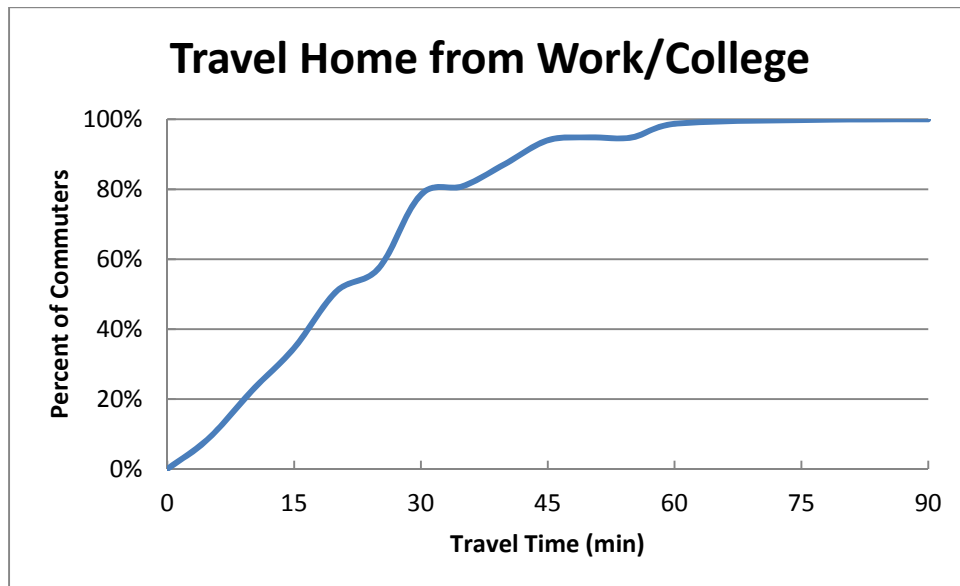

Figure F-12. Time to Travel Home from Work/College

“How long would it take the family to pack clothing, secure the house, and load the car?”

Figure F-13 presents the time required to prepare for leaving on an evacuation trip. In many ways this activity mimics a family’s preparation for a short holiday or weekend away from home. Hence, the responses represent the experience of the responder in performing similar activities.

The distribution shown in Figure F-13 has a long “tail.” Approximately 94% of households can be ready to leave home within 2 hours; the remaining households require up to an additional one hour and 15 minutes.

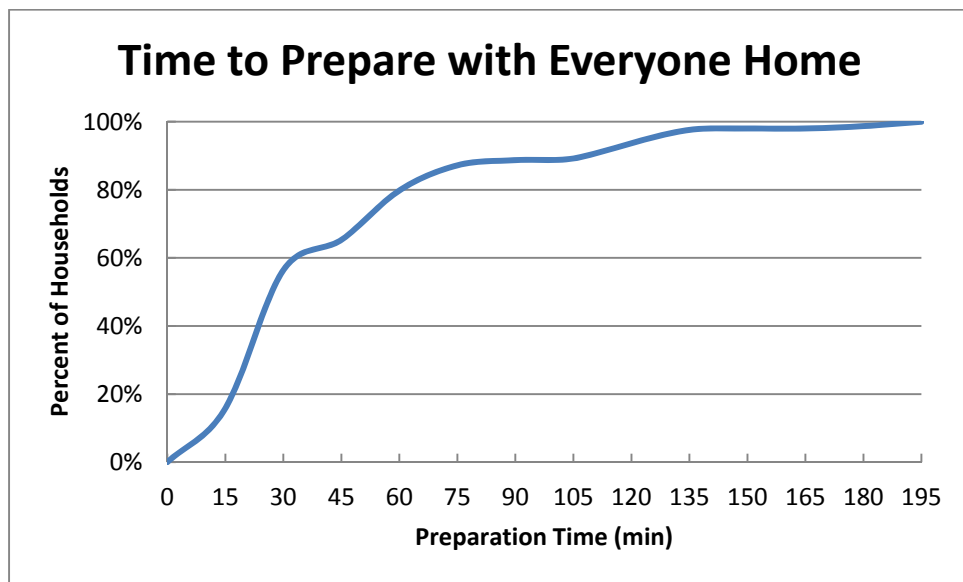

Figure F-13. Time to Prepare Home for Evacuation

F.4 Conclusions

The telephone survey provides valuable, relevant data associated with the EPZ population, which have been used to quantify demographics specific to the EPZ, and “mobilization time” which can influence evacuation time estimates.

ATTACHMENT A

Telephone Survey Instrument

Telephone Survey Instrument

Hello, my name is _____ and I'm working in cooperation with local emergency management agencies to identify local behavior during emergency situations. This information will be used for emergency planning and will be shared with local officials to enhance emergency response plans in your area for all hazards; emergency planning for some hazards may require evacuation. Your responses will greatly contribute to local emergency preparedness. I will not ask for your name and the survey shall take no more than 10 minutes to complete.

COL. 1 Unused
COL. 2 Unused
COL. 3 Unused
COL. 4 Unused
COL. 5 Unused
Sex COL. 8
 1 Male
 2 Female

INTERVIEWER: ASK TO SPEAK TO THE HEAD OF HOUSEHOLD OR THE SPOUSE OF THE HEAD OF HOUSEHOLD.
 (Terminate call if not a residence.)

DO NOT ASK:

1A.	Record area code. To Be Determined	<u>COL. 9-11</u>	
1B.	Record exchange number. To Be Determined	<u>COL. 12-14</u>	
2.	What is your home zip code?	<u>COL. 15-19</u>	
3A.	In total, how many running cars, or other running vehicles are usually available to the household? (DO NOT READ ANSWERS)	<u>COL. 20</u>	<u>SKIP TO</u>
		1 ONE	Q. 4
		2 TWO	Q. 4
		3 THREE	Q. 4
		4 FOUR	Q. 4
		5 FIVE	Q. 4
		6 SIX	Q. 4
		7 SEVEN	Q. 4
		8 EIGHT	Q. 4
		9 NINE OR MORE	Q. 4
		0 ZERO (NONE)	Q. 3B
		X DON'T KNOW/REFUSED	Q. 3B
3B.	In an emergency, could you get a ride out of the area with a neighbor or friend?	<u>COL. 21</u>	
		1 YES	
		2 NO	
		X DON'T KNOW/REFUSED	
4.	How many people usually live in this household? (DO NOT READ ANSWERS)	<u>COL. 22</u>	<u>COL. 23</u>
		1 ONE	0 TEN
		2 TWO	1 ELEVEN
		3 THREE	2 TWELVE
		4 FOUR	3 THIRTEEN
		5 FIVE	4 FOURTEEN
		6 SIX	5 FIFTEEN
		7 SEVEN	6 SIXTEEN

	8 EIGHT	7 SEVENTEEN
	9 NINE	8 EIGHTEEN
		9 NINETEEN OR MORE
		X DON'T KNOW/REFUSED
5. How many adults in the household commute to a job, or to college on a daily basis?	<u>COL. 24</u>	<u>SKIP TO</u>
	0 ZERO	Q. 9
	1 ONE	Q. 6
	2 TWO	Q. 6
	3 THREE	Q. 6
	4 FOUR OR MORE	Q. 6
	5 DON'T KNOW/REFUSED	Q. 9

INTERVIEWER: For each person identified in Question 5, ask Questions 6, 7, and 8.

6. Thinking about commuter #1, how does that person usually travel to work or college? (REPEAT QUESTION FOR EACH COMMUTER)

	Commuter #1	Commuter #2	Commuter #3	Commuter #4
	<u>COL. 25</u>	<u>COL. 26</u>	<u>COL. 27</u>	<u>COL. 28</u>
Rail	1	1	1	1
Bus	2	2	2	2
Walk/Bicycle	3	3	3	3
Drive Alone	4	4	4	4
Park & Ride (Car/Rail, Xpress bus)	5	5	5	5
Carpool-2 or more people	6	6	6	6
Taxi	7	7	7	7
Don't know/Refused	8	8	8	8

7. How much time on average, would it take Commuter #1 to travel home from work or college? (REPEAT QUESTION FOR EACH COMMUTER) (DO NOT READ ANSWERS)

<u>COMMUTER #1</u>		<u>COMMUTER #2</u>	
<u>COL. 29</u>	<u>COL. 30</u>	<u>COL. 31</u>	<u>COL. 32</u>
1 5 MINUTES OR LESS	1 46-50 MINUTES	1 5 MINUTES OR LESS	1 46-50 MINUTES
2 6-10 MINUTES	2 51-55 MINUTES	2 6-10 MINUTES	2 51-55 MINUTES
3 11-15 MINUTES	3 56 – 1 HOUR	3 11-15 MINUTES	3 56 – 1 HOUR
4 16-20 MINUTES	4 OVER 1 HOUR, BUT LESS THAN 1 HOUR 15 MINUTES	4 16-20 MINUTES	4 OVER 1 HOUR, BUT LESS THAN 1 HOUR 15 MINUTES
5 21-25 MINUTES	5 BETWEEN 1 HOUR 16 MINUTES AND 1 HOUR 30 MINUTES	5 21-25 MINUTES	5 BETWEEN 1 HOUR 16 MINUTES AND 1 HOUR 30 MINUTES
6 26-30 MINUTES	6 BETWEEN 1 HOUR 31	6 26-30 MINUTES	6 BETWEEN 1 HOUR 31

			MINUTES AND 1 HOUR 45 MINUTES				MINUTES AND 1 HOUR 45 MINUTES
			BETWEEN 1 HOUR 46				BETWEEN 1 HOUR 46
7	31-35 MINUTES	7	MINUTES AND 2 HOURS	7	31-35 MINUTES	7	MINUTES AND 2 HOURS
8	36-40 MINUTES	8	OVER 2 HOURS (SPECIFY _____)	8	36-40 MINUTES	8	OVER 2 HOURS (SPECIFY _____)
9	41-45 MINUTES	9		9	41-45 MINUTES	9	
		0				0	
		X	DON'T KNOW /REFUSED			X	DON'T KNOW /REFUSED

<u>COMMUTER #3</u>			<u>COMMUTER #4</u>				
<u>COL. 33</u>		<u>COL. 34</u>	<u>COL. 35</u>		<u>COL. 36</u>		
1	5 MINUTES OR LESS	1	46-50 MINUTES	1	5 MINUTES OR LESS	1	46-50 MINUTES
2	6-10 MINUTES	2	51-55 MINUTES	2	6-10 MINUTES	2	51-55 MINUTES
3	11-15 MINUTES	3	56 – 1 HOUR	3	11-15 MINUTES	3	56 – 1 HOUR
4	16-20 MINUTES	4	OVER 1 HOUR, BUT LESS THAN 1 HOUR 15 MINUTES	4	16-20 MINUTES	4	OVER 1 HOUR, BUT LESS THAN 1 HOUR 15 MINUTES
5	21-25 MINUTES	5	BETWEEN 1 HOUR 16 MINUTES AND 1 HOUR 30 MINUTES	5	21-25 MINUTES	5	BETWEEN 1 HOUR 16 MINUTES AND 1 HOUR 30 MINUTES
6	26-30 MINUTES	6	BETWEEN 1 HOUR 31 MINUTES AND 1 HOUR 45 MINUTES	6	26-30 MINUTES	6	BETWEEN 1 HOUR 31 MINUTES AND 1 HOUR 45 MINUTES
7	31-35 MINUTES	7	BETWEEN 1 HOUR 46 MINUTES AND 2 HOURS	7	31-35 MINUTES	7	BETWEEN 1 HOUR 46 MINUTES AND 2 HOURS
8	36-40 MINUTES	8	OVER 2 HOURS (SPECIFY _____)	8	36-40 MINUTES	8	OVER 2 HOURS (SPECIFY _____)
9	41-45 MINUTES	9		9	41-45 MINUTES	9	
		0				0	
		X	DON'T KNOW /REFUSED			X	DON'T KNOW /REFUSED

8. Approximately how much time does it take Commuter #1 to complete preparation for leaving work or college prior to starting the trip home? (REPEAT QUESTION FOR EACH COMMUTER) (DO NOT READ ANSWERS)

<u>COMMUTER #1</u>			<u>COMMUTER #2</u>				
<u>COL. 37</u>		<u>COL. 38</u>	<u>COL. 39</u>		<u>COL. 40</u>		
1	5 MINUTES OR LESS	1	46-50 MINUTES	1	5 MINUTES OR LESS	1	46-50 MINUTES
2	6-10 MINUTES	2	51-55 MINUTES	2	6-10 MINUTES	2	51-55 MINUTES
3	11-15 MINUTES	3	56 – 1 HOUR	3	11-15 MINUTES	3	56 – 1 HOUR
4	16-20 MINUTES	4	OVER 1 HOUR, BUT LESS THAN 1 HOUR 15 MINUTES	4	16-20 MINUTES	4	OVER 1 HOUR, BUT LESS THAN 1 HOUR 15 MINUTES
5	21-25 MINUTES	5	BETWEEN 1 HOUR 16 MINUTES AND 1 HOUR	5	21-25 MINUTES	5	BETWEEN 1 HOUR 16 MINUTES AND 1

		30 MINUTES		HOUR 30 MINUTES
6	26-30 MINUTES	6 BETWEEN 1 HOUR 31 MINUTES AND 1 HOUR 45 MINUTES	6	26-30 MINUTES
7	31-35 MINUTES	7 BETWEEN 1 HOUR 46 MINUTES AND 2 HOURS	7	31-35 MINUTES
8	36-40 MINUTES	8 OVER 2 HOURS (SPECIFY _____)	8	36-40 MINUTES
9	41-45 MINUTES	9	9	41-45 MINUTES
		0		0
		X DON'T KNOW /REFUSED		X DON'T KNOW /REFUSED

<u>COMMUTER #3</u>		<u>COMMUTER #4</u>	
<u>COL. 41</u>	<u>COL. 42</u>	<u>COL. 43</u>	<u>COL. 44</u>
1	5 MINUTES OR LESS	1	46-50 MINUTES
2	6-10 MINUTES	2	51-55 MINUTES
3	11-15 MINUTES	3	56 – 1 HOUR
4	16-20 MINUTES	4	OVER 1 HOUR, BUT LESS THAN 1 HOUR 15 MINUTES
5	21-25 MINUTES	5	BETWEEN 1 HOUR 16 MINUTES AND 1 HOUR 30 MINUTES
6	26-30 MINUTES	6	BETWEEN 1 HOUR 31 MINUTES AND 1 HOUR 45 MINUTES
7	31-35 MINUTES	7	BETWEEN 1 HOUR 46 MINUTES AND 2 HOURS
8	36-40 MINUTES	8	OVER 2 HOURS (SPECIFY _____)
9	41-45 MINUTES	9	
		0	0
		X DON'T KNOW /REFUSED	X DON'T KNOW /REFUSED

9. If you were advised by local authorities to evacuate, how much time would it take the household to pack clothing, medications, secure the house, load the car, and complete preparations prior to evacuating the area? (DO NOT READ ANSWERS)

<u>COL. 45</u>	<u>COL. 46</u>		
1	LESS THAN 15 MINUTES	1	3 HOURS TO 3 HOURS 15 MINUTES
2	15-30 MINUTES	2	3 HOURS 16 MINUTES TO 3 HOURS 30 MINUTES
3	31-45 MINUTES	3	3 HOURS 31 MINUTES TO 3 HOURS 45 MINUTES
4	46 MINUTES – 1 HOUR	4	3 HOURS 46 MINUTES TO 4 HOURS
5	1 HOUR TO 1 HOUR 15 MINUTES	5	4 HOURS TO 4 HOURS 15 MINUTES
6	1 HOUR 16 MINUTES TO 1 HOUR 30 MINUTES	6	4 HOURS 16 MINUTES TO 4 HOURS 30 MINUTES

- | | | | |
|---|--|---|--|
| 7 | 1 HOUR 31 MINUTES TO 1 HOUR 45 MINUTES | 7 | 4 HOURS 31 MINUTES TO 4 HOURS 45 MINUTES |
| 8 | 1 HOUR 46 MINUTES TO 2 HOURS | 8 | 4 HOURS 46 MINUTES TO 5 HOURS |
| 9 | 2 HOURS TO 2 HOURS 15 MINUTES | 9 | 5 HOURS TO 5 HOURS 30 MINUTES |
| 0 | 2 HOURS 16 MINUTES TO 2 HOURS 30 MINUTES | 0 | 5 HOURS 31 MINUTES TO 6 HOURS |
| X | 2 HOURS 31 MINUTES TO 2 HOURS 45 MINUTES | X | OVER 6 HOURS (SPECIFY _____) |
| Y | 2 HOURS 46 MINUTES TO 3 HOURS | | |

COL. 47

- 1 DON'T KNOW/REFUSED

10. Please choose one of the following (READ ANSWERS):

COL. 50

If you were at home and were asked to evacuate,

1 A

A. I would await the return of household commuters to evacuate together.

2 B

B. I would evacuate independently and meet other household members later.

X DON'T KNOW/REFUSED

11. How many vehicles would your household use during an evacuation? (DO NOT READ ANSWERS)

COL. 51

1 ONE

2 TWO

3 THREE

4 FOUR

5 FIVE

6 SIX

7 SEVEN

8 EIGHT

9 NINE OR MORE

0 ZERO (NONE)

X DON'T KNOW/REFUSED

12. If you have a household pet, would you take your pet with you if you were asked to evacuate the area? (READ ANSWERS)

COL. 54

1 DON'T HAVE A PET

2 YES

3 NO

X DON'T KNOW/REFUSED

13A. Emergency officials advise you to take shelter at home in an emergency. Would you: (READ ANSWERS)

COL. 52

A. SHELTER; or

1 A

B. EVACUATE

2 B

X DON'T KNOW/REFUSED

13B. Emergency officials advise you to take shelter at home now in an emergency and possibly evacuate later while people in areas of greater risk are advised to evacuate now. Would you: (READ ANSWERS)

A. SHELTER; or
B. EVACUATE

COL. 53
1 A
2 B
X DON'T KNOW/REFUSED

Thank you very much. _____
(TELEPHONE NUMBER CALLED)

IF REQUESTED:

For additional information, contact your County Emergency Management Agency during normal business hours.

County	EMA Phone
Wake	(919) 856-6480
Chatham	(919) 545-8160
Lee	(919) 718-4670
Harnett	(919) 893-7580

APPENDIX G

Traffic Management Plan

G. TRAFFIC MANAGEMENT PLAN

NUREG/CR-7002 indicates that the existing TCPs and SRBs identified by the offsite agencies should be used in the evacuation simulation modeling. The traffic and access control plans for the EPZ are described in the All County “Standard Operating Guideline for Traffic Control Point and Security Road Block Operations in Support of the Harris Nuclear Plant” (All County), dated January 1, 2016.

These plans were reviewed and the TCPs and SRBs were modeled accordingly. Modifications to the existing TCPs and a removal of a TCP, as discussed below, were made in areas where it proved to be beneficial to the ETE.

G.1 Traffic Control Points

As discussed in Section 9, traffic control points at intersections (which are controlled) are modeled as actuated signals. If an intersection has a pre-timed signal, stop, or yield control, and the intersection is identified as a traffic control point, the control type was changed to an actuated signal in the DYNEV II system.

Table K-2 provides the control type and node number for those nodes which are controlled. If the existing control was changed due to the point being a Traffic Control Point, the control type is indicated as a TCP in Table K-2. The TCPs within the study area are mapped as blue dots in Figure G-1 through Figure G-3.

In the 2012 ETE Study, KLD recommended additional TCPs due to the newly constructed NC-540 Toll and Judd Parkway which were incorporated into the county traffic management plans and as such are included in this study.

No additional TCPs were proposed, but TCP# E-03, located at the intersection of US-64 and Green Level Church Road is recommended for removal to allow vehicles to travel westbound on US-64 and access NC-540 Toll Road northbound.

Modified TCPs are recommended along US-64 and NC-55 to allow vehicles to access alternate major evacuation routes, like NC-540 and US-401. Table G-1 identifies the locations of the 5 modified TCPs. Figure G-4 through Figure G-8 provide schematics of the revised TCPs. Lee County TCP #2, in Lee County was modified because the signalized intersection was newly constructed as a traffic circle.

There are several commercial and residential areas on the west side of NC-55 bypass in Holly Springs. The roadways servicing these areas intersect NC-55 bypass; left turns from these roadways onto NC-55 bypass northbound are not permitted. Vehicles using these roadways must turn south on NC-55 bypass and then U-turn a short distance after the intersection to head north on NC-55 bypass. It is recommended that these U-turns be barricaded and vehicles emanating from the west side of NC-55 bypass be routed south to Holly Springs Rd, Avent Ferry Rd or S Main St (NC-55) where they are permitted to turn left and evacuate out of the EPZ either eastbound or northbound.

G.2 Security Road Blocks

As per the emergency traffic plans, it is assumed that SRBs will be established within 30 minutes of the advisory to evacuate to discourage through travelers from using major routes which traverse the EPZ. As discussed in Section 3.6, external traffic was considered on four routes which traverse the study area – US-1/I-440, US-401, US-421 and I-40 – in this analysis. The generation of these external trips (7,622 vehicles during day conditions, 3,049 vehicles in evening conditions) ceased at 30 minutes after the advisory to evacuate in the simulation.

The existing SRBs within the study area are mapped as orange dots in Figure G-1 through Figure G-3. As shown in Figure G-1, existing TCPs and SRBs exist on each of these routes on the periphery of the EPZ to stop the flow of traffic into the EPZ. This study did not identify any additional intersections as SRBs.

Table G-1. Proposed Modifications to Existing Traffic Control Points

TCP ID	Intersection	Proposed Modification to Existing TCP
Lee County		
2	Hawkins Avenue & US Hwy 1 Access Ramps	Intersection is a newly constructed traffic circle; location of existing TCP is moved to US-1 N On-Ramp
Wake County		
E-03	US Hwy 64 and Green Level Church Road	Remove this intersection as a TCP
E-12	SR-55 & Lufkin Road	Allow the southbound movement to continue on SR-55
F-01	SR-55 Bypass & Holly Springs Road	Allow southbound movement on SR-55
Q1-11	US-64 & Lake Pine Drive	Allow westbound movement on US-64
Q1-14	US-64 & Edinburgh Drive	Discourage turn on to US-64 westbound from Edinburgh Drive

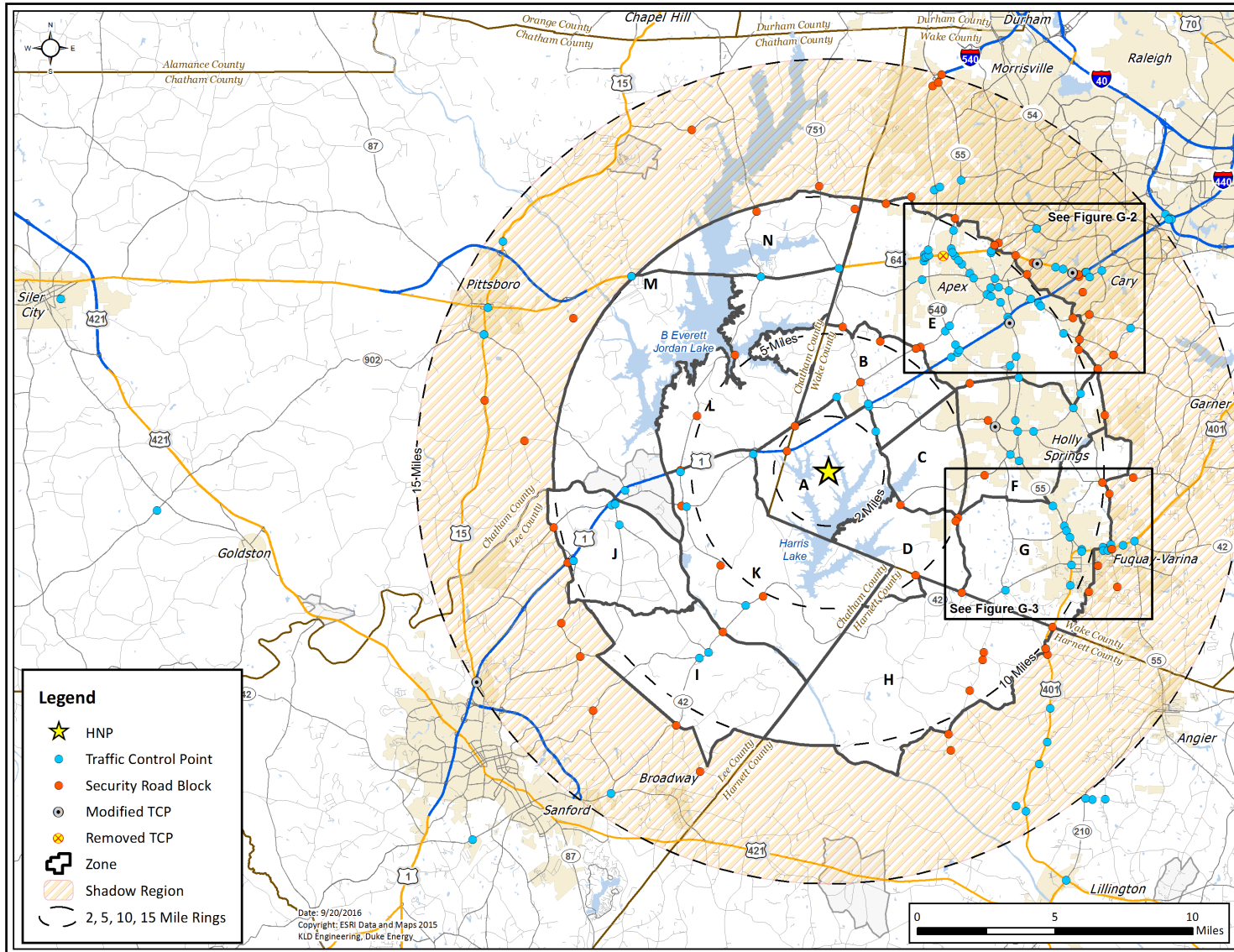

Figure G-1. Overview of Traffic Control Points and Security Road Blocks for the HNP Site

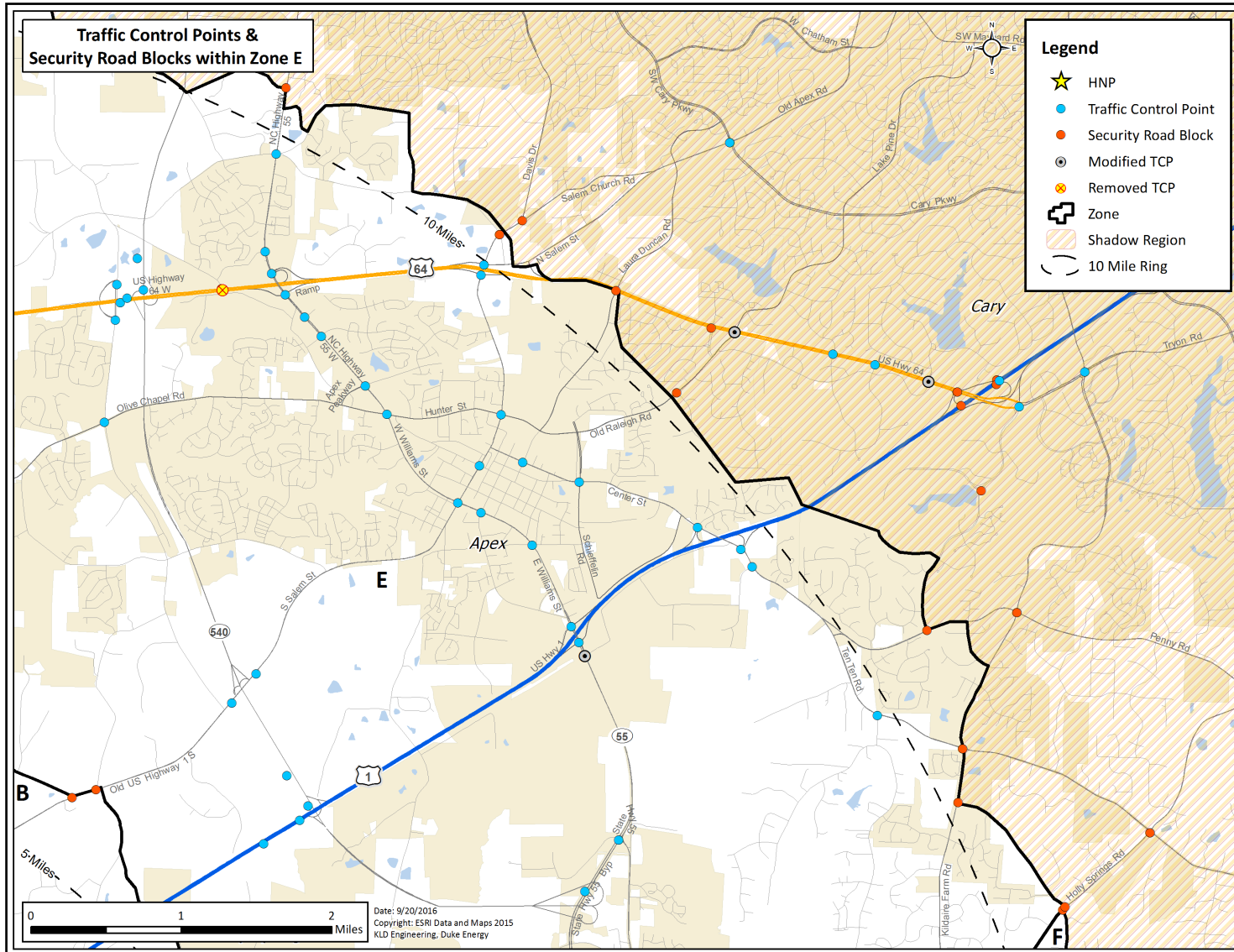

Figure G-2. Traffic Control Points and Security Road Blocks within Zone E

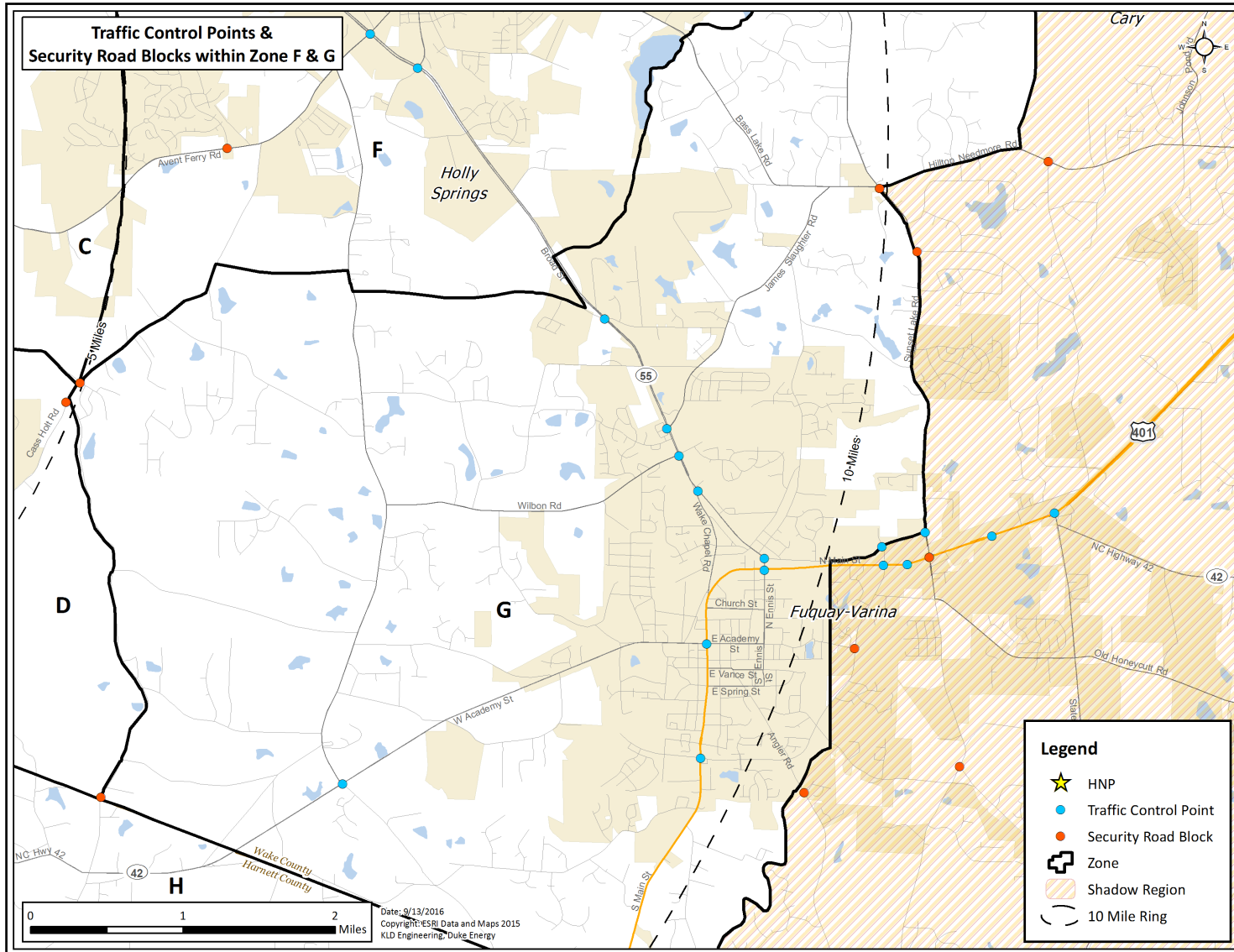

Figure G-3. Traffic Control Points and Security Road Blocks within Zones F and G

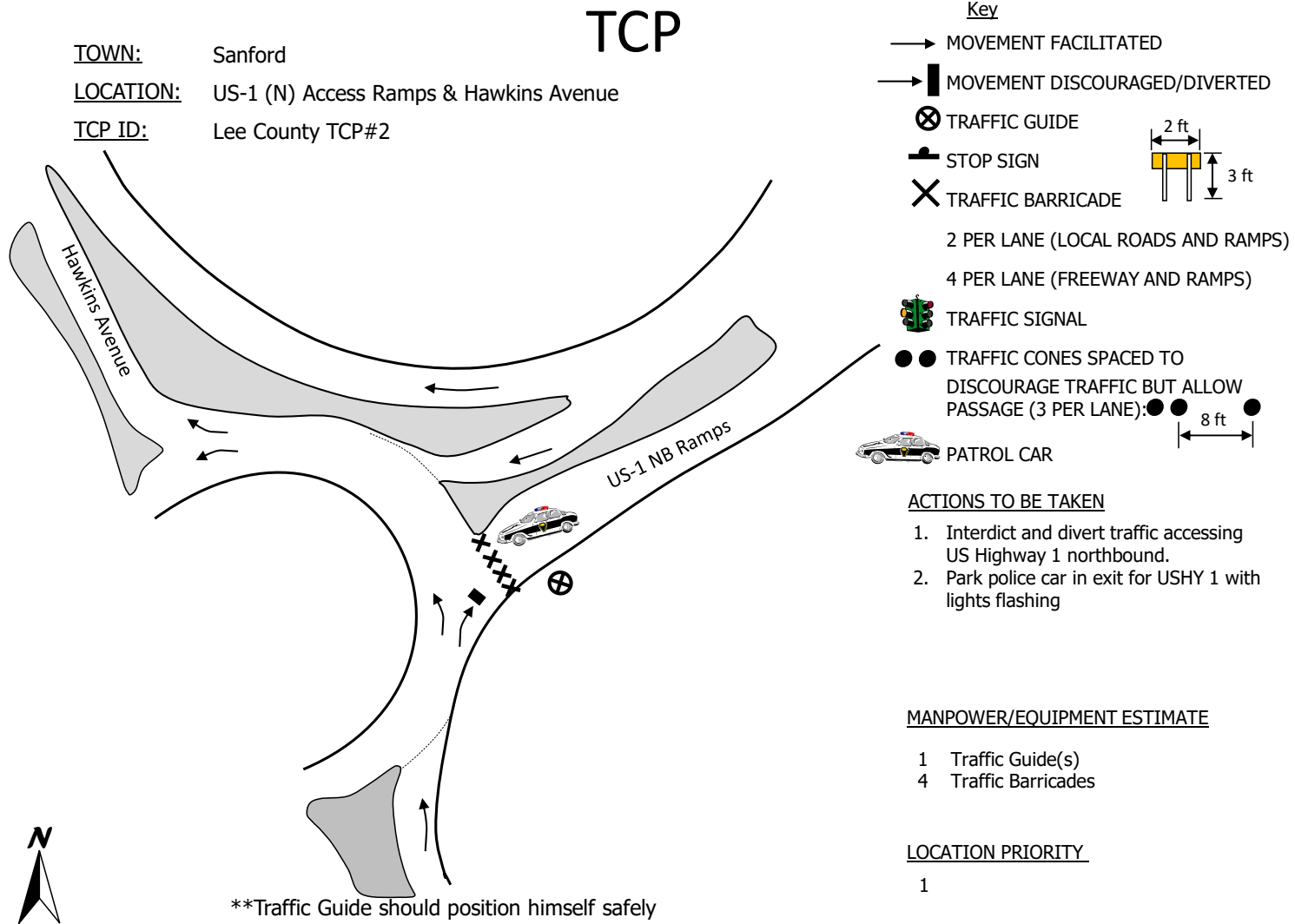

Figure G-4. Modified Traffic Control Point at US-1 North Access Ramps & Hawkins Avenue

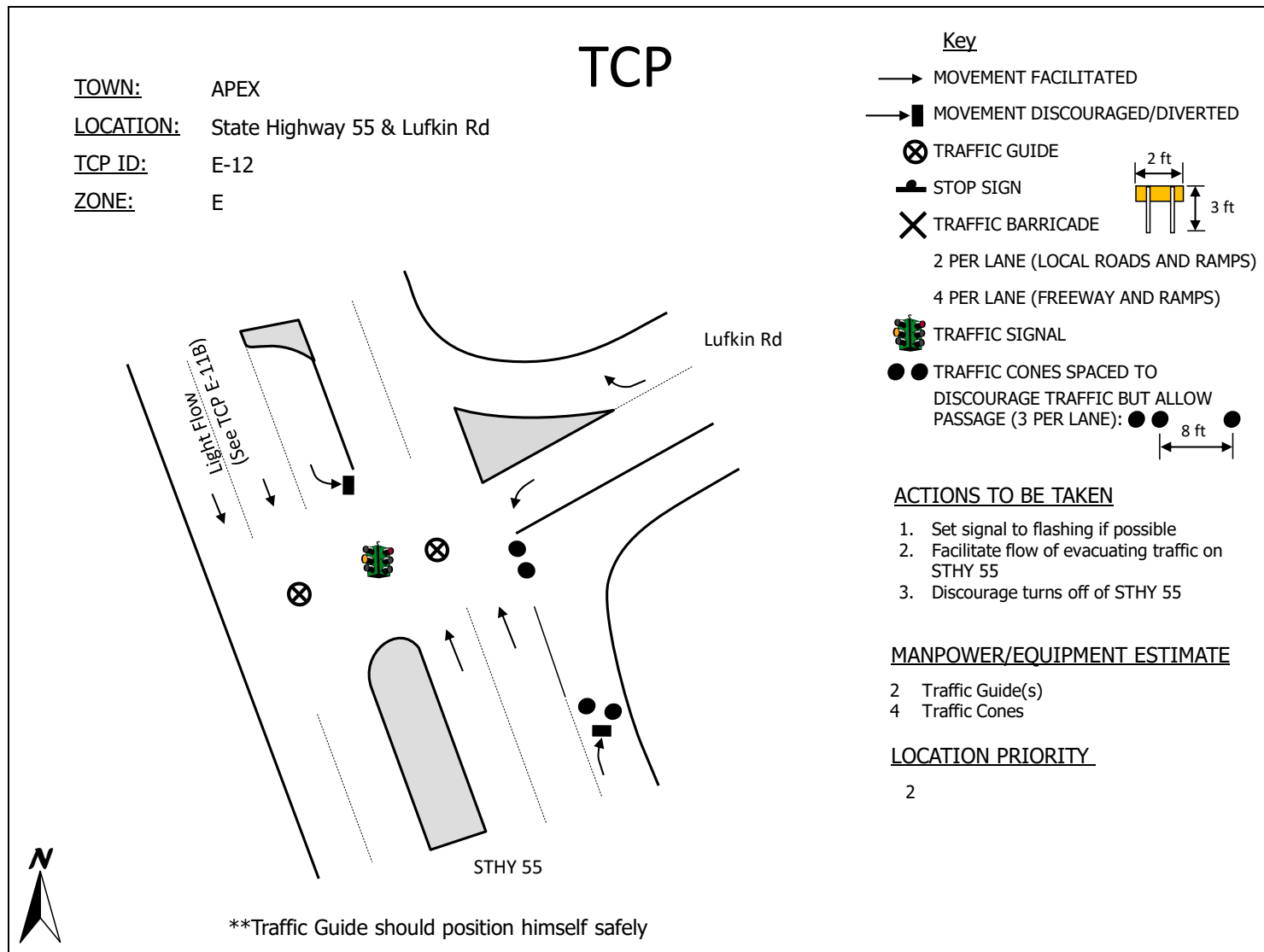

Figure G-5. Modified Traffic Control Point at SR-55 & Lufkin Road

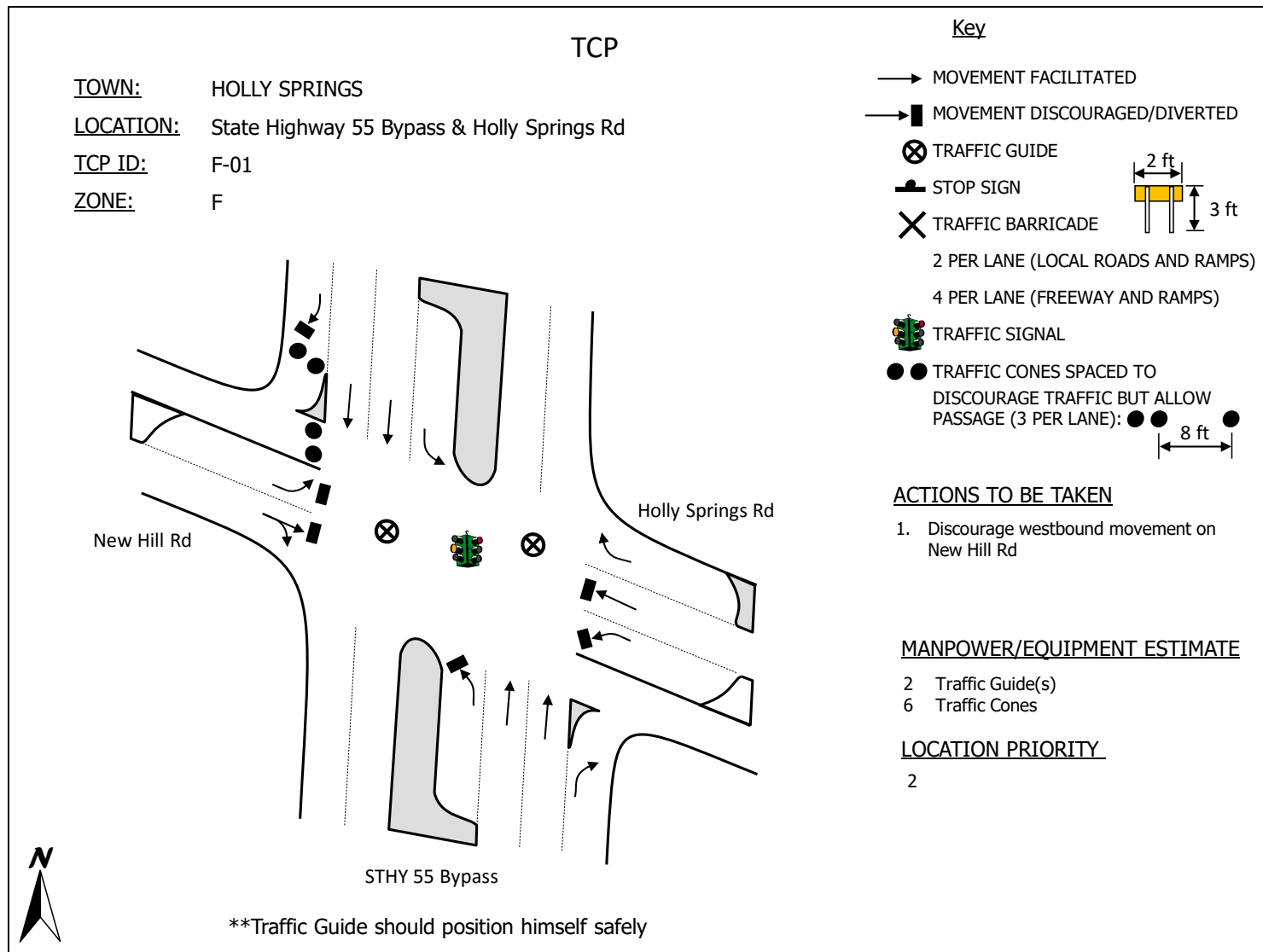
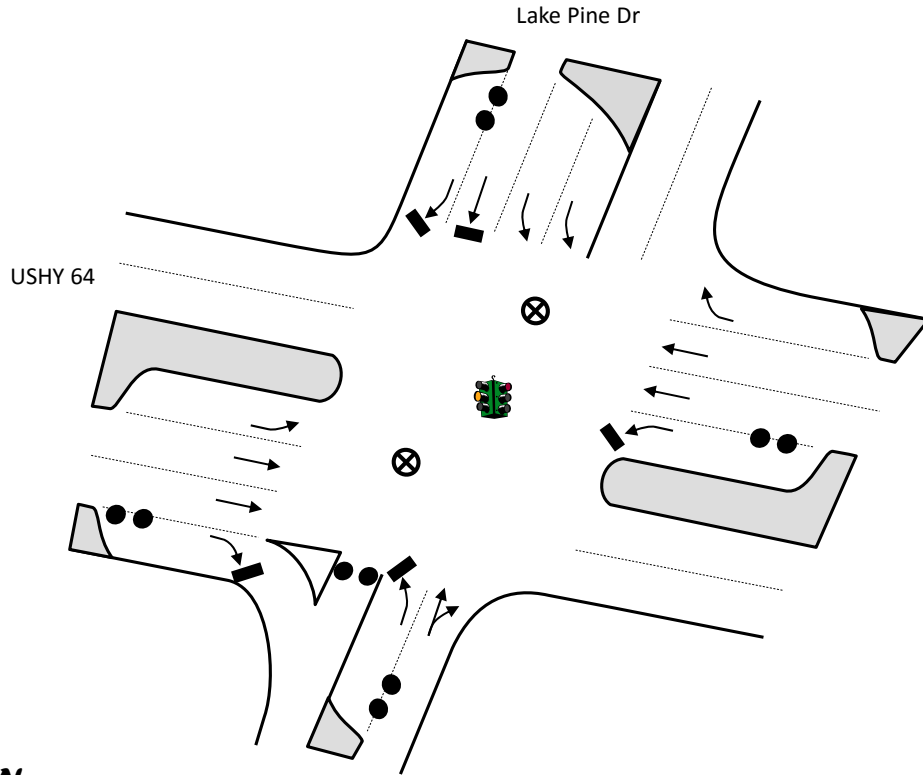

Figure G-6. Modified Traffic Control Point at SR-55 Bypass & Holly Springs Road

TCP

TOWN: APEX
LOCATION: U.S. Highway 64 & Lake Pine Drive
TCP ID: Q1-11



**Traffic Guide should position himself safely

Key

- MOVEMENT FACILITATED
- | MOVEMENT DISCOURAGED/DIVERTED
- ⊗ TRAFFIC GUIDE
- STOP SIGN
- ⊗ TRAFFIC BARRICADE
- 2 PER LANE (LOCAL ROADS AND RAMPS)
- 4 PER LANE (FREEWAY AND RAMPS)
- 🚦 TRAFFIC SIGNAL
- ● TRAFFIC CONES SPACED TO DISCOURAGE TRAFFIC BUT ALLOW PASSAGE (3 PER LANE): ● ● ● 8 ft

ACTIONS TO BE TAKEN

1. Discourage southbound movement on Lake Pine Dr.

MANPOWER/EQUIPMENT ESTIMATE

- 2 Traffic Guide(s)
- 12 Traffic Cones

LOCATION PRIORITY

3

Figure G-7. Modified Traffic Control Point at US-64 & Lake Pine Drive

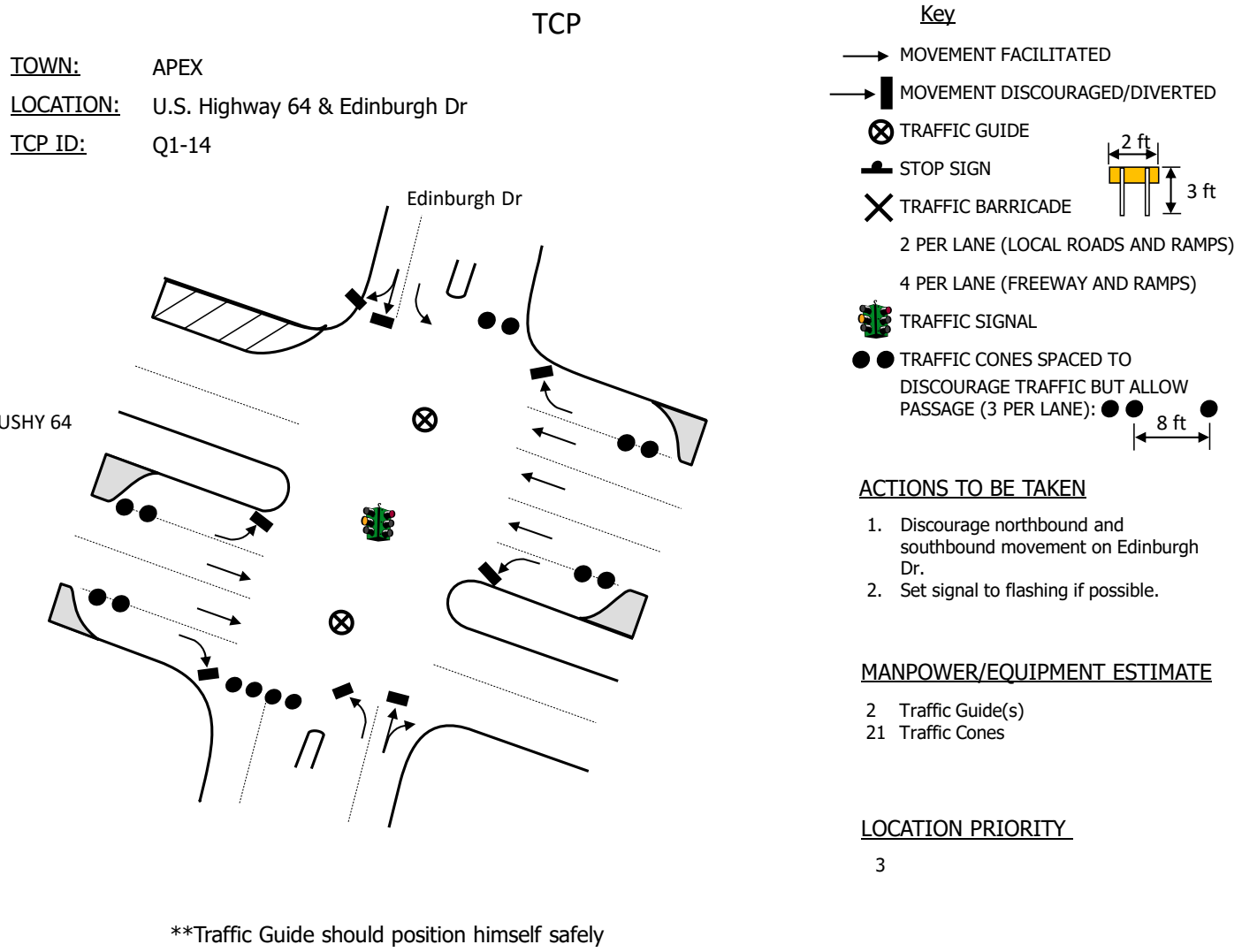

Key

- MOVEMENT FACILITATED
- | MOVEMENT DISCOURAGED/DIVERTED
- ⊗ TRAFFIC GUIDE
- STOP SIGN
- ⊗ TRAFFIC BARRICADE
- ● TRAFFIC CONES SPACED TO DISCOURAGE TRAFFIC BUT ALLOW PASSAGE (3 PER LANE):
 - 2 PER LANE (LOCAL ROADS AND RAMPS)
 - 4 PER LANE (FREEWAY AND RAMPS)
- 🚦 TRAFFIC SIGNAL
- ● TRAFFIC CONES SPACED TO DISCOURAGE TRAFFIC BUT ALLOW PASSAGE (3 PER LANE):
 - 2 ft (width)
 - 3 ft (height)
 - 8 ft (spacing)

ACTIONS TO BE TAKEN

1. Discourage northbound and southbound movement on Edinburgh Dr.
2. Set signal to flashing if possible.

MANPOWER/EQUIPMENT ESTIMATE

- 2 Traffic Guide(s)
- 21 Traffic Cones

LOCATION PRIORITY

3

Figure G-8. Modified Traffic Control Point at US-64 & Edinburgh Drive

APPENDIX H
Evacuation Regions

H EVACUATION REGIONS

This appendix presents the evacuation percentages for each Evacuation Region (Table H-1) and maps of all Evacuation Regions (Figure H-1 through Figure H-37). The percentages presented in Table H-1 are based on the methodology discussed in assumption 2 of Section 2.2 and shown in Figure 2-1.

Note the baseline ETE study assumes 20 percent of households will not comply with the shelter advisory, as per Section 2.5.2 of NUREG/CR-7002.

Table H-1. Percent of Zone Population Evacuating for Each Region

Radial Regions																	
Region	Description	Site PAR Description	Zone														
			A	B	C	D	E	F	G	H	I	J	K	L	M	N	
R01	2-Mile Radius	2-Mile Radius	100%	20%	20%	20%	20%	20%	20%	20%	20%	20%	20%	20%	20%	20%	
R02	5-Mile Radius	5-Mile Radius	100%	100%	100%	100%	20%	20%	20%	20%	20%	20%	100%	100%	20%	20%	
R03	Full EPZ	10-Mile Radius	100%	100%	100%	100%	100%	100%	100%	100%	100%	100%	100%	100%	100%	100%	
Evacuate 2-Mile Radius and Downwind to 5 Miles																	
Region	Wind Direction From:	Site PAR Description	Zone														
			A	B	C	D	E	F	G	H	I	J	K	L	M	N	
R04	NNW, N	327° - 010°	100%	20%	20%	100%	20%	20%	20%	20%	20%	20%	20%	100%	20%	20%	20%
R05	NNE, NE	011° - 056°	100%	20%	20%	20%	20%	20%	20%	20%	20%	20%	20%	100%	20%	20%	20%
R06	ENE, E, ESE	057° - 124°	100%	20%	20%	20%	20%	20%	20%	20%	20%	20%	20%	100%	100%	20%	20%
R07	SE, SSE, S	125° - 191°	100%	100%	20%	20%	20%	20%	20%	20%	20%	20%	20%	20%	100%	20%	20%
R08	SSW	192° - 214°	100%	100%	20%	20%	20%	20%	20%	20%	20%	20%	20%	20%	20%	20%	20%
R09	SW, WSW	215° - 259°	100%	100%	100%	20%	20%	20%	20%	20%	20%	20%	20%	20%	20%	20%	20%
R10	Site Specific Region*		100%	20%	100%	20%	20%	20%	20%	20%	20%	20%	20%	20%	20%	20%	20%
R11	W, WNW	260° - 304°	100%	20%	100%	100%	20%	20%	20%	20%	20%	20%	20%	20%	20%	20%	20%
R12	NW	305° - 326°	100%	20%	20%	100%	20%	20%	20%	20%	20%	20%	20%	20%	20%	20%	20%
Evacuate 2-Mile Radius and Downwind to the EPZ Boundary																	
Region	Wind Direction From:	Site PAR Description	Zone														
			A	B	C	D	E	F	G	H	I	J	K	L	M	N	
R13	N	348° - 010°	100%	20%	20%	100%	20%	20%	20%	20%	100%	100%	20%	100%	20%	20%	20%
R14	NNE	011° - 034°	100%	20%	20%	20%	20%	20%	20%	20%	100%	100%	100%	100%	20%	20%	20%
R15	NE	035° - 056°	100%	20%	20%	20%	20%	20%	20%	20%	20%	100%	100%	100%	20%	100%	20%
R16	ENE	057° - 079°	100%	20%	20%	20%	20%	20%	20%	20%	20%	100%	100%	100%	100%	100%	20%
R17	E	080° - 101°	100%	20%	20%	20%	20%	20%	20%	20%	20%	20%	100%	100%	100%	100%	20%
R18	ESE	102° - 124°	100%	20%	20%	20%	20%	20%	20%	20%	20%	20%	100%	100%	100%	100%	100%
R19	SE	125° - 146°	100%	100%	20%	20%	20%	20%	20%	20%	20%	20%	20%	20%	100%	100%	100%
R20	SSE, S	147° - 191°	100%	100%	20%	20%	100%	20%	20%	20%	20%	20%	20%	20%	100%	100%	100%
R21	SSW	192° - 214°	100%	100%	20%	20%	100%	20%	20%	20%	20%	20%	20%	20%	100%	20%	100%
R22	SW	215° - 236°	100%	100%	100%	20%	100%	100%	20%	20%	20%	20%	20%	20%	20%	20%	20%
R23	WSW	237° - 259°	100%	100%	100%	20%	100%	100%	100%	20%	20%	20%	20%	20%	20%	20%	20%
R24	W	260° - 281°	100%	100%	100%	100%	100%	100%	100%	20%	20%	20%	20%	20%	20%	20%	20%
R25	WNW	282° - 304°	100%	20%	100%	100%	20%	100%	100%	100%	20%	20%	20%	20%	20%	20%	20%
R26	NW	305° - 326°	100%	20%	100%	100%	20%	20%	20%	100%	100%	20%	20%	100%	20%	20%	20%
R27	NNW	327° - 347°	100%	20%	20%	100%	20%	20%	20%	100%	100%	20%	20%	100%	20%	20%	20%

Staged Evacuation - 2-Mile Radius Evacuates, then Evacuate Downwind to 5 Miles																
Region	Wind Direction From:	Site PAR Description	Zone													
			A	B	C	D	E	F	G	H	I	J	K	L	M	N
R28	-	5-Mile Radius	100%	100%	100%	100%	20%	20%	20%	20%	20%	20%	100%	100%	20%	20%
R29	NNW, N	327° - 010°	100%	20%	20%	100%	20%	20%	20%	20%	20%	20%	100%	20%	20%	20%
R30	NNE, NE	011° - 056°	100%	20%	20%	20%	20%	20%	20%	20%	20%	20%	100%	20%	20%	20%
R31	ENE, E, ESE	057° - 124°	100%	20%	20%	20%	20%	20%	20%	20%	20%	20%	100%	100%	20%	20%
R32	SE, SSE, S	125° - 191°	100%	100%	20%	20%	20%	20%	20%	20%	20%	20%	20%	100%	20%	20%
R33	SSW	192° - 214°	100%	100%	20%	20%	20%	20%	20%	20%	20%	20%	20%	20%	20%	20%
R34	SW, WSW	215° - 259°	100%	100%	100%	20%	20%	20%	20%	20%	20%	20%	20%	20%	20%	20%
R35	Site Specific Region*		100%	20%	100%	20%	20%	20%	20%	20%	20%	20%	20%	20%	20%	20%
R36	W, WNW	260° - 304°	100%	20%	100%	100%	20%	20%	20%	20%	20%	20%	20%	20%	20%	20%
R37	NW	305° - 326°	100%	20%	20%	100%	20%	20%	20%	20%	20%	20%	20%	20%	20%	20%
Shelter-in-Place until 90% ETE for R01, then Evacuate ¹			Zone(s) Shelter-in-Place							Zone(s) Evacuate						

* Region does not follow three-sector keyhole approach and is not used in PAR.

¹ 20% of population in these Zones will not comply with the shelter advisory, as per Section 2.5.2 of NUREG/CR-7002. Once 90% of the 2-mile Region has evacuated, the remaining population in these Zones will evacuate.

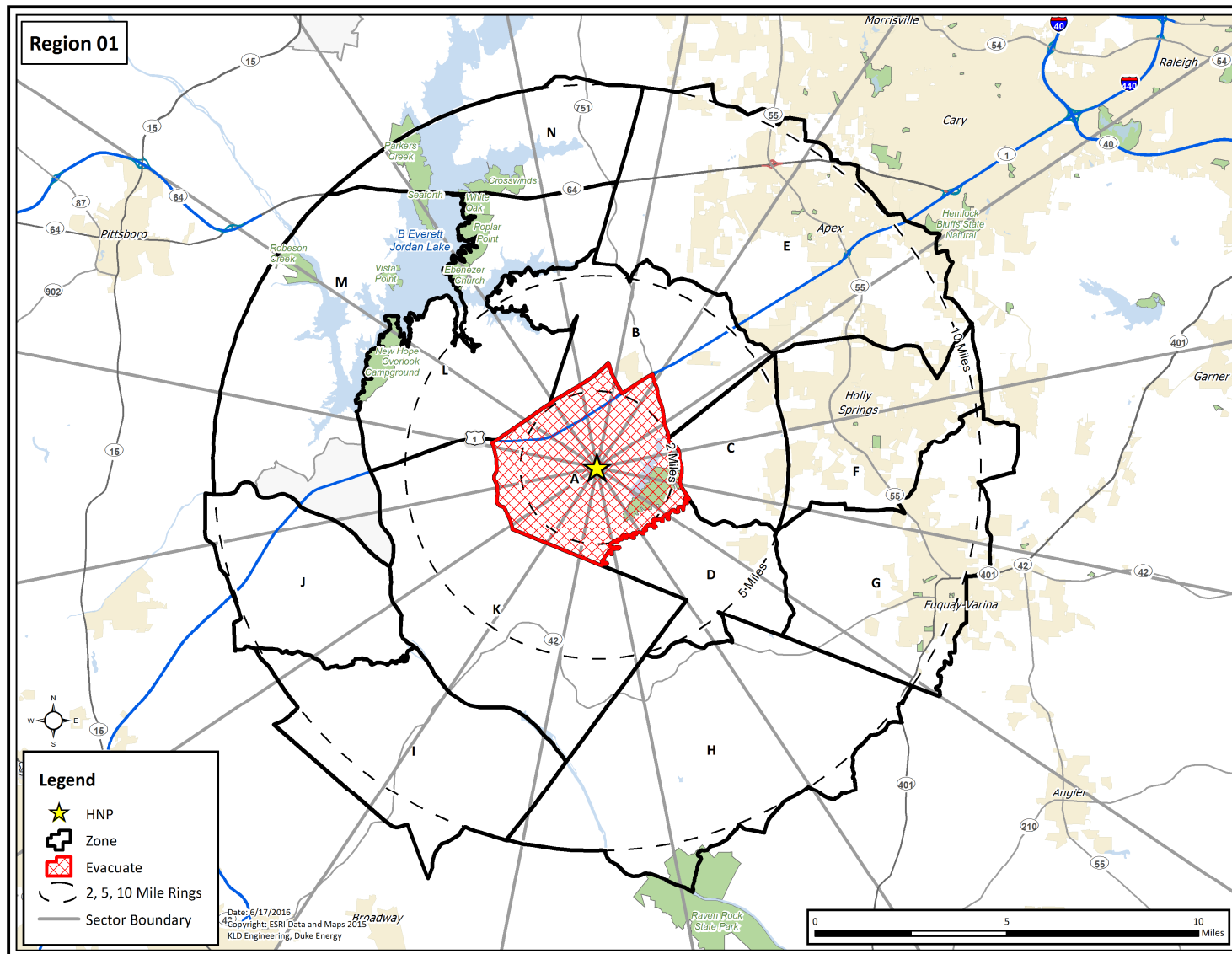

Figure H-1. Region R01

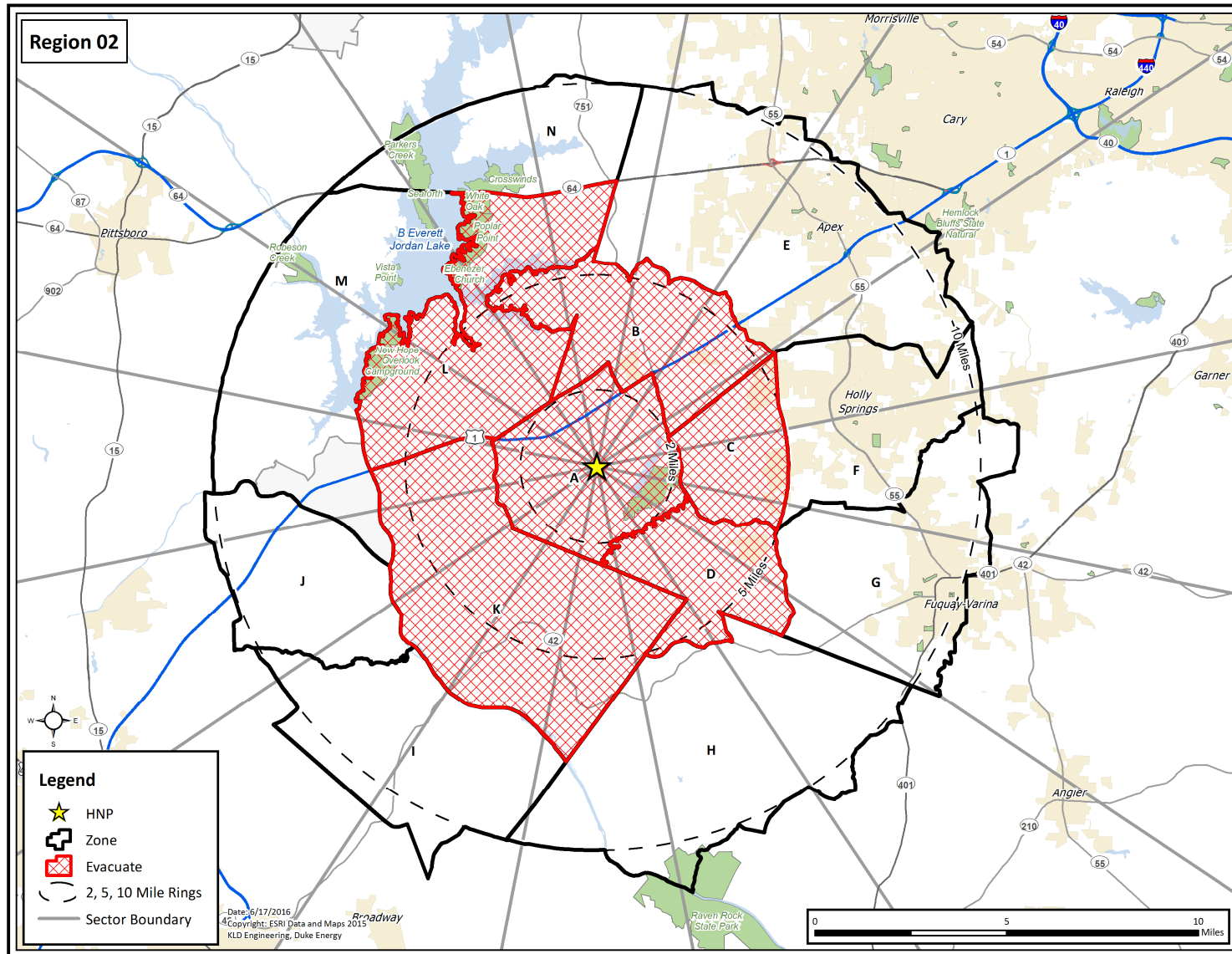

Figure H-2. Region R02

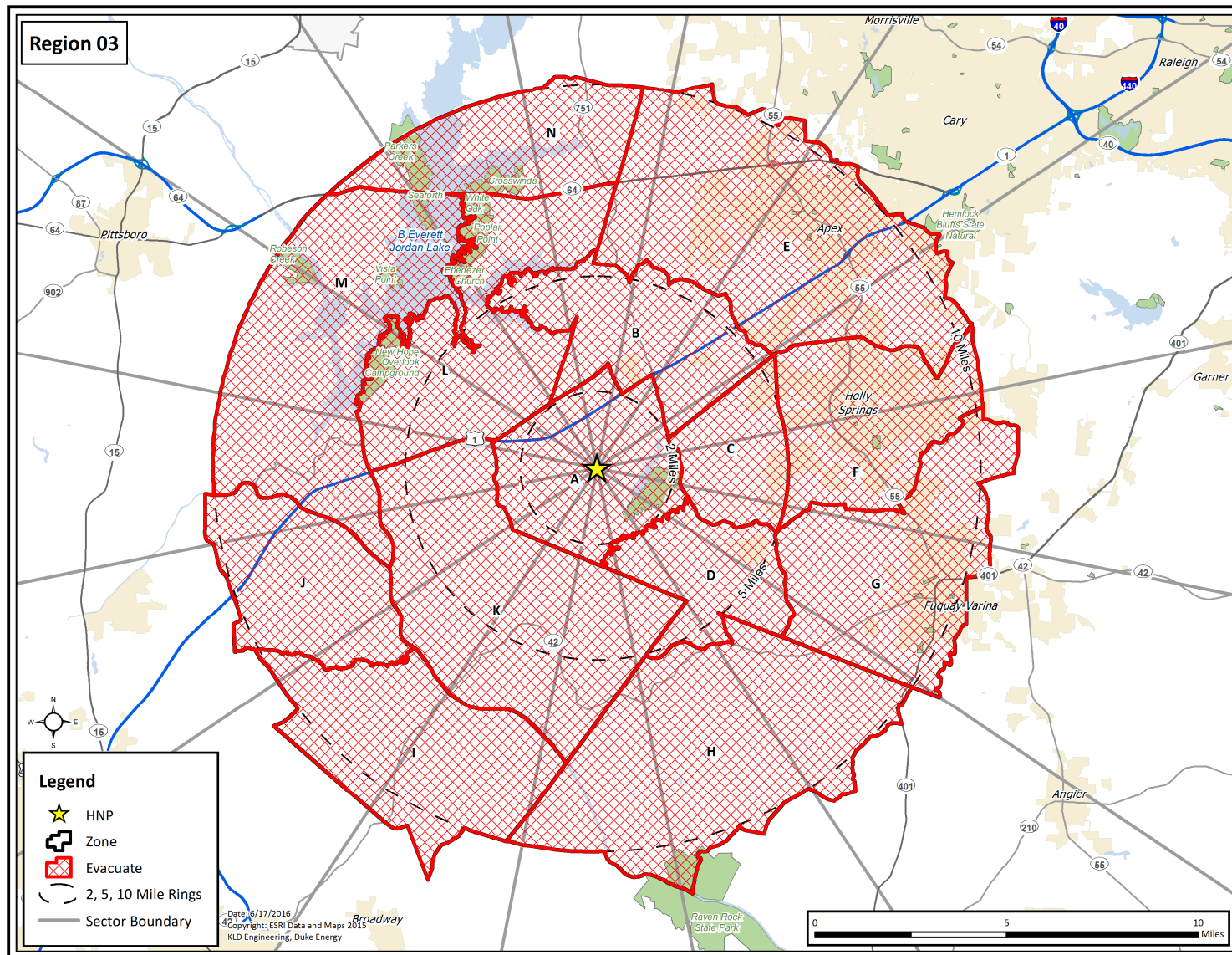

Figure H-3. Region R03

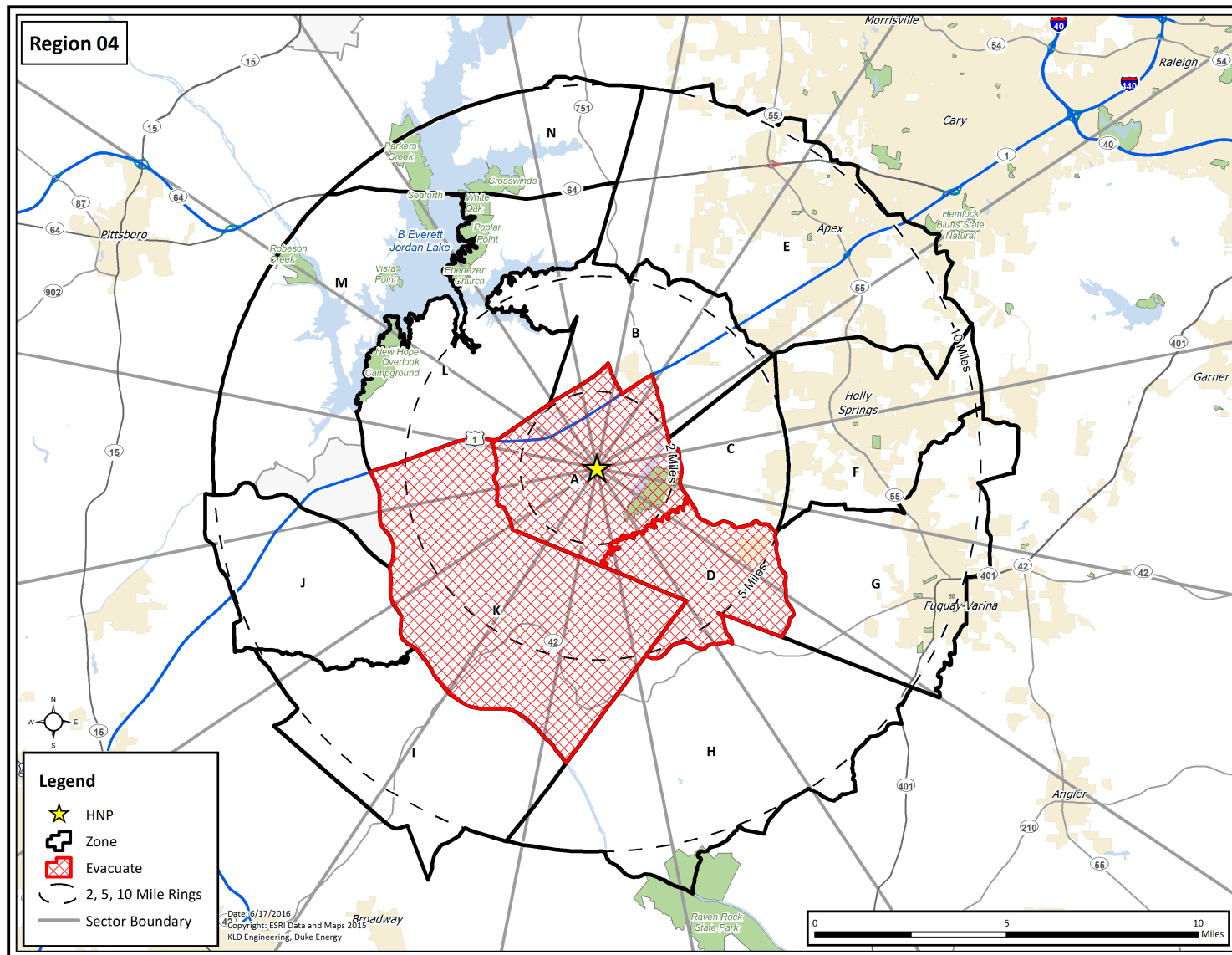

Figure H-4. Region R04

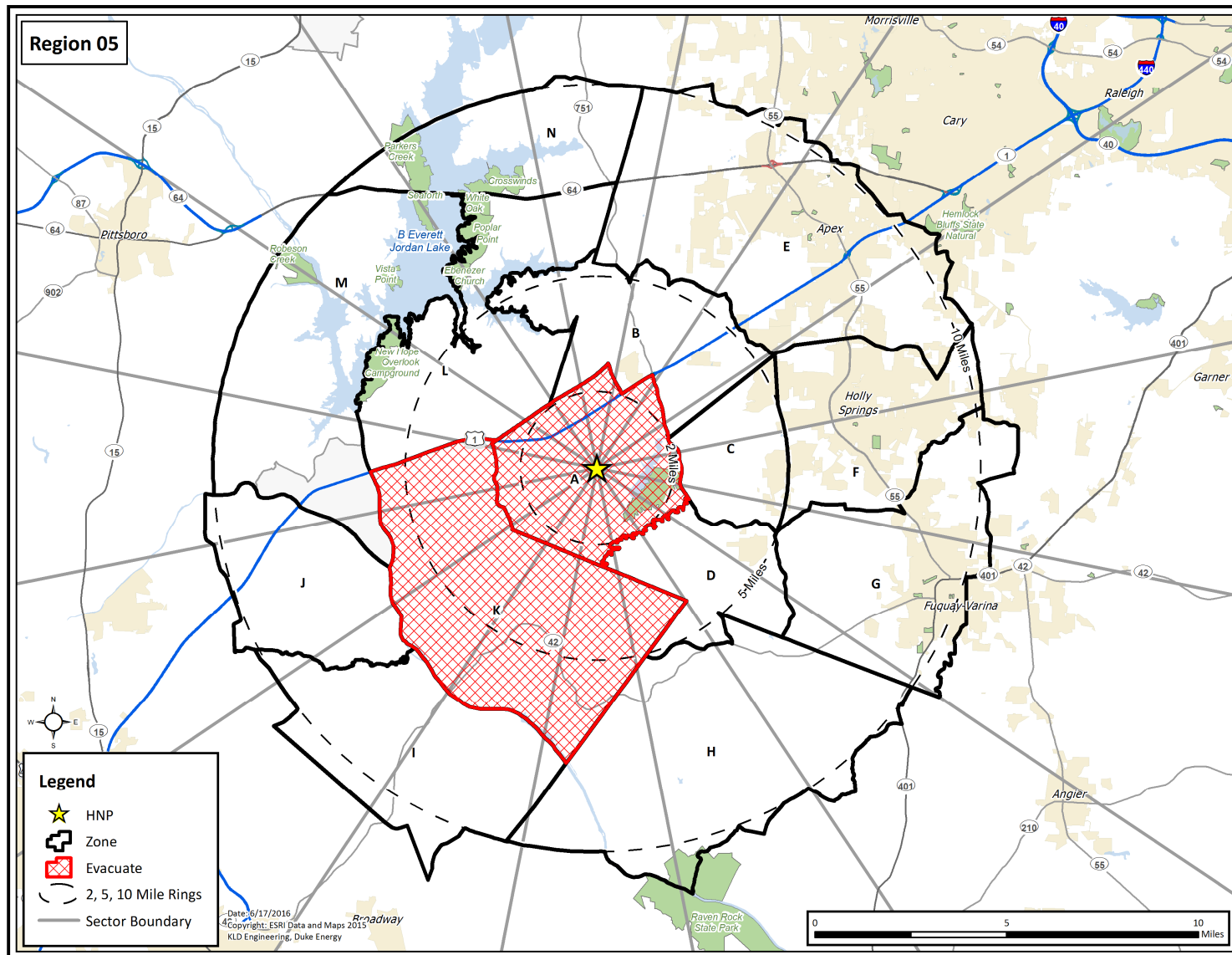

Figure H-5. Region R05

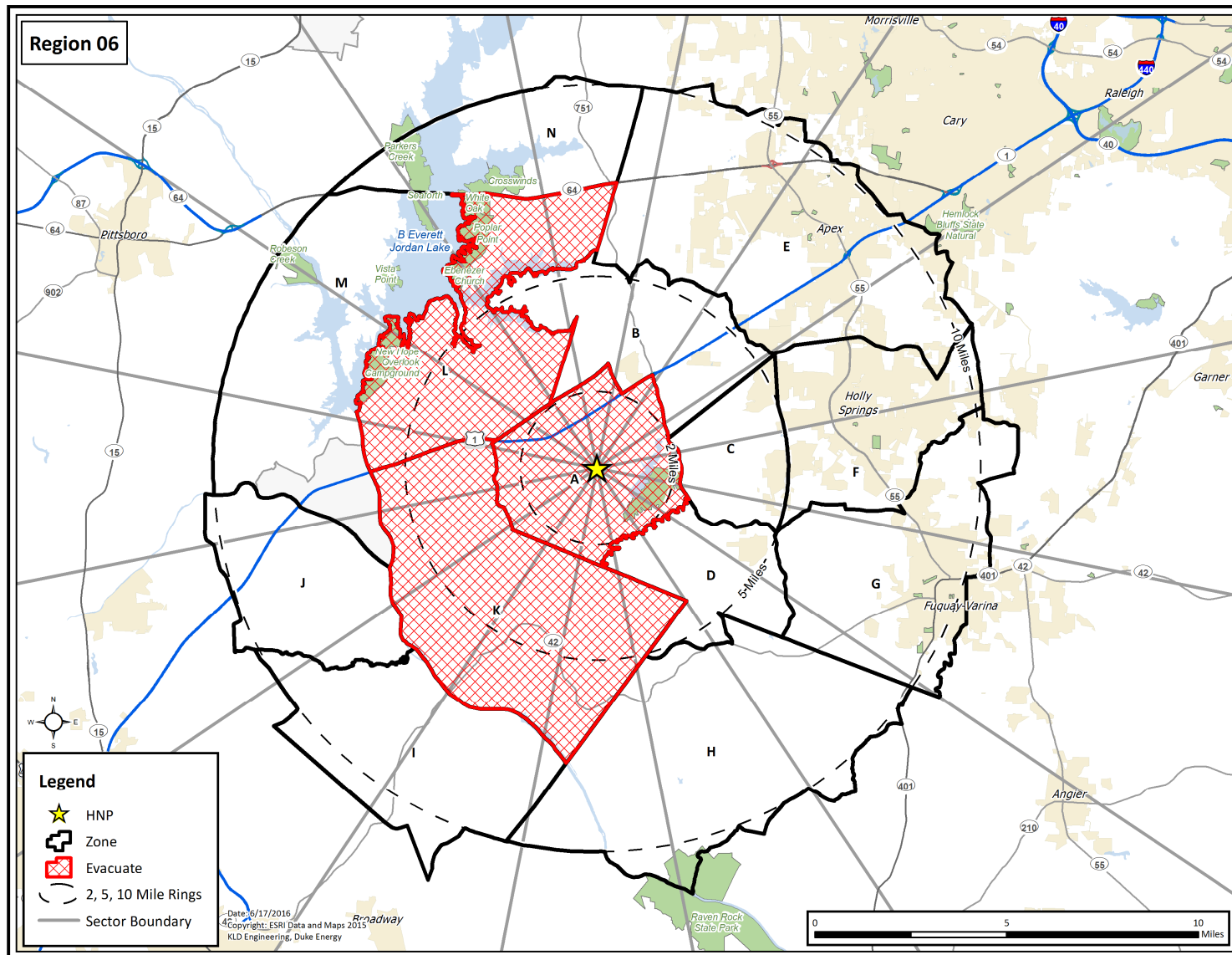

Figure H-6. Region R06

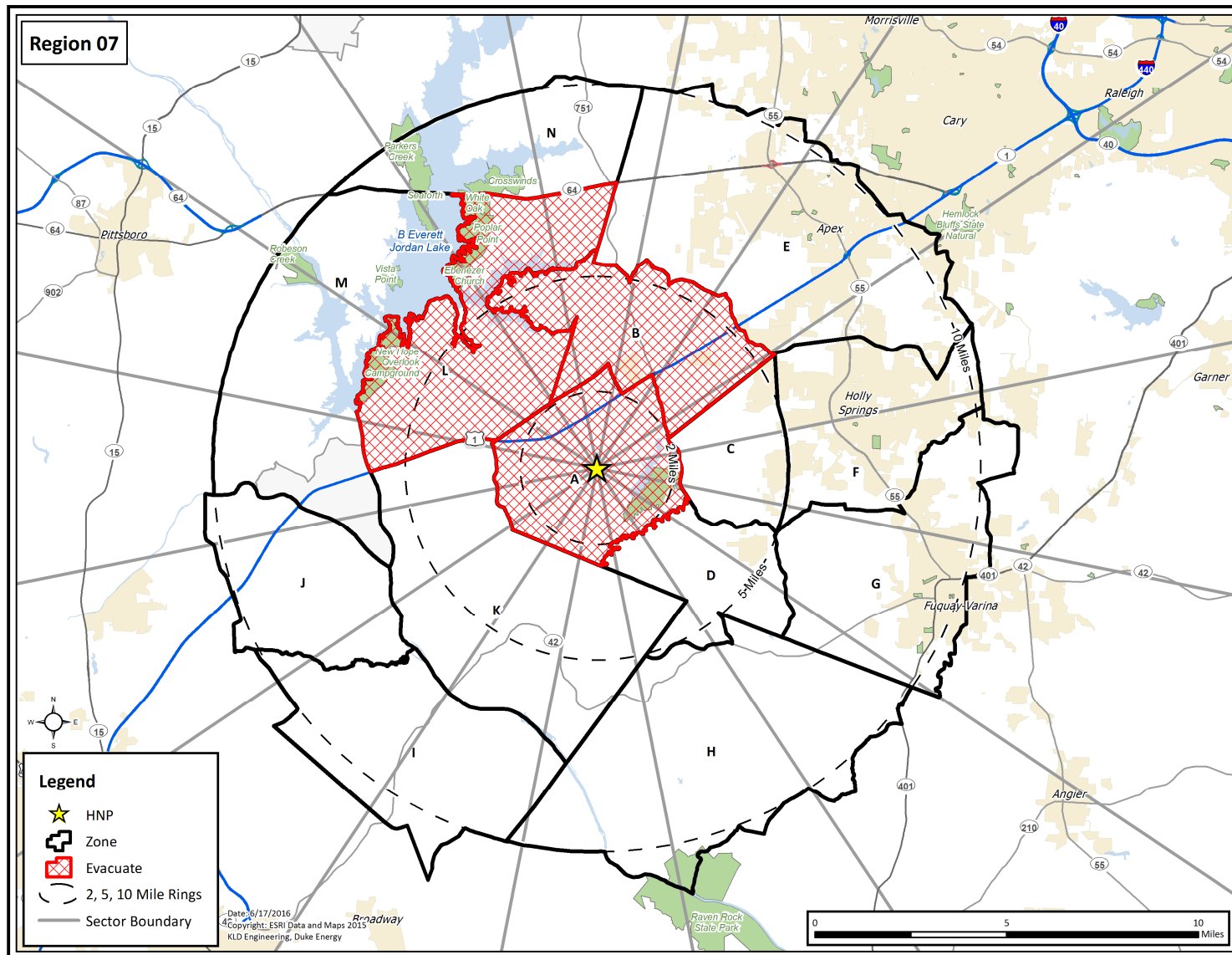

Figure H-7. Region R07

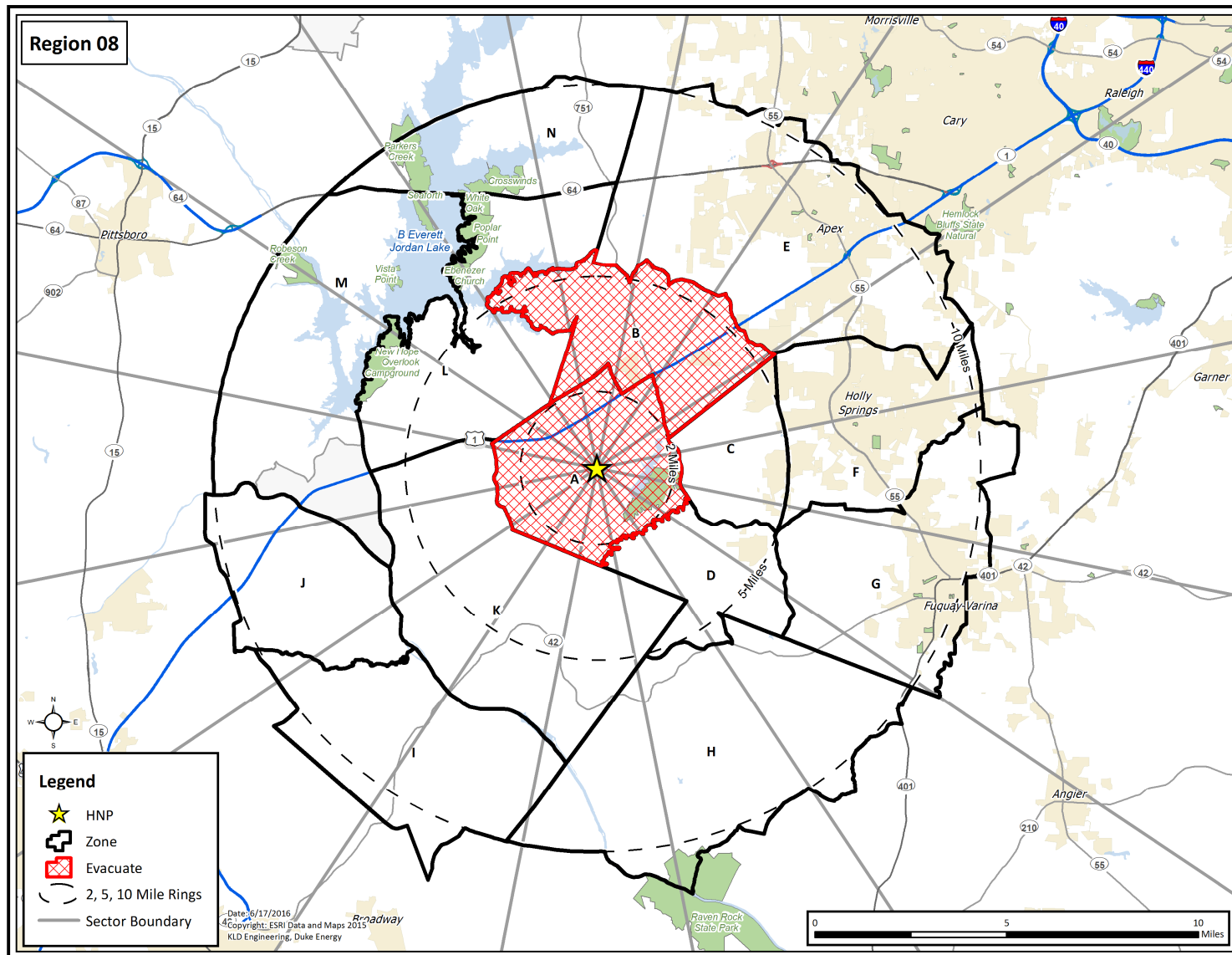

Figure H-8. Region R08

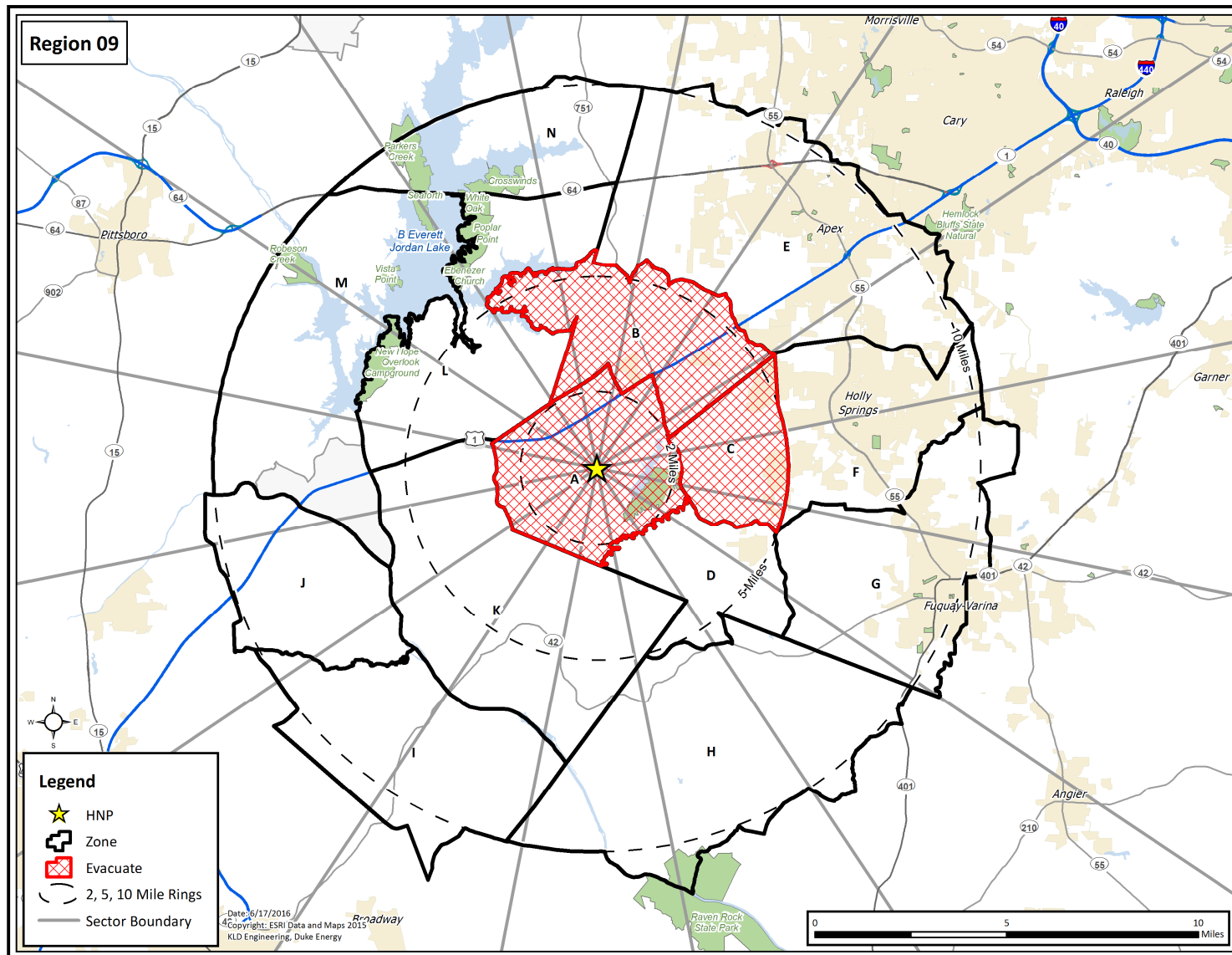

Figure H-9. Region R09

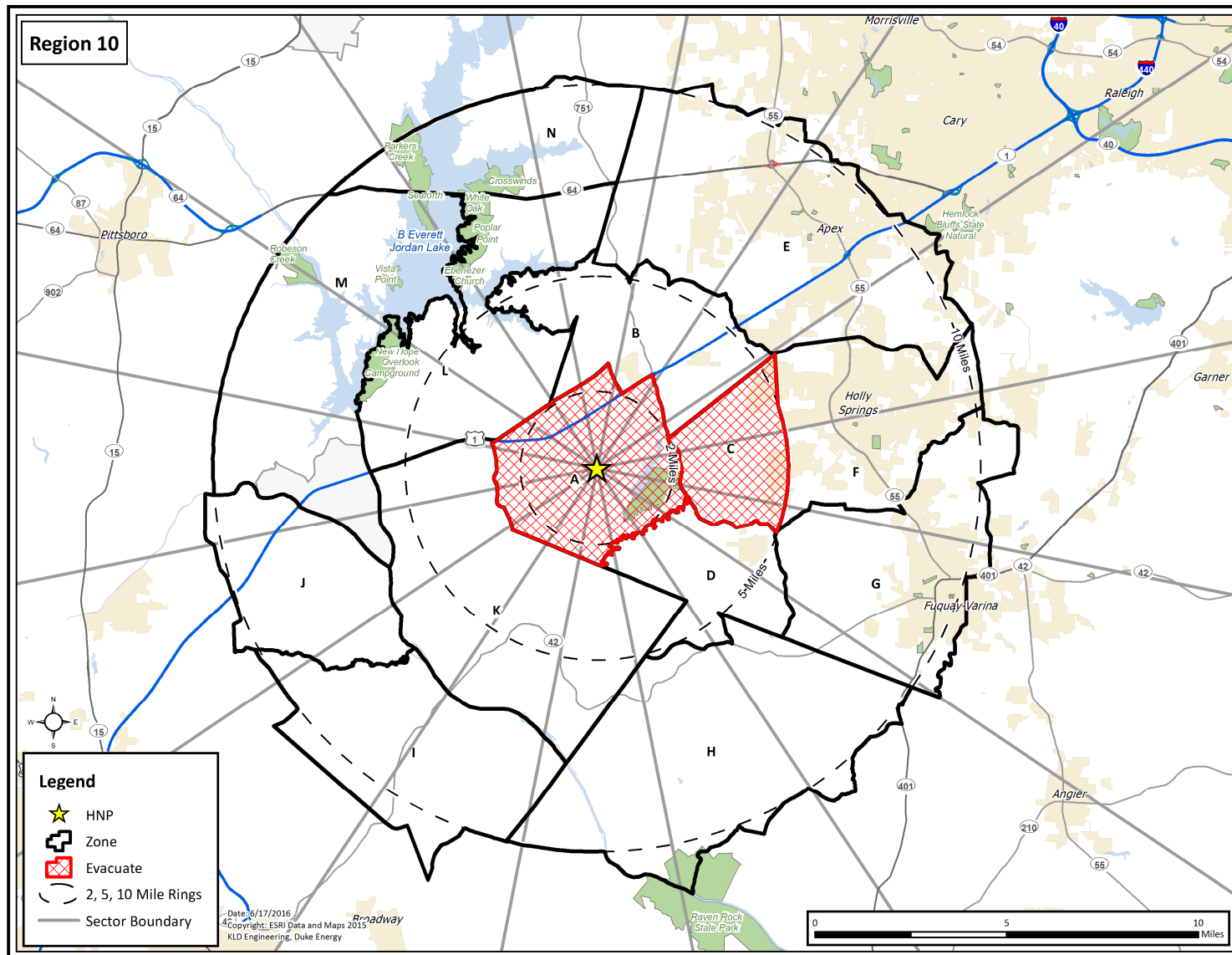

Figure H-10. Region R10

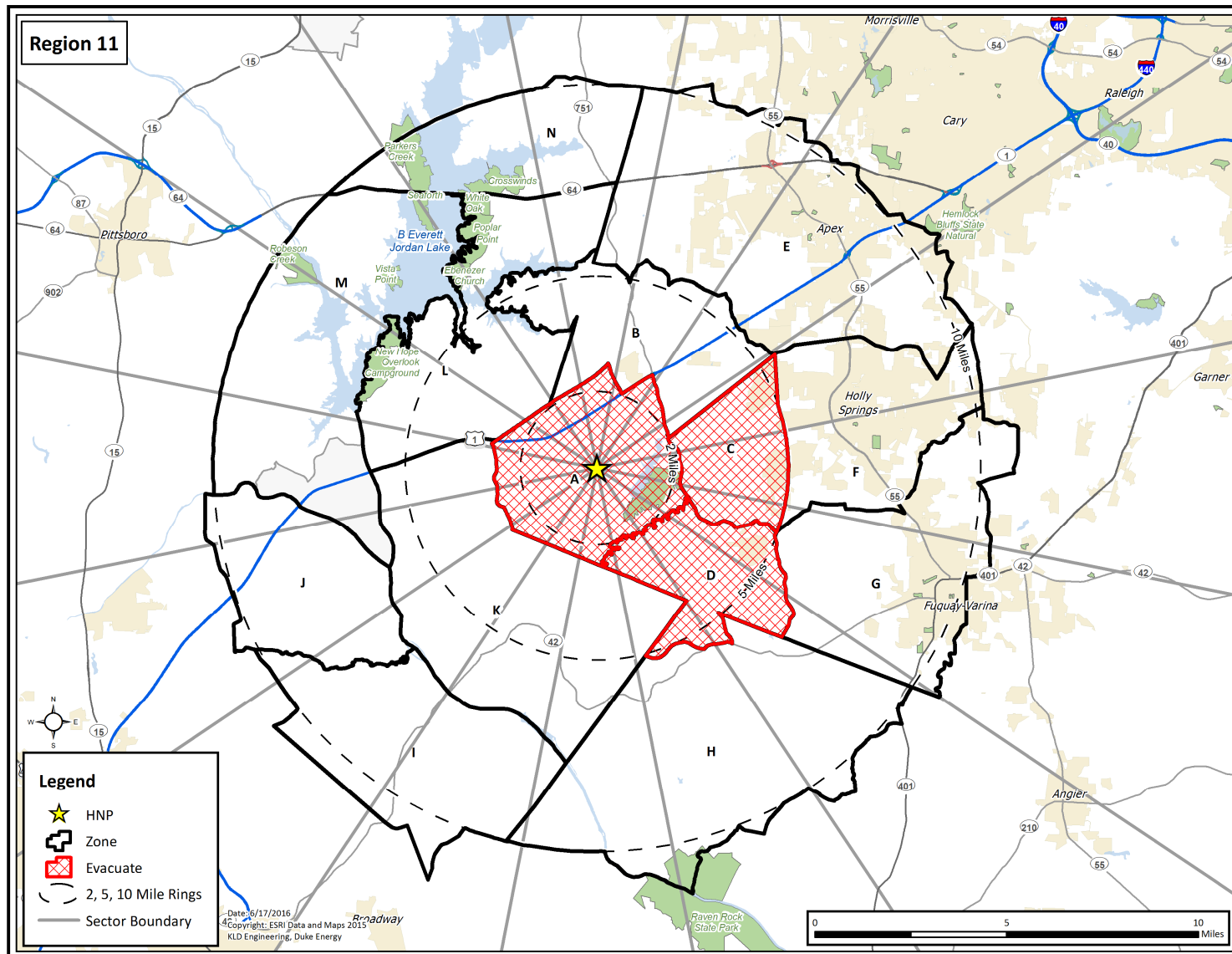

Figure H-11. Region R11

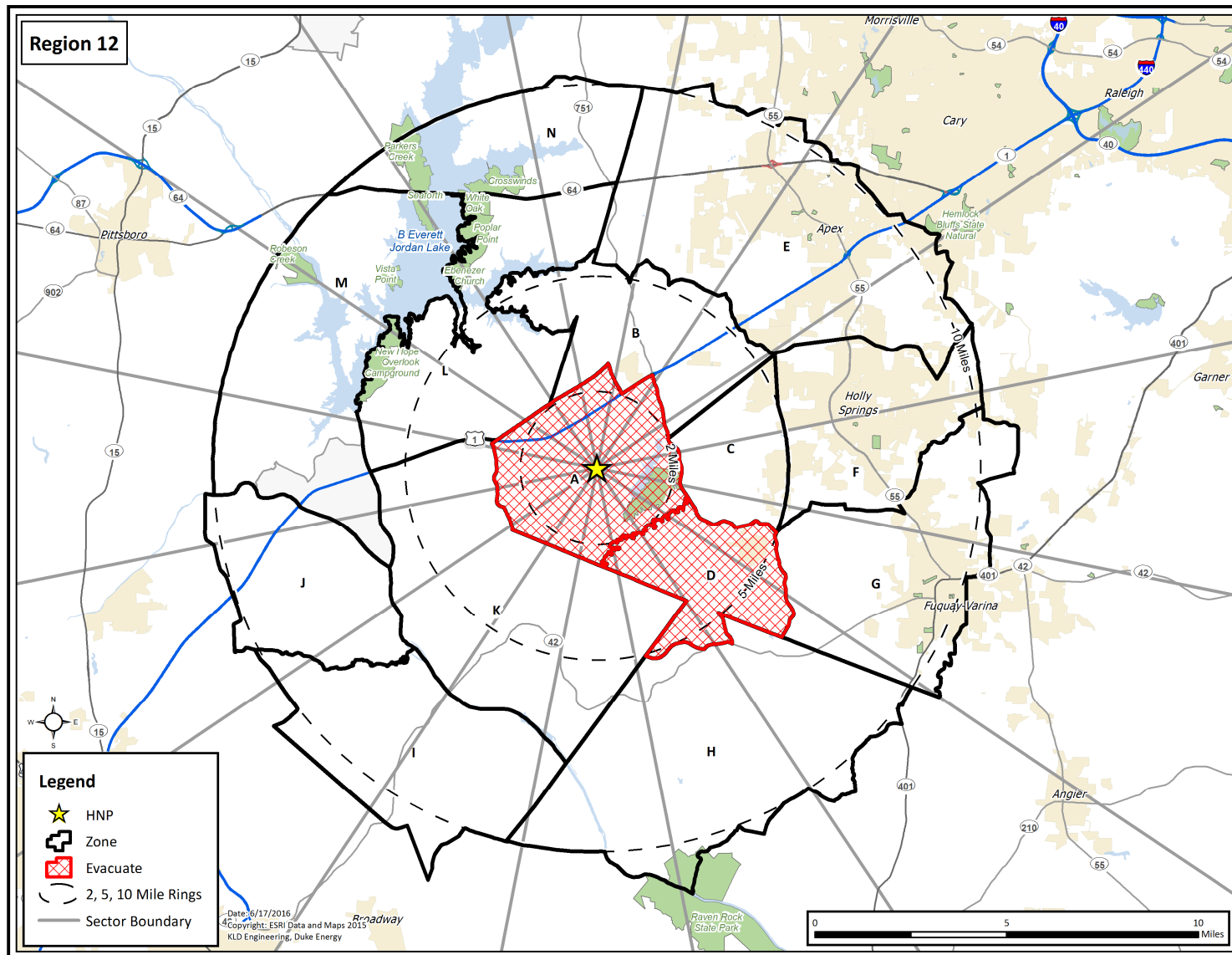

Figure H-12. Region R12

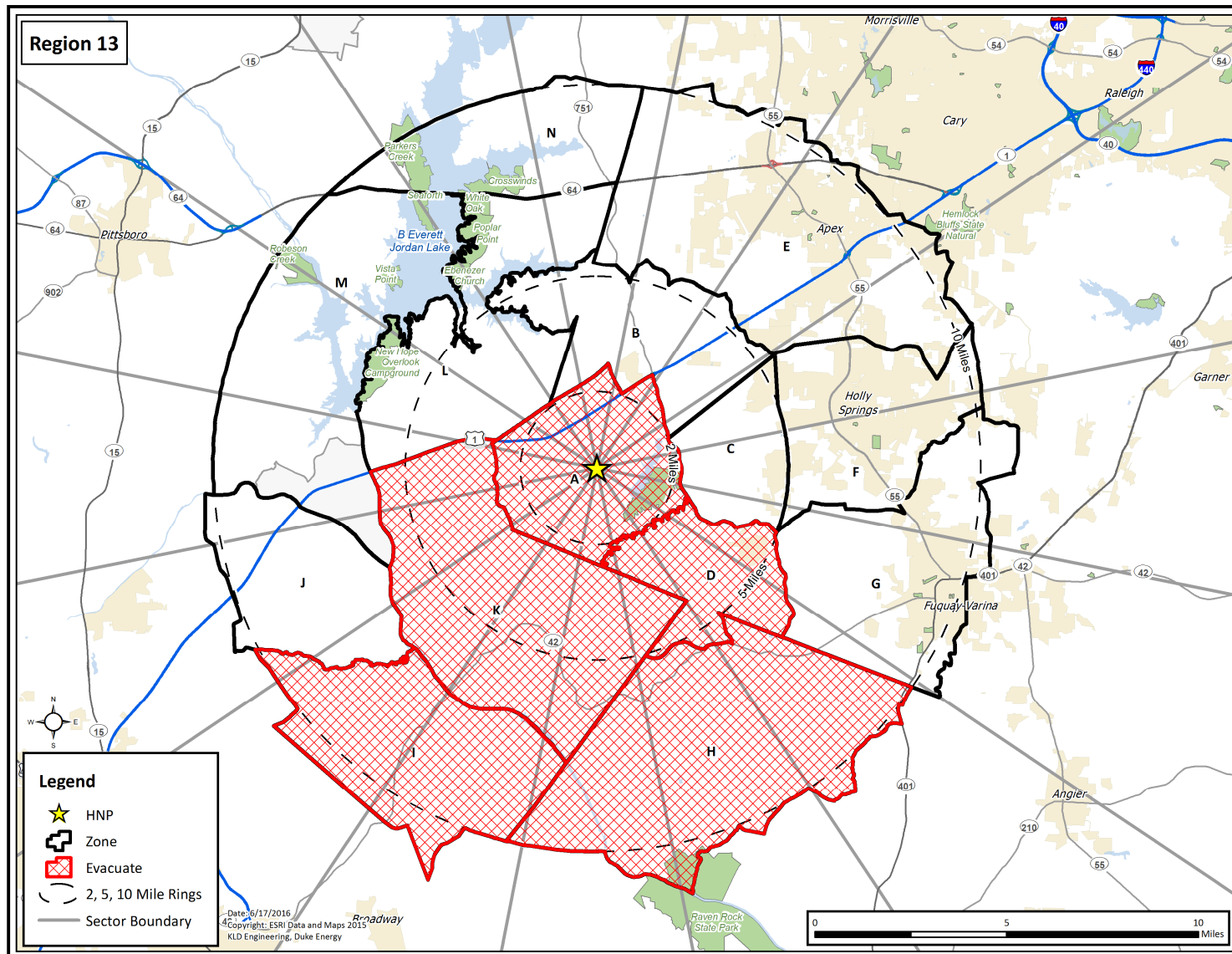

Figure H-13. Region R13

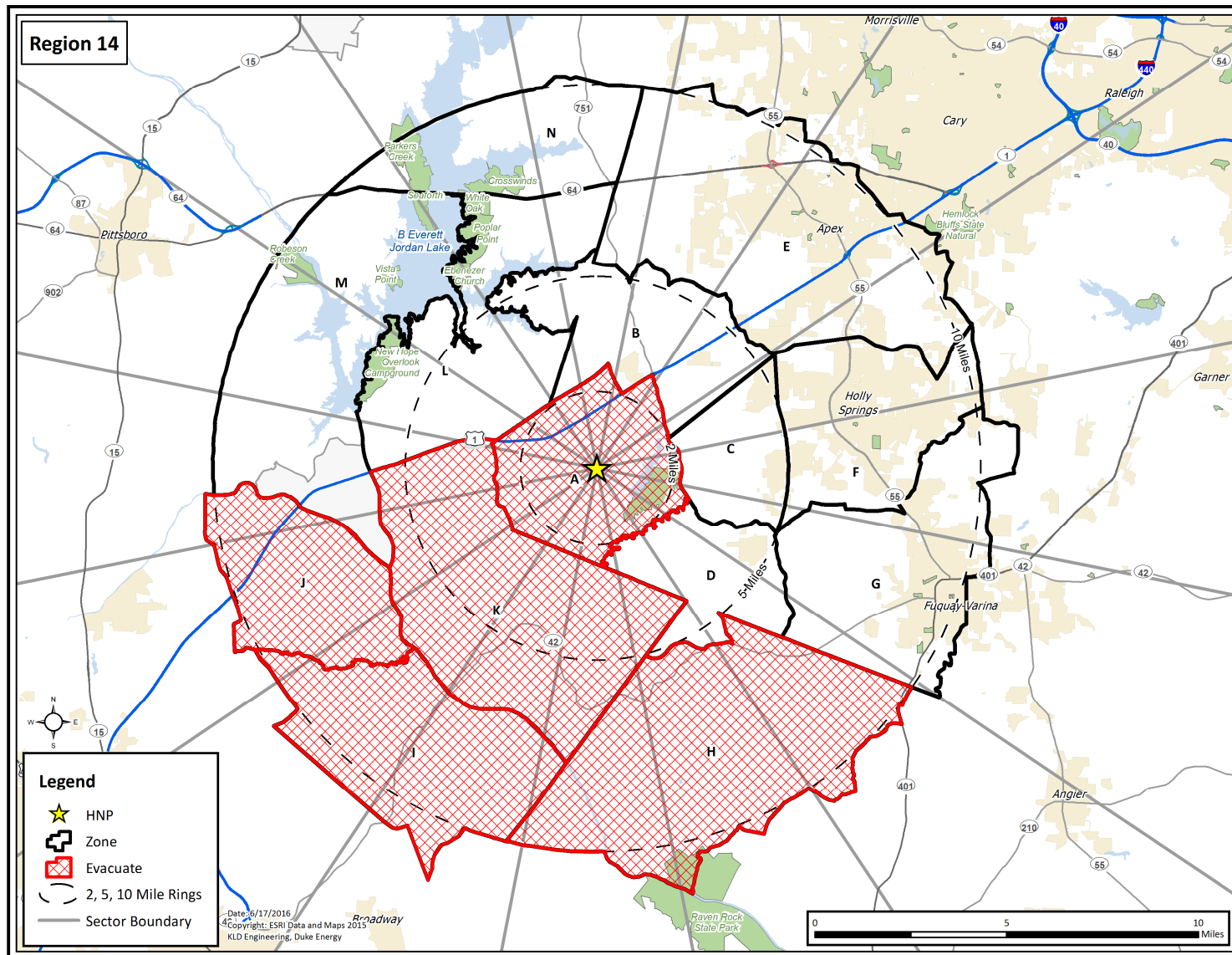

Figure H-14. Region R14

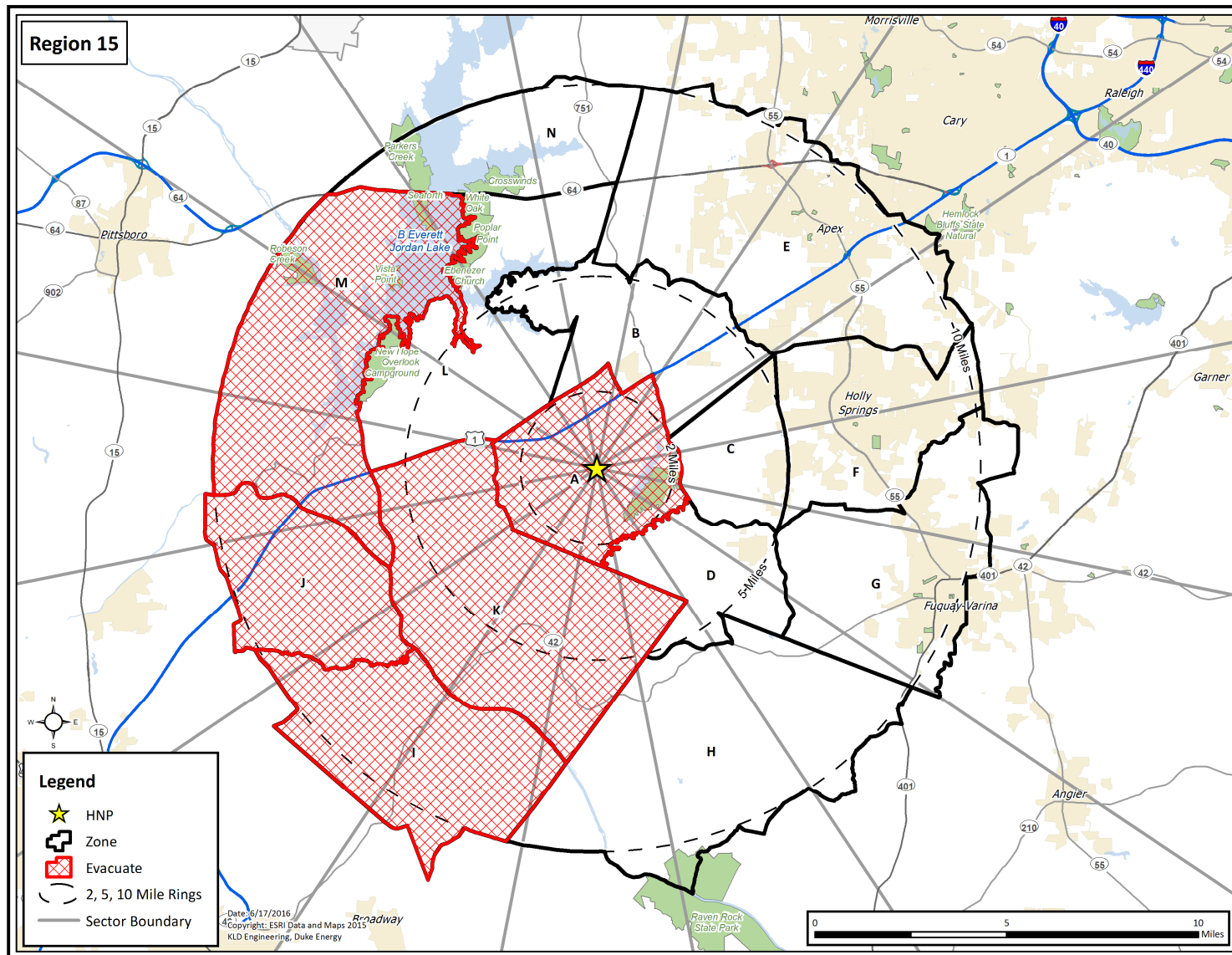

Figure H-15. Region R15

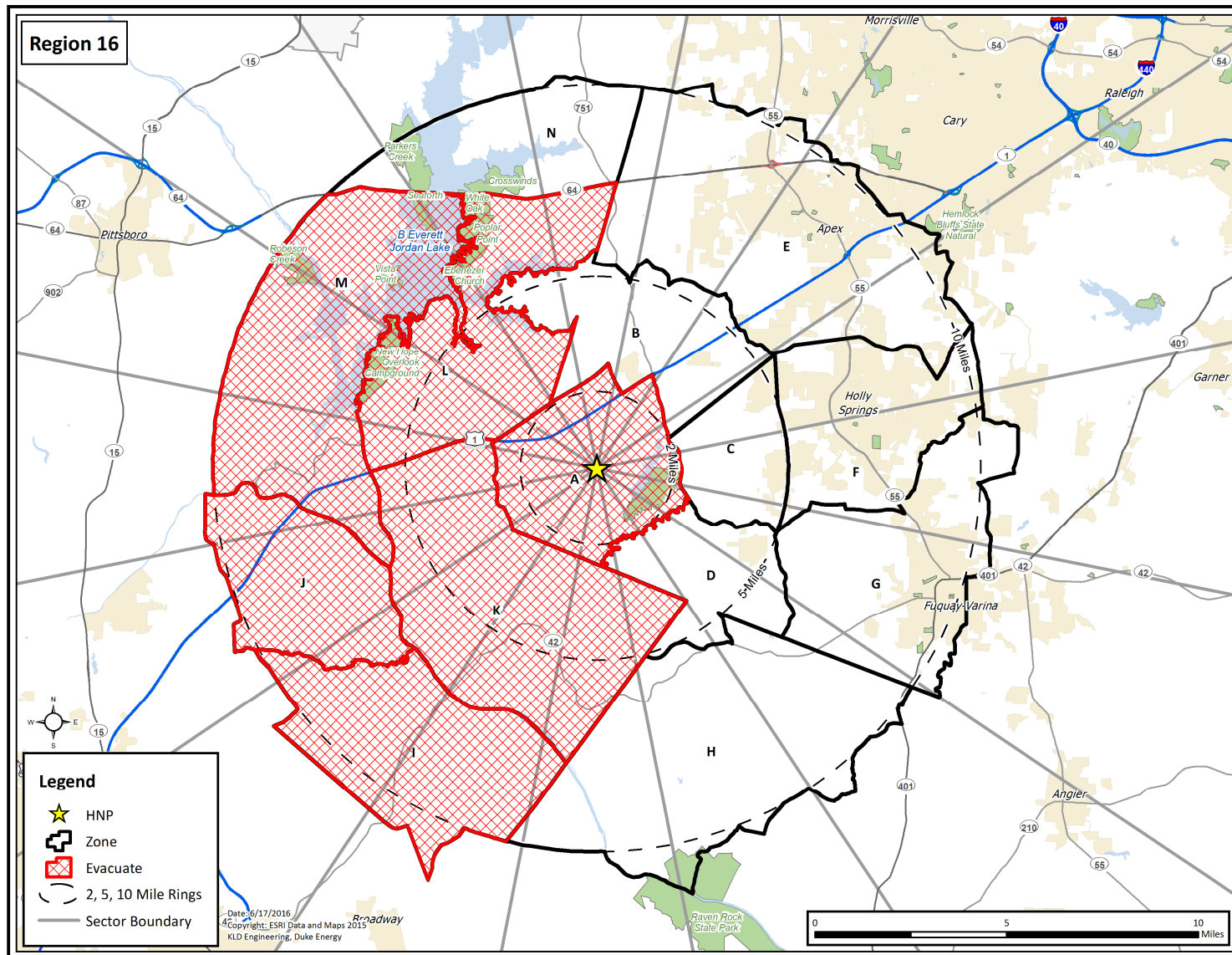

Figure H-16. Region R16

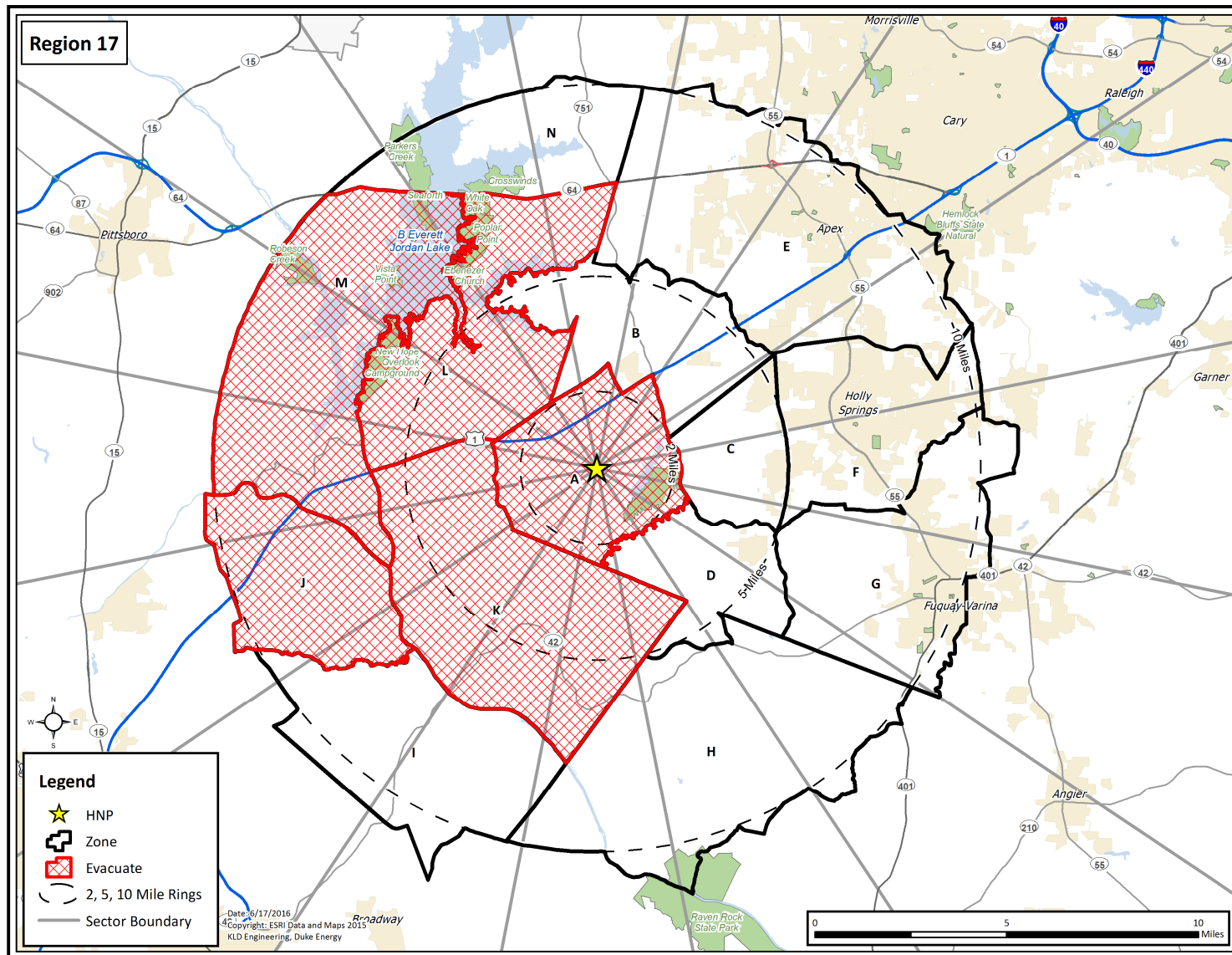

Figure H-17. Region R17

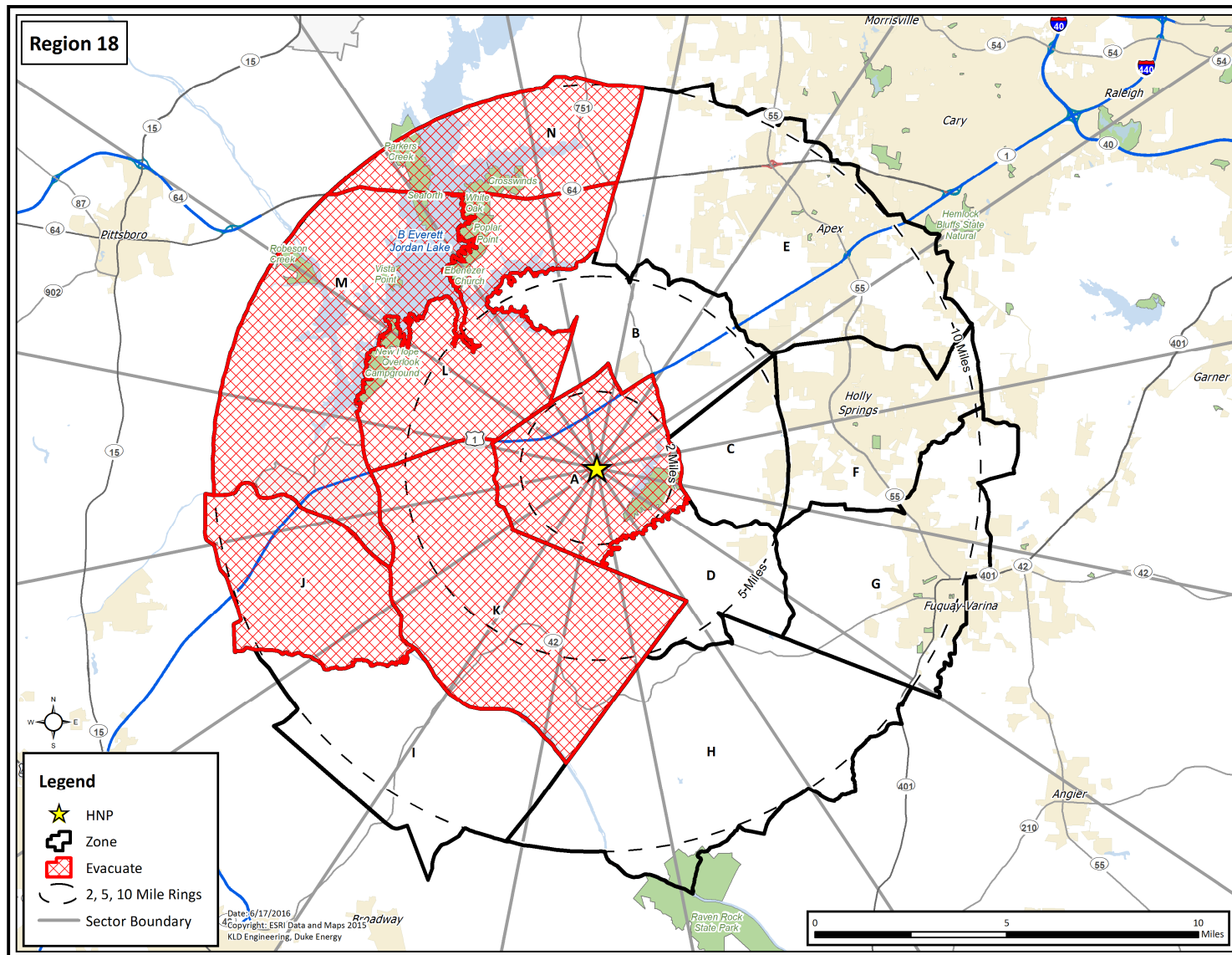

Figure H-18. Region R18

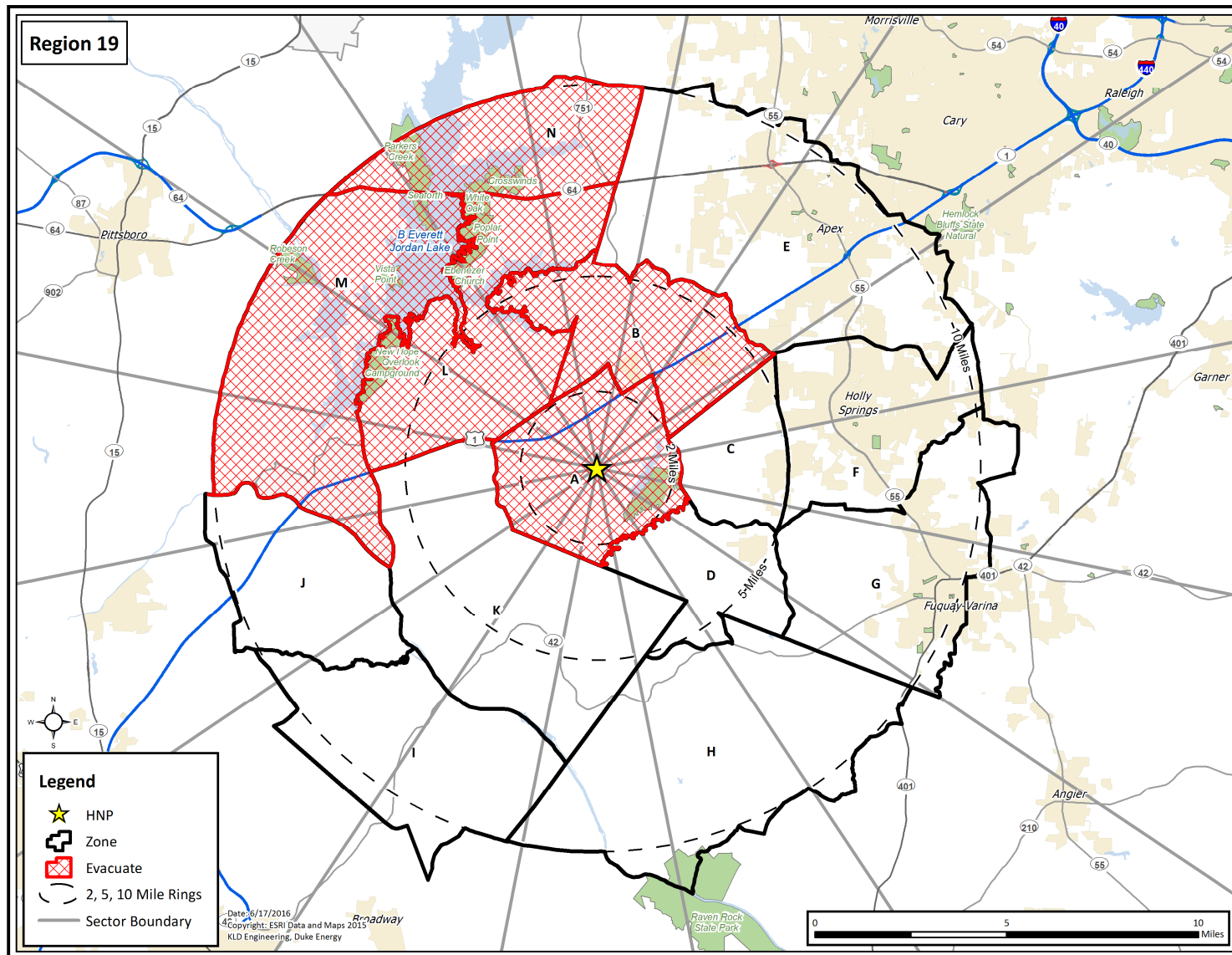

Figure H-19. Region R19

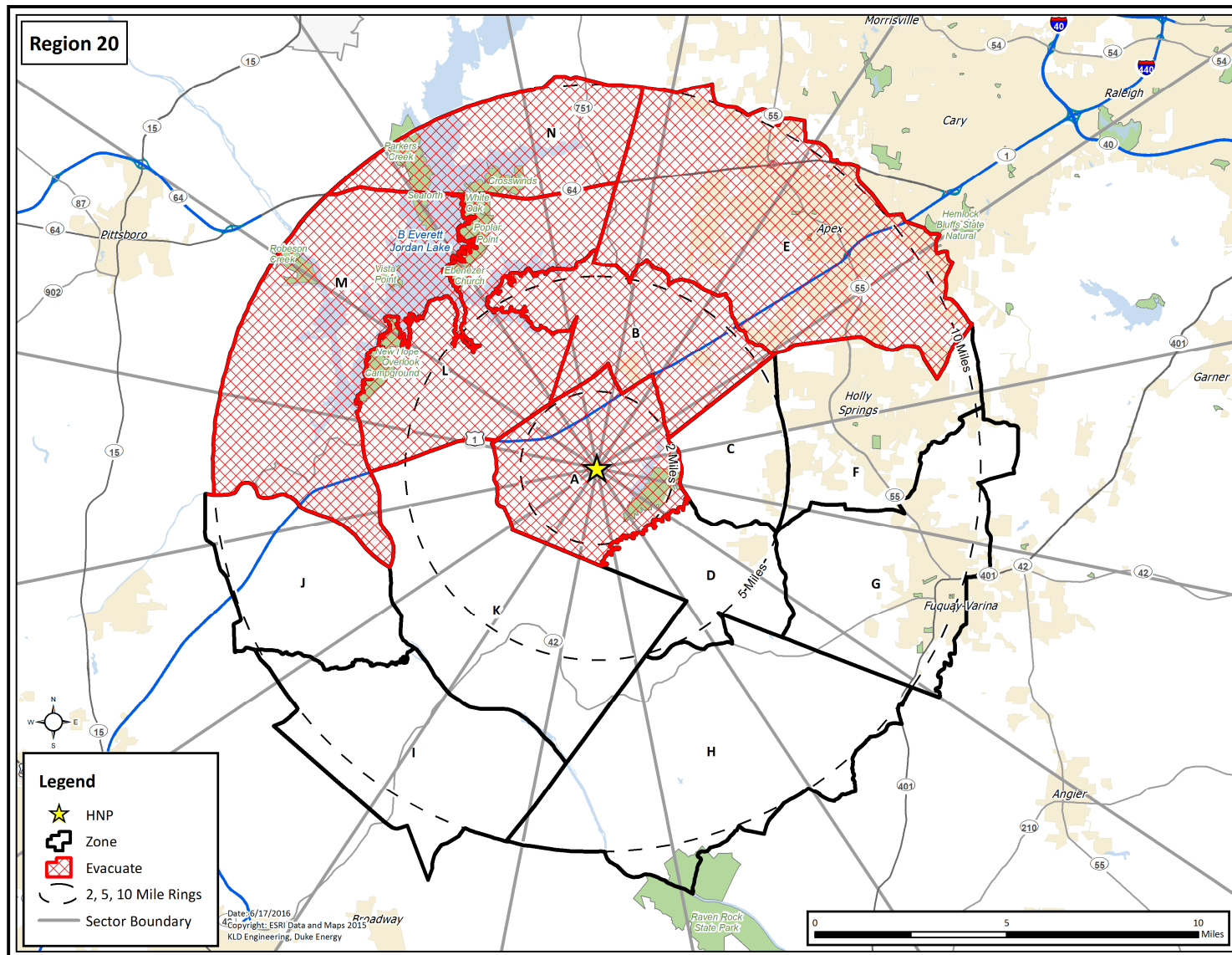

Figure H-20. Region R20

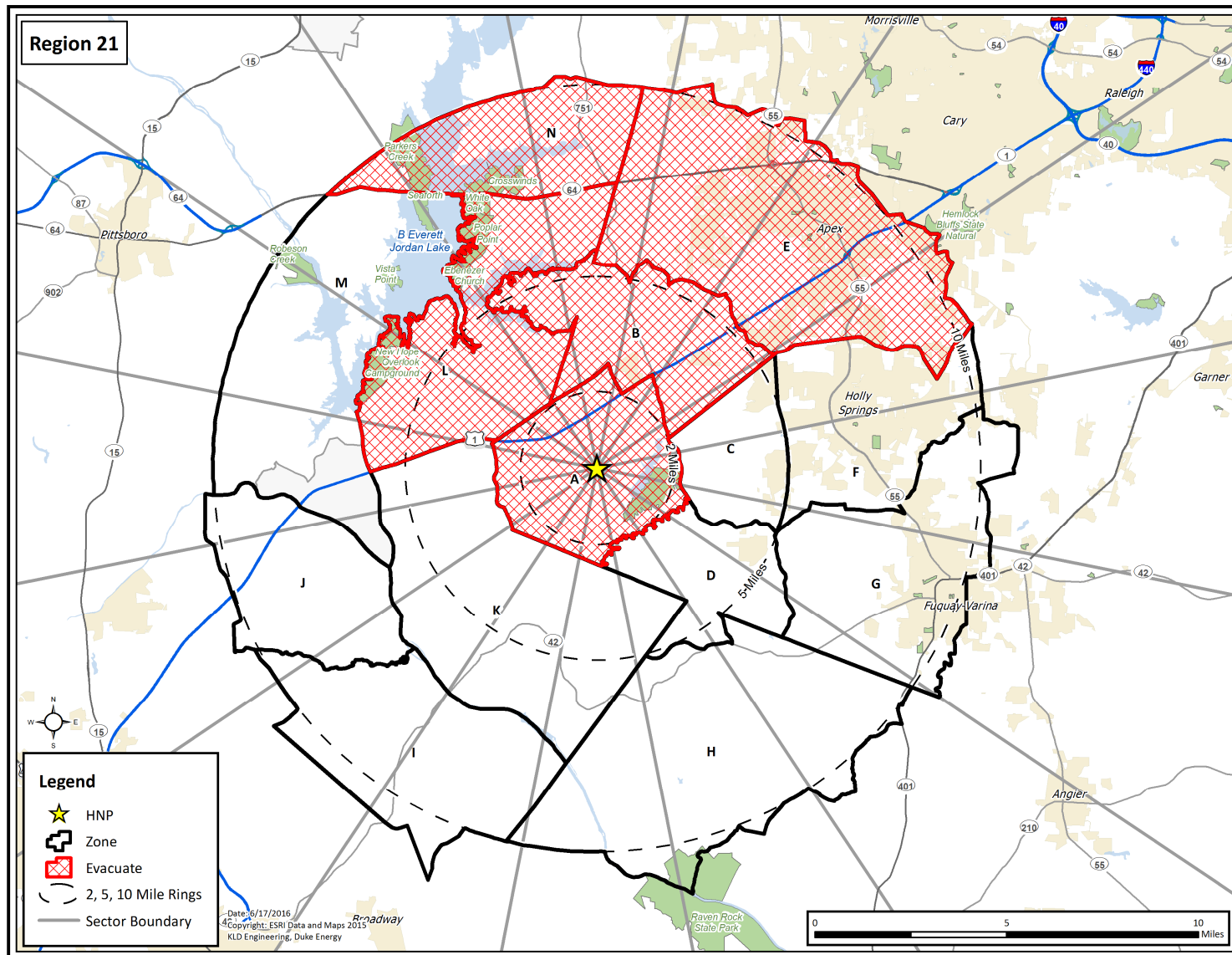

Figure H-21. Region R21

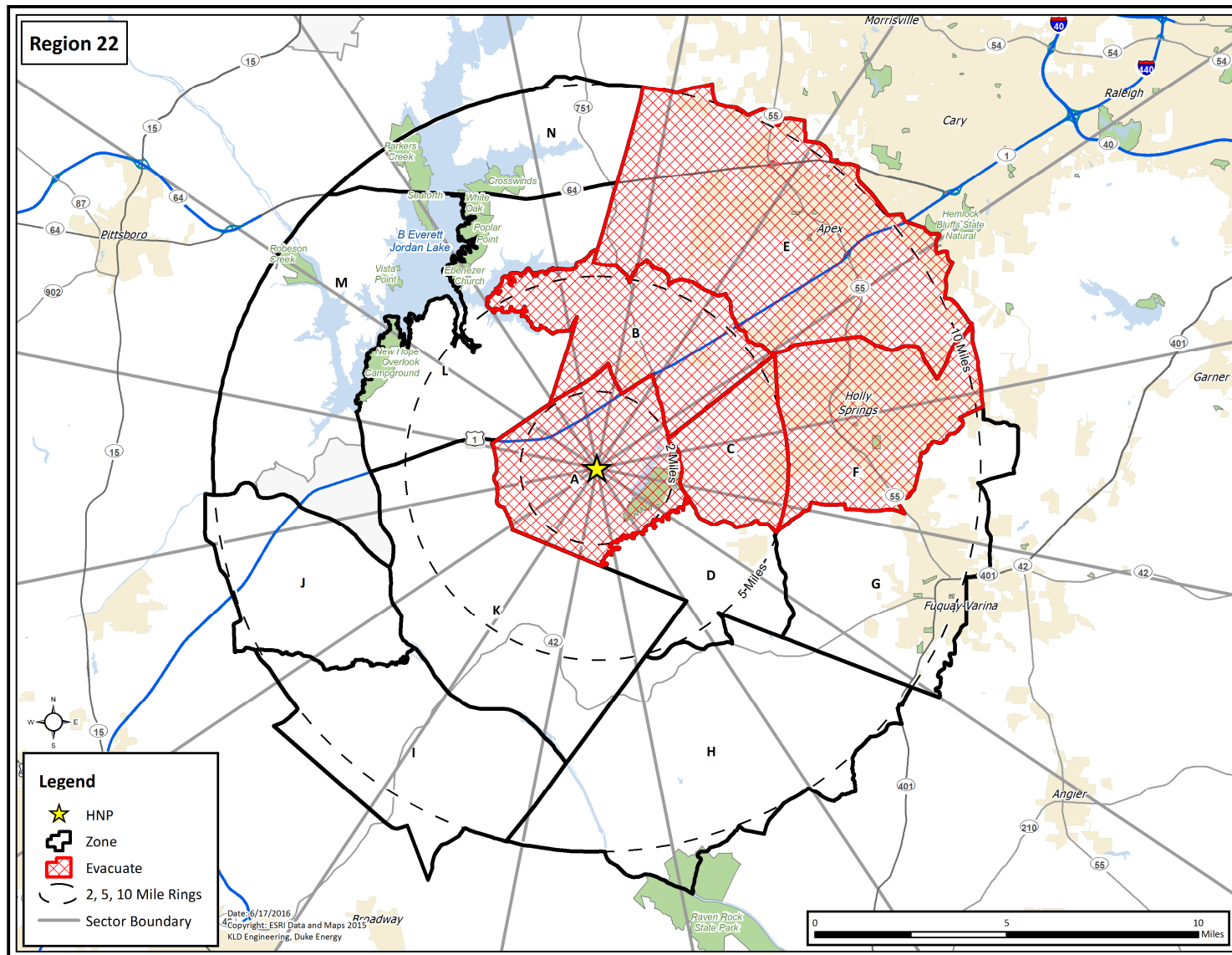

Figure H-22. Region R22

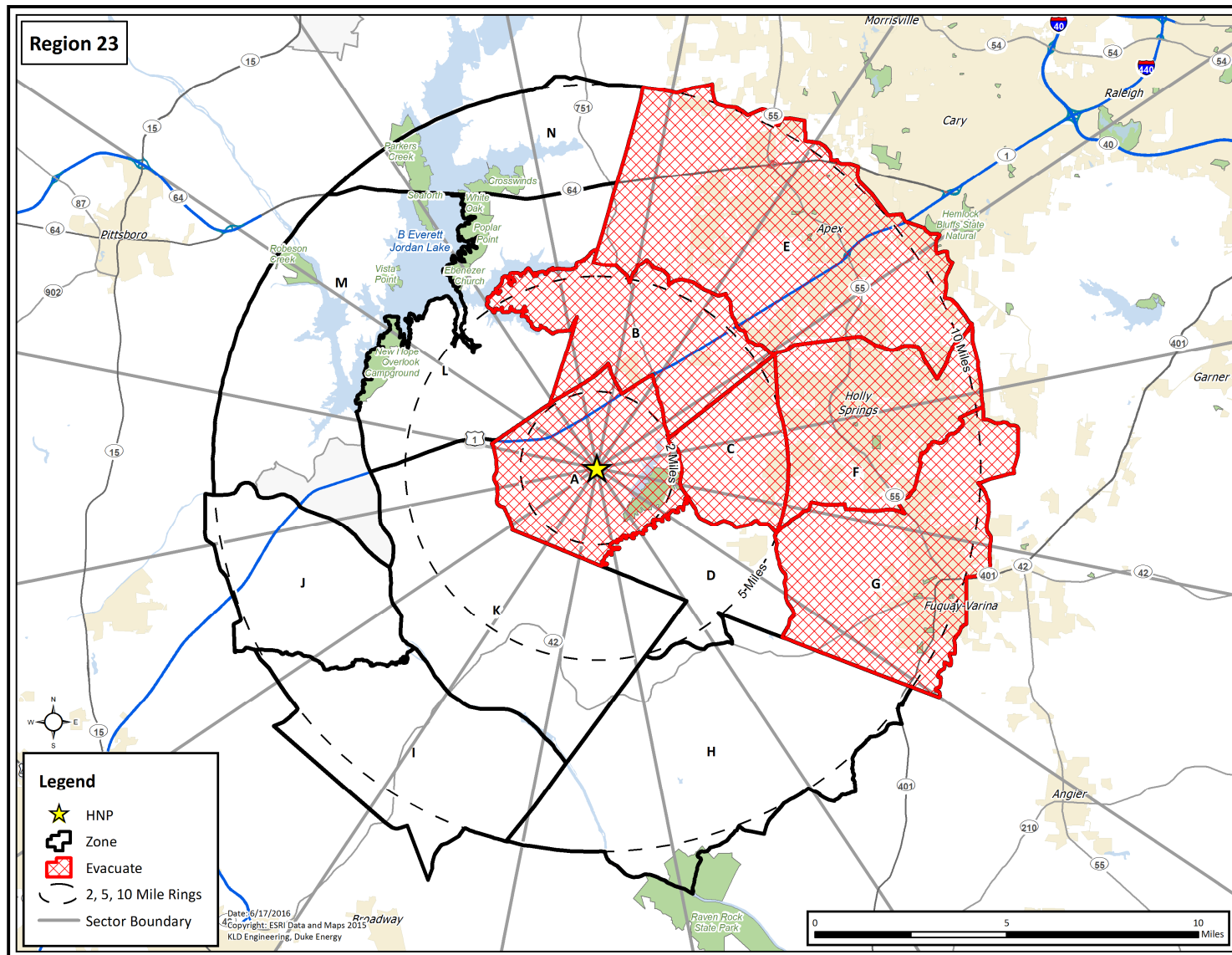

Figure H-23. Region R23

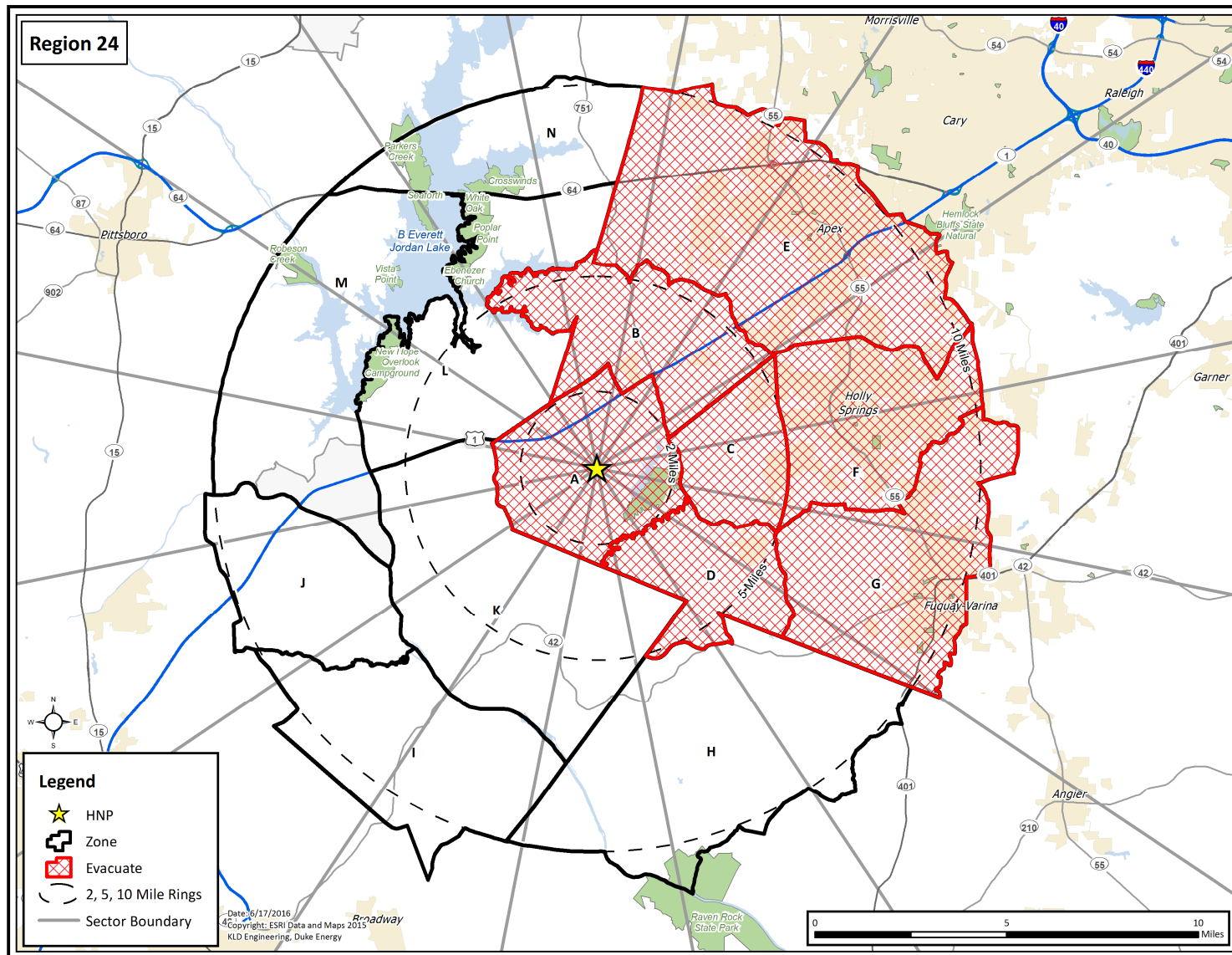

Figure H-24. Region R24

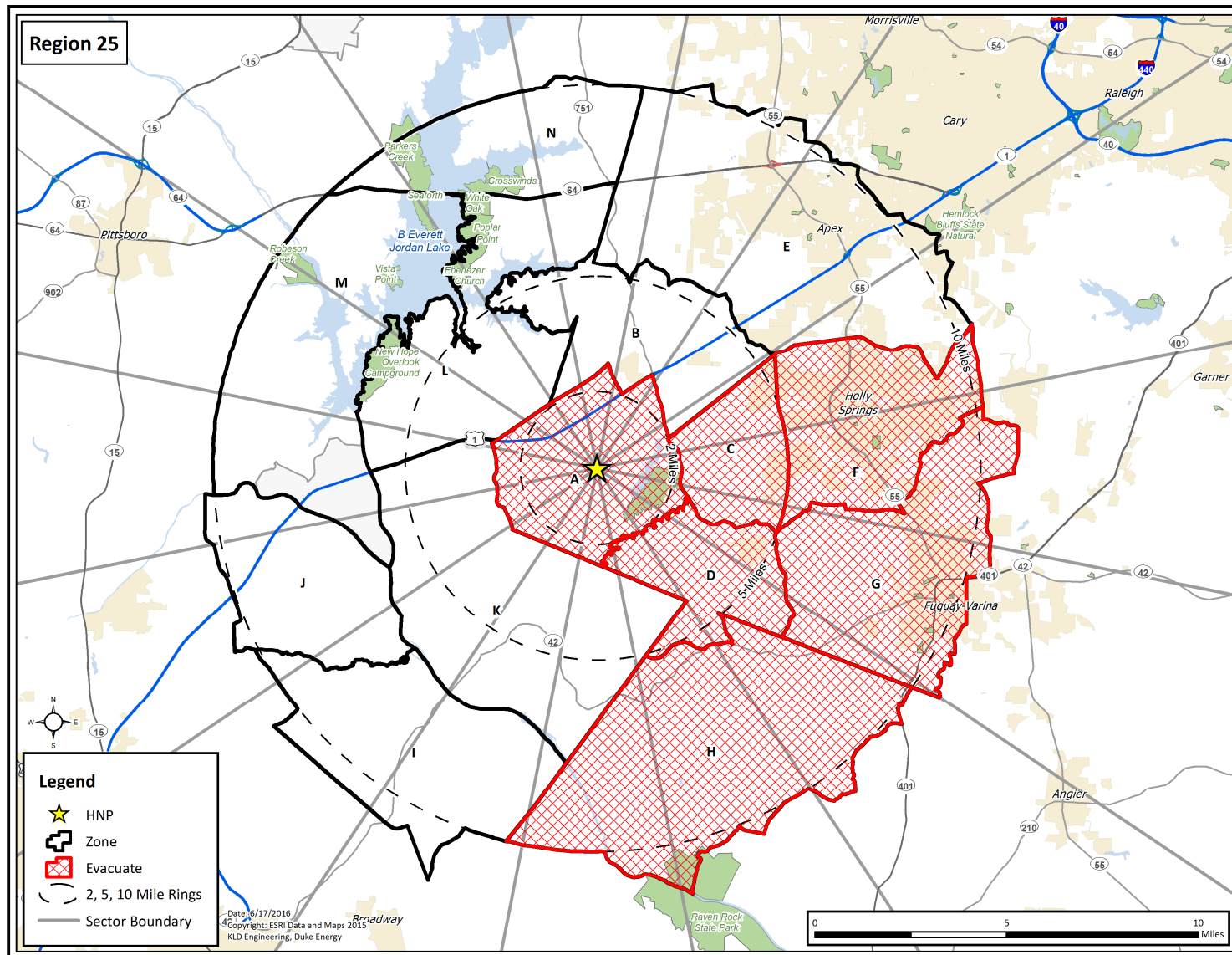

Figure H-25. Region R25

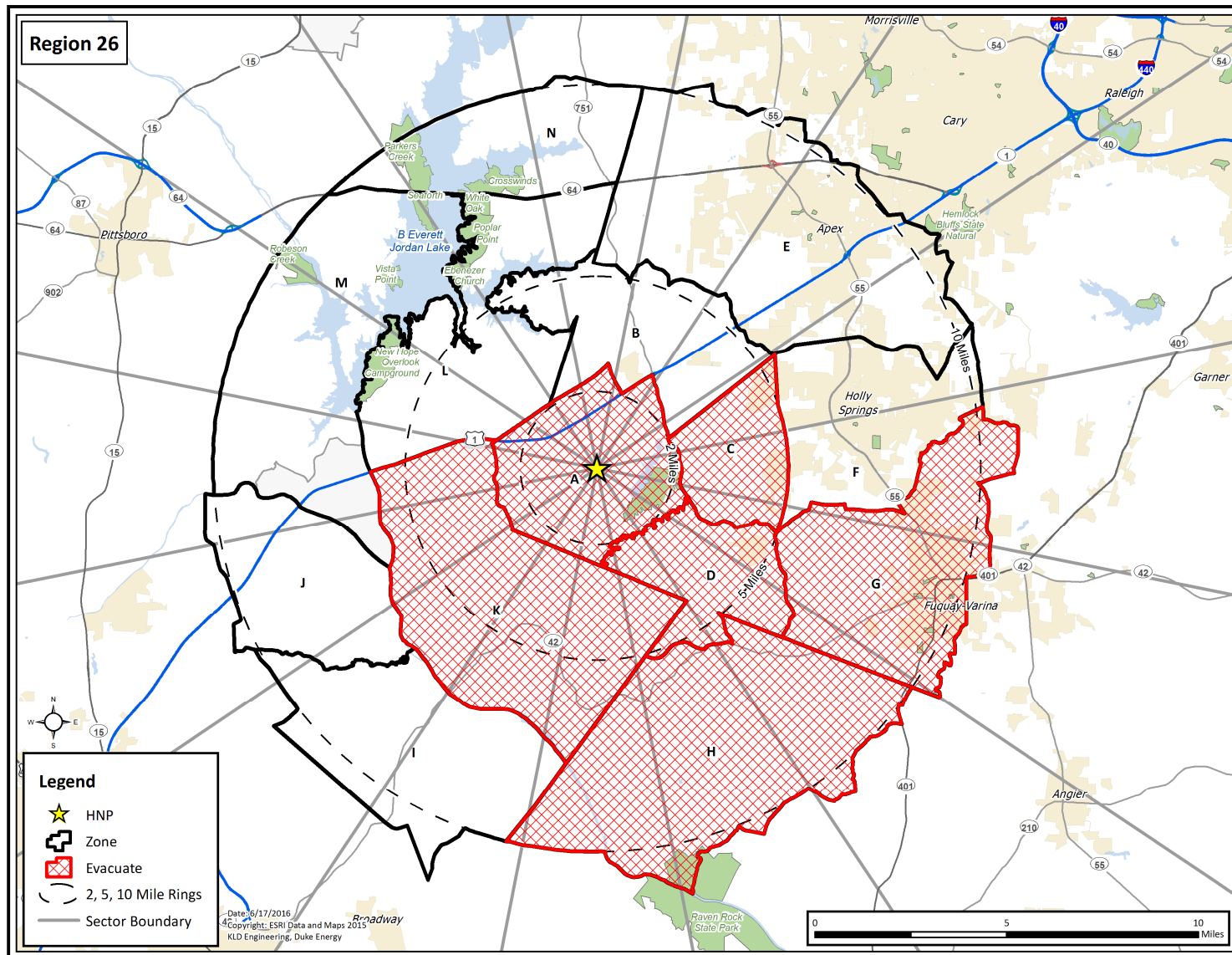

Figure H-26. Region R26

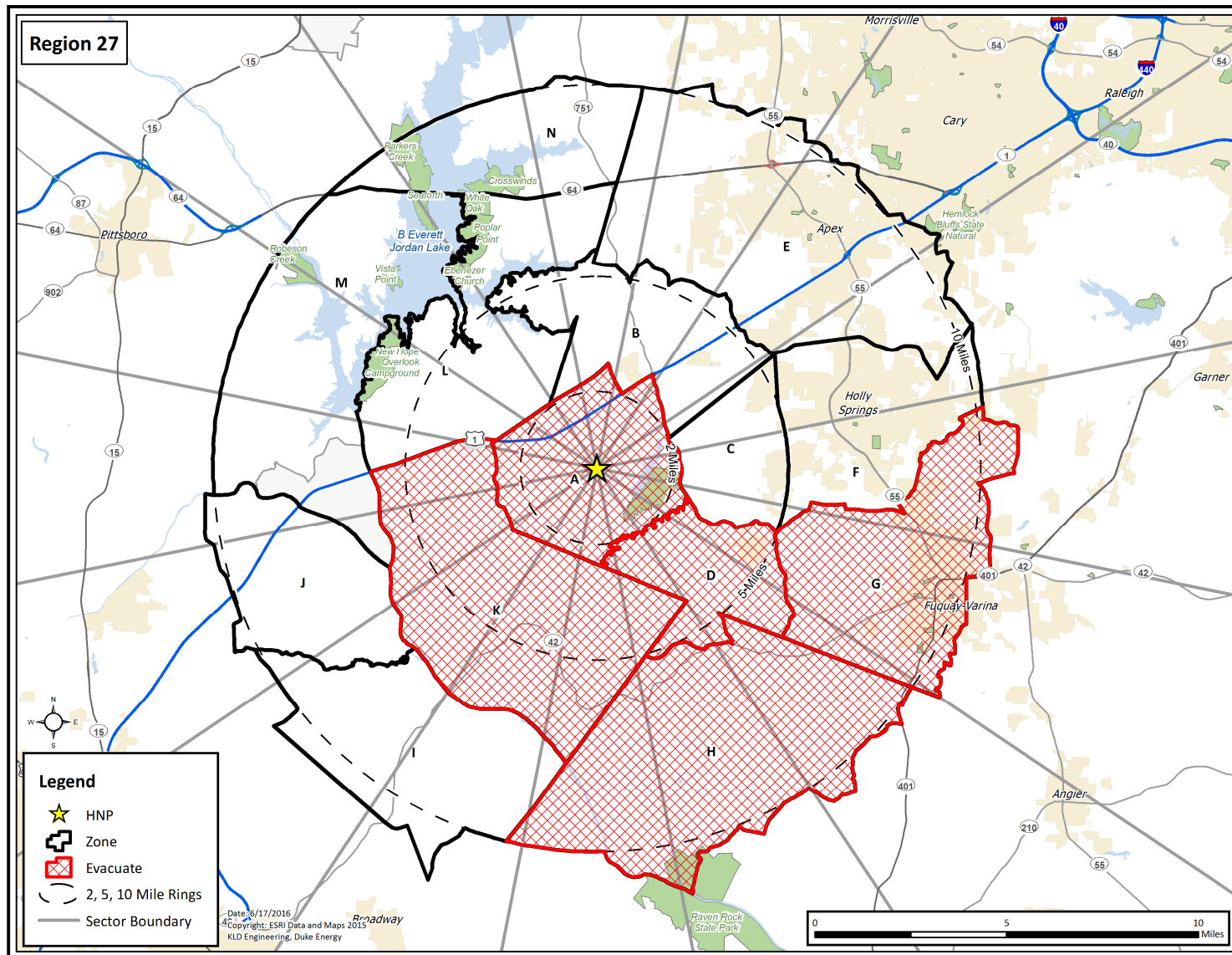

Figure H-27. Region R27

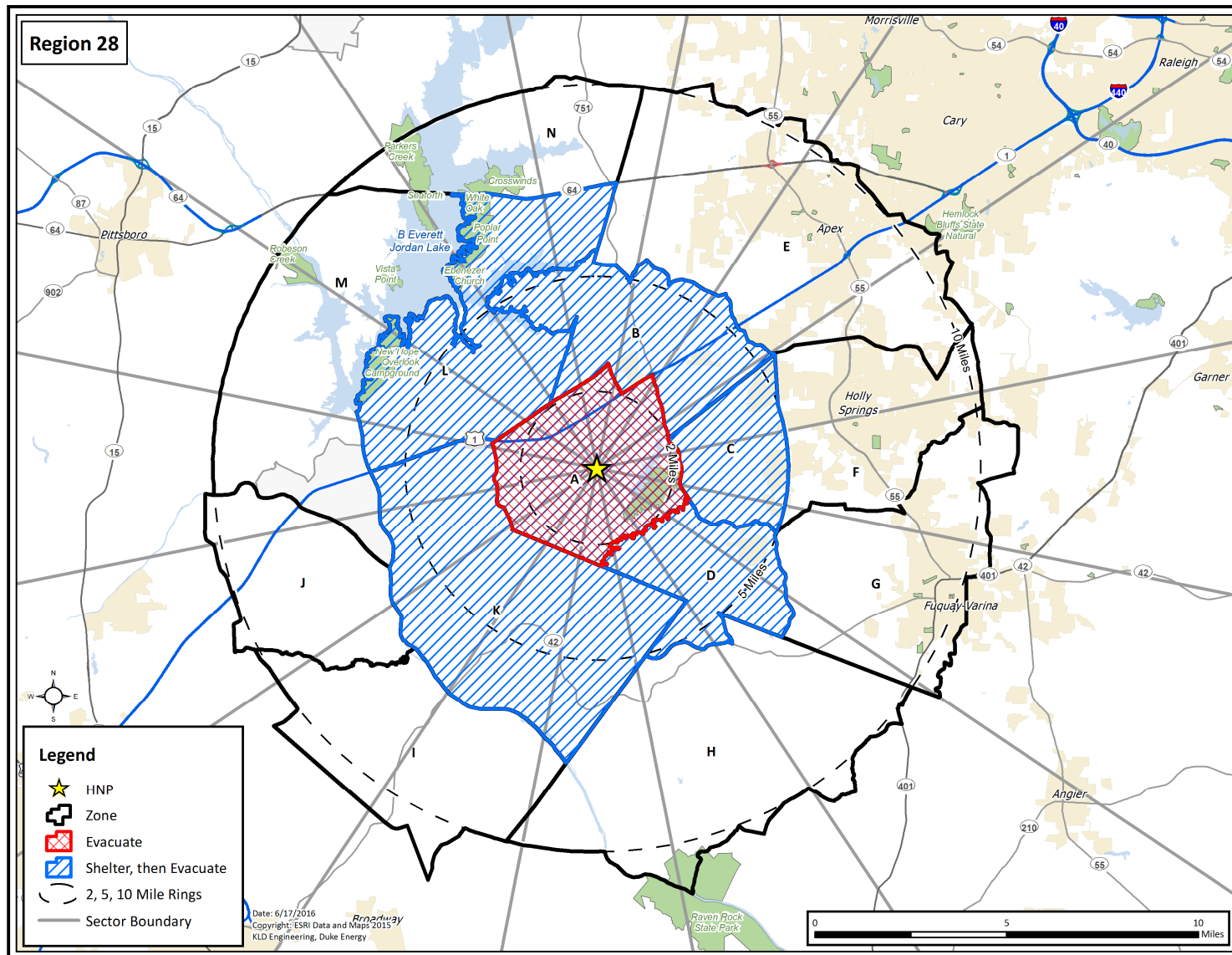

Figure H-28. Region R28

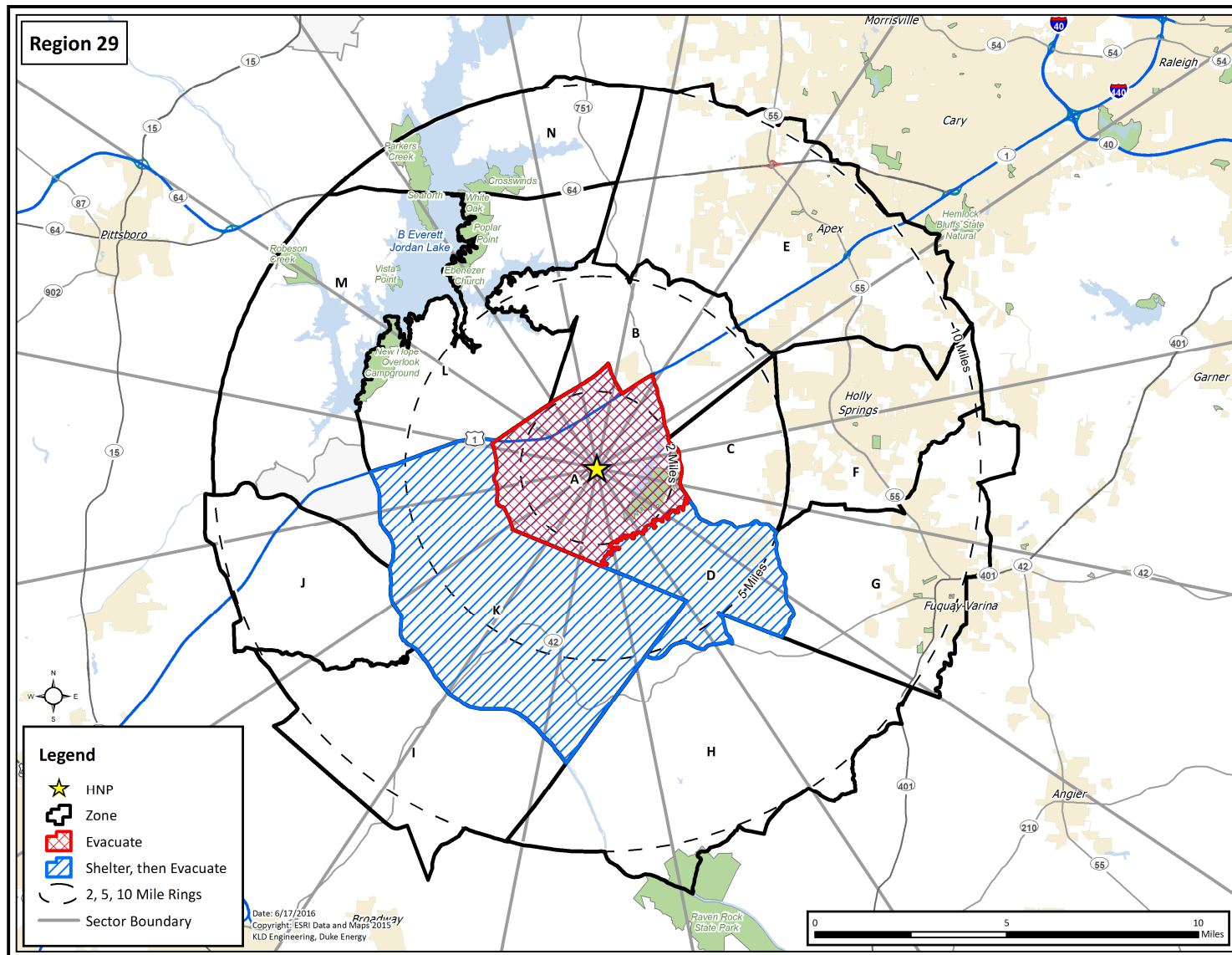

Figure H-29. Region R29

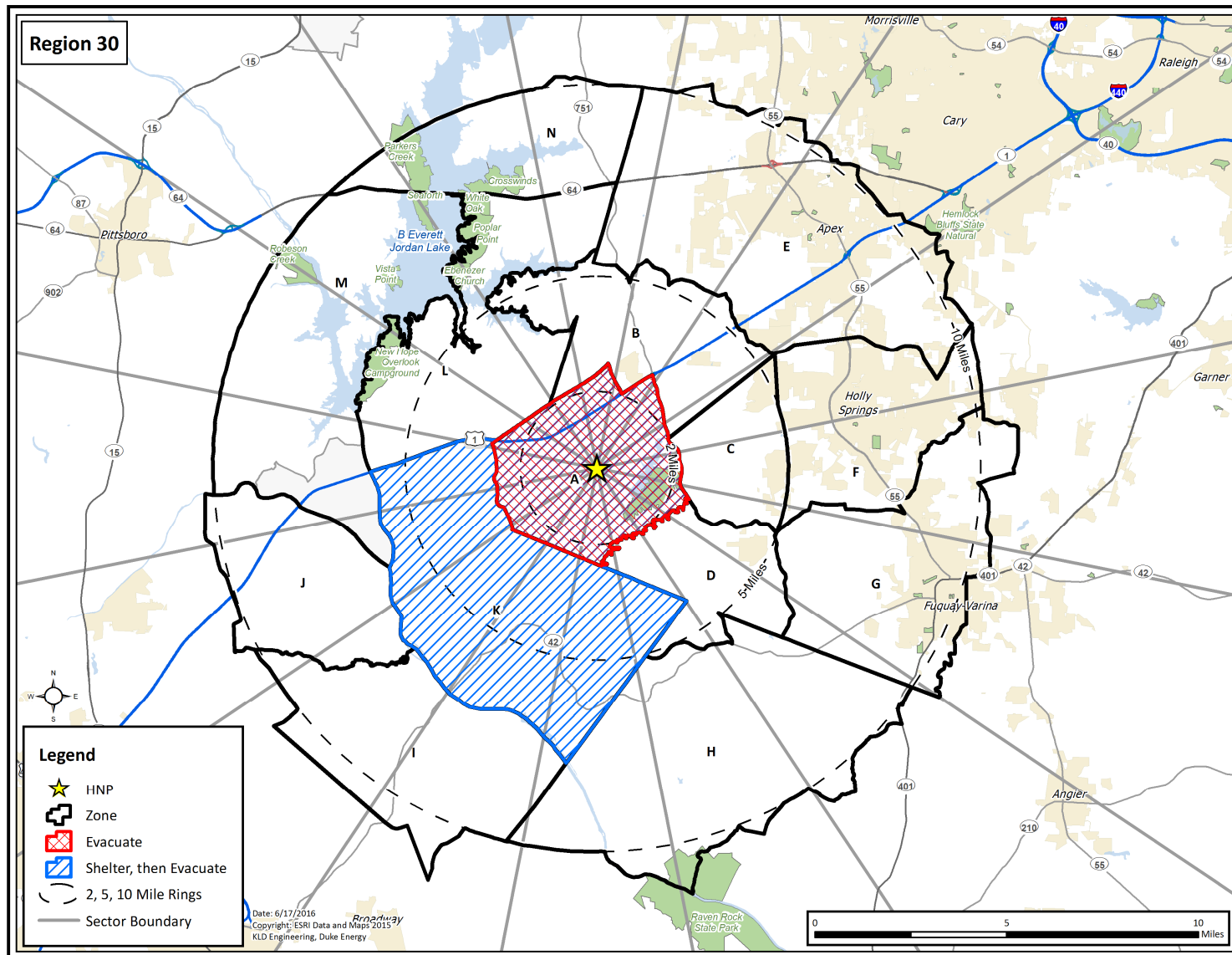

Figure H-30. Region R30

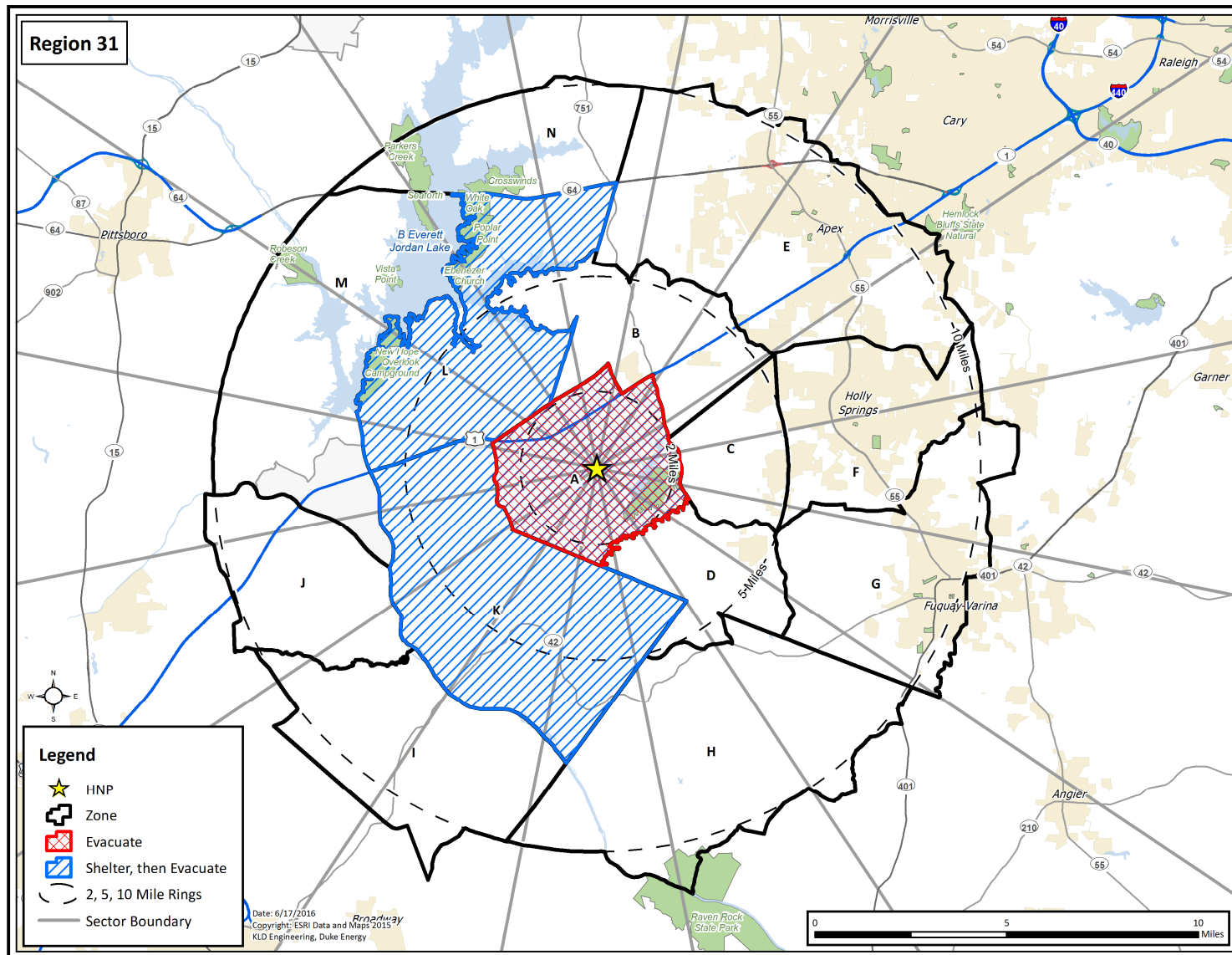

Figure H-31. Region R31

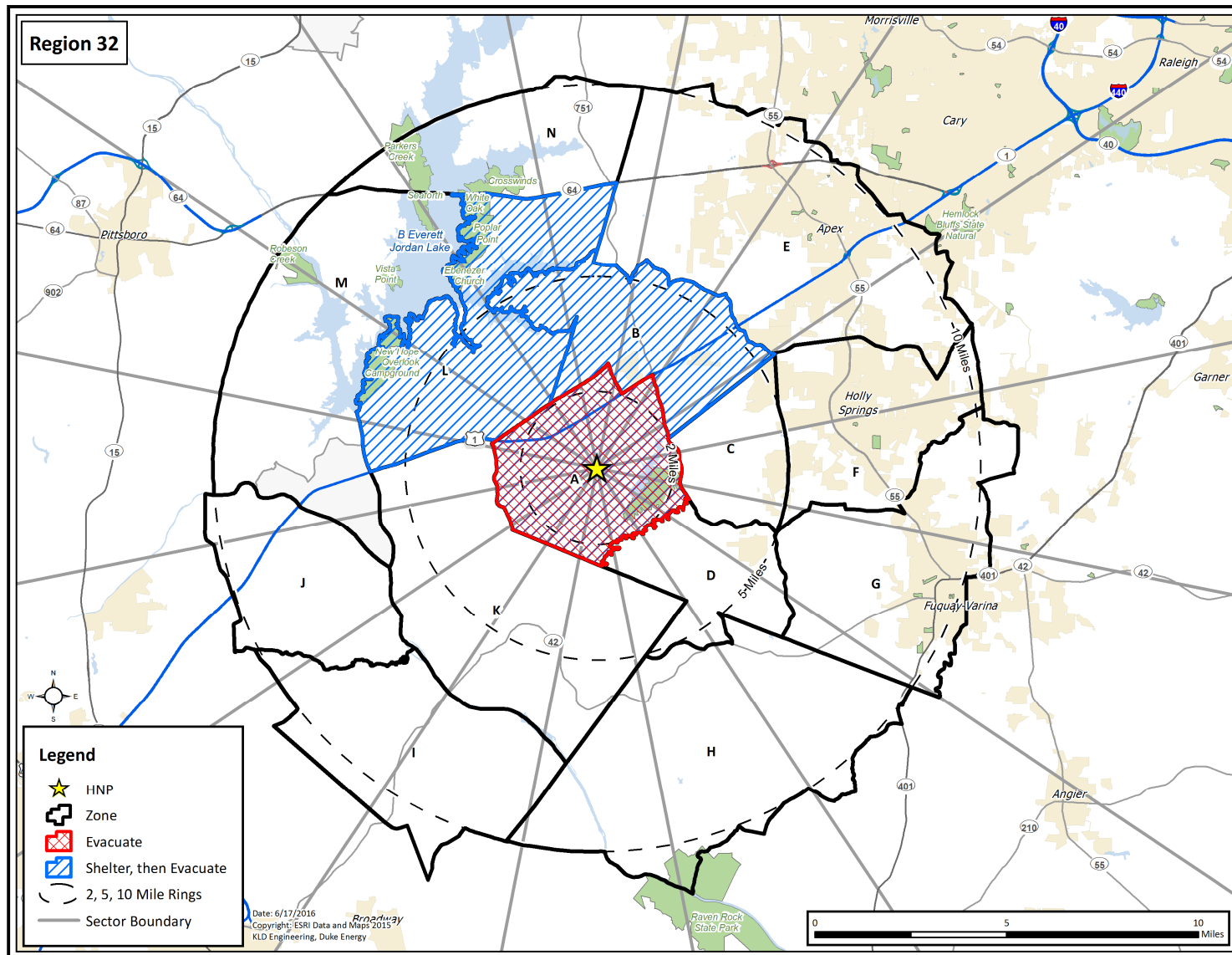

Figure H-32. Region R32

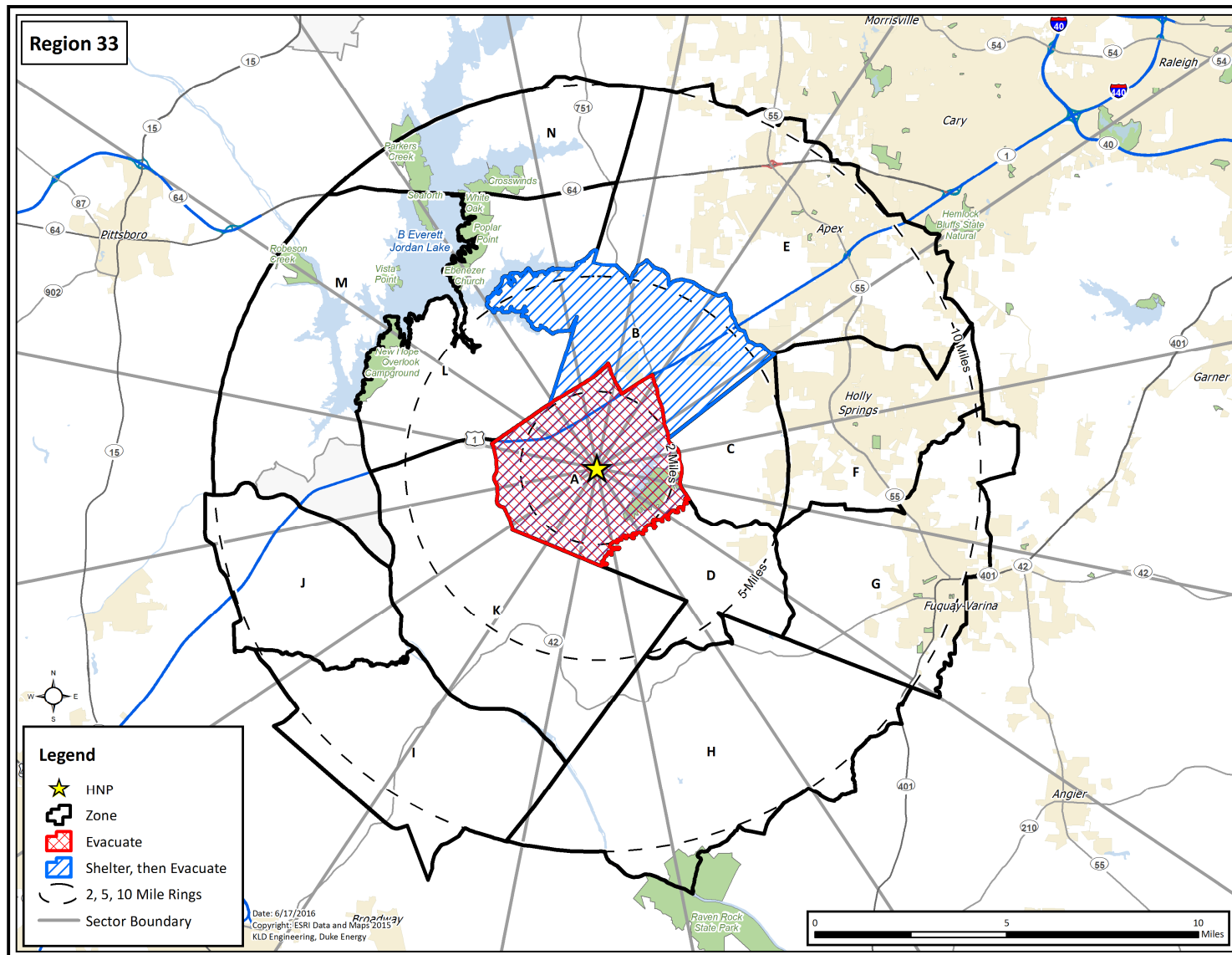

Figure H-33. Region R33

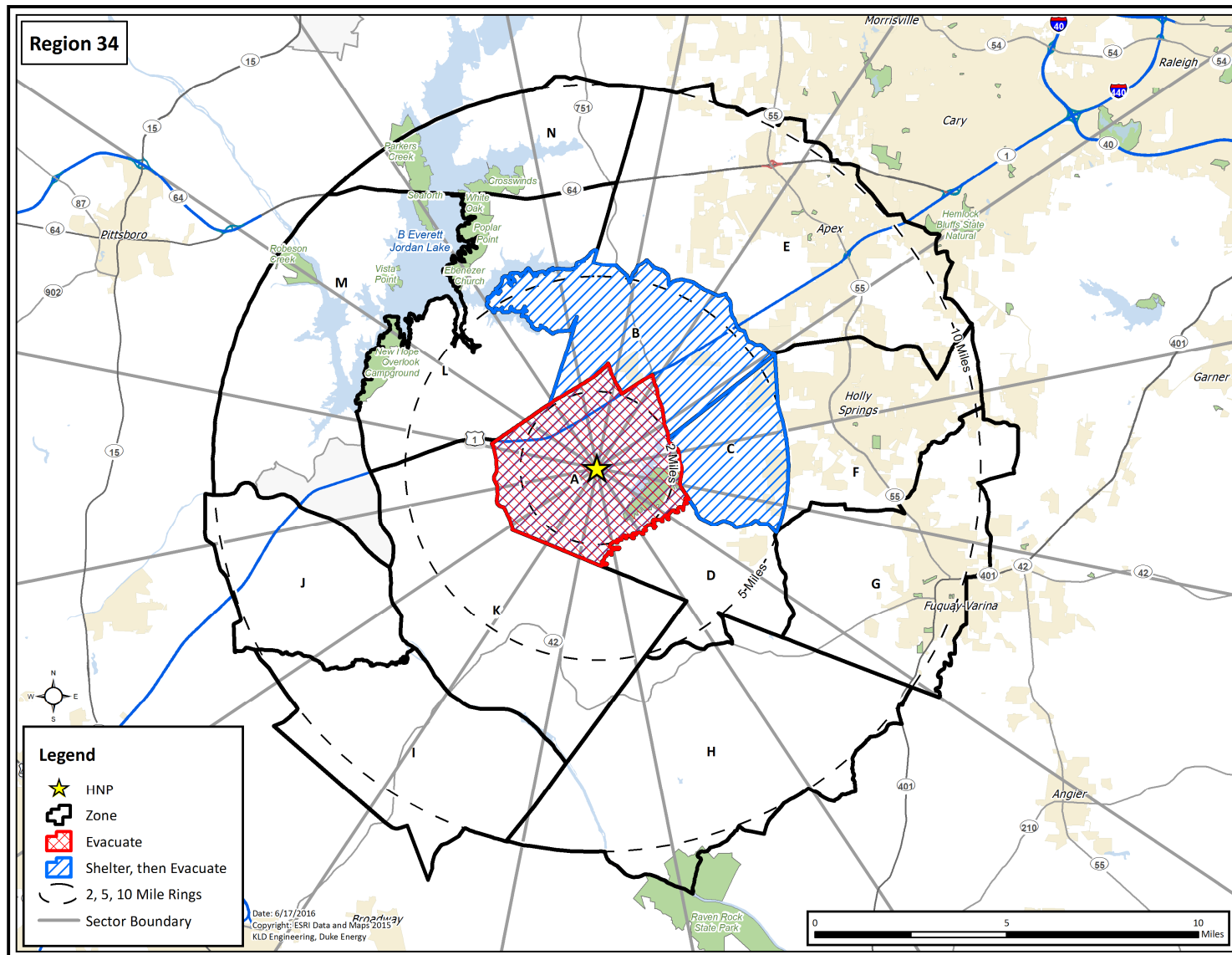

Figure H-34. Region R34

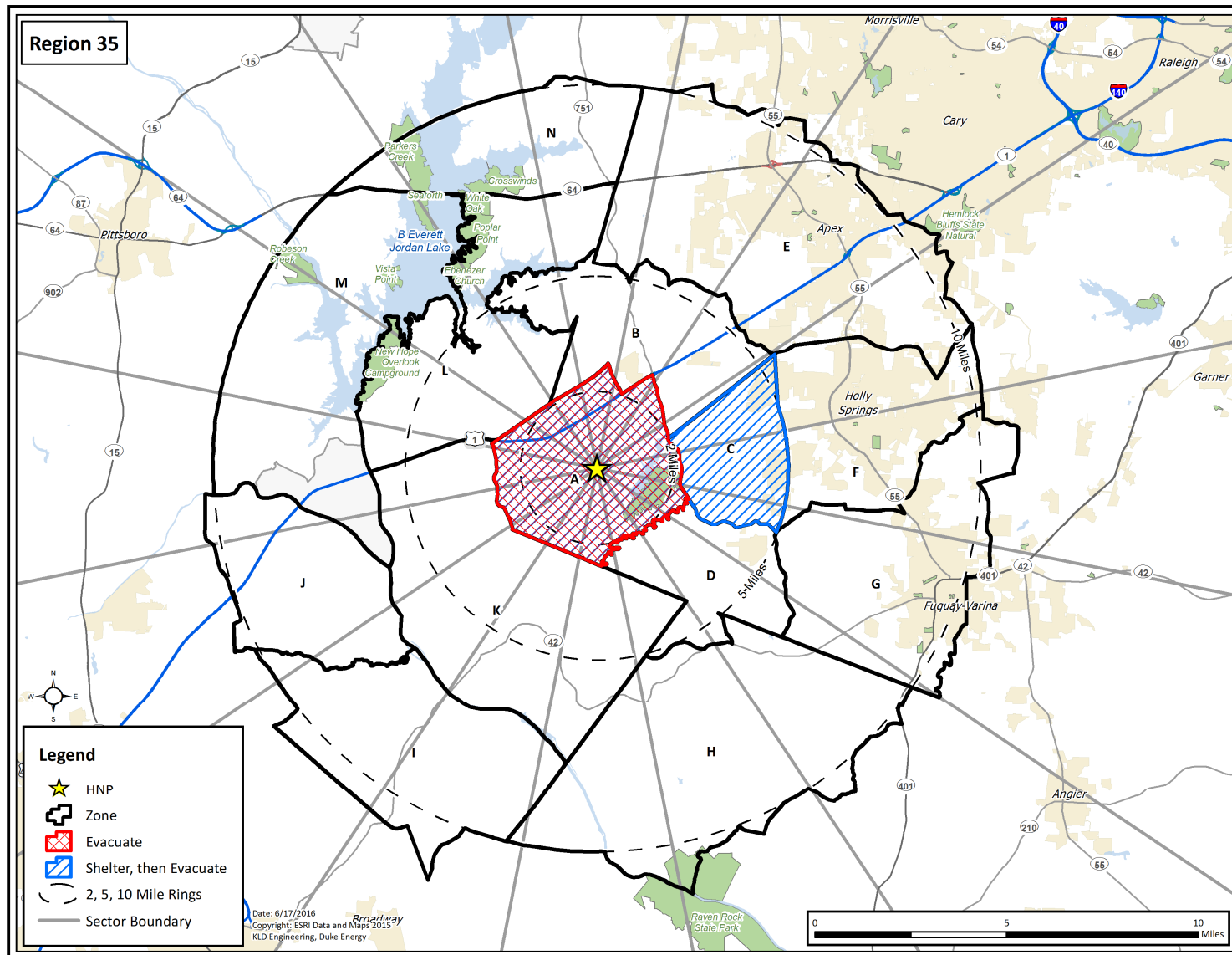

Figure H-35. Region R35

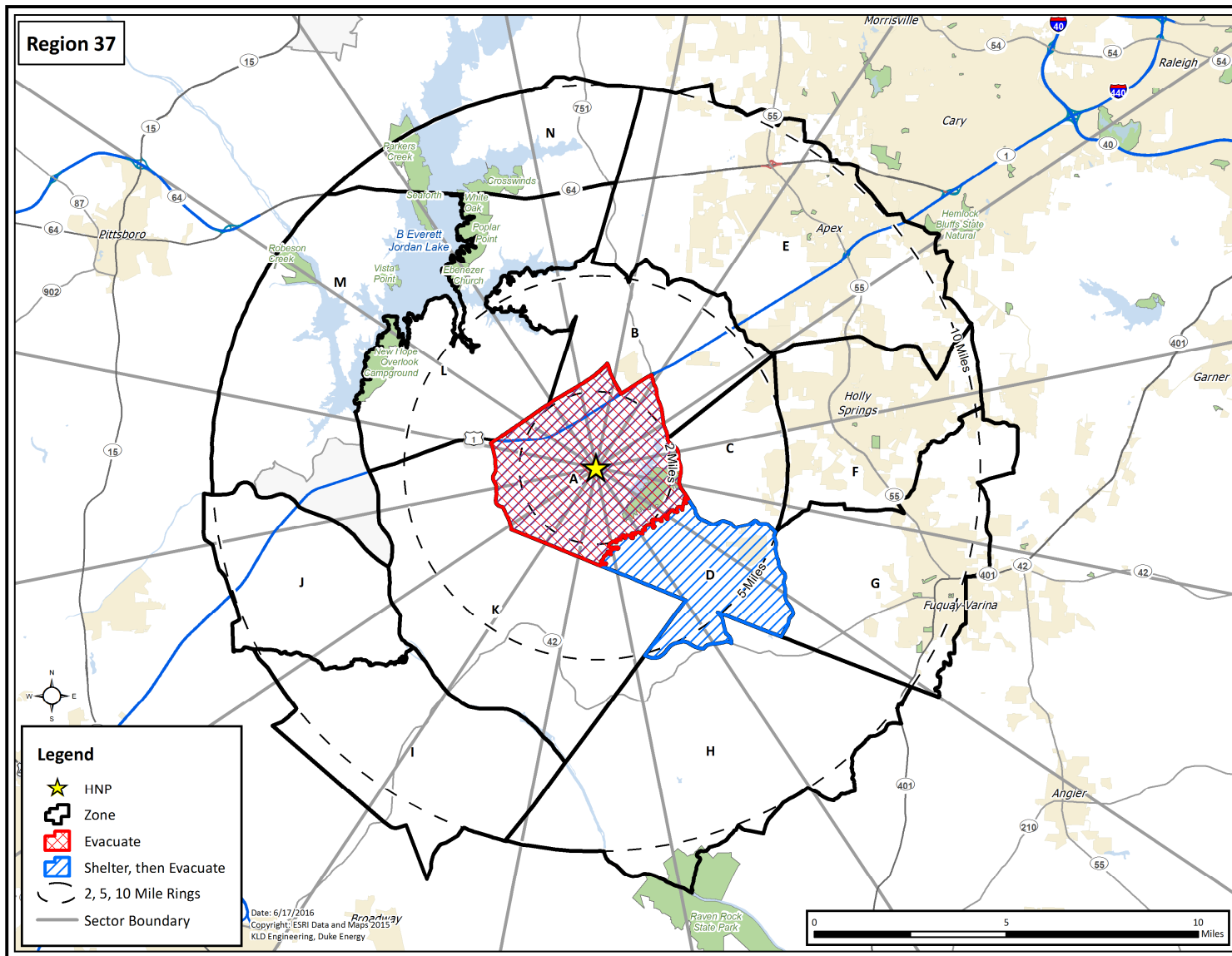

Figure H-37. Region R37

APPENDIX J

Representative Inputs to and Outputs from the DYNEV II System

J. REPRESENTATIVE INPUTS TO AND OUTPUTS FROM THE DYNEV II SYSTEM

This appendix presents data input to and output from the DYNEV II System. Table J-1 provides the volume and queues for the ten highest volume signalized intersections in the study area. Refer to Table K-2 and the figures in Appendix K for a map showing the geographic location of each intersection.

Table J-2 provides source (vehicle loading) and destination information for several roadway segments (links) in the analysis network. Refer to Table K-1 and the figures in Appendix K for a map showing the geographic location of each link.

Table J-3 provides network-wide statistics (average travel time, average speed and number of vehicles) for an evacuation of the entire EPZ (Region R03) for each scenario. Scenarios 7 and 8, which are rain and ice scenarios during a weeknight condition exhibit slower average speeds and longer average travel times than good weather scenarios.

Table J-4 provides statistics (average speed and travel time) for the major evacuation routes – NC-540 Toll, US-64, US-1, NC-42, NC-55 and US-401 – for an evacuation of the entire EPZ (Region R03) under Scenario 1 conditions. As discussed in Section 7.3 and shown in Figures 7-3 through 7-10, major roadways to the northeast, east, and southeast are congested for the majority of the evacuation. As such, the average speeds are comparably slower (and travel times longer) on the major roadways traveling in these directions than other major evacuation routes.

Table J-5 provides the number of vehicles discharged and the cumulative percent of total vehicles discharged for each link exiting the analysis network, for an evacuation of the entire EPZ (Region R03) under Scenario 1 conditions. Refer to Table K-1 and the figures in Appendix K for a map showing the geographic location of each link.

Figure J-1 through Figure J-14 plot the trip generation time versus the ETE for each of the 14 Scenarios considered. The distance between the trip generation and ETE curves is the travel time. Plots of trip generation versus ETE are indicative of the level of traffic congestion during evacuation. For low population density sites, the curves are close together, indicating short travel times and minimal traffic congestion. For higher population density sites, the curves are farther apart indicating longer travel times and the presence of traffic congestion. As seen in Figure J-1 through Figure J-14, the curves are spatially separated as a result of the traffic congestion in the EPZ, specifically in the population centers of Apex, Holly Springs and Fuquay-Varina, which was discussed in detail in Section 7.3.

Table J-1. Characteristics of the Ten Highest Volume Signalized Intersections

Node	Location	Intersection Control	Approach (Up Node)	Total Volume (Veh)	Max. Turn Queue (Veh)
193	US-401 and Ten-Ten Road	Actuated	542	6,252	22
			192	10,322	33
			223	357	0
			TOTAL	16,931	-
201	State Route 55 and US-401	TCP - Actuated	1458	8,605	0
			388	1,147	0
			985	2,139	0
			TOTAL	11,891	-
119	Lake Pine Drive and US-64	TCP - Actuated	120	5,486	80
			116	735	0
			1334	4,130	20
			1017	745	0
			TOTAL	11,096	-
61	US-401 and Donny Brook Road	Actuated	192	653	0
			1042	9,172	1
			1506	1,082	0
			TOTAL	10,907	-
474	SE Cary Parkway and Tryon Road	Actuated	473	6,666	112
			475	1,800	17
			723	2,191	75
			TOTAL	10,657	-
330	High House Road/Green Level West Road and State Route 55	TCP - Actuated	321	2,131	0
			400	8,023	0
			TOTAL	10,154	-
1816	US-401 and State Route 210/Main Street/US-421	TCP - Actuated	1826	4,390	0
			1817	368	0
			1818	5,331	0
			TOTAL	10,089	-
538	Ten-Ten Road and Lake Wheeler Road	Actuated	616	5,979	402
			546	3,980	83
			TOTAL	9,959	-

Node	Location	Intersection Control	Approach (Up Node)	Total Volume (Veh)	Max. Turn Queue (Veh)
41	US-401 and Hilltop Needmore Road	Actuated	736	2,402	0
			225	6,633	0
			196	747	0
			1616	132	0
			TOTAL	9,914	-
1042	US-401 and Chandler Ridge Circle	Actuated	1043	35	0
			61	656	0
			387	9,141	0
			TOTAL	9,832	-

Table J-2. Sample Simulation Model Input

Link Number	Vehicles Entering Network on this Link	Directional Preference	Destination Nodes	Destination Capacity
14	77	W	8230	3,800
			8590	4,500
			8127	1,700
308	67	NW	8190	2,850
505	64	NE	8359	6,750
			8020	6,750
743	64	N	8190	2,850
			8137	3,800
996	30	N	8276	1,275
1250	125	W	8230	3,800
			8590	4,500
			8127	1,700
1497	153	SW	8137	3,800
			8788	1,700
1729	72	NE	8359	6,750
			8020	6,750
			8375	4,500
2042	59	NE	8359	6,750
			8020	6,750
			8430	2,850
2419	41	SE	8666	1,700
			8222	3,800
			8392	1,700

Table J-3. Selected Model Outputs for the Evacuation of the Entire EPZ (Region R03)

Scenario	1	2	3	4	5	6	7
Network-Wide Average Travel Time (Min/Veh-Mi)	3.3	3.8	2.9	3.6	3.0	3.3	3.7
Network-Wide Average Speed (mph)	18.1	15.6	20.4	16.9	20.0	18.0	16.1
Total Vehicles Exiting Network	124,077	125,054	107,744	108,209	98,792	124,113	124,716
Scenario	8	9	10	11	12	13	14
Network-Wide Average Travel Time (Min/Veh-Mi)	4.4	3.0	3.6	4.0	3.0	3.0	3.7
Network-Wide Average Speed (mph)	13.7	20.1	16.7	15.0	20.0	20.4	16.4
Total Vehicles Exiting Network	124,929	104,879	105,461	105,658	97,417	101,494	123,963

Table J-4. Average Speed (mph) and Travel Time (min) for Major Evacuation Routes (Region R03, Scenario 1)

Route#	Length (miles)	1		2		3		4		5	
		Speed (mph)	Travel Time (min)	Speed	Travel Time	Speed	Travel Time	Speed	Travel Time	Speed	Travel Time
NC-540 Toll Northbound	8.5	71.6	7.1	71.7	7.1	71.7	7.1	65.0	7.8	71.7	7.1
US-64 Eastbound	8.9	8.1	65.4	38.1	14.0	53.8	9.9	54.4	9.8	60.8	8.7
US-64 Westbound	8.0	55.8	8.6	56.4	8.5	57.4	8.4	56.8	8.5	60.0	8.0
US-1 Northbound	9.4	27.1	20.9	28.3	20.0	73.1	7.7	69.8	8.1	73.1	7.7
US-1 Southbound	11.3	75.0	9.0	75.0	9.0	75.0	9.0	75.0	9.0	75.0	9.0
NC-42 Westbound	6.9	52.1	8.0	52.3	7.9	53.3	7.8	52.2	8.0	54.3	7.6
NC-55 Northbound	9.2	10.9	50.8	18.0	30.6	45.5	12.1	45.2	12.2	50.8	10.9
US-401 Northbound	8.8	25.4	20.9	36.5	14.5	42.9	12.3	44.2	12.0	43.7	12.1
US-401 Southbound	8.1	5.4	90.8	6.8	71.2	18.8	25.8	43.9	11.1	47.8	10.2

Table J-5. Simulation Model Outputs at Network Exit Links for Region R03, Scenario 1

Network Exit Link	Elapsed Time (hours)				
	1	2	3	4	5
	Cumulative Vehicles Discharged by the Indicated Time				
	Cumulative Percent of Vehicles Discharged by the Indicated Time				
26	4,124	6,642	9,298	10,303	10,396
	14%	9%	9%	9%	8%
210	52	232	321	351	354
	0%	0%	0%	0%	0%
247	1,123	2,704	2,995	3,066	3,072
	4%	4%	3%	3%	2%
319	460	1,298	1,590	1,681	1,694
	2%	2%	2%	1%	1%
377	2,144	5,041	7,594	9,786	10,893
	7%	7%	7%	8%	9%
689	694	2,592	3,854	4,523	4,591
	2%	4%	4%	4%	4%
929	744	1,325	1,458	1,490	1,494
	3%	2%	1%	1%	1%
1101	51	434	668	745	751
	0%	1%	1%	1%	1%
1153	814	2,167	3,425	4,625	5,327
	3%	3%	3%	4%	4%
1194	686	1,117	1,215	1,244	1,247
	2%	2%	1%	1%	1%
1231	49	267	369	399	401
	0%	0%	0%	0%	0%
1460	194	505	668	802	976
	1%	1%	1%	1%	1%
1464	700	1,630	2,215	2,581	3,006
	2%	2%	2%	2%	2%
1648	425	1,613	2,762	3,911	4,979
	1%	2%	3%	3%	4%
1874	476	3,714	6,229	6,607	6,629
	2%	5%	6%	6%	5%
1964	414	1,333	2,187	2,599	2,647
	1%	2%	2%	2%	2%
2307	533	1,902	2,753	3,118	3,196
	2%	3%	3%	3%	3%

Network Exit Link	Elapsed Time (hours)				
	1	2	3	4	5
	Cumulative Vehicles Discharged by the Indicated Time				
	Cumulative Percent of Vehicles Discharged by the Indicated Time				
2318	940	3,329	4,669	5,376	5,408
	3%	5%	5%	5%	4%
2405	216	313	343	352	354
	1%	0%	0%	0%	0%
2477	889	1,473	1,688	1,756	1,763
	3%	2%	2%	1%	1%
2550	1,003	1,794	2,091	2,171	2,179
	3%	3%	2%	2%	2%
2574	1,347	3,277	5,073	6,576	7,355
	5%	5%	5%	6%	6%
2633	423	1,353	1,898	2,166	2,374
	1%	2%	2%	2%	2%
2666	359	1,016	1,260	1,342	1,353
	1%	1%	1%	1%	1%
2707	747	2,057	2,713	3,068	3,132
	3%	3%	3%	3%	3%
2737	918	2,086	2,768	3,149	3,498
	3%	3%	3%	3%	3%
2817	853	3,280	5,566	5,875	5,900
	3%	5%	5%	5%	5%
2820	4,740	9,029	13,310	14,387	14,637
	16%	13%	13%	12%	12%
2822	3,407	7,586	11,702	13,642	13,823
	12%	11%	11%	12%	11%

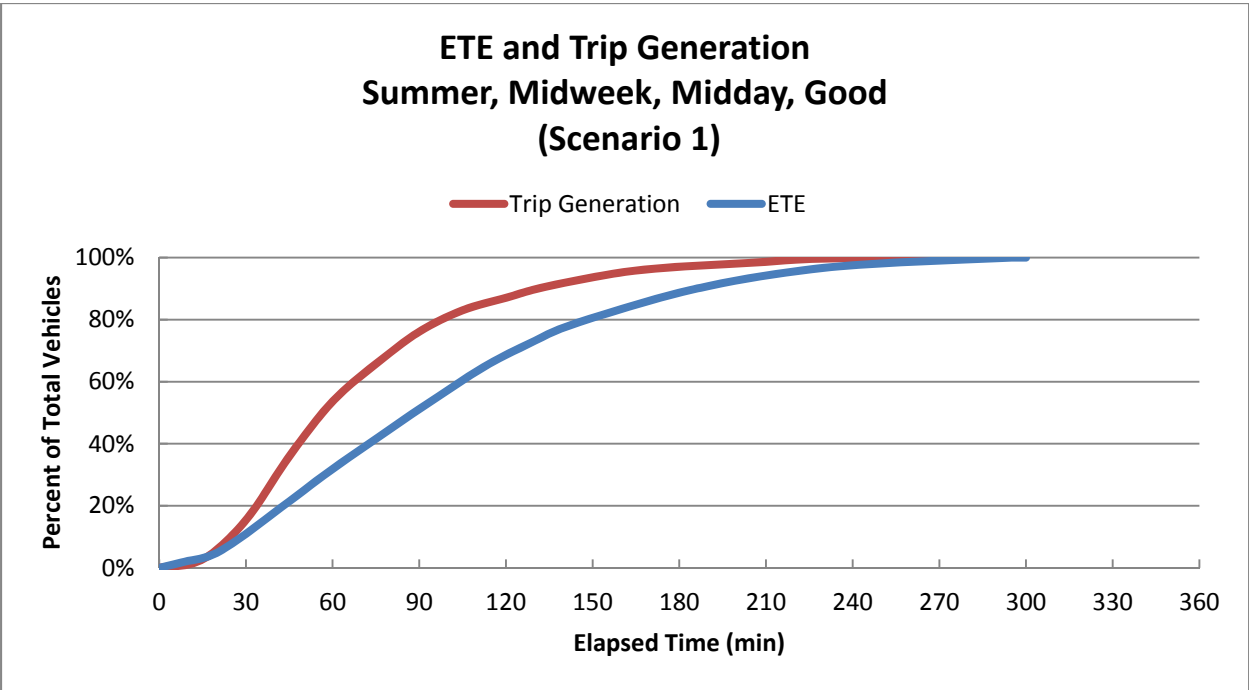

Figure J-1. ETE and Trip Generation: Summer, Midweek, Midday, Good Weather (Scenario 1)

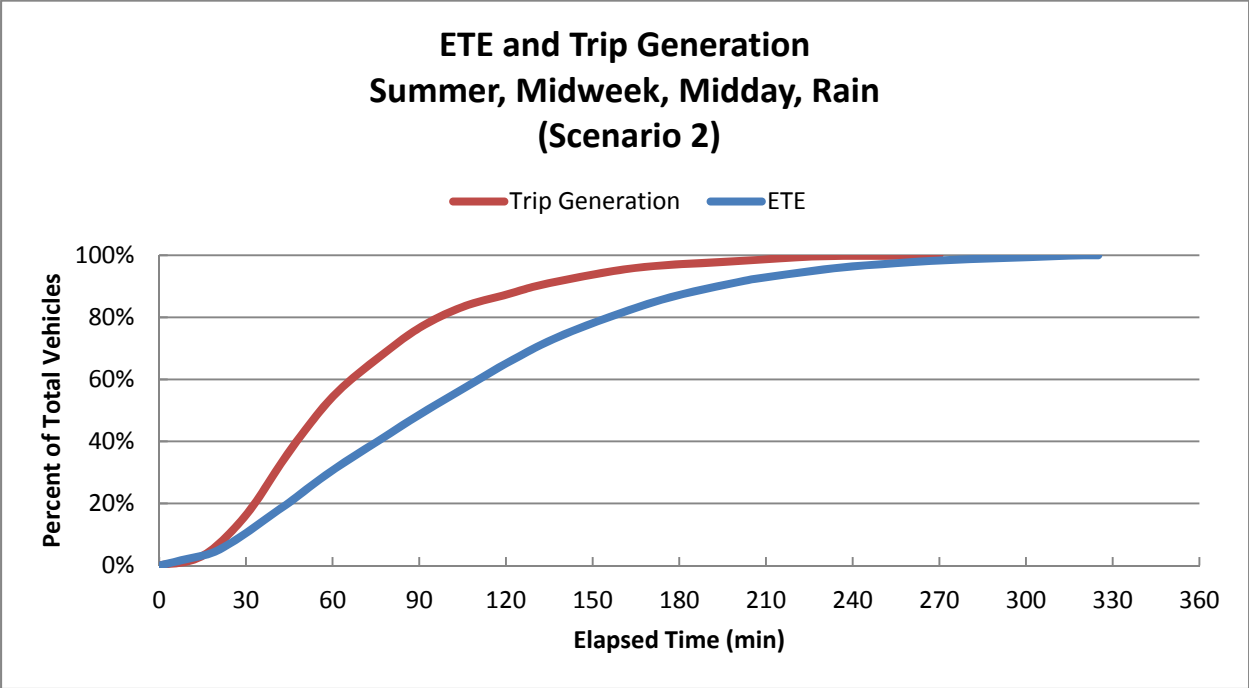

Figure J-2. ETE and Trip Generation: Summer, Midweek, Midday, Rain (Scenario 2)

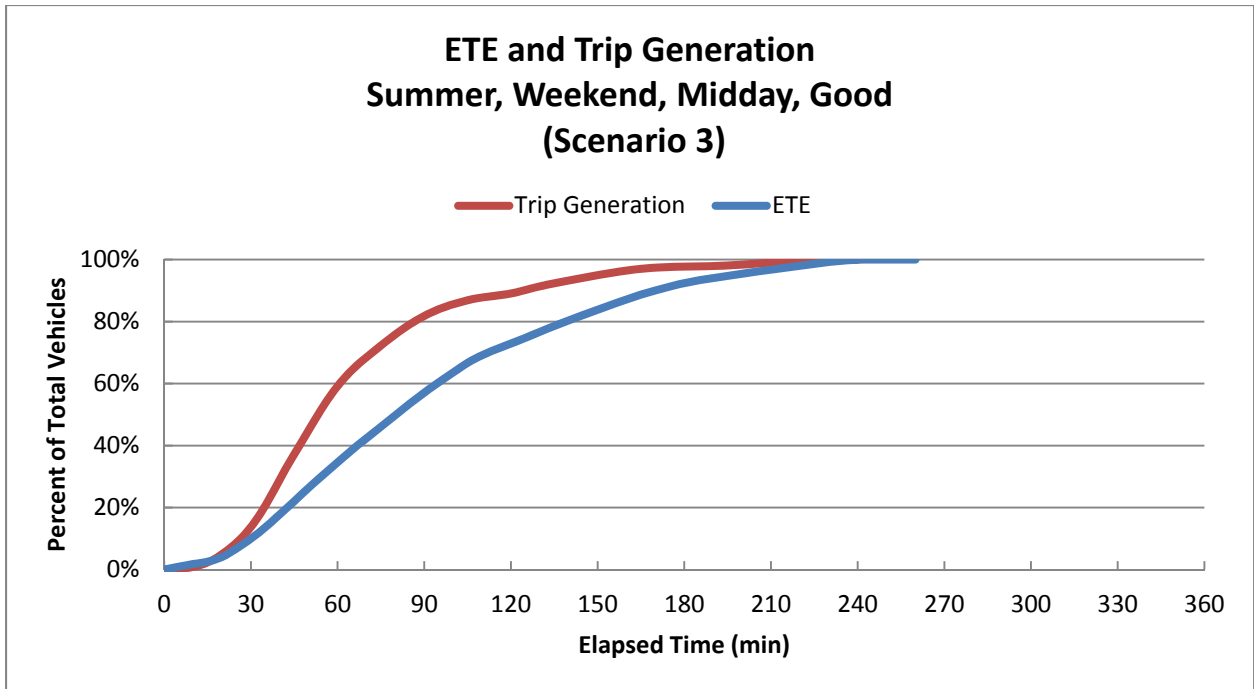

Figure J-3. ETE and Trip Generation: Summer, Weekend, Midday, Good Weather (Scenario 3)

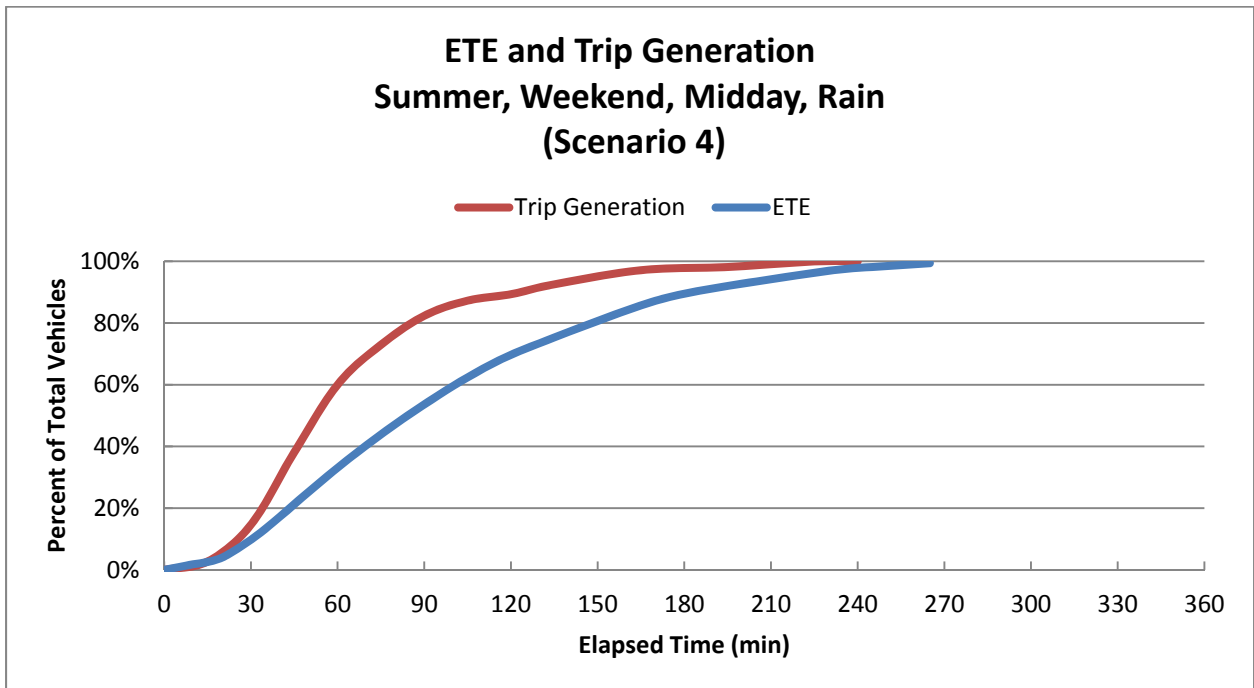

Figure J-4. ETE and Trip Generation: Summer, Weekend, Midday, Rain (Scenario 4)

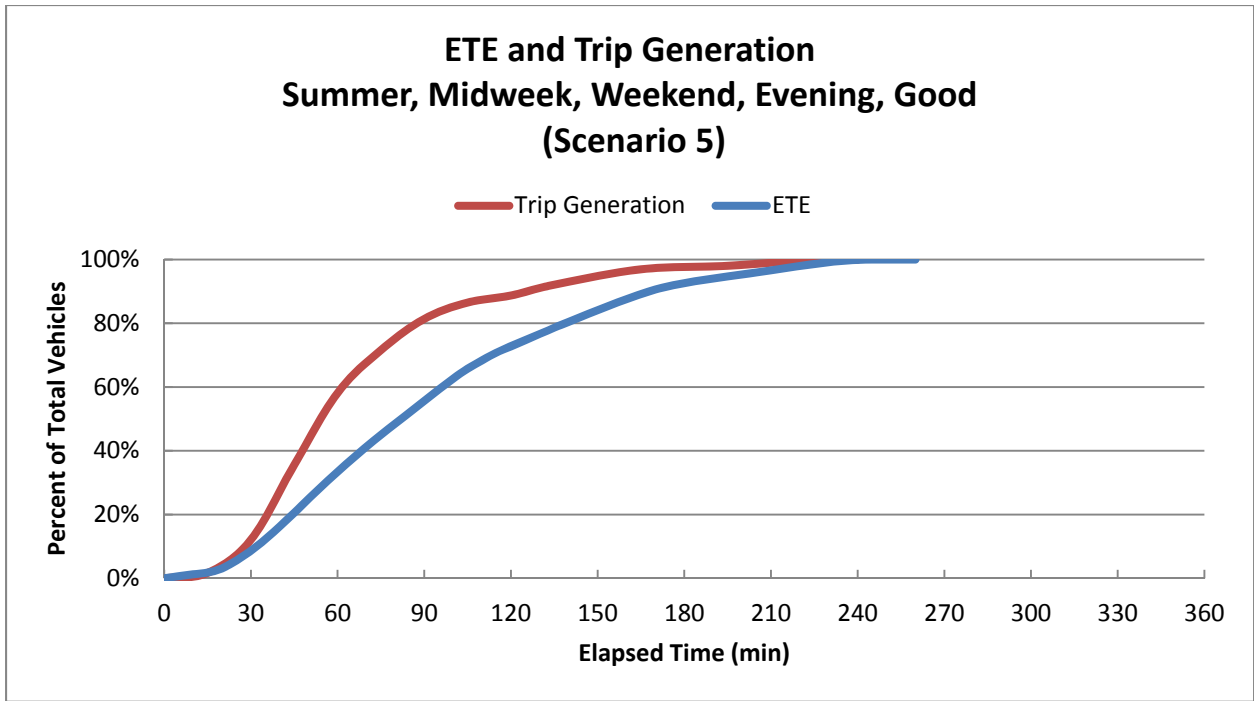

Figure J-5. ETE and Trip Generation: Summer, Midweek, Weekend, Evening, Good Weather (Scenario 5)

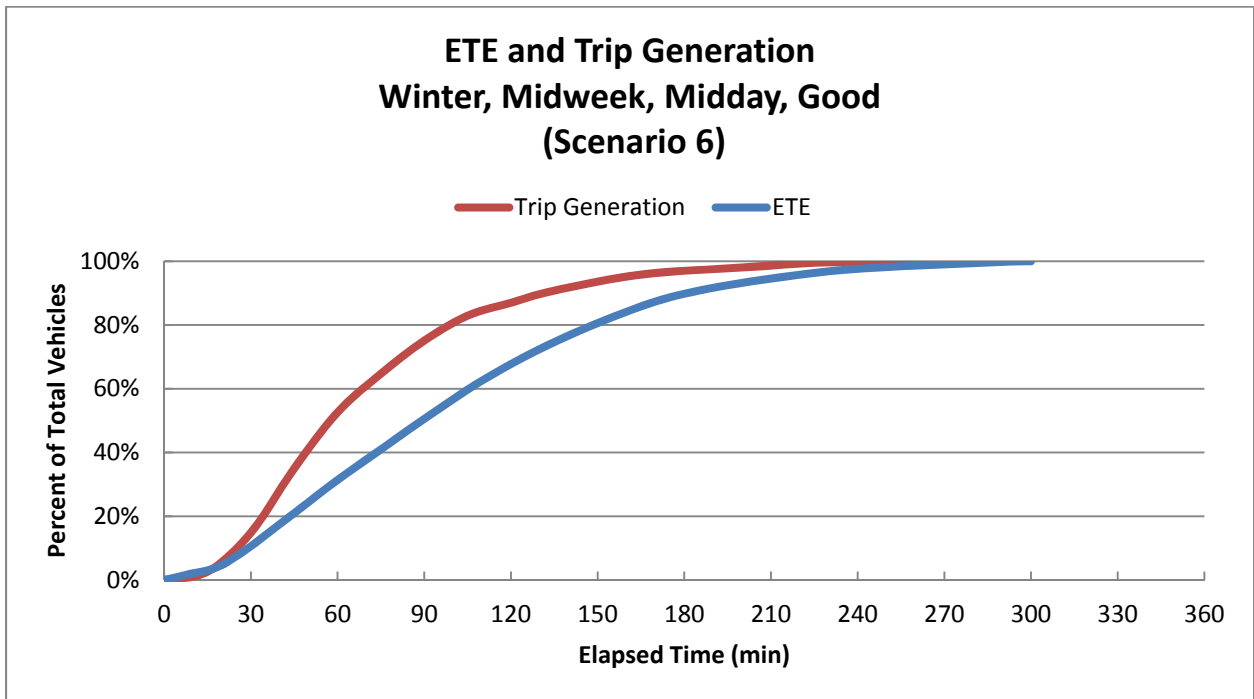

Figure J-6. ETE and Trip Generation: Winter, Midweek, Midday, Good Weather (Scenario 6)

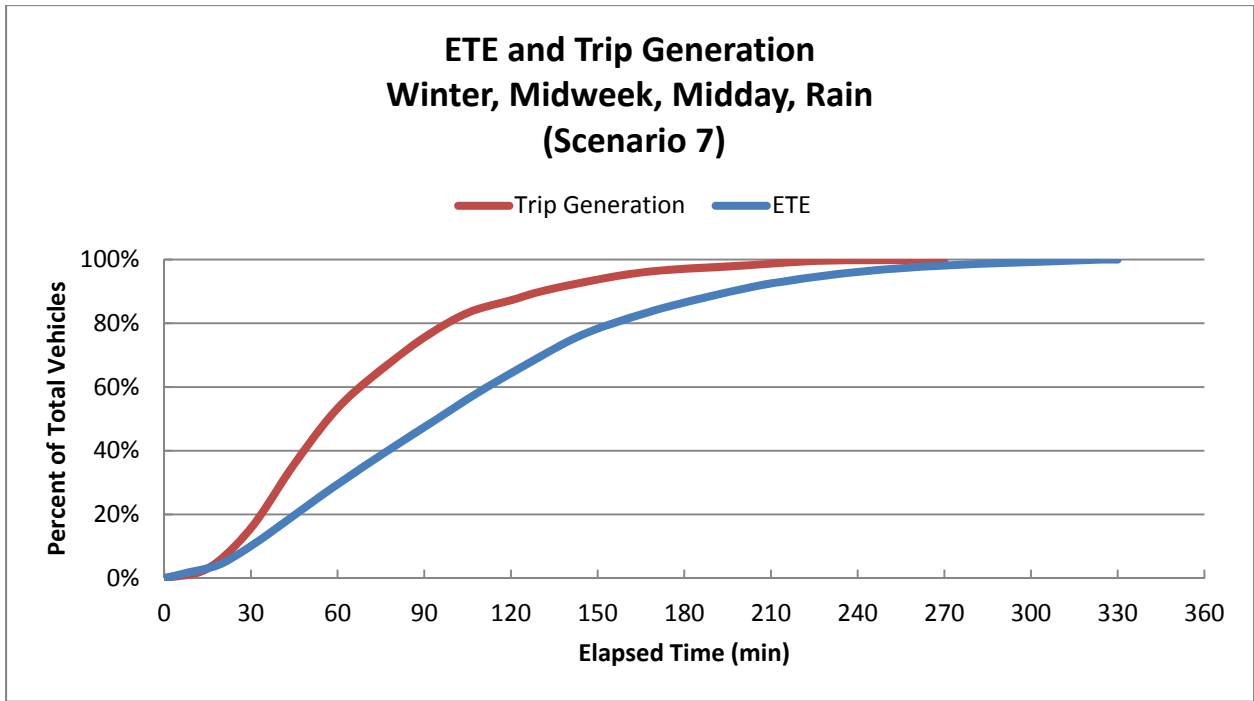

Figure J-7. ETE and Trip Generation: Winter, Midweek, Midday, Rain (Scenario 7)

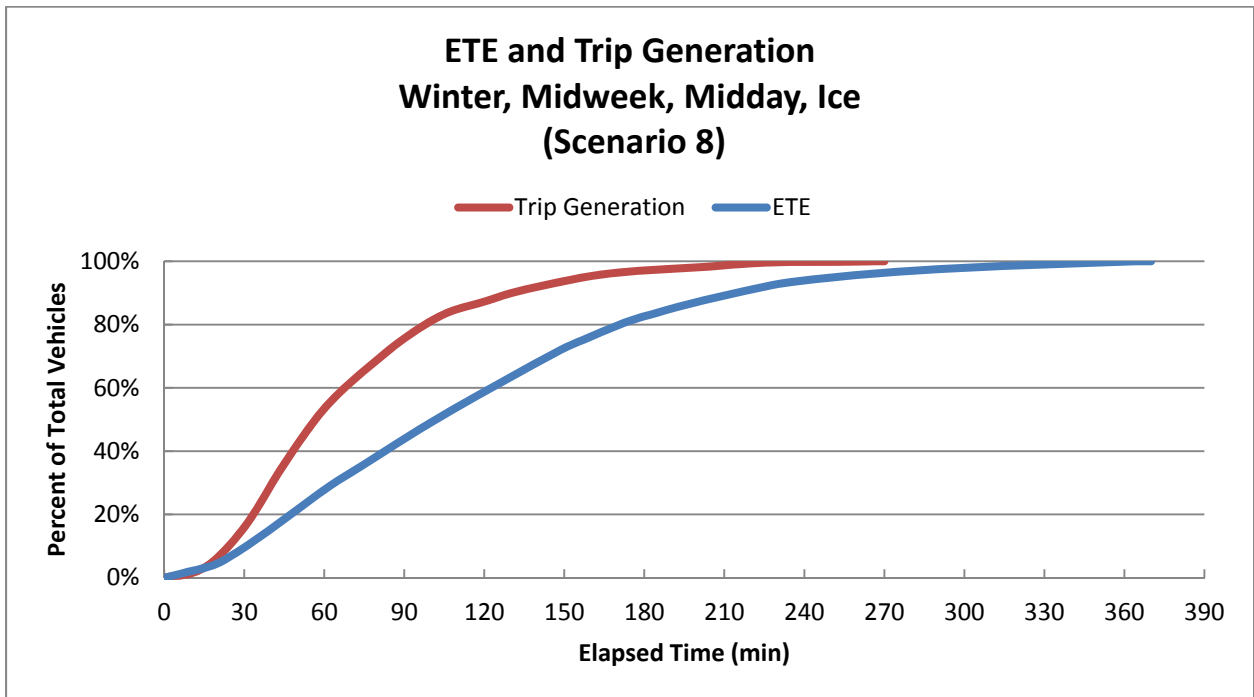

Figure J-8. ETE and Trip Generation: Winter, Midweek, Midday, Ice (Scenario 8)

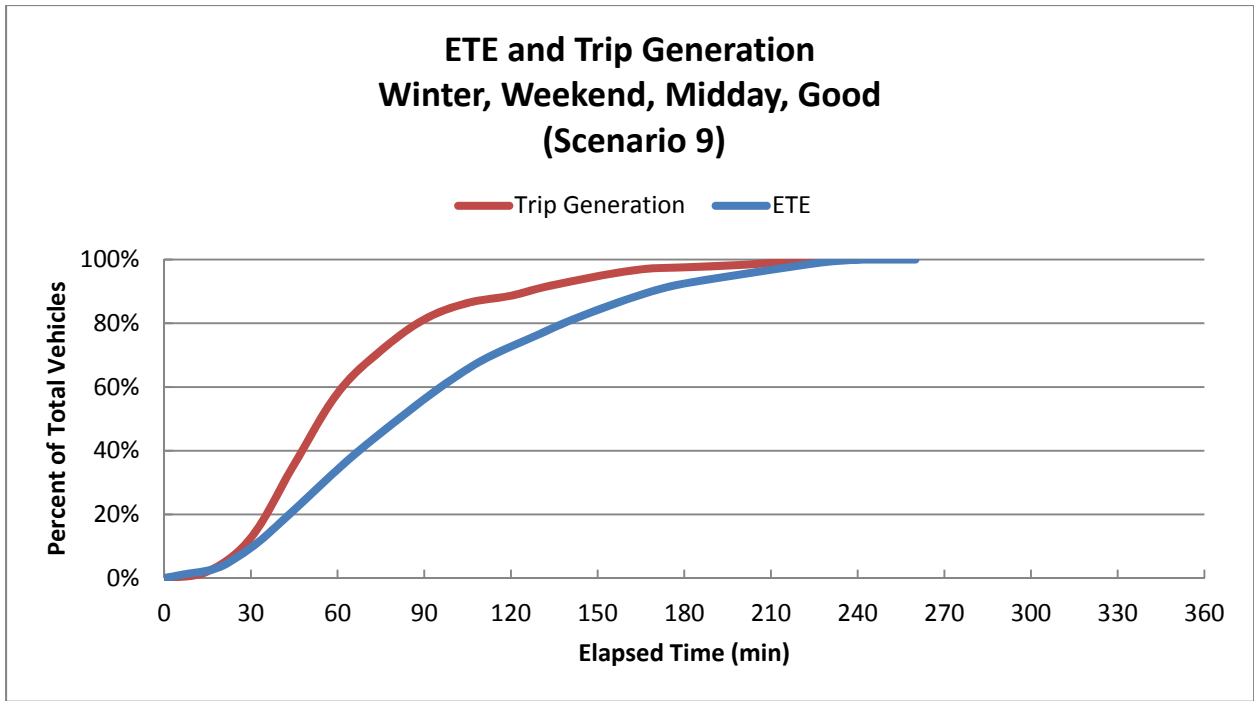

Figure J-9. ETE and Trip Generation: Winter, Weekend, Midday, Good Weather (Scenario 9)

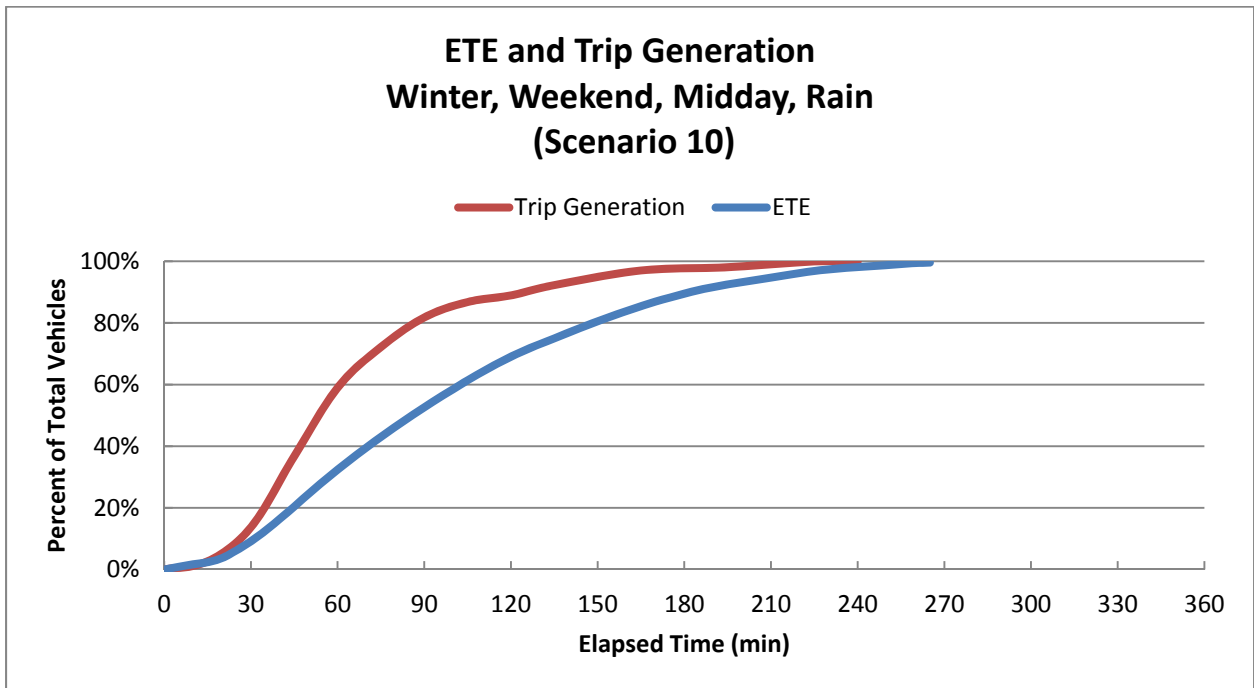

Figure J-10. ETE and Trip Generation: Winter, Weekend, Midday, Rain (Scenario 10)

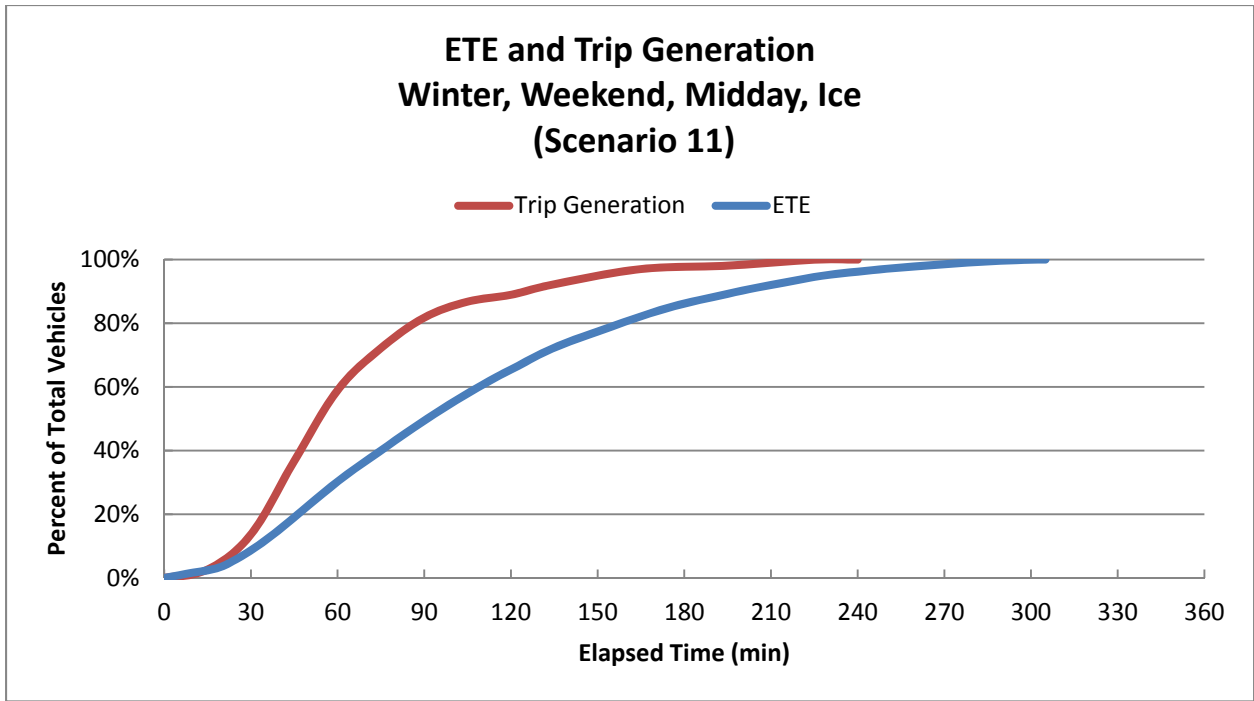

Figure J-11. ETE and Trip Generation: Winter, Weekend, Midday, Ice (Scenario 11)

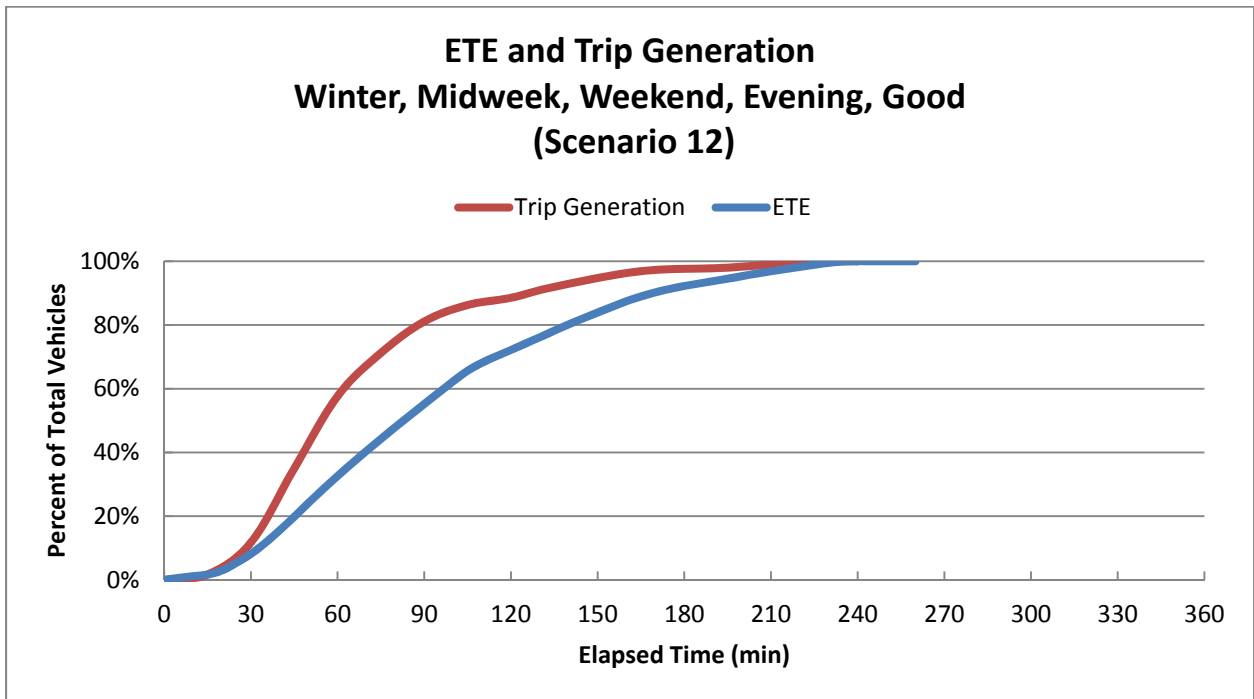

Figure J-12. ETE and Trip Generation: Winter, Midweek, Weekend, Evening, Good Weather (Scenario 12)

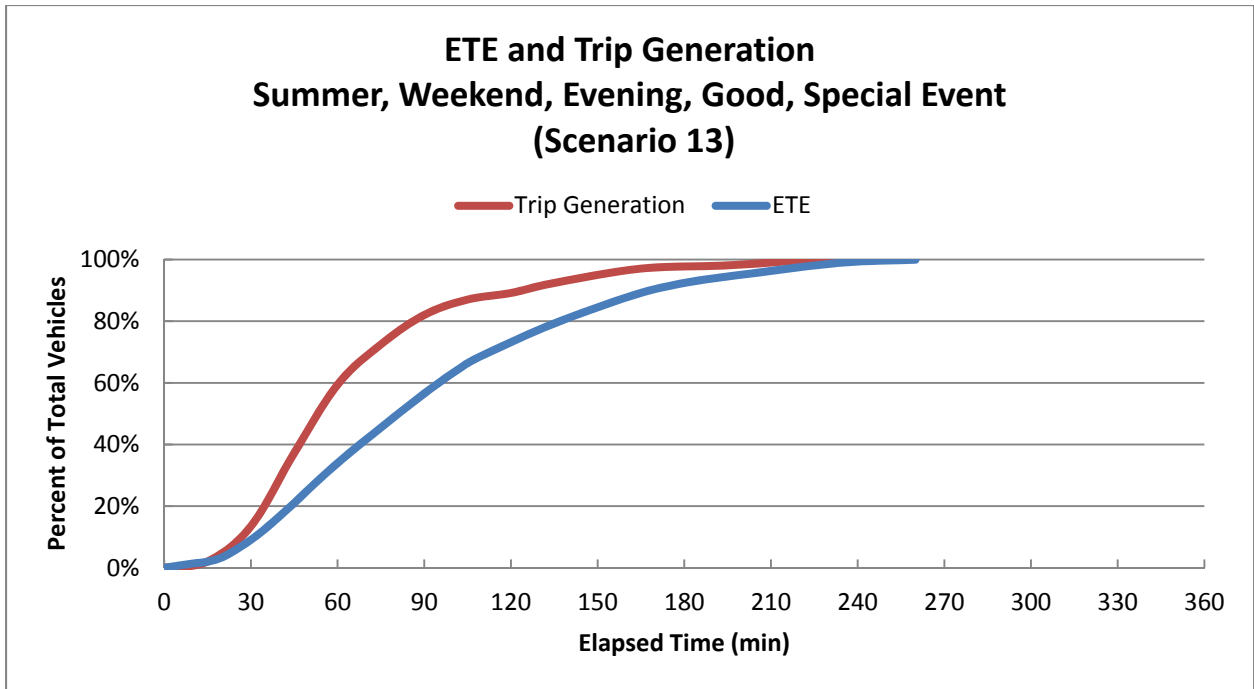

Figure J-13. ETE and Trip Generation: Summer, Weekend, Evening, Good Weather, Special Event (Scenario 13)

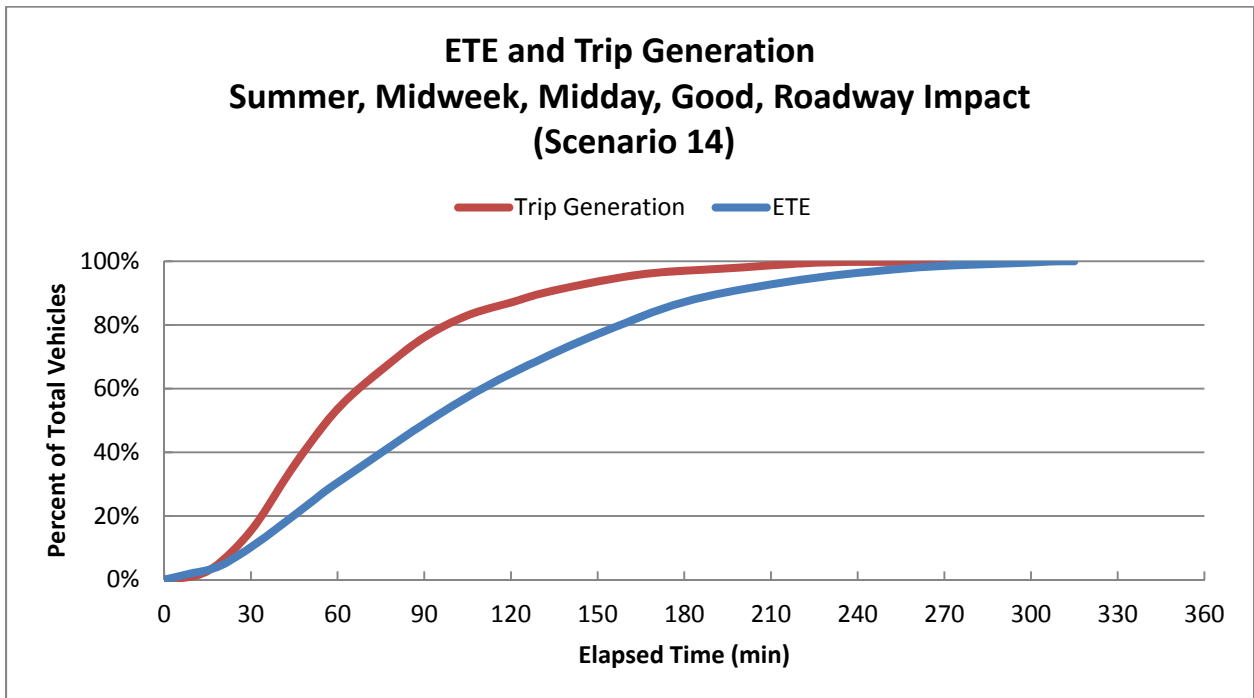

Figure J-14. ETE and Trip Generation: Summer, Midweek, Midday, Good Weather, Roadway Impact (Scenario 14)

APPENDIX K

Evacuation Roadway Network

K. EVACUATION ROADWAY NETWORK

As discussed in Section 1.3, a link-node analysis network was constructed to model the roadway network within the study area. Figure K-1 provides an overview of the link-node analysis network. The figure has been divided up into 43 more detailed figures (Figure K-2 through Figure K-44) which show each of the links and nodes in the network.

The analysis network was calibrated using the observations made during the field surveys conducted in March 2012 and March 2016. Table K-1 lists the characteristics of each roadway section modeled in the ETE analysis. Each link is identified by its road name and the upstream and downstream node numbers. The geographic location of each link can be observed by referencing the grid map number provided in Table K-1. The roadway type identified in Table K-1 is generally based on the following criteria:

- Freeway: limited access highway, 2 or more lanes in each direction, high free flow speeds
- Freeway ramp: ramp on to or off of a limited access highway
- Major arterial: 3 or more lanes in each direction
- Minor arterial: 2 or more lanes in each direction
- Collector: single lane in each direction
- Local roadway: single lane in each direction, local road with low free flow speeds

The term, “No. of Lanes” in Table K-1 identifies the number of lanes that extend throughout the length of the link. Many links have additional lanes on the immediate approach to an intersection (turn pockets); these have been recorded and entered into the input stream for the DYNEV II System.

As discussed in Section 1.3, lane width and shoulder width were not physically measured during the road survey. Rather, estimates of these measures were based on visual observations and recorded images.

Table K-2 identifies each node in the network that is controlled and the type of control (stop sign, yield sign, pre-timed signal, actuated signal, traffic control point) at that node. Uncontrolled nodes are not included in Table K-2. The location of each node can be observed by referencing the grid map number provided.

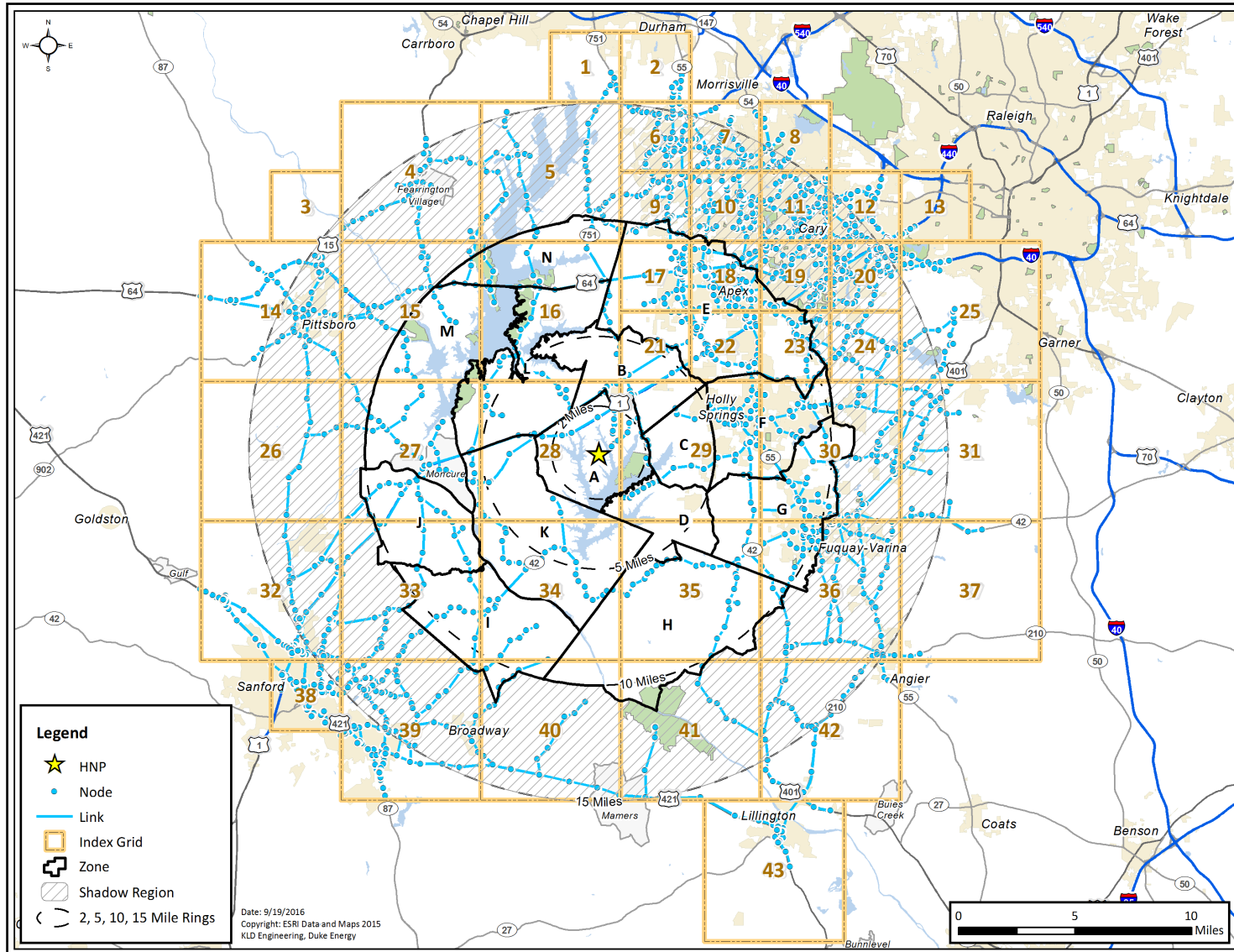

Figure K-1. Harris Link-Node Analysis Network

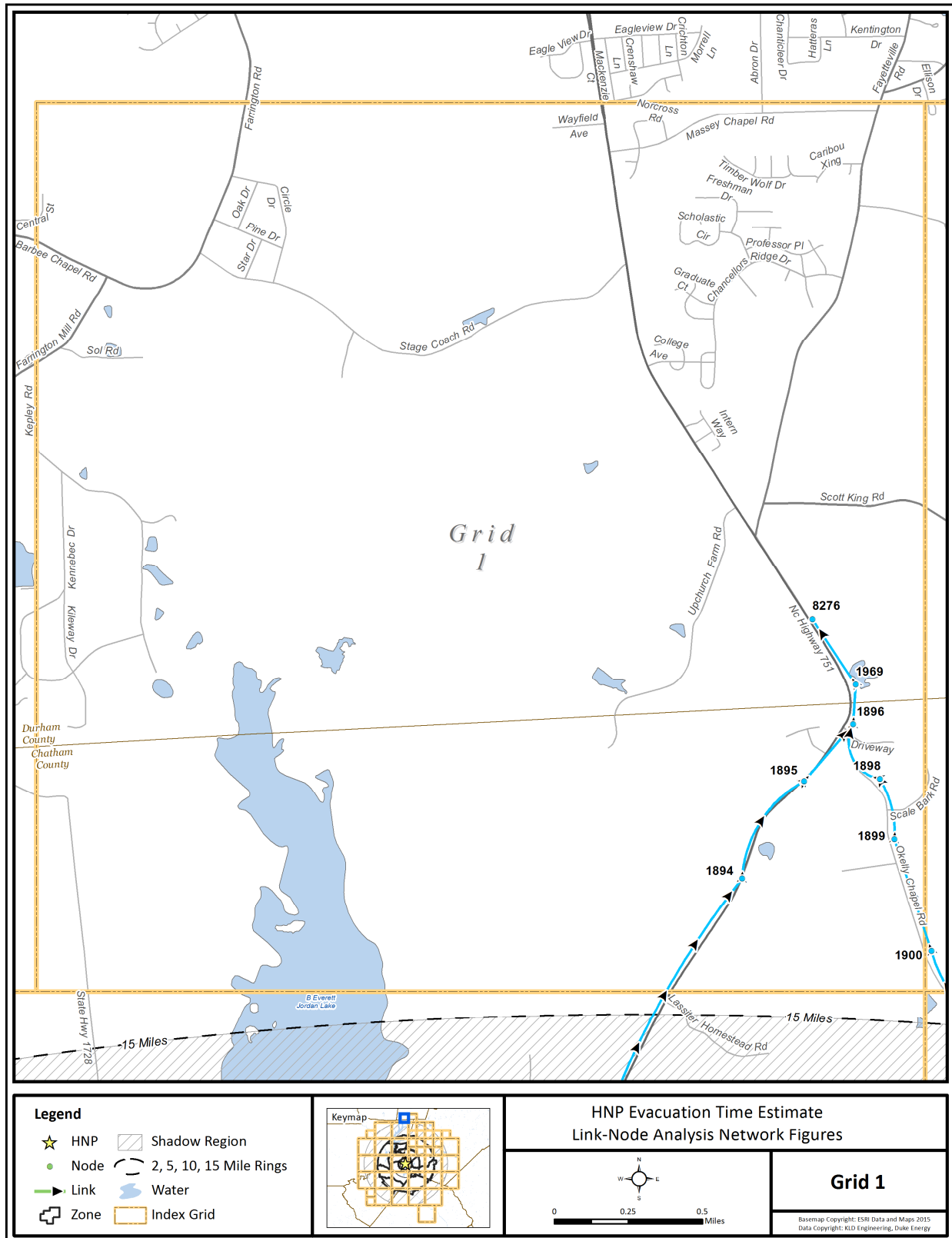

Figure K-2. Link-Node Analysis Network – Grid 1

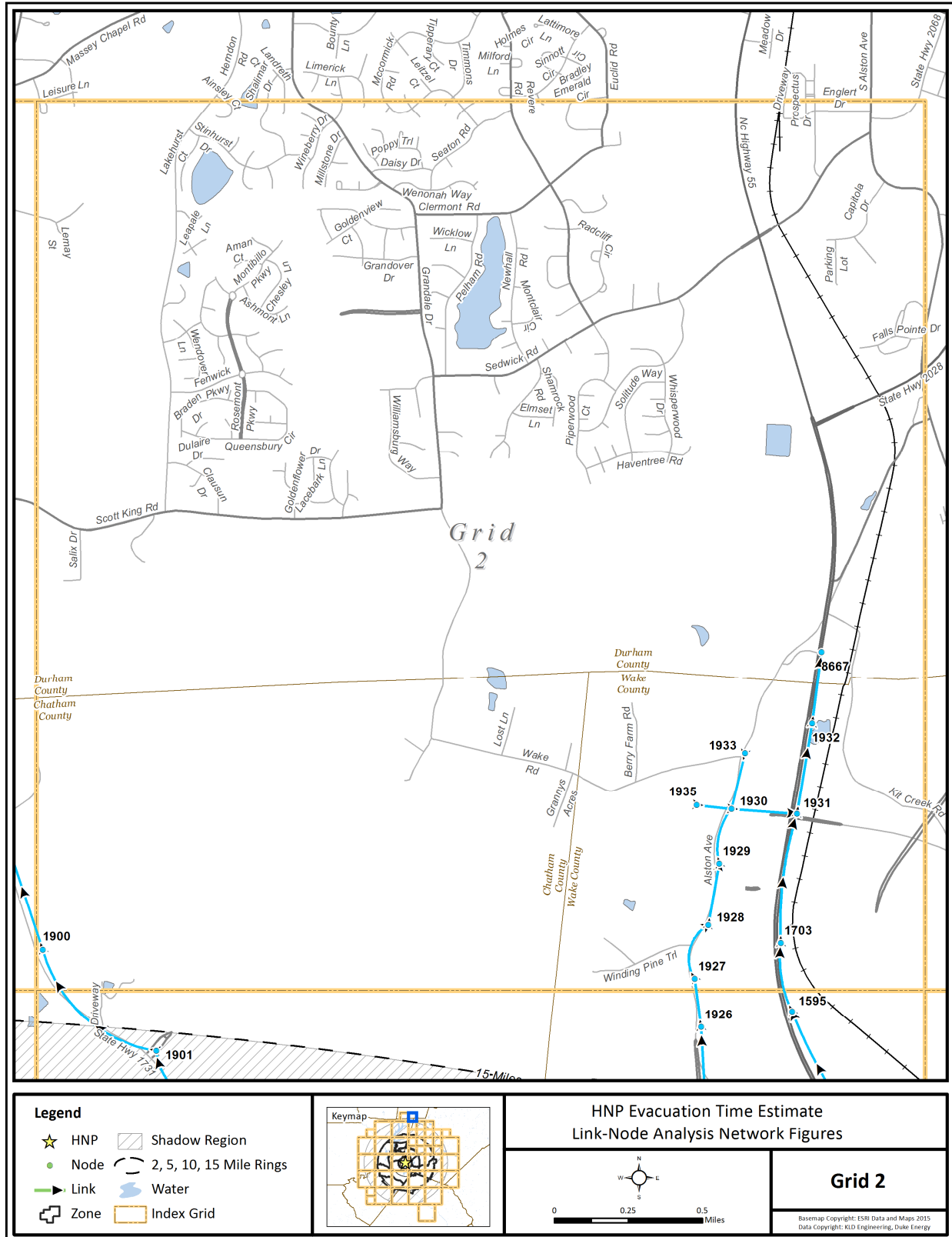

Figure K-3. Link-Node Analysis Network – Grid 2

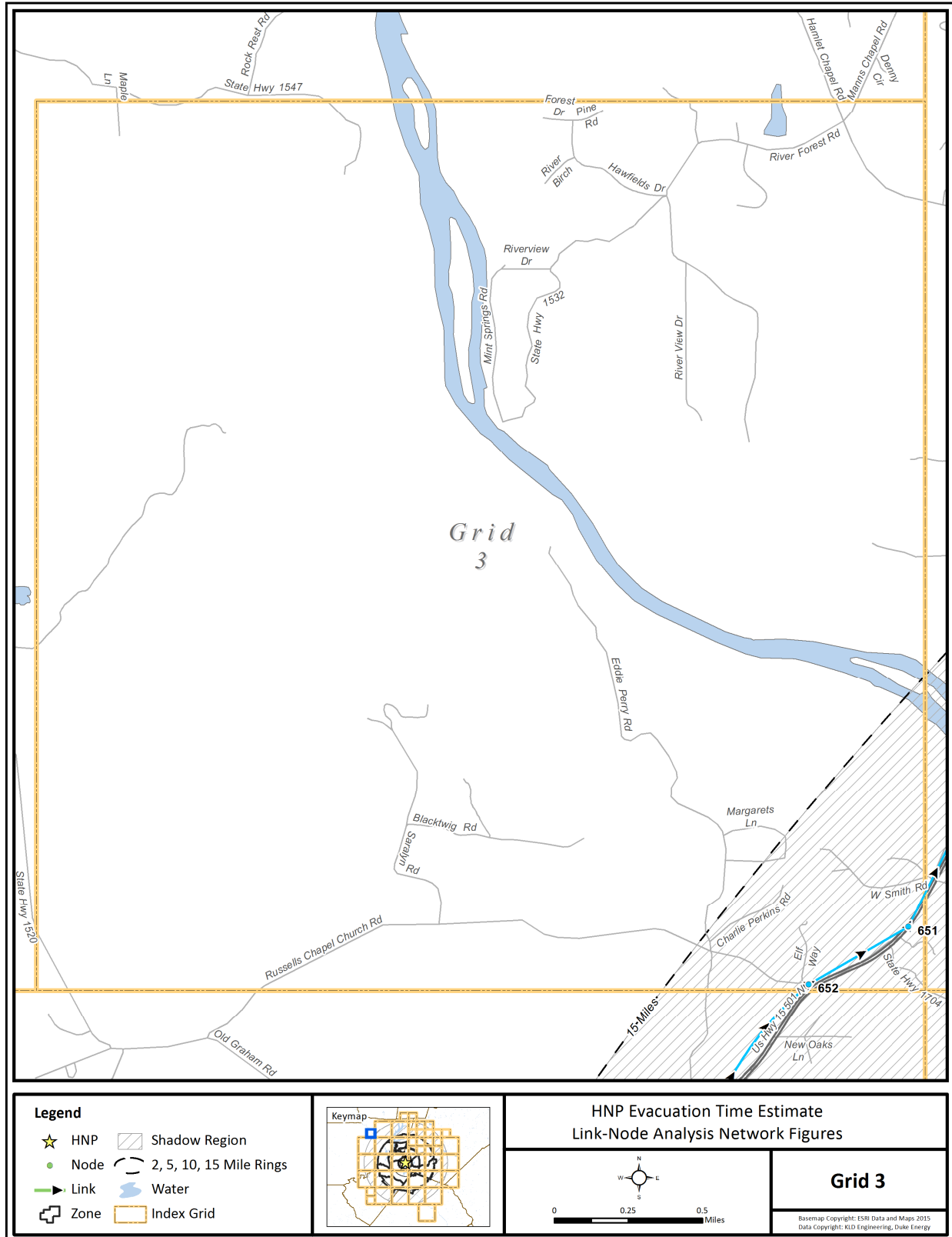

Figure K-4. Link-Node Analysis Network – Grid 3

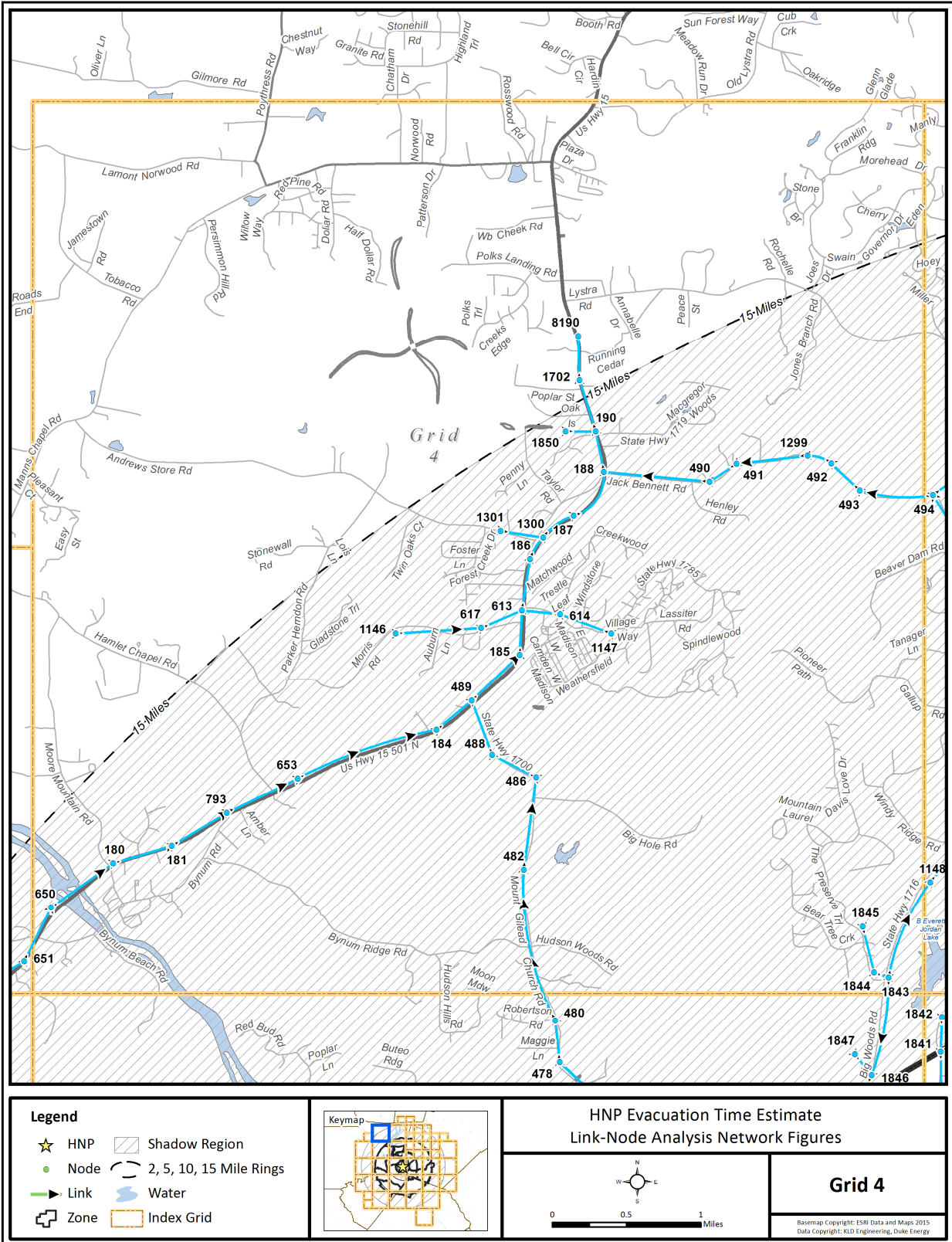

Figure K-5. Link-Node Analysis Network – Grid 4

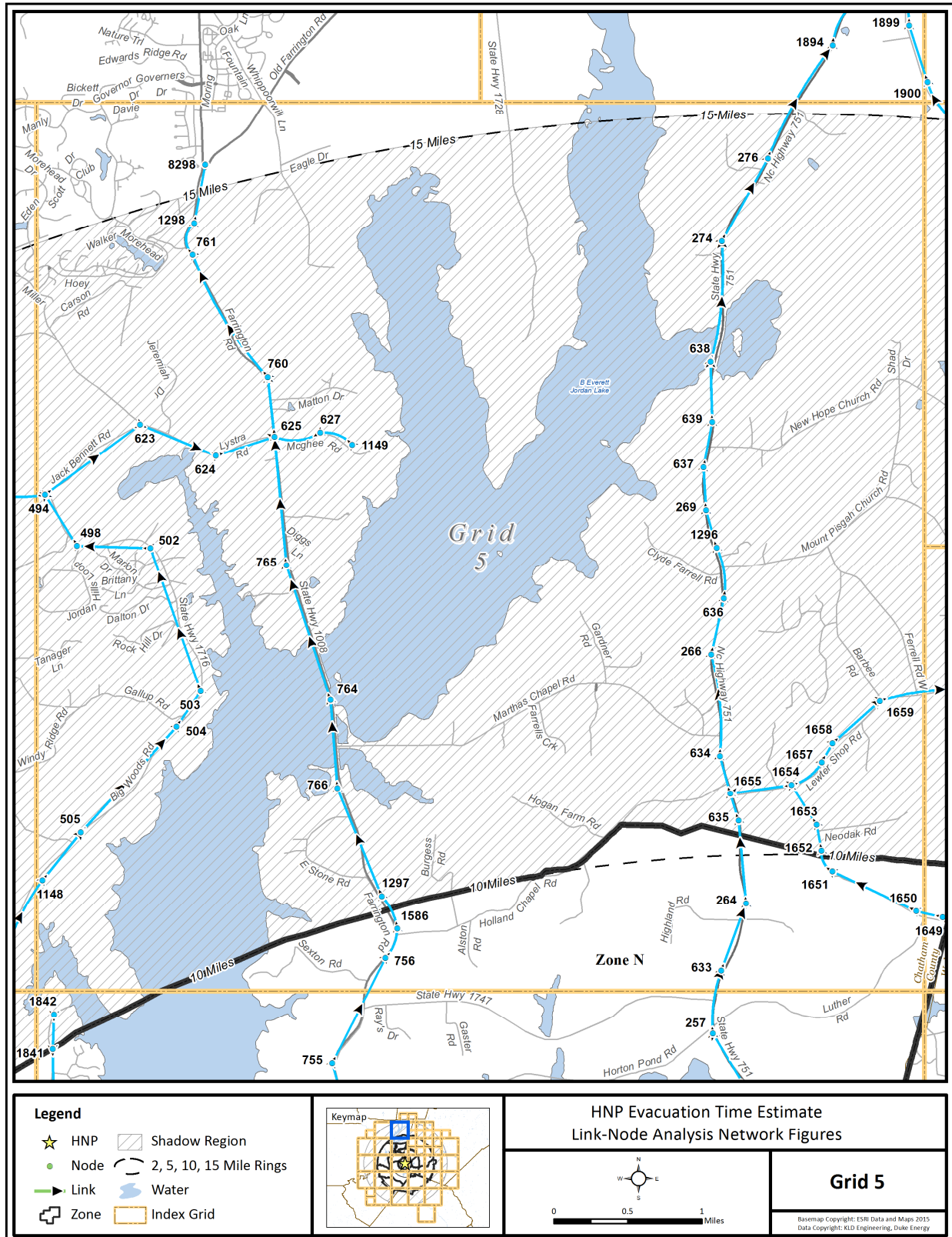

Figure K-6. Link-Node Analysis Network – Grid 5

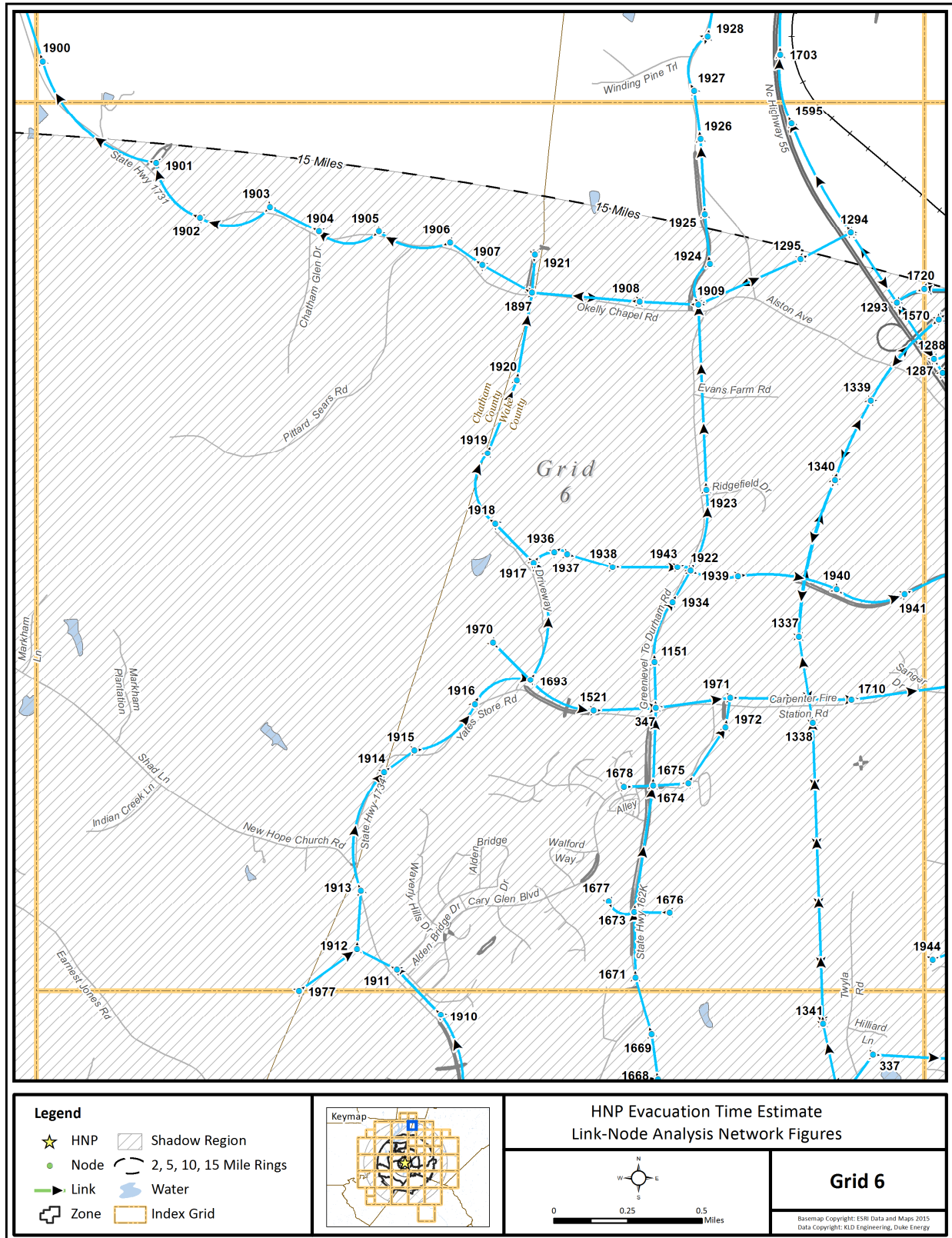

Figure K-7. Link-Node Analysis Network – Grid 6

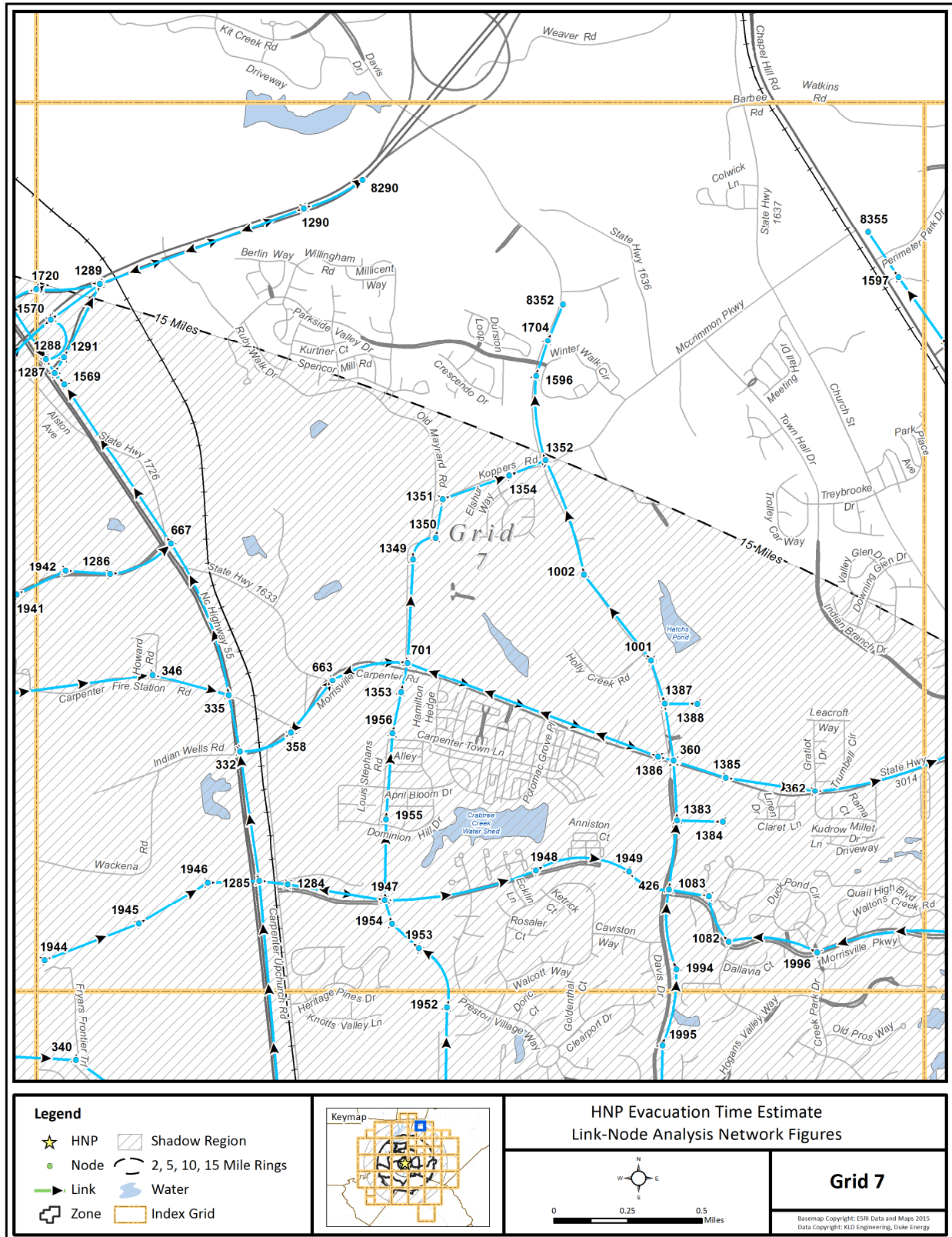

Figure K-8. Link-Node Analysis Network – Grid 7

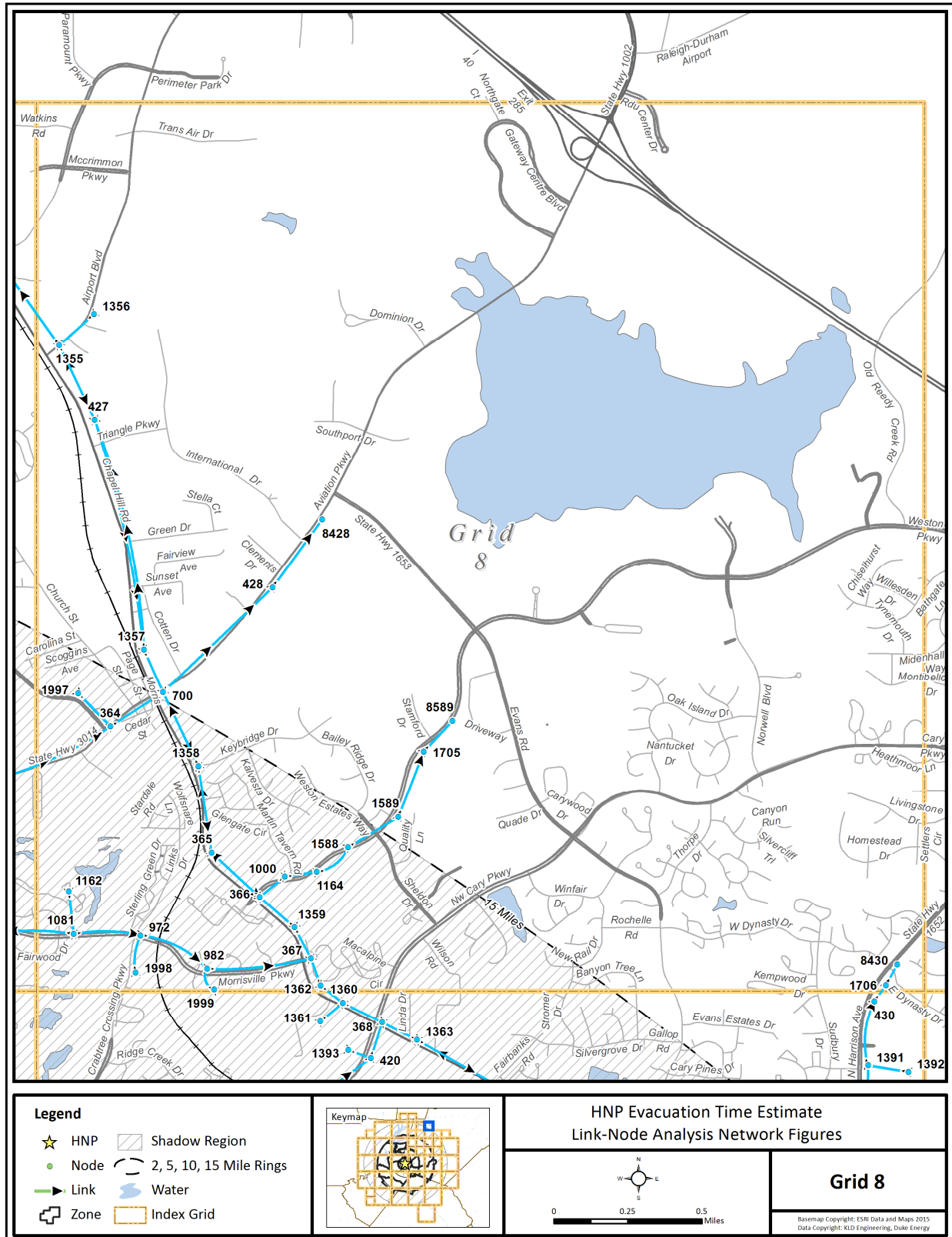

Figure K-9. Link-Node Analysis Network – Grid 8

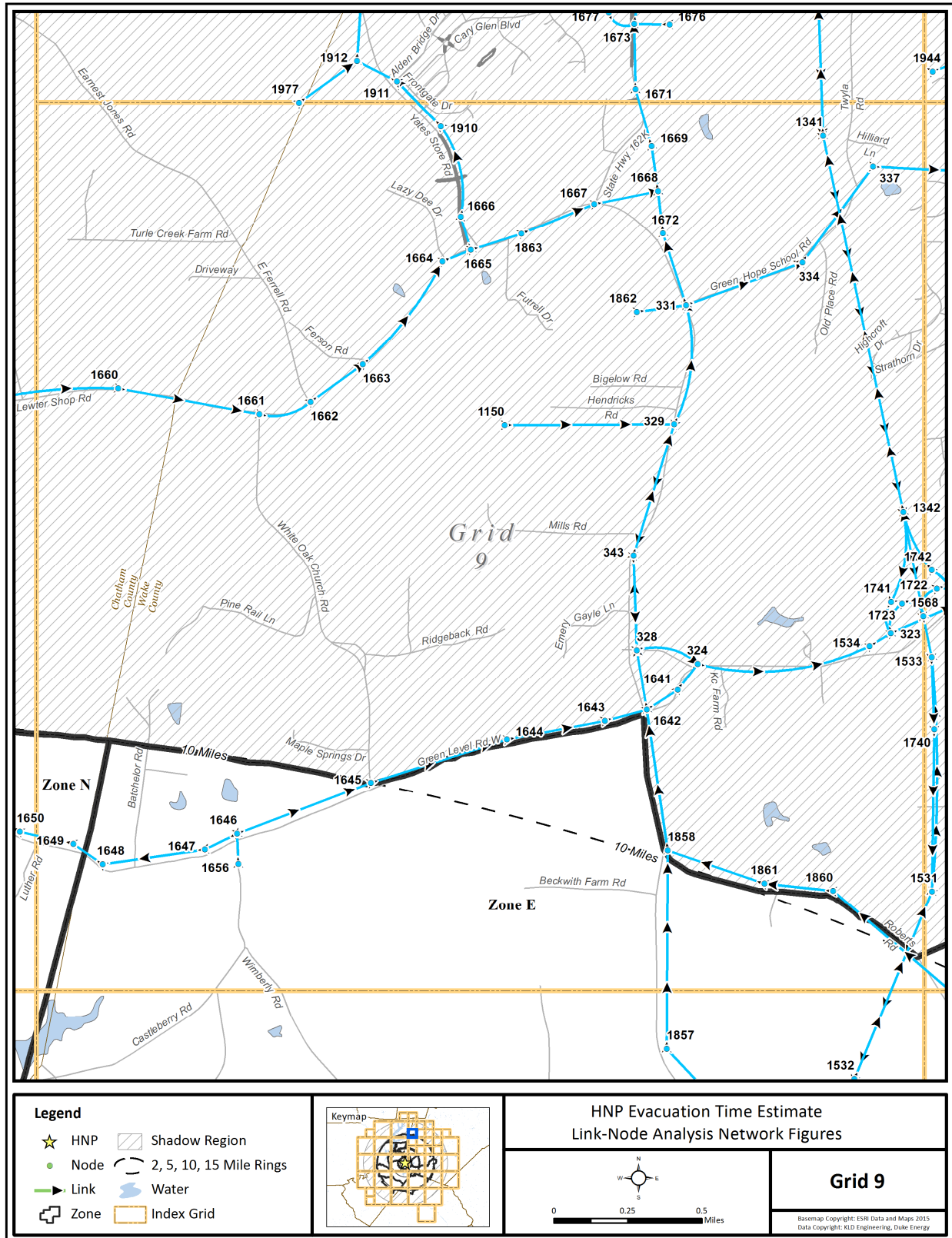

Figure K-10. Link-Node Analysis Network – Grid 9

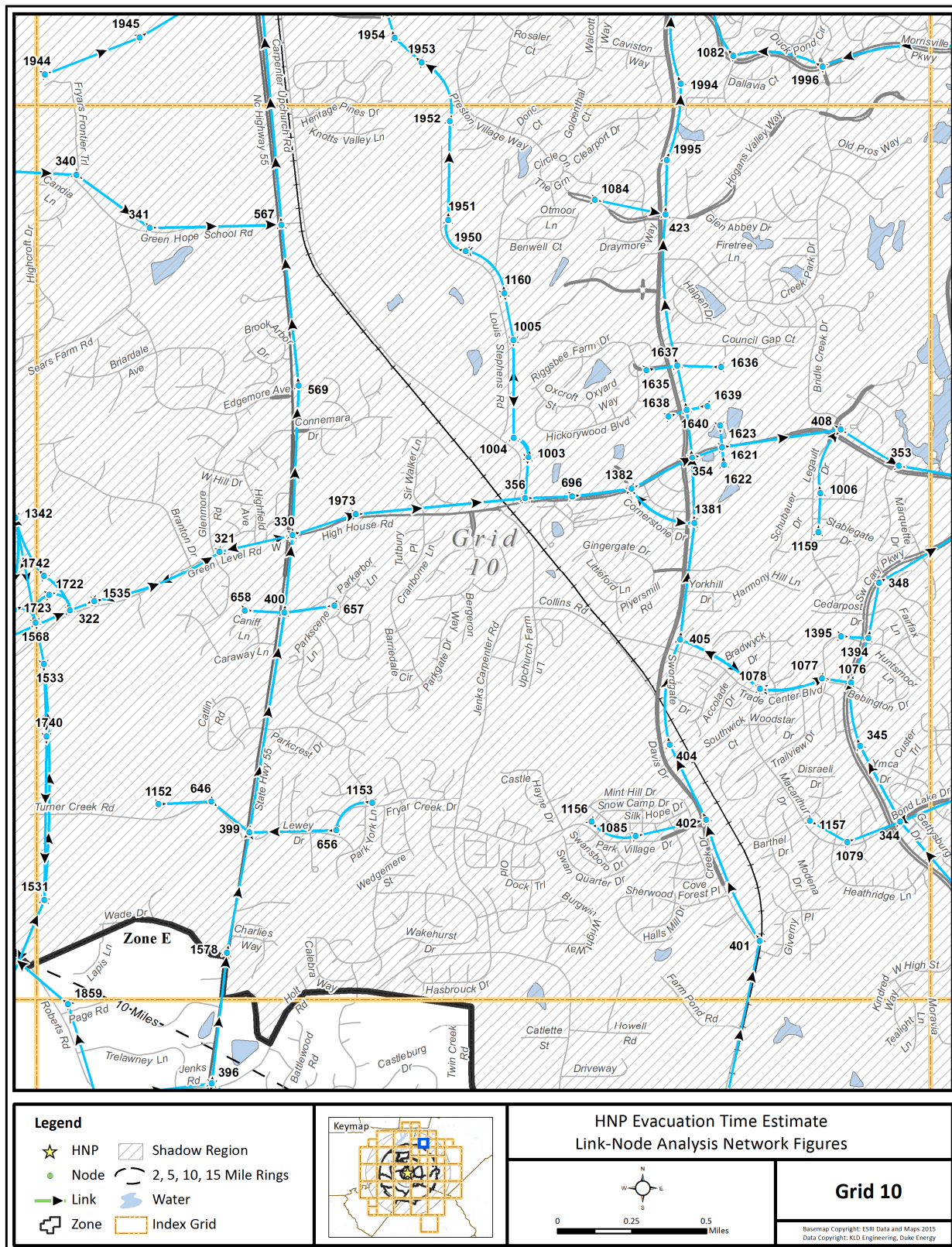

Figure K-11. Link-Node Analysis Network – Grid 10

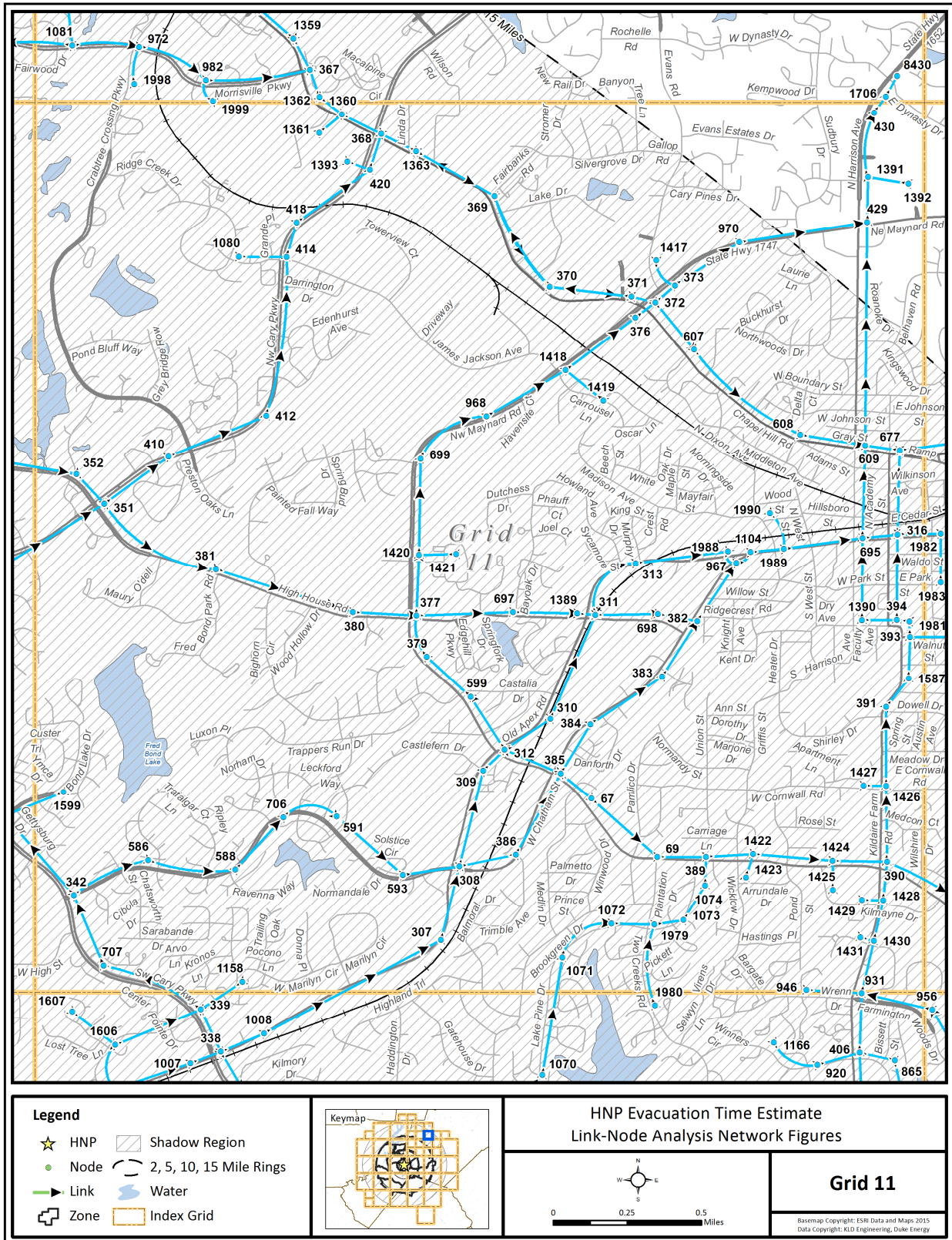

Figure K-12. Link-Node Analysis Network – Grid 11

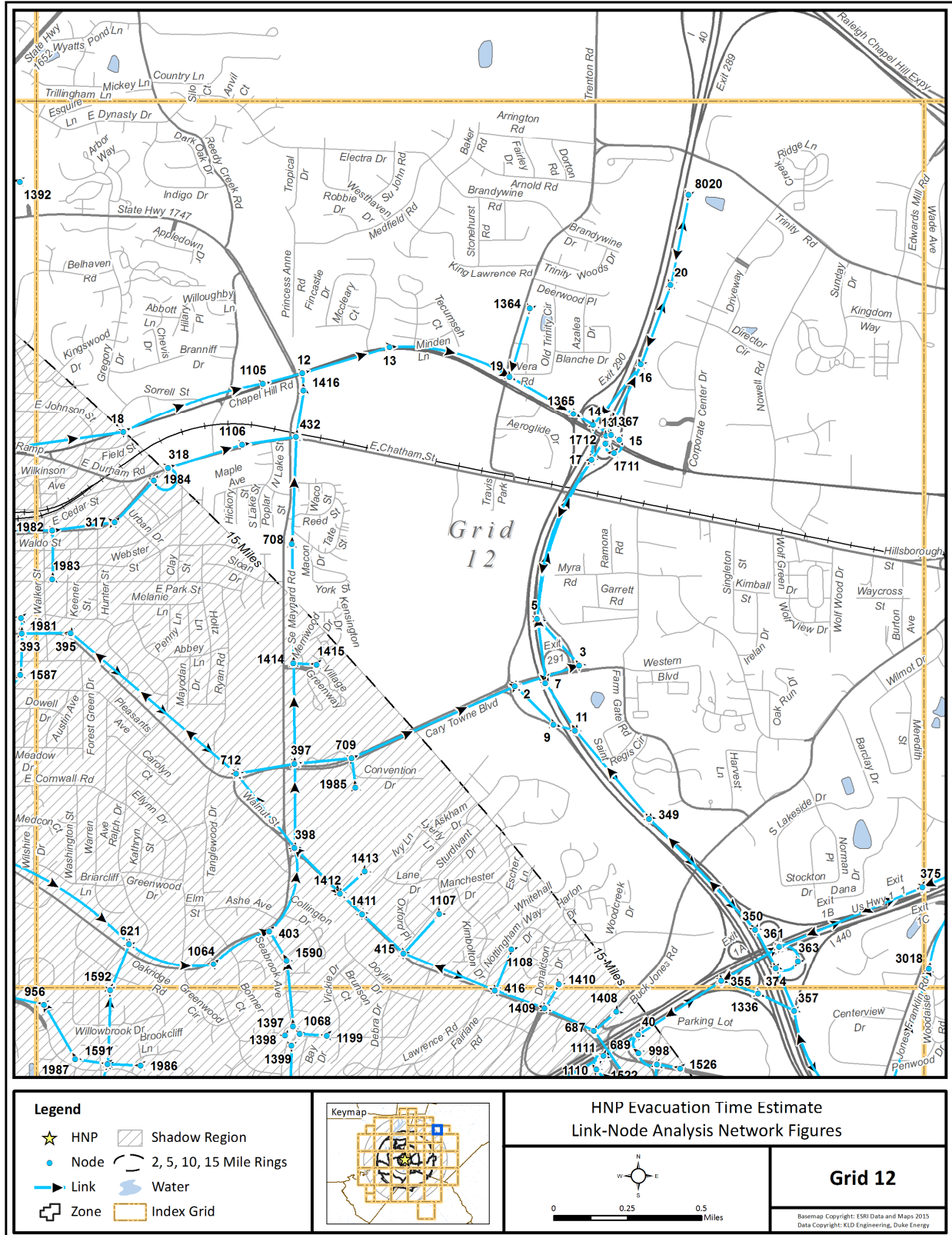

Figure K-13. Link-Node Analysis Network – Grid 12

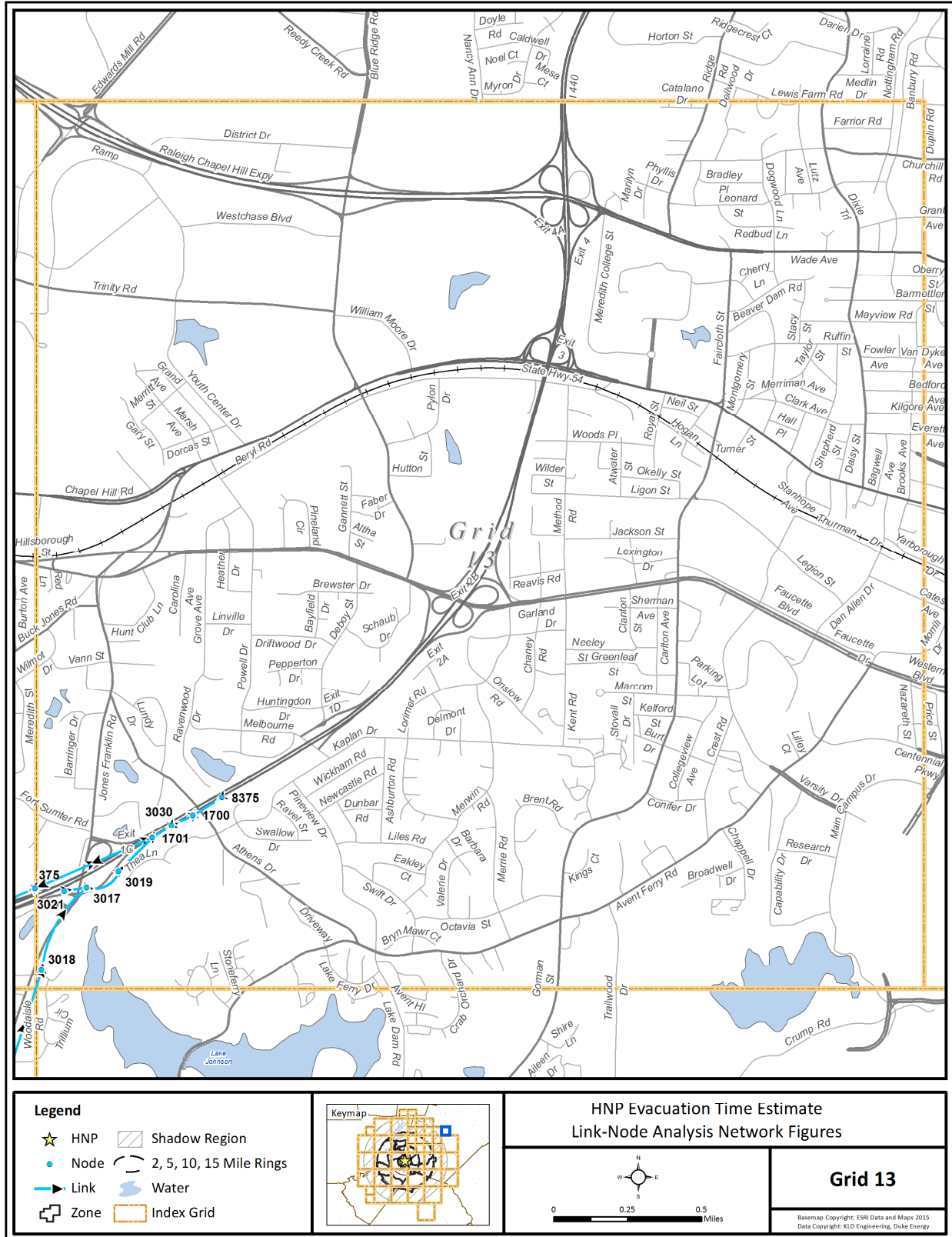

Figure K-14. Link-Node Analysis Network – Grid 13

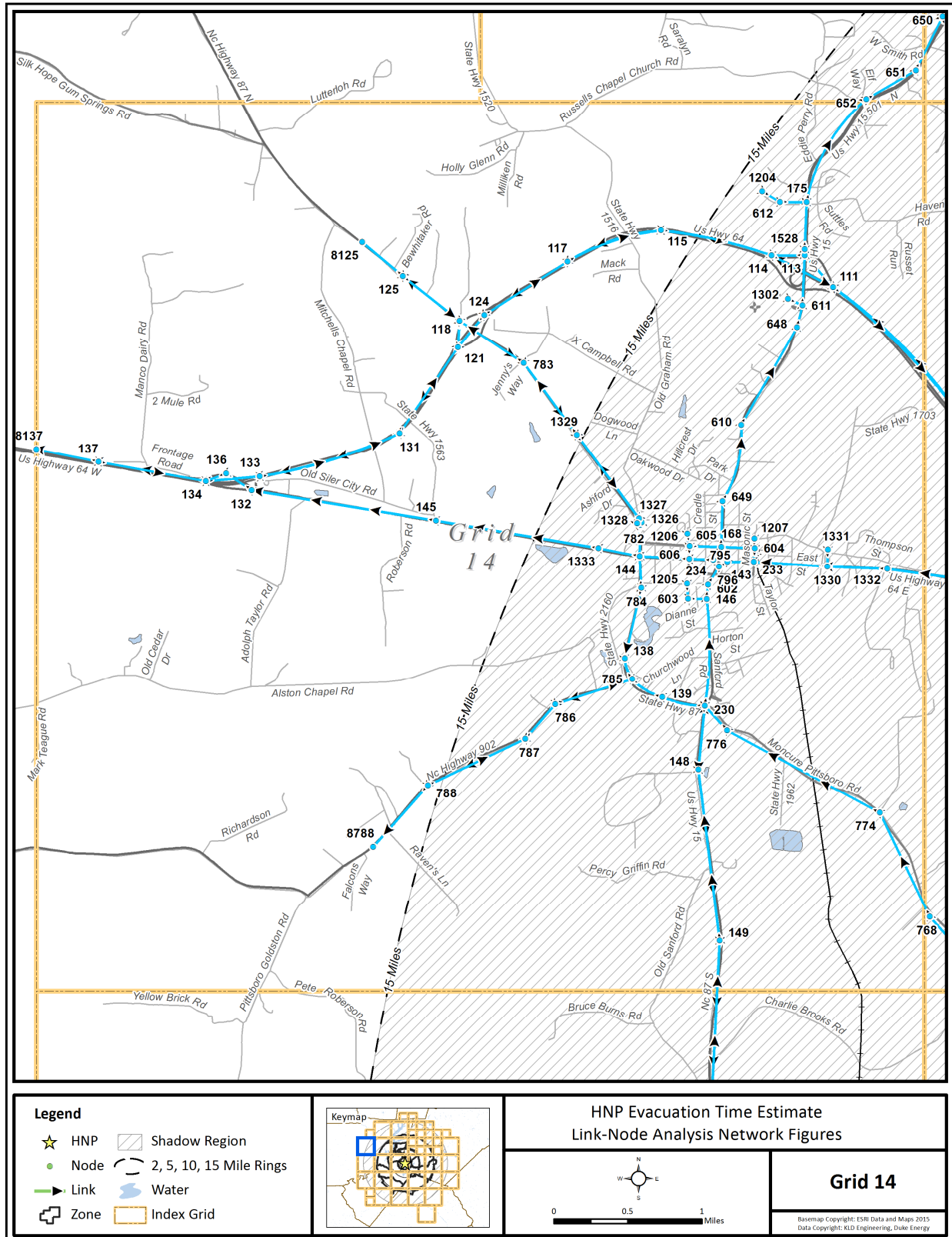

Figure K-15. Link-Node Analysis Network – Grid 14

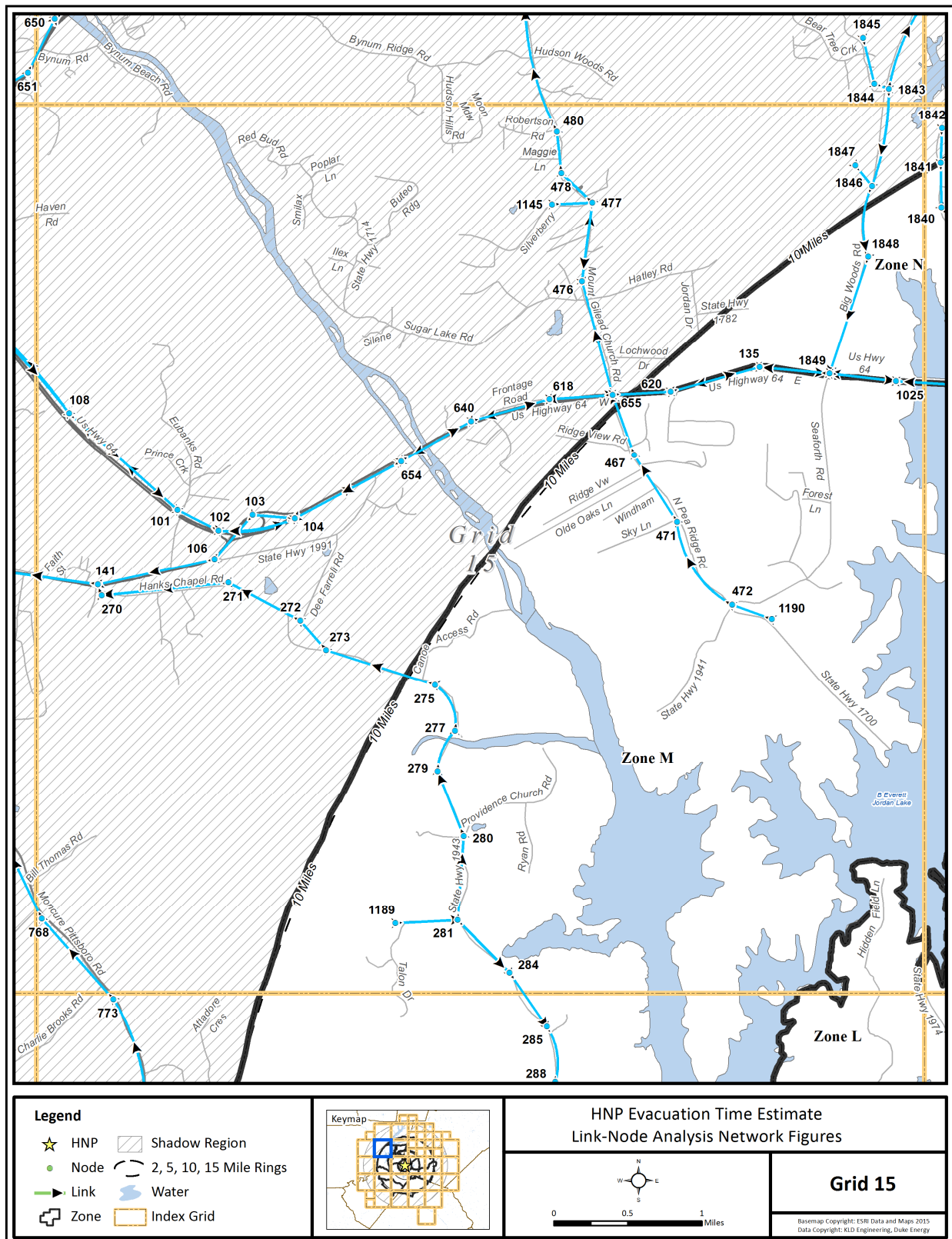

Figure K-16. Link-Node Analysis Network – Grid 15

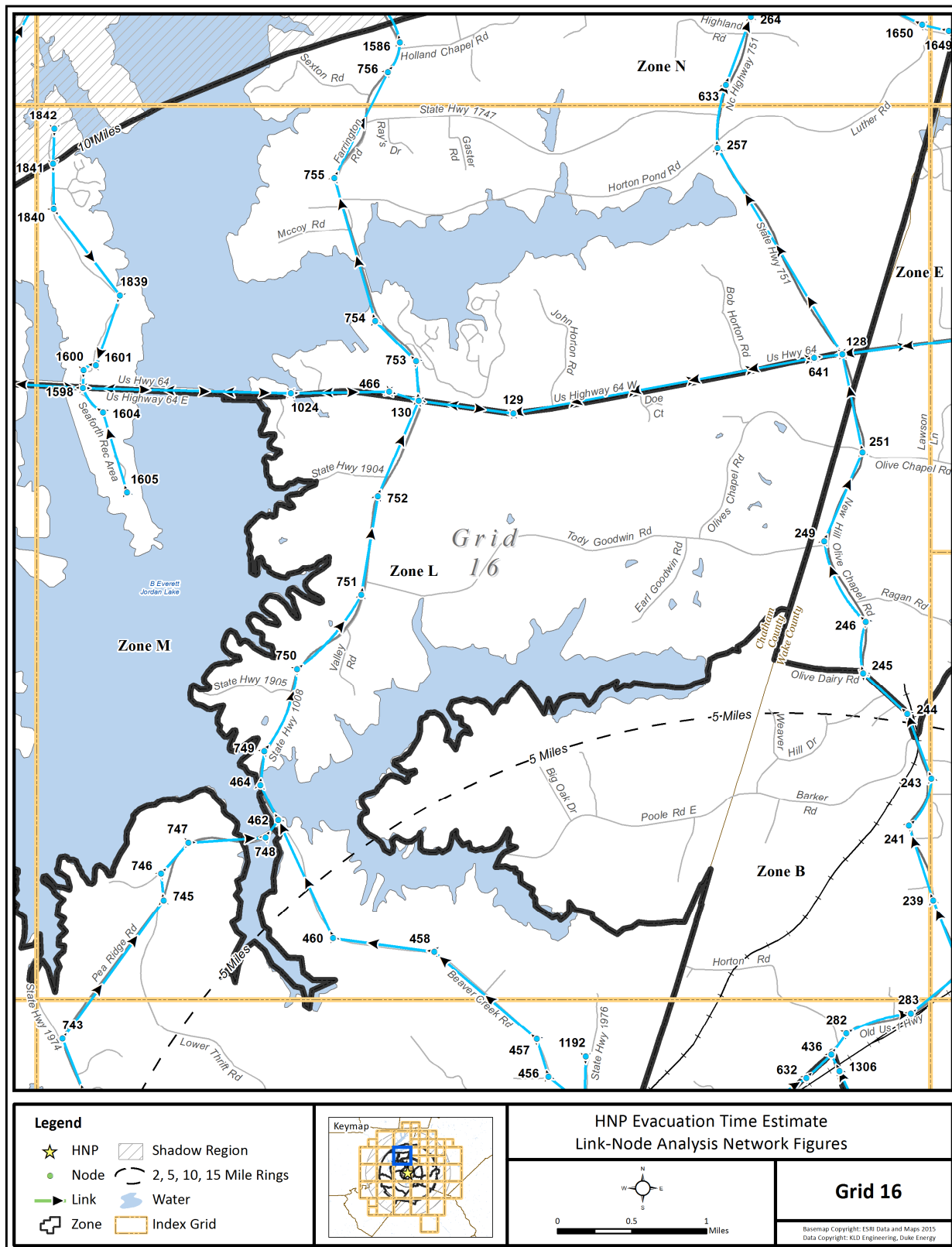

Figure K-17. Link-Node Analysis Network – Grid 16

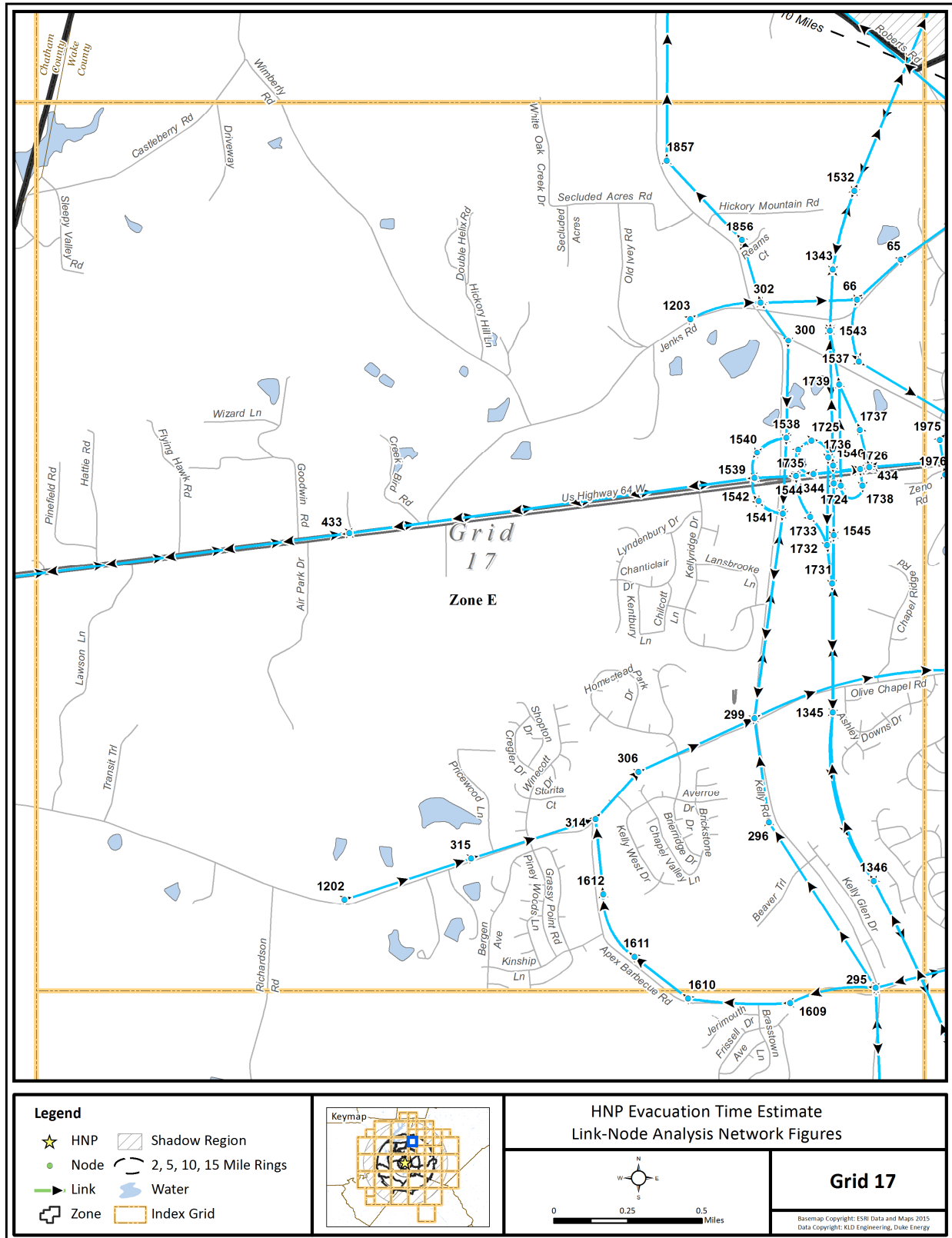

Figure K-18. Link-Node Analysis Network – Grid 17

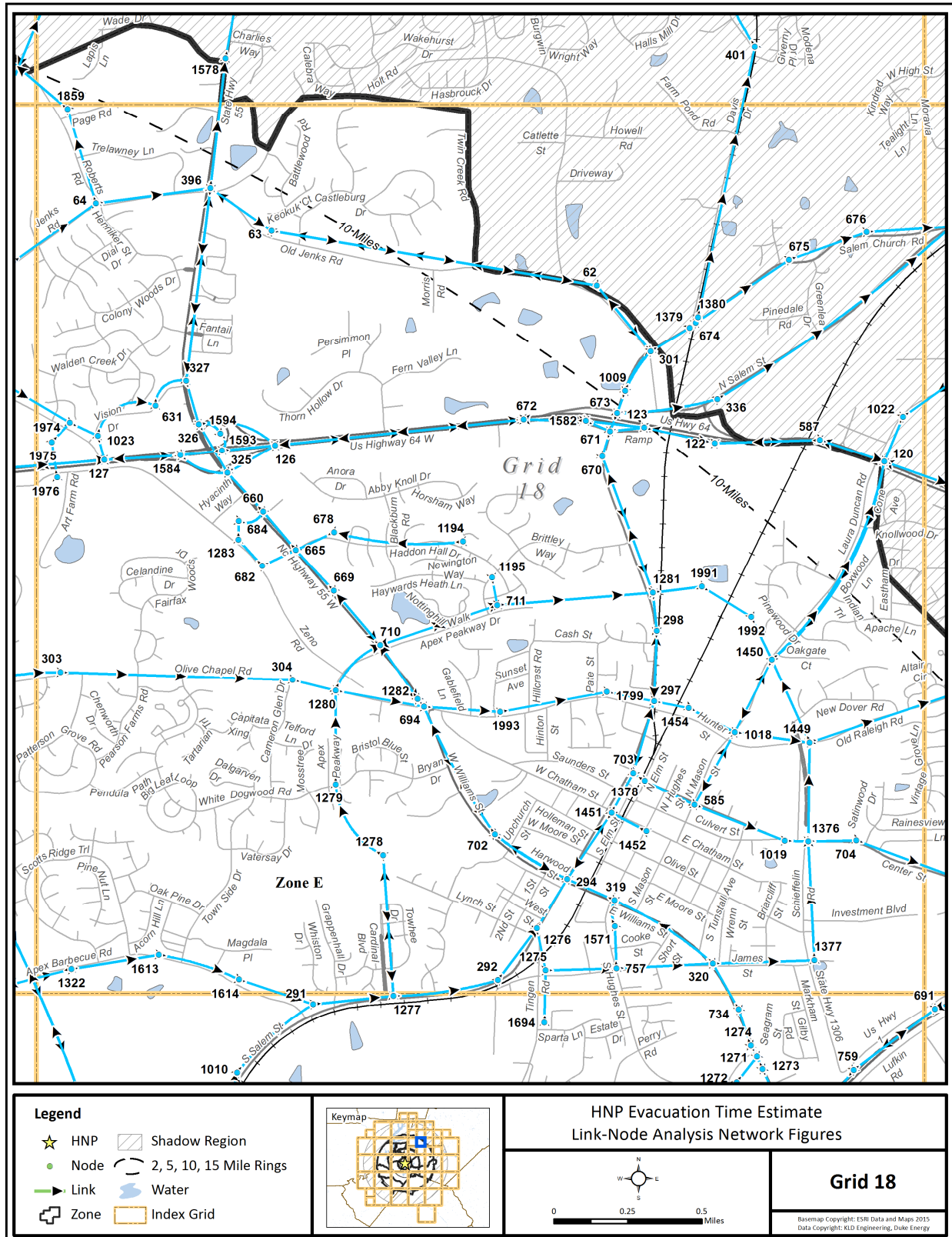

Figure K-19. Link-Node Analysis Network – Grid 18

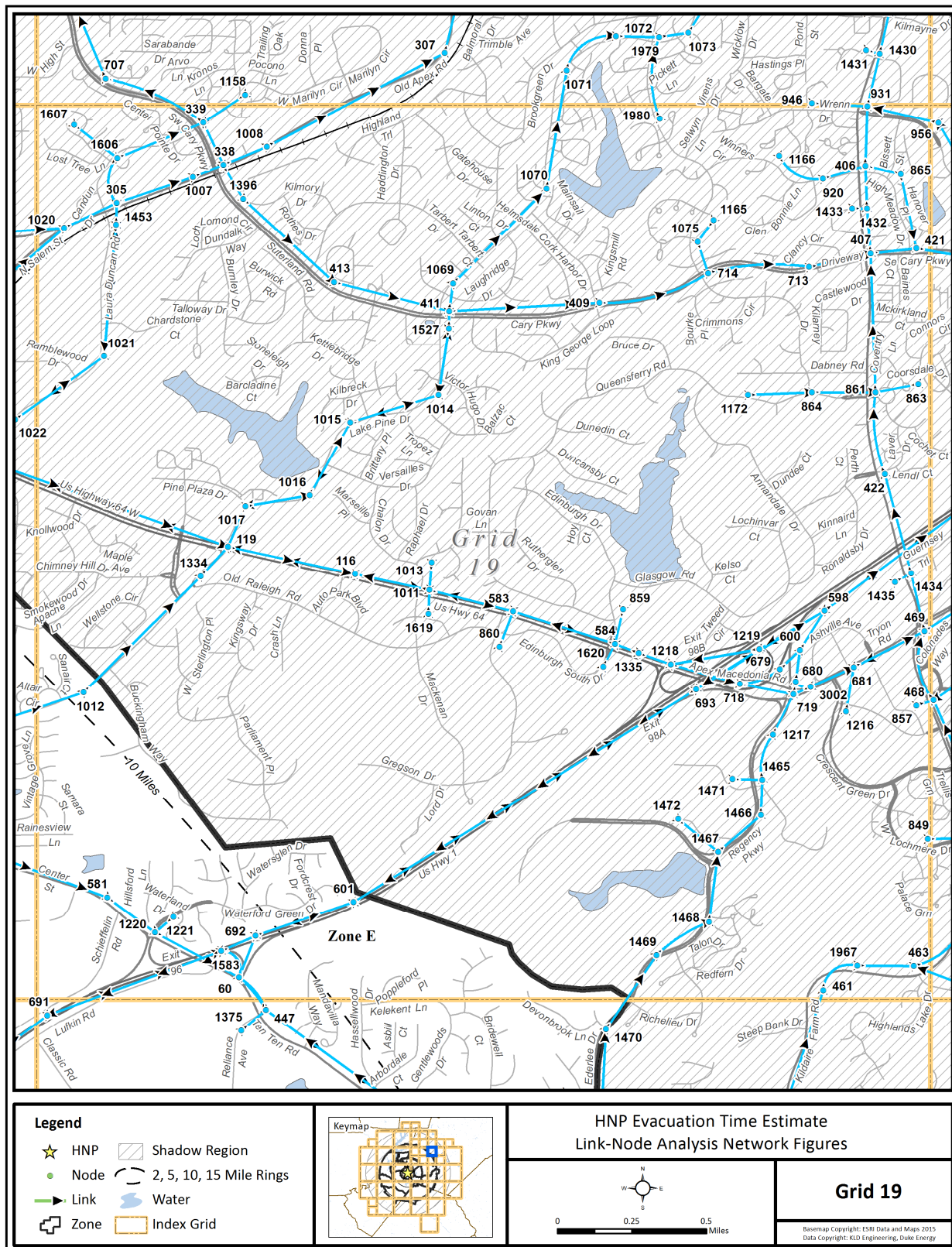

Figure K-20. Link-Node Analysis Network – Grid 19

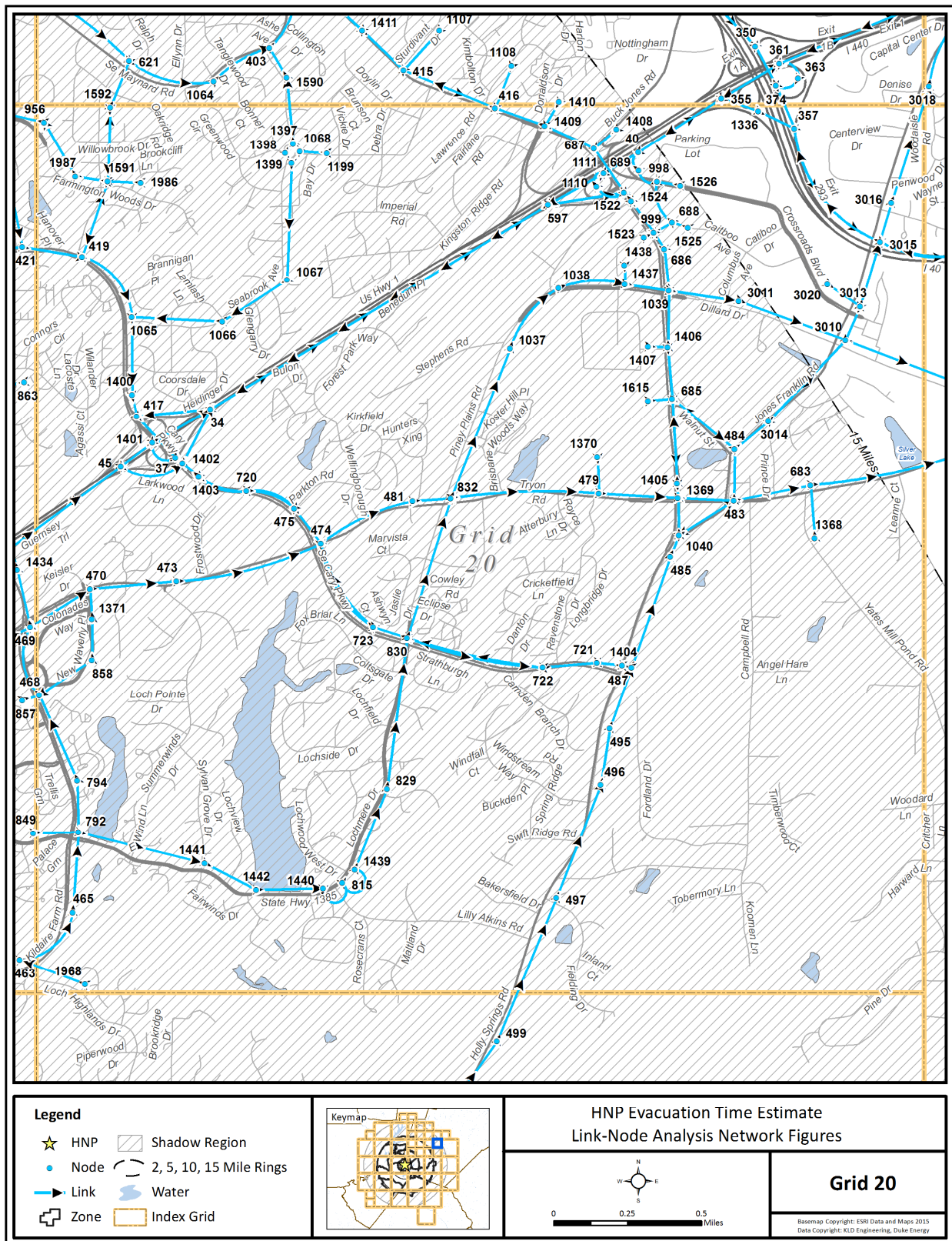

Figure K-21. Link-Node Analysis Network – Grid 20

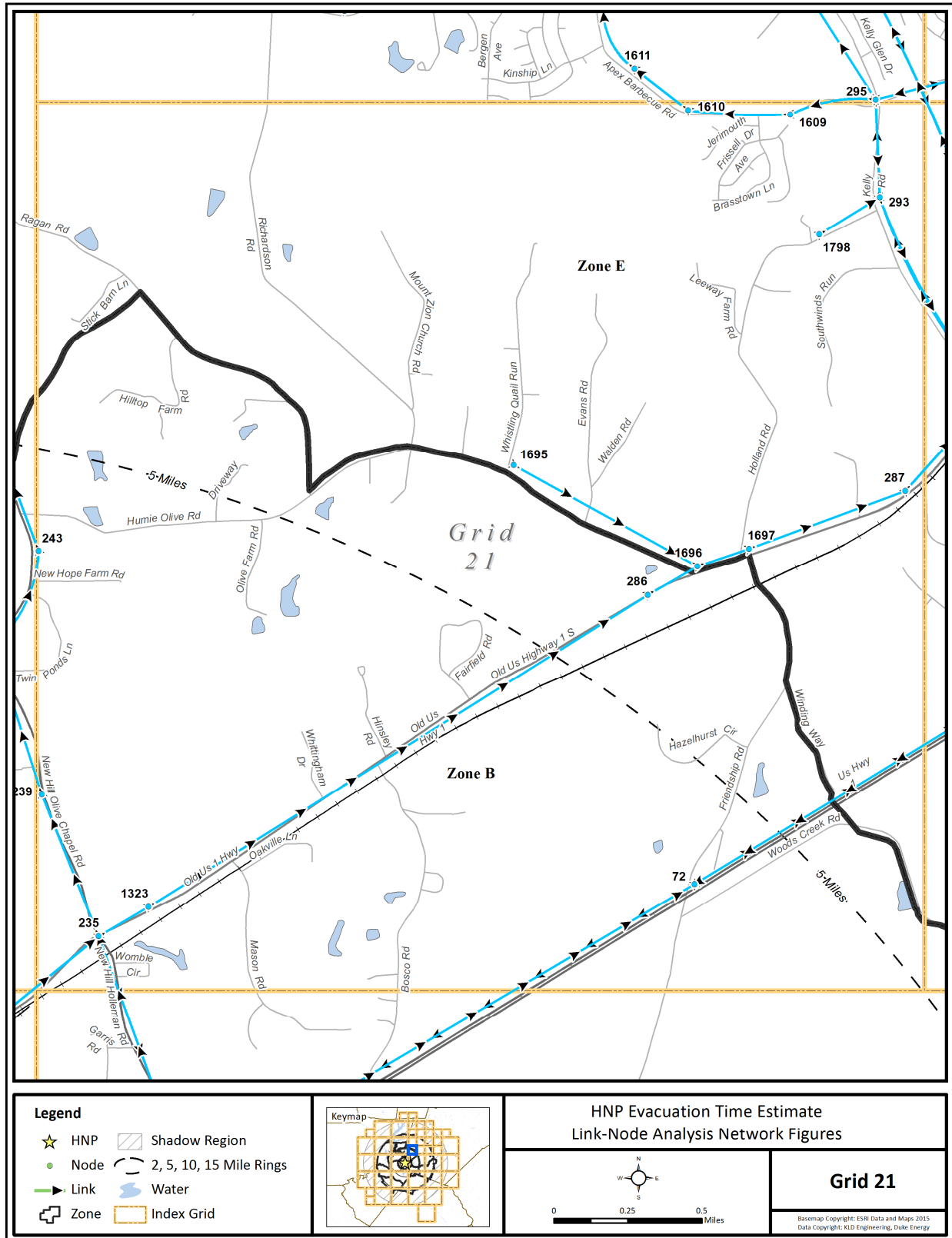

Figure K-22. Link-Node Analysis Network – Grid 21

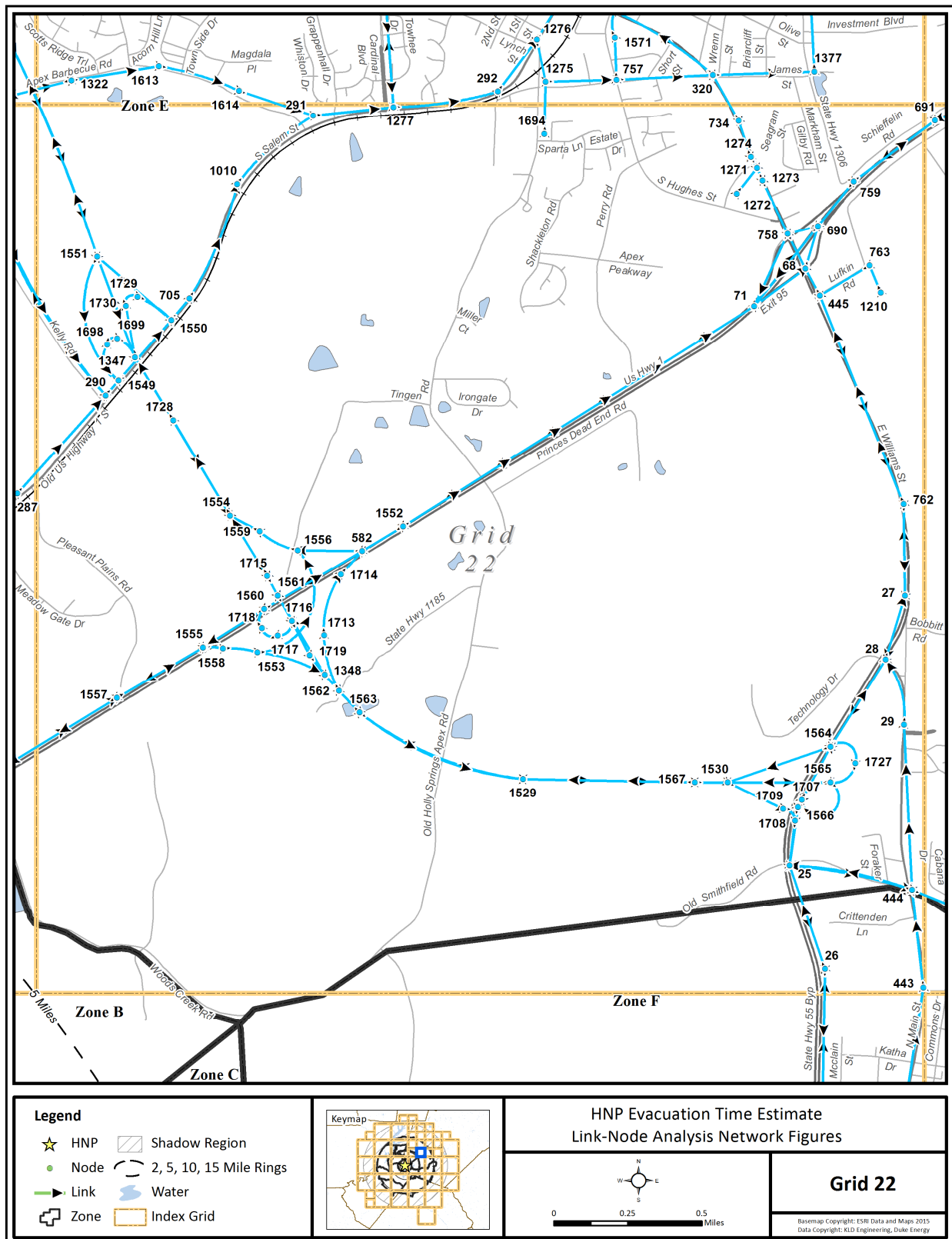

Figure K-23. Link-Node Analysis Network – Grid 22

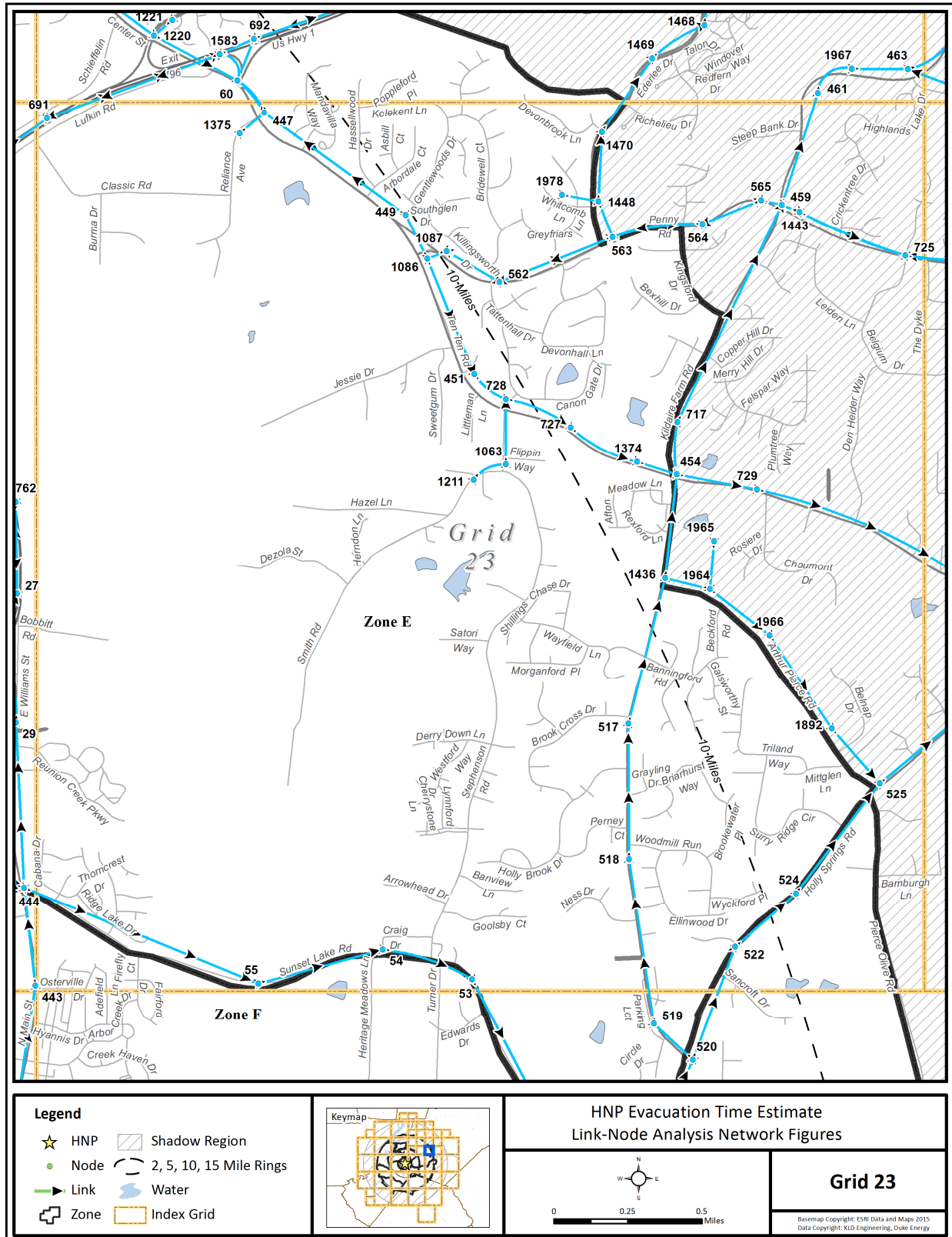

Figure K-24. Link-Node Analysis Network – Grid 23

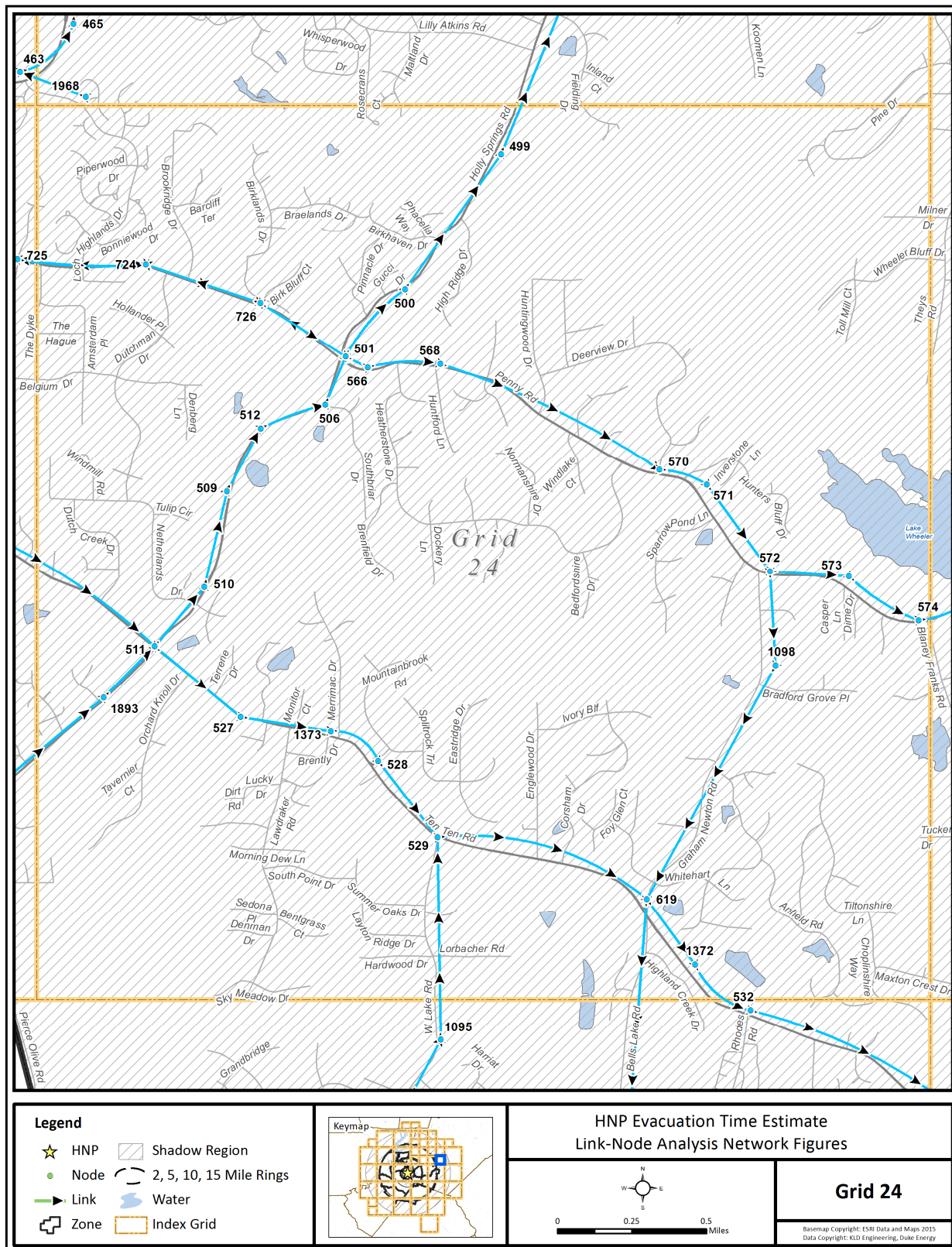

Figure K-25. Link-Node Analysis Network – Grid 24

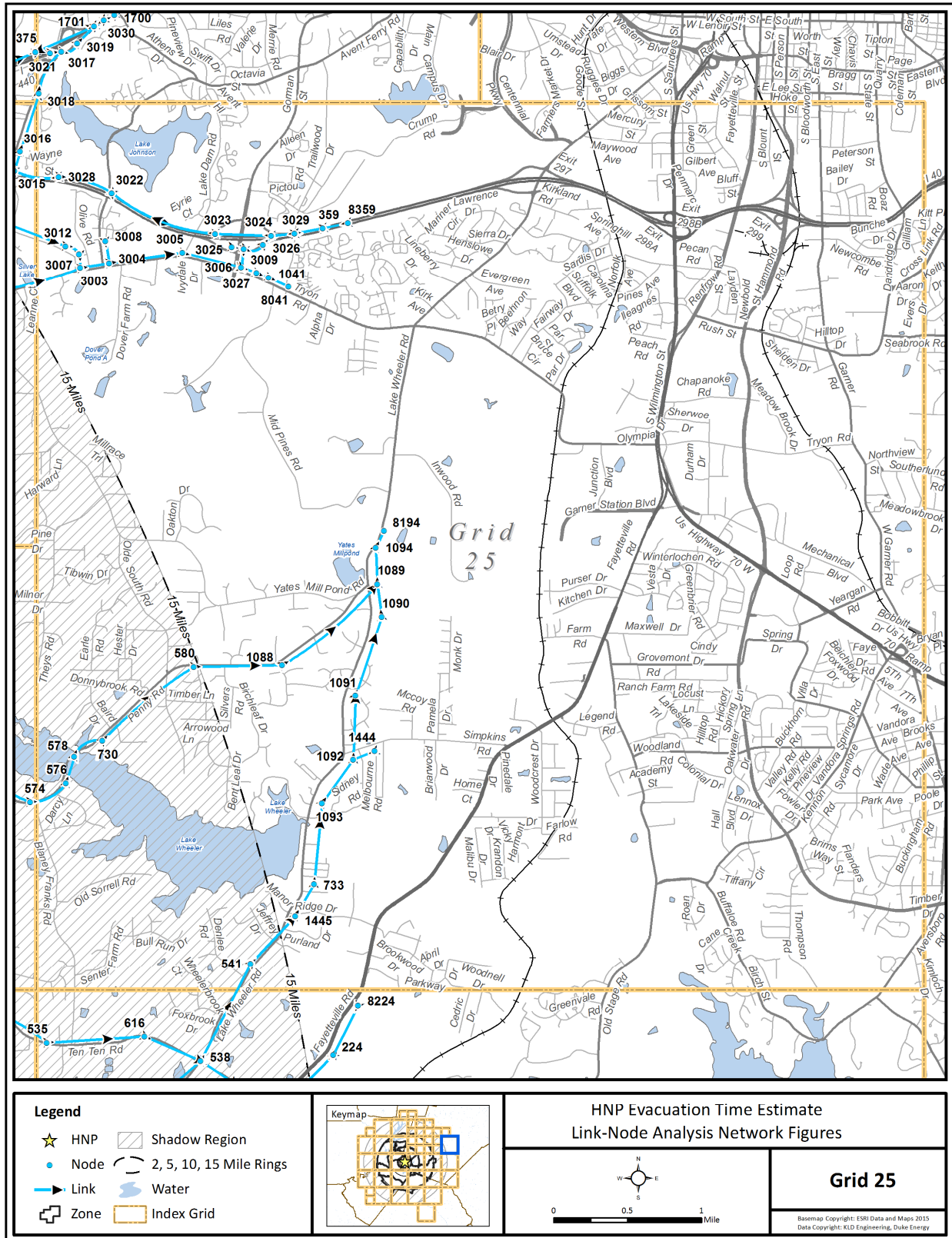

Figure K-26. Link-Node Analysis Network – Grid 25

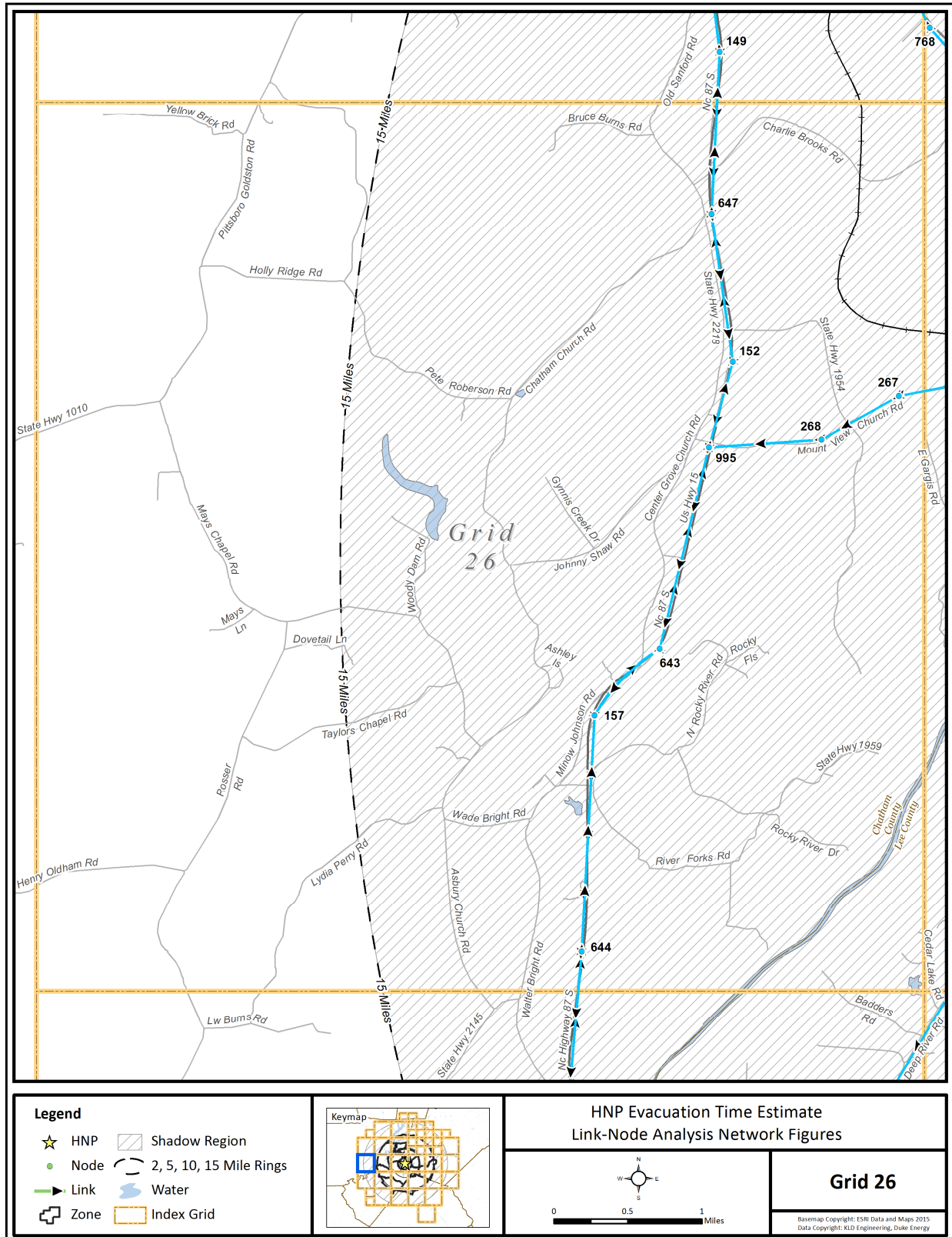

Figure K-27. Link-Node Analysis Network – Grid 26

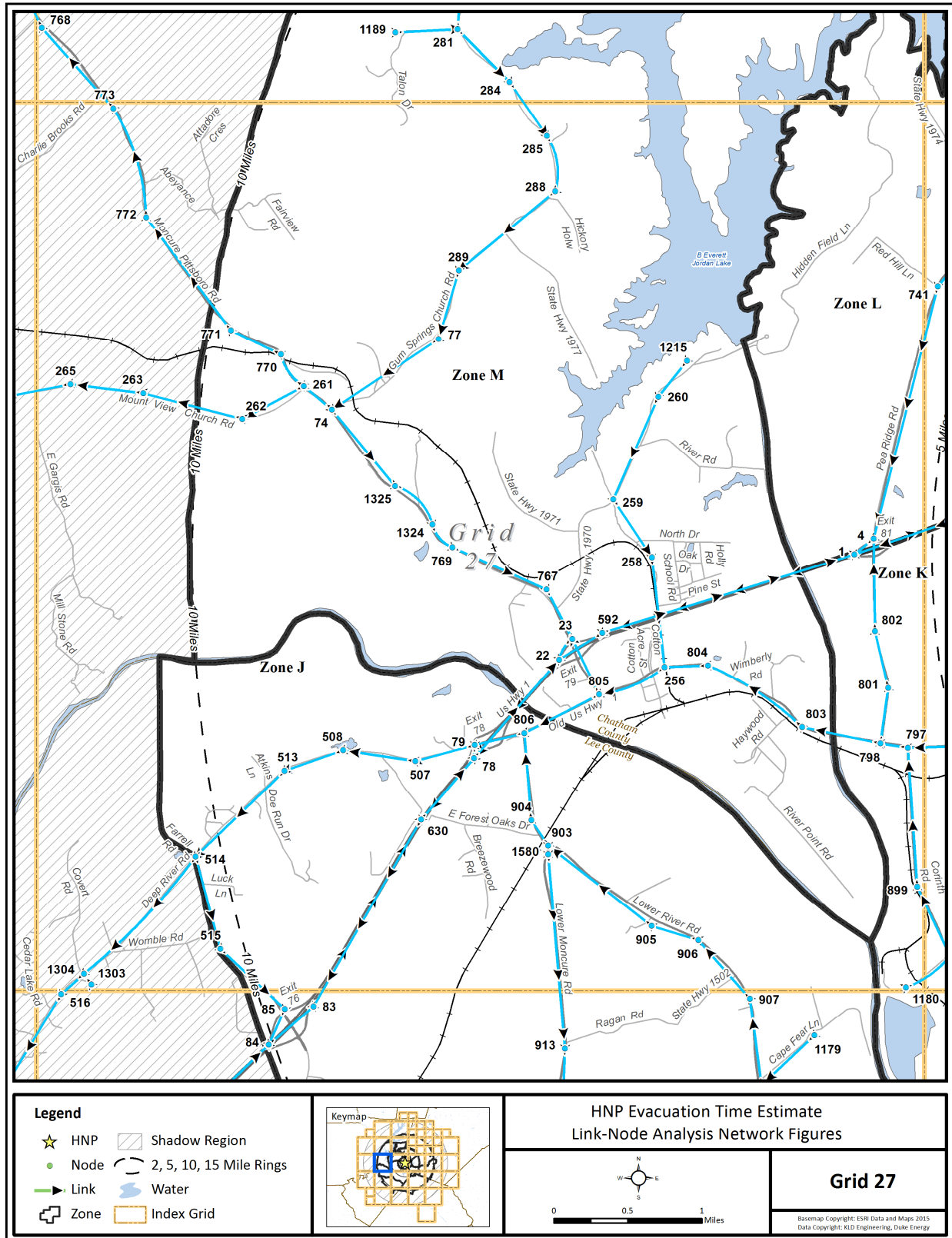

Figure K-28. Link-Node Analysis Network – Grid 27

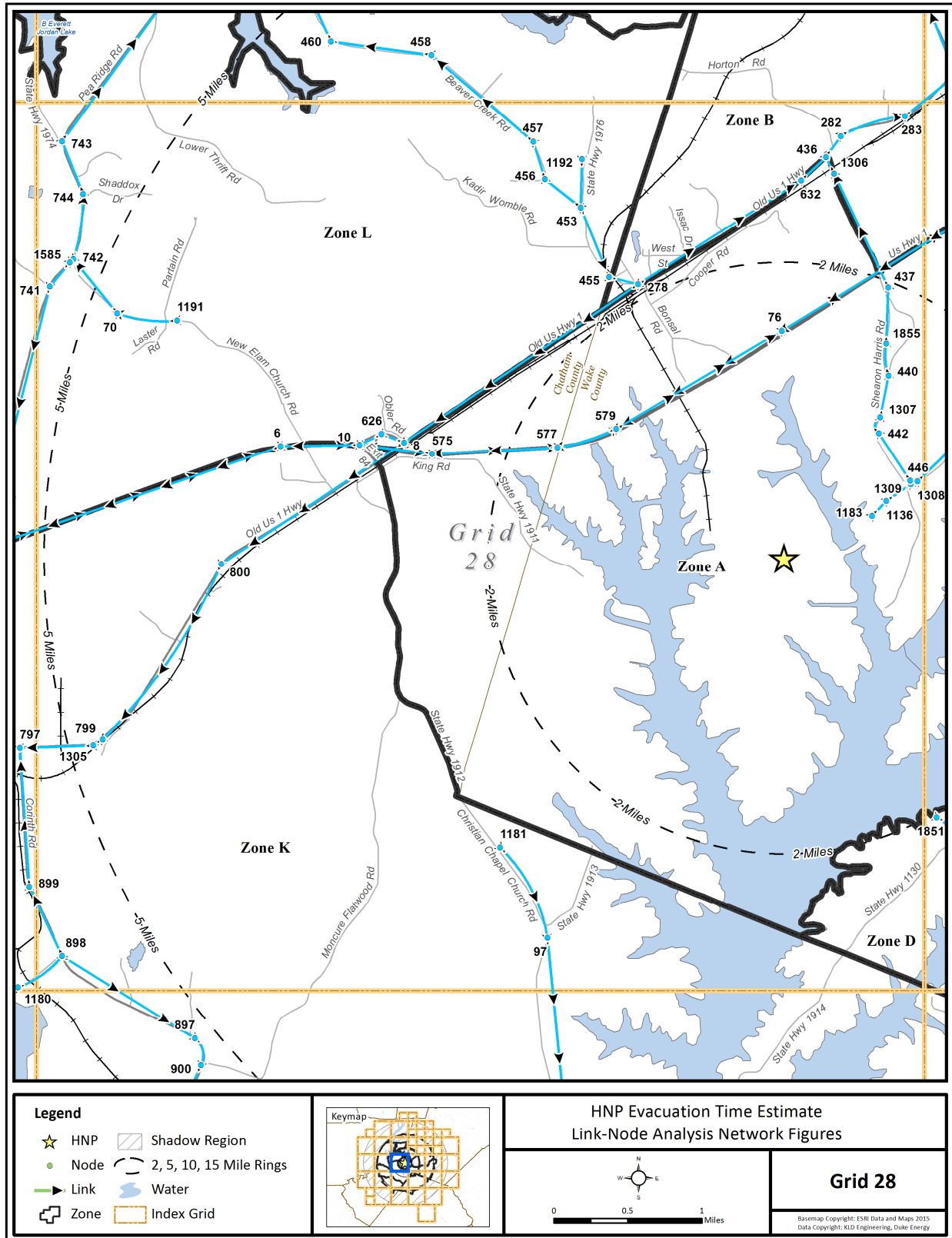

Figure K-29. Link-Node Analysis Network – Grid 28

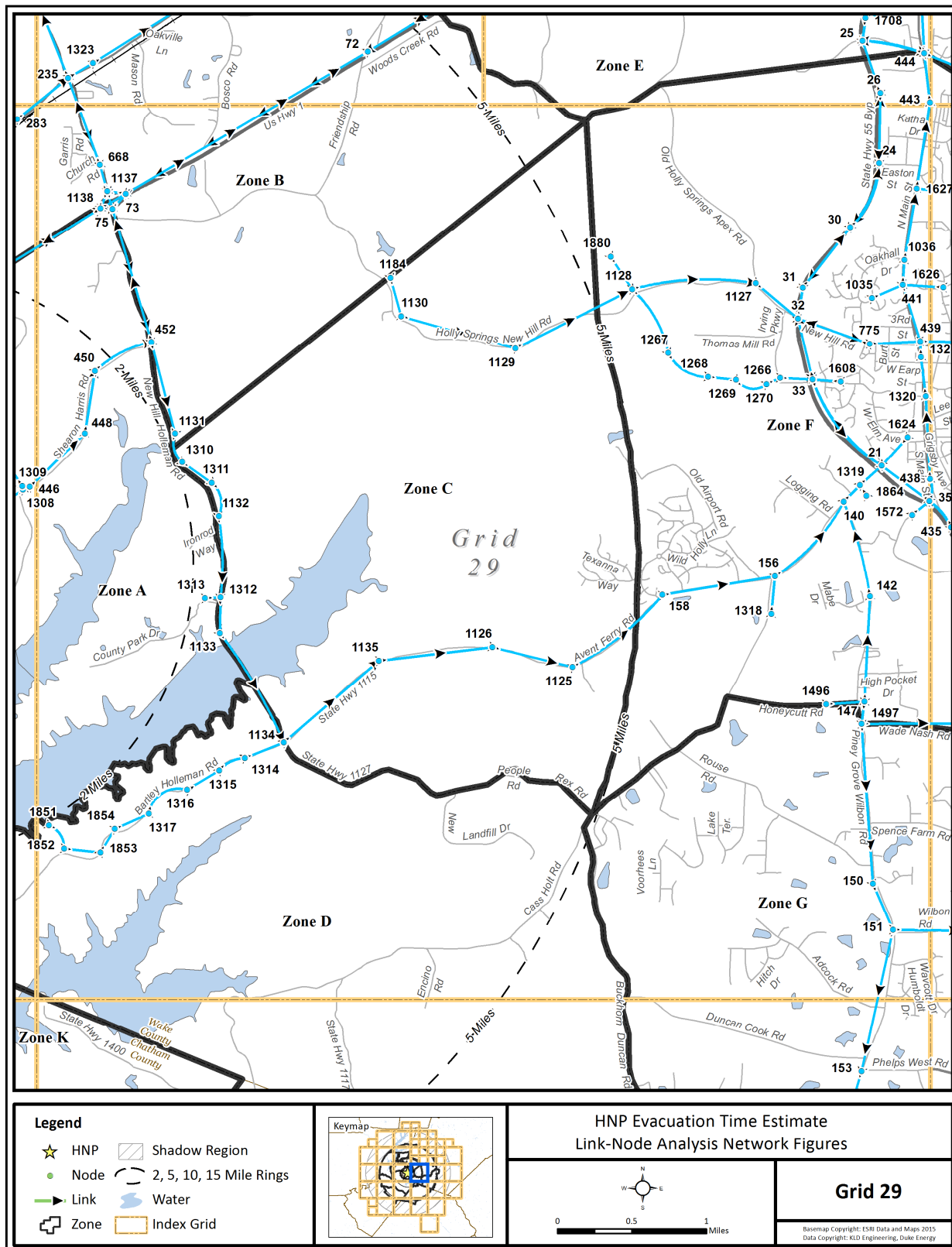

Figure K-30. Link-Node Analysis Network – Grid 29

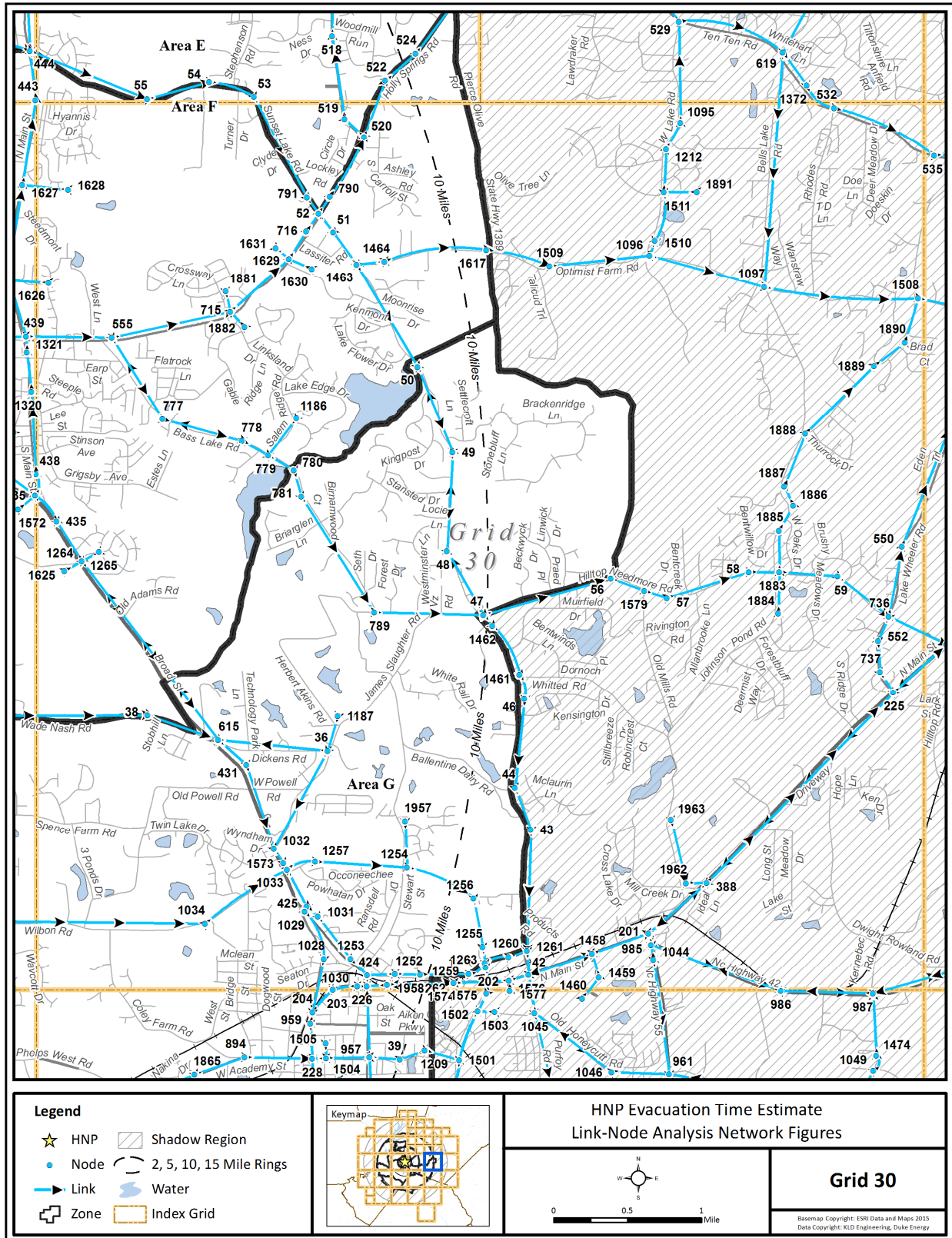

Figure K-31. Link-Node Analysis Network – Grid 30

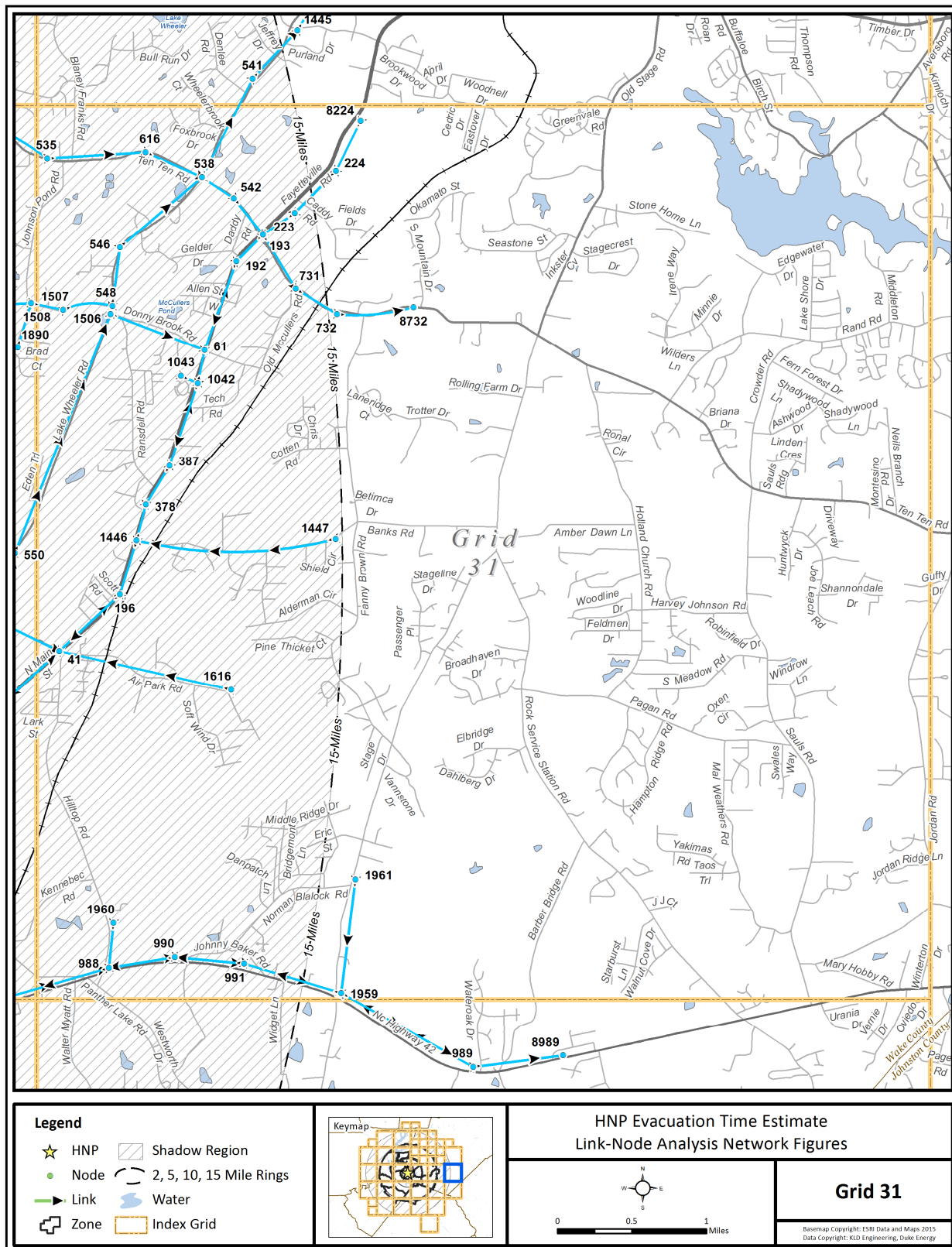

Figure K-32. Link-Node Analysis Network – Grid 31

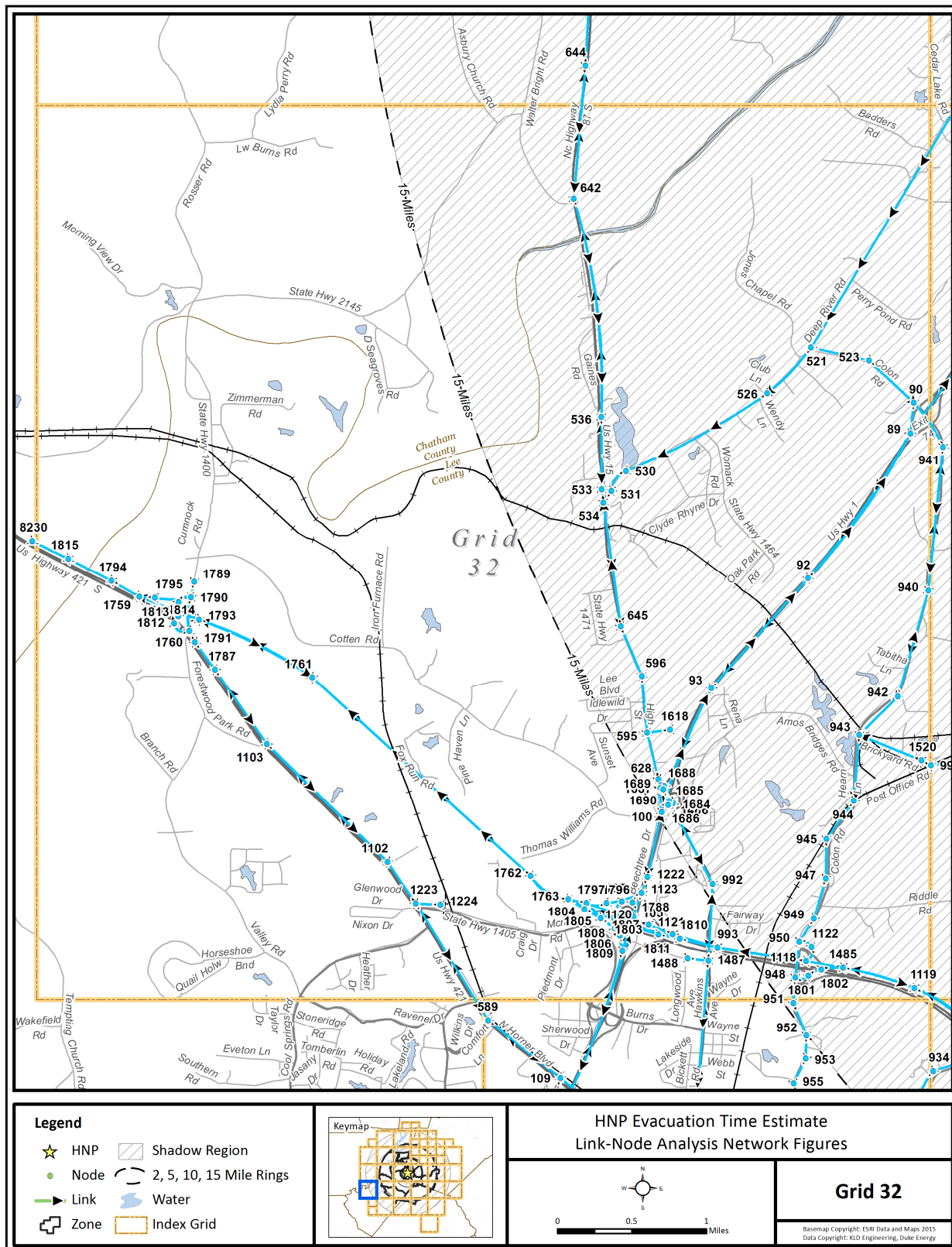

Figure K-33. Link-Node Analysis Network – Grid 32

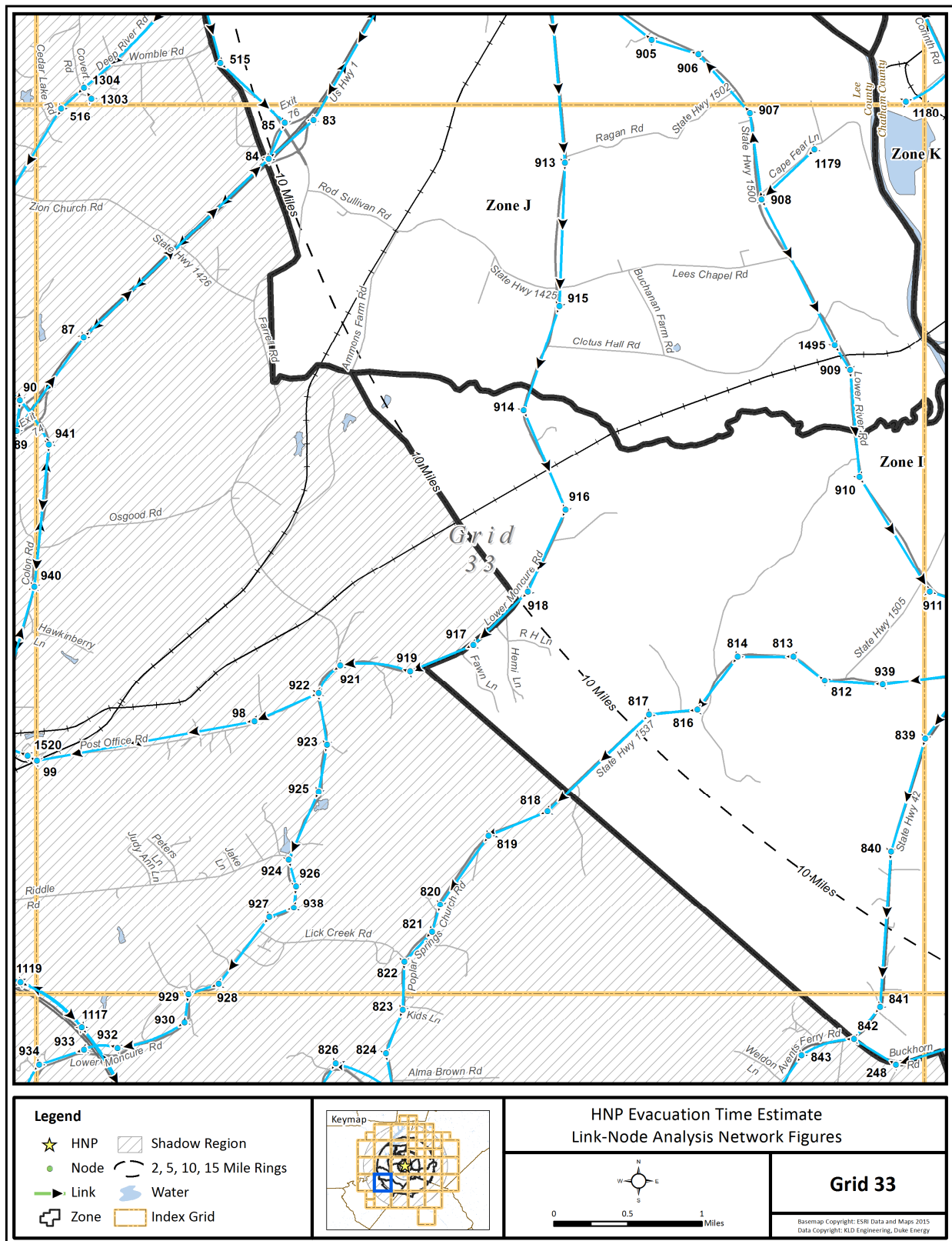

Figure K-34. Link-Node Analysis Network – Grid 33

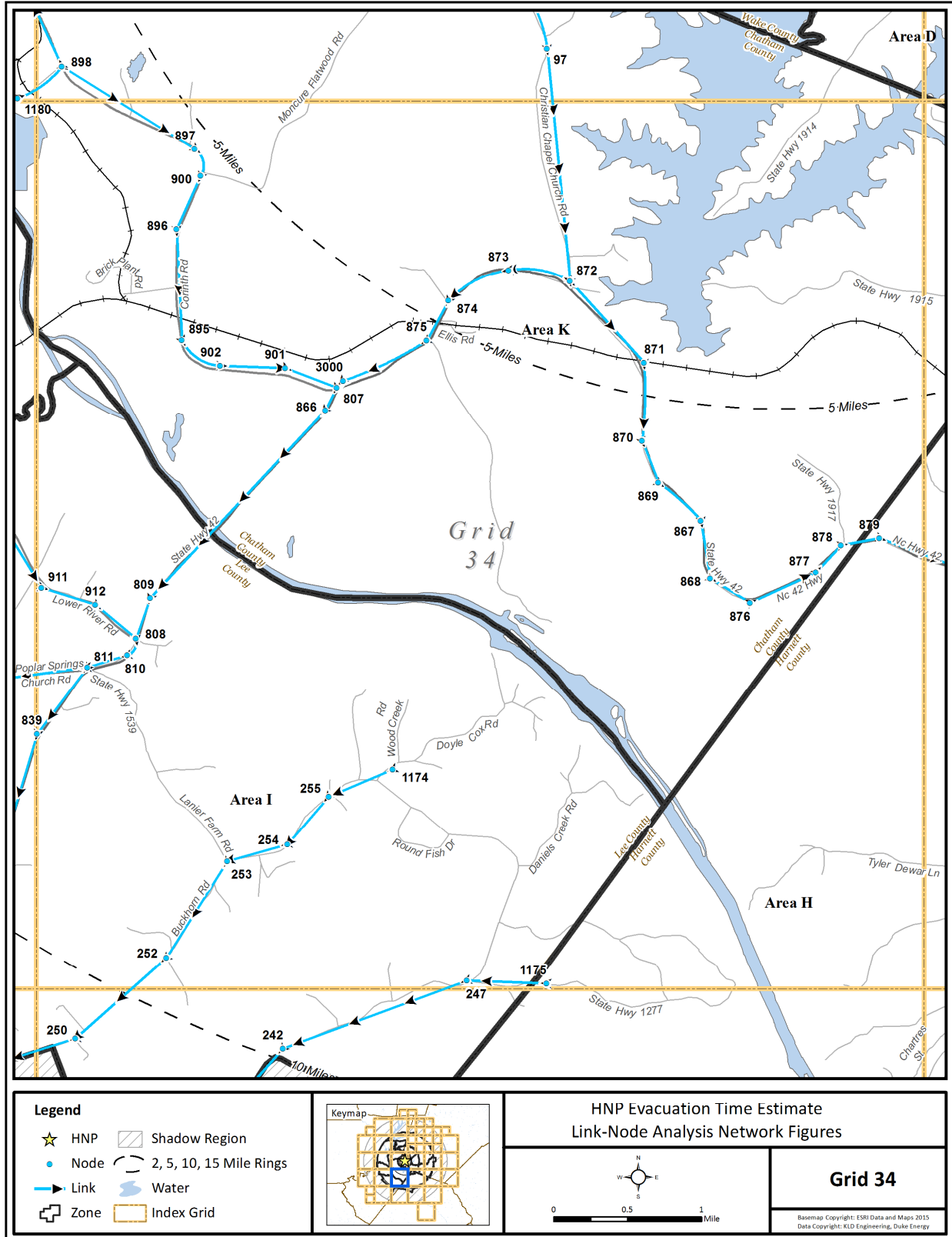

Figure K-35. Link-Node Analysis Network – Grid 34

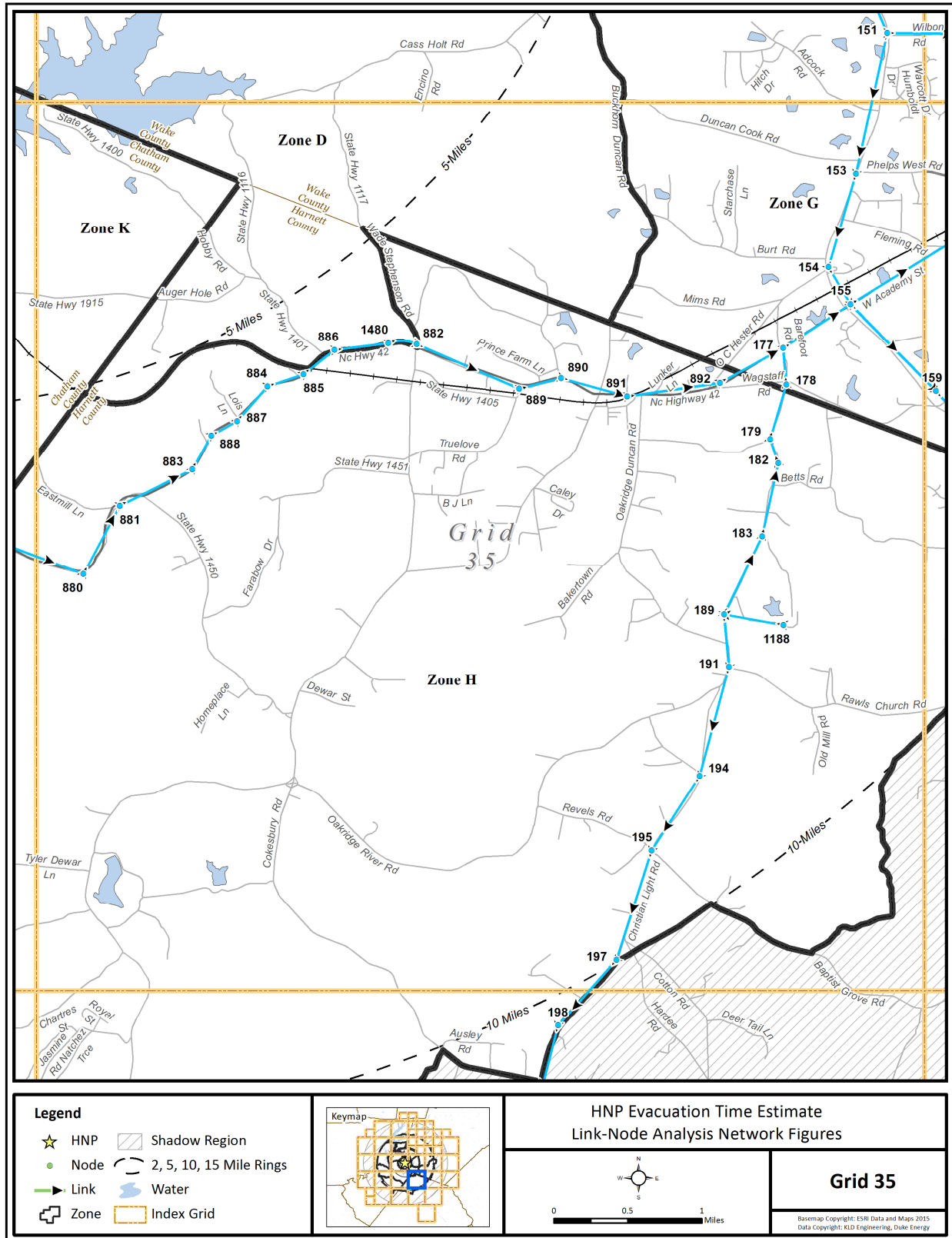

Figure K-36. Link-Node Analysis Network – Grid 35

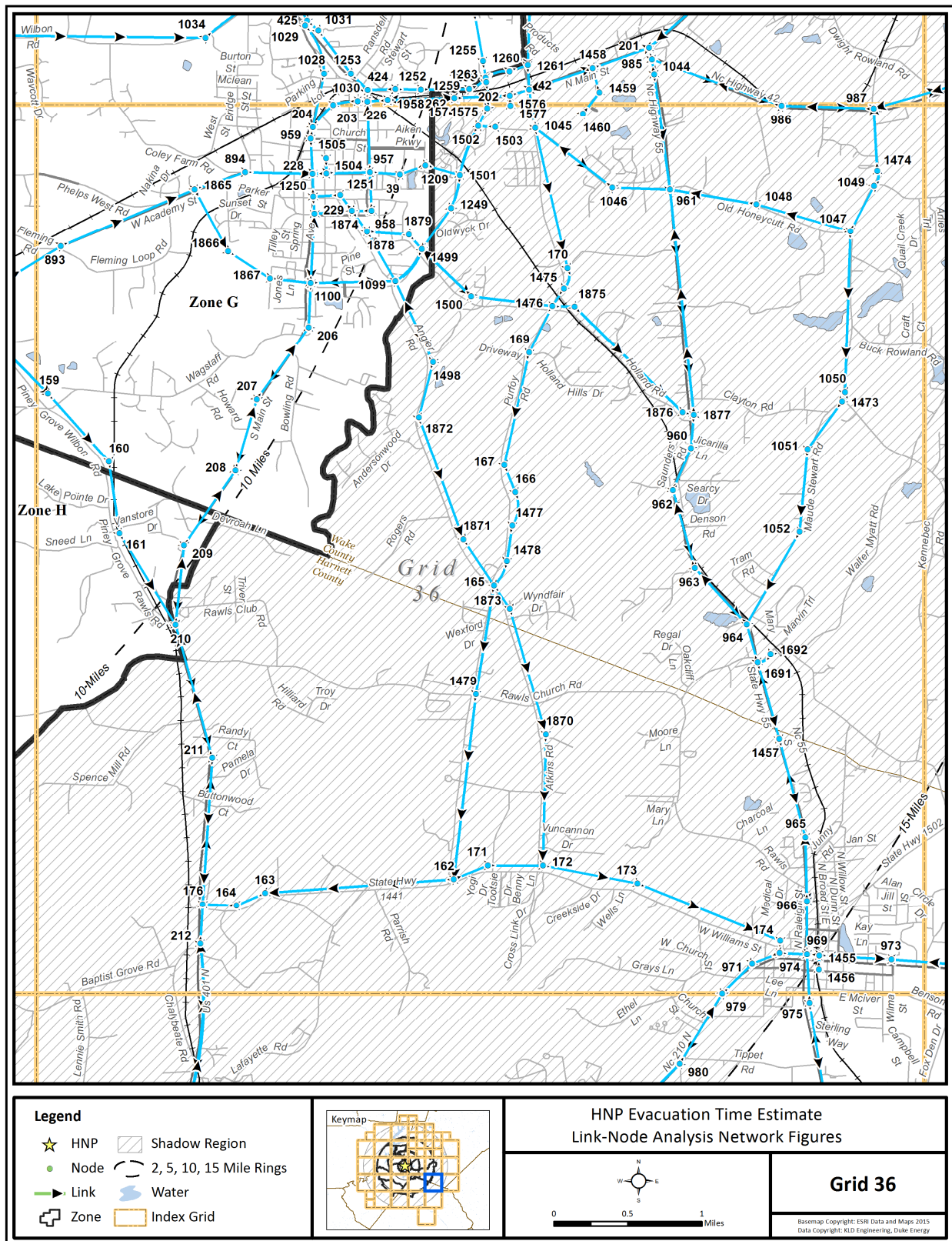

Figure K-37. Link-Node Analysis Network – Grid 36

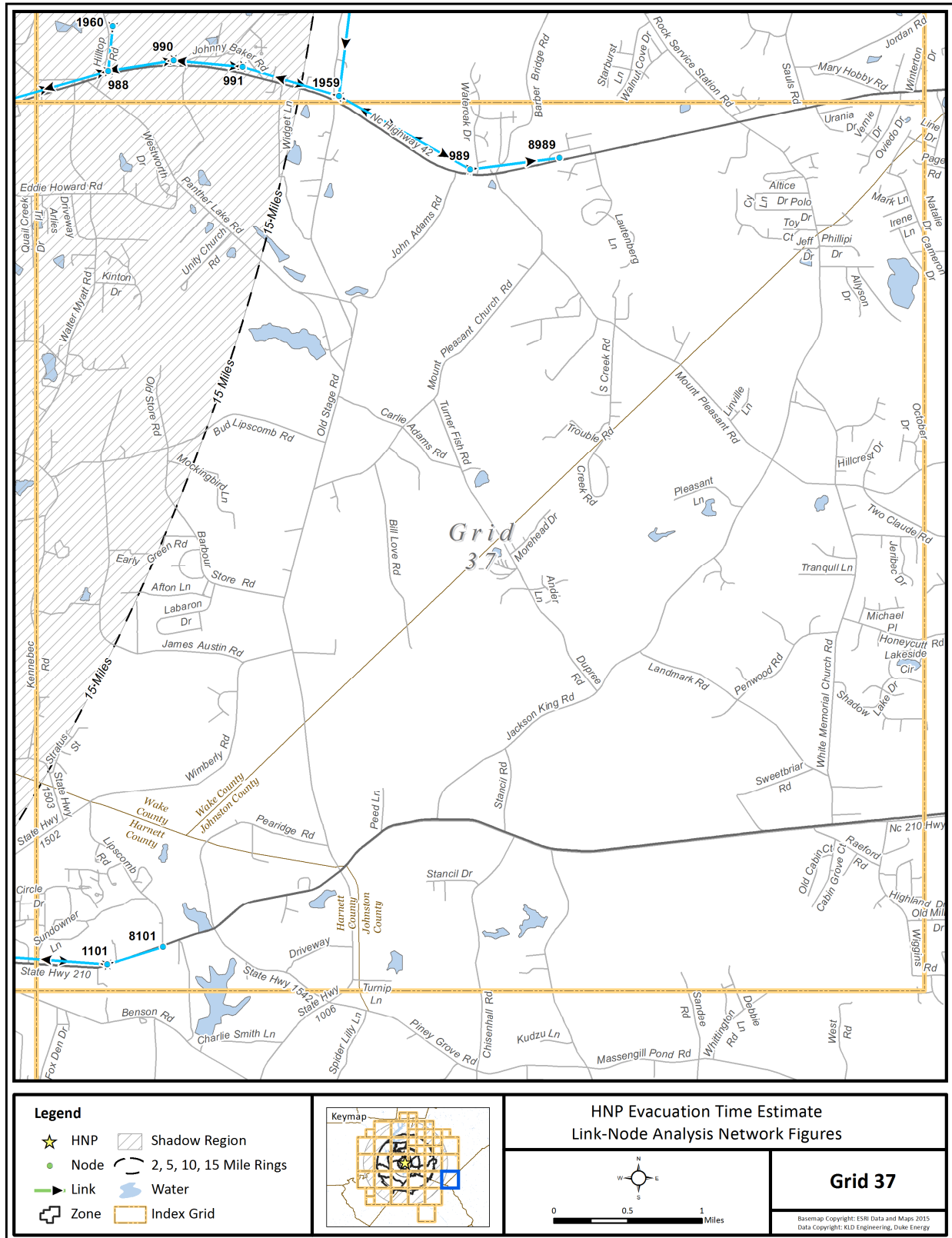

Figure K-38. Link-Node Analysis Network – Grid 37

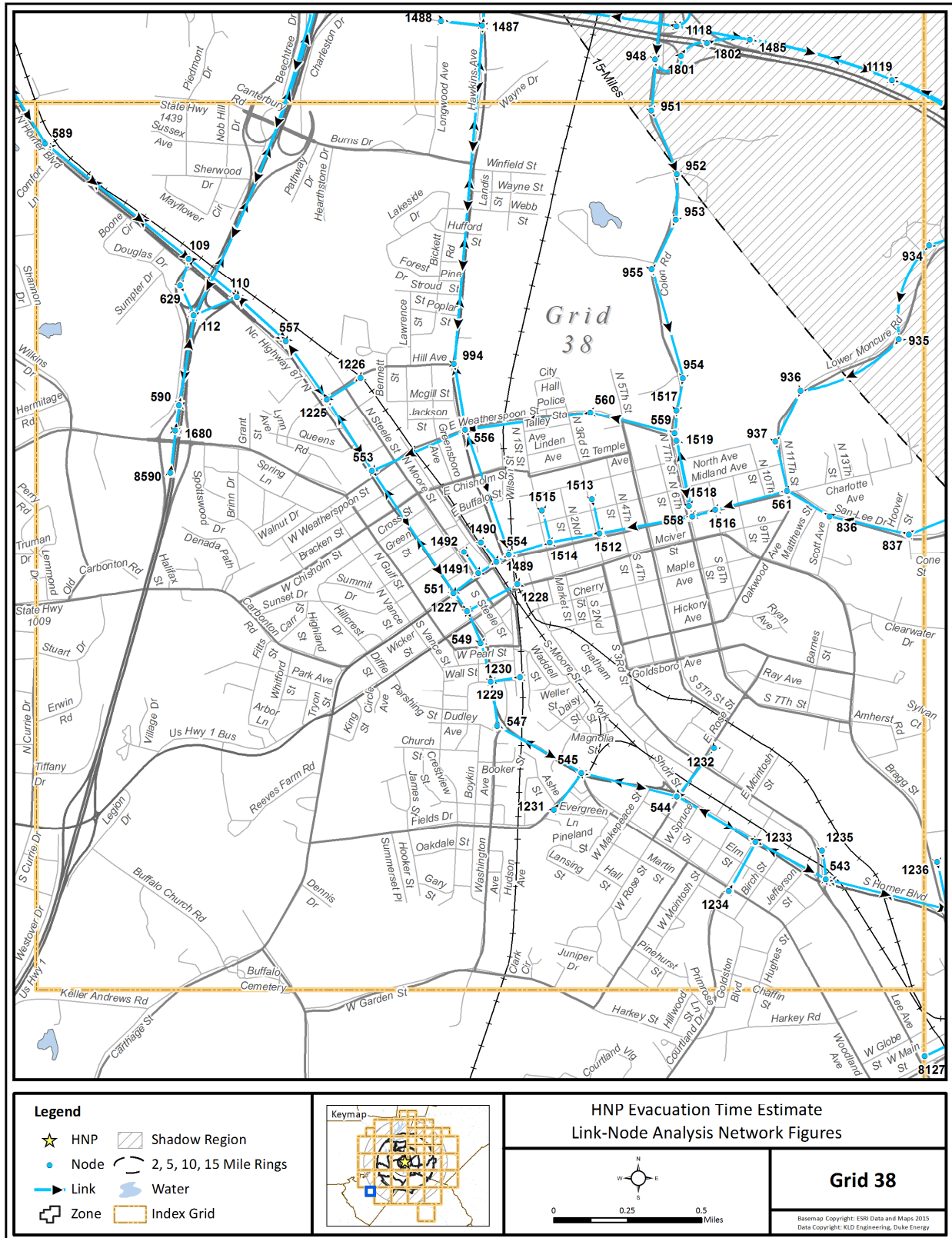

Figure K-39. Link-Node Analysis Network – Grid 38

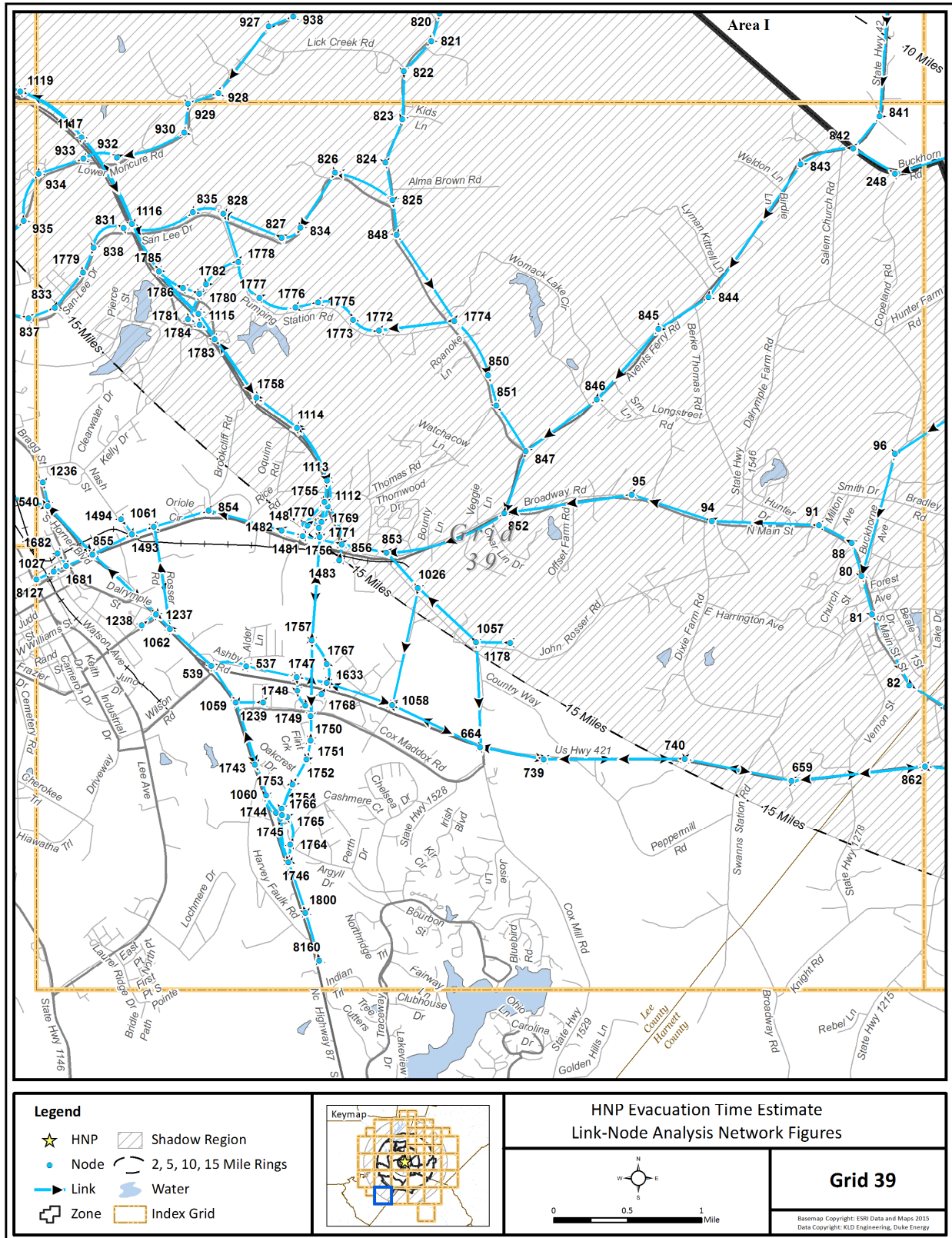

Figure K-40. Link-Node Analysis Network – Grid 39

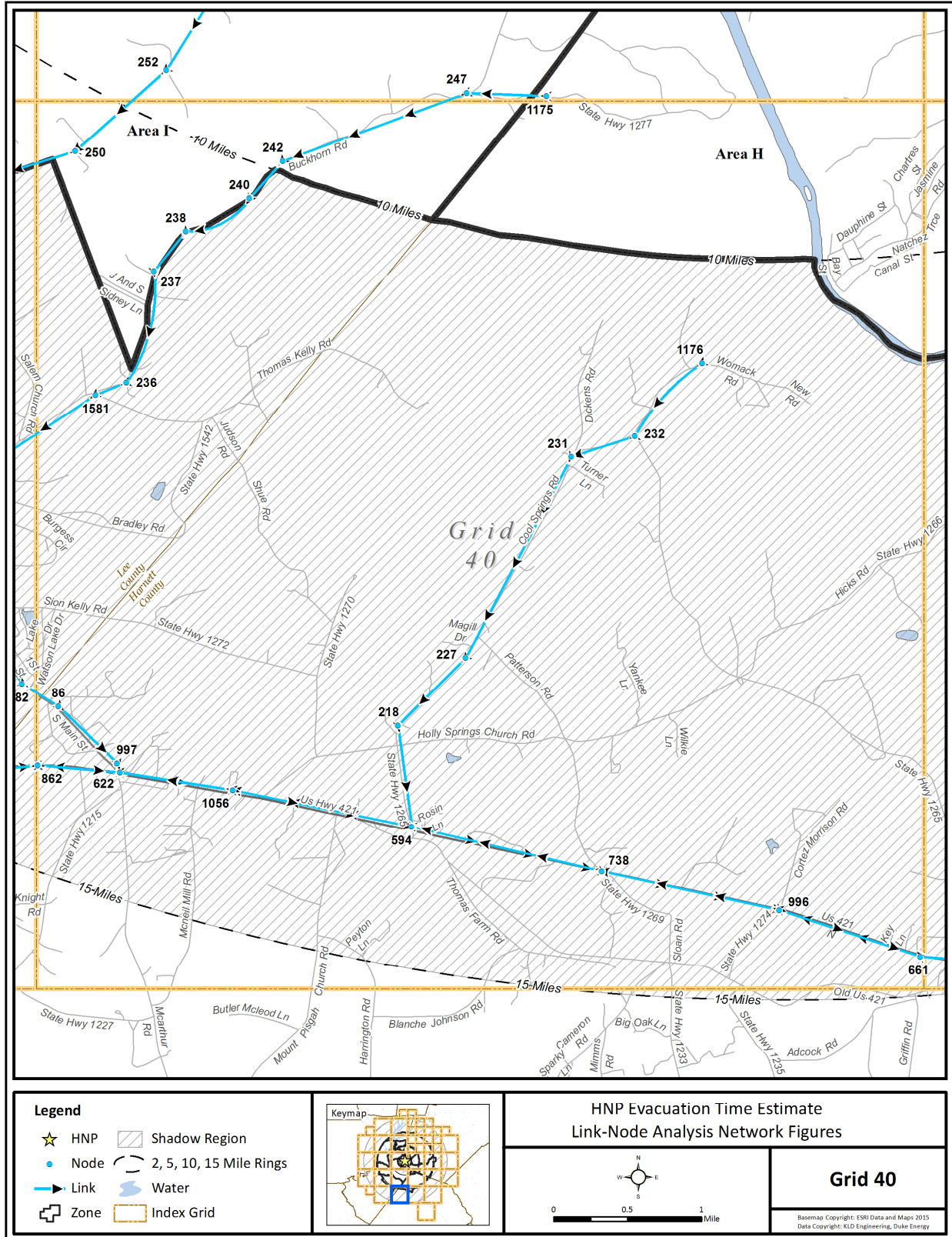

Figure K-41. Link-Node Analysis Network – Grid 40

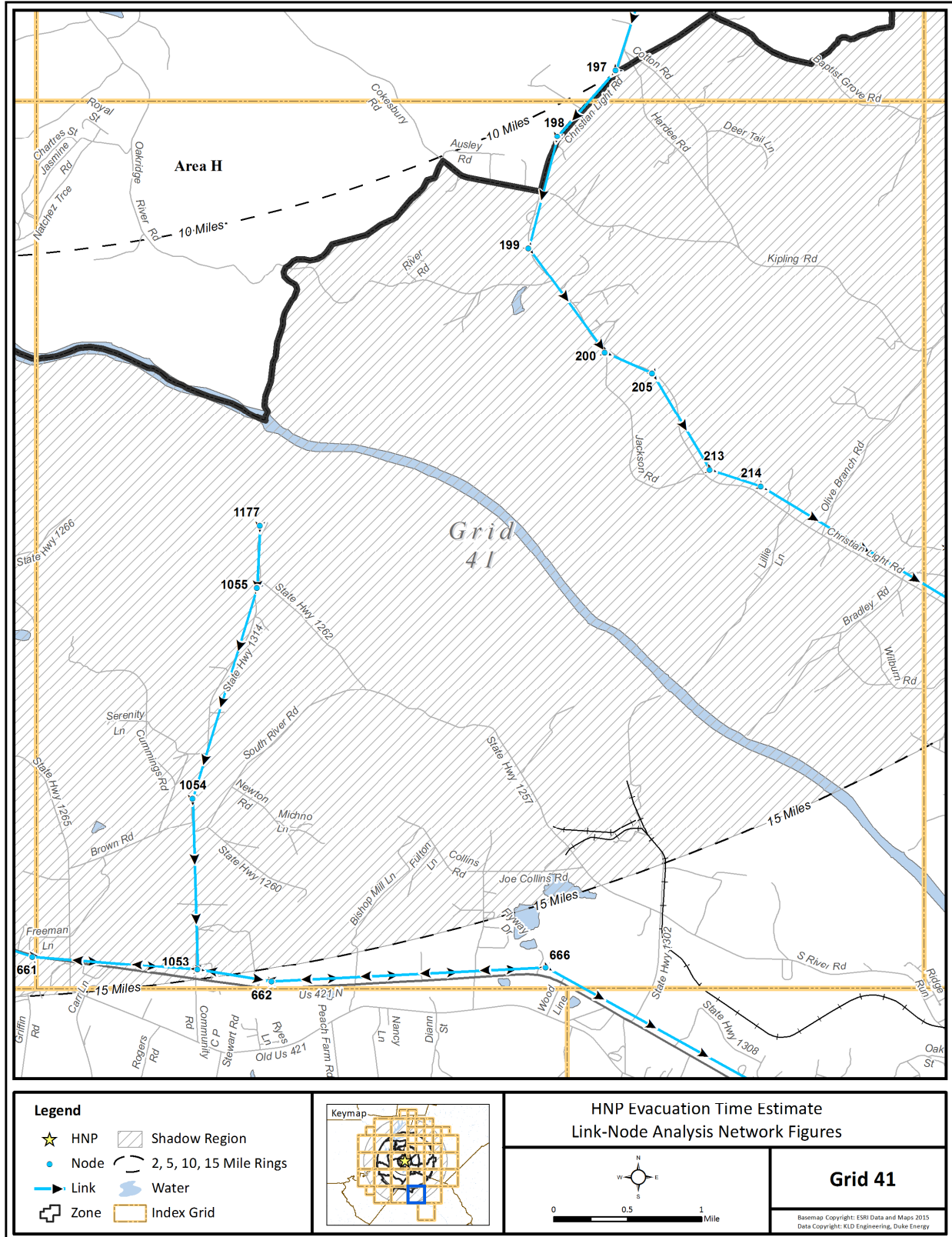

Figure K-42. Link-Node Analysis Network – Grid 41

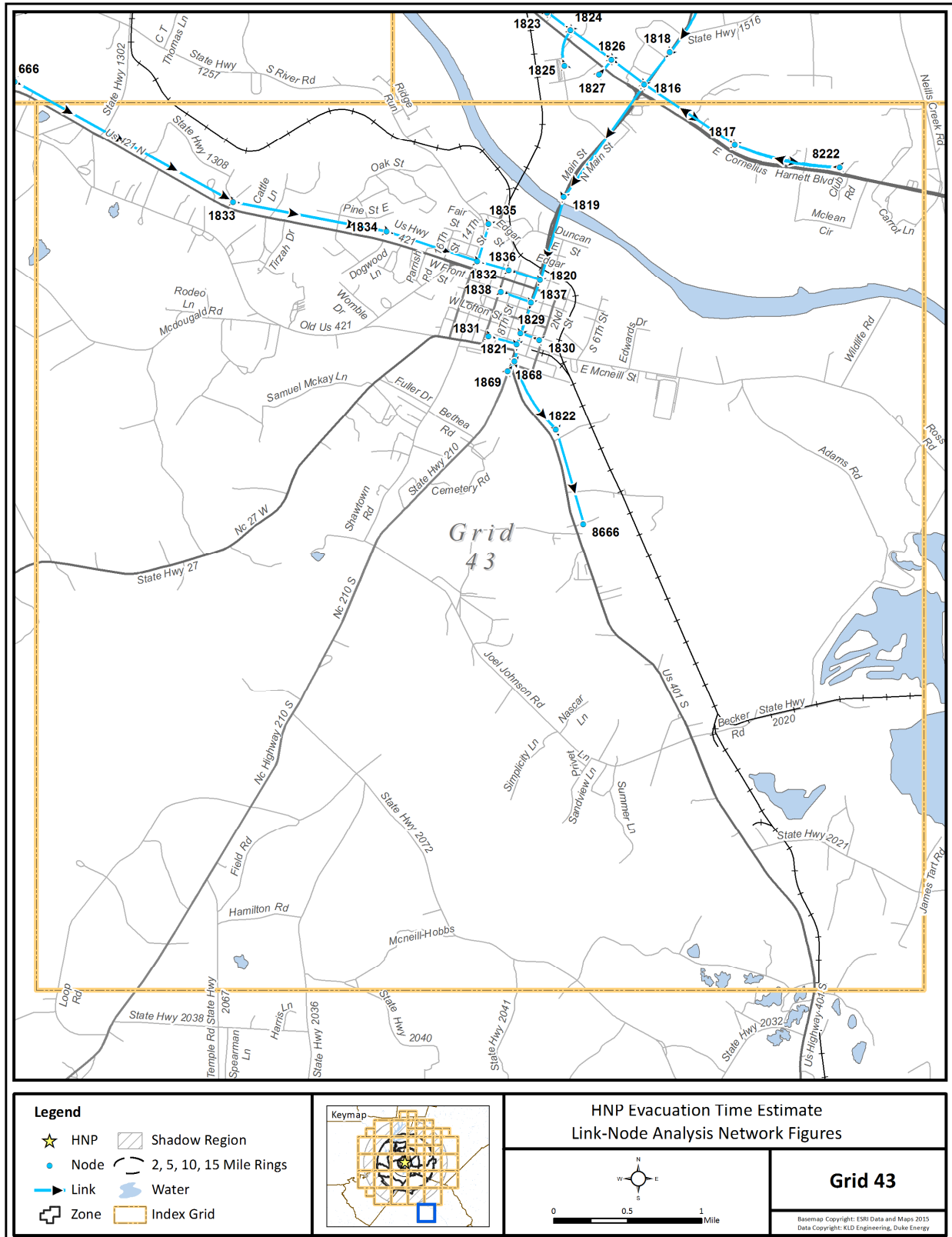

Figure K-44. Link-Node Analysis Network – Grid 43

Table K-1. Evacuation Roadway Network Characteristics

Link #	Up-Stream Node	Down-Stream Node	Roadway Name	Roadway Type	Length (ft.)	No. of Lanes	Lane Width (ft.)	Shoulder Width (ft.)	Saturation Flow Rate (pcphpl)	Free Flow Speed (mph)	Grid Map Number
1	1	6	US 1	FREEWAY	11855	2	13	10	2250	75	27
2	1	592	US 1	FREEWAY	9416	2	13	10	2250	75	27
3	2	3	CARY TOWNE BLVD	COLLECTOR	1204	1	13	0	1700	45	12
4	2	9	I-40 E ON-RAMP FROM CARY TOWNE BLVD	FREEWAY RAMP	971	1	14	4	1700	45	12
5	3	5	I-40 W ON-RAMP FROM CARY TOWNE BLVD	FREEWAY RAMP	1120	1	14	4	1700	50	12
6	4	1	US 1 S ON-RAMP FROM PEA RIDGE RD	FREEWAY RAMP	894	1	15	4	1700	45	27
7	5	7	I-40	FREEWAY	1156	3	13	8	2250	70	12
8	5	17	I-40	FREEWAY	3023	3	13	8	2250	70	12
9	6	1	US 1	FREEWAY	11855	2	13	10	2250	75	27
10	6	10	US 1	FREEWAY	2820	2	13	10	2250	75	28
11	7	5	I-40	FREEWAY	1156	3	13	8	2250	70	12
12	7	11	I-40	FREEWAY	999	3	13	8	2250	70	12
13	8	626	US 1 S ON-RAMP FROM OLD US 1	FREEWAY RAMP	858	1	14	3	1700	45	28
14	8	800	OLD US 1	COLLECTOR	7826	1	11	0	1700	60	28
15	9	11	I-40 E ON-RAMP FROM CARY TOWNE BLVD	FREEWAY RAMP	401	1	14	4	1700	45	12
16	10	6	US 1	FREEWAY	2820	2	13	10	2250	75	28
17	10	575	US 1	FREEWAY	2609	2	13	10	2250	75	28
18	11	7	I-40	FREEWAY	999	3	13	8	2250	70	12
19	11	349	I-40	FREEWAY	2050	3	13	8	2250	70	12
20	12	13	SR 54	MINOR ARTERIAL	1625	2	13	1	1900	55	12
21	13	19	SR 54	MINOR ARTERIAL	2234	2	13	1	1750	55	12
22	14	17	I-40 E ON-RAMP FROM SR 54	FREEWAY RAMP	627	1	15	7	1700	50	12

Link #	Up-Stream Node	Down-Stream Node	Roadway Name	Roadway Type	Length (ft.)	No. of Lanes	Lane Width (ft.)	Shoulder Width (ft.)	Saturation Flow Rate (pcphpl)	Free Flow Speed (mph)	Grid Map Number
23	14	1367	SR 54	MINOR ARTERIAL	372	2	12	1	1900	40	12
24	15	1711	I-40 W ON-RAMP FROM SR 54	FREEWAY RAMP	285	1	15	0	1350	30	12
25	16	14	I-40 OFF-RAMP	FREEWAY RAMP	1386	1	14	3	1750	45	12
26	16	20	I-40	FREEWAY	1510	3	13	8	2250	70	12
27	16	1366	I-40	FREEWAY	1431	3	13	8	2250	70	12
28	17	5	I-40	FREEWAY	3031	3	13	8	2250	70	12
29	17	1366	I-40	FREEWAY	501	2	13	8	2250	70	12
30	18	1105	CHAPEL HILL RD	COLLECTOR	2642	1	12	1	1700	55	12
31	19	1365	SR 54	MINOR ARTERIAL	1323	2	13	1	1900	55	12
32	20	16	I-40	FREEWAY	1510	3	13	8	2250	70	12
33	21	33	SR 55 BYPASS	MINOR ARTERIAL	3980	2	13	3	1750	60	29
34	21	35	SR 55 BYPASS	MINOR ARTERIAL	2105	2	13	3	1750	60	29
35	22	78	US 1	FREEWAY	4642	2	13	10	2250	75	27
36	22	592	US 1	FREEWAY	1811	2	13	10	2250	75	27
37	23	22	US 1 S ON-RAMP FROM MONCURE PITTSBORO RD	FREEWAY RAMP	884	1	12	4	1700	50	27
38	24	26	SR 55 BYPASS	MINOR ARTERIAL	2480	2	13	3	1900	60	29
39	24	30	SR 55 BYPASS	MINOR ARTERIAL	2529	2	13	3	1900	60	29
40	25	26	SR 55 BYPASS	MINOR ARTERIAL	1951	2	13	3	1900	60	22
41	25	444	OLD SMITHFIELD RD	COLLECTOR	2236	1	11	0	1750	40	22
42	25	1566	SR 55 BYPASS	MINOR ARTERIAL	1051	2	13	3	1900	60	22
43	26	24	SR 55 BYPASS	MINOR ARTERIAL	2480	2	13	3	1900	60	29
44	26	25	SR 55 BYPASS	MINOR ARTERIAL	1951	2	13	3	1900	60	22
45	27	28	SR 55	MINOR ARTERIAL	1185	2	13	0	1750	50	22
46	27	762	SR 55	MINOR ARTERIAL	1633	2	13	0	1900	50	22
47	28	27	SR 55	MINOR ARTERIAL	1185	2	13	0	1900	50	22
48	28	1564	SR 55 BYPASS	MINOR ARTERIAL	1834	2	13	3	1900	60	22
49	29	28	SR 55	COLLECTOR	1228	1	12	1	1750	40	22

Link #	Up-Stream Node	Down-Stream Node	Roadway Name	Roadway Type	Length (ft.)	No. of Lanes	Lane Width (ft.)	Shoulder Width (ft.)	Saturation Flow Rate (pcphpl)	Free Flow Speed (mph)	Grid Map Number
50	30	24	SR 55 BYPASS	MINOR ARTERIAL	2547	2	13	3	1900	60	29
51	30	31	SR 55 BYPASS	MINOR ARTERIAL	2716	2	13	3	1900	60	29
52	31	30	SR 55 BYPASS	MINOR ARTERIAL	2716	2	13	3	1900	60	29
53	31	32	SR 55 BYPASS	MINOR ARTERIAL	1104	2	13	3	1750	60	29
54	32	31	SR 55 BYPASS	MINOR ARTERIAL	1104	2	13	3	1900	60	29
55	32	33	SR 55 BYPASS	MINOR ARTERIAL	2226	2	13	3	1750	60	29
56	32	775	W HOLLY SPRINGS RD	COLLECTOR	2693	1	10	0	1700	45	29
57	33	21	SR 55 BYPASS	MINOR ARTERIAL	3992	2	13	3	1750	60	29
58	33	32	SR 55 BYPASS	MINOR ARTERIAL	2226	2	13	3	1750	60	29
59	34	417	US 1 OFF-RAMP	FREEWAY RAMP	1321	2	14	4	1750	50	20
60	34	597	US 1	FREEWAY	7048	4	13	10	2250	70	20
61	34	1401	US 1	FREEWAY	1193	3	13	10	2250	70	20
62	35	21	SR 55 BYPASS	MINOR ARTERIAL	2105	2	13	3	1750	60	29
63	35	435	SR 55	MINOR ARTERIAL	1213	2	13	0	1900	60	29
64	35	438	SR 55	COLLECTOR	796	1	12	1	1700	40	29
65	36	615	DICKENS RD	COLLECTOR	3924	1	10	0	1750	40	30
66	36	1032	JAMES SLAUGHTER RD	COLLECTOR	3980	1	12	0	1750	40	30
67	37	1401	US 1 N ON-RAMP FROM SE CARY PKWY	FREEWAY RAMP	869	1	12	0	1350	30	20
68	37	1402	SE CARY PKWY	MINOR ARTERIAL	165	2	13	0	1750	50	20
69	38	615	WADE NASH RD	COLLECTOR	2664	1	10	0	1750	40	30
70	39	957	E ACADEMY ST	COLLECTOR	1079	1	12	0	1750	30	36
71	39	1209	E ACADEMY ST	COLLECTOR	963	1	12	0	1350	30	36
72	40	355	US 1	FREEWAY	1761	5	13	10	2250	65	12
73	40	1111	US 1	FREEWAY	723	4	13	10	2250	65	20
74	41	196	US 401	MINOR ARTERIAL	2937	2	13	3	1900	55	31
75	41	225	US 401	MINOR ARTERIAL	2562	2	13	3	1900	55	30
76	42	1045	PURFOY RD	COLLECTOR	1379	1	13	3	1750	40	30

Link #	Up-Stream Node	Down-Stream Node	Roadway Name	Roadway Type	Length (ft.)	No. of Lanes	Lane Width (ft.)	Shoulder Width (ft.)	Saturation Flow Rate (pcphpl)	Free Flow Speed (mph)	Grid Map Number
77	42	1458	US 401	MINOR ARTERIAL	2396	2	12	0	1750	50	30
78	42	1576	US 401	MINOR ARTERIAL	718	2	12	0	1750	45	30
79	43	1261	SUNSET LAKE RD	COLLECTOR	4314	1	11	0	1750	50	30
80	44	43	SUNSET LAKE RD	COLLECTOR	1609	1	11	0	1700	50	30
81	45	598	US 1	FREEWAY	4211	4	13	10	2250	70	19
82	45	1401	US 1	FREEWAY	709	3	13	10	2250	70	20
83	45	1402	US 1 OFF-RAMP	FREEWAY RAMP	1140	1	14	0	1750	50	20
84	46	44	SUNSET LAKE RD	COLLECTOR	3172	1	11	0	1700	50	30
85	47	48	SUNSET LAKE RD	COLLECTOR	2625	1	11	0	1700	40	30
86	47	56	HILLTOP NEEDMORE RD	COLLECTOR	4727	1	12	0	1700	45	30
87	47	1462	SUNSET LAKE RD	COLLECTOR	509	1	11	0	1700	40	30
88	48	47	SUNSET LAKE RD	COLLECTOR	2625	1	11	0	1750	40	30
89	48	49	SUNSET LAKE RD	COLLECTOR	3530	1	11	0	1700	40	30
90	49	48	SUNSET LAKE RD	COLLECTOR	3530	1	11	0	1700	40	30
91	49	50	SUNSET LAKE RD	COLLECTOR	3292	1	11	0	1700	40	30
92	50	49	SUNSET LAKE RD	COLLECTOR	3292	1	11	0	1700	40	30
93	50	1463	SUNSET LAKE RD	COLLECTOR	4257	1	11	0	1750	40	30
94	51	52	SUNSET LAKE RD	MINOR ARTERIAL	849	2	11	0	1750	40	30
95	51	1463	SUNSET LAKE RD	COLLECTOR	1423	1	11	0	1750	40	30
96	52	51	SUNSET LAKE RD	MINOR ARTERIAL	849	2	11	0	1900	40	30
97	52	790	HOLLY SPRINGS RD	MINOR ARTERIAL	733	2	12	0	1900	45	30
98	53	791	SUNSET LAKE RD	COLLECTOR	4061	1	11	0	1700	45	23
99	54	53	SUNSET LAKE RD	COLLECTOR	1689	1	11	0	1700	45	23
100	55	54	SUNSET LAKE RD	COLLECTOR	2300	1	11	0	1700	45	23
101	56	1579	HILLTOP NEEDMORE RD	COLLECTOR	1275	1	12	0	1700	45	30
102	57	58	HILLTOP NEEDMORE RD	COLLECTOR	3071	1	12	0	1700	45	30
103	58	1883	HILLTOP NEEDMORE RD	COLLECTOR	1082	1	12	0	1750	45	30
104	59	736	HILLTOP NEEDMORE RD	COLLECTOR	2314	1	12	0	1750	40	30

Link #	Up-Stream Node	Down-Stream Node	Roadway Name	Roadway Type	Length (ft.)	No. of Lanes	Lane Width (ft.)	Shoulder Width (ft.)	Saturation Flow Rate (pcphpl)	Free Flow Speed (mph)	Grid Map Number
105	60	447	TEN-TEN RD	COLLECTOR	754	1	12	0	1750	50	23
106	60	692	US 1 N ON-RAMP FROM TEN-TEN RD	FREEWAY RAMP	790	1	15	2	1700	50	19
107	61	192	US 401	MINOR ARTERIAL	3333	2	13	3	1900	50	31
108	61	1042	US 401	MINOR ARTERIAL	1204	2	13	3	1750	55	31
109	62	63	OLD JENKS RD	COLLECTOR	5884	1	10	0	1700	45	18
110	62	301	OLD JENKS RD	COLLECTOR	1512	1	10	0	1750	45	18
111	63	62	OLD JENKS RD	COLLECTOR	5884	1	10	0	1700	45	18
112	63	396	OLD JENKS RD	COLLECTOR	1332	1	10	0	1750	45	18
113	64	396	JENKS RD	COLLECTOR	2060	1	10	0	1750	40	18
114	64	1859	ROBERTS RD	COLLECTOR	1751	1	10	0	1700	45	18
115	65	64	JENKS RD	COLLECTOR	1817	1	10	0	1700	40	17
116	66	65	JENKS RD	COLLECTOR	1052	1	10	0	1700	40	17
117	66	1537	GREEN LEVEL CHURCH RD	COLLECTOR	1132	1	12	0	1700	40	17
118	67	69	SW MAYNARD RD	MINOR ARTERIAL	1566	2	13	0	1900	40	11
119	68	445	SR 55	MINOR ARTERIAL	542	2	13	0	1750	50	22
120	68	690	US 1 N ON-RAMP FROM SR 55	FREEWAY RAMP	794	2	12	4	1900	50	22
121	68	758	SR 55	MINOR ARTERIAL	696	2	13	0	1750	50	22
122	69	389	SW MAYNARD RD	MINOR ARTERIAL	871	2	13	0	1900	40	11
123	70	742	NEW ELAM CHURCH RD	COLLECTOR	2474	1	9	0	1750	40	28
124	71	68	US 1 OFF-RAMP	FREEWAY RAMP	1134	2	12	4	1750	45	22
125	71	690	US 1	FREEWAY	1828	2	13	10	2250	70	22
126	71	1552	US 1	FREEWAY	7391	2	13	10	2250	70	22
127	72	73	US 1	FREEWAY	9943	2	13	10	2250	75	21
128	72	1557	US 1	FREEWAY	6480	2	13	10	2250	75	21
129	73	72	US 1	FREEWAY	9943	2	13	10	2250	75	21
130	73	1137	US 1 OFF-RAMP	FREEWAY RAMP	660	1	14	3	1750	45	29
131	73	1138	US 1	FREEWAY	1039	2	13	10	2250	75	29

Link #	Up-Stream Node	Down-Stream Node	Roadway Name	Roadway Type	Length (ft.)	No. of Lanes	Lane Width (ft.)	Shoulder Width (ft.)	Saturation Flow Rate (pcphpl)	Free Flow Speed (mph)	Grid Map Number
132	74	261	MONCURE PITTSBORO RD	COLLECTOR	1312	1	12	0	1700	60	27
133	74	1325	MONCURE PITTSBORO RD	COLLECTOR	3543	1	12	0	1700	60	27
134	75	73	US 1 N ON-RAMP FROM NEW HILL HOLLEMAN RD	FREEWAY RAMP	719	1	14	3	1700	50	29
135	75	452	NEW HILL HOLLEMAN RD	COLLECTOR	4905	1	11	1	1750	50	29
136	75	1137	NEW HILL HOLLEMAN RD	COLLECTOR	657	1	11	1	1750	50	29
137	76	579	US 1	FREEWAY	6880	2	13	10	2250	75	28
138	76	1138	US 1	FREEWAY	8607	2	13	10	2250	75	28
139	77	74	GUM SPRINGS CHURCH RD	COLLECTOR	4564	1	10	0	1700	50	27
140	78	22	US 1	FREEWAY	4642	2	13	10	2250	75	27
141	78	630	US 1	FREEWAY	2897	2	13	10	2250	75	27
142	79	78	US 1 S ON-RAMP FROM OLD US 1	FREEWAY RAMP	472	1	15	4	1700	50	27
143	79	507	DEEP RIVER RD	COLLECTOR	2193	1	11	0	1700	50	27
144	80	81	S MAIN ST	COLLECTOR	1427	1	13	4	1575	35	39
145	80	88	N MAIN ST	COLLECTOR	1224	1	13	4	1575	35	39
146	81	82	S MAIN ST	COLLECTOR	2857	1	12	0	1700	45	39
147	82	86	S MAIN ST	COLLECTOR	1535	1	12	0	1700	45	39
148	83	84	US 1	FREEWAY	2099	2	13	10	2250	75	33
149	83	630	US 1	FREEWAY	7691	2	13	10	2250	75	27
150	84	83	US 1	FREEWAY	2099	2	13	10	2250	75	33
151	84	87	US 1	FREEWAY	9152	2	13	10	2250	75	33
152	85	84	US 1 S ON-RAMP FROM FARRELL RD	FREEWAY RAMP	1395	1	13	2	1700	50	33
153	86	997	SEMINOLE RD	COLLECTOR	2910	1	12	0	1700	45	40
154	87	84	US 1	FREEWAY	9152	2	13	10	2250	75	33
155	87	89	US 1	FREEWAY	4128	2	13	10	2250	75	32
156	88	91	N MAIN ST	COLLECTOR	1333	1	12	0	1700	45	39

Link #	Up-Stream Node	Down-Stream Node	Roadway Name	Roadway Type	Length (ft.)	No. of Lanes	Lane Width (ft.)	Shoulder Width (ft.)	Saturation Flow Rate (pcphpl)	Free Flow Speed (mph)	Grid Map Number
157	89	87	US 1	FREEWAY	4128	2	13	10	2250	75	32
158	89	92	US 1	FREEWAY	6291	2	13	10	2250	75	32
159	90	89	US 1 S ON-RAMP FROM COLON RD	FREEWAY RAMP	1099	1	15	3	1700	50	32
160	90	941	COLON RD	COLLECTOR	1888	1	12	0	1700	60	32
161	91	94	N MAIN ST	COLLECTOR	3827	1	12	0	1700	45	39
162	92	89	US 1	FREEWAY	6299	2	13	10	2250	75	32
163	92	93	US 1	FREEWAY	5183	2	13	10	2250	75	32
164	93	92	US 1	FREEWAY	5183	2	13	10	2250	75	32
165	93	100	US 1	FREEWAY	4740	2	13	10	2250	75	32
166	94	95	BROADWAY RD	COLLECTOR	3002	1	12	0	1700	45	39
167	95	852	BROADWAY RD	COLLECTOR	4595	1	12	0	1750	45	39
168	96	80	E HARRINGTON AVE	COLLECTOR	4518	1	12	0	1700	40	39
169	97	872	CHRISTIAN CHAPEL CHURCH RD	COLLECTOR	8343	1	11	0	1700	40	28
170	98	99	POST OFFICE RD	COLLECTOR	7892	1	10	0	1700	40	33
171	99	1520	BRICKYARD RD	COLLECTOR	373	1	10	0	1350	30	32
172	100	93	US 1	FREEWAY	4737	2	13	10	2250	75	32
173	100	1222	US 1	FREEWAY	2354	3	13	10	2250	70	32
174	101	102	US 64	FREEWAY	1628	2	14	3	2250	70	15
175	101	108	US 64	FREEWAY	5182	2	14	3	2250	70	15
176	102	101	US 64	FREEWAY	1628	2	14	3	2250	70	15
177	102	104	US 64	FREEWAY	2791	2	14	3	2250	70	15
178	103	106	US 64 BUS	COLLECTOR	2080	1	14	4	1700	40	15
179	104	102	US 64	FREEWAY	2780	2	14	3	2250	70	15
180	104	103	US 64 OFF-RAMP	FREEWAY RAMP	1510	1	14	4	1700	40	15
181	104	654	US 64	MINOR ARTERIAL	4305	2	14	2	1900	60	15
182	105	1123	US 1	FREEWAY	906	3	13	10	2250	70	32
183	105	1803	US 1	FREEWAY	477	3	13	10	2250	70	32

Link #	Up-Stream Node	Down-Stream Node	Roadway Name	Roadway Type	Length (ft.)	No. of Lanes	Lane Width (ft.)	Shoulder Width (ft.)	Saturation Flow Rate (pcphpl)	Free Flow Speed (mph)	Grid Map Number
184	106	141	US 64 BUS	COLLECTOR	4255	1	12	0	1750	50	15
185	107	1788	US 1 S ON-RAMP FROM US 421 BYPASS	FREEWAY RAMP	387	1	15	2	1350	30	32
186	108	101	US 64	FREEWAY	5182	2	14	3	2250	70	15
187	108	111	US 64	FREEWAY	6289	2	14	3	2250	70	14
188	109	110	US 421 BUS	MINOR ARTERIAL	1096	2	13	2	1750	40	38
189	109	589	US 421 BUS	MINOR ARTERIAL	3287	2	13	2	1900	40	38
190	109	629	US 1 S ON-RAMP FROM US 421	FREEWAY RAMP	507	1	12	1	1700	40	38
191	110	109	US 421 BUS	MINOR ARTERIAL	1096	2	13	2	1750	40	38
192	110	557	US 421 BUS	MINOR ARTERIAL	1171	2	13	0	1900	40	38
193	111	108	US 64	FREEWAY	6278	2	14	3	2250	70	14
194	111	113	US 64 OFF-RAMP	FREEWAY RAMP	1514	1	14	3	1700	45	14
195	111	114	US 64	FREEWAY	2470	2	14	3	2250	70	14
196	112	105	US 1	FREEWAY	7183	3	13	10	2250	70	32
197	112	110	US 1 OFF-RAMP	FREEWAY RAMP	839	1	12	1	1750	45	38
198	112	590	US 1	FREEWAY	1609	3	13	2	2250	70	38
199	113	114	US 64 W ON-RAMP FROM US 15 S	FREEWAY RAMP	1184	1	14	3	1700	45	14
200	113	1528	US 15	MINOR ARTERIAL	215	2	12	2	1900	60	14
201	114	111	US 64	FREEWAY	2470	2	14	3	2250	70	14
202	114	115	US 64	FREEWAY	4048	2	14	3	2250	70	14
203	115	114	US 64	FREEWAY	4049	2	14	3	2250	70	14
204	115	117	US 64	FREEWAY	3546	2	14	3	2250	70	14
205	116	119	US 64	MINOR ARTERIAL	2305	2	13	9	1750	60	19
206	116	1011	US 64	MINOR ARTERIAL	1346	2	13	9	1750	60	19
207	117	115	US 64	FREEWAY	3538	2	14	3	2250	70	14
208	117	124	US 64	FREEWAY	3517	2	14	3	2250	70	14
209	118	121	US 64 W ON-RAMP FROM SR 87	FREEWAY RAMP	943	1	14	4	1700	45	14

Link #	Up-Stream Node	Down-Stream Node	Roadway Name	Roadway Type	Length (ft.)	No. of Lanes	Lane Width (ft.)	Shoulder Width (ft.)	Saturation Flow Rate (pcphpl)	Free Flow Speed (mph)	Grid Map Number
210	118	125	SR 87	COLLECTOR	2578	1	10	0	1700	60	14
211	118	783	SR 87	COLLECTOR	2738	1	10	0	1700	60	14
212	119	116	US 64	MINOR ARTERIAL	2305	2	13	9	1900	60	19
213	119	120	US 64	MINOR ARTERIAL	4356	2	13	9	1750	60	18
214	119	1017	LAKE PINE DR	MINOR ARTERIAL	784	2	13	0	1900	45	19
215	120	119	US 64	MINOR ARTERIAL	4356	2	13	9	1750	60	18
216	120	587	US 64	MINOR ARTERIAL	1213	2	13	9	1900	60	18
217	120	1022	LAURA DUNCAN RD	COLLECTOR	867	1	10	0	1700	50	18
218	120	1450	LAURA DUNCAN RD	COLLECTOR	4133	1	10	0	1750	40	18
219	121	124	US 64	FREEWAY	1491	2	14	3	2250	70	14
220	121	131	US 64	FREEWAY	3723	2	14	3	2250	70	14
221	122	123	US 64	FREEWAY	1290	2	13	2	2250	60	18
222	122	587	US 64	FREEWAY	1872	2	13	2	2250	60	18
223	123	122	US 64	FREEWAY	1290	2	13	2	2250	60	18
224	123	1582	US 64	FREEWAY	1050	2	13	2	2250	60	18
225	124	117	US 64	FREEWAY	3517	2	14	3	2250	70	14
226	124	121	US 64	FREEWAY	1491	2	14	3	2250	70	14
227	125	118	SR 87	COLLECTOR	2578	1	10	0	1700	60	14
228	126	326	US 64 OFF-RAMP	FREEWAY RAMP	1462	1	12	4	1750	45	18
229	126	672	US 64	MINOR ARTERIAL	4458	2	13	2	1900	60	18
230	126	1593	US 64	MINOR ARTERIAL	948	2	13	0	1900	60	18
231	127	434	US 64	MINOR ARTERIAL	2206	2	13	2	1900	60	17
232	127	1584	US 64	MINOR ARTERIAL	1362	2	13	0	1900	60	18
233	128	257	SR 751	COLLECTOR	8528	1	11	1	1700	60	16
234	128	433	US 64	MINOR ARTERIAL	8771	2	13	9	1900	60	16
235	128	641	US 64	MINOR ARTERIAL	1007	2	13	9	1900	60	16
236	129	130	US 64	MINOR ARTERIAL	3395	2	13	9	1750	60	16
237	129	641	US 64	MINOR ARTERIAL	10835	2	13	9	1900	60	16

Link #	Up-Stream Node	Down-Stream Node	Roadway Name	Roadway Type	Length (ft.)	No. of Lanes	Lane Width (ft.)	Shoulder Width (ft.)	Saturation Flow Rate (pcphpl)	Free Flow Speed (mph)	Grid Map Number
238	130	129	US 64	MINOR ARTERIAL	3395	2	13	9	1900	60	16
239	130	466	US 64	MINOR ARTERIAL	1095	2	13	9	1900	60	16
240	130	753	FARRINGTON POINT RD	COLLECTOR	1409	1	10	0	1700	50	16
241	131	121	US 64	FREEWAY	3723	2	14	3	2250	70	14
242	131	133	US 64	FREEWAY	5231	2	14	3	2250	70	14
243	132	136	US 64 W ON-RAMP FROM US 64 BUS	FREEWAY RAMP	1092	1	14	5	1700	45	14
244	133	131	US 64	FREEWAY	5235	2	14	3	2250	70	14
245	133	134	US 64	FREEWAY	1923	2	14	3	2250	70	14
246	134	133	US 64	FREEWAY	1923	2	14	3	2250	70	14
247	134	137	US 64	MINOR ARTERIAL	3888	2	12	4	1900	60	14
248	135	620	US 64	MINOR ARTERIAL	3286	2	14	2	1900	60	15
249	135	1849	US 64	MINOR ARTERIAL	2508	2	14	2	1900	60	15
250	136	134	US 64 W ON-RAMP FROM US 64 BUS	FREEWAY RAMP	772	1	14	5	1700	45	14
251	137	134	US 64	MINOR ARTERIAL	3888	2	12	4	1900	60	14
252	138	784	SR 87	COLLECTOR	2576	1	12	0	1700	50	14
253	138	785	SR 87	COLLECTOR	789	1	12	0	1700	50	14
254	139	785	SR 87	COLLECTOR	1256	1	12	0	1700	50	14
255	140	1319	AVENT FERRY RD	COLLECTOR	816	1	12	0	1750	40	29
256	141	1332	US 64 BUS	COLLECTOR	3551	1	12	0	1700	50	14
257	142	140	PINEY GROVE WILBON RD	COLLECTOR	3477	1	11	0	1750	50	29
258	143	795	US 64 BUS	COLLECTOR	341	1	15	0	900	20	14
259	144	782	SR 87	COLLECTOR	1126	1	10	0	1700	40	14
260	144	784	SR 87	COLLECTOR	1127	1	12	0	1700	40	14
261	144	1333	US 64 BUS	COLLECTOR	1495	1	13	1	1700	40	14
262	145	132	US 64 BUS	COLLECTOR	6657	1	13	1	1700	60	14
263	146	602	US 501	COLLECTOR	521	1	14	6	1700	40	14

Link #	Up-Stream Node	Down-Stream Node	Roadway Name	Roadway Type	Length (ft.)	No. of Lanes	Lane Width (ft.)	Shoulder Width (ft.)	Saturation Flow Rate (pcphpl)	Free Flow Speed (mph)	Grid Map Number
264	147	38	WADE NASH RD	COLLECTOR	6418	1	10	0	1700	40	29
265	147	150	PINEY GROVE WILBON RD	COLLECTOR	5685	1	11	0	1700	50	29
266	148	149	US 501	COLLECTOR	6172	1	12	1	1700	60	14
267	148	230	US 501	COLLECTOR	2278	1	12	1	1750	40	14
268	149	148	US 501	COLLECTOR	6172	1	12	1	1700	60	14
269	149	647	US 501	COLLECTOR	5765	1	12	1	1700	60	14
270	150	151	PINEY GROVE WILBON RD	COLLECTOR	1790	1	11	0	1700	50	29
271	151	153	PINEY GROVE WILBON RD	COLLECTOR	5117	1	11	0	1700	40	29
272	151	1034	WILBON RD	COLLECTOR	7360	1	10	0	1700	50	29
273	152	647	US 501	COLLECTOR	5329	1	12	1	1700	60	26
274	152	995	US 501	COLLECTOR	3168	1	12	1	1700	60	26
275	153	154	PINEY GROVE WILBON RD	COLLECTOR	3469	1	11	0	1700	40	35
276	154	155	PINEY GROVE WILBON RD	COLLECTOR	1540	1	11	0	1750	40	35
277	155	159	PINEY GROVE WILBON RD	COLLECTOR	4347	1	11	0	1700	50	35
278	155	893	SR 42	COLLECTOR	4105	1	12	4	1700	50	35
279	156	140	AVENT FERRY RD	COLLECTOR	3624	1	12	0	1750	40	29
280	157	643	US 501	COLLECTOR	3349	1	12	1	1700	60	26
281	157	644	US 501	COLLECTOR	8446	1	12	1	1700	60	26
282	158	156	AVENT FERRY RD	COLLECTOR	4039	1	12	0	1750	40	29
283	159	160	PINEY GROVE WILBON RD	COLLECTOR	3267	1	11	0	1700	50	36
284	160	161	PINEY GROVE RAWLS RD	COLLECTOR	2580	1	11	0	1700	50	36
285	161	210	PINEY GROVE RAWLS RD	COLLECTOR	3822	1	11	0	1750	45	36
286	162	163	EAST WILLIAMS ST	COLLECTOR	6746	1	12	0	1700	45	36
287	162	171	EAST WILLIAMS ST	COLLECTOR	1313	1	12	0	1700	45	36
288	163	164	EAST WILLIAMS ST	COLLECTOR	1119	1	12	0	1700	45	36
289	164	176	EAST WILLIAMS ST	COLLECTOR	1212	1	12	0	1700	45	36
290	165	1479	PURFOY RD	COLLECTOR	3933	1	11	1	1700	55	36
291	165	1873	ANGIER RD	COLLECTOR	1000	1	10	0	1700	45	36

Link #	Up-Stream Node	Down-Stream Node	Roadway Name	Roadway Type	Length (ft.)	No. of Lanes	Lane Width (ft.)	Shoulder Width (ft.)	Saturation Flow Rate (pcphpl)	Free Flow Speed (mph)	Grid Map Number
292	166	1477	PURFOY RD	COLLECTOR	1236	1	11	1	1575	35	36
293	167	166	PURFOY RD	COLLECTOR	1047	1	11	1	1700	50	36
294	168	649	US 501	COLLECTOR	1625	1	12	1	1700	40	14
295	169	167	PURFOY RD	COLLECTOR	4130	1	12	1	1700	50	36
296	170	1475	PURFOY RD	COLLECTOR	782	1	12	1	1700	40	36
297	171	172	EAST WILLIAMS ST	COLLECTOR	1959	1	12	0	1700	45	36
298	172	173	EAST WILLIAMS ST	COLLECTOR	3441	1	12	0	1700	45	36
299	173	174	EAST WILLIAMS ST	COLLECTOR	5486	1	12	0	1700	40	36
300	174	974	N JOHNSON ST	LOCAL ROADWAY	444	1	10	0	1575	35	36
301	175	652	US 15	MINOR ARTERIAL	4289	2	12	2	1900	60	14
302	175	1528	US 15	MINOR ARTERIAL	1701	2	12	2	1900	60	14
303	176	211	US 401	COLLECTOR	5249	1	13	2	1700	60	36
304	176	212	US 401	COLLECTOR	1408	1	13	2	1700	55	36
305	177	155	SR 42	COLLECTOR	2878	1	12	4	1750	50	35
306	178	177	BAREFOOT RD	COLLECTOR	1318	1	11	0	1700	40	35
307	179	178	CHRISTIAN LIGHT RD	COLLECTOR	2039	1	11	0	1700	45	35
308	180	181	US 15	MINOR ARTERIAL	2179	2	12	2	1900	60	4
309	181	793	US 15	MINOR ARTERIAL	2274	2	12	2	1900	60	4
310	182	179	CHRISTIAN LIGHT RD	COLLECTOR	905	1	11	0	1700	45	35
311	183	182	CHRISTIAN LIGHT RD	COLLECTOR	2661	1	11	0	1700	55	35
312	184	489	US 15	MINOR ARTERIAL	1625	2	12	2	1900	60	4
313	185	613	US 15	MINOR ARTERIAL	1580	2	12	2	1750	60	4
314	186	1300	US 15	MINOR ARTERIAL	905	2	12	2	1750	60	4
315	187	188	US 15	MINOR ARTERIAL	2005	2	12	2	1750	60	4
316	188	190	US 15	MINOR ARTERIAL	1490	2	12	2	1900	50	4
317	189	183	CHRISTIAN LIGHT RD	COLLECTOR	3101	1	11	0	1700	55	35
318	189	191	CHRISTIAN LIGHT RD	COLLECTOR	1868	1	11	0	1700	55	35
319	190	1702	US 15	MINOR ARTERIAL	1909	2	12	2	1425	40	4

Link #	Up-Stream Node	Down-Stream Node	Roadway Name	Roadway Type	Length (ft.)	No. of Lanes	Lane Width (ft.)	Shoulder Width (ft.)	Saturation Flow Rate (pcphpl)	Free Flow Speed (mph)	Grid Map Number
320	191	194	CHRISTIAN LIGHT RD	COLLECTOR	4021	1	11	0	1700	60	35
321	192	61	US 401	MINOR ARTERIAL	3333	2	13	3	1750	50	31
322	192	193	US 401	MINOR ARTERIAL	1336	2	13	3	1750	50	31
323	193	192	US 401	MINOR ARTERIAL	1336	2	13	3	1900	50	31
324	193	223	US 401	MINOR ARTERIAL	1366	2	13	3	1900	50	31
325	193	731	TEN-TEN RD	COLLECTOR	2236	1	12	0	1700	50	31
326	194	195	CHRISTIAN LIGHT RD	COLLECTOR	3173	1	11	0	1700	50	35
327	195	197	CHRISTIAN LIGHT RD	COLLECTOR	4104	1	11	0	1700	50	35
328	196	41	US 401	MINOR ARTERIAL	2937	2	13	3	1750	55	31
329	196	1446	US 401	MINOR ARTERIAL	2011	2	13	3	1750	55	31
330	197	198	CHRISTIAN LIGHT RD	COLLECTOR	3126	1	11	0	1700	60	35
331	198	199	CHRISTIAN LIGHT RD	COLLECTOR	4135	1	11	0	1700	60	41
332	199	200	CHRISTIAN LIGHT RD	COLLECTOR	4614	1	11	0	1700	60	41
333	200	205	CHRISTIAN LIGHT RD	COLLECTOR	1844	1	11	0	1700	50	41
334	201	388	US 401	MINOR ARTERIAL	2756	2	13	3	1750	60	30
335	201	985	SR 55	COLLECTOR	423	1	13	1	1700	45	30
336	201	1458	US 401	MINOR ARTERIAL	2137	2	12	0	1750	50	30
337	202	1574	US 401	MINOR ARTERIAL	1225	2	12	0	1900	40	30
338	202	1575	JUDD PKWY	COLLECTOR	426	1	13	1	1700	40	30
339	202	1576	US 401	MINOR ARTERIAL	751	2	12	0	1750	45	30
340	203	204	US 401	COLLECTOR	1080	1	12	0	1750	40	36
341	203	1030	US 401	COLLECTOR	891	1	12	0	1700	40	30
342	204	203	US 401	COLLECTOR	1080	1	12	0	1700	40	36
343	204	959	US 401	COLLECTOR	413	1	12	0	1700	40	36
344	205	213	CHRISTIAN LIGHT RD	COLLECTOR	4004	1	11	0	1700	60	41
345	206	207	US 401	COLLECTOR	3175	1	13	2	1700	50	36
346	206	1100	US 401	COLLECTOR	1582	1	12	0	1750	40	36
347	207	206	US 401	COLLECTOR	3175	1	13	2	1700	50	36

Link #	Up-Stream Node	Down-Stream Node	Roadway Name	Roadway Type	Length (ft.)	No. of Lanes	Lane Width (ft.)	Shoulder Width (ft.)	Saturation Flow Rate (pcphpl)	Free Flow Speed (mph)	Grid Map Number
348	207	208	US 401	COLLECTOR	2664	1	13	2	1700	50	36
349	208	207	US 401	COLLECTOR	2664	1	13	2	1700	50	36
350	208	209	US 401	COLLECTOR	3228	1	13	2	1700	60	36
351	209	208	US 401	COLLECTOR	3228	1	13	2	1700	60	36
352	209	210	US 401	COLLECTOR	2835	1	13	2	1750	60	36
353	210	209	US 401	COLLECTOR	2835	1	13	2	1700	60	36
354	210	211	US 401	COLLECTOR	4912	1	13	2	1700	60	36
355	211	176	US 401	COLLECTOR	5249	1	13	2	1700	60	36
356	211	210	US 401	COLLECTOR	4912	1	13	2	1750	60	36
357	212	176	US 401	COLLECTOR	1408	1	13	2	1700	55	36
358	212	735	US 401	COLLECTOR	6557	1	12	0	1750	45	36
359	213	214	CHRISTIAN LIGHT RD	COLLECTOR	1929	1	11	0	1700	50	41
360	214	215	CHRISTIAN LIGHT RD	COLLECTOR	8153	1	11	0	1750	60	41
361	215	219	US 401	COLLECTOR	2051	1	12	0	1700	60	42
362	215	220	US 401	COLLECTOR	4679	1	12	0	1700	60	42
363	216	217	US 401	COLLECTOR	828	1	12	0	1700	60	42
364	216	1240	US 401	COLLECTOR	1574	1	12	0	1700	50	42
365	217	216	US 401	COLLECTOR	828	1	12	0	1700	60	42
366	217	219	US 401	COLLECTOR	5377	1	12	0	1700	60	42
367	218	594	COOL SPRINGS RD	COLLECTOR	3627	1	10	0	1700	40	40
368	219	215	US 401	COLLECTOR	2051	1	12	0	1750	60	42
369	219	217	US 401	COLLECTOR	5377	1	12	0	1700	60	42
370	220	215	US 401	COLLECTOR	4679	1	12	0	1750	60	42
371	220	221	US 401	COLLECTOR	2253	1	12	0	1700	60	42
372	221	220	US 401	COLLECTOR	2253	1	12	0	1700	60	42
373	221	222	US 401	COLLECTOR	3017	1	12	0	1700	60	42
374	222	221	US 401	COLLECTOR	3017	1	12	0	1700	60	42
375	222	1823	US 401	COLLECTOR	2859	1	12	0	1700	60	42

Link #	Up-Stream Node	Down-Stream Node	Roadway Name	Roadway Type	Length (ft.)	No. of Lanes	Lane Width (ft.)	Shoulder Width (ft.)	Saturation Flow Rate (pcphpl)	Free Flow Speed (mph)	Grid Map Number
376	223	193	US 401	MINOR ARTERIAL	1366	2	13	3	1750	50	31
377	223	224	US 401	MINOR ARTERIAL	2076	2	13	3	1900	50	31
378	224	223	US 401	MINOR ARTERIAL	2076	2	13	3	1900	50	31
379	225	41	US 401	MINOR ARTERIAL	2562	2	13	3	1750	55	30
380	225	388	US 401	MINOR ARTERIAL	9503	2	13	3	1750	60	30
381	226	1030	US 401	COLLECTOR	338	1	12	0	1700	40	30
382	226	1958	US 401	MINOR ARTERIAL	727	2	12	0	1900	40	30
383	227	218	COOL SPRINGS RD	COLLECTOR	3435	1	10	0	1700	40	40
384	228	959	US 401	COLLECTOR	1247	1	12	0	1350	30	36
385	228	1250	US 401	COLLECTOR	812	1	12	0	1750	30	36
386	228	1504	E ACADEMY ST	COLLECTOR	488	1	12	0	1750	30	36
387	229	1100	US 401	COLLECTOR	2474	1	12	0	1750	30	36
388	229	1250	US 401	COLLECTOR	609	1	12	0	1750	30	36
389	230	139	SR 87	COLLECTOR	1561	1	12	0	1700	50	14
390	230	146	US 501	COLLECTOR	3803	1	12	1	1750	40	14
391	230	148	US 501	COLLECTOR	2278	1	12	1	1700	40	14
392	231	227	COOL SPRINGS RD	COLLECTOR	8113	1	10	0	1700	40	40
393	232	231	COOL SPRINGS RD	COLLECTOR	2375	1	10	0	1700	40	40
394	233	143	US 64 BUS	COLLECTOR	946	1	12	0	1750	35	14
395	234	606	US 64 BUS	COLLECTOR	852	1	12	0	1575	35	14
396	235	239	NEW HILL OLIVE CHAPEL RD	COLLECTOR	2729	1	11	1	1700	50	21
397	235	668	NEW HILL HOLLEMAN RD	COLLECTOR	3274	1	11	1	1700	50	21
398	235	1323	OLD US 1	COLLECTOR	1036	1	11	0	1700	40	21
399	236	1581	BUCKHORN RD	COLLECTOR	1191	1	10	0	1700	40	40
400	237	236	BUCKHORN RD	COLLECTOR	4143	1	10	0	1700	40	40
401	238	237	BUCKHORN RD	COLLECTOR	1827	1	10	0	1700	40	40
402	239	241	NEW HILL OLIVE CHAPEL RD	COLLECTOR	2796	1	11	1	1700	50	16
403	240	238	BUCKHORN RD	COLLECTOR	2633	1	10	0	1700	40	40

Link #	Up-Stream Node	Down-Stream Node	Roadway Name	Roadway Type	Length (ft.)	No. of Lanes	Lane Width (ft.)	Shoulder Width (ft.)	Saturation Flow Rate (pcphpl)	Free Flow Speed (mph)	Grid Map Number
404	241	243	NEW HILL OLIVE CHAPEL RD	COLLECTOR	1901	1	11	1	1700	40	16
405	242	240	BUCKHORN RD	COLLECTOR	1790	1	10	0	1700	40	40
406	243	244	NEW HILL OLIVE CHAPEL RD	COLLECTOR	2432	1	11	1	1700	50	16
407	244	245	NEW HILL OLIVE CHAPEL RD	COLLECTOR	2129	1	11	1	1700	50	16
408	245	246	NEW HILL OLIVE CHAPEL RD	COLLECTOR	1841	1	11	1	1700	50	16
409	246	249	NEW HILL OLIVE CHAPEL RD	COLLECTOR	3256	1	11	1	1700	50	16
410	247	242	BUCKHORN RD	COLLECTOR	7010	1	10	0	1700	40	34
411	248	842	BUCKHORN RD	COLLECTOR	1742	1	10	0	1750	40	39
412	249	251	NEW HILL OLIVE CHAPEL RD	COLLECTOR	3436	1	11	1	1700	50	16
413	250	248	BUCKHORN RD	COLLECTOR	2545	1	10	0	1700	40	39
414	251	128	NEW HILL OLIVE CHAPEL RD	COLLECTOR	3550	1	11	1	1750	40	16
415	252	250	BUCKHORN RD	COLLECTOR	4338	1	10	0	1700	40	34
416	253	252	BUCKHORN RD	COLLECTOR	4075	1	10	0	1700	40	34
417	254	253	BUCKHORN RD	COLLECTOR	2222	1	10	0	1700	40	34
418	255	254	BUCKHORN RD	COLLECTOR	2258	1	10	0	1700	40	34
419	256	805	OLD US 1	COLLECTOR	2551	1	11	0	1700	40	27
420	257	633	SR 751	COLLECTOR	2284	1	11	1	1700	60	5
421	258	256	MONCURE SCHOOL RD	COLLECTOR	3930	1	10	0	1700	50	27
422	259	258	MONCURE SCHOOL RD	COLLECTOR	2474	1	10	0	1700	40	27
423	260	259	JORDAN DAM RD	COLLECTOR	4007	1	11	0	1700	40	27
424	261	262	MT VIEW CHURCH RD	COLLECTOR	2481	1	10	0	1700	40	27
425	261	770	MONCURE PITTSBORO RD	COLLECTOR	1426	1	12	0	1700	50	27
426	262	263	MT VIEW CHURCH RD	COLLECTOR	3651	1	10	0	1700	40	27
427	263	265	MT VIEW CHURCH RD	COLLECTOR	2624	1	10	0	1700	40	27
428	264	635	SR 751	COLLECTOR	2978	1	11	1	1700	60	5
429	265	267	MT VIEW CHURCH RD	COLLECTOR	2163	1	10	0	1700	40	26
430	266	636	SR 751	COLLECTOR	2043	1	11	1	1700	60	5
431	267	268	MT VIEW CHURCH RD	COLLECTOR	3170	1	10	0	1700	40	26

Link #	Up-Stream Node	Down-Stream Node	Roadway Name	Roadway Type	Length (ft.)	No. of Lanes	Lane Width (ft.)	Shoulder Width (ft.)	Saturation Flow Rate (pcphpl)	Free Flow Speed (mph)	Grid Map Number
432	268	995	MT VIEW CHURCH RD	COLLECTOR	4016	1	10	0	1700	40	26
433	269	637	SR 751	COLLECTOR	1532	1	11	1	1700	60	5
434	270	141	HANKS CHAPEL RD	COLLECTOR	412	1	10	0	1750	30	15
435	271	270	HANKS CHAPEL RD	COLLECTOR	4544	1	10	0	1700	50	15
436	272	271	HANKS CHAPEL RD	COLLECTOR	2899	1	10	0	1700	50	15
437	273	272	HANKS CHAPEL RD	COLLECTOR	1395	1	10	0	1700	50	15
438	274	276	SR 751	COLLECTOR	3374	1	11	1	1700	60	5
439	275	273	HANKS CHAPEL RD	COLLECTOR	4074	1	10	0	1700	50	15
440	276	1894	SR 751	COLLECTOR	4660	1	11	1	1700	60	1
441	277	275	HANKS CHAPEL RD	COLLECTOR	1875	1	10	0	1700	40	15
442	278	8	OLD US 1	COLLECTOR	10095	1	11	0	1700	60	28
443	278	632	OLD US 1	COLLECTOR	6888	1	11	0	1700	60	28
444	279	277	HANKS CHAPEL RD	COLLECTOR	1596	1	10	0	1700	40	15
445	280	279	HANKS CHAPEL RD	COLLECTOR	2492	1	10	0	1700	50	15
446	281	280	GUM SPRINGS CHURCH RD	COLLECTOR	3014	1	10	0	1700	50	15
447	281	284	GUM SPRINGS CHURCH RD	COLLECTOR	2639	1	10	0	1700	50	15
448	282	283	OLD US 1	COLLECTOR	2405	1	11	0	1700	45	28
449	283	235	OLD US 1	COLLECTOR	2321	1	11	0	1750	40	16
450	284	285	GUM SPRINGS CHURCH RD	COLLECTOR	2335	1	10	0	1700	50	15
451	285	288	GUM SPRINGS CHURCH RD	COLLECTOR	2040	1	10	0	1700	40	27
452	286	1696	OLD US 1	COLLECTOR	1022	1	11	0	1700	50	21
453	287	290	OLD US 1	MINOR ARTERIAL	2354	2	11	0	1900	50	21
454	288	289	GUM SPRINGS CHURCH RD	COLLECTOR	4462	1	10	0	1700	50	27
455	289	77	GUM SPRINGS CHURCH RD	COLLECTOR	2544	1	10	0	1700	50	27
456	290	293	KELLY RD	COLLECTOR	4063	1	10	0	1700	50	21
457	290	1549	OLD US 1	COLLECTOR	354	1	11	0	1750	55	22
458	291	1277	S SALEM ST	COLLECTOR	1436	1	11	0	1700	40	22
459	292	1276	S SALEM ST	COLLECTOR	1151	1	11	0	1700	40	18

Link #	Up-Stream Node	Down-Stream Node	Roadway Name	Roadway Type	Length (ft.)	No. of Lanes	Lane Width (ft.)	Shoulder Width (ft.)	Saturation Flow Rate (pcphpl)	Free Flow Speed (mph)	Grid Map Number
460	293	290	KELLY RD	COLLECTOR	4057	1	10	0	1700	50	21
461	293	295	KELLY RD	COLLECTOR	1745	1	10	0	1750	50	21
462	294	319	SR 55	COLLECTOR	928	1	13	0	1750	35	18
463	294	702	SR 55	COLLECTOR	1519	1	12	0	1575	35	18
464	294	1451	S SALEM ST	COLLECTOR	1422	1	11	0	1750	30	18
465	295	293	KELLY RD	COLLECTOR	1745	1	10	0	1700	50	21
466	295	296	KELLY RD	COLLECTOR	3514	1	10	0	1700	50	17
467	295	1322	APEX BARBECUE RD	COLLECTOR	1539	1	10	0	1700	45	17
468	295	1609	APEX BARBECUE RD	COLLECTOR	1563	1	10	0	1700	45	21
469	296	299	KELLY RD	COLLECTOR	1872	1	10	0	1750	50	17
470	297	298	N SALEM ST	COLLECTOR	1256	1	11	0	1700	40	18
471	297	703	N SALEM ST	COLLECTOR	1325	1	15	0	1750	35	18
472	297	1454	HUNTER ST	COLLECTOR	630	1	12	0	900	20	18
473	298	297	N SALEM ST	COLLECTOR	1256	1	11	0	1750	40	18
474	298	1281	N SALEM ST	COLLECTOR	683	1	11	0	1750	40	18
475	299	303	OLIVE CHAPEL RD	COLLECTOR	3601	1	12	0	1700	40	17
476	299	1541	KELLY RD	COLLECTOR	3677	1	10	0	1750	50	17
477	300	1538	KELLY RD	COLLECTOR	1734	1	10	0	1750	50	17
478	301	62	OLD JENKS RD	COLLECTOR	1512	1	10	0	1700	45	18
479	301	1009	DAVIS DR	COLLECTOR	847	1	11	0	1700	45	18
480	301	1379	DAVIS DR	COLLECTOR	814	1	11	0	1700	45	18
481	302	66	JENKS RD	COLLECTOR	1720	1	10	0	1700	40	17
482	302	300	GREEN LEVEL CHURCH RD	COLLECTOR	840	1	12	0	1700	40	17
483	302	1856	GREEN LEVEL CHURCH RD	COLLECTOR	1158	1	12	0	1700	50	17
484	303	304	OLIVE CHAPEL RD	COLLECTOR	4141	1	12	0	1700	40	18
485	304	1280	OLIVE CHAPEL RD	COLLECTOR	795	1	12	0	1750	40	18
486	305	1007	OLD APEX RD	COLLECTOR	1430	1	11	0	1700	45	19
487	305	1453	LAURA DUNCAN RD	COLLECTOR	382	1	10	0	675	15	19

Link #	Up-Stream Node	Down-Stream Node	Roadway Name	Roadway Type	Length (ft.)	No. of Lanes	Lane Width (ft.)	Shoulder Width (ft.)	Saturation Flow Rate (pcphpl)	Free Flow Speed (mph)	Grid Map Number
488	306	299	OLIVE CHAPEL RD	COLLECTOR	2275	1	12	0	1750	40	17
489	307	308	OLD APEX RD	COLLECTOR	1355	1	12	1	1750	50	11
490	308	309	OLD APEX RD	COLLECTOR	1761	1	12	1	1700	45	11
491	308	386	W CHATHAM ST	COLLECTOR	1025	1	12	4	1700	45	11
492	309	312	OLD APEX RD	COLLECTOR	536	1	12	1	1750	45	11
493	310	311	OLD APEX RD	COLLECTOR	2013	1	12	1	1750	45	11
494	311	313	OLD APEX RD	COLLECTOR	1332	1	12	1	1700	40	11
495	311	698	HIGH HOUSE RD	COLLECTOR	1120	1	13	0	1700	40	11
496	312	310	OLD APEX RD	COLLECTOR	979	1	12	1	1700	45	11
497	312	385	SW MAYNARD RD	MINOR ARTERIAL	1087	2	13	0	1750	40	11
498	312	599	SW MAYNARD RD	MINOR ARTERIAL	1113	2	13	0	1900	40	11
499	313	1988	OLD APEX RD	COLLECTOR	1659	1	12	1	1700	40	11
500	314	306	OLIVE CHAPEL RD	COLLECTOR	1141	1	12	0	1700	40	17
501	315	314	OLIVE CHAPEL RD	COLLECTOR	2328	1	12	0	1700	40	17
502	316	677	N ACADEMY ST	COLLECTOR	1493	1	12	0	1750	30	11
503	316	695	W CHATHAM ST	COLLECTOR	627	1	12	0	1750	30	11
504	316	1982	E CHATHAM ST	COLLECTOR	771	1	12	0	1750	30	11
505	317	1984	E CHATHAM ST	COLLECTOR	1022	1	12	0	1350	30	12
506	318	1106	E CHATHAM ST	COLLECTOR	1386	1	12	0	1350	30	12
507	319	294	SR 55	COLLECTOR	928	1	13	0	1750	35	18
508	319	320	SR 55	COLLECTOR	2089	1	13	0	1750	35	18
509	320	319	SR 55	COLLECTOR	2089	1	13	0	1750	35	18
510	320	734	SR 55	COLLECTOR	939	1	13	4	1575	35	22
511	320	1377	JAMES ST	LOCAL ROADWAY	1814	1	10	0	1575	35	18
512	321	330	GREEN LEVEL WEST RD	COLLECTOR	1323	2	12	0	1750	50	10
513	321	1535	GREEN LEVEL WEST RD	COLLECTOR	2405	1	12	0	1700	50	10
514	322	1535	GREEN LEVEL WEST RD	MINOR ARTERIAL	457	2	12	0	1900	50	10
515	322	1742	SR 540 TOLL ON-RAMP FROM	FREEWAY RAMP	774	1	13	3	1700	45	10

Link #	Up-Stream Node	Down-Stream Node	Roadway Name	Roadway Type	Length (ft.)	No. of Lanes	Lane Width (ft.)	Shoulder Width (ft.)	Saturation Flow Rate (pcphpl)	Free Flow Speed (mph)	Grid Map Number
			GREEN LEVEL WEST RD								
516	323	322	GREEN LEVEL WEST RD	MINOR ARTERIAL	1301	2	12	0	1750	50	9
517	323	1723	SR 540 TOLL ON-RAMP FROM GREEN LEVEL WEST RD	FREEWAY RAMP	593	1	13	3	1350	30	9
518	324	1534	GREEN LEVEL WEST RD	COLLECTOR	3129	1	12	0	1700	50	9
519	325	126	US 64 E ON-RAMP FROM SR 55	FREEWAY RAMP	978	1	12	4	1700	50	18
520	325	326	SR 55	MINOR ARTERIAL	1006	2	12	0	1750	50	18
521	325	660	SR 55	MINOR ARTERIAL	940	2	12	0	1750	50	18
522	326	325	SR 55	MINOR ARTERIAL	1006	2	12	0	1750	50	18
523	326	327	SR 55	MINOR ARTERIAL	810	2	12	0	1750	50	18
524	326	1594	US 64 W ON-RAMP FROM SR 55	FREEWAY RAMP	446	1	13	3	1350	30	18
525	327	326	SR 55	MINOR ARTERIAL	810	2	12	0	1750	50	18
526	327	396	SR 55	MINOR ARTERIAL	3465	2	12	0	1750	50	18
527	328	324	BEAVER DAM RD	COLLECTOR	1162	1	12	0	1700	45	9
528	328	343	GREEN LEVEL CHURCH RD	COLLECTOR	1690	1	12	0	1700	50	9
529	329	331	GREEN LEVEL CHURCH RD	COLLECTOR	2179	1	12	0	1750	50	9
530	329	343	GREEN LEVEL CHURCH RD	COLLECTOR	2449	1	12	0	1700	50	9
531	330	321	GREEN LEVEL WEST RD	COLLECTOR	1323	1	12	0	1700	50	10
532	330	569	SR 55	MINOR ARTERIAL	2651	2	12	0	1900	55	10
533	330	1973	HIGH HOUSE RD	MINOR ARTERIAL	1182	2	13	0	1900	50	10
534	331	334	GREEN HOPE SCHOOL RD	COLLECTOR	2207	1	12	0	1700	50	9
535	331	1672	GREEN LEVEL CHURCH RD	COLLECTOR	1342	1	12	0	1700	50	9
536	332	335	SR 55	MINOR ARTERIAL	1013	2	12	6	1750	55	7
537	332	358	INDIAN WELLS RD	COLLECTOR	992	1	10	0	1575	35	7
538	334	337	GREEN HOPE SCHOOL RD	COLLECTOR	2121	1	12	0	1700	50	9
539	335	667	SR 55	MINOR ARTERIAL	2913	2	12	4	1750	55	7
540	336	1020	N SALEM ST	COLLECTOR	5199	1	11	0	1700	50	18
541	337	340	GREEN HOPE SCHOOL RD	COLLECTOR	1627	1	12	0	1700	40	9

Link #	Up-Stream Node	Down-Stream Node	Roadway Name	Roadway Type	Length (ft.)	No. of Lanes	Lane Width (ft.)	Shoulder Width (ft.)	Saturation Flow Rate (pcphpl)	Free Flow Speed (mph)	Grid Map Number
542	338	339	SW CARY PKWY	MINOR ARTERIAL	836	2	13	0	1900	50	19
543	338	1008	OLD APEX RD	MINOR ARTERIAL	840	2	12	1	1900	50	19
544	338	1396	SW CARY PKWY	MINOR ARTERIAL	691	2	13	0	1900	30	19
545	339	338	SW CARY PKWY	MINOR ARTERIAL	836	2	13	0	1750	50	19
546	339	707	SW CARY PKWY	MINOR ARTERIAL	1905	2	13	0	1900	50	11
547	340	341	GREEN HOPE SCHOOL RD	COLLECTOR	1599	1	12	0	1700	40	10
548	341	567	GREEN HOPE SCHOOL RD	COLLECTOR	2334	1	12	0	1750	50	10
549	342	344	SW CARY PKWY	MINOR ARTERIAL	1884	2	13	0	1750	50	11
550	342	586	W CHATHAM ST	COLLECTOR	1480	1	12	4	1700	45	11
551	343	328	GREEN LEVEL CHURCH RD	COLLECTOR	1690	1	12	0	1700	50	9
552	343	329	GREEN LEVEL CHURCH RD	COLLECTOR	2449	1	12	0	1700	50	9
553	344	345	SW CARY PKWY	MINOR ARTERIAL	1518	2	13	0	1900	50	10
554	345	1076	SW CARY PKWY	MINOR ARTERIAL	1146	2	13	0	1750	50	10
555	346	335	CARPENTER FIRE STATION RD	COLLECTOR	1404	1	12	0	1750	40	7
556	347	1151	GREEN LEVEL CHURCH RD	MINOR ARTERIAL	823	2	12	0	1900	40	6
557	347	1971	CARPENTER FIRE STATION RD	MINOR ARTERIAL	1340	2	12	0	1750	40	6
558	348	351	SW CARY PKWY	MINOR ARTERIAL	2515	2	13	0	1750	50	11
559	349	11	I-40	FREEWAY	2050	3	13	8	2250	70	12
560	349	350	I-40	FREEWAY	2742	3	13	8	2250	70	12
561	350	349	I-40	FREEWAY	2742	3	13	8	2250	70	12
562	350	374	I-40	FREEWAY	787	3	13	8	2250	70	12
563	351	381	HIGH HOUSE RD	MINOR ARTERIAL	2378	2	13	0	1900	50	11
564	351	410	NW CARY PKWY	MINOR ARTERIAL	1416	2	13	0	1900	50	11
565	352	351	HIGH HOUSE RD	MINOR ARTERIAL	724	2	13	0	1750	50	11
566	353	352	HIGH HOUSE RD	MINOR ARTERIAL	1320	2	13	0	1900	50	11
567	354	1621	HIGH HOUSE RD	MINOR ARTERIAL	561	2	13	0	1750	50	10
568	354	1640	DAVIS DR	MINOR ARTERIAL	859	2	13	0	1750	50	10
569	355	40	US 1	FREEWAY	1761	4	13	10	2250	65	12

Link #	Up-Stream Node	Down-Stream Node	Roadway Name	Roadway Type	Length (ft.)	No. of Lanes	Lane Width (ft.)	Shoulder Width (ft.)	Saturation Flow Rate (pcphpl)	Free Flow Speed (mph)	Grid Map Number
570	355	361	US 1	FREEWAY	1209	3	13	10	2250	65	12
571	355	1336	US 1 OFF-RAMP TO I-40 E	FREEWAY RAMP	700	2	12	4	1900	50	12
572	356	696	HIGH HOUSE RD	MINOR ARTERIAL	836	2	13	0	1900	50	10
573	356	1003	CARPENTER UPCHURCH RD	COLLECTOR	727	1	12	0	1700	40	10
574	357	374	I-40	FREEWAY	830	3	13	8	2250	70	12
575	357	3015	I-40	FREEWAY	2621	3	13	8	2250	70	20
576	358	332	INDIAN WELLS RD	COLLECTOR	989	1	10	0	1750	35	7
577	358	663	MORRISVILLE CARPENTER RD	COLLECTOR	1185	1	10	0	1700	40	7
578	359	3029	I-40	FREEWAY	1028	3	13	8	2250	65	25
579	360	1385	MORRISVILLE CARPENTER RD	MINOR ARTERIAL	978	2	11	0	1900	50	7
580	360	1386	MORRISVILLE CARPENTER RD	COLLECTOR	285	1	11	0	1700	50	7
581	360	1387	DAVIS DR	MINOR ARTERIAL	1019	2	13	0	1750	50	7
582	361	355	US 1	FREEWAY	1209	2	13	10	2250	65	12
583	361	363	US 1 OFF-RAMP TO I-40 W	FREEWAY RAMP	463	1	16	0	1350	30	12
584	361	375	I-440	FREEWAY	2766	3	13	0	2250	65	12
585	362	364	MORRISVILLE CARPENTER RD	COLLECTOR	3500	1	11	0	1750	50	8
586	363	374	US 1 OFF-RAMP TO I-40 W	FREEWAY RAMP	428	1	16	0	1350	30	12
587	364	700	MORRISVILLE CARPENTER RD	COLLECTOR	1119	1	11	0	1750	40	8
588	365	366	SR 54	MINOR ARTERIAL	1171	2	12	1	1750	50	8
589	365	1358	SR 54	COLLECTOR	1562	1	12	1	1700	50	8
590	366	365	SR 54	MINOR ARTERIAL	1171	2	12	1	1900	50	8
591	366	1000	WESTON PKWY	MINOR ARTERIAL	583	2	12	0	1900	45	8
592	366	1359	SR 54	MINOR ARTERIAL	823	2	12	1	1900	50	8
593	367	1359	SR 54	MINOR ARTERIAL	624	2	12	1	1900	50	8
594	367	1362	SR 54	MINOR ARTERIAL	511	2	12	1	1900	50	8
595	368	1360	SR 54	MINOR ARTERIAL	786	2	12	1	1750	50	11
596	368	1363	SR 54	MINOR ARTERIAL	698	2	12	1	1900	50	11
597	369	370	SR 54	COLLECTOR	1907	1	12	1	1700	45	11

Link #	Up-Stream Node	Down-Stream Node	Roadway Name	Roadway Type	Length (ft.)	No. of Lanes	Lane Width (ft.)	Shoulder Width (ft.)	Saturation Flow Rate (pcphpl)	Free Flow Speed (mph)	Grid Map Number
598	369	1363	SR 54	COLLECTOR	1603	1	12	1	1700	50	11
599	370	369	SR 54	COLLECTOR	1902	1	12	1	1700	45	11
600	370	371	SR 54	COLLECTOR	1464	1	12	1	1700	45	11
601	371	370	SR 54	COLLECTOR	1464	1	12	1	1700	45	11
602	371	372	SR 54	MINOR ARTERIAL	438	2	12	1	1750	40	11
603	372	371	SR 54	MINOR ARTERIAL	438	2	12	1	1900	40	11
604	372	373	NW MAYNARD RD	MINOR ARTERIAL	464	2	13	0	1750	50	11
605	372	607	CHAPEL HILL RD	MINOR ARTERIAL	1086	2	12	1	1900	40	11
606	373	970	NW MAYNARD RD	MINOR ARTERIAL	1378	2	13	0	1900	50	11
607	374	350	I-40	FREEWAY	787	3	13	8	2250	70	12
608	374	357	I-40	FREEWAY	830	3	13	8	2250	70	12
609	375	361	I-440	FREEWAY	2766	2	13	0	2250	65	12
610	375	1701	I-440	FREEWAY	2278	2	13	0	2250	65	13
611	376	372	NW MAYNARD RD	MAJOR ARTERIAL	446	3	13	0	1750	50	11
612	377	697	HIGH HOUSE RD	MINOR ARTERIAL	1721	2	13	0	1900	50	11
613	377	1420	NW MAYNARD RD	MINOR ARTERIAL	1081	2	13	0	1750	50	11
614	378	387	US 401	MINOR ARTERIAL	1605	2	13	3	1900	55	31
615	378	1446	US 401	MINOR ARTERIAL	1310	2	13	3	1750	55	31
616	379	377	SW MAYNARD RD	MINOR ARTERIAL	771	2	13	0	1750	40	11
617	380	377	HIGH HOUSE RD	MINOR ARTERIAL	1132	2	13	0	1750	50	11
618	381	380	HIGH HOUSE RD	MINOR ARTERIAL	2553	2	13	0	1900	50	11
619	382	967	W CHATHAM ST	COLLECTOR	1244	1	12	4	1350	30	11
620	383	382	W CHATHAM ST	COLLECTOR	1165	1	12	4	1700	45	11
621	384	383	W CHATHAM ST	COLLECTOR	1535	1	12	4	1700	45	11
622	385	67	SW MAYNARD RD	MINOR ARTERIAL	707	2	13	0	1900	40	11
623	385	312	SW MAYNARD RD	MINOR ARTERIAL	1087	2	13	0	1750	40	11
624	385	384	W CHATHAM ST	COLLECTOR	1021	1	12	4	1700	45	11
625	386	385	W CHATHAM ST	COLLECTOR	1658	1	12	4	1750	45	11

Link #	Up-Stream Node	Down-Stream Node	Roadway Name	Roadway Type	Length (ft.)	No. of Lanes	Lane Width (ft.)	Shoulder Width (ft.)	Saturation Flow Rate (pcphpl)	Free Flow Speed (mph)	Grid Map Number
626	387	378	US 401	MINOR ARTERIAL	1605	2	13	3	1900	55	31
627	387	1042	US 401	MINOR ARTERIAL	3103	2	13	3	1750	55	31
628	388	201	US 401	MINOR ARTERIAL	2756	2	13	3	1750	60	30
629	388	225	US 401	MINOR ARTERIAL	9503	2	13	3	1900	60	30
630	389	1422	SW MAYNARD RD	MINOR ARTERIAL	840	2	13	0	1750	40	11
631	390	621	SE MAYNARD RD	MINOR ARTERIAL	2804	2	13	0	1900	40	11
632	390	1426	KILDAIRE FARM RD	COLLECTOR	1360	1	14	3	1750	40	11
633	391	1587	KILDAIRE FARM RD	COLLECTOR	649	1	14	3	1700	40	11
634	392	975	SR 55	COLLECTOR	3478	1	12	0	1700	45	42
635	393	395	CARY TOWNE BLVD	COLLECTOR	873	1	13	0	1700	40	11
636	393	1981	KILDAIRE FARM RD	COLLECTOR	276	1	12	4	1125	25	11
637	394	316	S ACADEMY ST	COLLECTOR	1520	1	14	0	1750	30	11
638	395	393	CARY TOWNE BLVD	COLLECTOR	873	1	13	0	1750	40	11
639	395	712	CARY TOWNE BLVD	MINOR ARTERIAL	3871	2	13	0	1750	40	12
640	396	63	OLD JENKS RD	COLLECTOR	1332	1	10	0	1700	45	18
641	396	327	SR 55	MINOR ARTERIAL	3465	2	12	0	1750	50	18
642	396	1578	SR 55	MINOR ARTERIAL	2325	2	12	0	1900	55	10
643	397	709	CARY TOWNE BLVD	MINOR ARTERIAL	1019	2	13	0	1750	45	12
644	397	1414	SE MAYNARD RD	MINOR ARTERIAL	1790	2	13	0	1750	50	12
645	398	397	SE MAYNARD RD	MINOR ARTERIAL	1514	2	12	0	1750	45	12
646	398	712	WALNUT ST	MINOR ARTERIAL	1693	2	13	0	1750	40	12
647	398	1412	WALNUT ST	MINOR ARTERIAL	1149	2	13	0	1750	40	12
648	399	400	SR 55	MINOR ARTERIAL	3940	2	12	0	1750	60	10
649	400	330	SR 55	MINOR ARTERIAL	1382	2	12	0	1750	55	10
650	401	402	DAVIS DR	MINOR ARTERIAL	2362	2	13	0	1750	50	10
651	402	404	DAVIS DR	MINOR ARTERIAL	1481	2	13	0	1900	50	10
652	403	398	SE MAYNARD RD	MINOR ARTERIAL	1584	2	13	0	1750	40	12
653	404	405	DAVIS DR	MINOR ARTERIAL	1907	2	13	0	1750	50	10

Link #	Up-Stream Node	Down-Stream Node	Roadway Name	Roadway Type	Length (ft.)	No. of Lanes	Lane Width (ft.)	Shoulder Width (ft.)	Saturation Flow Rate (pcphpl)	Free Flow Speed (mph)	Grid Map Number
654	405	1078	WALDO ROOD BLVD	COLLECTOR	1673	1	12	0	1700	40	10
655	405	1381	DAVIS DR	MINOR ARTERIAL	2076	2	13	0	1750	50	10
656	406	865	HIGH MEADOW DR	COLLECTOR	644	1	11	4	1700	40	19
657	406	931	KILDAIRE FARM RD	MINOR ARTERIAL	1058	2	13	0	1750	40	19
658	407	421	SE CARY PKWY	MINOR ARTERIAL	814	2	13	0	1750	50	19
659	407	1432	KILDAIRE FARM RD	MINOR ARTERIAL	800	2	13	0	1750	40	19
660	408	353	HIGH HOUSE RD	MINOR ARTERIAL	1221	2	13	0	1900	50	10
661	409	714	SW CARY PKWY	MINOR ARTERIAL	2023	2	13	0	1750	50	19
662	410	412	NW CARY PKWY	MINOR ARTERIAL	1889	2	13	0	1900	50	11
663	411	409	SW CARY PKWY	MINOR ARTERIAL	2666	2	13	0	1900	50	19
664	411	1069	LAKE PINE DR	COLLECTOR	494	1	13	4	1700	40	19
665	411	1527	LAKE PINE DR	COLLECTOR	306	1	13	0	1700	45	19
666	412	414	NW CARY PKWY	MINOR ARTERIAL	2862	2	13	0	1750	50	11
667	413	411	SW CARY PKWY	MINOR ARTERIAL	2103	2	13	0	1750	50	19
668	414	418	NW CARY PKWY	MINOR ARTERIAL	640	2	13	0	1900	50	11
669	415	416	WALNUT ST	MINOR ARTERIAL	1770	2	13	0	1750	50	12
670	415	1411	WALNUT ST	MINOR ARTERIAL	1016	2	13	0	1900	40	12
671	416	415	WALNUT ST	MINOR ARTERIAL	1770	2	13	0	1750	40	12
672	416	1409	WALNUT ST	MAJOR ARTERIAL	937	3	13	0	1750	50	20
673	417	37	SE CARY PKWY	MAJOR ARTERIAL	1017	3	13	0	1900	50	20
674	418	420	NW CARY PKWY	MINOR ARTERIAL	1604	2	13	0	1750	50	11
675	419	1065	SE CARY PKWY	MINOR ARTERIAL	1448	2	13	0	1750	50	20
676	419	1591	HAMPTON VALLEY RD	COLLECTOR	1421	1	13	0	1350	30	20
677	420	368	NW CARY PKWY	MINOR ARTERIAL	670	1	13	0	1750	50	11
678	421	419	SE CARY PKWY	MINOR ARTERIAL	1085	2	13	0	1750	50	19
679	422	861	KILDAIRE FARM RD	MINOR ARTERIAL	1476	2	13	0	1750	50	19
680	423	1995	DAVIS DR	MINOR ARTERIAL	957	2	13	0	1900	50	10
681	424	226	SR 55	MINOR ARTERIAL	409	1	13	0	1750	25	30

Link #	Up-Stream Node	Down-Stream Node	Roadway Name	Roadway Type	Length (ft.)	No. of Lanes	Lane Width (ft.)	Shoulder Width (ft.)	Saturation Flow Rate (pcphpl)	Free Flow Speed (mph)	Grid Map Number
682	424	1252	BROAD ST	COLLECTOR	990	1	11	0	1700	40	30
683	425	1029	WAKE CHAPEL RD	COLLECTOR	186	1	11	0	1700	40	30
684	425	1031	SR 55	MINOR ARTERIAL	529	2	13	0	1900	45	30
685	426	1383	DAVIS DR	MINOR ARTERIAL	1239	2	13	0	1750	50	7
686	427	1355	SR 54	COLLECTOR	1480	1	12	1	1750	50	8
687	427	1357	SR 54	COLLECTOR	4194	1	12	1	1700	50	8
688	429	1391	N HARRISON AVE	MINOR ARTERIAL	803	2	12	0	1750	50	11
689	430	1706	N HARRISON AVE	MINOR ARTERIAL	356	2	12	0	1425	50	11
690	431	1032	SR 55	MINOR ARTERIAL	3151	2	13	0	1750	50	30
691	432	1416	NE MAYNARD RD	MINOR ARTERIAL	852	2	13	0	1900	40	12
692	433	128	US 64	MINOR ARTERIAL	8771	2	13	9	1750	60	16
693	433	1539	US 64	MINOR ARTERIAL	7297	2	13	9	1900	60	17
694	434	127	US 64	MINOR ARTERIAL	2206	2	13	9	1900	60	17
695	434	1734	US 64	MINOR ARTERIAL	1001	2	13	9	1900	60	17
696	434	1737	SR 540 TOLL ON-RAMP FROM US 64 W	FREEWAY RAMP	696	1	13	3	1700	45	17
697	435	35	SR 55	MINOR ARTERIAL	1217	2	13	0	1750	60	29
698	435	1264	SR 55	MINOR ARTERIAL	1676	2	13	0	1750	60	30
699	436	282	OLD US 1	COLLECTOR	922	1	11	0	1700	45	28
700	437	1306	SHEARON-HARRIS RD	COLLECTOR	4493	1	11	0	1700	55	28
701	438	1320	SR 55	COLLECTOR	2956	1	12	1	1700	40	29
702	439	441	SR 55	COLLECTOR	2104	1	12	1	1750	40	29
703	439	555	HOLLY SPRINGS RD	COLLECTOR	3065	1	12	0	1750	35	29
704	439	775	W HOLLY SPRINGS RD	COLLECTOR	1799	1	10	0	1700	45	29
705	440	1855	SHEARON-HARRIS RD	COLLECTOR	1157	1	11	0	1700	55	28
706	441	439	SR 55	COLLECTOR	2104	1	12	1	1750	40	29
707	441	1036	SR 55	COLLECTOR	874	1	12	1	1700	40	29
708	442	1307	SHEARON-HARRIS RD	COLLECTOR	671	1	11	0	1700	45	28

Link #	Up-Stream Node	Down-Stream Node	Roadway Name	Roadway Type	Length (ft.)	No. of Lanes	Lane Width (ft.)	Shoulder Width (ft.)	Saturation Flow Rate (pcphpl)	Free Flow Speed (mph)	Grid Map Number
709	443	444	SR 55	COLLECTOR	1753	1	12	1	1750	50	22
710	444	25	OLD SMITHFIELD RD	COLLECTOR	2239	1	11	0	1700	40	22
711	444	29	SR 55	COLLECTOR	2956	1	12	1	1700	50	22
712	444	55	SUNSET LAKE RD	COLLECTOR	4511	1	11	0	1700	45	23
713	445	68	SR 55	MINOR ARTERIAL	542	2	13	0	1750	50	22
714	445	762	SR 55	MINOR ARTERIAL	4014	2	13	0	1900	50	22
715	446	448	SHEARON-HARRIS RD	COLLECTOR	2724	1	11	0	1700	55	28
716	447	60	TEN-TEN RD	COLLECTOR	759	1	12	0	1750	50	23
717	447	449	TEN-TEN RD	COLLECTOR	3113	1	12	0	1700	50	23
718	448	450	SHEARON-HARRIS RD	COLLECTOR	2241	1	11	0	1700	55	29
719	449	447	TEN-TEN RD	COLLECTOR	3113	1	12	0	1750	50	23
720	449	1086	TEN-TEN RD	COLLECTOR	867	1	12	0	1700	50	23
721	450	452	SHEARON-HARRIS RD	COLLECTOR	2284	1	11	0	1750	55	29
722	451	728	TEN-TEN RD	COLLECTOR	728	1	12	0	1750	50	23
723	452	75	NEW HILL HOLLEMAN RD	COLLECTOR	4905	1	11	1	1750	50	29
724	452	1131	NEW HILL HOLLEMAN RD	COLLECTOR	3359	1	11	1	1700	50	29
725	453	455	BEAVER CREEK RD	COLLECTOR	2671	1	11	0	1700	50	28
726	453	456	BEAVER CREEK RD	COLLECTOR	1633	1	11	0	1700	50	28
727	454	717	KILDAIRE FARM RD	MINOR ARTERIAL	942	2	13	0	1900	50	23
728	454	729	TEN-TEN RD	MINOR ARTERIAL	1457	2	12	0	1900	50	23
729	455	278	BEAVER CREEK RD	COLLECTOR	1069	1	11	0	1700	50	28
730	456	457	BEAVER CREEK RD	COLLECTOR	1396	1	11	0	1700	60	28
731	457	458	BEAVER CREEK RD	COLLECTOR	4764	1	11	0	1700	60	16
732	458	460	BEAVER CREEK RD	COLLECTOR	3618	1	11	0	1700	60	16
733	459	461	KILDAIRE FARM RD	MINOR ARTERIAL	2088	2	13	0	1900	50	23
734	459	565	PENNY RD	MINOR ARTERIAL	381	2	12	0	1900	45	23
735	459	1443	PENNY RD	COLLECTOR	337	1	12	0	1700	45	23
736	460	462	BEAVER CREEK RD	COLLECTOR	4618	1	11	0	1750	60	16

Link #	Up-Stream Node	Down-Stream Node	Roadway Name	Roadway Type	Length (ft.)	No. of Lanes	Lane Width (ft.)	Shoulder Width (ft.)	Saturation Flow Rate (pcphpl)	Free Flow Speed (mph)	Grid Map Number
737	461	1967	KILDAIRE FARM RD	MINOR ARTERIAL	842	2	13	0	1900	40	19
738	462	464	BEAVER CREEK RD	COLLECTOR	1414	1	11	0	1700	60	16
739	463	465	KILDAIRE FARM RD	MINOR ARTERIAL	1311	2	13	0	1900	50	19
740	464	749	BEAVER CREEK RD	COLLECTOR	1199	1	11	0	1700	60	16
741	465	792	KILDAIRE FARM RD	MINOR ARTERIAL	1434	2	13	0	1750	50	20
742	466	130	US 64	MINOR ARTERIAL	1095	1	13	9	1750	60	16
743	466	1024	US 64	MINOR ARTERIAL	3482	2	14	2	1900	60	16
744	467	655	N PEA RIDGE RD	COLLECTOR	2293	1	10	0	1750	40	15
745	468	469	KILDAIRE FARM RD	MINOR ARTERIAL	1290	2	13	0	1750	50	19
746	469	470	TRYON RD	MINOR ARTERIAL	1260	2	13	0	1750	50	19
747	469	681	TRYON RD	MINOR ARTERIAL	1409	2	13	0	1750	50	19
748	469	1434	KILDAIRE FARM RD	MINOR ARTERIAL	1048	2	13	0	1750	50	19
749	470	473	TRYON RD	MINOR ARTERIAL	1552	2	13	0	1900	50	20
750	471	467	N PEA RIDGE RD	COLLECTOR	2822	1	10	0	1700	40	15
751	472	471	N PEA RIDGE RD	COLLECTOR	3673	1	10	0	1700	40	15
752	473	474	TRYON RD	MINOR ARTERIAL	2672	2	13	0	1750	50	20
753	474	475	SE CARY PKWY	MINOR ARTERIAL	787	2	13	0	1900	50	20
754	474	481	TRYON RD	MINOR ARTERIAL	1820	2	13	0	1900	50	20
755	474	723	SE CARY PKWY	MINOR ARTERIAL	1788	2	13	0	1900	50	20
756	475	474	SE CARY PKWY	MINOR ARTERIAL	787	2	13	0	1750	50	20
757	475	720	SE CARY PKWY	MINOR ARTERIAL	918	2	13	0	1900	50	20
758	476	477	MT GILDEAD CHURCH RD	COLLECTOR	2836	1	11	0	1700	40	15
759	476	655	MT GILDEAD CHURCH RD	COLLECTOR	4193	1	11	0	1750	40	15
760	477	476	MT GILDEAD CHURCH RD	COLLECTOR	2836	1	11	0	1700	40	15
761	477	478	MT GILDEAD CHURCH RD	COLLECTOR	1519	1	11	0	1700	40	15
762	478	480	MT GILDEAD CHURCH RD	COLLECTOR	1486	1	11	0	1700	40	15
763	479	1369	TRYON RD	MINOR ARTERIAL	1410	2	13	0	1750	50	20
764	480	482	MT GILDEAD CHURCH RD	COLLECTOR	5529	1	11	0	1700	40	4

Link #	Up-Stream Node	Down-Stream Node	Roadway Name	Roadway Type	Length (ft.)	No. of Lanes	Lane Width (ft.)	Shoulder Width (ft.)	Saturation Flow Rate (pcphpl)	Free Flow Speed (mph)	Grid Map Number
765	481	832	TRYON RD	MINOR ARTERIAL	681	2	13	0	1750	50	20
766	482	486	MT GILDEAD CHURCH RD	COLLECTOR	3327	1	11	0	1700	40	4
767	483	484	JONES FRANKLIN RD	COLLECTOR	921	1	11	1	1750	45	20
768	483	683	TRYON RD	MINOR ARTERIAL	1393	2	13	0	1750	50	20
769	483	1040	JONES FRANKLIN RD	COLLECTOR	1160	1	11	0	1750	45	20
770	484	483	JONES FRANKLIN RD	COLLECTOR	921	1	11	1	1750	45	20
771	484	685	MACEDONIA RD	COLLECTOR	1433	1	11	0	1750	45	20
772	484	3014	JONES FRANKLIN RD	COLLECTOR	782	1	11	1	1700	45	20
773	485	1040	HOLLY SPRINGS RD	MAJOR ARTERIAL	411	3	12	1	1750	50	20
774	486	488	MT GILDEAD CHURCH RD	COLLECTOR	1751	1	11	0	1700	40	4
775	487	485	HOLLY SPRINGS RD	COLLECTOR	2094	1	12	1	1700	50	20
776	487	1404	SE CARY PKWY	MINOR ARTERIAL	174	2	13	0	1900	50	20
777	488	489	MT GILDEAD CHURCH RD	COLLECTOR	2053	1	11	0	1700	40	4
778	489	185	US 15	MINOR ARTERIAL	2350	2	12	2	1900	60	4
779	490	188	JACK BENNETT RD	COLLECTOR	3773	1	12	0	1750	50	4
780	491	490	JACK BENNETT RD	COLLECTOR	1147	1	12	0	1700	50	4
781	492	1299	JACK BENNETT RD	COLLECTOR	903	1	12	0	1700	50	4
782	493	492	JACK BENNETT RD	COLLECTOR	1385	1	12	0	1700	55	4
783	494	493	JACK BENNETT RD	COLLECTOR	2627	1	12	0	1700	55	4
784	494	623	JACK BENNETT RD	COLLECTOR	4216	1	12	0	1700	55	5
785	495	487	HOLLY SPRINGS RD	COLLECTOR	1158	1	12	1	1750	50	20
786	496	495	HOLLY SPRINGS RD	COLLECTOR	1011	1	12	1	1700	50	20
787	497	496	HOLLY SPRINGS RD	COLLECTOR	2171	1	12	1	1700	50	20
788	498	494	BIG WOODS RD	COLLECTOR	2140	1	10	0	1700	40	5
789	499	497	HOLLY SPRINGS RD	COLLECTOR	2771	1	12	1	1700	50	24
790	500	499	HOLLY SPRINGS RD	COLLECTOR	2929	1	12	1	1700	50	24
791	501	500	HOLLY SPRINGS RD	COLLECTOR	1605	1	12	1	1700	50	24
792	501	566	PENNY RD	COLLECTOR	437	1	12	0	1700	40	24

Link #	Up-Stream Node	Down-Stream Node	Roadway Name	Roadway Type	Length (ft.)	No. of Lanes	Lane Width (ft.)	Shoulder Width (ft.)	Saturation Flow Rate (pcphpl)	Free Flow Speed (mph)	Grid Map Number
793	501	726	PENNY RD	COLLECTOR	1780	1	12	0	1700	50	24
794	502	498	BIG WOODS RD	COLLECTOR	2622	1	10	0	1700	40	5
795	503	502	BIG WOODS RD	COLLECTOR	5396	1	10	0	1700	40	5
796	504	503	BIG WOODS RD	COLLECTOR	1526	1	10	0	1700	40	5
797	505	504	BIG WOODS RD	COLLECTOR	5095	1	10	0	1700	40	5
798	506	501	HOLLY SPRINGS RD	COLLECTOR	928	2	12	1	1750	45	24
799	507	508	DEEP RIVER RD	COLLECTOR	2607	1	11	0	1700	50	27
800	508	513	DEEP RIVER RD	COLLECTOR	2212	1	11	0	1700	50	27
801	509	512	HOLLY SPRINGS RD	COLLECTOR	1264	1	12	1	1700	45	24
802	510	509	HOLLY SPRINGS RD	COLLECTOR	1738	1	12	1	1700	50	24
803	511	510	HOLLY SPRINGS RD	COLLECTOR	1370	1	12	1	1700	50	24
804	511	527	TEN-TEN RD	COLLECTOR	1971	1	12	0	1700	50	24
805	512	506	HOLLY SPRINGS RD	COLLECTOR	1225	1	12	1	1700	45	24
806	513	514	DEEP RIVER RD	COLLECTOR	4417	1	11	0	1700	50	27
807	514	515	FARRELL RD	COLLECTOR	3414	1	10	0	1700	40	27
808	514	1304	DEEP RIVER RD	COLLECTOR	5790	1	11	0	1700	50	27
809	515	85	FARRELL RD	COLLECTOR	3136	1	10	0	1700	40	27
810	516	521	DEEP RIVER RD	COLLECTOR	9879	1	11	0	1700	50	32
811	517	1436	KILDAIRE FARM RD	COLLECTOR	2671	1	12	1	1750	45	23
812	518	517	KILDAIRE FARM RD	COLLECTOR	2417	1	12	1	1700	45	23
813	519	518	KILDAIRE FARM RD	COLLECTOR	2970	1	12	1	1700	45	23
814	519	520	KILDAIRE FARM RD	COLLECTOR	948	1	12	1	1750	45	30
815	520	519	KILDAIRE FARM RD	COLLECTOR	948	1	12	1	1700	45	30
816	520	522	HOLLY SPRINGS RD	COLLECTOR	2148	1	12	1	1700	50	23
817	521	523	COLON RD	COLLECTOR	2115	1	12	0	1700	50	32
818	521	526	DEEP RIVER RD	COLLECTOR	2251	1	11	0	1700	50	32
819	522	524	HOLLY SPRINGS RD	COLLECTOR	1442	1	12	1	1700	50	23
820	523	90	COLON RD	COLLECTOR	2186	1	12	0	1700	50	32

Link #	Up-Stream Node	Down-Stream Node	Roadway Name	Roadway Type	Length (ft.)	No. of Lanes	Lane Width (ft.)	Shoulder Width (ft.)	Saturation Flow Rate (pcphpl)	Free Flow Speed (mph)	Grid Map Number
821	524	525	HOLLY SPRINGS RD	COLLECTOR	2478	1	12	1	1750	50	23
822	525	1893	HOLLY SPRINGS RD	COLLECTOR	2577	1	12	1	1700	50	23
823	526	530	DEEP RIVER RD	COLLECTOR	5729	1	11	0	1700	50	32
824	527	1373	TEN-TEN RD	COLLECTOR	1614	1	12	0	1700	50	24
825	528	529	TEN-TEN RD	COLLECTOR	1722	1	12	0	1750	50	24
826	529	619	TEN-TEN RD	COLLECTOR	3960	1	12	0	1750	50	24
827	530	531	DEEP RIVER RD	COLLECTOR	909	1	11	0	1700	40	32
828	531	533	DEEP RIVER RD	COLLECTOR	341	1	11	0	1350	30	32
829	531	534	DEEP RIVER RD	COLLECTOR	501	1	11	0	1700	40	32
830	532	535	TEN-TEN RD	COLLECTOR	3976	1	12	0	1700	50	30
831	533	534	US 501	MINOR ARTERIAL	477	2	12	1	1900	60	32
832	533	536	US 501	MINOR ARTERIAL	2574	2	12	1	1900	60	32
833	534	533	US 501	MINOR ARTERIAL	477	2	12	1	1900	60	32
834	534	645	US 501	COLLECTOR	4418	2	12	1	1900	60	32
835	535	616	TEN-TEN RD	COLLECTOR	3489	1	12	0	1700	50	31
836	536	533	US 501	MINOR ARTERIAL	2574	2	12	1	1900	60	32
837	536	642	US 501	COLLECTOR	7825	1	12	1	1700	60	32
838	537	539	US 421 BUS	MINOR ARTERIAL	1271	2	13	2	1750	50	39
839	537	1747	US 421	COLLECTOR	1843	1	13	2	1700	60	39
840	538	541	LAKE WHEELER RD	COLLECTOR	3915	1	13	0	1700	50	25
841	538	542	TEN-TEN RD	COLLECTOR	1354	1	12	0	1700	50	31
842	539	537	US 421	MINOR ARTERIAL	1278	2	13	2	1900	50	39
843	539	1059	SR 87	MINOR ARTERIAL	1594	2	12	0	1750	55	39
844	539	1062	US 421 BUS	MINOR ARTERIAL	1965	2	13	0	1750	50	39
845	540	543	US 421 BUS	MINOR ARTERIAL	2229	2	13	0	1750	40	39
846	540	855	US 421 BUS	MINOR ARTERIAL	2358	2	13	0	1750	40	39
847	541	1445	LAKE WHEELER RD	COLLECTOR	2329	1	13	0	1700	50	25
848	542	193	TEN-TEN RD	COLLECTOR	1653	1	12	0	1750	50	31

Link #	Up-Stream Node	Down-Stream Node	Roadway Name	Roadway Type	Length (ft.)	No. of Lanes	Lane Width (ft.)	Shoulder Width (ft.)	Saturation Flow Rate (pcphpl)	Free Flow Speed (mph)	Grid Map Number
849	543	540	US 421 BUS	MINOR ARTERIAL	2229	2	13	0	1750	40	39
850	543	1233	US 421 BUS	MINOR ARTERIAL	1419	2	13	0	1750	40	38
851	544	545	US 421 BUS	MINOR ARTERIAL	1759	2	13	0	1750	35	38
852	544	1233	US 421 BUS	MINOR ARTERIAL	1619	2	13	0	1750	40	38
853	545	544	US 421 BUS	MINOR ARTERIAL	1759	2	13	0	1750	35	38
854	545	547	US 421 BUS	MINOR ARTERIAL	1715	2	13	0	1900	35	38
855	546	538	LAKE WHEELER RD	COLLECTOR	3830	1	13	0	1750	50	31
856	547	545	US 421 BUS	MINOR ARTERIAL	1715	2	13	0	1750	35	38
857	547	1229	US 421 BUS	MINOR ARTERIAL	809	2	13	0	1750	35	38
858	548	546	LAKE WHEELER RD	COLLECTOR	2090	1	13	0	1700	50	31
859	548	1506	LAKE WHEELER RD	COLLECTOR	286	1	13	0	1700	40	31
860	549	1227	US 421 BUS	MINOR ARTERIAL	622	2	13	0	1750	35	38
861	549	1229	US 421 BUS	MINOR ARTERIAL	702	2	13	0	1750	35	38
862	550	1506	LAKE WHEELER RD	COLLECTOR	9129	1	13	0	1700	55	30
863	551	553	US 421 BUS	MINOR ARTERIAL	2628	2	13	0	1750	40	38
864	551	1227	US 421 BUS	MINOR ARTERIAL	405	2	13	0	1750	40	38
865	552	736	LAKE WHEELER RD	COLLECTOR	956	1	12	0	1750	45	30
866	552	737	LAKE WHEELER RD	COLLECTOR	1117	1	12	0	1700	45	30
867	553	551	US 421 BUS	MINOR ARTERIAL	2628	2	13	0	1750	40	38
868	553	1225	US 421 BUS	MINOR ARTERIAL	1511	2	13	0	1750	40	38
869	554	556	US 1 BUS	COLLECTOR	2361	1	12	1	1750	35	38
870	554	1489	US 1 BUS	MINOR ARTERIAL	261	2	11	0	1750	30	38
871	555	715	HOLLY SPRINGS RD	COLLECTOR	4315	1	12	0	1750	35	30
872	555	777	BASS LAKE RD	COLLECTOR	3419	1	12	0	1700	40	30
873	556	553	W WEATHERSPOON ST	COLLECTOR	1821	1	11	0	1750	40	38
874	556	554	US 1 BUS	COLLECTOR	2361	1	12	1	1575	35	38
875	556	994	US 1 BUS	COLLECTOR	1200	1	12	1	1700	40	38
876	557	110	US 421 BUS	MINOR ARTERIAL	1171	2	13	0	1750	40	38

Link #	Up-Stream Node	Down-Stream Node	Roadway Name	Roadway Type	Length (ft.)	No. of Lanes	Lane Width (ft.)	Shoulder Width (ft.)	Saturation Flow Rate (pcphpl)	Free Flow Speed (mph)	Grid Map Number
877	557	1225	US 421	MINOR ARTERIAL	1269	2	13	0	1750	40	38
878	558	1512	CHARLOTTE AVE	COLLECTOR	1684	2	11	0	1750	40	38
879	558	1519	N 7TH ST	COLLECTOR	1376	2	12	0	1900	40	38
880	559	560	E WEATHERSPOON ST	COLLECTOR	1545	1	11	0	1700	40	38
881	559	1518	N 7TH ST	COLLECTOR	1320	2	12	0	1900	40	38
882	560	556	E WEATHERSPOON ST	COLLECTOR	2258	1	11	0	1750	40	38
883	561	1516	CHARLOTTE AVE	COLLECTOR	1326	1	11	0	1700	40	38
884	562	563	PENNY RD	COLLECTOR	2171	1	12	0	1750	50	23
885	562	1087	PENNY RD	COLLECTOR	1094	1	12	0	1700	45	23
886	563	562	PENNY RD	COLLECTOR	2171	1	12	0	1700	50	23
887	563	564	PENNY RD	COLLECTOR	1629	1	12	0	1700	50	23
888	563	1448	EDERLEE DR	MINOR ARTERIAL	683	2	13	0	1900	45	23
889	564	563	PENNY RD	COLLECTOR	1632	1	12	0	1750	50	23
890	564	565	PENNY RD	COLLECTOR	1122	1	12	0	1700	50	23
891	565	459	PENNY RD	COLLECTOR	381	1	12	0	1750	45	23
892	565	564	PENNY RD	COLLECTOR	1122	1	12	0	1700	50	23
893	566	568	PENNY RD	COLLECTOR	1300	1	12	0	1700	40	24
894	567	1285	SR 55	MINOR ARTERIAL	4093	2	12	6	1750	55	10
895	568	570	PENNY RD	COLLECTOR	4328	1	12	0	1700	50	24
896	569	567	SR 55	MINOR ARTERIAL	2871	2	12	0	1750	55	10
897	570	571	PENNY RD	COLLECTOR	886	1	12	0	1700	50	24
898	571	572	PENNY RD	COLLECTOR	1901	1	12	0	1700	50	24
899	572	573	PENNY RD	COLLECTOR	1401	1	12	0	1700	50	24
900	572	1098	GRAHAM NEWTON RD	COLLECTOR	1664	1	12	0	1700	50	24
901	573	574	PENNY RD	COLLECTOR	1470	1	12	0	1700	45	24
902	574	576	PENNY RD	COLLECTOR	1466	1	12	0	1700	45	25
903	575	10	US 1	FREEWAY	2609	2	13	10	2250	75	28
904	575	577	US 1	FREEWAY	4474	2	13	10	2250	75	28

Link #	Up-Stream Node	Down-Stream Node	Roadway Name	Roadway Type	Length (ft.)	No. of Lanes	Lane Width (ft.)	Shoulder Width (ft.)	Saturation Flow Rate (pcphpl)	Free Flow Speed (mph)	Grid Map Number
905	576	578	PENNY RD	COLLECTOR	981	1	12	0	1700	45	25
906	577	575	US 1	FREEWAY	4474	2	13	10	2250	75	28
907	577	579	US 1	FREEWAY	2205	2	13	10	2250	75	28
908	578	730	PENNY RD	COLLECTOR	1230	1	12	0	1700	45	25
909	579	76	US 1	FREEWAY	6880	2	13	10	2250	75	28
910	579	577	US 1	FREEWAY	2201	2	13	10	2250	75	28
911	580	1088	PENNY RD	COLLECTOR	3154	1	12	0	1700	50	25
912	581	1220	CENTER ST	COLLECTOR	1050	1	12	0	1750	45	19
913	582	1552	US 1	FREEWAY	856	2	13	10	2250	75	22
914	582	1556	SR 540 TOLL ON-RAMP FROM US 1 S	FREEWAY RAMP	1148	1	13	3	1700	45	22
915	582	1560	US 1	FREEWAY	2028	2	13	10	2250	75	22
916	583	584	US 64	MINOR ARTERIAL	1898	2	13	9	1750	50	19
917	583	1011	US 64	MINOR ARTERIAL	1530	2	13	9	1750	60	19
918	584	583	US 64	MINOR ARTERIAL	1898	2	13	9	1750	60	19
919	584	1335	US 64	MINOR ARTERIAL	447	2	13	9	1900	50	19
920	585	1018	N MASON ST	COLLECTOR	1480	1	11	0	1750	40	18
921	585	1019	CENTER ST	COLLECTOR	1733	1	12	0	1700	40	18
922	586	588	W CHATHAM ST	COLLECTOR	1575	1	12	4	1700	45	11
923	587	120	US 64	MINOR ARTERIAL	1213	2	13	9	1750	60	18
924	587	122	US 64	FREEWAY	1872	2	13	2	2250	60	18
925	588	706	W CHATHAM ST	COLLECTOR	1264	1	12	4	1700	45	11
926	589	109	US 421 BUS	MINOR ARTERIAL	3287	2	13	2	1750	40	38
927	589	1223	US 421 BUS	MINOR ARTERIAL	4868	2	13	2	1750	60	32
928	590	112	US 1	FREEWAY	1609	3	13	2	2250	70	38
929	590	1680	US 1	FREEWAY	472	2	13	2	2250	70	38
930	591	593	W CHATHAM ST	COLLECTOR	1576	1	12	4	1700	45	11
931	592	1	US 1	FREEWAY	9416	2	13	10	2250	75	27

Link #	Up-Stream Node	Down-Stream Node	Roadway Name	Roadway Type	Length (ft.)	No. of Lanes	Lane Width (ft.)	Shoulder Width (ft.)	Saturation Flow Rate (pcphpl)	Free Flow Speed (mph)	Grid Map Number
932	592	22	US 1	FREEWAY	1811	2	13	10	2250	75	27
933	593	308	W CHATHAM ST	COLLECTOR	1019	1	12	4	1750	45	11
934	594	738	US 421	COLLECTOR	6976	1	13	2	1700	60	40
935	594	1056	US 421	COLLECTOR	6516	1	13	2	1700	60	40
936	595	596	US 501	COLLECTOR	2013	2	12	1	1900	60	32
937	595	628	US 501	COLLECTOR	1692	2	12	1	1900	60	32
938	596	595	US 501	COLLECTOR	2013	2	12	1	1750	60	32
939	596	645	US 501	COLLECTOR	1908	2	12	1	1900	60	32
940	597	34	US 1	FREEWAY	7048	3	13	10	2250	70	20
941	597	1111	US 1	FREEWAY	1142	3	13	10	2250	65	20
942	597	1522	US 1 N OFF-RAMP	FREEWAY RAMP	1374	1	13	2	1750	45	20
943	598	45	US 1	FREEWAY	4211	4	13	10	2250	70	19
944	598	1219	US 1	FREEWAY	1342	4	12	4	2250	65	19
945	599	379	SW MAYNARD RD	MINOR ARTERIAL	1059	2	13	0	1900	40	11
946	600	598	US 1 ON-RAMP FROM TRYON RD	FREEWAY RAMP	821	2	12	2	1900	50	19
947	601	692	US 1	FREEWAY	1839	2	13	10	2250	70	19
948	601	693	US 1	FREEWAY	7145	2	13	10	2250	70	19
949	602	796	US 501	COLLECTOR	750	1	14	6	1700	40	14
950	603	146	PITTSBORO ELEM SCHOOL RD	COLLECTOR	667	1	9	0	1750	40	14
951	604	168	E SALISBURY ST	LOCAL ROADWAY	1198	1	12	4	1750	35	14
952	604	233	N SMALL ST	COLLECTOR	480	1	12	4	1575	35	14
953	605	168	W SALISBURY ST	COLLECTOR	1122	1	12	4	1750	35	14
954	605	606	RECTORY ST	COLLECTOR	459	1	12	4	1575	35	14
955	606	144	US 64 BUS	COLLECTOR	1775	1	12	0	1750	40	14
956	607	608	CHAPEL HILL RD	COLLECTOR	2450	1	12	1	1700	40	11
957	608	609	CHAPEL HILL RD	COLLECTOR	1170	1	12	1	1750	40	11
958	609	429	N HARRISON AVE	MINOR ARTERIAL	3979	2	12	0	1750	45	11

Link #	Up-Stream Node	Down-Stream Node	Roadway Name	Roadway Type	Length (ft.)	No. of Lanes	Lane Width (ft.)	Shoulder Width (ft.)	Saturation Flow Rate (pcphpl)	Free Flow Speed (mph)	Grid Map Number
959	609	677	CHAPEL HILL RD	COLLECTOR	622	1	12	1	1750	40	11
960	610	648	US 501	COLLECTOR	4028	1	12	1	1700	50	14
961	611	113	US 15	MINOR ARTERIAL	1768	2	12	2	1900	50	14
962	612	175	NORTHWOOD HIGH SCHOOL RD	COLLECTOR	957	1	10	0	1750	40	14
963	613	186	US 15	MINOR ARTERIAL	1847	2	12	2	1900	60	4
964	614	613	VILLAGE WAY	COLLECTOR	1362	1	11	0	1750	40	4
965	615	431	SR 55	MINOR ARTERIAL	1331	2	13	0	1900	50	30
966	615	1264	SR 55	MINOR ARTERIAL	8038	2	13	0	1750	60	30
967	616	538	TEN-TEN RD	COLLECTOR	2183	1	12	0	1750	50	31
968	617	613	MORRIS RD	COLLECTOR	1581	1	11	0	1750	40	4
969	618	640	US 64	MINOR ARTERIAL	2901	2	14	2	1900	60	15
970	618	655	US 64	MINOR ARTERIAL	2257	2	14	2	1750	60	15
971	619	1097	BELL'S LAKE RD	COLLECTOR	8394	1	12	0	1700	50	30
972	619	1372	TEN-TEN RD	COLLECTOR	1442	1	12	0	1700	50	24
973	620	135	US 64	MINOR ARTERIAL	3286	2	14	2	1900	60	15
974	620	655	US 64	MINOR ARTERIAL	2082	2	14	2	1750	60	15
975	621	1064	SE MAYNARD RD	MINOR ARTERIAL	1576	2	13	0	1900	40	12
976	621	1592	HAMPTON VALLEY RD	COLLECTOR	895	1	13	0	1350	30	12
977	622	862	US 421	COLLECTOR	2946	1	13	2	1700	60	40
978	622	1056	US 421	COLLECTOR	4073	1	13	2	1700	60	40
979	623	624	LYSTRA RD	COLLECTOR	2929	1	12	0	1700	50	5
980	624	625	LYSTRA RD	COLLECTOR	2201	1	12	0	1750	50	5
981	625	760	FARRINGTON POINT RD	COLLECTOR	2145	1	10	0	1700	50	5
982	626	10	US 1 S ON-RAMP FROM OLD US 1	FREEWAY RAMP	875	1	14	3	1700	45	28
983	627	625	MCGHEE RD	LOCAL ROADWAY	1676	1	10	0	1750	40	5
984	628	100	US 1 S ON-RAMP FROM US 1 BUS	FREEWAY RAMP	1179	1	13	4	1700	50	32

Link #	Up-Stream Node	Down-Stream Node	Roadway Name	Roadway Type	Length (ft.)	No. of Lanes	Lane Width (ft.)	Shoulder Width (ft.)	Saturation Flow Rate (pcphpl)	Free Flow Speed (mph)	Grid Map Number
985	628	595	US 501	COLLECTOR	1692	2	12	1	1750	60	32
986	628	1687	US 1 BUS	COLLECTOR	227	1	12	4	1700	50	32
987	629	112	US 1 S ON-RAMP FROM US 421	FREEWAY RAMP	582	1	12	1	1700	50	38
988	630	78	US 1	FREEWAY	2897	2	13	10	2250	75	27
989	630	83	US 1	FREEWAY	7691	2	13	10	2250	75	27
990	631	327	VISION DR	COLLECTOR	794	1	12	0	1750	40	18
991	632	436	OLD US 1	COLLECTOR	1208	1	11	0	1750	60	28
992	633	264	SR 751	COLLECTOR	2549	1	11	1	1700	60	5
993	634	266	SR 751	COLLECTOR	3652	1	11	1	1700	60	5
994	635	1655	SR 751	COLLECTOR	1006	1	11	1	1700	60	5
995	636	1296	SR 751	COLLECTOR	1836	1	11	1	1700	50	5
996	637	639	SR 751	COLLECTOR	1650	1	11	1	1700	60	5
997	638	274	SR 751	COLLECTOR	4334	1	11	1	1700	60	5
998	639	638	SR 751	COLLECTOR	2148	1	11	1	1700	60	5
999	640	618	US 64	MINOR ARTERIAL	2901	2	14	2	1900	60	15
1000	640	654	US 64	MINOR ARTERIAL	2882	2	14	2	1900	60	15
1001	641	128	US 64	MINOR ARTERIAL	1007	1	13	9	1750	60	16
1002	641	129	US 64	MINOR ARTERIAL	10835	2	13	9	1900	60	16
1003	642	536	US 501	COLLECTOR	7829	1	12	1	1700	60	32
1004	642	644	US 501	COLLECTOR	4723	1	12	1	1700	60	26
1005	643	157	US 501	COLLECTOR	3342	1	12	1	1700	60	26
1006	643	995	US 501	COLLECTOR	7392	1	12	1	1700	60	26
1007	644	157	US 501	COLLECTOR	8446	1	12	1	1700	60	26
1008	644	642	US 501	COLLECTOR	4723	1	12	1	1700	60	26
1009	645	534	US 501	COLLECTOR	4418	2	12	1	1900	60	32
1010	645	596	US 501	COLLECTOR	1908	2	12	1	1900	60	32
1011	646	399	TURNER CREEK RD	COLLECTOR	870	1	10	0	1750	40	10
1012	647	149	US 501	COLLECTOR	5765	1	12	1	1700	60	14

Link #	Up-Stream Node	Down-Stream Node	Roadway Name	Roadway Type	Length (ft.)	No. of Lanes	Lane Width (ft.)	Shoulder Width (ft.)	Saturation Flow Rate (pcphpl)	Free Flow Speed (mph)	Grid Map Number
1013	647	152	US 501	COLLECTOR	5329	1	12	1	1700	60	26
1014	648	611	US 501	COLLECTOR	807	2	12	1	1750	50	14
1015	649	610	US 501	COLLECTOR	2837	1	12	1	1700	40	14
1016	650	180	US 15	MINOR ARTERIAL	2717	2	12	2	1900	60	4
1017	651	650	US 15	MINOR ARTERIAL	2126	2	12	2	1900	60	4
1018	652	651	US 15	MINOR ARTERIAL	2051	2	12	2	1900	60	3
1019	653	184	US 15	MINOR ARTERIAL	5248	2	12	2	1900	60	4
1020	654	104	US 64	MINOR ARTERIAL	4305	2	14	2	1900	60	15
1021	654	640	US 64	MINOR ARTERIAL	2882	2	14	2	1900	60	15
1022	655	476	MT GILDEAD CHURCH RD	COLLECTOR	4193	1	11	0	1700	40	15
1023	655	618	US 64	MINOR ARTERIAL	2257	2	14	2	1900	60	15
1024	655	620	US 64	MINOR ARTERIAL	2082	2	14	2	1900	60	15
1025	656	399	LEWEY DR	COLLECTOR	1537	1	10	0	1750	40	10
1026	657	400	PARKSCENE LN	COLLECTOR	891	1	10	0	1750	40	10
1027	658	400	PARKING LOT	COLLECTOR	705	1	10	0	1750	40	10
1028	659	740	US 421	COLLECTOR	3895	1	13	2	1700	60	39
1029	659	862	US 421	COLLECTOR	4785	1	13	2	1700	60	39
1030	660	325	SR 55	MINOR ARTERIAL	940	3	12	0	1750	50	18
1031	660	665	SR 55	MINOR ARTERIAL	899	2	12	0	1750	50	18
1032	661	996	US 421	COLLECTOR	5290	1	13	2	1700	60	40
1033	661	1053	US 421	COLLECTOR	5909	1	13	2	1700	60	40
1034	662	666	US 421	COLLECTOR	9804	1	13	2	1700	60	41
1035	662	1053	US 421	COLLECTOR	2673	1	13	2	1700	60	41
1036	663	358	MORRISVILLE CARPENTER RD	COLLECTOR	1185	1	10	0	1700	40	7
1037	663	701	MORRISVILLE CARPENTER RD	COLLECTOR	1402	1	10	0	1750	40	7
1038	664	739	US 421	COLLECTOR	2315	1	13	2	1700	60	39
1039	664	1058	US 421	COLLECTOR	3487	1	13	2	1750	60	39
1040	665	660	SR 55	MINOR ARTERIAL	899	2	12	0	1750	50	18

Link #	Up-Stream Node	Down-Stream Node	Roadway Name	Roadway Type	Length (ft.)	No. of Lanes	Lane Width (ft.)	Shoulder Width (ft.)	Saturation Flow Rate (pcphpl)	Free Flow Speed (mph)	Grid Map Number
1041	665	669	SR 55	MINOR ARTERIAL	991	2	12	0	1900	50	18
1042	666	662	US 421	COLLECTOR	9804	1	13	2	1700	60	41
1043	666	1833	US 421	COLLECTOR	8898	1	13	2	1700	60	41
1044	667	1569	SR 55	MINOR ARTERIAL	3414	2	12	4	1900	55	7
1045	668	235	NEW HILL HOLLEMAN RD	COLLECTOR	3274	1	11	1	1750	50	21
1046	668	1137	NEW HILL HOLLEMAN RD	COLLECTOR	967	1	11	1	1750	50	29
1047	669	665	SR 55	MINOR ARTERIAL	991	2	12	0	1750	50	18
1048	669	710	SR 55	MINOR ARTERIAL	1272	2	12	0	1750	50	18
1049	670	671	N SALEM ST	MINOR ARTERIAL	471	2	11	0	1750	45	18
1050	670	1281	N SALEM ST	COLLECTOR	2589	1	11	0	1750	40	18
1051	671	123	US 64 E ON-RAMP FROM N SALEM ST	FREEWAY RAMP	618	1	15	4	1700	50	18
1052	671	670	N SALEM ST	MINOR ARTERIAL	471	2	11	0	1900	45	18
1053	671	673	N SALEM ST	MINOR ARTERIAL	347	3	11	0	1750	45	18
1054	672	126	US 64	MINOR ARTERIAL	4458	2	13	2	1900	60	18
1055	672	1582	US 64	FREEWAY	1112	2	13	2	2250	60	18
1056	673	336	N SALEM ST	COLLECTOR	1809	1	11	0	1700	40	18
1057	673	671	N SALEM ST	MINOR ARTERIAL	347	1	11	0	1750	45	18
1058	673	1009	DAVIS DR	MINOR ARTERIAL	425	2	11	0	1900	45	18
1059	674	675	SALEM CHURCH RD	COLLECTOR	2001	1	12	0	1700	40	18
1060	674	1380	DAVIS DR	COLLECTOR	103	1	11	0	1350	30	18
1061	675	676	SALEM CHURCH RD	COLLECTOR	1466	1	12	0	1700	40	18
1062	676	1020	SALEM CHURCH RD	COLLECTOR	1521	1	12	0	1700	40	18
1063	677	18	CHAPEL HILL RD	COLLECTOR	2018	1	12	1	1700	40	11
1064	677	609	CHAPEL HILL RD	COLLECTOR	622	1	12	1	1750	40	11
1065	678	665	HADDON HALL DR	COLLECTOR	757	1	13	0	1750	40	18
1066	679	600	US 1 ON-RAMP FROM TRYON RD EB	FREEWAY RAMP	492	1	15	2	1700	45	19

Link #	Up-Stream Node	Down-Stream Node	Roadway Name	Roadway Type	Length (ft.)	No. of Lanes	Lane Width (ft.)	Shoulder Width (ft.)	Saturation Flow Rate (pcphpl)	Free Flow Speed (mph)	Grid Map Number
1067	680	600	US 1 ON-RAMP FROM TRYON RD WB	FREEWAY RAMP	564	1	12	0	1700	45	19
1068	681	469	TRYON RD	MINOR ARTERIAL	1409	2	13	0	1750	50	19
1069	681	3002	TRYON RD	MINOR ARTERIAL	836	2	12	0	1750	45	19
1070	682	665	HADDON HALL DR	COLLECTOR	664	1	12	0	1750	30	18
1071	682	1283	ZENO RD	COLLECTOR	629	1	12	0	1350	30	18
1072	683	3003	TRYON RD	MINOR ARTERIAL	3717	2	13	0	1750	50	25
1073	684	660	BEAVER CREEK COMMONS DR	MINOR ARTERIAL	496	2	11	0	1750	30	18
1074	685	484	MACEDONIA RD	COLLECTOR	1433	1	11	0	1750	45	20
1075	685	1405	WALNUT ST	MAJOR ARTERIAL	1516	3	13	0	1900	50	20
1076	685	1406	WALNUT ST	MAJOR ARTERIAL	916	3	13	0	1750	50	20
1077	686	999	WALNUT ST	MAJOR ARTERIAL	351	3	13	0	1750	50	20
1078	686	1039	WALNUT ST	MAJOR ARTERIAL	747	3	13	0	1750	50	20
1079	687	1409	WALNUT ST	MINOR ARTERIAL	972	2	13	0	1750	40	20
1080	687	1522	WALNUT ST	MAJOR ARTERIAL	956	3	13	0	1750	50	20
1081	688	998	CAITBOO AVE	MINOR ARTERIAL	797	2	12	0	1750	45	20
1082	689	40	US 1 N ON-RAMP FROM CROSSROADS BLVD	FREEWAY RAMP	341	1	14	0	1350	30	20
1083	690	71	US 1	FREEWAY	1828	2	13	10	2250	70	22
1084	690	758	US 1 OFF-RAMP	FREEWAY RAMP	554	2	12	4	1750	45	22
1085	690	759	US 1	FREEWAY	1017	4	13	10	2250	70	22
1086	691	759	US 1	FREEWAY	1812	2	13	10	2250	70	23
1087	691	1583	US 1	FREEWAY	3285	2	13	10	2250	70	23
1088	692	601	US 1	FREEWAY	1839	2	13	10	2250	70	19
1089	692	1583	US 1	FREEWAY	667	2	13	10	2250	70	19
1090	693	598	US 1	FREEWAY	2670	2	12	4	2250	65	19
1091	693	601	US 1	FREEWAY	7145	2	13	10	2250	70	19
1092	694	702	SR 55	COLLECTOR	2604	1	12	0	1700	50	18

Link #	Up-Stream Node	Down-Stream Node	Roadway Name	Roadway Type	Length (ft.)	No. of Lanes	Lane Width (ft.)	Shoulder Width (ft.)	Saturation Flow Rate (pcphpl)	Free Flow Speed (mph)	Grid Map Number
1093	694	1282	SR 55	MINOR ARTERIAL	178	2	12	0	1900	50	18
1094	694	1993	HUNTER ST	COLLECTOR	1363	1	16	0	1350	30	18
1095	695	316	W CHATHAM ST	COLLECTOR	627	1	12	0	1750	30	11
1096	695	609	N HARRISON AVE	MINOR ARTERIAL	1647	2	13	0	1750	30	11
1097	696	1382	HIGH HOUSE RD	MINOR ARTERIAL	1064	2	13	0	1750	50	10
1098	697	1389	HIGH HOUSE RD	MINOR ARTERIAL	1144	2	13	0	1900	50	11
1099	698	382	HIGH HOUSE RD	COLLECTOR	712	1	13	0	1700	40	11
1100	699	968	NW MAYNARD RD	MINOR ARTERIAL	1461	2	13	0	1900	50	11
1101	700	428	AVIATION PKWY	COLLECTOR	2697	1	11	0	1700	50	8
1102	700	1357	SR 54	COLLECTOR	828	1	12	1	1700	40	8
1103	700	1358	SR 54	COLLECTOR	1462	1	12	1	1700	40	8
1104	701	663	MORRISVILLE CARPENTER RD	COLLECTOR	1403	1	10	0	1700	40	7
1105	701	1349	LOUIS STEPHENS DR	COLLECTOR	1845	1	10	0	1700	40	7
1106	701	1386	MORRISVILLE CARPENTER RD	COLLECTOR	4769	1	11	0	1700	50	7
1107	702	294	SR 55	COLLECTOR	1520	1	12	0	1750	35	18
1108	702	694	SR 55	MINOR ARTERIAL	2604	1	12	0	1750	50	18
1109	703	297	N SALEM ST	COLLECTOR	1325	1	15	0	1750	35	18
1110	703	1378	CENTER ST	COLLECTOR	247	1	12	0	900	20	18
1111	703	1451	S SALEM ST	COLLECTOR	814	1	12	0	1750	30	18
1112	704	581	CENTER ST	COLLECTOR	2633	1	12	0	1700	45	18
1113	705	1010	OLD US 1	COLLECTOR	2213	1	11	0	1700	55	22
1114	706	591	W CHATHAM ST	COLLECTOR	1051	1	12	4	1700	45	11
1115	707	342	SW CARY PKWY	MINOR ARTERIAL	1360	2	13	0	1900	50	11
1116	708	432	SE MAYNARD RD	MINOR ARTERIAL	1912	2	13	0	1750	50	12
1117	709	2	CARY TOWNE BLVD	MINOR ARTERIAL	3193	2	13	0	1900	45	12
1118	710	669	SR 55	MINOR ARTERIAL	1272	2	12	0	1900	50	18
1119	710	711	APEX PEAKWAY	COLLECTOR	2205	1	12	0	1700	40	18
1120	710	1282	SR 55	MINOR ARTERIAL	1171	2	12	0	1900	50	18

Link #	Up-Stream Node	Down-Stream Node	Roadway Name	Roadway Type	Length (ft.)	No. of Lanes	Lane Width (ft.)	Shoulder Width (ft.)	Saturation Flow Rate (pcphpl)	Free Flow Speed (mph)	Grid Map Number
1121	711	710	APEX PEAKWAY	COLLECTOR	2205	1	12	0	1750	40	18
1122	711	1281	APEX PEAKWAY	COLLECTOR	2789	1	12	0	1750	40	18
1123	712	395	CARY TOWNE BLVD	MINOR ARTERIAL	3871	2	13	0	1900	40	12
1124	712	397	CARY TOWNE BLVD	MINOR ARTERIAL	1053	2	13	0	1750	45	12
1125	712	398	WALNUT ST	MINOR ARTERIAL	1693	2	13	0	1750	40	12
1126	713	407	SW CARY PKWY	MINOR ARTERIAL	1116	2	13	0	1750	50	19
1127	714	713	SW CARY PKWY	MINOR ARTERIAL	1802	2	13	0	1900	50	19
1128	715	1629	HOLLY SPRINGS RD	COLLECTOR	2831	1	12	0	1700	40	30
1129	716	52	HOLLY SPRINGS RD	MINOR ARTERIAL	762	2	12	0	1750	45	30
1130	717	459	KILDAIRE FARM RD	MINOR ARTERIAL	4300	2	13	0	1750	50	23
1131	718	679	US 1 ON-RAMP FROM TRYON RD EB	FREEWAY RAMP	766	2	15	2	1900	45	19
1132	718	719	TRYON RD	MAJOR ARTERIAL	969	3	12	0	1750	50	19
1133	719	680	US 1 ON-RAMP FROM TRYON RD WB	FREEWAY RAMP	228	2	12	0	1750	45	19
1134	719	681	TRYON RD	MAJOR ARTERIAL	1170	3	12	0	1750	45	19
1135	720	475	SE CARY PKWY	MINOR ARTERIAL	916	2	13	0	1900	50	20
1136	720	1403	SE CARY PKWY	MINOR ARTERIAL	901	2	13	0	1900	50	20
1137	721	722	SE CARY PKWY	MINOR ARTERIAL	970	2	13	0	1900	50	20
1138	721	1404	SE CARY PKWY	MINOR ARTERIAL	452	2	13	0	1900	50	20
1139	722	721	SE CARY PKWY	MINOR ARTERIAL	970	2	13	0	1900	50	20
1140	722	830	SE CARY PKWY	MINOR ARTERIAL	2480	2	13	0	1750	50	20
1141	723	474	SE CARY PKWY	MINOR ARTERIAL	1775	2	13	0	1750	50	20
1142	723	830	SE CARY PKWY	MINOR ARTERIAL	644	2	13	0	1750	50	20
1143	724	725	PENNY RD	COLLECTOR	2280	1	12	0	1700	50	23
1144	724	726	PENNY RD	COLLECTOR	2144	1	12	0	1700	50	24
1145	725	724	PENNY RD	COLLECTOR	2280	1	12	0	1700	50	23
1146	725	1443	PENNY RD	COLLECTOR	2045	1	12	0	1700	45	23

Link #	Up-Stream Node	Down-Stream Node	Roadway Name	Roadway Type	Length (ft.)	No. of Lanes	Lane Width (ft.)	Shoulder Width (ft.)	Saturation Flow Rate (pcphpl)	Free Flow Speed (mph)	Grid Map Number
1147	726	501	PENNY RD	COLLECTOR	1780	1	12	0	1750	50	24
1148	726	724	PENNY RD	COLLECTOR	2144	1	12	0	1700	50	24
1149	727	1374	TEN-TEN RD	COLLECTOR	1350	1	12	0	1700	50	23
1150	728	727	TEN-TEN RD	COLLECTOR	1272	1	12	0	1700	45	23
1151	729	511	TEN-TEN RD	COLLECTOR	5801	1	12	0	1750	50	23
1152	730	580	PENNY RD	COLLECTOR	4204	1	12	0	1700	50	25
1153	731	732	TEN-TEN RD	COLLECTOR	1711	1	12	0	1700	50	31
1154	733	1093	LAKE WHEELER RD	COLLECTOR	2918	1	13	0	1700	50	25
1155	734	320	SR 55	COLLECTOR	939	1	13	4	1750	35	22
1156	734	1274	SR 55	COLLECTOR	680	2	13	0	1900	50	22
1157	735	212	US 401	COLLECTOR	6565	1	12	0	1700	45	36
1158	735	1240	US 401	COLLECTOR	4505	1	12	0	1700	60	42
1159	736	41	HILLTOP NEEDMORE RD	COLLECTOR	2281	1	12	0	1750	40	30
1160	736	550	LAKE WHEELER RD	COLLECTOR	2531	1	13	0	1700	55	30
1161	736	552	LAKE WHEELER RD	COLLECTOR	956	1	12	0	1700	45	30
1162	737	225	LAKE WHEELER RD	COLLECTOR	865	1	12	0	1700	45	30
1163	738	594	US 421	COLLECTOR	6976	1	13	2	1700	60	40
1164	738	996	US 421	COLLECTOR	6491	1	13	2	1700	60	40
1165	739	664	US 421	COLLECTOR	2315	1	13	2	1750	60	39
1166	739	740	US 421	COLLECTOR	5028	1	13	2	1700	60	39
1167	740	659	US 421	COLLECTOR	3895	1	13	2	1700	60	39
1168	740	739	US 421	COLLECTOR	5028	1	13	2	1700	60	39
1169	741	4	PEA RIDGE RD	COLLECTOR	9288	1	11	0	1700	60	27
1170	742	744	PEA RIDGE RD	COLLECTOR	2353	1	11	0	1700	50	28
1171	742	1585	PEA RIDGE RD	COLLECTOR	180	1	11	0	1700	50	28
1172	743	745	PEA RIDGE RD	COLLECTOR	6068	1	11	0	1700	60	16
1173	744	743	PEA RIDGE RD	COLLECTOR	2014	1	11	0	1700	50	28
1174	745	746	PEA RIDGE RD	COLLECTOR	963	1	11	0	1700	50	16

Link #	Up-Stream Node	Down-Stream Node	Roadway Name	Roadway Type	Length (ft.)	No. of Lanes	Lane Width (ft.)	Shoulder Width (ft.)	Saturation Flow Rate (pcphpl)	Free Flow Speed (mph)	Grid Map Number
1175	746	747	PEA RIDGE RD	COLLECTOR	1452	1	11	0	1700	50	16
1176	747	748	PEA RIDGE RD	COLLECTOR	2753	1	11	0	1700	50	16
1177	748	462	PEA RIDGE RD	COLLECTOR	760	1	11	0	1750	50	16
1178	749	750	BEAVER CREEK RD	COLLECTOR	3177	1	11	0	1700	60	16
1179	750	751	BEAVER CREEK RD	COLLECTOR	3496	1	11	0	1700	60	16
1180	751	752	BEAVER CREEK RD	COLLECTOR	3520	1	11	0	1700	60	16
1181	752	130	BEAVER CREEK RD	COLLECTOR	3696	1	11	0	1750	50	16
1182	753	754	FARRINGTON POINT RD	COLLECTOR	2039	1	10	0	1700	50	16
1183	754	755	FARRINGTON POINT RD	COLLECTOR	5256	1	10	0	1700	60	16
1184	755	756	FARRINGTON POINT RD	COLLECTOR	4199	1	10	0	1700	55	5
1185	756	1586	FARRINGTON POINT RD	COLLECTOR	1143	1	10	0	1700	45	5
1186	757	320	JAMES ST	COLLECTOR	1721	2	10	0	1750	35	18
1187	757	1571	S HUGHES ST	COLLECTOR	750	1	10	0	1575	35	18
1188	758	68	SR 55	MINOR ARTERIAL	696	2	13	0	1750	50	22
1189	758	71	US 1 S ON-RAMP FROM SR 55	FREEWAY RAMP	1424	1	15	3	1700	45	22
1190	758	1273	SR 55	MINOR ARTERIAL	1050	2	13	0	1900	50	22
1191	759	690	US 1	FREEWAY	1017	2	13	10	2250	70	22
1192	759	691	US 1	FREEWAY	1812	3	13	10	2250	70	23
1193	760	761	FARRINGTON POINT RD	COLLECTOR	5144	1	10	0	1700	50	5
1194	761	1298	FARRINGTON POINT RD	COLLECTOR	1268	1	10	0	1275	45	5
1195	762	27	SR 55	MINOR ARTERIAL	1633	2	13	0	1900	50	22
1196	762	445	SR 55	MINOR ARTERIAL	4014	2	13	0	1750	50	22
1197	763	445	LUFKIN RD	COLLECTOR	1037	1	12	0	1750	40	22
1198	764	765	FARRINGTON POINT RD	COLLECTOR	5048	1	10	0	1700	60	5
1199	765	625	FARRINGTON POINT RD	COLLECTOR	4597	1	10	0	1750	60	5
1200	766	764	FARRINGTON POINT RD	COLLECTOR	3143	1	10	0	1700	60	5
1201	767	23	MONCURE PITTSBORO RD	COLLECTOR	1983	1	12	0	1700	50	27
1202	768	774	MONCURE PITTSBORO RD	COLLECTOR	4122	1	12	0	1700	60	14

Link #	Up-Stream Node	Down-Stream Node	Roadway Name	Roadway Type	Length (ft.)	No. of Lanes	Lane Width (ft.)	Shoulder Width (ft.)	Saturation Flow Rate (pcphpl)	Free Flow Speed (mph)	Grid Map Number
1203	769	767	MONCURE PITTSBORO RD	COLLECTOR	3679	1	12	0	1700	50	27
1204	770	771	MONCURE PITTSBORO RD	COLLECTOR	1978	1	12	0	1700	50	27
1205	771	772	MONCURE PITTSBORO RD	COLLECTOR	5034	1	12	0	1700	50	27
1206	772	773	MONCURE PITTSBORO RD	COLLECTOR	4092	1	12	0	1700	50	27
1207	773	768	MONCURE PITTSBORO RD	COLLECTOR	3841	1	12	0	1700	50	15
1208	774	776	MONCURE PITTSBORO RD	COLLECTOR	6189	1	12	0	1700	50	14
1209	775	32	W HOLLY SPRINGS RD	COLLECTOR	2693	1	10	0	1750	45	29
1210	775	439	W HOLLY SPRINGS RD	COLLECTOR	1799	1	10	0	1750	45	29
1211	776	230	MONCURE PITTSBORO RD	COLLECTOR	1184	1	12	0	1750	40	14
1212	777	555	BASS LAKE RD	COLLECTOR	3419	1	12	0	1750	40	30
1213	777	778	BASS LAKE RD	COLLECTOR	2948	1	12	0	1700	40	30
1214	778	777	BASS LAKE RD	COLLECTOR	2948	1	12	0	1700	40	30
1215	778	779	BASS LAKE RD	COLLECTOR	1056	1	12	0	1700	40	30
1216	779	778	BASS LAKE RD	COLLECTOR	1056	1	12	0	1700	40	30
1217	779	780	BASS LAKE RD	COLLECTOR	1059	1	12	0	1700	40	30
1218	780	781	BASS LAKE RD	COLLECTOR	973	1	12	0	1700	40	30
1219	781	789	BASS LAKE RD	COLLECTOR	4883	1	12	0	1700	40	30
1220	782	144	SR 87	COLLECTOR	1126	1	10	0	1750	40	14
1221	782	1326	SR 87	COLLECTOR	123	1	13	0	900	20	14
1222	783	118	SR 87	COLLECTOR	2738	1	10	0	1700	60	14
1223	783	1329	SR 87	COLLECTOR	3197	1	10	0	1700	60	14
1224	784	138	SR 87	COLLECTOR	2576	1	12	0	1700	50	14
1225	784	144	SR 87	COLLECTOR	1127	1	12	0	1750	40	14
1226	785	138	SR 87	COLLECTOR	791	1	12	0	1700	50	14
1227	785	786	SR 902	COLLECTOR	2886	1	10	0	1700	50	14
1228	786	785	SR 902	COLLECTOR	2886	1	10	0	1700	50	14
1229	786	787	SR 902	COLLECTOR	1633	1	10	0	1700	60	14
1230	787	786	SR 902	COLLECTOR	1633	1	10	0	1700	60	14

Link #	Up-Stream Node	Down-Stream Node	Roadway Name	Roadway Type	Length (ft.)	No. of Lanes	Lane Width (ft.)	Shoulder Width (ft.)	Saturation Flow Rate (pcphpl)	Free Flow Speed (mph)	Grid Map Number
1231	787	788	SR 902	COLLECTOR	3856	1	10	0	1700	60	14
1232	788	787	SR 902	COLLECTOR	3855	1	10	0	1700	60	14
1233	789	47	BASS LAKE RD	COLLECTOR	3904	1	12	0	1750	40	30
1234	790	520	HOLLY SPRINGS RD	COLLECTOR	2463	1	12	0	1750	50	30
1235	791	52	SUNSET LAKE RD	COLLECTOR	713	2	11	0	1750	45	30
1236	792	794	KILDAIRE FARM RD	MINOR ARTERIAL	919	2	13	0	1900	50	20
1237	792	1441	LOCHMERE DR	COLLECTOR	2322	1	11	0	1700	40	20
1238	793	653	US 15	MINOR ARTERIAL	2800	2	12	2	1900	60	4
1239	794	468	KILDAIRE FARM RD	MINOR ARTERIAL	1665	2	13	0	1750	50	20
1240	795	168	US 501	COLLECTOR	288	1	12	1	1750	35	14
1241	795	234	US 64 BUS	COLLECTOR	313	1	15	0	900	20	14
1242	796	143	US 64 BUS	COLLECTOR	345	1	15	0	1750	20	14
1243	797	798	OLD US 1	COLLECTOR	984	1	11	0	1700	60	27
1244	798	801	PEA RIDGE RD	COLLECTOR	1992	1	11	0	1700	50	27
1245	798	803	OLD US 1	COLLECTOR	2857	1	12	5	1700	60	27
1246	799	1305	OLD US 1	COLLECTOR	394	1	11	0	1700	45	28
1247	800	799	OLD US 1	COLLECTOR	7578	1	11	0	1700	60	28
1248	801	802	PEA RIDGE RD	COLLECTOR	2075	1	11	0	1700	50	27
1249	802	4	PEA RIDGE RD	COLLECTOR	3300	1	11	0	1700	50	27
1250	803	804	OLD US 1	COLLECTOR	4028	1	11	0	1700	45	27
1251	804	256	OLD US 1	COLLECTOR	1556	1	11	0	1700	45	27
1252	805	23	MONCURE PITTSBORO RD	COLLECTOR	2203	1	12	0	1700	50	27
1253	805	806	OLD US 1	COLLECTOR	3011	1	11	0	1750	50	27
1254	806	79	DEEP RIVER RD	COLLECTOR	1813	1	11	0	1700	50	27
1255	807	866	SR 42	COLLECTOR	904	1	12	1	1700	60	34
1256	808	810	SR 42	COLLECTOR	712	1	12	1	1700	55	34
1257	809	808	SR 42	COLLECTOR	1542	1	12	1	1750	55	34
1258	810	811	SR 42	COLLECTOR	1491	1	12	1	1700	55	34

Link #	Up-Stream Node	Down-Stream Node	Roadway Name	Roadway Type	Length (ft.)	No. of Lanes	Lane Width (ft.)	Shoulder Width (ft.)	Saturation Flow Rate (pcphpl)	Free Flow Speed (mph)	Grid Map Number
1259	811	839	SR 42	COLLECTOR	2975	1	12	1	1700	60	34
1260	811	939	POPLAR SPRINGS CHURCH RD	COLLECTOR	3343	1	10	0	1700	60	33
1261	812	813	POPLAR SPRINGS CHURCH RD	COLLECTOR	1410	1	10	0	1700	50	33
1262	813	814	POPLAR SPRINGS CHURCH RD	COLLECTOR	1992	1	10	0	1700	50	33
1263	814	816	POPLAR SPRINGS CHURCH RD	COLLECTOR	2378	1	10	0	1700	50	33
1264	815	1439	LOCHMERE DR	COLLECTOR	340	1	11	0	1575	35	20
1265	816	817	POPLAR SPRINGS CHURCH RD	COLLECTOR	1734	1	10	0	1700	50	33
1266	817	818	POPLAR SPRINGS CHURCH RD	COLLECTOR	4997	1	10	0	1700	60	33
1267	818	819	POPLAR SPRINGS CHURCH RD	COLLECTOR	2283	1	10	0	1700	60	33
1268	819	820	POPLAR SPRINGS CHURCH RD	COLLECTOR	3004	1	10	0	1700	60	33
1269	820	821	POPLAR SPRINGS CHURCH RD	COLLECTOR	1015	1	10	0	1700	50	33
1270	821	822	POPLAR SPRINGS CHURCH RD	COLLECTOR	1447	1	10	0	1700	50	33
1271	822	823	POPLAR SPRINGS CHURCH RD	COLLECTOR	1700	1	10	0	1700	50	33
1272	823	824	POPLAR SPRINGS CHURCH RD	COLLECTOR	1675	1	10	0	1700	60	39
1273	824	825	POPLAR SPRINGS CHURCH RD	COLLECTOR	1366	1	10	0	1700	60	39
1274	825	826	SAN-LEE DR	COLLECTOR	2286	1	10	0	1700	40	39
1275	825	848	POPLAR SPRINGS CHURCH RD	COLLECTOR	1233	1	10	0	1700	50	39
1276	826	834	SAN-LEE DR	COLLECTOR	2320	1	10	0	1700	40	39
1277	827	828	SAN-LEE DR	COLLECTOR	2248	1	10	0	1700	60	39
1278	828	835	SAN-LEE DR	COLLECTOR	1107	1	10	0	1700	60	39
1279	828	1778	PUMPING STATION RD	COLLECTOR	1800	1	9	1	1700	45	39
1280	829	830	LOCHMERE DR	COLLECTOR	2714	1	11	0	1750	45	20
1281	830	722	SE CARY PKWY	MINOR ARTERIAL	2484	2	13	0	1900	50	20
1282	830	723	SE CARY PKWY	MINOR ARTERIAL	644	2	13	0	1900	50	20
1283	830	832	PINEY PLAINS RD	COLLECTOR	2607	1	12	0	1750	40	20
1284	831	838	SAN-LEE DR	COLLECTOR	1402	1	10	0	1700	60	39
1285	832	479	TRYON RD	MINOR ARTERIAL	2648	2	13	0	1750	50	20
1286	832	1037	PINEY PLAINS RD	MINOR ARTERIAL	2880	2	13	0	1900	50	20

Link #	Up-Stream Node	Down-Stream Node	Roadway Name	Roadway Type	Length (ft.)	No. of Lanes	Lane Width (ft.)	Shoulder Width (ft.)	Saturation Flow Rate (pcphpl)	Free Flow Speed (mph)	Grid Map Number
1287	833	837	SAN-LEE DR	COLLECTOR	1009	1	10	0	1700	40	39
1288	834	827	SAN-LEE DR	COLLECTOR	784	1	10	0	1700	40	39
1289	835	831	SAN-LEE DR	COLLECTOR	2604	1	10	0	1700	60	39
1290	836	561	SAN-LEE DR	COLLECTOR	884	1	10	0	1750	40	38
1291	837	836	SAN-LEE DR	COLLECTOR	1452	1	10	0	1700	40	38
1292	838	1779	SAN-LEE DR	COLLECTOR	953	1	10	0	1700	40	39
1293	839	840	SR 42	COLLECTOR	4214	1	12	1	1700	60	33
1294	840	841	SR 42	COLLECTOR	5549	1	12	1	1700	60	33
1295	841	842	SR 42	COLLECTOR	1491	1	12	1	1750	50	39
1296	842	843	SR 42	COLLECTOR	1979	1	12	1	1700	50	39
1297	843	844	SR 42	COLLECTOR	5770	1	12	1	1700	60	39
1298	844	845	SR 42	COLLECTOR	2111	1	12	1	1700	60	39
1299	845	846	SR 42	COLLECTOR	3329	1	12	1	1700	60	39
1300	846	847	SR 42	COLLECTOR	3147	1	12	1	1700	60	39
1301	847	852	SR 42	COLLECTOR	2348	1	12	1	1750	60	39
1302	848	1774	POPLAR SPRINGS CHURCH RD	COLLECTOR	3713	1	10	0	1700	50	39
1303	849	792	LOCHMERE DR	COLLECTOR	805	1	11	0	1750	40	19
1304	850	851	POPLAR SPRINGS CHURCH RD	COLLECTOR	1117	1	10	0	1700	50	39
1305	851	847	POPLAR SPRINGS CHURCH RD	COLLECTOR	1955	1	10	0	1700	45	39
1306	852	853	SR 42	COLLECTOR	4499	1	12	1	1750	50	39
1307	853	856	SR 42	MINOR ARTERIAL	1625	2	12	1	1750	50	39
1308	854	1061	SR 42	COLLECTOR	2041	1	12	1	1750	50	39
1309	855	540	US 421 BUS	MINOR ARTERIAL	2358	2	13	0	1750	40	39
1310	855	1237	US 421 BUS	MINOR ARTERIAL	3112	2	13	0	1750	50	39
1311	855	1681	SR 78	COLLECTOR	1022	1	12	0	1750	50	39
1312	856	1112	US 421 BYPASS ON-RAMP FROM SR 42	FREEWAY RAMP	1455	1	12	3	1700	45	39
1313	856	1481	SR 42	COLLECTOR	1426	2	12	1	1750	50	39

Link #	Up-Stream Node	Down-Stream Node	Roadway Name	Roadway Type	Length (ft.)	No. of Lanes	Lane Width (ft.)	Shoulder Width (ft.)	Saturation Flow Rate (pcphpl)	Free Flow Speed (mph)	Grid Map Number
1314	857	468	WHOLEFOODS COMPLEX	COLLECTOR	320	2	12	0	1750	30	19
1315	858	468	NEW WAVERLY PL	MINOR ARTERIAL	1131	1	10	0	1750	30	20
1316	858	1371	NEW WAVERLY PL	MINOR ARTERIAL	730	2	10	0	1900	45	20
1317	859	584	EDINBURGH DR	COLLECTOR	627	1	12	0	1750	40	19
1318	860	583	GREGSON DR	COLLECTOR	670	1	13	0	1750	40	19
1319	861	407	KILDAIRE FARM RD	MINOR ARTERIAL	2464	2	13	0	1750	50	19
1320	862	622	US 421	COLLECTOR	2946	1	13	2	1750	60	40
1321	862	659	US 421	COLLECTOR	4785	1	13	2	1700	60	39
1322	863	861	CHADBURY LN	COLLECTOR	774	1	10	0	1750	40	19
1323	864	861	QUEENSFERRY RD	COLLECTOR	1127	1	10	0	1750	40	19
1324	865	421	HIGH MEADOW DR	COLLECTOR	1344	1	11	4	1750	40	19
1325	866	809	SR 42	COLLECTOR	9162	1	12	1	1700	60	34
1326	867	868	SR 42	COLLECTOR	2077	1	12	1	1700	45	34
1327	868	876	SR 42	COLLECTOR	1677	1	12	1	1700	45	34
1328	869	867	SR 42	COLLECTOR	2040	1	12	1	1700	60	34
1329	870	869	SR 42	COLLECTOR	1605	1	12	1	1700	60	34
1330	871	870	SR 42	COLLECTOR	2791	1	12	1	1700	60	34
1331	872	871	SR 42	COLLECTOR	3917	1	12	1	1700	60	34
1332	872	873	SR 42	COLLECTOR	2255	1	12	1	1700	40	34
1333	873	874	SR 42	COLLECTOR	2446	1	12	1	1700	40	34
1334	874	875	SR 42	COLLECTOR	1619	1	12	1	1700	40	34
1335	875	3000	SR 42	COLLECTOR	3320	1	12	1	1750	55	34
1336	876	877	SR 42	COLLECTOR	2590	1	12	1	1700	60	34
1337	877	878	SR 42	COLLECTOR	1308	1	12	1	1700	60	34
1338	878	879	SR 42	COLLECTOR	1391	1	12	1	1700	40	34
1339	879	880	SR 42	COLLECTOR	3487	1	12	1	1700	45	34
1340	880	881	SR 42	COLLECTOR	2751	1	12	1	1700	45	35
1341	881	883	SR 42	COLLECTOR	2893	1	12	1	1700	45	35

Link #	Up-Stream Node	Down-Stream Node	Roadway Name	Roadway Type	Length (ft.)	No. of Lanes	Lane Width (ft.)	Shoulder Width (ft.)	Saturation Flow Rate (pcphpl)	Free Flow Speed (mph)	Grid Map Number
1342	882	889	SR 42	COLLECTOR	4003	1	12	1	1700	60	35
1343	883	888	SR 42	COLLECTOR	1384	1	12	1	1700	45	35
1344	884	885	SR 42	COLLECTOR	1363	1	12	1	1700	45	35
1345	885	886	SR 42	COLLECTOR	1403	1	12	1	1700	45	35
1346	886	1480	SR 42	COLLECTOR	1939	1	12	1	1700	60	35
1347	887	884	SR 42	COLLECTOR	1643	1	12	1	1700	45	35
1348	888	887	SR 42	COLLECTOR	1063	1	12	1	1700	45	35
1349	889	890	SR 42	COLLECTOR	1543	1	12	1	1700	40	35
1350	890	891	SR 42	COLLECTOR	2444	1	12	1	1700	40	35
1351	891	892	SR 42	COLLECTOR	3349	1	12	1	1700	50	35
1352	892	177	SR 42	COLLECTOR	2569	1	12	1	1700	50	35
1353	893	1865	SR 42	COLLECTOR	5190	1	12	4	1700	50	36
1354	894	228	SR 42	COLLECTOR	2412	1	12	4	1750	25	36
1355	895	902	CORINTH RD	COLLECTOR	1687	1	11	0	1700	50	34
1356	896	895	CORINTH RD	COLLECTOR	3964	1	11	0	1700	50	34
1357	897	900	CORINTH RD	COLLECTOR	1056	1	11	0	1700	50	34
1358	898	897	CORINTH RD	COLLECTOR	5570	1	11	0	1700	50	28
1359	898	899	CORINTH RD	COLLECTOR	2736	1	11	0	1700	50	27
1360	899	797	CORINTH RD	COLLECTOR	4975	1	11	0	1750	50	27
1361	900	896	CORINTH RD	COLLECTOR	2095	1	11	0	1700	50	34
1362	901	807	CORINTH RD	COLLECTOR	1967	1	11	0	1750	50	34
1363	902	901	CORINTH RD	COLLECTOR	2322	1	11	0	1700	50	34
1364	903	904	LOWER MONCURE RD	COLLECTOR	1090	1	10	0	1700	55	27
1365	903	1580	LOWER MONCURE RD	COLLECTOR	313	1	10	0	1700	55	27
1366	904	806	LOWER MONCURE RD	COLLECTOR	3119	1	10	0	1750	55	27
1367	905	903	LOWER RIVER RD	COLLECTOR	4682	1	10	0	1750	55	27
1368	906	905	LOWER RIVER RD	COLLECTOR	1739	1	10	0	1700	55	27
1369	907	906	LOWER RIVER RD	COLLECTOR	2778	1	10	0	1700	55	27

Link #	Up-Stream Node	Down-Stream Node	Roadway Name	Roadway Type	Length (ft.)	No. of Lanes	Lane Width (ft.)	Shoulder Width (ft.)	Saturation Flow Rate (pcphpl)	Free Flow Speed (mph)	Grid Map Number
1370	908	907	LOWER RIVER RD	COLLECTOR	3108	1	10	0	1700	55	33
1371	908	1495	LOWER RIVER RD	COLLECTOR	5812	1	10	0	1700	55	33
1372	909	910	LOWER RIVER RD	COLLECTOR	3847	1	10	0	1700	55	33
1373	910	911	LOWER RIVER RD	COLLECTOR	4787	1	10	0	1700	55	33
1374	911	912	LOWER RIVER RD	COLLECTOR	2012	1	10	0	1700	55	34
1375	912	808	LOWER RIVER RD	COLLECTOR	1888	1	10	0	1750	55	34
1376	913	915	LOWER MONCURE RD	COLLECTOR	5105	1	10	0	1700	55	33
1377	914	916	LOWER MONCURE RD	COLLECTOR	3855	1	10	0	1700	50	33
1378	915	914	LOWER MONCURE RD	COLLECTOR	3930	1	10	0	1700	55	33
1379	916	918	LOWER MONCURE RD	COLLECTOR	3220	1	10	0	1700	50	33
1380	917	919	LOWER MONCURE RD	COLLECTOR	2444	1	10	0	1700	50	33
1381	918	917	LOWER MONCURE RD	COLLECTOR	2704	1	10	0	1700	50	33
1382	919	921	LOWER MONCURE RD	COLLECTOR	2522	1	10	0	1700	50	33
1383	920	406	HIGH MEADOW DR	COLLECTOR	785	1	11	4	1750	30	19
1384	921	922	LOWER MONCURE RD	COLLECTOR	1284	1	10	0	1700	50	33
1385	922	98	POST OFFICE RD	COLLECTOR	2492	1	10	0	1700	40	33
1386	922	923	LOWER MONCURE RD	COLLECTOR	1856	1	10	0	1700	50	33
1387	923	925	LOWER MONCURE RD	COLLECTOR	1698	1	10	0	1700	50	33
1388	924	926	LOWER MONCURE RD	COLLECTOR	986	1	10	0	1700	50	33
1389	925	924	LOWER MONCURE RD	COLLECTOR	2660	1	10	0	1700	50	33
1390	926	938	LOWER MONCURE RD	COLLECTOR	768	1	10	0	1700	40	33
1391	927	928	LOWER MONCURE RD	COLLECTOR	2977	1	10	0	1700	50	33
1392	928	929	LOWER MONCURE RD	COLLECTOR	1146	1	10	0	1700	50	33
1393	929	930	LOWER MONCURE RD	COLLECTOR	1033	1	10	0	1700	50	39
1394	930	932	LOWER MONCURE RD	COLLECTOR	2585	1	10	0	1700	50	39
1395	931	1430	KILDAIRE FARM RD	MINOR ARTERIAL	953	2	13	0	1750	40	11
1396	932	933	LOWER MONCURE RD	COLLECTOR	1226	1	10	0	1700	50	39
1397	933	934	LOWER MONCURE RD	COLLECTOR	1683	1	10	0	1700	50	39

Link #	Up-Stream Node	Down-Stream Node	Roadway Name	Roadway Type	Length (ft.)	No. of Lanes	Lane Width (ft.)	Shoulder Width (ft.)	Saturation Flow Rate (pcphpl)	Free Flow Speed (mph)	Grid Map Number
1398	934	935	LOWER MONCURE RD	COLLECTOR	1799	1	10	0	1700	50	39
1399	935	936	LOWER MONCURE RD	COLLECTOR	2004	1	10	0	1700	50	38
1400	936	937	LOWER MONCURE RD	COLLECTOR	1015	1	10	0	1700	50	38
1401	937	561	N 11TH ST	COLLECTOR	901	1	10	0	1750	40	38
1402	938	927	LOWER MONCURE RD	COLLECTOR	935	1	10	0	1700	40	33
1403	939	812	POPLAR SPRINGS CHURCH RD	COLLECTOR	2069	1	10	0	1700	60	33
1404	940	941	COLON RD	COLLECTOR	5111	1	12	0	1700	60	32
1405	940	942	COLON RD	COLLECTOR	3899	1	12	0	1700	60	32
1406	941	90	COLON RD	COLLECTOR	1886	1	12	0	1700	50	32
1407	941	940	COLON RD	COLLECTOR	5111	1	12	0	1700	60	32
1408	942	940	COLON RD	COLLECTOR	3899	1	12	0	1700	60	32
1409	942	943	COLON RD	COLLECTOR	1929	1	12	0	1700	60	32
1410	943	942	COLON RD	COLLECTOR	1929	1	12	0	1700	60	32
1411	943	944	COLON RD	COLLECTOR	2337	1	12	0	1700	60	32
1412	944	945	COLON RD	COLLECTOR	1669	1	12	0	1700	60	32
1413	945	947	COLON RD	COLLECTOR	1398	1	12	0	1700	60	32
1414	946	931	WRENN DR	COLLECTOR	981	1	11	0	1750	30	11
1415	947	949	COLON RD	COLLECTOR	1503	1	12	0	1700	60	32
1416	948	951	COLON RD	COLLECTOR	909	1	12	0	1700	60	32
1417	948	1801	US 421 BYPASS ON RAMP	FREEWAY RAMP	493	1	12	11	1700	40	32
1418	949	950	COLON RD	COLLECTOR	965	1	12	0	1700	60	32
1419	950	948	COLON RD	COLLECTOR	1271	1	12	0	1700	60	32
1420	950	1122	US 421 BYPASS ON-RAMP FROM COLON RD	FREEWAY RAMP	501	1	12	4	1350	30	32
1421	951	952	COLON RD	COLLECTOR	1229	1	12	0	1700	60	38
1422	952	953	COLON RD	COLLECTOR	816	1	12	0	1700	40	38
1423	953	955	COLON RD	COLLECTOR	976	1	12	0	1700	40	38
1424	954	1517	N 7TH ST	COLLECTOR	576	1	12	0	1700	40	38

Link #	Up-Stream Node	Down-Stream Node	Roadway Name	Roadway Type	Length (ft.)	No. of Lanes	Lane Width (ft.)	Shoulder Width (ft.)	Saturation Flow Rate (pcphpl)	Free Flow Speed (mph)	Grid Map Number
1425	955	954	COLON RD	COLLECTOR	2025	1	12	0	1700	40	38
1426	956	931	FARMINGTON WOODS DR	COLLECTOR	1294	1	10	0	1750	30	19
1427	957	39	E ACADEMY ST	COLLECTOR	1079	1	12	0	1350	30	36
1428	957	226	N ENNIS ST	LOCAL ROADWAY	2515	1	12	4	1750	30	30
1429	957	958	N ENNIS ST	LOCAL ROADWAY	1372	1	12	4	1350	30	36
1430	957	1504	E ACADEMY ST	COLLECTOR	1555	1	12	0	1750	30	36
1431	958	957	N ENNIS ST	LOCAL ROADWAY	1372	1	12	4	1750	30	36
1432	958	1874	E SPRING ST	LOCAL ROADWAY	701	1	13	0	1350	30	36
1433	959	204	US 401	COLLECTOR	413	1	12	0	1750	40	36
1434	959	228	US 401	COLLECTOR	1247	1	12	0	1750	30	36
1435	960	962	SR 55	COLLECTOR	1641	1	13	1	1700	55	36
1436	960	1877	SR 55	COLLECTOR	1198	1	13	1	1700	55	36
1437	961	1044	SR 55	COLLECTOR	4135	1	13	1	1700	50	30
1438	961	1046	OLD HONEYCUTT RD	COLLECTOR	2055	1	11	0	1700	40	36
1439	961	1877	SR 55	COLLECTOR	8091	1	13	1	1700	55	36
1440	962	960	SR 55	COLLECTOR	1641	1	13	1	1700	55	36
1441	962	963	SR 55	COLLECTOR	2865	1	13	1	1700	55	36
1442	963	962	SR 55	COLLECTOR	2865	1	13	1	1700	55	36
1443	963	964	SR 55	COLLECTOR	2727	1	13	1	1700	55	36
1444	964	963	SR 55	COLLECTOR	2727	1	13	1	1700	55	36
1445	964	1691	SR 55	COLLECTOR	1404	1	13	1	1750	50	36
1446	965	966	SR 55	COLLECTOR	2278	1	13	1	1700	45	36
1447	965	1457	SR 55	COLLECTOR	3636	1	13	1	1700	45	36
1448	966	965	SR 55	COLLECTOR	2278	1	13	1	1700	45	36
1449	966	969	SR 55	COLLECTOR	1897	1	13	1	1750	40	36
1450	967	1104	W CHATHAM ST TRAFFIC CIRCLE	COLLECTOR	332	1	12	0	900	20	11
1451	968	1418	NW MAYNARD RD	MINOR ARTERIAL	1631	2	13	0	1750	50	11
1452	969	966	SR 55	COLLECTOR	1897	1	13	1	1700	40	36

Link #	Up-Stream Node	Down-Stream Node	Roadway Name	Roadway Type	Length (ft.)	No. of Lanes	Lane Width (ft.)	Shoulder Width (ft.)	Saturation Flow Rate (pcphpl)	Free Flow Speed (mph)	Grid Map Number
1453	969	974	SR 210	COLLECTOR	985	1	13	1	1700	40	36
1454	969	975	SR 55	COLLECTOR	1730	1	12	0	1700	40	36
1455	969	1455	SR 210	COLLECTOR	435	1	12	1	1750	40	36
1456	970	429	NW MAYNARD RD	MINOR ARTERIAL	2308	2	13	0	1750	50	11
1457	971	974	SR 210	COLLECTOR	1046	1	13	1	1700	40	36
1458	971	979	SR 210	COLLECTOR	1504	1	13	1	1700	40	36
1459	972	982	MORRISVILLE PKWY	MINOR ARTERIAL	1350	2	12	0	1750	40	8
1460	973	1101	SR 210	COLLECTOR	3716	1	12	1	1700	50	36
1461	973	1455	SR 210	COLLECTOR	2577	1	12	1	1750	40	36
1462	974	969	SR 210	COLLECTOR	985	1	13	1	1750	40	36
1463	974	971	SR 210	COLLECTOR	1046	1	13	1	1700	40	36
1464	975	392	SR 55	COLLECTOR	3478	1	12	0	1700	45	42
1465	975	969	SR 55	COLLECTOR	1730	1	12	0	1750	40	36
1466	976	977	SR 210	COLLECTOR	4109	1	13	1	1700	60	42
1467	976	983	SR 210	COLLECTOR	5069	1	13	1	1700	60	42
1468	977	976	SR 210	COLLECTOR	4109	1	13	1	1700	60	42
1469	977	1248	SR 210	COLLECTOR	945	1	13	1	1750	60	42
1470	978	1248	SR 210	COLLECTOR	3312	1	13	1	1750	60	42
1471	978	1828	SR 210	COLLECTOR	6377	1	12	0	1700	60	42
1472	979	971	SR 210	COLLECTOR	1504	1	13	1	1700	40	36
1473	979	980	SR 210	COLLECTOR	2930	1	13	1	1700	60	42
1474	980	979	SR 210	COLLECTOR	2930	1	13	1	1700	60	42
1475	980	981	SR 210	COLLECTOR	2012	1	13	1	1700	60	42
1476	981	980	SR 210	COLLECTOR	2012	1	13	1	1700	60	42
1477	981	984	SR 210	COLLECTOR	1819	1	13	1	1700	60	42
1478	982	367	MORRISVILLE PKWY	MINOR ARTERIAL	1865	1	12	0	1750	40	8
1479	983	976	SR 210	COLLECTOR	5069	1	13	1	1700	60	42
1480	983	984	SR 210	COLLECTOR	3113	1	13	1	1700	60	42

Link #	Up-Stream Node	Down-Stream Node	Roadway Name	Roadway Type	Length (ft.)	No. of Lanes	Lane Width (ft.)	Shoulder Width (ft.)	Saturation Flow Rate (pcphpl)	Free Flow Speed (mph)	Grid Map Number
1481	984	981	SR 210	COLLECTOR	1818	1	13	1	1700	60	42
1482	984	983	SR 210	COLLECTOR	3113	1	13	1	1700	60	42
1483	985	201	SR 55	MAJOR ARTERIAL	423	2	13	1	1750	45	30
1484	985	986	SR 42	COLLECTOR	4908	1	12	1	1700	60	30
1485	985	1044	SR 55	COLLECTOR	534	1	13	1	1700	45	30
1486	986	985	SR 42	COLLECTOR	4908	1	12	1	1700	60	30
1487	986	987	SR 42	COLLECTOR	3297	1	12	1	1700	60	36
1488	987	986	SR 42	COLLECTOR	3297	1	12	1	1700	60	36
1489	987	988	SR 42	COLLECTOR	4537	1	12	1	1750	60	30
1490	988	987	SR 42	COLLECTOR	4537	1	12	1	1700	60	30
1491	988	990	SR 42	COLLECTOR	2374	1	12	1	1700	60	31
1492	989	1959	SR 42	COLLECTOR	5363	1	12	1	1750	60	31
1493	990	988	SR 42	COLLECTOR	2374	1	12	1	1750	60	31
1494	990	991	SR 42	COLLECTOR	2462	1	12	1	1700	60	31
1495	991	990	SR 42	COLLECTOR	2462	1	12	1	1700	60	31
1496	991	1959	SR 42	COLLECTOR	3592	1	12	1	1750	60	31
1497	992	1486	US 1 BUS	COLLECTOR	3136	1	12	1	1700	50	32
1498	992	1487	US 1 BUS	COLLECTOR	2731	1	12	1	1750	50	32
1499	993	1118	US 421 BYPASS	FREEWAY	3169	2	13	6	2250	70	32
1500	993	1683	US 421 BYPASS ON/OFF RAMP	FREEWAY RAMP	1653	1	13	6	1700	60	32
1501	993	1763	US 421 BYPASS	FREEWAY	5571	2	13	5	2250	70	32
1502	994	556	US 1 BUS	COLLECTOR	1200	1	12	1	1750	40	38
1503	994	1487	US 1 BUS	COLLECTOR	6041	1	12	1	1750	40	32
1504	995	152	US 501	COLLECTOR	3168	1	12	1	1700	60	26
1505	995	643	US 501	COLLECTOR	7392	1	12	1	1700	60	26
1506	996	661	US 421	COLLECTOR	5290	1	13	2	1700	60	40
1507	996	738	US 421	COLLECTOR	6491	1	13	2	1700	60	40
1508	997	622	SEMINOLE RD	COLLECTOR	344	1	12	0	1750	45	40

Link #	Up-Stream Node	Down-Stream Node	Roadway Name	Roadway Type	Length (ft.)	No. of Lanes	Lane Width (ft.)	Shoulder Width (ft.)	Saturation Flow Rate (pcphpl)	Free Flow Speed (mph)	Grid Map Number
1509	998	689	US 1 N ON-RAMP FROM CROSSROADS BLVD	FREEWAY RAMP	409	2	14	0	1900	30	20
1510	999	686	WALNUT ST	MAJOR ARTERIAL	351	3	13	0	1900	50	20
1511	999	688	MEETING ST	MINOR ARTERIAL	379	2	12	0	1750	30	20
1512	999	1524	WALNUT ST	MAJOR ARTERIAL	687	3	13	0	1900	50	20
1513	1000	366	WESTON PKWY	MINOR ARTERIAL	583	2	12	0	1750	40	8
1514	1000	1164	WESTON PKWY	MINOR ARTERIAL	577	2	12	0	1900	45	8
1515	1001	1002	DAVIS DR	MINOR ARTERIAL	1929	2	13	0	1900	50	7
1516	1001	1387	DAVIS DR	MINOR ARTERIAL	817	2	13	0	1750	50	7
1517	1002	1352	DAVIS DR	MINOR ARTERIAL	2152	2	13	0	1750	50	7
1518	1003	356	CARPENTER UPCHURCH RD	COLLECTOR	727	1	12	0	1750	40	10
1519	1003	1004	CARPENTER UPCHURCH RD	COLLECTOR	470	1	12	0	1350	30	10
1520	1004	1003	CARPENTER UPCHURCH RD	COLLECTOR	461	1	12	0	1350	30	10
1521	1004	1005	LOUIS STEPHENS DR	COLLECTOR	1740	1	12	0	1700	40	10
1522	1005	1004	LOUIS STEPHENS DR	COLLECTOR	1740	1	12	0	1700	45	10
1523	1005	1160	LOUIS STEPHENS DR	COLLECTOR	839	1	12	0	1700	40	10
1524	1006	408	LEGAULT DR	COLLECTOR	1239	1	13	0	1750	40	10
1525	1007	338	OLD APEX RD	MINOR ARTERIAL	573	2	11	0	1750	45	19
1526	1008	307	OLD APEX RD	COLLECTOR	3559	1	12	1	1700	50	11
1527	1009	301	DAVIS DR	COLLECTOR	843	1	11	0	1750	45	18
1528	1009	673	DAVIS DR	MINOR ARTERIAL	425	2	11	0	1750	45	18
1529	1010	291	S SALEM ST	COLLECTOR	1833	1	11	0	1750	40	22
1530	1011	116	US 64	MINOR ARTERIAL	1346	2	13	9	1900	60	19
1531	1011	583	US 64	MINOR ARTERIAL	1530	2	13	9	1750	60	19
1532	1012	1334	OLD RALEIGH RD	COLLECTOR	2921	1	12	0	1700	50	19
1533	1013	1011	CHALON DR	COLLECTOR	495	1	13	0	1750	40	19
1534	1014	1015	LAKE PINE DR	COLLECTOR	1637	1	13	0	1700	45	19
1535	1014	1527	LAKE PINE DR	COLLECTOR	1200	1	13	0	1700	45	19

Link #	Up-Stream Node	Down-Stream Node	Roadway Name	Roadway Type	Length (ft.)	No. of Lanes	Lane Width (ft.)	Shoulder Width (ft.)	Saturation Flow Rate (pcphpl)	Free Flow Speed (mph)	Grid Map Number
1536	1015	1014	LAKE PINE DR	COLLECTOR	1637	1	13	0	1700	45	19
1537	1015	1016	LAKE PINE DR	COLLECTOR	1479	1	13	0	1700	40	19
1538	1016	1015	LAKE PINE DR	COLLECTOR	1479	1	13	0	1700	40	19
1539	1016	1017	LAKE PINE DR	MINOR ARTERIAL	1151	2	13	0	1900	40	19
1540	1017	119	LAKE PINE DR	MINOR ARTERIAL	784	2	13	0	1750	45	19
1541	1017	1016	LAKE PINE DR	COLLECTOR	1151	1	13	0	1700	40	19
1542	1018	585	N MASON ST	COLLECTOR	1480	1	11	0	1750	40	18
1543	1018	1449	OLD RALEIGH RD	COLLECTOR	1345	1	12	0	1750	40	18
1544	1018	1450	LAURA DUNCAN RD	COLLECTOR	1455	1	10	0	1750	40	18
1545	1019	1376	CENTER ST	COLLECTOR	416	2	12	0	1750	40	18
1546	1020	305	OLD APEX RD	LOCAL ROADWAY	1032	1	11	0	1750	45	19
1547	1021	1022	LAURA DUNCAN RD	COLLECTOR	1939	1	10	0	1700	50	18
1548	1021	1453	LAURA DUNCAN RD	COLLECTOR	2337	1	10	0	1700	50	19
1549	1022	120	LAURA DUNCAN RD	COLLECTOR	867	1	10	0	1750	50	18
1550	1022	1021	LAURA DUNCAN RD	COLLECTOR	1939	1	10	0	1700	50	18
1551	1023	127	GREEN LEVEL CHURCH RD	COLLECTOR	448	1	12	0	1700	40	18
1552	1023	631	VISION DR	COLLECTOR	1319	1	12	0	1700	40	18
1553	1024	466	US 64	MINOR ARTERIAL	3482	2	14	2	1900	60	16
1554	1024	1598	US 64	MINOR ARTERIAL	7374	2	14	2	1900	60	16
1555	1025	1598	US 64	MINOR ARTERIAL	2663	2	14	2	1900	60	15
1556	1025	1849	US 64	MINOR ARTERIAL	2383	2	14	2	1900	60	15
1557	1026	853	COX MILL RD	COLLECTOR	1695	1	11	0	1750	60	39
1558	1026	1058	MT PISGAH CHURCH RD	COLLECTOR	4307	1	10	0	1750	50	39
1559	1028	204	WAKE CHAPEL RD	COLLECTOR	1956	1	11	0	1750	35	30
1560	1029	425	WAKE CHAPEL RD	COLLECTOR	186	1	11	0	1750	40	30
1561	1029	1028	WAKE CHAPEL RD	COLLECTOR	1864	1	11	0	1700	40	30
1562	1030	203	US 401	COLLECTOR	891	1	12	0	1700	40	30
1563	1030	226	US 401	MINOR ARTERIAL	338	2	12	0	1750	40	30

Link #	Up-Stream Node	Down-Stream Node	Roadway Name	Roadway Type	Length (ft.)	No. of Lanes	Lane Width (ft.)	Shoulder Width (ft.)	Saturation Flow Rate (pcphpl)	Free Flow Speed (mph)	Grid Map Number
1564	1031	1253	SR 55	COLLECTOR	1917	1	13	0	1350	30	30
1565	1032	1573	SR 55	MINOR ARTERIAL	606	2	13	0	1750	40	30
1566	1033	425	SR 55	MINOR ARTERIAL	1484	2	13	0	1750	40	30
1567	1033	1257	JUDD PKWY	COLLECTOR	1075	1	11	0	1700	45	30
1568	1034	1033	WILBON RD	COLLECTOR	3511	1	10	0	1750	45	30
1569	1035	441	OAKHALL DR	COLLECTOR	1196	1	13	0	1750	40	29
1570	1036	1627	SR 55	COLLECTOR	2565	1	12	1	1750	50	29
1571	1037	1038	PINEY PLAINS RD	MINOR ARTERIAL	1400	2	13	0	1900	50	20
1572	1038	1437	DILLARD DR	MINOR ARTERIAL	1190	2	13	0	1750	50	20
1573	1039	686	WALNUT ST	MAJOR ARTERIAL	747	3	13	0	1900	50	20
1574	1039	1406	WALNUT ST	MAJOR ARTERIAL	1011	3	13	0	1750	50	20
1575	1039	3011	DILLARD DR	MINOR ARTERIAL	1260	2	11	1	1900	45	20
1576	1040	483	JONES FRANKLIN RD	COLLECTOR	1160	1	11	0	1750	45	20
1577	1040	1369	HOLLY SPRINGS RD	MAJOR ARTERIAL	666	3	12	4	1750	50	20
1578	1042	61	US 401	MINOR ARTERIAL	1204	2	13	3	1750	55	31
1579	1042	387	US 401	MINOR ARTERIAL	3103	2	13	3	1900	55	31
1580	1043	1042	CHANDLER RIDGE CIRCLE	COLLECTOR	653	1	12	0	1750	30	31
1581	1044	961	SR 55	COLLECTOR	4135	1	13	1	1750	50	30
1582	1044	985	SR 55	MAJOR ARTERIAL	534	3	13	1	1900	45	30
1583	1045	42	PURFOY RD	COLLECTOR	1379	1	13	3	1750	40	30
1584	1045	170	PURFOY RD	COLLECTOR	5120	1	12	1	1700	50	36
1585	1045	1046	OLD HONEYCUTT RD	COLLECTOR	3473	1	11	0	1700	40	36
1586	1046	961	OLD HONEYCUTT RD	COLLECTOR	2056	1	11	0	1750	40	36
1587	1046	1045	OLD HONEYCUTT RD	COLLECTOR	3473	1	11	0	1750	40	36
1588	1047	1048	OLD HONEYCUTT RD	COLLECTOR	3497	1	11	0	1700	40	36
1589	1047	1049	KENNEBEC RD	COLLECTOR	1830	1	11	0	1700	45	36
1590	1047	1050	KENNEBEC RD	COLLECTOR	5732	1	11	0	1700	45	36
1591	1048	961	OLD HONEYCUTT RD	COLLECTOR	3129	1	11	0	1750	40	36

Link #	Up-Stream Node	Down-Stream Node	Roadway Name	Roadway Type	Length (ft.)	No. of Lanes	Lane Width (ft.)	Shoulder Width (ft.)	Saturation Flow Rate (pcphpl)	Free Flow Speed (mph)	Grid Map Number
1592	1049	1474	KENNEBEC RD	COLLECTOR	571	1	11	0	1575	35	36
1593	1050	1473	MAUDE STEWART RD	COLLECTOR	397	1	12	0	1575	35	36
1594	1051	1052	MAUDE STEWART RD	COLLECTOR	2963	1	12	0	1700	50	36
1595	1052	964	MAUDE STEWART RD	COLLECTOR	3782	1	12	0	1700	50	36
1596	1053	661	US 421	COLLECTOR	5909	1	13	2	1700	60	40
1597	1053	662	US 421	COLLECTOR	2673	1	13	2	1700	60	41
1598	1054	1053	RAVEN ROCK RD	COLLECTOR	6118	1	11	0	1700	40	41
1599	1055	1054	RAVEN ROCK RD	COLLECTOR	7852	1	11	0	1700	40	41
1600	1056	594	US 421	COLLECTOR	6516	1	13	2	1700	60	40
1601	1056	622	US 421	COLLECTOR	4073	1	13	2	1750	60	40
1602	1057	664	COX MILL RD	COLLECTOR	3760	1	11	0	1750	60	39
1603	1057	1026	COX MILL RD	COLLECTOR	2836	1	11	0	1700	60	39
1604	1058	664	US 421	COLLECTOR	3487	1	13	2	1750	60	39
1605	1058	1633	US 421	COLLECTOR	2465	1	13	2	1750	60	39
1606	1059	539	SR 87	MINOR ARTERIAL	1594	2	12	0	1750	55	39
1607	1059	1743	SR 87	MINOR ARTERIAL	2304	2	12	0	1900	55	39
1608	1060	1059	SR 87	MINOR ARTERIAL	3460	2	12	0	1750	55	39
1609	1060	1744	SR 87	MINOR ARTERIAL	724	2	12	0	1900	60	39
1610	1061	1062	ROSSER RD	COLLECTOR	3698	1	12	0	1750	40	39
1611	1061	1493	SR 42	COLLECTOR	820	1	12	1	1750	40	39
1612	1062	539	US 421 BUS	MAJOR ARTERIAL	1965	3	13	0	1750	50	39
1613	1062	1061	ROSSER RD	COLLECTOR	3698	1	12	0	1750	40	39
1614	1062	1237	US 421 BUS	MINOR ARTERIAL	732	2	13	0	1750	50	39
1615	1063	728	SMITH RD	COLLECTOR	1172	1	10	0	1750	40	23
1616	1064	403	SE MAYNARD RD	MINOR ARTERIAL	1162	2	13	0	1900	40	12
1617	1065	1400	SE CARY PKWY	MINOR ARTERIAL	1382	2	13	0	1900	50	20
1618	1066	1065	SEABROOK AVE	COLLECTOR	1617	1	13	0	1750	40	20
1619	1067	1066	SEABROOK AVE	COLLECTOR	1375	1	13	0	1700	40	20

Link #	Up-Stream Node	Down-Stream Node	Roadway Name	Roadway Type	Length (ft.)	No. of Lanes	Lane Width (ft.)	Shoulder Width (ft.)	Saturation Flow Rate (pcphpl)	Free Flow Speed (mph)	Grid Map Number
1620	1068	1397	SEABROOK AVE	COLLECTOR	179	1	13	0	900	20	20
1621	1069	1070	LAKE PINE DR	COLLECTOR	2358	1	13	4	1700	40	19
1622	1070	1071	LAKE PINE DR	COLLECTOR	2121	1	13	4	1700	40	11
1623	1071	1072	LAKE PINE DR	COLLECTOR	1148	1	13	4	1700	40	11
1624	1072	1979	LAKE PINE DR	COLLECTOR	767	1	13	4	1700	40	11
1625	1073	1074	LAKE PINE DR	COLLECTOR	727	1	13	4	1700	40	11
1626	1074	389	LAKE PINE DR	COLLECTOR	516	1	13	4	1700	40	11
1627	1075	714	TWO CREEKS RD	COLLECTOR	584	1	11	4	1750	30	19
1628	1076	1077	WALDO ROOD BLVD	COLLECTOR	520	1	12	0	1700	40	10
1629	1076	1394	SW CARY PKWY	MINOR ARTERIAL	843	2	13	0	1750	50	10
1630	1077	1076	WALDO ROOD BLVD	COLLECTOR	520	1	12	0	1750	40	10
1631	1077	1078	WALDO ROOD BLVD	COLLECTOR	1134	1	12	0	1700	40	10
1632	1078	405	WALDO ROOD BLVD	COLLECTOR	1670	1	12	0	1750	40	10
1633	1078	1077	WALDO ROOD BLVD	COLLECTOR	1137	1	12	0	1700	40	10
1634	1079	344	MAC ARTHUR DR	COLLECTOR	1003	1	13	3	1750	40	10
1635	1080	414	RAINBROOK DR	COLLECTOR	852	1	13	0	1750	40	11
1636	1081	972	MORRISVILLE PKWY	MINOR ARTERIAL	1201	2	12	0	1750	40	8
1637	1081	1996	MORRISVILLE PKWY	MINOR ARTERIAL	2627	2	12	0	1900	40	8
1638	1082	1083	MORRISVILLE PKWY	MINOR ARTERIAL	899	2	12	0	1900	40	7
1639	1083	426	MORRISVILLE PKWY	MINOR ARTERIAL	727	1	12	0	1750	40	7
1640	1084	423	PRESTON VILLAGE WAY	COLLECTOR	1284	1	11	5	1750	40	10
1641	1085	402	PARK VILLAGE DR	COLLECTOR	1278	1	14	0	1750	40	10
1642	1086	449	TEN-TEN RD	COLLECTOR	867	1	12	0	1700	50	23
1643	1086	451	TEN-TEN RD	COLLECTOR	2226	1	12	0	1700	50	23
1644	1086	1087	PENNY RD	COLLECTOR	368	1	12	0	1575	35	23
1645	1087	562	PENNY RD	COLLECTOR	1094	1	12	0	1700	45	23
1646	1087	1086	PENNY RD	COLLECTOR	368	1	12	0	1575	35	23
1647	1088	1089	PENNY RD	COLLECTOR	4481	1	12	0	1750	50	25

Link #	Up-Stream Node	Down-Stream Node	Roadway Name	Roadway Type	Length (ft.)	No. of Lanes	Lane Width (ft.)	Shoulder Width (ft.)	Saturation Flow Rate (pcphpl)	Free Flow Speed (mph)	Grid Map Number
1648	1089	1094	LAKE WHEELER RD	COLLECTOR	1293	1	13	0	1275	50	25
1649	1090	1089	LAKE WHEELER RD	COLLECTOR	1190	1	13	0	1750	50	25
1650	1091	1090	LAKE WHEELER RD	COLLECTOR	2975	1	13	0	1700	50	25
1651	1092	1091	LAKE WHEELER RD	COLLECTOR	2273	1	13	0	1700	50	25
1652	1093	1092	LAKE WHEELER RD	COLLECTOR	1892	1	13	0	1750	45	25
1653	1095	529	W LAKE RD	COLLECTOR	3587	1	10	2	1750	40	30
1654	1096	1097	OPTIMIST FARM RD	COLLECTOR	4241	1	12	0	1700	40	30
1655	1096	1510	W LAKE RD	COLLECTOR	563	1	10	2	1700	40	30
1656	1097	1508	OPTIMIST FARM RD	COLLECTOR	5517	1	12	0	1700	45	30
1657	1098	619	GRAHAM NEWTON RD	COLLECTOR	4732	1	12	0	1750	50	24
1658	1099	1100	JUDD PKWY	COLLECTOR	3019	1	13	1	1750	50	36
1659	1099	1498	ANGIER RD	COLLECTOR	3178	1	12	0	1700	40	36
1660	1099	1499	JUDD PKWY	COLLECTOR	1523	1	13	1	1750	50	36
1661	1100	206	US 401	COLLECTOR	1582	1	12	0	1700	40	36
1662	1100	229	US 401	COLLECTOR	2474	1	12	0	1350	30	36
1663	1100	1099	JUDD PKWY	COLLECTOR	3019	1	13	1	1750	50	36
1664	1101	973	SR 210	COLLECTOR	3716	1	12	1	1700	50	36
1665	1102	1103	US 421 BUS	MINOR ARTERIAL	5981	2	13	2	1900	60	32
1666	1102	1223	US 421 BUS	MINOR ARTERIAL	1778	2	13	2	1750	60	32
1667	1103	1102	US 421 BUS	MINOR ARTERIAL	5981	2	13	2	1900	60	32
1668	1103	1787	US 421 BUS	MINOR ARTERIAL	3209	2	13	2	1900	60	32
1669	1104	1989	W CHATHAM ST	MINOR ARTERIAL	593	1	12	0	1750	30	11
1670	1105	12	CHAPEL HILL RD	MINOR ARTERIAL	729	2	12	1	1750	55	12
1671	1106	432	E CHATHAM ST	COLLECTOR	966	1	12	0	1750	40	12
1672	1107	415	STURDIVANT DR	COLLECTOR	956	1	10	0	1750	40	12
1673	1108	416	NOTTINGHAM DR	COLLECTOR	806	1	10	0	1750	40	12
1674	1110	1111	US 1 N ON-RAMP FROM WALNUT ST	FREEWAY RAMP	283	1	15	0	1350	30	20

Link #	Up-Stream Node	Down-Stream Node	Roadway Name	Roadway Type	Length (ft.)	No. of Lanes	Lane Width (ft.)	Shoulder Width (ft.)	Saturation Flow Rate (pcphpl)	Free Flow Speed (mph)	Grid Map Number
1675	1111	40	US 1	FREEWAY	723	4	13	10	2250	65	20
1676	1111	597	US 1	FREEWAY	1142	4	13	10	2250	65	20
1677	1112	1113	US 421 BYPASS	FREEWAY	933	2	13	6	2250	70	39
1678	1113	1114	US 421 BYPASS	FREEWAY	2179	2	13	6	2250	70	39
1679	1113	1755	US 421 BYPASS	FREEWAY	768	2	12	4	2250	70	39
1680	1114	1113	US 421 BYPASS	FREEWAY	2175	2	12	4	2250	70	39
1681	1114	1758	US 421 BYPASS	FREEWAY	1820	2	13	6	2250	70	39
1682	1115	1783	US 421 BYPASS	FREEWAY	1065	2	12	4	2250	70	39
1683	1115	1785	US 421 BYPASS	FREEWAY	2092	2	13	6	2250	70	39
1684	1116	1117	US 421 BYPASS	FREEWAY	3603	2	13	6	2250	70	39
1685	1116	1785	US 421 BYPASS	FREEWAY	1945	2	13	6	2250	70	39
1686	1117	1116	US 421 BYPASS	FREEWAY	3595	2	13	6	2250	70	39
1687	1117	1119	US 421 BYPASS	FREEWAY	2763	2	13	6	2250	70	32
1688	1118	993	US 421 BYPASS	FREEWAY	3169	2	13	6	2250	70	32
1689	1118	1485	US 421 BYPASS	FREEWAY	1331	2	13	6	2250	70	32
1690	1119	1117	US 421 BYPASS	FREEWAY	2753	2	13	6	2250	70	32
1691	1119	1485	US 421 BYPASS	FREEWAY	2639	2	13	6	2250	70	32
1692	1120	107	US 1 S ON-RAMP FROM US 421 BYPASS	FREEWAY RAMP	536	1	15	2	1350	30	32
1693	1120	1797	US 421 BYPASS ON/OFF RAMP	FREEWAY RAMP	1202	1	13	6	1700	40	32
1694	1121	1120	US 421 BYPASS ON/OFF RAMP	FREEWAY RAMP	1133	1	13	6	1700	40	32
1695	1122	1118	US 421 BYPASS ON-RAMP FROM COLON RD	FREEWAY RAMP	578	1	12	4	1350	30	32
1696	1123	105	US 1	FREEWAY	906	3	13	10	2250	70	32
1697	1123	1222	US 1	FREEWAY	605	4	13	10	2250	70	32
1698	1123	1796	US 421 BYPASS ON RAMP FROM US 1	FREEWAY RAMP	1299	1	13	4	1700	45	32
1699	1125	158	AVENT FERRY RD	COLLECTOR	4107	1	12	0	1700	40	29

Link #	Up-Stream Node	Down-Stream Node	Roadway Name	Roadway Type	Length (ft.)	No. of Lanes	Lane Width (ft.)	Shoulder Width (ft.)	Saturation Flow Rate (pcphpl)	Free Flow Speed (mph)	Grid Map Number
1700	1126	1125	AVENT FERRY RD	COLLECTOR	2919	1	12	0	1700	40	29
1701	1127	32	NEW HILL RD	COLLECTOR	1944	2	10	0	1750	40	29
1702	1128	1127	NEW HILL RD	COLLECTOR	4423	1	10	0	1700	40	29
1703	1128	1267	GREEN OAKS PKWY	MINOR ARTERIAL	2630	2	12	0	1900	45	29
1704	1129	1128	HOLLY SPRINGS NEW HILL RD	COLLECTOR	4635	1	11	0	1700	40	29
1705	1130	1129	HOLLY SPRINGS NEW HILL RD	COLLECTOR	4200	1	11	0	1700	40	29
1706	1131	1310	NEW HILL HOLLEMAN RD	COLLECTOR	1110	1	11	1	1700	45	29
1707	1132	1312	NEW HILL HOLLEMAN RD	COLLECTOR	2888	1	11	1	1700	50	29
1708	1133	1134	NEW HILL HOLLEMAN RD	COLLECTOR	4496	1	11	1	1750	60	29
1709	1134	1135	AVENT FERRY RD	COLLECTOR	4441	1	12	0	1700	45	29
1710	1135	1126	AVENT FERRY RD	COLLECTOR	4056	1	12	0	1700	45	29
1711	1136	1308	PLANT ACCESS RD	COLLECTOR	1066	1	12	0	1700	40	28
1712	1137	75	NEW HILL HOLLEMAN RD	COLLECTOR	657	1	11	1	1750	50	29
1713	1137	668	NEW HILL HOLLEMAN RD	COLLECTOR	967	1	11	1	1700	50	29
1714	1137	1138	US 1 S ON-RAMP FROM NEW HILL HOLLEMAN RD	FREEWAY RAMP	663	1	14	3	1700	50	29
1715	1138	73	US 1	FREEWAY	1039	2	13	10	2250	75	29
1716	1138	75	US 1 OFF-RAMP	FREEWAY RAMP	423	1	14	3	1750	45	29
1717	1138	76	US 1	FREEWAY	8607	2	13	10	2250	75	28
1718	1145	477	SILVERBERRY RD	COLLECTOR	1436	1	9	0	1700	40	15
1719	1146	617	MORRIS RD	COLLECTOR	3041	1	11	0	1700	40	4
1720	1147	614	VILLAGE WAY	COLLECTOR	1937	1	11	0	1700	40	4
1721	1148	505	BIG WOODS RD	COLLECTOR	2194	1	10	0	1700	40	5
1722	1149	627	MCGHEE RD	LOCAL ROADWAY	1267	1	10	0	1700	40	5
1723	1150	329	HENDRICKS RD	LOCAL ROADWAY	3025	1	10	0	1575	35	9
1724	1151	1934	GREEN LEVEL CHURCH RD	MINOR ARTERIAL	1127	2	12	0	1900	40	6
1725	1152	646	TURNER CREEK RD	COLLECTOR	934	1	10	0	1700	40	10
1726	1153	656	FRYAR CREEK DR	COLLECTOR	871	1	10	0	1350	30	10

Link #	Up-Stream Node	Down-Stream Node	Roadway Name	Roadway Type	Length (ft.)	No. of Lanes	Lane Width (ft.)	Shoulder Width (ft.)	Saturation Flow Rate (pcphpl)	Free Flow Speed (mph)	Grid Map Number
1727	1156	1085	PARK VILLAGE DR	COLLECTOR	857	1	14	0	1700	40	10
1728	1157	1079	MAC ARTHUR DR	COLLECTOR	762	1	13	3	1700	40	10
1729	1158	339	LAURA DUNCAN RD	COLLECTOR	893	1	10	0	1700	40	11
1730	1159	1006	LEGAULT DR	COLLECTOR	686	1	13	0	1700	40	10
1731	1160	1005	LOUIS STEPHENS DR	COLLECTOR	839	1	12	0	1700	45	10
1732	1160	1950	LOUIS STEPHENS DR	COLLECTOR	1068	1	12	0	1700	40	10
1733	1162	1081	DOUBLE EAGLE CT	COLLECTOR	770	1	12	0	1700	40	8
1734	1164	1588	WESTON PKWY	MINOR ARTERIAL	728	2	12	0	1900	45	8
1735	1165	1075	TWO CREEKS RD	COLLECTOR	477	1	11	4	1350	30	19
1736	1166	920	HIGH MEADOW DR	COLLECTOR	914	1	11	4	1350	30	19
1737	1172	864	QUEENSFERRY RD	COLLECTOR	1134	1	10	0	1700	40	19
1738	1174	255	BUCKHORN RD	COLLECTOR	2483	1	10	0	1700	40	34
1739	1175	247	BUCKHORN RD	COLLECTOR	2849	1	10	0	1700	40	34
1740	1176	232	WOMACK RD	COLLECTOR	3576	1	10	0	1700	40	40
1741	1177	1055	RAVEN ROCK RD	COLLECTOR	2239	1	11	0	1700	40	41
1742	1178	1057	JOHN ROSSER RD	COLLECTOR	1229	1	10	0	1700	40	39
1743	1179	908	CAPE FEAR LN	COLLECTOR	2580	1	9	0	1700	40	33
1744	1180	898	CP AND L RD	COLLECTOR	1954	1	9	0	1700	40	27
1745	1181	97	CHRISTIAN CHAPEL CHURCH RD	COLLECTOR	3705	1	11	0	1700	40	28
1746	1183	1136	PLANT ACCESS RD	COLLECTOR	728	1	12	0	1700	40	28
1747	1184	1130	HOLLY SPRINGS NEW HILL RD	COLLECTOR	1408	1	11	0	1700	40	29
1748	1186	779	SALEM RIDGE RD	COLLECTOR	1665	1	10	0	1700	40	30
1749	1187	36	JAMES SLAUGHTER RD	COLLECTOR	1290	1	12	0	1700	40	30
1750	1188	189	BACKBREAK ACRES LN	COLLECTOR	2152	1	8	0	1575	35	35
1751	1189	281	BALD EAGLE DR	COLLECTOR	2218	1	10	0	1700	40	15
1752	1190	472	N PEA RIDGE RD	COLLECTOR	1507	1	10	0	1700	40	15
1753	1191	70	NEW ELAM CHURCH RD	COLLECTOR	2164	1	9	0	1700	40	28
1754	1192	453	DRIVEWAY	COLLECTOR	1732	1	8	0	1350	30	28

Link #	Up-Stream Node	Down-Stream Node	Roadway Name	Roadway Type	Length (ft.)	No. of Lanes	Lane Width (ft.)	Shoulder Width (ft.)	Saturation Flow Rate (pcphpl)	Free Flow Speed (mph)	Grid Map Number
1755	1194	678	HADDON HALL DR	COLLECTOR	2317	1	13	0	1700	40	18
1756	1195	711	BRITTLLEY WAY	LOCAL ROADWAY	508	1	11	0	1350	30	18
1757	1199	1068	GREENWOOD CIRCLE	COLLECTOR	488	1	11	0	1700	40	20
1758	1202	315	OLIVE CHAPEL RD	COLLECTOR	2376	1	12	0	1700	40	17
1759	1203	302	JENKS RD	COLLECTOR	1304	1	10	0	1700	40	17
1760	1204	612	NORTHWOOD HIGH SCHOOL RD	COLLECTOR	735	1	10	0	1700	40	14
1761	1205	603	PITTSBORO ELEM SCHOOL RD	COLLECTOR	531	1	9	0	1700	40	14
1762	1206	605	RECTORY ST	COLLECTOR	452	1	12	4	1575	35	14
1763	1207	604	N SMALL ST	COLLECTOR	354	1	12	4	1575	35	14
1764	1209	39	E ACADEMY ST	COLLECTOR	963	1	12	0	1350	30	36
1765	1209	1501	E ACADEMY ST	COLLECTOR	1279	1	12	0	1750	30	36
1766	1210	763	DRIVEWAY	COLLECTOR	519	1	12	0	1350	30	22
1767	1211	1063	SMITH RD	COLLECTOR	659	1	10	0	1700	40	23
1768	1212	1095	W LAKE RD	COLLECTOR	1085	1	10	2	1700	40	30
1769	1215	260	JORDAN DAM RD	COLLECTOR	1639	1	11	0	1700	40	27
1770	1216	681	CRESCENT GREEN DR	COLLECTOR	794	1	11	2	1750	40	19
1771	1217	719	REGENCY PKWY	MINOR ARTERIAL	801	2	13	0	1750	45	19
1772	1218	718	US 64	MAJOR ARTERIAL	1274	3	13	2	1900	50	19
1773	1218	1335	US 64	MINOR ARTERIAL	602	2	13	2	1900	50	19
1774	1219	693	US 1	FREEWAY	1328	3	12	4	2250	65	19
1775	1219	1218	US 1 OFF-RAMP	FREEWAY RAMP	1594	2	11	15	1750	50	19
1776	1220	60	CENTER ST	COLLECTOR	1684	1	12	0	1750	45	19
1777	1221	1220	WATERFORD GREEN DR	COLLECTOR	427	1	11	0	1750	40	19
1778	1222	100	US 1	FREEWAY	2352	3	13	10	2250	70	32
1779	1222	1123	US 1	FREEWAY	605	3	13	10	2250	70	32
1780	1223	589	US 421 BUS	MINOR ARTERIAL	4868	2	13	2	1900	60	32
1781	1223	1102	US 421 BUS	MINOR ARTERIAL	1778	2	13	2	1900	60	32
1782	1224	1223	MCNEILL RD	COLLECTOR	880	1	10	0	1750	45	32

Link #	Up-Stream Node	Down-Stream Node	Roadway Name	Roadway Type	Length (ft.)	No. of Lanes	Lane Width (ft.)	Shoulder Width (ft.)	Saturation Flow Rate (pcphpl)	Free Flow Speed (mph)	Grid Map Number
1783	1225	553	US 421 BUS	MINOR ARTERIAL	1509	2	13	0	1750	40	38
1784	1225	557	US 421 BUS	MINOR ARTERIAL	1267	2	13	0	1900	40	38
1785	1226	1225	HILL AVE	COLLECTOR	713	1	11	0	1750	40	38
1786	1227	549	US 421 BUS	MINOR ARTERIAL	622	2	13	0	1900	35	38
1787	1227	551	US 421 BUS	MINOR ARTERIAL	405	2	13	0	1750	40	38
1788	1228	1227	WICKER ST	COLLECTOR	1021	1	11	0	1750	35	38
1789	1229	547	US 421 BUS	MINOR ARTERIAL	806	2	13	0	1900	35	38
1790	1229	549	US 421 BUS	MINOR ARTERIAL	700	2	13	0	1900	35	38
1791	1230	1229	WALL ST	COLLECTOR	531	1	11	0	1750	40	38
1792	1231	545	FIELDS DR	COLLECTOR	814	1	11	0	1750	40	38
1793	1232	544	E ROSE ST	COLLECTOR	1082	1	11	0	1750	40	38
1794	1233	543	US 421 BUS	MINOR ARTERIAL	1419	2	13	0	1750	40	38
1795	1233	544	US 421 BUS	MINOR ARTERIAL	1618	2	13	0	1750	40	38
1796	1234	1233	W COURTLAND DR	COLLECTOR	992	1	11	0	1750	40	38
1797	1235	543	S 3RD ST	MINOR ARTERIAL	515	2	11	0	1750	40	38
1798	1236	540	BRAGG ST	MINOR ARTERIAL	867	2	11	0	1750	45	39
1799	1237	855	US 421 BUS	MINOR ARTERIAL	3112	2	13	0	1750	50	39
1800	1237	1062	US 421 BUS	MINOR ARTERIAL	732	2	13	0	1750	50	39
1801	1238	1237	E SEAWELL ST	COLLECTOR	649	1	11	0	1750	40	39
1802	1239	1059	COX MADDOX RD	COLLECTOR	979	1	11	0	1750	45	39
1803	1240	216	US 401	COLLECTOR	1574	1	12	0	1700	50	42
1804	1240	735	US 401	COLLECTOR	4505	1	12	0	1750	60	42
1805	1240	1241	HARNETT CENTRAL RD	COLLECTOR	728	1	11	0	1350	30	42
1806	1241	1242	HARNETT CENTRAL RD	COLLECTOR	972	1	11	0	1700	45	42
1807	1242	1243	HARNETT CENTRAL RD	COLLECTOR	2345	1	11	0	1700	45	42
1808	1243	1244	HARNETT CENTRAL RD	COLLECTOR	2978	1	11	0	1700	45	42
1809	1244	1245	HARNETT CENTRAL RD	COLLECTOR	1946	1	11	0	1700	45	42
1810	1245	1246	HARNETT CENTRAL RD	COLLECTOR	1140	1	11	0	1700	45	42

Link #	Up-Stream Node	Down-Stream Node	Roadway Name	Roadway Type	Length (ft.)	No. of Lanes	Lane Width (ft.)	Shoulder Width (ft.)	Saturation Flow Rate (pcphpl)	Free Flow Speed (mph)	Grid Map Number
1811	1246	1247	HARNETT CENTRAL RD	COLLECTOR	874	1	11	0	1700	45	42
1812	1247	1248	HARNETT CENTRAL RD	COLLECTOR	1006	1	11	0	1750	45	42
1813	1248	977	SR 210	COLLECTOR	945	1	13	1	1700	60	42
1814	1248	978	SR 210	COLLECTOR	3312	1	13	1	1700	60	42
1815	1249	1499	JUDD PKWY	COLLECTOR	1793	1	13	1	1750	50	36
1816	1249	1501	JUDD PKWY	COLLECTOR	1223	1	13	1	1750	50	36
1817	1250	228	US 401	COLLECTOR	812	1	12	0	1750	30	36
1818	1250	229	US 401	COLLECTOR	609	1	12	0	1350	30	36
1819	1251	1250	E VANCE ST	LOCAL ROADWAY	965	1	13	0	1750	30	36
1820	1252	424	BROAD ST	COLLECTOR	990	1	11	0	1750	40	30
1821	1252	1262	BROAD ST	COLLECTOR	918	1	11	0	1700	40	30
1822	1253	424	SR 55	MINOR ARTERIAL	835	1	15	0	1750	25	30
1823	1254	1256	JUDD PKWY	COLLECTOR	2644	1	11	0	1700	45	30
1824	1255	1258	JUDD PKWY	COLLECTOR	593	2	11	0	1750	45	30
1825	1256	1255	JUDD PKWY	COLLECTOR	1757	1	11	0	1700	45	30
1826	1257	1254	JUDD PKWY	COLLECTOR	3287	1	11	0	1750	45	30
1827	1258	1260	E BROAD ST	COLLECTOR	892	1	11	0	1700	40	30
1828	1258	1263	JUDD PKWY	COLLECTOR	164	1	11	0	1700	45	30
1829	1259	1258	E BROAD ST	COLLECTOR	714	1	11	0	1750	40	30
1830	1260	1261	E BROAD ST	COLLECTOR	694	1	11	0	1750	40	30
1831	1261	42	SUNSET LAKE RD	COLLECTOR	878	1	11	0	1750	35	30
1832	1262	1259	E BROAD ST	COLLECTOR	1723	1	11	0	1700	40	30
1833	1263	202	JUDD PKWY	COLLECTOR	513	1	11	0	1750	45	30
1834	1264	435	SR 55	MINOR ARTERIAL	1676	2	13	0	1900	60	30
1835	1264	615	SR 55	MINOR ARTERIAL	8038	2	13	0	1750	60	30
1836	1265	1264	TEAL LAKE DR	COLLECTOR	692	1	11	0	1750	35	30
1837	1266	33	GREEN OAKS PKWY	MINOR ARTERIAL	1159	2	12	0	1750	45	29
1838	1267	1268	GREEN OAKS PKWY	MINOR ARTERIAL	1728	2	12	0	1900	45	29

Link #	Up-Stream Node	Down-Stream Node	Roadway Name	Roadway Type	Length (ft.)	No. of Lanes	Lane Width (ft.)	Shoulder Width (ft.)	Saturation Flow Rate (pcphpl)	Free Flow Speed (mph)	Grid Map Number
1839	1268	1269	GREEN OAKS PKWY	MINOR ARTERIAL	990	2	12	0	1900	45	29
1840	1269	1270	GREEN OAKS PKWY	MINOR ARTERIAL	1182	2	12	0	1900	45	29
1841	1270	1266	GREEN OAKS PKWY	MINOR ARTERIAL	534	2	12	0	1900	45	29
1842	1271	1273	SR 55	MAJOR ARTERIAL	249	3	13	0	1900	50	22
1843	1271	1274	SR 55	COLLECTOR	220	1	13	0	1700	50	22
1844	1272	1271	APEX PEAKWAY	MINOR ARTERIAL	586	2	12	0	1750	55	22
1845	1273	758	SR 55	MINOR ARTERIAL	1050	3	13	0	1750	50	22
1846	1273	1271	SR 55	COLLECTOR	249	1	13	0	1750	50	22
1847	1274	734	SR 55	COLLECTOR	680	1	13	0	1700	50	22
1848	1274	1271	SR 55	MINOR ARTERIAL	216	3	13	0	1750	50	22
1849	1275	757	JAMES ST	COLLECTOR	1263	1	10	0	1575	35	18
1850	1276	294	S SALEM ST	COLLECTOR	1038	1	11	0	1750	35	18
1851	1276	1275	TINGEN RD	COLLECTOR	763	1	10	0	1575	35	18
1852	1277	292	S SALEM ST	COLLECTOR	1889	1	11	0	1700	40	22
1853	1277	1278	APEX PEAKWAY	COLLECTOR	2515	1	12	0	1700	40	22
1854	1278	1277	APEX PEAKWAY	COLLECTOR	2515	1	12	0	1700	40	22
1855	1278	1279	APEX PEAKWAY	COLLECTOR	1585	1	12	0	1700	40	18
1856	1279	1280	APEX PEAKWAY	COLLECTOR	1667	1	12	0	1750	40	18
1857	1280	694	OLIVE CHAPEL RD	COLLECTOR	1596	1	12	0	1750	40	18
1858	1280	710	APEX PEAKWAY	COLLECTOR	1153	1	12	0	1750	40	18
1859	1281	298	N SALEM ST	COLLECTOR	683	1	11	0	1700	40	18
1860	1281	670	N SALEM ST	COLLECTOR	2589	1	11	0	1700	40	18
1861	1281	1991	APEX PEAKWAY	COLLECTOR	879	1	12	4	1700	40	18
1862	1282	694	SR 55	MINOR ARTERIAL	178	1	12	0	1750	50	18
1863	1282	710	SR 55	MINOR ARTERIAL	1171	1	12	0	1750	50	18
1864	1283	684	ZENO RD	COLLECTOR	333	1	12	0	1350	30	18
1865	1284	1285	MORRISVILLE PKWY	MINOR ARTERIAL	512	2	12	1	1750	45	7
1866	1284	1947	MORRISVILLE PKWY	MINOR ARTERIAL	1756	2	12	1	1750	45	7

Link #	Up-Stream Node	Down-Stream Node	Roadway Name	Roadway Type	Length (ft.)	No. of Lanes	Lane Width (ft.)	Shoulder Width (ft.)	Saturation Flow Rate (pcphpl)	Free Flow Speed (mph)	Grid Map Number
1867	1285	332	SR 55	MINOR ARTERIAL	2335	2	12	6	1750	55	7
1868	1285	1284	MORRISVILLE PKWY	MINOR ARTERIAL	512	2	12	1	1900	45	7
1869	1286	667	MCCRIMMON PKWY	COLLECTOR	1238	1	12	4	1750	45	7
1870	1287	1288	SR 55	MINOR ARTERIAL	293	3	12	4	1900	55	7
1871	1287	1291	SR 55	MINOR ARTERIAL	331	2	12	4	1900	55	7
1872	1288	1287	SR 55	MINOR ARTERIAL	292	2	12	4	1750	55	7
1873	1288	1293	SR 55	MINOR ARTERIAL	1208	3	12	4	1750	55	6
1874	1289	1290	SR 540 TOLL	FREEWAY	3884	3	13	8	2250	70	7
1875	1289	1570	SR 540 TOLL	FREEWAY	1075	4	12	8	2250	70	7
1876	1289	1720	SR 540 TOLL OFF-RAMP	FREEWAY RAMP	1141	1	14	3	1700	50	6
1877	1290	1289	SR 540 TOLL	FREEWAY	3884	3	13	8	2250	70	7
1878	1291	1289	SR 540 TOLL ON-RAMP FROM SR 55	FREEWAY RAMP	1454	2	13	5	1900	50	7
1879	1293	1288	SR 55	MINOR ARTERIAL	1208	2	12	4	1900	55	6
1880	1293	1294	SR 55	MINOR ARTERIAL	1490	3	12	4	1750	55	6
1881	1294	1293	SR 55	MINOR ARTERIAL	1490	2	12	4	1750	55	6
1882	1294	1295	OKELLY CHAPEL RD	COLLECTOR	1014	2	11	1	1900	40	6
1883	1294	1595	SR 55	MINOR ARTERIAL	2217	3	12	4	1900	55	6
1884	1295	1294	OKELLY CHAPEL RD	COLLECTOR	1013	2	11	1	1750	40	6
1885	1295	1909	OKELLY CHAPEL RD	COLLECTOR	1994	1	11	1	1750	40	6
1886	1296	269	SR 751	COLLECTOR	1396	1	11	1	1700	60	5
1887	1297	766	FARRINGTON POINT RD	COLLECTOR	4184	1	10	0	1700	60	5
1888	1299	491	JACK BENNETT RD	COLLECTOR	2539	1	12	0	1700	55	4
1889	1300	187	US 15	MINOR ARTERIAL	1343	2	12	2	1900	60	4
1890	1301	1300	ANDREWS STORE RD	COLLECTOR	1536	1	10	0	1750	40	4
1891	1302	611	POWELL PLACE LN	COLLECTOR	559	1	15	0	1750	40	14
1892	1303	1304	COVERT RD	COLLECTOR	466	1	11	0	1350	30	27
1893	1304	516	DEEP RIVER RD	COLLECTOR	1092	1	11	0	1700	50	27

Link #	Up-Stream Node	Down-Stream Node	Roadway Name	Roadway Type	Length (ft.)	No. of Lanes	Lane Width (ft.)	Shoulder Width (ft.)	Saturation Flow Rate (pcphpl)	Free Flow Speed (mph)	Grid Map Number
1894	1305	797	OLD US 1	COLLECTOR	2630	1	11	0	1750	60	27
1895	1306	436	SHEARON-HARRIS RD	COLLECTOR	645	1	11	0	1750	35	28
1896	1307	440	SHEARON-HARRIS RD	COLLECTOR	1517	1	11	0	1700	55	28
1897	1308	446	PLANT ACCESS RD	COLLECTOR	261	1	12	0	1700	40	28
1898	1308	1309	PLANT ACCESS RD	COLLECTOR	131	1	12	0	1700	40	28
1899	1309	442	SHEARON-HARRIS RD	COLLECTOR	2020	1	11	0	1700	55	28
1900	1310	1311	NEW HILL HOLLEMAN RD	COLLECTOR	1275	1	11	1	1700	50	29
1901	1311	1132	NEW HILL HOLLEMAN RD	COLLECTOR	1273	1	11	1	1700	45	29
1902	1312	1133	NEW HILL HOLLEMAN RD	COLLECTOR	1262	1	11	1	1700	50	29
1903	1313	1312	COUNTY PARK DR	LOCAL ROADWAY	558	1	12	0	1125	25	29
1904	1314	1134	BARTLEY HOLLEMAN RD	COLLECTOR	1486	1	10	0	1750	40	29
1905	1315	1314	BARTLEY HOLLEMAN RD	COLLECTOR	1035	1	10	0	1700	40	29
1906	1316	1315	BARTLEY HOLLEMAN RD	COLLECTOR	1323	1	10	0	1700	40	29
1907	1317	1316	BARTLEY HOLLEMAN RD	COLLECTOR	1796	1	10	0	1700	40	29
1908	1318	156	CASS HOLT RD	COLLECTOR	1341	1	12	0	1750	45	29
1909	1319	21	AVENT FERRY RD	COLLECTOR	1041	2	12	0	1750	40	29
1910	1320	1321	SR 55	COLLECTOR	1395	1	12	1	1350	30	29
1911	1321	439	SR 55	COLLECTOR	564	1	12	1	1750	40	29
1912	1322	295	APEX BARBECUE RD	COLLECTOR	1538	1	10	0	1750	45	17
1913	1322	1613	APEX BARBECUE RD	COLLECTOR	1581	1	10	0	1700	45	18
1914	1323	286	OLD US 1	COLLECTOR	10502	1	11	0	1700	50	21
1915	1324	769	MONCURE PITTSBORO RD	COLLECTOR	1107	1	12	0	1700	50	27
1916	1325	1324	MONCURE PITTSBORO RD	COLLECTOR	1982	1	12	0	1700	50	27
1917	1326	1327	SR 87	COLLECTOR	174	1	13	0	900	20	14
1918	1327	1328	SR 87	COLLECTOR	208	1	13	0	900	20	14
1919	1327	1329	SR 87	COLLECTOR	3721	1	10	0	1700	50	14
1920	1328	782	SR 87	COLLECTOR	125	1	13	0	900	20	14
1921	1329	783	SR 87	COLLECTOR	3197	1	10	0	1700	60	14

Link #	Up-Stream Node	Down-Stream Node	Roadway Name	Roadway Type	Length (ft.)	No. of Lanes	Lane Width (ft.)	Shoulder Width (ft.)	Saturation Flow Rate (pcphpl)	Free Flow Speed (mph)	Grid Map Number
1922	1329	1327	SR 87	COLLECTOR	3721	1	10	0	1700	50	14
1923	1330	233	US 64 BUS	COLLECTOR	2622	1	12	0	1700	40	14
1924	1331	1330	FAIRGROUNDS RD	COLLECTOR	606	1	10	0	1750	35	14
1925	1332	1330	US 64 BUS	COLLECTOR	2141	1	12	0	1750	40	14
1926	1333	145	US 64 BUS	COLLECTOR	5884	1	13	1	1700	60	14
1927	1334	119	LAKE PINE DR	COLLECTOR	709	1	14	0	1750	50	19
1928	1335	584	US 64	MINOR ARTERIAL	447	2	13	9	1750	50	19
1929	1335	1218	US 64	MINOR ARTERIAL	602	2	13	2	1750	50	19
1930	1336	357	US 1 OFF-RAMP TO I-40 E	FREEWAY RAMP	710	1	12	4	1700	50	20
1931	1337	1338	SR 540 TOLL	FREEWAY	1556	3	12	8	2250	70	6
1932	1337	1340	SR 540 TOLL	FREEWAY	2869	3	12	8	2250	70	6
1933	1338	1337	SR 540 TOLL	FREEWAY	1556	3	12	8	2250	70	6
1934	1338	1341	SR 540 TOLL	FREEWAY	5378	3	12	8	2250	70	9
1935	1339	1340	SR 540 TOLL	FREEWAY	1563	3	12	8	2250	70	6
1936	1339	1570	SR 540 TOLL	FREEWAY	1910	4	12	8	2250	70	6
1937	1340	1337	SR 540 TOLL	FREEWAY	2874	3	12	8	2250	70	6
1938	1340	1339	SR 540 TOLL	FREEWAY	1562	3	12	8	2250	70	6
1939	1341	1338	SR 540 TOLL	FREEWAY	5378	3	12	8	2250	70	9
1940	1341	1342	SR 540 TOLL	FREEWAY	6859	3	12	8	2250	70	9
1941	1342	1341	SR 540 TOLL	FREEWAY	6859	3	12	8	2250	70	9
1942	1342	1568	SR 540 TOLL	FREEWAY	1893	3	12	8	2250	70	9
1943	1342	1741	SR 540 TOLL OFF-RAMP	FREEWAY RAMP	1645	1	13	3	1700	45	9
1944	1343	1532	SR 540 TOLL	FREEWAY	1454	3	12	8	2250	70	17
1945	1343	1543	SR 540 TOLL	FREEWAY	1083	3	12	8	2250	75	17
1946	1344	1545	SR 540 TOLL	FREEWAY	913	3	12	8	2250	75	17
1947	1344	1546	SR 540 TOLL	FREEWAY	316	3	12	8	2250	75	17
1948	1345	1346	SR 540 TOLL	FREEWAY	3164	3	12	8	2250	75	17
1949	1345	1545	SR 540 TOLL	FREEWAY	3164	3	12	8	2250	75	17

Link #	Up-Stream Node	Down-Stream Node	Roadway Name	Roadway Type	Length (ft.)	No. of Lanes	Lane Width (ft.)	Shoulder Width (ft.)	Saturation Flow Rate (pcphpl)	Free Flow Speed (mph)	Grid Map Number
1950	1346	1345	SR 540 TOLL	FREEWAY	3149	3	12	8	2250	75	17
1951	1346	1551	SR 540 TOLL	FREEWAY	5075	3	12	8	2250	75	22
1952	1347	1551	SR 540 TOLL	FREEWAY	1913	3	12	8	2250	75	22
1953	1347	1554	SR 540 TOLL	FREEWAY	3298	4	12	8	2250	75	22
1954	1347	1730	SR 540 TOLL OFF-RAMP	FREEWAY RAMP	931	1	13	4	1350	30	22
1955	1348	1561	SR 540 TOLL	FREEWAY	1636	3	12	8	2250	75	22
1956	1348	1562	SR 540 TOLL	FREEWAY	381	4	12	8	2250	75	22
1957	1349	1350	LOUIS STEPHENS DR	COLLECTOR	612	1	10	0	1125	25	7
1958	1350	1351	LOUIS STEPHENS DR	COLLECTOR	694	1	10	0	1125	25	7
1959	1351	1354	MCCRIMMON PKWY	MINOR ARTERIAL	1260	2	10	0	1900	40	7
1960	1352	1596	DAVIS DR	MINOR ARTERIAL	1533	2	13	0	1900	50	7
1961	1353	701	LOUIS STEPHENS DR	MINOR ARTERIAL	543	2	13	0	1750	45	7
1962	1354	1352	MCCRIMMON PKWY	MINOR ARTERIAL	701	2	10	0	1750	40	7
1963	1355	427	SR 54	COLLECTOR	1480	1	12	1	1700	50	8
1964	1355	1597	SR 54	COLLECTOR	1490	1	12	1	1700	50	8
1965	1356	1355	AIRPORT BLVD	COLLECTOR	834	1	12	0	1750	40	8
1966	1357	427	SR 54	COLLECTOR	4203	1	12	1	1700	50	8
1967	1357	700	SR 54	COLLECTOR	828	1	12	1	1750	40	8
1968	1358	365	SR 54	COLLECTOR	1562	1	12	1	1700	50	8
1969	1358	700	SR 54	COLLECTOR	1462	1	12	1	1750	40	8
1970	1359	366	SR 54	MINOR ARTERIAL	823	2	12	1	1750	50	8
1971	1359	367	SR 54	MINOR ARTERIAL	624	2	12	1	1750	50	8
1972	1360	368	SR 54	MINOR ARTERIAL	786	2	12	1	1750	50	11
1973	1360	1362	SR 54	MINOR ARTERIAL	500	2	12	1	1900	50	11
1974	1361	1360	MARKET CENTER DR	MINOR ARTERIAL	516	2	12	0	1750	40	11
1975	1362	367	SR 54	MINOR ARTERIAL	511	2	12	1	1750	50	8
1976	1362	1360	SR 54	MINOR ARTERIAL	500	2	12	1	1750	50	11
1977	1363	368	SR 54	MINOR ARTERIAL	698	2	12	1	1750	50	11

Link #	Up-Stream Node	Down-Stream Node	Roadway Name	Roadway Type	Length (ft.)	No. of Lanes	Lane Width (ft.)	Shoulder Width (ft.)	Saturation Flow Rate (pcphpl)	Free Flow Speed (mph)	Grid Map Number
1978	1363	369	SR 54	COLLECTOR	1603	1	12	1	1700	50	11
1979	1364	19	TRINITY RD	COLLECTOR	1271	1	11	0	1750	40	12
1980	1365	14	SR 54	MINOR ARTERIAL	397	2	13	1	1750	55	12
1981	1366	16	I-40	FREEWAY	1431	3	13	8	2250	70	12
1982	1366	17	I-40	FREEWAY	501	3	13	8	2250	70	12
1983	1367	15	SR 54	COLLECTOR	173	1	12	1	1700	40	12
1984	1368	683	YATES MILL POND RD	COLLECTOR	953	1	12	1	1750	50	20
1985	1369	483	TRYON RD	MINOR ARTERIAL	1003	2	13	0	1750	50	20
1986	1369	1405	WALNUT ST	MAJOR ARTERIAL	260	3	13	0	1900	50	20
1987	1370	479	TRYON SPRINGS RD	COLLECTOR	651	1	11	0	1750	30	20
1988	1371	470	NEW WAVERLY PL	MINOR ARTERIAL	536	1	10	0	1750	45	20
1989	1372	532	TEN-TEN RD	COLLECTOR	1307	1	12	0	1700	40	30
1990	1373	528	TEN-TEN RD	COLLECTOR	1047	1	12	0	1700	40	24
1991	1374	454	TEN-TEN RD	MINOR ARTERIAL	738	2	12	0	1750	50	23
1992	1375	447	RELIANCE AVE	COLLECTOR	570	1	10	0	1750	40	23
1993	1376	704	CENTER ST	COLLECTOR	859	1	12	0	1700	40	18
1994	1376	1449	APEX PEAKWAY	COLLECTOR	1766	1	12	4	1750	40	18
1995	1377	1376	SCHIEFFELIN RD	COLLECTOR	2125	1	10	0	1750	40	18
1996	1378	585	CENTER ST	COLLECTOR	985	1	12	0	1750	30	18
1997	1378	703	CENTER ST	COLLECTOR	247	1	12	0	1750	20	18
1998	1379	674	DAVIS DR	COLLECTOR	143	1	11	0	1350	30	18
1999	1380	401	DAVIS DR	COLLECTOR	4922	1	11	0	1700	50	10
2000	1381	354	DAVIS DR	MINOR ARTERIAL	1154	2	13	0	1750	50	10
2001	1381	1382	CORNERSTONE DR	COLLECTOR	1316	1	14	0	1750	45	10
2002	1382	354	HIGH HOUSE RD	MINOR ARTERIAL	1206	2	13	0	1750	50	10
2003	1382	1381	CORNERSTONE DR	COLLECTOR	1316	1	14	0	1750	45	10
2004	1383	360	DAVIS DR	MINOR ARTERIAL	1072	3	13	0	1750	50	7
2005	1384	1383	MORRISVILLE VILLAGE	COLLECTOR	818	1	12	0	1750	30	7

Link #	Up-Stream Node	Down-Stream Node	Roadway Name	Roadway Type	Length (ft.)	No. of Lanes	Lane Width (ft.)	Shoulder Width (ft.)	Saturation Flow Rate (pcphpl)	Free Flow Speed (mph)	Grid Map Number
2006	1385	362	MORRISVILLE CARPENTER RD	COLLECTOR	1613	1	11	0	1700	50	7
2007	1386	360	MORRISVILLE CARPENTER RD	COLLECTOR	283	2	11	0	1750	50	7
2008	1386	701	MORRISVILLE CARPENTER RD	COLLECTOR	4767	1	11	0	1750	50	7
2009	1387	360	DAVIS DR	MINOR ARTERIAL	1019	1	13	0	1750	50	7
2010	1387	1001	DAVIS DR	MINOR ARTERIAL	817	2	13	0	1900	50	7
2011	1388	1387	LAKE GROVE BLVD	COLLECTOR	580	1	11	0	1750	45	7
2012	1389	311	HIGH HOUSE RD	MINOR ARTERIAL	321	2	13	0	1750	50	11
2013	1390	394	DRY AVE	COLLECTOR	621	1	12	0	1750	40	11
2014	1390	695	S HARRISON AVE	COLLECTOR	1463	1	12	0	1750	30	11
2015	1391	430	N HARRISON AVE	MINOR ARTERIAL	1166	2	12	0	1900	50	11
2016	1392	1391	HARRISON POINT DR	COLLECTOR	729	1	12	0	1750	30	11
2017	1393	420	VILLAGE MARKET PL	COLLECTOR	427	1	12	0	1750	30	11
2018	1394	348	SW CARY PKWY	MINOR ARTERIAL	991	2	13	0	1900	50	10
2019	1395	1394	TOWNE VILLAGE DR	COLLECTOR	481	1	12	0	1750	30	10
2020	1396	413	SW CARY PKWY	MINOR ARTERIAL	2181	2	13	0	1900	50	19
2021	1397	1398	SEABROOK AVE	COLLECTOR	213	1	13	0	900	20	20
2022	1397	1590	SEABROOK AVE	COLLECTOR	1185	1	13	0	1350	30	12
2023	1398	1399	SEABROOK AVE	COLLECTOR	215	1	13	0	900	20	20
2024	1399	1067	SEABROOK AVE	COLLECTOR	2087	1	13	0	1350	30	20
2025	1400	417	SE CARY PKWY	MINOR ARTERIAL	389	3	13	0	1750	50	20
2026	1401	34	US 1	FREEWAY	1193	4	13	10	2250	70	20
2027	1401	45	US 1	FREEWAY	709	3	13	10	2250	70	20
2028	1402	34	US 1 N ON-RAMP FROM SE CARY	FREEWAY RAMP	1090	1	14	4	1700	50	20
2029	1402	1403	SE CARY PKWY	MINOR ARTERIAL	370	2	13	0	1900	50	20
2030	1403	720	SE CARY PKWY	MINOR ARTERIAL	903	2	13	0	1900	50	20
2031	1403	1402	SE CARY PKWY	MINOR ARTERIAL	370	1	13	0	1750	50	20
2032	1404	487	SE CARY PKWY	MINOR ARTERIAL	173	1	13	0	1750	50	20

Link #	Up-Stream Node	Down-Stream Node	Roadway Name	Roadway Type	Length (ft.)	No. of Lanes	Lane Width (ft.)	Shoulder Width (ft.)	Saturation Flow Rate (pcphpl)	Free Flow Speed (mph)	Grid Map Number
2033	1404	721	SE CARY PKWY	MINOR ARTERIAL	452	2	13	0	1900	50	20
2034	1405	685	WALNUT ST	MAJOR ARTERIAL	1516	3	13	0	1750	50	20
2035	1405	1369	WALNUT ST	MINOR ARTERIAL	260	2	13	0	1750	50	20
2036	1406	685	WALNUT ST	MAJOR ARTERIAL	916	3	13	0	1750	50	20
2037	1406	1039	WALNUT ST	MAJOR ARTERIAL	1011	3	13	0	1750	50	20
2038	1407	1406	SHOPPING CENTER	COLLECTOR	344	1	12	0	1750	30	20
2039	1408	687	BUCK JONES RD	MINOR ARTERIAL	530	1	12	0	1750	50	20
2040	1409	416	WALNUT ST	MINOR ARTERIAL	937	2	13	0	1750	40	20
2041	1409	687	WALNUT ST	MAJOR ARTERIAL	972	3	13	0	1750	50	20
2042	1410	1409	DONALDSON DR	COLLECTOR	498	1	12	0	1750	35	12
2043	1411	415	WALNUT ST	MINOR ARTERIAL	1016	2	13	0	1750	50	12
2044	1411	1412	WALNUT ST	MINOR ARTERIAL	536	2	13	0	1750	40	12
2045	1412	398	WALNUT ST	MINOR ARTERIAL	1149	2	13	0	1750	40	12
2046	1412	1411	WALNUT ST	MINOR ARTERIAL	537	2	13	0	1900	40	12
2047	1413	1412	CARY TOWNE CENTER	COLLECTOR	592	1	11	0	1750	30	12
2048	1414	708	SE MAYNARD RD	MINOR ARTERIAL	2124	2	13	0	1900	50	12
2049	1415	1414	VILLAGE GREENWAY	LOCAL ROADWAY	417	1	12	0	1750	30	12
2050	1416	12	NE MAYNARD RD	MINOR ARTERIAL	306	1	13	0	1750	50	12
2051	1417	373	EVANS RD	COLLECTOR	583	1	12	0	1750	50	11
2052	1418	376	NW MAYNARD RD	MINOR ARTERIAL	1557	2	13	0	1900	50	11
2053	1419	1418	CARROUSEL LN	LOCAL ROADWAY	864	1	12	0	1750	30	11
2054	1420	699	NW MAYNARD RD	MINOR ARTERIAL	1712	2	13	0	1900	50	11
2055	1421	1420	DOGWOOD FOREST DR	COLLECTOR	659	1	12	0	1750	30	11
2056	1422	1424	SW MAYNARD RD	MINOR ARTERIAL	1417	2	13	0	1750	40	11
2057	1423	1422	WICKLOW DR	COLLECTOR	438	1	12	0	1750	40	11
2058	1424	390	SW MAYNARD RD	MINOR ARTERIAL	971	2	13	0	1750	40	11
2059	1425	1424	KILMAYNE DR	COLLECTOR	525	1	12	0	1750	40	11
2060	1426	391	KILDAIRE FARM RD	COLLECTOR	1400	1	14	3	1700	40	11

Link #	Up-Stream Node	Down-Stream Node	Roadway Name	Roadway Type	Length (ft.)	No. of Lanes	Lane Width (ft.)	Shoulder Width (ft.)	Saturation Flow Rate (pcphpl)	Free Flow Speed (mph)	Grid Map Number
2061	1427	1426	W CORNWALL RD	COLLECTOR	402	1	11	0	1750	35	11
2062	1428	390	KILDAIRE FARM RD	MINOR ARTERIAL	689	2	13	0	1750	40	11
2063	1429	1428	KILMAYNE DR	COLLECTOR	379	1	12	0	1750	40	11
2064	1430	1428	KILDAIRE FARM RD	MINOR ARTERIAL	745	2	13	0	1750	40	11
2065	1431	1430	COMMONWEALTH CT	COLLECTOR	249	1	12	0	1750	30	11
2066	1432	406	KILDAIRE FARM RD	MINOR ARTERIAL	749	2	13	0	1750	40	19
2067	1433	1432	SHANNON OAKS CIRCLE	COLLECTOR	262	1	12	0	1750	30	19
2068	1434	422	KILDAIRE FARM RD	MINOR ARTERIAL	1814	2	13	0	1900	50	19
2069	1435	1434	WAKE MEDICAL DR	COLLECTOR	327	1	11	0	1750	40	19
2070	1436	454	KILDAIRE FARM RD	MINOR ARTERIAL	1855	2	13	0	1750	50	23
2071	1437	1039	DILLARD DR	MINOR ARTERIAL	796	2	13	0	1750	50	20
2072	1438	1437	MEETING ST	COLLECTOR	343	1	12	0	1750	40	20
2073	1439	829	LOCHMERE DR	COLLECTOR	1553	1	11	0	1700	40	20
2074	1440	815	LOCHMERE DR	COLLECTOR	372	1	11	0	1575	35	20
2075	1441	1442	LOCHMERE DR	COLLECTOR	1036	1	11	0	1700	40	20
2076	1442	1440	LOCHMERE DR	COLLECTOR	1189	1	11	0	1700	40	20
2077	1443	459	PENNY RD	COLLECTOR	337	1	12	0	1750	45	23
2078	1443	725	PENNY RD	COLLECTOR	2044	1	12	0	1700	45	23
2079	1444	1092	SIMPKINS RD	COLLECTOR	827	1	12	0	1750	50	25
2080	1445	733	LAKE WHEELER RD	COLLECTOR	1326	1	13	0	1700	45	25
2081	1446	196	US 401	MINOR ARTERIAL	2010	2	13	3	1900	55	31
2082	1446	378	US 401	MINOR ARTERIAL	1310	2	13	3	1900	55	31
2083	1447	1446	BANKS RD	COLLECTOR	7113	1	11	0	1750	40	31
2084	1448	563	EDERLEE DR	MINOR ARTERIAL	683	2	13	0	1750	40	23
2085	1448	1470	EDERLEE DR	MINOR ARTERIAL	1232	2	13	0	1900	45	23
2086	1449	1012	OLD RALEIGH RD	COLLECTOR	3036	1	12	0	1700	50	18
2087	1449	1450	APEX PEAKWAY	COLLECTOR	1621	1	12	4	1750	40	18
2088	1450	120	LAURA DUNCAN RD	COLLECTOR	4118	1	10	0	1750	40	18

Link #	Up-Stream Node	Down-Stream Node	Roadway Name	Roadway Type	Length (ft.)	No. of Lanes	Lane Width (ft.)	Shoulder Width (ft.)	Saturation Flow Rate (pcphpl)	Free Flow Speed (mph)	Grid Map Number
2089	1450	1018	LAURA DUNCAN RD	COLLECTOR	1455	1	10	0	1750	40	18
2090	1451	294	S SALEM ST	COLLECTOR	1423	1	11	0	1750	35	18
2091	1451	703	S SALEM ST	COLLECTOR	813	1	11	0	1750	30	18
2092	1452	1451	E CHATHAM ST	COLLECTOR	701	1	11	0	1750	30	18
2093	1453	305	LAURA DUNCAN RD	COLLECTOR	382	1	10	0	1750	15	19
2094	1453	1021	LAURA DUNCAN RD	COLLECTOR	2337	1	10	0	1700	50	19
2095	1454	1018	HUNTER ST	COLLECTOR	930	1	12	0	1750	40	18
2096	1455	969	SR 210	COLLECTOR	435	1	12	1	1750	40	36
2097	1455	973	SR 210	COLLECTOR	2577	1	12	1	1700	40	36
2098	1456	1455	S BROAD ST E	COLLECTOR	497	1	11	0	1750	30	36
2099	1457	965	SR 55	COLLECTOR	3636	1	13	1	1700	45	36
2100	1457	1691	SR 55	COLLECTOR	2840	1	13	1	1750	50	36
2101	1458	42	US 401	MINOR ARTERIAL	2396	2	12	0	1750	50	30
2102	1458	201	US 401	MINOR ARTERIAL	2136	2	12	0	1750	50	30
2103	1459	1458	LAKESHORE COMMONS AVE	COLLECTOR	898	1	10	0	1750	40	30
2104	1460	1459	LAKESHORE COMMONS AVE	COLLECTOR	960	1	10	0	1700	40	30
2105	1461	46	SUNSET LAKE RD	COLLECTOR	901	1	11	0	1700	40	30
2106	1462	1461	SUNSET LAKE RD	COLLECTOR	2023	1	11	0	1700	50	30
2107	1463	50	SUNSET LAKE RD	COLLECTOR	4257	1	11	0	1700	40	30
2108	1463	51	SUNSET LAKE RD	COLLECTOR	1423	1	11	0	1700	40	30
2109	1463	1464	OPTIMIST FARM RD	COLLECTOR	993	1	12	0	1700	40	30
2110	1464	1463	OPTIMIST FARM RD	COLLECTOR	993	1	12	0	1750	40	30
2111	1464	1617	OPTIMIST FARM RD	COLLECTOR	3717	1	12	0	1700	40	30
2112	1465	1217	REGENCY PKWY	MINOR ARTERIAL	842	2	13	0	1900	45	19
2113	1466	1465	REGENCY PKWY	MINOR ARTERIAL	625	2	13	0	1750	45	19
2114	1467	1466	REGENCY PKWY	MINOR ARTERIAL	1005	2	13	0	1900	45	19
2115	1468	1467	EDERLEE DR	MINOR ARTERIAL	1255	2	13	0	1750	45	19
2116	1469	1468	EDERLEE DR	MINOR ARTERIAL	1108	2	13	0	1900	45	19

Link #	Up-Stream Node	Down-Stream Node	Roadway Name	Roadway Type	Length (ft.)	No. of Lanes	Lane Width (ft.)	Shoulder Width (ft.)	Saturation Flow Rate (pcphpl)	Free Flow Speed (mph)	Grid Map Number
2117	1470	1469	EDERLEE DR	MINOR ARTERIAL	1590	2	13	0	1900	45	23
2118	1471	1465	REGENCY FOREST DR	COLLECTOR	530	1	12	0	1750	40	19
2119	1472	1467	REGENCY PKWY	MINOR ARTERIAL	918	2	13	0	1750	45	19
2120	1473	1051	MAUDE STEWART RD	COLLECTOR	2093	1	12	0	1700	50	36
2121	1474	987	KENNEBEC RD	COLLECTOR	2224	1	11	0	1700	50	36
2122	1475	1476	PURFOY RD	COLLECTOR	752	1	12	1	1700	50	36
2123	1476	169	PURFOY RD	COLLECTOR	1843	1	12	1	1700	50	36
2124	1476	1875	HOLLAND RD	COLLECTOR	797	1	12	0	1700	45	36
2125	1477	1478	PURFOY RD	COLLECTOR	1272	1	11	1	1700	50	36
2126	1478	165	PURFOY RD	COLLECTOR	993	1	11	1	1700	40	36
2127	1479	162	PURFOY RD	COLLECTOR	6642	1	10	1	1700	55	36
2128	1480	882	SR 42	COLLECTOR	1028	1	12	1	1700	50	35
2129	1481	1482	SR 42	MINOR ARTERIAL	776	2	12	1	1900	50	39
2130	1481	1770	US 421 BYPASS ON RAMP FROM SR 42	FREEWAY RAMP	416	1	12	4	1350	30	39
2131	1482	854	SR 42	COLLECTOR	2698	1	12	1	1700	50	39
2132	1483	856	PARKING LOT	COLLECTOR	569	1	11	0	1750	30	39
2133	1484	1481	US 421 BYPASS OFF-RAMP	FREEWAY RAMP	439	1	13	4	1750	45	39
2134	1485	1118	US 421 BYPASS	FREEWAY	1331	2	13	6	2250	70	32
2135	1485	1119	US 421 BYPASS	FREEWAY	2638	2	13	6	2250	70	32
2136	1486	992	US 1 BUS	COLLECTOR	3136	1	12	1	1700	50	32
2137	1486	1684	US 1 BUS	COLLECTOR	138	1	12	1	900	20	32
2138	1487	992	US 1 BUS	COLLECTOR	2731	1	12	1	1700	50	32
2139	1487	994	US 1 BUS	COLLECTOR	6041	1	12	1	1700	40	32
2140	1488	1487	MCNEILL RD	COLLECTOR	739	1	12	0	1750	45	32
2141	1489	1491	US 1 BUS	MINOR ARTERIAL	376	2	11	0	1750	30	38
2142	1490	1489	N MOORE ST	LOCAL ROADWAY	446	1	10	0	1750	30	38
2143	1491	551	US 1 BUS	MINOR ARTERIAL	572	2	11	0	1750	30	38

Link #	Up-Stream Node	Down-Stream Node	Roadway Name	Roadway Type	Length (ft.)	No. of Lanes	Lane Width (ft.)	Shoulder Width (ft.)	Saturation Flow Rate (pcphpl)	Free Flow Speed (mph)	Grid Map Number
2144	1492	1491	S STEELE ST	LOCAL ROADWAY	455	1	10	0	1750	30	38
2145	1493	855	SR 42	COLLECTOR	1578	1	12	1	1750	40	39
2146	1494	1493	NASH ST	COLLECTOR	657	1	11	0	1750	45	39
2147	1495	909	LOWER RIVER RD	COLLECTOR	1043	1	10	0	1700	45	33
2148	1496	1497	HONEYCUTT RD	COLLECTOR	1367	1	10	0	1700	40	29
2149	1497	142	PINEY GROVE WILBON RD	COLLECTOR	3730	1	11	0	1700	50	29
2150	1497	147	PINEY GROVE WILBON RD	COLLECTOR	790	1	11	0	1700	50	29
2151	1498	1099	ANGIER RD	COLLECTOR	3178	1	12	0	1750	50	36
2152	1498	1872	ANGIER RD	COLLECTOR	2049	1	10	0	1700	40	36
2153	1499	1099	JUDD PKWY	COLLECTOR	1511	1	13	1	1750	50	36
2154	1499	1249	JUDD PKWY	COLLECTOR	1793	1	13	1	1700	50	36
2155	1499	1500	HOLLAND RD	COLLECTOR	2431	1	12	0	1700	40	36
2156	1500	1476	HOLLAND RD	COLLECTOR	2910	1	12	0	1700	45	36
2157	1500	1499	HOLLAND RD	COLLECTOR	2431	1	12	0	1750	40	36
2158	1501	1249	JUDD PKWY	COLLECTOR	1221	1	13	1	1700	50	36
2159	1501	1502	JUDD PKWY	COLLECTOR	1868	1	13	1	1750	40	36
2160	1502	1501	JUDD PKWY	COLLECTOR	1871	1	13	1	1750	40	36
2161	1502	1575	JUDD PKWY	COLLECTOR	709	1	13	1	1700	40	36
2162	1503	1502	OLD HONEYCUTT RD	COLLECTOR	611	1	11	0	1750	40	36
2163	1504	228	E ACADEMY ST	COLLECTOR	488	1	12	0	1750	30	36
2164	1504	957	E ACADEMY ST	COLLECTOR	1555	1	12	0	1750	30	36
2165	1505	1504	N FUQUAY AVE	LOCAL ROADWAY	541	1	12	0	1750	30	36
2166	1506	61	DONNY BROOK RD	COLLECTOR	3572	1	12	0	1750	45	31
2167	1506	548	LAKE WHEELER RD	COLLECTOR	283	1	13	0	1700	55	31
2168	1507	548	OPTIMIST FARM RD	COLLECTOR	1782	1	12	0	1575	35	31
2169	1508	1507	OPTIMIST FARM RD	COLLECTOR	1168	1	12	0	1700	45	30
2170	1509	1096	OPTIMIST FARM RD	COLLECTOR	3594	1	12	0	1750	40	30
2171	1510	1096	W LAKE RD	COLLECTOR	563	1	10	2	1750	40	30

Link #	Up-Stream Node	Down-Stream Node	Roadway Name	Roadway Type	Length (ft.)	No. of Lanes	Lane Width (ft.)	Shoulder Width (ft.)	Saturation Flow Rate (pcphpl)	Free Flow Speed (mph)	Grid Map Number
2172	1510	1511	W LAKE RD	COLLECTOR	1788	1	10	2	1750	40	30
2173	1511	1212	W LAKE RD	COLLECTOR	1534	1	10	2	1700	40	30
2174	1511	1510	W LAKE RD	COLLECTOR	1791	2	10	2	1900	40	30
2175	1512	1514	CHARLOTTE AVE	COLLECTOR	904	2	11	0	1750	40	38
2176	1513	1512	N 3RD ST	LOCAL ROADWAY	624	1	12	0	1750	30	38
2177	1514	554	CHARLOTTE AVE	MINOR ARTERIAL	756	2	11	0	1900	40	38
2178	1515	1514	N 1ST ST	LOCAL ROADWAY	590	1	10	0	1750	30	38
2179	1516	558	CHARLOTTE AVE	COLLECTOR	424	2	11	0	1750	40	38
2180	1517	559	N 7TH ST	MINOR ARTERIAL	420	2	12	0	1750	40	38
2181	1518	558	N 7TH ST	COLLECTOR	193	1	12	0	1750	40	38
2182	1519	559	N 7TH ST	COLLECTOR	137	1	12	0	1750	40	38
2183	1520	943	BRICKYARD RD	COLLECTOR	2377	1	10	0	1700	40	32
2184	1521	347	CARPENTER FIRE STATION RD	MINOR ARTERIAL	1114	2	12	0	1750	40	6
2185	1522	687	WALNUT ST	MAJOR ARTERIAL	956	3	13	0	1750	40	20
2186	1522	1110	US 1 N ON-RAMP FROM WALNUT ST	FREEWAY RAMP	539	1	15	0	1350	30	20
2187	1522	1524	WALNUT ST	MAJOR ARTERIAL	197	3	13	0	1900	50	20
2188	1523	999	MEETING ST	COLLECTOR	189	1	12	0	1750	40	20
2189	1524	999	WALNUT ST	MAJOR ARTERIAL	687	4	13	0	1750	50	20
2190	1524	1522	WALNUT ST	MAJOR ARTERIAL	197	2	13	0	1750	50	20
2191	1525	688	CAITBOO AVE	MINOR ARTERIAL	301	1	12	0	1750	45	20
2192	1526	998	CROSSROADS BLVD	MINOR ARTERIAL	420	1	12	0	1750	50	20
2193	1527	411	LAKE PINE DR	COLLECTOR	306	1	13	0	1750	45	19
2194	1527	1014	LAKE PINE DR	COLLECTOR	1200	1	13	0	1700	45	19
2195	1528	113	US 15	COLLECTOR	215	1	12	2	1700	60	14
2196	1528	175	US 15	MINOR ARTERIAL	1701	2	12	2	1750	60	14
2197	1529	1563	SR 540 TOLL	FREEWAY	3172	3	12	8	2250	70	22
2198	1529	1567	SR 540 TOLL	FREEWAY	3070	3	12	8	2250	70	22

Link #	Up-Stream Node	Down-Stream Node	Roadway Name	Roadway Type	Length (ft.)	No. of Lanes	Lane Width (ft.)	Shoulder Width (ft.)	Saturation Flow Rate (pcphpl)	Free Flow Speed (mph)	Grid Map Number
2199	1530	1565	SR 540 TOLL	FREEWAY	1834	1	12	8	2250	50	22
2200	1530	1567	SR 540 TOLL	FREEWAY	581	3	12	8	2250	70	22
2201	1530	1709	SR 540 TOLL OFF-RAMP	FREEWAY RAMP	1101	1	13	3	1700	45	22
2202	1531	1532	SR 540 TOLL	FREEWAY	3616	3	12	8	2250	70	9
2203	1531	1533	SR 540 TOLL	FREEWAY	4193	3	12	8	2250	70	10
2204	1532	1343	SR 540 TOLL	FREEWAY	1455	3	12	8	2250	70	17
2205	1532	1531	SR 540 TOLL	FREEWAY	3616	3	12	8	2250	70	9
2206	1533	1568	SR 540 TOLL	FREEWAY	739	4	12	8	2250	70	9
2207	1533	1740	SR 540 TOLL	FREEWAY	1288	4	12	8	2250	70	10
2208	1534	323	GREEN LEVEL WEST RD	MINOR ARTERIAL	443	2	12	0	1750	50	9
2209	1535	321	GREEN LEVEL WEST RD	COLLECTOR	2406	1	12	0	1700	50	10
2210	1535	322	GREEN LEVEL WEST RD	MINOR ARTERIAL	457	1	12	0	1750	50	10
2211	1537	1974	GREEN LEVEL CHURCH RD	COLLECTOR	2053	1	12	0	1750	40	17
2212	1538	1540	KELLY RD LOOP	COLLECTOR	604	1	12	4	1350	30	17
2213	1538	1541	KELLY RD	COLLECTOR	1363	1	12	4	1750	50	17
2214	1539	433	US 64	MINOR ARTERIAL	7297	2	13	9	1900	60	17
2215	1539	1544	US 64	MINOR ARTERIAL	739	2	13	9	1900	60	17
2216	1540	1538	KELLY RD LOOP	COLLECTOR	601	1	12	4	1750	30	17
2217	1540	1539	KELLY RD LOOP	COLLECTOR	464	1	12	4	1350	30	17
2218	1541	299	KELLY RD	COLLECTOR	3677	1	10	0	1750	50	17
2219	1541	1542	KELLY RD LOOP	COLLECTOR	502	1	12	4	1350	30	17
2220	1542	1539	KELLY RD LOOP	COLLECTOR	436	1	12	4	1350	30	17
2221	1542	1541	KELLY RD LOOP	COLLECTOR	496	1	12	4	1750	30	17
2222	1543	1343	SR 540 TOLL	FREEWAY	1083	4	12	8	2250	75	17
2223	1543	1546	SR 540 TOLL	FREEWAY	2428	3	12	8	2250	75	17
2224	1544	1539	US 64	MINOR ARTERIAL	739	2	13	9	1900	60	17
2225	1544	1726	US 64	MINOR ARTERIAL	1151	2	13	9	1900	60	17
2226	1544	1733	SR 540 TOLL ON-RAMP FROM	FREEWAY RAMP	779	1	13	3	1700	45	17

Link #	Up-Stream Node	Down-Stream Node	Roadway Name	Roadway Type	Length (ft.)	No. of Lanes	Lane Width (ft.)	Shoulder Width (ft.)	Saturation Flow Rate (pcphpl)	Free Flow Speed (mph)	Grid Map Number
			US 64 E								
2227	1545	1344	SR 540 TOLL	FREEWAY	913	3	12	8	2250	75	17
2228	1545	1731	SR 540 TOLL	FREEWAY	867	3	12	8	2250	75	17
2229	1546	1344	SR 540 TOLL	FREEWAY	316	3	12	8	2250	75	17
2230	1546	1543	SR 540 TOLL	FREEWAY	2428	3	12	8	2250	75	17
2231	1549	1550	OLD US 1	COLLECTOR	1438	1	11	0	1750	55	22
2232	1549	1698	SR 540 TOLL ON-RAMP FROM OLD US 1	FREEWAY RAMP	757	1	13	3	1350	30	22
2233	1550	705	OLD US 1	COLLECTOR	501	1	11	0	1700	55	22
2234	1550	1551	SR 540 TOLL ON-RAMP FROM OLD US 1	FREEWAY RAMP	1737	1	13	3	1700	45	22
2235	1551	1346	SR 540 TOLL	FREEWAY	5074	3	12	8	2250	75	22
2236	1551	1347	SR 540 TOLL	FREEWAY	1913	3	12	8	2250	75	22
2237	1551	1549	SR 540 TOLL OFF-RAMP	FREEWAY RAMP	2396	1	13	4	1750	45	22
2238	1552	71	US 1	FREEWAY	7391	2	13	10	2250	70	22
2239	1552	582	US 1	FREEWAY	856	3	13	10	2250	75	22
2240	1553	1348	SR 540 TOLL ON-RAMP FROM US 1 N	FREEWAY RAMP	1272	1	13	3	1700	45	22
2241	1553	1556	SR 540 TOLL ON-RAMP FROM US 1 N	FREEWAY RAMP	2363	2	13	3	1900	30	22
2242	1554	1715	SR 540 TOLL	FREEWAY	1265	4	12	8	2250	75	22
2243	1554	1728	SR 540 TOLL	FREEWAY	1981	5	12	8	2250	75	22
2244	1555	1557	US 1	FREEWAY	1777	2	13	10	2250	75	22
2245	1555	1558	SR 540 TOLL ON-RAMP FROM US 1 N	FREEWAY RAMP	359	2	13	3	1900	45	22
2246	1555	1560	US 1	FREEWAY	1290	2	13	10	2250	75	22
2247	1556	1559	SR 540 TOLL ON-RAMP FROM US 1 S	FREEWAY RAMP	762	3	13	3	1900	45	22
2248	1557	72	US 1	FREEWAY	6480	2	13	10	2250	75	21

Link #	Up-Stream Node	Down-Stream Node	Roadway Name	Roadway Type	Length (ft.)	No. of Lanes	Lane Width (ft.)	Shoulder Width (ft.)	Saturation Flow Rate (pcphpl)	Free Flow Speed (mph)	Grid Map Number
2249	1557	1555	US 1	FREEWAY	1777	3	13	10	2250	75	22
2250	1558	1553	SR 540 TOLL ON-RAMP FROM US 1 N	FREEWAY RAMP	622	3	13	3	1900	45	22
2251	1559	1554	SR 540 TOLL ON-RAMP FROM US 1 S	FREEWAY RAMP	597	2	13	3	1900	45	22
2252	1560	582	US 1	FREEWAY	2028	3	13	10	2250	75	22
2253	1560	1555	US 1	FREEWAY	1290	2	13	10	2250	75	22
2254	1561	1715	SR 540 TOLL	FREEWAY	397	3	12	8	2250	75	22
2255	1561	1716	SR 540 TOLL	FREEWAY	515	5	12	8	2250	75	22
2256	1562	1348	SR 540 TOLL	FREEWAY	381	3	12	8	2250	75	22
2257	1562	1563	SR 540 TOLL	FREEWAY	538	4	12	8	2250	75	22
2258	1562	1713	US 1 ON RAMP FROM SR 540 TOLL	FREEWAY RAMP	1031	1	14	14	1700	45	22
2259	1563	1529	SR 540 TOLL	FREEWAY	3178	3	12	8	2250	70	22
2260	1563	1562	SR 540 TOLL	FREEWAY	538	3	12	8	2250	75	22
2261	1564	28	SR 55 BYPASS	MINOR ARTERIAL	1834	2	13	3	1750	60	22
2262	1564	1530	SR 540 TOLL ON-RAMP FROM SR 55 BYPASS	FREEWAY RAMP	1945	1	13	3	1700	45	22
2263	1564	1566	SR 55 BYPASS	MINOR ARTERIAL	1232	2	13	3	1900	60	22
2264	1564	1727	SR 540 TOLL ON-RAMP FROM SR 55 BYPASS	FREEWAY RAMP	731	1	13	3	1350	30	22
2265	1565	1530	SR 540 TOLL	FREEWAY	1834	2	12	8	2250	50	22
2266	1565	1707	SR 540 TOLL OFF-RAMP	FREEWAY RAMP	1421	1	13	3	1350	30	22
2267	1566	1707	SR 55 BYPASS	MINOR ARTERIAL	152	2	13	3	1900	60	22
2268	1566	1708	SR 55 BYPASS	MINOR ARTERIAL	242	2	13	3	1900	60	22
2269	1567	1529	SR 540 TOLL	FREEWAY	3070	3	12	8	2250	70	22
2270	1567	1530	SR 540 TOLL	FREEWAY	581	2	12	8	2250	70	22
2271	1568	1342	SR 540 TOLL	FREEWAY	1893	3	12	8	2250	70	9
2272	1568	1533	SR 540 TOLL	FREEWAY	739	4	12	8	2250	70	9

Link #	Up-Stream Node	Down-Stream Node	Roadway Name	Roadway Type	Length (ft.)	No. of Lanes	Lane Width (ft.)	Shoulder Width (ft.)	Saturation Flow Rate (pcphpl)	Free Flow Speed (mph)	Grid Map Number
2273	1568	1722	SR 540 TOLL OFF-RAMP	FREEWAY RAMP	605	1	13	3	1350	30	9
2274	1569	1287	SR 55	MINOR ARTERIAL	265	3	12	4	1750	55	7
2275	1570	1288	SR 540 TOLL OFF-RAMP	FREEWAY RAMP	1120	1	13	4	1350	30	7
2276	1570	1289	SR 540 TOLL	FREEWAY	1075	4	12	8	2250	70	7
2277	1570	1339	SR 540 TOLL	FREEWAY	1908	3	12	8	2250	70	6
2278	1571	319	S HUGHES ST	COLLECTOR	471	1	10	0	1750	35	18
2279	1572	35	RALPH STEVENS RD	COLLECTOR	774	2	12	0	1750	40	29
2280	1573	1033	SR 55	MINOR ARTERIAL	287	1	13	0	1750	40	30
2281	1574	202	US 401	MINOR ARTERIAL	1225	2	12	0	1750	40	30
2282	1574	1958	US 401	COLLECTOR	2387	2	12	0	1900	40	30
2283	1575	202	JUDD PKWY	COLLECTOR	426	1	13	1	1750	40	30
2284	1575	1502	JUDD PKWY	COLLECTOR	709	1	13	1	1750	40	36
2285	1576	42	US 401	MINOR ARTERIAL	718	2	12	0	1750	45	30
2286	1576	202	US 401	MINOR ARTERIAL	751	2	12	0	1750	45	30
2287	1577	1576	SHOPPING CENTER	LOCAL ROADWAY	362	1	10	0	1750	30	30
2288	1578	399	SR 55	MINOR ARTERIAL	2174	2	12	0	1750	55	10
2289	1579	57	HILLTOP NEEDMORE RD	COLLECTOR	846	1	12	0	1700	45	30
2290	1580	903	LOWER MONCURE RD	COLLECTOR	313	1	10	0	1750	55	27
2291	1580	913	LOWER MONCURE RD	COLLECTOR	6952	1	10	0	1700	55	27
2292	1581	96	BUCKHORN RD	COLLECTOR	3755	1	10	0	1700	40	39
2293	1582	123	US 64	FREEWAY	1050	2	13	2	2250	60	18
2294	1582	671	US 64 E OFF-RAMP	FREEWAY RAMP	468	1	15	4	1750	50	18
2295	1582	672	US 64	FREEWAY	1112	2	13	2	2250	60	18
2296	1583	60	US 1 N OFF-RAMP	FREEWAY RAMP	657	1	13	5	1750	30	19
2297	1583	691	US 1	FREEWAY	3285	2	13	10	2250	70	23
2298	1583	692	US 1	FREEWAY	667	2	13	10	2250	70	19
2299	1584	127	US 64	MINOR ARTERIAL	1361	2	13	0	1900	60	18
2300	1584	325	US 64 OFF-RAMP	FREEWAY RAMP	913	1	12	4	1750	45	18

Link #	Up-Stream Node	Down-Stream Node	Roadway Name	Roadway Type	Length (ft.)	No. of Lanes	Lane Width (ft.)	Shoulder Width (ft.)	Saturation Flow Rate (pcphpl)	Free Flow Speed (mph)	Grid Map Number
2301	1584	1593	US 64	MINOR ARTERIAL	747	2	13	0	1900	60	18
2302	1585	741	PEA RIDGE RD	COLLECTOR	1107	1	11	0	1700	50	28
2303	1585	742	PEA RIDGE RD	COLLECTOR	180	1	11	0	1750	50	28
2304	1586	1297	FARRINGTON POINT RD	COLLECTOR	1298	1	10	0	1700	45	5
2305	1587	393	KILDAIRE FARM RD	COLLECTOR	738	1	14	3	1750	40	11
2306	1588	1589	WESTON PKWY	MINOR ARTERIAL	1048	2	12	0	1900	45	8
2307	1589	1705	WESTON PKWY	MINOR ARTERIAL	1250	2	12	0	1425	45	8
2308	1590	403	SEABROOK AVE	COLLECTOR	606	1	13	0	1350	30	12
2309	1591	419	HAMPTON VALLEY RD	COLLECTOR	1421	1	13	0	1750	40	20
2310	1591	1592	HAMPTON VALLEY RD	COLLECTOR	1320	1	13	0	1350	30	20
2311	1591	1987	FARMINGTON WOODS DR	COLLECTOR	580	1	10	0	1350	30	20
2312	1592	621	HAMPTON VALLEY RD	COLLECTOR	895	1	13	0	1350	30	12
2313	1592	1591	HAMPTON VALLEY RD	COLLECTOR	1320	1	13	0	1350	30	20
2314	1593	126	US 64	MINOR ARTERIAL	948	2	13	0	1900	60	18
2315	1593	1584	US 64	MINOR ARTERIAL	747	2	13	0	1900	60	18
2316	1594	1593	US 64 W ON-RAMP FROM SR 55	FREEWAY RAMP	337	1	13	3	1350	30	18
2317	1595	1703	SR 55	MAJOR ARTERIAL	1256	3	12	4	1425	55	2
2318	1596	1704	DAVIS DR	MINOR ARTERIAL	669	2	13	0	1425	50	7
2319	1598	1024	US 64	MINOR ARTERIAL	7374	2	14	2	1900	60	16
2320	1598	1025	US 64	MINOR ARTERIAL	2663	2	14	2	1900	60	15
2321	1599	344	BOND LAKE DR	LOCAL ROADWAY	1130	1	12	0	1750	35	11
2322	1600	1598	PARKERS CREEK RECREATION RD	COLLECTOR	637	1	10	0	1575	35	16
2323	1601	1600	PARKERS CREEK RECREATION RD	COLLECTOR	480	1	10	0	1575	35	16
2324	1604	1598	SEAFORTH RECREATION AREA	COLLECTOR	1131	1	10	0	1575	35	16
2325	1605	1604	SEAFORTH RECREATION AREA	COLLECTOR	2978	1	10	0	1575	35	16
2326	1606	305	LAURA DUNCAN RD	COLLECTOR	843	1	10	0	1750	40	19

Link #	Up-Stream Node	Down-Stream Node	Roadway Name	Roadway Type	Length (ft.)	No. of Lanes	Lane Width (ft.)	Shoulder Width (ft.)	Saturation Flow Rate (pcphpl)	Free Flow Speed (mph)	Grid Map Number
2327	1606	339	LAURA DUNCAN RD	COLLECTOR	1650	1	10	0	1700	40	19
2328	1607	1606	SMOKEMONT DR	LOCAL ROADWAY	966	1	10	0	1350	30	19
2329	1608	33	W BALLENTINE ST	LOCAL ROADWAY	998	1	10	0	1750	35	29
2330	1609	1610	APEX BARBECUE RD	COLLECTOR	1826	1	10	0	1700	45	21
2331	1610	1611	APEX BARBECUE RD	COLLECTOR	1208	1	10	0	1700	45	21
2332	1611	1612	APEX BARBECUE RD	COLLECTOR	1295	1	10	0	1700	45	17
2333	1612	314	APEX BARBECUE RD	COLLECTOR	1350	1	10	0	1700	45	17
2334	1613	1614	APEX BARBECUE RD	COLLECTOR	1498	1	10	0	1700	45	18
2335	1614	291	APEX BARBECUE RD	COLLECTOR	1396	1	10	0	1750	45	22
2336	1615	685	MACEDONIA LAKE DR	LOCAL ROADWAY	434	1	12	0	1750	30	20
2337	1616	41	AIR PARK RD	COLLECTOR	6242	1	11	0	1750	45	31
2338	1617	1509	OPTIMIST FARM RD	COLLECTOR	2326	1	12	0	1700	40	30
2339	1618	595	OAK PARK RD	LOCAL ROADWAY	826	1	12	4	1750	30	32
2340	1619	1011	MACKENAN DR	COLLECTOR	423	1	12	4	1750	35	19
2341	1620	584	EDINBURGH S DR	COLLECTOR	452	1	12	4	1750	35	19
2342	1621	408	HIGH HOUSE RD	MINOR ARTERIAL	2145	2	13	0	1750	50	10
2343	1622	1621	LILLY RIDGE RD	COLLECTOR	328	1	12	4	1750	40	10
2344	1623	1621	MAGNESS DR	COLLECTOR	386	1	12	4	1750	40	10
2345	1624	21	AVENT FERRY RD	COLLECTOR	1362	1	12	4	1750	40	29
2346	1625	1264	RALPH STEVENS RD	COLLECTOR	712	1	12	4	1750	40	30
2347	1626	441	CAYMAN AVE	COLLECTOR	1438	1	12	4	1750	35	29
2348	1627	443	SR 55	COLLECTOR	3077	1	12	1	1700	50	29
2349	1628	1627	ANCHOR CREEK WAY	COLLECTOR	1643	1	12	4	1750	35	29
2350	1629	716	HOLLY SPRINGS RD	COLLECTOR	1169	1	12	0	1700	45	30
2351	1630	1629	SUNSET FAIRWAYS DR	LOCAL ROADWAY	886	1	12	0	1575	35	30
2352	1631	1629	SUNSET FAIRWAYS DR	LOCAL ROADWAY	617	1	12	0	1575	35	30
2353	1633	1058	US 421	COLLECTOR	2465	1	13	2	1750	60	39
2354	1633	1747	US 421	MINOR ARTERIAL	1095	2	13	2	1900	60	39

Link #	Up-Stream Node	Down-Stream Node	Roadway Name	Roadway Type	Length (ft.)	No. of Lanes	Lane Width (ft.)	Shoulder Width (ft.)	Saturation Flow Rate (pcphpl)	Free Flow Speed (mph)	Grid Map Number
2355	1633	1767	US 421 BYPASS ON RAMP FROM US 421	FREEWAY RAMP	680	1	14	10	1700	45	39
2356	1635	1637	RIGGSBEE FARM DR	COLLECTOR	554	1	12	4	1750	35	10
2357	1636	1637	MAGNESS DR	COLLECTOR	776	1	12	4	1750	35	10
2358	1637	423	DAVIS DR	MINOR ARTERIAL	2706	2	13	0	1750	50	10
2359	1638	1640	VALLEYSTONE DR	COLLECTOR	342	1	12	4	1750	35	10
2360	1639	1640	BRADFORD GREEN SQUARE	COLLECTOR	372	1	12	4	1750	35	10
2361	1640	1637	DAVIS DR	MINOR ARTERIAL	797	2	13	0	1750	50	10
2362	1641	324	GREEN LEVEL WEST RD	COLLECTOR	585	1	12	4	1700	45	9
2363	1642	328	GREEN LEVEL CHURCH RD	COLLECTOR	1073	1	12	0	1700	50	9
2364	1642	1641	GREEN LEVEL WEST RD	COLLECTOR	657	1	12	4	1700	45	9
2365	1643	1642	GREEN LEVEL WEST RD	COLLECTOR	773	1	12	4	1700	45	9
2366	1644	1643	GREEN LEVEL WEST RD	COLLECTOR	1777	1	12	4	1700	40	9
2367	1645	1644	GREEN LEVEL WEST RD	COLLECTOR	2548	1	12	4	1700	40	9
2368	1646	1645	GREEN LEVEL WEST RD	COLLECTOR	2550	1	12	4	1700	40	9
2369	1646	1647	GREEN LEVEL WEST RD	COLLECTOR	641	1	12	4	1700	40	9
2370	1647	1648	GREEN LEVEL WEST RD	COLLECTOR	1846	1	12	4	1700	40	9
2371	1648	1649	GREEN LEVEL WEST RD	COLLECTOR	639	1	12	4	1700	40	9
2372	1649	1650	GREEN LEVEL WEST RD	COLLECTOR	973	1	12	4	1700	40	5
2373	1650	1651	GREEN LEVEL WEST RD	COLLECTOR	3311	1	12	4	1700	40	5
2374	1651	1652	GREEN LEVEL WEST RD	COLLECTOR	865	1	12	4	1700	40	5
2375	1652	1653	GREEN LEVEL WEST RD	COLLECTOR	952	1	12	4	1700	40	5
2376	1653	1654	GREEN LEVEL WEST RD	COLLECTOR	1679	1	12	4	1700	40	5
2377	1654	1655	LEWTER SHOP RD	COLLECTOR	2201	1	12	4	1700	55	5
2378	1654	1657	LEWTER SHOP RD	COLLECTOR	1383	1	12	4	1700	50	5
2379	1655	634	SR 751	COLLECTOR	1392	1	11	1	1700	60	5
2380	1656	1646	LUTHER RD	COLLECTOR	545	1	12	4	1700	40	9
2381	1657	1658	LEWTER SHOP RD	COLLECTOR	779	1	12	4	1700	55	5

Link #	Up-Stream Node	Down-Stream Node	Roadway Name	Roadway Type	Length (ft.)	No. of Lanes	Lane Width (ft.)	Shoulder Width (ft.)	Saturation Flow Rate (pcphpl)	Free Flow Speed (mph)	Grid Map Number
2382	1658	1659	LEWTER SHOP RD	COLLECTOR	2258	1	12	4	1700	60	5
2383	1659	1660	LEWTER SHOP RD	COLLECTOR	3085	1	12	4	1700	60	5
2384	1660	1661	MORRISVILLE PKWY	COLLECTOR	2559	1	12	4	1700	60	9
2385	1661	1662	MORRISVILLE PKWY	COLLECTOR	966	1	12	4	1700	50	9
2386	1662	1663	MORRISVILLE PKWY	COLLECTOR	1147	1	12	4	1700	60	9
2387	1663	1664	MORRISVILLE PKWY	COLLECTOR	2334	1	12	4	1700	60	9
2388	1664	1665	MORRISVILLE PKWY	COLLECTOR	547	1	12	4	1700	60	9
2389	1665	1666	WELDON RIDGE BLVD	COLLECTOR	619	1	12	4	1700	40	9
2390	1665	1863	MORRISVILLE PKWY	COLLECTOR	946	1	12	4	1700	45	9
2391	1666	1910	WELDON RIDGE BLVD	COLLECTOR	1686	1	12	4	1700	40	9
2392	1667	1668	MORRISVILLE PKWY	MINOR ARTERIAL	1162	2	12	4	1750	60	9
2393	1668	1669	GREEN LEVEL CHURCH RD	MINOR ARTERIAL	810	2	12	4	1900	50	9
2394	1669	1671	GREEN LEVEL CHURCH RD	MINOR ARTERIAL	1054	2	12	4	1900	50	9
2395	1671	1673	GREEN LEVEL CHURCH RD	MINOR ARTERIAL	1156	2	12	4	1750	50	6
2396	1672	1668	GREEN LEVEL CHURCH RD	MINOR ARTERIAL	757	2	12	4	1750	50	9
2397	1673	1674	GREEN LEVEL CHURCH RD	MINOR ARTERIAL	2304	2	12	4	1750	50	6
2398	1674	347	GREEN LEVEL CHURCH RD	MINOR ARTERIAL	1375	2	12	4	1750	40	6
2399	1675	1674	CARY GLEN BLVD	COLLECTOR	627	1	12	4	1750	40	6
2400	1675	1972	CARY GLEN BLVD	COLLECTOR	1188	1	12	4	1700	40	6
2401	1676	1673	MILLS PARK DR	COLLECTOR	632	1	12	4	1750	40	6
2402	1677	1673	COURTLAND VIEW LN	COLLECTOR	537	1	12	4	1750	40	6
2403	1678	1674	CARY GLEN BLVD	COLLECTOR	526	1	12	4	1750	40	6
2404	1680	590	US 1	FREEWAY	472	2	13	2	2250	70	38
2405	1681	1027	SR 78	COLLECTOR	492	1	12	0	1700	50	39
2406	1682	1681	DALRYMPLE ST	LOCAL ROADWAY	535	1	12	0	1750	35	39
2407	1683	1121	US 421 BYPASS ON/OFF RAMP	FREEWAY RAMP	923	1	13	6	1700	40	32
2408	1684	1685	US 1 BUS	COLLECTOR	173	1	12	1	900	20	32
2409	1685	1686	US 1 BUS	COLLECTOR	153	1	12	1	900	20	32

Link #	Up-Stream Node	Down-Stream Node	Roadway Name	Roadway Type	Length (ft.)	No. of Lanes	Lane Width (ft.)	Shoulder Width (ft.)	Saturation Flow Rate (pcphpl)	Free Flow Speed (mph)	Grid Map Number
2410	1685	1690	US 1 BUS	COLLECTOR	479	1	12	4	1700	50	32
2411	1686	1486	US 1 BUS	COLLECTOR	128	1	12	1	900	20	32
2412	1687	628	US 1 BUS	COLLECTOR	227	1	12	4	1700	50	32
2413	1687	1689	US 1 BUS	COLLECTOR	109	1	12	0	900	20	32
2414	1688	1687	US 1 BUS	COLLECTOR	123	1	12	0	900	20	32
2415	1689	1690	US 1 BUS	COLLECTOR	125	1	12	0	900	20	32
2416	1690	1685	US 1 BUS	COLLECTOR	479	1	12	4	1700	50	32
2417	1690	1688	US 1 BUS	COLLECTOR	127	1	12	0	900	20	32
2418	1691	964	SR 55	COLLECTOR	1404	1	13	1	1700	50	36
2419	1691	1457	SR 55	COLLECTOR	2840	1	13	1	1700	50	36
2420	1692	1691	KENNEBEC RD	LOCAL ROADWAY	568	1	12	0	1750	35	36
2421	1693	1521	CARPENTER FIRE STATION RD	MINOR ARTERIAL	1277	2	12	0	1900	40	6
2422	1693	1917	YATES STORE RD	MINOR ARTERIAL	2178	2	12	1	1900	40	6
2423	1694	1275	TINGEN RD	COLLECTOR	932	1	10	1	1350	30	22
2424	1695	1696	HUMIE OLIVE RD	LOCAL ROADWAY	3740	1	12	0	1700	40	21
2425	1696	1697	OLD US 1	COLLECTOR	968	1	11	0	1700	50	21
2426	1697	287	OLD US 1	COLLECTOR	2960	1	11	0	1700	50	21
2427	1698	1699	SR 540 TOLL ON-RAMP FROM OLD US 1	FREEWAY RAMP	248	1	13	3	1350	30	22
2428	1699	1347	SR 540 TOLL ON-RAMP FROM OLD US 1	FREEWAY RAMP	476	1	13	3	1350	30	22
2429	1700	3030	I-440	FREEWAY	419	2	13	0	2250	65	13
2430	1701	375	I-440	FREEWAY	2278	3	13	0	2250	65	13
2431	1701	3030	I-440	FREEWAY	410	2	13	0	2250	65	13
2432	1703	1931	SR 55	MINOR ARTERIAL	2333	2	12	4	1750	55	2
2433	1707	1564	SR 55 BYPASS	MINOR ARTERIAL	1080	3	13	3	1900	60	22
2434	1708	25	SR 55 BYPASS	MINOR ARTERIAL	809	2	13	3	1900	60	22
2435	1709	1708	SR 540 TOLL OFF-RAMP	FREEWAY RAMP	322	1	13	3	1700	45	22

Link #	Up-Stream Node	Down-Stream Node	Roadway Name	Roadway Type	Length (ft.)	No. of Lanes	Lane Width (ft.)	Shoulder Width (ft.)	Saturation Flow Rate (pcphpl)	Free Flow Speed (mph)	Grid Map Number
2436	1710	346	CARPENTER FIRE STATION RD	COLLECTOR	3406	1	12	0	1700	40	6
2437	1711	1712	I-40 W ON-RAMP FROM SR 54	FREEWAY RAMP	267	1	15	0	1350	30	12
2438	1712	1366	I-40 W ON-RAMP FROM SR 54	FREEWAY RAMP	140	1	15	0	1350	30	12
2439	1713	1714	US 1 ON RAMP FROM SR 540 TOLL	FREEWAY RAMP	1139	1	14	14	1700	45	22
2440	1714	582	US 1 ON RAMP FROM SR 540 TOLL	FREEWAY RAMP	563	1	14	14	1700	45	22
2441	1715	1554	SR 540 TOLL	FREEWAY	1265	3	12	8	2250	75	22
2442	1715	1561	SR 540 TOLL	FREEWAY	396	4	12	8	2250	75	22
2443	1716	1717	US-1 ON RAMP FROM SR 540 TOLL	FREEWAY RAMP	394	1	16	5	1350	30	22
2444	1716	1719	SR 540 TOLL	FREEWAY	687	4	12	8	2250	75	22
2445	1717	1718	US-1 ON RAMP FROM SR 540 TOLL	FREEWAY RAMP	343	1	16	5	1350	30	22
2446	1718	1560	US-1 ON RAMP FROM SR 540 TOLL	FREEWAY RAMP	370	1	16	5	1350	30	22
2447	1719	1348	SR 540 TOLL	FREEWAY	434	3	12	8	2250	75	22
2448	1720	1293	SR 540 TOLL OFF-RAMP	FREEWAY RAMP	548	2	14	3	1750	50	6
2449	1722	322	SR 540 TOLL OFF-RAMP	FREEWAY RAMP	530	1	13	3	1750	30	10
2450	1723	1568	SR 540 TOLL ON-RAMP FROM GREEN LEVEL WEST RD	FREEWAY RAMP	509	1	13	3	1350	30	9
2451	1724	1739	SR 540 TOLL ON-RAMP FROM US 64 E	FREEWAY RAMP	1811	1	13	3	1700	45	17
2452	1725	1736	SR 540 TOLL RD ON-RAMP FROM US 64 W	FREEWAY RAMP	480	1	13	3	1350	30	17
2453	1726	434	US 64	MINOR ARTERIAL	163	2	13	9	1900	60	17
2454	1726	1738	SR 540 TOLL ON-RAMP FROM US 64 E	FREEWAY RAMP	297	1	13	3	1350	30	17
2455	1727	1565	SR 540 TOLL ON-RAMP FROM	FREEWAY RAMP	613	1	13	3	1350	30	22

Link #	Up-Stream Node	Down-Stream Node	Roadway Name	Roadway Type	Length (ft.)	No. of Lanes	Lane Width (ft.)	Shoulder Width (ft.)	Saturation Flow Rate (pcphpl)	Free Flow Speed (mph)	Grid Map Number
			SR 55 BYPASS								
2456	1728	1347	SR 540 TOLL	FREEWAY	1317	4	12	8	2250	75	22
2457	1729	1550	SR 540 TOLL OFF-RAMP	FREEWAY RAMP	733	1	13	4	1750	30	22
2458	1730	1729	SR 540 TOLL OFF-RAMP	FREEWAY RAMP	393	1	13	4	1350	30	22
2459	1731	1345	SR 540 TOLL	FREEWAY	2298	4	12	8	2250	75	17
2460	1732	1731	SR 540 TOLL ON-RAMP FROM US 64 E	FREEWAY RAMP	695	1	13	3	1700	45	17
2461	1733	1732	SR 540 TOLL ON-RAMP FROM US 64 E	FREEWAY RAMP	585	1	13	3	1700	45	17
2462	1734	1544	US 64	MINOR ARTERIAL	313	3	13	9	1900	60	17
2463	1734	1735	SR 540 TOLL RD ON-RAMP FROM US 64 W	FREEWAY RAMP	605	1	13	3	1350	30	17
2464	1735	1725	SR 540 TOLL RD ON-RAMP FROM US 64 W	FREEWAY RAMP	289	1	13	3	1350	30	17
2465	1736	1732	SR 540 TOLL RD ON-RAMP FROM US 64 W	FREEWAY RAMP	1555	1	13	3	1700	45	17
2466	1737	1739	SR 540 TOLL ON-RAMP FROM US 64 W	FREEWAY RAMP	891	1	13	3	1700	45	17
2467	1738	1724	SR 540 TOLL ON-RAMP FROM US 64 E	FREEWAY RAMP	728	1	13	3	1350	30	17
2468	1739	1543	SR 540 TOLL ON-RAMP FROM US 64 W	FREEWAY RAMP	983	1	13	3	1700	45	17
2469	1740	1531	SR 540 TOLL	FREEWAY	2904	3	12	8	2250	70	10
2470	1741	323	SR 540 TOLL OFF-RAMP	FREEWAY RAMP	579	1	13	3	1750	45	9
2471	1742	1342	SR 540 TOLL ON-RAMP FROM GREEN LEVEL WEST RD	FREEWAY RAMP	1164	1	13	3	1700	45	9
2472	1743	1060	SR 87	MINOR ARTERIAL	1156	2	12	0	1900	55	39
2473	1744	1745	SR 87	FREEWAY RAMP	269	1	12	0	1700	40	39
2474	1745	1746	SR 87	FREEWAY	1625	2	12	0	2250	60	39

Link #	Up-Stream Node	Down-Stream Node	Roadway Name	Roadway Type	Length (ft.)	No. of Lanes	Lane Width (ft.)	Shoulder Width (ft.)	Saturation Flow Rate (pcphpl)	Free Flow Speed (mph)	Grid Map Number
2475	1746	1764	NC 87	MINOR ARTERIAL	637	2	12	5	1900	55	39
2476	1746	1766	US 421 BYPASS	FREEWAY	1733	2	12	12	2250	55	39
2477	1746	1800	SR 87	MINOR ARTERIAL	1897	2	12	0	1900	60	39
2478	1747	537	US 421	MINOR ARTERIAL	1843	2	13	2	1900	60	39
2479	1747	1633	US 421	MINOR ARTERIAL	1094	1	13	2	1750	60	39
2480	1747	1748	US 421 BYPASS OFF RAMP TO SR 87	FREEWAY RAMP	498	1	12	11	1700	45	39
2481	1748	1749	US 421 BYPASS ON RAMP FROM US 421	FREEWAY RAMP	605	1	12	11	1700	45	39
2482	1749	1750	US 421 BYPASS ON RAMP FROM US 421	FREEWAY RAMP	426	1	12	11	1700	45	39
2483	1750	1751	US 421 BYPASS	FREEWAY	861	2	12	11	2250	70	39
2484	1751	1752	US 421 BYPASS	FREEWAY	683	2	12	11	2250	70	39
2485	1751	1757	US 421 BYPASS	FREEWAY	3577	2	12	4	2250	70	39
2486	1752	1751	US 421 BYPASS	FREEWAY	683	2	12	4	2250	70	39
2487	1752	1753	US 421 BYPASS	FREEWAY	1018	2	12	11	2250	55	39
2488	1753	1752	US 421 BYPASS	FREEWAY	1018	2	12	4	2250	70	39
2489	1753	1754	US 421 BYPASS	FREEWAY	948	2	12	11	2250	55	39
2490	1754	1745	US 421 BYPASS	FREEWAY	363	2	12	11	2250	60	39
2491	1755	1484	US 421 BYPASS OFF-RAMP	FREEWAY RAMP	1068	1	13	4	1700	45	39
2492	1755	1769	US 421 BYPASS	FREEWAY	722	2	12	4	2250	70	39
2493	1756	1112	US 421 BYPASS	FREEWAY	1124	2	12	4	2250	70	39
2494	1756	1757	US 421 BYPASS	FREEWAY	3701	2	12	4	2250	70	39
2495	1757	1750	US 421 BYPASS	FREEWAY	2716	2	12	4	2250	70	39
2496	1757	1756	US 421 BYPASS	FREEWAY	3701	2	12	4	2250	70	39
2497	1758	1114	US 421 BYPASS	FREEWAY	1820	2	12	4	2250	70	39
2498	1758	1115	US 421 BYPASS	FREEWAY	3611	2	13	6	2250	70	39
2499	1759	1793	US 421 BYPASS	FREEWAY	2266	2	13	6	2250	70	32

Link #	Up-Stream Node	Down-Stream Node	Roadway Name	Roadway Type	Length (ft.)	No. of Lanes	Lane Width (ft.)	Shoulder Width (ft.)	Saturation Flow Rate (pcphpl)	Free Flow Speed (mph)	Grid Map Number
2500	1759	1794	US 421 BYPASS	FREEWAY	1136	2	13	6	2250	70	32
2501	1760	1790	US 421	MINOR ARTERIAL	1198	2	13	2	1750	60	32
2502	1760	1791	US 421 BUS	MINOR ARTERIAL	441	2	13	2	1900	60	32
2503	1760	1812	US 421 ON RAMP FROM US 421 BUS	FREEWAY RAMP	692	1	16	8	1350	30	32
2504	1761	1762	US 421 BYPASS	FREEWAY	10465	2	13	6	2250	70	32
2505	1761	1793	US 421 BYPASS	FREEWAY	4519	2	13	6	2250	70	32
2506	1762	1761	US 421 BYPASS	FREEWAY	10464	2	13	6	2250	70	32
2507	1762	1763	US 421 BYPASS	FREEWAY	1617	2	13	6	2250	70	32
2508	1763	1762	US 421 BYPASS	FREEWAY	1608	2	13	6	2250	70	32
2509	1763	1804	US 421 BYPASS OF RAMP FROM US 1	FREEWAY RAMP	676	1	13	4	1700	45	32
2510	1763	1810	US 421 BYPASS	FREEWAY	4199	2	13	5	2250	70	32
2511	1764	1765	NC 87	MINOR ARTERIAL	1018	2	12	5	1900	55	39
2512	1765	1060	NC 87	MINOR ARTERIAL	1101	2	12	5	1900	55	39
2513	1766	1753	US 421 BYPASS	FREEWAY	1162	2	12	12	2250	55	39
2514	1767	1757	US 421 BYPASS ON RAMP FROM US 421	FREEWAY RAMP	1002	1	14	10	1700	45	39
2515	1768	1633	US 421 BYPASS OFF RAMP TO US 421	FREEWAY RAMP	469	1	14	10	1750	45	39
2516	1769	1756	US 421 BYPASS	FREEWAY	540	2	12	4	2250	70	39
2517	1770	1771	US 421 BYPASS ON RAMP FROM SR 42	FREEWAY RAMP	596	1	12	4	1350	30	39
2518	1771	1756	US 421 BYPASS ON RAMP FROM SR 42	FREEWAY RAMP	323	1	12	4	1700	45	39
2519	1772	1773	PUMPING STATION RD	COLLECTOR	1029	1	9	1	1700	45	39
2520	1773	1775	PUMPING STATION RD	COLLECTOR	1444	1	9	1	1700	45	39
2521	1774	850	POPLAR SPRINGS CHURCH RD	COLLECTOR	2291	1	10	0	1700	50	39
2522	1774	1772	PUMPING STATION RD	COLLECTOR	2716	1	9	1	1700	45	39

Link #	Up-Stream Node	Down-Stream Node	Roadway Name	Roadway Type	Length (ft.)	No. of Lanes	Lane Width (ft.)	Shoulder Width (ft.)	Saturation Flow Rate (pcphpl)	Free Flow Speed (mph)	Grid Map Number
2523	1775	1776	PUMPING STATION RD	COLLECTOR	817	1	9	1	1700	45	39
2524	1776	1777	PUMPING STATION RD	COLLECTOR	1371	1	9	1	1700	45	39
2525	1777	1778	PUMPING STATION RD	COLLECTOR	1572	1	9	1	1700	45	39
2526	1778	1782	KELLY DR	COLLECTOR	1442	1	9	1	1700	40	39
2527	1779	833	SAN-LEE DR	COLLECTOR	1626	1	10	0	1700	40	39
2528	1780	1781	KELLY DR	COLLECTOR	981	1	10	5	1700	45	39
2529	1780	1786	US 421 BYPASS ON RAMP FROM KELLY DR	FREEWAY RAMP	625	1	12	10	1700	45	39
2530	1781	1784	US 421 BYPASS ON RAMP FROM KELLY DR	FREEWAY RAMP	463	1	13	7	1700	45	39
2531	1782	1780	KELLY DR	COLLECTOR	417	1	10	5	1700	45	39
2532	1783	1758	US 421 BYPASS	FREEWAY	2547	2	12	4	2250	70	39
2533	1784	1783	US 421 BYPASS ON RAMP FROM KELLY DR	FREEWAY RAMP	749	1	13	7	1700	45	39
2534	1785	1115	US 421 BYPASS	FREEWAY	2098	2	13	6	2250	70	39
2535	1785	1116	US 421 BYPASS	FREEWAY	1943	2	13	6	2250	70	39
2536	1786	1785	US 421 BYPASS ON RAMP FROM KELLY DR	FREEWAY RAMP	1062	1	12	10	1700	45	39
2537	1787	1103	US 421 BUS	MINOR ARTERIAL	3209	2	13	2	1900	60	32
2538	1787	1791	US 421 BUS	MINOR ARTERIAL	1205	2	13	2	1900	60	32
2539	1788	105	US 1 S ON-RAMP FROM US 421 BYPASS	FREEWAY RAMP	544	1	15	2	1350	30	32
2540	1789	1790	US 421	MINOR ARTERIAL	568	2	12	2	1750	60	32
2541	1790	1760	US 421	MINOR ARTERIAL	1200	2	13	2	1900	60	32
2542	1790	1795	US 421 ON RAMP FROM US 421 BUS	FREEWAY RAMP	1280	2	14	4	1900	45	32
2543	1791	1760	US 421 BUS	MINOR ARTERIAL	441	2	13	2	1900	60	32
2544	1791	1787	US 421 BUS	MINOR ARTERIAL	1205	2	13	2	1900	60	32
2545	1792	1790	US 421 OFF RAMP TO US 421	FREEWAY RAMP	507	1	16	8	1750	35	32

Link #	Up-Stream Node	Down-Stream Node	Roadway Name	Roadway Type	Length (ft.)	No. of Lanes	Lane Width (ft.)	Shoulder Width (ft.)	Saturation Flow Rate (pcphpl)	Free Flow Speed (mph)	Grid Map Number
			BUS								
2546	1793	1759	US 421 BYPASS	FREEWAY	2266	2	13	6	2250	70	32
2547	1793	1761	US 421 BYPASS	FREEWAY	4514	2	13	6	2250	70	32
2548	1793	1814	US 421 OFF RAMP TO US 421 BUS	FREEWAY RAMP	728	1	16	8	1350	30	32
2549	1794	1759	US 421 BYPASS	FREEWAY	1135	2	13	6	2250	70	32
2550	1794	1815	US 421 BYPASS	MINOR ARTERIAL	1728	2	13	6	1900	70	32
2551	1795	1759	US 421 ON RAMP FROM US 421 BUS	FREEWAY RAMP	566	1	14	4	1700	45	32
2552	1796	1797	US 421 BYPASS ON RAMP FROM US 1	FREEWAY RAMP	729	1	13	4	1700	45	32
2553	1797	1763	US 421 BYPASS ON/OFF RAMP	FREEWAY RAMP	660	2	13	6	1900	60	32
2554	1798	293	HOLLAND RD	LOCAL ROADWAY	1264	1	12	0	1700	40	21
2555	1799	297	HUNTER ST	COLLECTOR	862	1	16	0	1750	30	18
2556	1800	1746	SR 87	MINOR ARTERIAL	1898	2	12	0	1900	60	39
2557	1801	1802	US 421 BYPASS ON RAMP	FREEWAY RAMP	522	1	12	11	1700	40	32
2558	1802	1485	US 421 BYPASS ON RAMP	FREEWAY RAMP	771	1	12	11	1700	40	32
2559	1803	1806	US 421 ON-RAMP FROM US 1	FREEWAY RAMP	431	1	15	2	1350	30	32
2560	1803	1809	US 1	FREEWAY	788	3	13	10	2250	70	32
2561	1804	1805	US 421 BYPASS OF RAMP FROM US 1	FREEWAY RAMP	661	1	13	4	1700	45	32
2562	1804	1807	US 421 BYPASS ON/OFF RAMP	FREEWAY RAMP	1562	1	13	6	1700	55	32
2563	1805	1809	US 421 BYPASS OF RAMP FROM US 1	FREEWAY RAMP	1433	1	13	4	1700	45	32
2564	1806	1808	US 421 ON-RAMP FROM US 1	FREEWAY RAMP	349	1	15	2	1350	30	32
2565	1807	1811	US 421 BYPASS ON/OFF RAMP	FREEWAY RAMP	1213	1	13	6	1700	55	32
2566	1808	1807	US 421 ON-RAMP FROM US 1	FREEWAY RAMP	522	1	15	2	1350	30	32
2567	1809	112	US 1	FREEWAY	5916	3	13	10	2250	70	32
2568	1810	993	US 421 BYPASS	FREEWAY	1378	2	13	5	2250	70	32

Link #	Up-Stream Node	Down-Stream Node	Roadway Name	Roadway Type	Length (ft.)	No. of Lanes	Lane Width (ft.)	Shoulder Width (ft.)	Saturation Flow Rate (pcphpl)	Free Flow Speed (mph)	Grid Map Number
2569	1811	1810	US 421 BYPASS ON/OFF RAMP	FREEWAY RAMP	769	1	13	6	1700	55	32
2570	1812	1813	US 421 ON RAMP FROM US 421 BUS	FREEWAY RAMP	347	1	16	8	1350	30	32
2571	1813	1793	US 421 ON RAMP FROM US 421 BUS	FREEWAY RAMP	756	1	16	8	1350	30	32
2572	1814	1792	US 421 OFF RAMP TO US 421 BUS	FREEWAY RAMP	312	1	16	8	1350	30	32
2573	1815	1794	US 421 BYPASS	MINOR ARTERIAL	1728	2	13	6	1900	70	32
2574	1816	1817	US 401	MINOR ARTERIAL	3900	2	12	0	1900	55	42
2575	1816	1819	US 421/N MAIN ST	MINOR ARTERIAL	4943	2	12	0	1900	50	42
2576	1816	1826	US 401	MINOR ARTERIAL	1458	2	12	0	1750	40	42
2577	1817	1816	US 401	MINOR ARTERIAL	3900	2	12	0	1750	55	42
2578	1818	1816	SR 210/N MAIN ST	MINOR ARTERIAL	1464	2	12	0	1750	40	42
2579	1819	1820	US 421	MINOR ARTERIAL	3085	2	12	4	1750	40	43
2580	1820	1837	US 421	MINOR ARTERIAL	875	2	13	2	1750	35	43
2581	1821	1868	US 421	COLLECTOR	605	1	13	2	1750	35	43
2582	1823	222	US 401	COLLECTOR	2862	1	12	0	1700	60	42
2583	1823	1824	US 401	MINOR ARTERIAL	1048	2	12	0	1750	40	42
2584	1824	1823	US 401	MINOR ARTERIAL	1048	2	12	0	1900	40	42
2585	1824	1826	US 401	MINOR ARTERIAL	1788	2	12	0	1750	40	42
2586	1825	1824	MCKINNEY PKWY	LOCAL ROADWAY	1326	1	12	0	1750	30	42
2587	1826	1816	US 401	MINOR ARTERIAL	1458	2	12	0	1750	40	42
2588	1826	1824	US 401	MINOR ARTERIAL	1788	2	12	0	1750	40	42
2589	1827	1826	DRIVEWAY	LOCAL ROADWAY	683	1	12	0	1750	30	42
2590	1828	1818	SR 210/N MAIN ST	COLLECTOR	5054	1	12	0	1700	55	42
2591	1829	1821	US 421	MINOR ARTERIAL	414	2	13	2	1750	35	43
2592	1830	1829	E MCNEILL ST	LOCAL ROADWAY	714	1	12	0	1750	30	43
2593	1831	1821	W OLD RD	LOCAL ROADWAY	1049	1	13	0	1750	30	43

Link #	Up-Stream Node	Down-Stream Node	Roadway Name	Roadway Type	Length (ft.)	No. of Lanes	Lane Width (ft.)	Shoulder Width (ft.)	Saturation Flow Rate (pcphpl)	Free Flow Speed (mph)	Grid Map Number
2594	1832	1836	US 421	COLLECTOR	1183	2	12	5	1900	40	43
2595	1833	1834	US 421	COLLECTOR	5571	1	13	2	1700	60	43
2596	1834	1832	US 421	COLLECTOR	3397	1	13	2	1750	40	43
2597	1835	1832	N 13TH ST	LOCAL ROADWAY	1391	1	12	1	1750	30	43
2598	1836	1820	US 421	COLLECTOR	1162	1	12	5	1750	40	43
2599	1837	1829	US 421	MINOR ARTERIAL	1145	2	13	2	1750	35	43
2600	1838	1837	W JAMES ST	LOCAL ROADWAY	1141	1	12	0	1750	30	43
2601	1839	1601	PARKERS CREEK RECREATION RD	COLLECTOR	2622	1	10	0	1575	35	16
2602	1840	1839	PARKERS CREEK RECREATION RD	COLLECTOR	3871	1	10	0	1575	35	16
2603	1841	1840	PARKERS CREEK RECREATION RD	COLLECTOR	1585	1	10	0	1575	35	16
2604	1842	1841	PARKERS CREEK RECREATION RD	COLLECTOR	1230	1	10	0	1575	35	16
2605	1843	1148	BIG WOODS RD	COLLECTOR	3721	1	10	0	1700	50	4
2606	1843	1846	BIG WOODS RD	COLLECTOR	3521	1	12	0	1700	50	4
2607	1844	1843	THE PRESERVE TRAIL	LOCAL ROADWAY	547	1	12	0	1350	30	4
2608	1845	1844	THE PRESERVE TRAIL	LOCAL ROADWAY	1671	1	12	0	1350	30	4
2609	1846	1848	BIG WOODS RD	COLLECTOR	2584	1	12	0	1700	50	15
2610	1847	1846	LEGACY WAY	LOCAL ROADWAY	939	1	12	0	1350	30	15
2611	1848	1849	BIG WOODS RD	COLLECTOR	4384	1	12	0	1700	50	15
2612	1849	135	US 64	MINOR ARTERIAL	2507	2	14	2	1900	60	15
2613	1849	1025	US 64	MINOR ARTERIAL	2382	2	14	2	1900	60	15
2614	1850	190	BRIAR CHAPEL PKWY	LOCAL ROADWAY	1073	1	12	0	1700	40	4
2615	1851	1852	BOAT RAMP DWY	LOCAL ROADWAY	1047	1	10	0	1350	30	29
2616	1852	1853	BARTLEY HOLLEMAN RD	COLLECTOR	1293	1	10	0	1700	40	29
2617	1853	1854	BARTLEY HOLLEMAN RD	COLLECTOR	980	1	10	0	1700	40	29

Link #	Up-Stream Node	Down-Stream Node	Roadway Name	Roadway Type	Length (ft.)	No. of Lanes	Lane Width (ft.)	Shoulder Width (ft.)	Saturation Flow Rate (pcphpl)	Free Flow Speed (mph)	Grid Map Number
2618	1854	1317	BARTLEY HOLLEMAN RD	COLLECTOR	1329	1	10	0	1700	40	29
2619	1855	437	SHEARON-HARRIS RD	COLLECTOR	2035	1	11	0	1700	55	28
2620	1856	1857	GREEN LEVEL CHURCH RD	COLLECTOR	1950	1	12	0	1700	50	17
2621	1857	1858	GREEN LEVEL CHURCH RD	COLLECTOR	3542	1	12	0	1700	50	9
2622	1858	1642	GREEN LEVEL CHURCH RD	COLLECTOR	2539	1	12	0	1700	50	9
2623	1859	1860	ROBERTS RD	COLLECTOR	2865	1	10	0	1700	45	9
2624	1860	1861	ROBERTS RD	COLLECTOR	1232	1	10	0	1700	45	9
2625	1861	1858	ROBERTS RD	COLLECTOR	1822	1	10	0	1700	45	9
2626	1862	331	GREEN HOPE SCHOOL RD	COLLECTOR	889	1	12	0	1750	40	9
2627	1863	1667	MORRISVILLE PKWY	MINOR ARTERIAL	1402	2	12	4	1900	60	9
2628	1864	1319	DRIVEWAY	LOCAL ROADWAY	447	1	12	0	1750	30	29
2629	1865	894	SR 42	COLLECTOR	1895	1	12	4	1700	50	36
2630	1865	1866	JUDD PKWY	COLLECTOR	2500	1	12	4	1700	40	36
2631	1866	1867	JUDD PKWY	COLLECTOR	1783	1	12	4	1700	40	36
2632	1867	1100	JUDD PKWY	COLLECTOR	1462	1	12	4	1750	40	36
2633	1868	1822	US 421	COLLECTOR	2878	1	13	2	1700	60	43
2634	1869	1868	NC 210	COLLECTOR	435	1	10	0	1750	40	43
2635	1870	172	ANGIER RD	COLLECTOR	4679	1	10	0	1700	45	36
2636	1871	165	ANGIER RD	COLLECTOR	1971	1	10	0	1700	45	36
2637	1872	1871	ANGIER RD	COLLECTOR	4633	1	10	0	1700	45	36
2638	1873	1870	ANGIER RD	COLLECTOR	4615	1	10	0	1700	45	36
2639	1874	229	E SPRING ST	LOCAL ROADWAY	1338	1	13	0	1350	30	36
2640	1874	1251	ANGIER RD	COLLECTOR	698	1	13	0	1125	25	36
2641	1874	1878	ANGIER RD	COLLECTOR	926	1	13	0	1350	30	36
2642	1875	1876	HOLLAND RD	COLLECTOR	5386	1	12	0	1700	45	36
2643	1876	1877	HOLLAND RD	COLLECTOR	423	1	12	0	1700	45	36
2644	1877	960	SR 55	COLLECTOR	1179	1	13	1	1700	55	36
2645	1877	961	SR 55	COLLECTOR	8072	1	13	1	1750	55	36

Link #	Up-Stream Node	Down-Stream Node	Roadway Name	Roadway Type	Length (ft.)	No. of Lanes	Lane Width (ft.)	Shoulder Width (ft.)	Saturation Flow Rate (pcphpl)	Free Flow Speed (mph)	Grid Map Number
2646	1878	1099	ANGIER RD	COLLECTOR	2027	1	13	0	1750	30	36
2647	1878	1879	HOLLAND RD	COLLECTOR	1491	1	10	0	1350	30	36
2648	1879	1499	HOLLAND RD	COLLECTOR	699	1	10	0	1750	30	36
2649	1880	1128	GREEN OAKS PKWY	LOCAL ROADWAY	1376	1	12	0	1575	35	29
2650	1881	715	LINKSLAND DR	LOCAL ROADWAY	747	1	12	0	1750	30	30
2651	1882	715	LINKSLAND DR	LOCAL ROADWAY	749	1	12	0	1750	30	30
2652	1883	59	HILLTOP NEEDMORE RD	COLLECTOR	2085	1	12	0	1700	45	30
2653	1883	1885	JOHNSON POND RD	COLLECTOR	1480	1	12	0	1700	40	30
2654	1884	1883	JOHNSON POND RD	COLLECTOR	1480	1	12	0	1750	40	30
2655	1885	1886	JOHNSON POND RD	COLLECTOR	1031	1	12	0	1700	40	30
2656	1886	1887	JOHNSON POND RD	COLLECTOR	752	1	12	0	1700	40	30
2657	1887	1888	JOHNSON POND RD	COLLECTOR	2033	1	12	0	1700	40	30
2658	1888	1889	JOHNSON POND RD	COLLECTOR	3437	1	12	0	1700	40	30
2659	1889	1890	JOHNSON POND RD	COLLECTOR	1383	1	12	0	1700	40	30
2660	1890	1508	JOHNSON POND RD	COLLECTOR	1641	1	12	0	1700	40	30
2661	1891	1511	MIDDLE CREEK PARK AVE	LOCAL ROADWAY	1178	1	12	0	1750	35	30
2662	1892	525	ARTHUR PIERCE RD	COLLECTOR	1296	1	10	0	1750	40	23
2663	1893	511	HOLLY SPRINGS RD	COLLECTOR	1275	1	12	1	1750	50	24
2664	1894	1895	SR 751	COLLECTOR	2132	1	11	1	1700	60	1
2665	1895	1896	SR 751	COLLECTOR	1335	1	11	1	1750	60	1
2666	1896	1969	SR 751	COLLECTOR	706	1	11	1	1275	60	1
2667	1897	1907	OKELLY CHAPEL RD	COLLECTOR	1010	1	11	1	1700	40	6
2668	1897	1908	OKELLY CHAPEL RD	COLLECTOR	1927	1	11	1	1700	40	6
2669	1898	1896	OKELLY CHAPEL RD	COLLECTOR	1235	1	10	3	1750	50	1
2670	1899	1898	OKELLY CHAPEL RD	COLLECTOR	1117	1	10	3	1700	50	1
2671	1900	1899	OKELLY CHAPEL RD	COLLECTOR	2102	1	10	3	1700	50	1
2672	1901	1900	OKELLY CHAPEL RD	COLLECTOR	2843	1	10	3	1700	50	2
2673	1902	1901	OKELLY CHAPEL RD	COLLECTOR	1304	1	10	3	1700	50	6

Link #	Up-Stream Node	Down-Stream Node	Roadway Name	Roadway Type	Length (ft.)	No. of Lanes	Lane Width (ft.)	Shoulder Width (ft.)	Saturation Flow Rate (pcphpl)	Free Flow Speed (mph)	Grid Map Number
2674	1903	1902	OKELLY CHAPEL RD	COLLECTOR	1348	1	10	3	1700	50	6
2675	1904	1903	OKELLY CHAPEL RD	COLLECTOR	976	1	10	3	1700	50	6
2676	1905	1904	OKELLY CHAPEL RD	COLLECTOR	1165	1	10	3	1700	50	6
2677	1906	1905	OKELLY CHAPEL RD	COLLECTOR	1340	1	10	3	1700	40	6
2678	1907	1906	OKELLY CHAPEL RD	COLLECTOR	698	1	10	3	1700	40	6
2679	1908	1897	OKELLY CHAPEL RD	COLLECTOR	1927	1	11	1	1700	40	6
2680	1908	1909	OKELLY CHAPEL RD	COLLECTOR	1049	1	11	1	1750	40	6
2681	1909	1295	OKELLY CHAPEL RD	COLLECTOR	1994	1	11	1	1700	40	6
2682	1909	1908	OKELLY CHAPEL RD	COLLECTOR	1049	1	11	1	1700	40	6
2683	1909	1924	GREEN LEVEL CHURCH RD	MINOR ARTERIAL	825	2	12	2	1900	45	6
2684	1910	1911	WELDON RIDGE BLVD	COLLECTOR	1120	1	12	4	1700	40	9
2685	1911	1912	WELDON RIDGE BLVD	COLLECTOR	803	1	12	4	1700	40	6
2686	1912	1913	YATES STORE RD	MINOR ARTERIAL	1046	2	12	0	1900	40	6
2687	1913	1914	YATES STORE RD	COLLECTOR	2267	1	12	1	1700	40	6
2688	1914	1915	YATES STORE RD	COLLECTOR	662	1	12	1	1700	40	6
2689	1915	1916	YATES STORE RD	COLLECTOR	1403	1	12	1	1700	40	6
2690	1916	1693	YATES STORE RD	MINOR ARTERIAL	1157	2	12	1	1900	40	6
2691	1917	1918	YATES STORE RD	MINOR ARTERIAL	973	2	12	1	1900	40	6
2692	1917	1936	MCCRIMMON PKW	COLLECTOR	427	1	14	0	1350	30	6
2693	1918	1919	YATES STORE RD	MINOR ARTERIAL	1404	2	12	1	1900	40	6
2694	1919	1920	YATES STORE RD	MINOR ARTERIAL	1405	2	12	1	1900	40	6
2695	1920	1897	YATES STORE RD	MINOR ARTERIAL	1591	2	12	1	1900	40	6
2696	1921	1897	YATES STORE RD	LOCAL ROADWAY	676	1	12	0	1700	40	6
2697	1922	1923	GREEN LEVEL CHURCH RD	COLLECTOR	1491	1	12	2	1700	40	6
2698	1922	1939	MCCRIMMON PKW	COLLECTOR	864	2	12	0	1900	45	6
2699	1923	1909	GREEN LEVEL CHURCH RD	COLLECTOR	3320	1	12	2	1750	40	6
2700	1924	1925	GREEN LEVEL CHURCH RD	MINOR ARTERIAL	891	2	12	2	1900	45	6
2701	1925	1926	GREEN LEVEL CHURCH RD	MINOR ARTERIAL	1340	2	12	2	1900	45	6

Link #	Up-Stream Node	Down-Stream Node	Roadway Name	Roadway Type	Length (ft.)	No. of Lanes	Lane Width (ft.)	Shoulder Width (ft.)	Saturation Flow Rate (pcphpl)	Free Flow Speed (mph)	Grid Map Number
2702	1926	1927	GREEN LEVEL CHURCH RD	COLLECTOR	869	1	12	1	1700	45	2
2703	1927	1928	GREEN LEVEL CHURCH RD	COLLECTOR	1091	1	12	1	1700	45	2
2704	1928	1929	GREEN LEVEL CHURCH RD	COLLECTOR	1110	1	12	1	1700	45	2
2705	1929	1930	GREEN LEVEL CHURCH RD	COLLECTOR	1028	1	12	1	1750	45	2
2706	1930	1931	KIT CREEK ROAD	COLLECTOR	1173	1	12	0	1750	40	2
2707	1931	1932	SR 55	MINOR ARTERIAL	1629	2	12	4	1425	55	2
2708	1933	1930	GREEN LEVEL CHURCH RD	COLLECTOR	1020	1	12	1	1750	45	2
2709	1934	1922	GREEN LEVEL CHURCH RD	COLLECTOR	648	2	12	2	1750	40	6
2710	1935	1930	KIT CREEK RD	LOCAL ROADWAY	621	1	12	0	1750	40	2
2711	1936	1937	MCCRIMMON PKW	COLLECTOR	264	1	14	0	900	20	6
2712	1937	1938	MCCRIMMON PKWY	COLLECTOR	842	1	14	0	1700	45	6
2713	1938	1943	MCCRIMMON PKWY	COLLECTOR	1155	1	14	0	1700	45	6
2714	1939	1940	MCCRIMMON PKW	COLLECTOR	1796	2	12	0	1900	45	6
2715	1940	1941	MCCRIMMON PKWY	COLLECTOR	1263	1	12	4	1700	45	6
2716	1941	1942	MCCRIMMON PKWY	COLLECTOR	971	1	12	4	1700	45	6
2717	1942	1286	MCCRIMMON PKWY	COLLECTOR	799	1	12	4	1700	45	7
2718	1943	1922	MCCRIMMON PKWY	COLLECTOR	254	2	14	0	1750	45	6
2719	1944	1945	MORRISVILLE PKWY	COLLECTOR	1804	1	12	1	1700	40	7
2720	1945	1946	MORRISVILLE PKWY	COLLECTOR	1434	1	12	1	1700	40	7
2721	1946	1285	MORRISVILLE PKWY	MINOR ARTERIAL	916	2	12	1	1750	40	7
2722	1947	1284	MORRISVILLE PKWY	MINOR ARTERIAL	1756	2	12	1	1900	45	7
2723	1947	1948	MORRISVILLE PKWY	MINOR ARTERIAL	2757	2	12	1	1900	45	7
2724	1947	1955	LOUIS STEPHENS DR	MINOR ARTERIAL	1438	2	13	0	1900	45	7
2725	1948	1949	MORRISVILLE PKWY	MINOR ARTERIAL	1739	2	12	1	1900	45	7
2726	1949	426	MORRISVILLE PKWY	MINOR ARTERIAL	802	1	12	1	1750	45	7
2727	1950	1951	LOUIS STEPHENS DR	COLLECTOR	736	1	12	0	1700	40	10
2728	1951	1952	LOUIS STEPHENS DR	COLLECTOR	1733	1	12	0	1700	40	10
2729	1952	1953	LOUIS STEPHENS DR	COLLECTOR	1238	1	12	0	1700	40	10

Link #	Up-Stream Node	Down-Stream Node	Roadway Name	Roadway Type	Length (ft.)	No. of Lanes	Lane Width (ft.)	Shoulder Width (ft.)	Saturation Flow Rate (pcphpl)	Free Flow Speed (mph)	Grid Map Number
2730	1953	1954	LOUIS STEPHENS DR	COLLECTOR	644	1	12	0	1700	40	7
2731	1954	1947	LOUIS STEPHENS DR	COLLECTOR	451	2	12	0	1750	40	7
2732	1955	1956	LOUIS STEPHENS DR	MINOR ARTERIAL	1542	2	13	0	1900	45	7
2733	1956	1353	LOUIS STEPHENS DR	MINOR ARTERIAL	745	2	13	0	1900	45	7
2734	1957	1254	STEWART ST	COLLECTOR	1659	1	10	0	1750	40	30
2735	1958	226	US 401	COLLECTOR	727	1	12	0	1750	40	30
2736	1958	1574	US 401	MINOR ARTERIAL	2387	2	12	0	1900	40	30
2737	1959	989	SR 42	COLLECTOR	5313	1	12	1	1700	60	31
2738	1959	991	SR 42	COLLECTOR	3542	1	12	1	1700	60	31
2739	1960	988	HILLTOP RD	LOCAL ROADWAY	1598	1	10	1	1750	40	31
2740	1961	1959	OLD STAGE RD	COLLECTOR	4063	1	11	2	1750	40	31
2741	1962	388	MILL CREEK DR	LOCAL ROADWAY	746	1	11	2	1750	40	30
2742	1963	1962	JOHNSON POND RD	COLLECTOR	2336	1	11	2	1700	40	30
2743	1964	1436	ARTHUR PIERCE RD	COLLECTOR	818	1	12	2	1750	40	23
2744	1964	1966	ARTHUR PIERCE RD	COLLECTOR	1349	1	12	2	1700	40	23
2745	1965	1964	ONYX CREEK DR	LOCAL ROADWAY	862	1	12	0	1350	30	23
2746	1966	1892	ARTHUR PIERCE RD	COLLECTOR	1988	1	12	2	1700	40	23
2747	1967	463	KILDAIRE FARM RD	MINOR ARTERIAL	1002	2	13	0	1750	50	19
2748	1968	463	LOCH HIGHLANDS DR	LOCAL ROADWAY	1247	1	12	2	1750	40	19
2749	1970	1693	CARPENTER FIRE STATION RD	COLLECTOR	944	1	12	0	1700	40	6
2750	1971	1710	CARPENTER FIRE STATION RD	MINOR ARTERIAL	2160	2	12	0	1900	40	6
2751	1972	1971	CARY GLEN BLVD	COLLECTOR	533	1	12	4	1750	40	6
2752	1973	356	HIGH HOUSE RD	MINOR ARTERIAL	2989	2	13	0	1750	50	10
2753	1974	1023	GREEN LEVEL CHURCH RD	COLLECTOR	551	1	12	0	1700	40	18
2754	1975	1974	CREEKSIDE LANDING DR	LOCAL ROADWAY	473	1	12	0	1750	40	18
2755	1976	1975	CREEKSIDE LANDING DR	LOCAL ROADWAY	638	1	12	0	900	20	18
2756	1977	1912	YATES STORE RD	MINOR ARTERIAL	1273	2	12	0	1900	40	9
2757	1978	1448	WHITCOMB LN	LOCAL ROADWAY	661	1	10	0	1700	40	23

Link #	Up-Stream Node	Down-Stream Node	Roadway Name	Roadway Type	Length (ft.)	No. of Lanes	Lane Width (ft.)	Shoulder Width (ft.)	Saturation Flow Rate (pcphpl)	Free Flow Speed (mph)	Grid Map Number
2758	1979	1073	LAKE PINE DR	COLLECTOR	518	1	13	4	1700	40	11
2759	1980	1979	TWO CREEKS RD	LOCAL ROADWAY	1466	1	12	6	1700	40	11
2760	1981	394	KILDAIRE FARM RD	COLLECTOR	229	1	12	4	1750	25	11
2761	1982	317	E CHATHAM ST	COLLECTOR	1118	1	12	0	1350	30	12
2762	1983	1982	WALKER ST	LOCAL ROADWAY	869	1	10	0	1750	30	12
2763	1984	318	E CHATHAM ST	COLLECTOR	423	1	12	0	900	20	12
2764	1985	709	SHOPPING CENTER	LOCAL ROADWAY	524	1	12	0	1750	30	12
2765	1986	1591	FARMINGTON WOODS DR	COLLECTOR	595	1	10	0	1350	30	20
2766	1987	956	FARMINGTON WOODS DR	COLLECTOR	1113	1	10	0	1350	30	20
2767	1988	967	W CHATHAM ST TRAFFIC CIRCLE	COLLECTOR	288	1	12	0	900	20	11
2768	1989	695	W CHATHAM ST	MINOR ARTERIAL	1414	2	12	0	1750	30	11
2769	1990	1989	N DIXON AVE	LOCAL ROADWAY	705	1	10	0	1750	30	11
2770	1991	1992	APEX PEAKWAY	COLLECTOR	1030	1	12	4	1700	40	18
2771	1992	1450	APEX PEAKWAY	COLLECTOR	770	1	12	4	1750	40	18
2772	1993	1799	HUNTER ST	COLLECTOR	1907	1	16	0	1750	30	18
2773	1994	426	DAVIS DR	MINOR ARTERIAL	1450	2	13	0	1750	50	7
2774	1995	1994	DAVIS DR	MINOR ARTERIAL	1387	2	13	0	1900	50	10
2775	1996	1082	MORRISVILLE PKWY	MINOR ARTERIAL	1622	2	12	0	1900	40	7
2776	1997	364	TOWN HALL DR	COLLECTOR	825	1	12	0	1750	40	8
2777	1998	972	CRABTREE CROSSING PKWY	LOCAL ROADWAY	670	1	12	0	1750	30	8
2778	1999	982	BRISTOL CREEK DR	LOCAL ROADWAY	435	1	12	0	1750	30	8
2779	3000	807	SR 42	COLLECTOR	331	1	12	1	1750	55	34
2780	3001	735	LAFAYETTE RD	LOCAL ROADWAY	673	1	12	0	1750	40	42
2781	3002	680	TRYON RD	COLLECTOR	292	1	12	0	1750	40	19
2782	3002	719	TRYON RD	MINOR ARTERIAL	334	2	12	0	1750	45	19
2783	3003	3004	TRYON RD	MINOR ARTERIAL	1045	2	13	0	1750	50	25
2784	3004	3005	TRYON RD	MINOR ARTERIAL	2641	2	13	0	1900	50	25
2785	3005	3006	TRYON RD	MINOR ARTERIAL	2158	2	13	0	1750	50	25

Link #	Up-Stream Node	Down-Stream Node	Roadway Name	Roadway Type	Length (ft.)	No. of Lanes	Lane Width (ft.)	Shoulder Width (ft.)	Saturation Flow Rate (pcphpl)	Free Flow Speed (mph)	Grid Map Number
2786	3006	3009	GORMAN ST	MINOR ARTERIAL	663	1	12	0	1750	45	25
2787	3006	3027	TRYON RD	MINOR ARTERIAL	582	2	13	0	1900	50	25
2788	3007	3003	DILLARD DR	MINOR ARTERIAL	486	2	11	1	1750	30	25
2789	3008	3004	AVENT FERRY RD	COLLECTOR	796	1	12	0	1750	45	25
2790	3009	3006	GORMAN ST	MINOR ARTERIAL	663	2	12	0	1750	45	25
2791	3009	3026	I-40 ON-RAMP	FREEWAY RAMP	716	1	12	4	1700	40	25
2792	3010	3012	DILLARD DR	MINOR ARTERIAL	2622	1	11	1	1700	45	25
2793	3010	3013	JONES FRANKLIN RD	COLLECTOR	651	1	11	1	1750	45	20
2794	3010	3014	JONES FRANKLIN RD	COLLECTOR	1995	1	11	1	1700	45	20
2795	3011	3010	DILLARD DR	MINOR ARTERIAL	2026	1	11	1	1750	45	20
2796	3012	3007	DILLARD DR	MINOR ARTERIAL	568	1	11	1	1700	45	25
2797	3013	3010	JONES FRANKLIN RD	COLLECTOR	651	1	11	1	1750	45	20
2798	3013	3016	JONES FRANKLIN RD	COLLECTOR	1936	1	11	1	1700	45	20
2799	3014	484	JONES FRANKLIN RD	COLLECTOR	782	1	11	1	1750	45	20
2800	3014	3010	JONES FRANKLIN RD	COLLECTOR	1995	1	11	1	1750	45	20
2801	3015	357	I-40	FREEWAY	2635	3	13	8	2250	70	20
2802	3015	3028	I-40	FREEWAY	1615	3	13	8	2250	70	25
2803	3016	3018	JONES FRANKLIN RD	COLLECTOR	2183	1	11	1	1700	45	13
2804	3017	3019	I-440 ON-RAMP	FREEWAY RAMP	650	1	12	0	1700	40	13
2805	3018	3017	JONES FRANKLIN RD	COLLECTOR	1711	1	11	1	1750	45	13
2806	3019	1701	I-440 ON-RAMP	FREEWAY RAMP	849	1	12	0	1700	40	13
2807	3020	3013	CROSSROADS BLVD	COLLECTOR	704	1	12	0	1750	45	20
2808	3021	3017	I-440 OFF-RAMP	FREEWAY RAMP	400	1	12	0	1750	40	13
2809	3022	3023	I-40	FREEWAY	4009	3	13	8	2250	70	25
2810	3022	3028	I-40	FREEWAY	2002	3	13	8	2250	70	25
2811	3023	3022	I-40	FREEWAY	4009	3	13	8	2250	70	25
2812	3023	3024	I-40	FREEWAY	1993	3	13	8	2250	70	25
2813	3024	3023	I-40	FREEWAY	1978	3	13	8	2250	70	25

Link #	Up-Stream Node	Down-Stream Node	Roadway Name	Roadway Type	Length (ft.)	No. of Lanes	Lane Width (ft.)	Shoulder Width (ft.)	Saturation Flow Rate (pcphpl)	Free Flow Speed (mph)	Grid Map Number
2814	3024	3029	I-40	FREEWAY	836	3	13	8	2250	70	25
2815	3025	3009	I-40 OFF-RAMP	FREEWAY RAMP	441	1	12	4	1750	40	25
2816	3026	3024	I-40 ON-RAMP	FREEWAY RAMP	432	1	12	4	1700	40	25
2817	3027	1041	TRYON RD	MINOR ARTERIAL	469	2	13	0	1425	50	25
2818	3028	3015	I-40	FREEWAY	1614	3	13	8	2250	70	25
2819	3028	3022	I-40	FREEWAY	2002	3	13	8	2250	70	25
2820	3029	359	I-40	FREEWAY	1028	3	13	8	2250	65	25
2821	3029	3024	I-40	FREEWAY	836	3	13	8	2250	70	25
2822	3030	1700	I-440	FREEWAY	417	2	13	0	2250	65	13
2823	3030	1701	I-440	FREEWAY	408	2	13	0	2250	65	13
2824	8020	20	I-40	FREEWAY	1643	3	13	8	2250	70	12
2825	8160	1800	SR 87	MINOR ARTERIAL	1774	2	12	0	1900	60	39
2826	8222	1817	US 401	MINOR ARTERIAL	3847	2	12	0	1900	55	43
2827	8224	224	US 401	MINOR ARTERIAL	1972	2	13	3	1900	50	31
2828	8230	1815	US 421 BYPASS	MINOR ARTERIAL	1414	2	13	6	1900	70	32
2829	8359	359	I-40	FREEWAY	911	3	13	8	2250	65	25
2830	8375	1700	I-440	FREEWAY	614	2	13	0	2250	65	13
2831	8590	1680	US 1	FREEWAY	752	2	13	2	2250	70	38
(Exit Link)	20	8020	I-40	FREEWAY	1643	3	13	8	2250	70	12
(Exit Link)	137	8137	US 64	MINOR ARTERIAL	2272	2	12	4	1900	60	14
(Exit Link)	224	8224	US 401	MINOR ARTERIAL	1972	2	13	3	1900	50	31
(Exit Link)	359	8359	I-40	FREEWAY	911	3	13	8	2250	65	25
(Exit Link)	428	8428	AVIATION PKWY	COLLECTOR	1499	1	11	0	1700	50	8
(Exit Link)	125	8125	SR 87	COLLECTOR	1885	1	10	0	1700	60	14
(Exit Link)	392	8392	SR 55	COLLECTOR	1130	1	12	0	1700	45	42
(Exit Link)	732	8732	TEN-TEN RD	COLLECTOR	2733	1	12	0	1700	50	31
(Exit Link)	788	8788	SR 902	COLLECTOR	2942	1	10	0	1700	60	14
(Exit Link)	989	8989	SR 42	COLLECTOR	3212	1	12	1	1700	60	37

Link #	Up-Stream Node	Down-Stream Node	Roadway Name	Roadway Type	Length (ft.)	No. of Lanes	Lane Width (ft.)	Shoulder Width (ft.)	Saturation Flow Rate (pcphpl)	Free Flow Speed (mph)	Grid Map Number
(Exit Link)	1027	8127	SR 78	COLLECTOR	679	1	12	0	1700	50	39
(Exit Link)	1041	8041	TRYON RD	MINOR ARTERIAL	777	2	13	0	1425	50	25
(Exit Link)	1094	8194	LAKE WHEELER RD	COLLECTOR	675	1	13	0	1275	50	25
(Exit Link)	1101	8101	SR 210	COLLECTOR	2082	1	12	1	1700	55	37
(Exit Link)	1290	8290	SR 540 TOLL	FREEWAY	1166	3	13	8	2250	70	7
(Exit Link)	1298	8298	FARRINGTON POINT RD	COLLECTOR	2121	1	10	0	1275	50	5
(Exit Link)	1597	8355	SR 54	COLLECTOR	964	1	12	1	1700	50	7
(Exit Link)	1680	8590	US 1	FREEWAY	752	2	13	2	2250	70	38
(Exit Link)	1700	8375	I-440	FREEWAY	614	2	13	0	2250	65	13
(Exit Link)	1702	8190	US 15	MINOR ARTERIAL	1572	2	12	2	1425	40	4
(Exit Link)	1704	8352	DAVIS DR	MINOR ARTERIAL	702	2	13	0	1425	50	7
(Exit Link)	1705	8589	WESTON PKWY	MINOR ARTERIAL	752	2	12	0	1425	45	8
(Exit Link)	1706	8430	N HARRISON AVE	MINOR ARTERIAL	419	2	12	0	1425	50	8
(Exit Link)	1800	8160	SR 87	MINOR ARTERIAL	1775	2	12	0	1900	60	39
(Exit Link)	1815	8230	US 421 BYPASS	MINOR ARTERIAL	1414	2	13	6	1900	70	32
(Exit Link)	1817	8222	US 401	MINOR ARTERIAL	3841	2	12	0	1900	55	43
(Exit Link)	1822	8666	US 421	COLLECTOR	215	1	13	2	1700	60	43
(Exit Link)	1932	8667	SR 55	MINOR ARTERIAL	1283	2	12	4	1425	55	2
(Exit Link)	1969	8276	SR 751	COLLECTOR	599	1	11	1	1275	60	1

Table K-2. Nodes in the Link-Node Analysis Network which are Controlled

Node	X Coordinate (ft)	Y Coordinate (ft)	Control Type	Grid Map Number
8	1999441	689656	TCP - Uncontrolled	28
12	2070278	744456	Actuated	12
14	2075469	743529	Actuated	12
19	2073980	744391	Actuated	12
21	2047960	689024	TCP - Actuated	29
25	2047282	704072	Stop	22
28	2048995	707746	TCP - Actuated	22
32	2044990	694251	TCP - Actuated	29
33	2045516	692088	Actuated	29
35	2049647	687765	TCP - Actuated	29
41	2082171	682459	Actuated	31
42	2067264	670650	TCP - Actuated	30
46	2067129	680499	TCP - Uncontrolled	30
47	2065658	683510	TCP - Actuated	30
52	2059768	697831	TCP - Actuated	30
60	2053271	718029	TCP - Actuated	19
61	2087320	693136	Actuated	31
68	2047566	714716	TCP - Actuated	22
74	1965194	690841	Stop	27
75	2020694	698128	TCP - Actuated	29
80	1984121	621542	Stop	39
90	1954065	659579	TCP - Uncontrolled	32
109	1941536	635649	Actuated	38
110	1942392	634964	Actuated	38
113	1950379	728023	Stop	14
119	2053077	725655	TCP - Actuated	19
120	2048972	727113	TCP - Actuated	18
127	2035059	727140	Stop	18
128	2014889	724659	TCP - Actuated	16
130	1999869	723007	TCP - Actuated	16
140	2046619	687740	Actuated	29
141	1956842	716368	Stop	15
143	1947621	717102	TCP - Actuated	14
144	1944491	717290	Actuated	14
146	1946879	715767	Actuated	14
155	2047057	662931	TCP - Actuated	35
156	2044173	685112	Actuated	29
158	2040189	684450	TCP - Uncontrolled	29
162	2064583	642505	Stop	36
165	2066016	652980	Stop	36
168	1947400	717626	Actuated	14
172	2067757	643002	Stop	36

Node	X Coordinate (ft)	Y Coordinate (ft)	Control Type	Grid Map Number
175	1950450	729938	TCP - Actuated	14
176	2055618	641611	Stop	36
177	2044645	661361	Stop	35
188	1974946	751975	Actuated	4
190	1974658	753437	Actuated	4
193	2089395	697215	Actuated	31
201	2071545	672139	TCP - Actuated	30
202	2065828	670408	TCP - Actuated	30
204	2059553	669309	Actuated	36
210	2054659	651585	TCP - Actuated	36
212	2055536	640205	TCP - Uncontrolled	36
215	2050868	620478	TCP - Actuated	42
225	2080280	680730	Stop	30
226	2061493	670229	TCP - Actuated	30
228	2059545	667658	TCP - Actuated	36
229	2059609	666239	Stop	36
230	1946818	711976	TCP - Actuated	14
233	1948567	717097	Stop	14
235	2019117	702763	TCP - Actuated	21
245	2015628	713362	TCP - Uncontrolled	16
256	1977056	681662	Stop	27
272	1964063	715075	TCP - Uncontrolled	15
278	2007800	695316	Stop	28
281	1969674	704394	Stop	15
290	2035080	712453	Stop	22
291	2038786	717442	Actuated	22
293	2033050	715946	Stop	21
294	2043315	719675	TCP - Actuated	18
295	2032980	717690	Actuated	17
297	2044865	722844	TCP - Actuated	18
299	2030814	722496	TCP - Actuated	17
301	2044802	729086	TCP - Actuated	18
302	2030927	729914	Stop	17
305	2051106	731750	Actuated	19
308	2057248	735717	Actuated	11
311	2059665	740195	Actuated	11
312	2058052	737803	Actuated	11
314	2027982	720698	Stop	17
316	2065050	741627	Actuated	11
319	2044160	719291	TCP - Actuated	18
320	2045913	718167	TCP - Actuated	18
322	2034441	740371	TCP - Actuated	10
323	2033247	739852	TCP - Actuated	9

Node	X Coordinate (ft)	Y Coordinate (ft)	Control Type	Grid Map Number
324	2029806	739306	Stop	9
325	2037254	726912	TCP - Actuated	18
326	2036746	727780	TCP - Actuated	18
327	2036517	728556	TCP - Actuated	18
329	2029384	743577	Stop	9
330	2038381	741705	TCP - Actuated	10
331	2029598	745706	Actuated	9
332	2037477	753597	Actuated	7
335	2037276	754590	Actuated	7
338	2052995	732417	TCP - Actuated	19
339	2052639	733173	Stop	19
344	2049149	736628	Actuated	10
347	2029058	754359	Actuated	6
350	2078364	734519	TCP - Uncontrolled	12
351	2050923	742172	Actuated	11
354	2045466	743072	Actuated	10
356	2042502	742352	Actuated	10
360	2045214	753433	Actuated	7
361	2078796	734213	TCP - Uncontrolled	12
364	2051011	754037	Actuated	8
366	2053670	750988	Actuated	8
367	2054584	749898	Actuated	8
368	2055855	748759	Actuated	11
372	2060736	745762	Actuated	11
373	2061087	746065	Actuated	11
377	2056482	740180	Actuated	11
382	2061486	740083	Stop	11
385	2059053	737377	Actuated	11
388	2073632	673939	Actuated	30
389	2061641	735889	Stop	11
390	2064862	735798	Actuated	11
393	2065274	739804	Actuated	11
394	2065036	740107	Actuated	11
396	2036952	731993	TCP - Actuated	18
397	2070141	737484	Actuated	12
398	2070139	735970	Actuated	12
399	2037620	736439	Actuated	10
400	2038241	740330	Actuated	10
402	2045714	736662	Actuated	10
403	2069690	734488	Stop	12
405	2045255	739858	Actuated	10
406	2064375	732401	Actuated	19
407	2064470	730856	Actuated	19

Node	X Coordinate (ft)	Y Coordinate (ft)	Control Type	Grid Map Number
408	2048098	743581	Actuated	10
411	2056997	729838	Actuated	19
414	2054173	746569	Actuated	11
415	2072084	734095	Actuated	12
416	2073721	733422	Actuated	20
417	2067320	727931	Actuated	20
419	2066348	730767	Actuated	20
420	2055654	748119	Actuated	11
421	2065279	730947	Actuated	19
423	2044996	747389	Actuated	10
424	2061502	670638	TCP - Actuated	30
425	2059347	673098	TCP - Actuated	30
426	2045132	751130	Actuated	7
429	2064511	747188	Actuated	11
432	2070166	743309	Actuated	12
434	2032860	726961	TCP - Uncontrolled	17
436	2014497	699837	TCP - Actuated	28
439	2049328	693442	TCP - Actuated	29
441	2048707	695452	TCP - Actuated	29
444	2049470	703635	TCP - Actuated	22
445	2047822	714238	TCP - Actuated	22
446	2017765	688277	Yield	28
447	2053751	717453	TCP - Actuated	23
452	2022080	693422	TCP - Actuated	29
453	2005753	698042	Stop	28
454	2061110	711000	TCP - Actuated	23
459	2062986	715813	TCP - Actuated	23
462	1994896	708148	TCP - Actuated	16
463	2065234	718228	Actuated	19
468	2065584	722944	Actuated	20
469	2065424	724164	TCP - Actuated	19
470	2066488	724840	Actuated	20
474	2070608	725651	Actuated	20
477	1974482	729991	Stop	15
479	2075572	726548	Actuated	20
483	2077982	726417	Actuated	20
484	2077996	727338	Actuated	20
487	2076159	723441	Actuated	20
489	1970256	743880	Stop	4
494	1986638	751160	Stop	5
501	2071003	713192	TCP - Actuated	24
511	2067620	708057	TCP - Actuated	24
516	1955536	669983	TCP - Uncontrolled	33

Node	X Coordinate (ft)	Y Coordinate (ft)	Control Type	Grid Map Number
520	2061399	700574	TCP - Actuated	30
525	2064730	705511	Actuated	23
529	2072634	704670	Actuated	24
533	1943002	656503	Stop	32
534	1943056	656030	Stop	32
538	2087233	699252	Actuated	31
539	1960903	618336	Actuated	39
540	1955065	624037	Actuated	39
543	1952902	624579	Actuated	38
544	1950250	626058	Actuated	38
545	1948541	626475	Actuated	38
548	2084052	694695	Stop	31
551	1946260	629682	Actuated	38
553	1944803	631869	Actuated	38
554	1947252	630371	Stop	38
555	2052393	693406	TCP - Actuated	30
556	1946472	632599	Actuated	38
558	1950524	631059	Pretimed	38
559	1950206	632538	Actuated	38
561	1952213	631516	Actuated	38
563	2059967	715242	TCP - Actuated	23
567	2038187	747209	Actuated	10
582	2039656	709678	TCP - Uncontrolled	22
583	2058130	724511	TCP - Actuated	19
584	2059939	723938	TCP - Actuated	19
585	2045587	720998	TCP - Actuated	18
594	1999732	612553	Stop	40
595	1944602	647896	Actuated	32
604	1948597	717577	Stop	14
605	1946279	717661	Stop	14
606	1946264	717201	Stop	14
609	2064473	743210	Actuated	11
611	1950297	726257	Actuated	14
613	1972036	747081	Actuated	4
615	2056184	679030	TCP - Actuated	30
619	2076342	703575	Actuated	24
621	2067189	734260	Stop	12
622	1989322	614478	Actuated	40
623	1990028	753667	Stop	5
625	1994828	753229	Actuated	5
631	2035972	728111	Stop	18
635	2011381	739559	TCP - Uncontrolled	5
655	1975202	723130	TCP - Actuated	15

Node	X Coordinate (ft)	Y Coordinate (ft)	Control Type	Grid Map Number
656	2039156	736476	Stop	10
660	2037891	726220	TCP - Actuated	18
664	1970509	615416	Actuated	39
665	2038474	725536	TCP - Actuated	18
667	2036248	757296	Actuated	7
671	2044078	727655	TCP - Actuated	18
673	2044205	727978	TCP - Actuated	18
677	2065089	743120	Actuated	11
680	2063142	723270	TCP - Actuated	19
681	2064167	723527	Actuated	19
683	2079347	726697	Actuated	20
684	2037454	726053	Stop	18
685	2076883	728241	Actuated	20
687	2075487	732703	Actuated	20
688	2076879	731385	Actuated	20
694	2040761	722747	TCP - Actuated	18
695	2064426	741563	Actuated	11
700	2051948	754649	Actuated	8
701	2040471	755173	Actuated	7
703	2044496	721572	Actuated	18
709	2071156	737580	Actuated	12
710	2039978	723845	TCP - Actuated	18
711	2042067	724551	Stop	18
712	2069102	737308	Actuated	12
714	2061590	730507	Actuated	19
715	2056610	694320	Actuated	30
719	2063100	723046	TCP - Actuated	19
728	2058065	712350	TCP - Actuated	23
735	2054859	633732	TCP - Actuated	42
736	2080119	683454	Actuated	30
742	1987652	696209	TCP - Actuated	28
757	2044194	718078	Stop	18
758	2047251	715337	TCP - Actuated	22
779	2057967	689209	Stop	30
782	1944504	718416	Yield	14
785	1944226	712920	Stop	14
792	2066284	720506	Actuated	20
796	1947325	716924	Yield	14
797	1985736	678784	TCP - Actuated	27
798	1984765	678941	TCP - Uncontrolled	27
806	1972050	679304	TCP - Actuated	27
807	1997055	659905	TCP - Actuated	34
808	1989890	650939	TCP - Actuated	34

Node	X Coordinate (ft)	Y Coordinate (ft)	Control Type	Grid Map Number
811	1988153	649903	TCP - Uncontrolled	34
822	1967780	639559	TCP - Uncontrolled	33
830	2072154	723972	Actuated	20
832	2072930	726461	Actuated	20
842	1983819	636801	TCP - Actuated	39
847	1972139	625999	Stop	39
852	1971374	623780	TCP - Actuated	39
853	1967154	622369	Actuated	39
855	1956669	622309	Actuated	39
856	1965556	622662	Actuated	39
861	2064554	728393	Actuated	19
872	2005387	663682	Stop	34
875	2000269	661575	TCP - Uncontrolled	34
898	1987245	671347	Stop	28
900	1992200	667455	TCP - Uncontrolled	34
903	1972910	675290	TCP - Actuated	27
908	1980523	666745	Stop	33
921	1965494	650136	TCP - Uncontrolled	33
931	2064408	733458	Actuated	19
943	1952130	647813	Stop	32
957	2061587	667715	Actuated	36
958	2061645	666344	Stop	36
961	2072289	667103	Actuated	36
964	2075035	651602	Stop	36
967	2062178	741117	Yield	11
969	2077185	639831	Actuated	36
972	2051546	750302	Actuated	8
974	2076201	639867	Stop	36
982	2052733	749712	Actuated	8
985	2071647	671728	Stop	30
987	2079564	669980	Stop	36
988	2083925	671232	Actuated	31
995	1946969	689499	Stop	26
998	2076612	732108	Actuated	20
999	2076549	731200	Actuated	20
1004	2042306	743429	Stop	10
1011	2056647	724891	TCP - Actuated	19
1018	2046306	722292	Actuated	18
1020	2050172	731311	Stop	19
1032	2058169	675161	TCP - Actuated	30
1033	2058645	674406	TCP - Actuated	30
1039	2076823	730163	Actuated	20
1040	2076999	725801	Actuated	20

Node	X Coordinate (ft)	Y Coordinate (ft)	Control Type	Grid Map Number
1042	2087084	691956	Actuated	31
1045	2067482	669288	Actuated	36
1053	2023776	607438	Stop	41
1058	1967356	616905	Actuated	39
1059	1961782	617005	Actuated	39
1061	1958849	623293	Actuated	39
1062	1959436	619642	Actuated	39
1065	2067235	729694	Actuated	20
1076	2048281	739098	Actuated	10
1081	2050352	750330	Stop	8
1086	2056661	714857	Stop	23
1089	2093541	716291	Actuated	25
1092	2092678	710015	Actuated	25
1096	2071591	696330	Actuated	30
1097	2075681	695207	Stop	30
1099	2062492	663830	Actuated	36
1100	2059473	663769	TCP - Actuated	36
1127	2043501	695500	TCP - Uncontrolled	29
1128	2039113	695287	Stop	29
1134	2026771	679228	TCP - Actuated	29
1137	2020516	698761	TCP - Actuated	29
1218	2060924	723579	TCP - Actuated	19
1219	2062495	723846	TCP - Uncontrolled	19
1220	2051786	718823	TCP - Actuated	19
1223	1936407	641843	Actuated	32
1225	1943997	633147	Actuated	38
1227	1946504	629359	Actuated	38
1229	1946927	628108	Actuated	38
1233	1951647	625241	Actuated	38
1237	1958936	620176	Actuated	39
1240	2053379	629477	TCP - Uncontrolled	42
1248	2062239	622864	TCP - Actuated	42
1250	2059561	666846	Actuated	36
1254	2062934	674488	Actuated	30
1258	2065716	671075	Actuated	30
1261	2067219	671527	TCP - Actuated	30
1264	2051320	685430	Actuated	30
1271	2046700	716513	Actuated	22
1277	2040215	717591	Stop	22
1280	2039190	723038	Actuated	18
1281	2044847	724779	Actuated	18
1285	2037823	751286	Actuated	7
1287	2034173	760332	Actuated	7

Node	X Coordinate (ft)	Y Coordinate (ft)	Control Type	Grid Map Number
1288	2034020	760581	Yield	7
1293	2033357	761591	Actuated	6
1294	2032537	762835	Actuated	6
1300	1972797	749669	Actuated	4
1304	1956343	670718	Stop	27
1309	2017498	688299	Stop	28
1312	2024531	684363	Stop	29
1319	2047189	688325	Actuated	29
1327	1944475	718639	Yield	14
1330	1951184	716926	Actuated	14
1351	2041095	758079	Stop	7
1352	2042931	758767	Actuated	7
1355	2050092	760836	Actuated	8
1360	2055151	749107	Actuated	11
1369	2076980	726467	Actuated	20
1376	2047614	720347	TCP - Actuated	18
1377	2047726	718225	Stop	18
1381	2045506	741919	Actuated	10
1382	2044392	742522	Actuated	10
1383	2045276	752361	Actuated	7
1387	2045058	754440	Actuated	7
1391	2064523	747992	Actuated	11
1394	2048586	739883	Actuated	10
1402	2068142	727083	Actuated	20
1406	2076798	729153	Actuated	20
1409	2074604	733109	Actuated	20
1412	2070953	735159	Actuated	12
1414	2070116	739275	Actuated	12
1418	2059138	744555	Actuated	11
1420	2056530	741260	Actuated	11
1422	2062479	735938	Actuated	11
1424	2063891	735820	Actuated	11
1426	2064848	737158	Actuated	11
1428	2064795	735112	Actuated	11
1430	2064628	734385	Actuated	11
1432	2064403	731653	Actuated	19
1434	2065187	725185	Actuated	19
1436	2060905	709157	Actuated	23
1437	2076035	730278	Actuated	20
1446	2084913	686383	Actuated	31
1448	2059714	715875	Stop	23
1449	2047639	722113	Actuated	18
1450	2046967	723588	Actuated	18

Node	X Coordinate (ft)	Y Coordinate (ft)	Control Type	Grid Map Number
1451	2044108	720856	TCP - Actuated	18
1455	2077617	639779	Actuated	36
1458	2069534	671416	TCP - Actuated	30
1463	2061130	696013	Actuated	30
1465	2062546	721534	Actuated	19
1467	2061765	720253	Actuated	19
1469	2060671	718419	TCP - Uncontrolled	19
1475	2068505	663574	TCP - Uncontrolled	36
1476	2068092	662945	Stop	36
1479	2065367	649100	Stop	36
1481	1964162	622963	Actuated	39
1486	1945467	645300	Yield	32
1487	1946776	639802	Actuated	32
1489	1947027	630239	Actuated	38
1491	1946708	630040	Actuated	38
1493	1958072	623031	Actuated	39
1497	2047357	680670	Stop	29
1499	2063442	664975	Actuated	36
1501	2064798	667610	TCP - Actuated	36
1502	2065455	669353	Actuated	36
1504	2060033	667669	Actuated	36
1508	2081170	694803	Stop	30
1511	2072104	698593	Actuated	30
1512	1948867	630758	Actuated	38
1514	1947978	630591	Actuated	38
1522	2076025	731913	Actuated	20
1538	2031386	727499	TCP - Actuated	17
1539	2030816	726775	Stop	17
1541	2031323	726138	TCP - Actuated	17
1544	2031555	726809	TCP - Uncontrolled	17
1549	2035314	712719	TCP - Actuated	22
1550	2036256	713805	TCP - Actuated	22
1553	2037789	707873	TCP - Uncontrolled	22
1555	2036817	707961	TCP - Uncontrolled	22
1564	2048015	706196	TCP - Uncontrolled	22
1576	2066578	670436	TCP - Actuated	30
1578	2037222	734302	TCP - Uncontrolled	10
1579	2071399	684366	TCP - Uncontrolled	30
1581	1988451	627968	TCP - Uncontrolled	40
1586	1999201	735691	TCP - Uncontrolled	5
1591	2066802	732113	Stop	20
1598	1987969	723455	Stop	16
1606	2051115	732541	Stop	19

Node	X Coordinate (ft)	Y Coordinate (ft)	Control Type	Grid Map Number
1621	2045992	743265	Actuated	10
1627	2049201	698853	Actuated	29
1629	2058716	696212	Stop	30
1637	2045202	744706	Actuated	10
1640	2045368	743925	Actuated	10
1642	2028893	738491	Stop	9
1646	2021590	736279	Stop	9
1654	2013265	740828	Stop	5
1655	2011086	740520	Stop	5
1668	2029097	747734	Actuated	9
1673	2028671	750706	Actuated	6
1674	2029012	752984	Actuated	6
1681	1955731	621905	Actuated	39
1684	1945530	645408	TCP - Uncontrolled	32
1685	1945387	645467	Yield	32
1687	1945104	646047	Yield	32
1690	1945178	645898	Yield	32
1691	2075417	650251	Actuated	36
1693	2026821	754857	Stop	6
1696	2029800	709364	Stop	21
1726	2032700	726931	TCP - Uncontrolled	17
1734	2031866	726845	TCP - Uncontrolled	17
1790	1928438	652681	Actuated	32
1816	2058677	607416	TCP - Actuated	42
1820	2054963	600425	Actuated	43
1821	2054137	598137	Actuated	43
1824	2056056	609331	Actuated	42
1826	2057507	608286	Actuated	42
1829	2054266	598530	Actuated	43
1832	2052718	601100	Actuated	43
1837	2054638	599613	Actuated	43
1843	1985059	734035	Stop	4
1846	1984459	730582	Stop	15
1849	1982945	723893	Stop	15
1852	2018982	675459	Stop	29
1858	2029272	735980	Stop	9
1868	2054057	597538	Actuated	43
1874	2060943	666344	Stop	36
1877	2073147	659058	Stop	36
1883	2076217	685036	Actuated	30
1896	2016726	769924	Actuated	1
1897	2026848	761770	Stop	6
1909	2029816	761559	Actuated	6

Node	X Coordinate (ft)	Y Coordinate (ft)	Control Type	Grid Map Number
1912	2023725	750055	Stop	6
1922	2029675	756802	Actuated	6
1930	2030394	768397	Actuated	2
1931	2031564	768308	Actuated	2
1936	2027245	757139	Yield	6
1947	2040064	750939	Actuated	7
1959	2092158	670342	Actuated	31
1962	2072886	673931	Stop	30
1964	2061700	708960	Stop	23
1971	2030386	754539	Actuated	6
1974	2034443	727807	Actuated	18
1979	2060721	734679	Stop	11
1982	2065821	741641	Actuated	12
1989	2063025	741369	Actuated	11
3003	2082948	727577	Actuated	25
3004	2083980	727746	Actuated	25
3006	2088689	727592	Actuated	25
3009	2088784	728248	Actuated	25
3010	2079973	729283	Actuated	20
3013	2080233	729880	Actuated	20
3017	2082271	735286	Actuated	13

¹Coordinates are in the North American Datum of 1983 North Carolina State Plane Zone

APPENDIX L
Zone Boundaries

L. ZONE BOUNDARIES

Zone A	<p><u>County: Wake</u></p> <p>This portion of the Zone includes the Harris Nuclear Plant and the central portion of the Harris Lake. It is bordered by Old US Hwy. 1 and New Hill- Holleman Rd. The lake forms the border to the south.</p> <p><u>County: Chatham</u></p> <p>This portion of the Zone includes Chatham County area west of the Harris Nuclear Plant and is bordered by Old US Hwy. 1, Christian Chapel Rd. and the Chatham-Wake County line.</p>
Zone B	<p><u>County: Wake</u></p> <p>This portion of the Zone includes the communities of New Hill and Bonsal and the areas around the following roads: Old US Hwy. 1, Humie Olive Rd., New Hill-Olive Chapel Rd., Friendship Rd., US Hwy. 1, Shearon Harris Rd. and New Hill Holleman Rd.</p> <p><u>County: Chatham</u></p> <p>This portion of the Zone includes the area west of New Hill-Olive Chapel Rd, bounded to the north by Beaver Creek, to the west by Jordan Lake, and to the south by Little Beaver Creek. It includes the New Hope Estates, Sears Plantation and Weaver Crossing subdivisions.</p>
Zone C	<p><u>County: Wake</u></p> <p>This Zone includes the community of Holleman’s Crossroads, the northeast portion of Harris Lake and the areas surrounding Avent Ferry Rd. and New Hill Rd.</p>
Zone D	<p><u>County: Wake</u></p> <p>This portion of the Zone includes the southeastern portion of Harris Lake and the area surrounding Cass Holt Rd. The Zone is bordered by Bartley Holleman Rd., Rex Rd., Buckhorn-Duncan Rd. and the Wake-Harnett/Wake-Chatham county lines.</p> <p><u>County: Harnett</u></p> <p>This portion of the Zone includes the areas surrounding Rollins Mill Rd., Hobby Rd. and Auger Hole Rd. The Zone is bordered by Harnett-Lee County line, Harnett-Wake County line and areas north of NC Hwy. 42.</p>
Zone E	<p><u>County: Wake</u></p> <p>This Zone includes the town of Apex, the community of Friendship and the areas surrounding US Hwy. 1, Old US Hwy. 1, US Hwy. 64, NC Hwy. 55, Tingen Rd. and Olive Chapel Rd. The Zone is bordered by the Wake- Chatham county line, the community of Green Level, Tenten Rd., Kildaire Farm Rd., Sunset Lake Rd. and Woods Creek Rd.</p>

Zone F	<p><u>County:</u> Wake</p> <p>This Zone includes the town of Holly Springs, Sunset Lake, Bass Lake and the areas surrounding NC Hwy. 55 Bypass, Holly Springs Rd., Avent Ferry Rd., Bass Lake Rd. and Cass Holt Rd.</p>
Zone G	<p><u>County:</u> Wake</p> <p>This Zone includes the town of Fuquay-Varina and the areas surrounding NC Hwy. 42, NC Hwy. 55, US Hwy. 401 (Main St.), Piney Grove-Wilbon Rd., Bass Lake Rd.(south of Bass Lake), James Slaughter Rd. and Sunset Lake Rd. (south of Sunset Lake). The Zone extends south to the Wake- Harnett county line and east along Kenneth Creek.</p>
Zone H	<p><u>County:</u> Harnett</p> <p>This Zone includes the community of Duncan, Camp Agape, Raven Rock Park, West Horse Trail Loop, the areas surrounding Avents Creek and the following roads: NC Hwy. 42 Rawls Church Rd., Baptist Grove Rd., Christian Light Rd., Cokesbury Rd. and River Rd. This Zone is bordered by the Chatham-Harnett-Wake county lines, Avents Creek, Christian Light Rd., Hector Creek, Rawls Church Rd. and US Hwy. 401.</p>
Zone I	<p><u>County:</u> Lee</p> <p>This Zone is bordered by the Cape Fear River and the Lee- Harnett county line. It includes the areas surrounding Poplar Springs Church Rd., Buckhorn Rd. and NC Hwy. 42. The Zone also includes areas northeast of NC Hwy. 42 and where Lower Moncure Rd. intersects RH Lane Rd.</p>
Zone J	<p><u>County:</u> Lee</p> <p>This Zone is bordered by the Deep River and Cape Fear River, and includes areas surrounding Lower Moncure Rd., Lees Chapel Rd., Rod Sullivan Rd., Deep River Rd., Lower River Rd., Ferrell Rd. and US Hwy. 1.</p>
Zone K	<p><u>County:</u> Chatham</p> <p>This Zone includes the communities of Merry Oaks and Corinth, the southern portion of Harris Lake and the areas surrounding the following roads: Old US Hwy. 1, Christian Chapel Rd., Moncure-Flat Wood Rd., Corinth Rd. and NC Hwy. 42. This Zone is bordered by the Chatham-Wake county line (on the south side), Christian Chapel Rd. (on the east side), the Chatham-Harnett county line, the Cape Fear River, the Haw River and US Hwy. 1.</p>
Zone L	<p><u>County:</u> Chatham</p> <p>This Zone includes the eastern portion of Jordan Lake and the areas around the following roads: Olive Chapel Rd., Tody Goodwin Rd., Farrington Rd., Poole Rd. east, East Goodwin Rd., New Elam Rd., Pea Ridge Rd., W.H. Jones Rd. and Old US Hwy. 1. This Zone is bordered by the Chatham-Wake county line, the eastern shore of Jordan Lake, US Hwy. 1 and the Haw River.</p>

Zone M	<p><u>County:</u> Chatham</p> <p>This Zone includes the communities of Haywood, Moncure, Hank’s Chapel, and Griffin’s Crossroads; Jordan Lake; and the areas surrounding the following roads: North Pea Ridge Rd., Gum Springs Church Rd., Clark Poe Rd., Moncure-Pittsboro Rd., Jordan Dam Rd., Mt. View Church Rd. and Providence Church Rd. East. This Zone is bordered by US Hwy. 64, the eastern shore of Jordan Lake, the Haw River and the Deep River. Also included are all areas north and east from the point where the Rocky River enters the Deep River to US Hwy. 64 at Griffin’s Crossroads.</p>
Zone N	<p><u>County:</u> Chatham</p> <p>This Zone includes the northern portion of Jordan Lake and the areas surrounding the following roads: Farrington Rd., Horton Pond Rd. and NC Hwy. 751. This Zone is bordered by US Hwy. 64, the Chatham- Wake county line, Green Level Rd. and Hollands Chapel Rd. Also, all areas east of the Farrington Rd. and Hollands Chapel Rd. intersection to US Hwy. 64 at Wilsonville Crossroads.</p>

APPENDIX M

Evacuation Sensitivity Studies

M. EVACUATION SENSITIVITY STUDIES

This appendix presents the results of a series of sensitivity analyses. These analyses are designed to identify the sensitivity of the ETE to changes in some base evacuation conditions.

M.1 Effect of Changes in Trip Generation Times

A sensitivity study was performed to determine whether changes in the estimated trip generation time have an effect on the ETE for the entire EPZ. Specifically, if the tail of the mobilization distribution were truncated (i.e., if those who responded most slowly to the Advisory to Evacuate could be persuaded to respond much more rapidly) or expanded, how would the ETE be affected? The case considered was Scenario 6, Region 3; a winter, midweek, midday, good weather evacuation of the entire EPZ. Table M-1 presents the results of this study.

Table M-1. Evacuation Time Estimates for Trip Generation Sensitivity Study

Trip Generation Time	Evacuation Time Estimate for Entire EPZ	
	90 th Percentile	100 th Percentile
2 Hours 30 Minutes	3:00	5:00
3 Hours 30 Minutes	3:00	5:00
4 Hours 30 Minutes (Base)	3:00	5:00
5 Hours 30 Minutes	3:20	5:40

Reducing the trip generation time by an hour or 2 hours has no impact on the 90th or 100th percentile ETE. The 90th and 100th percentile ETE are not sensitive to truncating the tail of the mobilization time distribution. An increase in mobilization time by 1 hour increases the 90th percentile ETE by 20 minutes and the 100th percentile ETE by 40 minutes.

As discussed in Section 7.3, traffic congestion persists within the EPZ for about 5 hours due to the large population within Apex, Holly Springs and Fuquay-Varina. As such, congestion dictates the 100th percentile ETE until 5 hours after the Advisory to Evacuate. After this time, trip generation, (plus a 10-minute travel time to the EPZ boundary), dictates the 100th percentile ETE.

M.2 Effect of Changes in the Number of People in the Shadow Region Who Relocate

A sensitivity study was conducted to determine the effect on ETE of changes in the percentage of people who decide to relocate from the Shadow Region. The case considered was Scenario 6, Region 3; a winter, midweek, midday, good weather evacuation for the entire EPZ. The movement of people in the Shadow Region has the potential to impede vehicles evacuating from an Evacuation Region within the EPZ. Refer to Sections 3.2 and 7.1 for additional information on population within the Shadow Region.

Table M-2 presents the ETE for each of the cases considered. The results show that a reduction and/or elimination of the shadow evacuation has minimal (5 minutes at the 100th percentile) to no impact on the ETE. Tripling the shadow percentage increases the ETE by 20 and 25 minutes for the 90th percentile and 100th percentile ETE, respectively. A full evacuation of the shadow population results in an increase of ETE by 50 minutes at the 90th percentile and 1 hour and 10 minutes at the 100th percentile.

Note, the telephone survey results presented in Appendix F indicate that 16 percent of households would elect to evacuate if advised to shelter, which differs from the assumption of 20 percent non-compliance suggested in NUREG/CR-7002. A sensitivity study was considered using a 16 percent shadow evacuation and the 90th and 100th percentile ETEs were minimally affected – 5 minutes at the 100th percentile and no impact at the 90th percentile.

Reducing the shadow evacuation has little impact on ETE because the traffic congestion in the major population centers within the EPZ is significant and dictates the ETE. Increasing the shadow evacuation, however, does have a significant impact on ETE because the additional vehicles using roadways outside the EPZ reduces the available roadway capacity for EPZ evacuees thereby exacerbating the traffic congestion in the major population centers.

Table M-2. Evacuation Time Estimates for Shadow Sensitivity Study

Percent Shadow Evacuation	Evacuating Shadow Vehicles	Evacuation Time Estimate for Entire EPZ	
		90 th Percentile	100 th Percentile
0	0	3:00	4:55
16	23,390	3:00	4:55
20 (Base)	29,237	3:00	5:00
60	87,711	3:20	5:25
100	146,185	3:50	6:10

M.3 Effect of Changes in EPZ Resident Population

A sensitivity study was conducted to determine the effect on ETE of changes in the resident population within the study area (EPZ plus Shadow Region). As population in the study area changes over time, the time required to evacuate the public may increase, decrease, or remain the same. Since the ETE is related to the demand to capacity ratio present within the study area, changes in population will cause the demand side of the equation to change and could impact ETE.

As per the NRC's response to the Emergency Planning Frequently Asked Question (EPFAQ) 2013-001, the ETE population sensitivity study must be conducted to determine what percentage increase in permanent resident population causes an increase in the 90th percentile ETE of 25 percent or 30 minutes, whichever is less. The sensitivity study must use the scenario with the longest 90th percentile ETE (excluding the roadway impact scenario and the special event scenario if it is a 1 day per year special event).

Thus, the sensitivity study was conducted using the following planning assumptions:

1. The percent change in population within the study area was increased up to 18%. Changes in population were applied to permanent residents only (as per federal guidance), in both the EPZ area and the Shadow Region.
2. The transportation infrastructure remained fixed; the presence of new roads or highway capacity improvements were not considered.
3. The study was performed for the 2-Mile Region (R01), the 5-Mile Region (R02) and the entire EPZ (R03).
4. The scenario (excluding roadway impact and special event) which yielded the highest 90th percentile ETE values was selected as the case to be considered in this sensitivity study (Scenario 8 – Winter, Midweek, Midday, Ice Condition).

Table M-3 presents the results of the sensitivity study. Section IV of Appendix E to 10 CFR Part 50, and NUREG/CR-7002, Section 5.4, require licensees to provide an updated ETE analysis to the NRC when a population increase within the EPZ causes the longest 90th percentile ETE values (for the 2-Mile Region, 5-Mile Region or entire EPZ) to increase by 25 percent or 30 minutes, whichever is less. Note that the base ETE values for the 2-Mile Region (R01) and 5-Mile Region (R02) are less than 2 hours; R01 criterion for updating is 14 minutes (0:55 multiplied by 25%) and R02 criterion for updating is 28 minutes (1:50 multiplied by 25%). Base ETE value for the entire EPZ (R03) is greater than 2 hours; therefore its criterion for updating is 30 minutes.

Those percent population changes which result in a 90th percentile ETE change greater than the respective criterion for each region are highlighted in red below – a 17% or greater increase in the study area population. Duke Energy will have to estimate the study area population on an annual basis. If the study area population increases by 17% or more, an updated ETE analysis will be needed.

Table M-3. ETE Variation with Population Change

EPZ and 20% Shadow Resident Population	Base	Population Change		
		16%	17%	18%
	180,025	208,829	210,629	212,430
ETE for 90 th Percentile				
Region	Base	Population Change		
		16%	17%	18%
2-MILE	0:55	0:55	0:55	0:55
5-MILE	1:50	1:55	1:55	1:55
FULL EPZ	3:35	4:00	4:05	4:05
ETE for 100 th Percentile				
Region	Base	Population Change		
		16%	17%	18%
2-MILE	4:30	4:30	4:30	4:30
5-MILE	4:35	4:35	4:35	4:35
FULL EPZ	6:10	6:55	7:00	7:00

M.4 Effect of 50% Reduction in Capacity and Free Flow Speed for Ice Scenarios

Due to the likelihood that ice on electrical lines could potentially cause loss of power at the plant, a sensitivity study was performed to determine the effect on ETE of a significant ice storm which would result in reductions in link capacity and free flow speed of 50%. The two ice scenarios (Scenarios 8 and 11) were considered for this study for the 2-Mile Region (R01), the 5-Mile Region (R02) and the entire EPZ (R03).

Table M-4 and Table M-5 present the results of the sensitivity study. The 2-Mile Region and 5-Mile Region are not materially impacted, with at most a 10 minute increase in 90th percentile ETE and no change in 100th percentile ETE. The 90th percentile for the full EPZ (R03) increases by 1 hour and 55 minutes for Scenario 8 and 1 hour and 25 minutes for Scenario 11; the 100th percentile ETE increases by 4 hours and 5 minutes for Scenario 8 and 3 hours and 40 minutes for Scenario 11.

Considering a reduction in capacity of greater than 50% would not be prudent, as the better protective action in such extreme weather conditions would be to shelter-in-place rather than evacuate.

Table M-4. ETE Variation for 50% Ice Reduction – Scenario 8

Region	Scenario 8 (Base 20% Reduction) Winter, Midweek, Midday, Ice		Scenario 8 (50% Reduction) Winter, Midweek, Midday, Ice	
	90 th Percentile	100 th Percentile	90 th Percentile	100 th Percentile
2-MILE	0:55	4:30	1:00	4:30
5-MILE	1:50	4:35	1:55	4:35
FULL EPZ	3:35	6:10	5:30	10:15

Table M-5. ETE Variation for 50% Ice Reduction – Scenario 11

Region	Scenario 11 (Base 20% Reduction) Winter, Weekend, Midday, Ice		Scenario 11 (50% Reduction) Winter, Weekend, Midday, Ice	
	90 th Percentile	100 th Percentile	90 th Percentile	100 th Percentile
2-MILE	0:50	4:30	1:00	4:30
5-MILE	1:40	4:35	1:50	4:35
FULL EPZ	3:20	5:05	4:45	7:45

M.5 Enhancements in Evacuation Time

NUREG/CR-7002 recommends that the ETE study consider potential enhancements that could improve ETE. According to the Institute of Nuclear Power Operations (INPO) timeline for the March 2011 accident at the Fukushima Daiichi Power Station, nearly 18 hours elapsed between the loss of power at the site and the first release to the atmosphere. The 90th percentile ETE for an evacuation of the entire EPZ (Region R03) is less than 3 hours and 40 minutes for all scenarios. The possible countermeasures to reduce ETE are:

- Reduce the number of vehicles on the road by educating the public to use fewer vehicles to evacuate. This is very difficult to implement as evacuees are unlikely to leave a significant economic asset such as a personal vehicle behind.
- Use contraflow or reverse-laning. This technique is so manpower and equipment intensive, 90 percent of evacuees will have already left the EPZ by the time contraflow is established. As such, ETE benefits would be minimal. Also, contraflow is a significant liability in that vehicles are traveling the wrong way on a road. Most offsite agencies are hesitant to use contraflow for this reason alone.
- Identify special treatments at critical intersections – i.e., if northbound and eastbound are both viable evacuation directions from the plant, cones and barricades could be used to channelize the intersection such that one traffic stream is directed northbound and the other eastbound to eliminate any vehicle conflict at the intersection and keep the intersection flowing continuously. This is also manpower and equipment dependent and will have little impact on ETE.

Critical intersections were identified where the use of additional traffic control could lessen ETE. Additional critical intersections were identified where the modification or removal of an existing Traffic Control Point could improve the evacuation process; refer to Appendix G.

With the exception of Traffic Control, no other enhancements are recommended for this site. The 90th percentile ETE are significantly less than the elapsed time before a release during the Fukushima Daiichi nuclear accident in Japan. Significant manpower and equipment would be needed to implement potential enhancements. The time needed to secure needed personnel and equipment would offset any potential ETE benefits.

This appendix documents sensitivity studies on critical variables that could impact ETE. Possible improvements to ETE are further discussed below:

- Reducing trip generation time does not impact the percentile ETE since congestion continues beyond the trip generation (Section M.1). For all scenarios, congestion persists for about 5 hours. Reducing trip generation time will not affect the ETE. Even though trip generation does not dictate the ETE, public outreach should be considered to inform people within the EPZ to mobilize quickly.
- A decrease in the percent shadow evacuation has minimal to no change in the ETE for the 90th percentile and 100th percentile ETEs. Increasing the percent shadow evacuation

increases the 90th percentile and 100th percentile ETEs (Section M.2). As such, public outreach could be considered to inform those people within the EPZ (and potentially beyond the EPZ) that if they are not advised to evacuate, they should not.

- Population growth results in more evacuating vehicles which could significantly increase ETE (Section M.3). Public outreach to inform those people within the EPZ to evacuate as a family in a single vehicle would reduce the number of evacuating vehicles and could reduce ETE or offset the impact of population growth.
- Evacuating during a significant ice storm can have a significant impact on ETE when evacuating the entire EPZ (Section M.4). The county emergency management agencies and local police should ensure that roadways are passable and safe to drive on prior to ordering an evacuation under extreme weather conditions.

APPENDIX N

ETE Criteria Checklist

N. ETE CRITERIA CHECKLIST

Table N-1. ETE Review Criteria Checklist

NRC Review Criteria	Criterion Addressed in ETE Analysis	Comments
1.0 Introduction		
a. The emergency planning zone (EPZ) and surrounding area should be described.	Yes	Section 1
b. A map should be included that identifies primary features of the site, including major roadways, significant topographical features, boundaries of counties, and population centers within the EPZ.	Yes	Figures 1-1, 3-1, 6-1
c. A comparison of the current and previous ETE should be provided and includes similar information as identified in Table 1-1, "ETE Comparison," of NUREG/CR-7002.	Yes	Table 1-3
1.1 Approach		
a. A discussion of the approach and level of detail obtained during the field survey of the roadway network should be provided.	Yes	Section 1.3
b. Sources of demographic data for schools, special facilities, large employers, and special events should be identified.	Yes	Sections 2.1, 3, 8
c. Discussion should be presented on use of traffic control plans in the analysis.	Yes	Section 1.3, Section 2.2, Section 9, Appendix G
d. Traffic simulation models used for the analyses should be identified by name and version.	Yes	Section 1.3, Table 1-3, Appendix B, Appendix C

NRC Review Criteria	Criterion Addressed in ETE Analysis	Comments
e. Methods used to address data uncertainties should be described.	Yes	Section 3 – avoid double counting Section 5, Appendix F – 4.5% sampling error at 95% confidence interval for telephone survey
1.2 Assumptions		
a. The planning basis for the ETE includes the assumption that the evacuation should be ordered promptly and no early protective actions have been implemented.	Yes	Section 2.3 – Assumption 1 Section 5.1 Section 8
b. Assumptions consistent with Table 1-2, “General Assumptions,” of NUREG/CR-7002 should be provided and include the basis to support their use.	Yes	Sections 2.2, 2.3
1.3 Scenario Development		
a. The ten scenarios in Table 1-3, Evacuation Scenarios, should be developed for the ETE analysis, or a reason should be provided for use of other scenarios.	Yes	Table 2-1, Section 6
1.3.1 Staged Evacuation		
a. A discussion should be provided on the approach used in development of a staged evacuation.	Yes	Sections 5.4.2, 7.2
1.4 Evacuation Planning Areas		
a. A map of EPZ with emergency response planning areas (ERPAs) should be included.	Yes	Figure 6-1
b. A table should be provided identifying the ERPAs considered for each ETE calculation by downwind direction in each sector.	Yes	Tables 6-1, 7-5, H-1

NRC Review Criteria	Criterion Addressed in ETE Analysis	Comments
c. A table similar to Table 1-4, "Evacuation Areas for a Staged Evacuation Keyhole," of NUREG/CR-7002 should be provided and includes the complete evacuation of the 2, 5, and 10 mile areas and for the 2 mile area/5 mile keyhole evacuations.	Yes	Tables 7-3, 7-4
2.0 Demand Estimation		
a. Demand estimation should be developed for the four population groups, including permanent residents of the EPZ, transients, special facilities, and schools.	Yes	Permanent residents, employees, transients – Section 3, Appendix E Special facilities, schools – Section 8, Appendix E
2.1 Permanent Residents and Transient Population		
a. The US Census should be the source of the population values, or another credible source should be provided.	Yes	Section 3.1
b. Population values should be adjusted as necessary for growth to reflect population estimates to the year of the ETE.	Yes	Population estimates are based upon 2010 US Census data and are projected to 2016 using 2015 population changes published by the US Census (See Section 3.1)
c. A sector diagram should be included, similar to Figure 2-1, "Population by Sector," of NUREG/CR-7002, showing the population distribution for permanent residents.	Yes	Figure 3-3
2.1.1 Permanent Residents with Vehicles		
a. The persons per vehicle value should be between 1 and 2 or justification should be provided for other values.	Yes	2.03 persons per vehicle based on telephone survey results – see Table 1-3

NRC Review Criteria	Criterion Addressed in ETE Analysis	Comments
b. Major employers should be listed.	Yes	Census data used – see Section 3.4, Appendix E – Table E-4
2.1.2 Transient Population		
a. A list of facilities which attract transient populations should be included, and peak and average attendance for these facilities should be listed. The source of information used to develop attendance values should be provided.	Yes	Sections 3.3, 3.4, Appendix E, Section 6 – page 6-4
b. The average population during the season should be used, itemized and totaled for each scenario.	Yes	Tables 3-6, 3-7 and Appendix E itemize the transient population and employee estimates. These estimates are multiplied by the scenario specific percentages provided in Table 6-3 to estimate average transient population by scenario – see page 6-4.
c. The percent of permanent residents assumed to be at facilities should be estimated.	Yes	Sections 3.3, 3.4
d. The number of people per vehicle should be provided. Numbers may vary by scenario, and if so, discussion on why values vary should be provided.	Yes	Sections 3.3, 3.4
e. A sector diagram should be included, similar to Figure 2-1 of NUREG/CR-7002, showing the population distribution for the transient population.	Yes	Figure 3-7 – transients Figure 3-9 – employees
2.2 Transit Dependent Permanent Residents		
a. The methodology used to determine the number of transit dependent residents should be discussed.	Yes	Section 8.1, Table 8-1

NRC Review Criteria	Criterion Addressed in ETE Analysis	Comments
b. Transportation resources needed to evacuate this group should be quantified.	Yes	Section 8.1, Tables 8-5, 8-10
c. The county/local evacuation plans for transit dependent residents should be used in the analysis.	Yes	Sections 8.1, 8.4
d. The methodology used to determine the number of people with disabilities and those with access and functional needs who may need assistance and do not reside in special facilities should be provided. Data from local/county registration programs should be used in the estimate, but should not be the only set of data.	Yes	Section 8.5
e. Capacities should be provided for all types of transportation resources. Bus seating capacity of 50% should be used or justification should be provided for higher values.	Yes	Section 2.3 – Assumption 8 Sections 3.5, 8
f. An estimate of this population should be provided and information should be provided that the existing registration programs were used in developing the estimate.	Yes	Table 8-1 – transit dependents Section 8.5 – special needs
g. A summary table of the total number of buses, ambulances, or other transport needed to support evacuation should be provided and the quantification of resources should be detailed enough to assure double counting has not occurred.	Yes	Section 8.4 – page 8-6 Table 8-5

NRC Review Criteria	Criterion Addressed in ETE Analysis	Comments
2.3 Special Facility Residents		
a. A list of special facilities, including the type of facility, location, and average population should be provided. Special facility staff should be included in the total special facility population.	Yes	Appendix E, Tables E-1, E-2, E-3 – list facilities, type, location, and population
b. A discussion should be provided on how special facility data was obtained.	Yes	Sections 8.2, 8.3
c. The number of wheelchair and bed-bound individuals should be provided.	Yes	Section 8.3, Tables 8-4, E-3
d. An estimate of the number and capacity of vehicles needed to support the evacuation of the facility should be provided.	Yes	Section 8.3 Tables 8-4, 8-5
e. The logistics for mobilizing specially trained staff (e.g., medical support or security support for prisons, jails, and other correctional facilities) should be discussed when appropriate.	Yes	Section 8.4 – Medical Staff No jails in EPZ
2.4 Schools		
a. A list of schools including name, location, student population, and transportation resources required to support the evacuation, should be provided. The source of this information should be provided.	Yes	Table 8-2 Section 8.2
b. Transportation resources for elementary and middle schools should be based on 100% of the school capacity.	Yes	Table 8-2
c. The estimate of high school students who will use their personal vehicle to evacuate should be provided and a basis for the values used should be discussed.	Yes	Section 8.2

NRC Review Criteria	Criterion Addressed in ETE Analysis	Comments
d. The need for return trips should be identified if necessary.	Yes	There are sufficient resources to evacuate schools in a single wave. However, Section 8.4 and Figure 8-1 discuss the potential for a multiple wave evacuation
2.5.1 Special Events		
a. A complete list of special events should be provided and includes information on the population, estimated duration, and season of the event.	Yes	Section 3.8 –2 events suggested by offsite agencies
b. The special event that encompasses the peak transient population should be analyzed in the ETE.	Yes	Section 3.8
c. The percent of permanent residents attending the event should be estimated.	Yes	Section 3.8
2.5.2 Shadow Evacuation		
a. A shadow evacuation of 20 percent should be included for areas outside the evacuation area extending to 15 miles from the NPP.	Yes	Section 2.2 – Assumption 2 Figures 2-1, 7-1 Section 3.2, 7.1
b. Population estimates for the shadow evacuation in the 10 to 15 mile area beyond the EPZ are provided by sector.	Yes	Section 3.2 Figure 3-5 Table 3-5
c. The loading of the shadow evacuation onto the roadway network should be consistent with the trip generation time generated for the permanent resident population.	Yes	Section 5 – Table 5-8 (footnote)

NRC Review Criteria	Criterion Addressed in ETE Analysis	Comments
2.5.3 Background and Pass Through Traffic		
a. The volume of background traffic and pass through traffic is based on the average daytime traffic. Values may be reduced for nighttime scenarios.	Yes	Sections 3.6, 3.7, 6 Tables 3-8, 6-3, 6-4
b. Pass through traffic is assumed to have stopped entering the EPZ about two hours after the initial notification.	Yes	Section 2.3 – Assumption 12 (offsite agencies indicated pass through traffic would be diverted within 30 minutes) Section 3.6 Table 6-3 – External Through Traffic footnote
2.6 Summary of Demand Estimation		
a. A summary table should be provided that identifies the total populations and total vehicles used in analysis for permanent residents, transients, transit dependent residents, special facilities, schools, shadow population, and pass-through demand used in each scenario.	Yes	Tables 3-9, 3-10, 6-4
3.0 Roadway Capacity		
a. The method(s) used to assess roadway capacity should be discussed.	Yes	Section 4
3.1 Roadway Characteristics		
a. A field survey of key routes within the EPZ has been conducted.	Yes	Section 1.3, Appendix D

NRC Review Criteria	Criterion Addressed in ETE Analysis	Comments
b. Information should be provided describing the extent of the survey, and types of information gathered and used in the analysis.	Yes	Section 1.3, Appendix D
c. A table similar to that in Appendix A, "Roadway Characteristics," of NUREG/CR-7002 should be provided.	Yes	Appendix K, Table K-1
d. Calculations for a representative roadway segment should be provided.	Yes	Section 4
e. A legible map of the roadway system that identifies node numbers and segments used to develop the ETE should be provided and should be similar to Figure 3-1, "Roadway Network Identifying Nodes and Segments," of NUREG/CR-7002.	Yes	Appendix K, Figures K-1 through K-44 present the entire link-node analysis network at a scale suitable to identify all links and nodes
3.2 Capacity Analysis		
a. The approach used to calculate the roadway capacity for the transportation network should be described in detail and identifies factors that should be expressly used in the modeling.	Yes	Section 4
b. The capacity analysis identifies where field information should be used in the ETE calculation.	Yes	Section 1.3, Section 4
3.3 Intersection Control		
a. A list of intersections should be provided that includes the total number of intersections modeled that are unsignalized, signalized, or manned by response personnel.	Yes	Appendix K, Table K-2

NRC Review Criteria	Criterion Addressed in ETE Analysis	Comments
b. Characteristics for the 10 highest volume intersections within the EPZ are provided including the location, signal cycle length, and turn lane queue capacity.	Yes	Table J-1
c. Discussion should be provided on how signal cycle time is used in the calculations.	Yes	Section 4.1, Appendix C
3.4 Adverse Weather		
a. The adverse weather condition should be identified and the effects of adverse weather on mobilization time should be considered.	Yes	Table 2-1, Section 2.3 – Assumption 15 Mobilization time – Section 2.3, Assumption 16, Table 2-2
b. The speed and capacity reduction factors identified in Table 3-1, “Weather Capacity Factors,” of NUREG/CR-7002 should be used or a basis should be provided for other values.	Yes	Table 2-2 – based on HCM 2010. The factors provided in Table 3-1 of NUREG/CR-7002 are from HCM 2000.
c. The study identifies assumptions for snow removal on streets and driveways, when applicable.	No	Not Applicable, EPZ is not located in an area with snow. Area is prone to ice, which was considered.
4.0 Development of Evacuation Times		
4.1 Trip Generation Time		
a. The process used to develop trip generation times should be identified.	Yes	Section 5
b. When telephone surveys are used, the scope of the survey, area of survey, number of participants, and statistical relevance should be provided.	Yes	Appendix F

NRC Review Criteria	Criterion Addressed in ETE Analysis	Comments
c. Data obtained from telephone surveys should be summarized.	Yes	Appendix F
d. The trip generation time for each population group should be developed from site specific information.	Yes	Section 5, Appendix F
4.1.1 Permanent Residents and Transient Population		
a. Permanent residents are assumed to evacuate from their homes but are not assumed to be at home at all times. Trip generation time includes the assumption that a percentage of residents will need to return home prior to evacuating.	Yes	Section 5 discusses trip generation for households with and without returning commuters. Table 6-3 presents the percentage of households with returning commuters and the percentage of households either without returning commuters or with no commuters. Appendix F presents the percent households who will await the return of commuters. Section 2.3, Assumption 18
b. Discussion should be provided on the time and method used to notify transients. The trip generation time discusses any difficulties notifying persons in hard to reach areas such as on lakes or in campgrounds.	Yes	Section 5.4.3
c. The trip generation time accounts for transients potentially returning to hotels prior to evacuating.	Yes	Section 5.4.3, Figure 5-1
d. Effect of public transportation resources used during special events where a large number of transients should be expected should be considered.	Yes	Section 3.8

NRC Review Criteria	Criterion Addressed in ETE Analysis	Comments
e. The trip generation time for the transient population should be integrated and loaded onto the transportation network with the general public.	Yes	Section 5, Table 5-8
4.1.2 Transit Dependent Residents		
a. If available, existing plans and bus routes should be used in the ETE analysis. If new plans should be developed with the ETE, they have been agreed upon by the responsible authorities.	Yes	Section 8.4 – pages 8-7, 8-8. Pre-established bus routes do not exist. Basic bus routes were developed for the ETE analysis – see Figure 8-2, Table 8-10. State and local emergency management agencies reviewed and approved the ETE study including these prescribed routes.
b. Discussion should be included on the means of evacuating ambulatory and non-ambulatory residents.	Yes	Sections 8.4, 8.5
c. The number, location, and availability of buses, and other resources needed to support the demand estimation should be provided.	Yes	Section 8.4, Table 8-5
d. Logistical details, such as the time to obtain buses, brief drivers, and initiate the bus route should be provided.	Yes	Sections 8 (page 8-1), 8.4, Figure 8-1
e. Discussion should identify the time estimated for transit dependent residents to prepare and travel to a bus pickup point, and describes the expected means of travel to the pickup point.	Yes	Section 2.3 – Assumption 6 Section 8.4, page 8-8
f. The number of bus stops and time needed to load passengers should be discussed.	Yes	Section 2.3 – Assumption 7 Section 8.4
g. A map of bus routes should be included.	Yes	Figure 8-2

NRC Review Criteria	Criterion Addressed in ETE Analysis	Comments
h. The trip generation time for non-ambulatory persons includes the time to mobilize ambulances or special vehicles, time to drive to the home of residents, loading time, and time to drive out of the EPZ should be provided.	Yes	Section 8.5
i. Information should be provided to supports analysis of return trips, if necessary.	Yes	Section 8.4 Figure 8-1 Tables 8-11 through 8-13
4.1.3 Special Facilities		
a. Information on evacuation logistics and mobilization times should be provided.	Yes	Section 2.3 – Assumption 6 Section 8.4, Tables 8-7 through 8-9, 8-14 through 8-16
b. Discussion should be provided on the inbound and outbound speeds.	Yes	Section 8.4
c. The number of wheelchair and bed-bounds individuals should be provided, and the logistics of evacuating these residents should be discussed.	Yes	Section 8.4, Tables 8-4, 8-14 through 8-16
d. Time for loading of residents should be provided	Yes	Section 2.3 – Assumption 7 Section 8.4
e. Information should be provided that indicates whether the evacuation can be completed in a single trip or if additional trips should be needed.	Yes	Section 8.4
f. If return trips should be needed, the destination of vehicles should be provided.	Yes	Section 8.4

NRC Review Criteria	Criterion Addressed in ETE Analysis	Comments
g. Discussion should be provided on whether special facility residents are expected to pass through the reception center prior to being evacuated to their final destination.	Yes	Section 8.4
h. Supporting information should be provided to quantify the time elements for the return trips.	Yes	Section 8.4
4.1.4 Schools		
a. Information on evacuation logistics and mobilization time should be provided.	Yes	Section 8.4
b. Discussion should be provided on the inbound and outbound speeds.	Yes	School bus routes are presented in Table 8-6 School bus speeds are presented in Tables 8-7 through 8-9 Section 8.4 discusses inbound and outbound speeds
c. Time for loading of students should be provided.	Yes	Tables 8-7 through 8-9, Discussion in Section 8.4
d. Information should be provided that indicates whether the evacuation can be completed in a single trip or if additional trips are needed.	Yes	Section 8.4 – page 8-6 Table 8-5
e. If return trips are needed, the destination of school buses should be provided.	Yes	Return trips are not needed. Sufficient resources to evacuate in single wave – page 8-6

NRC Review Criteria	Criterion Addressed in ETE Analysis	Comments
f. If used, reception centers should be identified. Discussion should be provided on whether students are expected to pass through the reception center prior to being evacuated to their final destination.	Yes	Table 8-3. Students are evacuated to relocation schools where they will be picked up by parents or guardians
g. Supporting information should be provided to quantify the time elements for the return trips.	Yes	Return trips are not needed. Tables 8-7 through 8-9 provide time needed to arrive at relocation school, which could be used to compute a second wave evacuation if necessary
4.2 ETE Modeling		
a. General information about the model should be provided and demonstrates its use in ETE studies.	Yes	DYNEV II System (Ver. 4.0.19.2). Section 1.3, Table 1-3, Appendix B, Appendix C
b. If a traffic simulation model is not used to conduct the ETE calculation, sufficient detail should be provided to validate the analytical approach used. All criteria elements should have been met, as appropriate.	No	Not applicable as a traffic simulation model was used
4.2.1 Traffic Simulation Model Input		
a. Traffic simulation model assumptions and a representative set of model inputs should be provided.	Yes	Appendices B and C describe the simulation model assumptions and algorithms Table J-2 – model inputs

NRC Review Criteria	Criterion Addressed in ETE Analysis	Comments
b. A glossary of terms should be provided for the key performance measures and parameters used in the analysis.	Yes	Appendix A Tables C-1, C-2, C-3
4.2.2 Traffic Simulation Model Output		
a. A discussion regarding whether the traffic simulation model used must be in equilibration prior to calculating the ETE should be provided.	Yes	Appendix B
b. The minimum following model outputs should be provided to support review: <ol style="list-style-type: none"> 1. Total volume and percent by hour at each EPZ exit node. 2. Network wide average travel time. 3. Longest queue length for the 10 intersections with the highest traffic volume. 4. Total vehicles exiting the network. 5. A plot that provides both the mobilization curve and evacuation curve identifying the cumulative percentage of evacuees who have mobilized and exited the EPZ. 6. Average speed for each major evacuation route that exits the EPZ. 	Yes	<ol style="list-style-type: none"> 1. Table J-5. 2. Table J-3. 3. Table J-1. 4. Table J-3. 5. Figures J-1 through J-14 (one plot for each scenario considered). 6. Table J-4. Network wide average speed also provided in Table J-3.
c. Color coded roadway maps should be provided for various times (i.e., at 2, 4, 6 hrs., etc.) during a full EPZ evacuation scenario, identifying areas where long queues exist including level of service (LOS) "E" and LOS "F" conditions, if they occur.	Yes	Figures 7-3 through 7-10

NRC Review Criteria	Criterion Addressed in ETE Analysis	Comments
4.3 Evacuation Time Estimates for the General Public		
a. The ETE should include the time to evacuate 90% and 100% of the total permanent resident and transient population	Yes	Tables 7-1, 7-2
b. The ETE for 100% of the general public should include all members of the general public. Any reductions or truncated data should be explained.	Yes	Section 5.4.1 – truncating survey data to eliminate statistical outliers Table 7-2 – 100 th percentile ETE for general population
c. Tables should be provided for the 90 and 100 percent ETEs similar to Table 4-3, “ETEs for Staged Evacuation Keyhole,” of NUREG/CR-7002.	Yes	Tables 7-3, 7-4
d. ETEs should be provided for the 100 percent evacuation of special facilities, transit dependent, and school populations.	Yes	Sections 8.4 and 8.5 Tables 8-7 through 8-9, 8-11 through 8-16
5.0 Other Considerations		
5.1 Development of Traffic Control Plans		
a. Information that responsible authorities have approved the traffic control plan used in the analysis should be provided.	Yes	Section 9, Appendix G
b. A discussion of adjustments or additions to the traffic control plan that affect the ETE should be provided.	Yes	
5.2 Enhancements in Evacuation Time		
a. The results of assessments for improvement of evacuation time should be provided.	Yes	Appendix M

NRC Review Criteria	Criterion Addressed in ETE Analysis	Comments
b. A statement or discussion regarding presentation of enhancements to local authorities should be provided.	Yes	Results of the ETE study were formally presented to local authorities at the final project meeting. Recommended enhancements were discussed.
5.3 State and Local Review		
a. A list of agencies contacted and the extent of interaction with these agencies should be discussed.	Yes	Table 1-1
b. Information should be provided on any unresolved issues that may affect the ETE.	Yes	Results of the ETE study were formally presented to state and local agencies at the final project meeting. Comments on the draft report were provided and were addressed in the final report. There are no unresolved issues.
5.4 Reviews and Updates		
a. A discussion of when an updated ETE analysis is required to be performed and submitted to the NRC.	Yes	Appendix M, Section M.3
5.5 Reception Centers and Congregate Care Center		
a. A map of congregate care centers and reception centers should be provided.	Yes	Figure 10-1
b. If return trips are required, assumptions used to estimate return times for buses should be provided.	Yes	Section 8.4 discusses a multi-wave evacuation procedure. Figure 8-1
c. It should be clearly stated if it is assumed that passengers are left at the reception center and are taken by separate buses to the congregate care center.	Yes	Section 2.3 – Assumption 5i Section 10