

MXD-D1

SERVICE MANUAL

US Model
Canadian Model
AEP Model
UK Model
E Model



U.S. and foreign patents licensed from Dolby Laboratories Licensing Corporation.

CD SECTION	Model Name Using Similar Mechanism	NEW
	CD Mechanism Type	CDM14M-5BD20X
	Base Unit Type	BU-5BD20X
	Optical Pick-up Type	KSS-213B/K-N
MD SECTION	Model Name Using Similar Mechanism	MDS-302
	MD Mechanism Type	MDM2BR
	Base Unit Type	MBU-2
	Optical Pick-up Type	KMS-210A/J-N

SPECIFICATIONS

CD player section

System	Compact Disc digital audio system
Laser	Semiconductor laser ($\lambda = 780 \text{ nm}$) Emission duration: continuous
Laser output	Less than $44.6 \mu\text{W}^*$ * This output is the value measured at a distance of 200 mm from the objective lens surface on the Optical Pick-up Block with 7 mm aperture.
Frequency response	5 to 20,000 Hz $\pm 0.3 \text{ dB}$
Signal-to-noise ratio	More than 98 dB
Wow and flutter	Below measurable limit

MD deck section

System	MiniDisc digital audio system
Disc	MiniDisc
Recording system	Magnetic field modulation overwrite system
Playback scanning system	No-contact optical scanning (using a semiconductor laser)
Laser	Semiconductor laser ($\lambda = 780 \text{ nm}$) Emission duration: continuous

Laser output

Less than $44.6 \mu\text{W}^*$

* This output is the value measured at a distance of 200 mm from the objective lens surface on the Optical Pick-up Block with 7 mm aperture.

Laser diode properties

Material: GaAlAs

Recording time

74 minutes max. (using MDW-74)

Revolutions (CLV)

Approx. 400 rpm to 900 rpm

Error correction

Advanced Cross Interleave Reed Solomon Code (ACIRC)

Sampling frequency

44.1 kHz

Coding

Adaptive Transform Acoustic Coding (ATRAC)

Modulation system

EFM (Eight-to-Fourteen Modulation)

Number of channels

2 stereo channels

Frequency response

5 to 20,000 Hz $\pm 0.3 \text{ dB}$

Signal-to-noise ratio

98 dB or more (during playback)

Wow and flutter

Below measurable limit

— Continue on next page —

COMPACT DISC Mini DISC DECK
SONY®



Inputs

	Jack type	Input impedance	Rated input	Minimum input
LINE (ANALOG) IN	Phono jacks	47 kilohms	500 mVrms	125 mVrms
MIC	Phone jack	600 kilohms	0.8 mVrms	0.3 mVrms

Outputs

	Jack type	Rated output	Load impedance
PHONES	Stereo phone jack	10 mW	32 ohms
LINE (ANALOG) OUT	Phono jacks	2 Vrms (at 50 kilohms)	Over 10 kilohms
DIGITAL OUT OPTICAL	Square optical connector jack	-18 dBm	Wave length: 660 nm

General

Power requirements

Where purchased	Power requirements
Continental Europe and UK	220 - 230 V AC, 50/60 Hz
Singapore	110 - 120, 220 - 240V AC, 50/60 Hz
US and Canada	120V, 60Hz

Power consumption 28 W

Dimensions (approx.) (w/h/d) incl. projecting parts
430 × 107 × 280 mm
(17 × 4 1/4 × 11 1/8 in.)

Mass (approx.) 4.5 kg (9 lb 14 oz)

Supplied accessories

- Audio connecting cords (2)
- Optical cable (1)
- Remote commander (remote) RM-D11M (1)
- Sony SUM-3 (NS) batteries (2)

Design and specifications are subject to change without notice.

CAUTION

Danger of explosion if battery is incorrectly replaced. Replace only with the same or equivalent type recommended by the equipment manufacturer. Discard used batteries according to manufacture's instructions.

ADVARSEL!

Lithiumbatteri - Eksplosionsfare ved fejlagtig håndtering. Udskiftning må kun ske med batteri af samme fabrikat og type. Levér det brugte batteri tilbage til leverandøren.

ADVARSEL

Eksplosjonsfare ved feilaktig skifte av batteri. Benytt samme batteritype eller en tilsvarende type anbefalt av apparatfabrikanten. Brukte batterier kasseres i henhold til fabrikantens instruksjoner.

VARNING

Explosionsfara vid felaktigt batteribyte. Använd samma batterityp eller en likvärdig typ som rekommenderas av apparattillverkaren. Kassera använt batteri enligt gällande föreskrifter.

VAROITUS

Paristo voi räjähtää, jos se on virheellisesti asennettu. Vaihda paristo ainoastaan laitevalmistajan suosittelemaan tyyppiin. Hävitä käytetty paristo valmistajan ohjeiden mukaisesti.

MODEL IDENTIFICATION

— BACK PANEL —

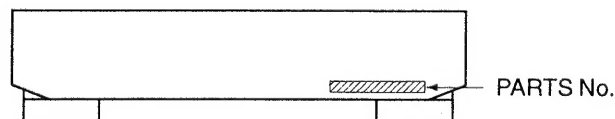

MODEL	PARTS No.
US model	4-983-203-1□
Canadian model	4-983-203-2□
AEP, German model	4-983-203-3□
UK model	4-983-203-4□
Singapore model	4-983-203-5□

The laser component in this product is capable of emitting radiation exceeding the limit for Class 1.

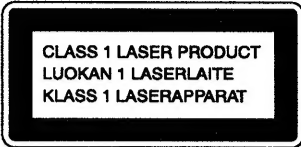

This appliance is classified as a CLASS 1 LASER product. The CLASS 1 LASER PRODUCT MARKING is located on the rear exterior.

The following caution label is located inside the unit.

CAUTION	; INVISIBLE LASER RADIATION WHEN OPEN. AVOID EXPOSURE TO BEAM.
ADVARSEL	; USYNLIG LASERSTRÅLING VED ÅBNING NÅR SIKKERHEDSAFBRYDEDE ER UDE AF FUNKTION. UNDGÅ UDSÆTTELSE FOR STRÅLING.
VARO!	; AVATTRESSA JA SUOJALUKITUS OHITETTAESSA OLET ALLITINNA LASERÄÄTTELYLE.
VARNING	; LASERSTRÅLING NÅR DENNA DEL ÄR ÖPPNAD OCH SPÅRREN ÄR URKOPPLAD.
ADVARSEL	; USYNLIG LASERSTRÅLING NÅR DEKSEL ÅPNES. UNNGÅ EKSPONERING FOR STRÅLEN.

CAUTION

Use of controls or adjustments or performance of procedures other than those specified herein may result in hazardous radiation exposure.

Notes on chip component replacement

- Never reuse a disconnected chip component.
- Notice that the minus side of a tantalum capacitor may be damaged by heat.

Flexible Circuit Board Repairing

- Keep the temperature of soldering iron around 270°C during repairing.
- Do not touch the soldering iron on the same conductor of the circuit board (within 3 times).
- Be careful not to apply force on the conductor when soldering or unsoldering.

SAFETY-RELATED COMPONENT WARNING !!

COMPONENTS IDENTIFIED BY MARK Δ OR DOTTED LINE WITH MARK Δ ON THE SCHEMATIC DIAGRAMS AND IN THE PARTS LIST ARE CRITICAL TO SAFE OPERATION. REPLACE THESE COMPONENTS WITH SONY PARTS WHOSE PART NUMBERS APPEAR AS SHOWN IN THIS MANUAL OR IN SUPPLEMENTS PUBLISHED BY SONY.

SAFETY CHECK-OUT

After correcting the original service problem, perform the following safety checks before releasing the set to the customer:

Check the antenna terminals, metal trim, "metallized" knobs, screws, and all other exposed metal parts for AC leakage. Check leakage as described below.

LEAKAGE

The AC leakage from any exposed metal part to earth Ground and from all exposed metal parts to any exposed metal part having a return to chassis, must not exceed 0.5 mA (500 microampers). Leakage current can be measured by any one of three methods.

1. A commercial leakage tester, such as the Simpson 229 or RCA WT-540A. Follow the manufacturers' instructions to use these instruments.
2. A battery-operated AC milliammeter. The Data Precision 245 digital multimeter is suitable for this job.
3. Measuring the voltage drop across a resistor by means of a VOM or battery-operated AC voltmeter. The "limit" indication is 0.75 V, so analog meters must have an accurate low-voltage scale. The Simpson 250 and Sanwa SH-63Trd are examples of a passive VOM that is suitable. Nearly all battery operated digital multimeters that have a 2V AC range are suitable. (See Fig. A)

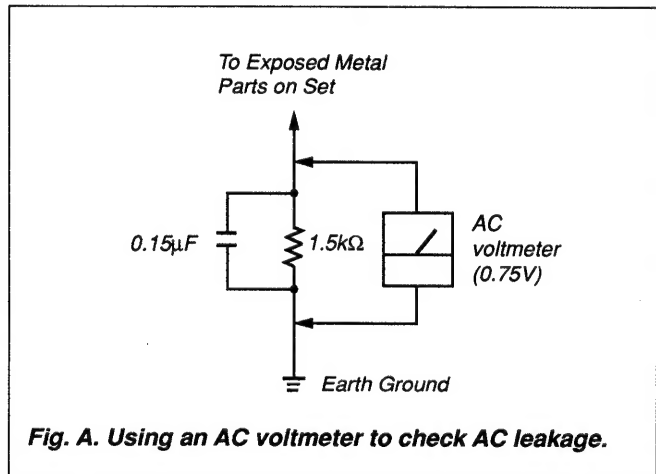

Fig. A. Using an AC voltmeter to check AC leakage.

ATTENTION AU COMPOSANT AYANT RAPPORT À LA SÉCURITÉ!!

LES COMPOSANTS IDENTIFIÉS PAR UNE MARQUE Δ SUR LES DIAGRAMMES SCHÉMATIQUES ET LA LISTE DES PIÈCES SONT CRITIQUES POUR LA SÉCURITÉ DE FONCTIONNEMENT. NE REMPLACER CES COMPOSANTS QUE PAR DES PIÈCES SONY DONT LES NUMÉROS SONT DONNÉS DANS CE MANUEL OU DANS LES SUPPLÉMENTS PUBLIÉS PAR SONY.

TABLE OF CONTENTS

<p>1. SERVICING NOTE 5</p> <p>2. GENERAL 7</p> <p>3. DISASSEMBLY</p> <p>3-1. Front Panel 25</p> <p>3-2. CD Base Unit (BU-5BD20X) 25</p> <p>3-3. MD Mechanism Deck 26</p> <p>3-4. Slider (MD Mechanism) 26</p> <p>3-5. MD Base Unit (MBU-2), Loading Motor Assembly) 27</p> <p>3-6. Slider Assembly Mounting (MD Mechanism) 27</p> <p>4. TEST MODE</p> <p>4-1. Setting the Test Mode 28</p> <p>4-2. Exiting the Test Mode 28</p> <p>4-3. Basic Operations of the Test Mode 28</p> <p>4-4. Selecting the Test Mode 28</p> <p style="padding-left: 20px;">4-4-1. Operating the Continuous Playback Mode 28</p> <p style="padding-left: 20px;">4-4-2. Operating the Continuous Recording Mode 29</p> <p style="padding-left: 20px;">4-4-3. Non-Volatile Memory Mode 29</p> <p>4-5. Functions of Other buttons 29</p> <p>4-6. Test Mode Displays 30</p> <p>4-7. Meanings of Other Displays 30</p> <p>4-8. Precautions for Use of Test Mode 30</p> <p>5. ELECTRICAL ADJUSTMENTS</p> <p>MD Section 31</p> <p>CD Section 36</p> <p>6. DIAGRAMS</p> <p>6-1. Circuit Boards Location 38</p> <p>6-2. Block Diagrams</p> <ul style="list-style-type: none"> • MD Section 39 • CD Section 43 • Audio Section 46 <p>6-3. Schematic Diagram — CD Section — 49</p> <p>6-4. Printed Wiring Board — CD Section — 51</p> <p>6-5. IC Block Diagrams — CD Section — 53</p> <p>6-6. Printed Wiring Board — RF Section — 54</p> <p>6-7. Schematic Diagram — RF Section — 57</p> <p>6-8. Schematic Diagram — Digital Section — 62</p> <p>6-9. Printed Wiring Board — Digital Section — 67</p> <p>6-10. Printed Wiring Board — Audio Section — 72</p> <p>6-11. Schematic Diagram — Audio Section — 75</p> <p>6-12. Schematic Diagram — Display Section — 79</p> <p>6-13. Printed Wiring Board — Display Section — 83</p> <p>6-14. IC Block Diagrams — Digital Section — 87</p>	<p>6-15. IC Pin Functions</p> <ul style="list-style-type: none"> • IC101 Digital Signal Processor (CXD2545Q)/BD board (CD) 89 • IC101 RF Amplifier (CXA1981AR)/BD board (MD) ... 92 • IC121 Digital signal processor, digital servo processor, EFM/ACIRC encoder/decoder (CXD2535BR) 93 • IC201 MD System Control (RU8X11AMF-0102)/Digital board 96 • IC251 CD/MD Format Converter (CXD8640Q)/Digital board 99 • IC271 Shock-Proof Memory Controller, ATRAC Encoder/Decoder (CXD2536CR)/Digital board 100 • IC301 A/D Converter (CXD8566M)/Digital board 102 • IC701 CD System Control, Key Control, Fluorescent Indicator Tube Driver (M38197MA-145FP)/Display board 103 <p>7. EXPLODED VIEWS</p> <p>7-1. Front Panel Section 105</p> <p>7-2. Chassis Section 106</p> <p>7-3. Mechanism Section (MDM-2BR) 107</p> <p>7-4. MD Base Unit Section (MBU-2) 108</p> <p>7-5. CD Mechanism Section (CDM14-5BD20X) 109</p> <p>7-6. CD Base Unit Section (BU-5BD20X) 110</p> <p>8. ELECTRICAL PARTS LIST 111</p>
--	--

SECTION 1 SERVICING NOTE

HOW TO OPEN THE DISC TRAY WHEN POWER SWITCH TURNS OFF

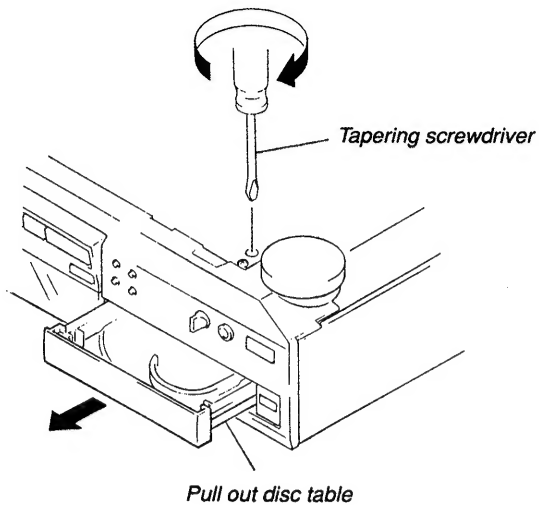

Insert a tapering screwdriver into the aperture of the unit bottom, and turn in the direction of arrow (to OUT direction).

** To close the disc table, turn the driver in the reverse direction (to IN direction).*

NOTES ON HANDLING THE OPTICAL PICK-UP BLOCK OR BASE UNIT

The laser diode in the optical pick-up block may suffer electrostatic break-down because of the potential difference generated by the charged electrostatic load, etc. on clothing and the human body.

During repair, pay attention to electrostatic break-down and also use the procedure in the printed matter which is included in the repair parts.

The flexible board is easily damaged and should be handled with care.

NOTES ON LASER DIODE EMISSION CHECK

The laser beam on this model is concentrated so as to be focused on the disc reflective surface by the objective lens in the optical pick-up block. Therefore, when checking the laser diode emission, observe from more than 30 cm away from the objective lens.

LASER DIODE AND FOCUS SEARCH OPERATION CHECK

Carry out the "S curve check" in "CD section adjustment" and check that the S curve waveform is output three times.

Note for replacement of IC121 and IC171 on the BD board

IC121 on the BD board of this unit has modified from CXD2535AR to CXD2535BR due to an improvement.

Some contents of nonvolatile memory in the IC171 are modified according to this modification. When replacing IC171, the previous contents for IC121 (CXD2535AR) are written as an initialized value from the system control IC. (When replacing IC171, turn the power on once to write an initialized value.)

In case the IC171 on the BD board is replaced, which uses CXD2535BR to IC121, see the following procedure to rewrite the contents of nonvolatile memory. As for replacement of IC121, use CXD2535BR to rewrite the contents of IC171.

Table Comparison between CXD2535AR and CXD2535BR regarding the contents of nonvolatile memory

ADDRESS	CXD2535AR	CXD2535BR
15	90	93
2D	33	1A
2E	33	1A

• How to rewrite the nonvolatile memory

- ① Plug in the power plug to an outlet pressing the AMS knob, and release the AMS knob.
- ② Turn the AMS knob to be displayed "EEP MODE".
If the YES button is pressed, the display will be changed to "EEP ** @@".
(* : Address, @@ : data)
- ③ Turn the AMS knob to be displayed "EEP 15 @@".
- ④ If the AMS knob is pressed, "EEP 15 @@ > @@" will be displayed. So turn the AMS knob to be displayed "EEP 15 @@ > 93".
- ⑤ Pressing the YES button, "Complete!" is displayed once, "EEP 15 93" is displayed, and the data is rewritten.
- ⑥ As for the address 2D and 2E, rewrite each of them to "1A" following the steps ③ to ⑤ as well.
- ⑦ After the all modification are complete, press the NO button to be displayed "EEP MODE".
- ⑧ Press the REPEAT button. In case a disc is unloaded, the display "STANDBY" will be appeared and return to normal operation.
After 5-6 seconds, unplug the power plug. In case a disc is loaded, "STANDBY" is displayed once and the disc is ejected. After that, unplug the power plug from an outlet to be out from the EEP rewriting mode.

Note : The modification in the contents of nonvolatile memory is not reflected if the power is not turned off once.

SECTION 2 GENERAL

• Location of parts and Controls

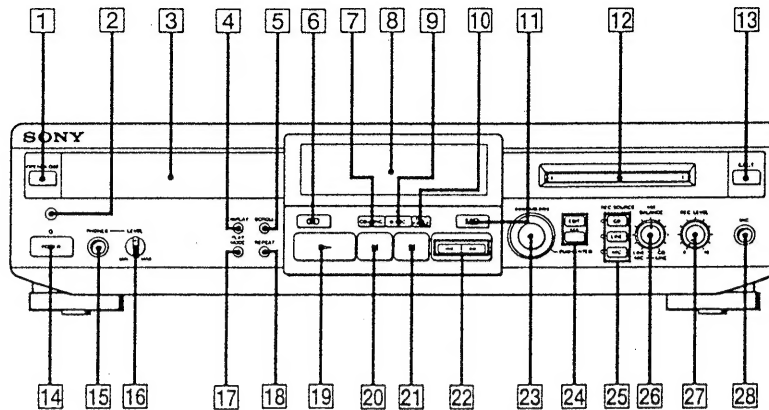

- | | |
|---|--|
| 1 OPEN/CLOSE \triangle (CD) button | 15 PHONES jack |
| 2 Remote sensor | 16 PHONES LEVEL knob |
| 3 Disc tray (CD) | 17 PLAY MODE button |
| 4 DISPLAY button | 18 REPEAT button |
| 5 SCROLL (MD) button | 19 \triangleright (play) button |
| 6 CD button | 20 \parallel (pause) button |
| 7 CD SYNC. button | 21 \blacksquare (stop) button |
| 8 Display window | 22 \lll / \ggg (Fast backward/fast forward) buttons |
| 9 ● REC (recording) button | 23 \lll AMS \ggg knob |
| 10 REC PAUSE button | 24 EDIT/NO/YES buttons |
| 11 MD button | 25 REC SOURCE SELECTOR buttons |
| 12 Disc compartment (MD) | 26 MIX BALANCE knob |
| 13 EJECT \triangle (MD) button | 27 REC LEVEL knob |
| 14 POWER switch | 28 MIC jack |

Playing a CD

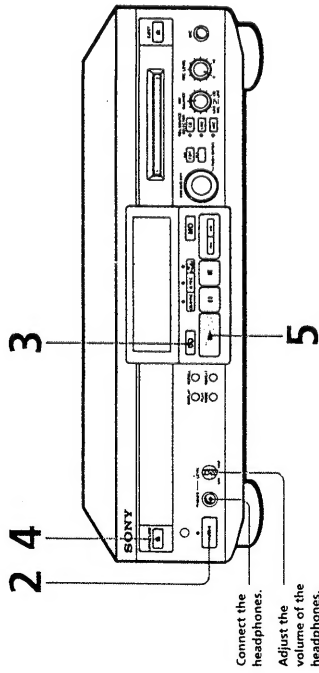

Connect the headphones.
Adjust the volume of the headphones.

- 1** Turn on the amplifier and set the source selector to the position for TAPE (MD).
- 2** Press **POWER**. The **POWER** indicator changes from red to green.
- 3** Press **CD** (or set **CD/MD** to **CD**) to switch the function of the buttons to **CD**.
- 4** Press **OPEN/CLOSE** to insert a **CD**. Press the button again to close the disc tray.

When you play an 8-cm CD
Place it on the inner circle of the disc tray.

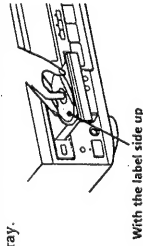

With the label side up

- 5** Press **▷**. The player starts playing. Adjust the volume on the amplifier.
- | | |
|------------------------------|---|
| To Stop playing | Press ■ . |
| To Pause playing | Press II . Press the button again or press ▷ to resume playing. |
| To Go to the next track | Turn AMS clockwise (or press ▶▶ on the remote). |
| To Go to the preceding track | Turn AMS counterclockwise (or press ◀◀ on the remote). |
| To Take out the CD | Press OPEN/CLOSE (or EJECT) after stopping playing. |

You can locate and play a track while the player is stopped
1 Turn **AMS** (or press **◀◀** or **▶▶**) until the number of the track you want to play appears.
2 Press **AMS** or **▷**.

To use headphones
Connect them to **PHONES** jack. Use **PHONES LEVEL** to adjust the volume.

Playing an MD

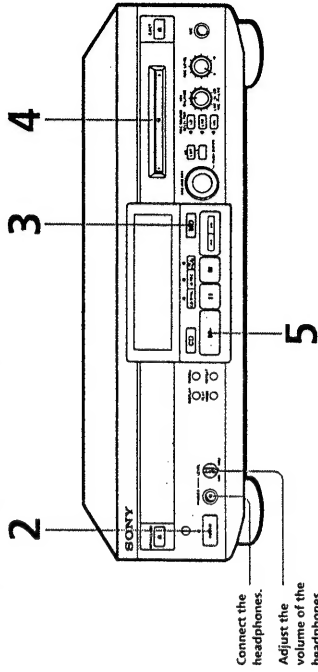

Connect the headphones.
Adjust the volume of the headphones.

- 1** Turn on the amplifier and set the source selector to the position for TAPE (MD).
- 2** Press **POWER**. The **POWER** indicator changes from red to green.
- 3** Press **MD** (or set **CD/MD** to **MD**) to switch the function of the buttons to **MD**.

4 Insert an MD.

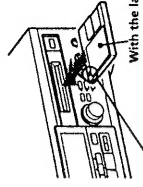

With the arrow pointing this way.

- 5** Press **▷**. The player starts playing. Adjust the volume on the amplifier.
- | | |
|------------------------------|---|
| To Stop playing | Press ■ . |
| To Pause playing | Press II . Press the button again or press ▷ to resume playing. |
| To Go to the next track | Turn AMS clockwise (or press ▶▶ on the remote). |
| To Go to the preceding track | Turn AMS counterclockwise (or press ◀◀ on the remote). |
| To Take out the MD | Press EJECT after stopping playing. |

You can locate and play back a track while the player is stopped
1 Turn **AMS** (or press **◀◀** or **▶▶**) until the number of the track you want to play appears.
2 Press **AMS** or **▷**.

To use headphones
Connect them to **PHONES** jack. Use **PHONES LEVEL** to adjust the volume.

Recording a CD on an MD (CD Synchro-Recording)

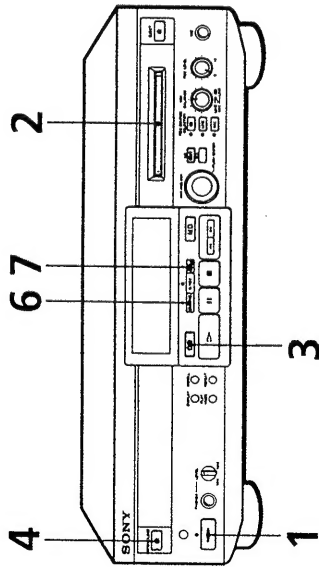

You can easily make digital recordings from a CD on an MD, marking track numbers in the same sequence as the original CD.
Before recording, see "Notes on Recording" on page 23.

When you play an 8-cm CD
Place it on the inner circle of the disc tray.

- 1** Press **POWER**.
The **POWER** indicator changes from red to green.
- 2** Insert a recordable MD.
- 3** Press **CD** (or set **CD/MD** to **CD**) to switch the function of the buttons to **CD**.
- 4** Press **OPEN/CLOSE** to insert a **CD**. Press the button again to close the disc tray.
- 5** Select the playing mode of the **CD** (**Program Play**, **Shuffle Play**, etc.).
See "Playing CDs."
- 6** Press **CD-SYNC**.
REC PAUSE indicator flashes and **REC** indicator lights up.
The **MD** deck section stands by for recording, and the **CD** player section stands by for playing.
- 7** Press **REC PAUSE**.
Recording starts. The **MD** deck section and the **CD** player section will automatically stop after recording.

When "TOC" flashes in the display the player is currently updating the Table Of Contents (TOC). Do not move the unit or pull out the AC power cord.
If you do, recorded material may not be saved normally.

Do not disconnect the unit from the power source immediately after recording

If you do, recorded material may not be saved to the MD. To save the material after recording, press **EJECT** to take out the MD or change the player to standby by pressing **POWER**. "TOC" will flash in the display at this time. After "TOC" stops flashing and goes out, you can pull out the AC power cord.

To	Press
Stop recording	■
Pause recording	REC PAUSE or ■. Press the button again or press ▷ to resume recording.
Take out the CD	OPEN/CLOSE to after pausing playback.
Take out the MD	EJECT to after stopping recording.

• Whenever you pause recording, the track number increases by one. For example, if you paused recording while recording on track 4, the track number increases by one and recording continues on the new track when restarted.

To protect an MD against accidental erasure

To make it impossible to record on an MD, slide the tab in the direction by the arrow, opening the slot. To allow recording, close the slot.

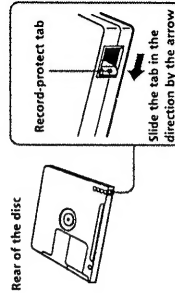

Checking Remaining Time of a CD

Press CD (or set CD/MD to CD) to switch the function of the buttons to CD.

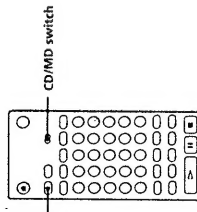
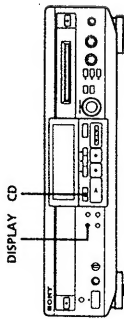

The display is usually as follows:

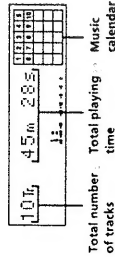

Total number of tracks
Total playing time

Checking the track number and remaining time of the current track

Press DISPLAY repeatedly while playing a CD. Each time you press the button, the display changes as follows:

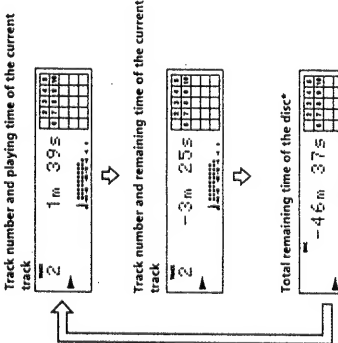

* Total remaining time of the program appears during Program Play.

The music calendar display

- This display lights according to the number of tracks on the CD. If the total track number exceeds 25, appears to the right of number 25 in the music calendar.
- As each track is played, the corresponding number disappears.

Locating a Specific Track on a CD

You can quickly locate any track, while playing a CD by using AMS (Automatic Music Sensor), M.SCAN and M.SCAN number buttons or M.SCAN on the remote. Press CD (or set CD/MD to CD) to switch the function of the buttons to CD.

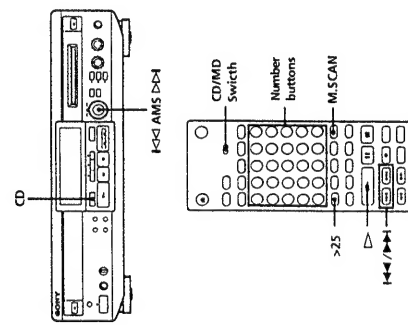

To locate	Do the following:
The next or succeeding tracks	While playing, turn AMS clockwise (or press M.SCAN repeatedly) until you find the track.
The current or preceding tracks	While playing, turn AMS counterclockwise (or press M.SCAN repeatedly) until you find the track.
A specific track directly	Press number buttons to enter the track number.
By scanning each track (music scan)	<ol style="list-style-type: none"> Press M.SCAN before you start playing. When you find the track you want, press M.SCAN to start playing.

When you directly locate a track with a number over 25

You must press >25 first, before entering the corresponding digits. To enter "0," press button 10. Example: To play track number 20, Press >25 once, then 3 and 10.

You can extend the playing time during music scan. While the player is stopped, press M.SCAN repeatedly until the playing time you want (6, 10 or 20 seconds) appears in the display. Each time you press the button, the display changes as follows:

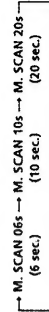

- To pause playing at the beginning of a track: Turn AMS (or press M.SCAN or M.SCAN) after pausing playing.
- To go quickly to the beginning of the last track: Turn AMS counterclockwise (or press M.SCAN) while the display shows the total number of tracks and total playing time of the disc.

Locating a Particular Point in a Track on a CD

You can also use **◀▶** and **▶▶** to locate a particular point in a track on a CD during playing or playing pause. Press CD (or set CD/MD to CD) to switch the function of the buttons to CD.

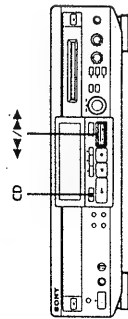

Press

To locate a point
While monitoring the sound
▶▶ (forward) or ◀◀ (backward) and keep pressing until you find the point.

Quickly by observing the display during playing pause
▶▶ or ◀◀ and keep pressing until you find the point. There is no sound output during this operation.

Note

If the CD reaches the end while you are pressing ▶▶ during sound monitoring, the player stops.

Playing Tracks on a CD Repeatedly (Repeat Play)

You can play tracks repeatedly in any play mode.

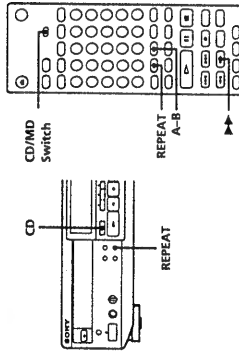

1 Press CD (or set CD/MD to CD).

2 Press REPEAT.

"REPEAT" appears in the display. The player repeats the tracks as follows:

When the CD is played in	The player repeats
Normal play (page 6)	All the tracks
Shuffle Play (page 13)	All the tracks in random order
Program Play (page 14)	The same program

Repeating the current track

While the track you want to repeat is playing in normal play, press REPEAT several times until "REPEAT 1" appears in the display.

To cancel Repeat Play

Press REPEAT several times until "REPEAT" or "REPEAT 1" disappears from the display. The player returns to the original playing mode.

Repeating a specific portion (A-B Repeat)

You can play a specific portion of a track repeatedly. This might be useful when you want to memorize lyrics. Note that you can only repeat a portion within the boundaries of a single track.

1 While playing a CD, press A-B at the starting point (point A) of the portion to be played repeatedly. "REPEAT A-B" flashes in the display.

2 Continue playing the track or press ▶▶ until you reach the ending point (point B), then press A-B again. "REPEAT A-B" lights continuously. The player starts to play the specified portion repeatedly.

To cancel A-B Repeat
Press REPEAT.

Setting new starting and ending points

You can repeat the portion immediately after the currently specified portion by changing the starting and ending points.

1 Press A-B while "REPEAT A-B" appears in the display. The current ending point B becomes the new starting point A and "REPEAT A-B" flashes in the display.
2 Continue playing the track or press ▶▶ until you reach the new ending point (point B), then press A-B again. "REPEAT A-B" lights continuously and the player starts playing repeatedly the newly specified portion.

Note

If you turn off the unit, the player will recall the last setting of the Repeat Play function the next time you turn on the unit. The A-B Repeat settings, however, are lost.

Playing Tracks on a CD in Random Order (Shuffle Play)

You can have the player "shuffle" tracks and play them in random order.

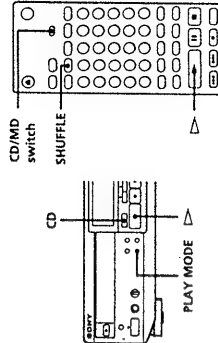

1 Press CD (or set CD/MD to CD).
2 Press PLAY MODE repeatedly (or SHUFFLE once) so that "SHUFFLE" appears in the display when the player is stopped.

3 Press ▶▶ to start Shuffle Play. "S" appears in the display while the player is "shuffling" the tracks.

To cancel Shuffle Play

Press PLAY MODE repeatedly (or CONTINUE once) when the player is stopped so that "SHUFFLE" disappears.

You can specify tracks during Shuffle Play

- ▶▶ To play the next track, turn AMS clockwise (or press ▶▶).
- ▶▶ To play from the beginning of the current track again, turn AMS counterclockwise (or press ◀◀). You cannot use AMS (or ◀◀) to go to tracks that have already been played.

Note

If you turn off the unit while the Shuffle Play function is selected, the Shuffle Play function will be still selected the next time you turn on the unit.

Playing Tracks on a CD in the Desired Order (Program Play)

You can specify the playing order of the tracks on a CD and create your own programs containing up to 25 tracks.

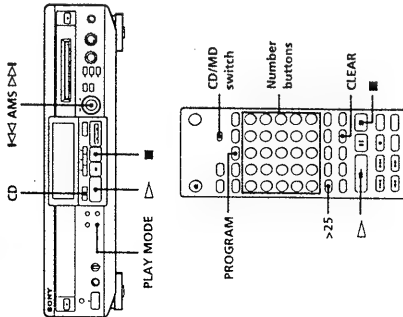

- 1 Press CD (or set CD/MD to CD).
- 2 Press PLAY MODE repeatedly (or PROGRAM once) so that "PROGRAM" appears in the display when the player is stopped.
- 3 Do either a) or b):
 - a) When using the remote Press the number buttons to enter the tracks you want to program in the order you want. To program a track with a number over 25 Use the >25 button (see page 11). If you have made a mistake Press CLEAR, then press the right number button.
 - b) When using the controls on the unit You can program the tracks by checking the total program time.
 - 1 Turn AMS until the track number you want appears in the display.
 - 2 Press AMS or PLAY MODE.

Looping Part of a CD (Loop Play) [I]

With the loop function, you can repeat part of a CD during playback. This lets you create original recordings.

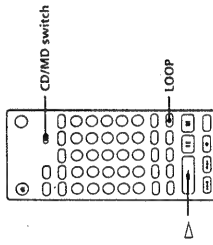

- 1 Set CD/MD to CD.
- 2 Press LOOP repeatedly and choose either NORMAL or RHYTHM. See "The difference between NORMAL and RHYTHM." Each time you press LOOP, the display changes as follows:
 - ← NORMAL 1 NORMAL 5
 - ← RHYTHM 5 RHYTHM 1
- 3 Press Δ. The player starts playing.
- 4 Keep pressing LOOP at the point you want to repeat, and release LOOP when you want to stop repeating. You can also change the mode of the loop (NORMAL 1 to 5, and RHYTHM 1 to 5), turning AMS on the unit while pressing LOOP.

The difference between NORMAL and RHYTHM

The original track can be looped in two ways, NORMAL and RHYTHM.

Original
Hey, Come on everybody!...

In NORMAL mode
After repeating a particular portion, the normal play starts from the point you started pressing LOOP.

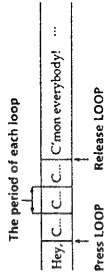

In RHYTHM mode
After repeating a particular portion, the normal play starts jumping over the period of the loop.

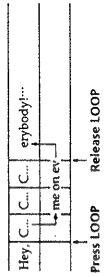

You can choose the loop length from 1 (about 0.25 second) to 5 (about 1 second).

Useful Tips When Recording from CDs

The Auto Space, Auto Pause and Rec-It functions described in this section make recording from CDs to tapes or MDs more easy.
Press CD (or set CD/MD to CD) to switch the function of the buttons to CD.

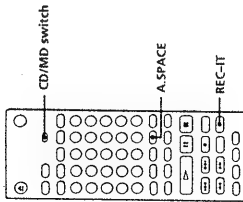

Inserting blank spaces while recording to tape (Auto Space)

The Auto Space function inserts a 3-second blank space between each track while recording from CDs to tapes, allowing you to use the AMS function during later playback.

Press A SPACE repeatedly until "A SPACE" appears in the display.

To cancel Auto Space
Press A SPACE repeatedly until "A SPACE" disappears.

Note

If the Auto Space function is on while recording a selection containing multiple track numbers, (for example, a medley or symphony), blank spaces will be inserted within the selection whenever the track number changes.

Pausing after each track (Auto Pause)

When the Auto Pause function is on, the player pauses after playing each track. Auto Pause is convenient when recording single tracks or multiple, non-consecutive tracks on tapes or MDs.

Press A SPACE repeatedly until "A PAUSE" appears in the display.

To restart playing
Press ▷ or II.

To cancel Auto Pause
Press A SPACE repeatedly until "A PAUSE" disappears.

Note

If you turn off the unit, the player will recall the last setting of the Auto Space and Auto Pause functions the next time you turn on the unit.

Recording the current track on an MD (Rec-It)

You can record the track being played from the beginning on an MD. The player will automatically stop after recording.

This function works only when a recordable MD is in the player.

Press REC-IT while playing the track you want to record.

Checking Remaining Time of an MD

Press MD (or set CD/MD to MD) to switch the function of the buttons to MD.

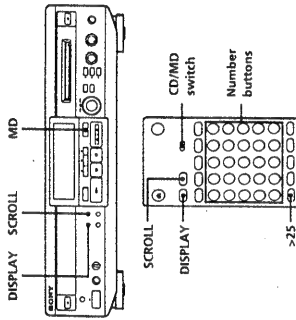

Checking the total number of tracks, total disc playing time, remaining recordable time of the disc and disc title

Each time you press DISPLAY while the player is stopped, the display changes as follows:

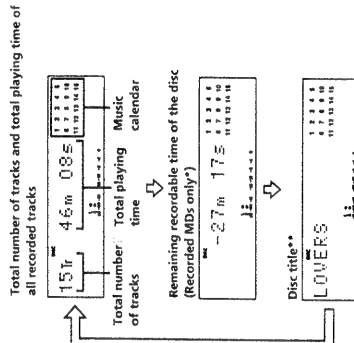

For premastered MDs, the disc title appears instead of the remaining recordable time of the disc.
** To label a recordable MD, see "Labeling Recordings" on page 35.

When you insert an MD, the disc title, total number of tracks, and total disc playing time appear in the display.

Note

When you insert a new MD or turn off the unit and turn it on again, the last item displayed will reappear. If, however, you disconnect the AC power cord, the display will show the total number of tracks and total playing time of all recorded tracks the next time you turn on the unit, no matter what the last display was.

Checking remaining time and track title

Each time you press DISPLAY while playing an MD, the display changes as follows:

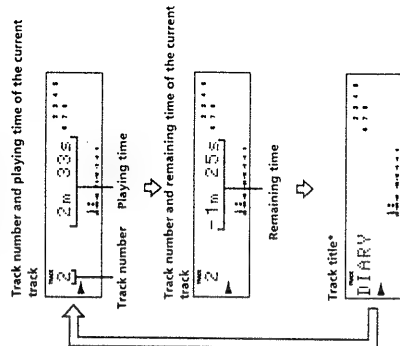

If no title is recorded, "No Name" appears, followed by the elapsed playing time.

The music calendar display

- This display lights according to the number of tracks on the MD. If the total track number exceeds 25, appears to the right of number 25 in the music calendar.
- All the track numbers appears within a grid if the MD is a premastered disc, or without a grid if the MD is a recordable disc.
- As each track is played, the corresponding number disappears.

You can check the track title at any time while playing an MD

Press SCROLL.
Since the display shows up to 12 characters at a time, press SCROLL again to see the rest of the track title if the title has 13 characters or more.
Press SCROLL again to pause scrolling, and again to continue scrolling.

Locating a Specific Track on an MD

You can quickly locate any track while playing a disc by using AMS (Automatic Music Sensor), **◀▶** and **▶▶**, number buttons or M.SCAN on the remote. Press MD (or set CD/MD to MD) to switch the function of the buttons to MD.

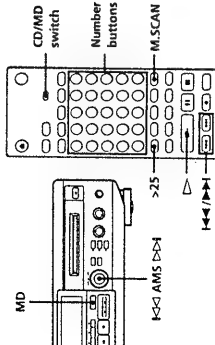

- To locate**
The next or succeeding tracks
- Do the following:**
While playback, turn AMS clockwise (or press **▶▶** repeatedly) until you find the track.
- The current or preceding tracks
- While playback, turn AMS counterclockwise (or press **◀◀** repeatedly) until you find the track.
- A specific track directly
- Press number buttons to enter the track number.
- By scanning each track (music scan)
- 1 Press M.SCAN before you start playing.
 - 2 When you find the track you want, press **▶▶** to start playing.

- When you directly locate a track with a number over 25**
- You must press >25 first, before entering the corresponding digits.
Press >25 once if it is a 2-digit track number, and twice if it is a 3-digit track number.
To enter "0," press button 10.
- Examples:
- To play track number 30
Press >25 once, then 3 and 10.
 - To play track number 100
Press >25 twice, then 1, 10 and 10.

You can extend the playing time during music scan

While the player is stopped, press M.SCAN repeatedly until the playing time you want (6, 10 or 20 seconds) appears in the display. Each time you press the button, the display changes as follows:

→ M.SCAN 06s → M.SCAN 10s → M.SCAN 20s
(6 sec.) (10 sec.) (20 sec.)

To pause playback at the beginning of a track
Turn AMS (or press **◀◀** or **▶▶**) after pausing playback.

To go quickly to the beginning of the last track
Turn AMS counterclockwise (or press **◀◀**) while the display shows the total number of tracks and total disc playing time, remaining recordable time of the disc, or disc title (see page 17).

Locating a Particular Point in a Track on an MD

You can also use **◀◀** and **▶▶** to locate a particular point in a track during playback or playback pause. Press MD (or set CD/MD to MD) to switch the function of the buttons to MD.

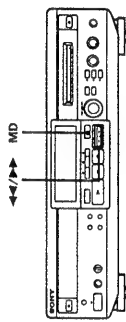

- To locate a point**
- While monitoring the sound
- Press **▶▶** (forward) or **◀◀** (backward) and keep pressing until you find the point.
- Quickly by observing the display during playback pause
- Press **▶▶** or **◀◀** and keep pressing until you find the point. There is no sound output during this operation.

- Notes**
- If the MD reaches the end while you are pressing **▶▶** during sound monitoring, the player stops.
 - Tracks that are only a few seconds long may be too short to scan using the search function. For such tracks, it is better to play the MD at normal speed.

Playing Tracks on an MD Repeatedly (Repeat Play)

You can play tracks repeatedly in any play mode.

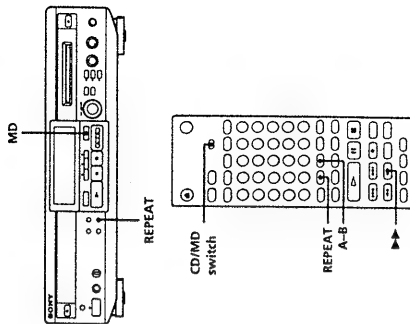

- 1 Press MD (or set CD/MD to MD).
- 2 Press REPEAT.
"REPEAT" appears in the display. The player repeats the tracks as follows:

When the MD is played in	The player repeats
Normal Play (page 7)	All the tracks
Shuffle Play (page 20)	All the tracks in random order
Program Play (page 21)	The same program

Repeating the current track

While the track you want to repeat is playing in normal play, press REPEAT several times until "REPEAT 1" appears in the display.

To cancel Repeat Play
Press REPEAT several times until "REPEAT" or "REPEAT 1" disappears from the display.
The player returns to the original playing mode.

(Continued)

Repeating a specific portion (A-B Repeat)

You can play a specific portion of a track repeatedly. This might be useful when you want to memorize lyrics.

Note that you can only repeat a portion within the boundaries of a single track.

- 1 While playing an MD, press A-B at the starting point (point A) of the portion to be played repeatedly. "REPEAT A-B" flashes in the display.
- 2 Continue playing the track or press  until you reach the ending point (point B), then press A-B again. "REPEAT A-B" lights continuously. The player starts to play the specified portion repeatedly.

To cancel A-B Repeat
Press REPEAT.

Setting new starting and ending points

You can repeat the portion immediately after the currently specified portion by changing the starting and ending points.

- 1 Press A-B while "REPEAT A-B" appears in the display. The current ending point B becomes the new starting point A and "REPEAT A-B" flashes in the display.
- 2 Continue playing the track or press  until you reach the new ending point (point B), then press A-B again. "REPEAT A-B" lights continuously and the player starts playing repeatedly the newly specified portion.

Note

If you turn off the unit or disconnect the AC power cord, the player will recall the last setting of the Repeat Play function the next time you turn on the unit.
The A-B Repeat settings, however, are lost.

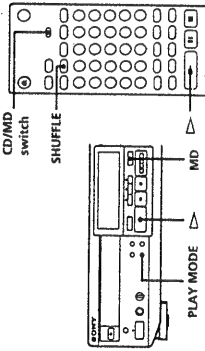

Playing tracks on an MD in Random Order (Shuffle Play)

You can have the player "shuffle" tracks and play them in random order.



- 1 Press MD (or set CD/MD to MD).
 - 2 Press PLAY MODE repeatedly (or SHUFFLE once) so that "SHUFFLE" appears in the display when the player is stopped.
 - 3 Press  to start Shuffle Play. "E3" appears in the display while the player is "shuffling" the tracks.
- To cancel Shuffle Play**
Press PLAY MODE repeatedly (or CONTINUE once) when the player is stopped so that "SHUFFLE" disappears.

You can specify tracks during Shuffle Play

- To play the next track, turn AMS clockwise (or press ).
- To play from the beginning of the current track again, turn AMS counterclockwise (or press ). You cannot use AMS (or ) to go to tracks that have already been played.

Note

If you turn off the unit or disconnect the AC power cord while the Shuffle Play function is selected, the Shuffle Play function will be still selected the next time you turn on the unit.

Playing Tracks on an MD in the Desired Order (Program Play)

You can specify the playback order of the tracks on an MD and create your own programs containing up to 25 tracks.

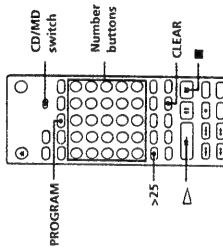
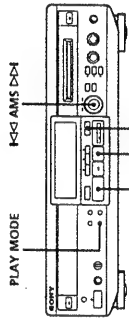

- 1 Press MD (or set CD/MD to MD).
- 2 Press PLAY MODE repeatedly (or PROGRAM once) so that "PROGRAM" appears in the display when the player is stopped.
 - a) When using the remote Press the number buttons to enter the tracks you want to program in the order you want.
 - b) To program a track with a number over 25 Use the >25 button (see page 18). If you have made a mistake Press CLEAR, then press the right number button.
- 3 Do either a) or b). Press the number buttons to enter the tracks you want to program in the order you want.
 - a) When using the remote Press the number buttons to enter the tracks you want to program in the order you want.
 - b) To program a track with a number over 25 Use the >25 button (see page 18). If you have made a mistake Press CLEAR, then press the right number button.

- 4 Repeat step 3 to enter other tracks. Each time you enter a track, the total program time is added up and appears in the display. You can program up to 25 tracks.
- 5 Press  to start Program Play.

To cancel Program Play
Press PLAY MODE repeatedly (or CONTINUE once) when the player is stopped so that "PROGRAM" disappears.

You can program the same track repeatedly

While the track number appears in the display, press AMS as many times as you want.

The program remains even after Program Play ends. When you press , you can play the same program again.

Note

The program created by the Program Play function is lost when you turn off the unit or disconnect the AC power cord.

Changing the track order

You can change the order of the tracks in your program before you start playing.

To

Erase the last track in the program . Each time you press the button, the last track will be cleared.

Add tracks to the end of the program Tracks on an MD in the Desired Order.

Change the whole program completely 1 Press  while the player is stopped. 2 Do steps 3 and 4 in "Playing Tracks on an MD in the Desired Order."

Useful Tips When Recording from MDs to Tape

The Auto Space and Auto Pause functions described in this section make recording from MDs to tape more easy.
Press MD (or set CD/MD to MD) to switch the function of the buttons to MD.

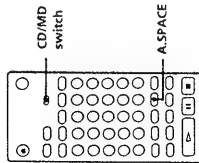

Inserting blank spaces while recording to tape (Auto Space)

The Auto Space function inserts a 3-second blank space between each track while recording from MDs to tapes, allowing you to use the AMS function during later playback.

Press A.SPACE repeatedly until "A.SPACE" appears in the display.

To cancel Auto Space
Press A.SPACE repeatedly until "A.SPACE" disappears.

Note

If the Auto Space function is on while recording a selection containing multiple track numbers, (for example, a medley or symphony), blank spaces will be inserted within the selection whenever the track number changes.

Pausing after each track (Auto Pause)

When the Auto Pause function is on, the player pauses after playing each track. Auto Pause is convenient when recording single tracks or multiple, non-consecutive tracks.

Press A.SPACE repeatedly until "A.PAUSE" appears in the display.

To restart playback
Press ▷ or II.

To cancel Auto Pause
Press A.SPACE repeatedly until "A.PAUSE" disappears.

Note

If you turn off the unit, the player will recall the last setting of the Auto Space and Auto Pause functions the next time you turn on the unit.

Notes on Recording

The MD allows you to digitally record and play back music with the excellent audio quality that approaches the digital sound of CDs. In addition, because MDs are opto-magnetic discs, they are free from problems such as stretching or becoming tangled like ordinary cassette tapes. The recording method is also different from that used with cassette tapes, so you can write track numbers and edit the recordings.

Digital Recording and Analog Recording

This unit uses the following recording methods, depending on the sound source to be recorded or how the unit is connected to the sound source.

Digital recording

When recording from the CD player section, the MD deck section records a digital signal in the form of a digital signal.

However, if you select sound sources to be recorded with REC SOURCE SELECTOR, the recording method will automatically become analog recording.

Analog recording

If you select sound sources to be recorded with REC SOURCE SELECTOR, the MD deck section converts an analog signal into a digital signal and records the digital signal. Even if you record from the CD player section, the signal is converted to an analog signal and is then converted back into a digital signal.
For example:

- When recording from audio equipment (a cassette deck, DAT deck, etc.) connected to the LINE (ANALOG IN) jacks (LINE is selected.)
- When recording from the CD player section, and CD is selected with REC SOURCE SELECTOR (CD is selected.)
- When recording the sound through a microphone (MIC is selected.)
- When recording while mixing sounds from a microphone and CD, etc. (CD and MIC are selected.)

MD recording and the Serial Copy Management System

Since the MD deck section uses the SCMS (Serial Copy Management System), MDs recorded through the digital input jack cannot be used to make copies digitally onto other MDs (see page 42).

Track Marking

Track marking is essentially the writing of track numbers while recording. By writing track numbers at specified points, you can quickly locate those points afterwards using the Automatic Music Sensor function. The method of writing track numbers differs, depending on the sound source being recorded. You can also write track numbers manually.

MD track numbers (TOC)

In an MD, all of the information on track numbers (track sequence), the starting and ending points of tracks, etc., are recorded in an area called the "Table Of Contents" (TOC) that is managed apart from the music. As a result, not only can you instantaneously find the start of a track, but you can also quickly edit recorded tracks simply by changing the TOC information (see pages 30 to 37).

For example, with a cassette tape, erasing a track entails re-recording the track with no sound from the start. With an MD, you can delete a track simply by overwriting the information in the TOC.

When recording from a CD digitally

The MD deck section automatically marks track numbers in the same sequence as the original CD. However, if recording is paused, the portion recorded up to that point is counted as one track, so if recording is started again, the track number increases by one.

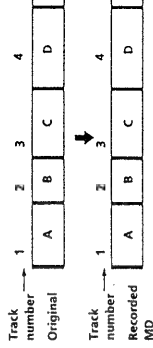

(Continued)

When "LEVEL-SYNC" is displayed during analog recording
 The track number is written in sync with the level of the input signal from the sound source. In other words, if the input signal from the sound source is continuously at or below a certain fixed level for several seconds, a track number is written the next time the input signal exceeds that level (see "Marking track numbers automatically" on page 28).

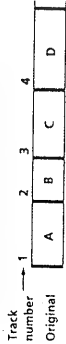

If the level does not drop below a certain fixed level continuously for several seconds because the interval between tracks is short, etc., no track number is written.

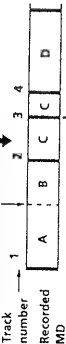

If the level does drop below a certain fixed level continuously for several seconds, even if in the middle of a track, a track number is written.

Note
 When you select MIC with REC SOURCE SELECTOR, the track number is not written automatically even if "LEVEL-SYNC" appears in the display.

Other cases
 Only one track number is written at the start of a recording. The entire recording is counted as one track. You can mark track numbers during recording, either manually or automatically (see "Marking track numbers manually" on page 28).

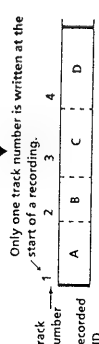
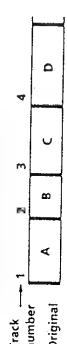

Only one track number is written at the start of a recording.

When "TOC" flashes in the display
 Do not move the unit or pull out the AC power cord. If you do, the recorded material may not be saved normally because the MD deck section is updating the Table Of Contents (TOC).



Do not disconnect the AC power cord immediately after recording
 If you do, the recorded material may not be saved to the MD.

To protect an MD against accidental erasure
 To make it impossible to record on an MD, slide the tab in the direction by the arrow, opening the slot. "Protected" appears in the display if you attempt to record on the MD. To allow recording, close the slot.

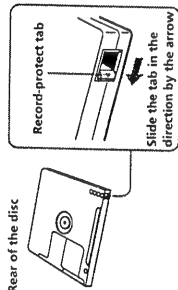

Useful Tips for Recording

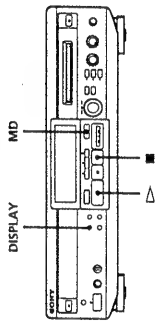

Press MD (or set CD/MD to MD) to switch the function of the buttons to MD.

Checking the remaining recordable time on the MD

When you press DISPLAY repeatedly while the MD player is stopped, the display changes as follows (see page 17):

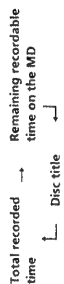

When you press DISPLAY while recording, the remaining recordable time on the MD appears.

Playing back tracks just recorded

Do this procedure to immediately play back tracks that have just been recorded.

- 1 Press immediately after stopping recording. Playback starts from the first track of the material just recorded.
- 2 Press again after stopping recording. Playback starts from the first track of the MD.

Recording on an MD Manually

You can start recording from the end of the existing material or record over the existing tracks just as you would on an analog cassette tape.

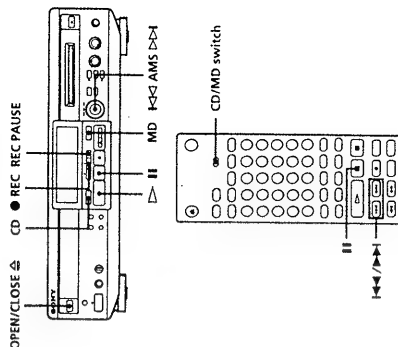

- 1 Turn on the amplifier and set the source selector to the position for the sound source you want to record. When you want to record from the CD player section, press OPEN/CLOSE and insert a CD.
- 2 Press MD (or set CD/MD to MD).
- 3 Insert a recordable MD.

(Continued)

- Decide a point on the MD where you want to start recording.

To record on a brand new MD or start recording from the end of the existing material. Skip this step.

To record from a specific point of a recorded track. Press **▶** to start playback, and press **II** at the point where you want to start recording.

To record erasing the previously recorded tracks. Turn **AMS** (or press **◀◀** or **▶▶** repeatedly) until the number of the track to be recorded over appears in the display.

- Press **● REC**.
REC PAUSE indicator flashes and REC indicator lights up.
The player stands by for recording.

Analog recording

- Adjust the recording level.
For details, see "Adjusting the Recording Level" on page 27.

- Press **▶** or **II**.
Recording starts.

- Start playing the sound source you want to record.

To stop analog recording
Press **■**.

Digital recording

- Press **CD** (or set **CD/MD** to **CD**).

- Press **REC PAUSE**.
Recording starts.

- Start playing the track you want to record.

To pause digital recording
Press **REC PAUSE**.

To stop digital recording
After pressing **MD** (or setting **CD/MD** to **MD**), press **■**.

To stop playing a CD
After pressing **CD** (or setting **CD/MD** to **CD**), press **■**.



While "TRACK" flashes in the display
The player is recording over an existing track, and stops flashing when it reaches the end of the recorded portion.

Note

You cannot record from the middle of an existing track when the "PROGRAM" or "SHUFFLE" appears in the display.

Adjusting the Recording Level

When recording sound sources selected by the **REC SOURCE SELECTOR** buttons, adjust the recording level before starting recording. You cannot adjust the recording level during digital recording.



- Do steps 1 to 5 in "Recording on an MD Manually" on page 25.
- Press one or two of the **REC SOURCE SELECTOR** buttons to select the sound source you want to record.

- Play the portion of the sound source with the strongest signal level.

- While monitoring the sound, turn **REC LEVEL** to adjust the recording level so that the **OVER** indication (red) of the peak level meters does not turn on.

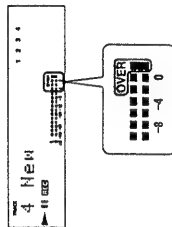

- Stop playing the sound source.
- To start recording, do the procedure starting from step 7 (Analog recording) in "Recording on an MD Manually" on page 26.

Recording the Mixed Sounds (Microphone Mixing)

You can "mix" sound by playing the **CD** player section, sound sources connected to the unit, or singing or speaking into a microphone (not supplied). The mixed sounds can then be recorded on an MD. You can also enjoy cross-fading with the **CD** player section and connected sound source.

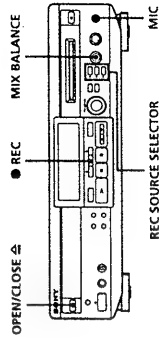

- Connect a microphone (not supplied) to the **MIC** jack.
- Turn on the amplifier and set the source selector to the position for the sound source you want to record.
When you want to record from the **CD** player section, press **OPEN/CLOSE** and insert a **CD**.
- Insert a recordable **MD**.

- Press **● REC**.
The **MD** deck section stands by for recording.
- Press one or two of the **REC SOURCE SELECTOR** buttons to select the sound sources you want to mix.
You can select up to two sound sources.

(Continued)

- 6 Adjust the balance of the sound sources you want to record.
Turn MIX BALANCE according to the sound sources you have selected in the following ways:

If you have selected	Turn MIX BALANCE
LINE and CD	Counterclockwise to raise the level of the sound source connected through the LINE (ANALOG) IN jacks and clockwise to raise the level of the CD.
MIC and CD	Counterclockwise to raise the level of the microphone and clockwise to raise the level of the CD.
MIC and LINE	Counterclockwise to raise the level of the microphone and clockwise to raise the level of the sound source connected through the LINE (ANALOG) IN jacks.

When selecting only one sound source
Adjust MIX BALANCE at the center.

- 7 Do steps 3 to 6 in "Adjusting the Recording Level" on page 27.

To stop recording
Press ■.

When you finish mixing
Disconnect the microphone and adjust MIX BALANCE at the center.

Marking Track Numbers while Recording (Track Marking)

You can mark track numbers either manually or automatically. By marking track numbers at specific points, you can quickly locate those points afterwards, using the AMS function or editing functions.

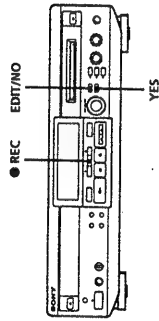

Marking track numbers manually (Manual Track Marking)

You can mark track numbers at any time while recording on an MD.

Press ● REC at the point you want to add a track mark while recording.

Marking track numbers automatically (Automatic Track Marking)

The player adds track marks differently in the following cases:

- When recording digitally from the CD player section: The player automatically marks track numbers in the same sequence as the original CD.
- Other cases
When "LEVEL_SYNC" appears in the display, the player marks a new track number whenever the input signal from the sound source is continuously at or below a certain level for several seconds, and then exceeds that level (Automatic Track Marking).
If "LEVEL_SYNC" does not light up, set the LevelSync to ON as follows:

Starting Recording with 6 Seconds of Prestored Audio Data (Time Machine Recording)

When recording from an FM or satellite broadcast, the first few seconds of material are often lost due to the time it takes you to ascertain the contents and press the record button. To prevent the loss of this material, the Time Machine Recording function constantly stores 6 seconds of the most recent audio data in a buffer memory so that when you begin recording the sound source, the recording actually begins with the 6 seconds of audio data stored in the buffer memory in advance, as shown in the illustration below:

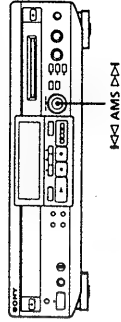
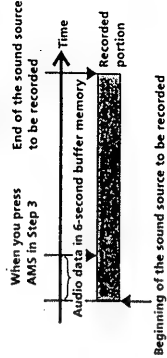

- Do steps 1 to 5 in "Recording on an MD Manually" on page 25.
The player stands by for recording.
- Start playing the sound source you want to record.
The most recent 6 seconds of audio data is stored in the buffer memory.
- Press AMS to start Time Machine Recording.
Recording of the sound source starts with the 6 seconds of audio data stored in the buffer memory.

To stop Time Machine Recording
Press ■.

Note
The player starts storing audio data when it is in recording pause and you start playing the sound source. With less than 6 seconds of playing of the sound source and audio data stored in the buffer memory, Time Machine Recording starts with less than 6 seconds of audio data.

Notes on Editing

You can edit the recorded tracks after recording, using the following functions:

- Erase function allows you to erase recorded tracks simply by specifying the corresponding track number.
- Divide function allows you to divide tracks at specified points so that you can quickly locate those points afterwards, using the AMS function.
- Combine function allows you to combine two consecutive tracks into one.
- Move function allows you to change the order of tracks by moving a specific track to a track position you want.
- Title function allows you to create titles for your recorded MDs and tracks.

Before editing, press MD (or set CD/MD to MD) to switch the function of the buttons to MD.

If "Protected" appears in the display, the player could not edit because the record-protect slot on the MD is open. Edit after closing the slot.

When "TOC" flashes in the display, Do not move the unit or pull out the AC power cord. After editing, "TOC" lights continuously until you eject the MD or turn off the power. "TOC" flashes while the player is updating the TOC. When the player finishes updating the TOC, "TOC" goes off.

Erasing Recordings (Erase Function)

There are three methods for erasing recordings:

- Erasing a single track
- Erasing all tracks on an MD
- Erasing a portion of a track

When you erase a track, the total number of tracks on the MD decreases by one and all tracks following the erased one are renumbered.

Unlike cassette tapes, there is no need to record over a previously recorded track in order to erase it.

To avoid confusion when erasing multiple tracks, you should proceed in order of high to low track number to prevent the renumbering of tracks that have not been erased yet.

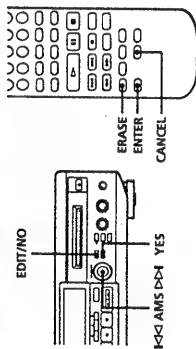

Erasing a single track

You can erase a track and the track title simply by specifying the corresponding track number.

Example: Erasing B

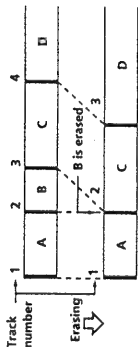

- 1 Turn AMS until the track number you want to erase appears in the display (or press the corresponding number button on the remote).
- 2 Press EDIT/NO repeatedly (or ERASE once) so that "Erase ?" appears in the display. The track number you selected starts flashing in the music calendar.
- 3 Press YES (or ENTER). When the track selected in step 1 has been erased, "Complete" appears for a few seconds and the total number of tracks in the music calendar decreases by one. If you erase a track during playback, the track following the deleted one begins playing afterwards.
- 4 Repeat steps 1 to 3 to erase more tracks.

To cancel the Erase function

Press EDIT/NO (or CANCEL), or turn AMS to change the track number. "Erase ?" disappears from the display.

Note

If "Erase ?" appears in the display, the track was recorded or edited on another MD deck and is record-protected. If this indication appears, press YES (or ENTER) to erase the track.

Erasing all tracks on an MD

You can erase all recorded tracks, track titles and the disc title (all information recorded on an MD) at one time.

Note, however, that once erased, MD data cannot be recovered.

- 1 While the player is stopped, press EDIT/NO repeatedly (or ERASE once) so that "All Erase ?" appears in the display.
- 2 Press YES (or ENTER). All tracks in the music calendar start flashing.
- 3 Press YES (or ENTER) again. When the disc title, all recorded tracks, and track titles on the MD have been erased, "Complete" appears for a few seconds. All the track numbers disappear from the music calendar.

To cancel the Erase function

Press EDIT/NO (or CANCEL) or so that "All Erase ?" disappears from the display.

Erasing a portion of a track

By using the Divide (see page 32), Erase (see page 30) and Combine (see page 33) functions, you can erase specific portions of a track.

Example: Erasing a portion of track A

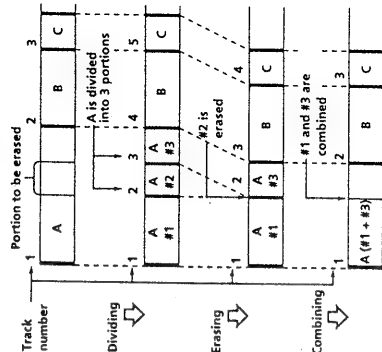

Dividing Recorded Tracks (Divide Function)

With the Divide function, you can mark a new track number at points that you want to randomly access afterwards. Use this function to add tracks to MDs recorded from an analog source (and therefore contain no track numbers), or to divide an existing track into multiple portions. When you divide a track, the total number of tracks on the MD increases by one and all tracks following the divided one are renumbered.

Example: Dividing track 2 to create a new track for C

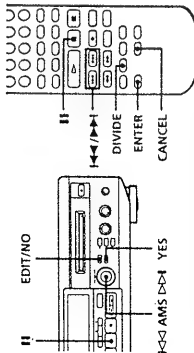
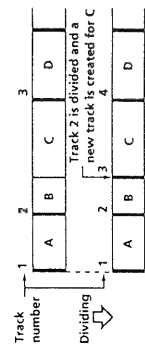

- 1 While playing the MD, press **II** at the point where you want to create a new track. The player pauses playing.
- 2 Press EDIT/NO repeatedly (or DIVIDE once) so that "Divide ?" appears in the display.
- 3 Press YES (or ENTER) to divide the track. "Rehearsal" alternates with "Position ok?" in the display, the track to be divided starts flashing in the music calendar, and the starting portion of the new track begins playing repeatedly.
- 4 If the starting position is incorrect, press EDIT/NO (or CANCEL) or **■**. (If it is correct, skip to step 7.)

- 5 While monitoring the sound, turn AMS (or press **←→** or **▶▶**) to find the starting position of the new track. The starting portion of the new track is played back repeatedly. "Rehearsal" alternates with "Position ok?" in the display.

The starting position can be moved within a maximum range of -128 to +127 steps of about 0.06 second each within a track.

- 6 If the starting position is still incorrect, repeat step 5 until it is correct.

- 7 Press YES or AMS (or ENTER) when the position is correct.

When the track has been divided, "Complete" appears for a few seconds and the newly created track begins playing. The new track will have no track title even if the original track was labeled. The track number in the music calendar increases by one.

To cancel the Divide function Press **■** (or CANCEL).

You can undo a track division Combine the tracks again (see "Combining Recorded Tracks" on page 33) then redivide the tracks if necessary.

You can divide a track while recording Use the Track Marking function (see page 28).

Combining Recorded Tracks (Combine Function)

Use the Combine function while the player is stopped, playing or in pause to combine consecutive tracks on a recorded MD. This function is useful for combining several songs into a single medley, or several independently recorded portions into a single track. When you combine two tracks, the total number of tracks decreases by one and all tracks following the combined tracks are renumbered.

Example: Combining B and C

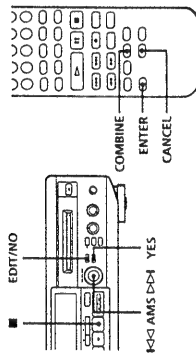
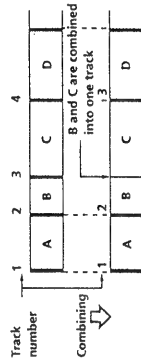

- 1 Turn AMS until the second track of the two to be combined appears (or press the corresponding number button on the remote). For example, when combining tracks 3 and 4, turn AMS until 4 appears (or press button 4).

- 2 Press EDIT/NO repeatedly (or COMBINE once) so that "Combine ?" appears in the display.

- 3 Press YES (or ENTER). "Rehearsal" alternates with "Track ok?" in the display. The point where the two tracks will join (i.e., the end of the first track and the beginning of the second track) repeatedly plays back and the respective track number flashes in the music calendar.

- 4 If the point is incorrect, press EDIT/NO (or CANCEL) or **■**, then start from step 1 again. If it is correct, skip to step 5.

- 5 If the point is correct, press YES (or ENTER). When the tracks have been combined, "Complete" appears for a few seconds and the total number of tracks in the music calendar decreases by one. If both of the combined tracks have track titles, the title of the second track is erased.

To cancel the Combine function Press EDIT/NO (or CANCEL) or **■**.

You can undo a track combination Divide the tracks again (see "Dividing Recorded Tracks" on page 32), then repeat the Combine function with the correct tracks if necessary.

Note If "Sorry" appears in the display, the tracks cannot be combined. This sometimes happens when you have edited the same track many times, and is due to a technical limitation of the MD system, not a mechanical error.

Moving Recorded Tracks (Move Function)

Use the Move function to change the order of any track. After you move a track, the track numbers between the new and old track positions are automatically renumbered.

Example: Moving track C to track position 2

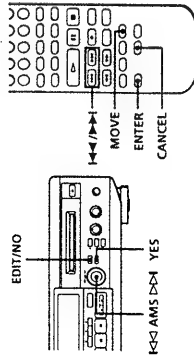
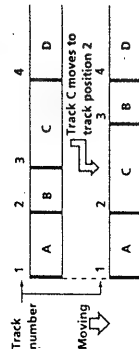

1 Turn AMS until the track number you want to move appears in the display (or press the corresponding number button on the remote).

2 Press EDIT/NO repeatedly (or MOVE once) so that "Move ?" appears in the display.

3 Press YES (or ENTER). The track number to be moved and the new track position appears.

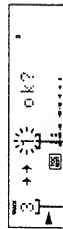

Track number New track to be moved position

4 Turn AMS until the new track position appears (or press F44 or F41).

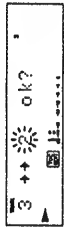

5 Press YES or AMS (or ENTER). After you have moved the track, "Complete" appears for a few seconds and the moved track begins playing back if the player is in playback mode.

To cancel the Move function Press EDIT/NO (or CANCEL) or ■.

Labeling Recordings (Title Function)

You can create titles for your recorded MDs and tracks. Titles — which may consist of uppercase and lowercase letters, numbers and symbols for a maximum of about 1,700 characters per disc — appear in the display during MD operation. See "Labeling tracks and MDs with the remote" on page 36 for use of the remote.

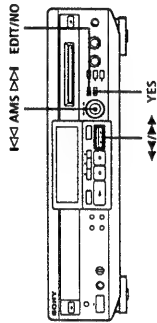

Use the following procedure to label a track or an MD. You can label a track while it is playing, pausing or recording. If the track is playing or recording, be sure to finish labeling before the track ends. If the track ends before you have completed the labeling procedure, the characters already entered are not recorded and the track will remain unlabeled.

1 Press EDIT/NO repeatedly until "Name in ?" appears in the display, then do the following:

- To label Make sure that the player is playing, pausing, recording the track to be labeled, or stopped after locating the track to be labeled
- An MD Stopped with no track number appearing in the display

2 Press YES. A flashing cursor appears in the display.



3 Turn AMS to select the character.



The selected character flashes. Letters, numbers, and symbols appear in sequential order as you turn AMS. You can use the following symbols in titles: ! " # \$ % & ' () * + , - . / : ; < = > ? @ _

4 Press AMS to enter the selected character. The cursor shifts rightwards and waits for the input of the next character.

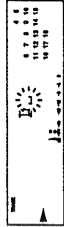

5 Repeat steps 3 and 4 until you have entered the entire title.

If you entered the wrong character Press ← or → until the character to be corrected starts flashing, and repeat steps 3 and 4 to enter the correct character.

To erase a character Press ← or → until the character to be erased starts flashing, then press EDIT/NO.

To enter a space Press AMS or → while the cursor is flashing.

6 Press YES. This completes the labeling procedure and the title appears on the left side of the display.

To cancel labeling Press ■.

Note You cannot label a track or an MD while you are recording over an existing track.

(Continued)

Labeling tracks and MDs with the remote

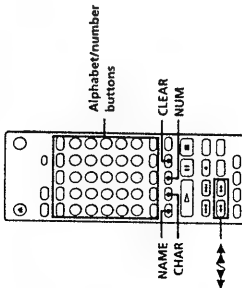

1 Press NAME so that a flashing cursor appears in the display, then do the following:

To label	Make sure that the player is
A track	Playing, pausing, recording the track to be labeled, or stopped after locating the track to be labeled
An MD	Stopped with no track number appearing in the display

2 Select the character type as follows:

To select	Press
Uppercase letters	CHAR repeatedly until "Selected ABC" appears in the display
Lowercase letters	CHAR repeatedly until "Selected abc" appears in the display
Numbers	NUM repeatedly until "Selected 123" appears in the display

3 Enter one character at a time. After you enter a character, the cursor shifts rightwards and waits for the input of the next character.

4 Repeat steps 2 and 3 until you have entered the entire title.

If you entered the wrong character Press ← or → until the character to be corrected starts flashing. Press CLEAR to erase the incorrect character, then enter the correct one.

5 Press NAME again. The entered title appears on the left side of the display after the label has been recorded.

To cancel labeling Press ■.

Changing an existing title

1 Press NAME so that a track title or disc title appears in the display, then do the following:

To change	Make sure that the player is
A track title	Playing, pausing the track whose title is to be changed, or stopped after locating the track whose title is to be changed
A disc title	Stopped with no track number appearing in the display

2 Keep pressing CLEAR (or EDIT/NO on the unit) until the current title is erased.

3 Enter the new title. Do steps 3 to 5 of "Labeling Recordings" on page 35, or steps 2 to 4 of "Labeling tracks and MDs with the remote" on this page.

4 Press NAME.

Erasing all titles on a disc (Name Erase)

Use this function to erase all titles on an MD simultaneously. Note that once erased, titles cannot be recovered.

1 Press EDIT/NO repeatedly while the player is stopped until "All Erase ?" appears in the display.

2 Press EDIT/NO again. "Name Erase ?" appears in the display.

3 Press YES. All titles are erased.

To cancel the Name Erase function Press ■.

You can erase all recorded tracks and titles See "Erasing all tracks on an MD" on page 31.

Undoing the Last Edit (Undo Function)

You can use the Undo function to cancel the last edit and restore the contents of the MD to the condition that existed before editing was done. Note, however, that you cannot undo an edit if you do any of the following after the edit:

- Press the REC button on the unit
- Press the button or the CD-SYNC button on the remote
- Update the TOC by turning off the power or ejecting the MD
- Disconnect the AC power cord

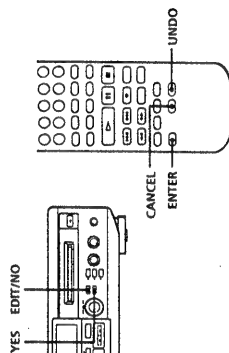

1 With the player stopped and no track number appearing in the display, press EDIT/NO repeatedly (or UNDO once) so that "Undo ?" appears in the display. "Undo ?" does not appear if no editing has been done.

2 Press YES (or ENTER). One of the following messages appears in the display, depending on the type of editing to be undone:

Editing done:	Message:
Erasing a single track	"Erase Undo ?"
Erasing all tracks on an MD	"Erase Undo ?"
Dividing a track	"Divide Undo ?"
Combining tracks	"Combine Undo ?"
Moving a track	"Move Undo ?"
Labeling a track or an MD	"Name Undo ?"
Changing an existing title	"Name Undo ?"
Erasing all titles on an MD	"Name Undo ?"

3 Press YES (or ENTER) again. "Complete" appears for a few seconds and the contents of the MD are restored to the condition that existed before the edit.

To cancel the Undo function Press EDIT/NO (or CANCEL) or ■.

Guide to the Serial Copy Management System

An MD recorded with digital input cannot be used to make another recording with digital input. As a digital audio component, this MD deck conforms with the Serial Copy Management System standards. The Serial Copy Management System restricts copies made by recording digital signal to first-generation copies only. However, subsequent recording from the second-generation copy onto another recordable DAT tape or MD is possible only through the analog input jack on the DAT or MD deck.

There are three general rules that apply to this unit.

Rule 1

You can record from digital sound sources (CDs, DATs or premastered MDs) onto a DAT tape or recordable MD via digital input jack on the DAT or MD deck. You cannot, however, record from this recorded DAT tape or MD onto another DAT tape or recordable MD via the digital input jack on the DAT or MD deck.

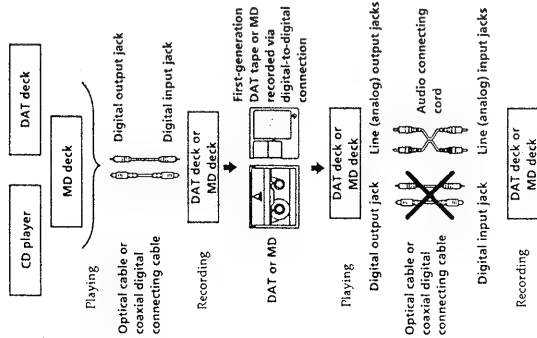

Rule 2

You can record the digital input signal of a digital satellite broadcast onto a DAT tape or recordable MD via the digital input jack on the DAT or MD deck which is capable of handling a sampling frequency of 32 kHz or 48 kHz. (This unit supports 44.1 kHz only.) You can then record the contents of this recorded DAT tape or MD (first-generation) onto another DAT tape or recordable MD via digital input jack on the DAT or MD deck to create a second-generation digital copy. Note, however, that on some BS tuners, second-generation digital copying may not be possible.

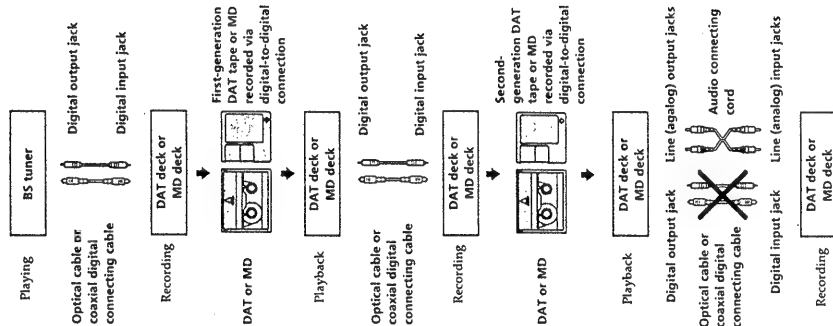

Rule 3

You can record a DAT tape or MD on which an analog record, FM broadcast, or other analog source was recorded onto another DAT tape or MD via the DAT or MD deck's digital output jack. You cannot, however, make a second-generation DAT tape or MD copy via the DAT or MD deck's digital output jack.

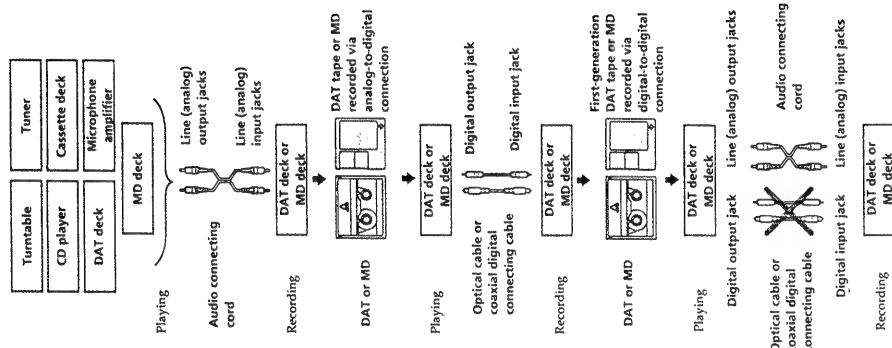

SECTION 3 DISASSEMBLY

Note: Follow the disassembly procedure in the numerical order given.

3-1. FRONT PANEL

- In order to remove the front panel block when the power supply does not turn on, rotate the cam with tapering driver as the figure shows, and the loading part will be moved. Then pull out the loading part by your hand to remove the loading panel as the figure shows. After that take out the front panel block.

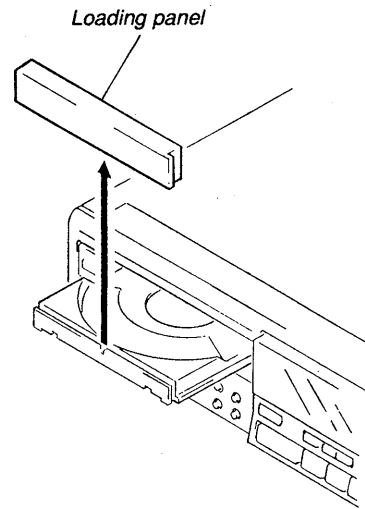
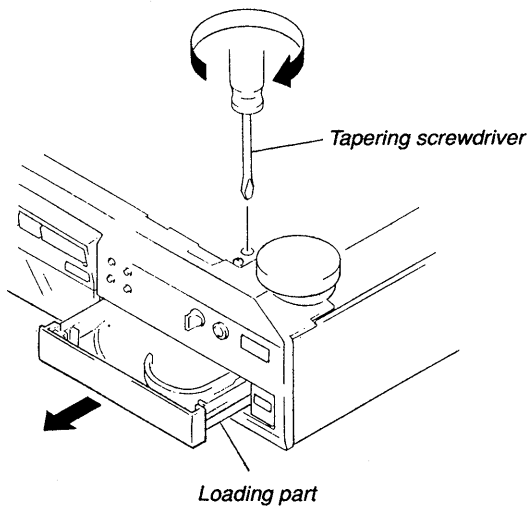

3-2. CD BASE UNIT (BU-5BD20X)

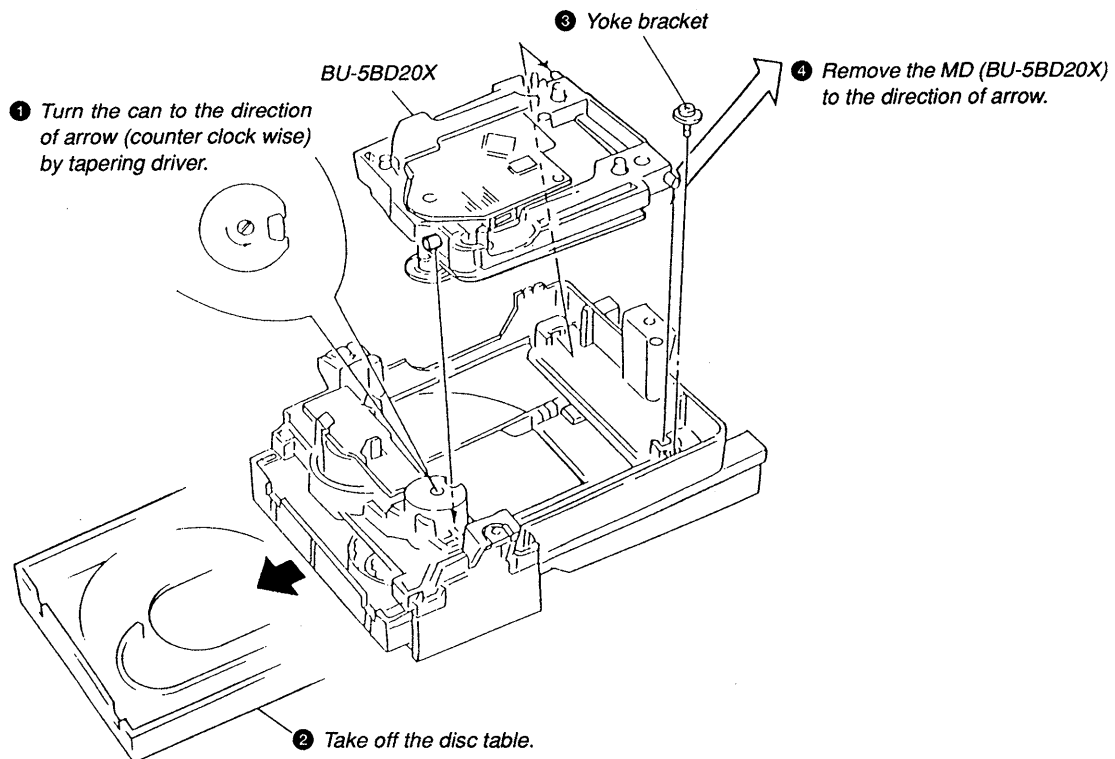

3-3. MD MECHANISM DECK

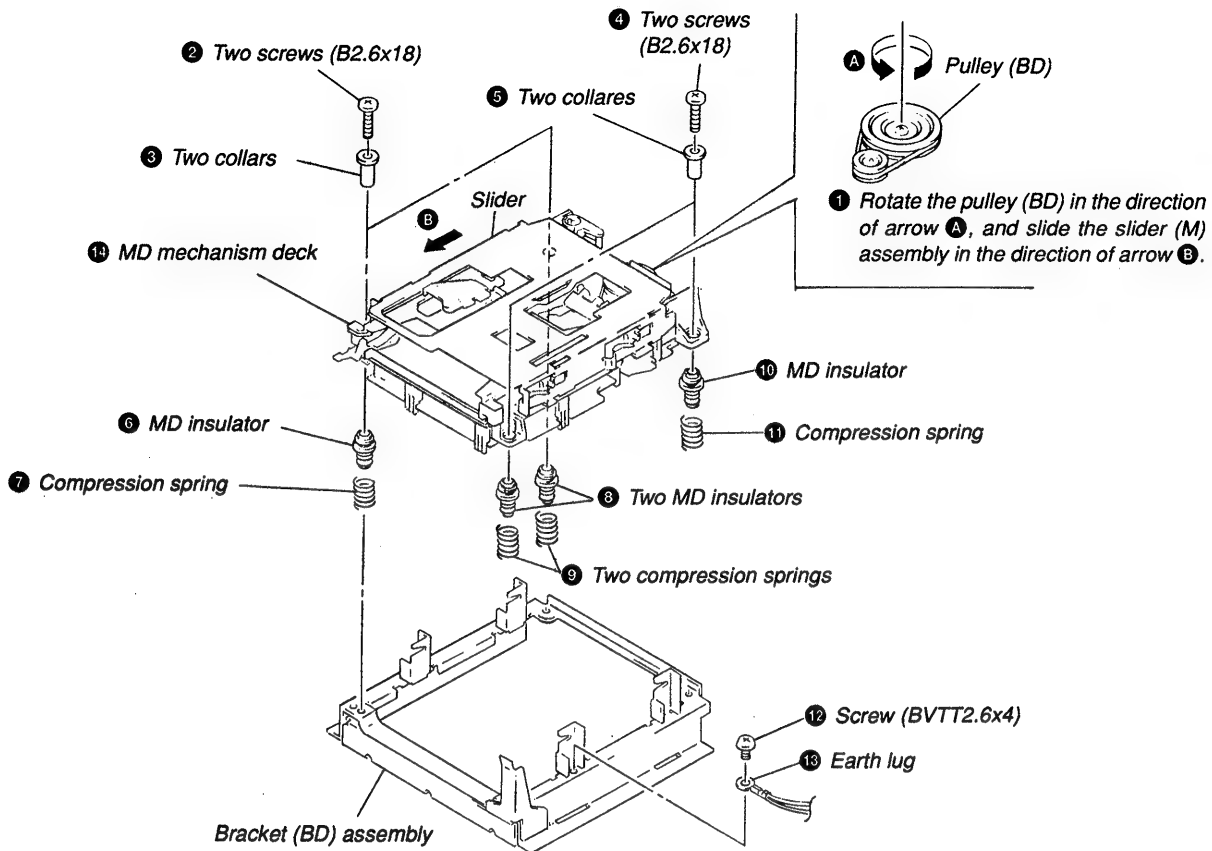

3-4. SLIDER (MD MECHANISM)

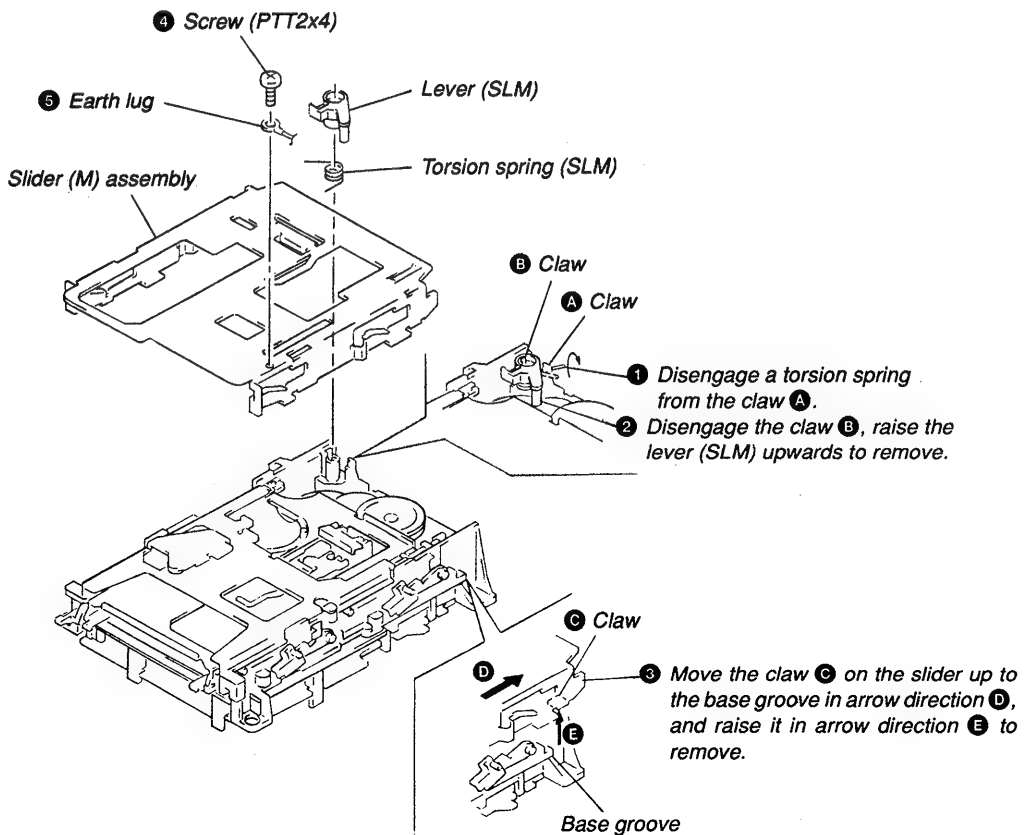

3-5. MD BASE UNIT (MBU-2), LOADING MOTOR ASSEMBLY

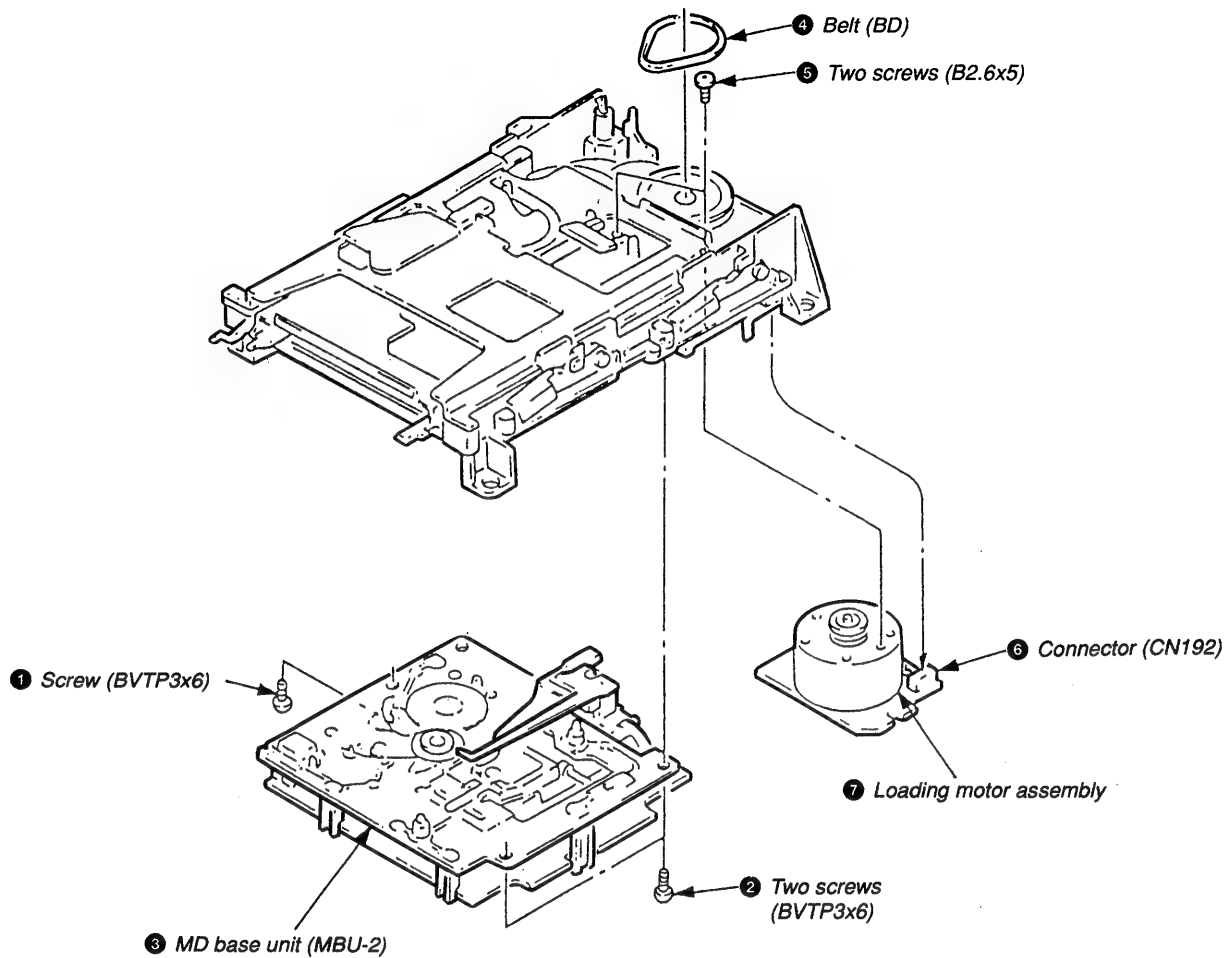

3-6. SLIDER ASSEMBLY MOUNTING (MD MECHANISM)

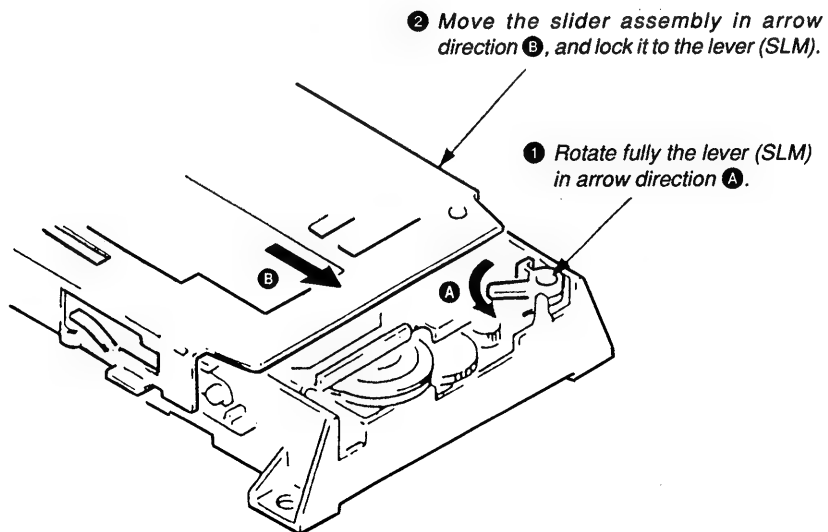

SECTION 4

TEST MODE

4-1. Setting the Test Mode

While pressing the AMS knob, insert the power plug into the power supply inlet, and release the AMS knob.

4-2. Exiting the Test Mode

Press the REPEAT button. Unplug the power plug from an outlet. after 5-6 seconds.

4-3. Basic Operations of the Test Mode

All operations are performed using the AMS knob, YES button, and NO button.

The functions of these buttons are as follows.

Function	Contents
AMS knob	Changes parameters and modes
YES button	Proceeds onto the next step. Finalizes input.
NO button	Returns to previous step. Stops operations.

4-4. Selecting the Test Mode

Eight test modes are selected by turning the AMS knob.

Display	Contents
TEMP ADJUST	Temperature compensation offset adjustment
LDPWR ADJUST	Laser power adjustment
EFBAL ADJUST	Traverse adjustment
FBIAS ADJUST	Focus bias adjustment
FBIAS CHECK	Focus bias check
CPLAY MODE	Continuous playback mode
CREC MODE	Continuous recording mode
EEP MODE	Non-volatile memory mode *

For detailed description of each adjustment mode, refer to 5. Electrical Adjustments.

If a different adjustment mode has been selected by mistake, press the NO button to exit from it.

* The EEP MODE is not used in servicing. If set accidentally, press the NO button immediately to exit it.

4-4-1. Operating the Continuous Playback Mode

1. Entering the continuous playback mode

- ① Set the disc in the unit (either MO or CD).
- ② Rotate the AMS knob and display "CPLAY MODE".
- ③ Press the YES button to change the display to "CPLAY IN".
- ④ When access completes, the display changes to "C1 = 0000 AD = 00".

Note : The "0" displayed are arbitrary numbers.

2. Changing the parts to be played back

- ① Press the YES button during continuous playback to change the display to "CPLAY MID", "CPLAY OUT".
When pressed another time, the parts to be played back can be changed.
- ② When access completes, the display changes to "C1 = 0000 AD = 00".

Note : The "0" displayed are arbitrary numbers.

3. Ending the continuous playback mode

- ① Press the NO button. The display will change to "CPLAY MODE".
- ② Press the EJECT button and remove the disc.

Note 1 : The playback start addresses for IN, MID, and OUT are as follows.

IN 40h cluster
MID 300h cluster
OUT 700h cluster

4-4-2. Operating the Continuous Recording Mode

1. Entering the continuous recording mode
 - ① Set the MO disc in the unit.
 - ② Rotate the AMS knob and display "CREC MODE".
 - ③ Press the YES button to change the display to "CREC IN".
 - ④ When access completes, the display changes to "CREC (■■■■)" and **REC** lights up.

Note : The "■■■■" displayed are arbitrary numbers.
2. Changing the parts to be recorded
 - ① When the YES button is pressed during continuous recording, the display changes to "CREC MID", "CREC OUT" and **REC** goes off.
When pressed another time, the parts to be recorded can be changed.
 - ② When access completes, the display changes to "CREC (■■■■)" and **REC** lights up.

Note : The "■■■■" displayed are arbitrary numbers.
3. Ending the continuous recording mode
 - ① Press the NO button. The display changes to "CREC MODE" and **REC** goes off.
 - ② Press the EJECT button and remove the disc.

Note 1 : The recording start addresses for IN, MID, and OUT are as follows.
 IN 40h cluster
 MID 300h cluster
 OUT 700h cluster

Note 2 : The NO button can be used to stop recording anytime.

Note 3 : During the test mode, the erasing-protection tab will not be detected. Therefore be careful not to set the continuous recording mode when a disc not to be erased is set in the unit.

Note 4 : Do not perform continuous recording for long periods of time above 5 minutes.

Note 5 : During continuous recording, be careful not to apply vibration.

4-4-3. Non-Volatile Memory Mode

This mode reads and writes the contents of the non-volatile memory.
 It is not used in servicing. If set accidentally, press the NO button immediately to exit it.

4-5. Functions of Other buttons

Function	Contents
▷	Sets continuous playback when pressed in the STOP state. When pressed during continuous playback, the tracking servo turns ON/OFF.
■	Stops continuous playback and continuous recording.
▶▶	The sled moves to the outer circumference only when this is pressed.
◀◀	The sled moves to the inner circumference only when this is pressed.
● REC	Turns recording ON/OFF when pressed during continuous playback.
SCROLL	Switches between the pit and groove modes when pressed.
PLAY MODE	Switches the spindle servo mode (CLVS and A).
DISPLAY	Switches the display when pressed. Returns to previous step. Stops operations.

Note : The erasing-protection tab is not detected during the test mode. Recording will start regardless of the position of the erasing-protection tab when the ● REC button is pressed.

4-6. Test Mode Displays

Each time the DISPLAY button is pressed, the display changes in the following order.

MODE display→Error rate display→Address display

1. MODE display
Displays "TEMP ADJUST", "CPLAY MODE", etc.
2. Error rate display
Error rates are displayed as follows.
C1 = 0000 AD = 0000
C1 = : Indicates C1 error
AD = : Indicates ADER
3. Address display
Addresses are displayed as follows.
h = 0000 s = 0000 (MO pit and CD)
h = 0000 a = 0000 (MO groove)
h = : Header address
s = : SUBQ address
a = : ADIP address
* is displayed when the address cannot be read.

4-7. Meanings of Other Displays

Display	Contents		
	Light	Off	Blinking
▷	During continuous playback	STOP	
	Tracking servo OFF	Tracking servo ON	
REC	Recording mode ON	Recording mode OFF	
CLOCK	CLV LOCK	CLV UNLOCK	
TRACK	Pit	Groove	
DISC	High reflection	Low reflection	
DATE	CLV-S	CLV-A	
A. SPACE	ABCD adjustment completed		
A - B	(Focus auto gain successful Tracking auto gain successful)		(Focus auto gain successful Tracking auto gain failed)

4-8. Precautions for Use of Test Mode

- ① As loading related operations will be performed regardless of the test mode operations being performed, be sure to check that the disc is stopped before setting and removing it.
Even if the EJECT button is pressed while the disc is rotating during continuous playback, continuous recording, etc., the disc will not stop rotating.
Therefore, it will be ejected while rotating.
Always press the NO button first before pressing the EJECT button.
- ② The erasing-protection tab is not detected in the test mode. Therefore, when modes which output the recording laser power such as continuous recording mode and traverse adjustment mode, etc. are set, the recorded contents will be erased regardless of the position of the tab. When using a disc that is not to be erased in the test mode, be careful not to enter the continuous recording mode and traverse adjustment mode.

SECTION 5

ELECTRICAL ADJUSTMENTS

MD SECTION

Precautions for Checking Laser Diode Emission

To check the emission of the laser diode during adjustments, never view directly from the top as this may lose your eye-sight.

Precautions for Use of optical pick-up (KMS-210A)

As the laser diode in the optical pick-up is easily damaged by static electricity, solder the laser tap of the flexible board when using it. Before disconnecting the connector, desolder first. Before connecting the connector, be careful not to remove the solder. Also take adequate measures to prevent damage by static electricity. Handle the flexible board with care as it breaks easily.

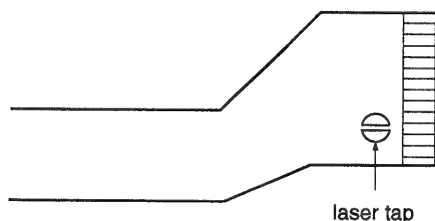

Optical pickup flexible board

Precautions for Adjustments

- 1) When replacing the following parts, perform the adjustments and checks with ○ in the order shown in the following table.

	Optical Pick-up	BD Board		
		IC171	D101	IC101, IC121, IC191
1. Temperature compensation offset adjustment	X	○	○	○
2. Laser power adjustment	○	X	X	○
3. Traverse adjustment	○	○	X	○
4. Focus bias adjustment	○	○	X	○
5. Error rate check	○	○	X	○

- 2) Set the test mode when performing adjustments. After completing the adjustments, exit the test mode.
- 3) Perform the adjustments in the order shown.
- 4) Use the following tools and measuring devices.
 - MD test disc (CD) TDYS-1 (Parts No. 4-963-646-01)
 - Laser power meter LPM-8001 (Parts No. J-2501-046-A)
 - Oscilloscope
 - Digital voltmeter
 - Thermometer
- 5) When observing several signals on the oscilloscope, etc., make sure that VC and ground do not connect inside the oscilloscope. (VC and ground will become short-circuited.)

Creating MO Continuously Recorded Disc

- * This disc is used in focus bias adjustment and error rate check. The following describes how to create a MO continuous recording disc.
 1. Insert a MO disc (blank disc) commercially available.
 2. Rotate the AMS knob and display "CREC MODE".
 3. Press the YES button and display "CREC IN".
 4. Press the YES button again to display "CREC MID". "CREC (0300)" is displayed for a moment and recording starts.
 5. Complete recording within 5 minutes.
 6. Press the NO button and stop recording.
 7. Press the EJECT button and remove the MO disc.

The above has been how to create a continuous recording data for the focus bias adjustment and error rate check.

Note :

- Be careful not to apply vibration during continuous recording.

Temperature Compensation Offset Adjustment

Save the temperature data at that time in the non-volatile memory as 25 °C reference data.

Note :

1. Usually, do not perform this adjustment.
2. Perform this adjustment in an ambient temperature of 22 °C to 28 °C. Perform it immediately after the power is turned on when the internal temperature of the unit is the same as the ambient temperature.
3. When D101 has been replaced, perform this adjustment after the temperature of this part has become the ambient temperature.

Adjusting Method :

1. Rotate the AMS knob and display "TEMP ADJUST".
2. Press the YES button and select the "TEMP ADJUST" mode.
3. "TEMP = []" and the current temperature data will be displayed.
4. To save the data, press the YES button.
When not saving the data, press the NO button.
5. When the YES button is pressed, "TEMP = [] SAVE" will be displayed for some time, followed by "TEMP ADJUST".
When the NO button is pressed, "TEMP ADJUST" will be displayed.

Specifications :

The "TEMP = []" should be within "E0 - EF", "F0 - FF", "00 - 0F", "10 - 1F" and "20 - 2F".

Laser Power Adjustment

Connection :

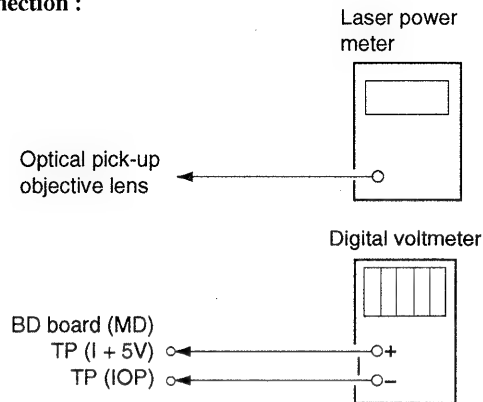

Adjusting Method :

1. Set the laser power meter on the objective lens of the optical pick-up. (When it cannot be set properly, press the ◀ button or ▶ button and move the optical pick-up.)
Connect the digital voltmeter to TP (IOP) and TP (I+5V).
2. Rotate the AMS knob and display "LDPWR ADJUST".
(Laser power : For adjustment)
3. Press the YES button twice and display "LD \$ 4B = 3.5 mW".
4. Adjust RV102 of the BD board (MD) so that the reading of the laser power meter becomes $3.4^{+0.1}_{-0}$ mW.
5. Press the YES button and display "LD \$ 96 = 7.0 mW".
(Laser power : MO writing)
6. Check that the laser power meter and digital voltmeter readings satisfy the specified value.

Specification :

Laser power meter reading : 7.0 ± 0.3 mW

Digital voltmeter reading : Optical pick-up displayed value $\pm 10\%$

(Optical pick-up label)

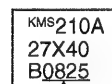

lop = 82.5 mA in this case

lop (mA) = Digital voltmeter reading (mV) / 1 ()

7. Press the YES button and display "LD \$ 0F = 0.7 mW".
(Laser power : MO reading)
8. Check that the laser power meter at this time satisfies the specified value.

Specification :

Laser power meter reading : 0.70 ± 0.1 mW

9. Press the NO button and display "LDPWR ADJUST", and stop laser emission.
(The NO button is effective at all times to stop the laser emission.)

Traverse Adjustment

Connection :

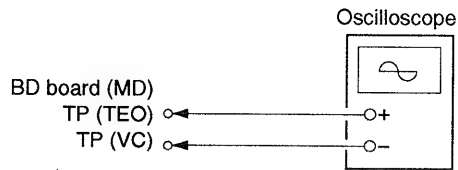

Adjusting method :

1. Connect an oscilloscope to TP (TEO) and TP (VC) of the BD board (MD).
2. Load a MO disc (any available on the market).
3. Press the ◀ button or ▶ button and move the optical pick-up outside the pit.
4. Rotate the AMS knob and display "EFBAL ADJUST".
5. Press the YES button and display "EFBAL MO-W". (Laser power WRITE power/Focus servo ON/tracking servo OFF/spindle (S) servo ON)
6. Adjust RV101 of the BD board (MD) so that the waveform of the oscilloscope becomes the specified value. (MO groove write power traverse adjustment)

(Traverse Waveform)

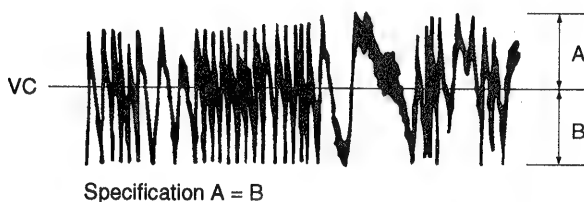

7. Press the YES button and display "EFB = \$ MO-R". (Laser power : MO reading)
8. Rotate the AMS knob so that the waveform of the oscilloscope becomes the specified value. (When the AMS knob is rotated, the \$ of "EFB-\$" changes and the waveform changes.) In this adjustment, waveform varies at intervals of approx. 3%. Adjust the waveform so that the specified value is satisfied as much as possible. (MO groove read power traverse adjustment)

(Traverse Waveform)

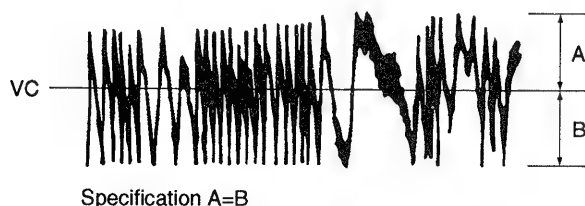

9. Press the YES button, display "EFB = \$ SAVE" for a moment and save the adjustment results in the non-volatile memory. Next "EFBAL MO-P" is displayed.
10. Press the YES button and display "EFB = \$ MO-P". The optical pick-up moves to the pit area automatically and servo is imposed.

11. Rotate the AMS knob until the waveform of the oscilloscope moves closer to the specified value. In this adjustment, waveform varies at intervals of approx. 3%. Adjust the waveform so that the specified value is satisfied as much as possible.

(Traverse Waveform)

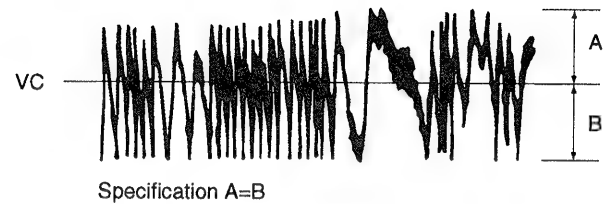

12. Press the YES button, display "EFB = \$ SAVE" for a moment and save the adjustment results in the non-volatile memory. Next "EFBAL CD" is displayed. The disc stops rotating automatically.
13. Press the EJECT button and remove the MO disc.
14. Load the test disc TDYS-1.
15. Press the YES button and display "EFB = \$ CD". Servo is imposed automatically.
16. Rotate the AMS knob so that the waveform of the oscilloscope moves closer to the specified value. In this adjustment, waveform varies at intervals of approx. 3%. Adjust the waveform so that the specified value is satisfied as much as possible.

(Traverse Waveform)

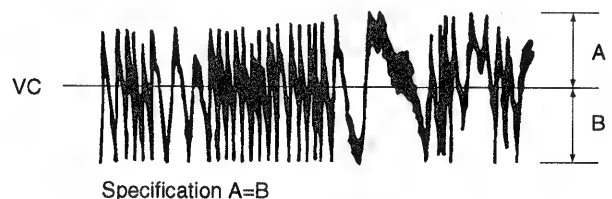

17. Press the YES button, display "EFB = \$ SAVE" for a moment and save the adjustment results in the non-volatile memory. Next "EFBAL ADJUST" is displayed.
18. Press the EJECT button and remove the test disc TDYS-1.

Note 1) Data will be erased during MO reading if a recorded disc is used in this adjustment.

Note 2) If the traverse waveform is not clear, connect the oscilloscope as shown in the following figure so that it can be seen more clearly.

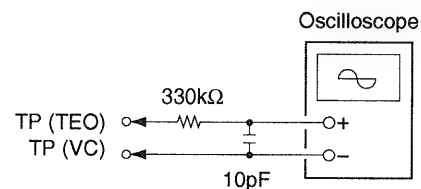

Focus Bias Adjustment

Adjusting Method :

1. Load a continuously recorded disc (Refer to "Page 31 Creating MO Continuously Recorded Disc").
2. Rotate the AMS knob and display "CPLAY MODE".
3. Press the YES button twice and display "CPLAY MID".
4. Press the NO button when "C1 = 0000 AD = 00" is displayed.
5. Rotate the AMS knob and display "FBIAS ADJUST".
6. Press the YES button and display "0000/00 a = 00".
The first four digits indicate the C1 error rate, the two digits after [/] indicate ADER, and the 2 digits after [a =] indicate the focus bias value.
7. Rotate the AMS knob in the clockwise direction and find the focus bias value at which the C1 error rate becomes 220.
8. Press the YES button and display "0000/00 b = 00".
9. Rotate the AMS knob in the counterclockwise direction and find the focus bias value at which the C1 error rate becomes 220.
10. Press the YES button and display "0000/00 c = 00".
11. Check that the C1 error rate is below 50 and ADER is 00. Then press the YES button.
12. If the "(00)" in "00 - 00 - 00 (00)" is above 20, press the YES button.
If below 20, press the NO button and repeat the adjustment from step 2 again.
13. Press the NO button and press the EJECT button to remove the continuously recorded disc.

Note 1: The relation between the C1 error and focus bias is as shown in the following figure. Find points a and b in the following figure using the above adjustment. The focal point position C is automatically calculated from points a and b.

Note 2: As the C1 error rate changes, perform the adjustment using the average value.

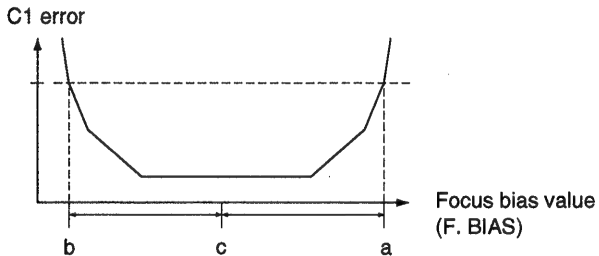

Error Rate Check

CD Error Rate Check

Checking Method :

1. Load a test disc TDYS-1.
2. Rotate the AMS knob and display "CPLAY MODE".
3. Press the YES button twice and display "CPLAY MID".
4. "C1 = 0000 AD = 00" is displayed.
5. Check that the C1 error rate is below 20.
6. Press the NO button, stop playback, press the EJECT button, and remove the test disc.

MO Error Rate Check

Checking Method :

1. Load a continuously recorded disc (Refer to "Page 31 Creating MO Continuously Recorded Disc").
2. Rotate the AMS knob and display "CPLAY MODE".
3. Press the YES button twice and display "CPLAY MID".
4. "C1 = 0000 AD = 00" is displayed.
5. If the C1 error rate is below 50, check that ADER is 00.
6. Press the NO button, stop playback, press the EJECT button, and remove the continuously recorded disc.

Focus Bias Check

Change the focus bias and check the focus tolerance amount.

Checking Method :

1. Load a continuously recorded disc (Refer to "Page 31 Creating MO Continuously Recorded Disc").
2. Rotate the AMS knob and display "CPLAY MODE".
3. Press the YES button twice and display "CPLAY MID".
4. Press the NO button when "C1 = 0000 AD = 00" is displayed.
5. Rotate the AMS knob and display "FBIAS CHECK".
6. Press the YES button and display "0000/00 c = 00".
The first four digits indicate the C1 error rate, the two digits after [/] indicate ADER, and the 2 digits after [c =] indicate the focus bias value.
Check that the C1 error is below 50 and ADER is 00.
7. Press the YES button and display "0000/00 b = 00".
Check that the C1 error is not below 220 and ADER is not above 00 every time.
8. Press the YES button and display "0000/00 a = 00".
Check that the C1 error is not below 220 and ADER is not above 00 every time.
9. Press the NO button, next press the EJECT button, and remove the continuously recorded disc.

Note 1: If the C1 error and ADER are above 00 at points a or b, the focus bias adjustment may not have been carried out properly. Adjust perform the beginning again.

Adjusting Points and Connecting Points

[BD BOARD] (MD) (COMPONENT SIDE)

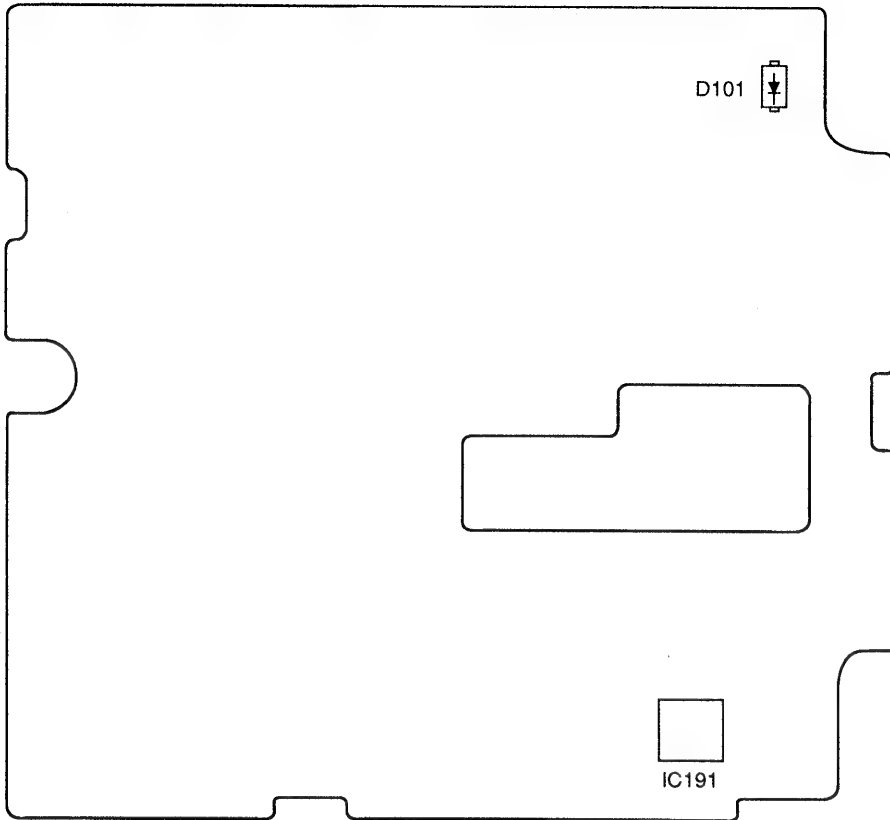

[BD BOARD] (MD) (CONDUCTOR SIDE)

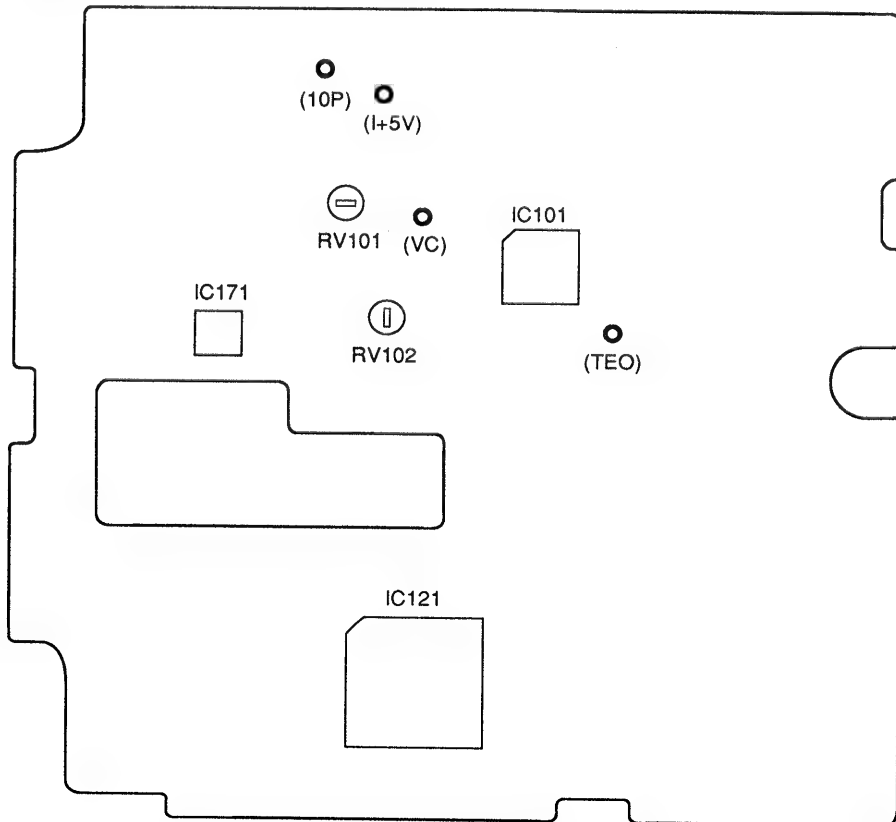

CD SECTION

Note:

1. CD Block is basically designed to operate without adjustment. Therefore, check each item in order given.
2. Use YEDS-18 disc (3-702-101-01) unless otherwise indicated.
3. Use an oscilloscope with more than $10M\Omega$ impedance.
4. Clean the object lens by an applicator with neutral detergent when the signal level is low than specified value with the following checks.

S Curve Check

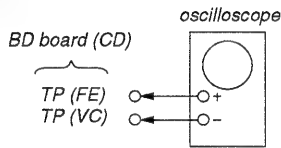

Procedure :

1. Connect oscilloscope to test point TP (FE) on BD board (CD).
2. Connect between test point TP (FE) and TP (VC) by lead wire.
3. Turned Power switch on.
4. Put disc (YEDS-18) in and turned Power switch on again and actuate the focus search. (actuate the focus search when disc table is moving in and out.)
5. Check the oscilloscope waveform (S-curve) is symmetrical between A and B. And confirm peak to peak level within 3 ± 1 Vp-p.

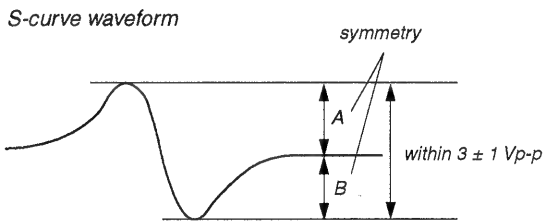

6. After check, remove the lead wire connected in step 2.

Note : • Try to measure several times to make sure than the ratio of A : B or B : A is more than 10 : 7.

- Take sweep time as long as possible and light up the brightness to obtain best waveform.

RF Level Check

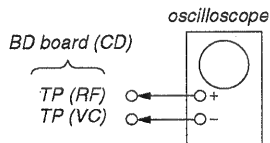

Procedure :

1. Connect oscilloscope to test point TP (RF) on BD board (CD).
2. Turned Power switch on.
3. Put disc (YEDS-18) in to play the number five track.
4. Confirm that oscilloscope waveform is clear and check RF signal level is correct or not.

Note: A clear RF signal waveform means that the shape “ $\hat{\diamond}$ ” can be clearly distinguished at the center of the waveform.

RF signal waveform

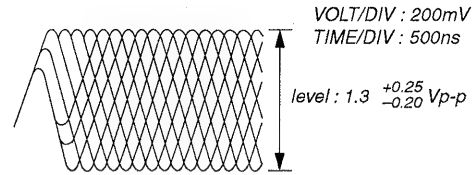

E-F Balance (1 Track Jump) Check

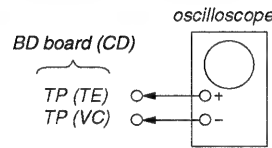

Procedure :

1. Connect oscilloscope to test point TP (TE) on BD board (CD).
2. Turned Power switch on.
3. Put disc (YEDS-18) in to play the number five track.
4. Press the “|| (Pause)” button. (Becomes the 1 track jump mode)
5. Check the level B of the oscilloscope's waveform and the A (DC voltage) of the center of the Traverse waveform.

Confirm the following :

$$A/B \times 100 = \text{less than } \pm 20\%$$

1 track jump waveform

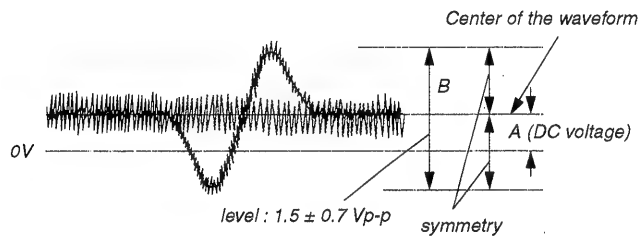

RF PLL Free-run Frequency Check

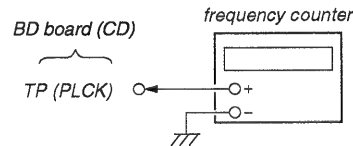

Procedure :

1. Connect frequency counter to TP (PLCK) with lead wire.
2. Turned Power switch on.
3. Put the disc (YEDS-18) in to play the number five track. Confirm that reading on frequency counter is 4.3218MHz.

Adjustment Location :

[BD BOARD] — Side A —

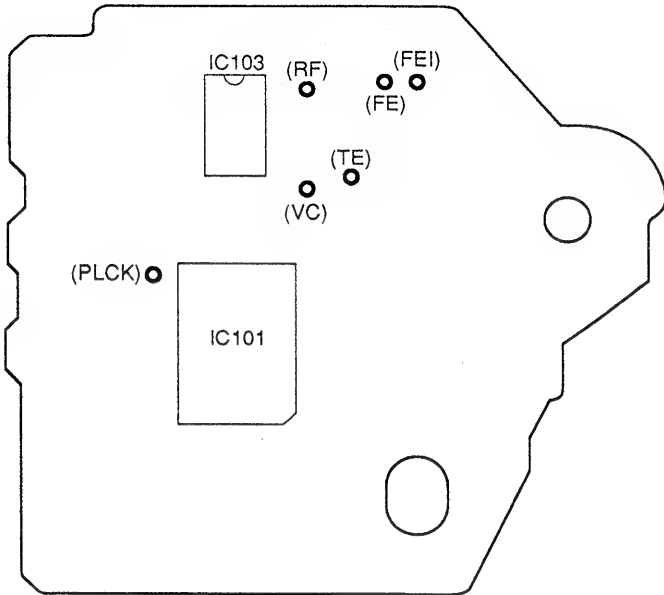

SECTION 6 DIAGRAMS

6-1. CIRCUIT BOARDS LOCATION

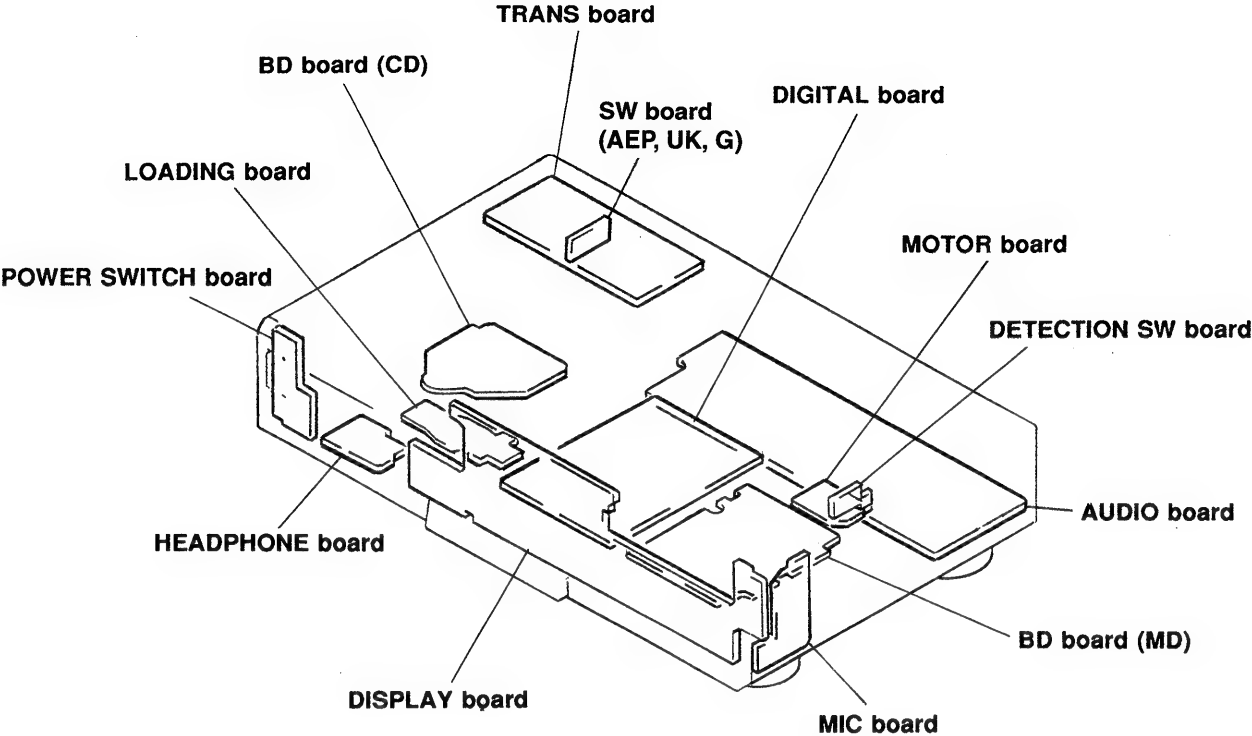

6-2. BLOCK DIAGRAMS
— MD SECTION —

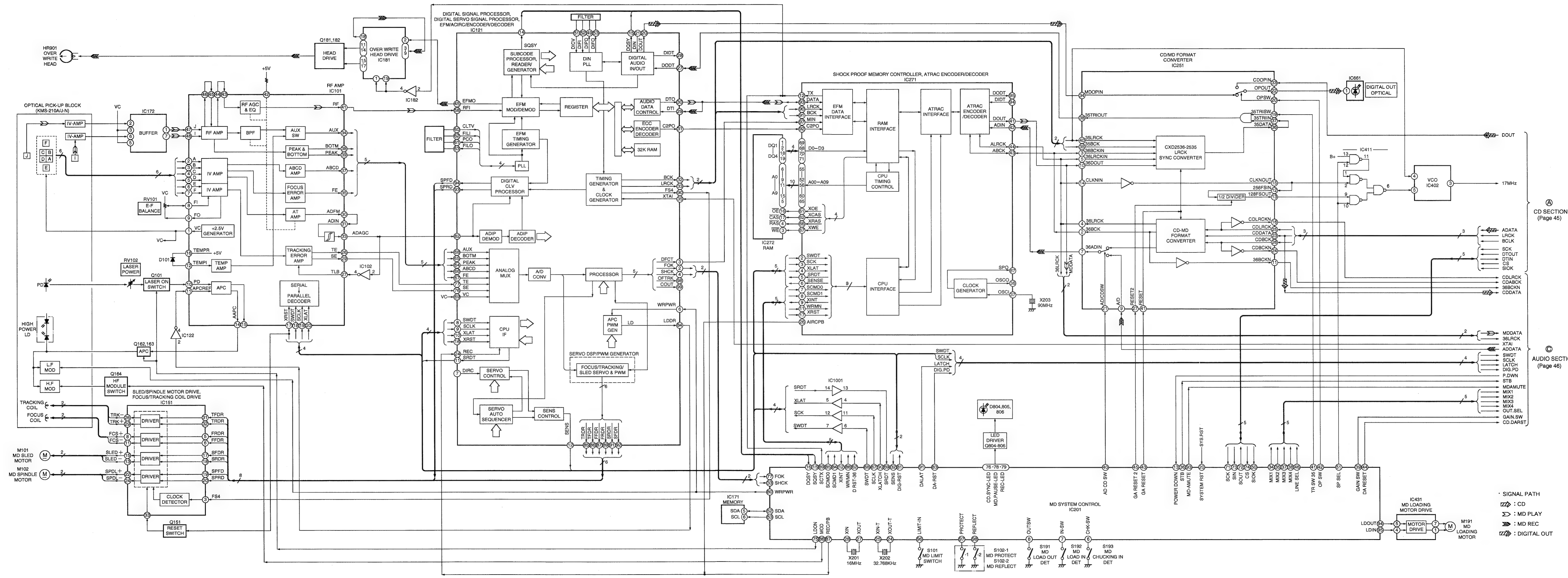

Ⓐ CD SECTION
(Page 45)

Ⓑ AUDIO SECTION
(Page 46)

SIGNAL PATH

- ⊃ : CD
- ⊃ : MD PLAY
- ⊃ : MD REC
- ⊃ : DIGITAL OUT

— CD SECTION —

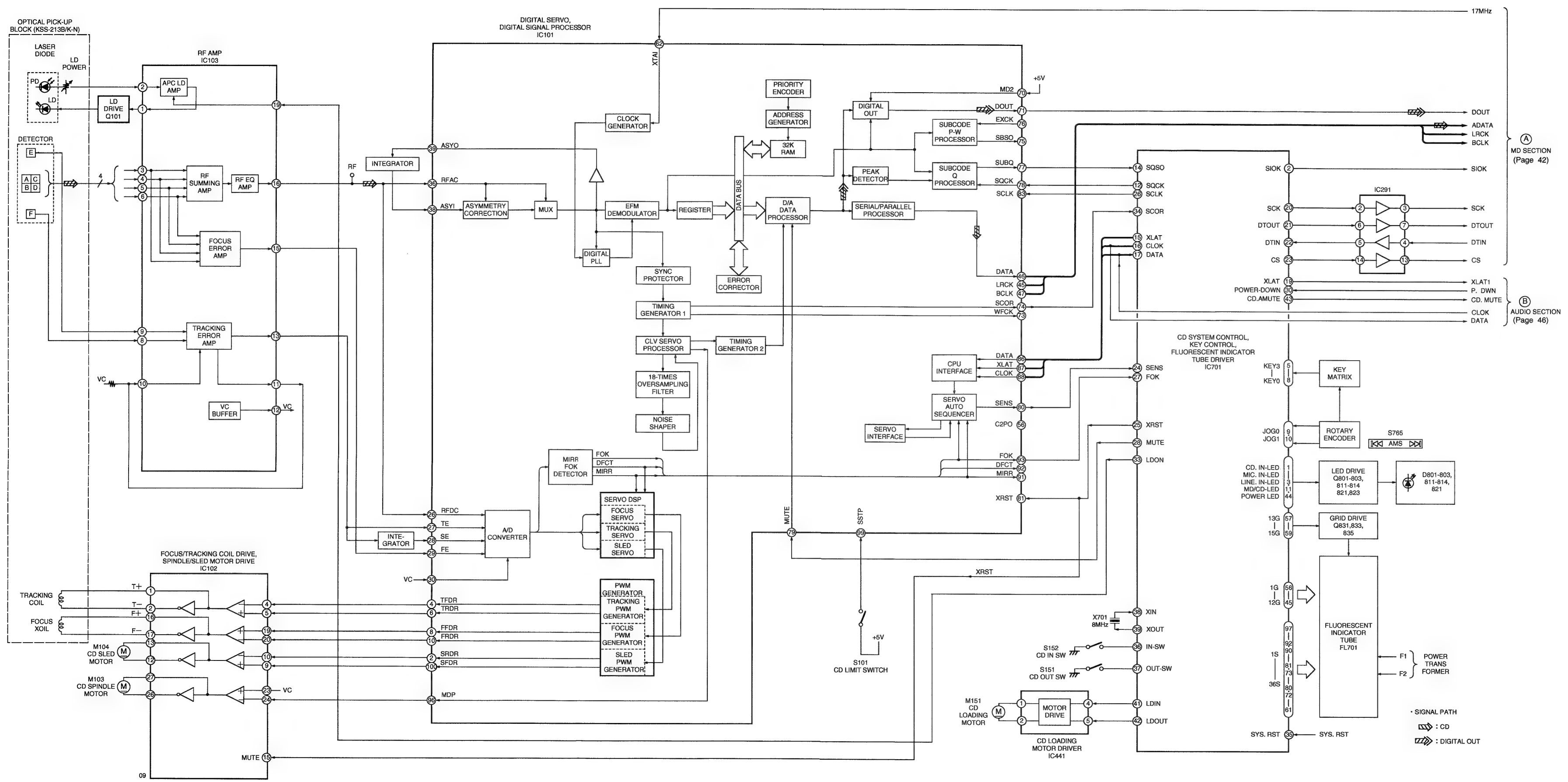

— AUDIO SECTION —

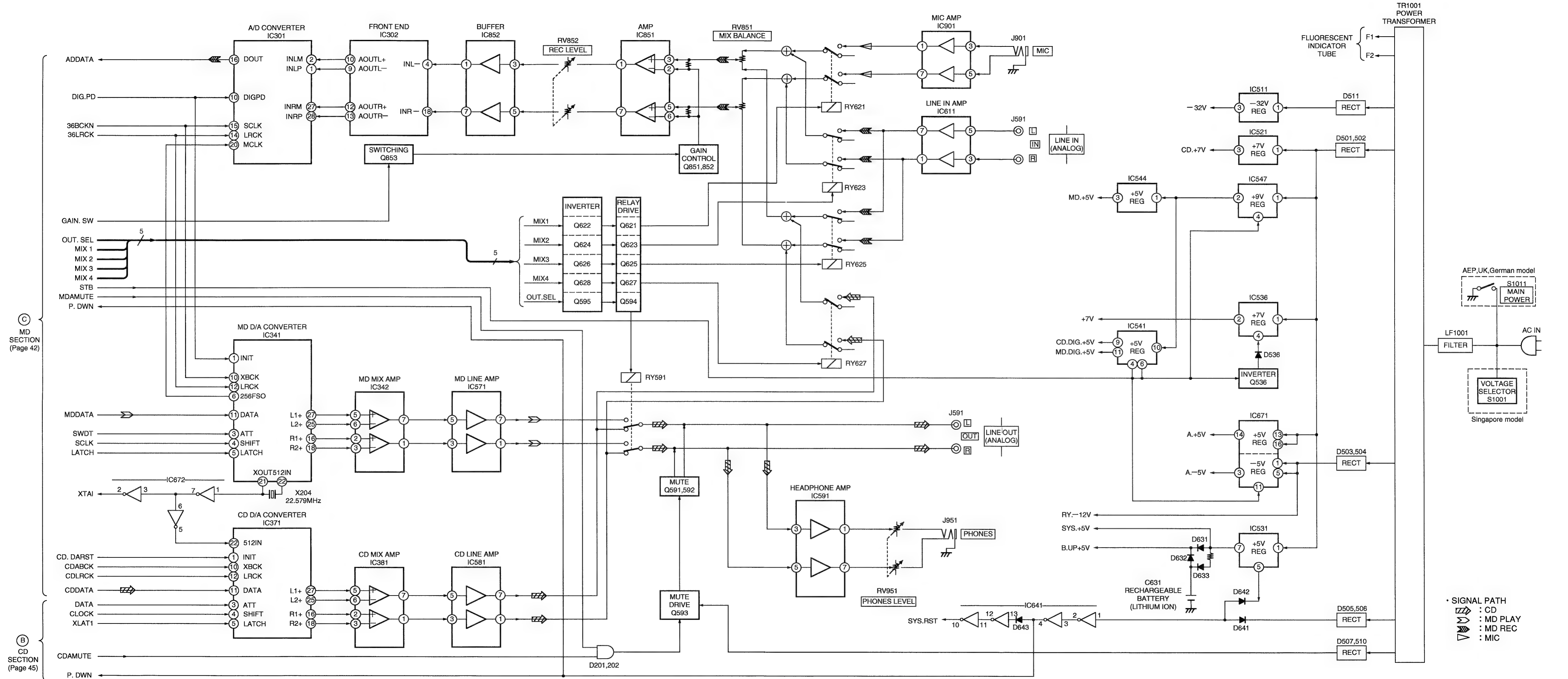

6-3. SCHEMATIC DIAGRAM — CD SECTION —
 • See page 89 for IC Pin Functions. (IC101)

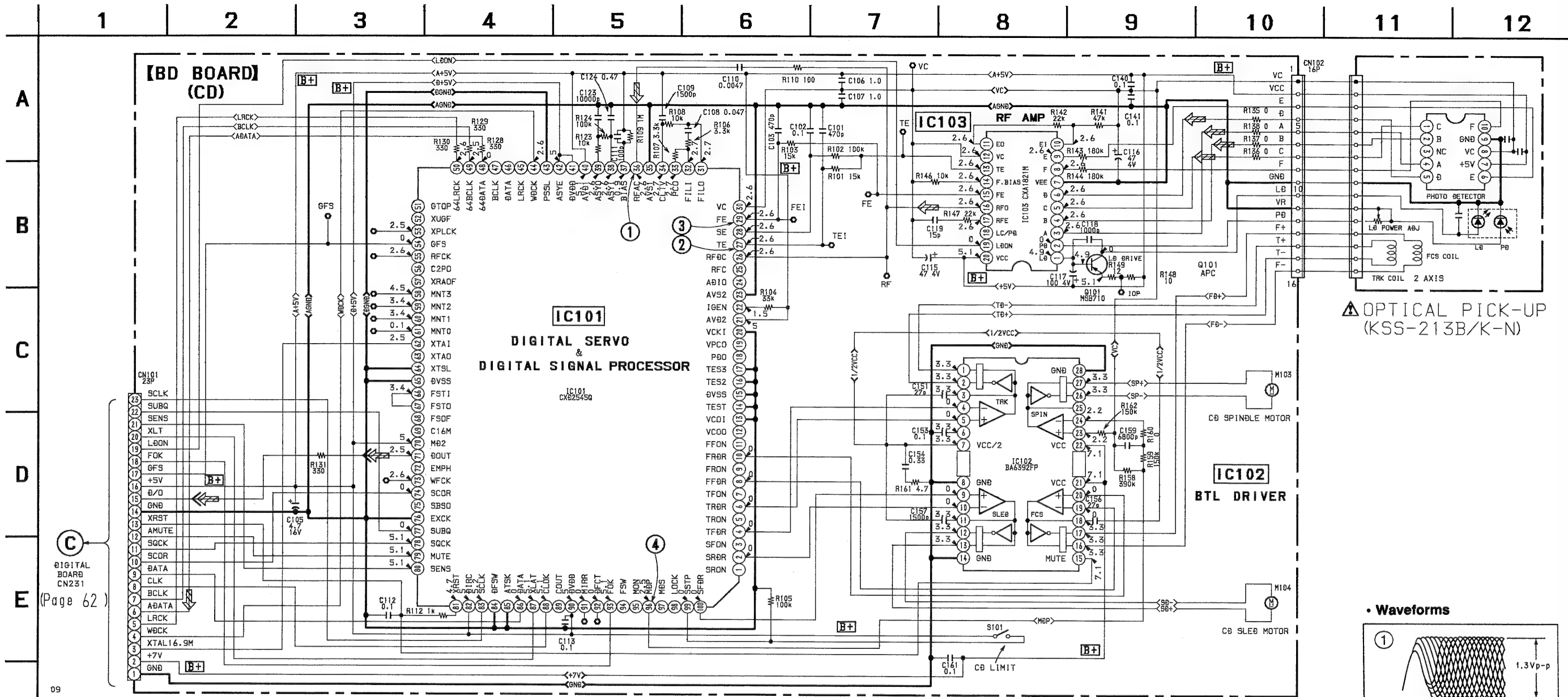

OPTICAL PICK-UP (KSS-213B/K-N)

DIGITAL BOARD CN231 (Page 62)

NOTE

- All capacitors are in μF unless otherwise noted. $\text{pF} = \mu\mu\text{F}$. 50W or less are not indicated except for electrolytics and tantalums.
- All resistors are in Ω and $1/4\text{W}$ or less unless otherwise specified.

Note:
 The components identified by mark Δ or dotted line with mark Δ are critical for safety. Replace only with part number specified.

Note:
 Les composants identifiés par une marque Δ sont critiques pour la sécurité. Ne les remplacer que par une pièce portant le numéro spécifié.

- **[B+]** :B+ Line.
- Voltages and waveforms are dc with respect to ground under no-signal conditions, no mark:CB STOP
- Voltages are taken with a VOM (Input impedance $10\text{M}\Omega$). Voltage variations may be noted due to normal production tolerances.
- Waveforms are taken with a oscilloscope. Voltage variations may be noted due to normal production tolerances.
- Circled numbers refer to waveforms.

- Signal path.
- \Rightarrow :CB
- \Rightarrow :digital out

• Waveforms

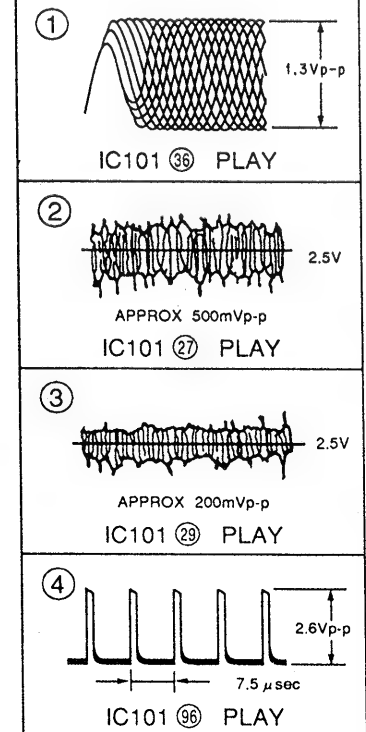

6-4. PRINTED WIRING BOARD — CD SECTION —
 • See page 38 for Circuit Boards Location.

• Semiconductor Location

Ref. No.	Location
IC101	C-2
IC102	C-7
IC103	B-2
Q101	A-8

1 2 3 4 5 6 7 8 9

A

B

C

D

E

F

【BD BOARD】(CD)(SIDE A)

【BD BOARD】(CD)(SIDE B)

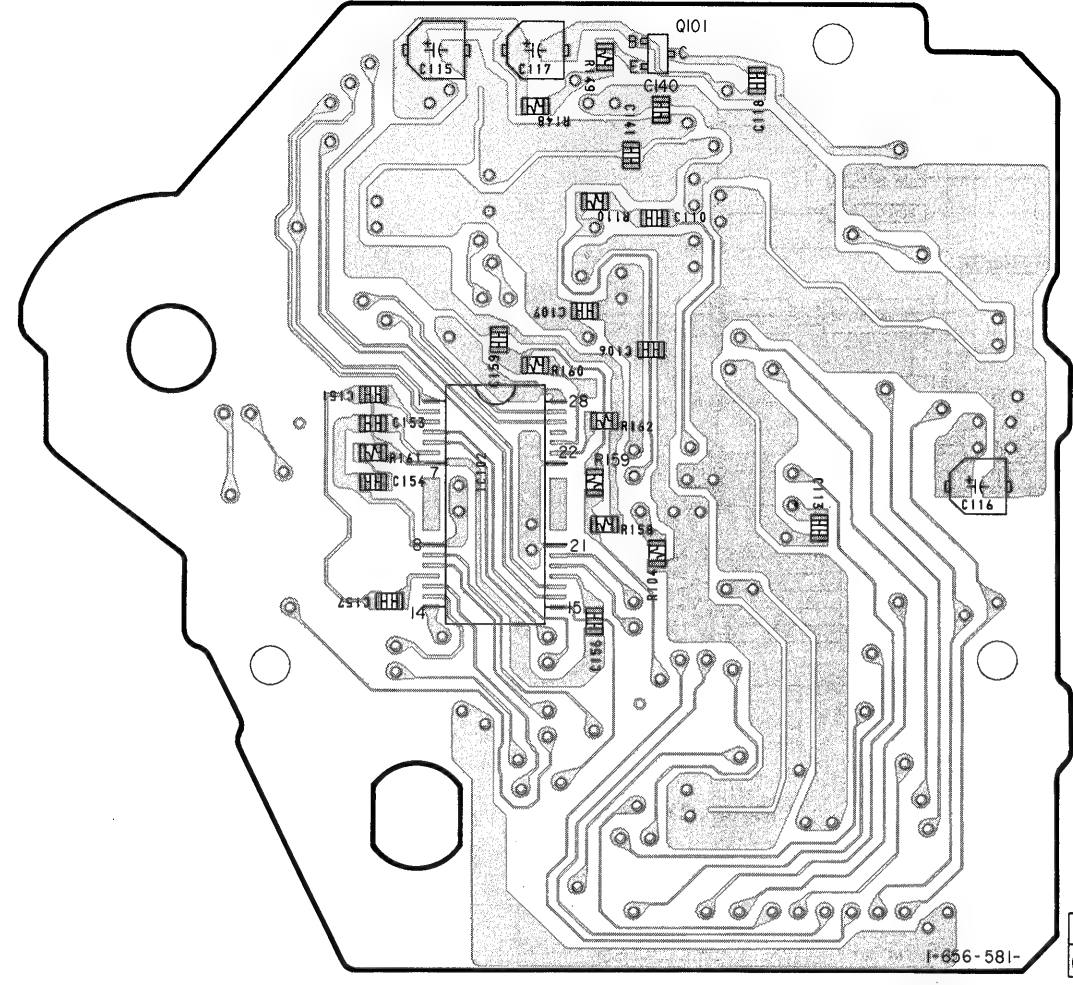
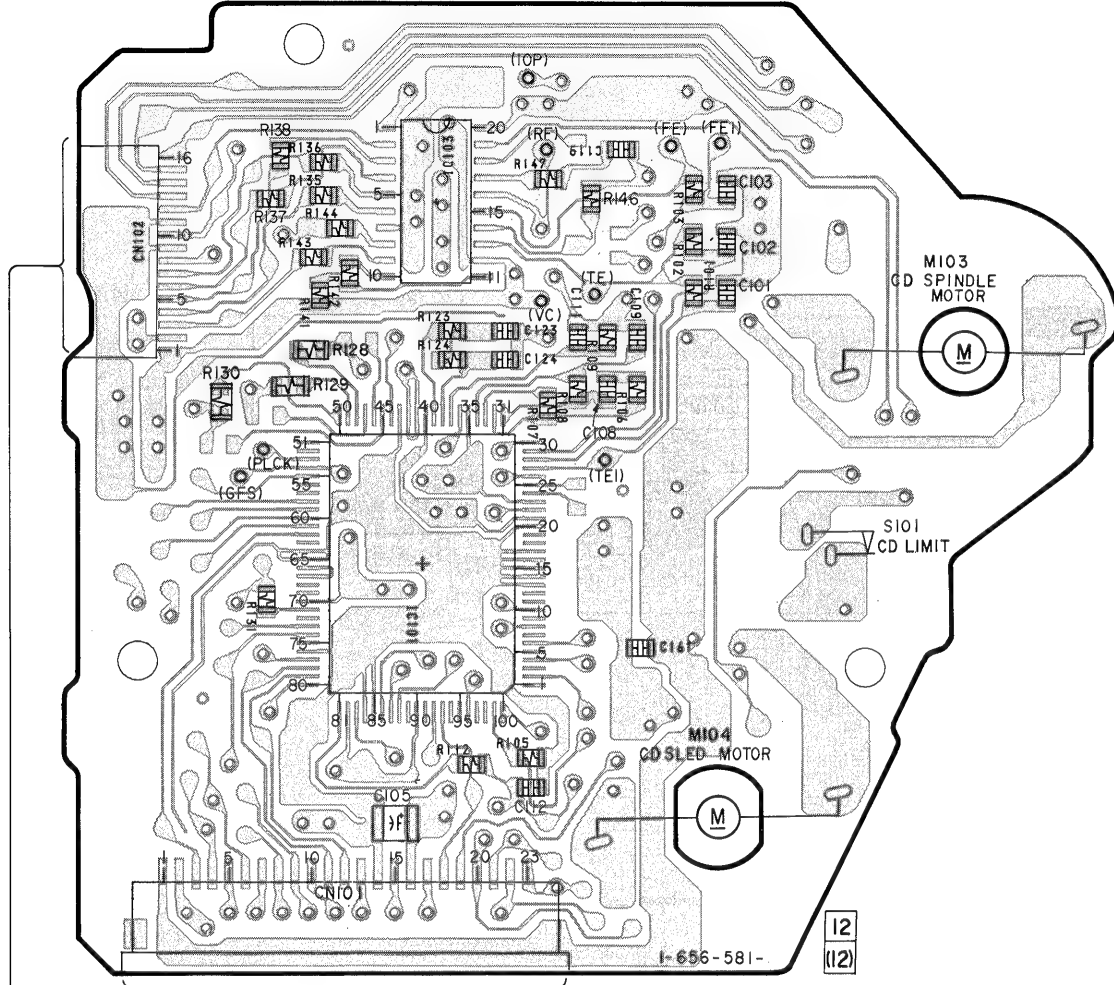

DIGITAL BOARD
 CN231 (Page 68)

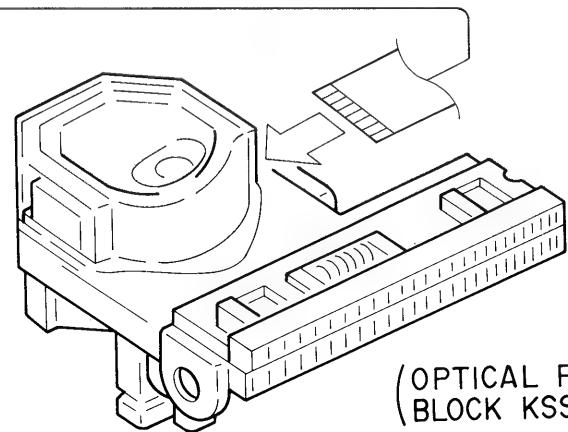

(OPTICAL PICK-UP
 BLOCK KSS-213B/K-N)

Note:
 • ● : Through hole.
 • □ : Pattern from the side which enable seeing.
 (The other layer's patterns are not indicated.)

6-5. IC BLOCK DIAGRAMS — CD SECTION —

IC101 CXD2545Q

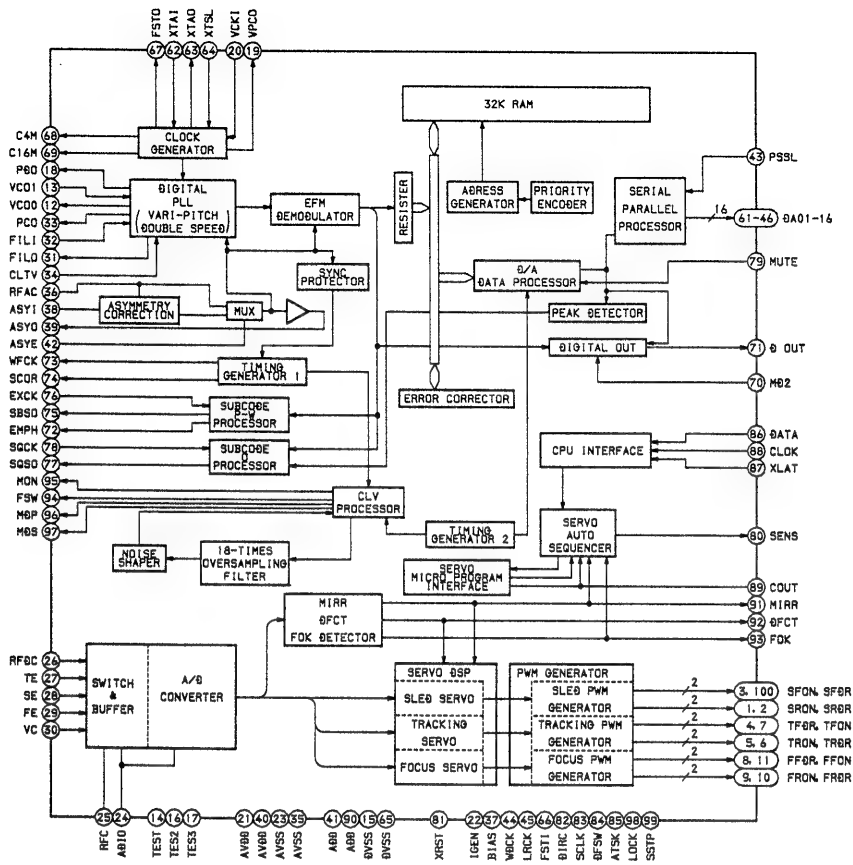

IC102 BA6392FP

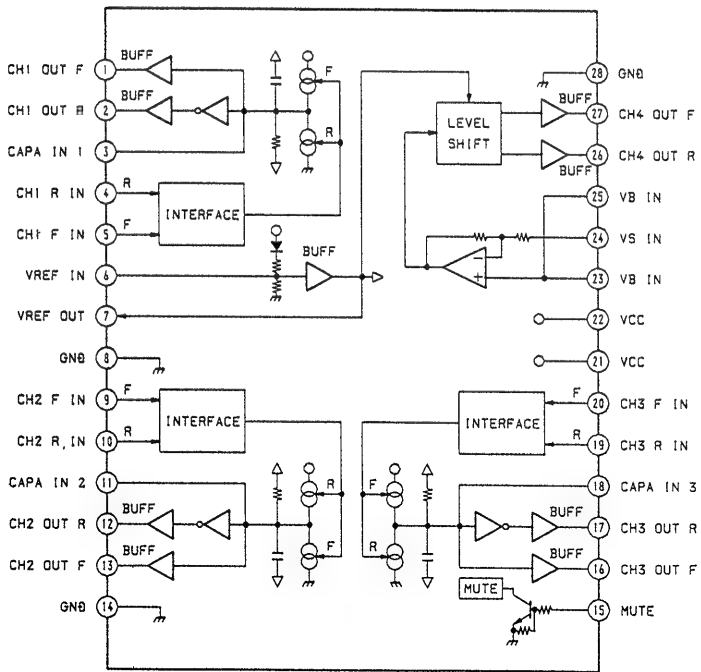

IC103 CXA1821M

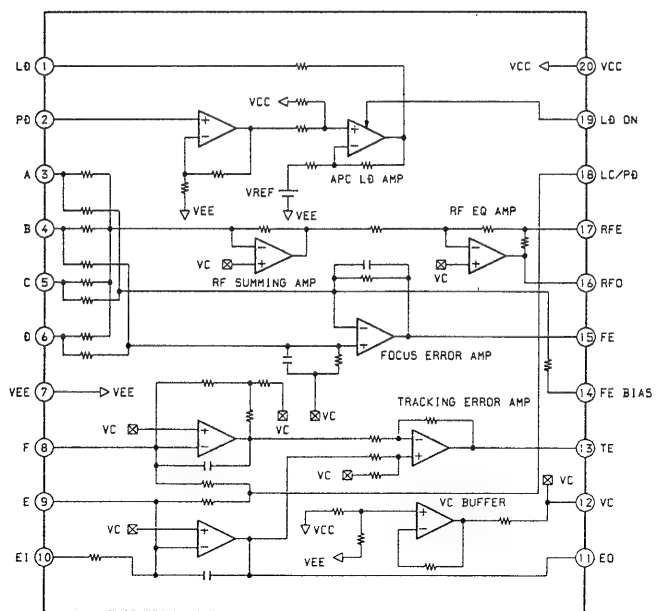

6-6. PRINTED WIRING BOARD — RF SECTION —
 • See page 38 for Circuit Boards Location.

• Waveforms

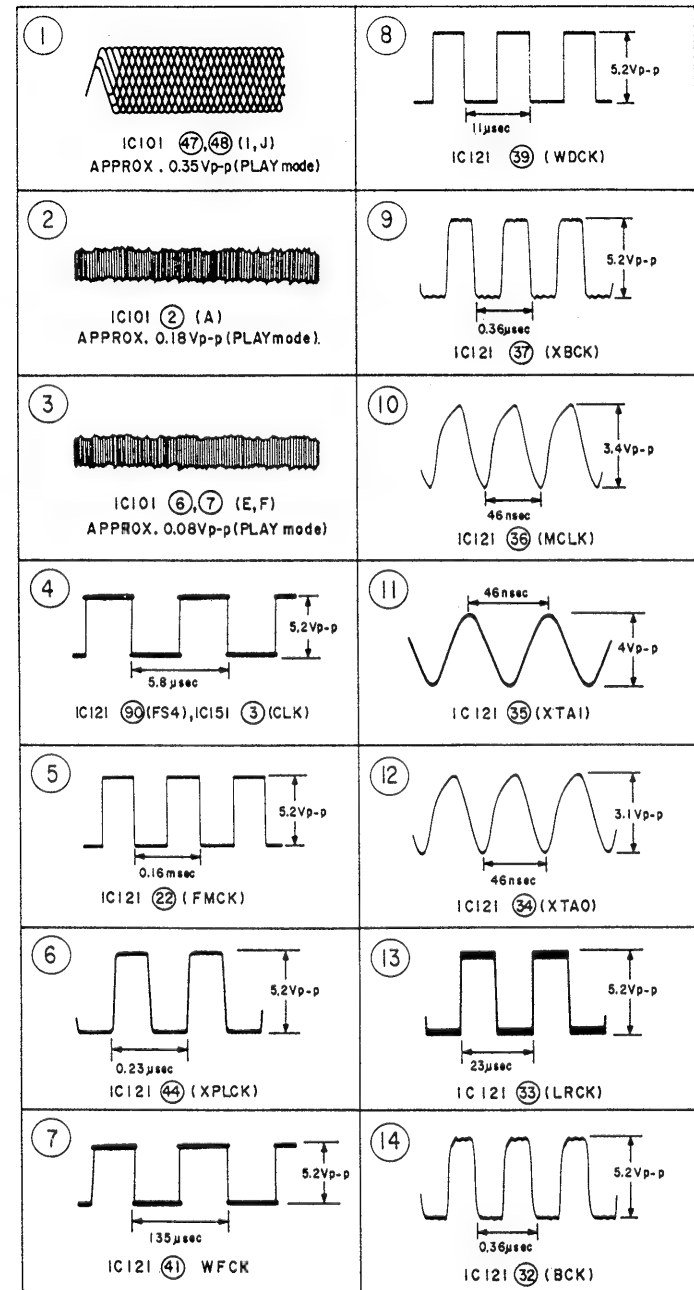

• Semiconductor Location

Ref. No.	Location
D101	C-6
D155	F-11
D161	B-8
D181	C-2
D183	C-2
IC101	D-10
IC102	D-11
IC121	F-9
IC122	D-9
IC151	G-12
IC171	D-8
IC172	C-10
IC181	C-12
IC182	C-11
IC191	G-5
Q101	B-9
Q151	F-11
Q162	B-10
Q163	B-8
Q164	B-8
Q181	C-1
Q182	C-1

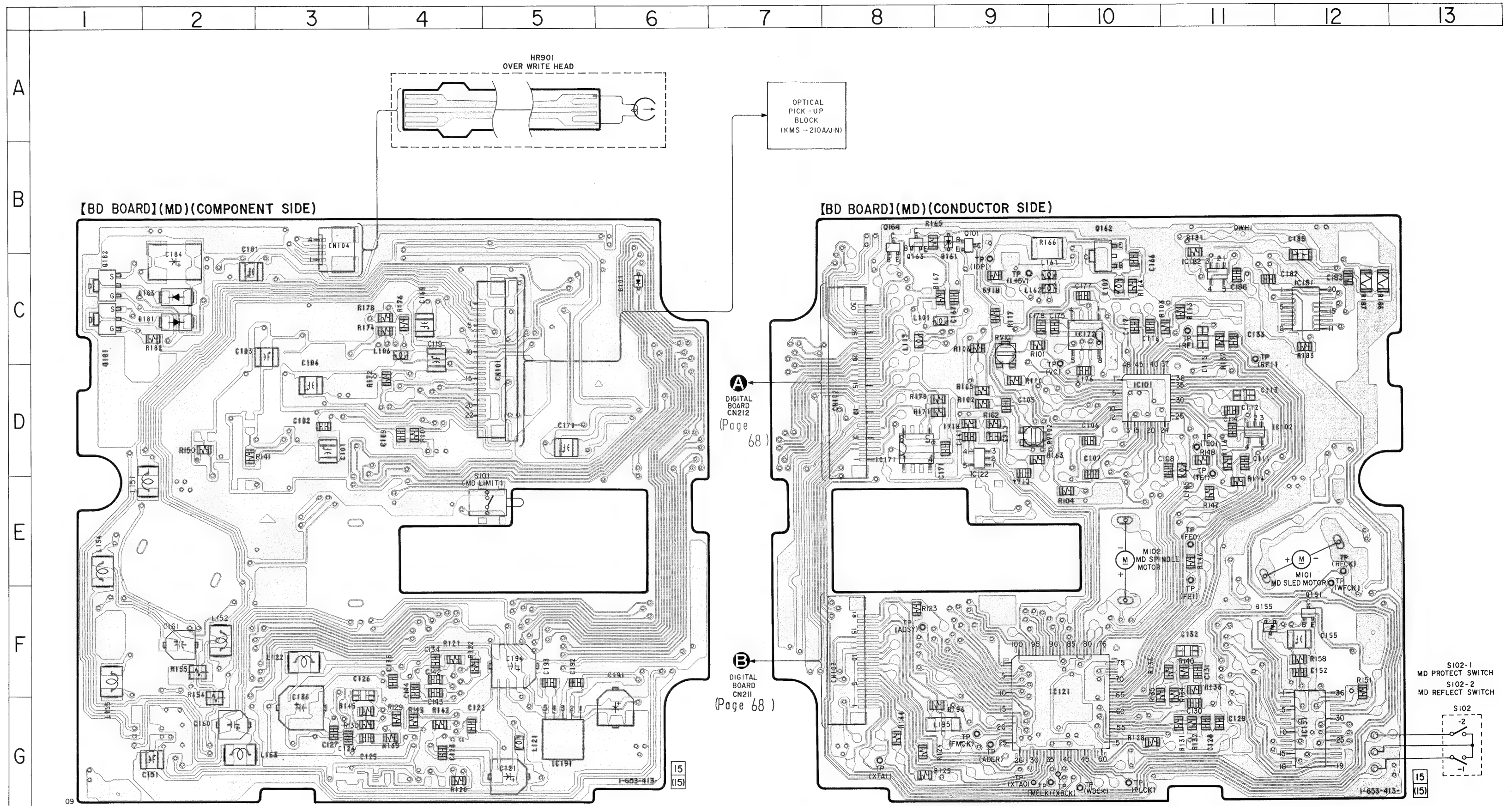

Note:
 • ● : Through hole.
 • □ : Pattern from the side which enable seeing.
 (The other layer's patterns are not indicated.)

6-7. SCHEMATIC DIAGRAM — RF SECTION —
• See page 92 for IC Pin Functions. (IC101, 121)

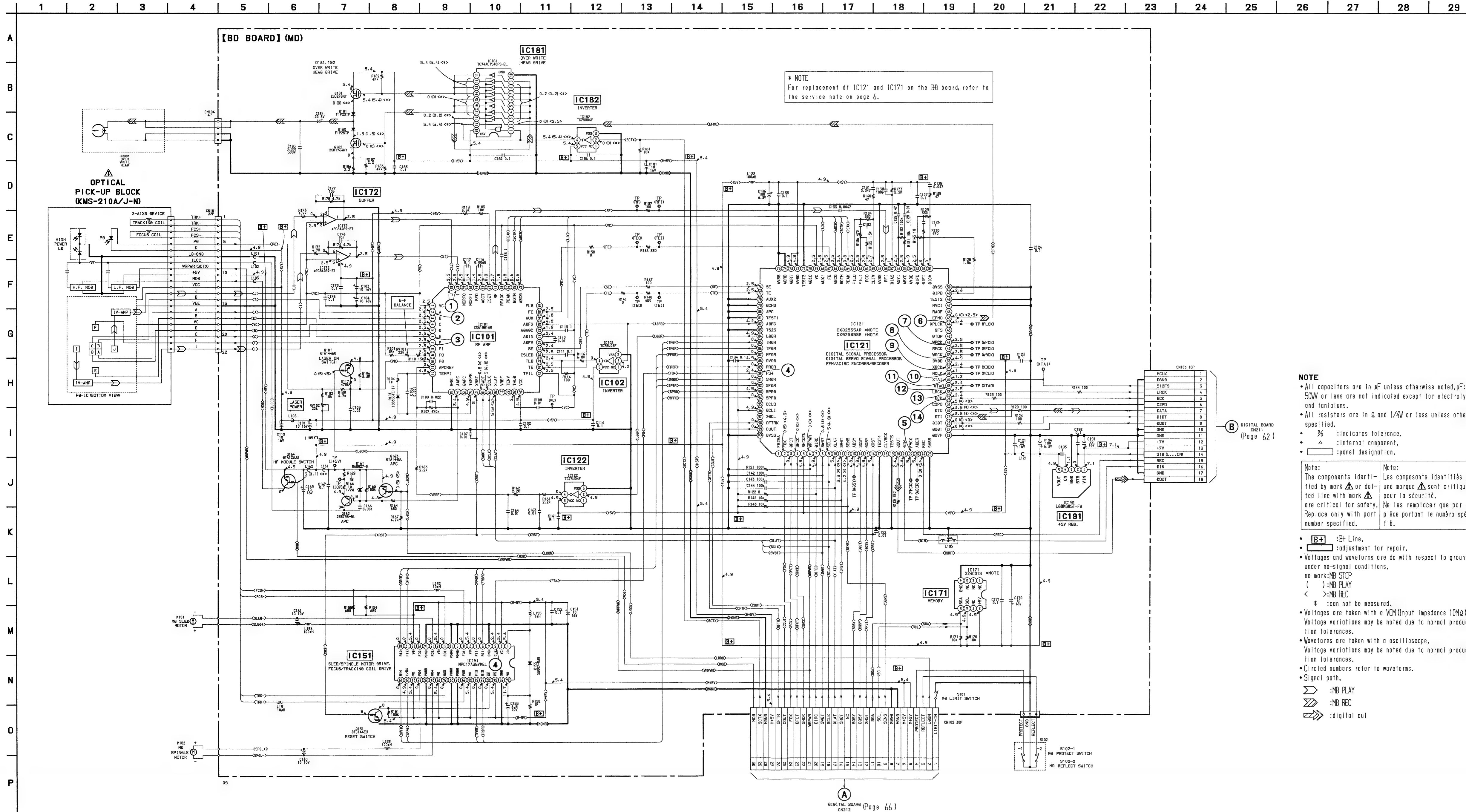

* NOTE
For replacement of IC121 and IC171 on the BD board, refer to the service note on page 6.

NOTE
• All capacitors are in μF unless otherwise noted, pF: μF 50W or less are not indicated except for electrolytics and tantalums.
• All resistors are in Ω and $1/4\text{W}$ or less unless otherwise specified.
• % indicates tolerance.
• Δ : internal component.
• \square : panel designation.

Note:
The components identified by mark Δ or dotted line with mark Δ are critical for safety. Replace only with part number specified.

Note:
Les composants identifiés par une marque Δ sont critiques pour la sécurité. Ne les remplacer que par une pièce portant le numéro spécifié.

- \square : Δ H Line.
- \square : adjustment for repair.
- Voltages and waveforms are dc with respect to ground under no-signal conditions, no work: MB STOP
() : MB PLAY
< > : MB REC
- * : can not be measured.
- Voltages are taken with a VOM (input impedance 10M Ω). Voltage variations may be noted due to normal production tolerances.
- Waveforms are taken with an oscilloscope. Voltage variations may be noted due to normal production tolerances.
- Circled numbers refer to waveforms.
- Signal path.
- \Rightarrow : MB PLAY
- \Rightarrow : MB REC
- \Rightarrow : digital out

• IC Block Diagrams

IC121 CXD2535BR

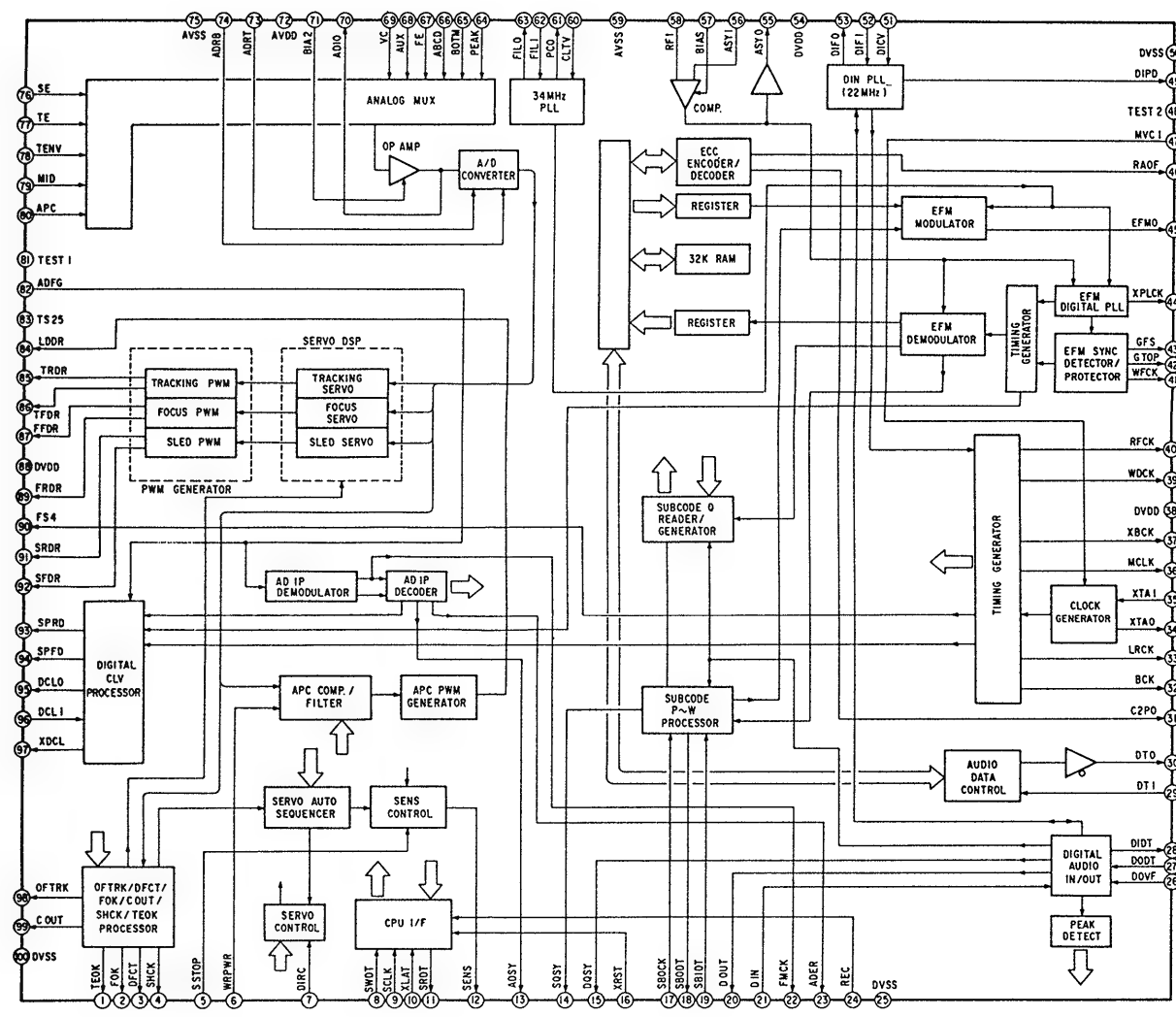

IC151 MPC17A38VMEL

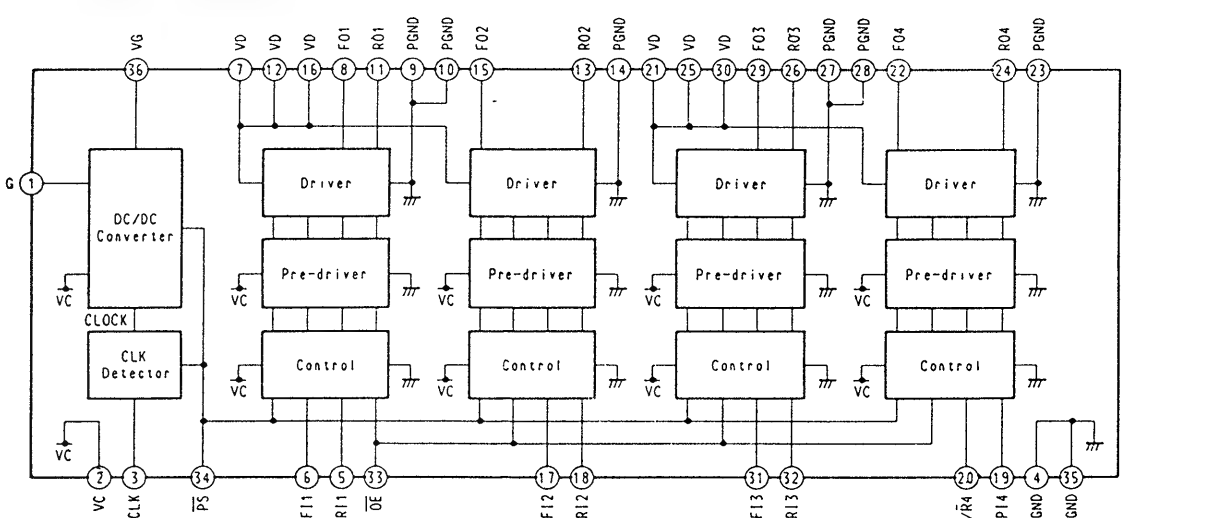

IC171 X24C01S

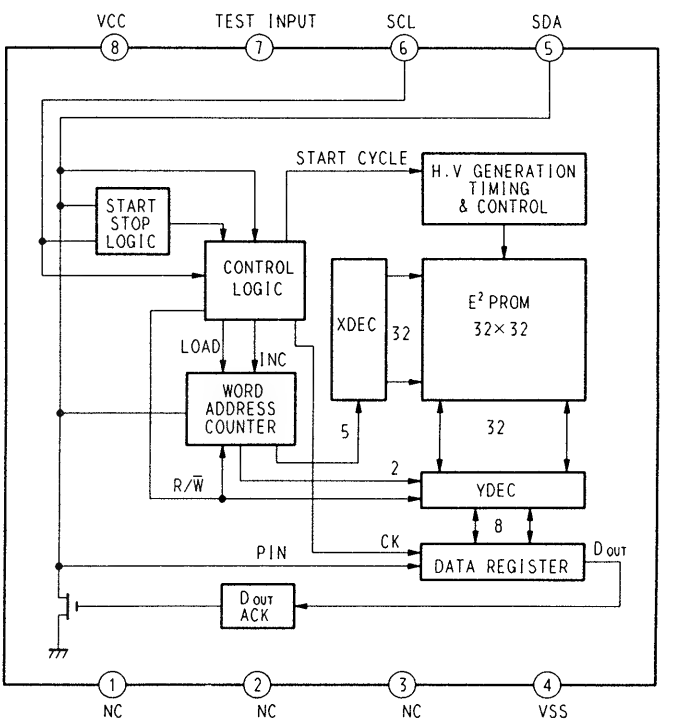

6-8. SCHEMATIC DIAGRAM — DIGITAL SECTION —
• See page 87 for IC Block Diagrams.
• See page 96 for IC Pin Functions. (IC201, 251, 271, 301)

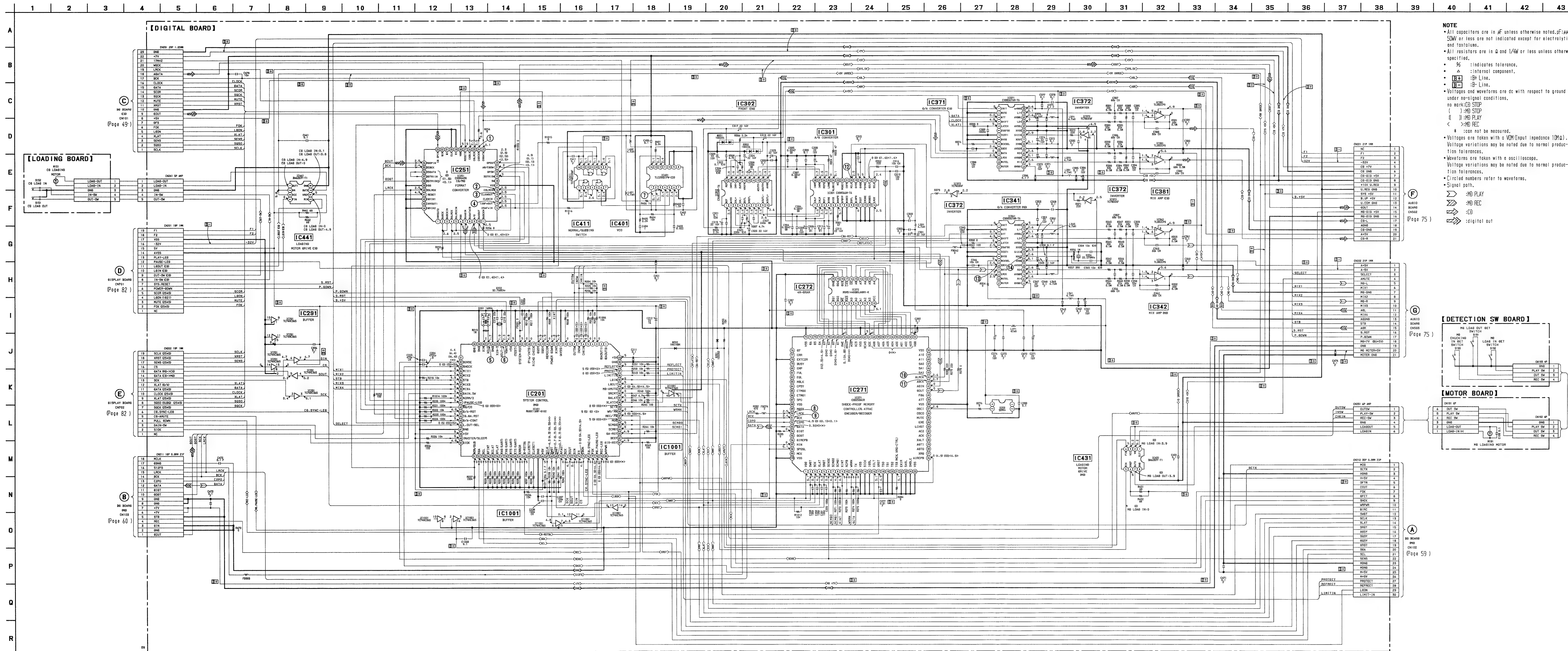

NOTE
• All capacitors are in μF unless otherwise noted, $\text{pF} = \mu\text{F} \times 10^{-6}$ and $\text{fF} = \mu\text{F} \times 10^{-9}$.
• All resistors are in Ω and $1/\text{K}$ or less unless otherwise specified.
• $\%$: indicates tolerance.
• Δ : internal component.
• INT : INT Line.
• L : L Line.
• Voltages and waveforms are dc with respect to ground under no-signal conditions.
• no mark: CD STOP
() : MD STOP
(∞) : MD PLAY
< : MD REC
* : can not be measured.
• Voltages are taken with a VOM (input impedance $10\text{M}\Omega$).
• Voltage variations may be noted due to normal production tolerances.
• Waveforms are taken with an oscilloscope.
• Voltage variations may be noted due to normal production tolerances.
• Circled numbers refer to waveforms.
• Signal path.

[DIGITAL BOARD]
DET2 2P 1.50M
DET1 2P 1.50M
DET3 2P 1.50M
DET4 2P 1.50M
DET5 2P 1.50M
DET6 2P 1.50M
DET7 2P 1.50M
DET8 2P 1.50M
DET9 2P 1.50M
DET10 2P 1.50M
DET11 2P 1.50M
DET12 2P 1.50M
DET13 2P 1.50M
DET14 2P 1.50M
DET15 2P 1.50M
DET16 2P 1.50M
DET17 2P 1.50M
DET18 2P 1.50M
DET19 2P 1.50M
DET20 2P 1.50M
DET21 2P 1.50M
DET22 2P 1.50M
DET23 2P 1.50M
DET24 2P 1.50M
DET25 2P 1.50M
DET26 2P 1.50M
DET27 2P 1.50M
DET28 2P 1.50M
DET29 2P 1.50M
DET30 2P 1.50M
DET31 2P 1.50M
DET32 2P 1.50M
DET33 2P 1.50M
DET34 2P 1.50M
DET35 2P 1.50M
DET36 2P 1.50M
DET37 2P 1.50M
DET38 2P 1.50M
DET39 2P 1.50M
DET40 2P 1.50M
DET41 2P 1.50M
DET42 2P 1.50M
DET43 2P 1.50M
DET44 2P 1.50M
DET45 2P 1.50M
DET46 2P 1.50M
DET47 2P 1.50M
DET48 2P 1.50M
DET49 2P 1.50M
DET50 2P 1.50M
DET51 2P 1.50M
DET52 2P 1.50M
DET53 2P 1.50M
DET54 2P 1.50M
DET55 2P 1.50M
DET56 2P 1.50M
DET57 2P 1.50M
DET58 2P 1.50M
DET59 2P 1.50M
DET60 2P 1.50M
DET61 2P 1.50M
DET62 2P 1.50M
DET63 2P 1.50M
DET64 2P 1.50M
DET65 2P 1.50M
DET66 2P 1.50M
DET67 2P 1.50M
DET68 2P 1.50M
DET69 2P 1.50M
DET70 2P 1.50M
DET71 2P 1.50M
DET72 2P 1.50M
DET73 2P 1.50M
DET74 2P 1.50M
DET75 2P 1.50M
DET76 2P 1.50M
DET77 2P 1.50M
DET78 2P 1.50M
DET79 2P 1.50M
DET80 2P 1.50M
DET81 2P 1.50M
DET82 2P 1.50M
DET83 2P 1.50M
DET84 2P 1.50M
DET85 2P 1.50M
DET86 2P 1.50M
DET87 2P 1.50M
DET88 2P 1.50M
DET89 2P 1.50M
DET90 2P 1.50M
DET91 2P 1.50M
DET92 2P 1.50M
DET93 2P 1.50M
DET94 2P 1.50M
DET95 2P 1.50M
DET96 2P 1.50M
DET97 2P 1.50M
DET98 2P 1.50M
DET99 2P 1.50M
DET100 2P 1.50M

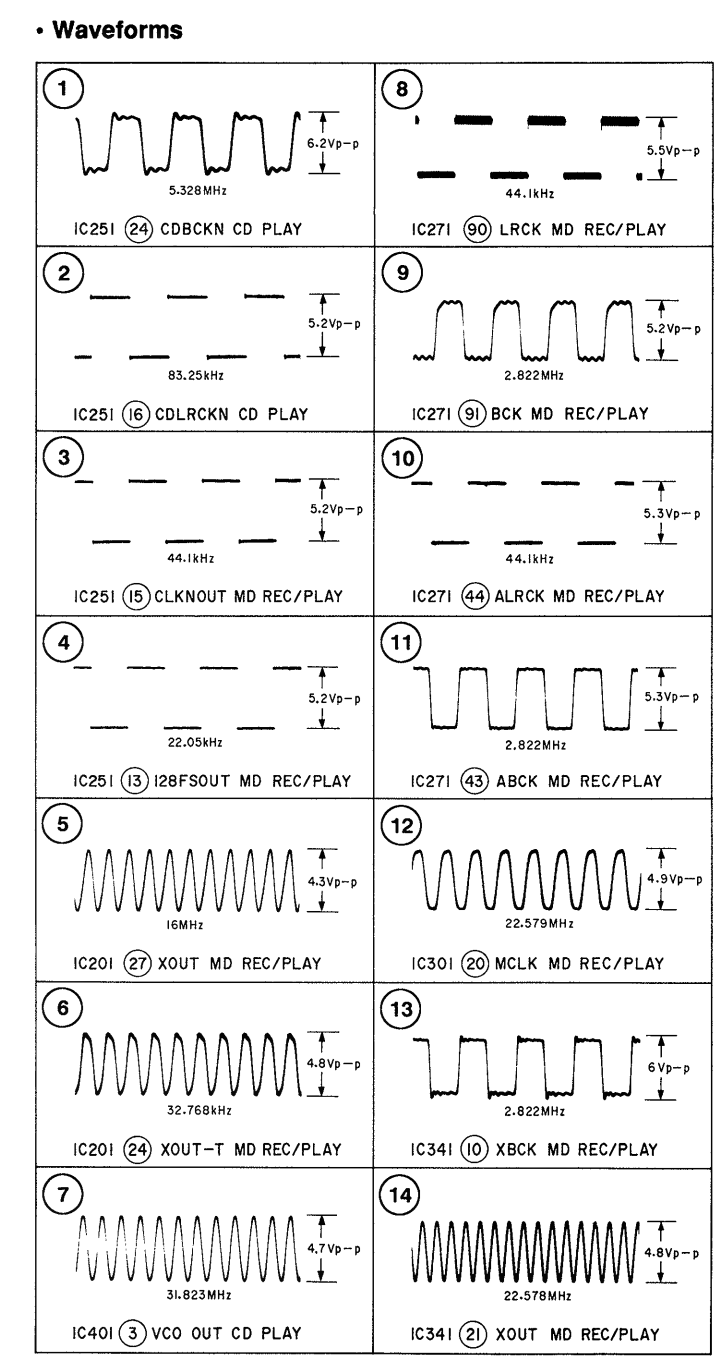
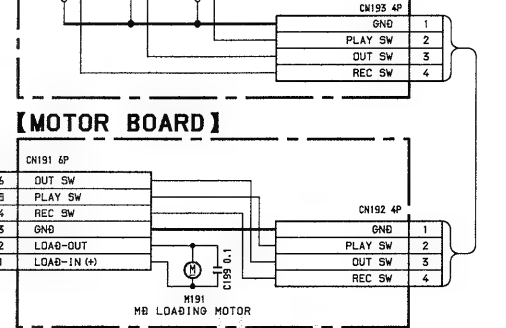

6-9. PRINTED WIRING BOARD — DIGITAL SECTION —
 • See page 38 for Circuit Boards Location.

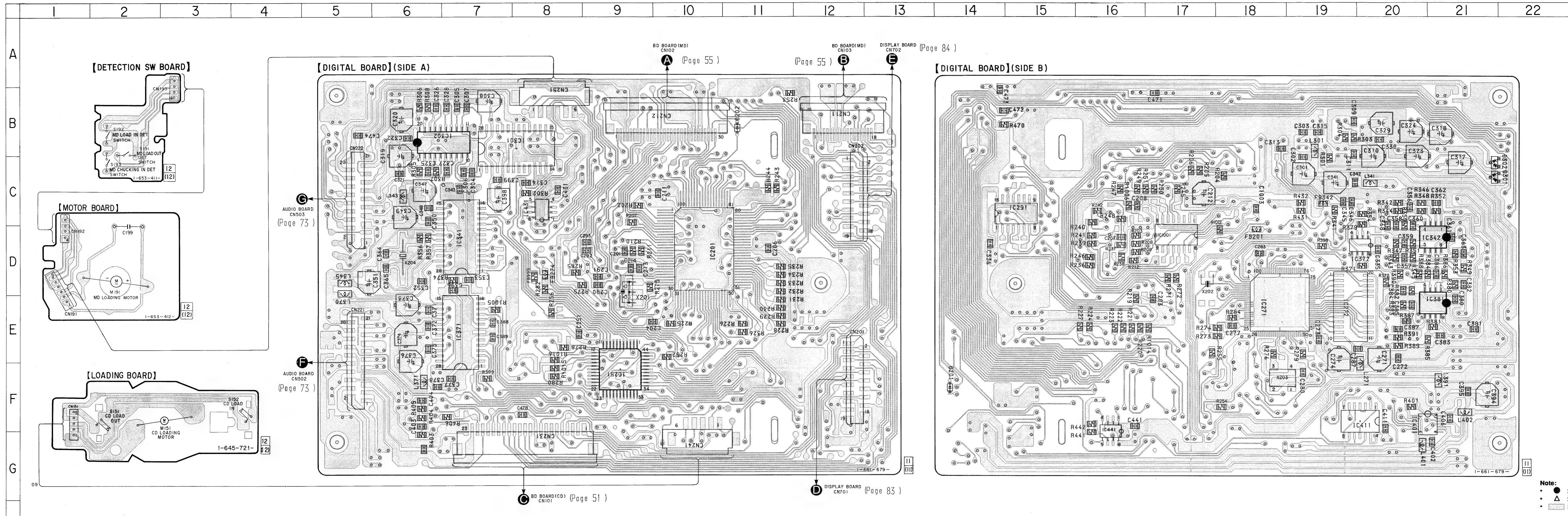

• Semiconductor Location

Ref. No.	Location
D201	F-14
D202	B-11
D301	C-22
D302	B-22
IC201	D-10
IC251	F-9
IC271	D-18
IC272	D-19
IC291	C-15
IC301	B-8
IC302	B-6
IC341	D-7
IC342	C-21
IC371	E-7
IC372	D-20
IC381	D-21
IC401	F-20
IC411	F-20
IC431	C-8
IC441	F-16
IC1001	C-17

Note:
 • : Through hole.
 • Δ : Internal component.
 • : Pattern from the side which enable seeing.
 (The other layer's patterns are not indicated.)
 • Abbreviation
 CND : Canadian model.

• IC Block Diagrams

IC511 M5293L

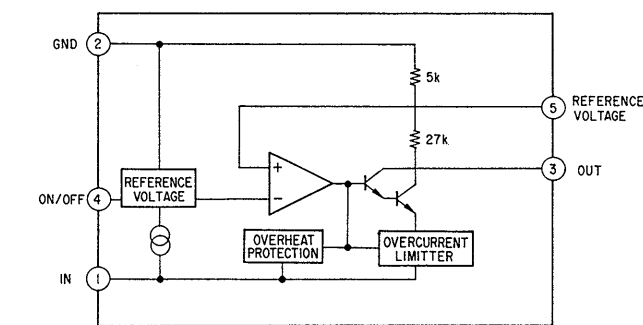

IC531 LA5602

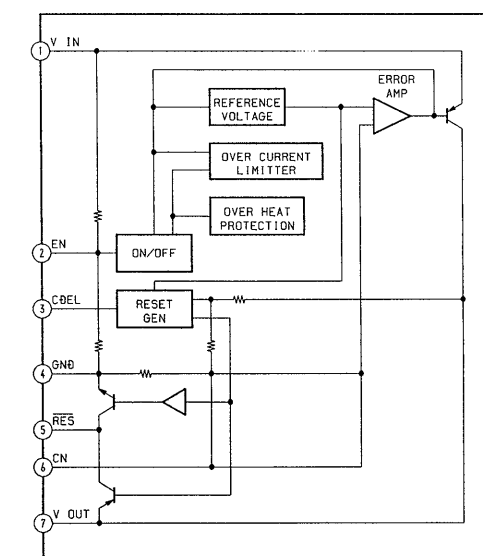

IC541 BA3960

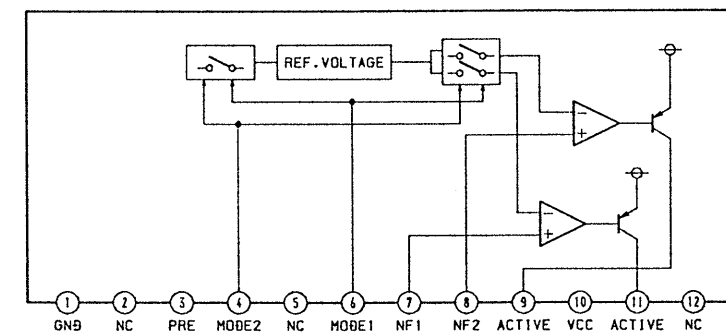

IC671 M5294P

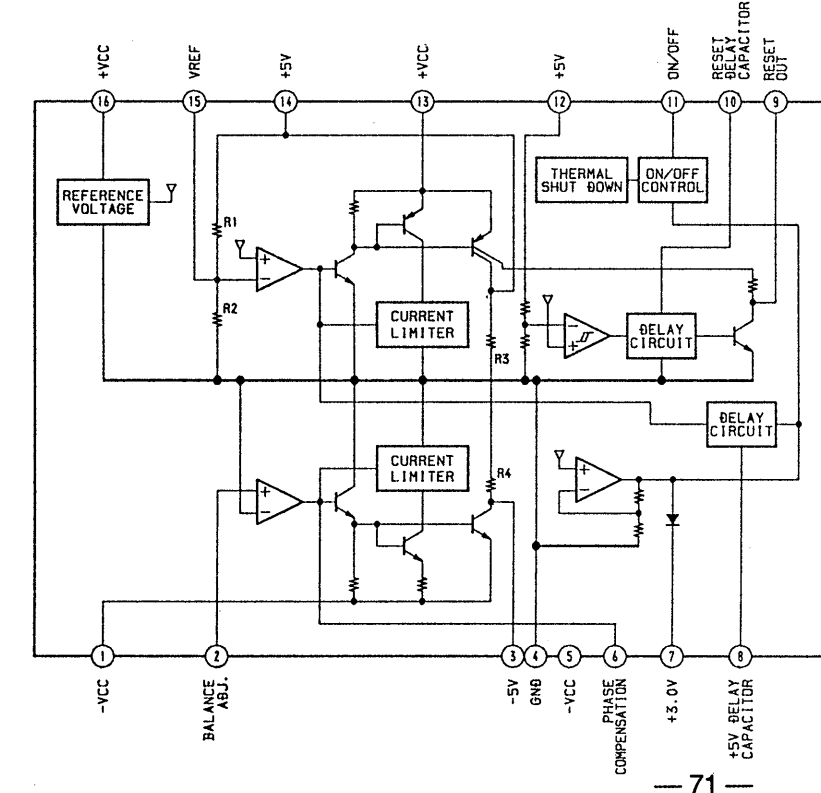

• Semiconductor Location

Ref. No.	Location
D501	B-14
D502	B-13
D503	B-14
D504	B-13
D505	B-14
D506	B-14
D507	B-14
D508	B-13
D509	B-8
D510	C-13
D511	C-14
D512	C-14
D536	C-9
D544	C-12
D582	E-9
D591	E-3
D621	E-1
D623	E-2
D625	E-3
D627	E-3
D631	D-11
D632	D-10
D633	D-10
D641	C-11
D642	C-10
D643	C-9
IC511	B-14
IC521	D-14
IC531	B-10
IC536	B-9
IC541	D-12
IC544	C-11
IC547	C-13
IC571	E-5
IC581	D-5
IC591	B-4
IC611	B-2
IC641	D-9
IC661	A-5
IC671	B-7
IC901	G-3
Q536	C-9
Q591	C-4
Q592	C-3
Q593	E-6
Q594	E-4
Q595	E-4
Q621	E-2
Q622	E-7
Q623	E-2
Q624	E-7
Q625	E-3
Q626	E-4
Q627	E-3
Q628	E-4

Note:
 • : parts extracted from the component side.
 • : Through hole.
 • : Pattern from the side which enable seeing.
 • : Pattern on the rear side.
 • Abbreviation
 CND : Canadian model.
 G : German model.
 SP : Singapore model.

6-10. PRINTED WIRING BOARD — AUDIO SECTION —
 • See page 38 for Circuit Boards Location.

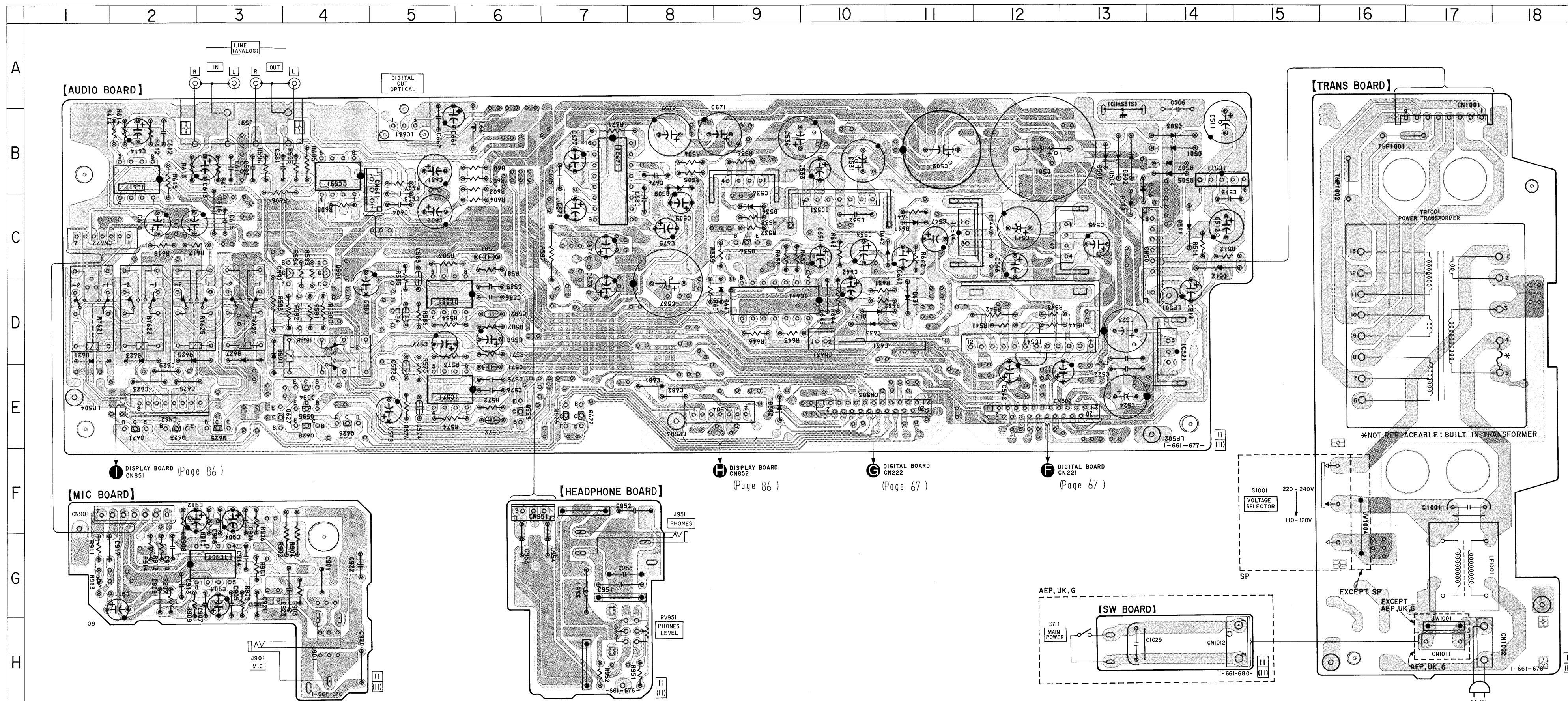

6-11. SCHEMATIC DIAGRAM — AUDIO SECTION —

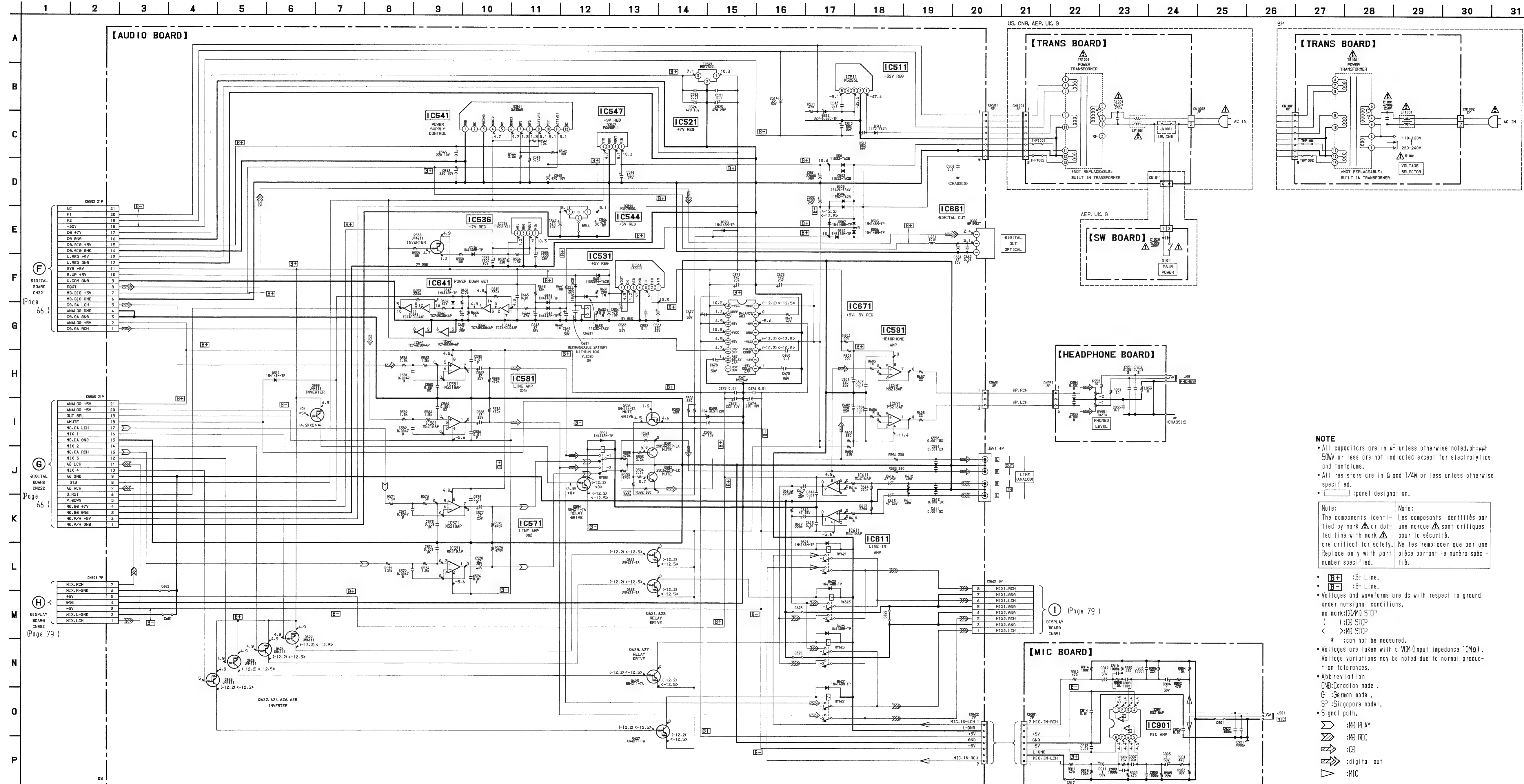

NOTE

- All capacitors are in μF unless otherwise noted. $\mu\text{F} = \mu\text{F}$. 50WV or less are not indicated except for electrolytics and tantalums.
- All resistors are in Ω and $1/4\text{W}$ or less unless otherwise specified.
- : panel designation.

Note: The components identified by mark Δ or dotted line with mark Δ are critical for safety. Replace only with part number specified.

Note: Les composants identifiés par une marque Δ sont critiques pour la sécurité. Ne les remplacer que par une pièce portant le numéro spécifié.

- : Bt Line.
- : D- Line.
- Voltagés and waveforms are dc with respect to ground under no-signal conditions.
- () : CB STOP
- < : MD STOP
- > : MD STOP
- * : can not be measured.
- Voltagés are taken with a VOM (input impedance $10\text{M}\Omega$). Voltage variations may be noted due to normal production tolerances.
- Abbreviation:
 - CND: Canadian model.
 - G : German model.
 - SP : Singapore model.
- Signal path:
 - : MD PLAY
 - ↔ : MD REC
 - ↔ : CD
 - ↔ : digital out
 - ▽ : MIC

6-12. SCHEMATIC DIAGRAM — DISPLAY SECTION —
• See page 103 for IC Pin Functions. (IC701)

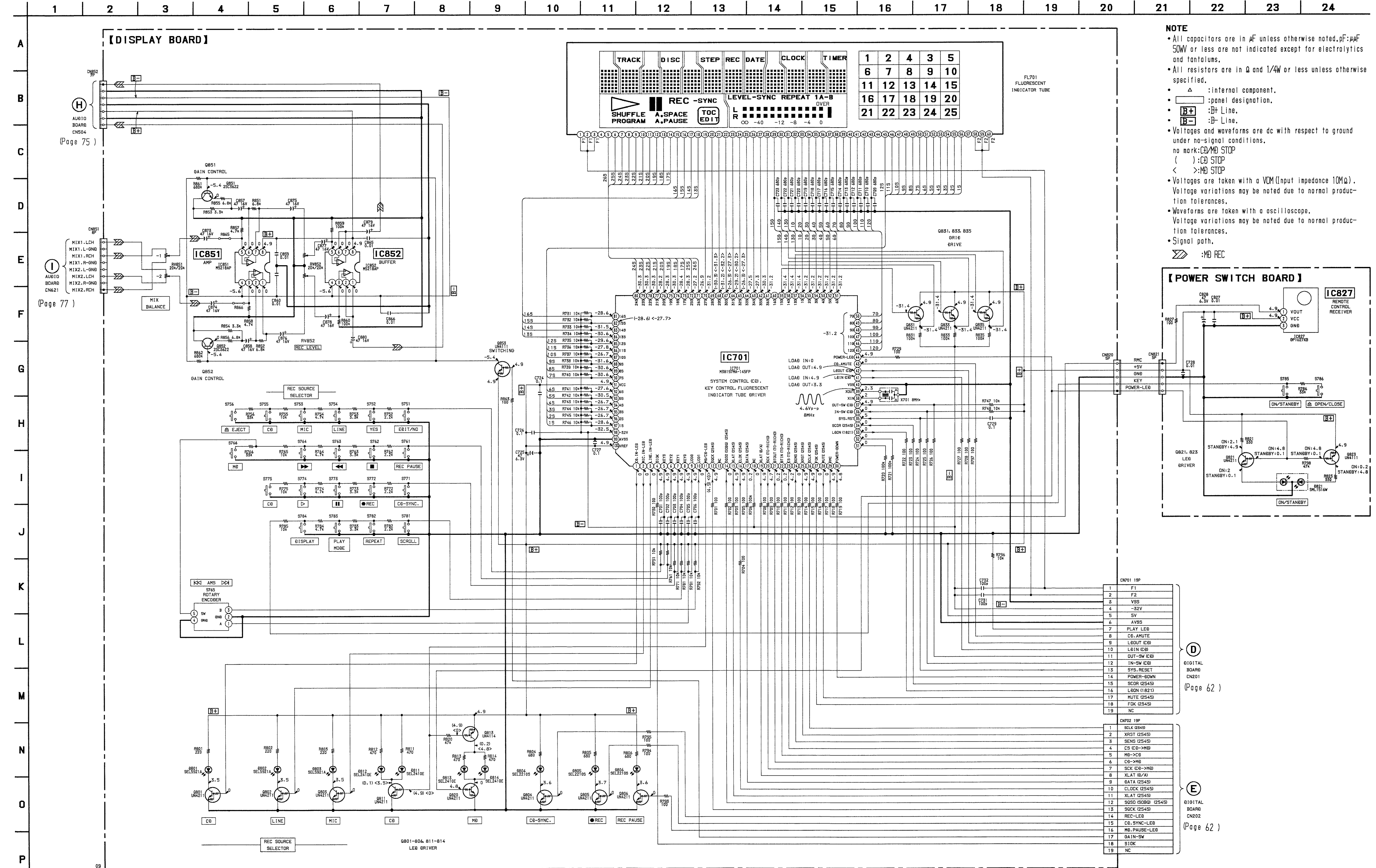

NOTE

- All capacitors are in μF unless otherwise noted, pF: μF 50W or less are not indicated except for electrolytics and tantalums.
- All resistors are in Ω and $1/4\text{W}$ or less unless otherwise specified.
- \triangle : internal component.
- \square : panel designation.
- B+ : B+ Line.
- B- : B- Line.
- Voltages and waveforms are dc with respect to ground under no-signal conditions.
- no mark: CD/MD STOP
- () : CD STOP
- < : MD STOP
- Voltages are taken with a VOM (input impedance 10M Ω). Voltage variations may be noted due to normal production tolerances.
- Waveforms are taken with an oscilloscope. Voltage variations may be noted due to normal production tolerances.
- Signal path.
- MB REC

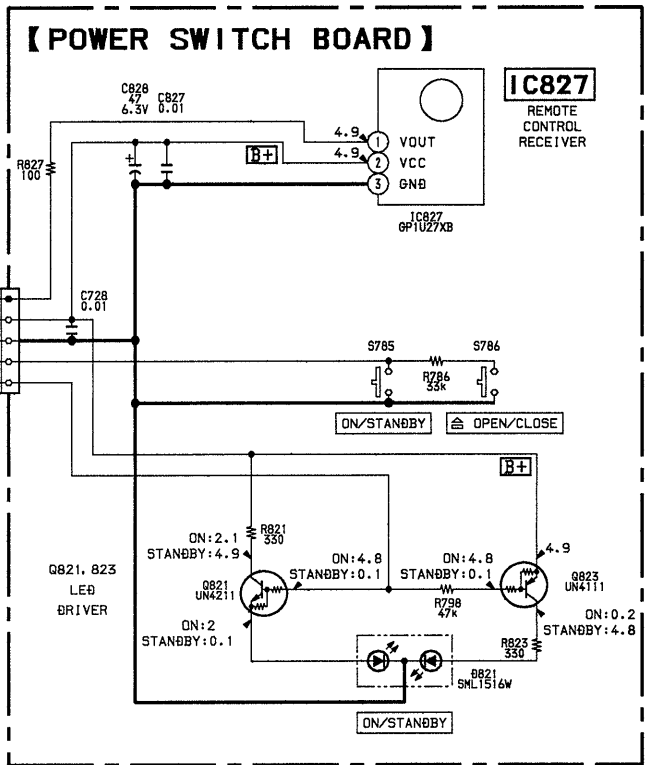

D
DIGITAL BOARD
CN201
(Page 62)

E
DIGITAL BOARD
CN202
(Page 62)

6-13. PRINTED WIRING BOARD — DISPLAY SECTION —
 • See page 38 for Circuit Boards Location.

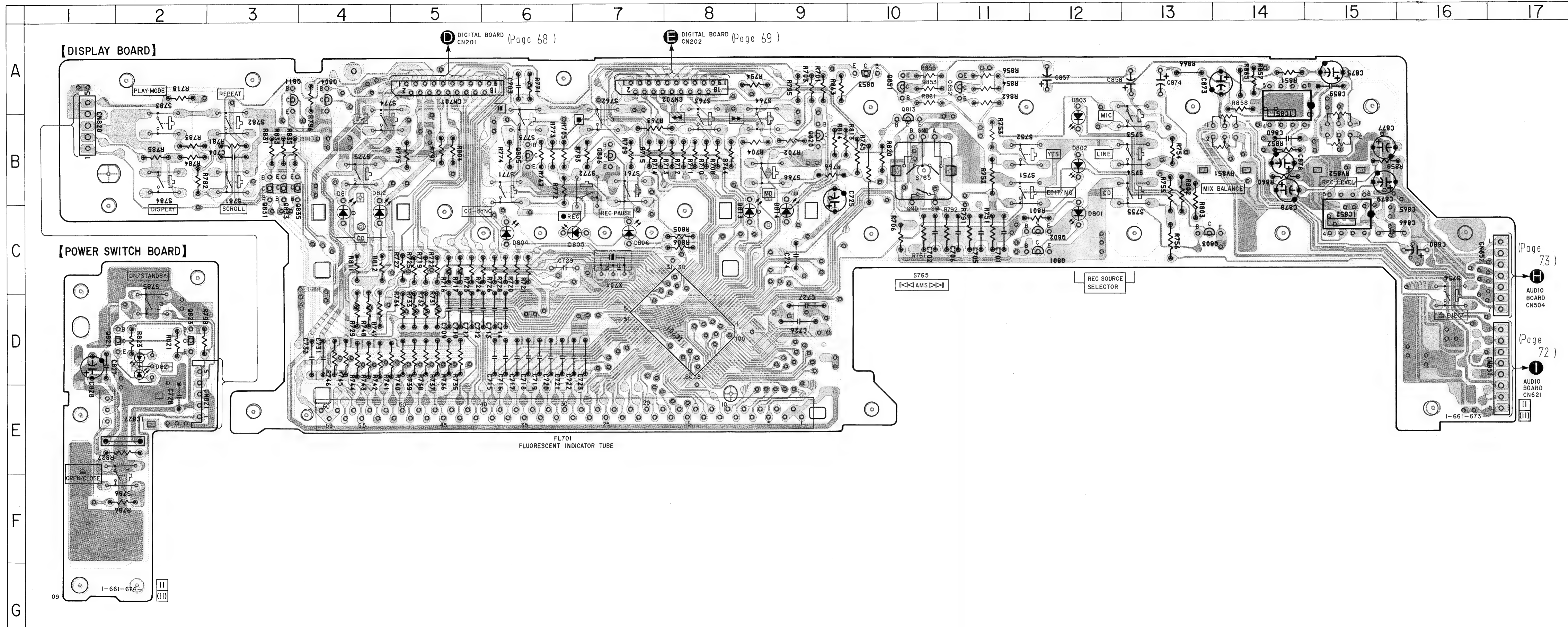

• Semiconductor Location

Ref. No.	Location
D801	C-12
D802	B-12
D803	A-12
D804	C-6
D805	C-7
D806	C-7
D811	B-4
D812	B-4
D813	C-8
D814	C-9
D821	D-2
IC701	D-8
IC827	E-2
IC851	B-14
IC852	C-15
Q801	C-12
Q802	C-12
Q803	C-13
Q804	A-4
Q805	B-6
Q806	B-7
Q811	A-3
Q813	A-10
Q820	B-9
Q821	D-1
Q823	D-2
Q831	C-3
Q833	C-3
Q835	C-3
Q851	A-10
Q852	A-11
Q853	A-10

Note:
 • — : parts extracted from the component side.
 • — : parts extracted from the conductor side.
 • ● : Through hole.
 • [Pattern] : Pattern from the side which enable seeing.
 • [Pattern] : Pattern on the rear side.

6-14. IC BLOCK DIAGRAMS — DIGITAL SECTION —

IC251 CXD8640Q

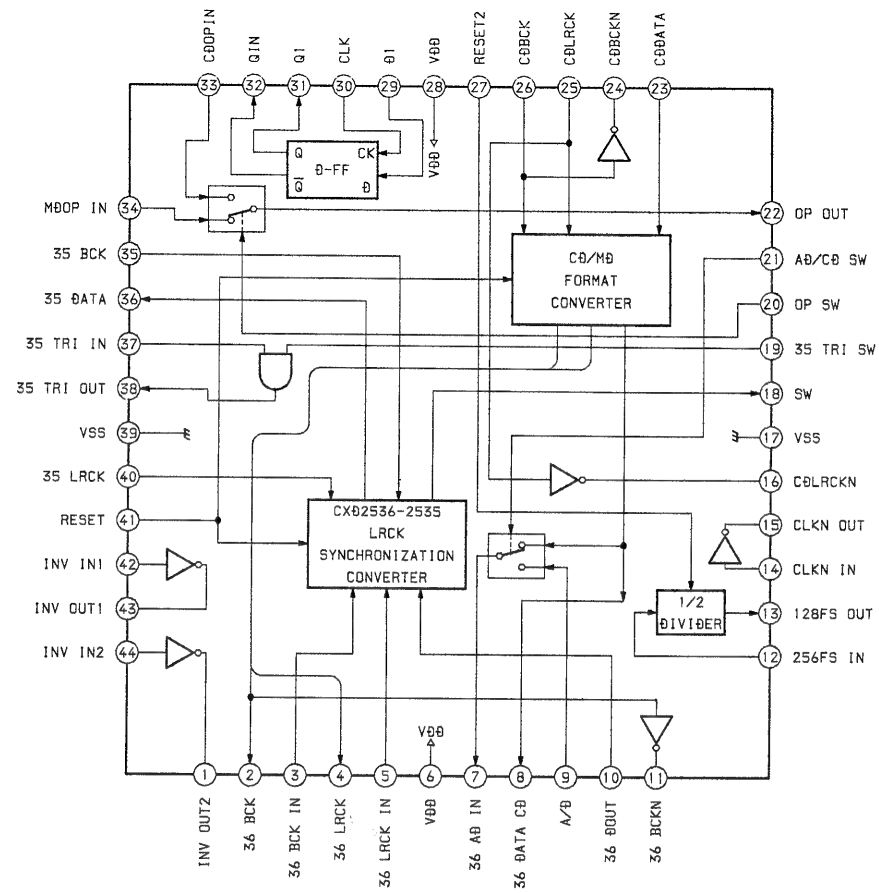

IC301 CXD8566M-T6

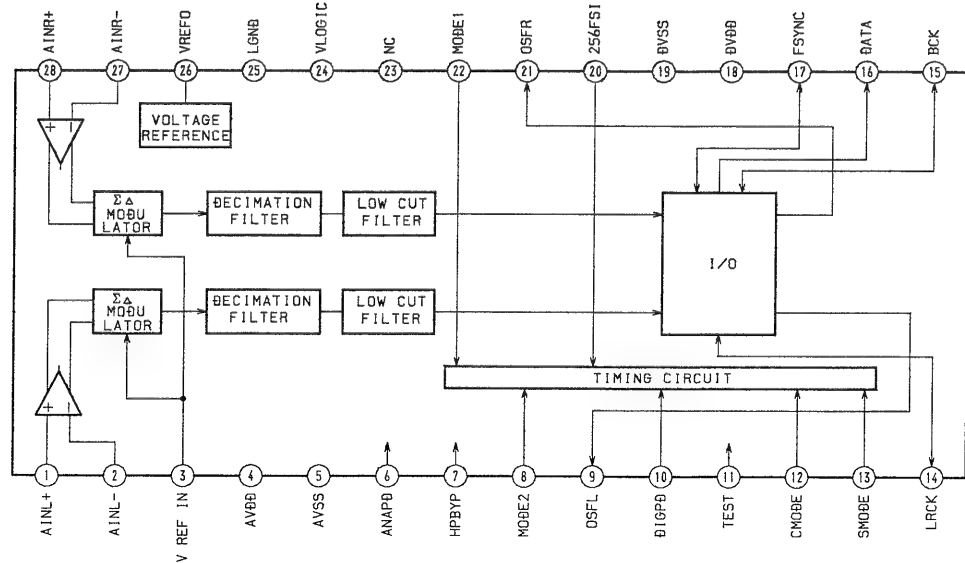

IC302 CXA8054-T6

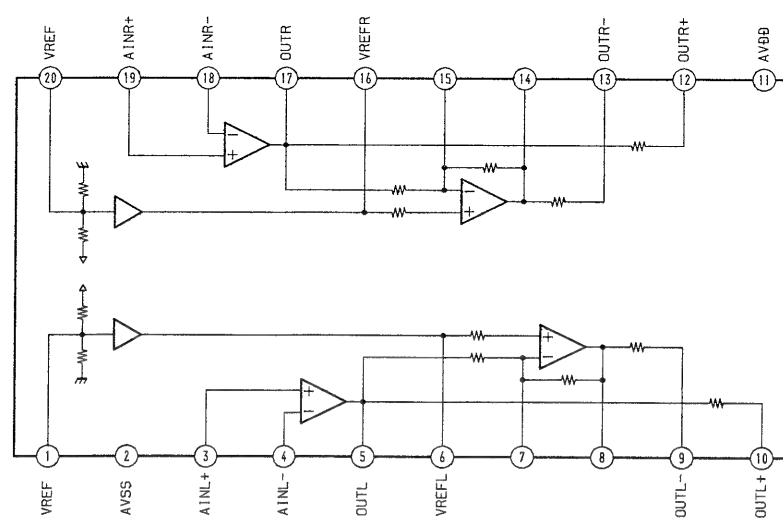

IC341, 371 CXD8567AM-T6

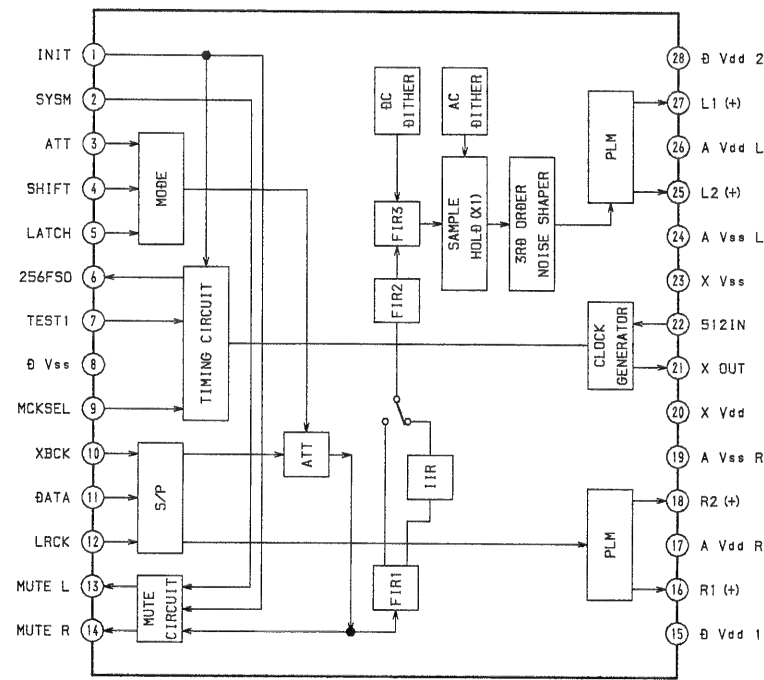

IC401 TLC2932IPW-E20

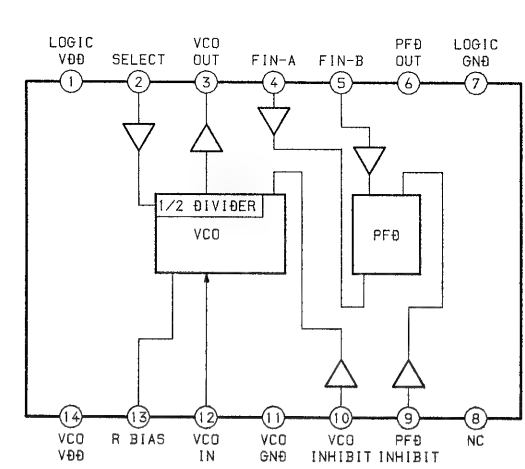

IC431, 441 BA6287F-T1

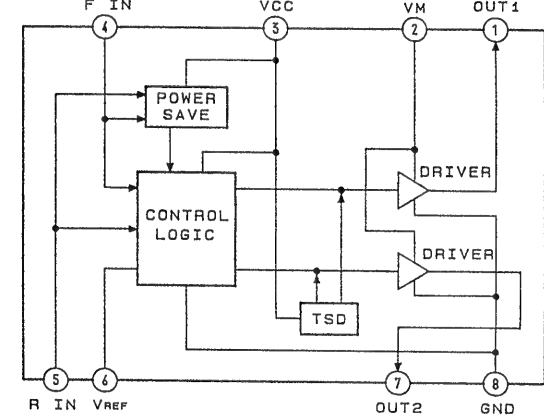

6-15. IC PIN FUNCTIONS

• IC101 DIGITAL SIGNAL PROCESSOR (CXD2545Q)/BD board (CD)

Pin No.	Pin Name	I/O	Function
1	SRON	O	Sled drive output (Not used) (Open)
2	SRDR	O	Sled drive output
3	SFON	O	Sled drive output (Not used) (Open)
4	TFDR	O	Tracking drive output
5	TRON	O	Tracking drive output (Not used) (Open)
6	TRDR	O	Tracking drive output
7	TFON	O	Tracking drive output (Not used) (Open)
8	FFDR	O	Focus drive output
9	FRON	O	Focus drive output (Not used) (Open)
10	FRDR	O	Focus drive output
11	FFON	O	Focus drive output (Not used) (Open)
12	VCOO	O	VCO output for analog EFM PLL (Not used) (Open)
13	VCOI	I	VCO output for analog EFM PLL (Ground)
14	TEST	I	TEST pin connected normally to Ground
15	DVss	—	Digital Ground
16	TES2	I	TEST pin connected normally to Ground
17	TES3	I	TEST pin connected normally to Ground
18	PDO	O	Charge-pump output for analog EFM PLL (Not used) (Open)
19	VPCO	O	Charge-pump output for variable pitch PLL (Not used) (Open)
20	VCKI	I	Clock input from variable pitch external VCO (Ground)
21	AVD2	—	Analog power supply (+5V)
22	IGEN	I	Power supply pin for operational amplifiers
23	AVS2	—	Analog Ground
24	ADIO	I	(Not used) (Open)
25	RFC	O	(Not used) (Open)
26	RFDC	I	RF signal input
27	TE	I	Tracking error signal input
28	SE	I	Sled error signal input
29	FE	I	Focus error signal input
30	VC	I	Center voltage input pin
31	FILO	O	Filter output for master PLL
32	FILI	I	Filter input for master PLL
33	PCO	O	Charge-pump output for master PLL
34	CLTV	I	Control voltage input for master VCO
35	AVS1	—	Analog Ground
36	RFAC	I	EFM signal input
37	BIAS	I	Asymmetry circuit constant current input
38	ASYI	I	Asymmetry compare voltage input
39	ASYO	O	EFM full swing output
40	AVD1	—	Analog power supply (+5V)

• Abbreviation

EFM : Eight to Fourteen Modulation

PLL : Phase Locked Loop

VCO : Voltage Controlled Oscillator

Pin No.	Pin Name	I/O	Function
41	DVDD	—	Digital power supply (+5V)
42	ASYE	I	Asymmetry circuit ON/OFF (+5V)
43	PSSL	I	Audio data output mode selection input (Ground)
44	WDCK	O	48-bit slot D/A interface. Word clock.
45	LRCK	O	48-bit slot D/A interface. LR clock. (Not used) (Open)
46	DATA	O	DA 16 output when PSSL=1. 48-bit slot serial data when PSSL=0 (Not used) (Open)
47	BCLK	O	DA 15 output when PSSL=1. 48-bit slot data when PSSL=0 (Not used) (Open)
48	64DATA	O	DA 14 output when PSSL=1. 64-bit slot data when PSSL=0
49	64BCLK	O	DA 13 output when PSSL=1. 64-bit slot data when PSSL=0
50	64LRCK	O	DA 12 output when PSSL=1. 64-bit slot data when PSSL=0
51	GTOP	O	DA 11 output when PSSL=1. GTOP output when PSSL=0 (Not used) (Open)
52	XUGF	O	DA 10 output when PSSL=1. XUGF output when PSSL=0 (Not used) (Open)
53	XPLCK	O	DA 09 output when PSSL=1. XPLCK output when PSSL=0
54	GFS	O	DA 08 output when PSSL=1. GFS output when PSSL=0
55	RFCK	O	DA 07 output when PSSL=1. RFCK output when PSSL=0
56	C2PO	O	DA 06 output when PSSL=1. C2PO output when PSSL=0 (Not used) (Open)
57	XRAOF	O	DA 05 output when PSSL=1. XRAOF output when PSSL=0 (Not used) (Open)
58	MNT3	O	DA 04 output when PSSL=1. MNT3 output when PSSL=0
59	MNT2	O	DA 03 output when PSSL=1. MNT2 output when PSSL=0
60	MNT1	O	DA 02 output when PSSL=1. MNT1 output when PSSL=0
61	MNT0	O	DA 01 output when PSSL=1. MNT0 output when PSSL=0
62	XTAI	I	X'tal oscillator circuit input
63	XTAO	O	X'tal oscillator circuit output (Not used) (Open)
64	XTSL	I	X'tal selection input pin (Ground)
65	DVss	—	Digital Ground
66	FSTI	I	2/3 divider output of pins 62, 63
67	FSTO	O	2/3 divider output of pins 62, 63
68	FSOF	O	(Not used) (Open)
69	C16M	O	16.9344 MHz output (Not used) (Open)
70	MD2	I	Digital-out ON/OFF control pin (+5V)
71	DOUT	O	Digital-out output pin
72	EMPH	O	Playback disc output in emphasis mode (Not used) (Open)
73	WFCK	O	WFCK output
74	SCOR	O	Sub-code sync output
75	SBSO	O	Sub-P through Sub-W serial output (Not used) (Open)
76	EXCK	I	Clock input for SBSO read-out (Ground)
77	SUBQ	O	Sub-Q 80-bit output
78	SQCK	I	Clock input for SQSO read-out.
79	MUTE	I	Muting selection pin
80	SENS	O	SENS output

- Abbreviation
WFCK : Write Frame Clock

Pin No.	Pin Name	I/O	Function
81	XRST	I	System reset
82	DIRC	I	Used in 1-track jump mode (+5v)
83	SCLK	I	SENS serial data read-out clock
84	DFSW	I	Defect selection pin (Ground)
85	ATSK	I	Input pin for anti-shock (Ground)
86	DATA	I	Serial data input, supplied from CPU
87	XLAT	I	Latch input, supplied from CPU
88	CLOK	I	Serial data transfer clock input, supplied from CPU
89	COUT	O	Numbers of track counted signal output (Not used) (Open)
90	DVDD	-	Digital power supply (+5V)
91	MIRR	O	Mirror signal output
92	DFCT	O	Defect signal output
93	FOK	O	Focus OK output
94	FSW	O	Output to select spindle motor output filter (Not used) (Open)
95	MON	O	Output to control ON/OFF of spindle motor (Not used) (Open)
96	MDP	O	Output to control spindle motor servo
97	MDS	O	Output to control spindle motor servo (Not used) (Open)
98	LOCK	O	GFS is sampled by 460 Hz. H when GFS is H (Not used) (Open)
99	SSTP	I	Input signal to detect disc inner most track
100	SFDR	O	Sled drive output

- Abbreviation
DFCT: Defect
GFS : Guarded Frame Sync

• IC101 RF Amplifier (CXA1981AR)/BD board (MD)

Pin No.	Pin Name	I/O	Function
1	VC	O	Middle point voltage (2.5V) generation output pin
2 to 7	A to F	I	Input of signal from optical block detector
8	FI	I	F operation amplifier input
9	FO	O	F operation amplifier output
10	PD	I	Front monitor. Connected to photo diode
11	APCREP	I	Input pin for setting laser power
12	TEMPI	I	Temperature sensor connection pin
13	GND	—	Ground pin
14	AAPC	O	APC LD amplifier output pin
15	DAPC	O	Not used (Open)
16	TEMPR	O	Temperature sensor reference voltage output pin
17	XRST	I	Input of reset signal from MD system controller (IC201). Reset: "L"
18	SWDT	I	Input of write data signal from MD system controller (IC201)
19	SCLK	I	Input of clock signal from MD system controller (IC201)
20	XLAT	I	Input of latch signal from MD system controller (IC201)
21	VREF	O	Reference voltage output. Not used in this unit (Open)
22	TENV	O	Not used (Open)
23	THLD	I	Not used (Connected to VC)
24	VCC	—	Power supply pin (+5V)
25	TFIL	I	Not used (Open)
26	TE	O	Output of tracking error signal to CXD2535BR (IC121)
27	TLB	I	Input pin of add signal to tracking error
28	CSLED	I	Sled error LPF pin
29	SE	O	Output of sled error signal to CXD2535BR (IC121)
30	ADFM	O	ADIP FM signal output
31	ADIN	I	Inputs ADIP FM signal by AC coupling
32	ADAGC	I	Connection pin of external capacitor for ADIP AGC
33	ADFG	O	Output of ADIP dual FM signal to CXD2535BR (IC121) (22.05 kHz \pm 1 kHz)
34	AUX	O	Output of auxiliary signal to CXD2535BR (IC121)
35	FE	O	Output of focus error signal to CXD2535BR (IC121)
36	FLB	I	Not used (Open)
37	ABCD	O	Output of light amount signal to CXD2535BR (IC121)
38	BOTM	O	Output of bottom hold signal of light amount signal to CXD2535BR (IC121)
39	PEAK	O	Output of peak hold signal of light amount signal to CXD2535BR (IC121)
40	RFAGC	I	Connection pin of RF AGC circuit external capacitor
41	RF	O	Output of playback EFM RF signal to CXD2535BR (IC121)
42	ISET	I	Internal circuit constant setting pin. 22 kHz BPF center frequency
43	AGCT	I	Inputs RF signal by AC coupling
44	RFO	O	Output pin of RF signal
45	MORFI	I	Inputs MO RF signal by AC coupling
46	MORFO	O	Output pin of MO RF signal
47, 48	I, J	I	Input of signal from optical block detector

• IC121 Digital signal processor, digital servo processor, EFM/ACIRC encoder/decoder (CXD2535BR)

Pin No.	Pin Name	I/O	Function
1	FS256	O	11.2896 MHz clock output (MCLK). (Not used) (Open)
2	FOK	O	Output of FOK signal to MD system controller (IC201) Outputs "H" when focus is set
3	DFCT	O	Outputs defect ON/OFF switching signal to CXD2536CR (IC271)
4	SHCK	O	Outputs track jump detection signal to MD system controller (IC201)
5	SHCKEN	I	Track jump detection enable input. (Not used) (Fixed at "H")
6	WRPWR	I	Inputs laser power switching signal from MD system controller (IC201)
7	DIRC	I	Not used (Fixed at "H")
8	SWDT	I	Inputs write data signal from MD system controller (IC201)
9	SCLK	I	Inputs serial clock signal from MD system controller (IC201)
10	XLAT	I	Inputs serial latch signal from MD system controller (IC201)
11	SRDT	O	Outputs write data signal to MD system controller (IC201)
12	SENS	O (3)	Outputs internal status (SENSE) to MD system controller (IC201)
13	ADSY	O	ADIP sync signal output. (Not used) (Open)
14	SQSY	O	Output subcode Q sync (SCOR) to MD system controller (IC201) Outputs "L" every 13.3 msec. Outputs "H" at all most mostly
15	DQSY	O	Outputs digital-in U-bit CD format subcode Q sync (SCOR) to MD system controller (IC201). Outputs "L" every 13.3 msec Outputs "H" at all most mostly
16	XRST	I	Inputs reset signal from MD system controller (IC201). Reset: "L"
17	TEST4	I	Test input (Fixed at "L")
18	CLVSCK	O	Not used (Open)
19	TEST5	I	Test input (Fixed at "L")
20	DOUT	O	Digital audio signal output pin (For optical output) (Not used)
21	DIN	I	Digital audio signal input pin (For optical input)
22	FMCK	O	ADIP FM demodulation clock signal output
23	ADER	O	ADIP CRC flag output. "H":Error
24	REC	I	Input of recording/playback switching signal from MD system controller (IC201) Recording: "H". Playback: "L"
25	DVSS	—	Ground pin (Digital)
26	DOVF	I	Digital audio output validity flag input pin. (Fixed at "L")
27	DODT	I	Input pin of 16bit data for digital audio output from CXD8640Q (IC251)
28	DIDT	O	Output pin of 16bit data for digital audio input to CXD2536CR (IC271)
29	DTI	I	Input pin of recording audio data signal from CXD2536CR (IC271)
30	DTO	O (3)	Output pin of playback audio data signal to CXD2536CR (IC271)
31	C2PO	O	Outputs C2PO signal to CXD2536CR (IC271). (Output indicating data error status). Playback: C2PO ("H"). Digital recording: D.In-Vflag. Analog recording: "L"
32	BCK	O	Outputs bit clock signal (2.8224 MHz) to CXD8640Q (IC251) (MCLK)
33	LRCK	O	Outputs L/R clock signal (44.1 kHz) to CXD8640Q (IC251) (MCLK)
34	XTAO	O	System clock (512 fs=22.5792 MHz) signal output. (Not used) (Open)
35	XTAI	I	Input of system clock (512fs=22.5792 MHz) signal input from CXD2536CR (IC271)
36	MCLK	O	MCLK clock (22.5792 MHz) signal output
37	XBCK	O	Pin 32 (BCK) inversion output
38	DVDD	—	Power supply pin (+5V) (Digital)
39	WDCK	O	WDCK clock (88.2 kHz) signal output (MCL)
40	RFCK	O	RFCK clock (7.35 kHz) signal output (MCLK)

Pin No.	Pin Name	I/O	Function
41	WFCK	O	WFCK clock (7.35 kHz) signal output (Playback: EFM decoder PLL. Recording: EFM encoder PLL)
42	GTOP	O	"H": Opens playback EFM frame sync protection window
43	GFS	O	"H": Playback EFM sync and interpolation protection timing match
44	XPLCK	O	EFM decoder PLL clock output (98 fs=4.3218 MHz) Falling edge and EFM signal edge match
45	EFMO	O	EFM signal output (Recording)
46	RAOF	O	Internal RAM overflow detection signal output (decoder monitor output) Outputs "H" when the disc rotation exceeds $\pm 4F$ jitter margin during playback
47	MVCI	I	Digital-in PLL oscillation input. (Not used) (Fixed at "L")
48	TEST2	I	Test pin (Fixed at "L")
49	DIPD	O (3)	Digital-in PLL phase comparison output Internal VCO: (Frequency: Low \rightarrow "H"). External VCO: (Frequency: Low \rightarrow "L")
50	DVSS	—	Ground pin (Digital)
51	DICV	I (A)	Digital-in PLL internal VCO control voltage input
52	DIFI	I (A)	Filter input when digital-in PLL internal VCO is used
53	DIFO	O (A)	Filter output when digital-in PLL internal VCO is used
54	AVDD	—	Power supply pin (+5V) (Analog)
55	ASYO	O	Playback EFM full-swing output (L=VSS, H=VDD)
56	ASYI	I (A)	Playback EFM asymmetry compare voltage input
57	BIAS	I (A)	Playback EFM asymmetry circuit constant current input
58	RFI	I (A)	Inputs playback EFM RF signal from CXA1981AR (IC101)
59	AVSS	—	Ground pin (Analog)
60	CLTV	I (A)	Decoder PLL master clock PLL VCO control voltage input
61	PCO	O (3)	Decoder PLL master clock PLL phase comparison output
62	FILI	I (A)	Decoder PLL master clock PLL filter input
63	FILO	O (3)	Decoder PLL master clock PLL filter output
64	PEAK	I (A)	Inputs peak hold signal for light amount signal from CXA1981AR (IC101)
65	BOTM	I (A)	Inputs bottom hold signal for light amount signal from CXA1981AR (IC101)
66	ABCD	I (A)	Light amount signal from CXA1981AR (IC101)
67	FE	I (A)	Input of focus error signal from CXA1981AR (IC101)
68	AUX1	I (A)	Input of auxiliary signal from CXA1981AR (IC101)
69	VC	I (A)	Input of middle point voltage (+2.5V) from CXA1981AR (IC101)
70	ADIO	O (A)	A/D converter input signal monitor output
71	TEST3	I (A)	Test input (Fixed at "L")
72	AVDD	—	Power supply pin (+5V) (Analog)
73	ADRT	I (A)	A/D converter operation range upper limit voltage input (Fixed at "H")
74	ADRB	I (A)	A/D converter operation range lower limit voltage input (Fixed at "L")
75	AVSS	—	Ground pin (Analog)
76	SE	I (A)	Input of sled error signal from CXA1981AR (IC101)
77	TE	I (A)	Input of tracking error signal from CXD1981AR (IC101)
78	AUX2	I (A)	Auxiliary input pin 2. (Not used). (Fixed at "L")
79	DCHG	I (A)	Connected to ground
80	APC	I (A)	Laser APC input. (Not used) (Fixed at "L")

Pin No.	Pin Name	I/O	Function
81	TEST1	I	Test pin (Fixed at "L")
82	ADFG	I	Input of ADIP dual FM signal from CXA1981AR (IC101) (22.05 kHz \pm 1 kHz) (TTL Schmidt input)
83	TS25	I	Test pin (Fixed at "L")
84	LDDR	O	Laser APC signal output
85	TRDR	O	Tracking servo drive signal output (-)
86	TFDR	O	Tracking servo drive signal output (+)
87	FFDR	O	Focus servo drive signal output (+)
88	DVDD	-	Power supply pin (+5V) (Digital)
89	FRDR	O	Focus servo drive signal output (-)
90	FS4	O	176.4 kHz clock signal output (MCLK)
91	SRDR	O	Sled servo drive signal output (-)
92	SFDR	O	Sled servo drive signal output (+)
93	SPRD	O	Spindle servo drive signal output (-)
94	SPFD	O	Spindle servo drive signal output (+)
95	DCLO	O	Not used normally (Open)
96	DCLI	I	Not used normally (Fixed at "H")
97	XDCL	O	Not used normally (Open)
98	OFTRK	O	Off track signal output
99	COUT	O	Traverse count signal output
100	DVSS	-	Ground pin (Digital)

* (3) of I/O is 3-state output, (A) is analog output.

• IC201 MD System Controller (RU8X11AMF-0102)/Digital board

Pin No.	Pin Name	I/O	Function
1	(DAOUT 0)	O	Test pin. Test mode: C1 signal output. (Not used) (Open)
2	(DAOUT 1)	O	Test pin. Test mode: ADER signal output. (Not used) (Open)
3	DOUBLE OK	I	Double-speed switching input. "L": Enable, "H": Disable (Fixed at "H")
4, 5	NC	I	Not used (Open)
6	CHKIN	I	Detection input from the MD chucking-in switch (S193). When chucking: "L"
7	INSW	I	Detection input from the MD loading-in switch (S191). When the magnetic head is lowered: "L", others: "H"
8	OUTSW	I	Detection input from the MD loading-out switch (S192). When loaded out: "L", others: "H"
9	NC	I	Not used (Open)
10	NC	I	Not used (Open)
11	(AVSS)	—	Ground (Analog)
12	XINT	I	Interrupt status input from CXD2536CR (IC271)
13	POWER DOWN	I	Power down detection input. Power down: "L"
14	REMOCON	I	Remote control signal input (Not used) (Open)
15	SQSY	I	ATP addressing or subcode Q sync (SCOR) input from CXD2535BR (IC121). "L" is input every 13.3 msec. Normally "H"
16	DQSY	I	Digital-in U-bit CD format subcode Q sync (SCOR) input from CXD2535BR (IC121). "L" is input every 13.3 msec. Normally "H"
17	RICHO CHECK	O	Square wave output at 100 Hz (Fixed at "L")
18	(P16/INTS)	O	Not used (Fixed at "L")
19	NC	O	Not used (Open)
20	SYSTEM-RST	I	System reset signal input. "L" is input for several hundreds msec after the power supply activation, then it is changed to "H"
21	(TEST)	I	Test pin. (Fixed at "L")
22	+5V	—	Power supply (+5V)
23	VBAT	—	Power supply pin to RTC (clock), RAM (+5V)
24	XOUT-T	O	Clock output (32.768 kHz) (RTC)
25	XIN-T	I	Clock input (32.768 kHz) (RTC)
26	GND	—	Ground
27	XOUT	O	Main clock output. (16 MHz)
28	XIN	I	Main clock input. (16 MHz)
29	GND	—	Ground
30	(8M)	O	8 MHz clock output (Not used) (Open)
31	NC	O	Not used (Open)
32	SENSE	I	Internal status (SENSE) input from CXD2535BR (IC121)
33	SHOCK	I	Track jump signal input from CXD2535BR (IC121)
34, 35	MIX1, 2	O	Input switching relay control output. "L": ON, "H": OFF.
36	STB	O	Strobe signal output to the power supply circuit. ON: "H", standby: "L"
37, 38	MIX3, 4	O	Input switching relay control output. "L": ON, "H": OFF.
39	GAIN.SW	O	Switching output of MIX circuit 2 input/1 input
40	NORM/2	O	Data output control output to CXD2536CR (IC271). "H": A/D, "L": CD
41	TRG SW 35	O	Data output control output to CXD2535BR (IC121)

Pin No.	Pin Name	I/O	Function
42	MD/CD	O	Optical out output switching control output
43	G/A-RST	O	Reset control output to the CD-MD format conversion circuit and the CXD2536CR to CXD2535BR LRCK Sync conversion circuit
44	CD.DA.RST	O	Reset signal output to CD D/A CONVERTER (IC371)
45	G/A-CONT	O	Reset output to the dividing circuit
46	L.OUT-SEL	O	Line switching relay control output of CD/MD. "L": CD, "H": MD
47	GND	—	Ground
48	+5V	—	Power supply (+5V)
49	(MASTER/SLAVE)	I	Master/slave switching input (Fixed at "H")
50	SIOK	O	Communication response output with the M38197MA-145FP (IC701). "H": Communication OK.
51	NOR/DUB	O	Switching output of normal speed/double speed. "L": Normal speed, "H": Double speed
52	SDA	I/O	Data signal input/output with the backup memory (IC171)
53	SCL	O	Clock signal output to the backup memory (IC171)
54	DFINT	O	} Not used (Fixed at "L")
55	DCLAT	O	
56	DFLAT	O	
57	RXD(UART)	I	
58	TXD(UART)	O	
59	RTS(UART)	I	
60	CTS(UART)	O	
61	ERROR	I	
62	D-RST36	O	Reset signal output to CXD2536CR (IC271)
63	CLKSET0	I	} Pin for selecting a destination of the character display. "H": Supporting Katakana (Japanese letter), "L": Not supporting Katakana (Japanese letter) (Fixed at "L")
64	CLKSET1	I	
65	GND	—	Ground
66	+5V	—	Power supply (+5V)
67	SCLK	O	Clock signal output to the serial bus
68	SWDT	O	Write data signal output to the serial bus
69	SRDT	I	Read data signal input from the serial bus
70	AFAST	I	Not used (Fixed at "L")
71	SCK	I	Serial clock input from the M38197MA-145FP (IC701)
72	SOUT	O	Serial data output to the M38197MA-145FP (IC701)
73	SIN	I	Serial data input from M38197MA-145FP (IC701)
74	CS	I	Chip select output to the M38197MA-145FP (IC701)
75	LDON	O	Laser ON/OFF control output. "H": Laser ON
76	CD.SYNC-LED	O	Drive output to CD SYNC. display LED (D805)
77	FOK	I	FOK signal input from CXD2535BR (IC121). "H" is input when focusing
78	REC-LED	O	Drive output to ● REC display LED (D804)
79	MD.PAUSE LED	O	Drive output to REC PAUSE display LED (D806)
80	WRPWR	O	Laser power switching signal output to the optical pick-up block and CXD2535BR (IC121)
81	DIG RST	O	Reset signal output to CXD1981AR (IC101) and CXD2535BR (IC121) and motor driver (IC151). Reset: "L"
82	NC	O	Not used (Fixed at "L")
83	DA RST	O	Reset signal output to the MD D/A converter (IC341), A/D converter (IC301). Reset: "L"

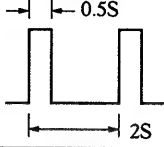
Pin No.	Pin Name	I/O	Function
84, 85	SCMD1, SCMD0	O	Serial command control mode output to CXD2536CR (IC271)
86	MOD	O	Laser modulation switching signal output. Playback power: "L", stop: "H". Recording power: 
87	REC/ $\overline{\text{PB}}$	O	Record/playback switching signal output to CXD2535BR (IC121). Recording: "H", playback: "L"
88	WR/ $\overline{\text{MN}}$	O	Write/monitor mode switching signal output to CXD2536CR (IC271)
89	SCTX	O	Write data transfer timing output to CXD2536CR (IC271). Also serves as ON/OFF output of the magnetic head
90	XLATCH	O	Latch signal output to the serial bus
91	DALAT	O	Latch signal output to the MD D/A converter (IC341)
92	SRCMT	O	Not used (Fixed at "L")
93	MD-AMUTE	O	Line out muting output
94	LDOUT	O	} MD loading motor (M191) control output*1
95	LDIN	O	
96	LIMIT IN	I	Detection from the MD limit-in switch (S101). Sled limit-in: "L"
97	PROTECT	I	Recording-protect claw detection input from the MD protect detection switch (S102-1). When protected: "H"
98	REFLECT	I	Disc reflection rate detection input from the MD reflect detection switch (S102-2). Disc with lower reflection rate: "H"
99	GND	-	Ground
100	+5V	-	Power supply (+5V)

*1 Loading motor control

Operation Pin	IN	OUT	BRAKE
LDIN 95 pin	"H"	"L"	"H"
LDOUT 94 pin	"L"	"H"	"H"

• IC251 CD/MD Format Converter (CXD8640Q)/Digital board

Pin No.	Pin Name	I/O	Function
1	INVOUT2	O	Inverter output (2) (Not used) (Open)
2	36BCK	O	BCK output for the CXD2536CR (IC271)
3	36BCKIN	I	BCK input from the CXD2536CR (IC271)
4	36LRCK	O	LRCK output for the CXD2536CR (IC271)
5	36LRCKIN	I	LRCK input from the CXD2536CR (IC271)
6	VDD	—	Power supply (+5V)
7	36ADIN	O	Audio data output for the CXD2536CR (IC271)
8	36DATA CD	O	Format conversion output of CD data (Not used) (Open)
9	A/D	I	Data input from the A/D converter (IC301)
10	36DOUT	I	Data input for the D/A converter from the CXD2536CR (IC271)
11	36BCKN	O	Inverted BCK output of the CXD2536CR (IC271)
12	256FsIN	I	Input to the dividing circuit
13	128FsOUT	O	Output from the dividing circuit
14	CLKNIN	I	CLK inverter input
15	CLKNOUT	O	CLK inverter output
16	CDLRCKN	O	Inverted LRCK output of CD
17	VSS	—	Ground
18	SW	O	Results output of LRCK phase comparison of the CXD2535BR (IC121) and CXD2536CR (IC271) (Not used) (Open)
19	35TRISW	I	Data output control input to the CXD2535BR (IC121)
20	OPSW	I	Optical out output switching input. "H": CD, "L": MD
21	AD/CDSW	I	Data output control to the CXD2536CR (IC271). "H": A/D, "L": CD
22	OPOUT	O	Optical output
23	CDDATA	I	Data input from CD
24	CDBCKN	O	Inverted BCK output of CD
25	CDLRCK	I	LRCK input from CD
26	CDBCK	I	BCK input from CD
27	RESET2	I	Reset input of the dividing circuit
28	VDD	—	Power supply (+5V)
29	D1	I	Data input of the D flip-flop circuit (Not used) (Fixed at "L")
30	CLK	I	Clock input of the D flip-flop circuit (Not used) (Fixed at "L")
31	Q1	O	Output of the D flip-flop circuit (Not used) (Open)
32	Q1N	O	Inverted output of the D flip-flop circuit (Not used) (Open)
33	CDOPIN	I	Optical data input from CD
34	MDOPIN	I	Optical data input from MD
35	35BCK	I	BCK input from the CXD2535BR (IC121)
36	35DATA	O	LRCK Sync conversion data output of the CXD2535BR (IC121) and CXD2536CR (IC271).
37	35TRIIN	I	Data control circuit input from the CXD2535BR (IC121)
38	35TRIOUT	O	Data control circuit output to the CXD2535BR (IC121)
39	VSS	—	Ground
40	35LRCK	I	LRCK input from the CXD2535BR (IC121)
41	RESET	I	Reset input of the CD-MD format conversion circuit and the LRCK Sync conversion circuit of the CXD2535BR (IC121) to CXD2536CR (IC271)
42	INVIN1	I	Inverter input (1) (Not used) (Fixed at "L")
43	INVOUT1	O	Inverter output (1) (Not used) (Open)
44	INVIN2	I	Inverter input (2) (Not used) (Fixed at "L")

• IC271 Shock-Proof Memory Controller, ATRAC Encoder/Decoder (CXD2536CR)/Digital board

Pin No.	Pin Name	I/O	Function
1	VDD	—	Power supply pin (+5V)
2	SWDT	I	Input of write data signal from MD system controller (IC201)
3	SCK	I	Input of serial clock signal from MD system controller (IC201)
4	XLAT	I	Input of serial latch signal from MD system controller (IC201)
5	SRDT	O/Z	Output of read data signal to MD system controller (IC201)
6	SENSE	O/Z	Output of internal status (SENSE) to MD system controller (IC201)
7	SCMD0	I	} Input of serial command control mode from MD system controller (IC201) (Fixed at "H")
8	SCMD1	I	
9	XINT	O	Output of interrupt status to MD system controller (IC201)
10	RCPB	I	Recording/playback switching input. (Not used) (Fixed at "L")
11	WRMN	I	Input of write/monitor mode switching signal from MD system controller (IC201)
12	TX	I	Input of write data transmission timing from MD system controller (IC201) Also used as magnetic field head ON/OFF output
13	VSS	—	Ground pin
14	SICK	I	} Chip reservation pin (Fixed at "L")
15	IDSL	I	
16	XILT	I	Chip reservation pin (Fixed at "H")
17	XRST	I	Input of reset signal from MD system controller (IC201). Reset: "L"
18 to 20	TS0 to TS2	I	Test pin (Fixed at "L")
21	TS3	I	Test pin (Fixed at "L")
22	EXIR	I	Chip reservation pin (Fixed at "L")
23	SASL	I	Block selection in single use. "L": ATRAC. "H": RAM controller (Fixed at "L")
24	SNGLE	I	Normally fixed at "L. Fixed at "H" when used as ATRAC or RAM controller for single. (Fixed at "L")
25	VSS	—	Ground pin
26	AIRCPB	O	Output pin of ATRAC and external audio block recording/playback mode signal. (Not used)
27	XRQ	I/O	ATRAC I/F XRQ signal input/output pin. (Not used)
28	ADTO	I/O	ATRAC decode data signal input/output pin. (Not used)
29	ADTI	I/O	ATRAC encode data signal input/output. (Not used)
30	XALT	I/O	ATRAC I/F XALT signal input/output pin. (Not used)
31	ACK	I/O	ATRAC I/F ACK signal input/output pin. (Not used)
32	AC2	I/O	ATRAC I/F error data signal input/output pin. (Not used)
33	LCHST	I/O	ATRAC I/F Lch start data signal input/output pin. (Not used)
34	EXE	I/O	ATRAC I/F EXE signal input/output pin. (Not used)
35	MUTE	I/O	ATRAC I/F MUTE signal input/output pin. (Not used)
36	OSCO	O	Clock output (90 MHz) (Open)
37	OSCI	I	Clock input (90 MHz)
38	VSS	—	Ground pin
39	ATT	I/O	ATRAC I/F ATT signal input/output pin. (Not used) (Open)
40	F86	O	ATRAC block 11.6 msec timing signal output pin. (Not used) (Open)
41	DOUT	O	Output of monitor/decode audio data signal to MD D/A converter (IC341)
42	ADIN	I	Input of recording signal from A/D converter (IC301)
43	ABCK	O	Output of bit clock signal to A/D and MD D/A converters (IC301, IC341)
44	ALRCK	O	Output of L/R clock to A/D and MD D/A converters (IC301, IC341)
45 to 47	SA2 to SA0	O	Address signal output. (Not used) (Open)

Pin No.	Pin Name	I/O	Function
48, 49	A11, A10	O	Address signal output. (Not used) (Open)
50	VSS	—	Ground pin
51	VDD	—	Power supply pin (+5V)
52 to 55	A03 to A00	O	Output of address signal to RAM (IC272)
56 to 60	A04 to A08	O	Output of address signal to RAM (IC272)
61	XOE	O	Output of output enable control signal to RAM (IC272)
62	XCAS	O	Output of column address strobe signal to RAM (IC272)
63	VSS	—	Ground pin
64	XCS	O	Output of chip select signal to RAM (IC272). (Not used) (Open)
65	A09	O	Output of address signal to RAM (IC272)
66	XRAS	O	Output of row address strobe signal to RAM (IC272)
67	XWE	O	Output of read/write control signal to RAM (IC272)
68, 69	D1, D0	I/O	} Input/output pin of data signal to/from RAM (IC272)
70, 71	D2, D3	I/O	
72 to 74	D4 to D6	I/O	Data signal input/output pin. (Not used) (Open)
75	VSS	—	Ground pin
76	D7	I/O	Data signal input/output pin. (Not used) (Open)
77	ERR	I/O	Input/output pin of error (C2PO) data to external RAM. (Not used) (Open)
78	EXTC2R	I	External RAM selection input for error data writing ("H": External RAM). (Fixed at "L")
79	BUSY	O	RAM access BUSY signal output. (Not used) (Open)
80	EMP	O	EMPTY or immediately before FULL of ATRAC data (When DSC=ASC+1: "H"). (Not used) (Open)
81	FUL	O	FULL or immediately before EMPTY of ATRAC data (When ASC=DSC+1: "H"). (Not used) (Open)
82	EQL	O	ATRAC data EMPTY (When DSC=ASC: "H"). (Not used) (Open)
83	MDLK	O	Indicates recording/playback data main/sub ("H": Sub, Linking: "L": Main). (Not used) (Open)
84	CPSY	O	Interpolation sync signal output. (Not used) (Open)
85	CTMD0	O	} DSC counter mode output. (Not used) (Open)
86	CTMD1	O	
87	SPO	O	Output of system clock (512fs=22.5792 MHz) signal to CXD2535BR (IC121) (Not used) (Open)
88	VSS	—	Ground pin
89	MDSY	O	Main data sync detection signal output. (Not used) (Open)
90	LRCK	I	Input of L/R clock signal from CXD2535BR (IC121) (44.1 kHz)
91	BCK	I	Input of bit clock signal from CXD2535BR (IC121) (2.8224 MHz)
92	C2PO	I	Input of C2PO signal from CXD2535BR (IC121) (Shows data error status) Playback:C2PO ("H"). Digital recording: D.In-Vflag. Analog recording: "L"
93	DATA	I/O	Recording:Output of recording audio data signal to CXD2535BR (IC121) Playback:Input of playback audio data signal from CXD2535BR (IC121)
94	DIDT	I	Input of digital audio input 16-bit data from CXD2535BR (IC121)
95	DODT	O	Output of digital audio output 16-bit data to CXD2535BR (IC121)
96	DIRCPB	O	Disc drive and EFM encoder/decoder recording/playback mode output. (Not used) (Open)
97	MIN	I	Input of defect ON/OFF switching signal from CXD2535BR (IC121)
98	SPOSL	I	Pin 87 (SPO) input/output switching input pin ("L":IN. "H":OUT). (Fixed at "H")
99	MCKTI	O	RAM controller internal master clock output pin. (Not used) (Open)
100	VSS	—	Ground pin

* O/Z: In case of no output data, it becomes high impedance

• IC301 A/D Converter (CXD8566M)/Digital board

Pin No.	Pin Name	I/O	Function
1	INLP	I	Lch analog (+) input
2	INLM	I	Lch analog (-) input
3	REFI	I	Reference voltage input (+3.2V)
4	AVDD	-	Modulator analog power supply (+5V)
5	AVss	-	Modulator analog ground
6	ANAPD	I	Modulator power down. "H": Normal operation, "L": Power down. (Fixed at "H")
7	HPBYP	I	Test pin. (Fixed at "L")
8	MODE2	I	Mode setting. (Fixed at "L")
9	OSFL	O	Lch overflow flag output (Not used) (Open)
10	DIGPD	I	Decimation filter power down. "H": Normal operation, "L": Power down/reset
11	TEST	I	Test pin. (Fixed at "L")
12	CMODE	I	Master clock selection. "H": 384fs, "L": 256fs. (Fixed at "L")
13	MODE0	I	Mode setting. (Fixed at "L")
14	LRCK	I/O	Master mode: LRCK output, slave mode: LRCK input
15	SCLK	I/O	Master mode: BCK output, slave mode: BCK input
16	DOUT	O	DATA output
17	FSYNC	I/O	Master mode: FSYNC output, slave mode: FSYNC input (Fixed at "H")
18	DVDD	-	Decimation filter power supply (+5V)
19	DVss	-	Decimation filter ground
20	MCLK	I	Master clock input (256fs)
21	OSFR	O	Rch overflow flag output (Not used) (Open)
22	MODE1	I	Mode setting. (Fixed at "L")
23	NC	-	Not used (Open)
24	VLOGIC	-	Modulator logic power supply (+5V)
25	LGND	-	Modulator logic ground
26	REFO	O	Reference voltage output
27	INRM	I	Rch analog (-) input
28	INRP	I	Rch analog (+) input

• IC701 CD System Control, Key Control, Fluorescent Indicator Tube Driver (M38197MA-145FP)/Display board

Pin No.	Pin Name	I/O	Function
1	CD.IN-LED	O	Input select LED drive of the MIX circuit
2	MIC.IN-LED	O	
3	LINE.IN-LED	O	
4	SIOK	I	Communication response input from the MD system control (IC201). "H": Communication OK
5 to 8	KEY3 to KEY0	I	Key input (A/D)
9, 10	JOG0, JOG1	I	JOG dial pulse input from the rotary encoder (S765)
11	MD/CD-LED	O	CD/MD switching LED drive
12	SQCK	O	Sub Q reading clock output
13	NC	—	Not used (Open)
14	SQSO	I	Sub Q data input
15	XLAT	O	Latch output to the CXD2545Q (IC101)
16	CLOK	O	Serial clock output to the CXD2545Q (IC101) and CD D/A converter (IC371)
17	DATA	O	Serial data output to the CXD2545Q (IC101) and CD D/A converter (IC371)
18	NC	—	Not used (Fixed at "L")
19	XLAT	O	Latch output to the CD D/A converter (IC371)
20	SCK	O	Serial clock output to the MD system control (IC201)
21	DTOUT	O	Serial data output to the MD system control (IC201)
22	DTIN	I	Serial data input from the MD system control (IC201)
23	CS	O	Chip select output to the MD system control (IC201)
24	SENS	I	SENSE input from the CXD2545Q (IC101)
25	XRST	O	Reset output to the CXD2545Q (IC101)
26	SCLK	O	SENSE serial data reading clock output
27	FOK	I	FOK input from the CXD2545Q (IC101)
28	MUTE	O	Mute switching output to the CXD2545Q (IC101)
29	RMC	I	Remote control signal input
30	POWER-DOWN	I	Power down detection input
31, 32	NC	—	Not used (Fixed at "L")
33	LDON	O	Laser diode ON/OFF output. "L": OFF, "H": ON
34	SCOR	I	Sub code sync detection input
35	SYS.RST	I	System reset input
36	IN-SW	I	CD loading IN switch input
37	OUT-SW	I	CD loading OUT switch input
38	XIN	I	Clock (8 MHz)
39	XOUT	O	
40	Vss	—	Ground
41	LDIN	O	CD loading motor control output
42	LDOUT	O	
43	CD.AMUTE	O	Analog mute control output. "L": ON, "H": OFF
44	POWER-LED	O	ON/STANDBY LED (D821) drive output

Pin No.	Pin Name	I/O	Function
45 to 56	12G to 1G	O	} Grid output to the fluorescent indicator tubes
57 to 59	13G to 15G	O	
60	16G	O	Not used (Open)
61 to 72	36S to 25S	O	} Segment output to the fluorescent indicator tubes
73 to 80	17S to 24S	O	
81 to 90	16S to 7S	O	
91	V _{cc}	—	+5V power supply
92 to 97	6S to 1S	O	Segment output to the fluorescent indicator tubes
98	-32V	—	-32V power supply for the fluorescent indicator tubes
99	AV _{ss}	—	Ground (analog)
100	V _{REF}	—	+5V power supply (A/D converter)

SECTION 7 EXPLODED VIEWS

NOTE:

- Items marked " * " are not stocked since they are seldom required for routine service. Some delay should be anticipated when ordering these items.
- The mechanical parts with no reference number in the exploded views are not supplied.

- Hardware (# mark) list and accessories and packing materials are given in the last of this parts list.
- Abbreviation
 CND : Canadian model
 G : German model
 SP : Singapore model

The components identified by mark Δ or dotted line with mark Δ are critical for safety. Replace only with part number specified.

Les composants identifiés par une marque Δ sont critiques pour la sécurité. Ne les remplacer que par une pièce portant le numéro spécifié.

7-1. FRONT PANEL SECTION

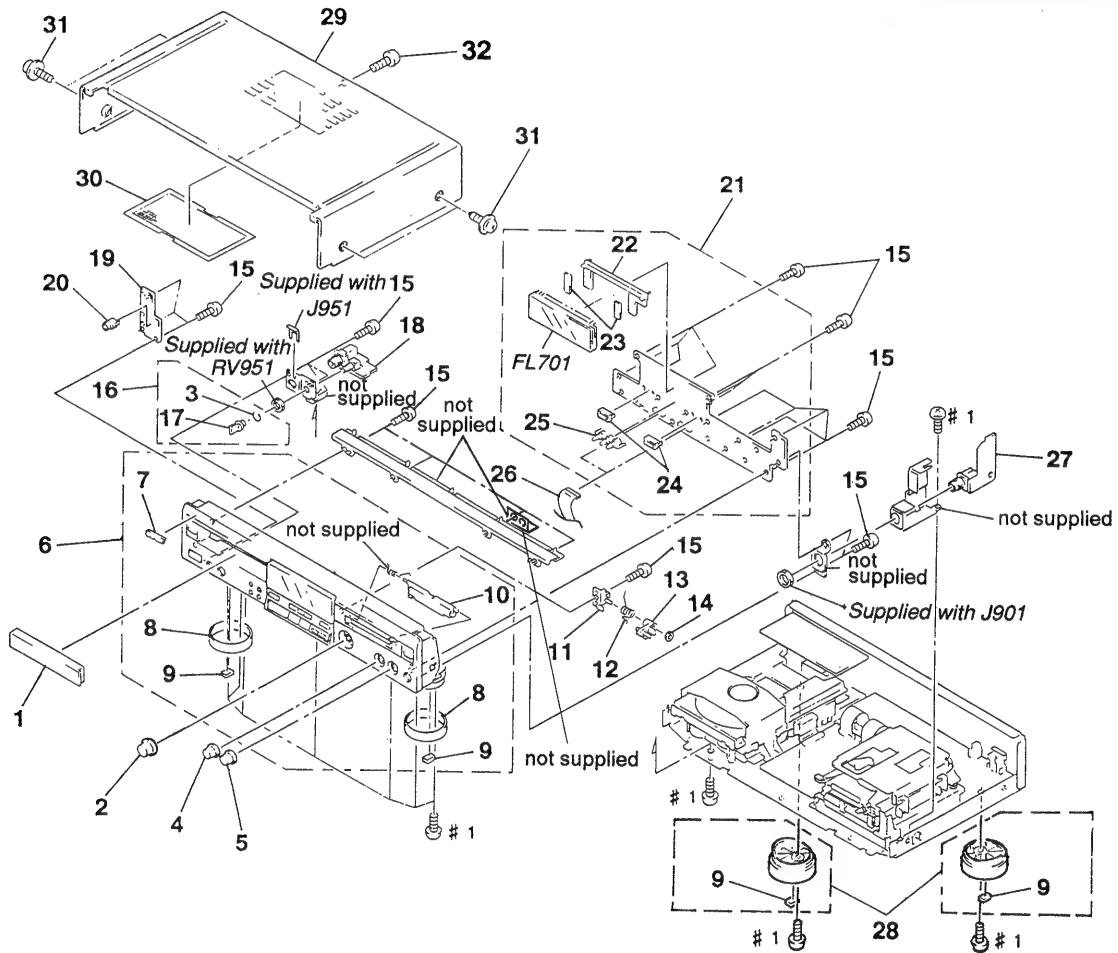

Ref. No.	Part No.	Description	Remark	Ref. No.	Part No.	Description	Remark
1	4-983-175-01	PANEL, LOADING		* 19	1-661-674-11	POWER SWITCH BOARD	
2	4-983-657-01	KNOB (AMS)		* 20	4-972-608-01	HOLDER (DIA. 5), LED	
3	3-354-981-01	SPRING (SUS), RING		* 21	A-4699-065-A	DISPLAY BOARD, COMPLETE	
4	4-983-188-11	KNOB (RB) (MIX BALANCE)		* 22	4-956-134-01	HOLDER (FL TUBE)	
5	4-983-188-01	KNOB (RB) (REC LEVEL)		23	2-389-320-01	CUSHION	
6	X-4947-273-1	PANEL ASSY, FRONT (AEP, G, UK, SP)		* 24	4-983-190-01	HOLDER (LED-2)	
6	X-4947-274-1	PANEL ASSY, FRONT (US, CND)		* 25	4-983-189-01	HOLDER (LED-3)	
7	4-963-404-21	EMBLEM (5-A), SONY		26	1-777-239-11	WIRE (FLAT TYPE) (19 CORE)	
8	4-981-435-11	RING (DIA. 50), ORNAMENTAL (AEP, G, UK, SP)		* 27	A-4699-069-A	MIC BOARD, COMPLETE (AEP, G, UK, SP)	
9	4-983-762-02	CUSHION		* 27	A-4699-070-A	MIC BOARD, COMPLETE (US, CND)	
10	4-977-669-31	LID (CARTRIDGE)		28	X-4947-389-1	FOOT ASSY (F50150S) (AEP, G, UK, SP)	
11	X-4945-242-1	BRACKET (LEVER LID) ASSY		28	X-4947-390-2	FOOT ASSY (F50150S) (US, CND)	
12	4-969-215-01	SPRING, TORSION		29	4-980-420-61	CASE (409526)	
13	4-969-213-01	LEVER (LID)		* 30	4-986-123-01	FILTER (CASE) (CND, AEP, G, UK, SP)	
14	3-681-678-00	WASHER, SLIT		31	3-363-099-01	SCREW (CASE 3 TP2)	
15	4-951-620-01	SCREW (2. 6X8), +BVTP		32	3-703-685-21	SCREW +BV 3X8	
16	A-2003-693-A	KNOB (DIA. 10) ASSY (PHONES LEVEL)		FL701	1-517-353-11	INDICATOR TUBE, FLUORESCENT	
17	3-354-931-01	KNOB (DIA. 10)					
* 18	1-661-675-11	HEADPHONE BOARD					

7-2. CHASSIS SECTION

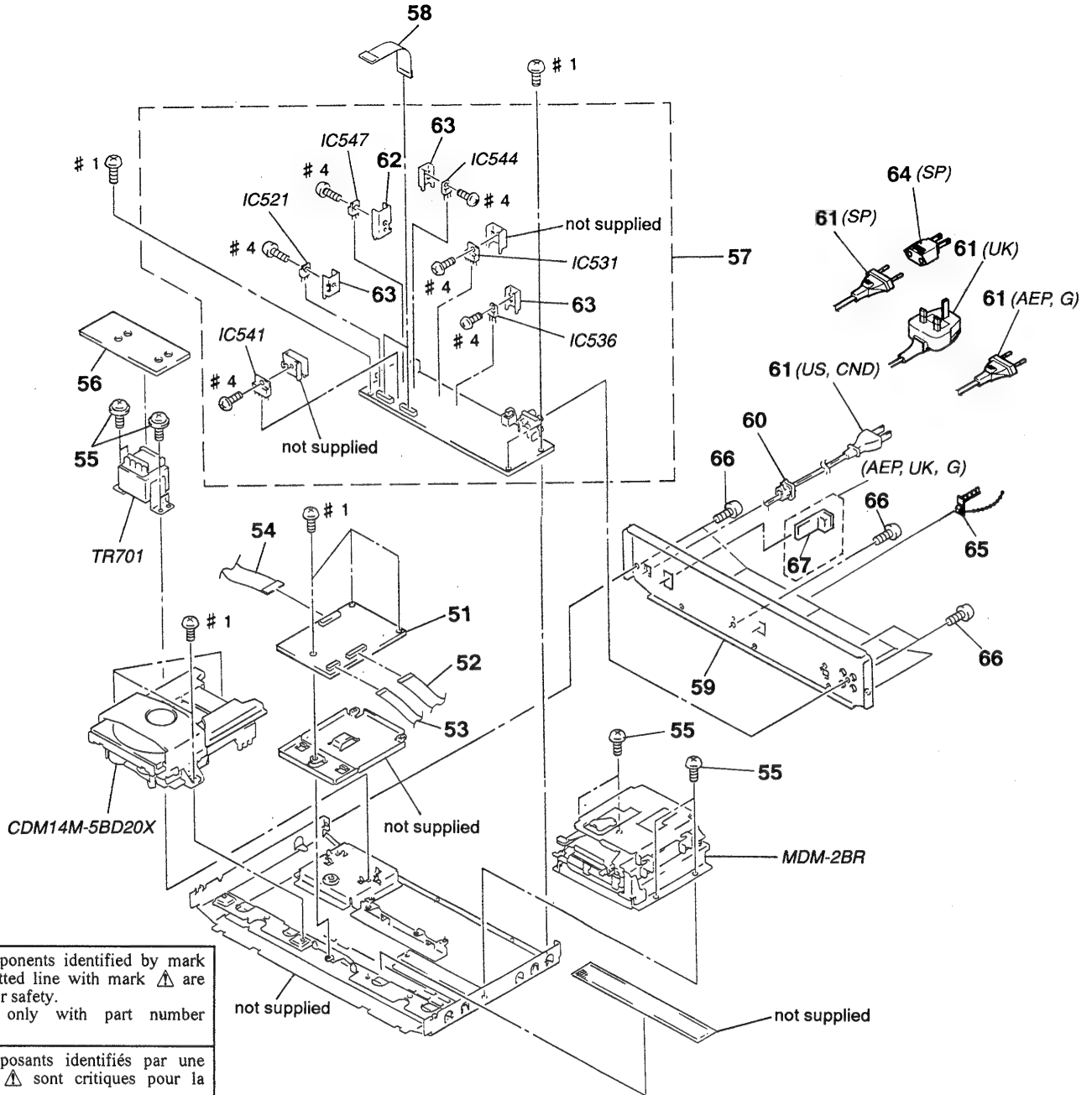

Ref. No.	Part No.	Description	Remark	Ref. No.	Part No.	Description	Remark
* 51	A-4699-072-A	DIGITAL BOARD, COMPLETE (US, CND)		* 60	3-703-244-00	BUSHING (2104), CORD (AEP, G, UK, SP)	
* 51	A-4699-436-A	DIGITAL BOARD, COMPLETE (AEP, G, UK, SP)		* 60	3-703-571-11	BUSHING (S) (4516), CORD (US, CND)	
52	1-777-245-11	WIRE (FLAT TYPE) (30 CORE)		\triangle 61	1-558-945-21	CORD, POWER (POLAR, SPT-1) (US, CND)	
53	1-777-244-11	WIRE (FLAT TYPE) (18 CORE)		\triangle 61	1-575-651-21	CORD, POWER (AEP, G)	
54	1-777-557-11	WIRE (FLAT TYPE) (23 CORE)		\triangle 61	1-696-586-21	CORD, POWER (UK)	
55	4-886-821-11	SCREW, S TIGHT, +PTTWH 3X6		\triangle 61	1-751-275-11	CORD, POWER (SP)	
* 56	1-661-678-11	TRANS BOARD		* 62	4-941-237-11	HEAT SINK	
* 57	A-4699-060-A	AUDIO BOARD, COMPLETE (AEP, G, UK, SP)		* 63	3-309-144-21	HEAT SINK	
* 57	A-4699-061-A	AUDIO BOARD, COMPLETE (US, CND)		\triangle 64	1-569-008-11	ADAPTOR, CONVERSION 2P (SP)	
58	1-777-240-11	WIRE (FLAT TYPE) (21 CORE)		65	4-956-370-02	BAND, PLUG FIXED (UK)	
* 59	4-983-203-11	PANEL, BACK (US)		66	3-704-515-11	SCREW BV/RING. 3X10	
* 59	4-983-203-22	PANEL, BACK (CND)		67	1-661-680-11	SW BOARD (AEP, G, UK)	
* 59	4-983-203-31	PANEL, BACK (AEP, G)		\triangle TR701	1-429-702-11	TRANSFORMER, POWER (US, CND)	
* 59	4-983-203-41	PANEL, BACK (UK)		\triangle TR701	1-429-703-11	TRANSFORMER, POWER (AEP, G, UK)	
* 59	4-983-203-52	PANEL, BACK (SP)		\triangle TR701	1-429-704-11	TRANSFORMER, POWER (SP)	

7-3. MD MECHANISM SECTION (MDM-2BR)

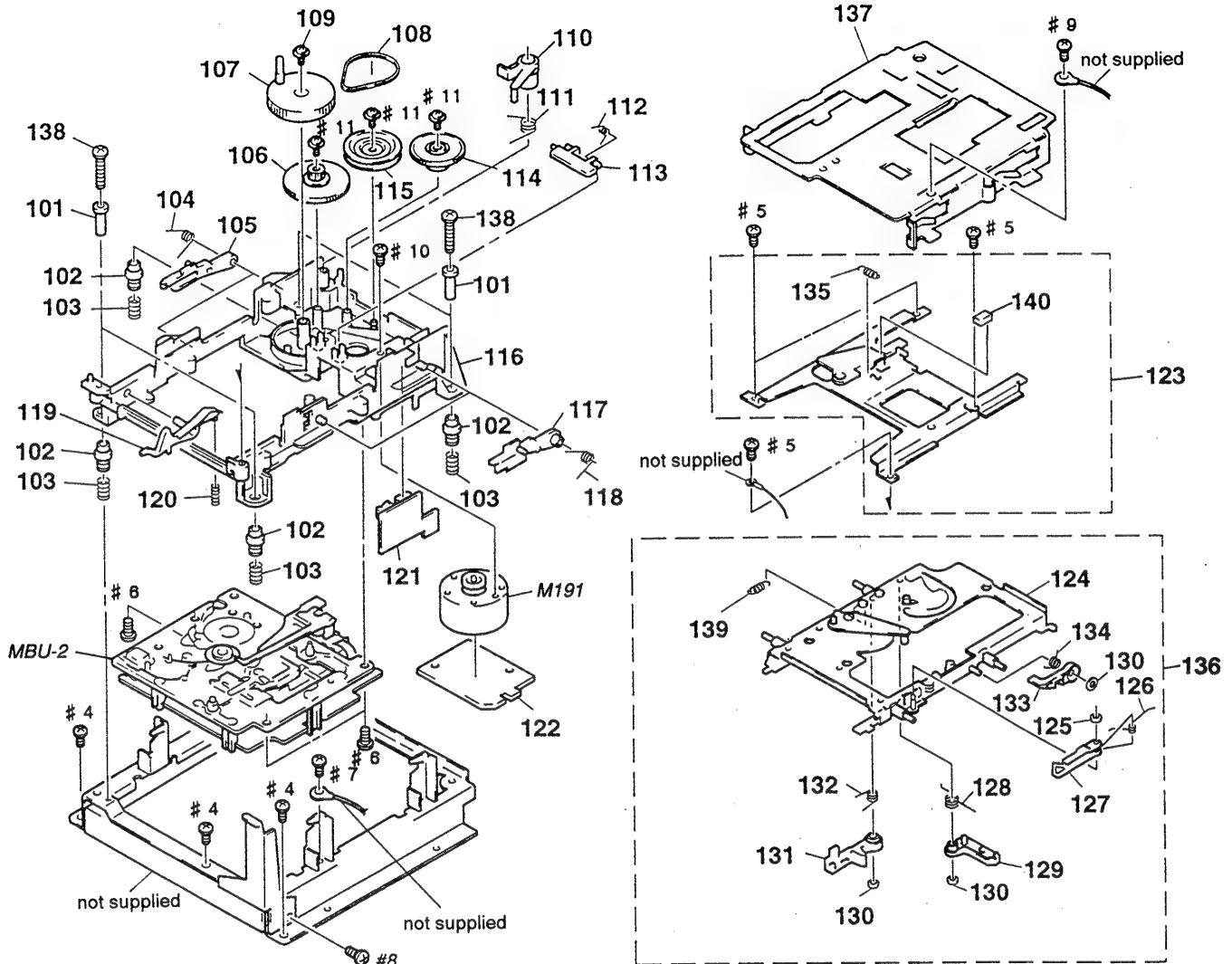

Ref. No.	Part No.	Description	Remark	Ref. No.	Part No.	Description	Remark
101	4-983-100-01	COLLAR (DAMPER)		* 122	1-653-412-11	MOTOR BOARD	
102	4-967-671-01	INSULATOR (MD)		123	A-4672-087-A	BRACKET (LVO) ASSY	
103	4-967-673-01	SPRING, COMPRESSION		124	X-4947-136-2	HOLDER ASSY	
104	4-967-668-01	SPRING (UDL), TORSION		125	4-968-919-11	WASHER, STOPPER	
105	4-967-667-01	LEVER (UDL)					
106	4-977-610-01	GEAR (BD-B)		126	4-967-646-01	SPRING (SHT), TORSION	
107	X-4945-069-1	CAM ASSY		127	4-967-645-01	LEVER (SHT)	
108	4-967-656-01	BELT (BD)		128	4-983-106-02	SPRING (LM), TORSION	
109	4-933-134-01	SCREW (+PTPWH M2. 6X6)		129	4-967-639-01	LEVER (LM)	
110	4-967-637-01	LEVER (SLM)		130	4-968-919-01	WASHER, STOPPER	
111	4-984-426-01	SPRING (SLM), TORSION		131	4-967-641-01	LEVER (L)	
112	4-968-273-01	SPRING (OWH), TORSION		132	4-967-642-01	SPRING (L), TORSION	
113	4-968-272-01	LEVER (OWH)		133	4-982-040-01	LEVER (LOCK)	
114	4-977-609-01	GEAR (BD-A)		134	4-982-099-01	SPRING (LOCK), TORSION	
115	4-977-608-01	PULLEY (BD)		135	4-967-664-05	SPRING, TENSION	
116	4-977-777-01	BASE (BD)		136	A-4672-071-B	HOLDER COMPLETE ASSY	
117	4-967-669-01	LEVER (UDR)		* 137	X-4945-872-1	SLIDER (M) ASSY	
118	4-967-670-01	SPRING (UDR), TORSION		138	4-972-910-01	SCREW (2. 6X18), +B	
119	4-979-400-01	LEVER (DOOR)		139	4-971-743-02	SPRING, TENSION	
120	4-970-710-01	SPRING, COMPRESSION		140	4-983-110-01	CUSHION (LVO)	
* 121	1-653-411-11	DETECTION SW BOARD		M191	A-4660-646-A	MOTOR (LOADING) ASSY (MD)	

7-4. MD BASE UNIT SECTION (MBU-2)

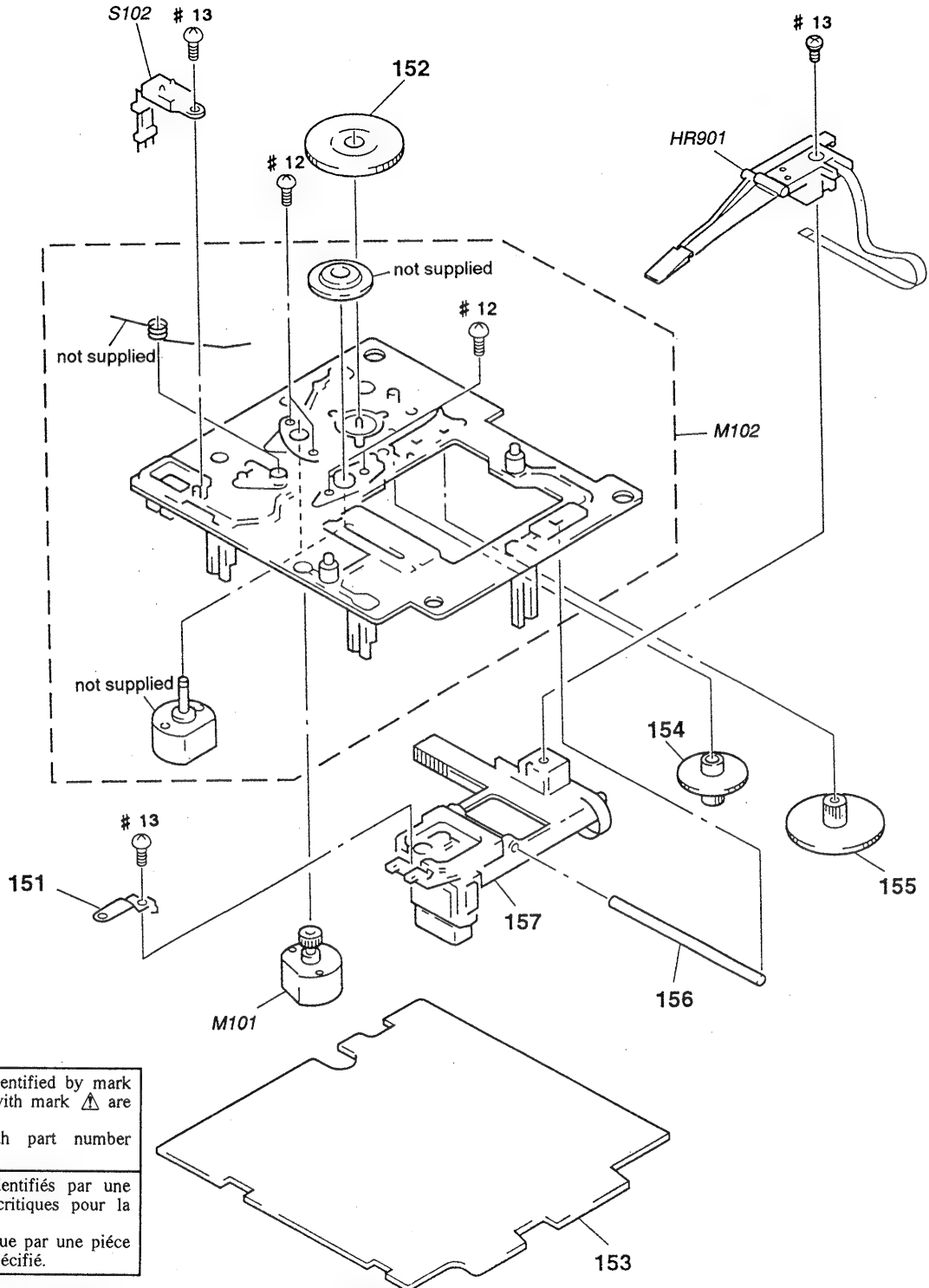

Ref. No.	Part No.	Description	Remark	Ref. No.	Part No.	Description	Remark
151	4-967-679-01	SPRING (OP), LEAF		\triangle 157	8-583-009-11	OPTICAL PICK-UP BLOCK KMS-210A/J-N (MD)	
152	4-967-675-01	GEAR (SL-A)		HR901	1-500-304-21	HEAD, OVER LIGHT	
* 153	A-4673-174-A	BD BOARD, COMPLETE (MD)		M101	A-4660-651-A	MOTOR (SLED) ASSY (MD)	
154	4-967-676-01	GEAR (SL-B)		M102	A-4660-650-A	CHASSIS ASSY, BU (SPINDLE) (MD)	
155	4-967-677-01	GEAR (SL-C)		S102	1-762-148-11	SWITCH, PUSH (2 KEY)	
156	4-967-678-01	SHAFT (OP)					

7-5. CD MECHANISM SECTION (CDM14M-5BD20X)

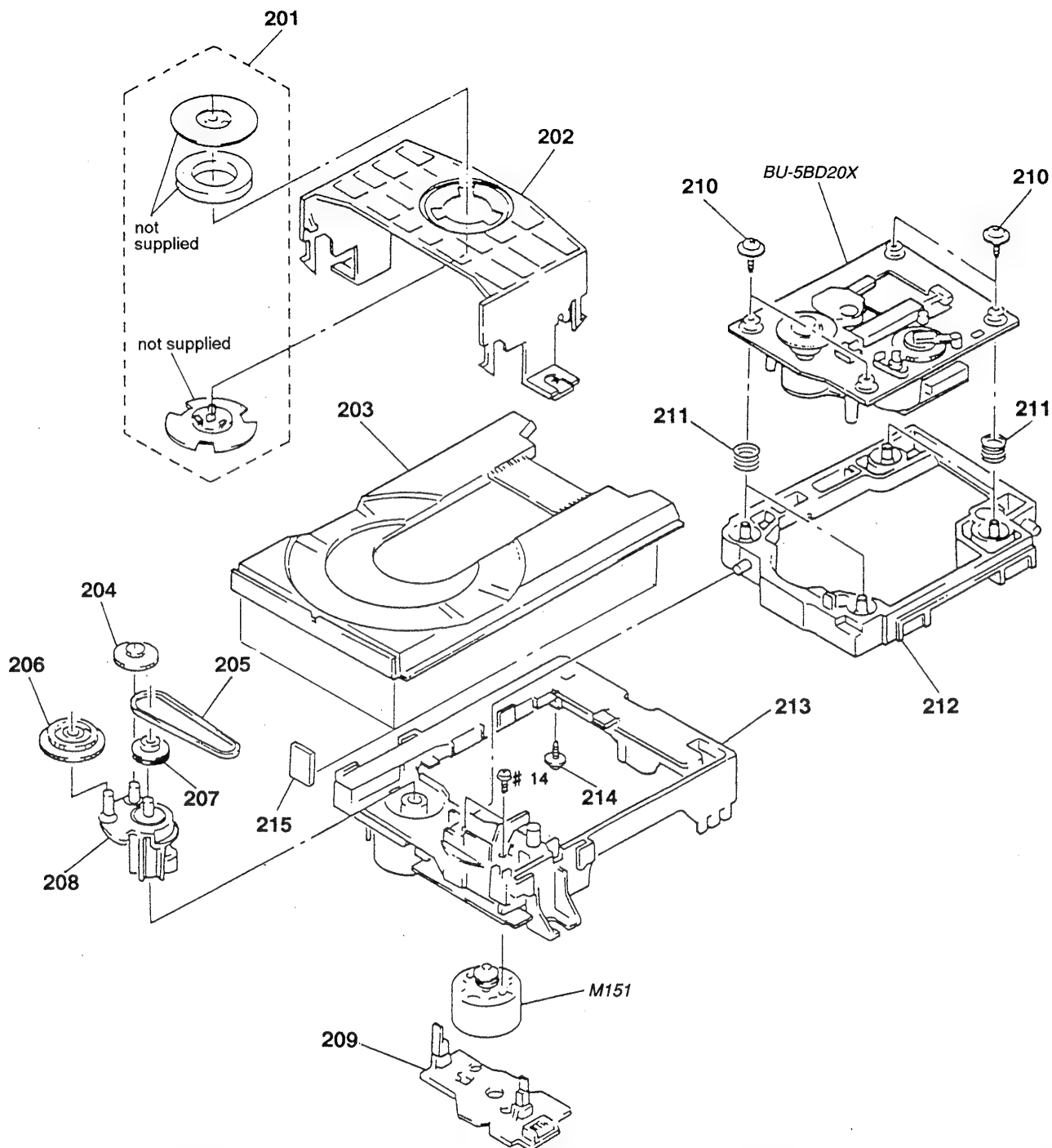

Ref. No.	Part No.	Description	Remark	Ref. No.	Part No.	Description	Remark
201	1-452-538-11	MAGNET		210	4-933-134-01	SCREW (+PTPWH M2. 6X6)	
202	4-933-110-41	HOLDER (MG)		211	4-959-996-01	SPRING (932), COMPRESSION	
203	4-961-487-01	TABLE, DISK		212	4-933-129-01	HOLDER (BU)	
204	4-967-268-01	GEAR (C)		213	4-933-111-01	CHASSIS (MD)	
205	4-927-649-01	BELT		* 214	4-917-583-21	BRACKET, YOKE	
206	4-933-107-01	GEAR (PL)		215	4-925-315-31	DAMPER	
207	4-927-651-01	PULLEY (S)		M151	A-4604-363-A	MOTOR (L) ASSY (LOADING) (CD)	
208	4-933-109-01	CAM					
* 209	1-645-721-11	LOADING BOARD					

7-6. CD BASE UNIT SECTION (BU-5BD20X)

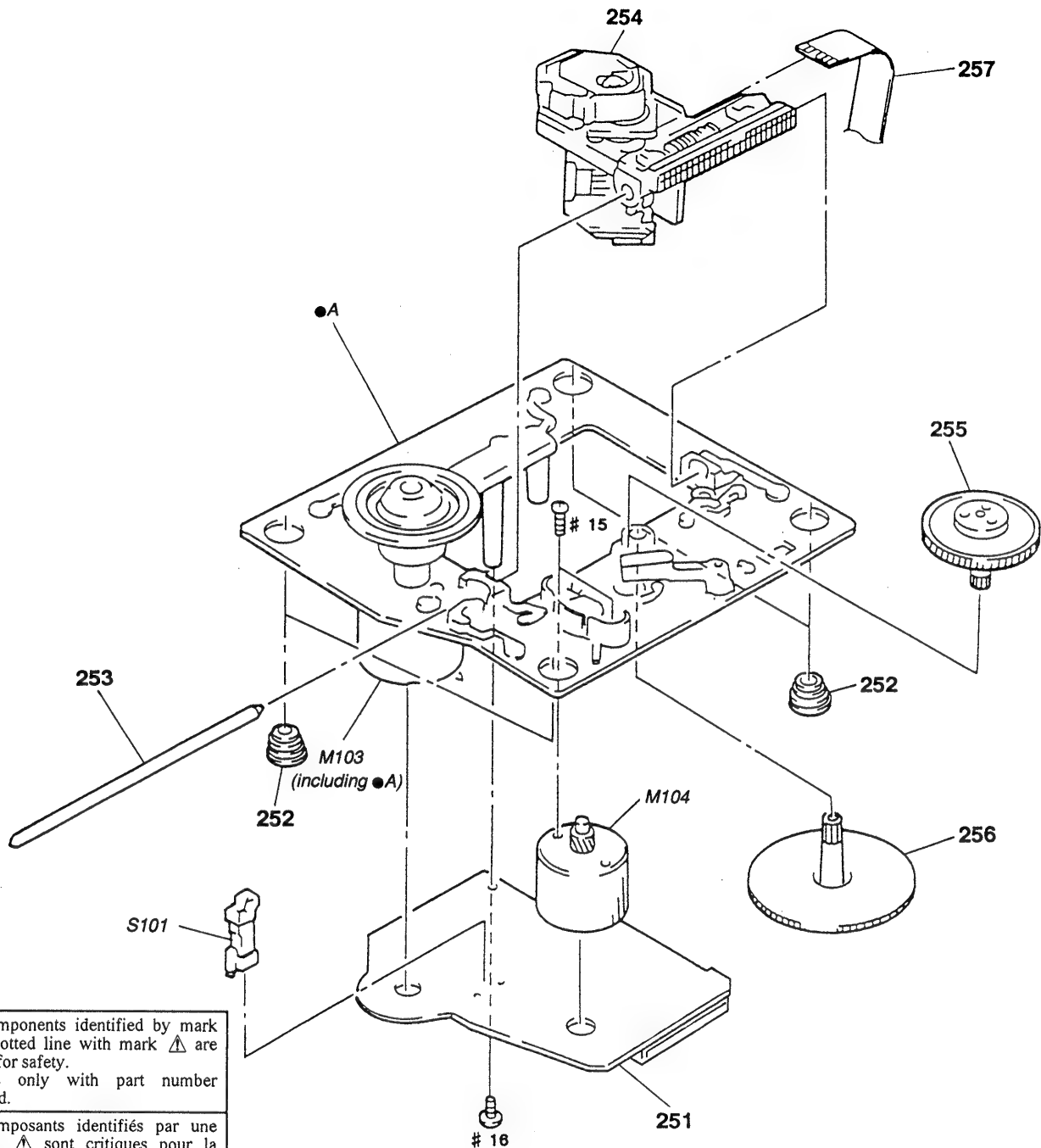

The components identified by mark ▲ or dotted line with mark ▲ are critical for safety. Replace only with part number specified.

Les composants identifiés par une marque ▲ sont critiques pour la sécurité. Ne les remplacer que par une pièce portant le numéro spécifié.

Ref. No.	Part No.	Description	Remark	Ref. No.	Part No.	Description	Remark
* 251	A-4699-259-A	BD BOARD, COMPLETE (CD)		256	4-917-564-01	GEAR (P), FLATNESS	
252	4-951-940-01	INSULATOR (BU)		257	1-769-069-11	WIRE (FLAT TYPE) (16 CORE)	
253	4-917-565-01	SHAFT, SLED		M103	X-4917-523-3	MOTOR ASSY (SPINDLE) (CD)	
▲254	8-848-367-11	OPTICAL PICK-UP BLOCK KSS-213B/K-N (CD)		M104	X-4917-504-1	MOTOR ASSY (SLED) (CD)	
255	4-917-567-01	GEAR (M)		S101	1-572-085-11	SWITCH, LEAF (CD LIMIT)	

SECTION 8

ELECTRICAL PARTS LIST

AUDIO

NOTE:

The components identified by mark Δ or dotted line with mark Δ are critical for safety. Replace only with part number specified.
Les composants identifiés par une marque Δ sont critiques pour la sécurité. Ne les remplacer que par une pièce portant le numéro spécifié.
When indicating parts by reference number, please include the board name.

- Due to standardization, replacements in the parts list may be different from the parts specified in the diagrams or the components used on the set.
- Items marked "*" are not stocked since they are seldom required for routine service. Some delay should be anticipated when ordering these items.
- RESISTORS
All resistors are in ohms
METAL: Metal-film resistor
METAL OXIDE: Metal Oxide-film resistor
F : nonflammable
- SEMICONDUCTORS
In each case, u: μ , for example:
uA...: μ A..., uPA...: μ PA..., uPB...: μ PB...,
uPC...: μ PC..., uPD...: μ PD...

- CAPACITORS
uF : μ F
- COILS
uH : μ H
- Abbreviation
CND : Canadian model
G : German model
SP : Singapore model

* NOTE For replacement of IC121 and IC171 on the BD board, refer to the service note on page 6.
--

Ref. No.	Part No.	Description	Remark	Ref. No.	Part No.	Description	Remark
*	A-4699-060-A	AUDIO BOARD, COMPLETE (AEP, G, UK, SP)		C578	1-124-910-11	ELECT	47uF 20% 50V
	*****			C581	1-130-479-00	MYLAR	0.0047uF 5% 50V
*	A-4699-061-A	AUDIO BOARD, COMPLETE (US, CND)		C582	1-130-479-00	MYLAR	0.0047uF 5% 50V
	*****			C583	1-130-471-00	MYLAR	0.001uF 5% 50V
*	3-309-144-21	HEAT SINK		C584	1-130-471-00	MYLAR	0.001uF 5% 50V
*	4-941-237-11	HEAT SINK		C585	1-162-306-11	CERAMIC	0.01uF 30% 16V
	7-685-871-01	SCREW +BVTT 3X6 (S)		C586	1-162-306-11	CERAMIC	0.01uF 30% 16V
	< CAPACITOR >			C587	1-124-910-11	ELECT	47uF 20% 50V
	C501	1-117-208-21 CAPACITOR	2200uF 25V	C588	1-124-910-11	ELECT	47uF 20% 50V
	C502	1-128-548-11 ELECT	470uF 20% 25V	C591	1-162-294-31	CERAMIC	0.001uF 10% 50V
	C505	1-126-967-11 ELECT	47uF 20% 10V	C592	1-162-294-31	CERAMIC	0.001uF 10% 50V
	C506	1-164-159-11 CERAMIC	0.1uF 50V	C601	1-104-666-11	ELECT	220uF 20% 25V
	C511	1-128-554-51 ELECT	330uF 20% 63V	C602	1-104-666-11	ELECT	220uF 20% 25V
	C512	1-126-950-11 ELECT	330uF 20% 35V	C603	1-162-306-11	CERAMIC	0.01uF 30% 16V
	C513	1-164-159-11 CERAMIC	0.1uF 50V	C604	1-162-306-11	CERAMIC	0.01uF 30% 16V
	C514	1-126-965-11 ELECT	22uF 20% 50V	C611	1-162-294-31	CERAMIC	0.001uF 10% 50V
	C521	1-164-159-11 CERAMIC	0.1uF 50V	C612	1-162-294-31	CERAMIC	0.001uF 10% 50V
	C522	1-162-306-11 CERAMIC	0.01uF 30% 16V	C613	1-124-910-11	ELECT	47uF 20% 50V
	C523	1-126-941-11 ELECT	470uF 20% 25V	C614	1-124-910-11	ELECT	47uF 20% 50V
	C524	1-126-925-11 ELECT	470uF 20% 10V	C615	1-162-306-11	CERAMIC	0.01uF 30% 16V
	C531	1-126-941-11 ELECT	470uF 20% 25V	C616	1-162-306-11	CERAMIC	0.01uF 30% 16V
	C532	1-164-159-11 CERAMIC	0.1uF 50V	C617	1-124-910-11	ELECT	47uF 20% 50V
	C533	1-124-903-11 ELECT	1uF 20% 50V	C618	1-124-910-11	ELECT	47uF 20% 50V
	C534	1-126-925-11 ELECT	470uF 20% 10V	C631	1-528-739-11	BATTERY, LITHIUM	
	C536	1-126-942-51 ELECT	1000uF 20% 25V	C641	1-126-964-11	ELECT	10uF 20% 50V
	C537	1-126-937-11 ELECT	4700uF 20% 16V	C642	1-104-664-11	ELECT	47uF 20% 25V
	C541	1-126-942-51 ELECT	1000uF 20% 25V	C643	1-162-306-11	CERAMIC	0.01uF 30% 16V
	C542	1-126-923-11 ELECT	220uF 20% 10V	C651	1-104-664-11	ELECT	47uF 20% 25V
	C543	1-126-923-11 ELECT	220uF 20% 10V	C661	1-126-967-11	ELECT	47uF 20% 10V
	C545	1-126-925-11 ELECT	470uF 20% 10V	C662	1-162-306-11	CERAMIC	0.01uF 30% 16V
	C546	1-126-925-11 ELECT	470uF 20% 10V	C671	1-126-941-11	ELECT	470uF 20% 25V
	C547	1-126-925-11 ELECT	470uF 20% 10V	C672	1-126-941-11	ELECT	470uF 20% 25V
	C571	1-130-479-00 MYLAR	0.0047uF 5% 50V	C673	1-126-923-11	ELECT	220uF 20% 10V
	C572	1-130-479-00 MYLAR	0.0047uF 5% 50V	C674	1-126-923-11	ELECT	220uF 20% 10V
	C573	1-130-471-00 MYLAR	0.001uF 5% 50V	C675	1-162-306-11	CERAMIC	0.01uF 30% 16V
	C574	1-130-471-00 MYLAR	0.001uF 5% 50V	C676	1-162-306-11	CERAMIC	0.01uF 30% 16V
	C575	1-162-306-11 CERAMIC	0.01uF 30% 16V	C677	1-124-903-11	ELECT	1uF 20% 50V
	C576	1-162-306-11 CERAMIC	0.01uF 30% 16V	C678	1-124-903-11	ELECT	1uF 20% 50V
	C577	1-124-910-11 ELECT	47uF 20% 50V	C679	1-124-903-11	ELECT	1uF 20% 50V
				C680	1-164-159-11	CERAMIC	0.1uF 50V

AUDIO

Ref. No.	Part No.	Description	Remark	Ref. No.	Part No.	Description	Remark
< CONNECTOR >							
CN502	1-770-649-11	CONNECTOR, FFC/FPC 21P		IC671	8-759-631-40	IC M5294P	
CN503	1-770-649-11	CONNECTOR, FFC/FPC 21P		< JACK >			
* CN504	1-564-709-11	PIN, CONNECTOR (SMALL TYPE) 7P		J591	1-770-720-11	JACK, PIN 4P (LINE (ANALOG))	
CN601	1-766-276-11	PIN, CONNECTOR 3P		< COIL >			
* CN621	1-564-710-11	PIN, CONNECTOR (SMALL TYPE) 8P		L661	1-410-509-11	INDUCTOR 10uH	
* CN622	1-564-709-11	PIN, CONNECTOR (SMALL TYPE) 7P		< TRANSISTOR >			
* CN631	1-564-704-11	PIN, CONNECTOR (SMALL TYPE) 2P		Q536	8-729-422-57	TRANSISTOR UN4111	
< DIODE >				Q591	8-729-141-26	TRANSISTOR 2SC3622A-LK	
D501	8-719-200-82	DIODE 11ES2		Q592	8-729-141-26	TRANSISTOR 2SC3622A-LK	
D502	8-719-200-82	DIODE 11ES2		Q593	8-729-902-80	TRANSISTOR DTA114YS	
D503	8-719-200-82	DIODE 11ES2		Q594	8-729-661-94	TRANSISTOR RT1N141SK-TP	
D504	8-719-200-82	DIODE 11ES2		Q595	8-729-422-57	TRANSISTOR UN4111	
D505	8-719-987-63	DIODE 1N4148M		Q621	8-729-900-80	TRANSISTOR DTC114ES	
D506	8-719-987-63	DIODE 1N4148M		Q622	8-729-422-57	TRANSISTOR UN4111	
D507	8-719-987-63	DIODE 1N4148M		Q623	8-729-900-80	TRANSISTOR DTC114ES	
D508	8-719-987-63	DIODE 1N4148M		Q624	8-729-422-57	TRANSISTOR UN4111	
D509	8-719-109-74	DIODE RD4. 3ES-B1		Q625	8-729-900-80	TRANSISTOR DTC114ES	
D510	8-719-987-63	DIODE 1N4148M		Q626	8-729-422-57	TRANSISTOR UN4111	
D511	8-719-200-02	DIODE 10E2		Q627	8-729-900-80	TRANSISTOR DTC114ES	
D512	8-719-014-88	DIODE UZP-6. 8BC		Q628	8-729-422-57	TRANSISTOR UN4111	
D536	8-719-987-63	DIODE 1N4148M		< RESISTOR >			
D582	8-719-987-63	DIODE 1N4148M		R505	1-249-415-11	CARBON 680 5% 1/4W F	
D591	8-719-987-63	DIODE 1N4148M		R506	1-249-415-11	CARBON 680 5% 1/4W F	
D621	8-719-987-63	DIODE 1N4148M		R511	1-249-437-11	CARBON 47K 5% 1/4W	
D623	8-719-987-63	DIODE 1N4148M		R536	1-249-419-11	CARBON 1.5K 5% 1/4W F	
D625	8-719-987-63	DIODE 1N4148M		R537	1-249-411-11	CARBON 330 5% 1/4W	
D627	8-719-987-63	DIODE 1N4148M		R538	1-247-807-31	CARBON 100 5% 1/4W	
D631	8-719-210-21	DIODE 11EQS04		R539	1-247-807-31	CARBON 100 5% 1/4W	
D632	8-719-210-21	DIODE 11EQS04		R541	1-249-429-11	CARBON 10K 5% 1/4W	
D633	8-719-200-82	DIODE 11ES2		R542	1-249-429-11	CARBON 10K 5% 1/4W	
D641	8-719-987-63	DIODE 1N4148M		R543	1-247-843-11	CARBON 3.3K 5% 1/4W	
D642	8-719-987-63	DIODE 1N4148M		R544	1-247-843-11	CARBON 3.3K 5% 1/4W	
D643	8-719-987-63	DIODE 1N4148M		R571	1-215-425-00	METAL 1.5K 1% 1/4W	
< IC >				R572	1-215-425-00	METAL 1.5K 1% 1/4W	
IC511	8-759-633-42	IC M5293L		R573	1-215-425-00	METAL 1.5K 1% 1/4W	
IC521	8-759-604-86	IC M5F7807L		R574	1-215-425-00	METAL 1.5K 1% 1/4W	
IC531	8-759-061-65	IC LA5602		R575	1-247-895-00	CARBON 470K 5% 1/4W	
IC536	8-759-520-49	IC PQ30RV21		R576	1-247-895-00	CARBON 470K 5% 1/4W	
IC541	8-759-290-19	IC BA3960		R581	1-215-425-00	METAL 1.5K 1% 1/4W	
IC544	8-759-231-53	IC TA7805S		R582	1-215-425-00	METAL 1.5K 1% 1/4W	
IC547	8-759-054-12	IC PQ09RA1		R583	1-215-425-00	METAL 1.5K 1% 1/4W	
IC571	8-759-634-51	IC M5218AP		R584	1-215-425-00	METAL 1.5K 1% 1/4W	
IC581	8-759-634-51	IC M5218AP		R585	1-247-895-00	CARBON 470K 5% 1/4W	
IC591	8-759-634-51	IC M5218AP		R586	1-247-895-00	CARBON 470K 5% 1/4W	
IC611	8-759-634-51	IC M5218AP		R591	1-249-415-11	CARBON 680 5% 1/4W F	
IC641	8-759-917-18	IC SN74HCU04AN		R592	1-249-415-11	CARBON 680 5% 1/4W F	
IC661	8-749-921-12	IC GP1F32T (DIGITAL OUT OPTICAL)					

Ref. No.	Part No.	Description	Remark	Ref. No.	Part No.	Description	Remark
R593	1-249-421-11	CARBON	2.2K 5% 1/4W F	C103	1-163-005-11	CERAMIC CHIP 470PF	10% 50V
R594	1-249-421-11	CARBON	2.2K 5% 1/4W F	C105	1-135-155-21	TANTALUM CHIP 4.7uF	10% 16V
R595	1-249-411-11	CARBON	330 5% 1/4W	C106	1-164-346-11	CERAMIC CHIP 1uF	16V
R596	1-249-411-11	CARBON	330 5% 1/4W	C107	1-164-346-11	CERAMIC CHIP 1uF	16V
R597	1-247-899-11	CARBON	680K 5% 1/4W	C108	1-163-035-00	CERAMIC CHIP 0.047uF	50V
R598	1-247-895-00	CARBON	470K 5% 1/4W	C109	1-163-145-00	CERAMIC CHIP 0.0015uF	5% 50V
R599	1-247-895-00	CARBON	470K 5% 1/4W	C110	1-163-017-00	CERAMIC CHIP 0.0047uF	5% 50V
R601	1-249-411-11	CARBON	330 5% 1/4W	C111	1-163-251-11	CERAMIC CHIP 100PF	5% 50V
R602	1-249-411-11	CARBON	330 5% 1/4W	C112	1-163-038-91	CERAMIC CHIP 0.1uF	25V
R603	1-249-411-11	CARBON	330 5% 1/4W	C113	1-163-038-91	CERAMIC CHIP 0.1uF	25V
R604	1-249-411-11	CARBON	330 5% 1/4W	C115	1-126-607-11	ELECT CHIP 47uF	20% 4V
R605	1-249-417-11	CARBON	1K 5% 1/4W F	C116	1-126-607-11	ELECT CHIP 47uF	20% 4V
R606	1-249-417-11	CARBON	1K 5% 1/4W F	C117	1-126-209-11	ELECT 100uF	20% 4V
R607	1-249-397-11	CARBON	22 5% 1/4W F	C118	1-163-275-11	CERAMIC CHIP 0.001uF	5% 50V
R608	1-249-397-11	CARBON	22 5% 1/4W F	C119	1-163-231-11	CERAMIC CHIP 15PF	5% 50V
R611	1-249-439-11	CARBON	68K 5% 1/4W	C123	1-164-232-11	CERAMIC CHIP 0.01uF	50V
R612	1-249-439-11	CARBON	68K 5% 1/4W	C124	1-164-005-11	CERAMIC CHIP 0.47uF	25V
R613	1-247-887-00	CARBON	220K 5% 1/4W	C140	1-163-038-91	CERAMIC CHIP 0.1uF	25V
R614	1-247-887-00	CARBON	220K 5% 1/4W	C141	1-163-038-91	CERAMIC CHIP 0.1uF	25V
R615	1-249-417-11	CARBON	1K 5% 1/4W F	C151	1-163-237-11	CERAMIC CHIP 27PF	5% 50V
R616	1-249-417-11	CARBON	1K 5% 1/4W F	C153	1-163-038-91	CERAMIC CHIP 0.1uF	25V
R617	1-247-887-00	CARBON	220K 5% 1/4W	C154	1-164-336-11	CERAMIC CHIP 0.33uF	25V
R618	1-247-887-00	CARBON	220K 5% 1/4W	C156	1-163-237-11	CERAMIC CHIP 27PF	5% 50V
R631	1-215-404-00	METAL	200 1% 1/4W	C157	1-163-145-00	CERAMIC CHIP 0.0015uF	5% 50V
R632	1-215-414-00	METAL	510 1% 1/4W	C159	1-163-019-00	CERAMIC CHIP 0.0068uF	10% 50V
R641	1-247-807-31	CARBON	100 5% 1/4W	C161	1-163-038-91	CERAMIC CHIP 0.1uF	25V
R642	1-249-417-11	CARBON	1K 5% 1/4W F			< CONNECTOR >	
R643	1-249-436-11	CARBON	39K 5% 1/4W F	CN101	1-770-072-11	CONNECTOR, FFC 23P	
R644	1-249-437-11	CARBON	47K 5% 1/4W	CN102	1-770-014-11	CONNECTOR, FFC/FFC 16P	
R645	1-247-891-00	CARBON	330K 5% 1/4W			< IC >	
R646	1-249-417-11	CARBON	1K 5% 1/4W F	IC101	8-752-369-78	IC CXD2545Q	
R651	1-249-425-11	CARBON	4.7K 5% 1/4W F	IC102	8-759-176-09	IC BA6392FP	
R652	1-249-437-11	CARBON	47K 5% 1/4W	IC103	8-752-072-45	IC CXA1821M-T6	
R653	1-247-891-00	CARBON	330K 5% 1/4W			< TRANSISTOR >	
R671	1-249-437-11	CARBON	47K 5% 1/4W	Q101	8-729-010-08	TRANSISTOR MSB710-R	
		< RELAY >				< RESISTOR >	
RY591	1-515-787-21	RELAY		R101	1-216-077-00	METAL CHIP 15K 5%	1/10W
RY621	1-515-787-21	RELAY		R102	1-216-097-91	METAL GLAZE 100K 5%	1/10W
RY623	1-515-787-21	RELAY		R103	1-216-077-00	METAL CHIP 15K 5%	1/10W
RY625	1-515-787-21	RELAY		R104	1-216-085-00	METAL CHIP 33K 5%	1/10W
RY627	1-515-787-21	RELAY		R105	1-216-097-91	METAL GLAZE 100K 5%	1/10W
*****				R106	1-216-061-00	METAL CHIP 3.3K 5%	1/10W
*	A-4699-259-A	BD BOARD, COMPLETE (CD)		R107	1-216-061-00	METAL CHIP 3.3K 5%	1/10W
		*****		R108	1-216-073-00	METAL CHIP 10K 5%	1/10W
		< CAPACITOR >		R109	1-216-121-91	METAL GLAZE 1M 5%	1/10W
C101	1-163-005-11	CERAMIC CHIP 470PF	10% 50V	R110	1-216-025-91	METAL GLAZE 100 5%	1/10W
C102	1-163-038-91	CERAMIC CHIP 0.1uF	25V				

BD (CD)**BD (MD)**

Ref. No.	Part No.	Description	Remark	Ref. No.	Part No.	Description	Remark
R112	1-216-049-91	METAL GLAZE	1K 5% 1/10W	C121	1-126-395-11	ELECT	22uF 20% 16V
R123	1-216-073-00	METAL CHIP	10K 5% 1/10W	C122	1-164-232-11	CERAMIC CHIP	0.01uF 50V
R124	1-216-097-91	METAL GLAZE	100K 5% 1/10W	C123	1-163-038-91	CERAMIC CHIP	0.1uF 25V
R128	1-216-037-00	METAL CHIP	330 5% 1/10W	C124	1-163-038-91	CERAMIC CHIP	0.1uF 25V
R129	1-216-037-00	METAL CHIP	330 5% 1/10W	C125	1-104-760-11	CERAMIC CHIP	0.047uF 10% 50V
R130	1-216-037-00	METAL CHIP	330 5% 1/10W	C126	1-107-682-11	CERAMIC CHIP	1uF 10% 16V
R131	1-216-037-00	METAL CHIP	330 5% 1/10W	C127	1-163-038-91	CERAMIC CHIP	0.1uF 25V
R135	1-216-295-91	CONDUCTOR, CHIP (2012)		C128	1-164-232-11	CERAMIC CHIP	0.01uF 50V
R136	1-216-295-91	CONDUCTOR, CHIP (2012)		C129	1-107-823-11	CERAMIC CHIP	0.47uF 10% 16V
R137	1-216-295-91	CONDUCTOR, CHIP (2012)		C130	1-163-251-11	CERAMIC CHIP	100PF 5% 50V
R138	1-216-295-91	CONDUCTOR, CHIP (2012)		C131	1-104-760-11	CERAMIC CHIP	0.047uF 10% 50V
R141	1-216-089-91	METAL GLAZE	47K 5% 1/10W	C132	1-107-682-11	CERAMIC CHIP	1uF 10% 16V
R142	1-216-081-00	METAL CHIP	22K 5% 1/10W	C133	1-163-017-00	CERAMIC CHIP	0.0047uF 5% 50V
R143	1-216-103-00	METAL CHIP	180K 5% 1/10W	C134	1-163-038-91	CERAMIC CHIP	0.1uF 25V
R144	1-216-103-00	METAL CHIP	180K 5% 1/10W	C135	1-163-038-91	CERAMIC CHIP	0.1uF 25V
R146	1-216-073-00	METAL CHIP	10K 5% 1/10W	C136	1-126-206-11	ELECT CHIP	100uF 20% 6.3V
R147	1-216-081-00	METAL CHIP	22K 5% 1/10W	C141	1-163-038-91	CERAMIC CHIP	0.1uF 25V
R148	1-216-001-00	METAL CHIP	10 5% 1/10W	C142	1-163-251-11	CERAMIC CHIP	100PF 5% 50V
R149	1-216-003-11	METAL GLAZE	12 5% 1/10W	C143	1-163-251-11	CERAMIC CHIP	100PF 5% 50V
R158	1-216-111-91	METAL GLAZE	390K 5% 1/10W	C144	1-163-251-11	CERAMIC CHIP	100PF 5% 50V
R159	1-216-101-00	METAL CHIP	150K 5% 1/10W	C151	1-104-913-11	TANTAL. CHIP	10uF 20% 16V
R160	1-216-295-91	CONDUCTOR, CHIP (2012)		C152	1-163-038-91	CERAMIC CHIP	0.1uF 25V
R161	1-216-308-00	METAL CHIP	4.7 5% 1/10W	C155	1-104-916-11	TANTAL. CHIP	6.8uF 20% 20V
R162	1-216-101-00	METAL CHIP	150K 5% 1/10W	C160	1-104-601-11	ELECT CHIP	10uF 20% 10V
< SWITCH >				C161	1-104-601-11	ELECT CHIP	10uF 20% 10V
S101	1-572-085-11	SWITCH, LEAF (CD LIMIT)		C163	1-164-232-11	CERAMIC CHIP	0.01uF 50V
*****				C164	1-164-232-11	CERAMIC CHIP	0.01uF 50V
*****				C166	1-163-275-11	CERAMIC CHIP	0.001uF 5% 50V
*	A-4673-174-A	BD BOARD, COMPLETE (MD)		C167	1-163-038-91	CERAMIC CHIP	0.1uF 25V
*****				C169	1-104-913-11	TANTAL. CHIP	10uF 20% 16V
< CAPACITOR >				C170	1-104-913-11	TANTAL. CHIP	10uF 20% 16V
C101	1-104-913-11	TANTAL. CHIP	10uF 20% 16V	C171	1-163-038-91	CERAMIC CHIP	0.1uF 25V
C102	1-163-038-91	CERAMIC CHIP	0.1uF 25V	C175	1-163-038-91	CERAMIC CHIP	0.1uF 25V
C103	1-104-913-11	TANTAL. CHIP	10uF 20% 16V	C176	1-163-227-11	CERAMIC CHIP	10PF 0.5PF 50V
C104	1-104-913-11	TANTAL. CHIP	10uF 20% 16V	C177	1-163-227-11	CERAMIC CHIP	10PF 0.5PF 50V
C105	1-164-232-11	CERAMIC CHIP	0.01uF 50V	C178	1-163-038-91	CERAMIC CHIP	0.1uF 25V
C106	1-163-275-11	CERAMIC CHIP	0.001uF 5% 50V	C181	1-104-913-11	TANTAL. CHIP	10uF 20% 16V
C107	1-164-232-11	CERAMIC CHIP	0.01uF 50V	C182	1-163-038-91	CERAMIC CHIP	0.1uF 25V
C108	1-164-232-11	CERAMIC CHIP	0.01uF 50V	C183	1-163-038-91	CERAMIC CHIP	0.1uF 25V
C109	1-163-037-11	CERAMIC CHIP	0.022uF 10% 25V	C184	1-107-836-11	ELECT CHIP	22uF 20% 8V
C111	1-164-004-11	CERAMIC CHIP	0.1uF 10% 25V	C185	1-164-611-11	CERAMIC CHIP	0.001uF 10% 500V
C112	1-164-232-11	CERAMIC CHIP	0.01uF 50V	C186	1-163-038-91	CERAMIC CHIP	0.1uF 25V
C113	1-107-682-11	CERAMIC CHIP	1uF 10% 16V	C191	1-126-395-11	ELECT	22uF 20% 16V
C114	1-163-038-91	CERAMIC CHIP	0.1uF 25V	C192	1-163-038-91	CERAMIC CHIP	0.1uF 25V
C115	1-107-682-11	CERAMIC CHIP	1uF 10% 16V	C193	1-164-346-11	CERAMIC CHIP	1uF 16V
C116	1-163-019-00	CERAMIC CHIP	0.0068uF 10% 50V	C194	1-126-206-11	ELECT CHIP	100uF 20% 6.3V
C117	1-164-004-11	CERAMIC CHIP	0.1uF 10% 25V	< CONNECTOR >			
C119	1-104-913-11	TANTAL. CHIP	10uF 20% 16V	CN101	1-766-508-11	CONNECTOR, FFC/FPC (ZIF)	22P
				CN102	1-766-510-21	CONNECTOR, FFC/FPC	30P

Ref. No.	Part No.	Description	Remark	Ref. No.	Part No.	Description	Remark
CN103	1-766-509-21	CONNECTOR, FFC/FPC 18P				< RESISTOR >	
CN104	1-766-898-21	HOUSING, CONNECTOR (PC BOARD) 4P					
		< DIODE >					
D101	8-719-988-62	DIODE 1SS355		R101	1-216-077-00	METAL CHIP 15K 5%	1/10W
D155	8-719-031-17	DIODE 1SS322-TE85L		R102	1-216-073-00	METAL CHIP 10K 5%	1/10W
D161	8-719-421-15	DIODE MA8027-L		R103	1-216-073-00	METAL CHIP 10K 5%	1/10W
D181	8-719-033-60	DIODE F1P2STP		R104	1-216-049-91	METAL GLAZE 1K 5%	1/10W
D183	8-719-033-60	DIODE F1P2STP		R105	1-216-065-00	METAL CHIP 4.7K 5%	1/10W
		< IC >					
IC101	8-752-072-68	IC CXA1981AR		R106	1-216-133-00	METAL CHIP 3.3M 5%	1/10W
IC102	8-759-243-19	IC TC7SU04F		R107	1-216-113-00	METAL CHIP 470K 5%	1/10W
IC121	8-752-375-06	IC CXD2535AR * NOTE		R110	1-216-077-00	METAL CHIP 15K 5%	1/10W
IC121	8-752-375-36	IC CXD2535BR * NOTE		R113	1-216-061-00	METAL CHIP 3.3K 5%	1/10W
IC122	8-759-243-19	IC TC7SU04F		R114	1-216-025-91	METAL GLAZE 100 5%	1/10W
IC151	8-759-179-60	IC MPC17A38VMEL					
IC171	8-759-504-12	IC X24C01S * NOTE		R116	1-216-069-00	METAL CHIP 6.8K 5%	1/10W
IC172	8-759-149-73	IC uPC842G2		R117	1-216-113-00	METAL CHIP 470K 5%	1/10W
IC181	8-759-095-65	IC TC74ACT540FS		R120	1-216-025-91	METAL GLAZE 100 5%	1/10W
IC182	8-759-243-19	IC TC7SU04F		R121	1-216-097-91	METAL GLAZE 100K 5%	1/10W
IC191	8-759-822-99	IC L88MS05T-FA		R122	1-216-295-91	CONDUCTOR, CHIP (2012)	
		< COIL >					
L101	1-414-234-11	INDUCTOR, FERRITE BEAD		R123	1-216-037-00	METAL CHIP 330 5%	1/10W
L102	1-414-234-11	INDUCTOR, FERRITE BEAD		R124	1-216-025-91	METAL GLAZE 100 5%	1/10W
L103	1-414-234-11	INDUCTOR, FERRITE BEAD		R125	1-216-025-91	METAL GLAZE 100 5%	1/10W
L105	1-414-234-11	INDUCTOR, FERRITE BEAD		R128	1-216-053-00	METAL CHIP 1.5K 5%	1/10W
L106	1-414-234-11	INDUCTOR, FERRITE BEAD		R129	1-216-037-00	METAL CHIP 330 5%	1/10W
L121	1-414-234-11	INDUCTOR, FERRITE BEAD					
L122	1-412-039-51	INDUCTOR CHIP 100uH		R130	1-216-041-00	METAL CHIP 470 5%	1/10W
L151	1-412-622-51	INDUCTOR 10uH		R131	1-216-073-00	METAL CHIP 10K 5%	1/10W
L152	1-412-622-51	INDUCTOR 10uH		R132	1-216-097-91	METAL GLAZE 100K 5%	1/10W
L153	1-412-039-51	INDUCTOR CHIP 100uH		R133	1-216-129-00	METAL CHIP 2.2M 5%	1/10W
L154	1-412-039-51	INDUCTOR CHIP 100uH		R134	1-216-037-00	METAL CHIP 330 5%	1/10W
L155	1-410-980-51	INDUCTOR CHIP 1mH					
L161	1-414-234-11	INDUCTOR, FERRITE BEAD		R135	1-216-053-00	METAL CHIP 1.5K 5%	1/10W
L162	1-414-234-11	INDUCTOR, FERRITE BEAD		R136	1-216-041-00	METAL CHIP 470 5%	1/10W
L195	1-233-316-21	FILTER, CHIP EMI		R137	1-216-025-91	METAL GLAZE 100 5%	1/10W
		< TRANSISTOR >		R139	1-216-017-91	METAL GLAZE 47 5%	1/10W
Q101	8-729-905-12	TRANSISTOR DTA144EU		R140	1-216-017-91	METAL GLAZE 47 5%	1/10W
Q151	8-729-905-18	TRANSISTOR DTC144EU					
Q162	8-729-101-07	TRANSISTOR 2SB798-DL		R141	1-216-295-91	CONDUCTOR, CHIP (2012)	
Q163	8-729-905-12	TRANSISTOR DTA144EU		R142	1-216-073-00	METAL CHIP 10K 5%	1/10W
Q164	8-729-924-19	TRANSISTOR DTA123JU		R143	1-216-073-00	METAL CHIP 10K 5%	1/10W
Q181	8-729-018-75	TRANSISTOR 2SJ278MY		R144	1-216-025-91	METAL GLAZE 100 5%	1/10W
Q182	8-729-017-65	TRANSISTOR 2SK1764KY		R145	1-216-121-91	METAL GLAZE 1M 5%	1/10W
				R146	1-216-037-00	METAL CHIP 330 5%	1/10W
				R147	1-216-025-91	METAL GLAZE 100 5%	1/10W
				R148	1-216-045-00	METAL CHIP 680 5%	1/10W
				R150	1-216-295-91	CONDUCTOR, CHIP (2012)	
				R151	1-216-097-91	METAL GLAZE 100K 5%	1/10W
				R154	1-220-262-11	METAL GLAZE 680 5%	1/4W
				R155	1-220-262-11	METAL GLAZE 680 5%	1/4W
				R158	1-216-121-91	METAL GLAZE 1M 5%	1/10W
				R161	1-216-057-00	METAL CHIP 2.2K 5%	1/10W
				R162	1-216-057-00	METAL CHIP 2.2K 5%	1/10W
				R163	1-216-057-00	METAL CHIP 2.2K 5%	1/10W
				R164	1-216-045-00	METAL CHIP 680 5%	1/10W
				R165	1-216-097-91	METAL GLAZE 100K 5%	1/10W
				R166	1-220-250-11	METAL GLAZE 10 5%	1/2W

*** NOTE**

For replacement of IC121 and IC171 on the BD board, refer to the service note on page 6.

BD (MD)

DETECTION SW

DIGITAL

Ref. No.	Part No.	Description	Remark	Ref. No.	Part No.	Description	Remark
R167	1-216-065-00	METAL CHIP	4.7K 5% 1/10W	C213	1-163-235-11	CERAMIC CHIP	22PF 5% 50V
R169	1-219-724-11	METAL CHIP	1 1% 1/4W	C214	1-163-235-11	CERAMIC CHIP	22PF 5% 50V
R170	1-216-073-00	METAL CHIP	10K 5% 1/10W	C251	1-163-038-91	CERAMIC CHIP	0.1uF 25V
R171	1-216-073-00	METAL CHIP	10K 5% 1/10W	C271	1-126-395-11	ELECT	22uF 20% 16V
R172	1-216-065-00	METAL CHIP	4.7K 5% 1/10W	C272	1-163-038-91	CERAMIC CHIP	0.1uF 25V
R174	1-216-065-00	METAL CHIP	4.7K 5% 1/10W	C273	1-163-038-91	CERAMIC CHIP	0.1uF 25V
R176	1-216-065-00	METAL CHIP	4.7K 5% 1/10W	C274	1-126-395-11	ELECT	22uF 20% 16V
R178	1-216-065-00	METAL CHIP	4.7K 5% 1/10W	C277	1-163-031-11	CERAMIC CHIP	0.01uF 50V
R181	1-216-073-00	METAL CHIP	10K 5% 1/10W	C280	1-163-038-91	CERAMIC CHIP	0.1uF 25V
R182	1-216-089-91	METAL GLAZE	47K 5% 1/10W	C283	1-163-038-91	CERAMIC CHIP	0.1uF 25V
R183	1-216-089-91	METAL GLAZE	47K 5% 1/10W	C287	1-163-038-91	CERAMIC CHIP	0.1uF 25V
R186	1-216-134-00	METAL CHIP	2.2 5% 1/8W	C290	1-163-251-11	CERAMIC CHIP	100PF 5% 50V
R187	1-216-134-00	METAL CHIP	2.2 5% 1/8W	C291	1-163-251-11	CERAMIC CHIP	100PF 5% 50V
< VARIABLE RESISTOR >				C292	1-163-251-11	CERAMIC CHIP	100PF 5% 50V
RV101	1-241-396-11	RES, ADJ, METAL GLAZE	22K	C293	1-163-251-11	CERAMIC CHIP	100PF 5% 50V
RV102	1-241-396-11	RES, ADJ, METAL GLAZE	22K	C301	1-126-395-11	ELECT	22uF 20% 16V
< SWITCH >				C302	1-163-038-91	CERAMIC CHIP	0.1uF 25V
S101	1-572-467-41	SWITCH, PUSH (1 KEY) (MD LIMIT)		C303	1-163-038-91	CERAMIC CHIP	0.1uF 25V
*****				C304	1-163-017-00	CERAMIC CHIP	0.0047uF 5% 50V
*	1-653-411-11	DETECTION SW BOARD		C305	1-163-017-00	CERAMIC CHIP	0.0047uF 5% 50V
*****				C306	1-163-017-00	CERAMIC CHIP	0.0047uF 5% 50V
< CONNECTOR >				C307	1-163-017-00	CERAMIC CHIP	0.0047uF 5% 50V
CN193	1-770-010-21	CONNECTOR, BOARD TO BOARD	4P	C308	1-126-395-11	ELECT	22uF 20% 16V
< SWITCH >				C309	1-163-038-91	CERAMIC CHIP	0.1uF 25V
S191	1-762-149-11	SWITCH, PUSH (1 KEY) (MD LOAD OUT DET)		C310	1-126-395-11	ELECT	22uF 20% 16V
S192	1-762-149-11	SWITCH, PUSH (1 KEY) (MD LOAD IN DET)		C311	1-163-038-91	CERAMIC CHIP	0.1uF 25V
S193	1-762-149-11	SWITCH, PUSH (1 KEY) (MD CHUCKING IN DET)		C313	1-163-227-11	CERAMIC CHIP	10PF 0.5PF 50V
*****				C314	1-163-227-11	CERAMIC CHIP	10PF 0.5PF 50V
*	A-4699-436-A	DIGITAL BOARD, COMPLETE (AEP, G, UK, SP)		C315	1-163-038-91	CERAMIC CHIP	0.1uF 25V
*****				C317	1-126-395-11	ELECT	22uF 20% 16V
*	A-4699-072-A	DIGITAL BOARD, COMPLETE (US, CND)		C318	1-126-395-11	ELECT	22uF 20% 16V
*****				C319	1-126-395-11	ELECT	22uF 20% 16V
< CAPACITOR >				C320	1-126-395-11	ELECT	22uF 20% 16V
C201	1-163-009-11	CERAMIC CHIP	0.001uF 10% 50V	C321	1-163-038-91	CERAMIC CHIP	0.1uF 25V
C203	1-163-133-00	CERAMIC CHIP	470PF 5% 50V	C322	1-163-038-91	CERAMIC CHIP	0.1uF 25V
C204	1-163-017-00	CERAMIC CHIP	0.0047uF 5% 50V	C323	1-126-395-11	ELECT	22uF 20% 16V
C206	1-163-038-91	CERAMIC CHIP	0.1uF 25V	C324	1-126-395-11	ELECT	22uF 20% 16V
C207	1-163-251-11	CERAMIC CHIP	100PF 5% 50V	C325	1-163-125-00	CERAMIC CHIP	220PF 5% 50V
C208	1-163-251-11	CERAMIC CHIP	100PF 5% 50V	C326	1-163-125-00	CERAMIC CHIP	220PF 5% 50V
C211	1-163-038-91	CERAMIC CHIP	0.1uF 25V	C327	1-163-001-11	CERAMIC CHIP	220PF 10% 50V
C212	1-126-395-11	ELECT	22uF 20% 16V	C328	1-163-001-11	CERAMIC CHIP	220PF 10% 50V
C330	1-163-038-91	CERAMIC CHIP	0.1uF 25V	C329	1-126-395-11	ELECT	22uF 20% 16V
C335	1-163-038-91	CERAMIC CHIP	0.1uF 25V	C330	1-163-038-91	CERAMIC CHIP	0.1uF 25V
C336	1-163-038-91	CERAMIC CHIP	0.1uF 25V	C335	1-163-038-91	CERAMIC CHIP	0.1uF 25V
C341	1-126-395-11	ELECT	22uF 20% 16V	C336	1-163-038-91	CERAMIC CHIP	0.1uF 25V
C342	1-163-038-91	CERAMIC CHIP	0.1uF 25V	C341	1-126-395-11	ELECT	22uF 20% 16V
C343	1-163-038-91	CERAMIC CHIP	0.1uF 25V	C342	1-163-038-91	CERAMIC CHIP	0.1uF 25V
C345	1-163-227-11	CERAMIC CHIP	10PF 0.5PF 50V	C343	1-163-038-91	CERAMIC CHIP	0.1uF 25V
C346	1-163-227-11	CERAMIC CHIP	10PF 0.5PF 50V	C345	1-163-227-11	CERAMIC CHIP	10PF 0.5PF 50V

Ref. No.	Part No.	Description	Remark	Ref. No.	Part No.	Description	Remark
C347	1-126-395-11	ELECT	22uF 20%	16V	C473	1-163-038-91	CERAMIC CHIP 0.1uF 25V
C348	1-163-038-91	CERAMIC CHIP	0.1uF	25V	C474	1-163-038-91	CERAMIC CHIP 0.1uF 25V
C349	1-126-395-11	ELECT	22uF 20%	16V	C478	1-163-227-91	CERAMIC CHIP 10PF 0.5PF 50V
C350	1-163-038-91	CERAMIC CHIP	0.1uF	25V	C1003	1-163-038-91	CERAMIC CHIP 0.1uF 25V
C351	1-126-395-11	ELECT	22uF 20%	16V	< CONNECTOR >		
C352	1-163-038-91	CERAMIC CHIP	0.1uF	25V	CN201	1-778-691-11	CONNECTOR (FFC) 19P
C353	1-163-038-91	CERAMIC CHIP	0.1uF	25V	CN202	1-778-691-11	CONNECTOR (FFC) 19P
C356	1-163-113-00	CERAMIC CHIP	68PF 5%	50V	CN211	1-766-509-21	CONNECTOR, FFC/FPC 18P
C357	1-163-113-00	CERAMIC CHIP	68PF 5%	50V	CN212	1-766-510-21	CONNECTOR, FFC/FPC 30P
C358	1-163-239-11	CERAMIC CHIP	33PF 5%	50V	CN221	1-778-692-11	CONNECTOR (FFC) 21P
C359	1-163-239-11	CERAMIC CHIP	33PF 5%	50V	CN222	1-778-692-11	CONNECTOR (FFC) 21P
C360	1-163-038-91	CERAMIC CHIP	0.1uF	25V	CN231	1-770-072-11	CONNECTOR, FFC 23P
C361	1-163-038-91	CERAMIC CHIP	0.1uF	25V	CN241	1-778-315-11	PIN, CONNECTOR (PC BOARD) 5P
C362	1-163-239-11	CERAMIC CHIP	33PF 5%	50V	* CN251	1-770-154-11	PIN, CONNECTOR (PC BOARD) 6P
C363	1-163-239-11	CERAMIC CHIP	33PF 5%	50V	< DIODE >		
C364	1-163-229-11	CERAMIC CHIP	12PF 5%	50V	D201	8-719-016-74	DIODE 1SS352
C365	1-163-229-11	CERAMIC CHIP	12PF 5%	50V	D202	8-719-987-63	DIODE 1N4148M
C368	1-163-038-91	CERAMIC CHIP	0.1uF	25V	D301	8-719-800-76	DIODE 1SS226
C371	1-163-038-91	CERAMIC CHIP	0.1uF	25V	D302	8-719-800-76	DIODE 1SS226
C372	1-163-038-91	CERAMIC CHIP	0.1uF	25V	< FERRITE BEAD >		
C373	1-126-395-11	ELECT	22uF 20%	16V	FB201	1-216-295-91	CONDUCTOR, CHIP (2012)
C374	1-126-395-11	ELECT	22uF 20%	16V	FB274	1-216-295-91	CONDUCTOR, CHIP (2012)
C375	1-163-038-91	CERAMIC CHIP	0.1uF	25V	FB342	1-216-295-91	CONDUCTOR, CHIP (2012)
C376	1-126-395-11	ELECT	22uF 20%	16V	FB999	1-216-295-91	CONDUCTOR, CHIP (2012)
C377	1-163-038-91	CERAMIC CHIP	0.1uF	25V	< IC >		
C378	1-163-038-91	CERAMIC CHIP	0.1uF	25V	IC201	8-759-425-97	IC RU8X11AMF-0102
C380	1-163-038-91	CERAMIC CHIP	0.1uF	25V	IC251	8-759-430-24	IC CXD8640Q
C381	1-163-038-91	CERAMIC CHIP	0.1uF	25V	IC271	8-752-371-17	IC CXD2536R
C382	1-163-239-11	CERAMIC CHIP	33PF 5%	50V	IC272	8-759-329-31	IC MSM514400CSJADR1-K
C383	1-163-239-11	CERAMIC CHIP	33PF 5%	50V	IC291	8-759-187-04	IC TC74HC365AF-TP1
C384	1-163-239-11	CERAMIC CHIP	33PF 5%	50V	IC301	8-759-352-63	IC CXD8566M
C385	1-163-239-11	CERAMIC CHIP	33PF 5%	50V	IC302	8-759-352-59	IC CXA8054M
C386	1-163-113-00	CERAMIC CHIP	68PF 5%	50V	IC341	8-759-362-47	IC CXD8567AM
C387	1-163-113-00	CERAMIC CHIP	68PF 5%	50V	IC342	8-759-981-48	IC TL082M
C388	1-163-227-11	CERAMIC CHIP	10PF 0.5PF	50V	IC371	8-759-362-47	IC CXD8567AM
C389	1-163-009-11	CERAMIC CHIP	0.001uF 10%	50V	IC372	8-759-242-70	IC TC7WU04F
C394	1-126-395-11	ELECT	22uF 20%	16V	IC381	8-759-981-48	IC TL082M
C395	1-163-038-91	CERAMIC CHIP	0.1uF	25V	IC401	8-759-295-09	IC TLC2932IPW
C396	1-163-038-91	CERAMIC CHIP	0.1uF	25V	IC411	8-759-032-01	IC MC74HC00AF
C398	1-126-395-11	ELECT	22uF 20%	16V	IC431	8-759-040-83	IC BA6287F
C399	1-163-038-91	CERAMIC CHIP	0.1uF	25V	IC441	8-759-040-83	IC BA6287F
C402	1-163-038-91	CERAMIC CHIP	0.1uF	25V	IC1001	8-759-187-04	IC TC74HC365AF-TP1
C403	1-163-037-11	CERAMIC CHIP	0.022uF 10%	25V	< COIL >		
C404	1-164-346-91	CERAMIC CHIP	1uF	16V	L271	1-412-336-41	INDUCTOR 4.7uH
C406	1-163-038-91	CERAMIC CHIP	0.1uF	25V	L301	1-412-336-41	INDUCTOR 4.7uH
C411	1-163-038-91	CERAMIC CHIP	0.1uF	25V			
C431	1-163-038-91	CERAMIC CHIP	0.1uF	25V			
C441	1-163-038-91	CERAMIC CHIP	0.1uF	25V			
C471	1-163-038-91	CERAMIC CHIP	0.1uF	25V			
C472	1-163-038-91	CERAMIC CHIP	0.1uF	25V			

Ref. No.	Part No.	Description	Remark	Ref. No.	Part No.	Description	Remark
L341	1-412-336-41	INDUCTOR	4. 7uH	R249	1-216-073-00	METAL CHIP	10K 5% 1/10W
L343	1-412-336-41	INDUCTOR	4. 7uH	R250	1-216-073-00	METAL CHIP	10K 5% 1/10W
L345	1-412-336-41	INDUCTOR	4. 7uH	R251	1-216-073-00	METAL CHIP	10K 5% 1/10W
L370	1-412-336-41	INDUCTOR	4. 7uH	R252	1-216-025-91	METAL GLAZE	100 5% 1/10W
L371	1-412-336-41	INDUCTOR	4. 7uH	R253	1-216-073-00	METAL CHIP	10K 5% 1/10W
L391	1-412-336-41	INDUCTOR	4. 7uH	R254	1-216-295-91	CONDUCTOR, CHIP (2012)	
L401	1-412-336-41	INDUCTOR	4. 7uH	R255	1-216-295-91	CONDUCTOR, CHIP (2012)	
L402	1-412-336-41	INDUCTOR	4. 7uH	R256	1-216-295-91	CONDUCTOR, CHIP (2012)	
< RESISTOR >				R260	1-216-073-00	METAL CHIP	10K 5% 1/10W
R202	1-216-073-00	METAL CHIP	10K 5% 1/10W	R261	1-216-073-00	METAL CHIP	10K 5% 1/10W
R203	1-216-073-00	METAL CHIP	10K 5% 1/10W	R271	1-216-097-91	METAL GLAZE	100K 5% 1/10W
R204	1-216-073-00	METAL CHIP	10K 5% 1/10W	R272	1-216-097-91	METAL GLAZE	100K 5% 1/10W
R205	1-216-073-00	METAL CHIP	10K 5% 1/10W	R273	1-216-097-91	METAL GLAZE	100K 5% 1/10W
R206	1-216-073-00	METAL CHIP	10K 5% 1/10W	R274	1-216-097-91	METAL GLAZE	100K 5% 1/10W
R207	1-216-097-91	METAL GLAZE	100K 5% 1/10W	R275	1-216-097-91	METAL GLAZE	100K 5% 1/10W
R208	1-216-097-91	METAL GLAZE	100K 5% 1/10W	R276	1-216-295-91	CONDUCTOR, CHIP (2012)	
R209	1-216-097-91	METAL GLAZE	100K 5% 1/10W	R278	1-216-295-91	CONDUCTOR, CHIP (2012)	
R211	1-216-097-91	METAL GLAZE	100K 5% 1/10W	R279	1-216-033-00	METAL CHIP	220 5% 1/10W
R212	1-216-097-91	METAL GLAZE	100K 5% 1/10W	R280	1-216-033-00	METAL CHIP	220 5% 1/10W
R215	1-216-121-91	METAL GLAZE	1M 5% 1/10W	R282	1-216-041-00	METAL CHIP	470 5% 1/10W
R219	1-216-073-00	METAL CHIP	10K 5% 1/10W	R284	1-216-295-91	CONDUCTOR, CHIP (2012)	
R220	1-216-097-91	METAL GLAZE	100K 5% 1/10W	R285	1-216-295-91	CONDUCTOR, CHIP (2012)	
R221	1-216-097-91	METAL GLAZE	100K 5% 1/10W	R301	1-216-017-91	METAL GLAZE	47 5% 1/10W
R222	1-216-073-00	METAL CHIP	10K 5% 1/10W	R302	1-216-033-00	METAL CHIP	220 5% 1/10W
R223	1-216-097-91	METAL GLAZE	100K 5% 1/10W	R303	1-216-017-91	METAL GLAZE	47 5% 1/10W
R224	1-216-097-91	METAL GLAZE	100K 5% 1/10W	R304	1-216-017-91	METAL GLAZE	47 5% 1/10W
R226	1-216-073-00	METAL CHIP	10K 5% 1/10W	R305	1-216-057-00	METAL CHIP	2. 2K 5% 1/10W
R227	1-216-097-91	METAL GLAZE	100K 5% 1/10W	R306	1-216-057-00	METAL CHIP	2. 2K 5% 1/10W
R228	1-216-097-91	METAL GLAZE	100K 5% 1/10W	R307	1-216-065-00	METAL CHIP	4. 7K 5% 1/10W
R229	1-216-097-91	METAL GLAZE	100K 5% 1/10W	R308	1-216-065-00	METAL CHIP	4. 7K 5% 1/10W
R230	1-216-097-91	METAL GLAZE	100K 5% 1/10W	R326	1-216-025-91	METAL GLAZE	100 5% 1/10W
R231	1-216-097-91	METAL GLAZE	100K 5% 1/10W	R341	1-216-025-91	METAL GLAZE	100 5% 1/10W
R232	1-216-097-91	METAL GLAZE	100K 5% 1/10W	R342	1-216-687-11	METAL CHIP	33K 0. 5% 1/10W
R233	1-216-097-91	METAL GLAZE	100K 5% 1/10W	R343	1-216-687-11	METAL CHIP	33K 0. 5% 1/10W
R234	1-216-097-91	METAL GLAZE	100K 5% 1/10W	R344	1-216-687-11	METAL CHIP	33K 0. 5% 1/10W
R235	1-216-097-91	METAL GLAZE	100K 5% 1/10W	R345	1-216-687-11	METAL CHIP	33K 0. 5% 1/10W
R236	1-216-073-00	METAL CHIP	10K 5% 1/10W	R346	1-208-814-11	METAL CHIP	22K 0. 50% 1/10W
R237	1-216-097-91	METAL GLAZE	100K 5% 1/10W	R347	1-208-814-11	METAL CHIP	22K 0. 50% 1/10W
R238	1-216-097-91	METAL GLAZE	100K 5% 1/10W	R348	1-208-814-11	METAL CHIP	22K 0. 50% 1/10W
R239	1-216-073-00	METAL CHIP	10K 5% 1/10W	R349	1-208-814-11	METAL CHIP	22K 0. 50% 1/10W
R240	1-216-073-00	METAL CHIP	10K 5% 1/10W	R350	1-216-695-11	METAL CHIP	68K 0. 5% 1/10W
R241	1-216-073-00	METAL CHIP	10K 5% 1/10W	R351	1-216-695-11	METAL CHIP	68K 0. 5% 1/10W
R242	1-216-097-91	METAL GLAZE	100K 5% 1/10W	R352	1-216-695-11	METAL CHIP	68K 0. 5% 1/10W
R243	1-216-073-00	METAL CHIP	10K 5% 1/10W	R353	1-216-695-11	METAL CHIP	68K 0. 5% 1/10W
R244	1-216-073-00	METAL CHIP	10K 5% 1/10W	R354	1-216-295-91	CONDUCTOR, CHIP (2012)	
R245	1-216-025-91	METAL GLAZE	100 5% 1/10W	R356	1-216-121-91	METAL GLAZE	1M 5% 1/10W
R246	1-216-073-00	METAL CHIP	10K 5% 1/10W	R357	1-216-039-00	METAL CHIP	390 5% 1/10W
R247	1-216-065-00	METAL CHIP	4. 7K 5% 1/10W	R371	1-216-033-00	METAL CHIP	220 5% 1/10W
R248	1-216-097-91	METAL GLAZE	100K 5% 1/10W	R372	1-216-033-00	METAL CHIP	220 5% 1/10W
				R374	1-216-295-91	CONDUCTOR, CHIP (2012)	

DIGITAL **DISPLAY**

Ref. No.	Part No.	Description	Remark	Ref. No.	Part No.	Description	Remark
R379	1-414-235-11	INDUCTOR, FERRITE BEAD		C704	1-162-282-31	CERAMIC	100PF 10% 50V
R380	1-216-695-11	METAL CHIP	68K 0.5% 1/10W	C705	1-162-282-31	CERAMIC	100PF 10% 50V
R381	1-216-695-11	METAL CHIP	68K 0.5% 1/10W	C706	1-162-282-31	CERAMIC	100PF 10% 50V
R382	1-216-695-11	METAL CHIP	68K 0.5% 1/10W	C709	1-162-292-31	CERAMIC	680PF 10% 50V
R383	1-216-695-11	METAL CHIP	68K 0.5% 1/10W	C710	1-162-292-31	CERAMIC	680PF 10% 50V
R384	1-208-814-11	METAL CHIP	22K 0.50% 1/10W	C711	1-162-292-31	CERAMIC	680PF 10% 50V
R385	1-208-814-11	METAL CHIP	22K 0.50% 1/10W	C712	1-162-292-31	CERAMIC	680PF 10% 50V
R386	1-208-814-11	METAL CHIP	22K 0.50% 1/10W	C713	1-162-292-31	CERAMIC	680PF 10% 50V
R387	1-208-814-11	METAL CHIP	22K 0.50% 1/10W	C714	1-162-292-31	CERAMIC	680PF 10% 50V
R388	1-216-687-11	METAL CHIP	33K 0.5% 1/10W	C715	1-162-292-31	CERAMIC	680PF 10% 50V
R389	1-216-687-11	METAL CHIP	33K 0.5% 1/10W	C716	1-162-292-31	CERAMIC	680PF 10% 50V
R390	1-216-687-11	METAL CHIP	33K 0.5% 1/10W	C717	1-162-292-31	CERAMIC	680PF 10% 50V
R391	1-216-687-11	METAL CHIP	33K 0.5% 1/10W	C718	1-162-292-31	CERAMIC	680PF 10% 50V
R398	1-216-295-91	CONDUCTOR, CHIP (2012)		C719	1-162-292-31	CERAMIC	680PF 10% 50V
R399	1-216-295-91	CONDUCTOR, CHIP (2012)		C720	1-162-292-31	CERAMIC	680PF 10% 50V
R401	1-216-060-00	METAL GLAZE	3K 5% 1/10W	C721	1-162-292-31	CERAMIC	680PF 10% 50V
R403	1-216-655-11	METAL CHIP	1.5K 0.5% 1/10W	C722	1-162-292-31	CERAMIC	680PF 10% 50V
R404	1-208-810-11	METAL CHIP	15K 0.50% 1/10W	C723	1-162-292-31	CERAMIC	680PF 10% 50V
R405	1-216-659-11	METAL CHIP	2.2K 0.5% 1/10W	C724	1-164-159-11	CERAMIC	0.1uF 50V
R406	1-216-049-91	METAL GLAZE	1K 5% 1/10W	C725	1-126-154-11	ELECT	47uF 20% 6.3V
R431	1-216-021-00	METAL CHIP	68 5% 1/10W	C726	1-164-159-11	CERAMIC	0.1uF 50V
R432	1-216-021-00	METAL CHIP	68 5% 1/10W	C727	1-164-159-11	CERAMIC	0.1uF 50V
R441	1-216-021-00	METAL CHIP	68 5% 1/10W	C729	1-164-159-11	CERAMIC	0.1uF 50V
R442	1-216-021-00	METAL CHIP	68 5% 1/10W	C731	1-162-282-31	CERAMIC	100PF 10% 50V
R470	1-216-295-91	CONDUCTOR, CHIP (2012)		C732	1-162-282-31	CERAMIC	100PF 10% 50V
R1005	1-216-295-91	CONDUCTOR, CHIP (2012)		C857	1-126-786-11	ELECT	47uF 20% 16V
R1006	1-216-073-00	METAL CHIP	10K 5% 1/10W	C858	1-126-786-11	ELECT	47uF 20% 16V
R1012	1-216-073-00	METAL CHIP	10K 5% 1/10W	C859	1-162-306-11	CERAMIC	0.01uF 30% 16V
R1014	1-216-097-91	METAL GLAZE	100K 5% 1/10W	C860	1-162-306-11	CERAMIC	0.01uF 30% 16V
R1015	1-216-295-91	CONDUCTOR, CHIP (2012)		C865	1-162-306-11	CERAMIC	0.01uF 30% 16V
R1016	1-216-295-91	CONDUCTOR, CHIP (2012)		C866	1-162-306-11	CERAMIC	0.01uF 30% 16V
< VIBRATOR >				C873	1-126-786-11	ELECT	47uF 20% 16V
X201	1-760-902-11	VIBRATOR, CERAMIC (CHIP TYPE) (16MHz)		C874	1-126-786-11	ELECT	47uF 20% 16V
X202	1-760-872-11	VIBRATOR, CRYSTAL (32.768kHz)		C875	1-126-786-11	ELECT	47uF 20% 16V
X203	1-767-229-11	OSCILLATOR, CRYSTAL (90MHz)		C876	1-126-786-11	ELECT	47uF 20% 16V
X204	1-767-151-11	VIBRATOR, CRYSTAL (22.579MHz)		C877	1-126-786-11	ELECT	47uF 20% 16V
*****				C878	1-126-786-11	ELECT	47uF 20% 16V
* A-4699-065-A DISPLAY BOARD, COMPLETE				C879	1-126-786-11	ELECT	47uF 20% 16V
*****				C880	1-126-786-11	ELECT	47uF 20% 16V
2-389-320-01 CUSHION				< CONNECTOR >			
* 4-956-134-01 HOLDER (FL TUBE)				CN701	1-770-167-11	CONNECTOR, FFC/FPC 19P	
* 4-983-189-01 HOLDER (LED-3)				CN702	1-770-167-11	CONNECTOR, FFC/FPC 19P	
* 4-983-190-01 HOLDER (LED-2)				< DIODE >			
< CAPACITOR >				D801	8-719-046-36	DIODE	SEL5921A-TP15 (CD)
C701	1-162-282-31	CERAMIC	100PF 10% 50V	D802	8-719-046-36	DIODE	SEL5921A-TP15 (LINE)
C702	1-162-282-31	CERAMIC	100PF 10% 50V	D803	8-719-046-36	DIODE	SEL5921A-TP15 (MIC)
C703	1-162-282-31	CERAMIC	100PF 10% 50V	D804	8-719-029-27	DIODE	SEL2210S-D-TP6S (CD-SYNC.)
				D805	8-719-029-27	DIODE	SEL2210S-D-TP6S (● REC)

DISPLAY

Ref. No.	Part No.	Description	Remark	Ref. No.	Part No.	Description	Remark
D806	8-719-029-27	DIODE SEL2210S-D-TP6S (REC PAUSE)		R721	1-249-441-11	CARBON 100K 5%	1/4W
D811	8-719-301-43	DIODE SEL2410E-C (CD)		R722	1-247-807-31	CARBON 100 5%	1/4W
D812	8-719-301-43	DIODE SEL2410E-C (CD)		R723	1-247-807-31	CARBON 100 5%	1/4W
D813	8-719-301-43	DIODE SEL2410E-C (MD)		R724	1-247-807-31	CARBON 100 5%	1/4W
D814	8-719-301-43	DIODE SEL2410E-C (MD)		R725	1-247-807-31	CARBON 100 5%	1/4W
< FLUORESCENT INDICATOR >				R726	1-247-807-31	CARBON 100 5%	1/4W
FL701	1-517-353-11	INDICATOR TUBE, FLUORESCENT		R727	1-247-807-31	CARBON 100 5%	1/4W
< IC >				R728	1-247-807-31	CARBON 100 5%	1/4W
IC701	8-759-425-98	IC M38197MA-145FP		R729	1-247-807-31	CARBON 100 5%	1/4W
IC851	8-759-634-51	IC M5218AP		R730	1-247-807-31	CARBON 100 5%	1/4W
IC852	8-759-634-51	IC M5218AP		R731	1-249-429-11	CARBON 10K 5%	1/4W
< TRANSISTOR >				R732	1-249-429-11	CARBON 10K 5%	1/4W
Q801	8-729-900-80	TRANSISTOR DTC114ES		R733	1-249-429-11	CARBON 10K 5%	1/4W
Q802	8-729-900-80	TRANSISTOR DTC114ES		R734	1-249-429-11	CARBON 10K 5%	1/4W
Q803	8-729-900-80	TRANSISTOR DTC114ES		R735	1-249-429-11	CARBON 10K 5%	1/4W
Q804	8-729-900-80	TRANSISTOR DTC114ES		R736	1-249-429-11	CARBON 10K 5%	1/4W
Q805	8-729-900-80	TRANSISTOR DTC114ES		R737	1-249-429-11	CARBON 10K 5%	1/4W
Q806	8-729-900-80	TRANSISTOR DTC114ES		R738	1-249-429-11	CARBON 10K 5%	1/4W
Q811	8-729-900-80	TRANSISTOR DTC114ES		R739	1-249-429-11	CARBON 10K 5%	1/4W
Q813	8-729-902-80	TRANSISTOR DTA114YS		R740	1-249-429-11	CARBON 10K 5%	1/4W
Q820	8-729-900-80	TRANSISTOR DTC114ES		R741	1-249-429-11	CARBON 10K 5%	1/4W
Q831	8-729-900-80	TRANSISTOR DTC114ES		R742	1-249-429-11	CARBON 10K 5%	1/4W
Q833	8-729-900-80	TRANSISTOR DTC114ES		R743	1-249-429-11	CARBON 10K 5%	1/4W
Q835	8-729-900-80	TRANSISTOR DTC114ES		R744	1-249-429-11	CARBON 10K 5%	1/4W
Q851	8-729-141-26	TRANSISTOR 2SC3622A-LK		R745	1-249-429-11	CARBON 10K 5%	1/4W
Q852	8-729-141-26	TRANSISTOR 2SC3622A-LK		R746	1-249-429-11	CARBON 10K 5%	1/4W
Q853	8-729-422-57	TRANSISTOR UN4111		R747	1-249-429-11	CARBON 10K 5%	1/4W
< RESISTOR >				R748	1-249-429-11	CARBON 10K 5%	1/4W
R701	1-247-807-31	CARBON 100 5%	1/4W	R751	1-249-429-11	CARBON 10K 5%	1/4W
R702	1-247-807-31	CARBON 100 5%	1/4W	R752	1-249-421-11	CARBON 2. 2K 5%	1/4W F
R703	1-247-807-31	CARBON 100 5%	1/4W	R753	1-247-843-11	CARBON 3. 3K 5%	1/4W
R704	1-247-807-31	CARBON 100 5%	1/4W	R754	1-249-425-11	CARBON 4. 7K 5%	1/4W F
R705	1-247-807-31	CARBON 100 5%	1/4W	R755	1-249-429-11	CARBON 10K 5%	1/4W
R706	1-249-441-11	CARBON 100K 5%	1/4W	R756	1-249-435-11	CARBON 33K 5%	1/4W
R708	1-247-807-31	CARBON 100 5%	1/4W	R761	1-249-429-11	CARBON 10K 5%	1/4W
R709	1-247-807-31	CARBON 100 5%	1/4W	R762	1-249-421-11	CARBON 2. 2K 5%	1/4W F
R710	1-247-807-31	CARBON 100 5%	1/4W	R763	1-247-843-11	CARBON 3. 3K 5%	1/4W
R711	1-247-807-31	CARBON 100 5%	1/4W	R764	1-249-425-11	CARBON 4. 7K 5%	1/4W F
R712	1-247-807-31	CARBON 100 5%	1/4W	R765	1-249-429-11	CARBON 10K 5%	1/4W
R713	1-247-807-31	CARBON 100 5%	1/4W	R766	1-249-435-11	CARBON 33K 5%	1/4W
R714	1-247-807-31	CARBON 100 5%	1/4W	R771	1-249-429-11	CARBON 10K 5%	1/4W
R715	1-247-807-31	CARBON 100 5%	1/4W	R772	1-249-421-11	CARBON 2. 2K 5%	1/4W F
R716	1-247-807-31	CARBON 100 5%	1/4W	R773	1-247-843-11	CARBON 3. 3K 5%	1/4W
R717	1-247-807-31	CARBON 100 5%	1/4W	R774	1-249-425-11	CARBON 4. 7K 5%	1/4W F
R718	1-247-807-31	CARBON 100 5%	1/4W	R775	1-249-429-11	CARBON 10K 5%	1/4W
R719	1-247-807-31	CARBON 100 5%	1/4W	R781	1-249-429-11	CARBON 10K 5%	1/4W
R720	1-249-441-11	CARBON 100K 5%	1/4W	R782	1-249-421-11	CARBON 2. 2K 5%	1/4W F
				R783	1-247-843-11	CARBON 3. 3K 5%	1/4W
				R784	1-249-425-11	CARBON 4. 7K 5%	1/4W F
				R785	1-249-429-11	CARBON 10K 5%	1/4W

DISPLAY

HEADPHONE

LOADING

Ref. No.	Part No.	Description	Remark
R791	1-249-429-11	CARBON	10K 5% 1/4W
R792	1-249-429-11	CARBON	10K 5% 1/4W
R793	1-247-807-31	CARBON	100 5% 1/4W
R794	1-247-807-31	CARBON	100 5% 1/4W
R795	1-247-807-31	CARBON	100 5% 1/4W
R796	1-249-429-11	CARBON	10K 5% 1/4W
R797	1-247-807-31	CARBON	100 5% 1/4W
R801	1-249-409-11	CARBON	220 5% 1/4W F
R802	1-249-409-11	CARBON	220 5% 1/4W F
R803	1-249-409-11	CARBON	220 5% 1/4W F
R804	1-249-415-11	CARBON	680 5% 1/4W F
R805	1-249-415-11	CARBON	680 5% 1/4W F
R806	1-249-415-11	CARBON	680 5% 1/4W F
R811	1-249-413-11	CARBON	470 5% 1/4W F
R812	1-249-413-11	CARBON	470 5% 1/4W F
R813	1-249-413-11	CARBON	470 5% 1/4W F
R814	1-249-413-11	CARBON	470 5% 1/4W F
R820	1-249-437-11	CARBON	47K 5% 1/4W
R831	1-249-441-11	CARBON	100K 5% 1/4W
R833	1-249-441-11	CARBON	100K 5% 1/4W
R835	1-249-441-11	CARBON	100K 5% 1/4W
R851	1-249-427-11	CARBON	6.8K 5% 1/4W F
R852	1-249-427-11	CARBON	6.8K 5% 1/4W F
R853	1-247-843-11	CARBON	3.3K 5% 1/4W
R854	1-247-843-11	CARBON	3.3K 5% 1/4W
R855	1-249-427-11	CARBON	6.8K 5% 1/4W F
R856	1-249-427-11	CARBON	6.8K 5% 1/4W F
R857	1-249-425-11	CARBON	4.7K 5% 1/4W F
R858	1-249-425-11	CARBON	4.7K 5% 1/4W F
R859	1-249-441-11	CARBON	100K 5% 1/4W
R860	1-249-441-11	CARBON	100K 5% 1/4W
R861	1-247-899-11	CARBON	680K 5% 1/4W
R862	1-247-899-11	CARBON	680K 5% 1/4W
R863	1-247-807-31	CARBON	100 5% 1/4W
< VARIABLE RESISTOR >			
RV851	1-223-762-11	RES, VAR, CARBON 20K/20K (MIX BALANCE)	
RV852	1-223-762-11	RES, VAR, CARBON 20K/20K (REC LEVEL)	
< SWITCH >			
S751	1-554-303-21	SWITCH, TACTILE (EDIT/NO)	
S752	1-554-303-21	SWITCH, TACTILE (YES)	
S753	1-554-303-21	SWITCH, TACTILE (MIC)	
S754	1-554-303-21	SWITCH, TACTILE (LINE)	
S755	1-554-303-21	SWITCH, TACTILE (CD)	
S756	1-554-303-21	SWITCH, TACTILE (△ EJECT)	
S761	1-554-303-21	SWITCH, TACTILE (REC PAUSE)	
S762	1-554-303-21	SWITCH, TACTILE (■)	
S763	1-554-303-21	SWITCH, TACTILE (◀◀)	
S764	1-554-303-21	SWITCH, TACTILE (▶▶)	

Ref. No.	Part No.	Description	Remark
S765	1-467-818-11	ENCODER, ROTARY (◀◀ AMS ▶▶)	
S766	1-554-303-21	SWITCH, TACTILE (MD)	
S771	1-554-303-21	SWITCH, TACTILE (CD-SYNC.)	
S772	1-554-303-21	SWITCH, TACTILE (● REC)	
S773	1-554-303-21	SWITCH, TACTILE (■)	
S774	1-554-303-21	SWITCH, TACTILE (▷)	
S775	1-554-303-21	SWITCH, TACTILE (CD)	
S781	1-554-303-21	SWITCH, TACTILE (SCROLL)	
S782	1-554-303-21	SWITCH, TACTILE (REPEAT)	
S783	1-554-303-21	SWITCH, TACTILE (PLAY MODE)	
S784	1-554-303-21	SWITCH, TACTILE (DISPLAY)	
< VIBRATOR >			
X701	1-767-163-11	VIBRATOR, CERAMIC (8MHz)	

* 1-661-675-11	HEADPHONE BOARD		

< CAPACITOR >			
C951	1-162-294-31	CERAMIC	0.001uF 10% 50V
C952	1-162-294-31	CERAMIC	0.001uF 10% 50V
C953	1-162-294-31	CERAMIC	0.001uF 10% 50V
C954	1-162-294-31	CERAMIC	0.001uF 10% 50V
C955	1-164-159-11	CERAMIC	0.1uF 50V
< JACK >			
J951	1-770-306-11	JACK (LARGE TYPE) (PHONES)	
< COIL >			
L953	1-412-473-21	INDUCTOR	0uH
< RESISTOR >			
R951	1-249-393-11	CARBON	10 5% 1/4W F
R952	1-249-393-11	CARBON	10 5% 1/4W F
< VARIABLE RESISTOR >			
RV951	1-225-302-11	RES, VAR, CARBON 1K/1K (PHONES LEVEL)	

* 1-645-721-11	LOADING BOARD		

< CONNECTOR >			
* CN151	1-568-943-11	PIN, CONNECTOR 5P	
< SWITCH >			
S151	1-572-086-11	SWITCH, LEAF (CD LOAD OUT)	

LOADING

MIC

MOTOR

POWER SWITCH

Ref. No.	Part No.	Description	Remark
S152	1-572-086-11	SWITCH, LEAF (CD LOAD IN)	

*	A-4699-069-A	MIC BOARD, COMPLETE (AEP, G, UK, SP)	

*	A-4699-070-A	MIC BOARD, COMPLETE (US, CND)	

		< CAPACITOR >	
C903	1-115-871-91	ELECT 1uF 20% 50V	
C904	1-115-871-91	ELECT 1uF 20% 50V	
C905	1-162-294-31	CERAMIC 0.001uF 10% 50V	
C906	1-162-294-31	CERAMIC 0.001uF 10% 50V	
C907	1-162-282-31	CERAMIC 100PF 10% 50V	
C908	1-162-282-31	CERAMIC 100PF 10% 50V	
C909	1-162-294-31	CERAMIC 0.001uF 10% 50V	
C910	1-162-294-31	CERAMIC 0.001uF 10% 50V	
C911	1-115-871-91	ELECT 1uF 20% 50V	
C912	1-115-871-91	ELECT 1uF 20% 50V	
C913	1-162-306-11	CERAMIC 0.01uF 30% 16V	
C914	1-162-306-11	CERAMIC 0.01uF 30% 16V	
C921	1-162-294-31	CERAMIC 0.001uF 10% 50V	
C922	1-162-294-31	CERAMIC 0.001uF 10% 50V	
C923	1-162-306-11	CERAMIC 0.01uF 30% 16V	
		< IC >	
IC901	8-759-634-51	IC M5218AP	
		< JACK >	
J901	1-770-306-21	JACK (LARGE TYPE) (MIC)	
		< RESISTOR >	
R901	1-249-413-11	CARBON 470 5% 1/4W F	
R902	1-249-413-11	CARBON 470 5% 1/4W F	
R903	1-249-429-11	CARBON 10K 5% 1/4W	
R904	1-249-429-11	CARBON 10K 5% 1/4W	
R905	1-249-433-11	CARBON 22K 5% 1/4W	
R906	1-249-433-11	CARBON 22K 5% 1/4W	
R907	1-249-431-11	CARBON 15K 5% 1/4W	
R908	1-249-431-11	CARBON 15K 5% 1/4W	
R909	1-249-413-11	CARBON 470 5% 1/4W F	
R910	1-249-413-11	CARBON 470 5% 1/4W F	
R911	1-249-413-11	CARBON 470 5% 1/4W F	
R912	1-249-413-11	CARBON 470 5% 1/4W F	
R913	1-249-441-11	CARBON 100K 5% 1/4W	
R914	1-249-441-11	CARBON 100K 5% 1/4W	

Ref. No.	Part No.	Description	Remark
*	1-653-412-11	MOTOR BOARD	

		< CAPACITOR >	
C199	1-164-159-11	CERAMIC 0.1uF 50V	
		< CONNECTOR >	
* CN191	1-568-944-11	PIN, CONNECTOR 6P	
CN192	1-770-011-41	CONNECTOR, BOARD TO BOARD 4P	

*	1-661-674-11	POWER SWITCH BOARD	

*	4-972-608-01	HOLDER (DIA. 5), LED	
		< CAPACITOR >	
C728	1-162-306-11	CERAMIC 0.01uF 30% 16V	
C827	1-162-306-11	CERAMIC 0.01uF 30% 16V	
C828	1-126-513-11	ELECT 47uF 20% 6.3V	
		< DIODE >	
D821	8-719-313-40	DIODE SML1516W (ON/STANDBY)	
		< IC >	
IC827	8-759-332-18	IC GP1U27XB	
		< TRANSISTOR >	
Q821	8-729-900-80	TRANSISTOR DTC114ES	
Q823	8-729-422-57	TRANSISTOR UN4111	
		< RESISTOR >	
R786	1-249-435-11	CARBON 33K 5% 1/4W	
R798	1-249-437-11	CARBON 47K 5% 1/4W	
R821	1-249-411-11	CARBON 330 5% 1/4W	
R823	1-249-411-11	CARBON 330 5% 1/4W	
R827	1-247-807-31	CARBON 100 5% 1/4W	
		< SWITCH >	
S785	1-554-303-21	SWITCH, TACTILE (ON/STANDBY)	
S786	1-554-303-21	SWITCH, TACTILE (△ OPEN/CLOSE)	

Ref. No.	Part No.	Description	Remark
*	1-661-680-11	SW BOARD (AEP, G, UK) *****	
	1-769-745-11	LEAD (WITH CONNECTOR) (2 CORE) < CAPACITOR >	
△C1029	1-113-924-11	CERAMIC 4700PF 20% 250V < SWITCH >	
△S1011	1-692-664-11	SWITCH, AC POWER SEESAW (MAIN POWER)	

*	1-661-678-11	TRANS BOARD ***** < CAPACITOR >	
△C1001	1-113-924-11	CERAMIC 0.0047uF 20% 250V < CONNECTOR >	
	CN1001	1-564-523-11	PLUG, CONNECTOR 8P
*	CN1002	1-580-230-31	PIN, CONNECTOR (PC BOARD) 2P
	CN1011	1-564-321-00	PIN, CONNECTOR 2P (AEP, G, UK)
			< LINE FILTER >
△LF1001	1-424-485-11	FILTER, LINE < SWITCH >	
△S1001	1-572-675-11	SWITCH, POWER VOLTAGE CHANGE (SP) < TRANSFORMER >	
△TR1001	1-429-702-11	TRANSFORMER, POWER (US, CND)	
△TR1001	1-429-703-11	TRANSFORMER, POWER (AEP, G, UK)	
△TR1001	1-429-704-11	TRANSFORMER, POWER (SP)	

		MISCELLANEOUS *****	
26	1-777-239-11	WIRE (FLAT TYPE) (19 CORE)	
52	1-777-245-11	WIRE (FLAT TYPE) (30 CORE)	
53	1-777-244-11	WIRE (FLAT TYPE) (18 CORE)	
54	1-777-557-11	WIRE (FLAT TYPE) (23 CORE)	
58	1-777-240-11	WIRE (FLAT TYPE) (21 CORE)	
△61	1-558-945-21	CORD, POWER (POLAR. SPT-1) (US, CND)	
△61	1-575-651-21	CORD, POWER (AEP, G)	
△61	1-696-586-21	CORD, POWER (UK)	
△61	1-751-275-11	CORD, POWER (SP)	
△64	1-569-008-11	ADAPTOR, CONVERSION 2P (SP)	
△157	8-583-009-11	OPTICAL PICK-UP BLOCK KMS-210A/J-N (MD)	

Ref. No.	Part No.	Description	Remark
201	1-452-538-11	MAGNET	
△254	8-848-367-11	OPTICAL PICK-UP BLOCK KSS-213B/K-N (CD)	
257	1-769-069-11	WIRE (FLAT TYPE) (16 CORE)	
FL701	1-517-353-11	INDICATOR TUBE, FLUORESCENT	
HR901	1-500-304-21	HEAD, OVER LIGHT (RF322-74A)	
M101	A-4660-651-A	MOTOR (SLED) ASSY (MD)	
M102	A-4660-650-A	CHASSIS ASSY, BU (SPINDLE) (MD)	
M103	X-4917-523-3	MOTOR ASSY (SPINDLE) (CD)	
M104	X-4917-504-1	MOTOR ASSY (SLED) (CD)	
M151	A-4604-363-A	MOTOR (L) ASSY (LOADING) (CD)	
M191	A-4660-646-A	MOTOR (LOADING) ASSY (MD)	
S101	1-572-085-11	SWITCH, LEAF (CD LIMIT)	
S102	1-762-148-11	SWITCH, PUSH (2 KEY)	
△TR701	1-429-702-11	TRANSFORMER, POWER (US, CND)	
△TR701	1-429-703-11	TRANSFORMER, POWER (AEP, G, UK)	
△TR701	1-429-704-11	TRANSFORMER, POWER (SP)	

		ACCESSORIES & PACKING MATERIALS *****	
	1-473-761-11	REMOTE COMMANDER (RM-D11M)	
	1-558-271-11	CORD, CONNECTION (AUDIO connecting cable, 108cm) (US, CND, AEP, G, UK)	
	1-590-925-31	CORD, CONNECTION (AUDIO connecting cable, 100cm) (SP)	
	3-856-489-11	MANUAL, INSTRUCTION (ENGLISH, FRENCH, SPANISH, PORTUGUESE) (AEP, G, UK, SP)	
	3-856-489-21	MANUAL, INSTRUCTION (ENGLISH) (US)	
	3-856-489-31	MANUAL, INSTRUCTION (ENGLISH, FRENCH) (CND)	
	3-856-489-41	MANUAL, INSTRUCTION (GERMAN, DUTCH, SWEDISH, ITALIAN) (AEP, G)	
	3-856-489-51	MANUAL, INSTRUCTION (CHINESE) (SP)	
	4-983-537-01	COVER, BATTERY (For RM-D11M)	
*	4-984-971-01	CUSHION	
*	4-985-197-01	INDIVIDUAL CARTON	

		***** HARDWARE LIST *****	
#1	7-685-646-79	SCREW +BVTP 3X8 TYPE2 N-S	
#2	7-682-548-04	SCREW +B 3X8	
#3	7-685-647-79	SCREW +BVTP 3X10 TYPE2 N-S	
#4	7-685-871-01	SCREW +BVTT 3X6 (S)	
#5	7-685-104-19	SCREW +P 2X6 TYPE2 NON-SLIT	
#6	7-685-645-79	SCREW +BVTP 3X6 TYPE2 N-S	
#7	7-621-773-86	SCREW +BVTT 2.6X4 (S)	
#8	7-685-862-09	SCREW +BVTT 2.6X6 (S)	
#9	7-621-255-25	SCREW +PTT 2X4 (S)	
#10	7-621-775-20	SCREW +B 2.6X5	

<p>The components identified by mark △ or dotted line with mark △ are critical for safety. Replace only with part number specified.</p>	<p>Les composants identifiés par une marque △ sont critiques pour la sécurité. Ne les remplacer que par une pièce portant le numéro spécifié.</p>
---	---

MXD-D1

<u>Ref. No.</u>	<u>Part No.</u>	<u>Description</u>	<u>Remark</u>
#11	7-621-770-67	SCREW +PTT 2. 6X6 (S)	
#12	7-627-852-08	SCREW, PRECISION +P 1. 7X2. 5	
#13	7-685-105-19	TPG +P 2X8, TYPE 2, NON-SLIT	
#14	7-621-775-10	SCREW +B 2. 6X4	
#15	7-621-255-15	SCREW +P 2X3	
#16	7-685-134-19	SCREW +BTP 2. 6X8 TYPE2 N-S	

MXD-D1

SONY®

SERVICE MANUAL

US Model
Canadian Model
AEP Model
UK Model
E Model

SUPPLEMENT-1

File this supplement with the service manual.

**Subject : 1. CORRECTION
2. SERVICING NOTE
3. PARTS CHANGED
4. ADDITION OF COUNTERMEASURE BOARD
AND BOARD CHANGED**

(ECN-CD600977)

1. CORRECTION

 : Indicates corrected portion.

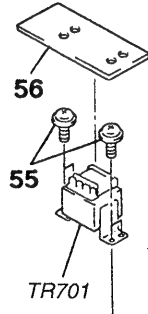
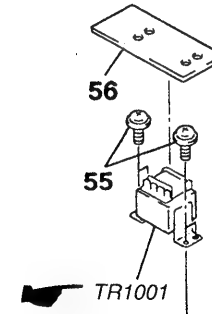
Page	INCORRECT				CORRECT			
	Ref. No.	Part No.	Description	Remark	Ref. No.	Part No.	Description	Remark
	*** EXPLODED VIEWS ***				*** EXPLODED VIEWS ***			
106	△ TR701	1-429-702-11	TRANSFORMER, POWER (US,CND)		△ TR1001	1-429-702-11	TRANSFORMER, POWER (US,CND)	
	△ TR701	1-429-703-11	TRANSFORMER, POWER (AEP,G,UK)		△ TR1001	1-429-703-11	TRANSFORMER, POWER (AEP,G,UK)	
	△ TR701	1-429-704-11	TRANSFORMER, POWER (SP)		△ TR1001	1-429-704-11	TRANSFORMER, POWER (SP)	
								
123	*** MISCELLANEOUS ***				*** MISCELLANEOUS ***			
	△ TR701	1-429-702-11	TRANSFORMER, POWER (US,CND)		△ TR1001	1-429-702-11	TRANSFORMER, POWER (US,CND)	
	△ TR701	1-429-703-11	TRANSFORMER, POWER (AEP,G,UK)		△ TR1001	1-429-703-11	TRANSFORMER, POWER (AEP,G,UK)	
	△ TR701	1-429-704-11	TRANSFORMER, POWER (SP)		△ TR1001	1-429-704-11	TRANSFORMER, POWER (SP)	

- Abbreviation
CND : Canadian model
G : German model
SP : Singapore model

The components identified by mark △ or dotted line with mark △ are critical for safety. Replace only with part number specified.

Les composants identifiés par une marque △ sont critiques pour la sécurité. Ne les remplacer que par une pièce portant le numéro spécifié.

2. SERVICING NOTE

FORCED RESET

The system microprocessor can be reset in the following way.

Use these methods when the unit cannot be operated normally due to the overrunning of the microprocessor, etc.

Method:

Disconnect the power plug, and short-circuit CN631 of the AUDIO board with a pair of tweezers, etc.

[AUDIO BOARD] (Component side)

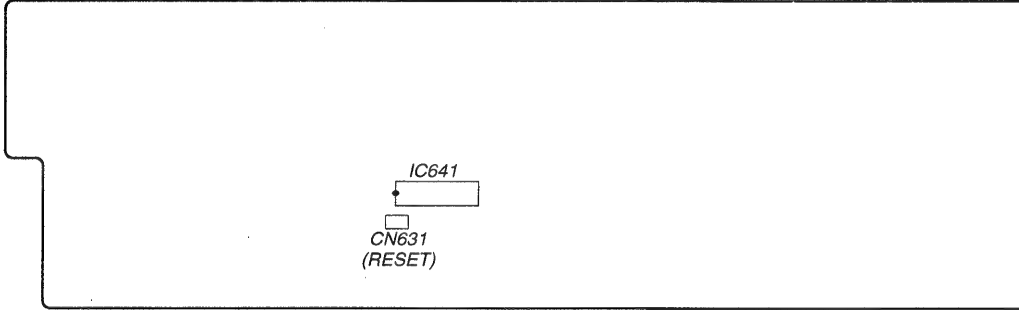

3. PARTS CHANGED

 : Indicates changed portion.

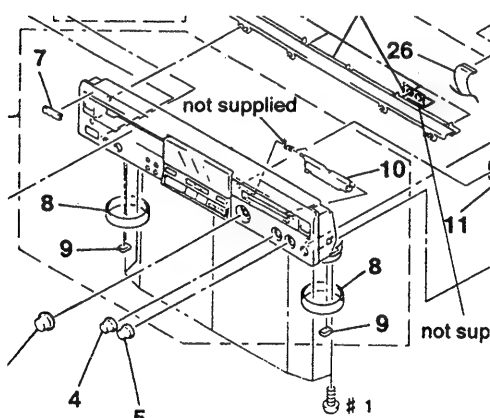
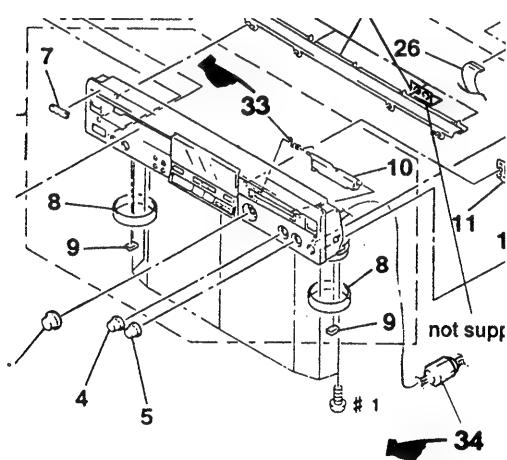
Page	FORMER				NEW			
	Ref. No.	Part No.	Description	Remark	Ref. No.	Part No.	Description	Remark
105	*** EXPLODED VIEWS ***				*** EXPLODED VIEWS ***			
					33	4-976-593-01	SPRING (LID), TORSION	
					34	1-500-051-11	BEAD, FERRITE (WITH CASE) (AEP,G,UK)	
								

- Abbreviation
G : German model

 : Indicates changed portion.

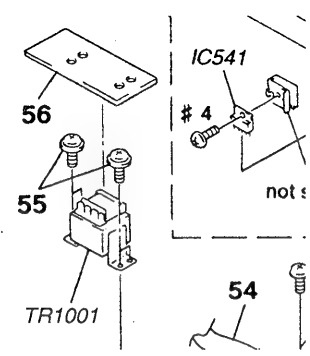
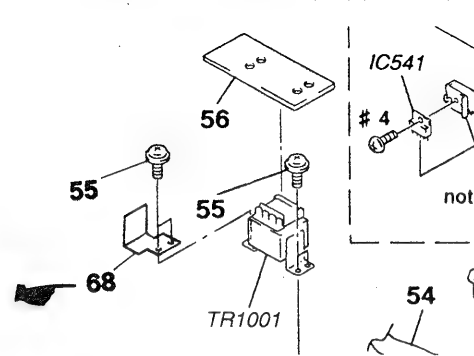
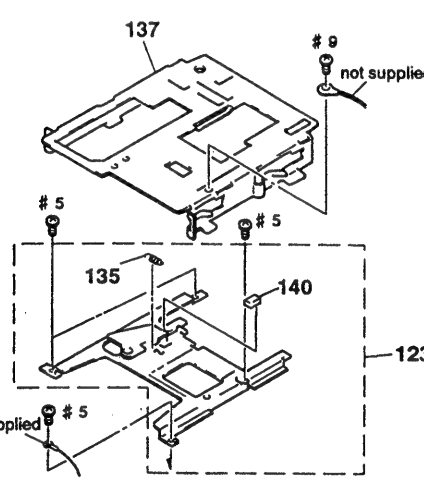
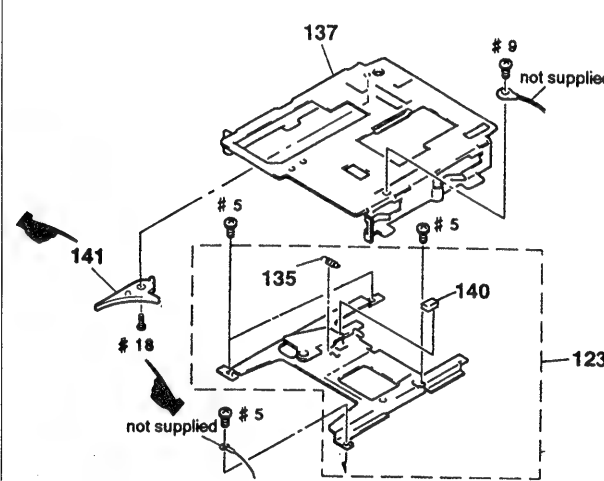
Page	FORMER				NEW			
	Ref. No.	Part No.	Description	Remark	Ref. No.	Part No.	Description	Remark
106					68	4-988-612-01	INSULATOR (SW) (AEP,G,UK)	
								
107					141	4-991-727-01	STOPPER (SLD)	
								
109	213	4-933-111-01	CHASSIS (MD)		213	4-933-111-41	CHASSIS (MD)	
123	<p>*** ACCESSORIES & PACKING MATERIALS ***</p> <p>*** HARDWARE LIST ***</p> <p>#7 7-621-773-86 SCREW +BVTT 2.6X4 (S)</p> <p>#9 7-621-255-25 SCREW +PTT 2X4 (S)</p>				<p>*** ACCESSORIES & PACKING MATERIALS ***</p> <p>1-690-863-11 CABLE, OPTICAL</p> <p>*** HARDWARE LIST ***</p> <p>#7 7-685-860-09 SCREW +BVTT 2.6X4 (S)</p> <p>#9 7-685-781-09 SCREW +PTT 2X4 (S)</p>			
124					#17	7-685-646-99	SCREW +BVTT 3X8 (B)	
					#18	7-685-850-04	SCREW +BVTT 2X3 (S)	

- Abbreviation
- G : German model

4. ADDITION OF COUNTERMEASURE BOARD AND BOARD CHANGED

Due to circuit changes made, the digital board with suffix No.- **11** described in the previous manual is not used in this unit. Consequently refer to this Supplement when repairing the digital board.

ADDITION OF COUNTERMEASURE BOARD

Some models of this unit have been incorporated with the countermeasure board.
The countermeasure board is not provided as a service part.

Countermeasure Board Electrical Parts List

Ref. No.	Part No.	Description	Remark
	Not supplied	*** COUNTERMEASURE BOARD ***	
		< CAPACITOR >	
C2001	1-163-038-91	CERAMIC (CHIP) 0.1uF	25V
C2002	1-163-038-91	CERAMIC (CHIP) 0.1uF	25V
		< DIODE >	
D2001	8-719-016-74	DIODE 1SS352	
		< IC >	
IC2001	8-759-926-07	IC SN74HC132ANS	
		< RESISTOR >	
R2001	1-216-049-91	METAL GLAZE 1K 5%	1/10W
R2002	1-216-113-00	METAL CHIP 470K 5%	1/10W

This countermeasure board is not required according to the version of the system control microprocessor (digital board, IC201). When replacing IC201 of the digital board, order the new type (RU8X11AMF-0107 (8-759-447-81)).

Digital board IC201 (System control microprocessor)		Countermeasure board
Former type	RU8X11AMF-0102	Used
New type	RU8X11AMF-0107	Not used
	⋮ wards	

How to distinguish the model of IC201 of the main board

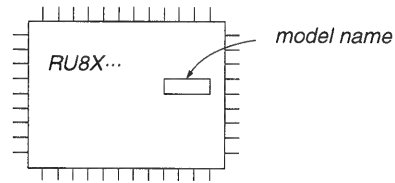

Note: When replaced with the new type microprocessor (RU8X11AMF-0107), the countermeasure board will no longer be required. But since the unit will operate normally even if it is attached, it is not necessary to remove it.

The mounted parts of the digital board differ according to whether the countermeasure board is incorporated or not. When servicing, refer to the following Table of Differences.

Table of Differences

Countermeasure Board Incorporated				Countermeasure Board Not Incorporated			
Ref. No.	Part No.	Description	Remark	Ref. No.	Part No.	Description	Remark
		*** DIGITAL BOARD ***				*** DIGITAL BOARD ***	
		< CONNECTOR >				< CONNECTOR >	
CN2003	1-750-491-31	PIN, CONNECTOR (PC BOARD) 3P				Not used	
CN2004	1-750-492-31	PIN, CONNECTOR (PC BOARD) 4P				Not used	
		< IC >				< IC >	
IC201	8-759-425-97	IC RU8X11AMF-0102		IC201	8-759-447-81	IC RU8X11AMF-0107	
		< RESISTOR >				< RESISTOR >	
		Not used		R1007	1-216-049-91	METAL GLAZE 1K 5% 1/10W	
		Not used		R2001	1-216-295-91	CONDUCTOR, CHIP (2012)	

Refer to the section of “BOARD CHANGED” (page 6) for the schematic diagram and Printed Wiring Board.

Note: If the countermeasure board does not function due to damage, etc, perform the following measures.

[DIGITAL BOARD] (Side B)

Location: C, 14 to 15

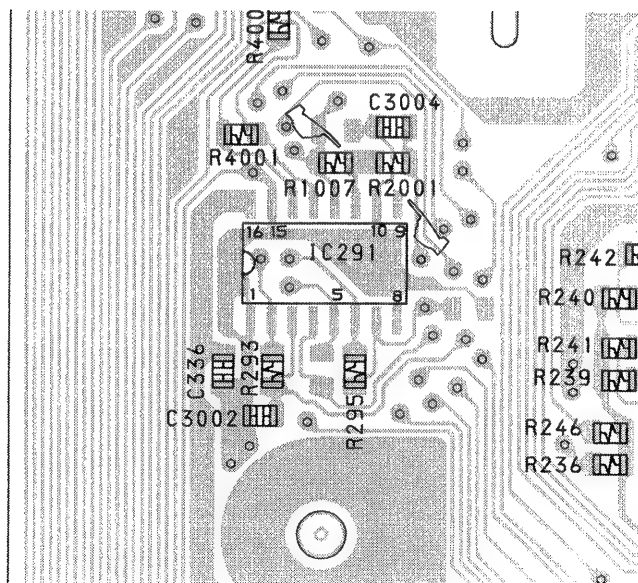

1. Remove the countermeasure board.
2. Mount R1007 and R2001 shown in the left figure. (↖)
3. Replace the system control microprocessor (digital board, IC201) with a new type.

BOARD CHANGED

PRINTED WIRING BOARD — DISPLAY SECTION —

• Semiconductor Location

Ref. No.	Location
D801	C-12
D802	B-12
D803	B-12
D804	C-6
D805	C-6
D806	C-7
D811	C-4
D812	C-4
D813	C-8
D814	C-9
D821	D-2
IC701	D-8
IC827	E-2
IC851	B-14
IC852	C-15
Q801	C-12
Q802	C-12
Q803	C-13
Q804	A-3
Q805	B-6
Q806	B-7
Q811	A-2
Q813	B-10
Q820	B-9
Q821	D-1
Q823	D-2
Q831	B-3
Q833	B-3
Q835	B-3
Q851	A-10
Q852	A-11
Q853	A-10

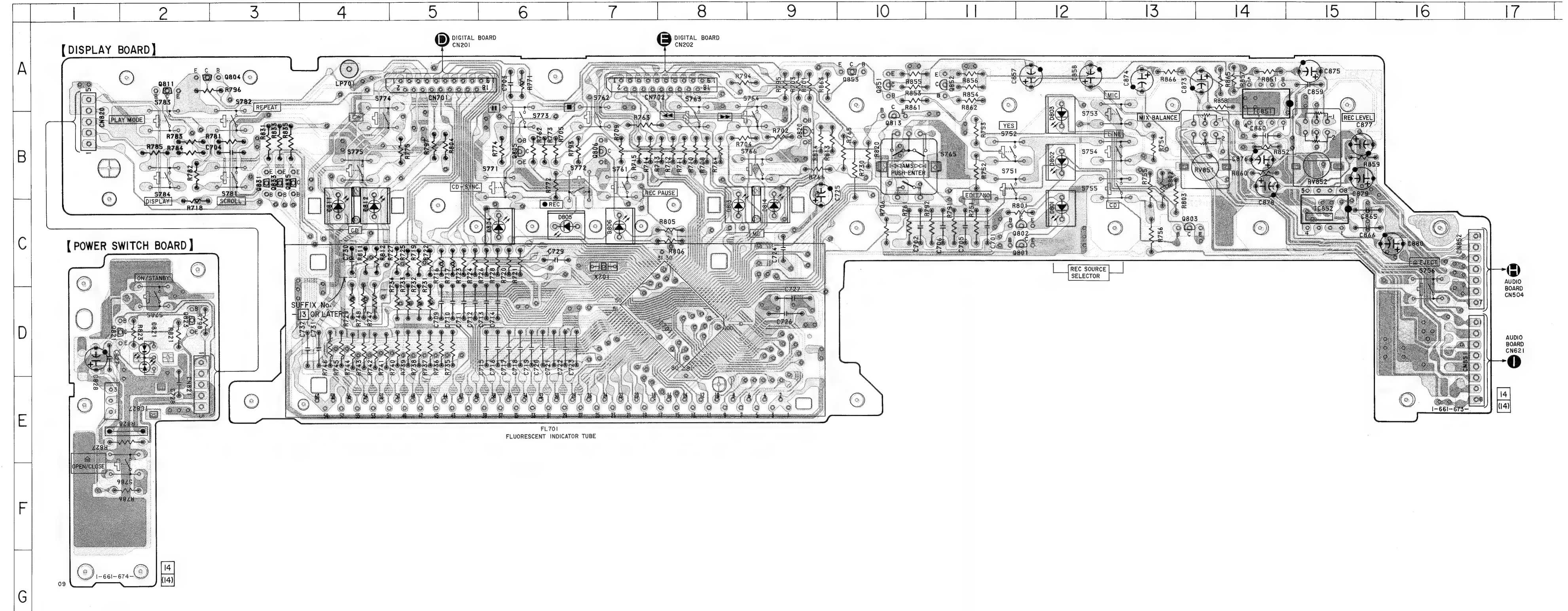

Note on Printed Wiring Boards:
Note:
 • — : parts extracted from the component side.
 • ○ : Through hole.
 • [Pattern] : Pattern of the rear side.
 • [Pattern] : Pattern from the side which enables seeing.

SCHEMATIC DIAGRAM — DISPLAY SECTION —

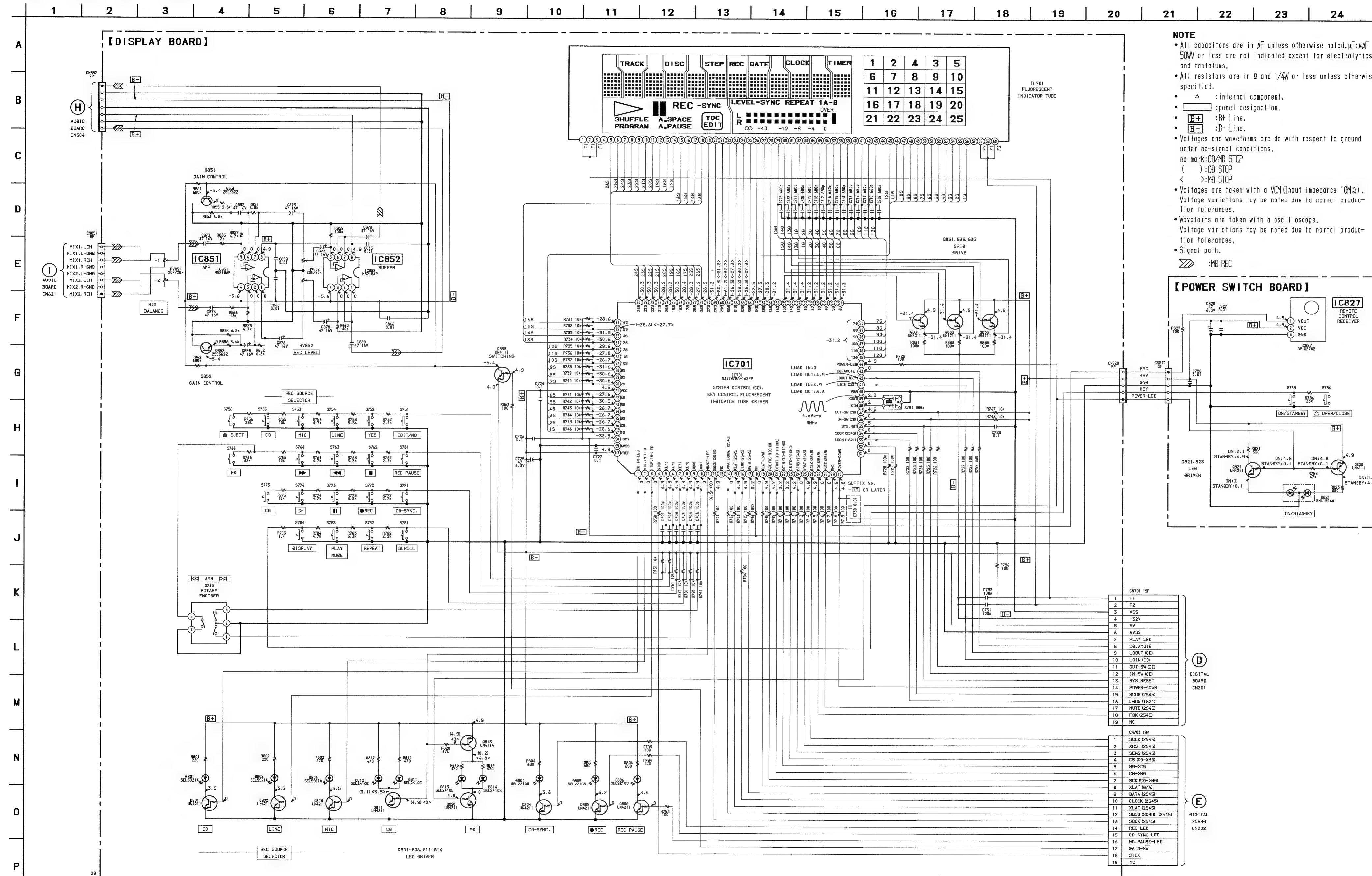

PRINTED WIRING BOARD — DIGITAL SECTION —

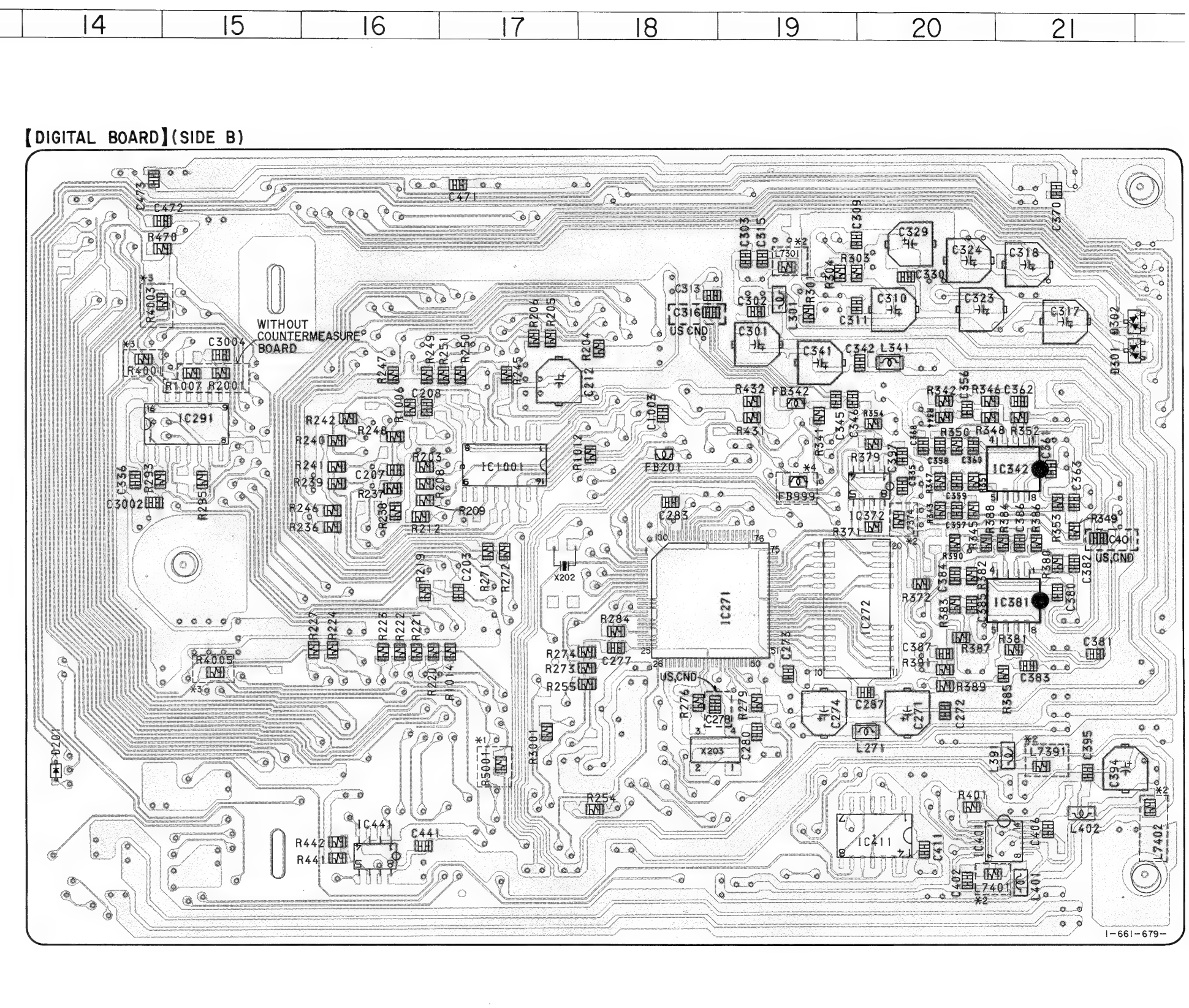
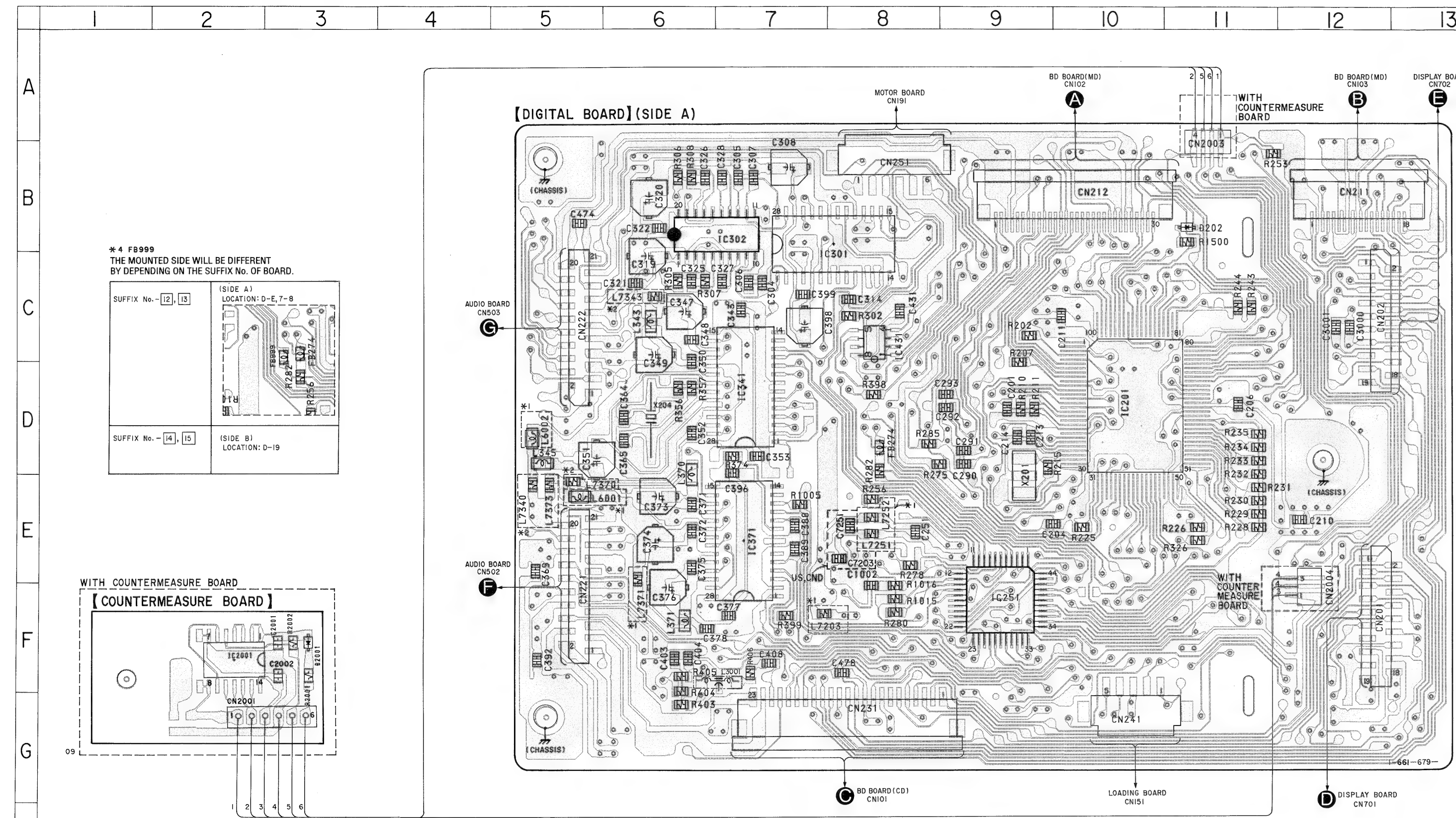

• Semiconductor Location

Ref. No.	Location
D201	F-14
D302	B-11
D301	C-21
D302	B-21
D2001	F-3
IC201	D-10
IC251	F-9
IC271	E-19
IC272	E-20
IC291	C-15
IC301	B-8
IC302	B-7
IC341	D-7
IC342	D-21
IC371	E-7
IC372	D-20
IC381	E-21
IC401	F-20
IC411	F-20
IC431	C-8
IC441	F-16
IC1001	D-17
IC2001	F-2

Note on Printed Wiring Boards:
Note:
 • ○ : Through hole.
 • □ : Pattern from the side which enables seeing.
 (The other layers' patterns are not indicated.)
 • Abbreviation
 CND : Canadian model.
 • *1 : mount from the suffix No. -13.
 • *2 : mount from the suffix No. -14.
 • *3 : mount from the suffix No. -15.

• Semiconductor Location

Ref. No.	Location
D501	B-14
D502	B-13
D503	B-14
D504	B-13
D505	B-14
D506	B-13
D507	B-14
D508	B-13
D509	B-8
D510	C-13
D511	C-14
D512	C-14
D536	C-9
D582	E-9
D591	D-3
D621	D-1
D623	D-2
D625	D-2
D627	D-3
D631	D-11
D632	D-10
D633	D-10
D641	C-11
D642	C-10
D643	D-9
D644	D-10
IC511	B-14
IC521	D-14
IC531	C-10
IC536	B-9
IC541	D-12
IC544	C-11
IC547	C-13
IC571	E-5
IC581	D-5
IC591	B-4
IC611	B-2
IC641	D-9
IC661	B-5
IC671	B-7
IC901	G-3
Q536	C-9
Q591	C-4
Q592	C-3
Q593	E-6
Q594	E-4
Q595	E-4
Q621	E-2
Q622	E-7
Q623	E-2
Q624	E-7
Q625	E-3
Q626	E-4
Q627	E-3
Q628	E-4

Note on Printed Wiring Boards:
Note:
 • — : parts extracted from the component side.
 • ○ : Through hole.
 • — : Pattern of the rear side.
 • — : Pattern from the side which enables seeing.
Abbreviation
 CND : Canadian model.
 G : German model.
 SP : Singapore model.
 *1 : mount from the suffix No. -13.
 *2 : mount from the suffix No. -14.

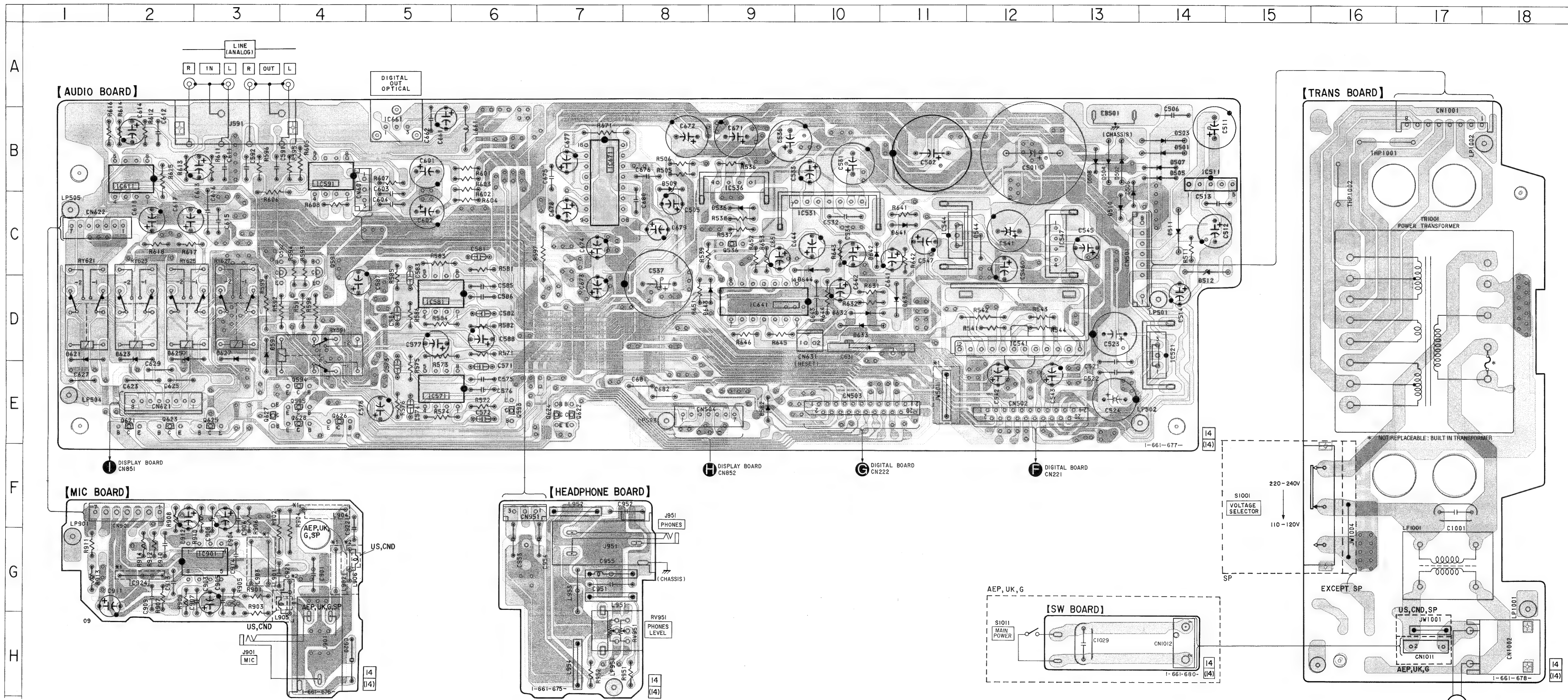

SCHEMATIC DIAGRAM — AUDIO SECTION —

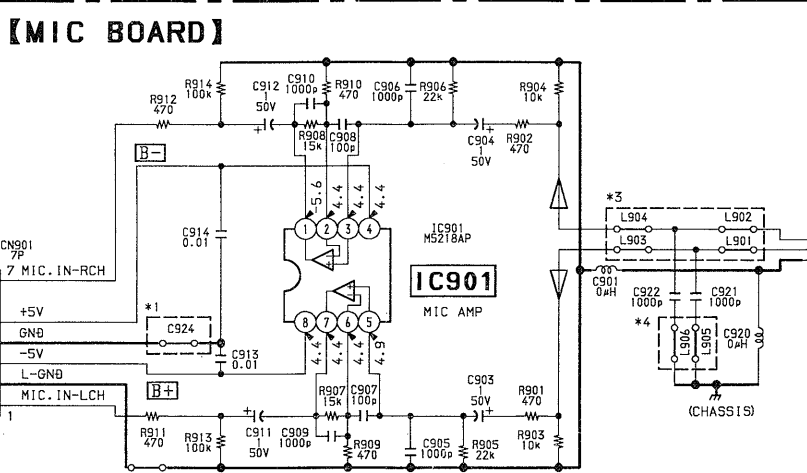
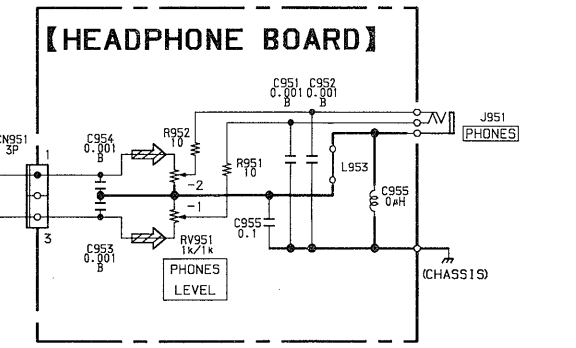
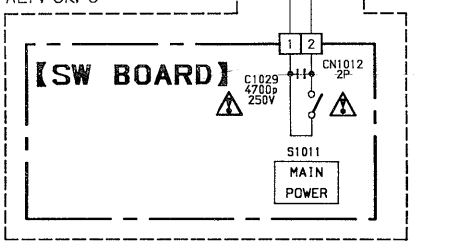
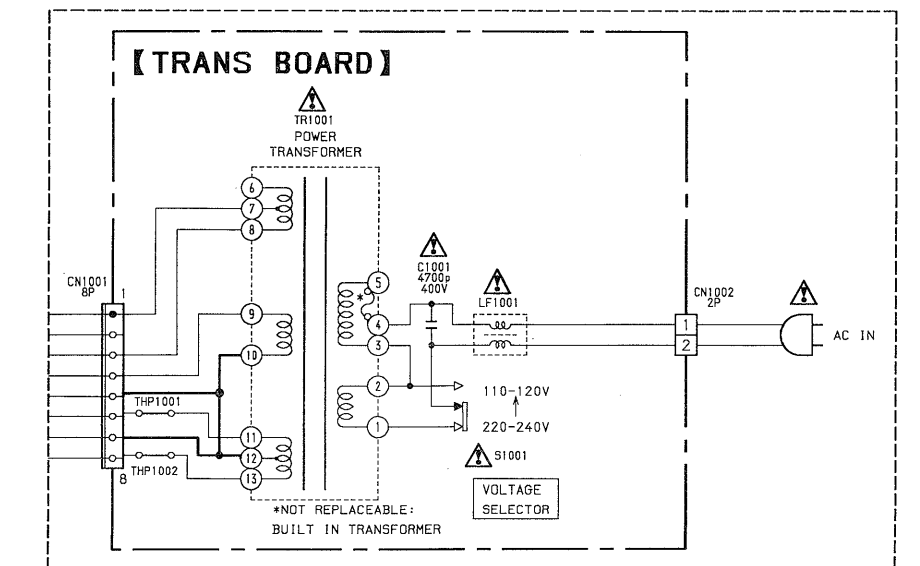
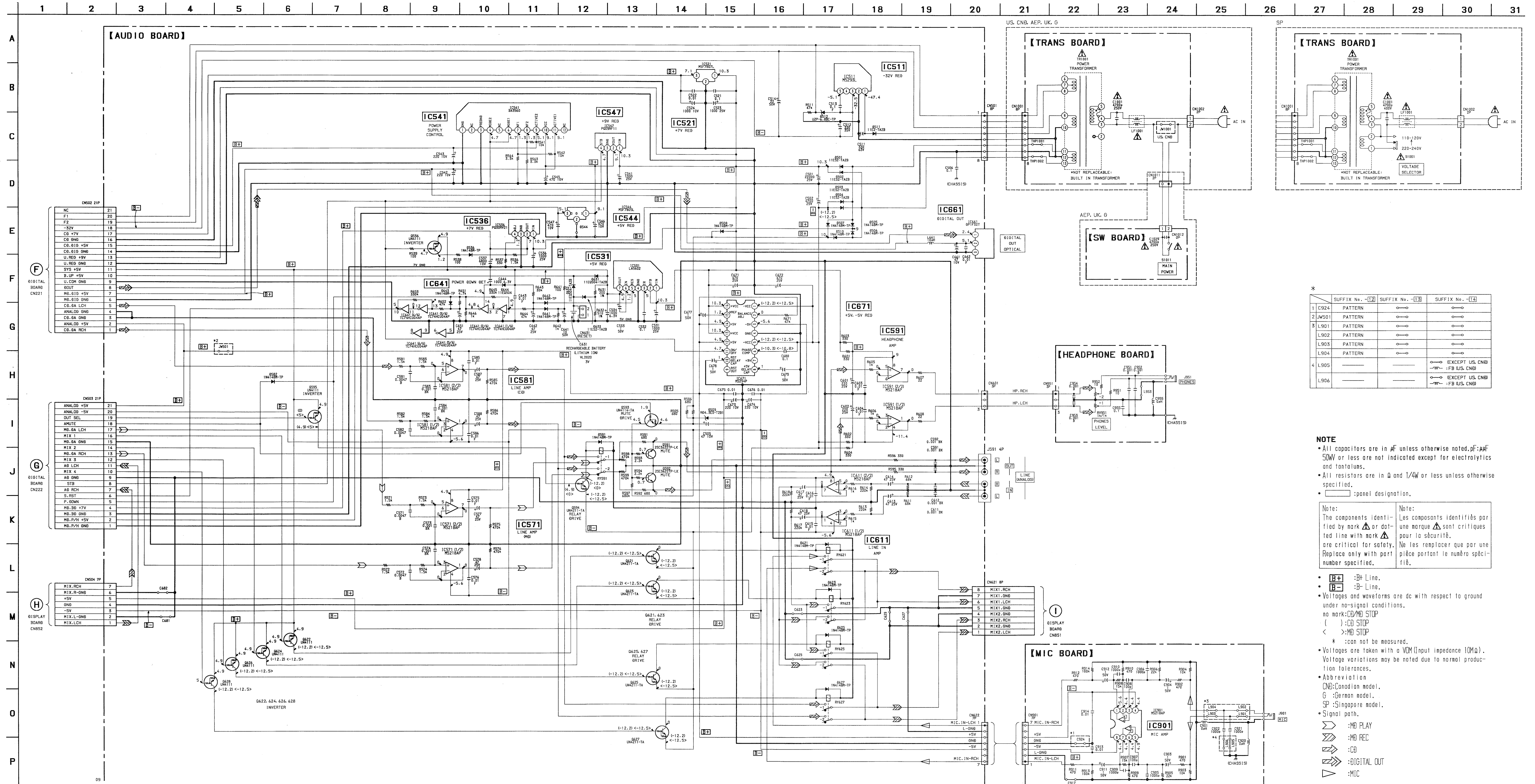

* SUFFIX No. - [12] SUFFIX No. - [13] SUFFIX No. - [14]

1	C924	PATTERN	↔	↔
2	JWS01	PATTERN	↔	↔
3	L901	PATTERN	↔	↔
	L902	PATTERN	↔	↔
	L903	PATTERN	↔	↔
	L904	PATTERN	↔	↔
4	L905		↔	↔ (EXCEPT US, CNB)
	L906		↔	↔ (EXCEPT US, CNB)

NOTE
 • All capacitors are in μF unless otherwise noted, pF: pF
 50W or less are not indicated except for electrolytics and tantalums.
 • All resistors are in Ω and 1/4W or less unless otherwise specified.
 • \square : panel designation.

Note: The components identified by mark Δ or dotted line with mark Δ are critical for safety. Replace only with part number specified.
 Note: Les composants identifiés par une marque Δ sont critiques pour la sécurité. Ne les remplacer que par une pièce portant le numéro spécifié.

- \square : B+ Line.
- \square : B- Line.
- Voltages and waveforms are dc with respect to ground under no-signal conditions.
- no mark: CB/MB STOP
- (): CB STOP
- < >: MB STOP
- * : can not be measured.
- Voltages are taken with a VOM (input impedance 10M Ω). Voltage variations may be noted due to normal production tolerances.
- Abbreviation
 CNB: Canadian model.
 G : German model.
 SP : Singapore model.
- Signal path.
- MB PLAY
- MB REC
- CB
- DIGITAL OUT
- MIC

ELECTRICAL PARTS LIST

AUDIO

NOTE:

The components identified by mark Δ or dotted line with mark Δ are critical for safety. Replace only with part number specified.

Les composants identifiés par une marque Δ sont critiques pour la sécurité. Ne les remplacer que par une pièce portant le numéro spécifié.

When indicating parts by reference number, please include the board name.

- Due to standardization, replacements in the parts list may be different from the parts specified in the diagrams or the components used on the set.
- -XX, -X mean standardized parts, so they may have some difference from the original one.
- Items marked "*" are not stocked since they are seldom required for routine service. Some delay should be anticipated when ordering these items.
- RESISTORS
All resistors are in ohms
METAL: Metal-film resistor
METAL OXIDE: Metal Oxide-film resistor
F : nonflammable
- SEMICONDUCTORS
In each case, u: μ . for example:
uA...: μ A..., uPA...: μ PA..., uPB...: μ PB..., uPC...: μ PC..., uPD...: μ PD...
- CAPACITORS
uF : μ F
- COILS
uH : μ H
- Abbreviation
CND : Canadian model
G : German model
SP : Singapore model

Ref. No.	Part No.	Description	Remark	Ref. No.	Part No.	Description	Remark
*	A-4699-060-A	AUDIO BOARD, COMPLETE (AEP,G,UK,SP)		C585	1-162-306-11	CERAMIC	0.01uF 20% 16V
		*****		C586	1-162-306-11	CERAMIC	0.01uF 20% 16V
				C587	1-124-910-11	ELECT	47uF 20% 50V
*	A-4699-061-A	AUDIO BOARD, COMPLETE (US,CND)		C588	1-124-910-11	ELECT	47uF 20% 50V

		< CAPACITOR >		C591	1-162-294-31	CERAMIC	0.001uF 10% 50V
C501	1-117-208-11	ELECT	22000uF 20% 25V	C592	1-162-294-31	CERAMIC	0.001uF 10% 50V
C502	1-128-548-11	ELECT	4700uF 20% 25V	C601	1-104-666-11	ELECT	220uF 20% 25V
C505	1-126-967-11	ELECT	47uF 20% 10V	C602	1-104-666-11	ELECT	220uF 20% 25V
C506	1-164-159-11	CERAMIC	0.1uF 50V	C603	1-162-306-11	CERAMIC	0.01uF 20% 16V
C511	1-128-554-11	ELECT	330uF 20% 63V	C604	1-162-306-11	CERAMIC	0.01uF 20% 16V
C512	1-126-950-11	ELECT	330uF 20% 35V	C611	1-162-294-31	CERAMIC	0.001uF 10% 50V
C513	1-164-159-11	CERAMIC	0.1uF 50V	C612	1-162-294-31	CERAMIC	0.001uF 10% 50V
C514	1-126-965-11	ELECT	22uF 20% 50V	C613	1-124-910-11	ELECT	47uF 20% 50V
C521	1-164-159-11	CERAMIC	0.1uF 50V	C614	1-124-910-11	ELECT	47uF 20% 50V
C522	1-162-306-11	CERAMIC	0.01uF 20% 16V	C615	1-162-306-11	CERAMIC	0.01uF 20% 16V
C523	1-126-942-61	ELECT	1000uF 20% 25V	C616	1-162-306-11	CERAMIC	0.01uF 20% 16V
C524	1-126-926-11	ELECT	1000uF 20% 10V	C617	1-124-910-11	ELECT	47uF 20% 50V
C531	1-126-942-61	ELECT	1000uF 20% 25V	C618	1-124-910-11	ELECT	47uF 20% 50V
C532	1-164-159-11	CERAMIC	0.1uF 50V	C631	1-528-739-11	BATTERY, LITHIUM (VL2020 3V)	
C533	1-126-960-11	ELECT	1uF 20% 50V	C641	1-126-964-11	ELECT	10uF 20% 50V
C534	1-126-916-11	ELECT	1000uF 20% 6.3V	C642	1-104-664-11	ELECT	47uF 20% 25V
C536	1-126-942-61	ELECT	1000uF 20% 25V	C643	1-162-306-11	CERAMIC	0.01uF 20% 16V
C537	1-126-930-11	ELECT	6800uF 20% 10V	C644	1-126-916-11	ELECT	1000uF 20% 6.3V
C541	1-126-942-61	ELECT	1000uF 20% 25V	C651	1-104-664-11	ELECT	47uF 20% 25V
C542	1-126-923-11	ELECT	220uF 20% 10V	C661	1-126-967-11	ELECT	47uF 20% 10V
C543	1-126-923-11	ELECT	220uF 20% 10V	C662	1-162-306-11	CERAMIC	0.01uF 20% 16V
C545	1-126-925-11	ELECT	470uF 20% 10V	C671	1-126-941-11	ELECT	470uF 20% 25V
C546	1-126-925-11	ELECT	470uF 20% 10V	C672	1-126-941-11	ELECT	470uF 20% 25V
C547	1-126-925-11	ELECT	470uF 20% 10V	C673	1-126-923-11	ELECT	220uF 20% 10V
C571	1-130-479-00	MYLAR	0.0047uF 5% 50V	C674	1-126-923-11	ELECT	220uF 20% 10V
C572	1-130-479-00	MYLAR	0.0047uF 5% 50V	C675	1-162-306-11	CERAMIC	0.01uF 20% 16V
C573	1-130-471-00	MYLAR	0.001uF 5% 50V	C676	1-162-306-11	CERAMIC	0.01uF 20% 16V
C574	1-130-471-00	MYLAR	0.001uF 5% 50V	C677	1-126-960-11	ELECT	1uF 20% 50V
C575	1-162-306-11	CERAMIC	0.01uF 20% 16V	C678	1-126-960-11	ELECT	1uF 20% 50V
C576	1-162-306-11	CERAMIC	0.01uF 20% 16V	C679	1-126-960-11	ELECT	1uF 20% 50V
C577	1-124-910-11	ELECT	47uF 20% 50V	C680	1-164-159-11	CERAMIC	0.1uF 50V
C578	1-124-910-11	ELECT	47uF 20% 50V			< CONNECTOR >	
C581	1-130-479-00	MYLAR	0.0047uF 5% 50V	CN502	1-770-649-11	CONNECTOR, FFC/FPC 21P	
C582	1-130-479-00	MYLAR	0.0047uF 5% 50V	CN503	1-770-649-11	CONNECTOR, FFC/FPC 21P	
C583	1-130-471-00	MYLAR	0.001uF 5% 50V	* CN504	1-564-709-11	PIN, CONNECTOR (SMALL TYPE) 7P	
C584	1-130-471-00	MYLAR	0.001uF 5% 50V	CN601	1-766-276-11	PIN, CONNECTOR (PC BOARD) 3P	
				* CN621	1-564-710-11	PIN, CONNECTOR (SMALL TYPE) 8P	

AUDIO

Ref. No.	Part No.	Description	Remark
* CN622	1-564-709-11	PIN, CONNECTOR (SMALL TYPE) 7P	
* CN631	1-564-704-11	PIN, CONNECTOR (SMALL TYPE) 2P	
< DIODE >			
D501	8-719-200-82	DIODE 11ES2	
D502	8-719-200-82	DIODE 11ES2	
D503	8-719-200-82	DIODE 11ES2	
D504	8-719-200-82	DIODE 11ES2	
D505	8-719-987-63	DIODE 1N4148M	
D506	8-719-987-63	DIODE 1N4148M	
D507	8-719-987-63	DIODE 1N4148M	
D508	8-719-987-63	DIODE 1N4148M	
D509	8-719-109-74	DIODE RD4.3ES-B1	
D510	8-719-987-63	DIODE 1N4148M	
D511	8-719-200-02	DIODE 10E2	
D512	8-719-014-88	DIODE UZP-6.8BC	
D536	8-719-987-63	DIODE 1N4148M	
D582	8-719-987-63	DIODE 1N4148M	
D591	8-719-987-63	DIODE 1N4148M	
D621	8-719-987-63	DIODE 1N4148M	
D623	8-719-987-63	DIODE 1N4148M	
D625	8-719-987-63	DIODE 1N4148M	
D627	8-719-987-63	DIODE 1N4148M	
D631	8-719-210-21	DIODE 11EQS04	
D632	8-719-210-21	DIODE 11EQS04	
D633	8-719-200-82	DIODE 11ES2	
D641	8-719-987-63	DIODE 1N4148M	
D642	8-719-987-63	DIODE 1N4148M	
D643	8-719-987-63	DIODE 1N4148M	
D644	8-719-210-21	DIODE 11EQS04	
< IC >			
IC511	8-759-633-42	IC M5293L	
IC521	8-759-604-86	IC M5F7807L	
IC531	8-759-061-65	IC LA5602	
IC536	8-759-520-49	IC PQ30RV21	
IC541	8-759-290-19	IC BA3960	
IC544	8-759-231-53	IC TA7805S	
IC547	8-759-054-12	IC PQ09RA1	
IC571	8-759-634-51	IC M5218AP	
IC581	8-759-634-51	IC M5218AP	
IC591	8-759-634-51	IC M5218AP	
IC611	8-759-634-51	IC M5218AP	
IC641	8-759-917-18	IC SN74HCU04AN	
IC661	8-749-921-12	IC GP1F32T (DIGITAL OUT OPTICAL)	
IC671	8-759-631-40	IC M5294P	
< JACK >			
J591	1-770-720-11	JACK, PIN 4P (LINE (ANALOG))	

Ref. No.	Part No.	Description	Remark
< COIL >			
L661	1-410-509-11	INDUCTOR 10uH	
< TRANSISTOR >			
Q536	8-729-422-57	TRANSISTOR UN4111	
Q591	8-729-141-26	TRANSISTOR 2SC3622A-LK	
Q592	8-729-141-26	TRANSISTOR 2SC3622A-LK	
Q593	8-729-902-80	TRANSISTOR DTA114YS	
Q594	8-729-900-80	TRANSISTOR DTC114ES	
Q595	8-729-422-57	TRANSISTOR UN4111	
Q621	8-729-900-80	TRANSISTOR DTC114ES	
Q622	8-729-422-57	TRANSISTOR UN4111	
Q623	8-729-900-80	TRANSISTOR DTC114ES	
Q624	8-729-422-57	TRANSISTOR UN4111	
Q625	8-729-900-80	TRANSISTOR DTC114ES	
Q626	8-729-422-57	TRANSISTOR UN4111	
Q627	8-729-900-80	TRANSISTOR DTC114ES	
Q628	8-729-422-57	TRANSISTOR UN4111	
< RESISTOR >			
R505	1-249-415-11	CARBON	680 5% 1/4W F
R506	1-249-415-11	CARBON	680 5% 1/4W F
R511	1-249-437-11	CARBON	47K 5% 1/4W
R536	1-249-419-11	CARBON	1.5K 5% 1/4W F
R537	1-249-411-11	CARBON	330 5% 1/4W
R538	1-247-807-31	CARBON	100 5% 1/4W
R539	1-247-807-31	CARBON	100 5% 1/4W
R541	1-249-429-11	CARBON	10K 5% 1/4W
R542	1-249-429-11	CARBON	10K 5% 1/4W
R543	1-247-843-11	CARBON	3.3K 5% 1/4W
R544	1-247-843-11	CARBON	3.3K 5% 1/4W
R571	1-215-425-00	METAL	1.5K 1% 1/4W
R572	1-215-425-00	METAL	1.5K 1% 1/4W
R573	1-215-425-00	METAL	1.5K 1% 1/4W
R574	1-215-425-00	METAL	1.5K 1% 1/4W
R575	1-247-895-00	CARBON	470K 5% 1/4W
R576	1-247-895-00	CARBON	470K 5% 1/4W
R581	1-215-425-00	METAL	1.5K 1% 1/4W
R582	1-215-425-00	METAL	1.5K 1% 1/4W
R583	1-215-425-00	METAL	1.5K 1% 1/4W
R584	1-215-425-00	METAL	1.5K 1% 1/4W
R585	1-247-895-00	CARBON	470K 5% 1/4W
R586	1-247-895-00	CARBON	470K 5% 1/4W
R591	1-249-415-11	CARBON	680 5% 1/4W F
R592	1-249-415-11	CARBON	680 5% 1/4W F
R593	1-249-421-11	CARBON	2.2K 5% 1/4W F
R594	1-249-421-11	CARBON	2.2K 5% 1/4W F
R595	1-249-411-11	CARBON	330 5% 1/4W
R596	1-249-411-11	CARBON	330 5% 1/4W
R597	1-247-899-11	CARBON	680K 5% 1/4W
R598	1-247-895-00	CARBON	470K 5% 1/4W

AUDIO	DIGITAL
--------------	----------------

Ref. No.	Part No.	Description			Remark
R599	1-247-895-00	CARBON	470K	5%	1/4W
R601	1-249-411-11	CARBON	330	5%	1/4W
R602	1-249-411-11	CARBON	330	5%	1/4W
R603	1-249-411-11	CARBON	330	5%	1/4W
R604	1-249-411-11	CARBON	330	5%	1/4W
R605	1-249-417-11	CARBON	1K	5%	1/4W F
R606	1-249-417-11	CARBON	1K	5%	1/4W F
R607	1-249-397-11	CARBON	22	5%	1/4W F
R608	1-249-397-11	CARBON	22	5%	1/4W F
R611	1-249-439-11	CARBON	68K	5%	1/4W
R612	1-249-439-11	CARBON	68K	5%	1/4W
R613	1-247-887-00	CARBON	220K	5%	1/4W
R614	1-247-887-00	CARBON	220K	5%	1/4W
R615	1-249-417-11	CARBON	1K	5%	1/4W F
R616	1-249-417-11	CARBON	1K	5%	1/4W F
R617	1-247-887-00	CARBON	220K	5%	1/4W
R618	1-247-887-00	CARBON	220K	5%	1/4W
R631	1-215-404-00	METAL	200	1%	1/4W
R632	1-215-414-00	METAL	510	1%	1/4W
R641	1-247-807-31	CARBON	100	5%	1/4W
R642	1-249-417-11	CARBON	1K	5%	1/4W F
R643	1-249-436-11	CARBON	39K	5%	1/4W
R644	1-249-437-11	CARBON	47K	5%	1/4W
R645	1-247-891-00	CARBON	330K	5%	1/4W
R646	1-249-417-11	CARBON	1K	5%	1/4W F
R651	1-249-425-11	CARBON	4.7K	5%	1/4W F
R652	1-249-437-11	CARBON	47K	5%	1/4W
R653	1-247-891-00	CARBON	330K	5%	1/4W
R671	1-249-437-11	CARBON	47K	5%	1/4W
< RELAY >					
RY591	1-515-787-21	RELAY			
RY621	1-515-787-21	RELAY			
RY623	1-515-787-21	RELAY			
RY625	1-515-787-21	RELAY			
RY627	1-515-787-21	RELAY			

*	A-4699-436-A	DIGITAL BOARD, COMPLETE (AEP,G,UK,SP)			

*	A-4699-072-A	DIGITAL BOARD, COMPLETE (US,CND)			

< CAPACITOR >					
C201	1-163-009-11	CERAMIC CHIP	0.001uF	10%	50V
C203	1-163-133-00	CERAMIC CHIP	470PF	5%	50V
C204	1-163-017-00	CERAMIC CHIP	0.0047uF	5%	50V
C206	1-163-038-91	CERAMIC CHIP	0.1uF		25V
C207	1-163-251-11	CERAMIC CHIP	100PF	5%	50V
C208	1-163-251-11	CERAMIC CHIP	100PF	5%	50V
C210	1-163-038-91	CERAMIC CHIP	0.1uF		25V
C211	1-163-038-91	CERAMIC CHIP	0.1uF		25V

Ref. No.	Part No.	Description			Remark
C212	1-126-395-11	ELECT	22uF	20%	16V
C213	1-163-235-11	CERAMIC CHIP	22PF	5%	50V
C214	1-163-235-11	CERAMIC CHIP	22PF	5%	50V
C251	1-163-038-91	CERAMIC CHIP	0.1uF		25V
C271	1-126-395-11	ELECT	22uF	20%	16V
C272	1-163-038-91	CERAMIC CHIP	0.1uF		25V
C273	1-163-038-91	CERAMIC CHIP	0.1uF		25V
C274	1-126-395-11	ELECT	22uF	20%	16V
C277	1-163-031-11	CERAMIC CHIP	0.01uF		50V
C278	1-163-227-11	CERAMIC CHIP	10PF	0.5PF	50V (US,CND)
C280	1-163-038-91	CERAMIC CHIP	0.1uF		25V
C283	1-163-038-91	CERAMIC CHIP	0.1uF		25V
C287	1-163-038-91	CERAMIC CHIP	0.1uF		25V
C290	1-163-251-11	CERAMIC CHIP	100PF	5%	50V
C291	1-163-251-11	CERAMIC CHIP	100PF	5%	50V
C292	1-163-251-11	CERAMIC CHIP	100PF	5%	50V
C293	1-163-251-11	CERAMIC CHIP	100PF	5%	50V
C301	1-126-395-11	ELECT	22uF	20%	16V
C302	1-163-038-91	CERAMIC CHIP	0.1uF		25V
C303	1-163-038-91	CERAMIC CHIP	0.1uF		25V
C304	1-163-017-00	CERAMIC CHIP	0.0047uF	5%	50V
C305	1-163-017-00	CERAMIC CHIP	0.0047uF	5%	50V
C306	1-163-017-00	CERAMIC CHIP	0.0047uF	5%	50V
C307	1-163-017-00	CERAMIC CHIP	0.0047uF	5%	50V
C308	1-126-395-11	ELECT	22uF	20%	16V
C309	1-163-038-91	CERAMIC CHIP	0.1uF		25V
C310	1-126-395-11	ELECT	22uF	20%	16V
C311	1-163-038-91	CERAMIC CHIP	0.1uF		25V
C313	1-163-227-11	CERAMIC CHIP	10PF	0.5PF	50V
C314	1-163-227-11	CERAMIC CHIP	10PF	0.5PF	50V
C315	1-163-038-91	CERAMIC CHIP	0.1uF		25V
C316	1-163-227-11	CERAMIC CHIP	10PF	0.5PF	50V (US,CND)
C317	1-126-395-11	ELECT	22uF	20%	16V
C318	1-126-395-11	ELECT	22uF	20%	16V
C319	1-126-395-11	ELECT	22uF	20%	16V
C320	1-126-395-11	ELECT	22uF	20%	16V
C321	1-163-038-91	CERAMIC CHIP	0.1uF		25V
C322	1-163-038-91	CERAMIC CHIP	0.1uF		25V
C323	1-126-395-11	ELECT	22uF	20%	16V
C324	1-126-395-11	ELECT	22uF	20%	16V
C325	1-163-259-91	CERAMIC CHIP	220PF	5%	50V
C326	1-163-259-91	CERAMIC CHIP	220PF	5%	50V
C327	1-163-001-11	CERAMIC CHIP	220PF	10%	50V
C328	1-163-001-11	CERAMIC CHIP	220PF	10%	50V
C329	1-126-395-11	ELECT	22uF	20%	16V
C330	1-163-038-91	CERAMIC CHIP	0.1uF		25V
C335	1-163-038-91	CERAMIC CHIP	0.1uF		25V
C336	1-163-038-91	CERAMIC CHIP	0.1uF		25V
C341	1-126-395-11	ELECT	22uF	20%	16V
C342	1-163-038-91	CERAMIC CHIP	0.1uF		25V

DIGITAL

Ref. No.	Part No.	Description	Remark	Ref. No.	Part No.	Description	Remark
C343	1-163-038-91	CERAMIC CHIP	0.1uF	25V	C404	1-164-346-11	CERAMIC CHIP 1uF 16V
C345	1-163-227-11	CERAMIC CHIP	10PF	0.5PF 50V	C406	1-163-038-91	CERAMIC CHIP 0.1uF 25V
C346	1-163-227-11	CERAMIC CHIP	10PF	0.5PF 50V	C408	1-163-009-11	CERAMIC CHIP 0.001uF 10% 50V
C347	1-126-395-11	ELECT	22uF	20% 16V	C411	1-163-038-91	CERAMIC CHIP 0.1uF 25V
C348	1-163-038-91	CERAMIC CHIP	0.1uF	25V	C431	1-163-038-91	CERAMIC CHIP 0.1uF 25V
C349	1-126-395-11	ELECT	22uF	20% 16V	C441	1-163-038-91	CERAMIC CHIP 0.1uF 25V
C350	1-163-038-91	CERAMIC CHIP	0.1uF	25V	C471	1-163-038-91	CERAMIC CHIP 0.1uF 25V
C351	1-126-395-11	ELECT	22uF	20% 16V	C472	1-163-038-91	CERAMIC CHIP 0.1uF 25V
C352	1-163-038-91	CERAMIC CHIP	0.1uF	25V	C473	1-163-038-91	CERAMIC CHIP 0.1uF 25V
C353	1-163-038-91	CERAMIC CHIP	0.1uF	25V	C474	1-163-038-91	CERAMIC CHIP 0.1uF 25V
C356	1-163-113-00	CERAMIC CHIP	68PF	5% 50V	C478	1-163-227-11	CERAMIC CHIP 10PF 0.5PF 50V
C357	1-163-113-00	CERAMIC CHIP	68PF	5% 50V	C1002	1-163-121-00	CERAMIC CHIP 150PF 5% 50V
C358	1-163-239-11	CERAMIC CHIP	33PF	5% 50V	C1003	1-163-038-91	CERAMIC CHIP 0.1uF 25V
C359	1-163-239-11	CERAMIC CHIP	33PF	5% 50V	C3000	1-163-251-11	CERAMIC CHIP 100PF 5% 50V
C360	1-163-038-91	CERAMIC CHIP	0.1uF	25V	C3001	1-163-251-11	CERAMIC CHIP 100PF 5% 50V
C361	1-163-038-91	CERAMIC CHIP	0.1uF	25V	C3002	1-163-263-11	CERAMIC CHIP 330PF 5% 50V
C362	1-163-239-11	CERAMIC CHIP	33PF	5% 50V	C3004	1-163-009-11	CERAMIC CHIP 0.001uF 10% 50V
C363	1-163-239-11	CERAMIC CHIP	33PF	5% 50V	C7203	1-163-038-91	CERAMIC CHIP 0.1uF 25V
C364	1-163-229-11	CERAMIC CHIP	12PF	5% 50V			(US,CND)(SUFFIX No. -13 or LATER)
C365	1-163-229-11	CERAMIC CHIP	12PF	5% 50V	C7251	1-163-038-91	CERAMIC CHIP 0.1uF 25V
C368	1-163-038-91	CERAMIC CHIP	0.1uF	25V			(US,CND)(SUFFIX No. -13 or LATER)
C369	1-163-038-91	CERAMIC CHIP	0.1uF	25V			< CONNECTOR >
C370	1-163-038-91	CERAMIC CHIP	0.1uF	25V	CN201	1-778-691-11	CONNECTOR, FFC/FPC 19P
C371	1-163-038-91	CERAMIC CHIP	0.1uF	25V	CN202	1-778-691-11	CONNECTOR, FFC/FPC 19P
C372	1-163-038-91	CERAMIC CHIP	0.1uF	25V	CN211	1-766-509-21	CONNECTOR, FFC/FPC 18P
C373	1-126-395-11	ELECT	22uF	20% 16V	CN212	1-766-510-21	CONNECTOR, FFC/FPC 30P
C374	1-126-395-11	ELECT	22uF	20% 16V	CN221	1-778-692-11	CONNECTOR, FFC/FPC 21P
C375	1-163-038-91	CERAMIC CHIP	0.1uF	25V	CN222	1-778-692-11	CONNECTOR, FFC/FPC 21P
C376	1-126-395-11	ELECT	22uF	20% 16V	CN231	1-770-072-11	CONNECTOR,(LIF(NON-ZIF))FFC 23P
C377	1-163-038-91	CERAMIC CHIP	0.1uF	25V	CN241	1-778-315-11	PIN, CONNECTOR (PC BOARD) 5P
C378	1-163-038-91	CERAMIC CHIP	0.1uF	25V	* CN251	1-770-154-11	PIN, CONNECTOR (PC BOARD) 6P
C380	1-163-038-91	CERAMIC CHIP	0.1uF	25V			< DIODE >
C381	1-163-038-91	CERAMIC CHIP	0.1uF	25V	D201	8-719-016-74	DIODE 1SS352
C382	1-163-239-11	CERAMIC CHIP	33PF	5% 50V	D202	8-719-016-74	DIODE 1SS352
C383	1-163-239-11	CERAMIC CHIP	33PF	5% 50V	D301	8-719-800-76	DIODE 1SS226
C384	1-163-239-11	CERAMIC CHIP	33PF	5% 50V	D302	8-719-800-76	DIODE 1SS226
C385	1-163-239-11	CERAMIC CHIP	33PF	5% 50V			< FERRITE BEAD >
C386	1-163-113-00	CERAMIC CHIP	68PF	5% 50V	FB201	1-216-295-91	CONDUCTOR, CHIP (2012)
C387	1-163-113-00	CERAMIC CHIP	68PF	5% 50V	FB274	1-216-295-91	CONDUCTOR, CHIP (2012)
C388	1-163-227-11	CERAMIC CHIP	10PF	0.5PF 50V	FB342	1-216-295-91	CONDUCTOR, CHIP (2012)
C389	1-163-009-11	CERAMIC CHIP	0.001uF	10% 50V	FB999	1-163-275-11	CERAMIC CHIP 0.001MF 5% 50V
C392	1-163-038-91	CERAMIC CHIP	0.1uF	25V			< IC >
C394	1-126-395-11	ELECT	22uF	20% 16V	IC201	8-759-425-97	IC RU8X11AMF-0102
C395	1-163-038-91	CERAMIC CHIP	0.1uF	25V			(WITH COUNTERMEASURE BOARD)
C396	1-163-038-91	CERAMIC CHIP	0.1uF	25V	IC201	8-759-447-81	IC RU8X11AMF-0107
C397	1-163-227-11	CERAMIC CHIP	10PF	0.5PF 50V			(WITHOUT COUNTERMEASURE BOARD)
C398	1-126-395-11	ELECT	22uF	20% 16V	IC251	8-759-430-24	IC CXD8640Q
C399	1-163-038-91	CERAMIC CHIP	0.1uF	25V	IC271	8-752-371-17	IC CXD2536R
C401	1-163-038-91	CERAMIC CHIP	0.1uF	25V	IC272	8-759-329-31	IC MSM514400CSJADR1-K
				(US,CND)			
C402	1-163-038-91	CERAMIC CHIP	0.1uF	25V			
C403	1-163-037-11	CERAMIC CHIP	0.022uF	10% 25V			

Ref. No.	Part No.	Description	Remark	Ref. No.	Part No.	Description	Remark
IC291	8-759-187-04	IC TC74HC365AF-TP1		L7340	1-410-985-11	INDUCTOR CHIP 0.22uH (US,CND) (SUFFIX No. -14 or LATER)	
IC301	8-759-352-63	IC CXD8566M		L7343	1-216-295-91	CONDUCTOR, CHIP (2012)(AEP,G,UK,SP) (SUFFIX No. -14 or LATER)	
IC302	8-759-352-59	IC CXA8054M		L7343	1-412-963-11	INDUCTOR 100uH (US,CND) (SUFFIX No. -14 or LATER)	
IC341	8-759-362-47	IC CXD8567AM		L7370	1-216-295-91	CONDUCTOR, CHIP (2012)(AEP,G,UK,SP) (SUFFIX No. -14 or LATER)	
IC342	8-759-981-48	IC TL082M		L7370	1-412-963-11	INDUCTOR 100uH (US,CND) (SUFFIX No. -14 or LATER)	
IC371	8-759-362-47	IC CXD8567AM		L7371	1-216-295-91	CONDUCTOR, CHIP (2012)(AEP,G,UK,SP) (SUFFIX No. -13 or LATER)	
IC372	8-759-242-70	IC TC7WU04F		L7371	1-412-963-11	INDUCTOR 100uH (US,CND) (SUFFIX No. -13 or LATER)	
IC381	8-759-981-48	IC TL082M		L7373	1-216-295-91	CONDUCTOR, CHIP (2012)(AEP,G,UK,SP) (SUFFIX No. -14 or LATER)	
IC401	8-759-295-09	IC TLC2932IPW		L7373	1-410-985-11	INDUCTOR CHIP 0.22uH (US,CND) (SUFFIX No. -14 or LATER)	
IC411	8-759-032-01	IC MC74HC00AF		L7374	1-216-295-91	CONDUCTOR, CHIP (2012) (SUFFIX No. -14 or LATER)	
IC431	8-759-040-83	IC BA6287F		L7391	1-216-295-91	CONDUCTOR, CHIP (2012)(AEP,G,UK,SP) (SUFFIX No. -14 or LATER)	
IC441	8-759-040-83	IC BA6287F		L7391	1-412-963-11	INDUCTOR 100uH (US,CND) (SUFFIX No. -14 or LATER)	
IC1001	8-759-187-04	IC TC74HC365AF-TP1		L7401	1-216-295-91	CONDUCTOR, CHIP (2012) (SUFFIX No. -14 or LATER)	
		< COIL >		L7402	1-216-295-91	CONDUCTOR, CHIP (2012) (SUFFIX No. -14 or LATER)	
L271	1-412-336-41	INDUCTOR 4.7uH (AEP,G,UK,SP)				< RESISTOR >	
L271	1-412-947-11	INDUCTOR 4.7uH (US,CND)		R202	1-216-073-00	METAL CHIP 10K 5% 1/10W	
L301	1-412-336-41	INDUCTOR 4.7uH		R203	1-216-073-00	METAL CHIP 10K 5% 1/10W	
L341	1-412-336-41	INDUCTOR 4.7uH (AEP,G,UK,SP)		R204	1-216-073-00	METAL CHIP 10K 5% 1/10W	
L341	1-412-963-11	INDUCTOR 100uH (US,CND)		R205	1-216-073-00	METAL CHIP 10K 5% 1/10W	
L343	1-216-296-91	CONDUCTOR, CHIP (3216)(US,CND)		R206	1-216-073-00	METAL CHIP 10K 5% 1/10W	
L343	1-412-336-41	INDUCTOR 4.7uH (AEP,G,UK,SP)		R207	1-216-097-91	METAL GLAZE 100K 5% 1/10W	
L345	1-412-336-41	INDUCTOR 4.7uH (AEP,G,UK,SP)		R208	1-216-097-91	METAL GLAZE 100K 5% 1/10W	
L345	1-412-963-11	INDUCTOR 100uH (US,CND)		R209	1-216-097-91	METAL GLAZE 100K 5% 1/10W	
L370	1-216-296-91	CONDUCTOR, CHIP (3216)(US,CND)		R210	1-216-097-91	METAL GLAZE 100K 5% 1/10W	
L370	1-412-336-41	INDUCTOR 4.7uH (AEP,G,UK,SP)		R211	1-216-097-91	METAL GLAZE 100K 5% 1/10W	
L371	1-216-296-91	CONDUCTOR, CHIP (3216)(US,CND)		R212	1-216-097-91	METAL GLAZE 100K 5% 1/10W	
L371	1-412-336-41	INDUCTOR 4.7uH (AEP,G,UK,SP)		R215	1-216-121-91	METAL GLAZE 1M 5% 1/10W	
L391	1-216-296-91	CONDUCTOR, CHIP (3216)(US,CND)		R219	1-216-073-00	METAL CHIP 10K 5% 1/10W	
L391	1-412-336-41	INDUCTOR 4.7uH (AEP,G,UK,SP)		R220	1-216-097-91	METAL GLAZE 100K 5% 1/10W	
L401	1-412-336-41	INDUCTOR 4.7uH		R221	1-216-097-91	METAL GLAZE 100K 5% 1/10W	
L402	1-412-336-41	INDUCTOR 4.7uH		R222	1-216-073-00	METAL CHIP 10K 5% 1/10W	
L3001	1-239-493-11	FILTER, EMI		R223	1-216-097-91	METAL GLAZE 100K 5% 1/10W	
L6001	1-216-296-91	CONDUCTOR, CHIP (3216)(AEP,G,UK,SP) (SUFFIX No. -13 or LATER)		R224	1-216-097-91	METAL GLAZE 100K 5% 1/10W	
L6001	1-412-963-11	INDUCTOR 100uH (US,CND) (SUFFIX No. -13 or LATER)		R225	1-216-097-91	METAL GLAZE 100K 5% 1/10W	
L6002	1-216-296-91	CONDUCTOR, CHIP (3216)(AEP,G,UK,SP) (SUFFIX No. -13 or LATER)		R226	1-216-073-00	METAL CHIP 10K 5% 1/10W	
L6002	1-412-963-11	INDUCTOR 100uH (US,CND) (SUFFIX No. -13 or LATER)		R227	1-216-097-91	METAL GLAZE 100K 5% 1/10W	
L7203	1-216-295-91	CONDUCTOR, CHIP (2012)(AEP,G,UK,SP) (SUFFIX No. -13 or LATER)		R228	1-216-097-91	METAL GLAZE 100K 5% 1/10W	
L7203	1-414-235-11	INDUCTOR, FERRITE BEAD (US,CND) (SUFFIX No. -13 or LATER)		R229	1-216-097-91	METAL GLAZE 100K 5% 1/10W	
L7251	1-216-295-91	CONDUCTOR, CHIP (2012)(AEP,G,UK,SP) (SUFFIX No. -13 or LATER)		R230	1-216-097-91	METAL GLAZE 100K 5% 1/10W	
L7251	1-414-235-11	INDUCTOR, FERRITE BEAD (US,CND) (SUFFIX No. -13 or LATER)					
L7252	1-216-295-91	CONDUCTOR, CHIP (2012) (SUFFIX No. -13 or LATER)					
L7301	1-216-295-91	CONDUCTOR, CHIP (2012)					
L7340	1-216-295-91	CONDUCTOR, CHIP (2012)(AEP,G,UK,SP) (SUFFIX No. -14 or LATER)					

DIGITAL

Ref. No.	Part No.	Description	Quantity	Percentage	Remark
R231	1-216-097-91	METAL GLAZE	100K	5%	1/10W
R232	1-216-097-91	METAL GLAZE	100K	5%	1/10W
R233	1-216-097-91	METAL GLAZE	100K	5%	1/10W
R234	1-216-097-91	METAL GLAZE	100K	5%	1/10W
R235	1-216-097-91	METAL GLAZE	100K	5%	1/10W
R236	1-216-073-00	METAL CHIP	10K	5%	1/10W
R237	1-216-097-91	METAL GLAZE	100K	5%	1/10W
R238	1-216-097-91	METAL GLAZE	100K	5%	1/10W
R239	1-216-073-00	METAL CHIP	10K	5%	1/10W
R240	1-216-073-00	METAL CHIP	10K	5%	1/10W
R241	1-216-073-00	METAL CHIP	10K	5%	1/10W
R242	1-216-097-91	METAL GLAZE	100K	5%	1/10W
R243	1-216-073-00	METAL CHIP	10K	5%	1/10W
R244	1-216-073-00	METAL CHIP	10K	5%	1/10W
R245	1-216-025-91	METAL GLAZE	100	5%	1/10W
R246	1-216-073-00	METAL CHIP	10K	5%	1/10W
R247	1-216-065-00	METAL CHIP	4.7K	5%	1/10W
R248	1-216-097-91	METAL GLAZE	100K	5%	1/10W
R249	1-216-073-00	METAL CHIP	10K	5%	1/10W
R250	1-216-073-00	METAL CHIP	10K	5%	1/10W
R251	1-216-073-00	METAL CHIP	10K	5%	1/10W
R253	1-216-073-00	METAL CHIP	10K	5%	1/10W
R254	1-216-295-91	CONDUCTOR, CHIP (2012)			
R255	1-216-295-91	CONDUCTOR, CHIP (2012)			
R256	1-216-295-91	CONDUCTOR, CHIP (2012)			
R271	1-216-097-91	METAL GLAZE	100K	5%	1/10W
R272	1-216-097-91	METAL GLAZE	100K	5%	1/10W
R273	1-216-097-91	METAL GLAZE	100K	5%	1/10W
R274	1-216-097-91	METAL GLAZE	100K	5%	1/10W
R275	1-216-097-91	METAL GLAZE	100K	5%	1/10W
R276	1-216-041-00	METAL CHIP	470	5%	1/10W (US,CND)
R276	1-216-295-91	CONDUCTOR, CHIP (2012)			(AEP,G,UK,SP)
R278	1-216-295-91	CONDUCTOR, CHIP (2012)			
R279	1-216-033-00	METAL CHIP	220	5%	1/10W
R280	1-216-033-00	METAL CHIP	220	5%	1/10W
R282	1-216-041-00	METAL CHIP	470	5%	1/10W
R284	1-216-295-91	CONDUCTOR, CHIP (2012)			
R285	1-216-295-91	CONDUCTOR, CHIP (2012)			
R293	1-216-049-91	METAL GLAZE	1K	5%	1/10W
R295	1-216-049-91	METAL GLAZE	1K	5%	1/10W
R301	1-216-017-91	METAL GLAZE	47	5%	1/10W
R302	1-216-033-00	METAL CHIP	220	5%	1/10W
R303	1-216-017-91	METAL GLAZE	47	5%	1/10W
R304	1-216-017-91	METAL GLAZE	47	5%	1/10W
R305	1-216-057-00	METAL CHIP	2.2K	5%	1/10W
R306	1-216-057-00	METAL CHIP	2.2K	5%	1/10W
R307	1-216-673-11	METAL CHIP	8.2K	0.5%	1/10W
R308	1-216-673-11	METAL CHIP	8.2K	0.5%	1/10W
R326	1-216-025-91	METAL GLAZE	100	5%	1/10W
R341	1-216-033-00	METAL CHIP	220	5%	1/10W
R342	1-216-687-11	METAL CHIP	33K	0.5%	1/10W

Ref. No.	Part No.	Description	Quantity	Percentage	Remark
R343	1-216-687-11	METAL CHIP	33K	0.5%	1/10W
R344	1-216-687-11	METAL CHIP	33K	0.5%	1/10W
R345	1-216-687-11	METAL CHIP	33K	0.5%	1/10W
R346	1-216-683-11	METAL CHIP	22K	0.5%	1/10W
R347	1-216-683-11	METAL CHIP	22K	0.5%	1/10W
R348	1-216-683-11	METAL CHIP	22K	0.5%	1/10W
R349	1-216-683-11	METAL CHIP	22K	0.5%	1/10W
R350	1-216-695-11	METAL CHIP	68K	0.5%	1/10W
R351	1-216-695-11	METAL CHIP	68K	0.5%	1/10W
R352	1-216-695-11	METAL CHIP	68K	0.5%	1/10W
R353	1-216-695-11	METAL CHIP	68K	0.5%	1/10W
R354	1-216-295-91	CONDUCTOR, CHIP (2012)			
R356	1-216-121-91	METAL GLAZE	1M	5%	1/10W
R357	1-216-039-00	METAL CHIP	390	5%	1/10W
R371	1-216-033-00	METAL CHIP	220	5%	1/10W (AEP,G,UK,SP)
R371	1-216-041-00	METAL CHIP	470	5%	1/10W (US,CND)
R372	1-216-033-00	METAL CHIP	220	5%	1/10W (AEP,G,UK,SP)
R372	1-216-041-00	METAL CHIP	470	5%	1/10W (US,CND)
R374	1-216-295-91	CONDUCTOR, CHIP (2012)			
R379	1-216-033-00	METAL CHIP	220	5%	1/10W
R380	1-216-695-11	METAL CHIP	68K	0.5%	1/10W
R381	1-216-695-11	METAL CHIP	68K	0.5%	1/10W
R382	1-216-695-11	METAL CHIP	68K	0.5%	1/10W
R383	1-216-695-11	METAL CHIP	68K	0.5%	1/10W
R384	1-216-683-11	METAL CHIP	22K	0.5%	1/10W
R385	1-216-683-11	METAL CHIP	22K	0.5%	1/10W
R386	1-216-683-11	METAL CHIP	22K	0.5%	1/10W
R387	1-216-683-11	METAL CHIP	22K	0.5%	1/10W
R388	1-216-687-11	METAL CHIP	33K	0.5%	1/10W
R389	1-216-687-11	METAL CHIP	33K	0.5%	1/10W
R390	1-216-687-11	METAL CHIP	33K	0.5%	1/10W
R391	1-216-687-11	METAL CHIP	33K	0.5%	1/10W
R398	1-216-295-91	CONDUCTOR, CHIP (2012)			
R399	1-216-295-91	CONDUCTOR, CHIP (2012)			
R401	1-216-060-00	METAL GLAZE	3K	5%	1/10W
R403	1-216-655-11	METAL CHIP	1.5K	0.5%	1/10W
R404	1-216-679-11	METAL CHIP	15K	0.5%	1/10W
R405	1-216-659-11	METAL CHIP	2.2K	0.5%	1/10W
R406	1-216-033-00	METAL CHIP	220	5%	1/10W
R431	1-216-021-00	METAL CHIP	68	5%	1/10W
R432	1-216-021-00	METAL CHIP	68	5%	1/10W
R441	1-216-021-00	METAL CHIP	68	5%	1/10W
R442	1-216-021-00	METAL CHIP	68	5%	1/10W
R470	1-216-295-91	CONDUCTOR, CHIP (2012)			
R1005	1-216-295-91	CONDUCTOR, CHIP (2012)			
R1006	1-216-073-00	METAL CHIP	10K	5%	1/10W
R1007	1-216-049-91	METAL GLAZE	1K	5%	1/10W (WITHOUT COUNTERMEASURE BOARD)
R1012	1-216-073-00	METAL CHIP	10K	5%	1/10W

Ref. No.	Part No.	Description	Remark
R1014	1-216-097-91	METAL GLAZE 100K	5% 1/10W
R1015	1-216-295-91	CONDUCTOR, CHIP (2012)	
R1016	1-216-295-91	CONDUCTOR, CHIP (2012)	
R1500	1-216-025-91	METAL GLAZE 100	5% 1/10W
R2001	1-216-295-91	CONDUCTOR, CHIP (2012) (WITHOUT COUNTERMEASURE BOARD)	
R3001	1-216-295-91	CONDUCTOR, CHIP (2012)	
R4001	1-216-049-91	METAL GLAZE 1K	5% 1/10W (SUFFIX No. -15 or LATER)
R4003	1-216-025-91	METAL GLAZE 100	5% 1/10W (SUFFIX No. -15 or LATER)
R4005	1-216-295-91	CONDUCTOR, CHIP (2012) (SUFFIX No. -15 or LATER)	
R5001	1-216-049-91	METAL GLAZE 1K	5% 1/10W (SUFFIX No. -13 or LATER)
< VIBRATOR >			
X201	1-760-902-11	VIBRATOR, CERAMIC (CHIP TYPE)(16MHz)	
X202	1-760-872-11	VIBRATOR, CRYSTAL (32.768kHz)	
X203	1-767-229-11	OSCILLATOR, CRYSTAL (90MHz)	
X204	1-767-151-11	VIBRATOR, CRYSTAL (22.579MHz)	

*	A-4699-065-A	DISPLAY BOARD, COMPLETE	

	2-389-320-01	CUSHION	
*	4-956-134-01	HOLDER (FL TUBE)	
*	4-983-189-01	HOLDER (LED-3)	
*	4-983-190-01	HOLDER (LED-2)	
< CAPACITOR >			
C701	1-162-282-31	CERAMIC 100PF	10% 50V
C702	1-162-282-31	CERAMIC 100PF	10% 50V
C703	1-162-282-31	CERAMIC 100PF	10% 50V
C704	1-162-282-31	CERAMIC 100PF	10% 50V
C705	1-162-282-31	CERAMIC 100PF	10% 50V
C706	1-162-282-31	CERAMIC 100PF	10% 50V
C709	1-162-292-31	CERAMIC 680PF	10% 50V
C710	1-162-292-31	CERAMIC 680PF	10% 50V
C711	1-162-292-31	CERAMIC 680PF	10% 50V
C712	1-162-292-31	CERAMIC 680PF	10% 50V
C713	1-162-292-31	CERAMIC 680PF	10% 50V
C714	1-162-292-31	CERAMIC 680PF	10% 50V
C715	1-162-292-31	CERAMIC 680PF	10% 50V
C716	1-162-292-31	CERAMIC 680PF	10% 50V
C717	1-162-292-31	CERAMIC 680PF	10% 50V
C718	1-162-292-31	CERAMIC 680PF	10% 50V
C719	1-162-292-31	CERAMIC 680PF	10% 50V
C720	1-162-292-31	CERAMIC 680PF	10% 50V
C721	1-162-292-31	CERAMIC 680PF	10% 50V
C722	1-162-292-31	CERAMIC 680PF	10% 50V
C723	1-162-292-31	CERAMIC 680PF	10% 50V

Ref. No.	Part No.	Description	Remark
C724	1-164-159-11	CERAMIC	0.1uF 50V
C725	1-126-154-11	ELECT	47uF 20% 6.3V
C726	1-164-159-11	CERAMIC	0.1uF 50V
C727	1-164-159-11	CERAMIC	0.1uF 50V
C729	1-164-159-11	CERAMIC	0.1uF 50V
C730	1-162-306-11	CERAMIC	0.01uF 20% 16V
C731	1-162-282-31	CERAMIC	100PF 10% 50V
C732	1-162-282-31	CERAMIC	100PF 10% 50V
C857	1-126-786-11	ELECT	47uF 20% 16V
C858	1-126-786-11	ELECT	47uF 20% 16V
C859	1-162-306-11	CERAMIC	0.01uF 20% 16V
C860	1-162-306-11	CERAMIC	0.01uF 20% 16V
C865	1-162-306-11	CERAMIC	0.01uF 20% 16V
C866	1-162-306-11	CERAMIC	0.01uF 20% 16V
C873	1-126-786-11	ELECT	47uF 20% 16V
C874	1-126-786-11	ELECT	47uF 20% 16V
C875	1-126-786-11	ELECT	47uF 20% 16V
C876	1-126-786-11	ELECT	47uF 20% 16V
C877	1-126-786-11	ELECT	47uF 20% 16V
C878	1-126-786-11	ELECT	47uF 20% 16V
C879	1-126-786-11	ELECT	47uF 20% 16V
C880	1-126-786-11	ELECT	47uF 20% 16V
< CONNECTOR >			
CN701	1-770-167-11	CONNECTOR, FFC/FPC 19P	
CN702	1-770-167-11	CONNECTOR, FFC/FPC 19P	
< DIODE >			
D801	8-719-046-36	DIODE SEL5921A-TH15 (REC SOURCE SELECTOR, CD)	
D802	8-719-046-36	DIODE SEL5921A-TH15 (REC SOURCE SELECTOR, LINE)	
D803	8-719-046-36	DIODE SEL5921A-TH15 (REC SOURCE SELECTOR, MIC)	
D804	8-719-029-27	DIODE SEL2210S-D-TP6S (CD-SYNC.)	
D805	8-719-029-27	DIODE SEL2210S-D-TP6S (● REC)	
D806	8-719-029-27	DIODE SEL2210S-D-TP6S (REC PAUSE)	
D811	8-719-301-43	DIODE SEL2410E-CD-TP6 (CD)	
D812	8-719-301-43	DIODE SEL2410E-CD-TP6 (CD)	
D813	8-719-301-43	DIODE SEL2410E-CD-TP6 (MD)	
D814	8-719-301-43	DIODE SEL2410E-CD-TP6 (MD)	
< FLUORESCENT INDICATOR >			
FL701	1-517-353-11	INDICATOR TUBE, FLUORESCENT	
< IC >			
IC701	8-759-455-12	IC M38197MA-162FP	
IC851	8-759-634-51	IC M5218AP	
IC852	8-759-634-51	IC M5218AP	
< TRANSISTOR >			
Q801	8-729-900-80	TRANSISTOR DTC114ES	

DISPLAY

Ref. No.	Part No.	Description	Remark	Ref. No.	Part No.	Description	Remark
Q802	8-729-900-80	TRANSISTOR DTC114ES		R738	1-249-429-11	CARBON 10K 5%	1/4W
Q803	8-729-900-80	TRANSISTOR DTC114ES		R739	1-249-429-11	CARBON 10K 5%	1/4W
Q804	8-729-900-80	TRANSISTOR DTC114ES		R740	1-249-429-11	CARBON 10K 5%	1/4W
Q805	8-729-900-80	TRANSISTOR DTC114ES		R741	1-249-429-11	CARBON 10K 5%	1/4W
Q806	8-729-900-80	TRANSISTOR DTC114ES		R742	1-249-429-11	CARBON 10K 5%	1/4W
Q811	8-729-900-80	TRANSISTOR DTC114ES		R743	1-249-429-11	CARBON 10K 5%	1/4W
Q813	8-729-902-80	TRANSISTOR DTA114YS		R744	1-249-429-11	CARBON 10K 5%	1/4W
Q820	8-729-900-80	TRANSISTOR DTC114ES		R745	1-249-429-11	CARBON 10K 5%	1/4W
Q831	8-729-900-80	TRANSISTOR DTC114ES		R746	1-249-429-11	CARBON 10K 5%	1/4W
Q833	8-729-900-80	TRANSISTOR DTC114ES		R747	1-249-429-11	CARBON 10K 5%	1/4W
Q835	8-729-900-80	TRANSISTOR DTC114ES		R748	1-249-429-11	CARBON 10K 5%	1/4W
Q851	8-729-141-26	TRANSISTOR 2SC3622A-LK		R751	1-249-429-11	CARBON 10K 5%	1/4W
Q852	8-729-141-26	TRANSISTOR 2SC3622A-LK		R752	1-249-421-11	CARBON 2.2K 5%	1/4W F
Q853	8-729-422-57	TRANSISTOR UN4111		R753	1-247-843-11	CARBON 3.3K 5%	1/4W
< RESISTOR >				R754	1-249-425-11	CARBON 4.7K 5%	1/4W F
R701	1-247-807-31	CARBON 100 5%	1/4W	R755	1-249-429-11	CARBON 10K 5%	1/4W
R702	1-247-807-31	CARBON 100 5%	1/4W	R756	1-249-435-11	CARBON 33K 5%	1/4W
R703	1-247-807-31	CARBON 100 5%	1/4W	R761	1-249-429-11	CARBON 10K 5%	1/4W
R704	1-247-807-31	CARBON 100 5%	1/4W	R762	1-249-421-11	CARBON 2.2K 5%	1/4W F
R705	1-247-807-31	CARBON 100 5%	1/4W	R763	1-247-843-11	CARBON 3.3K 5%	1/4W
R706	1-249-441-11	CARBON 100K 5%	1/4W	R764	1-249-425-11	CARBON 4.7K 5%	1/4W F
R708	1-247-807-31	CARBON 100 5%	1/4W	R765	1-249-429-11	CARBON 10K 5%	1/4W
R709	1-247-807-31	CARBON 100 5%	1/4W	R766	1-249-435-11	CARBON 33K 5%	1/4W
R710	1-247-807-31	CARBON 100 5%	1/4W	R771	1-249-429-11	CARBON 10K 5%	1/4W
R711	1-247-807-31	CARBON 100 5%	1/4W	R772	1-249-421-11	CARBON 2.2K 5%	1/4W F
R712	1-247-807-31	CARBON 100 5%	1/4W	R773	1-247-843-11	CARBON 3.3K 5%	1/4W
R713	1-247-807-31	CARBON 100 5%	1/4W	R774	1-249-425-11	CARBON 4.7K 5%	1/4W F
R714	1-247-807-31	CARBON 100 5%	1/4W	R775	1-249-429-11	CARBON 10K 5%	1/4W
R715	1-247-807-31	CARBON 100 5%	1/4W	R781	1-249-429-11	CARBON 10K 5%	1/4W
R716	1-247-807-31	CARBON 100 5%	1/4W	R782	1-249-421-11	CARBON 2.2K 5%	1/4W F
R717	1-247-807-31	CARBON 100 5%	1/4W	R783	1-247-843-11	CARBON 3.3K 5%	1/4W
R718	1-247-807-31	CARBON 100 5%	1/4W	R784	1-249-425-11	CARBON 4.7K 5%	1/4W F
R719	1-247-807-31	CARBON 100 5%	1/4W	R785	1-249-429-11	CARBON 10K 5%	1/4W
R720	1-249-441-11	CARBON 100K 5%	1/4W	R791	1-249-429-11	CARBON 10K 5%	1/4W
R721	1-249-441-11	CARBON 100K 5%	1/4W	R792	1-249-429-11	CARBON 10K 5%	1/4W
R722	1-247-807-31	CARBON 100 5%	1/4W	R793	1-247-807-31	CARBON 100 5%	1/4W
R723	1-247-807-31	CARBON 100 5%	1/4W	R794	1-247-807-31	CARBON 100 5%	1/4W
R724	1-247-807-31	CARBON 100 5%	1/4W	R795	1-247-807-31	CARBON 100 5%	1/4W
R725	1-247-807-31	CARBON 100 5%	1/4W	R796	1-249-429-11	CARBON 10K 5%	1/4W
R726	1-247-807-31	CARBON 100 5%	1/4W	R797	1-249-411-11	CARBON 330 5%	1/4W
R727	1-247-807-31	CARBON 100 5%	1/4W	R801	1-249-409-11	CARBON 220 5%	1/4W F
R728	1-247-807-31	CARBON 100 5%	1/4W	R802	1-249-409-11	CARBON 220 5%	1/4W F
R729	1-247-807-31	CARBON 100 5%	1/4W	R803	1-249-409-11	CARBON 220 5%	1/4W F
R730	1-247-807-31	CARBON 100 5%	1/4W	R804	1-249-415-11	CARBON 680 5%	1/4W F
R731	1-249-429-11	CARBON 10K 5%	1/4W	R805	1-249-415-11	CARBON 680 5%	1/4W F
R732	1-249-429-11	CARBON 10K 5%	1/4W	R806	1-249-415-11	CARBON 680 5%	1/4W F
R733	1-249-429-11	CARBON 10K 5%	1/4W	R811	1-249-413-11	CARBON 470 5%	1/4W F
R734	1-249-429-11	CARBON 10K 5%	1/4W	R812	1-249-413-11	CARBON 470 5%	1/4W F
R735	1-249-429-11	CARBON 10K 5%	1/4W	R813	1-249-413-11	CARBON 470 5%	1/4W F
R736	1-249-429-11	CARBON 10K 5%	1/4W	R814	1-249-413-11	CARBON 470 5%	1/4W F
R737	1-249-429-11	CARBON 10K 5%	1/4W	R820	1-249-437-11	CARBON 47K 5%	1/4W
				R831	1-249-441-11	CARBON 100K 5%	1/4W

DISPLAY

HEADPHONE

MIC

Ref. No.	Part No.	Description	Remark
R833	1-249-441-11	CARBON 100K	5% 1/4W
R835	1-249-441-11	CARBON 100K	5% 1/4W
R851	1-249-427-11	CARBON 6.8K	5% 1/4W F
R852	1-249-427-11	CARBON 6.8K	5% 1/4W F
R853	1-249-427-11	CARBON 6.8K	5% 1/4W F
R854	1-249-427-11	CARBON 6.8K	5% 1/4W F
R855	1-249-426-11	CARBON 5.6K	5% 1/4W
R856	1-249-426-11	CARBON 5.6K	5% 1/4W
R857	1-249-425-11	CARBON 4.7K	5% 1/4W F
R858	1-249-425-11	CARBON 4.7K	5% 1/4W F
R859	1-249-441-11	CARBON 100K	5% 1/4W
R860	1-249-441-11	CARBON 100K	5% 1/4W
R861	1-247-899-11	CARBON 680K	5% 1/4W
R862	1-247-899-11	CARBON 680K	5% 1/4W
R863	1-247-807-31	CARBON 100	5% 1/4W
R865	1-249-430-11	CARBON 12K	5% 1/4W
R866	1-249-430-11	CARBON 12K	5% 1/4W
< VARIABLE RESISTOR >			
RV851	1-223-762-11	RES, VAR, CARBON 20K/20K (MIX BALANCE)	
RV852	1-223-762-11	RES, VAR, CARBON 20K/20K (REC LEVEL)	
< SWITCH >			
S751	1-554-303-21	SWITCH, TACTILE (EDIT/NO)	
S752	1-554-303-21	SWITCH, TACTILE (YES)	
S753	1-554-303-21	SWITCH, TACTILE (REC SOURCE SELECTOR, MIC)	
S754	1-554-303-21	SWITCH, TACTILE (REC SOURCE SELECTOR, LINE)	
S755	1-554-303-21	SWITCH, TACTILE (REC SOURCE SELECTOR, CD)	
S756	1-554-303-21	SWITCH, TACTILE (≡ EJECT)	
S761	1-554-303-21	SWITCH, TACTILE (REC.PAUSE)	
S762	1-554-303-21	SWITCH, TACTILE (■)	
S763	1-554-303-21	SWITCH, TACTILE (◀◀)	
S764	1-554-303-21	SWITCH, TACTILE (▶▶)	
S765	1-467-818-11	ENCODER, ROTARY (◀◀ AMS ▶▶)	
S766	1-554-303-21	SWITCH, TACTILE (MD)	
S771	1-554-303-21	SWITCH, TACTILE (CD-SYNC.)	
S772	1-554-303-21	SWITCH, TACTILE (● REC)	
S773	1-554-303-21	SWITCH, TACTILE (▨)	
S774	1-554-303-21	SWITCH, TACTILE (▷)	
S775	1-554-303-21	SWITCH, TACTILE (CD)	
S781	1-554-303-21	SWITCH, TACTILE (SCROLL)	
S782	1-554-303-21	SWITCH, TACTILE (REPEAT)	
S783	1-554-303-21	SWITCH, TACTILE (PLAY MODE)	
S784	1-554-303-21	SWITCH, TACTILE (DISPLAY)	
< VIBRATOR >			
X701	1-767-163-11	VIBRATOR, CERAMIC (8MHz)	

Ref. No.	Part No.	Description	Remark
*	1-661-675-11	HEADPHONE BOARD *****	
< CAPACITOR >			
C951	1-162-294-31	CERAMIC 0.001uF	10% 50V
C952	1-162-294-31	CERAMIC 0.001uF	10% 50V
C953	1-162-294-31	CERAMIC 0.001uF	10% 50V
C954	1-162-294-31	CERAMIC 0.001uF	10% 50V
C955	1-412-473-21	INDUCTOR 0UH	
< JACK >			
J951	1-770-306-11	JACK (LARGE TYPE)(PHONES)	
< RESISTOR >			
R951	1-249-393-11	CARBON 10	5% 1/4W F
R952	1-249-393-11	CARBON 10	5% 1/4W F
< VARIABLE RESISTOR >			
RV951	1-225-302-11	RES, VAR, CARBON 1K/1K (PHONES LEVEL)	

*	A-4699-069-A	MIC BOARD, COMPLETE (AEP,G,UK,SP) *****	
*	A-4699-070-A	MIC BOARD, COMPLETE (US,CND) *****	
< CAPACITOR >			
C901	1-412-473-51	INDUCTOR 0UH	
C903	1-115-871-11	ELECT 1uF	20% 50V
C904	1-115-871-11	ELECT 1uF	20% 50V
C905	1-162-294-31	CERAMIC 0.001uF	10% 50V
C906	1-162-294-31	CERAMIC 0.001uF	10% 50V
C907	1-162-282-31	CERAMIC 100PF	10% 50V
C908	1-162-282-31	CERAMIC 100PF	10% 50V
C909	1-162-294-31	CERAMIC 0.001uF	10% 50V
C910	1-162-294-31	CERAMIC 0.001uF	10% 50V
C911	1-115-871-11	ELECT 1uF	20% 50V
C912	1-115-871-11	ELECT 1uF	20% 50V
C913	1-162-306-11	CERAMIC 0.01uF	20% 16V
C914	1-162-306-11	CERAMIC 0.01uF	20% 16V
C920	1-412-473-21	INDUCTOR 0UH	
C921	1-162-294-31	CERAMIC 0.001uF	10% 50V
C922	1-162-294-31	CERAMIC 0.001uF	10% 50V
< IC >			
IC901	8-759-634-51	IC M5218AP	
< JACK >			
J901	1-770-306-21	JACK (LARGE TYPE)(MIC)	

MIC

POWER SWITCH

SWITCH

TRANS

Ref. No.	Part No.	Description	Remark
		< COIL >	
L905	1-412-911-11	INDUCTOR, FERRITE BEAD (US,CND) (SUFFIX No. -14 or LATER)	
L906	1-412-911-11	INDUCTOR, FERRITE BEAD (US,CND) (SUFFIX No. -14 or LATER)	
		< RESISTOR >	
R901	1-249-413-11	CARBON 470 5% 1/4W F	
R902	1-249-413-11	CARBON 470 5% 1/4W F	
R903	1-249-429-11	CARBON 10K 5% 1/4W	
R904	1-249-429-11	CARBON 10K 5% 1/4W	
R905	1-249-433-11	CARBON 22K 5% 1/4W	
R906	1-249-433-11	CARBON 22K 5% 1/4W	
R907	1-249-431-11	CARBON 15K 5% 1/4W	
R908	1-249-431-11	CARBON 15K 5% 1/4W	
R909	1-249-413-11	CARBON 470 5% 1/4W F	
R910	1-249-413-11	CARBON 470 5% 1/4W F	
R911	1-249-413-11	CARBON 470 5% 1/4W F	
R912	1-249-413-11	CARBON 470 5% 1/4W F	
R913	1-249-441-11	CARBON 100K 5% 1/4W	
R914	1-249-441-11	CARBON 100K 5% 1/4W	

*	1-661-674-11	POWER SWITCH BOARD *****	
*	4-972-608-01	HOLDER (DIA. 5), LED < CAPACITOR >	
C728	1-162-306-11	CERAMIC 0.01uF 20% 16V	
C827	1-162-306-11	CERAMIC 0.01uF 20% 16V	
C828	1-126-513-11	ELECT 47uF 20% 6.3V	
		< DIODE >	
D821	8-719-313-40	DIODE SEL1516W (ON/STANDBY) < IC >	
IC827	8-759-332-18	IC GP1U27XB < TRANSISTOR >	
Q821	8-729-900-80	TRANSISTOR DTC114ES	
Q823	8-729-422-57	TRANSISTOR UN4111 < RESISTOR >	
R786	1-249-435-11	CARBON 33K 5% 1/4W	
R798	1-249-437-11	CARBON 47K 5% 1/4W	
R821	1-249-411-11	CARBON 330 5% 1/4W	
R823	1-249-411-11	CARBON 330 5% 1/4W	
R827	1-247-807-31	CARBON 100 5% 1/4W	

Ref. No.	Part No.	Description	Remark
		< SWITCH >	
S785	1-554-303-21	SWITCH, TACTILE (ON/STANDBY)	
S786	1-554-303-21	SWITCH, TACTILE (≡ OPEN/CLOSE)	

*	1-661-680-11	SWITCH BOARD (AEP,G,UK) *****	
	1-769-745-11	LEAD (WITH CONNECTOR) (2 CORE) < CAPACITOR >	
△C1029	1-113-924-11	CERAMIC 0.0047uF 20% 250V	
		< CONNECTOR >	
CN1011	1-564-321-00	PIN, CONNECTOR 2P < SWITCH >	
△S1011	1-692-664-11	SWITCH, AC POWER SEESAW (MAIN POWER)	

*	1-661-678-11	TRANS BOARD *****	
		< CAPACITOR >	
△C1001	1-113-924-11	CERAMIC 0.0047uF 20% 250V (EXCEPT SP)	
△C1001	1-162-599-12	CERAMIC 0.0047uF 20% 400V (SP)	
		< CONNECTOR >	
CN1001	1-564-523-11	PLUG, CONNECTOR 8P	
* CN1002	1-580-230-31	PIN, CONNECTOR (PC BOARD) 2P < LINE FILTER >	
△LF1001	1-424-485-11	FILTER, LINE < SWITCH >	
△S1001	1-572-675-11	SWITCH, POWER VOLTAGE CHANGE (VOLTAGE SELECTOR)(SP) < TRANSFORMER >	
△TR1001	1-429-702-11	TRANSFORMER, POWER (US,CND)	
△TR1001	1-429-703-11	TRANSFORMER, POWER (AEP,G,UK)	
△TR1001	1-429-704-11	TRANSFORMER, POWER (SP)	

The components identified by mark △ or dotted line with mark △ are critical for safety. Replace only with part number specified.

Les composants identifiés par une marque △ sont critiques pour la sécurité. Ne les remplacer que par une pièce portant le numéro spécifié.

<u>Ref. No.</u>	<u>Part No.</u>	<u>Description</u>	<u>Remark</u>
		MISCELLANEOUS *****	
△ 61	1-558-945-21	CORD, POWER (POLAR. SPT-1) (US,CND)	
△ 61	1-575-651-21	CORD, POWER (AEP,G)	
△ 61	1-696-586-21	CORD, POWER (UK)	
△ 61	1-751-275-11	CORD, POWER (SP)	
FL701	1-517-353-11	INDICATOR TUBE, FLUORESCENT	
△ TR1001	1-429-702-11	TRANSFORMER, POWER (US,CND)	
△ TR1001	1-429-703-11	TRANSFORMER, POWER (AEP,G,UK)	
△ TR1001	1-429-704-11	TRANSFORMER, POWER (SP)	

<p>The components identified by mark △ or dotted line with mark △ are critical for safety. Replace only with part number specified.</p>	<p>Les composants identifiés par une marque △ sont critiques pour la sécurité. Ne les remplacer que par une pièce portant le numéro spécifié.</p>
---	---

