

About Zhang's premodels for Siegel disks of quadratic rational maps.

Arnaud Chéritat

CNRS, Univ. Toulouse

Feb. 2011

Let us show the result of a computer experiment,
and then we will explain what lies behind.

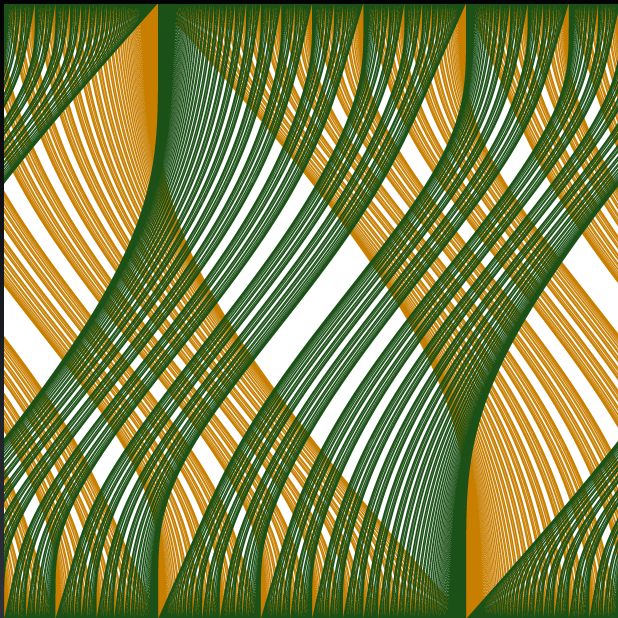

Siegel disks

A Siegel disk is a (maximal) domain on which a holomorphic map is conjugated to a rotation, whose angle divided by one turn is called the *rotation number*.

Golden mean rotation
number

$$P(z) = e^{2i\pi \frac{\sqrt{5}-1}{2}} z + z^2$$

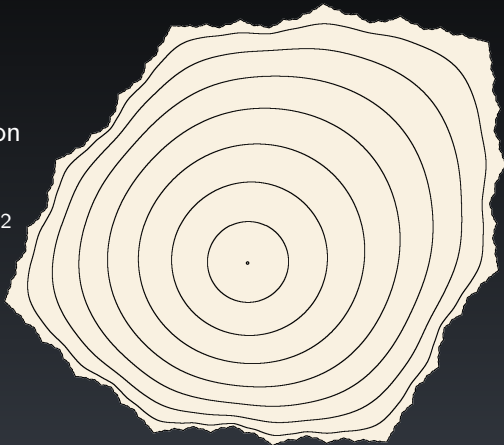

Quasiconformal models of Siegel disks

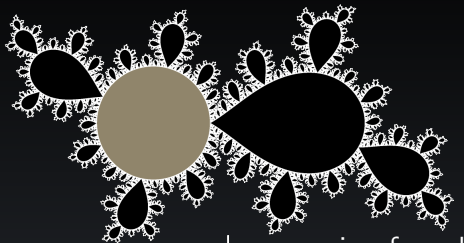

modified
degree 3
Blaschke
fraction

quasiconformal
conjugacy

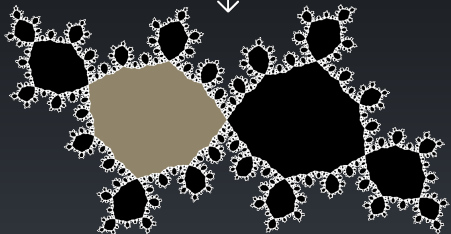

degree 2
polynomial

Quasiconformal models of Siegel disks

1. Take a map: $B(z) \mapsto z^2 \frac{z-3}{1-3z}$.

It restricts to an analytic circle homeomorphism on the unit circle S^1 with a unique critical point $z = 1$.

Quasiconformal models of Siegel disks

1. Take a map: $B(z) \mapsto z^2 \frac{z-3}{1-3z}$.

It restricts to an analytic circle homeomorphism on the unit circle S^1 with a unique critical point $z = 1$.

2. Compose with a rotation to adjust the rotation number of $z \mapsto e^{2\pi i\tau} B(z)$ to a given bounded type number.

Then the Poincaré semiconjugacy to a rotation is bijective and quasisymmetric.

Quasiconformal models of Siegel disks

1. Take a map: $B(z) \mapsto z^2 \frac{z-3}{1-3z}$.

It restricts to an analytic circle homeomorphism on the unit circle S^1 with a unique critical point $z = 1$.

2. Compose with a rotation to adjust the rotation number of $z \mapsto e^{2\pi i\tau} B(z)$ to a given bounded type number.

Then the Poincaré semiconjugacy to a rotation is bijective and quasymmetric.

3. Modify it: inside the unit disk, replace by a q.c. rotation $\rightsquigarrow \tilde{B}$ (possible iff the Poincaré map is quasymmetric).

Then \tilde{B} has an invariant ellipse field.

Quasiconformal models of Siegel disks

1. Take a map: $B(z) \mapsto z^2 \frac{z-3}{1-3z}$.

It restricts to an analytic circle homeomorphism on the unit circle S^1 with a unique critical point $z = 1$.

2. Compose with a rotation to adjust the rotation number of $z \mapsto e^{2\pi i\tau} B(z)$ to a given bounded type number.

Then the Poincaré semiconjugacy to a rotation is bijective and quasymmetric.

3. Modify it: inside the unit disk, replace by a q.c. rotation $\rightsquigarrow \tilde{B}$ (possible iff the Poincaré map is quasymmetric).

Then \tilde{B} has an invariant ellipse field.

4. The straightening of the ellipse field conjugates \tilde{B} to a rational map, and simple observations show that this map is Möbius conjugated to a quadratic polynomial.

Quasiconformal models of Siegel disks

premodel B \rightsquigarrow q.c. model \rightsquigarrow holomorphic map

Yampolsky and Zakeri

... studied degree 2 rational maps with 2 period 1 Siegel disks.

By the Fatou-Shishikura inequality, all the other cycles of such maps must be repelling and by the Fatou-Sullivan classification of components, every Fatou components is eventually mapped to one of the Siegel disks under iteration.

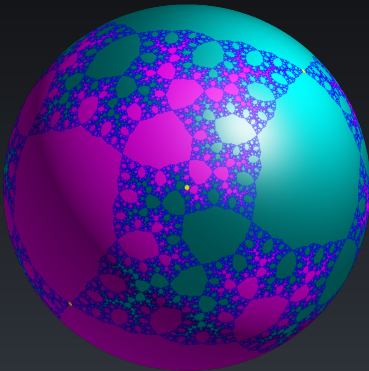

Multipliers of fixed points

(compare Milnor)

A quadratic rational map has 1, 2, or 3 fixed points.

Lemma

If R is a quadratic rational map and $z_1 \neq z_2$ are two fixed points of R of multipliers λ_1 and λ_2 then $\lambda_1\lambda_2 \neq 1$.

In particular, two Siegel disks of period one cannot have opposite rotation numbers.

Lemma

For all pair λ_1, λ_2 with $\lambda_1\lambda_2 \neq 1$, there exists a quadratic rational map, unique up to Möbius conjugacy, with a fixed point z_1 of multiplier λ_1 and a fixed point $z_2 \neq z_1$ of multiplier λ_2 .

This map has a third fixed point unless $\lambda_1 = 1$ or $\lambda_2 = 1$.

Yampolsky and Zakeri

Let α, β with $\alpha + \beta \notin \mathbb{Z}$. Let $R_{\alpha, \beta}$ be the quadratic rational map, unique up to Möbius conjugacy, with a fixed point of multiplier $e^{2\pi i \alpha}$ and another fixed point of multiplier $e^{2\pi i \beta}$.

Let $P_\alpha = e^{2\pi i \alpha} z + z^2$ be the quadratic polynomial (also unique up to Möbius conjugacy) with a fixed point of multiplier $e^{2\pi i \alpha}$.

Theorem (Yampolsky Zakeri)

For all bounded type irrationals α, β with $\alpha + \beta \notin \mathbb{Z}$, the map $R_{\alpha, \beta}$ is the mating of P_α with P_β .

Their proof makes use of a quasiconformal model, whose premodel is a degree 3 Blaschke fraction f with the following properties:

- f is a orientation preserving homeomorphism on the circle, with only one critical point on the circle, and rotation number α
- f fixes ∞ with multiplier $e^{2\pi i\beta}$

The surgery implies right away that the boundary of one Siegel disk of $R_{\alpha,\beta}$ is a quasicircle containing a critical point. Since $R_{\alpha,\beta}$ and $R_{\beta,\alpha}$ are Möbius conjugate, the same is true for the other Siegel disk of $R_{\alpha,\beta}$.

To prove the mating, they used a combinatorial description of the Julia sets of P_α and P_β and $R_{\alpha,\beta}$ in terms of drops.

Yampolsky and Zakeri

Picture of the quasiconformal model

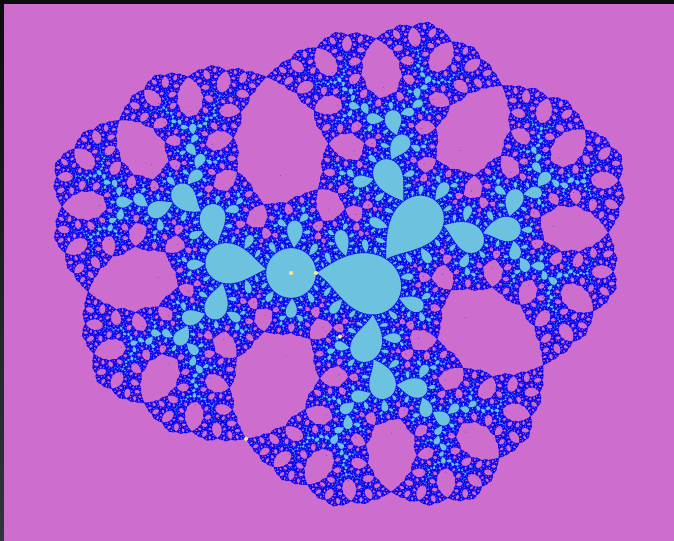

Drops and wakes

Their diameter tends to 0

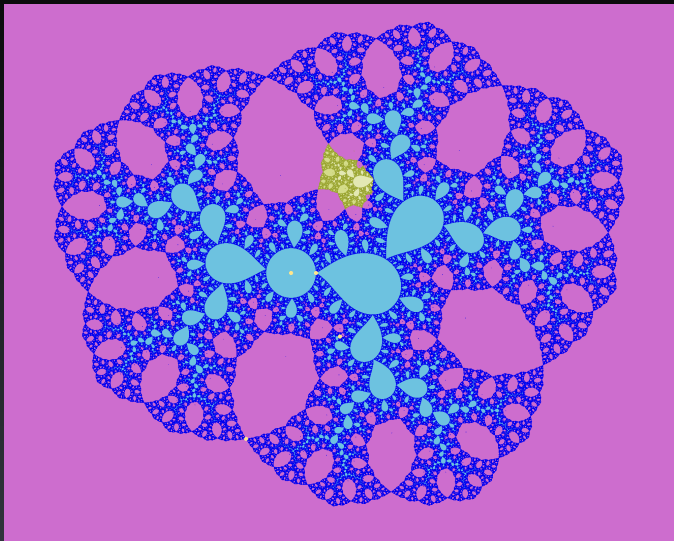

Petersen and Zakeri

Petersen and Zakeri extended the class of rotation number for which a surgery is possible to a class PZ, using *trans-quasiconformal* surgery.

$$[a_0; a_1, a_2, \dots] \in \text{PZ} \iff \log a_n = \mathcal{O}(\sqrt{n}).$$

A map is trans-q.c. when it is a homeomorphism in the Sobolev space H^1 and the area of the set of points where the differential has distortion $> K$ decreases exponentially with K .

P and Z were able to complete the proof that the surgery works in the case of quadratic polynomials.

Unlike the case of bounded type numbers, which has measure zero, almost every real belongs to the class PZ.

Zhang Gaofei is proving that a trans q.c.-conformal surgery is also possible for the rational maps studied by Yampolsky and Zakeri.

Petersen and Zakeri

Petersen and Zakeri extended the class of rotation number for which a surgery is possible to a class PZ, using *trans-quasiconformal* surgery.

$$[a_0; a_1, a_2, \dots] \in \text{PZ} \iff \log a_n = \mathcal{O}(\sqrt{n}).$$

A map is trans-q.c. when it is a homeomorphism in the Sobolev space H^1 and the area of the set of points where the differential has distortion $> K$ decreases exponentially with K .

P and Z were able to complete the proof that the surgery works in the case of quadratic polynomials.

Unlike the case of bounded type numbers, which has measure zero, almost every real belongs to the class PZ.

Zhang Gaofei is proving that a trans q.c.-conformal surgery is also possible for the rational maps studied by Yampolsky and Zakeri.

... so he is kind of mixing Yampolsky-Zakeri with Petersen-Zakeri.

$YZ + PZ$

the problem

A slight subtlety arises: unlike quasiconformal surgery, trans-quasiconformal surgery requires to check a non-obvious area estimate on the ellipse field form. This field is defined by pulling back an ellipse field on the unit disk by the model, and pull-back arguments nearly always require to handle the post-critical set, i.e. the closure of the orbits of the critical points.

If the pre-model is the Blaschke fraction used by Yampolsky and Zakeri, then the critical point on the unit circle has an orbit which is contained in the unit circle and dense. *But* a priori, the other critical point does not necessarily have a nice behavior: it could even have an orbit which is dense in the Julia set. Then the area estimate cannot be done and nothing can be said on $R_{\alpha,\beta}$.

Zhang's premodels

Zhang's solution

Solution: take a premodel which preserves two circles.

Definition (Zhang's premodel)

Let σ_1 and σ_R be the reflections across the unit circle C_1 and the circle C_R of equation $|z| = R$. A *Zhang's premodel* is a holomorphic map

$B : \mathbb{C} \setminus \{0\} \rightarrow \widehat{\mathbb{C}}$ such that

- B commutes with σ_1 and σ_R (in particular B must leave C_1 and C_R invariant)
- the restrictions of B to C_1 and C_R are two orientation preserving homeomorphisms, each with only one critical point, of local degree 3
- 0 has exactly 1 preimage between the two circles, and this preimage is not a critical point

Zhang's premodels

Topol. picture in the fund. annulus bounded by C_1 and C_r

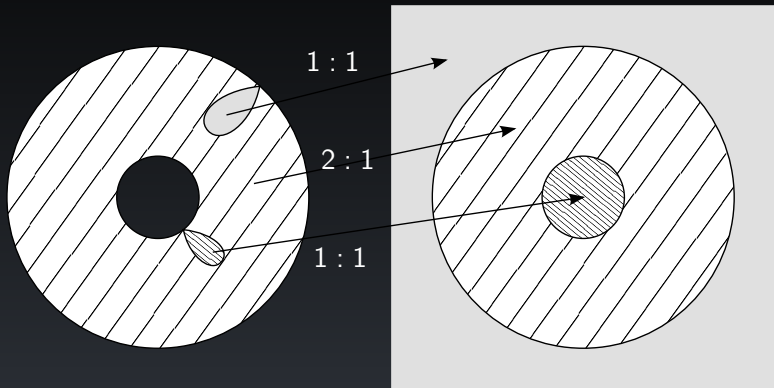

Zhang's premodels

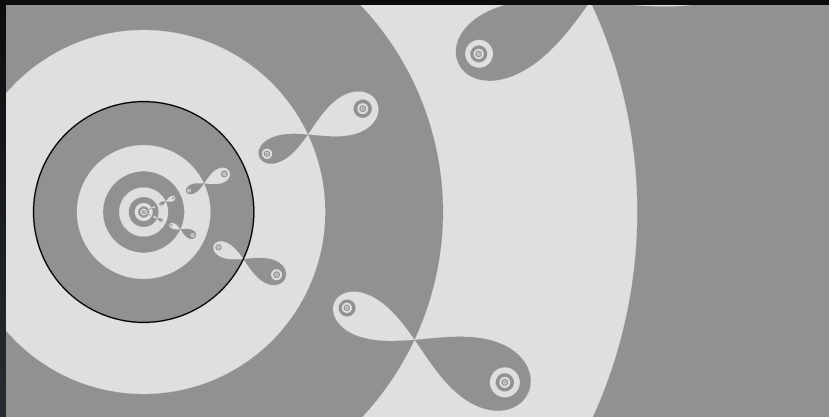

This image is topologically correct, not conformally.

Existence of premodels with prescribed rotation numbers

Theorem (Zhang)

For all real numbers α, β with $\alpha - \beta \notin \mathbb{Z}$, there exists such a premodel with rotation number α on C_1 and β on C_R .

Zhang's proof:

- Construct the map $B_{\alpha, \beta}$ as a limit of maps $B_{p/q, p'/q'}$ where $p/q \rightarrow \alpha$ and $p'/q' \rightarrow \beta$ (the rotation number of a map depends continuously on the map).
- The map $B_{p/q}$ is constructed so that the two critical points are periodic.
- Its existence follows from Thurston's algorithm, working on a torus instead of a sphere.

Zhang's method is constructive and implementable on a computer.

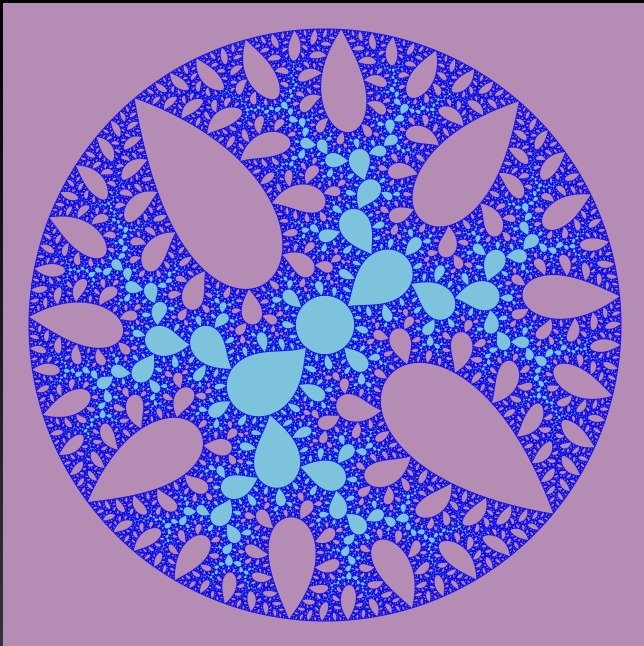

Other constructions of the premodels

Shishikura's method

Shishikura devised a kind of reverse quasiconformal surgery:

rational map with a Siegel disk \rightsquigarrow rational map leaving S^1 invariant

it transforms an invariant curve inside the Siegel disk into S^1 , so the new map does not have a critical point on S^1 . If one varies the curve and let it tend to the boundary of the Siegel disk, then *in the case of polynomials*, using compactness of the set of Blaschke fraction thereby obtained, Shishikura was able to get as a limit a map with a critical point on S^1 .

Other constructions of the premodels

Shishikura's method

Shishikura devised a kind of reverse quasiconformal surgery:

rational map with a Siegel disk \rightsquigarrow rational map leaving S^1 invariant

it transforms an invariant curve inside the Siegel disk into S^1 , so the new map does not have a critical point on S^1 . If one varies the curve and let it tend to the boundary of the Siegel disk, then *in the case of polynomials*, using compactness of the set of Blaschke fraction thereby obtained, Shishikura was able to get as a limit a map with a critical point on S^1 .

Zakeri adapted it to some class of entire maps.

Zhang adapted it to all rational maps.

Note that such a surgery can be adapted to transform simultaneously two Siegel disks (or more) of period 1 into round disks, i.e. create a map with two invariant circles (or more).

Other constructions of the premodels

Riemann surfaces

Conjugate things by $z \mapsto -\log(z)/2i\pi$, which sends \mathbb{C}^* to the cylinder \mathbb{C}/\mathbb{Z} , sending 0 to the lower end and ∞ to the upper end. A Zhang's premodel must map things as follows:

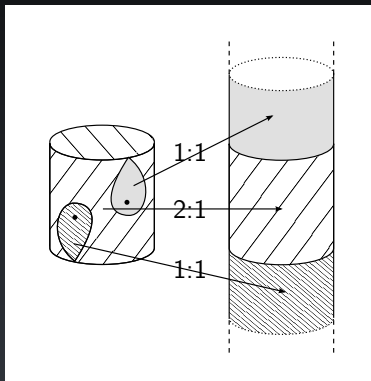

Three constructions of the premodels

III. Riemann surfaces.

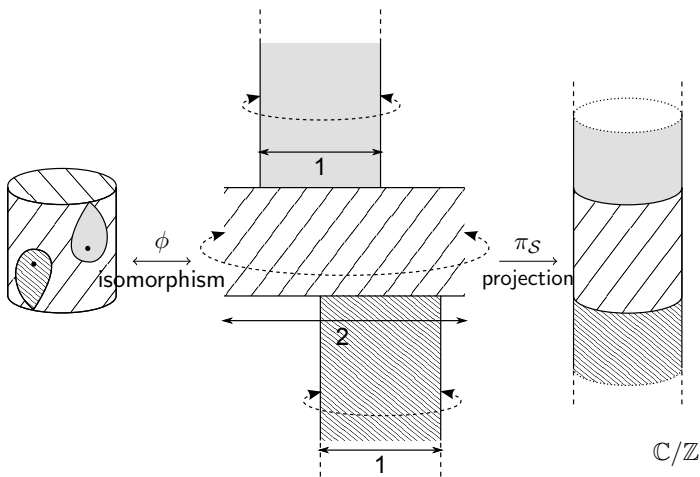

Three constructions of the premodels

III. Riemann surfaces.

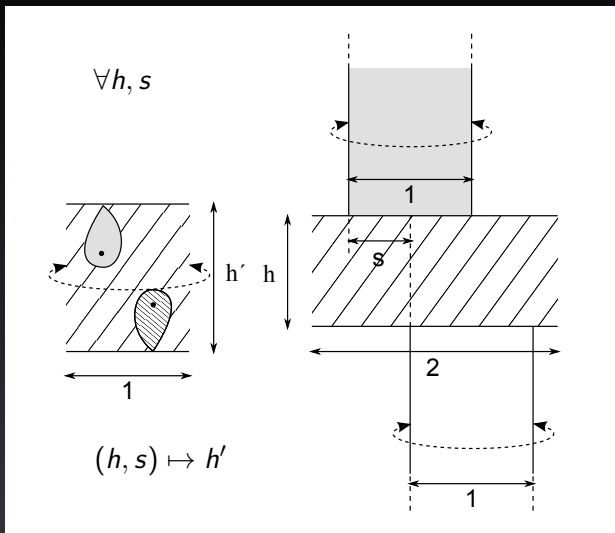

Three constructions of the premodels

III. Riemann surfaces.

We want the circles bounding the fundamental annulus to be invariant, so we consider only the pairs $(h, s) \in]0, +\infty[\times \mathbb{R}/2\mathbb{Z}$ such that $h'(h, s) = h$. We therefore get the amusing problem of determining the shape of this set.

Two approaches:

- Working with modulus estimates.
- Working with explicit formulae, if they exist.

Zhang's infinite Blaschke fraction formula

Let a and b be the zero and the pole of B in the fundamental annulus $1 < |z| < R$. Then

$$B(z) = e^{2i\pi\tau} z \prod_{k=0}^{+\infty} \left(\frac{z - a_k}{1 - \overline{a_k}z} \frac{1 - \overline{b_k}z}{z - b_k} \right)^{(-1)^k}$$

where $a_k = R^k a$, $b_k = R^k b$.

The condition $h = h'$ translates into: $|b| = |a|$.

However, for arbitrary a, b, R with $1 < |a| = |b| < R$, such a map does not necessarily have critical points on C_1 and C_R .

Zhang's infinite Blaschke fraction formula

First, a Zhang's premodel necessarily has the following symmetry:
 $B(R/z) = \lambda R/B(z)$ where $|\lambda| = 1$. It implies that $|b| = R/|a|$, so:

$$|a| = |b| = \sqrt{R}.$$

But this is not enough, and there still remains to adjust $\arg(b/a)$ and R .

Numerical study of the pairs (h, s)

Using these formulae, one can numerically trace the corresponding values of (h, s) :

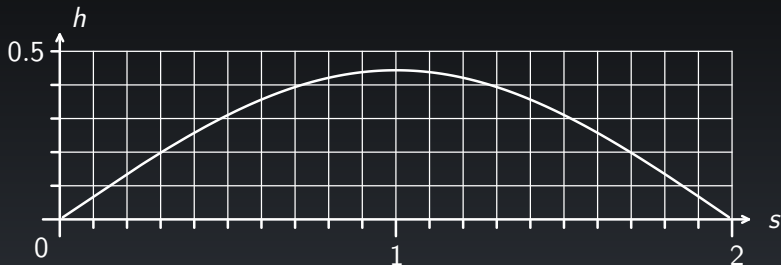

It is very close to a sine curve, but different.

Numerical study of h, s, α

Let $\alpha = \arg(a/b)/2\pi \in]0, 1[$.

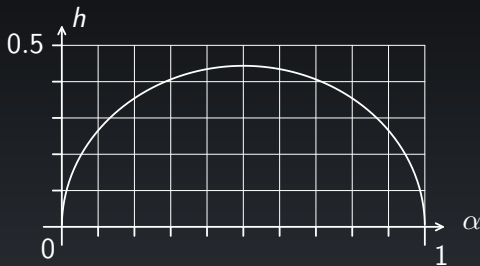

Numerical study of the rotation number

We thus have a two parameters family of Zhang's premodels $B(z) = e^{2i\pi\tau} B_\alpha(z)$, depending on $\alpha \in]0, 1[$ and on $\tau \in \mathbb{R}/\mathbb{Z}$.

Let the horizontal coordinate be τ and the vertical one be α .

Let us draw in red the set where the rotation number of B on C_1 is irrationnal, and in blue the set where the rotation number of B on C_R is irrationnal.

Numerical study of the rotation number

$$\frac{\arg(a/b)}{2\pi}$$

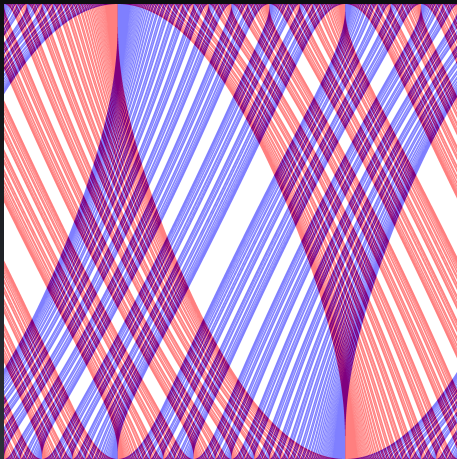

\mathcal{T}

Observations and conjectures

- The Arnold' tongues with the same rotation number do not intersect (this follows from a Th...n obstruction on the corresponding torus map).
- The intersection of the two laminations are transverse.
- For a fixed τ , with the particular convention chosen in the picture, the rotation number is a monotone function of α .
- The order of contact of the tongues with the horizontal axis is 2.

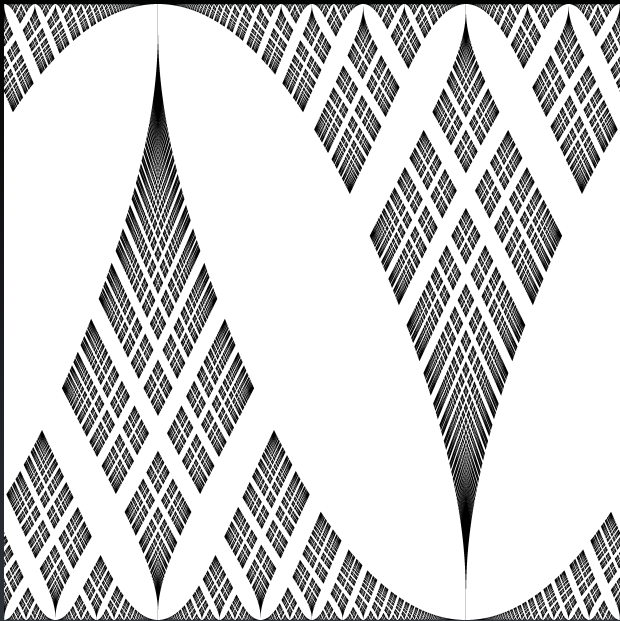

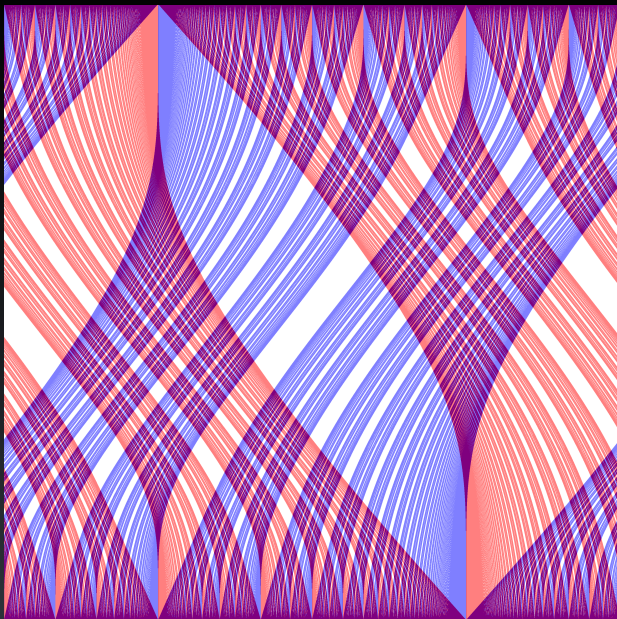

And of course. . .



Happy Birthday
Jack!