

INSTALLATION INSTRUCTIONS

FOR RENAISSANCE™ PACKAGED GAS ELECTRIC UNITS

RGED SERIES 7.5, 8.5, 10.0 & 12.5 TON [26.4, 29.9, 35.2 & 44.0 KW]

60 HZ MODELS

WITH R-410A REFRIGERANT

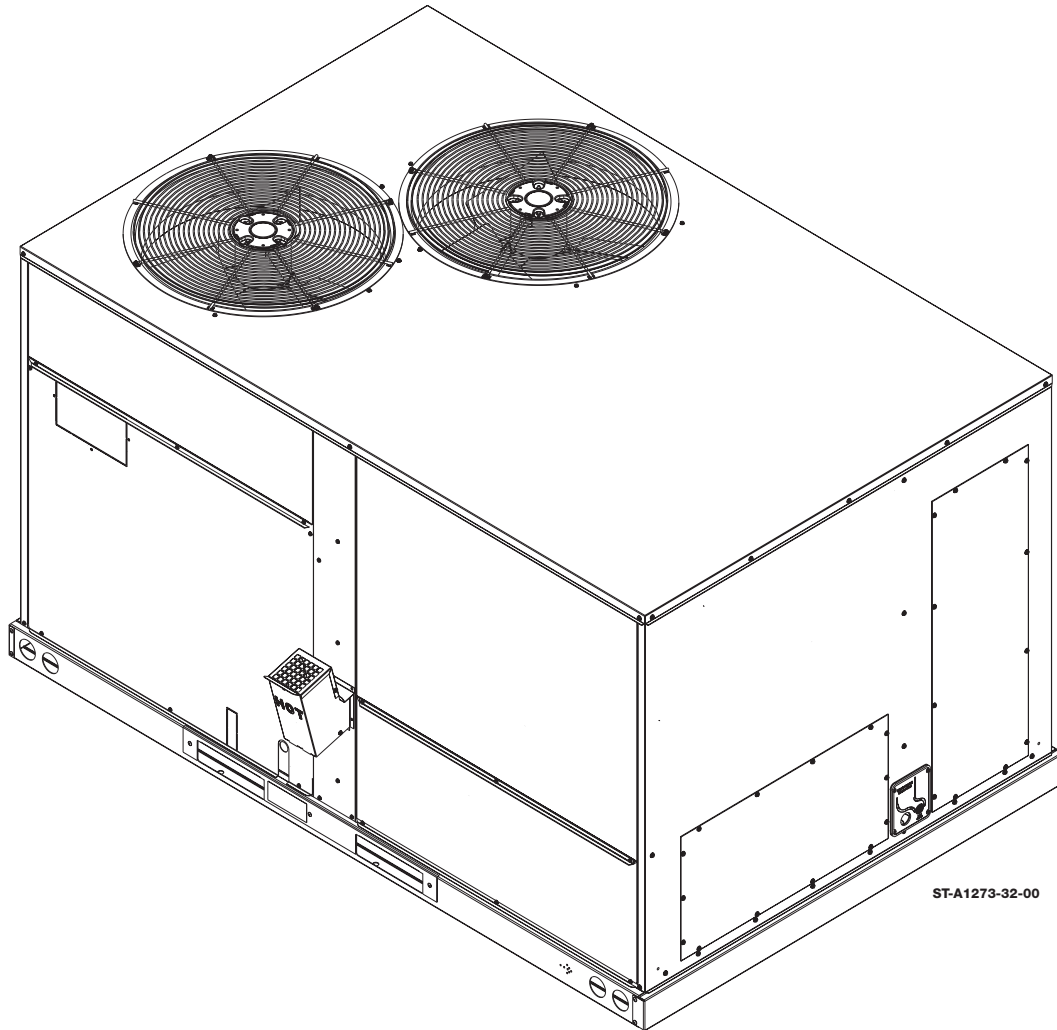

ST-A1273-32-00

CONTENTS

A. Important Safety and General Information	4	P. Appendices	79
B. General Specifications	5	A - General Product Data	79
C. Installation of the Unit	11	B - Electrical Data	81
D. Duct and Venting	20	C - Air Flow Performance Data	85
E. Electrical	27	D - Heat & Cool Performance Data	93
F. Control/Thermostat Wiring	31	E - Gas Heat Performance Data	101
G. Gas	34	F - Refrigerant Charging Charts	102
J. Startup and Operation	46	G - Wiring Diagrams & Schematics	114
K. Test and Balance	54	J - Unit Tie-Down	159
M. Humidity Control	55	R. Information for the Owner	164
N. Diagnostics	58	S. Installation Check List and Job Site Sheet	165

DO NOT DESTROY THIS MANUAL. PLEASE READ CAREFULLY AND KEEP IN A SAFE PLACE FOR FUTURE REFERENCE BY A SERVICEMAN.



RECOGNIZE THIS SYMBOL AS AN INDICATION OF IMPORTANT SAFETY INFORMATION!

▲ WARNING

IF THE INFORMATION IN THESE INSTRUCTIONS IS NOT FOLLOWED EXACTLY, A FIRE OR EXPLOSION MAY RESULT, CAUSING PROPERTY DAMAGE, PERSONAL INJURY OR DEATH.

▲ WARNING

THESE INSTRUCTIONS ARE INTENDED AS AN AID TO QUALIFIED SERVICE PERSONNEL FOR PROPER INSTALLATION, ADJUSTMENT AND OPERATION OF THIS UNIT. READ THESE INSTRUCTIONS THOROUGHLY BEFORE ATTEMPTING INSTALLATION OR OPERATION. FAILURE TO FOLLOW THESE INSTRUCTIONS MAY RESULT IN IMPROPER INSTALLATION, ADJUSTMENT, SERVICE OR MAINTENANCE, POSSIBLY RESULTING IN FIRE, ELECTRICAL SHOCK, CARBON MONOXIDE POISONING, EXPLOSION, PROPERTY DAMAGE, PERSONAL INJURY OR DEATH.

▲ WARNING

PROPOSITION 65 WARNING: THIS PRODUCT CONTAINS CHEMICALS KNOWN TO THE STATE OF CALIFORNIA TO CAUSE CANCER, BIRTH DEFECTS OR OTHER REPRODUCTIVE HARM.

▲ WARNING

- Do not store or use gasoline or other flammable vapors and liquids, or other combustible materials in the vicinity of this or any other appliance.
- WHAT TO DO IF YOU SMELL GAS
 - Do not try to light any appliance.
 - Do not touch any electrical switch; do not use any phone in your building.
 - Immediately call your gas supplier from a neighbor's phone. Follow the gas supplier's instructions.
 - If you cannot reach your gas supplier, call the fire department.
 - Do not return to your home until authorized by the gas supplier or fire department.
- DO NOT RELY ON SMELL ALONE TO DETECT LEAKS. DUE TO VARIOUS FACTORS, YOU MAY NOT BE ABLE TO SMELL FUEL GASES.
 - U.L. recognized fuel gas and CO detectors are recommended in all applications, and their installation should be in accordance with the manufacturer's recommendations and/or local laws, rules, regulations, or customs.
- Improper installation, adjustment, alteration, service or maintenance can cause injury, property damage or death. Refer to this manual. Installation and service must be performed by a qualified installer, service agency or the gas supplier. In the commonwealth of Massachusetts, installation must be performed by a licensed plumber or gas fitter for appropriate fuel.

DO NOT DESTROY THIS MANUAL. PLEASE READ CAREFULLY AND KEEP IN A SAFE PLACE FOR FUTURE REFERENCE BY A SERVICEMAN.

CONTENTS (DETAILED)

A. Important Safety and General Information	4	J. Startup and Operation	46
A.1. Important Safety and General Information	4	J.1. Final Inspection	46
A.2. Agency Performance Audit and Efficiency Testing Notice	4	J.2. Turning on Power for the First time	46
A.3. Importance of a Quality Installation	4	J.3. Checking and Adjusting Air Flow	47
A.4. Importance of Air Flow and Setup	4	J.4. Checking Cooling Operation	49
A.5. Checking Product and Inspection	4	J.5. Checking Heating Operation	51
B. General Specifications	5	K. Test and Balance	54
B.1. Safety Warnings	5	K.1 Air Flow Charts and Information	54
B.2. Major Components	6	K.2. Air Flow Adjustments	54
B.3. Product Data Information	6	M. Humidity Control	55
C. Installation of the Unit	11	M.1. Dehumidification System Information	55
C.1. General	11	M.2. Humidity Sensor Installation	56
C.2. Tool and Refrigerant	11	M.3. Humidity Control Settings and Configuration	57
C.3. Choosing a Location	12	N. Diagnostics	58
C.4. Setting the Unit	14	N.1. Diagnostics Chart	58
C.5. Installing Condensate Drain	18	N.2. Alarm Codes - Full List	60
C.6. Final Installation Inspection	19	N.3. Common Mistakes	78
D. Duct and Venting	20	P. Appendices	79
D.1. Air Flow and Static Pressure	20	Appendix A - General Product Data	79
D.2. Duct Requirements and Best Practices	20	Appendix B - Electrical Data	81
D.3. Filters	21	Appendix C - Air Flow Performance Data	85
D.4. Economizers and Fresh Air Dampers	23	Appendix D - Heat & Cool Performance Data	93
D.5. Smoke Detectors	26	Appendix E - Gas Heat Performance Data	101
E. Electrical	27	Appendix F - Refrigerant Charging Charts	102
E.1. Electrical Safety Information	27	Appendix G - Wiring Diagrams & Schematics	114
E.2. Electrical Data	29	Appendix J - Unit Tie-Down	159
E.3. Electrical Connections	29	R. Information for the Owner	164
F. Control/Thermostat Wiring	31	R.1 Information for the Owner: Maintenance and service.....	164
F.1. T-Stat Field Connections	31	R.2 Product Model and Serial Number	164
F.2. Routing Control Wiring	33	S. Installation Check List and Job Site Sheet	165
F.3. Measuring Control Voltage Loads	33		
G. Gas	34		
G.1. Gas Piping Requirements	34		
G.2. Procedure: Connecting Gas Lines to Gas Valve	38		
G.3. LP Conversion	39		
G.4. Operation and Testing	40		

A. IMPORTANT SAFETY AND GENERAL INFORMATION

A.1 Introduction

This booklet contains the installation and operating instructions for your 7.5 ton, 8.5 ton, 10 ton, or 12.5 ton combination gas heating/electric cooling unit. There are some precautions that should be taken to ensure proper operation. Improper installation can result in unsatisfactory operation or dangerous conditions.

Read this booklet and any instructions packaged with separate equipment required to make up the system prior to installation. Give this booklet to the owner and explain its provisions. The owner should retain this booklet for future reference.

The images contained within this document may not be an exact representation of every unit, accessory, installation, etc. We reserve the right to change the content of this document at any time.

⚠ WARNING: The manufacturer's warranty does not cover any damage or defect to the air conditioner caused by the attachment or use of any components, accessories or devices (other than those authorized by the manufacturer) into, onto or in conjunction with the air conditioner.

You should be aware that the use of unauthorized components, accessories or devices may adversely affect the operation of the air conditioner and may also endanger life and property. The manufacturer disclaims any responsibility for such loss or injury resulting from the use of such unauthorized components, accessories or devices.

A.2 Agency Performance Audit and Efficiency Testing Notice

NOTICE: BREAK-IN PERIOD

Prior to agency testing, run the compressor for 16 hours at 115°f outdoor ambient temperature and 80° dry bulb / 75° wet bulb indoor ambient temperature.

NOTICE: EFFICIENCY TESTING NOTICE

For purposes of verifying or testing efficiency ratings, the test procedure in title 10 Appendix M to Subpart B of Part 430 (Uniform Test Method for Measuring the Energy Consumption of Central Air Conditioners and Heat Pumps) and the clarifying provisions provided in the standards listed below that were applicable at the date of manufacture should be used for test set up and performance.

SETUP

- ASHRAE 37 - 2009 (RA 2019)

PERFORMANCE:

- ANSI/ASHRAE 90.1:
 - 2013 for ZT models and some ZS models
 - 2007 for ZR models and some ZS models
- ANSI/ASHRAE 103 (2017)
- AHRI Operations for Unitary Large AC Equipment 340/360 (2015)
- CSA Z21.47 (2016)

SAFETY

UL 1995 5th Edition

CSA Z21.47 (2016)

A.3. Importance of a Quality Installation

Optimal system performance and longevity depend upon a quality and proper installation. Failure to properly setup and commission this unit could result in undesirable operation and subsequent faults and potential failures.

Carefully follow all guidelines listed in the manual and industry best practices. Conform to all local code requirements. Contact your local technical representative with any questions or concerns.

A.4. Importance of Air Flow and Setup

Optimal system performance is also dependent upon having the ideal airflow across the condensing and evaporating coils, and upon matching the charge weight to the manufacturer's spec for the unit. Improper or restricted air flow, and incorrect charge weight, will hinder the performance of the unit. Please refer to the manufacturer's recommended clearances for setting the unit and the included guide for setting air flow. Refer to the rating plate for the charge weight.

A.5. Checking Product and Inspection

Upon receiving the unit, inspect it for any damage from shipment. Claims for damage, either shipping or concealed, should be filed immediately with the shipping company. **IMPORTANT:** Check the unit model number, heating size, electrical characteristics, and accessories to determine if they are correct.

B. GENERAL SPECIFICATIONS

B.1 Safety Warnings

⚠️WARNING: Use only with type of gas approved for this unit. Refer to the unit rating plate.

⚠️WARNING: Install this unit only in a location and position as specified in the location requirements and considerations section of these instructions. Provide adequate combustion and ventilation air to the unit space as specified in the venting section of these instructions.

⚠️WARNING: Provide adequate combustion and ventilation air to the unit space as specified in the combustion and ventilation air section of these instructions.

⚠️WARNING: Combustion products must be discharged outdoors. Refer to local building codes for ducting combustion exhaust.

⚠️WARNING: Never test for gas leaks with an open flame. Use a commercially available soap solution made specifically for the detection of leaks to check all connections, as specified in gas supply and piping section of these instructions.

⚠️WARNING: Always install unit to operate within the unit's intended temperature-rise range with a duct system which has an external static pressure within the allowable range, as specified in ducting section of these instructions. See also unit rating plate.

⚠️WARNING: When a unit is installed so that supply ducts carry air circulated by the unit to areas outside the space containing the unit, the return air shall also be handled by duct(s) sealed to the unit casing and terminating outside the space containing the unit.

⚠️WARNING: This unit may be used to heat the building or structure during construction if the following installation requirements are met. Installation must comply with all installation instructions including:

- Furnace operating under thermostatic control;
- Return air duct sealed to the furnace;
- Air filters in place;
- Set furnace input rate and temperature rise per rating plate marking;
- Return air temperature maintained between 55°F (13°C) and 80°F (27°C);
- Clean furnace, duct work and components upon substantial completion of the construction process, and verify furnace operating conditions including ignition input rate, temperature rise and venting, according to the instructions.

B. GENERAL SPECIFICATIONS

B.2. Major Components

The unit includes a hermetically-sealed refrigerating system consisting of a scroll compressor, condenser coil, evaporator coil with TXV, a circulation air blower, a condenser fan, a heat exchanger assembly, gas burner and control assembly, combustion air motor

and fan, and all necessary internal electrical wiring. The cooling system of these units is factory evacuated, charged, and performance tested. Refrigerant amount and type are indicated on rating plate.

B.3. Product Data Information

B.3.1. Dimensional Information

IMPORTANT: This unit must be mounted level in both directions to allow water to drain from the condenser section and condensate pan.

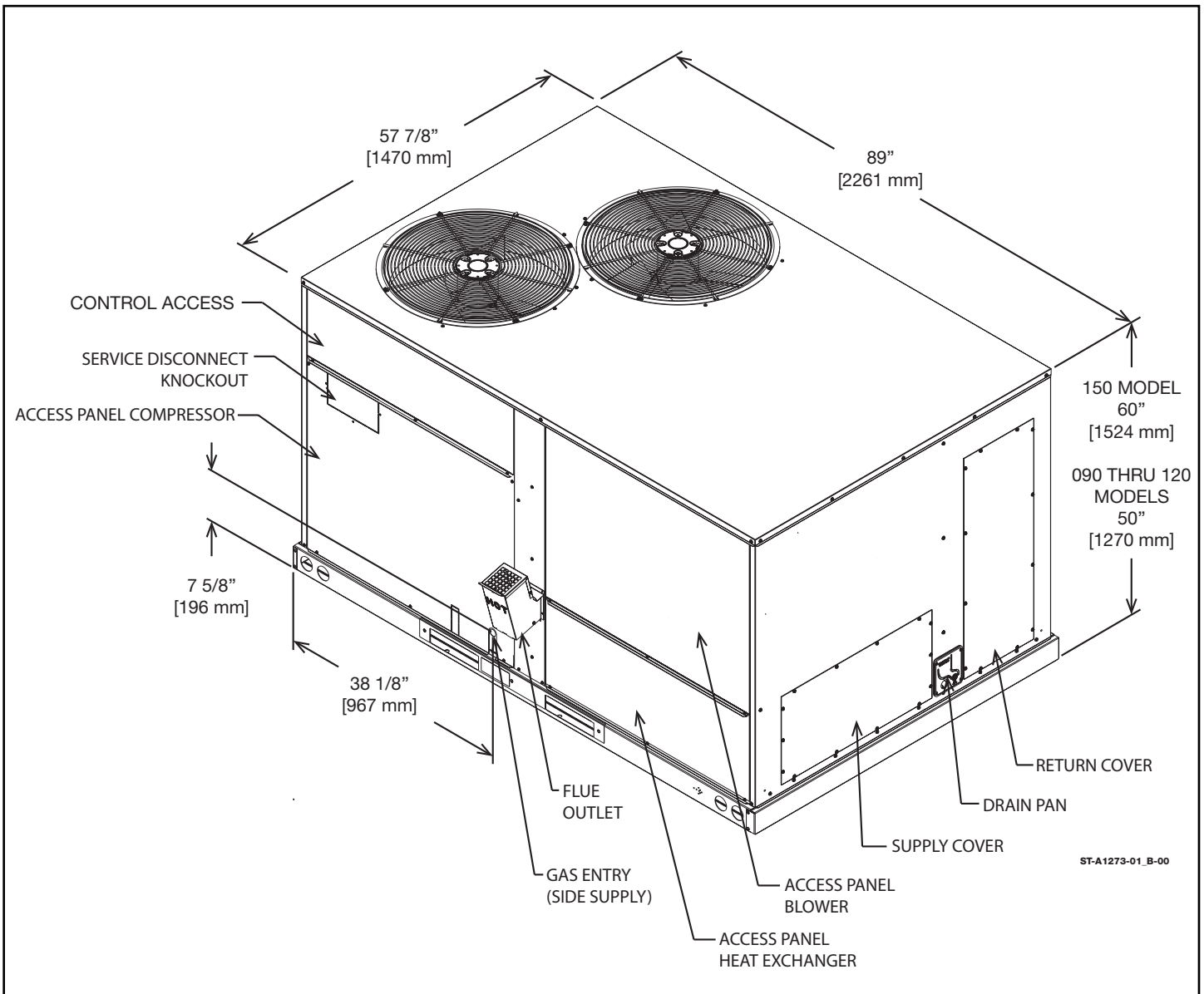

B. GENERAL SPECIFICATIONS

B.3. Product Data Information

B.3.1. Dimensional Information (Cont.)

IMPORTANT: This unit must be mounted level in both directions to allow water to drain from the condenser section and condensate pan.

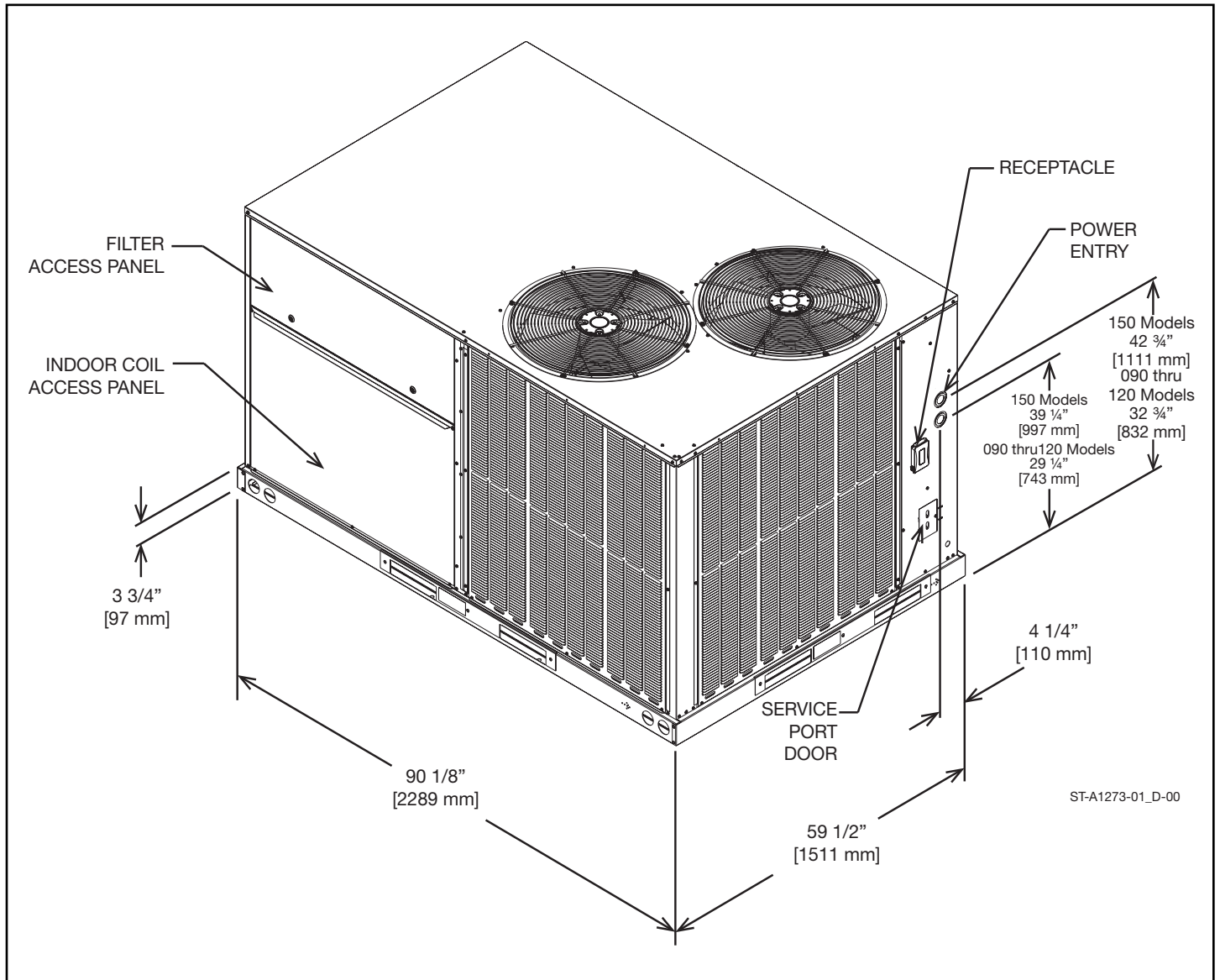

B.3.2. Product Specifications

The packaged Gas Electric rooftop unit is available with 150k, 205k, and 225k BTUHs heating input (either factory installed or field installed). Cooling capacity is 7.5, 8.5, 10, and 12.5 nominal tons. Units are convertible from horizontal supply/return to bottom supply/return by relocation of supply/return cover panels. See section **C.3.5. Cover Panel Installation/ Conversion Procedure** for more details.

The units are weatherized for mounting outside of the building.

⚠ WARNING: Units are not design certified to be installed inside the structure. Doing so can cause inadequate unit performance as well as property damage or death.

B. GENERAL SPECIFICATIONS

B.3. Product Data Information

B.3.3. General Data

See **Appendix A** towards the end of this manual for General Data.

B.3.4. Electrical Data Reference

See **Appendix B** towards the end of this manual for Electrical Data.

B.3.5. Air Flow Performance Data

See **Appendix C** towards the end of this manual for Air Flow Performance Data.

B.3.6. Supply and Return Duct Dimensions

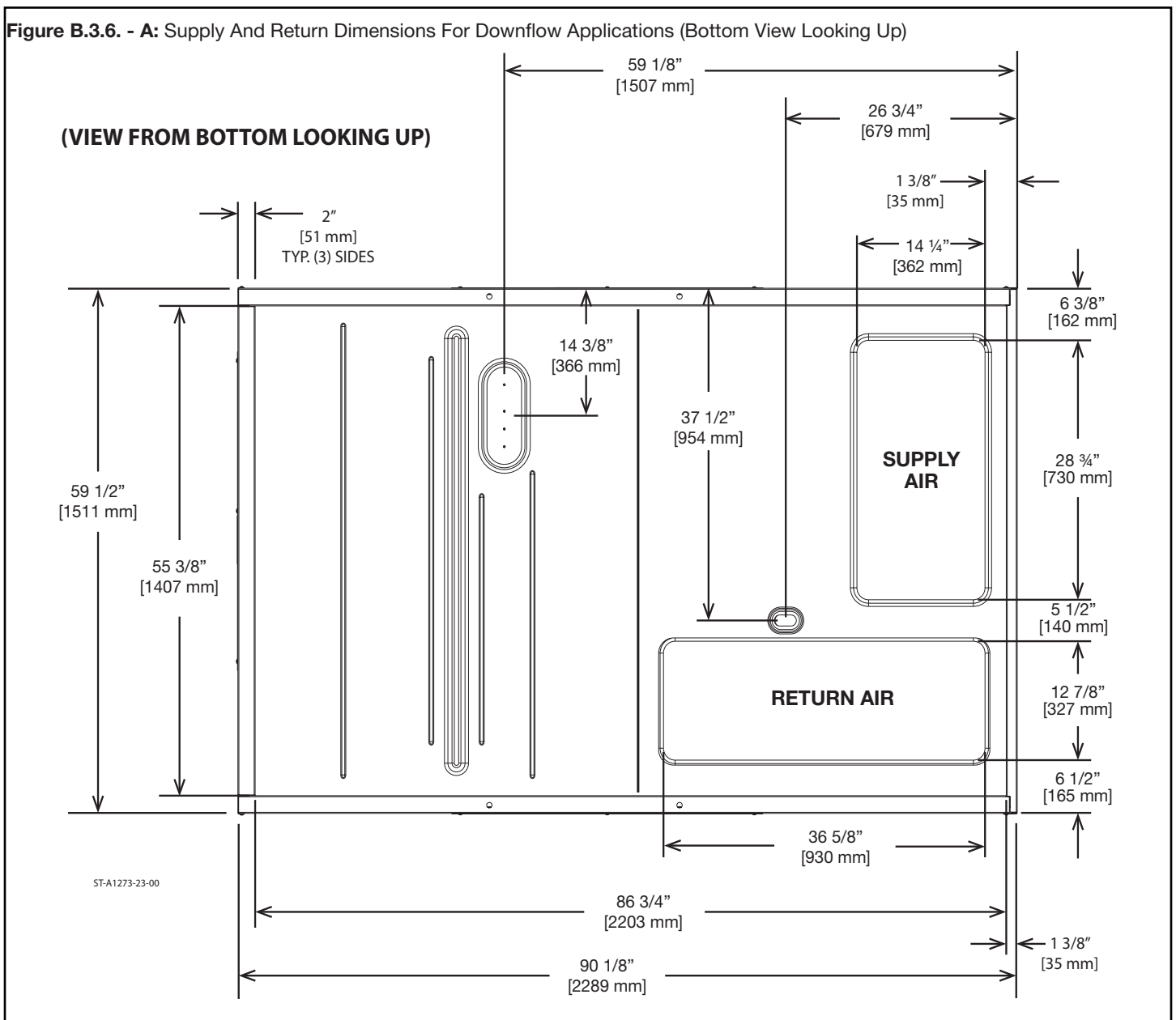

B. GENERAL SPECIFICATIONS

B.3.6. Supply and Return Duct Dimensions

Figure B.3.6. - B: Supply And Return Dimensions For Horizontal Applications

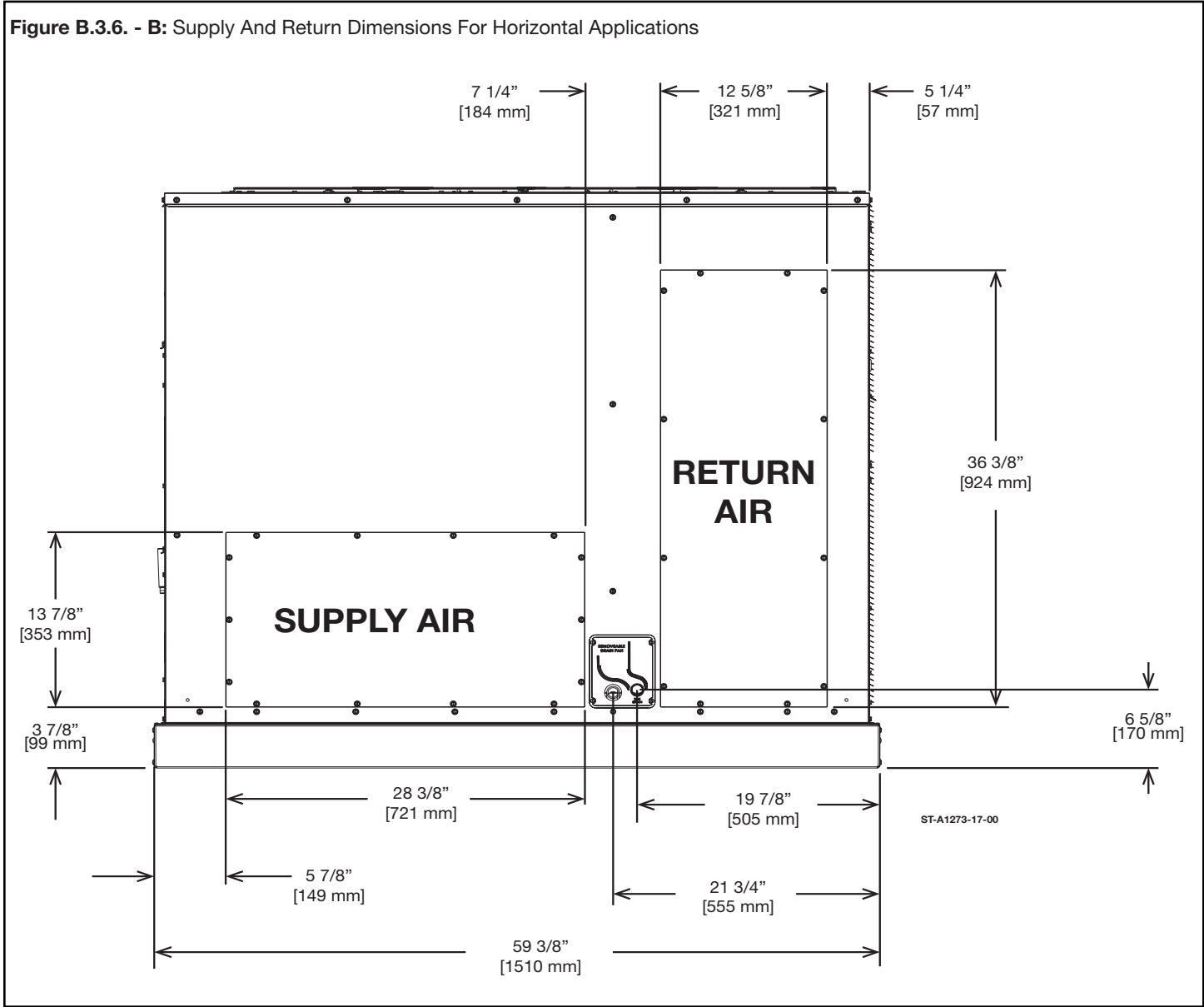

B. GENERAL SPECIFICATIONS

B.3. Product Data Information

B.3.7. Curb Dimensions

NOTE: See section C.3.3. Rooftop Installation for more information for installing the unit on a curb.

Figure B.3.7. – A: Roofcurb Complete Assembly

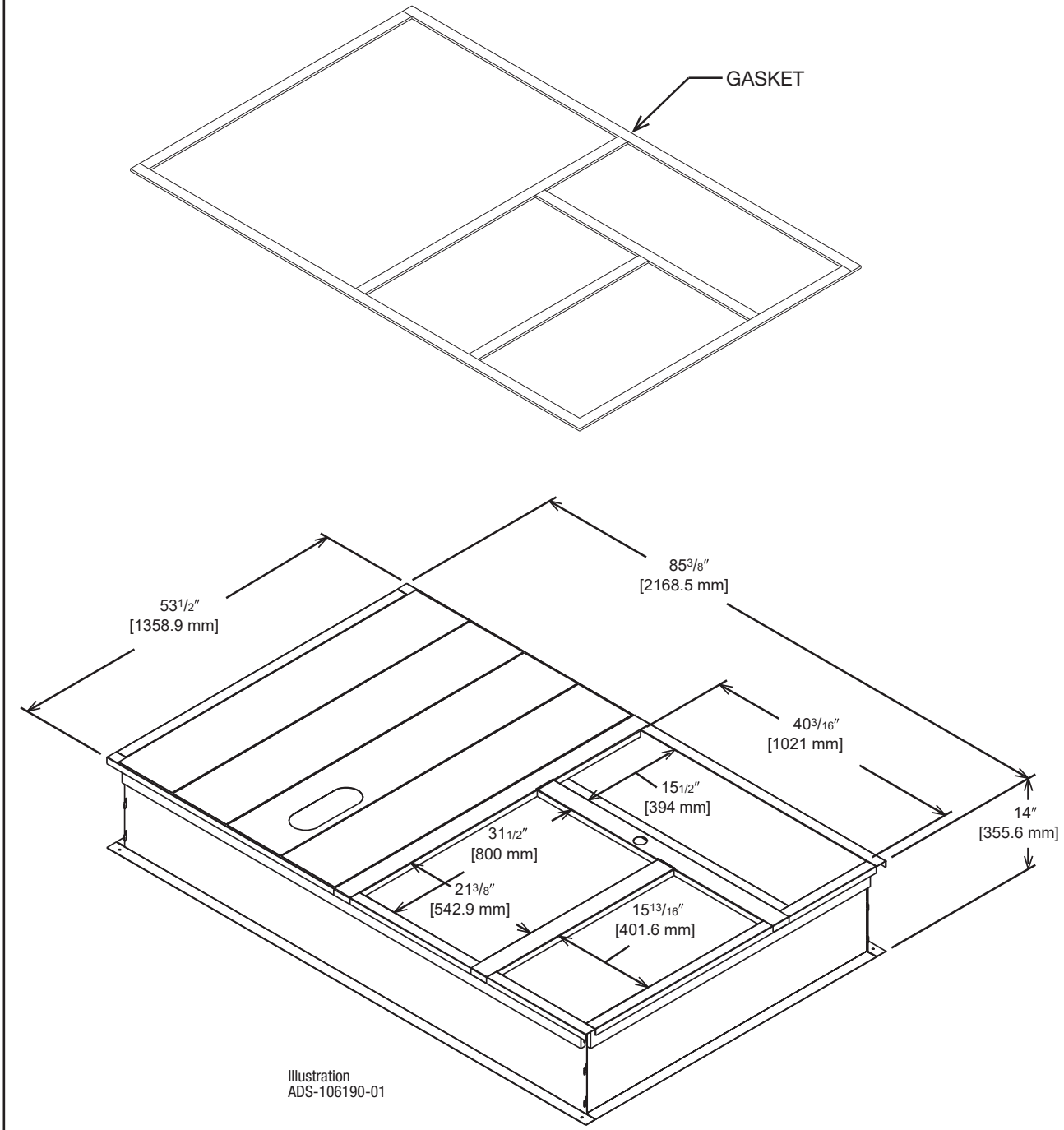

C. INSTALLATION OF THE UNIT

C.1. General

C.1.1. Installation

Install this unit in accordance with The American National Standard Z223.1-latest edition booklet entitled “National Fuel Gas Code”, and the requirements or codes of the local utility or other authority having jurisdiction. Additional helpful publications available from the “National Fire Protection Association are:

- NFPA-90A - Installation of Air Conditioning and Ventilating Systems 2018 or latest edition.
- NFPA-90B - Warm Air Heating and Air Conditioning Systems 2018 or latest edition.

These publications are available from:

National Fire Protection
Association, Inc.
NFPA.ORG

C.1.2. Pre-Installation Checkpoints

Before attempting any installation, carefully consider the following points:

- Structural strength of supporting members (Rooftop Installation)
- Clearances and provision for servicing
- Power supply and wiring
- Gas supply and piping
- Air duct connections and sizing
- Drain facilities and connections
- Location for minimum noise and vibration - away from bedroom windows

C.2. Tool and Refrigerant

C.2.1. Tools Required for Installing and Servicing R-410A Models

Manifold Sets:

- Up to 800 PSIG High Side
- Up to 250 PSIG Low Side
- 550 PSIG Low Side Retard

Manifold Hoses:

- Service Pressure Rating of 800 PSIG
- Zero-loss fittings

Recovery Cylinders:

- 400 PSIG Pressure Rating

Dept. of Transportation

- 4BA400 or BW400

C.2.2. Specifications of R-410A

All units are factory charged with R-410a Refrigerant.

Combustibility: At pressures above 1 atmosphere, mixture of R-410A and air can become combustible. **R-410A and air should never be mixed in tanks or supply lines, or be allowed to accumulate in storage tanks. Leak checking should never be done with a mixture of R-410A and air.** Leak checking can be performed safely with nitrogen or a mixture of R-410A and nitrogen.

C.2.3. Quick Reference Guide for R-410A

Ensure that servicing equipment is designed to operate with R-410A.

- R-410A refrigerant cylinders are pink.
- R-410A, as with other HFC's is only compatible with POE oils.
- Vacuum pumps will not remove moisture from POE oil.
- R-410A systems are to be charged with liquid refrigerants.
- Do not install a suction line filter drier in the liquid line.
- A liquid line filter drier is standard on every unit.
- Desiccant (drying agent) must be compatible for POE oils and R-410A.

C.2.4. Evaporator Coil/TXV

The thermostatic expansion valve is specifically designed to operate with R- 410A. The existing evaporator must be replaced with the factory specified TXV evaporator specifically designed for R-410A.

⚠WARNING: Disconnect all power to unit before starting maintenance. Failure to do so can cause electrical shock resulting in personal injury or death. Regular maintenance will reduce the buildup of contaminants and help to protect the unit's finish.

C. INSTALLATION OF THE UNIT

C.3. Choosing a Location

C.3.1. Unit Location: Allowable Clearances and Operational Issues

The unit location must comply with the allowable clearances listed in **Figure C.3.1. - A**. Failure to comply with the recommended clearances may result in operational issues such as decreased capacity, restricted condenser airflow, and condenser motor fatigue.

Figure C.3.1. - A: Allowable Clearances

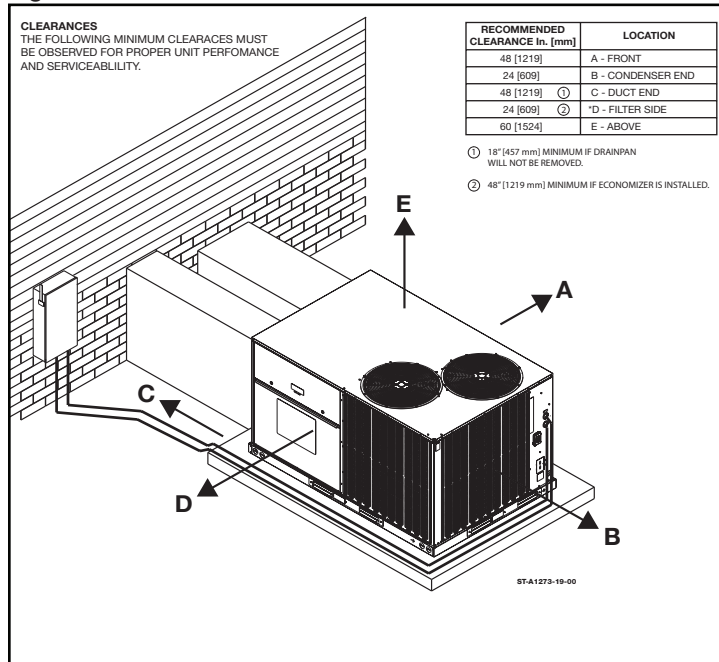

C.3.2. Outside Installation

WARNING: These units are designed certified for outdoor installation only. Installation inside any part of a structure can result in inadequate unit performance as well as property damage. Installation inside can also cause recirculation of flue products into the conditioned space resulting in personal injury or death.

1. Select a location where external water drainage cannot collect around unit.
2. Provide a level slab sufficiently high enough above grade to prevent surface water from entering the unit
3. Locate the unit to provide proper access for inspection and servicing as shown in **Figure C.3.1. - A**.
4. Locate unit where operating sounds will not disturb owner or neighbors.
5. Locate unit so roof runoff water does not pour directly on the unit. Provide gutter or other shielding at roof level. Do not locate unit in an area where excessive snow drifting may occur or accumulate.
6. Where snowfall is anticipated, the height of the unit above the ground level must be considered. Mount unit high enough to be above anticipated

maximum area snowfall and to allow combustion air to enter the combustion air inlet.

7. Select an area which will keep the areas of the vent, air intake, and A/C condenser fins free and clear of obstructions such as weeds, shrubs, vines, snow, etc. Inform the user accordingly.

C.3.3. Rooftop Installation

1. Before locating the unit on the roof, make sure that the roof structure is adequate to support the weight involved. (See Electrical & Physical Tables in this manual.) **THIS IS VERY IMPORTANT AND IS THE INSTALLER'S RESPONSIBILITY.**

2. For rigging and roofcurb details, see **Section C.4.3.**

3. The location of the unit on the roof should be such as to provide proper access for inspection and servicing.

IMPORTANT: If unit will not be put into service immediately, block off supply and return air openings to prevent excessive condensation.

C.3.4. Corrosive Environments

The metal parts of this unit may be subject to rust or deterioration in adverse environmental conditions. This oxidation could shorten the equipment's useful life. Salt spray, fog or mist in seacoast areas, sulphur or chlorine from lawn watering systems, and various chemical contaminants from industries such as paper mills and petroleum refineries are especially corrosive.

If the unit is to be installed in an area where contaminants are likely to be a problem, give special attention to the equipment location and exposure.

1. Avoid having lawn sprinkler heads spray directly on the unit cabinet.
2. In coastal areas, install the unit on the side of the building away from the waterfront.
3. In some situations, fencing or shrubs may give some protection against contaminants. Be mindful of the allowable clearances.
4. Frequent washing of the cabinet, fan blade and coil with fresh water will remove most of the salt or other contaminants that build up on the unit.
5. Regular cleaning and waxing of the cabinet with an automobile polish will provide some protection.
6. A good liquid cleaner may be used several times a year to remove matter that will not wash off with water.

Several different types of protective coatings are offered in some areas. These coatings may provide some benefit, but the effectiveness of such coating materials cannot be verified by the equipment manufacturer. The best protection is frequent cleaning, maintenance and minimal exposure to contaminants.

C. INSTALLATION OF THE UNIT

C.3.5. Cover Panel Installation/Conversion Procedure

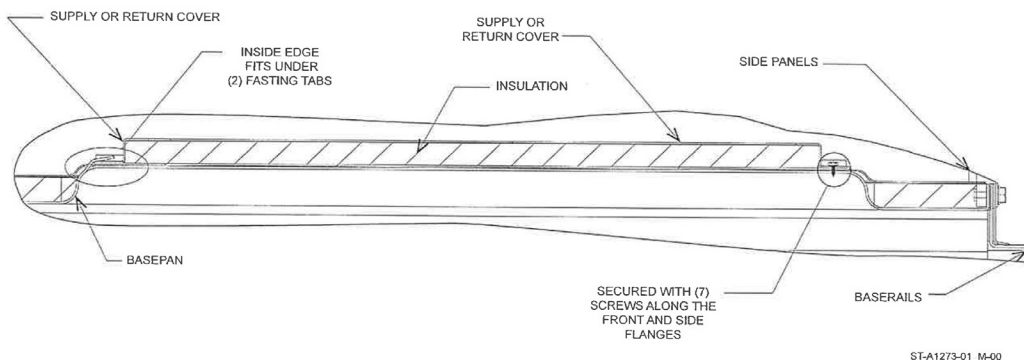
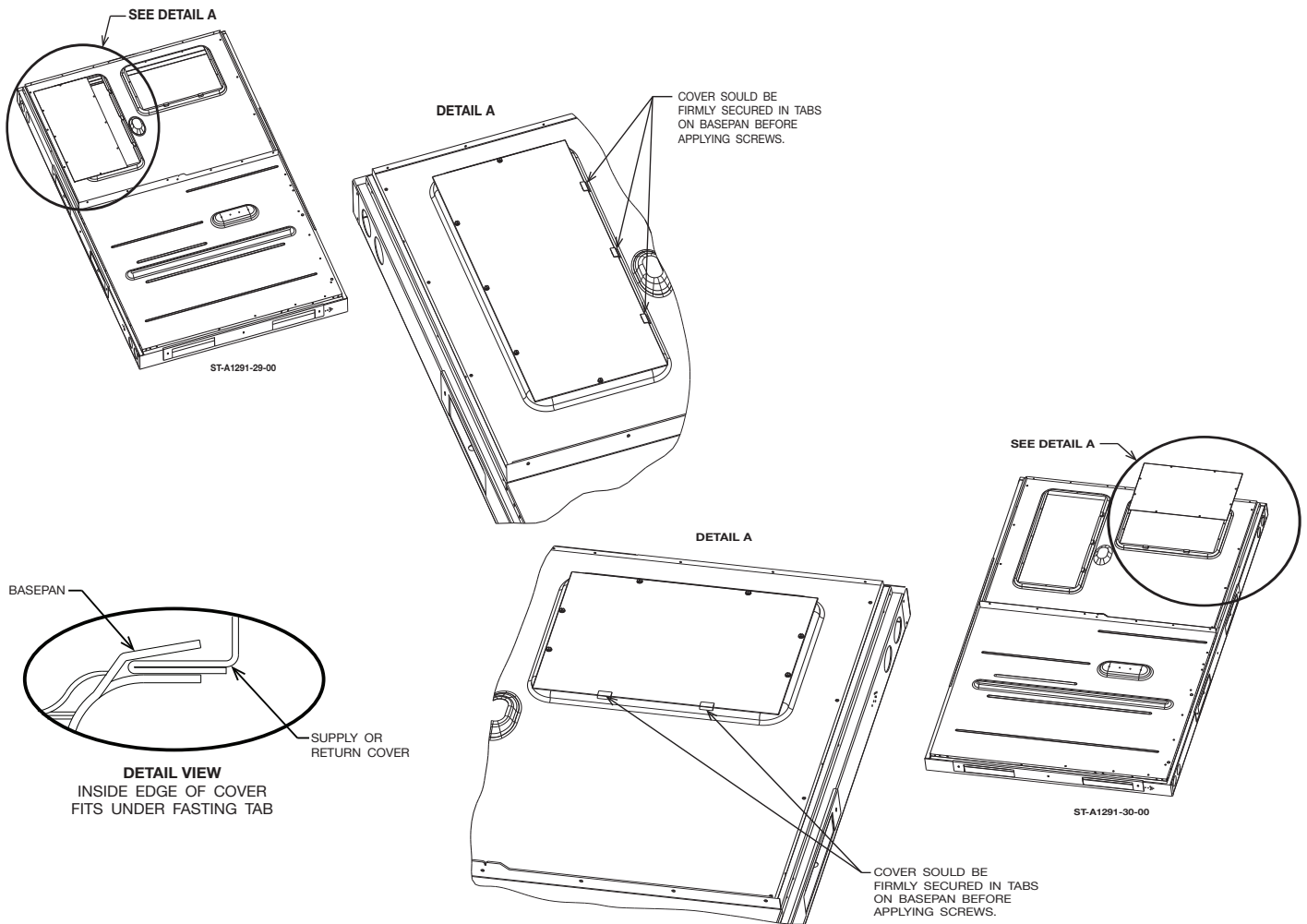

Figure C.3.5. – A: Downflow to Horizontal Conversion



FROM DOWNFLOW TO HORIZONTAL

1. Remove the covers from the supply and return openings on the unit. **See Figure B.3.6. – B** for reference.
2. Install the covers over the supply and return openings in the basepan, painted side up, inserting the leading flange under the bracket provided. Place the back flange to top of the front bracket provided. **See Figure C.3.5. – A** for reference.
3. Secure the return and supply cover to front bracket with screws.

C. INSTALLATION OF THE UNIT

C.4. Setting the Unit

C.4.1. Removing Shipping Material

There will be three types of shipping material that will need to be removed: The wood board basepan protection underneath, the wooden skid on the top, and the condenser coil protection (on non - louver panel units).

- **Wood Board Basepan Protection** – Remove the screws that attach the metal brackets for each of the forklift fork-entry points, and remove the brackets. This will release the protection boards from underneath, and it may be removed when the unit is lifted.
- **Shipping Screws** – Shipping screws are type #2 square head screws.

Figure C.4.1. – A: Basepan Protection Assembly

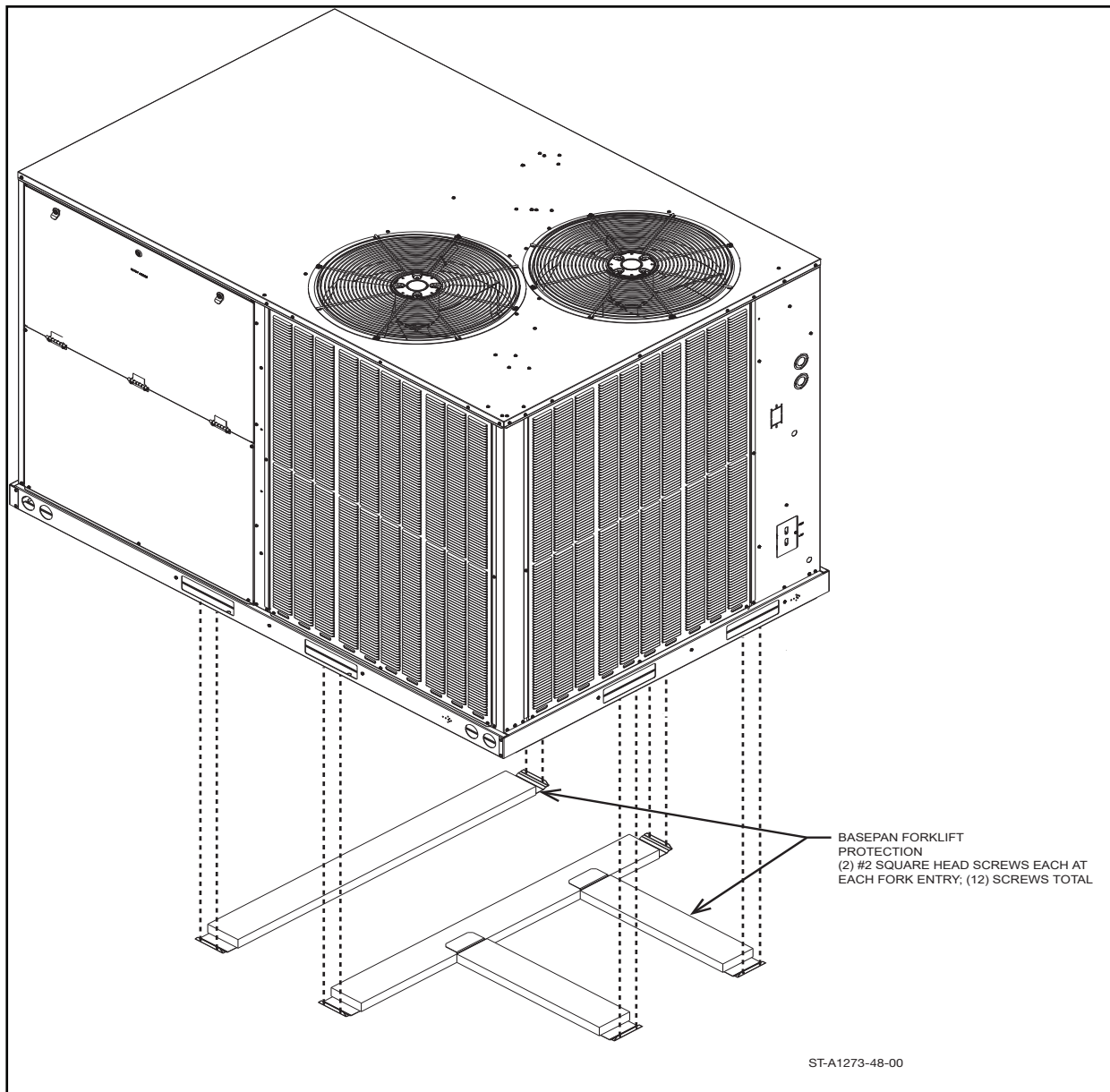

C. INSTALLATION OF THE UNIT

• **Wooden Skid** – Remove the screws from the metal brackets located in the middle along both long sides of the unit. This will detach the two sections of the wooden skid and allow them to be lifted off. If the unit is to be lifted by a crane, it is recommended to leave the top skid on until after the unit is on the roof to provide extra protection if spreader bars are not used.

Figure C.4.1. – A: Wooden Skid Assembly

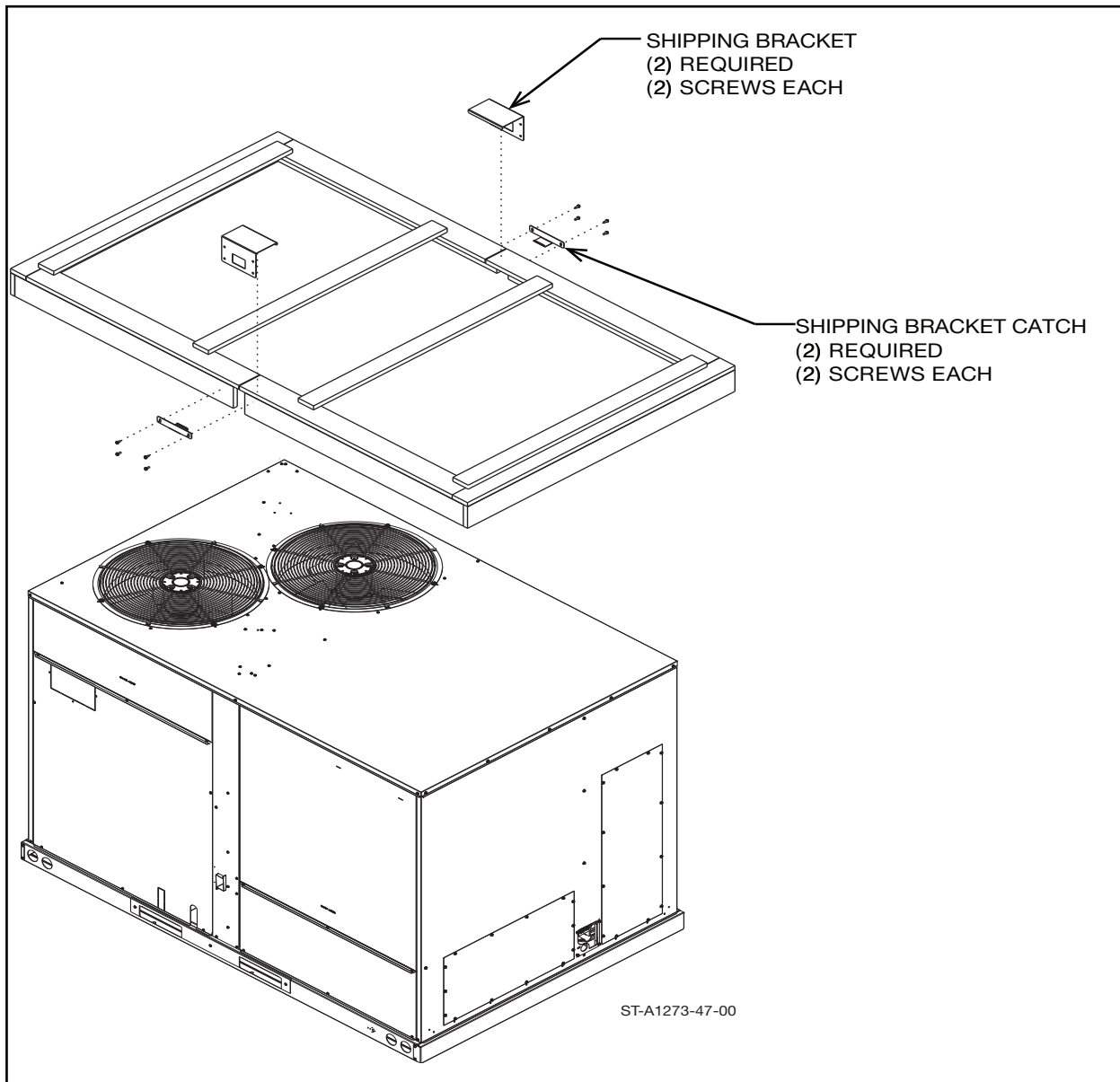

C. INSTALLATION OF THE UNIT

- **Condenser Coil Protection** – Remove the screws along the perimeter of the coil protector. This will allow the protector to be removed. If the unit has louver panels, it will not have the condenser coil protection.

Figure C.4.1. – C: Condenser Coil Protection Assembly

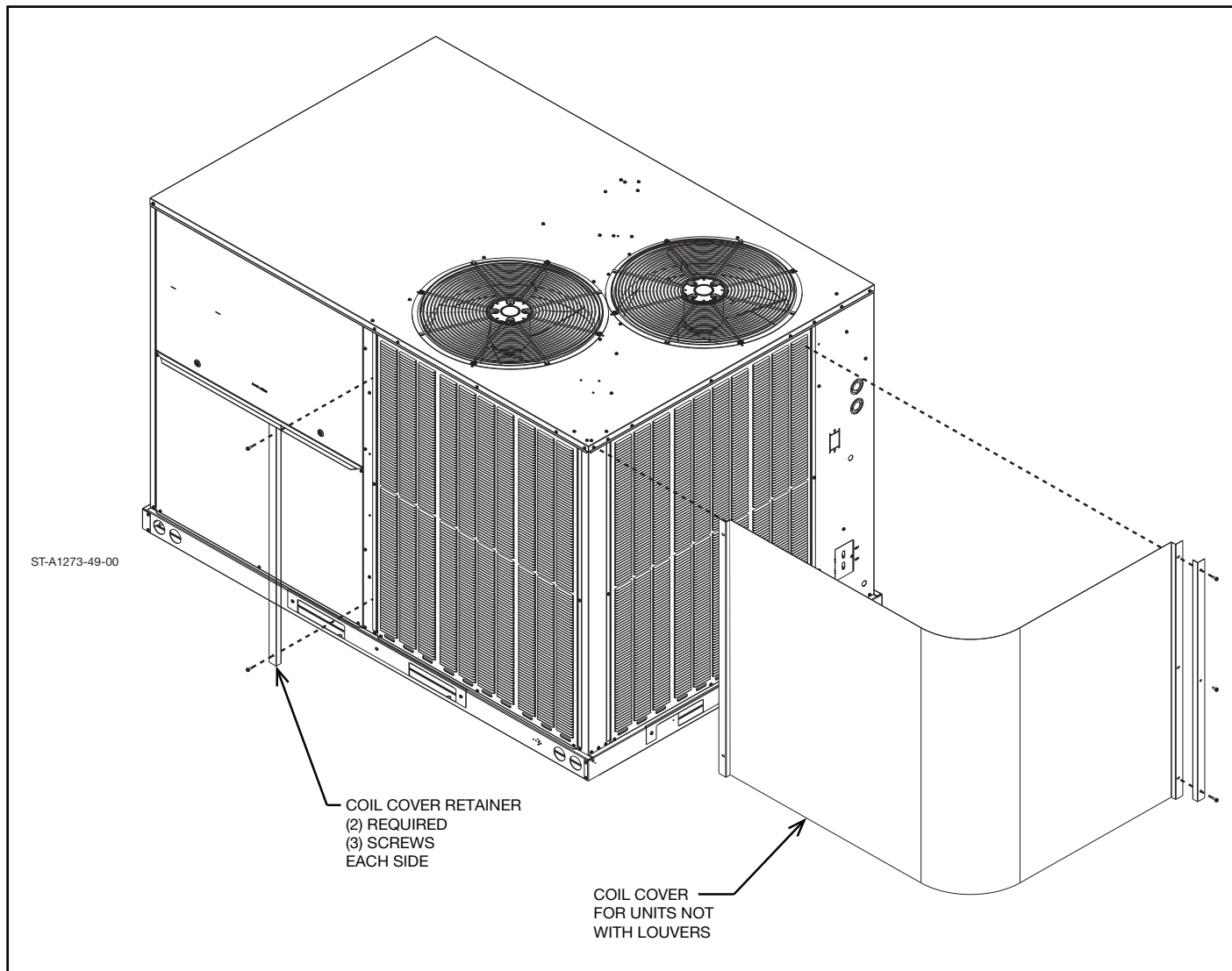

C. INSTALLATION OF THE UNIT

C.4.2. Lifting the Unit

Figure C.4.2. – A : Lifting Detail

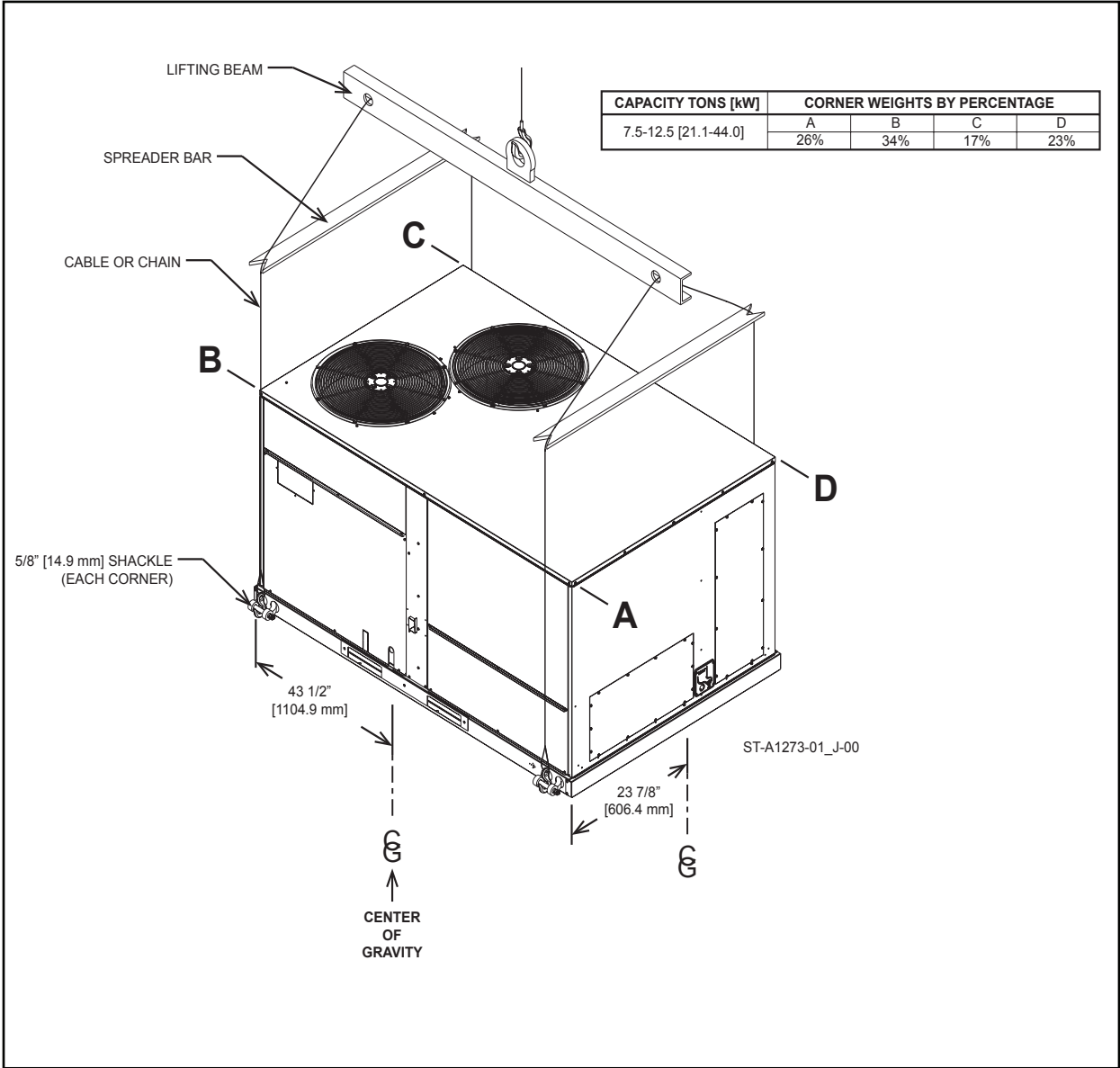

C. INSTALLATION OF THE UNIT

C.4.3. On a Roof Curb

Refer to **Figure C.3.1. - A** in section **C.3.1. "Unit Location: Allowable Clearances and Operational Issues"** before installing the unit on a roof curb.

Only use manufacturer-approved roofcurb products for the unit.

C.4.3.1. Installing the Roof Curb

Refer to the separate Installation Instructions for installing a roof curb.

C.4.3.2. Setting the Unit

Figure C.4.3.2. - A: Setting the unit on Roofcurb Assembly

C.4.3.3. High Wind and Seismic Tie-Down Methods

The units must be secured in compliance with ASCE 7-10 and the Florida Building Code 5th Edition. Please refer to **Appendix J: Unit Tie-Down Methods**.

C.4.4. On a Slab

C.4.4.1. Setting the Unit

Set the unit on a stable concrete pad with adequate clearances around the sides of the unit, and make sure the unit is level before securing.

Before setting/securing the unit, use this opportunity to convert the unit from a downflow configuration to a sideflow configuration if necessary. Refer to section **C.3.5. Cover Panel Installation/Conversion Procedure**.

C.4.4.2. High Wind and Seismic Tie-Down Methods

Slab-installed units must also be secured in compliance with ASCE 7-10 and the Florida Building Code 5th Edition. Please refer to **Appendix J: Unit Tie-Down Methods**.

C.5. Installing Condensate Drain

IMPORTANT: Install a condensate trap to ensure proper condensate drainage. See **Figure C.5.1 - A** for reference.

The condensate drain pan has a threaded female 3/4 inch NPT (11.5 TPI) connection. Drain line must be no smaller than drain pan outlet and adequately sized to accommodate the condensate discharge from the unit. Drain line must be routed to an acceptable drain or outdoors in accordance with local codes. Consult local codes or ordinances for specific requirements of condensate drain piping and disposal.

DO NOT connect condensate drain line to a closed sewer pipe.

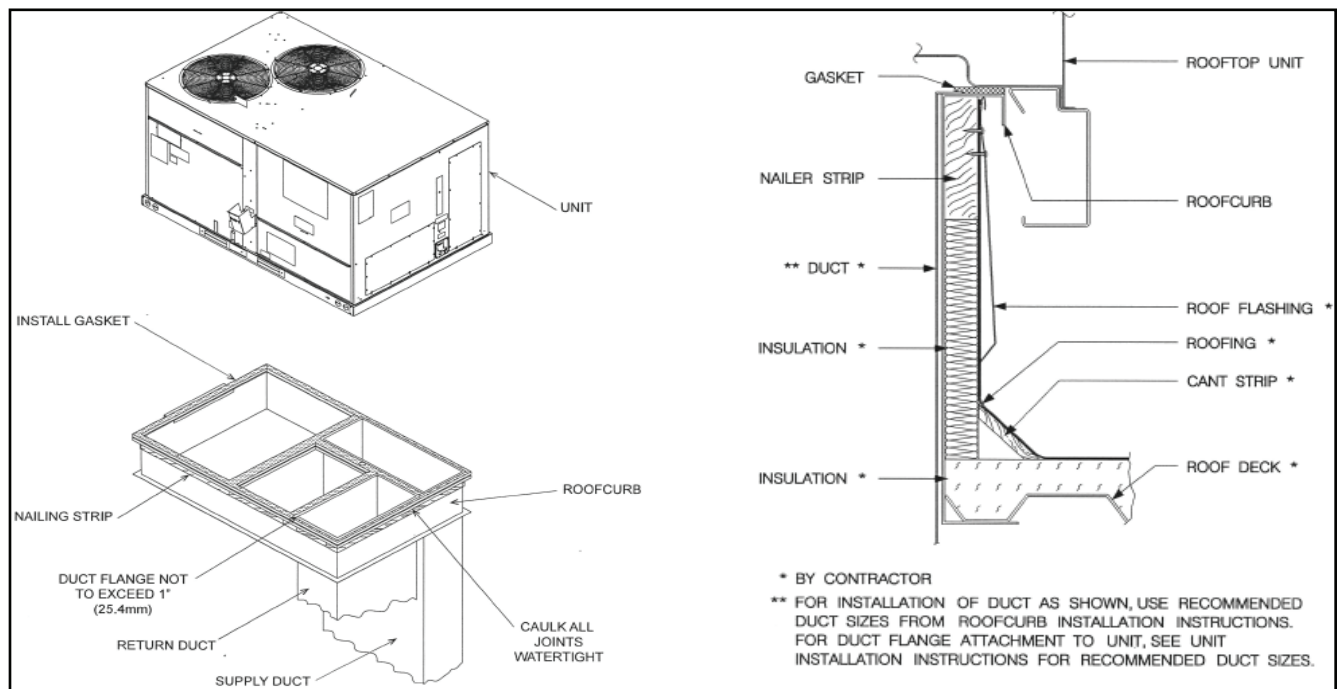

C. INSTALLATION OF THE UNIT

C.5.1. Determine Drain Trap Height Requirement

The drain line should be a minimum of 3 inches deep, plus 1 inch for every inch of external static pressure from the blower and duct system. For Example, if the external duct static is 1 inch of water column, the drain trap from the bottom of the trap to the bottom of the drain outlet should be 4 inches, the drain outlet should be 3 inches below the drain connection on the condensate pan. Ensure the outlet of the trap is routed to a suitable drain location as required by local code. See **Figure C.5.1 - A** for reference.

Figure C.5.1 – A: Condensate Drain Trap

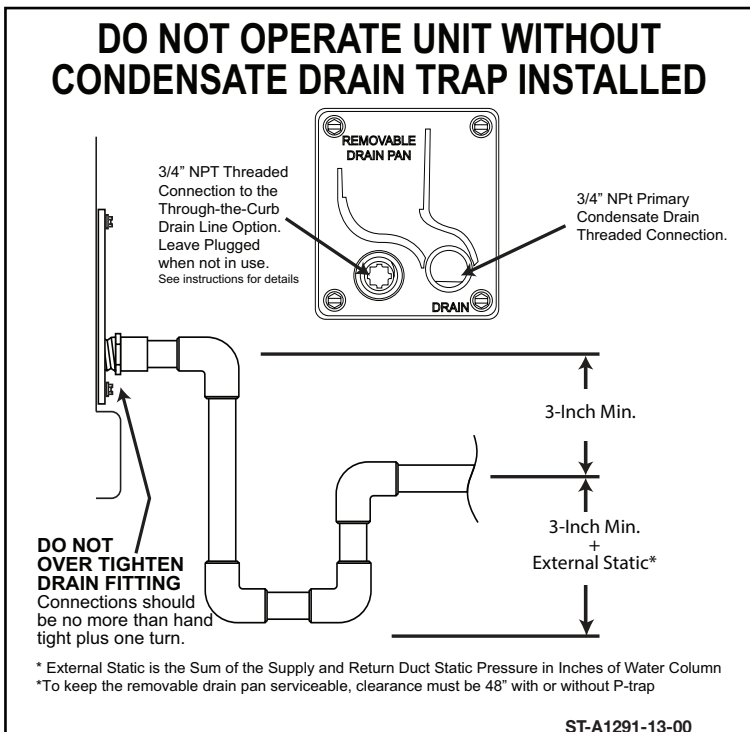

C.5.2. Keeping the Condensate Drain Pan Serviceable

To use the removable drain pan feature of this unit, some of the condensate line joints should be assembled for easy removal and cleaning. Drain line **MUST NOT** block service access panels.

C.5.3. Connecting the Drain trap

- Use a thin layer of Teflon tape or paste on drain pan connections and install only hand tight.
- Do not over tighten drain pan connections as damage to the drain pan may occur.
- Drain line must be routed to an acceptable drain or outdoors in accordance with local codes.
- Drain line should slope away from unit a minimum of 1/8" per foot to ensure proper drainage.

C.5.4. Connecting the Drain to the Through the Curb Option

The through the curb drain option is available for installations in freezing conditions or that do not want water draining on the roof. Use adapters and elbows to turn out of the drain opening on the right and into the curb drain opening on the left. Under the unit connect a 3/4" male threaded fitting, use thread sealant, into the opening between the supply and return duct openings under the unit. Install a properly sized drain trap in the conditioned space of the building and route to a suitable drain location as code requires.

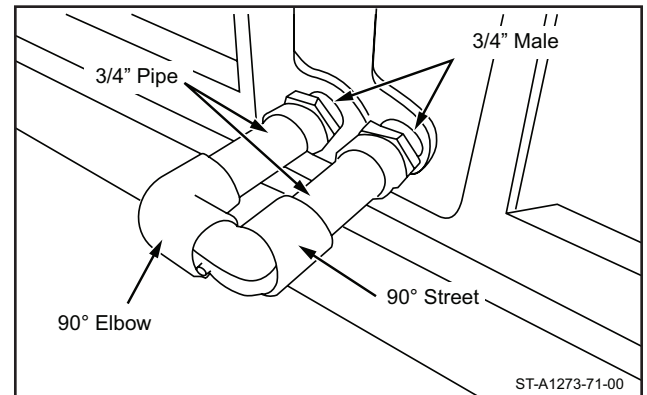

C.5.5. Freezing Condition Considerations

- Drain line may need insulation or freeze protection in certain applications.
- Drain line should slope away from unit a minimum of 1/8" per foot to ensure proper drainage.

C.6. Final Installation Inspection

C.6.1. Remove Shipping Material

Before the unit is secured to the slab/roofcurb, check that all shipping material has been removed. See section **C.4.1.** for how to remove shipping material.

NOTE: Failure to remove the condenser coil protector on non-louver panel units will negatively impact performance and be harmful to system components. Failure to remove the cardboard basepan protector will block all indoor airflow for downflow configurations.

Open all compartments to ensure there are no tools or other misc parts remaining in the unit from setup. This is most important on the blower section to avoid damage to the blower assembly.

C. INSTALLATION OF THE UNIT

C.6.2. Checking Level and Slope

This unit must be mounted level in both directions to allow water to properly drain from the condenser section and condensate pan.

C.6.3. Condensation and Sweating

In certain regions or climates, portions of the exterior of the unit may condensate or sweat during cooling operation. This is normal and expected.

C.6.4. Install Flue Hood for Gas Heat

These gas heat package units are shipped with the flue hood fastened onto the condenser basepan in the compressor access section.

Remove the flue hood from the basepan, and install it over the flue opening on the outside of the unit before operating.

D. DUCT AND VENTING

D.1. Air Flow and Static Pressure

See [Appendix C](#) towards the end of this manual for Air Flow Performance Data. For Air Flow adjustment and set up, see section [J.3. "Checking and Adjusting Air Flow"](#).

D.2. Duct Requirements and Best Practices

The installing contractor should fabricate ductwork in accordance with local codes.

Use industry manuals as a guide when sizing and designing the duct system.

Contact Air Conditioning Contractors of America at www.acca.org

⚠ WARNING: DO NOT, under any circumstances, connect return ductwork to any other heat producing device such as fireplace insert, stove, etc. Unauthorized use of such devices may result in fire, carbon monoxide poisoning, explosion, personal injury, property damage or death.

Place the unit as close to the conditioned space as possible allowing clearances as indicated. Run ducts as directly as possible to supply and return outlets. Use of non-flammable weatherproof flexible connectors on both supply and return connections at unit to reduce noise transmission is recommended.

On ductwork exposed to outside temperature and humidity, use a minimum of 2" of insulation and a vapor barrier. Distribution system in attic, furred space or crawl space should be insulated with at least 2" of insulation. Half-inch to 1" thick insulation is usually sufficient for ductwork inside the air conditioned space.

Provide balancing dampers for each branch duct in the supply system.

Properly support ductwork from the structure.

IMPORTANT: In the event that the return air ducts must be run through an "unconfined" space containing other fuel burning equipment, it is imperative that the user/homeowner must be informed against future changes in construction which might change this to a "confined space." Also, caution the user/homeowner against any future installation of additional equipment (such as power ventilators, clothes dryers, etc.), within the existing unconfined and/or confined space which might create a negative pressure within the vicinity of other solid, liquid, or gas fueled appliances.

D.2.1. Supply Duct Systems

A properly designed supply duct system, meeting all local codes and best practices, must be installed to ensure proper air flow and minimize the static pressure on the blower. The following dimensions are approximations. The installer is responsible for verifying all dimensions before installation.

The supply duct opening for roof curb installations is 28 3/4" x 14 1/4", the supply duct opening for horizontal ducted installations is 28 3/8" x 13 7/8". **See Figure B.3.6. – A and B** for reference.

D.2.2. Return Duct Systems

A properly designed return duct system, meeting all local codes and best practices, must be installed to ensure proper air flow and minimize the static pressure on the blower. The following dimensions are approximations. The installer is responsible for verifying all dimensions before installation.

The return duct opening for roof curb installations is 36 5/8" x 12 7/8", the return duct opening for horizontal ducted installations is 36 3/8" x 12 5/8". **See Figure B.3.6. – A and – B** for reference.

D. DUCT AND VENTING

D.2.3. Isolation for Noise Abatement

Noise from operational vibration can occur with this equipment, the use of flexible duct adapters and vibration damping curb adapters maybe required depending upon the building type and use. Consult with a local mechanical engineer on the duct and building design to determine if any noise abatement solutions need to be considered before installation.

D.3. Filters

D.3.1. Installing Filters

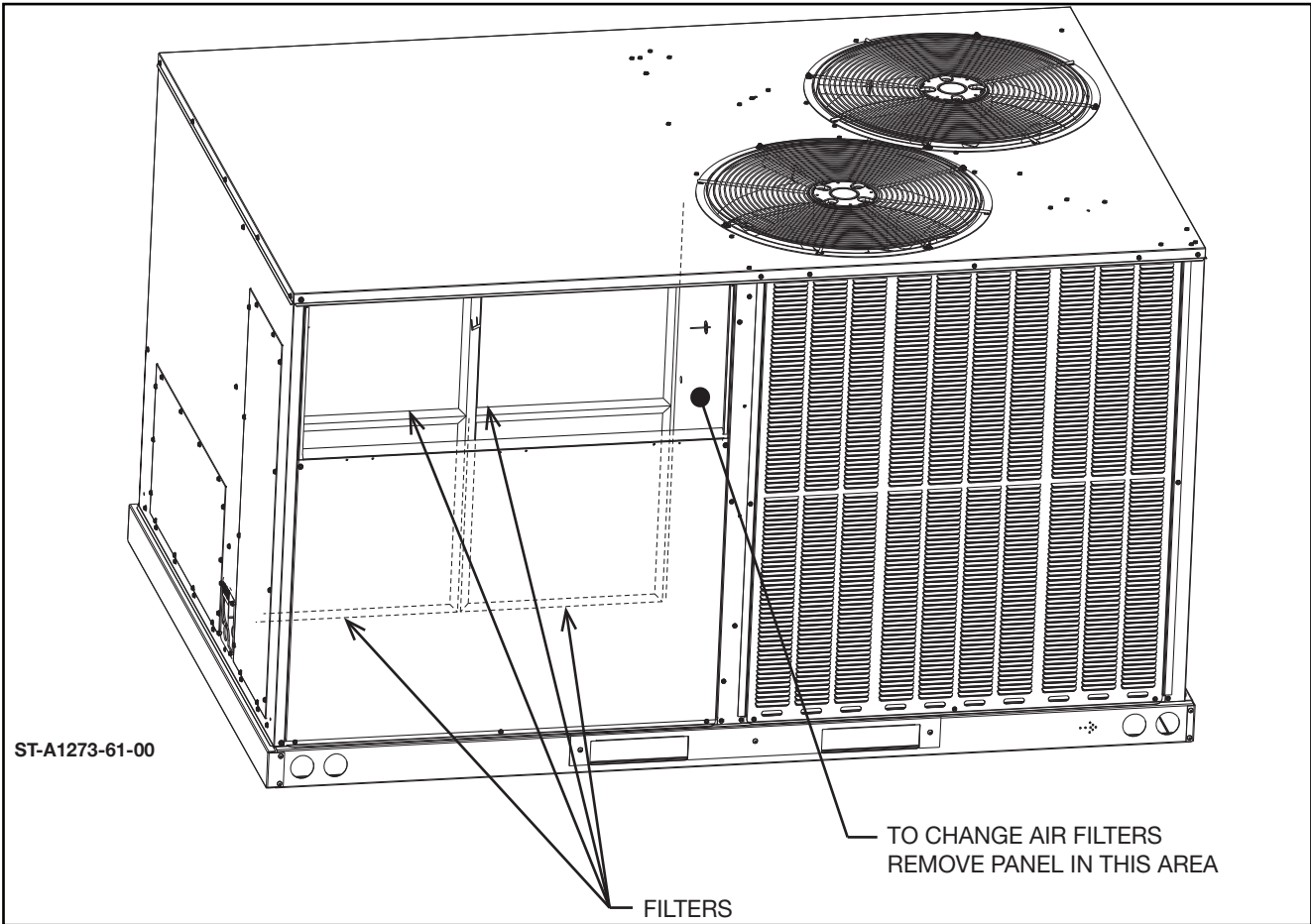

D. DUCT AND VENTING

D.3. Filters

D.3.1. Installing Filters (Cont.)

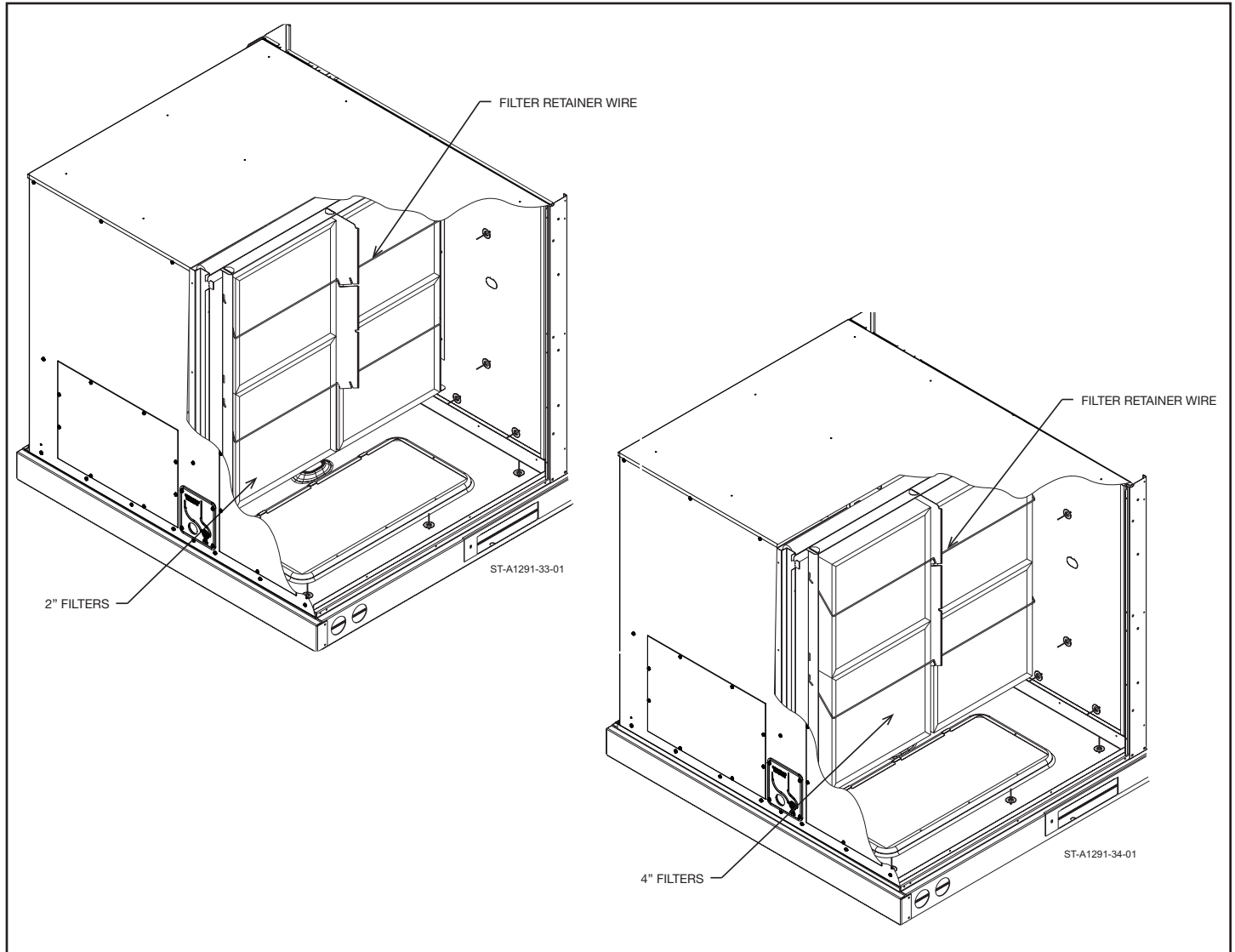

This product will accept both 2" and 4" filters. A new unit ships with four 2" x 20" x 20" filters. For units with an economizer, only use 2" filters due to fitment clearances. To replace filters, follow these steps:

1. Remove "Filter Access" panel.
2. Pull downwards on retainer wire and rotate upwards to unlock filters.
3. Secure retainer wire in notch.
4. Remove and discard current filters.
5. Install new filters with airflow arrow pointing towards evaporator coil.
6. Rotate retainer wire downward to original position and secure in notch.
7. Install "Filter Access" panel.

D. DUCT AND VENTING

D.4. Economizers and Fresh Air Dampers

D.4.1. Economizer Information

ECONOMIZERS - Mechanical devices used to make the Heating Ventilation and Air Conditioning (HVAC) unit more efficient by regulating the return air and outside air. Economizers for this product come in several configurations.

The Downflow Economizer is designed specifically for units setup in a downflow configuration. The downflow economizer fits inside the package unit and sits over the return-air opening along the bottom of the unit. All economizers are equipped with horizontal gear driven blades and a gravity relief damper (Barometric Relief).

The Horizontal Economizer is designed specifically for units setup in a horizontal flow configuration. The horizontal economizer utilizes independently actuated return-air and fresh air dampers to enable the most efficient handling of air achievable with this platform. The horizontal economizer also includes an externally-mounted (to the duct work) gravity relief damper.

All units with economizers come shipped from the factory with a parts bag and a separate document for Economizer Installation & Operation instructions. Refer to that document for information on how to install the economizer, connect the controls, and adjust the airflow. Accessory economizers purchased separately will also come with the parts bag and instructional document.

For reference, the Installation Instructions for economizers may be found in the parts bag of the unit for factory installed economizers, in the box with the field installed economizer, or on the manufacturer's website.

Figure D.4.1. – A: Downflow Economizer with Hood

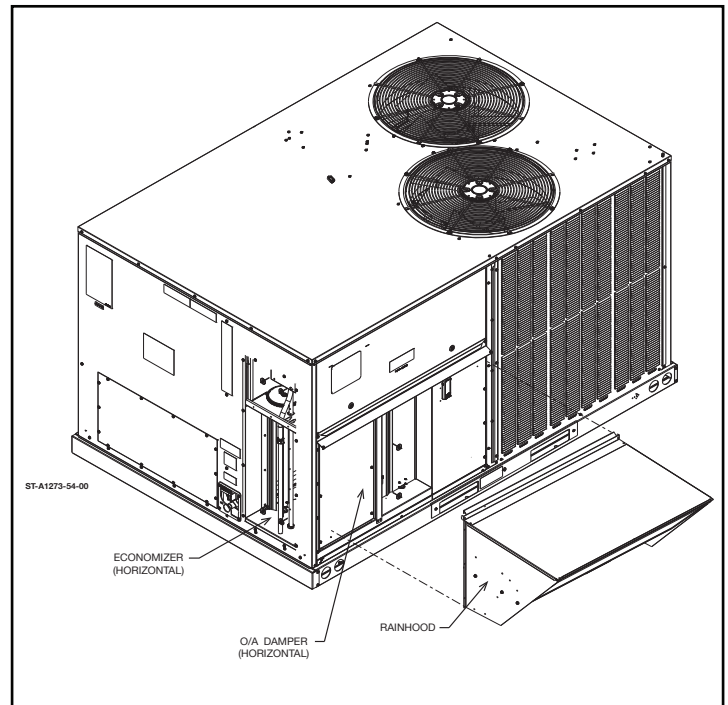
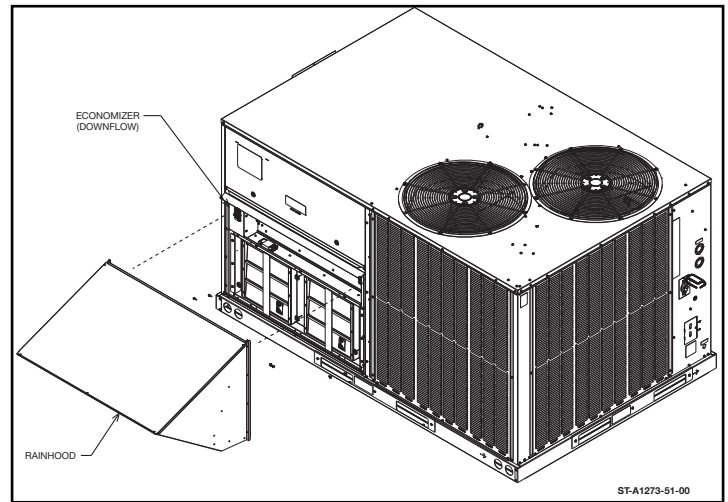

Note: Louver protections are optional.

D. DUCT AND VENTING

D.4.2. Fresh Air Dampers

MANUAL DAMPER HOODS – Manual damper hoods are often installed as a low cost substitute for an economizer.

The idea is to manually set the blade located inside the hood to restrict the opening by introducing Static Pressure, thereby balancing the outside air with the return air entering the RTU.

The drawback to a manual damper is that it is open 24 hours a day, 365 days a year. Therefore they introduce outside air during occupied and unoccupied modes increasing the load on the rooftop unit.

MOTORIZED DAMPER HOODS – A motorized damper is economical, and provides more comfort than a manually adjusted hood damper.

The motorized damper is coupled to an actuator, and designed to open when the RTU fan is running,

and close when the fan is off. The advantage of the motorized damper is that the outside air is no longer a factor once the RTU fan is cycled off.

By connecting a Timer, CO2 Sensor or Smoke Detector in series between the RTU fan (“G” on the Thermostat) and actuator, the damper can be controlled during “Unoccupied” hours, or allow the damper to only introduce outside air during “On-Demand Occupancy.”

Fresh Air Dampers come shipped with a separate document for Installation & Operation instructions. Refer to that document for information on how to install and adjust the dampers.

For reference, the Installation Instructions for Fresh Air Dampers may be found in the parts bag for the factory installed dampers, in the box for field installed dampers, or on the manufacturer’s website for the product.

Figure D.4.2. – A: Fresh Air Damper

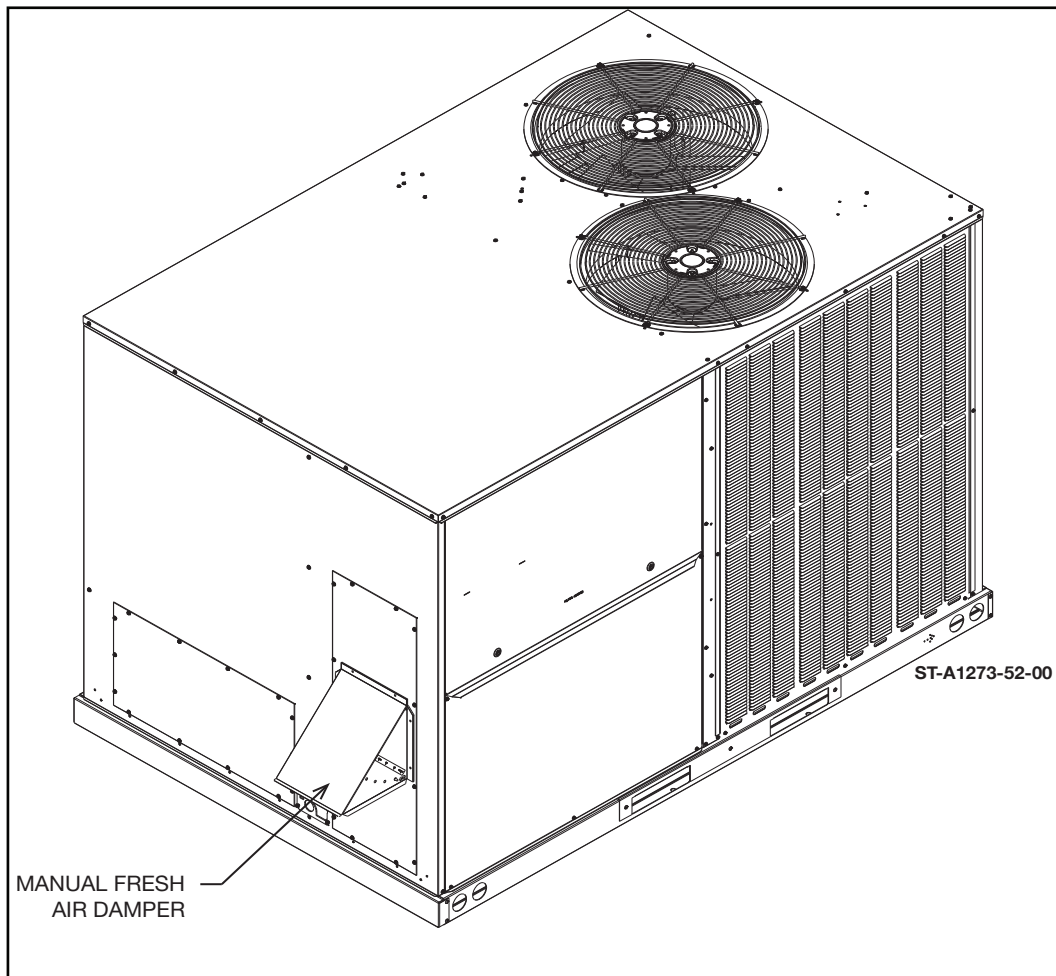

D. DUCT AND VENTING

D.4.3. Powered Exhaust

POWER EXHAUST - This accessory is a motorized fan designed to remove air from the conditioned space efficiently. While this is useful for removing a high positive pressurization, caution must be taken in the setup of the system to avoid creating a negative pressure within the conditioned space. If negative pressure occurs, leaky windows, doors, and electrical fixtures will allow the outside air to creep in causing drafts or hot spots within a room.

Figure D.4.3. – A: Powered Exhaust

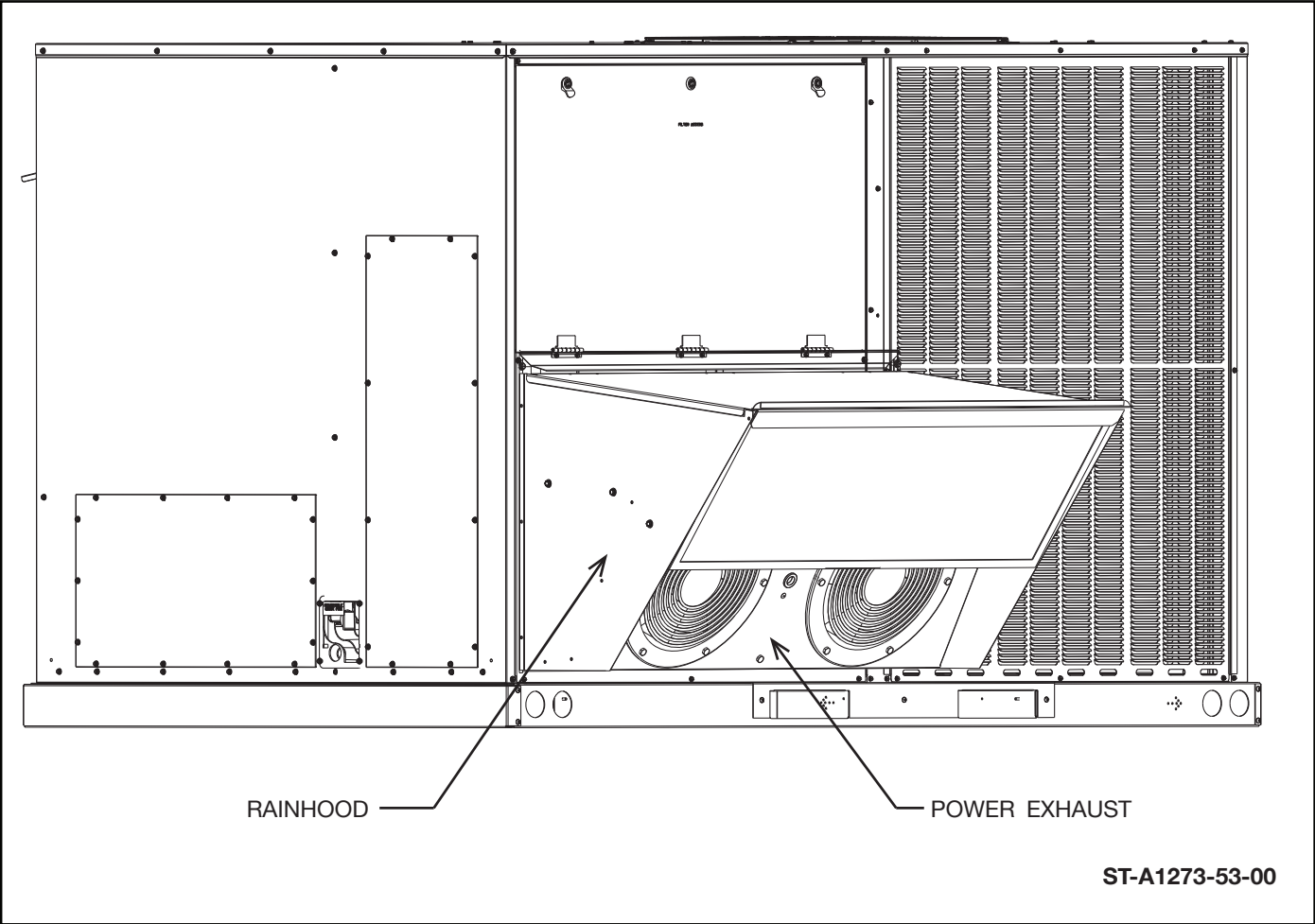

ST-A1273-53-00

D. DUCT AND VENTING

D.5. Smoke Detectors

Figure D.5. – A: Smoke Detector Assembly

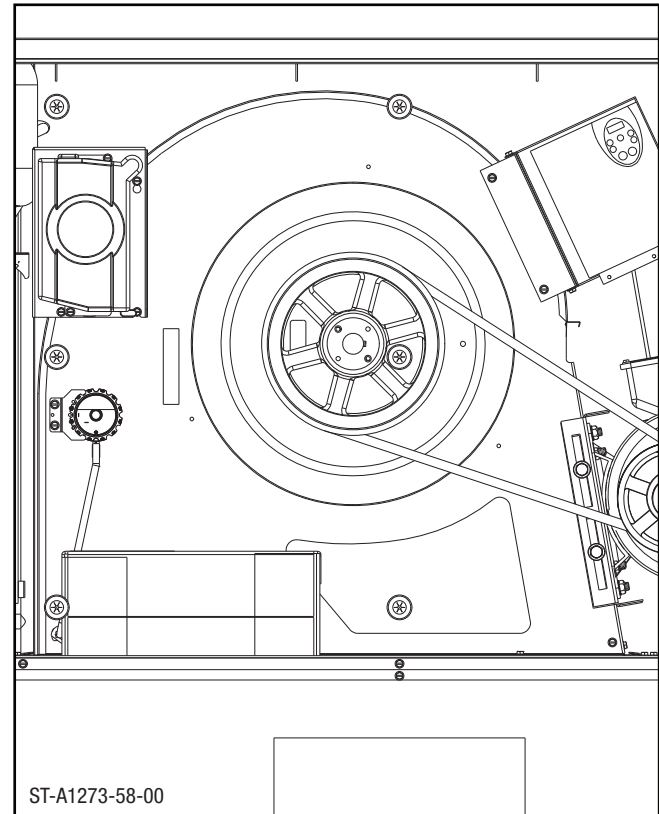
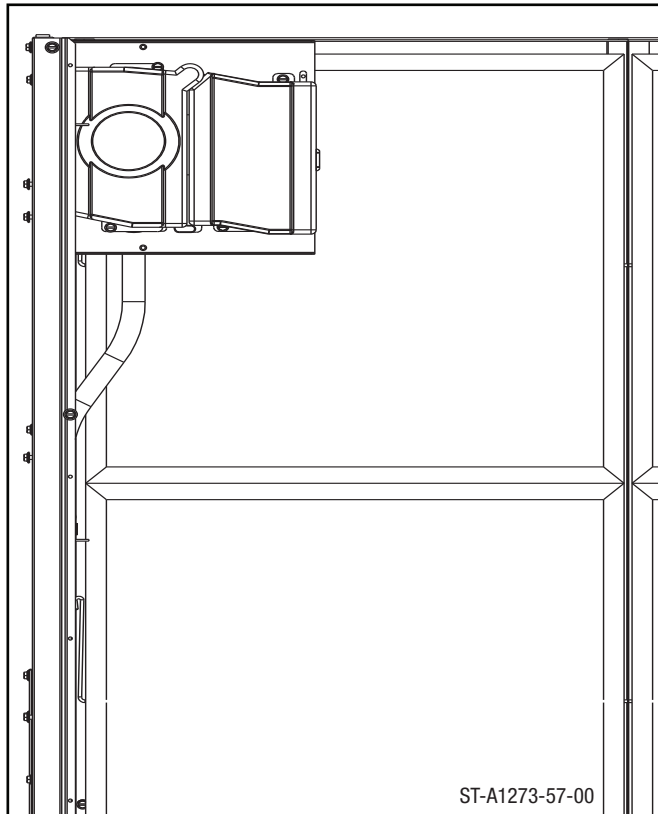

D.5.1. Supply Duct Smoke Detectors

D.5.1.1. Field Installed – Installation, Wiring, and Setup

Field install Supply and Return Duct Smoke Detectors come shipped with a separate document for Installation & Operation instructions. Refer to the separate Installation Instructions for installing, wiring, and setup of a supply and return smoke detector.

D.5.1.2. Factory Installed – Inspection and Setup

Inspect the smoke detector assembly for any damage during shipping. Use **Figure D.5. – A** for reference. Confirm that all wiring connections are still secure. Refer to the separate Installation Instructions for smoke detector for wiring diagrams and additional assembly instructions.

D.5.1.3. Field Installed 3rd Party Smoke Detectors or Fire Control Panels

See **Section F.1.2.** for the proper connection points for a remote smoke detector. DO NOT break 24vac to the Thermostat: shutdown will not occur. DO NOT break 24vac from the transformer: it can overload the smoke detector controls.

E.1. Electrical Safety Information

E.1.1. Information on Power Supply

⚠WARNING: Turn off the main electrical power at the branch circuit disconnect closest to the unit before attempting any wiring. Failure to do so can cause electrical shock resulting in personal injury or death.

1. All wiring should be made in accordance with the **National Electrical Code**. Consult the local power company to determine the availability of sufficient power to operate the unit. Check the voltage at power supply to make sure it corresponds to the unit's RATED VOLTAGE REQUIREMENT. Install a branch circuit disconnect near the rooftop, in accordance with the N.E.C., C.E.C. or local codes.

2. It is important that proper electrical power is available at the unit. Voltage should not vary more than 10% from that stamped on the unit nameplate. On **three phase units**, phases must be balanced within 3%.

3. For branch circuit wiring (main power supply to unit disconnect), the minimum wire size for the length of run can be determined from the **N.E.C.** using the circuit ampacity found on the unit rating plate. Use the smallest wire size allowable in **Figure F. – A** from the unit disconnect to unit.

4. For through the base wiring entry reference **Figure F.2. – A: Power and Control Routing**. All fittings and conduit are field supplied for this application. Reference the chart with **Figure F.2. – B: Hole Sizing for Conduit** for proper hole and conduit size.

NOTES:

1. For branch circuit wiring (main power supply to unit disconnect), the minimum wire size for the length of run can be determined from **Appendix B “Electrical Data”** or the unit rating plate for circuit ampacity and the National Electrical Code to determine proper wire sizing. From the unit disconnect to unit, the smallest wire size allowable in **Figure F. – A** for the circuit ampacity may be used, as the disconnect must be in sight of the unit.

2. Wire size based on 75°C rated wire insulation for 1% voltage drop.

3. For more than 3 conductors in a raceway or cable, see the National Electrical Code (or C.E.C. in Canada) for derating the ampacity of each conductor.

IMPORTANT: This unit is approved for use with copper conductors only connected to unit contactor.

WARRANTY MAY BE JEOPARDIZED IF ALUMINUM WIRE IS CONNECTED TO UNIT CONTACTOR.

E. ELECTRICAL

E.1.1. Information on Power Supply (Cont.)

Special instructions apply for power wiring with aluminum conductors:

Warranty is void if connections are not made per instructions.

Attach a length (6" or more) of recommended size copper wire to the unit contactor terminals L1, L2 and L3 for three phase.

Select the equivalent aluminum wire size from the tabulation below:

Splice copper wire pigtailed to aluminum wire with U.L. recognized connectors for copper-aluminum splices. Please exercise the following instructions very carefully to obtain a positive and lasting connection:

1. Strip insulation from aluminum conductor.
2. Coat the stripped end of the aluminum wire with the recommended inhibitor, and wire brush the aluminum surface through inhibitor. INHIBITORS: Brundy-Pentex "A"; Alcoa-No. 2EJC; T & B-KPOR Shield.
3. Clean and recoat aluminum conductor with inhibitor.
4. Make the splice using the above listed wire nuts or split bolt connectors.
5. Coat the entire connection with inhibitor and wrap with electrical insulating tape.

NOTE: Wiring to be done in the field between the unit and devices not attached to the unit, or between separate devices which are field installed and located, shall conform with the temperature limitation for Type T wire [63°F rise (35°C)] when installed in accordance with the manufacturer's instructions.

E.1.2. 208/240 Volt Operation and Required Adjustments

E.1.2.1. Low Voltage Transformer Tap Adjustment for 208Volt

Transformer is factory wired for 230 volts on 208-230 volt models and must be changed for 208 volt applications. See unit wiring diagram for 208 volt wiring.

E.2. Electrical Data

See [Appendix B](#) towards the end of this manual for Electric Data.

E.3. Electrical Connections

Figure E.3. – A: Typical Thermostat Wiring

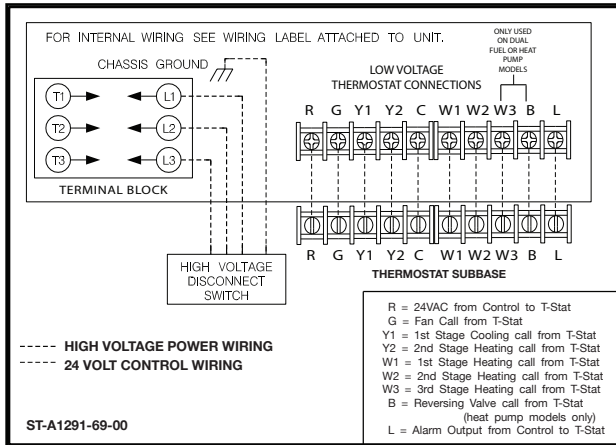

Use to [Appendix B](#) “Electrical Data” and National Electrical Code for circuit ampacity to determine proper wire sizing.

Refer to [Figure F.2. – A: Power and Control Routing](#) for location of wiring entrances, and [Figure F.2. – B: Hole Sizing for Conduit](#).

E.3.1. Field Supplied Disconnect

The field supplied service disconnect will come with a separate Installation Instruction document. Please refer to that document for more information.

E.3.1.1. Mounting Disconnect on Cabinet

Attach the disconnect to the top of the left hand side of the control box, above the knockouts and refrigerant test ports. Do not use screws above or below the label specifying “TO PREVENT COIL DAMAGE – DO NOT ADD SCREWS HERE, ABOVE, OR BELOW LABEL” as hidden coil and tubing could be damaged. An example of this label is shown below.

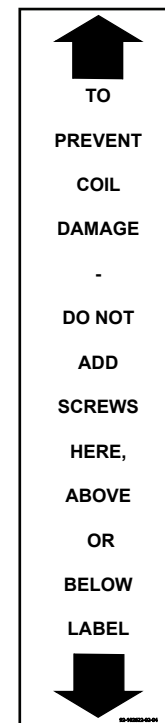

Figure E.3.1.1. – A: Standard Location for Mounting Disconnect

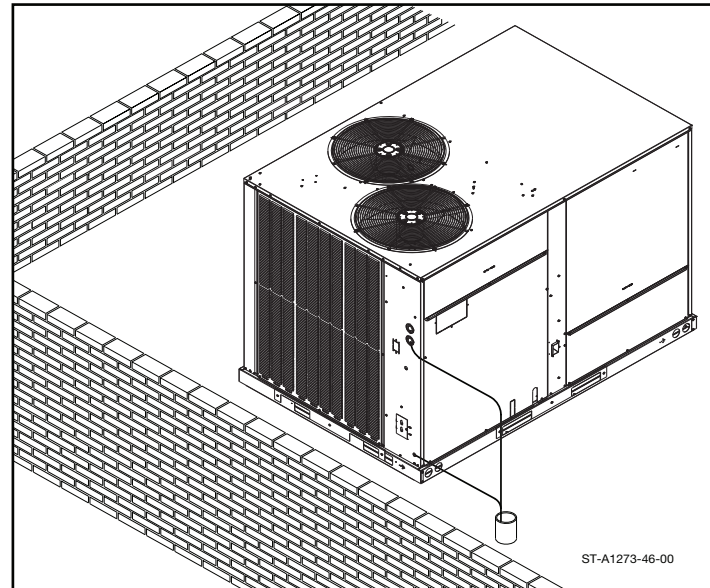

Figure E.3.1.1. – B: Label Showing Where to NOT Use Screws

E.3.1.2. Routing Wires into Cabinet

See [Figure F.2. – A: Electrical and Piping Routing](#) for conduit entry points and routing locations for wiring into the control box.

See [Figure E.3. – A: Typical Thermostat Wiring](#) for wiring to the terminal block and thermostat in the control box.

E. ELECTRICAL

E.3.1.3. Routing Wires through Curb (Option)

Use liquid tight connectors and tubing to connect the electrical and low voltage control cables between the base of the cabinet at the raised section (See **Figure B.3.6. - A: Supply And Return Dimensions For Downflow Applications** for location of raised section) and bottom of the control panel. Conduit and fittings must meet all applicable codes.

Use Silicon and gaskets to seal the connection at the base pan

E.3.1.4. Connecting to Contactor Terminal Blocks

The recommended torque for securing wiring to the contactor is **40 in-lb**.

See **Figure E.3. - A: Typical Thermostat Wiring** for wiring to the contactor.

E.3.2. Factory Installed Disconnect

Refer to **Appendix G** for the unit wiring diagrams, and to **Figure F.2. - A** for locations to route wires into the cabinet or through the curb/basepan of the unit.

E.3.2.1. Routing Wires into Cabinet

Refer to section **E.3.1.1.** and/or section **F.2.** for routing wires into the cabinet with a factory installed disconnect.

E.3.2.2. Routing wires through Curb (Option)

Refer to **Section E.3.1.3.** for routing wires through the curb with a factory installed disconnect.

E.3.3. Connecting the Convenience Outlet

E.3.3.1. Non-powered

The non-powered convenience outlet, if purchased as an option for the unit, will come shipped in a box within the blower compartment of the unit. It will need to be removed and installed into its proper configuration.

For connecting the non-powered convenience outlet and all other information, refer to the installation instructions for the accessory.

E.3.4. Checking Phase and Motor Rotation

When using 3 phase power the only device that is rotation dependent is the compressor. The outdoor fan and indoor blower do not require any adjustment and will turn backwards if the phase is incorrect. Verify the direction of rotation for the indoor blower motor before starting up the compressors.

E.3.4.1. Checking Phase with VFD Drive

On any models with an ECM Direct Drive Blower Motor or belt drive units with a Variable Frequency Drive, VFD, the motor will always rotate in the correct direction.

Correction phase must be checked by the operation of the compressor.

E.3.5. Grounding Requirements

Refer to local codes as required. Must be grounded to a common earth ground.

National Electric Code (NEC) / International Building Code / Canadian Electrical Code

A diagram of the internal wiring of this unit is located on the inside of control access panel and in this manual. If any of original wire as supplied with the appliance must be replaced, the wire gauge and insulation must be same as original wiring.

The low voltage wiring should be sized as shown in **Figure F. - A: Field Wire Size for 24v Thermostat Circuits**.

F. CONTROL / THERMOSTAT WIRING

Figure F. - A

FIELD WIRE SIZE FOR 24 VOLT THERMOSTAT CIRCUITS						
THERMOSTAT LOAD - AMPS	SOLID COPPER WIRE - AWG.					
	3.0	16	14	12	10	10
2.5	16	14	12	12	12	10
2.0	16	16	14	12	12	10
	LENGTH OD RUN - FEET (1)					
	50	100	150	200	250	300

ST-A1291-14-00

(1) THE TOTAL WIRE LENGTH IS THE DISTANCE FROM THE FURNACE TO THE THERMOSTAT AND BACK TO THE FURNACE.

NOTE: DO NOT USE CONTROL WIRING SMALLER THAN NO. 18 AWG.

Install the room thermostat in accordance with the instruction sheet packed in the box with the thermostat. Run the thermostat lead wires through the control entry opening (**Figure F.2. - A: Electrical and Piping Routing**) and connect to the low voltage thermostat connections (see **Appendix G** for wiring diagrams and **Section F.1.** for T-Stat field connections). Never install the thermostat on an outside wall or where it will be influenced by drafts, concealed hot or cold water pipes or ducts, lighting fixtures, radiation from fireplace, sun rays, lamps, televisions, radios or air streams from registers. Refer to instructions packed with the thermostat for "heater" selection or adjustment.

F.1. T-Stat field connections

F.1.1. Misc. Connections

Refer to **Appendix G** for the unit wiring diagrams and to **Figure E.3. - A: Typical Thermostat Wiring**.

Figure F.1.1. - A: Core Command Terminal Locations

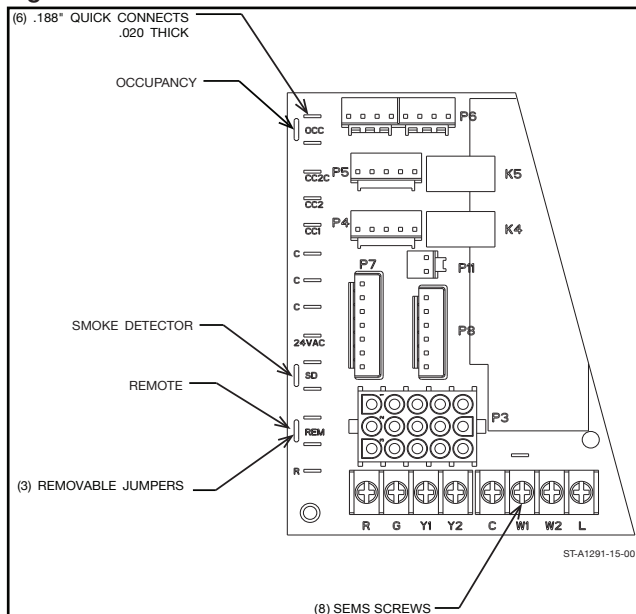

F.1.2. Occupancy Connections / Remote Connections / Etc.

Figure F.1.2. - A: Occupancy and Remote Connections

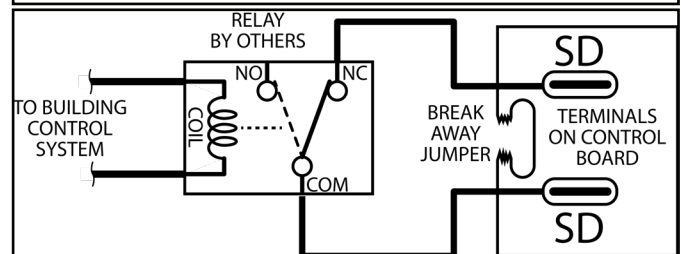
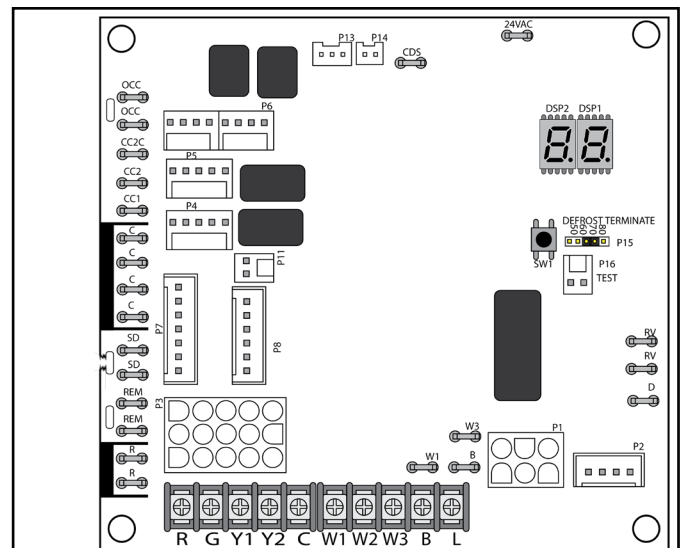
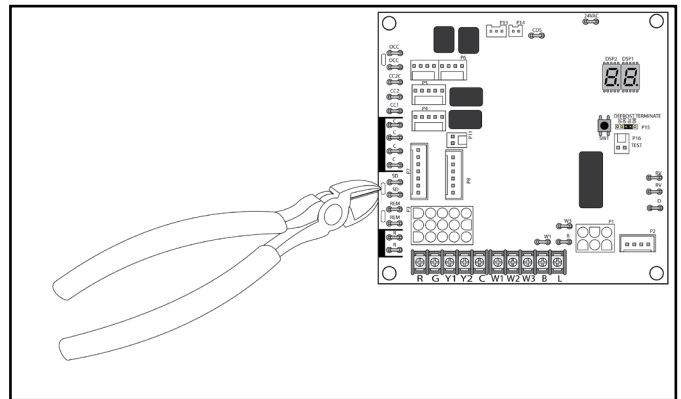

NOTE: This is an example of breaking the jumper for Smoke Detector connections, apply the same process for the Occupancy and/or Remote connections.

These features are only available on the Non-DDC Furnace, Heat pump, or cooling only control boards.

OCC – Occupancy Control. This feature shuts down the dampers on the economizer or motorized damper option when outdoor/fresh air is not required for the building. Locate the terminals at the left side of the board mark "OCC". See **Figure F.1.2. - A: Occupancy and Remote Connections** for reference.

F. CONTROL / THERMOSTAT WIRING

F.1.2. Occupancy Connections / Remote Connections / Etc. (Cont.)

For connecting Remote Smoke Detectors or Fire Control Panels to this control DO NOT break the 24VAC to the thermostat or from the power supply transformer. Either could cause an undesirable operating condition that would not shut the unit down in the event of an emergency situation. See the instructions for the type of control board this unit is equipped with.

Using cutters or a small screw driver, break the edge of the board between the terminals marked with "OCC". Use 3/16" blade connector, and a minimum of 18AWG wire to connect to a Normally Closed Dry Contact Relay or Switch. Do not connect multiple control boards to the same dry contact relay or switch.

REM – Remote Shutdown Control. This feature allows the unit to be turned off remotely ignoring the thermostat calls for cooling or heat. Locate the terminals at the left side of the board mark "REM". See **Figure F.1.2. – A: Occupancy and Remote Connections** for reference.

Using cutters or a small screw driver, break the edge of the board between the terminals marked with "REM". Use 3/16" blade connector, and a minimum of 18AWG wire to connect to a Normally Closed Dry Contact Relay or Switch. Do not connect multiple control boards to the same dry contact relay or switch.

F.1.3. Connecting a Smoke Detector

F.1.3.1. Core Command Connection

SD – Remote Smoke Detection. This feature allows for the proper shutdown of the controls in the event of an emergency situation. Locate the terminals at the left side of the board mark "SD". See **Figure F.1.2. – A: Occupancy and Remote Connections** for reference.

Using cutters or a small screw driver, break the edge of the board between the terminals marked with "SD". Use 3/16" blade connector, and a minimum of 18AWG wire to connect to a Normally Closed Dry Contact Relay, or in common Fire Control Panels and Smoke Detectors, the Auxiliary Connections for C and NC. See the instructions for the remote devices. Do not connect multiple control boards to the same dry contact relay.

F.1.3.2. DDC Control Connection

In the air-filter section or on the side economizer, locate the 12-pin Molex jumper plug with the long Red, short Yellow and

Orange wire loops; see **Figure F.1.3.2. – A** for reference. Cut the Red wire loop and connect these to a minimum of 18AWG wire that will be connected to a Normally Closed Dry Contact Relay, or in common Fire Control Panels and Smoke Detectors, the Auxiliary Connections for C and NC. See the instructions for the remote devices. Do not connect multiple control boards to the same dry contact relay.

F.1.4. Building Management / Control Connections Using DDC –

In an application where a third party building management / controls are in use or will be incorporated, units with the integral Rooftop Unit Controller (RTU-C) are communication compatible with the system that supports the BACnet Application Specific Controller device profile, LonMark Space Comfort Controller functional profile, or LonMark Discharge Air Controller functional profile. This is accomplished with a field installed BACnet or LonMark communication module. Refer to the Clear Control™/DDC manual for more detail.

Figure F.1.5.3. – A: Wiring Harness location in Air-Filter Section

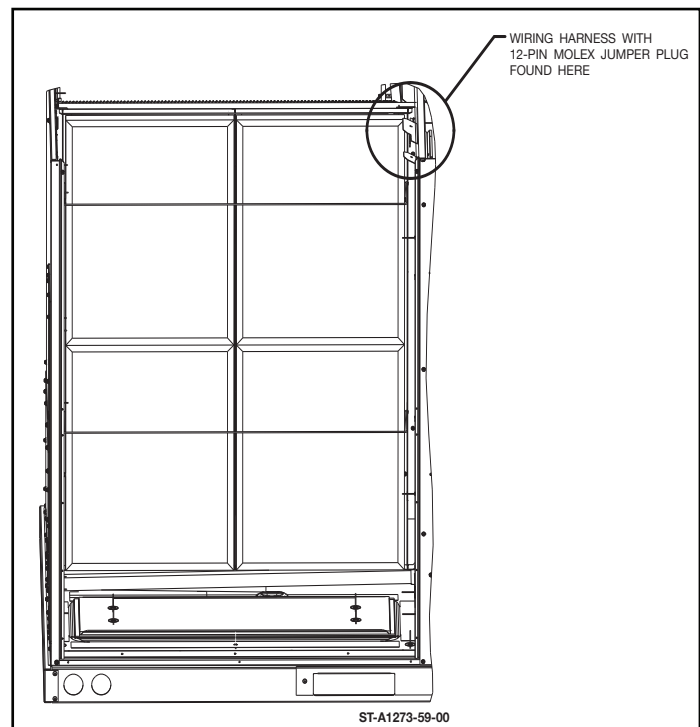

F. CONTROL / THERMOSTAT WIRING

F.2. Routing Control wiring

Figure F.2. – A: Electrical and Piping Routing

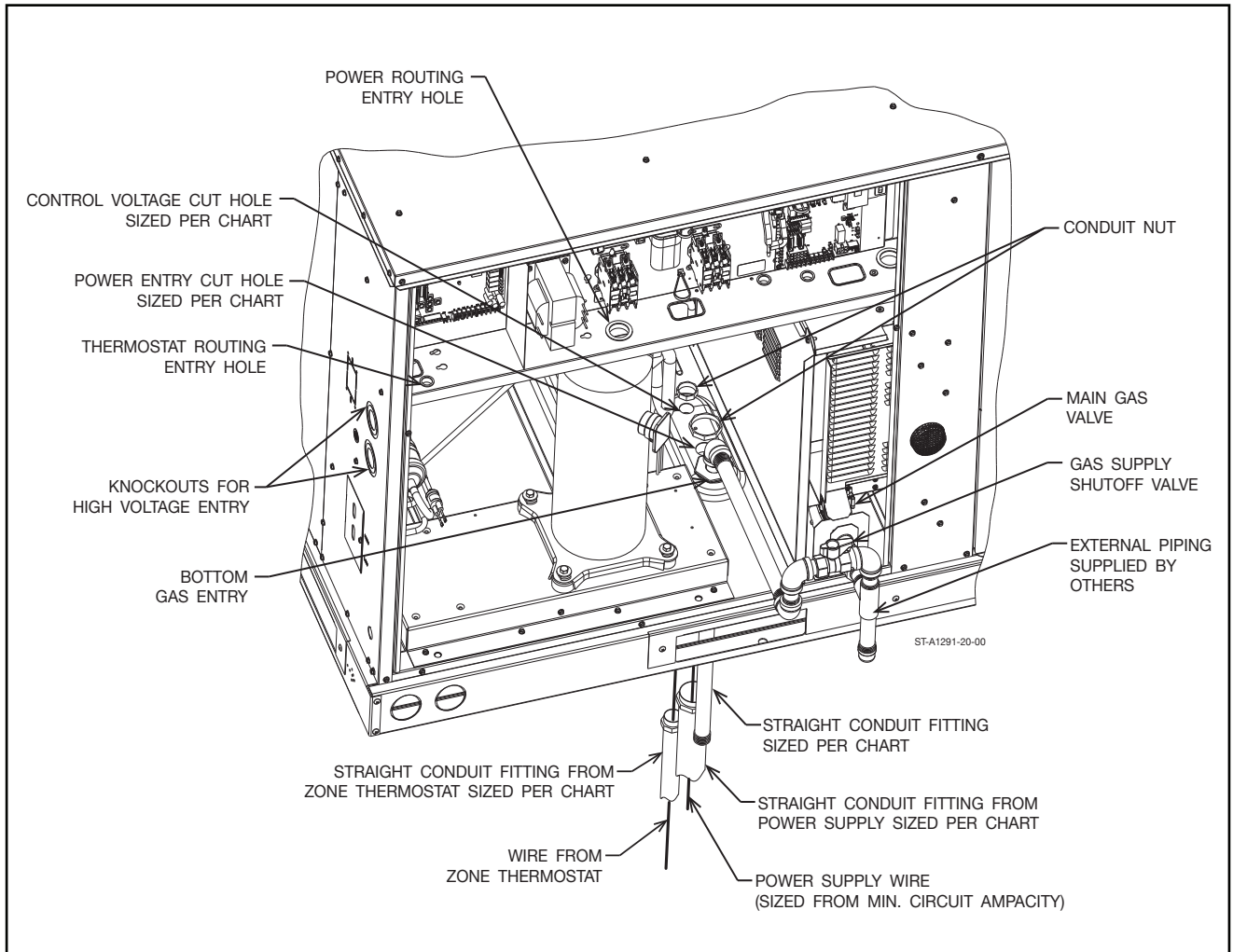

Figure F.2. – B: Hole Sizing for Conduit

	WIRE SIZE, AWG											
	14	12	10	8	6	4	3	2	1	0	00	000
CONDUIT SIZE	1/2"	1/2"	1/2"	3/4"	1"	1"	1-1/4"	1-1/4"	1-1/2"	1-1/2"	2"	2"
HOLE SIZE	7/8"	7/8"	7/8"	1-31/32"	1-23/64"	1-23/64"	1-23/32"	1-23/32"	1-31/32"	1-31/32"	2-15/32"	2-15/32"

NOTES: 1. DETERMINE REQUIRED WIRE SIZE FROM MINIMUM CIRCUIT AMPACITY SHOWN IN INSTALLATION & OPERATING INSTRUCTION.
 2. BOTTOM POWER ENTRY WILL NOT ACCOMMODATE WIRE LARGER THAN #2 AWG (SHADED AREA).

F.3. Measuring Control Voltage Loads

Use a voltmeter to measure the low voltage and low voltage amp draws during operation. Accessories such as remote smoke detectors and excessive wire length can increase the amp draw on the low voltage wiring. Verify that the total amp draw on the 24Vac side is less than 0.3A in full operation.

G. GAS

G.1. Gas Piping Requirements

Install gas piping in accordance with local codes and regulations of the local utility company. In the absence of local codes, the installation must conform to the specifications of the national Fuel Gas Code, ANSI Z223.1 – latest edition.

IMPORTANT: Connect this unit only to gas supplied by a commercial utility.

G.1.1. Pipe Material Requirements

Ridged black iron pipe and fittings are recommended for the gas lines, or other materials as local codes allow or considered best practice. The use of flexible connectors is not recommended. Install a Union joint near the unit, after the cut off valve, for service.

G.1.2. Tools Required

Pipe wrenches, Pliers, gas rated thread sealant, and leak detection fluid or soap and water is required.

G.1.3. Code Requirements

Local codes should be followed for the installation and marking of the gas piping. In the absence of local codes follow the National Fuel Gas Code NFPA 54 ANSI Z223.1 (Latest Revision), International Fuel Gas Code IFGC 408.4(Latest Revision), or the Canadian CANCGA B149.1HB (Latest Revision), must be followed.

G.1.4. Gas Pressures and Regulation

IMPORTANT: ENSURE that the furnace gas valve is not to be subjected to high gas line supply pressures.

DISCONNECT the furnace and its individual manual gas stop from the gas supply piping during any pressure testing that exceeds 1/2 PSIG (3.48 kPa). Natural gas supply pressure must be 5” to 10.5” w.c. LP gas supply pressure must be 11” to 13” w.c. This pressure must be maintained with all other gas-fired appliances in operation. The minimum gas supply pressure to the gas valve for proper furnace input adjustments is 5” w.c. for natural gas, however 6” to 7” is recommended. The minimum gas supply pressure is 11” w.c. for LP gas.

See sections **J.5.1.1. “Measuring and Adjusting Supply Gas Pressures”** and **J.5.1.2. “Measuring and Adjusting Manifold Gas Pressures”** for more details.

⚠️ WARNING

ELEVATIONS ABOVE 2000 FT. REQUIRE THAT THE FURNACE INPUT RATING BE ADJUSTED AND THAT THE SIZE OF THE BURNER ORIFICES BE RECALCULATED BASED ON ELEVATION AND GAS HEATING VALUE. THE BURNER ORIFICES MAY (OR MAY NOT) NEED TO BE CHANGED. SEE THE SECTION TITLED “HIGH ALTITUDE INSTALLATIONS” OF THIS BOOK FOR INSTRUCTIONS.

⚠ WARNING

NEVER PURGE A GAS LINE INTO THE COMBUSTION CHAMBER. NEVER USE MATCHES, FLAME OR ANY IGNITION SOURCE FOR CHECKING LEAKAGE. FAILURE TO ADHERE TO THIS WARNING CAN CAUSE A FIRE OR EXPLOSION RESULTING IN PROPERTY DAMAGE, PERSONAL INJURY OR DEATH. TO CHECK FOR GAS LEAKAGE, USE AN APPROVED CHLORIDE-FREE SOAP AND WATER SOLUTION, OR OTHER APPROVED METHOD.

GAS VALVE

This furnace has a 24-volt gas valve. It has ports for measuring supply and manifold gas pressure. The valve body contains a pressure regulator to maintain proper manifold gas pressure. A control switch is on the valve body. It can be set to only the “ON” or “OFF” positions. The gas valve is a slow-opening valve. See Figure **G.1.4. - A.**

When energized, it takes 2 to 3 seconds to fully open.

Figure G.1.4. - A White-Rodgers Two-Stage Gas Valve

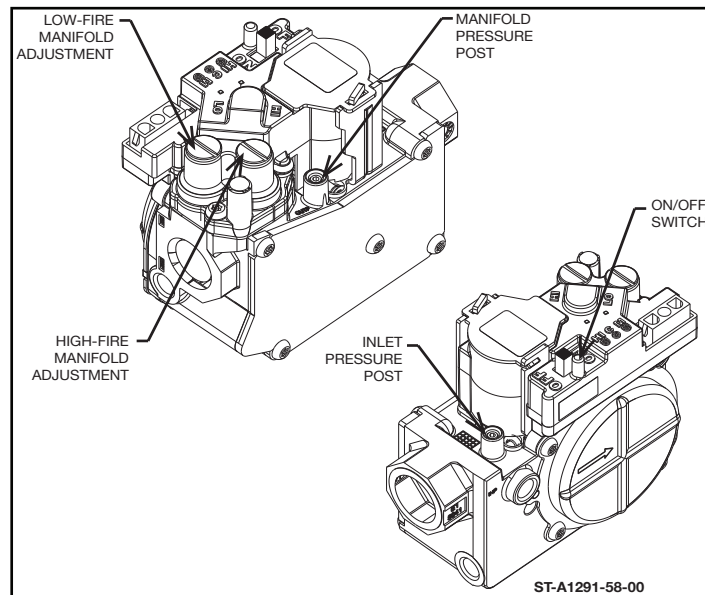

Figure G.1.4. - B: Burner Assembly Front View

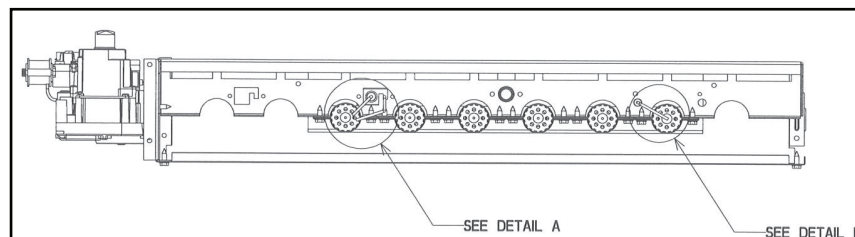
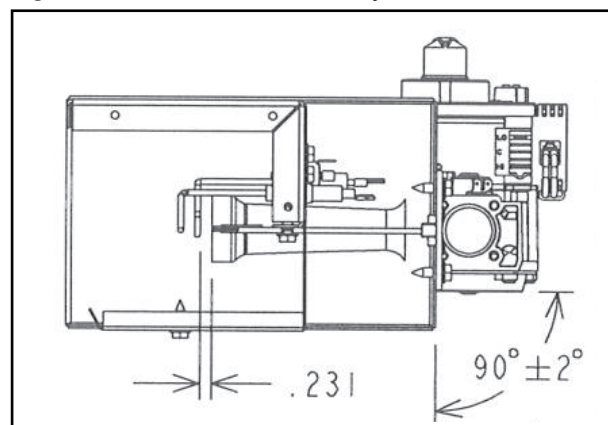

Figure G.1.4. - C: Burner Assembly Side View



G. GAS

For 75,000 BTU input furnaces, the outside manifold orifice taps are plugged. The ignitor and flame sense are located on the outside of the center burner.

Ignitor location is critical for insuring a consistent carryover of the burner flame during ignition. The top of the electrode at dimension (0,0) must remain inside the hatched area

Figure G.1.4. - D: Ignitor Location

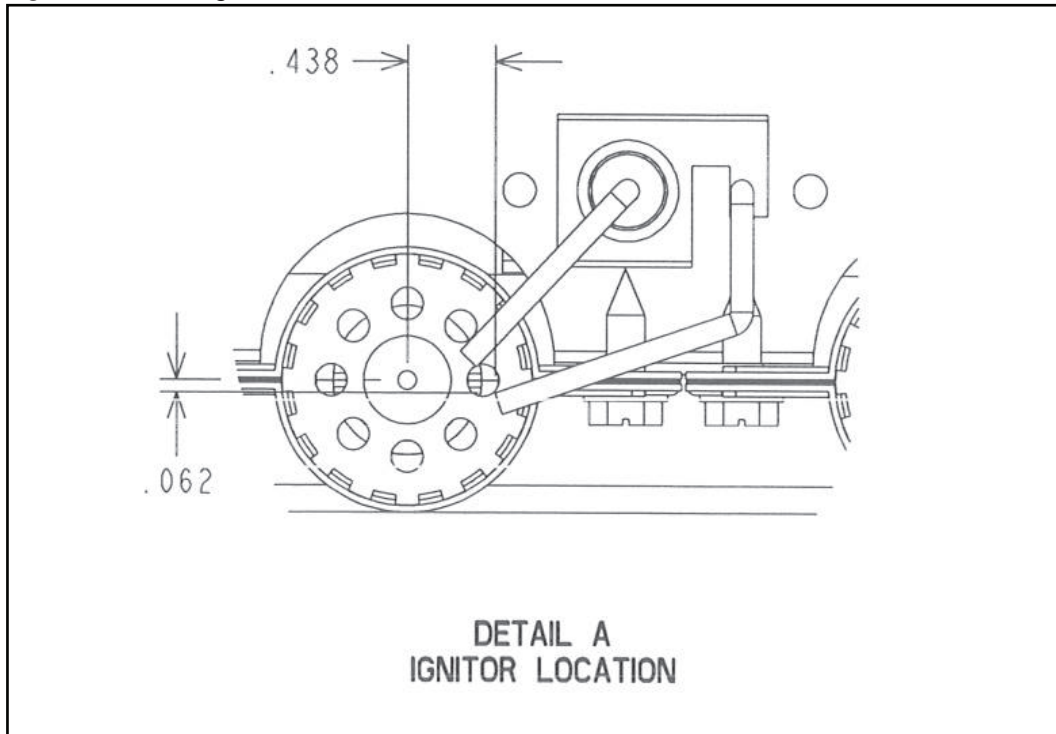

Correct location of the flame sensor will help to eliminate weak or no flame sense issues.

Figure G.1.4. - E: Flame Sense Location

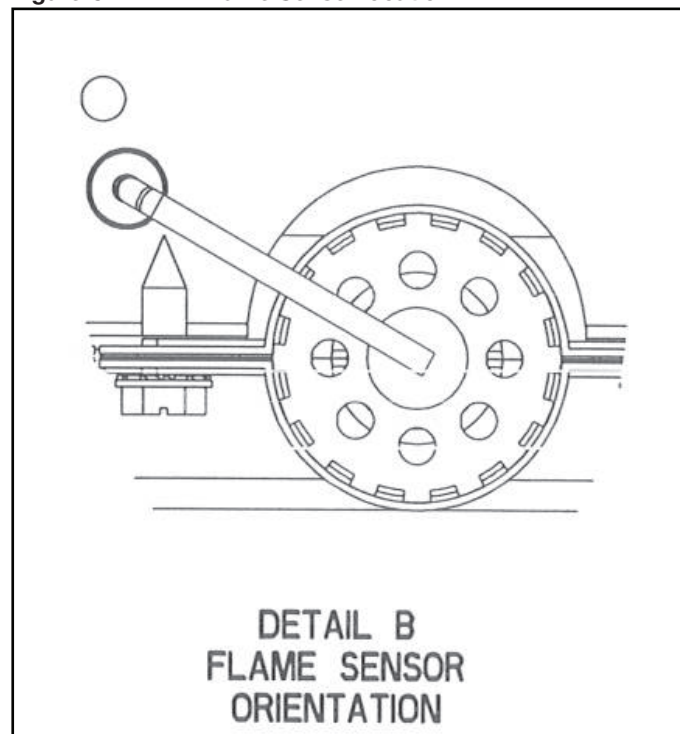

G.1.5. Sealing Threaded Connections – Best Practice

Use a gas rated and approved liquid, paste, or tape thread sealant on all threaded connections. Apply sealant to the male threads and tighten the fitting using wrenches to hold both the fitting and the pipe. **DO NOT OVERTIGHTEN THE PIPE GOING INTO THE GAS VALVE, DAMAGE MAY OCCUR.** Test all threaded connections with leak test fluid or soap and water.

G.1.6. Gas Pipe Sizing and Capacity

Size the gas line to the furnace adequate enough to prevent undue pressure drop and never less than 3/4" pipe.

See **Table G.1.6. - A** for Gas Pipe Capacity. The capacities of gas pipe of different diameters and lengths in Cubic Ft/hr with pressure drop of 0.3 in. and specific gravity of 0.60 (natural gas) are shown in **Table G.1.6. - A**. After determining the pipe length, select the pipe size which will provide the minimum cubic foot/hour required for the gas input rating of the furnace.

By formula:

$$\frac{\text{ft}^3}{\text{hr}} \text{ required} = \frac{\text{Gas Input of Furnace } \frac{\text{BTU}}{\text{hr}}}{\text{Heating Value of Gas } \frac{\text{BTU}}{\text{hr}}}$$

The gas input of the furnace is marked on the furnace rating plate. The heating value of the gas (BTU/FT³) may be determined by consulting the local natural gas utility or the L.P. gas supplier.

Table G.1.1 - A

NATURAL GAS PIPE CAPACITY TABLE (CU FT/HR)										
Maximum capacity of pipe in thousands of BTU/hr of natural gas										
Inlet pressure: less than 2 psi										
Pressure Drop: 0.3 in. W.C.										
Specific Gravity: 0.60										
Nominal Iron Pipe* Size, Inches	Length of Pipe, Feet									
	10	20	30	40	50	60	70	80	90	100
1/2	131	90	72	62	55	50	46	42	40	38
3/4	273	188	151	129	114	104	95	89	83	79
1.0	514	353	284	243	215	195	179	167	157	148
1-1/4	1,060	726	583	499	442	400	368	343	322	304
1-1/2	1,580	1,090	873	747	662	600	552	514	484	455

After the length of pipe has been determined, select the pipe size which will provide the minimum cubic feet per hour required for the gas input rating of the furnace. By formula:

$$\text{Cubic feet per hour required} = \frac{\text{Gas Input of Furnace (BTU/HR)}}{\text{Heating Value of Gas (BTU/FT}^3\text{)}}$$

The gas input of the furnace is marked on the furnace rating plate. Call your local natural gas utility for the heating value of the gas (BTU/FT³).

*Schedule 40 metallic pipe.

Reference the **National Fuel Gas Code NFPA 54, ANSI Z223.1- Pipe Sizing** for more information.

G. GAS

G.2. Procedure: Connecting Gas Lines to Gas Valve

1. Place backup wrench on valve, shown below in **Figure G.2. - A.**

Figure G.2. - A: Backup Wrench Location

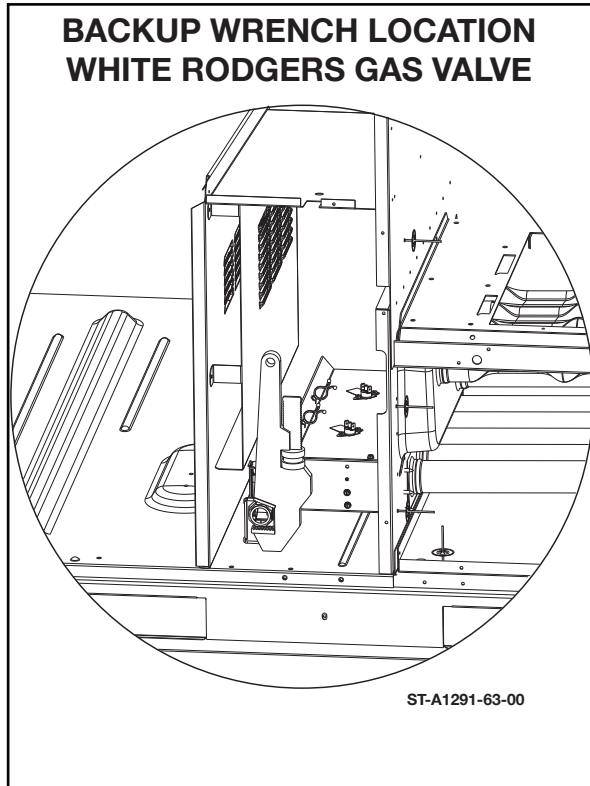

2. Connect the gas line to the gas valve supplied with unit. Routing can be through the gas pipe opening shown in **Figure G.2.1.** or through the base as shown in **Figure F.2. - A: Electrical and Piping Routing.**

In making gas connections, avoid strains as they may cause noise and damage the controls. A backup wrench is required to be used on the valve to avoid damage.

3. Size the gas line to the furnace adequate enough to prevent undue pressure drop and never less than 3/4" pipe. See **Section G.1.6** on Gas Pipe Sizing and Capacity.
4. Install a drip leg or sediment trap in the gas supply line as close to the unit as possible. See **Section G.2.1** on Drip Leg Requirements.
5. Install an outside ground joint union to connect the gas supply to the control assembly at the burner tray.
6. Gas valves have been factory installed. Install a manual gas valve where local codes specify a shut-off valve outside the unit casing. (**See Figure G.2.1.**)

7. Make sure piping is tight. **A pipe compound resistant to the action of liquefied petroleum gases must be used at all threaded pipe connections.**

IMPORTANT: Any additions, changes or conversions required for the furnace to satisfactorily meet the application should be made by a qualified installer, service agency or the gas supplier, using factory specified or approved parts. In the commonwealth of Massachusetts, installation must be performed by a licensed plumber or gas fitter for appropriate fuel.

IMPORTANT: Disconnect the furnace and its individual shutoff valve from the gas supply piping during any pressure testing of that system at test pressures in excess of 1/2 pound per square inch gauge or isolate the system from the gas supply piping system by closing its individual manual shutoff valve during any pressure testing of this gas supply system at pressures equal to or less than 1/2 PSIG.

IMPORTANT: Check the rating plate to make certain the appliance is equipped to burn the type of gas supplied. Care should be taken after installation of this equipment that the gas control valve not be subjected to high gas supply line pressure.

G.2.1. Drip Leg Requirement

When connecting the supply gas to the gas valve, install a drip leg/sediment trap in compliance with the International Residential Code G2419.4.

Figure G.2.1. – A: Drip Leg

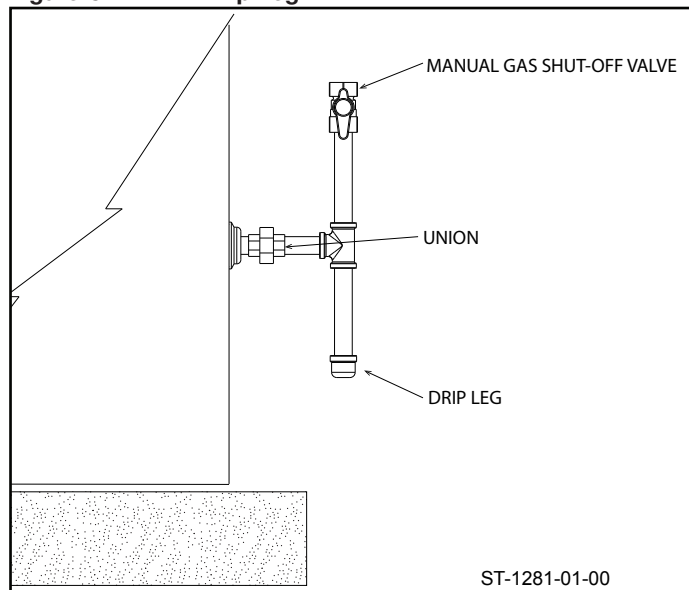

G.2.2. Purging Gas Lines

It may be necessary to purge any air from the gas lines prior to operation. This can be done through the gas pressure tap on the gas valve or at a union in the gas line. Follow best practices to purge the gas line. Ensure all fittings are sealed and tight after purging.

G.2.3. Leak Testing

To check for gas leaks, use a soap and water solution or other approved method. **DO NOT USE AN OPEN FLAME.**

G.3. LP Conversion

WARNING: DO NOT use an open flame to check for leaks. The use of an open flame can result in fire, explosion, property damage, personal injury or death.

WARNING: This unit is equipped at the factory for use on natural gas only. Conversion to lp gas requires a special kit supplied by the distributor or manufacturer. Mailing addresses are listed on the furnace rating plate, parts list and warranty. Failure to use the proper conversion kit can cause fire, carbon monoxide poisoning, explosion, personal injury, property damage or death.

NOTE: The valve can be converted to use liquefied petroleum (LP) gas by replacing the high and low fire pressure regulator springs with the conversion kit springs. The LP kit springs allow the regulator to maintain the proper manifold pressure at high and low fire for LP gas.

NOTE: Order the correct LP conversion kit from the furnace manufacturer.

See Conversion Kit Index shipped with unit and table below for proper LP kit number.

A qualified technician must perform furnace conversion to LP gas.

Model Number	Kit Number U.S./Canadian
RGED 150k, 105k, 225 k	FP39

ORIFICE INSTALLATION

LP Gas is a manufactured gas that has consistent heating value across most regions. The Sea Level input should still be reduced by 4% per thousand ft. above 2,000 feet and the orifice size must be selected based on the reduced input selection chart in High Alt. Instruction Section.

To change orifice spuds for conversion to LP:

1. Shut off the gas supply and remove gas connection to the gas valve.
2. Remove the gas manifold.
3. Replace the natural gas orifices with LP orifices.
4. Reassemble in reverse order.
5. Refer to section **J.5.1.1. Measuring and Adjusting Supply Gas Pressures** for confirming inlet pressure and adjusting manifold pressure.

WARNING: LP tanks from local LP supplier must not be used to store anything (such as fertilizer) except LP gas. This includes all delivery vessels (LP trucks). If material other than LP gas is used in the same vessels/tank as the LP gas, the LP gas can become contaminated and damage the furnace. This will void the manufacturer's warranty. Contact the supplier to make sure fertilizer is not used in the same tanks used to store and deliver LP gas.

G. GAS

Table G.3 - A

LP GAS PIPE CAPACITY TABLE (CU FT/HR)												
Maximum capacity of pipe in thousands of BTU/hr of undiluted liquified petroleum gases (at 11.0" W.C. inlet pressure)												
(Based on a Pressure Drop of 0.5" W. C.)												
Nominal Iron Pipe* Size, Inches	Length of Pipe, Feet											
	10	20	30	40	50	60	70	80	90	100	125	150
1/2	275	189	152	129	114	103	96	89	83	78	69	63
3/4	567	393	315	267	237	217	196	182	173	162	146	132
1.0	1,071	732	590	504	448	409	378	346	322	307	275	252
1-1/4	2,205	1,496	1,212	1,039	913	834	771	724	677	630	567	511
1-1/2	3,307	2,299	1,858	1,559	1,417	1,275	1,181	1,086	1,023	976	866	787
2.0	6,221	4,331	3,465	2,992	2,646	2,394	2,205	2,047	1,921	1,811	1,606	1,496

Example (LP): Input BTU requirement of unit, 120,000
Equivalent length of pipe, 60 ft. = 3/4" Inside Diameter required

*Schedule 40 metallic pipe.
Reference the **National Fuel Gas Code NFPA 54, ANSI Z223.1- Pipe Sizing** for more information.

G.4. Operation and Testing

G.4.1. Warnings

⚠ WARNING: DO NOT attempt to manually light this furnace with a match or any open flame. Attempting to do so can cause an explosion or fire resulting in property damage, personal injury or death.

⚠ WARNING: The spark ignitor and ignition lead from the ignition control are high voltage.

Keep hands or tools away to prevent electrical shock. Shut off electrical power before servicing any of the controls. Failure to adhere to this warning can result in personal injury or death.

⚠ WARNING: Should overheating occur or the gas supply fail to shut off, turn off the manual gas control valve to the furnace. Failure to do so can result in an explosion or fire causing severe personal injury or death!

G.4.2. First Time Operation

G.4.2.2. Normal Furnace Sequence Of Operation

1. Thermostat initiates call for heat.
2. Core Command runs self-diagnostic. Core Command confirms the Main Limit Control (MLC) is closed; the Negative Pressure Control (NPC) is open and checks Manual Reset Limit Controls (MRLC) for continuity.
3. Core Command energizes Induced Draft Motor (IDM).
4. Core Command confirms NPC is closed.
5. If NPC is closed, the Core Command starts a

30-second prepurge.

6. Following 30 second prepurge, the Core Command energizes the Spark Electrode (SE) up to 7 seconds or until the Remote Flame Sensor proves burner flame. Core Command de-energizes the SE and begins the 20-second blower ON delay.

7. The furnace will respond to thermostat command following 20-second blower ON delay.

Sequences- system doesn't light or doesn't sense flame:

• NPC Remains Open After the IDM is Energized:

1. The IDM will run for 60 seconds in an attempt to close the NPC. IDM is de-energized then energized and the ignition attempt is repeated.
2. After four attempts to close the NPC, the system will enter a 1-hour lockout period.

• Failed Ignition or Core Command Doesn't Sense Flame:

1. Following the 30-second prepurge period, the SE and gas valve are energized up to 8 seconds.
2. If flame is not sensed during the 8-second period after the gas valve is energized, the gas valve and SE are de-energized.
3. IDM is de-energized and the Core Command verifies that the NPC is open. Once the NPC is confirmed open, the Core Command will begin a second ignition attempt.
4. The system will attempt three tries at ignition. Following a third failed attempt the system will enter a 1-hour lockout period.

G.4.2.3. Single-Stage Thermostat and Auto-Staging: 208-230V, 575V & 460V

Application where a single-stage thermostat is used with this two-stage furnace. Furnace will run at low-fire input for a 15 minute period. If thermostat demand is not satisfied, Core Command will automatically stage to highfire until thermostat demand is met. To accommodate auto-staging, simply secure a jumper wire between W1 and W2 on the Core Command. See **Figure G.4.2.3. - A** for details.

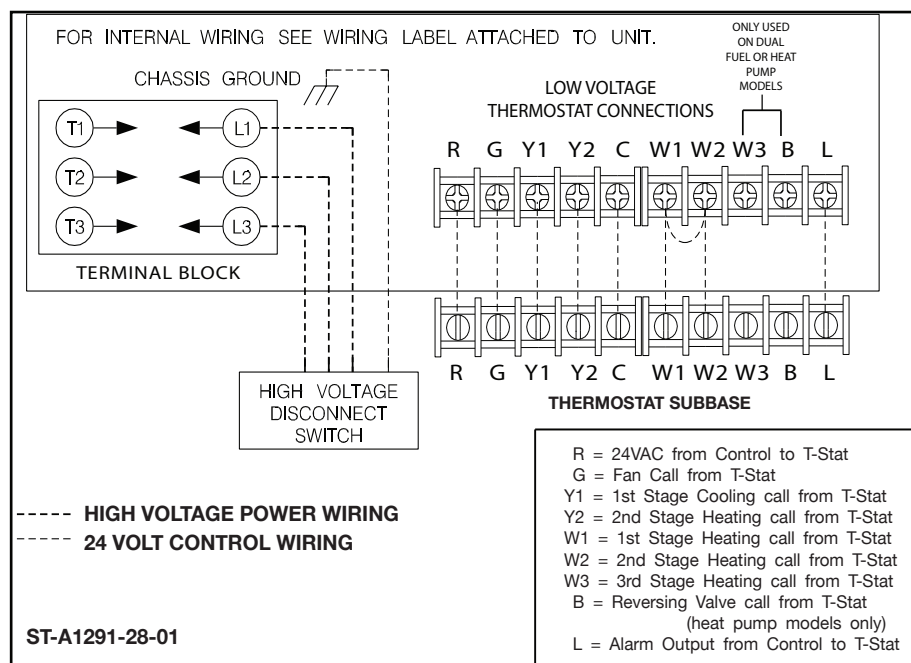

G.4.2.4. Gas Pressure Testing and Adjustment

Refer to **Section J.5.1.1** for detailed instructions on testing and adjusting gas pressure.

G.4.2.5. Flame inspection

Inspect burner flame after the indoor blower motor is energized. Burner flame should be directed down the center of primary heat exchanger tube with little or no lifting. Carry-over flame should not impinge on center panel. Any flame turbulence could be an indication of an air leak between the burner and heat exchanger compartment or a partially blocked burner orifice.

Natural Gas Flame: almost completely blue with some yellow in the center of the flame.

LP Gas Flame: predominantly a blue flame with some yellow tipping.

G.4.2.6. Orifice Selection and High Altitude Adjustments

Notice: derating of the heating input for high altitude in the field is unlawful in Canada (refer to can/cga 2.17). Units installed in altitudes greater than 2,000 feet (610 meters) must be shipped from the factory or from a factory authorized conversion station with the heating input derated by 10% so as to operate properly in altitudes from 2,000 - 4,500 feet (610 - 1,373 meters).

NATURAL GAS AT HIGH ALTITUDES

Furnaces installed above 2,000 feet require the furnace to be de-rated 4% per thousand feet above sea level.

IMPORTANT: Factory installed orifices are calculated and sized based on a sea level Natural Gas heating value of 1050 BTU per cubic ft.

NOTE: Orifices are available through your local distributor. Reference the following tables for approximate orifice sizing.

The following are examples of orifice sizing using the "Flow of Gas Through Fixed Orifices" section in the National Fuel Gas Code.

For a simplified estimation of orifice size based on gas heating value and elevation, the following tables may be used. However, calculations are the best method.

G. GAS

Example: 900 BTU/ft³ Regional Natural Gas Heating Value

$$I/H = Q$$

$$25000 / 900 = 27.78 \text{ ft}^3$$

I = Sea Level input (per burner): 25000

H = Sea Level Heating Value: 900

Q = 27.78 ft³ Natural Gas per hour.

From Table E1.1a of National Fuel Gas Code, 2015 (3.5" w.c.).

Orifice required at Sea Level: #40

from the National Fuel Gas Code. Orifice required at 5000 ft. elevation (4% de-rate per thousand ft): #42

Orifice required at 8000 ft. elevation (4% de-rate per thousand ft.): #44

Example: 1050 BTU/ft³ Regional Natural Gas Heating Value

$$I / H = Q$$

$$25000 / 1050 = 23.81 \text{ ft}^3$$

I = Sea Level input (per burner): 25000

H = Sea Level Heating Value: 1050

Q = 23.81 ft³ Natural Gas per hour.

From the National Fuel Gas Code, (3.5" w.c.).

Orifice required at Sea Level: #43 From the National Fuel Gas Code,

Orifice required at 5000 ft. elevation (4% de-rate per thousand ft.): #45

Orifice required at 8000 ft elevation (4% de-rate per thousand ft): #47

ORIFICE ORDERING INFORMATION

Orifice sizes are selected by adding the 2-digit drill size required in the orifice part number. Drill sizes available are 39 through 64; metric sizes available 1.10mm (-90) and 1.15mm (-91):

Orifice Part Number 62-22175-(drill size)

Example 1:

60 drill size orifice required

Part # 62-22175-60

Example 2:

1.15mm drill size orifice required

Part # 62-22175-91

NATURAL GAS ORIFICE SELECTION BASED ON HEATING VALUE & ELEVATION*

HIGH ALTITUDE

Notes:

1. Furnaces are factory equipped with orifices sized for 1050 sea level heating value gas.
2. Installer must be aware of the local heating value (sea level standard) to use the chart below.
3. This chart is based on the National Fuel Gas Code (NFGC) and based on natural gas with a specific gravity of 0.60
4. The recommended orifices below allow the furnace to operate within 10% of design rate. However, NFGC calculations are the best method.
5. Furnace operation is optimized when operating at design rate. Installer is responsible to verify rate.

NATURAL GAS ORIFICE SELECTION BASED ON HEATING VALUE & ELEVATION*

22,800 BTU/burner

		ELEVATION								
Grey Cells Indicate Factory Orifice Size	Sea Level to 2,000'	2001' to 3,000'	3,001' to 4,000'	4,001' to 5,000'	5,001' to 6,000'	6,001 to 7,000'	7,001' to 8,000'	8,001' to 9,000'	9,001' to 10,000'	
Gas Heating Value (BTU's/ft3) @ Sea Level**	1,100	44	45	45	45	46	47	47	48	48
	1,050	43	44	44	44	45	45	46	47	47
	1,000	43	43	44	44	45	45	46	47	47
	950	42	42	43	43	43	44	44	45	46
	900	42	42	43	43	43	44	44	45	46
	850	40	41	42	42	42	43	43	44	44
	800	39	40	41	41	42	42	43	43	44
	750	37	38	39	39	40	41	42	42	43
	700	36	37	38	38	39	40	41	41	42

20,800 BTU/burner (50 HZ model)

		ELEVATION								
Grey Cells Indicate Factory Orifice Size	Sea Level to 2,000' FT	2001' to 3,000' FT	3,001' to 4,000' FT	4,001' to 5,000' FT	5,001' to 6,000' FT	6,001 to 7,000' FT	7,001' to 8,000' FT	8,001' to 9,000' FT	9,001' to 10,000' FT	
Gas Heating valve (BTU/ft3)	1100	46	47	47	47	48	48	49	49	50
	1050	45	46	47	47	47	48	48	49	49
	1000	44	45	45	45	46	47	47	48	48
	950	43	44	44	44	45	45	46	47	47
	900	43	44	44	44	45	45	45	47	47
	850	42	42	43	43	43	44	44	45	46
	800	41	42	42	42	43	43	44	44	45
	750	40	41	42	42	42	43	43	44	44
	700	38	39	40	41	41	42	42	43	43

19,000 BTU/burner (50 HZ model)

		ELEVATION								
Grey Cells Indicate Factory Orifice Size	SEA LEVEL TO 2,000 FT	2,001 TO 3,000 FT	3,001 TO 4,000 FT	4,001 TO 5,000 FT	5,001 TO 6,000 FT	6,001 TO 7,000 FT	7,001 TO 8,000 FT	8,001 TO 9,000 FT	9,001 TO 10,000 FT	
Gas Heating valve (BTU/ft3)	1100	47	48	48	49	49	49	50	50	51
	1050	46	47	47	47	48	48	49	49	50
	1000	45	46	47	47	47	48	48	49	49
	950	45	46	47	47	47	48	48	49	49
	900	44	45	45	45	46	47	47	48	48
	850	43	44	44	44	45	45	46	47	47
	800	43	44	44	44	45	45	46	47	47
	750	42	42	43	43	43	44	44	45	46
	700	40	41	42	42	42	43	43	44	44

* Tables are derived from the National Fuel Gas Code. To determine the correct orifice for your installation consult the National Fuel Gas Code

** Be sure to use sea level heating value. Heating value may be obtained from a local utility, heating value must be converted to sea level equivalent sea level equivalent in order to use this table.

G. GAS

NATURAL GAS ORIFICE SELECTION BASED ON HEATING VALUE & ELEVATION*

19,000 BTU/burner (50 HZ model)

Grey Cells Indicate Factory Orifice Size		ELEVATION								
		Sea Level to 2,000'	2,001' to 3,000'	3,001' to 4,000'	4,001' to 5,000'	5,001' to 6,000'	6,001 to 7,000'	7,001' to 8,000'	8,001' to 9,000'	9,001' to 10,000'
Gas Heat- ing Value (BTU's/ ft3) @ Sea Level**	1,100	47	48	48	49	49	49	50	50	51
	1,050	46	47	47	47	48	48	49	49	50
	1,000	45	46	47	47	47	48	48	49	49
	950	45	46	47	47	47	48	48	49	49
	900	44	45	45	45	46	47	47	48	48
	850	43	44	44	44	45	45	46	47	47
	800	43	44	44	44	45	45	46	47	47
	750	42	42	43	43	43	44	44	45	46
	700	40	41	42	42	42	43	43	44	44

* Tables are derived from the National Fuel Gas Code. To determine the correct orifice for your installation consult the National Fuel Gas Code

** Be sure to use sea level heating value. Heating value may be obtained from a local utility, heating value must be converted to sea level equivalent sea level equivalent in order to use this table.

LP GAS AT HIGH ALTITUDES

NOTICE: The conversion shall be carried out by a manufacturer's authorized representative, in accordance with the requirements of the manufacturer, provincial, or territorial authorities having jurisdiction and in accordance with the requirements of the CSA b149.1 Or CSA b149.2 Installation codes.

NOTE: Keep any parts removed during LP conversion procedure stored with the product literature for future use.

LP Gas is a manufactured gas that has consistent heating value across most regions.

The NFGC guidelines are used with the following exception:

The recommended LP Gas high altitude orifice selections differ slightly in that the NFGC LP orifice chart, as they are not accurate for these products. The National Fuel Gas Code LP orifices are based on an 11" of water column pressure at the orifice, which differs from products that use 10" of water column at the orifice. This difference requires a deviation from the NFGC orifice size recommendations. The Sea Level input should still be reduced by 4% per thousand ft. and the orifice size must be selected based on the reduced input in the following tables.

LP Gas BTU/hr per Burner based on Orifice Size & Elevation

Orifice Pressure: 10" W.C.

BTU/hr per burner	Electrical Frequency	ELEVATION								
		SEA LEVEL TO 2,000 FT	2,001 TO 3,000 FT	3,001 TO 4,000 FT	4,001 TO 5,000 FT	5,001 TO 6,000 FT	6,001 TO 7,000 FT	7,001 TO 8,000 FT	8,001 TO 9,000 FT	9,001 TO 10,000 FT
25,000 BTU/hr	60 HZ models	54	54	54	54	55	55	56	56	56
22,800 BTU/hr		54	55	55	55	55	55	56	56	56
20,800 BTU/hr	50 HZ models	55	55	55	56	56	56	56	56	57
19,000 BTU/hr		56	56	57	57	57	58	59	59	60

LP Gas BTU/hr per Burner based on Orifice Size & Elevation

Orifice Pressure: 10" W.C.

BTU/hr per burner	ELEVATION	
	Sea Level to 2,000'	2,001' to 3,000'
20,000 BTU/hr	55	56
25,000 BTU/hr	54	54

J. STARTUP AND OPERATION

J.1. Final Inspection

J.1.1. Check for Refrigerant Leaks

Inspect the unit for any damage to the coils and tubing that could cause a leak.

J.1.2. Check Level of Unit

Refer to [Section C.6.2](#), for setting/checking the level of the unit.

J.1.3. Check Electrical Connections for Proper Torque

Use an Inch Pound rated torque wrench to ensure proper torque. **DO NOT CONFUSE THIS WITH A FOOT POUND RATED WRENCH, Damage will occur.**

Recommended torques for securing wiring:

- To the contactor: 40 in-lb.
- From the T-stat to the control board: 8.0 in-lb.

Figure J.1.3. – A: Where to Wire for Thermostat

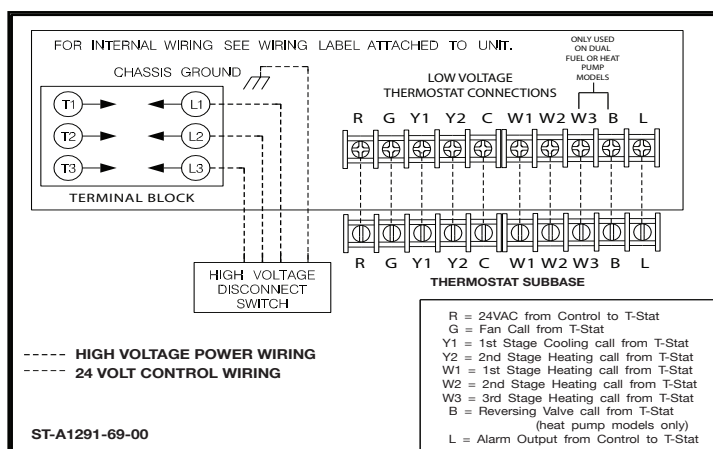

J.1.4. Check Control Cables For Proper Connection

Verify all cables are seated and connected in the unit as some might come loose during shipping and transport.

J.1.5. Check For Gas Leaks

Double Check for any gas leaks on the installed piping. Refer to [Section G.2.3](#), for more information.

J.1.6. Check Filter Installation

Verify that filters are seated and oriented correctly in the unit as some might come displaced during shipping and transport. Refer to [Section D.3](#), for more information on filters and filter installation.

J.1.7. Check Condensate Drain Installation

Verify the Condensate Drain Trap is a minimum of 3 inches deep, plus the Blower Fan Static Pressure. Verify the Outlet of the drain trap is a minimum of 3 inches below the outlet of the drain pan. Ensure the outlet of the trap is routed to a suitable drain location as required by local code. Refer to [Section C.5](#) and [Figure C.5.1](#) – A for more information.

J.1.8. Check Blower Compartment for Accessories

Open all compartments to ensure there are no tools or other misc parts remaining in the unit from setup. This is most important on the blower section to avoid damage to the blower assembly.

J.2. Turning on Power for the First time

J.2.1. Checking for Proper 3-Phase Voltage

Verify that proper power has been supplied to the unit. This is critical for correct operation of the compressor.

J.2.2. Check For Proper Phase

Verify that the compressor is running correctly.

J.2.2.1. Standard Blower Rotation

As a reminder, all units with a belt drive motor may run backwards if the unit is wired incorrectly. See [Section E.3.4. Checking Phase and Motor Rotation](#) for more information.

J.2.2.2. VFD Blower Rotation

As a reminder, all units with VFD driven blower motor will have the correct rotation even if the phase to the unit is wired incorrectly. See [Section E.3.4.1. Checking Phase with VFD Drive](#) for more information.

J.2.3. Checking Low (Control) Voltage

Use a voltmeter to measure the low voltage and low voltage amp draws during operation. Accessories such as remote smoke detectors and excessive wire length can increase the amp draw on the low voltage wiring. Verify that the total amp draw on the 24Vac side is less than 0.3A in full operation. Refer to [Figure F. – A](#) for proper low voltage wire lengths.

J. STARTUP AND OPERATION

J.3. Checking and Adjusting Air Flow

For Economizer and Diffuser Pressure Drop Data, please refer to the end of [Appendix C: Airflow Performance Data](#).

Figure J.3. – A: Static Pressure and Air Temp Measurement Location

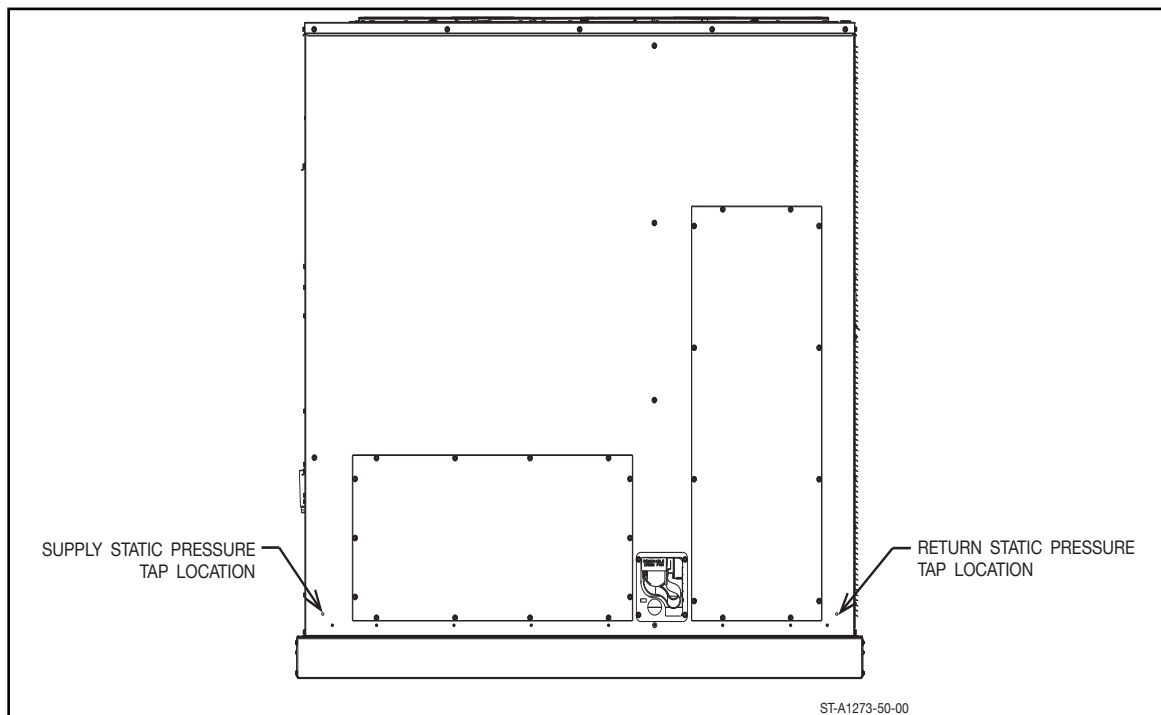

J.3.1. Static Pressures and Measurements

- To measure the static pressure of the system, locate the locating dimples near the supply/return duct openings, and drill a hole to the size necessary for the test probe. The location of these dimples are shown in **Figure J.3. - A**.
- NOTE: After taking airflow measurements, seal these openings per best practice to prevent airflow leakage and water entry into the unit.
- NOTE: Drilling test tap locations in other panels or doors could put the test probe in a turbulent zone providing false readings.

J.3.1.1. Using Tools

Use a calibrated monometer to measure the static pressure of the blower. Insert the meter probe into the tap location. Make sure any economizer or outside air dampers are closed and run the fan at the maximum, full speed setting. Record the reading for the return air and supply air separately.

J. STARTUP AND OPERATION

J.3.2. Air Flow Measurements and Adjustments

- Measure the supply/ return static to get the unit static pressure by drilling out the simple locations shown in Figure J.3.2 - A.
- Take the measured static pressure and match to the static listed on the airflow table to find your CFM.

Use the charts and guide provided in the Installation and Operation instructions provided with the unit to calculate the airflow, against the measured static pressures and number of turns on the adjustable blower sheave. Verify the measured air flow against the charts.

Figure J.3.2. – A: Blower Assembly and Motor

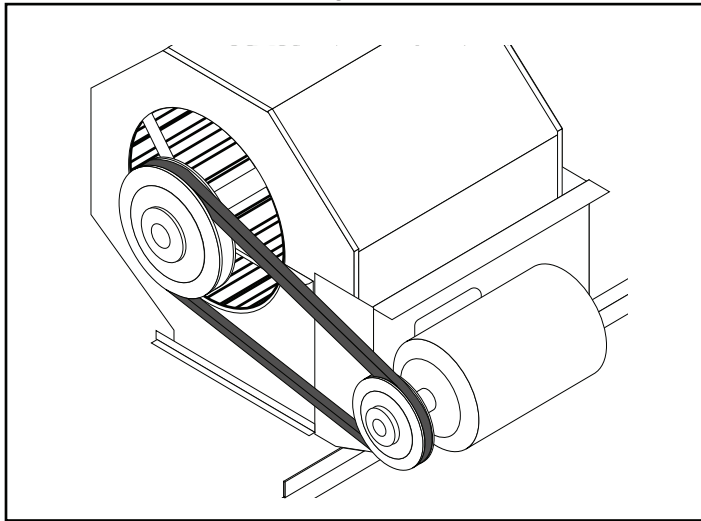

If adjustment is needed, turn off the power to the entire system, and adjust the adjustable blower sheave. To do this, loosen the belt tension and remove the belt. Using an Allen wrench to loosen the set screw on the end of the adjustable blower sheave, turn the blower sheave in until it is fully closed.

Figure J.3.2. – B: Adjustable Blower Sheave

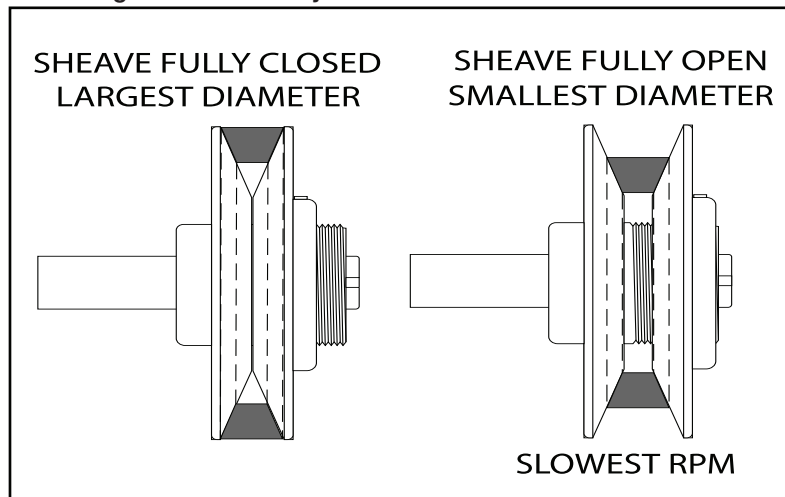

Using the charts determine the total number of turns needed on the sheave. Make those turns in half turn increments, once set, align the set screw with the Flat section on the sheave threads. Tighten the set screw to secure the sheave.

Reinstall the belt and tension properly and power on the system. Allow the thermostat to call for a fan, make sure the VFD ramps the blower to 100% or 60hz.

Once the fan is at speed, measure the air flow and static pressure, compare against the charts. If additional adjustment is needed repeat the adjustment procedure.

J. STARTUP AND OPERATION

J.3.2.1. Adjusting Fresh Air Flow with Economizer

See the above sections for measuring airflow, and refer to the I&O included with the Economizers for more information on adjusting airflow.

These I&Os can also be found on the manufacturer's website.

J.3.2.2. Adjusting Fresh Air Flow with Damper

All dampers are field install accessories. See the above sections for measuring airflow, and refer to the I&O included with the fresh air dampers for more information on adjusting airflow. Refer to local building codes for any fresh air requirements.

These I&Os can also be found on the manufacturer's website.

J.4. Checking Cooling Operation

Note: In the below section, first and second stage cooling applies to ONLY the 6 ton units. For 3-5T units, only first stage applies.

COOLING SEQUENCE OF OPERATION

A. Call for cooling.

1. The zone thermostat contacts close, and a call for cooling is initiated.
2. Inputs 'Y1' and 'G' to the control are energized.
3. The control senses input to 'Y1' and 'G'. After a 1sec delay, the control energizes both the indoor blower and first stage compressor.
4. The control enters normal operating loop where all inputs are continuously checked.
5. Zone thermostat is satisfied.
6. The blower will continue to run for a preset period of time after the zone thermostat is satisfied.
7. The control goes into standby mode displaying a "O".

B. Call for second stage cooling. After first stage cooling established; starting from A6.

1. If a call for second stage cooling is initiated after a call for first stage cooling is established, the control energizes 'Y2' and energizes the second stage compressor.
2. Then the control enters the normal operating loop where all inputs are continuously checked.

C. Second stage satisfied and first stage still called for; starting from B2.

1. 'Y2' is de-energized and the second compressor stage is de-energized.

D. First stage and second stage called simultaneously.

1. The zone thermostat contacts close, and a call for first and second stage cooling is initiated.
2. Inputs 'Y1', 'Y2' and 'G' to the control are energized.
3. The control senses 'Y1', 'Y2' and 'G'. After a 1sec delay, the control energizes the indoor blower, and the first and second compressor stages.

E. First stage and second stage removed simultaneously.

1. Upon a loss of 'Y1' and 'Y2', the compressor is de-energized. The control de-energizes the indoor blower relay, and cuts off the blower after an indoor blower delay.
2. The control goes into standby mode displaying a "O".

CONTINUOUS FAN MODE

A 'G' input only indicates a zone thermostat call for continuous indoor blower operation.

TIME DELAY BYPASS for non-DDC units

The Time Delay Bypass resets the ICC (Integrated Compressor Control) from any lockout mode or bypasses compressor anti-short cycle delay timer. To bypass the time delay, press the SW1 button with an insulated probe for 1sec and then release.

FAULT RECALL OPERATION for non-DDC units

To enter FAULT RECALL mode, press the SW1 button with an insulated probe for 2sec and release. Upon entering and exiting the FAULT RECALL mode, the top bottom segments of the 7-segment display will be activated. The ICC will automatically scroll through the stored faults on the 7-segment display. Each fault is displayed one time with the top segment of the 7-segment display activated between faults. Each fault is displayed with the most recent fault displayed first. An "O" will be displayed when no faults are stored. The ICC will automatically exit the FAULT RECALL mode after displaying stored faults.

J. STARTUP AND OPERATION

An example of one LPC fault and one HPC fault scrolled on the display is shown as: -21-23

CLEAR FAULT HISTORY for non-DDC units.

To clear FAULT HISTORY, press the SW1 button with an insulated probe for 5sec and release. The top and bottom segments of the 7-segment display will be activated and flash to indicate the history has been cleared.

Example: =====

TEST MODE for DDC Units

For units with DDC, there is a "Run Test" mode that will aid in diagnostics during installation.

Please refer to the [Clear Control I&O](#).

Figure: Clear Control under Test mode for DDC

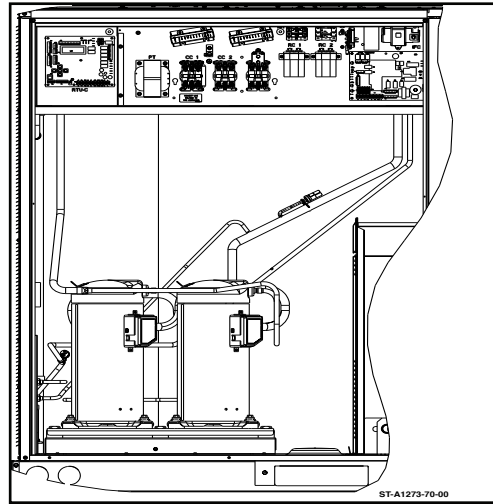

J.4.1. Checking Refrigerant Pressures

To check refrigerant pressures, attach R410a manifold gauges to the high/lo service ports. The upper port is the high pressure port, and the lower is the low pressure port. **BE SURE TO USE ZERO LOSS FITTINGS WHILE MEASURING PRESSURE; ANY LOSS OF CHARGE MAY IMPACT PERFORMANCE.**

See section [C.2.1. Tools Required for Installing and Servicing R-410A Models](#).

Figure J.4.1. -A: Service Port Location

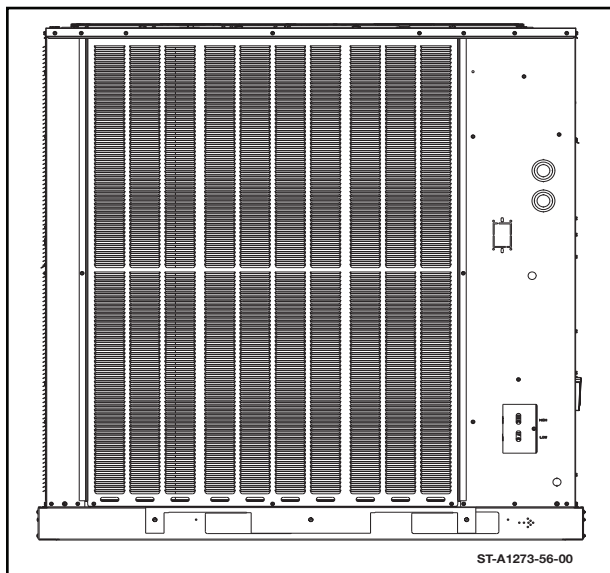

J.4.1.1. Refrigerant Pressure Charts

See [Appendix F](#) towards the end of this manual for Refrigerant Pressure Charts.

J.4.2. Checking Sub Cooling for Adjusting Charge Weight

See [Appendix F](#) towards the end of this manual for Refrigerant Charging Charts.

NOTE: This procedure is very important for optimizing this product's performance.

How to check the unit's subcooling to fine-tune refrigerant charge:

1. The Indoor ambient temperature must be between 72 °F and 82 °F dry bulb at the indoor coil.
2. Confirm the indoor air supply is at the rated CFM listed in [Appendix A](#).
3. Allow the system to run long enough for temperatures and pressures to stabilize; at least fifteen minutes.
4. Measure liquid pressure and line temperature at the liquid line service port (refer to section [J.4.2.1](#) below for the liquid line temperature measurement location). **USE ZERO LOSS FITTINGS WHILE MEASURING PRESSURE; ANY LOSS OF CHARGE MAY IMPACT PERFORMANCE.**
5. To find the saturation temperature at the measured pressure, subtract the measured liquid line temperature from the saturation pressure to get the sub-cooling.
6. Check if the Sub-Cooling is within +/- 1.5 °F tolerance.
7. If the sub-cooling values are significantly different (> 20 psig) from those listed on the table in Appendix F, there may be an airflow or component issue. Refer to section M. Diagnostics for more information.

J. STARTUP AND OPERATION

J.4.2.1. Measuring Air Temperature and Liquid Line Temperature

Measuring air temperature:

1. Insert a thermometer in the supply air duct as close to the unit as possible.
2. Insert a thermometer in the return air duct as close to the filters as possible.
3. If preferred, use the locations shown in **Figure J.4.2.1. - A: Line Temperature Measurement Location** instead of the supply/return ductwork.
4. Operate the unit for a minimum of 15 minutes in cooling mode.
5. When the thermometer in the supply air duct stops changing (approximately five minutes), subtract the return air temperature from the supply air temperature. This is the cooling mode temperature difference.

If the measured temperature difference is not reducing, or if the return air is not reaching the thermostat set point, the air flow is too low. Airflow must be increased by either removing the restrictions in the duct system, or by changing the air flow. See **Section J.3.2. Air Flow Measurements and Adjustments** for changing air flow.

IMPORTANT: Some high-efficiency filters have a greater than normal resistance to airflow. This can negatively affect airflow. BE SURE TO CHECK THE AIRFLOW if using any filter other than the factory-provided filter.

Measuring line temperature:

1. Attach a thermometer or thermocouple to the liquid refrigerant line right after the filter-dryer. See **Figure J.4.2.1. - A: Line Temperature Measurement Location**.
2. Operate the unit for a minimum of 15 minutes in cooling mode.
3. When the measurement of the temperature stops changing (approximately five minutes), record the temperature.

Figure J.4.2.1. – A: Line Temperature Measurement Location

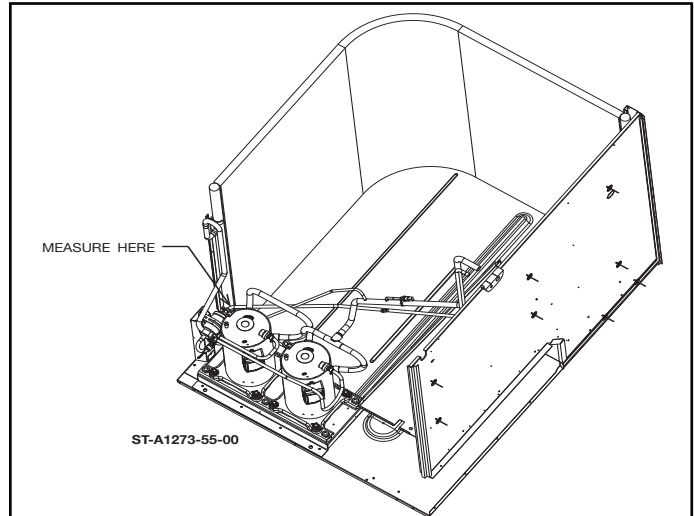

J.4.3. Measuring Compressor Electrical Loads

See **Appendix B** towards the end of this manual for Compressor Electrical Data.

J.5. Checking Heating Operation

J.5.1. Gas Furnace

J.5.1.1. Measuring and Adjusting Supply Gas Pressures

The maximum gas inlet pressure to the furnace should be 10.5" WC for natural gas and 13.0" WC for LP gas the minimum gas inlet pressure for purposes of input adjustments to the furnace should be 5.0" WC for natural gas and 11.0" WC for LP gas.

The inlet pressure tap is on the input side of the gas valve. A calibrated manometer is required to measure gas pressure readings accurately.

1. Ensure the gas is shut off to the furnace at the manual gas valve installed outside the unit.
2. Remove the inlet pressure tap plug using a 3/16" allen wrench; see Figure G.1.4. –A.
3. Install a 1/8" NPT pressure tap fitting and tighten using a 7/16" open end wrench.
4. Connect manometer using 1/4" I.D. hose over the pressure tap fitting.
5. Turn on the gas supply and operate the furnace and all other gas-fire units on the same gas line as the furnace.
6. Note or adjust the inlet gas pressure to give:
 - A: 5" - 10.5" W.C. for natural gas
 - B: 11" - 13" W.C. for LP gas

J. STARTUP AND OPERATION

7. Shut off the gas at the manual gas-valve a remove the manometer and hose.

8. Replace 1/8" NPT pressure tap fitting with the pressure tap plug and tighten using a 3/16" allen wrench.

9. Turn ON the gas supply and check for gas leaks using an approved leak detector. Do NOT use a flame of any kind to check for leaks. Repair any leaks and repeat.

If the supply gas inlet pressure is above the specified ranges, install an in-line gas regulator to the furnace for the natural gas units. For LP gas furnace, have the LP supplier reduce the inlet pressure at the regulator.

If the supply gas inlet pressure is below the specified ranges, either remove the restrictions in the gas supply piping or enlarge the gas pipe for a natural gas furnace; see **Table G.1.6. - A.** For LP gas furnaces have the LP supplier adjust the inlet pressure at the regulator; see **Table G.3. - A.**

J.5.1.2. Measuring and Adjusting Manifold Gas Pressures

The manifold pressure should be set at 3.5" WC high fire, 1.7" WC low fire, for natural gas and 10.0" W.C. high fire and 4.9" W.C. low fire for LP gas. Only small variations in the gas flow should be made by means of the pressure regulator adjustment. In no case should the final manifold pressure vary more than ± 0.3 " WC for natural gas and ± 0.5 " WC for LP gas from the above specified pressures.

1. Ensure the gas is shut off to the furnace at the manual gas valve installed outside the unit.

2. Remove the manifold pressure tap plug using a 3/16" allen wrench; see **Figure G.1.4. - A.**

3. Install a 1/8" NPT pressure tap fitting and tighten using a 7/16" open end wrench.

4. Connect manometer using 1/4" I.D. hose over the pressure tap fitting.

4. Turn on the gas supply and operate the furnace by applying a heat call

5. Note or adjust the manifold gas pressure to give:

C. 3.5" (± 0.3 ") W.C. high fire, 1.7" (± 0.3 ") W.C low fire for natural gas

D. 10.0" (± 0.5 ")W.C. high fire and 4.9" (± 0.5) W.C. low fire for LP gas

6. To adjust the pressure regulators, remove adjustment screw cover.

7. Using the 3/32'allen wrench, turn the adjustment screw clockwise increase pressure, or counterclockwise to decrease the outlet pressure.

8. Replace the adjustment screw cover.

9. Shut off the gas at the manual gas-valve a remove the manometer and hose.

10. Replace 1/8" NPT pressure tap fitting with the pressure tap plug and tighten using a 3/16" allen wrench.

11. Turn ON the gas supply and apply a heat call to the furnace. Then check for gas leaks using an approved leak detector. Do NOT use a flame of any kind to check for leaks.

Repair any leaks and repeat.

METER TIME IN MINUTES AND SECONDS FOR NORMAL INPUT RATING OF FURNACE QUIPPED FOR NATURAL GAS									
INPUT (BTU/HR)	METER SIZE (FT ³ /REV)	HEATING VALUE OF GAS (BTU/FT ³)							
		900		1000		1050		1100	
		MIN	SEC	MIN	SEC	MIN	SEC	MIN	SEC
75,000	ONE	0	43	0	48	0	50	0	53
	TEN	7	12	8	0	8	24	8	48
100,000	ONE	0	32	0	36	0	38	0	40
	TEN	5	24	6	0	6	18	6	36
120,000	ONE	0	27	0	30	0	32	0	33
	TEN	4	30	5	0	5	15	5	30

RATE (BTU/HR) = $\frac{\text{HEATING VALUE OF GAS X 3600}}{\text{TIME (IN SECONDS) FOR 1 CUBIC FOOT OF GAS}}$

J. STARTUP AND OPERATION

J.5.1.3. Verifying BTU Performance and Capacity

Checking furnace input is important to prevent over-firing beyond its design rated input.

NEVER SET INPUT ABOVE THAT SHOWN ON THE RATING PLATE FOR ELEVATIONS UP TO 2,000 FT. Use the following table or formula to determine input rate. Start the furnace and measure the time required to burn on cubic foot of gas. Prior to checking the furnace input, make certain that all other gas appliances are shut off, with the exception of pilot burners.

Time the meter with only the furnace in operation.

The factory installed orifice on a furnace is sized for natural gas having a heating value of 1050 BTU/cu.ft and a specific gravity of 0.60. Since heating values vary geographically, the manifold pressure and/or gas orifice size may need to be changed to adjust the furnace to its nameplate input. Consult the local gas utility to obtain the yearly average heating value. Refer to section **G.4.2.6. Orifice Selection and High Altitude Adjustments** for more info.

NOTE: Refer to the High Altitude Section of this manual and the National Fuel Gas Code for high altitude rate adjustment above 2,000 ft.

To change the orifice spuds, shut the manual gas-valve and remove the gas manifold. Replace all the orifice with correct sizes based on the Orifice Selection Charts, and carefully replace the manifold in its position.

J.5.1.4. To Shut Down Furnace

1. Set the thermostat to the lowest setting.
2. Turn off all electric power to the appliance if service is to be performed.
3. Remove control door.
4. Move control switch/knob on the gas valve to the "OFF" position.
5. Replace control door.

⚠ WARNING: SHOULD OVERHEATING OCCUR OR THE GAS SUPPLY FAIL TO SHUT OFF, SHUT OFF THE MANUAL GAS VALVE TO THE APPLIANCE BEFORE SHUTTING OFF THE ELECTRICAL SUPPLY. FAILURE TO DO SO CAN RESULT IN AN EXPLOSION OR FIRE CAUSING PROPERTY DAMAGE, SEVERE PERSONAL INJURY OR DEATH!

J.5.1.5. Checking Air Temperatures

The importance of proper air flow over the heat exchanger cannot be over emphasized. One of the most common causes of heat exchanger failure is over-heating due to low air flow.

To determine whether the heating air flow is correct, follow the steps to check the temperature rise.

1. Insert a thermometer in the supply air duct as close to the furnace as possible yet out of a direct line from the heat exchanger. (See **Figure J.3. – A: Static Pressure and Air Temp Measurement Location**)
2. Insert a thermometer in the return air duct as close to the filters as possible.
3. Operate the furnace for a minimum of 15 minutes in the gas heat mode.
4. When the thermometer in the supply air duct stops rising (approximately five minutes), subtract the return air temperature from the supply air temperature. The difference is the temperature rise.
5. Compare the measured temperature rise to the approved temperature rise range listed on the furnace name plate or in **Appendix E: Heating Performance**.

If the measured temperature rise is above the approved range, the air flow is too low. Airflow must be increased by removing the restrictions in the duct system, or by changing the air flow. If the measured temperature rise is below the approved range, the air flow is too much. Check the duct sizing or see Section **J.3.2. Air Flow Measurements and Adjustments**.

IMPORTANT: Some high-efficiency filters have a greater than normal resistance to airflow. This can adversely affect furnace operation. **BE SURE TO CHECK THE AIRFLOW** if using any filter other than the factory-provided filter.

K. TEST AND BALANCE

K.1. Air Flow Charts and Information

See Appendix C towards the end of this manual for Air Flow Performance Data.

K.2. Air Flow Adjustments

K.2.1. Blower Speed for 7.5-12.5 Ton Units

See Section J.3.2. Air Flow Measurements and Adjustments on how to increase the blower speed and increase airflow for the 7.5-12.5T units.

K.2.2. Economizer Adjustments

Do not Fix a minimum position on an economizer, set the minimum position through the control board only. See the instructions provided with the economizer for more info. The part numbers for these instructions are listed in section D.4.1. Economizer Information.

M. HUMIDITY CONTROL

M.1 Dehumidification System Information

With the factory installed dehumidification option, in addition to a thermostat or space temperature sensor that is normally present, an indoor relative humidity sensor is installed in the occupied space and connected to the Rooftop Unit Controller (RTU-C) which then controls the capacity of the cooling coil to remove moisture from the supply air and maintain space relative humidity below an adjustable limit visible on the RTU-C display.

The default value is the ASHRAE recommended limit of 60% RH. With this option, a refrigerant reheat coil is installed downstream from the evaporator coil. When the space humidity is too high and reheat is energized, this coil uses some of the heat that is normally rejected to the outside by the condenser coil to instead reheat the cold air from the evaporator coil just enough to avoid overcooling the space. Providing “neutral air” to the occupied space.

Because the demand for dehumidification can be different from the cooling demand, the unit will first satisfy the demand for cooling and then if the space humidity is still too high, dehumidification mode is energized. When in dehumidification mode, the supply air leaving the unit will be near the entering air temperature, but at a much lower humidity. The unit will exit the dehumidification mode when the humidity set point is satisfied; or if the load is increased, it will return to normal cooling mode.

Reheat is not available during the gas-heating mode.

Figure M.1. - A

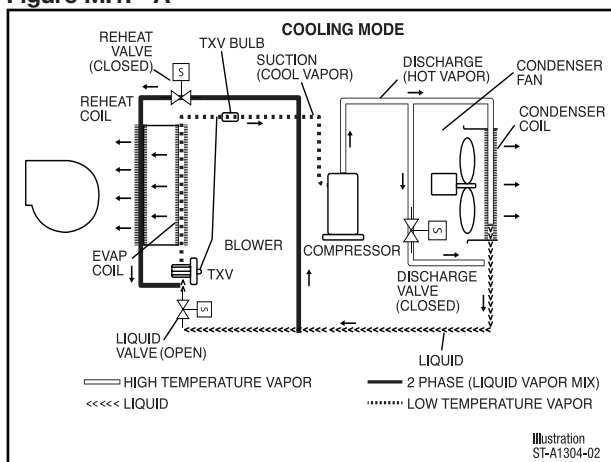

Figure M.1. - A shows the refrigerant path during the normal cooling mode. The liquid refrigerant leaves the TXV with the sudden pressure drop causing the liquid to expand to a vapor and absorbing the heat from the supply

air going through the evaporator coil. The refrigerant vapor then travels to the compressor where it is elevated to a higher pressure and temperature.

The superheated refrigerant vapor next carries the heat to the outside coil where the heat is then rejected and the refrigerant condenses into a subcooled liquid where the process repeats itself.

Figure M.1. - B

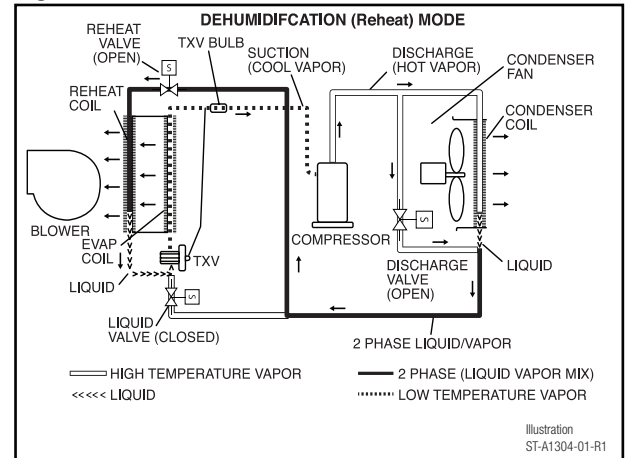

Figure M.1. - B shows the refrigerant path during the reheat mode. When the reheat cycle is energized by the RTU-C, the reheat solenoid valve, upstream of the reheat coil opens. The liquid solenoid valve ahead of the TXV, closes. The discharge solenoid valve, in the compressor discharge line, opens. The liquid refrigerant leaves the TXV with the sudden pressure drop causing the liquid to expand to a vapor and absorbing the heat from the supply air going through the evaporator coil. The refrigerant vapor then travels to the compressor where it is elevated to a higher pressure and temperature. The refrigerant next carries the heat to a parallel path between the outside condenser coil and a bypass circuit. Some of the heat is rejected outdoors. The ratio of heat rejected outdoors versus indoors is controlled by an outdoor fan motor controller (OFMC) that monitors the two phase temperature and varies the fan speed. This 2-phase refrigerant vapor is then sent to the reheat coil. As the refrigerant travels through the reheat coil is condenses into a subcooled liquid where the process repeats itself.

M. HUMIDITY CONTROL

M.2 Humidity Sensor Installation

The Humidity control unit requires the use of a zone mounted humidity sensor. The sensor should be located in the conditioned space, approximately 5ft from the floor, on an interior wall. Take care to locate it away from direct sunlight and away from air flow from vents or drafts from doors. The humidity sensors output is a 0-10VDC signal and will be connected to the DDC Control.

The Rheem ZNS-5 meets the requirement and includes an optional space temperature sensor. The control wiring should be a minimum of 18AWG Solid Copper wire with 5 Conductors and is connected from the DDC Control to the sensor as follows:

- RED = R to V+ (+24VAC)
- GREEN = Field Config 1 & 2 (Right most terminal) to GROUND
- BLUE = Field Config 2 (3rd terminal from right) to VOut
- WHITE = S & P (Left most terminal) to Temp -
- YELLOW = S (2nd terminal from left) to Temp+

See the installation instructions for additional details.

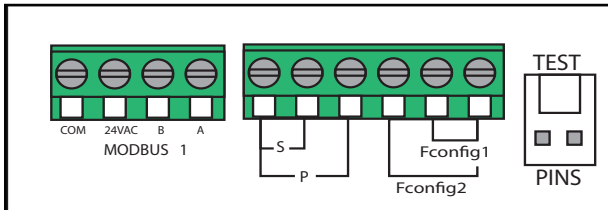

ZNS-5 HUMIDITY/TEMPERATURE SENSOR

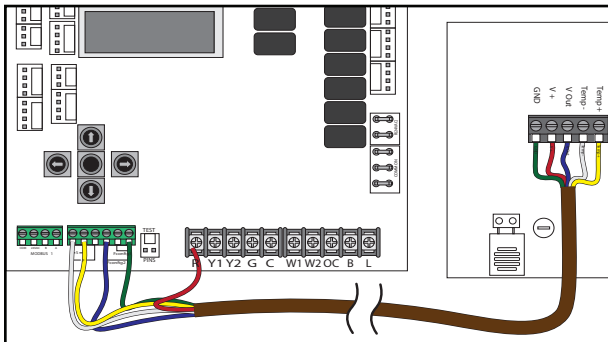

HONEYWELL DUCT MOUNTED HUMIDITY SENSOR

This optional wires the same except the temperature sensor connects directly to a Honeywell Thermostat.

RED = R to V+ (+24VAC)

GREEN = Field Config 1 & 2 (Right most terminal) to GROUND

BLUE = Field Config 2 (3rd terminal from right) to VOut

Other = Honeywell S- Terminal to Yellow Wire

Other = Honeywell S+ Terminal to Green Wire

See the installation instructions for additional details.

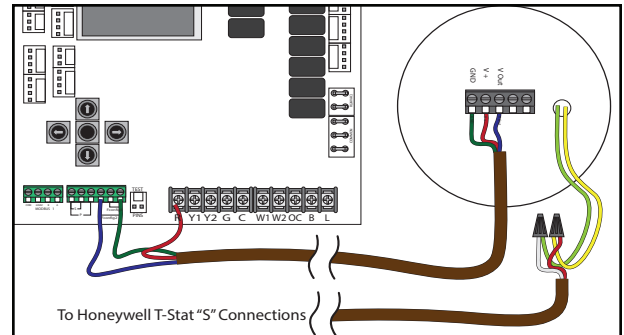

M. HUMIDITY CONTROL

M.3 Humidity Control Settings and Configuration

The Clear Control is designed to operate in conjunction with the zone sensor discussed earlier in the guide. These are the steps to verify the zone sensor and adjust the humidity set-point and operating modes. The system can be programmed to a humidity level as low as 35%, and can be set to run dehumidification as part of the cooling cycle or as a stand alone system regardless of the cooling or fan call status from the thermostat, recommended.



NOTICE: The system will not operate the humidity control when the outdoor ambient temperature is below 60°F, this is because the humidity control uses hot refrigerant bypassed from the outdoor coil. When the ambient temperature is too low, insufficient heat will be retained in the refrigerant to properly operate the Reheat system for proper dehumidification. The Reheat system in this packaged unit is not designed for industrial or process applications, it is intended for human comfort zones.

Navigate through the Clear Control menu to "Humidity Control" it should say Enabled. If it says "Disabled" press the Enter button twice to Enable rh Control.

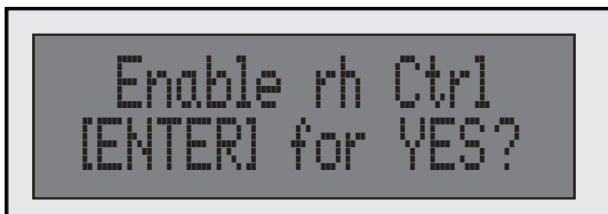

Next set the desired Relative Humidity Set-point. This set-point will be where the control will run the associated dehumidification cycles to bring the humidity in the zone down to this percentage.



Now set the Reheat Mode, there are three functions to choose from, Reheat in Occupied, will only run dehumidification when there is a Fan or Cooling Call. Reheat in Unoccupied, will on run dehumidification when there is no fan or cooling call; Reheat ALL, (recommended) will run reheat based on the humidity reading regardless of the thermostat operation.



Checking the Humidity Sensor reading, Navigate to Humidity Control then down to Indoor rh, this will display the reading from the humidity zone sensor. If this shows "4%" then it means that the zone sensor is not connected properly or malfunctioning.

Verify a 0-10VDC signal across the Field Cnfg 2 terminals on the control board. 10VDC = 100%, 5VDC - 50%.

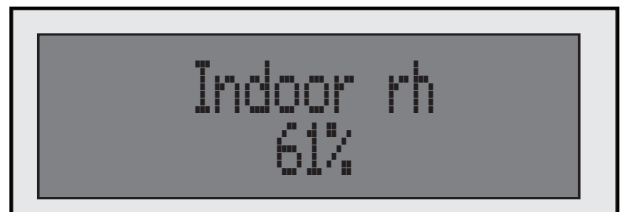

The humidity control system is also equipped with an Outdoor Fan Motor Controller, OFMC, this controller changes the speed of the outdoor fans to allow for more or less heat in the bypassed refrigerant used to operate the reheat system. Adjustments to the OFMC are not needed unless undesirable operation occurs.

Consult the Installation instructions provided with the system for details on the OFMC operation and adjustments.

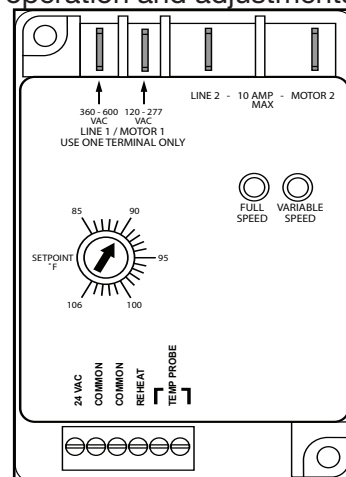

OFMC	
Factory Settings	
Unit	Setpoint
90	90°
102	90°
120	94°

N. DIAGNOSTICS

N.1. Diagnostics Chart

N.1.1. Cooling Diagnostics Chart

▲ WARNING

DISCONNECT ALL POWER TO UNIT BEFORE SERVICING. CONTACTOR MAY BREAK ONLY ONE SIDE. FAILURE TO SHUT OFF POWER CAN CAUSE ELECTRICAL SHOCK RESULTING IN PERSONAL INJURY OR DEATH.

SYMPTOM	POSSIBLE CAUSE	REMEDY
Unit will not run	<ul style="list-style-type: none"> • Power off or loose electrical connection • Thermostat out of calibration-set too high • Defective contactor • Blown fuses • Transformer defective • High pressure control open (if provided) • Interconnecting low voltage wiring damaged 	<ul style="list-style-type: none"> • Check for correct voltage at compressor contactor in control box • Reset • Check for 24 volts at contactor coil - replace if contacts are open • Replace fuses • Check wiring-replace transformer • Reset-also see high head pressure remedy- • Replace thermostat wiring"
Condenser fan runs, compressor doesn't	<ul style="list-style-type: none"> • Run capacitor defective (single phase only) • Loose connection • Compressor stuck, grounded or open motor winding open internal overload. • Low voltage condition 	<ul style="list-style-type: none"> • Replace • Check for correct voltage at compressor - check & tighten all connections • Wait at least 2 hours for overload to reset. If still open, replace the compressor. At compressor terminals, voltage must be within 10% of rating plate volts when unit is operating."
Insufficient cooling	<ul style="list-style-type: none"> • Improperly sized unit • Improper airflow • Incorrect refrigerant charge • Air, non-condensibles or moisture in system • Incorrect voltage 	<ul style="list-style-type: none"> • Recalculate load • Check - should be approximately 400 CFM [188.78 L/s] per ton. • Charge per procedure attached to unit service panel. • Recover refrigerant, evacuate & recharge, add filter drier • At compressor terminals, voltage must be within 10% of rating plate volts when unit is operating."
Compressor short cycles	<ul style="list-style-type: none"> • Incorrect voltage • Defective overload protector • Refrigerant undercharge 	<ul style="list-style-type: none"> • At compressor terminals, voltage must be \pm 10% of nameplate marking when unit is operating. • Replace - check for correct voltage • Add refrigerant
Registers sweat	<ul style="list-style-type: none"> • Low evaporator airflow • Room thermostat set too low 	<ul style="list-style-type: none"> • Increase speed of blower or reduce restriction - replace air filter • Raise thermostat set point
High head-low vapor pressures	<ul style="list-style-type: none"> • Restriction in liquid line, expansion device or filter drier • Flow check piston size too small • Incorrect capillary tubes 	<ul style="list-style-type: none"> • Remove or replace defective component • Change to correct size piston • Change coil assembly
High head-high or normal vapor pressure - Cooling mode	<ul style="list-style-type: none"> • Dirty condenser coil • Refrigerant overcharge • Condenser fan not running • Air or non-condensibles in system 	<ul style="list-style-type: none"> • Clean coil • Correct system charge • Repair or replace • Recover refrigerant, evacuate & recharge
High head-high or normal vapor pressure - Heating mode	<ul style="list-style-type: none"> • Low air flow - condenser coil • Refrigerant overcharge • Air or non-condensibles in system • Dirty condenser coil 	<ul style="list-style-type: none"> • Check filters - correct to speed • Correct system charge • Recover refrigerant, evacuate & recharge • Check filter - clean coil
Low head-high vapor pressures	<ul style="list-style-type: none"> • Defective Compressor valves 	<ul style="list-style-type: none"> • Replace compressor
Low vapor - cool compressor - iced evaporator coil	<ul style="list-style-type: none"> • Low evaporator airflow • Operating below 65°F outdoors • Moisture in system • Liquid line limiting refrigerant flow 	<ul style="list-style-type: none"> • Increase speed of blower or reduce restriction - replace air filter • Add Low Ambient Kit • Recover refrigerant - evacuate & recharge - add filter drier • Replace drier
High vapor pressure	<ul style="list-style-type: none"> • Excessive load • Defective compressor 	<ul style="list-style-type: none"> • Recheck load calculation • Replace
Fluctuating head & vapor pressures	<ul style="list-style-type: none"> • Severe overcharge • Air or non-condensibles in system 	<ul style="list-style-type: none"> • Adjust refrigerant charge • Recover refrigerant, evacuate & recharge
Gurgle or pulsing noise at expansion device or liquid line	<ul style="list-style-type: none"> • Air or non-condensibles in system 	<ul style="list-style-type: none"> • Recover refrigerant, evacuate & recharge

N.1.2. Gas Heating Diagnostics Chart

▲ WARNING

DISCONNECT ALL POWER TO UNIT BEFORE SERVICING. CONTACTOR MAY BREAK ONLY ONE SIDE. FAILURE TO SHUT OFF POWER CAN CAUSE ELECTRICAL SHOCK RESULTING IN PERSONAL INJURY OR DEATH.

SYMPTOM	POSSIBLE CAUSE	REMEDY
Induced draft blower motor (IDM) does not start	No 208/230 Vac to IDM Faulty low voltage transformer Wired incorrectly No line voltage to integrate furnace control (IFC) Faulty IDM	Check the wiring from the board to the motor - check for power at the motor - replace the IFC Replace transformer Check wiring per the diagram in the I&O Check unit power connect - check power at L1 and L2 - Replace the IFC If IDM is receiving power and will not start, replace the IDM
Ignitor will not spark	Bad wire or corroded ignitor Negative pressure switch not closing Open rollout limit Open limit control Ignitor is not grounded Ignitor wired incorrectly Faulty IFC	Check wire for damage - check the connection to the high voltage spark tower - replace corroded ignitor Check for blocked hose - check for exhaust blockage - check that the negative pressure on the IDM is enough to close pressure switch - replace pressure switch Check for blockage in the intake, heat exchanger, and exhaust - clear blockage and reset limit Check temperature rise (see general data in I&O) - check for proper airflow - check for proper gas pressure - replace the limit Check that ignitor is firmly secured to burner assembly Check wiring per the diagram in the I&O Replace IFC
No ignition/burner will not light	No inlet pressure Gas valve is not receiving 24 V Gas valve is not opening Orifice is blocked	Check for gas pressure Check wiring from IFC to gas valve - check for power at the gas valve - replace IFC Replace valve Remove orifice and clean - replace orifice if it is damaged
Flame not sustained	Flame sense wired incorrectly Flame sense damage or not in correct position Flame sense dirty or corroded Microamps are low or not present Unit is not properly grounded Faulty IFC	Check wiring per the diagram in the I&O Check flame sense position - replace flame sense Clean flame sense with steel wool Check for 4 microamps - replace flame sensor Check unit grounding - correct bad grounding Replace IFC
Indoor blower motor (IBM) does not start after 30 seconds	No 208/230 Vac across IBM motor terminals on the IFC Dead capacitor Faulty IBM	Check the wiring per the diagram in the I&O - replace IFC Replace capacitor Replace IBM
Heating does not stop after call for heat has been satisfied	Thermostat wired incorrectly/faulty thermostat Faulty valve	Check thermostat wiring is correct - check that thermostat is operating correctly - replace thermostat Remove gas valve lead and check if valve closes - replace valve
After 5 second post-purge, IDM stops, or IBM does not stop running after off delay (specified in furnace section of I&O)	Open limit control Open rollout limit	Check temperature rise (see general data in I&O) - check for proper airflow - check for proper gas pressure - replace the limit Check for blockage in the intake, heat exchanger, and exhaust - clear blockage and reset limit

N. DIAGNOSTICS

N.2. Alarm Codes – Full List

Alarm Codes		
CODE	Description	FAULT LEVEL
0	STAND BY	None
c	COMPRESSOR ON - Low (Flashing if in time delay)	None
C	COMPRESSOR ON - High (Flashing if in time delay)	None
E	Economizer Cooling - No Compressor	None
F	CONTINUOUS FAN	None
h	GAS HEAT ON - LOW-FIRE	None
H	GAS HEAT ON -HIGH-FIRE	None
4	Comfort Alert Code 4 for Compressor Circuit 1	Shutdown
5	Comfort Alert Code 5 for Compressor Circuit 1	Shutdown
6	Comfort Alert Code 6 for Compressor Circuit 1	Shutdown
7	Comfort Alert Code 7 for Compressor Circuit 1	Shutdown
8	Comfort Alert Code 8 for Compressor Circuit 1	Shutdown
9	Comfort Alert Code 9 for Compressor Circuit 1	Shutdown
11	FAILED IGNITION	Problem
12	LO FLAME SENSE	Warning
13	FLAME LOST	Problem
14	UNEXPECTED FLAME	Shutdown
15	2ND STAGE GAS VALVE IMPOPER VOLTAGE	Problem
20	REFRIGERANT LOW PRESSURE SWITCH OPEN - CIRCUIT 1	Problem
21	REFRIGERANT LOW PRESSURE SWITCH OPEN - CIRCUIT 2	Problem
22	MAIN LIMIT OPEN	Problem
29	REFRIGERANT HIGH PRESSURE SWITCH OPEN - CIRCUIT 1	Problem
30	REFRIGERANT HIGH PRESSURE SWITCH OPEN - CIRCUIT 2	Problem
33	MRLC (Rollout Limit) OPEN	Problem
34	Comfort Alert Code 4 for Compressor Circuit 2	Shutdown
35	Comfort Alert Code 5 for Compressor Circuit 2	Shutdown
36	Comfort Alert Code 6 for Compressor Circuit 2	Shutdown
37	Comfort Alert Code 7 for Compressor Circuit 2	Shutdown
38	Comfort Alert Code 8 for Compressor Circuit 2	Shutdown
39	Comfort Alert Code 9 for Compressor Circuit 2	Shutdown
42	Invalid Thermostat Selection	Warning
44	1ST. STAGE COMBUSTION PRESS SWITCH CLOSED	Problem
46	1ST. STAGE COMBUSTION PRESS SWITCH OPEN	Problem
49	FREEZE SWITCH OPEN - CIRCUIT 1	Problem
50	FREEZE SWITCH OPEN - CIRCUIT 2	Problem
55	2nd stage COMBUSTION PRESSURE SWITCH CLOSED	Problem
57	2ND STAGE COMBUSTION PRESSURE SWITCH OPEN	Problem, s hutdown
59	Condensate Drain Plugged	Shutdown
61	BLOWER FAULT - NO RUN	Shutdown
83	Condenser Coil Temp Sensor Fail-OAT	Problem
84	Outdoor Air Temperature Sensor Fail-OAT	Problem
88	Emergency Stop Fault	Shutdown
93	CONTROL Fault	Shutdown
97	Smoke Detection	Shutdown

N. DIAGNOSTICS

N.2.1. Cooling Alarm Codes and Diagnostics

All Core Command come standard with a 7-segment diagnostic display. During standby mode with no fault codes present, the display will read "0" (zero). During normal thermostat heating, cooling or continuous fan operation, a letter will be displayed to describe the mode of operation as follows:

C = Cooling
 F = Continuous Fan Operation
 H = Gas Heating Operation

When the control senses a fault present, it will display a code to help in diagnoses. A list of normal operating codes and potential fault codes follows:

Alarm Codes - Cooling Only		
CODE	DESCRIPTION	FAULT LEVEL
0	Standby	None
c	Compressor On – Low (Flashing If In Time Delay)	None
C	Compressor On – High (Flashing If In Time Delay)	None
E	Economizer Cooling – No Compressor	None
F	Continuous Fan	None
4	Comfort Alert Code 4 For Compressor Circuit 1	Shutdown
5	Comfort Alert Code 5 For Compressor Circuit 1	Shutdown
6	Comfort Alert Code 6 For Compressor Circuit 1	Shutdown
7	Comfort Alert Code 7 For Compressor Circuit 1	Shutdown
8	Comfort Alert Code 8 For Compressor Circuit 1	Shutdown
9	Comfort Alert Code 9 For Compressor Circuit 1	Shutdown
20	Refrigerant Low Pressure Switch Open – Circuit 1	Problem
29	Refrigerant High Pressure Switch Open – Circuit 1	Problem
49	Freeze Switch Open – Circuit 1	Problem
59	Condensate Drain Plugged	Shutdown
83	Condenser Coil Temp Sensor Fail-Oct	Problem
84	Outdoor Air Temperature Sensor Fail-Oat	Problem
88	Emergency Stop Fault	Shutdown
93	Control Fault	Shutdown
97	Smoke Detection	Shutdown

The method for displaying a two-digit fault is to display the first digit for one second immediately followed by the second digit – which is also displayed for a duration of one second. A ½ second pause is then displayed. Cycle repeats

until the fault is cleared. Each fault is flashed (displayed) a minimum of two times even if the fault condition has cleared before the fault can be displayed twice.

Normal Operation Mode:

0	Displayed anytime there is no fault present and no thermostat call present
c	COMPRESSOR ON - Low (Flashing if in time delay)
C	COMPRESSOR ON - High (Flashing if in time delay)
E	When the system uses Economizer Cooling with No Compressor
F	Displayed anytime thermostat calls for continuous fan

N. DIAGNOSTICS

Fault Codes with Descriptions and Solutions:

Alarm Codes - Cooling Only		
CODE	DESCRIPTION	FAULT LEVEL
0	STANDBY	None
c	COMPRESSOR ON – Low (Flashing if in time delay)	None
C	COMPRESSOR ON – High (Flashing if in time delay)	None
E	Economizer Cooling – No Compressor	None
F	CONTINUOUS FAN	None
4	Comfort Alert Code 4 for Compressor Circuit 1	Shutdown
	ALARM Designation: Locked Rotor Circuit 1	
	DESCRIPTION:	
	1. Circuit 1 shutdown and retry after Anti-Short Cycle Delay (ASCD) Maximum is 3 attempts.	
	SOLUTION/STATUS/Possible - Troubleshooting Information	
	1. Low line voltage	
	2. Excessive Refrigerant in compressor	
3. Seized bearings in compressor		
5	Comfort Alert Code 5 for Compressor Circuit 1	Shutdown
	ALARM Designation: Open Circuit 1	
	DESCRIPTION:	
	1. Circuit 1 shutdown and retry after ASCD.	
	Note: This alarm is sent by the Comfort Alert Module only after the fault has been sensed for a minimum of 4 hours.	
	SOLUTION/STATUS/Possible - Troubleshooting Information	
	1. Condensing unit power disconnect is open	
	2. Compressor circuit breaker or fuses are open	
3. Compressor contactor has failed open High pressure switch is open and requires manual reset		
4. Broken supply wires or connector is notmaking contact		
5. Unusually long compressor protector reset time due to extreme ambient temperature		
6. Compressor windings are damaged		
6	Comfort Alert Code 6 for Compressor Circuit 1	Shutdown
	ALARM Designation: Missing Phase Circuit 1	
	DESCRIPTION:	
	1. Circuit 1 shutdown	
	SOLUTION/STATUS/Possible - Troubleshooting Information	
	1. Compressor fuse is open on one phase	
2. Broken wire or connector on one phase		
3. Compressor motor winding is damaged		
4. Utility supply has dropped one phase		

Fault Codes with Descriptions and Solutions:

Alarm Codes - Cooling Only		
CODE	DESCRIPTION	FAULT LEVEL
7	Comfort Alert Code 7 for Compressor Circuit 1	Shutdown
	ALARM Designation: Reverse Phase Circuit 1	
	DESCRIPTION:	
	1. Run outdoor and indoor fans continuously for circuit 1 and change mode of operation to Unoccupied Auto. This procedure prevents the Space Temperature from reaching extreme values.	
	SOLUTION/STATUS/Possible - Troubleshooting Information	
	1. Compressor running backward due to supply phase reversal	
8	Comfort Alert Code 8 for Compressor Circuit 1	Shutdown
	ALARM Designation: Welded Contactor Circuit 1	
	DESCRIPTION:	
	1. Circuit 1 shutdown	
	SOLUTION/STATUS/Possible - Troubleshooting Information	
	1. Compressor contactor has failed closed	
	2. Thermostat demand signal not connected to module	
9	Comfort Alert Code 9 for Compressor Circuit 1	Shutdown
	ALARM Designation: Low Voltage Circuit 1	
	DESCRIPTION:	
	1. Circuit 1 Shutdown and wait for voltage to return to operational levels.	
	SOLUTION/STATUS/Possible - Troubleshooting Information	
	1. Control circuit transformer is overloaded	
	2. Low line voltage to compressor	
20	DESCRIPTION: REFRIGERANT LOW PRESSURE SWITCH OPEN – CIRCUIT 1	Problem
	CAUSE:	
	1. Low evaporator airflow	
	2. Refrigerant undercharge	
	3. Restriction in liquid line, expansion device or filter drier	
	4. Operating below 65°F outdoors	
	5. Moisture in system	
	SOLUTION: The solution will depend on the cause.	
	1. Increase speed of blower or reduce restriction - replace air filter filter	
	2. Check for leaks - add refrigerant	
3. Remove or replace defective component		
4. Add Low Ambient Kit		
5. Recover refrigerant - evacuate & recharge - add or replace filter drier		

N. DIAGNOSTICS

Fault Codes with Descriptions and Solutions:

Alarm Codes - Cooling Only		
CODE	DESCRIPTION	FAULT LEVEL
29	DESCRIPTION: REFRIGERANT HIGH PRESSURE SWITCH OPEN – CIRCUIT 1	Problem
	CAUSE:	
	1. Restriction in liquid line, expansion device or filter drier	
	2. Refrigerant overcharge	
	3. Condenser fan not running	
	4. Air or non-condensibles in system	
	SOLUTION: The solution will depend on the cause.	
	1. Recover refrigerant - evacuate & recharge remove or replace defective component	
	2. Remove refrigerant	
49	FREEZE SWITCH OPEN – CIRCUIT 1	Problem
	DESCRIPTION:	
	1. Occurs when sensors are either open or shorted.	
	SOLUTION: The solution will depend on the cause.	
59	Condensate Drain Plugged	Shutdown
	DESCRIPTION:	
	1. Condensate line is blocked water inside of unit	
	SOLUTION: The solution will depend on the cause.	
	1. Remove blockage	
83	Condenser Coil Temp Sensor Fail-OCT	Problem
	DESCRIPTION:	
	1. No defrost operation, but unit continues to operate in either heating or cooling.	
	SOLUTION: The solution will depend on the cause.	
	1. Extreme temperatures	
	2. Replace the sensor	
	3. Check that sensor is installed correctly on control	

Fault Codes with Descriptions and Solutions:

Alarm Codes - Cooling Only		
CODE	DESCRIPTION	FAULT LEVEL
84	Outdoor Air Temperature Sensor Fail-OAT	Problem
	DESCRIPTION:	
	1. No defrost operation, but unit continues to operate in either heating or cooling.	
	2. The heat source continues to be heat pump, independently of the outdoor air temperature	
	SOLUTION: The solution will depend on the cause.	
	1. Extreme temperatures	
	2. Replace the sensor	
88	Emergency Stop Fault	Shutdown
	DESCRIPTION:	
	1. Complete shutdown	
	SOLUTION: The solution will depend on the cause. 1. Cannot be cleared by the 'Clear All Alarms" command. Must be cleared by changing the Emergency Stop Fault network value.	
93	CONTROL Fault	Shutdown
	DESCRIPTION:	
	1. Internal Control fault.	
	SOLUTION: The solution will depend on the cause. 1. Replace Control	
91	Smoke Detection	Shutdown
	DESCRIPTION:	
	1. RTU-C reads the smoke detection input as open -- complete shutdown.	
	SOLUTION: The solution will depend on the cause. 1. If not due to a fire, Replace the sensor, Check sensor is installed correctly on control 2. Check Smoke Detection Circuit, if no Smoke Detector is installed, ensure Economizer Smoke Bypass plug is installed	

N. DIAGNOSTICS

N.2.2. Heating Alarm Codes and Diagnostics

All Core Command come standard with a 7-segment diagnostic display. During standby mode with no fault codes present, the display will read "0" (zero). During normal thermostat heating, cooling or continuous fan operation, a letter will be displayed to describe the mode of operation as follows:

C = Cooling

F = Continuous Fan Operation

H = Gas Heating Operation

When the control senses a fault present, it will display a code to help in diagnoses. A list of normal operating codes and potential fault codes follows:

Alarm Codes - Heating Only		
CODE	DESCRIPTION	FAULT LEVEL -0, 1, 2, 3*
0	STANDBY	None
F	CONTINUOUS FAN	None
h	GAS HEAT ON - LOW-FIRE	None
H	GAS HEAT ON - HIGH-FIRE	None
11	FAILED IGNITION	Problem
12	LO FLAME SENSE	Warning
13	FLAME LOST	Problem
14	UNEXPECTED FLAME	Shutdown
15	HIGH-FIRE GAS VALVE IMPROPER VOLTAGE	Problem
22	MAIN LIMIT OPEN	Problem
33	MRLC (Rollout Limit) OPEN	Problem
42	INVALID THERMOSTAT SELECTION	Warning
44	LOW-FIRE NEGATIVE PRESSURE CONTROL CLOSED	Problem
46	LOW-FIRE NEGATIVE PRESSURE CONTROL OPEN	Problem
55	High-Fire NEGATIVE PRESSURE CONTROL CLOSED	Problem
57	HIGH-FIRE NEGATIVE PRESSURE CONTROL OPEN	Problem, Shutdown
61	BLOWER FAULT - NO RUN	Shutdown
97	SMOKE DETECTION	Shutdown

The method for displaying a two-digit fault is to display the first digit for one second immediately followed by the second digit – which is also displayed for a duration of one second. A ½ second pause is then displayed. Cycle repeats

until the fault is cleared. Each fault is flashed (displayed) a minimum of two times even if the fault condition has cleared before the fault can be displayed twice.

Normal Operation Mode:

0	Displayed anytime there is no fault present and no thermostat call present
F	Displayed anytime thermostat calls for continuous fan
h	Lower-case "h" displayed anytime thermostat calls for low-fire heat
H	Upper-case "H" displayed anytime thermostat calls for high-fire heat

Fault Codes with Descriptions and Solutions:

Alarm Codes - Heating Only	
CODE	FAILED IGNITION
11	DESCRIPTION: This fault is displayed when a failed ignition has occurred three times in a row. The Core Command will enter a one-hour lockout following the third ignition attempt.
	CAUSE:
	1. Flame sense rod is unable to sense flame
	2. Gas valve is turned OFF.
	3. The ignitor is not working properly.
	4. The Core Command is not working properly
	5. Burner flame is not carrying over from first burner to the last.
	SOLUTION: the solution will depend on the cause.
	1. Clean or replace flame sense rod. Confirm flame sense is in burner flame. Check wire and all connections between flame sense and Core Command. Make sure furnace is properly grounded.
	2. Turn gas valve ON.
3. Replace or reposition the ignitor. Refer to section G.1.4 for proper ignitor location. Check wire and all connections between ignitor and Core Command.	
4. Replace furnace Core Command.	
5. Check manifold pressure during ignition (see Measuring and Adjusting Manifold Gas Pressures section). Watch the burner during ignition if the first burner lights but the second, third and so on do not light (incomplete carry-over), the burner may need to be replaced.	
12	LOW FLAME SENSE
	DESCRIPTION: Furnace operation will continue in low and high-fire modes. This problem may be elevated to the level of fault code "13" or "11" if flame cannot be sensed at all.
	CAUSE:
	1. Most common cause is that the flame sense rod may need cleaning.
	2. Flame sense rod may not be properly connected.
	3. Wiring between the rod and furnace control may be shorted or opened.
	SOLUTION:
	1. Clean or replace flame sense rod.
2. Check wire and all connections between the flame sense and Core Command.	
3. Make sure the furnace is properly grounded.	

N. DIAGNOSTICS

Fault Codes with Descriptions and Solutions:

Alarm Codes - Heating Only	
CODE	FLAME LOST
13	DESCRIPTION: if flame is lost after it is established, subsequent ignition attempts will follow and normal operation should resume.
	CAUSE:
	1. Most common cause is that the flame sense rod may need cleaning.
	2. My not be properly connected.
	3. Wiring between flame sense and Core Command may be shorted or opened.
	4. Improperly mounted
	5. Improperly grounded.
	6. Burner flame pattern may be unstable.
	SOLUTION:
	1. Clean or replace the flame sense rod.
	2. Check wire and all connections between the flame sense and Core Command.
	3. Confirm flame sense rod is in the flame. See section G.1.4 for proper flame sense location.
	4. Confirm furnace is properly grounded.
5. Check that all burner assembly components are properly installed. Confirm that burner flame is steady and directed down the center of tube. If turbulence is noted, check for air leaks between the burner and blower compartment.	
14	UNEXPECTED FLAME
	DESCRIPTION: this fault should rarely if ever be seen in the field. Furnace will not operate with this fault present.
	CAUSE:
	1. Field mis-wiring of 24VAC to the gas valve main solenoid.
	2. Faulty gas valve stuck in the "OPEN" position.
	3. Faulty furnace Core Command (signal improperly sensed when it should not be sensed at all).
	SOLUTION:
	1. Correct wiring
2. Replace the gas valve.	
3. Replace the Core Command.	
15	HIGH-FIRE GAS VALVE IMPROPER VOLTAGE
	DESCRIPTION: High-fire coil energized during call for low-fire heat. This fault should rarely if ever be seen in the field.
	CAUSE: Gas valve relay contacts on Core Command welded shut. Hi and low-fire miswired.
	SOLUTION:
	1. Replace Core Command if gas valve wiring is correct
2. Turn off power to unit. Use a pin remover to reverse locations for BLUE and WHITE/BLACK wires in 3-pin connector.	

Fault Codes with Descriptions and Solutions:

Alarm Codes - Heating Only	
CODE	MAIN LIMIT OPEN
22	DESCRIPTION: The furnace will not operate in gas heat mode.
	CAUSE:
	1. No airflow or dead blower
	2. Insufficient airflow
	3. Faulty limit control
	4. Loose or faulty wiring.
	5. Incorrect blower tap
	6. Furnace input is too high.
	SOLUTION:
	1. Check for proper blower operation. If a blower motor fault has occurred fault code "61" should also be present. Check the wiring to the motor then the motor.
	2. Check filters and ductwork. Determine static pressure and confirm it is not above published values found in the Checking and Adjusting Airflow section.
	3. Replace the limit control
	4. Check wiring and connections.
5. Confirm proper blower speed taps for high and low-fire.	
6. Insure properly sized burner orifices are installed. Check manifold pressure at high and low-fire and compare to values found in Measuring and Adjusting Manifold Gas Pressures section. Check rate and compare to nameplate input, high and low-fire. Adjust as necessary.	
33	MRLC (Manual Reset Limit Control) OPEN
	DESCRIPTION: The MRLC is also known as the rollout limit. There are two rollout limits on RGEC gas units. When one or more of these limits open, they must be manually reset to the closed position. This fault can occur when burner flames are not directed down the center of the burner tube and roll out into the burner assembly. This fault indicates a serious problem that must be repaired before furnace operation can continue.
	CAUSE:
	1. Faulty limit.
	2. Loose or faulty wiring.
	3. Damaged heat exchanger
	4. Insufficient combustion air or blocked flue pipe.
	5. Overfired condition.
	6. Air leak between burner and blower compartment.
	SOLUTION:
	1. Replace limit if limit will not reset. Observe flame pattern for normal operation after limit has been replaced.
	2. Check wiring and connections. Replace and/or repair as necessary

N. DIAGNOSTICS

Fault Codes with Descriptions and Solutions:

33	3. Confirm that burner flame is steady and directed down center of burner tube. If flame turbulence is evident, note if turbulence began when indoor blower motor was energized. This could be an indicator of a damaged heat exchanger, i.e. breached primary tube or loose swedge joint.
	4. Confirm louvered panels are unobstructed. Confirm flue pipe is unobstructed.
	5. Insure properly sized burner orifices are installed. Check manifold pressure at high and low-fire and compare to values found in Measuring and Adjusting Manifold Gas Pressures section. Check rate and compare to nameplate input, high and low-fire. Adjust as necessary.
	6. Check that all burner assembly components are properly installed. Confirm that burner flame is steady and directed down the center of tube. If turbulence is noted, check for air leaks between the burner and blower compartment.
44	LOW FIRE NEGATIVE PRESSURE CONTROL (NPC) CLOSED (230V & 575V ONLY)
	DESCRIPTION: The low-fire NPC should be open when the inducer is not operating. Before any heat cycle can begin, the NPC is tested to confirm the contacts are open. An ignition sequence will not occur if the low-fire NPC remains closed.
	CAUSE:
	1. NPC contacts are welded shut/faulty switch.
	2. loose or faulty wiring
	SOLUTION:
1. Replace low fire NPC. 2. Check wiring or connections, replace or repair as necessary	

Fault Codes with Descriptions and Solutions:

46	LOW FIRE NEGATIVE PRESSURE CONTROL (NPC) OPEN (230V & 575V ONLY)
	DESCRIPTION: Core command will energize the inducer for 30 seconds (pre-purge) in an attempt to close the low fire NPC. The Core Command will make four attempts to close the low-fire NPC before declaring a fault and entering a one hour lockout.
	CAUSE:
	1. Faulty inducer.
	2. Faulty Core Command
	3. Loose or faulty wiring.
	4. Disconnected, blocked, split or cut pressure switch hose.
	5. Severe wind gusts (sporadic)
	6. Faulty low fire pressure switch
	SOLUTION:
1. Repair or replace inducer. Check inducer pressure to confirm negative pressure is adequate to close pressure switch.	
46	2. Replace Core Command after confirming that NPC contacts are closed while inducer is running.
	3. Check NPC wiring and connections to Core Command.
	4. Confirm pressure switch hose is attached to pressure port on IDM and port on pressure switch. Confirm there is no split or cut in hose.
	5. Consider using the flue "snorkel" accessory.
55	6. Replace pressure switch.
	HIGH-FIRE NEGATIVE PRESSURE CONTROL (NPC) CLOSED
	DESCRIPTION: The high-fire NPC should be open when the inducer is not operating. Before any heat cycle can begin, the NPC is tested to confirm the contacts are open. An ignition sequence will not occur if the high-fire NPC remains closed.
	CAUSE:
	1. NPC contacts are welded shut/faulty switch.
	2. Loose or faulty wiring
	SOLUTION:
1. Replace high-fire NPC.	
2. Check wiring or connections, replace or repair as necessary	

N. DIAGNOSTICS

57	High-Fire NEGATIVE PRESSURE CONTROL (NPC) OPEN (230V & 575V ONLY)
	DESCRIPTION: Furnace will ignite and operate in low-fire mode. Fault display established when thermostat calls for high-fire mode. Inducer high speed is energized and will remain on high speed for 60 seconds in an attempt to close high fire pressure switch. If pressure switch does not close after 60 seconds the inducer will drop to low speed and furnace will continue operation at low fire until high fire pressure switch closes or thermostat demand is satisfied.
	CAUSE:
	1. Faulty inducer or tap pressure inadequate to close high-fire NPC
	2. Faulty Core Command
	3. Loose or faulty wiring.
	4. Disconnected, blocked, split or cut pressure switch hose.
	5. Severe wind gusts (sporadic)
	6. Faulty high fire pressure switch
	SOLUTION:
	1. Repair or replace inducer. Check inducer pressure to confirm negative pressure is adequate to close pressure switch.
	2. Replace Core Command after confirming that NPC contacts are closed while inducer is running.
	3. Check NPC wiring and connections to Core Command.
	4. Confirm pressure switch hose is attached to pressure port on IDM and port on pressure switch. Confirm there is no split or cut in hose.
5. Consider using the flue hood accessory.	
6. Replace pressure switch.	

Fault Codes with Descriptions and Solutions:

BLOWER FAULT - MOTOR CANNOT RUN	
61	<p>DESCRIPTION: This is a critical blower fault- such as an internal thermal overload that prevents the motor from running. Furnace will shut down if this fault occurs during heating operation. No other operations, including thermostat calls, will occur until this fault is cleared. this fault will occur during heating operation after the main limit control has been open for more than 150 seconds (2 min:30 sec.). If this happens, the Core Command determines that the motor is not functional and enters a hard lockout condition requiring repair of the motor and manual reset of power to the furnace.</p>
	<p>CAUSE:</p>
	<p>1. The motor has tripped on thermal overload because of a restriction or bearing failure.</p>
	<p>2. Wiring to the motor has become compromised.</p>
	<p>3. The blower wheel has become damaged or is not properly attached to the motor shaft.</p>
	<p>4. The motor has failed catastrophically.</p>
	<p>SOLUTION:</p>
	<p>1. Remove restriction or replace motor</p>
	<p>2. Inspect and replace or repair wiring and/or connections to the motor</p>
	<p>3. Replace blower wheel and/or attach wheel to motor shaft properly.</p>
<p>4. Replace motor.</p>	

N. DIAGNOSTICS

Fault Codes with Descriptions and Solutions:

460V NEGATIVE PRESSURE CONTROL FAULTS	
55 & 44	NEGATIVE PRESSURE CONTROL (NPC) CLOSED
	460V furnace uses a single-speed inducer and one pressure switch for low and high-fire operation. The NPC should be open when the inducer is not operating.
	DESCRIPTION: Before any heat cycle can begin, the NPC is tested to confirm the contacts are open. An ignition sequence will not occur if the NPC remains closed. Core Command will flash a “55” & “44” fault code (230V & 460V units use same Core Command, “44” is normal under this scenario).
	See CAUSE and SOLUTION for fault code “55” above.
57 & 46	NEGATIVE PRESSURE CONTROL (NPC) OPEN
	DESCRIPTION: The inducer will run for 20 seconds in an attempt to close the pressure switch. At that time the Core Command will flash a “57” & “46” fault code (230V & 460V units use same Core Command, “46” is normal under this scenario). Inducer will continue to run an additional 40 seconds before being de-energized. After a five minute period the Core Command will make another attempt to close the pressure switch. This cycle will repeat until the pressure switch closes or call for heat is removed.
	See CAUSE and SOLUTION for fault code “57” above.

N.2.3. Non-Applicable Fault Codes

The controls used in this product are common with a few other product families. Because of this, there are several fault codes that are programmed into the controls but DO NOT APPLY to this product. If one of these fault codes appear, clear the fault and continue

diagnostics. If the code persists, power down the unit and reapply power before continuing diagnostics.

These non-applicable fault codes are listed below:

Alarm Codes - NON-APPLICABLE FAULT CODES		
21	REFRIGERANT LOW PRESSURE SWITCH OPEN – CIRCUIT 2	Problem
30	REFRIGERANT HIGH PRESSURE SWITCH OPEN – CIRCUIT 2	Problem
34	Comfort Alert Code 4 for Compressor Circuit 2	Shutdown
35	Comfort Alert Code 5 for Compressor Circuit 2	Shutdown
36	Comfort Alert Code 6 for Compressor Circuit 2	Shutdown
37	Comfort Alert Code 7 for Compressor Circuit 2	Shutdown
38	Comfort Alert Code 8 for Compressor Circuit 2	Shutdown
39	Comfort Alert Code 9 for Compressor Circuit 2	Shutdown
50	FREEZE SWITCH OPEN – CIRCUIT 2	Problem

N. DIAGNOSTICS

N.2.5. VFD Codes

N.2.5.1. Yaskawa VFD Codes

Some units come equipped with a Yaskawa V1000 Variable Frequency Drive attached to the blower assembly in the blower motor compartment.

When the drive detects a fault, the ALM indicator LED remains lit without flashing. If the LED flashes, the drive has detected a minor fault or alarm. Conditions such as overvoltage or external faults can trip both faults and minor faults, therefore it is important to note whether the LED remains lit or if the LED flashes.

When the control senses a fault present, it will display a code to help in diagnoses. A list of normal operating codes and potential fault codes can be found below and on the following page.

More fault codes can be found on the manufacturer's website. In the blower compartment, on the right side VFD assembly there is a label that gives the model number of the VFD. Use that model number to find the VFD Installation Manual on the manufacturer's website.

Digital Operator Display	Name	Minor Fault Output (H2 - □□ = 10)
CE	MEMOBUS/Modbus Communication Error	YES
CrST	Can Not Reset	YES
dnE	Drive Disabled	YES
EF1 to EF7	External Fault (input terminal S1 to S7)	YES
HCA	Current Alarm	YES
LT-1	Cooling Fan Maintenance Alarm	No Output <1>
LT-2	Capacitor Maintenance Alarm	No Output <1>
LT-3	Soft Charge Bypass Relay Maintenance Time	No Output <1>
LT-4	IGBT Maintenance Time (50%)	No Output <1>
oH	Heatsink Overheat	YES
oH2	Drive Overheat	YES
oH3	Motor Overheat	YES
oL3	Overtorque 1	YES
oL4	Overtorque 2	YES
oL5	Mechanical Weakening Direction 1	YES
oS	Overspeed (for Simple V/f with PG)	YES
oV	Overvoltage	YES
Pgo	PG Disconnect (for Simple V/f with PG)	YES

N. DIAGNOSTICS

N.2.5.1. Yaskawa VFD Codes (Cont.)

Digital Operator Display	Name
bUS	Option Communication Error
CE	MEMOBUS/Mobus Communication Error
CF	Control Fault
CPF02	A/D Conversion Error
CPF07	Terminal Board Communication Fault
CPF08	EEPROM Serial Communications Fault
CPF011	RAM Fault
CPF012	FLASH Memory Fault
CPF013	Watchdog Circuit Exception
CPF014	Control Circuit Fault
CPF016	Clock Fault
CPF017	Timing Fault
CPF018	Control Circuit Fault
CPF019	Control Circuit Fault
CPF020 or CPF21	RAM Fault
	FLASH Memory Fault
	Watchdog Circuit Exception
	Clock Fault
EF0	Option External Fault
EF1 to EF7	External Fault (input terminal S1 to S7)
Err	EEPROM Write Error
GF	Ground Fault
LF	Output Phase Loss
LF2	Current Imbalance
oC	Overcurrent
oH	Heat Sink Overheat
oH1	Heat Sink Overheat
oL1	Motor Overload
oL2	Drive Overload
oL3	Overtorque Detection 1
oL4	Overtorque Detection 2
oL5	Mechanical Weakening Detection 1
oL6	Overvoltage
oL7	Input Phase Loss
oL8	IGBT Short Circuit
oL9	Undervoltage
oL10	Control Power Supply Undervoltage
oL11	Soft Charge Circuit Fault

N.2.5. VFD Codes (Cont.)

This VFD Section may not be applicable to all unit configurations. See **Appendix G** towards the end of this manual for Low Voltage Connections for VFDs.

N.2.5.2. Mitsubishi VFD Codes

Some units come equipped with a Mitsubishi FR-E800 Variable Frequency Drive attached to the blower assembly in the blower motor compartment.

When the drive detects a fault, an “E” with a Three Character Fault Code will be displayed on the LED display (Example: E.LUP). The drive may not stop the drive from running unless it is

not corrected. The drive will store the last 10 fault codes, a condensed list of fault codes and operating codes can be found below.

More fault codes can be found on the manufacturer’s website. In the blower compartment, on the right side VFD assembly there is a label that gives the model number of the VFD. Use that model number to find the VFD Installation Manual on the manufacturer’s website.

Operation Panel Indication	Code	Name
E.OC1	16 (H10)	Overcurrent trip during acceleration
E.OC2	17 (H11)	Overcurrent trip during constant speed
E.OC3	18 (H12)	Overcurrent trip during deceleration or stop
E.OV1	32 (H20)	Regenerative overvoltage trip during acceleration
E.OV2	33 (H21)	Regenerative overvoltage trip during constant speed
E.OV3	34 (H22)	Regenerative overvoltage trip during deceleration or stop
E.THT	48 (H30)	Inverter overload trip (electronic thermal relay function)
E.THM	49 (H31)	Motor overload trip (electronic thermal relay function)
E.FIN	64 (H40)	Heat sink overheat
E.UVT	81 (H51)	Undervoltage
E.ILF	82 (H52)	Input phase loss
E.OLT	96 (H60)	Stall prevention stop
E.SOT	97 (H61)	Loss of synchronism detection
E.LUP	98 (H62)	Upper limit fault detection
E.LDN	99 (H63)	Lower limit fault detection
E.BE	112 (H70)	Brake transistor alarm detection
E.GF	128 (H80)	Output side earth (ground) fault overcurrent
E.LF	129 (H81)	Output phase loss
E.OHT	144 (H91)	External thermal relay operation
E.PTC	145 (H91)	PTC thermistor operation
E.OPT	160 (HA0)	Option Fault

N. DIAGNOSTICS

N.3. Common Mistakes

- These are a list of common mistakes made during installation.
- Drain Pan Connections, drain trap connected to the wrong outlet side, not connected at all, or insufficient trap depth.
- Connecting a W2 call only to try and get full heat all the time, Connect both W1 and W2 together if the job requirement or thermostat is setup for single stage heating.
- Connecting a Y2 call only to try and get full cooling all the time, Connect both Y1 and Y2 together if the job requirement or thermostat is setup for single stage cooling.
- Economizer connections, not installing the 3-wire jumper plug into the economizer wiring harness, if a factory option smoke detector is not used, this will cause a Smoke Detection Fault.

Appendix A – General Product Data

Model (-)GEDZT Series	ZT090	ZT102	ZT120	ZT150
Cooling Performance^A				
Gross Cooling Capacity Btu [kW]	88,000 [25.78]	99,000 [29.01]	118,000 [34.57]	148,000 [43.36]
EER	11	11	11	10.8
IEER ^B	14.6	14.6	14.6	14
Nominal CFM/AHRI Rated CFM [L/s]	3000/3175 [1416/1498]	3400/3225 [1604/1522]	4000/3480 [1888/1642]	5000/4150 [2360/1959]
AHRI Net Cooling Capacity Btu [kW]	85,000 [24.9]	96,000 [28.13]	114,000 [33.4]	142,000 [41.61]
Net Sensible Capacity Btu [kW]	62,700 [18.37]	68,300 [20.01]	79,600 [23.32]	98,600 [28.89]
Net Latent Capacity Btu [kW]	22,300 [6.53]	27,700 [8.12]	34,400 [10.08]	43,400 [12.72]
Net System Power kW	7.73	8.73	10.36	13.15
Compressor				
No./Type	1/Scroll	1/Scroll	1/Scroll	2/Tandem Scroll
No. Stages	2	2	2	2
Outdoor Sound Rating (dB)^C				
	88	88	88	88
Outdoor Coil - Fin Type				
	Louvered	Louvered	Louvered	Louvered
Tube Type	MicroChannel	MicroChannel	MicroChannel	MicroChannel
MicroChannel Depth in. [mm]	0.71 [18]	0.81 [20.6]	1 [25.4]	1 [25.4]
Face Area sq. ft. [sq. m]	25.4 [2.36]	25.6 [2.38]	25.6 [2.38]	31.5 [2.93]
Rows / FPI [FPcm]	1 / 23 [9]	1 / 23 [9]	1 / 23 [9]	1 / 23 [9]
Indoor Coil - Fin Type				
	Louvered	Louvered	Louvered	Louvered
Tube Type	MicroChannel	MicroChannel	MicroChannel	MicroChannel
MicroChannel Depth in. [mm]	1 [25.4]	1.26 [32]	1.26 [32]	1 [25.4]
Face Area sq. ft. [sq. m]	11 [1.02]	10.9 [1.01]	10.9 [1.01]	13.8 [1.28]
Rows / FPI [FPcm]	1 / 20 [8]	1 / 20 [8]	1 / 20 [8]	2 / 18 [7]
Refrigerant Control	TX Valves	TX Valves	TX Valves	TX Valves
Drain Connection No./Size in. [mm]	1/0.75 [19.05]	1/0.75 [19.05]	1/0.75 [19.05]	1/0.75 [19.05]
Outdoor Fan - Type				
	Propeller	Propeller	Propeller	Propeller
No. Used/Diameter in. [mm]	2/24 [609.6]	2/24 [609.6]	2/24 [609.6]	2/24 [609.6]
Drive Type/No. Speeds	Direct/1	Direct/1	Direct/1	Direct/1
CFM [L/s]	8000 [3775]	8000 [3775]	8500 [4011]	9000 [4247]
No. Motors/HP	2 at 1/5 HP	2 at 1/5 HP	2 at 1/3 HP	2 at 3/4 HP
Motor RPM	820	820	1075	1100
Indoor Fan - Type				
	FC Centrifugal	FC Centrifugal	FC Centrifugal	FC Centrifugal
No. Used/Diameter in. [mm]	1/15x15 [381x381]	1/15x15 [381x381]	1/15x15 [381x381]	1/15x15 [381x381]
Drive Type	Belt (Adjustable)	Belt (Adjustable)	Belt (Adjustable)	Belt (Adjustable)
No. Speeds	2	2	2	2
No. Motors	1	1	1	1
Motor RPM	1725	1725	1725	1725
Motor Frame Size	56	56	56	184
Filter - Type				
	Disposable	Disposable	Disposable	Disposable
Furnished	Yes	Yes	Yes	Yes
(NO.) Size Recommended in. [mm x mm x mm]	(4)2x20x20 [51x508x508]	(4)2x20x20 [51x508x508]	(4)2x20x20 [51x508x508]	(4)2x20x20 [51x508x508]
Refrigerant Charge Oz. [g]				
	100 [2835]	122 [3458]	136 [3856]	186 [5273]
Weights				
Net Weight lbs. [kg]	839 [381]	868 [394]	896 [406]	1094 [496]
Ship Weight lbs. [kg]	878 [398]	907 [411]	935 [424]	1133 [514]

Note: Please look at the rating plates pasted on the side of the unit to understand the model number of your unit.

P. APPENDICES

Appendix A – General Product Data (Cont.)

GENERAL DATA - RGEDZT MODELS; ZT SERIES

7.5 - 12.5 TON [26.4 - 44.0 kW]

NOTES:

A. Cooling Performance is rated at 95° F ambient, 80° F entering dry bulb, 67° F entering wet bulb. Gross capacity does not include the effect of fan motor heat. AHRI capacity is net and includes the effect of fan motor heat. Units are suitable for operation to 20% of nominal cfm. Units are certified in accordance with the Unitary Air Conditioner Equipment certification program, which is based on AHRI Standard 340/360.

B. EER and Integrated Energy Efficiency Ratio (IEER) are rated in accordance with AHRI Standard 340/360 and with DOE test procedures.

C. Outdoor Sound Rating shown is tested in accordance with AHRI Standard 270.

Appendix B – Electrical Data

ELECTRICAL DATA - RGEDZT SERIES							
		090ACF15 090ACF20	090ACG15 090ACG20 090ACH15 090ACH20	090ADF15 090ADF20	090ADG15 090ADG20 090ADH15 090ADH20	090AYF15 090AYF20	090AYG15 090AYG20 090AYH15 090AYH20
Unit Information	Unit Operating Voltage Range	187-253	187-253	414-506	414-506	523-632	523-632
	Volts	208/230	208/230	460	460	575	575
	Phase	3	3	3	3	3	3
	Hz	60	60	60	60	60	60
	Minimum Circuit Ampacity	41	44	17	19	15	16
	Minimum Overcurrent Protection Device Size	50	50	20	25	20	20
	Maximum Overcurrent Protection Device Size	60	60	25	25	20	20
Compressor Motor	No.	1	1	1	1	1	1
	Volts	208/230	208/230	460	460	575	575
	Phase	3	3	3	3	3	3
	RPM	3500	3500	3500	3500	3500	3500
	HP, Compressor	7	7	7	7	7	7
	Amps (RLA), Comp.	25.3	25.3	9.6	9.6	8.4	8.4
	Amps (LRA), Comp.	184	184	84	84	60	60
Condenser Motor	No.	2	2	2	2	2	2
	Volts	208/230	208/230	460	460	575	575
	Phase	1	1	1	1	1	1
	HP	1/5	1/5	1/5	1/5	1/5	1/5
	Amps (FLA, each)	1.2	1.2	0.8	0.8	0.6	0.6
	Amps (LRA, each)	2.3	2.3	1.4	1.4	1	1
Evaporator Fan	No.	1	1	1	1	1	1
	Volts	208/230	208/230	460	460	575	575
	Phase	3	3	3	3	3	3
	HP	2	3	2	3	2	3
	Amps (FLA, each)	6.6	9.1	3.2	4.6	2.5	3.5
	Amps (LRA, each)	47.0	74.5	24.0	38.1	19.0	30.0

P. APPENDICES

Appendix B – Electrical Data (Cont.)

ELECTRICAL DATA - RGEDZT SERIES									
		102ACF15 102ACF22	102ACG15 102ACG22	102ACH15 102ACH22	102ADF15 102ADF22	102ADG15 102ADG22	102ADH15 102ADH22	102AYF15 102AYF22	102AYG15 102AYG22 102AYH15 102AYH22
Unit Information	Unit Operating Voltage Range	187-253	187-253	187-253	414-506	414-506	414-506	523-632	523-632
	Volts	208/230	208/230	208/230	460	460	460	575	575
	Phase	3	3	3	3	3	3	3	3
	Hz	60	60	60	60	60	60	60	60
	Minimum Circuit Ampacity	46	48	51	21	22	24	16	17
	Minimum Overcurrent Protection Device Size	60	60	60	25	25	30	20	20
	Maximum Overcurrent Protection Device Size	70	70	70	30	30	35	25	25
Compressor Motor	No.	1	1	1	1	1	1	1	1
	Volts	208/230	208/230	208/230	460	460	460	575	575
	Phase	3	3	3	3	3	3	3	3
	RPM	3500	3500	3500	3500	3500	3500	3500	3500
	HP, Compressor	7 1/2	7 1/2	7 1/2	7 1/2	7 1/2	7 1/2	7 1/2	7 1/2
	Amps (RLA), Comp.	28.8	28.8	28.8	12.5	12.5	12.5	9.7	9.7
	Amps (LRA), Comp.	223	223	223	100	100	100	70	70
Condenser Motor	No.	2	2	2	2	2	2	2	2
	Volts	208/230	208/230	208/230	460	460	460	575	575
	Phase	1	1	1	1	1	1	1	1
	HP	1/5	1/5	1/5	1/5	1/5	1/5	1/5	1/5
	Amps (FLA, each)	1.2	1.2	1.2	0.8	0.8	0.8	0.6	0.6
	Amps (LRA, each)	2.3	2.3	2.3	1.4	1.4	1.4	1.0	1.0
Evaporator Fan	No.	1	1	1	1	1	1	1	1
	Volts	208/230	208/230	208/230	460	460	460	575	575
	Phase	3	3	3	3	3	3	3	3
	HP	2	3	3	2	3	3	2	3
	Amps (FLA, each)	7	9.1	12	3.5	4.6	6	2.5	3.5
	Amps (LRA, each)	47	74.5	74.5	24.0	38.1	38.1	19.0	30.0

Appendix B – Electrical Data (Cont.)

ELECTRICAL DATA - RGEDZT SERIES									
		120ACF15 120ACF22	120ACG15 120ACG22	120ACH15 120ACH22	120ADF15 120ADF22	120ADG15 120ADG22	120ADH15 120ADH22	120AYF15 120AYF22	120AYG15 120AYG22 120AYH15 120AYH22
Unit Information	Unit Operating Voltage Range	187-253	187-253	187-253	414-506	414-506	414-506	523-632	523-632
	Volts	208/230	208/230	208/230	460	460	460	575	575
	Phase	3	3	3	3	3	3	3	3
	Hz	60	60	60	60	60	60	60	60
	Minimum Circuit Ampacity	54	56	58	26	27	28	19	20
	Minimum Overcurrent Protection Device Size	70	70	70	30	35	35	25	25
	Maximum Overcurrent Protection Device Size	80	80	90	35	40	40	25	30
Compressor Motor	No.	1	1	1	1	1	1	1	1
	Volts	208/230	208/230	208/230	460	460	460	575	575
	Phase	3	3	3	3	3	3	3	3
	RPM	3500	3500	3500	3500	3500	3500	3500	3500
	HP, Compressor	10	10	10	10	10	10	10	10
	Amps (RLA), Comp.	32.6	32.6	32.6	14.8	14.8	14.8	11.1	11.1
	Amps (LRA), Comp.	240	240	240	130	130	130	93.7	93.7
Condenser Motor	No.	2	2	2	2	2	2	2	2
	Volts	208/230	208/230	208/230	460	460	460	575	575
	Phase	1	1	1	1	1	1	1	1
	HP	1/3	1/3	1/3	1/3	1/3	1/3	1/3	1/3
	Amps (FLA, each)	2.4	2.4	2.4	1.4	1.4	1.4	1.0	1.0
	Amps (LRA, each)	4.7	4.7	4.7	2.4	2.4	2.4	4.7	4.7
Evaporator Fan	No.	1	1	1	1	1	1	1	1
	Volts	208/230	208/230	208/230	460	460	460	575	575
	Phase	3	3	3	3	3	3	3	3
	HP	2	3	3	2	3	3	2	3
	Amps (FLA, each)	7.9	10.1	12	3.9	5.1	6	2.5	3.5
	Amps (LRA, each)	47.0	74.5	74.5	24.0	38.1	38.1	19.0	30.0

P. APPENDICES

Appendix B – Electrical Data (Cont.)

ELECTRICAL DATA - RGEDZT SERIES							
		150ACF15 150ACF22	150ACG15 150ACG22	150ADF15 150ADF22	150ADG15 150ADG22	150AYF15 150AYF22	150AYG15 150AYG22
Unit Information	Unit Operating Voltage Range	187-253	187-253	414-506	414-506	523-632	523-632
	Volts	208/230	208/230	460	460	575	575
	Phase	3	3	3	3	3	3
	Hz	60	60	60	60	60	60
	Minimum Circuit Ampacity	70	75	34	37	25	27
	Minimum Overcurrent Protection Device Size	80	90	40	40	30	30
	Maximum Overcurrent Protection Device Size	90	90	40	45	30	30
Compressor Motor	No.	2	2	2	2	2	2
	Volts	208/230	208/230	460	460	575	575
	Phase	3	3	3	3	3	3
	RPM	3500	3500	3500	3500	3500	3500
	HP, Compressor 1	6	6	6	6	6	6
	Amps (RLA), Comp. 1	22.4	22.4	10.6	10.6	7.7	7.7
	Amps (LRA), Comp. 1	149	149	75	75	54	54
	HP, Compressor 2	6	6	6	6	6	6
	Amps (RLA), Comp. 2	22.4	22.4	10.6	10.6	7.7	7.7
Amps (LRA), Comp. 2	149	149	75	75	54	54	
Condenser Motor	No.	2	2	2	2	2	2
	Volts	208/230	208/230	460	460	575	575
	Phase	1	1	1	1	1	1
	HP	3/4	3/4	3/4	3/4	3/4	3/4
	Amps (FLA, each)	4.2	4.2	2.3	2.3	1.6	1.6
	Amps (LRA, each)	10.1	10.1	4.9	4.9	3.4	3.4
Evaporator Fan	No.	1	1	1	1	1	1
	Volts	208/230	208/230	460	460	575	575
	Phase	3	3	3	3	3	3
	HP	3	5	3	5	3	5
	Amps (FLA, each)	10.4	16	5.2	8	4.4	5.9
	Amps (LRA, each)	74.5	95.0	38.1	47.5	30.0	38.0

Appendix C – Air Flow Performance Data

Air Flow CFM [L/s]		External Static Pressure - Inches of Water [Pa]																																							
		0.1 [0.2]		0.2 [0.6]		0.3 [0.7]		0.4 [1.0]		0.5 [1.2]		0.6 [1.5]		0.7 [1.7]		0.8 [2.0]		0.9 [2.2]		1.0 [2.5]		1.1 [2.7]		1.2 [3.0]		1.3 [3.2]		1.4 [3.5]		1.5 [3.7]		1.6 [4.0]		1.7 [4.2]		1.8 [4.5]		1.9 [4.7]		2.0 [5.0]	
		RPM	BHP	RPM	BHP	RPM	BHP	RPM	BHP	RPM	BHP	RPM	BHP	RPM	BHP	RPM	BHP	RPM	BHP	RPM	BHP	RPM	BHP	RPM	BHP	RPM	BHP	RPM	BHP	RPM	BHP	RPM	BHP	RPM	BHP	RPM	BHP	RPM	BHP	RPM	BHP
2400 [1133]	-	551	782	585	814	619	848	652	885	684	926	717	969	748	1016	780	1065	810	1116	841	1174	870	1233	900	1284	929	1359	957	1427	985	1496	1010	1572	1039	1649	1065	1729	1091	1813		
2500 [1180]	-	562	816	596	848	629	884	661	923	693	964	725	1009	756	1057	787	1108	817	1162	846	1219	876	1279	904	1343	833	1409	860	1478	887	1550	1014	1628	1040	1704	1066	1789	1092	1870		
2600 [1227]	-	574	851	607	885	639	922	671	962	702	1006	73	1052	764	1101	794	1153	823	1209	852	1267	881	1329	909	1393	837	1461	864	1531	990	1605	1016	1682	1042	1764	1067	1844	1092	1930		
2700 [1274]	553	857	585	889	618	925	650	983	681	1004	712	1049	742	1096	772	1147	801	1201	830	1256	858	1317	886	1380	914	1446	941	1515	967	1587	993	1662	1019	1740	1044	1821	1068	1905	1092	1993	
2800 [1321]	565	896	597	930	629	966	660	1006	691	1049	721	1095	751	1144	780	1196	808	1251	837	1309	864	1370	892	1434	919	1501	945	1572	971	1645	996	1721	1021	1801	1045	1883	1069	1969	1093	2057	
2900 [1368]	577	937	609	972	640	1010	670	1051	701	1096	730	1143	759	1193	788	1246	816	1303	843	1362	871	1425	897	1490	923	1559	949	1630	974	1705	999	1783	1023	1864	1047	1948	1070	2035	1093	2124	
3000 [1416]	590	981	621	1017	651	1057	681	1098	710	1145	739	1193	768	1244	796	1300	823	1357	850	1418	877	1482	903	1549	928	1619	951	1692	978	1768	1002	1847	1026	1929	1049	2014	1072	2103	1094	2194	
3100 [1463]	602	1027	633	1065	662	1105	692	1149	720	1196	749	1246	777	1299	804	1355	831	1414	857	1476	883	1541	908	1610	933	1681	956	1755	982	1833	1005	1913	1028	1997	1051	2083	1073	2173	1094	2266	
3200 [1510]	615	1075	645	1114	674	1157	702	1202	731	1250	756	1301	785	1356	812	1413	838	1473	864	1537	889	1603	914	1673	938	1746	962	1821	986	1900	1008	1982	1031	2067	1053	2155	1074	2246	1095	2340	
3300 [1557]	628	1126	657	1166	685	1210	713	1256	741	1306	768	1359	794	1414	820	1473	846	1535	871	1600	896	1668	920	1739	944	1813	967	1890	988	1970	1012	2053	1033	2139	1055	2229	1075	2321	1096	2416	
3400 [1604]	640	1179	669	1221	697	1266	724	1314	751	1365	777	1419	803	1476	829	1536	854	1599	878	1665	902	1734	926	1807	949	1882	971	1960	993	2042	1015	2126	1036	2214	1057	2305	1077	2398	1097	2495	
3500 [1652]	653	1235	681	1278	708	1324	735	1373	761	1425	787	1481	812	1539	837	1601	861	1666	885	1733	909	1803	932	1877	954	1954	976	2034	997	2116	1018	2202	1039	2291	1059	2383	1078	2478	1097	2576	
3600 [1699]	666	1292	693	1337	720	1384	746	1435	771	1489	797	1545	821	1605	845	1668	869	1734	892	1803	915	1875	938	1950	959	2028	981	2109	1001	2193	1022	2280	1042	2371	1061	2464	1080	2560	1098	2660	

NOTE: A/F-Drive left of the first bold line, B/G-Drive between the bold lines, C/H-Drive right of both bold lines.

Drive Package	A/F					B/G					C/H																																				
Motor H.P. [W]	2 [1491.4]					3 [2237.1]					3 [2237.1]																																				
Blower Sheave	AK84H					AK84H					AK84H																																				
Motor Sheave	1VL407/8					1VP507/8					1VP507/8																																				
Belt	A49					A50					A51																																				
Turns Open	0	1	2	3	4	5	0	1	2	3	4	5	0	1	2	3	4	5	0	1	2	3	4	5	0	1	2	3	4	5	0	1	2	3	4	5	0	1	2	3	4	5					
RPM	767	721	678	635	590	548	992	949	908	866	823	782	1108	1067	1029	987	946	905	864	823	782	741	700	660	620	580	540	500	460	420	380	340	300	260	220	180	140	100	60	20	0	0	0	0	0	0	0

Notes:
 1. Factory sheave settings are shown in bold type.
 2. Do not set sheave below minimum or maximum turns open shown.
 3. Re-adjustment of sheave required to achieve rated airflow at AHR minimum External Static Pressure.
 4. Add component resistance (below) to duct resistance to determine total External Static Pressure.

Airflow	AIRFLOW CORRECTION FACTORS *				Wet Coil	Vertical Economizer RA Damper Open	COMPONENT AIRFLOW RESISTANCE				Pressure Drop MERV 13
	Total MBH	Sensible MBH	Power kW	Resistance - Inches of Water [kPa]			Concentric Diffuser RXRN-AEF2000 & Concentric Adapter RXMC-DD01 (Flush)	Concentric Diffuser RXRN-AED2000 & Concentric Adapter RXMC-DD01 (Drop)	Pressure Drop MERV 8	Pressure Drop MERV 13	
2400 [1133]	0.96	0.89	0.98	0.04 [0.1]	0.01 [0.0]	0.66 [1.6]	0.53 [1.3]	0.093 [0.2]	0.047 [0.1]		
2500 [1180]	0.96	0.90	0.99	0.05 [0.1]	0.02 [0.0]	0.71 [1.8]	0.57 [1.4]	0.098 [0.2]	0.055 [0.1]		
2600 [1227]	0.97	0.92	0.99	0.05 [0.1]	0.02 [0.1]	0.75 [1.9]	0.60 [1.5]	0.103 [0.2]	0.062 [0.1]		
2700 [1274]	0.97	0.93	0.99	0.05 [0.1]	0.03 [0.1]	0.80 [2.0]	0.65 [1.6]	0.108 [0.3]	0.070 [0.2]		
2800 [1321]	0.98	0.95	0.99	0.06 [0.1]	0.04 [0.1]	0.85 [2.1]	0.69 [1.7]	0.113 [0.3]	0.078 [0.2]		
2900 [1368]	0.98	0.96	1.00	0.06 [0.2]	0.04 [0.1]	0.91 [2.3]	0.74 [1.8]	0.117 [0.3]	0.085 [0.2]		
3000 [1416]	0.99	0.97	1.00	0.07 [0.2]	0.05 [0.1]	0.96 [2.4]	0.79 [2.0]	0.122 [0.3]	0.093 [0.2]		
3100 [1463]	1.00	0.99	1.00	0.07 [0.2]	0.06 [0.2]	1.02 [2.5]	0.86 [2.1]	0.127 [0.3]	0.100 [0.2]		
3200 [1510]	1.00	1.00	1.01	0.07 [0.2]	0.07 [0.2]	1.08 [2.7]	0.92 [2.3]	0.132 [0.3]	0.108 [0.3]		
3300 [1557]	1.01	1.02	1.01	0.08 [0.2]	0.08 [0.2]	1.15 [2.9]	0.99 [2.5]	0.137 [0.3]	0.115 [0.3]		
3400 [1604]	1.01	1.03	1.01	0.08 [0.2]	0.09 [0.2]	1.21 [3.0]	1.05 [2.6]	0.142 [0.3]	0.123 [0.3]		
3500 [1652]	1.02	1.05	1.01	0.09 [0.2]	0.10 [0.2]	1.29 [3.2]	1.09 [2.7]	0.147 [0.4]	0.131 [0.3]		
3600 [1699]	1.02	1.06	1.02	0.09 [0.2]	0.11 [0.3]	1.36 [3.4]	1.13 [2.8]	0.152 [0.4]	0.138 [0.3]		

*Multiply correction factor times gross performance data resulting sensible capacity cannot exceed total capacity.

P. APPENDICES

Appendix C – Air Flow Performance Data (Cont.)

Model RGED21090 - Sideflow Voltage 208/230, 460, 575 — 3 phase 60 Hz																																								
Air Flow CFM [L/s]	External Static Pressure - Inches of Water [Pa]																																							
	0.1 [0.03]	0.2 [0.05]	0.3 [0.07]	0.4 [1.0]	0.5 [1.2]	0.6 [1.5]	0.7 [1.7]	0.8 [2.0]	0.9 [2.2]	1.0 [2.5]	1.1 [2.7]	1.2 [3.0]	1.3 [3.2]	1.4 [3.5]	1.5 [3.7]	1.6 [4.0]	1.7 [4.2]	1.8 [4.5]	1.9 [4.7]	2.0 [5.0]																				
	RPM	BHP	RPM	BHP	RPM	BHP	RPM	BHP	RPM	BHP	RPM	BHP	RPM	BHP	RPM	BHP	RPM	BHP	RPM	BHP	RPM																			
2400 [1133]	—	—	558	822	594	853	629	887	653	925	697	965	730	1009	763	1056	794	1106	826	1159	856	1216	886	1275	915	1338	943	1404	971	1474	988	1546	1025	1622	1051	1700	1076	1782		
2500 [1180]	—	—	—	—	568	848	604	881	638	917	672	956	706	988	738	1044	769	1092	801	1144	831	1199	861	1258	890	1319	919	1384	947	1452	974	1523	1001	1597	1027	1674	1052	1755	1077	1838
2600 [1227]	—	—	543	846	579	877	613	912	647	950	681	991	713	1053	745	1082	777	1132	807	1186	837	1243	867	1303	895	1366	923	1433	951	1502	978	1575	1004	1651	1029	1720	1054	1812	1078	1888
2700 [1274]	—	—	554	877	589	910	623	946	657	986	689	1029	722	1074	753	1124	784	1176	814	1231	844	1290	872	1352	901	1417	928	1485	955	1556	981	1631	1007	1708	1032	1789	1056	1873	1079	1981
2800 [1321]	—	—	566	911	600	946	634	984	666	1026	699	1070	730	1118	761	1169	792	1223	821	1280	850	1340	878	1404	906	1470	933	1540	959	1613	985	1690	1010	1769	1034	1852	1058	1938	1081	2027
2900 [1368]	543	916	577	949	611	986	644	1026	676	1069	708	1115	739	1164	770	1217	799	1273	828	1332	857	1394	885	1459	912	1528	938	1599	964	1674	989	1752	1014	1833	1037	1918	1061	2005	1083	2096
3000 [1416]	555	955	589	990	622	1029	655	1070	687	1115	718	1163	748	1214	778	1269	807	1326	836	1387	864	1451	891	1519	918	1588	944	1662	969	1738	994	1818	1017	1901	1041	1987	1063	2077	1085	2169
3100 [1463]	568	998	601	1035	634	1075	666	1118	697	1165	728	1215	758	1268	787	1324	816	1383	844	1445	871	1511	898	1580	924	1652	949	1727	974	1806	998	1887	1022	1972	1044	2060	1066	2151	1088	2245
3200 [1510]	581	1044	614	1083	646	1125	677	1170	708	1218	738	1270	768	1324	796	1382	824	1443	852	1507	879	1575	905	1646	931	1719	955	1796	980	1876	1003	1960	1026	2046	1048	2136	1070	2229	1091	2325
3300 [1557]	594	1093	626	1134	658	1178	689	1225	719	1275	749	1328	778	1384	806	1444	833	1507	860	1573	887	1642	912	1714	937	1790	962	1869	985	1951	1008	2036	1031	2124	1052	2216	1073	2310	1094	2408
3400 [1604]	607	1146	639	1189	670	1234	701	1283	730	1333	759	1389	788	1448	815	1509	843	1574	869	1642	895	1713	920	1787	944	1864	969	1945	991	2023	991	2109	1014	2195	1036	2285	1057	2386	1077	2494
3500 [1652]	621	1203	652	1247	683	1294	713	1344	742	1398	770	1455	798	1515	825	1578	852	1644	878	1714	903	1786	928	1862	952	1941	975	2023	997	2109	1019	2198	1041	2290	1061	2385	1081	2483	1101	2584
3600 [1699]	635	1262	666	1308	696	1357	725	1409	754	1465	782	1523	809	1585	836	1650	862	1718	897	1789	912	1864	936	1941	959	2022	982	2106	1004	2194	1025	2284	1046	2378	1066	2474	1086	2574	1104	2677

NOTE: Air-Drive left of the first bold line, B/G-Drive between the bold lines, C/H-Drive right of both bold lines.

Drive Package	A/F		B/G		C/H													
Motor H.P. [W]	2 [1491.4]		3 [2237.1]		3 [2237.1]													
Blower/Sheave	AK84H		AK84H		AK84H													
Motor Sheave	1VL4077/8		1VP5077/8		1VP5677/8													
Belt	A49		A50		A51													
Turns Open	0	1	2	3	4	5	0	1	2	3	4	5	0	1	2	3	4	5
RPM	765	720	676	633	589	544	989	949	908	865	823	780	1108	1067	1029	987	946	905

- Notes:
1. Factory sheave settings are shown in bold type.
 2. Do not set sheave below minimum or maximum turns open shown.
 3. Re-adjustment of sheave required to achieve rated airflow at AHR1 minimum External Static Pressure.
 4. Add component resistance (below) to duct resistance to determine total External Static Pressure.

Airflow	AIRFLOW CORRECTION FACTORS *				COMPONENT AIRFLOW RESISTANCE					Pressure Drop MERV 13
	Wet Coil		Horizontal Economizer RA Damper Open		Concentric Diffuser RXRN-AEF2000 & Concentric Adapter RXMC-DD01 (Flush)		Concentric Diffuser RXRN-AED2000 & Concentric Adapter RXMC-DD01 (Drop)			
	Total MBH	Sensible MBH	Power kW	Resistance — Inches of Water [kPa]	Resistance — Inches of Water [kPa]	Resistance — Inches of Water [kPa]	Resistance — Inches of Water [kPa]	Resistance — Inches of Water [kPa]	Resistance — Inches of Water [kPa]	
2400 [1133]	0.96	0.89	0.98	0.04 [0.1]	0.21 [0.05]	0.66 [1.6]	0.53 [1.3]	0.093 [0.02]	0.047 [0.01]	
2500 [1180]	0.96	0.90	0.99	0.05 [0.1]	0.25 [0.06]	0.71 [1.8]	0.57 [1.4]	0.098 [0.02]	0.055 [0.01]	
2600 [1227]	0.97	0.92	0.99	0.05 [0.1]	0.28 [0.07]	0.75 [1.9]	0.60 [1.5]	0.103 [0.02]	0.062 [0.01]	
2700 [1274]	0.97	0.93	0.99	0.05 [0.1]	0.32 [0.08]	0.80 [2.0]	0.65 [1.6]	0.108 [0.03]	0.070 [0.02]	
2800 [1321]	0.98	0.95	0.99	0.06 [0.1]	0.36 [0.09]	0.85 [2.1]	0.69 [1.7]	0.113 [0.03]	0.078 [0.02]	
2900 [1368]	0.98	0.96	1.00	0.06 [0.2]	0.39 [1.0]	0.91 [2.3]	0.71 [1.8]	0.117 [0.03]	0.085 [0.02]	
3000 [1416]	0.99	0.97	1.00	0.07 [0.2]	0.43 [1.1]	0.96 [2.4]	0.79 [2.0]	0.122 [0.03]	0.093 [0.02]	
3100 [1463]	1.00	0.99	1.00	0.07 [0.2]	0.47 [1.2]	1.02 [2.5]	0.86 [2.1]	0.127 [0.03]	0.100 [0.02]	
3200 [1510]	1.00	1.00	1.01	0.07 [0.2]	0.51 [1.3]	1.08 [2.7]	0.92 [2.3]	0.132 [0.03]	0.108 [0.03]	
3300 [1557]	1.01	1.02	1.01	0.08 [0.2]	0.54 [1.4]	1.15 [2.9]	0.99 [2.5]	0.137 [0.03]	0.115 [0.03]	
3400 [1604]	1.01	1.03	1.01	0.08 [0.2]	0.58 [1.4]	1.21 [3.0]	1.05 [2.6]	0.142 [0.03]	0.123 [0.03]	
3500 [1652]	1.02	1.05	1.02	0.09 [0.2]	0.62 [1.5]	1.29 [3.2]	1.09 [2.7]	0.147 [0.04]	0.131 [0.03]	
3600 [1699]	1.02	1.06	1.02	0.09 [0.2]	0.66 [1.6]	1.36 [3.4]	1.13 [2.8]	0.152 [0.04]	0.138 [0.03]	

*Multiply correction factor times gross performance data resulting sensible capacity cannot exceed total capacity.

P. APPENDICES

Appendix C - Air Flow Performance Data (Cont.)

Model RGEDT102 - Sideflow	Voltage 208/230, 460, 575 — 3 phase 60 Hz																			
	External Static Pressure - Inches of Water (Pa)																			
	0.1 [0.2]	0.2 [0.5]	0.3 [0.7]	0.4 [1.0]	0.5 [1.2]	0.6 [1.5]	0.7 [1.7]	0.8 [2.0]	0.9 [2.2]	1.0 [2.5]	1.1 [2.7]	1.2 [3.0]	1.3 [3.2]	1.4 [3.5]	1.5 [3.7]	1.6 [4.0]	1.7 [4.2]	1.8 [4.6]	1.9 [4.7]	2.0 [5.0]
CFM [L/s]																				
RPM	2700 [1274]	2900 [1321]	2900 [1368]	3000 [1416]	3100 [1463]	3200 [1510]	3300 [1557]	3400 [1604]	3500 [1652]	3600 [1699]	3700 [1746]	3800 [1793]	3900 [1840]	4000 [1888]	4100 [1935]					
BHP	—	—	—	—	—	—	—	—	—	—	—	—	—	—	—	—	—	—	—	—
RPM	—	—	—	—	—	—	—	—	—	—	—	—	—	—	—	—	—	—	—	—
BHP	577	596	613	633	656	687	720	757	800	854	918	992	1084	1196	1338	1510	1716	2000	2380	2960
RPM	828	887	954	1033	1131	1252	1401	1577	1784	2029	2324	2683	3118	3653	4304	5097	6053	7216	8731	10660
BHP	0.55	0.60	0.64	0.69	0.74	0.79	0.84	0.89	0.94	0.99	1.04	1.09	1.14	1.19	1.24	1.29	1.34	1.39	1.44	1.49
RPM	1066	1131	1208	1297	1400	1518	1657	1828	2034	2280	2574	2923	3344	3848	4446	5153	5999	7031	8406	10215
BHP	0.69	0.74	0.79	0.84	0.89	0.94	0.99	1.04	1.09	1.14	1.19	1.24	1.29	1.34	1.39	1.44	1.49	1.54	1.59	1.64
RPM	1348	1425	1514	1616	1734	1879	2057	2274	2538	2858	3243	3705	4256	4915	5703	6656	7813	9256	11071	13315
BHP	0.83	0.88	0.93	0.98	1.03	1.08	1.13	1.18	1.23	1.28	1.33	1.38	1.43	1.48	1.53	1.58	1.63	1.68	1.73	1.78
RPM	1656	1743	1844	1961	2095	2259	2459	2703	3003	3374	3834	4395	5081	5919	6942	8192	9711	11574	13871	16719
BHP	1.00	1.05	1.10	1.15	1.20	1.25	1.30	1.35	1.40	1.45	1.50	1.55	1.60	1.65	1.70	1.75	1.80	1.85	1.90	1.95

NOTE: AF- Drive left of the first bold line, B/G-Drive between the bold lines, CH-Drive right of both bold lines.

Drive Package	AF	B/G				CH												
Motor H.P. [W]	2 [1491.4]	3 [2237.1]				3 [2237.1]												
Blower Sheave	AK79H	AK79H				AK79H												
Motor Sheave	1VL407/8	1VP507/8				1VP567/8												
Belt	A49	A50				A51												
Turns Open	0	1	2	3	4	5	0	1	2	3	4	5						
RPM	802	754	707	662	616	555	1048	1005	960	916	870	827	1170	1126	1085	1044	1000	956

Notes:

1. Factory shave settings are shown in bold type.
2. Do not set shaves below minimum or maximum turns open shown.
3. Re-adjustment of shaves required to achieve rated airflow at AHR minimum External Static Pressure.
4. Add component resistance below to duct resistance to determine total External Static Pressure.

Airflow	AIRFLOW CORRECTION FACTORS *		Wet Coil	Horizontal Economizer RA Damper Open	Concentric Diffuser RXRN-AEF2000 & Concentric Adapter RXMC-DD01 (Flush)	Concentric Diffuser RXRN-AED2000 & Concentric Adapter RXMC-DD01 (Drop)	COMPONENT AIRFLOW RESISTANCE		
	Total MBH	Sensible MBH					Power kW	Resistance - Inches of Water	Resistance - Inches of Water
CFM [L/s]	0.97	0.93	0.99	0.32 [0.08]	0.80 [2.0]	0.65 [1.6]	0.80 [2.0]	0.65 [1.6]	0.80 [2.0]
2700 [1274]	0.98	0.94	0.99	0.36 [0.09]	0.85 [2.1]	0.69 [1.7]	0.85 [2.1]	0.69 [1.7]	0.85 [2.1]
2800 [1321]	0.98	0.96	0.99	0.39 [1.0]	0.91 [2.3]	0.74 [1.8]	0.91 [2.3]	0.74 [1.8]	0.91 [2.3]
2900 [1368]	0.99	0.97	1.00	0.43 [1.1]	0.96 [2.4]	0.79 [2.0]	0.96 [2.4]	0.79 [2.0]	0.96 [2.4]
3000 [1416]	0.99	0.98	1.00	0.47 [1.2]	1.02 [2.5]	0.86 [2.1]	1.02 [2.5]	0.86 [2.1]	1.02 [2.5]
3100 [1463]	1.00	1.00	1.00	0.51 [1.3]	1.08 [2.7]	0.92 [2.3]	1.08 [2.7]	0.92 [2.3]	1.08 [2.7]
3200 [1510]	1.01	1.01	1.00	0.54 [1.4]	1.15 [2.9]	0.99 [2.5]	1.15 [2.9]	0.99 [2.5]	1.15 [2.9]
3300 [1557]	1.01	1.01	1.00	0.58 [1.4]	1.21 [3.0]	1.05 [2.6]	1.21 [3.0]	1.05 [2.6]	1.21 [3.0]
3400 [1604]	1.02	1.04	1.01	0.62 [1.5]	1.29 [3.2]	1.09 [2.7]	1.29 [3.2]	1.09 [2.7]	1.29 [3.2]
3500 [1652]	1.02	1.06	1.01	0.66 [1.6]	1.36 [3.4]	1.13 [2.8]	1.36 [3.4]	1.13 [2.8]	1.36 [3.4]
3600 [1699]	1.03	1.07	1.02	0.70 [1.7]	1.43 [3.6]	1.18 [2.9]	1.43 [3.6]	1.18 [2.9]	1.43 [3.6]
3700 [1746]	1.03	1.09	1.02	0.74 [1.8]	1.50 [3.7]	1.23 [3.1]	1.50 [3.7]	1.23 [3.1]	1.50 [3.7]
3800 [1793]	1.04	1.10	1.02	0.77 [1.9]	1.59 [4.0]	1.31 [3.3]	1.59 [4.0]	1.31 [3.3]	1.59 [4.0]
3900 [1840]	1.05	1.12	1.02	0.81 [2.0]	1.68 [4.2]	1.38 [3.4]	1.68 [4.2]	1.38 [3.4]	1.68 [4.2]
4000 [1888]	1.05	1.13	1.03	0.85 [2.1]	1.74 [4.3]	1.44 [3.6]	1.74 [4.3]	1.44 [3.6]	1.74 [4.3]
4100 [1935]	0.070 [0.2]	0.078 [0.2]	0.085 [0.2]	0.108 [0.3]	0.113 [0.3]	0.117 [0.3]	0.113 [0.3]	0.117 [0.3]	0.113 [0.3]
Pressure Drop	MERV 8	MERV 8	MERV 8	MERV 8	MERV 8	MERV 8	MERV 8	MERV 8	MERV 8
Pressure Drop	MERV 13	MERV 13	MERV 13	MERV 13	MERV 13	MERV 13	MERV 13	MERV 13	MERV 13

*Multiply correction factor times gross performance data resulting sensible capacity cannot exceed total capacity.

P. APPENDICES

Appendix C – Air Flow Performance Data (Cont.)

Model RGEDZT120 - Sideflow Voltage 208/230, 460, 575 – 3 phase 60 Hz		External Static Pressure - Inches of Water [kPa]																																						
		0.1 [0.02]	0.2 [0.05]	0.3 [0.07]	0.4 [0.10]	0.5 [0.12]	0.6 [0.15]	0.7 [0.17]	0.8 [0.20]	0.9 [0.22]	1.0 [0.25]	1.1 [0.27]	1.2 [0.30]	1.3 [0.32]	1.4 [0.35]	1.5 [0.37]	1.6 [0.40]	1.7 [0.42]	1.8 [0.45]	1.9 [0.47]	2.0 [0.50]																			
Air Flow CFM [L/s]	RPM	BHP	RPM	BHP	RPM	BHP	RPM	BHP	RPM	BHP	RPM	BHP	RPM	BHP	RPM	BHP	RPM	BHP	RPM	BHP	RPM	BHP	RPM	BHP																
	3200 [151.0]	675	1018	607	1057	637	1089	667	1143	697	1191	727	1240	756	1283	785	1348	814	1408	842	1466	870	1529	897	1595	924	1664	951	1735	979	1809	1004	1885	1030	1965	1055	2047	1080	2131	1105
3300 [155.7]	688	1060	618	1101	649	1145	679	1192	708	1242	737	1294	766	1349	795	1405	823	1466	850	1528	878	1595	905	1663	932	1734	958	1808	984	1884	1010	1963	1035	2045	1060	2128	1085	2216	1109	2306
3400 [160.4]	699	1106	630	1150	660	1196	690	1245	719	1297	746	1352	776	1409	804	1469	832	1531	859	1597	886	1664	913	1735	939	1808	965	1884	990	1963	1016	2044	1040	2128	1065	2215	1089	2305	1113	2397
3500 [165.2]	713	1156	643	1202	672	1251	701	1302	730	1357	758	1413	786	1473	814	1535	841	1600	868	1668	894	1738	920	1811	946	1887	972	1965	997	2046	1022	2130	1046	2217	1070	2306	1094	2397	1117	2492
3600 [169.9]	726	1210	655	1256	684	1310	713	1364	741	1420	769	1479	796	1541	823	1606	850	1673	877	1745	903	1816	929	1892	954	1970	979	2050	1004	2134	1028	2220	1052	2309	1076	2400	1099	2484	1122	2581
3700 [174.6]	739	1268	668	1319	696	1373	724	1428	752	1488	779	1550	806	1614	833	1681	860	1751	886	1823	911	1888	937	1976	962	2054	986	2140	1011	2225	1035	2314	1058	2405	1081	2496	1104	2596	1127	2695
4000 [188.8]	798	1467	706	1525	733	1586	760	1650	787	1716	813	1785	839	1856	864	1930	888	2007	914	2087	938	2169	962	2254	986	2341	1009	2430	1032	2520	1055	2610	1077	2719	1099	2820	1121	2923	1142	3030
4200 [198.3]	831	1576	740	1648	767	1713	794	1781	820	1850	846	1921	871	1994	897	2070	921	2147	944	2226	967	2307	989	2392	1011	2479	1032	2567	1053	2653	1076	2741	1098	2830	1120	2923	1141	3024	1161	3129
4400 [207.6]	854	1704	778	1799	805	1868	832	1940	858	2014	881	2091	904	2171	927	2250	949	2331	969	2414	991	2499	1014	2587	1036	2677	1058	2768	1080	2860	1102	2954	1124	3050	1146	3147	1167	3245	1188	3342
4600 [217.1]	877	1977	797	2048	824	2124	851	2204	877	2284	902	2368	927	2454	951	2543	975	2634	998	2728	1021	2824	1045	2921	1068	3020	1091	3120	1114	3220	1138	3321	1162	3424	1186	3528	1210	3634	1233	3741
4700 [221.8]	890	2077	810	2151	836	2228	862	2309	887	2391	912	2476	937	2564	961	2654	985	2746	1008	2841	1030	2938	1059	3037	1080	3138	1100	3240	1121	3344	1142	3450	1162	3557	1183	3667	1203	3786	1223	3911
4800 [226.5]	902	2180	816	2257	842	2337	868	2419	894	2504	919	2592	943	2683	967	2776	991	2872	1017	3072	1037	3176	1058	3282	1077	3389	1097	3504	1116	3619	1135	3766	1153	3955	1171	4111	1188	4274	1205	4436

NOTE: A/F-Drive left of the first bold line, B/G-Drive between the bold lines, C/H-Drive right of both bold lines.

Drive Package	A/F	B/G	C/H
Motor H.P. [W]	2 [1491.4]	3 [2237.1]	3 [2237.1]
Blower Sheave	AK79H	AK79H	AK79H
Motor Sheave	1V4077/8	1VP5077/8	1VP5677/8
Belt	A49	A50	A51
Turns Open	0	1 2 3 4 5	1 2 3 4 5
RPM	798	753 707 663 616 556 1041 998	824 1155 1119 1078 1037 994 951

- 1. Factory shown settings are shown in bold type. Do not set blower to minimum or maximum RPM.
- 2. Re-adjustment of blower required to achieve rated airflow at AHR minimum External Static Pressure.
- 3. Re-adjustment of blower required to achieve rated airflow at AHR maximum External Static Pressure.
- 4. Add component resistance (below) to duct resistance to determine total External Static Pressure.

Airflow	AIRFLOW CORRECTION FACTORS *			COMPONENT AIRFLOW RESISTANCE					
	Total MBH	Sensible MBH	Power kW	Horizontal Economizer RA Damper Open	Concentric Diffuser RXRN-AEF2000 & Concentric Adapter RXMC-DD01 (Flush)	Concentric Diffuser RXRN-AED2000 & Concentric Adapter RXMC-DD01 (Drop)	Pressure Drop MERV 8	Pressure Drop MERV 13	
CFM [L/s]				Resistance - Inches of Water [kPa]					
3200 [151.0]	0.97	0.93	0.99	0.51 [13]	0.74 [18]	0.56 [14]	0.132 [03]	0.108 [03]	
3300 [155.7]	0.98	0.94	0.99	0.54 [14]	0.79 [20]	0.59 [15]	0.137 [03]	0.115 [03]	
3400 [160.4]	0.98	0.96	0.99	0.58 [14]	0.84 [21]	0.62 [15]	0.142 [03]	0.123 [03]	
3500 [165.2]	0.99	0.97	1.00	0.62 [15]	0.90 [22]	0.66 [16]	0.147 [04]	0.131 [03]	
3600 [169.9]	0.99	0.98	1.00	0.66 [16]	0.95 [24]	0.69 [17]	0.152 [04]	0.138 [03]	
3700 [174.6]	1.00	0.99	1.00	0.70 [17]	1.00 [25]	0.73 [18]	0.157 [04]	0.146 [04]	
3800 [179.3]	1.00	1.01	1.00	0.74 [18]	1.04 [26]	0.76 [19]	0.162 [04]	0.153 [04]	
3900 [184.0]	1.01	1.02	1.00	0.77 [19]	1.09 [27]	0.80 [20]	0.167 [04]	0.161 [04]	
4000 [188.8]	1.01	1.03	1.01	0.81 [20]	1.13 [28]	0.84 [21]	0.171 [04]	0.169 [04]	
4100 [193.5]	1.02	1.04	1.01	0.85 [21]	1.19 [30]	0.88 [22]	0.176 [04]	0.176 [04]	
4200 [198.2]	1.02	1.06	1.01	0.89 [22]	1.24 [31]	0.92 [23]	0.181 [04]	0.184 [04]	
4300 [202.9]	1.03	1.07	1.01	0.93 [23]	1.31 [33]	0.97 [24]	0.186 [05]	0.191 [05]	
4400 [207.6]	1.03	1.08	1.01	0.97 [24]	1.37 [34]	1.02 [25]	0.191 [05]	0.199 [05]	
4500 [212.3]	1.04	1.09	1.02	1.01 [25]	1.43 [35]	1.07 [27]	0.196 [05]	0.207 [05]	
4600 [217.1]	1.04	1.11	1.02	1.06 [26]	1.48 [37]	1.11 [28]	0.201 [05]	0.214 [05]	
4700 [221.8]	1.05	1.12	1.02	1.10 [27]	1.54 [38]	1.15 [29]	0.206 [05]	0.222 [05]	
4800 [226.5]	1.05	1.13	1.02	1.14 [28]	1.59 [40]	1.19 [30]	0.211 [05]	0.229 [06]	

*Multiply correction factor times gross performance data resulting sensible capacity cannot exceed total capacity.

Appendix C – Air Flow Performance Data (Cont.)

Table with columns for Air Flow CFM [L/s], External Static Pressure - Inches of Water [hPa], and various RPM/BHP values for different motor configurations.

Table with columns for Motor H.P. [kW], Blower Sheave, Motor Sheave, Belt, Turns Open, and RPM values for configurations F, G, and H.

NOTE: F-Drive left of the bold line, G-Drive right of the bold line.

- Notes: 1. Factory shave settings are shown in bold type. 2. Do not set shaves below minimum or maximum turns open shown. 3. Re-adjustment of shaves required to achieve rated airflow at AFR minimum External Static Pressure. 4. Add component resistance (below) to duct resistance to determine total External Static Pressure.

Table with columns for Airflow CFM [L/s], Airflow Correction Factors (Sensible MBH, Total MBH, Power kW), Wet Coil, Vertical Economizer RA Damper Open, Concentric Diffuser/Adapter RMXC-AD03, and Concentric Diffuser/Adapter RMXC-AED03B & RMXC-AD03C (Drop).

*Multiply correction factor times gross performance data resulting sensible capacity cannot exceed total capacity.

Appendix D - Cooling Data for RGEDZT 7.5 Ton

COOLING PERFORMANCE DATA - RGEDZT090																				
Entering Indoor Air @ 80°F [26.7°C] dbE 1																				
WDE	71°F [21.7°C]				67°F [19.4°C]				63°F [17.2°C]				61°F [16.1°C]				59°F [15°C]			
	CFM [L/s]	3600 [1699]	2775 [1310]	2400 [1133]	3600 [1699]	2775 [1310]	2400 [1133]	3600 [1699]	2775 [1310]	2400 [1133]	3600 [1699]	2775 [1310]	2400 [1133]	3600 [1699]	2775 [1310]	2400 [1133]	3600 [1699]	2775 [1310]	2400 [1133]	
DR		0.17	0.13	0.11	0.17	0.13	0.11	0.17	0.13	0.11	0.17	0.13	0.11	0.17	0.13	0.11	0.17	0.13	0.11	
75°F [23.9°C]	Total BTUH [kW]	119.6 [35.0]	113.5 [33.2]	110.7 [32.4]	112.7 [33.0]	107.3 [31.3]	104.3 [30.6]	107.8 [31.6]	102.3 [30.0]	99.8 [29.2]	106.4 [31.2]	100.9 [29.6]	98.4 [28.8]	105.8 [31.0]	100.4 [29.4]	97.9 [28.7]	105.8 [31.0]	100.4 [29.4]	97.9 [28.7]	
	Sens BTUH [kW]	70.3 [20.6]	61.8 [18.1]	57.9 [17.0]	83.3 [24.4]	73.2 [21.4]	68.5 [20.1]	96 [28.1]	84.3 [24.7]	79 [23.2]	102.2 [29.9]	89.7 [26.3]	84.1 [24.6]	105.8 [31.0]	94.9 [27.8]	88.9 [26.1]	105.8 [31.0]	94.9 [27.8]	88.9 [26.1]	
	Power	5.2	5.1	5	5.1	4.9	4.9	5.1	4.9	4.9	5	4.9	4.9	5	4.9	4.8	5	4.9	4.8	
80°F [26.7°C]	Total BTUH [kW]	116.1 [34.0]	110.1 [32.3]	107.4 [31.5]	109.2 [32.0]	103.6 [30.4]	101.1 [29.6]	104.3 [30.6]	99 [29.0]	96.5 [28.3]	102.9 [30.1]	97.6 [28.6]	95.2 [27.9]	102.3 [30.0]	97.1 [28.4]	94.7 [27.7]	102.3 [30.0]	97.1 [28.4]	94.7 [27.7]	
	Sens BTUH [kW]	68.4 [20.1]	60.1 [17.6]	56.3 [16.5]	81.4 [23.9]	71.5 [20.9]	67 [19.6]	94.1 [27.6]	82.7 [24.2]	77.4 [22.7]	100.3 [29.4]	88.1 [25.8]	82.5 [24.2]	102.3 [30.0]	93.2 [27.3]	87.4 [25.6]	102.3 [30.0]	93.2 [27.3]	87.4 [25.6]	
	Power	5.6	5.4	5.4	5.5	5.4	5.3	5.5	5.3	5.3	5.4	5.3	5.2	5.4	5.3	5.2	5.4	5.3	5.2	
85°F [29.4°C]	Total BTUH [kW]	112.6 [33.0]	106.8 [31.3]	104.2 [30.5]	105.7 [31.0]	100.3 [29.4]	97.8 [28.7]	100.8 [29.5]	95.6 [28.0]	93.3 [27.3]	99.3 [29.1]	94.2 [27.6]	91.9 [26.9]	98.8 [28.9]	93.7 [27.5]	91.4 [26.8]	98.8 [28.9]	93.7 [27.5]	91.4 [26.8]	
	Sens BTUH [kW]	66.6 [19.5]	58.5 [17.1]	54.8 [16.0]	79.5 [23.3]	69.8 [20.5]	65.4 [19.2]	92.3 [27.0]	81 [23.7]	75.9 [22.2]	98.4 [28.8]	86.4 [25.3]	81 [23.7]	98.8 [28.9]	91.6 [26.8]	85.8 [25.1]	98.8 [28.9]	91.6 [26.8]	85.8 [25.1]	
	Power	6	5.9	5.8	6	5.8	5.8	5.9	5.8	5.7	5.9	5.7	5.7	5.9	5.7	5.6	5.9	5.7	5.6	
90°F [32.2°C]	Total BTUH [kW]	109 [31.9]	103.4 [30.3]	100.9 [29.6]	102.1 [29.9]	96.9 [28.4]	94.5 [27.7]	97.2 [28.5]	92.2 [27.0]	90 [26.4]	95.8 [28.1]	90.9 [26.6]	88.6 [26.0]	95.2 [27.9]	90.3 [26.5]	88.1 [25.8]	95.2 [27.9]	90.3 [26.5]	88.1 [25.8]	
	Sens BTUH [kW]	64.7 [19.0]	56.8 [16.7]	53.2 [15.6]	77.7 [22.8]	68.2 [20.0]	63.9 [18.7]	90.4 [26.5]	79.4 [23.1]	74.4 [21.8]	95.8 [28.1]	84.8 [24.8]	79.4 [23.3]	95.2 [27.9]	90 [26.4]	84.3 [24.7]	95.2 [27.9]	90 [26.4]	84.3 [24.7]	
	Power	6.6	6.4	6.3	6.5	6.4	6.3	6.5	6.3	6.2	6.4	6.3	6.2	6.4	6.2	6.2	6.4	6.2	6.2	
95°F [35°C]	Total BTUH [kW]	105.4 [30.9]	100 [29.3]	97.5 [28.6]	98.5 [28.9]	93.5 [27.4]	91.2 [26.7]	93.6 [27.4]	88.8 [26.0]	86.6 [25.4]	92.2 [27.0]	87.4 [25.6]	85.3 [25.0]	91.6 [26.8]	86.9 [25.5]	84.8 [24.8]	91.6 [26.8]	86.9 [25.5]	84.8 [24.8]	
	Sens BTUH [kW]	62.9 [18.4]	55.2 [16.2]	51.7 [15.2]	75.8 [22.2]	66.6 [19.5]	62.4 [18.3]	88.6 [26.0]	77.8 [22.6]	72.9 [21.4]	92.2 [27.0]	83.2 [24.4]	77.9 [22.8]	91.6 [26.8]	86.9 [25.5]	82.8 [24.3]	91.6 [26.8]	86.9 [25.5]	82.8 [24.3]	
	Power	7.2	7	6.9	7.2	7	6.9	7.1	6.9	6.8	7.1	6.9	6.8	7	6.8	6.8	7	6.9	6.8	
100°F [37.8°C]	Total BTUH [kW]	101.7 [29.8]	96.5 [28.3]	94.2 [27.6]	94.9 [27.8]	90 [26.4]	87.8 [25.7]	90 [26.4]	85.4 [25.0]	83.3 [24.4]	88.5 [25.9]	84 [24.6]	81.9 [24.0]	88 [25.8]	83.4 [24.5]	81.4 [23.9]	88 [25.8]	83.4 [24.5]	81.4 [23.9]	
	Sens BTUH [kW]	61 [17.9]	53.6 [15.7]	50.2 [14.7]	74 [21.7]	65 [19.0]	60.9 [17.8]	86.7 [25.4]	76.2 [22.3]	71.4 [20.9]	88.5 [25.9]	81.6 [23.9]	76.4 [22.4]	88 [25.8]	83.4 [24.5]	81.3 [23.8]	88 [25.8]	83.4 [24.5]	81.3 [23.8]	
	Power	7.9	7.7	7.6	7.9	7.7	7.6	7.8	7.6	7.5	7.8	7.6	7.5	7.7	7.5	7.4	7.7	7.5	7.4	
105°F [40.6°C]	Total BTUH [kW]	98.1 [28.7]	93 [27.3]	90.7 [26.6]	91.2 [26.7]	86.5 [25.4]	84.4 [24.7]	86.3 [25.3]	81.9 [24.0]	79.8 [23.4]	84.8 [24.9]	80.5 [23.6]	78.5 [23.0]	84.3 [24.7]	79.9 [23.4]	78 [22.9]	84.3 [24.7]	79.9 [23.4]	78 [22.9]	
	Sens BTUH [kW]	59.3 [17.4]	52 [15.2]	48.8 [14.3]	72.2 [21.2]	63.4 [18.6]	59.4 [17.4]	84.9 [24.9]	74.6 [21.9]	69.9 [20.5]	84.8 [24.9]	80 [23.4]	74.9 [22.0]	84.3 [24.7]	79.9 [23.4]	78 [22.9]	84.3 [24.7]	79.9 [23.4]	78 [22.9]	
	Power	8.7	8.5	8.4	8.6	8.4	8.3	8.6	8.4	8.3	8.5	8.3	8.2	8.5	8.3	8.2	8.5	8.3	8.2	
110°F [43.3°C]	Total BTUH [kW]	94.3 [27.6]	89.5 [26.2]	87.3 [25.6]	87.5 [25.6]	83 [24.3]	81 [23.7]	82.6 [24.2]	78.3 [23.0]	76.4 [22.4]	81.1 [23.8]	76.9 [22.5]	75.1 [22.0]	80.5 [23.6]	76.4 [22.4]	74.5 [21.8]	80.5 [23.6]	76.4 [22.4]	74.5 [21.8]	
	Sens BTUH [kW]	57.5 [16.8]	50.5 [14.8]	47.3 [13.9]	70.4 [20.6]	61.9 [18.1]	57.9 [17.0]	82.6 [24.2]	73 [21.4]	68.4 [20.1]	81.1 [23.8]	76.9 [22.5]	73.5 [21.5]	80.5 [23.6]	76.4 [22.4]	74.5 [21.8]	80.5 [23.6]	76.4 [22.4]	74.5 [21.8]	
	Power	9.5	9.3	9.2	9.5	9.2	9.1	9.4	9.2	9.1	9.4	9.2	9	9.4	9.1	9	9.4	9.1	9	
115°F [46.1°C]	Total BTUH [kW]	90.6 [26.5]	85.9 [25.2]	83.8 [24.6]	83.7 [24.5]	79.4 [23.3]	77.5 [22.7]	78.8 [23.1]	74.8 [21.9]	72.9 [21.4]	77.3 [22.7]	73.4 [21.5]	71.6 [21.0]	76.8 [22.5]	72.8 [21.3]	71.1 [20.8]	76.8 [22.5]	72.8 [21.3]	71.1 [20.8]	
	Sens BTUH [kW]	55.7 [16.3]	48.9 [14.3]	45.8 [13.4]	68.7 [20.1]	60.3 [17.7]	56.5 [16.6]	78.8 [23.1]	71.5 [20.9]	67 [19.6]	77.3 [22.7]	73.4 [21.5]	71.6 [21.0]	76.8 [22.5]	72.8 [21.3]	71.1 [20.8]	76.8 [22.5]	72.8 [21.3]	71.1 [20.8]	
	Power	10.5	10.2	10.1	10.4	10.2	10	10.4	10.1	10	10.3	10.1	9.9	10.3	10	9.9	10.3	10	9.9	
120°F [48.9°C]	Total BTUH [kW]	86.8 [25.4]	82.3 [24.1]	80.3 [23.5]	79.9 [23.4]	75.8 [22.2]	74 [21.7]	75 [22.0]	71.1 [20.8]	69.4 [20.3]	73.5 [21.6]	69.8 [20.4]	68.1 [19.9]	73 [21.4]	69.2 [20.3]	67.5 [19.8]	73 [21.4]	69.2 [20.3]	67.5 [19.8]	
	Sens BTUH [kW]	54 [15.8]	47.4 [13.9]	44.4 [13.0]	66.9 [19.6]	58.8 [17.2]	55.1 [16.1]	75 [22.0]	70 [20.5]	65.5 [19.2]	73.5 [21.6]	69.8 [20.4]	68.1 [19.9]	73 [21.4]	69.2 [20.3]	67.5 [19.8]	73 [21.4]	69.2 [20.3]	67.5 [19.8]	
	Power	11.5	11.2	11.1	11.4	11.1	11	11.4	11.1	11	11.3	11.1	10.9	11.3	11	10.9	11.3	11	10.9	
125°F [51.7°C]	Total BTUH [kW]	82.9 [24.3]	78.7 [23.1]	76.8 [22.5]	76.1 [22.3]	72.2 [21.2]	70.4 [20.6]	71.2 [20.9]	67.5 [19.8]	65.8 [19.3]	69.7 [20.4]	66.1 [19.4]	64.5 [18.9]	69.1 [20.3]	65.6 [19.2]	64 [18.8]	69.1 [20.3]	65.6 [19.2]	64 [18.8]	
	Sens BTUH [kW]	52.3 [15.3]	45.9 [13.4]	43 [12.6]	65.2 [19.1]	57.3 [16.8]	53.7 [15.7]	71.2 [20.9]	67.5 [19.8]	64.1 [18.8]	69.7 [20.4]	66.1 [19.4]	64.5 [18.9]	69.1 [20.3]	65.6 [19.2]	64 [18.8]	69.1 [20.3]	65.6 [19.2]	64 [18.8]	
	Power	12.6	12.3	12.1	12.5	12.2	12.1	12.5	12.1	12	12.4	12.1	12	12.4	12.1	11.9	12.4	12.1	11.9	

Outdoor Dry Bulb Temperature

P. APPENDICES

Appendix D - Cooling Data for RGEDZT 8.5 Ton

wBE		COOLING PERFORMANCE DATA - RGEDZT102																
		Entering Indoor Air @ 80°F [26.7°C] dbE 1																
		71°F [21.7°C]			67°F [19.4°C]			63°F [17.2°C]			61°F [16.1°C]			59°F [15°C]				
CFM [L/s]		4100 [1935]	3200 [1510]	2700 [1274]	4100 [1935]	3200 [1510]	2700 [1274]	4100 [1935]	3200 [1510]	2700 [1274]	4100 [1935]	3200 [1510]	2700 [1274]	4100 [1935]	3200 [1510]	2700 [1274]		
DR	Total BTUH [kW]	129.9 [38.1]	123.6 [36.2]	120.1 [35.2]	113.4 [33.2]	116.7 [34.2]	118.3 [34.7]	117.5 [34.4]	111.8 [32.8]	109.3 [32.0]	108.6 [31.8]	118.3 [34.7]	117.5 [34.4]	118.3 [34.7]	112.2 [32.9]	109.3 [32.0]	109.3 [32.0]	
	Sens BTUH [kW] Power	81.3 [23.8] 6.2	71.9 [21.1] 6.1	66.6 [19.5] 6	79 [23.1] 5.9	85.2 [25.0] 6	96.4 [28.2] 6.1	110.1 [32.3] 6.1	116.1 [34.0] 6	102.6 [30.1] 5.9	90.2 [26.4] 5.8	108.6 [31.8] 5.8	116.1 [34.0] 6	117.5 [34.4] 6	118.3 [34.6] 6	118.3 [34.6] 6	118.3 [34.6] 6	118.3 [34.6] 6
80°F [26.7°C]	Total BTUH [kW]	125.7 [36.8]	119.5 [35.0]	116.1 [34.0]	109.5 [32.1]	112.7 [33.0]	114.3 [34.7]	113.3 [33.2]	107.8 [31.6]	105.4 [30.9]	104.7 [30.7]	113.3 [33.2]	113.3 [33.2]	113.3 [33.2]	113.7 [33.3]	108.2 [31.7]	105.1 [30.8]	105.1 [30.8]
	Sens BTUH [kW] Power	79.2 [23.2] 6.6	70 [20.5] 6.4	64.9 [19.0] 6.3	77.2 [22.6] 6.2	83.3 [24.4] 6.3	94.3 [27.6] 6.5	108.3 [31.6] 6.4	113.3 [33.2] 6.4	95.4 [28.0] 6.3	88.5 [25.9] 6.2	104.7 [30.7] 6.2	113.3 [33.2] 6.4	113.3 [33.2] 6.4	113.7 [33.3] 6.4	105.5 [30.9] 6.2	105.5 [30.9] 6.2	105.5 [30.9] 6.2
85°F [29.4°C]	Total BTUH [kW]	121.4 [35.6]	115.5 [33.8]	112.2 [32.9]	105.6 [30.9]	108.7 [31.8]	114.2 [33.5]	109.8 [32.2]	104.4 [30.6]	101.5 [29.7]	100.9 [29.5]	109.8 [32.2]	109.8 [32.2]	109.8 [32.2]	109.5 [32.1]	104.2 [30.5]	101.2 [29.7]	101.2 [29.7]
	Sens BTUH [kW] Power	77 [22.6] 6.9	68.1 [20.0] 6.8	63.1 [18.5] 6.7	75.5 [22.1] 6.6	81.4 [23.9] 6.7	92.1 [27.0] 6.9	105.8 [31.0] 6.8	109.8 [32.2] 6.8	93.5 [27.4] 6.6	86.7 [25.4] 6.6	100.9 [29.5] 6.6	109.8 [32.2] 6.8	109.8 [32.2] 6.8	109.5 [32.1] 6.7	103.6 [30.4] 6.6	103.6 [30.4] 6.6	103.6 [30.4] 6.6
90°F [32.2°C]	Total BTUH [kW]	117.1 [34.3]	111.4 [32.7]	108.3 [31.7]	101.6 [29.8]	104.6 [30.7]	110 [32.2]	105.5 [30.9]	100.4 [29.4]	97.5 [28.6]	97.5 [28.6]	104.8 [30.7]	104.8 [30.7]	104.8 [30.7]	105.2 [30.8]	100.1 [29.3]	97.3 [28.5]	97.3 [28.5]
	Sens BTUH [kW] Power	74.9 [21.9] 7.4	66.2 [19.4] 7.2	61.4 [18.0] 7.1	73.7 [21.6] 7	79.5 [23.3] 7.1	89.9 [26.4] 7.3	103.5 [30.4] 7.2	105.5 [30.9] 7.2	91.5 [26.8] 7.1	84.9 [24.9] 7	104.8 [30.7] 7	104.8 [30.7] 7.2	104.8 [30.7] 7.2	105.2 [30.8] 7.2	100.1 [29.3] 7	94.3 [27.6] 6.9	94.3 [27.6] 6.9
95°F [35°C]	Total BTUH [kW]	112.9 [33.1]	107.4 [31.5]	104.3 [30.6]	97.7 [28.6]	100.5 [29.5]	105.7 [31.0]	101.2 [29.7]	96.3 [28.2]	93.6 [27.4]	93.6 [27.4]	100.5 [29.4]	100.5 [29.4]	100.5 [29.4]	100.9 [29.6]	96 [28.1]	93.3 [27.3]	93.3 [27.3]
	Sens BTUH [kW] Power	72.6 [21.3] 7.8	64.2 [18.8] 7.6	59.5 [17.4] 7.5	71.9 [21.1] 7.4	77.5 [22.7] 7.6	87.7 [25.7] 7.7	101.2 [29.7] 7.7	101.2 [29.7] 7.7	89.9 [26.3] 7.5	83.1 [24.4] 7.4	100.5 [29.4] 7.6	100.5 [29.4] 7.6	100.5 [29.4] 7.6	100.9 [29.6] 7.6	96 [28.1] 7.4	92.4 [27.1] 7.3	92.4 [27.1] 7.3
100°F [37.8°C]	Total BTUH [kW]	106.6 [31.8]	103.3 [30.3]	100.4 [29.4]	93.7 [27.5]	96.5 [28.3]	101.4 [29.7]	97 [28.4]	92.2 [27.0]	89.6 [26.3]	89.6 [26.3]	96.2 [28.2]	96.2 [28.2]	96.2 [28.2]	96.7 [28.3]	92 [26.9]	89.3 [26.2]	89.3 [26.2]
	Sens BTUH [kW] Power	70.4 [20.6] 8.3	62.2 [18.2] 8.1	57.7 [16.9] 8	70 [20.5] 7.9	75.5 [22.1] 8	85.5 [25.0] 8.2	97 [28.4] 8.2	97 [28.4] 8.2	87.7 [25.7] 8	81.3 [23.8] 7.8	96.2 [28.2] 7.8	96.2 [28.2] 7.8	96.2 [28.2] 7.8	96.7 [28.3] 8.1	92 [26.9] 7.9	89.3 [26.2] 7.8	89.3 [26.2] 7.8
105°F [40.6°C]	Total BTUH [kW]	104.3 [30.6]	99.2 [29.1]	96.4 [28.2]	89.7 [26.3]	92.4 [27.1]	97.1 [28.4]	92.7 [27.2]	88.1 [25.8]	85.6 [25.1]	85.6 [25.1]	92.7 [27.2]	92.7 [27.2]	92.7 [27.2]	92.4 [27.1]	87.9 [25.7]	85.4 [25.0]	85.4 [25.0]
	Sens BTUH [kW] Power	68.1 [20.0] 8.8	60.2 [17.6] 8.6	55.8 [16.4] 8.5	68.1 [20.0] 8.4	73.5 [21.5] 8.5	83.2 [24.4] 8.7	92.7 [27.2] 8.7	92.7 [27.2] 8.7	85.6 [25.8] 8.4	79.4 [23.3] 8.3	92.7 [27.2] 8.3	92.7 [27.2] 8.3	92.7 [27.2] 8.3	92.4 [27.1] 8.6	87.9 [25.7] 8.4	85.4 [25.0] 8.3	85.4 [25.0] 8.3
110°F [43.3°C]	Total BTUH [kW]	99.9 [29.3]	95.1 [27.9]	92.4 [27.1]	85.7 [25.1]	88.2 [25.9]	92.8 [27.2]	88.3 [25.9]	84 [24.6]	81.6 [23.9]	81.6 [23.9]	87.6 [25.7]	87.6 [25.7]	87.6 [25.7]	88 [25.8]	83.7 [24.5]	81.4 [23.8]	81.4 [23.8]
	Sens BTUH [kW] Power	65.8 [19.3] 9.3	58.1 [17.0] 9.1	53.9 [15.8] 9	66.2 [19.4] 8.9	71.4 [20.9] 9	80.8 [23.7] 9.3	88.3 [25.9] 9.2	88.3 [25.9] 9.2	83.6 [24.5] 9	77.5 [22.7] 8.9	87.6 [25.7] 9.2	87.6 [25.7] 9.2	87.6 [25.7] 9.2	88 [25.8] 9.1	83.7 [24.5] 8.9	81.4 [23.8] 8.8	81.4 [23.8] 8.8
115°F [46.1°C]	Total BTUH [kW]	95.6 [28.0]	91 [26.7]	88.4 [25.9]	81.7 [24.0]	84.1 [24.7]	88.4 [25.9]	84 [24.6]	79.9 [23.4]	77.6 [22.8]	77.6 [22.8]	83.2 [24.4]	83.2 [24.4]	83.2 [24.4]	83.7 [24.5]	79.6 [23.3]	77.4 [22.7]	77.4 [22.7]
	Sens BTUH [kW] Power	61 [17.4] 9.9	56 [16.4] 9.7	51.9 [15.2] 9.5	64.3 [18.8] 9.5	69.3 [20.3] 9.6	78.4 [23.0] 9.8	84 [24.6] 9.8	84 [24.6] 9.8	79.9 [23.4] 9.5	75.5 [22.5] 9.4	83.2 [24.4] 9.7	83.2 [24.4] 9.7	83.2 [24.4] 9.7	83.7 [24.5] 9.7	79.6 [23.3] 9.5	77.4 [22.7] 9.4	77.4 [22.7] 9.4
120°F [48.9°C]	Total BTUH [kW]	91.3 [26.7]	86.8 [25.4]	84.4 [24.7]	77.7 [22.8]	80 [23.4]	84.1 [24.6]	79.6 [23.3]	75.8 [22.2]	73.6 [21.6]	73.6 [21.6]	78.9 [23.1]	78.9 [23.1]	78.9 [23.1]	79.3 [23.3]	75.5 [22.1]	73.3 [21.5]	73.3 [21.5]
	Sens BTUH [kW] Power	61 [17.4] 10.5	53.9 [15.8] 10.3	50 [14.6] 10.1	62.3 [18.3] 10.1	67.2 [19.7] 10.2	76 [22.3] 10.5	84 [24.6] 10.4	84 [24.6] 10.4	75.8 [22.2] 10.1	73.6 [21.6] 10	78.9 [23.1] 10.4	78.9 [23.1] 10.4	78.9 [23.1] 10.4	79.3 [23.3] 10.3	75.5 [22.1] 10.1	73.3 [21.5] 9.9	73.3 [21.5] 9.9
125°F [51.7°C]	Total BTUH [kW]	86.9 [25.5]	82.7 [24.2]	80.3 [23.5]	73.7 [21.6]	75.8 [22.2]	79.7 [23.4]	75.3 [22.1]	71.6 [21.0]	69.6 [20.4]	69.6 [20.4]	74.5 [21.8]	74.5 [21.8]	74.5 [21.8]	75 [22.0]	71.3 [20.9]	69.3 [20.3]	69.3 [20.3]
	Sens BTUH [kW] Power	58.5 [17.1] 11.2	51.7 [15.2] 10.9	48 [14.1] 10.7	60.3 [17.7] 10.8	65 [19.1] 10.8	73.6 [21.6] 11.1	79.7 [23.4] 11.1	79.7 [23.4] 11.1	71.6 [21.0] 10.8	69.6 [20.4] 10.6	74.5 [21.8] 11	74.5 [21.8] 11	74.5 [21.8] 11	75 [22.0] 11	71.3 [20.9] 10.7	69.3 [20.3] 10.5	69.3 [20.3] 10.5

Outdoor Dry Bulb Temperature

Appendix D - Cooling Data for RGEDZT 10 Ton

COOLING PERFORMANCE DATA - RGEDZT120															
Entering Indoor Air @ 80°F [26.7°C] dbE															
w/E	71°F [21.7°C]			67°F [19.4°C]			63°F [17.2°C]			61°F [16.1°C]			59°F [15°C]		
	CFM [L/s]	4800 [2265]	3200 [1510]	4800 [2265]	3200 [1510]	4800 [2265]	3200 [1510]	4800 [2265]	3200 [1510]	4800 [2265]	3200 [1510]	4800 [2265]	3200 [1510]	4800 [2265]	
DR	0.09	0.03	0	0.09	0.03	0.09	0.03	0.09	0.03	0.09	0.03	0.09	0.03	0.03	
75°F [23.9°C]	Total BTUH [kW]	155.3 [45.5]	147.8 [43.3]	143.8 [42.2]	136.9 [40.1]	142.8 [41.8]	135.8 [39.8]	132.2 [38.7]	141.5 [41.5]	134.7 [39.5]	131.1 [38.4]	141.4 [41.4]	134.5 [39.4]	130.9 [38.4]	
	Sens BTUH [kW] Power	97.3 [28.5] 7.5	86.1 [25.2] 7.3	80.2 [23.5] 7.2	95.4 [28.0] 7.1	132.9 [38.9] 7.3	117.5 [34.4] 7.1	109.5 [32.1] 7	140.6 [41.2] 7.2	124.3 [36.4] 7.1	115.8 [33.9] 7	141.4 [41.4] 7.2	130.4 [38.2] 7	121.4 [35.6] 6.9	
80°F [26.7°C]	Total BTUH [kW]	150.6 [44.1]	143.4 [42.0]	139.5 [40.9]	136.2 [39.9]	138.1 [40.5]	131.4 [38.5]	127.9 [37.5]	136.9 [40.1]	130.2 [38.2]	126.8 [37.1]	136.7 [40.1]	130.1 [38.1]	126.6 [37.1]	
	Sens BTUH [kW] Power	94.9 [27.8] 7.9	84 [24.6] 7.7	78.2 [22.9] 7.6	103.3 [29.4] 7.5	130.5 [38.2] 7.7	115.4 [33.8] 7.5	107.5 [31.5] 7.4	136.9 [40.1] 7.7	122.2 [35.8] 7.5	113.8 [33.4] 7.4	136.7 [40.1] 7.6	128.3 [37.6] 7.4	119.5 [35.0] 7.3	
85°F [29.4°C]	Total BTUH [kW]	146 [42.8]	138.9 [40.7]	135.2 [39.6]	128.3 [37.6]	133.5 [39.1]	127 [37.2]	123.6 [36.2]	132.2 [38.7]	125.8 [36.9]	122.5 [35.9]	132.1 [38.7]	125.7 [36.8]	122.3 [35.9]	
	Sens BTUH [kW] Power	92.5 [27.1] 8.3	81.8 [24.0] 8.1	76.2 [22.3] 8	91.5 [26.8] 8	128.1 [37.5] 8.2	113.3 [33.2] 8	105.5 [30.9] 7.9	132.2 [38.7] 8.1	120.1 [35.2] 7.9	111.9 [32.8] 7.8	132.1 [38.7] 8.1	125.7 [36.8] 7.9	117.5 [34.4] 7.8	
90°F [32.2°C]	Total BTUH [kW]	141.4 [41.4]	134.5 [39.4]	131 [38.4]	124 [36.3]	128.8 [37.8]	122.6 [35.9]	119.3 [35.0]	127.6 [37.4]	121.4 [35.6]	118.2 [34.6]	127.5 [37.4]	121.3 [35.5]	118.1 [34.6]	
	Sens BTUH [kW] Power	90.1 [26.4] 8.8	79.7 [23.3] 8.6	74.2 [21.7] 8.5	89.5 [26.2] 8.4	125.6 [36.8] 8.6	111.1 [32.6] 8.4	103.5 [30.3] 8.3	127.6 [37.4] 8.6	117.9 [34.5] 8.4	109.8 [32.2] 8.3	127.5 [37.4] 8.5	121.3 [35.5] 8.3	115.5 [33.8] 8.2	
95°F [35°C]	Total BTUH [kW]	136.8 [40.1]	130.2 [38.1]	126.7 [37.1]	123 [36.1]	124.2 [36.4]	118.2 [34.6]	115.1 [33.7]	123 [36.0]	117 [34.3]	113.9 [33.4]	122.9 [36.0]	116.9 [34.3]	113.8 [33.3]	
	Sens BTUH [kW] Power	87.6 [25.7] 9.3	77.5 [22.7] 9.1	72.2 [21.1] 9	87.4 [25.6] 8.9	123.1 [36.1] 9.1	108.9 [31.9] 8.9	101.5 [29.7] 8.8	123 [36.0] 9.1	115.7 [33.9] 8.9	107.8 [31.6] 8.8	122.9 [36.0] 9.1	116.9 [34.3] 8.8	113.4 [33.2] 8.7	
100°F [37.8°C]	Total BTUH [kW]	132.2 [38.7]	125.8 [36.9]	122.4 [35.9]	118.7 [34.8]	119.6 [35.1]	113.8 [33.4]	110.8 [32.5]	118.4 [34.7]	112.7 [33.0]	109.7 [32.1]	118.3 [34.7]	112.5 [33.0]	109.5 [32.1]	
	Sens BTUH [kW] Power	85.1 [24.9] 9.9	75.2 [22.0] 9.6	70.1 [20.5] 9.5	85.3 [25.0] 9.4	119.6 [35.1] 9.7	106.7 [31.3] 9.5	99.4 [29.1] 9.3	118.4 [34.7] 9.6	112.7 [33.0] 9.4	105.7 [31.0] 9.3	118.3 [34.7] 9.6	112.5 [33.0] 9.4	109.5 [32.1] 9.2	
105°F [40.6°C]	Total BTUH [kW]	127.6 [37.4]	121.4 [35.6]	118.2 [34.6]	111.2 [32.6]	115.1 [33.7]	108.5 [32.1]	106.6 [31.2]	113.8 [33.4]	108.3 [31.7]	105.4 [30.9]	113.7 [33.3]	108.2 [31.7]	105.3 [30.9]	
	Sens BTUH [kW] Power	82.5 [24.2] 10.5	73 [21.4] 10.2	68 [19.9] 10.1	83.2 [24.4] 10	115.1 [33.7] 10.3	104.4 [30.6] 10	97.3 [28.5] 9.9	113.8 [33.4] 10.2	108.3 [31.7] 10	103.6 [30.4] 9.8	113.7 [33.3] 10.2	108.2 [31.7] 9.9	105.3 [30.9] 9.8	
110°F [43.3°C]	Total BTUH [kW]	123 [36.1]	117.1 [34.3]	114 [33.4]	109.9 [32.2]	110.5 [32.4]	105.1 [30.8]	102.3 [30.0]	109.3 [32.0]	104 [30.5]	101.2 [29.7]	109.1 [32.0]	103.8 [30.4]	101.1 [29.6]	
	Sens BTUH [kW] Power	79.9 [23.4] 11.1	70.6 [20.7] 10.8	65.8 [19.3] 10.7	81.1 [23.8] 10.6	110.5 [32.4] 10.9	102.1 [29.9] 10.6	95.1 [27.9] 10.5	109.3 [32.0] 10.8	104 [30.5] 10.6	101.2 [29.7] 10.4	109.1 [32.0] 10.8	103.8 [30.4] 10.5	101.1 [29.6] 10.4	
115°F [46.1°C]	Total BTUH [kW]	118.5 [34.7]	112.7 [33.0]	108.7 [32.2]	102.8 [30.1]	105.9 [31.0]	100.8 [29.5]	98.1 [28.8]	104.7 [30.7]	99.6 [29.2]	97 [28.4]	104.6 [30.6]	98.5 [29.2]	96.8 [28.4]	
	Sens BTUH [kW] Power	77.2 [22.6] 11.7	68.3 [20.0] 11.4	63.6 [18.6] 11.3	78.9 [23.1] 11.2	105.9 [31.0] 11.5	99.8 [29.2] 11.2	92.9 [27.2] 11.1	104.7 [30.7] 11.5	99.6 [29.2] 11.2	97 [28.4] 11.1	104.6 [30.6] 11.4	98.5 [29.2] 11.2	96.8 [28.4] 11	
120°F [46.9°C]	Total BTUH [kW]	113.9 [33.4]	108.4 [31.8]	105.5 [30.9]	98.6 [28.9]	101.4 [29.7]	96.5 [28.3]	90.7 [26.6]	100.2 [29.4]	95.3 [27.9]	92.8 [27.2]	100 [29.3]	95.2 [27.9]	92.6 [27.1]	
	Sens BTUH [kW] Power	74.5 [21.8] 12.4	65.9 [19.3] 12.1	61.4 [18.0] 11.9	76.7 [22.5] 11.8	101.4 [29.7] 12.2	96.5 [28.3] 11.9	90.7 [26.6] 11.7	100.2 [29.4] 12.1	95.3 [27.9] 11.9	92.8 [27.2] 11.7	100 [29.3] 12.1	95.2 [27.9] 11.8	92.6 [27.1] 11.7	
125°F [51.7°C]	Total BTUH [kW]	109.4 [32.1]	104.1 [30.5]	101.3 [29.7]	94.4 [27.7]	96.9 [28.4]	92.2 [27.0]	88.7 [26.3]	95.6 [28.0]	91 [26.7]	88.6 [26.0]	95.5 [28.0]	90.9 [26.6]	88.5 [25.9]	
	Sens BTUH [kW] Power	71.8 [21.0] 13.1	63.5 [18.6] 12.8	59.2 [17.3] 12.6	79.9 [23.4] 12.7	96.9 [28.4] 12.9	92.2 [27.0] 12.6	88.5 [25.9] 12.4	95.6 [28.0] 12.9	91 [26.7] 12.5	88.6 [26.0] 12.4	95.5 [28.0] 12.8	90.9 [26.6] 12.5	88.5 [25.9] 12.3	

Outdoor Dry Bulb Temperature

P. APPENDICES

Appendix D – Cooling Data for RGEDZT 12.5 Ton

COOLING PERFORMANCE DATA - RGEDZT150												
Entering Indoor Air @ 80°F [26.7°C] dbE 1												
wB/E	71°F [21.7°C]			67°F [19.4°C]			63°F [17.2°C]			DR	CFM [L/s]	
	4500 [2124]	3750 [1770]	3000 [1416]	4500 [2124]	3750 [1770]	3000 [1416]	4500 [2124]	3750 [1770]	3000 [1416]			
75°F [23.9°C]	179.6 [62.6] 113.4 [33.2] 10.2	173.3 [50.8] 97.4 [28.5] 10	167.0 [48.9] 82.6 [24.2] 9.9	172.2 [50.5] 131.0 [38.4] 10.1	166.2 [48.7] 113.8 [33.3] 9.9	160.2 [46.9] 97.7 [28.6] 9.8	167.3 [49.0] 147.4 [43.2] 10.0	161.4 [47.3] 128.9 [37.8] 9.9	155.5 [45.6] 111.5 [32.7] 9.7	0.09	0.01	0.09
80°F [26.7°C]	155.5 [45.6] 111.5 [32.7] 10.6	168.9 [49.5] 95.3 [27.9] 10.4	162.8 [47.7] 80.9 [23.7] 10.3	162.8 [47.7] 80.9 [23.7] 10.5	162.8 [47.7] 80.9 [23.7] 10.4	155.9 [45.7] 95.9 [28.1] 10.2	162.7 [47.7] 144.9 [42.5] 10.4	157.0 [46.0] 126.8 [37.2] 10.3	151.3 [44.3] 109.8 [32.2] 10.1	0.09	0.01	0.09
85°F [29.4°C]	170.5 [60.0] 108.5 [31.8] 11.1	164.5 [48.2] 93.2 [27.3] 10.9	158.5 [46.4] 79.1 [23.2] 10.7	163.1 [47.8] 126.1 [36.9] 11.0	157.4 [46.1] 109.6 [32.1] 10.8	151.6 [44.4] 94.1 [27.6] 10.6	158.1 [46.3] 142.4 [41.7] 10.9	152.5 [44.7] 124.6 [36.5] 10.7	147.0 [43.1] 108.0 [31.6] 10.5	0.09	0.01	0.09
90°F [32.2°C]	165.9 [48.6] 105.8 [31.0] 11.6	160.1 [46.9] 91.0 [26.7] 11.4	154.3 [45.2] 77.2 [22.6] 11.2	158.5 [46.4] 123.4 [36.2] 11.5	153.0 [44.8] 107.4 [31.5] 11.3	147.4 [43.2] 92.3 [27.0] 11.1	153.5 [45.0] 139.7 [40.9] 11.4	148.1 [43.4] 122.4 [35.9] 11.2	142.8 [41.8] 106.2 [31.1] 11.1	0.09	0.01	0.09
95°F [35°C]	161.4 [47.3] 103.3 [30.3] 12.1	155.7 [45.6] 88.8 [26.0] 11.9	150.0 [43.9] 75.3 [22.1] 11.6	154.0 [45.1] 120.9 [35.4] 12.0	148.6 [43.5] 105.2 [30.8] 11.8	143.2 [42.0] 90.5 [26.5] 11.6	149.0 [43.7] 137.2 [40.2] 11.9	143.8 [42.1] 120.3 [35.2] 11.7	138.5 [40.6] 104.3 [30.6] 11.5	0.09	0.01	0.09
100°F [37.8°C]	156.8 [45.9] 100.6 [29.5] 12.6	151.3 [44.3] 86.5 [25.3] 12.4	145.8 [42.7] 73.4 [21.5] 12.2	149.4 [43.8] 118.2 [34.6] 12.5	144.2 [42.3] 102.9 [30.1] 12.3	139.0 [40.7] 88.6 [26.0] 12.1	144.5 [42.3] 134.6 [39.4] 12.4	139.4 [40.8] 118.0 [34.6] 12.2	134.3 [39.3] 102.4 [30.0] 12.0	0.09	0.01	0.09
105°F [40.6°C]	152.3 [44.6] 98.0 [28.7] 13.2	147.0 [43.1] 84.3 [24.7] 13.0	141.6 [41.5] 71.5 [20.9] 12.7	144.9 [42.5] 115.6 [33.9] 13.1	139.8 [41.0] 100.6 [29.5] 12.9	134.8 [39.5] 86.7 [25.4] 12.6	139.9 [41.0] 131.9 [38.6] 13.0	135.0 [39.6] 115.7 [33.9] 12.8	130.1 [38.1] 100.5 [29.4] 12.5	0.09	0.01	0.09
110°F [43.3°C]	147.8 [43.3] 95.3 [27.9] 13.8	142.6 [41.8] 82.0 [24.0] 13.5	137.4 [40.3] 69.6 [20.4] 13.3	140.4 [41.1] 112.9 [33.1] 13.7	135.5 [39.7] 98.4 [28.8] 13.5	130.6 [38.3] 84.8 [24.8] 13.2	135.4 [39.7] 129.2 [37.9] 13.6	130.7 [38.3] 113.5 [33.3] 13.4	125.9 [36.9] 98.6 [28.9] 13.1	0.09	0.01	0.09
115°F [46.1°C]	143.3 [42.0] 92.6 [27.1] 14.4	138.3 [40.5] 79.7 [23.4] 14.2	133.3 [39.1] 67.7 [19.8] 13.9	135.9 [39.8] 110.1 [32.3] 14.3	131.2 [38.4] 96.0 [28.1] 14.1	126.4 [37.0] 82.7 [24.2] 13.8	130.9 [38.4] 126.4 [37.0] 14.2	126.4 [37.0] 111.1 [32.6] 14.0	121.8 [35.7] 96.6 [28.3] 13.7	0.09	0.01	0.09

Outdoor Dry Bulb Temperature

Appendix D – Reheat Data for RGEDZT 7.5 Ton

GROSS SYSTEMS PERFORMANCE DATA (LOW REHEAT MODE) - RGEDZT090											
Entering Indoor Air @ 75°F [23.9°C] dbE 1											
wbE		65.3°F [18.5°C]			64°F [17.8°C]			62.5°F [16.9°C]			
CFM [L/s]		1800 [850]	1700 [802]	1200 [566]	1800 [850]	1700 [802]	1200 [566]	1800 [850]	1700 [802]	1200 [566]	
Outdoor Dry Bulb Temperature	60°F [15.6°C]	Total BTUH [kW] Sens BTUH [kW] Power	29.7 [8.7] 6.5 [1.9] 3.2	29.4 [8.6] 6.3 [1.8] 3.1	27.9 [8.2] 5.4 [1.6] 3.1	27.0 [7.9] 9.0 [2.6] 3.2	26.7 [7.8] 8.7 [2.6] 3.2	25.3 [7.4] 7.5 [2.2] 3.1	26.6 [7.8] 11.4 [3.4] 3.2	26.4 [7.7] 11.1 [3.3] 3.2	24.9 [7.3] 9.6 [2.8] 3.1
	65°F [18.3°C]	Total BTUH [kW] Sens BTUH [kW] Power	29.5 [8.6] 5.0 [1.5] 3.2	29.2 [8.5] 4.9 [1.4] 3.2	27.6 [8.1] 4.2 [1.2] 3.1	26.7 [7.8] 7.6 [2.2] 3.3	26.4 [7.7] 7.4 [2.2] 3.2	25.0 [7.3] 6.3 [1.9] 3.2	26.4 [7.7] 10.0 [2.9] 3.2	26.1 [7.6] 9.7 [2.9] 3.2	24.7 [7.2] 8.4 [2.5] 3.1
	70°F [21.1°C]	Total BTUH [kW] Sens BTUH [kW] Power	28.8 [8.4] 3.7 [1.1] 3.2	28.5 [8.4] 3.6 [1.0] 3.2	27.0 [7.9] 3.1 [0.9] 3.1	26.0 [7.6] 6.2 [1.8] 3.3	25.8 [7.6] 6.0 [1.8] 3.3	24.4 [7.1] 5.2 [1.5] 3.2	25.7 [7.5] 8.6 [2.5] 3.3	25.4 [7.5] 8.4 [2.5] 3.3	24.1 [7.1] 7.2 [2.1] 3.2
	75°F [23.9°C]	Total BTUH [kW] Sens BTUH [kW] Power	27.8 [8.1] 2.3 [0.7] 3.3	27.5 [8.1] 2.3 [0.7] 3.3	26.0 [7.6] 2.0 [0.6] 3.2	25.0 [7.3] 4.9 [1.4] 3.4	24.7 [7.2] 4.7 [1.4] 3.4	23.4 [6.9] 4.1 [1.2] 3.3	24.7 [7.2] 7.3 [2.1] 3.4	24.4 [7.2] 7.1 [2.1] 3.4	23.1 [6.8] 6.1 [1.8] 3.3
	80°F [26.7°C]	Total BTUH [kW] Sens BTUH [kW] Power	26.3 [7.7] 1.1 [0.3] 3.4	26.0 [7.6] 1.0 [0.3] 3.4	24.6 [7.2] 0.9 [0.3] 3.3	23.5 [6.9] 3.6 [1.0] 3.5	23.3 [6.8] 3.5 [1.0] 3.5	22.1 [6.5] 3.0 [0.9] 3.4	23.2 [6.8] 6.0 [1.8] 3.5	23.0 [6.7] 5.9 [1.7] 3.5	21.7 [6.4] 5.1 [1.5] 3.4
	85°F [29.4°C]	Total BTUH [kW] Sens BTUH [kW] Power	24.5 [7.2] -0.2 [-0.1] 3.6	24.2 [7.1] -0.2 [0.0] 3.6	22.9 [6.7] -0.1 [0.0] 3.5	21.7 [6.4] 2.4 [0.7] 3.7	21.5 [6.3] 2.3 [0.7] 3.6	20.3 [6.0] 2.0 [0.6] 3.6	21.4 [6.3] 4.8 [1.4] 3.6	21.1 [6.2] 4.7 [1.4] 3.6	20.0 [5.9] 4.0 [1.2] 3.5
	90°F [32.2°C]	Total BTUH [kW] Sens BTUH [kW] Power	22.2 [6.5] -1.3 [-0.4] 3.8	22.0 [6.4] -1.3 [-0.4] 3.7	20.8 [6.1] -1.1 [-0.3] 3.6	19.5 [5.7] 1.2 [0.3] 3.8	19.3 [5.6] 1.1 [0.3] 3.8	18.2 [5.3] 1.0 [0.3] 3.7	19.1 [5.6] 3.6 [1.1] 3.8	18.9 [5.5] 3.5 [1.0] 3.8	17.9 [5.3] 3.0 [0.9] 3.7

GROSS SYSTEMS PERFORMANCE DATA (HIGH REHEAT MODE) - RGEDZT090											
Entering Indoor Air @ 75°F [23.9°C] dbE 1											
wbE		65.3°F [18.5°C]			64°F [17.8°C]			62.5°F [16.9°C]			
CFM [L/s]		3600 [1699]	2900 [1369]	2400 [1133]	3600 [1699]	2900 [1369]	2400 [1133]	3600 [1699]	2900 [1369]	2400 [1133]	
Outdoor Dry Bulb Temperature	60°F [15.6°C]	Total BTUH [kW] Sens BTUH [kW] Power	41.7 [12.2] 8.9 [2.6] 5	39.9 [11.7] 8.0 [2.4] 4.9	38.7 [11.3] 7.4 [2.2] 4.8	40.1 [11.8] 12.8 [3.7] 4.9	38.4 [11.3] 11.5 [3.4] 4.8	37.2 [10.9] 10.5 [3.1] 4.8	40.0 [11.7] 18.5 [5.4] 4.9	38.3 [11.2] 16.7 [4.9] 4.8	37.1 [10.9] 15.3 [4.5] 4.8
	70°F [21.1°C]	Total BTUH [kW] Sens BTUH [kW] Power	39.8 [11.7] 5.9 [1.7] 5.1	38.1 [11.2] 5.3 [1.6] 5	36.9 [10.8] 4.9 [1.4] 4.9	38.3 [11.2] 9.8 [2.9] 5.1	36.7 [10.7] 8.8 [2.6] 5	35.5 [10.4] 8.1 [2.4] 4.9	38.1 [11.2] 15.5 [4.6] 5	36.5 [10.7] 14.0 [4.1] 4.9	35.4 [10.4] 12.8 [3.8] 4.9
	80°F [26.7°C]	Total BTUH [kW] Sens BTUH [kW] Power	36.7 [10.7] 2.1 [0.6] 5.4	35.1 [10.3] 1.9 [0.5] 5.3	34.0 [10.0] 1.7 [0.5] 5.2	35.1 [10.3] 5.9 [1.7] 5.3	33.7 [9.9] 5.3 [1.6] 5.2	32.6 [9.6] 4.9 [1.4] 5.1	35.0 [10.3] 11.7 [3.4] 5.3	33.5 [9.8] 10.5 [3.1] 5.2	32.5 [9.5] 9.6 [2.8] 5.1
	90°F [32.2°C]	Total BTUH [kW] Sens BTUH [kW] Power	32.3 [9.5] -2.7 [-0.8] 5.8	30.9 [9.1] -2.4 [-0.7] 5.6	30.0 [8.8] -2.2 [-0.6] 5.6	30.8 [9.0] 1.2 [0.3] 5.7	29.5 [8.6] 1.0 [0.3] 5.6	28.5 [8.4] 1.0 [0.3] 5.5	30.6 [9.0] 6.9 [2.0] 5.7	29.3 [8.6] 6.2 [1.8] 5.6	28.4 [8.3] 5.7 [1.7] 5.5
	100°F [37.8°C]	Total BTUH [kW] Sens BTUH [kW] Power	26.7 [7.8] -8.3 [-2.4] 6.3	25.5 [7.5] -7.4 [-2.2] 6.2	24.7 [7.3] -6.8 [-2.0] 6.1	25.1 [7.4] -4.4 [-1.3] 6.2	24.1 [7.1] -4.0 [-1.2] 6.1	23.3 [6.8] -3.7 [-1.1] 6	25.0 [7.3] 1.3 [0.4] 6.2	23.9 [7.0] 1.2 [0.4] 6.1	23.2 [6.8] 1.1 [0.3] 6.0
	110°F [43.3°C]	Total BTUH [kW] Sens BTUH [kW] Power	19.8 [5.8] -14.7 [-4.3] 6.9	19.0 [5.6] -13.2 [-3.9] 6.8	18.4 [5.4] -12.2 [-3.6] 6.7	18.3 [5.4] -10.9 [-3.2] 6.9	17.5 [5.1] -9.8 [-2.9] 6.7	17.0 [5.0] -9.0 [-2.6] 6.6	18.1 [5.3] -5.1 [-1.5] 6.9	17.4 [5.1] -4.6 [-1.4] 6.7	16.8 [4.9] -4.2 [-1.2] 6.6
	120°F [48.9°C]	Total BTUH [kW] Sens BTUH [kW] Power	11.7 [3.4] -22.1 [-6.5] 7.8	11.2 [3.3] -19.8 [-5.8] 7.6	10.8 [3.2] -18.2 [-5.3] 7.5	10.1 [3.0] -18.2 [-5.3] 7.7	9.7 [2.8] -16.4 [-4.8] 7.5	9.4 [2.8] -15.1 [-4.4] 7.4	10.0 [2.9] -12.5 [-3.7] 7.7	9.6 [2.8] -11.2 [-3.3] 7.5	9.3 [2.7] -10.3 [-3.0] 7.4

P. APPENDICES

Appendix D – Reheat Data for RGEDZT 8.5 Ton

GROSS SYSTEMS PERFORMANCE DATA (LOW REHEAT MODE) - RGEDZT102											
Entering Indoor Air @ 75°F [23.9°C] dbE 1											
wbE		65.3°F [18.5°C]			64°F [17.8°C]			62.5°F [16.9°C]			
CFM [L/s]		2100 [991]	1700 [802]	1400 [661]	2100 [991]	1700 [802]	1400 [661]	2100 [991]	1700 [802]	1400 [661]	
Outdoor Dry Bulb Temperature	60°F [15.6°C]	Total BTUH [kW] Sens BTUH [kW] Power	36.6 [10.7] 7.1 [2.1] 3.9	35.1 [10.3] 6.4 [1.9] 3.8	33.9 [10.3] 5.9 [1.7] 3.7	34.5 [10.1] 9.0 [2.6] 3.8	33.1 [9.7] 8.1 [2.4] 3.8	32.1 [9.4] 7.4 [2.2] 3.7	31.9 [9.3] 10.7 [3.1] 3.8	30.6 [9.0] 9.7 [2.8] 3.8	29.6 [8.7] 8.9 [2.6] 3.7
	65°F [18.3°C]	Total BTUH [kW] Sens BTUH [kW] Power	35.5 [10.4] 6.1 [1.8] 3.9	34.0 [10.0] 5.5 [1.6] 3.8	32.9 [9.6] 5.0 [1.5] 3.8	33.4 [9.8] 8.0 [2.3] 3.9	32.1 [9.4] 7.2 [2.1] 3.8	31.0 [9.1] 6.6 [1.9] 3.8	30.8 [9.0] 9.7 [2.8] 3.9	29.5 [8.6] 8.7 [2.6] 3.8	28.6 [8.4] 8.0 [2.4] 3.8
	70°F [21.1°C]	Total BTUH [kW] Sens BTUH [kW] Power	34.1 [10.0] 4.8 [1.4] 4.0	32.7 [9.6] 4.3 [1.3] 3.9	31.7 [9.3] 4.0 [1.2] 3.9	32.1 [9.4] 6.7 [2.0] 4.0	30.8 [9.0] 6.0 [1.8] 3.9	29.8 [8.7] 5.5 [1.6] 3.9	29.5 [8.6] 8.5 [2.5] 4.0	28.3 [8.3] 7.6 [2.2] 3.9	27.4 [8.0] 7.0 [2.0] 3.9
	75°F [23.9°C]	Total BTUH [kW] Sens BTUH [kW] Power	32.7 [9.6] 3.3 [1.0] 4.1	31.3 [9.2] 3.0 [0.9] 4.0	30.3 [8.9] 2.8 [0.8] 4.0	30.6 [9.0] 5.2 [1.5] 4.1	29.4 [8.6] 4.7 [1.4] 4.0	28.4 [8.3] 4.3 [1.3] 4.0	28.0 [8.2] 7.0 [2.0] 4.1	26.8 [7.9] 6.3 [1.8] 4.0	26.0 [7.6] 5.8 [1.7] 4.0
	80°F [26.7°C]	Total BTUH [kW] Sens BTUH [kW] Power	31.0 [9.1] 1.7 [0.5] 4.3	29.7 [8.7] 1.5 [0.4] 4.2	28.8 [8.4] 1.4 [0.4] 4.1	29.0 [8.5] 3.6 [1.0] 4.3	27.8 [8.1] 3.2 [0.9] 4.2	26.9 [7.9] 2.9 [0.9] 4.1	26.3 [7.7] 5.3 [1.6] 4.3	25.2 [7.4] 4.8 [1.4] 4.2	24.4 [7.2] 4.4 [1.3] 4.1
	85°F [29.4°C]	Total BTUH [kW] Sens BTUH [kW] Power	29.1 [8.5] -0.2 [-0.1] 4.4	27.9 [8.2] -0.2 [-0.1] 4.3	27.0 [7.9] -0.2 [-0.1] 4.3	27.1 [7.9] 1.7 [0.5] 4.4	26.0 [7.6] 1.5 [0.4] 4.3	25.1 [7.4] 1.4 [0.4] 4.3	24.4 [7.2] 3.4 [1.0] 4.4	23.4 [6.9] 3.1 [0.9] 4.3	22.7 [6.6] 2.8 [0.8] 4.3
	90°F [32.2°C]	Total BTUH [kW] Sens BTUH [kW] Power	27.1 [7.9] -2.3 [-0.7] 4.6	26.0 [7.6] -2.1 [-0.6] 4.5	25.2 [7.4] -1.9 [-0.6] 4.4	25.0 [7.3] -0.4 [-0.1] 4.6	24.0 [7.0] -0.4 [-0.1] 4.5	23.2 [6.8] -0.4 [-0.1] 4.4	22.4 [6.6] 1.3 [0.4] 4.6	21.5 [6.3] 1.2 [0.3] 4.5	20.8 [6.1] 1.1 [0.3] 4.4

GROSS SYSTEMS PERFORMANCE DATA (HIGH REHEAT MODE) - RGEDZT102											
Entering Indoor Air @ 75°F [23.9°C] dbE 1											
wbE		65.3°F [18.5°C]			64°F [17.8°C]			62.5°F [16.9°C]			
CFM [L/s]		4100 [1935]	2900 [1369]	2700 [1274]	4100 [1935]	2900 [1369]	2700 [1274]	4100 [1935]	2900 [1369]	2700 [1274]	
Outdoor Dry Bulb Temperature	60°F [15.6°C]	Total BTUH [kW] Sens BTUH [kW] Power	57.6 [16.9] 12.7 [3.7] 6.6	53.6 [15.7] 10.7 [3.1] 6.4	52.9 [15.5] 10.3 [3.0] 6.3	45.7 [13.4] 14.6 [4.3] 5.2	42.5 [12.5] 12.2 [3.6] 5.0	42.0 [12.5] 11.8 [3.5] 5.0	51.3 [15.0] 20.5 [6.0] 6.3	47.7 [14.0] 17.2 [5.0] 6.1	47.1 [13.8] 16.6 [4.9] 6.0
	70°F [21.1°C]	Total BTUH [kW] Sens BTUH [kW] Power	52.7 [15.5] 10.1 [3.0] 6.4	49.1 [14.4] 8.5 [2.5] 6.1	48.4 [14.2] 8.2 [2.4] 6.1	40.9 [12.0] 11.9 [3.5] 5.0	38.0 [11.1] 10.0 [2.9] 4.8	37.5 [11.0] 9.7 [2.8] 4.8	46.4 [13.6] 17.9 [5.2] 6.0	43.2 [12.7] 15.0 [4.4] 5.8	42.6 [12.5] 14.5 [4.2] 5.8
	80°F [26.7°C]	Total BTUH [kW] Sens BTUH [kW] Power	46.3 [13.6] 5.6 [1.9] 6.4	43.1 [12.6] 4.7 [1.4] 6.1	42.6 [12.5] 4.5 [1.3] 6.1	34.5 [10.1] 7.4 [2.2] 5.0	32.1 [9.4] 6.2 [1.8] 4.8	31.6 [9.3] 6.0 [1.8] 4.8	40.0 [11.7] 13.3 [3.9] 6.1	37.2 [10.9] 11.2 [3.3] 5.8	36.7 [10.8] 10.8 [3.2] 5.8
	90°F [32.2°C]	Total BTUH [kW] Sens BTUH [kW] Power	38.4 [11.2] -0.9 [-0.3] 6.6	35.7 [10.5] -0.7 [-0.2] 6.4	35.2 [10.3] -0.7 [-0.2] 6.4	26.5 [7.8] 0.9 [0.3] 5.2	24.7 [7.2] 0.8 [0.2] 5.1	24.3 [7.1] 0.8 [0.2] 5.0	32.1 [9.4] 6.9 [2.0] 6.3	29.8 [8.7] 5.8 [1.7] 6.1	29.4 [8.6] 5.6 [1.6] 6.1
	100°F [37.8°C]	Total BTUH [kW] Sens BTUH [kW] Power	28.9 [8.5] -9.2 [-2.7] 7.2	26.9 [7.9] -7.7 [-2.3] 6.9	26.5 [7.8] -7.5 [-2.2] 6.9	17.0 [5.0] -7.4 [-2.2] 5.8	15.8 [4.6] -6.2 [-1.8] 5.6	15.6 [4.6] -6.0 [-1.8] 5.5	22.6 [6.6] -1.5 [-0.4] 6.8	21.0 [6.1] -1.2 [-0.4] 6.6	20.7 [6.1] -1.2 [-0.4] 6.6
	110°F [43.3°C]	Total BTUH [kW] Sens BTUH [kW] Power	17.9 [5.2] -19.5 [-5.7] 7.9	16.6 [4.9] -16.3 [-4.8] 7.7	16.4 [4.8] -15.8 [-4.6] 7.6	6.0 [1.8] -17.7 [-5.2] 6.5	5.6 [1.6] -14.8 [-4.3] 6.3	5.5 [1.6] -14.3 [-4.2] 6.3	11.5 [3.4] -11.7 [-3.4] 7.6	10.7 [3.1] -9.8 [-2.9] 7.4	10.6 [3.1] -9.5 [-2.8] 7.3
	120°F [48.9°C]	Total BTUH [kW] Sens BTUH [kW] Power	5.3 [1.5] -31.6 [-9.3] 9	4.9 [1.4] -26.5 [-7.8] 8.7	4.9 [1.4] -25.7 [-7.5] 8.6	-6.6 [-1.9] -29.8 [-8.7] 7.6	-6.1 [-1.8] -25.0 [-7.3] 7.3	-6.0 [-1.8] -24.2 [-7.1] 7.3	-1.0 [-0.3] -23.9 [-7.0] 8.7	-1.0 [-0.3] -20.0 [-5.9] 8.4	-1.0 [-0.3] -19.4 [-5.7] 8.3

Appendix D – Reheat Data for RGEDZT 10 Ton

GROSS SYSTEMS PERFORMANCE DATA (LOW REHEAT MODE) - RGEDZT120											
Entering Indoor Air @ 75°F [23.9°C] dbE 1											
wbE		65.3°F [18.5°C]			64°F [17.8°C]			62.5°F [16.9°C]			
CFM [L/s]		3000 [1416]	2400 [1133]	2000 [944]	3000 [1416]	2400 [1133]	2000 [944]	3000 [1416]	2400 [1133]	2000 [944]	
Outdoor Dry Bulb Temperature	60°F [15.6°C]	Total BTUH [kW] Sens BTUH [kW] Power	46.5 [13.6] 12.9 [3.8] 4.6	44.4 [13.0] 11.6 [3.4] 4.5	43.1 [12.6] 10.7 [3.1] 4.4	43.1 [12.6] 13.8 [4.0] 4.5	41.2 [12.1] 12.3 [3.6] 4.4	40.0 [11.7] 11.4 [3.3] 4.3	40.3 [11.8] 18.5 [5.4] 4.5	38.6 [11.3] 16.5 [4.8] 4.4	37.4 [11.0] 15.3 [4.5] 4.3
	65°F [18.3°C]	Total BTUH [kW] Sens BTUH [kW] Power	45.7 [13.4] 10.5 [3.1] 4.6	43.7 [12.8] 9.4 [2.8] 4.5	42.4 [12.4] 8.7 [2.5] 4.5	42.4 [12.4] 11.4 [3.3] 4.6	40.5 [11.9] 10.2 [3.0] 4.5	39.3 [11.3] 9.4 [2.8] 4.4	39.6 [11.6] 16.1 [4.7] 4.5	37.8 [11.1] 14.4 [4.2] 4.4	36.7 [10.8] 13.3 [3.9] 4.4
	70°F [21.1°C]	Total BTUH [kW] Sens BTUH [kW] Power	44.7 [13.1] 8.3 [2.4] 4.7	42.7 [12.5] 7.4 [2.2] 4.6	41.4 [12.1] 6.9 [2.0] 4.6	41.3 [12.1] 9.2 [2.7] 4.7	39.3 [11.6] 8.2 [2.4] 4.6	38.3 [11.2] 7.6 [2.2] 4.5	38.5 [11.3] 13.9 [4.1] 4.6	36.9 [10.8] 12.4 [3.6] 4.5	35.7 [10.5] 11.4 [3.4] 4.5
	75°F [23.9°C]	Total BTUH [kW] Sens BTUH [kW] Power	43.4 [12.7] 6.3 [1.8] 4.9	41.5 [12.2] 5.6 [1.7] 4.8	40.2 [11.8] 5.2 [1.5] 4.7	40.0 [11.7] 7.2 [2.1] 4.8	38.3 [11.2] 6.4 [1.9] 4.7	37.1 [10.9] 5.9 [1.7] 4.7	37.2 [10.9] 11.9 [3.5] 4.8	35.6 [10.4] 10.6 [3.1] 4.7	34.5 [10.1] 9.8 [2.9] 4.6
	80°F [26.7°C]	Total BTUH [kW] Sens BTUH [kW] Power	41.8 [12.2] 4.5 [1.3] 5.1	40.0 [11.7] 4.0 [1.2] 5.0	38.8 [11.4] 3.7 [1.1] 4.9	38.4 [11.3] 5.4 [1.6] 5.0	36.8 [10.8] 4.8 [1.4] 4.9	35.6 [10.4] 4.4 [1.3] 4.9	35.7 [10.5] 10.1 [2.9] 5.0	34.1 [10.0] 9.0 [2.6] 4.9	33.1 [9.7] 8.3 [2.4] 4.8
	85°F [29.4°C]	Total BTUH [kW] Sens BTUH [kW] Power	40.0 [11.7] 2.9 [0.8] 5.4	38.2 [11.2] 2.6 [0.8] 5.3	37.1 [10.9] 2.4 [0.7] 5.2	36.6 [10.7] 3.8 [1.1] 5.3	35.0 [10.3] 3.4 [1.0] 5.2	33.9 [9.9] 3.1 [0.9] 5.1	33.8 [9.9] 8.5 [2.5] 5.3	32.4 [9.5] 7.6 [2.2] 5.2	31.4 [9.2] 7.0 [2.0] 5.1
	90°F [32.2°C]	Total BTUH [kW] Sens BTUH [kW] Power	37.9 [11.1] 1.5 [0.4] 5.7	36.2 [10.6] 1.3 [0.4] 5.6	35.1 [10.3] 1.2 [0.4] 5.5	34.5 [10.1] 2.4 [0.7] 5.6	33.0 [9.7] 2.1 [0.6] 5.5	32.0 [9.4] 2.0 [0.6] 5.4	31.7 [9.3] 7.1 [2.1] 5.6	30.4 [8.9] 6.3 [1.9] 5.5	29.4 [8.6] 5.8 [1.7] 5.4

GROSS SYSTEMS PERFORMANCE DATA (HIGH REHEAT MODE) - RGEDZT120											
Entering Indoor Air @ 75°F [23.9°C] dbE 1											
wbE		65.3°F [18.5°C]			64°F [17.8°C]			62.5°F [16.9°C]			
CFM [L/s]		4800 [2265]	3800 [1793]	3200 [1510]	4800 [2265]	3800 [1793]	3200 [1510]	4800 [2265]	3800 [1793]	3200 [1510]	
Outdoor Dry Bulb Temperature	60°F [15.6°C]	Total BTUH [kW] Sens BTUH [kW] Power	58.1 [17.0] 10.5 [3.1] 7.0	55.4 [16.2] 9.3 [2.7] 6.9	53.9 [15.8] 8.6 [2.5] 6.8	55.5 [16.3] 15.6 [4.6] 6.9	53.0 [15.5] 13.9 [4.1] 6.8	51.4 [15.1] 12.9 [3.8] 6.7	53.1 [15.6] 19.9 [5.8] 6.9	50.7 [14.9] 17.7 [5.2] 6.8	49.2 [14.4] 16.4 [4.8] 6.7
	70°F [21.1°C]	Total BTUH [kW] Sens BTUH [kW] Power	53.4 [15.7] 8.3 [2.4] 7.1	51.0 [14.9] 7.4 [2.2] 7.0	49.5 [14.5] 6.8 [2.0] 6.9	50.8 [14.9] 13.4 [3.9] 7.0	48.5 [14.2] 12.0 [3.5] 6.9	47.1 [13.8] 11.1 [3.2] 6.8	48.4 [14.2] 17.7 [5.2] 7.0	46.2 [13.5] 15.8 [4.6] 6.9	44.9 [13.2] 14.6 [4.3] 6.8
	80°F [26.7°C]	Total BTUH [kW] Sens BTUH [kW] Power	48.4 [14.2] 4.5 [1.3] 7.4	46.2 [13.5] 4.0 [1.2] 7.3	44.9 [13.2] 3.7 [1.1] 7.2	45.8 [13.4] 9.7 [2.8] 7.3	43.7 [12.8] 8.6 [2.5] 7.2	42.5 [12.4] 8.0 [2.3] 7.1	43.4 [12.7] 14.0 [4.1] 7.3	41.5 [12.1] 12.5 [3.6] 7.2	40.3 [11.8] 11.5 [3.4] 7.1
	90°F [32.2°C]	Total BTUH [kW] Sens BTUH [kW] Power	43.1 [12.6] -0.8 [-0.2] 7.9	41.1 [12.0] -0.7 [-0.2] 7.7	39.9 [11.7] -0.6 [-0.2] 7.6	40.5 [11.9] 4.4 [1.3] 7.8	38.6 [11.3] 3.9 [1.1] 7.7	37.5 [11.0] 3.6 [1.1] 7.5	38.1 [11.2] 8.7 [2.5] 7.8	36.3 [10.6] 7.7 [2.3] 7.6	35.3 [10.3] 7.2 [2.1] 7.5
	100°F [43.3°C]	Total BTUH [kW] Sens BTUH [kW] Power	37.4 [11.0] -7.6 [-2.2] 8.6	35.7 [10.5] -6.8 [-2.0] 8.4	34.6 [10.2] -6.3 [-1.8] 8.3	34.8 [10.2] -2.5 [-0.7] 8.5	33.2 [9.7] -2.2 [-0.6] 8.3	32.2 [9.4] -2.0 [-0.6] 8.2	32.4 [9.4] 1.8 [0.5] 8.5	30.9 [9.1] 1.6 [0.5] 8.3	30.0 [8.8] 1.5 [0.4] 8.2
	110°F [43.3°C]	Total BTUH [kW] Sens BTUH [kW] Power	31.3 [9.2] -16.0 [-4.7] 9.5	29.9 [8.8] -14.3 [-4.2] 9.3	29.0 [8.5] -13.2 [-3.9] 9.2	28.7 [8.4] -10.9 [-3.2] 9.4	27.4 [8.0] -9.7 [-2.8] 9.2	26.6 [7.8] -9.0 [-2.6] 9.1	26.3 [7.7] -6.6 [-1.9] 9.4	25.1 [7.4] -5.9 [-1.7] 9.2	24.4 [7.1] -5.5 [-1.6] 9.0
	120°F [48.9°C]	Total BTUH [kW] Sens BTUH [kW] Power	24.9 [7.3] -26.0 [-7.6] 10.6	23.8 [7.0] -23.2 [-6.8] 10.3	23.1 [6.8] -21.5 [-6.3] 10.2	22.3 [6.5] -20.9 [-6.1] 10.5	21.3 [6.2] -18.6 [-5.5] 10.2	20.7 [6.1] -17.2 [-5.0] 10.1	19.9 [5.8] -16.6 [-4.9] 10.5	19.0 [5.6] -14.8 [-4.3] 10.2	18.5 [5.4] -13.7 [-4.0] 10.1

P. APPENDICES

Appendix D – Reheat Data for RGEDZT 12.5 Ton

GROSS SYSTEMS PERFORMANCE DATA (LOW REHEAT MODE) - RGEDZT150											
Entering Indoor Air @ 75°F [23.9°C] dbE 1											
wbE		65.3°F [18.5°C]			64°F [17.8°C]			62.5°F [16.9°C]			
CFM [L/s]		3000 [1416]	2400 [1133]	2000 [944]	3000 [1416]	2400 [1133]	2000 [944]	3000 [1416]	2400 [1133]	2000 [944]	
Outdoor Dry Bulb Temperature	60°F [15.6°C]	Total BTUH [kW] Sens BTUH [kW] Power	46.5 [13.6] 12.9 [3.8] 4.6	44.4 [13.0] 11.6 [3.4] 4.5	43.1 [12.6] 10.7 [3.1] 4.4	43.1 [12.6] 13.8 [4.0] 4.5	41.2 [12.1] 12.3 [3.6] 4.4	40.0 [11.7] 11.4 [3.3] 4.3	40.3 [11.8] 18.5 [5.4] 4.5	38.6 [11.3] 16.5 [4.8] 4.4	37.4 [11.0] 15.3 [4.5] 4.3
	65°F [18.3°C]	Total BTUH [kW] Sens BTUH [kW] Power	45.7 [13.4] 10.5 [3.1] 4.6	43.7 [12.8] 9.4 [2.8] 4.5	42.4 [12.4] 8.7 [2.5] 4.5	42.3 [12.4] 11.4 [3.3] 4.6	40.5 [11.9] 10.2 [3.0] 4.5	39.3 [11.5] 9.4 [2.8] 4.4	39.6 [11.6] 16.1 [4.7] 4.5	37.8 [11.1] 14.4 [4.2] 4.4	36.7 [10.8] 13.3 [3.9] 4.4
	70°F [21.1°C]	Total BTUH [kW] Sens BTUH [kW] Power	44.7 [13.1] 8.3 [2.4] 4.7	42.7 [12.5] 7.4 [2.2] 4.6	41.4 [12.1] 6.9 [2.0] 4.6	41.3 [12.1] 9.2 [2.7] 4.7	39.5 [11.6] 8.2 [2.4] 4.6	38.3 [11.2] 7.6 [2.2] 4.5	38.5 [11.3] 13.9 [4.1] 4.6	36.9 [10.8] 12.4 [3.6] 4.5	35.7 [10.5] 11.4 [3.4] 4.5
	75°F [23.9°C]	Total BTUH [kW] Sens BTUH [kW] Power	43.4 [12.7] 6.3 [1.8] 4.9	41.5 [12.2] 5.6 [1.7] 4.8	40.2 [11.8] 5.2 [1.5] 4.7	40.0 [11.7] 7.2 [2.1] 4.8	38.3 [11.2] 6.4 [1.9] 4.7	37.1 [10.9] 5.9 [1.7] 4.7	37.2 [10.9] 11.9 [3.5] 4.8	35.6 [10.4] 10.6 [3.1] 4.7	34.5 [10.1] 9.8 [2.9] 4.6
	80°F [26.7°C]	Total BTUH [kW] Sens BTUH [kW] Power	41.8 [12.2] 4.5 [1.3] 5.1	40.0 [11.7] 4.0 [1.2] 5.0	38.8 [11.4] 3.7 [1.1] 4.9	38.4 [11.3] 5.4 [1.6] 5.0	36.8 [10.8] 4.8 [1.4] 4.9	35.6 [10.4] 4.4 [1.3] 4.9	35.7 [10.5] 10.1 [2.9] 5.0	34.1 [10.0] 9.0 [2.6] 4.9	33.1 [9.7] 8.3 [2.4] 4.8
	85°F [29.4°C]	Total BTUH [kW] Sens BTUH [kW] Power	40.0 [11.7] 2.9 [0.8] 5.4	38.2 [11.2] 2.6 [0.8] 5.3	37.1 [10.9] 2.4 [0.7] 5.2	36.6 [10.7] 3.8 [1.1] 5.3	35.0 [10.3] 3.4 [1.0] 5.3	33.9 [9.9] 3.1 [0.9] 5.1	33.8 [9.9] 8.5 [2.5] 5.3	32.4 [9.5] 7.6 [2.2] 5.2	31.4 [9.2] 7.0 [2.0] 5.1
	90°F [32.2°C]	Total BTUH [kW] Sens BTUH [kW] Power	37.9 [11.1] 1.5 [0.4] 5.7	36.2 [10.6] 1.3 [0.4] 5.6	35.1 [10.3] 1.2 [0.4] 5.5	34.5 [10.1] 2.4 [0.7] 5.6	33.0 [9.7] 2.1 [0.6] 5.5	32.0 [9.4] 2.0 [0.6] 5.4	31.7 [9.3] 7.1 [2.1] 5.6	30.4 [8.9] 6.3 [1.9] 5.5	29.4 [8.6] 5.8 [1.7] 5.4

GROSS SYSTEMS PERFORMANCE DATA (HIGH REHEAT MODE) - RGEDZT150											
Entering Indoor Air @ 75°F [23.9°C] dbE 1											
wbE		65.3°F [18.5°C]			64°F [17.8°C]			62.5°F [16.9°C]			
CFM [L/s]		6000 [2832]	4100 [1935]	4000 [1888]	6000 [2832]	4100 [1935]	4000 [1888]	6000 [2832]	4100 [1935]	4000 [1888]	
Outdoor Dry Bulb Temperature	60°F [15.6°C]	Total BTUH [kW] Sens BTUH [kW] Power	99.3 33.3 [9.7] 9.5	91.5 [26.8] 27.4 [8.0] 9.1	91.1 [26.7] 27.0 [7.9] 9.1	101.6 [29.8] 40.1 [11.8] 9.3	93.7 [27.4] 33.0 [9.7] 8.9	93.2 [27.3] 32.6 [9.6] 8.9	92.7 [27.2] 46.4 [13.6] 9.3	85.5 [25.2] 38.1 [11.2] 8.9	85.2 [25.0] 37.7 [11.0] 8.9
	70°F [21.1°C]	Total BTUH [kW] Sens BTUH [kW] Power	94.4 [27.7] 27.0 [7.9] 9.7	87.1 [25.5] 22.2 [6.5] 9.3	86.7 [25.4] 21.9 [6.4] 9.3	96.7 [28.3] 33.9 [9.9] 9.5	89.2 [26.1] 27.9 [8.2] 9.2	88.8 [26.0] 27.5 [8.1] 9.2	87.9 [25.8] 40.1 [11.7] 9.5	81.1 [23.8] 33.0 [9.7] 9.2	80.7 [23.7] 32.6 [9.5] 9.1
	80°F [26.7°C]	Total BTUH [kW] Sens BTUH [kW] Power	87.6 [25.7] 20.1 [5.9] 10.2	80.8 [23.7] 16.5 [4.8] 9.8	80.4 [23.6] 16.3 [4.8] 9.8	89.9 [26.3] 27.0 [7.9] 10.0	82.9 [24.3] 22.2 [6.5] 9.6	82.5 [24.5] 21.9 [6.4] 9.6	81.1 [23.8] 33.2 [9.7] 10.0	74.8 [21.9] 27.3 [8.0] 9.6	74.4 [21.8] 27.0 [7.9] 9.6
	90°F [32.9°C]	Total BTUH [kW] Sens BTUH [kW] Power	78.7 [23.1] 12.5 [3.7] 11.0	72.6 [21.3] 10.3 [3.0] 10.5	72.3 [21.2] 10.2 [3.0] 10.5	81.0 [23.7] 19.4 [5.7] 10.8	74.7 [21.9] 15.9 [4.7] 10.4	74.4 [21.8] 15.8 [4.6] 10.3	72.2 [21.2] 25.6 [7.5] 10.8	66.6 [19.5] 21.0 [6.2] 10.3	66.3 [19.4] 20.8 [6.1] 10.3
	100°F [37.8°C]	Total BTUH [kW] Sens BTUH [kW] Power	67.8 [19.9] 4.3 [1.3] 11.9	62.5 [18.3] 3.5 [1.0] 11.5	62.3 [18.2] 3.5 [1.0] 11.4	70.1 [20.5] 11.2 [3.3] 11.8	64.7 [18.9] 9.2 [2.7] 11.3	64.4 [18.9] 9.1 [2.7] 11.3	61.3 [18.0] 17.4 [5.1] 11.8	56.5 [16.6] 14.3 [4.2] 11.3	56.3 [16.5] 14.1 [4.1] 11.3
	110°F [43.3°C]	Total BTUH [kW] Sens BTUH [kW] Power	54.9 [16.1] -4.6 [-1.3] 13.2	50.6 [14.8] -3.8 [-1.1] 12.6	50.4 [14.8] -3.7 [-1.1] 12.6	57.2 [16.8] 2.3 [0.7] 13.0	52.7 [15.5] 1.9 [0.5] 12.5	52.5 [15.4] 1.9 [0.5] 12.4	48.4 [14.2] 8.5 [2.5] 13.0	44.6 [13.1] 7.0 [2.0] 12.5	44.4 [13.0] 6.9 [2.0] 12.4
	120°F [48.9°C]	Total BTUH [kW] Sens BTUH [kW] Power	40.0 [11.7] -14.1 [-4.1] 14.6	36.8 [10.8] -11.6 [-3.4] 14.1	36.7 [10.8] -11.5 [-3.4] 14.0	42.3 [12.4] -7.2 [-2.1] 14.5	39.0 [11.4] -6.0 [-1.7] 13.9	38.8 [11.4] -5.9 [-1.7] 13.9	33.4 [9.8] -1.0 [-0.3] 14.4	30.8 [9.0] -0.9 [-0.2] 13.9	30.7 [9.0] -0.8 [-0.2] 13.8

Appendix E – Heating Performance

Models: RGED Gas Heat Performance Specifications

208-230V, 575V, 460V						
Tonnage	7.5-Ton		8.5-Ton		10-Ton	
Heating Input BTU [kW] (High-Fire / Low-Fire)	150,000/105,000	205,000/143,500	150,000/105,000	225,000/157,500	150,000/105,000	225,000/157,500
	[43.95/30.76]	[60.06/42.06]	[43.95/30.76]	[65.92/46.16]	[43.95/30.76]	[65.92/46.16]
Heating Output BTU [kW] (High-Fire / Low-Fire)	121,500/85,050	166,050/116,235	121,500/85,050	182,250/127,575	121,500/85,050	182,250/127,575
	[35.6/24.92]	[48.66/34.07]	[35.6/24.92]	[53.4/37.39]	[35.6/24.92]	[53.4/37.39]
High-Fire Rise Range °F [°C]	25-55 [13.9-30.6]	35-65 [19.4-36.1]	15-45 [8.3-25]	35-65 [19.4-36.1]	20-50 [11.1-27.8]	35-65 [19.4-36.1]
	10-40 [5.6-22.2]	20-50 [11.1-27.8]	5-35 [2.8-19.4]	15-45 [8.3-25]	10-40 [5.6-22.2]	15-45 [8.3-25]
Main Limit Temp °F	145	145	145	155	145	145
	350	350	350	350	350	350
Rating ESP In. W.C.	0.33	0.33	0.33	0.33	0.33	0.33
Maximum ESP In. W.C.	0.8	0.8	0.8	0.8	0.8	0.8
Max Outlet Air Temp °F [°C]	200 [93.3]	185 [85.0]	200 [93.3]	200 [93.3]	200 [93.3]	185 [85.0]
% AFUE	81.0%	81.0%	81.0%	81.0%	81.0%	81.0%
% Steady State Efficiency	81.0%	81.0%	81.0%	81.0%	81.0%	81.0%

208-230V, 575V, 460V		
Tonnage	12.5-Ton	
Heating Input BTU [kW] (High-Fire / Low-Fire)	150,000/105,000	225,000/157,500
	[43.95/30.76]	[65.92/46.16]
Heating Output BTU [kW] (High-Fire / Low-Fire)	121,500/85,050	182,250/127,575
	[35.6/24.92]	[53.4/37.39]
High-Fire Rise Range °F [°C]	15-45 [8.3-25]	25-55 [13.9-30.6]
	5-35 [2.8-19.4]	10-40 [5.6-22.2]
Main Limit Temp °F	145	145
	350	350
Rating ESP In. W.C.	0.33	0.33
Maximum ESP In. W.C.	0.8	0.8
Max Outlet Air Temp °F [°C]	195 [90.6]	200 [93.3]
% AFUE	81.0%	81.0%
% Steady State Efficiency	81.0%	81.0%

P. APPENDICES

Appendix F – Refrigerant Charging Charts

SYSTEM CHARGE CHART - REFRIGERANT 410A
7.5 TON

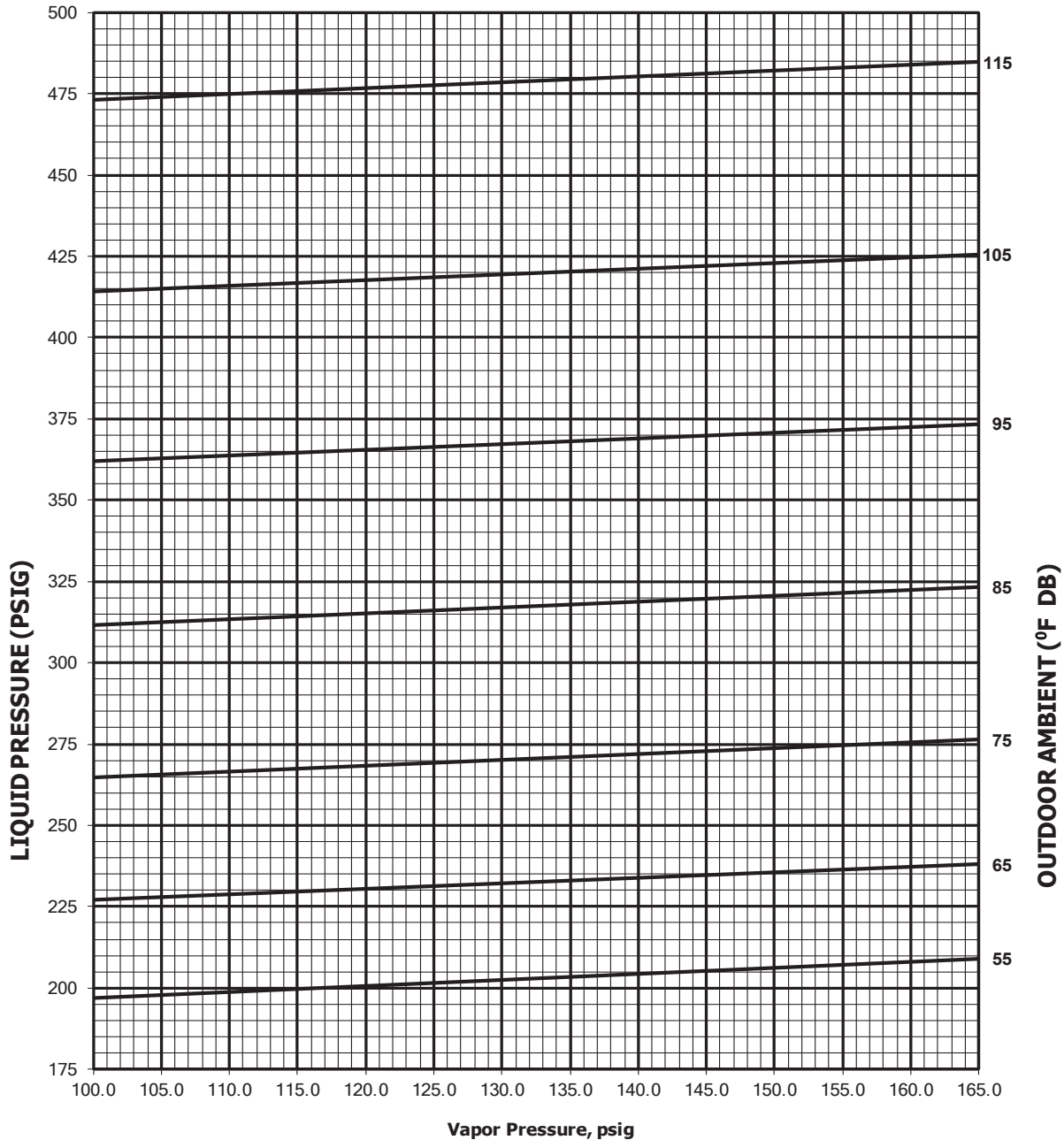

CAUTION: 1. RETURN AIR TEMPERATURE MUST BE WITHIN COMFORT CONDITIONS BEFORE FINAL REFRIGERANT CHECK!

- INSTRUCTIONS:**
1. MEASURE PRESSURE AT COMPRESSOR SUCTION AND LIQUID.
 2. MEASURE OUTDOOR AMBIENT TO UNIT.
 3. PLACE X ON CHART WHERE SUCTION AND LIQUID INTERSECT.
 4. IF X IS BELOW OUTDOOR AMBIENT LINE, ADD CHARGE AND REPEAT STEPS 1-3.
 5. IF X IS ABOVE OUTDOOR AMBIENT LINE, RECOVER EXCESS CHARGE AND REPEAT STEPS 1-3.

Appendix F – Refrigerant Charging Charts (Cont.)

SYSTEM CHARGE CHART - REFRIGERANT 410A
8.5 TON

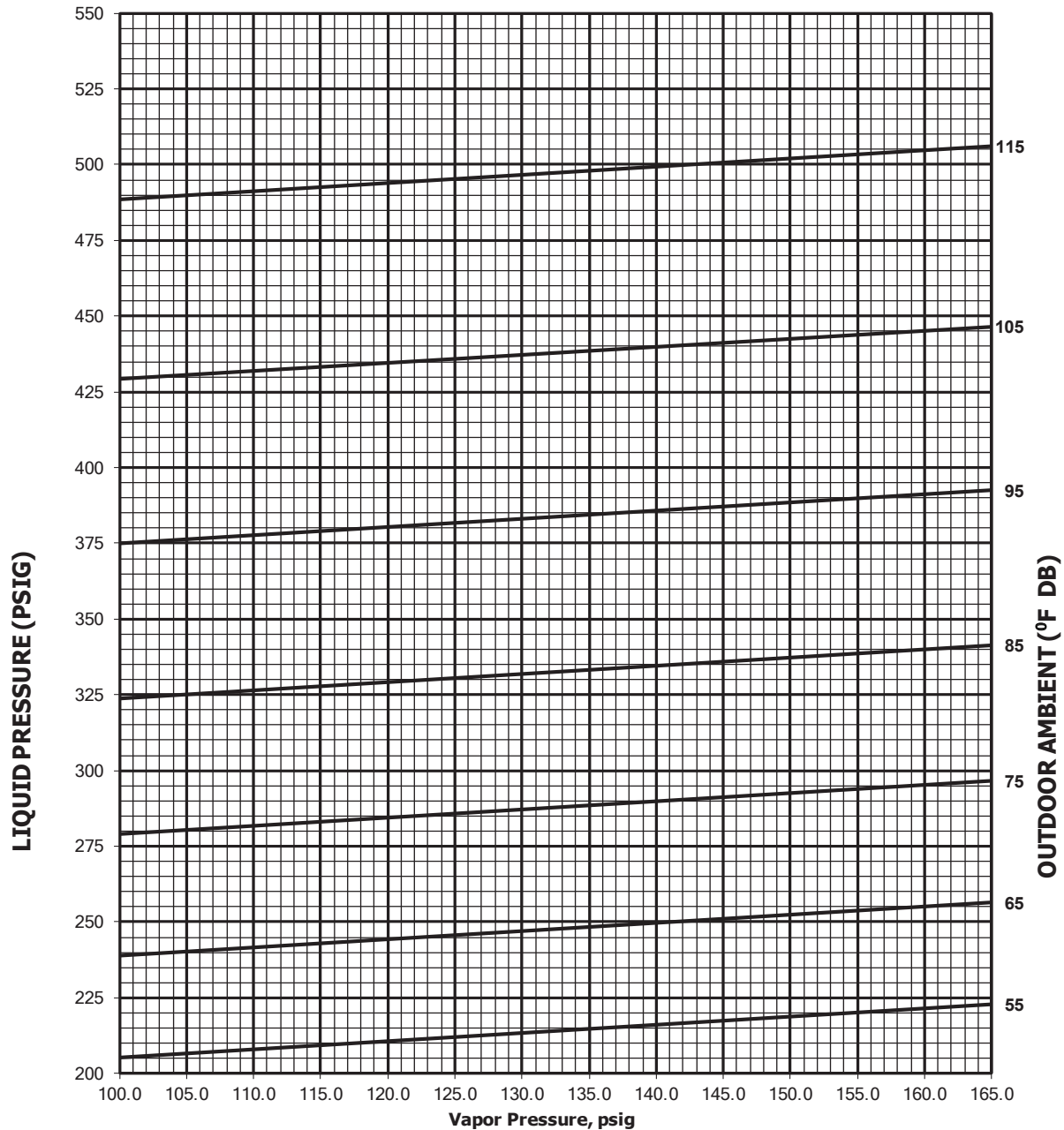

CAUTION: 1. RETURN AIR TEMPERATURE MUST BE WITHIN COMFORT CONDITIONS BEFORE FINAL REFRIGERANT CHECK!

- INSTRUCTIONS:**
1. MEASURE PRESSURE AT COMPRESSOR SUCTION AND LIQUID.
 2. MEASURE OUTDOOR AMBIENT TO UNIT.
 3. PLACE X ON CHART WHERE SUCTION AND LIQUID INTERSECT.
 4. IF X IS BELOW OUTDOOR AMBIENT LINE, ADD CHARGE AND REPEAT STEPS 1-3.
 5. IF X IS ABOVE OUTDOOR AMBIENT LINE, RECOVER EXCESS CHARGE AND REPEAT STEPS 1-3.

P. APPENDICES

Appendix F – Refrigerant Charging Charts (Cont.)

SYSTEM CHARGE CHART - REFRIGERANT 410A
10 TON

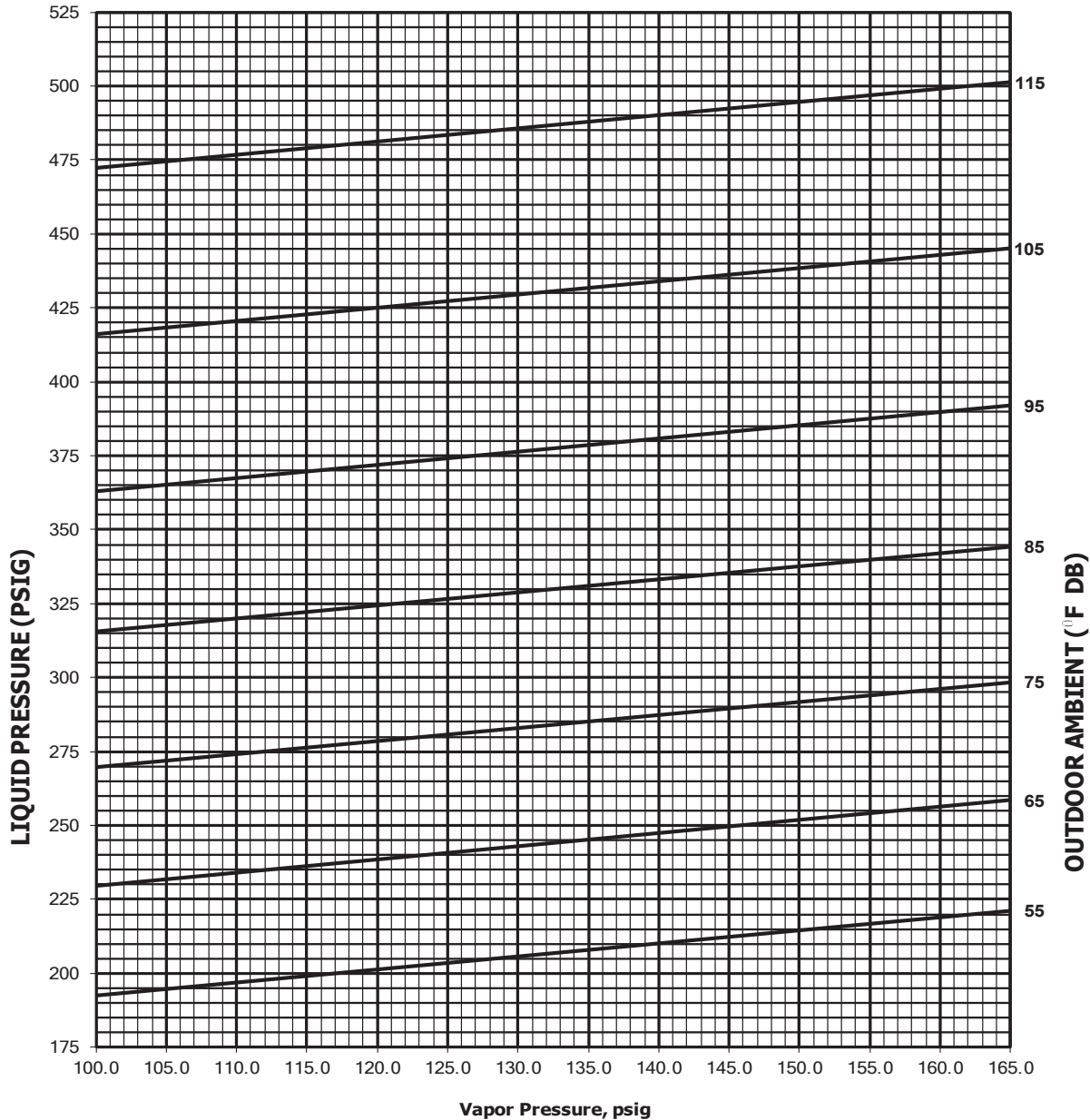

CAUTION: 1. RETURN AIR TEMPERATURE MUST BE WITHIN COMFORT CONDITIONS BEFORE FINAL REFRIGERANT CHECK!

- INSTRUCTIONS:**
1. MEASURE PRESSURE AT COMPRESSOR SUCTION AND LIQUID.
 2. MEASURE OUTDOOR AMBIENT TO UNIT.
 3. PLACE X ON CHART WHERE SUCTION AND LIQUID INTERSECT.
 4. IF X IS BELOW OUTDOOR AMBIENT LINE, ADD CHARGE AND REPEAT STEPS 1-3.
 5. IF X IS ABOVE OUTDOOR AMBIENT LINE, RECOVER EXCESS CHARGE AND REPEAT STEPS 1-3.

92-106138-03-00

Appendix F – Refrigerant Charging Charts (Cont.)

12.5-Ton AC Charging Chart

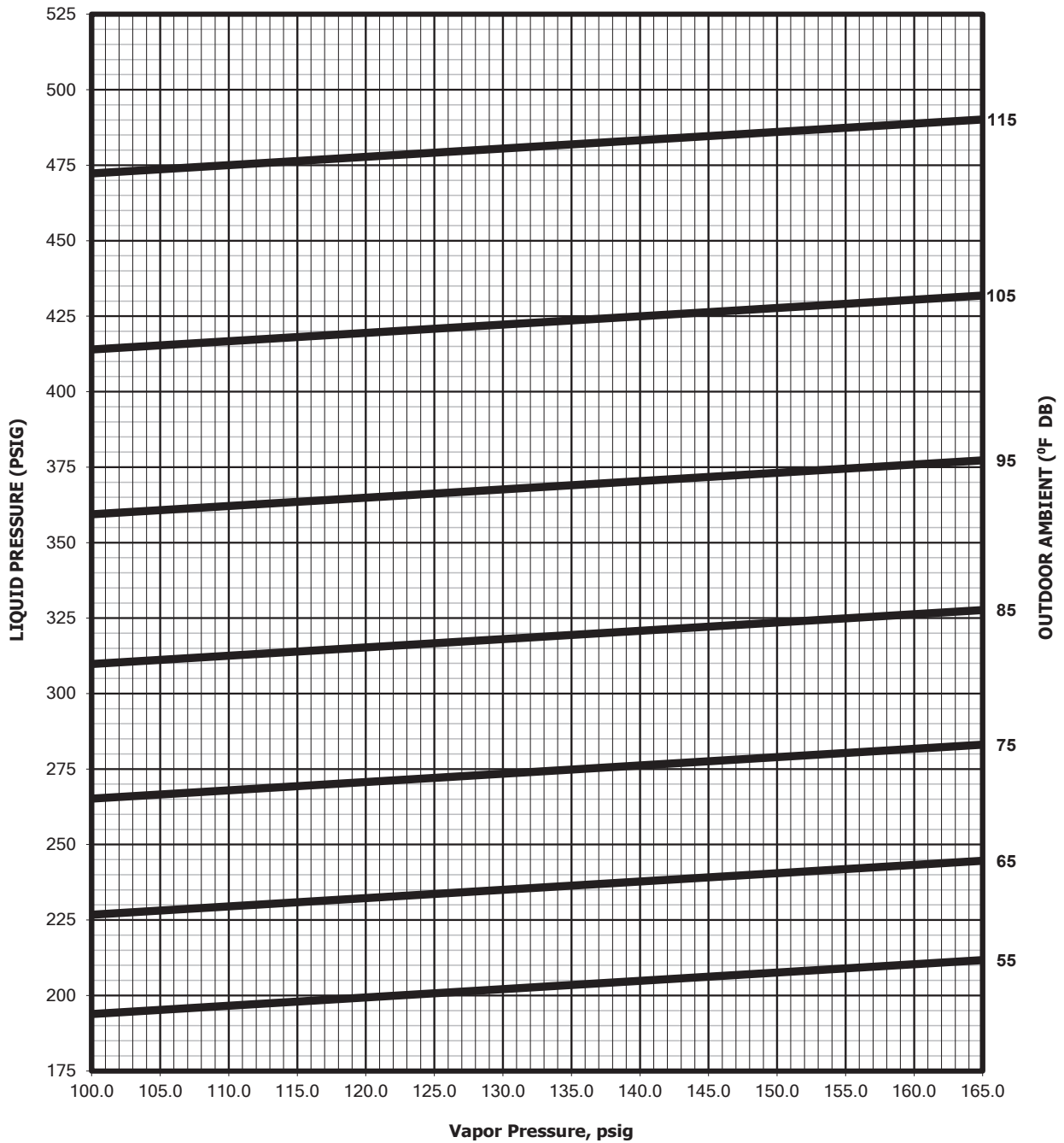

- CAUTION:** 1. RETURN AIR TEMPERATURE MUST BE WITHIN COMFORT CONDITIONS BEFORE FINAL REFRIGERANT CHECK!
- INSTRUCTIONS:** 1. MEASURE PRESSURE AT COMPRESSOR SUCTION AND LIQUID.
 2. MEASURE OUTDOOR AMBIENT TO UNIT.
 3. PLACE X ON CHART WHERE SUCTION AND LIQUID INTERSECT.
 4. IF X IS BELOW OUTDOOR AMBIENT LINE, ADD CHARGE AND REPEAT STEPS 1-3.
 5. IF X IS ABOVE OUTDOOR AMBIENT LINE, RECOVER EXCESS CHARGE AND REPEAT STEPS 1-3.

92-106138-04-00



P. APPENDICES

Appendix F – Refrigerant Charging Charts (Cont.)

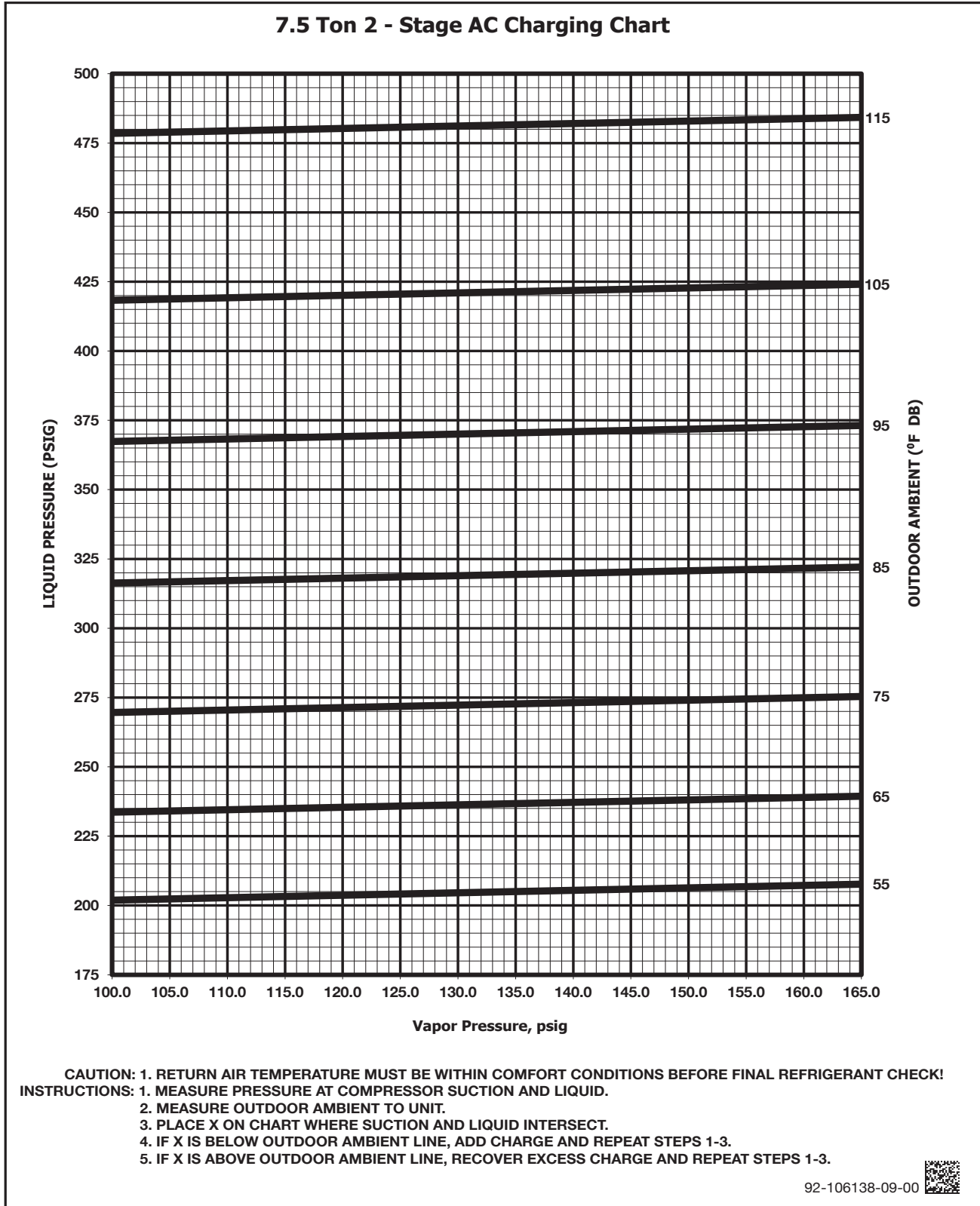

Appendix F – Refrigerant Charging Charts (Cont.)

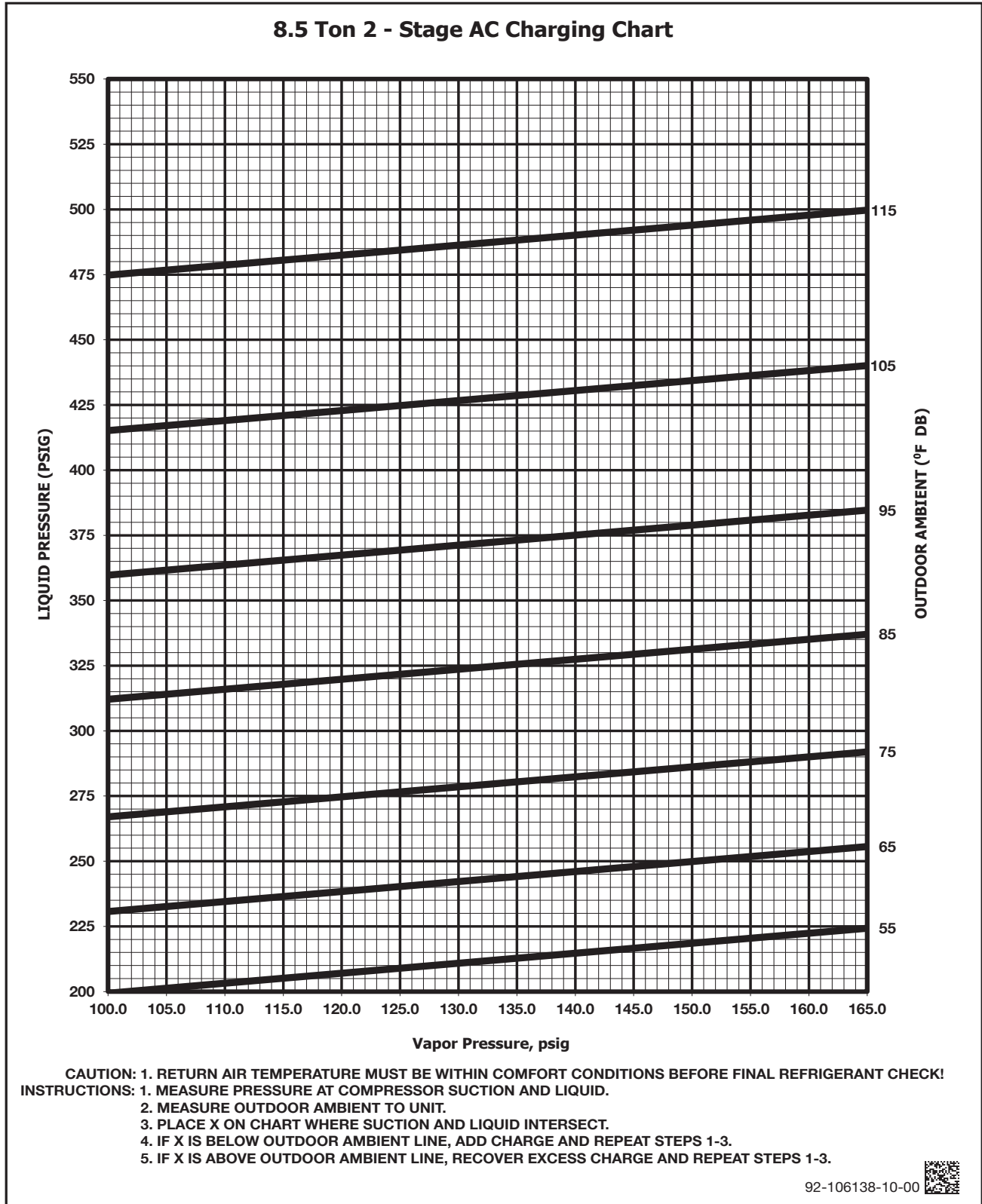

P. APPENDICES

Appendix F – Refrigerant Charging Charts (Cont.)

10-Ton 2 Stage AC Charging Chart

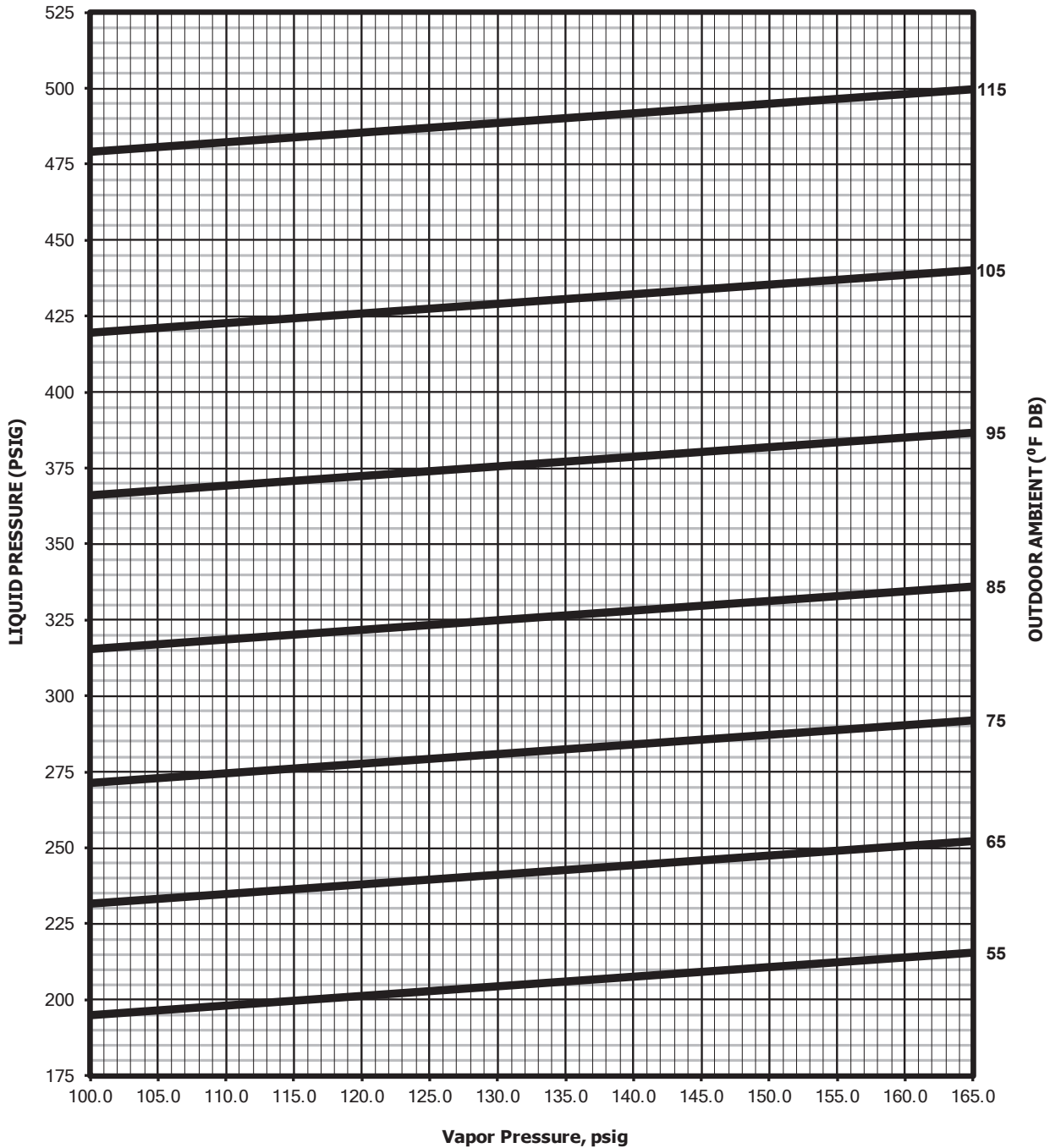

CAUTION: 1. RETURN AIR TEMPERATURE MUST BE WITHIN COMFORT CONDITIONS BEFORE FINAL REFRIGERANT CHECK!

INSTRUCTIONS: 1. MEASURE PRESSURE AT COMPRESSOR SUCTION AND LIQUID.

2. MEASURE OUTDOOR AMBIENT TO UNIT.

3. PLACE X ON CHART WHERE SUCTION AND LIQUID INTERSECT.

4. IF X IS BELOW OUTDOOR AMBIENT LINE, ADD CHARGE AND REPEAT STEPS 1-3.

5. IF X IS ABOVE OUTDOOR AMBIENT LINE, RECOVER EXCESS CHARGE AND REPEAT STEPS 1-3.

92-106138-11-00



Appendix F – Refrigerant Charging Charts (Cont.)

7.5 Ton [26.4 kW] 2 - Stage AC Re-Heat Charging Chart

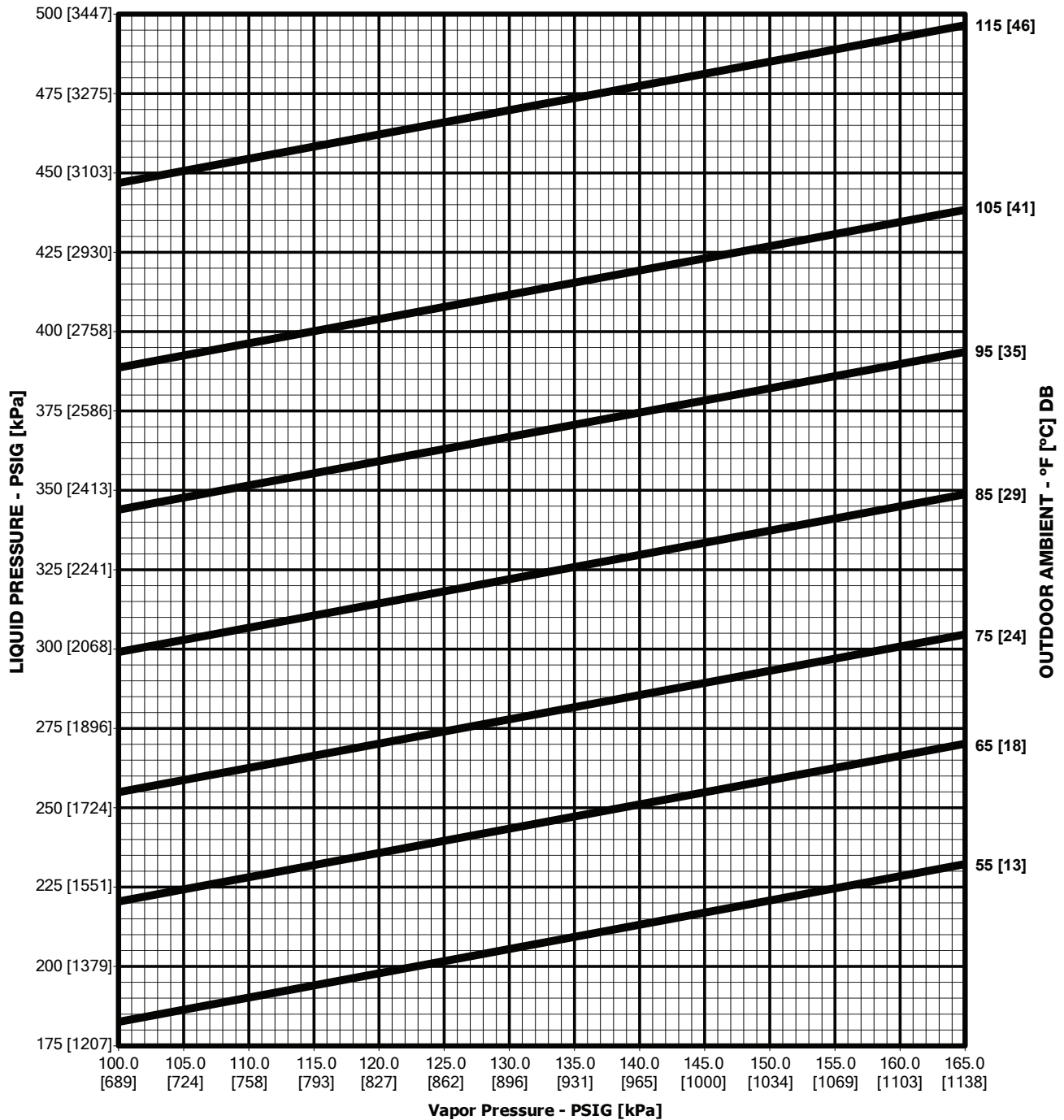

- CAUTION:** 1. RETURN AIR TEMPERATURE MUST BE WITHIN COMFORT CONDITIONS BEFORE FINAL REFRIGERANT CHECK!
- INSTRUCTIONS:**
1. MEASURE PRESSURE AT COMPRESSOR SUCTION AND LIQUID.
 2. MEASURE OUTDOOR AMBIENT TO UNIT.
 3. PLACE X ON CHART WHERE SUCTION AND LIQUID INTERSECT.
 4. IF X IS BELOW OUTDOOR AMBIENT LINE, ADD CHARGE AND REPEAT STEPS 1-3.
 5. IF X IS ABOVE OUTDOOR AMBIENT LINE, RECOVER EXCESS CHARGE AND REPEAT STEPS 1-3.

P. APPENDICES

Appendix F – Refrigerant Charging Charts (Cont.)

8.5 Ton [29.9 kW] 2 - Stage AC Re-Heat Charging Chart

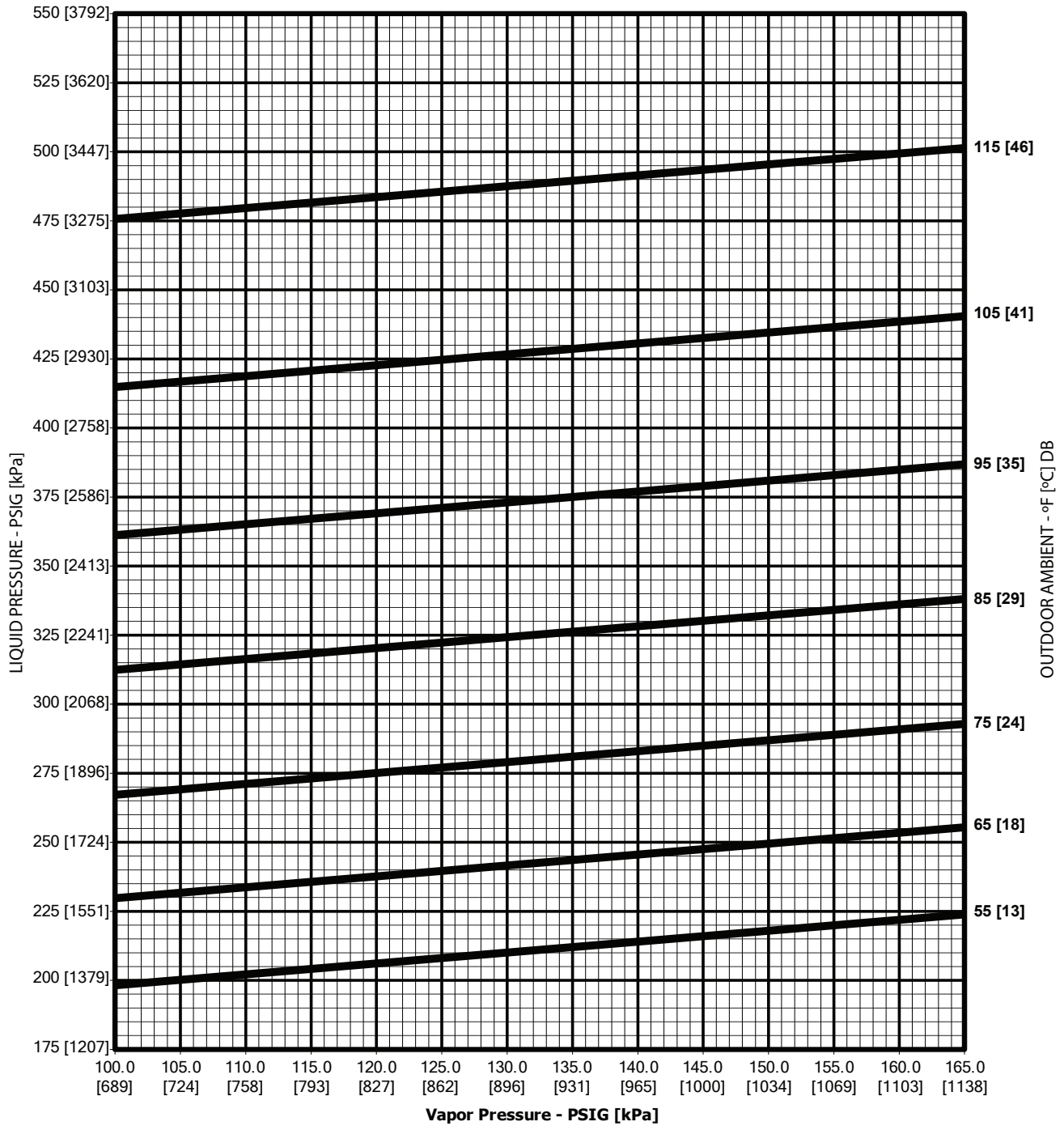

- CAUTION: 1. RETURN AIR TEMPERATURE MUST BE WITHIN COMFORT CONDITIONS BEFORE FINAL REFRIGERANT CHECK!**
- INSTRUCTIONS:**
1. MEASURE PRESSURE AT COMPRESSOR SUCTION AND LIQUID.
 2. MEASURE OUTDOOR AMBIENT TO UNIT.
 3. PLACE X ON CHART WHERE SUCTION AND LIQUID INTERSECT.
 4. IF X IS BELOW OUTDOOR AMBIENT LINE, ADD CHARGE AND REPEAT STEPS 1-3.
 5. IF X IS ABOVE OUTDOOR AMBIENT LINE, RECOVER EXCESS CHARGE AND REPEAT STEPS 1-3.



Appendix F – Refrigerant Charging Charts (Cont.)

10-Ton [35.2 kW] 2 Stage AC Re-Heat Charging Chart

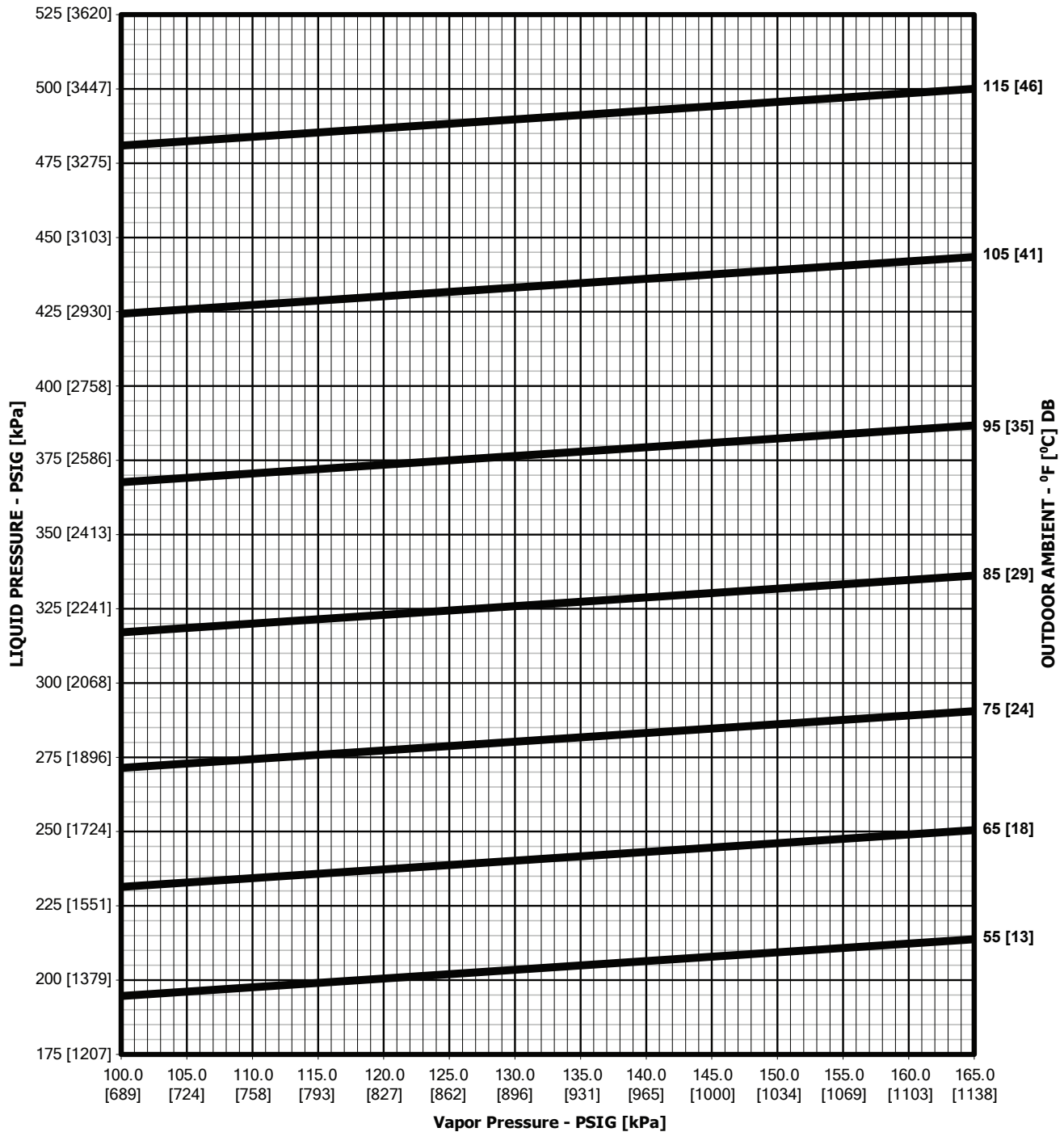

- CAUTION:** 1. RETURN AIR TEMPERATURE MUST BE WITHIN COMFORT CONDITIONS BEFORE FINAL REFRIGERANT CHECK!
- INSTRUCTIONS:** 1. MEASURE PRESSURE AT COMPRESSOR SUCTION AND LIQUID.
 2. MEASURE OUTDOOR AMBIENT TO UNIT.
 3. PLACE X ON CHART WHERE SUCTION AND LIQUID INTERSECT.
 4. IF X IS BELOW OUTDOOR AMBIENT LINE, ADD CHARGE AND REPEAT STEPS 1-3.
 5. IF X IS ABOVE OUTDOOR AMBIENT LINE, RECOVER EXCESS CHARGE AND REPEAT STEPS 1-3.

P. APPENDICES

Appendix F – Refrigerant Charging Charts (Cont.)

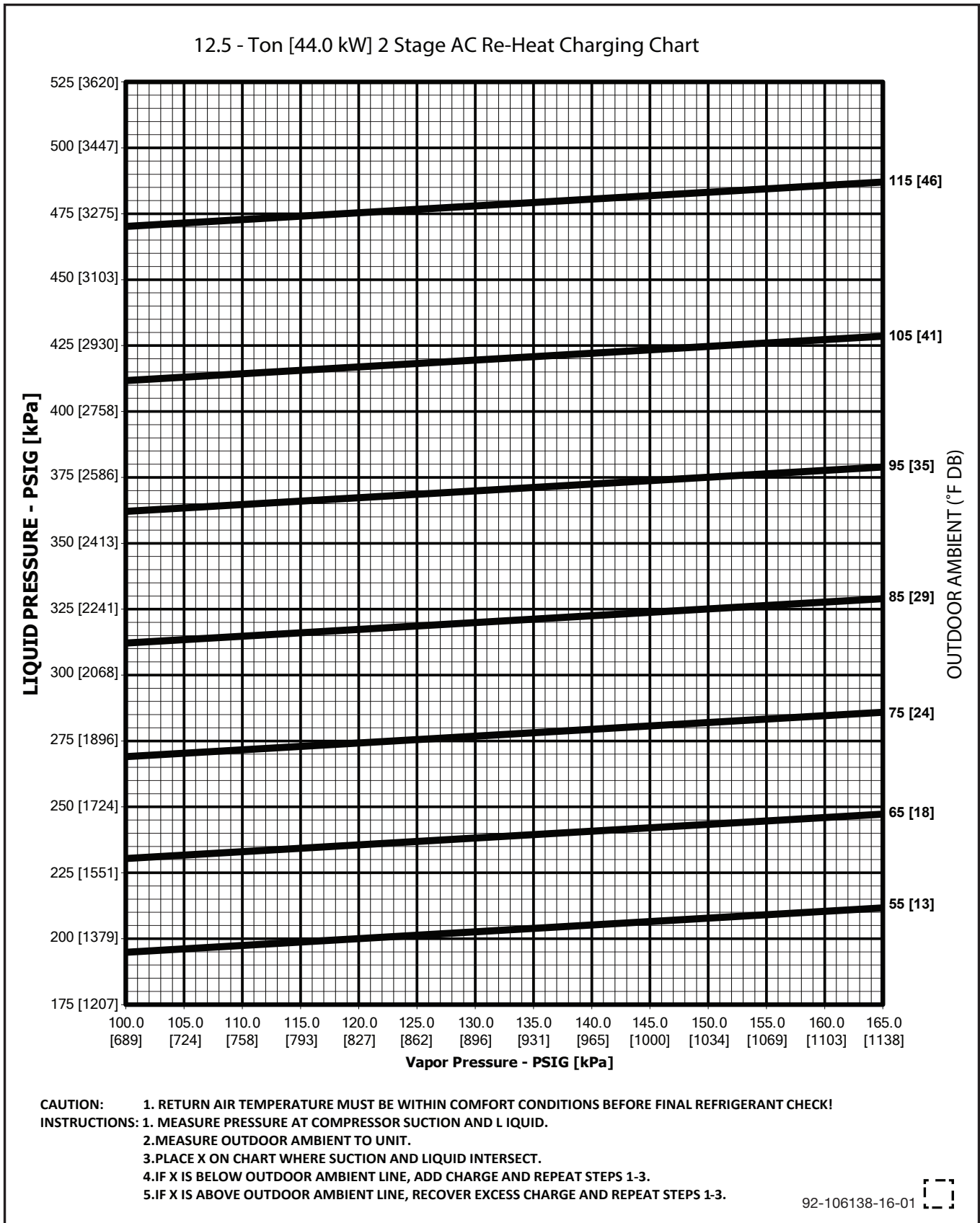

Appendix F – Refrigerant Charging Charts (Cont.)

SYSTEM CHARGE CHART – REFRIGERANT 410 A

PRESSURE REQUIREMENTS – GROSS CHARGE CHECK (REFER CHARGE CHART)

OUTDOOR DRY BULB (°F)	7.5 -TON	8.5 -TON	10 -TON	12.5 -TON
	LIQUID /VAPOR PRESSURE (PSIG)			
115	510.2/147.22	504.13/141.62	500.9/138.5	497.1/138.6
105	450.64/144.8	443.53/139.2	436.5/143.9	438.5/136.5
95	398.19/144	393.38/136.06	389.3/134.1	384.6/134.9
85	354.59/140.06	341.45/135.13	337.5/132.1	336.1/133.5
75	311.67/136.7	297.72/133.41	294.2/130.4	293.1/132.1
65	272.9/132.96	261.32/130.57	255.3/128.6	255.2/130
55	243.58/131.27	230.36/127.47	218.1/125.8	219.8/125.8

SUB COOLING REQUIREMENTS – FINAL CHARGE VERIFICATION

OUTDOOR DRY BULB (°F)	7.5 -TON	8.5 -TON	10 -TON	12.5 -TON
	SUBCOOLING (°F)			
115	12.1	15.6	15.8	13.3
105	10.8	14.9	14.2	13
95	9.8	14.2	15.5	12.4
85	9.8	13	13.8	10.8
75	8.1	11.7	13	9.7
65	11.7	11.2	12	9.3
55	11.8	12.2	10.7	10.6

1. This is required to fine-tune unit charge.
2. The Indoor ambient temperature must be between 72 °F and 82 °F dry bulb at the indoor coil.
3. Confirm the indoor air supply is at the rated CFM listed in **Appendix A**.
4. Allow the system to run long enough for temperatures and pressures to stabilize; at least fifteen minutes.
5. Measure liquid pressure and line temperature at the liquid line service port (refer to **Section J.4.2.1** for the liquid line temperature measurement location). BE SURE TO USE ZERO LOSS FITTINGS WHILE MEASURING 82
6. To find the saturation temperature at the measured pressure, subtract the measured liquid line temperature from the saturation pressure to get the sub-cooling.
7. Check if the Sub-Cooling is within +/- 2.0 °F tolerance.
8. If the sub-cooling values are significantly different (> 20 psig) from those listed on the table in **Appendix F**, there may be an airflow or component issue. Refer to section M. Diagnostics for more information.

P. APPENDICES

Appendix G. Wiring Diagrams & Schematics

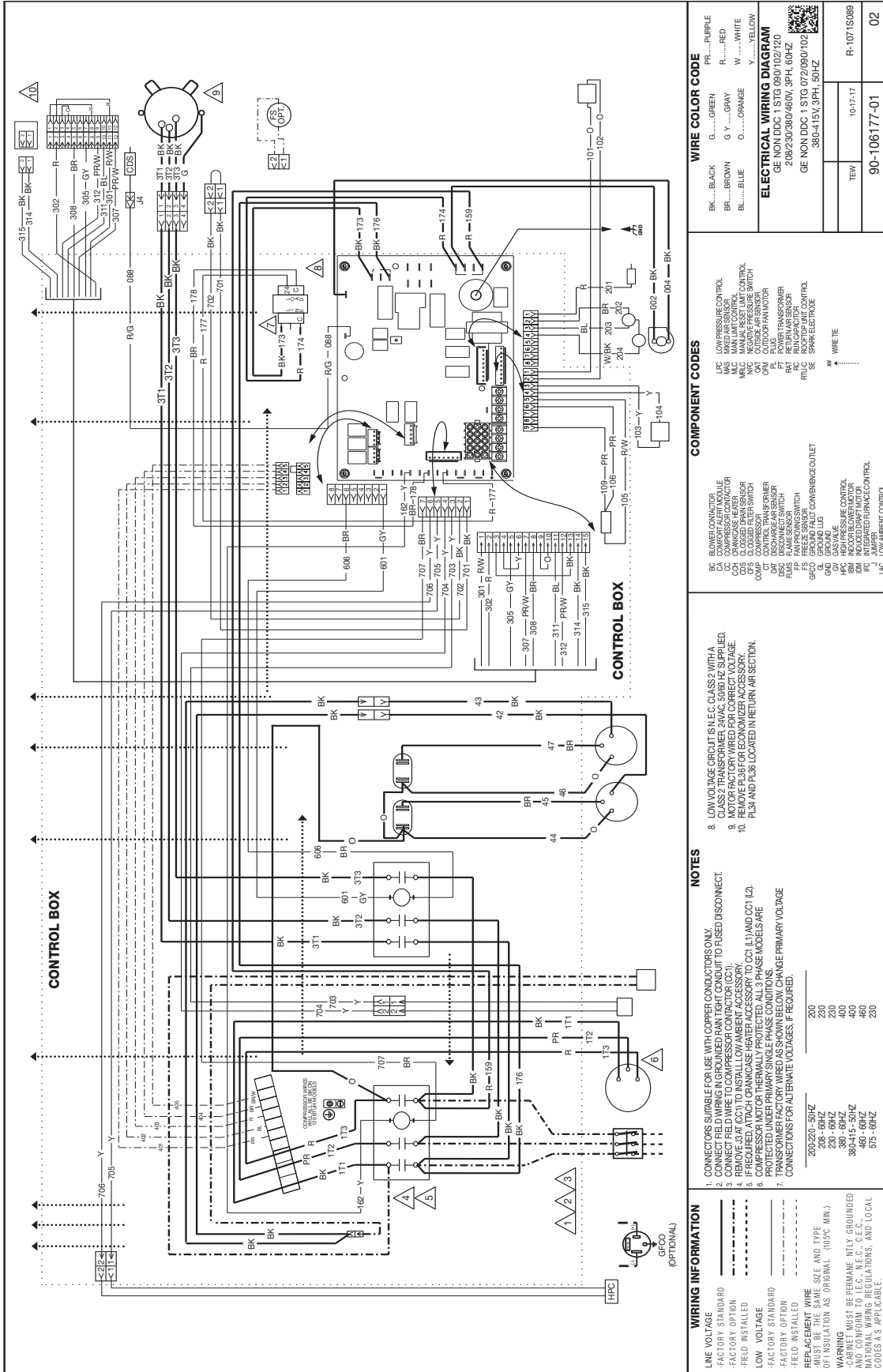

Appendix G. Wiring Diagrams & Schematics (Cont.)

The diagram illustrates the electrical control system for a compressor. It features a power supply (L1, L2, L3) connected to a main control circuit. Key components include:

- Compressor (COMP):** The primary load, connected through a contactor (C) and a fuse (F).
- Control Circuit:** Includes a fuse (F), a thermal protector (TP), and a pressure switch (PS).
- Sensors:** Various sensors (S) for pressure, temperature, and flow are connected to the control circuit.
- Relays and Switches:** Includes a remote switch, a selector relay, and a detector relay.
- Wiring:** Shows detailed wiring paths with terminal numbers and wire types (e.g., FLD, FLD-OPTION).

CODE	Description	WIRE COLOR
B	COMPRESSION LOW PRESSURE SWITCH OPEN - CIRCUIT 1	FR...PURPLE
C	COMPRESSION HIGH PRESSURE SWITCH OPEN - CIRCUIT 1	R...RED
D	COMPRESSION LOW PRESSURE SWITCH OPEN - CIRCUIT 2	W...WHITE
E	COMPRESSION HIGH PRESSURE SWITCH OPEN - CIRCUIT 2	Y...YELLOW
F	CONDENSER FAN MOTOR	
G	CONDENSER FAN MOTOR	
H	CONDENSER FAN MOTOR	
I	CONDENSER FAN MOTOR	
J	CONDENSER FAN MOTOR	
K	CONDENSER FAN MOTOR	
L	CONDENSER FAN MOTOR	
M	CONDENSER FAN MOTOR	
N	CONDENSER FAN MOTOR	
O	CONDENSER FAN MOTOR	
P	CONDENSER FAN MOTOR	
Q	CONDENSER FAN MOTOR	
R	CONDENSER FAN MOTOR	
S	CONDENSER FAN MOTOR	
T	CONDENSER FAN MOTOR	
U	CONDENSER FAN MOTOR	
V	CONDENSER FAN MOTOR	
W	CONDENSER FAN MOTOR	
X	CONDENSER FAN MOTOR	
Y	CONDENSER FAN MOTOR	
Z	CONDENSER FAN MOTOR	

WIRE COLOR CODE	WIRE COLOR
FR...PURPLE	FR...PURPLE
R...RED	R...RED
W...WHITE	W...WHITE
Y...YELLOW	Y...YELLOW

ELECTRICAL WIRING SCHEMATIC

GE NON DDC 1 STG 090702/120
 20925038004600, 3PH, 60HZ
 GE NON DDC 1 STG 0702090/102
 380-415V, 3PH, 50HZ

APPROVED: _____ DATE: 10/17/17
 MODELED BY: TEW
 ORIGINAL RELEASE NO: R-1071S089
 PART NO.: 90-106178-01 REV: 04

ALARM CODES

CODE	Description	WIRE COLOR
B	COMPRESSION LOW PRESSURE SWITCH OPEN - CIRCUIT 1	FR...PURPLE
C	COMPRESSION HIGH PRESSURE SWITCH OPEN - CIRCUIT 1	R...RED
D	COMPRESSION LOW PRESSURE SWITCH OPEN - CIRCUIT 2	W...WHITE
E	COMPRESSION HIGH PRESSURE SWITCH OPEN - CIRCUIT 2	Y...YELLOW
F	CONDENSER FAN MOTOR	
G	CONDENSER FAN MOTOR	
H	CONDENSER FAN MOTOR	
I	CONDENSER FAN MOTOR	
J	CONDENSER FAN MOTOR	
K	CONDENSER FAN MOTOR	
L	CONDENSER FAN MOTOR	
M	CONDENSER FAN MOTOR	
N	CONDENSER FAN MOTOR	
O	CONDENSER FAN MOTOR	
P	CONDENSER FAN MOTOR	
Q	CONDENSER FAN MOTOR	
R	CONDENSER FAN MOTOR	
S	CONDENSER FAN MOTOR	
T	CONDENSER FAN MOTOR	
U	CONDENSER FAN MOTOR	
V	CONDENSER FAN MOTOR	
W	CONDENSER FAN MOTOR	
X	CONDENSER FAN MOTOR	
Y	CONDENSER FAN MOTOR	
Z	CONDENSER FAN MOTOR	

COMPONENT CODES

UPC LOW PRESSURE CONTROL
 MAS MATED AIR SENSOR
 MRLC MANUAL RESET LIMIT CONTROL
 MRC MANUAL RESET LIMIT CONTROL
 OAT OUTSIDE AIR SENSOR
 ORV OUTDOOR FAN MOTOR
 PFC POWER TRANSFORMER
 PFM FAN MOTOR
 PFC FAN CAPACITOR
 PFC FAN CAPACITOR
 PFC SPARK ELECTRODE

NOTES

- CONNECTORS SUITABLE FOR USE WITH COPPER CONDUCTORS ONLY.
- CONNECT FELD WIRING IN GROUNDED RAN TIGHT CONDUIT TO FUSED DISCONNECT.
- REMOVE J2 AT (C2) TO INSTALL LOW AMBIENT ACCESSORY (CCA).
- REMOVE J2 AT (C2) TO INSTALL LOW AMBIENT ACCESSORY (CC1, L1) AND CCI (L2).
- COMPRESSOR MOTOR THERMALLY PROTECTED, ALL 3 PHASE MODELS ARE PROTECTED UNDER PRIMARY SINGLE PHASE CONDITIONS.
- TRANSFORMER FACTORY WIRING AS SHOWN BELOW CHANGE PRIMARY VOLTAGE CONNECTIONS FOR ALTERNATE VOLTAGES, IF REQUIRED.

PRIMARY VOLTAGE	TRANSFORMER TERM.
200 - 208V 60HZ	200
208 - 60HZ	230
230 - 60HZ	230
380 - 415V 50HZ	400
480 - 60HZ	460
575 - 60HZ	230

WIRING INFORMATION

LINE VOLTAGE: _____
 FACTORY STANDARD: _____
 FACTORY OPTION: _____
 FELD INSTALLED: _____
 LOW VOLTAGE: _____
 FACTORY STANDARD: _____
 FACTORY OPTION: _____
 FELD INSTALLED: _____

REPLACEMENT WIRE SIZE AND TYPE OF INSULATION AS ORIGINAL (105°C MIN.)

WARNING: CABINET MUST BE PERMANENTLY GROUNDED AND CONFORM TO NEC, N.E.C. C.E.C. AND LOCAL REGULATIONS, AND LOCAL CODES AS APPLICABLE.

P. APPENDICES

Appendix G. Wiring Diagrams & Schematics (Cont.)

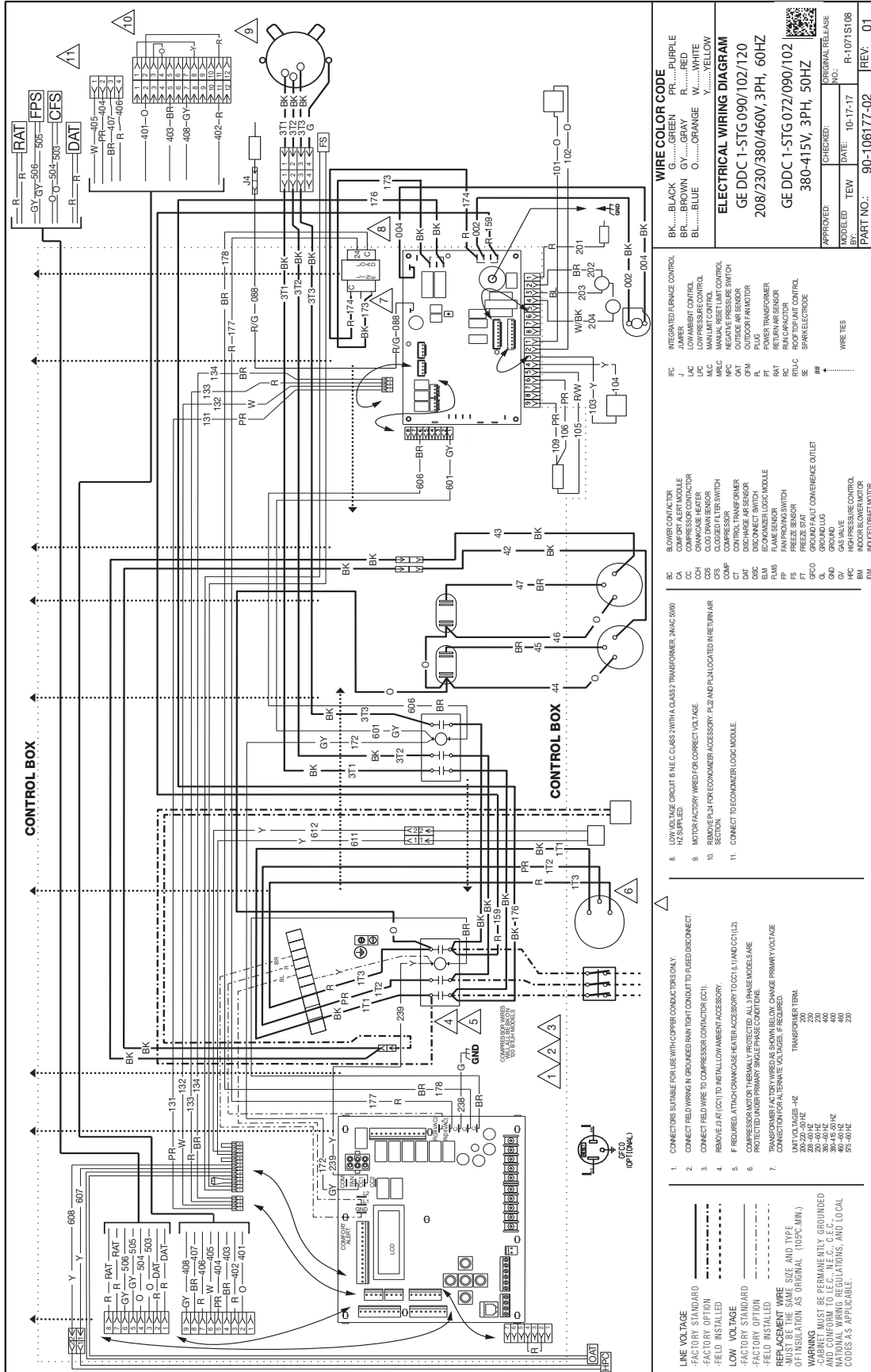

Appendix G. Wiring Diagrams & Schematics (Cont.)

RTU-C 1188-100

Thermostat connections: T1, T2, T3, T4, T5, T6, T7, T8, T9, T10, T11, T12, T13, T14, T15, T16, T17, T18, T19, T20, T21, T22, T23, T24, T25, T26, T27, T28, T29, T30, T31, T32, T33, T34, T35, T36, T37, T38, T39, T40, T41, T42, T43, T44, T45, T46, T47, T48, T49, T50, T51, T52, T53, T54, T55, T56, T57, T58, T59, T60, T61, T62, T63, T64, T65, T66, T67, T68, T69, T70, T71, T72, T73, T74, T75, T76, T77, T78, T79, T80, T81, T82, T83, T84, T85, T86, T87, T88, T89, T90, T91, T92, T93, T94, T95, T96, T97, T98, T99, T100.

Zone Sensor connections: ZS1, ZS2, ZS3, ZS4, ZS5, ZS6, ZS7, ZS8, ZS9, ZS10, ZS11, ZS12, ZS13, ZS14, ZS15, ZS16, ZS17, ZS18, ZS19, ZS20, ZS21, ZS22, ZS23, ZS24, ZS25, ZS26, ZS27, ZS28, ZS29, ZS30, ZS31, ZS32, ZS33, ZS34, ZS35, ZS36, ZS37, ZS38, ZS39, ZS40, ZS41, ZS42, ZS43, ZS44, ZS45, ZS46, ZS47, ZS48, ZS49, ZS50, ZS51, ZS52, ZS53, ZS54, ZS55, ZS56, ZS57, ZS58, ZS59, ZS60, ZS61, ZS62, ZS63, ZS64, ZS65, ZS66, ZS67, ZS68, ZS69, ZS70, ZS71, ZS72, ZS73, ZS74, ZS75, ZS76, ZS77, ZS78, ZS79, ZS80, ZS81, ZS82, ZS83, ZS84, ZS85, ZS86, ZS87, ZS88, ZS89, ZS90, ZS91, ZS92, ZS93, ZS94, ZS95, ZS96, ZS97, ZS98, ZS99, ZS100.

Smoke Detector connections: SD1, SD2, SD3, SD4, SD5, SD6, SD7, SD8, SD9, SD10, SD11, SD12, SD13, SD14, SD15, SD16, SD17, SD18, SD19, SD20, SD21, SD22, SD23, SD24, SD25, SD26, SD27, SD28, SD29, SD30, SD31, SD32, SD33, SD34, SD35, SD36, SD37, SD38, SD39, SD40, SD41, SD42, SD43, SD44, SD45, SD46, SD47, SD48, SD49, SD50, SD51, SD52, SD53, SD54, SD55, SD56, SD57, SD58, SD59, SD60, SD61, SD62, SD63, SD64, SD65, SD66, SD67, SD68, SD69, SD70, SD71, SD72, SD73, SD74, SD75, SD76, SD77, SD78, SD79, SD80, SD81, SD82, SD83, SD84, SD85, SD86, SD87, SD88, SD89, SD90, SD91, SD92, SD93, SD94, SD95, SD96, SD97, SD98, SD99, SD100.

Other components: COMP, IBM, DISC (OPTIONAL), IFC, K10, 24VAC, L1, L2, L3, L4, L5, L6, L7, L8, L9, L10, L11, L12, L13, L14, L15, L16, L17, L18, L19, L20, L21, L22, L23, L24, L25, L26, L27, L28, L29, L30, L31, L32, L33, L34, L35, L36, L37, L38, L39, L40, L41, L42, L43, L44, L45, L46, L47, L48, L49, L50, L51, L52, L53, L54, L55, L56, L57, L58, L59, L60, L61, L62, L63, L64, L65, L66, L67, L68, L69, L70, L71, L72, L73, L74, L75, L76, L77, L78, L79, L80, L81, L82, L83, L84, L85, L86, L87, L88, L89, L90, L91, L92, L93, L94, L95, L96, L97, L98, L99, L100.

ALARM CODES		FAULT LEVEL
CODE	Description	(0-1,2,3)
0	STANDBY	0
1	COMPRESSOR ON - Low (Flashing in time delay)	0
2	COMPRESSOR ON - High (Flashing in time delay)	0
3	Compressor Cooling - No Compressor	0
4	Compressor Fan	0
5	Refrigerant Low Stage	0
6	Refrigerant High Stage	0
7	Comer Alert Code 4 for Compressor Circuit 1	3
8	Comer Alert Code 5 for Compressor Circuit 1	3
9	Comer Alert Code 6 for Compressor Circuit 1	3
10	Comer Alert Code 7 for Compressor Circuit 1	3
11	Comer Alert Code 8 for Compressor Circuit 1	3
12	Comer Alert Code 9 for Compressor Circuit 1	3
13	Comer Alert Code 4 for Compressor Circuit 2	3
14	Comer Alert Code 5 for Compressor Circuit 2	3
15	Comer Alert Code 6 for Compressor Circuit 2	3
16	Comer Alert Code 7 for Compressor Circuit 2	3
17	Comer Alert Code 8 for Compressor Circuit 2	3
18	Comer Alert Code 9 for Compressor Circuit 2	3
19	Comer Alert Code 4 for Compressor Circuit 3	3
20	Comer Alert Code 5 for Compressor Circuit 3	3
21	Comer Alert Code 6 for Compressor Circuit 3	3
22	Comer Alert Code 7 for Compressor Circuit 3	3
23	Comer Alert Code 8 for Compressor Circuit 3	3
24	Comer Alert Code 9 for Compressor Circuit 3	3
25	Comer Alert Code 4 for Compressor Circuit 4	3
26	Comer Alert Code 5 for Compressor Circuit 4	3
27	Comer Alert Code 6 for Compressor Circuit 4	3
28	Comer Alert Code 7 for Compressor Circuit 4	3
29	Comer Alert Code 8 for Compressor Circuit 4	3
30	Comer Alert Code 9 for Compressor Circuit 4	3
31	Comer Alert Code 4 for Compressor Circuit 5	3
32	Comer Alert Code 5 for Compressor Circuit 5	3
33	Comer Alert Code 6 for Compressor Circuit 5	3
34	Comer Alert Code 7 for Compressor Circuit 5	3
35	Comer Alert Code 8 for Compressor Circuit 5	3
36	Comer Alert Code 9 for Compressor Circuit 5	3
37	Comer Alert Code 4 for Compressor Circuit 6	3
38	Comer Alert Code 5 for Compressor Circuit 6	3
39	Comer Alert Code 6 for Compressor Circuit 6	3
40	Comer Alert Code 7 for Compressor Circuit 6	3
41	Comer Alert Code 8 for Compressor Circuit 6	3
42	Comer Alert Code 9 for Compressor Circuit 6	3
43	Comer Alert Code 4 for Compressor Circuit 7	3
44	Comer Alert Code 5 for Compressor Circuit 7	3
45	Comer Alert Code 6 for Compressor Circuit 7	3
46	Comer Alert Code 7 for Compressor Circuit 7	3
47	Comer Alert Code 8 for Compressor Circuit 7	3
48	Comer Alert Code 9 for Compressor Circuit 7	3
49	Comer Alert Code 4 for Compressor Circuit 8	3
50	Comer Alert Code 5 for Compressor Circuit 8	3
51	Comer Alert Code 6 for Compressor Circuit 8	3
52	Comer Alert Code 7 for Compressor Circuit 8	3
53	Comer Alert Code 8 for Compressor Circuit 8	3
54	Comer Alert Code 9 for Compressor Circuit 8	3
55	Comer Alert Code 4 for Compressor Circuit 9	3
56	Comer Alert Code 5 for Compressor Circuit 9	3
57	Comer Alert Code 6 for Compressor Circuit 9	3
58	Comer Alert Code 7 for Compressor Circuit 9	3
59	Comer Alert Code 8 for Compressor Circuit 9	3
60	Comer Alert Code 9 for Compressor Circuit 9	3
61	Comer Alert Code 4 for Compressor Circuit 10	3
62	Comer Alert Code 5 for Compressor Circuit 10	3
63	Comer Alert Code 6 for Compressor Circuit 10	3
64	Comer Alert Code 7 for Compressor Circuit 10	3
65	Comer Alert Code 8 for Compressor Circuit 10	3
66	Comer Alert Code 9 for Compressor Circuit 10	3
67	Comer Alert Code 4 for Compressor Circuit 11	3
68	Comer Alert Code 5 for Compressor Circuit 11	3
69	Comer Alert Code 6 for Compressor Circuit 11	3
70	Comer Alert Code 7 for Compressor Circuit 11	3
71	Comer Alert Code 8 for Compressor Circuit 11	3
72	Comer Alert Code 9 for Compressor Circuit 11	3
73	Comer Alert Code 4 for Compressor Circuit 12	3
74	Comer Alert Code 5 for Compressor Circuit 12	3
75	Comer Alert Code 6 for Compressor Circuit 12	3
76	Comer Alert Code 7 for Compressor Circuit 12	3
77	Comer Alert Code 8 for Compressor Circuit 12	3
78	Comer Alert Code 9 for Compressor Circuit 12	3
79	Comer Alert Code 4 for Compressor Circuit 13	3
80	Comer Alert Code 5 for Compressor Circuit 13	3
81	Comer Alert Code 6 for Compressor Circuit 13	3
82	Comer Alert Code 7 for Compressor Circuit 13	3
83	Comer Alert Code 8 for Compressor Circuit 13	3
84	Comer Alert Code 9 for Compressor Circuit 13	3
85	Comer Alert Code 4 for Compressor Circuit 14	3
86	Comer Alert Code 5 for Compressor Circuit 14	3
87	Comer Alert Code 6 for Compressor Circuit 14	3
88	Comer Alert Code 7 for Compressor Circuit 14	3
89	Comer Alert Code 8 for Compressor Circuit 14	3
90	Comer Alert Code 9 for Compressor Circuit 14	3
91	Comer Alert Code 4 for Compressor Circuit 15	3
92	Comer Alert Code 5 for Compressor Circuit 15	3
93	Comer Alert Code 6 for Compressor Circuit 15	3
94	Comer Alert Code 7 for Compressor Circuit 15	3
95	Comer Alert Code 8 for Compressor Circuit 15	3
96	Comer Alert Code 9 for Compressor Circuit 15	3
97	Comer Alert Code 4 for Compressor Circuit 16	3
98	Comer Alert Code 5 for Compressor Circuit 16	3
99	Comer Alert Code 6 for Compressor Circuit 16	3
100	Comer Alert Code 7 for Compressor Circuit 16	3

WIRE COLOR CODE

BK...BLACK G...GREEN PR...PURPLE
 BR...BROWN G Y...GRAY R...RED
 BL...BLUE O...ORANGE W...WHITE
 Y...YELLOW

ELECTRICAL WIRING SCHEMATIC

GE DDC 4 STG 080/102/120
 208/230/50/40/60V, 3PH, 60HZ
 GE DDC 4 STG 079 080/102
 208/230/50/40/60V, 3PH, 50HZ

APPROVED: [Signature] **DATE:** 10-24-17
MODELED BY: TEW **NO.:** R-071S108
PART NO.: 90-106178-02 **REV.:** 01

COMPONENT CODES

BC BLOWER CONTACTOR
 CC COMPRESSOR CONTACTOR
 CO CONDENSATE OVERFLOW SWITCH
 CS COMPRESSOR SAFETY SWITCH
 CR COMPRESSOR RELAY
 CSF COMPRESSOR SAFETY FUSE
 CSF2 COMPRESSOR SAFETY FUSE 2
 CSF3 COMPRESSOR SAFETY FUSE 3
 CSF4 COMPRESSOR SAFETY FUSE 4
 CSF5 COMPRESSOR SAFETY FUSE 5
 CSF6 COMPRESSOR SAFETY FUSE 6
 CSF7 COMPRESSOR SAFETY FUSE 7
 CSF8 COMPRESSOR SAFETY FUSE 8
 CSF9 COMPRESSOR SAFETY FUSE 9
 CSF10 COMPRESSOR SAFETY FUSE 10
 CSF11 COMPRESSOR SAFETY FUSE 11
 CSF12 COMPRESSOR SAFETY FUSE 12
 CSF13 COMPRESSOR SAFETY FUSE 13
 CSF14 COMPRESSOR SAFETY FUSE 14
 CSF15 COMPRESSOR SAFETY FUSE 15
 CSF16 COMPRESSOR SAFETY FUSE 16
 CSF17 COMPRESSOR SAFETY FUSE 17
 CSF18 COMPRESSOR SAFETY FUSE 18
 CSF19 COMPRESSOR SAFETY FUSE 19
 CSF20 COMPRESSOR SAFETY FUSE 20
 CSF21 COMPRESSOR SAFETY FUSE 21
 CSF22 COMPRESSOR SAFETY FUSE 22
 CSF23 COMPRESSOR SAFETY FUSE 23
 CSF24 COMPRESSOR SAFETY FUSE 24
 CSF25 COMPRESSOR SAFETY FUSE 25
 CSF26 COMPRESSOR SAFETY FUSE 26
 CSF27 COMPRESSOR SAFETY FUSE 27
 CSF28 COMPRESSOR SAFETY FUSE 28
 CSF29 COMPRESSOR SAFETY FUSE 29
 CSF30 COMPRESSOR SAFETY FUSE 30
 CSF31 COMPRESSOR SAFETY FUSE 31
 CSF32 COMPRESSOR SAFETY FUSE 32
 CSF33 COMPRESSOR SAFETY FUSE 33
 CSF34 COMPRESSOR SAFETY FUSE 34
 CSF35 COMPRESSOR SAFETY FUSE 35
 CSF36 COMPRESSOR SAFETY FUSE 36
 CSF37 COMPRESSOR SAFETY FUSE 37
 CSF38 COMPRESSOR SAFETY FUSE 38
 CSF39 COMPRESSOR SAFETY FUSE 39
 CSF40 COMPRESSOR SAFETY FUSE 40
 CSF41 COMPRESSOR SAFETY FUSE 41
 CSF42 COMPRESSOR SAFETY FUSE 42
 CSF43 COMPRESSOR SAFETY FUSE 43
 CSF44 COMPRESSOR SAFETY FUSE 44
 CSF45 COMPRESSOR SAFETY FUSE 45
 CSF46 COMPRESSOR SAFETY FUSE 46
 CSF47 COMPRESSOR SAFETY FUSE 47
 CSF48 COMPRESSOR SAFETY FUSE 48
 CSF49 COMPRESSOR SAFETY FUSE 49
 CSF50 COMPRESSOR SAFETY FUSE 50
 CSF51 COMPRESSOR SAFETY FUSE 51
 CSF52 COMPRESSOR SAFETY FUSE 52
 CSF53 COMPRESSOR SAFETY FUSE 53
 CSF54 COMPRESSOR SAFETY FUSE 54
 CSF55 COMPRESSOR SAFETY FUSE 55
 CSF56 COMPRESSOR SAFETY FUSE 56
 CSF57 COMPRESSOR SAFETY FUSE 57
 CSF58 COMPRESSOR SAFETY FUSE 58
 CSF59 COMPRESSOR SAFETY FUSE 59
 CSF60 COMPRESSOR SAFETY FUSE 60
 CSF61 COMPRESSOR SAFETY FUSE 61
 CSF62 COMPRESSOR SAFETY FUSE 62
 CSF63 COMPRESSOR SAFETY FUSE 63
 CSF64 COMPRESSOR SAFETY FUSE 64
 CSF65 COMPRESSOR SAFETY FUSE 65
 CSF66 COMPRESSOR SAFETY FUSE 66
 CSF67 COMPRESSOR SAFETY FUSE 67
 CSF68 COMPRESSOR SAFETY FUSE 68
 CSF69 COMPRESSOR SAFETY FUSE 69
 CSF70 COMPRESSOR SAFETY FUSE 70
 CSF71 COMPRESSOR SAFETY FUSE 71
 CSF72 COMPRESSOR SAFETY FUSE 72
 CSF73 COMPRESSOR SAFETY FUSE 73
 CSF74 COMPRESSOR SAFETY FUSE 74
 CSF75 COMPRESSOR SAFETY FUSE 75
 CSF76 COMPRESSOR SAFETY FUSE 76
 CSF77 COMPRESSOR SAFETY FUSE 77
 CSF78 COMPRESSOR SAFETY FUSE 78
 CSF79 COMPRESSOR SAFETY FUSE 79
 CSF80 COMPRESSOR SAFETY FUSE 80
 CSF81 COMPRESSOR SAFETY FUSE 81
 CSF82 COMPRESSOR SAFETY FUSE 82
 CSF83 COMPRESSOR SAFETY FUSE 83
 CSF84 COMPRESSOR SAFETY FUSE 84
 CSF85 COMPRESSOR SAFETY FUSE 85
 CSF86 COMPRESSOR SAFETY FUSE 86
 CSF87 COMPRESSOR SAFETY FUSE 87
 CSF88 COMPRESSOR SAFETY FUSE 88
 CSF89 COMPRESSOR SAFETY FUSE 89
 CSF90 COMPRESSOR SAFETY FUSE 90
 CSF91 COMPRESSOR SAFETY FUSE 91
 CSF92 COMPRESSOR SAFETY FUSE 92
 CSF93 COMPRESSOR SAFETY FUSE 93
 CSF94 COMPRESSOR SAFETY FUSE 94
 CSF95 COMPRESSOR SAFETY FUSE 95
 CSF96 COMPRESSOR SAFETY FUSE 96
 CSF97 COMPRESSOR SAFETY FUSE 97
 CSF98 COMPRESSOR SAFETY FUSE 98
 CSF99 COMPRESSOR SAFETY FUSE 99
 CSF100 COMPRESSOR SAFETY FUSE 100

NOTES

- CONNECTORS SUITABLE FOR USE WITH COPPER CONDUCTORS ONLY.
- CONNECT FIELD WIRE TO COMPRESSOR CONTACTOR (CC).
- REMOVE IS AT (CCT1) TO INSTALL LOW AMBIENT ACCESSORY.
- IF REQUIRED, ATTACH CRANK CASE HEATER ACCESSORY TO CCT1 (L1) AND CCT1 (L2).
- COMPRESSOR MOTOR THERMALLY PROTECTED. ALL 3 PHASE MODELS ARE PROTECTED UNDER PRIMARY SINGLE PHASE CONDITIONS.
- CONNECTIONS FOR ALTERNATE VOLTAGES, IF REQUIRED.

UNIT VOLTAGES - HZ

200-230-50/40	TRANSFORMER TERM.	230
208-60/40		230
380-60/40		230
380-60/40		400
380-60/40		460
575-60/40		230

P. APPENDICES

Appendix G. Wiring Diagrams & Schematics (Cont.)

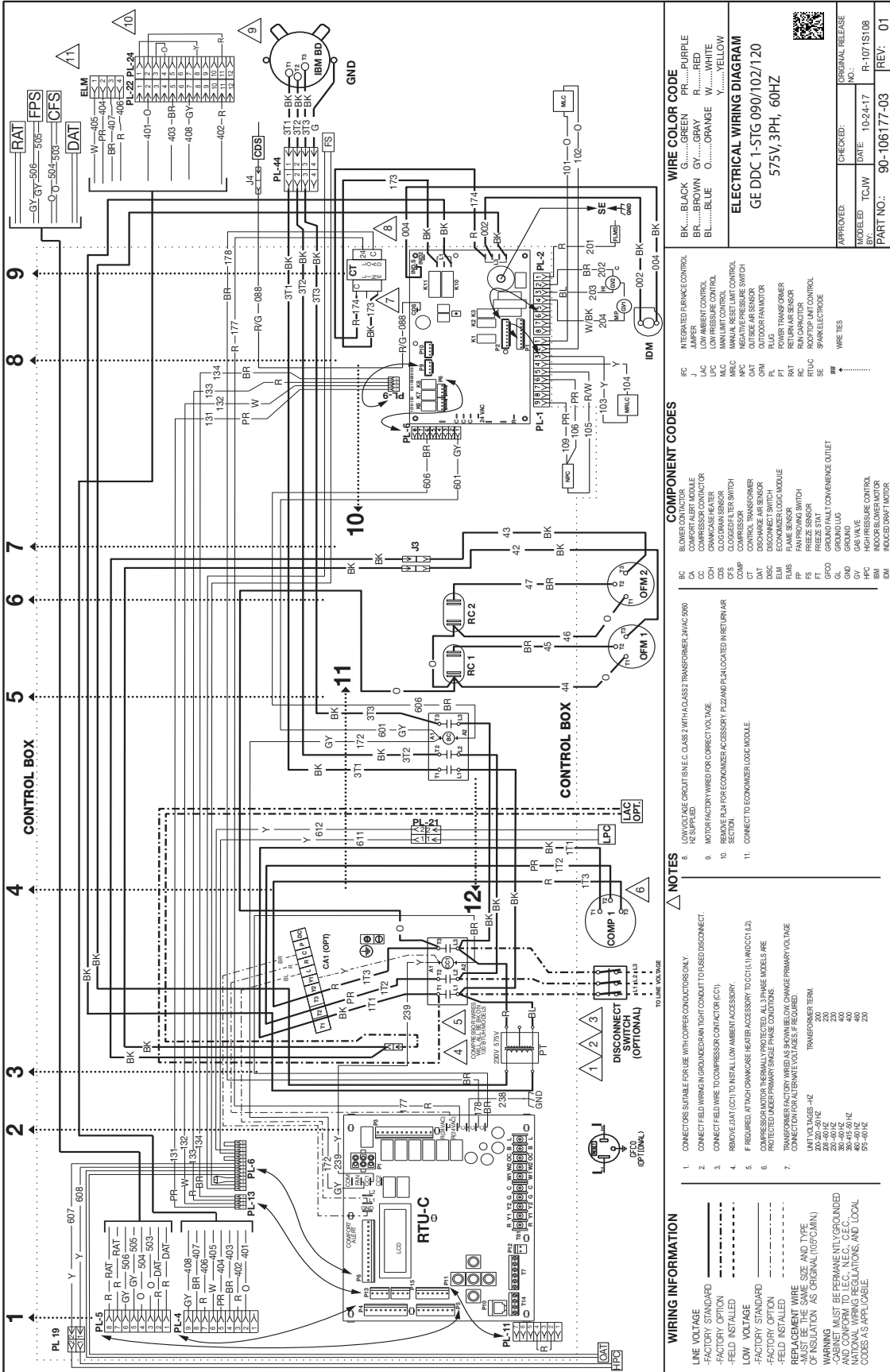

Appendix G. Wiring Diagrams & Schematics (Cont.)

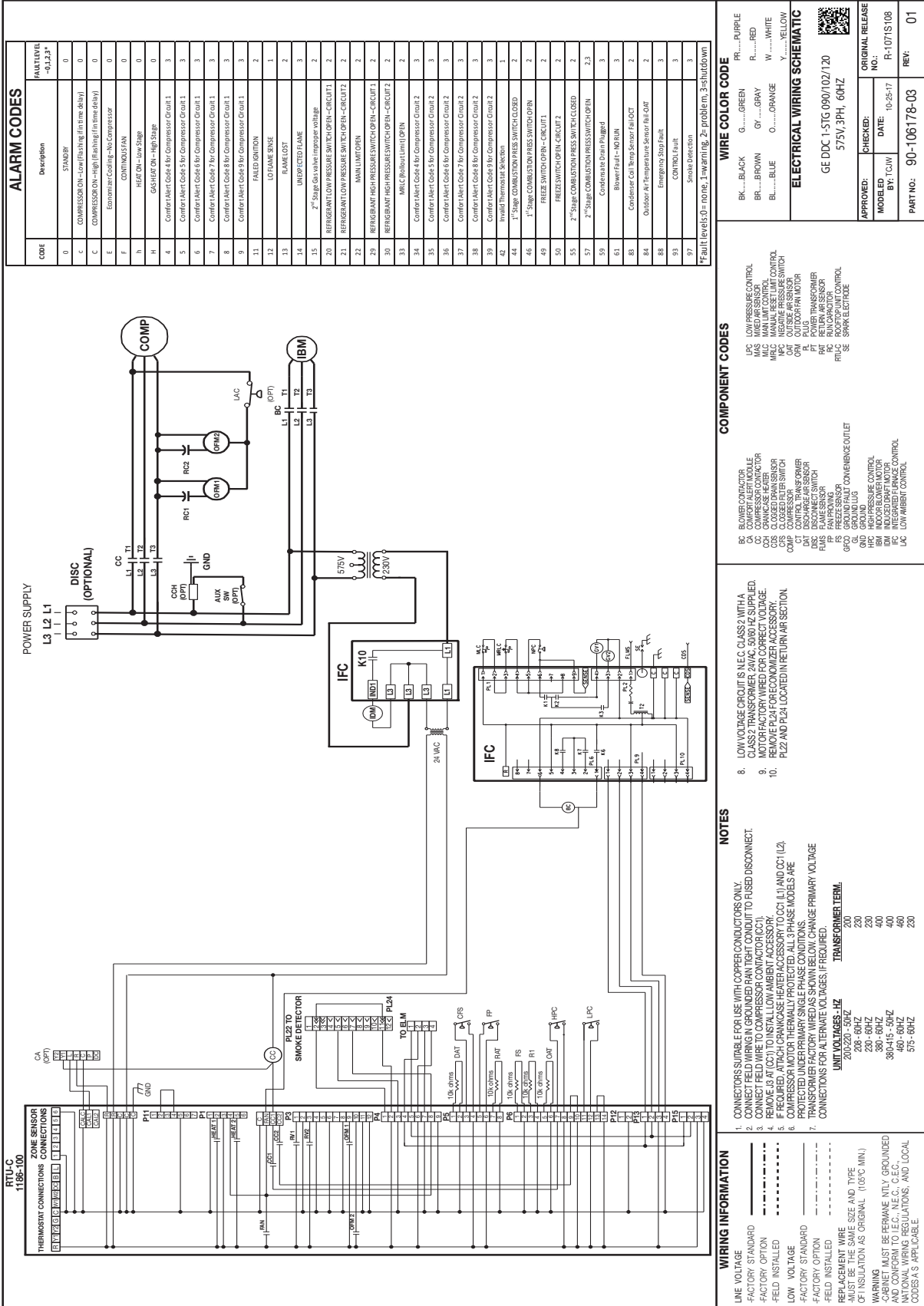

P. APPENDICES

Appendix G. Wiring Diagrams & Schematics (Cont.)

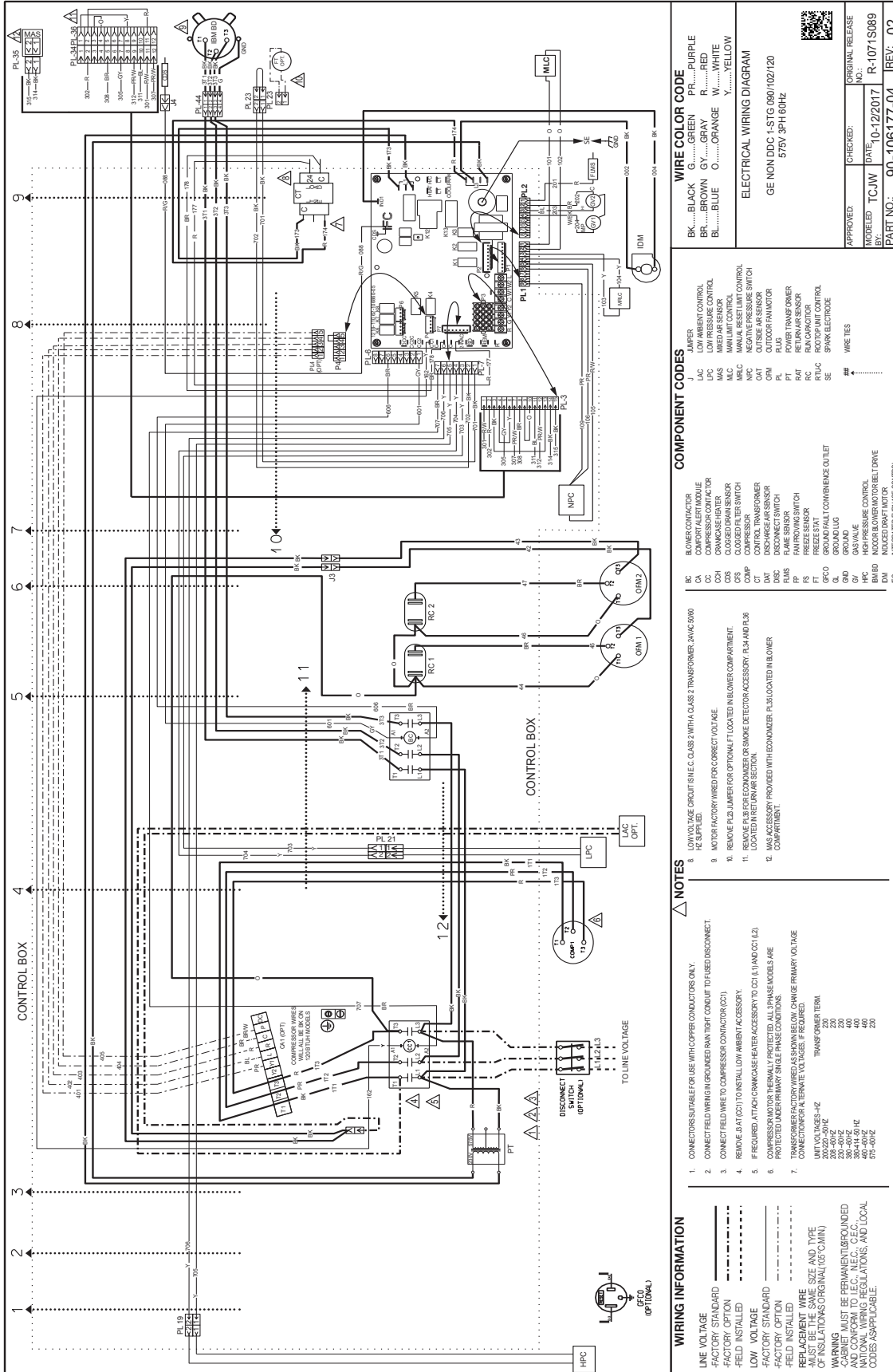

Appendix G. Wiring Diagrams & Schematics (Cont.)

ALARM CODES	
CODE	Description
0	STANDBY
C	COMPRESSION - Low (Flashing) (in time delay)
C	COMPRESSION - High (Flashing) (in time delay)
E	Economizer Cooling - no Compressor
F	CONTROLS FAN
H	HEATON - Low Stage
H	GAS HEATON - High Stage
4	Comfort Alert Code 4 for Compressor Circuit 1
5	Comfort Alert Code 5 for Compressor Circuit 1
6	Comfort Alert Code 6 for Compressor Circuit 1
7	Comfort Alert Code 7 for Compressor Circuit 1
8	Comfort Alert Code 8 for Compressor Circuit 1
9	Comfort Alert Code 9 for Compressor Circuit 1
11	FAILED IGNITION
12	LO FLAME SENSE
13	FLAME LOST
14	UNEXPECTED FLAME
15	2 nd Stage Gas Valve Amps over voltage
20	REFRIGERANT LOW PRESSURE SWITCH OPEN - CIRCUIT 1
21	REFRIGERANT LOW PRESSURE SWITCH OPEN - CIRCUIT 2
22	MANUAL LIMIT OPEN
23	REFRIGERANT HIGH PRESSURE SWITCH OPEN - CIRCUIT 1
30	REFRIGERANT HIGH PRESSURE SWITCH OPEN - CIRCUIT 2
33	MBC (Refract Limit) OPEN
34	Comfort Alert Code 4 for Compressor Circuit 2
35	Comfort Alert Code 5 for Compressor Circuit 2
36	Comfort Alert Code 6 for Compressor Circuit 2
37	Comfort Alert Code 7 for Compressor Circuit 2
38	Comfort Alert Code 8 for Compressor Circuit 2
41	Inhibit Thermostat Selection
42	1 st Stage COMBUSTION PRESS SWITCH CLOSED
46	1 st Stage COMBUSTION PRESS SWITCH OPEN
49	FREEZE SWITCH OPEN - CIRCUIT 1
50	FREEZE SWITCH OPEN - CIRCUIT 2
55	2 nd Stage COMBUSTION PRESS SWITCH CLOSED
57	2 nd Stage COMBUSTION PRESS SWITCH OPEN
59	Condensate Drain Plugged
61	Blower fault - NORM
83	Condenser Oil Temp Sensor Fail - OCT
84	Outdoor Air Temperature Sensor Fail - OCT
86	Emergency Stop Fault
93	CONTROL Fault
97	Smoke Detection

WIRE COLOR CODE	
Color	Code
Black	BL.....BLACK
Green	G.....GREEN
Purple	PR.....PURPLE
Brown	BR.....BROWN
Gray	GY.....GRAY
Red	R.....RED
White	W.....WHITE
Blue	BL.....BLUE
Orange	O.....ORANGE
Yellow	Y.....YELLOW

ELECTRICAL WIRING SCHEMATIC	
GE NON DDC 1-5TG 090/102/120	576V 3PH 60HZ
APPROVED:	CHECKED:
MODELED BY: TCM	DATE: 10-19-17
PART NO.: 90-106178-04	REV: 03

COMPONENT CODES	
Code	Description
LAC	LOW AMBIENT CONTROL
LPC	LOW PRESSURE CONTROL
LTC	LOW TEMPERATURE CONTROL
MPC	MANUAL PRESSURE SWITCH
NPC	NEGATIVE PRESSURE SWITCH
OAI	OUTSIDE AIR SENSOR
ORI	OUTDOOR FAN MOTOR
COI	COIL
CON	CONTROL TRANSFORMER
PT	POWER TRANSFORMER
DAT	DISCHARGE AIR SENSOR
DIS	DISCHARGE SWITCH
ES	EMERGENCY STOP MODULE
FUS	FUSE
FP	FAN PROTECT
FS	FREEZE SENSOR
FREE	FREEZE SWITCH
GFCO	GROUND FAULT COMMENCEMENT OUTLET
GL	GROUND LUS
HC	HIGH PRESSURE CONTROL
HM	HIGH MOTOR BLOWER MOTOR
IM	INDOOR FAN MOTOR
IND	INDOOR FAN MOTOR
INT	INTERFEROMETER CONTROL

NOTES	
1.	CONNECTORS SUITABLE FOR USE WITH COPPER CONDUCTORS ONLY.
2.	CONNECT FIELD WIRING IN GROUNDING RAIN TIGHT CONTACT TO USED DISCONNECT.
3.	CONNECT FIELD WIRE TO COMPRESSOR CONTACTOR (CC).
4.	REMOVE L3 AT (CC) TO INSTALL LOW AMBIENT ACCESSORY.
5.	IF REQUIRED, ATTACH FRAMING CASE HEATER ACCESSORY TO (CC), (L1) AND (CC) (L2).
6.	COMPRESSOR MOTOR THERMALLY PROTECTED. ALL 3-PHASE MODELS ARE PROTECTED UNDER PRIMARY WIRING SINGLE PHASE CONDITIONS.
7.	TRANSFORMER FACTORY WIRING AS SHOWN BELOW. CHANGE PRIMARY VOLTAGE CONNECTIONS FOR ALTERNATE VOLTAGES, IF REQUIRED.

LIMIT VOLTAGES - HZ	
Transformer Term.	Limit Voltage (Hz)
200	200-240
230	230
240	240
277	277
380-415	380-415
460	460
575	575-602

WIRING INFORMATION	
LINE VOLTAGE	FACTORY STANDARD
REPLACEMENT WIRE	MUST BE THE SAME SIZE AND TYPE
OF INSULATION	AS ORIGINAL (105°C MIN.)
WARNING	CABINET MUST BE PERMANENTLY GROUNDED AND CONFORM TO I.E.C. N.E.C. C.E.C. NATIONAL WIRING REGULATIONS, AND LOCAL CODES AS APPLICABLE.

P. APPENDICES

Appendix G. Wiring Diagrams & Schematics (Cont.)

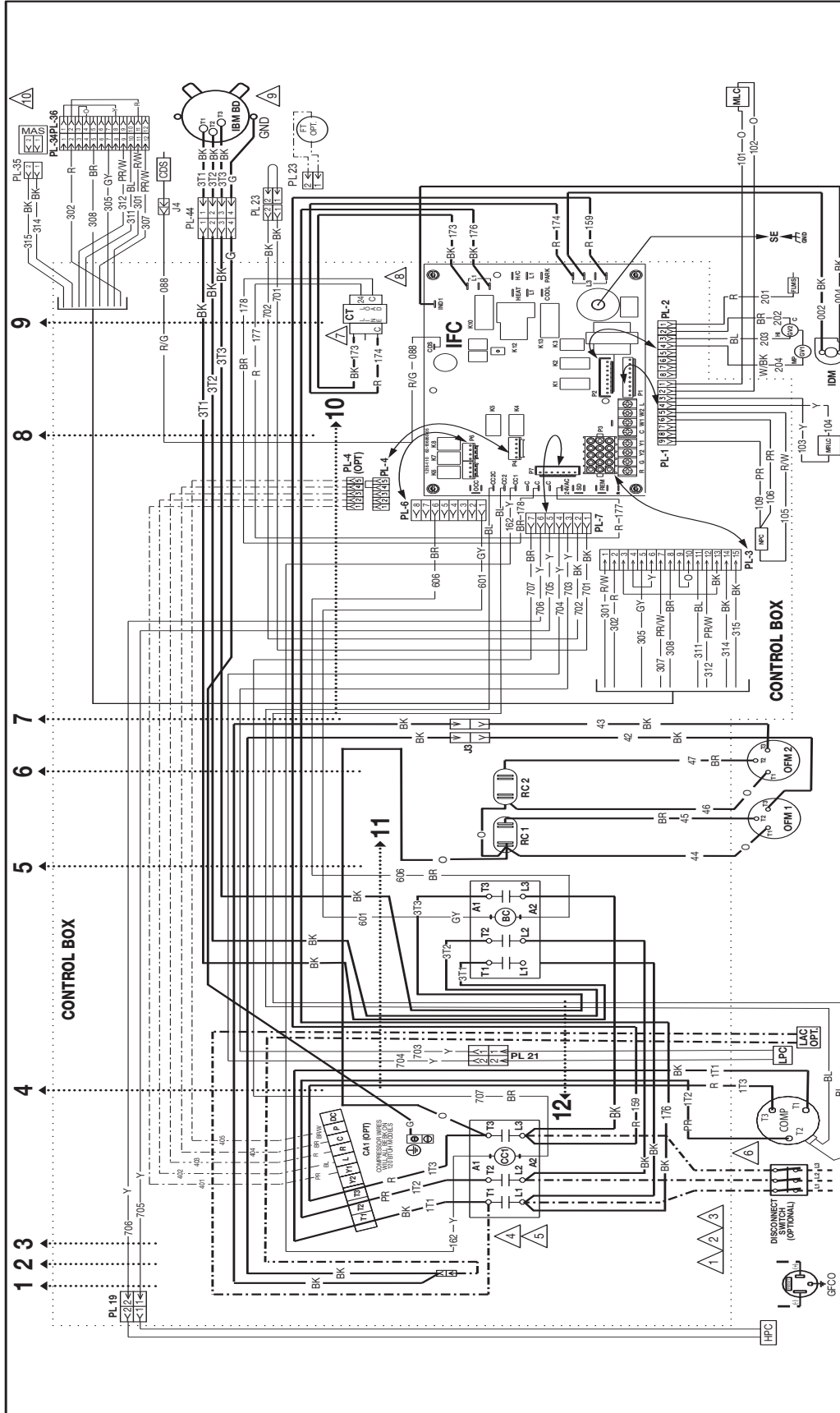

WIRING INFORMATION	
LINE VOLTAGE	— FACTORY STANDARD
	— FACTORY OPTION
	— FIELD INSTALLED
LOW VOLTAGE	— FACTORY STANDARD
	— FACTORY OPTION
REPLACEMENT WIRE	— MUST BE THE SAME SIZE AND TYPE OF INSULATION AS ORIGINAL (115°C MIN)
WARNING	— CABINET MUST BE PERMANENTLY GROUNDED AND CONFORM TO I.E.C., N.E.C., C.E.C., NATIONAL WIRING REGULATIONS, AND LOCAL CODES AS APPLICABLE.

NOTES	
1.	CONNECTORS SUITABLE FOR USE WITH COPPER CONDUCTORS ONLY.
2.	CONNECT FIELD WIRING IN GROUNDING RAIN TIGHT CONDUIT TO FUSED DISCONNECT.
3.	REMOVE (CO) TO INSTALL COMPRESSOR CONTACTOR (CO).
4.	REMOVE (CA) TO INSTALL LOW AMBIENT ACCESSORY.
5.	REQUIRED FOR LOW VOLTAGE ACCESSORY (CO) (L) AND CO (L2).
6.	PROTECTED UNDER PRIMARY SINGLE PHASE CONDITION. PHASE MODELS ARE
7.	TRANSFORMER FACTORY WIRING AS SHOWN BE ONLY. CHANGE PRIMARY VOLTAGE CONNECTIONS FOR ALTERNATE VOLTAGES, IF REQUIRED.

UNIT VOLTAGES - 1/2	TRANSFORMER TERN.
200-230-292V	200
230-292V	230
292-380V	400
380-415-506V	400
460-600V	460
575-600V	230

WIRE COLOR CODE	
BK.....BLACK	G.....GREEN
BR.....BROWN	GY.....GRAY
BL.....BLUE	O.....ORANGE
.....PURPLERED
.....WHITEYELLOW

ELECTRICAL WIRING DIAGRAM	
GE NON DDC 2-STG 090/102/120 208/230/460V 3 PH 60 HZ	

COMPONENT CODES	
BC	BLOWER CONTACTOR
CA	COMPART ALERT MODULE
CC	CAPACITOR
CR	CRACKLE FASTER
CS	CLOSED DRIFT SENSOR
CS	CLOSED FUELER SWITCH
CS	CLOSED FUELER SWITCH
CT	CONTROL TRANSFORMER
DA	DISCHARGE AIR SENSOR
DC	DRIFT CAPACITOR
DM	INDUCED DRAFT MOTOR
FP	FAN PROWING SWITCH
FS	FREEZE SENSOR
GS	GAS VALVE
GND	GROUND
GM	GROUNDING TERMINAL
IBM	INDUCED BLOWER MOTOR
IC	INTERLOCK CONTACTOR
IO	INDUCED DRAFT MOTOR
IP	INTERPRET PURPSE CONTROL
LAC	LOW AMBIENT CONTROL

WIRE COLOR CODE	
BK.....BLACK	G.....GREEN
BR.....BROWN	GY.....GRAY
BL.....BLUE	O.....ORANGE
.....PURPLERED
.....WHITEYELLOW

ELECTRICAL WIRING DIAGRAM	
GE NON DDC 2-STG 090/102/120 208/230/460V 3 PH 60 HZ	

APPROVED:	
CHECKED:	DATE: 10-26-17
MODELED:	BR:TCW
PART NO:	90-106177-05
REV:	02

Appendix G. Wiring Diagrams & Schematics (Cont.)

ALARM CODES		
CODE	Description	FAULT BFL NO./1,2,3
0	STANDBY	0
C	COMPRESSOR ON - Low Flashing (in time delay)	0
C	COMPRESSOR ON - High Flashing (in time delay)	0
E	Economizer Cooling - No Compressor	0
F	CONTINUOUS FAN	0
h	HEATON - Low Stage	0
H	G/S HEATON - High Stage	0
4	CombiAlert Code 4 for Compressor Circuit 1	3
5	CombiAlert Code 5 for Compressor Circuit 1	3
6	CombiAlert Code 6 for Compressor Circuit 1	3
7	CombiAlert Code 7 for Compressor Circuit 1	3
8	CombiAlert Code 8 for Compressor Circuit 1	3
9	CombiAlert Code 9 for Compressor Circuit 1	3
11	FAILED IGNITION	2
12	IGNITION SENSE	1
13	FLAME LOST	2
14	UNEXPECTED FLAME	3
15	2 nd Stage Gas Valve improper voltage	2
21	REFRIGERANT LOW PRESSURE SWITCH OPEN - CIRCUIT 1	2
22	REFRIGERANT HIGH PRESSURE SWITCH OPEN - CIRCUIT 1	2
29	REFRIGERANT HIGH PRESSURE SWITCH OPEN - CIRCUIT 2	2
30	REFRIGERANT HIGH PRESSURE SWITCH OPEN - CIRCUIT 3	2
33	IMC (Reburn Limit) OPEN	2
34	CombiAlert Code 4 for Compressor Circuit 2	3
35	CombiAlert Code 5 for Compressor Circuit 2	3
36	CombiAlert Code 6 for Compressor Circuit 2	3
37	CombiAlert Code 7 for Compressor Circuit 2	3
38	CombiAlert Code 8 for Compressor Circuit 2	3
39	CombiAlert Code 9 for Compressor Circuit 2	3
42	Initial Throttle Limit Selection	1
44	1 st Stage COMBUSTION PRESS SWITCH CLOSED	2
46	1 st Stage COMBUSTION PRESS SWITCH OPEN	2
49	FREZE SWITCH OPEN - CIRCUIT 1	2
50	FREZE SWITCH OPEN - CIRCUIT 2	2
55	2 nd Stage COMBUSTION PRESS SWITCH CLOSED	2
57	2 nd Stage COMBUSTION PRESS SWITCH OPEN	2,3
59	Condensate Drain Plugged	3
61	Blower Fault - NO RUN	3
83	Condensate Coil Temp. Sensor Fail/OK	2
84	Outdoor Air Temperature Sensor Fail/OUT	2
88	Emergency Stop Fault	3
93	CONTROL Fault	3
97	Smoke detection	3

*Fault levels 0 = none, 1=warning, 2= problem, 3=shutdown

WIRE COLOR CODE		
Color	Code	Code
Black	BK.....	BLACK
Green	G.....	GREEN
Purple	PR.....	PURPLE
Brown	BR.....	BROWN
Gray	GY.....	GRAY
Red	R.....	RED
Blue	BL.....	BLUE
Orange	W.....	WHITE
Yellow	Y.....	YELLOW

ELECTRICAL WIRING SCHEMATIC		
APPROVED:	CHECKED:	ORIGINAL RELEASE NO.:
MODELED:	DATE:	R-107/1S/08
BFT/JAW	10/27-17	
PART NO.:	90-106178-05	REV: 02

GE NON DDC 2-STG 08/10/120
208/230/460V 3 PH 60 HZ

COMPONENT CODES			
Code	Description	Code	Description
LPC	LOW PRESSURE CONTROL	PL	PLUG
CA	CAMFOR ALERT MODULE	PI	PISTON TRANSFER
M/C	MANUAL RESET CONTROL	PT	PT PISTON SENSOR
MLC	MANUAL LIMIT CONTROL	PC	RELAY
NP	NEGATIVE PRESSURE SWITCH	FC	INTEGRATED FLAME CONTROL
OC	OUTDOOR FAN MOTOR	US	UNLOCKER SOLENOID
FL	FAN		
FR	FREEZE		
PT	PISTON SENSOR		
PC	RELAY		
PL	PLUG		
PI	PISTON TRANSFER		
PT	PT PISTON SENSOR		
PC	RELAY		
FC	INTEGRATED FLAME CONTROL		
US	UNLOCKER SOLENOID		

NOTES		
1.	CONNECTORS SUITABLE FOR USE WITH COPPER CONDUCTORS ONLY.	
2.	CONNECT FELD WIRING IN GROUNDING RAIN TIGHT CONDUIT TO FUSED DISCONNECT.	
3.	REMOVE L3 AT (CT) TO INSTALL LOW AMBIENT ACCESSORY.	
4.	REMOVE L3 AT (C) TO INSTALL LOW AMBIENT ACCESSORY.	
5.	IF REQUIRED, ATTACH CRANKCASE HEATER ACCESSORY TO CC1 (L1) AND CC1 (L2).	
6.	COMPRESSOR MOTOR THERMALLY PROTECTED; ALL 3 PHASE MODELS ARE PROTECTED WITH THERMAL SWING SENSE IN ADDITION.	
7.	TERMINAL BLOCK WIRING AS SHOWN FOR PHASE PRIMARY VOLTAGE CONNECTIONS FOR ALTERNATE VOLTAGES IF REQUIRED.	
UNIT VOLTAGES - HZ	TRANSFORMER TERM.	
200-60HZ	200	
208-60HZ	230	
381-60HZ	400	
381-60HZ	460	
460-60HZ	400	
575-60HZ	230	

WIRING INFORMATION		
LINE VOLTAGE	REPLACEMENT WIRE	WARNING
-FACTORY STANDARD	-MUST BE THE SAME SIZE AND TYPE OF INSULATION AS ORIGINAL. (105°C MIN.)	-CABINET MUST BE PERMANENTLY GROUNDED AND CONFORM TO I.E.C., N.E.C., C.E.C., NATIONAL WIRING REGULATIONS, AND LOCAL CODES AS APPLICABLE.
-FACTORY OPTION		
-FIELD INSTALLED		
LOW VOLTAGE		
-FACTORY STANDARD		
-FACTORY OPTION		
-FIELD INSTALLED		

P. APPENDICES

Appendix G. Wiring Diagrams & Schematics (Cont.)

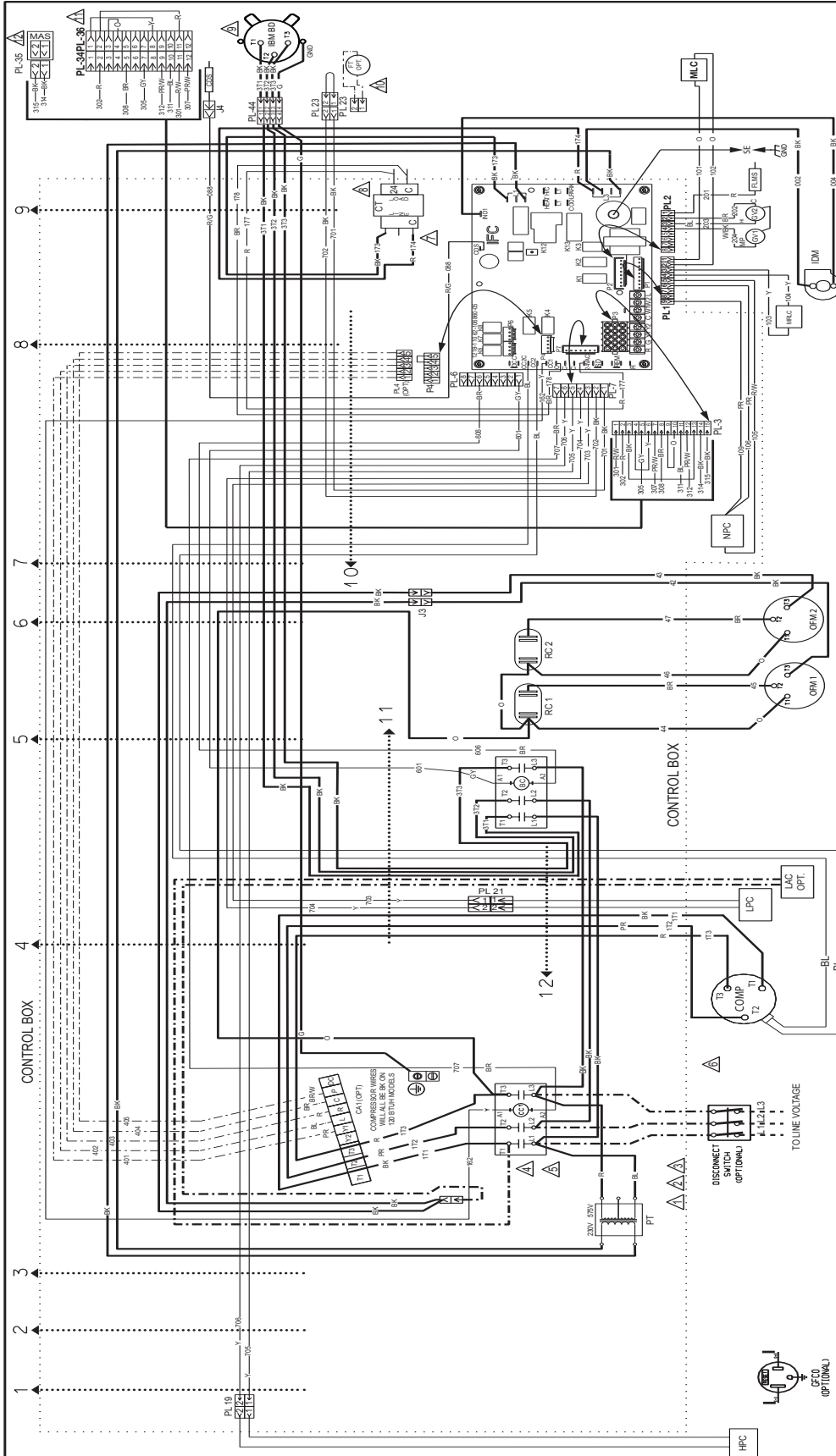

WIRING INFORMATION

- LINE VOLTAGE
- FACTORY STANDARD
- FACTORY OPTION
- FIELD INSTALLED
- LOW VOLTAGE
- FACTORY STANDARD
- FACTORY OPTION
- FIELD INSTALLED
- REPLACEMENT WIRE
- FACTORY WIRE SIZE AND TYPE
- FIELD WIRE SIZE AND TYPE
- OF INSULATION AS ORIGINAL (105 C.M.A.N)

WARNING: MUST BE PERMANENTLY GROUNDED AND CONFORM TO I.E.C., N.E.C., C.E.C., NATIONAL WIRING REGULATIONS, AND LOCAL CODES AS APPLICABLE.

NOTES

1. CONNECTORS SUITABLE FOR USE WITH COPPER CONDUCTORS ONLY.
2. CONNECT FIELD WIRING IN GROUNDING RIGID CONDUIT TO USED DISCONNECT.
3. CONNECT FIELD WIRE TO COMPRESSOR CONTACTOR (C21).
4. REMOVE DAT C21 TO INSTALL LOW AMBIENT ACCESSORY.
5. IF REQUIRED, ATTACH CRANKCASE HEATER ACCESSORY TO C21 (L1 AND C21 L2).
6. COMPRESSOR MOTOR TERMINALLY PROTECTED. ALL PHASE MODELS ARE PROTECTED UNDER PRIMARY SINGLE PHASE CONDITIONS.
7. TRANSFORMER FACTORY WIRING AS SHOWN BELOW. CHANGE PRIMARY VOLTAGE CONNECTIONS FOR ALTERNATE VOLTAGES. F REQUIRED.

UNIT VOLTAGE-4Z	TRANSFORMER TERNAL
200-250-50HZ	200
200-50HZ	200
230-40HZ	230
380-40HZ	400
480-50HZ	480
575-40HZ	230

COMPONENT CODES

BC	BLOWER CONTACTOR
CA	COMPACT ALERT MODULE
CC	COMPRESSOR CONTACTOR
CCH	CRANKCASE HEATER
CS	CLOSED DOOR SENSOR
CCS	COMPRESSOR CONTACTOR
COMP	CONTROL TRANSFORMER
DAT	DISCONNECT SWITCH
FANS	FLAME SENSOR
FP	FAN PROWING SWITCH
FS	FREZE SENSIR
FT	FREZE STAT
GFCO	GROUND FAULT COMMENCEMENT OUTLET
GL	GROUND LUG
GRD	GROUND
HT	HIGH TEMPERATURE CONTROL
HPC	INDOOR POWER MOTOR BELT DRIVE
RC1	INDOOR FAN MOTOR
RC2	INDOOR FAN MOTOR
FC	INTEGRATED FURNACE CONTROL

WIRE COLOR CODE

BK.....	BLACK
GR.....	GREEN
PR.....	PURPLE
BR.....	BROWN
GY.....	GRAY
RD.....	RED
BL.....	BLUE
OR.....	ORANGE
WH.....	WHITE
Y.....	YELLOW

NOTES

8. LOW VOLTAGE CIRCUIT IN I.E.C. CLASS 2 WITH A CLASS 2 TRANSFORMER. 24VAC 50/60 HZ SUPPLIED.
9. MOTOR FACTORY WIRING FOR CORRECT VOLTAGE.
10. REMOVE PL23 JUMPER FOR OPTIONAL FT LOCATED IN BLOWER COMPARTMENT.
11. REMOVE PL8 FOR ECONOMIZER OR SMOKE DETECTOR ACCESSORY PL34 AND PL38 LOCATED IN RETURN AIR SECTION.
12. THIS ACCESSORY PROVIDED WITH ECONOMIZER PL8 LOCATED IN BLOWER COMPARTMENT.

ELECTRICAL WIRING DIAGRAM

GE NON DDC 2 STG 089102/120
575V 3PH 60HZ

APPROVED:	CHECKED:	ORIGINAL RELEASE NO.:
MODELED:	DATE:	
BY:	10-30-17	R-10715108
PART NO.:	90-106177-06	REV: 02

Appendix G. Wiring Diagrams & Schematics (Cont.)

CODE	Description	FAULT LEVEL -0, -1, 2, 3*
0	STANDBY	0
C	COMPRESSOR ON - Low Flushing (in time delay)	0
C	COMPRESSOR ON - High Flushing (in time delay)	0
E	Economizer Coasting - No Compressor	0
F	CONTINUOUS FAN	0
H	HEATON - Low Stage	0
H	HEATON - High Stage	0
4	Combin Alert Code 4 for Compressor Circuit 1	3
5	Combin Alert Code 5 for Compressor Circuit 1	3
6	Combin Alert Code 6 for Compressor Circuit 1	3
7	Combin Alert Code 7 for Compressor Circuit 1	3
8	Combin Alert Code 8 for Compressor Circuit 1	3
9	Combin Alert Code 9 for Compressor Circuit 1	3
11	FAILED IGNITION	2
13	LO FLAME SENSE	1
14	FLAME LOST	2
15	UNEXPECTED FLAME	3
20	REFRIGERANT LOW PRESSURE SWITCH OPEN - CIRCUIT 1	2
21	REFRIGERANT LOW PRESSURE SWITCH OPEN - CIRCUIT 2	2
22	MAIN LIMIT OPEN	2
29	REFRIGERANT HIGH PRESSURE SWITCH OPEN - CIRCUIT 1	2
30	REFRIGERANT HIGH PRESSURE SWITCH OPEN - CIRCUIT 2	2
33	MRC (Relief Limit) OPEN	2
34	Combin Alert Code 4 for Compressor Circuit 2	3
35	Combin Alert Code 5 for Compressor Circuit 2	3
36	Combin Alert Code 6 for Compressor Circuit 2	3
37	Combin Alert Code 7 for Compressor Circuit 2	3
38	Combin Alert Code 8 for Compressor Circuit 2	3
39	Combin Alert Code 9 for Compressor Circuit 2	3
42	Inboard Thermostat Selection	1
44	1 st Stage COMBUSTION PRESS SWITCH CLOSED	2
46	1 st Stage COMBUSTION PRESS SWITCH OPEN	2
49	FREEZE SWITCH (OPEN - CIRCUIT 1)	2
50	FREEZE SWITCH (OPEN - CIRCUIT 2)	2
55	2 nd Stage COMBUSTION PRESS SWITCH CLOSED	2
57	2 nd Stage COMBUSTION PRESS SWITCH OPEN	2, 3
59	Condensate Drain Plugged	3
61	Blower Fault - MOTOR	3
83	Condenser Coil Temp Sensor Fail-OC	2
86	Outdoor Air Temperature Sensor Fail-OC	2
88	Emergency Stop Fault	3
95	CONTROL Fault	3
97	Smoke Detection	3
*Fault level 0 = None, 1=warning, 2=problem, 3=shutdown		

ALARM CODES

CODE	Description	FAULT LEVEL
0	STANDBY	0
C	COMPRESSOR ON - Low Flushing (in time delay)	0
C	COMPRESSOR ON - High Flushing (in time delay)	0
E	Economizer Coasting - No Compressor	0
F	CONTINUOUS FAN	0
H	HEATON - Low Stage	0
H	HEATON - High Stage	0
4	Combin Alert Code 4 for Compressor Circuit 1	3
5	Combin Alert Code 5 for Compressor Circuit 1	3
6	Combin Alert Code 6 for Compressor Circuit 1	3
7	Combin Alert Code 7 for Compressor Circuit 1	3
8	Combin Alert Code 8 for Compressor Circuit 1	3
9	Combin Alert Code 9 for Compressor Circuit 1	3
11	FAILED IGNITION	2
13	LO FLAME SENSE	1
14	FLAME LOST	2
15	UNEXPECTED FLAME	3
20	REFRIGERANT LOW PRESSURE SWITCH OPEN - CIRCUIT 1	2
21	REFRIGERANT LOW PRESSURE SWITCH OPEN - CIRCUIT 2	2
22	MAIN LIMIT OPEN	2
29	REFRIGERANT HIGH PRESSURE SWITCH OPEN - CIRCUIT 1	2
30	REFRIGERANT HIGH PRESSURE SWITCH OPEN - CIRCUIT 2	2
33	MRC (Relief Limit) OPEN	2
34	Combin Alert Code 4 for Compressor Circuit 2	3
35	Combin Alert Code 5 for Compressor Circuit 2	3
36	Combin Alert Code 6 for Compressor Circuit 2	3
37	Combin Alert Code 7 for Compressor Circuit 2	3
38	Combin Alert Code 8 for Compressor Circuit 2	3
39	Combin Alert Code 9 for Compressor Circuit 2	3
42	Inboard Thermostat Selection	1
44	1 st Stage COMBUSTION PRESS SWITCH CLOSED	2
46	1 st Stage COMBUSTION PRESS SWITCH OPEN	2
49	FREEZE SWITCH (OPEN - CIRCUIT 1)	2
50	FREEZE SWITCH (OPEN - CIRCUIT 2)	2
55	2 nd Stage COMBUSTION PRESS SWITCH CLOSED	2
57	2 nd Stage COMBUSTION PRESS SWITCH OPEN	2, 3
59	Condensate Drain Plugged	3
61	Blower Fault - MOTOR	3
83	Condenser Coil Temp Sensor Fail-OC	2
86	Outdoor Air Temperature Sensor Fail-OC	2
88	Emergency Stop Fault	3
95	CONTROL Fault	3
97	Smoke Detection	3

WIRE COLOR CODE

BK.....BLACK
 BR.....BROWN
 BL.....BLUE
 G.....GREEN
 GR.....GRAY
 O.....ORANGE
 R.....RED
 W.....WHITE
 Y.....YELLOW

COMPONENT CODES

BC BLOWER CONTROL
 CA COMPACT ALERT MODULE
 CC COMBUSTION PRESSURE SWITCH
 CCH COIL HEAT EXCHANGER
 COIS COIL OVERHEAT SENSOR
 CTS COIL TEMPERATURE SENSOR
 COT CONTROL TRANSFORMER
 DAT DISCHARGE AIR SENSOR
 DSC DISCONNECT SWITCH
 FMS FAN MOTOR
 FFF FAN FORWARD
 FRS FREEZE SENSOR
 GFCO GROUND FAULT COMBENSANCE OUTLET
 GL GROUND LUG
 HPC HIGH PRESSURE CONTROL
 IBM INDOOR BLOWER MOTOR
 IM INDOOR MOTOR
 IFC INTEGRATED FURNACE CONTROL

WIRING INFORMATION

LINE VOLTAGE
 -FACTORY STANDARD
 -FACTORY OPTION
 -FIELD INSTALLED
 LOW VOLTAGE
 -FACTORY STANDARD
 -FACTORY OPTION
 -FIELD INSTALLED
 REPLACEMENT WIRE MUST BE THE SAME SIZE AND TYPE AS ORIGINAL
 -CABINET MUST BE PERMANENTLY GROUNDED AND CONFORM TO I.E.C. N.E.C. C.E.C. NATIONAL WIRING REGULATIONS, AND LOCAL CODES AS APPLICABLE.

NOTES

- CONNECTORS SUITABLE FOR USE WITH COPPER CONDUCTORS ONLY.
- CONNECT FELD WIRING IN GROUNDING PAIN TRAIL CONTINUIT TO USED DISCONNECT.
- CONNECT FELD WIRE TO COMPRESSOR CONTACTOR (CC).
- REMOVE B AT CCI TO INSTALL LOW AMBIENT ACCESSORY.
- IF REQUIRED, ATTACH FRAMICASE HEATER ACCESSORY TO CCI (L1) AND CCI (L2).
- COMPRESSOR MOTOR THERMALLY PROTECTED. ALL 3-PHASE MODELS ARE PROTECTED UNDER PRIMARY SINGLE PHASE CONDITIONS.
- TRANSFORMER FACTORY WIRING AS SHOWN BELOW. CHANGE PRIMARY VOLTAGE CONNECTIONS FOR ALTERNATE VOLTAGES, IF REQUIRED.

UNIT VOLTAGES - HZ

TRANSFORMER TERM.	200-220-250HZ	230
1	201-60HZ	230
2	201-60HZ	230
3	201-60HZ	230
4	201-60HZ	230
5	380-415-50HZ	400
6	461-60HZ	460
7	515-60HZ	230

ALARM CODES

CODE	Description	FAULT LEVEL
0	STANDBY	0
C	COMPRESSOR ON - Low Flushing (in time delay)	0
C	COMPRESSOR ON - High Flushing (in time delay)	0
E	Economizer Coasting - No Compressor	0
F	CONTINUOUS FAN	0
H	HEATON - Low Stage	0
H	HEATON - High Stage	0
4	Combin Alert Code 4 for Compressor Circuit 1	3
5	Combin Alert Code 5 for Compressor Circuit 1	3
6	Combin Alert Code 6 for Compressor Circuit 1	3
7	Combin Alert Code 7 for Compressor Circuit 1	3
8	Combin Alert Code 8 for Compressor Circuit 1	3
9	Combin Alert Code 9 for Compressor Circuit 1	3
11	FAILED IGNITION	2
13	LO FLAME SENSE	1
14	FLAME LOST	2
15	UNEXPECTED FLAME	3
20	REFRIGERANT LOW PRESSURE SWITCH OPEN - CIRCUIT 1	2
21	REFRIGERANT LOW PRESSURE SWITCH OPEN - CIRCUIT 2	2
22	MAIN LIMIT OPEN	2
29	REFRIGERANT HIGH PRESSURE SWITCH OPEN - CIRCUIT 1	2
30	REFRIGERANT HIGH PRESSURE SWITCH OPEN - CIRCUIT 2	2
33	MRC (Relief Limit) OPEN	2
34	Combin Alert Code 4 for Compressor Circuit 2	3
35	Combin Alert Code 5 for Compressor Circuit 2	3
36	Combin Alert Code 6 for Compressor Circuit 2	3
37	Combin Alert Code 7 for Compressor Circuit 2	3
38	Combin Alert Code 8 for Compressor Circuit 2	3
39	Combin Alert Code 9 for Compressor Circuit 2	3
42	Inboard Thermostat Selection	1
44	1 st Stage COMBUSTION PRESS SWITCH CLOSED	2
46	1 st Stage COMBUSTION PRESS SWITCH OPEN	2
49	FREEZE SWITCH (OPEN - CIRCUIT 1)	2
50	FREEZE SWITCH (OPEN - CIRCUIT 2)	2
55	2 nd Stage COMBUSTION PRESS SWITCH CLOSED	2
57	2 nd Stage COMBUSTION PRESS SWITCH OPEN	2, 3
59	Condensate Drain Plugged	3
61	Blower Fault - MOTOR	3
83	Condenser Coil Temp Sensor Fail-OC	2
86	Outdoor Air Temperature Sensor Fail-OC	2
88	Emergency Stop Fault	3
95	CONTROL Fault	3
97	Smoke Detection	3

WIRING INFORMATION

LINE VOLTAGE
 -FACTORY STANDARD
 -FACTORY OPTION
 -FIELD INSTALLED
 LOW VOLTAGE
 -FACTORY STANDARD
 -FACTORY OPTION
 -FIELD INSTALLED
 REPLACEMENT WIRE MUST BE THE SAME SIZE AND TYPE AS ORIGINAL
 -CABINET MUST BE PERMANENTLY GROUNDED AND CONFORM TO I.E.C. N.E.C. C.E.C. NATIONAL WIRING REGULATIONS, AND LOCAL CODES AS APPLICABLE.

COMPONENT CODES

BC BLOWER CONTROL
 CA COMPACT ALERT MODULE
 CC COMBUSTION PRESSURE SWITCH
 CCH COIL HEAT EXCHANGER
 COIS COIL OVERHEAT SENSOR
 CTS COIL TEMPERATURE SENSOR
 COT CONTROL TRANSFORMER
 DAT DISCHARGE AIR SENSOR
 DSC DISCONNECT SWITCH
 FMS FAN MOTOR
 FFF FAN FORWARD
 FRS FREEZE SENSOR
 GFCO GROUND FAULT COMBENSANCE OUTLET
 GL GROUND LUG
 HPC HIGH PRESSURE CONTROL
 IBM INDOOR BLOWER MOTOR
 IM INDOOR MOTOR
 IFC INTEGRATED FURNACE CONTROL

NOTES

- LOW VOLTAGE CIRCUIT IS I.E.C. CLASS 2 WITH A CLASS 2 MOTOR.
- MOTOR FACTORY WIRING FOR CORRECT VOLTAGE.
- REMOVE PLS FOR ECONOMIZER ACCESSORY.
- PL3 AND PLS LOCATED IN RETURN AIR SECTION.
- CONNECT TO ECONOMIZER LOGIC MODULE.

WIRING INFORMATION

LINE VOLTAGE
 -FACTORY STANDARD
 -FACTORY OPTION
 -FIELD INSTALLED
 LOW VOLTAGE
 -FACTORY STANDARD
 -FACTORY OPTION
 -FIELD INSTALLED
 REPLACEMENT WIRE MUST BE THE SAME SIZE AND TYPE AS ORIGINAL
 -CABINET MUST BE PERMANENTLY GROUNDED AND CONFORM TO I.E.C. N.E.C. C.E.C. NATIONAL WIRING REGULATIONS, AND LOCAL CODES AS APPLICABLE.

NOTES

- CONNECTORS SUITABLE FOR USE WITH COPPER CONDUCTORS ONLY.
- CONNECT FELD WIRING IN GROUNDING PAIN TRAIL CONTINUIT TO USED DISCONNECT.
- CONNECT FELD WIRE TO COMPRESSOR CONTACTOR (CC).
- REMOVE B AT CCI TO INSTALL LOW AMBIENT ACCESSORY.
- IF REQUIRED, ATTACH FRAMICASE HEATER ACCESSORY TO CCI (L1) AND CCI (L2).
- COMPRESSOR MOTOR THERMALLY PROTECTED. ALL 3-PHASE MODELS ARE PROTECTED UNDER PRIMARY SINGLE PHASE CONDITIONS.
- TRANSFORMER FACTORY WIRING AS SHOWN BELOW. CHANGE PRIMARY VOLTAGE CONNECTIONS FOR ALTERNATE VOLTAGES, IF REQUIRED.

UNIT VOLTAGES - HZ

TRANSFORMER TERM.	200-220-250HZ	230
1	201-60HZ	230
2	201-60HZ	230
3	201-60HZ	230
4	201-60HZ	230
5	380-415-50HZ	400
6	461-60HZ	460
7	515-60HZ	230

ALARM CODES

CODE	Description	FAULT LEVEL
0	STANDBY	0
C	COMPRESSOR ON - Low Flushing (in time delay)	0
C	COMPRESSOR ON - High Flushing (in time delay)	0
E	Economizer Coasting - No Compressor	0
F	CONTINUOUS FAN	0
H	HEATON - Low Stage	0
H	HEATON - High Stage	0
4	Combin Alert Code 4 for Compressor Circuit 1	3
5	Combin Alert Code 5 for Compressor Circuit 1	3
6	Combin Alert Code 6 for Compressor Circuit 1	3
7	Combin Alert Code 7 for Compressor Circuit 1	3
8	Combin Alert Code 8 for Compressor Circuit 1	3
9	Combin Alert Code 9 for Compressor Circuit 1	3
11	FAILED IGNITION	2
13	LO FLAME SENSE	1
14	FLAME LOST	2
15	UNEXPECTED FLAME	3
20	REFRIGERANT LOW PRESSURE SWITCH OPEN - CIRCUIT 1	2
21	REFRIGERANT LOW PRESSURE SWITCH OPEN - CIRCUIT 2	2
22	MAIN LIMIT OPEN	2
29	REFRIGERANT HIGH PRESSURE SWITCH OPEN - CIRCUIT 1	2
30	REFRIGERANT HIGH PRESSURE SWITCH OPEN - CIRCUIT 2	2
33	MRC (Relief Limit) OPEN	2
34	Combin Alert Code 4 for Compressor Circuit 2	3
35	Combin Alert Code 5 for Compressor Circuit 2	3
36	Combin Alert Code 6 for Compressor Circuit 2	3
37	Combin Alert Code 7 for Compressor Circuit 2	3
38	Combin Alert Code 8 for Compressor Circuit 2	3
39	Combin Alert Code 9 for Compressor Circuit 2	3
42	Inboard Thermostat Selection	1
44	1 st Stage COMBUSTION PRESS SWITCH CLOSED	2
46	1 st Stage COMBUSTION PRESS SWITCH OPEN	2
49	FREEZE SWITCH (OPEN - CIRCUIT 1)	2
50	FREEZE SWITCH (OPEN - CIRCUIT 2)	2
55	2 nd Stage COMBUSTION PRESS SWITCH CLOSED	2
57	2 nd Stage COMBUSTION PRESS SWITCH OPEN	2, 3
59	Condensate Drain Plugged	3
61	Blower Fault - MOTOR	3
83	Condenser Coil Temp Sensor Fail-OC	2
86	Outdoor Air Temperature Sensor Fail-OC	2
88	Emergency Stop Fault	3
95	CONTROL Fault	3
97	Smoke Detection	3

P. APPENDICES

Appendix G. Wiring Diagrams & Schematics (Cont.)

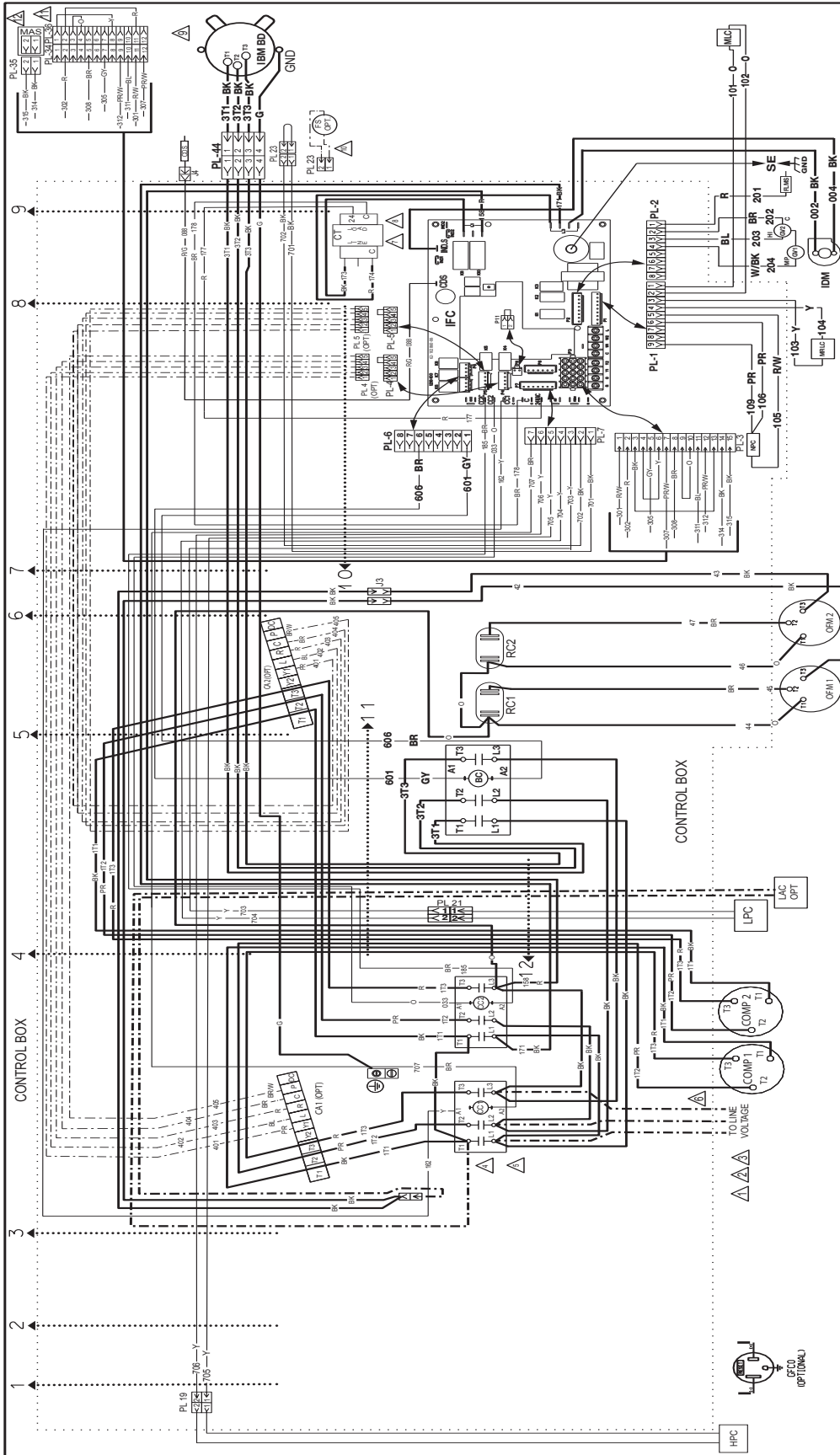

WIRE COLOR CODE

BK.....BLACK G.....GREEN PR.....PURPLE
 BR.....BROWN GY.....GRAY R.....RED
 BL.....BLUE O.....ORANGE W.....WHITE
 Y.....YELLOW

ELECTRICAL WIRING DIAGRAM

GE NON DDC 2-STG 150
 208/230/380/460V 3 PH 60-HZ

GE NON DDC 2-STG 120
 380-415V 3PH 50-HZ

COMPONENT CODES

LAC	LOW AMBIENT CONTROL
LPC	LOW PRESSURE CONTROL
MRC	MANUAL RESET UNIT CONTROL
NPC	NEGATIVE PRESSURE SWITCH
OAT	OUTSIDE AIR SENSOR
OPH	OUTDOOR FAN/HOTDRY
PT	POWER TRANSFORMER
RAT	RETURN AIR SENSOR
RC	ROOM AIR FAN/ACTOR
RTU-C	ROOM TOP UNIT CONTROL
SE	SPARK ELECTRODE

NOTES

- CONNECTORS SUITABLE FOR USE WITH COPPER CONDUCTORS ONLY.
- CONNECT FELD WIRING IN GROUNDING RAIL RIGHT CONDUIT TO PAGED DISCONNECT.
- CONNECT FELD WIRE TO COMPRESSOR CONTACTOR (C1).
- REMOVE LACT (C1) TO INSTALL LOW AMBIENT ACCESSORY.
- IF REQUIRED, AT EACH OR MAKE HEATER ACCESSORY TO C1 (L) AND C2 (L).
- COMPRESSOR MOTORS THEMSELVES PROTECTED, ALL 3-PHASE MODELS ARE PROTECTED UNDER PRIMARY SINGLE PHASE CONDITIONS.
- TRANSFORMER FACTORY WIRE AS SHOWN BELOW, CHANGE PRIMARY VOLTAGE TO MATCH FACTORY WIRE VOLTAGES REQUIRED.

WIRING INFORMATION

LINE VOLTAGE

- FACTORY STANDARD
- FACTORY OPTION
- FIELD INSTALLED

LOW VOLTAGE

- FACTORY STANDARD
- FACTORY OPTION
- FIELD INSTALLED

REPLACEMENT WIRE

MUST BE THE SAME SIZE AND TYPE OF INSULATION AS ORIGINAL (USE C. MIN)

WARNING

CABINET MUST BE PERMANENTLY GROUNDED AND CONFORM TO I.E.C. N.E.C. C.E.C. NATIONAL WIRING REGULATIONS AND LOCAL CODES AS APPLICABLE

WIRE M/T

WIRE TIES

APPROVED: _____

CHECKED: _____

DATE: 03-01-18

NO.: R-1071S208

PART NO.: 90-106177-07

REV: 00

P. APPENDICES

Appendix G. Wiring Diagrams & Schematics (Cont.)

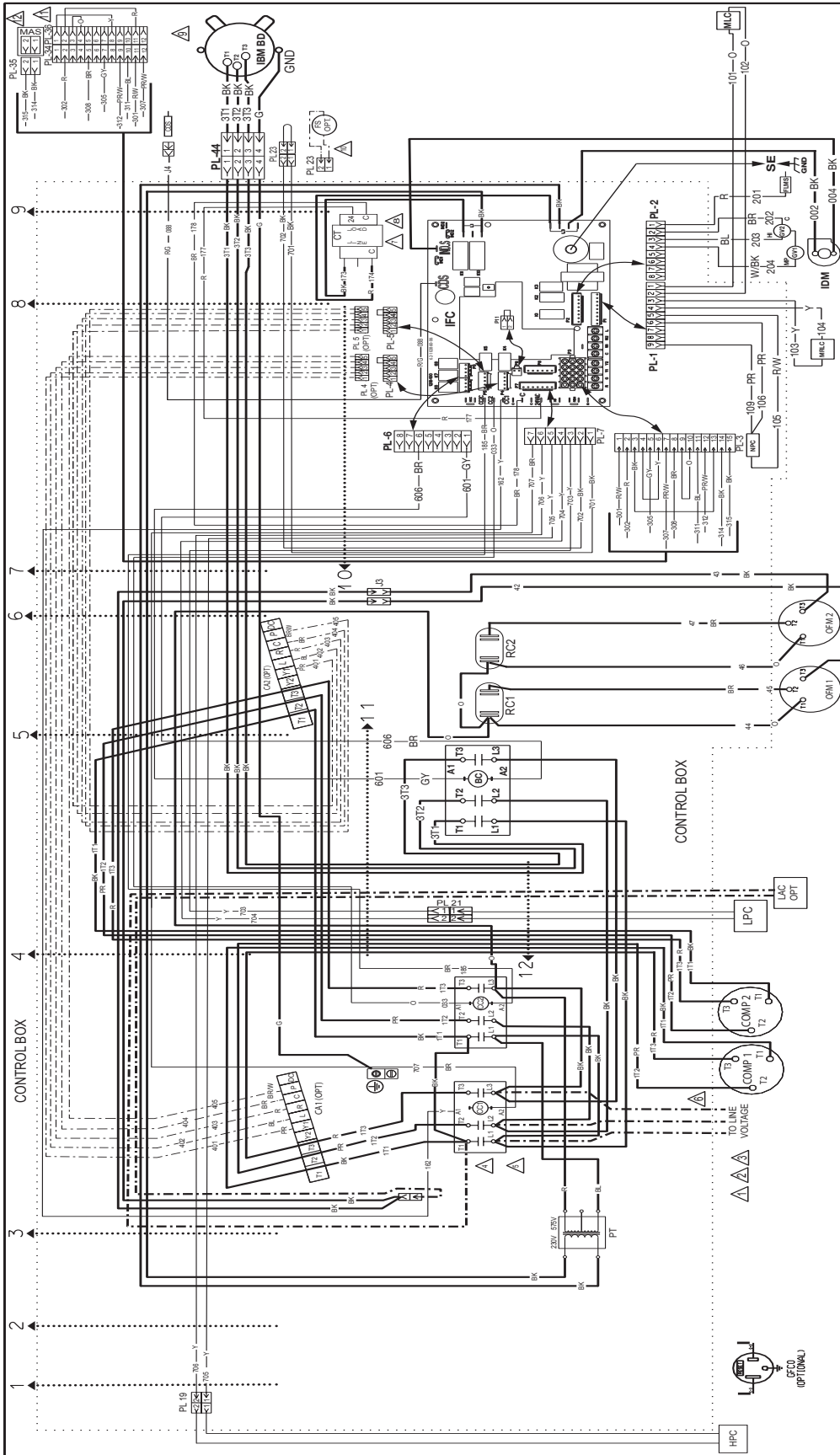

WIRING INFORMATION

LINE VOLTAGE
 -FACTORY STANDARD
 -FACTORY OPTION
 -FIELD INSTALLED
 -FIELD VOLTAGE
 -FACTORY STANDARD
 -FACTORY OPTION
 -FIELD INSTALLED

BEFORE WIRE MUST BE THE SAME SIZE AND TYPE OF INSULATION AS ORIGINAL (166C, MN).

WARNING: CABINET MUST BE PERMANENTLY GROUNDED AND CONFORM TO I.E.C., N.E.C., C.E.C., NATIONAL WIRING REGULATIONS AND LOCAL CODES AS APPLICABLE.

NOTES

- CONNECTORS SUITABLE FOR USE WITH COPPER CONDUCTORS ONLY.
- CONNECT FIELD WIRING IN GROUNDED RAIN TIGHT CONDUIT TO AVOID DISCONNECT.
- CONNECT FIELD WIRE TO COMPRESSOR CONTACTOR (CC).
- REMOVE J.B. AT (CC) TO INSTALL LOW AMBIENT ACCESSORY.
- IF REQUIRED, ATTACH CORKWICK HEATER ACCESSORY TO (C1) AND (C2) (L1).
- COMPRESSOR MOTOR IS INHERENTLY PROTECTED. ALL PHASE MODELS ARE PROTECTED UNDER PRIMARY SINGLE PHASE CONDITIONS.
- TRANSFORMER FACTORY WIRE AS SHOWN BELOW. CHANGE PRIMARY VOLTAGE TO CORRESPONDING ORIGINAL VOLTAGES IF REQUIRED.

UNIT VOLTAGES-HZ	TRANSFORMER TERN
200-240/12	200
200-240/24	200
230-40/12	230
230-40/24	230
380-40/12	400
380-40/24	400
460-40/12	460
460-40/24	460
575-40/12	575

COMPONENT CODES

BC	BLOWER CONTACTOR	WIRE NUT
CA	COMFORT ALERT MIDDLE	WIRE TIES
CC	COMPRESSOR CONTACTOR	
CD	DISCONNECT	
CS	CORKWICK HEATER ACCESSORY	
CS	CORKWICK HEATER ACCESSORY PLUG AND PLUG LOCATED IN RETURN AIR SECTION	
COMP	COMPRESSOR	
CONT	CONTROL TRANSFORMER	
DAT	DISCHARGE AIR SENSOR	
DISC	DISCONNECT SWITCH	
FLMS	FLAME SENSOR	
FP	FAN PROOFING	
FS	FREEZE SENSOR	
GFCO	GROUND FAULT COMBENSANCE OUTLET	
GL	GROUND	
GRD	GROUND	
GRD	GROUND	
IM	INTEGRATED PERFORMANCE CONTROL	
IM	INTEGRATED PERFORMANCE CONTROL	
IM	INTEGRATED PERFORMANCE CONTROL	
J	JUMPER	

WIRE COLOR CODE

BK.....BLACK	G.....GREEN	PR.....PURPLE
BR.....BROWN	GY.....GRAY	R.....RED
BL.....BLUE	O.....ORANGE	W.....WHITE
	Y.....YELLOW	

ELECTRICAL WIRING DIAGRAM

GENIUM DDC-2-STG 150
 575V/3 PH 60 HZ

WIRING INFORMATION

LINE VOLTAGE
 -FACTORY STANDARD
 -FACTORY OPTION
 -FIELD INSTALLED
 -FIELD VOLTAGE
 -FACTORY STANDARD
 -FACTORY OPTION
 -FIELD INSTALLED

BEFORE WIRE MUST BE THE SAME SIZE AND TYPE OF INSULATION AS ORIGINAL (166C, MN).

WARNING: CABINET MUST BE PERMANENTLY GROUNDED AND CONFORM TO I.E.C., N.E.C., C.E.C., NATIONAL WIRING REGULATIONS AND LOCAL CODES AS APPLICABLE.

NOTES

- CONNECTORS SUITABLE FOR USE WITH COPPER CONDUCTORS ONLY.
- CONNECT FIELD WIRING IN GROUNDED RAIN TIGHT CONDUIT TO AVOID DISCONNECT.
- CONNECT FIELD WIRE TO COMPRESSOR CONTACTOR (CC).
- REMOVE J.B. AT (CC) TO INSTALL LOW AMBIENT ACCESSORY.
- IF REQUIRED, ATTACH CORKWICK HEATER ACCESSORY TO (C1) AND (C2) (L1).
- COMPRESSOR MOTOR IS INHERENTLY PROTECTED. ALL PHASE MODELS ARE PROTECTED UNDER PRIMARY SINGLE PHASE CONDITIONS.
- TRANSFORMER FACTORY WIRE AS SHOWN BELOW. CHANGE PRIMARY VOLTAGE TO CORRESPONDING ORIGINAL VOLTAGES IF REQUIRED.

UNIT VOLTAGES-HZ	TRANSFORMER TERN
200-240/12	200
200-240/24	200
230-40/12	230
230-40/24	230
380-40/12	400
380-40/24	400
460-40/12	460
460-40/24	460
575-40/12	575

COMPONENT CODES

LAC	LOW AMBIENT CONTROL	WIRE NUT
LPC	LOW PRESSURE CONTROL	WIRE TIES
MRC	MANUAL RESET UNIT CONTROL	
NRC	NEGATIVE PRESSURE SWITCH	
OUT	OUTSIDE AIR SENSOR	
PT	POTENTIAL TRANSFORMER	
PT	POTENTIAL TRANSFORMER	
RAT	RETURN AIR SENSOR	
RC	ROOM AIR SENSOR	
RTUC	ROOM TOP AIR CONTROL	
SE	SPARK ELECTRODE	

WIRE COLOR CODE

BK.....BLACK	G.....GREEN	PR.....PURPLE
BR.....BROWN	GY.....GRAY	R.....RED
BL.....BLUE	O.....ORANGE	W.....WHITE
	Y.....YELLOW	

ELECTRICAL WIRING DIAGRAM

GENIUM DDC-2-STG 150
 575V/3 PH 60 HZ

APPROVED:	CHECKED:	ORIGINAL RELEASE
NO.	NO.	NO.
MODELED:	DATE:	R-1071S208
TC/W	03-01-18	
PART NO.:	90-106177-08	REV: 00

Appendix G. Wiring Diagrams & Schematics (Cont.)

ALARM CODES	
CODE	Description
0	STANDBY
C	COMPRESSOR ON - Low (Flashing in time delay)
C	COMPRESSOR ON - High (Flashing in time delay)
E	Economizer Cooling - No Compressor
F	CONTINUOUS FAN
H	HEAT ON - Low Stage
H	HEAT ON - High Stage
4	Combust Alert Code 4 for Compressor Circuit 1
5	Combust Alert Code 5 for Compressor Circuit 1
6	Combust Alert Code 6 for Compressor Circuit 1
7	Combust Alert Code 7 for Compressor Circuit 1
8	Combust Alert Code 8 for Compressor Circuit 1
9	Combust Alert Code 9 for Compressor Circuit 1
11	FAILED IGNITION
12	IGNITION SENSE
13	FLAME LOST
14	UNEXPECTED FLAME
15	2 nd Stage Gas Valve Impinger Voltage
20	REFRIGERANT LOW PRESSURE SWITCH OPEN - CIRCUIT 1
21	REFRIGERANT LOW PRESSURE SWITCH OPEN - CIRCUIT 2
22	MAXIMUM OPEN
29	REFRIGERANT HIGH PRESSURE SWITCH OPEN - CIRCUIT 1
30	REFRIGERANT HIGH PRESSURE SWITCH OPEN - CIRCUIT 2
34	MILC (Refract) Luminol
36	Combust Alert Code 4 for Compressor Circuit 2
35	Combust Alert Code 5 for Compressor Circuit 2
36	Combust Alert Code 6 for Compressor Circuit 2
37	Combust Alert Code 7 for Compressor Circuit 2
38	Combust Alert Code 8 for Compressor Circuit 2
39	Combust Alert Code 9 for Compressor Circuit 2
42	Invalid Thermostat Selection
44	1 st Stage COMBUSTION PRESS SWITCH CLOSED
46	1 st Stage COMBUSTION PRESS SWITCH OPEN
49	FREZE SWITCH OPEN - CIRCUIT 1
50	FREZE SWITCH OPEN - CIRCUIT 2
55	2 nd Stage COMBUSTION PRESS SWITCH CLOSED
57	2 nd Stage COMBUSTION PRESS SWITCH OPEN
59	Condensate Drain Plugged
61	Blower Fault - NO RUN
88	Condensate Coil Temp Sensor Fail - OCT
84	Outdoor Air Temperature Sensor Fail - OAT
88	Emergency Stop Fault
93	CONTROL FAULT
97	Smoke Detection

WIRING INFORMATION

- LINE VOLTAGE
- FACTORY STANDARD
- FACTORY OPTION
- FIELD INSTALLED
- LOW VOLTAGE
- FACTORY STANDARD
- FACTORY OPTION
- FIELD INSTALLED
- REPLACEMENT WIRE SIZE AND TYPE MUST BE THE SAME
- OF INSULATION AS ORIGINAL (105°C MIN.)
- WARNING
- CABINET MUST BE PERMANENTLY GROUNDED AND CONFORM TO I.E.C., N.E.C., C.E.C., NATIONAL WIRING REGULATIONS, AND LOCAL CODES AS APPLICABLE.

NOTES

1. CONNECTORS SUITABLE FOR USE WITH COPPER CONDUCTORS ONLY.
2. CONNECT FIELD WIRING IN GROUNDED RAIN TIGHT CONDUIT TO FUSED DISCONNECT.
3. CONNECT FIELD WIRE TO COMPRESSOR CONTACTOR (CC1).
4. REMOVE BATT (CC1) TO INSTALL LOW AMBIENT HEATER ACCESSORY.
5. IF REQUIRED, ATTACH ORANGE HEATER ACCESSORY TO CC1 (L1) AND CC1 (L2).
6. COMPRESSOR MOTOR THERMALLY PROTECTED. ALL 3 PHASE MODELS ARE PROTECTED UNDER PRIMARY SINGLE PHASE CONDITIONS.
7. TRANSFORMER FACTORY WIRED AS SHOWN BELOW. CHANGE PRIMARY VOLTAGE CONNECTIONS FOR ALTERNATE VOLTAGES, IF REQUIRED.

UNIT VOLTAGES - HZ

200-270-50HZ	TRANSFORMER TERM.
208-276-50HZ	200
230-276-50HZ	200
230-276-60HZ	200
230-276-60HZ	200
380-415-50HZ	400
460-500-50HZ	400
460-500-60HZ	400
575-600HZ	200

COMPONENT CODES

- BC BLOWER CONTACTOR
- CA CONTACT ALERT MODULE
- CC1 COMPRESSOR CONTACTOR
- CC2 COMPRESSOR CONTACTOR
- CH CHANGECASE HEATER
- CO2 CO2 GAS PANIC SENSOR
- CO3 CO2 GAS PANIC SENSOR
- CO5 CO2 GAS PANIC SWITCH
- CO6 CO2 GAS PANIC SWITCH
- CO7 CO2 GAS PANIC SWITCH
- CO8 CO2 GAS PANIC SWITCH
- CO9 CO2 GAS PANIC SWITCH
- CO10 CO2 GAS PANIC SWITCH
- CO11 CO2 GAS PANIC SWITCH
- CO12 CO2 GAS PANIC SWITCH
- CO13 CO2 GAS PANIC SWITCH
- CO14 CO2 GAS PANIC SWITCH
- CO15 CO2 GAS PANIC SWITCH
- CO16 CO2 GAS PANIC SWITCH
- CO17 CO2 GAS PANIC SWITCH
- CO18 CO2 GAS PANIC SWITCH
- CO19 CO2 GAS PANIC SWITCH
- CO20 CO2 GAS PANIC SWITCH
- CO21 CO2 GAS PANIC SWITCH
- CO22 CO2 GAS PANIC SWITCH
- CO23 CO2 GAS PANIC SWITCH
- CO24 CO2 GAS PANIC SWITCH
- CO25 CO2 GAS PANIC SWITCH
- CO26 CO2 GAS PANIC SWITCH
- CO27 CO2 GAS PANIC SWITCH
- CO28 CO2 GAS PANIC SWITCH
- CO29 CO2 GAS PANIC SWITCH
- CO30 CO2 GAS PANIC SWITCH
- CO31 CO2 GAS PANIC SWITCH
- CO32 CO2 GAS PANIC SWITCH
- CO33 CO2 GAS PANIC SWITCH
- CO34 CO2 GAS PANIC SWITCH
- CO35 CO2 GAS PANIC SWITCH
- CO36 CO2 GAS PANIC SWITCH
- CO37 CO2 GAS PANIC SWITCH
- CO38 CO2 GAS PANIC SWITCH
- CO39 CO2 GAS PANIC SWITCH
- CO40 CO2 GAS PANIC SWITCH
- CO41 CO2 GAS PANIC SWITCH
- CO42 CO2 GAS PANIC SWITCH
- CO43 CO2 GAS PANIC SWITCH
- CO44 CO2 GAS PANIC SWITCH
- CO45 CO2 GAS PANIC SWITCH
- CO46 CO2 GAS PANIC SWITCH
- CO47 CO2 GAS PANIC SWITCH
- CO48 CO2 GAS PANIC SWITCH
- CO49 CO2 GAS PANIC SWITCH
- CO50 CO2 GAS PANIC SWITCH
- CO51 CO2 GAS PANIC SWITCH
- CO52 CO2 GAS PANIC SWITCH
- CO53 CO2 GAS PANIC SWITCH
- CO54 CO2 GAS PANIC SWITCH
- CO55 CO2 GAS PANIC SWITCH
- CO56 CO2 GAS PANIC SWITCH
- CO57 CO2 GAS PANIC SWITCH
- CO58 CO2 GAS PANIC SWITCH
- CO59 CO2 GAS PANIC SWITCH
- CO60 CO2 GAS PANIC SWITCH
- CO61 CO2 GAS PANIC SWITCH
- CO62 CO2 GAS PANIC SWITCH
- CO63 CO2 GAS PANIC SWITCH
- CO64 CO2 GAS PANIC SWITCH
- CO65 CO2 GAS PANIC SWITCH
- CO66 CO2 GAS PANIC SWITCH
- CO67 CO2 GAS PANIC SWITCH
- CO68 CO2 GAS PANIC SWITCH
- CO69 CO2 GAS PANIC SWITCH
- CO70 CO2 GAS PANIC SWITCH
- CO71 CO2 GAS PANIC SWITCH
- CO72 CO2 GAS PANIC SWITCH
- CO73 CO2 GAS PANIC SWITCH
- CO74 CO2 GAS PANIC SWITCH
- CO75 CO2 GAS PANIC SWITCH
- CO76 CO2 GAS PANIC SWITCH
- CO77 CO2 GAS PANIC SWITCH
- CO78 CO2 GAS PANIC SWITCH
- CO79 CO2 GAS PANIC SWITCH
- CO80 CO2 GAS PANIC SWITCH
- CO81 CO2 GAS PANIC SWITCH
- CO82 CO2 GAS PANIC SWITCH
- CO83 CO2 GAS PANIC SWITCH
- CO84 CO2 GAS PANIC SWITCH
- CO85 CO2 GAS PANIC SWITCH
- CO86 CO2 GAS PANIC SWITCH
- CO87 CO2 GAS PANIC SWITCH
- CO88 CO2 GAS PANIC SWITCH
- CO89 CO2 GAS PANIC SWITCH
- CO90 CO2 GAS PANIC SWITCH
- CO91 CO2 GAS PANIC SWITCH
- CO92 CO2 GAS PANIC SWITCH
- CO93 CO2 GAS PANIC SWITCH
- CO94 CO2 GAS PANIC SWITCH
- CO95 CO2 GAS PANIC SWITCH
- CO96 CO2 GAS PANIC SWITCH
- CO97 CO2 GAS PANIC SWITCH
- CO98 CO2 GAS PANIC SWITCH
- CO99 CO2 GAS PANIC SWITCH
- CO100 CO2 GAS PANIC SWITCH

WIRE COLOR CODE

- BK.....BLACK
- BR.....BROWN
- BL.....BLUE
- GY.....GRAY
- OR.....ORANGE
- GR.....GREEN
- GY.....GRAY
- W.....WHITE
- Y.....YELLOW
- PR.....PURPLE
- R.....RED

ELECTRICAL WIRING SCHEMATIC

GE NON DDC 2-STG 150
575V 3PH 60HZ

APPROVED: _____ CHECKED: _____ ORIGINAL RELEASE NO.: _____
 MODELED BY: JHB DATE: 3/19/2016 R-1071S208
 PART NO.: 90-106178-08 REV: 00

P. APPENDICES

Appendix G. Wiring Diagrams & Schematics (Cont.)

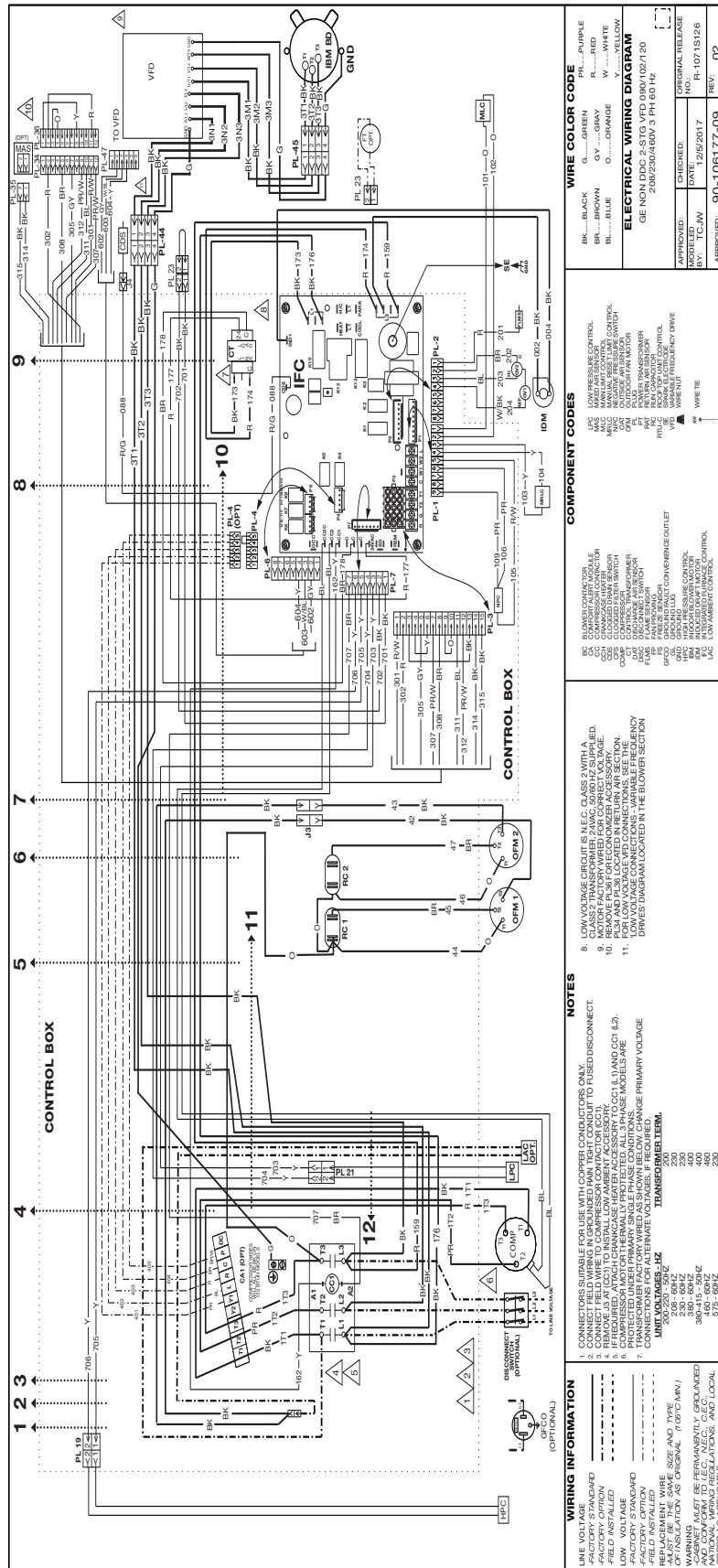

LINE VOLTAGE	FACTORY STANDARD	FIELD INSTALLED	LOW VOLTAGE	FACTORY STANDARD	FIELD INSTALLED	APPLICABLE WAVE SIZE AND TYPE	INSULATION AS ORIGINAL (LF07C MV.)	CABINET MUST BE PERMANENTLY GROUNDING	NATIONAL WIRING PRACTICES AND LOCAL CODES AS APPLICABLE
WIRING INFORMATION 1. CONNECTORS SUITABLE FOR USE WITH COPPER CONDUCTORS ONLY. 2. CONNECT FIELD WIRING IN GROUNDING PAN. DO NOT CONDUIT TO FUSED DISCONNECT. 3. REMOVE IS AT (CO) TO INSTALL LOW AMBIENT ACCESSORY (CC) (A HAND CO) (L/A). 4. COMPRESSOR MOTOR IS THERMALLY PROTECTED. ALL 3-PHASE MODELS ARE THERMALLY PROTECTED. 5. TRANSFORMER FACTORY WIRED AS SHOWN BELOW. CHANGE PRIMARY VOLTAGE CONNECTIONS FOR ALTERNATE VOLTAGES, IF REQUIRED. 6. TRANSFORMER FACTORY WIRED AS SHOWN BELOW. CHANGE PRIMARY VOLTAGE CONNECTIONS FOR ALTERNATE VOLTAGES, IF REQUIRED. 7. TRANSFORMER FACTORY WIRED AS SHOWN BELOW. CHANGE PRIMARY VOLTAGE CONNECTIONS FOR ALTERNATE VOLTAGES, IF REQUIRED. 8. TRANSFORMER FACTORY WIRED AS SHOWN BELOW. CHANGE PRIMARY VOLTAGE CONNECTIONS FOR ALTERNATE VOLTAGES, IF REQUIRED. 9. TRANSFORMER FACTORY WIRED AS SHOWN BELOW. CHANGE PRIMARY VOLTAGE CONNECTIONS FOR ALTERNATE VOLTAGES, IF REQUIRED. 10. TRANSFORMER FACTORY WIRED AS SHOWN BELOW. CHANGE PRIMARY VOLTAGE CONNECTIONS FOR ALTERNATE VOLTAGES, IF REQUIRED. 11. TRANSFORMER FACTORY WIRED AS SHOWN BELOW. CHANGE PRIMARY VOLTAGE CONNECTIONS FOR ALTERNATE VOLTAGES, IF REQUIRED.									
NOTES 8. LOW VOLTAGE CIRCUIT IS N.E.C. CLASS 2 WITH A CLASS 2 TRANSFORMER 2VAC 50/60 HZ SUPPLIED. 9. REMOVE PLUG FOR ECONOMIZER ACCESSORY. 10. REMOVE PLUG FOR ECONOMIZER ACCESSORY. 11. FOR LOW VOLTAGE WID CONNECTIONS, SEE THE LOW VOLTAGE CONNECTIONS - VARIABLE FREQUENCY DRIVE MANUAL.									
COMPONENT CODES BK BLK...BLACK BR...BROWN BU...BLUE O...ORANGE GR...GRAY GY...GREEN WH...WHITE W...WHITE PUR...PURPLE R...RED Y...YELLOW V...VIOLET BK-BK...BLACK BK-GR...BLACK-GRAY BK-WH...BLACK-WHITE BK-YL...BLACK-YELLOW BK-RD...BLACK-RED BK-BL...BLACK-BLUE BK-OR...BLACK-ORANGE BK-GR...BLACK-GRAY BK-GY...BLACK-GREEN BK-WH...BLACK-WHITE BK-YL...BLACK-YELLOW BK-RD...BLACK-RED BK-BL...BLACK-BLUE BK-OR...BLACK-ORANGE									
WIRE COLOR CODE BK...BLACK BR...BROWN BU...BLUE O...ORANGE GR...GRAY GY...GREEN WH...WHITE W...WHITE PUR...PURPLE R...RED Y...YELLOW V...VIOLET BK-BK...BLACK BK-GR...BLACK-GRAY BK-WH...BLACK-WHITE BK-YL...BLACK-YELLOW BK-RD...BLACK-RED BK-BL...BLACK-BLUE BK-OR...BLACK-ORANGE									
ELECTRICAL WIRING DIAGRAM GE NON-DDC 2-STD VFD 08V/102/120 208/230/460V 3 PH 60 HZ									
APPROVED: 90-106177-09 DATE: 2/26/2017 REV: 02 ORIGINAL RELEASE NO: R-10715126									

Appendix G. Wiring Diagrams & Schematics (Cont.)

ALARM CODES

CODE	Description	ALARM LEVEL -0,1,2,3*
0	STANDBY	0
1	COMPRESSOR ON-Low (Faulted in time delay)	0
2	COMPRESSOR ON-High (Faulted in time delay)	0
3	Refrigerant Gas/High Pressure	0
4	Refrigerant Gas/Low Pressure	0
5	Refrigerant Gas/High Stage	0
6	Refrigerant Gas/Low Stage	0
7	Compressor Code 1 for Compressor Circuit 1	3
8	Compressor Code 2 for Compressor Circuit 1	3
9	Compressor Code 3 for Compressor Circuit 1	3
10	Compressor Code 4 for Compressor Circuit 1	3
11	Compressor Code 5 for Compressor Circuit 1	3
12	Compressor Code 6 for Compressor Circuit 1	3
13	Compressor Code 7 for Compressor Circuit 1	3
14	Compressor Code 8 for Compressor Circuit 1	3
15	Compressor Code 9 for Compressor Circuit 1	3
16	Compressor Code 10 for Compressor Circuit 1	3
17	Compressor Code 11 for Compressor Circuit 1	3
18	Compressor Code 12 for Compressor Circuit 1	3
19	Compressor Code 13 for Compressor Circuit 1	3
20	Compressor Code 14 for Compressor Circuit 1	3
21	Compressor Code 15 for Compressor Circuit 1	3
22	Compressor Code 16 for Compressor Circuit 1	3
23	Compressor Code 17 for Compressor Circuit 1	3
24	Compressor Code 18 for Compressor Circuit 1	3
25	Compressor Code 19 for Compressor Circuit 1	3
26	Compressor Code 20 for Compressor Circuit 1	3
27	Compressor Code 21 for Compressor Circuit 1	3
28	Compressor Code 22 for Compressor Circuit 1	3
29	Compressor Code 23 for Compressor Circuit 1	3
30	Compressor Code 24 for Compressor Circuit 1	3
31	Compressor Code 25 for Compressor Circuit 1	3
32	Compressor Code 26 for Compressor Circuit 1	3
33	Compressor Code 27 for Compressor Circuit 1	3
34	Compressor Code 28 for Compressor Circuit 1	3
35	Compressor Code 29 for Compressor Circuit 1	3
36	Compressor Code 30 for Compressor Circuit 1	3
37	Compressor Code 31 for Compressor Circuit 1	3
38	Compressor Code 32 for Compressor Circuit 1	3
39	Compressor Code 33 for Compressor Circuit 1	3
40	Compressor Code 34 for Compressor Circuit 1	3
41	Compressor Code 35 for Compressor Circuit 1	3
42	Compressor Code 36 for Compressor Circuit 1	3
43	Compressor Code 37 for Compressor Circuit 1	3
44	Compressor Code 38 for Compressor Circuit 1	3
45	Compressor Code 39 for Compressor Circuit 1	3
46	Compressor Code 40 for Compressor Circuit 1	3
47	Compressor Code 41 for Compressor Circuit 1	3
48	Compressor Code 42 for Compressor Circuit 1	3
49	Compressor Code 43 for Compressor Circuit 1	3
50	Compressor Code 44 for Compressor Circuit 1	3
51	Compressor Code 45 for Compressor Circuit 1	3
52	Compressor Code 46 for Compressor Circuit 1	3
53	Compressor Code 47 for Compressor Circuit 1	3
54	Compressor Code 48 for Compressor Circuit 1	3
55	Compressor Code 49 for Compressor Circuit 1	3
56	Compressor Code 50 for Compressor Circuit 1	3
57	Compressor Code 51 for Compressor Circuit 1	3
58	Compressor Code 52 for Compressor Circuit 1	3
59	Compressor Code 53 for Compressor Circuit 1	3
60	Compressor Code 54 for Compressor Circuit 1	3
61	Compressor Code 55 for Compressor Circuit 1	3
62	Compressor Code 56 for Compressor Circuit 1	3
63	Compressor Code 57 for Compressor Circuit 1	3
64	Compressor Code 58 for Compressor Circuit 1	3
65	Compressor Code 59 for Compressor Circuit 1	3
66	Compressor Code 60 for Compressor Circuit 1	3
67	Compressor Code 61 for Compressor Circuit 1	3
68	Compressor Code 62 for Compressor Circuit 1	3
69	Compressor Code 63 for Compressor Circuit 1	3
70	Compressor Code 64 for Compressor Circuit 1	3
71	Compressor Code 65 for Compressor Circuit 1	3
72	Compressor Code 66 for Compressor Circuit 1	3
73	Compressor Code 67 for Compressor Circuit 1	3
74	Compressor Code 68 for Compressor Circuit 1	3
75	Compressor Code 69 for Compressor Circuit 1	3
76	Compressor Code 70 for Compressor Circuit 1	3
77	Compressor Code 71 for Compressor Circuit 1	3
78	Compressor Code 72 for Compressor Circuit 1	3
79	Compressor Code 73 for Compressor Circuit 1	3
80	Compressor Code 74 for Compressor Circuit 1	3
81	Compressor Code 75 for Compressor Circuit 1	3
82	Compressor Code 76 for Compressor Circuit 1	3
83	Compressor Code 77 for Compressor Circuit 1	3
84	Compressor Code 78 for Compressor Circuit 1	3
85	Compressor Code 79 for Compressor Circuit 1	3
86	Compressor Code 80 for Compressor Circuit 1	3
87	Compressor Code 81 for Compressor Circuit 1	3
88	Compressor Code 82 for Compressor Circuit 1	3
89	Compressor Code 83 for Compressor Circuit 1	3
90	Compressor Code 84 for Compressor Circuit 1	3
91	Compressor Code 85 for Compressor Circuit 1	3
92	Compressor Code 86 for Compressor Circuit 1	3
93	Compressor Code 87 for Compressor Circuit 1	3
94	Compressor Code 88 for Compressor Circuit 1	3
95	Compressor Code 89 for Compressor Circuit 1	3
96	Compressor Code 90 for Compressor Circuit 1	3
97	Compressor Code 91 for Compressor Circuit 1	3
98	Compressor Code 92 for Compressor Circuit 1	3
99	Compressor Code 93 for Compressor Circuit 1	3
100	Compressor Code 94 for Compressor Circuit 1	3

*Fault level 1=0 = none, 1=warning, 2=problem, 3=shutdown

WIRE COLOR CODE

BK.....BLACK	G.....GREEN	PR.....PURPLE
BR.....BROWN	GY.....GRAY	R.....RED
BL.....BLUE	O.....ORANGE	W.....WHITE
Y.....YELLOW		

ELECTRICAL WIRING SCHEMATIC

GE NON DDC 2-STG VFD 0901/02/10
208/230/480V 3 PH 60 HZ

APPROVED:	CHECKED:	ORIGINAL RELEASE
BY: TEW	DATE: 1/28/2017	NO.: R-1071 S126
MODELED:		
PART NO.: 90-106178-09		REV: 04

COMPONENT CODES

LPC	LOW PRESSURE CONTROL
MAS	MIXED AIR SENSOR
CCM	COMBUSTION MONITOR
MELC	MANUAL RESET LIMIT CONTROL
NPS	NEGATIVE PRESSURE SWITCH
CH	CHARGE AIR SENSOR
CHM	CHARGE MOTOR
PT	PRESSURE TRANSDUCER
RA	RETURN AIR SENSOR
RTM	ROOM TEMP UNIT CONTROL
SE	SMOKE DETECTOR
SW	SWITCH
VFD	VARIABLE FREQUENCY DRIVE

NOTES

- CONNECTORS SUITABLE FOR USE WITH COPPER CONDUCTORS ONLY.
- CONNECT FIELD WIRING IN GROUNDED RAIN TIGHT CONDUIT TO FUSED DISCONNECT.
- CONNECT FIELD WIRE TO COMPRESSOR CONTACTOR (CC1).
- REMOVE GAT (CC1) TO INSTALL LOW AMBIENT ACCESSORY.
- IF REQUIRED, ATD CHARGE HEATER ACCESSORY TO CC1 (L1) AND CC1 (L2).
- PROTECTED UNDER PRIMARY SINGLE PHASE CONDITIONS.
- TRANSFORMER FACTORY WIRES AS SHOWN BELOW CHANGE PRIMARY VOLTAGE CONNECTIONS FOR ALTERNATE VOLTAGES, IF REQUIRED.
- LOW VOLTAGE CIRCUIT (S.E.C. CLASS 2) WITH CLASS 2 TRANSFORMER 24VAC, 500VAZ SUPPLIED. MOTOR FACTORY WIRED FOR CORRECT VOLTAGE. REMOVE PLUG FOR ECONOMIZER ACCESSORY. PL33 AND PL36 LOCATED IN RETURN AIR SECTION.

UNIT VOLTAGES - HZ

200/230 - 50HZ	TRANSFORMER TERM.
200	200
208 - 60HZ	230
230 - 60HZ	300
380 - 60HZ	400
380-415 - 50HZ	480
480 - 60HZ	480
575 - 60HZ	200

WIRING INFORMATION

LINE VOLTAGE
-FACTORY STANDARD
-FACTORY OPTION
-FIELD INSTALLED

LOW VOLTAGE
-FACTORY STANDARD
-FACTORY OPTION
-FIELD INSTALLED

REPLACEMENT WIRE
-MUST BE THE SAME SIZE AND TYPE
-MUST BE INSULATION AS ORIGINAL (105°C MIN)

WARNING
-CABINET MUST BE PERMANENTLY GROUNDED
-G.C. AND L.C. ALL NATIONAL WIRING REG. METHODS, AND LOCAL CODES AS APPLICABLE.

ALTERNATIVE VFD CONNECTIONS

P. APPENDICES

Appendix G. Wiring Diagrams & Schematics (Cont.)

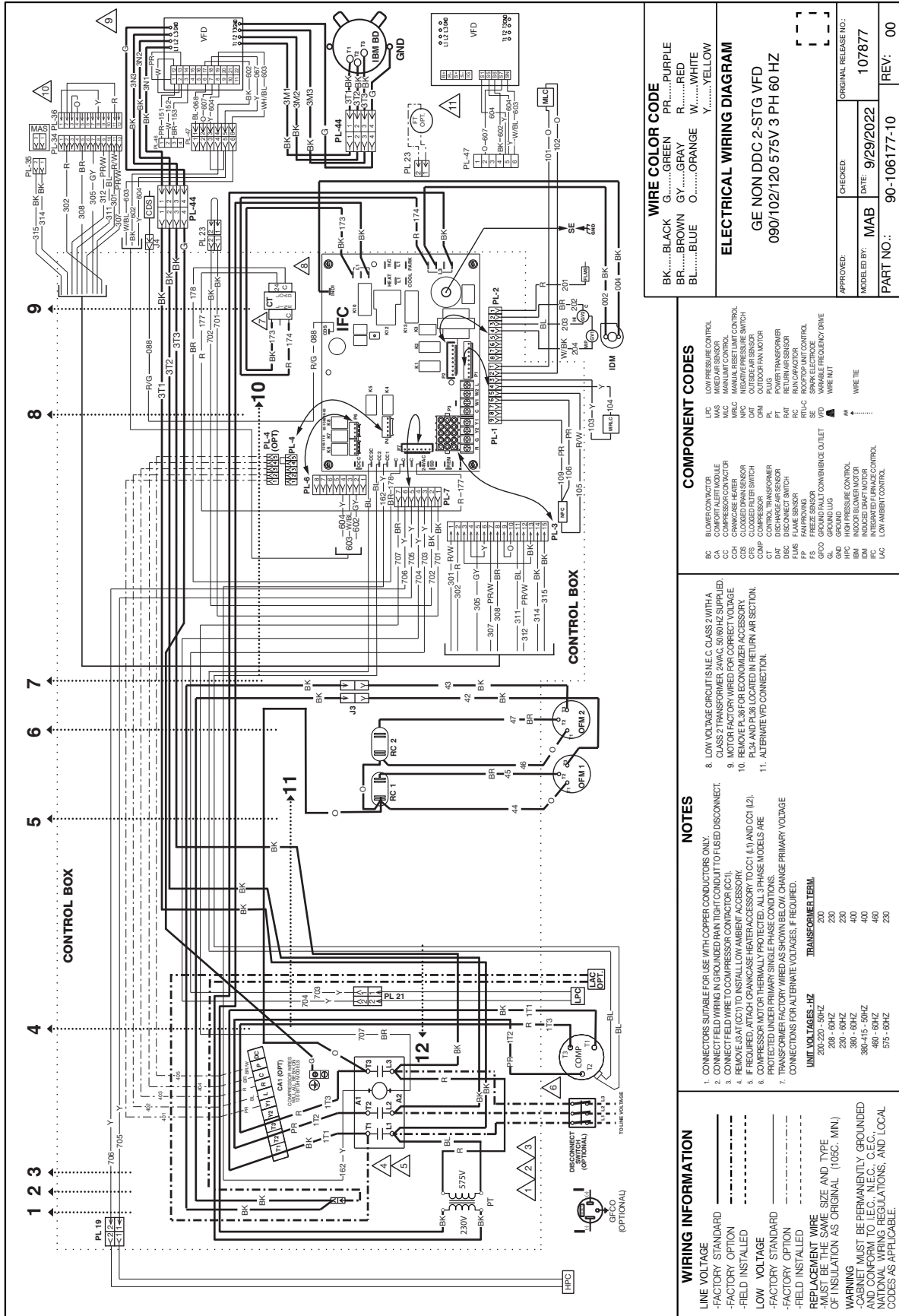

WIRE COLOR CODE	
BK.....BLACK	G.....GREEN
BR.....BROWN	GY.....GRAY
BL.....BLUE	O.....ORANGE
	PR.....PURPLE
	R.....RED
	W.....WHITE
	Y.....YELLOW

ELECTRICAL WIRING DIAGRAM	
GE NON DDC 2-STG VFD	
090/102/120 575V 3 PH 60 HZ	
APPROVED:	CHECKED:
MODEL BY: MAB	DATE: 9/29/2022
PART NO.: 90-106177-10	ORIGINAL RELEASE NO: 107877
	REV: 00

COMPONENT CODES
<ul style="list-style-type: none"> BS BLUVER CONTACTOR CA COMPRESSOR CONTACTOR CC1 COMPRESSOR CONTACTOR CC2 COMPRESSOR CONTACTOR CC3 COMPRESSOR CONTACTOR CC4 COMPRESSOR CONTACTOR CC5 COMPRESSOR CONTACTOR CC6 COMPRESSOR CONTACTOR CC7 COMPRESSOR CONTACTOR CC8 COMPRESSOR CONTACTOR CC9 COMPRESSOR CONTACTOR CC10 COMPRESSOR CONTACTOR CC11 COMPRESSOR CONTACTOR CC12 COMPRESSOR CONTACTOR CC13 COMPRESSOR CONTACTOR CC14 COMPRESSOR CONTACTOR CC15 COMPRESSOR CONTACTOR CC16 COMPRESSOR CONTACTOR CC17 COMPRESSOR CONTACTOR CC18 COMPRESSOR CONTACTOR CC19 COMPRESSOR CONTACTOR CC20 COMPRESSOR CONTACTOR CC21 COMPRESSOR CONTACTOR CC22 COMPRESSOR CONTACTOR CC23 COMPRESSOR CONTACTOR CC24 COMPRESSOR CONTACTOR CC25 COMPRESSOR CONTACTOR CC26 COMPRESSOR CONTACTOR CC27 COMPRESSOR CONTACTOR CC28 COMPRESSOR CONTACTOR CC29 COMPRESSOR CONTACTOR CC30 COMPRESSOR CONTACTOR CC31 COMPRESSOR CONTACTOR CC32 COMPRESSOR CONTACTOR CC33 COMPRESSOR CONTACTOR CC34 COMPRESSOR CONTACTOR CC35 COMPRESSOR CONTACTOR CC36 COMPRESSOR CONTACTOR CC37 COMPRESSOR CONTACTOR CC38 COMPRESSOR CONTACTOR CC39 COMPRESSOR CONTACTOR CC40 COMPRESSOR CONTACTOR CC41 COMPRESSOR CONTACTOR CC42 COMPRESSOR CONTACTOR CC43 COMPRESSOR CONTACTOR CC44 COMPRESSOR CONTACTOR CC45 COMPRESSOR CONTACTOR CC46 COMPRESSOR CONTACTOR CC47 COMPRESSOR CONTACTOR CC48 COMPRESSOR CONTACTOR CC49 COMPRESSOR CONTACTOR CC50 COMPRESSOR CONTACTOR CC51 COMPRESSOR CONTACTOR CC52 COMPRESSOR CONTACTOR CC53 COMPRESSOR CONTACTOR CC54 COMPRESSOR CONTACTOR CC55 COMPRESSOR CONTACTOR CC56 COMPRESSOR CONTACTOR CC57 COMPRESSOR CONTACTOR CC58 COMPRESSOR CONTACTOR CC59 COMPRESSOR CONTACTOR CC60 COMPRESSOR CONTACTOR CC61 COMPRESSOR CONTACTOR CC62 COMPRESSOR CONTACTOR CC63 COMPRESSOR CONTACTOR CC64 COMPRESSOR CONTACTOR CC65 COMPRESSOR CONTACTOR CC66 COMPRESSOR CONTACTOR CC67 COMPRESSOR CONTACTOR CC68 COMPRESSOR CONTACTOR CC69 COMPRESSOR CONTACTOR CC70 COMPRESSOR CONTACTOR CC71 COMPRESSOR CONTACTOR CC72 COMPRESSOR CONTACTOR CC73 COMPRESSOR CONTACTOR CC74 COMPRESSOR CONTACTOR CC75 COMPRESSOR CONTACTOR CC76 COMPRESSOR CONTACTOR CC77 COMPRESSOR CONTACTOR CC78 COMPRESSOR CONTACTOR CC79 COMPRESSOR CONTACTOR CC80 COMPRESSOR CONTACTOR CC81 COMPRESSOR CONTACTOR CC82 COMPRESSOR CONTACTOR CC83 COMPRESSOR CONTACTOR CC84 COMPRESSOR CONTACTOR CC85 COMPRESSOR CONTACTOR CC86 COMPRESSOR CONTACTOR CC87 COMPRESSOR CONTACTOR CC88 COMPRESSOR CONTACTOR CC89 COMPRESSOR CONTACTOR CC90 COMPRESSOR CONTACTOR CC91 COMPRESSOR CONTACTOR CC92 COMPRESSOR CONTACTOR CC93 COMPRESSOR CONTACTOR CC94 COMPRESSOR CONTACTOR CC95 COMPRESSOR CONTACTOR CC96 COMPRESSOR CONTACTOR CC97 COMPRESSOR CONTACTOR CC98 COMPRESSOR CONTACTOR CC99 COMPRESSOR CONTACTOR CC100 COMPRESSOR CONTACTOR

NOTES
<ol style="list-style-type: none"> CONNECTORS SUITABLE FOR USE WITH COPPER CONDUCTORS ONLY. CONNECT FELD WIRING IN GROUNDED RAIN TIGHT CONDUIT TO FUSED DISCONNECT. MOTOR FACTORY WIRING FOR CORRECT STAGE. REMOVE J3 AT (CC1) TO INSTALL LOW AMBIENT ACCESSORY. IF REQUIRED, ATTACH CRANKCASE HEATER ACCESSORY TO CC1 (L1) AND CC2 (L2). COMPRESSOR MOTOR THERMALLY PROTECTED. ALL 3 PHASE MODELS ARE PROTECTED UNDER PRIMARY SINGLE PHASE CONDITIONS. TRANSFORMER FACTORY WIRING AS SHOWN BELOW. CHANGE PRIMARY VOLTAGE CONNECTIONS FOR ALTERNATE VOLTAGES, IF REQUIRED.

WIRING INFORMATION
<ul style="list-style-type: none"> LINE VOLTAGE -FACTORY STANDARD -FACTORY OPTION -FIELD INSTALLED LOW VOLTAGE -FACTORY STANDARD -FACTORY OPTION -FIELD INSTALLED REPLACEMENT WIRE -MUST BE THE SAME SIZE AND TYPE OF INSULATION AS ORIGINAL (10SC. MN)

Appendix G. Wiring Diagrams & Schematics (Cont.)

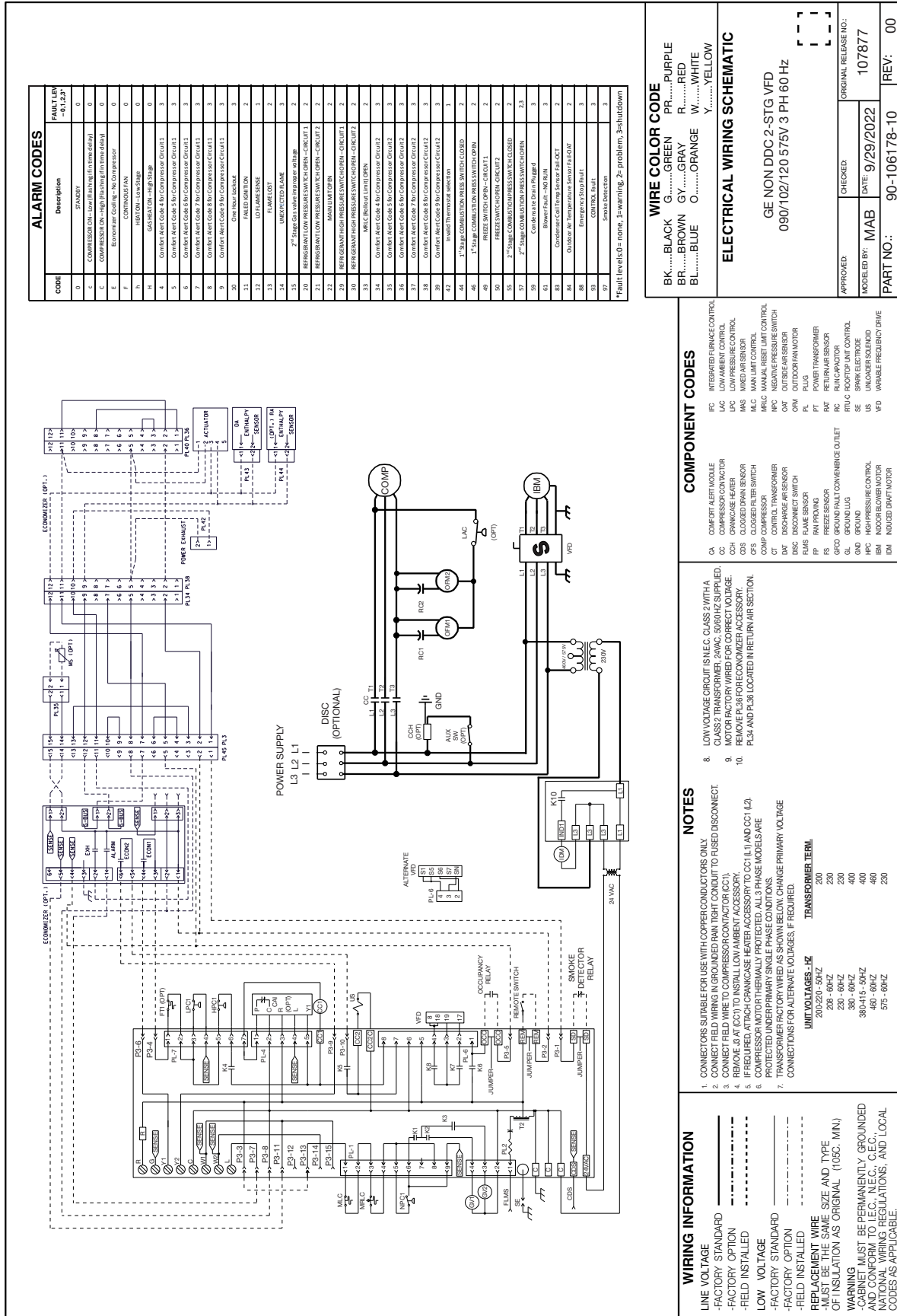

CODE	Description	FAULT LVL -0, 1, 2, 3*
0	STANDBY	0
1	COMPRESSION ON - Low (Blow by Oil Free drain)	0
2	COMPRESSION ON - High (Blow by Oil Free drain)	0
3	Economizer Gas In - No Compressor	0
4	CONTROL GAS FAN	0
5	HEATON - Low Stage	0
6	GAS HEATON - High Stage	0
7	Combiner Alert Code 1 for Compressor Circuit 1	3
8	Combiner Alert Code 2 for Compressor Circuit 1	3
9	Combiner Alert Code 3 for Compressor Circuit 1	3
10	Combiner Alert Code 4 for Compressor Circuit 1	3
11	Combiner Alert Code 5 for Compressor Circuit 1	3
12	Combiner Alert Code 6 for Compressor Circuit 1	3
13	Combiner Alert Code 7 for Compressor Circuit 1	3
14	Combiner Alert Code 8 for Compressor Circuit 1	3
15	Combiner Alert Code 9 for Compressor Circuit 1	3
16	Combiner Alert Code 10 for Compressor Circuit 1	3
17	Combiner Alert Code 11 for Compressor Circuit 1	3
18	Combiner Alert Code 12 for Compressor Circuit 1	3
19	Combiner Alert Code 13 for Compressor Circuit 1	3
20	Combiner Alert Code 14 for Compressor Circuit 1	3
21	Combiner Alert Code 15 for Compressor Circuit 1	3
22	Combiner Alert Code 16 for Compressor Circuit 1	3
23	Combiner Alert Code 17 for Compressor Circuit 1	3
24	Combiner Alert Code 18 for Compressor Circuit 1	3
25	Combiner Alert Code 19 for Compressor Circuit 1	3
26	Combiner Alert Code 20 for Compressor Circuit 1	3
27	Combiner Alert Code 21 for Compressor Circuit 1	3
28	Combiner Alert Code 22 for Compressor Circuit 1	3
29	Combiner Alert Code 23 for Compressor Circuit 1	3
30	Combiner Alert Code 24 for Compressor Circuit 1	3
31	Combiner Alert Code 25 for Compressor Circuit 1	3
32	Combiner Alert Code 26 for Compressor Circuit 1	3
33	Combiner Alert Code 27 for Compressor Circuit 1	3
34	Combiner Alert Code 28 for Compressor Circuit 1	3
35	Combiner Alert Code 29 for Compressor Circuit 1	3
36	Combiner Alert Code 30 for Compressor Circuit 1	3
37	Combiner Alert Code 31 for Compressor Circuit 1	3
38	Combiner Alert Code 32 for Compressor Circuit 1	3
39	Combiner Alert Code 33 for Compressor Circuit 1	3
40	Combiner Alert Code 34 for Compressor Circuit 1	3
41	Combiner Alert Code 35 for Compressor Circuit 1	3
42	Combiner Alert Code 36 for Compressor Circuit 1	3
43	Combiner Alert Code 37 for Compressor Circuit 1	3
44	Combiner Alert Code 38 for Compressor Circuit 1	3
45	Combiner Alert Code 39 for Compressor Circuit 1	3
46	Combiner Alert Code 40 for Compressor Circuit 1	3
47	Combiner Alert Code 41 for Compressor Circuit 1	3
48	Combiner Alert Code 42 for Compressor Circuit 1	3
49	Combiner Alert Code 43 for Compressor Circuit 1	3
50	Combiner Alert Code 44 for Compressor Circuit 1	3
51	Combiner Alert Code 45 for Compressor Circuit 1	3
52	Combiner Alert Code 46 for Compressor Circuit 1	3
53	Combiner Alert Code 47 for Compressor Circuit 1	3
54	Combiner Alert Code 48 for Compressor Circuit 1	3
55	Combiner Alert Code 49 for Compressor Circuit 1	3
56	Combiner Alert Code 50 for Compressor Circuit 1	3
57	Combiner Alert Code 51 for Compressor Circuit 1	3
58	Combiner Alert Code 52 for Compressor Circuit 1	3
59	Combiner Alert Code 53 for Compressor Circuit 1	3
60	Combiner Alert Code 54 for Compressor Circuit 1	3
61	Combiner Alert Code 55 for Compressor Circuit 1	3
62	Combiner Alert Code 56 for Compressor Circuit 1	3
63	Combiner Alert Code 57 for Compressor Circuit 1	3
64	Combiner Alert Code 58 for Compressor Circuit 1	3
65	Combiner Alert Code 59 for Compressor Circuit 1	3
66	Combiner Alert Code 60 for Compressor Circuit 1	3
67	Combiner Alert Code 61 for Compressor Circuit 1	3
68	Combiner Alert Code 62 for Compressor Circuit 1	3
69	Combiner Alert Code 63 for Compressor Circuit 1	3
70	Combiner Alert Code 64 for Compressor Circuit 1	3
71	Combiner Alert Code 65 for Compressor Circuit 1	3
72	Combiner Alert Code 66 for Compressor Circuit 1	3
73	Combiner Alert Code 67 for Compressor Circuit 1	3
74	Combiner Alert Code 68 for Compressor Circuit 1	3
75	Combiner Alert Code 69 for Compressor Circuit 1	3
76	Combiner Alert Code 70 for Compressor Circuit 1	3
77	Combiner Alert Code 71 for Compressor Circuit 1	3
78	Combiner Alert Code 72 for Compressor Circuit 1	3
79	Combiner Alert Code 73 for Compressor Circuit 1	3
80	Combiner Alert Code 74 for Compressor Circuit 1	3
81	Combiner Alert Code 75 for Compressor Circuit 1	3
82	Combiner Alert Code 76 for Compressor Circuit 1	3
83	Combiner Alert Code 77 for Compressor Circuit 1	3
84	Combiner Alert Code 78 for Compressor Circuit 1	3
85	Combiner Alert Code 79 for Compressor Circuit 1	3
86	Combiner Alert Code 80 for Compressor Circuit 1	3
87	Combiner Alert Code 81 for Compressor Circuit 1	3
88	Combiner Alert Code 82 for Compressor Circuit 1	3
89	Combiner Alert Code 83 for Compressor Circuit 1	3
90	Combiner Alert Code 84 for Compressor Circuit 1	3
91	Combiner Alert Code 85 for Compressor Circuit 1	3
92	Combiner Alert Code 86 for Compressor Circuit 1	3
93	Combiner Alert Code 87 for Compressor Circuit 1	3
94	Combiner Alert Code 88 for Compressor Circuit 1	3
95	Combiner Alert Code 89 for Compressor Circuit 1	3
96	Combiner Alert Code 90 for Compressor Circuit 1	3
97	Combiner Alert Code 91 for Compressor Circuit 1	3
98	Combiner Alert Code 92 for Compressor Circuit 1	3
99	Combiner Alert Code 93 for Compressor Circuit 1	3
100	Combiner Alert Code 94 for Compressor Circuit 1	3

*Fault levels: 0 - none, 1 - warning, 2 - problem, 3 - shutdown

WIRE COLOR CODE	WIRE COLOR CODE
BK.....BLACK	G.....GREEN
BR.....BROWN	GY.....GRAY
BL.....BLUE	O.....ORANGE
	PR.....PURPLE
	R.....RED
	W.....WHITE
	Y.....YELLOW

ELECTRICAL WIRING SCHEMATIC

GE NON DDC 2-STG VFD
090/102/120/575V 3 PH 60 Hz

APPROVED:	CHECKED:	ORIGINAL RELEASE NO.:
MODELED BY: MAB	DATE: 9/29/2022	107877
PART NO.:	90-106178-10	REV: 00

COMPONENT CODES	COMPONENT CODES
CA	COMPACT ALERT MODULE
CC	COMPRESSOR CONTACTOR
CC1	COMPRESSOR CONTACTOR
CC2	COMPRESSOR CONTACTOR
CC3	COMPRESSOR CONTACTOR
CC4	COMPRESSOR CONTACTOR
CC5	COMPRESSOR CONTACTOR
CC6	COMPRESSOR CONTACTOR
CC7	COMPRESSOR CONTACTOR
CC8	COMPRESSOR CONTACTOR
CC9	COMPRESSOR CONTACTOR
CC10	COMPRESSOR CONTACTOR
CC11	COMPRESSOR CONTACTOR
CC12	COMPRESSOR CONTACTOR
CC13	COMPRESSOR CONTACTOR
CC14	COMPRESSOR CONTACTOR
CC15	COMPRESSOR CONTACTOR
CC16	COMPRESSOR CONTACTOR
CC17	COMPRESSOR CONTACTOR
CC18	COMPRESSOR CONTACTOR
CC19	COMPRESSOR CONTACTOR
CC20	COMPRESSOR CONTACTOR
CC21	COMPRESSOR CONTACTOR
CC22	COMPRESSOR CONTACTOR
CC23	COMPRESSOR CONTACTOR
CC24	COMPRESSOR CONTACTOR
CC25	COMPRESSOR CONTACTOR
CC26	COMPRESSOR CONTACTOR
CC27	COMPRESSOR CONTACTOR
CC28	COMPRESSOR CONTACTOR
CC29	COMPRESSOR CONTACTOR
CC30	COMPRESSOR CONTACTOR
CC31	COMPRESSOR CONTACTOR
CC32	COMPRESSOR CONTACTOR
CC33	COMPRESSOR CONTACTOR
CC34	COMPRESSOR CONTACTOR
CC35	COMPRESSOR CONTACTOR
CC36	COMPRESSOR CONTACTOR
CC37	COMPRESSOR CONTACTOR
CC38	COMPRESSOR CONTACTOR
CC39	COMPRESSOR CONTACTOR
CC40	COMPRESSOR CONTACTOR
CC41	COMPRESSOR CONTACTOR
CC42	COMPRESSOR CONTACTOR
CC43	COMPRESSOR CONTACTOR
CC44	COMPRESSOR CONTACTOR
CC45	COMPRESSOR CONTACTOR
CC46	COMPRESSOR CONTACTOR
CC47	COMPRESSOR CONTACTOR
CC48	COMPRESSOR CONTACTOR
CC49	COMPRESSOR CONTACTOR
CC50	COMPRESSOR CONTACTOR
CC51	COMPRESSOR CONTACTOR
CC52	COMPRESSOR CONTACTOR
CC53	COMPRESSOR CONTACTOR
CC54	COMPRESSOR CONTACTOR
CC55	COMPRESSOR CONTACTOR
CC56	COMPRESSOR CONTACTOR
CC57	COMPRESSOR CONTACTOR
CC58	COMPRESSOR CONTACTOR
CC59	COMPRESSOR CONTACTOR
CC60	COMPRESSOR CONTACTOR
CC61	COMPRESSOR CONTACTOR
CC62	COMPRESSOR CONTACTOR
CC63	COMPRESSOR CONTACTOR
CC64	COMPRESSOR CONTACTOR
CC65	COMPRESSOR CONTACTOR
CC66	COMPRESSOR CONTACTOR
CC67	COMPRESSOR CONTACTOR
CC68	COMPRESSOR CONTACTOR
CC69	COMPRESSOR CONTACTOR
CC70	COMPRESSOR CONTACTOR
CC71	COMPRESSOR CONTACTOR
CC72	COMPRESSOR CONTACTOR
CC73	COMPRESSOR CONTACTOR
CC74	COMPRESSOR CONTACTOR
CC75	COMPRESSOR CONTACTOR
CC76	COMPRESSOR CONTACTOR
CC77	COMPRESSOR CONTACTOR
CC78	COMPRESSOR CONTACTOR
CC79	COMPRESSOR CONTACTOR
CC80	COMPRESSOR CONTACTOR
CC81	COMPRESSOR CONTACTOR
CC82	COMPRESSOR CONTACTOR
CC83	COMPRESSOR CONTACTOR
CC84	COMPRESSOR CONTACTOR
CC85	COMPRESSOR CONTACTOR
CC86	COMPRESSOR CONTACTOR
CC87	COMPRESSOR CONTACTOR
CC88	COMPRESSOR CONTACTOR
CC89	COMPRESSOR CONTACTOR
CC90	COMPRESSOR CONTACTOR
CC91	COMPRESSOR CONTACTOR
CC92	COMPRESSOR CONTACTOR
CC93	COMPRESSOR CONTACTOR
CC94	COMPRESSOR CONTACTOR
CC95	COMPRESSOR CONTACTOR
CC96	COMPRESSOR CONTACTOR
CC97	COMPRESSOR CONTACTOR
CC98	COMPRESSOR CONTACTOR
CC99	COMPRESSOR CONTACTOR
CC100	COMPRESSOR CONTACTOR

NOTES

- CONNECTORS SUITABLE FOR USE WITH COPPER CONDUCTORS ONLY.
- CONNECT FIELD WIRE TO COMPRESSOR CONTACTOR (CC).
- REMOVE LB AT CC11 TO INSTALL LOW AMBIENT ACCESSORY TO CC1 (L1) AND CC1 (L2).
- IF REQUIRED, ATTACH CRANKCASE HEATER ACCESSORY TO CC1 (L1) AND CC1 (L2).
- COMPRESSOR MOTOR THERMALLY PROTECTED, ALL 3 PHASE MODELS ARE PROTECTED UNDER PRIMARY SINGLE PHASE CONDITIONS.
- TRANSFORMER FACTORY WIRING AS SHOWN BELOW, CHANGE PRIMARY VOLTAGE CONNECTIONS FOR ALTERNATE VOLTAGES, IF REQUIRED.

UNIT VOLTAGES - HZ

200-220-50HZ	200
230-60HZ	230
230-60HZ	230
380-415-50HZ	400
480-500-60HZ	500
575-60HZ	600

TRANSFORMER TURNS

200	200
230	230
400	400
500	500
600	600

WIRING INFORMATION

- LINE VOLTAGE
- FACTORY STANDARD
- FIELD INSTALLED
- LOW VOLTAGE
- FACTORY STANDARD
- FIELD INSTALLED
- REPLACEMENT WIRE MUST BE THE SAME SIZE AND TYPE OF INSULATION AS ORIGINAL (100% MIN.)
- WARNING: ALL WIRING MUST BE PERMANENTLY GROUNDED AND CONFORM TO I.E.C., N.E.C., C.E.C. AND NATIONAL WIRING REGULATIONS, AND LOCAL CODES AS APPLICABLE.

P. APPENDICES

Appendix G. Wiring Diagrams & Schematics (Cont.)

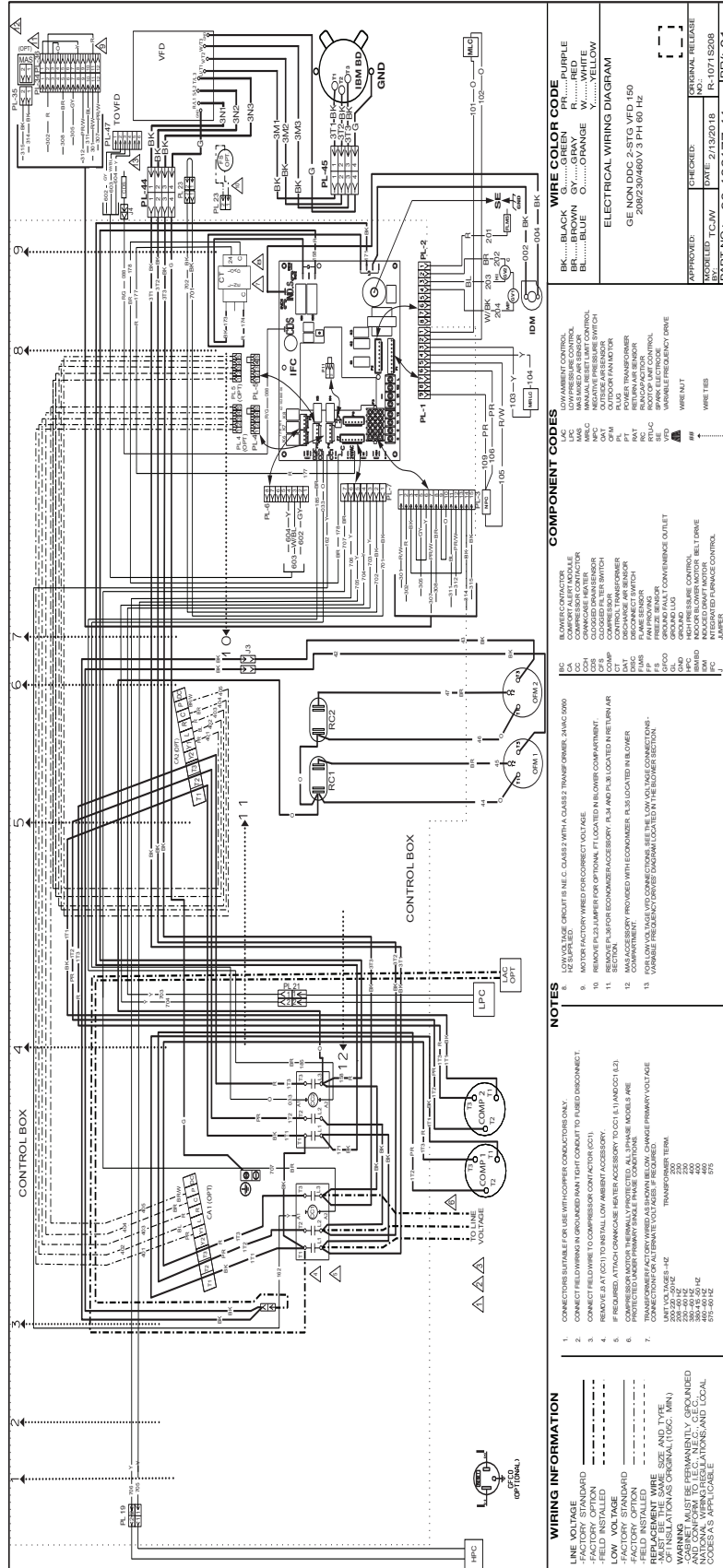

Appendix G. Wiring Diagrams & Schematics (Cont.)

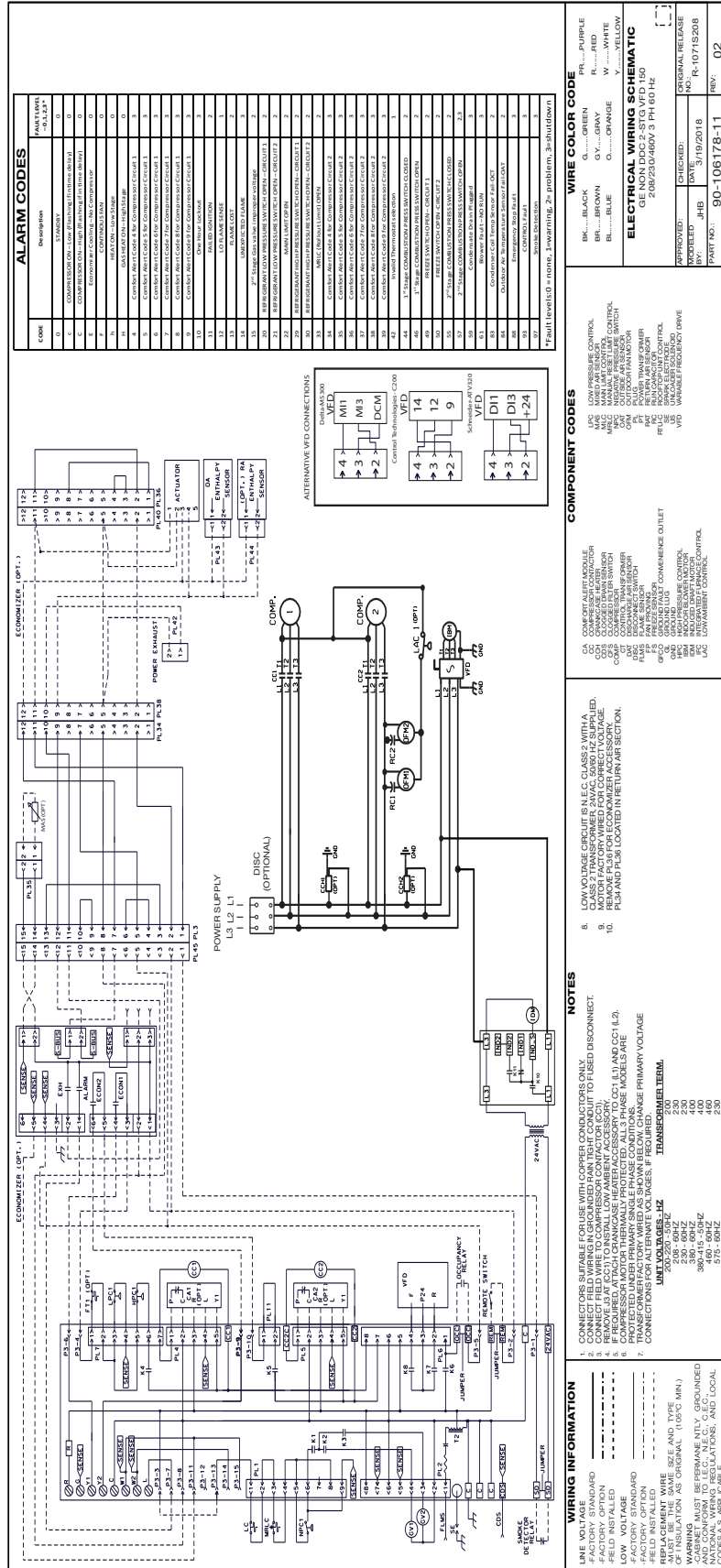

P. APPENDICES

Appendix G. Wiring Diagrams & Schematics (Cont.)

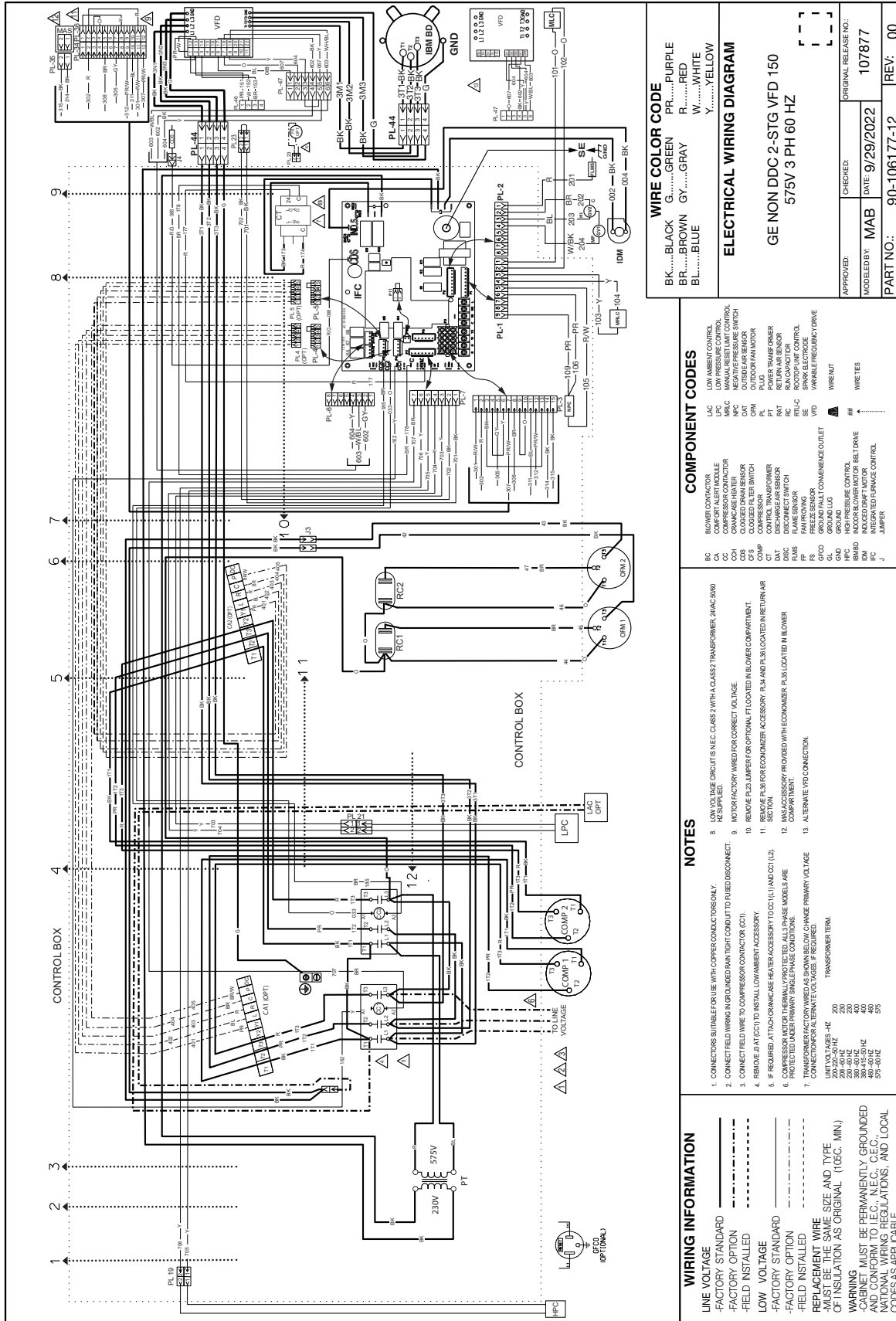

Appendix G. Wiring Diagrams & Schematics (Cont.)

The diagram illustrates the electrical connections for a GE Non DDC 2-STG VFD 150. It includes a power supply section with L1, L2, and L3 lines, an economizer (OPT. 1) with various sensors and relays, two compressors (COMP. 1 and 2) with their respective control circuits, and a control panel with numerous relays (R1-R12), sensors (ENTHALPY, PRESSURE, TEMPERATURE), and a terminal block (TERMINAL 1-12). A 24VAC transformer is also shown.

ALARM CODES	
CODE	Description
0	STANDBY
1	COMPRESSOR ON-Low (Running, first time delay)
2	COMPRESSOR ON-High (Running, first time delay)
3	Economizer Cooling, No Compressor
4	CONTINUOUS FAN
5	HEAT REAT ON-High Range
6	HEAT REAT ON-Low Range
7	Combin Alert Code 1 for Compressor Circuit 1
8	Combin Alert Code 2 for Compressor Circuit 1
9	Combin Alert Code 3 for Compressor Circuit 1
10	Combin Alert Code 4 for Compressor Circuit 1
11	Combin Alert Code 5 for Compressor Circuit 1
12	Combin Alert Code 6 for Compressor Circuit 1
13	Combin Alert Code 7 for Compressor Circuit 1
14	Combin Alert Code 8 for Compressor Circuit 1
15	Combin Alert Code 9 for Compressor Circuit 1
16	Combin Alert Code 10 for Compressor Circuit 1
17	Combin Alert Code 11 for Compressor Circuit 1
18	Combin Alert Code 12 for Compressor Circuit 1
19	Combin Alert Code 13 for Compressor Circuit 1
20	Combin Alert Code 14 for Compressor Circuit 1
21	Combin Alert Code 15 for Compressor Circuit 1
22	Combin Alert Code 16 for Compressor Circuit 1
23	Combin Alert Code 17 for Compressor Circuit 1
24	Combin Alert Code 18 for Compressor Circuit 1
25	Combin Alert Code 19 for Compressor Circuit 1
26	Combin Alert Code 20 for Compressor Circuit 1
27	Combin Alert Code 21 for Compressor Circuit 1
28	Combin Alert Code 22 for Compressor Circuit 1
29	Combin Alert Code 23 for Compressor Circuit 1
30	Combin Alert Code 24 for Compressor Circuit 1
31	Combin Alert Code 25 for Compressor Circuit 1
32	Combin Alert Code 26 for Compressor Circuit 1
33	Combin Alert Code 27 for Compressor Circuit 1
34	Combin Alert Code 28 for Compressor Circuit 1
35	Combin Alert Code 29 for Compressor Circuit 1
36	Combin Alert Code 30 for Compressor Circuit 1
37	Combin Alert Code 31 for Compressor Circuit 1
38	Combin Alert Code 32 for Compressor Circuit 1
39	Combin Alert Code 33 for Compressor Circuit 1
40	Combin Alert Code 34 for Compressor Circuit 1
41	Combin Alert Code 35 for Compressor Circuit 1
42	Combin Alert Code 36 for Compressor Circuit 1
43	Combin Alert Code 37 for Compressor Circuit 1
44	Combin Alert Code 38 for Compressor Circuit 1
45	Combin Alert Code 39 for Compressor Circuit 1
46	Combin Alert Code 40 for Compressor Circuit 1
47	Combin Alert Code 41 for Compressor Circuit 1
48	Combin Alert Code 42 for Compressor Circuit 1
49	Combin Alert Code 43 for Compressor Circuit 1
50	Combin Alert Code 44 for Compressor Circuit 1
51	Combin Alert Code 45 for Compressor Circuit 1
52	Combin Alert Code 46 for Compressor Circuit 1
53	Combin Alert Code 47 for Compressor Circuit 1
54	Combin Alert Code 48 for Compressor Circuit 1
55	Combin Alert Code 49 for Compressor Circuit 1
56	Combin Alert Code 50 for Compressor Circuit 1
57	Combin Alert Code 51 for Compressor Circuit 1
58	Combin Alert Code 52 for Compressor Circuit 1
59	Combin Alert Code 53 for Compressor Circuit 1
60	Combin Alert Code 54 for Compressor Circuit 1
61	Combin Alert Code 55 for Compressor Circuit 1
62	Combin Alert Code 56 for Compressor Circuit 1
63	Combin Alert Code 57 for Compressor Circuit 1
64	Combin Alert Code 58 for Compressor Circuit 1
65	Combin Alert Code 59 for Compressor Circuit 1
66	Combin Alert Code 60 for Compressor Circuit 1
67	Combin Alert Code 61 for Compressor Circuit 1
68	Combin Alert Code 62 for Compressor Circuit 1
69	Combin Alert Code 63 for Compressor Circuit 1
70	Combin Alert Code 64 for Compressor Circuit 1
71	Combin Alert Code 65 for Compressor Circuit 1
72	Combin Alert Code 66 for Compressor Circuit 1
73	Combin Alert Code 67 for Compressor Circuit 1
74	Combin Alert Code 68 for Compressor Circuit 1
75	Combin Alert Code 69 for Compressor Circuit 1
76	Combin Alert Code 70 for Compressor Circuit 1
77	Combin Alert Code 71 for Compressor Circuit 1
78	Combin Alert Code 72 for Compressor Circuit 1
79	Combin Alert Code 73 for Compressor Circuit 1
80	Combin Alert Code 74 for Compressor Circuit 1
81	Combin Alert Code 75 for Compressor Circuit 1
82	Combin Alert Code 76 for Compressor Circuit 1
83	Combin Alert Code 77 for Compressor Circuit 1
84	Combin Alert Code 78 for Compressor Circuit 1
85	Combin Alert Code 79 for Compressor Circuit 1
86	Combin Alert Code 80 for Compressor Circuit 1
87	Combin Alert Code 81 for Compressor Circuit 1
88	Combin Alert Code 82 for Compressor Circuit 1
89	Combin Alert Code 83 for Compressor Circuit 1
90	Combin Alert Code 84 for Compressor Circuit 1
91	Combin Alert Code 85 for Compressor Circuit 1
92	Combin Alert Code 86 for Compressor Circuit 1
93	Combin Alert Code 87 for Compressor Circuit 1
94	Combin Alert Code 88 for Compressor Circuit 1
95	Combin Alert Code 89 for Compressor Circuit 1
96	Combin Alert Code 90 for Compressor Circuit 1
97	Combin Alert Code 91 for Compressor Circuit 1
98	Combin Alert Code 92 for Compressor Circuit 1
99	Combin Alert Code 93 for Compressor Circuit 1
100	Combin Alert Code 94 for Compressor Circuit 1

WIRING INFORMATION

- LINE VOLTAGE
- FACTORY STANDARD
- FACTORY OPTION
- FIELD INSTALLED

LOW VOLTAGE

- FACTORY STANDARD
- FACTORY OPTION
- FIELD INSTALLED

REPLACEMENT WIRE

- MUST BE THE SAME SIZE AND TYPE
- MUST BE PERMANENTLY GROUNDED AND CONFORM TO I.E.C., N.E.C., C.E.C. AND LOCAL CODES AS APPLICABLE.

WARNING

CABINET MUST BE PERMANENTLY GROUNDED AND CONFORM TO I.E.C., N.E.C., C.E.C. AND LOCAL CODES AS APPLICABLE.

NOTES

1. CONNECTORS SUITABLE FOR USE WITH COPPER CONDUCTORS ONLY.
2. CONNECT FIELD WIRING IN GROUNDED PAINT TIGHT CONDUIT TO FUSED DISCONNECT.
3. CONNECT FIELD WIRE TO COMPRESSOR CONTACTOR (CCT).
4. FIELD WIRE TO ECONOMIZER HEATER ACCESSORY TO CCT (L1 AND CCT L2).
5. FIELD WIRE TO ECONOMIZER HEATER ACCESSORY TO CCT (L1 AND CCT L2).
6. COMPRESSOR MOTOR THERMALLY PROTECTED. ALL 3 PHASE MODELS ARE PROTECTED UNDER PRIMARY SINGLE PHASE CONDITIONS.
7. TRANSFORMER FACTORY WIRE AS SHOWN BELOW. CHANGE PRIMARY VOLTAGE CONNECTIONS FOR ALTERNATE VOLTAGES, IF REQUIRED.

UNIT VOLTAGES - 1Ø	TRANSFORMER TERN.
200-208-50/60HZ	200
230-230-50/60HZ	230
230-230-60HZ	230
380-415-50/60HZ	400
380-415-60HZ	400
460-480-50/60HZ	460
460-480-60HZ	460
575-600HZ	550

NOTES

8. LOW VOLTAGE CIRCUIT IS N.E.C. CLASS 2 WITH A CLASS 2 TRANSFORMER, 24VAC, 50/60 HZ SUPPLIED.
9. MOTOR FACTORY WIRE FOR CORRECT VOLTAGE.
10. REMOVE PLUS FOR ECONOMIZER ACCESSORY. PLUS AND PLUS LOCATED IN RETURN AIR SECTION.

COMPONENT CODES

CA	COMPONENT ALTERNATE MODULE
CC	COMPRESSOR CONTACTOR
COH	COMPRESSOR HEATER
COB	CLOSED DOOR SENSOR
COE	CLOSED FILTER SWITCH
COF	CONTROL TRANSFORMER
DAT	DISCHARGE AIR SENSOR
DISC	DISCONNECT SWITCH
FLMS	FLAME SENSOR
FAN	FAN PROWING
FP	POWER TRANSFORMER
RET	RETURN AIR SENSOR
ROF	ROOF TOP UNIT CONTROL
RLAC	ROOF TOP UNIT CONTROL
SE	SPARK ELECTRODE
US	UNLOCKER SOLENOID
VFD	VARIABLE FREQUENCY DRIVE
IND	INDOOR BLOWER MOTOR
DM	INDOOR DRAFFT MOTOR

WIRE COLOR CODE

BK.....BLACK G.....GREEN PR.....PURPLE
 BR.....BROWN Gy.....GRAY R.....RED
 BL.....BLUE O.....ORANGE W.....WHITE
 Y.....YELLOW

ELECTRICAL WIRING SCHEMATIC

GE NON DDC 2-STG VFD 150
 575V 3 PH 60 HZ

APPROVED: _____ CHECKED: _____ ORIGINAL RELEASE NO.: _____
 MODELED BY: MAB DATE: 9/29/2022 107877
 PART NO.: 90-106178-12 REV: 00

P. APPENDICES

Appendix G. Wiring Diagrams & Schematics (Cont.)

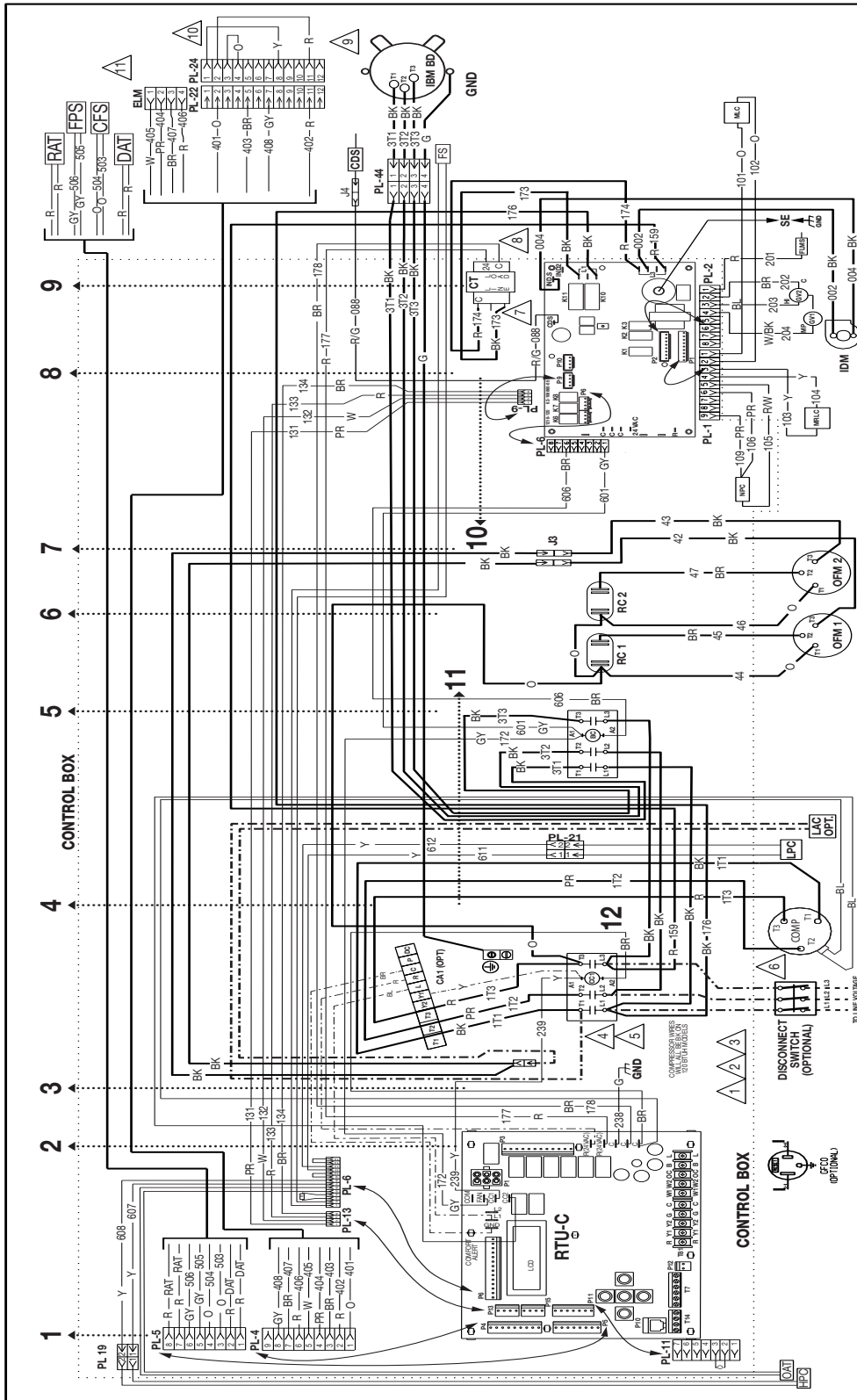

WIRE COLOR CODE BK.....BLACK G.....GREEN PR.....PURPLE BR.....BROWN GY.....GRAY R.....RED BL.....BLUE O.....ORANGE W.....WHITE Y.....YELLOW	ELECTRICAL WIRING DIAGRAM GE DDC 2-STG 090/102/120 208/230/380/480V, 3PH, 60HZ GE DDC 2-STG 072/090/102 380-415V, 3PH, 50HZ	CHECKED: _____ DATE: 11/13/2017 APPROVED: _____ TC:JW ORIGINAL RELEASE NO.: R-1071S126 PART NO.: 90-106177-13 REV: 01
--	--	---

COMPONENT CODES	<p>BC BLOWER CONTACTOR</p> <p>CA COMPRESSOR CONTACTOR</p> <p>CC COIL</p> <p>CCS CLOSURE SENSOR</p> <p>COMP COMPRESSOR</p> <p>CONTR CONTROL TRANSFORMER</p> <p>DAT DISCHARGE AIR SENSOR</p> <p>DSC DISCONNECT SWITCH</p> <p>EUM ECONOMIZER LOGIC MODULE</p> <p>FLS FLAME SENSOR</p> <p>FAN FAN PROTECT SWITCH</p> <p>RET RETURN AIR SENSOR</p> <p>RC RETURN AIR CONTROL</p> <p>RETC RETURN AIR CONTROL</p> <p>SE SHOCK ELECTRODE</p> <p>UN UNDERPRESSURE OUTLET</p> <p>GS GAS VALVE</p> <p>GV GAS VALVE</p> <p>HPC HIGH PRESSURE CONTROL</p> <p>IM MOTOR BLOWER MOTOR</p> <p>RC1</p> <p>RC2</p> <p>OPM 1</p> <p>OPM 2</p>
------------------------	--

NOTES	<p>8. LOW VOLTAGE PROTECT (N.E.C. CLASS WITH A CLASS 2 TRANSFORMER) AND 50/60 HZ SUPPLIED.</p> <p>9. MOTOR FACTORY WIRE FOR CORRECT VOLTAGE.</p> <p>10. REMOVE PL-2 FOR ECONOMIZER ACCESSORY. PL-2 AND PL-24 LOCATED IN RETURN AIR SECTION.</p> <p>11. CONNECT TO ECONOMIZER LOGIC MODULE.</p>
--------------	--

WIRING INFORMATION	<p>1. CONNECTORS SUITABLE FOR USE WITH COPPER CONDUCTORS ONLY.</p> <p>2. CONNECT FIELD WIRING IN GROUNDED RAIN TIGHT CONDUIT TO RUSED DISCONNECT.</p> <p>3. CONNECT FIELD WIRE TO COMPRESSOR CONTACTOR (CC).</p> <p>4. REMOVE S.A.T (CC) TO INSTALL LOW AMBIENT ACCESSORY.</p> <p>5. IF REQUIRED, ATTACH CRANKCASE HEATER ACCESSORY TO CC (L) AND CC (R).</p> <p>6. COMPRESSOR MOTOR THERMALLY PROTECTED. ALL 3 PHASE MODELS ARE PROTECTED UNDER PRIMARY SINGLE PHASE CONDITIONS.</p> <p>7. TRANSFORMER FACTORY WIRE AS SHOWN BELOW. CHANGE PRIMARY VOLTAGE CONNECTION FOR ALTERNATE VOLTAGES. IF REQUIRED.</p>
---------------------------	---

WIRING INFORMATION	<p>LINE VOLTAGE _____</p> <p>-FACTORY STANDARD _____</p> <p>-FACTORY OPTION _____</p> <p>-FIELD INSTALLED _____</p> <p>LOW VOLTAGE _____</p> <p>-FACTORY STANDARD _____</p> <p>-FACTORY OPTION _____</p> <p>-FIELD INSTALLED _____</p> <p>REPLACEMENT WIRE _____</p> <p>-MUST BE THE SAME SIZE AND TYPE</p> <p>OF INSULATION AS ORIGINAL (105C. MIN.)</p> <p>WARNING</p> <p>-CABINET MUST BE PERMANENTLY GROUNDED AND CONFORM TO I.E.C., N.E.C., C.E.C., NATIONAL WIRING REGULATIONS, AND LOCAL CODE AS APPLICABLE.</p>
---------------------------	---

Appendix G. Wiring Diagrams & Schematics (Cont.)

RTU-C 1188-100

ZONE SENSOR CONNECTIONS

THERMOSTAT CONNECTIONS

COMPONENTS: COMP, IBM, IFC, K10, DISC (OPTIONAL), CC, GND, CA (OPT), P11, P12, P13, P14, P15, P16, P17, P18, P19, P20, P21, P22, P23, P24, P25, P26, P27, P28, P29, P30, P31, P32, P33, P34, P35, P36, P37, P38, P39, P40, P41, P42, P43, P44, P45, P46, P47, P48, P49, P50, P51, P52, P53, P54, P55, P56, P57, P58, P59, P60, P61, P62, P63, P64, P65, P66, P67, P68, P69, P70, P71, P72, P73, P74, P75, P76, P77, P78, P79, P80, P81, P82, P83, P84, P85, P86, P87, P88, P89, P90, P91, P92, P93, P94, P95, P96, P97, P98, P99, P100.

CODE	Description	WARRANTY LABEL -0,1,2,3*
0	STANDBY	0
C	COMPRESSOR ON-Low (Flashing in time delay)	0
C	COMPRESSOR ON-High (Flashing in time delay)	0
E	Economizer Cooling-M Compressor	0
F	CONTINUOUS FAN	0
H	HEATON-Low Stage	0
H	HEATON-High Stage	0
4	CombinAlert Code 4 for Compressor Circuit 1	3
5	CombinAlert Code 5 for Compressor Circuit 1	3
6	CombinAlert Code 6 for Compressor Circuit 1	3
7	CombinAlert Code 7 for Compressor Circuit 1	3
8	CombinAlert Code 8 for Compressor Circuit 1	3
9	CombinAlert Code 9 for Compressor Circuit 1	3
11	FAULT ON/TON	2
12	UPFLAME SENSE	1
13	FLAME LOST	2
14	UNEXPECTED FLAME	3
15	2 nd Stage Gas Valve Improper Voltage	2
20	REFRIGERANT LOW PRESSURE SWITCH OPEN-CIRCUIT 1	2
21	REFRIGERANT LOW PRESSURE SWITCH OPEN-CIRCUIT 2	2
22	MANUAL LIMIT OPEN	2
29	REFRIGERANT HIGH PRESSURE SWITCH OPEN-CIRCUIT 1	2
30	REFRIGERANT HIGH PRESSURE SWITCH OPEN-CIRCUIT 2	2
33	MRLC (Recoil Limit) OPEN	2
34	CombinAlert Code 4 for Compressor Circuit 2	3
35	CombinAlert Code 5 for Compressor Circuit 2	3
36	CombinAlert Code 6 for Compressor Circuit 2	3
37	CombinAlert Code 7 for Compressor Circuit 2	3
38	CombinAlert Code 8 for Compressor Circuit 2	3
39	CombinAlert Code 9 for Compressor Circuit 2	3
42	Invalid Thermostat Selection	1
44	1 st Stage COMBUSTION PRESS SWITCH CLOSED	2
46	1 st Stage COMBUSTION PRESS SWITCH OPEN	2
49	FREEZE SWITCH OPEN-CIRCUIT 1	2
50	FREEZE SWITCH OPEN-CIRCUIT 2	2
55	2 nd Stage COMBUSTION PRESS SWITCH CLOSED	2
57	2 nd Stage COMBUSTION PRESS SWITCH OPEN	2,3
59	Condensate Drain Plugged	3
61	Blower Fan-NO RUN	3
83	Condenser Coil Temp Sensor Fail-DOT	2
84	Outdoor Air Temperature Sensor Fail-DOT	2
88	Emergency Stop Fault	3
93	CONTROL FAULT	3
97	Sense Detection	3

*Fault 11=level 0=none, 1=warning, 2=problem, 3=shutdown

WIRING INFORMATION

LINE VOLTAGE: _____

-FACTORY STANDARD: _____

-FACTORY OPTION: _____

-FIELD INSTALLED: _____

LOW VOLTAGE: _____

-FACTORY STANDARD: _____

-FACTORY OPTION: _____

-FIELD INSTALLED: _____

REPLACEMENT WIRE: _____

-MUST BE THE SAME SIZE AND TYPE OF INSULATION AS ORIGINAL.

WARNING: _____

-CABINET MUST BE PERMANENTLY GROUND AND CONFORM TO I.E.C., N.E.C., C.E.C., NATIONAL WIRING REGULATIONS, AND LOCAL CODES AS APPLICABLE.

NOTES

- CONNECTORS SUITABLE FOR USE WITH COPPER CONDUCTORS ONLY.
- CONNECTED WIRING IN GROUNDED RAN TEST CIRCUIT TO BE DISCONNECTED.
- CONNECT FELD WIRE TO COMPRESSOR CONTACTOR (CC).
- BEFORE RATCH CRANK/ASE HEATER ACCESSORY TO CCT, L1 AND CCT (L2).
- COMPRESSOR MOTOR THERMALLY PROTECTED, ALL 3 PHASE MODELS ARE PROTECTED UNDER PRIMARY SINGLE PHASE CONDITIONS.
- TRANSFORMER FACTORY WIRE AS SHOWN BELOW CHANGE PRIMARY VOLTAGE CONNECTIONS FOR ALTERNATE VOLTAGES, IF REQUIRED.

UNIT VOLTAGES - Hz

200-220-50Hz	TRANSFORMER TERM.	200
230-50Hz		230
230-60Hz		230
380-50Hz		400
380-60Hz		460
575-50Hz		575

COMPONENT CODES

BC: BLOWER CONTACTOR
CC: COMPRESSOR CONTACTOR
CCH: CRANK/ASE HEATER
COS: CLOSED DRAIN SENSOR
COMP: COMPRESSOR
CT: CONTROL TRANSFORMER
DAT: DISCHARGE AIR SENSOR
FAS: FAN RUNNING
FP: FAN FAILURE
GL: GROUND LUG
GND: GROUND
IB: GAS VALVE
H: HIGH PRESSURE CONTROL
IBM: INDOOR BLOWER MOTOR
IM: INDOOR FAN MOTOR
FC: INTERFERERENCE CONTROL
LAC: LOW AMBIENT CONTROL

WIRE COLOR CODE

BK.....BLACK
BR.....BROWN
BL.....BLUE
G.....GREEN
GY.....GRAY
O.....ORANGE
R.....RED
W.....WHITE
Y.....YELLOW

ELECTRICAL WIRING SCHEMATIC

GE DDC 2 STG 090102/120
208/230/380/480V, 3PH, 60HZ
GE DDC 2 STG 072090/102
380-415V, 3PH, 50HZ

APPROVED: _____
MODELED BY: TC/W
DATE: 11-14-17
NO.: _____
ORIGINAL RELEASE: R-1071S126

PART NO: 90-106178-13
REV: 01

P. APPENDICES

Appendix G. Wiring Diagrams & Schematics (Cont.)

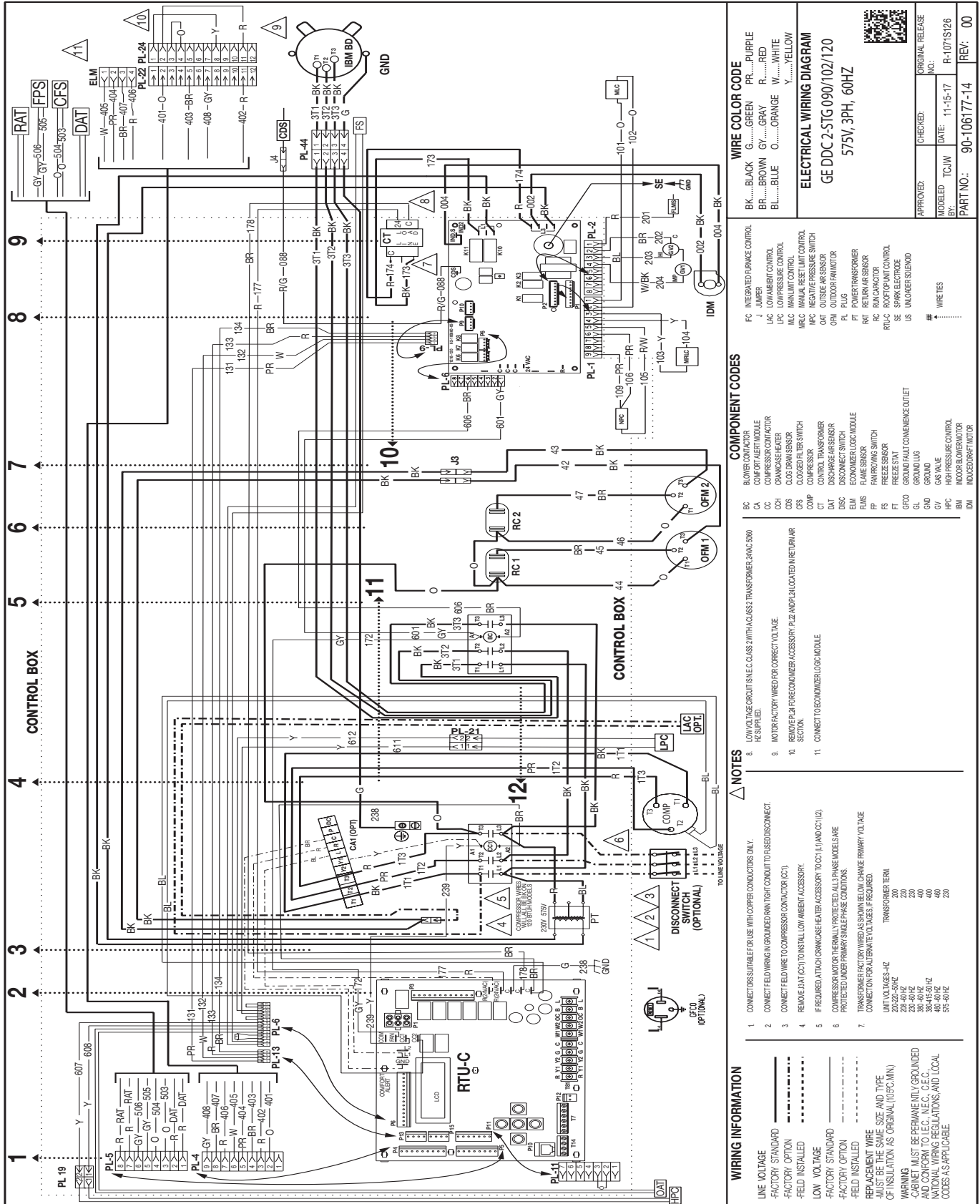

WIRE COLOR CODE

BK.....BLACK G.....GREEN PR.....PURPLE
 BR.....BROWN GV.....GRAY R.....RED
 BL.....BLUE O.....ORANGE W.....WHITE
 Y.....YELLOW

ELECTRICAL WIRING DIAGRAM

GE DDC 2-STG 090/102/120
 575V, 3PH, 60HZ

COMPONENT CODES

BC BLOWER CONTACTOR
 CA COMPRESSOR CONTACTOR
 CC CROWBAR CONTACTOR
 CH CHAMBER HEATER
 CDS CLOG DOWN SENSOR
 CFS COMPRESSOR
 CVP COMPRESSOR
 DAT DATA TRANSFORMER
 DISC DISCONNECT SWITCH
 ELM ECONOMIZER LOGIC MODULE
 FLS FUSE SENSOR
 FR FAN SPEED SENSOR
 FT FRESH AIR FAN
 GEO GROUND FAULT COMMENCEMENT OUTLET
 GND GROUND
 GV GAS VALVE
 HPC HIGH PRESSURE CONTROL
 IDM INDOOR FLOW MOTOR
 IM INDUCED DRAFT MOTOR

WIRE COLOR CODE

FC INTEGRATED FURNACE CONTROL
 IAC LOW AMBIENT CONTROL
 LPC LOW PRESSURE CONTROL
 MLC MANUAL RESET LIMIT CONTROL
 MPC NEGATIVE PRESSURE SWITCH
 OAT OUTSIDE AIR SENSOR
 OIM OUTDOOR FAN MOTOR
 PL PLUG
 PF POWER TRANSFORMER
 RAT RETURN AIR SENSOR
 RUC RETURN AIR CONTROL
 SE SPRINKLER ELECTRIC
 US UNDER-SILO/GROUD

NOTES

- CONNECTORS SUITABLE FOR USE WITH COPPER CONDUCTORS ONLY.
- CONNECT FELD WIRING IN GROUNDING RAIL TRIGHT CONDUIT TO FUSED DISCONNECT.
- CONNECT FELD WIRE TO COMPRESSOR CONTACTOR (C2).
- REMOVE BATT (C2) TO INSTALL LOW AMBIENT ACCESSORY.
- IF REQUIRED, ATTACH CHAMBER HEATER ACCESSORY TO C1 (L1 AND C1 (L2)). COMPRESSOR MOTOR IS THEMALLY PROTECTED. ALL 3-PHASE MODEL ARE PROTECTED UNDER PRIMARY SNAKE PHASE CONDITIONS.
- TRANSFORMER FACTORY WIRING AS SHOWN BELOW. CHANGE PRIMARY VOLTAGE CONNECTION FOR ALTERNATE VOLTAGES IF REQUIRED.

WIRING INFORMATION

LINE VOLTAGE _____
 FACTORY STANDARD _____
 FACTORY OPTION _____
 FELD INSTALLED _____
 LOW VOLTAGE _____
 FACTORY STANDARD _____
 FACTORY OPTION _____
 FELD INSTALLED _____
 REPLACEMENT WIRE _____
 MUST BE THE SAME SIZE AND TYPE _____
 OF INSULATION AS ORIGINAL (105°C MIN.)
 WARNING
 CABINET MUST BE PERMANENTLY GROUNDED _____
 AND CONFORM TO I.E.C., N.E.C., C.E.C., _____
 NATIONAL WIRING REGULATIONS, AND LOCAL _____
 CODES AS APPLICABLE.

TRANSFORMER DATA

TRANSFORMER TERM	200	230	230	230	400	480	480	575
200-230-542Z								
230-401Z								
384-455-54Z								
460-491Z								
575-491Z								

APPROVED:

CHECKED: _____
 MODELED: _____
 DATE: 11-15-17
 BY: _____
 TCAW: _____
 ORIGINAL RELEASE NO.: R-1071S126
 PART NO.: 90-106177-14
 REV: 00

Appendix G. Wiring Diagrams & Schematics (Cont.)

ALARM CODES

CODE	Description	FAULT LEVEL -0,1,2,3*
0	STANDBY	0
C	COMPRESSION-LOW (Flashing) (In time delay)	0
C	COMPRESSION-HIGH (Flashing) (In time delay)	0
E	Evaporator Coil/No-Compressor	0
F	CONTROLS FAN	0
H	HEATON-Low Stage	0
H	GS-HEATON-High Stage	0
4	Comford Alert Code 4 for Compressor Circuit 1	3
5	Comford Alert Code 5 for Compressor Circuit 1	3
6	Comford Alert Code 6 for Compressor Circuit 1	3
7	Comford Alert Code 7 for Compressor Circuit 1	3
8	Comford Alert Code 8 for Compressor Circuit 1	3
9	Comford Alert Code 9 for Compressor Circuit 1	3
11	FAILED IGNITION	1
12	LO FLAME SENSE	1
13	FUEL LOST	2
14	UNEXPECTED FLAME	3
15	2 nd Stage Gas valve improper voltage	2
20	REFRIGERANT LOW PRESSURE SWITCH OPEN - CIRCUIT 1	2
21	REFRIGERANT LOW PRESSURE SWITCH OPEN - CIRCUIT 2	2
22	MANUAL LIMIT OPEN	2
23	REFRIGERANT HIGH PRESSURE SWITCH OPEN - CIRCUIT 1	2
30	REFRIGERANT HIGH PRESSURE SWITCH OPEN - CIRCUIT 2	2
33	ABC (Rebut Limit) OPEN	2
34	Comford Alert Code 4 for Compressor Circuit 2	3
35	Comford Alert Code 5 for Compressor Circuit 2	3
36	Comford Alert Code 6 for Compressor Circuit 2	3
37	Comford Alert Code 7 for Compressor Circuit 2	3
38	Comford Alert Code 8 for Compressor Circuit 2	3
39	Comford Alert Code 9 for Compressor Circuit 2	3
42	Invalid Thermostat selection	1
44	1 st Stage COMBUSTION PRESS SWITCH CLOSED	2
46	1 st Stage COMBUSTION PRESS SWITCH OPEN	2
48	FREEZE SWITCH OPEN - CIRCUIT 1	2
50	FREEZE SWITCH OPEN - CIRCUIT 2	2
55	2 nd Stage COMBUSTION PRESS SWITCH CLOSED	2
57	2 nd Stage COMBUSTION PRESS SWITCH OPEN	2,3
59	Condensate Drain Plugged	3
61	Blower fault-NO RUN	3
88	Condenser Coil Temp Sensor Fail-OC	2
84	Outdoor Air Temperature Sensor Fail/OC	2
86	Emergency Stop Fault	3
98	CONTROL Fault	3
97	Smoke Detection	3

*Fault levels 0=none, 1=warning, 2=problem, 3=shutdown

COMPONENT CODES

LPC	LOW PRESSURE CONTROL
CA	COMFORT ALERT MODULE
MFC	MANUAL LIMIT CONTROL
MFC	MANUAL RESET LIMIT CONTROL
NPC	NEGATIVE PRESSURE SWITCH
OCN	OUTDOOR AIR CONTROL
PL	PLUG
PT	POWER TRANSFORMER
PC	RELAY CONTACTOR
PC	RELAY CONTACTOR
RTUC	ROOM THERMISTOR CONTROL
SS	SPARK ELECTRODE
US	UNDERBURN SILENCER

RTU-C 1186-100

POWER SUPPLY
L3 L2 L1
6 6 6
0 0 0

ZONE SENSOR CONNECTIONS
CA (OPT)
P1 P2 P3 P4 P5 P6 P7 P8 P9 P10 P11 P12 P13 P14 P15 P16 P17 P18 P19 P20 P21 P22 P23 P24 P25 P26 P27 P28 P29 P30 P31 P32 P33 P34 P35 P36 P37 P38 P39 P40 P41 P42 P43 P44 P45 P46 P47 P48 P49 P50 P51 P52 P53 P54 P55 P56 P57 P58 P59 P60 P61 P62 P63 P64 P65 P66 P67 P68 P69 P70 P71 P72 P73 P74 P75 P76 P77 P78 P79 P80 P81 P82 P83 P84 P85 P86 P87 P88 P89 P90 P91 P92 P93 P94 P95 P96 P97 P98 P99 P100

WIRING INFORMATION

- LINE VOLTAGE
- FACTORY STANDARD
- FACTORY OPTION
- FIELD INSTALLED
- LOW VOLTAGE
- FACTORY STANDARD
- FACTORY OPTION
- FIELD INSTALLED
- REPLACEMENT WIRE
- MUST BE THE SAME SIZE AND TYPE OF INSULATION AS ORIGINAL (105°C MIN)
- WARNING
- WIRING MUST BE PERMANENTLY GROUNDED AND CONFORM TO I.E.C. N.E.C. C.E.C. AND NATIONAL WIRING REGULATIONS. AND LOCAL CODES AS APPLICABLE.

NOTES

- CONNECTORS SUITABLE FOR USE WITH COPPER CONDUCTORS ONLY.
- CONNECT FIELD WIRING IN GROUND/RAIN TIGHT CONDUIT TO FUSED DISCONNECT.
- CONNECT FIELD WIRE TO COMPRESSOR CONTACTOR (CC).
- REMOVE J3 AT CC TO INSTALL LOW AMBIENT ACCESSORY.
- IF REQUIRED, ATTACH CHAMKASE-HEATER ACCESSORY TO CC, L1 AND CC(L2).
- COMPRESSOR MOTOR THERMALLY PROTECTED ALL 3 PHASE MODELS ARE PROTECTED UNDER PRIMARY SINGLE PHASE CONDITIONS.
- TRANSFORMER FACTORY WIRED AS SHOWN BELOW. CHANGE PRIMARY VOLTAGE CONNECTIONS FOR ALTERNATE VOLTAGES, IF REQUIRED.

UNIT VOLTAGES - HZ

UNIT VOLTAGES - HZ	TRANSFORMER TERM.
200-220-50HZ	200
208-60HZ	200
230-60HZ	230
380-60HZ	400
380-415-50HZ	460
460-60HZ	460
575-60HZ	230

NOTES

- LOW VOLTAGE CIRCUIT IS N.E.C. CLASS 2 WITH A CLASS 2 TRANSFORMER, 24VAC, 50/60 HZ SUPPLIED.
- MOTOR FACTORY WIRED FOR CORRECT VOLTAGE.
- REMOVE PL24 FOR ECONOMIZER ACCESSORY.
- PL22 AND PL24 LOCATED IN RETURN AIR SECTION.

WIRE COLOR CODE

BK.....BLACK	G.....GREEN
BR.....BROWN	GY.....GRAY
BL.....BLUE	W.....WHITE
Y.....YELLOW	

ELECTRICAL WIRING SCHEMATIC

GE DDC 2-5TG 090/102/120
575V, 3PH, 60HZ

APPROVED:	CHECKED:	ORIGINAL RELEASE NO.:
MODELED BY: TCJM	DATE: 11-20-17	R-1071S/26
PART NO.: 90-106178-14	REV: 01	

P. APPENDICES

Appendix G. Wiring Diagrams & Schematics (Cont.)

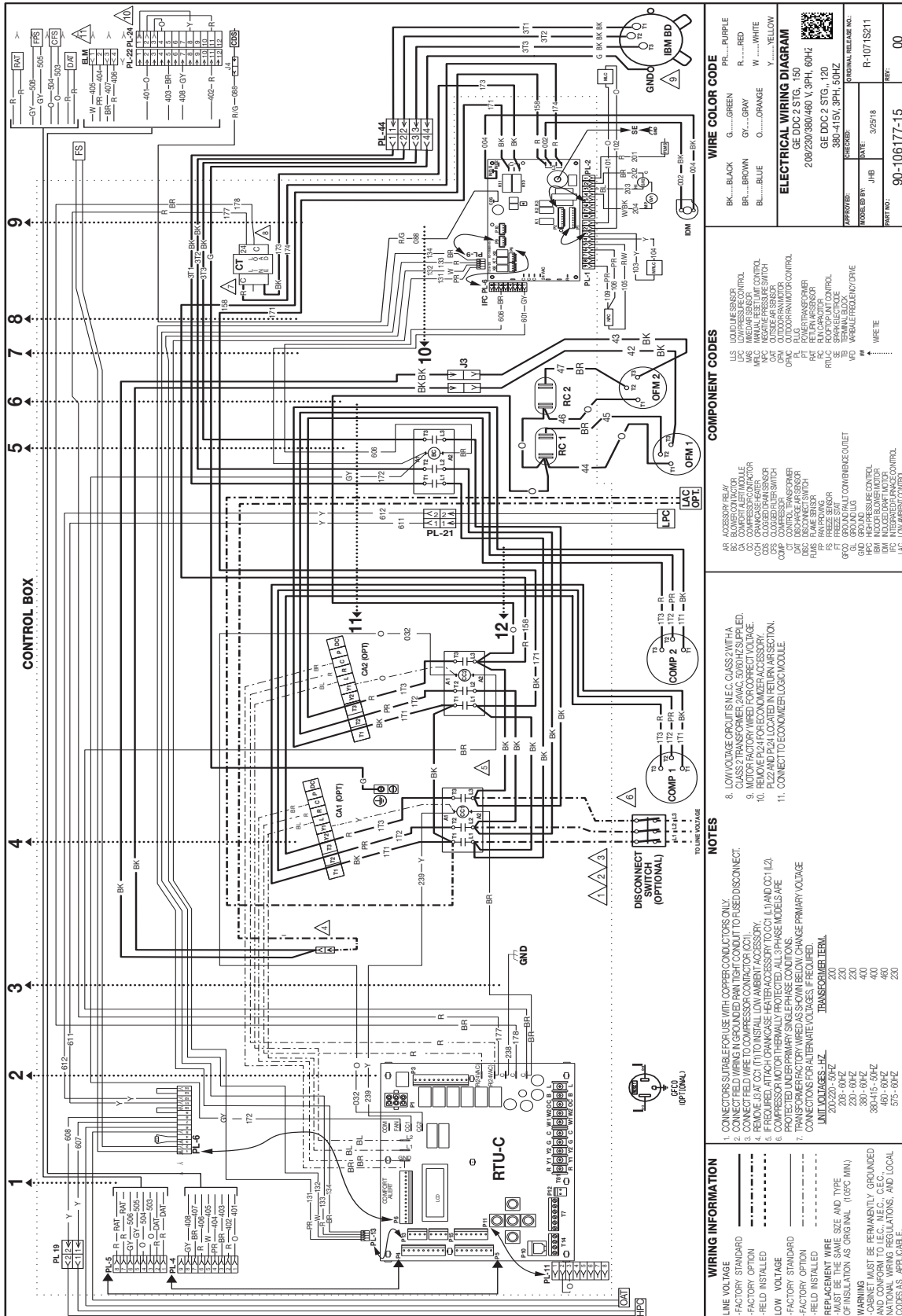

Appendix G. Wiring Diagrams & Schematics (Cont.)

RTU-C 1185-100

ZONE SENSOR CONNECTIONS

THERMOSTAT CONNECTIONS

POWER SUPPLY

COMP.

DISC (OPTIONAL)

RELAYS: RC1, RC2, RC3

SENSORS: IFC, LFC, PLS20, PLS21, PLS22, PLS23, PLS24, PLS25, PLS26, PLS27, PLS28, PLS29, PLS30, PLS31, PLS32, PLS33, PLS34, PLS35, PLS36, PLS37, PLS38, PLS39, PLS40, PLS41, PLS42, PLS43, PLS44, PLS45, PLS46, PLS47, PLS48, PLS49, PLS50, PLS51, PLS52, PLS53, PLS54, PLS55, PLS56, PLS57, PLS58, PLS59, PLS60, PLS61, PLS62, PLS63, PLS64, PLS65, PLS66, PLS67, PLS68, PLS69, PLS70, PLS71, PLS72, PLS73, PLS74, PLS75, PLS76, PLS77, PLS78, PLS79, PLS80, PLS81, PLS82, PLS83, PLS84, PLS85, PLS86, PLS87, PLS88, PLS89, PLS90, PLS91, PLS92, PLS93, PLS94, PLS95, PLS96, PLS97, PLS98, PLS99, PLS100

ALARM CODE	Description	FAULT LEVEL -0, 1, 2, 3*
0	STANDBY	0
C	COMPRESSOR ON - Low (Rising) (in time delay)	0
C	COMPRESSOR ON - High (Rising) (in time delay)	0
E	Economizer Cooling - No Compressor	0
F	CONTINUOUS FAN	0
h	HEAT ON - Low Stage	0
H	GAS HEAT ON - High Stage	0
4	CombiAlert Code 4 for Compressor Circuit 1	3
5	CombiAlert Code 5 for Compressor Circuit 1	3
6	CombiAlert Code 6 for Compressor Circuit 1	3
7	CombiAlert Code 7 for Compressor Circuit 1	3
8	CombiAlert Code 8 for Compressor Circuit 1	3
9	CombiAlert Code 9 for Compressor Circuit 1	3
11	FAILED IGNITION	2
12	LOW FLAME SIZE	1
13	FLAME LOSS	2
14	UNEXPECTED FLAME	3
15	2 nd Stage Gas valve improper voltage	2
20	REFRIGERANT LOW PRESSURE SWITCH OPEN - CIRCUIT 1	2
21	REFRIGERANT LOW PRESSURE SWITCH OPEN - CIRCUIT 2	2
22	MANUAL LIMIT OPEN	2
29	REFRIGERANT HIGH PRESSURE SWITCH OPEN - CIRCUIT 1	2
30	REFRIGERANT HIGH PRESSURE SWITCH OPEN - CIRCUIT 2	2
33	MRLC Rollout Limit (TOP)	2
34	CombiAlert Code 4 for Compressor Circuit 2	3
35	CombiAlert Code 5 for Compressor Circuit 2	3
36	CombiAlert Code 6 for Compressor Circuit 2	3
37	CombiAlert Code 7 for Compressor Circuit 2	3
38	CombiAlert Code 8 for Compressor Circuit 2	3
39	CombiAlert Code 9 for Compressor Circuit 2	3
42	Invalid Thermostat Selection	1
44	1 st Stage COMBUSTION PRESS SWITCH CLOSED	2
46	1 st Stage COMBUSTION PRESS SWITCH OPEN	2
49	FREEZE SWITCH OPEN - CIRCUIT 1	2
50	FREEZE SWITCH OPEN - CIRCUIT 2	2
55	2 nd Stage COMBUSTION PRESS SWITCH CLOSED	2
57	2 nd Stage COMBUSTION PRESS SWITCH OPEN	2
59	Condensate Drain Plogged	3
61	Blower Fan Start - NO RUN	3
83	Condenser Coil Temp Sensor Fail (OCT)	2
84	Outdoor Air Temperature Sensor Fail (OAT)	2
93	Emergency Stop Fault	3
97	Smoke Detector	3

*Fault levels: 0 = none, 1 = warning, 2 = problem, 3 = shutdown

WIRING INFORMATION

LINE VOLTAGE

-FACTORY STANDARD

-FACTORY OPTION

-FIELD INSTALLED

LOW VOLTAGE

-FACTORY STANDARD

-FACTORY OPTION

-FIELD INSTALLED

REPLACEMENT WIRE

-MUST BE THE SAME SIZE AND TYPE OF INSULATION AS ORIG. (NAT. 105°C MIN.)

WIRING

-CABINET MUST BE PERMANENTLY GROUNDED AND CONFORM TO I.E.C., N.E.C., C.E.C., NATIONAL WIRING REGULATIONS, AND LOCAL CODES AS APPL. CABLE.

WIRING INFORMATION

1. CONNECTORS SUITABLE FOR USE WITH COPPER CONDUCTORS ONLY.

2. CONNECT FIELD WIRING IN GROUNDING RING TO GROUND TO FUSED DISCONNECT.

3. CONNECT FIELD WIRE TO COMPRESSOR CONTACTOR (CCT).

4. REMOVE (OAT) TO SMALL LOW AMBIENT ACCESSORY.

5. IF REQUIRED, ATTACH CRANKCASE HEATER ACCESSORY TO CCT (L1) AND CCT (L2).

6. COMPRESSOR MOTOR THERMAL PROTECTORS (MTP) PROVIDED ALL PHASE MODELS ARE REQUIRED. FACTORY WIRING IS SHOWN FOR ALL PHASE MODELS.

7. FIELD WIRING FOR WIRELESS COMMUNICATIONS (WLC) CHARGE PRIMARY VOLTAGE CONNECTIONS FOR ALTERNATE VOLTAGES, IF REQUIRED.

UNIT VOLTAGES - HZ

UNIT VOLTAGES - HZ	TRANSFORMER TERM.
200/220 - 3PHZ	200
208 - 6PHZ	230
230 - 6PHZ	230
380 - 6PHZ	400
380-415 - 3PHZ	400
460 - 6PHZ	460
575 - 6PHZ	575

COMPONENT CODES

BC BLOWER CONTACTOR

CA CONTACTOR ALERT MODULE

CC CONTACTOR CONTACTOR

CH CRANKCASE HEATER

CS CLOSED DRAIN SENSOR

CS2 CLOSED FILTER SWITCH

CT CONTACTOR TRANSFORMER

DT DISCHARGE AP SENSOR

DSE DISCHARGE SWITCH

FA FAN START

FP FAN PROTECT

FR FREEZE SENSOR

GC0 GROUND FAULT COMMENCEMENT OUTLET

GND GROUND

GV GAS VALVE

HA HEAT ANTI-FREEZE CONTROL

HM INDUCED DRAFF MOTOR

IM INDUCED MOTOR

IFC INTEGRATED FURNACE CONTROL

LFC LOW AMBIENT CONTROL

LPC LOW PRESSURE CONTROL

MFC MANUAL RESET LIMIT CONTROL

MFC NEGATIVE PRESSURE SWITCH

MFC OUTDOOR FAN MOTOR

OM OUTDOOR FAN MOTOR

PL PLZ

PLZ20 PLZ21 PLZ22 PLZ23 PLZ24 PLZ25 PLZ26 PLZ27 PLZ28 PLZ29 PLZ30 PLZ31 PLZ32 PLZ33 PLZ34 PLZ35 PLZ36 PLZ37 PLZ38 PLZ39 PLZ40 PLZ41 PLZ42 PLZ43 PLZ44 PLZ45 PLZ46 PLZ47 PLZ48 PLZ49 PLZ50 PLZ51 PLZ52 PLZ53 PLZ54 PLZ55 PLZ56 PLZ57 PLZ58 PLZ59 PLZ60 PLZ61 PLZ62 PLZ63 PLZ64 PLZ65 PLZ66 PLZ67 PLZ68 PLZ69 PLZ70 PLZ71 PLZ72 PLZ73 PLZ74 PLZ75 PLZ76 PLZ77 PLZ78 PLZ79 PLZ80 PLZ81 PLZ82 PLZ83 PLZ84 PLZ85 PLZ86 PLZ87 PLZ88 PLZ89 PLZ90 PLZ91 PLZ92 PLZ93 PLZ94 PLZ95 PLZ96 PLZ97 PLZ98 PLZ99 PLZ100

PLZ20 TO ELIM

PLZ21 TO ELIM

PLZ22 TO ELIM

PLZ23 TO ELIM

PLZ24 TO ELIM

PLZ25 TO ELIM

PLZ26 TO ELIM

PLZ27 TO ELIM

PLZ28 TO ELIM

PLZ29 TO ELIM

PLZ30 TO ELIM

PLZ31 TO ELIM

PLZ32 TO ELIM

PLZ33 TO ELIM

PLZ34 TO ELIM

PLZ35 TO ELIM

PLZ36 TO ELIM

PLZ37 TO ELIM

PLZ38 TO ELIM

PLZ39 TO ELIM

PLZ40 TO ELIM

PLZ41 TO ELIM

PLZ42 TO ELIM

PLZ43 TO ELIM

PLZ44 TO ELIM

PLZ45 TO ELIM

PLZ46 TO ELIM

PLZ47 TO ELIM

PLZ48 TO ELIM

PLZ49 TO ELIM

PLZ50 TO ELIM

PLZ51 TO ELIM

PLZ52 TO ELIM

PLZ53 TO ELIM

PLZ54 TO ELIM

PLZ55 TO ELIM

PLZ56 TO ELIM

PLZ57 TO ELIM

PLZ58 TO ELIM

PLZ59 TO ELIM

PLZ60 TO ELIM

PLZ61 TO ELIM

PLZ62 TO ELIM

PLZ63 TO ELIM

PLZ64 TO ELIM

PLZ65 TO ELIM

PLZ66 TO ELIM

PLZ67 TO ELIM

PLZ68 TO ELIM

PLZ69 TO ELIM

PLZ70 TO ELIM

PLZ71 TO ELIM

PLZ72 TO ELIM

PLZ73 TO ELIM

PLZ74 TO ELIM

PLZ75 TO ELIM

PLZ76 TO ELIM

PLZ77 TO ELIM

PLZ78 TO ELIM

PLZ79 TO ELIM

PLZ80 TO ELIM

PLZ81 TO ELIM

PLZ82 TO ELIM

PLZ83 TO ELIM

PLZ84 TO ELIM

PLZ85 TO ELIM

PLZ86 TO ELIM

PLZ87 TO ELIM

PLZ88 TO ELIM

PLZ89 TO ELIM

PLZ90 TO ELIM

PLZ91 TO ELIM

PLZ92 TO ELIM

PLZ93 TO ELIM

PLZ94 TO ELIM

PLZ95 TO ELIM

PLZ96 TO ELIM

PLZ97 TO ELIM

PLZ98 TO ELIM

PLZ99 TO ELIM

PLZ100 TO ELIM

NOTES

8. LOW VOLTAGE CIRCUIT IS N.E.C. CLASS 2 WITH A CLASS 2 TRANSFORMER, 2VAC, 50/60 HZ SUPPLIED.

9. MOTOR FACTORY WIRED FOR CORRECT VOLTAGE.

10. REMOVE PLZ FOR ECONOMIZER ACCESSORY. PLZ2 AND PLZ4 LOCATED IN RETURN AIR SECTION.

ELECTRICAL WIRING SCHEMATIC

GE DDC 2 STG 150

208/230/380/460V, 3PH, 60HZ

GE DDC 2 STG 150

380-415V, 3PH, 50HZ

APPROVED BY: JHB

DATE: 03-19-18

ORIGINAL RELEASE NO.: P-107 IS208

PART NO.: 90-106178-15

REV: 00

WIRE COLOR CODE

BK...BLACK

BR...BROWN

BL...BLUE

GR...GREEN

GY...GRAY

OR...ORANGE

WH...WHITE

Y...YELLOW

Appendix G. Wiring Diagrams & Schematics (Cont.)

ALARM CODES

CODE	Description	FAULT LEVEL -0, 1, 2, 3*
0	STANDBY	0
C	COMPRESSOR ON—Low (Flashing in time delay)	0
C	COMPRESSOR ON—High (Flashing in time delay)	0
E	Economizer Cooling—No Compressor	0
F	CONTINUOUS	0
h	HEAT ON—Low Stage	0
h	GAS HEAT ON—High Stage	0
4	Combin Alert Code 4 for Compressor Circuit 1	3
5	Combin Alert Code 5 for Compressor Circuit 1	3
6	Combin Alert Code 6 for Compressor Circuit 1	3
7	Combin Alert Code 7 for Compressor Circuit 1	3
8	Combin Alert Code 8 for Compressor Circuit 1	3
9	Combin Alert Code 9 for Compressor Circuit 1	3
11	FAILED IGNITION	2
12	LO FLAME SENSE	1
13	FLAME LOST	2
14	UNEXPECTED FLAME	3
15	2 nd Stage Gas valve improve voltage	2
20	REFRIGERANT LOW PRESSURE SWITCH OPEN—CIRCUIT 1	2
21	REFRIGERANT LOW PRESSURE SWITCH OPEN—CIRCUIT 2	2
22	MANUAL LIMIT OPEN	2
29	REFRIGERANT HIGH PRESSURE SWITCH OPEN—CIRCUIT 1	2
30	REFRIGERANT HIGH PRESSURE SWITCH OPEN—CIRCUIT 2	2
34	MRLC Rollout Limit OPEN	2
34	Combin Alert Code 4 for Compressor Circuit 2	3
35	Combin Alert Code 5 for Compressor Circuit 2	3
36	Combin Alert Code 6 for Compressor Circuit 2	3
37	Combin Alert Code 7 for Compressor Circuit 2	3
38	Combin Alert Code 8 for Compressor Circuit 2	3
39	Combin Alert Code 9 for Compressor Circuit 2	3
42	Invalid Thermostat Selection	1
44	1 st Stage COMBUSTION PRESS SWITCH CLOSED	2
46	1 st Stage COMBUSTION PRESS SWITCH OPEN	2
49	FREEZE SWITCH OPEN—CIRCUIT 1	2
50	FREEZE SWITCH OPEN—CIRCUIT 2	2
55	2 nd Stage COMBUSTION PRESS SWITCH CLOSED	2, 3
57	2 nd Stage COMBUSTION PRESS SWITCH OPEN	2, 3
59	Combin Alert Code Arranged	3
61	Blower Fault—NO RUN	2
83	Condenser Coil Temp Sensor Fail OCT	2
84	Outdoor Air Temperature Sensor Fail OCT	2
88	Emergency Stop Fault	3
93	CONTROL FAULT	3
97	Smoke Detection	3

* Fault levels: 0=none, 1=warning, 2=problem, 3=shutdown

WIRE COLOR CODE

BK.....BLACK	G.....GREEN	PR.....PURPLE
BR.....BROWN	GY.....GRAY	R.....RED
BL.....BLUE	OR.....ORANGE	W.....WHITE
RE.....RED/BLACK	Y.....YELLOW	

ELECTRICAL WIRING SCHEMATIC

GE DDC 2 STG 150
575V 3PH, 60HZ

APPROVED:	CHECKED:	ORIGINAL RELEASE NO.:
MODELED BY: JHB	DATE: 03-19-18	P-107 IS208
PART NO.:	90-106178-16	REV: 00

COMPONENT CODES

BC	BLOWER CONTACTOR
CA	COMFORT ALERT MODULE
CC	CONTROL CENTER FOR
CC1	COMBUSTION PRESS SWITCH
CC2	CLOSED DOOR SENSOR
CC3	CLOSED DOOR SWITCH
CC4	COMBUSTION PRESS SWITCH
CC5	CONTROL TRANSFORMER
CC6	DISCHARGE SENSOR
CC7	FAN SPEED SWITCH
CC8	FAN SPEED SWITCH
CC9	FAN SPEED SWITCH
CC10	FAN SPEED SWITCH
CC11	FAN SPEED SWITCH
CC12	FAN SPEED SWITCH
CC13	FAN SPEED SWITCH
CC14	FAN SPEED SWITCH
CC15	FAN SPEED SWITCH
CC16	FAN SPEED SWITCH
CC17	FAN SPEED SWITCH
CC18	FAN SPEED SWITCH
CC19	FAN SPEED SWITCH
CC20	FAN SPEED SWITCH
CC21	FAN SPEED SWITCH
CC22	FAN SPEED SWITCH
CC23	FAN SPEED SWITCH
CC24	FAN SPEED SWITCH
CC25	FAN SPEED SWITCH
CC26	FAN SPEED SWITCH
CC27	FAN SPEED SWITCH
CC28	FAN SPEED SWITCH
CC29	FAN SPEED SWITCH
CC30	FAN SPEED SWITCH
CC31	FAN SPEED SWITCH
CC32	FAN SPEED SWITCH
CC33	FAN SPEED SWITCH
CC34	FAN SPEED SWITCH
CC35	FAN SPEED SWITCH
CC36	FAN SPEED SWITCH
CC37	FAN SPEED SWITCH
CC38	FAN SPEED SWITCH
CC39	FAN SPEED SWITCH
CC40	FAN SPEED SWITCH
CC41	FAN SPEED SWITCH
CC42	FAN SPEED SWITCH
CC43	FAN SPEED SWITCH
CC44	FAN SPEED SWITCH
CC45	FAN SPEED SWITCH
CC46	FAN SPEED SWITCH
CC47	FAN SPEED SWITCH
CC48	FAN SPEED SWITCH
CC49	FAN SPEED SWITCH
CC50	FAN SPEED SWITCH
CC51	FAN SPEED SWITCH
CC52	FAN SPEED SWITCH
CC53	FAN SPEED SWITCH
CC54	FAN SPEED SWITCH
CC55	FAN SPEED SWITCH
CC56	FAN SPEED SWITCH
CC57	FAN SPEED SWITCH
CC58	FAN SPEED SWITCH
CC59	FAN SPEED SWITCH
CC60	FAN SPEED SWITCH
CC61	FAN SPEED SWITCH
CC62	FAN SPEED SWITCH
CC63	FAN SPEED SWITCH
CC64	FAN SPEED SWITCH
CC65	FAN SPEED SWITCH
CC66	FAN SPEED SWITCH
CC67	FAN SPEED SWITCH
CC68	FAN SPEED SWITCH
CC69	FAN SPEED SWITCH
CC70	FAN SPEED SWITCH
CC71	FAN SPEED SWITCH
CC72	FAN SPEED SWITCH
CC73	FAN SPEED SWITCH
CC74	FAN SPEED SWITCH
CC75	FAN SPEED SWITCH
CC76	FAN SPEED SWITCH
CC77	FAN SPEED SWITCH
CC78	FAN SPEED SWITCH
CC79	FAN SPEED SWITCH
CC80	FAN SPEED SWITCH
CC81	FAN SPEED SWITCH
CC82	FAN SPEED SWITCH
CC83	FAN SPEED SWITCH
CC84	FAN SPEED SWITCH
CC85	FAN SPEED SWITCH
CC86	FAN SPEED SWITCH
CC87	FAN SPEED SWITCH
CC88	FAN SPEED SWITCH
CC89	FAN SPEED SWITCH
CC90	FAN SPEED SWITCH
CC91	FAN SPEED SWITCH
CC92	FAN SPEED SWITCH
CC93	FAN SPEED SWITCH
CC94	FAN SPEED SWITCH
CC95	FAN SPEED SWITCH
CC96	FAN SPEED SWITCH
CC97	FAN SPEED SWITCH
CC98	FAN SPEED SWITCH
CC99	FAN SPEED SWITCH
CC100	FAN SPEED SWITCH

NOTES

- CONNECTORS SUITABLE FOR USE WITH COPPER CONDUCTORS ONLY.
- CONNECT FIELD WIRING TO GROUND IN TIGHT CONDUIT TO RISE DISCONNECT.
- CONNECT FIELD WIRE TO COMPRESSOR CONTACTOR (CC).
- REMOVE 0.6 AT (CC) TO INSTALL LOW AMBIENT ACCESSORY.
- IF REQUIRED, ATTACH LOW AMBIENT HEATER ACCESSORY TO CC1 (L) AND CC1 (L2).
- PROTECTS UNDER PRIMARY SINGLE PHASE CONDITIONS.
- TRANSFORMER FACTORY WIRING AS SHOWN BELOW UNLESS CHANGED TO CHANGE PRIMARY VOLTAGE.
- CONNECTORS FOR ALTERNATE VOLTAGES, IF REQUIRED.

UNIT VOLTAGES—HZ	TRANSFORMER TERM.
208/220—50HZ	200
208—60HZ	230
230—60HZ	230
380—60HZ	400
380-415—50HZ	400
460—60HZ	460
575—60HZ	575

WIRING INFORMATION

LINE VOLTAGE

- FACTORY STANDARD
- FACTORY OPTION
- FIELD INSTALLED

LOW VOLTAGE

- FACTORY STANDARD
- FACTORY OPTION
- FIELD INSTALLED

REPLACEMENT WIRE

- MUST BE THE SAME SIZE AND TYPE OF INSULATION AS ORIGINAL.
- CABINET MUST BE PERMANENTLY GROUNDED AND CONFORM TO I.E.C., N.E.C., C.E.C., NATIONAL WIRING REGULATIONS, AND LOCAL CODES AS APPL. CABLE.

P. APPENDICES

Appendix G. Wiring Diagrams & Schematics (Cont.)

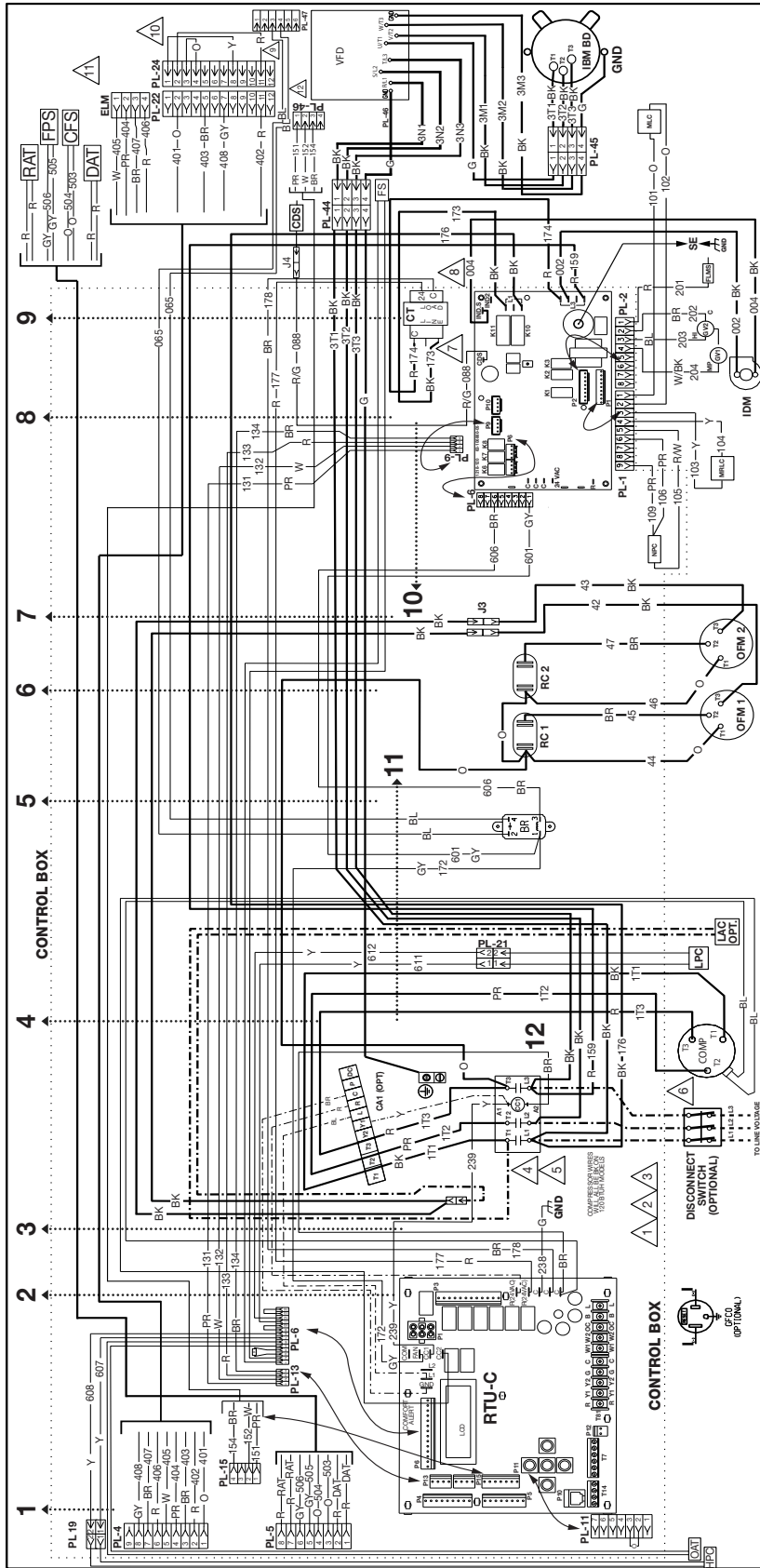

WIRE COLOR CODE	
BK.....BLACK	G.....GREEN
BR.....BROWN	GY.....GRAY
BL.....BLUE	O.....ORANGE
	W.....WHITE
	Y.....YELLOW

ELECTRICAL WIRING DIAGRAM	
GE DDC 2-5TG VFD 090/102/120	
208/230/380/460V, 3PH, 60HZ	
GE DDC 2-5TG VFD 072/090/102	
380-415V, 3PH, 50HZ	

APPROVED:	CHECKED:	ORIGINAL RELEASE NO.:
TCJW	12/4/2017	R-107/15126
PART NO.:	90-106177-17	REV: 01

COMPONENT CODES	
BC	BLOWER/CONTRACTOR
CC	COMPONENT MODULE
CA	CONVERTER
CH	CHARGE HEATER
CO	COMBUSTION
CS	COOLING
CCS	COOLING SENSING
CO	COOLING SWITCH
COB	COOLING BLOWER
CC	CONTROL
DT	DISCHARGE
FC	FAN
FL	FLAME
FM	FAN MOTOR
FLS	FLAME SENSOR
FCM	FAN MOTOR CONTROL
FP	FAN PROOF
FT	FREESTAR
GL	GROUND LUG
GO	GROUNDING
GV	GAS VALVE
HPC	HIGH PRESSURE CONTROL
BM	BLUETOOTH MOTOR
DM	DIFFUSION MOTOR
FC	INTEGRATED FURNACE CONTROL
LAC	LOW AMBIENT CONTROL
MAC	MANUAL CONTROL
MALC	MANUAL LIMIT CONTROL
MRC	MANUAL RESET LIMIT CONTROL
NPC	NEGATIVE PRESSURE SWITCH
OPM	OUTDOOR FAN MOTOR
PL	PLUG
PT	POTENTIOMETER
RC	RELAY
RC	RELAY CONTROL
RLC	RELAY CONTROL
SE	SPARK ELECTRODE
US	USER SWITCH
VFD	VARIABLE FREQUENCY DRIVE
W	WIRE/UNT
W	WIRE/UNT

NOTES	
1	CONNECTORS SUITABLE FOR USE WITH COPPER CONDUCTORS ONLY.
2	CONNECT FIELD WIRE TO COMPRESSOR CONTACTOR (CCL).
3	FIELD WIRE TO COMPRESSOR CONTACTOR (CCL) IS TO BE USED DISCONNECT.
4	FIELD WIRE TO COMPRESSOR CONTACTOR (CCL) IS TO BE USED DISCONNECT.
5	FIELD WIRE TO COMPRESSOR CONTACTOR (CCL) IS TO BE USED DISCONNECT.
6	COMPRESSOR FAN MOTOR IS PROTECTED BY ALL PHASES IN CASE OF A SHORT CIRCUIT.
7	TRANSFORMER FACTORY WIRING AS SHOWN BELOW CHANGE PRIMARY VOLTAGE CONNECTION FOR ALTERNATE VOLTAGES IF REQUIRED.

WIRING INFORMATION	
LINE VOLTAGE	FACTORY STANDARD
	FACTORY OPTION
	FIELD INSTALLED
LOW VOLTAGE	FACTORY STANDARD
	FACTORY OPTION
	FIELD INSTALLED
	REPLACE WIRE
	MUST BE THE SAME SIZE AND TYPE
	OF INSULATION AS ORIGINAL (105C, MIN.)
	WARNING
	CABINET MUST BE PERMANENTLY GROUNDED
	AND CONFORM TO I.E.C., N.E.C., C.E.C.,
	NATIONAL WIRING REGULATIONS, AND LOCAL
	CODE AS APPLICABLE.

P. APPENDICES

Appendix G. Wiring Diagrams & Schematics (Cont.)

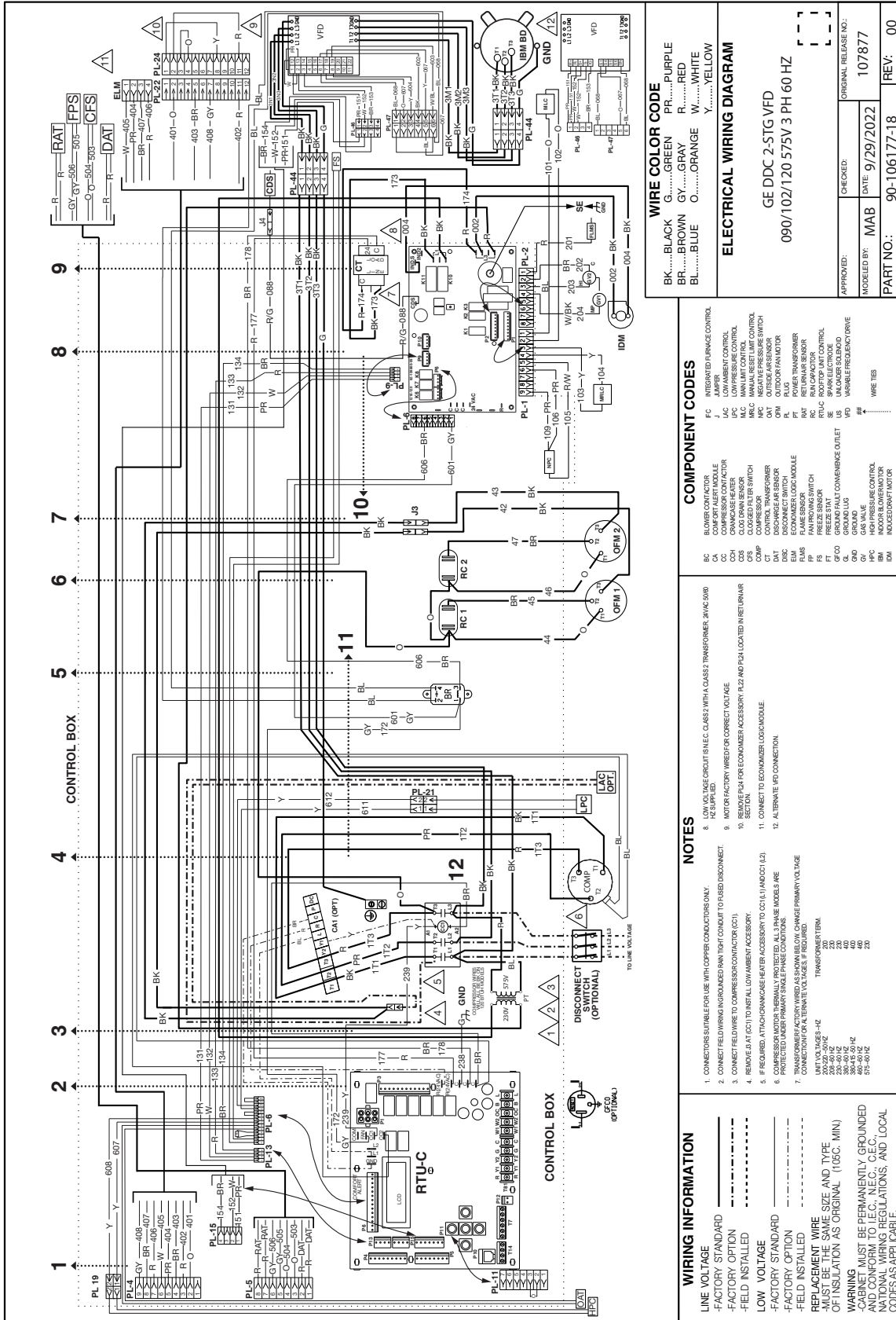

Appendix G. Wiring Diagrams & Schematics (Cont.)

POWER SUPPLY
L3 L2 L1
1 1 1
DISC (OPTIONAL)
CC
L1 L2 L3
GND
GPH
AKK (OPT.)

COMPONENTS: COMP, IBM, VFD, BR, P15, IFC, K10, L1, L2, L3, R1C1, R1C2, R1C3, R1C4, R1C5, R1C6, R1C7, R1C8, R1C9, R1C10, R1C11, R1C12, R1C13, R1C14, R1C15, R1C16, R1C17, R1C18, R1C19, R1C20, R1C21, R1C22, R1C23, R1C24, R1C25, R1C26, R1C27, R1C28, R1C29, R1C30, R1C31, R1C32, R1C33, R1C34, R1C35, R1C36, R1C37, R1C38, R1C39, R1C40, R1C41, R1C42, R1C43, R1C44, R1C45, R1C46, R1C47, R1C48, R1C49, R1C50, R1C51, R1C52, R1C53, R1C54, R1C55, R1C56, R1C57, R1C58, R1C59, R1C60, R1C61, R1C62, R1C63, R1C64, R1C65, R1C66, R1C67, R1C68, R1C69, R1C70, R1C71, R1C72, R1C73, R1C74, R1C75, R1C76, R1C77, R1C78, R1C79, R1C80, R1C81, R1C82, R1C83, R1C84, R1C85, R1C86, R1C87, R1C88, R1C89, R1C90, R1C91, R1C92, R1C93, R1C94, R1C95, R1C96, R1C97, R1C98, R1C99, R1C100.

ALARM CODES	
CODE	Description
0	STANDBY
1	COMBUSTION PRESS. HIGH (IN TIME) CIRCUIT 1
2	COMBUSTION PRESS. HIGH (IN TIME) CIRCUIT 2
3	COMBUSTION PRESS. HIGH (IN TIME) CIRCUIT 3
4	COMBUSTION PRESS. HIGH (IN TIME) CIRCUIT 4
5	COMBUSTION PRESS. HIGH (IN TIME) CIRCUIT 5
6	COMBUSTION PRESS. HIGH (IN TIME) CIRCUIT 6
7	COMBUSTION PRESS. HIGH (IN TIME) CIRCUIT 7
8	COMBUSTION PRESS. HIGH (IN TIME) CIRCUIT 8
9	COMBUSTION PRESS. HIGH (IN TIME) CIRCUIT 9
10	COMBUSTION PRESS. HIGH (IN TIME) CIRCUIT 10
11	COMBUSTION PRESS. HIGH (IN TIME) CIRCUIT 11
12	COMBUSTION PRESS. HIGH (IN TIME) CIRCUIT 12
13	COMBUSTION PRESS. HIGH (IN TIME) CIRCUIT 13
14	COMBUSTION PRESS. HIGH (IN TIME) CIRCUIT 14
15	COMBUSTION PRESS. HIGH (IN TIME) CIRCUIT 15
16	COMBUSTION PRESS. HIGH (IN TIME) CIRCUIT 16
17	COMBUSTION PRESS. HIGH (IN TIME) CIRCUIT 17
18	COMBUSTION PRESS. HIGH (IN TIME) CIRCUIT 18
19	COMBUSTION PRESS. HIGH (IN TIME) CIRCUIT 19
20	COMBUSTION PRESS. HIGH (IN TIME) CIRCUIT 20
21	COMBUSTION PRESS. HIGH (IN TIME) CIRCUIT 21
22	COMBUSTION PRESS. HIGH (IN TIME) CIRCUIT 22
23	COMBUSTION PRESS. HIGH (IN TIME) CIRCUIT 23
24	COMBUSTION PRESS. HIGH (IN TIME) CIRCUIT 24
25	COMBUSTION PRESS. HIGH (IN TIME) CIRCUIT 25
26	COMBUSTION PRESS. HIGH (IN TIME) CIRCUIT 26
27	COMBUSTION PRESS. HIGH (IN TIME) CIRCUIT 27
28	COMBUSTION PRESS. HIGH (IN TIME) CIRCUIT 28
29	COMBUSTION PRESS. HIGH (IN TIME) CIRCUIT 29
30	COMBUSTION PRESS. HIGH (IN TIME) CIRCUIT 30
31	COMBUSTION PRESS. HIGH (IN TIME) CIRCUIT 31
32	COMBUSTION PRESS. HIGH (IN TIME) CIRCUIT 32
33	COMBUSTION PRESS. HIGH (IN TIME) CIRCUIT 33
34	COMBUSTION PRESS. HIGH (IN TIME) CIRCUIT 34
35	COMBUSTION PRESS. HIGH (IN TIME) CIRCUIT 35
36	COMBUSTION PRESS. HIGH (IN TIME) CIRCUIT 36
37	COMBUSTION PRESS. HIGH (IN TIME) CIRCUIT 37
38	COMBUSTION PRESS. HIGH (IN TIME) CIRCUIT 38
39	COMBUSTION PRESS. HIGH (IN TIME) CIRCUIT 39
40	COMBUSTION PRESS. HIGH (IN TIME) CIRCUIT 40
41	COMBUSTION PRESS. HIGH (IN TIME) CIRCUIT 41
42	COMBUSTION PRESS. HIGH (IN TIME) CIRCUIT 42
43	COMBUSTION PRESS. HIGH (IN TIME) CIRCUIT 43
44	COMBUSTION PRESS. HIGH (IN TIME) CIRCUIT 44
45	COMBUSTION PRESS. HIGH (IN TIME) CIRCUIT 45
46	COMBUSTION PRESS. HIGH (IN TIME) CIRCUIT 46
47	COMBUSTION PRESS. HIGH (IN TIME) CIRCUIT 47
48	COMBUSTION PRESS. HIGH (IN TIME) CIRCUIT 48
49	COMBUSTION PRESS. HIGH (IN TIME) CIRCUIT 49
50	COMBUSTION PRESS. HIGH (IN TIME) CIRCUIT 50
51	COMBUSTION PRESS. HIGH (IN TIME) CIRCUIT 51
52	COMBUSTION PRESS. HIGH (IN TIME) CIRCUIT 52
53	COMBUSTION PRESS. HIGH (IN TIME) CIRCUIT 53
54	COMBUSTION PRESS. HIGH (IN TIME) CIRCUIT 54
55	COMBUSTION PRESS. HIGH (IN TIME) CIRCUIT 55
56	COMBUSTION PRESS. HIGH (IN TIME) CIRCUIT 56
57	COMBUSTION PRESS. HIGH (IN TIME) CIRCUIT 57
58	COMBUSTION PRESS. HIGH (IN TIME) CIRCUIT 58
59	COMBUSTION PRESS. HIGH (IN TIME) CIRCUIT 59
60	COMBUSTION PRESS. HIGH (IN TIME) CIRCUIT 60
61	COMBUSTION PRESS. HIGH (IN TIME) CIRCUIT 61
62	COMBUSTION PRESS. HIGH (IN TIME) CIRCUIT 62
63	COMBUSTION PRESS. HIGH (IN TIME) CIRCUIT 63
64	COMBUSTION PRESS. HIGH (IN TIME) CIRCUIT 64
65	COMBUSTION PRESS. HIGH (IN TIME) CIRCUIT 65
66	COMBUSTION PRESS. HIGH (IN TIME) CIRCUIT 66
67	COMBUSTION PRESS. HIGH (IN TIME) CIRCUIT 67
68	COMBUSTION PRESS. HIGH (IN TIME) CIRCUIT 68
69	COMBUSTION PRESS. HIGH (IN TIME) CIRCUIT 69
70	COMBUSTION PRESS. HIGH (IN TIME) CIRCUIT 70
71	COMBUSTION PRESS. HIGH (IN TIME) CIRCUIT 71
72	COMBUSTION PRESS. HIGH (IN TIME) CIRCUIT 72
73	COMBUSTION PRESS. HIGH (IN TIME) CIRCUIT 73
74	COMBUSTION PRESS. HIGH (IN TIME) CIRCUIT 74
75	COMBUSTION PRESS. HIGH (IN TIME) CIRCUIT 75
76	COMBUSTION PRESS. HIGH (IN TIME) CIRCUIT 76
77	COMBUSTION PRESS. HIGH (IN TIME) CIRCUIT 77
78	COMBUSTION PRESS. HIGH (IN TIME) CIRCUIT 78
79	COMBUSTION PRESS. HIGH (IN TIME) CIRCUIT 79
80	COMBUSTION PRESS. HIGH (IN TIME) CIRCUIT 80
81	COMBUSTION PRESS. HIGH (IN TIME) CIRCUIT 81
82	COMBUSTION PRESS. HIGH (IN TIME) CIRCUIT 82
83	COMBUSTION PRESS. HIGH (IN TIME) CIRCUIT 83
84	COMBUSTION PRESS. HIGH (IN TIME) CIRCUIT 84
85	COMBUSTION PRESS. HIGH (IN TIME) CIRCUIT 85
86	COMBUSTION PRESS. HIGH (IN TIME) CIRCUIT 86
87	COMBUSTION PRESS. HIGH (IN TIME) CIRCUIT 87
88	COMBUSTION PRESS. HIGH (IN TIME) CIRCUIT 88
89	COMBUSTION PRESS. HIGH (IN TIME) CIRCUIT 89
90	COMBUSTION PRESS. HIGH (IN TIME) CIRCUIT 90
91	COMBUSTION PRESS. HIGH (IN TIME) CIRCUIT 91
92	COMBUSTION PRESS. HIGH (IN TIME) CIRCUIT 92
93	COMBUSTION PRESS. HIGH (IN TIME) CIRCUIT 93
94	COMBUSTION PRESS. HIGH (IN TIME) CIRCUIT 94
95	COMBUSTION PRESS. HIGH (IN TIME) CIRCUIT 95
96	COMBUSTION PRESS. HIGH (IN TIME) CIRCUIT 96
97	COMBUSTION PRESS. HIGH (IN TIME) CIRCUIT 97
98	COMBUSTION PRESS. HIGH (IN TIME) CIRCUIT 98
99	COMBUSTION PRESS. HIGH (IN TIME) CIRCUIT 99
100	COMBUSTION PRESS. HIGH (IN TIME) CIRCUIT 100

WIRE COLOR CODE
BK.....BLACK G.....GREEN PR.....PURPLE
BR.....BROWN GR.....GRAY R.....RED
BL.....BLUE O.....ORANGE W.....WHITE
Y.....YELLOW

ELECTRICAL WIRING SCHEMATIC
GE DDC 2-STG VFD
090/102/120 575V 3 PH 60 HZ

APPROVED: _____
MODELED BY: MAB
DATE: 9/29/2022
ORIGINAL RELEASE NO.: 107877
PART NO.: 90-106178-18
REV: 00

WIRING INFORMATION

LINE VOLTAGE _____

-FACTORY STANDARD _____

-FIELD INSTALLED _____

LOW VOLTAGE _____

-FACTORY STANDARD _____

-FIELD INSTALLED _____

REPLACEMENT WIRE SIZE AND TYPE _____

OF INSULATION AS ORIGINAL (105C: MIN)

WARNING: MUST BE PERMANENTLY GROUNDED AND CONFORM TO I.E.C., N.E.C., G.E.C., NATIONAL WIRING REGULATIONS, AND LOCAL CODES AS APPLICABLE.

NOTES

- CONNECTORS SUITABLE FOR USE WITH COPPER CONDUCTORS ONLY.
- CONNECT FIELD WIRING IN GROUNDED RAN TIGHT CONDUIT TO FUSED DISCONNECT.
- REMOVE (AK, CC1) TO INSTALL LOW AMBIENT ACCESSORY.
- IF REQUIRED, ATTACH ORANGE CASE HEATER ACCESSORY TO CC1 (L1) AND CC2 (L2).
- COMPRESSOR MOTOR THERMALLY PROTECTED. ALL 3 PHASE MODELS ARE PROTECTED UNDER PRIMARY SINGLE PHASE CONDITIONS.
- TRANSFORMER FACTORY WIRE AS SHOWN BELOW. CHANGE PRIMARY VOLTAGE CONNECTIONS FOR ALTERNATE VOLTAGES, IF REQUIRED.

UNIT VOLTAGES - HZ	TRANSFORMER TAP
200-220-50HZ	200
208-60HZ	230
230-60HZ	250
380-415-50HZ	400
460-60HZ	480
575-60HZ	230

COMPONENT CODES

BR BLOWER RELAY
CA COMFORT ALERT MODULE
CC1 ORANGE CASE HEATER
CC2 CLOSED DRAIN SENSOR
COM COMPRESSOR
CT CONTROL TRANSFORMER
DISC DISCONNECT SWITCH
FLMS FLAME SENSORS
GPH GROUND FAULT CONVENIENCE OUTLET
GPH1 GROUND FAULT CONVENIENCE OUTLET
GPH2 GROUND FAULT CONVENIENCE OUTLET
GPH3 GROUND FAULT CONVENIENCE OUTLET
GPH4 GROUND FAULT CONVENIENCE OUTLET
GPH5 GROUND FAULT CONVENIENCE OUTLET
GPH6 GROUND FAULT CONVENIENCE OUTLET
GPH7 GROUND FAULT CONVENIENCE OUTLET
GPH8 GROUND FAULT CONVENIENCE OUTLET
GPH9 GROUND FAULT CONVENIENCE OUTLET
GPH10 GROUND FAULT CONVENIENCE OUTLET
GPH11 GROUND FAULT CONVENIENCE OUTLET
GPH12 GROUND FAULT CONVENIENCE OUTLET
GPH13 GROUND FAULT CONVENIENCE OUTLET
GPH14 GROUND FAULT CONVENIENCE OUTLET
GPH15 GROUND FAULT CONVENIENCE OUTLET
GPH16 GROUND FAULT CONVENIENCE OUTLET
GPH17 GROUND FAULT CONVENIENCE OUTLET
GPH18 GROUND FAULT CONVENIENCE OUTLET
GPH19 GROUND FAULT CONVENIENCE OUTLET
GPH20 GROUND FAULT CONVENIENCE OUTLET
GPH21 GROUND FAULT CONVENIENCE OUTLET
GPH22 GROUND FAULT CONVENIENCE OUTLET
GPH23 GROUND FAULT CONVENIENCE OUTLET
GPH24 GROUND FAULT CONVENIENCE OUTLET
GPH25 GROUND FAULT CONVENIENCE OUTLET
GPH26 GROUND FAULT CONVENIENCE OUTLET
GPH27 GROUND FAULT CONVENIENCE OUTLET
GPH28 GROUND FAULT CONVENIENCE OUTLET
GPH29 GROUND FAULT CONVENIENCE OUTLET
GPH30 GROUND FAULT CONVENIENCE OUTLET
GPH31 GROUND FAULT CONVENIENCE OUTLET
GPH32 GROUND FAULT CONVENIENCE OUTLET
GPH33 GROUND FAULT CONVENIENCE OUTLET
GPH34 GROUND FAULT CONVENIENCE OUTLET
GPH35 GROUND FAULT CONVENIENCE OUTLET
GPH36 GROUND FAULT CONVENIENCE OUTLET
GPH37 GROUND FAULT CONVENIENCE OUTLET
GPH38 GROUND FAULT CONVENIENCE OUTLET
GPH39 GROUND FAULT CONVENIENCE OUTLET
GPH40 GROUND FAULT CONVENIENCE OUTLET
GPH41 GROUND FAULT CONVENIENCE OUTLET
GPH42 GROUND FAULT CONVENIENCE OUTLET
GPH43 GROUND FAULT CONVENIENCE OUTLET
GPH44 GROUND FAULT CONVENIENCE OUTLET
GPH45 GROUND FAULT CONVENIENCE OUTLET
GPH46 GROUND FAULT CONVENIENCE OUTLET
GPH47 GROUND FAULT CONVENIENCE OUTLET
GPH48 GROUND FAULT CONVENIENCE OUTLET
GPH49 GROUND FAULT CONVENIENCE OUTLET
GPH50 GROUND FAULT CONVENIENCE OUTLET
GPH51 GROUND FAULT CONVENIENCE OUTLET
GPH52 GROUND FAULT CONVENIENCE OUTLET
GPH53 GROUND FAULT CONVENIENCE OUTLET
GPH54 GROUND FAULT CONVENIENCE OUTLET
GPH55 GROUND FAULT CONVENIENCE OUTLET
GPH56 GROUND FAULT CONVENIENCE OUTLET
GPH57 GROUND FAULT CONVENIENCE OUTLET
GPH58 GROUND FAULT CONVENIENCE OUTLET
GPH59 GROUND FAULT CONVENIENCE OUTLET
GPH60 GROUND FAULT CONVENIENCE OUTLET
GPH61 GROUND FAULT CONVENIENCE OUTLET
GPH62 GROUND FAULT CONVENIENCE OUTLET
GPH63 GROUND FAULT CONVENIENCE OUTLET
GPH64 GROUND FAULT CONVENIENCE OUTLET
GPH65 GROUND FAULT CONVENIENCE OUTLET
GPH66 GROUND FAULT CONVENIENCE OUTLET
GPH67 GROUND FAULT CONVENIENCE OUTLET
GPH68 GROUND FAULT CONVENIENCE OUTLET
GPH69 GROUND FAULT CONVENIENCE OUTLET
GPH70 GROUND FAULT CONVENIENCE OUTLET
GPH71 GROUND FAULT CONVENIENCE OUTLET
GPH72 GROUND FAULT CONVENIENCE OUTLET
GPH73 GROUND FAULT CONVENIENCE OUTLET
GPH74 GROUND FAULT CONVENIENCE OUTLET
GPH75 GROUND FAULT CONVENIENCE OUTLET
GPH76 GROUND FAULT CONVENIENCE OUTLET
GPH77 GROUND FAULT CONVENIENCE OUTLET
GPH78 GROUND FAULT CONVENIENCE OUTLET
GPH79 GROUND FAULT CONVENIENCE OUTLET
GPH80 GROUND FAULT CONVENIENCE OUTLET
GPH81 GROUND FAULT CONVENIENCE OUTLET
GPH82 GROUND FAULT CONVENIENCE OUTLET
GPH83 GROUND FAULT CONVENIENCE OUTLET
GPH84 GROUND FAULT CONVENIENCE OUTLET
GPH85 GROUND FAULT CONVENIENCE OUTLET
GPH86 GROUND FAULT CONVENIENCE OUTLET
GPH87 GROUND FAULT CONVENIENCE OUTLET
GPH88 GROUND FAULT CONVENIENCE OUTLET
GPH89 GROUND FAULT CONVENIENCE OUTLET
GPH90 GROUND FAULT CONVENIENCE OUTLET
GPH91 GROUND FAULT CONVENIENCE OUTLET
GPH92 GROUND FAULT CONVENIENCE OUTLET
GPH93 GROUND FAULT CONVENIENCE OUTLET
GPH94 GROUND FAULT CONVENIENCE OUTLET
GPH95 GROUND FAULT CONVENIENCE OUTLET
GPH96 GROUND FAULT CONVENIENCE OUTLET
GPH97 GROUND FAULT CONVENIENCE OUTLET
GPH98 GROUND FAULT CONVENIENCE OUTLET
GPH99 GROUND FAULT CONVENIENCE OUTLET
GPH100 GROUND FAULT CONVENIENCE OUTLET

P. APPENDICES

Appendix G. Wiring Diagrams & Schematics (Cont.)

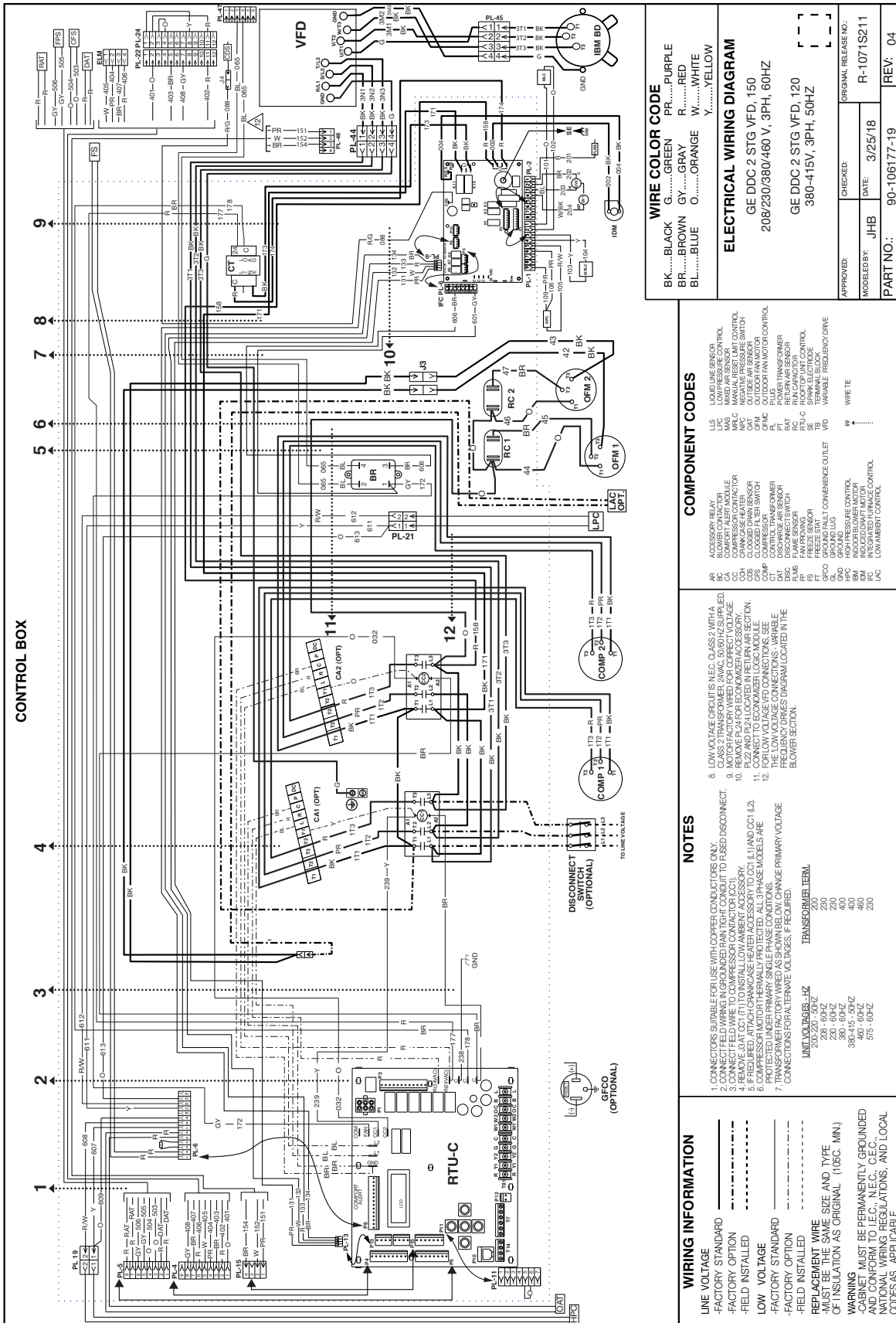

P. APPENDICES

Appendix G. Wiring Diagrams & Schematics (Cont.)

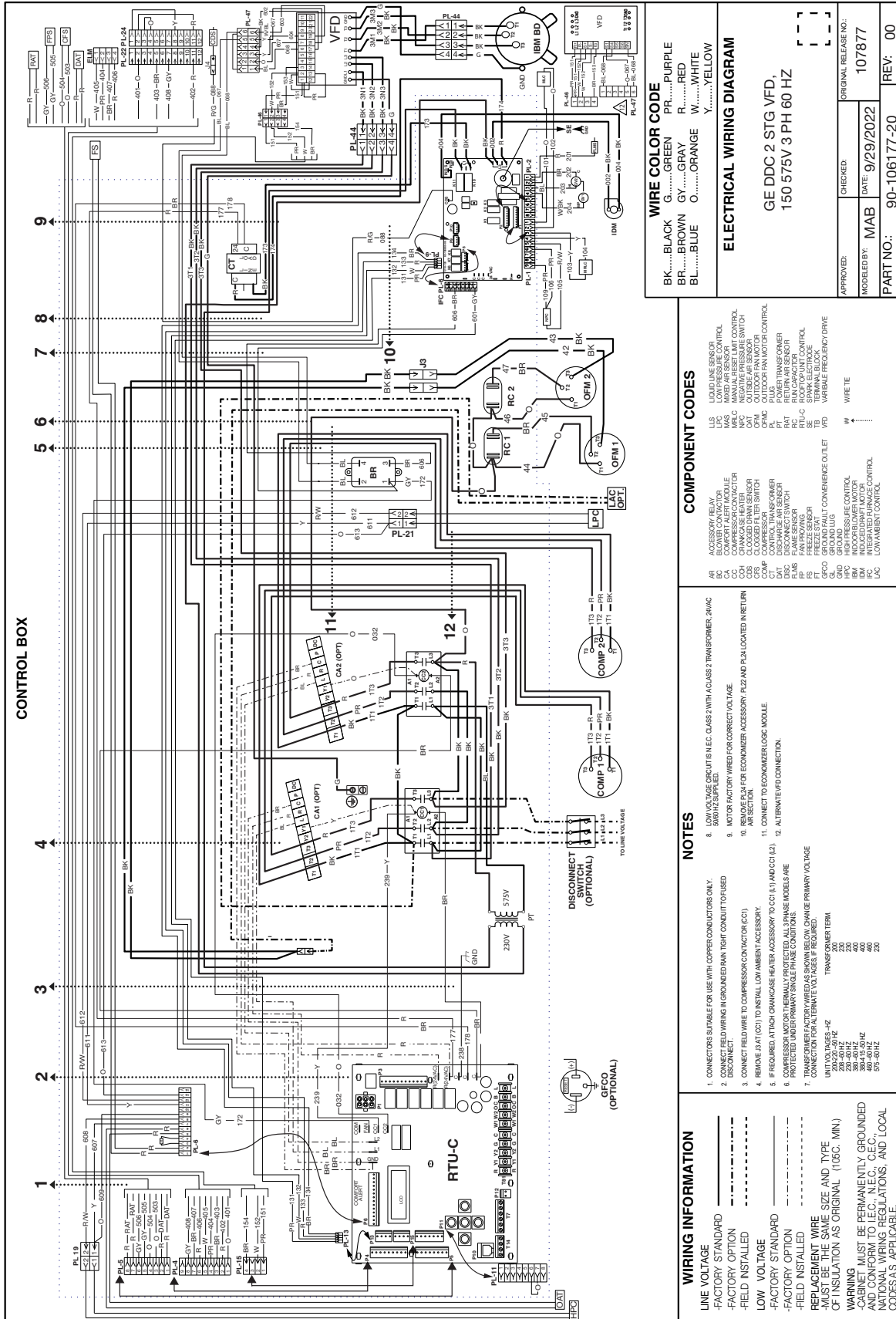

Appendix G. Wiring Diagrams & Schematics (Cont.)

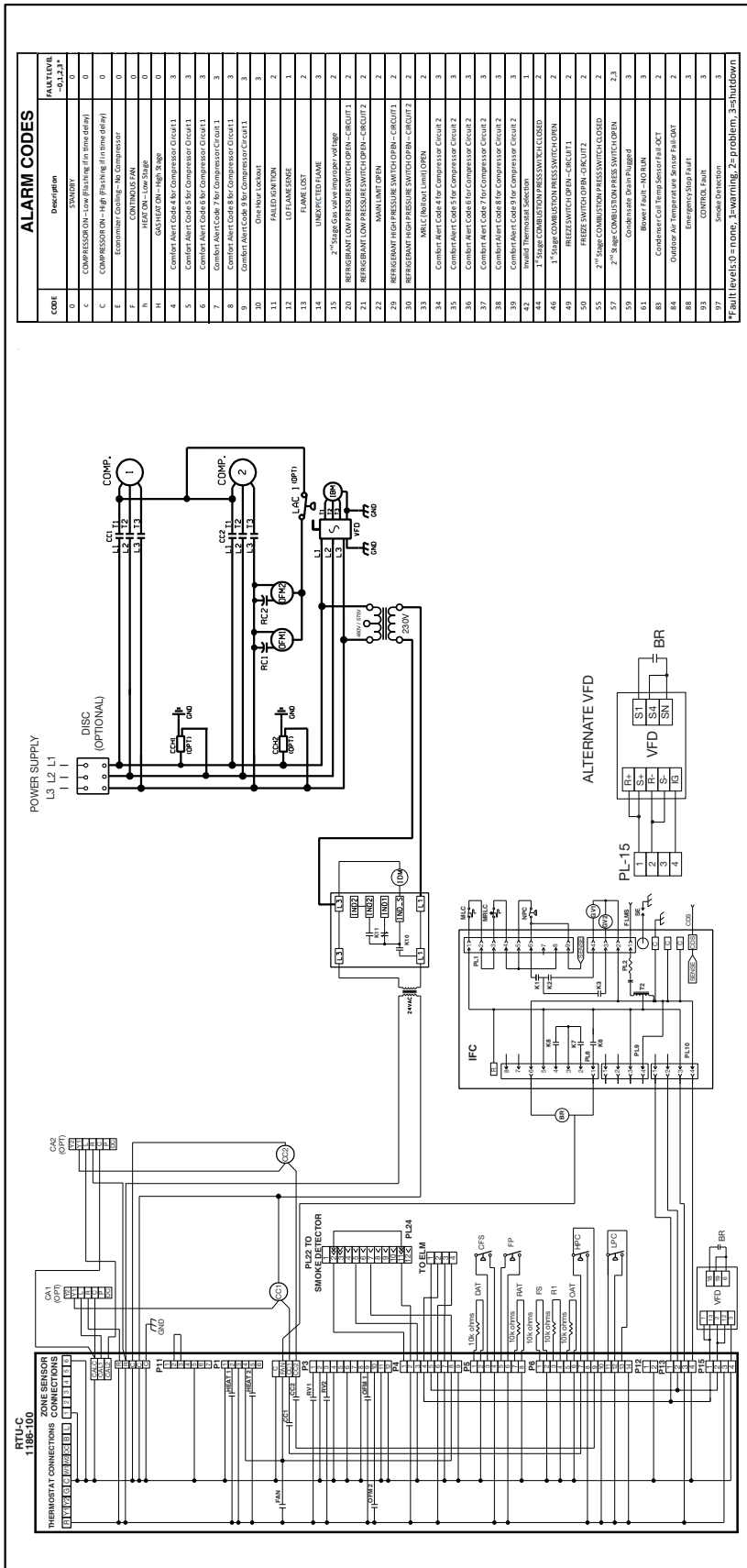

CODE	Description	FAULT LEVEL
0	STANDBY	0
1	COMPRESSOR ON - Low Pressure (in time delay)	0
2	COMPRESSOR ON - High Pressure (in time delay)	0
3	Evaporator Coil - No Compressor	0
4	CONDENSER FAN	0
5	HEAT ON - Low Stage	0
6	HEAT ON - High Stage	0
7	COMPRESSOR STOP - High Pressure	0
8	COMPRESSOR STOP - Low Pressure	0
9	COMPRESSOR STOP - High Pressure (in time delay)	0
10	COMPRESSOR STOP - Low Pressure (in time delay)	0
11	One Hour Lockout	3
12	FAILED MOTION	2
13	LO FLAME SENSE	1
14	UNEXPECTED FLAME	3
15	2 nd Stage Gas Valve Proponent Voltage	2
16	REFRIGERANT LOW PRESSURE SWITCH OPEN - CIRCUIT 1	2
17	REFRIGERANT LOW PRESSURE SWITCH OPEN - CIRCUIT 2	2
18	MANUAL LIMIT OPEN	2
19	REFRIGERANT HIGH PRESSURE SWITCH OPEN - CIRCUIT 1	2
20	REFRIGERANT HIGH PRESSURE SWITCH OPEN - CIRCUIT 2	2
21	MILC (No/Out Limit) OPEN	2
22	Combustion Alert Code 4 for Compressor Circuit 2	3
23	Combustion Alert Code 5 for Compressor Circuit 3	3
24	Combustion Alert Code 6 for Compressor Circuit 2	3
25	Combustion Alert Code 7 for Compressor Circuit 3	3
26	Combustion Alert Code 8 for Compressor Circuit 2	3
27	Combustion Alert Code 9 for Compressor Circuit 3	3
28	Invalid Thermistor Selection	1
29	1 st Stage COMBUSTION PRESS SWITCH CLOSED	2
30	2 nd Stage COMBUSTION PRESS SWITCH CLOSED	2
31	FREEZE SWITCH OPEN - CIRCUIT 1	2
32	FREEZE SWITCH OPEN - CIRCUIT 2	2
33	2 nd Stage COMBUSTION PRESS SWITCH OPEN	2.3
34	Compressor Drive Plugged	3
35	Blower Fault - NO RUN	3
36	Condenser Coil Temp Sensor Fail-OUT	2
37	Outdoor Air Temperature Sensor Fail-OUT	2
38	Emergency Stop Fault	3
39	Control Fault	3
40	Smoke detection	3

*Fault levels: 0 = none, 1=warning, 2=problem, 3=shutdown

WIRE COLOR CODE
 BK.....BLACK G.....GREEN PR.....PURPLE
 BR.....BROWN GR.....GRAY R.....RED
 BL.....BLUE O.....ORANGE W.....WHITE
 Y.....YELLOW

ELECTRICAL WIRING SCHEMATIC
 GE DDC 2-STG VFD
 150 575V 3 PH 60 HZ

APPROVED: MAB	CHECKED:	ORIGINAL RELEASE NO.:
MODIFIED BY:	DATE: 9/29/2022	107877
PART NO.:	90-106178-20	REV: 00

COMPONENT CODES	DESCRIPTION
BR	BLOWER MOTOR
CA	COMPRESSOR CONTACTOR
CC	CRANKCASE HEATER
CD	CLOCK DRIVEN SWITCH
CE	CONDENSER FAN MOTOR
CF	CONTROL TRANSFORMER
CG	DISCHARGE AIR SENSOR
CH	DISCONNECT SWITCH
CI	FLAME SENSOR
CJ	FAN RUNNING
CK	GRAND FAN CONTROL
CL	GROUND LUG
CM	GROUNDING
CN	HIGH PRESSURE CONTROL
CO	INDICATOR MOTOR
CP	INTEGRATED FAN CONTROL
CQ	LOW AMBIENT CONTROL
CR	MANUAL RESET UNIT CONTROL
CS	MIXED AIR SENSOR
CT	NEGATIVE PRESSURE SWITCH
CU	OUTSIDE AIR SENSOR
CV	OUTDOOR FAN MOTOR
CW	PLUG
CX	POWER TRANSFORMER
CY	ROOM AIR SENSOR
CZ	RUN CAPACITOR
DA	SMOKE DETECTOR
DB	SPRINKLER UNIT CONTROL
DC	TEMPERATURE SENSOR
DD	UNILAMER SOLENOID
DE	VERIFIABLE FREQUENCY DRIVE

- NOTES**
- CONNECTORS SUITABLE FOR USE WITH COPPER CONDUCTORS ONLY.
 - CONNECT FIELD WIRING IN GROUNDED RAIN TIGHT CONDUIT TO FUSED DISCONNECT.
 - CONNECT FIELD WIRE TO COMPRESSOR CONTACTOR (CC).
 - REMOVE 6 AT (C) TO INSTALL LOW AMBIENT ACCESSORY (LAC).
 - REMOVE PL24 FOR ECONOMIZER ACCESSORY.
 - COMPRESSOR MOTOR THERMALLY PROTECTED. ALL 3 PHASE MODELS ARE PROTECTED UNDER PRIMARY SINGLE PHASE CONDITIONS.
 - TRANSFORMER FACTORY WIRE AS SHOWN BELOW. CHANGE PRIMARY VOLTAGE CONNECTIONS FOR ALTERNATE VOLTAGES. IF REQUIRED.

UNIT VOLTAGES - HZ	TRANSFORMER TERNAL
200-220 - 50HZ	200
208 - 60HZ	230
230 - 60HZ	230
380-415 - 50HZ	400
460 - 60HZ	480
575 - 60HZ	230

WIRING INFORMATION

- LINE VOLTAGE
- FACTORY STANDARD
- FACTORY OPTION
- FIELD INSTALLED
- LOW VOLTAGE
- FACTORY STANDARD
- FACTORY OPTION
- FIELD INSTALLED

REPLACEMENT WIRE - MUST BE THE SAME SIZE AND TYPE OF INSULATION AS ORIGINAL (105C, MIN.)

WARNING - CABINET MUST BE PERMANENTLY GROUNDED AND CONFORM TO I.E.C., N.E.C., C.E.C., NATIONAL WIRING REGULATIONS, AND LOCAL CODES AS APPLICABLE.

P. APPENDICES

Appendix G. Wiring Diagrams & Schematics (Cont.)

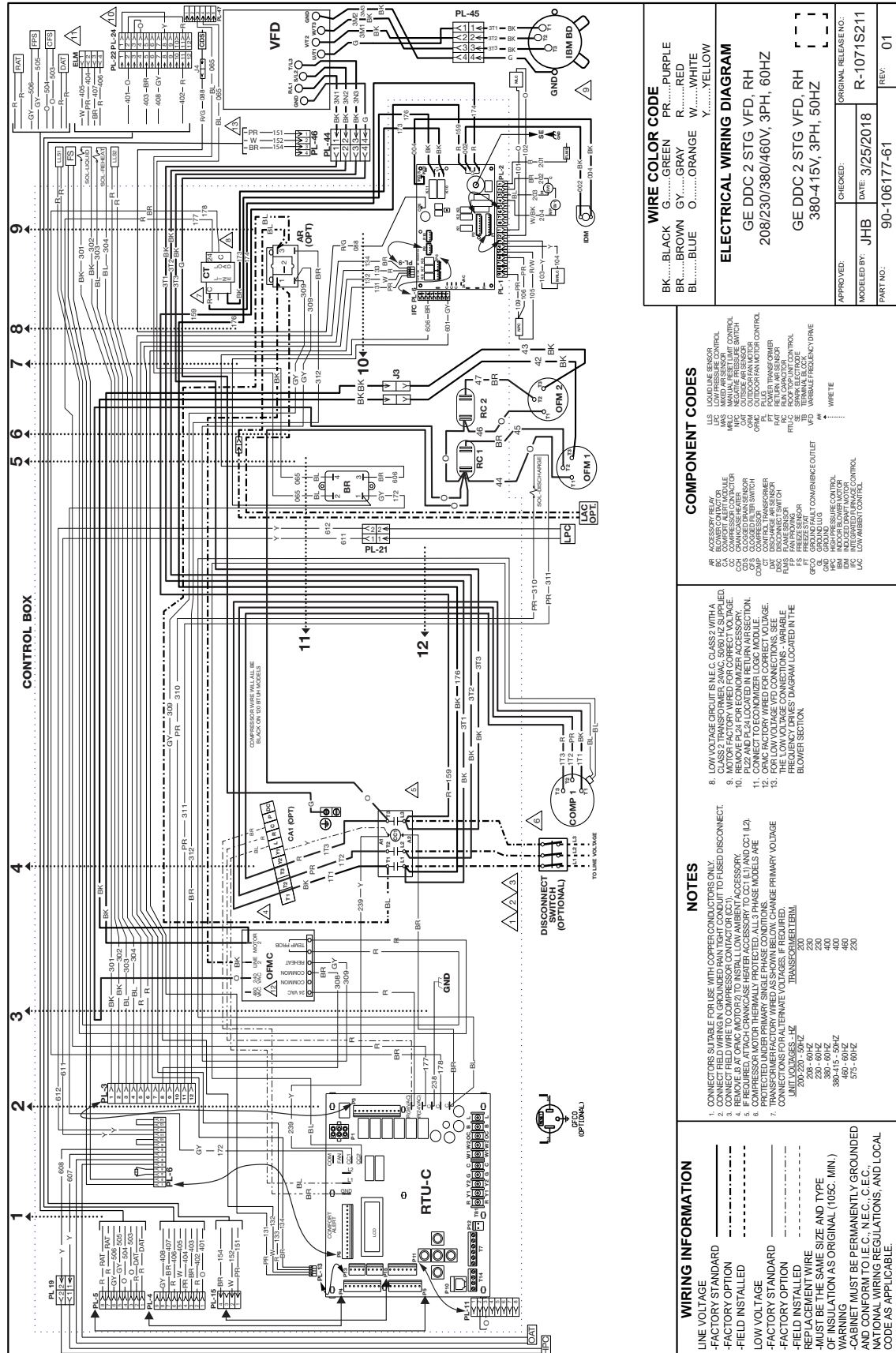

WIRE COLOR CODE
 BK.....BLACK G.....GREEN PR.....PURPLE
 BR.....BROWN Gy.....GRAY R.....RED
 BL.....BLUE O.....ORANGE W.....WHITE
 Y.....YELLOW

ELECTRICAL WIRING DIAGRAM
 GE DDC 2 STG VFD, RH
 208/230/380/460V, 3PH, 60HZ
 GE DDC 2 STG VFD, RH
 380-415V, 3PH, 50HZ

APPROVED:	CHECKED:	ORIGINAL RELEASE NO.:
MODELED BY: JHB	DATE: 3/25/2018	R-1071S211
PART NO.:	90-106177-61	REV. 01

COMPONENT CODES

AB	ACCESSORY RELAY	UB	UNDERVOLTAGE LOCKOUT
AC	AC CONTACTOR	UC	UNDERVOLTAGE CONTROL
AD	ADAPTOR	UD	UNDERVOLTAGE DISCONNECT
AE	ALARM BELL	UE	UNDERVOLTAGE FUSE
AF	ALARM BELL	UF	UNDERVOLTAGE FUSE
AG	ALARM BELL	UG	UNDERVOLTAGE FUSE
AH	ALARM BELL	UH	UNDERVOLTAGE FUSE
AI	ALARM BELL	UI	UNDERVOLTAGE FUSE
AJ	ALARM BELL	UJ	UNDERVOLTAGE FUSE
AK	ALARM BELL	UK	UNDERVOLTAGE FUSE
AL	ALARM BELL	UL	UNDERVOLTAGE FUSE
AM	ALARM BELL	UM	UNDERVOLTAGE FUSE
AN	ALARM BELL	UN	UNDERVOLTAGE FUSE
AO	ALARM BELL	UO	UNDERVOLTAGE FUSE
AP	ALARM BELL	UP	UNDERVOLTAGE FUSE
AQ	ALARM BELL	UQ	UNDERVOLTAGE FUSE
AR	ALARM BELL	UR	UNDERVOLTAGE FUSE
AS	ALARM BELL	US	UNDERVOLTAGE FUSE
AT	ALARM BELL	UT	UNDERVOLTAGE FUSE
AV	ALARM BELL	UV	UNDERVOLTAGE FUSE
AW	ALARM BELL	UW	UNDERVOLTAGE FUSE
AX	ALARM BELL	UX	UNDERVOLTAGE FUSE
AY	ALARM BELL	UY	UNDERVOLTAGE FUSE
AZ	ALARM BELL	UZ	UNDERVOLTAGE FUSE
BA	BLOWER	VA	VARIABLE FREQUENCY DRIVE
BB	BLOWER	VB	VARIABLE FREQUENCY DRIVE
BC	BLOWER	VC	VARIABLE FREQUENCY DRIVE
BD	BLOWER	VD	VARIABLE FREQUENCY DRIVE
BE	BLOWER	VE	VARIABLE FREQUENCY DRIVE
BF	BLOWER	VF	VARIABLE FREQUENCY DRIVE
BG	BLOWER	VG	VARIABLE FREQUENCY DRIVE
BH	BLOWER	VH	VARIABLE FREQUENCY DRIVE
BI	BLOWER	VI	VARIABLE FREQUENCY DRIVE
BJ	BLOWER	VJ	VARIABLE FREQUENCY DRIVE
BK	BLOWER	VK	VARIABLE FREQUENCY DRIVE
BL	BLOWER	VL	VARIABLE FREQUENCY DRIVE
BM	BLOWER	VM	VARIABLE FREQUENCY DRIVE
BN	BLOWER	VN	VARIABLE FREQUENCY DRIVE
BO	BLOWER	VO	VARIABLE FREQUENCY DRIVE
BP	BLOWER	VP	VARIABLE FREQUENCY DRIVE
BQ	BLOWER	VQ	VARIABLE FREQUENCY DRIVE
BR	BLOWER	VR	VARIABLE FREQUENCY DRIVE
BS	BLOWER	VS	VARIABLE FREQUENCY DRIVE
BT	BLOWER	VT	VARIABLE FREQUENCY DRIVE
BU	BLOWER	UV	VARIABLE FREQUENCY DRIVE
BV	BLOWER	VW	VARIABLE FREQUENCY DRIVE
BW	BLOWER	VX	VARIABLE FREQUENCY DRIVE
BX	BLOWER	VY	VARIABLE FREQUENCY DRIVE
BY	BLOWER	VZ	VARIABLE FREQUENCY DRIVE
BZ	BLOWER	WA	WATER TIGHT CONDUIT
CA	CONTROL	WA	WATER TIGHT CONDUIT
CB	CONTROL	WB	WATER TIGHT CONDUIT
CC	CONTROL	WC	WATER TIGHT CONDUIT
CD	CONTROL	WD	WATER TIGHT CONDUIT
CE	CONTROL	WE	WATER TIGHT CONDUIT
CF	CONTROL	WF	WATER TIGHT CONDUIT
CG	CONTROL	WG	WATER TIGHT CONDUIT
CH	CONTROL	WH	WATER TIGHT CONDUIT
CI	CONTROL	WI	WATER TIGHT CONDUIT
CJ	CONTROL	WJ	WATER TIGHT CONDUIT
CK	CONTROL	WK	WATER TIGHT CONDUIT
CL	CONTROL	WL	WATER TIGHT CONDUIT
CM	CONTROL	WM	WATER TIGHT CONDUIT
CN	CONTROL	WN	WATER TIGHT CONDUIT
CO	CONTROL	WO	WATER TIGHT CONDUIT
CP	CONTROL	WP	WATER TIGHT CONDUIT
CQ	CONTROL	WQ	WATER TIGHT CONDUIT
CR	CONTROL	WR	WATER TIGHT CONDUIT
CS	CONTROL	WS	WATER TIGHT CONDUIT
CT	CONTROL	WT	WATER TIGHT CONDUIT
CU	CONTROL	WU	WATER TIGHT CONDUIT
CV	CONTROL	WV	WATER TIGHT CONDUIT
CW	CONTROL	WX	WATER TIGHT CONDUIT
CX	CONTROL	WY	WATER TIGHT CONDUIT
CY	CONTROL	WZ	WATER TIGHT CONDUIT
CA	CONTROL	XA	EXHAUST
CB	CONTROL	XB	EXHAUST
CC	CONTROL	XC	EXHAUST
CD	CONTROL	XD	EXHAUST
CE	CONTROL	XE	EXHAUST
CF	CONTROL	XF	EXHAUST
CG	CONTROL	XG	EXHAUST
CH	CONTROL	XH	EXHAUST
CI	CONTROL	XI	EXHAUST
CJ	CONTROL	XJ	EXHAUST
CK	CONTROL	XK	EXHAUST
CL	CONTROL	XL	EXHAUST
CM	CONTROL	XM	EXHAUST
CN	CONTROL	XN	EXHAUST
CO	CONTROL	XO	EXHAUST
CP	CONTROL	XP	EXHAUST
CQ	CONTROL	XQ	EXHAUST
CR	CONTROL	XR	EXHAUST
CS	CONTROL	XS	EXHAUST
CT	CONTROL	XT	EXHAUST
CU	CONTROL	XU	EXHAUST
CV	CONTROL	XV	EXHAUST
CW	CONTROL	XW	EXHAUST
CX	CONTROL	XZ	EXHAUST
CY	CONTROL	YA	YIELD
CA	CONTROL	YB	YIELD
CB	CONTROL	YC	YIELD
CC	CONTROL	YD	YIELD
CD	CONTROL	YE	YIELD
CE	CONTROL	YF	YIELD
CF	CONTROL	YG	YIELD
CG	CONTROL	YH	YIELD
CH	CONTROL	YI	YIELD
CI	CONTROL	YJ	YIELD
CJ	CONTROL	YK	YIELD
CK	CONTROL	YL	YIELD
CL	CONTROL	YM	YIELD
CM	CONTROL	YN	YIELD
CO	CONTROL	YO	YIELD
CP	CONTROL	YP	YIELD
CQ	CONTROL	YQ	YIELD
CR	CONTROL	YR	YIELD
CS	CONTROL	YS	YIELD
CT	CONTROL	YT	YIELD
CU	CONTROL	YU	YIELD
CV	CONTROL	YV	YIELD
CW	CONTROL	YW	YIELD
CX	CONTROL	YZ	YIELD
CY	CONTROL	ZA	ZENER
CA	CONTROL	ZB	ZENER
CB	CONTROL	ZC	ZENER
CC	CONTROL	ZD	ZENER
CD	CONTROL	ZE	ZENER
CE	CONTROL	ZF	ZENER
CF	CONTROL	ZG	ZENER
CG	CONTROL	ZH	ZENER
CH	CONTROL	ZI	ZENER
CI	CONTROL	ZJ	ZENER
CJ	CONTROL	ZK	ZENER
CK	CONTROL	ZL	ZENER
CL	CONTROL	ZM	ZENER
CM	CONTROL	ZN	ZENER
CO	CONTROL	ZO	ZENER
CP	CONTROL	ZP	ZENER
CQ	CONTROL	ZQ	ZENER
CR	CONTROL	ZR	ZENER
CS	CONTROL	ZS	ZENER
CT	CONTROL	ZT	ZENER
CU	CONTROL	ZU	ZENER
CV	CONTROL	ZV	ZENER
CW	CONTROL	ZW	ZENER
CX	CONTROL	ZX	ZENER
CY	CONTROL	ZY	ZENER
CA	CONTROL	ZA	ZENER

NOTES

- CONNECTORS SUITABLE FOR USE WITH COPPER CONDUCTORS ONLY.
- CONNECT FIELD WIRE TO COMPRESSOR CONTACTOR (CC) AS NECESSARY.
- IF REQUIRED, ATTACH WIRING KIT AS SUB-ACCESSORY TO CCT L1 AND CCT L2.
- COMPRESSOR MOTOR THERMALLY PROTECTED. ALL 3 PHASE MODELS ARE PROTECTED UNDER PRIMARY SINGLE PHASE CONDITIONS.
- CONNECTIONS FOR ALTERNATE VOLTAGES, IF REQUIRED, ARE LIMITED TO:

VOLTAGES	TRANSFORMER TERM.
208-230-60HZ	230
380-415-50HZ	400
460-500-60HZ	460
575-600-60HZ	575
- LOW VOLTAGE OPTI-V (S.E.C. CLASS 9) WITH A CLASS 2 TRANSFORMER, 2VAC, 500HZ SUPPLIED.
- MOTOR FACTORY WIRED FOR CORRECT VOLTAGE.
- REMOVING FUSE FOR ECONOMIZER TRANSFORMATION.
- CONNECT TO ECONOMIZER LOGIC MODULE.
- OPTIC MOTOR THERMALLY PROTECTED. ALL 3 PHASE MODELS ARE PROTECTED UNDER PRIMARY SINGLE PHASE CONDITIONS.
- THE LOW VOLTAGE CONNECTIONS - VARIABLE FREQUENCY DRIVES DIAGRAM LOCATED IN THE BLOWER SECTION.

WIRING INFORMATION

- LINE VOLTAGE _____
- FACTORY STANDARD _____
- FACTORY OPTION _____
- FIELD INSTALLED _____
- LOW VOLTAGE _____
- FACTORY STANDARD _____
- FIELD INSTALLED _____
- REPLACEMENT WIRE _____
- MUST BE THE SAME SIZE AND TYPE _____
- OF INSULATION AS ORIGINAL (105C. MIN.) _____
- WARNING _____
- CABINET MUST BE PERMANENTLY GROUNDED _____
- AND CONFORM TO I.E.C., N.E.C., E.E.C. _____
- NATIONAL WIRING REGULATIONS, AND LOCAL _____
- CODE AS APPLICABLE.

Appendix G. Wiring Diagrams & Schematics (Cont.)

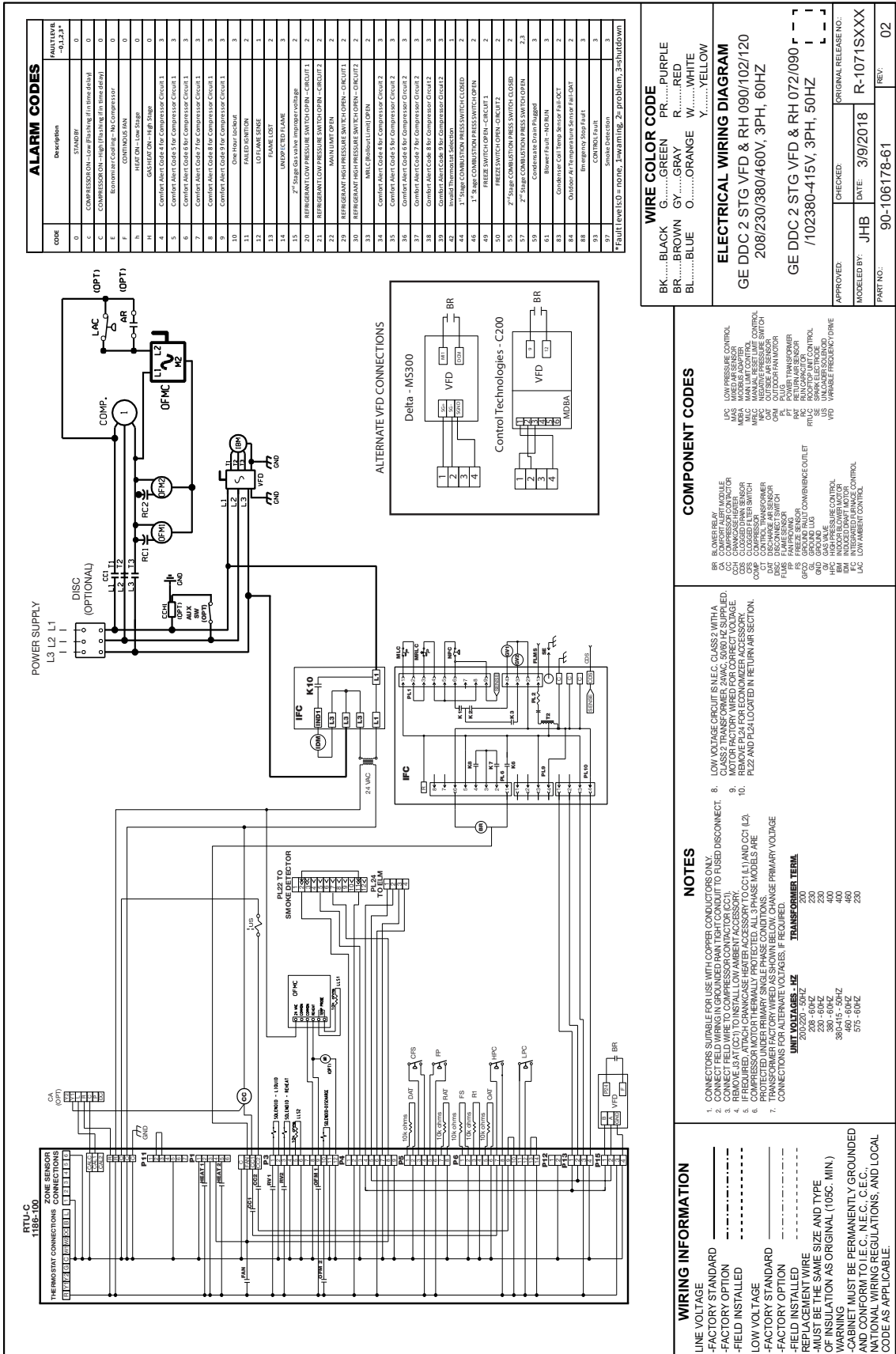

P. APPENDICES

Appendix G. Wiring Diagrams & Schematics (Cont.)

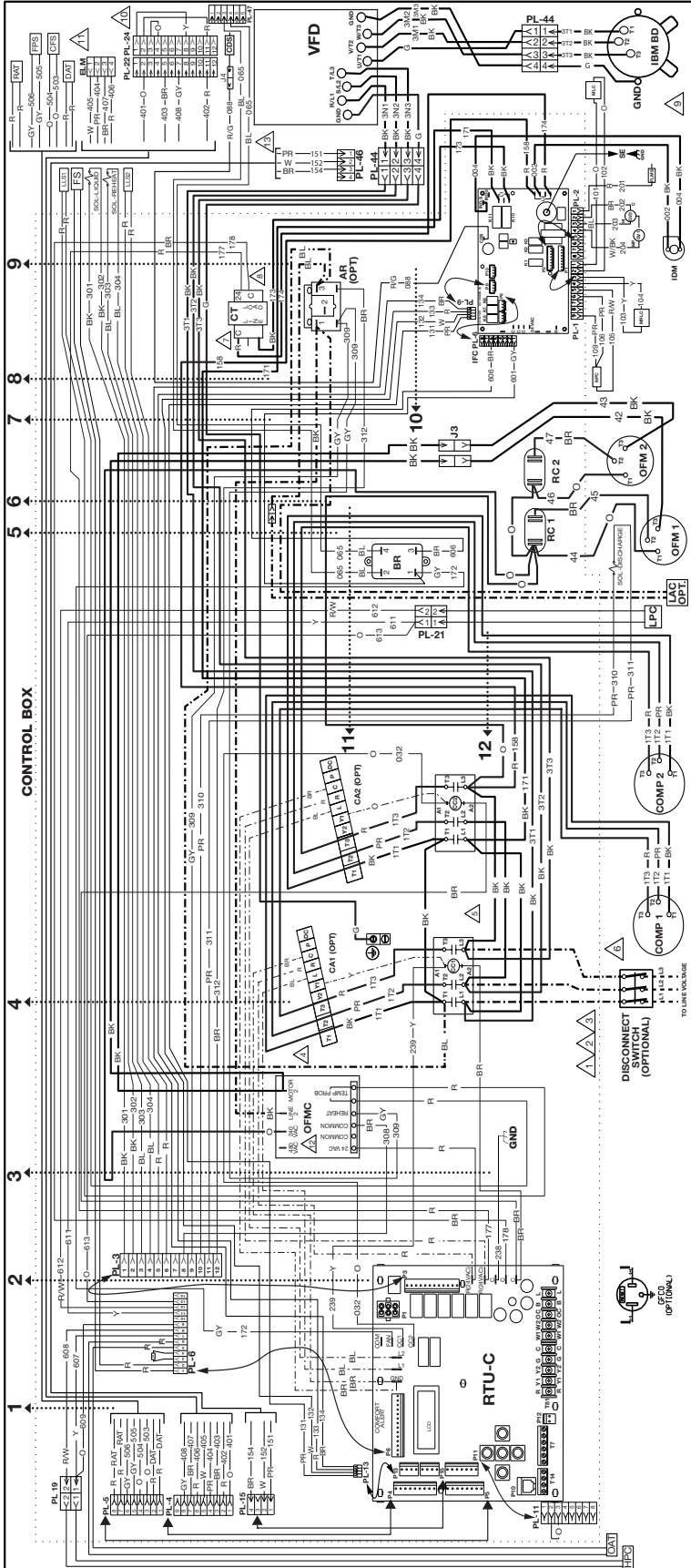

WIRE COLOR CODE	
BK.....BLACK	G.....GREEN
BR.....BROWN	GY.....GRAY
BL.....BLUE	O.....ORANGE
	Y.....YELLOW
	P.....PURPLE
	R.....RED
	W.....WHITE
ELECTRICAL WIRING DIAGRAM	
GE DDC 2 STG VFD, RH 150	
208/230/380/460 V, 3PH, 60HZ	
GE DDC 2 STG VFD, RH 120	
380-415V, 3PH, 50HZ	
APPROVED:	CHECKED:
MOELED BY: JHB	DATE: 3/25/2018
ORIGINAL RELEASE NO.: R-1071S211	
PART NO.: 90-106177-62	REV: 02

COMPONENT CODES	
AR	ACCESSORY RELAY
CA	CONTACT ALARM
CM	COMBINATION MOTOR
CR	CRANKCASE HEATER
CS	CLOSED CIRCUIT SWITCH
CT	CURRENT TRANSFORMER
DA	DISCHARGE ASSISTOR
FB	FAN MOTOR
FE	FREEZE SENSOR
FR	FREQUENCY DRIVE
GR	GROUND
IND	INDUCTION MOTOR
IR	INDUCTION RESISTANCE MOTOR
LA	LOW AMBIENT CONTROL
LAC	LOW AMBIENT CONTROL
LS	LIQUID LEVEL SENSOR
MA	MAKING AIR SENSOR
MC	MOTOR COMPRESSOR
ME	MECHANICAL PRESSURE SWITCH
MI	INDUCTION MOTOR
OM	OUTDOOR FAN MOTOR
OPAC	OUTDOOR FAN MOTOR CONTROL
PT	PRESSURE TRANSDUCER
RF	REFRIGERANT FLOW SENSOR
RG	REFRIGERANT GAS SENSOR
RS	REFRIGERANT SENSING
SE	SPACE HEATER
WD	WEARABLE FREQUENCY DRIVE
WT	WEARABLE FREQUENCY DRIVE
WIRE	WIRE
WIRE	WIRE

- NOTES**
- CONNECTORS SUITABLE FOR USE WITH COPPER CONDUCTORS ONLY.
 - CONNECT FELD WIRING IN GROUNDING RAIN TIGHT CONDUIT TO RUSED. DISCONNECT.
 - CONNECT FELD WIRE TO COMPRESSOR CONTACT (CR-CO).
 - IF REQUIRED, ATTACH CRANKCASE HEATER ACCESSORY TO CO(L) AND CO(R) LA.
 - COMPRESSOR MOTOR THERMALLY PROTECTED. ALL 3-PHASE MODELS ARE THERMALLY PROTECTED.
 - COMPRESSOR FACTORY WIRING SHOWN BELOW. CHANGE PRIMARY VOLTAGE CONNECTIONS FOR ALTERNATE VOLTAGES, IF REQUIRED.
 - LIMIT VOLTAGES:

200-208-004Z	TRANSFORMER ITEM:
230-230-004Z	230
380/415-504Z	230
380/415-504Z	230
460-460-04Z	460
575-575-04Z	460
 - LOW VOLTAGE CIRCUIT (N.E.C. CLASS 2 WITH A CLASS 2 TRANSFORMER, 24VAC, 50/60 HZ SUPPLIED).
 - MOTOR FACTORY WIRING FOR CORRECT VOLTAGE.
 - INDUCTION MOTOR (IND) AND INDUCTION RESISTANCE MOTOR (IR) MUST BE WIRING IN RETURN AIR SECTION. PL22 AND PL24 LOCATED IN RETURN AIR SECTION.
 - CONNECT TO ECONOMIZER LOGIC MODULE.
 - INDUCTION MOTOR (IND) AND INDUCTION RESISTANCE MOTOR (IR) MUST BE WIRING IN RETURN AIR SECTION. PL22 AND PL24 LOCATED IN RETURN AIR SECTION.
 - FOR LOW VOLTAGE CONNECTIONS, SEE FREQUENCY DRIVES DIAGRAM LOCATED IN THE BELOW SECTION.

- WIRING INFORMATION**
- LINE VOLTAGE
 - FACTORY STANDARD
 - FACTORY OPTION
 - FIELD INSTALLED
 - LOW VOLTAGE
 - FACTORY STANDARD
 - FIELD INSTALLED
 - REPLACEMENT WIRE
 - MUST BE THE SAME SIZE AND TYPE
 - MUST BE THE SAME SIZE AND TYPE
 - OF INSULATION AS ORIGINAL (105C. MIN.)
 - WARNING
 - CABINET MUST BE PERMANENTLY GROUNDED AND CONFORM TO I.E.C., N.E.C., C.E.C. NATIONAL WIRING REGULATIONS, AND LOCAL CODE AS APPLICABLE.

Appendix G. Wiring Diagrams & Schematics (Cont.)

RTU-C 1188-100
THERMOSTAT CONNECTIONS

POWER SUPPLY
L1, L2, L3, N, GND

SMOKE DETECTOR
P1, P2, P3, P4, P5, P6, P7, P8, P9, P10

Delta-MS300
VFD

Control Technologies-C200
VFD

ALARM CODES		
CODE	Description	FAULT LEVEL
0	STATUS	-0, L2, 3
1	STATUS	0
2	COMPRESSOR ON - Low Pressure (In Home Area)	0
3	COMPRESSOR ON - High Pressure (In Home Area)	0
4	COMPRESSOR ON - High Pressure (In Home Area)	0
5	COMPRESSOR ON - High Pressure (In Home Area)	0
6	COMPRESSOR ON - High Pressure (In Home Area)	0
7	COMPRESSOR ON - High Pressure (In Home Area)	0
8	COMPRESSOR ON - High Pressure (In Home Area)	0
9	COMPRESSOR ON - High Pressure (In Home Area)	0
10	COMPRESSOR ON - High Pressure (In Home Area)	0
11	COMPRESSOR ON - High Pressure (In Home Area)	0
12	COMPRESSOR ON - High Pressure (In Home Area)	0
13	COMPRESSOR ON - High Pressure (In Home Area)	0
14	COMPRESSOR ON - High Pressure (In Home Area)	0
15	COMPRESSOR ON - High Pressure (In Home Area)	0
16	COMPRESSOR ON - High Pressure (In Home Area)	0
17	COMPRESSOR ON - High Pressure (In Home Area)	0
18	COMPRESSOR ON - High Pressure (In Home Area)	0
19	COMPRESSOR ON - High Pressure (In Home Area)	0
20	COMPRESSOR ON - High Pressure (In Home Area)	0
21	COMPRESSOR ON - High Pressure (In Home Area)	0
22	COMPRESSOR ON - High Pressure (In Home Area)	0
23	COMPRESSOR ON - High Pressure (In Home Area)	0
24	COMPRESSOR ON - High Pressure (In Home Area)	0
25	COMPRESSOR ON - High Pressure (In Home Area)	0
26	COMPRESSOR ON - High Pressure (In Home Area)	0
27	COMPRESSOR ON - High Pressure (In Home Area)	0
28	COMPRESSOR ON - High Pressure (In Home Area)	0
29	COMPRESSOR ON - High Pressure (In Home Area)	0
30	COMPRESSOR ON - High Pressure (In Home Area)	0
31	COMPRESSOR ON - High Pressure (In Home Area)	0
32	COMPRESSOR ON - High Pressure (In Home Area)	0
33	COMPRESSOR ON - High Pressure (In Home Area)	0
34	COMPRESSOR ON - High Pressure (In Home Area)	0
35	COMPRESSOR ON - High Pressure (In Home Area)	0
36	COMPRESSOR ON - High Pressure (In Home Area)	0
37	COMPRESSOR ON - High Pressure (In Home Area)	0
38	COMPRESSOR ON - High Pressure (In Home Area)	0
39	COMPRESSOR ON - High Pressure (In Home Area)	0
40	COMPRESSOR ON - High Pressure (In Home Area)	0
41	COMPRESSOR ON - High Pressure (In Home Area)	0
42	COMPRESSOR ON - High Pressure (In Home Area)	0
43	COMPRESSOR ON - High Pressure (In Home Area)	0
44	COMPRESSOR ON - High Pressure (In Home Area)	0
45	COMPRESSOR ON - High Pressure (In Home Area)	0
46	COMPRESSOR ON - High Pressure (In Home Area)	0
47	COMPRESSOR ON - High Pressure (In Home Area)	0
48	COMPRESSOR ON - High Pressure (In Home Area)	0
49	COMPRESSOR ON - High Pressure (In Home Area)	0
50	COMPRESSOR ON - High Pressure (In Home Area)	0
51	COMPRESSOR ON - High Pressure (In Home Area)	0
52	COMPRESSOR ON - High Pressure (In Home Area)	0
53	COMPRESSOR ON - High Pressure (In Home Area)	0
54	COMPRESSOR ON - High Pressure (In Home Area)	0
55	COMPRESSOR ON - High Pressure (In Home Area)	0
56	COMPRESSOR ON - High Pressure (In Home Area)	0
57	COMPRESSOR ON - High Pressure (In Home Area)	0
58	COMPRESSOR ON - High Pressure (In Home Area)	0
59	COMPRESSOR ON - High Pressure (In Home Area)	0
60	COMPRESSOR ON - High Pressure (In Home Area)	0
61	COMPRESSOR ON - High Pressure (In Home Area)	0
62	COMPRESSOR ON - High Pressure (In Home Area)	0
63	COMPRESSOR ON - High Pressure (In Home Area)	0
64	COMPRESSOR ON - High Pressure (In Home Area)	0
65	COMPRESSOR ON - High Pressure (In Home Area)	0
66	COMPRESSOR ON - High Pressure (In Home Area)	0
67	COMPRESSOR ON - High Pressure (In Home Area)	0
68	COMPRESSOR ON - High Pressure (In Home Area)	0
69	COMPRESSOR ON - High Pressure (In Home Area)	0
70	COMPRESSOR ON - High Pressure (In Home Area)	0
71	COMPRESSOR ON - High Pressure (In Home Area)	0
72	COMPRESSOR ON - High Pressure (In Home Area)	0
73	COMPRESSOR ON - High Pressure (In Home Area)	0
74	COMPRESSOR ON - High Pressure (In Home Area)	0
75	COMPRESSOR ON - High Pressure (In Home Area)	0
76	COMPRESSOR ON - High Pressure (In Home Area)	0
77	COMPRESSOR ON - High Pressure (In Home Area)	0
78	COMPRESSOR ON - High Pressure (In Home Area)	0
79	COMPRESSOR ON - High Pressure (In Home Area)	0
80	COMPRESSOR ON - High Pressure (In Home Area)	0
81	COMPRESSOR ON - High Pressure (In Home Area)	0
82	COMPRESSOR ON - High Pressure (In Home Area)	0
83	COMPRESSOR ON - High Pressure (In Home Area)	0
84	COMPRESSOR ON - High Pressure (In Home Area)	0
85	COMPRESSOR ON - High Pressure (In Home Area)	0
86	COMPRESSOR ON - High Pressure (In Home Area)	0
87	COMPRESSOR ON - High Pressure (In Home Area)	0
88	COMPRESSOR ON - High Pressure (In Home Area)	0
89	COMPRESSOR ON - High Pressure (In Home Area)	0
90	COMPRESSOR ON - High Pressure (In Home Area)	0
91	COMPRESSOR ON - High Pressure (In Home Area)	0
92	COMPRESSOR ON - High Pressure (In Home Area)	0
93	COMPRESSOR ON - High Pressure (In Home Area)	0
94	COMPRESSOR ON - High Pressure (In Home Area)	0
95	COMPRESSOR ON - High Pressure (In Home Area)	0
96	COMPRESSOR ON - High Pressure (In Home Area)	0
97	COMPRESSOR ON - High Pressure (In Home Area)	0

WIRING INFORMATION

- LINE VOLTAGE
- FACTORY STANDARD
- FACTORY OPTION
- FIELD INSTALLED
- LOW VOLTAGE
- FACTORY STANDARD
- FIELD INSTALLED
- REPLACEMENT WIRE
- MUST BE THE SAME SIZE AND TYPE OF INSULATION AS ORIGINAL (105C. MIN.)
- WARNING
- CABINET MUST BE PERMANENTLY GROUNDED AND CONFORM TO I.E.C., N.E.C., C.E.C. NATIONAL WIRING REGULATIONS, AND LOCAL CODE AS APPLICABLE.

NOTES

- CONNECTORS SUITABLE FOR USE WITH COPPER CONDUCTORS ONLY
- CONNECT FIELD WIRE TO COMPRESSOR CONTACTOR (CC1)
- REMOVE (BAT (C)) TO INSTALL LOW AMBIENT ACCESSORY
- COMPRESSOR MOTOR THERMALLY PROTECTED. ALL 3 PHASE MODELS ARE PROTECTED UNDER PRIMARY SINGLE PHASE CONDITIONS.
- TRANSFORMER FACTORY WIRED AS SHOWN BELOW. CHANGE PRIMARY VOLTAGE CONNECTIONS TO MATCH PAGES 11 AND 12. TRANSFORMER TERN: 200-220-50/2Z, 200-220-50/2Z, 200-220-50/2Z, 380-415-50/2Z, 400-415-50/2Z, 460-480-50/2Z, 575-600/2Z
- LOW VOLTAGE CIRCUIT IS N.E.C. CLASS 2 WITH A CLASS 2 TRANSFORMER, 240V, 50/60 HZ SUPPLIED. REMOVE P12A FOR ECONOMIZER ACCESSORY.
- P12Z AND P12AL LOCATED IN RETURN AIR SECTION.

COMPONENT CODES

- AR ACCESSORY/WAY
- BR BRACKET
- CC COMPRESSOR CONTACTOR
- CD CONDENSER DRUM
- CO COIL
- COM COMPRESSOR
- DAT DATA
- DC DIRECT CURRENT SWITCH
- DR DRAIN
- EP EPIC
- GF GAS FLOW
- GR GRAB
- HT HIGH TEMPERATURE
- HTC HIGH TEMPERATURE CONTROL
- HW HIGH WIRE
- IM INTERMEDIATE MOTOR
- INT INTEGRATED CONTROL
- JFC JUNCTION FIELD CONTROL
- LPS LOW PRESSURE SWITCH
- MAS MAIN AIR SENSOR
- MCC MAIN AIR CONTROL
- MSC MAIN AIR SWITCH
- MTC MAIN AIR THERMISTOR
- ONV OUTDOOR AIR VENT
- PL PLUG
- RF RETURN AIR SENSOR
- RLU RETURN AIR CONTROL
- RUU RETURN AIR UNIT CONTROL
- US UNIFORM
- USC UNIFORM SPEED
- VFD VARIABLE FREQUENCY DRIVE

WIRE COLOR CODE

BK.....BLACK G.....GREEN PR.....PURPLE
 BR.....BROWN GR.....GRAY R.....RED
 BL.....BLUE O.....ORANGE W.....WHITE
 Y.....YELLOW

ELECTRICAL WIRING DIAGRAM

GE DDC 2 STG VFD & RH 150
 208/230/380/460V, 3PH, 60HZ

APPROVED: JHB DATE: 3/19/2018 ORIGINAL RELEASE NO: R-1071S208

PART NO: 90-106178-62 REV: 02

P. APPENDICES

Appendix G. Wiring Diagrams & Schematics (Cont.)

<p>DELTA - MS300 MODELS</p>	<p>CONTROL TECHNOLOGIES - C200 MODELS</p>	<p>WIRE COLOR CODE</p> <table style="width: 100%; border: none;"> <tr> <td>BK.....BLACK</td> <td>O.....ORANGE</td> </tr> <tr> <td>BR.....BROWN</td> <td>PR.....PURPLE</td> </tr> <tr> <td>BL.....BLUE</td> <td>R.....RED</td> </tr> <tr> <td>G.....GREEN</td> <td>W.....WHITE</td> </tr> <tr> <td>GY.....GRAY</td> <td>Y.....YELLOW</td> </tr> </table> <p>COMPONENT CODES</p> <p>PL PLUG VFD VARIABLE FREQUENCY DRIVE MDBA MODBUS ADAPTER</p>	BK.....BLACK	O.....ORANGE	BR.....BROWN	PR.....PURPLE	BL.....BLUE	R.....RED	G.....GREEN	W.....WHITE	GY.....GRAY	Y.....YELLOW
BK.....BLACK	O.....ORANGE											
BR.....BROWN	PR.....PURPLE											
BL.....BLUE	R.....RED											
G.....GREEN	W.....WHITE											
GY.....GRAY	Y.....YELLOW											
<p>NOTES</p> <ol style="list-style-type: none"> 1. CONNECTORS SUITABLE FOR USE WITH COPPER CONDUCTORS ONLY. 2. PL46 IS ONLY NECESSARY ON DDC UNITS. 3. MDBA IS ONLY NECESSARY ON DDC UNITS. 												
<p>SCHNEIDER - ATV320 MODELS</p>	<p>SCHNEIDER - ATV212 MODELS</p>											
<p>WIRING INFORMATION</p> <p>LINE VOLTAGE</p> <p>-FACTORY STANDARD _____</p> <p>-FACTORY OPTION - - - - -</p> <p>-FIELD INSTALLED - - - - -</p> <p>LOW VOLTAGE</p> <p>-FACTORY STANDARD _____</p> <p>-FACTORY OPTION - - - - -</p> <p>-FIELD INSTALLED - - - - -</p> <p>REPLACEMENT WIRE</p> <p>-MUST BE THE SAME SIZE AND TYPE OF INSULATION AS ORIGINAL (105C. MIN.)</p> <p>WARNING</p> <p>-CABINET MUST BE PERMANENTLY GROUNDED AND CONFORM TO I.E.C., N.E.C., C.E.C., NATIONAL WIRING REGULATIONS, AND LOCAL CODES AS APPLICABLE.</p>												
<p>ORIGINAL RELEASE NO.: 111615</p>	<p>ELECTRICAL WIRING DIAGRAM</p>	<p>MODELED BY: V.YAN DATE: 5/26/2023</p>										
<p>APPROVED: CHECKED:</p>	<p>LOW VOLTAGE CONNECTIONS - VARIABLE FREQUENCY DRIVES</p>	<p>PART NO.: 90-109493-01 REV: 01</p>										

J. Unit Tie-Down



160 SW 12TH AVE SUITE 106, DEERFIELD BEACH, FL 33442
(954) 354-0660 | ENGINEERINGEXPRESS.COM

Technical Evaluation Report

DIVISION: 23 08 00-COMMISSIONING OF HVAC

FL 26981.1
THIS DOCUMENT CONTAINS (4) PAGES

EVALUATION SUBJECT: RHEEM PACKAGED UNITS

TER-20-28788

REPORT HOLDER:

RHEEM MANUFACTURING COMPANY, INC.
1100 ABERNATHY ROAD SUITE 1400
ATLANTA, GA, USA
770-351-3000 | RHEEM.COM



SCOPE OF EVALUATION (compliance with the following codes):

THIS IS A STRUCTURAL (WIND) PERFORMANCE EVALUATION ONLY. NO ELECTRICAL OR COOLING PERFORMANCE RATINGS OR CERTIFICATIONS ARE OFFERED OR IMPLIED HEREIN.

This Product Evaluation Report is being issued in accordance with the requirements of the 7th Edition Florida Building Code (2020) per FBC Section 104.11, FMC 301.15, FBC Building Ch. 16, ASCE-7-16, FBC Building 1522.2, FBC Residential M1202.1, M1301.1, & FS 471.025. The product noted on this report has been tested and evaluated as summarized herein.

SUBSTANTIATING DATA:

• Product Evaluation Documents Test Reports

Substantiating documentation has been submitted to provide this TER and is summarized in the sections below.

Test Report: 0320.01-18 (American Test Lab of South FL)

• Structural Engineering Calculations

Structural engineering calculations have been prepared which evaluate the product based on comparative and/or rational analysis to qualify the following design criteria:

- Maximum allowable uplift, sliding, & overturning moment for ground and roof applications
- Maximum unit anchorage to steel curb

NOTE: No 33% increase in allowable stress has been used in the design of this product.

INSTALLATION:

The product(s) listed above shall be installed in strict compliance with this product evaluation & manufacturer-provided model specifications. The product components shall be of the material specified in the manufacturer-provided product specifications. All screws must be installed in accordance with the applicable provisions & anchor manufacturer's published installation instructions.

LIMITATIONS & CONDITIONS OF USE:

Use of this product shall be in strict accordance with this product evaluation as noted herein. The supporting host structure shall be designed to resist all superimposed loads as determined by others on a site-specific basis as may be required by the Authority Having Jurisdiction. Host structure conditions which are not accounted for in this product's respective anchor schedule shall be designed for on a site-specific basis by a registered professional engineer. No evaluation is offered for the host supporting structure by use of this document; Adjustment factors noted herein and the applicable codes must be considered, where applicable.

All supporting components which are permanently installed shall be protected against corrosion, contamination, and other such damage at all times.

Fasteners must penetrate the supporting members such that the full length of the threaded portion is embedded within the main member.

This evaluation does not offer any evaluation to meet large missile impact debris requirements which typically are not required for this type of product.

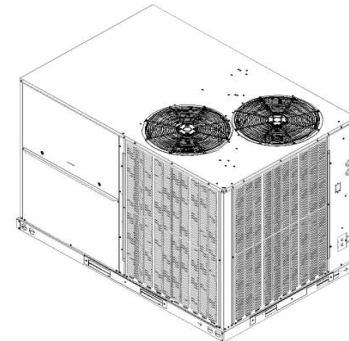

NOTE: GRAPHICAL DEPICTIONS IN THIS REPORT ARE FOR ILLUSTRATIVE PURPOSES ONLY AND MAY DIFFER IN APPEARANCE

UNIT CASING MATERIAL:

20ga galv. sheet steel ASTM A653 Type B.

Removable Top & side covers secured with #10 Sheet metal Hex Head Screws

Knockouts provided for utility & control connections.

FINISH:

Baked Enamel

INSTALLATION:

Shall follow manufacturer specifications as well as information provided herein

OPTIONS:

This evaluation is valid for models shown in the last page

STRUCTURAL PERFORMANCE:

Models referenced herein are subject to the following design limitations:

Maximum Rated Wind Pressure:

200psf Lateral 133psf Uplift

VISIT ECALC.IO/28788

FOR SITE SPECIFIC DEVIATIONS
& MORE INFORMATION ABOUT THIS DOCUMENT
OR SCAN THIS QR CODE

VISIT ENGINEERINGEXPRESS.COM/STORE FOR
ADDITIONAL PLANS, REPORTS & RESOURCES



ENGINEER SIGNATURE AND SEAL :

Frank Bennardo, P.E.
ENGINEERING EXPRESS®
FL PE #0046549 FLCA #9885

P. APPENDICES

J. Unit Tie-Down (Cont.)

RHEEM PACKAGED UNITS

Engineering Express® | TER-20-28788

SECTION 2 PRODUCT INSTALLATION

GROUND MOUNT APPLICATIONS

CONFIGURATION A

Note: Design & installation of ground host is by others per site specific conditions

Opposite side similar

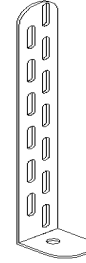
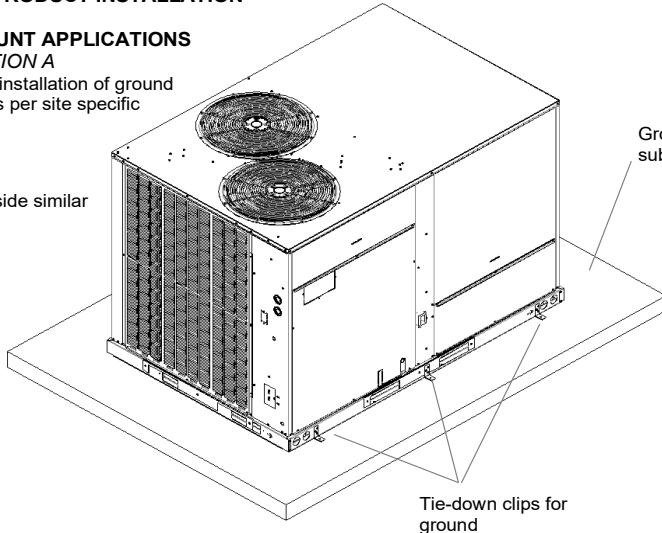

TIE-DOWN CLIP
(GROUND APPLICATION)

Miami Tech CUTD 1" wide ASTM A653 galvanized steel 0.07" thick of varying length (FL19731.2) or equivalent for all cabinets tied down to a ground structure; fasten clip to structure using anchor from Anchor Schedule A to Host Structure Table and (3) #12 SAE Gr 2 self-drilling screw to fasten clip to unit base rail. Install in unit with quantities shown ((3) per side). Locate clips at 8.5" min away from the appropriate corner using three clips per side and three clips opposite side in the same configuration.

ANCHOR SCHEDULE TO HOST STRUCTURE

Pressure Lateral (Uplift) (psf)	Concrete	Steel Curb With Clip	Steel Curb Screw
Ground	A	-	-
Up to 81 (64)	-	-	C
Up to 200 (133)	-	B	-

A. – 5/16" DEWALT ULTRACON Anchor embedded 2" in 3,515 psi concrete. 3 1/8" from edge minimum & 5" spacing minimum. NOA No. 17-1227.22

B. – #12 TEK Screws, (14) screws per clip, (5) top front side, (4) top back side and (5) bottom front side.

C. – 3/8" SAE Grade 5 Self-Drilling Screw at 6" O.C, (15) per long side and (10) per short side.

STEEL CURB

(ROOF APPLICATION)

Steel curb to be a minimum of 16ga ASTM A653 steel

Curb Clip to be 14ga ASTM A653 steel min (Microhold)

CURB MOUNT APPLICATIONS

CONFIGURATION B

Note: Design & installation of curb to host by others per site specific conditions

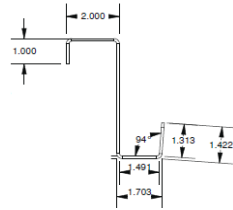
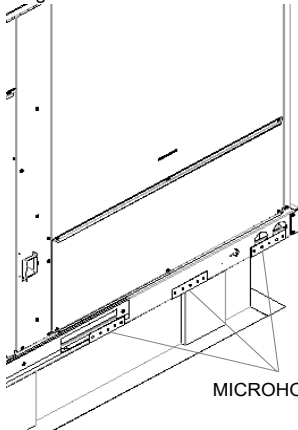

Curb Clip A

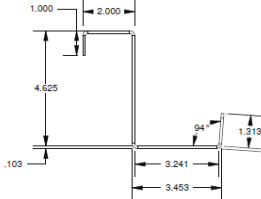

Curb Clip C

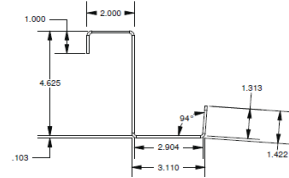

Curb Clip B

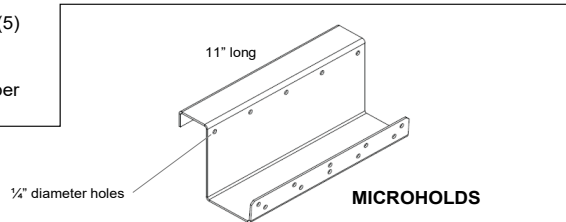

IN ALL CONDITIONS IT IS THE RESPONSIBILITY OF THE PERMIT HOLDER TO ENSURE THE HOST STRUCTURE IS CAPABLE OF WITHSTANDING FORCES BY SITE-SPECIFIC DESIGN. NO WARRANTY OF ANY KIND, EXPRESSED OR IMPLIED, IS OFFERED BY RHEEM MANUFACTURING COMPANY, OR ENGINEERING EXPRESS AS TO THE INTEGRITY OF THE HOST STRUCTURE TO CARRY LOADS INCURRED BY THIS UNIT.

CORP OFC: 160 SW 12TH AVENUE SUITE 106, DEERFIELD BEACH, FLORIDA 33442
(954) 354-0660 | (866) 396-9999 | ENGINEERINGEXPRESS.COM | TEAM@ENGINEERINGEXPRESS.COM

J. Unit Tie-Down (Cont.)

RHEEM PACKAGED UNITS

Engineering Express® | TER-20-28788

CURB CLIP LOCATION

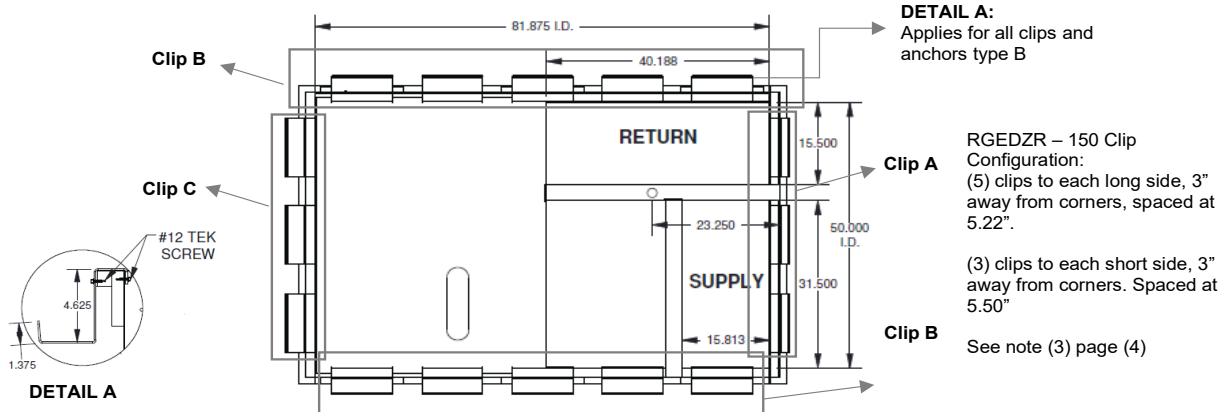

Unit Model			Number of Clips (Pcs)
(-)GEC - 036	(-)ACC - 036	(-)HPC - 036	4 LS - 2 SS
(-)GEC - 048	(-)ACC - 048	(-)HPC - 048	4 LS - 2 SS
(-)GEC - 060	(-)ACC - 060	(-)HPC - 060	4 LS - 2 SS
(-)GEC - 072	(-)ACC - 072	(-)HPC - 072	4 LS - 2 SS
(-)GED - 090	(-)ACD - 090	(-)HPD - 090	5 LS - 3 SS
(-)GED - 102	(-)ACD - 102	(-)HPD - 102	5 LS - 3 SS
(-)GED - 120	(-)ACD - 120	(-)HPD - 120	5 LS - 3 SS
(-)GED - 150	(-)ACD - 150		5 LS - 3 SS

Unit Model Note: ‘(-)’ designates equivalent trade brands with similar cabinetry and may vary depending on brand

#Clip Designation (5 LS= 5 clips each Long Side;
3 SS= 3 clips each Short Side) equally spaced

See pressures on page (2) for alternative anchor limitations

ALTERNATIVE ANCHORAGE TO CURB

STEEL CURB WITH SCREW CONFIGURATION C

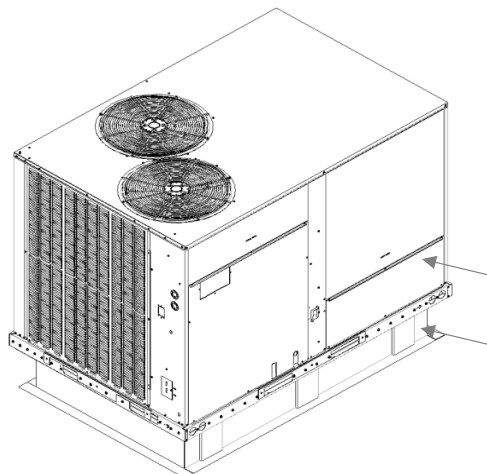

DETAIL B

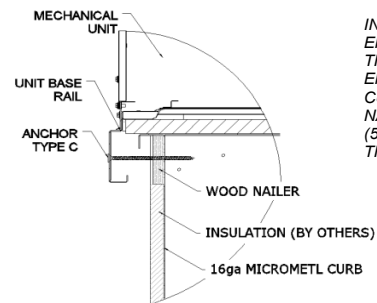

DETAIL B

INSTALLER TO ENSURE THAT THREADED PORTION ENGAGES STEEL CURB BEYOND WOOD NAILER WITH MINIMUM (5) PITCHES PAST THE THREAD PLANE

Mechanical Unit Curb Mounted

P. APPENDICES

J. Unit Tie-Down (Cont.)

RHEEM PACKAGED UNITS

Engineering Express® | TER-20-28788

SECTION 3 MODELS SUMMARY, DIMENSION & NOTES

Unit Model	Operating Dimensions w/ screw heads			Operating Weight (lbs)
	Width (in)	Length (in)	Height (in)	
RGEDZR - 150	59 1/2	90 1/10	59 7/10	1070

TESTED UNIT LIMITATIONS

1. The unit model listed above was tested and designed as worst-case configurations of model units listed in *Evaluation Model Series Matrix*, remaining unit models are certified by this approval as long as they have identical construction as those listed above and are of equal or lesser dimensions (length, width, height).
2. Dimensions shown are measured from outermost points of unit, including screw heads.
3. Curb clips shall be as close as possible from the shown locations; installers shall verify any interference between clip attachment and internal components of the unit and move clip within the tolerance allowed.

REQUIRED WIND PRESSURES

Design pressures calculated for use with these units shall be determined by others on a job-specific basis in accordance with the governing code. Site specific load requirements for wind load shall be determined in accordance with ASCE 7 and the codes referenced herein by separate engineering certification and shall be less or equal to design pressures capacity values listed herein for any assembly as shown.

TEST REPORTS UTILIZED

Design and certification of the unit cabinetry is approved through American Test Lab of South Florida Report #: 0320.01-18
Tested according ASTM E330-05 and TAS 202-94.

Unit Model	Operating Dimensions w/ screw heads			Operating Weight (lbs)
	Width (in)	Length (in)	Height (in)	
(-)ACC - 036	46 3/4	78 3/8	41 3/8	453
(-)ACC - 048	46 3/4	78 3/8	41 3/8	477
(-)ACC - 060	46 3/4	78 3/8	41 3/8	482
(-)ACC - 072	46 3/4	78 3/8	41 3/8	689
(-)ACD - 090	59 15/32	89 5/16	49 1/4	722
(-)ACD - 102	59 15/32	89 5/16	49 1/4	748
(-)ACD - 120	59 15/32	89 5/16	49 1/4	777
(-)ACD - 150	59 1/2	90 1/10	59 7/10	946

Unit Model	Operating Dimensions w/ screw heads			Operating Weight (lbs)
	Width (in)	Length (in)	Height (in)	
(-)GEC - 036	46 3/4	78 3/8	41 3/8	453
(-)GEC - 048	46 3/4	78 3/8	41 3/8	477
(-)GEC - 060	46 3/4	78 3/8	41 3/8	482
(-)GEC - 072	46 3/4	78 3/8	41 3/8	689
(-)GED - 090	59 15/32	89 5/16	49 1/4	846
(-)GED - 102	59 15/32	89 5/16	49 1/4	872
(-)GED - 120	59 15/32	89 5/16	49 1/4	901

Unit Model	Operating Dimensions w/ screw heads			Operating Weight (lbs)
	Width (in)	Length (in)	Height (in)	
(-)HPC - 036	78 3/8	46 3/4	41 3/8	528
(-)HPC - 048	78 3/8	46 3/4	41 3/8	551
(-)HPC - 060	78 3/8	46 3/4	41 3/8	553
(-)HPC - 072	78 3/8	46 3/4	41 3/8	553
(-)HPD - 090	89 5/16	59 1/2	49 1/4	786
(-)HPD - 102	89 5/16	59 1/2	49 1/4	822
(-)HPD - 120	89 5/16	59 1/2	59 7/10	874

Unit Model Note: ‘(-)’ designates equivalent trade brands with similar cabinetry and may vary depending on brand

J. Unit Tie-Down (Cont.)

RHEEM PACKAGED UNITS

Engineering Express® | TER-20-28788

UNIT VIEWS & ELEVATIONS

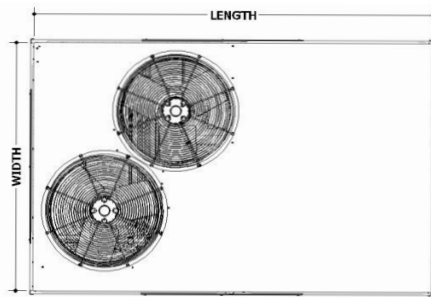

TOP VIEW

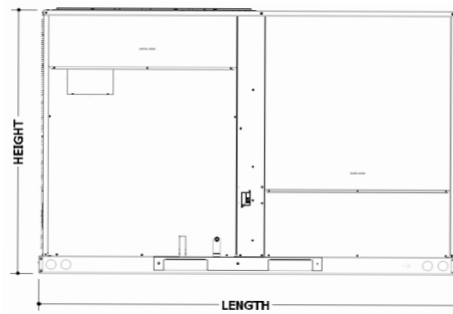

ELEVATION VIEW

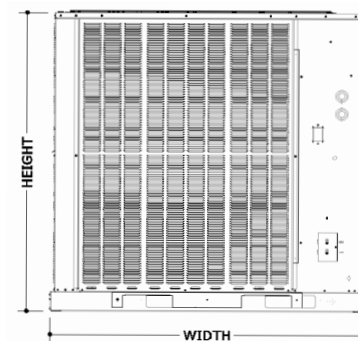

SIDE VIEW

Note: RGEDZR-150 illustration selected for dimensional purposes

R. INFORMATION FOR THE OWNER

R.1. Information for the Owner: Maintenance and service

For routine maintenance, general diagnostics for cooling and heating, and other generalized information regarding filter changing, cleaning the condensate pan, cleaning the coils, and general inspections, refer to the included User's Information Manual for the owner.

R.2. Product Model and Serial Number

The product model and serial number are both located on the rating plate found on the supply/return panel of the unit.

S. INSTALLATION CHECK LIST AND JOB SITE SHEET

Commercial Job Site Information

Site Information and Application Details:

Business Name : _____ Model Number : _____
(Please include all letters and digits of the model number)

Address : _____
 City : _____ State : _____ Zip : _____

Site Contact : _____ Serial Number : _____
(Please include all letters and digits of the serial number)

Phone : _____ Mobile : _____ Date of Install : _____
(When was the unit installed, month, day, and year)

Email : _____

Business Name : _____ Technician Name : _____
 Address : _____ Visit Date: _____
 City : _____ State : _____ Zip : _____ Technician Name : _____
 Site Contact : _____ Visit Date: _____
 Phone : _____ Mobile : _____ Technician Name : _____
 Email : _____ Visit Date: _____

Distributor and Support Details:

Distributor Name : _____ Rep Name : _____
 City : _____ State : _____ Visit Date: _____

Unit Setup and Operational Information

Voltage and Amperage Information :

Line Voltage Measurements :

Base Voltage : 208 240 460 Phase : 1 3
(Circle one) (Circle one)

Measured Line Voltage : _____

Phase A to B : _____ Phase A to Ground : _____
 Phase B to C : _____ Phase B to Ground : _____
 Phase C to A : _____ Phase C to Ground : _____

Breaker Size : _____ Conductor Size: _____

24VAC Low Voltage Measurements :

Transformer Tap : 208 240 460
(Circle one)

24VAC Measured Voltage : R to C : _____
 24VAC Measured Amp Load : _____
 Transformer Load: _____
 T-stat Load: _____

Amperage and Power Measurements :

	Full Running Load	Blower	Compressor 1	Compressor 2	Outdoor Fans
Phase A :	_____	_____	_____	_____	_____
Phase B :	_____	_____	_____	_____	_____
Phase C :	_____	_____	_____	_____	_____

Circuit 1 :

Suction Line	Liquid Line
Pressure (PSI) : _____	Pressure (PSI) : _____
Temperature (°F) : _____	Temperature (°F) : _____
Superheat (°F) : _____	Sub-cooling (°F) : _____

Circuit 2 :

Suction Line	Liquid Line
Pressure (PSI) : _____	Pressure (PSI) : _____
Temperature (°F) : _____	Temperature (°F) : _____
Sub-cooling (°F) : _____	Sub-cooling (°F) : _____

Outdoor Air Temperature (°F) : _____ Return Air Temperature (°F) : _____ Supply Air Temperature (°F) : _____
 Outdoor Air Wet Bulb (°F) : _____ Return Air Wet Bulb (°F) : _____ Supply Air Wet Bulb (°F) : _____

S. INSTALLATION CHECK LIST AND JOB SITE SHEET

Commercial Job Site Information

Air Flow CFM :

Building Design CFM : _____
 Operating System CFM : _____

Blower Speed :

Motor RPM : _____
 Blower RPM : _____
 Blower Sheave Turns : _____
(Turns are measured from a fully closed position)

Static Pressure :

Return Static Pressure : _____
 Supply Static Pressure : _____
 Total Static Pressure : _____

Variable Frequency Drive (VFD) : (low fan speed settings are located in DDC Control)

Factory Equipped: Yes No
(Circle one) Power Setting (uLu) : _____ Low Fan Speed % : _____
 Active VFD Display (Hz) : _____ Runs to 45hz on Start?: Yes No
(Circle one) 1stg Cooling Speed % : _____
 LOC/REM Light On?: Yes No
(Circle one) Runs to 60hz 2nd Stage?: Yes No
(Circle one) Low Economizer % : _____

Economizer Setup and Information :

Outdoor Air:

Design CFM : _____
 Design % : _____
 Measured CFM : _____
 Measured % : _____

Blade Position and Settings:

Minimum Position - Low : _____
 Minimum Position - High : _____
 Min Position Shaft Angle : _____
 Measured % : _____

Program Settings:

Enthalpy Zone Setting : A B C D E
(Circle one)
 Mixed Air Temperature : _____
 Min Position Shaft Angle : _____
 Measured % : _____

Heat or Furnace Information :

Gas Heat :

Fuel Type : Natural LP <small>(Circle one)</small>	Voltage: _____	Amperage: _____	Pressure Switches <small>(measured in inches w.c.)</small>			
Input BTU : _____	Line 1 Line 2	Line 1 Line 2	RPM	Low	High	Close Open
Measured BTU : _____	Inducer 1: _____					
Line Gas Pressure : _____	Inducer 2: _____					
Manifold Pressure - Low : _____	Inducer 3: _____					
Manifold Pressure - High : _____	Inducer 4: _____					
Number of Orifices : _____	Main Limit Closed: Yes No <small>(Circle one)</small>	Over Temp Limit Closed: Yes No <small>(Circle one)</small>				
Orifice Size : _____	Spark Visible at Igniter : Yes No <small>(Circle one)</small>	Burner Flames Blue : Yes No <small>(Circle one)</small>				
Flame Signal - microamp (s) : _____						

Electric Heat :

System Voltage : 208 240 460
(Circle one) Stage 1 Amps: _____ Stage 2 Amps: _____ Stage 1 Watts: _____ Stage 2 Watts: _____
 Total Kw input Rating : _____ Phase A : _____
 Phase B : _____
 Phase C : _____

Notes and Comments :



