

# Central Battery Systems AC/AC

## EasiCheck EC140 – Module with control input



### EasiCheck EC140 Addressable Changeover Module

EC140 addressable changeover relay can be used to supply several luminaires for emergency operation fed from a static inverter central power supply. The changeover relay automatically illuminates the emergency luminaire in the event of power failure or when a test is in operation. EC140 addressable changeover relay illuminates the emergency luminaires when a test is in progress enabling a SVAEL monitoring device within the luminaire to report the luminaire status back to the EC1002 panel to display luminaires condition indicating a fault with audible warning and location of faulty luminaires.

- Compact Design
- can be addressed in the range 0 to 255
- Works on a wide range of luminaires
- Networkable with 64 panels
- Central PC monitoring

EasiCheck EC140 Changeover relay



10

EC140ENC remote enclosure



Remote enclosure dimensions in mm (L x W x H) 280 x 102 x 53, 0.7 mm steel painted RAL 9016, Degree of protection: IP20

Enclosure Material	Galvanised steel
Type of mounting	Within mains / slave luminaire or remote enclosure
Dimensions in mm (L x H x D)	220 x 34 x 40
Weight	0.3 kg
Communications	Easichack Data Loop
Connections	Max. 2.5 mm <sup>2</sup> (2 x 2.5 mm <sup>2</sup> when mounted within FMENCA)
Monitoring range	No monitoring (use EC 141)
Degree of protection	IP20
Temperature Range	0 °C to +50 °C

### Ordering details

Scope of supply	Order No.
Easichack test interface (Slave)	EC140
EC140 mounted in remote enclosure	EC140ENC

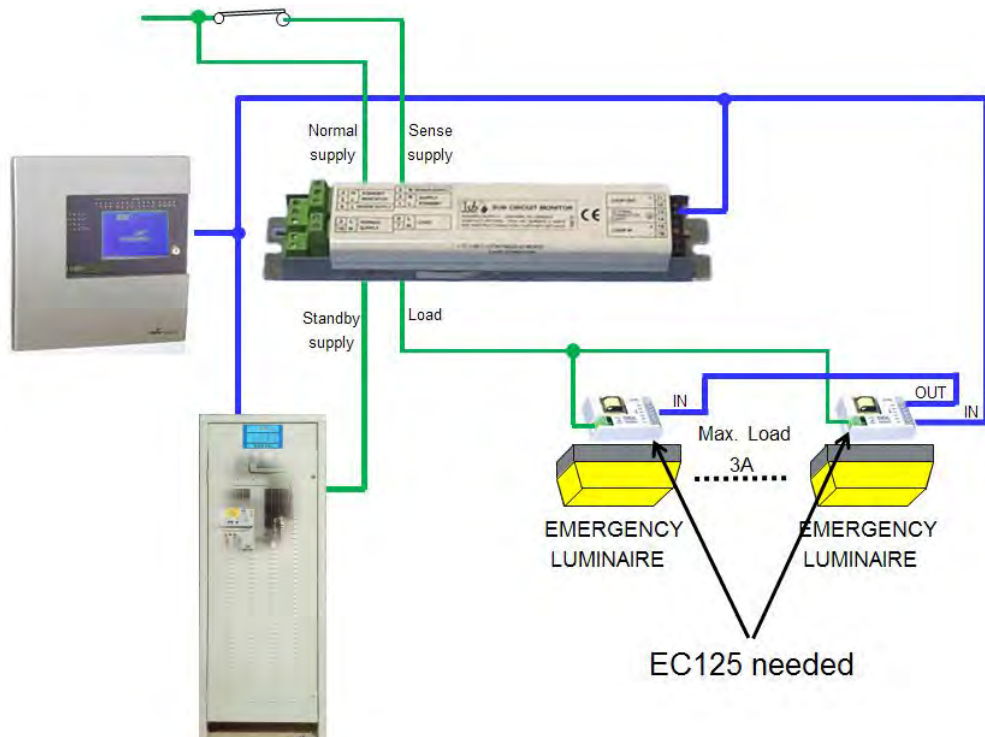



### EasiCheck EC141 Addressable Changeover Module

EC141 interface can be fitted within mains luminaire to convert luminaire to emergency operation with addressable testing, alternatively mounted within a remote enclosure supplying a standard mains luminaire. EC141 monitors and report the AC current drawn by the luminaire to the control panel along with its address/location. In the event of a luminaire reporting incorrect power consumption, the EC1002 panel displays a fault with audible warning and location of a faulty luminaire.

- Compact Design
- can be addressed in the range 0 to 255
- Works on a wide range of luminaires
- Networkable with 64 panels
- Central PC monitoring
- User selectable measuring range (via link)

EasiCheck EC141



EC140ENC remote enclosure



Remote enclosure dimensions in mm  
(L x W x H) 280 x 102 x 53,  
0.7 mm steel painted RAL 9016,  
Degree of protection: IP20

Enclosure Material	Galvanised steel
Type of mounting	Within mains / slave luminaire or remote enclosure
Dimensions in mm (L x H x D)	220 x 34 x 40
Weight	0.3 kg
Communications	Easichack Data Loop
Connections	Max. 2.5 mm <sup>2</sup> (2 x 2.5 mm <sup>2</sup> when mounted within FMENCA)
Measurement	AC current
Monitoring range	34- 250 mA (no link) 250- 800 mA (link fitted)
Degree of protection	IP20
Temperature Range	0 °C to +50 °C

10

### Ordering details

Scope of supply	Order No.
Easichack test interface (Slave)	EC141
EC141 mounted in remote enclosure	EC141ENC

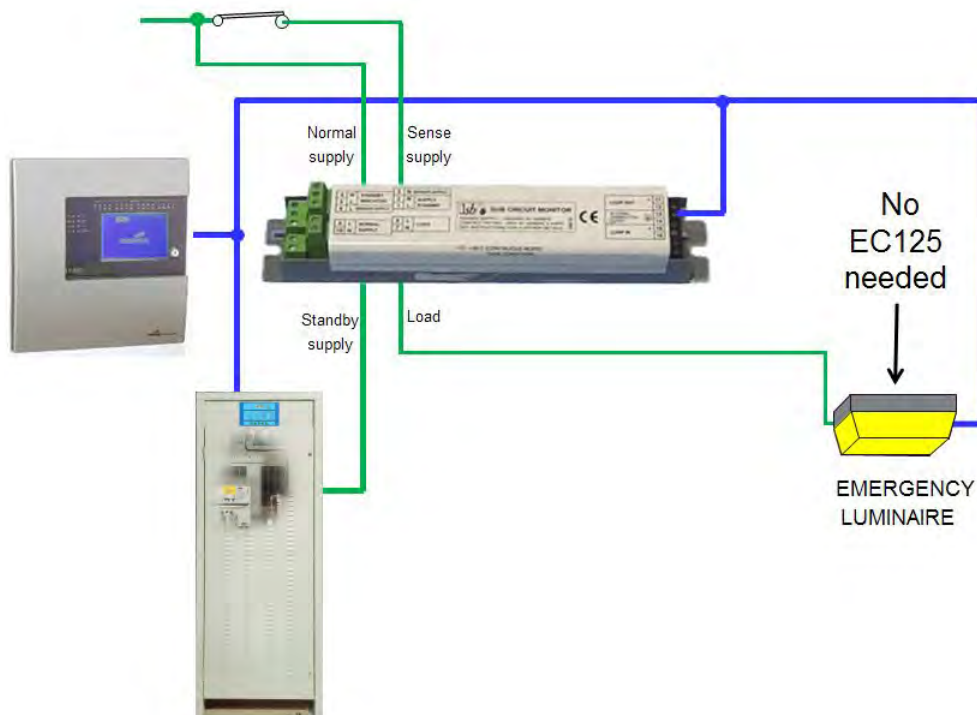

# Central Battery Systems AC/AC

EasiCheck EC141 – Monitoring module with control input

10

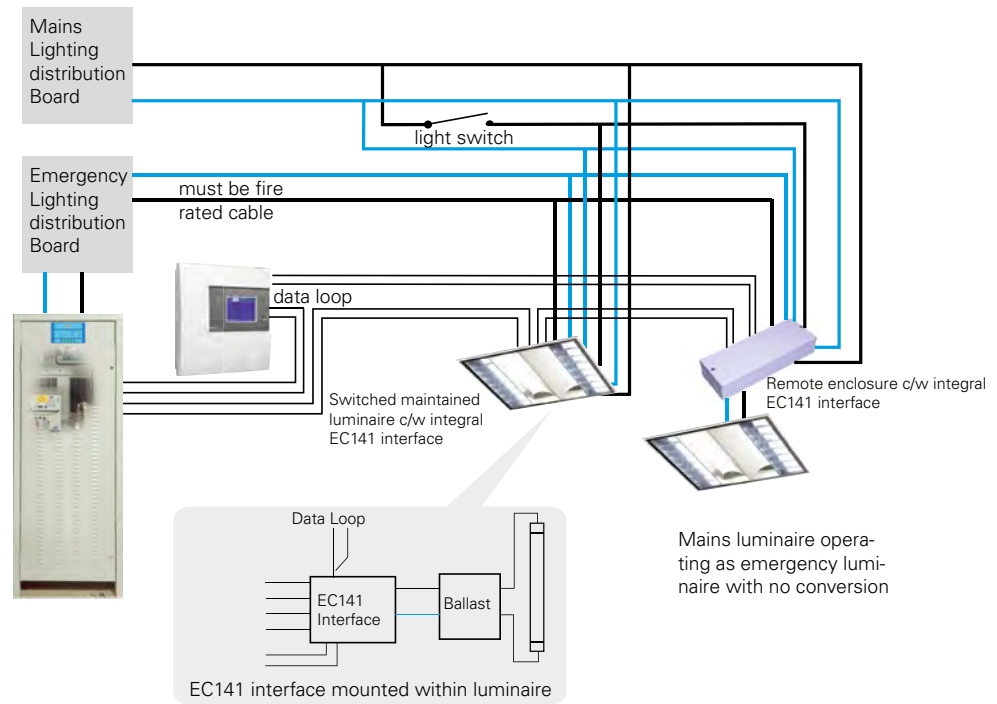



### ACM1 - Changeover module

- Utilise mains luminaires as emergency lighting
- Controls up to 750VA
- Simple single or multiple luminaire control
- Rated to switch 480V
- Auxiliary contact for inhibiting dimming control
- Operates luminaire at full lumen output
- Ultra compact profile for ease of integration or remote mounting
- Heavy duty terminals

ACM1 - Static Inverter Conversions



Dimensions

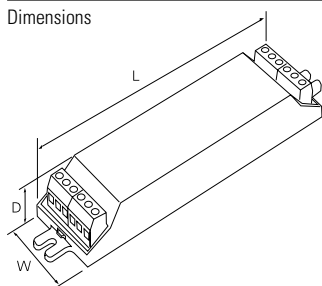

Description	L (mm)	W (mm)	D (mm)
ACM1	158	38	33
ACM1ENC	285	100	55

Rated voltage ranges	230 V, 50 Hz
Controls of	up to 750 VA
Degree of protection	IP20
Dimensions in mm (H x L x W)	33 x 158 x 38
Housing material / colour	Module case- polycarbonate, white finish Remote enclosure- steel, white finish
Weight	ACM1: 0.30 kg ACM1ENC: 0.90 kg
Auxiliary contact	1 A at 240 V DC

10

### Ordering details

Description	Order No.
Active Control Module (max 750 VA)	ACM1
ACM1 mounted in remote enclosure	ACM1ENC

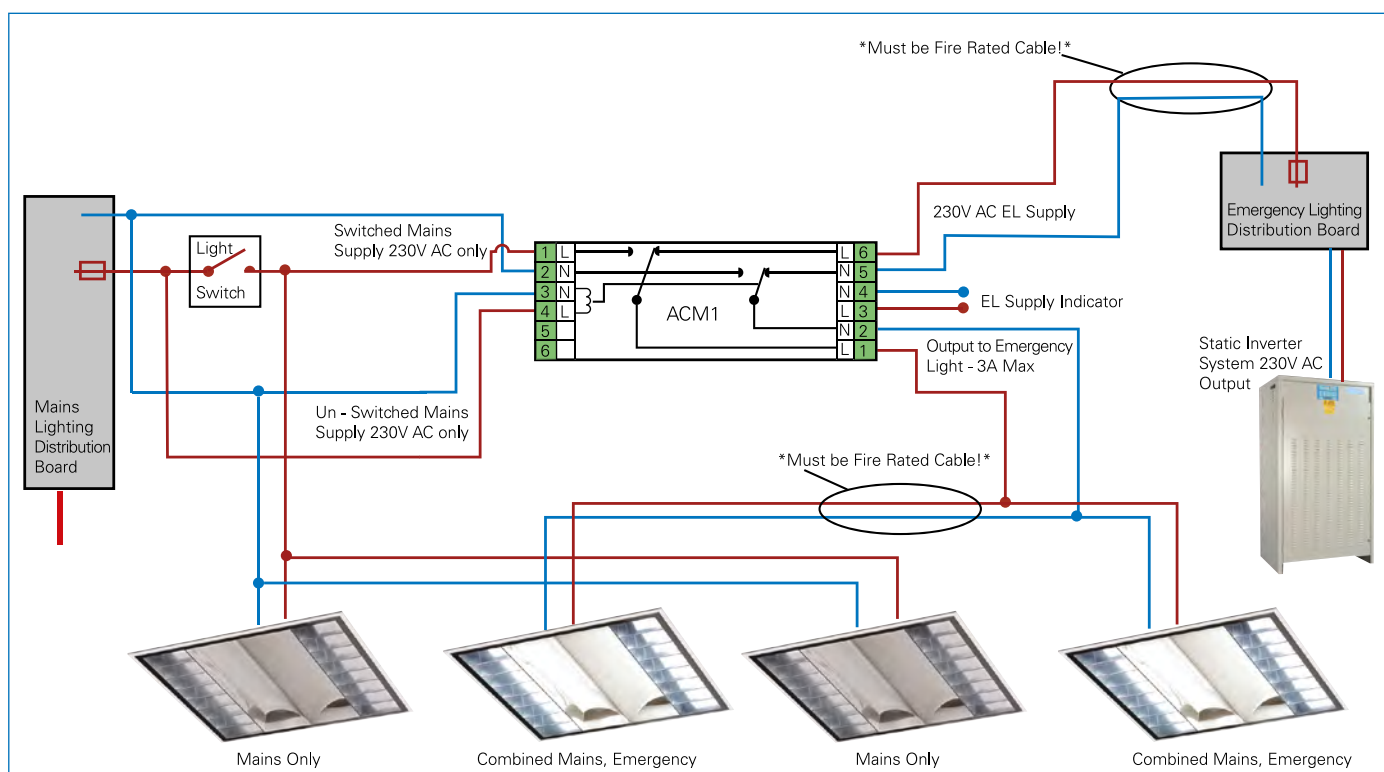
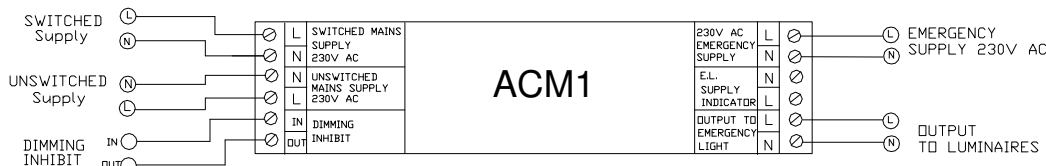

Typical ACM1 schematic diagram







### Central Battery Systems AC/AC

#### AT-S+

Features .....	443
What is STAR+? .....	444
Easy planning .....	445
Strong in detail .....	446
Distribution box SU1 and SOU1 .....	448
Distribution box ESF30 SU2 and ESF30 SOU2 .....	449
Substations with functional integrity of 30 minutes .....	450
Across fire compartments-specific installation example .....	452
Components and options .....	453
Technical data .....	464
Installation example .....	468
Specifications .....	470
Technical drawings .....	472

# Central Battery Systems AC/AC

Automatic Test System AT-S+ with STAR+ Technology – Fire compartment-specific installation example

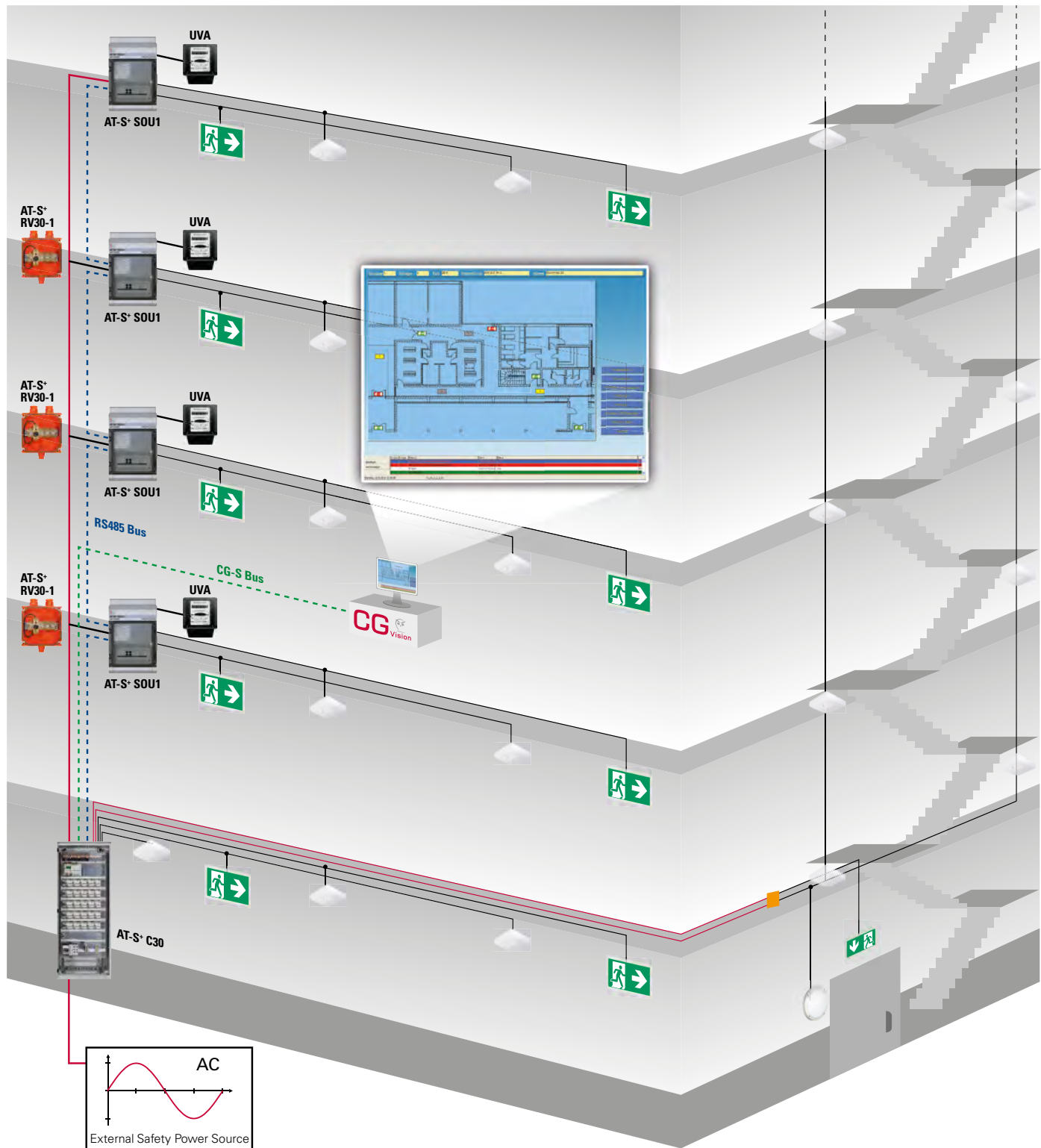

## AT-S+ SOU1

Distribution box for area by area installation allows electricity costs allocation per rental area



## Reliable STAR technology for AC safety power sources

AT-S+ offers all the known benefits of our STAR technology, now also for AC safety power sources. It is the perfect symbiosis of CEWA GUARD and STAR technology.

The Automatic Test System AT-S+ individually monitors each CG-S luminaire (up to 20 per circuit), and it does all this using the power supply cable alone.

The new STAR+ technology allows the switching mode of every connected V-CG-S luminaire to be freely programmed within a 50 or 60 Hz supply network using the system's controller.

This means that maintained light, switched maintained light and non-maintained light modes can be combined in one and the same circuit – there is no need for separate data cables!

The control module with its nonvolatile program memory and large graphic display automatically monitors and controls all components of the test system as well as emergency luminaires connected to it. Faults occurring are shown by the display, forwarded via freely configurable signal contacts and saved to an inspection book.

An integral search function automatically detects all system-dependent luminaires and modules that are assigned an address during installation. A central monitoring device can be connected via an interface.

### Features:

- Shortened inspection effort due to STAR+ technology; automatic function monitoring of up to 20 luminaires per circuit
- Reduced installation expenditures by STAR+ technology; freely programmable mixed operation of the switching modes per luminaire in one circuit
- Less installation costs as no data line is required to the luminaires
- Automatic luminaire search function
- Plain text display on the control module down to the last luminaire
- Flexible data storage for test log and system configuration with memory card
- 30 minutes functionality in compliance with model directive for fire protection requirements on electrical wiring systems (MLAR model conduit systems directive), version 11/2005, tested by national material testing office



# Central Battery Systems AC/AC

Automatic Test System AT-S+ with STAR+ Technology – What is STAR+?

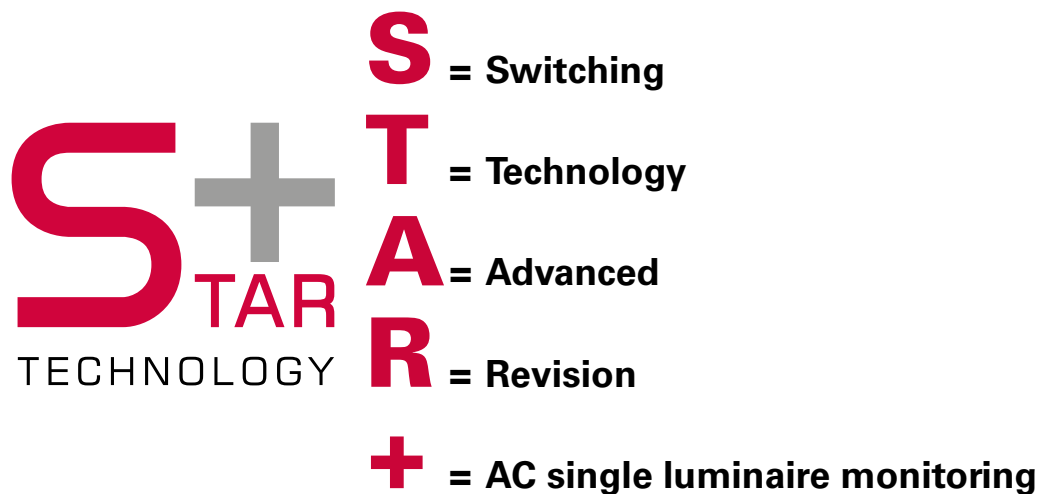

10

## Identify STAR+ market requirements and consistently implement them!

The continuing development of the CEWA GUARD monitoring system has led to the creation of the

**Switching  
 Technology  
 Advanced  
 Revision,**

or **STAR** for short. This **CG-STAR** technology allows different switching modes to be implemented in one and the same circuit, and the switching mode of each individual luminaire can be re-programmed at any time.

As a result, this technology offers not just the proven CEWA Guard safety when it comes to operating a safety lighting system, it also gives planners the confidence and flexibility of knowing that the system can respond and adapt at any time to any changes that are made to a building and its use.

We have united both forms of technology to STAR+ to take advantage of CEWA GUARD and STAR technology in projects in which batteries as power sources for safety services are not needed, but where generators, dual systems (secondary power supply) or central converter systems are used. This now gives you a highly flexible test system with all the familiar benefits.

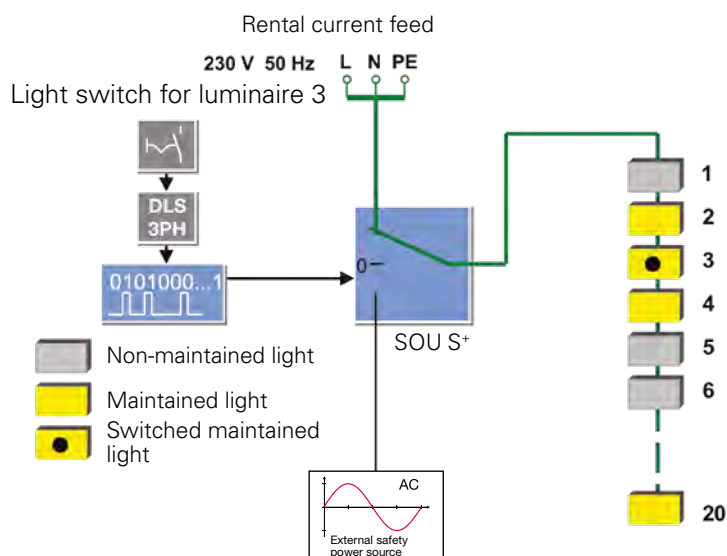

Operation of the STAR+ technology

### Your Advantages:

The number of outgoing circuits needed can be sharply reduced, since continuously operating, stand-by and switchable permanent lighting can be realised in one common circuit.

This allows the use of shorter cable distances, reduces installation costs and minimises the effects of burning materials. Any mode of operation can be assigned at a later date – without encroachment in the lighting installation. This enables simple project planning without having to take all possible types of operation into account.

With symbiosis of CEWA GUARD technology and the patented STAR technology to STAR+ technology, no supplementary data line to the luminaires is needed even with use of an AC power source for safety services.



### Conventional Installation:

- Maintained light 1 (DS)
- Non-maintained light 1 (BS)
- Non-maintained light 2 (BS)
- Maintained light 2 (DS)
- Switched maintained light 1 (3-PM-IO)
- Switched maintained light 2 (3-PM-IO)

10

- Each type of switching mode requires two circuits
- Only one type of switching mode is possible per circuit
- Any later modifications involve a large amount of work and expense

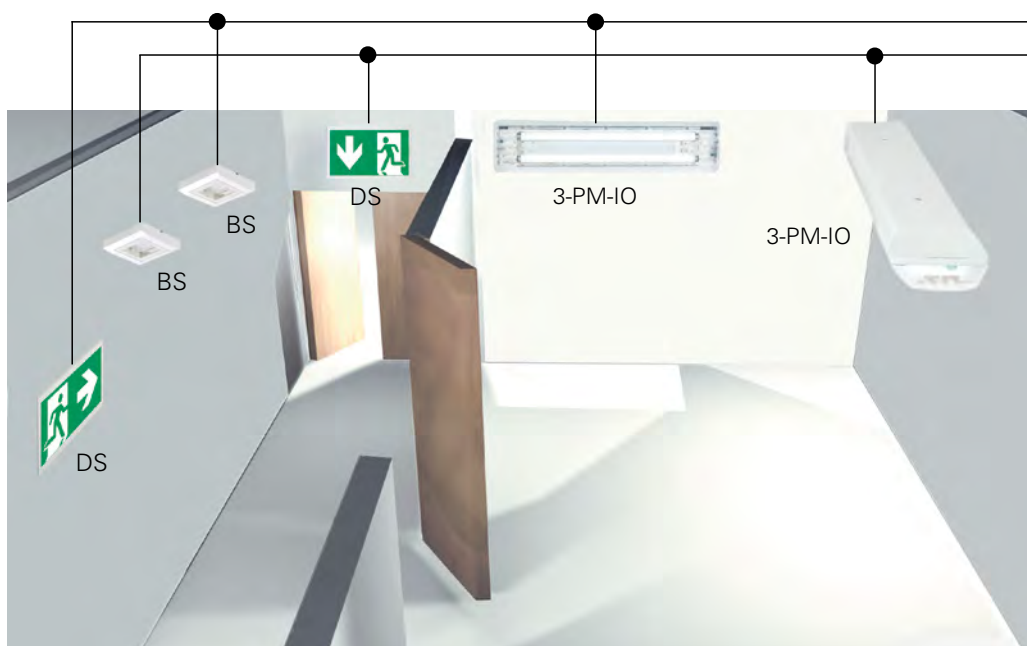

### AT-S+ Installation with STAR+ Technology:

- All types of switching modes
- All types of switching modes

- Only two outgoing circuits for all types of switching modes
- Maintained light, non-maintained light and switched maintained light are possible in one common circuit
- Later circuit modifications do not pose any problems

# Central Battery Systems AC/AC

Automatic Test System AT-S+ with STAR+ Technology – Strong in detail

## AT-S+ cabinet

- Cable infeed from above
- Triple deck tension spring installation terminal with neutral wire disconnect terminal
- Control unit CU S+
- DC/DC converter.2
- AC module
- Fuse circuit breaker D02 25 A per field
- Circuit switching modules SU S+ 2 x 6 A
- Fuse circuit breaker
- 6-fold mains distribution box (optional)
- Cable infeed from below

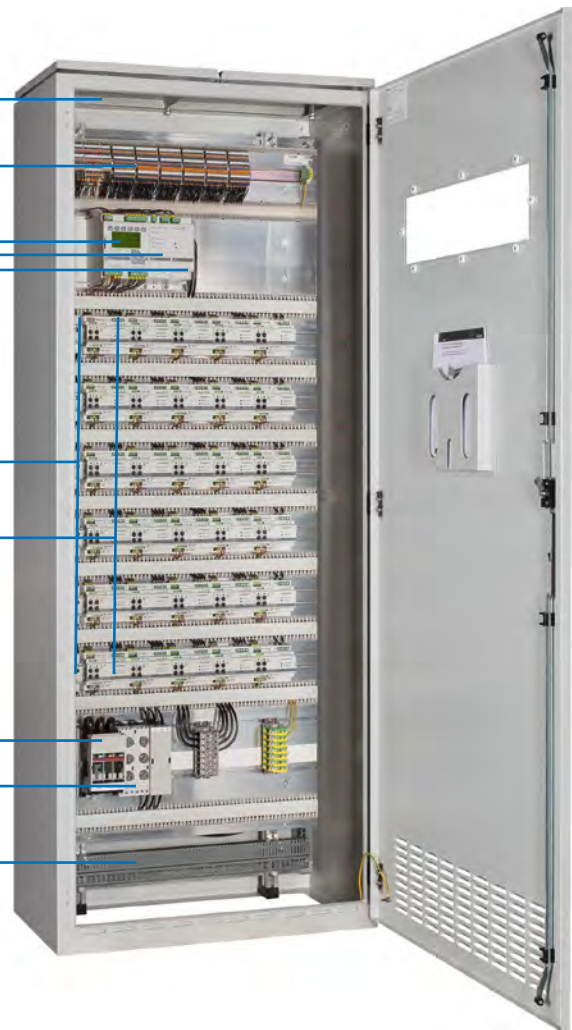

10

## Large connection compartment for convenient wiring

All connections on triple deck installation terminals in the upper part of the central unit.

The control unit, DC/DC converter and the AC module are wired at terminal as standard.

Wiring of the SU-S+ modules at terminals is optional.





### Freely programmable control unit

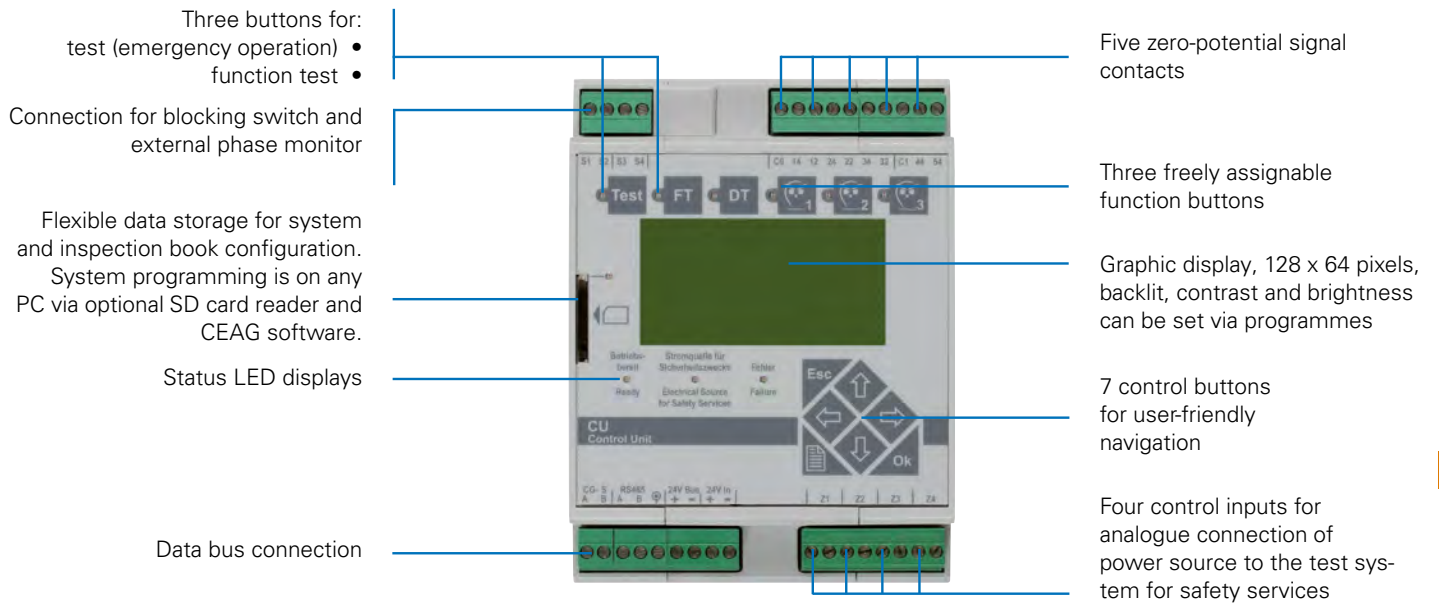

10

### Switching unit SU S+ 2 x 6 A

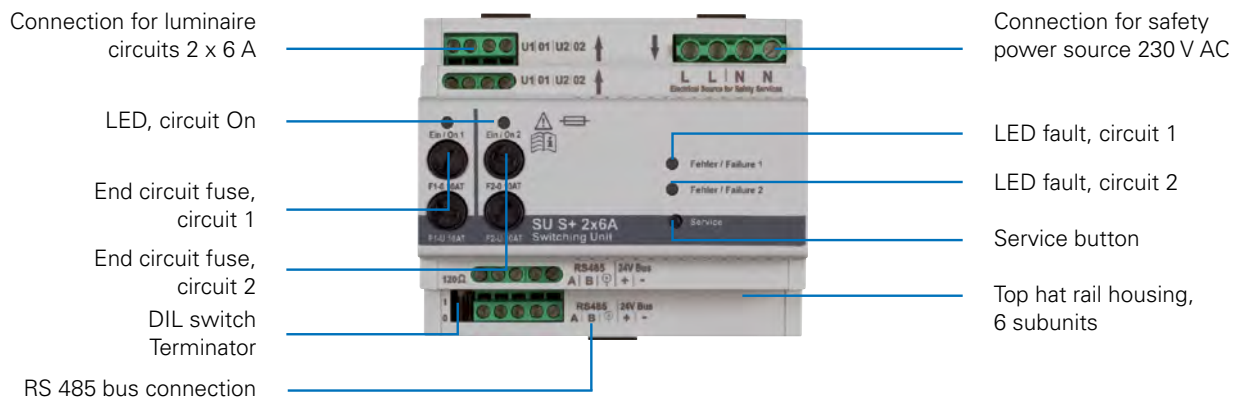

### Switching over unit SOU S+ 2 x 4 A

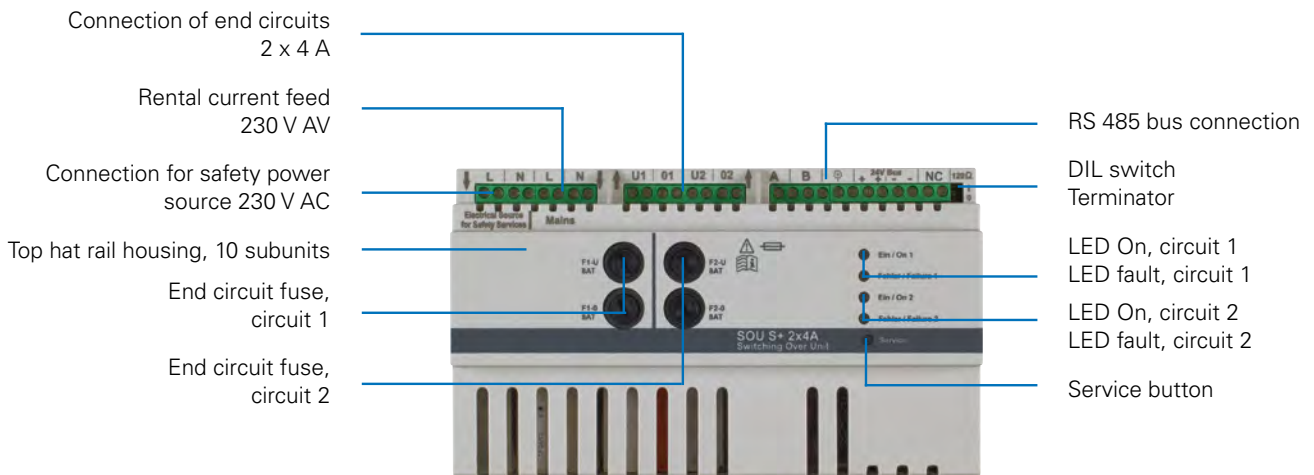

# Central Battery Systems AC/AC

Automatic Test System AT-S+ with STAR+ Technology – Distribution box SU1 and SOU1

## AT-S+ SU1

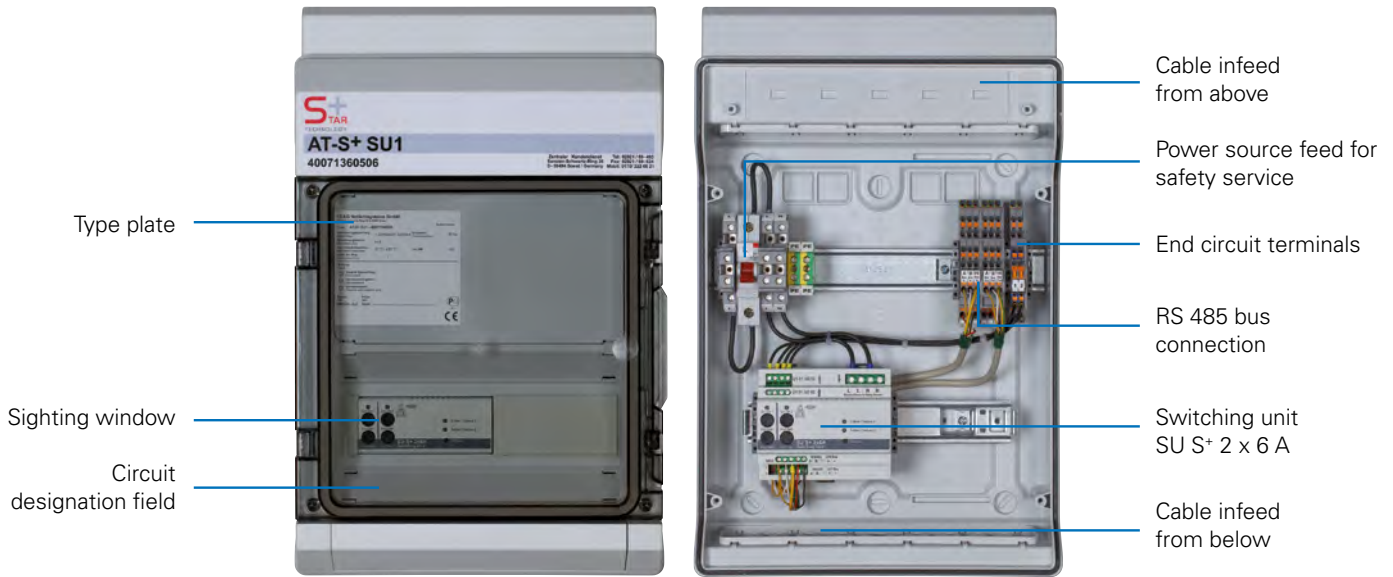

## AT-S+ SOU1

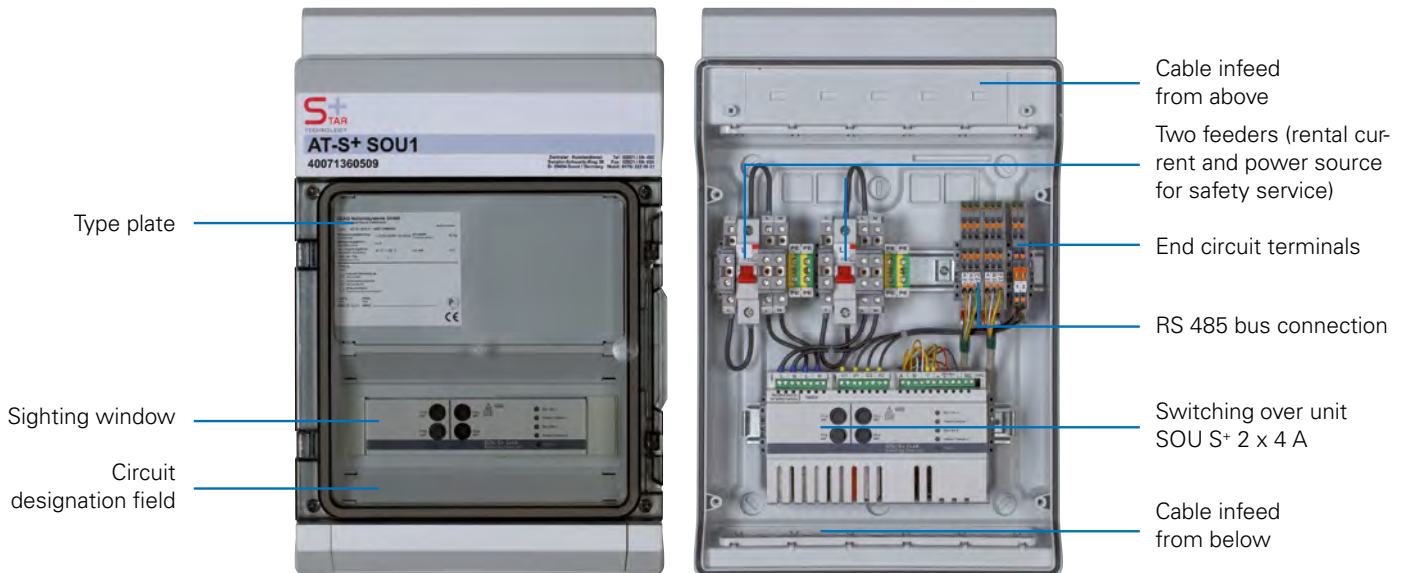

### AT-S+ ESF30 SU2



10

### AT-S+ ESF30 SOU2

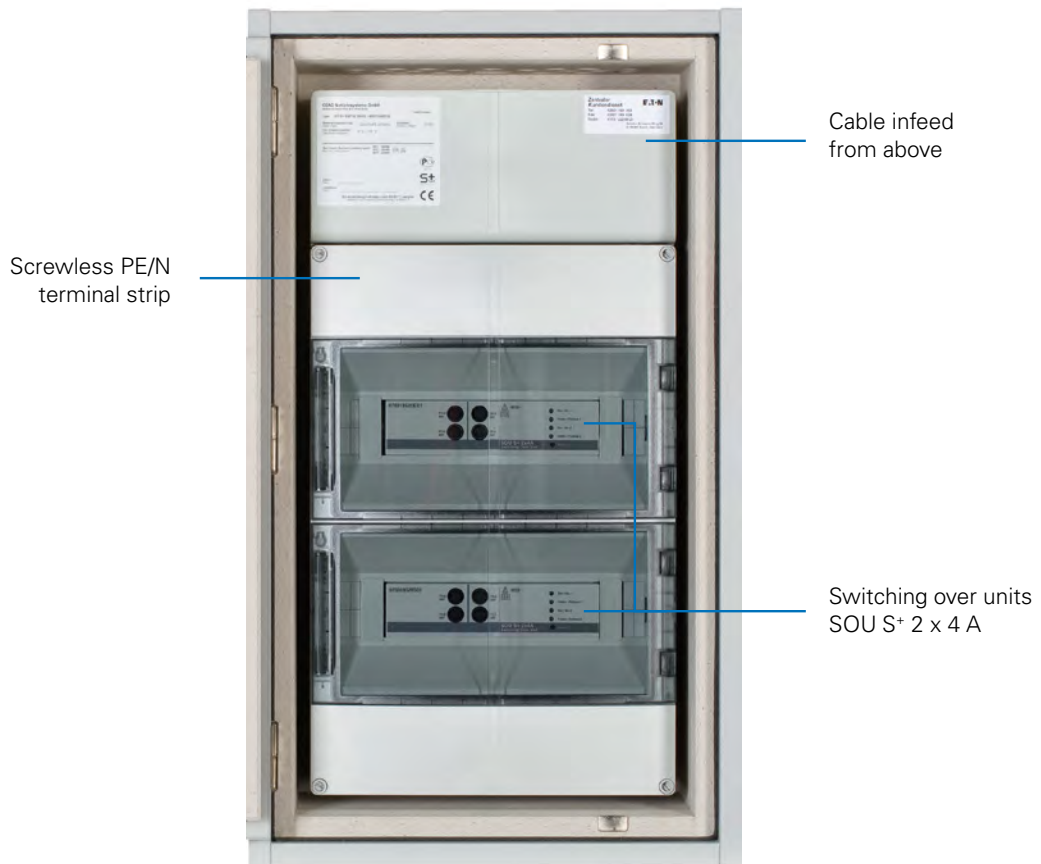

# Central Battery Systems AC/AC

Automatic Test System AT-S+ with STAR+ Technology – Substations with functional integrity of 30 minutes

10



## Safe operation under the most extreme environmental conditions

There are different types of sub-distributors available for compliance with the requirements on functional integrity of MLAR 11/2005.



AT-S+ ESF30 C10-P



### Sub-distributor in sheet steel housing

In accordance with the model guideline on fire protection requirements pertaining to wire systems (MLAR specimen guideline on wire systems), version 11/2005, verified by a National Material Testing Office.

Approved by the Deutsches Institut für Bautechnik (DIBT- German Institute for Civil Engineering) as an electrical distributor with functional integrity, including electrical equipment and technical air ventilation with approval number: Z-86-2-1.



### Electric distributor with functional integrity

Experimental design for application as an electrical distributor with functional integrity. The functioning of all the installed electronic components was tested in a fire test.





AT-S+ ESF30 SOU2

### Sub-distributor in Priodec housing

In accordance with the model guideline on fire protection requirements pertaining to wire systems (MLAR specimen guideline on wire systems), version 11/2005, verified by a National Material Testing Office.

Approved by the Deutsches Institut für Bautechnik (DIBT- German Institute for Civil Engineering) as an empty enclosure for fire protection with a fire resistance rating of minimum 30 minutes in case of external fire exposure, approval number of the empty enclosure: Z-86.1-46

Functional integrity exceeding 30 minutes is certified in an expert opinion, based on a fire test.



10

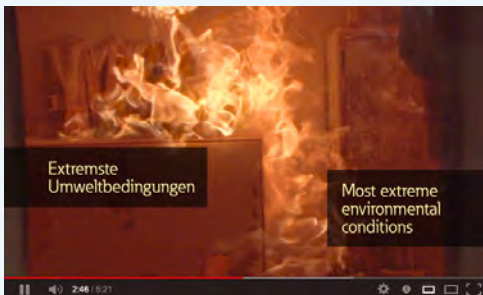

Please scan the following QR code for direct access:



### Fire test in a video documentation

Please watch the video documentation of the fire test of the types of enclosures presented here:

<http://youtu.be/dk8qieMSiTI>

# Central Battery Systems AC/AC

Automatic Test System AT-S+ with STAR+ Technology – Across fire compartments-specific installation example

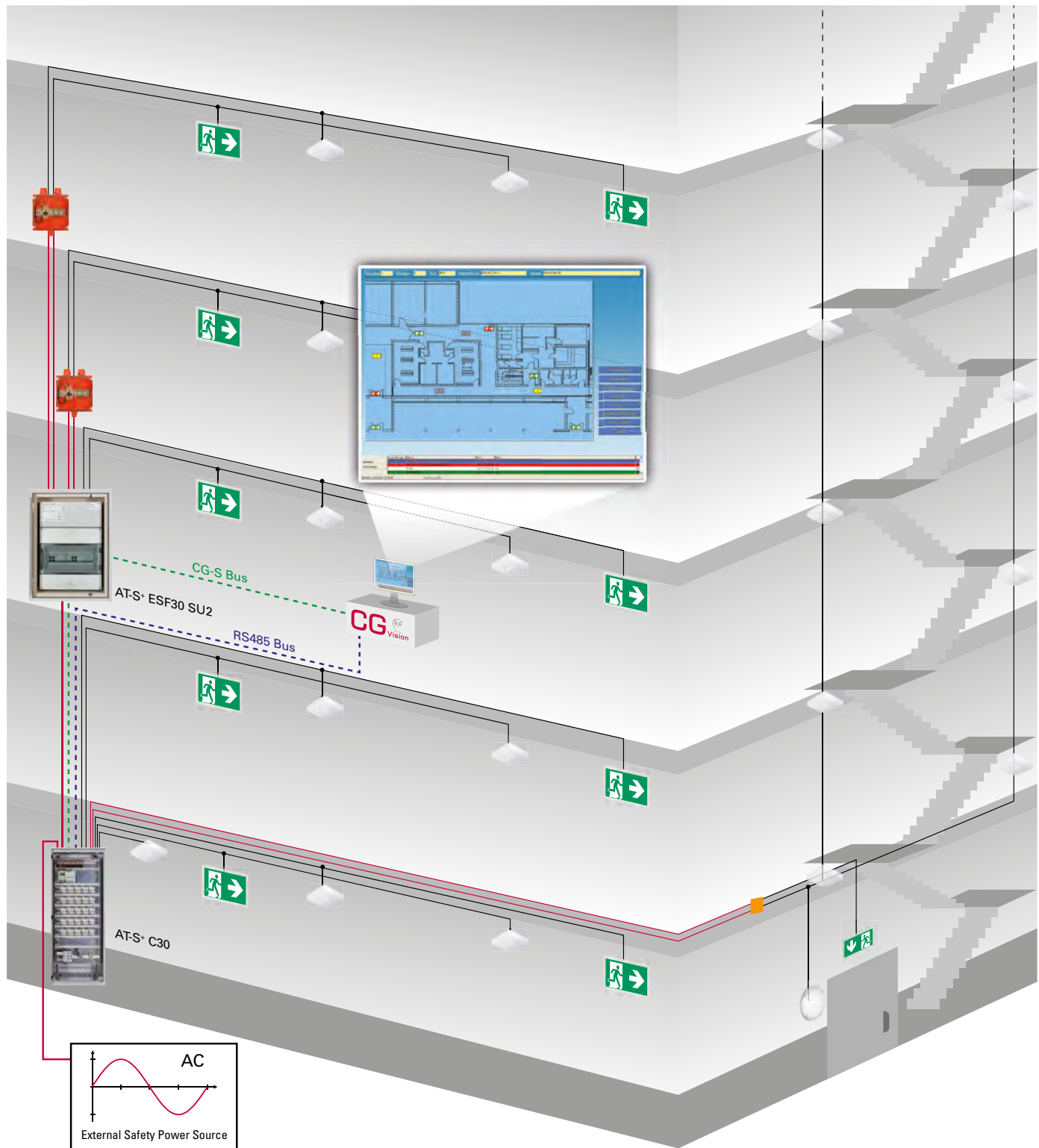

**AT-S+ ESF30 SU2**

Distribution box for across fire compartments-specific installation



### Controle module

A freely programmable control module with non-volatile program memory and graphic display monitors and controls the test system. All functions such as mains/emergency light switching of the devices and the emergency luminaires are tested automatically. Any faults that occur are signalled immediately. An interface enables a central monitoring facility to be connected.

In the event of a short circuit or open circuit in current loops, differential monitors immediately power on the system (maintained light) or put the system in readiness.

- Non-volatile memory
- Automatic luminaire search function
- Individual luminaire monitoring
- Automatic DLS/TLS search function
- Selective manual reset/circuit
- Selective emergency light/circuit
- Password function
- Final circuit fuse monitoring
- Control module with multi-master mode M<sup>3</sup>

### Sealed keypad with 2 keys for:

- Test (mains failure)
- Function test start / cancel (Key DT without function)



### 3 freely assignable function keys for:

- System disable/enable
- Manual reset
- Cancel function test
- Show fault list
- Maintained light off/on
- Power on complete safety lighting system (continuity lighting)
- Mains failure simulation UV-A (emergency operation)



### 7 control keys

for user-friendly navigation



### LED indicators for:

- Ready
- Electrical Source for Safety Services
- Failure

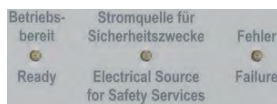

### Graphic display:

128 x 64 pixels, backlit, program adjustable contrast and brightness.

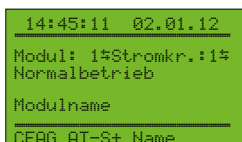

### Displays include:

- Date/Time
- Power source for safety services ready for operation
- Infeed of safety lighting from power source for safety services
- Power source for safety services faulty
- Manual reset
- Test mode
- Delay-time on mains return (remaining time in min.)
- Luminaire failure with location label
- UV-AV failure (location specification)
- Failure/programming information

### Connections

#### • Connection for disable switch:

24V control loops for blocking the installation during factory shutdowns with differential loop monitoring for short-circuit and open circuit detection. Differential monitoring: Short-circuit or open circuit result in readiness for operation of the system.

#### • Connection for phase monitor:

24V current loop for requesting emergency lighting using differential loop monitoring for the detection of short-circuit and open circuits. Differential monitoring: Short-circuit or open circuit result in immediate power on (maintained light) of the system.

#### • Connection for zero-potential signal contacts and buzzers:

Connection for zero-potential signal contacts, 24 V 0.5 A:  
3 relays with common potential, 1 x switching contact each,  
One or several from 11 different messages can be assigned to each zero-potential contact. Freely programmable, DIN VDE specification can be called up at any time as a pre-setting.

2 relays with common potential, 1 x open contact each with fixed assignment.

#### • Connection for analog inputs:

4 of freely assignable 24 V analog inputs, switch function can be programmed negated and non-negated, e.g. for start / cancel function test, disable / enable system, manual reset, maintained light on / off, power on safety lighting as continuity lighting.



# Central Battery Systems AC/AC

Automatic Test System AT-S+ with STAR+ Technology – Components and options



Display	128 x 64 pixel graphic display, program adjustable contrast
Illumination	backlighting, program adjustable brightness
Keypad	sealed, with 6 function and 7 control keys
Readout	Infeed of safety lighting from power source for safety services Power source for safety services ready for operation AC isolation fault External fan fault Luminaire failure with location label Manual reset Delay-time on mains return UV-AV failure (location specification) Test mode Date/Time Failure information Programming information
Status	– Ready – Electrical Source for Safety Services – Failure

## Potential-free signal contacts, buzzer

3 freely configurable relays with common potential, 1 x switching contact each, 2 relays with fixed assignment and common potential, 1 x open contact each, 24 V 0.5 A; buzzer. Freely programmable, DIN VDE specification can be called up at any time as a pre-setting.

### Default setting AT-S+

Designation	Relay 1 C0/14/12	Relay 2 C0/24/22	Relay 3 C0/34/32	Relay 4 C1/44	Relay 5 C1/54	Buzzer
Ready for operation		X				
Mains failure S3/S4	X				Permanently configured for control of a technical cabinet ventilation. Default setting >40°C ON < 35°C OFF.	
Mains failure DLS/3PH	X					
Ext. source error	X					
Circuit fault	X					
Luminaire fault	X					
Device fault	X					
Ext. source active			X			
ISO error	X					
Function test				X (permanently configured)		
Invert contact		X				

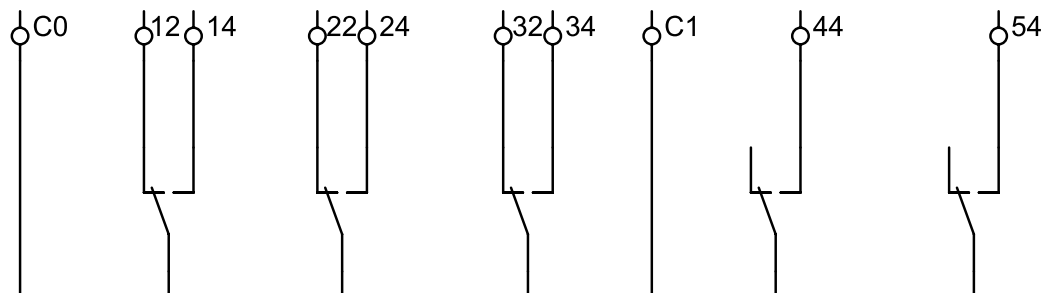

### Ordering details

Type	Model	Order No.
Control module CU-S+ with SD	Plug-in module	4 0071 360 371

SD card



SD card reader



### Secure-Digital-Card

Flexible data storage for system and log book configuration, e.g. of the mandatory archiving of log book information for a minimum of 4 years.

The system can also be programmed at any PC using optional SD-card reader and CEAG software. Texts can also be entered on the control module in the switch cabinet.

Storage of:

- 360,000 log book entries
- Location texts for the luminaires (20 characters per luminaire)
- Location texts of external modules such as phase monitor, DLS, TLS (20 characters per module)
- Circuit names (20 characters per circuit)
- System name (20 characters)

### Ordering details

Type	Model	Order No.
SD card	SD card formatted for AT-S+	40071347911
SD card reader	SD card reader for USB-Port	40064070561
Software	Software for external programming of the AT-S+ via PC	40071347152

10

### SD-Card (Secure-Digital-Card)

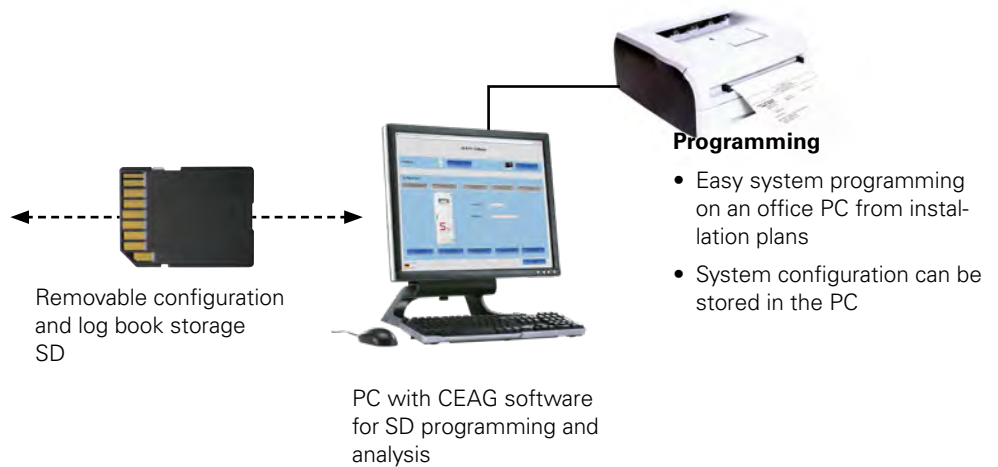
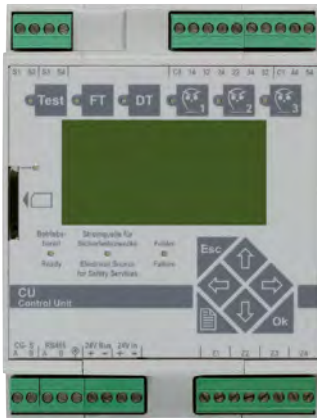

# Central Battery Systems AC/AC

Automatic Test System AT-S+ with STAR+ Technology – Components and options

DC Converter PSU.1E



## DC Converter PSU.1E

The DC/DC converter.2 converts the 220 V DC battery voltage to 24 V DC and 6 V DC to supply the modules and processor.

After more than 13 SKU CG-S 4 x 1.5 A or 26 SKU CG-S 2 x 3 A / 1 x 6 A a second DC/DC converter is needed. Please observe that all DC/DC converters are operated on the same module assembly frame next to each other:

- Supplies 26 SKUs CG-S 2 x 3 A/1 x 6 A or 12 SKUs 4 x 1.5 A
- Incoming supply can be run via AC/AC
- Gear tray mounting

24 V external	20 W continuous rating Outgoing circuit with front panel connector Isolated voltage
24 V internal	100 W continuous rating 140 W peak rating (20 ms)

### Ordering details

Type	Order No.
DC Converter PSU.1E	40071361981

AC module



## AC module

The AC supply in combination with the DC/DC converter.2 assumes supply of the internal system voltage.

### Ordering details

Type	Order No.
AC module	40071346311

Mains distribution board

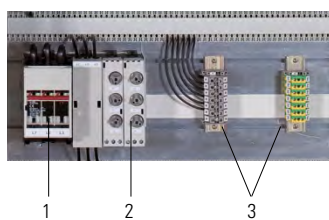

## Mains distribution board

The mains supply to a AT-S+ C30 or AT-S+ C16 system comes via a modular mains distribution board. This includes a size 00C load disconnecter (1) with a maximum conductor size of 50 mm<sup>2</sup> and allows the connection of up to 6 distribution terminals for slave stations to modular size D02-E18 outgoing mains circuits (2) with the necessary terminals for neutral and ground (3).

The same mains distribution boards must also be used three-phase for feeders to powerful slave-stations (accommodates up to 2 slave stations in this case). The components are simply plugged on from the front and securely contacted.

Mains distribution module D02-E18



Current rating	63 A
Rated operating voltage	400 V
Box terminal for circulator conductor	to 16 mm <sup>2</sup>
Material	Polyamide (PA 6.6), 30 % glass-fibre-reinforced
Scope of supply	incl. 3 pcs. screw caps E18 and 3 pcs. D02-fuse inserts 25 A

### Ordering details

Type	Scope of supply	Order No.
Mains distribution module for track mounting	incl. 3 pcs. screw caps E18 and 3 pcs. D02-fuse inserts 25 A	40071347160

SU S+ 2 x 6 A



### Switching unit SU S+ 2 x 6 A

- Up to 20 luminaires can be monitored individually
- Easy access to fuses
- LED indicates fault and Run/ON for each circuit
- Supplies ballast and LED luminaires
- Service-friendly modular units are wired up and ready to connect to 3-tier 4 mm<sup>2</sup> disconnect neutral terminals

Hybrid operation of maintained light, non-maintained light and switched maintained light per module can be programmed with no additional data cable.

Fusing	10 AT/250 V, 5 x 20
Continuous current rating	6 A per circuit
Max. inrush current	250 A/ms per circuit
Switching time	450 ms
Own consumption	10.5 W (max.)
Module width	6 subunits (H x W x D = 107 x 90 x 58 mm)

10

### Ordering details

Type	Scope of supply	Order No.
SU S+ 2 x 6 A	Switching unit SU S+ 2 x 6 A	40071360350
Spare part	Fuse 10 AT (5 x 20) 250 V (PU 10 pcs.)	40071360483

SOU S+ 2 x 4 A



### Switching over unit SOU S+ 2 x 4 A

- Up to 20 luminaires can be monitored individually
- Separate AV-feed for rental current
- Easy access to fuses
- LED indicates fault and Run/ON for each circuit
- Supplies ballast and LED luminaires
- Service-friendly modular units are wired up and ready to connect to 3-tier 4 mm<sup>2</sup> disconnect neutral terminals inside the distribution box

Hybrid operation of maintained light, non-maintained light and switched maintained light in a single circuit can be programmed with no additional data cable.

Fusing	8 AT/250 V, 6.3 x 32
Continuous current rating	4 A per circuit
Max. inrush current	250 A/ms per circuit
Switching time	450 ms
Own consumption	9 W (max.)
Module width	10 subunits (H x W x D = 178 x 108 x 60 mm)

### Ordering details

Type	Scope of supply	Order No.
SOU S+ 2 x 4 A	Switching over unit SOU S+ 2 x 4 A	40071360461
Spare part	Fuse 8 AT (6.3 x 32) 250 V (PU 10 pcs.)	40071360484

# Central Battery Systems AC/AC

Automatic Test System AT-S+ with STAR+ Technology – Components and options

F3 remote indication



## F3 remote indication

The F3 remote indication ensures display of the most important installation functions. Blocking of emergency lighting operation is possible via a key switch during idle operation times.

Differential loop monitoring leads to operational readiness of the system with short circuits or wire-break detection.

LED displays: system readiness, source for safety services, failure. As such the F3 remote indication fulfills the requirement that remote switching is only permissible when operation by unauthorized persons is not possible.

Connection terminals wall surface-mounting 2.5 mm<sup>2</sup> rigid and flexible

Dimensions mm (H x W x D) 160 x 80 x 55

Connection terminals for flush-mounting 1.5 mm<sup>2</sup> rigid or 1 mm<sup>2</sup> flexible

Dimensions mm (H x W x D) 80 x 80 x 55

Colour enclosure sim. RAL 7035 Light grey

F3 remote indication for flush-mounting



## Ordering details

Type	Scope of supply	Order No.
F3 remote indication	Module surface-mounting	40071338497
F3 remote indication recessed	Performance for installation in the flush-mounted switch or empty space box acc. to DIN VDE 0606	40071347490

## Remote switch

Control loop for blocking the installation during factory shutdowns with differential loop monitoring for short-circuit and open circuit detection.

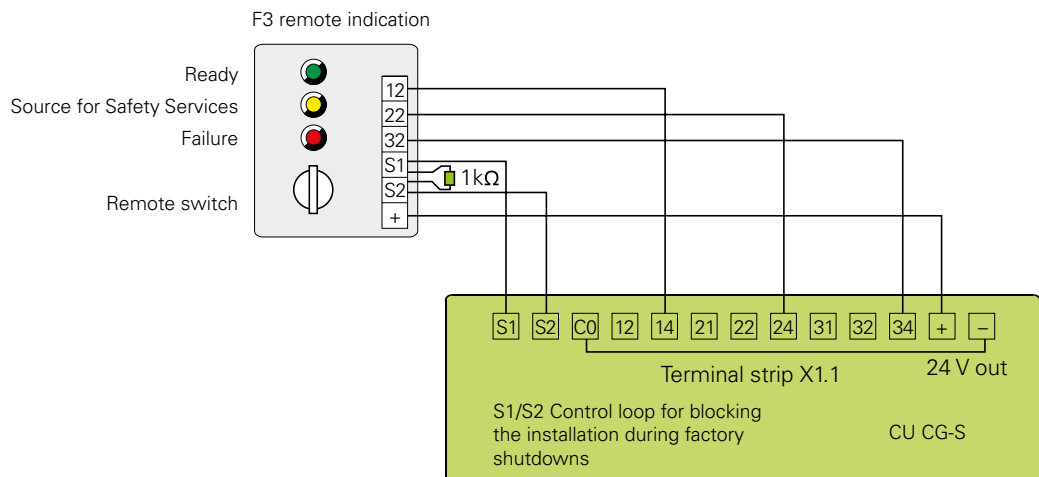

Differential monitoring:

A short-circuit or open circuit causes the system to be enabled.

F3 switch closed:

System ready

F3 switch open (1 kΩ):

System blocked

CEAG 3-PM-IO Modul



CEAG 3-PM-IO-INV Modul

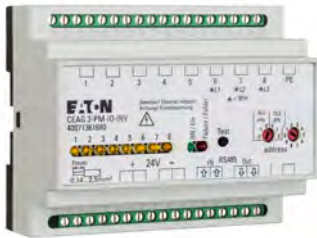

### External CEAG 3-PM-IO and CEAG 3-PM-IO-INV module

To avoid risks from mains failures, it is necessary to permanently monitor the function of the general lighting light distributors in order to switch on the safety lighting in the event of a fault. Thus, the CEAG 3-PM-IO and CEAG 3-PM-IO-INV modules are an important part of the safety system.

- Permanent function monitoring of the entire system by bus technology
- Automatic logging of all test results in the test log book
- Test button for mains / emergency light failure thus no interruption of the mains voltage necessary and thus no malfunctions of the operational processes
- 3-PM-IO Modul: Eight measurement inputs for monitoring up to three phases and up to five\* light switches
- 3-PM-IO-INV Modul: Eight inverted measurement inputs for monitoring up to three phases and up to five\* light switches
- Freely configurable assignment of the measuring inputs to the emergency lighting
- No E30 wiring of bus illumination due to Fail Save Bus technology

\* If the phase monitor function is not required, all eight measurement inputs can be used for light switch enquiry.

10

	CEAG 3-PM-IO	CEAG 3-PM-IO-INV
Rated voltage	24 V DC (min. 19 V, max. 30 V)	
Current consumption (all 8 channel connected)	20 mA ± 5 mA	
Degree of protection	IP20	
Insulation class	I	
Ambient temperature	- 10 ° to + 40 °C	
Input channels 8	8 (potential free $U_N = 230 V$ )	8 (potential free $U_N = 230 V$ )
3-PM (channel 1-8)	3-PM (Chan. 1-8) > 195 V-> ON	3-PM (Chan. 1-8) < 195 V-> OFF
3-PH (channel 1-5)	< 138 V-> OFF	> 138 V-> ON
Data bus / Address range	RS 485 / 1-25	
Weight	0.2 kg	
Dimensions (L x W x H) mm	105 x 85 x 60	
Mounting	DIN-rail	
Connection terminals	2.5 mm <sup>2</sup> rigid and flexible	

### Ordering details

Type	Scope of supply	Order No.
CEAG 3-PM-IO-Modul with Test-Taster	Module for DIN rail mounting	40071361670
CEAG 3-PM-IO-INV-Modul with Test-Taster	Module for DIN rail mounting with inverse switching logic	40071361680
DIN mounting rail	4 pcs. DIN-rails for mounting external modules in the cabinet incl. mounting accessories	40071347125

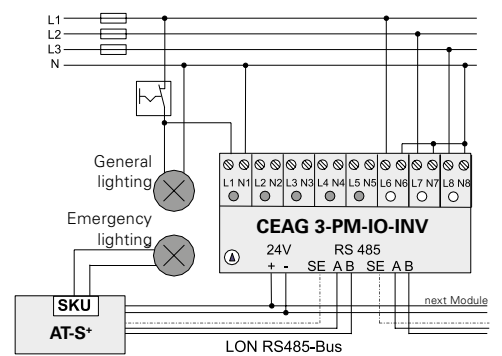
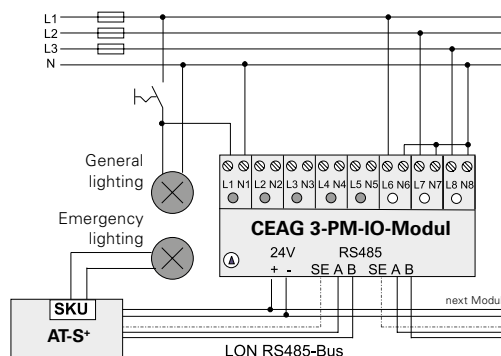

# Central Battery Systems AC/AC

Automatic Test System AT-S+ with STAR+ Technology – Components and options

## Bus technology according to RS 485

An RS 485 bus is used for data communication with external bus modules (DLS/3PH). A connection to a central building services management system (BMS) can be made with the CG-S bus. An isolated 24V/0.5 A power supply (SELV) is available for the external modules. The maximum line length depends on the required power and the conductor size.

10

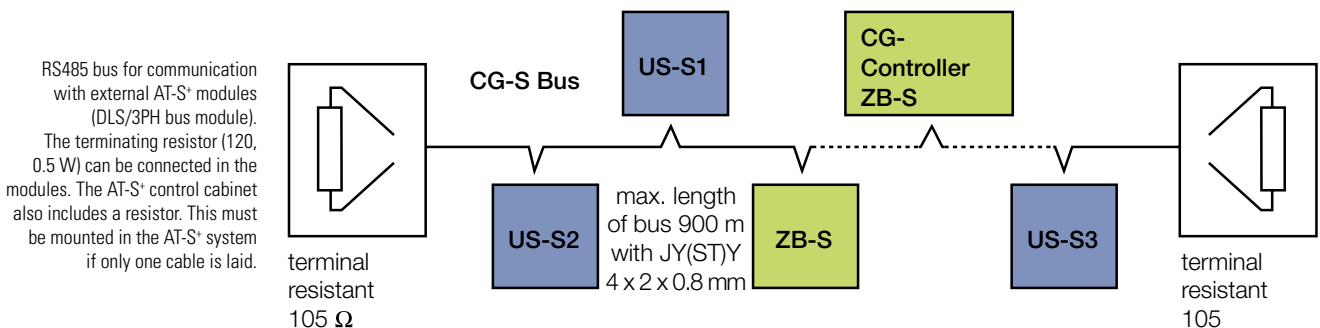
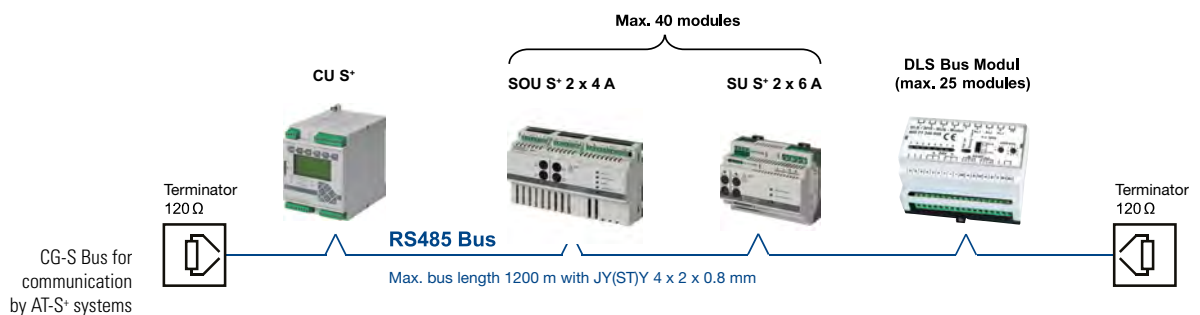
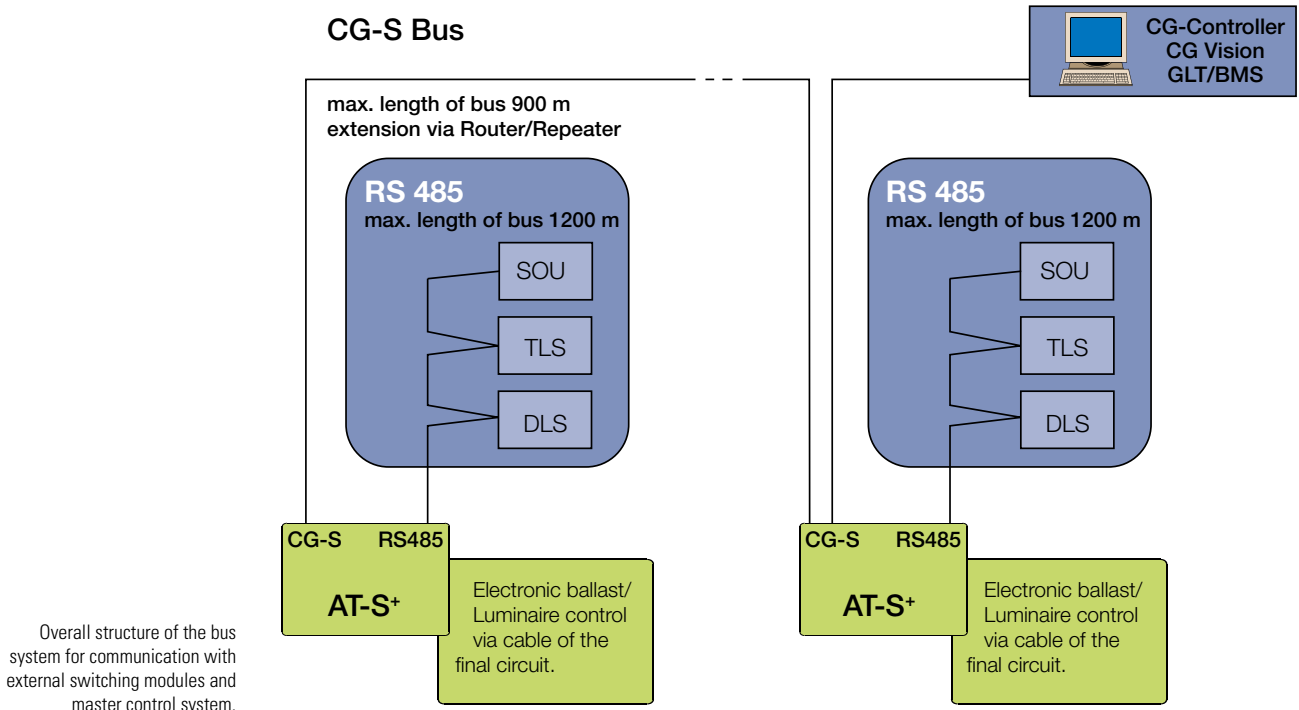

### Notes:

- Bus topology: linear, double terminated (no spur lines allowed)
- The absolutely essential terminating resistors are supplied in a plastic pack in the control cabinet. Cable type (minimum requirement): JY(ST)Y 4 x 2 x 0.8 mm (twisted pair, screened). The conductor size required for the 24 V bus voltage will depend on the line length and the number of bus modules ( $U_{min} = 19\text{ V DC}$ ).
- DLS = external maintained light switching module (DLS/3PH bus module)
- SOU S+ = switching over unit
- SU S+ = switching over unit
- CGVision = visualisation software





### PC programming software AT-S+

Programming software for preset memory cards of the AT-S+ for the quick pre-programming via PC and simple reading and editing of the logbook. For documentation all files are saveable on memory card and hard disk.

Prints for documentation: Detailed prints of the programmed system configuration with the following details:

- individual name of the device
- the date and time of automatic function tests, incl. distance
- manual reset: yes/no
- delay on mains return: 0-15 min
- selective emergency light: yes/no
- Lon switch: yes/no
- assignments of the 5 relays
- assignments of the 3 function keys
- assignments of the 4 option inputs
- number, type and individual name of the bus modules



Detailed print of the programmed electrical circuits (line diagram) with the following details per electrical circuit:

- electrical circuit / module number and type
- individual electrical circuit name
- type of monitoring
- switching mode of the electrical circuit
- number of luminaires
- address and individual name per luminaire
- switching mode of each luminaire

Logbook prints with the following options:

- fault event (35 different fault events, separate or completely generic)
- time period of the logbook (date and time)
- individual comment per print
- luminaire failure: Detail of the individual luminaire and electrical circuit names

### Ordering details

Type	Scope of supply	Order No.
Software	PC-Software for AT-S+, for alternative programming of the system configuration on PC	40071610233

# Central Battery Systems AC/AC

Automatic Test System AT-S+ with STAR+ Technology – Components and options

Webmodule CG-S



## Webmodule CG-S (ZB-S/AT-S+)

Webmodule ZB-S/AT-S+ for visualisation and monitoring of a central battery system, type ZB-S/AT-S+ via a local ethernet (LAN) or internet (WWW) with a conventional WEB browser. Access to the web-module via internet (WWW) must be administrated from an IT department on-site. Integrated mail-client for comfortable, event orientated failure information, for up to 5 E-mail recipients. Access via administrator account or guest account, with password protection.

- Easy menu structure
- Any type of display devices can be used with a WEB browser, for example notebook, tablet PC, iPad or smartphone
- Full visualisation and monitoring of a AT-S+ (automatic test system) via ethernet (LAN) with conventional WEB browser (e.g. Internet Explorer, Firefox etc.)
- Display of all actual operation modes
- Local failure information of each emergency circuit and luminaires with destination information in plain text
- Permanent actual information of the charging unit and battery
- Parallel access to the web module from different workstations possible (max. 8)
- Integrated mail client for comfortable failure notification via encrypted mail
- Type of different failures for the mail transmission is selectable
- Up to 5 mail recipients programmable
- Actualisation cycle of the web browser via the web module is adjustable
- Authenticated access via administrator account with password protection
- Encrypted transmission
- Adjustable guest accounts with restricted access with password protection
- Static or dynamic (DHCP) IP-addressing possible
- Supports IPv4/IPv6 (Internet Protocol version 4/version 6)
- Any number of modules can be operated in parallel
- Overview display of all active web modules in local ethernet with status display and hyperlink function
- Includes 2 modbus sockets as standard

Example: AT-S+ Device status



Example: SKU-Status

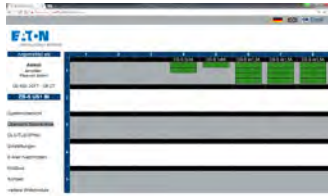

### Cyber Security

See White paper WP152002EN  
"Cybersecurity considerations for  
electrical distribution systems"

www.eaton.com

Supply voltage device	24 V DC
Rated power	< 1.1 W
Connection	RJ45
Degree of protection	IP20
Weight	0.05 kg
Dimensions	90 x 35 x 31
Enclosure	Polycarbonate

### Ordering details

Type	Scope of supply	Order No.
Webmodule CG-S (ZB-S/AT-S+)	Module for DIN-rail mounting, incl. connection without patch line RJ45	40071361383

### Notes:

If a webmodule integrated in the AT-S+ is supplied by the DC/DC.2 converter (external 24 V), a maximum of 20 DLS/3-phase modules or TLS bus modules can be connected.

### Connection example:

Directer access via IP-address,  
e.g.: 192.168.100.5

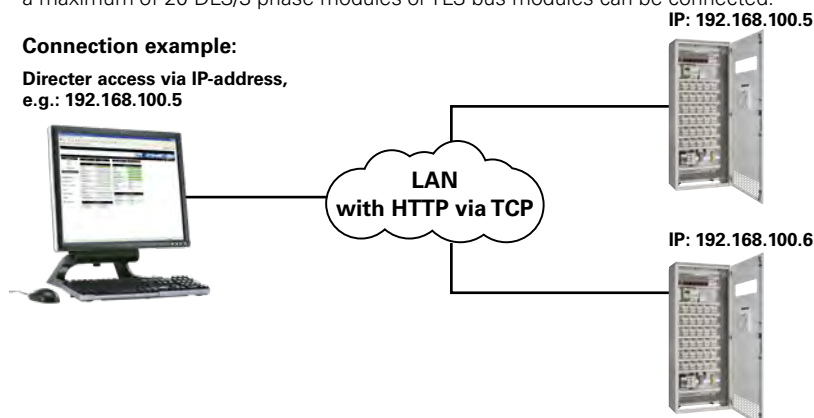

AT-S+ C30



### Ordering details

Type	Scope of supply	Order No.
Automatic Test System AT-S+ C30	Automatic Test System type AT-S+ C30 incl. CU-S+, DC/DC.2 and AC module 30 free module slots	40071360500
Automatic Test System AT-S+ C16	Automatic Test System type AT-S+ C16 incl. CU-S+, DC/DC.2 and AC module 16 free module slots	40071360501
Automatic Test System AT-S+ C4	Automatic Test System type AT-S+ C4 incl. CU-S+, DC/DC.2 and AC module 4 free module slots	40071360502
Automatic Test System AT-S+ C0	Automatic Test System type AT-S+ C0 incl. CU-S+, DC/DC.2 und AC module no free module slot	40071360503
Distribution box AT-S+ SU4	Distribution box type AT-S+ SU4 incl. 4 switching units SU S+ 2 x 6 A	40071360504
Distribution box AT-S+ SU2	Distribution box type AT-S+ SU2 incl. 2 switching units SU S+ 2 x 6 A	40071360505
Distribution box AT-S+ SU1	Distribution box type AT-S+ SU1 incl. 1 switching unit SU S+ 2 x 6 A	40071360506
Distribution box AT-S+ SOU2	Distribution box type AT-S+ SOU2 incl. 2 switching over units SOU S+ 2 x 4 A	40071360508
Distribution box AT-S+ SOU1	Distribution box type AT-S+ SOU1 incl. 1 switching over unit SOU S+ 2 x 4 A	40071360509

10

AT-S+ ESF30 C10-P



### Ordering details

Type	Scope of supply	Order No.
Automatic Test System AT-S+ ESF30 C30-P	Cabinet for automatic test system with 30 minutes functionality, incl. CU S+ control unit, DC/DC.2 converter, AC supply with space reserve for expansion to max. 60 end circuits, but maximum of 30 SU-S+ 2 x 6 A circuit assemblies	40071360723
Automatic Test System AT-S+ ESF30 C10-P	Cabinet for automatic test system with 30 minutes functionality, incl. CU S+ control unit, DC/DC.2 converter, AC supply with space reserve for expansion to max. 20 end circuits, but maximum of 10 SU-S+ 2 x 6 A circuit assemblies	40071360722
Automatic Test System AT-S+ ESF30 SU5	Distribution box for automatic test system with 30 minutes functionality, incl. 5 SU-S+ 2 x 6 A circuit assemblies	40071360730
Automatic Test System AT-S+ ESF30 SU4	Distribution box for automatic test system with 30 minutes functionality, incl. 4 SU-S+ 2 x 6 A circuit assemblies	40071360727
Automatic Test System AT-S+ ESF30 SU2	Distribution box for automatic test system with 30 minutes functionality, incl. 2 SU-S+ 2 x 6 A circuit assemblies	40071360724
Automatic Test System AT-S+ ESF30 SOU5	Distribution box for automatic test system with 30 minutes functionality, incl. 5 SOU-S+ 2 x 4 A circuit assemblies	40071360733
Automatic Test System AT-S+ ESF30 SOU3	Distribution box for automatic test system with 30 minutes functionality, incl. 3 SOU-S+ 2 x 4 A circuit assemblies	40071360731
Automatic Test System AT-S+ ESF30 SOU2	Distribution box for automatic test system with 30 minutes functionality, incl. 2 SOU-S+ 2 x 4 A circuit assemblies	40071360728
Automatic Test System AT-S+ ESF30 SOU1	Distribution box for automatic test system with 30 minutes functionality, incl. 1 SOU-S+ 2 x 4 A circuit assemblies	40071360725
AT-S+ RV30-1	E30 junction box AT-S+RV30-1 for small cabinets type AT-S+/SU with 1 Neozed fuse inside	40036071031
Reduction	Reduction M32 to M20 cable glands for E30 junction boxes incl. M20 cable gland	40071071033

AT-S+ RV30-1



# Central Battery Systems AC/AC

Automatic Test System AT-S+ with STAR+ Technology – Technical data

Type	AT-S+ C30	AT-S+ C16	AT-S+ C4	AT-S+ C0
Modules:				
Control module: CU-S+	1	1	1	1
DC/DC.2-converter	1	1	1	1
AC module	1	1	1	1
Switching unit SU S+ 2 x 6 A	0-30	0-16	0-4	–
Switching over unit SOU S+ 2 x 4 A	–	–	–	–
Safety load disconnecter mains feed	yes	yes	yes	–
Load disconnecter mains feed	–	–	–	yes
No. of branching distributors	6	6	4	–
Electrical cabinet construction:				
Rated voltage	400/230 V	400/230 V	400/230 V	230 V
Rated frequency	50 or 60 Hz	50 or 60 Hz	50 or 60 Hz	50 or 60 Hz
AC network	TN-C-S	TN-C-S	TN-C-S	TN-C-S
Insulation class	1	1	1	1
Degree of protection	IP20	IP20	IP54	IP54
Max. current rating mains [ $\Sigma$ L1, L2, L3] [A]	90	74	48	–
Max. rated power mains [KVA]	20.7	17	11	–
Three-phase distribution	yes	yes	yes	no
Connection cross-section for mains supply	50 mm <sup>2</sup>	50 mm <sup>2</sup>	50 mm <sup>2</sup>	4 mm <sup>2</sup>
Connection cross-section for branching distributors	16 mm <sup>2</sup>	16 mm <sup>2</sup>	16 mm <sup>2</sup>	–
Max. conductor size final circuits	4 mm <sup>2</sup>	4 mm <sup>2</sup>	4 mm <sup>2</sup>	4 mm <sup>2</sup>
Max. number of final circuit terminals	60	32	8	–
Mechanical cabinet construction:				
Cabinet height (max.)	2050	1800	800	600
Cabinet width (max.)	800	600	600	400
Cabinet depth (max.)	400	400	250	250
Material	Sheet steel	Sheet steel	Sheet steel	Sheet steel
Design	Cabinet	Cabinet	Wall cabinet / surface mounted	Wall cabinet / surface mounted
Door stop	right	right	right	right
Outer coating	Textured powder paint	Textured powder paint	Textured powder paint	Textured powder paint
Colour	RAL 7035	RAL 7035	RAL 7035	RAL 7035
Partial viewing door	yes	yes	yes	yes
Lock	3 mm two-way	3 mm two-way	3 mm two-way	3 mm two-way
Cable entry from above	yes	yes	yes	yes
Cable entry from below	yes	yes	no	no
Base (optional)	100/200	100/200	–	–

\*1 housing has insulation class II. The earth conductor must however be routed in the housing.

# Central Battery Systems AC/AC

Automatic Test System AT-S+ with STAR+ Technology – Technical data

AT-S+ SU4	AT-S+ SU2	AT-S+ SU1	AT-S+ SOU2	AT-S+ SOU1
–	–	–	–	–
–	–	–	–	–
–	–	–	–	–
4	2	1	–	–
–	–	–	2	1
–	–	–	–	–
yes	yes	yes	yes	yes
–	–	–	–	–
230 V	230 V	230 V	230 V	230 V
50 or 60 Hz	50 or 60 Hz	50 or 60 Hz	50 or 60 Hz	50 or 60 Hz
TN-C-S	TN-C-S	TN-C-S	TN-C-S	TN-C-S
2*1	2*1	2*1	2*1	2*1
IP65	IP65	IP65	IP65	IP65
25	16	10	25	10
5,7	3,7	2,3	5,7	2,3
no	no	no	no	no
10 mm <sup>2</sup>	10 mm <sup>2</sup>	10 mm <sup>2</sup>	10 mm <sup>2</sup>	10 mm <sup>2</sup>
–	–	–	–	–
4 mm <sup>2</sup>	4 mm <sup>2</sup>	4 mm <sup>2</sup>	4 mm <sup>2</sup>	4 mm <sup>2</sup>
8	4	2	4	2
583	458	458	583	458
295	295	295	295	295
129	129	129	129	129
Plastic	Plastic	Plastic	Plastic	Plastic
Wall cabinet / surface mounted	Wall cabinet / surface mounted	Wall cabinet / surface mounted	Wall cabinet / surface mounted	Wall cabinet / surface mounted
right	right	right	right	right
–	–	–	–	–
RAL 7035	RAL 7035	RAL 7035	RAL 7035	RAL 7035
yes	yes	yes	yes	yes
on request	on request	on request	on request	on request
yes	yes	yes	yes	yes
yes	yes	yes	yes	yes
–	–	–	–	–

10

# Central Battery Systems AC/AC

Automatic Test System AT-S+ with STAR+ Technology – Technical data

Type	AT-S+ ESF30 C30-P	AT-S+ ESF30 C10-P	AT-S+ ESF30 SU5
Modules:			
Control module: CU-S+	1	1	-
DC/DC.2-converter	1	1	-
AC module	1	1	-
Switching unit SU S+ 2 x 6 A	30	10	5
Switching over unit SOU S+ 2 x 4 A	-	-	-
No. of branching distributors	0	0	0
Electrical cabinet construction:			
Rated voltage	400/230 V	230 V	230 V
Rated frequency	50 or 60 Hz	50 or 60 Hz	50 or 60 Hz
AC network	TN-C-S*1	TN-C-S*1	TN-C-S*1
Insulation class	I*2	I*2	I*2
Degree of protection	IP42	IP42	IP65
Max. total rated current [A] depends on ambient temperature at 230 V, 50 or 60 Hz:			
+25 °C	50	35	26
+30 °C	50	27	20
+35 °C	40	20	14
Max. rated power mains [KVA] depends on ambient temperature at 230 V, 50 or 60 Hz:			
+25 °C	11.50	8.05	5.98
+30 °C	11.50	6.20	4.60
+35 °C	9.20	4.60	3.22
Three-phase distribution	Yes	Yes	No
Max. connection cross-section for mains supply [qmm]	35	35	10
Max. conductor size final circuits [qmm]	4	4	4
Max. number of final circuit terminals	60	20	10
Mechanical cabinet construction:			
Dimensions [mm]:			
height (max.),	2253 (incl. fan)	1253 (incl. fan)	835
width (max.),	918	918	396
depth (max.)	596	496	230
Weight [kg] approx.	330	169	61
Material / version:	Coated gypsum fibre-board / floor-standing cabinet	Coated gypsum fibre-board / floor-standing cabinet	Coated gypsum fibre-board / wall cabinet
Type of mounting	Wall mounting*3	Wall mounting*3	Wall mounting*3
Door stop	Right	Right	Left
Colour RAL	7035	7035	7035
Cable entry	From above*4	From above*4	From above
Base (optional)	Yes	-	-
Approvals / Verifications			
ABZ housing incl. components Z-86.2 ...	Applied for	Applied for	Applied for
ABZ empty housing Z-86.1 ...	Yes	Yes	Applied for
Fire test for functional integrity, short report MPA NRW	Yes	Yes	Yes
VDE certificate	-	-	Yes
Specialised company declaration	Yes	Yes	Yes

\*1: Further networks on request

\*2: Protective insulation acc. to VDE 0106

\*3: Housings must be adapted to the masonry so that the housing is horizontal.  
The masonry must be designed for functional integrity of at least 30 minutes.  
The functional integrity of the masonry must not be impaired by the installation.

\*4: Cable infeed from below on request

# Central Battery Systems AC/AC

Automatic Test System AT-S+ with STAR+ Technology – Technical data

AT-S+ ESF30 SU4	AT-S+ ESF30 SU2	AT-S+ ESF30 SOU5	AT-S+ ESF30 SOU3	AT-S+ ESF30 SOU2	AT-S+ ESF30 SOU1
-	-	-	-	-	-
-	-	-	-	-	-
-	-	-	-	-	-
4	2	-	-	-	-
-	-	5	3	2	1
0	0	0	0	0	0
230 V	230 V	230 V	230 V	230 V	230 V
50 or 60 Hz	50 or 60 Hz	50 or 60 Hz	50 or 60 Hz	50 or 60 Hz	50 or 60 Hz
TN-C-S <sup>*1</sup>	TN-C-S <sup>*1</sup>	TN-C-S <sup>*1</sup>	TN-C-S <sup>*1</sup>	TN-C-S <sup>*1</sup>	TN-C-S <sup>*1</sup>
I <sup>*2</sup>	I <sup>*2</sup>	I <sup>*2</sup>	I <sup>*2</sup>	I <sup>*2</sup>	I <sup>*2</sup>
IP65	IP65	IP65	IP65	IP65	IP65
21	18	33	20	15	8
16	14	28	17	12	6
11	11	16	10	9	5
4.83	4.14	7.59	4.60	3.45	1.725
3.68	3.22	6.44	3.91	2.76	1.380
2.53	2.53	3.68	2.30	1.53	1.150
No	No	No	No	No	No
10	10	10	10	10	10
4	4	4	4	4	4
8	4	10	6	4	4
685	535	1135	835	685	535
396	396	396	396	396	396
230	230	230	230	230	230
51	32.7	81	61	51	34
Coated gypsum fi- bre-board / wall cabinet	Coated gypsum fi- bre-board / wall cabinet	Coated gypsum fi- bre-board / wall cabinet	Coated gypsum fi- bre-board / wall cabinet	Coated gypsum fi- bre-board / wall cabinet	Coated gypsum fi- bre-board / wall cabinet
Wall mounting <sup>*3</sup>	Wall mounting <sup>*3</sup>	Wall mounting <sup>*3</sup>	Wall mounting <sup>*3</sup>	Wall mounting <sup>*3</sup>	Wall mounting <sup>*3</sup>
Left	Left	Left	Left	Left	Left
7035	7035	7035	7035	7035	7035
From above	From above	From above	From above	From above	From above
-	-	-	-	-	-
Applied for	Applied for	Applied for	Applied for	Applied for	Applied for
Applied for	Applied for	Applied for	Applied for	Applied for	Applied for
Yes	Yes	Yes	Yes	Yes	Yes
Yes	Yes	Yes	Yes	Yes	Yes
Yes	Yes	Yes	Yes	Yes	Yes

10



# Central Battery Systems AC/AC

Automatic Test System AT-S+ with STAR+ Technology – Installation example

Main distributor general lighting

10

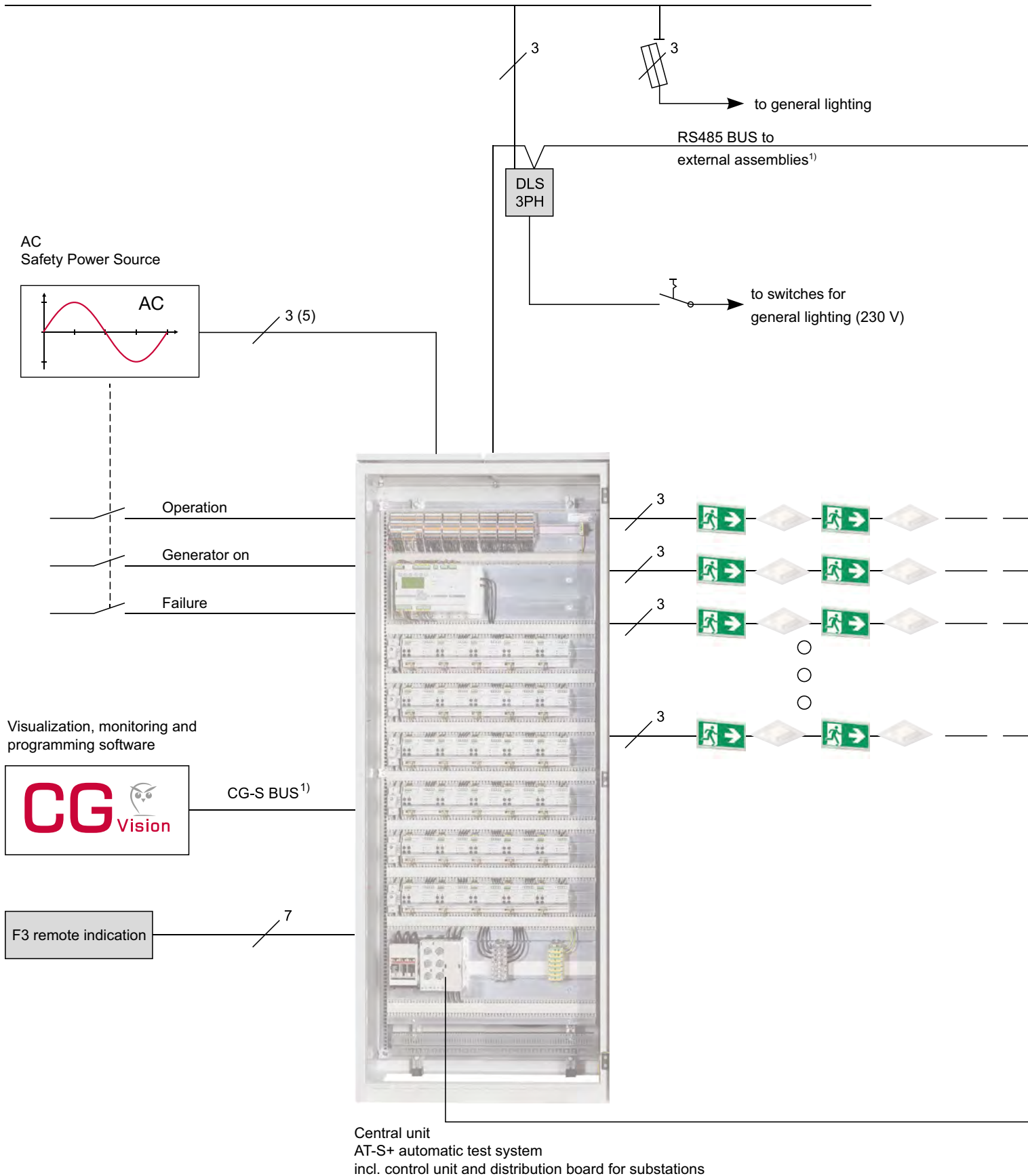

Sub-distributor for general lighting

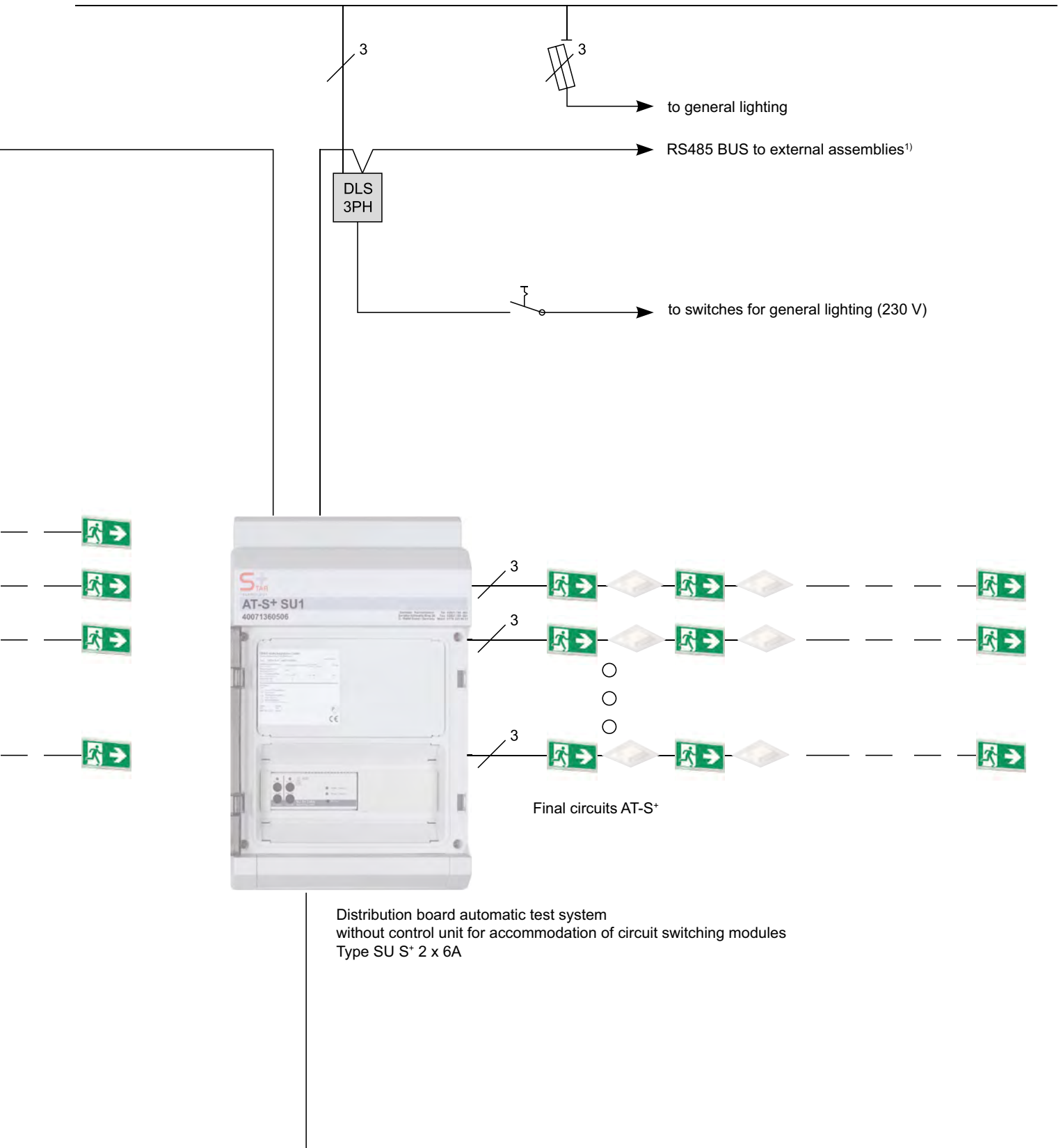

<sup>1)</sup> bus specifications see page AT-S+ bus technology

# Central Battery Systems AC/AC

## Automatic Test System AT-S+ with STAR+ Technology – Specifications

Automatic Test System AT-S+



### Automatic Test System AT-S+

AT-S+ automatic test system for 230V / AC safety and escape sign luminaires.

Suitable for safety lighting systems with an AC power source for safety purposes according to DIN VDE 0100-718, DIN VDE 0100-560, DIN EN 50172 and V DIN V VDE 0108. With automatic testing device and single luminaire monitoring with individual display of state and name per luminaire in connection with system-connected ECG including monitoring module without supplementary data line.

Developed, manufactured and tested according to ISO 9001.

The switching mode of each safety and escape sign luminaire with system-connected ECG or monitoring module is freely programmed in the control unit of the test system without a supplementary control line.

The CEAG STAR+ technology enables the number of end circuits to be strongly reduced as the mixed operation of maintained light, switched maintained light and non-maintained light is implemented in a common circuit.

Assignment of all operating modes is via the control unit without encroaching in the luminaire installation. Selection of the non-maintained light or maintained light operating modes via possibly slide switch, coding switch or jumpers on the monitoring module or ECG is not permitted. Surplus costs to installation lines caused by use of devices from other manufacturers or additional components cannot be made valid.

Electronic assemblies in service-compatible module design wired ready for connection to triple deck installation terminals with N isolating terminal and PE connection.

Connection compartments from above or below on touch-protected connection terminals. With optionally installed mains distribution box for mains cable feed to the substations including fusing. Design with modular plug technology.

### Bus technologies

CG-S bus technology based on LONWorks® technology.

For data communication of the test system with the connected substations or monitoring facilities such as CGVision (visualisation software), the 2-pole bidirectional CG-S data bus is used, integrated as standard in the AT-S+ control unit.

Via an optionally available interface box, all types of building management technology based on LONWorks® can communicate with the systems via the CG-S bus.

Alternatively, all OPC-compatible building management technologies can be connected via the CG-S bus with an optionally available OPC server and the interface box.

As such the CG-S bus enables direct calling up of extensive status messages and control commands without supplementary modules.

16 virtual switching inputs via external LON sensors enable circuits or even single luminaires to be independently switched directly.

Networking of all AT-S+ distributors control unit also possible via differing media such as optical waveguide, ethernet and LAN via optionally available components.

Status and error messages can be called up per single luminaire.

External assemblies such DLS/3PH bus module, DLS/3PH inverted bus module and TLS bus module are connected via the RS485 bus.

Communication with the system-connected luminaires is exclusively via the connected energy line.

The central system automatically detects the assemblies addressed during installation and the system-connected luminaires via a search function.

### Control unit

A freely programmable control unit with non-volatile program memory and graphic display monitors and controls the test system. All functions such as mains/emergency switching

of the devices and connected emergency luminaires are tested automatically. Errors occurring are reported immediately.

An interface enables connection of a central monitoring facility.

Differential monitoring with short circuiting or interruption of control current loops leads to immediate switching on (maintained light) of the system or operational readiness of the system.

Display:

128 x 64 pixel, backlit, contrast and brightness settable via program

Displays:

Power source for safety purposes ready for operation, infeed of safety lighting from power source for safety purposes, power source for safety purposes faulty, manual resetting, follow-on emergency light (residual time in mins.), test operation, date / time, uV-AV failure with location specification in plain text, error information, programming information, inspection book.

LED displays: Ready for operation, power source feed for safety purposes, error

Foil keyboard:

- separate keys for system test, function test.
- 3 freely programmable function buttons for e.g.: Block/release system, manual resetting, switch on / off maintained light, display fault list, switch on / off corridor lighting, mains failure UV simulation
- 7 control buttons for user-friendly navigation in querying and programming mode.

Furthermore, each assembly has a separate service button for directly showing the current assembly status in the display (immediate analysis).

Programming options:

Single luminaire monitoring, individual name (20 characters) per device, circuit, luminaire and bus module, device address, selective manual resetting, follow-on emergency light (1-60 mins.) selective emergency light, LON switch, timer

function, automatic function test, menu language selection

Connection for blocking switch: Control loop for blocking system during idle operating times with differential loop monitoring for short circuit and wirebreak detection.

Differential monitoring: Short circuit or interruption lead to operational readiness of the system.

Connection for phase monitor: 24V current loop for emergency light request with differential loop monitoring for short circuit and wirebreak detection.

Differential monitoring: Short circuit or interruption lead to immediate switching on (maintained light) of the system.

Connection for zero-potential signal contacts, buzzers:

5 potentialfree relays contacts, each 3 x changeover contact, 2 x normally open contact. 30V DC/AC, 0,5A, buzzer

One or several from 11 different messages can be assigned to each contact. Freely programmable, DIN VDE specification as presetting can be called up at any time.

Connection for 24 inputs: 4 freely assignable 24V inputs, can be programmed either inverted or non-inverted for e.g.: Power source for safety purposes ready for operation, infeed of safety lighting from power source for safety purposes, power source for safety purposes faulty, start/abort function test, block/release system, manual resetting, switch on/off maintained light, switch on safety lighting as corridor lighting, external AC isolation fault, external fan fault.

Memory card: Memory card for archiving of device configuration and specified inspection book information over at least 4 years.

Saving of:

- 300,000 inspection book entries
- Target location texts of luminaires (20 characters per luminaire)

- Target location texts of external modules such as phase monitors, DLS, TLS (20 characters per module)
- Circuit names (20 characters per luminaire)
- System name (20 characters)

With optional CEAG software, programming is possible offline via PC.

### Circuit modules

The circuit modules monitored emergency luminaires with electronic ballasts for AC operation. The STAR+ monitoring tests functionality of the connected luminaires.

- Monitoring of up to 20 luminaires per circuit with individual status display via the control unit
- Mixed operation within one circuit for maintained light, switched maintained light and non-maintained light (A supplementary data line to the luminaires is not required).
- Typical switching over time mains/safety source: 450ms
- Free programming for maintained light, switched maintained light or non-maintained operation
- Fuses on the front of the assembly are easily accessible
- Permanent monitoring of fuses
- LED displays for fault and operation/ON per circuit
- Service button for configuration
- Housing for DIN rail mounting
- Automatic luminaire search function

### External DLS/3PH bus module

The external DLS/3PH bus module for installation into the sub-distribution of the general lighting can be used as phase monitor and light switch query (DLS) for the general switching of safety and general lighting.

8 DLS inputs (2.5 sq.mm) with LED display or 5 DLS inputs in combination with 3 phase monitor inputs can be activated via selector switch.

Monitoring thresholds acc. to DIN EN 60598-2-22: 60-85%  $U_{NOM}$

Connection of RS485 bus and 24V module supply.

Addressable via coding switch, LED displays for fault, switching state on, operation.

Housing for DIN rail mounting

Freely programmable assignment of independent DLS inputs per emergency light circuit or luminaire and individual name per bus module in control unit.

With use a 3-phase monitor, detailed phase failure display with location of failed sub-distribution for general lighting via clear text display in control unit.

### External DLS/3PH bus module inverted

The external DLS/3PH bus module inverted for installation into the sub-distribution of the general lighting can be used as phase monitor and light switch query (DLS) with inverted switching logic for the common switching of safety and general lighting or for monitoring of automatic cutouts.

8 inverted DLS inputs (2.5 sq.mm) with LED display or 5 inverted DLS inputs in combination with 3 phase monitor inputs can be activated via selector switch.

Monitoring thresholds acc. to DIN EN 60598-2-22: 60-85%  $U_{NOM}$

Connection of RS485 bus and 24V module supply.

Addressable via coding switch, LED displays for fault, switching state on, operation.

Housing for DIN rail mounting.

Freely programmable assignment of independent inverted DLS inputs per emergency light circuit or luminaire and individual name per bus module in control unit.

With use a 3-phase monitor, detailed phase failure display with location of failed sub-distribution for general lighting via clear text display in control unit.

### Supplier information:

CEAG Notlichtsysteme GmbH  
Senator-Schwartz-Ring 26  
D-59494 Soest/Germany  
Telefon +49 (0) 2921/69-870  
Telefax +49 (0) 2921/69-617  
Internet www.ceag.de  
e-mail info-n@ceag.de

ISO 9001:4500 certification must also be verified.

Manufacturers without ISO 9001:4500 certification are not permitted.

LONWorks®: registered trademark of Echelon Corporation

# Central Battery Systems AC/AC

Automatic Test System AT-S+ with STAR+ Technology – Technical drawings

10

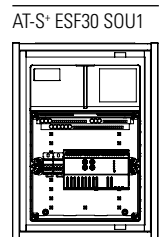
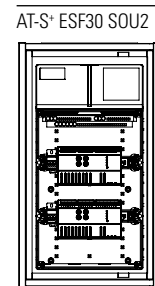
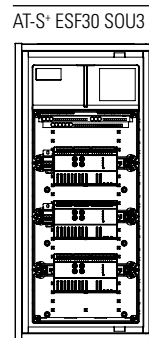
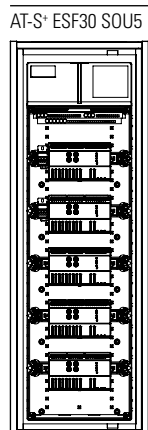
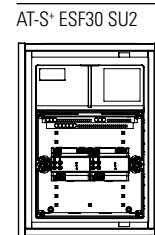
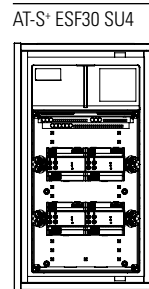
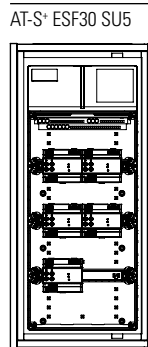
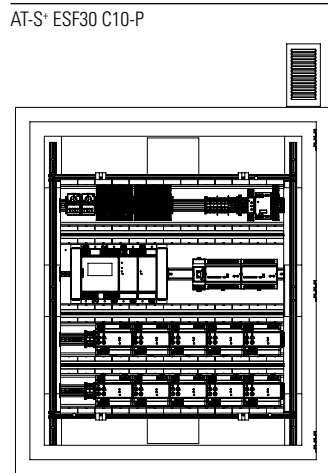
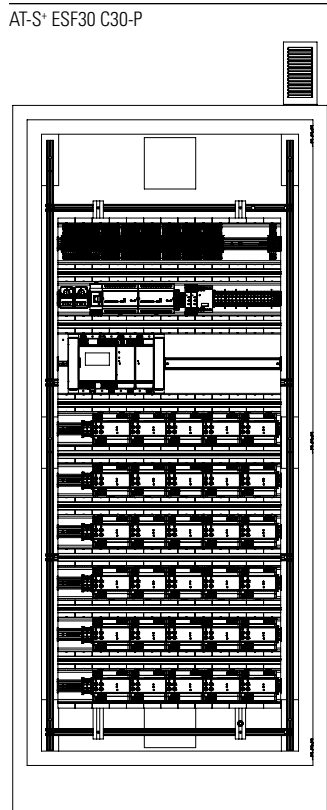
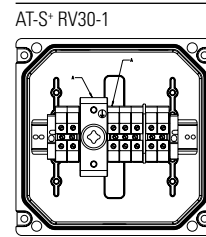
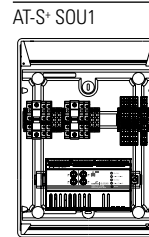
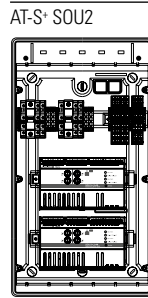
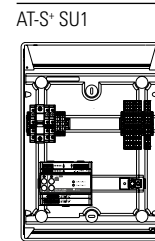
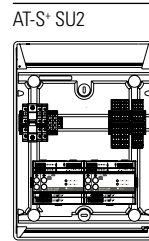
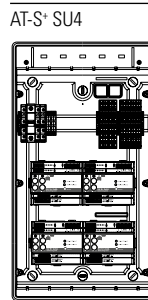
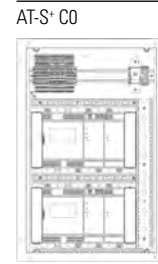
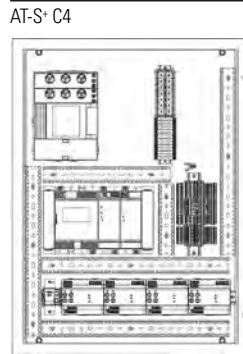
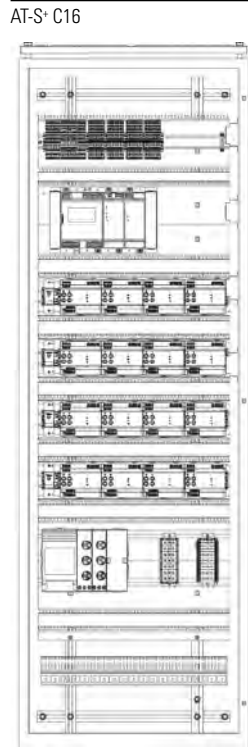
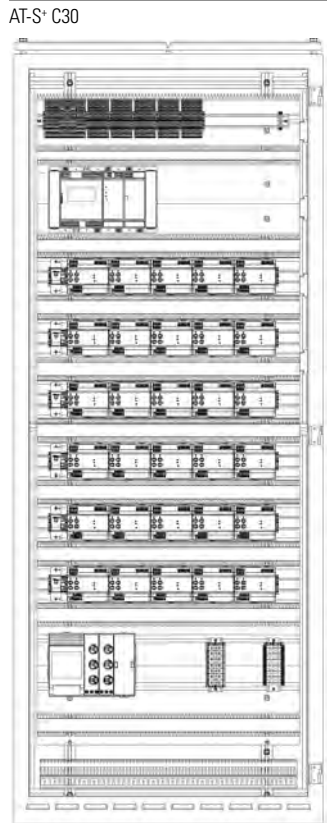











### Central Battery Systems DC/DC

- Overview ..... 476
- Features and benefits ..... 478
- Application example..... 480
- Technical data ..... 482
- Tender text..... 485

# Central Battery Systems DC/DC

## Overview

	Central Power System	Low Power System	AC/AC power source	AC/DC power source	DC/DC power source
<b>11.1</b> SelvGuard 	●	●			●

Circuit Monitoring	CEWA GUARD Technology (CG)	STAR Technology (S)	STAR+ Technology (S+)	EasiCheack (EC) Technology	AE-CU Technology
●					

Single luminaire  
monitoring in battery  
operation (DC)

Freely programmable  
switching mode in one  
and the same circuit

STAR technology and  
single luminaire  
monitoring in AC  
operation

## Features and benefits of SelvGuard



11

- Increased safety for installers, end-users and fire fighters with SELV end circuits. No risk of dangerous electrical shock on the end circuits side.
- Increased project flexibility with 8 end circuits per LPS
- Reduced number of stock keeping units for distributors with freely programmable switched maintained operation mode. No additional emergency lighting distribution board required.
- Easy access and navigation due to a graphical LCD and navigation joystick
- Increased safety of the system and accuracy of reporting by 2 embedded secure inputs. Avoid loss of function due to interrupted circuit. No need to use expensive fire resistant cables.
- Increased functionality and flexibility with use of 3 freely programmable voltage inputs for: switch on/off one or the other end circuit groups, start/cancel function test or duration test, external ventilation monitoring, etc.
- Increased reporting and monitoring with use of 3 freely programmable changeover output contacts for: mains/emergency operation, charger failure, circuit fault, deep discharge protection reached, function/duration test results, etc.
- Reduced operation and maintenance cost with timely reporting of battery state with individual battery voltage monitoring
- Additional safety and security with easy remote reporting by optional remote display with integrated buzzer (e.g. to use at reception desk).

## SelvGuard – Safety Extra Low Voltage



900 - 1200 W



300 - 600 W

### SelvGuard

Eaton SelvGuard is a Low Power System (LPS), providing 48V DC supply to the emergency lighting luminaires. The system is suitable for small and medium emergency lighting applications like: small-medium retail stores, health care, education, leisure and hospitality, etc.

Eaton SelvGuard was designed in accordance with EN 50171, it is a protection Class I system and has eight SELV (Safe Extra Low Voltage) end circuits.

SelvGuard comes in two different sizes to accommodate up to 600 W luminaire load in 600x600x250mm and 900-1200W luminaire load in 700x600x400 mm (H x W x D).

The LPS consists of a power supply unit which provides power for the end circuits and charging the batteries, a measure and control unit, a battery compartment separated from the electronic components, two poles circuit breakers for each end circuit and a graphical LCD for enhanced visualization.

The system works perfectly with our 48V DC emergency lighting luminaires like CrystalWay, Planete 400 Disc, Planete 45, Planete 400, BXP, Planete Tube 45, NexiTech 1000, etc.

# Central Battery Systems DC/DC

Application example



## CrystalWay

High aesthetic exit sign luminaire



## NexiTech 1000lm

High flux LED safety luminaire used to illuminate large or high ceiling areas



## Planète Tube 45

Aesthetic tubular exit sign and safety luminaire

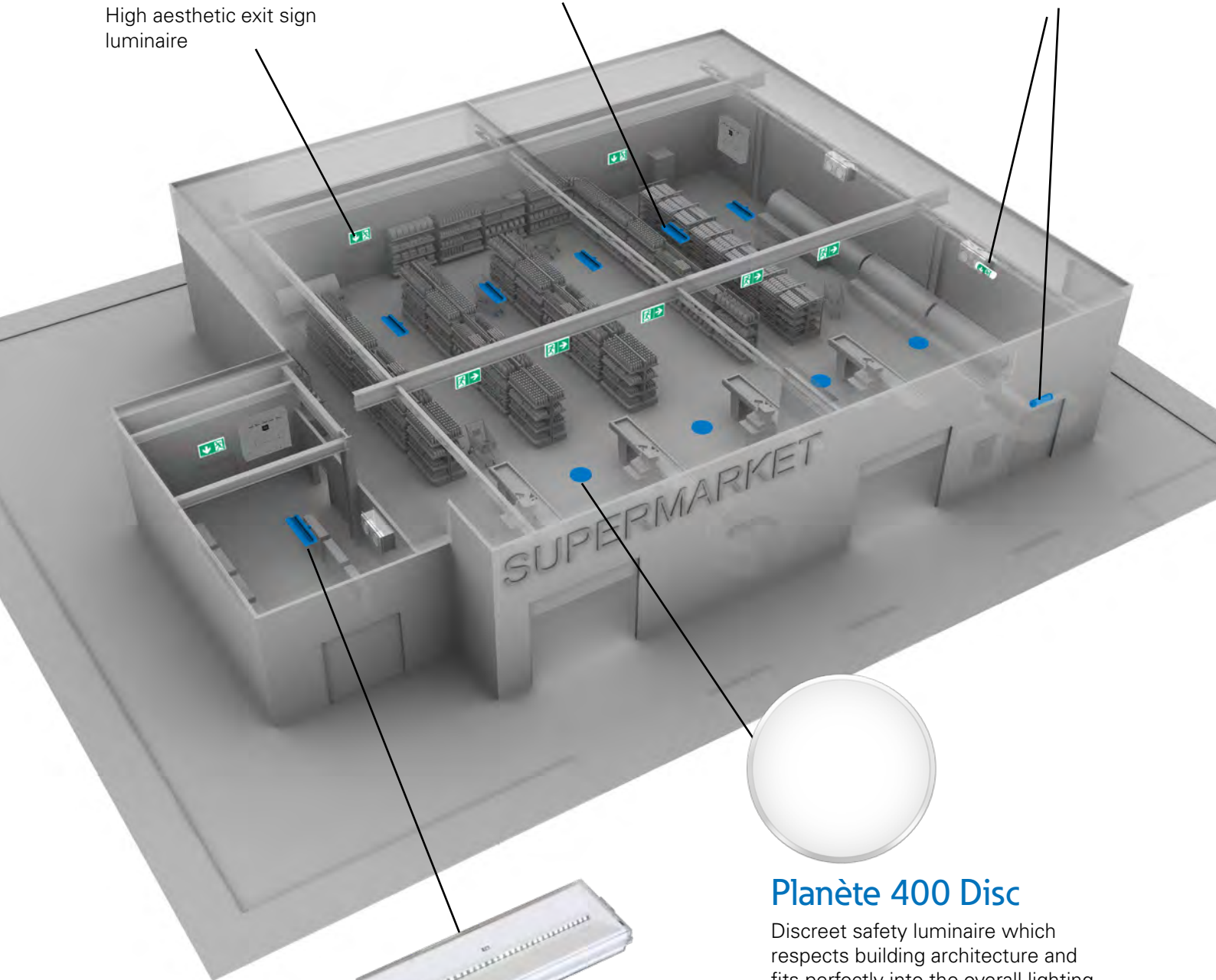

## Planète 400 Disc

Discreet safety luminaire which respects building architecture and fits perfectly into the overall lighting concept

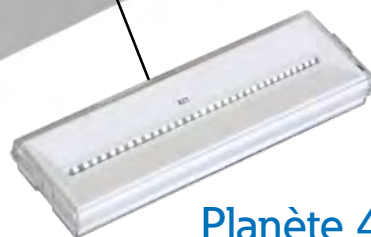

## Planète 400

High energy efficiency safety luminaire which allows to minimize the consumption and to considerably reduce the capacity of the battery of the central power supply.



# Installation example



11

Normal mode

Emergency mode

**Non-maintained:**

Operation mode in which the emergency luminaires are switched on only when the supply to the general lighting fails.



**Maintained:**

Operation mode in which the emergency luminaires are switched on all the times, regardless of the general lighting status.





# Central Battery Systems DC/DC

## Technical data

SelvGuard 300 and 600



SelvGuard 600



### SelvGuard

Low Power System with 48V DC supply to the emergency lighting luminaires.

- Increased safety of the installer, end-user and fire fighting brigade due to no risk of dangerous electrical shock.
- 8 SELV end circuits – the end circuits are split in two end circuit groups of 6 and 2 end circuits respectively as default; groups can be also wired differently e.g. 4 and 4 circuits; either group can be programmed as maintained or non-maintained
- 2 secure inputs to integrate a 3 phase monitor and to activate rest or inhibit mode (e.g. via a key switch, DLS or TLS)
- 3 freely programmable voltage inputs to switch one or the other end circuit groups Output 1/Output 2, start function (FT) or duration test (DT), cancel DT/FT, manual reset, deep discharge receipt and ventilation monitoring
- 3 freely programmable switchover output contacts for mains operation, mains failure, charger fault, circuit fault, common system fault, deep discharge protection, function test (FT) and battery duration test (DT)
- Individual battery voltage monitoring
- Optional remote display with 3xLEDs, a 5 way joystick and buzzer for remote alarms and notifications

#### SelvGuard 300 SelvGuard 600 SelvGuard 900 SelvGuard 1200

Input voltage	230V AC (198-253 V AC), 50 Hz (47- 63 Hz)			
Recommended upstream protection	10 A type C	13 A type C	25 A type C	32 A type C
Nominal output voltage	48 V DC			
Total maximum output power (Output 1+2), 1h discharge time	283 W*	600 W*	900 W	1200 W
Max power Output 1 (standard configuration- circuit 1 to 6)	283 W	600 W	900 W	1200 W
Max power Output 2 (standard configuration- circuit 7 and 8)	200 W	200 W	200 W	200 W
Nominal output current (total)	5.9 A	12.5 A	18.75 A	25 A
End circuits	8 (SELV Protected)			
End circuit groups (Output 1 / Output 2)	two end circuit groups**: Output1 (6 circuits); Output2 (2 circuits)			
Circuit breaker rating (Output1/Output2)	4 A / 4 A	4 A / 4 A	6 A / 4 A	6 A / 4 A
Battery	4 x 12 V / 11.2Ah	4 x 12 V / 26 Ah	4 x 12 V / 37.5 Ah	4 x 12 V / 50 Ah
Dimensions (H x W x D)	600 x 600 x 250 mm		700 x 600 x 400 mm	
Max. ambient temperature	For storage:-20 °C to + 40 °C, For operation:-5 °C to + 35 °C			
Humidity	5 % - 90 % RH			
Altitude	< 1000 m			
Noise level	50 dB			
Housing color	RAL 7035			
Degree of protection / insulation class	IP20 / Class I			
Weight (approx.) without battery	30 kg		50 kg	
Weight (approx.) with batteries	45 kg	66 kg	98 kg	120 kg

\*Based on the rated 5 year life time required by EN50171 for LPS systems

\*\*Different setup can be arranged on site, taking into consideration total power, and power for Output 2 (e.g. 4+4)

NOTE: According to most battery manufacturers, for maximum battery service life, battery should operate at 20°C

SelvGuard 900 and 1200



SelvGuard 1200



## Ordering details

Type	Scope of supply	Order No.
SelvGuard 300	SelvGuard 283 W, 8 end circuits, 1 hour	SG48-300-8C1H
SelvGuard 600	SelvGuard 600 W, 8 end circuits, 1 hour	SG48-600-8C1H
SelvGuard 900	SelvGuard 900 W, 8 end circuits, 1 hour	SG48-900-8C1H
SelvGuard 1200	SelvGuard 1200 W, 8 end circuits, 1 hour	SG48-1200-8C1H

SelvGuard 300 and 600 – Dimensions in mm

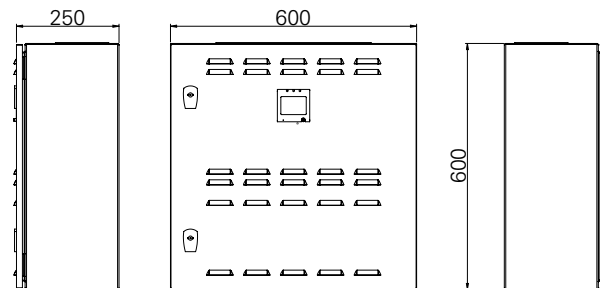

SelvGuard 900 and 1200 – Dimensions in mm

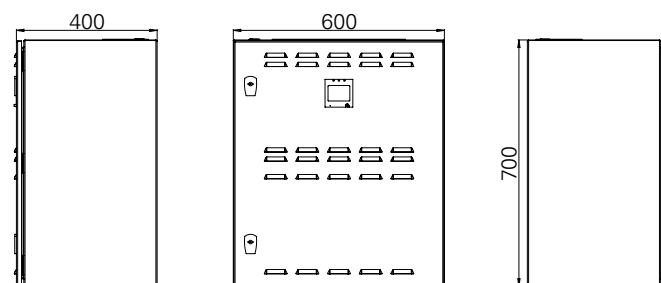

## Calculation example

Connect the following luminaires to SelvGuard- SG48-300-8C1H:

- 30 CrystalWay luminaires (LUM22211) – 1.9W / luminaire
- 20 Planete 400 luminaires (LUM22130) – 6W / luminaire
- 4 RC 18W luminaires (LUM21047) – 26W / luminaire

### On Output 1 end circuits with non-maintained functionality:

Planete400	= 20 x 6 W	120 W	
RC18	= 4 x 26 W	104 W	
<b>Total</b>		= 224 W	<b>&lt; 283 W --&gt; OK</b>

### On Output 2 end circuits with maintained functionality:

CrystalWay	= 30 x 1.9 W	57 W	
<b>Total</b>		= 57 W	<b>&lt; 200 W --&gt; OK</b>
<b>Total:</b>	224 W + 57 W = <b>281 W</b>		<b>&lt; 283 W --&gt; OK</b>

# Central Battery Systems DC/DC

## Technical data

Remote Display



### Remote Display

Graphical back-lit LCD with 128x64 pixels resolution. It has the ability to send information remotely (e.g. Reception desk); provides enhanced security and reporting of EL events to ease evacuation; reduces the time to check system status and alarm; compatible with any SelvGuard LPS

- IP 20
- 500m max distance
- Power 6W, J-Y(ST)Y or CAT5 (or better) cable
- 8 line with 20 characters each for better visualization
- 3 status LEDs
- 5 way joystick for easy navigation
- buzzer for acoustic alarms and notifications
- one remote display can be connected to one SelvGuard LPS

Remote Display 30°



### Ordering details

Type	Scope of supply	Order No.
Remote display 30°	Remote display for remote indication SG48, 30° mounting base	SG48-RC-LCD-30
Remote display 55°	Remote display for remote indication SG48, 55° mounting base	SG48-RC-LCD-55

Remote Display 55°



### Remote display 30°

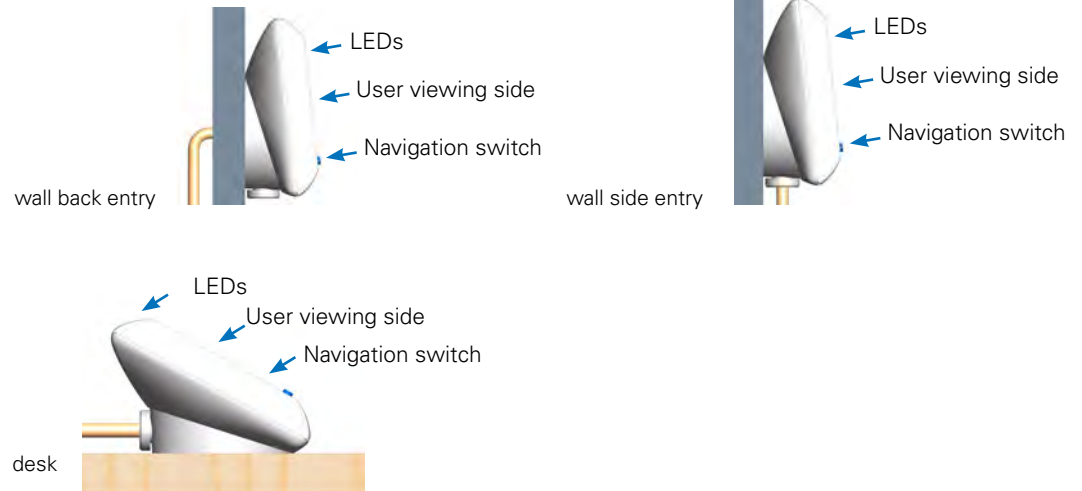

### Remote display 55°

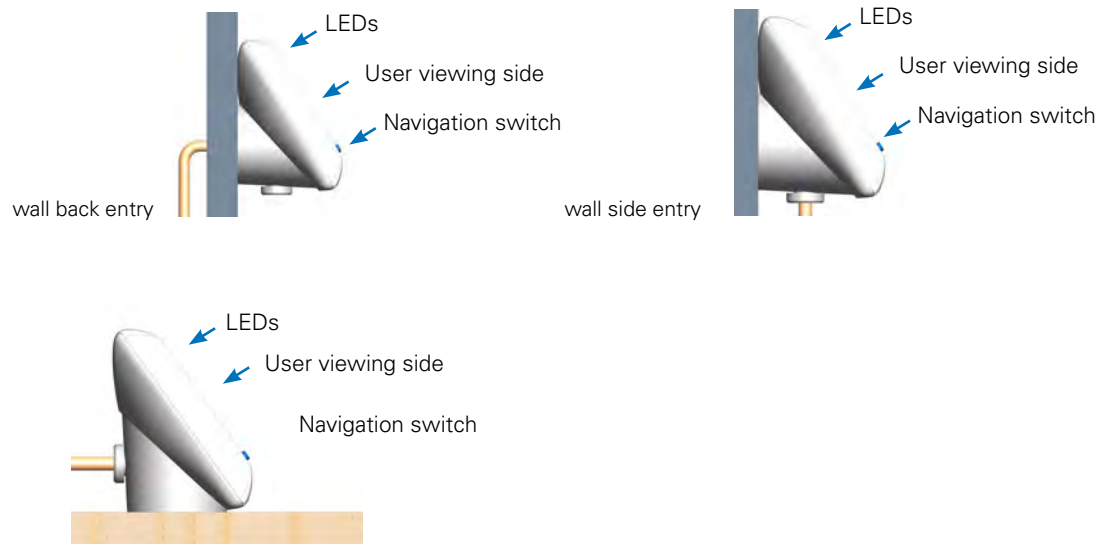

## SelvGuard emergency lighting power supply in a compact design

SELV (Safety Extra Low Voltage) Low Power System according to EN 50171 for the power supply of 48 V DC escape and exit sign luminaires. It is suitable for emergency lighting systems according to EN 50172, IEC 60364-5-56 (DIN VDE 0100-560), DIN V VDE V 0108-100, requirements of ERP decree December 11, 2009 and ERT decree February 26, 2003. It features a duration and function test capability as well as an individual battery voltage monitoring system. The LPS is equipped with a 128 x 64 pixels, back-lit graphical LCD to display the state and alarms, set parameters and control end circuit groups. The system is equipped with 8 SELV end circuits divided into two groups of 2 and 6 end circuits respectively, that can either be switched on/off via LCD functionality or an external input (e.g. a key switch), offering the possibility of maintained mode, switched maintained mode and non-maintained mode operation. In case of different output set up needed, the installer can change the busbar and connect for example: 4 by 4 outputs together to suit the installation need. The power per output group should not exceed the values stated in the data sheet of the product. With this function you don't need to use an additional distribution board that has this emergency lighting function. Inputs and outputs are made from the top side of the LPS through predefined holes designed with rubber protective tape, reducing thus the cost of metric cable glands.

### Battery Monitoring

The LPS has built in battery monitoring capabilities, monitoring thus battery string voltage and current, individual battery voltage and battery compartment temperature.

### Optional Remote Display

The LPS is able to send information remotely via an optional back-lit Graphical Display 128 x 64 pixels, with 3xLEDs, a 5 way joystick for reporting and visualization and a buzzer with snooze function for remote alarms and notifications (e.g. reception desk)

The remote display is connected to the LPS via a bus directly on the controller. In case of an interruption of physical connection, a fault message will be shown on the local display along with an alarm. A coin cell will help maintain RTC (Real Time Clock) during power-off conditions (e.g. after a deep discharge event).

Display values: output voltage and current, output active power, output voltage, output current, battery charge percentage, battery fault, duration time, faults and event log. It can display battery voltage, besides battery current and battery compartment temperature which is shown by.

LED displays: System readiness, battery operation, sum failure.

5 way joystick:

- Navigation through the menu (scroll, select, edit)
- Snooze function (buzzer)

### Connections and communication

2 secure inputs to integrate a 3 phase monitors or to activate rest or inhibit mode (e.g. via a key switch)

3 freely programmable voltage inputs to switch one of the output groups, start function (FT) or duration test (DT), cancel DT/FT, manual reset, deep discharge receipt and ventilation monitoring.

3 freely programmable change-over output contacts can be used to remotely signalize: for mains operation, mains failure, charger fault, circuit fault, com-

mon system fault, deep discharge protection, function test (FT) and battery duration test (DT)

### Circuit components

8 SELV end circuits which can be grouped into two groups that can be freely programmed to have different functions as always on (maintained) or off during normal supply (non-maintained). These functions can be selected via the LDC on front of the LPS.

- Two groups of 6 and 2 end circuits respectively
- Can be used as maintained or non-maintained

### Charging technology

The sealed maintenance-free lead batteries are charged gradually based on an microprocessor-controlled IU charging curve in function of temperature. Force charge is activated in function of the battery charge level to ensure that the batteries are charged without exceeding the gas development voltage. The charge monitoring procedure verifies the charging process continuously and it reports any faults immediately, including interruption of the battery circuit, faulty charging unit.

- 3 LEDs for status: System on mains, System on battery, Active fault
- Temperature sensor built into the battery compartment

### 48V VRLA block battery

Only closed and non-spillable VRLA batteries are used. Rated operating time 1, 1.5, 2, 3, 5, 6, 8 hours respectively

- extremely low gas emissions
- Period of use: 10 years (283W, 600W, 900W and 1200W) at 20°C
- low self-discharge
- Design according to IEC 60896-21/22:2004
- electrolyte and air oxygen sealed terminals

EATON is a member of the "Stiftung Gemeinsames Rücknahmesystem Batterien [joint battery recycling programme] (GRS)" in Germany.

In this manner batteries undergo a controlled and complete recycling cycle. This means that possible polluting materials are recovered and reused for new products.

Specifications have been quoted based on EATON products. Specifications can be compared based on this product. The tenderer can submit a tender based on a variant solution including an equivalent product (proof by the tenderer). Detailed product descriptions must be attached to the offer for the evaluation of equivalence:

References

Eaton  
CEAG Notlichtsysteme GmbH  
Senator-Schwartz-Ring 26  
D-59494 Soest/Germany

Telephone +49 (0) 2921/69-870

Fax +49 (0) 2921/69-617

Internet: [www.ceag.de](http://www.ceag.de)

Email: [info-n@ceag.de](mailto:info-n@ceag.de)

A ISO 9001:4500 certification must be further provided as proof.

Manufacturers without the ISO 9001:4500 certification are not permitted.

# Central Battery Systems DC/DC

Tender text

SelvGuard 300



## SelvGuard 300

SG48-300-8C1H

Compact emergency lighting supply unit acc. to EN 50171 for supply of 48V DC safety and exit sign luminaires. Suitable for safety lighting installations according to EN 50172, IEC 60364-5-56 (DIN VDE 0100-560) and DIN V VDE V 0108-100 and requirements of ERP decree December 11, 2009 and ERT decree February 26, 2003. With automatic function and yearly duration testing device.

The switching mode of the end circuit groups of 6 and 2 respectively can be freely set by LCD menu as maintained or non-maintained.

If different output grouping is needed, this can be done on site at the responsibility of the installer (e.g. 4 by 4 outputs)

Rated operating duration: 1, 1.5, 2, 3, 5, 8 hours according with the duration table.

Consisting of:

Graphical Display, with 3xLEDs, a 5 way joystick navigation and a buzzer with snooze function for alarms and notifications.

Charging facility with microprocessor-controlled, temperature-compensated charging

48V DC power supply unit to supply emergency light circuits in normal or emergency operation mode.

Sheet steel housing for wall mounting consisting of mounting unit with front door and integrated cable infeed and end circuits from the top. With freely accessible, password-protected operating panel.

Protection rating: IP 20

Dimensions (mm): 600 x 600 x 250 (H x W x D)

Color: RAL 7035

Equipped as standard with:

8 x SELV emergency lighting circuits. Maximum of 300 W per circuit (Output1) and maximum

of 200 W per circuit (Output2), but not more than 283W in total (Output 1+2).

2 x freely configurable, secure monitoring inputs (e.g. to connect 3 phase monitors, key switches, etc.).

3 x freely configurable, 12 volt contact inputs

4 x 12V / 11.2 Ah batteries

Accessories:

- Remote display, surface-mounted
- F3 remote display, surface-mounted
- F3 remote display, flush-mounted

Type: SG48-300-8C1H

Manufacturer: EATON

11

SelvGuard 600



## SelvGuard 600

SG48-600-8C1H

Compact emergency lighting supply unit acc. to EN 50171 for supply of 48V DC safety and exit sign luminaires. Suitable for safety lighting installations according to EN 50172, IEC 60364-5-56 (DIN VDE 0100-560) and DIN V VDE V 0108-100 and requirements of ERP decree December 11, 2009 and ERT decree February 26, 2003. . With automatic function and yearly duration testing device.

The switching mode of the end circuit groups of 6 and 2 respectively can be freely set by LCD menu as maintained or non-maintained.

If different output grouping is needed, this can be done on site at the responsibility of the installer (e.g. 4 by 4 outputs)

Rated operating duration: 1, 1.5, 2, 3, 5, 8 hours according with the duration table.

Consisting of:

Graphical Display, with 3xLEDs, a 5 way joystick for navigation and a buzzer with snooze function for alarms and notifications.

Charging facility with microprocessor-controlled, temperature-compensated charging

48V DC converter for supply of emergency light circuits in normal or emergency operation mode.

Sheet steel housing for wall mounting consisting of mounting unit with front door and integrated cable infeed and end circuits from the top. With freely accessible, password-protected operating panel.

Protection rating: IP 20

Dimensions (mm): 600 x 600 x 250 (H x W x D)

Color: RAL 7035

Equipped as standard with:

8 x SELV emergency lighting circuits. Maximum of 600 W per circuit (Output1) and maximum

of 200 W per circuit (Output2), but not more than 600W in total (Output 1+2).

2 x freely configurable, secure inputs (e.g. to connect 3 phase monitors, key switches, etc.).

3 x freely configurable, 12 volt contact inputs

4 x 12 V / 26 Ah batteries

Accessories:

- Remote display, surface-mounted
- F3 remote display, surface-mounted
- F3 remote display, flush-mounted

Type: SG48-600-8C1H

Manufacturer: EATON



SelvGuard 900



## SelvGuard 900

SG48-900-8C1H

Compact emergency lighting supply unit acc. to EN 50171 for supply of 48V DC safety and exit sign luminaires. Suitable for safety lighting installations according to EN 50172, IEC 60364-5-56 (DIN VDE 0100-560) and DIN V VDE V 0108-100 and requirements of ERP decree December 11, 2009 and ERT decree February 26, 2003. With automatic function and yearly duration testing device.

The switching mode of the end circuit groups of 6 and 2 respectively can be freely set by LCD menu as maintained or non-maintained.

If different output grouping is needed, this can be done on site at the responsibility of the installer (e.g. 4 by 4 outputs)

Rated operating duration: 1, 1.5, 2, 3, 5, 8 hours according with the duration table.

Consisting of:

Graphical Display, with 3xLEDs, a 5 way joystick for navigation and a buzzer with snooze function for alarms and notifications.

Charging facility with microprocessor-controlled, temperature-compensated charging

48V DC converter for supply of emergency light circuits in normal or emergency operation mode.

Sheet steel housing for wall mounting consisting of mounting unit with front door and integrated cable infeed and end circuits from the top. With freely accessible, password-protected operating panel.

Protection rating: IP 20

Dimensions (mm): 700 x 600 x 400 (H x W x D)

Color RAL 7035

Equipped as standard with:

8 x SELV emergency lighting circuits. Maximum of 900 W per circuit (Output1) and maximum

of 200 W per circuit (Output2), but not more than 900W in total (Output 1+2).

2 x freely configurable, secure inputs (e.g. to connect 3 phase monitors, key switches, etc.).

3 x freely configurable, 12 volt contact inputs

4 x 12 V / 37.5 Ah batteries

Accessories:

- Remote display, surface-mounted

- F3 remote display, surface-mounted

- F3 remote display, flush-mounted

Type: SG48-900-8C1H

Manufacturer: EATON

11

SelvGuard 1200



## SelvGuard 1200

SG48-1200-8C1H

Compact emergency lighting supply unit acc. to EN 50171 for supply of 48V DC safety and exit sign luminaires. Suitable for safety lighting installations according to EN 50172, IEC 60364-5-56 (DIN VDE 0100-560) and DIN V VDE V 0108-100 and requirements of ERP decree December 11, 2009 and ERT decree February 26, 2003. With automatic function and yearly duration testing device.

The switching mode of the end circuit groups of 6 and 2 respectively can be freely set by LCD menu as maintained or non-maintained.

If different output grouping is needed, this can be done on site at the responsibility of the installer (e.g. 4 by 4 outputs)

Rated operating duration: 1, 1.5, 2, 3, 5, 8 hours according with the duration table.

Consisting of:

Graphical Display, with 3xLEDs, a 5 way joystick for navigation and a buzzer with snooze function for alarms and notifications.

Charging facility with microprocessor-controlled, temperature-compensated charging

48V DC converter for supply of emergency light circuits in normal or emergency operation mode.

Sheet steel housing for wall mounting consisting of mounting unit with front door and integrated cable infeed and end circuits from the top. With freely accessible, password-protected operating panel.

Protection rating: IP 20

Dimensions (mm): 700 x 600 x 400 (H x W x D)

Color RAL 7035

Equipped as standard with:

8 x SELV emergency lighting circuits. Maximum of 1200 W per

circuit (Output1) and maximum of 200 W per circuit (Output2), but not more than 1200W in total (Output 1+2).

2 x freely configurable, secure inputs (e.g. to connect 3 phase monitors, key switches, etc.).

3 x freely configurable, 12 volt contact inputs

4 x 12 V / 50 Ah batteries

Accessories:

- Remote display, surface-mounted

- F3 remote display, surface-mounted

- F3 remote display, flush-mounted

Type: SG48-1200-8C1H

Manufacturer: EATON



# Central Battery Systems DC/DC

Tender text

LCD remote display



## LCD remote display

SG48-RC-LCD 30  
SG48-RC-LCD 55

Graphical Display, with 128x64 pixel resolution for better visualization of one SelvGuard. It is equipped with 3 status LEDs, a 5 way joystick for easy navigation through display menu and alarms. It also features a buzzer with snooze function for acoustic alarms and notifications. It comes in two mounting variants: with a 30 degrees or 55 degrees base. Each of the bases can be used for wall or desk mount (e.g. hotel reception desk).

The remote display is connected to the LPS via a bus directly on the measure and control unit. In case of an interruption of physical connection, the remote display will turn off and an alarm will show on the LPS LCD.

Display values: output voltage and current, output active power, output voltage, output current, battery charge percentage, battery fault, duration time, faults and event log. Optionally it can display battery voltage, besides battery current and battery compartment temperature which is shown by default, if the LPS is equipped with such functionality.

LED displays: System readiness, battery operation, sum failure.

The remote display is backed up by the LPS where configuration parameters are also stored.

5 way joystick:

- Navigation through the menu (scroll, select, edit)
- Snooze function (buzzer)

Type:

SG48-RC-LCD 30  
SG48-RC-LCD 55

Manufacturer: EATON



An aerial, high-angle photograph of a modern public space, likely a transit hub or a large office lobby. The floor is made of large, light-colored square tiles. In the upper half, several groups of people are walking in various directions. Some are sitting on long, dark-colored benches. In the lower half, a wide escalator with a glass railing is visible, with a line of people waiting to use it. The overall atmosphere is one of a busy, active environment.

# From static to adaptive escape routing



## Adaptive Evacuation

From static to adaptive escape routing.....	493
Benefits of adaptive Evacuation.....	494
Performance.....	496
Application example.....	497
Control matrix.....	498
AE-CU-W wall housing .....	500
AE-CU-E installation variant.....	502
AE-CU Interface .....	503
GuideLed DX 10011 CG-S .....	504
GuideLed DXC 10011 CG-S .....	505
GuideLed DX 11011 CG-S .....	506
GuideLed DXC 11011 CG-S.....	507
GuideLed DX 10021, 10022, 10023, 10024 CG-S.....	508
GuideLed DXC 10021, 10022, 10023, 10024 CG-S .....	510
GuideLed DX 11021, 11022, 11023, 11024 CG-S .....	512
GuideLed DXC 11021, 11022, 11023, 11024 CG-S.....	514





12



## WorkSafe

### Protect your people and property

Specify superior escape route management technology in complex buildings with Eaton's unique adaptive **emergency lighting evacuation system**.

Risk management for commercial buildings is evolving rapidly. An increasingly urbanised and complex environment, combined with a rising diversity of safety threats, compels the owners and managers of buildings to re-evaluate the way they protect the people, property and business continuity that may be at risk in an emergency. It is not only a legal obligation but a moral, financial and reputational imperative. In situations involving fire, terrorism, major crime, extreme weather and civil unrest, buildings must be able to detect, alert and evacuate. The safe and timely completion of this process is dependent on planning, equipment, training and infrastructure being in place. However, evacuation poses particular challenges when a proportion of occupants are unfamiliar with layout and procedures, and particularly if they are in large, densely-populated, high-risk or complex premises such as railway stations, shopping centres, airports, stadia, government buildings or leisure facilities. Research into crowd behaviour and advances in scenario-modelling technology have highlighted the need for evacuation strategies that are more adaptable to differing circumstances and buildings. In particular, fixed emergency exit routes, indicated by static signage, can lead to congestion, delays and, in some instances, may direct people towards a hazard. Panic is heightened and decision-making can be impaired. Eaton has developed an Adaptive Evacuation System that is capable of identifying the safest exit route in a given circumstance and guiding people towards it via digital signage. The ability of such systems to enhance safety has been confirmed by academic research and technical organisations.

## Adaptive evacuation

*Adaptive:*

*Capable of changing in response to changes in environment.*

Building upon decades of expertise in the delivery of life safety systems, and particularly emergency lighting technologies, Eaton's Adaptive Evacuation System enables faster, safer and more agile evacuations, particularly when deployed alongside a public address/voice alarm solution that provides additional guidance. When installed, the system is programmed with a range of potential exit routes. Based on information from CCTV, fire detection and other devices that pinpoint the nature and location of a hazard, it can select the safest and fastest route for occupants and an appointed system operator within the building is given the opportunity to accept or reject this recommendation, so that occupants can be directed accordingly. Unlike 'active' and 'dynamic' systems, Eaton's technology is fully adaptable and its instructions can be modified in real-time. It has been extensively tested and conforms with current regulatory requirements, although the technology is so new that standards are still to be fully defined.

# Adaptive escape sign luminaires for building evacuation as a supportive system-technical measure.

## Aim of protection:

Safe self-rescue to ensure that rescue forces can take care of injured or disabled persons.

Facing the diverse risks of fire, terrorism, violent crime, extreme weather and civil unrest, the owners and managers of commercial buildings must ensure the ability to detect, alert and evacuate, which is dependent on planning, equipment, training and infrastructure being in place. However, evacuation poses additional challenges when occupants may include visitors who are not familiar with layout and procedures, and particularly if they are in large, highly-populated, high-risk or complex premises such as railway stations, shopping centres, airports, stadia, government buildings or leisure facilities. Fixed emergency exit routes, denoted by static signage, are inflexible to changing circumstances and may inadvertently direct people towards danger, as in the case of the deadly attack on Nairobi's Westgate shopping mall in 2013. Building upon decades of expertise in the delivery of life safety systems, Eaton has pioneered the development of an Adaptive Evacuation System, which is capable of switching between a number of predefined routes and guiding people towards the safest available exit in a given scenario.

## Benefits:

- More efficient, quicker and safer evacuation
- Escape routing adapt continuously to the risk
- Assistance to save oneself
- Relief of the rescuers
- Possible compensation measure for constructional scarcities

In hazard situations caused by e.g. fire, attacks, technical plant faults (e.g. gas accidents) and natural catastrophes, only safe escape routes can be used.

## Static escape route guidance:

Exit sign luminaires designate the escape route out of the building always in the same direction, **independently** of a danger situation.

no change



## Dynamic escape route guidance:

Exit sign luminaires **block** unsafe escape routes in evacuation situations, thereby guiding those fleeing out of the building via the safe escape routes.

State 1



State 2



## Adaptive escape route guidance:

Exit sign luminaires **block** unsafe escape routes and **release these as soon as they become safe again**. This enables dynamic hazard situations (e.g. in case of fire or attacks) to be flexibly responded to.

Normal



Blocked



Open again





# Adaptive Evacuation

Benefits of adaptive Evacuation

## Representation of an adaptive Evacuation:

### Before the occurrence:

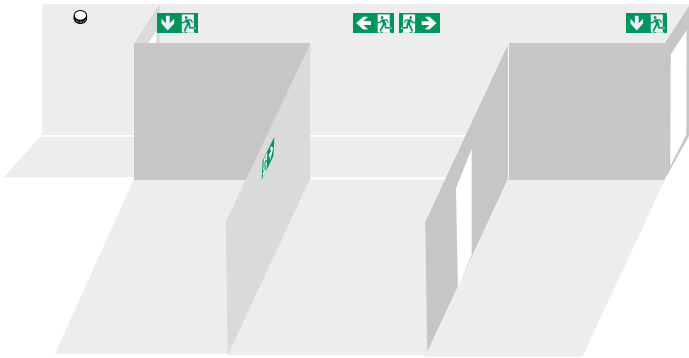

Exit sign luminaires show the fastest exit route.

12

### During the occurrence:

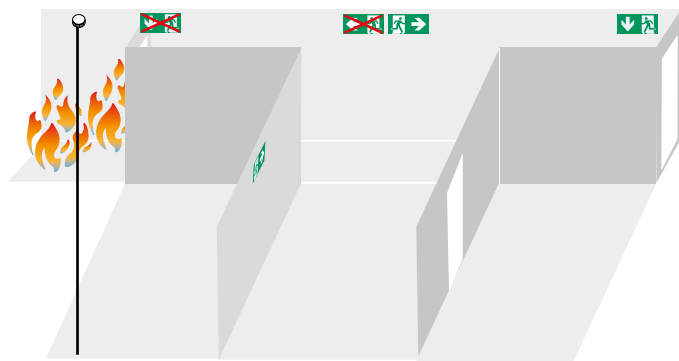

Exit sign luminaires block the unsafe exit route as they receive information of e.g. a Fire detector, video monitoring, locking systems, evacuation systems. The safest exit route out of the building is now shown.

Alarm e.g. via:

Fire detector,  
video monitoring,  
locking systems,  
evacuation systems

### After the occurrence:

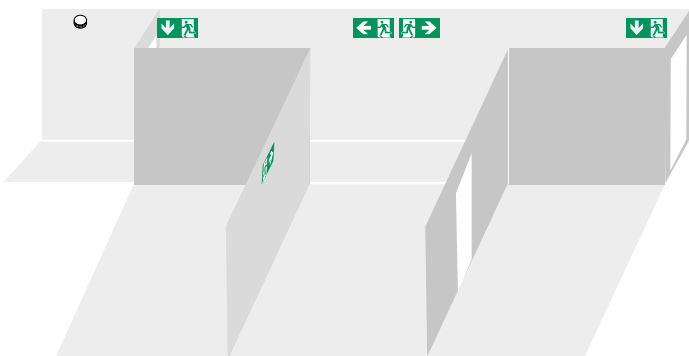

Once the exit route is open again, the exit sign luminaires show it. Therefore it can be flexibly and dynamically reacted on hazard e.g. fire or attacks.

## Benefits of adaptive Evacuation:



- AE-CU technology in combination with GuideLed DXC exit sign luminaires enable dynamic danger situations such as in cases of fire, attacks or natural catastrophes to be actively responded to
- Decentral configuration of the AE-CU for up to 240 GuideLed DXC exit sign luminaires. This enables flexible, low-cost planning.
- Short circuit and open circuit resistant loop bus technology. This means no E30 cable routing of the loop bus line is required because these are fail-safe with the first fault case.
- Separate operating units for safety lighting and for the programming of scenarios provides increased safety with subsequent modifications.
- Due to separate cable routing of the 230V end circuits and 24V loop bus line to the adaptive GuideLed DXC exit sign luminaires, the hybrid operation of static and adaptive exit sign luminaires and the integration of escape luminaires and luminaires for general lighting is possible in the same circuit.
- An integrated search function automatically detects all GuideLed DXC exit sign luminaires connected up during installation.
- Self-addressing of the connected DXC luminaires simplifies the process for installation and commissioning.
- The control unit with nonvolatile program memory and large touch display automatically monitors and controls all components in the AE-CU system as well as the functionality of the connected adaptive luminaires.
- Connection of central visualization is possible via an interface.
- Networking the AE-CU with EATON fire detection technology provides system integrity between alerting and evacuation
- Already installed ZB-S and LP-STAR systems could be expanded with the AE-CU



## From static to adaptive escape route guidance

System-technical measures for ensuring self-rescue in cases of evacuation have top priority in dynamic hazard situations. AE-CU technology in combination with GuideLed DXC exit sign luminaires enable dynamic danger situations such as in cases of fire, attacks or natural catastrophes to be actively responded to. The shortest route out of a building is not always the safest.

The AE-CU system reliably triggers up to 240 adaptive exit sign luminaires via a short circuit and open circuit resistant loop bus.

The hazard scenario can be freely assigned to each adaptive exit sign luminaire via the AE-CU.

The control unit with nonvolatile program memory and large touch display automatically monitors and controls all components in the AE-CU system as well as the functionality of the connected adaptive luminaires. Faults occurring are shown on the display, forwarded via signal contacts and saved to an inspection book.

An integrated search function automatically detects all GuideLed DXC exit sign luminaires connected up during installation. Connection of central visualization is possible via an interface.

## The solution for simple structured applications

### Application example:

#### Triggering of GuideLed DX luminaires via potential-free contacts:

Potential-free signal contacts of fire detectors, CCTV or key switches to indicate areas as „locked, blocked or unsafe“. As an example for areas where entry is forbidden for a specific time due to construction measures. Parallel connection of the DX inputs is not possible.

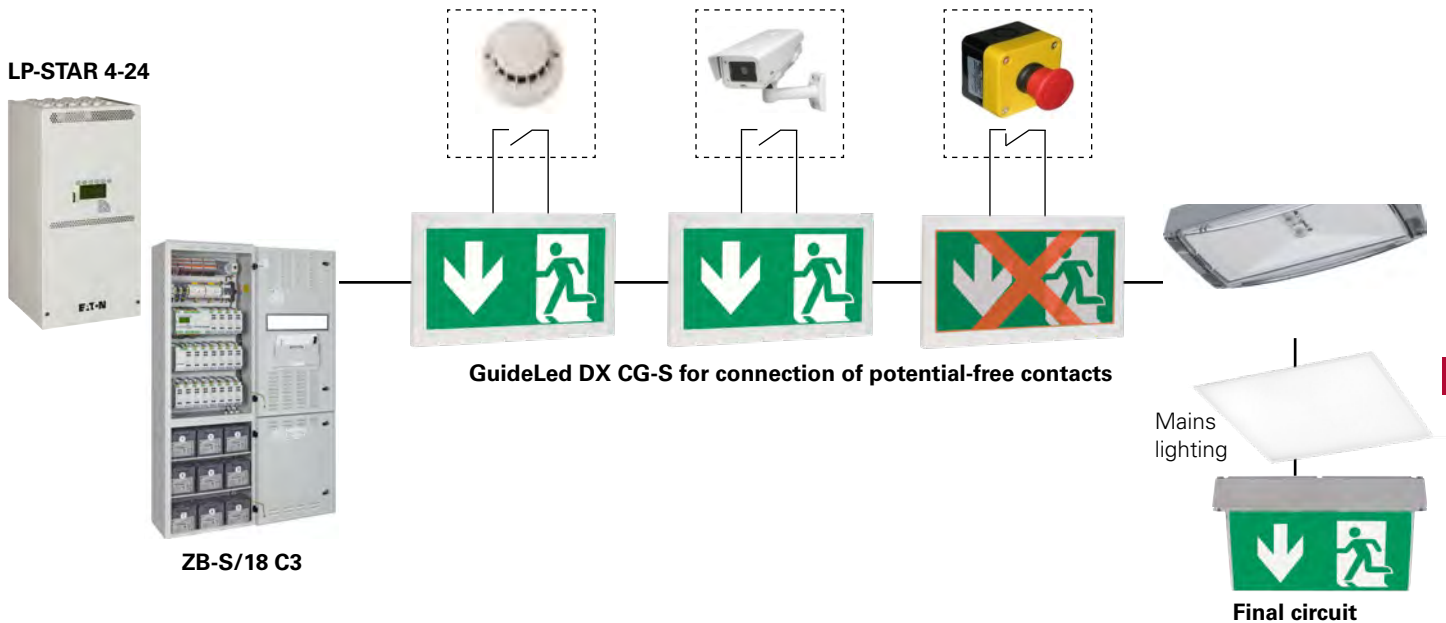

## The solution for simple and complex structured applications

### Application example:

#### Actuation of GuideLed DXC luminaires via the loop bus:

Loop bus and power supply via separate cabling. Therefore the hybrid operation of DXC luminaires, static luminaires and third-party luminaires is possible in one circuit.

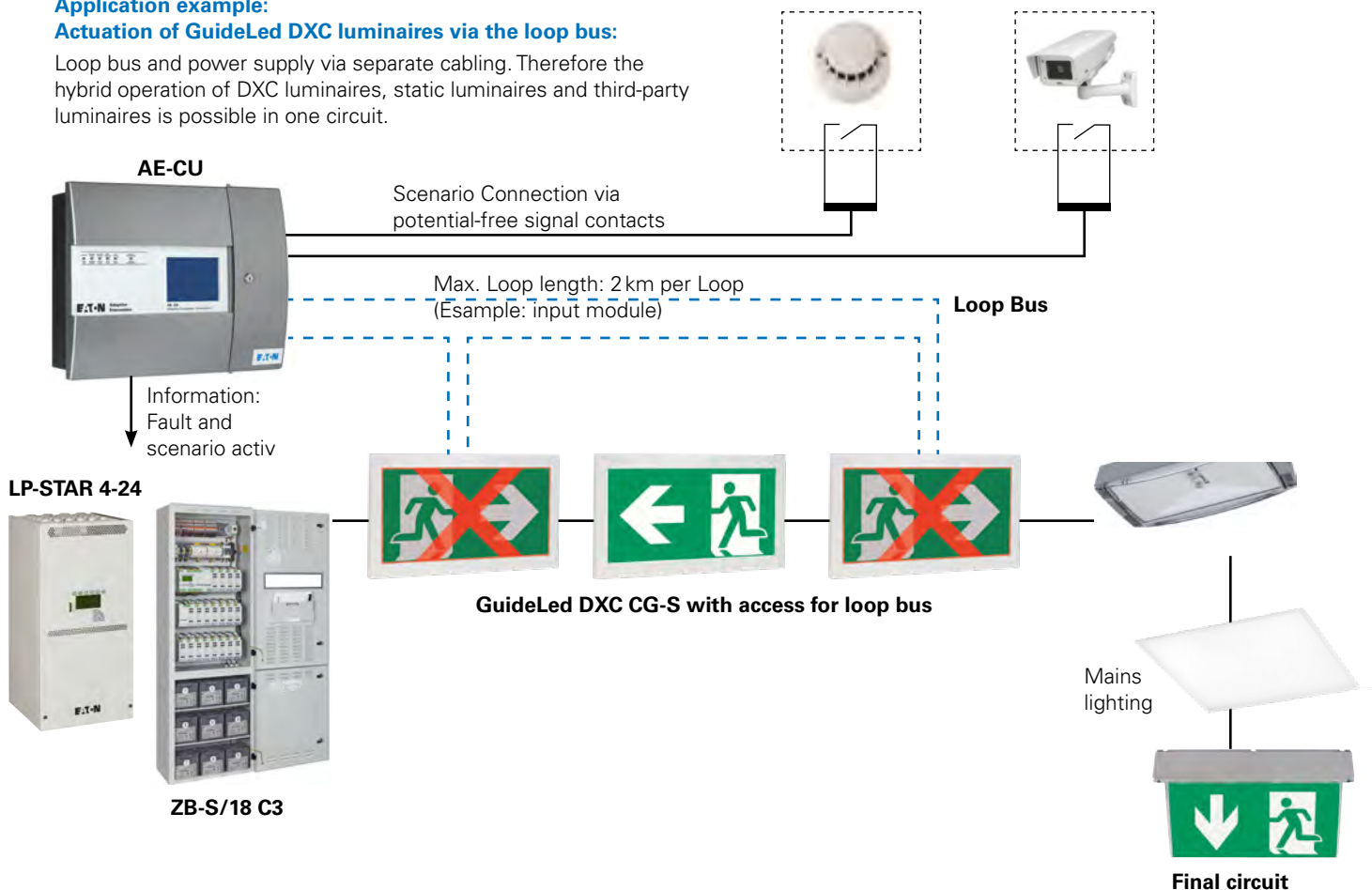



# Adaptive Evacuation

## Control matrix

### Application example:

#### Short circuit and open circuit resistant loop bus technology

- ① short circuit-isolated separation
- ② **still** safeguarded via loop communication after isolation of the short circuit

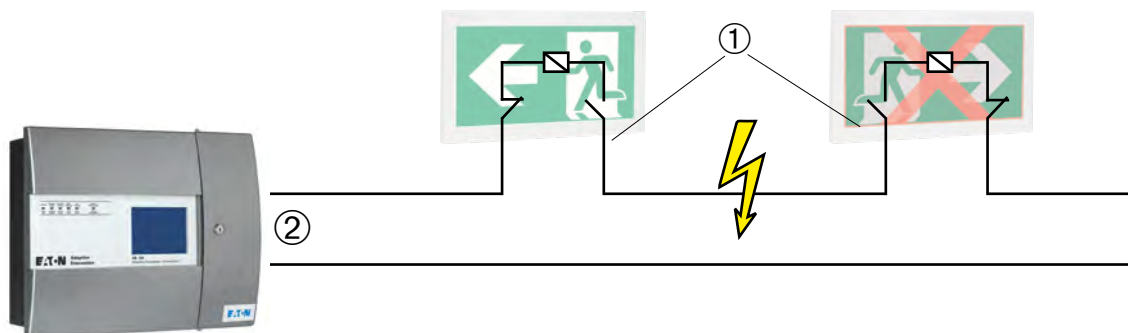

12

## AE-CU control matrix

### Example: Client training center at a workplace

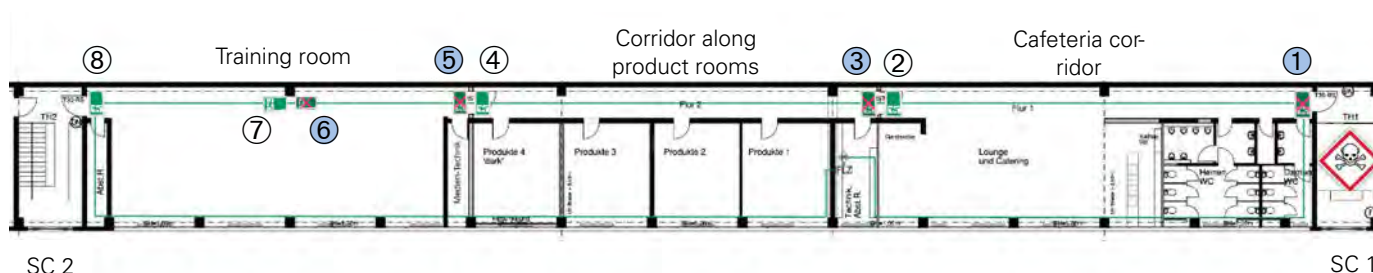

No.	Luminaire description:	Scenario:	SC 1 blocked	Corridor 1 + Cafeteria blocked	Corridor 2 + product rooms blocked	Training room blocked	SC 2 blocked
①	Corridor 1, at door to SC 1		X				
②	Corridor 1, at door to corridor 2				X	X	X
③	Corridor 2, at door to corridor 1		X	X			
④	Corridor 2, at door to training room					X	X
⑤	Training room at door to corridor 2		X	X	X		
⑥	Training room middle direction corridor 2		X	X	X		
⑦	Training room middle direction SC 2						X
⑧	Training room at door to SC 2						X

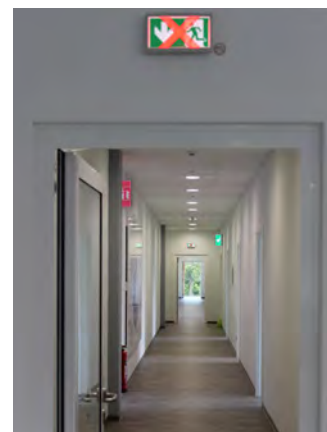
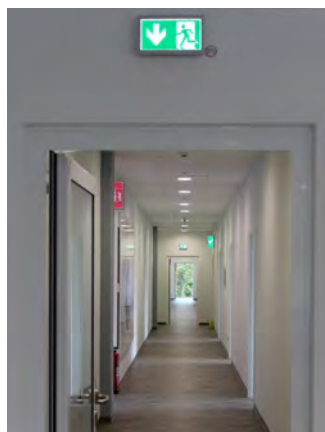
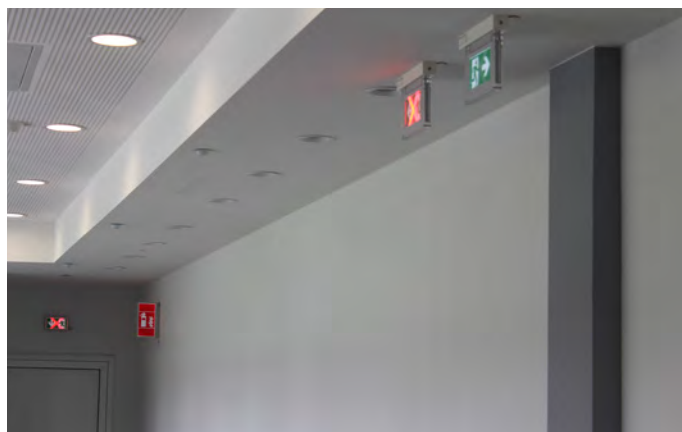

# Adaptive evacuation – installation example

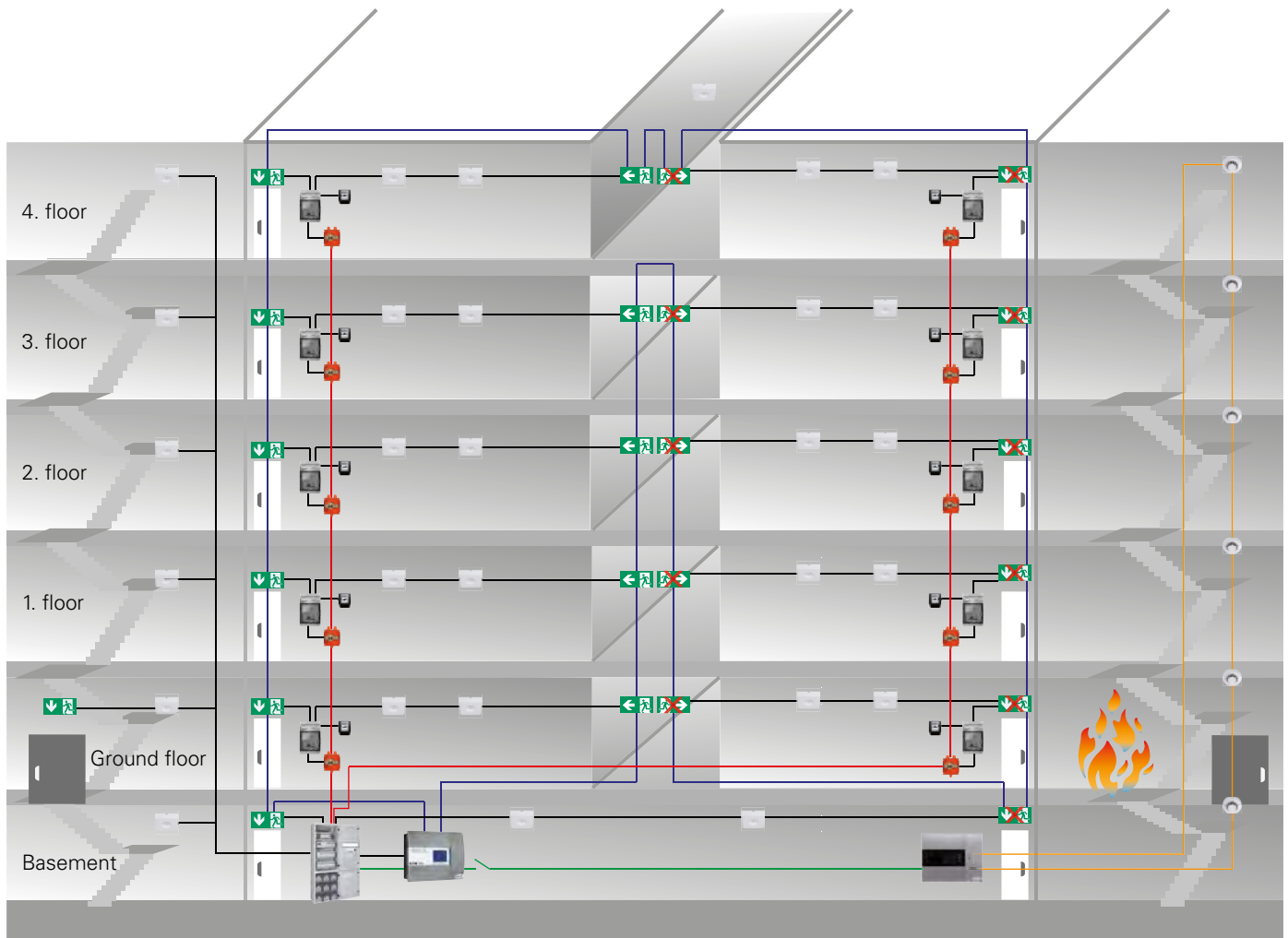

\* Due to simplification, only one circuit is shown pro fire zone/staircase/flat

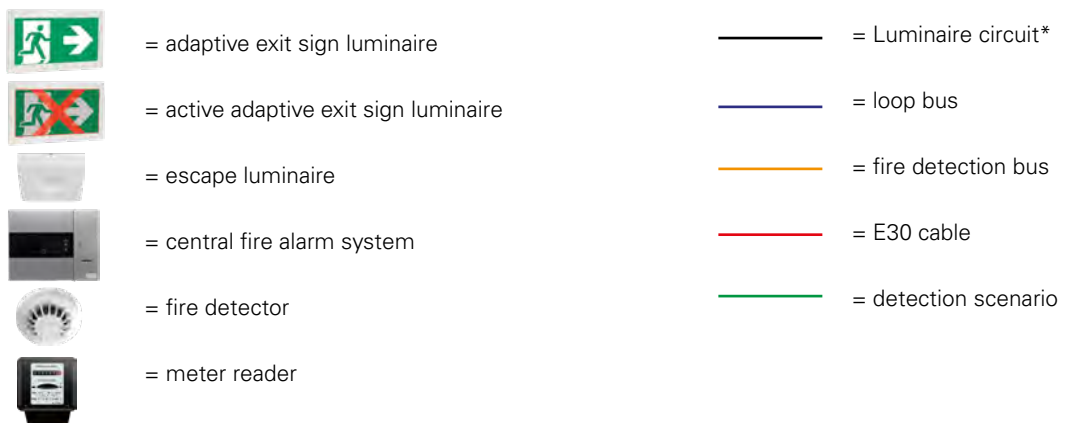



# Adaptive Evacuation

## AE-CU-W wall housing

AE-CU-W



### AE-CU-W

Adaptive Evacuation Control Unit for wall mounting with integrated battery-supported power supply using loop technique for controlling addressable adaptive exit sign luminaires with 230V / 216V AC/DC technology for safety lighting systems acc. to DIN VDE 0100-560, DIN EN 50172 and V DIN V VDE 0108-100. With automatic testing device and monitoring of loop bus communication and individual display of condition and name of loop BUS connection per GuideLed DXC luminaire.

- Adaptive system – Escape routing adapt continuously to the risk
- Self-addressing of the connected DXC luminaires simplifies the process for installation and commissioning
- Simple handling by Touch Display and optional PC programming software
- AE-CU for the adaptive control of up to 240 GuideLed DXC luminaires
- Four short circuit and open circuit resistant loop lines each with 60 GuideLED DXC luminaires
- Two scenarios freely programmable for building evacuation, factory provided integrated. More than two scenarios on request
- A maximum of six ZB-S/US-S or LP-STAR systems can be connected per AE-CU. More than six ZB-S or LP-STAR systems on request
- Automatic software address-setting of all GuideLed DXC luminaires for scenario control
- Number of scenarios could be extended via scenario boxes with 8 or 16 scenarios
- Number of scenario inputs individual extendable
- Functionality also at power failure by inbuilt battery supply
- Universal applicable and with hazard alert systems combinable by potential free scenario inputs
- No E30 cable routing of the loop bus line is required because these are fail-safe with the first fault case

Primary rated voltage	230 V AC +10%, -15%
Primary rated current	75 mA
Nominal frequency	50 Hz
Protection rating	IP 30
Insulation class	I
Ambient temperature	-5°C to +40°C
Secondary rated voltage	18,5 V - 29,5 V
Battery	2 x 12 V / 12 Ah
Max. battery current	3.5 A
Charge characteristic	Constant voltage temperature-compensated
Min. backup power time	30 h
Weight with battery	14 kg
Dimensions (HxWxD in mm)	395 x 495 x 180
Basic housing material	Sheet steel, powder-coated
Material of front	Plastic
<b>Inputs</b>	
Addressable loop line	4
Scenario active inputs	2 (more on request)
Maximum ring length	2,000 m / I(ST)Y 4 x 2 x 0.8 mm
Maximum number of GuideLed DX/DXC luminaires per loop	60
<b>Outputs</b>	
Zero-potential changeover contact	2
Contact load	24 V / 1 A
Fuse	1.35 A

### Ordering details

Type	Scope of supply	Order No.
AE-CU-W	Surface- / Recessed mounted wall housing	40071361359

Dimensions in mm

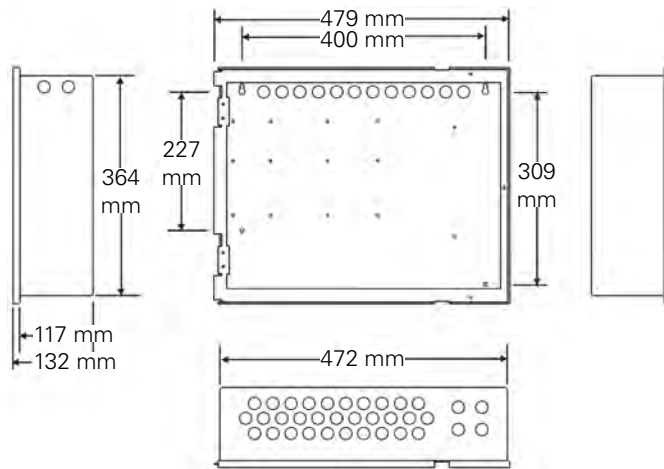

### 1 LED displays:

Power On, Scenario Active, General Fault, CPU Fault, Power Fault, General Disablement

### 2 Touch display, operating messages:

Scenario Active, Fault, Disablement

### 3 Fault messages:

Battery fault (AE-CU wall assembly), double address, earth fault, loop short circuit, charge fault, mains fault, loop communication fault, loop driver fault, trouble fault relay, CPU fault, loop overload, loop break at address, break-loop +loop

12

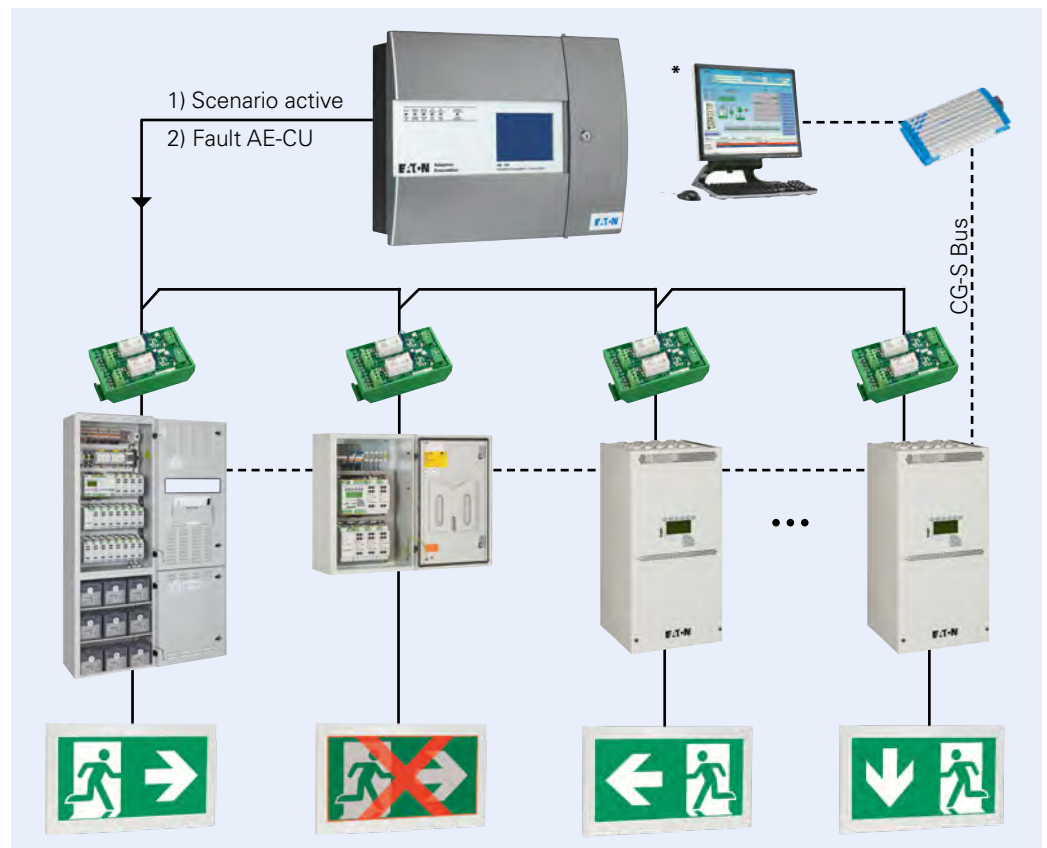

\* At connection of a CGVision the messages „Scenario active” and „sum failure AE-CU” are shown on the control unit of the systems and on the CGVision. This messages are also listed in the test book with date and time.

# Adaptive Evacuation

## AE-CU-E installation variant

AE-CU-E



### AE-CU-E

Adaptive Evacuation Control Unit for assembly in ZB-S/18-AE units using loop technique for controlling addressable adaptive exit sign luminaires with 230V / 216V AC/DC technology for safety lighting systems acc. to DIN VDE 0100-560, DIN EN 50172 and V DIN VDE 0108-100. With automatic testing device and monitoring of loop bus communication and individual display of condition and name of loop BUS connection per GuideLed DXC luminaire.

Primary rated voltage	28.5 V/DC
Primary rated current	4.2 A
Protection rating	IP 20
Insulation class	I
Ambient temperature	-5°C to+40°C
Secondary rated voltage	18.5 V- 29.6 V
Weight	8 kg
Dimensions (HxWxD in mm)	200 x 500 x 190
Material	Sheet steel, powder-coated

#### Inputs

Addressable loop line	4
Scenario active inputs	2 (more on request)
Maximum ring length	2,000 m / I(ST)Y 4 x 2 x 0.8 mm
Maximum number of GuideLed DX/DXC luminaires per loop	60

#### Outputs

Zero-potential changeover contact	2
Contact load	24 V / 1 A
Fuse	1.35 A

### Ordering details

Type	Scope of supply	Order No.
*AE-CU-E	Installation variant for ZB-S/18-AE	40071361360

\*note: not suitable for ATS+ and LP-STAR systems

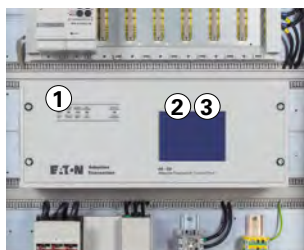

#### 1 LED displays:

Power On, Scenario Active, General Fault, CPU Fault, Power Fault, General Disablement

#### 2 Touch display, operating messages:

Scenario Active, Fault, Disablement

#### 3 Fault messages:

Battery fault (AE-CU wall assembly), double address, earth fault, loop short circuit, charge fault, mains fault, loop communication fault, loop driver fault, trouble fault relay, CPU fault, loop overload, loop break at address, break-loop +loop

Relay module



### Relay module

Information units ,scenario active' and ,fault' are reported to the ZB-S or LP-STAR by the AE-CU via the relay module (installed in a ZB-S/US-S). Six ZB-S/US-S can be connected per AE-CU. More on request.

### Ordering details

Type	Scope of supply	Order No.
Relay module	Relay module connection set for use per ZB-S/US-S or LP-STAR systems for connection to a AE-CU	40071361422

\*Note: Relay module must be mounted externally at sub stations with functional integrity.

# Adaptive Evacuation – Luminaires

## GuideLed DX 10011 CG-S

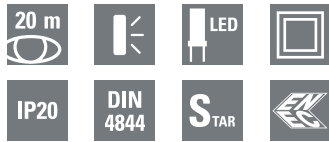

### GuideLed DX 10011 CG-S

- Escape sign luminaire with LED Lightguide technology for wall-mounting
- Additional function: Displaying a red 'X' to signify an area as closed or blocked
- **DX: activation via a switching input on the supply module e.g. smoke detector or panic switch via potential free contact**
- For adaption to the respective ambient conditions, the power supply module is equipped with different selectable operating modes, e.g. static or flashing red 'X'
- Very good perceptibility on account of high luminance of the white contrasting colour > 500 cd/m<sup>2</sup> in keeping with standard ISO 3864-1 and high uniformity L<sub>min</sub>/L<sub>max</sub> > 0.8
- Reduced battery costs on account of especially low power consumption
- Minimum service requirement due to high service life of the LEDs (50,000 hours)
- Installation of the LED pictogram without tools on the mounting set
- Without power supply: still visible pictogramm

GuideLed DX 10011 CG-S



Viewing distance	20 m
Luminous $\Phi_e/\Phi_v$ at the end of rated operating time (EBLF)	100 %
Housing material	PC, PMMA
Housing colour	Light grey RAL 7035
Weight	0.65 kg
Type of mounting	Wall mounting
Connection terminal	Mains 3 x 2 x 2.5 mm <sup>2</sup> Switch input 2 x 2 x 1.5 mm <sup>2</sup>
Connection voltage	220 - 240 V AC, 50/60 Hz 176 V - 275 V DC
Current consumption - battery operation (220 V)	7 mA
Power consumption mains operation (apparent power / effective power)	4.7 VA / 2.2 W
Inrush current	1.5 A
Permissible ambient temperature	-20 °C to +40 °C
Light source	LED batten

Dimensions in mm

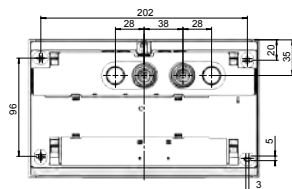
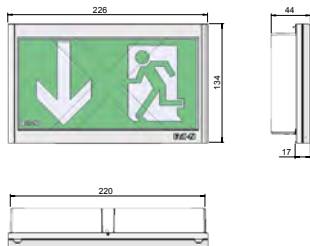

Please observe a distance of 10 mm above for mounting!

### Ordering details - fastening set

Type	Scope of supply (LED pictograms must ordered sepearte)	Order No.
GuideLed DX 1x011 CG-S	Wall mounting set for GuideLed DX 10011 CG-S, Surface mounting, including LED supply with additional switching input and CG-S technology (20 addresses)	40071354646

### Ordering details - LED pictograms (fastening set required)

Type	Scope of supply	Order No.
PL acc. to ISO 7010 <sup>1</sup>	LED piktogram for GuideLed DX/DXC 10011 CG-S, arrow left (PL), acc. to ISO 7010, 20 m	40071355550
PR acc. to ISO 7010 <sup>1</sup>	LED piktogram for GuideLed DX/DXC 10011 CG-S, arrow right (PR), acc. to ISO 7010, 20 m	40071355551
PU, acc. to ISO 7010 <sup>1</sup>	LED piktogram for GuideLed DX/DXC 10011 CG-S, arrow down (PU), acc. to ISO 7010, 20 m	40071355552
PO acc. to ISO 7010 <sup>1</sup>	LED piktogram for GuideLed DX/DXC 10011 CG-S, arrow up (PO), acc. to ISO 7010, 20 m	40071355553

<sup>1</sup> with additional option: red X

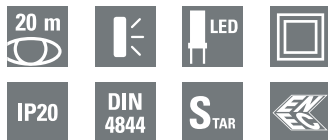

### GuideLed DXC 10011 CG-S

- Escape sign luminaire with LED Lightguide technology for wall-mounting
- Additional function: Displaying a red 'X' to signify an area as closed or blocked
- **DXC: for connection to the adaptive evacuation system EATON AE-CU via an integrated bus module**
- For adaption to the respective ambient conditions, the power supply module is equipped with different selectable operating modes, e.g. static or flashing red 'X'
- Very good perceptibility on account of high luminance of the white contrasting colour > 500 cd/m<sup>2</sup> in keeping with standard ISO 3864-1 and high uniformity L<sub>min</sub>/L<sub>max</sub> > 0.8
- Reduced battery costs on account of especially low power consumption
- Minimum service requirement due to high service life of the LEDs (50,000 hours)
- Installation of the LED pictogram without tools on the mounting set
- Without power supply: still visible pictogramm

GuideLed DXC 10011 CG-S



Dimensions in mm

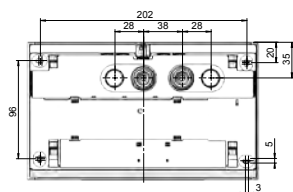
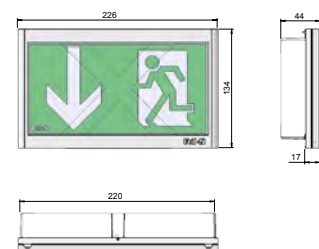

Please observe a distance of 10 mm above for mounting!

Viewing distance	20 m
Luminous $\Phi_E/\Phi_N$ at the end of rated operating time (EBLF)	100 %
Housing material	PC, PMMA
Housing colour	Light grey RAL 7035
Weight	0.7 kg
Type of mounting	Wall mounting
Connection terminal	Mains 3 x 2 x 2.5 mm <sup>2</sup> Bus interface 2 x 2 x 1.5 mm <sup>2</sup>
Connection voltage	220 - 240 V AC, 50/60 Hz 176 V - 275 V DC
Current consumption - battery operation (220 V)	7 mA
Power consumption mains operation (apparent power / effective power)	4.7 VA / 2.2 W
Inrush current	1.5 A
Permissible ambient temperature	-20 °C to +40 °C
Light source	LED batten

12

### Ordering details - fastening set

Type	Scope of supply (LED pictograms must ordered separate)	Order No.
GuideLed DXC 1x011 CG-S	Wall mounting set for GuideLed DXC 10011 CG-S, surface mounting, including LED supply and CG-S technology (20 addresses), with integrated bus interface for connection to an AE-CU	40071355085

### Ordering details - LED pictograms (fastening set required)

Type	Scope of supply	Order No.
PL acc. to ISO 7010 <sup>1</sup>	LED piktogram for GuideLed DX/DXC 10011 CG-S, arrow left (PL), acc. to ISO 7010, 20 m	40071355551
PR acc. to ISO 7010 <sup>1</sup>	LED piktogram for GuideLed DX/DXC 10011 CG-S, arrow right (PR), acc. to ISO 7010, 20 m	40071355552
PU, acc. to ISO 7010 <sup>1</sup>	LED piktogram for GuideLed DX/DXC 10011 CG-S, arrow down (PU), acc. to ISO 7010, 20 m	40071355553
PO acc. to ISO 7010 <sup>1</sup>	LED piktogram for GuideLed DX/DXC 10011 CG-S, arrow up (PO), acc. to ISO 7010, 20 m	40071355553

<sup>1</sup> with additional option: red X



# Adaptive Evacuation – Luminaires

## GuideLed DX 11011 CG-S



### GuideLed DX 11011 CG-S

- Escape sign luminaire with LED Lightguide technology for wall-mounting
- Additional function: Displaying a red 'X' to signify an area as closed or blocked
- **DX: activation via a switching input on the supply module e.g. smoke detector or panic switch via potential free contact**
- For adaption to the respective ambient conditions, the power supply module is equipped with different selectable operating modes, e.g. static or flashing red 'X'
- Very good perceptibility on account of high luminance of the white contrasting colour > 500 cd/m<sup>2</sup> in keeping with standard ISO 3864-1 and high uniformity L<sub>min</sub>/L<sub>max</sub> > 0.8
- Reduced battery costs on account of especially low power consumption
- Minimum service requirement due to high service life of the LEDs (50,000 hours)
- Installation of the LED pictogram without tools on the mounting set
- Without power supply: still visible pictogramm

GuideLed DX 11011 CG-S



12

Dimensions in mm

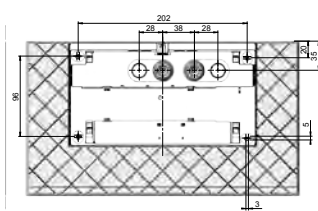
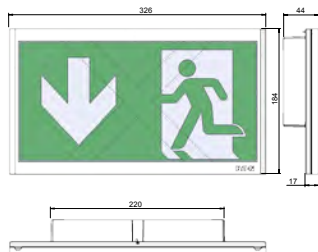

Please observe a distance of 10 mm above for mounting!

Viewing distance	30 m
Luminous $\Phi_E/\Phi_N$ at the end of rated operating time (EBLF)	100 %
Housing material	PC, PMMA
Housing colour	Light grey RAL 7035
Weight	0.79 kg
Type of mounting	Wall mounting
Connection terminal	Mains 3 x 2 x 2.5 mm <sup>2</sup> Switch input 2 x 2 x 1.5 mm <sup>2</sup>
Connection voltage	220 - 240 V AC, 50/60 Hz 176 V - 275 V DC
Current consumption - battery operation (220 V)	12 mA
Power consumption mains operation (apparent power / effective power)	5.9 VA / 3.1 W
Inrush current	1.5 A
Permissible ambient temperature	-20 °C to +40 °C
Light source	LED batten

### Ordering details - fastening set

Type	Scope of supply (LED pictograms must ordered sepearte)	Order No.
GuideLed DX 1x011 CG-S	Wall mounting set for GuideLed DX 11011 CG-S, surface mounting, including LED supply with additional switching input and CG-S technology (20 addresses)	40071354646

### Ordering details - LED pictograms (fastening set required)

Type	Scope of supply	Order No.
PL acc. to ISO 7010 <sup>1</sup>	LED piktogram for GuideLed DX/DXC 11011 CG-S, arrow left (PL), acc. to ISO 7010, 30 m	40071355555
PR acc. to ISO 7010 <sup>1</sup>	LED piktogram for GuideLed DX/DXC 11011 CG-S, arrow right (PR), acc. to ISO 7010, 30 m	40071355556
PU, acc. to ISO 7010 <sup>1</sup>	LED piktogram for GuideLed DX/DXC 11011 CG-S, arrow down (PU), acc. to ISO 7010, 30 m	40071355365
PO acc. to ISO 7010 <sup>1</sup>	LED piktogram for GuideLed DX/DXC 11011 CG-S, arrow up (PO), acc. to ISO 7010, 30 m	40071355558

<sup>1</sup> with additional option: red X



## GuideLed DXC 11011 CG-S

- Escape sign luminaire with LED Lightguide technology for wall-mounting
- Additional function: Displaying a red 'X' to signify an area as closed or blocked
- **DXC: for connection to the adaptive evacuation system EATON AE-CU via an integrated bus module**
- For adaption to the respective ambient conditions, the power supply module is equipped with different selectable operating modes, e.g. static or flashing red 'X'
- Very good perceptibility on account of high luminance of the white contrasting colour > 500 cd/m<sup>2</sup> in keeping with standard ISO 3864-1 and high uniformity L<sub>min</sub>/L<sub>max</sub> > 0.8
- Reduced battery costs on account of especially low power consumption
- Minimum service requirement due to high service life of the LEDs (50,000 hours)
- Installation of the LED pictogram without tools on the mounting set
- Without power supply: still visible pictogramm

GuideLed DXC 11011 CG-S



Dimensions in mm

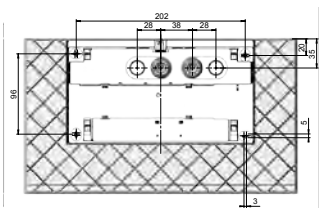
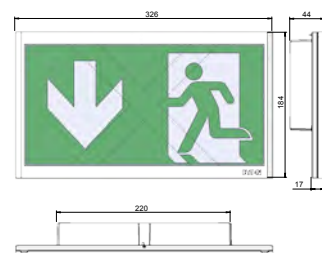

Please observe a distance of 10 mm above for mounting!

Viewing distance	30 m
Luminous $\Phi_E/\Phi_N$ at the end of rated operating time (EBLF)	100 %
Housing material	PC, PMMA
Housing colour	Light grey RAL 7035
Weight	0.7 kg
Type of mounting	Wall mounting
Connection terminal	Mains 3 x 2 x 2.5 mm <sup>2</sup> Bus interface 2 x 2 x 1.5 mm <sup>2</sup>
Connection voltage	220 - 240 V AC, 50/60 Hz 176 V - 275 V DC
Current consumption - battery operation (220 V)	12 mA
Power consumption mains operation (apparent power / effective power)	5.9 VA / 3.1 W
Inrush current	1.5 A
Permissible ambient temperature	-20 °C to +40 °C
Light source	LED batten

12

## Ordering details - fastening set

Type	Scope of supply (LED pictograms must ordered separte)	Order No.
GuideLed DXC 1x011 CG-S	Wall mounting set for GuideLed DXC 11011 CG-S, surface mounting, including LED supply and CG-S technology (20 addresses), with integrated bus interface for connection to an AE-CU	40071355085

## Ordering details - LED pictograms (fastening set required)

Type	Scope of supply	Bestell-Nr.
PL acc. to ISO 7010 <sup>1</sup>	LED piktogram for GuideLed DX/DXC 11011 CG-S, arrow left (PL) acc. to ISO 7010, 30 m	40071355555
PR acc. to ISO 7010 <sup>1</sup>	LED piktogram for GuideLed DX/DXC 11011 CG-S, arrow right (PR), acc. to ISO 7010, 30 m	40071355556
PU, acc. to ISO 7010 <sup>1</sup>	LED piktogram for GuideLed DX/DXC 11011 CG-S, arrow down (PU), acc. to ISO 7010, 30 m	40071355365
PO acc. to ISO 7010 <sup>1</sup>	LED piktogram for GuideLed DX/DXC 11011 CG-S, arrow up (PO), acc. to ISO 7010, 30 m	40071355558

<sup>1</sup> with additional option: red X

# Adaptive Evacuation – Luminaires

GuideLed DX 10021, 10022, 10023, 10024 CG-S

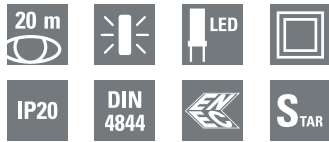

## GuideLed DX 10021, 10022, 10023, 10024 CG-S

- Escape sign luminaire with LED Lightguide technology for wall-mounting
- Additional function: Displaying a red 'X' to signify an area as closed or blocked
- **DX: activation via a switching input on the supply module e.g. smoke detector or panic switch via potential free contact**
- For adaption to the respective ambient conditions, the power supply module is equipped with different selectable operating modes, e.g. static or flashing red 'X'
- Very good perceptibility on account of high luminance of the white contrasting colour > 500 cd/m<sup>2</sup> in keeping with standard ISO 3864-1 and high uniformity L<sub>min</sub>/L<sub>max</sub> > 0.8
- Reduced battery costs on account of especially low power consumption
- Minimum service requirement due to high service life of the LEDs (50,000 hours)
- Without power supply: still visible pictogramm

GuideLed DX 10021 CG-S



Dimensions in mm

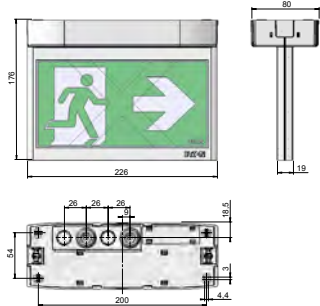

Viewing distance	20 m
Luminous $\Phi_e/\Phi_{N_e}$ at the end of rated operating time (EBLF)	100 %
Housing material	PC, PMMA
Housing colour	Light grey RAL 7035
Weight	0.68 kg (10021 LED CG-S) 0.77 kg (10022 LED CG-S) 0.95 kg (10023 LED CG-S) 1.03 kg (10024 LED CG-S)
Type of mounting	Ceiling, suspended, recessed installation mounting
Connection terminal	Mains 3 x 2 x 2.5 mm <sup>2</sup> Switch input 2 x 2 x 1.5 mm <sup>2</sup>
Connection voltage	220 - 240 V AC, 50/60 Hz 176 V - 275 V DC
Current consumption - battery operation (220 V)	one-sided 7 mA two-sided 12 mA
Power consumption mains operation (apparent power / effective power)	one-sided 4.7 VA / 2.2 W two-sided 6.0 VA / 3.1 W
Inrush current	1.5 A
Permissible ambient temperature	-20 °C to +40 °C
Light source	LED batten

GuideLed DX 10022 CG-S



Dimensions in mm

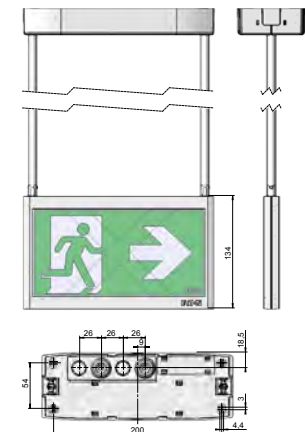

## Ordering details - fastening set

Scope of supply (LED pictograms must ordered separate)

Order No.

Ceiling installation set for GuideLed DX10021 CG-S with canopy incl. LED supply with additional switching input and CG-S technology (20 addresses)	40071355295
Ceiling installation set for GuideLed 10022 DX CG-S with canopy and tube suspension 0.5 m, incl. LED supply with additional switching input and CG-S technology (20 addresses)	40071355481
Ceiling installation set for GuideLed 10023 DX CG-S with canopy and tube suspension 1.5 m, incl. LED supply with additional switching input and CG-S technology (20 addresses)	40071355482
Ceiling installation set for GuideLed 10024 DX CG-S incl. recessed installation housing incl. LED supply with additional switching input and CG-S technology (20 addresses)	40071355483

GuideLed DX 10024 CG-S



Dimensions in mm

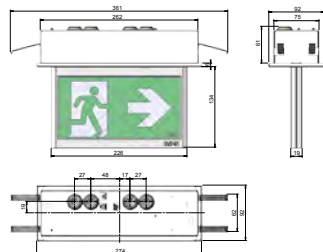

## Ordering details - LED pictograms (fastening set required)

### Scope of supply

		Order No.
LED piktogram PL/PR, for GuideLed DX/DXC 10021/10022/10023/10024 CG-S, ISO 7010 <sup>1</sup> , 20 m		40071355330
LED piktogram PU/PU, for GuideLed DX/DXC 10021/10022/10023/10024 CG-S, ISO 7010 <sup>1</sup> , 20 m		40071355531
LED piktogram PL/BL, for GuideLed DX/DXC 10021/10022/10023/10024 CG-S, ISO 7010 <sup>1</sup> , 20 m		40071355532
LED piktogram PR/BL, for GuideLed DX/DXC 10021/10022/10023/10024 CG-S, ISO 7010 <sup>1</sup> , 20 m		40071355533
LED piktogram PU/BL, for GuideLed DX/DXC 10021/10022/10023/10024 CG-S, ISO 7010 <sup>1</sup> , 20 m		40071355534
LED piktogram PL/PR-R**, for GuideLed DX/DXC 10021/10022/10023/10024 CG-S, ISO 7010 <sup>1</sup> , 20 m		40071355535
LED piktogram PL/PR-W**, for GuideLed DX/DXC 10021/10022/10023/10024 CG-S, ISO 7010 <sup>1</sup> , 20 m		40071355536

<sup>1</sup> with additional option: red X

\*\* R = Arrow from mounting wall  
W = Arrow to mounting wall

# Adaptive Evacuation – Luminaires

GuideLed DXC 10021, 10022, 10023, 10024 CG-S

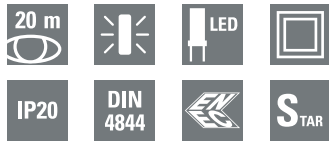

## GuideLed DXC 10021, 10022, 10023, 10024 CG-S

- Escape sign luminaire with LED Lightguide technology for wall-mounting
- Additional function: Displaying a red 'X' to signify an area as closed or blocked
- **DXC: for connection to the adaptive evacuation system EATON AE-CU via an integrated bus module**
- For adaption to the respective ambient conditions, the power supply module is equipped with different selectable operating modes, e.g. static or flashing red 'X'
- Very good perceptibility on account of high luminance of the white contrasting colour > 500 cd/m<sup>2</sup> in keeping with standard ISO 3864-1 and high uniformity L<sub>min</sub>/L<sub>max</sub> > 0.8
- Reduced battery costs on account of especially low power consumption
- Minimum service requirement due to high service life of the LEDs (50,000 hours)
- Without power supply: still visible pictogramm

GuideLed DXC 10021 CG-S



Dimensions in mm

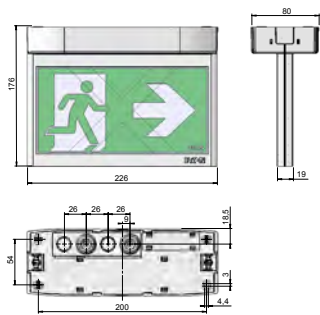

Viewing distance	20 m
Luminous $\Phi_E/\Phi_N$ at the end of rated operating time (EBLF)	100 %
Housing material	PC, PMMA
Housing colour	Light grey RAL 7035
Weight	0.68 kg (10021 LED CG-S) 0.77 kg (10022 LED CG-S) 0.95 kg (10023 LED CG-S) 1.03 kg (10024 LED CG-S)
Type of mounting	Ceiling, suspended, recessed installation
Connection terminal	Mains 3 x 2 x 2.5 mm <sup>2</sup> Bus interface 2 x 2 x 1.5 mm <sup>2</sup>
Connection voltage	220 - 240 V AC, 50/60 Hz 176 V - 275 V DC
Current consumption - battery operation (220 V)	one-sided 7 mA two-sided 12 mA
Power consumption mains operation (apparent power / effective power)	one-sided 4.7 VA / 2.2 W two-sided 6.0 VA / 3.1 W
Inrush current	1.5 A
Permissible ambient temperature	-20 °C to +40 °C
Light source	LED batten

GuideLed DXC 10022 CG-S



Dimensions in mm

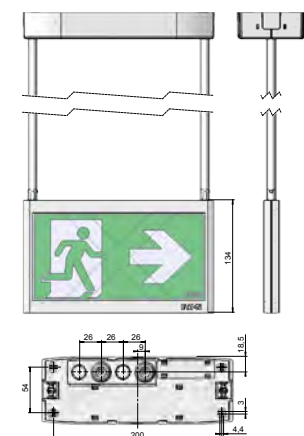

## Ordering details - fastening set

Scope of supply (LED pictograms must ordered separate)	Order No.
Ceiling installation set for GuideLed DXC 10021 CG-S with canopy incl. LED supply and CG-S technology (20 addresses), with integrated bus interface for connection to an AE-CU	40071355488
Ceiling installation set for GuideLed DXC 10022 CG-S with canopy and tube suspension 0.5 m incl. LED supply and CG-S technology (20 addresses), with integrated bus interface for connection to an AE-CU	40071355489
Ceiling installation set for GuideLed DXC 10023 CG-S with canopy and tube suspension 1.5 m incl. LED supply and CG-S technology (20 addresses), with integrated bus interface for connection to an AE-CU	40071355490
Ceiling installation set for GuideLed DXC 10024 CG-S incl. recessed installation housing incl. LED supply and CG-S technology (20 addresses), with integrated bus interface for connection to an AE-CU	40071355491



GuideLed DXC 10024 CG-S



Dimensions in mm

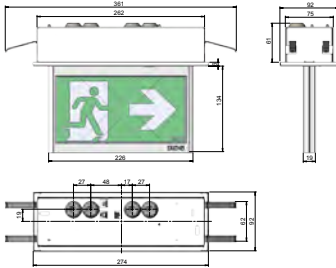

## Ordering details - LED pictograms (fastening set required)

### Scope of supply

		Order No.
LED piktogram PL/PR, for GuideLed DX/DXC 10021/10022/10023/10024 CG-S, ISO 7010 <sup>1</sup> , 20 m		40071355330
LED piktogram PU/PU, for GuideLed DX/DXC 10021/10022/10023/10024 CG-S, ISO 7010 <sup>1</sup> , 20 m		40071355531
LED piktogram PL/BL, for GuideLed DX/DXC 10021/10022/10023/10024 CG-S, ISO 7010 <sup>1</sup> , 20 m		40071355532
LED piktogram PR/BL, for GuideLed DX/DXC 10021/10022/10023/10024 CG-S, ISO 7010 <sup>1</sup> , 20 m		40071355533
LED piktogram PU/BL, for GuideLed DX/DXC 10021/10022/10023/10024 CG-S, ISO 7010 <sup>1</sup> , 20 m		40071355534
LED piktogram PL/PR-R**, for GuideLed DX/DXC 10021/10022/10023/10024 CG-S, ISO 7010 <sup>1</sup> , 20 m		40071355535
LED piktogram PL/PR-W**, for GuideLed DX/DXC 10021/10022/10023/10024 CG-S, ISO 7010 <sup>1</sup> , 20 m		40071355536

<sup>1</sup> with additional option: red X

\*\* R = Arrow from mounting wall  
W = Arrow to mounting wall

# Adaptive Evacuation – Luminaires

GuideLed DX 11021, 11022, 11023, 11024 CG-S

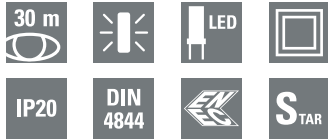

GuideLed DX 11021 CG-S



Dimensions in mm

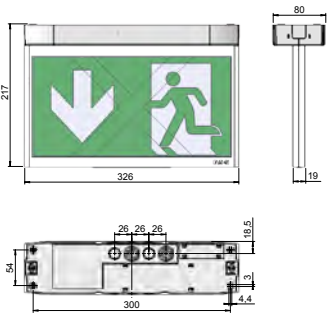

## GuideLed DX 11021, 11022, 11023, 11024 CG-S

- Escape sign luminaire with LED Lightguide technology for wall-mounting
- Additional function: Displaying a red 'X' to signify an area as closed or blocked
- **DX: activation via a switching input on the supply module e.g. smoke detector or panic switch via potential free contact**
- For adaption to the respective ambient conditions, the power supply module is equipped with different selectable operating modes, e.g. static or flashing red 'X' Very good perceptibility on account of high luminance of the white contrasting colour  
> 500 cd/m<sup>2</sup> in keeping with standard ISO 3864-1 and high uniformity L<sub>min</sub>/L<sub>max</sub> > 0.8
- Reduced battery costs on account of especially low power consumption
- Minimum service requirement due to high service life of the LEDs (50,000 hours)
- Without power supply: still visible pictogramm

Viewing distance	30 m
Luminous $\Phi_e/\Phi_n$ at the end of rated operating time (EBLF)	100 %
Housing material	PC, PMMA
Housing colour	Light grey RAL 7035
Weight	0.99 kg (11021 LED CG-S) 1.08 kg (11022 LED CG-S) 1.26 kg (11023 LED CG-S) 1.38 kg (11024 LED CG-S)
Type of mounting	Ceiling, suspended, recessed installation
Connection terminal	Mains 3 x 2 x 2.5 mm <sup>2</sup> Switch input 2 x 2 x 1.5 mm <sup>2</sup>
Connection voltage	220 - 240 V AC, 50/60 Hz 176 V - 275 V DC
Current consumption - battery operation (220 V)	one-sided 12 mA two-sided 17 mA
Power consumption mains operation (apparent power / effective power)	one-sided 5.9 VA / 3.1 W two-sided 7.6 VA / 4.3 W
Inrush current	1.5 A
Permissible ambient temperature	-20 °C to +40 °C
Light source	LED batten

## Ordering details - fastening set

Scope of supply (LED pictograms must ordered separate)	Order No.
Ceiling installation set for GuideLed DX 11021 CG-S with canopy incl. LED supply with additional switching input and CG-S technology (20 addresses)	40071355484
Ceiling installation set for GuideLed DX 11022 CG-S with canopy and tube suspension 0.5 m incl. LED supply with additional switching input and CG-S technology (20 addresses)	40071355485
Ceiling installation set for GuideLed DX 11023 CG-S with canopy and tube suspension 1.5 m incl. LED supply with additional switching input and CG-S technology (20 addresses)	40071355486
Ceiling installation set for GuideLed DX 11024 CG-S incl. recessed installation housing incl. LED supply with additional switching input and CG-S technology (20 addresses)	40071355487

GuideLed DX 11022 / 11023 CG-S



Dimensions in mm

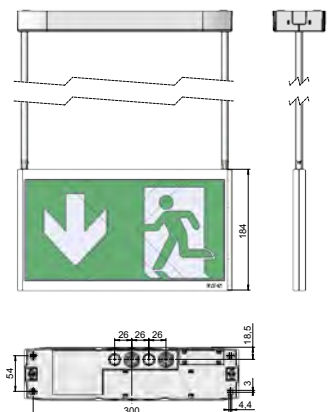

GuideLed DX 11024 CG-S



Dimensions in mm

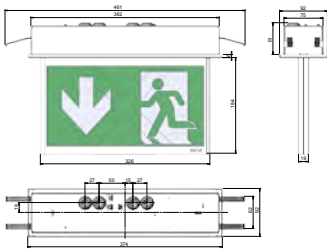

## Ordering details - LED pictograms (fastening set required)

### Scope of supply

		Order No.
LED piktogram PL/PR, for GuideLed DX/DXC 11021/11022/11023/11024 CG-S, ISO 7010 <sup>1</sup> , 30 m		40071355540
LED piktogram PU/PU, for GuideLed DX/DXC 11021/11022/11023/11024 CG-S, ISO 7010 <sup>1</sup> , 30 m		40071355541
LED piktogram PL/BL, for GuideLed DX/DXC 11021/11022/11023/11024 CG-S, ISO 7010 <sup>1</sup> , 30 m		40071355542
LED piktogram PR/BL, for GuideLed DX/DXC 11021/11022/11023/11024 CG-S, ISO 7010 <sup>1</sup> , 30 m		40071355543
LED piktogram PU/BL, for GuideLed DX/DXC 11021/11022/11023/11024 CG-S, ISO 7010 <sup>1</sup> , 30 m		40071355544
LED piktogram PL/PR-R**, for GuideLed DX/DXC 11021/11022/11023/11024 CG-S, ISO 7010 <sup>1</sup> , 30 m		40071355545
LED piktogram PL/PR-W**, for GuideLed DX/DXC 11021/11022/11023/11024 CG-S, ISO 7010 <sup>1</sup> , 30 m		40071355546

<sup>1</sup> with additional option: red X

\*\* R = Arrow from mounting wall  
W = Arrow to mounting wall

# Adaptive Evacuation – Luminaires

GuideLed DXC 11021, 11022, 11023, 11024 CG-S

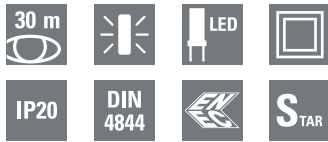

GuideLed DXC 11021 CG-S



Dimensions in mm

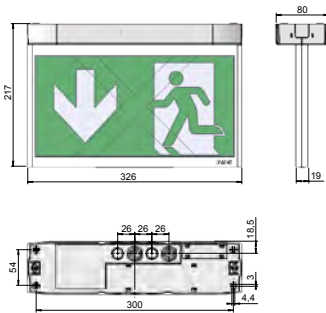

## GuideLed DXC 11021, 11022, 11023, 11024 CG-S

- Escape sign luminaire with LED Lightguide technology for wall-mounting
- Additional function: Displaying a red 'X' to signify an area as closed or blocked
- **DXC: for connection to the adaptive evacuation system EATON AE-CU via an integrated bus module**
- For adaption to the respective ambient conditions, the power supply module is equipped with different selectable operating modes, e.g. static or flashing red 'X'
- Very good perceptibility on account of high luminance of the white contrasting colour > 500 cd/m<sup>2</sup> in keeping with standard ISO 3864-1 and high uniformity L<sub>min</sub>/L<sub>max</sub> > 0.8
- Reduced battery costs on account of especially low power consumption
- Minimum service requirement due to high service life of the LEDs (50,000 hours)
- Without power supply: still visible pictogramm

Viewing distance	30 m
Luminous $\Phi_c/\Phi_v$ at the end of rated operating time (EBLF)	100 %
Housing material	PC, PMMA
Housing colour	Light grey RAL 7035
Weight	0.99 kg (11021 LED CG-S) 1.08 kg (11022 LED CG-S) 1.26 kg (11023 LED CG-S) 1.38 kg (11024 LED CG-S)
Type of mounting	Ceiling, suspended, recessed installation
Connection terminal	Mains 3 x 2 x 2.5 mm <sup>2</sup> Switch input 2 x 2 x 1.5 mm <sup>2</sup>
Connection voltage	220 - 240 V AC, 50/60 Hz 176 V - 275 V DC
Current consumption - battery operation (220 V)	one-sided 12 mA two-sided 17 mA
Power consumption mains operation (apparent power / effective power)	one-sided 5.9 VA / 3.1 W two-sided 7.6 VA / 4.3 W
Inrush current	1.5 A
Permissible ambient temperature	-20 °C to +40 °C
Light source	LED batten

## Ordering details - fastening set

Scope of supply (LED pictograms must ordered separte)	Order No.
Ceiling installation set for GuideLed DXC 11021 CG-S with canopy incl. LED supply and CG-S technology (20 addresses), with integrated bus interface for connection to an AE-CU	40071355492
Ceiling installation set for GuideLed DXC 11022 CG-S with canopy and tube suspension 0.5 m incl. LED supply and CG-S technology (20 addresses), with integrated bus interface for connection to an AE-CU	40071355493
Ceiling installation set for GuideLed DXC 11023 CG-S with canopy and tube suspension 1.5 m incl. LED supply and CG-S technology (20 addresses), with integrated bus interface for connection to an AE-CU	40071355494
Ceiling installation set for GuideLed DXC 11024 CG-S incl. recessed installation housing incl. LED supply and CG-S technology (20 addresses) with integrated bus interface for connection to an AE-CU	40071355495

GuideLed DXC 11022 / 11023 CG-S



Dimensions in mm

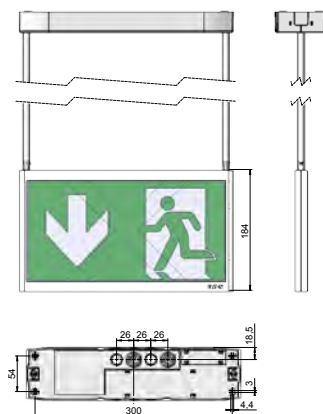

GuideLed DXC 11024 CG-S



Dimensions in mm

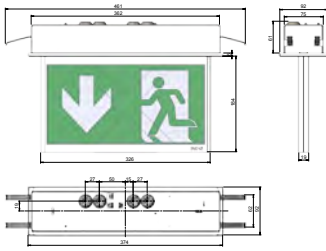

## Ordering details - LED pictograms (fastening set required)

### Scope of supply

		Order No.
LED piktogram PL/PR, for GuideLed DX/DXC 11021/11022/11023/11024 CG-S, ISO 7010 <sup>1</sup> , 30 m		40071355540
LED piktogram PU/PU, for GuideLed DX/DXC 11021/11022/11023/11024 CG-S, ISO 7010 <sup>1</sup> , 30 m		40071355541
LED piktogram PL/BL, for GuideLed DX/DXC 11021/11022/11023/11024 CG-S, ISO 7010 <sup>1</sup> , 30 m		40071355542
LED piktogram PR/BL, for GuideLed DX/DXC 11021/11022/11023/11024 CG-S, ISO 7010 <sup>1</sup> , 30 m		40071355543
LED piktogram PU/BL, for GuideLed DX/DXC 11021/11022/11023/11024 CG-S, ISO 7010 <sup>1</sup> , 30 m		40071355544
LED piktogram PL/PR-**, for GuideLed DX/DXC 11021/11022/11023/11024 CG-S, ISO 7010 <sup>1</sup> , 30 m		40071355545
LED piktogram PL/PR-W**, for GuideLed DX/DXC 11021/11022/11023/11024 CG-S, ISO 7010 <sup>1</sup> , 30 m		40071355546

<sup>1</sup> with additional option: red X

\*\* R = Arrow from mounting wall  
W = Arrow to mounting wall



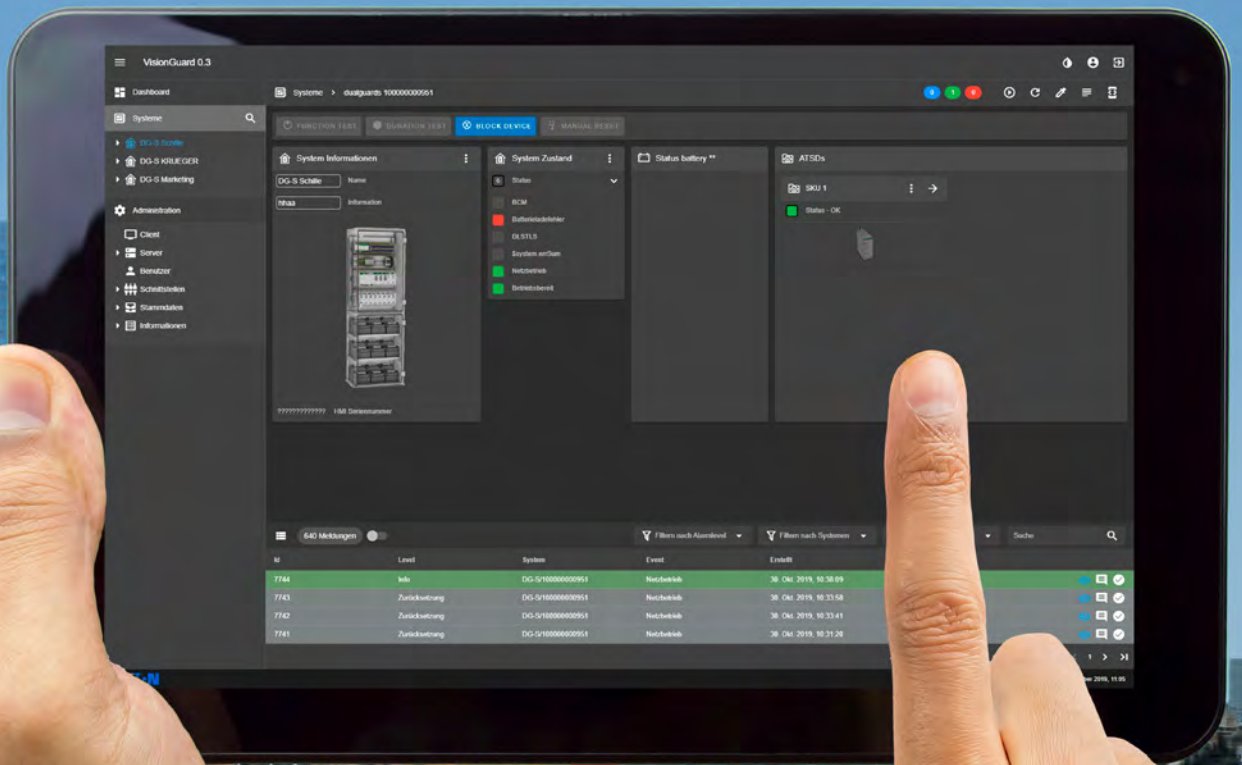

**Central Visualisation**



**VisionGuard and CGVision Overview** ..... 518

**VisionGuard**

VisionGuard product description..... 519  
 VisionGuard – visualization software ..... 519  
 The main features of VisionGuard..... 520  
 VisionGuard - a modern client-server architecture ..... 520  
 The benefits of using VisionGuard..... 521  
 A single software for a wide range of tasks ..... 522  
 VisionGuard overview ..... 523  
 VisionGuard application examples ..... 524  
 Insights into the software ..... 526  
 A convincing technology ..... 528  
 Log book with filter function ..... 529  
 Monitoring software ..... 530

**CGVision**

Central Visualisation - Visualisation software CGVision **Phase out 2021** ..... 532

## VisionGuard and CGVision – Information on the updates



	<b>CGVision</b>	<b>VisionGuard</b>
Windows versions	WIN7 /WIN 10 (32/64Bit) /WIN Server 2008 /WIN Server 2012	WIN 10 (64Bit) /WIN Server 2012 / WIN Server 2016 /WIN Server 2019
Client/Server Architecture	–	•
Client software	–	standard web browser
Display Resolution	Fixed resolution optimized for 1280 x 1024	responsive Webdesign optimized for 1920x1080
Comfort display	–	light / dark mode
max. parallel Client access	1	no limit
USB-Dongle license	•	optional
Soft license	–	•
Suitable EML systems	ZVL220/GVL24.1/CG48/ Euro.ZB.1/ ZB96/CG2000/ ZB-S/AT-S+/LP-STAR/ CGLine400/CGLine+	DualGuard-S prepared for new systems 2021 (ZB-S/AT-S+/LP-STAR CGLine+ in preparation)
Number of possible EML systems	up to 480 32 eml in 15 groups	Voumen licenses 3/10/25/50/100/500
Password protection	simple	complex
UAC (User Account Control)	–	4 roles
Navigation structure	15 groups / 32 devices	flexible explore navigation (in preparation)
Logbook with filter	•	•
Alarm list	•	•
E-Mail function	•	•
Print function	•	•
Export function (for external applications)	•	optional
Backup function	•	•
Building layout programming	.bmp based	.dwg based
Zoom / Pan function	–	•
Bacnet interface (BMS)	optional	optional
OPC-Interface	OPC- DA2	OPC UA
Modbus TCP	–	•
		<i>in planning phase</i>

# VisionGuard – a powerful visualization software with a new design



As the successor to our successful CGVision software, the powerful new visualization software VisionGuard offers state-of-the-art monitoring, control and configuration. Designed for all current Windows environments based on WIN10 or Windows Server 2016/2019, the software covers all common application types, from dedicated PC workstations to virtualized environments with remote access. The intelligent and user-friendly VisionGuard visualization software offers maximum reliability, even when it comes to controlling and monitoring large emergency lighting systems. Up to 500 individual emergency lighting systems with over a million light points can be monitored via a single control room monitor. Especially for larger buildings such as airports, universities, museums, sports and industrial facilities, this software is the ideal choice to ensure the optimized and cost-effective operation of emergency lighting systems. VisionGuard is also a powerful tool for small projects thanks to the user-friendly display of all status information, the extensive notification functions and the mobile application for tablets or smartphones.

### Web-based client/server structure

VisionGuard is a modern web-based visualization software that relies on a streamlined and clutter-free design. During the development of VisionGuard, we focused on the essentials, namely to offer a design that's highly user-friendly, in line with the motto "less is more!" Such a user-friendly design is not only more effective, but also ensures that users are much more likely to accurately process information.

### Versatile display

The responsive web design, which automatically adjusts to the display settings of the device in question, allows unrestricted use of the software across different display sizes and resolutions, on any smartphone or tablet. As a result, users don't have to commit to any particular display sizes or manufacturers.

### Highly user-friendly

The VisionGuard display function (web client) supports all common web browsers, such as Chrome, Edge, Firefox, Safari, etc., so that the software can also be used with alternative operating systems such as iOS or Linux.

In addition, this eliminates the need for special client software and reduces costs and complexity to a minimum, since the software does not need to be maintained and supported by IT specialists.

### Fast and reliable

In addition to the advantages outlined above, the web-based design delivers maximum performance at high speed, including improved and optimized loading speeds. Contrary to other solutions that leave users waiting impatiently, the software comes with an integrated progress bar that indicates the remaining time for each type of action.

# The main features of VisionGuard

VisionGuard – visualization software

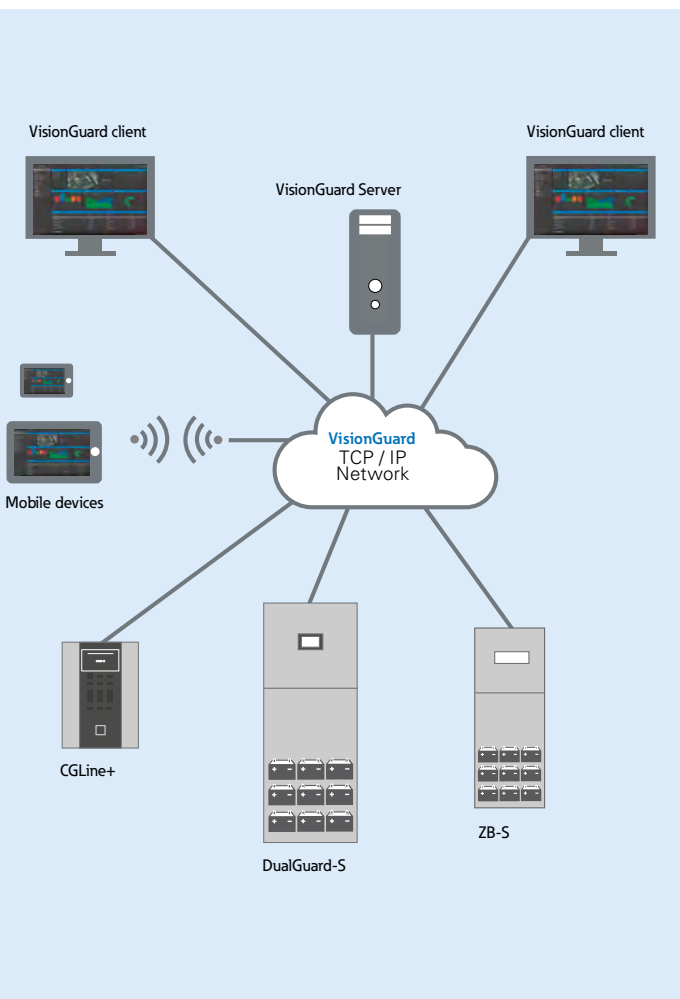

## VisionGuard - a modern client-server architecture

VisionGuard's modern web-based client-server architecture meets all the requirements of today's Windows-based IT environments. This web-based client-server design is compatible with any of the browsers that are currently in use for PC workstations. This eliminates the need for any special proprietary client software, which would have to be installed separately and with special administrator rights. This saves time and the involvement of an IT specialist.

What's more, the responsive web design, which can be used with any standard browser, enables the use of mobile devices such as tablets or smartphones, running on any operating system (e.g. Android, iOS).



## VisionGuard – a modern design

- A modern web-based design that provides a quick overview and is easy to use
- Customizable login page (background image)
- A modern dashboard starting page
- Clear and innovative presentation of system information by means of widgets (graphic window system)
- Responsive web design for different display sizes and resolutions for use with mobile devices such as tablets or smartphones
- The web-based design enables the use of VisionGuard with any operating system, such as Windows, Mac OS, iOS or Linux





## The benefits of using VisionGuard

- Multi-user operation: A web-based client/server architecture that can be accessed independently and in parallel from different workstations
  - Dongle-free software licensing
  - Tiered versions, from 3 to 500 emergency lighting systems
  - State-of-the-art, web-based dashboard design with widgets (graphic window system)
  - Responsive web-based design for different display sizes
  - Optimized for Full HD (1920 x 1080 dpi)
  - Full visualization, control and configuration down to the level of each system/luminaire
  - User access control with four user roles (supervisor, administrator, power user and user)
  - Detailed email function
  - Advanced printing functions
  - Cyber security tested (EATON)
- In preparation:**
- Full configuration of emergency lighting systems down to luminaire level
  - Connection to CG-S systems (ZB-S/AT-S+ and LP-STAR) and CGLine+ single battery systems
  - AutoCAD-based floor plan programming (vector graphics) with zoom & pan function
  - Optional BMS interfaces (BACnet, Modbus/TCP, OPC-UA)
  - Optional data export function to external programs (e.g. SAP)

# A single software for a wide range of tasks

VisionGuard – visualization software



## VisionGuard - A single software for a wide range of tasks

The powerful VisionGuard visualization software is able to control and monitor even large emergency lighting systems with maximum reliability. CEAG has more than 40 years of experience in this field. As market leader, we are always aware of our special responsibility, because in our field, light means life!

A monitoring tool for the really big tasks: Up to 500 individual emergency lighting systems with over a million light points can be monitored via a single control room monitor. Especially for larger buildings such as airports, universities, museums, sports and industrial facilities, this software is the ideal choice to ensure the optimized and cost-effective operation of the entire emergency lighting system.

Compared to VisionGuard, web server solutions offer only a fraction of the performance. The strengths of the CEAG software are its complexity and configurability. It can manage entire emergency lighting systems with unprecedented transparency and efficiency.

### **Every safety luminaire counts**

The only thing that matters in an emergency is that the system offers 100 percent protection. Building operators also need to document that this is really the case. VisionGuard records all the relevant details in an electronic log book, with status information that can be printed out automatically and at pre-defined intervals. Control in its most economical form.

## Responsive web design

The responsive web design automatically adjusts to the display size/resolution, to make sure that the display is ideally matched to the screen size of any smartphone. Even the navigation menu automatically adjusts to the screen size.

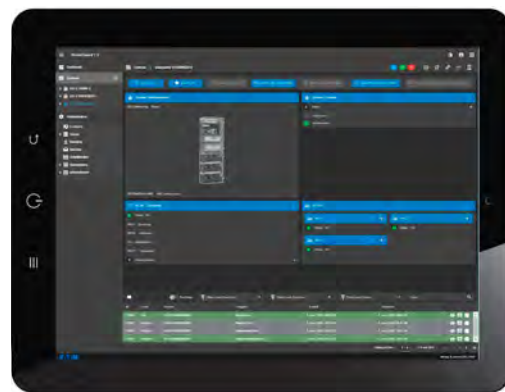

## Tablets

Tablets offer a larger screen than smartphones while still being easy to handle, which makes them ideal for mobile applications. They offer the perfect balance between size and portability.

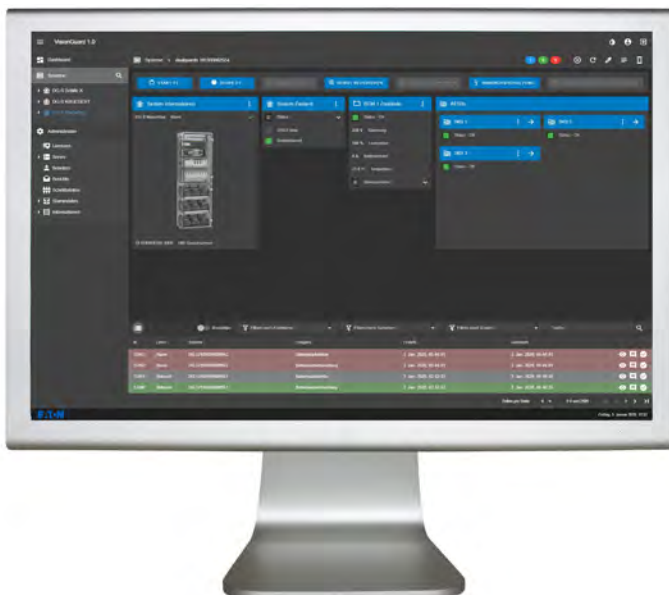

## Full HD

The VisionGuard interface is optimized for a resolution of 1920x1080, which corresponds to Full HD. This means crystal-clear images even on larger screens.

# VisionGuard application examples

VisionGuard – visualization software

## Application example: VisionGuard used as a workstation

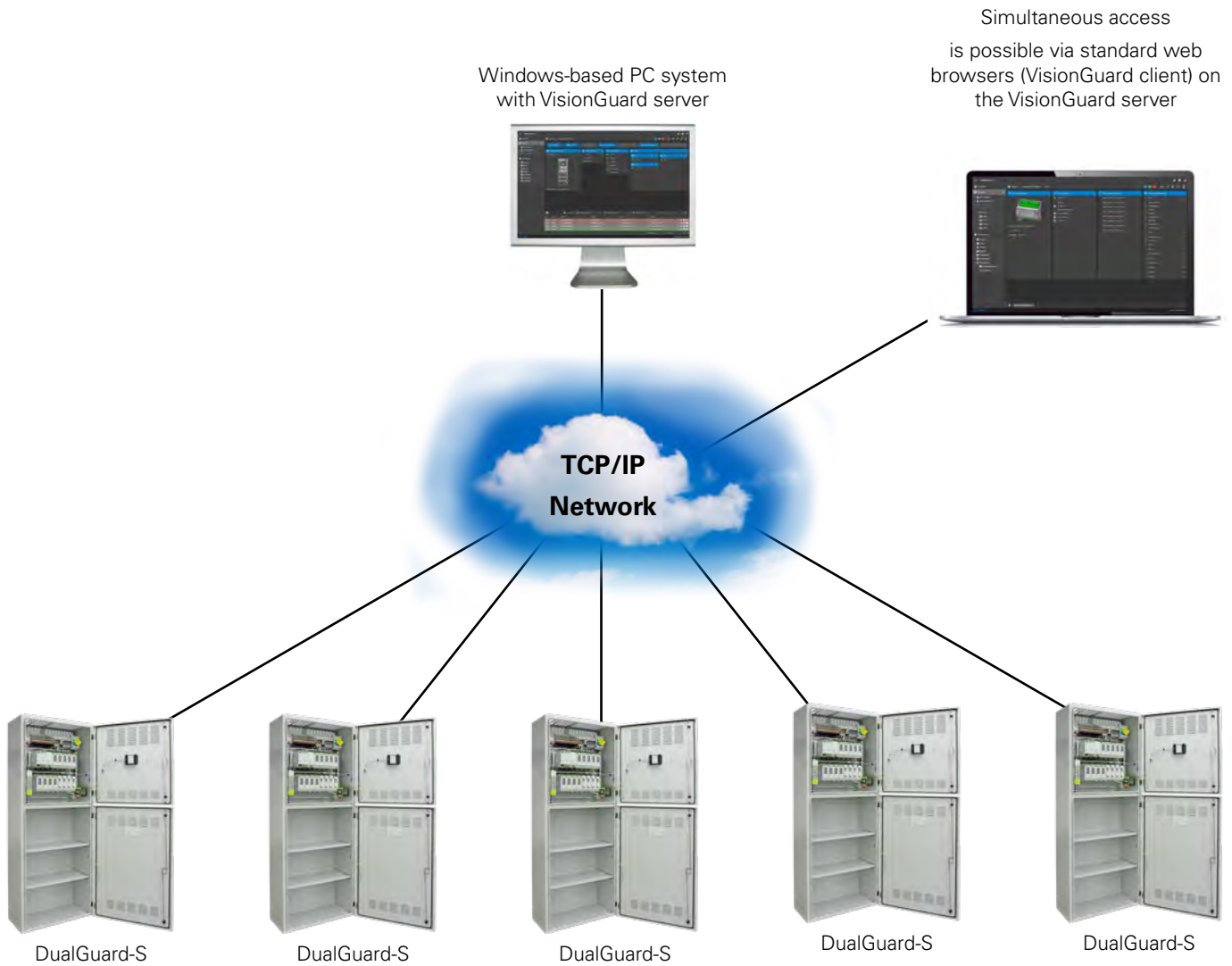

The VisionGuard server software can be installed on any Windows-based PC system. VisionGuard can be accessed via any locally installed web browser. The system can also be easily accessed remotely via a web browser from any PC within the network.



## Application example: VisionGuard used as a server installation

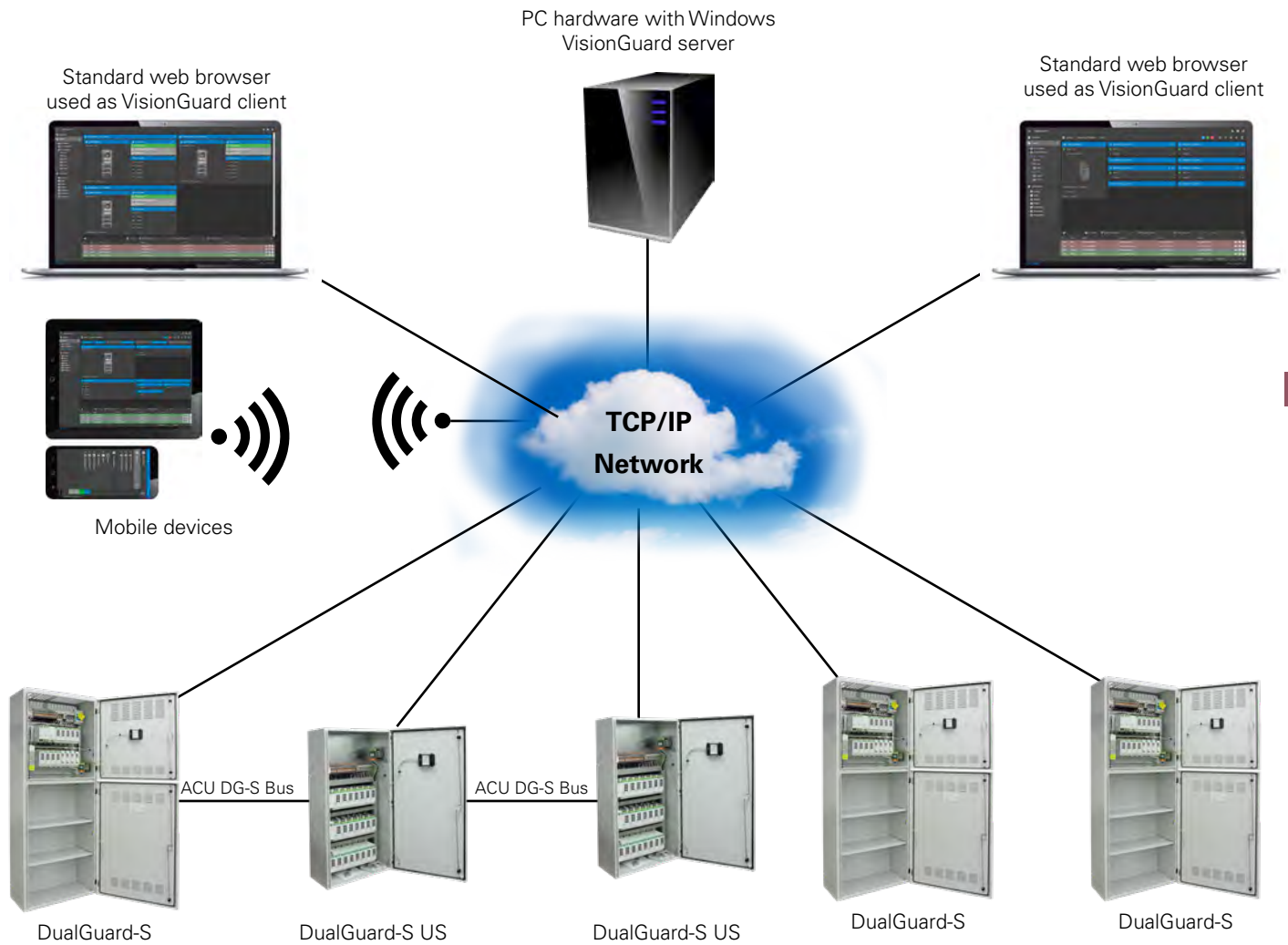

13

The VisionGuard server software can be installed in physical or virtual Windows-based server environments. Dongle-free software licensing eliminates the need for license servers. VisionGuard can be accessed via networked display devices such as PC workstations, mobile PCs or smartphones and from any web browser, so that any operating system, such as iOS, macOS or Android, can be used.



# Insights into the software

VisionGuard – visualization software

## Login – a safe start

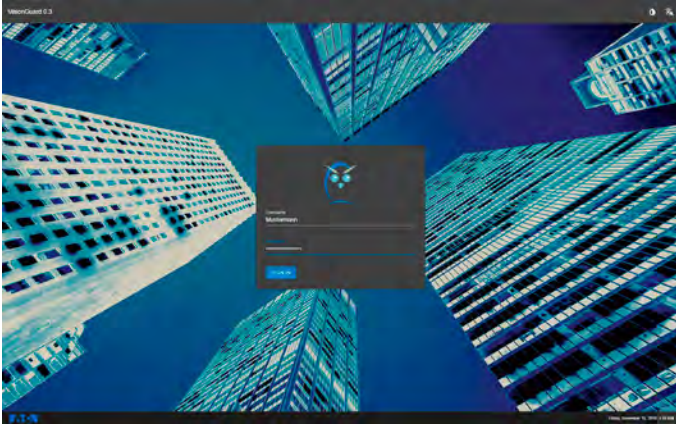

## Light/dark mode

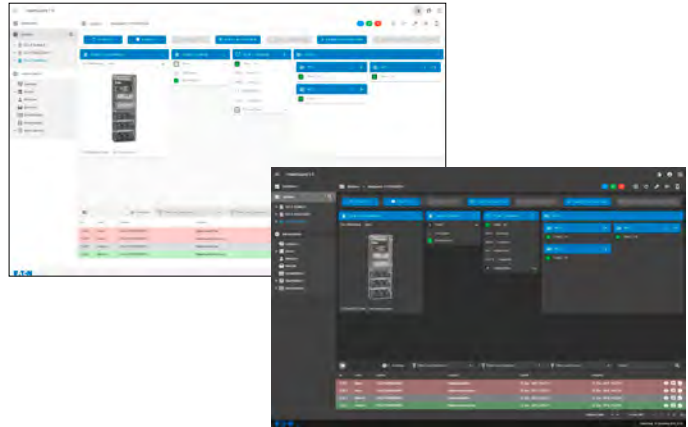

13

To prevent unauthorized access, operators with assigned access rights must first enter their secure password.

The popular light/dark mode can be switched on any screen via the droplet icon

## Dashboard – everything at a glance

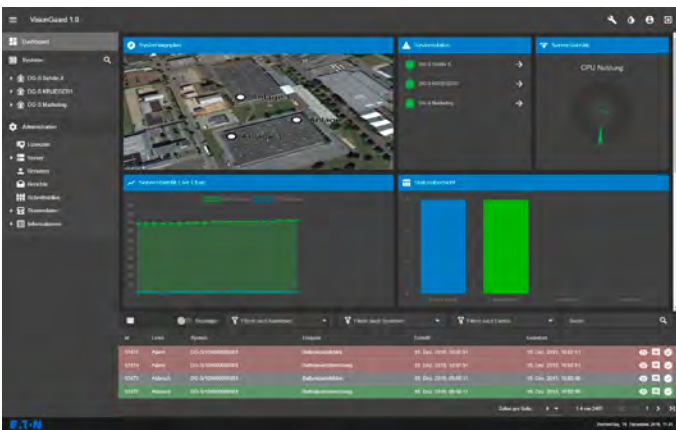

After logging in, the start-up dashboard will appear, featuring a useful summary with information about the system. In the dashboard, it is possible to set up widgets in the form of a graphical window system with summary information about the project in question.

## Navigation menu – easy orientation

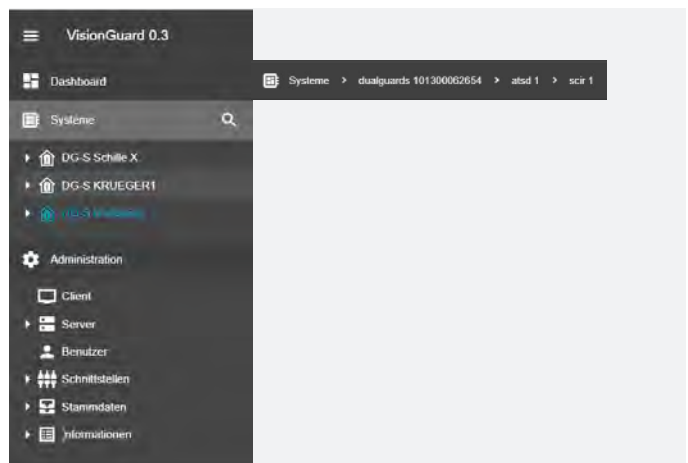

Orientation made easy, thanks to the navigation menu with its helpful “breadcrumb” trail

# System overview – Important information at a glance

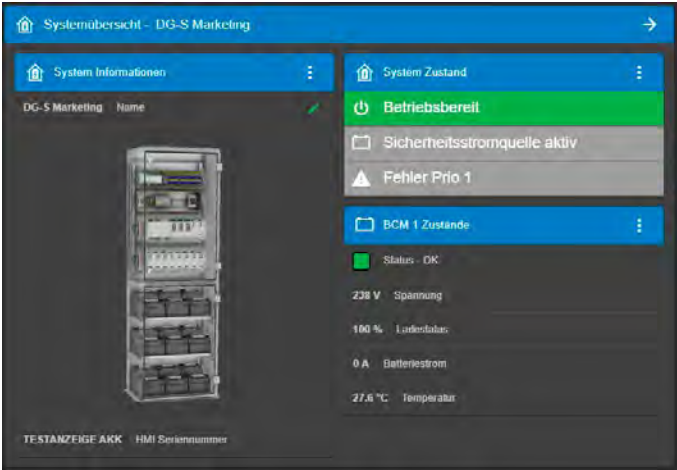

The system overview provides a quick view of the status of each system, with the messages "Normal operation", "Battery operation" and "Sum failure", including analog battery values.

# Systems System overview

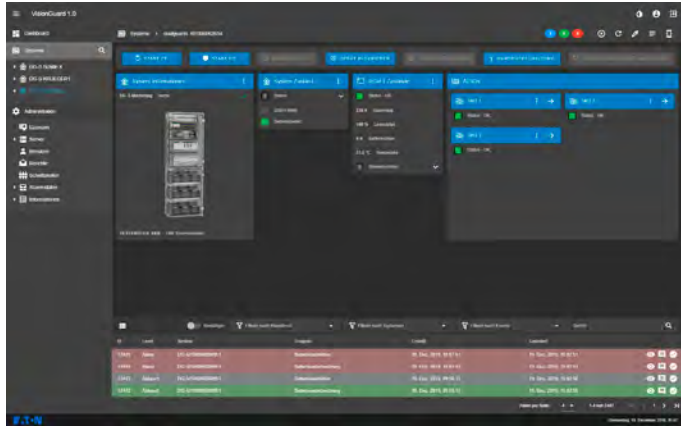

The system overview displays all the important status information of the system, with a focus on what is actually necessary.

# Systems Detailed view

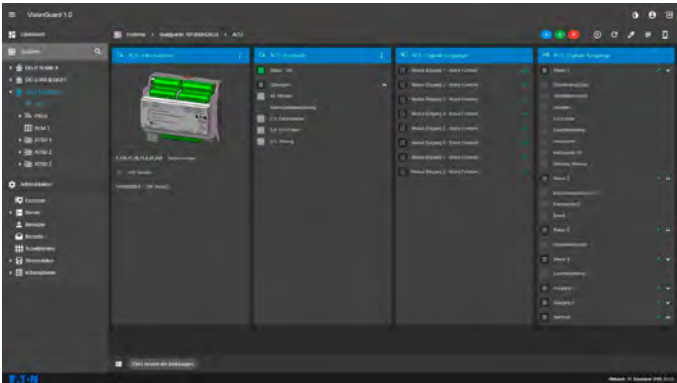

The detailed system view provides more detailed status information. In the detailed system view, all DualGuard components are clearly arranged in the form of an explorer structure. Clicking on a component will open widgets with detailed information.

# Alarm list – the latest events



The events are arranged in different colors by category. A date/time stamp indicates when the event occurred. The filter function makes it easy to search for specific events.

# A convincing technology

VisionGuard – visualization software



## A convincing technology

...with orientation made easy

VisionGuard is the ideal monitoring solution for complex emergency lighting systems, from small projects to large-scale emergency lighting installations such as those found at airports. The software reduces the workload to a minimum, with fully automated processes and notification tools.



# A user-friendly log book with filter function

All events are fully recorded in an electronic log book over a period of at least 4 years in accordance with DIN EN 50172 / DIN VDE V 0108-100-1. Comprehensive filter functions greatly simplify the retrieval of specific events.

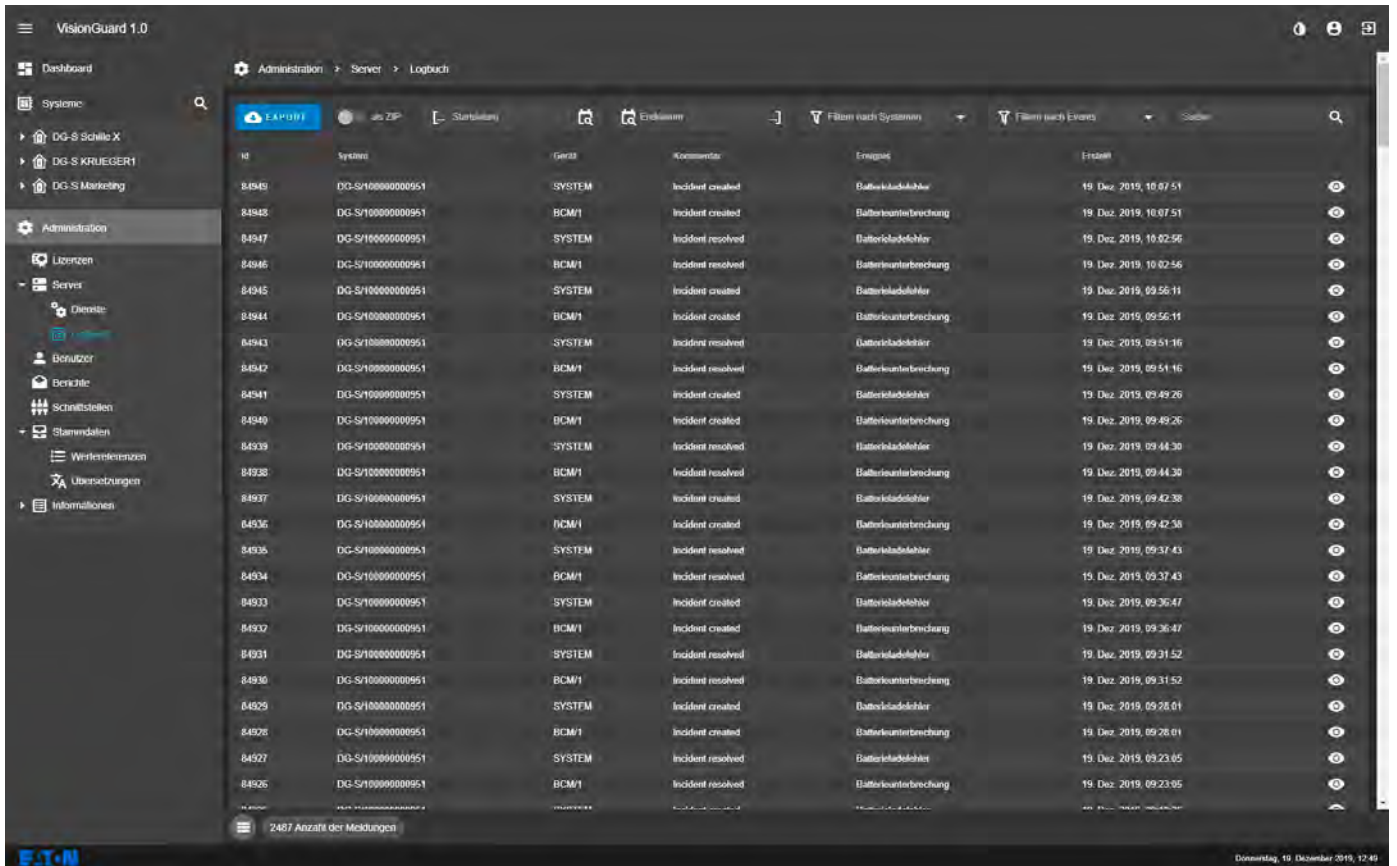

13

Seamless recording of all events

The adjustable email function provides information about alarms and sends status reports after function testing with detailed information down to luminaire level

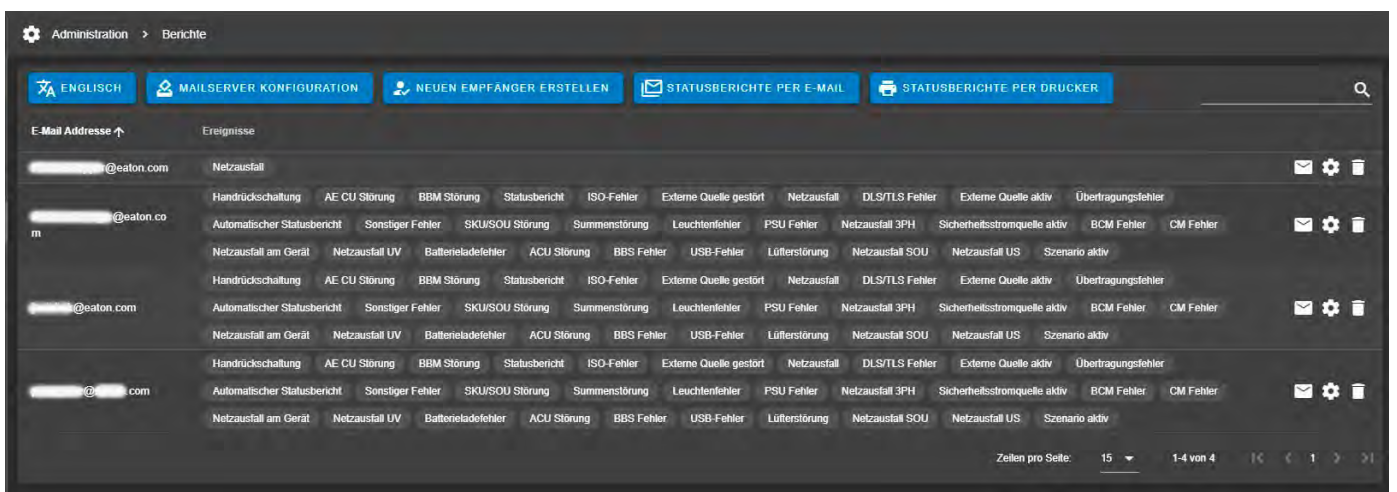

Email settings menu with adjustable alarm notifications

# Monitoring software

VisionGuard – visualization software

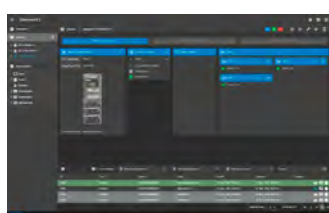
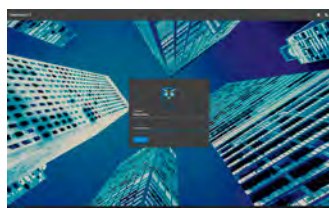

## Monitoring software

- A modern web-based client/server architecture
- Full monitoring of up to 500 emergency lighting systems with over 1,000,000 light points
- Extremely versatile: full visualization, monitoring and programming of up to 500 emergency lighting systems with over 1,000,000 emergency luminaires.
- Orientation made easy: With luminaire texts and additional information fields for each luminaire, alongside aerial views and floor plans of the emergency lighting systems and luminaires.
- Transparent and user-friendly log books and extensive print functions provide a clear overview.
- Automatic notifications: The integrated email function with numerous setting options conveniently sends information via email and thereby eliminates the need for in-person inspections.

### VisionGuard - system hardware / software requirements:

<b>Server</b>	Standard PC (tower, rack), virtual machine
Operating system	Windows® 10 (64 Bit), Windows® Server 2016, Windows® Server 2019
Processor	min. Intel i5 or AMD Ryzen 5
Working memory	min. 8 GB RAM
Hard drive (recommended)	256 GB SSD
Resolution	Full HD 1920x1080 or higher
<b>Client</b>	Standard Windows PC workstation
Graphics	DirectX 12
Software	Standard web browser, such as Edge, Chrome, Firefox, Safari
Display	min. 19"
Ideal resolution	Full HD 1920x1080 or higher
Peripheral devices	Keyboard, mouse, printer

## VisionGuard

- A modern web-based client/server architecture
- Independent, simultaneous access from different PC workstations
- Dongle-free software licensing
- Multi-user operation: A web-based client/server architecture that can be accessed independently and in parallel from different workstations
- Dongle-free software licensing
- Tiered versions, from 3 to 500 emergency lighting systems
- State-of-the-art, web-based dashboard design with widgets (graphic window system)
- Responsive, web-based design for different display sizes
- Optimized for Full HD (1920 x 1080 dpi)
- Full visualization, control and configuration down to the level of each system/luminaire
- User access control with four user roles (supervisor, administrator, power user and user)
- Detailed email function
- Advanced printing functions
- Cyber security certified (EATON)

### Volume licensing

Basic version for 3 devices

Basic version for 10 devices

Basic version for 25 devices

Basic version for 50 devices

Basic version for 100 devices

Basic version for 500 devices





### 24" TFT display

Large TFT flat screen with IPS display and high resolution (1920 x 1200) for displaying the VisionGuard visualization, monitoring and programming software via a PC system.

### PC-Miditower

A powerful PC system for installing and operating the VisionGuard visualization, monitoring and programming software. Includes WIN 10 Prof. (64 Bit), PC: high-performance Intel i5 processor, 8 GB RAM / 64 Bit, 256 GB SSD, 1 TB HD, mouse and keyboard.

### Software order information

Part no.	Included with delivery	Article no.
VisionGuard basic version 3	Certificate with download link and license key	40071362800
VisionGuard basic version 10	Certificate with download link and license key	40071362805
VisionGuard basic version 25	Certificate with download link and license key	40071362810
VisionGuard basic version 50	Certificate with download link and license key	40071362815
VisionGuard basic version 100	Certificate with download link and license key	40071362820
VisionGuard basic version 500	Certificate with download link and license key	40071362825

### Hardware order information

Part no.	Included with delivery	Article no.
PC-Miditower	with high-performance Intel i5 processor, includes optical mouse and WIN 10 Prof. (64 bit), VisionGuard software pre-installation included	40071362880
24" TFT display	IPS display with 1920 x 1200 native resolution	40071347155
Inkjet printer colour	optional	40071340753
Laser printer colour	High quality colour laser printer DIN A4	40071362850



## A software for giant tasks

The high performance CGVision visualisation software controls and monitors even large-scale safety lighting systems with maximum reliability. This is backed up by CEAG, a company belonging to Cooper Industries, with over 40 years of expertise and experience. As market leader we are always aware of our special responsibility. Because where we are active, light means life!

The monitoring tool for really large-scale tasks: up to 480 individual emergency lighting systems with over one million light points can be kept in view on a monitor in the control room. With larger buildings in particular such as airports, universities, museums, sports centres and industrial facilities, the software is the ideal partner for optimal and therefore also economical operation of the complete safety lighting.

Web server solutions can only achieve a fraction of this compared to CGVision. Complexity and configurability are the strengths with which the CEAG software convinces. The management of the complete safety lighting is implemented with exemplary clarity and efficiency.

### Every safety luminaire counts

Because when the worst comes to the worst, only 100 percent protection is enough. Every operator must document such cases. CGVision records all relevant details in an electronic inspection book. Status printouts can be implemented automatically and according to set times.

Control in its most cost-efficient form.





# Clarity counts



In the main group screen, up to 15 buildings (or other device groups) can be defined. With green everything is fine, red means that a defect has occurred.



The device group affected by the defect can be opened as simply as that. A maximum of 480 emergency lighting systems with up to 32 devices per group can be visualised here.

13

# Intuitive operating concept

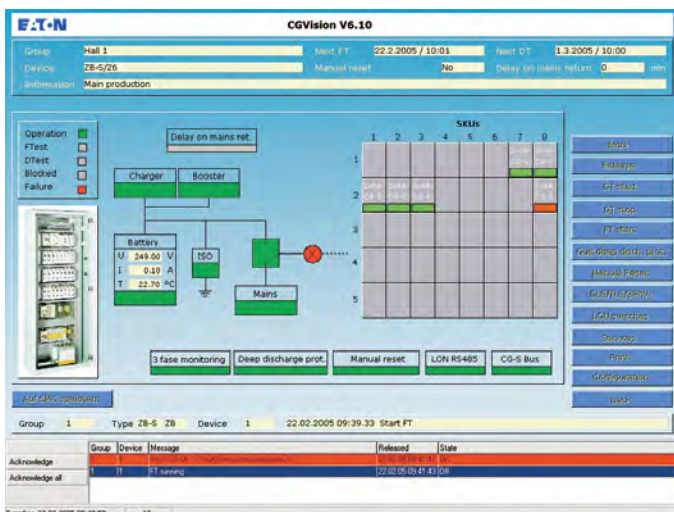

Red signals a problem. The device image gives a quick overview and supplies detailed, highlighted status information.



The software recognises colours on the circuit level as well. What is the luminaire status? Are the maximum of 20 luminaires switched off or defective? One glance is enough.

# Central Visualisation

Visualisation software CGVision

## Documenting, controlling, reacting

CGVision tests the complete system once weekly in automatic mode according to legislative requirements. Complex control rounds are a thing of the past.



13

CGVision tests the complete system once weekly in automatic mode according to legislative requirements. Complex control rounds are a thing of the past.

If an 'emergency light defect' is reported, the error can be localised conveniently and safely on the screen. The display shows in which subsystem the defect has occurred, which circuit module is affected, the position specification of the luminaire and how the switching type was programmed. The software interface is no cryptic intellectual challenge but can be operated highly intuitively.

It is also possible to integrate a detailed building plan into the software that precisely positions the safety luminaires with a coloured status display at their locations. Safety-relevant controls of the work of house technicians or external service providers can be implemented directly on the screen. If the display changes from red to yellow, the light point again functions perfectly.

But the graphical display possibilities do not end there: even the location-specific display as part of an aerial view is possible. You can't get an overview more quickly.

### More comfort with an interface to building technology

CGVision and the emergency lighting systems can be connected without complex installations via existing LAN and telecommunication cables. The most common interfaces for building technology are offered. A connection to the building control systems is also simple: CGVision offers an OPC interface for this, or optionally a BACnet interface.

The software is also optimal for decentral solutions: various locations can be controlled via the company-internal intranet without limitations. In this way, efficiency and economy are united as one.



**BMS**

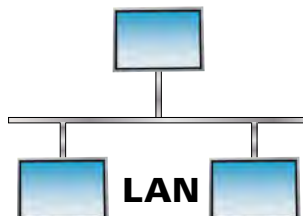

**CGVision**

# Graphical display possibilities

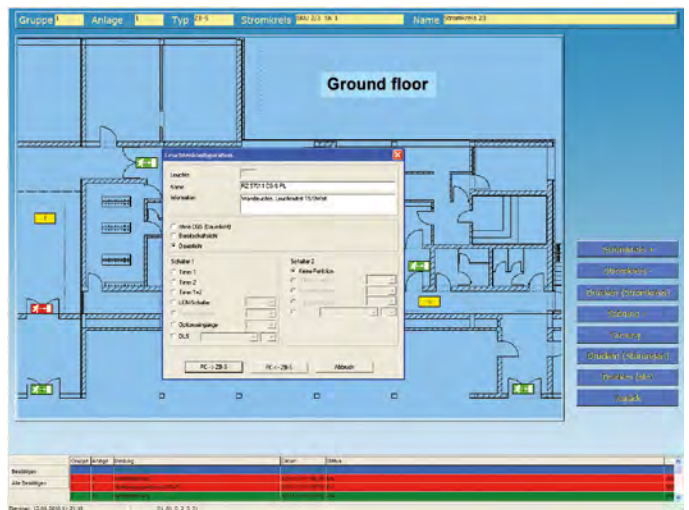
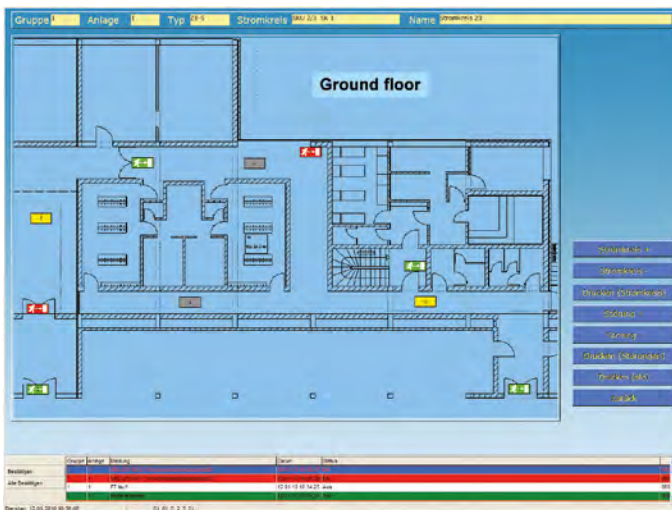

13

Clear and concise display of the luminaires in the layout plans is also optionally possible. A special graphics tool enables the simple import of CAD plans in .dwg or .dxf format.

The luminaires can be reprogrammed with respect to their switching types, e.g. from maintained light to standby light with only a few clicks of the mouse in the layout image.

# Orientation becomes child's play

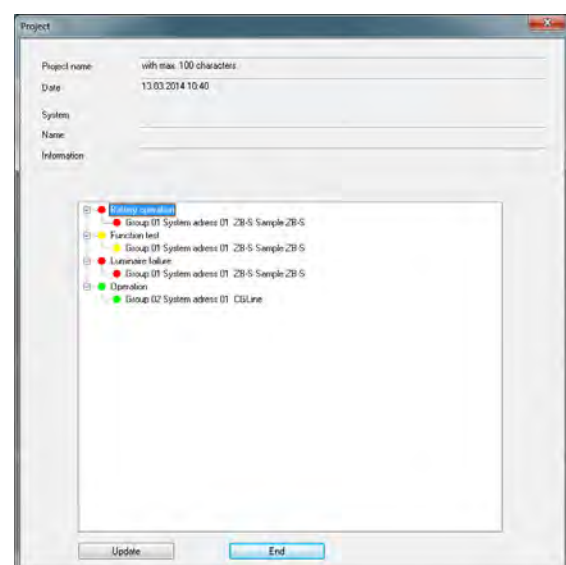
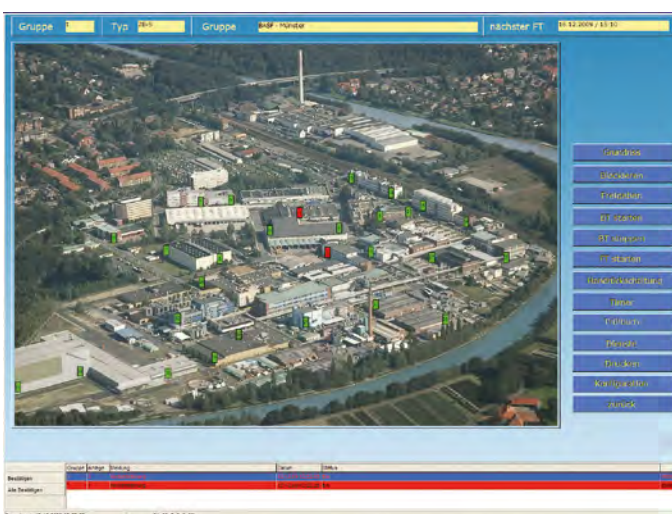

Display of the emergency lighting systems in an aerial view or area plan simplifies orientation enormously!

In addition, all systems can be displayed clearly within an Explorer structure along with detailed information.



## Technology that always pays for itself ...

... and not only because our light saves lives.

CGVision is the ideal tool for the central monitoring and fully automated inspection of complex emergency lighting systems. The workload is reduced enormously because control rounds are no longer necessary. The team of technicians or external service providers are only then required when a defect is reported. Personnel-intensive resources are therefore spared.

Decentral implementation in particular where several locations are interconnected via

intranet pays for itself rapidly. If for example the safety lighting systems of six locations are monitored centrally at one location, thanks to the powerfully functional CEAG software this is possible by only one person. The person responsible has all light points in view from one control room and also has their functional efficiency under control, even at a distance of 500 kilometres. In times past this task would have occupied more than half a dozen technicians.

# Fully automatic functions optimise work and time invested



Time-controlled, automatic system status printouts

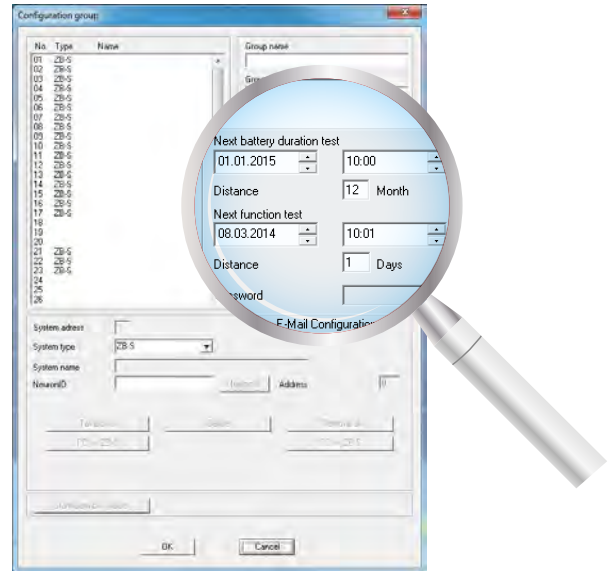

Self-executing tests

# Professional functions for total convenience

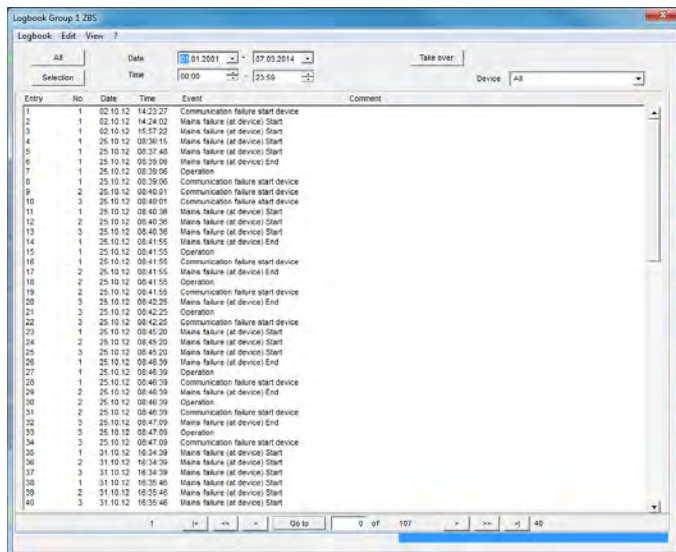

Innovative inspection books with intuitive operation

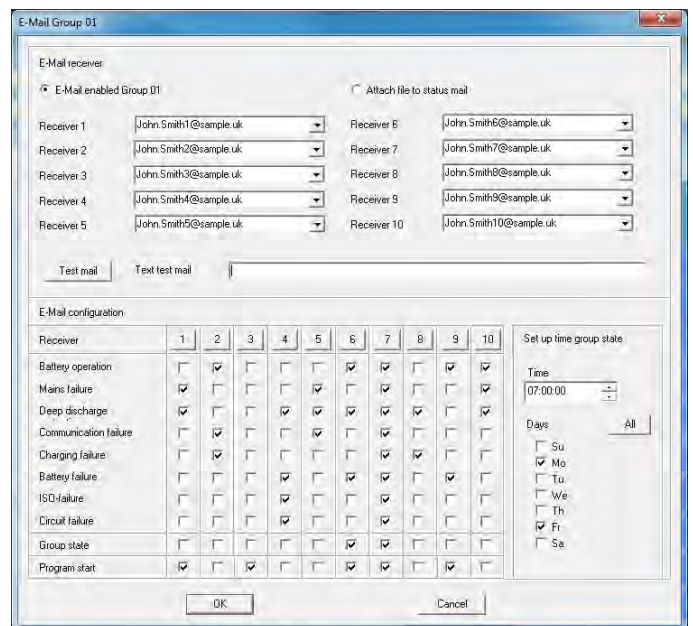

Notification per e-mail

# Phase out 2021: CGVision

Visualisation software CGVision



## The correct license for your application

**13** CGVision visualisation software is available in three different packages in the Basic or Pro versions.

The packages essentially differ with the CG-S interface for connecting the existing emergency light systems to the CG-S bus. All packages have dongle licenses for all EGA devices that can be connected to CGVision (ZB96/Euro ZB.1/GVL24.1/CG48 or ZVL220, optionally available CG-S/IP router+ 1P required)

**Package I** contains a CG-S/IP interface, for connecting CG-S based systems such as ZB-S, AT-S+ or CG2000 via ethernet (IP network). For this purpose optional CG-S/IP-Router are necessary.

**Package II** does not contain a CG-S interface, e.g. only with use of a CGLine+ self-contained luminaire system via CGLine+ Web-Controller.

**Package III** contains a CG-S/USB interface for connecting CG-S based systems via a standard 2-wire bus line (CG-S bus).

All **Pro Packages** contain in addition to the Basic Packages convenient layout programming enabling the display of the systems in building plans or aerial views, or the display of emergency luminaires circuit-related in building layouts. The image format is typically .bmp format. Converting a .dwg based AutoCAD file is also possible. Positioning luminaires in the layout is via drag & drop.



### Overview CGVision licences

	Basic Package I	Basic Package II	Basic Package III	Pro Package I	Pro Package II	Pro Package III
CG-S/IP interface	X	-	-	X	-	-
EGA licences	X	X	X	X	X	X
CGLine 400 licences	X	X	X	X	X	X
CGLine+ licences	X	X	X	X	X	X
Ethernet I/O licences	X	X	X	X	X	X
CG-S/USB interfacebox	-	-	X	-	-	X
Graphic visualisation of the devices	-	-	-	X	X	X
Visualisation in a building layout	-	-	-	X	X	X



# Phase out 2021: CGVision Package I

CGVision Package I (Basic or Pro) contains the CG-S/IP interface (USB dongle) enabling CG-S bus-based emergency light systems such as ZB-S, LP-STAR, AT-S<sup>+</sup> and CG2000 to be connected to the CGVision visualisation software with the aid of CG-S/IP routers (optionally available) via an ethernet-based network (TCP/IP).

Any number of ZB-S, AT-S<sup>+</sup> or CG2000 systems, also in mixed state, can be connected to a CG-S/IP router+ 1PV2. In CGVision the systems must however be assigned own device groups.

In addition, the CGVision Package I version contains all dongle licenses for EGA devices (ZB96, EuroZB.1, GVL24.1, CG48 or ZVL220), CGLine+, CGLine or Ethernet I/O modules on CGVision.

## CGVision Package I application example

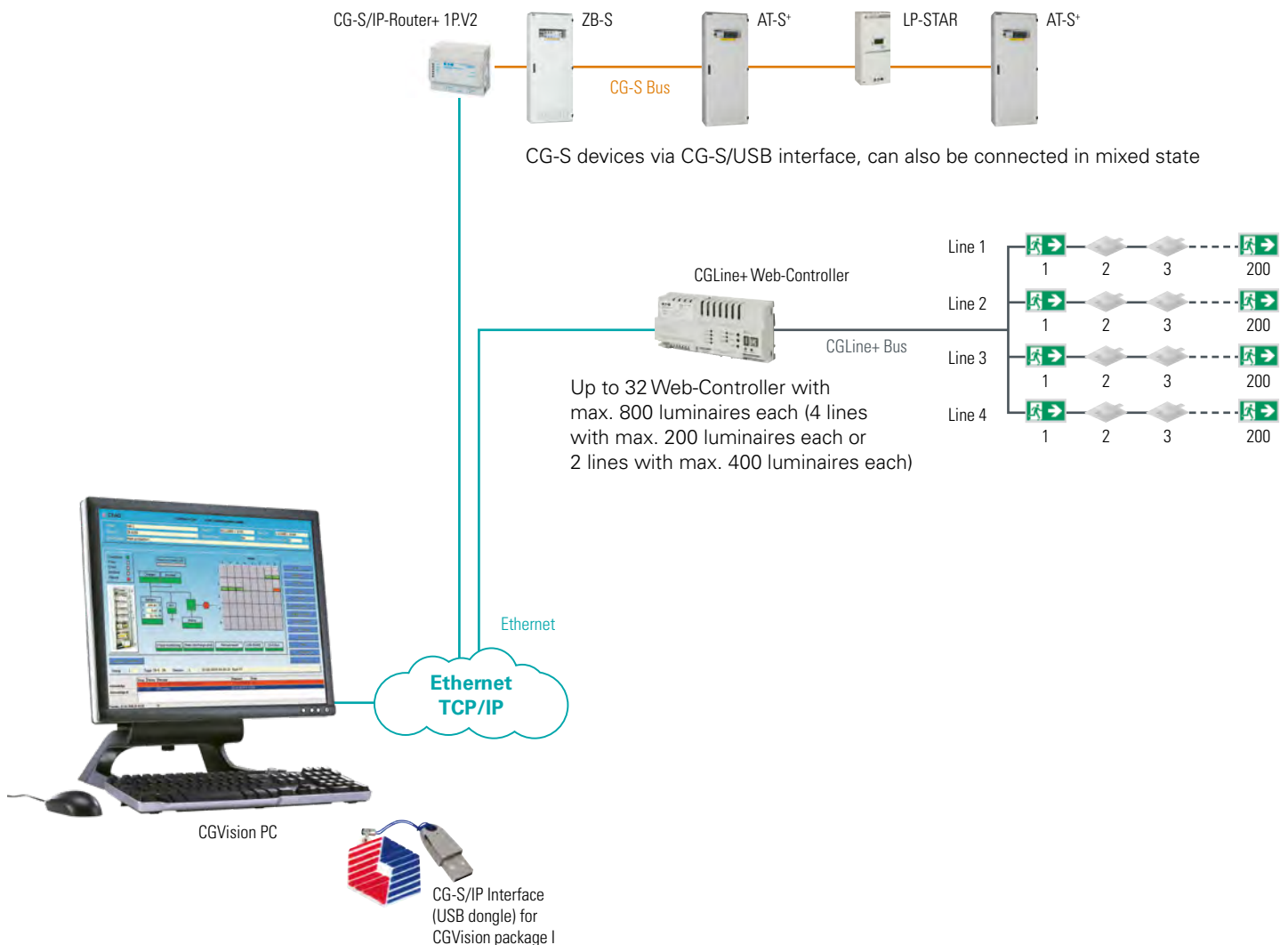

# Phase out 2021: CGVision

Visualisation software CGVision

## Phase out 2021: CGVision Package II

CGVision Package II (Basic or Pro) does not contain the CG-S interface.

The package contains all dongle licenses for EGA devices (ZB96, EuroZB.1, GVL24.1, CG48 or ZVL220), CGLine+, CGLine or Ethernet I/O modules on CGVision. Thus only visualisation of EGA devices or CGLine+ self-contained luminaires without CG-S bus-based devices is possible.

The license for the I/O Ethernet module is also provided, enabling visualisation of devices from other manufacturers via potential-free contacts.

13

### CGVision Package II application example

F3 remote indication

CGLine+ Web-Controller

CGLine+ Bus

Up to 32 Web-Controller with max. 800 luminaires each (4 lines with max. 200 luminaires each or 2 lines with max. 400 luminaires each)

Ethernet

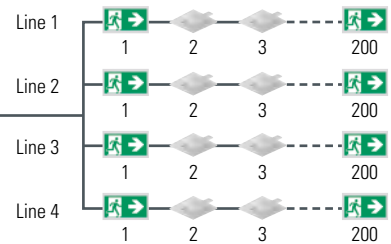

Ethernet TCP/IP

CGVision PC

USB licence dongle for CGVision Package II



# Phase out 2021: CGVision Package III

CGVision Package III (Basic or Pro) contains the CG-S/USB interface (USB box), enabling CG-S bus-based emergency light systems such as ZB-S, LP-STAR, AT-S+ and CG2000 to be connected to the CGVision visualisation software via a standard bus cable.

Any number of ZB-S, CGLine+, AT-S+ or CG2000 systems, also in mixed state, can be connected. In CGVision the systems must however be assigned own device groups.

Increasing the distance of the bus cable is possible via optionally available repeaters or routers.

In addition, the CGVision Package III version contains all dongle licenses for EGA devices (ZB96, EuroZB.1, GVL24.1, CG48 or ZVL220), CGLine+, CGLine or Ethernet I/O modules on CGVision.

## CGVision Package III application example

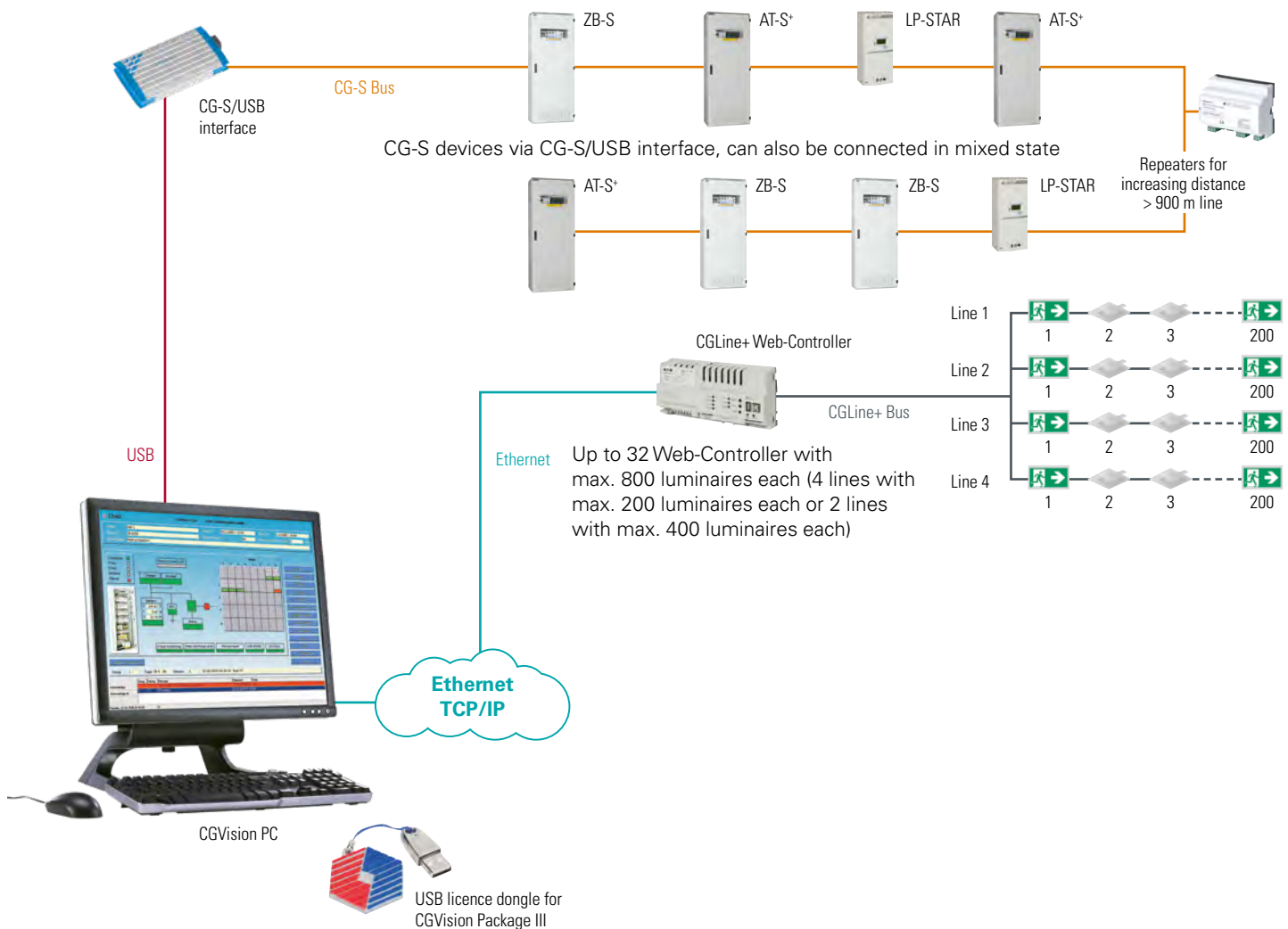

# Phase out 2021: CGVision

Visualisation software CGVision



## Monitoring and programming software

- Extremely diverse: complete visualisation, monitoring and programming of up to 480 emergency lighting systems with over 1,000,000 emergency luminaires
- Ideal orientation: luminaire texts and supplementary information fields for each luminaire as well as the display of emergency lighting systems and luminaires in aerial views or layouts makes orientation child's play
- Clear and user-friendly inspection books as well as extensive printing functions offer convenient information possibilities
- Automatic notification: an integrated e-mail function with many setting possibilities informs conveniently per e-mail. Thus control rounds are no longer necessary



Operating system	Windows® 7 (32 Bit/64 Bit), Windows® 10 (32/64 Bit), Windows® Server 2012 (no server/client)
Processor	at least 2 GHz
RAM	at least 4 GB RAM / 32 Bit or 8 GB RAM / 64 Bit recommended
Hard disk	10 GB free hard disk storage
Graphics board	at least 128 MB (no shared memory)
Drives	CD-ROM / DVD
Monitor	at least 17" (min. 1280 x 1024 dpi)
Mouse, keyboard	1 x each
USB port	1 x (CG-S interface/dongle license) 1 x USB for printer

13



## CGVision

- Detailed system information are available at every time
- Simple menu guidance
- Up to 480 emergency lighting devices are monitor- and programmable, a segmentation in up to 15 groups of devices is possible (one device group per device family)
- Up to 32 pcs. CGLine+ WEB-Controller with up to 25,600 CGLine+ luminaires are monitor- and programmable
- Up to 8 pcs. CGLine WEB-Interfaces with up to 3,200 self contained luminaires are monitor- and programmable
- Free input of texts and additional information at each level (up to 100 signs) and cognition of destination for luminaires (ZB-S/CG 2000 up to 20 signs)
- Inquiry of the current working conditions of all mounted systems
- Clearly-presented display in explore structure (tree structure) possible
- Constant display of the 5 latest events in an alarm list
- Localised failure display about each emergency circuit and luminaries with destination data in plain text in connection with function tests
- Always current information on charging unit and battery
- Storage and retrieval possibility of all log book entries over a period of 4 years at least
- Free programmable function- and duration test
- Configurable automatic print functions
- Integrated e-mail client program with status information for each device group
- Up to 10 e-mail recipients each device group configuring
- Connection of a building management system (BMS) via integrated OPC-server possible
- Optional BACnet server (only for ZB-S / CG2000) for BACnet based BMS available

## Overview CGVision licences

	Basic Package I	Basic Package II	Basic Package III	Pro Package I	Pro Package II	Pro Package III
CG-S/IP interface	X	-	-	X	-	-
EGA licences	X	X	X	X	X	X
CGLine 400 licences	X	X	X	X	X	X
CGLine+ licences	X	X	X	X	X	X
Ethernet I/O licences	X	X	X	X	X	X
CG-S/USB interfacebox	-	-	X	-	-	X
Graphic visualisation of the devices	-	-	-	X	X	X
Visualisation in a building layout	-	-	-	X	X	X

## Features of all packages

- CGLine+ Licence (release via USB-dongle) for visualisation of CGLine+ self-contained luminaires via CGLine+ WEB-Controller on CGVision. Up to 32 pcs. CGLine PC-interfaces with up to 25,600 pcs. CGLine+ self-contained luminaires can be controlled and monitored.
- CGLine Licence (release via USB-dongle) for visualisation of CGLine self-contained luminaires via CGLine WEB-interface on CGVision. Up to 8 pcs. CGLine PC-interfaces with up to 3,200 pcs. CGLine self-contained luminaires can be controlled and monitored.
- Ethernet I/O-License (released via USB-dongle) for visualisation of devices via pot.-free In-/Outputs. 8 digital inputs for visualisation and 7 relay outputs 24V, to control of diverse functions, e.g. Start function test.

## In addition all CGVision Software Pro Packages contain:

- Graphic visualisation of the devices in a .bmp graphic, e.g. area plan, aerial map
- Circuit orientated visualisation of luminaires in a building layout

Licence (Dongle) Basic Package I

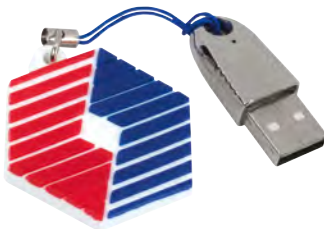

## Special features of CGVision Software Basic Package I

- CG-S/IP-Interface (USB-dongle) for the connection of CEAG emergency lighting systems with STAR technology (AT-S+, ZB-S, LP-STAR, CG 2000) via an ethernet (TCP/IP), directly via the LAN-interface (RJ45) of the PC. For the connection of CEAG emergency lighting systems with STAR-Technology via an ethernet, CG-S/IP-Routers+ 1P are necessary, which are optionally available.
- EGA-Licences (release via USB-dongle) for the visualisation of EGA-devices on CGVision. Up to 8 EGA-lines of each device family (ZB96, Euro ZB.1, GVL 24.1, CG48, and ZVL220) possible. Max. 15 EGA-lines in total on CGVision connectable. For the connection of CEAG emergency lighting systems with EGA-technology at CGVision via EGA-Interface-Box (one box each line) or via EGA/PC-interface-2 (each interface up to two lines) on a PC.

Licence (Dongle) Basic Package II

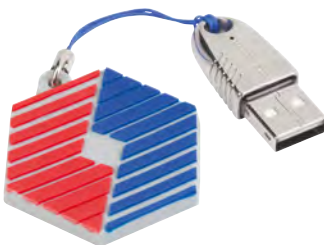

## Special features of CGVision Software Basic Package II

- EGA-Licences (release via USB-dongle) for the visualisation of EGA-devices on CGVision. Up to 8 EGA-lines of each device family (ZB96, Euro ZB.1, GVL 24.1, CG48, and ZVL220) possible. Max. 15 EGA-lines in total on CGVision connectable. For the connection of CEAG emergency lighting systems with EGA-technology at CGVision via EGA-Interface-Box (one box each line) or via EGA/PC-interface-2 (each interface up to two lines) on a PC.

Licence (Dongle) Basic Package III

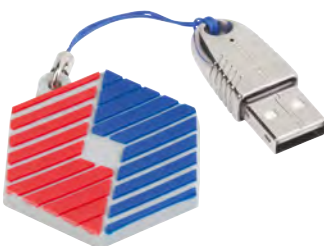

## Special features of CGVision Software Basic Package III

- CG-S/USB-Interfacebox for the connection of CEAG emergency lighting systems with STAR technology (AT-S+, ZB-S, CG 2000) via a conventional two-conductor cable data bus.
- EGA-Licences (release via USB-dongle) for the visualisation of EGA-devices on CGVision. Up to 8 EGA-lines of each device family (ZB96, Euro ZB.1, GVL 24.1, CG48, and ZVL220) possible. Max. 15 EGA-lines in total on CGVision connectable. For the connection of CEAG emergency lighting systems with EGA-technology at CGVision via EGA-Interface-Box (one box each line) or via EGA/PC-interface-2 (each interface up to two lines) on a PC.

# Phase out 2021: CGVision

## Visualisation software CGVision

Licence BACnet-Server (Dongle)



### BACnet Server for CGVision

BACnet Server for CGVision to connect a BACnet based BMS to CGVision with ZB-S/CG2000 systems via BACnet/IP. The BACnet Server provides event-driven BACnet-objects with relevant status indications of ZB-S/CG2000 systems with STAR technology.

The BACnet interface provides following information each ZB-S/CG2000 system:

- 35 status information (e.g. mains failure, battery operation, luminaire sum failure etc.)
- 3 sum messages, mirroring of free programmable relay contacts
- 4 analogue battery values (Battery voltage, charge-/discharge current, temperature, capacity)
- 4 ZB-S control commands (e.g. start function test)
- 16 switch commands, to switch circuits or luminaires, which are programmed to LON-switch

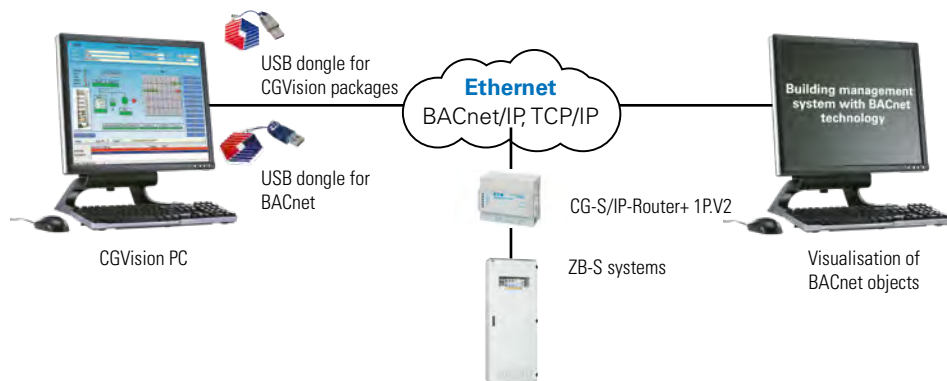

## 24" TFT screen

Generous TFT high resolution flat screen for display of CGVision visualisation, monitoring and programming software via a PC system.

## PC miditower

High performance PC system for installation and operation of CGVision visualisation, monitoring and programming software, incl. WIN 10 Prof. (64 Bit), PC: High performance processor, 8 GB RAM / 64 Bit, 256 GB SSD, 1 TB HDD and mouse.

## Ordering specifications software

Scope of delivery	Order No.
CGVision Basic Package I (including CG-S/IP-Interface)	40071361020
CGVision Basic Package II (EGA components to be ordered separately)	40071361022
CGVision Basic Package III (including CG-S/USB-Interface, EGA components to be ordered separately)	40071361024
CGVision Pro Package I (including CG-S/IP-Interface and visualisation in a building layout)	40071361021
CGVision Pro Package II (including visualisation in a building layout, EGA components to be ordered separately)	40071361023
CGVision Pro Package III (including CG-S/USB-Interface and visualisation in a building layout, EGA components to be ordered separately)	40071361025

13

## Ordering specifications optional licenses

Scope of delivery	Order No.
CGVision CEAG BACnet-Server (dongle) with 1000 data points, version: USB-Port	40071360336

## Hardware order information

Part no.	Included with delivery	Article no.
PC-Miditower	with high-performance Intel i5 processor, includes optical mouse and WIN 10 Prof. (64 bit), CGVision software pre-installation included	40071347144
24" TFT display	IPS display with 1920 x 1200 native resolution	40071347155
Inkjet printer colour	optional	40071340753
Laser printer colour	High quality colour laser printer DIN A4	40071362850



4-channel repeater for CG-S bus



### CG-S bus components

- Powerful amplifier modules for expansion of bus structure
- Signal amplification and regeneration
- Generation of CG-S network segments
- Active interference suppression with logical filter function (router)
- Expansion of network capacity
- With diagnosis function
- Visualise without limits with transmission via TCP/IP
- Use existing ethernet-based corporate networks
- Any media possible (copper, LAN, WLAN, glass fibre)
- Convenient networking via standard network components

### CG-S bus repeater

- 4-channel repeater for connecting of CG-S bus networks and expansion of network capacity of a CG-S bus network via physical division into two or more CG-S bus network segments.

### Order specifications CG-S Bus (ZB-S, CG2000)

Scope of delivery	Order No.
4-channel repeater for CG-S bus	40071070583

CG-S/IP router+ 1PV2



CG-S/IP router+ 1PV2 connection box



CG-S/USB Interfacebox



### CG-S/IP router+ 1PV2

- CG-S/IP router+ 1PV2 for connection of CEAG emergency lighting systems with CG-S bus to CGVision via an existing on-site ethernet (with TCP/IP). Simple, building-wide connection of decentrally located emergency lighting systems with STAR technology with coupling of CG-S/IP routers+ 1PV2 configured as clients via ethernet. Connection to CGVision can either be implemented via a USB port with the CG-S/USB interface box and a CG-S/IP router+ 1PV2, or directly via the LAN interface of the PC. The CG-S/IP interface is required for this. Management of all CG-S network components is implemented via any CG-S/IP router+ 1PV2 in the network configured as a configuration server and administering all participants in a channel list with their IP addresses.
- CG-S/IP-router+ connection box incl. CG-S/IP router+ 1PV2 and 24V/1.25A DC power supply for external mounting.
- CG-S/IP interface for operation of CEAG emergency lighting systems with CG-S bus technology and CG-S/IP router+ 1PV2 via ethernet to CGVision visualisation, monitoring and programming software. The CG-S/IP interface enables connection of the emergency lighting systems via CG-S/IP router+ 1PV2 through the ethernet directly via the LAN interface of the PC.

13

### Order specifications CG-S Bus/Ethernet

Scope of delivery	Order No.
CG-S/IP router+ 1PV2 (Ethernet)	40071361090
CG-S/IP router+ 1PV2-connection box incl. CG-S/IP router+ 1PV2 (ethernet) and 24V/DC power supply	40071361092

### Order specifications CG-S Bus (ZB-S, CG2000)

Scope of delivery	Order No.
CG-S/USB interface box, surface mounted housing, without license key, replacement part	40071347137



## CEAG contact person

You can find further information at [www.ceag.de](http://www.ceag.de)

We are also available for you personally.

Our technical sales representatives are available on-site for creating interesting and economic escape lighting concepts according to specific requirements and complying with valid regulations.

## Emergency Lighting - A truly global support network

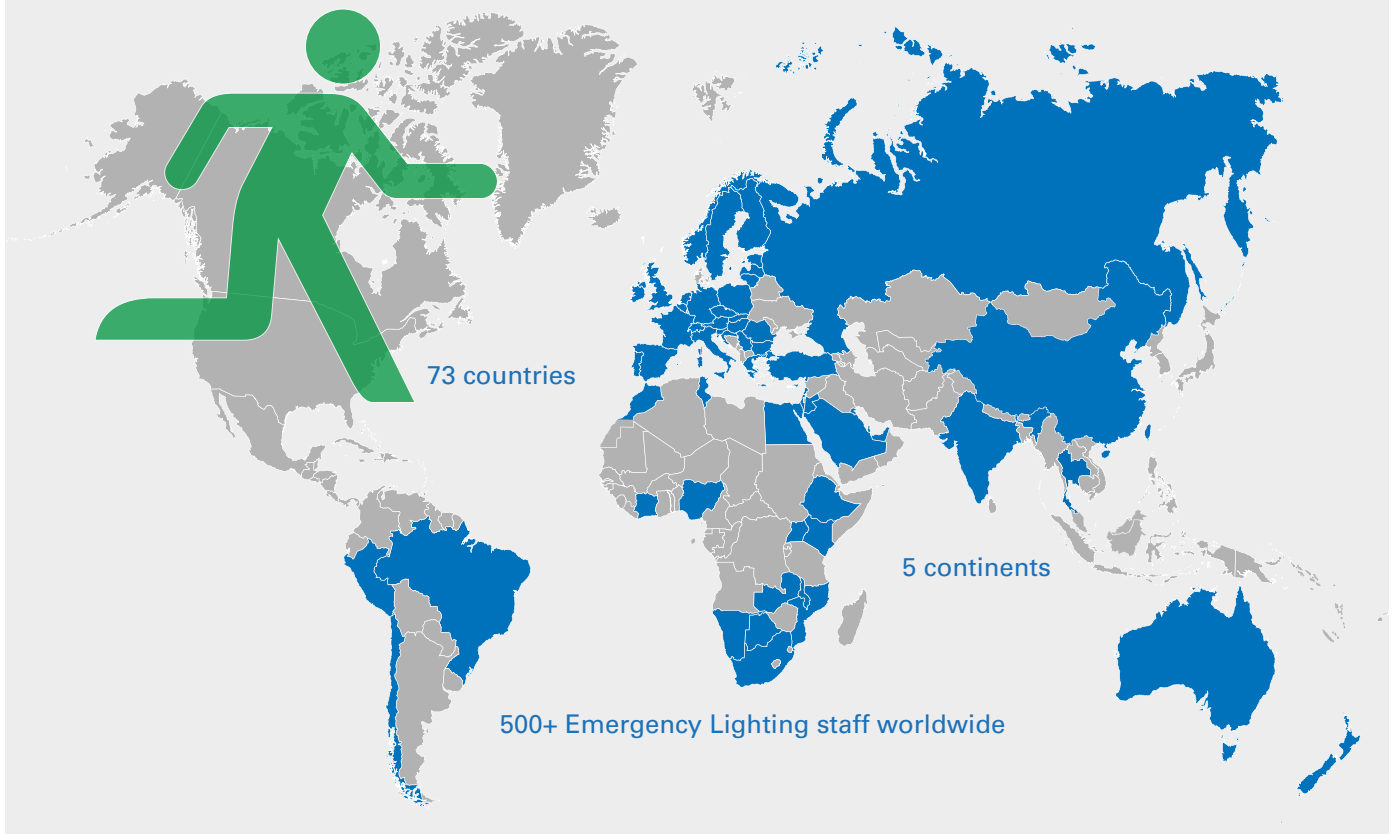

Australia	Finland	Luxembourg	Romania
Austria	France	Macedonia	Russian Fed.
Bahrain	Germany	Malawi	Saudi Arabia
Baltics	Greece	Monaco	Serbia
Belarus	Hong Kong	Montenegro	Singapore
Belgium	Hungary	Morocco	Slovakia
Botswana	Iceland	Mozambique	Slovenia
Brazil	India	Nairobi	South Africa
Bulgaria	Ireland	Namibia	Spain
Chile	Israel	Netherlands	Sweden
China	Italy	Nigeria	Switzerland
Croatia	Ivory Coast	Norway	Thailand
Cyprus	Jordan	Oman	Tunisia
Czech Republic	Kuwait	Peru	Turkey
Denmark	Lagos	Poland	Uganda
Egypt	Latvia	Portugal	Ukraine
Estonia	Lebanon	Qatar	United Kingdom
Ethiopia	Lithuania	Reunion	Utd. Arab Emir.
			Zambia

Please visit [www.ceag.de/en](http://www.ceag.de/en) to find the contact person responsible for your country.

Eaton's mission is to improve the quality of life and the environment through the use of power management technologies and services. We provide sustainable solutions that help our customers effectively manage electrical, hydraulic, and mechanical power – more safely, more efficiently, and more reliably. Eaton's 2019 revenues were \$21.4 billion, and we sell products to customers in more than 175 countries. We have approximately 95,000 employees. For more information, visit **Eaton.com**.

To find your contact person, please visit **www.ceag.de/en**.

**ELLISCO** > +64 9 570 5267  
> info@ellis.co.nz  
> www.ellis.co.nz

**Eaton**  
EMEA Headquarters  
Route de la Longeraie 7  
1110 Morges, Switzerland

**CEAG Notlichtsysteme GmbH**  
Senator-Schwartz-Ring 26  
59494 Soest, Germany  
Phone: +49 (0) 2921 69-870  
Fax: +49 (0) 2921 69-617  
E-Mail: info-n@eaton.com  
Web: www.ceag.de

Changes to the products, to the information contained in this document, and to prices are reserved; so are errors and omissions. Only order confirmations and technical documentation by Eaton is binding. Photos and pictures also do not warrant a specific layout or functionality. Their use in whatever form is subject to prior approval by Eaton. The same applies to Trademarks (especially Eaton, Moeller, and Cutler-Hammer, CEAG). The Terms and Conditions of Eaton apply, as referenced on Eaton Internet pages and Eaton order confirmations.



© 2020 Eaton  
All Rights Reserved  
Publication No. BR451014EN  
Order No. 40071860327

Eaton is a registered trademark.  
All other trademarks are property  
of their respective owners.

Follow us on social media to get the latest product and support information.

