

2013

# MAINTENANCE SECTION REFERENCE BOOK



LAST REVISED: 02/11/13

Prepared by:

**MAINTENANCE STAFF**





WYOMING  
DEPARTMENT OF TRANSPORTATION

Prepared by:  
Maintenance Staff



## ☺ PREFACE ☺

This maintenance prepared book uses Planning's reference book as the foundation for roadway information.

**Information contained in this book, is only as correct, as the information the staff has received.**

It adds the following information:

Maintenance Crew numbers by locations (page 6)

Maintenance section designations and section breaks by crew

Department Shop locations

Port of Entry locations

Rest Area locations

Seasonal Road Closure locations

Road Closure gate mainline locations ( **NOT including gates on ramps** )

Remote Weather sensors (RWIS) both SSI and Visala sites (page 17)

Changeable Message sign locations (CMS)

Structure ID's [#; \*] ID#; \* *structure type or lane*

Federal Roadway Classifications by number, *see classification table page 8.*

At grade railroad crossing ID numbers

Variable Speed Limit Sign (VSL)

WYO- link Tower Sites (pages 9 – 11)

Airport Maintenance Sections



## REFERENCE MARKERS

Reference Markers can be placed at one (1) mile increments along each route and at all of the following locations:

- 1) Junctions of intersecting state routes**
- 2) District boundaries**
- 3) County lines**
- 4) State lines**
- 5) Place names (not incorporated)**

Stencils, panel attachments on flashboards or Reference Markers can be placed at all major structures. Direct stenciling can be used on all structures where compliance can be obtained as illustrated on the standard plan sheet. Panel attachments on flashboards will be used where direct stenciling cannot be used. As the third and last consideration, the Reference Marker will be physically set.

## PURPOSE

The primary purpose of a reference marker system is to establish a satisfactory and uniform system of highway identification and designation that is adaptable to all Divisions in the Department. This system must supply detailed and specific information. The system must be simple and contain a usable device that can be compatible with all departmental operations.

Enforcement agencies may be able to use these markers as an aid to the reporting of highway accident locations.

In addition to their value as a location reference for the traveling public and for locating accidents and other highway incidents, Reference Markers can be related to data processing systems of the Department's Divisions for maintenance and administration.

## COUNTY MAPS AND PHYSICAL FEATURE LOCATIONS

These maps were prepared from many sources, including: construction records, plans, field inventory, etc. and show principal features of the highway and the contiguous area. (See diagrams included with the instructions.)

Adjusting Reference Marker distances at physical features locations will ensure the proper placement of the Reference Markers and ensure that an accumulated error will not occur on long sections.

This information can be used when placing the Reference Markers initially, as a control for all Divisions when adapting to the Reference Marker system, for keeping the system current.

Reference Markers should be placed at one mile increments of the roadway and intersections, structures and Reference Marker equations, as per standard plans.

## SUGGESTED PLACEMENT

For interstate or multilane highways, individual Reference Markers will be placed in each direction of travel. Reference Markers on the westbound and southbound roadways will be in descending order and will correspond numerically to Reference Markers in the eastbound and northbound roadways. Reference Marker placement will be controlled by accurate measurement of the eastbound or northbound roadway with any distance irregularities occurring on the westbound or southbound roadway. The Reference Marker for the latter will be placed as nearly opposite the accurately placed markers as possible.

Reference Marker placement on two-lane highways will consist of a single Reference Marker, placed on the right commencing at the west or south terminus.

For placement at junctions, the Reference Marker may be placed on the opposite side of the roadway.

If physical conditions prevent the placement of a Reference Marker at its correct location, it may be moved in either direction as much as 50 feet. If the Reference Marker cannot be placed within this degree of accuracy, it can be omitted.

Reference Marker paddles can be mounted on each side of posts to be specified and will be placed in line with delineators, or two (2) feet back from the face of any curb. (See standard plan sheet.)

The stencil or Reference Marker placement at structure locations can be placed at the beginning end of the structure in the direction of travel.

In the event a Reference Marker is omitted in the field, Planning should be notified in order to make the necessary corrections for each map. This should be accomplished since these maps are master control for all Reference Marker locations.

## EQUATIONS

This plan provides for equations when required. Equations are usually the result of construction or new alignment. The **AHEAD (AH)** and **BACK (BK)** Reference Markers are placed at the first full location point on either side of an equation location. When construction lengthens a route one or more miles, **BACK (BK)** Reference Markers need to be placed with the first set of duplicate Reference Marker numbers.

When reporting an accident, or any other correspondence, it is imperative the equation designation AH or BK and Alpha letters should be included with the Reference Marker number. This is the only way locations can be properly and accurately identified.

See Plate 5 on page 216.



## MAINTENANCE

The Reference Marker maps will be kept as current as possible, utilizing every available source of information.

District personnel will place Reference Markers at new locations in accordance with the new construction plans. These changes will show all equations, when required.

The interchanges and layouts will be kept current for new interchanges, intersections and other information concerning the basic Reference Marker instructions.

The following is a listing of all county abbreviations that are used.

<u>County</u>	<u>#</u>	<u>Abbrev.</u>	<u>County</u>	<u>#</u>	<u>Abbrev.</u>
Albany	5	AL	Natrona	1	NA
Big Horn	9	BH	Niobrara	14	NI
Campbell	17	CL	Park	11	PA
Carbon	6	CB	Platte	8	PL
Converse	13	CO	Sheridan	3	SH
Crook	18	CR	Sublette	23	SB
Fremont	10	FR	Sweetwater	4	SW
Goshen	7	GO	Teton	22	TE
Hot Springs	15	HS	Uinta	19	UI
Johnson	16	JO	Washakie	20	WA
Laramie	2	LA	Weston	21	WE
Lincoln	12	LN			

## RESPONSIBILITIES OF THE DISTRICT CONSTRUCTION PERSONNEL

- 1)** Acquire the Reference Markers required for the initial installation.
- 2)** Spot the locations on the roadway for the initial installation.
- 3)** Ensure that placement of these Reference Markers are at the proper locations, utilizing maps, plans, etc. that are furnished.
- 4)** Report to the Planning Division any Reference Markers that were not or cannot be placed due to physical impossibilities in the field.
- 5)** Keep the Reference Marker system current by replacing and resetting Reference Markers due to damage, construction, or other revisions.
- 6)** Initial stenciling of all structures and re-stenciling, as necessary.

## SPECIAL INSTRUCTIONS

The following is a listing of other abbreviations used on the physical feature Reference Marker locations:

<u>Explanation</u>	<u>Abbreviation</u>
Air Force Base	AFB
Changeable Message Sign (type)	C.M.sign (dynamic or drum)
Changeable Message Sign	CMS
Construction	Const.
Conversion	Conv.
Continued	-cont-
County	Co.
Creek	Cr.
Department	Dept.
East	E.
Eastbound	EB
East Corporate Limits	ECL
East Urban Limits	EUL
Fort	Ft.
Interchange	Int.
Interstate	I
Junction	Jct.
Main Line (GIS)	ML
Maintenance	Maint.
Reference Marker	RM
Mountain	Mtn.
National Highway System	NHS
North	N.
Northbound	NB
North Corporate Limits	NCL
North Urban Limits	NUL
Optional turn (free right)	OT
Railroad	RR
Ramp	RP
Reference Marker	RM
Remote weather information sensors	RWIS
River	Rv.
Road	Rd.
Remote Weather Sensor Site	RWIS
Separation	Sep.
Service Road	Sr. Rd.
Service Road “maps”	SR
South	S.
Southbound	SB
South Corporate Limits	SCL
South Urban Limits	SUL

State Highway	SH
State Highway System	SHS
Turnout	TO
Variable Speed Limit Sign	VSL
West	W.
Westbound	WB
West Corporate Limits	WCL
West Urban Limits	WUL
Wye Connections	Wye Conn

# 55 crew sites - 59 crews

## Maintenance Crew numbers by District

### District One

District Office Laramie

1031	Laramie	1038	Arlington
1032	Laramie	1039	Pine Bluffs
1034	Cheyenne	1040	Elk Mountain
1035	Cheyenne	1041	Rawlins
1036	Medicine Bow	1042	Saratoga
1037	Baggs		

### District Two

District Office Casper

2031	Casper	2038	Torrington
2033	Chugwater	2039	Wheatland
2034	Douglas	2040	Kaycee
2035	Lusk	2041	Shirley Rim
2036	Muddy Gap	2042	Casper
2037	Midwest		

### District Three

District Office Rock Springs

3031	Rock Springs	3038	Granger
3032	Rock Springs	3039	Jackson
3033	Afton	3040	Kemmerer
3034	Cokeville	3041	Labarge
3035	Pinedale	3042	Lyman
3036	Evanston	3043	Patrick Draw
3037	Farson	3044	Wamsutter

### District Four

District Office Sheridan

4031	Sheridan	4039	Hulett
4033	Sheridan	4040	Moorcroft
4035	Gillette	4041	Newcastle
4036	Buffalo	4042	Sundance
4037	Pole Creek	4043	Reno Junction
4038	Burgess Junction		

### District Five

District Office Basin

5031	Basin	5037	Shoshoni
5032	Cody and Russell Cr.	5038	South Pass
5033	Dubois and Togwotee	5039	Tensleep
5034	Lander	5040	Thermopolis
5035	Lovell	5041	Worland
5036	Meeteetse	5042	Riverton

There are maps of each district 1 through 5 added to this book following the state/county map on page 23. These maps pages 25 through 34, if in color, are colored to match each district's level of snow removal service per roadway section as per their snow plan.

The maps at the front of each county are colored to match the five different levels of Maintenance QC/QA collection selection. Maintenance has grouped the twelve different classifications into five.

## **ROAD COLOR TABLE**

<b>Group#</b>	<b>Description</b>
<b>I.</b>	#1 Rural and #11 Urban Interstate
<b>II.</b>	#14 Urban Principal Arterial Other & #12 Urban Principal Arterial Other Expressway (NHS)
<b>III.</b>	# 16 Urban Minor Arterial, #17 Urban Collector & #19 Urban Local (non NHS)
<b>IV.</b>	#3 Rural Principal Arterial Other (NHS)
<b>V.</b>	# 6 Rural Minor Arterial, #7 Rural Major Collector, #8 Rural Minor Collector & # 9 Rural Local (non NHS)

## ROAD CLASSIFICATION TABLE

### Planning's Functional Class Code

RURAL		URBAN	
<b>1</b>	Interstate	<b>11</b>	Interstate
<b>2</b>	Principal Arterial Other	<b>12</b>	Principal Arterial Expressway
<b>6</b>	Minor Arterial	<b>14</b>	Principal Arterial Other
<b>7</b>	Major Collector	<b>16</b>	Minor Arterial
<b>8</b>	Minor Collector	<b>17</b>	Collector
<b>9</b>	Local Road	<b>19</b>	Local Road

### MAINTENANCE QC/QA COLLECTION GROUPING

RURAL		URBAN	
<b>1</b>	Interstate	<b>1</b>	Interstate
<b>3</b>	Principal Arterial Other	<b>2</b>	Principal Arterial Expressway
<b>5</b>	Minor Arterial	<b>2</b>	Principal Arterial Other
<b>5</b>	Major Collector	<b>4</b>	Minor Arterial
<b>5</b>	Minor Collector	<b>4</b>	Collector
<b>5</b>	Local Road	<b>4</b>	Local Road

DISTRICT ONE RADIO TOWER SITES

Dist	Maint. Sect.	Cat.	Start RM	End RM	Tower Name	Maint. Site	ML #	Closest Route	GPS Coordinates			
LOCATION			COMMENTS								LANDOWNER	
1	TR 01A	TS	52.075	52.075	<b>Baggs Hill</b>	Baggs	18	WY 789	N41.00653	W107.62246		
<i>East of Baggs</i>					<i>off WY 789 RM 52.075</i>					Purple Sage, LLC		
1	TR 01B	TS	12.000	12.000	<b>Divide Hill</b>	Rawlins	18	WY 789	N41.54898	W107.71732		
<i>West of Rawlins</i>					<i>12 miles South of I-80 @exit 187, off WY 789 RM 12.00</i>					BLM		
1	TR 01C	TS	8.590	8.590	<b>Nine Mile Hill</b>	Rawlins	21	US 287	41.88108333	107.3231111		
<i>North of Rawlins</i>					<i>6.6 miles North of Rawlins bypass, off US 287 RM 8.590</i>					Sandstone Sheep Co.		
<i>Have shared road repair/maintenance with others and BLM for their road.</i>												
1	TR 01D	TS	16.465	16.465	<b>North Albin</b>	Pine Bluffs	1105	WY 216	N41.47692	W104.10169		
<i>North of Albin</i>					<i>17 miles north of Albin, off WY 216 RM 16.465</i>							
1	TR 01G	TS	5.797	5.797	<b>Russell Hill</b>	Pine Bluffs	1104	WY 215	N41.25792	W104.10440		
<i>North of Pine Bluffs</i>					<i>off WY 215 RM 5.797 onto county road #218</i>							
1	TR 01H	TS	36.465	36.465	<b>Sherman Beacon Hill</b>	Laramie	107	WY 210	N41.26246	W105.43112		
<i>East of Laramie</i>					<i>off WY 210 RM 36.465 onto West Pilot Hill Rd.</i>							
1	TR 01J	TS	132.522	132.522	<b>Shirley Mtn.</b>	Medicine Bow	77	WY 77	N42.16551	W106.58086		
<i>North of Medicine Bow</i>					<i>off WY 77 RM 132.522 onto county road #102</i>							
1	TR 01K	TS	290.440	290.440	<b>Strouss Hill</b>	Laramie	80	I-80	N41.48819	W106.05006		
<i>West of Laramie</i>					<i>off I-80 exit 290 on county road #59</i>							
1	TR 01M	TS	1.370	1.370	<b>US 85 South</b>	Cheyenne	180	US 85	41.02152778	104.7853889		
<i>South of Cheyenne</i>					<i>off US 85 RM 1.370</i>							
1	TR 01N	TS	47.250	47.250	<b>Whitcomb Hill</b>	Cheyenne	25	I-25	41.65130556	104.8928056		
<i>North of Cheyenne</i>					<i>36 miles north of Cheyenne @RM 47.250, off I-25 County line Inter.</i>							
1	TR 01P	TS	36.440	36.440	<b>North Flat Top</b>	Baggs	18	WY 789	N41.22139	W107.83281		
<i>North of Baggs</i>					<i>off WY 789 @RM 36.440 onto Robber's Gulch road</i>							
1	TR 01R	TS	42.040	42.040	<b>Pinkham Mtn</b>	Laramie	26	WY 230	40.94397222	106.2491389		
<i>Southwest of laramie</i>					<i>off WY 230 around RM 42.040</i>							
1	TR 01S	TS	3.000	3.000	<b>Jelm Mtn.</b>	Laramie	101	WY 10	41.08522222	105.9802222		
<i>Southwest of laramie</i>					<i>off WY 10 around RM 3.00</i>					Not in AA yet.....		
1	TR 01T	TS	249.000	249.000	<b>Halleck Ridge</b>	Elk Mtn.	80	I-80	????	????		
<i>Northwest of Elk Mtn.</i>					<i>off I-80 south around RM 249.0</i>							

DISTRICT TWO RADIO TOWER SITES

Dist	Maint. Sect.	Cat.	Start RM	End RM	Tower Name	Maint. Site	ML #	Closest Route	GPS Coordinates		
			<i>LOCATION</i>					<i>COMMENTS</i>		<i>LANDOWNER</i>	
2	TR 02A	TS	8.909	8.909	Casper Mtn.	Casper	1301	WY 251	N42.74020	W106.30622	
			<i>South of Casper</i>		<i>off WY 251 RM 8.909 End SHS, onto Casper Mtn Road</i>						
2	TR 02B	TS	11.280	11.280	Flat Top	Douglas	40	US 18/20	N42.82810	W105.05618	
			<i>North of Shawnee</i>		<i>off US 18/2020 RM 11.280 onto county road north @Shawnee</i>						
2	TR 02C	TS	49.200	49.200	Lonetree	Douglas	43	WY 59	N43.39066	W105.40424	
			<i>North of Bill WY.</i>		<i>off WY 59 RM 49.200 onto county road #34</i>						
2	TR 02D	TS	16.960	16.960	Morton Hill	Douglas	43	WY 59	N42.91016	W105.33076	
			<i>North of Douglas</i>		<i>off WY 59 RM 16.960 onto ?</i>						
2	TR 02G	TS	1.500	1.500	Muddy Gap Hill	Muddy Gap	20	US 287	N42.35439	W107.48980	
			<i>Southwest of Muddy gap</i>		<i>off US 287 RM 1.500 left onto dirt road</i>						
2	TR 02H	TS	100.333	100.333	Pine Ridge	Wheatland	319	WY 319	N42.34753	W105.03208	
			<i>North of Wheatland</i>		<i>off I-25 exit 100 onto WY 319 north RM 100.333 right onto dirt road</i>						
2	TR 02J	TS	104.136	104.136	77 Hill	Lusk	1401	WY 270	N42.84930	W104.61564	
			<i>North of Manville</i>		<i>off WY 270 RM 104.136</i>						
2	TR 02M	TS	11.911	11.911	Virgin Hill	Wheatland	1604	WY 316	N42.04359	W104.69677	
			<i>East of Wheatland</i>		<i>off WY 316 RM 11.991 End SHS, onto Antelope Gulch Road</i>						
2	TR 02N	TS	246.560	246.560	Tisdale Mtn.	Kaycee	25	I-25	N43.50101	W106.57602	
			<i>South of Kaycee</i>		<i>off I-25 @ exit 246 Powder River Inter.</i>						



DISTRICT THREE RADIO TOWER SITES

Dist	Maint. Sect.	Cat	Start RM	End RM	Tower Name	Maint. Site	ML #	Closest Route	GPS Coordinates	
LOCATION					COMMENTS			LANDOWNER		
3	TR 03A	TS	6.300	6.300	Aspen Mtn.	Rock Springs	1903	WY 430	N41.42606	W109.12843
<i>South of Rock Springs</i>					<i>off WY 430 @RM 6.300 onto county road #27</i>					
3	TR 03B	TS	53.310	53.310	Church Buttes	Lyman	80	I-80	N41.41521	W110.08262
<i>Northeast of Lyman</i>					<i>off I-80 @ exit 53.310 Church Buttes Inter. onto Church Butte Rd</i>					
3	TR 03C	TS	158.550	158.550	Delaney Rim	Wamsutter	80	I-80	N41.56405	W108.28301
<i>South of Tipton</i>					<i>off I-80 @ exit 158.550 Tipton Inter. Onto road through Tipton</i>					
3	TR 03D	TS	13.860	13.860	First Divide	Evanston	80	I-80	N41.28217	W110.78153
<i>East of Evanston</i>					<i>off I-80 @ exit 13.860 First Divide Inter. onto</i>					
3	TR 03G	TS	4.486	4.486	Hogsback Ridge	Labarge	1203	WY 235	42.3258333	110.3188889
<i>West of Labarge</i>					<i>North off end of WY 235 then off county road section</i>					
3	TR 03H	TS	37.645	37.645	Oyster Ridge	Kemmerer	11	US 189	41.79158333	110.5400833
<i>East of Kemmerer</i>					<i>off US 189 RM 37.645 onto Aspen Ave.</i>					
3	TR 03J	TS	38.427	38.427	Sage Jct./Twin buttes	Cokeville	12	US 30	41.84883333	110.8485278
<i>South of Cokeville</i>					<i>off US 30 @RM to Rock Creek county road</i>					
3	TR 03K	TS	69.810	69.810	Salt Pass	Afton	10	US 89	N42.48889	W110.89363
<i>South of Afton</i>					<i>off US 89 RM 69.810</i>					
3	TR 03M	TS	152.478	152.478	Snow King	Jackson	10	US 26/89	N43.45243	W110.75326
<i>South of Jackson</i>					<i>off US 26/89/191 RM 152.478 onto private road</i>					
3	TR 03N	TS	0.000	0.000	Hell Hole Ridge	Cokeville	12	US 30	N42°19'25.06	W111°12'44.46
<i>Northwest of Cokeville "in Idaho"</i>					<i>off US 30 in Idaho RM is Stateline 0.00</i>					
3	TR 03P	TS	94.120	94.120	Narrows Hill	Afton	10	US 89	N42.85084	W110.98041
<i>North of Afton</i>					<i>off US 89 RM 94.120 across from WY 238 north</i>					
3	TR 03R	TS	0.000		Rendezvous Peak	Jackson	2001	WY 390	?	?
<i>Teton Village</i>					<i>off WY 390 @ Teton Village Road</i>					
3	TR 03T	TS	184.290	184.290	Latham	Wamsutter	80	I-80	N41.74946	W107.83047
<i>Northeast of Wamsutter</i>					<i>off I-80 @ exit 184.290 Cont. Divide Inter.</i>					
3	TR 03W	TS	120.940	120.940	Aspen Ridge	Pinedale	13	US 189	N43°3.379	W110°8.213
<i>North of Daniel</i>					<i>off US 189/191 @ RM 120.940</i>					

DISTRICT FOUR RADIO TOWER SITES

Dist	Maint. Sect.	Cat.	Start RM	End RM	Tower Name	Maint. Site	ML #	Closest Route	GPS Coordinates	
LOCATION					COMMENTS			LANDOWNER		
4	TR 04A	TS	35.617	35.617	Banner Ridge	Sheridan	60	US 87	N44.60806	W106.92361
<i>East of Story WY.</i>					<i>off US 87 on county road #28</i>					
4	TR 04B	TS	15.683	15.683	Jim Cr. Hill	Sheridan	302	US 14/16	N44°35'58.98	W106°45'3.15
<i>Southeast of Sheridan</i>					<i>off US 14/16 @RM 15.683</i>					
4	TR 04C	TS	237.445	237.445	Mount Pisgah	Newcastle	85	US 85	N43.99464	W104.14427
<i>North of Newcastle</i>					<i>off US 85 @RM 237.445 @Flying V ranch south approach</i>					
4	TR 04D	TS	43.475	43.475	Pumkin Buttes	Reno Jct.	300	WY 50	N43.72312	W105.88324
<i>West of Wright WY.</i>					<i>off WY 50 @RM 43.475 on Christenson road</i>					
4	TR 04G	TS	141.240	141.240	Rozet Hill	Gillette	90	I-90	N44.33859	W105.24887
<i>North of Rozet</i>					<i>off I-90 @exit 141 Rozet Inter. north onto Adon road</i>					
4	TR 04H	TS	291.080	291.080	Tisdale Divide	Buffalo	25	I-25	N44.23322	W106.70066
<i>South of Buffalo</i>					<i>off I-25 @exit 291 Trabing Rd Inter. west onto Trabing road</i>					
4	TR 04J	TS	199.340	199.340	Warren Peak	Sundance	607	US 14	N44.47168	W104.44305
<i>West of Sundance</i>					<i>off US 14 around RM 199.340 north onto Warren Peak road</i>					
4	TR 04K	TS	72.797	72.797	Chicken Cr.	Gillette	302	US 14/16	N44.70976	W105.75929
<i>Northeast of Gillette</i>					<i>off US 14/16 @RM 73.0 close to "Spotted Horse WY"</i>					
4	TR 04M	TS	0.000		Bush Hill	Sundance			?	?
<i>North of Sundance</i>					<i>May be going away?</i>					
4	TR 04N	TS	38.640	38.640	Duncan Lake	Burgess Jct.	37	US 14	?	?
<i>southeast of Granite Pass</i>					<i>micro wave repeater site off US 14 on the Duncan Lake rd.</i>					

DISTRICT FIVE RADIO TOWER SITES

Dist	Maint. Sect.	Cat.	Start RM	End RM	Tower Name	Maint. Site	ML #	Closest Route	GPS Coordinates	
LOCATION					COMMENTS			LANDOWNER		
5	TR 05A	TS	48.470	48.470	Cedar Mtn.	Cody	31	US 14/16/20	N44°29'50.74	W109°09'12.84
<i>West of Cody</i>					<i>off US 14/16/20 @RM 48.470</i>					
5	TR 05B	TS	110.500	110.500	Copper Mtn.	Shoshoni	34	US 20	N43.43750	W107.99670
<i>Northeast of Shoshoni</i>					<i>off US 20 @RM 110.5 onto Birdseye road</i>					
5	TR 05C	TS	32.791	32.791	Dead Indian Hill	Cody	1507	WY 296	N44.75320	W109.37577
<i>North of Cody</i>					<i>off WY 296 @ RM 32.791</i>					
5	TR 05D	TS	27.160	27.160	Winkelman Dome	Lander	15	US 287	N43.13705	W108.91753
<i>North of Lander</i>					<i>off US 287 RM 27.160 ,north of Ft. Washakie WY.</i>					
5	TR 05G	TS	23.030	23.030	Jade Mtn.	Lander	20	US 287	N42.40003	W107.95872
<i>East of Lander</i>					<i>off US 287/WY 789 RM 23.030, south of Jeffery City off Crooks Gap rd</i>					
5	TR 05H	TS	70.000	70.000	McCullough Peaks	Cody	31	US 14/16/20	N44.58725	W108.85175
<i>East of Cody</i>					<i>off US 14/16/20 @RM 70.0</i>					
5	TR 05J	TS	45.875	45.875	South Pass	South Pass	14	WY 28	N42°30'41.58	W108°46'42.53
<i>Close to South Pass maintenance camp</i>					<i>off WY 28 @RM 45.875</i>					
5	TR 05K	TS	196.574	196.574	Torchlight Hill	Basin	34	US 16/20	N44°23'30.11	W107°59'19.92
<i>Northeast of Basin</i>					<i>off US 16/20 RM 196.574 East onto Torchlight road (Lane 42C)</i>					
5	TR 05M	TS	50.690	50.690	Waltman Hill	Shoshoni	34	US 20/26	N43.03956	W107.28531
<i>East of Shoshoni</i>					<i>off US 20/26 @RM 50.690 south of Waltman</i>					
5	TR 05N	TS	53.414	53.414	Windy Ridge	Dubois	30	US 26	N43.50045	W109.58806
<i>Northwest of Dubois</i>					<i>off US 26 RM 53.414 @Airport road</i>					
5	TR 05P	TS	169.413	169.413	Rattlesnake Ridge	Worland	34	US 16/20	N44.05272	W107.84912
<i>North of Worland</i>					<i>off US 16/20 @ RM169.413 onto county road #11 then east on Ln #8</i>					
5	TR 05R	TS	48.934	48.934	3 Mile Hill	Meeteetse	33	WY 120	N44.14030	W108.82193
<i>Southeast of Meeteetse</i>					<i>off WY 120 around RM 48.934</i>					



## OFF Highway Sites

County	District	Route	Maint. Sect.	RM	Cat.	SITE
PORTS OF ENTRY						
Albany	1	US 287 / US 30	AL 02P	401.960	PO	Laramie
Carbon	1	WY 789	CB 08P	52.220	PO	Baggs
Laramie	1	I-80	LA 01P	371.890	PO	Cheyenne
Laramie	1	I-25	LA 03P	6.350	PO	Cheyenne
Laramie	1	US 85	LA 05P	4.120	PO	Cheyenne
Goshen	2	US 26/85	GO 01P	95.360	PO	Torrington
Natrona	2	WY 254	NA 10P	1.590	PO	Casper
Niobrara	2	US 18/20	NI 02P	40.880	PO	Lusk
Lincoln	3	US 30	LN 03P	52.490	PO	Kemmerer
Lincoln	3	US 26	LN 13P	0.550	PO	Alpine
Uinta	3	I-80	UI 01P	0.400	PO	Evanston
Campbell	4	WY 51	CL 02P	127.480	PO	Gillette
Crook	4	I-90	CR 01P	189.000	PO	Sundance
Sheridan	4	I-90	SH 01P	16.340	PO	Sheridan
Weston	4	US 16	WE 02P	247.340	PO	Newcastle
Park	5	US 310	BH 03P	254.700	PO	Frannie

County	District	Route	Maint. Sect.	RM	Cat.	SITE
DEPARTMENT SITES						
Albany	1	US 287 / US 30	DH 01A	401.960	YD	Laramie
Carbon	1	WY 72	EM 01A	15.200	YD	Elk Mtn.
Carbon	1	WY 13	AR 01A	16.890	YD	Arlington
Carbon	1	WY 130/230	SG 01A	23.200	YD	Saratoga
Carbon	1	WY 789	BG 01A	51.900	YD	Baggs
Carbon	1	I-80	RW 01A	215.350	YD	Rawlins
Carbon	1	US 30/287	MB 01A	270.290	YD	Medicine Bow
Laramie	1	I-25	HQ 01A	12.700	YD	Cheyenne
Laramie	1	US 30	PB 01A	402.670	YD	Pine Bluffs
Carbon	2	US 287	MG 02A	43.260	YD	Muddy gap
Carbon	2	WY 487	SR 02A	45.100	YD	Shirley Rim
Converse	2	I-25 SR		8.951	YD	NEW Douglas
Converse	2	US 20/26 BUS.	DG 02A	137.800	YD	Douglas
Goshen	2	WY 159	TT 02A	0.580	YD	Torrington
Johnson	2	WY 192	KC 02A	0.150	YD	Kaycee
Natrona	2	WY 387	MW 02A	99.370	YD	Midwest
Natrona	2	I-25	DH 02A	186.790	YD	Casper
Niobrara	2	US 85	LK 02A	150.180	YD	Lusk
Platte	2	WY 321	CW 02A	55.660	YD	Chugwater
Platte	2	US 87 BUS.	WL 02A	79.070	YD	Wheatland
Platte	2	I-25 SR	WL 02B	3.740	YD	Wheatland

^ - continued next page -

<i>County</i>	<i>District</i>	<i>Route</i>	<i>Maint. Sect.</i>	<i>RM</i>	<i>Cat.</i>	<i>SITE</i>
<b>DEPARTMENT SITES</b>						
Lincoln	3	WY 232	CV 03A	0.140	YD	Cokeville
Lincoln	3	US 30	KM 03A	38.070	YD	Kemmerer
Lincoln	3	US 189	LB 03A	84.890	YD	LaBarge
Lincoln	3	US 26/89	AF 03A	86.070	YD	Afton
Sublette	3	US 191	PN 03A	100.590	YD	Pinedale
Sweetwater	3	US 191	DH 03A	2.300	YD	Rock Springs
Sweetwater	3	US 191	FS 03A	41.000	YD	Farson
Sweetwater	3	US 30	GN 03A	93.850	YD	Granger
Sweetwater	3	I-80	PD 03A	146.850	YD	Patrick Draw
Sweetwater	3	I-80	WS 03A	173.410	YD	Wamsutter
Teton	3	US 26/89/189	JK 03A	145.250	YD	Jackson
Uinta	3	WY 89	ET 03A	1.040	YD	Evanston
Uinta	3	I-80 BUS.	LM 03A	43.310	YD	Lyman
Campbell	4	US 14/16	RJ 04A	71.990	YD	Reno Jct.
Campbell	4	I-90	GL 04A	129.100	YD	Gillette
Crook	4	WY 24	HL 04A	14.840	YD	Hulett
Crook	4	I-90	MC 04A	153.410	YD	Moorcroft
Crook	4	I-90	SD 04A	189.000	YD	Sundance
Johnson	4	US 16	PC 04A	69.300	YD	Pole Cr.
Johnson	4	US 16	BF 04A	91.540	YD	Buffalo
Johnson	4	I-25	BF 04B	298.020	YD	Buffalo
Johnson	4	I-25	BF 04B	298.020	YD	NEW Buffalo site
Sheridan	4	WY 334	DH 04A	0.000	YD	Sheridan
Sheridan	4	WY 336	DH 04B	1.450	YD	NEW Sheridan site
Sheridan	4	US 14A	BJ 04A	98.640	YD	Burgess Jct.
Weston	4	US 16	NC 04A	248.820	YD	Newcastle
Park	5	US 14/16/20	CD 05A	55.140	YD	Cody
Big Horn	5	US 16/20	DH 05A	196.420	YD	Basin
Big Horn	5	US 310 WY 789	LV 05A	236.060	YD	Lovell
Fremont	5	US 26/287	TG 05A	33.680	YD	Togwotee
Fremont	5	WY 28 SR	SP 05A	49.200	YD	South Pass
Fremont	5	US 26/287	DB 05A	54.760	YD	Dubois
Fremont	5	US 26/287	LD 05A	81.050	YD	Lander
Fremont	5	US 20/26	SS 05A	99.470	YD	Shoshoni
Fremont	5	US 26/287	RT 05A	130.580	YD	Riverton
Hot Springs	5	US 20	TM 05A	130.450	YD	Thermopolis
Park	5	WY 296	RC 05A	20.400	YD	Russell Cr.
Park	5	WY 120	MT 05A	50.200	YD	Meeteetse
Washakie	5	WY 433	WL 05A	0.250	YD	Worland
Washakie	5	US 16	TS 05A	28.010	YD	Tensleep

<i>County</i>	<i>District</i>	<i>Route</i>	<i>Maint. Sect.</i>	<i>RM</i>	<i>Cat.</i>	<i>SITE</i>
<b>REMOTE LOADER SHED SITES</b>						
Lincoln	3	US 26/89	AF 981	118.320	LS	Alpine
Lincoln	3	US 30	CV 981	30.500	LS	Sage Jct.
Sublette	3	US 191	FS 982	75.500	LS	WY 351 Jct.
Sweetwater	3	I-80	PD 981	130.840	LS	Point of Rocks
Sweetwater	3	I-80	WS 981	158.550	LS	Tipton Int.
Sweetwater	3	US 191	RS 981	2.900	LS	Rock Springs N.
Sweetwater	3	WY 28	FS 981	102.000	LS	WY 372 Jct.
Uinta	3	I-80	LM 981	30.400	LS	Bigelow Int.
Uinta	3	I-80	ET 981	18.290	LS	Lazear Int.

<i>County</i>	<i>District</i>	<i>Route</i>	<i>Maint. Sect.</i>	<i>RM</i>	<i>Cat.</i>	<i>SITE Name</i>
<b>REST AREAS / INFORMATION CENTERS</b>						
Albany	1	I-80 / US 30	AL 01R	323.050	RA	Summit
Carbon	1	I-80	CB 01R	228.340	RA	Ft. Steele
Carbon	1	I-80	CB 01S	267.190	RA	Wagonhound
Laramie	1	I-80	LA 01R	401.460	RA	Pine Bluffs
Laramie	1	I-25	LA03W	4.850	RA	SE Welcome Center
Laramie	1	US 85	LA 05R	53.800	RA	Meriden
Carbon	2	WY 487	CB 13R	45.100	RA	Shirley Rim
Converse	2	I-25	CO 01R	126.470	RA	Orin Jct.
Johnson	2	I-25	JO 01R	254.250	RA	Kaycee
Natrona	2	WY 220	NA 04R	62.830	RA	Independence Rock
Niobrara	2	US 18/20	NI 02R	39.290	RA	Lusk
Platte	2	I-25	PL 01R	92.370	RA	Dwyer Jct.
Platte	2	US 26	PL 04R	17.800	RA	Guernsey
Platte	2	I-25	PL 25R	54.590	RA	Chugwater
Lincoln	3	US 26/89	LN 01R	97.490	RA	Star Valley
Sweetwater	3	I-80	SW 80R	143.500	RA	Bitter Cr. WB
Sweetwater	3	I-80	SW 80S	144.200	RA	Bitter Cr. EB
Uinta	3	I-80	UI 01R	41.990	RA	Lyman
Crook	4	I-90	CR 01A	153.410	RA	Moorcroft
Crook	4	I-90	CR 01S	189.000	RA	Sundance
Crook	4	I-90	CR 01W	199.310	RA	Black Hills Welcome
Johnson	4	I-90	JO 03R	88.670	RA	Powder River
Niobrara	4	US 85	NI 01R	196.040	RA	Mule Cr.
Sheridan	4	I-90	SH 01R	23.150	RA	Sheridan
Sheridan	4	US 14/14A	SH 04R	58.400	RA	Medicine Wheel
Weston	4	US 16	WE 02R	220.800	RA	Upton
Big Horn	5	US 14/16/20	BH 03R	206.700	RA	Greybull
Fremont	5	US 26/287	FR 03R	96.380	RA	Diversion Dam
Fremont	5	WY 28	FR 05R	34.000	RA	South Pass
Fremont	5	US 26/287	FR 10R	42.110	RA	Sweetwater Station
Hot Springs	5	WY 120	HS 01R	37.100	RA	Gooseberry Cr.
Natrona	5	US 20/26	NA 05R	53.210	RA	Waltman





# STATEWIDE RWIS SITES

RWIS = remote weather information site

District	ML #	Route	Maint. Sect.	Map #	RM	DIR	Name	Under Const
1	22	WY 230	CB 11A	7	113.200		Skyline	
1	23	US 287	AL 02C	8	420.360	I	Pumpkin Vine	
1	25	I-25	LA 03A	9	3.290	B	Wyo hill (1)	
1	25	I-25	LA 03A	10	3.520	D	Wyo hill (2)	
1	25	I-25	LA 03A	11	4.020	D	Wyo hill (3)	
1 & 2	25	I-25	LA 03A	12	28.150	D	Whitaker	
1 & 2	25	I-25	LA03B	76	46.770	B	Bear Creel	
1	80	I-80	CB 01A	33	221.550	I	Sinclair	
1	80	I-80	CB 01A	34	234.500	I	Walcott Junction	
1	80	I-80	CB 01B	35	244.800	I	Dana Ridge	
1	80	I-80	CB 01B	36	249.100	I	RM 249	
1	80	I-80	CB 01B	37	252.160	D	Halleck Ridge	
1	80	I-80	CB 01B	38	256.170	I	Elk Mountain	
1	80	I-80	CB 01B	39	262.000	I	Picture	
1	80	I-80	CB 01B	40	266.580	D	Wagonhound	
1	80	I-80	CB 01C	41	269.500	I	Foot Creek	
1	80	I-80	CB 01C	42	271.800	D	Arlington	
1	80	I-80	CB 01C	43	273.850	I	Arlington East	
1	80	I-80	CB 01C	44	279.360	I	Cooper Cove	
1	80	I-80	AL 01A	45	283.750	I	Strouss Hill	
1	80	I-80	AL 01A	46	289.500	D	Quealy Dome	
1	80	I-80	AL 01A	47	297.660	D	Herrick Lane Int.	
1	80	I-80	AL 01B	48	325.900	I	East of Summit	
1	80	I-80	AL 01B	49	329.370	I	Vedauwoo	
1	80	I-80	AL 01B	68	333.320	I	Lone Tree	
1	80	I-80	AL 01B	69	336.500	D	Buford East	
1	80	I-80	LA 01A	50	340.500	I	Remount	
1	80	I-80	LA 01A	70	347.690	D	Otto Road	
1	80	I-80	LA 01A	71	353.000	D	RM 353	
1	80	I-80	LA 01A	72	373.000	D	?	<b>New 2012</b>
1	85	US 85	LA 05B	51	46.800		Gun Barrel	
2	21	WY 220	NA 04A	6	80.100	D	Pathfinder Hill	
2 & 1	25	I-25	LA 03A	12	30.250	D	Whitaker	
2	25	I-25	PL 01A	13	70.800	D	Bordeaux	
2	25	I-25	PL 01B	14	98.710	D	Coleman	
2	25	I-25	CO 01A	15	164.250	D	Deer Creek	
2	25	I-25	NA 01A	16	207.160	I	Twenty Mile Hill	
2 & 4	25	I-25	JO 01A	17	267.320	D	I-25 Divide	
2 & 5	34	US 20/26	NA 05B	19	57.420	I	Hiland	
2	258	WY-258	NA 16Y	74	13.770	I	?	<b>New 2013</b>
2	34	US 20/26	NA 05A	75	30	D	?	<b>New 2013</b>

- continued next page -

# STATEWIDE RWIS SITES

RWIS = remote weather information site

District	ML #	Route	Maint. Sect.	Map #	RM	DIR	Name	Under Const
3	13	US 191	SW04B	62	40.450	I	Farson	
3	13	US 191	SB 02D	2	127.000		Rim	
3	80	I-80	UI 01A	22	4.200	I	Evanston	
3	80	I-80	UI 01A	63	10.160	D	Painter Interchange	
3	80	I-80	UI 01A	23	13.860	I	First Divide	
3	80	I-80	UI 01A	64	17.660	D	US 189 Interchange	
3	80	I-80	UI 01A	65	20.950	D	Coal Road	
3	80	I-80	UI 01A	66	23.350	D	Leroy Interchange	
3	80	I-80	UI 01A	67	27.600	D	French Interchange	
3	80	I-80	UI 01B	24	52.650	D	Church Buttes	
3	80	I-80	SW 01C	1	82.310	I	Peru Hill	
3	80	I-80	SW 01D	25	90.550	D	Cemetery Separation	
3	80	I-80	SW 01D	26	97.900	I	Rock Springs	
3	80	I-80	SW 01G	27	111.500	D	Baxter Road.	
3	80	I-80	SW 01E	28	124.500	D	Farren jct.	
3	80	I-80	SW 01E	29	129.800	D	Point of Rocks	
3	80	I-80	SW 01E	30	141.830	I	Bittercreek	
3	80	I-80	SW 01E	31	156.720	D	GL road	
3	80	I-80	SW 01A	32	184.270	I	Continental Divide	
3	1906	WY 372	SW 12B	60	36.000		Shute Creek	
3	2000	WY 22	TE 04A	61	11.170	I	Teton pass	
4 & 2	25	I-25	JO 01A	17	267.320	D	I-25 Divide	
4 & 2	42	WY 387	CL 03A	20	131.790	I	Pine tree Jct.	
4	43	WY 59	CL 04A	21	86.990	I	Belle Fourche	
4	90	I-90	SH 01A	52	0.100	D	MT state line	
4	90	I-90	SH 01B	53	43.660	I	Piney Creek (in johnson county)	
4	90	I-90	JO 03B	54	83.300	I	West of Powder River	
4	90	I-90	JO 03B	55	91.530	D	Dead Horse	
4	90	I-90	CL 01A	56	108.000	I	West of Gillette	
4	90	I-90	CR 01B	57	170.510	I	Inya Kara	
4	90	I-90	CR 01B	58	205.900	I	Beulah Int.	
5	14	WY 28	FR 05A	3	41.350		South Pass	
5	14	WY 28	FR 05A	4	59.500		Red Canyon	
5	20	US 26	FR 02B	5	48.140		Beaver Rim	
5	33	WY 120	PA 03A	18	61.530	I	Meeteetse Rim	
5 & 2	34	US 20/26	NA 05B	19	57.420	I	Hiland	
5	1507	WY 296	PA 16A	59	32.960		Chief Joseph	
5	36	US-16	WA	73	44.01		Big Horn Co. Line	

## Airports (AP)

	Maint.	Crew	RM	Code	Cat.	*ML#	*Route
Dist 1	<b>CY 99A</b>	1034	11.220	CYS	CHEYENNE	AP	<b>180 US 85 Bus</b>
	<b>MB 99A</b>	1036	271.840	80V	MEDICINE BOW	AP	<b>23 US 30</b>
	<b>DX 99A</b>	1037	8.490	9U4	DIXON / BAGGS	AP	<b>401 WY 70</b>
	<b>PB 99A</b>	1039	401.762	82V	PINEBLUFFS	AP	<b>1111 US 30</b>
	<b>LR 99A</b>	1031	0.360	LAR	LARAMIE	AP	<b>110 WY 14</b>
	<b>RW 99A</b>	1041	215.150	RWL	RAWLINS	AP	<b>54 I 80 Bus</b>
	<b>SG 99A</b>	1042	20.920	SAA	SARATOGA	AP	<b>22 WY 130</b>
	<b>HN 99A</b>	1040	3.500	?	HANNA	AP	<b>404 WY 72</b>
Dist 2	<b>CS 99A</b>	2031	9.886	CPR	CASPER	AP	<b>34 US 20/26</b>
	<b>DG 99A</b>	2034	2.419	DGW	DOUGLAS	AP	<b>43 WY 59</b>
	<b>LK 99A</b>	2035	43.719	LSK	LUSK	AP	<b>39 US 20</b>
	<b>TT 99A</b>	2038	50.260	TOR	TORRINGTON	AP	<b>28 US 26</b>
	<b>GN 99A</b>	2039	16.032	7V6	GUERNSEY	AP	<b>27 US 26</b>
	<b>WT 99A</b>	2039	0.820	EAN	WHEATLAND	AP	<b>1604 WY 316</b>
	<b>GD 99A</b>	2034	213.176	?	GLENDO	AP	<b>319 WY 319</b>
Dist 3	<b>AF 99A</b>	3033	84.215	AFO	AFTON	AP	<b>10 US 89</b>
	<b>CV 99A</b>	3034	0.600	U06	COKEVILLE	AP	<b>1200 WY 231</b>
	<b>PD 99A</b>	3035	93.447	PNA	PINEDALE	AP	<b>13 US 191</b>
	<b>ET 99A</b>	3036	1.234	EVW	EVANSTON	AP	<b>2112 I 80sr</b>
	<b>JK 99A</b>	3039	162.840	JAC	JACKSON	AP	<b>10 US 26/89/191</b>
	<b>KM 99A</b>	3040	1.112	EMM	KEMMERER	AP	<b>1202 WY 233</b>
	<b>BM 99A</b>	3035	107.970	BPI	BIG PINEY/MARBLETON	AP	<b>11 US 189</b>
	<b>FB 99A</b>	3042	6.461	FBR	FT. BRIDGER	AP	<b>2103 WY 412</b>
	<b>RS 99A</b>	3032	4.400	RKS	ROCK SPRINGS	AP	<b>1904 WY 370</b>
	<b>GR 99A</b>	3038	5.665	?	GREEN RIVER	AP	<b>1900 WY 530</b>
Dist 4	<b>BF 99A</b>	4036	300.210	BYG	BUFFALO	AP	<b>59 I 90 Bus</b>
	<b>GL 99A</b>	4034	118.350	GCC	GILLETTE	AP	<b>43 WY 59</b>
	<b>HL 99A</b>	4039	16.156	HLT	HULETT	AP	<b>601 WY 24</b>
	<b>NC 99A</b>	4041	241.380	ECS	NEWCASTLE	AP	<b>44 US 16</b>
	<b>UP 99A</b>	4041	1.028	83V	UPTON	AP	<b>2302 WY 116</b>
	<b>SD 99A</b>	4033	1.350	SHR	SHERIDAN	AP	<b>332 WY 332</b>
Dist 5	<b>GB 99A</b>	5031	207.720	GEY	GREYBULL	AP	<b>34 US 14/16/20</b>
	<b>CD 99A</b>	5032	54.500	COD	CODY	AP	<b>31 US 14/16/20</b>
	<b>PW 99A</b>	5035	20.100	POY	POWELL	AP	<b>1506 WY 295</b>
	<b>DB 99A</b>	5033	53.415	U25	DUBOIS	AP	<b>30 US 26/287</b>
	<b>LD 99A</b>	5034	81.050	LND	LANDER	AP	<b>20 US 26/287</b>
	<b>LV 99A</b>	5035	242.760	U68	LOVELL/COWLEY	AP	<b>34 US 14/16/20</b>
	<b>SS 99A</b>	5037	100.927	49U	SHOSHONI	AP	<b>34 US 20</b>
	<b>TM 99A</b>	5040	132.830	THP	THERMOPOLIS	AP	<b>34 US 20</b>
	<b>WL 99A</b>	5041	2.590	WRL	WORLAND	AP	<b>2201 WY 432</b>
	<b>RT 99A</b>	5042	130.321	RIW	RIVERTON	AP	<b>30 US 26/287</b>

\* note: ML and Route may be just the closest Department highway to the Airport



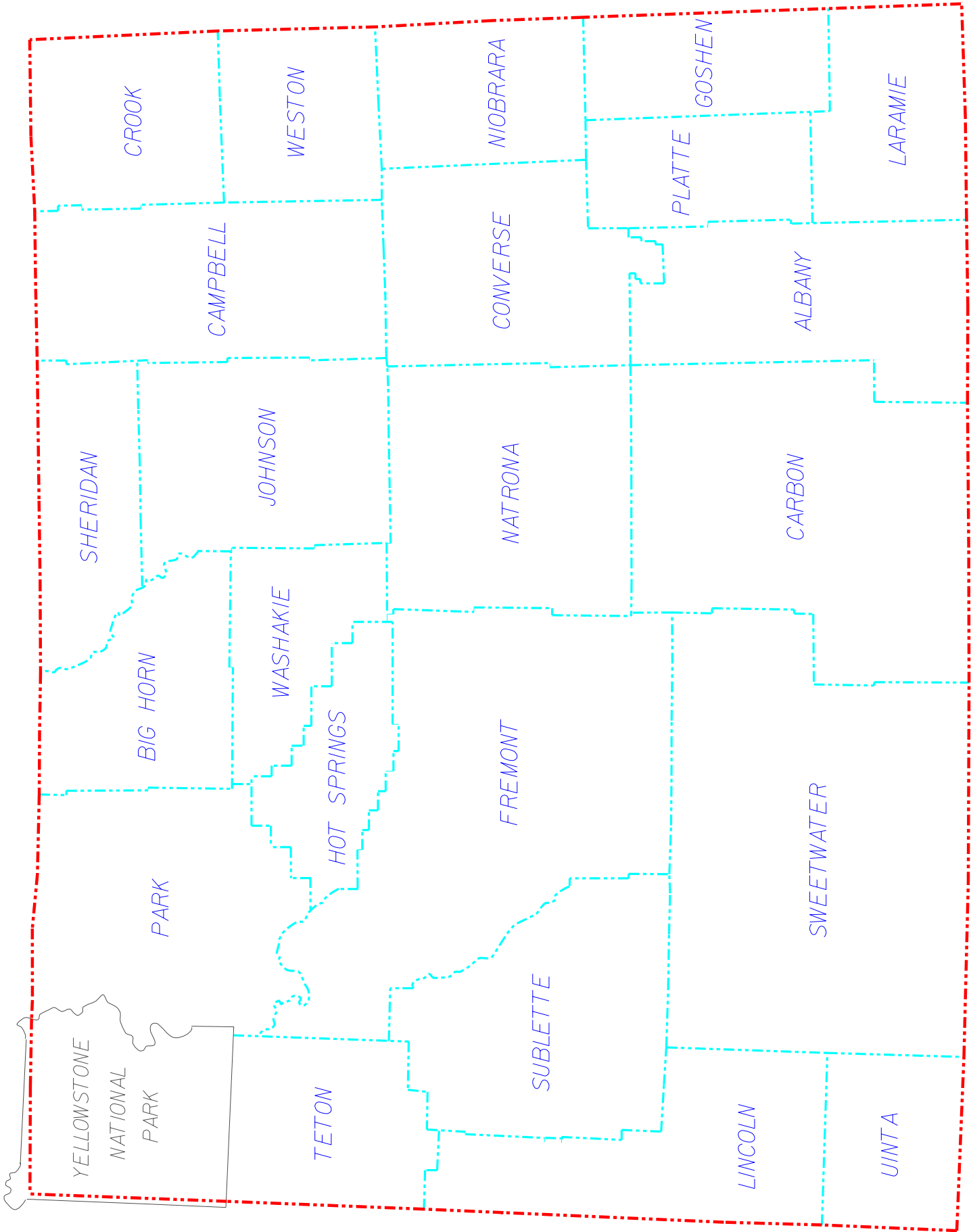



# Map legend :

- ..... ROAD/CLOSE GATE
- ◆ RWIS - WEATHER SITE
- ◆ INFORMATION CENTER SITE
- ◆ REST AREA SITE
- ◆ TELECOMM SITE
- ◆ CHANGEABLE MESSAGE SIGN
- ◆ VARIABLE SPEED LIMIT SIGN
- ◆ 24 HOUR
- ◆ 20 HOUR
- ◆ 16 HOUR
- ◆ NO DRIFTING OR RIDGES
- ◆ AS AVAILABLE
- ◆ CLOSED SEASONALLY
- ◆ NOT DEPT.-PLOWED

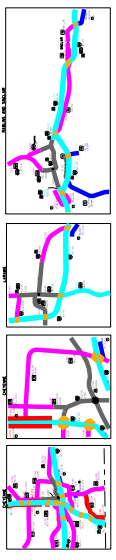
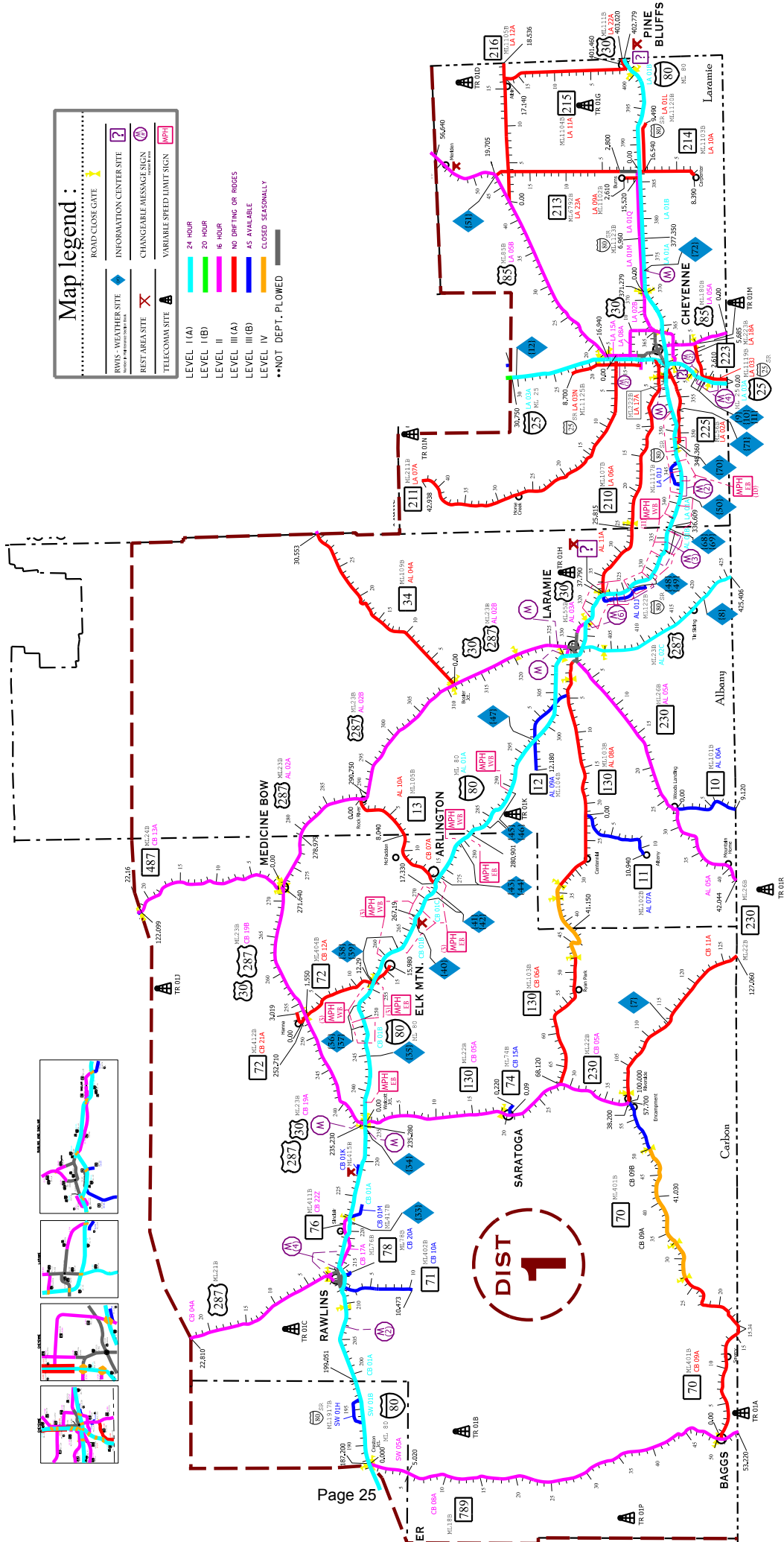

RAWLINS AND SINCLAIR

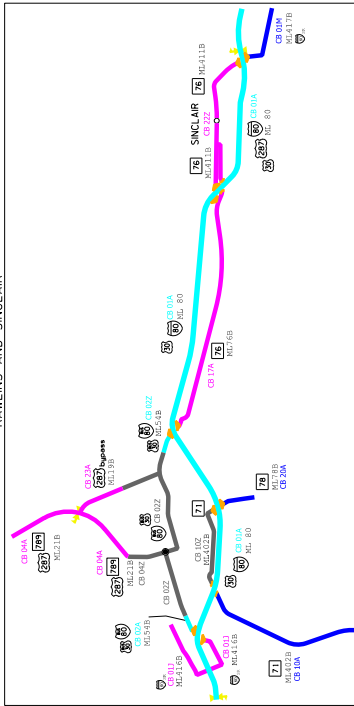

LARAMIE

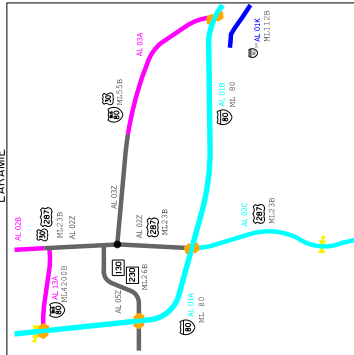

CHEYENNE

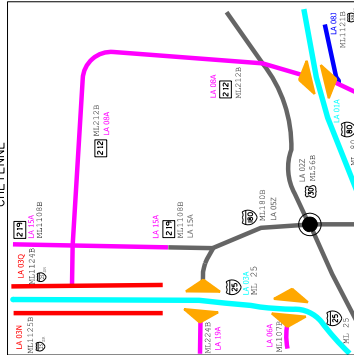

CHEYENNE

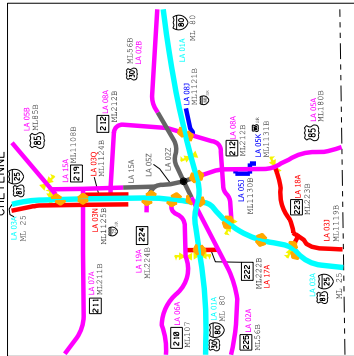



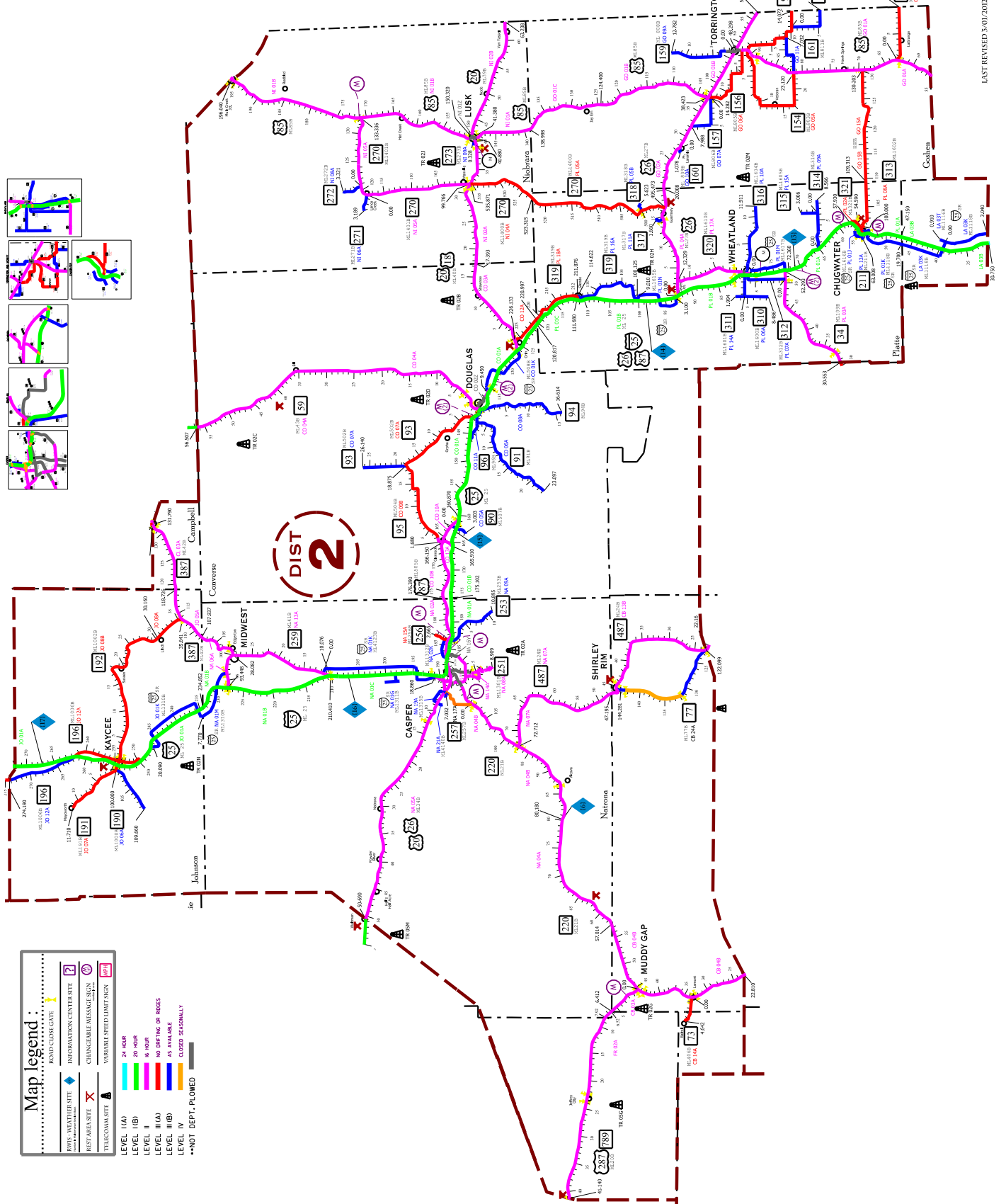

Map legend:	
.....	RAND/CLOSE GATE
.....	INFORMATION CENTER SITE
.....	CHANGIBLE MESSAGE SIGN
.....	VARIABLE SPEED LIMIT SIGN
.....	REST AREA SITE
.....	TELECOMM SITE
.....	LEVEL I(A)
.....	LEVEL I(B)
.....	LEVEL II
.....	LEVEL III(A)
.....	LEVEL III(B)
.....	LEVEL IV
.....	**NOT DEPT. PLOWED



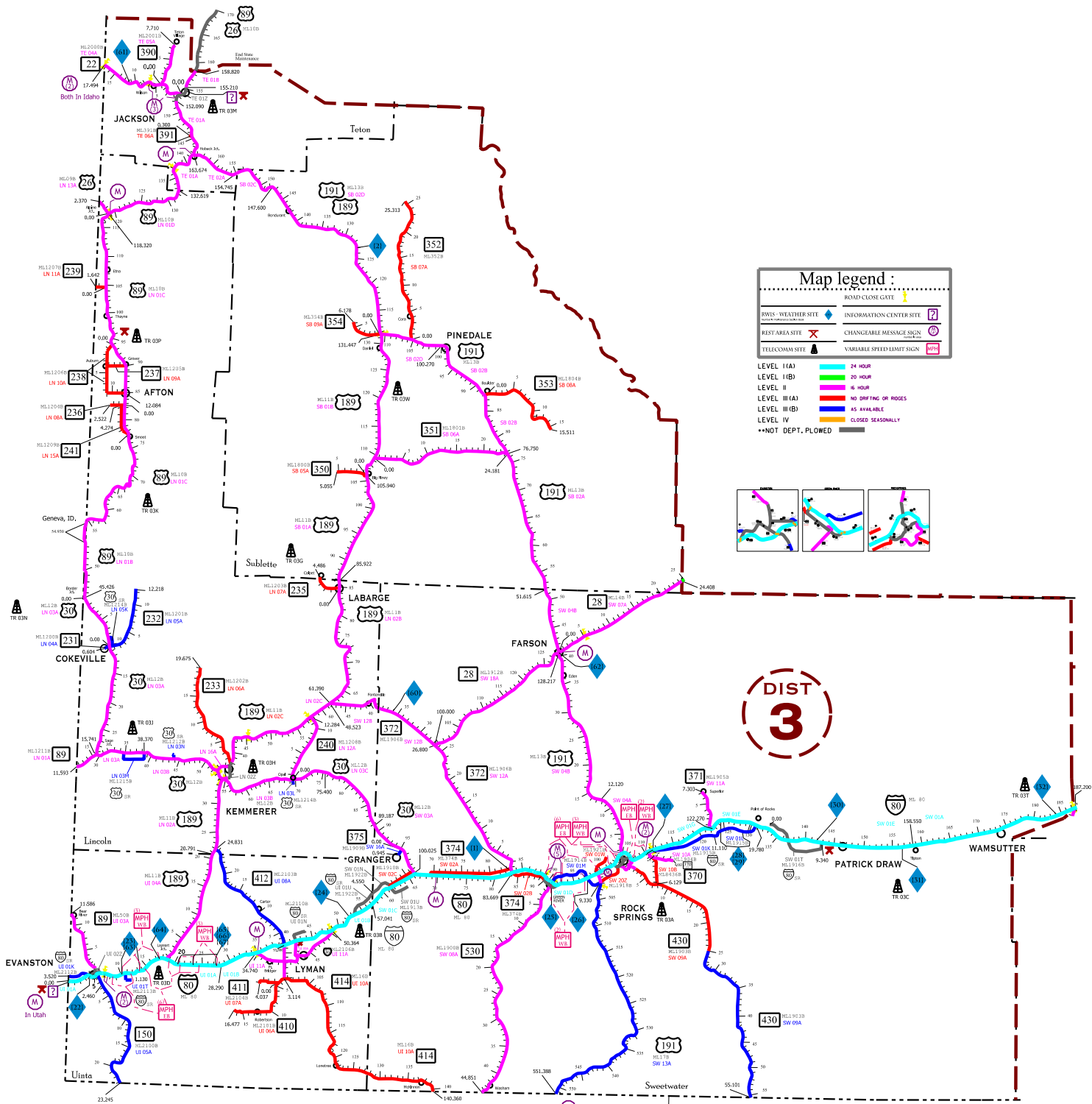

LAST REVISED 5/01/2012

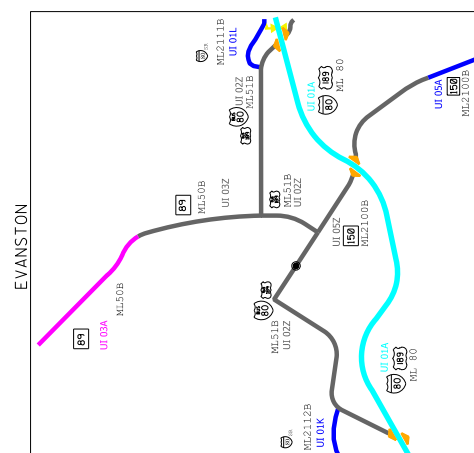
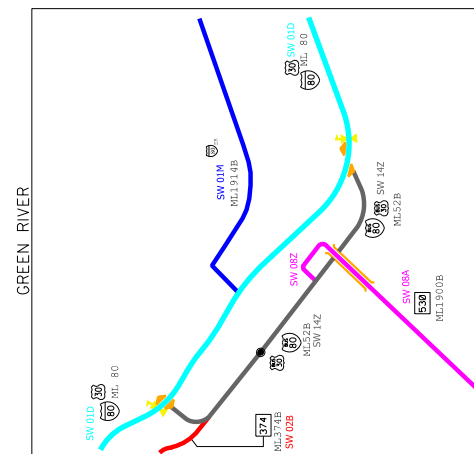
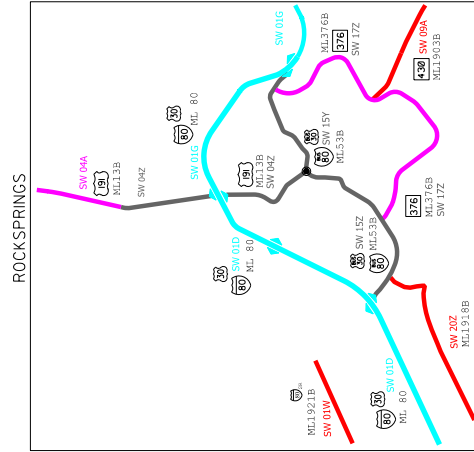

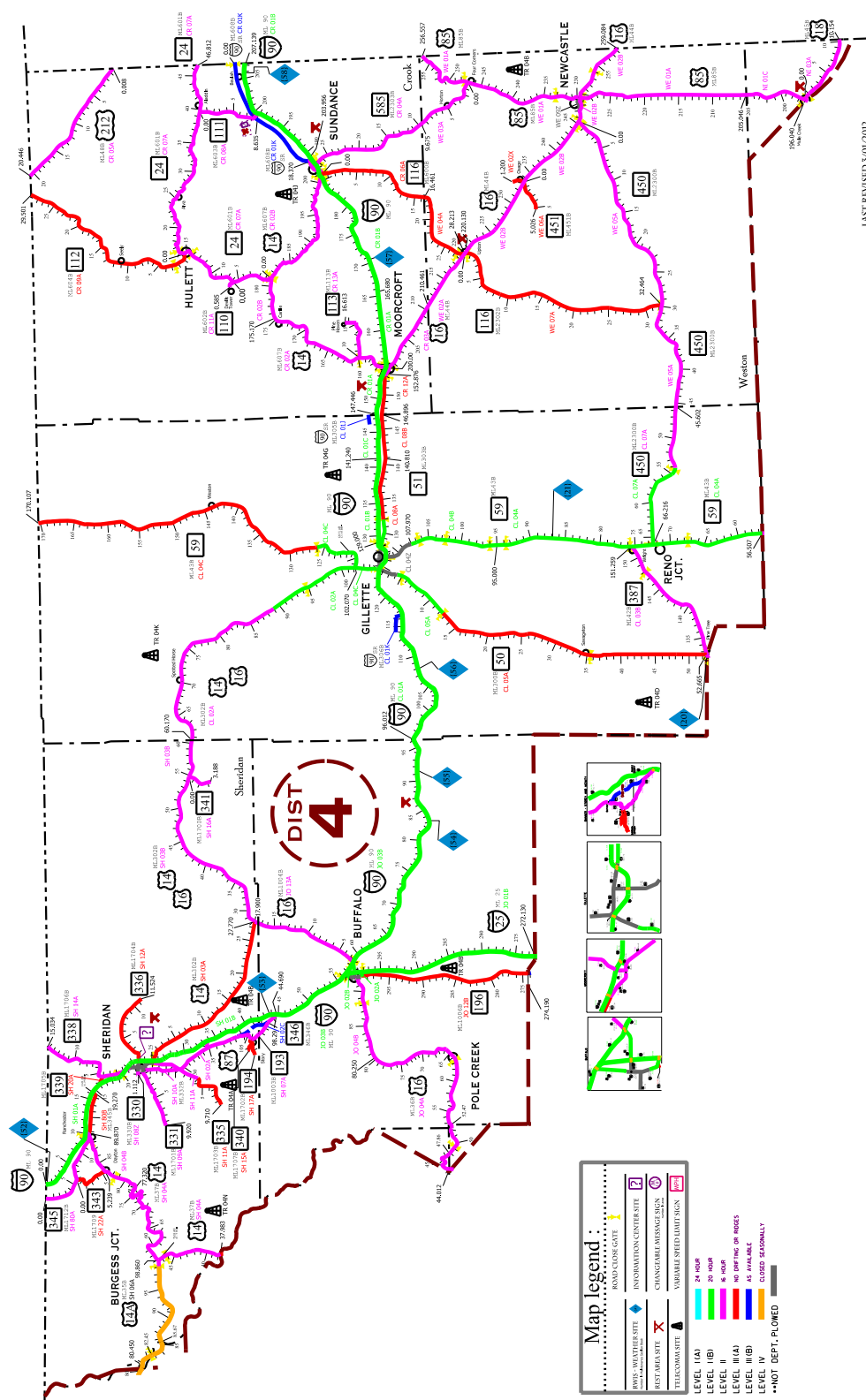

LAST REVISED 3/01/2012

**Map legend:**

- ..... INFORMATION CENTER SITE
- ..... FOUNDATION CREST
- ..... CHANGING ADVANCE SIGN
- ..... VARIABLE SPEED LIMIT SIGN
- ..... TRUCKWAY SIGN
- ..... 24 HOUR
- ..... 20 HOUR
- ..... 8 HOUR
- ..... NO DRIFTING OR RIDGES
- ..... AS AVAILABLE
- ..... CLOSED SEASONALLY
- ..... \*\*NOT DEPT. FLOWED

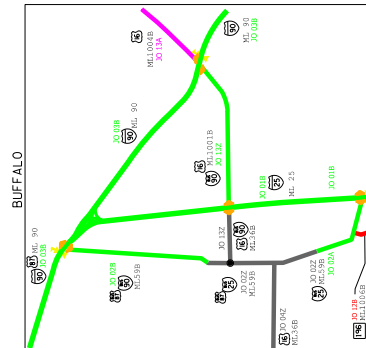
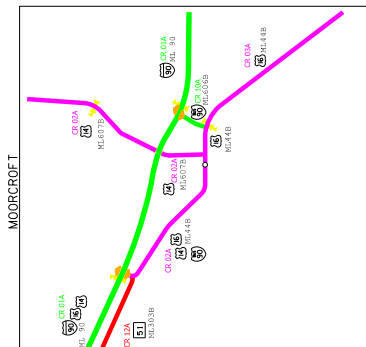
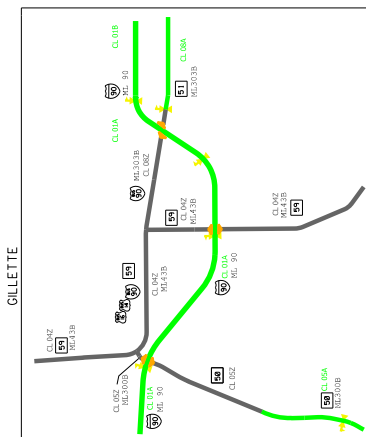
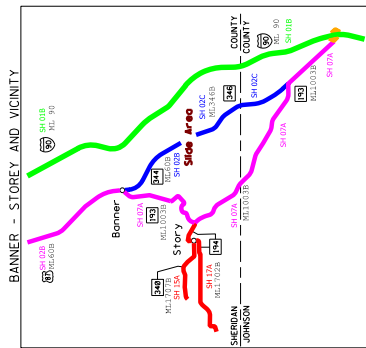







Left Blank Intentionally



Natrona Converse

Carbon

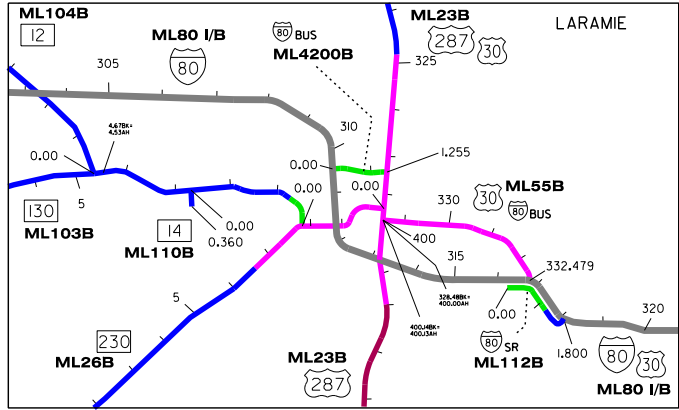
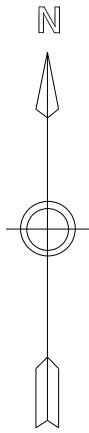

**ROAD COLOR TABLE**

	Rural & Urban Interstate #'s "1 & 11"
	Urban Principal Arterial Other & Expressway (NHS) #'s "12 & 14"
	Urban Minor Arterial, Collector & Local (non NHS) #'s "16, 17 & 19"
	Rural Principal Arterial Other (NHS) # "2"
	Rural Minor Arterial, Major & Minor Collectors & Local (non NHS) #'s "6, 7, 8 & 9"

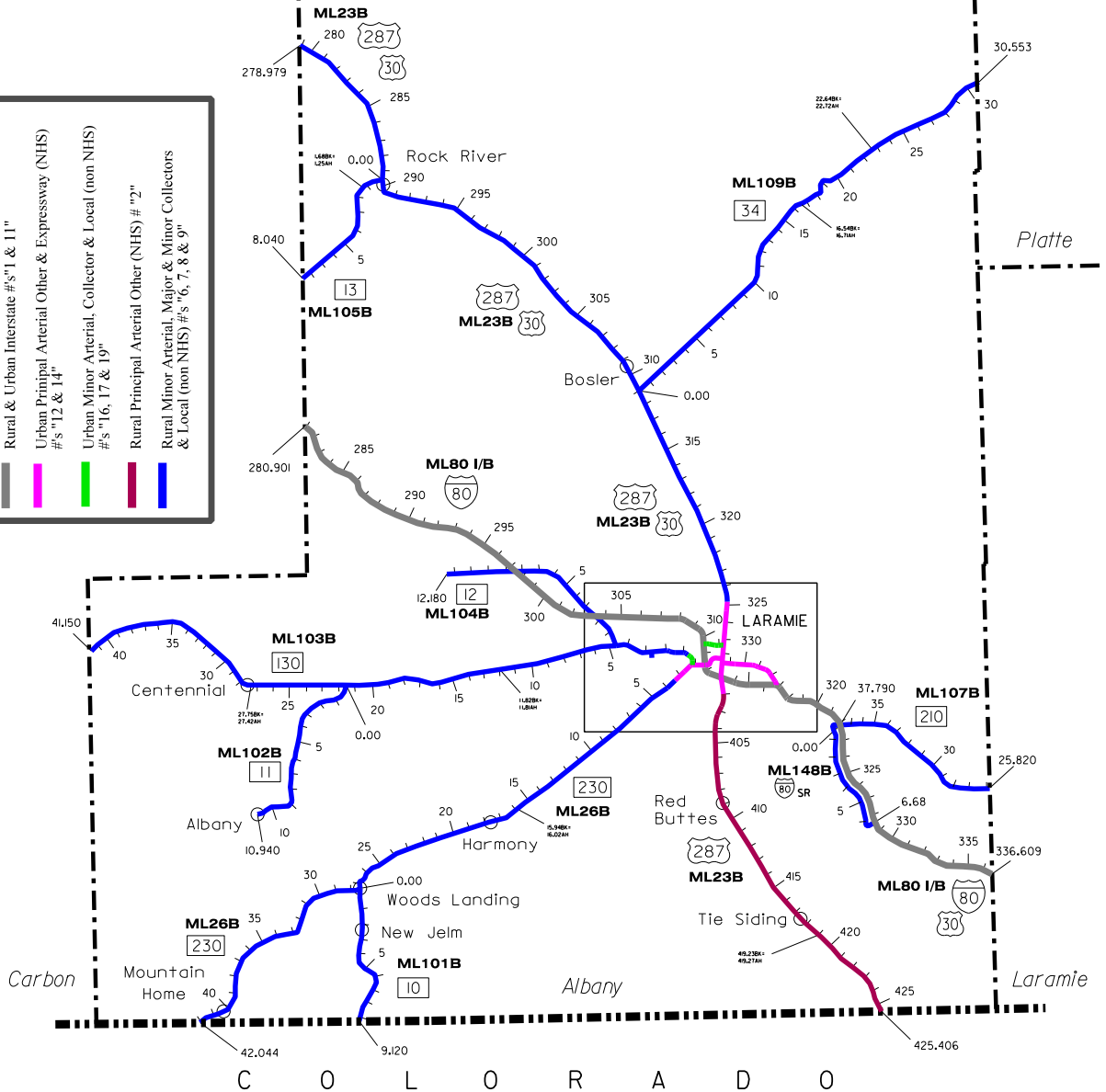



# Albany

•• class "classification break"

## County 5

Maint. Section	class	RM	I-80 & US 30	Maint. Section	class	RM	I-80 & US 30
		<b>ML - 80</b>				<b>ML - 80</b>	
							<i>(CONTINUED)</i>
	1	280.901	Carbon Co. Line		1	317.680	<b>EB VSL sign</b>
		283.750	Strouss Hill <b>RWIS</b> site {45}			317.890	<b>E.B. Road Close Gate R/R</b>
<b>AL 01A</b>		285.090	Co. Rd. Sep. [AWE;EB, AWF;WB]	<b>AL 01B</b>		318.030	Co. Rd. Sep. [AXS;EB, AXT;WB]
1031		285.440	Four Mile Cr. [AWG;SS]	1032		318.500	<b>WB VSL sign</b>
		288.620	Machinery Pass Sep. [AWH;EB, AWI;WB]			319.070	Unnamed Draw [GBD;SS]
		289.438	<b>WB VSL sign</b> Quealy Dome <b>RWIS</b> site {46}			320.987	Medicine Bow Nat'l. Forest Boundary
		290.020	Bellamy & Loback Ditch [AWJ; SS]			322.600	WB C.M.Sign (dynamic) <b>WB VSL sign</b>
		290.440	Quealy Dome Int. [AWK;EB, AWL;WB]			323.049	WY 210 (RM 37.792) [BLJ;SS] Happy Jack Summit Int. <b>Summit Rest Area AL 01R</b>
		293.888	Unnamed Draw [AWM;EB, AWN;WB]				WB C.M.Sign (dynamic)
		295.916	Unnamed Draw [AWO;EB, AWP;WB]			323.850	<b>EB VSL sign</b>
		297.663	WY 12 (RM 8.51); Herrick Lane Int. [AWQ;EB, AWR;WB] Herrick Lane <b>RWIS</b> site {47}			324.900	EB C.M.Sign (dynamic)
		297.740	Brown's Cr. [AWS;SS]			325.780	<b>WB VSL sign</b>
		298.110	Sand Cr. [AWT;SS]			325.820	<b>EB VSL sign</b>
		298.532	Poverty Draw [AWU;SS]			325.900	Summit <b>RWIS</b> site {48}
		298.942	Unnamed Draw [AWV;EB, AWW;WB]			326.250	EB C.M.Sign (dynamic)
		300.438	Machinery Pass. Sep. [AWX;EB, AWY;WB]			326.600	Blair Rd. Sep. [AXU;EB, AXV;WB]
		302.910	Herrick Lane Sep. [FQI;EB, FQJ;WB]			326.821	Medicine Bow Nat'l. Forest Boundary
	1	308.650	Two Rivers Rd. Sep. [AXB;EB, AXC;WB]			328.740	<b>WB VSL sign</b>
••		309.910	WUL Laramie			328.820	EB C.M.Sign (dynamic)
	11	310.452	I-80 BUS (RM 0.00); Curtis St. Int. [CXZ;SS] WCL Laramie <b>W.B. Road Close Gate R/R</b>			329.201	Medicine Bow Nat'l. Forest Boundary
		311.020	WB C.M. Sign (dynamic)			329.316	Vedauwoo Int. [AXW;EB, AXX;WB]
		311.160	Coalmont Br. UPRR Sep. [AXD;EB, AXE;WB]			329.370	Vedauwoo <b>RWIS</b> site {49}
		311.760	WY 130/230 (RM 1.32) Snowy Range Rd. Int. [KLH;EB, KLI;WB]			329.880	<b>EB VSL sign</b>
		312.440	Laramie Rv. [AXJ;EB, AXK;WB]			330.633	Medicine Bow Nat'l. Forest Boundary
		312.923	SCL Laramie			331.290	WB C.M.Sign (dynamic)
		313.010	UPRR Sep. [LBL;EB, LBMWB]			332.290	<b>WB VSL sign</b>
		313.100	WCL Laramie			333.320	<b>EB VSL sign</b> Lone Tree <b>RWIS</b> site {68}
		313.191	US 30/287 (RM 400.93); Third St. Int. [LBN;EB, LBO;WB]			334.300	<b>WB VSL sign</b>
→		313.790	Maint. Break			334.500	WB C.M.Sign (dynamic)
		313.990	15th St. Sep. [?]			335.106	Buford Int. [AXZ;EB, AYA;WB]
<b>AL 01B</b>		314.185	ECL Laramie			336.100	WB C.M.Sign (dynamic)
1032		316.201	Moonlight Ranch Rd. Sep. [AXQ;SS]			336.160	<b>EB VSL sign</b>
		316.702	US 30 (RM 332.48); Grand Av. Int. [CLS;SS] Begin US 30			336.500	Buford East <b>RWIS</b> site {69}
	11	317.200	EB C.M.Sign (dynamic)		1	336.609	Laramie Co. Line
••		317.420	EUL Laramie				

→ -cont- next column

Maint. Section	class	RM	US 287, US 30 & I-80 BUS
		<b>ML - 23B</b>	
<b>AL 02A</b>	6	278.979	Carbon Co. Line
1036		288.974	WY 13 (RM 0.00)
		289.221	NCL Rock River
		290.509	Rock Cr. [KTW;SS]
		290.749	SCL Rock River
		292.468	Begin 4-Lane
<b>AL 02B</b>		308.712	End 4-Lane
1031		309.066	Bosler
		310.661	Laramie Rv. [CJC;SS]
		310.710	<b>N.B. Road Close Gate R/R</b>
		310.847	WY 34 (RM 0.00)
		311.367	Boughton Canal
		313.892	Floodwater Cr. [CJE;SS]
	6	320.500	<b>N.B. Road Close Gate R/R</b>
	14	325.250	NUL Laramie
			Begin 5 -Lane
		326.000	NB C.M.Sign (dynamic)
		327.315	NCL Laramie
		327.372	I-80 BUS (RM 1.26); N. Laramie Conn. Begin I-80 Bus.
		328.219	WY 130/230 (RM 0.00)
		328.481	US 30 & I-80 BUS. (RM 328.48) End US 30 & I-80 Bus.
<b>AL 02Z</b>			BK= -72.519 mi
1032		400.000	AH Equation
			<b>REMOVED EQUATION</b>
		400.777	Spring Cr. [BUU;SS]
		400.936	I-80 (RM 313.19); Third St. Int. [LBN;EB, LBO;WB], Begin NHS
		401.259	UPRR Sep. [LIS;SS]
		401.960	<b>Dept. Shop - Laramie DH 01A</b> <b>Laramie Port-of-Entry AL 02P</b>
		402.317	SCL Laramie
	14	403.900	<b>S.B. Road Close Gate R/R</b>
<b>AL 02C</b>		404.400	SUL Laramie
1032	2	409.581	Harney Cr. [BUX;SS]
		413.253	UPRR Sep. [BUY;SS]
		417.366	Tie Siding
		419.230	BK= - 0.04 mi.
		419.270	AH Equation
		420.360	Pumpkin Vine <b>RWIS</b> site {8}
	2	425.406	Colorado State Line End WY NHS

Maint. Section	class	RM	US 30 & I-80 Bus.
		<b>ML - 55B</b>	
<b>AL 03Z</b>	14	328.481	US 30/287 (RM 328.48)
1032		330.638	Spring Cr. [DLN;SS]
		331.444	ECL Laramie
<b>AL 03A</b>		332.180	Oriole lane
1032		332.204	Begin Divided Section
	14	332.479	I-80 (RM 316.70); Grand Ave. Int. [CLS;SS]

**I-80 Bus.**

*North Laramie Connector*

		RM	
		<b>ML - 4200B</b>	
	16	0.000	I-80 (RM 310.45); Curtis St. Int.
<b>AL 13A</b>		0.332	CL Laramie
1031		0.447	Laramie Rv. [CXY;SS]
		1.043	UPRR Sep. [BLB;SS]
		1.255	US 30/287 (RM 327.37)

**WY 10**

		RM	
		<b>ML - 101B</b>	
	7	0.000	WY 230 (RM 27.30) Woods Landing
<b>AL 06A</b>		0.780	Laramie Rv. [LIL;SS]
1032		3.200	Jelm Mountain Rd
		8.200	Mountain Home Rd
		9.117	Colorado State Line

**WY 11**

		RM	
		<b>ML - 102B</b>	
	7	0.000	WY 130 (RM 21.62)
<b>AL 07A</b>		3.200	Dinwiddie Rd
1031		10.935	Albany / End SHS

**WY 12**

		RM	
		<b>ML - 104B</b>	
	7	0.000	WY 130 (RM 4.70)
<b>AL 09A</b>		2.634	Herrick Lane Sep.
1031		7.570	Flood Channel [CIS;SS]
		8.070	Little Laramie Rv. [CIT;SS]
		8.152	I-80 (RM 297.66); Herrick Ln. Int. [AWQ;EB, AWR;WB]
		10.180	W. Fork Little Laramie Rv. [CIU;SS]
		12.182	End SHS

**WY 13**

		RM	
		<b>ML - 105B</b>	
	7	0.000	US 30/287 (RM 288.97)
<b>AL 10A</b>		0.321	UPRR Sep. [EUQ;SS]
1038		1.676	BK= + 0.431 mi.
		1.245	AH Equation
		2.360	Rock Creek [CIV;SS]
		8.035	Carbon County Line

Maint. Section	class	RM	WY 14 <i>Airport Spur</i>
		***	<b>ML - 110B</b>
<b>AL 14A</b>	7	0.000	WY 130 Mainline (RM 2.78)
1031		0.360	Airport / End SHS
<b>WY 34</b>			
			<b>ML - 109B</b>
<b>AL 04A</b>	6	0.000	US 30/287 (RM 310.85)
1031		0.020	<b>E.B. Road Close Gate R/R</b>
		10.660	Sybille Rd (east)
			REMOVED EQUATION
			REMOVED EQUATION
		25.680	BK= - 0.037 mi.
		25.717	AH Equation
			North Sybille Cr. [DJU;SS]
		27.300	Sybille Rd (south)
		28.367	BK= - 0.013 mi.
		28.380	AH Equation
		30.553	Platte County line
			District Boundary
<b>WY 130 &amp; 230</b>			
			<b>ML - 26B</b>
<b>AL 05Z</b>	14	0.000	US 30/287 (RM 328.22)
1032		0.180	Clark Street Viaduct UPRR Sep. [CIF;SS]
		0.420	RR at Grade Crossing #810692D
		0.661	Big Laramie River [DCZ;SS]
		1.320	I-80 (RM 311.76);
			Snowy Range Rd. Int. [KLH;EB, KLI;WB]
		1.470	Pierce street
		2.120	WY 130 (RM 0.00)
			End WY 130
	14	2.432	WCL Laramie
		3.450	WUL Laramie
<b>AL 05A</b>	6	9.970	Harmony Rd (west)
1032		15.940	BK= - 0.08 mi.
		16.020	AH Equation
		17.750	Harmony Rd (north)
		22.341	Pioneer Canal [CIH;SS]
		26.300	Fox Cr. [CI;SS]
		26.540	Fox Cr. Rd
		27.340	WY 10 (RM 0.00)
			Woods Landing
		28.481	Medicine Bow Nat'l. Forest Boundary
		35.700	Fox Park Rd
		40.100	Mountain Home Rd
		41.400	UPRR Sep. [FND;SS]
	6	42.040	Colorado State Line

Maint. Section	class	RM	WY 130
			<b>ML - 103B</b>
<b>AL 08Z</b>		0.000	WY 130/230 (RM 2.10)
1031	16		
		0.733	WCL & WUL Laramie
	7	2.779	WY 14 (RM 0.00); Airport spur
<b>AL 08A</b>			<b>W.B. Road Close Gate swing</b>
1031		4.668	BK= + 0.137 mi.
		4.531	AH Equation
		4.702	WY 12 (RM 0.00)
		11.823	BK= + 0.011 mi.
		11.812	AH Equation
		13.150	Big Hollow Rd (south)
		13.300	Mandel Lane (north)
		19.945	Lake Hattie Canal [CIL;SS]
		21.621	WY 11 (RM 0.00)
		22.037	Little Laramie Rv. [DJN;SS]
		26.600	Dinwiddie Rd (south)
		26.759	N. Fork Little Laramie Rv. [DJM;SS]
		27.752	BK= + 0.33 mi.
		27.422	AH Equation at Centennial
		28.713	Medicine Bow Nat'l. Forest Boundary
		30.590	N. Fork Little Laramie Rv. [DDJ;SS]
		33.960	<b>W.B. Road Close No barricades</b>
<b>AL 08A</b>		34.500	<b>W.B. Road Close barricades</b>
1031		35.146	Brooklyn Lake Rd
		35.810	<b>W.B. Road Close Gate swing</b>
			<i>Seasonal Closure</i>
	7	41.150	Carbon County Line
<b>WY 210</b>			
			<b>ML - 107B</b>
	7	25.815	Laramie County Line
<b>AL 11A</b>		26.445	Medicine Bow Nat'l. Forest Boundary
1032		33.681	S.F. Lodgepole Cr. [FDX;SS]
		35.670	Happy Jack Rec. Area
		37.700	<b>E.B. Road Close Gate swing</b>
		37.792	I-80 (RM 323.049); Summit Int.
			[BLJ;SS]
<b>I-80 SV. RD.</b>			
			<b>ML - 112B</b>
	17	0.000	Jct. Moonlight Rd Sep. [?]
<b>AL 01K</b>	17	1.230	EUL Laramie
1032		1.280	Urban Break
	9	1.800	End Sv. Rd. @Co. Rd. Sep. [?]
<b>I-80 SV. RD.</b>			
			<b>ML - 148B</b>
<b>AL 01J</b>	9	0.000	Jct. Happy Jack Rd. Int.
1032			WY 210(RM 37.79)
		6.680	End Sv. Rd. @Jct. Vedauwoo Rd. Int.





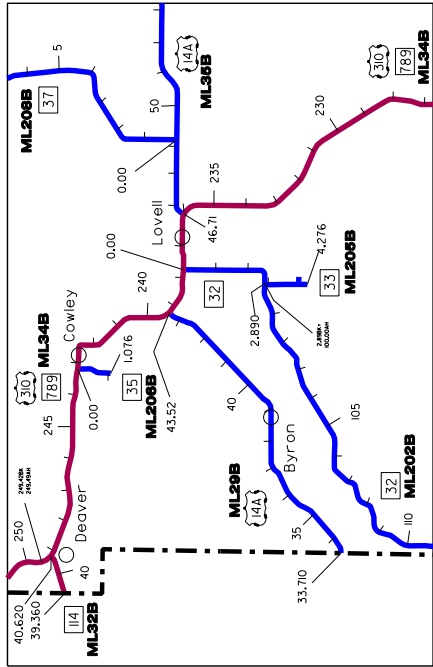

**ROAD COLOR TABLE**

- Rural & Urban Interstate #s "1 & 11"
- Urban Principal Arterial Other & Expressway (NHS) #s "12 & 14"
- Urban Minor Arterial, Collector & Local (non NHS) #s "16, 17 & 19"
- Rural Principal Arterial Other (NHS) # "2"
- Rural Minor Arterial, Major & Minor Collectors & Local (non NHS) #s "6, 7, 8 & 9"

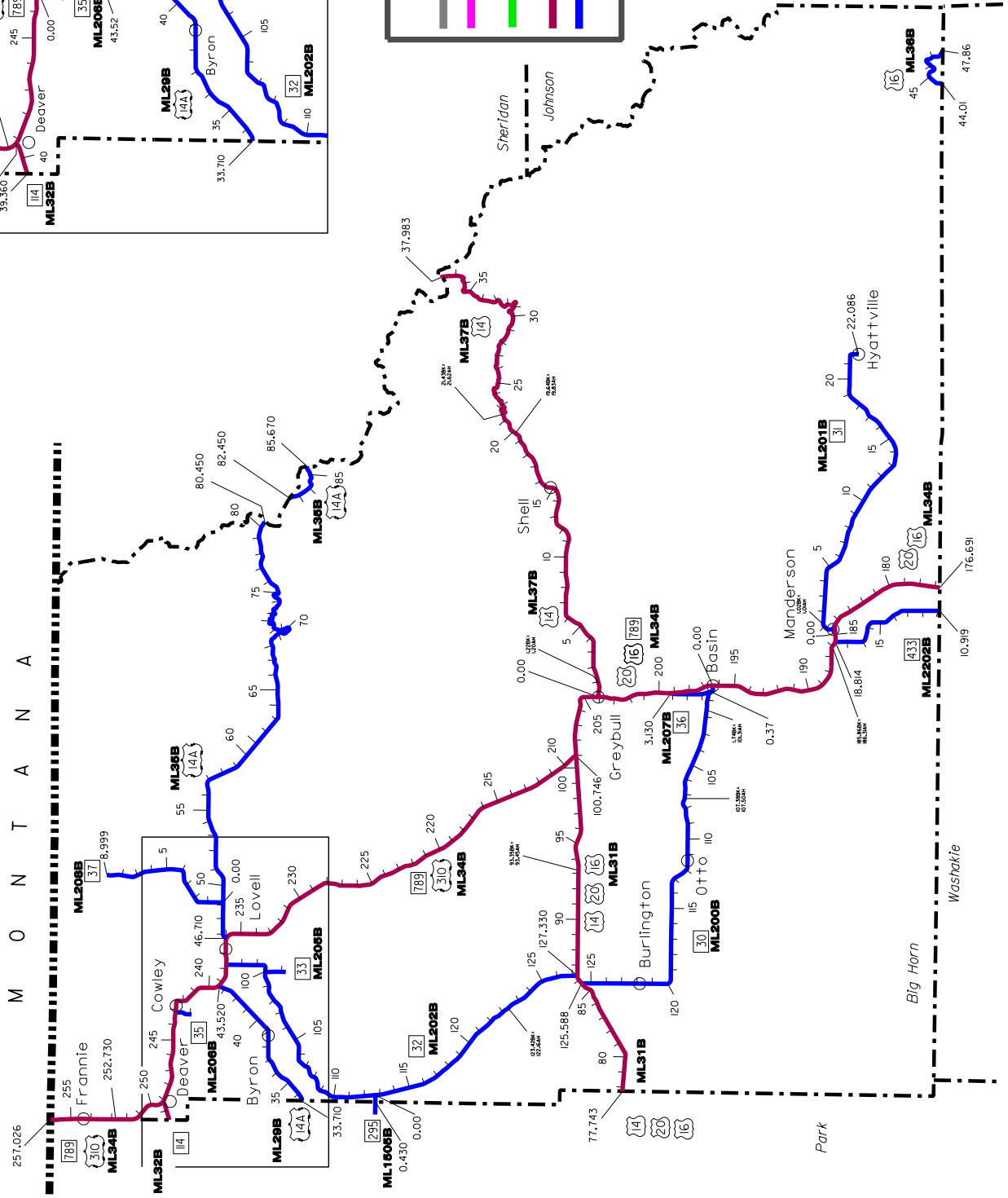
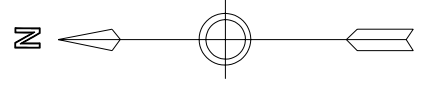



# Big Horn

•• class "classification break"

## County 9

Maint. Section	CREW	CLASS	RM	US 14, 16 & 20	Maint. Section	CREW	CLASS	RM	US 14, 16, 20, 310 & WY 789
			<b>ML - 31B</b>					<b>ML - 34B</b>	
<b>BH 01A</b>	5031	2	77.743	Park Co. Line Cont. NHS					<i>(CONTINUED)</i>
			85.655	WY 30 (RM 125.59)				205.062	NCL Greybull
			86.264	WY 32 (RM 127.33)	<b>BH 03C</b>	5031	2	205.287	Dry Cr. [CCX;SS]
			87.360	Emblem				205.506	BNRR Sep. [CCY;SS]
			93.353	BK= - 0.95 mi.				205.720	County Rd (north)
			93.448	AH Equation				206.700	<b>Airport Rest Area BH 03R</b>
			93.960	County Rd (south)				207.720	Airport Rd
			94.064	Dry Cr.[CAC;SS]				209.033	US 14,16,20 (RM 100.75)
			100.746	US 310 (RM 209.03)					End US 14, 16 & 20
								211.654	Little Dry Cr. [CCZ;SS]
								228.820	East fork Sand Draw [HOI;SS]
								229.200	Maint. Break
								234.830	County Rd (north)
<b>BH 03A</b>	5031	2	176.691	Washakie County Line Cont. NHS	<b>BH 03B</b>	5035	2	235.830	County Rd (east & west)
			178.190	Rairden Rd				236.060	US 14A (RM 0.00)
			184.203	ECL Manderson					Begin US 14A,
			184.346	WY 31 East Mainline (RM 0.00)					<b>Dept. Shop - Lovell LV 05A</b>
			184.556	BNRR Sep. [DIQ;SS]					Approx. 2 Blks. S. on McKinley Av.
			184.950	WY 31 West Spur (RM 0.00)					Cont. NHS
			185.038	WCL Manderson				236.260	ECL Lovell, Cont. NHS
			185.052	Big Horn Rv. [DIV;SS]	<b>BH 03Y</b>	5035	2	236.357	Begin Divided Section
			185.517	WY 433 (RM 18.81)					
			185.862	BK= - 0.448 mi.				237.286	WCL Lovell
			186.310	AH Equation, Cont. NHS				237.415	End Divided Section
			187.770	Orchard Bench Rd (south)	<b>BH 03D</b>	5035	2	237.897	WY 32 (RM 0.00)
			188.056	Dobie Cr. [CCR;SS]				238.778	Shoshone Rv. [BSO;SS]
			188.723	Big Horn Canal [BSL;SS]				239.259	US 14A (RM 43.52)
			191.147	Elk Cr. [JBY;SS]					End US 14A
			191.659	Big Horn Canal [HNP;SS]				239.630	Sage Cr. [CDB;SS]
			194.660	Antelope Cr. [CCU;SS]				239.758	BNRR Sep. [CDC;SS]
			194.970	Orchard Bench Rd (north)				242.409	ECL Cowley
			195.741	SCL Basin				242.480	Begin Divided Section
			196.415	WY 30 (RM 0.00)				242.965	End Divided Section
				<b>Dept. Shop - Basin DH 05A</b>				243.187	WCL Cowley,
				1 Blk. East on "C" St.					WY 35 (RM 0.00)
			196.720	NCL Basin				245.390	County Rd (north)
			197.175	ECL Basin				246.661	Sidon Canal [CYU;SS]
			197.330	NCL Basin				247.074	Sage Cr. [CDD;SS]
			199.270	WY 36 (RM 3.13)				248.533	ECL Deaver
			202.770	Greybull Rv. [CCV;SS]				249.167	WY 114 (RM 40.62)
			203.566	BNRR Sep. [LCY;SS]				249.346	NCL Deaver
			203.633	SCL Greybull				249.420	BK= - 0.07 mi.
<b>BH 03Z</b>	5031	2	204.054	US 14 (RM 0.00)				249.490	AH Equation
				Begin US 14 & US 310				252.727	Park County Line
			205.062	NCL Greybull					Cont. NHS

-cont- in Park County

Maint. Section	CREW	class	RM	US 14A
				<b>ML - 35B</b>
<b>BH 04A</b>	5035	6	46.710	US 14,16,20 (RM 236.06)
			48.110	Sand Draw [DBQ;SS]
			49.170	WY 37 (RM 0.00)
			54.700	Big Horn Nat'l. Recreation Boundary
			55.430	RR at Grade Crossing #091517A
			55.760	County Rd (south)
			56.890	Yellowtail Reservoir [CDN;SS]
			58.790	E. Boundary Big Horn Nat'l. Recreation Area
			68.730	<b>E.B. Road Close Gate R/R</b> <i>Seasonal Closure (local traffic)</i>
			70.800	WB Truck Run-away Ramp
			71.720	Big Horn Nat'l. Forest Boundary
			71.980	Big Horn Nat'l. Forest Boundary
			72.090	Big Horn Nat'l. Forest Boundary
			72.100	WB Truck Run-away Ramp
			73.080	Big Horn Nat'l. Forest Boundary
			73.360	Big Horn Nat'l. Forest Boundary
			73.600	Big Horn Nat'l. Forest Boundary
			73.760	Big Horn Nat'l. Forest Boundary
			76.350	WB Truck Run-away Ramp
			76.400	<b>E.B. Road Close Gate swing</b> <i>Seasonal Closure</i>
			80.450	Big Horn Co. line / District Boundary
<b>SH 06A</b>	4038	6	82.450	Sheridan Co. line
			85.670	Big Horn Co. Line

-cont- in Sheridan County

Maint. Section	CREW	class	RM	US 14A
				<b>ML - 29B</b>
<b>BH 11A</b>	5035	6	33.710	Park County Line
			34.330	Sidon Canal [EUP;SS]
			36.170	Sidon Canal [EWI;SS]
			36.460	Sidon Canal [EWJ;SS]
			38.030	Begin Divided Section
			38.280	WCL Byron
			39.360	ECL Byron
			39.390	End Divided Section
			43.520	US 310 (RM 239.259)

Maint. Section	CREW	class	RM	US 14
				<b>ML - 37B</b>
<b>BH 06Z</b>	5031	2	0.000	US 14,16,20 (RM 204.05)
				Begin NHS
			0.415	Big Horn Rv. [FEV;SS]
				ECL Greybull
<b>BH 06A</b>	5031	2	1.215	BK= + 0.016 mi.
			1.199	AH Equation
			2.120	County Rd (north)
			4.925	Alkali Draw [LJE;SS]
			5.886	Potato Draw [LJF;SS]
			12.248	Red Gulch [CEG;SS]
			15.300	Shell Canal
			15.340	Shell
			15.390	Spring Branch Cr.
			15.880	Shell Cr. [FSA;SS]
			19.630	Shell Cr. [FSB;SS]
				<b>E.B. Road Close Gate R/R</b>
			19.636	BK = -.189 mi.
			19.825	AH Equation
			20.359	Big Horn Nat'l. Forest Boundary
			21.430	BK= - 0.192 mi.
			21.622	AH Equation
			26.711	Shell Cr. [CEL;SS]
			31.760	Hyattville Rd
			35.070	<b>E.B. Road Close Gate R/R</b>
			37.983	Sheridan Co. Line / District Boundary
				Cont. NHS

Maint. Section	CREW	class	RM	US 16
				<b>ML - 36B</b>
<b>JO 04A</b>	4037	2	44.012	Washakie County Line
			47.087	East Ten Sleep Cr. [EWU;SS]
			47.860	Washakie County Line

-cont- in Big Horn County

Maint. Section	CREW	class	RM	WY 30
				<b>ML - 200B</b>
<b>BH 07A</b>	5031	7	0.000	US 16,20 (RM 196.42)
			0.370	WY 36 (RM 0.37)
			0.650	WCL Basin
			1.743	BK= - 99.07 mi.
			101.312	AH Equation
			107.216	Greybull Rv. [KTS;SS]
			107.360	Greybull River Rd
			107.378	BK= - 0.122 mi.
			107.500	AH Equation
			108.845	McKenney Draw [CJD;SS]
			111.799	Otto
			121.250	Burlington SCL
			122.250	Burlington NCL
			125.588	US 14,16,20 (RM 85.66)

Maint. Section	class	RM	WY 31
			<b>ML - 201B</b>
<b>BH 08A</b>	7	0.000	US 16,20 (RM 184.35)
		0.424	WY 31 Spur (RM 0.31)
5031		0.930	NCL Manderson
		1.019	Nowood Rv. [BLN;SS] BK= + 0.01 mi.
		1.010	AH Equation
		5.492	Nowood Rv. [CJF;SS]
		6.500	County Rd (south)
		13.635	Nowood Rv. [CJG;SS]
		14.740	County Rd (south)
		19.383	Alkali Cr. [CJH;SS]
		21.890	Medicine Lodge Cr. [CJI;SS]
		22.086	Hyattville End SHS

WY 31 West Spur			
			<b>ML - 203B</b>
<b>BH 08B</b>	7	0.000	US 16,20 (RM 184.95)
		0.270	BNRR at Grade Crossing #090842T
5031		0.310	WY 31 (RM 0.42); Mainline Manderson

WY 32			
			<b>ML - 202B</b>
<b>BH 09A</b>	7	0.000	US 310 (RM 237.80)
		2.888	BK= - 97.11 mi.
5035		100.000	AH Equation WY 33 (RM 2.89)
		100.486	Foster Gulch [CJJ;SS]
		104.280	Sand Cr. [CUD;SS]
		105.260	Coon Cr. [CJL;SS]
		107.530	Whistle Cr. [CJM;SS]
		110.570	Lovell Canal [CJN;SS]
		112.720	WY 295 (RM 0.00)
	7	115.720	Whistle Cr. [EAD;SS]
<b>BH 09B</b>		119.500	Unnamed Draw [CJP;SS]
		123.414	BK= + 1.252 mi.
5031		122.163	AH Equation
		126.678	Dry. Cr. [CJQ;SS]
		127.326	US 14,16,20 (RM 86.26)

WY 33			
			<b>ML - 205B</b>
<b>BH 10A</b>	8	2.888	WY 32 (RM100.00)
		4.276	End SHS
5035			

Maint. Section	class	RM	WY 35
			<b>ML - 206B</b>
<b>BH 12A</b>	9	0.000	US 310 (RM 243.187)
		0.715	Sage Cr. [CJW;SS]
5035		1.076	End SHS

WY 36			
			<b>ML - 207B</b>
<b>BH 13A</b>	9	0.373	WY 30 (RM 0.37)
		1.230	NCL Basin
5031		3.130	US 16,20 (RM 199.270)

WY 37			
			<b>ML - 208B</b>
<b>BH 14A</b>	7	0.000	US 14A (RM 2.45)
		0.900	RR at Grade Crossing #091508B
		1.235	Shoshone Rv. [CJX;SS]
5035		1.650	County Rd (west)
		7.397	Big Horn Nat'l. Rec. Area Bndry
		8.999	End SHS

WY 114			
			<b>ML - 32B</b>
-cont-			from Park Co.
<b>PA 05A</b>	2	39.355	Park County Line Cont. NHS
		40.140	WCL Deaver
5035		40.570	RR at Grade Crossing #090667E
		40.621	US 310 (RM 249.167)
			End NHS

WY 295			
			<b>ML - 1505B</b>
<b>PA 10A</b>	7	0.000	WY 32 (RM 112.72)
		0.420	Park County Line
5035			

→ -cont- in Park County

WY 433			
			<b>ML - 2202B</b>
<b>BH 16A</b>	7	10.919	Washakie County Line
		11.270	Five Mile Cr. [CXK;SS]
5041		12.420	Rairden Rd
		18.814	US 14,16,20 (RM 185.52)



ROAD COLOR TABLE

- Rural & Urban Interstate #'s "1 & 11"
- Urban Principal Arterial Other & Expressway (NHS) #'s "12 & 14"
- Urban Minor Arterial, Collector & Local (non NHS) #'s "16, 17 & 19"
- Rural Principal Arterial Other (NHS) # "2"
- Rural Minor Arterial, Major & Minor Collectors & Local (non NHS) #'s "6, 7, 8 & 9"

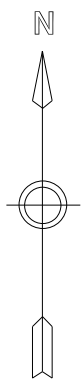
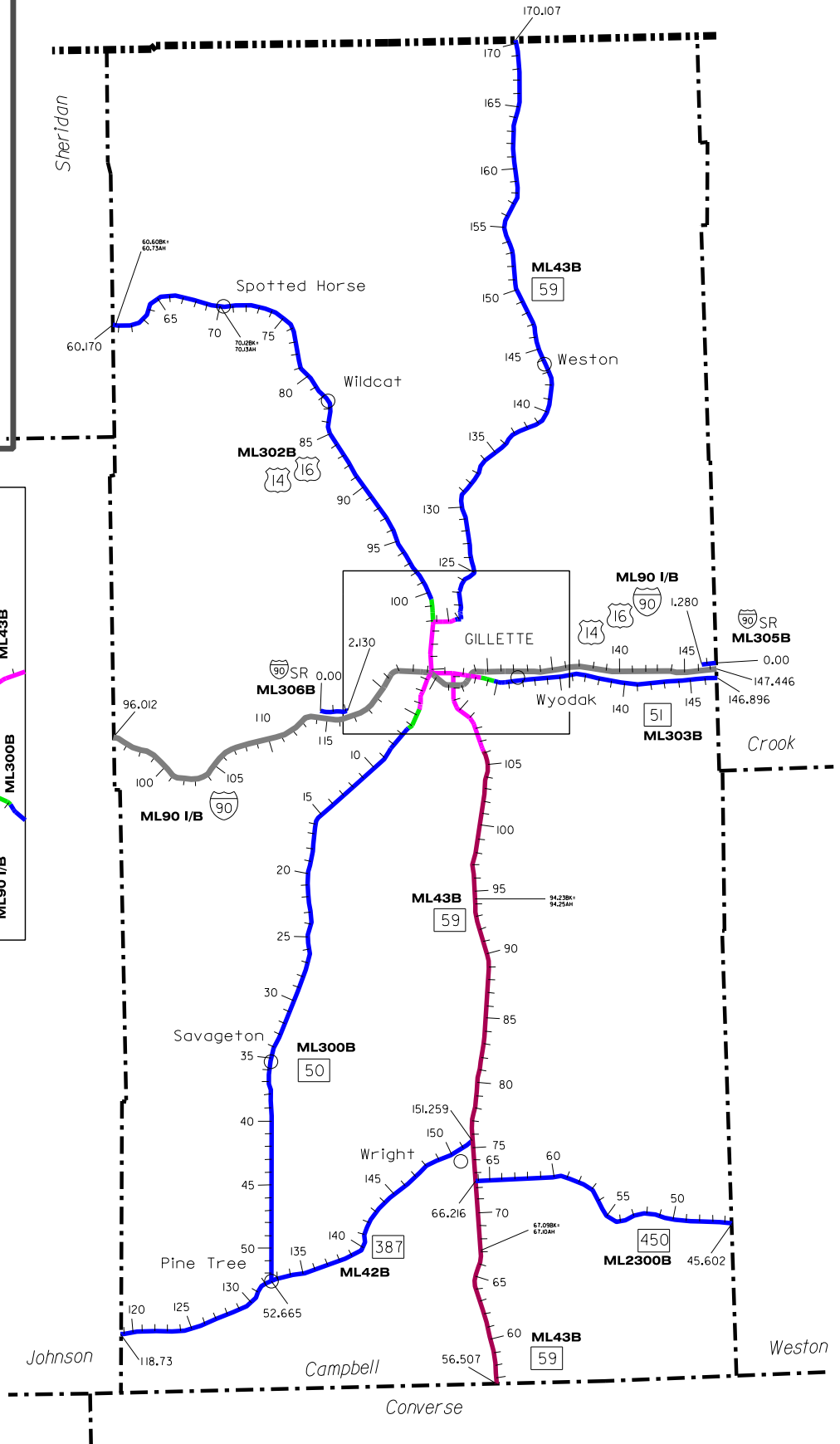
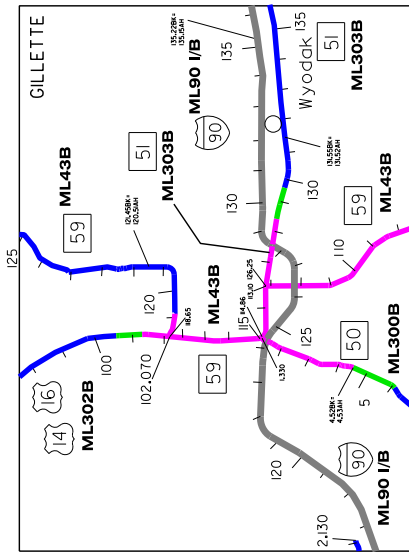





# Campbell

•• class "classification break"

## County 17

Maint. Section	class	RM	I-90 & US 14/16
		<b>ML - 90</b>	
	1	96.012	Johnson Co. Line
		98.332	Machinery Pass Sep. [BFB;EB, BFC;WB]
		102.521	Barber Cr. Int. [BFD;EB, BFE;WB]
		106.139	Kingsbury Rd. Int. [BFF;EB, BFG;WB]
		108.000	West Gillette <b>RWIS</b> site {56}
<b>CL 01A</b>		111.907	Lowery Sep. [BFH;EB, BFI;WB]
4035		112.721	W. Fork Wild Horse Cr. [BFJ;EB, BFK;WB]
		113.259	E. Fork Wild Horse Cr. [BFL;EB, BFM;WB]
		113.967	Wild Horse Cr. Rd. Int. [BFN;EB, BFO;WB]
		116.237	Force Rd. Int. [BFP;EB, BFQ;WB]
		117.230	Co. Rd. Sep. [BFR;EB, BFS;WB]
		120.041	Machinery Pass Sep. [BFT;EB, BFU;WB]
	1	122.065	Machinery Pass Sep. [BFV;EB, BFW;WB]
••		122.270	WUL Gillette
	11	124.027	WCL Gillette
		124.264	US 14/16, WY 50, I-90 BUS; West Gillette Int. (RM 114.86) [BFX;EB, BFY;WB]
		124.300	<b>W.B. Road Close Gate R/R</b>
		124.880	Burma Rd. Overpass [MCO;SS]
		125.570	Savageton Rd. Overpass [CRA;EB, CSC;WB]
		126.300	<b>W.B. Road Close Gate R/R</b>
		126.390	WY 59; WY 59 Int. (RM 112.16) [CYK;EB, CYL;WB]
		127.140	Co. Rd. Int. [CYM;EB, CYN;WB]
		127.670	Stone Pile Cr. [CYO;SS]
		127.800	<b>E.B. Road Close Gate R/R</b>
		128.090	US 14/16; East Gillette Int. (RM 127.57) BNRR [DAI;SS] ECL Gillette Begin US 14 & 16
→		129.104	Garner Lake Rd. Int. [FIT;SS] <b>Dept. Shop Gillette GL 04A</b> north on Garner Lake Rd. <b>E.B. Road Close Gate R/R</b>
	11	130.254	Coal Rd Overpass [DAK;EB, DAL;WB]
••		130.350	EUL Gillette
	1	132.385	Wyodak Coal Rd. Overpass [CDK;EB, CDL;WB]
<b>CL 01B</b>		132.991	Wyodak Int. [CDM;SS]
4035		134.435	Machinery Pass Sep. [CFG;EB, CFW;WB]
		135.235	BK= + 0.087 mi.
		135.148	AH Equation
		135.413	BNRR Sep. [DAT;EB, DAU;WB]
		135.749	Unnamed Draw [DBC;SS]
		139.300	Co. Rd. Sep. [DBD;SS]
	1	141.129	Unnamed Draw [DAZ;SS]
→		141.237	Rozet Int. [DBG;SS] [DBA;EBR, DBB;WBR]

Maint. Section	class	RM	I-90 & US 14/16
		<b>ML - 90</b>	
		(CONTINUED)	
		141.237	Rozet Int. [DBG;SS] [DBA;EBR, DBB;WBR]
	1	142.265	Machinery Pass Sep. [DAV;EB, DAW;WB]
<b>CL 01C</b>		144.357	Co. Rd. Overpass [DBT;EB, DBU;WB]
4040		146.710	Gray Rd. Overpass [BGG;EB, BGH;WB]
	1	147.446	Crook Co. Line
		<b>US 14, 16, WY 59 &amp; I-90 Bus.</b>	
		<b>ML - 43B</b>	
	2	56.507	Converse Co. Line / District Boundary
		57.183	Spring Cr. [DIR;SS]
		<b>REMOVED EQUATION</b>	
<b>CL 04A</b>		67.490	Edwards Rd (east)
4043		67.500	<b>S.B. Road Close Gate R/R</b>
		71.990	<b>Dept. Shop - Reno Jct. RJ 04A</b>
		72.393	WY 450 (RM 66.22)
		74.927	SCL of Wright
		75.064	WY 387 (RM 151.26)
		75.192	NCL of Wright
		75.800	<b>N.B. Road Close Gate R/R</b>
		77.370	East Fork Hay Cr. [DCF;SS]
		79.959	Hay Cr. [DCG;SS]
		80.361	Dry Cr. [DCH;SS]
		81.400	Breen Rd
		82.098	Unnamed Draw [DCI;SS]
		86.990	Belle Fourche <b>RWIS</b> site {21}
		87.059	Belle Fourche Rv. [FBP;SS]
		93.746	Haight Rd (east)
		93.700	<b>S.B. Road Close Gate R/R</b>
		94.232	BK= - 0.013 mi.
		94.245	AH Equation
→		95.000	Maint. Crew Break
		96.000	<b>S.B. Road Close Gate R/R</b>
		97.430	Caballo Cr. [CXP;SS]
<b>CL 04B</b>		97.740	Hoe Creek Rd
4035		98.323	Bone Pile Cr. [CGQ;SS]
		102.400	<b>S.B. Road Close Gate R/R</b>
		102.839	Tisdale Cr. [MFU;SS]
		103.410	Mine Rd
	2	106.500	<b>S.B. Road Close Gate R/R</b>
••		106.860	SUL Gillette
→	14	107.970	Union Chapel Rd
<b>CL 04Z</b>		109.176	Antelope Cr. [CBH;SS]
4035		109.720	Southern Drive
	14	110.600	SCL Gillette

→ -cont- next page

Maint. Section	class	RM	US 14, 16, WY 59 & I-90 Bus.
CREW		<b>ML - 43B</b>	
-cont-		<i>(CONTINUED)</i>	
CL 04Z	14	111.272	Donkey Cr. [CBJ;SS]
		111.440	Lakeway Rd
		111.603	Homestead Trickle [MBF;SS]
4035		112.160	I-90; WY 59 Int. (RM 126.39) [CYK;EB, CYL;WB]
		113.054	WY 51 (RM 126.25)
		113.950	Rohan Ave.
		114.855	WY 50 (RM 1.33) Begin US 14 & 16
		114.965	Stone Pile Cr. [DEH;SS]
		115.038	BNRR Sep. [?]
		115.412	NCL Gillette Maint. Crew Break
CL 04C		117.860	Hannum Rd
4035		118.350	North Fork LittleRawhide Cr. [GDP;SS]
		118.650	US 14/16 (RM 102.07) End US 14/16
		120.440	Little Powder Rv. Rd
		121.450	BK= + 0.94 mi.
	14	120.510	AH Equation
	●●	120.819	NUL Gillette
	6	122.618	BNRR Sep. [DIJ;SS]
		123.872	BNRR Sep. [DIJ;SS]
		124.000	Dry Fork Creek [GFX;SS]
		125.210	Burlington Supply Ditch [CSH;SS]
		125.580	Dry Fork [HVK;SS]
		126.090	<b>N.B. Road Close Gate R/R</b>
		126.609	Little Powder Rv. [KNX;SS]
		130.235	Corral Cr. [KNY;SS]
		132.790	Cedar Cr.
		135.600	Cow Creek Rd (east)
		136.250	Little Powder Rv. [LWT;SS]
		142.468	Coal Creek [CHE;SS]
		143.890	Weston
		144.201	Unnamed Draw [CHF;SS]
		149.020	Unnamed Draw [CHG;SS]
		150.889	Horse Cr. [CHH;SS]
		153.032	White Tail Cr. [CHI;SS]
		155.390	Recluse Rd
		155.632	Elk Cr. [CHJ;SS]
		157.835	Unnamed Draw [CHK;SS]
		164.435	Olmstead Cr. [CHL;SS]
		166.717	Unnamed Draw [BLD;SS]
	6	170.107	Montana State Line

Maint. Section	class	RM	US 14 & 16
CREW		<b>ML - 302B</b>	
	7	60.170	Sheridan Co. Line
		60.596	BK= - 0.129 mi.
		60.725	AH Equation
		69.578	Spotted Horse Cr. [DCK;SS]
		70.121	BK= - 0.012 mi.
CL 02A		70.133	AH Equation
4035		70.200	Spotted Horse
		75.600	Recluse Rd
		80.041	Horse Cr. [EOH;SS]
		85.653	North Wildcat Cr. [EOG;SS]
		88.029	South Wildcat Cr. [CLF;SS]
		93.800	Collins Rd (northeast)
		95.350	<b>W.B. Road Close Gate R/R</b>
		96.137	Rawhide Cr. [CLH;SS]
		99.432	BK= + 0.03 mi.
		99.402	AH Equation
	7	99.710	Little Rawhide Cr. [MFJ;SS]
		100.400	Haul Road Bridge [MFH;SS]
	●●	100.768	NUL Gillette
		101.360	Future Little Rawhide Cr. [MFI;SS]
	17	101.770	N. Fork Little Rawhide Cr.
		102.070	WY 59 (RM 118.83)
		<b>WY 50</b>	
		<b>ML - 300B</b>	
	14	1.330	WY 59 (RM 114.86)
CL 05A		1.533	West Gillette Int. (RM 124.26) [BFX;EB, BFY;WB]
4035		1.683	CL Gillette
		3.040	Lakewood Rd
		3.878	CL Gillette
		4.300	4J Rd
	14	4.325	SCL Gillette
		<b>REMOVED EQUATION</b>	
	●●	4.870	Urban Break
	17	5.000	<b>S.B. Road Close Gate R/R</b>
	●●	6.050	SUL Gillette
	7	8.570	Lewis Rd (west)
		12.400	<b>S.B. Road Close Gate R/R</b>
		35.330	Savageton
		35.400	<b>S.B. Road Close Gate R/R</b>
		40.210	Mud Spring Cr. [FKC;SS]
		44.260	S. Branch Four Mile Cr. [FKD;SS]
		52.600	<b>N.B. Road Close Gate R/R</b>
	7	52.665	WY 387 (RM 131.79)

Maint. Section	class	RM	WY 51
			<b>ML - 303B</b>
	14	126.249	WY 59 (RM 113.05)
<b>CL 08Z</b>		126.411	Stonepile Creek [EGL;SS]
4035		126.474	Gurley Av. Viaduct
		127.480	<b>Gillette Port-of-Entry CL 02P</b>
		127.571	I-90; East Gillette Int. (RM 128.09) & US 14/16 (RM 127.57)
		127.676	ECL Gillette
→	14	128.452	Gardner Lake Rd
		●●	128.491 UL Gillette
<b>CL 08A</b>	16		
4035		●●	129.730 EUL Gillette
	7	131.549	BK= + 0.032 mi.
		131.517	AH Equation
		131.561	Donkey Cr. [LIZ;SS]
		132.160	WYODAK Mine Rd
		132.200	<b>E.B. Road Close Gate R/R</b>
		136.029	BNRR Sep. WEST WYE [DHD;SS]
		136.169	BNRR Sep. EAST WYE [DHE;SS]
		136.410	Dry Donkey Cr. [DHF;SS]
		139.919	Unnamed Draw [BGC;SS]
→		140.810	Rozet
		142.287	Donkey Cr. [BGD;SS]
<b>CL 08B</b>		143.600	Donkey Cr. [BGE;SS]
4040		144.363	BNRR Sep. [LIM;SS]
	7	146.896	Crook Co. Line

			WY 387
			<b>ML - 42B</b>
	6	118.726	Johnson Co. Line
<b>CL 03A</b>		118.871	Dry Fork Powder Rv. [DIT;SS]
2037		131.300	<b>W.B. Road Close Gate swing</b>
→		131.793	WY50 (RM 52.67)
			Pine Tree Jct. <b>RWIS</b> site {20}
<b>CL 03B</b>			District Boundary
4043		137.120	Clark Elen-Turnercrst Rd.
		147.900	<b>W.B. Road Close Gate R/R</b>
		149.776	Hay Cr. [DZR;SS]
		150.138	Unnamed Draw [DZS;SS]
		150.630	WCL of Wright
		150.760	Wright Visitor Center
	6	151.259	WY 59 (RM 75.06)

Maint. Section	class	RM	WY 450
			<b>ML - 2300B</b>
	6	45.602	Weston Co. Line
		55.500	<b>E.B. Road Close Gate R/R</b>
<b>CL 07A</b>		55.711	Coal Rd Overpass [DDT;SS]
4043		56.924	BNRR Sep. [DEX;SS]
		60.573	BNRR Sep. [DKO;SS]
		66.140	<b>W.B. Road Close Gate R/R</b>
		66.216	WY 59 (RM 72.39)

			I-90 SV. RD.
			<b>ML - 305B</b>
<b>GRAVEL</b>			
	9	0.000	From Crook County Line (I-90 MP 147.45)
<b>CL 01J</b>		0.760	Gray Rd sep. [?]
4040		1.280	End Sv. Rd. @Farm Unit (I-90 MP 146.18)

			I-90 SV. RD.
			<b>ML - 306B</b>
<b>GRAVEL</b>			
	9	0.000	Wild Horse CR. Int. (I-90 MP 113.97)
<b>CL 01K</b>		2.130	Jct. Force Rd Int. (I-90 MP 116.24)
4035			



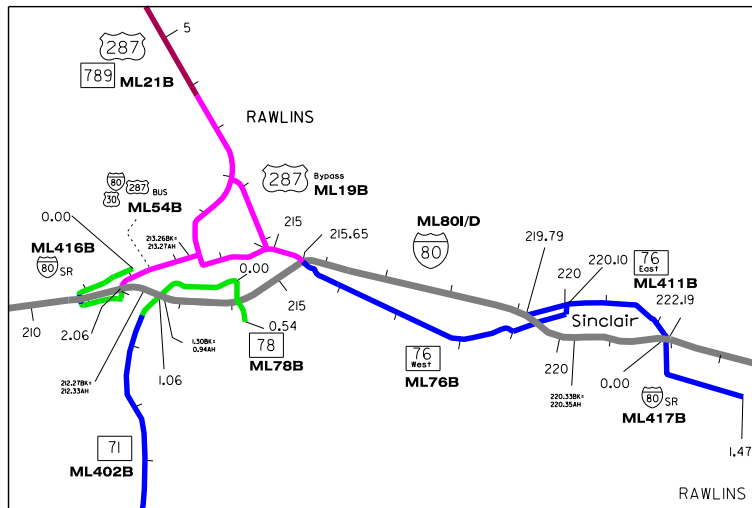
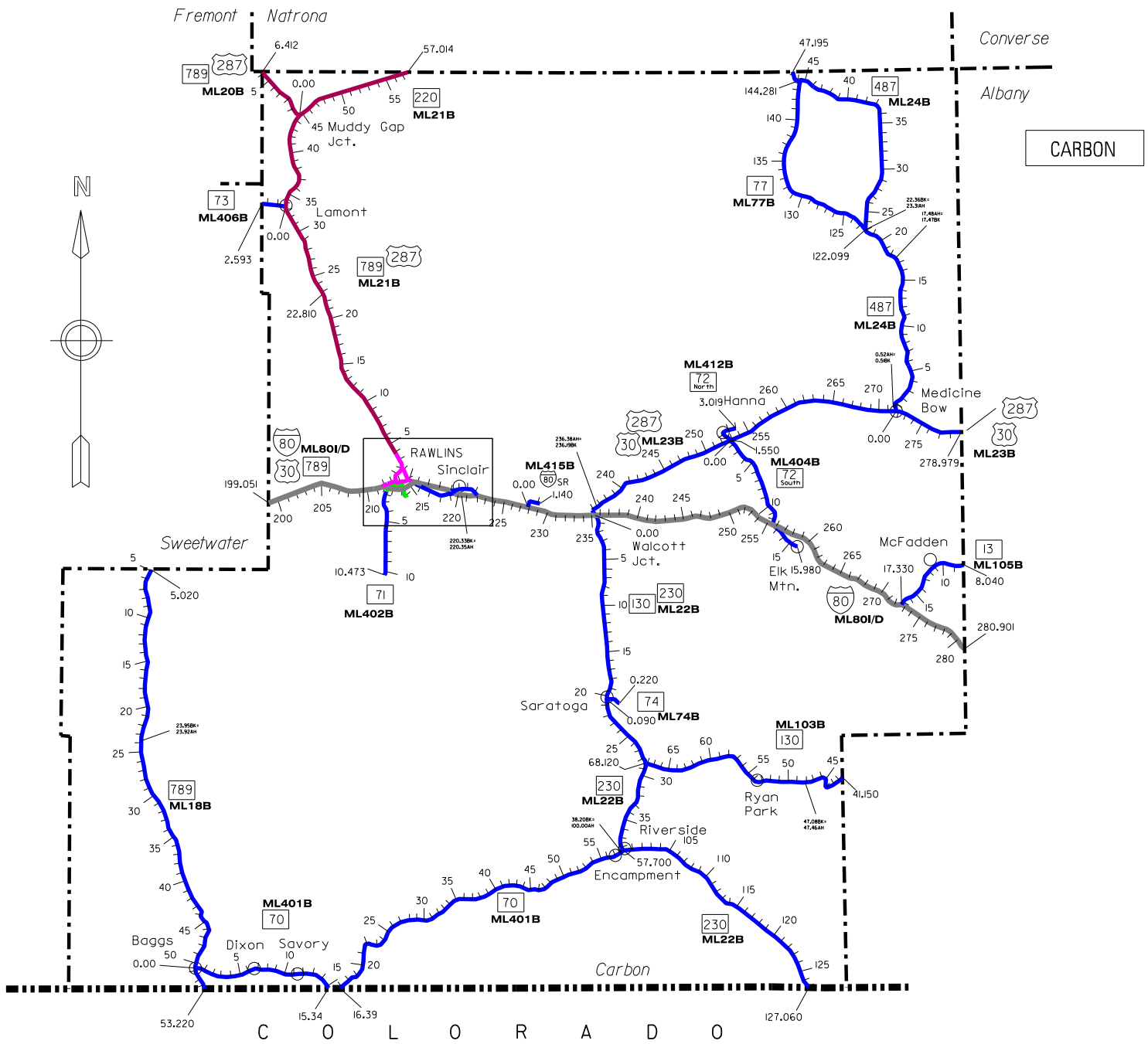

ROAD COLOR TABLE	
	Rural & Urban Interstate #'s "1 & 11"
	Urban Principal Arterial Other & Expressway (NHS) #'s "12 & 14"
	Urban Minor Arterial, Collector & Local (non NHS) #'s "16, 17 & 19"
	Rural Principal Arterial Other (NHS) # "2"
	Rural Minor Arterial, Major & Minor Collectors & Local (non NHS) #'s "6, 7, 8 & 9"



# Carbon

## County 6

•• class "classification break"

+ Indicates Non State System

Maint. Section	class	RM	I-80 , US 30/287 & WY 789
CREW		<b>ML - 80</b>	
	1	199.051	Sweetwater Co. Line
		201.164	Daley Int. [ATB;EB, ATC;WB]
		202.144	Separation Cr. [ATD;EB, ATE;WB]
		204.175	Knobbs Int. [ATF;EB, ATG;WB]
<b>CB 01A</b>		206.182	Hadsell Int. [ATH;EB, ATI;WB]
1041		206.900	EB C.M.Sign (dynamic) WB C.M.Sign (dynamic)
		208.635	Four Mile Draw [ATJ;EB, ATK;WB]
		209.459	Johnson Rd. Int. [ATL;EB, ATM;WB]
		209.460	<b>W.B. Road Close Gate R/R</b>
	1	210.978	Two Mile Draw Sep. [ATN;EB, ATO;WB]
••		211.200	WUL Rawlins
11		211.780	US 30/I-80/287 BUS, WY 789 (RM 211.75); Spruce Street Int. [IYI;SS] End WY 789
		212.270	BK= - 0.061 mi.
		212.331	AH=
		212.407	UPRR Sep. [ATQ;EB, ATR;WB]
		212.544	WCL Rawlins
		212.738	Sage Cr. Rd Sep. [ATS;EB, ATT;WB]
		214.110	WY 78 (RM 0.152); Thayer Int.[ATU;SS]
		214.630	ECL Rawlins
		215.190	Machinery Pass Sep.[ATV;EB, ATW;WB]
		215.350	UPRR Sep. [ATX;EB, ATY;WB]
		215.570	US 30/I-80/287 BUS, WY 789/76 (RM 215.65); Cedar Street Int. [MTQ;EB, MFR;WB]
	11		Begin US 287
••		215.820	EUL Rawlins
	1	217.500	EB C.M.Sign (dynamic) WB C.M.Sign (dynamic)
		218.821	WCL Sinclair
		218.951	Sugar Cr. [KHY;SS]
		219.590	WY 76 (RM 219.79); West Sinclair Int. [KHZ;EB, KJA;WB]
		219.757	UPRR Sep. [KJB;EB, KJC;WB]
		220.330	BK= - 0.02 mi.
		220.350	AH Equation
		221.006	ECL Sinclair
		221.550	Sinclair <b>RWIS</b> site {33}
<b>CB 01A</b>		221.700	<b>E.B. Road Close Gate R/R</b>
1041		221.926	WY 76 (RM 222.19); E.Sinclair Int.[DAB;SS]
		228.341	Ft. Steele Int. [AUI;EB, AUJ;WB] <b>Ft. Steele Rest Area CB 01R</b>
		229.027	North Platte Rv. [AUK;EB, LCQ;WB]
	1	229.335	Co. Rd Sep. [AUM;EB, AUN;WB]

-cont- next column

Maint. Section	class	RM	I-80
CREW		<b>ML - 80</b>	
			(CONTINUED)
	1	234.500	Walcott Jct. <b>RWIS</b> site {34}
<b>CB 01A</b>		234.580	Machinery Pass Sep. [AUO;EB, AUP;WB]
1041		234.600	EB C.M.Sign (dynamic)
		234.660	Walcott Jct <b>RWIS</b> site {34}
		235.230	<b>E.B. Road Close Gate swing</b>
→		235.280	US 30/287 (RM 235.23); Saratoga Int. [AUQ;EB, AUR;WB] WY 130/230 (RM 0.00)
		236.478	UPRR Sep. [AUS;EB, AUT;WB]
<b>CB 01B</b>		238.155	Peterson Int. [AUV;EB, AUV;WB]
1040		238.550	<b>EB VSL signs</b>
		243.892	Machinery Pass Sep.[AUW;EB, AUX;WB]
		244.800	Dana Ridge (1) <b>RWIS</b> site {35}
		245.939	Machinery Pass Sep.[AUZ;EB, AUZ;WB]
		246.900	<b>EB &amp; WB VSL signs</b>
		249.100	Elk Mtn (2) <b>RWIS</b> site {36}
		250.000	<b>EB &amp; WB VSL signs</b>
		252.160	Halleck Ridge <b>RWIS</b> site {37}
		252.402	Machinery Pass Sep.[AVA;EB, AVB;WB]
		254.900	<b>WB VSL signs</b>
		255.602	WY 72 (RM 12.29); W. Elk Mountain Int. [CMI;SS]
		256.170	<b>EB VSL signs</b>
			Elk Mtn (3) <b>RWIS</b> site {38}
		258.952	Medicine Bow Rv. [AVC;EB, AVD;WB]
		259.539	E. Fork Medicine Bow Rv. [AVE;EB, AVF;WB]
		259.770	<b>WB VSL signs</b>
		260.232	E. Elk Mountain Int. [AVG;EB, AVH;WB]
		262.000	CR 402 <b>RWIS</b> site {39}
		262.400	<b>EB VSL signs</b>
		263.632	Machinery Pass Sep.[AVI;EB, AVJ;WB]
		266.580	<b>WB VSL signs</b>
			Wagonhound <b>RWIS</b> site {40}
→		267.186	Wagonhound Int. [AVK;EB, AVL;WB] <b>Wagonhound Rest Area CB 01S</b>
<b>CB 01C</b>		267.710	<b>EB VSL signs</b>
1038		269.500	Foote Cr. <b>RWIS</b> site {41}
		270.446	Co. Rd. Overpass [AVM;EB, AVN;WB]
		271.800	<b>WB VSL signs</b>
			Arlington <b>RWIS</b> site {42}
		272.056	WY 13 (RM 17.33); Arlington Int. [AVO;EB, AVP;WB]
		272.496	Rock Cr. [AVQ;EB, AVR;WB]
		272.757	Machinery Pass Sep.[AVS;EB, AVT;WB]
		273.430	Canon Ditch [AVU;EB, AVV;WB]
		273.850	<b>EB VSL signs</b>
	1		Arlington <b>RWIS</b> site {43}

-cont- next page

Maint. Section	class	RM	I-80
CREW			<b>ML - 80</b>
-cont-			(CONTINUED)
<b>CB 01C</b>	1	275.370	Machinery Pass Sep.[AVW;EB, AVX;WB]
		278.116	Machinery Pass Sep.[AVY;EB, AVZ;WB]
1038		279.359	<b>WB VSL signs</b>
			Cooper Cove <b>RWIS</b> site {44}
		279.859	Cooper Cove Int. [AWA;EB, AWB;WB]
		280.360	<b>EB VSL signs</b>
		280.901	Albany Co. Line

US 30/I-80/287 BUS & WY 789			
Maint. Section	class	RM	
			<b>ML - 54B</b>
<b>CB 02A</b>	14	211.870	I-80 (RM 211.78); Spruce Street Int. [IYI;SS] and County Rd
1041		212.020	WCL Rawlins
		213.257	BK= -0.013 mi.
		213.270	AH Equation
<b>CB 02Z</b>		213.400	US 287 (RM 0.20)
1041			End WYO 789 Bus./Begin US 287 Bus.
		213.640	3rd & Cedar street
		214.883	US 287 Bypass (RM 0.77)
			Begin NHS
		215.149	Airport Rd
		215.200	EB C.M.Sign (dynamic)
		215.350	<b>Dept. Shop Rawlins RW 01A</b>
		215.423	ECL Rawlins
	14	215.651	I-80 (RM 215.57); Cedar Street Int. & WY 76 (RM 215.65)
			End NHS

US 30 /287			
Maint. Section	class	RM	
			<b>ML - 23B</b>
<b>CB 19A</b>	6	235.230	I-80 (RM 235.28); Saratoga Int. [AUQ;EB, AUR;WB] & WY 130/230 (RM 0.00)
1036		235.460	EB C.M.Sign (dynamic)
		235.500	<b>E.B. Road Close Gate R/R</b>
		236.191	BK= - 0.186 mi.
		236.377	AH Equation
		246.697	St. Mary's Cr. [CIP;SS]
		252.714	WY 72 (RM 1.55 south) & (0.00 north); Hanna Jct.
<b>CB 19B</b>		260.315	UPRR Sep. [CTV;SS]
1036		260.387	Unnamed Draw [MKT;SS]
		268.744	First Sand Cr. [BKQ;SS]
		270.290	<b>Dept. Shop - Medicine Bow MB 01A</b>
		271.144	WCL Medicine Bow
		271.440	<b>W.B. Road Close Gate swing</b>
		271.640	WY 487 (RM 0.00)
		272.320	<b>E.B. Road Close Gate R/R</b>
		272.653	ECL Medicine Bow
		274.599	Medicine Bow Rv. [BKE;SS]
	6	278.979	Albany County Line

Maint. Section	class	RM	US 287 & WY 789
CREW			<b>ML - 20B</b>
	2	0.000	WY 220 (RM 44.31)
<b>CB 03A</b>			Begin NHS
2036		0.020	<b>W.B. Road Close Gate R/R</b>
		0.162	Muddy Cr. [BSP;SS]
		2.030	WB C.M.Sign (dynamic)
		6.412	Fremont Co. Line
			Cont. NHS

US 287 Bypass			
Maint. Section	class	RM	
			<b>ML - 19B</b>
	14	0.768	US 30/287, I-80 BUS (RM 214.88)
		1.027	E. Daley St.
<b>CB 23A</b>		1.217	NCL Rawlins
1041		1.225	E. Murray Street
		2.002	Aberdeen blvd.
		2.282	US 287 Mainline (RM 1.92)

US 287 & WY 789/220			
Maint. Section	class	RM	
			<b>ML - 21B</b>
	14	0.197	US 30,I-80 BUS. (RM 213.40)
<b>CB 04Z</b>		0.450	City Shop
1041		0.750	End Divided Section
		1.187	NCL Rawlins
<b>CB 04A</b>		1.919	US 287 Bypass (RM 2.29)
1041	14	2.030	NB C.M.Sign (dynamic)
		2.080	<b>N.B. Road Close Gate R/R</b>
		3.090	NUL Rawlins
	2		Begin NHS
		13.792	Bell Springs Draw [BTW;SS]
		15.250	Union 76 Rd
		22.810	District Boundary
		30.837	Antelope Pass Sep. [BTX;SS]
<b>CB 04B</b>		32.580	<b>S.B. Road Close Gate R/R</b>
2036		33.264	WY 73 (RM 0.00)
		33.300	<b>N.B. Road Close Gate R/R</b>
		37.380	Unnamed Draw [LGK;SS]
		42.290	Unnamed Draw [GUL;SS]
		42.745	Muddy Cr. [BTY;SS]
		43.080	<b>W.B. Road Close Gate swing</b>
		43.260	<b>Dept. Shop - Muddy Gap MG 02A</b>
		44.311	WY 220 (RM 0.00)
			End US 287 & WY 789/Begin WY 220
		44.350	<b>E.B. Road Close Gate R/R</b>
		53.298	Unnamed Draw
		55.764	Pete Cr. [BUB;SS]
	2	57.014	Natrona Co. Line



Maint. Section	class	RM	WY 13
			<b>ML - 105B</b>
<b>CB 07A</b>	7	8.035	Albany Co. Line
		9.468	Three Mile Cr. [CIW;SS]
1038		10.670	Big Harrison Ditch [DJT;SS]
		11.240	McFadden
		14.051	Rock Cr. [DJS;SS]
		16.890	<b>Dept. Shop - Arlington AR 01A</b>
		17.325	I-80 (RM 272.06); Arlington Int. [AVO;EB, AVP;WB]

Maint. Section	class	RM	WY 71
			<b>ML - 402B</b>
	16	0.000	WY 78 (RM 0.00)
<b>CB 10Z</b>	●●	0.760	Urban Break
1041	17	1.300	BK= + 0.36 mi.
		0.940	AH Equation
		1.060	Sage Cr. Rd Sep. [ATS;EB, ATT;WB]
			I-80 (RM 212.74)
	17	1.249	SCL Rawlins
<b>CB 10A</b>	●●	2.270	SUL Rawlins
1041	7	10.474	End SHS

Maint. Section	class	RM	WY 70
			<b>ML - 401B</b>
<b>CB 09A</b>	7	0.000	WY 789 (RM 50.70)
		0.320	ECL Baggs
1037		0.998	Ledford Slough [FSD;SS]
		2.352	Irrigation Canal
		5.830	Irrigation Canal [JDI;SS]
		6.050	Little Snake Rv. [BLY;SS]
		6.588	WCL Dixon
		7.094	ECL Dixon
		7.342	Cottonwood Cr. [CLT;SS]
		11.381	Savery
		11.667	Savery Cr. [JCP;SS]
		15.344	Colorado St. Line West
			<b>1.06 mi. in Colorado</b>
		16.390	Colorado St. Line East
		22.280	West Medicine Bow Nat'l. Forest Boundary
		26.900	<b>E.B. Road Close Gate swing</b> <i>Seasonal Closure</i>
		30.682	BK= - 0.251 mi.
		30.933	AH Equation
		32.900	<b>E.B. Road Close Gate swing</b> <i>1st Seasonal Closure</i>
		41.030	Maint. Break
		50.000	<b>W.B. Road Close Gate swing</b> <i>Seasonal Closure</i>
<b>CB 09B</b>		50.630	East Medicine Bow Nat'l. Forest Boundry
1042		50.680	Hog Park Rd
		55.790	WCL Encampment
		57.460	CL Encampment & Riverside
	7	57.701	WY 230 (RM 38.20)

Maint. Section	class	RM	WY 72 (north)
			<b>ML - 412B</b>
	7	0.000	US 30/287 (RM 252.71); Hanna Jct. WY 72 (MP 1.55) south
<b>CB 21A</b>		0.714	SCL Hanna
1040		1.321	UPRR Sep. [CMF;SS]
		2.739	CL Hanna
		2.980	CL Hanna
		3.020	End SHS

Maint. Section	class	RM	WY 72 (south)
			<b>ML - 404B</b>
	7	1.550	US 30/287 (RM 252.71); Hanna Jct. WY 72 (RM 0.00) north
<b>CB 12A</b>		1.590	<b>S.B. Road Close Gate R/R</b>
1040		6.340	Unnamed Draw [MDK;SS]
		12.030	<b>N.B. Road Close Gate R/R</b>
		12.294	I-80 (RM 255.60)
			W. Elk Mountain Int. [CMI;SS]
		15.200	<b>Dept. Shop - Elk Mountain EM 01A</b>
		15.684	WCL Elk Mountain
		15.772	Hedsell Slough Cr. [DDI;SS]
	7	15.976	End SHS

Maint. Section	class	RM	WY 73
			<b>ML - 406B</b>
<b>CB 14A</b>	7	0.000	US 287 (RM 33.26) @LAMONT
2036		2.593	Sweetwater Co. Line

-cont- in Sweetwater county

Maint. Section	class	RM	WY 74
			<b>ML - 74B</b>
	+	0.000	WY 130 (RM 20.28) <i>0.09 mi. not on SHS</i>
<b>CB 15A</b>	8	0.090	Begin State
		0.150	North Platte Rv. [CMW;SS]
1042		0.218	End SHS

WY 76 (east)			
Maint. Section	class	RM	WY 76 (east)
			<b>ML - 411B</b>
	7	219.794	I-80 (RM 219.59); W. Sinclair Int. [KHZ;EB, KJA;WB]
<b>CB 22Z</b>		220.006	WY 76 (RM 220.01)
1041		220.910	RR at Grade Crossing (Spur)#81092K
		220.920	RR at Grade Crossing (Spur)#81092K
		221.042	ECL Sinclair
		221.678	UPRR Sep. [CID;SS]
		222.186	I-80 (RM 221.926); E. Sinclair Int. [DAB;SS]

WY 76 (west)			
Maint. Section	class	RM	WY 76 (west)
			<b>ML - 76B</b>
	8	215.650	I-80 (RM 215.57); Cedar Street Int. [MFQ;EB, MFR;WB]
<b>CB 17A</b>			US 30, I-80 BUS. (RM 215.65)
1041		219.029	WCL Sinclair
		219.824	UPRR Sep. [?]
		220.010	Lincoln Avenue

WY 77			
Maint. Section	class	RM	WY 77
			<b>ML - 77B</b>
	8	122.099	WY 487 (RM 22.162) <b>N.B. Road Close Gate swing</b>
<b>CB 24A</b>		128.932	Muddy Cr. [BLZ;SS]
2041	8	131.124	Class. Break
	9	132.550	<b>N.B. Road Close Gate swing</b> <i>Seasonal Closure</i>
		138.609	Shirley Basin Road
		142.300	<b>S.B. Road Close Gate swing</b> <i>Seasonal Closure</i>
	9	144.281	WY 487 (RM 46.03)

WY 78			
Maint. Section	class	RM	WY 78
			<b>ML - 78B</b>
<b>CB 20A</b>	16	0.000	WY 71 (RM 0.00)
1041		0.152	I-80 (RM 214.11); Thayer Int. [ATU;SS]
		0.540	End SHS

Maint. Section	class	RM	WY 130
			<b>ML - 103B</b>
	7	41.150	Albany Co. Line
		47.082	BK= - 0.376 mi.
		47.458	AH Equation
<b>CB 06A</b>		47.900	<b>E.B. Road Close Gate swing</b> <i>Seasonal Closure</i>
1042		53.670	Ryan Park
		55.542	South Brush Creek [MNJ;SS]
		56.300	Medicine Bow Nat'l. Forest Boundary
		57.050	North Brush Cr. [CIO;SS]
		57.785	Unnamed Draw [BLI;SS]
		65.920	Elk Hollow [KMA;SS]
		67.152	North Platte Rv. [KMB;SS]
	7	68.119	WY 230 (MP 28.09)

WY 130/230			
Maint. Section	class	RM	WY 130/230
			<b>ML - 22B</b>
	6	0.000	I-80 (RM 235.28); Saratoga Int. [AUQ;EB, AUR;WB]
			& US 30/287 (RM 235.23)
<b>CB 05A</b>		0.350	<b>S.B. Road Close Gate swing</b>
1042		2.111	Pass Cr. [DIX;SS]
		4.540	Rattlesnake Rd
		8.660	Pass Creek Rd
		17.040	Lake Cr. [GVF;SS]
		17.660	Fish Hatchery Rd
		18.710	<b>N.B. Road Close Gate swing</b>
		19.653	NCL Saratoga
		20.000	North Platte Rv. [BUR;SS]
		20.280	WY 74 (RM 0.00)
		20.700	Old Dept Site
		21.428	SCL Saratoga
		22.286	Spring Cr. [BUS;SS]
		23.200	<b>Dept. Shop - Saratoga SG 01A</b>
		28.090	WY 130 (RM 68.119) End WY 130 / Begin WY 230
		30.113	Cow Cr. [BUT;SS]
		38.148	NCL Riverside
	6	38.200	BK= - 61.80 mi.
			<b>Maint. Brk. @ Equation</b>
	6	100.000	AH Equation WY 70 (RM 57.701)
<b>CB 11A</b>		100.346	Encampment Rv. [DJK;SS]
1042		100.424	ECL Riverside
		100.540	Finch Rd (north)
		101.200	<b>E.B. Road Close Gate swing</b>
		104.170	Indian Creek Rd (north)
		109.538	Beaver Cr. [DHG;SS]
		109.950	Beaver Creek Rd (west)
		113.200	Skyline <b>RWIS</b> site {7}
		118.401	Big Cr. [FHF;SS]
		119.240	Big Creek Rd (west)

Maint. Section	class	RM	WY 487
CREW			<b>ML - 24B</b>
	6	0.000	US 30/287 (RM 271.64)
<b>CB 13A</b>			<b>REMOVED EQUATION</b>
1036		0.740	<b>N.B. Road Close Gate swing</b>
		0.812	Medicine Bow Rv. [CML;SS]
		1.170	NCL Medicine Bow
		4.013	Little Medicine Bow Rv. [CMM;SS]
		13.140	T.B. Cr.
			<b>REMOVED EQUATION</b>
		17.563	Marshall Rd
		22.160	WY 77 (RM 122.099)/ Dist. Boundary
		22.355	BK= - 0.959 mi.
<b>CB 13B</b>		23.314	AH Equation
2041		33.640	Sand Creek [FFE;SS]
		37.500	Shirley Basin Rd
		45.100	<b>Shirley Basin Rest Area CB 13R</b>
			<b>Dept. Shop - Shirley Rim SR 02A</b>
		45.130	<b>S.B. Road Close Gate R/R</b>
		46.025	WY 77 (RM 144.281)
	6	47.195	Natrona Co. Line

Maint. Section	class	RM	I-80 SV. RD.
CREW			<b>ML - 415B</b>
	9	0.000	I-80 (RM 228.34); Ft. Steele Int.
<b>CB 01K</b>			[AUI;EB, AUJ;WB] (northside)
1041		0.500	Ft. Steele Rest Area
		0.740	North Platte Rv. [DLT;NSR]
		1.140	End Sv. Rd. @Co. Rd. Sep.
			[AUM;EB, AUN;WB] (RM 229.34)

Maint. Section	class	RM	I-80 SV. RD.
			<b>ML - 416B</b>
	17	0.000	From 23rd Street West
<b>CB 01J</b>		1.130	WUL Rawlins
1041	9	1.150	I-80 (RM 210.98) 2 Mile Draw Sep.
	9		[ATN;EB, ATO;WB]
		1.310	WUL Rawlins
	19	2.060	End Sv. Rd. @Jct. I-80 (RM 211.78)

Maint. Section	class	RM	I-80 SV. RD.
			<b>ML - 417B</b>
<b>CB 01M</b>	9	0.000	I-80 (RM 221.93); East Sinclair Int.
1041			[DAB;SS]
		1.470	End Sv. Rd. @Cattle Guard

Maint. Section	class	RM	WY 789
CREW			<b>ML - 18B</b>
	6	5.018	Sweetwater Co. Line
<b>CB 08A</b>		20.590	Muddy Cr. [CLM;SS]
1037		23.948	BK= + 0.026 mi.
		23.922	AH Equation
		28.890	Mexican Flats Rd
		30.366	Muddy Cr. [CLO;SS]
		36.710	Robber's Gulch [GRJ;SS]
		37.930	Little Robber's Gulch [GRK;SS]
		43.380	Cottonwood Creek [GRM;SS]
		45.000	Deer Underpass [MGJ;SS]
		47.620	<b>N.B. Road Close location R/R Gate</b>
		49.520	Poison Butte & Gov. Rd (west)
		50.310	Little Snake Rv. [DJF;SS]
		50.337	NCL Baggs
		50.698	WY 70 (RM 0.00)
		50.820	SCL Baggs
		51.900	<b>Dept. Shop - Baggs BG 01A</b>
		52.070	<b>Baggs Port-of-Entry CB 08P</b>
	6	53.223	Colorado State Line



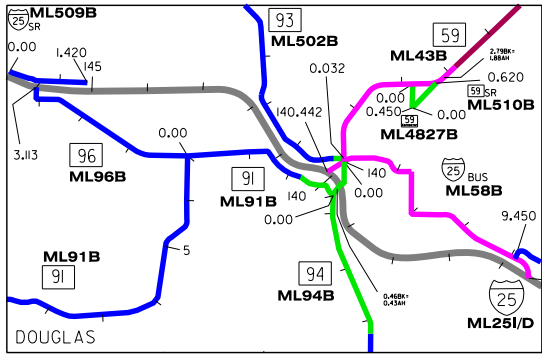
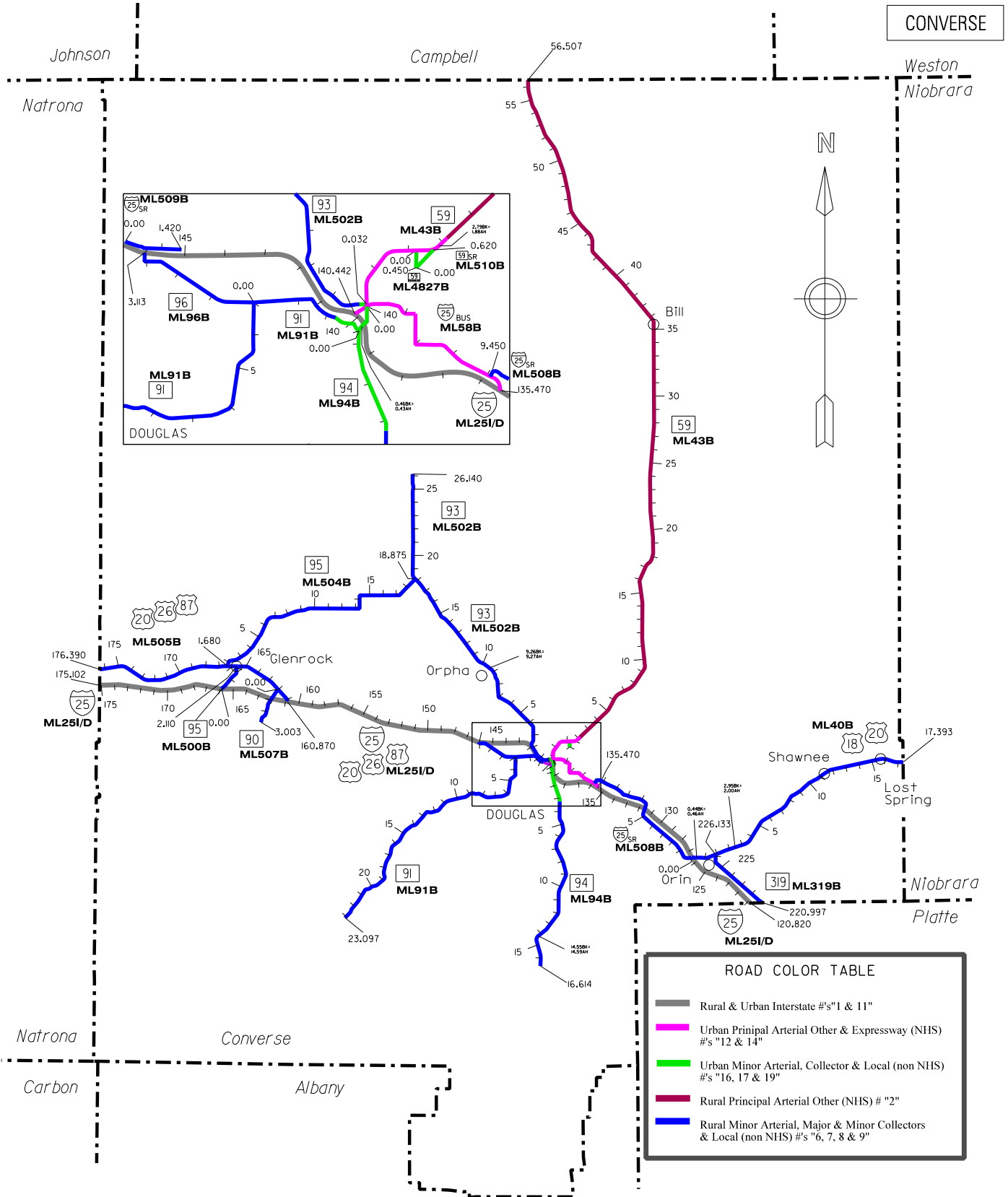

ROAD COLOR TABLE	
<span style="color: grey;">—</span>	Rural & Urban Interstate #s "1 & 11"
<span style="color: magenta;">—</span>	Urban Principal Arterial Other & Expressway (NHS) #s "12 & 14"
<span style="color: green;">—</span>	Urban Minor Arterial, Collector & Local (non NHS) #s "16, 17 & 19"
<span style="color: red;">—</span>	Rural Principal Arterial Other (NHS) # "2"
<span style="color: blue;">—</span>	Rural Minor Arterial, Major & Minor Collectors & Local (non NHS) #s "6, 7, 8 & 9"



# Converse

•• class "classification break"

## County 13

Maint. Section	class	RM	I-25, US 20/26/87	Maint. Section	class	RM	I-25
<b>CREW</b>		<b>ML - 25</b>		<b>CREW</b>		<b>ML - 25</b>	
							<i>(CONTINUED)</i>
	1	120.817	Platte Co. Line		1	164.572	Machinery Pass Sep.[AHD;NB, AHE;SB]
		123.524	Indian Cr. [CZO;NB, CZP;SB]	<b>CO 01A</b>	2034	164.851	Deer Cr. [AHF;NB, AHG;SB]
<b>CO 01A</b>		124.024	Machinery Pass Sep.[CZQ;NB, CZR;SB]			165.909	WY 95 (RM 0.00); Deer Cr. Int.
2034		125.519	North Platte Rv. [CZS;NB, CZT;SB]		1		[AHH;NB, AHI;SB]
		126.059	BNRR Sep. [CZU;NB, CZV;SB]	<b>CO 01B</b>	2031	170.679	Dwyer Rd Sep. [AHJ;NB, AHK;SB]
		126.131	C&NW RR Sep. [CZW;NB, CZX;SB]			172.122	Machinery Pass Sep. [AHL;NB, AHM;SB]
		126.430	Sand Creek [LHT;SS]			174.660	Co. Rd Sep. [AHN;SS]
		126.467	US 18/20 (RM 0.00); Orin Jct. Int. [CZC;SS] Begin US 26			175.102	Natrona Co. Line
			<b>Orin Jct. Rest Area CO 01R</b>				
		126.720	<b>S. B. Road Close Gate R/R</b>				<b>US 18/20</b>
		131.590	Co. Rd Sep. [AFO;NB, AFP;SB]				<b>ML - 40B</b>
		133.730	NB & SB C.M.Sign (dynamic)		2	0.000	I-25 (RM 126.47);Orin Jct. Int. [CZC;SS]
	1	134.900	<b>S.B. Road Close Gate R/R</b>			0.437	BK= - 0.018 mi.
••		135.440	EUL Douglas	<b>CO 03A</b>		0.455	AH Equation
	11	135.472	US 20/26/87 & I-25 BUS. (RM 135.48); E. Douglas Int. [AFQ;NB, AFR;SB]	2034		0.962	C&NW RR Sep. [DBE;SS]
		137.408	Golf Course Rd Sep. [AFT;NB, AFU;SB]			1.620	BNRR Sep. [MCP;SS]
		137.558	BNRR Sep. [AFV;NB, AFW;SB]			1.836	WY 319 (RM 226.133)
		137.601	Irvine Co. Rd. [AFX;NB, AFY;SB]				<b>E.B. Road Close Gate swing</b>
		138.654	North Platte Rv. [AFZ;NB, AGA;SB]			2.885	Shawnee Cr. [DBF;SS]
		139.750	ECL Douglas			2.945	BK= + 0.942 mi.
		139.760	Esterbrook Rd Sep. [AGB;NB, AGC;SB]			2.003	AH Equation
		139.970	<b>N.B. Road Close Gate R/R</b>			7.302	Fero Draw [CEV;SS]
	11	140.028	WCL Douglas			8.174	Unnamed Draw [CEW;SS]
••		140.110	US 20/26/87 & I-25 BUS. (RM 140.44); W. Douglas Int. [BLM;SS]			11.275	Shawnee
	1	141.569	Six Mile Cr. [AGD;SS]			13.730	Watkins Draw [CEX;SS]
		141.710	SB C.M.Sign (dynamic)			15.594	WCL Lost Springs
		141.720	NB C.M.Sign (dynamic)			15.734	ECL Lost Springs
		143.316	Five Mile Cr. [AGF;NB, AGG;SB]			15.900	Lost Cr. [CEY;SS]
		146.003	WY 96 (RM 3.11); LaPrele Int. [AGH;NB, AGI;SB]		2	17.390	Niobrara Co. Line / Cont. NHS
		147.457	LaPrele Cr. [AGJ;NB, AGK;SB];				<b>US 20/26/87 BUS. &amp; I-25 BUS.</b>
		149.780	Alkali Cr. [AGL;SS]				<b>ML - 58B</b>
		150.442	Inez Int. [AGM;NB, AGN;SB]		14	135.476	I-25 (RM 135.47); E. Douglas Int. [AFQ;NB, AFR;SB]
		151.166	Natural Bridge Int. [AGO;SB, AGP;NB]	<b>CO 02Z</b>	2034	135.570	SB C.M.Sign (dynamic)
		154.244	Barber Int. [FXN;MSS]			135.834	End Divided Section
		155.383	Little Boxelder Cr. [AGR;NB, AGS;SB]			135.928	ECL Douglas
		155.870	Boxelder Cr. [AGT;NB, AGU;SB]			137.800	<b>Dept. Shop - Douglas DG 02A</b>
		156.178	Bixby Int.[AGV;NB,AGW;SB]			138.020	4th & Richards streets
		160.871	US 20/26/87 (RM 160.87);E. Glenrock Int. [AGX;NB, AGY;SB], End US 20/26/87			138.755	Begin 4 Lane
		162.038	Boxelder Rd Sep. [AGZ;NB, AHA;SB]			139.460	North Platte Rv. [MAC;SS]
		163.950	Morman Canyon Rd Sep. [AHB;NB, AHC;SB]			138.936	End 4 Lane
	1	164.250	Deer Creek <b>RWIS</b> site {15}				RR at Grade Crossing #089293E
			<b>-cont- next column</b>			139.458	North Platte Rv. [CNN;SS]
						140.075	WY 59 & WY 94 (RM's 0.00)
							WCL Douglas
					14	140.442	I-25 (RM 140.10); West Douglas Int. [BLM;SS]

Maint. Section	class	RM	US 20/26/87
<b>ML - 505B</b>			
<b>CO 10A</b>	7	160.870	I-25 (RM 160.87); East Glenrock Int.
		161.120	<b>N.B. Road Close Gate R/R</b>
			<b>S.B. Road Close Gate R/R</b>
2034		162.054	WY 90 (RM 0.00)
		162.868	Middle Fork Dry Cr. [CWO;SS]
<b>CO 10Z</b>		163.627	ECL Glenrock
		165.440	Deer Cr. [CNW;SS]
2034		165.538	Begin Divided Section
<b>CO 10Y</b>		165.710	WY 95 (RM 2.13)
			Crew Break
2031		166.030	End Divided Section
		166.150	WCL Glenrock
		166.220	WY 95 (RM 1.68)
<b>CO 10B</b>		171.510	Cole Creek Rd
2031		172.430	Big Wash Cr.
		175.370	Big Muddy Cr. [JDR;SS]
7		176.390	Natrona Co. Line.

Maint. Section	class	RM	WY 59 Connector
<b>ML - 4827B</b>			
<b>CO 24A</b>	16	0.000	WY 59 Mainline (RM 2.20)
2034		0.450	Jct. 4th St. End SHS
<b>WY 90</b>			
<b>ML - 507B</b>			
<b>CO 05A</b>	8	0.000	US 20/26/87 (RM 162.05)
2034		0.855	Boxelder Rd Sep. [AGZ;NB, AHA;SB]
		3.003	End SHS
<b>WY 91</b>			
<b>ML - 91B</b>			
<b>CO 06Z</b>	17	0.000	WY 94 (RM 0.505)
2034		0.039	SCL Douglas
	17	0.224	WCL Douglas
	●●	0.780	WUL Douglas
<b>CO 06A</b>	8	1.882	Six Mile Cr.
2034		2.988	WY 96 (RM 0.00)
	8	23.097	End SHS

<b>WY 59</b>			
<b>ML - 43B</b>			
	14	0.000	US 20/26/87 bus. (RM 140.08)
<b>CO 04Z</b>		0.065	WY 93 (RM 0.03)
2034		0.140	Riverbend Drive
		0.220	<b>N.B. Road Close Gate swing</b>
		0.380	SCL Douglas
		0.663	NCL Douglas
<b>CO 04A</b>		0.706	North Platte Rv. [FDB;SS]
2034		1.156	BNRR Sep. [FDC;SS]
		1.950	<b>S.B. Road Close Gate swing</b>
		2.200	WY 59 Conn. (RM 0.00)
			4th Street
		2.600	Jct. Sv. Rd. ML 510 (RM 0.62)
		2.789	BK= + 0.912 mi.
	14	1.877	AH Equation
	●●	3.100	NUL Douglas
	2	3.190	NB C.M.Sign (dynamic)
		3.620	<b>N.B. Road Close Gate R/R</b>
		6.254	Antelope Cr. [CFS;SS]
		10.700	Walker Rd (east)
		17.608	BNRR Sep. [?]
		21.992	Lightning Cr. [DIS;SS]
		26.543	Box Cr. [DJC;SS]
		28.460	Mikes Draw [HUQ;SS]
		32.800	Unnamed Draw [HUT;SS]
		36.220	County Rd (east)
		40.419	BNRR Sep. [DIP;SS]
		42.776	S. Fork Cheyenne Rv. [JJW;SS]
		43.100	<b>Cheyenne River Rest Area CO 04R</b>
		43.660	Dilts Hollow [HUW;SS]
		54.076	Antelope Cr. [JFB;SS]
2		56.507	Campbell Co. Line / District Boundary

<b>WY 93</b>			
<b>ML - 502B</b>			
	17	0.032	WY 59 (RM 0.065)
<b>CO 07A</b>	17	0.060	CL Douglas
2034	●●	0.270	WUL Douglas, End U-0502
	7	1.706	Six Mile Cr. [CMZ;SS]
		3.150	Five Mile Cr.
		8.660	North Platte Rv. [FMA;SS]
		8.720	RR at Grade Crossing #089301U
		8.810	Orpha
		9.259	BK= - 0.014 mi.
		9.273	AH Equation
		18.212	WY 95 (RM 18.876)
	7	26.140	End SHS



Maint. Section	class	RM	WY 94
			<b>ML - 94B</b>
	16	0.000	US 20/26/87 bus. (RM 140.08)
<b>CO 08Z</b>		0.460	BK= + 0.031 mi.
2034		0.429	AH Equation
			Esterbrook Rd Sep. [AGB;NB, AGC;SB]
			SCL Douglas
	16	0.505	WY 91 (RM 0.00)
		3.290	SUL Douglas
<b>CO 08A</b>	8	3.860	County Rd (west)
2034		4.062	Bed Tick Cr. [CNC;SS]
		5.206	Esmay Draw [CND;SS]
		7.510	Warm Springs
		8.619	Wagonhound Cr. [CNE;SS]
		14.550	BK= - 0.042 mi.
		14.592	AH Equation
		14.920	West Fork LaBonte Cr. [CNF;SS]
	8	16.614	End SHS

Maint. Section	class	RM	WY 319
			<b>ML - 319B</b>
	8	220.997	Platte Co. Line
		221.915	Valley Ditch [FEH;SS]
<b>CO 12A</b>		224.500	Indian Cr. [CZA;SS]
2034		225.309	North Platte Rv. [CZB;SS]
		226.110	<b>S.B. Road Close Gate swing</b>
		226.133	US 18/20 (RM 1.84)

**I-25 SV. RD.  
E. Yellowstone Hwy/Orin Way**

Maint. Section	class	RM	WY 319
			<b>ML - 508B</b>
	9	0.000	Begin @ I-25; Orin Jct. Int. (RM 126.47)
<b>CO 01K</b>		2.910	Schneider Draw
2034		5.130	I-25 Sep. (RM 131.59)
			[AFO;NB, AFP;SB]
		8.951	<b>NEW_Dept. Shop - Douglas DG 02A</b>
		9.450	End Sv. Rd. @US 20/26/87 bus. (RM 135.47)

**WY 95**

Maint. Section	class	RM	WY 95
			<b>ML - 500B</b>
	7	0.000	I-25 (RM 165.909); Deer Cr. Int. [AHH;NB, AHI;SB]
<b>CO 13A</b>		1.340	SCL Glenrock
2034		2.110	US 20/26/87 (RM 165.70)

**I-25 SV. RD.**

Maint. Section	class	RM	WY 319
			<b>ML - 509B</b>
	9	0.000	Begin at Dead End
<b>CO 01L</b>		0.43	Mi. NW of LaPrele Int.
2034		0.430	I-25 (LaPrele Int.)
		1.420	End at Dead End
		0.99	Mi. SE of LaPrele Int.

**WY 95**

Maint. Section	class	RM	WY 95
			<b>ML - 504B</b>
<b>CO 09Z</b>	7	1.680	US 20/26/87 (RM 166.22)
2034		1.870	CL Glenrock
		2.110	NCL Glenrock
		2.700	North Platte Rv. [JDN;SS]
		2.820	River Approach
		2.830	North Platte Rv. [JDO;SS]
<b>CO 09B</b>		3.060	BNRR Sep. [JDP;SS]
2034		6.667	Railroad Sep. [DDE;SS]
		7.378	Sand Cr. [DDD;SS]
		15.230	LeuengerLane (south)
	7	18.876	WY 93 (RM 18.21)

**WY 59 SV. RD.**

Maint. Section	class	RM	WY 319
			<b>ML - 510B</b>
	19	0.000	Begin at NCL of Douglas Old WYO 59 (4th St. Rd.)
<b>CO 04K</b>		0.620	End Sv. Rd. at WY 59 (RM 2.60)
2034			

**WY 95 SV. RD.**

Maint. Section	class	RM	WY 319
			<b>6th Street ML - 19628B</b>
<b>CO 09K</b>	8	100.251	W. Platte St.
2034		100.400	End SHS @WY 95 (RM 2.37). Glenrock

**WY 96**

Maint. Section	class	RM	WY 96
			<b>ML - 96B</b>
<b>CO 11A</b>	8	0.000	WY 91 (RM 2.99)
2034		3.113	I-25 (RM 146.00); LaPrele Int. [AGH;NB, AGI;SB]



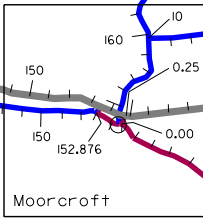
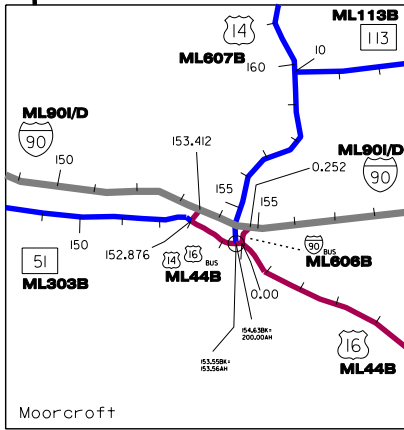
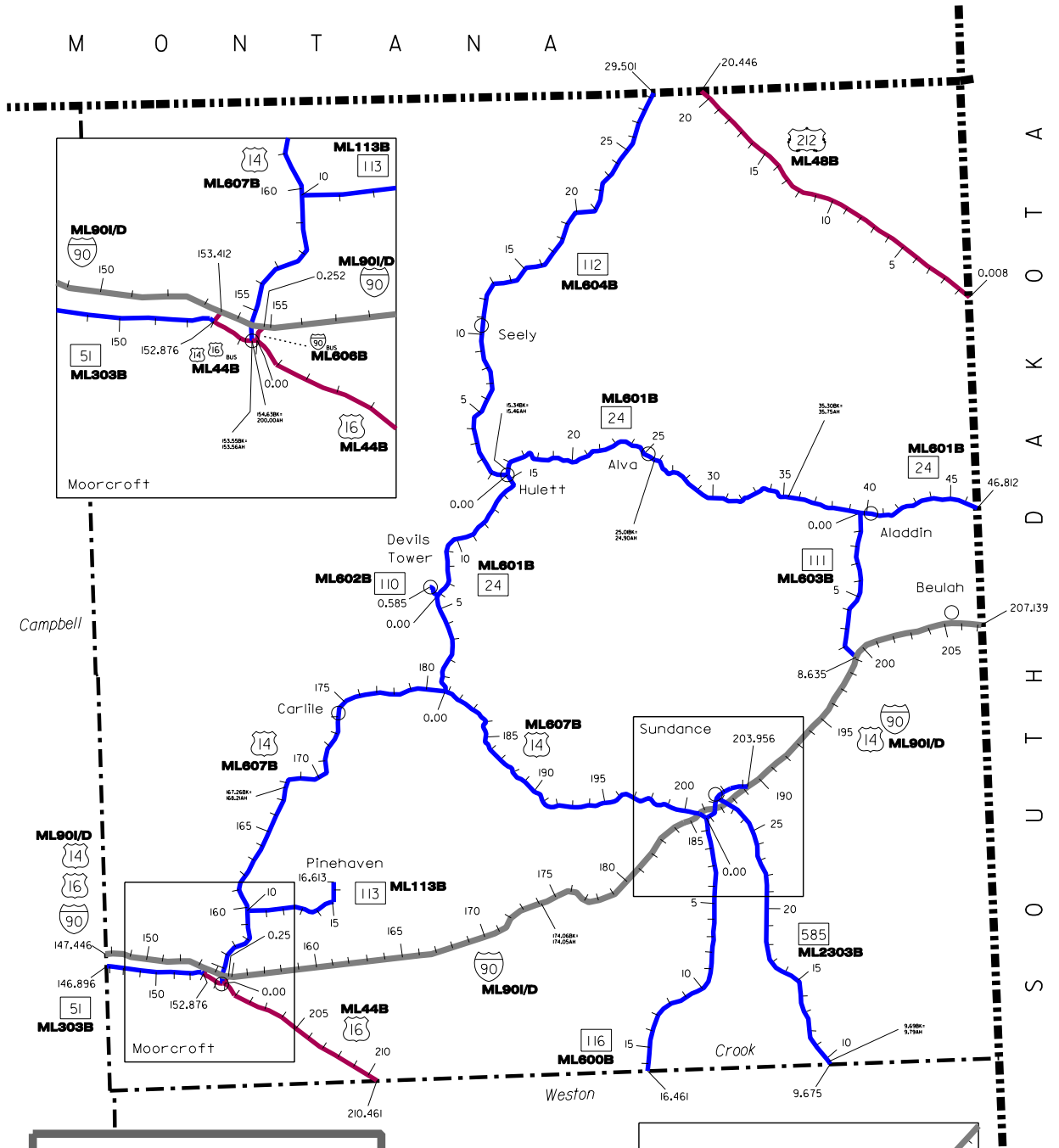
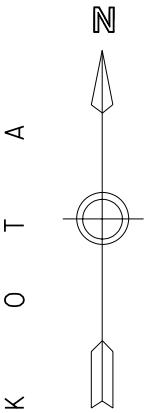

ROAD COLOR TABLE	
	Rural & Urban Interstate #'s "1 & 11"
	Urban Principal Arterial Other & Expressway (NHS) #'s "12 & 14"
	Urban Minor Arterial, Collector & Local (non NHS) #'s "16, 17 & 19"
	Rural Principal Arterial Other (NHS) # "2"
	Rural Minor Arterial, Major & Minor Collectors & Local (non NHS) #'s "6, 7, 8 & 9"

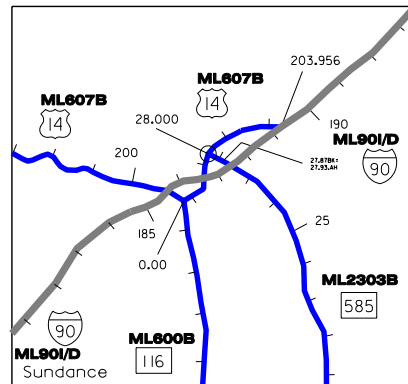



# Crook

•• class "classification break"

## County 18

Maint. Section	Class	RM	I-90 & US 14/16	Maint. Section	Class	RM	I-90 & US 14
CREW		<b>ML - 90</b>		CREW		<b>ML - 90</b>	
	1	147.446	Campbell Co. Line			<i>(CONTINUED)</i>	
<b>CR 01A</b>	4040	147.590	Well Cr. [BGI;EB, BGJ;WB]	<b>CR 01B</b>	4042	184.350	Cundy Creek [GDM;SS]
		148.760	Machinery Pass Sep. [BGL;EB, BGM;WB]			185.540	Unnamed Draw [BJC;SS]
		152.020	"D" Rd Overpass [BGN;EB, BGO;WB]			185.700	<b>W.B. Road Close Gate R/R</b>
		152.260	Donkey Cr. [BGP;EB, BGQ;WB]			185.730	US 14 (RM 200.54); West Sundance Int.
		152.920	Bell Fourche Rv. [BGS;EB, BGT;WB]				[BJD;EB, BJE;WB]
		153.412	I-90 BUS.(RM 153.41);W. Moorcroft Int.			186.437	WCL Sundance
			[BGV;EB, BGW;WB] , End US 14 & 16			186.598	CL Sundance
			<b>Dept. Shop Moorcroft MC 04A</b>			186.610	US 14 Overpass [BJF;EB, BJG;WB]
			<b>Moorcroft Rest Area CR 01R</b>			186.690	CL Sundance
		153.735	WCL Moorcroft			186.943	CL Sundance
		153.900	<b>W.B. Road Close Gate R/R</b>			187.533	WY 585 (RM 27.43); WY 585 Int.
		154.353	US 14 Highway Sep. [BGX;EB, BGY;WB]				[BJH;EB, BJI;WB]
		154.686	I-90 BUS.(RM 0.25); E. Moorcroft Int.			187.646	CL Sundance
			[BGZ;EB, BHA;WB] Spur			187.783	ECL Sundance
		154.769	ECL Moorcroft			188.100	Machinery Pass Sep. [BJJ;EB, BJK;WB]
			<b>E.B. Road Close Gate R/R</b>			188.998	US 14 (RM 203.96); East Sundance Int.
		155.064	Co. Rd Sep. [BHB;EB, BHC;WB]				[BJL;EB, BJM;WB] , Begin US 14
		155.992	Co. Rd Sep. [BHD;EB, BHE;WB]				<b>E.B. Road Close Gate R/R</b>
		157.621	Co. Rd Sep. [BHF;EB, BHG;WB]				<b>Dept. Shop - Sundance SD 04A</b>
		160.658	Wind Cr. Int. [BHH;EB, BHI;WB]				<b>Sundance Rest Area CR 01S</b>
161.465	Wind Cr. [BHJ;EB, BHK;WB]		<b>Sundance Port-of-Entry CR 01P</b>				
161.940	Machinery Pass Sep. [BHL;EB, BHM;WB]	190.437	Mach. Pass Sep. [DAM;EB, DAN;WB]				
164.595	Mule Cr. [BHN;SS]	191.920	Moskee Int. [DAP;EB, DAQ;WB]				
165.677	Pine Ridge Int. [BHO;SS]	195.001	Co. Rd Overpass [DHU;EB, DHV;WB]				
166.909	Co. Rd Sep. [BHP;EB, BHQ;WB]	197.463	Mach. Pass Sep.[DHW;EB, DHX;WB]				
167.417	Tom Cat Cr. [BHR;EB, BHS;WB]	199.310	WY 111 (RM 8.63); Aladdin Int.				
168.112	Co. Rd Sep. [BHT;EB, BHU;WB]		[DHY;EB, DHZ;WB] , Overpass				
169.426	Arch Cr. [BHV;EB, BHW;WB]		<b>Black Hills Welcome Center CR 01W</b>				
169.561	Co. Rd Sep. [BHX;EB, BHY;WB]	201.478	Mach. Pass Sep.[DHJ;EB, DHK;WB]				
170.510	Inya Kara <b>RWIS</b> site {57}	202.686	Mach. Pass Sep.[DHL;EB, DHM;WB]				
170.649	Co. Rd Sep. [BHZ;EB, BIA;WB]	205.288	Rifle Pit Rd Overpass				
171.264	Co. Rd Sep. [BIB;SS]		[DHN;EB,DHO;WB]				
171.860	Inyan Kara Cr. [BIC;EB, BID;WB]	205.346	Sand Cr. [DHP;EB, DHQ;WB]				
172.092	Inyan Kara Int. [BIE;EB, BIF;WB]	205.895	Beulah Int. Underpass [DHR;SS]				
173.006	Houston Cr. [BIG;EB, BIH;WB]		Beulah Int. <b>RWIS</b> site {58}				
173.158	Co. Rd Sep. [BIJ;EB, BIJ;WB]	206.492	Mach. Pass Sep. [DHS;EB, DHT;WB]				
173.951	Co. Rd Sep. [BIK;EB, BIL;WB]	207.139	South Dakota State Line				
174.058	BK= + 0.011 mi.						
174.047	AH Equation						
174.475	Co. Rd Sep. [BIM;EB, BIN;WB]						
175.375	Co. Rd Sep. [BIO;EB, BIP;WB]						
177.784	Co. Rd Sep. [BIQ;EB, BIR;WB]						
178.190	Co. Rd Sep. [BIS;EB, BIT;WB]						
178.916	Coal Divide Int. [BIU;EB, BIV;WB]						
179.439	Beaver Cr. [BIW;EB, BIX;WB]						
181.823	Machinery Pass Sep. [BIY;EB, BIZ;WB]						
1	182.695	Co. Rd Sep. [BJA;EB, BJB;WB]					
		<b>I-90 Bus.</b>					
		<b>ML - 606B</b>					
		<b>CR 10A</b>	2	0.000	US 16 (RM 200.20) Mainline (NHS)		
		4040		0.252	I-90 (RM 154.686); E. Moorcroft Int.		
					[BGZ;EB, BHA;WB]		

→ -cont- next column

Maint. Section	class	RM	US 14, 16 & I-90 Bus.
		<b>ML - 44B</b>	
<b>CR 03Z</b>	2	153.412	I-90 (RM 153.41); West Moorcroft Int. [BGV;EB, BGW;WB] , Begin NHS
4040		153.548	BK= - 0.013 mi.
		153.562	AH Equation
			WY 51 (RM 152.88)
		153.928	WCL Moorcroft
<b>CR 03A</b>	2	154.628	BK= - 45.37 mi.
4040		200.000	AH Equation
			US 14 (RM 154.63)
			End US 14
		200.207	I-90 BUS. Spur (RM 0.00)
			End I-90 Bus.
		200.454	ECL Moorcroft
		200.510	<b>S.B. Road Close Gate R/R</b>
	2	210.461	Weston Co. Line
			Cont. NHS

			US 14
		<b>ML - 607B</b>	
<b>CR 02A</b>	7	154.628	US 14,16 BUS. (RM 154.63).
4040		154.970	US 14 Highway Sep.
		155.060	<b>N.B. Road Close Gate R/R</b>
		155.239	NCL Moorcroft
		159.670	WY 113 (RM 10.00)
		159.720	<b>N.B. Road Close Gate R/R</b>
		160.235	Belle Fourche Rv. [BFZ;SS]
		164.450	Lone Tree Creek [JGX;SS]
		167.260	BK= - 0.95 mi.
		168.210	AH Equation
		175.173	Carlile
		175.850	Cabin Creek Rd (north)
<b>CR 02B</b>		176.303	Cabin Cr. [FBT;SS]
4042		179.332	Belle Fourche Rv. [FBU;SS]
		179.684	Black Hills Nat'l. Forest Boundary
		181.050	<b>W.B. Road Close Gate R/R</b>
		181.140	<b>E.B. Road Close Gate R/R</b>
		181.190	WY 24 (RM 0.00)
		186.895	E. Black Hills Nat'l. Forest Boundary
		199.356	Taylor Divide Rd
		200.310	<b>W.B. Road Close Gate R/R</b>
		200.474	Unnamed Draw [DCD;SS]
		200.545	I-90 (RM 185.73); West Sundance Int. [BJD;EB, BJE;WB]
			Begin US 14 Bus. & I-90 Bus.
		200.736	WY 116 (RM 0.00)
		200.855	South Fork Sundance Cr. [BKI;SS]
		201.350	US 14 Sep.
		201.472	WCL Sundance
		201.648	South Fork Sundance Cr. [CYA;SS]
	7	201.892	North Fork Sundance Cr.

→ -cont- next column

Maint. Section	class	RM	US 14, 16 & I-90 Bus.
		<b>ML - 607B</b>	
		<i>(CONTINUED)</i>	
<b>CR 02B</b>	7	202.196	WY 585 (RM 28.05)
4042		202.654	ECL Sundance
		203.956	I-90 (RM 189.00); East Sundance Int. [BJL;EB, BJM;WB]

			US 212
		<b>ML - 48B</b>	
<b>CR 05A</b>	2	0.008	South Dakota State Line, Begin NHS
4039		2.000	Chicago Cr. [DCJ;SS]
		17.750	Little Missouri Rd (west)
		20.446	Montana State Line, End WY NHS

			WY 24
		<b>ML - 601B</b>	
<b>CR 07A</b>	7	0.000	US 14 (RM 181.19)
4039		0.743	Miller Cr. [DEC;SS]
		2.009	N. Boundary Black Hills Nat'l. Forest
		5.980	WY 110 (RM 0.00); Devils Tower Spur
		6.711	Lytle Cr. [FBQ;SS]
		14.070	<b>S.B. Road Close Gate R/R</b>
		14.080	Cook Lake Rd
		14.790	Belle Fourche Rv. [FFD;SS]
			SCL Hulett
		14.840	<b>Dept. Shop - Hulett HL 04A</b>
		15.131	WY 112 (RM 0.00)
		15.190	SCL Hulett
		15.340	BK= - 0.123 mi.
		15.463	AH Equation
		15.480	Belle Fourche Rv. [CNX;SS]
		15.948	NCL Hulett
		16.750	<b>E.B. Road Close Gate R/R</b>
		18.370	Bush Draw [FON;SS]
		19.793	Red Canyon Cr. [KMH;SS]
		22.949	Black Hills Nat'l. Forest Boundary
		25.460	Alva
		26.510	Beaver Cr. [KQB;SS]
		32.982	W. Boundary Black Hills Nat'l. Forest
		33.410	E. Boundary Black Hills Nat'l. Forest
		39.380	WY 111 (RM 0.00)
		39.880	Aladdin
		40.608	BK= +0.569 mi.
		40.039	AH Equation
		41.600	Oak Creek Rd
		42.100	Craco Ranch Rd
		43.972	South Fork Hay Cr. [FBI;SS]
		46.812	South Dakota State Line

Maint. Section	class	RM	WY 51
CREW			<b>ML - 303B</b>
	7	146.896	Campbell Co. Line
<b>CR 12A</b>		147.041	Well Cr. [BGK;SS]
4040		151.667	Donkey Cr. [BGR;SS]
		152.334	Belle Fourche Rv. [KGG;SS]
		152.720	<b>W.B. Road Close Gate R/R</b>
		152.876	US 14,16 bus. (RM 153.56)

			WY 110
			<b>ML - 602B</b>
<b>CR 11A</b>	7	0.000	WY 24 (RM 5.98) Mainline
4039		0.585	Devils Tower Nat'l. Monument boundry End SHS

			WY 111
			<b>ML - 603B</b>
<b>CR 08A</b>	7	0.000	WY 24 (RM 39.38)
4042		0.158	South Fork Hay Cr. [COE;SS]
		1.040	Unnamed Draw [JCO;SS]
		1.920	Unnamed Draw [JAT;SS]
		4.000	Upper Red Water Creek Rd (west)
		4.566	Red Water Cr. [COF;SS]
		8.500	I-90 SR ML-608B (RM 8.28)
		8.632	I-90 (RM 199.31); Aladdin Int. Overpass [DHY;EB, DHZ;WB]

			WY 112
			<b>ML - 604B</b>
<b>CR 09A</b>	7	0.000	WY 24 (RM 15.13)
4039		0.420	NCL Hulett
		1.290	New Haven Rd
		2.450	<b>N.B. Road Close Gate R/R</b>
		10.500	Seely
		29.501	Montana State Line

			WY 113
			<b>ML - 113B</b>
<b>CR 13A</b>	7	10.000	US 14 (RM 159.67) With 0.18 mi. Wye Conn.
4040		13.700	Wind Creek [IUF;SS]
		15.090	Jct. county Rd
		16.050	SCL Pinehaven
		16.613	End SHS @Pinehaven

			WY 116
			<b>ML - 600B</b>
<b>CR 06A</b>	7	0.000	US 14 (RM 200.74)
4042		0.107	Sundance Cr. [CNG;SS]
		0.180	<b>S.B. Road Close Gate R/R</b>
		3.317	Cundy Cr. [CNH;SS]
		4.876	Beaver Cr. [BMF;SS]
		6.640	Mason Creek Rd (east)
		12.786	Inyan Kara Cr. [CNJ;SS]
		16.462	Weston Co. Line

Maint. Section	class	RM	WY 585
CREW			<b>ML - 2303B</b>
	6	9.675	Weston Co. Line
		9.750	BK= - 0.11 mi.
<b>CR 04A</b>		9.860	AH Equation
4042		11.330	Inyan Kara Cr. [FUX;SS]
		13.260	Soldier Cr. [FUY;SS]
		19.130	Banks Rd (west)
		22.026	Silver Cr. [FUW;SS]
		26.910	<b>S.B. Road Close Gate R/R</b>
		27.431	I-90 (RM 187.53); WY 585 Int.
		27.736	SCL Sundance
		27.940	Sundance Cr. [FQK;SS]
		28.000	US 14 (RM 202.20)

			I-90 SV. RD.
			<b>ML - 608B</b>
	9	0.000	Begin Sv. Rd. @South Dakota St. Line
		0.040	<b>E.B. Road Close Gate R/R</b>
<b>CR 01K</b>		1.850	Sand Creek Bridge [FLC;NSR]
4042		5.870	Andy's Draw Bridge [BJR;NSR]
		8.000	<i>I-90 RM; 199.31</i> <i>Black Hills Welcome Center CR 01W</i>
		8.280	WY 111 (RM 8.50)
			I-90 (RM 199.31); Aladdin Int.
		8.750	Alkali Creek Bridge [BJQ;NSR]
		10.150	Rocky Ford Creek Bridge [BJP;NSR]
		12.780	Sundance Creek Bridge [BJO;NSR]
		16.060	Sundance Creek Bridge [BJN;NSR]
		16.900	Machinery Pass. [DAO;NSR]
		18.370	End Sv. Rd. @US 14 (RM 203.96)

			I-90 SV. RD.
			<b>ML - 609B</b>
<b>CR 01N</b>	9	0.000	From Jct. I-90 (RM 189.00)
4042		0.080	<i>I-90 RM; 189.00</i> <i>Dept. Shop - Sundance SD 04A</i> <i>Sundance Rest Area CR 01S</i> <i>Sundance Port-of-Entry CR 01P</i>
		0.350	End Sv. Rd. @Locked Gate





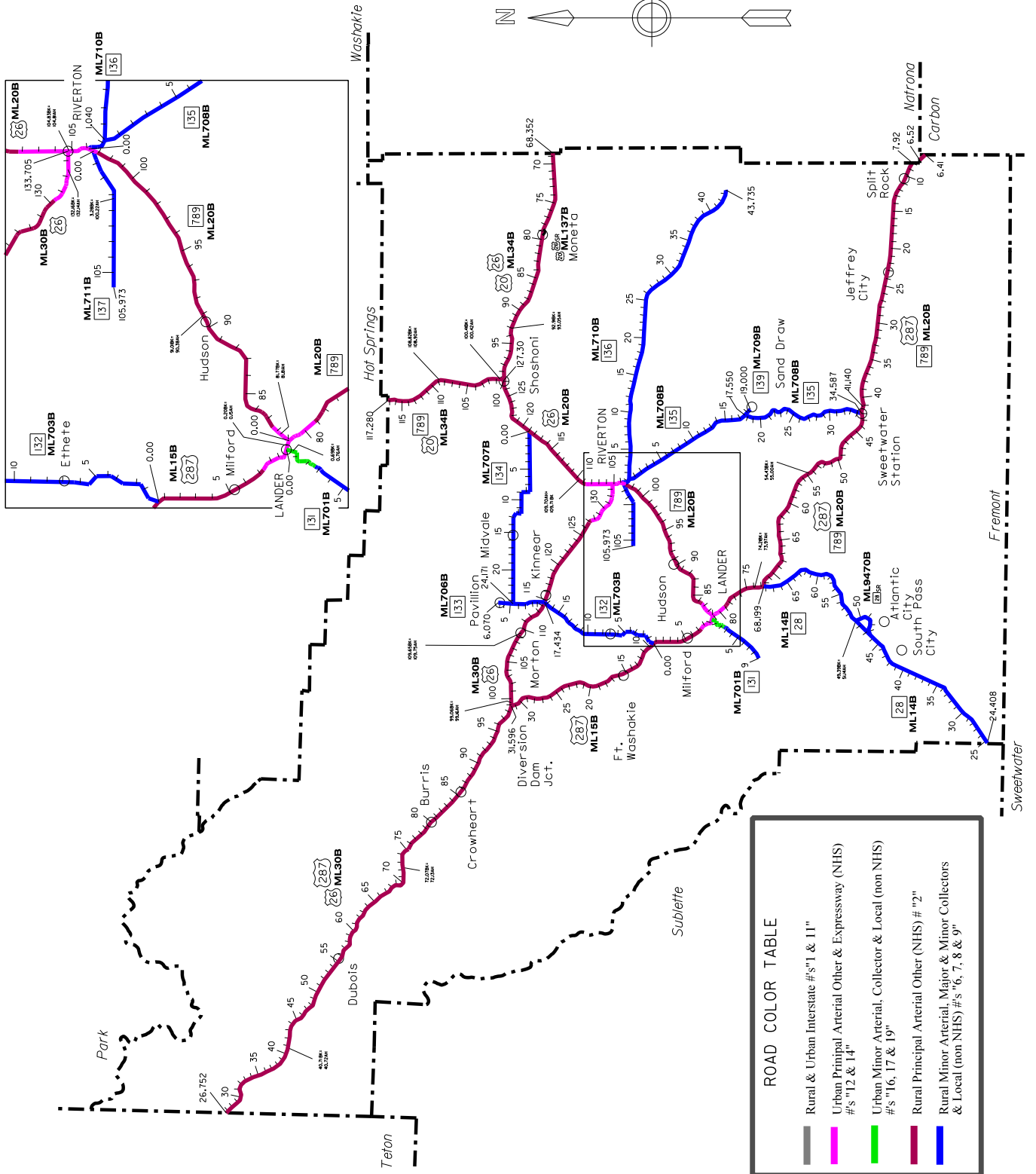
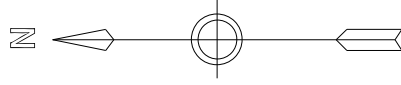



# Fremont

## County 10

•• class "classification break"

+ Indicates Non State System

Maint. Section	class	RM	US 20/26 & WY 789
		<b>ML - 34B</b>	
	2	68.352	Natrona Co. Line, Cont. NHS
<b>FR 04A</b>		78.780	<b>E.B. Road Close Gate R/R</b>
5037		79.270	Town Of Moneta
		REMOVED EQUATION	
		99.070	Bonneville Rd
		99.400	RR at Grade Crossing #188783U
		99.470	<b>Dept. Shop - Shoshoni SS 05A</b>
		99.480	<b>E.B. Road Close Gate R/R</b>
		99.529	ECL Shoshoni
		100.038	US 26, WY 789 (RM 127.30) End US 26, Begin WY 789
		REMOVED EQUATION	
		100.470	NCL Shoshoni
		102.711	Badwater Cr. [CBV;SS]
		102.879	BNRR Sep. [CBW;SS]
		103.140	Bonneville Rd
		103.410	<b>N.B. Road Close Gate R/R</b>
		108.824	BK= - 0.078 mi.
		108.902	AH Equation
		110.200	Birdseye Creek [HLL;SS]
		113.050	Boysen Camp Rd
		115.574	Wind River Indian Res. Boundary
<b>HS 02A</b>		116.173	Tunnel #1 [BKL;SST]
5040		116.292	Tunnel #2 [CBY;SST]
		116.392	Tunnel #3 [CBZ;SST]
	2	117.281	Hot Springs Co. Line Cont. NHS

→ -cont- in Hot springs County

Maint. Section	class	RM	US 26, US 287 & WY 789
		<b>ML - 20B</b>	
	2	6.412	Carbon Co. Line
		6.518	Natrona Co. Line, Cont. NHS (1.40 mi. in Natrona Co.)
<b>FR 02A</b>		7.917	Natrona Co. Line, Cont. NHS
2036		12.651	Cottonwood Cr. [FFF;SS]
		17.490	Unnamed Draw [FEX;SS]
		22.410	Jeffrey City (east)
		22.550	<b>E.B. Road Close Gate R/R</b>
		23.400	Jeffrey City (west)
		23.810	<b>W.B. Road Close Gate R/R</b>
		25.360	O'Brian Creek [KJL;SS]
	2	32.630	Ice Slough Cr. [FEY;SS]
		41.140	District Boundary

Maint. Section	class	RM	US 26, US 287 & WY 789
		<b>ML - 20B</b>	
		(CONTINUED)	
		41.140	District Boundary
<b>FR 02B</b>	2	41.622	Sweetwater Rv. [DJE;SS]
5034		41.900	Bison Basin Rd
		42.106	WY 135 (RM 34.59) <b>Sweetwater Station Rest Area</b>
			<b>FR 10R</b>
		42.120	<b>E.B. Road Close Gate R/R</b>
		46.340	Antelope Cr. [DDB;SS]
		48.140	Beaver Rim <b>RWIS</b> site {5}
		54.130	Old Highway
		54.286	Beaver Cr. [CXN;SS]
		54.429	BK= - 0.575 mi.
		55.004	AH Equation
		57.762	Stockdrive Overpass [BZY;SS]
		60.522	Stockdrive Overpass [BZZ;SS]
		62.066	Stockdrive Overpass [CAB;SS]
		64.045	Twin Cr. [CBS;SS]
		65.728	Twin Cr. [BTJ;SS]
		67.956	Twin Cr. [BPB;SS]
		71.810	Little Popo Agie Rv. [BTL;SS]
		72.750	<b>E.B. Road Close Gate R/R</b>
		72.868	WY 28 (RM 68.20)
		73.300	SB C.M.Sign (dynamic)
		73.660	Dry Lake
		74.205	BK= + 0.235 mi.
		73.970	AH Equation
		74.180	County Rd (west)
		74.350	Willow Creek Rd
	2	74.445	Willow Cr. [DED;SS]
		79.230	SUL Lander
	14		Mortimore Lane
		80.195	SCL Lander
<b>FR 02Y</b>		80.340	CL Lander
5034		80.470	CL Lander
		80.770	Leedy Drive
		80.940	SB C.M.Sign (dynamic)
		81.047	US 287 (RM 0.00) End US 287, <b>Dept. Shop - Lander LD 05A</b>
			Web Cam
		81.740	NCL Lander
		81.774	BK= - 0.37 mi.
<b>FR 02C</b>		81.811	AH Equation
5034	14	82.100	Childrens Home
		83.440	NUL Lander
	2	87.700	Lyons Valley Rd
		90.590	Little Popo Agie Rv. [DDV;SS]

→ -cont- next page

Maint. Section	class	RM	US 26, US 287 & WY 789
CREW		<b>ML - 20B</b>	
-cont-		<i>(CONTINUED)</i>	
<b>FR 02C</b>	2	90.640	WCL Hudson
5034		91.010	BK= + 0.627 mi.
		90.383	AH Equation , Cont. NHS
		90.389	Wind River Indian Res. Boundary
		90.600	ECL Hudson
		90.650	WCL Hudson
		91.315	Sweaney Draw [DAS;SS]
		91.410	Hudson Draw [GTV;SS]
		92.054	WY 138 (RM 0.00)
		92.740	Rogers & Gregg Ditch [DAX;SS]
		99.184	Beaver Cr. [DAY;SS]
		101.610	Elmwood Rd
		102.928	Little Wind Rv. [DBH;SS]
		103.484	WY 137 (RM 0.00)
		103.835	WY 135 (RM 100.00)
			Web Cam
	2	104.134	Wind Rv. [BTS;SS]
	●●	104.162	SUL Riverton
→	14	104.308	SCL Riverton
		104.825	BK= + 0.012 mi.
<b>FR 02Z</b>		104.813	AH Equation
5042		105.169	US 26,WY 789 (RM 133.71)
			Begin US 26
		106.320	Webbwood Rd
→		106.340	CL Riverton
		107.110	Wyoming Penitentiary farm
<b>FR 02D</b>		107.540	Madden Draw
5042		107.790	CL Riverton
		107.930	Madden Draw [FNB;SS]
	14	107.940	NCL Riverton
	●●	108.340	NUL Riverton
	2	109.010	Haymaker Draw [FNO;SS]
		109.110	Burma Rd
		109.413	BK= - 0.287 mi.
		109.700	AH Equation
		110.440	Hutchinson & Delfelders Rds
		111.203	Brown Draw [MHE;SS]
		112.210	County Rd (east & west)
		117.117	Wind River Indian Res. Boundary
→		119.040	WY 134 (RM 0.00)
		123.432	Boysen Reservoir [LCU;SS]
<b>FR 02E</b>		123.890	Wind River Indian Res. W. Boundary
5037		124.909	Wind River Indian Res. E. Boundary
		126.145	Poison Cr. [DDC;SS]
		126.942	WCL Shoshoni
	2	127.299	US 20,26 ,WY 789 (RM 100.04)
			End NHS

Maint. Section	class	RM	US 26 & US 287
CREW		<b>ML - 30B</b>	
2		26.752	Teton Co. Line, Cont. NHS
		32.492	Brooks Lake Cr. [LVY;SS]
		33.680	<b>Dept. Shop - Togwotee TG 05A</b>
<b>FR 03A</b>		35.400	<b>W.B. Road Close Gate R/R</b>
5033		40.681	BK= -0.039 mi
		40.720	AH
			Shoshone Nat'l Forest Boundary
		43.384	Long Cr. [FLY;SS]
		45.663	Wind Rv. [JBN;SS]
		46.120	Union Rass Rd
		46.425	Wind Rv. [JBO;SS]
		47.860	Dunoir Rd
		49.299	Wagon Gulch Cr.
		53.250	WB C.M.Sign (dynamic)
		53.340	WCL Dubois
		54.760	<b>Dept. Shop - Dubois DB 05A</b>
		55.472	Horse Cr. [DHH;SS]
		56.470	ECL Dubois
		56.968	Wind Rv. [EUW;SS]
		59.200	Jakey's Fork [EUV;SS]
		60.339	N. Fork Torrey Cr. [EUV;SS]
		60.413	S. Fork Torrey Cr. [EUT;SS]
		63.671	Wind Rv. [EVB;SS]
		66.906	Wind Rv. [EVC;SS]
		67.191	Wind River Indian Res. Boundary
		69.370	Little Red Cr. [FJC;SS]
		70.450	Red Cr. [FLG;SS]
		72.070	BK= - 0.058 mi.
		72.128	AH Equation
		73.284	Dinwoody Cr. [FLR;SS]
		76.380	Dinwoody Canal [FLS;SS]
		79.440	Little Dry Creek [FJP;SS]
		79.610	Big Dry Cr. [EWN;SS]
		79.650	Burris
		84.520	Smith Draw [FIQ;SS]
		85.240	Crowheart
		86.000	Meadow Cr. [FFW;SS]
		87.140	Willow Cr. [FFX;SS]
		90.630	Sand Cr. [FFY;SS]
		91.600	Indian Creek [FGM;SS]
		95.440	Bull Lake Cr. [DZT;SS]
		96.380	<b>Diversion Dam Rest Area FR 03R</b>
→		98.790	US 287(RM 31.596);Diversion Dam Jct.
			End US 287
<b>FR 03B</b>		99.062	BK= - 0.94 mi.
5042		99.156	AH Equation
		99.650	Winchester Draw [BYU;SS]
		99.660	Old Highway
		102.810	Big Wind Rv. [BYV;SS]
		104.870	Wind River Indian Res. Boundary
		105.660	Old Highway
		109.645	BK= - 0.105 mi.
	2	109.750	AH Equation

→ -cont- next page

Maint. Section	class	RM	US 26 & US 287
CREW		<b>ML - 30B</b>	
-cont-		<i>(CONTINUED)</i>	
<b>FR 03B</b>	2	110.360	Pilot Butte Reservoir Overflow [DJJ;SS]
5042		111.200	Wind River Indian Res. Boundary
		113.400	Wind River Indian Res. Boundary
		113.870	Wind River Indian Res. Boundary
		114.040	Wind River Indian Res. Boundary
		114.640	WY 132 (RM 17.43) & WY 133 (RM 0.00)
	2	124.980	Eight Mile Rd
		126.980	Service Rd (north)
	●●	127.210	WUL Riverton
	14	129.070	Wind River Indian Res. Boundary
		130.390	Hill Street
		130.580	<b>Dept. Shop - Riverton RT 05A</b>
	→	130.670	LaClair Canal [DJD;SS] WCL Riverton
<b>FR 03Z</b>		130.850	College View Drive
5042		132.161	BK= + 0.025 mi.
		132.136	AH Equation
		133.020	Wyo. Central Canal #2 [BYX;SS]
		133.230	Begin Divided Section
		133.330	Third Street
	14	133.705	US 26 (RM 105.17) End NHS
		<b>US 287</b>	
		<b>ML - 15B</b>	
	14	0.000	US 287 (RM 81.05) Begin NHS
<b>FR 01Z</b>		0.171	Middle Popo Agie Rv. [DIY;SS]
5034		0.202	BK= + 0.05 mi.
		0.152	AH Equation
		0.562	WY 131 (RM 0.00)
		1.256	Baldwin Creek Rd
		1.580	Squaw Cr. [BSJ;SS]
		1.630	Tweed Lane
	→	1.850	NCL Lander
	14	1.938	Baldwin Cr. [BSK;SS]
<b>FR 01A</b>	●●	2.340	WUL Lander
5034	2	3.610	Steel Pipe Flume
		4.720	Milford
		5.040	Wind River Indian Res. Boundary
		5.140	Popo Agie Rv. [BSM;SS]
		8.320	Plunkett Rd
		9.279	WY 132 (RM 0.00)
		14.207	Trout Cr. [BSN;SS]
		14.680	Wind River Rd
		15.620	Fort Washakie
		16.131	Little Wind Rv. [CXM;SS]
	2	31.596	US 287 (RM 98.79) End NHS

Maint. Section	class	RM	WY 28
CREW		<b>ML - 14B</b>	
	6	24.408	Sublette Co. Line / District Boundary
		30.430	<b>EB VSL sign</b>
		34.105	Sweetwater Rv. [DLO;SS]
<b>FR 05A</b>		34.310	<b>South Pass Rest Area FR 05R</b>
5038		34.514	EB C.M.Sign (dynamic)
		35.000	<b>EB/WB VSL sign</b>
		38.610	South Pass County Rd
		41.350	South Pass <b>RWIS</b> site {3}
		43.490	Shoshone Nat'l. Forest Boundary
		44.290	Shoshone Nat'l. Forest Boundary
		44.700	W. Atlantic City Rd
		45.022	Shoshone Nat'l. Forest Boundary
		45.828	Shoshone Nat'l. Forest Boundary
		46.597	Shoshone Nat'l. Forest Boundary
		46.700	<b>WB VSL sign</b>
		46.910	<b>W.B. Road Close Gate R/R</b>
		46.920	WY 28 Loop (RM 46.73) south
		47.040	WB C.M.Sign (dynamic) <b>EB VSL sign</b>
		48.800	<b>WB VSL sign</b>
		49.050	WY 28 Loop (RM 50.17) north
		49.150	<b>EB VSL sign</b>
		49.337	BK= - 1.803 mi.
		51.140	AH Equation
		52.099	Beaver Cr. [FBG;SS]
		53.080	E. Shoshone Nat'l. Forest Boundary
		55.630	Johnnie Lee Spring [KMI;SS]
		58.000	<b>EB/WB VSL sign</b>
		59.500	Red Canyon <b>RWIS</b> site {4}
		62.300	<b>WB VSL sign</b>
		62.500	<b>W.B. Road Close Gate R/R</b>
		63.090	WB C.M.Sign (dynamic)
		67.211	Little Popo Agie Rv. [COL;SS]
		67.670	Red Canyon Rd
	6	68.199	US 287, WY 789 (RM 72.87)
		<b>WY 28 SV. RD.</b>	
		<b>ML - 9470B</b>	
	6	46.719	WY 28 Mainline, south (RM 46.92)
<b>FR 14A</b>		47.521	Shoshone Nat'l. Forest Boundary
5038		48.685	Shoshone Nat'l. Forest Boundary
		49.170	E. Atlantic City Rd
		49.200	<b>Dept. Shop - South Pass SP 05A</b> <b>W.B. Road Close Gate R/R</b>
		50.170	WY 28 Mainline, north (RM 49.05)

**Maint.  
Section**

CREW	class	RM	WY 131
			<b>ML - 701B</b>
	+	0.000	US 287 (RM 0.56)
			<b>REMOVED EQUATION</b>
		1.748	End City / Begin State SCL Lander
<b>FR 06A</b>	16	2.130	Mortimore Lane
5034	●●	2.310	SUL Lander
	7	3.430	Hornecker Cr. [KMK;SS]
	7	7.115	Middle Popo Agie Rv. [BMR;SS]
	●●	7.250	NUL Satellite of Lander (The Sinks)
	17		
	●●	7.700	SUL Satellite of Lander (The Sinks)
	7	9.000	End SHS

WY 132			
CREW	class	RM	WY 132
			<b>ML - 703B</b>
	7	0.000	US 287 (RM 9.28)
		0.297	Mill Cr. [COO;SS]
<b>FR 07A</b>		4.690	Riverton Rd
5034		3.000	Coolidge Canal [COP;SS]
		6.978	Ethete
		7.683	Little Wind Rv. [FKK;SS]
		16.317	Wind Rv. [LZX;SS]
		16.821	Wind River Indian Res. Boundary
		17.434	US 26 (RM 114.64)

WY 133			
CREW	class	RM	WY 133
			<b>ML - 706B</b>
	7	0.000	US 26 (RM 114.64)
<b>FR 08A</b>		1.590	Pilot Canal [FOS;SS]
5037		2.360	Pilot Drain [FOT;SS]
		4.060	WY 134 (RM 24.17)
		6.070	End SHS @WCL Pavillion

WY 134			
CREW	class	RM	WY 134
			<b>ML - 707B</b>
	7	0.000	US 26,789 (RM 119.04)
<b>FR 09A</b>		1.870	County Rd (north & south)
5037		4.000	Sand Gulch [JLA;SS]
		7.820	Burma Rd
		15.610	Midvale
		24.171	WY 133 (RM 4.06)

**Maint.  
Section**

CREW	class	RM	WY 135
			<b>ML - 708B</b>
	7	100.000	WY 789 (RM 103.84)
<b>FR 10C</b>		100.631	Little Wind Rv. [LBV;SS]
5042		101.040	BK= +1.040 mi
			WY 136 (RM 1.04)
	7	0.000	AH Equation
<b>FR 10A</b>		7.351	Wind River Indian Res. Boundary
5042		17.558	WY 139 (RM 17.55)
		17.700	<b>S.B. Road Close Gate R/R</b>
		34.587	US 287, WY 789 (RM 42.11)
			<b>N.B. Road Close Gate R/R</b>
			Sweetwater Station

WY 136			
CREW	class	RM	WY 136
			<b>ML - 710B</b>
	7	1.040	WY 135 (RM 0.01)
<b>FR 11A</b>		1.556	Unnamed Draw [COW;SS]
5042		12.123	Wind River Indian Res. Boundary
		18.160	County Rd (north & south)
		22.600	Conant Creek [JOZ;SS]
		37.160	County Rd (north)
		43.735	End SHS

WY 137			
CREW	class	RM	WY 137
			<b>ML - 711B</b>
	7	0.000	WY 789 (RM 103.48)
<b>FR 12A</b>		2.970	WY 138 (RM 8.030)
5034		3.246	BK= -96.754 mi
		100.000	AH Equation
		105.973	End SHS

WY 139			
CREW	class	RM	WY 139
			<b>ML - 709B</b>
	7	17.545	WY 135 (RM 17.58)
<b>FR 10B</b>		18.996	Sand Draw
5042			End SHS

US 20/26 SV. RD.			
CREW	class	RM	US 20/26 SV. RD.
			<b>ML - 713B</b>
	9	0.000	US 20, 26 (RM 79.27)
<b>FR 07J</b>		0.240	Town Of Moneta
5037		0.470	US 20, 26 (RM 78.82)

Niobrara

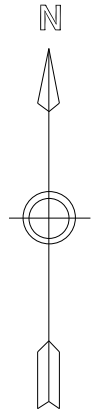

**ROAD COLOR TABLE**

	Rural & Urban Interstate #'s "1 & 11"
	Urban Principal Arterial Other & Expressway (NHS) #'s "12 & 14"
	Urban Minor Arterial, Collector & Local (non NHIS) #'s "16, 17 & 19"
	Rural Principal Arterial Other (NHS) # "2"
	Rural Minor Arterial, Major & Minor Collectors & Local (non NHS) #'s "6, 7, 8 & 9"

Platte

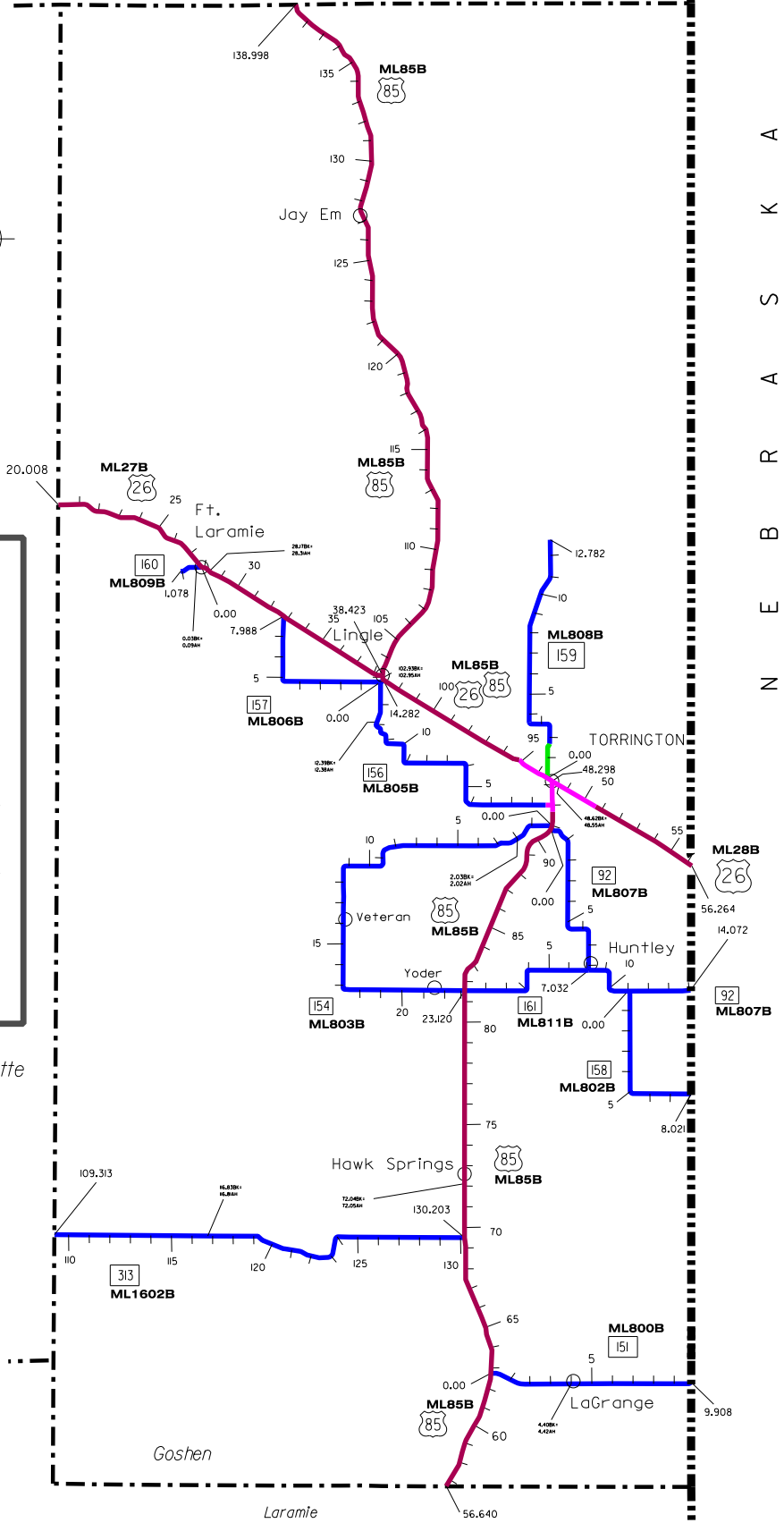





# Goshen

•• class "classification break"

## County 7

Maint. Section	class	RM	US 26
			<b>ML - 27B</b>
	2	20.008	Platte Co. Line
			County Line Draw [BXO;SS]
<b>GO 02A</b>		22.580	Cottonwood Cr. [BXP;SS]
2038		25.393	Interstate Canal [BXQ;SS]
		27.826	WCL Ft. Laramie
		27.867	WY 160 (RM 0.00)
		28.119	ECL Ft. Laramie
		28.165	BK= - 0.145 mi.
		28.310	AH Equation
		31.330	Sand Draw [BXR;SS]
		32.720	WY 157 (RM 7.99)
		37.370	County Rd (south & north)
		38.120	<b>W.B. Road Close Gate R/R</b>
		38.187	WCL Lingle, Begin Divided Section
	2	38.423	US 85 (RM 103.07) End Divided Section

Maint. Section	class	RM	US 26
			<b>ML - 28B</b>
	14	48.298	US 26,85 (RM 93.20) Cont. NHS
<b>GO 02Z</b>		48.616	BK= + 0.071 mi.
2038		48.545	AH Equation
		49.209	ECL Torrington
<b>GO 02B</b>	14	50.260	Arrowhead Rd
2038	••	50.710	EUL Torrington
		51.895	Torrington Prison Road
	2	56.264	Nebraska St. Line End WY NHS

Maint. Section	class	RM	US 26/85 & WY 92
			<b>ML - 85B</b>
	2	56.644	Laramie Co. Line / District Boundary Cont. NHS
<b>GO 01A</b>		62.447	Bear Cr. [BWG;SS]
2038		62.746	WY 151 (RM 0.00) <b>S.B. Road Close Gate R/R</b>
		69.496	WY 313 (130.20)
			<b>REMOVED EQUATION</b>
		72.510	RR at Grade Crossing #816466A
		72.565	Hawk Springs
		77.531	Lone Tree Cr. [BWH;SS]
		81.310	Irrigation Canal [BWI;SS]
		81.420	<b>S.B. Road Close Gate R/R</b>
		81.540	WY 152 (RM 0.00) & WY 161 (RM 0.00) WY 154 (RM 23.12)
		82.230	RR at Grade Crossing #816334P
	2	82.559	Springer Canal [BWJ;SS]

Maint. Section	class	RM	US 26/85 & WY 92
			<b>ML - 85B</b>
			<i>(CONTINUED)</i>
	2	88.680	<b>S.B. Road Close Gate R/R</b>
<b>GO 01A</b>		89.140	Old Highway
2038		90.825	WY 92 (RM 0.00) Begin WY 92
		91.020	WY 154 (RM 0.00)
	2	91.284	Cherry Cr. [BWK;SS]
	••	91.764	SUL Torrington
	14	91.870	RR at Grade Crossing #816439D
		92.018	WY 156 (RM 0.00) End WY 92
<b>GO 01Z</b>			SCL Torrington
2038		92.557	North Platte Rv. [JBI;SS]
		93.150	RR at Grade Crossing #089208M
		93.195	US 26 (RM 48.30) Begin US 26
		93.463	WY 159 (RM 0.00)
	14	93.628	WCL Torrington
	••	95.250	WUL Torrington
<b>GO 01B</b>	2	95.360	<b>Torrington Port-of-Entry GO 01P</b>
2038		97.990	Vaughn Rd
		100.330	Buttermilk Rd
		101.791	Rawhide Cr. [KMJ;SS]
		102.637	SCL Lingle
		102.850	WY 156 (RM 14.28)
		102.933	BK= - 0.013 mi.
		102.946	AH Equation
		103.070	US 26 (RM 38.42) End US 26
		103.255	NCL Lingle
		103.657	Interstate Canal [BWN;SS]
		103.830	<b>N.B. Road Close Gate R/R</b>
		106.760	County Rd (east)
		113.087	Unnamed Draw [BWO;SS]
		115.399	Dry Rawhide Cr. [BWP;SS]
		116.675	Rawhide Cr. [BWQ;SS]
		116.930	Six Mile Cr. [BWR;SS]
		124.064	Rawhide Cr. [DEE;SS]
		124.400	Maint. Break County Rd (west)
<b>GO 01C</b>		126.508	Rawhide Cr. [DEF;SS]
2035		127.360	Jay Em
	2	138.998	Niobrara Co. Line, Continue NHS

Maint. Section	class	RM	US 85 free right
			<b>OT - 813I</b>
<b>GO 01K</b>	14	0.000	US 85 (RM 93.20)
2038		0.040	US 26 (RM 43.80)

→ -cont- next column

Maint. Section	class	RM	WY 92
CREW			<b>ML - 807B</b>
	7	0.000	US 85,26 (RM 90.83)
<b>GO 08A</b>		7.750	RR at Grade Crossing #816323C
2038		8.288	WY 161 (RM 7.03)
		10.986	WY 158 South Spur (RM 0.00)
		13.793	Horse Cr. [CXX;SS]
		14.072	Nebraska State Line

Maint. Section	class	RM	WY 151
			<b>ML - 800B</b>
	7	0.000	US 26,85 (RM 62.75)
<b>GO 03A</b>		1.447	Bear Cr. [DLR;SS]
2038		3.840	WCL LaGrange
		3.891	Horse Cr. [DLS;SS]
		4.340	ECL LaGrange
		4.402	BK= - 0.019 mi.
		4.421	AH Equation
		4.430	RR at Grade Crossing #816028X
		9.908	Nebraska State Line

Maint. Section	class	RM	WY 154
			<b>ML - 803B</b>
	7	0.000	US 26,85 (RM 91.01)
<b>GO 05A</b>		1.490	County Rd (south)
2038		2.034	BK= + 0.014 mi.
		2.020	AH Equation
		4.354	Cherry Cr. [FBX;SS]
		5.660	RR at Grade Crossing #816371S
		12.906	Cherry Cr. [FBW;SS]
		13.834	Veteran
		15.647	Ft. Laramie Canal [CPC;SS]
		19.430	RR at Grade Crossing #816343N
		20.380	RR at Grade Crossing #816341A
		20.870	RR at Grade Crossing #816445G
		21.111	County Road (Old WY 152)
	*	22.130	Ft. Laramie Canal [COZ;SS]
	*	23.116	US 26,85 (RM 81.54)

\* Added from WY 152 when given to County

Maint. Section	class	RM	WY 156
CREW			<b>ML - 805B</b>
	16	0.000	US 26,85 (RM 92.02)
		0.140	RR at Grade Crossing #906305D
<b>GO 06A</b>	16	0.200	RR at Grade Crossing #816442L
2038		0.251	WUL Torrington
	7	6.120	County Rd (north)
		10.880	County Rd (west)
		12.119	Platte Rv. [EOY;SS]
		12.193	Platte Rv. Overflow [EOZ;SS]

**REMOVED EQUATION**

		14.137	SCL Lingle
		14.156	WY 157 (RM 0.00)
		14.250	RR at Grade Crossing #089227S
	7	14.282	US 26,85 (RM 102.89)

Maint. Section	class	RM	WY 157
			<b>ML - 806B</b>
	7	0.000	WY 156 (RM 14.156)
<b>GO 07A</b>		0.063	WCL Lingle
2038		2.000	North Platte Rv. [FEE;SS]
		4.660	County Rd (south)
		6.539	Unnamed Draw [CPG;SS]
		7.032	North Platte Rv. [FEG;SS]
		7.940	RR at Grade Crossing #089237X
		7.988	US 26 (RM 32.772)

Maint. Section	class	RM	WY 158
			<b>ML - 802B</b>
<b>GO 14A</b>	7	0.000	WY 92 (RM 10.986)
2038		1.550	Horse Cr. [FBY;SS]
		8.021	Nebraska State Line

Maint. Section	class	RM	WY 159
			<b>ML - 808B</b>
	16	0.000	US 85,26 (RM 93.46)
<b>GO 09Z</b>		0.430	27th avenue
2038		0.580	<b>Dept. Shop - Torrington TT 02A</b>
	16	1.430	NCL Torrington
		1.663	NUL Torrington
<b>GO 09A</b>	7		Class. Break
2038		3.622	WY 159 (RM )
	8		Class. Break
		4.193	County Rd (east)
		4.285	Interstate Canal [CPM;SS]
	8	12.782	End SHS

Maint.		WY 160	
Section	class	RM	
<b>ML - 809B</b>			
CREW	7		
<b>GO 10A</b> 2038		0.000	US 26 (RM 27.87)
		0.028	BK= - 0.062 mi.
		0.090	AH Equation
		0.110	RR at Grade Crossing #089243B
		0.120	WCL Ft. Laramie
		0.874	North Platte Rv. [CPN;SS]
		1.078	End SHS

Maint.		WY 313	
Section	class	RM	
<b>ML - 1602B</b>			
CREW	7		
<b>GO 15B</b> 2033		109.313	Platte Co. Line
		116.830	BK= + 0.02 mi.
			<b>Maint. Brk. @ Equation</b>
<b>GO 15A</b> 2038	7	116.810	AH Equation
		130.203	US 85 (RM 69.50)
<b>W.B. Road Close Gate swing</b>			

		WY 161	
Section	class	RM	
<b>ML - 811B</b>			
CREW	7		
<b>GO 11A</b> 2038		0.000	US 85,26 (RM 81.54) & WY 152 (RM 0.00)
		2.740	Horse Cr. [CPO;SS]
		2.929	Horse Cr. [CPP;SS]
		4.329	E. Springer Lateral
		5.567	E. Springer Lateral [CPR;SS]
		6.860	E. Springer Lateral
		7.032	WY 92 (RM 8.288)



ROAD COLOR TABLE

	Rural & Urban Interstate #s "1 & 11"
	Urban Principal Arterial Other & Expressway (NHS) #s "12 & 14"
	Urban Minor Arterial, Collector & Local (non NHS) #s "16, 17 & 19"
	Rural Principal Arterial Other (NHS) # "2"
	Rural Minor Arterial, Major & Minor Collectors & Local (non NHS) #s "6, 7, 8 & 9"

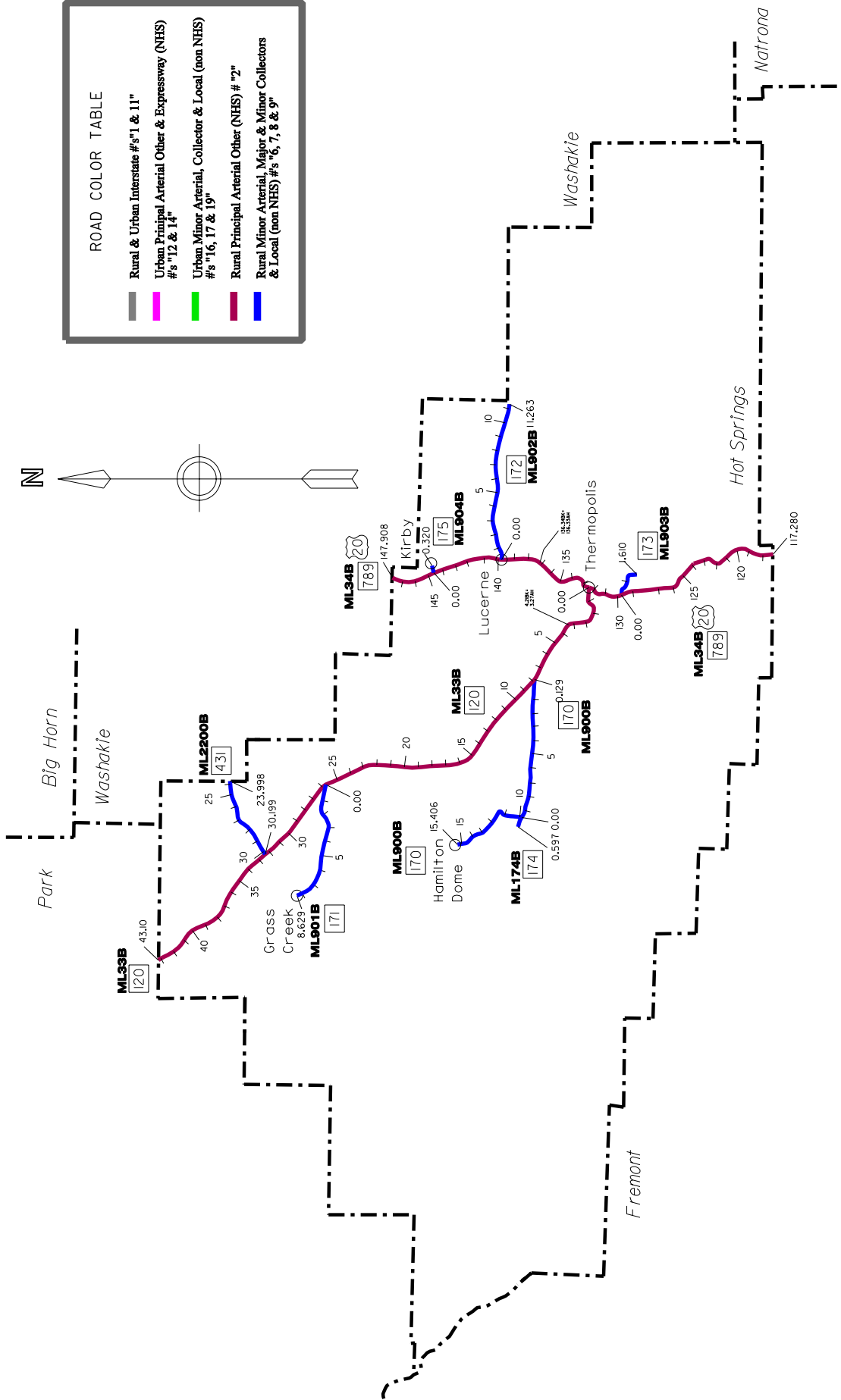



# Hot Springs

•• class "classification break"

## County 15

Maint. Section	class	RM	US 20 & WY 789	Maint. Section	class	RM	WY 120
		<b>ML - 34B</b>				<b>ML - 33B</b>	
<b>-cont-</b>			from Fremont County		2	0.000	US 20 (RM 132.528)
<b>HS 02A</b>	2	117.281	Fremont Co. Line, Cont. NHS	<b>HS 01Z</b>			Begin NHS
		127.393	Wind River Indian Res. Boundary	5040		0.078	End Divided Section
5040		127.480	County Rd (east)	→		0.939	WCL Thermopolis
		127.620	<b>S.B. Road Close Gate R/R</b>			3.592	Irrigation Ditch [CAK;SS]
		128.319	Big Horn Rv. [BRM;SS]	<b>HS 01A</b>		4.208	BK= + 0.935 mi.
		128.469	BNRR Sep. [CCB;SS]	5040		3.273	AH Equation
		129.884	WY 173 (RM 0.00)			5.150	Missouri Flat Rd
		130.200	Unnamed Draw [HLU;SS]			5.628	Owl Cr. [FBH;SS]
		130.450	<b>Dept. Shop - Thermopolis TM 05A</b>			8.129	WY 170 (RM 0.13)
		130.850	Begin Curb & Gutter				<b>N.B. Road Close Gate R/R</b>
→		131.500	SCL Thermopolis			20.200	Hamilton Dome Rd
<b>HS 02Z</b>		132.528	Broadway Av. (RM 0.00)			20.421	Cottonwood Cr. [FLQ;SS]
5040		132.979	Hot Springs St. Park Boundary	→		25.779	WY 171 (RM 0.00)
		133.150	Old Dept. Shop site			25.810	Grass Cr. [FLA;SS]
→		134.110	N. Boundary Hot Springs St. Park	<b>HS 01B</b>		32.290	WY 431 (RM 30.20)
			NCL Thermopolis	5036		33.997	Oil Draw
		135.044	Red Lane Gulch [CCC;SS]			34.510	Four Mile Rd
<b>HS 02B</b>		136.343	BK= + 0.012 mi.			36.733	Gooseberry Cr. [FRW;SS]
5040		136.331	AH Equation			37.100	<b>Gooseberry Cr. Rest Area HS 01R</b>
		137.780	County Rd (east & west)			40.490	Unnamed Draw [JRB]
		138.419	Owl Cr. [CCE;SS]			42.100	Buffalo Creek [JQY;SS]
		139.780	Unnamed Draw [CCF;SS]			43.097	Park Co. Line, Cont. NHS
		139.800	WY 172 (RM 0.00)		2		
		142.798	County Rd (west)				<b>WY 170</b>
		143.389	Coal Draw [CCG;SS]				<b>ML - 900B</b>
		144.591	WY 175 (RM 0.00)		7	0.129	WY 120 (RM 8.13)
		145.756	Sand Draw [CCH;SS]	<b>HS 03A</b>		0.338	Unnamed Draw
		146.527	Unnamed Draw [CCI;SS]	5040		6.384	Shoshone Indian Res. Boundary
		147.908	Washakie Co. Line			6.392	Owl Cr. [CPU;SS]
2			Cont. NHS			9.743	WY 174 (RM 0.00)
						10.683	Owl Cr. [CPV;SS]
						11.646	Shoshone Indian Res. Boundary
						15.406	Hamilton Dome
							End SHS
							<b>WY 171</b>
							<b>ML - 901B</b>
				<b>HS 04A</b>	7	0.000	WY 120 (RM 25.67)
				5040		5.592	Spring Gulch [CPW;SS]
						8.629	Grass Cr.
							End SHS

Maint. Section	class	RM	WY 172
CREW			<b>ML - 902B</b>
<b>HS 05A</b>	7	0.000	US 20 (RM 139.798)
5040		0.260	RR at Grade Crossing #090474F
		0.781	Big Horn Rv. [CPX;SS]
		1.899	Kirby Cr. [CPY;SS]
		2.000	County Rd (north)
		2.090	Kirby Ditch [LCT;SS]
		11.263	End SHS

Maint. Section	class	RM	WY 431
CREW			<b>ML - 2200B</b>
<b>HS 07A</b>	7	23.988	Washakie Co. Line
5036		25.445	Gooseberry Cr. [CWY;SS]
		30.199	WY 120 (RM 32.29)

			WY 173
			<b>ML - 903B</b>
<b>HS 06A</b>	7	0.000	US 20 (RM 129.884)
5040		0.806	BNRR Sep. [JOD;SS]
		1.449	Big Horn Rv. [JOE;SS]
		1.619	End SHS

			WY 174
			<b>ML - 174B</b>
<b>HS 08A</b>	8	0.000	WY 170 (RM 9.74)
5040		0.597	End SHS

			WY 175
			<b>ML - 904B</b>
<b>HS 09A</b>	7	0.000	US 20 (RM 144.591)
5040		0.301	WCL Kirby
		0.320	End SHS



ROAD COLOR TABLE	
	Rural & Urban Interstate #'s "1 & 11"
	Urban Prinsipal Arterial Other & Expressway (NHS) #'s "12 & 14"
	Urban Minor Arterial, Collector & Local (non NHS) #'s "16, 17 & 19"
	Rural Prinsipal Arterial Other (NHS) # "2"
	Rural Minor Arterial, Major & Minor Collectors & Local (non NHS) #'s "6, 7, 8 & 9"

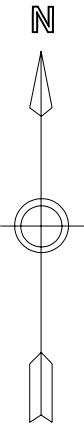
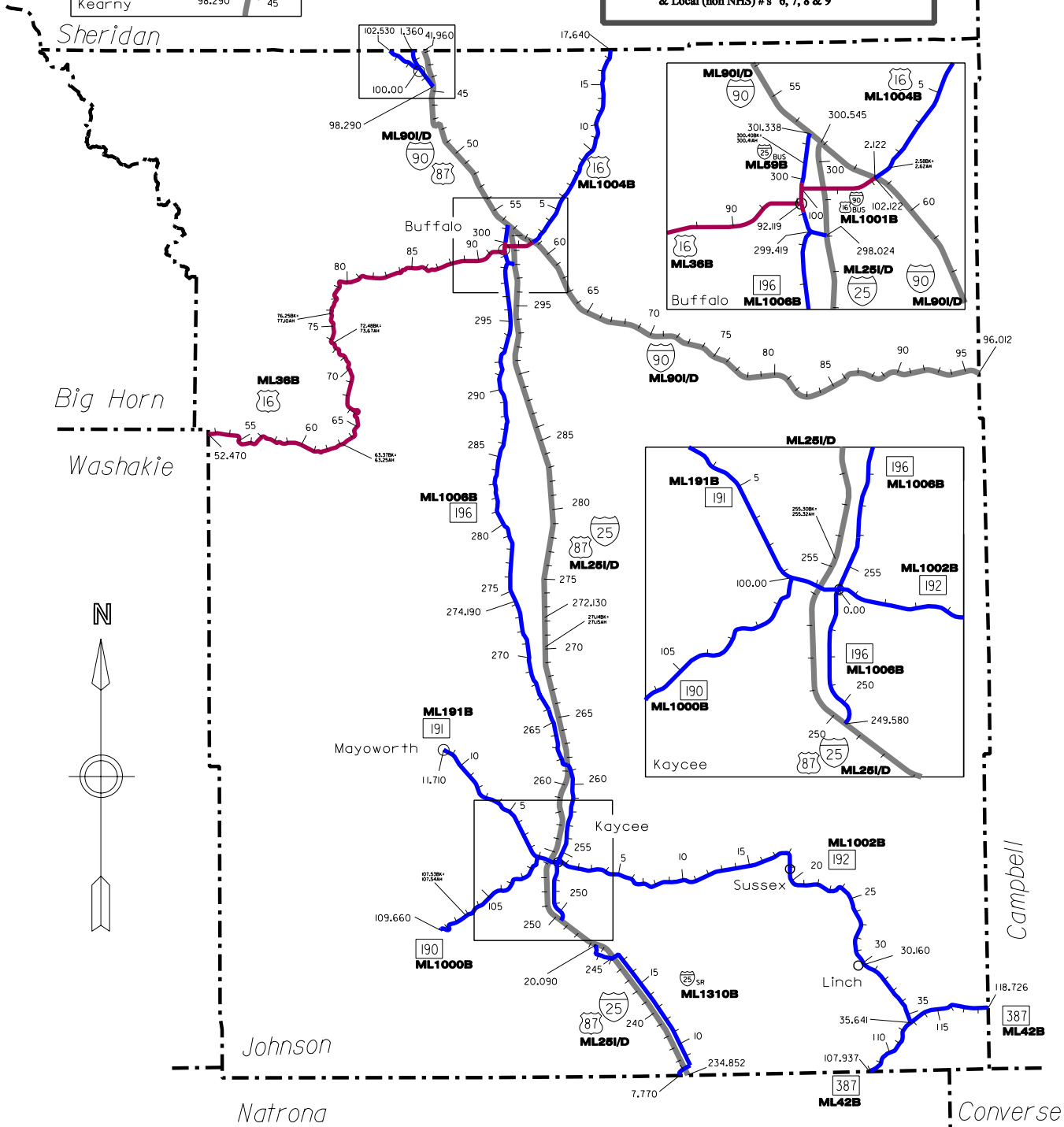
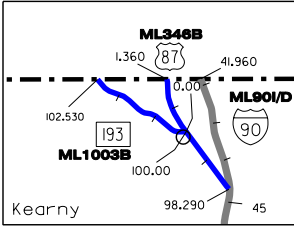



# Johnson

class "classification break"

## County 16

Maint. Section	class	RM	I-25 & US 87
CREW			<b>ML - 25</b>
<b>JO 01A</b>	1	234.852	Natrona Co. Line
2040		235.380	Tisdale Mtn. Rd Int. [AJJ;NB, AJK;SB]
		241.820	Machinery Pass Sep. [AJR;NB, AJS;SB]
		244.960	Service. Rd Sep. [AJT;NB, AJU;SB]
		246.300	S. Fork Powder Rv. [AJV;NB, AJW;SB]
		246.560	Powder Rv. Int. [AJY;NB, AJZ;SB]
		247.530	Murphy Cr. [AKA;NB, AKB;SB]
		247.660	Co. Rd Sep. [AKC;NB, AKD;SB]
		249.690	WY 196 (RM 249.58); T.T.T. Int. [AKE;NB, AKF;SB]
		253.670	Barnum Rd Sep. [AKG;SS]
		253.960	Middle Fk Powder Rv. [AKH;NB, AKI;SB]
		254.130	<b>S.B. Road Close Gate R/R</b>
		254.250	WY 190/191 (RM 0.16); Kaycee Int. [AKJ;NB, AKK;SB]
			<b>Kaycee Rest Area JO 01R</b>
		254.260	<b>N.B. Road Close Gate R/R</b>
		255.300	BK= - 0.02 mi.
		255.320	AH Equation
		256.940	Oil Field Rd Underpass [AKL;SS]
		258.980	N. Fork Powder Rv. [AKM;NB, AKN;SB]
		261.430	US 87 Sep. [AKO;NB, AKP;SB]
		264.010	Antelope Cr. [KDS;NB, KDT;SB]
		265.480	Reno Rd Int. [AKQ;NB, AKR;SB]
		267.320	I-25 Divide <b>RWIS</b> site {17}
		269.220	Machinery Pass Sep. [AKS;NB, AKT;SB]
			<b>REMOVED EQUATION</b>
		271.880	Machinery Pass Sep. [AKU;NB, AKV;SB]
		272.130	District Boundary
		276.220	Machinery Pass Sep. [AKW;NB, AKX;SB]
<b>JO 01B</b>		278.260	S. Fork Crazy Woman Cr. [AKY;NB, AKZ;SB]
4036		278.840	Machinery Pass Sep. [ALA;NB, ALB;SB]
		279.560	Middle Fork Crazy Woman Cr. [ALC;NB, ALD;SB]
		280.180	Middle Fork Rd. Int. [ALE;NB, ALF;SB]
		289.550	Co. Stock Dr Overpass [ALG;NB, ALH;SB]
		291.080	Trabing Rd Int. [ALI;SS]
		291.750	Machinery Pass Sep. [ALJ;NB, ALK;SB]
		293.830	Bull Cr. [ALL;NB, ALM;SB]
		294.270	Overpass Sep. [ALN;NB, ALO;SB]
		296.270	Machinery Pass Sep. [ALP;NB, ALQ;SB]
		298.020	I-25 BUS (RM 298.02); So. Buffalo Int. [ALR;NB, ALS;SB]
			<b>New Dept. Shop - Buffalo BF 04B</b>
		298.200	<b>S.B. Road Close Gate R/R</b>
		298.560	Co. Rd Overpass Sep. [ALT;NB, ALU;SB]
	1	299.170	Clear Cr. [ALV;SS]

-cont- next column

Maint. Section	class	RM	I-25 & US 87
CREW			<b>ML - 25</b>
<b>JO 01B</b>			(CONTINUED)
-cont-	1	299.320	I-90 BUS(RM 100.61);Buf-Ucross Int. [ALW;NB, ALX;SB]
4036		299.560	French Cr. Sep. [ALY;NB, ALZ;SB]
		300.545	I-90 (RM 56.85);Buff Tri-Level Int. [CQP;WBR, CQV;EB]
			<b>I-90 &amp; US 87</b>
			<b>ML - 90</b>
			from Sheridan County
<b>SH 01B</b>	1	41.959	Sheridan Co. Line
4033		43.659	Piney Creek <b>RWIS</b> site {53}
		44.122	Piney Cr. [BCN;EB, BCO;WB]
		44.506	Lake DeSmet Ditch [BCP;EB, BCQ;WB]
		44.687	US 87 (RM 0.00); Piney Cr. Int. [BCR;EB, BCS;WB]
<b>JO 03B</b>		47.024	Machinery Pass Sep. [BCT;EB, BCU;WB]
4036		47.705	Shell Cr. Int. [BCV;EB, BCW;WB]
		48.100	Middle Fork Shell Cr [LIA;EB, LIB;WB]
		51.362	Lake DeSmet Int. [BCX;EB, BCY;WB]
		53.827	Rock Cr. Rd. Int. [BCZ;EB, CTS;WB]
		55.020	Rock Cr. Machinery Pass & Drainage Sep. [BDB;EB, BDC;WB]
		55.600	<b>W.B. Road Close Gate R/R</b>
		56.357	US 16.87 BUS (RM 301.34); N. Buffalo Int. [BDD;EB, BDE;WB]
		56.846	I-25 (RM 300.55) ; Buff Tri-Level Int. [CQP;WBR, CQV;EB], End US 87
		58.383	Clear Cr. [BDH;EB, BDI;WB]
		58.600	<b>E.B. Road Close Gate R/R</b>
		58.653	I-90 BUS (RM 102.12); US 16 Int. US 16 (RM 2.12), [BDJ;EB, BDK;WB]
		60.980	Co. Rd Sep. [BDL;EB, BDM;WB]
		63.510	Negro Cr. [BDN;EB, BDO;WB]
		65.227	Machinery Pass Sep. [BDP;EB, BDQ;WB]
		65.975	Red Hills Int. [BDR;EB, BDS;WB]
		67.391	Co. Rd Sep. [BDT;EB, BDU;WB]
		67.638	East Fork Dry Cr. [BDV;EB, BDW;WB]
		69.641	Dry Cr. Int. [BDX;EB, BDY;WB]
		73.013	Crazy Woman Int. [BDZ;EB, BEA;WB]
		73.183	Crazy Woman Cr. [BEB;EB, BEC;WB]
		75.412	Co. Rd Sep. [BED;EB, BEE;WB]
		77.914	Schoonover Rd Int. [BEF;EB, BEG;WB]
		79.293	Machinery Pass Sep. [BEH;EB, BEI;WB]
		80.238	Co. Rd Sep. [BEJ;EB, BEK;WB]
		82.828	Indian Cr. Int. [BEL;EB, BEM;WB]
		83.300	Powder River <b>RWIS</b> site {54}
		84.186	Co. Rd Sep. [BEN;EB, BEO;WB]
	1	85.085	Co. Rd Sep. [BEP;EB, BEQ;WB]

-cont- next page

Maint.  
Section

CREW  
-cont-

class

**RM I-90 & US 87**  
**ML - 90**

(CONTINUED)

<b>JO 03B</b>	1	88.673	Powder River Int. [BER;EB, BES;WB]
			<b>Powder River Rest Area JO 03R</b>
4036		88.983	Powder Rv. [BET;EB, BEU;WB]
		90.801	Dead Horse Cr. [BEV;EB, BEW;WB]
		91.491	Dead Horse Int. BEX;EB, BEY;WB]
		91.530	Dead Horse <b>RWIS</b> site {55}
		93.854	Co. Rd Sep. [BEZ;EB, BFA;WB]
		96.012	Campbell Co. Line

**I-25/I-90 BUS & US 16/87 BUS**

**ML - 59B**

<b>JO 02A</b>	6	298.024	I-25 (RM 298.02); South Buffalo Int. [ALR;NB, ALS;SB], Begin I-25 Bus.
4036		298.120	SCL Buffalo
		298.450	WY 196 (RM 299.42)
		298.670	Maint Break
<b>JO 02Z</b>	6	299.179	Clear Cr. [BMQ;SS]
4036		299.280	US 16 (RM 92.12)
	2		, Begin US 16
		299.697	I 90 BUS (RM 100.00)
	6		, Begin I-90 Bus.
			End US 16 & I-25 Bus.
		299.727	NCL Buffalo
		300.210	Old Highway
<b>JO 02B</b>			<b>REMOVED EQUATION</b>
4036		300.418	French Cr. [AXY;SS]
	6	301.338	I-90 (RM 56.36); N. Buffalo Int. [BDD;EB, BDE;WB]

**US 16 & I-90 BUS**

**ML - 36B**

-cont-			from Washakie County
	2	52.470	Washakie Co. Line
<b>JO 04A</b>		63.270	Hazelton Rd
4037		63.360	<b>W.B. Road Close Gate R/R</b>
		63.374	BK= + 0.127 mi.
		63.247	AH Equation
		69.300	<b>Dept. Shop - Pole Creek PC 04A</b>
		72.479	BK= - 1.191 mi.
		73.670	AH Equation
		76.245	BK= - 0.854 mi.
		77.099	AH Equation
		80.250	Maint. Break
<b>JO 04B</b>		83.466	Big Horn Nat'l. Forest Boundary
		86.???	EB Truck Run-Away Ramp
4036		88.200	<b>W.B. Road Close Gate R/R</b>
		90.830	WCL Buffalo
<b>JO 04Z</b>		91.540	<b>Dept. Shop - Buffalo BF 04A</b>
4036		91.570	CL Buffalo
		91.799	CL Buffalo
	2	92.119	I 25 BUS (RM 299.28)

Maint.  
Section

CREW

class

**RM US 16 & I-90 BUS**  
**ML - 1001B**

	2	100.000	US 16,87 BUS (RM 299.70)
<b>JO 13Z</b>			, Begin I-90 Bus.
4036		100.548	ECL Buffalo
		100.610	I-25 (RM 299.32); Buffalo-Ucross Int.
		100.740	French Cr. [CQQ;SS]
		101.295	W. Clear Cr. [MIA;MSS]
		101.482	Clear Cr. [MCI;SS]
		102.122	I-90 (RM 58.65) ; US 16 Int.
			, End I-90 Bus.

**US 16**

**ML - 1004B**

	7	2.122	I-90 (RM 58.65); US 16 Int.
<b>JO 13A</b>		2.262	Unnamed Draw [CQT;SS]
4036		2.300	<b>N.B. Road Close Gate R/R</b>
		2.582	BK= - 0.04 mi.
		2.622	AH Equation
		2.700	Kumor Road (north)
		4.895	Clear Cr. [FQH;SS]
		5.840	Road to Dam
		8.020	Watt Draw [FFO;SS]
		17.640	Sheridan Co. Line

-cont- in Sheridan County

**US 87 & WY 193**

**ML - 1003B**

	7	98.290	I-90 (RM 44.69); Piney Cr. Int.
<b>SH 07A</b>		99.650	Piney Cr. [DAA;SS]
4033		100.000	WY 346 (RM 0.00)
			, End US 87
		100.134	Piney Cr. [CQK;SS]
		100.171	Piney Cr. Overflow [IHZ;MSS]
		102.527	Sheridan Co. Line

-cont- in Sheridan County

**US 87**

**ML - 346B**

<b>SH 02C</b>	9	0.000	US 87/WY 193 (RM 100.00)
4033		1.360	Sheridan Co. Line

-cont- in Sheridan County

Maint. Section	class	RM	WY 190
			<b>ML - 1000B</b>
	7	1.099	BK= - 98.901 mi.
<b>JO 06A</b>		100.000	AH Equation
2040			WY 191 (RM 1.10)
		103.935	Alkali Cr. [LYX;SS]
		105.300	Cottonwood Cr. [LYW;SS]
			<b>REMOVED EQUATION</b>
		108.347	Red Fork Powder Rv. [LYV;SS]
		109.660	End SHS

			WY 191
			<b>ML - 191B</b>
	8	0.000	WY 196 (RM 254.08)
<b>JO 07A</b>		0.280	I-25 (RM 254.25); Kaycee Int.
2040			<b>Kaycee Rest Area JO 01R</b>
			Unnamed Draw [KQM;SS]
		1.099	WY 190 (RM 100.00 AH)
		5.649	N. Fork Powder Rv. [JAW;SS]
		11.710	Mayoworth

			WY 192
			<b>ML - 1002B</b>
	7	0.000	WY 196 (RM 254.08) & WY 191 (RM 0.00)
<b>JO 08B</b>		0.150	<b>Dept. Shop Kaycee KC 02A</b>
2040		0.500	<b>E.B. Road Close Gate swing</b>
		4.382	N. Fork Powder Rv. [CQF;SS]
		9.967	15 Mile Draw [JOF;SS]
		19.611	Powder Rv. [CQH;SS]
		19.641	Sussex
		20.707	Coal Cr. [CQI;SS]
		21.097	Carpenter Cr. [CQJ;SS]
		30.164	Linch
<b>JO 08A</b>		35.600	<b>W.B. Road Close Gate swing</b>
2037	7	35.641	WY 387 (RM 112.791)

Maint. Section	class	RM	WY 196
			<b>ML - 1006B</b>
	7	249.580	I-25 (RM 249.69); T.T.T. Int.
<b>JO 12A</b>			[AKE;NB, AKF;SB]
2040		253.100	<b>S.B. Road Close Gate swing</b>
		253.617	Middle Fork Powder Rv. [DCE;SS]
		253.690	SCL Kaycee
		254.004	NCL Kaycee
		254.082	WY 191 (RM 0.00) & WY 192 (RM 0.00)
		254.300	<b>N.B. Road Close Gate swing</b>
		258.025	North Fork Powder Rv. [COQ;SS]
		261.430	US 87 Sep. (I-25)
		264.180	Antelope Creek [JSZ;SS]
		270.157	Unnamed Draw
		273.377	S. Fork Crazy Woman Cr. [FMB;SS]
		274.191	Beaver Cr. [FMC;SS]
			District Boundary
<b>JO 12B</b>		278.842	Middle Fork Crazy Woman Cr. [FMD;SS]
4036		284.713	Muddy Cr. [FHJ;SS]
		287.630	N. Fork Crazy Woman Cr. [FHU;SS]
		294.589	Bull Cr. [FKO;SS]
		297.040	County Rd (west)
		298.297	Steel Flume
		298.820	Steel Flume
	7	299.419	I 25 BUS (RM 298.45)



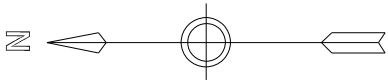
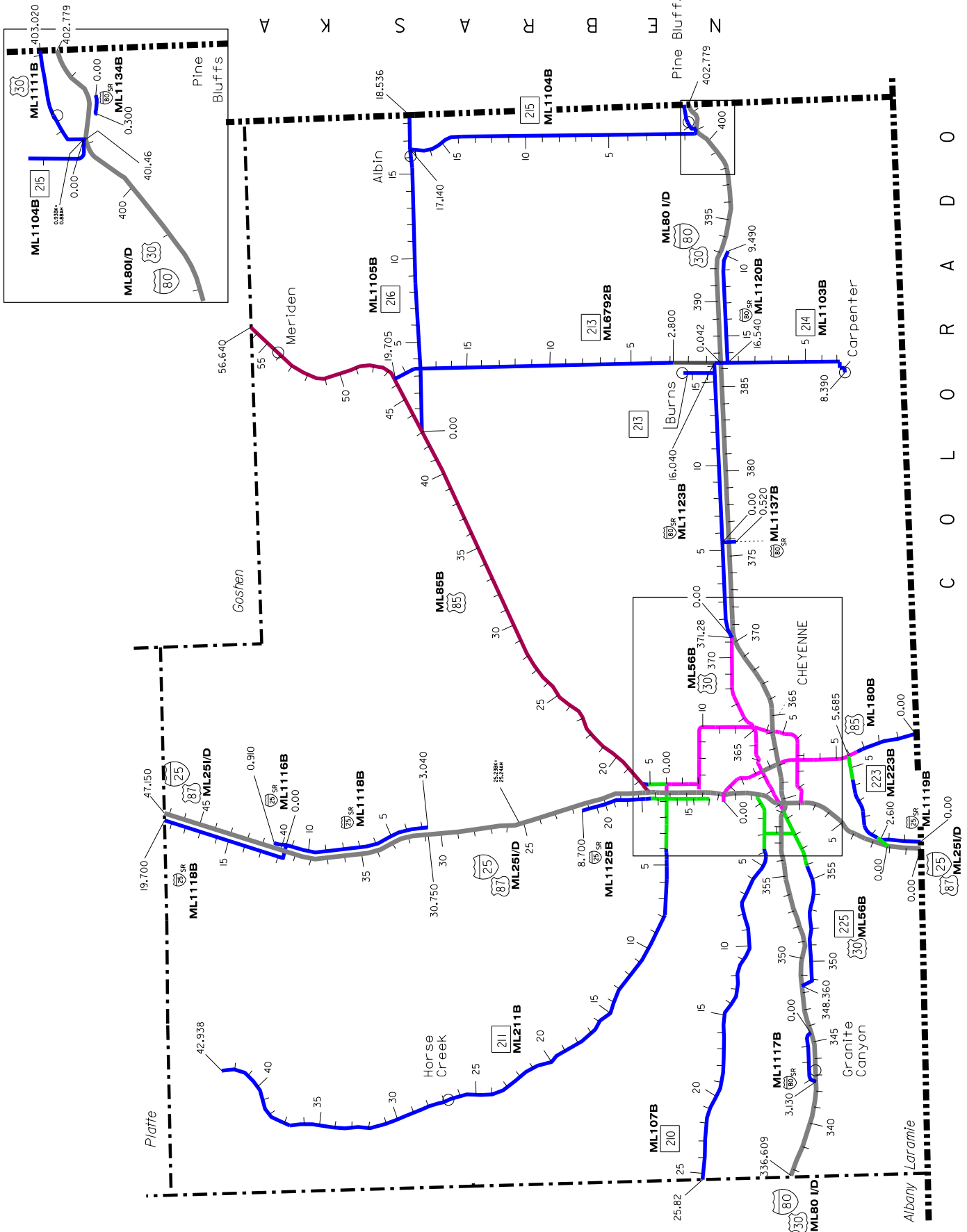

			WY 387
			<b>ML - 42B</b>
	6	107.937	Natrona Co. Line
<b>JO 05A</b>		111.369	Meadow Cr. [CGS;SS]
2037		112.791	WY 192 (RM 35.64)
		116.846	J. J. Draw [DIU;SS]
		118.726	Campbell Co. Line

			I-25 SV. RD.
			<b>ML - 1310B</b>
	9	7.770	Natrona Co. Line
<b>JO 01K</b>		9	
2040		8.370	I-25 (RM 235.38) Tisdale Int.
	8		[AJJ;NB, AJK;SB]
			Class. Break
		18.100	I-25 (RM 244.96), Service. Rd Sep. [AJT;NB, AJU;SB]
		19.420	Bridge Powder Rv. [AJX;WSR]
	8	20.090	I-25 (RM 246.56); Powder River Int.
			[AJY;NB, AJZ;SB]
			End Sv. Rd.





### ROAD COLOR TABLE

	Rural & Urban Interstate #'s "1 & 11"
	Urban Principal Arterial Other & Expressway (NHS) #'s "12 & 14"
	Urban Minor Arterial, Collector & Local (non NHS) #'s "16, 17 & 19"
	Rural Principal Arterial Other (NHS) # "2"
	Rural Minor Arterial, Major & Minor Collectors & Local (non NHS) #'s "6, 7, 8 & 9"

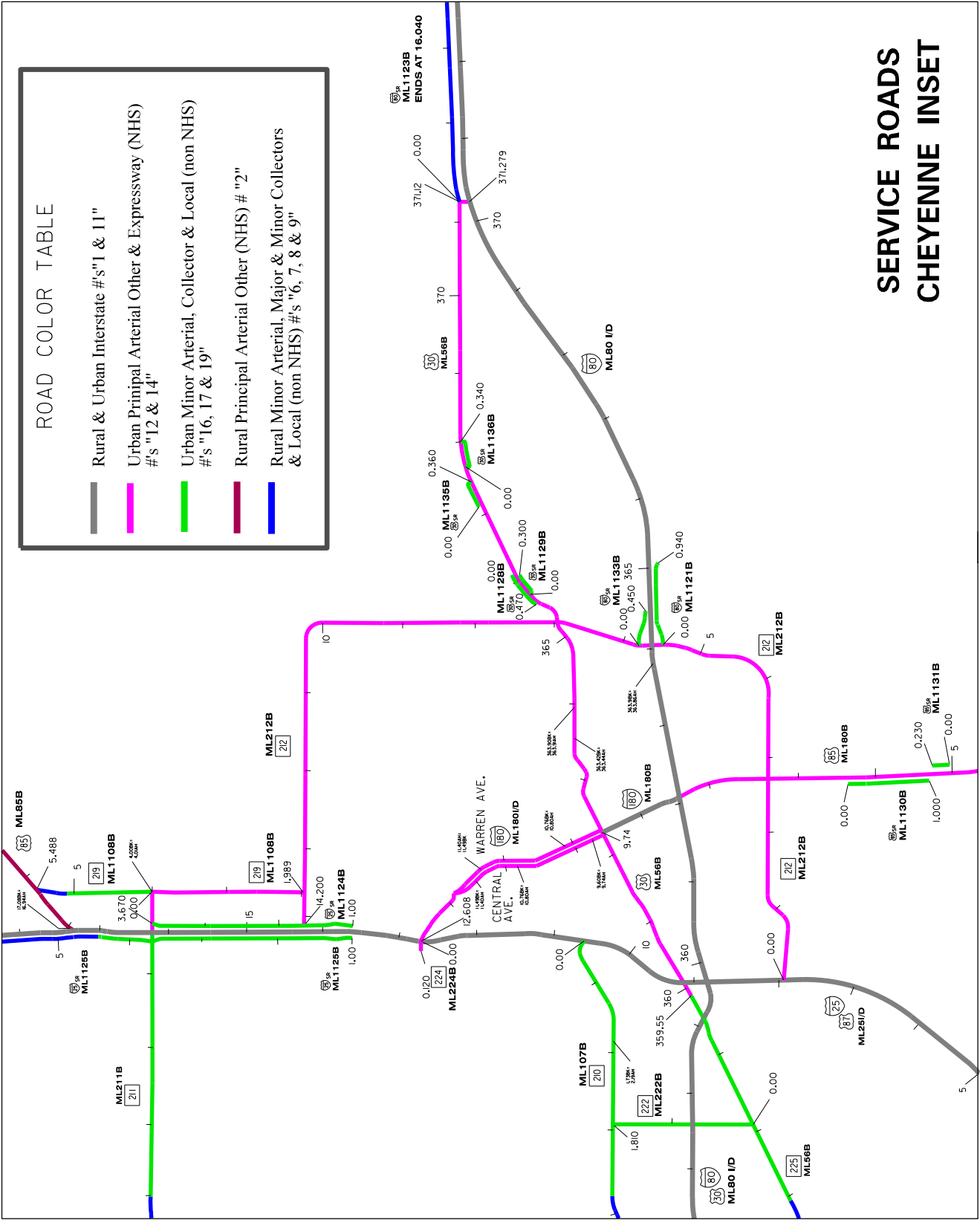

# SERVICE ROADS CHEYENNE INSET

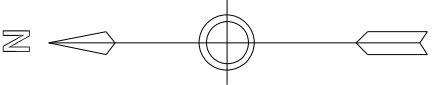



# Laramie

class "classification break"

## County 2

Maint. Section	class	RM	I-25 & US 87/85	Maint. Section	class	RM	I-25 & US 87
			<b>ML - 25</b>				<b>ML - 25</b>
	11	0.000	Colorado State Line				<i>(CONTINUED)</i>
		0.389	Machinery Pass Sep. [AAA;NB, AAB;SB]			14.700	NB C.M. Sign (dynamic)
		0.971	Duck Cr. [AAC;SS]				SB C.M. Sign (dynamic)
<b>LA 03A</b>		1.240	NB C.M. Sign (dynamic)			16.230	WY 211 (RM 0.51); Iron Mountain Int.
1034		1.564	Lone Tree Cr. [AAE;SS]		11		[CRB;SS] NUL Cheyenne
		2.600	<b>N.B. Road Close Gate R/R</b>			17.236	US 85 (RM 16.939); Torrington Int.
		2.662	WY 223 (RM 0.00); Terry Rd Int.		1		[ABQ;NB], End US 85
			[AAG;NB, AAH;SB]			18.800	<b>N.B. Road Close Gate R/R</b>
		3.289	UPRR Sep. [AAI;NB, AAJ;SB]			19.255	Co. Rd Overpass [ABR;NB,ABS;SB]
			Wyo Hill (1) <b>RWIS</b> site {9}			21.318	Ridley Rd Int. [ABT;SS]
		3.150	NB C.M. Sign (blankout)			22.737	Machinery Pass Sep. [ABU;NB, ABV;SB]
		3.340	SB C.M. Sign (blankout)			23.657	Lodge Pole Cr. [ABW;NB, ABX;SB]
		3.520	Wyo Hill (2) <b>RWIS</b> site {10}				<b>REMOVED EQUATION</b>
		3.850	NB C.M. Sign (blankout)			25.452	Missile Site "A" Int. [ABY;SS]
		4.016	C&S RR Co. Rd Sep. [AAK;NB, AAL;SB]			28.152	Whitaker <b>RWIS</b> site {12}
			Wyo Hill (3) <b>RWIS</b> site {11}			29.510	Whitaker Rd Int. [ABZ;SS]
		4.230	SB C.M. Sign (blankout)			30.750	District Boundary
		4.850	Co. Rd. (RM 0.00); High Plains Int.			31.024	Machinery Pass Sep. [ACA;NB, ACB;SB]
			[MFT;SS]			33.098	Machinery Pass Sep. [ACC;NB, ACD;SB]
			<b>SE Welcome Center LA 03W</b>			33.227	Horse Cr. [ACE;NB, ACF;SB]
		4.900	<b>S.B. Road Close Gate R/R</b>			34.443	Nimmo Rd Int. [ACH;SS]
		5.940	SB C.M. Sign (dynamic)			35.799	Little Bear Cr. [ACI;NB, ACJ;SB]
		6.350	<b>Port-of-Entry (N.B.) LA 03P</b>			37.663	Co. Rd Sep. [ACL;NB, ACM;SB]
		7.030	SUL Cheyenne			39.235	Indian Hills Int. [ACN;NB, ACO;SB]
		7.853	WY 212 (RM 0.00); College Drive Int.			40.515	South Fork Bear Cr. [DCM;NB, DCN;SB]
			[KEF;SS]			41.836	Middle Fork Bear Cr. [DCO;NB, DCP;SB]
		8.090	<b>S.B. Road Close Gate R/R</b>			43.661	North Fork Bear Cr. [DCQ;NB, DCR;SB]
		8.440	Clear Cr. [AAN;NB, AAO;SB]			45.211	Cantler Draw [DCS;NB, DCT;SB]
		8.840	I-80 (RM 359.60) I-25 & I-80 Int			46.149	Co. Rd Overpass [DCU;NB, DCV;SB]
			[AAR;NB, AAS;SB]			46.770	Bear Cr. <b>RWIS</b> site {76}
		9.143	US 30 (RM 360.10); UPRR & US 30 Int.		1	47.151	Platte Co. Line
			[AAV;NB, AAW;SB]				
		10.026	Military Reservation Boundary				
		10.373	Crow Cr. [AAY;NB, AAZ;SB]				
		10.586	Missile Drive Int. [ABB;NB, ABC;SB]				
		10.779	BNRR Sep. [ABE;NB, ABF;SB]				
		11.239	Randall Avenue Int. [MCJ;NB, MCK;SB]				
		12.120	SCL Cheyenne				
		12.130	Military Reservation Boundary				
		12.146	Country Club Rd Sep. [ABK;SS]				
		12.238	Lake Absaraca [ABL;NB, ABM;SB]				
		12.299	Lake Absaraca [ABN;NB, ABO;SB]				
		12.697	US 85 (RM 12.61); Central Avenue Int.				
			[EOI;SS], & WY 224 (RM 0.00)				
			, Begin US 85,				
			<b>Headquarters Cheyenne HQ 01A</b>				
		13.230	Western Hills Ped. Overpass [DFQ;SS]				
		13.834	Vandehei Int. [ABP;SS]				
	11	14.354	NCL Cheyenne				

-cont- next column

Maint. Section	class	RM	I-80 & US 30
CREW		<b>ML - 80</b>	
	1	336.609	Albany County Line
		338.100	<b>WB VSL sign</b>
<b>LA 01A</b>		339.318	Remount Int. [AYB;EB, AYC;WB]
1035		339.860	<b>EB VSL sign</b>
		340.500	Remount <b>RWIS</b> site {50}
		340.649	UPRR Ozone Sep. [AYD;EB, AYE;WB]
		341.010	EB C.M.Sign (dynamic)
		341.600	<b>WB VSL sign</b>
		342.559	CO. RD. (RM 0.00); Harriman Int. [AYF;EB, AYG;WB]
		343.240	<b>EB VSL sign</b>
		343.670	WB C.M.Sign (dynamic)
		344.690	<b>WB VSL sign</b>
		345.500	Warren Int. [AYH;EB, AYI;WB]
		345.900	<b>EB VSL sign</b>
		346.440	UPRR Otto Sep. [AYJ;EB, AYK;WB]
		347.690	<b>WB VSL sign</b> Otto Road <b>RWIS</b> site {70}
		348.363	WY 225 (RM 348.36); Otto Int. [AYL;EB, AYM;WB]
		349.150	<b>EB VSL sign</b>
		353.000	<b>WB VSL sign</b> RM 353 <b>RWIS</b> site {71}
		353.990	Co. Rd Sep. [AYN;EB, AYO;WB]
		355.210	Co. Rd Sep. [AYP;EB, AYQ;WB]
●		356.190	WB C.M.Sign (dynamic)
11		356.740	WUL Cheyenne
		357.677	WY 222 (RM .79) RoundTop Int. [AYR;EB, AYS;WB]
		357.900	<b>W.B. Road Close Gate R/R</b>
		359.080	WY 225 (RM 359.55); Lincolnway Int. [AYU;EB, AYW;WB]
		359.599	I-25 (RM 8.84); I-25 & I-80 Int. [AAR;NB, AAS;SB]
		359.992	S.W. Drive Sep. [AYZ;EB, AZA;WB]
		360.160	Unnamed Draw [AZB;SS]
		360.386	BNRR Sep. [DJY;SS]
		360.410	WCL Cheyenne
		360.775	Parsley Blvd. Sep. [AZD;SS]
		361.033	Cribbon Ave Ped. Overpass [AZE;SS]
		361.791	Walterscheid. Sep. [AZF;EB, AZG;WB, AZH;WBR]
		362.000	CL Cheyenne
		362.037	US 85 (RM 8.50) & I-180; US 85 Int. [AZI;EB, AZJ;WB]
		362.650	Wilson Haul Rd Sep. [ADR;EB, CBG;WB]
		363.750	<b>E.B. Road Close Gate R/R</b>
		363.910	BK= + 0.053 mi.
		363.857	AH Equation
		363.869	Crow Cr. [DBZ;EB, DCA;WB, DCB;EBR, DCC;WBR]

→ -cont- next column

Maint. Section	class	RM	I-80 & US 30
CREW		<b>ML - 80</b>	
			(CONTINUED)
		364.000	WY 212 (RM 5.62); Sun Valley Int. [DBW;SS]
		364.310	CL Cheyenne
<b>LA 01A</b>		364.800	ECL Cheyenne
1035		364.999	BNRR Sep. [DBN;EB, DBO;WB]
		367.424	Campstool Rd Int. [DBR;EB, DBS;WB]
		370.100	<b>E.B. Road Close Gate R/R</b>
		370.394	US 30 (RM 371.28); Archer Int. [CGC;SS]
	11	371.410	EUL Cheyenne
	1	371.890	<b>W.B. Port-of-Entry LA 01P</b>
		373.000	WB C.M.Sign (dynamic) <b>RWIS</b> site {72}
		375.379	Co. Rd Sep. [AZP;EB, AZQ;WB]
		377.350	CO. RD. (RM 0.00); Hillsdale Int. [AZR;EB, AZS;WB]
<b>LA 01B</b>		380.360	Co. Rd Sep. [AZT;EB, AZU;WB]
1039		383.356	Co. Rd Sep. [AZV;EB, AZW;WB]
		385.847	Unnamed Draw [AZX;EB, AZY;WB]
		386.389	WY 213 (RM 0.00); Burns-Carpenter Int. [AZZ;EB, BAA;WB]
			& WY 214 (RM 0.00)
		388.058	Unnamed Draw [BAB;SS]
		391.385	Egbert Int. [BAD;EB, BAE;WB]
		396.443	Co. Rd Sep. [BAF;EB, BAG;WB]
		400.580	Co. Rd Sep. [BAH;EB, BAI;WB]
		401.116	WCL Pine Bluffs
		401.164	Muddy Cr. [BAJ;EB, BAK;WB]
		401.200	<b>E.B. Road Close Gate R/R</b>
		401.300	<b>W.B. Road Close Gate R/R</b>
		401.456	US 30 (RM 401.46); West Pine Bluffs Int. [BAM;EB, BAN;WB]
			<b>Pine Bluffs Rest Area LA 01R</b>
		402.143	Beech Street Sep. [BAO;EB, BAP;WB]
		402.778	ECL Pine Bluffs
	1		Nebraska State Line

Maint. Section	class	RM	US 30 & WY 225
<b>ML - 56B</b>			
<b>LA 02A</b>	8	348.360	I-80 (RM 348.36); Otto Int. [AYJ;EB, AYK;WB]
	1035		<b>E.B. Road Close Gate swing</b> <b>W.B. Road Close Gate swing</b>
	8	355.980	WUL Cheyenne
	17	358.014	WY 222 (RM 0.00)
		359.220	Begin Divided Section
	17		Begin 4-lane
	14	359.550	I-80 (RM 359.08); Lincolnway Int. [AYU;EB, AYS;WB], End WY 225 Begin US 30 & I-80 Bus.
		360.098	I-25 (RM 9.14) UPRR & US 30 Sep.
		360.750	Cutler Rd.
		360.843	Westland Rd. End Divided Section
		360.890	BNRR Sep.
		361.173	WCL Cheyenne
		361.510	Missile Dr.
<b>LA 02Z</b>		361.541	Crow Cr. [FJK;SS]
1035		361.830	RR at Grade Crossing #245696X
		362.280	US 85 (RM 9.74); Central Ave.
		362.345	US 85 (RM 9.74); Warren Ave.
		363.187	Dunn Ave.
		363.320	Hugar Ave.
		363.385	Logan Ave.
		363.421	BK= - 0.015 mi. Big Horn Ave.
		363.436	AH Equation
		363.643	Converse Ave.
<b>REMOVED EQUATION</b>			
		363.909	Hot Springs Ave.
		364.785	Ridge Rd
<b>LA 02Z</b>		365.230	WY 212 (RM 6.88) End I-80 Bus.
1035			
		365.630	ECL Cheyenne
		366.109	Dry Cr. [AZL;SS]
<b>LA 02B</b>		366.701	End 4- lane
1035		367.930	Del Range Blvd.
		370.731	UPRR Sep. [AZO;SS]
	14	371.279	I-80 (RM 370.39); Archer Int. Underpass [CGC;SS]

Maint. Section	class	RM	US 85, US 87 BUS, I-180 & I-25 BUS
<b>ML - 180B</b>			
	6	0.000	Colorado State Line
	6	3.200	Chalk Bluffs Rd.
<b>LA 05A</b>		3.540	SUL Cheyenne
1035	14	3.801	Begin Divided Section
		4.116	WY 223 (RM 5.69) <b>Cheyenne Port-of-Entry LA 05P</b>
		4.130	<b>S.B. Road Close Gate swing</b>
		5.759	End Divided Section
		6.298	Wallick Rd.
		7.307	WY 212 (RM 2.71) Begin I-25 Bus.
		7.740	Allison Draw [JBH;SS]
		8.338	CO. RD. (RM 0.00) Begin Divided Section
		8.500	I-80 (RM 362.04); US 85 Int. Begin I-180 & US 87 Bus.
	14		Begin NHS
		8.510	SCL Cheyenne
<b>LA 05Z</b>	11	8.669	Deming Drive Sep. [DER;SS]
1035		8.717	Crow Cr. [DEP;SS]
		8.850	5th Street
		8.975	Pedestrian Overpass [DEO;SS]
		9.120	9th Street
		9.374	UPRR Sep. [EAL;NB, EAJ;SB]
	11	9.595	BK= -0.145 mi.
	14	9.740	AH Equation End I-180, End NHS
<b>LA 05Z</b>	14	9.740	US 30 (RM 362.35); Lincolnway
1035		10.676	Pershing Blvd.
		10.758	BK= -0.045
		10.803	AH Equation
		11.214	8th Ave.
		11.445	BK= + 0.046 mi.
		11.399	AH Equation
		11.790	WY 219 (RM 0.00) Yellowstone Ave.
	14	12.608	I-25 (RM 12.70); Central Avenue Int. WY 224 (RM 0.00), End I-25 & 87 Bus.

US 30			
<i>Pine Bluffs City Route</i>			
<b>ML - 1111B</b>			
<b>LA 22A</b>	7	401.460	I-80 (RM 401.46); West Pine Bluffs Int. [BAM;EB, BAN;WB]
1039		22.000	WY 215 (RM 0.00)
		402.670	<b>Dept. Shop - Pine Bluffs PB 01A</b> south on Walnut St.
		403.017	Nebraska State Line

Maint. Section	class	RM	US 85
			<b>ML - 85B</b>
	2	16.939	I-25 (RM 17.24); Torrington Int.[ABQ;NB] Begin NHS
<b>LA 05B</b>		17.290	End Divided Section
1034		17.651	WY 219 (RM 5.49)
		17.790	<b>N.B. Road Close Gate swing</b>
		23.757	Lodgepole Cr. [FFH;SS]
		43.016	WY 216 (RM 0.00)
		46.500	Gun Barrel <b>RWIS</b> site {51}
		46.690	WY 213 (RM 19.705)
		52.587	Little Horse Cr. [BWE;SS]
		53.800	<b>Meriden Rest Area LA 05R</b>
		54.149	Horse Cr. [BWF;SS]
		54.220	Meriden
		56.644	Goshen Co. Line / District Boundary
	2		Cont. NHS

Maint. Section	class	RM	WY 212 & I-25 BUS
			<b>ML - 212B</b>
	14	0.000	I-25 (RM 7.85);College Dr. Int.[KEF;SS]
<b>LA 08A</b>		0.250	Southwest Drive
1034		0.660	RR at Grade Crossing #245617J
		0.980	BK= 0.099 mi.
		0.881	AH Equation
		1.220	Parsley Blvd.
		2.230	Walterschied Rd.
		2.350	Allison Draw [KSA;SS]
		2.705	US 85 (RM 7.31) End I-25 bus
		3.250	Avenue "C"
		4.003	LCCC College
		4.510	Allison Draw [KSG;SS]
		5.094	Fox farm Rd. (RM 1.84)
		5.381	Crow Cr. [DBV;SS]
		5.622	I-80(RM 364.00);Sun Valley Int.[DBW;SS]
		5.951	UP & BNRR Sep. [DBX;SS]
		6.040	Henderson Ditch [DBY;SS]
		6.100	SCL Cheyenne
		6.509	12th Street
		6.875	US 30 (RM 365.23)
		7.148	Pershing Blvd.
		7.932	Dry Cr. [DEV;SS]
		8.147	Dell Range Blvd.
		8.160	CL Cheyenne
		8.270	CL Cheyenne
		8.370	NCL Cheyenne
		10.430	Ridge Rd.
		12.050	Powder House Rd.
		13.567	WY 219 (RM 2.00)
		14.060	I-25 SR ML1124B (RM 1.66)

			WY 210
			<b>ML - 107B</b>
	16	0.000	I-25 (RM 10.59)
<b>LA 06A</b>		0.160	Missile Drive to Warren Gate #2
1035		0.230	Crow Cr. [FLF;SS]
		1.727	BK= - 0.467 mi.
		2.194	AH and FE Warren AFB Boundary
		2.941	WY 222 (RM 1.81)
	16	2.950	<b>W.B. Road Close Gate R/R</b>
●●		3.920	UL Cheyenne
	7	4.320	Diamond Cr. [LMQ;SS]
		9.700	Unnamed Draw [CIZ;SS]
		14.420	Crystal Lake Rd.
		23.860	Granite Res. Rd.
		24.600	<b>W.B. Road Close Gate swing</b>
	7	25.815	Albany Co. Line

			WY 211
			<b>ML - 211B</b>
	14	0.000	WY 219 (RM 4.01)
●●		0.510	I-25 (RM 16.23); Iron Mountain Int.
<b>LA 07A</b>	17		[CRB;SS]
1034	17	3.790	WY 222 (RM 8.29); Round Top Rd.
●●		4.070	UL Cheyenne
	7	9.260	Unnamed Draw [CRC;SS]
		17.030	RR at Grade Crossing #245526D
		17.291	S. Fork Lodgepole Cr. [CRD;SS]
		20.455	Middle Fork Lodgepole Cr. [CRE;SS]
		20.760	RR at Grade Crossing #245528S
		20.827	Dry Draw [CRF;SS]
		25.098	Dry Horse Cr. [CRG;SS]
		26.557	S. Fork Horse Cr. [CRH;SS]
		26.676	Horse Creek Townsite
		27.236	Horse Cr. [CRI;SS]
		42.600	RR at Grade Crossing #245662D
		42.690	Chugwater Cr. [DDL;SS]
	7	42.938	End SHS

\*\*\*ML 1102 given to the County.

Maint. Section	class	RM	WY 213
CREW			<b>ML - 6792B</b>
		0.042	I-80 (RM 386.39); Burns-Carpenter Int. [AZZ;EB, BAA;WB] & WY 214 (RM 0.00)
		0.100	I-80 SR ML1123B (RM 16.040)
		1.050	County Rd #212
		1.595	CL Burns
		2.089	County Rd #213
		2.224	East 3rd St.
		2.348	East 2nd St.
		2.604	UPRR Bridge [MDM;SS]
	7	3.050	CL Burns (Louth Rd)
		4.042	County Rd 215 (Hillsdale Ridge Rd)
<b>LA 23A</b>		4.567	Lodgepole Cr. [DOT;SS]
1039		5.038	County Rd 216 (Landfill Rd)
		6.036	County Rd 217 (Martin Rd)
		6.180	Unnamed Draw
		6.910	Spring Cr
		7.033	County Rd 218 (Deselms Rd)
		8.030	County Rd 219 (Lyon Rd)
		8.770	Unnamed Draw
		9.027	County Rd 220 (Anderson Rd)
		9.440	Antelope Draw
		11.029	County Rd 222 (King Rd)
		13.030	Chivington Draw
		14.019	County Rd 225 (Ogle Rd)
		15.018	County Rd 226 (Golden Prairie Rd)
		16.056	County Rd 227
	7	17.058	County Rd 228
	●●	18.085	WY 216 (RM 3.85) & Class. Break
	8	19.705	US 85 (RM 46.69)

			WY 214
			<b>ML - 1103B</b>
	7	0.000	I-80 (RM 386.39); Burns-Carpenter Int. [AZZ;EB, BAA;WB] & WY 213 (RM 0.00)
<b>LA 10A</b>		0.212	Unnamed Draw
1039		2.123	Unnamed Draw [CRM;SS]
		2.870	Unnamed Draw [MFA;SS]
		4.340	Unnamed Draw [MFB;SS]
		8.334	Carpenter
		8.394	End SHS

Maint. Section	class	RM	WY 215
CREW			<b>ML - 1104B</b>
	7	0.000	US 30 (RM 401.52)
<b>LA 11A</b>		0.219	UPRR Sep. [FBF;SS]
1039		0.934	BK= + 0.05 mi.
		0.884	AH Equation
		0.894	Lodgepole Cr. [CRN;SS]
		1.671	Spring Cr. [CRO;SS]
		1.798	NCL Pine Bluffs
		10.030	Unnamed Draw [JZA;SS]
		13.160	Unnamed Draw [CRP;SS]
		15.860	Unnamed Draw
		17.140	WY 216 (RM 16.47)

			WY 216
			<b>ML - 1105B</b>
	7	0.000	US 85 (RM 43.02)
<b>LA 12A</b>		3.850	WY 213 (RM 18.09)
1039		15.828	WCL Albin
		16.150	RR at Grade Crossing #816056B
	7	16.180	ECL Albin
	●●	16.465	WY 215 (RM 17.14)
	8	18.536	Nebraska State Line

			WY 219
			<b>ML - 1108B</b>
	14	1.989	End City, County / Begin State
<b>LA 15A</b>		2.000	WY 212 (RM 13.57); Four Mile Rd
1034		3.000	Riding Club Rd.
	14		<b>REMOVED EQUATION</b>
	16	4.007	WY 211 (RM 0.00)
	●●	5.010	NUL Cheyenne
	7	5.480	US 85 (RM 17.65)

			WY 222
			<b>ML - 222B</b>
	17	0.000	US 30/WY 225 (RM 358.01)
<b>LA 17A</b>		0.779	I-80 (RM 357.68) RoundTop Int.
1035		1.812	WY 210 (RM 2.941)
			End SHS

			WY 223
			<b>ML - 223B</b>
	17	0.000	I-25 (RM 2.66); Terry Ranch Rd Int.
<b>LA 18A</b>		0.260	Service Rd Right
1035	●●	0.640	Class Break
	7	0.858	UPRR Sep. [CYD;SS]
	●●	4.030	WUL Cheyenne
	17	5.685	US 85 (RM 4.12)

Maint. Section	class	RM	WY 224
<b>LA 19A</b>	14	0.000	I-25 (RM 12.70) (NHS) & US 85 (RM 12.61)
1034		0.050	Bishop Blvd.
		0.119	FE Warren AFB Boundary End SHS, & NHS, Cheyenne Headquarters HQ 01A

I-25 SV. RD.			
ML - 1116B			
<b>LA 03T</b>	9	0.000	ML 1118 (RM 11.49)
2033		0.910	End Sv. Rd. @County Rd. north of Interchange

I-25 SV. RD.			
ML - 1118B			
<b>LA 03K</b>	9	3.040	District Boundary
2033		5.600	Horse Creek [ACG;ESR]
		8.230	Little Bear Cr. [ACK;ESR]
		11.490	ML 1116
		11.670	I-25 (RM 39.24)Indian Hills Int. N.
		12.960	S. Fork Bear Cr. [ACP;WSR]
		14.310	Middle Fork Bear Cr. [ACQ;WSR]
		16.150	N. Fork Bear Cr. [ACR;WSR]
		17.760	Cantel Draw [ACS;WSR]
	9	19.700	Platte Co. Line

I-25 SV. RD.			
ML - 1119B			
<b>LA 03J</b>	9	0.000	From Colo. State Line
1034		0.970	Duck Cr.
		1.560	Lone Tree Cr.
		2.610	WY 223 (RM 0.26); Terry Rd. Int.

I-25 SV. RD.			
ML - 1124B			
<b>LA 03Q</b>	17	1.000	end city/begin state
1034		1.080	Vandehei Av.
		1.660	WY 212 (RM 14.20)
		1.650	NCL Cheyenne
		3.670	NUL Cheyenne
			WY 211 (RM 0.46)

I-25 SV. RD.			
ML - 1125B			
<b>LA 03N</b>	17	1.000	end city/begin state
1034		1.143	Vandehei Av.
		1.800	NCL Cheyenne
	17	3.550	WY 211 (RM 0.50)
	●●	4.879	NUL Cheyenne
	8	8.700	County Rd (Ridley Rd. Int)

Maint. Section	class	RM	I-80 SV. RD.
<b>LA 01J</b>	9	0.000	I-80 (RM 345.50) Warren Int.
1035		3.130	End Sv. Rd. Jct. Harriman Int. (I-80 RM 342.56)

I-80 SV. RD.			
ML - 1120B			
<b>LA 01L</b>	9	9.490	Begin Sv. Rd. @end Co. Rd
1039		14.790	Bridge
		16.540	WY 214 (RM 0.10)

I-80 SV. RD.			
ML - 1121B			
<b>LA 08J</b>	17	0.000	WY 212 (RM 5.53)
1035		0.940	End Sv. Rd. @Private Rd.

I-80 SV. RD.			
ML - 1123B			
<b>LA 01M</b>	7	0.000	US 30 (RM 371.12) Archer Int.
1035		0.160	E.B. Road Close Gate swing
		6.960	Maint. Break @ Hillsdale Int.
<b>LA 01Q</b>		15.450	Unnamed Draw [BJT;NSR]
1039	7	15.520	County Road to Burns
		16.040	WY 213 (RM 0.10)

I-80 SV. RD.			
ML - 1134B			
<b>LA 01T</b>	9	0.000	Beech St.
1039		0.300	Private Res.

I-80 SV. RD.			
ML - 1137B			
<b>LA 01W</b>	9	0.000	ML 1123 (RM 4.99) south side of I-80
1035		0.020	I-80 Co. Rd. Sep. (RM 375.38)
		0.520	Dead End

Maint.

Section

CREW

class

RM

US 30 SV. RD.

ML - 1128B

LA 02N 19

0.000 Polk Av.

1035

0.470 Cleveland St.

US 30 SV. RD.

ML - 1129B

LA 02J 19

0.000 US 30 (RM 365.80)

1035

0.300 Polk Av.

US 30 SV. RD.

ML - 1135B

LA 02K 19

0.000 Whitney Rd. (east)

1035

0.360 US 30 (RM 367.42)

US 30 SV. RD.

ML - 1136B

LA 02M 19

0.000 US 30 (RM 367.61)

1035

0.340 US 30 (RM 367.95)

US 85 SV. RD.

ML - 1130B

LA 05J 19

0.000 US 85 (RM 6.31)

1035

1.000 US 85 (RM 5.28)

US 85 SV. RD.

ML - 1131B

LA 05K 19

0.000 US 85 (RM 5.02)

1035

0.230 US 85 (RM 5.25)

Maint.

Section

CREW

class

RM





**ROAD COLOR TABLE**

	Rural & Urban Interstate #s "1 & 11"
	Urban Principal Arterial Other & Expressway (NHS) #s "12 & 14"
	Urban Minor Arterial, Collector & Local (non NHS) #s "16, 17 & 19"
	Rural Principal Arterial Other (NHS) # "2"
	Rural Minor Arterial, Major & Minor Collectors & Local (non NHS) #s "6, 7, 8 & 9"

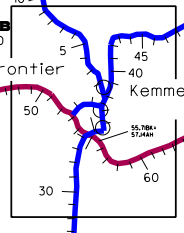
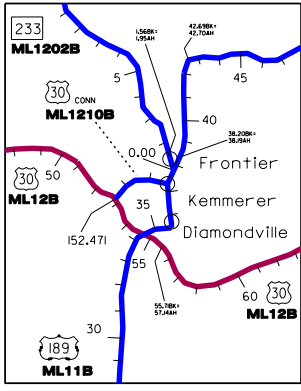
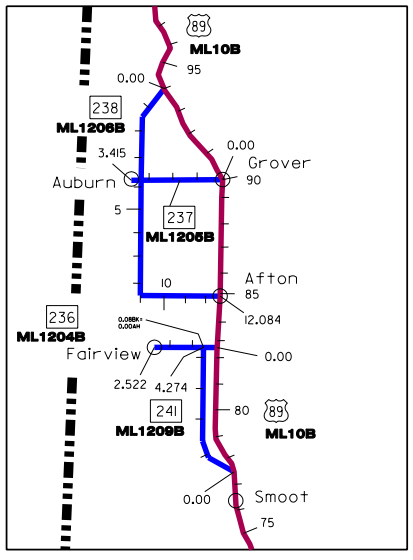
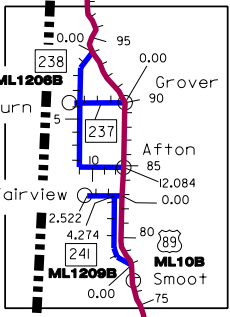
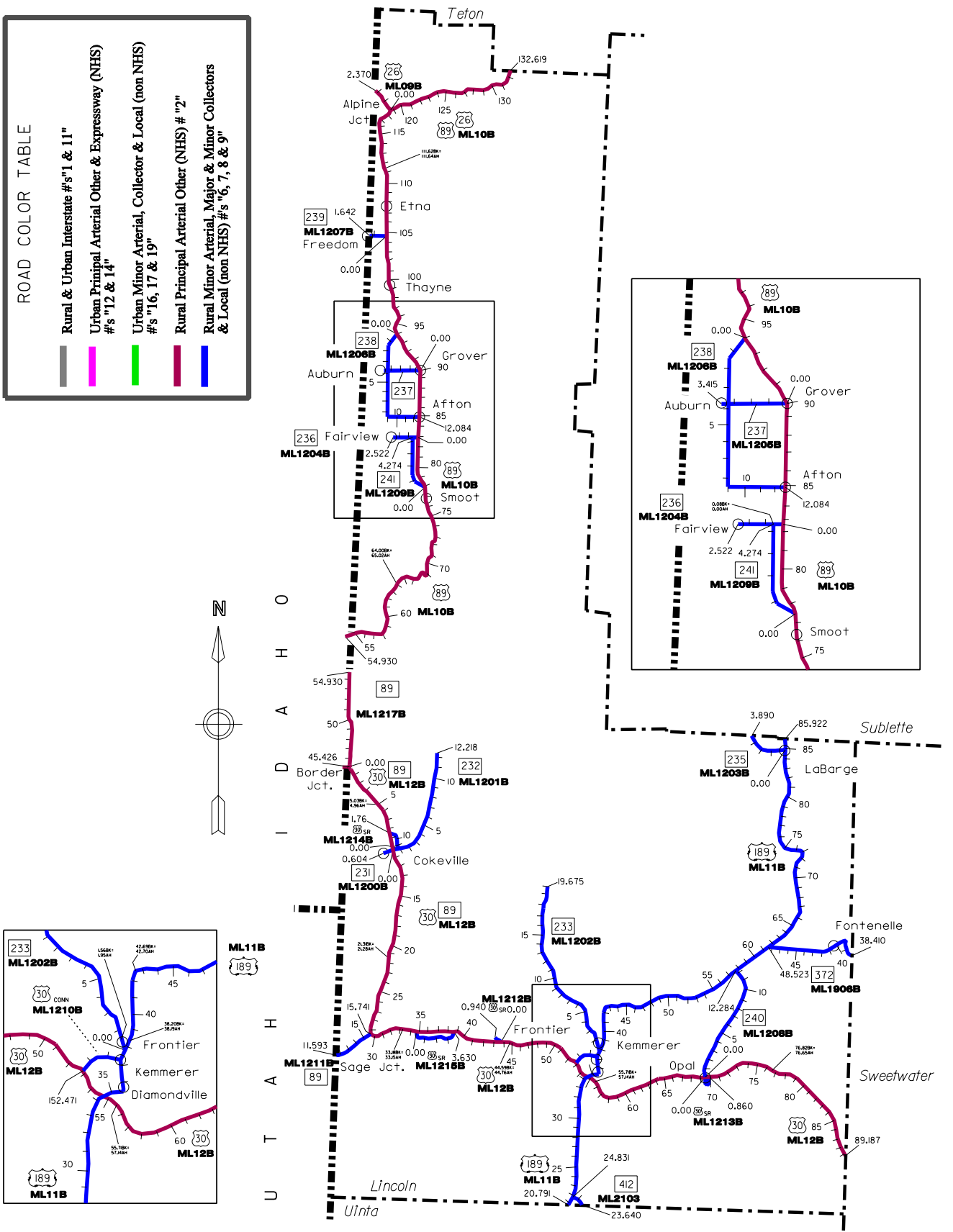



# Lincoln

•• class "classification break"

## County 12

Maint. Section	class	RM	WY 89
<b>LN 01A</b>	6	11.593	Utah State Line
3034		15.681	UPRR Sep. [BNY;SS]
		15.741	US 30 (RM 29.89); Sage Junction

WY 89			
Maint. Section	class	RM	WY 89
<b>LN 01B</b>	2	45.426	WY 89 (RM 0.24); Border Junction
3034			Begin NHS
		45.560	Border Jct. Wye.
		54.926	Idaho State Line

US 26/89			
Maint. Section	class	RM	US 26/89
<b>LN 01C</b>	2	54.926	Idaho State Line
3033			End WY 89 / Begin US 89
		61.475	Bridger Nat'l. Forest Boundary
		63.997	BK= - 1.025 mi.
		65.022	AH Equation
		70.760	County Rd
		71.307	Bridger Nat'l. Forest Boundary
		72.095	Salt River [FDU;SS]
		77.714	Smoot
		77.823	Cottonwood Cr. [DJG;SS]
		78.844	WY 241 (RM 0.00)
		82.095	Dry Cr. [DBM;SS]
		82.976	WY 236 (RM 0.00)
		84.220	SCL Afton
		84.981	WY 238 (RM 12.08)
		85.090	Begin Divided Section
		85.220	End Divided Section
		85.730	Swift Cr. [FCJ;SS]
		86.070	<b>Dept. Shop - Afton AF 03A</b>
		86.240	NCL Afton
		89.966	WY 237 (RM 0.00)
		94.120	WY 238 (RM 0.00)
		95.185	Salt Rv. [BOC;SS], Cont. NHS
		96.210	Salt Rv. [BOD;SS]
		97.490	<b>Star Valley Rest Area LN 01R</b>
		98.166	Etna Irrigation Canal [BOE;SS]
		99.423	Etna Irrigation Canal [KKL;SS]
		99.440	SCL Thayne
		100.352	Etna Irrigation District Canal [BOG;SS]
		100.839	NCL Thayne
		104.390	WY 239 (RM 0.00)
		107.880	Etna
		111.624	BK= - 0.018 mi.
	2	111.642	AH Equation

-cont- next column

Maint. Section	class	RM	US 26/89
<b>LN 01C</b>	2	117.367	WCL Alpine
3033		117.730	Greys River Rd
		117.840	NCL Alpine
		118.000	Snake Rv. [BOH;SS]
		118.322	US 26 (RM 0.00)Alpine Spur
			Begin US 26
			Remote loader site <b>AF 981</b>
		118.935	Targhee Nat'l. Forest Boundary
		118.980	<b>E.B. Road Close Gate R/R</b>
		119.000	NB C.M.Sign (dynamic)
	2	132.619	Teton Co. Line / Cont. NHS

(CONTINUED)

US 26			
Maint. Section	class	RM	US 26
<b>LN 13A</b>	2	0.000	US 26/89 (RM 118.32); Alpine Junction
3033			Begin NHS
		0.550	<b>Alpine Port-of-Entry LN 13P</b>
		2.370	Idaho State Line
			End WY NHS

US 30 & US 189			
Maint. Section	class	RM	US 30 & US 189
<b>LN 02A</b>	6	20.791	Uinta Co. Line
3040		21.410	WY 412 (RM 24.83)
		29.840	Shull Point Rd
		29.837	UPRR Sep. [EWR;SS]
		31.490	UPRR Sep. [EWS;SS]
		32.730	Elkol Rd
		33.220	SCL Kemmerer
		33.249	UPRR Sep. [EWT;SS]
		33.858	ECL Kemmerer
		34.510	US 30/189 Int. (RM 54.55) [DHA;SS]
			Begin US 30
		35.055	WCL Diamondville
		36.330	CL Kemmerer
			NCL Diamondville
		37.280	US 30 (RM 154.52) Connector
			End US 30
		37.349	UPRR Sep. [EFE;SS]
		37.561	Ham's Fork Rv. [EFH;SS]
		38.071	WY 233 (RM 0.00)
			<b>Dept. Shop - Kemmerer KM 03A</b>
		38.148	NCL Kemmerer
		42.695	Pomeroy Basin Rd
			REMOVED EQUATION
	6		REMOVED EQUATION

-cont- next page

Maint. Section	class	RM	US 30 & US 189
CREW		<b>ML - 11B</b>	
-cont-		(CONTINUED)	
LN 02C	6	42.940	Willow Cr. [LPG;SS]
3040		45.200	<b>N.B. Road Close Gate R/R</b>
		57.460	<b>S.B. Road Close Gate R/R</b>
		57.490	WY 240 (RM 12.28)
		61.390	WY 372 (RM 48.59)
		66.487	Reservoir Rd
LN 02B		70.160	Fontennelle Cr. Rd
3041		77.367	Muddy Cr. [FFP;SS]
		82.927	LaBarge Cr. [FFQ;SS]
		83.960	LaBarge Cr. Rd
		84.640	SCL LaBarge
		84.874	WY 235 (RM 0.00)
		84.890	<b>Dept. Shop - LaBarge LB 03A</b>
		85.467	Birch Cr. [FFV;SS]
	6	85.922	Sublette Co. Line / NCL LaBarge

Maint. Section	class	RM	US 30 & WY 89
		<b>ML - 12B</b>	
LN 03A	2	0.000	Idaho State Line
3034		0.240	WY 89 (RM 45.43); Border Jct.
			Begin WY 89
			Begin NHS
		5.026	BK= + 0.069 mi.
		4.957	AH Equation
		9.950	Smith's Fork Rv. [BQT;SS]
		10.348	NCL Cokeville
		10.387	Spring Cr. [BQU;SS]
		10.582	WY 231 (RM 0.00)
			& WY 232 (RM 0.00)
		10.841	SCL Cokeville
		13.909	Stock Pass [BQV;SS]
		14.010	Sublette Cr. [BQW;SS]
		18.267	Horse Cr. [BQX;SS]
		21.312	BK= + 0.034 mi.
		21.278	AH Equation
		29.891	US 26 (RM 15.74); Sage Jct.
			End WY 89
		30.500	Game Crossing [LFN;SS]
			Remote loader site <b>CV 981</b>
		33.180	BK= + 0.028 mi.
		33.152	AH Equation
		34.010	Sage Jct. RWIS site
		34.918	Stock Trail Sep. [BRA;SS]
		35.240	Game Underpass [LXU;SS]
		35.960	Game Underpass [LXT;SS]
		37.430	Game Underpass [LXS;SS]
		38.370	Maint. Break
LN 03B		38.220	Game Underpass [LXR;SS]
3040		39.695	UPRR Sep. [BRB;SS]
		38.99	Game Underpass [LXQ;SS]

-cont- next column

Maint. Section	class	RM	US 30 & WY 89
CREW		<b>ML - 12B</b>	
-cont-		(CONTINUED)	
LN 03B	2	40.620	Game Underpass [LXP;SS]
3040		44.589	BK= - 0.174 mi.
		44.763	AH Equation
		45.756	South Fork Twin Cr. [BRC;SS]
		52.161	UPRR Sep. [FLU;SS]
		52.330	Power Plant Rd.
		52.490	US 30 (RM 152.47) Connector
			Begin US 30 Bypass
			WCL Kemmerer
			<b>Kemmerer Port-of-Entry LN 03P</b>
		52.600	<b>W.B. Road Close Gate R/R</b>
		54.400	<b>E.B. Road Close Gate R/R</b>
		54.550	US 30 (RM 34.51)
			End US 30 Bypass
		55.128	ECL Kemmerer
		55.714	BK= - 1.425 mi.
		57.139	AH Equation
		58.028	Ham's Fork Rv. & UPRR Sep. [BRE;SS]
		69.317	WY 240 (RM 0.00)
		69.360	WCL Opal, Cont. NHS
		69.947	ECL Opal
		71.848	UPRR Sep.
		75.400	Maint. Break
LN 03C		76.819	BK= + 0.17 mi.
3038		76.649	AH Equation
	2	89.187	Sweetwater Co. Line

Maint. Section	class	RM	US 30 connector
		<b>ML - 1210B</b>	
LN 16A	6	152.471	US 30 (RM 52.49) Mainline
3040		152.400	<b>W.B. Road Close Gate R/R</b>
		154.328	WCL Kemmerer
		154.518	US 189 (RM 37.28)

Maint. Section	class	RM	US 30 connector
		<b>ML - 1216B</b>	
LN 19A	2	0.240	US 30 (RM 0.48), Border Jct. (NHS)
3034		0.470	WY 89 (RM 45.67), (NHS)

Maint. Section	class	RM	WY 231
CREW			<b>ML - 1200B</b>
<b>LN 04A</b>	7	0.000	US 30 (RM 10.58) & WY 232 (RM 0.00)
3034		0.196	Spring Cr. [CRS;SS]
		0.604	End SHS

Maint. Section	class	RM	WY 232
CREW			<b>ML - 1201B</b>
<b>LN 05A</b>	7	0.000	US 30 (RM 10.58) & WY 231 (RM 0.00)
3034		0.090	ECL Cokeville
		0.140	Dept. Shop - Cokeville CV 03A
		2.920	Pine Creek Rd
		12.218	End SHS

Maint. Section	class	RM	WY 233
CREW			<b>ML - 1202B</b>
<b>LN 06A</b>	7	0.000	US 30 (38.07)
3040		0.303	NCL Kemmerer
		0.610	Branch Ham's Fork Rv. [JXN;SS]
		0.710	Frontier
		1.100	Jct. Airport Spur
		1.562	BK= - 0.388 mi.
		1.950	AH Equation
		4.426	Ham's Fork Rv. [CRV;SS]
		19.675	End SHS

Maint. Section	class	RM	WY 235
CREW			<b>ML - 1203B</b>
<b>LN 07A</b>	7	0.000	US 189 (RM 84.87)
3041		0.620	WCL LaBarge
		3.893	Sublette Co. Line

→ -cont- in Sublette County

Maint. Section	class	RM	WY 236
CREW			<b>ML - 1204B</b>
<b>LN 08A</b>	7	0.000	US 26 (RM 82.98)
3033		0.081	BK= + 0.081 mi.
		0.000	AH Equation WY 241 (RM 4.27)
		1.547	Salt Rv. [EOQ;SS]
		2.522	Fairview
			End SHS

Maint. Section	class	RM	WY 237
CREW			<b>ML - 1205B</b>
<b>LN 09A</b>	7	0.000	US 26 (RM 89.97) Grover
3033		1.671	Spring Cr.
		2.062	E. Channel Salt Rv. [LMD;SS]
		2.123	W. Channel Salt Rv. [LMC;SS]
		2.494	Unnamed Draw
		3.279	WY 238 (RM 3.88)
		3.415	Auburn
			End SHS

Maint. Section	class	RM	WY 238
CREW			<b>ML - 1206B</b>
<b>LN 10A</b>	7	0.000	US 89 (RM 94.12)
3033		0.070	Canal
		0.278	Salt Rv. [CSB;SS]
		3.878	WY 237 (RM 3.28)
		9.070	Irrigation Canal [CYJ;SS]
		9.345	Crow Cr. [CYT;SS]
		9.884	W. Channel Salt Rv. [FOL;SS]
		10.177	E. Channel Salt Rv. [CYW;SS]
		11.832	WCL Afton
		12.084	US 89 (RM 84.98)

Maint. Section	class	RM	WY 239
CREW			<b>ML - 1207B</b>
<b>LN 11A</b>	7	0.000	US 26 (RM 104.39)
3033		0.943	Salt Rv. [CSD;SS]
		1.642	Idaho State Line

Maint. Section	class	RM	WY 240
CREW			<b>ML - 1208B</b>
<b>LN 12A</b>	7	0.000	US 30 (RM 69.32)
3040		7.450	Exxon Rd
		12.284	US 189 (RM 57.49)

Maint. Section	class	RM	WY 241
CREW			<b>ML - 1209B</b>
<b>LN 15A</b>	7	0.000	US 89 (RM 78.84)
3033		4.274	WY 236 (RM 0.00 AH)

Maint. Section	class	RM	WY 372
CREW			<b>ML - 1906B</b>
<b>LN 12B</b>	7	38.409	Sweetwater Co. Line
3041		40.289	Fontenelle
		48.523	US 189 (RM 61.24)

-cont- from Sweetwater County

**Maint.**

Section	class	RM	WY 412
CREW			<b>ML - 2103B</b>

-cont- <b>UI 08A</b>	7	from Uinta County	
		23.643	Uinta Co. Line
3042		24.831	US 189 (RM 21.41)

US 30 SV. RD.			
<b>ML - 1212B</b>			

<b>LN 03N</b>	8	0.000	US 30 (RM 43.80)
		0.330	Twin Cr. [ESZ;NSR]
3040		0.650	Railroad Sep.
		0.940	End Sv. Rd. Near Historical Site

US 30 SV. RD.			
<b>ML - 1213B</b>			

<b>LN 03L</b>	9	0.000	US 30 (RM 69.30)
		0.210	WCL Opal
3040		0.710	ECL Opal
		0.860	US 30 (RM 69.78)

**Maint.**

Section	class	RM	US 30 SV. RD.
CREW			<b>ML - 1214B</b>

	9	0.000	WY 232 (RM 0.29)
<b>GRAVEL</b>		0.240	Spring Cr. [MRU;SS]
<b>LN 05K</b>		0.250	SCL Cokeville
3034		0.540	NCL Cokeville
		0.550	Collette Cr. [MRT;MSS]
		0.680	Smith Fork Rv. [MRV;SS]
		1.760	US 30 (RM 9.86)

US 30 SV. RD.			
<b>ML - 1215B</b>			

<b>LN 03M</b>	9	0.000	US 30 (RM 34.85)
3034		3.630	US 30 (RM 38.47)

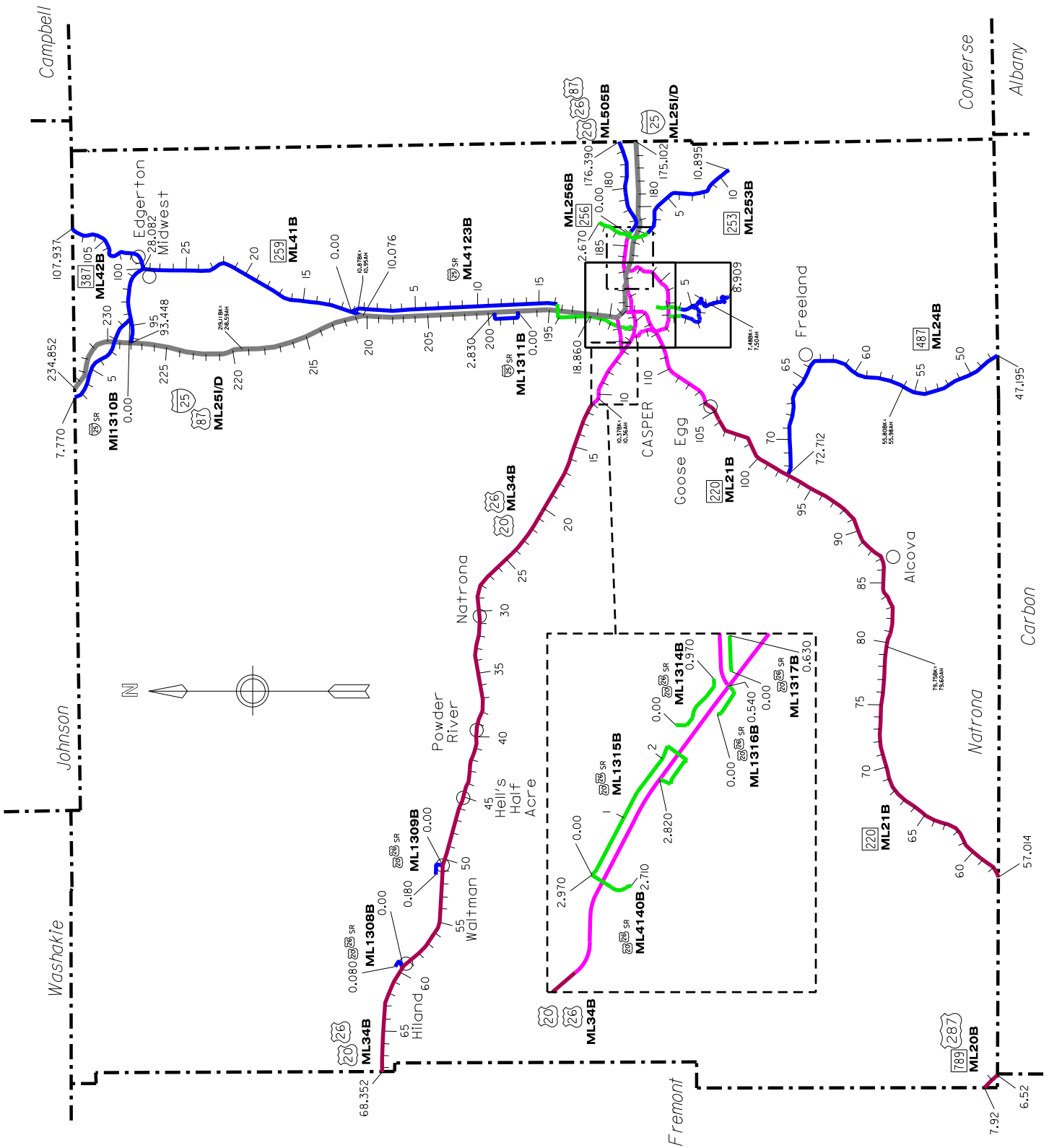

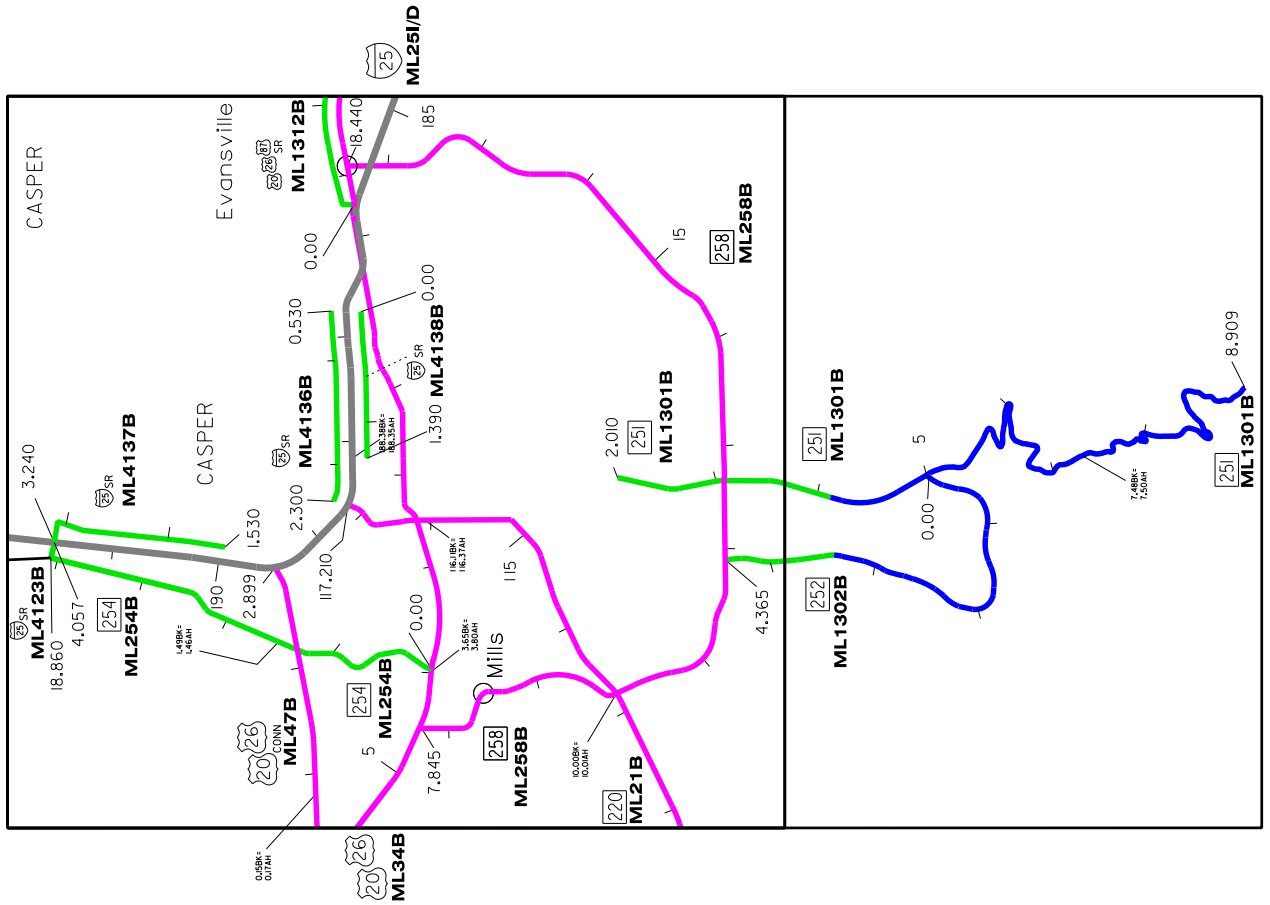
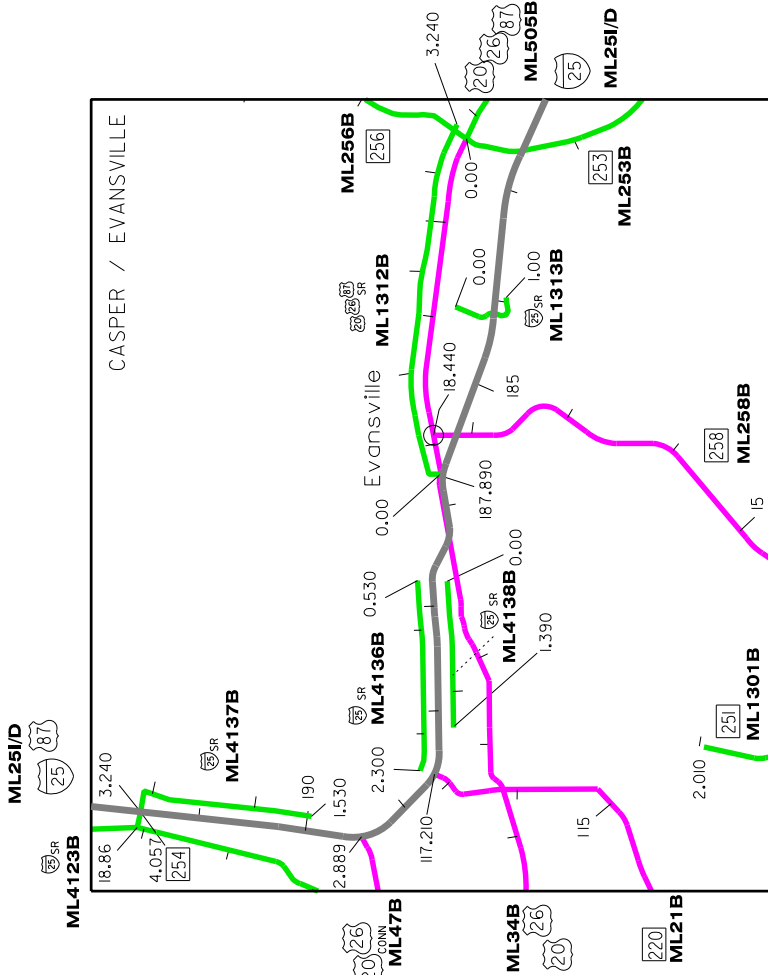

ROAD COLOR TABLE	
	Rural & Urban Interstate #'s "1 & 11"
	Urban Principal Arterial Other & Expressway (NHS) #'s "12 & 14"
	Urban Minor Arterial, Collector & Local (non NHS) #'s "16, 17 & 19"
	Rural Principal Arterial Other (NHS) # "2"
	Rural Minor Arterial, Major & Minor Collectors & Local (non NHS) #'s "6, 7, 8 & 9"



# Natrona

class "classification break"

## County 1

+ Indicates Non State System

Maint. Section	class	RM	I-25, US 20/26/87	Maint. Section	class	RM	I-25, US 20/26/87
		<b>ML - 25</b>				<b>ML - 25</b>	
		<i>(CONTINUED)</i>					
<b>NA 01A</b>	1	175.102	Converse Co. Line	<b>NA 01B</b>	1	219.093	BK= + 0.507 mi.
		175.588	Co. Rd Sep. [AHO;NB, AHP;SB]			218.586	AH Equation
2031	1	179.531	Dry Muddy Cr. [AHQ;NB, AHR;SB]	2037		221.346	Castle Cr. [DFD;SB, DFE;NB]
●●		182.060	EUL Casper			222.231	Machinery Pass Sep. [DFE;SB, DFG;NB]
11		182.530	WY 253 (RM 0.48); Hat Six Int. [CSE;SS]			223.780	Midwest Int. [DFH;SS]
			EUL Casper			226.091	Machinery Pass Sep. [DFI;SB, DFJ;NB]
		182.680	<b>S.B. Road Close Gate R/R</b>			227.644	<b>N.B. Road Close Gate R/R</b>
		184.040	Unnamed Draw			227.985	WY 387 (RM 93.45); Smokey Gap Int. [DFK;SB, DFL;NB]
		184.148	Co. Rd Sep. [AHT;NB, AHU;SB]			228.284	<b>S.B. Road Close Gate R/R</b>
			SB C.M. Sign (dynamic)			230.068	US 87 Sep. [DFM;NB, DFN;SB]
		185.354	WY 258(RM 18.22); Evansville Int. [LXB;NB, LXC;SB]			232.723	Dugout Cr. [DFO;NB, DFP;SB]
		185.740	C&NW RR Sep. [AHX;NB, AHY;SB]	1		234.852	Johnson Co. Line
		185.750	ECL Casper				
		186.290	WCL Casper				<b>US 20/26</b>
		186.452	E. Yellowstone St. Int. [CWZ;SS]				<b>Connector</b>
		186.599	BNRR Sep. [AIA;SS]				<b>ML - 47B</b>
		186.760	CL Casper				
		186.785	Bryan Stock Trail Int. [AIB;SS]	12		0.000	US 20/26 (RM 6.05);Mainline
			<b>Dept. Shop - Casper DH 02A</b>	<b>NA 12A</b>			Begin NHS
			0.2 mi. N. on Bryan Stock Trail	2042		0.148	BK= -0.020 mi.
→		187.527	McKinley Street Int. [AIF;NB, DKU;SB]			0.168	AH Equation
		188.185	WY 255 (RM 0.65); Center Street Int. [AIH;NB, DKV;SB]			0.189	Old Yellowstone Hwy. Sep [CDF;EB, CDG;WB]
<b>NA 01C</b>		188.355	North Platte Rv. [AIJ;NB, DKW;SB]			0.353	Railroad X-ing
2042		188.386	BK= + 0.033 mi.			0.994	BNRR & Casper Cr.[CDI;WB, CTT;EB]
		188.353	AH Equation			2.086	WY 254 (RM 1.40)
		188.600	WY 220 (RM 117.213); Poplar St. Int. [FDG;NB, FDH;SB]			2.899	I-25 (RM 189.51) Shoshoni Int.
		189.170	WCL Casper				End NHS
		189.507	US 20/26 (RM 2.90) Shoshoni Int. [EWO;NB, EWP;SB] End US 20 & 26				<b>US 20/26/87</b>
		191.430	<b>N.B. Road Close Gate R/R</b>				<b>ML - 505B</b>
		191.644	WY 254 (RM 4.06); Wardwell Rd Int. [AIS;NB, AIT;SB]	7		176.390	Converse Co. Line
				<b>NA 02A</b> ●●		183.720	EUL Casper
		194.264	Eight Mile Sep. [AIU;NB, AIV;SB]	2031	16	183.896	Begin 4-Lane Section
●●		194.339	NUL Casper	●●		184.064	WY 253 (RM 0.00)
1		197.522	Ormsby Rd Int. [AIW;NB, AIX;SB]		14		& WY 256 (RM 0.00)
		204.620	Co. Rd Sep. [AIZ;NB, AJA;SB]				EB C.M. Sign (dynamic)
		207.160	Twenty Mile Hill <b>RWIS</b> site {16}			184.158	Claude Cr. [BLV;SS]
		210.120	<b>N.B. Road Close Gate R/R</b>			185.277	Elkhorn Cr. [BLW;WB, CON;EB]
→		210.412	WY 259(RM 10.08);Horse Ranch Cr.Int. [DOI;NB, DOJ;SB]	→		186.748	ECL Evansville
				<b>NA 02Z</b>		186.820	End 4-Lane Section
<b>NA 01B</b>		214.730	Teapot Rock Sep. [DLV;SS]	2031		186.877	WY 258 (RM 18.43)
2037		216.430	Ranch Rd Int. [LGC;SS]			186.990	Begin Divided Section
		218.747	S. Fork Castle Cr. [DLY;NB, DLZ;SB]			187.254	WCL Evansville & ECL Casper
			<b>-cont- next column</b>				End Divided Section
						187.893	I-25 (RM 186.45) Yellowstone St. Int. [CWZ;SS]
				14			

Maint. Section	class	RM	US 20/26/87 & I-25 BUS
			<b>ML - 34B</b>
<b>NA 05Z</b>	14	0.000	I-25 (RM186.45) Yellowstone Int. [BMA;SS]
2042		0.050	US 20/26/87 (RM 187.99)
		0.160	BK= + 0.06 mi.
		0.100	AH Equation
		0.111	ECL Casper
		1.634	WY 251 (RM 0.00)
		1.700	WY 255 (RM 0.17)
			End US 87 Bus. & I-25 Bus.
		2.086	North Platte Rv. [DEN;SS]
		2.337	WY 220 (RM 116.476)
		2.854	WCL Casper
<b>NA 05A</b>		3.649	BK= - 0.153 mi.
2042		3.802	AH Equation
		3.860	Casper Cr. [DDF;SS]
		3.931	WY 254 (RM 0.00)
		4.099	C&NW RR Sep. [DDG;SS]
		4.518	WY 258 (RM 7.85); Mills Spur Begin NHS
		4.531	ECL Mills, Cont. NHS
		4.640	WCL Mills
		6.052	US 20/26 Connector (RM 0.00)
			<b>WY 257 (RM 7.302)</b>
		10.365	BK= + 0.008 mi.
	14	10.357	AH Equation
	●	11.760	WUL Casper
		12.000	EB & WB C.M. Sign (dynamic)
	2	12.889	County Rd (north & south)
		12.900	<b>W.B. Road Close Gate R/R</b>
		16.379	Johnson Lateral [CBI;SS]
		18.390	Bucknum Rd
		19.976	Casper Canal [CBK;SS]
		20.879	S. Fork Casper Cr. [CBL;SS]
		27.944	Middle Fork Casper Cr. [EWK;SS]
		28.998	Middle Fork Casper Cr. [EWL;SS]
		29.811	Middle Fork Casper Cr. [EWM;SS]
		30.000	<b>RWIS site { }</b>
		30.460	Natrona
		39.608	Powder Rv.
		40.146	Wyatt Draw [CBR;SS]
		41.191	S. Fork Powder Rv. [CBT;SS]
		45.158	Hell's Half Acre
		50.689	Waltman Town / District Boundary
<b>NA 05B</b>		53.210	<b>Waltman Rest Area NA 05R</b>
5037			Web Cam
		57.420	Hiland <b>RWIS</b> site {19}
		59.499	Hiland
	2	68.352	Fremont Co. Line / Cont. NHS

Maint. Section	class	RM	US 287 & WY 789
			<b>ML - 20B</b>
<b>FR 02A</b>	2	6.518	Fremont Co. Line (NHS)
2036		7.917	Fremont Co. Line (NHS)
			-cont- in Fremont County
			<b>WY 220</b>
			<b>ML - 21B</b>
	2	57.014	Carbon Co. Line / Cont. NHS
		57.623	Rush Cr. [BUC;SS]
<b>NA 04A</b>		62.734	Sweetwater Rv. [BUD;SS]
2036		62.830	<b>Independence Rock Rest Area NA 04R</b>
		65.670	Buzzard Rd
		65.869	Dry Cr. [BUE;SS]
		72.289	Horse Cr. [BUF;SS]
		79.750	BK= + 0.147 mi.
		79.603	AH Equation
		80.100	Pathfinder Hill <b>RWIS</b> site {6}
		80.180	Maint. Break
		85.814	Casper Canal [BUG;SS]
<b>NA 04B</b>		86.480	<b>W.B. Road Close Gate R/R</b>
2031		86.636	Eagle Cr. [BUH;SS]
		94.329	North Platte Rv. [LIK;SS]
		96.813	Bates Cr. [BUJ;SS]
		97.250	<b>W.B. Road Close Gate swing</b>
		97.305	WY 487 (RM 72.71)
		101.110	Unnamed Draw [GUY;SS]
	2	101.300	Cottonwood Cr. [BUK;SS]
	●	106.030	SUL Casper
		108.050	<b>WY 257 (RM 0.00)</b>
	14	108.110	Begin 4-Lane
		108.200	<b>S.B. Road Close Gate R/R</b>
		110.520	WB C.M. Sign (drum)
		112.249	EB C.M. Sign (dynamic)
		110.896	WCL Casper
		113.360	WY 258 (RM 10.01); Mills Spur Rd End NHS
<b>NA 04Z</b>		113.700	WB C.M. Sign (dynamic)
2031		114.820	Garden Cr. [KWN;SS]
		115.237	End 4-Lane
		116.110	BK= - 0.259 mi.
		116.369	AH Equation
		116.405	North Platte Rv. [BUN;SS]
		116.476	US 20/26, I-25 BUS (RM 2.337)
		116.731	BNRR Sep. [BUO;SS]
	14	117.213	I-25 (RM 188.60); Poplar St. Int.

Maint. Section	class	RM	WY 251
CREW			<b>ML - 1301B</b>
	+	0.000	US 20/26 BUS (RM 1.63) City Section
	+	0.100	BK= + 0.10 mi.
	+	0.000	AH Equation
<b>NA 08Z</b>	16	2.010	End City / Begin State
2031		3.028	WY 258 (RM 12.65)
	16	3.577	SCL Casper
	●●	4.067	SUL Casper
<b>NA 08A</b>	7	4.467	<b>S.B. Road Close Gate swing</b>
2031		4.943	WY 252 (RM 0.00); Gothmore Park Spur
		5.490	Road Closed "Flashing Beacon"
		7.484	BK= - 0.012 mi.
		7.496	AH Equation
		8.746	Road Closed "Flashing Beacon"
		8.909	End SHS

WY 252 Gothmore Park Spur			
			<b>ML - 1302B</b>
	7	0.000	WY 251 (RM4.94); Mainline
<b>NA 14A</b>	7	0.400	<b>S.B. Road Close Gate swing</b>
2031	●●	3.361	SUL Casper
	16	3.990	SCL Casper
<b>NA 14Z</b>			
2031	16	4.365	WY 258 (RM 11.91)

WY 253			
			<b>ML - 253B</b>
	17	0.000	US 20/26 (RM 184.064) & WY 256 (RM 0.00)
<b>NA 09A</b>		0.479	I-25 (RM 182.53); Hat Six Int. [CSE;SS]
2031	17	1.690	SUL Casper
	8	2.780	Dry Muddy Cr. [CSF;SS]
		10.895	End SHS

WY 254			
			<b>ML - 254B</b>
	16	0.000	US 20/26 (RM 3.93) Casper Cr. [DEZ;SS]
<b>NA 10A</b>		0.188	RR at grade crossing #064979U
2042		0.790	NCL Mills
		1.398	US 20/26 (RM 2.09); Salt Cr. Int.[CYF;SS]
		1.491	BK= + 0.03 mi.
		1.461	AH Equation
	16	1.590	<b>Casper Port-of-Entry NA 10P</b>
		1.880	<b>North Yard (Dept.) CA 02A</b>
	●●	3.900	Class Break
	17	4.057	I-25 (RM 191.64); Wardwell Rd Int. [AIS;NB, AIT;SB]

Maint. Section	class	RM	WY 256
CREW			<b>ML - 256B</b>
	17	0.000	US 20/26 (RM 184.06) & WY 253 (RM 0.00)
<b>NA 15A</b>		0.190	RR at Grade Crossing #089336V
2031		0.570	North Platte Rv. [CSG;SS]
		2.665	End SHS

WY 257 Casper West Belt			
			<b>ML - 257B</b>
	?	0.000	WY 220 (RM 108.08)
<b>NA 17A</b>		1.910	North Platte River [??;SS]
2042		2.670	Oregon Trail Turnout
		3.767	Unnamed Draw (Wetland Area)
		4.256	Overflow Drain
		6.130	Robertson Rd.
		7.302	US 20/26 (RM 6.05)

WY 258 Casper Outer Belt			
			<b>ML - 258B</b>
	14	7.845	NCL Mills
<b>NA 16Z</b>			US 20/26 BUS (RM 4.52) Begin NHS
2031		8.737	SCL Mills & NCL Casper
		9.150	EB C.M. Sign (dynamic)
		8.745	Platte Rv. [CWD;SS]

WY 259 REMOVED EQUATION			
			<b>ML - 259B</b>
	2031	10.009	WY 220 (RM 113.26) End NHS
		11.909	WY 252 (RM 4.37)Spur
		12.610	WY 251 (RM 3.03)
		12.652	CL Casper
		13.520	Mckinley St
		13.770	<b>RWIS</b> site {74}
		16.588	WB C.M. Sign (dynamic)
		15.530	CL Casper
		17.250	Ped. Overpass [FGN;SS]
		17.940	WB C.M. Sign (dynamic)
		18.010	2nd St
		18.080	NCL Casper
		18.220	I-25 (RM 185.35); Evansville Int.
		18.346	SCL Evansville
	14	18.440	US 20,26 (RM 186.88)

WY 259 ML - 41B			
	6	10.076	I-25 (RM 210.41); Horse Ranch Cr. Int. [DOI;NB, DOJ;SB]
<b>NA 13A</b>		14.723	East Teapot Cr. [LBC;SS]
2037		15.478	Teapot Cr. [LDB;SS]
		27.690	Salt Cr. [LDB;SS]
		28.082	WY 387 (RM 100.00)

Maint. Section	class	RM	WY 387
<b>NA 06A</b>	6		<b>ML - 42B</b>
2037		93.448	I-25 (RM 227.99); Smokey Gap Int. [DFK;SB, DFL;NB]
		97.911	Bothwell Draw [AJH;SS]
		98.360	Salt Cr. [AJG;SS]
		99.370	<b>Dept. Shop - Midwest MW 02A</b>
		100.000	WY 259 (RM 28.21) Conn.; Midwest Jct.
		100.878	WCL Edgerton
		101.437	NCL Edgerton
		101.930	<b>N.B. Road Close Gate R/R</b>
		103.767	Coal Draw [DDA;SS]
		107.937	Johnson Co. Line

Maint. Section	class	RM	WY 487
<b>NA 07A</b>	6		<b>ML - 24B</b>
2041		47.195	Carbon Co. Line
		55.790	Sand Cr. [DLP;SS]
		55.795	BK= - 0.186 mi.
		55.981	AH Equation
		61.070	Bates Cr. [DLQ;SS]
		66.130	Little Red Cr. [FGC;SS]
		72.680	<b>E.B. Road Close Gate R/R</b>
		72.712	WY 220 (RM 97.305)

Maint. Section	class	RM	US 20/26 SV. RD.
<b>NA 05M</b>	9		<b>ML - 1308B</b>
5037		0.000	US 20/26 (RM 59.50); HILAND
		0.080	US 20/26 (RM 59.58); HILAND

Maint. Section	class	RM	US 20/26 SV. RD.
<b>NA 05N</b>	9		<b>ML - 1309B</b>
5037		0.000	US 20/26 (RM 50.69); WALTMAN
		0.180	Arminto Rd

Maint. Section	class	RM	I-25 SV. RD.
<b>NA 01M</b>	8		<b>ML - 1310B</b>
2037		0.000	WY 387 (RM 96.28)
		0.023	<b>N.B. Road Close Gate R/R</b>
		1.890	Bridge
		3.120	I-25 Machinery Pass Sep.(RM 230.07) [DFM;NB, DFN;SB]
		5.580	Dougout Cr. [AJI;WSR]
		7.770	Johnson Co. Line

Maint. Section	class	RM	I-25 SV. RD.
<b>NA 01G</b>	9		<b>ML - 1311B</b>
2042		0.000	From Dead End N.
		0.750	Ormsby Rd
			Unnamed Draw [AIY;ESR]
		2.830	End Sv. Rd. @Access Opposite I-25 (RM 199.52)

Maint. Section	class	RM	US 20/26/87 SV. RD.
<b>NA 02K</b>	19		<b>ML - 1312B</b>
2031		0.000	US 20/26/87 (RM 187.26); In Evansville
		0.010	CL Evansville / Casper
		0.510	ECL Evansville
		1.980	Elkhorn Cr. [BLX;NSR]
		3.210	WY 256
		3.240	End Sv. Rd. @Dead End

Maint. Section	class	RM	US 20/26 SV. RD.
<b>NA 18A</b>	19		<b>ML - 1314B</b>
2042		0.000	Old Yellowstone Hwy
		0.970	Old Yellowstone Hwy

Maint. Section	class	RM	US 20/26 SV. RD.
<b>NA 19A</b>	19		<b>ML - 1315B</b>
2042		0.000	SV. RD. ML 4140
		1.180	Co. Rd. #119
		2.280	US 20/26 (RM 6.22)
		2.820	US 20/26 (RM 6.67)

Maint. Section	class	RM	US 20/26 SV. RD.
<b>NA 20A</b>	19		<b>ML - 1316B</b>
2042		0.000	Zero Rd
		0.430	WY 257 (RM 7.19)

Maint. Section	class	RM	US 20/26 SV. RD. (CHASE RD)
<b>NA 12B</b>	19		<b>ML - 1317B</b>
2042		0.000	Old Yellowstone Highway
		0.630	End SR @private resident

Maint. Section	class	RM	I-25 SV. RD.
<b>NA 01K</b>	9		<b>ML - 4123B</b>
2042		0.000	WY 259 (RM 10.58)
		0.750	Sheep Cr. [AJC;ESR]
		0.800	Horse Cr. [AJB;ESR]
		16.110	Salt Cr. Hwy.
			NUL Casper
		18.860	Wardwell Rd

Maint. Section	class	RM	I-25 SV. RD. ("F" ST)
<b>NA 01F</b>	17		<b>ML - 4136B</b>
2042		0.000	US 20/26 (RM 189.81)
			East Yellowstone
		0.230	RR at grade crossing # 095107P
		0.530	Bryan Stock Trail
		2.030	Bridge North Platte Rv. [AIK;ESR]
		2.300	Rancho Rd. / Poplar Street

revise per WY 257 construction

**Maint.**

**Section**

class

RM

**I-25 SV. RD. (RANCHO RD)**

**ML - 4137B**

**NA 01J**

17

1.530 NCL Casper @JCS Way

2042

3.240 Wardwell Rd

**I-25 SV. RD.**

**ML - 4138B**

**NA 01E**

17

0.000 Jct. Bryan Stock Trail

2042

1.390 Center St. (RM 0.63)

**US 20/26 SV. RD.**

**ML - 4140B**

**NA 21A**

17

2.710 Seven Mile Rd.

2042

2.900 US 20/26 (RM 8.40)

2.970 Sv. Rd. ML 1315



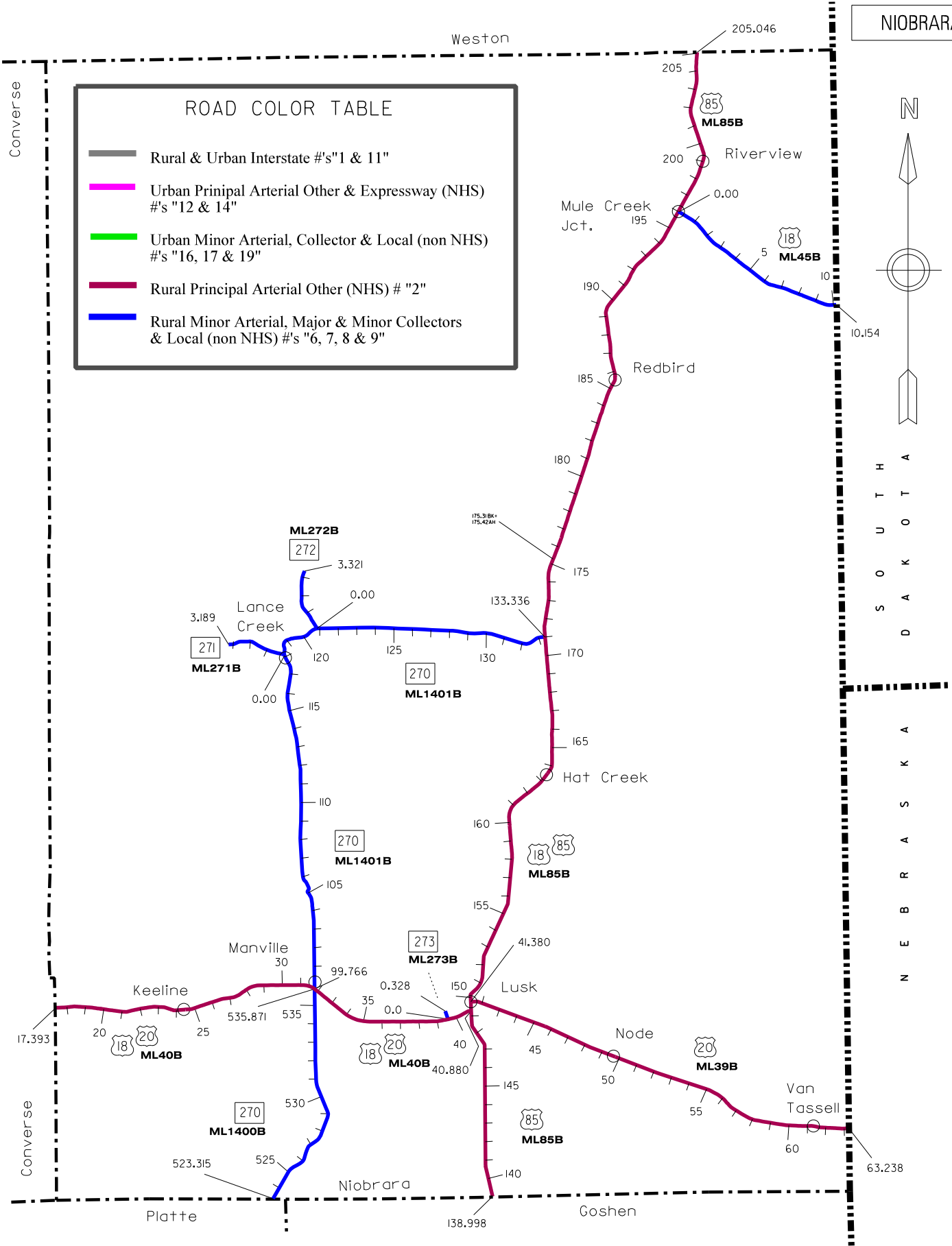

**ROAD COLOR TABLE**

	Rural & Urban Interstate #'s "1 & 11"
	Urban Principal Arterial Other & Expressway (NHS) #'s "12 & 14"
	Urban Minor Arterial, Collector & Local (non NHS) #'s "16, 17 & 19"
	Rural Principal Arterial Other (NHS) # "2"
	Rural Minor Arterial, Major & Minor Collectors & Local (non NHS) #'s "6, 7, 8 & 9"

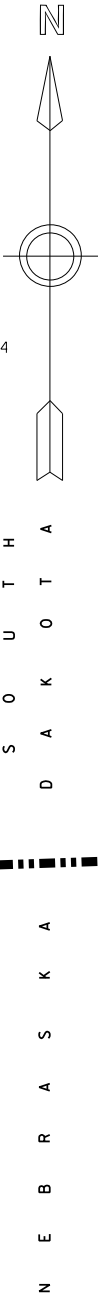





# Niobrara

•• class "classification break"

## County 14

Maint. Section	class	RM	US 85/18/20
CREW			<b>ML - 85B</b>
	2	138.998	Goshen Co. Line, Cont. NHS
<b>NI 01A</b>		147.270	County Rd (northeast)
2035		148.570	<b>S.B. Road Close Gate R/R</b>
		148.990	SCL Lusk
<b>NI 01Z</b>		149.272	US 18/20 (RM 40.884) EAST
2035		149.773	Begin US 18 & 20
		150.008	US 18/20 (RM 41.39) WEST
		150.082	End US 20
		150.082	C&NW RR Sep. [FDD;SS]
		150.082	Niobrara Rv. [FDE;SS]
		150.180	<b>Dept. Shop - Lusk LK 02A</b>
		150.321	NCL Lusk
<b>NI 01B</b>		150.400	<b>N.B. Road Close Gate R/R</b>
2035		170.954	WY 270 (RM 133.34)
		173.738	SB C.M. Sign (dynamic)
		175.313	Old Woman Cr. [BW;SS]
		175.313	BK= - 0.111 mi.
		175.424	AH Equation
		185.100	Red Bird
		185.547	Old Woman Cr. [FEW;SS]
		195.050	Mule Cr. [FGP;SS]
		196.015	<b>S. B. Road Close Gate R/R</b>
		196.042	District Boundary
<b>NI 01C</b>			US 18 (RM 0.00); Mule Cr. Junction
4041			End US 18
			<b>Mule Cr. Rest Area NI 01R</b>
		196.150	<b>N.B. Road Close Gate R/R</b>
		199.760	Cheyenne Rv. [FRA;SS]
		201.980	Bobcat Cr. [FRB;SS]
		202.780	Robbers Roost Cr. [JOH;SS]
	2	205.046	Weston Co. Line
			Cont. NHS
			<b>US 18</b>
			<b>ML - 45B</b>
<b>NI 03A</b>		0.000	US 85 (RM 196.042) Mule Cr. Jct.
4041		6.330	Begin NHS
		10.154	Old Highway
			South Dakota State Line
			End WY NHS

Maint. Section	class	RM	US 18/20
CREW			<b>ML - 40B</b>
	2	17.390	Converse Co. Line
<b>NI 02A</b>			Cont. NHS
2035		24.590	Keeline
		30.790	<b>W.B. Road Close Gate R/R</b>
		31.781	WY 270 (RM 535.87)
			& WY 270 (RM 99.77)
		32.800	Stockpass [HTF;SS]
		33.195	Manville Rd
		38.770	<b>W.B. Road Close Gate R/R</b>
		39.230	EB C.M. Sign (dynamic)
		39.290	<b>Lusk Rest Area NI 02R</b>
		39.591	WY 273 (RM 0.00)
		40.605	WCL Lusk
<b>NI 02X</b>		40.790	<b>Lusk Port-of-Entry NI 02P</b>
2035	2	40.884	US 85/18/20 (RM 149.272) South
			<b>US 20</b>
			<b>ML - 39B</b>
	2	41.380	US 85/18/20 (RM 149.27) north
<b>NI 02Z</b>			End US 18 & US 85
2035			Both NHS
		41.718	Niobrara Rv. [LJA;SS]
		41.850	<b>E.B. Road Close Gate R/R</b>
		41.891	ECL Lusk
		49.687	Node
<b>NI 02B</b>		55.690	S. Fork Niobrara Rv. [FDY;SS]
2035		57.848	C&NW RR Sep. [EOS;SS]
		60.616	WCL Van Tassell
		60.920	Niobrara Rv. [CFC;SS]
		61.170	Railroad X-ing #188616
		61.885	ECL Van Tassell
		62.575	Van Tassell Cr. [FDZ;SS]
	2	63.238	Nebraska State Line
			End WY NHS

Maint.

Maint. Section	class	RM	WY 270
			<b>ML - 1400B</b>
	7	523.315	Platte Co. Line
<b>NI 04A</b>		533.980	Unnamed Draw [JUH;SS]
2035		535.800	<b>S.B. Road Close Gate swing</b>
		535.871	US 18,20 (RM 31.78) & WY 270 (RM 99.77)

Maint.

Maint. Section	class	RM	WY 272
			<b>ML - 272B</b>
	8	0.000	WY 270 (RM 120.86)
<b>NI 08A</b>		2.063	Lance Cr. [BTK;SS]
2035		3.321	End SHS

WY 270

Maint. Section	class	RM	WY 270
			<b>ML - 1401B</b>
	7	99.766	US 18,20 (RM 31.781) & WY 270 (RM 535.87)
<b>NI 05A</b>		100.000	SCL Manville
2035		100.300	<b>N.B. Road Close Gate R/R</b>
		100.380	RR at Grade Crossing #188641D
		100.510	NCL Manville
		116.020	Cherry Creek Bridge [KJT;SS]
		118.090	WY 271 (RM 0.00) Airport Spur
		118.920	Carbon Black Draw
		120.860	WY 272 (RM 0.00)
		122.910	Provost Draw [LOU;SS]
		132.650	Old Woman Cr. [LUI;SS]
		133.300	<b>E.B. Road Close Gate swing</b>
		133.336	US 85/18/20 (RM 170.954)

WY 273

Maint. Section	class	RM	WY 273
			<b>ML - 273B</b>
	9	0.000	US 18/20 (RM 39.591)
<b>NI 09A</b>		0.328	End SHS
2035			Country Club

WY 271

*Airport Spur*

Maint. Section	class	RM	WY 271
			<b>ML - 271B</b>
	8	0.000	WY 270 (RM 118.09)Mainline
<b>NI 06A</b>		0.170	Lance Cr. [LMG;SS]
2035		0.521	Oil Cr.
		2.527	Sheep Cr.
		2.855	Little Lightning Cr. [LMJ;SS]
		3.189	End SHS

M O N T A N A

PARK

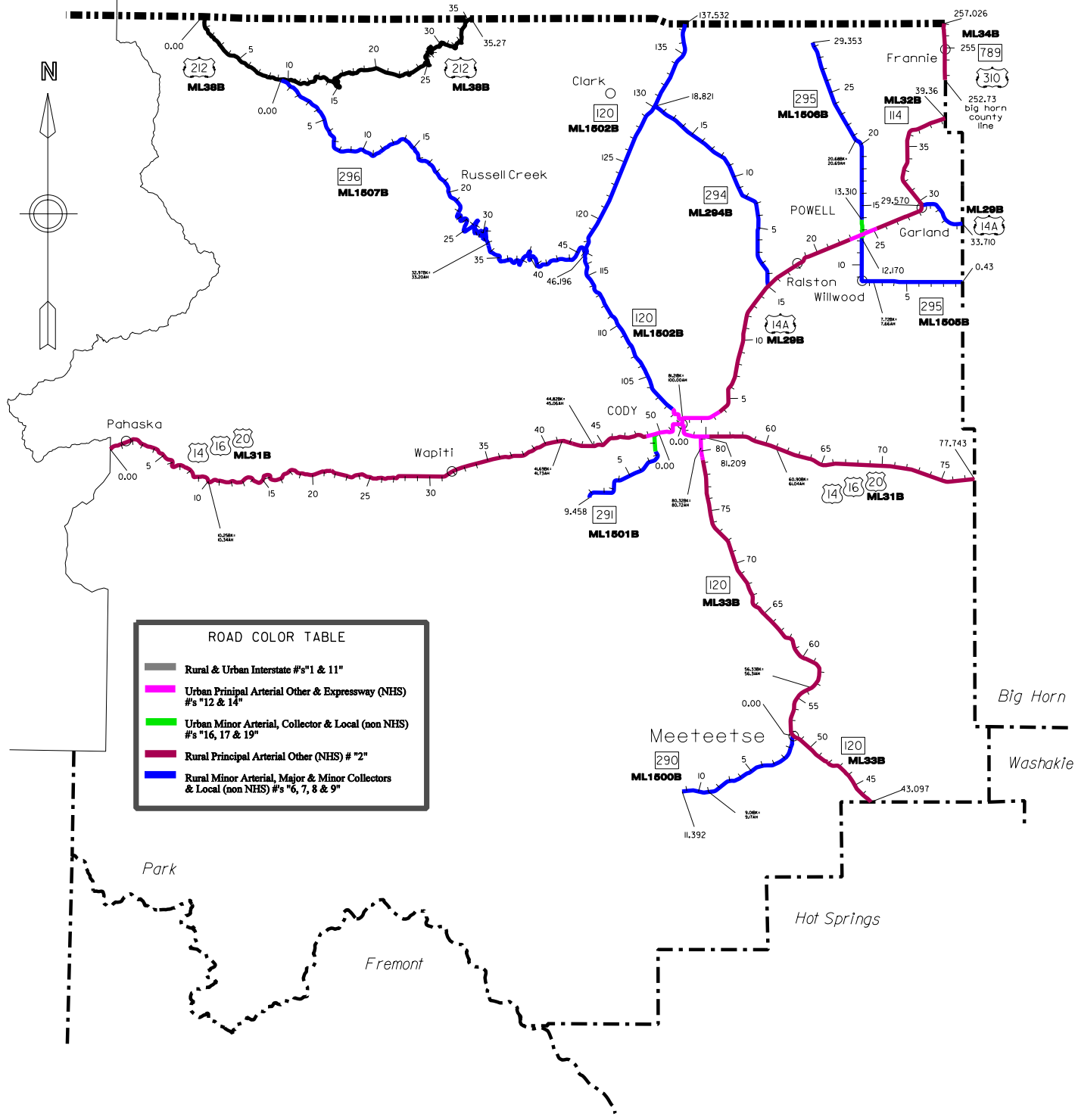

ROAD COLOR TABLE	
	Rural & Urban Interstate #'s "1 & 11"
	Urban Principal Arterial Other & Expressway (NHS) #'s "12 & 14"
	Urban Minor Arterial, Collector & Local (non NHS) #'s "16, 17 & 19"
	Rural Principal Arterial Other (NHS) # "2"
	Rural Minor Arterial, Major & Minor Collectors & Local (non NHS) #'s "6, 7, 8 & 9"



# Park

•• class "classification break"

## County 11

+ Indicates Non State System

Maint. Section	class	RM	US 14/16/20 & WY 120
CREW		<b>ML - 31B</b>	
	2	0.000	W. Boundary Shoshone Nat'l. Forest E. Boundary Yellowstone Park Begin NHS
<b>PA 01A</b>		0.280	Unnamed Draw [JIG;SS]
5032		2.000	<b>Road Closure @Pahaska Lodge</b> <i>Seasonal Closure</i>
		2.040	Pahaska
		2.264	N. Fork Shoshone Rv. [JIM;SS]
		3.701	Grinnel Cr. [JIO;SS]
		4.680	50 Mile Cr. [JIP;SS]
		6.169	Morman Cr. [JIR;SS]
		8.339	Libby Cr. [JIU;SS]
		9.960	Goff Cr. [JIV;SS]
		10.248	BK= - 0.172 mi.
		10.420	AH equation
		12.382	Gunbarrel Cr. [JJA;SS]
		13.556	Cliff Cr.
		14.490	Newton Cr. [JJC;SS]
		15.680	N. Fork Shoshone Rv. [KTB;SS]
		15.830	N. Fork Shoshone Rv. [KTC;SS]
		16.850	Moss Cr. [JF;SS]
		19.740	Clearwater Cr. [JJI;SS]
		20.308	N. Fork Shoshone Rv. [JJJ;SS]
		22.048	Elk's Fork Rv. [JJK;SS]
		24.841	Clocktower Cr. [JBQ;SS]
		27.471	Shoshone Nat'l. Forest Boundary
		31.830	Wapiti
		32.011	N. Fork Shoshone Rv. [DZU;SS]
		36.402	Trout Cr. [DZO;SS]
		40.930	Rattlesnake Canyon Rd
		41.689	BK= - 0.043 mi.
		41.732	AH Equation
		44.820	BK= - 0.242 mi.
		45.062	AH Equation
		45.367	Tunnel [BZQ;SST]
		45.780	Tunnel [BZR;SST]
		45.847	Tunnel [BZS;SST]
	2	46.685	Shoshone Rv. [BZT;SS]
	••	48.748	WUL Cody
	→ 14	48.993	WCL Cody
		49.370	Historical Pullout
<b>PA 01Z</b>		49.510	Demaris Dr.
5032		49.867	WY 291 (RM 0.00)
		50.400	Gulch St
		50.740	Sulphur Cr [FGL;SS]
		51.390	Cody Ave
		51.890	11th St
	14	52.357	US 14A (RM 0.00) BEGIN WY 120
			→ -cont- next column

Maint. Section	class	RM	US 14/16/20 & WY 120
CREW		<b>ML - 31B</b>	
			<i>(CONTINUED)</i>
<b>-cont-</b>			
<b>PA 01Z</b>	14	52.870	Newton Ave
5032		52.950	SCL Cody & Stamped Ave.
	→	53.190	END Curb & Gutter Section
		53.732	Beck Lake [BZU;SS], Cont. NHS
<b>PA 01B</b>		54.040	26th St
5032		54.576	WY 120 (RM 81.21), Cont. NHS End WY 120
		55.112	Beacon Hill Rd
		55.120	CL Cody.
		55.140	<b>Dept. Shop - Cody CD 05A</b>
	14	55.200	ECL Cody
	••	56.370	EUL Cody
	2	57.163	Sage Cr. [BZW;SS]
		58.630	Sage Cr. Rd
		60.901	BK= - 0.142 mi.
		61.043	AH Equation
		61.670	Oregon Basin Rd
		74.724	Dry Cr. [CAA;SS]
	2	77.743	Big Horn Co. Line/ Cont. NHS
			<b>US 14A, WY 120 &amp; WY 114</b>
		<b>ML - 29B</b>	
	14	0.000	US 14A (RM 52.36) Begin NHS
<b>PA 02Z</b>		0.250	Salsbury Ave
5032		0.436	WY 120 (RM 100.00) End WYO 120
		0.550	Begin Divided Section
		0.685	End Divided Section
		1.150	Blackburn Ave
	→ 14	2.440	ECL Cody
	••	3.600	EUL Cody
<b>PA 02A</b>	2	3.766	Sage Cr. [CAD;SS]
5032		4.120	County Rd (south)
		6.515	Shoshone Rv. [CAE;SS]
		6.810	Historical Pullout
		10.940	Iron Cr. [LXN;SS]
		12.180	Unnamed Draw [LXO;SS]
		13.513	Garland Canal [LXU;SS]
		14.147	County Rd (east)
		14.720	Eagle Cr.
		15.040	WY 294 (RM 0.00)
		18.114	Ralston
		18.680	RR at Grade Crossing #090690Y
		18.700	Alkali Cr. [LSI;SS]
	2	18.834	Garland Canal [LSJ;SS]
	••	22.860	WUL Powell
	14		Cont. NHS
	→	23.586	WCL Powell, Cont. NHS

Maint. Section	CREW	class	RM	US 14A, WY 120 & WY 114
<b>ML - 29B</b>				
<i>(CONTINUED)</i>				
<b>PA 02Y</b>	14		23.586	WCL Powell, Cont. NHS
	5032		23.820	Begin Divided Section
			24.040	WY 295 (RM 12.64) NORTH
<b>PA 02X</b>			24.080	WY 295 (RM 12.57) SOUTH
	5035		24.730	ECL Powell
	14		24.830	End Divided Section
<b>PA 02B</b>			25.250	EUL Powell
	5035		28.970	Bitter Cr. [CAH;SS]
			29.520	WY 114 (RM 29.57)
			30.140	BNRR Sep. [FCK;SS]
			33.710	Big Horn Co. Line

**US 212**  
**ML - 38B**  
*(+ Park Service Highway)*

+	0.000	Montana State Line (West)
+	1.040	Index Cr.
+	1.950	Fox Cr.
+	4.460	Clark's Fork Rv.
+	6.380	Crazy Cr.
+	7.990	Gilbert Cr.
+	8.755	BK= - 0.354 mi.
+	9.109	AH Equation
+	9.400	WY 296 (RM 0.00)
+	10.590	Lake Cr.
+	18.330	Beartooth Cr.
+	20.230	Little Beartooth Cr.
+	21.030	Little Beartooth Cr.
+	23.280	Long Lake
+	35.270	Montana State Line (East)

**US 310 & WY 789**  
**ML - 34B**

-cont-				from Big Horn County
	2		252.729	Big Horn Co. Line Cont. NHS
<b>BH 03D</b>			254.650	SCL Frannie
	5035		254.700	<b>Frannie Port-of-Entry BH 03P</b> Web Cam
			255.390	NCL Frannie
			257.010	Sage Cr. [CDE;SS]
			257.026	Montana State Line End WY NHS

Maint. Section	CREW	class	RM	WY 120
<b>ML - 33B</b>				
		2	43.097	Hot Springs Co. Line / Cont. NHS
			49.720	<b>S.B. Road Close Gate R/R</b>
<b>PA 03A</b>			50.200	<b>Dept. Shop - Meeteetse MT 05A</b>
	5036		51.050	Old dept. shop site
			51.380	SCL Meeteetse
			51.633	WY 290 (RM 0.00)
			51.718	NCL Meeteetse
			51.733	Greybull Rv. [LBB;SS]
			52.426	Spring Cr. [CAU;SS]
			54.258	Meeteetse Cr. [CAV;SS]
			54.320	Rd West
			56.325	BK= + 0.015 mi.
			56.310	AH Equation
			58.000	Burlington Rd
			58.250	<b>N.B. Road Close Gate R/R</b>
			58.402	Cottonwood Cr. [CAW;SS]
			61.530	Meeteetse Rim <b>RWIS</b> site {18}
			62.357	Little Dry Cr. [CAX;SS]
			66.020	Dry Cr. [HJS;SS]
			66.600	County Rd (east)
			69.000	Oregon Basin Rd
			72.909	Sage Cr. [CAY;SS]
		2	74.000	Maint. Break
<b>PA 03B</b>			79.160	SUL Cody
	5032	14	79.903	Cody Canal [DIW;SS]
			80.315	BK= - 0.409 mi.
			80.724	AH Equation
			81.073	Alkali Lake [BQY;SS]
			81.160	<b>S.B. Road Close Gate R/R</b>
		14	81.209	BK= - 18.79 mi. US 14/16/20 (RM 81.21)

**WY 120**  
**ML - 1502B**

<b>PA 08Z</b>	14		100.000	AH Equation
	5032			US 14A (RM 0.44)
			100.410	NCL Cody
		14	100.530	Shoshone Rv. [FUV;SS]
<b>PA 08A</b>			101.460	NUL Cody
	5032	6	102.681	Heart Mountain Canal [FLK;SS]
			105.003	Cottonwood Cr. [FLL;SS]
			106.234	Cottonwood Cr. [FLM;SS]
			107.713	Cottonwood Cr. [FLN;SS]
			108.205	Unnamed Draw
			116.910	WY 296 (RM 46.20)
			128.885	Clark's Fork Rv. [CTH;SS]
			129.510	Clark's Fork Rv. [CTI;SS]
			130.100	WY 294 (RM 18.82)
			135.140	Big Sand Coulee [LBY;SS]
		6	137.532	Montana State Line

Maint. Section	class	RM	WY 114
CREW			<b>ML - 32B</b>
	2	29.570	US 14A (RM 29.52)
		30.140	BNRR Overpasss [FCK;SS]
		34.229	Deaver Canal [CAI;SS]
<b>PA 05A</b>		36.349	County Rd (north)
5035		36.620	RR at Grade Crossing #091482B
		36.650	Deaver Canal [CAI;SS]
		39.355	Big Horn Co. Line
			Cont. NHS

→ -cont- in Big horn Co.

			WY 290
			<b>ML - 1500B</b>
	7	0.000	WY 120 (RM 51.63)
<b>PA 06A</b>		0.456	SCL Meeteetse
5036		6.040	Wood Rv. [LIN;SS]
		9.009	BK= - 0.164 mi.
		9.173	AH Equation
		11.392	End SHS

			WY 291
			<b>ML - 1501B</b>
<b>PA 07Z</b>	16	0.000	US 14/16/20 (RM 49.867)
5032			
		0.360	SCL Cody
	16	0.400	Trailer Park
<b>PA 07A</b>	●●	1.660	SUL Cody
5032	7	3.142	Cody Canal W. Sulphur [JLW;SS]
		4.640	County Rd (south)
		4.845	Cody Canal [JLX;SS]
		5.460	Diamond Cr.
		7.060	Cody Canal [JLZ;SS]
		9.458	End SHS

			WY 294
			<i>Badger Basin Rd</i>
			<b>ML - 294B</b>
	7	0.000	US 14A (RM 15.04)
		0.020	RR at Grade Crossing #090695H
<b>PA 09A</b>		0.299	Garland Canal [CTM;SS]
5032		3.976	Alkali Cr. [CTN;SS]
		10.620	Big Sandy Coulee [FIZ;SS]
		13.470	Unnamed Draw [FJA;SS]
		18.821	WY 120 (RM 130.10)

Maint. Section	class	RM	WY 295
CREW			<b>ML - 1505B</b>
-cont-			from Big Horn County
	7	0.432	Big Horn Co. Line
<b>PA 10A</b>		2.983	Roan Wash [CTO;SS]
5035		7.715	BK= + 0.051 mi.
		7.664	AH Equation
		8.226	Willwood Draw [FKB;SS]
		8.682	Willwood
	7	9.551	Shoshone Rv. [CTQ;SS]
●●		11.869	SUL Powell
	16	12.170	SCL Powell
			End State / Begin City
+		12.510	RR at Grade Crossing #090681A
			RR at Grade Crossing #090682G
+		12.549	Garland Canal [CTR;SS]
+		12.570	US 14A (RM 24.08)

			WY 295
			<b>ML - 1506B</b>
		12.640	US 14A (RM 24.00)
<b>PA 10Z</b>	16	13.310	Begin State / End City
5035			7th St
	16	13.820	NCL Powell
<b>PA 10B</b>	●●	14.053	NUL Powell
5035	7	18.200	Frannie Canal [EOV;SS]
			<b>REMOVED EQUATION</b>
	7	29.353	End SHS
			Elk Basin

			WY 296
			<i>Chief Joseph</i>
			<b>ML - 1507B</b>
	7	0.000	US 212 (RM 9.40)
		1.108	Lake Cr. [CTZ;SS]
<b>PA 16A</b>		3.411	Muddy Cr. [CTY;SS]
5032		6.211	Clark's Fork Rv. [CTX;SS]
		7.600	Crandall Cr. [CAN;SS]
		20.400	<b>Dept. Shop - Russell Creek RC 05A</b>
		22.982	Sunlight Cr. [EUC;SS]
		23.480	Sunlight Basin Rd
		25.080	Dead Indian Cr. [FOK;SS]
		32.960	Chief Joseph <b>RWIS</b> site {59}
		32.971	BK= - 0.229 mi.
		33.200	AH Equation
		38.200	Shoshoni NF Boundry
		46.120	Pat O'Hara Cr. [AGE;SS]
		46.196	WY 120 (RM 116.91)









# Platte

## County 8

•• class "classification break"

+ Indicates Non State System

Maint. Section	class	RM	I-25 & US 87
			<b>ML - 25</b>
	1	47.151	Laramie Co. Line
		47.250	Co. Line Int. Underpass [DCW;SS]
<b>PL 01A</b>		50.660	Co. Rd Overpass [DCX;NB, DCY;SB]
2033		51.619	BK= - 0.016 mi.
		51.635	AH Equation
			NB C.M. Sign (dynamic)
		53.488	SCL Chugwater
		53.877	Old US 87 Sep. [ACT;NB, ACU;SB]
		54.031	Chugwater Cr. [ACV;NB, ACW;SB]
		54.140	BNRR Sep. [ACY;NB, ACZ;SB]
		54.340	<b>S.B Road Close Gate R/R</b>
		54.500	CL Chugwater
		54.590	WY 313 (RM 54.59); Chugwater Int.
			[ADB;NB, ADC;SB]
			& WY 211 (RM 63.95)
			<b>Chugwater Rest Area PL 25R</b>
		54.830	<b>N.B. Road Close Gate R/R</b>
		55.013	CL Chugwater
		56.460	NCL Chugwater
		57.649	WY 321 (RM 57.93); Ty Basin Int.
			[ADD;NB, ADE;SB]
		59.013	Unnamed Draw [ADF;NB, ADG;SB]
		59.400	SB C.M. Sign (dynamic)
		64.037	Richeau Cr. [ADH;NB, ADI;SB]
		65.253	WY 314 (RM 0.00); Slater Rd Int.
			[CUG;SS]
		66.200	Hunton Int. [ADJ;SS]
		68.454	Antelope Int. [ADK;NB, ADL;SB]
		69.700	NB C.M. Sign (dynamic)
		70.621	Bordeaux Int. [ADM;NB, AND;SB]
		70.800	Bordeaux <b>RWIS</b> site {13}
		71.500	SB C.M. Sign (dynamic)
		72.360	Maint. Break
		73.025	WY 34 (RM 52.29); WY 34 Int.
			[ADO;NB, ADP;SB]
<b>PL 01B</b>		76.620	Rock Cr. [CBU;SS]
2039		77.000	SB C.M. Sign (dynamic)
		77.820	<b>S.B. Road Close Gate R/R</b>
		78.347	SCL Wheatland
		78.931	US 87 BUS (RM 78.93);S.Wheatland Int.
			[CKR;SS]
		79.278	South Street Overpass [BRH;NB, CBF;SB]
		79.447	#2 Canal [BPF;NB, BTF;SB]
		79.594	Pedestrian Underpass
		79.846	Oak Street Underpass [CGT;SS]
		80.096	NCL Wheatland
		80.853	US 87 BUS (RM 81.89);N. Wheatland Int.
	1		[BTH;NB, BTI;SB]

Maint. Section	class	RM	I-25 & US 87
			<b>ML - 25</b>
			<i>(CONTINUED)</i>
	1	80.920	BK= - 0.053 mi.
		80.973	AH Equation
		81.503	BNRR Sep. [ADT;NB, ADU;SB]
		82.020	<b>N.B. Road Close Gate R/R</b>
		82.198	Fairview Sep. [ADV;SS]
<b>PL 01B</b>		84.003	Laramie Rv. [ADW;NB,ADX;SB]
2039		84.744	Laramie Rv. Int. [ADY;NB, ADZ;SB]
		87.032	Laramie Rv. [AEA;NB, AEB;SB]
		87.505	N. Laramie Rv. Int. [AEC;NB, AED;SB]
		88.625	Fish Cr. [AEE;NB, AEF;SB]
		92.371	US 26 (RM 0.00); Dwyer Jct. Int.
			[AEG;NB, AEH;SBR], Begin US 26
			<b>Dwyer Jct. Rest Area PL 01R</b>
		92.860	<b>N.B. Road Close Gate R/R</b>
		94.825	El Rancho Int. [AEJ;NB, AEK;SB]
		95.140	Spring Cr. [AEL;NB, AEM;SB]
		95.696	Spring Cr. [AEO;NB, AEP;SB]
		96.443	Co. Rd Sep. [AEQ;NB, AER;SB]
		96.721	Cottonwood Cr. [AET;NB, AEU;SB]
		98.506	Co. Rd Sep. [AEV;NB, AEW;SB]
		98.710	Coleman <b>RWIS</b> site {14}
		100.125	WY 319 (RM 100.13); Cassa Int.
			[AEX;NB, AEY;SB]
		100.560	South Bear Cr. [AEZ;NB, AFA;SB]
		103.993	Middle Bear Cr. [AFB;NB, AFC;SB]
		104.043	Middle Bear Int. [AFD;NB, AFE;SB]
		108.736	BK= - 0.045 mi.
		108.781	AH Equation
		109.118	Machinery Pass Sep. [AFF;NB, AFG;SB]
		109.486	Horseshoe Cr. [AFH;NB, AFI;SB]
		110.552	Horseshoe Cr. Sep. [AFJ;NB, AFK;SB]
		111.396	SCL Glendo
		111.675	WY 319 (RM 111.68); Glendo Int.
			[AFL;NB, AFM;SB]
<b>PL 01C</b>		112.176	NCL Glendo
2034		114.675	Co. Rd Overpass [CHD;NB, CZH;SB]
		117.483	Elkhorn Co. Rd Sep [CZI;NB, CZJ;SB]
		117.683	Elkhorn Cr. [CZK;NB, CZL;SB]
		119.866	Machinery Pass Sep. [CZM;NB, CZN;SB]
	1	120.817	Converse Co. Line

→ -cont- next column

Maint. Section	class	RM	US 26
			<b>ML - 27B</b>
<b>PL 04A</b>	2	0.000	I-25 (RM 92.37); Dwyer Jct. [AEG;NB, AEH;SBR], Begin NHS
2039		1.300	County Rd (north)
		2.600	WY 320 (RM 12.33)
		3.280	Dwyer Rd.
		4.096	BNRR Sep. [BPG;SS]
		12.180	Wendover Rd.
		14.400	<b>W.B. Road Close Gate R/R</b>
		14.417	WY 317 (RM 0.00)
		14.740	North Platte Rv. [EOE;SS]
		14.780	WCL Guernsey
		15.501	ECL Guernsey
		16.222	BNRR Sep. [BXM;SS]
		16.500	<b>Yard (Dept.) GU 02A</b>
		16.549	WY 270 (RM 495.47)
		17.800	<b>Guernsey Rest Area PL 04R</b>
		18.706	Whalen Draw [BXN;SS]
		20.008	Co. Line Draw [BXO;SS]/Goshen Co Line Cont. NHS

Maint. Section	class	RM	WY 34
			<b>ML - 109B</b>
<b>PL 03A</b>	6	30.553	Albany Co. Line / District Boundary
2039		32.380	<b>W.B. Road Close Gate R/R</b>
		32.567	South Sybille Cr. [DZQ;SS]
		34.020	Sybille Cr. [EVZ;SS]
		35.883	Blue Grass Cr. [EVL;SS]
		36.850	Wheatland Tunnel Rd.
		41.629	Sybille Cr. [EVK;SS]
		44.450	County Rd. (south)
		44.844	Canal #3 [EVJ;SS]
		44.981	Sand Cr. [EVI;SS]
		45.179	Canal #3 [DJV;SS]
		46.450	County Rd. (north & south)
		46.532	Lateral #1 [EVH;SS]
		50.590	BK= +0.081 mi
		50.509	AH Equation
		50.640	<b>W.B. Road Close Gate R/R</b>
		50.655	WY 312 (RM 0.00)
		52.293	I-25 (RM 73.03); WY 34 Int. [ADO;NB, ADP;SB]

Maint. Section	class	RM	US 87 Bus.
			<b>ML - 57B</b>
<b>PL 19A</b>	6	78.931	I-25 (RM 78.93); S. Wheatland Int. [CKR;SS]
2039		79.070	<b>Dept. Shop - Wheatland WL 02A</b>
		79.404	WY 310 (RM 0.00) & WY 312 (RM 7.30)
		80.017	Wheatland Canal #2 [KBR;SS]
		80.096	WY 316 (RM 0.00)
		80.474	Oak St.
		80.670	CL Wheatland
		80.920	BK= - 0.014 mi.
		80.934	AH Equation
		80.964	CL Wheatland
		81.027	WY 320 (RM 0.00)
		81.714	NCL Wheatland
		81.891	I-25 (RM 80.85); N. Wheatland Int. [BTH;NB, BTI;SB]

Maint. Section	class	RM	WY 211
			<b>ML - 211B</b>
<b>PL 13A</b>	7	63.008	Begin SHS
2033		63.034	WCL Chugwater
		63.160	NCL Chugwater
		63.954	I-25 (RM 54.59); Chugwater Int. [ADB;NB, ADC;SB]

Maint. Section	class	RM	WY 270
			<b>ML - 1400B</b>
<b>PL 05A</b>	7	495.473	US 26 (RM 16.549)
2039		499.830	SCL Hartville
		500.000	WY 318 (RM 4.53)
		500.020	<b>N.B. Road Close Gate swing</b>
		500.210	WCL Hartville
		517.810	Miller Draw [FGF;SS]
		522.289	BK= -0.947 mi.
		523.236	AH Equation
		523.315	Niobrara Co. Line

Maint. Section	class	RM	WY 310
			<b>ML - 1600B</b>
	+	0.000	US 87 bus. (RM 79.40) & WY 312 (RM 7.30)
			<b>REMOVED EQUATION</b>
			Oak Street
	+	0.628	Oak Street Underpass [CGT;SS]
	7	1.002	WCL Wheatland
<b>PL 06A</b>			End City Section / Begin State
2039		1.438	WY DVLPMPT #2 Canal [CBA;SS]
		4.160	WY DVLPMPT Canal [CBB;SS]
		4.499	WY 311 (RM 0.00)
		4.510	WY DVLPMPT Canal [CBX;SS]
		8.486	End SHS @Co. Rd. to Reservoir

			WY 311 North Spur
			<b>ML - 1601B</b>
<b>PL 14A</b>	7	0.000	WY 310 (RM 4.50)
2039		1.994	End SHS @Co. Rd.

			WY 312
			<b>ML - 312B</b>
	8	0.000	WY 34 (RM 50.655)
		2.930	Rock Cr. [CCD;SS]
<b>PL 07A</b>		5.990	County Rd. (west)
2039		6.230	WCL Wheatland
		7.180	South Street Overpass
		7.304	US 87 Bus. (RM 79.40)

			WY 313
			<b>ML - 1602B</b>
	7	100.000	WY 321 (RM 55.18)
<b>PL 08A</b>		100.050	RR at Grade Crossing #245470L
2033		100.270	<b>E.B. Road Close Gate swing</b>
		100.483	Chugwater Cr. [CUF;SS]
		100.739	ECL Chugwater
		116.830	BK= +0.020
		116.180	AH Equation
		109.313	Goshen Co. Line

			WY 314
			<b>ML - 314B</b>
	8	0.000	I-25 (RM 65.25); Slater Rd Int. [CUG;SS]
<b>PL 09A</b>		1.969	Richeau Cr. [CUH;SS]
2033		2.840	RR at Grade Crossing #245478R
		3.000	Slater
		3.284	Chugwater Cr. [CUI;SS]
		6.563	WY 315 (RM 0.00) North Spur
		8.566	End SHS

Maint. Section	class	RM	WY 315 North Spur
			<b>ML - 1605B</b>
<b>PL 15A</b>	8	0.000	WY 314 (RM 6.56)
2033		2.840	RR at Grade Crossing #245478R
		3.000	Slater
		3.006	End SHS

			WY 316
			<b>ML - 1604B</b>
	+	0.000	US 87 Bus. (RM 80.10)
	+	0.070	8th St.
	7	0.091	End City Section / Begin State
<b>PL 10Z</b>		0.120	RR at Grade Crossing #245492L
2039		0.210	Rock Cr. [KET;SS]
		0.530	Front St.
		0.810	Airport Rd.
		0.820	ECL Wheatland
<b>PL 10A</b>	7	3.212	Chugwater Cr. [LHG;SS]
2039		7.858	Class. Break
	8	11.911	End SHS

			WY 317
			<b>ML - 317B</b>
<b>PL 11A</b>	8	0.000	US 26 (RM 14.417)
2039		1.660	Guernsey Reservoir
			End SHS

			WY 318
			<b>ML - 318B</b>
<b>PL 05B</b>	7	4.529	WY 270 (RM 500.00)
2039		5.180	ECL Hartville
		5.623	End SHS

			WY 319
			<b>ML - 319B</b>
	8	100.125	I-25 (RM 100.13); Cassa Int. [AEX;NB, AEY;SB]
<b>PL 16A</b>		104.822	South Bear Cr.
2039		105.830	Cassa
		106.347	Middle Bear Cr. [CUM;SS]
		108.035	North Bear Cr. [CUN;SS]
		112.454	Horseshoe Cr. [FJB;SS]
		114.189	Whiskey Cr. [CZF;SS]
		114.282	SCL Glendo
		114.309	BNRR Sep. [MIO;SS]
		114.622	BK= - 97.26 mi.
			<b>Maint. Brk. @ Equation</b>
		211.876	AH Equation WY 319 (RM 111.88) Glendo Connector
<b>PL 18A</b>		212.413	NCL Glendo
2034		214.289	Dry Wash [CZG;SS]
		217.893	Elkhorn Cr. [CYY;SS]
	8	220.997	Converse Co. Line

Maint. Section	class	RM	WY 319 Glendo Connector
			<b>ML - 1606B</b>
<b>PL 20A</b>	8	111.676	I-25 (RM 111.68); Glendo Int.
2034		111.830	RR at Grade Crossing #089268W
		111.876	WY 319 (RM 211.88)

Maint. Section	class	RM	WY 320
			<b>ML - 1610B</b>
	7	0.000	US 87 Bus. (RM 81.03)
		0.057	CL Wheatland
<b>PL 17A</b>		0.480	County Rd. (west)
2039		1.217	Wheatland Cr. [CNI;SS]
		2.180	Power Plant Rd.
		2.370	<b>N.B. Road Close Gate swing</b>
		2.518	Wheatland Cr. [CUE;SS]
		3.913	Laramie Rv. [FEJ;SS]
		4.500	UVA Rd.
		5.036	North Laramie Rv. [FFM;SS]
		12.329	US 26 (RM 2.60)

Maint. Section	class	RM	WY 321
			<b>ML - 321B</b>
<b>PL 02A</b>		54.590	I-25 (RM 54.59); Chugwater Int.
2033			[ADB;NB, ADC;SB]
			& WY 211 (RM 63.95)
		54.840	WCL Chugwater
	9	55.180	WY 313 (RM 100.00)
		55.660	<b>Dept. Shop - Chugwater CW 02A</b>
		55.700	<b>N.B. Road Close Gate swing</b>
		56.640	NCL Chugwater
		57.781	BK= - 0.057 mi.
		57.838	AH Equation
		57.930	I-25 (RM 57.65); Ty Basin Int.
		57.930	End SHS @Cattleguard

Maint. Section	class	RM	I-25 SV. RD.
			<b>ML - 1118B</b>
	9	19.700	Laramie Co. Line
<b>PL 01K</b>		26.000	CL Chugwater
2033		26.430	I-25 Overpass
		26.580	Chugwater Cr. [ACX;ESR]
		26.900	Railroad Sep. [ADA;ESR]
		27.060	<b>S.B. Road Close Gate swing</b>
		27.100	WY 321 (RM 55.01)

Maint. Section	class	RM	I-25 SV. RD.
			<b>ML - 1615B</b>
	9	3.100	I-25 (RM 94.83); El Rancho Int.
<b>PL 01N</b>		3.560	Spring Cr. [AEN;WSR]
2039		5.030	I-25 Sep. (RM 96.44)
		5.360	Cottonwood Cr. [AES;ESR]
		9.010	WY 319 (RM 100.20)

Maint. Section	class	RM	I-25 SV. RD.
			<b>ML - 1616B</b>
<b>PL 01J</b>	9	0.000	WY 211 (RM 63.81)
2033		0.510	CL Chugwater
		1.390	End Sv. Rd. @Trail

Maint. Section	class	RM	I-25 SV. RD.
			<b>ML - 1617B</b>
	9	0.000	16th & Cole Streets
		0.130	15th st.
<b>PL 01M</b>		0.200	14th st.
2039		0.550	South CL Wheatland
		2.020	Gibson Rd.
		3.040	Snook Rd.
		3.740	<b>Yard (Dept.) WL 02B</b>
		6.000	I-25 (RM 73.03) WY 34 Int.

Maint. Section	class	RM	I-25 SV. RD.
			<b>ML - 1618B</b>
<b>PL 01H</b>	9	0.000	South Chugwater Rd.
2033		0.410	CL of Chugwater

Maint. Section	class	RM	I-25 SV. RD.
			<b>ML - 1619B</b>
	8	0.000	I-25 (RM 78.93)
<b>PL 22A</b>		0.700	CL Wheatland
2039	●●	0.090	Class. Break
	9	2.450	Rock Cr. [ADQ;WSR]
		3.250	End Sv. Rd. @Dead End

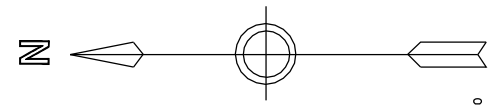

**ROAD COLOR TABLE**

	Rural & Urban Interstate #s "1 & 11"
	Urban Principal Arterial Other & Expressway (NHS) #s "12 & 14"
	Urban Minor Arterial, Collector & Local (non NHS) #s "16, 17 & 19"
	Rural Principal Arterial Other (NHS) # "2"
	Rural Minor Arterial, Major & Minor Collectors & Local (non NHS) #s "6, 7, 8 & 9"

M O N T A N A

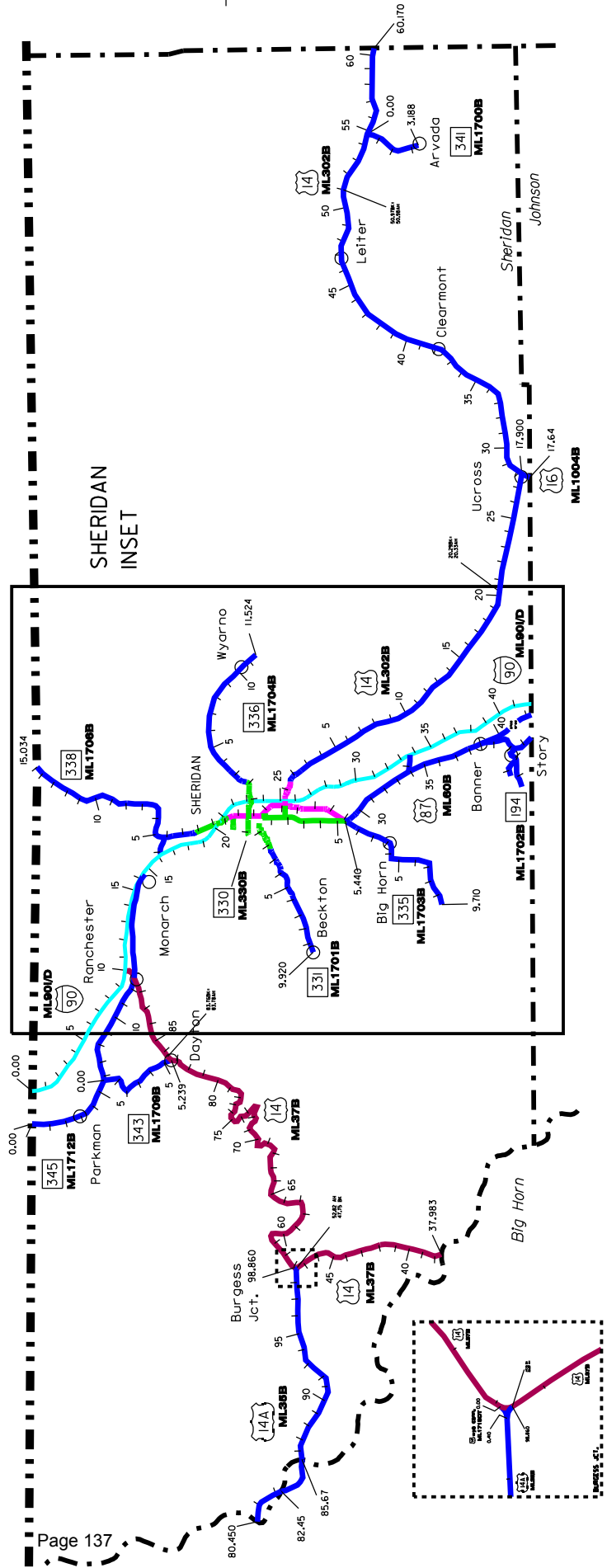

M O N T A N A

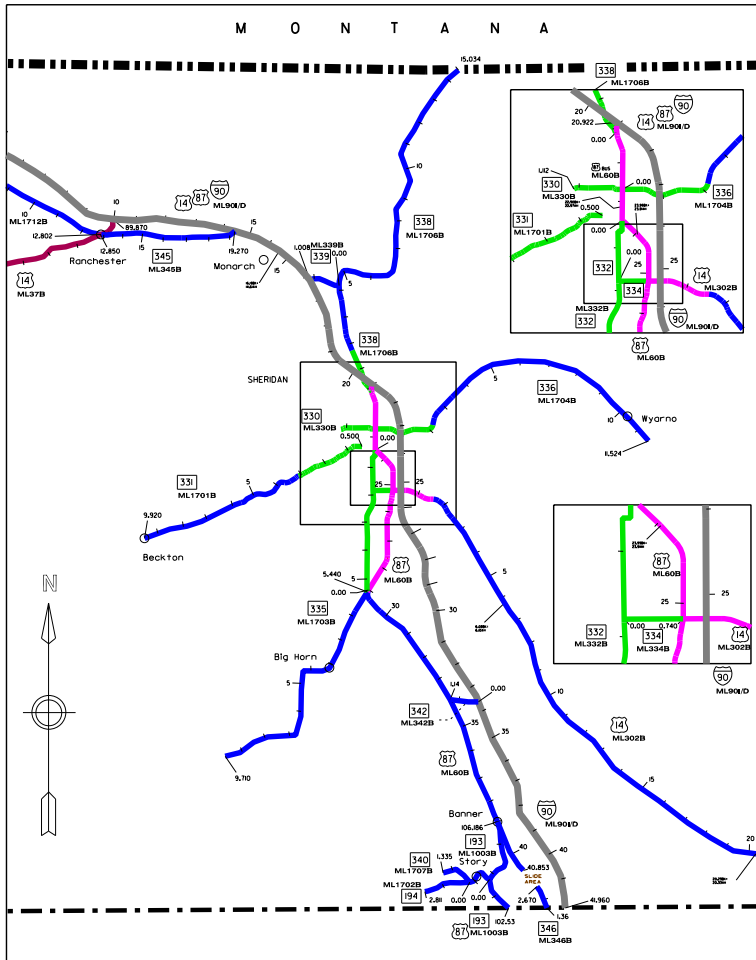

SHERIDAN INSET



# Sheridan

•• class "classification break"

## County 3

+ Indicates Non State System

Maint. Section	CREW	CLASS	RM	I-90, US 87 & US 14
<b>ML - 90</b>				
		1	0.000	Montana State Line
			0.100	State Line <b>RWIS</b> site {52}
			1.794	Parkman Int. [EEO;EB, EOP;WB]
<b>SH 01A</b>			4.190	Machinery Pass Sep. [EUI;EB, EUJ;WB]
4033			6.300	Machinery Pass Sep. [EUK;EB, EUL;WB]
			8.414	Machinery Pass Sep. [EVD;EB, EVE;WB]
			9.300	<b>W.B. Road Closed Gate R/R</b>
			9.882	US 14 (RM 89.87); Ranchester Int. [DZX;EB, DZY;WB], Begin US 14
			11.014	County Rd Overpass [DZZ;EB, EAA;WB]
			11.861	Machinery Pass Sep. [EAB;EB, EAC;WB]
			13.288	Co. Rd Sep. [EAG;EB, EAH;WB]
			14.155	Machinery Pass Sep. [EAE;EB, EAF;WB]
			16.185	BK= + 1.576 mi.
			14.609	AH Equation
			14.618	WY 345 (RM 19.27); Acme Int. [BAV;EB, BAW;WB]
			14.890	BNRR Sep. [BAX;EB, BAY;WB]
			15.010	Tongue Rv. [BAZ;EB, BBA;WB]
			16.341	WY 339 (RM 1.01); Dietz Int.[LLW;SS]
				<b>Sheridan Port-of-Entry SH 01P</b>
			16.600	<b>W.B. Road Closed Gate R/R</b>
			17.700	Co. Rd Sep. [BBB;EB, BBC;WB]
		1	18.390	Co. Rd Sep. [BBD;EB, BBE;WB]
		••	18.930	NUL Sheridan
		11	19.460	Co. Rd Sep. [BBF;EB, BBG;WB]
			20.531	Old Highway Sep. [BBH;EB, BBI;WB]
			20.592	Big Goose Cr. [BBJ;EB, BBK;WB]
			20.920	I-90 BUS (RM 20.92); N. Sheridan Int. [BBL;EB, BBM;WB]
			21.100	BNRR & Co. Rd Sep. [BBN;EB, BBO;WB]
			21.970	Co. Rd Sep. [BBP;EB, BBQ;WB]
			23.156	WY 336 (RM 0.95); 5th St. Int. [KKY;EB, KKZ;WB]
				<b>Sheridan Info. Center &amp; Rest Area SH 01R</b>
			23.540	Co. Rd Sep. [BBT;EB, BBU;WB]
			23.730	BNRR Sep. [BBV;EB, BBW;WB]
			24.510	Machinery Pass Sep. [BBX;EB, BBY;WB]
		11	25.200	<b>E.B. Road Closed Gate R/R</b>
		→	25.300	US 14 BUS (0.29); US 14 Int. [BBZ;EB, BCA;WB] End US 14 & 87

Maint. Section	CREW	CLASS	RM	I-90, US 87 & US 14
<b>ML - 90</b>				
<i>(CONTINUED)</i>				
		→	25.300	US 14 BUS (0.29); US 14 Int. [BBZ;EB, BCA;WB], End US 14 & 87
		11		
<b>SH 01B</b>		••	29.230	SUL Sheridan
4033		1	32.981	Meade Cr. [BCB;EB, BCC;WB]
			33.598	WY 342 (RM 0.00); Meade Rd Int. [BCD;EB, BCE;WB]
			36.097	Pompey Cr. Rd Sep. [BCF;EB, BCG;WB]
			36.339	Machinery Pass Sep. [BCH;EB, BCI;WB]
			37.155	Prairie Dog Co. Rd Int[BCJ;EB, BCK;WB]
			37.561	Machinery Pass Sep [BCL;EB, BCM;WB]
		1	41.959	Johnson Co. Line
		→		<b>-cont- Johnson Co.</b>
<b>US 14A</b>				
<b>ML - 35B</b>				
		-cont-		from Big Horn county
		6	80.450	Big Horn Co. Line/District Boundry
			82.450	Sheridan Co. Line
			82.400	<b>W.B. Road Close Gate R/R</b>
<b>SH 06A</b>			85.670	Big Horn Co. Line
4038			93.680	N. Fork Tongue River [HPP;SS]
			98.100	<b>W.B. Road Close Gate R/R</b> <i>Seasonal Closure</i>
			98.640	<b>Dept. Shop - Burgess Jct. BJ 04A</b>
			98.690	Wye Connector (RM 0.410)
			98.860	US 14 (RM 47.75); Burgess Jct. End US 14A / Begin NHS US 14
<b>US 14 Y Conn.</b>				
<b>OT - 1718</b>				
<b>SH 24A</b>		6	0.000	Begin East Wye US 14 (RM 57.06)
4038			0.410	End East Wye US 14A (RM 98.69)

Maint. Section	class	RM	US 14/14A
			<b>ML - 37B</b>
<b>SH 04A</b>	2	37.983	Big Horn Co. Line / District Boundary
4038			Cont. NHS
		38.210	Hunt Mtn. Rd.
		42.510	Wolf Rd.
		46.100	<b>W.B. Road Closed Gate R/R</b>
		47.750	US 14A/14 (RM 98.86); Burgess Jct.
			BK= - 9.07 mi.
		56.820	AH
		57.060	Overhead Sign
			Wye Connector (RM 0.00)
		58.406	<b>Medicine Wheel Visitor Center</b>
			<b>SH 04R</b>
		60.164	South Fork Tongue Rv. [JBZ;SS]
		69.868	BK= - 2.742 mi.
		76.590	Big Horn Nat'l. Forest
		77.320	Maint. Break
		81.400	<b>W.B. Road Closed Gate R/R</b>
		82.801	WCL Dayton
		82.847	Little Tongue Rv. [CDP;SS]
<b>SH 04B</b>		83.535	Tongue Rv. [CDQ;SS]
4033		83.553	NCL Dayton
		83.643	WY 343 (RM 5.24)
		83.760	BK= - 0.02 mi.
		83.780	AH Equation
		88.454	WCL Ranchester
		88.600	Unnamed Draw [HQC;SS]
		89.380	BNRR Sep. [CDR;SS]
		89.548	WY 345 (RM 12.80)
			Begin US 87
		89.548	WY 345 (RM 12.85); ECL Ranchester
	2	89.870	I-90 (RM 9.882); Ranchester Int.
			End NHS

Maint. Section	class	RM	US 14/87 BUS & US 14/16
			<b>ML - 302B</b>
<b>SH 03A</b>	14	0.000	US 87 (RM 25.16); East Spur
4033			& WY 334 (RM 0.74)
		0.290	I-90 (RM 25.30); US 14 Int.
			End US 14 bus & US 87 Bus.
			Begin US 14
	14	1.480	Wakely Rd.
	●●	1.610	EUL Sheridan
	7	2.090	Deadman Cr. [IZV;SS]
		4.910	Prairie Dog Cr. [DLG;SS]
		5.280	Upper Cat Rd. (east)
		6.081	BK= - 0.023 mi.
		6.104	AH Equation
		7.280	Meade Cr Rd (east)
		10.480	Upper Prairie Dog Rd.
		14.910	Dow Prong Rd (north)
		19.370	Lower Piney Rd (south)
		20.275	BK= - 0.053 mi.
		20.328	AH Equation
		21.420	Piney Cr. [DLH;SS]
		25.417	Boxelder Cr. [DLI;SS]
		27.765	US 16 (RM 17.90); Ucross Jct.
			Begin US 16
<b>SH 03B</b>		27.855	Piney Cr. [FLE;SS]
4036		27.960	Ucross
		28.316	Coal Cr. [FLD;SS]
		29.440	Donkey Cr. [IYX;SS]
		33.081	Unnamed Draw
		35.890	Ulm Rd
		36.087	Lonetree Cr. [FDP;SS]
		37.750	Town Draw [FJO;SS]
		37.800	SCL Clearmont
		38.650	NCL Clearmont
		39.464	Whitimore Draw [CKO;SS]
		41.410	Blackstump Draw [CKP;SS]
		43.839	Deadman Cr. [LCN;SS]
		45.983	Clear Cr. [BTG;SS]
		46.950	Leiter
		50.988	BK= - 0.014 mi.
		50.974	AH Equation
		52.668	BNRR Sep. [FHX;SS]
		54.720	US 14/16 (RM 0.00); Arvada Spur
		55.063	Powder Rv. [FHY;SS]
	7	60.170	Campbell Co. Line

Maint. Section	class	RM	US 14/87 BUS, I-90 BUS & US 87
		<b>ML - 60B</b>	
	14	20.922	I-90 (RM 20.92); N. Sheridan Int.
		21.140	WY 338 (RM 0.00)
<b>SH 02Z</b>			End Divided Section
4033		21.650	RR at Grade Crossing #098901V
		21.662	WY 337 (RM 0.00)
			Begin 4-Lane
		21.720	NCL Sheridan
		22.220	Begin Divided Section
<b>SH 02A</b>		22.605	WY 330 (RM 0.00)
4033			& WY 336 (RM 0.00)
		22.792	Motel Ped. Overpass
		22.894	Little Goose Cr. [BMS;SS]
		22.899	BK= - 0.069 mi.
		22.968	AH Equation
			End Divided Section
		23.337	WY 331 (RM 0.00)
		23.460	WY 332 (RM 0.00)
		23.990	BK= + 0.079 mi.
		23.911	AH Equation
		24.200	SCL Sheridan
		24.314	Little Goose Cr. [DEM;SS]
		25.159	US 14 BUS (RM 0.00)
			& WY 334 (RM 0.74)
			End US 14 Bus., US 87 Bus. & I-90 Bus.
			Begin US 87
		25.870	Sheridan Jr College
		27.698	Little Goose Cr. [CZY;SS]
	14	29.110	WY 335 (RM 0.00)
	●●	29.150	SUL Sheridan
	7	29.677	Little Goose Cr. [CZZ;SS]
		32.770	Kruse Rd.
	7	33.926	WY 342 (RM 1.14)
		35.617	Bird Farm Rd.
	●●	38.899	US 87/WY 193 (RM 106.19)
	9	40.853	<b>Roadway Ends @Slide Area</b>
		<b>US 16</b>	
		<b>ML - 1004B</b>	
<b>-cont-</b>		from Johnson county	
<b>JO 13A</b>	7	17.640	Johnson Co. Line
4036		17.900	US 14 (RM 27.765)

Maint. Section	class	RM	WY 193
		<b>ML - 1003B</b>	
<b>-cont-</b>		from Johnson county	
	7	102.527	Johnson Co. Line
<b>SH 07A</b>		103.582	S. Piney Cr. [FFA;SS]
4033		103.919	WY 194 (RM 0.00)
		103.982	N. Piney Cr. [FFB;SS]
		104.340	Scenic Overlook
		106.186	US 87 (RM 38.90)
		<b>WY 194</b>	
		<i>Fish Hatchery road</i>	
		<b>ML - 1702B</b>	
	7	0.000	WY 193 (RM 103.92); Mainline
<b>SH 17A</b>		0.350	Prairie Dog Cr. [CQO;SS]
4033		0.593	WY 340 (RM 0.00)
		1.079	Prairie Dog Cr. [BMW;SS]
		2.811	End SHS
		<b>WY 330</b>	
		<b>ML - 330B</b>	
	16	0.000	US 14 (RM 22.61)
			& WY 336 (RM 0.00)
<b>SH 08Z</b>		0.080	Val Vista St.
4033		0.190	Big Goose Cr. [CUO;SS]
		1.040	Kentucky St.
		1.110	WCL Sheridan
			End SHS / Begin Non-State
	+	3.070	WUL Sheridan
		<b>WY 331</b>	
		<b>ML - 1701B</b>	
	+	0.000	US 14 (RM 23.34)
	+	0.500	Big Goose Cr. [DKQ;SS]
	16	0.723	End City / Begin State
<b>SH 09A</b>			Highland Ave.
4033	16	0.860	WCL Sheridan
	●●	3.100	WUL Sheridan
	7	4.060	Big Goose Cr. [CUQ;SS]
		6.480	Big Goose Cr. [CUR;SS]
	7	9.916	Beckton, End SHS

Maint. Section	class	RM	WY 332
CREW			<b>ML - 332B</b>
	+	0.000	US 14,87,I-90 bus. (RM 23.46)
	16	0.557	SCL Sheridan
<b>SH 10A</b>			End City / Begin State
4033		1.350	Airport Spur Road
		1.620	WY 334 (RM 0.00);East Spur
		5.440	WY 335 (RM 0.00)

Maint. Section	class	RM	WY 334
			<b>ML - 334B</b>
	16	0.000	WY 332 (RM 1.62); Mainline
<b>SH 19A</b>			Dept. Shop - Sheridan DH 04A
4033		0.360	Little Goose Cr. [JNN;SS]
		0.740	US 14 (RM 25.16)
			US 14 Bus. (RM 0.00)

Maint. Section	class	RM	WY 335
			<b>ML - 1703B</b>
	17	0.000	US 87 (RM 29.11)
<b>SH 11A</b>	●●	0.050	SUL Sheridan
4033	7	0.160	WY 332 (RM 5.440)
		3.140	Big Horn
		7.020	Little Goose Canyon Rd (south)
		7.200	Colorado Colony Ditch [DAH;SS]
		9.710	End SHS

Maint. Section	class	RM	WY 336
			<b>ML - 1704B</b>
<b>SH 12Z</b>	16	0.000	US 14 (RM 22.61)
4033			& WY 330 (RM 0.00)
		0.140	RR at Grade Crossing #104171R
	16	0.630	ECL Sheridan
<b>SH 12A</b>	●●	0.950	I-90 (RM 23.156); 5th Street Int.
4033	17	1.180	Sheridan Info. Center & Rest Area
			SH 01R ( I-90 MP 23.15)
	17	1.250	Maint. Break
		1.450	New Dept. Shop - Sheridan DH 04B
	●●	2.180	EUL Sheridan
	7	3.412	Prairie Dog Cr. [CUT;SS]
		4.450	Lower Prairie Dog Rd (north)
		5.570	Wildcat Cr. [CUU;SS]
		7.040	RR at Grade Crossing #098799S
		7.250	RR at Grade Crossing #098798K
		8.437	Dutch Cr. [CUV;SS]
		9.580	Negro Draw [ILJ;SS]
		10.350	WYARNO
	7	11.524	End SHS

Maint. Section	class	RM	WY 338
CREW			<b>ML - 1706B</b>
	17	0.002	US 14 (RM 21.14)
<b>SH 14A</b>		0.160	Big Goose Cr. [FEC;SS]
4033	17	0.596	Old Highway Sep.
	●●	1.710	NUL Sheridan
	7	3.285	Big Goose Cr. & BNRR Sep. [FEF;SS]
		4.145	WY 339 (RM 0.00); Jensik Connector
		10.500	Ash Cr Oil Field Rd.
		10.730	Tongue Rv. [FLO;SS]
		11.130	Ash Cr [FSC;SS]
		13.220	Young's Cr. [FQM;SS]
	7	15.034	Montana State Line

Maint. Section	class	RM	WY 339
			<b>ML - 1705B</b>
	7	0.000	WY 338 (RM 4.15); Mainline
<b>SH 20A</b>		0.020	BNRR at Grade Crossing #104137J
4033		0.060	Big Goose Cr. [CVC;SS]
		1.008	I-90 (RM 16.341); Dietz Int.[LLW;SS]

Maint. Section	class	RM	WY 340
			<b>ML - 1707B</b>
<b>SH 15A</b>	7	0.000	WY 194 (RM 0.59)
4033		1.355	End SHS

Maint. Section	class	RM	WY 341 Arvada Spur
			<b>ML - 1700B</b>
<b>SH 16A</b>	7	0.000	US 14/16 (RM 54.82)
4036		1.850	RR at Grade Crossing #098763J
		3.188	Arvada / End SHS

Maint. Section	class	RM	WY 342
			<b>ML - 342B</b>
<b>SH 21A</b>	8	0.000	I-90 (RM 33.598); Meade Rd. Int.
4033		1.136	US 87 (RM 33.93)

Maint. Section	class	RM	WY 343
			<b>ML - 1709B</b>
<b>SH 22A</b>	7	0.000	WY 345 (RM 5.80)
4033		0.020	RR at Grade Crossing #104141Y
		5.239	US 14A/14 (RM 83.643)

Maint.

Section

CREW

class

RM

WY 345

**ML - 1712B**

7

**SH 80A**

4033

- 0.000 Montana State Line
- 5.795 WY 343 (RM 0.00)
- 9.621 Unnamed Draw [BAQ;SS]
- 11.386 Five Mile Cr. [BAR;SS]
- 12.264 NCL Ranchester
- 12.400 **N.B. Road Closed Gate R/R**
- 12.802 US 14/14A (RM 89.548)

Maint.

Section

CREW

class

RM

**ML - 1712B**

WY 345

**ML - 345B**

9

**SH 80B**

4033

- 12.849 US 14/14A (RM 89.55)
- 12.890 ECL Ranchester
- 14.295 Six Mile Cr. [BAS;SS]
- 15.530 Early Cr. [BAT;SS]
- 18.096 Slater Cr. [BAU;SS]
- 19.267 I-90 (RM 14.618); Acme Int.  
End SHS

WY 346

**ML - 346B**

-cont-

**SH 02C**

4033

from Johnson county

9

- 1.360 Johnson County line
- 2.670 **Roadway Ends @Slide Area**



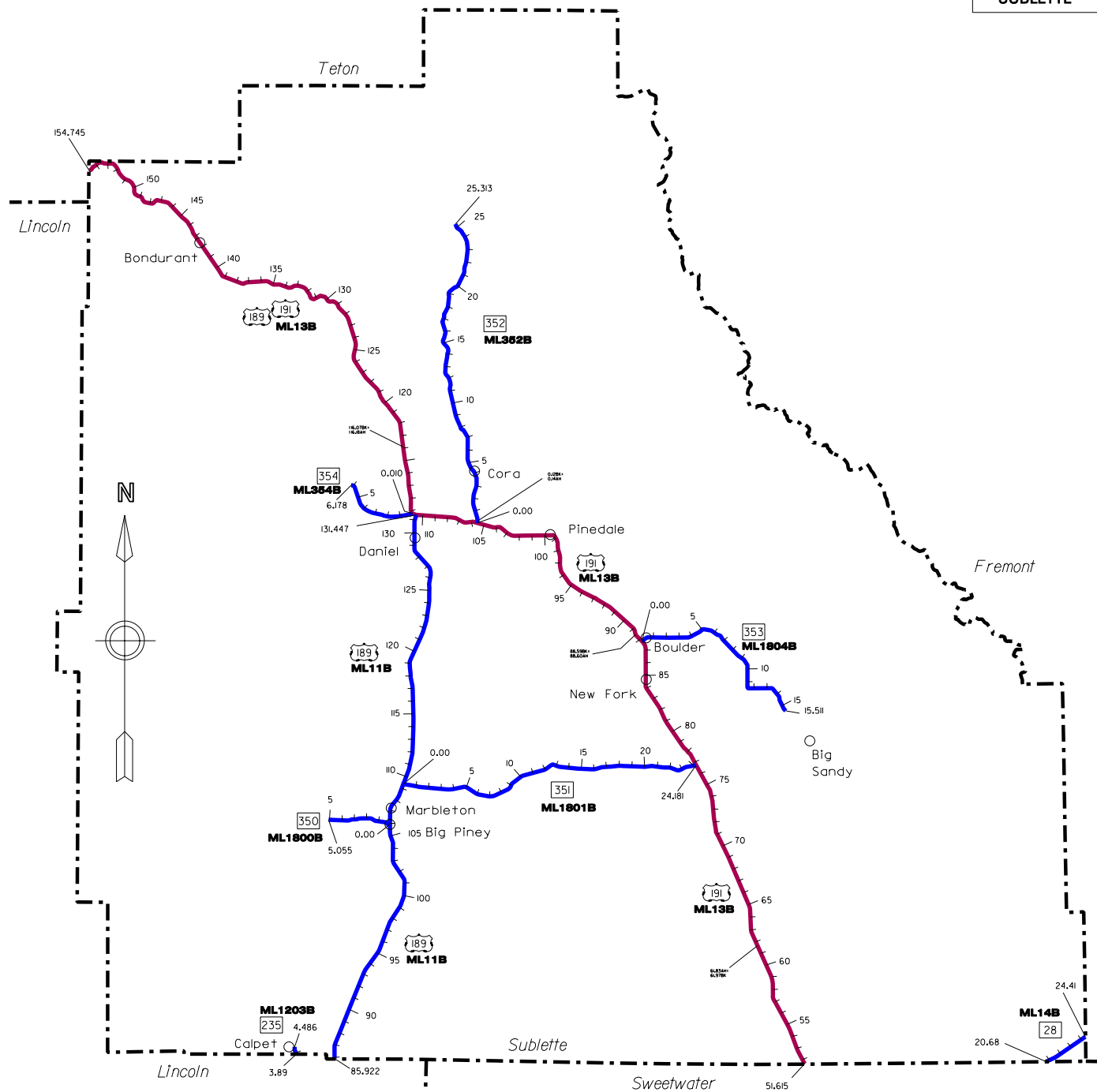

ROAD COLOR TABLE	
	Rural & Urban Interstate #'s "1 & 11"
	Urban Prinipal Arterial Other & Expressway (NHS) #'s "12 & 14"
	Urban Minor Arterial, Collector & Local (non NHS) #'s "16, 17 & 19"
	Rural Principal Arterial Other (NHS) # "2"
	Rural Minor Arterial, Major & Minor Collectors & Local (non NHS) #'s "6, 7, 8 & 9"





# Sublette

•• class "classification break"

## County 23

Maint. Section	class	RM	US 189
CREW		<b>ML - 11B</b>	
	6	85.922	Lincoln Co. Line
<b>SB 01A</b>			NCL Labarge
3041		90.080	Unnamed Draw [FJF;SS]
		90.770	Unnamed Draw [FJH;SS]
		93.395	Dry Wash [BQD;SS]
		96.520	Oil Field Rd
		97.494	Dry Piney Cr.
		104.620	South Piney Rd
		104.842	South Piney Cr. [BQF;SS]
		105.420	County Rd
		105.810	SCL Big Piney
		105.943	WY 350 (RM 0.00)
		106.096	North Piney Cr. [BQG;SS]
<b>SB 01B</b>		106.315	NCL Big Piney
3035		106.929	SCL Marbleton
		107.470	NCL Marbleton
		107.960	Meadow Cr.
		107.970	Airport Rd
		109.384	WY 351 (RM 0.00)
		116.332	Muddy Cr. [JAZ;SS]
		120.394	S. Cottonwood Cr. [KEY;SS]
		120.559	N. Cottonwood Cr. [KEZ;SS]
		123.327	Green River Supply Canal [BQL;SS]
		123.699	Green River Supply Canal [BQM;SS]
		127.380	Cottonwood Rd
		128.180	Desmet Rd
		128.887	Horse Cr. [BQN;SS]
		129.560	Daniel
		129.713	Prairie Rv. [DMA;SS]
		130.374	S. Fork Green Rv. [DMB;SS]
		130.515	N. Fork Green Rv. [DMC;SS]
		130.920	Faler Cr. [DMD;SS]
	6	131.448	US 191/189 (RM 110.47) Daniel Jct.

### US 191/189 Y Conn

Maint. Section	class	RM	US 191/189 Y Conn
CREW		<b>OT - 1805</b>	
<b>SB 01N</b>	6	0.000	US 189 (RM 131.31)
3035		0.306	US 191/189 (RM 110.24)

### US 191 & 189

Maint. Section	class	RM	US 191 & 189
CREW		<b>ML - 13B</b>	
	2	51.615	Sweetwater Co. Line
<b>SB 02A</b>		REMOVED EQUATION	
3037		75.500	Remote loader site <b>FS 982</b>
		76.750	WY 351 (RM 24.18)
		84.260	East Fork Rv. [BNQ;SS]
<b>SB 02B</b>		84.500	Fish Hatchery Rd
3035	2	87.789	WY 353 (RM 0.00); Boulder

-cont- next column

Maint. Section	class	RM	US 191/189
CREW		<b>ML - 13B</b>	
		(CONTINUED)	
<b>SB 02B</b>	2	88.229	Boulder Cr. [BRN;SS]
3035		88.600	BK= - 0.010 mi.
		88.600	AH Equation
		92.648	Pole Cr. [DGW;SS]
		92.778	Wenz Airport Rd
		95.478	S. Bench Rd
		98.478	Fayette-Pole Cr Rd
		98.990	SCL Pinedale
<b>SB 02Z</b>		99.388	Fremont Lake Rd
3035		99.878	Pine Cr. [BRP;SS]
		100.268	WCL Pinedale
		100.590	<b>Dept. Shop - Pinedale PN 03A</b>
		100.780	Barber Cr [JBF;SS]
		101.028	Ehman Ln
<b>SB 02D</b>		101.178	New Fork Rv. [JBE;SS]
3035		102.578	Duck Cr. [JBD;SS]
		104.403	Wildlife Crossing [MJE;SS]
		105.540	WY 352 (RM 0.00)
		105.860	Duck Cr.
		105.888	Stock Pass [JOI;SS]
		106.303	Wildlife Crossing [MJD;SS]
		106.803	Wildlife Crossing [MJC;SS]
		110.466	US 189 (RM 131.45); Daniel Jct. Begin US 189
		110.748	WY 354 (RM 0.01)
		111.903	Wildlife Crossing [MJB;SS]
		112.275	Animal Over Pass
		112.603	Wildlife Crossing [MJA;SS]
		113.103	Wildlife Crossing [MIZ;SS]
		113.928	Fish Hatchery Rd
		110.790	<b>N.B. Road Close Gate R/R</b>
		116.065	BK= - 0.11 mi.
		116.175	AH Equation
		120.176	Green Rv. [DAC;SS]
		123.627	Hay Gulch [BRU;SS]
		127.010	Rim <b>RWIS</b> site {2}
		127.448	North Beaver Cr. [BRV;SS]
		129.446	Teton-Bridger Nat'l. Forest Boundary
		138.640	Muddy Cr. [BRW;SS]
		138.978	Hoback Rv. [DJB;SS]
		142.746	Bondurant
		145.280	Lower Hoback Rv. [DIZ;SS]
		147.600	Maint. Break
		147.800	Hoback Rv. [BRZ;SS]
<b>SB 02C</b>		148.776	Cliff Cr. [BSA;SS]
3039		150.947	Hoback Rv. [BSB;SS]
		151.260	Hoback Rv. [BSC;SS]
		152.026	Hoback Rv. [BSD;SS]
		153.756	Hoback Rv. [BSE;SS]
	2	154.745	Teton Co. Line

Maint. Section	class	RM	WY 28
CREW			<b>ML - 14B</b>
-cont-			from Sweetwater county
<b>SW 07A</b>	6	20.678	Sweetwater Co. Line
3037		24.408	Fremont Co. Line
			District Boundary

			WY 235
			<b>ML - 1203B</b>
-cont-			from Lincoln county
<b>LN 07A</b>	7	3.893	Lincoln Co. Line
3041		3.991	Unnamed Draw
		4.486	Calpet
			End SHS

			WY 350
			<b>ML - 1800B</b>
<b>SB 05A</b>	7	0.000	US 189 (RM 105.94)
3041		1.390	WCL Big Piney
		5.055	End SHS

			WY 351
			<b>ML - 1801B</b>
	7	0.000	US 189 (RM 109.38)
<b>SB 06A</b>		0.386	Muddy Cr. [CVE;SS]
3035		7.298	Green Rv. [CVF;SS]
		12.820	New Fork Rv. [KFL;SS]
		12.910	Paridise Rd
		24.181	US 191/189 (RM 76.75)

			WY 352
			<b>ML - 352B</b>
	7	0.000	US 191/189 (RM 105.54)
<b>SB 07A</b>		0.124	BK= - 0.012 mi.
3035		0.136	AH Equation
		4.180	Cora
		7.800	Forty Rod Rd
		22.212	Bridger Nat'l. Forest Boundary
		23.678	Bridger Nat'l. Forest Boundary
		25.313	End SHS @
			Bridger Nat'l. Forest Boundary



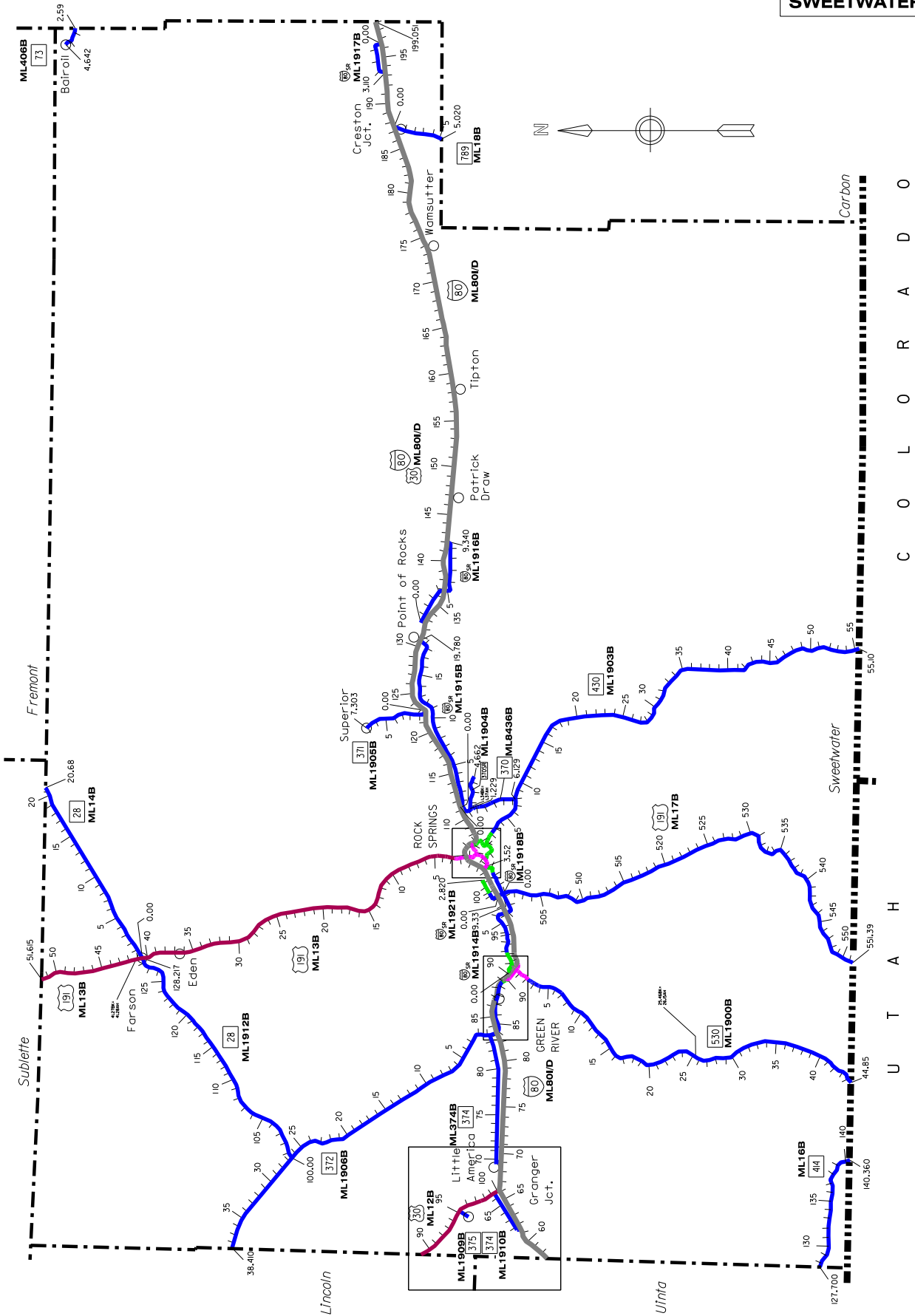

Maint. Section	class	RM	WY 353
CREW			<b>ML - 1804B</b>
	7	0.000	US 191/189 (RM 87.80)
<b>SB 08A</b>		2.330	Unnamed Draw [IMW;SS]
3035		6.700	Silver Cr.[CVH;SS]
		14.400	East Fork Rv. [CVI;SS]
		15.511	End SHS

			WY 354
			<b>ML - 354B</b>
<b>SB 09A</b>	7	0.011	US 191/189 (RM 110.75); Daniel Jct.
3035		1.258	Green Rv. [CVJ;SS]
		6.178	End SHS

SWEETWATER



# ROAD COLOR TABLE

-  Rural & Urban Interstate #'s "1 & 11"
-  Urban Principal Arterial Other & Expressway (NHS) #'s "12 & 14"
-  Urban Minor Arterial, Collector & Local (non NHS) #'s "16, 17 & 19"
-  Rural Principal Arterial Other (NHS) # "2"
-  Rural Minor Arterial, Major & Minor Collectors & Local (non NHS) #'s "6, 7, 8 & 9"

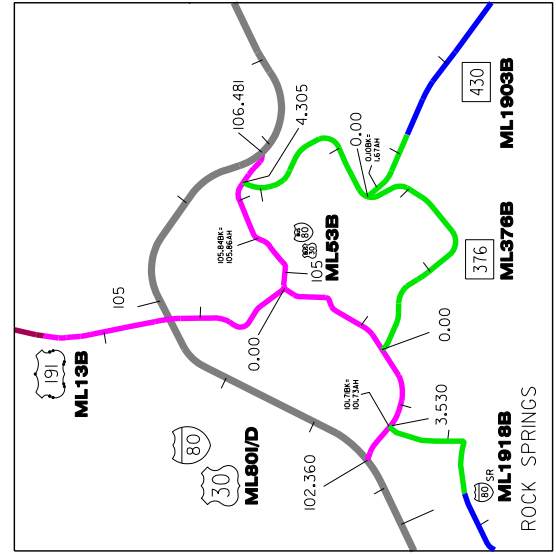
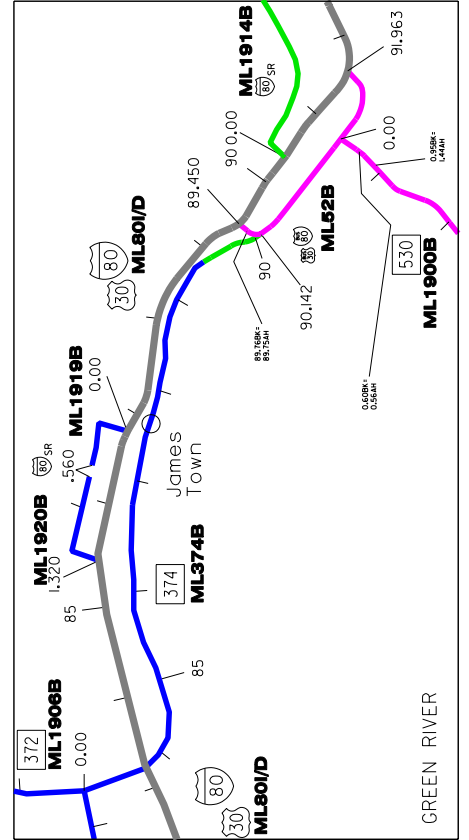
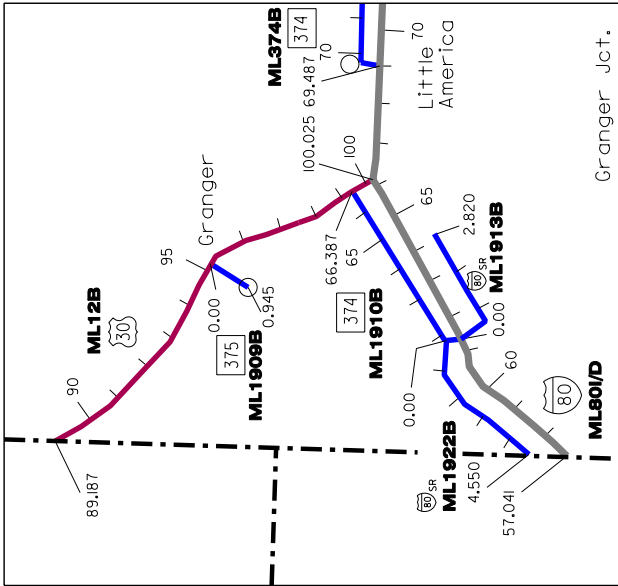

# Sweetwater

## County 4

•• class "classification break"

+ Indicates Non State System

Maint. Section	class	RM	I-80, US 30 & WY 789	
CREW		<b>ML - 80</b>		
	1	57.041	Uinta Co. Line	
<b>SW 01C</b>		58.863	Machinery Pass Sep. [AOG;EB, AOH;WB]	
		61.591	WY 374 (RM 61.59); Cedar Mtn Rd Int. [AOI;EB, AOJ;WB]	
	3038	66.168	US 30 (RM 100.03); Granger Jct. Int. [CWL;NB, IYG;SB], Begin US 30	
		68.972	WY 374 (RM 69.49); Little America Int. [AOL;EB, AOM;WB]	
		69.700	WB C.M.Sign (dynamic)	
		72.296	Westvaco Int. [AON;EB, AOO;WB]	
		76.627	UPRR Sep.	
		77.343	Machinery Pass Sep. [AOP;EB, AOQ;WB]	
		77.478	Black's Fork Rv. [AOR;EB, AOS;WB]	
		79.542	Co. Rd Sep. [AOT;EB, AOU;WB]	
		82.307	UPRR Sep. [AOV;EB, AOW;WB] Peru Hill <b>RWIS</b> site {1}	
		83.007	WY 372 (RM 0.00); LaBarge Int. & WY 374 (RM 83.67), [CXU;SS]	
		85.697	Covered Wagon Rd Int. [AOX;EB, AOY;WB]	
	<b>SW 01D</b>	3031	86.380	Green Rv. [AOZ;EB, APA;WB]
			87.459	Blue Rim Rd Sep. [APB;EB, APC;WB]
		88.800	<b>EB VSL signs</b>	
1		88.900	EB C.M.Sign (dynamic)	
••		89.000	WUL Green Rv.	
11			<b>E.B. Road Close Gate R/R</b>	
		89.445	I80/US 30 BUS (RM 89.45); W. Green River Int. [KED;EB, KEE;WB]	
		89.500	EB C.M.Sign (dynamic)	
		89.647	WCL Green Rv.	
		89.693	Co. Rd Sep. [APG;EB, APH;WB] EB C.M.Sign (dynamic)	
	90.080	<b>EB VSL signs</b>		
	90.214	Tunnel [API;EBT, APJ;WBT]		
	90.450	<b>WB VSL signs</b>		
	90.500	Cemetery Separation <b>RWIS</b> site {25}		
	90.648	Cemetery Rd Sep. [APK;EB, APL;WB] WB C.M.Sign (dynamic)		
	91.000	<b>W.B. Road Close Gate R/R</b>		
	91.532	I80/US 30 BUS (RM 91.96); E. Green River Int. [LEU;EB, LEV;WB]		
	92.654	ECL & EUL Green River		
	92.750	<b>EB VSL signs</b>		
	92.800	WB C.M.Sign (dynamic)		
	97.000	WB C.M.Sign (dynamic)		
11	97.055	Machinery Pass Sep. [APP;EB, APQ;WB]		

-cont- next column

Maint. Section	class	RM	I-80, US 30 & WY 789	
CREW		<b>ML - 80</b>		
		(CONTINUED)		
	11	97.900	Rock Springs West <b>RWIS</b> site {26}	
			<b>WB VSL signs</b>	
		99.900	<b>EB VSL signs</b>	
<b>SW 01D</b>	3031	99.138	US 191 (RM 500.00); Flaming Gorge Int. [CVS;SS]	
		100.270	WUL Rock Springs	
		101.162	Stock Drive Underpass [APR;SS]	
		101.449	WCL Rock Springs	
		101.687	BK= - 0.041 mi. <b>WB VSL signs</b>	
		101.728	AH Equation	
		101.986	Alkali Flat [APS;SS]	
		102.358	I-80/US 30 BUS (RM 102.36); Dewar Dr Int. [LYB;EB, LYC;WB]	
		103.200	<b>EB &amp; WB VSL signs</b>	
		103.820	College Drive Int. [FHW;SS]	
		104.500	<b>EB &amp; WB VSL signs</b>	
		104.674	UPRR & Co. Rd Killpecker Cr. Sep. [LRY;WB, LRX;EB]	
		104.825	US 191 (RM 1.32); Elk Street Int. [LEN;WB, LEM;EB]	
	<b>SW 01G</b>	3032	105.199	CL Rock Springs
			105.730	<b>EB VSL signs</b>
		105.858	Co. Rd Sep. [LYN;EB, LYO;WB]	
		106.357	CL Rock Springs	
		106.701	Swanson Rd Sep. [LYD;EB, LYE;WB]	
		106.800	<b>WB VSL sign</b>	
		107.056	I-80 & US 30 BUS (RM 106.48); Pilot Butte Int. [LYF;EB, LYG;WB]	
11		107.259	ECL Rock Springs	
••		107.810	EUL Rock Springs	
1		110.300	EB & WB C.M.Sign (dynamic) <b>WB VSL signs</b>	
	110.801	Gunn Draw [AQK;EB, AQL;WB]		
	111.161	WY 370 (RM 0.00); Baxter Rd Int. [AQM;EB, AQN;WB] <b>E.B. Road Close Gate R/R</b>		
	111.500	Baxter Rd. <b>RWIS</b> site {27}		
	117.392	Dry Lake Stockpass [AQO;EB, AQP;WB]		
	118.661	Machinery Pass Sep [AQQ;EB, AQR;WB]		
	122.272	WY 371 (RM 0.00); Superior Int. [AQS;EB, AQT;WB]		
<b>SW 01E</b>	3043	124.308	Machinery Pass Sep [AQU;EB, AQV;WB]	
		124.500	MM 124.5 <b>RWIS</b> site {28}	
		127.552	Machinery Pass Sep [AQW;EB, AQX;WB]	
	1	129.800	Point of Rocks <b>RWIS</b> site {29}	

-cont- next page

Maint. Section	class	RM	I-80. US 30 & WY 789
CREW		<b>ML - 80</b>	
-cont-		<i>(CONTINUED)</i>	
	1	130.840	Point of Rocks Int. [AQY;EB, AQZ;WB] Remote Loader site <b>PD 981</b>
<b>SW 01E</b>		132.278	10 Mile Draw [ARA;SS]
3043		132.592	UPRR Sep. (Jim Bridger Spur)
		135.045	Black Butte CO. Rd [ARC;EB, ARD;WB]
		136.958	County Rd Sep. [ARE;EB, ARF;WB]
		139.509	Red Hill Int. [ARG;EB, ARH;WB]
		141.830	Bittercreek <b>RWIS</b> site {30}
		142.170	Bitter Cr. Int. [ARI;EB, ARJ;WB]
		143.500	<b>Bitter Cr. Rest Area WBL SW 80R</b>
		144.200	<b>Bitter Cr. Rest Area EBL SW 80S</b>
		145.257	Co. Rd Sep. [ARK;EB, ARL;WB]
		146.848	Patrick Draw Int. [ARM;EB, ARN;WB] <b>Dept. Shop Patrick Draw PD 03A</b>
		148.089	Co. Rd Sep. [ARO;EB, ARP;WB]
		150.807	Table Rock Int. [ARQ;EB, ARR;EB]
		152.455	Bar X Int. [ARS;EB, ART;WB]
		154.060	BLM Rd Int.
		156.030	G.L. Rd Int.
		156.720	Tipton <b>RWIS</b> site {31}
	1	158.545	Tipton Int. [ ARW;EB, ARX;WB] Remote loader site <b>WS 981</b>
<b>SW 01A</b>		165.582	Red Desert Int. [ARY;EB, ARZ;WB]
3044		165.710	Unnamed Draw [MFK;SS]
		166.920	Booster Rd
		168.940	Frewen Rd
		170.680	Rasmussen Rd Int. [LZR;EB, LZS;WB]
		172.362	Machinery Pass Sep. [ASD;EB, ASE;WB]
		173.413	Wamsutter Int. [LZT;EB, LSU;WB] <b>Dept. Shop Wamsutter WS 03A</b>
		173.886	Co. Rd Sep. [LZV;EB, LZW;WB]
		177.516	Latham Draw
		180.677	Machinery Pass Sep. [ASL;EB, ASM;WB]
		184.270	Continental Divide <b>RWIS</b> site {32}
		184.288	Cont. Divide Int. [ASN;EB, ASO;WB]
		187.204	WY 789 (RM 0.00); Creston Jct. Int. [ASP;EB, ASQ;WB], Begin WY 789 District Boundary
<b>SW 01B</b>		187.430	<b>W.B. Road Close Gate R/R</b>
1041		193.041	Piker Springs Sep. [ASR;EB, ASS;WB]
		193.287	Piker Springs Cr. [AST;EB, ASU;WB]
		196.157	Riner Int. [ASV;EB, ASW;WB]
		197.956	Machinery Pass Sep [ASX;EB, ASY;WB]
		198.447	Filmore Cr. [ASZ;EB, ATA;WB]
	1	199.051	Carbon County Line

Maint. Section	class	RM	I-80 & US 30 BUS
CREW		<b>ML - 52B</b>	
	14	89.450	I-80 (RM 89.45); W. Green River Int. [KED;EB, KEE;WB]
		89.600	WCL Green River
<b>SW 14Z</b>			End Divided Section
3031		89.693	WY 374 (RM 90.14)
		<b>REMOVED EQUATION</b>	
		91.100	UPRR Sep.
		91.220	WY 530 (RM 0.00)
		91.650	Begin Divided Section
		91.963	I-80 (RM 91.53); E. Green River Int. [LEU;EB, LEV;WB]
		<b>I-80 &amp; US 30 BUS</b>	
		<b>ML - 53B</b>	
	14	102.360	I-80 (RM 102.36); Dewar Drive Int. [APV;EB, APW;WB]
<b>SW 15Z</b>		103.587	WY 376 (RM 0.00)
3031		103.750	BK= - 0.019 mi.
		103.769	AH Equation
		104.310	Bitter Cr. [FSE;SS]
		104.800	RR at Grade Crossing #810360J
		104.830	US 191 (RM 0.00)
		105.250	Bitter Cr. [DKE;SS]
<b>SW 15Y</b>		105.842	BK= - 0.018 mi.
3032		105.860	AH Equation
			Ninth St.
		106.087	WY 376 (RM 4.31)
		106.312	Begin Divided Section
	14	106.481	I-80 (RM 107.06); Pilot Butte Int. [AQH;EB, AQI;WB]
		<b>US 30</b>	
		<b>ML - 12B</b>	
	2	89.187	Lincoln Co. Line Cont. NHS
<b>SW 03A</b>		93.850	<b>Dept. Shop - Granger GN 03A</b> Off System Approx. 0.5 mi. S.
3038		94.855	NCL Granger
		95.173	UPRR Sep. [JBB;SS]
		95.342	WY 375 (RM 0.00)
		95.546	Black's Fork Rv. [JBC;SS]
		96.135	SCL Granger
		99.539	WY 374 (RM 66.39)
		100.025	I-80 (RM 66.17); Granger Jct. Int. [CWL;NB, IYG;SB] End NHS

Maint. Section	class	RM	US 191
			<b>ML - 13B</b>
	14	0.000	I-80 BUS (RM 104.83)
<b>SW 04Z</b>		0.100	Bitter Cr. [DNR;SS]
3032		0.220	Railroad X-ing
		0.640	(old) Dept. Shop
		1.315	I-80 (RM 104.83); Elk Street Int.
			[AQA;WB, LEM;EB]
		2.274	NCL Rock Springs
	14		NB C.M.Sign (dynamic)
<b>SW 04A</b>	●●	2.560	NUL Rock Springs
3032	2	2.300	<b>Dept. Shop - Rock Springs DH 03A</b>
		2.900	<b>North Yard (Dept.)</b>
			Remote loader site <b>RS 981</b>
		4.509	Reliance Rd
		4.540	RR at Grade Crossing #810356U
		4.695	Killpecker Cr. [BRJ;SS]
		12.120	Maint. Break
<b>SW 04B</b>		13.140	Blue Rim Rd
3037		36.110	Eden
		39.816	Little Sandy Rv. [BRK;SS]
		40.453	WY 28 (RM 0.00) ML 14B
			WY 28 (RM 128.22) ML 1912B
			<b>RWIS site {62}</b>
			Farson
		40.801	Big Sandy Rv. [BRL;SS]
		41.000	<b>Dept. Shop - Farson FS 03A</b>
		41.272	BK= - 0.011 mi.
		41.283	AH Equation
		41.960	Farson Cutoff Rd
		42.460	County Rd
		49.060	Eden Reservoir Rd
	2	51.615	Sublette Co. Line
			<b>US 191</b>
			<b>ML - 17B</b>
	6	500.000	I-80 (RM 99.14); Flaming Gorge Int.
			[CVS;SS]
<b>SW 13A</b>		500.303	UPRR Sep. [CWA;SS]
3031		500.620	Bitter Cr. [CWB;SS]
		500.800	SB C.M.Sign (dynamic)
		502.400	<b>S.B. Road Close Gate R/R</b>
		513.182	County Reservoir Rd
			<b>REMOVED EQUATION</b>
		550.680	Basin Rd
		551.388	Utah State Line
		244.200	NB C.M.Sign (dynamic)
			<i>Across state line</i>

Maint. Section	class	RM	WY 28
			<b>ML - 14B</b>
	6	0.000	US 191 (RM 40.45)
			& WY 28 (RM 128.22) Farson
<b>SW 07A</b>		0.700	EB C.M.Sign (dynamic)
3037		3.230	Little Sandy Rv. [DZW;SS]
		4.400	Eden Reservoir Rd
		5.350	<b>E.B. Road Close Gate R/R</b>
		6.170	Eden Canal [FBD;SS]
		20.678	Sublette Co. Line
			→ -cont- in Sublette Co.

			WY 28
			<b>ML - 1912B</b>
	7	100.000	WY 372 (RM 26.76)
<b>SW 18A</b>		102.000	Remote loader site <b>FS 981</b>
3037		102.810	Green River [FBS;SS]
		128.100	Big Sandy Rv. [FFC;SS]
		128.217	US 191 (RM 40.45)
			& WY 28 (RM 0.00) Farson

			WY 73
			<b>ML - 406B</b>
			-cont- from Carbon county
<b>CB 14A</b>	7	2.593	Carbon Co. Line
2036		4.310	Bairoil Corp. Limits
		4.642	Bairoil
			End SHS

			WY 370
			<b>ML - 1904B</b>
	7	0.000	I-80 (RM 111.16); Baxter Rd Int.
			[AQM;EB, AQN;WB]
<b>SW 10A</b>		0.060	I-80 SR ML1915
3032		0.661	UPRR Sep. [DCL;SS]
		1.040	Bitter Cr. [EOT;SS]
		1.229	WY 370 -cont-'s on <i>ML8436</i>
			→ -cont- WY 370 SR

			WY 370
			<i>Middle Baxter Road</i>
			<b>ML - 8436B</b>
			(CONTINUED)
	7	1.229	WY 370 (RM 1.229)
<b>SW 10B</b>		2.261	Unnamed Draw
3032		5.172	Unnamed Draw
		6.129	WY 430 (RM 7.835)

\*\* New Route added to system March 2011

Maint. Section	class	RM	WY 371
			<b>ML - 1905B</b>
<b>SW 11A</b>	7	0.000	I-80 (RM 122.27); Superior Int. [AQS;EB, AQT;WB]
3043		6.779	SCL Superior
		7.160	NCL Superior
		7.303	End SHS

	class	RM	WY 372
			<b>ML - 1906B</b>
<b>SW 12A</b>	7	0.000	WY 374 (RM 83.56)
3038		12.670	RR at Grade Crossing #810373K
		12.900	Soda Ash Rd
		26.758	WY 28 (RM 100.00)
<b>SW 12B</b>	→	26.800	Maint. Break
3041		33.700	Exxon Rd
		36.010	Shute Creek <b>RWIS</b> site {60}
	7	38.409	Lincoln County Line

→ -cont- in Lincoln Co.

	class	RM	WY 374
			<b>ML - 374B</b>
<b>SW 02A</b>	7	69.487	I-80 (RM 68.97); Little America Int. [AOL;EB, AOM;WB]
3038		69.582	Little America Rd
		72.165	Unnamed Draw [BKB;SS]
		72.310	FMC Rd
		72.910	Tenneco Rd
		73.960	Allied Rd
		77.300	UPRR Sep.
		78.127	Black's Fork Rv. [BKC;SS]
		81.090	Unnamed Draw [DEB;SS]
		82.667	UPRR Sep. [BKD;SS]
			<b>REMOVED EQUATION</b>
		83.555	WY 372 (RM 0.00)
	→	83.670	I-80 (RM 83.01); LaBarge Int. [CXU;SS]
	7		
	●	86.330	Class Break
<b>SW 02B</b>	6	87.165	Green River [CXW;SS]
3031		88.149	Greasewood Draw [CXV;SS]
		88.595	Unnamed Draw [CHM;SS]
	●	89.470	WUL Green River
	16	90.030	WCL Green River
		90.142	I 80 BUS (RM 89.69)

Maint. Section	class	RM	WY 374
			<b>ML - 1910B</b>
<b>SW 02C</b>	7	61.590	I-80 (RM 61.59); Cedar Mtn Rd Int. [AOI;EB, AOJ;WB]
3038		66.387	US 30 (RM 99.54)

	class	RM	WY 375
			<b>ML - 1909B</b>
<b>SW 16A</b>	7	0.000	US 30 (RM 95.34)
3038		0.945	Granger

	class	RM	WY 376
			<b>ML - 376B</b>
<b>SW 17Z</b>	16	0.000	US 30 BUS (RM 103.59)
3032		0.080	Bitter Cr. [DBP;SS]
		0.260	UPRR Sep. [DBL;SS]
		1.280	SCL Rock Springs
		1.460	SCL Rock Springs
		2.350	WY 430 (RM 0.00)
		2.520	Hampshire St. Overpass [DEU;SS]
		2.600	UPRR Sep. [DET;SS]
		4.090	UPRR & Bitter Cr. Sep. [DEW;SS]
		4.305	US 30 BUS (RM 106.09)

	class	RM	WY 414
			<b>ML - 16B</b>
<b>UI 10A</b>	7	127.696	from Uinta county Uinta Co. Line
3042		130.027	Burnt Fork Cr. [CGZ;SS]
		140.360	Utah State Line

	class	RM	WY 430
			<b>ML - 1903B</b>
<b>SW 09Z</b>	16	0.000	WY 376 (RM 2.35); Merchant St.
3032		0.074	Old Highway
		0.098	BK= - 1.576 mi.
		1.674	AH Equation
	16	1.806	Dead Horse Canyon Cr.[CVV;SS]
	→ ●	2.224	SCL & SUL Rock Springs
		7.835	WY 373 (RM 7.835)
<b>SW 09A</b>	7	15.501	Salt Wells Cr. [CVW;SS]
3032		30.139	North Alkali Cr. [CVX;SS]
		55.101	Colorado State Line



Maint. Section	class	RM	WY 530
<b>ML - 1900B</b>			
SW 08Z	14	0.000	I 80 BUS (RM 91.22)
3038		0.319	UPRR Sep. [DDH;SB, JQL;NB]
		0.597	BK= + 0.039 mi.
		0.558	AH Equation
		0.776	Green River [CVL;NB, DNI;SB]
		0.948	BK= - 0.489 mi.
	14	1.437	AH Equation
		2.743	SCL & SUL Green River
SW 08A	7	14.020	Black's Fork Rv. [CDA;SS]
3038		24.290	Unnamed Draw [KSW;SS]
		25.110	Buckboard Wash
		25.457	BK= - 0.776 mi.
		26.233	AH Equation
		26.240	Dry. Cr.
		31.020	Squaw Hollow
		31.600	Squaw Hollow Rd
		32.893	BK= +0.03 mi
		32.863	AH Equation
		35.152	Reservoir Draw
		36.440	Anvil Draw
		37.070	Anvil Wash
		37.551	Unnamed Draw
		39.034	Twin Buttes Draw
		44.208	Henry's Fork Rv. [CVT;SS]
	7	44.851	Utah State Line
<b>WY 789</b>			
<b>ML - 18B</b>			
SW 05A	6	0.000	I-80 9RM 187.20); Creston Jct. Int.
1037			[ASP;EB, ASQ;WB]
		0.200	S.B. Road Close Gate R/R
		1.339	UPRR Sep. [CLL;SS]
		5.018	Carbon Co. Line
<b>I-80 SV. RD.</b>			
<b>ML - 1913B</b>			
SW 01U	9	0.000	I-80 (RM 61.59)
3038		2.820	End Sv. Rd. @Dead End
<b>I-80 SV. RD.</b>			
<b>ML - 1914B</b>			
SW 21A	19	0.000	Cemetery Rd. Sep. I-80 (RM 90.65)
3031		1.940	CL & UL Green River
	9	7.220	Machinery Pass Sep. (RM 97.05)
		9.330	US 191 (RM 500.03)

Maint. Section	class	RM	I-80 SV. RD.
<b>ML - 1915B</b>			
SW 01K	9	0.000	WY 370 (RM 0.06)
3032		6.260	Bridge
		11.110	Maint. Break
SW 01L		12.100	Bridge
3043		14.820	Bridge
	9	19.780	Point of Rocks Int. I-80 (RM 130.84)
<b>I-80 SV. RD.</b>			
<b>ML - 1916B</b>			
SW 01T	9	0.000	From Jct. S-County 1911
3043		0.030	RR at Grade Crossing #810376F
		3.960	I-80 (RM 136.96); Black Butte Int.
		9.340	Bitter Creek Int. (RM 142.17)
<b>I-80 SV. RD.</b>			
<b>ML - 1917B</b>			
SW 01H	9	0.000	I-80 (RM 196.16); Riner Int.
1041			[ASV;EB, ASW;WB]
		2.870	Piker Cr. [KMY;WSR]
		3.110	Piker Springs Sep. (RM 193.04)
<b>I-80 SV. RD.</b>			
<b>ML - 1918B</b>			
SW 20A	8	0.000	US 191 (RM 500.08)
3031		1.150	UL Rock Springs
	16	2.360	CL Rock Springs
SW 20Z		3.530	US 30 BUS (RM 102.75)
3031			
<b>I-80 SV. RD.</b>			
<b>ML - 1921B</b>			
SW 01W	9	0.000	I-80 (RM 99.14); Flaming Gorge Int.
3031			[CVS;SS]
		1.280	UL Rock Springs
	16	2.820	CL Rock Springs
			Alkali Flat [APT;SSR]
			End state maintenance
	+	3.220	Dewar Dr.
<b>I-80 SV. RD.</b>			
<b>ML - 1922B</b>			
SW 01N	9	0.000	WY 374 (RM 61.59)
3038		4.550	Uinta County Line

Maint.  
Section  
CREW

class

RM

WY 370 SV. RD.  
*Airport Road*

Maint.  
Section  
CREW

class

RM

**ML - 1904B**

-cont- from WY 370

SW 10A

3032

*	1.343	BK= - 0.021 mi.
*	1.367	AH Equation
*	4.400	Airport
*	4.662	End SHS

\* this portion to be given to Sweetwater County within the next couple years.

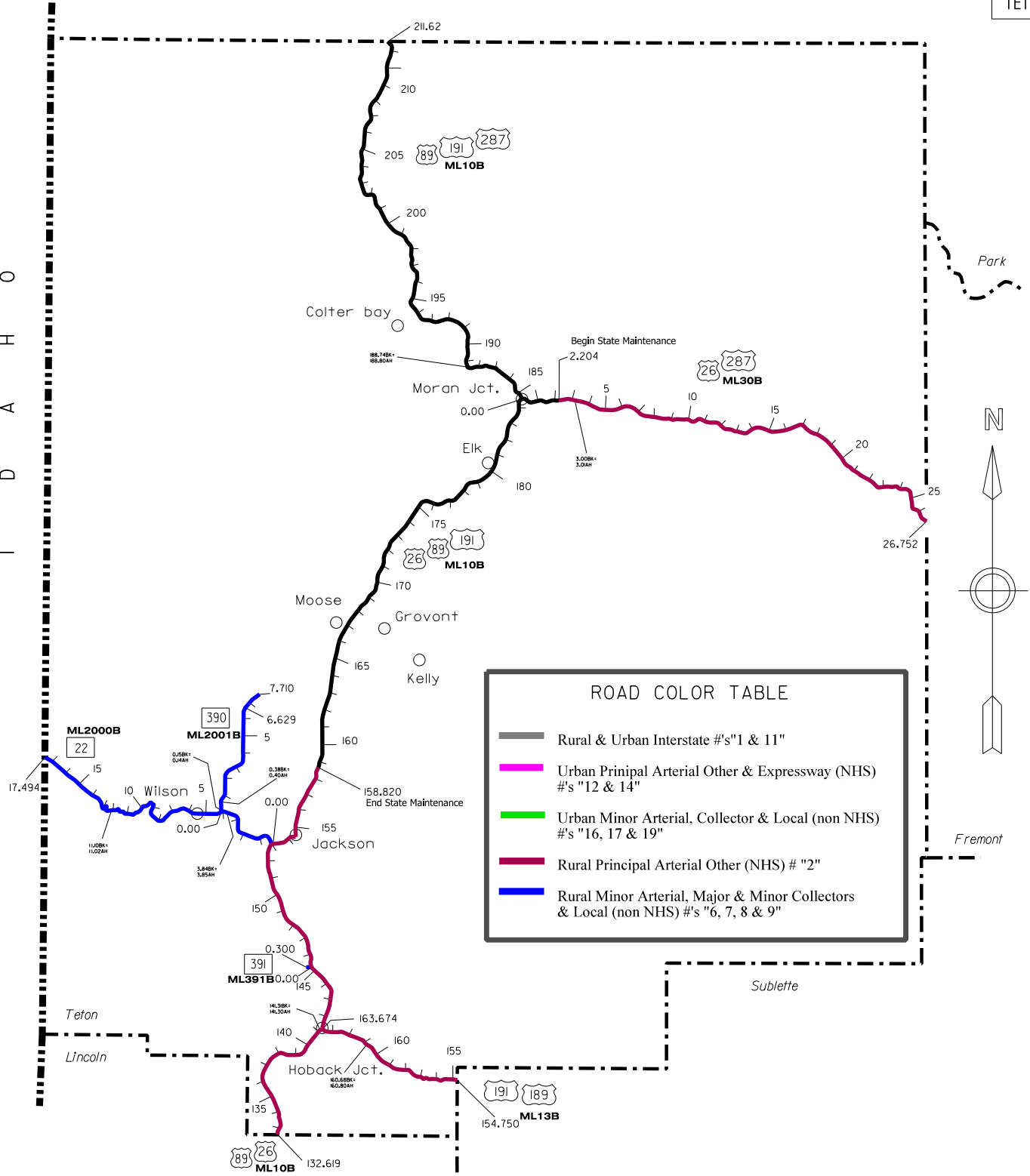



# Teton

## County 22

class "classification break"

+ Indicates Non State System

Maint. Section	class	RM	US 26/89/189/191/287
		<b>ML - 10B</b>	
	2	132.619	Lincoln Co. Line Cont. NHS
<b>TE 01A</b>		136.232	Dog Cr.
3039		136.420	Bridger & Teton Nat'l. Forest
		137.080	<b>W.B. Road Close Gate R/R</b>
		140.604	Fall Cr. [BOJ;SS]
		140.850	Bridger & Teton Nat'l. Forest
		141.079	Snake Rv. [BOK;SS]
		<b>REMOVED EQUATION</b>	
		141.310	US 189/191 (RM 163.67); Hoback Jct. Begin US 189 & 191
		141.500	SB C.M.Sign (dynamic)
		142.781	Snake Rv. [BOL;SS]
		145.250	WY 391 (RM 0.00) <b>Dept. Shop Jackson JK 03A</b>
		145.639	Bridger & Teton Nat'l. Forest
		146.090	Snake Rv. [BOM;SS]
		146.387	Flat Cr. [BON;SS]
		147.226	Bridger & Teton Nat'l. Forest
		147.303	Bridger & Teton Nat'l. Forest
		148.710	S. Park Rd
		149.762	Bridger & Teton Nat'l. Forest
		150.010	Bridger & Teton Nat'l. Forest
		151.880	SCL Jackson
		152.050	High School Rd
		152.090	Maint. Break
		152.159	Flat Cr. [BOO;SS]
<b>TE 01Z</b>		152.520	CL Jackson
3039		153.000	NB C.M.Sign (dynamic)
		153.045	WY 22 (RM 0.00)
		153.920	CL Jackson
		153.100	SB C.M.Sign (dynamic)
		153.976	Flat Cr. [BOP;SS]
		154.460	End US 189
		154.870	City Shop
		154.930	Jackson Info. Center
		154.982	S. Boundary Elk Refuge
		155.120	Flat Cr. [FFG;SS]
		155.213	NCL Jackson
<b>TE 01B</b>			Bridger & Teton Nat'l. Forest
3039	2	158.818	Grand Teton Nat'l. Park Boundary N. Boundary Elk Refuge

Maint. Section	class	RM	US 26/89/189/191/287
		<b>ML - 10B</b>	
		<i>(CONTINUED)</i>	
		<b>( End of State Maintenance Responsibility)</b>	
		+ 158.818	Grand Teton Nat'l. Park Boundary N. Boundary Elk Refuge
		+ 160.735	Gros Ventre Rv.
		+ 160.991	N. Branch Gros Ventre Rv.
		+ 161.340	Kelly Rd
		+ 162.840	Airport Rd
		+ 166.791	Moose Rd
		+ 180.386	Creek
		+ 180.763	Spread Cr.
		+ 184.410	Buffalo Fork Rv.
		+ 184.581	US 26/287 (RM 0.00); Moran Jct. <b>End US 26 (*State Hwy.*)</b> <b>Begin US 287 (*Park SV. Hwy.*)</b> End NHS
		+ 185.456	Pacific Cr.
		+ 188.514	Begin Divided Section
		+ 188.590	Old Rd
		+ 188.672	End Divided Section
		+ 188.742	BK= - 0.06 mi.
		+ 188.802	AH Equation
		+ 189.479	Jackson Lake Lodge Bridge
		+ 191.720	Pilgrim Cr.
		+ 194.150	Colter Bay Rd
		+ 198.890	Arizona Cr.
		+ 204.849	Grand Teton Nat'l. Park Boundary Teton Nat'l. Forest Boundary
		+ 209.180	Snake Rv.
		+ 211.621	Yellowstone Nat'l. Park Boundry S. Entrance
		<b>US 26 &amp; US 191/189 Wye Connector</b>	
		<b>ML - 2004B</b>	
<b>TE 01N</b>	2	141.156	US 26,89,189,191/287 (RM 141.30)
3039		141.286	US 191/189 (RM 163.67)

Maint. Section	class	RM	US 26/287
CREW			<b>ML - 30B</b>
	+	0.000	US 26,89,189,191/287 (RM 184.58) ; Moran Jct. Begin NHS
	+	2.190	End of Non-State system
<b>TE 03A</b>	2	2.204	Begin State Maint. District Boundary
5033			Teton Nat'l. Park Forest Boundary
		2.729	Lava Cr. [EWQ;SS]
			<b>REMOVED EQUATION</b>
		3.510	Buffalo Valley Rd
		3.530	Buffalo Fork Rv. [LWC;SS]
		3.640	Grand Teton Nat'l. Park Boundary Forest Boundary
		4.567	Grand Teton & Teton Nat'l. Forest Boundary
		7.829	BK= +0.309 mi
		7.520	AH Equation
		8.400	<b>E.B. Road Close Location R/R</b>
		8.410	Black Rock Cr. [MHM;SS]
		10.621	Unnamed Draw [MHQ;SS]
		24.140	Unnamed Draw [MBJ;SS]
		25.330	Teton & Shoshone Nat'l. Forest Boundary
		26.752	Fremont Co. Line Cont. NHS
			<b>US 191/189</b>
			<b>ML - 13B</b>
<b>TE 02A</b>	2	154.745	Sublette Co. Line
3039		154.810	Hoback Rv. [BSF;SS]
		156.506	Hoback Rv. [BSG;SS]
		157.960	Hoback Rv. [BSH;SS]
		160.676	BK= - 0.119 mi.
		160.795	AH Equation
		163.674	US 26/89/189/191/287 (RM 141.30) Hoback Jct.

Maint. Section	class	RM	WY 22
CREW			<b>ML - 2000B</b>
ID 31		0.010	EB C.M.Sign (dynamic) <i>Across state line</i>
ID 33		150.700	EB C.M.Sign (dynamic) <i>Across state line</i>
	6	0.000	US 26/89/89 (RM 153.05)
<b>TE 04A</b>		0.660	Spring Gulch Rd
3039		3.755	Snake Rv. [BMV;SS]
			<b>REMOVED EQUATION</b>
		4.055	WY 390 (RM 0.00)
		5.400	Fish Cr. [CEA;SS]
		5.530	Wilson
		6.500	NB C.M.Sign (dynamic)
		6.920	<b>W.B. Road Close Gate R/R</b>
		6.986	Teton Nat'l. Forest Boundary
		11.097	BK= + 0.076 mi.
		11.021	AH Equation Teton & Targhee Nat'l. Forest Boundary
		11.170	Teton Pass <b>RWIS</b> site {61}
		17.480	<b>E.B. Road Close Gate R/R</b>
		17.494	Idaho State Line
			<b>WY 390</b>
			<b>ML - 2001B</b>
	7	0.000	WY 22 (RM 4.06)
<b>TE 05A</b>		0.149	BK= + 0.011 mi.
3039		0.138	AH Equation
		0.382	BK= - 0.018 mi.
		0.400	AH Equation
		2.260	Cheney Lane
	7	3.840	Granite Cr. [LME;SS]
	●●	6.629	Class. Break
	9	6.490	Teton Village Rd
		7.550	Granite Cr. [FOM;SS]
	9	7.710	Grand Teton Nat'l. Park Boundary End SHS
			<b>WY 391</b>
			<b>ML - 391B</b>
<b>TE 06A</b>	8	0.000	US 26,89 (RM 145.25)
3039		0.300	End @Jackson Dept. Shop

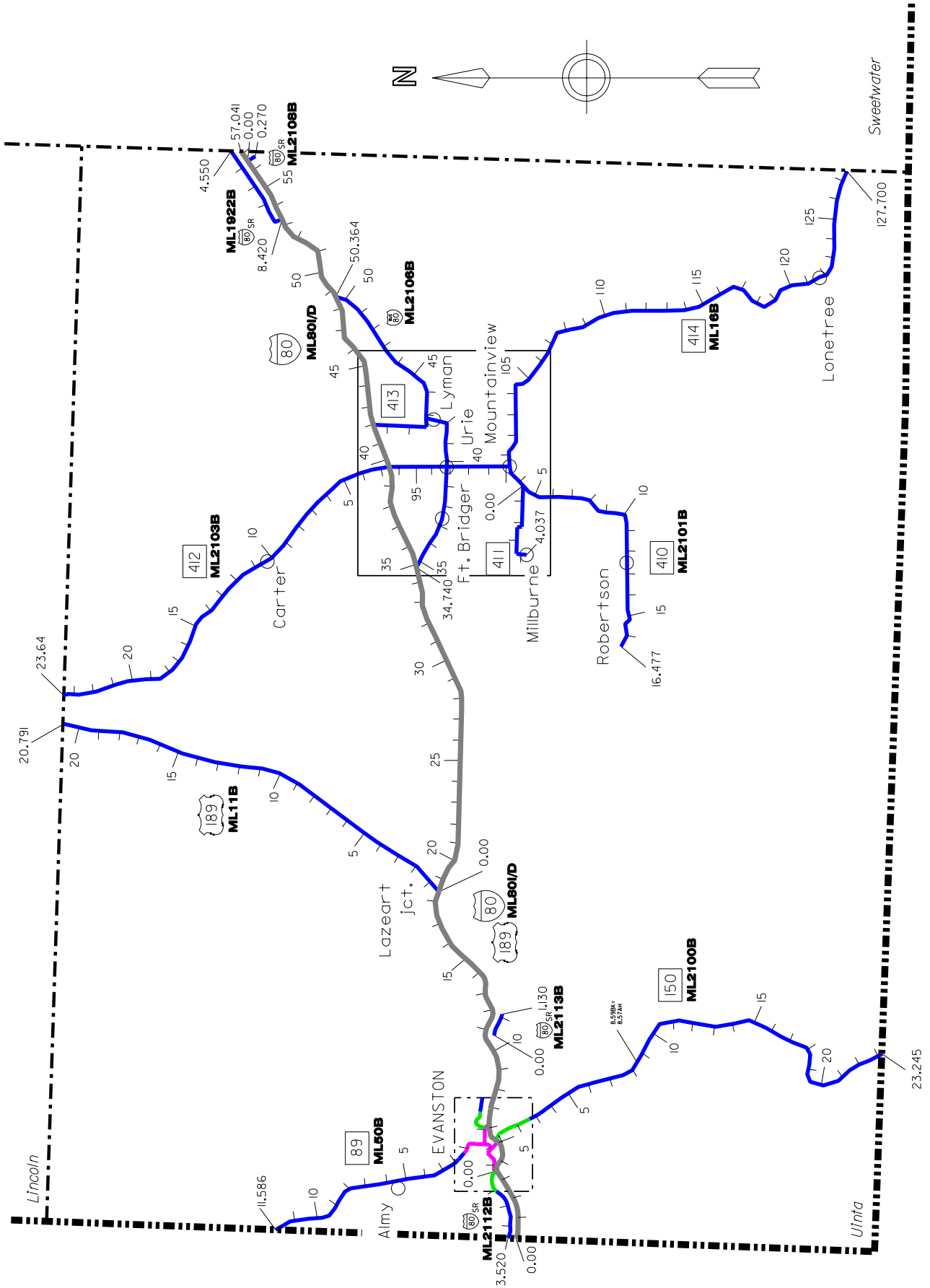

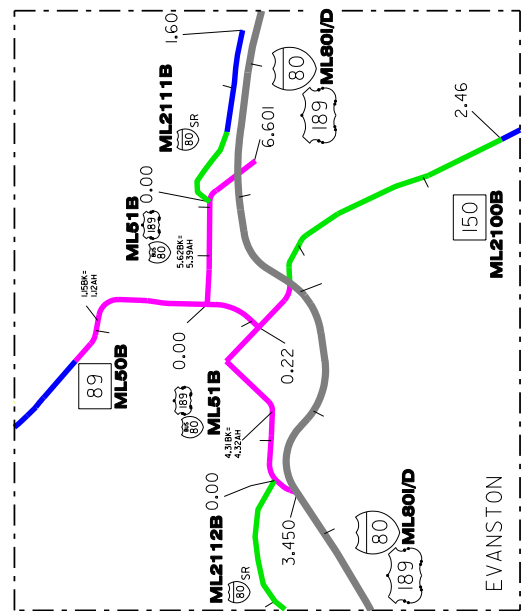
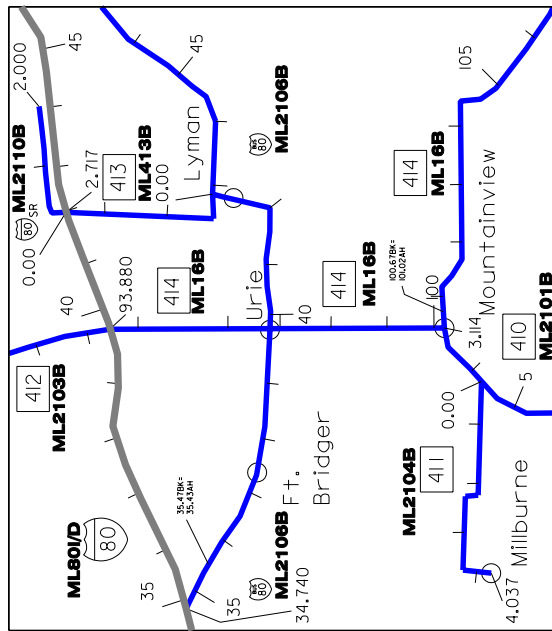

### ROAD COLOR TABLE

- Rural & Urban Interstate #'s "1 & 11"
- Urban Principal Arterial Other & Expressway (NHS) #'s "12 & 14"
- Urban Minor Arterial, Collector & Local (non NHS) #'s "16, 17 & 19"
- Rural Principal Arterial Other (NHS) # "2"
- Rural Minor Arterial, Major & Minor Collectors & Local (non NHS) #'s "6, 7, 8 & 9"



# Uinta

class "classification break"

## County 19

Maint. Section	class	RM	I-80 & US 189
		<b>ML - 80</b>	
		194.300	EB C.M.Sign (dynamic)
			<i>Across state line</i>
	1	0.000	Utah State Line
	1	0.400	<b>Evanston Port-of-Entry UI 01P</b>
	●●	2.180	WUL Evanston
<b>UI 01A</b>	11	2.820	WCL Evanston
3036		3.453	I-80/US 189 BUS (RM 3.45); W. Evanston Int. [AMF;EB, AMG;WB]
		4.200	Evanston <b>RWIS</b> site {22}
		4.513	Yellow Cr. Rd Sep. [AMH;EB, AMI;WB]
		5.263	WY 150 (RM 0.65); State Hospital Rd Int [FGR;EB, FGS;WB]
		5.911	Bear River & UPRR Sep. [AML;EB, AMM;WB]
		6.257	I-80/US 189 BUS (RM 6.43); E. Evanston Int. [AMN;EB, AMO;WB]
			<b>Evanston Info. Center</b>
	11	6.700	ECL Evanston
	●●	6.767	EUL Evanston
	1	7.000	<b>E.B. Road Close Gate R/R</b>
		7.100	EB C.M.Sign (dynamic)
		7.500	WB C.M.Sign (dynamic)
		8.450	<b>EB VSL sign</b>
		10.160	<b>WB VSL sign</b> Painter Int. <b>RWIS</b> site {63}
		10.683	Painter Int. [AMQ;EB, AMR;WB]
		11.860	<b>EB VSL sign</b>
		12.652	Machinery Pass Sep. [AMS;EB, AMT;WB]
		13.450	<b>WB VSL sign</b>
		13.862	Divide Int. [AMU;EB, AMV;WB] First Divide <b>RWIS</b> site {23}
		14.590	<b>EB VSL sign</b>
		15.640	Guild Sep. [AMW;EB, AMX;WB]
		16.871	Machinery Pass Sep. [AMY;EB, AMZ;WB]
		17.660	<b>WB VSL sign</b> US 189 <b>RWIS</b> site {64}
		18.293	US 189 (RM 0.00); US 189 Int. [ANA;EB, ANB;WB], End US 189 Remote loader site <b>ET 981</b>
		19.000	<b>EB VSL sign</b>
		20.950	<b>WB VSL sign</b> Coal Road <b>RWIS</b> site {65}
		21.050	<b>EB VSL sign</b>
		21.750	Coal Int.
		23.120	Bar Hat Int.
		23.350	<b>WB VSL sign</b> Leroy Int. <b>RWIS</b> site {66}
		23.600	UPRR Sep. [ANE;EB, ANF;WB]
		23.906	Leroy Int. [ANG;EB, ANH;WB]

-cont- next column

Maint. Section	class	RM	I-80 & US 189
		<b>ML - 80</b>	
			<i>(CONTINUED)</i>
		-cont-	
<b>UI 01A</b>	1	24.560	<b>EB VSL sign</b>
3036		27.600	<b>WB VSL sign</b> French Int. <b>RWIS</b> site {67}
		28.290	Maint. Break
	1	28.710	French Int.
<b>UI 01B</b>		30.398	Bigelow Int. [ANJ;EB, ANK;WB] Remote loader site <b>LM 981</b>
3042		33.180	Union Int.
		34.740	I-80 BUS (RM 34.74); Ft. Bridger Int. [ANM;EB, ANN;WB]
		34.850	<b>W.B. Road Close Gate R/R</b>
		35.530	WB C.M.Sign (dynamic)
		37.020	Machinery Pass Sep. [ANO;EB, ANP;WB]
		39.896	WY 414(RM 93.88);Carter-Mt.View Int. [ANQ;EB, ANR;WB]
			& WY 412 (RM 2.81)
		41.987	WY 413 (RM 2.72); North Lyman Int. [ANS;EB, ANT;WB]
		41.990	<b>Lyman Rest Area UI 01R</b>
		44.850	Black's Fork Rv. [ANU;EB, ANV;WB]
		46.560	Co. Rd Sep. [ANW;EB, ANX;WB]
		47.430	Smith's Fork Cr. [ANY;EB, ANZ;WB]
		48.330	I-80 BUS(RM 50.36);Bridger Valley Int. [AOA;EB, AOB;WB]
		48.900	<b>E.B. Road Close Gate R/R</b>
		52.650	Church Butte <b>RWIS</b> site {24}
		53.306	Church Buttes Int. [AOC;EB, AOD;WB]
		56.717	Service Rd Sep. [AOE;EB, AOF;WB]
	1	57.041	Sweetwater Co. Line
			<b>I-80 BUS</b>
		<b>ML - 2106B</b>	
	6	34.740	I-80 (RM 34.74); Ft. Bridger Int. [ANM;EB, ANN;WB]
		35.350	End 4-Lane Section
<b>UI 11A</b>		35.466	BK= + 0.036 mi.
3042		35.430	AH Equation
		36.273	Black's Fork Rv. [LQU;SS]
		36.743	Little Black's Fork Rv. [LRC;SS]
		36.860	Groshon Cr. [BJY;SS]
		37.270	Ft. Bridger
		39.239	Lyman Canal [BJZ;SS]
		39.780	WY 414 (RM 96.69) Urie
		42.350	SCL Lyman

-cont- next page

Maint.  
Section

CREW	class	RM	I-80 BUS
			<b>ML - 2106B</b>
			(CONTINUED)
	6	42.840	WY 413 (RM 0.00)
<b>UI 11A</b>		43.310	<b>Dept. Shop - Lyman LM 03A</b>
3042		44.090	ECL Lyman
		48.720	Smith's Fork Rv. [BKA;SS]
		50.364	I-80 (RM 48.30); Bridger Valley Int. [AOA;EB, AOB;WB]

**I-80 BUS & US 189 BUS**

CREW	class	RM	I-80 BUS & US 189 BUS
			<b>ML - 51B</b>
	14	3.450	I-80 (RM 3.45); W. Evanston Int. [AMF;EB, AMG;WB]
<b>UI 02Z</b>		4.307	BK= - 0.031 mi.
3036		4.324	AH Equation
		5.128	WY 150 (RM 0.22)
		5.308	UPRR Sep. [FEM;SS]
		5.526	Bear Rv. [FEN;SS]
		5.578	WY 89 (RM 0.00)
		5.623	BK= + 0.229 mi.
		5.394	AH Equation
		6.434	I-80 (RM 6.26); E. Evanston Int.
		6.560	Dumcomb Hollow Drainage [FFJ;SS]
		6.601	End SHS @Rest Area

**US 189**

CREW	class	RM	US 189
			<b>ML - 11B</b>
	6	0.000	I-80 (RM 18.29); US 189 Int. [ANA;EB, ANB;WB]
<b>UI 04A</b>		0.764	Albert Cr. [FFZ;SS]
3036		18.900	Albert Cr. [FBA;SS]
		19.640	Little Muddy Cr. [FBB;SS]
		20.791	Lincoln Co. Line

**WY 89**

CREW	class	RM	WY 89
			<b>ML - 50B</b>
	14	0.000	US 189 BUS (RM 5.58)
<b>UI 03Z</b>		1.040	<b>Dept. Shop - Evanston ET 03A</b>
3036		1.153	BK= + 0.03 mi.
	14	1.122	AH Equation
<b>UI 03A</b>		1.263	NCL & NUL Evanston
3036	6	5.170	Almy
		5.491	Red Willow Cr. [DLU;SS]
		7.380	Whitney Canyon Rd
		7.988	Bear Rv. [DIM;SS]
		8.118	Bear Rv. Overflow [DIL;SS]
		8.340	SCL Bear River
		8.711	Chapman Canal [DIK;SS]
		9.510	NCL Bear River
	6	11.586	Utah State Line

Maint.  
Section

CREW	class	RM	WY 150
			<b>ML - 2100B</b>
	14	0.216	US 189 BUS (RM 5.13)
<b>UI 05Z</b>		0.500	2nd St
3036		0.651	I-80 (RM 5.26); State Hospital Rd Int. [FGR;EB, FGS;WB]
	16	1.150	Saddle Ridge Rd
		1.470	Aspen Groves Rd
		1.970	Hayden Ave
	16	2.457	SCL Evanston
		2.670	SUL Evanston
	7	8.404	Bear Rv. [FHG;SS]
<b>UI 05A</b>		8.590	BK= + 0.02 mi.
3036		8.570	AH Equation
		9.950	Aspen Tunnel Rd
		14.900	Hillard Flat Rd
		19.120	Mill Cr [LNB;SS]
		19.460	Chalk Creek Rd
	7	23.245	Utah State Line

**WY 410**

CREW	class	RM	WY 410
			<b>ML - 2101B</b>
	7	3.114	WY 414 (RM 99.87)
<b>UI 06A</b>		3.856	SCL Mountain View
3042		4.004	Smith's Fork Cr. [CWF;SS]
		4.188	WY 411 (RM 0.00)
		12.345	Robertson
		12.765	Smith's Fork Cr. [CWG;SS]
		13.294	Willow Cr. [CWH;SS]
		3.000	Unnamed Draw [CWI;SS]
		15.306	Black's Fork Cr. [CWJ;SS]
		15.538	Black's Fork Cr. Overflow [CWK;SS]
		16.477	End SHS

**WY 411**

CREW	class	RM	WY 411
			<b>ML - 2104B</b>
	7	0.000	WY 410 (RM 4.19)
<b>UI 07A</b>		0.367	Smith's Fork Cr. [KSO;SS]
3042		2.320	Black Fork Canal [KSP;SS]
		3.228	Black's Fork Cr. Overflow [CWN;SS]
		3.257	Black's Fork Rv. [CGP;SS]
		4.037	Millburne
			End SHS

**WY 412**

CREW	class	RM	WY 412
			<b>ML - 2103B</b>
	7	2.806	I-80 (RM 39.90); Carter-Mtn View Int. [ANQ;EB, ANR;WB]
<b>UI 08A</b>			& WY 414 (RM 93.88)
3042		9.918	Big Muddy Cr. [JMZ;SS]
		10.330	RR at Grade Crossing #810478Y @Carter
		23.643	Lincoln Co. Line

-cont- In Lincoln Co.

Maint. Section	CREW	class	RM	WY 413
<b>ML - 413B</b>				
<b>UI 09A</b>	3042	8	0.000	I-80 BUS (RM 42.84)
				NCL Lyman
			1.032	Rollins Rd
			2.341	Black's Fork Rv. [CWR;SS]
			2.718	I-80 (RM 41.99); N. Lyman Int.
<b>WY 414</b>				
<b>ML - 16B</b>				
<b>UI 10A</b>	3042	7	93.880	I-80 (RM 39.90); Carter-Mtn View Int. [ANQ;EB, ANR;WB]
				WY 412 (RM 2.81)
			94.309	Black's Fork Rv. [FNA;SS]
			95.170	Bridger-Black fork Rd
			96.690	I-80 BUS (RM 39.78)
			98.980	NCL Mountain View
			99.870	WY 410 (RM 3.11)
			99.890	Smith's Fork Rv. [FQN;SS]
			100.659	BK= - 0.371 mi.
			101.030	AH Equation ECL Mountain View
			105.120	Little Dry Cr. [CWT;SS]
			105.590	Leavitt Draw [CWU;SS]
			108.680	Cottonwood Cr. [LVG;SS]
			120.610	Henry's Fork Rv. [CWW;SS]
			121.810	Lonetree
	123.500	Beaver Cr. [CWX;SS]		
7	127.696	Sweetwater Co. Line		

→ -cont- In Sweetwater Co.

Maint. Section	CREW	class	RM	I-80 SV. RD.
<b>ML - 2108B</b>				
<b>UI 01M</b>	3042	9	0.000	I-80 Sv. Rd. Sep.(RM 56.72)
			0.270	ML 1922
<b>I-80 SV. RD.</b>				
<b>ML - 1922B</b>				
<b>UI 01U</b>	3042	9	4.550	From Sweetwater County Line
			8.420	I-80 (RM 53.31);Church Buttes Int.
<b>I-80 SV. RD.</b>				
<b>ML - 2110B</b>				
<b>UI 01N</b>	3042	9	0.000	I-80 (RM 41.99);Lyman Int.
			2.000	End Sv. Rd. @Cattleguard
<b>I-80 SV. RD.</b>				
<b>ML - 2111B</b>				
<b>UI 01L</b>	3036	19	0.000	US 189 BUS (RM 6.43)
		19	0.450	CL Evanston
		●●	0.600	UL Evanston
		9	1.600	End Sv. Rd. Highway Patrol Pistol Range
<b>I-80 SV. RD.</b>				
<b>ML - 2112B</b>				
<b>UI 13Z</b>	3036	16	0.000	US 189 BUS (RM 3.68)
		→ 16	1.060	CL Evanston
<b>UI 13A</b>	3036	●●	1.350	UL Evanston
		9	1.590	Bridge
			3.520	End Sv. Rd. @Utah State Line
<b>I-80 SV. RD.</b>				
<b>ML - 2113B</b>				
<b>UI 01T</b>	3036	9	0.000	I-80 (RM 10.68);@Painter Int.
			1.130	End SHS @County RD. I-80 (RM 11.80)



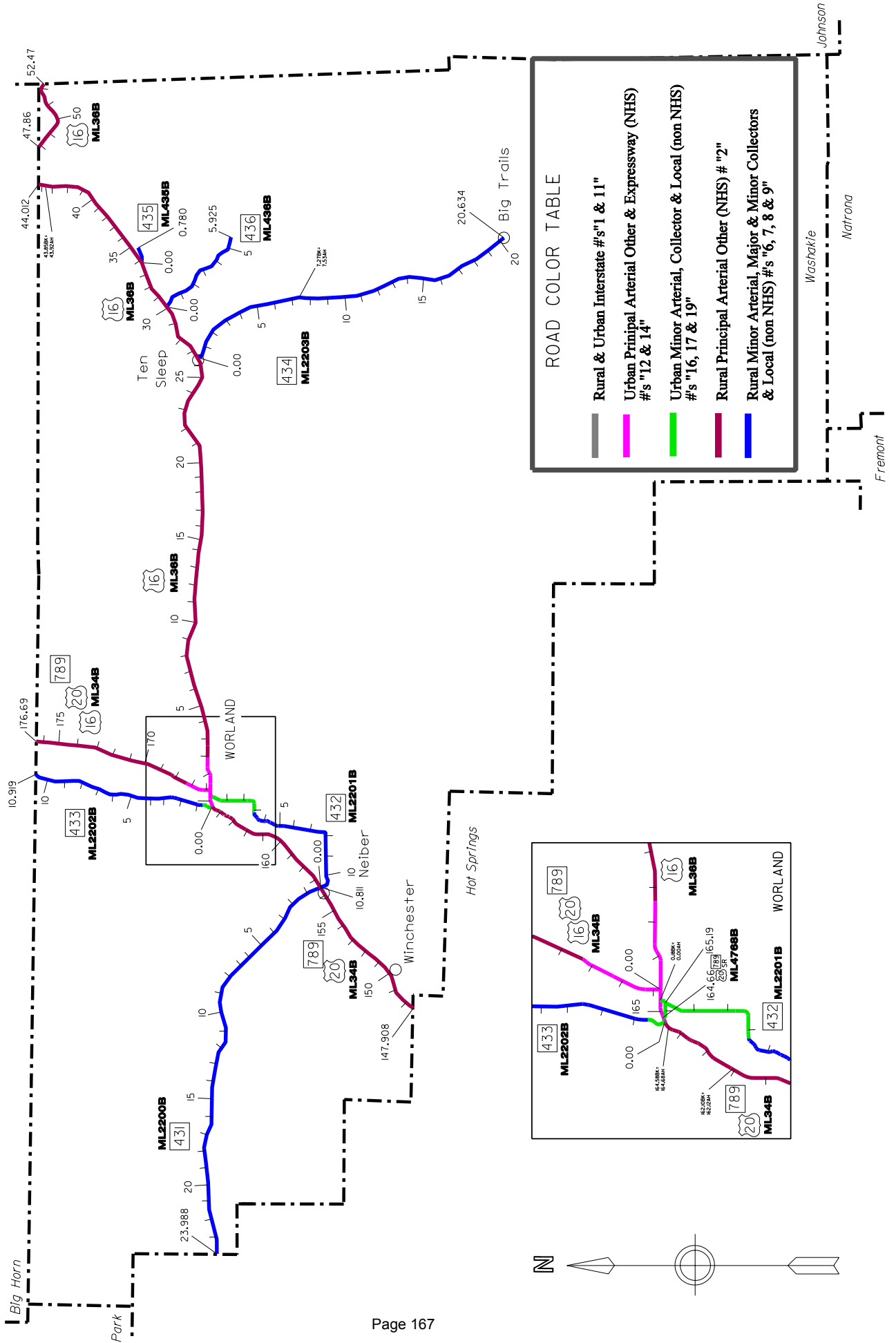



# Washakie

•• class "classification break"

## County 20

+ Indicates Non State System

Maint. Section	CLASS	RM	US 16/20 & WY 789
<b>ML - 34B</b>			
	2	147.908	Hot Springs Co. Line Cont. NHS
<b>WA 01A</b>		148.640	Chatham Rd
5041		150.346	Cottonwood Cr. [CCJ;SS]
		156.532	Gooseberry Cr. [CCK;SS]
		156.641	WY 431 (RM 0.00) & WY 432 (RM 10.81)
		160.040	WY Industrial Institute
		162.104	BK= - 0.018 mi.
		162.122	AH Equation
	2	163.862	Big Horn Canal [LVK;SS]
	••	163.890	WUL Worland
	14	164.338	Fifteen Mile Cr. [LVL;SS]
		164.584	BK= - 0.091 mi.
		164.675	AH Equation
		164.717	WY 433 (RM 0.00) W. River Rd
		164.798	WCL Worland
<b>WA 01Z</b>		165.003	Big Horn Rv. [CCN;SS]
5041		165.360	RR at Grade Crossing #090867N
		165.379	WY 432 (RM 0.00) Railroad Ave
		165.703	US 16 (RM 0.00) Begin US 16
	14	166.593	NCL Worland
	••	167.220	NUL Worland
<b>WA 01B</b>	2	168.822	Slick Cr. [FDF;SS]
5041		171.000	Unnamed Draw [KMR;SS]
	2	176.691	Big Horn Co. Line Cont. NHS

US 16			
<b>ML - 36B</b>			
	14	0.000	US 20, WY 789 (RM 165.70)
<b>WA 02Z</b>		0.270	Begin Divided Section
5041		0.313	Lower Hanover Canal [CDS;SS]
		0.360	15th St
	14	1.580	ECL Worland
	••	1.940	EUL Worland
<b>WA 02A</b>	2	2.590	County Rd (north)
5041		2.638	Slick Cr. [LYY;SS]
		4.568	Old Tensleep Highway
		6.580	Maint. Break
		10.290	Old Tensleep Highway
<b>WA 02B</b>		17.180	Cottonwood Cr. [CDU;SS]
5039		18.190	Old Tensleep Highway
		25.758	Nowood Rv. [CDV;SS]
		25.890	Lower Nowood Rd
		26.357	WCL Ten Sleep
	2	26.421	WY 434 (RM 0.00)

-cont- next column

Maint. Section	CLASS	RM	US 16
<b>ML - 36B</b>			
<i>(CONTINUED)</i>			
	2	26.762	ECL Ten Sleep
		28.010	<b>Dept. Shop - Tensleep TS 05A</b>
		28.908	Ten Sleep Cr. [CDW;SS]
<b>WA 02B</b>		29.648	Ten Sleep Branch Cr. [CDX;SS]
5039		30.038	WY 436 (RM 0.00)
		30.697	Canyon Cr. [CDY;SS]
		32.573	Ten Sleep Cr. [CDZ;SS]
		33.899	WY 435 (RM 0.00)
		34.000	<b>E.B. Road Close Gate R/R</b>
		34.084	Big Horn Nat'l. Forest Boundary
		39.810	WB Truck Run-away Ramp
		41.720	Ten Sleep Cr. [FRY;SS]
		42.905	East Ten Sleep Cr. [CEB;SS]
		43.849	BK= - 0.073 mi.
		43.922	AH Equation
		44.012	Big Horn Co. Line / District Boundary
		47.860	Big Horn Co. Line
<b>JO 04A</b>		49.410	<b>E.B. Road Close Gate R/R</b>
4037	2	52.470	Johnson Co. Line

-cont- in Johnson Co.

WY 431			
<b>ML - 2200B</b>			
<b>WA 03A</b>	7	0.000	US 20, WY 789 (RM 156.641) & WY 432 (RM 10.81)
5041		7.210	Homestead Ln.
		10.000	Maint. Break
<b>WA 03B</b>		23.238	Badlands Look out
5036	7	23.988	Hot Springs Co. Line

WY 432			
<b>ML - 2201B</b>			
	+	0.000	US 20 (RM 165.379)
	+	0.180	ML 4768 (RM 165.19)
	16	0.700	SCL Worland
<b>WA 04A</b>			End City / Begin state
5041		1.480	Lower Hanover Canal [EWV;SS]
	16	2.590	Airport Rd
	••	3.470	SUL Worland
	7	3.988	BK= + 0.179 mi.
		3.809	AH Equation
			Nowater Cr. [CXA;SS]
		4.790	County Rd (west)
		6.523	Upper Hanover Canal [CXB;SS]
		8.400	Upper Hanover Canal [CXC;SS]
		10.367	Big Horn Rv. [CXD;SS]
		10.730	RR at Grade Crossing #090494S
	7	10.811	US 20, WY 789 (RM 156.641) & WY 431 (RM 0.00)

Maint.		WY 433	
Section	class	RM	
<b>ML - 2202B</b>			
CREW			
	16	0.000	US 20, WY 789 (RM 164.717)
<b>WA 05Z</b>		0.184	Big Horn Canal [LVQ;SS]
5041		0.250	<b>Dept. Shop - Worland WL 05A</b>
	16	0.542	SCL Worland
	7	0.623	NCL & NUL Worland
			End Curb & Gutter
<b>WA 05A</b>		2.668	Dry Draw [CGV;SS]
5041		4.439	Big Horn Canal [CXF;SS]
		4.628	Ten Mile Cr. [CXG;SS]
		4.889	Big Horn Canal [CXH;SS]
		5.900	Lane 6A
		7.148	Dry Draw [CXI;SS]
		7.991	Big Horn Canal [KDR;SS]
	7	10.919	Big Horn Co. Line

Maint.		WY 435	
Section	class	RM	
<b>ML - 435B</b>			
CREW			
<b>WA 07A</b>	9	0.000	US 16 (RM 33.90)
5039		0.780	End SHS
	+	0.950	Tensleep Cr [CYG;SS]

		WY 436	
<b>ML - 436B</b>			
<b>WA 09A</b>	8	0.000	US 16 (RM 30.04)
5039		2.520	WYDOT Pit
		5.925	End SHS

		US 20 SV. RD.	
<b>ML - 4768B</b>			
	17	164.660	US 20, WY 789 (RM 164.84)
<b>WA 01X</b>		164.870	Big Horn River Bridge [EOJ;SS]
5041		164.940	WCL Worland
		165.190	End Sv. Rd. @begin City St.

		WY 434	
<b>ML - 2203B</b>			
	7	0.000	US 16 (RM 26.42)
		0.189	SCL Ten Sleep
<b>WA 06A</b>		0.280	Ten Sleep Cr. [DJP;SS]
5039		7.274	BK= - 0.258 mi.
		7.532	AH Equation
			Spring Cr Rd
		12.059	Otter Cr. [CXL;SS]
		20.634	End SHS @Big Trails



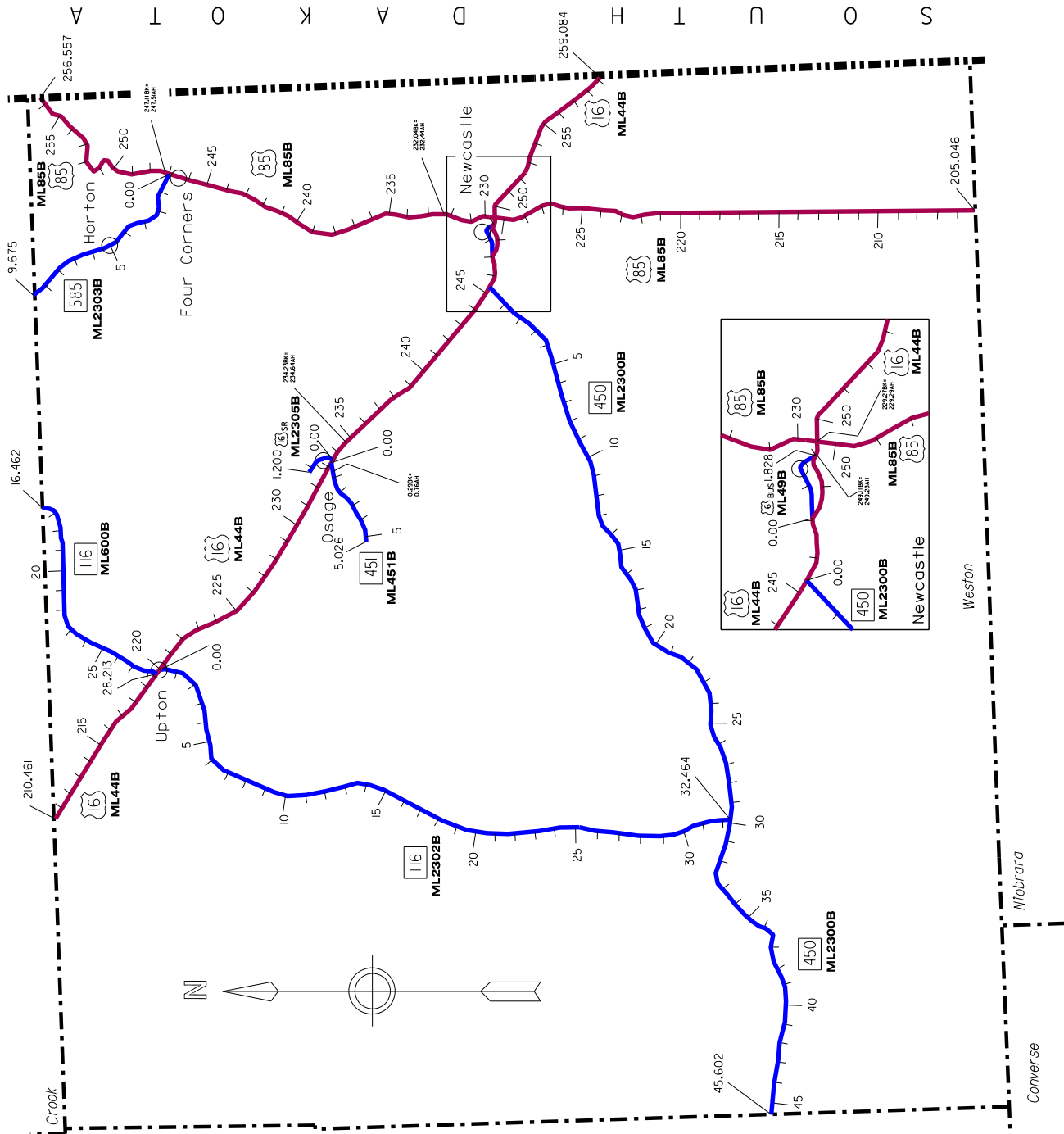

ROAD COLOR TABLE	
	Rural & Urban Interstate #'s "1 & 11"
	Urban Principal Arterial Other & Expressway (NHS) #'s "12 & 14"
	Urban Minor Arterial, Collector & Local (non NHS) #'s "16, 17 & 19"
	Rural Principal Arterial Other (NHS) # "2"
	Rural Minor Arterial, Major & Minor Collectors & Local (non NHS) #'s "6, 7, 8 & 9"



# Weston

•• class "classification break"

## County 21

Maint. Section	class	RM	US 16	Maint. Section	class	RM	US 16
<b>WE 02A</b>	2	210.461	Crook Co. Line	<b>WE 09Z</b>	6	0.000	US 16 (RM 247.34)
4040			Cont. NHS	4041		0.580	Cambria Cr. [CHU;SS]
		212.429	E. Branch Wind Cr. [CHN;SS]			1.090	RR at Grade Crossing #064920E
		213.260	Thornton			1.450	Old Highway
		219.245	WCL Upton				CL Newcastle
		219.827	WY 116 (RM 28.21) north			1.828	US 16 (RM 248.99)
		220.131	WY 116 (RM 0.00) south				
<b>WE 02B</b>	2		Cont. NHS				
4041		220.510	ECL Upton				<b>US 85</b>
		220.800	<b>Upton Rest Area WE 02R</b>				<b>ML - 85B</b>
		222.364	BNRR Sep. [CHO;SS]	2	205.046	Niobrara Co. Line	
		226.314	Pine Cr. [CHP;SS]			Cont. NHS	
		228.881	Turner Cr. [CHQ;SS]	<b>WE 01A</b>	208.610	Sheep Cr.	
		233.293	WY 451 (RM 0.00)	4041	211.939	Beaver Cr. [JBJ;SS]	
		234.234	BK= - 0.402 mi.		222.410	W. Branch Blacktail Cr.	
		234.636	AH Equation		223.100	Blacktail Cr.	
		239.161	Skull Cr. [CHR;SS]		226.040	Old Highway	
		241.380	Airport Rd		228.960	BNRR Sep. [BXJ;SS]	
		242.924	Oil Cr. [CHS;SS]		228.980	SCL Newcastle	
		245.087	Alum Cr. [CHT;SS]		229.000	<b>S.B. Road Closed Gate R/R</b>	
		245.600	<b>W.B. Road Closed Gate R/R</b>		229.060	NCL Newcastle	
		245.668	WY 450 (RM 0.00)		229.271	US 16 (RM 249.82)	
		247.322	WCL Newcastle			BK= - 0.019 mi.	
		247.343	US 16 (RM 0.00)		229.290	AH Equation	
			CL Newcastle,		230.100	Musser Rd	
			End US 16 / Begin US 16 Bypass		232.040	BK= - 0.396 mi.	
			<b>Newcastle Port-of-Entry WE 02P</b>		232.436	AH Equation	
		247.677	Cambria Cr. [DBI;SS]		233.290	<b>N.B. Road Closed Gate R/R</b>	
		248.220	Stampede St		238.047	BK= -0.053 mi (NEW)	
		248.275	CL Newcastle		238.100	AH Equation	
		248.696	BNRR Sep. [DBJ;SS]		240.550	Red Butte Cr.	
		248.820	<b>Dept. Shop - Newcastle NC 04A</b>		247.112	BK= - 0.396 mi.	
		248.991	US 16 (RM 1.83)		247.508	AH Equation	
			End US 16 Bypass / Begin US 16		247.300	WY 585 (RM 0.00); Four Corners	
		249.108	BK= - 0.174 mi.			<b>N.B. Road Closed Gate R/R</b>	
		249.282	AH Equation		250.950	Buckhorn	
		249.664	ECL Newcastle		253.529	Black Hills Nat'l. Forest Boundary	
		249.816	US 85 (RM 229.27)		253.933	Black Hills Nat'l. Forest Boundary	
		251.820	Salt Cr Rd		256.557	South Dakota State Line	
		252.829	Salt Cr. [CHV;SS]	2		End WY NHS	
		254.000	<b>E.B. Road Closed Gate R/R</b>				
		254.335	Stockade Beaver Cr. [CHW;SS]				
		254.620	Grieves/Fisher Rd				
		258.686	Whoopup Cr. [CHX;SS]				
	2	259.084	South Dakota State Line				
			End WY NHS				

Maint. Section	class	RM	WY 116 (NORTH)
			<b>ML - 600B</b>
<b>WE 04A</b>	7	16.462	Crook Co. Line
4041		16.710	Mason Cr. [FQB;SS]
		17.574	Mason Cr. [FPZ;SS]
		17.880	Mason Cr Stockpass [FQA;SS]
		18.207	Mason Cr. [FPY;SS]
		19.064	Sage Cr.
		22.363	Dry Draw
		26.305	Unnamed Draw
		27.500	<b>N.B. Road Closed Gate R/R</b>
		27.638	CL Upton
		28.213	US 16 (RM 219.827)

Maint. Section	class	RM	WY 451
			<b>ML - 451B</b>
	8	0.000	US 16 (RM 233.29)
<b>WE 06A</b>			<b>REMOVED EQUATION</b>
4041		4.390	Beaver Cr. [FLB;SS]
		5.026	End SHS
			<b>WY 585</b>
			<b>ML - 2303B</b>
<b>WE 03A</b>	6	0.000	US 85 (RM 247.603)
4041			Four Corners Jct.
		9.675	Crook Co. Line

Maint. Section	class	RM	WY 116 (SOUTH)
			<b>ML - 2302B</b>
<b>WE 07A</b>	7	0.000	US 16 (RM 220.131)
4041		0.205	BNRR Sep. [DGD;SS]
		0.328	SCL Upton
		0.600	<b>S.B. Road Closed Gate R/R</b>
		0.715	Iron Cr. [FQC;SS]
		1.647	Coyote Cr. [FQD;SS]
		2.642	Beaver Cr. [FQE;SS]
		3.270	Lone Tree Cr.
		6.525	North Fork Soda Cr. [FQF;SS]
		7.183	South Fork Soda Cr. [FQG;SS]
		12.570	Unnamed Draw
		13.000	Unnamed Draw
		13.150	Buffalo Cr.
		20.270	W. Fork Hay Cr. [LUS;SS]
		25.764	Lodgepole Cr. [DDN;SS]
		32.460	<b>W.B. Road Closed Gate swing</b>
		32.464	WY 450 (RM 29.81)

Maint. Section	class	RM	US 16 SV. RD. Rd. to Osage
			<b>ML - 2305B</b>
<b>WE 02X</b>	8	0.000	US 16 (RM 233.49)
4041		0.750	Class Break
	9	1.200	End Sv. Rd. at 0.09 mi. N. of Apostol Ave.

Maint. Section	class	RM	WY 450
			<b>ML - 2300B</b>
<b>WE 05A</b>	6	0.000	US 16 (RM 245.67)
4041		0.300	<b>W.B. Road Closed Gate R/R</b>
		1.963	Oil Cr. [FPA;SS]
		3.559	Skull Cr. [FLX;SS]
		6.932	Beaver Cr. [KPB;SS]
		9.695	Mush Cr. [FLW;SS]
		12.080	Seeley Rd (north)
		15.220	S. Beaver Cr. [KPC;SS]
		23.650	Lodgepole Cr. [KPD;SS]
		29.810	WY 116 (RM 32.46)
		29.890	Wildcat Cr. [LZD;MSS]
		36.310	Black Thunder Cr. [DFX;SS]
		45.602	Campbell Co. Line

# INTERCHANGE LAYOUTS

## I-25

**Terry Road Interchange**  
RM: 2.66 EXIT # 2

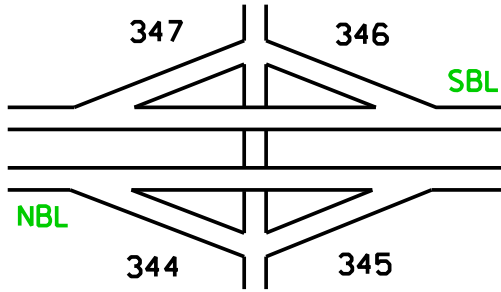

**I-25 & I-80 Interchange**  
RM: 8.84 EXIT # 8

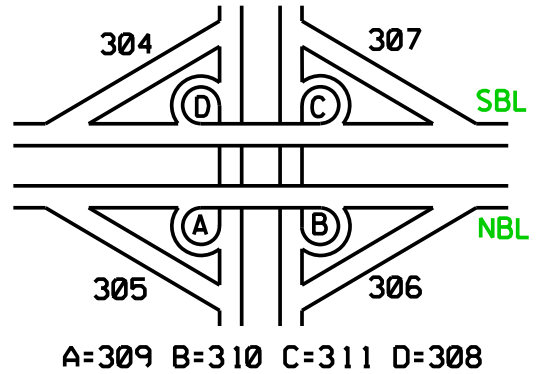

**High Plains Interchange**  
RM: 4.85 EXIT # 4

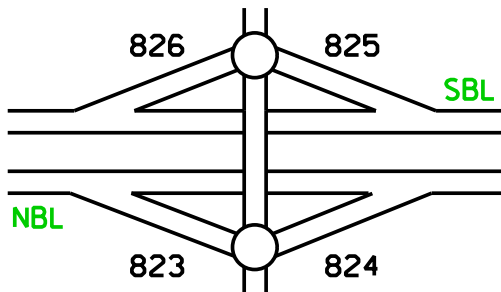

**U.P.R.R. & U.S. 30 Interchange**  
RM: 9.14 EXIT # 9

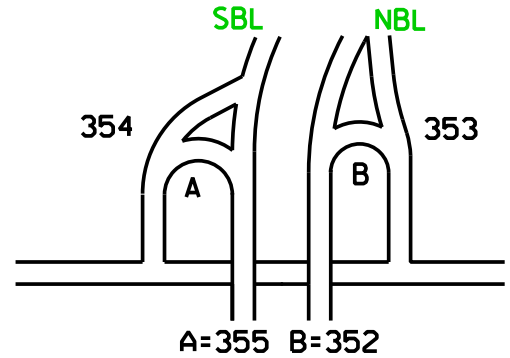

**College Drive Interchange**  
RM: 7.85 EXIT # 7

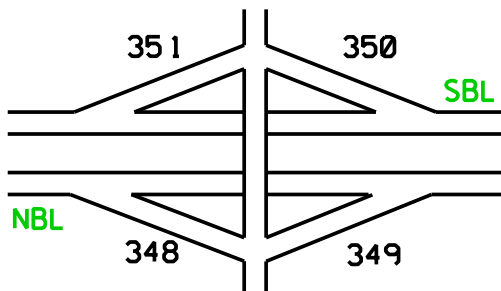

**Missile Drive Interchange**  
RM: 10.59 EXIT # 10

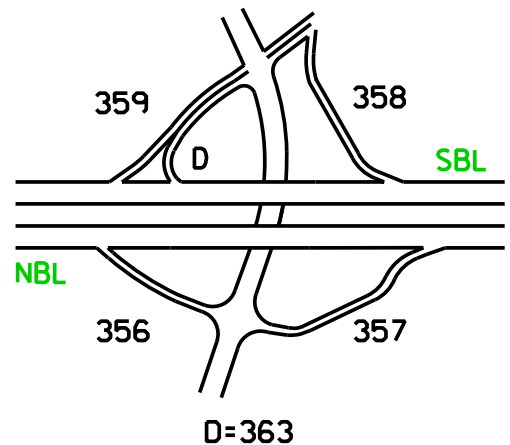

**Randall Ave. Interchange**

RM: 11.24      EXIT # 11

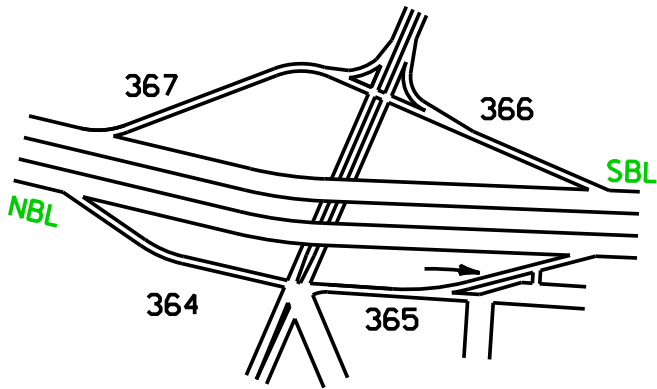

**U.S.- 87 & 85 Interchange**

RM: 17.24      EXIT # 17

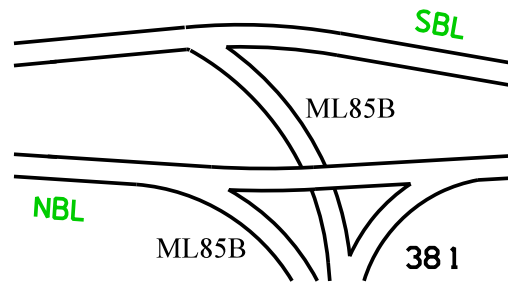

**Central Ave. Interchange**

RM: 12.70      EXIT # 12

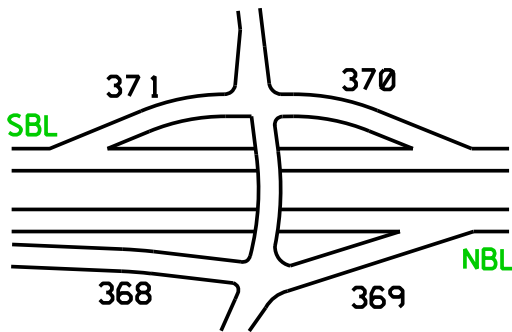

**Ridley Road Interchange**

RM: 21.32      EXIT # 21

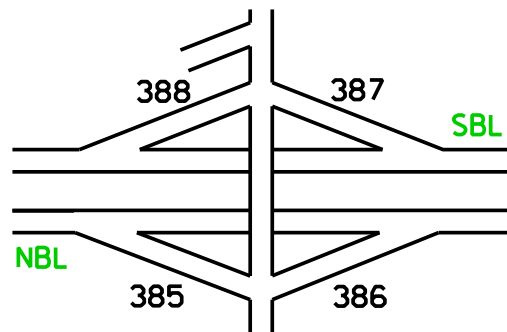

**Vandehei Interchange**

RM: 13.83      EXIT # 13

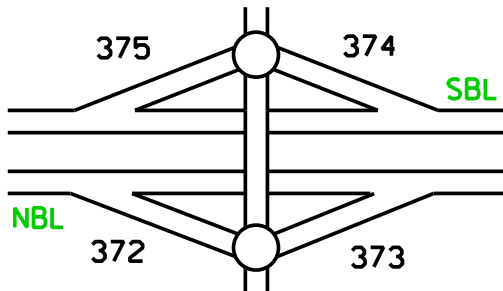

**Missile Site "A" Interchange**

RM: 25.45      EXIT # 25

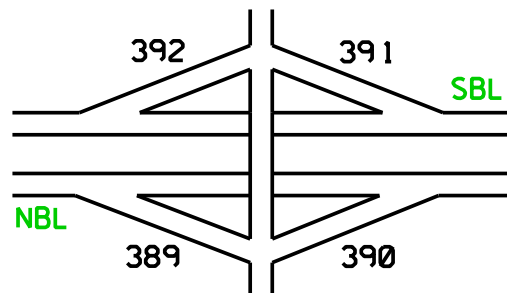

**Iron Mtn. & US 85 N. Interchange**

RM: 16.23      EXIT # 16

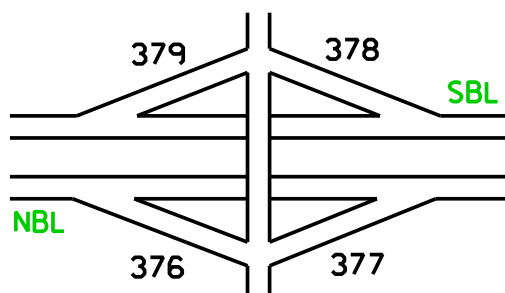

**Whitaker Road Interchange**

RM: 29.51      EXIT # 29

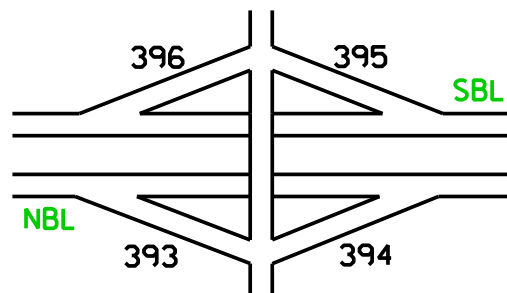

**Nimmo Road Interchange**

RM: 34.44      EXIT \* 34

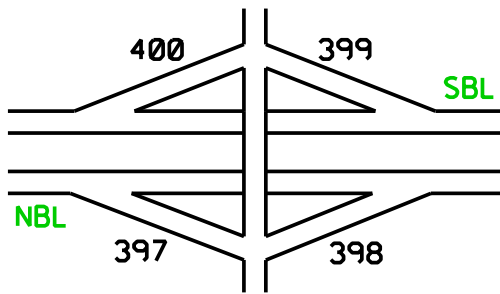

**TY Basin Interchange**

RM: 57.65      EXIT \* 57

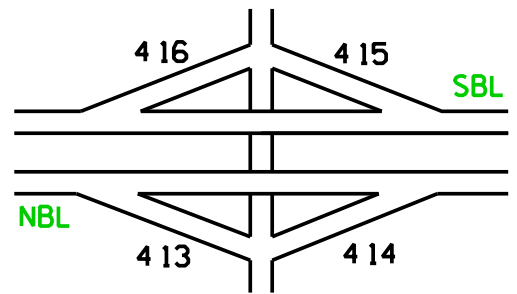

**Indian Hills Interchange**

RM: 39.24      EXIT \* 39

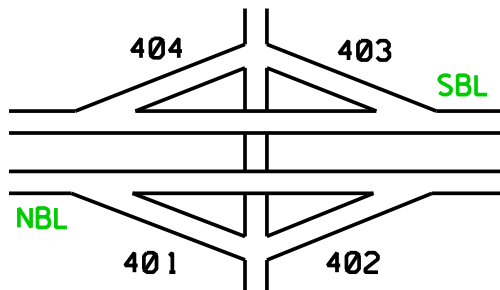

**Slater Road Interchange**

RM: 65.25      EXIT \* 65

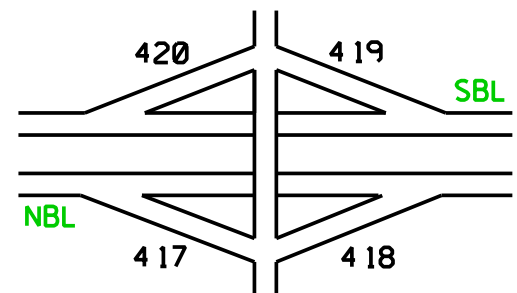

**County Line Interchange**

RM: 47.25      EXIT \* 47

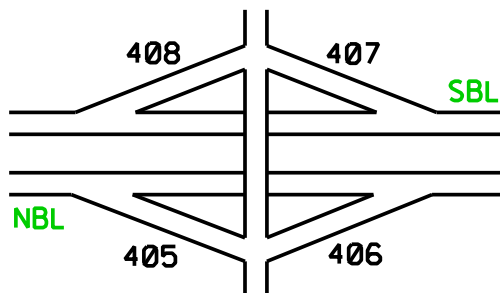

**Hunton Interchange**

RM: 66.20      EXIT \* 66

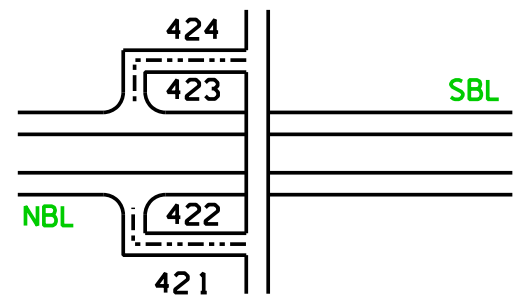

**Chugwater Interchange**

RM: 54.59      EXIT \* 54

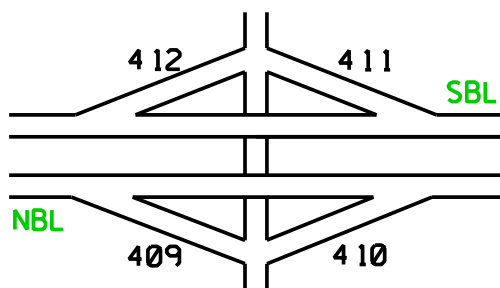

**Antelope Interchange**

RM: 68.45      EXIT \* 68

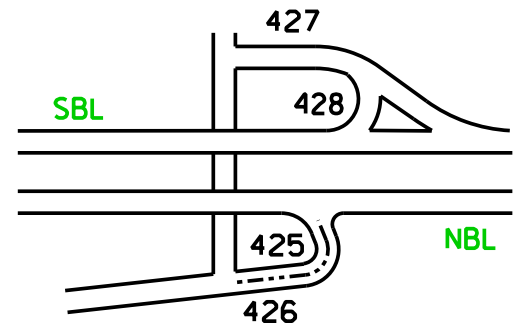

**Bordeaux Interchange**

RM: 70.62

EXIT # 70

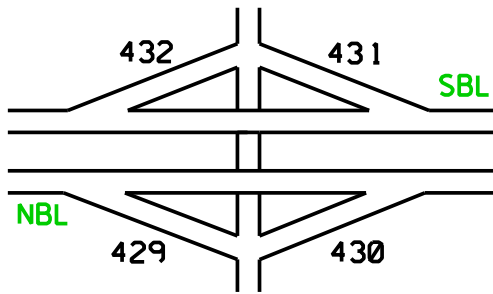

**Laramie River Interchange**

RM: 84.74

EXIT # 84

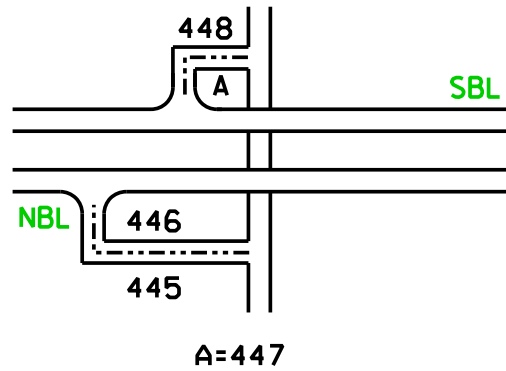

**Wyoming 34 Interchange**

RM: 73.03

EXIT # 73

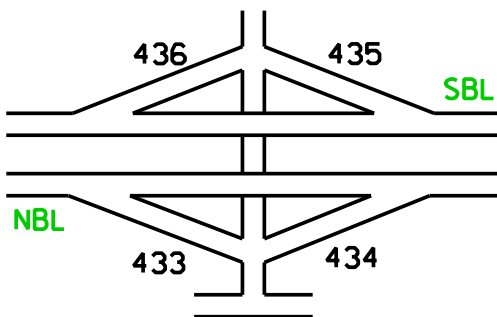

**N. Laramie River Interchange**

RM: 87.51

EXIT # 87

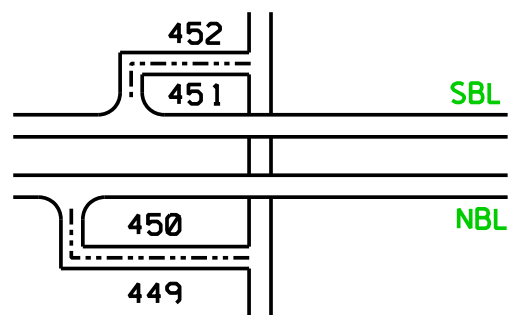

**South Wheatland Interchange**

RM: 78.93

EXIT # 78

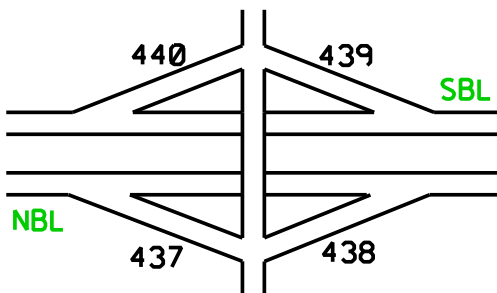

**Dwyer Jct. Interchange**

RM: 92.37

EXIT # 92

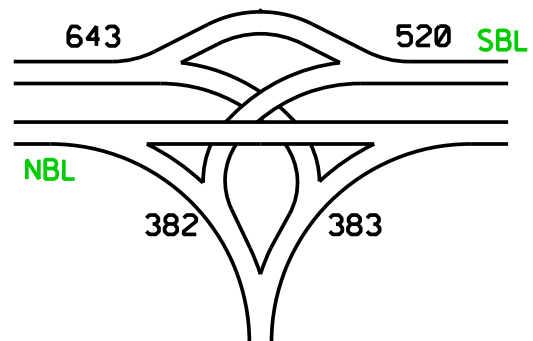

**North Wheatland Interchange**

RM: 80.85

EXIT # 80

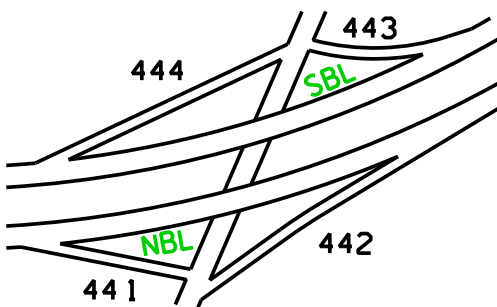

**El Rancho Interchange**

RM: 94.83

EXIT # 94

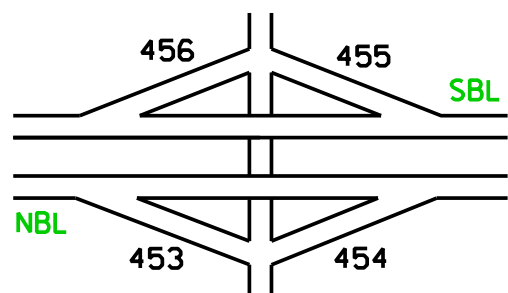



**Cassa Interchange**  
 RM: 100.13 EXIT \* 100

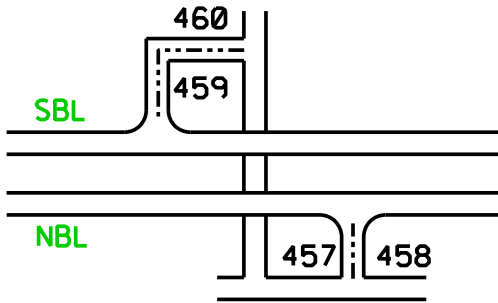

**East Douglas Interchange**  
 RM: 135.47 EXIT \* 135

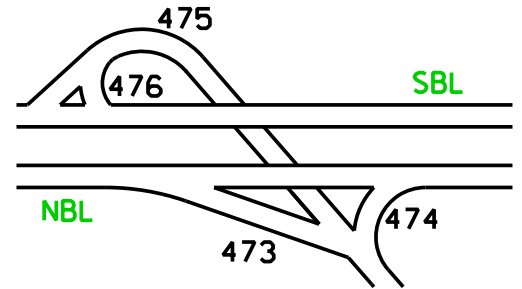

**Middle Bear Interchange**  
 RM: 104.04 EXIT \* 104

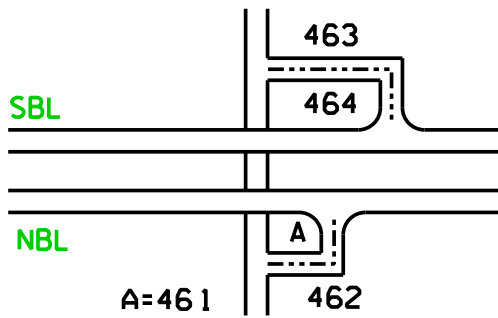

**West Douglas Interchange**  
 RM: 140.10 EXIT \* 140

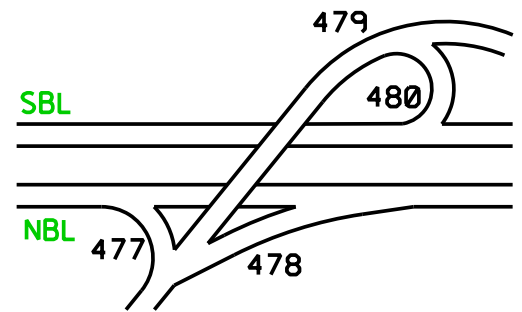

**Glendo Interchange**  
 RM: 111.68 EXIT \* 111

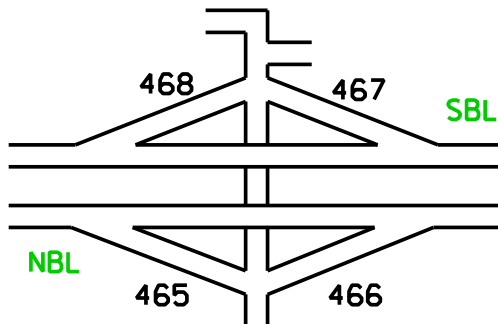

**LaPrele Interchange**  
 RM: 146.00 EXIT \* 146

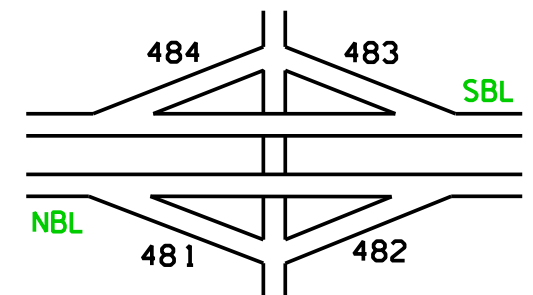

**Orin Junction Interchange**  
 RM: 126.47 EXIT \* 126

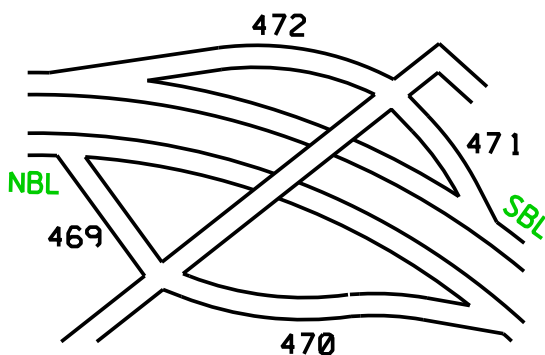

**Inez Interchange**  
 RM: 150.44 EXIT \* 150

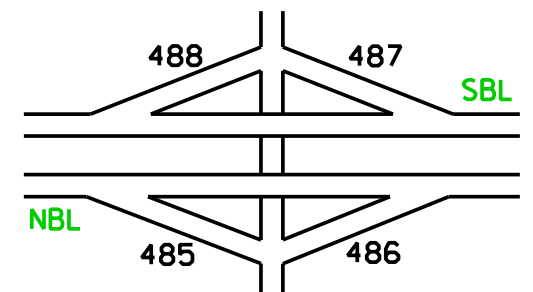

**Natural Bridge Interchange**

RM: 151.17      EXIT \* 151

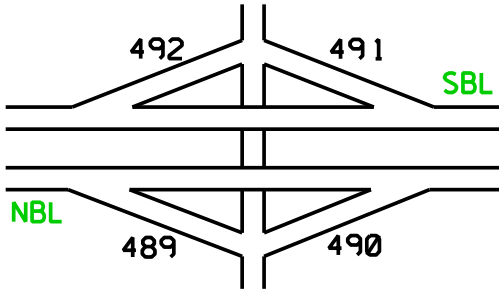

**Deer Creek Interchange**

RM: 165.91      EXIT \* 165

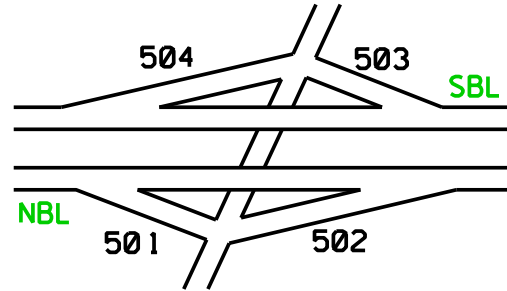

**Barber Interchange**

RM: 154.24      EXIT \* 154

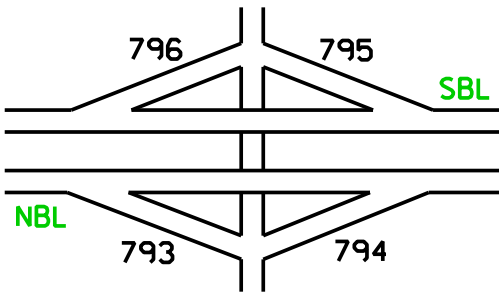

**Hat Six Interchange**

RM: 182.53      EXIT \* 182

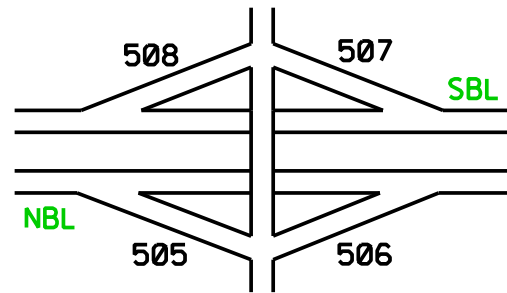

**Bixby Interchange**

RM: 156.18      EXIT \* 156

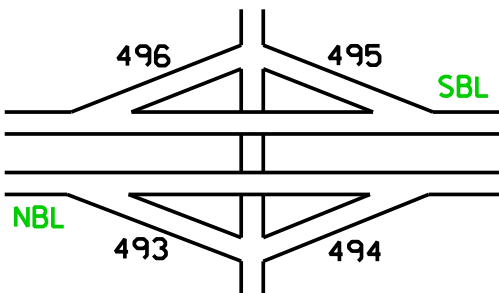

**Evansville Interchange**

RM: 185.35      EXIT \* 185

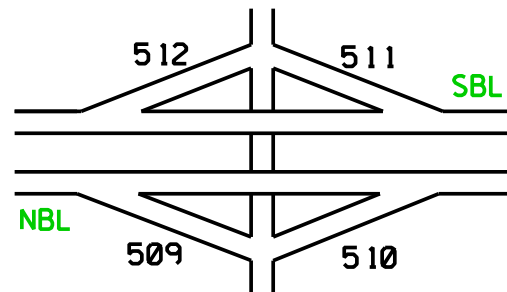

**E. Glenrock Interchange**

RM: 160.87      EXIT \* 160

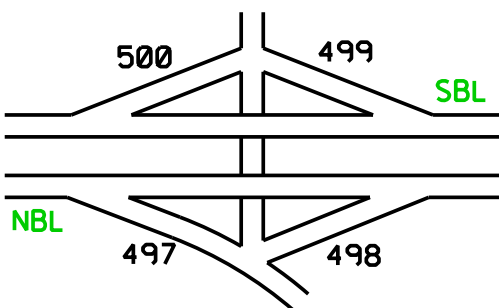

**Yellowstone Street Interchange**

RM: 186.36      EXIT \* 186\*A'

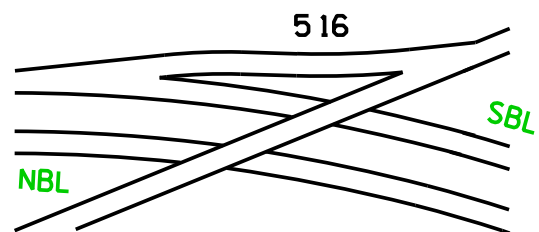

**Bryan Stock Trail Interchange**  
 RM: 186.79 EXIT \* 186\*B\*

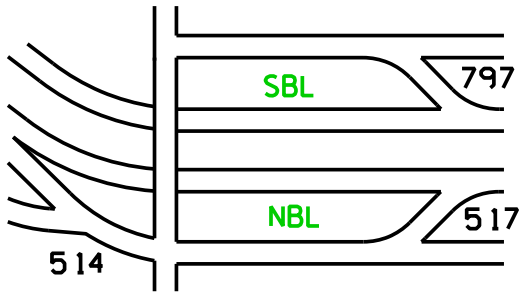

**Shoshoni Interchange**  
 RM: 189.51 EXIT \* 189

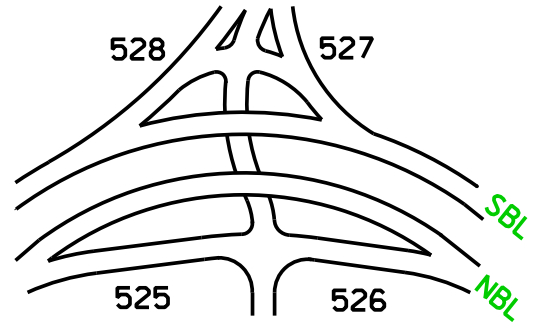

**McKinley St. Interchange**  
 RM: 187.53 EXIT \* 187

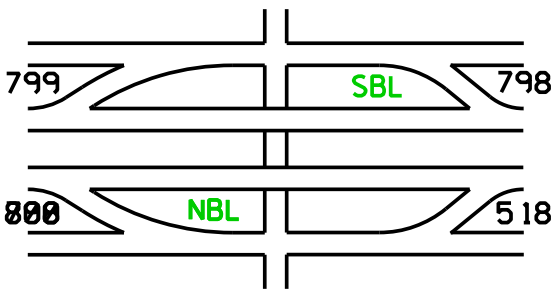

**Wardwell Road Interchange**  
 RM: 191.64 EXIT \* 191

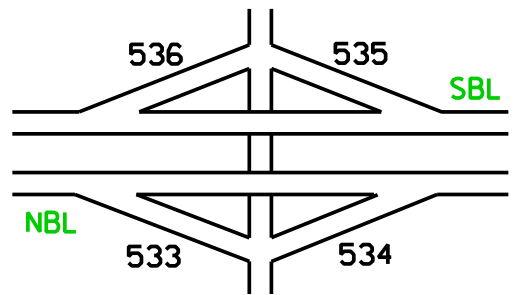

**Center St. Interchange**  
 RM: 188.19 EXIT \* 188\*A\*

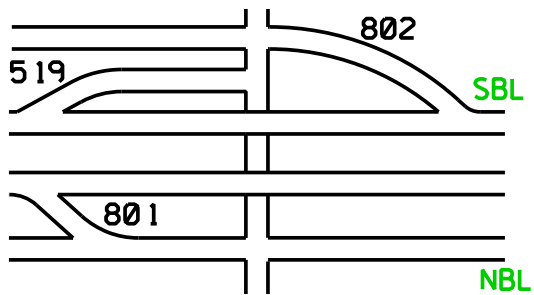

**Ormsby Road Interchange**  
 RM: 197.52 EXIT \* 197

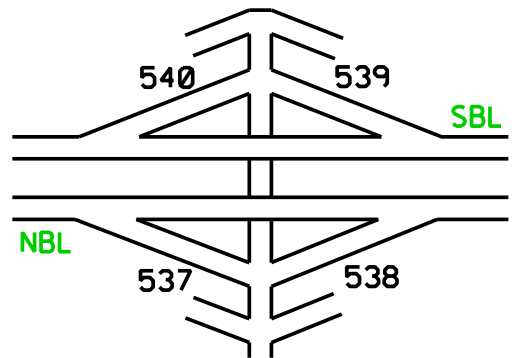

**Poplar St. Interchange**  
 RM: 188.60 EXIT \* 188\*B\*

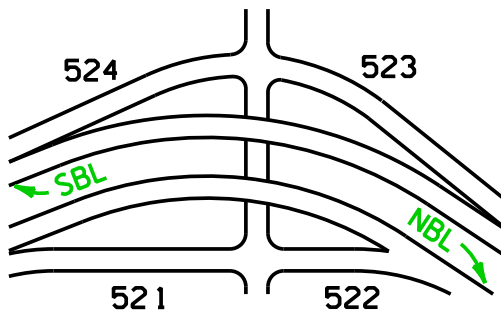

**Horse Ranch Creek Interchange**  
 RM: 210.41 EXIT \* 210

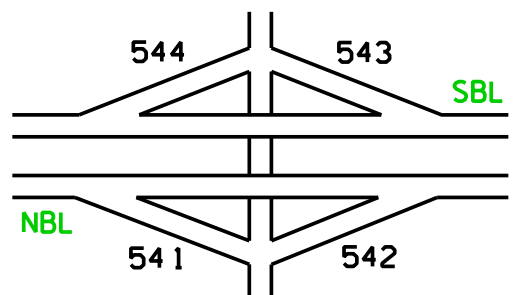

Ranch Road Interchange

RM: 216.43 EXIT # 216

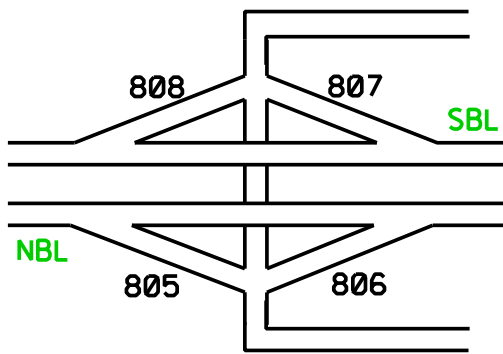

Powder River Interchange

RM: 246.56 EXIT # 246

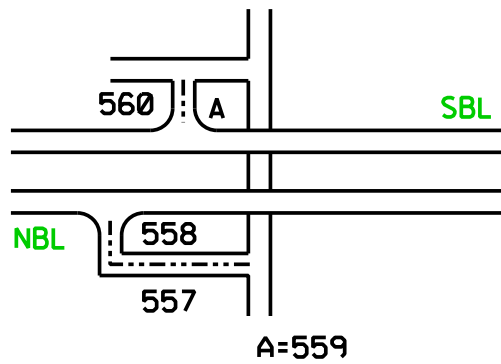

Midwest Interchange

RM: 223.78 EXIT # 223

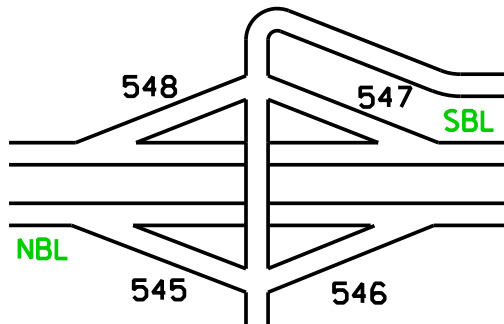

T. T. Interchange

RM: 249.69 EXIT # 249

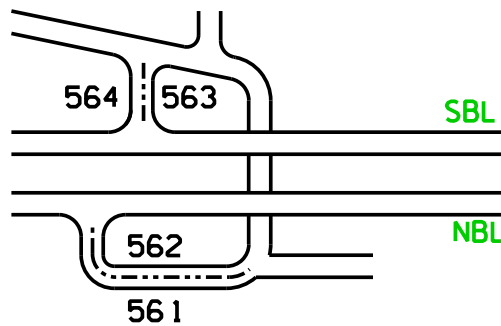

Smokey Gap Interchange

RM: 227.99 EXIT # 227

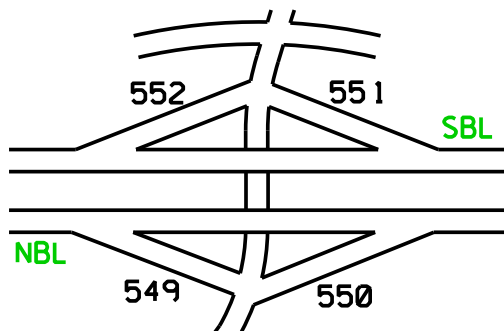

Kaycee Interchange

RM: 254.25 EXIT # 254

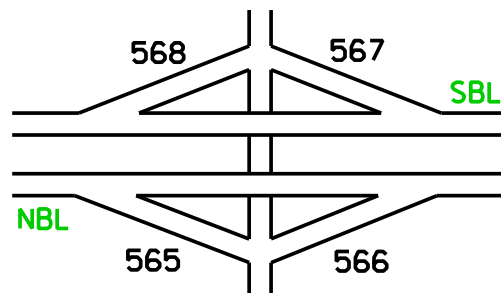

Tisdale Mtn. Road Interchange

RM: 235.38 EXIT # 235

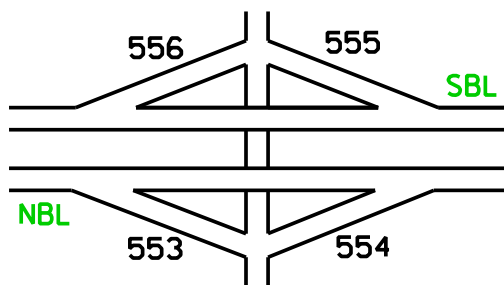

Reno Road Interchange

RM: 265.48 EXIT # 265

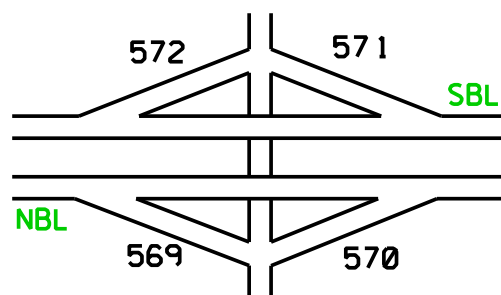

Middle Fork Road Interchange

RM: 280.18

EXIT # 280

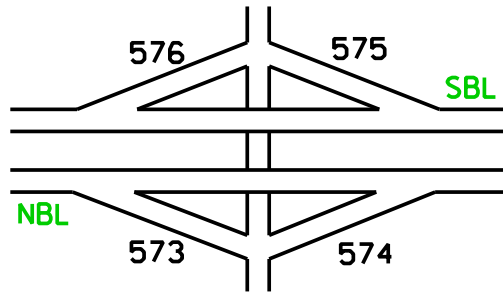

Buffalo Tri-Level Interchange

RM: 300.55

EXIT # 300

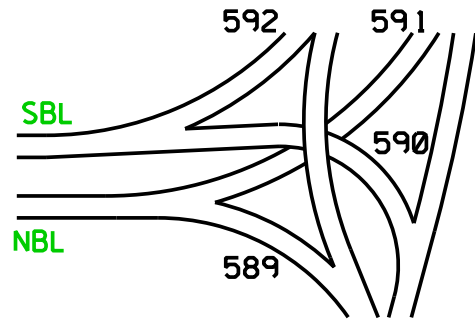

Trabing Road Interchange

RM: 291.08

EXIT # 291

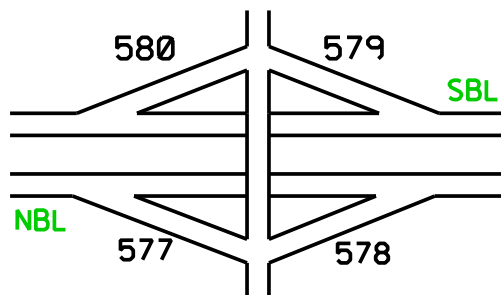

South Buffalo Interchange

RM: 298.02

EXIT # 298

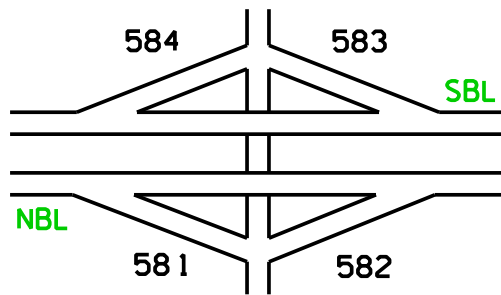

Buffalo-Ucross Interchange

RM: 299.32

EXIT # 299

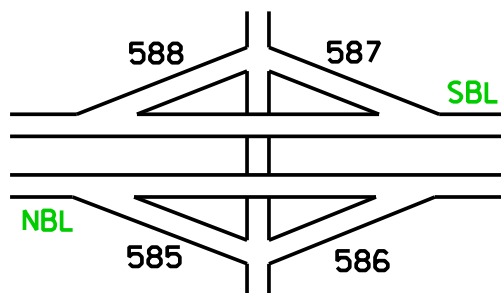



# INTERCHANGE LAYOUT

## I - 80

### W. Evanston Interchange

RM: 3.45

EXIT # 3

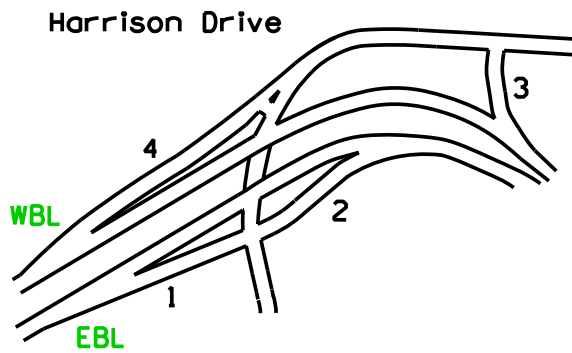

### Painter Interchange

RM: 10.68

EXIT # 10

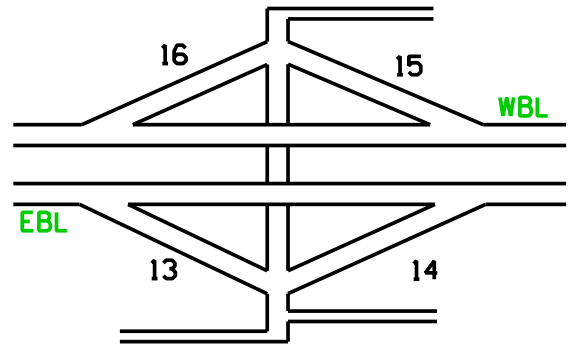

### State Hospital Rd. Interchange

RM: 5.26

EXIT # 5

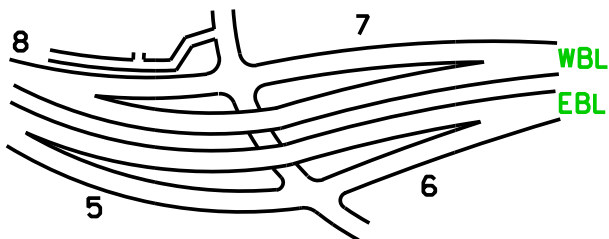

### Divide Interchange

RM: 13.86

EXIT # 13

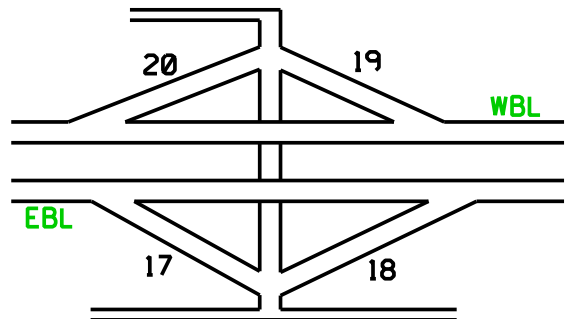

### E. Evanston Interchange

RM: 6.26

EXIT # 6

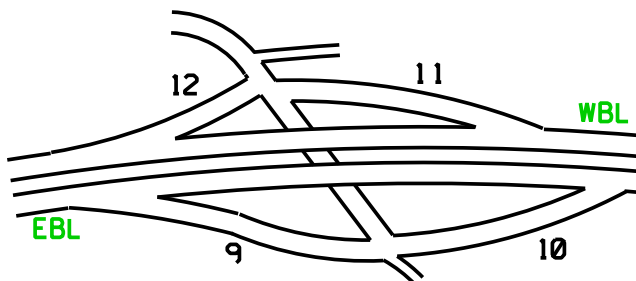

### U.S. 189 Interchange

RM: 18.29

EXIT # 18

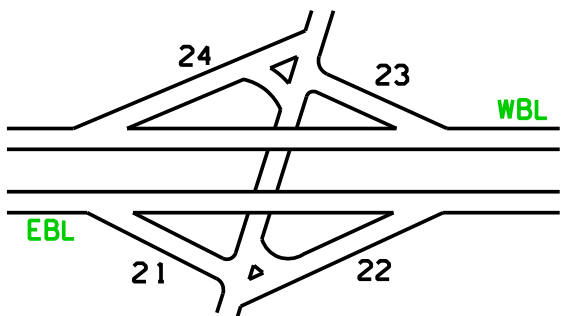

**Coal Interchange**

RM: 21.75

EXIT # 21

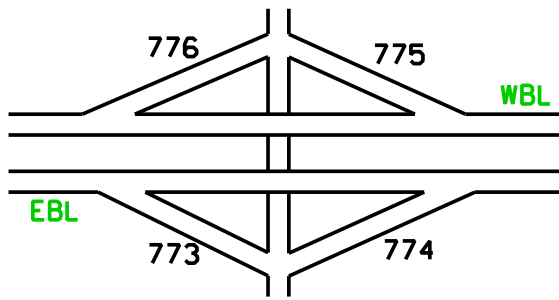

**Bigelow Interchange**

RM: 30.40

EXIT # 30

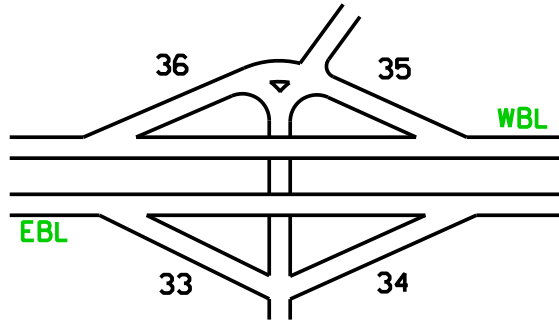

**Bar Hat Interchange**

RM: 23.12

EXIT # 23

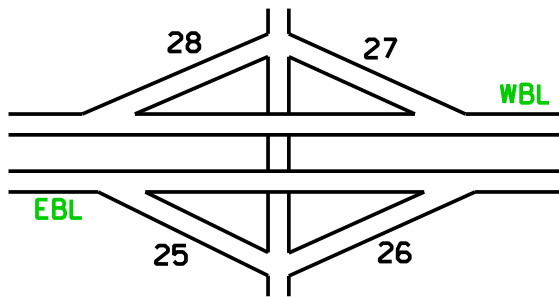

**Union Interchange**

RM: 33.18

EXIT # 33

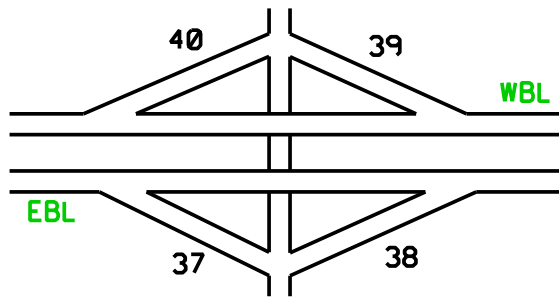

**Leroy Interchange**

RM: 23.91

EXIT # 24

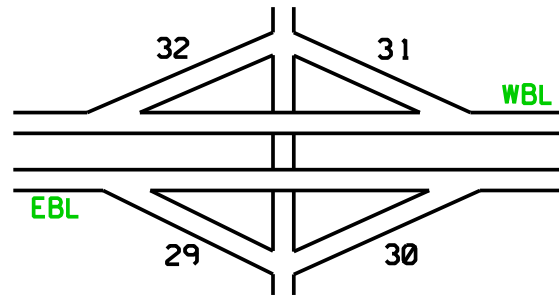

**Fort Bridger Interchange**

RM: 34.74

EXIT # 34

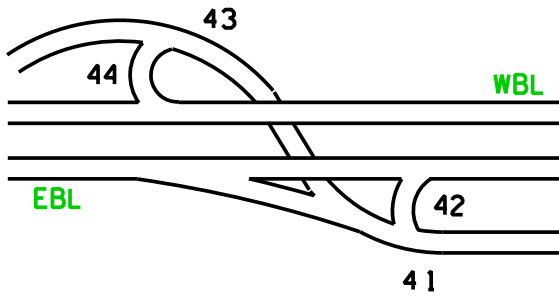

**French Interchange**

RM: 28.71

EXIT # 28

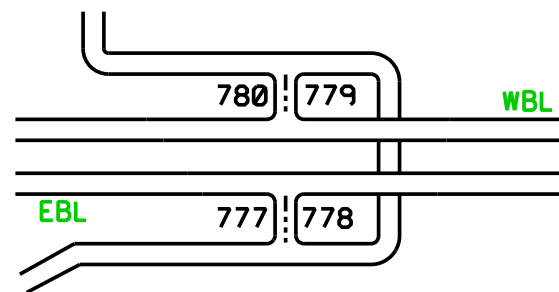

**Carter-Mountainview Interchange**

RM: 39.90

EXIT # 39

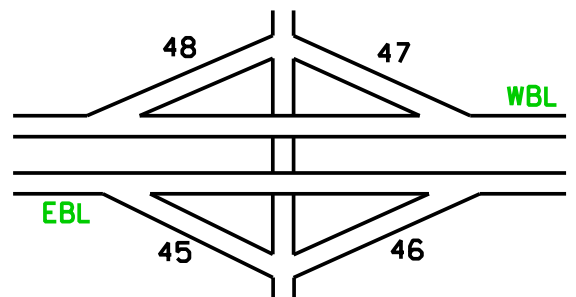



**North Lyman Interchange**

RM: 41.99

EXIT # 41

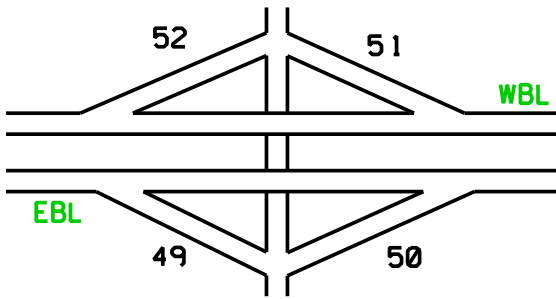

**Granger Jct. Interchange**

RM: 66.17

EXIT # 66

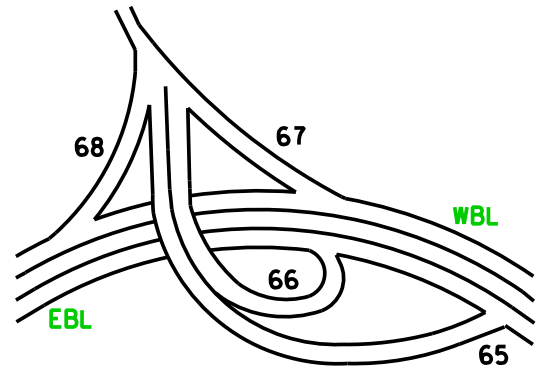

**Bridger Valley Interchange**

RM: 48.30

EXIT # 48

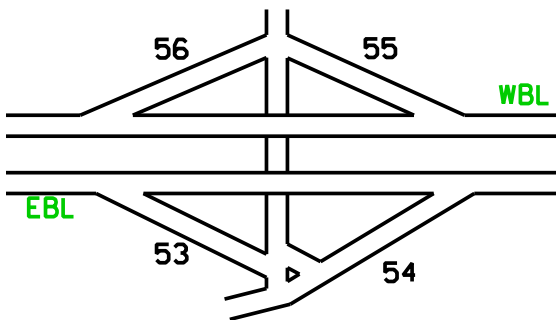

**Little America Interchange**

RM: 68.97

EXIT # 68

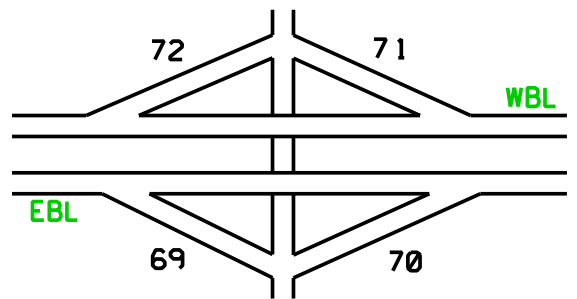

**Church Buttes Interchange**

RM: 53.31

EXIT # 53

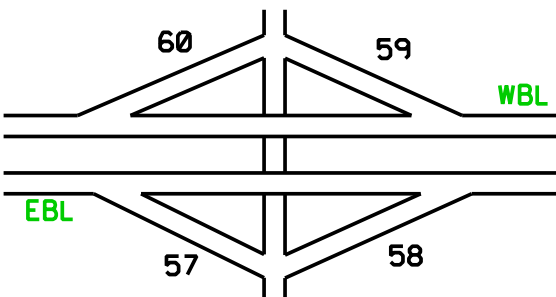

**Westvaco Interchange**

RM: 72.30

EXIT # 72

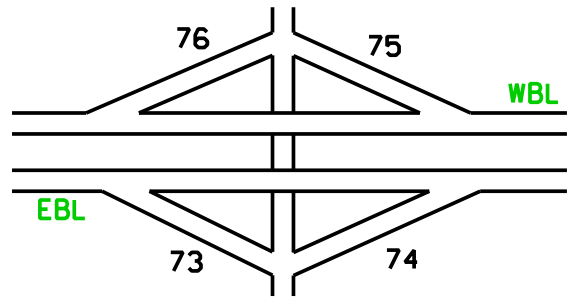

**Cedar Mountain Road Interchange**

RM: 61.59

EXIT # 61

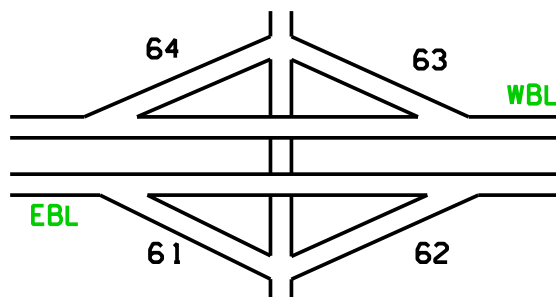

**LaBarge Interchange**

RM: 83.01

EXIT # 83

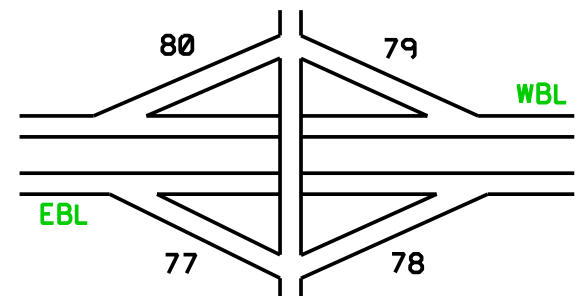

Covered Wagon Road Interchange

EXIT \* 85 (RM 85.70)

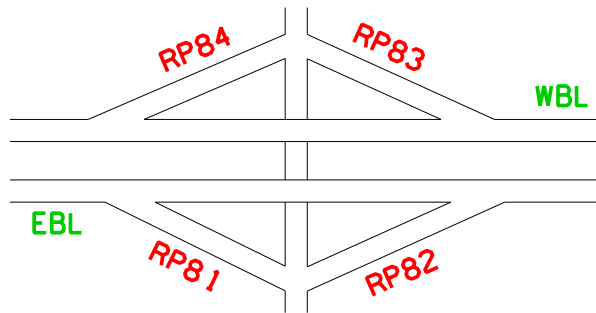

Dewar Drive Interchange

EXIT \* 102 (RM 102.36)

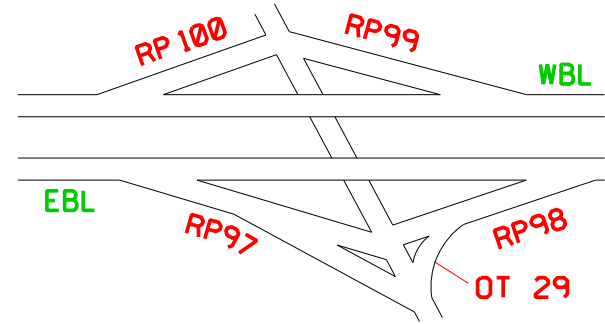

W. Green River Interchange

EXIT \* 89 (RM 89.45)

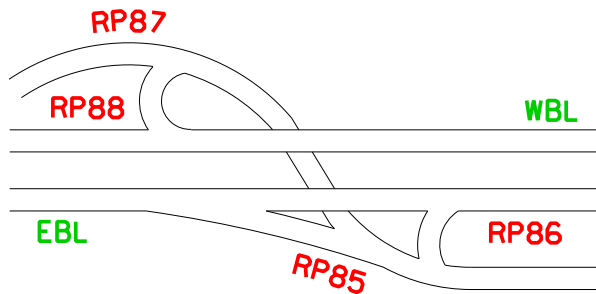

College Drive Interchange

EXIT \* 103 (RM 103.82)

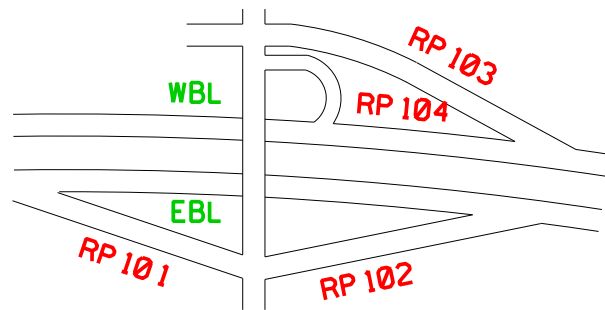

E. Green River Interchange

EXIT \* 91 (RM 91.53)

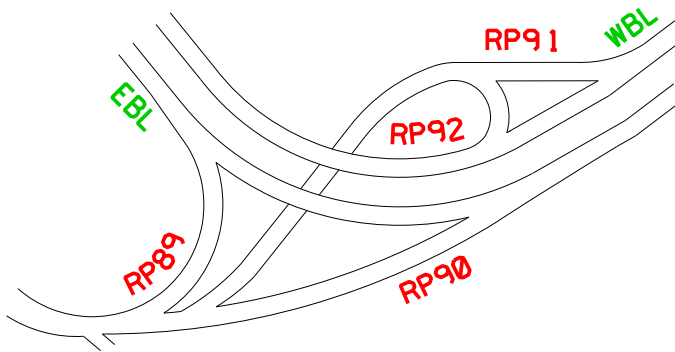

Elk Street Interchange

EXIT \* 104 (RM 104.83)

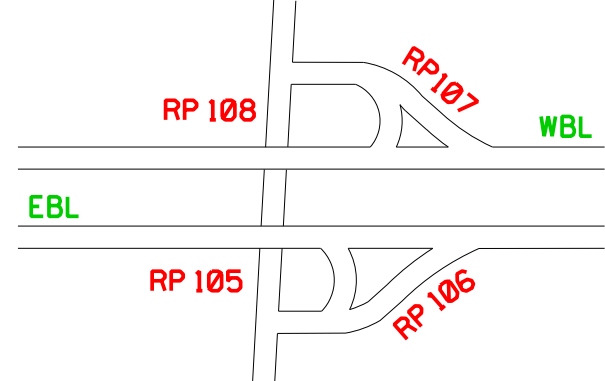

Flaming Gorge Interchange

EXIT \* 99 (RM 99.14)

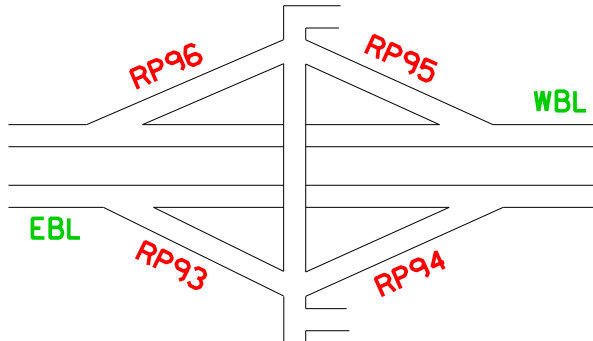

Pilot Butte Interchange

EXIT \* 107 (RM 107.06)

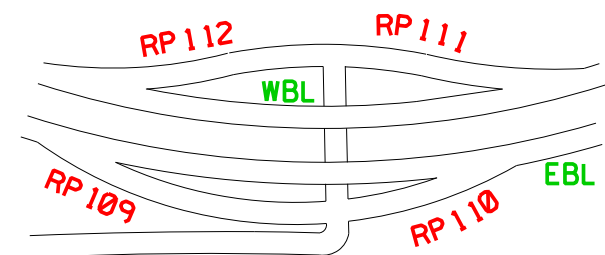

**Baxter Road Interchange**

RM: III.I6

EXIT # III

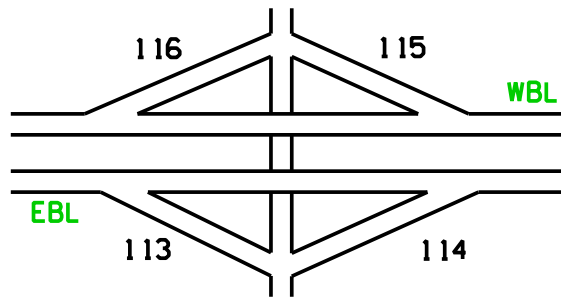

**Red Hill Interchange**

RM: I39.5I

EXIT # I39

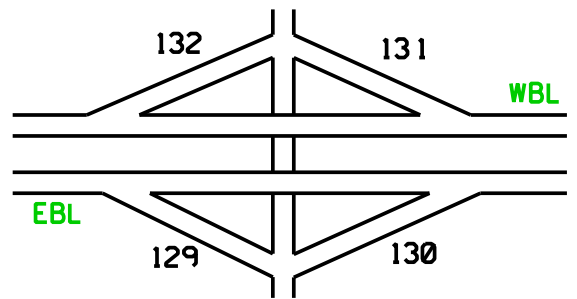

**Superior Interchange**

RM: I22.27

EXIT # I22

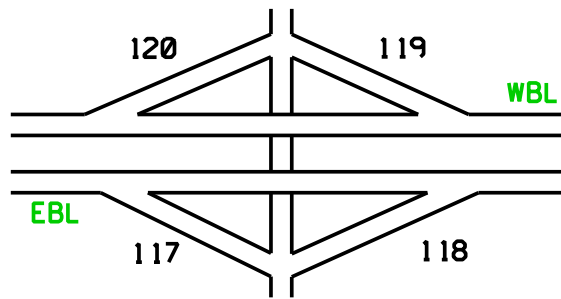

**Bitter Creek Interchange**

RM: I42.I7

EXIT # I42

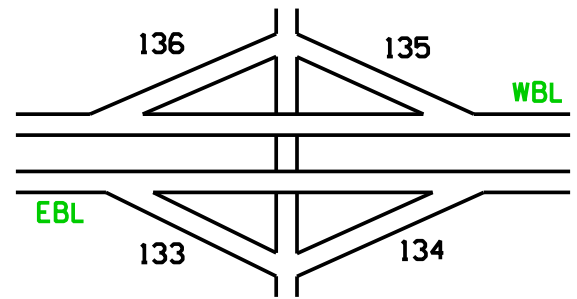

**Point Of Rocks Interchange**

RM: I30.84

EXIT # I30

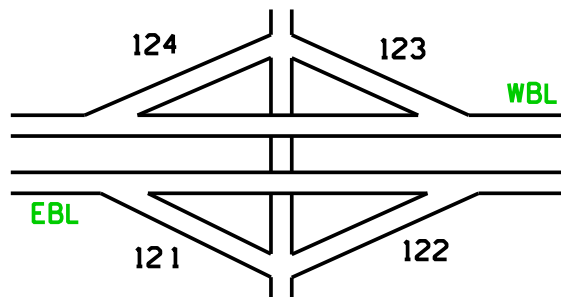

**Patrick Draw Interchange**

RM: I46.85

EXIT # I46

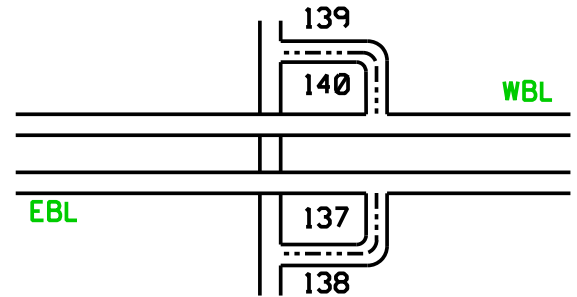

**Black Butte Interchange**

RM: I36.96

EXIT # I36

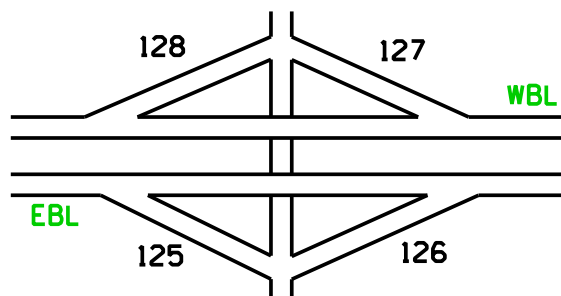

**Table Rock Interchange**

RM: I50.8I

EXIT # I50

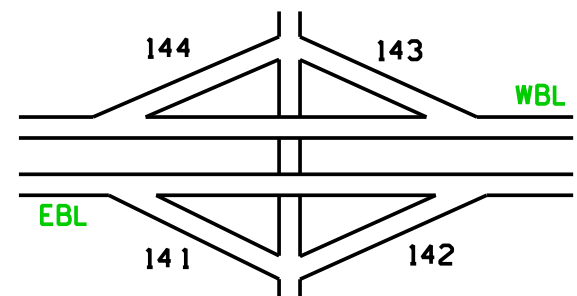

**Bar X Interchange**

RM: 152.46

EXIT # 152

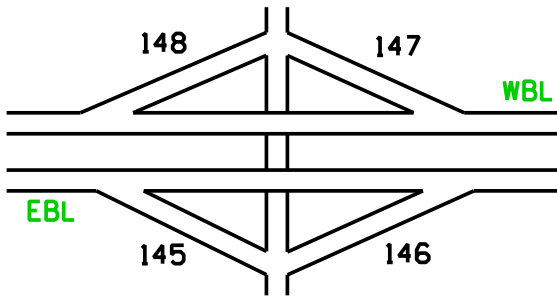

**Red Desert Interchange**

RM: 165.58

EXIT # 165

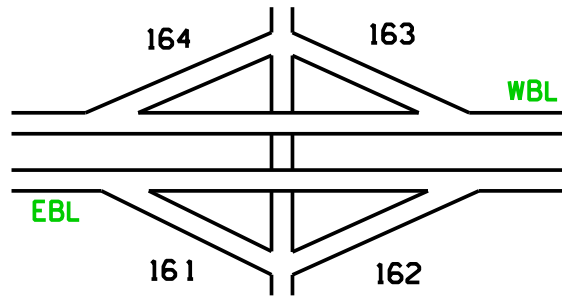

**BLM Road Interchange**

RM: 154.06

EXIT # 154

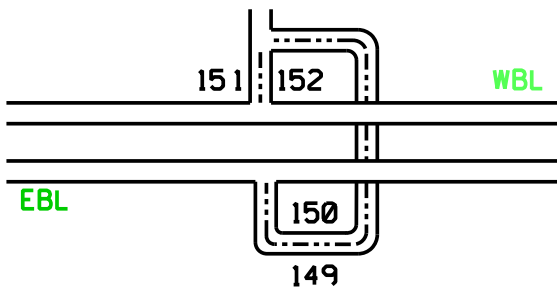

**G. L. Road Interchange**

RM: 156.03

EXIT # 156

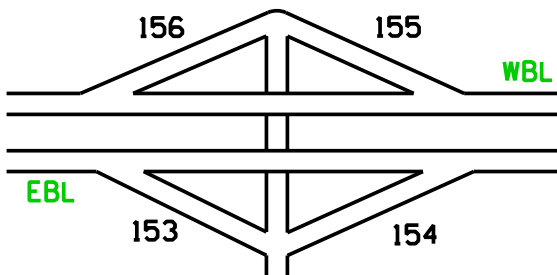

**Tipton Interchange**

RM: 158.55

EXIT # 158

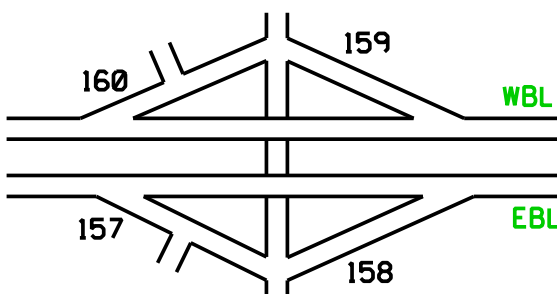

**Rasmussen Road Interchange**

RM: 170.68

EXIT # 170

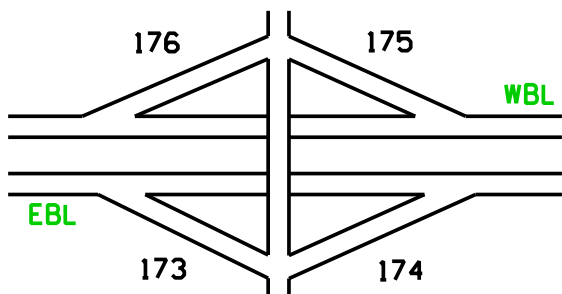

I-80 Interchanges

166 Booster Road  
and  
168 Frewen Road

Were removed fall of 2010

**Wamsutter Interchange**

RM: 173.41

EXIT # 173

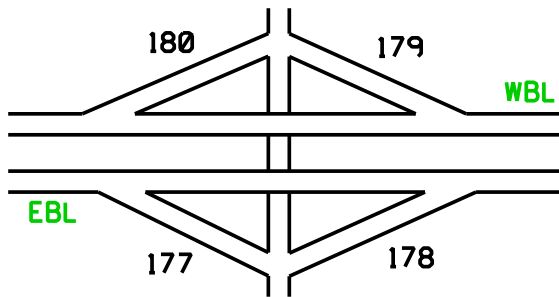

**Daley Interchange**

RM: 201.16

EXIT # 201

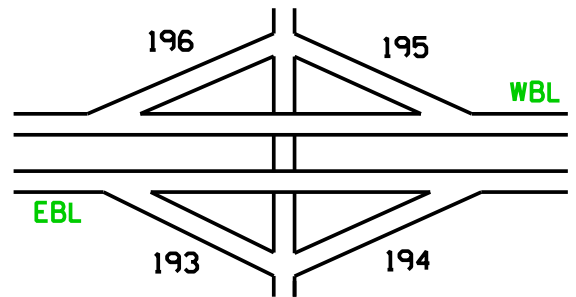

**Continental Divide Interchange**

RM: 184.29

EXIT # 184

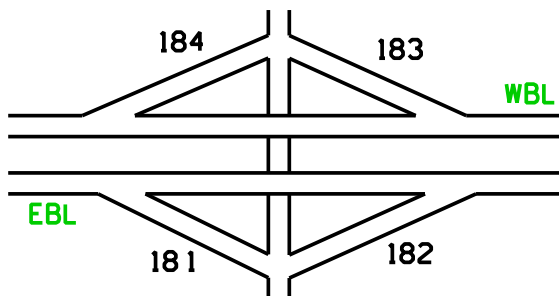

**Knobbs Interchange**

RM: 204.18

EXIT # 204

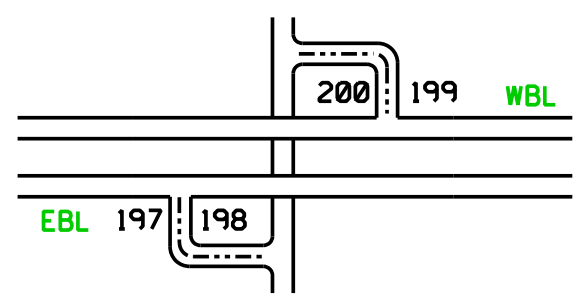

**Wyo. 789 Interchange**

RM: 187.20

EXIT # 187

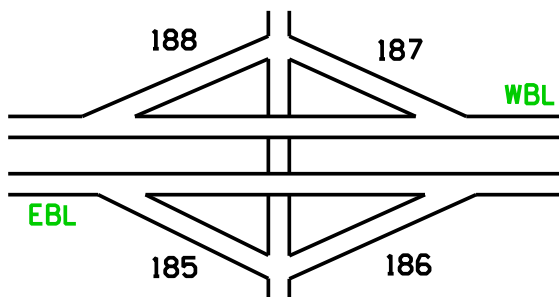

**Hadsell Interchange**

RM: 206.18

EXIT # 206

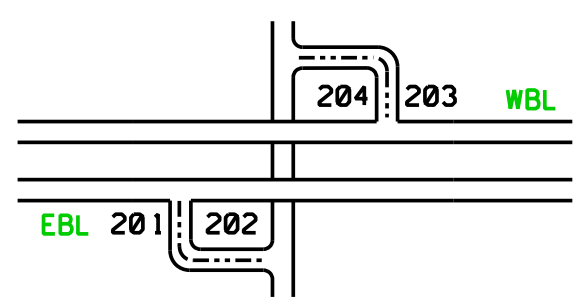

**Riner Interchange**

RM: 196.16

EXIT # 196

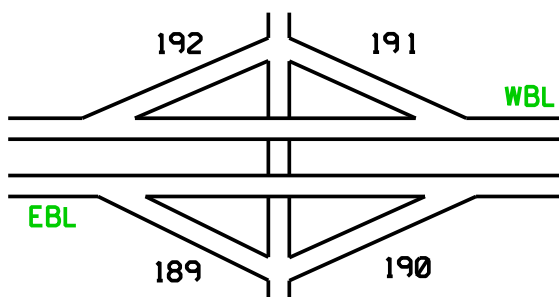

**Johnson Road Interchange**

RM: 209.46

EXIT # 209

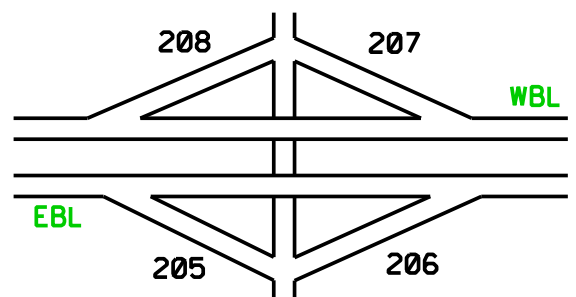

**Spruce St. Interchange**

RM: 211.78

EXIT # 211

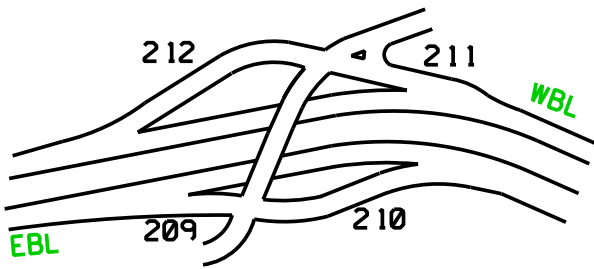

**E. Sinclair Interchange**

RM: 221.93

EXIT # 221

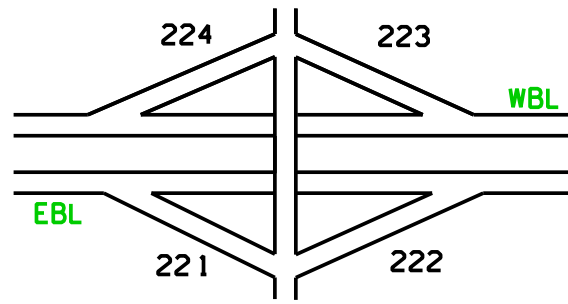

**Higley Blvd Interchange**

RM: 214.11

EXIT # 214

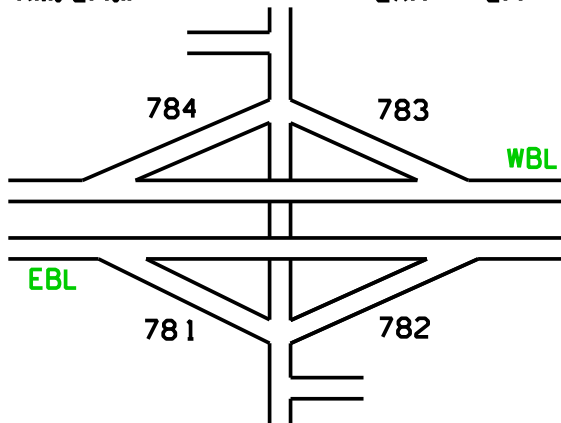

**Fort Steele Interchange**

RM: 228.34

EXIT # 228

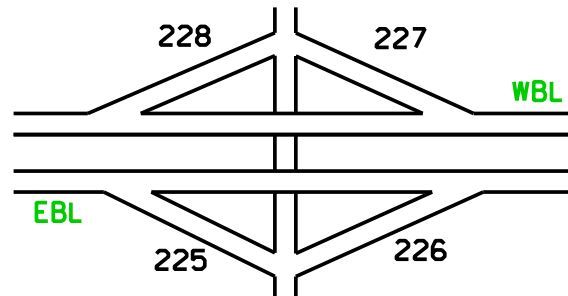

**Cedar St. Interchange**

RM: 215.57

EXIT # 215

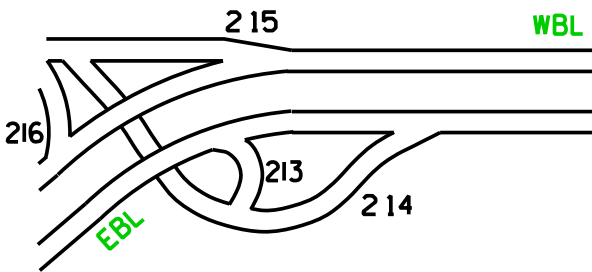

**Saratoga Interchange**

RM: 235.28

EXIT # 235

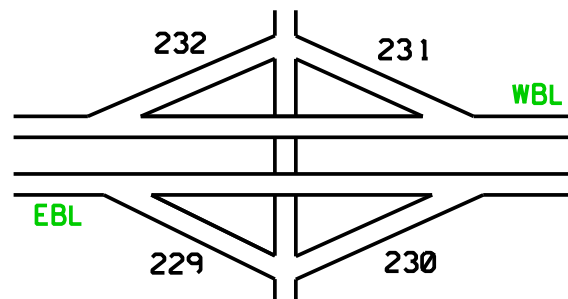

**W. Sinclair Interchange**

RM: 219.59

EXIT # 219

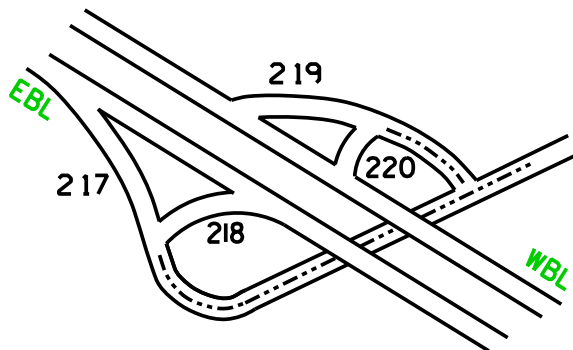

**Peterson Interchange**

RM: 238.15

EXIT # 238

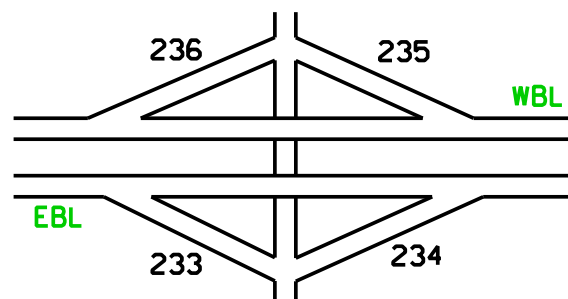

**West Elk Mountain Interchange**

RM: 255.60

EXIT # 255

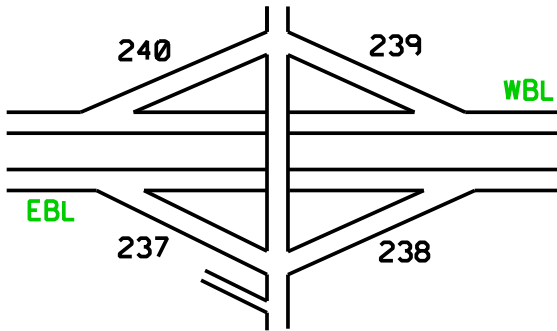

**Cooper Cove Interchange**

RM: 279.86

EXIT # 279

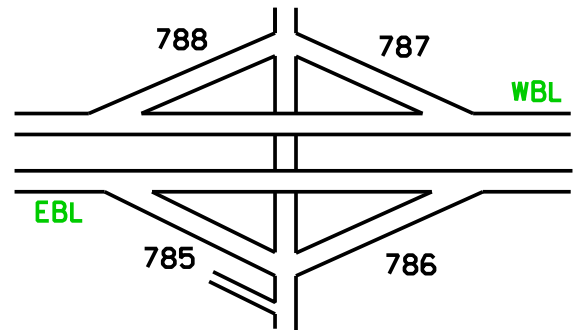

**East Elk Mountain Interchange**

RM: 260.23

EXIT # 260

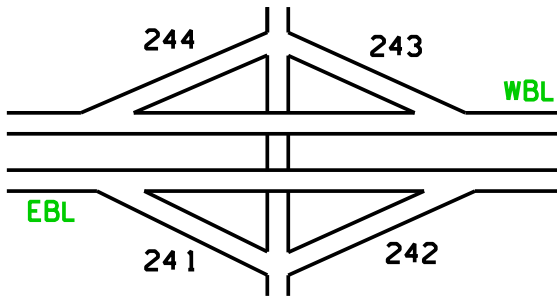

**Ouealy Dome Interchange**

RM: 290.44

EXIT # 290

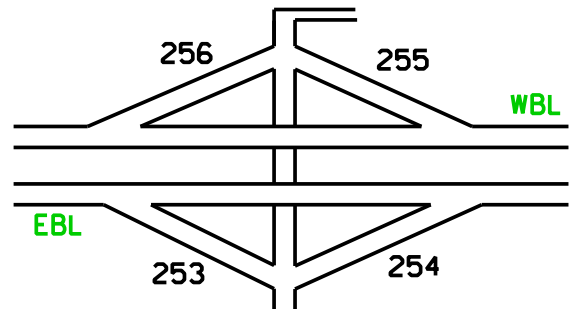

**Wagonhound Interchange**

RM: 267.19

EXIT # 267

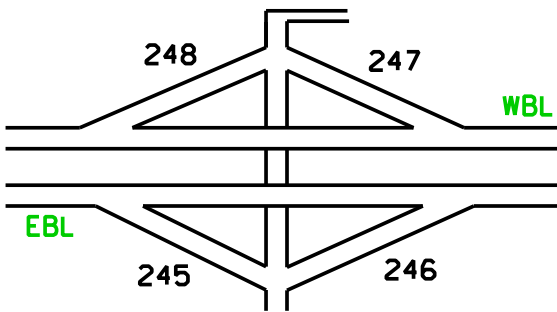

**Herrick Lane Interchange**

RM: 297.66

EXIT # 297

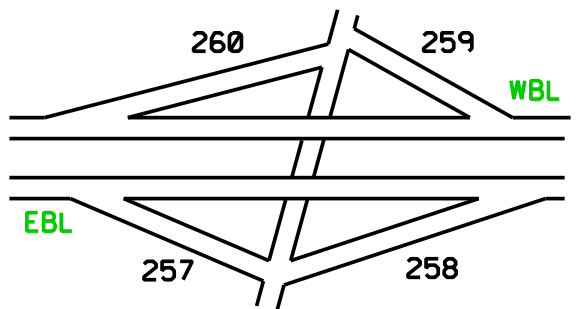

**Arlington Interchange**

RM: 272.06

EXIT # 272

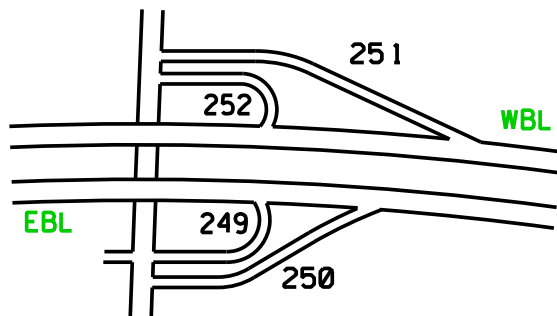

**Curtis Street Interchange**

RM: 310.45

EXIT # 310

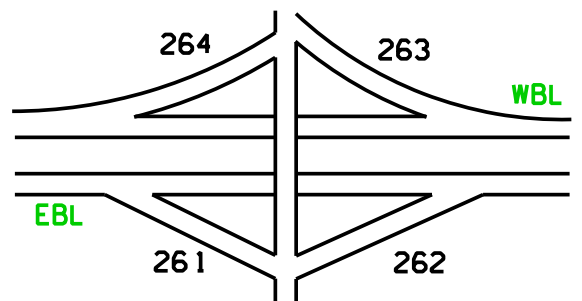

**Snowy Range Rd. Interchange**

RM: 311.76

EXIT \* 311

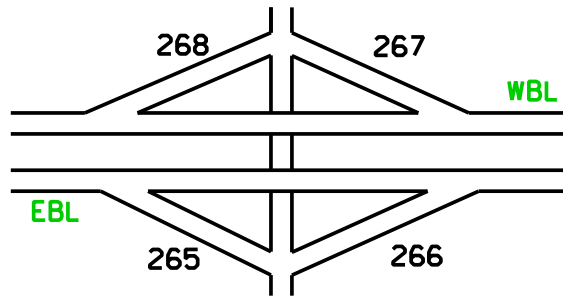

**Vedauwoo Interchange**

RM: 329.32

EXIT \* 329

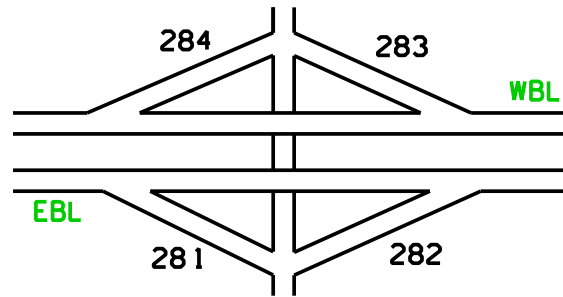

**Third Street Interchange**

RM: 313.19

EXIT \* 313

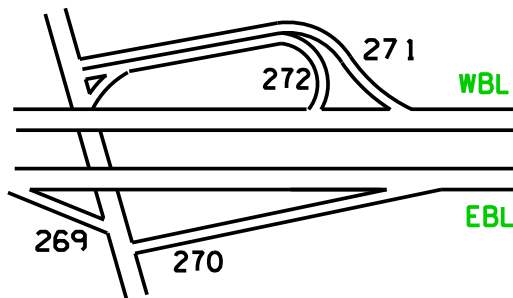

**Buford Interchange**

RM: 335.11

EXIT \* 335

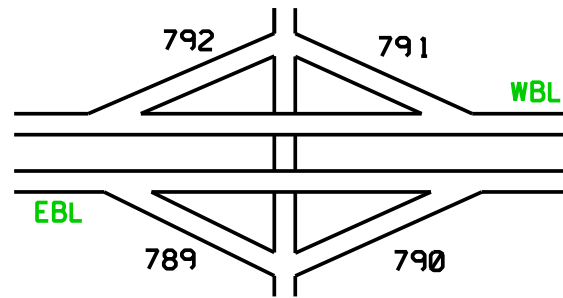

**Grand Avenue Interchange**

RM: 316.70

EXIT \* 316

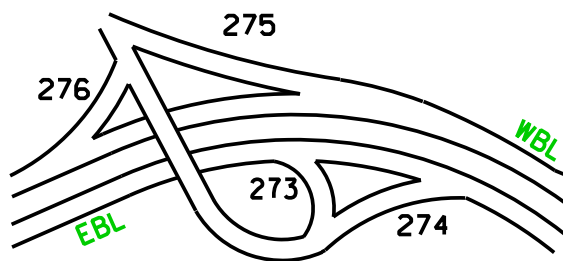

**Remount Interchange**

RM: 339.32

EXIT \* 339

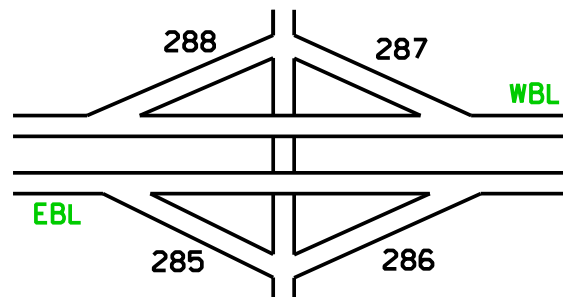

**Happy Jack Summit Interchange**

RM: 323.05

EXIT \* 323

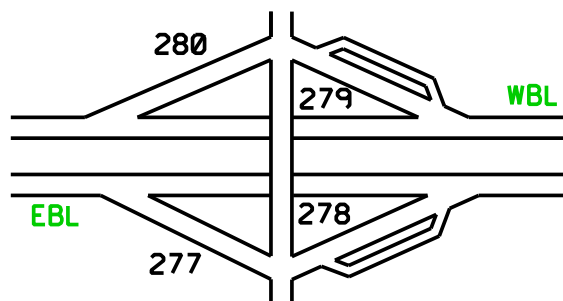

**Harriman Interchange**

RM: 342.56

EXIT \* 342

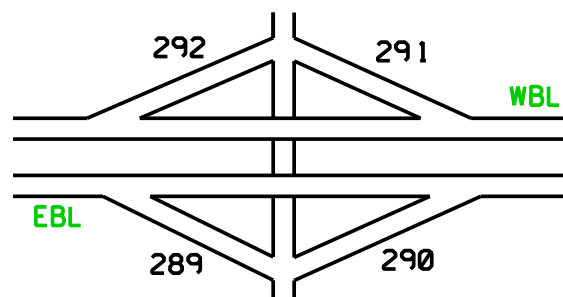



**Warren Interchange**

RM: 345.50

EXIT # 345

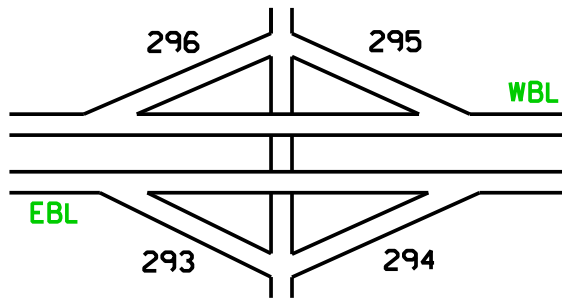

**I-25 & I-80 Interchange**

RM: 359.60

EXIT # 359 B

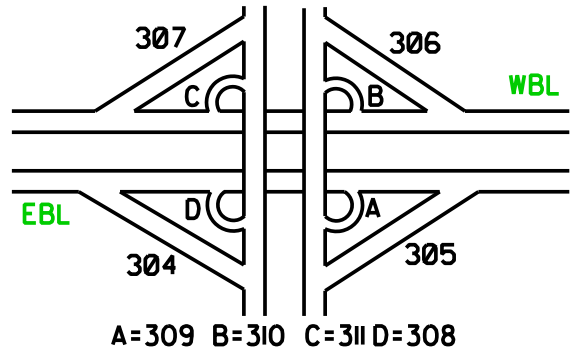

**Otto Interchange**

RM: 348.36

EXIT # 348

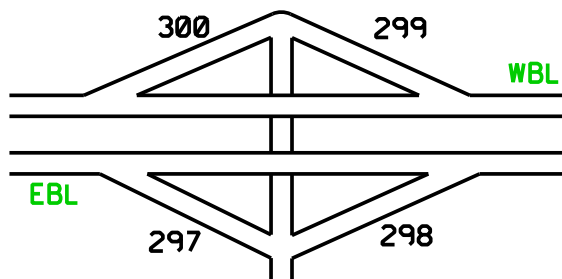

**U.S. 85 Interchange**

RM: 362.04

EXIT # 362

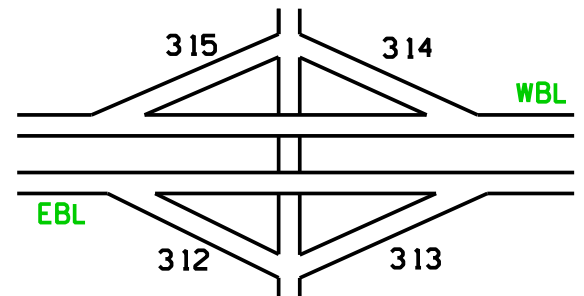

**RoundTop Interchange**

RM: 357.68

EXIT # 357

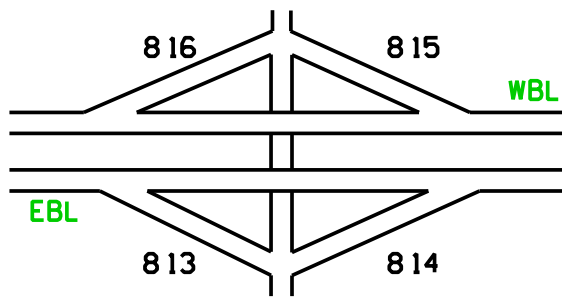

**Sun Valley Interchange**

RM: 364.00

EXIT # 364

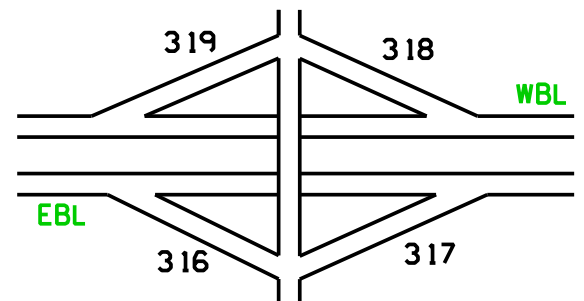

**Lincolnway Interchange**

RM: 359.08

EXIT # 359 A

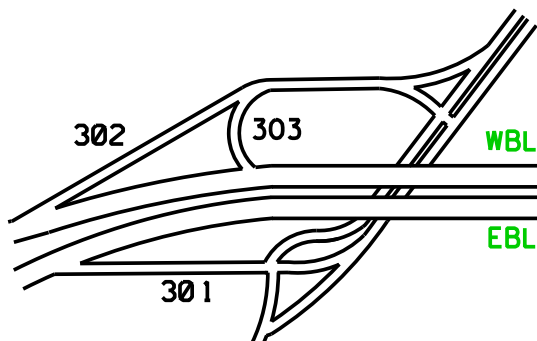

**Campstool Road Interchange**

RM: 367.42

EXIT # 367

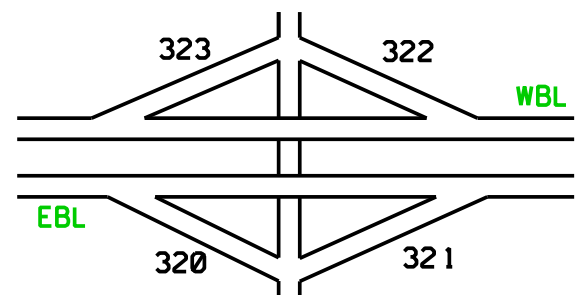

Archer Interchange

RM: 370.39

EXIT # 370

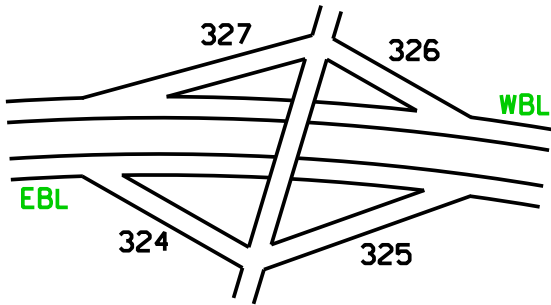

W. Pine Bluffs Interchange

RM: 401.46

EXIT # 401

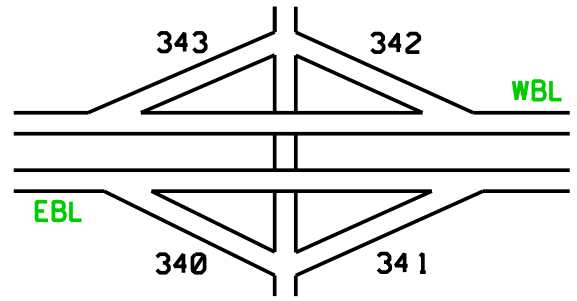

Hillsdale Interchange

RM: 377.35

EXIT # 377

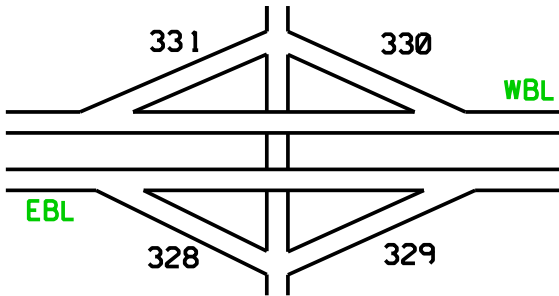

Burns- Carpenter Interchange

RM: 386.39

EXIT # 386

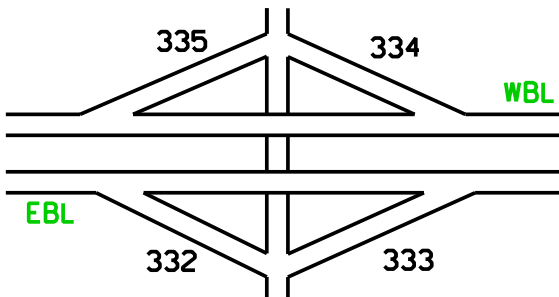

Egbert Interchange

RM: 391.39

EXIT # 391

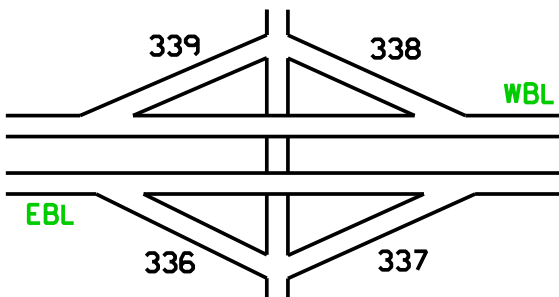

# INTERCHANGE LAYOUTS

## I - 90

**Parkman Interchange**

RM: 1.79

EXIT # 1

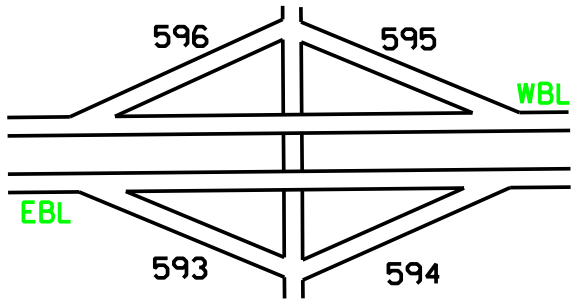

**N. Sheridan Interchange**

RM: 20.92

EXIT # 20

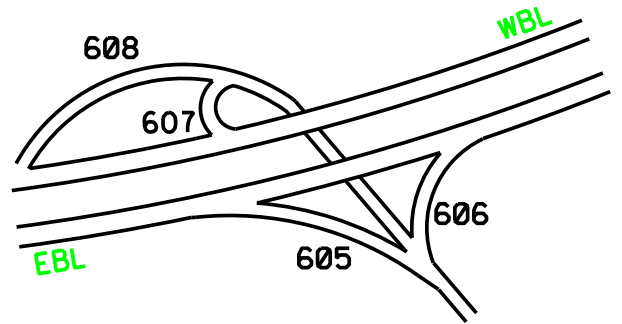

**Ranchester Interchange**

RM: 9.88

EXIT # 9

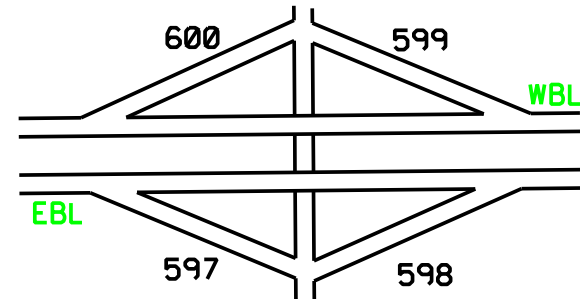

**5th Street Interchange**

RM: 23.15

EXIT # 23

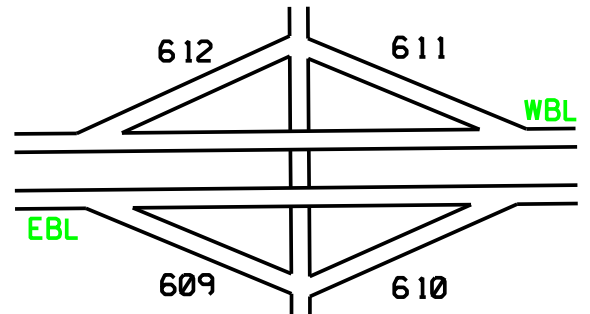

**Acme Interchange**

RM: 14.62

EXIT # 14

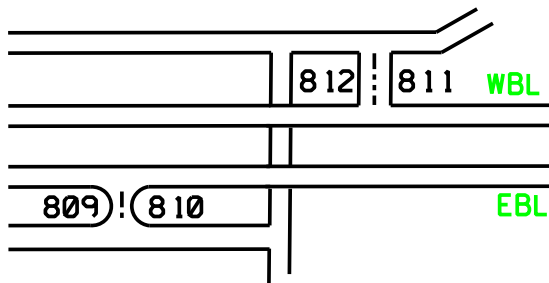

**U.S. 14 Interchange**

RM: 25.30

EXIT # 25

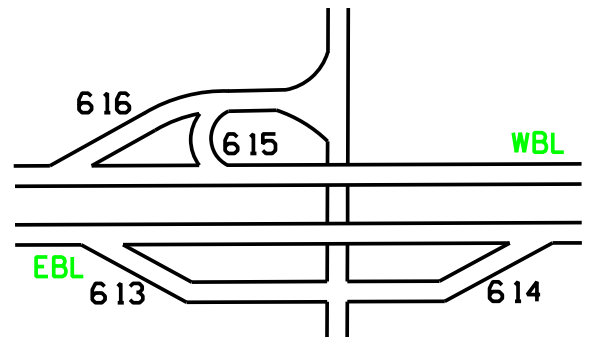

**Dietz Interchange**

RM: 16.34

EXIT # 16

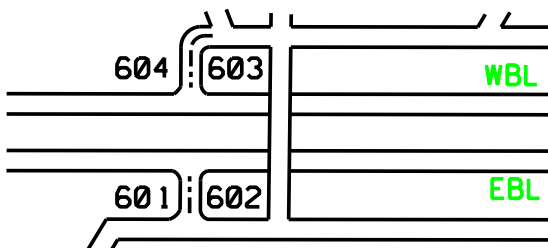

Meade Rd. Interchange

RM: 33.60

EXIT \* 33

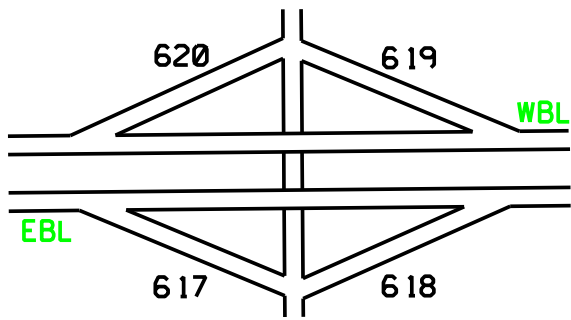

Lake DeSmet Interchange

RM: 51.36

EXIT \* 51

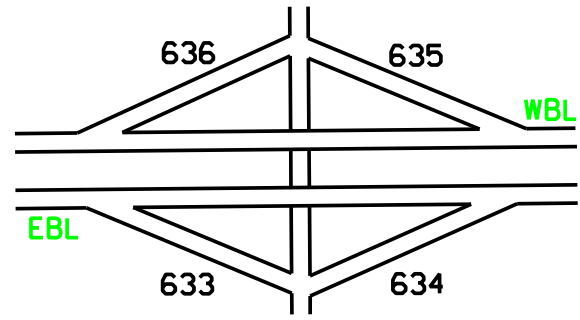

Prairie Dog Co. Rd. Interchange

RM: 37.16

EXIT \* 37

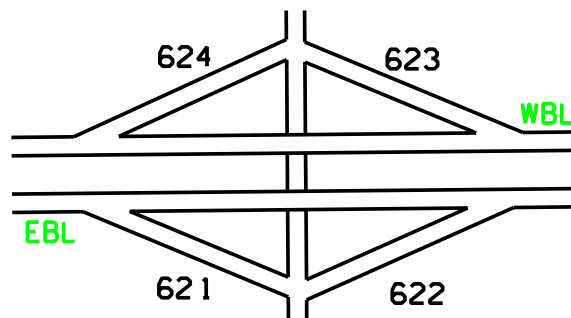

Rock Creek Rd. Interchange

RM: 53.83

EXIT \* 53

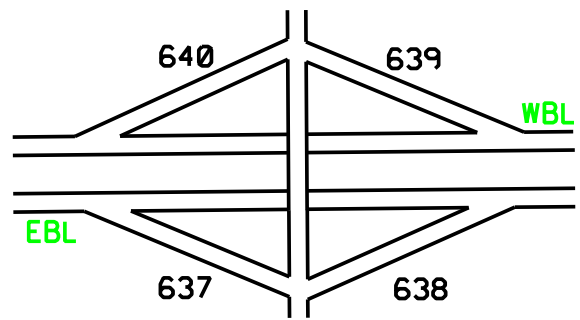

Piney Creek Interchange

RM: 44.69

EXIT \* 44

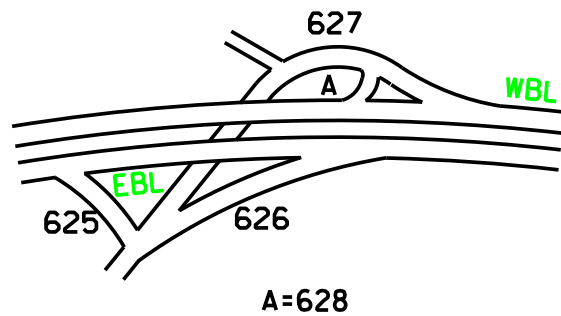

U.S. 87 N. Buffalo Interchange

RM: 56.36

EXIT \* 56"A"

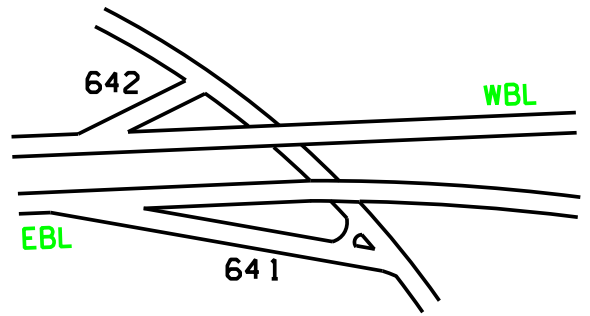

Shell Creek Interchange

RM: 47.71

EXIT \* 47

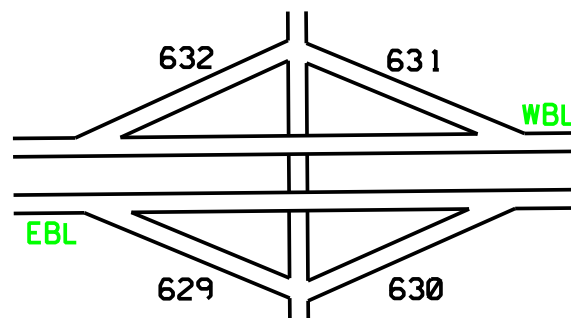

Buffalo Tri-Level Interchange

RM: 56.85

EXIT \* 56"B" / 300

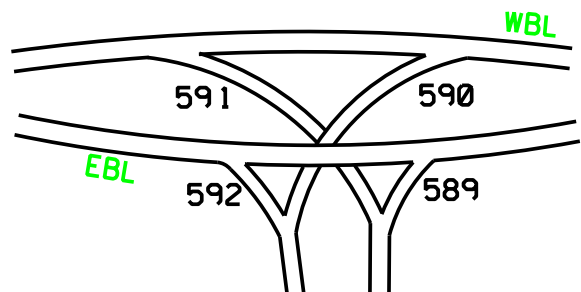

U.S. 16 Interchange

RM: 58.65

EXIT \* 58

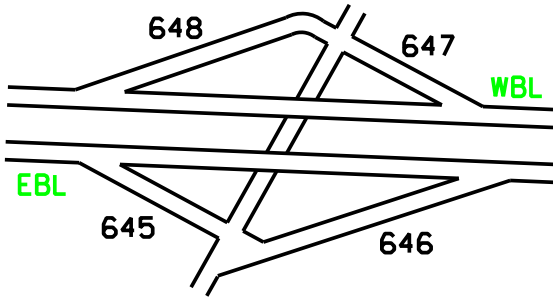

Schoonover Rd. Interchange

RM: 77.91

EXIT \* 77

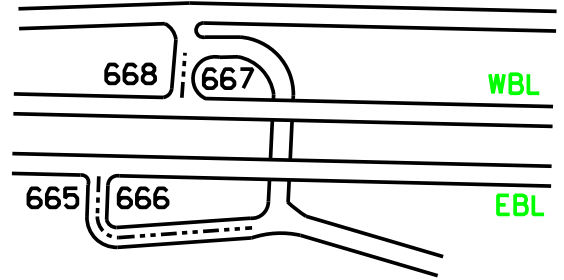

Red Hills Interchange

RM: 65.98

EXIT \* 65

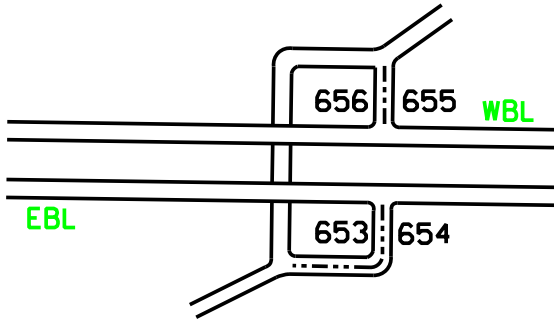

Indian Creek Interchange

RM: 82.83

EXIT \* 82

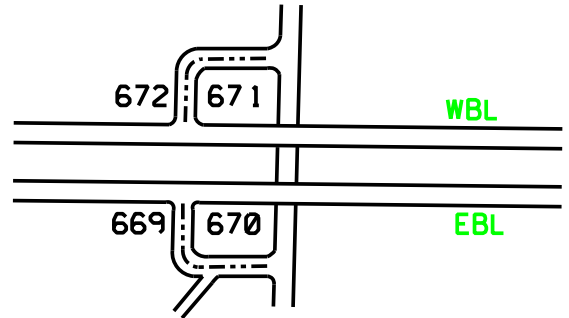

Dry Creek Interchange

RM: 69.64

EXIT \* 69

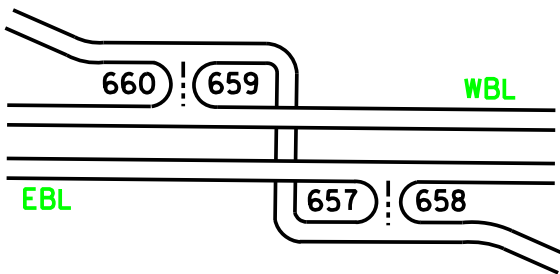

Powder River Interchange

RM: 88.67

EXIT \* 88

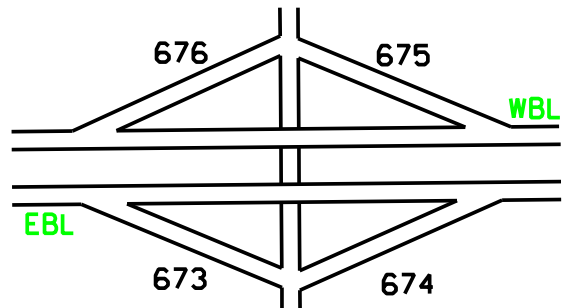

Crazy Woman Interchange

RM: 73.01

EXIT \* 73

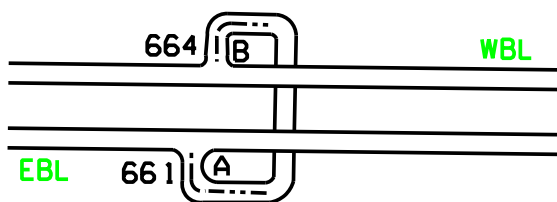

A=662 B=663

Dead Horse Interchange

RM: 91.49

EXIT \* 91

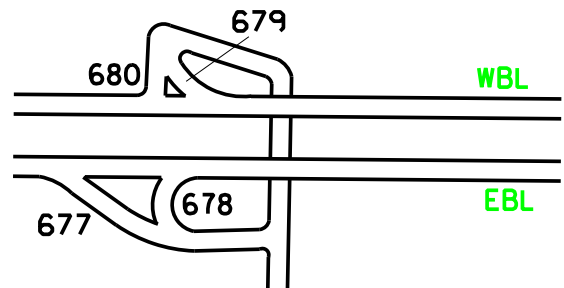

**Barber Creek Interchange**

RM: 102.52

EXIT # 102

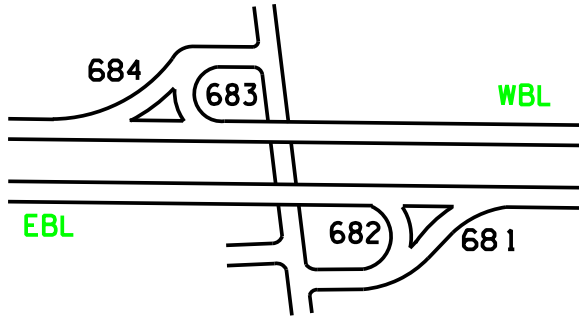

**West Gillette Interchange**

RM: 124.26

EXIT # 124

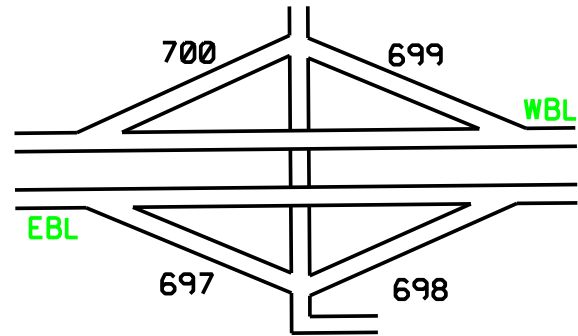

**Kingsbury Rd. Interchange**

RM: 106.14

EXIT # 106

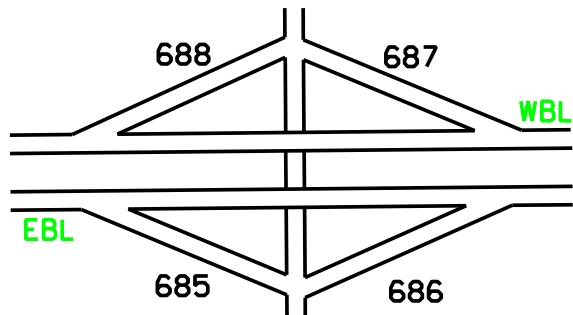

**Wyo. 59 Interchange**

RM: 126.39

EXIT # 126

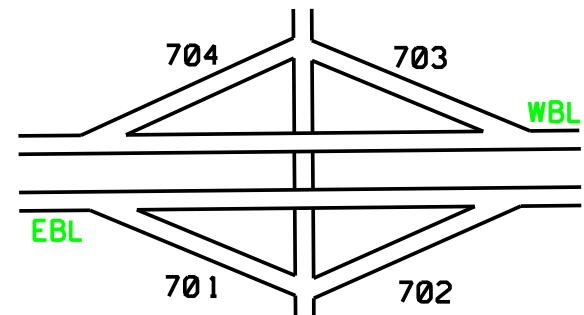

**Wild Horse Creek Rd. Interchange**

RM: 113.97

EXIT # 113

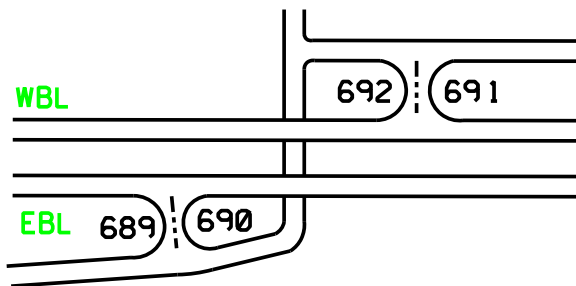

**East Gillette Interchange**

RM: 128.09

EXIT # 128

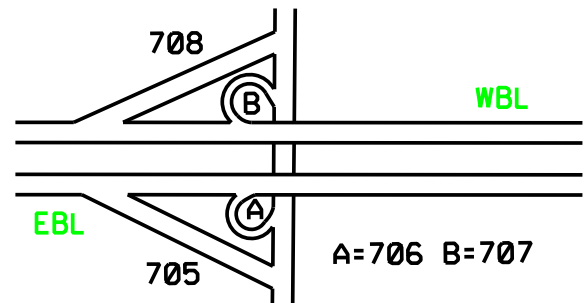

**Force Rd. Interchange**

RM: 116.24

EXIT # 116

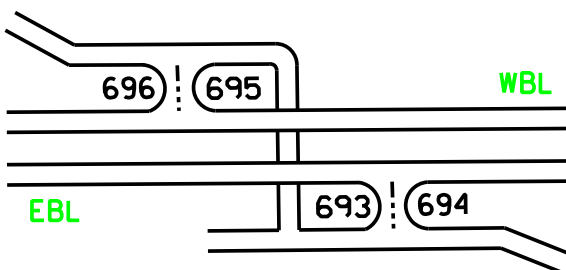

**Garner Lake Rd. Interchange**

RM: 129.10

EXIT # 129

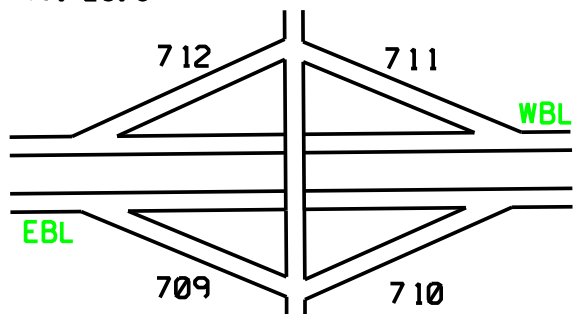

**Wyodak Interchange**

RM: 132.99

EXIT # 132

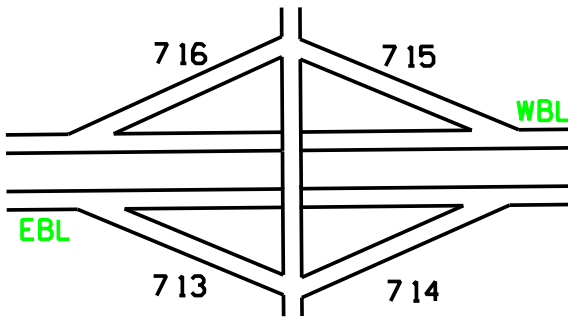

**Wind Creek Interchange**

RM: 160.66

EXIT # 160

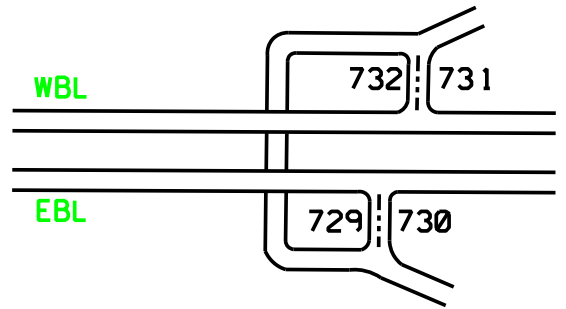

**Rozet Interchange**

RM: 141.24

EXIT # 141

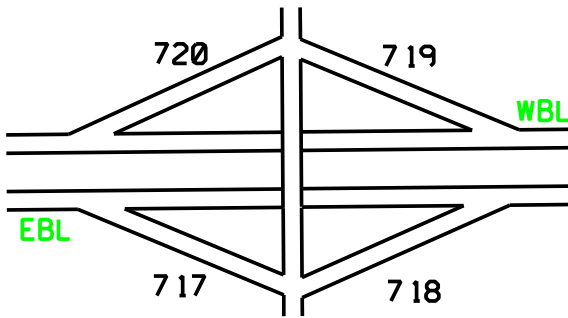

**Pine Ridge Interchange**

RM: 165.68

EXIT # 165

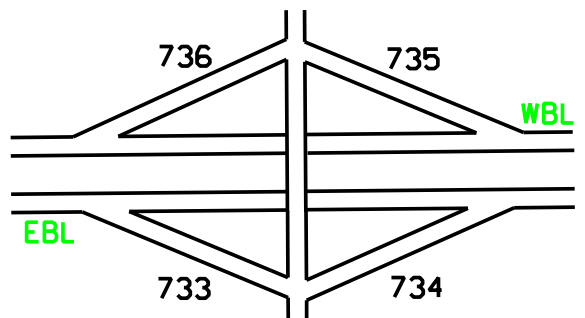

**W. Moorcroft Interchange**

RM: 153.41

EXIT # 153

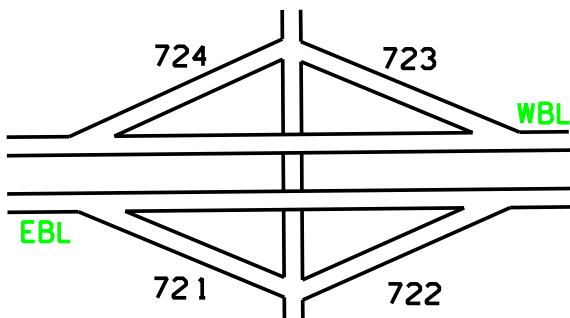

**Inyan Kara Interchange**

RM: 172.09

EXIT # 172

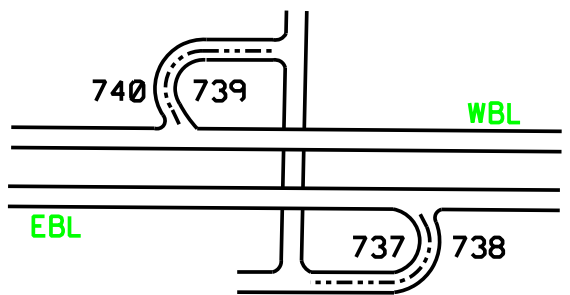

**E. Moorcroft Interchange**

RM: 154.69

EXIT # 154

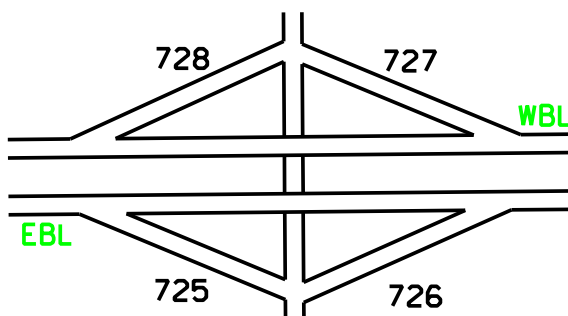

**Coal Divide Interchange**

RM: 178.92

EXIT # 178

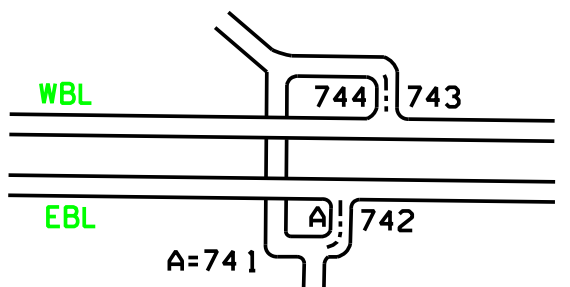

**West Sundance Interchange**

RM: 185.73

EXIT \* 185

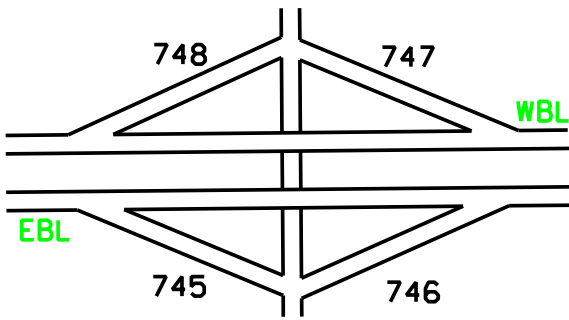

**Moskee Interchange**

RM: 191.92

EXIT \* 191

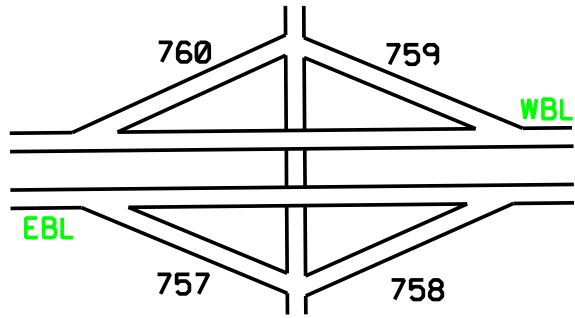

**WYO 585 Interchange**

RM: 187.53

EXIT \* 187

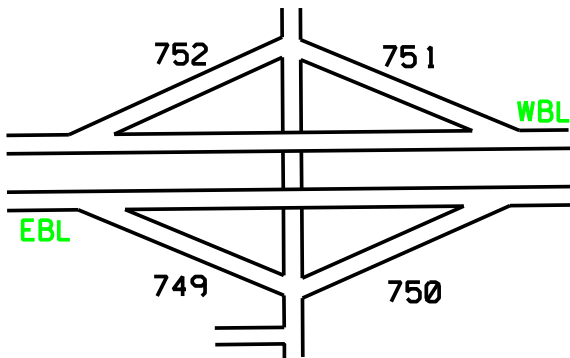

**Aladdin Interchange**

RM: 199.31

EXIT \* 199

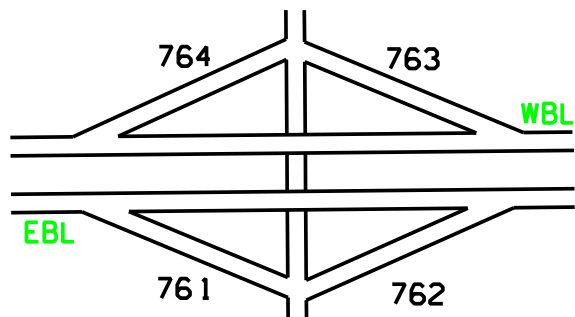

**East Sundance Interchange**

RM: 189.00

EXIT \* 189

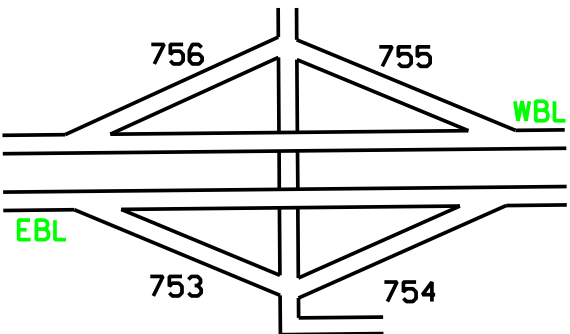

**Beulah Interchange**

RM: 205.90

EXIT \* 205

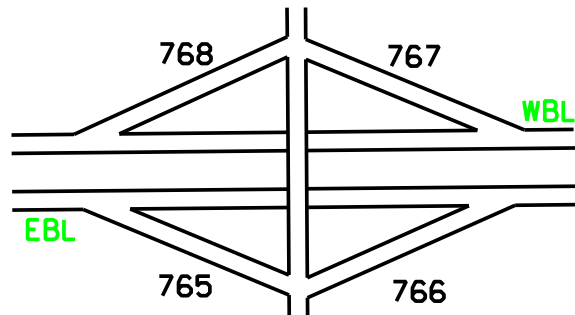



# INTERCHANGE LAYOUTS

## OTHER

Kemmerer Interchange

RM: 54.55

EXIT # 3

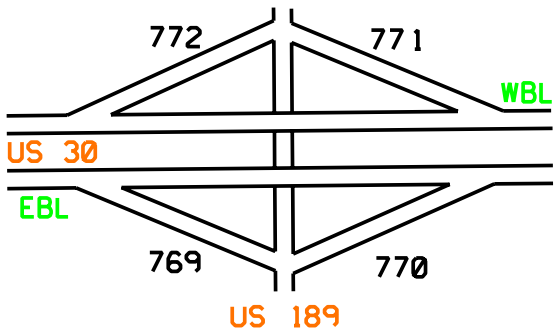

Salt Creek Interchange "Casper"

RM: 3.93

EXIT # 54

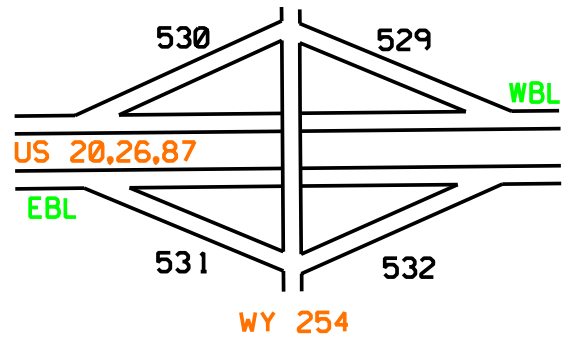



New ML number						Old SYS number	
cat.	ID #	dir	BEGIN RM	END RM	reference markers		mileposts
ML	9	B	0.000	2.370		P 10 spur	
ML	10	B	54.930	211.620		P 10	54.93 up
ML	11	B	0.000	131.447		P 11	
ML	12	B	0.000	100.025		P 12	
ML	13	B	0.000	163.674		P 13	
ML	14	B	0.000	68.199		P 14	
ML	15	B	0.000	31.596		P 15	
ML	16	B	93.880	140.360		P 16	
ML	17	B	500.000	551.388		P 17	
ML	18	B	0.000	53.220		P 18	
ML	19	B	0.770	2.290		P 21 bypass	
ML	20	B	0.000	127.299		P 20	
ML	21	B	0.200	117.210		P 21	
ML	22	B	0.000	127.060		P 22	
ML	23	B	235.230	425.406		P 23 & S 410	
ML	24	B	0.000	72.712		P 24	
ML	25	I & D	0.000	300.545		I 25	
ML	26	B	0.000	42.040		P 26	
ML	27	B	0.000	38.423		P 27	
ML	28	B	48.298	56.264		P 27	
ML	29	B	0.000	43.520		P 32* & P 39	*0.00 to 29.52
ML	30	B	2.204	133.705		P 30	
ML	31	B	0.000	100.746		P 31	
ML	32	B	29.570	40.620		P 32	29.57 to 40.62
ML	33	B	0.000	81.209		P 33	0.00 to 81.21
ML	34	B	0.000	257.026		P 34	
ML	35	B	46.710	98.860	* RM's 46.71 to 98.86	P 35	0.00 to 56.82
ML	36	B	0.000	92.119		P 36	0.00 to 92.12
ML	37	B	0.000	89.870		P 35* & P 37	*56.82 to 89.87
ML	38	B	0.000	35.270		P 38	
ML	39	B	41.380	63.238		P 40	41.39 to 63.24
ML	40	B	0.000	40.880		P 40	0.00 to 40.88
ML	41	B	10.076	28.082		P 42 conn.	
ML	42	B	93.448	151.259		P 42	
ML	43	B	0.000	170.107	* RM's 114.86 to 113.10	P 62* & P 43	*124.46 to 126.22
ML	44	B	153.410	259.084		P 44	
ML	45	B	0.000	10.154		P 45	
ML	47	B	0.000	2.899		P 34 spur	
ML	48	B	0.008	20.446		P 48	
ML	49	B	0.000	1.828		P 49	
ML	50	B	0.000	11.586		P 10	0.00 to 11.59
ML	51	B	3.450	6.601		P 51	
ML	52	B	89.450	91.963		P 52	
ML	53	B	102.360	106.481		P 53	
ML	54	B	211.870	215.650		P 54	
ML	55	B	325.250	332.479		P 55	
ML	56	B	348.360	371.279		P 56, SH 225 & U 1110	
ML	57	B	78.930	81.892		P 57	

New ML number					Old SYS number		
cat.	ID #	dir	BEGIN RM	END RM	reference markers		mileposts
ML	58	B	135.470	140.442		P 58	
ML	59	B	298.024	301.338		P 59	
ML	60	B	20.922	40.853		P 60, S/U 1708 & SH 344	
ML	74	B	0.090	0.220		SH 74	
ML	76	B	215.650	220.010		SH 76	
ML	77	B	122.099	144.281		SH 77	
ML	78	B	0.000	1.230		U 78	
ML	80	I & D	0.000	402.779		I 80	
ML	85	B	0.000	256.557		P 25	16.94 up
ML	90	I & D	0.000	207.139		I 90	
ML	91	B	0.000	23.097		SH/U 91	
ML	94	B	0.000	16.614		SH/U 94	
ML	96	B	0.000	3.113		SH 96	
ML	101	B	0.000	9.120		S 101	
ML	102	B	0.000	10.940		S 102	
ML	103	B	0.000	68.120		S/U 103	
ML	104	B	0.000	12.180		S 104	
ML	105	B	0.000	17.330		S 105	
ML	107	B	0.000	37.790		S/U 107	
ML	109	B	0.000	52.293		S 109	
ML	110	B	0.000	0.360		S 103 spur	
ML	112	B	0.000	1.800		SRI-80-0112	
ML	113	B	10.000	16.613		SH 113	
ML	138	B	0.000	8.135		SH 138	
ML	148	B	0.000	6.680		SRI-80-A148	
ML	153	B	0.000	1.020		SH 153	
ML	174	B	0.000	0.597		SH 174	
ML	180	B	0.000	12.608		I 180 & P 25*	*0.00 to 12.61
ML	191	B	0.000	11.710		SH 191	
ML	200	B	0.000	125.588		S 200	
ML	201	B	0.000	22.086		S 201	
ML	202	B	0.000	127.330		S 202	
ML	203	B	0.000	0.310		S 201 spur	
ML	205	B	2.888	4.276		SH 33	
ML	206	B	0.000	1.076		SH 35	
ML	207	B	0.373	3.130		SH 36	
ML	208	B	0.000	8.999		S 208	
ML	211	B	0.000	63.954		SH 211 & U 1100	
ML	212	B	0.000	13.570		U 212	
ML	217	B	0.000	4.420		SH 217	
ML	218	B	0.000	1.770		SH 218	
ML	221	B	0.000	1.840		U 221	
ML	222	B	0.000	4.080		U 222	
ML	223	B	0.000	5.685		SH/U 223	
ML	224	B	0.000	0.120		U 224	
ML	253	B	0.000	10.895		SH/U 253	
ML	254	B	0.000	4.057		U 254	
ML	255	B	0.167	0.650		U 255	

New ML number						Old SYS number	
cat.	ID #	dir	BEGIN RM	END RM	reference markers		mileposts
ML	256	B	0.000	2.665		U 256	
ML	258	B	7.854	18.440		U 258	
ML	271	B	0.000	3.189		SH 271	
ML	272	B	0.000	3.321		SH 272	
ML	273	B	0.000	0.328		SH 273	
ML	294	B	0.000	18.821		SH 294	
ML	300	B	1.330	52.665	* RM's 1.53 to 1.33	P 62* & S/U 300	*124.26 to 124.46
ML	302	B	0.000	102.070		P 61 & S/U 302	
ML	303	B	124.264	152.876		P 62* & S/U 303	*126.22 to 127.57
ML	305	B	0.000	1.280		SRI-90-0068	
ML	306	B	0.000	2.130		SRI-90-0289	
ML	312	B	0.000	7.304		SH 312	
ML	314	B	0.000	8.566		SH 314	
ML	317	B	0.000	1.660		SH 317	
ML	318	B	4.527	5.623		SH 318	
ML	319	B	100.125	226.133		SH 319	
ML	321	B	54.590	57.927		SH321	
ML	330	B	0.000	1.112		U 330	
ML	332	B	0.557	5.440		U 332	
ML	334	B	0.000	0.740		U 334	
ML	337	B	0.000	0.880		U 337	
ML	342	B	0.000	1.136		SH 342	
ML	345	B	0.000	19.270		SH 345	
ML	346	B	0.000	2.670		SH 346	
ML	352	B	0.000	25.313		SH 352	
ML	354	B	0.011	6.178		SH 354	
ML	374	B	69.487	90.142		SH/U 374	
ML	376	B	0.000	4.305		U 376	
ML	391	B	0.000	0.300		SH 391	
ML	401	B	0.000	57.700		S 401	
ML	402	B	0.000	10.473		S/U 402	
ML	404	B	1.550	15.980		S 404	
ML	406	B	0.000	4.642		S 406	
ML	411	B	219.790	222.190		S 411	
ML	412	B	0.000	3.020		S 412	
ML	413	B	0.000	2.717		SH 413	
ML	415	B	0.000	1.140		SRI-80-0028	
ML	416	B	0.000	2.060		SRI-80-0156	
ML	417	B	0.000	1.470		SRI-80-0158	
ML	418	B	0.000	0.280		SRI-80-0159	
ML	435	B	0.000	0.780		SH 435	
ML	436	B	0.000	5.925		SH 436	
ML	451	B	0.000	5.026		SH 451	
ML	500	B	0.000	2.110		S 504	0.00 to 2.13
ML	502	B	0.032	26.140		S/U 502	
ML	504	B	1.680	18.875		S 504	1.68 to 18.88
ML	505	B	1.380	187.890		S/U 505	
ML	507	B	0.000	3.003		SH 90	

New ML number					Old SYS number		
cat.	ID #	dir	BEGIN RM	END RM	reference markers		mileposts
ML	508	B	0.000	9.450		SRI-25-0108	
ML	509	B	0.000	1.420		SRI-25-0145	
ML	510	B	0.000	0.620		SRP-43-0150	
ML	600	B	0.000	28.213		S 600	
ML	601	B	0.000	46.812		S 601	
ML	602	B	0.000	0.585		S 601 spur	
ML	603	B	0.000	8.635		S 603	
ML	604	B	0.000	29.501		S 604	
ML	606	B	0.000	0.252		P 44 spur	
ML	607	B	153.412	203.956		S 607	
ML	608	B	0.000	18.370		SRI-90-0146	
ML	609	B	0.000	0.350		SRI-90-0147	
ML	610	B	0.000	1.070		SRI-90-0148	
ML	701	B	1.750	9.000		S/U 701	
ML	703	B	0.000	17.434		S 703	
ML	706	B	0.000	6.070		S 706	
ML	707	B	0.000	24.171		S 707	
ML	708	B	0.000	101.040		S 708 & S 710*	*0.00 to 1.06
ML	709	B	17.550	19.000		S 708 spur	
ML	710	B	0.000	43.735		S 710	1.06 to 43.74
ML	711	B	0.000	105.973		S 711	
ML	713	B	0.000	0.470		SRP-34-0389	
ML	714	B	0.000	0.280		SRP-30-0391	
ML	800	B	0.000	9.908		S 800	
ML	801	B	0.000	9.800		S 801	
ML	802	B	0.000	8.021		S 807 spur	
ML	803	B	0.000	21.110		S 803	
ML	805	B	0.000	14.282		S/U 805	
ML	806	B	0.000	7.988		S 806	
ML	807	B	0.000	14.072		S 807	
ML	808	B	0.000	12.782		S/U 808 & SH 159	
ML	809	B	0.000	1.078		S 809	
ML	811	B	0.000	7.032		S 811	
ML	900	B	0.129	15.406		S 900	
ML	901	B	0.000	8.629		S 901	
ML	902	B	0.000	11.263		S 902	
ML	903	B	0.000	1.610		S 903	
ML	904	B	0.000	0.320		S 904	
ML	1000	B	0.000	109.660		S 1000	
ML	1001	B	100.000	102.122		P 36	100.00 to 102.12
ML	1002	B	0.000	35.641		S 1002	
ML	1003	B	98.290	106.186		S 1003	
ML	1004	B	2.122	17.900		S 1004	
ML	1006	B	249.580	299.419		S 1006	
ML	1103	B	0.000	8.390		S 1103	
ML	1104	B	0.000	17.140		S 1104	
ML	1105	B	0.000	18.536		S 1105 & SH 216	
ML	1108	B	1.989	5.488		S/U 1108	

New ML number						Old SYS number	
cat.	ID #	dir	BEGIN RM	END RM	reference markers		mileposts
ML	1111	B	401.460	403.020		S 1111	
ML	1116	B	0.000	0.910		SRI-25-0016	
ML	1117	B	0.000	3.130		SRI-80-0057	
ML	1118	B	0.000	27.100		SRI-25-0085	
ML	1119	B	0.000	2.610		SRI-25-0105	
ML	1120	B	0.000	16.540		SRI-80-0234	
ML	1121	B	0.000	0.940		SRI-80-M275	
ML	1122	B	0.000	3.030		SRI-80-M276	
ML	1123	B	0.000	16.040		SRI-80-0278	
ML	1124	B	0.000	3.670		SRI-25-M279	
ML	1125	B	0.000	8.700		SRI-25-0280	
ML	1126	B	0.000	0.640		SRU-1108-0282	
ML	1127	B	0.000	0.640		SRU-1108-0288	
ML	1128	B	0.000	0.470		SRP-56-0353	
ML	1129	B	0.000	0.300		SRP-56-0354	
ML	1130	B	0.000	1.000		SRP-25-0395	
ML	1131	B	0.000	0.230		SRP-25-0396	
ML	1132	B	0.000	0.230		SRI-25-0403	
ML	1133	B	0.000	0.450		SRI-80-M432	
ML	1134	B	0.000	0.300		SRI-80-0433	
ML	1135	B	0.000	0.360		SRP-56-0434	
ML	1136	B	0.000	0.340		SRP-56-0435	
ML	1137	B	0.000	0.520		SRI-80-0436	
ML	1200	B	0.000	0.604		S 1200	
ML	1201	B	0.000	12.218		S 1201	
ML	1202	B	0.000	19.675		S 1202	
ML	1203	B	0.000	4.486		S 1203	
ML	1204	B	0.000	2.522		S 1204	
ML	1205	B	0.000	3.415		S 1205	
ML	1206	B	0.000	12.084		S 1206	
ML	1207	B	0.000	1.642		S 1207	
ML	1208	B	0.000	12.284		S 1208	
ML	1209	B	0.000	4.274		S 1209	
ML	1210	B	152.471	154.518		P 12 conn	
ML	1211	B	11.593	15.741		P 10	11.59 to 15.74
ML	1212	B	0.000	0.940		SRP-12-0121	
ML	1213	B	0.000	0.860		SRP-12-0198	
ML	1214	B	0.000	1.760		SRP-12-0245	
ML	1215	B	0.000	3.630		SRP-12-0246	
ML	1216	B	0.240	0.470		P 12-wye	
ML	1217	B	45.426	54.930		P 10	45.43 to 54.93
ML	1301	B	2.010	8.909		S/U 1301	
ML	1302	B	0.000	4.365		S/U 1301 spur	
ML	1308	B	0.000	0.080		SRP-34-0009	
ML	1309	B	0.000	0.180		SRP-34-0010	
ML	1310	B	0.000	20.090		SRI-25-0075 & SRI-25-0097	
ML	1311	B	0.000	2.830		SRI-25-0076	
ML	1312	B	0.000	3.240		SRU-505-0169	

New ML number						Old SYS number	
cat.	ID #	dir	BEGIN RM	END RM	reference markers		mileposts
ML	1313	B	0.000	1.000		SRI-25-0188	
ML	1314	B	0.000	0.970		SRP-34-0189	
ML	1315	B	0.000	2.820		SRP-34-0190	
ML	1316	B	0.000	0.540		SRP-34-0191	
ML	1317	B	0.000	0.630		SRP-34-0200	
ML	1400	B	495.473	535.871		S 1400	
ML	1401	B	99.766	133.336		S 1401	
ML	1500	B	0.000	11.392		S 1500	
ML	1501	B	0.000	9.458		S/U 1501	
ML	1502	B	100.000	137.532		P 33	100.00 to 137.53
ML	1505	B	0.000	13.310		S/U 1505	0.00 to 12.57
ML	1506	B	13.310	29.353		S/U 1505	12.64 to 29.35
ML	1507	B	0.000	46.196		S 1507	
ML	1600	B	1.002	8.486		S 1600	
ML	1601	B	0.000	1.994		S 1600 & SH 311	
ML	1602	B	54.590	130.203		S 1602	
ML	1604	B	0.091	11.911		S 1604 & SH 316	
ML	1605	B	0.000	3.006		SH 315	
ML	1606	B	111.676	111.876		SH 319 conn	
ML	1610	B	0.000	12.329		S 1610	
ML	1615	B	3.100	9.010		SRI-25-0054	
ML	1616	B	0.000	1.390		SRI-25-0082	
ML	1617	B	0.000	6.000		SRI-25-0125	
ML	1618	B	0.000	0.410		SRI-25-0149	
ML	1619	B	0.000	3.250		SRI 25-0005	
ML	1700	B	0.000	3.188		S 302 spur	
ML	1701	B	0.723	9.920		S/U 1701	
ML	1702	B	0.000	2.811		S 1003 spur	
ML	1703	B	0.000	9.710		S/U 1703	
ML	1704	B	0.000	11.524		S/U 1704	
ML	1705	B	0.000	1.008		S 1706 spur	
ML	1706	B	0.002	15.034		S/U 1706	
ML	1707	B	0.000	1.355		S 1707	
ML	1709	B	0.000	5.239		S 1709	
ML	1712	B	0.000	12.800		S 1712	
ML	1800	B	0.000	5.055		S 1800	
ML	1801	B	0.000	24.181		S 1801	
ML	1804	B	0.000	15.511		S 1804	
ML	1900	B	0.000	44.851		S/U 1900	
ML	1903	B	0.000	55.101		S/U 1903	
ML	1904	B	0.000	4.662		S 1904	
ML	1905	B	0.000	7.303		S 1905	
ML	1906	B	0.000	48.523		S 1906	
ML	1909	B	0.000	0.945		S 1909	
ML	1910	B	61.590	66.387		S 1910	
ML	1911	B	0.000	1.960		S 1911	
ML	1912	B	100.000	128.217		S 1912	
ML	1913	B	0.000	2.820		SRI-80-0045A	



New ML number						Old SYS number	
cat.	ID #	dir	BEGIN RM	END RM	reference markers		mileposts
ML	1914	B	0.000	9.330		SRI-80-0088	
ML	1915	B	0.000	19.780		SRI-80-0200	
ML	1916	B	0.000	9.340		SRI-80-0210	
ML	1917	B	0.000	3.110		SRI-80-0283	
ML	1918	B	0.000	3.530		SRI-80-0368	
ML	1919	B	0.000	0.560		SRI-80-0369	0.00 to 0.56
ML	1920	B	0.000	1.320	* RM's 0.66 to 0.00	SRI-80-0369	0.56 to 1.32
ML	1921	B	0.000	2.820		SRI-80-0370	
ML	1922	B	0.000	8.420	* RM's 4.55 to 8.42	SRI-80-0131A&0371	0.00 to 3.87
ML	1923	B	0.000	0.460		SRI-80-0377	
ML	2000	B	0.000	17.494		S 2000	
ML	2001	B	0.000	7.710		S 2001 & SH 390	
ML	2003	B	0.000	3.590		SRP-10-0132	
ML	2004	B	141.156	141.286		P 10 wye	
ML	2100	B	0.216	23.245		S/U 2100	
ML	2101	B	3.114	16.477		S 2101	
ML	2103	B	2.806	24.831		S 2103	
ML	2104	B	0.000	4.037		SH 411	
ML	2106	B	34.740	50.364		S 2106	
ML	2108	B	0.000	0.270		SRI-80-0100	
ML	2110	B	0.000	2.000		SRI-80-0132	
ML	2111	B	0.000	1.600		SRI-80-0133	
ML	2112	B	0.000	3.520		SRI-80-M134	
ML	2113	B	0.000	1.130		SRI-80-0180	
ML	2200	B	0.000	30.199		S 2200	
ML	2201	B	0.700	10.811		S/U 2201	
ML	2202	B	0.000	18.814		S/U 2202	
ML	2203	B	0.000	20.634		S 2203	
ML	2206	B	0.300	1.690		SRP-36-0076	
ML	2207	B	0.000	0.200		SRP-36-0076A	
ML	2300	B	0.000	66.216		S 2300	
ML	2302	B	0.000	32.464		S 2302	
ML	2303	B	0.000	28.000		S 2303	
ML	2305	B	0.000	1.200		SRP-44-W16	
ML	4123	B	0.000	18.860		SRI-25-0081&M4123	
ML	4136	B	0.530	2.300		SRI-25-M4136	
ML	4137	B	1.530	3.240		SRI-25-M4137	
ML	4138	B	0.000	1.390		SRI-25-M4138	
ML	4140	B	2.710	2.970		SRP-34-4140	
ML	4150	B	0.000	0.510		SRP-34-4140	
ML	4200	B	0.000	1.255		U 4200	
ML	4768	B	164.660	165.190		SRP-34-M4768	
ML	4827	B	0.000	0.450		P 43 conn	
ML	6792	B	0.042	19.500			
ML	8436	B	0.000	4.900		COUNTY ROAD	
ML	9470	B	46.720	50.170		re-aligned P14	
OT	419	I	0.030	0.040			

New ML number					Old SYS number		
cat.	ID #	dir	BEGIN RM	END RM	<i>reference markers</i>		<i>mileposts</i>
OT	<b>420</b>	I	0.040	214.930			
OT	<b>813</b>	I	0.000	0.040			
OT	<b>814</b>	I	0.000	0.100			
OT	<b>1718</b>	I	0.000	0.410			
OT	<b>1719</b>	I	0.000	0.046			
OT	<b>1805</b>	I	0.000	0.306			
OT	<b>1806</b>	I	0.000	0.080			

REFERENCE MARKER SYSTEM  
 PLACEMENT AT SEPARATED  
 ROADWAY LOCATIONS

Plate 2

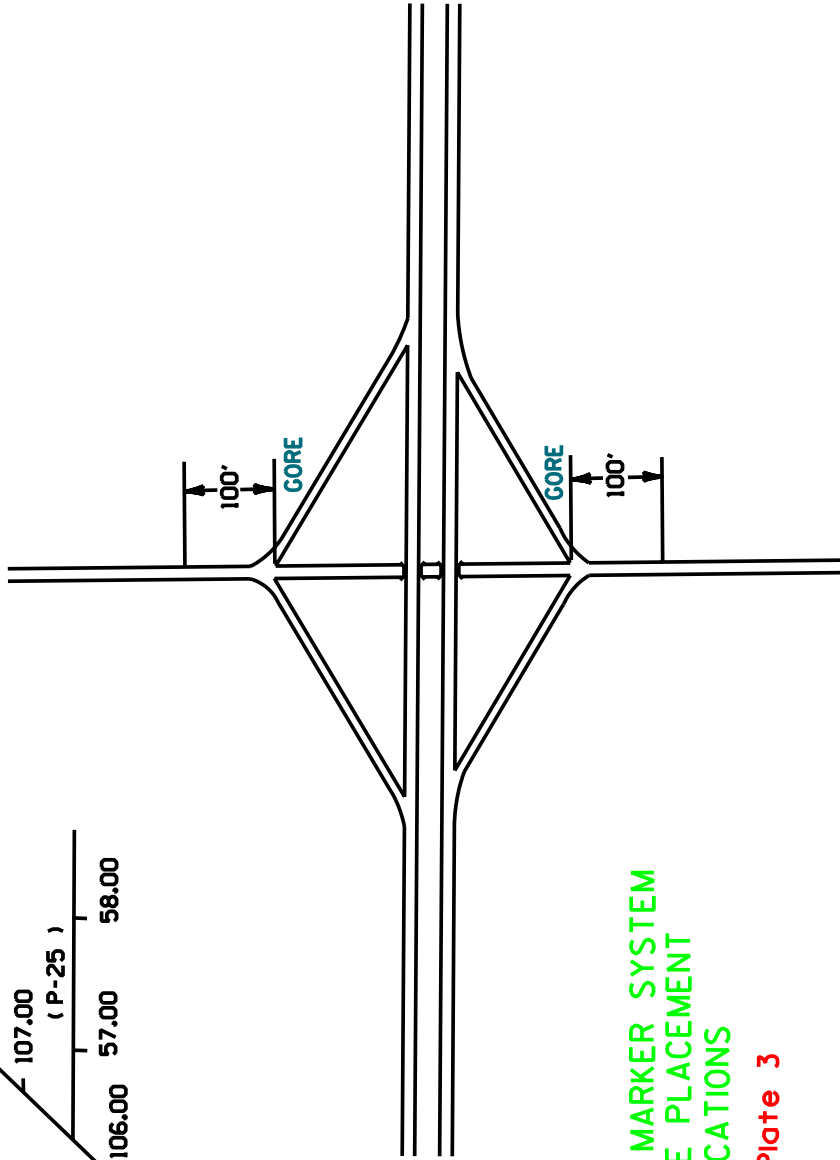

REFERENCE MARKER SYSTEM  
 OVERLAPPING ROUTES

Plate 1

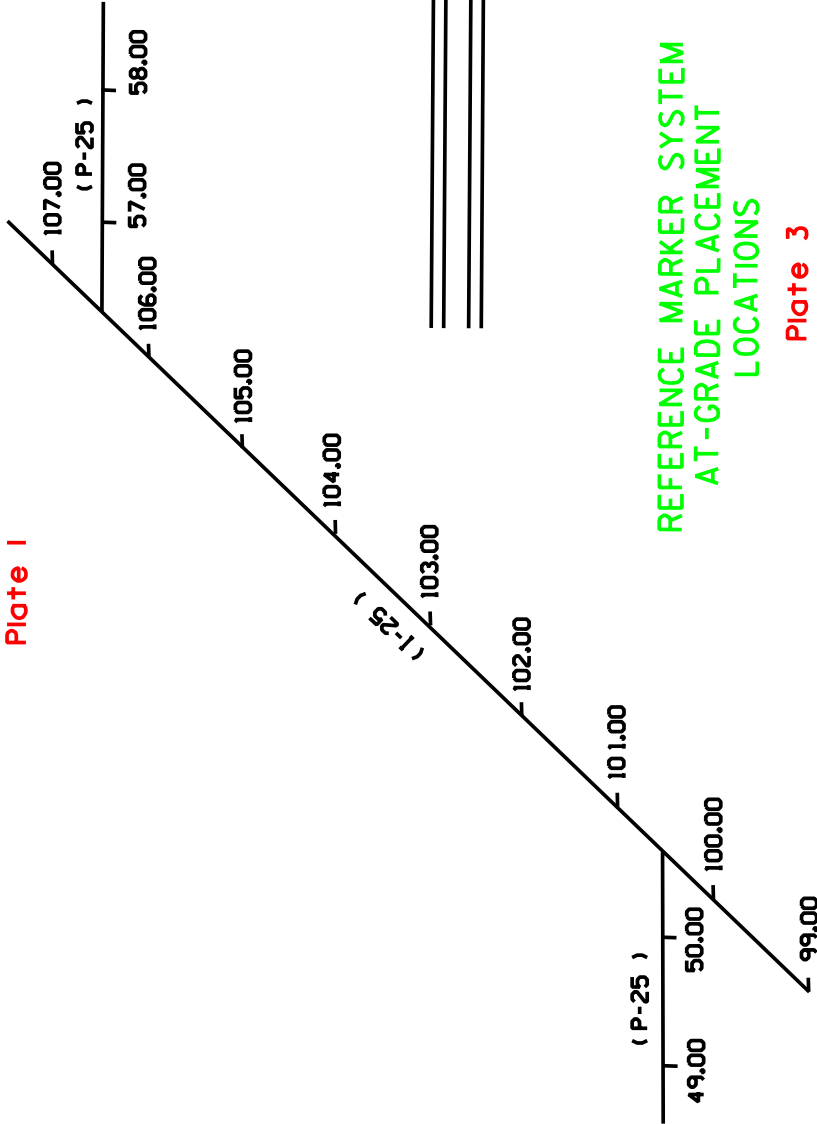

REFERENCE MARKER SYSTEM  
 AT-GRADE PLACEMENT  
 LOCATIONS

Plate 3

" T " INTERSECTION

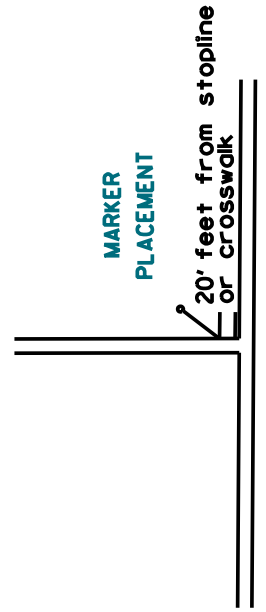

REFERENCE MARKER SYSTEM  
 DISTANCE COMPUTATION POINTS  
 AT INTERSECTIONS

Plate 4

AT GRADE INTERSECTIONS

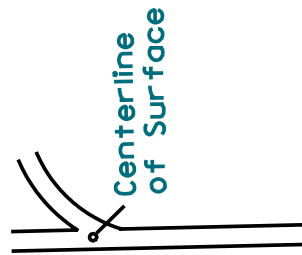
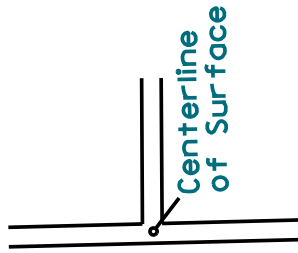

Distances are computed from the centerline of the surface for at grade intersections.

SEPARATED INTERSECTIONS

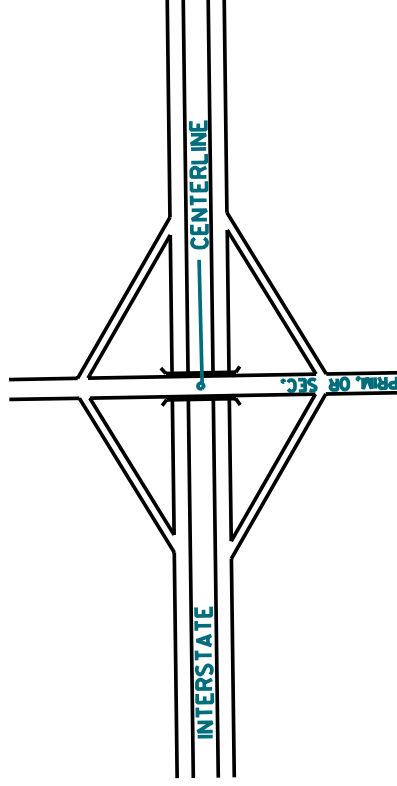
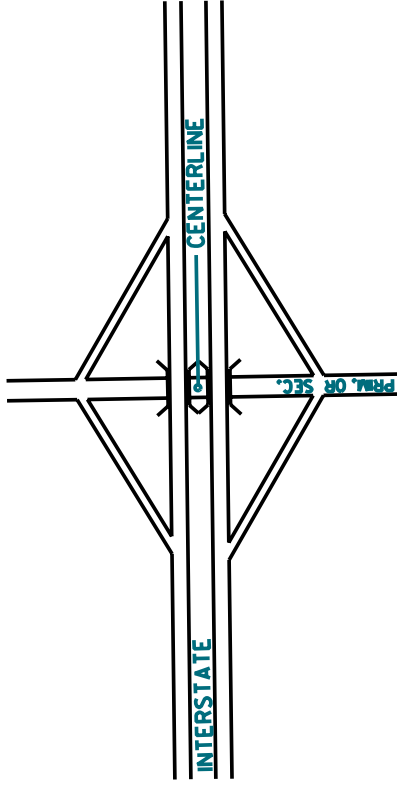

Distances are computed from the centerline for separated intersections

REFERENCE MARKER SYSTEM  
 TYPICAL TREATMENT FOR  
 EQUATIONS  
 Plate 5

