

6341

1 / 4

U.S. & Canada Toll-Free 1-888-588-2700 Web Site <http://www.simplicity.com> E-mail info@simplicity.com

Thank you for purchasing this New Look pattern. We have made every effort to provide you with a high quality product. Gracias por haber comprado este patrón de New Look. Hemos hecho todos los esfuerzos para ofrecerle un producto de alta calidad.

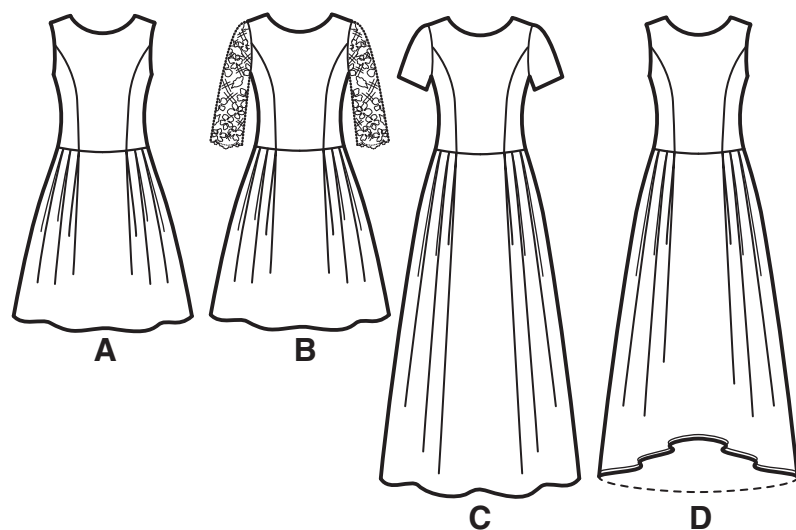

11 pieces given

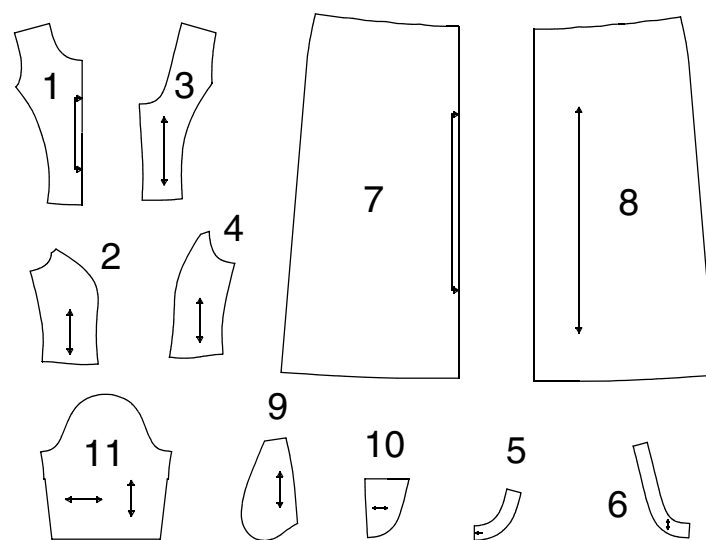

- 1-BODICE FRONT -A,B,C,D
- 2-BODICE SIDE FRONT -A,B,C,D
- 3-BODICE BACK -A,B,C,D
- 4-BODICE SIDE BACK -A,B,C,D
- 5-FRONT INTERFACING -A,B,C,D
- 6-BACK INTERFACING -A,B,C,D
- 7-SKIRT FRONT -A,B,C,D
- 8-SKIRT BACK -A,B,C,D
- 9-POCKET -A,B,C,D
- 10-BACK INSET -B
- 11-SLEEVE -B,C

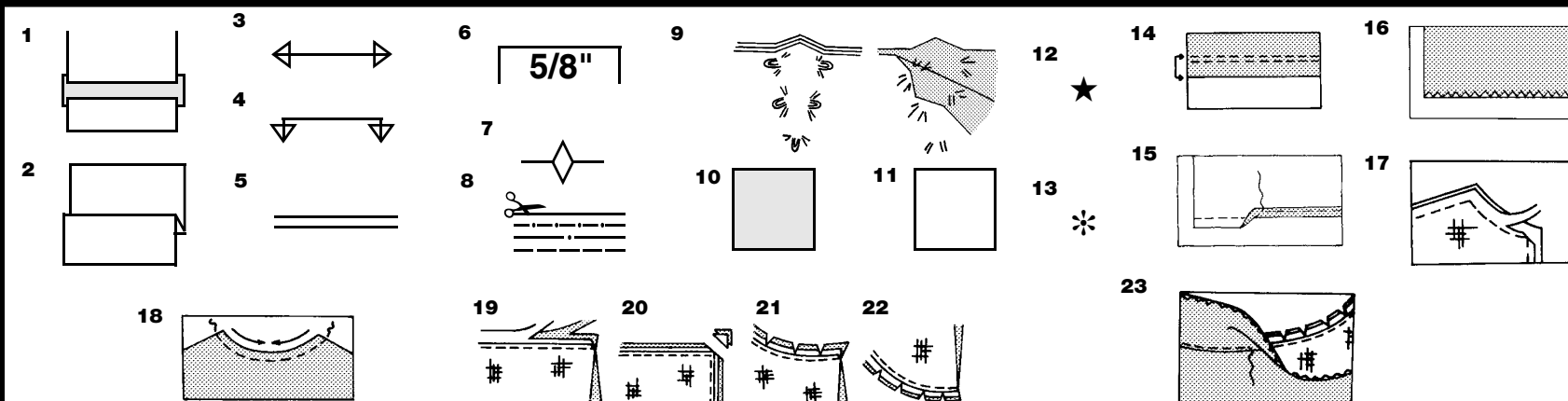

How To Use Your Multi Size Pattern

- First Prepare Your Pattern**
Select the pattern pieces according to the view you are making.
This pattern is made to body measurements with ease allowed for comfort and style. If your body measurements differ from those on the pattern envelope adjust the pieces before placing them on the fabric.
Check your back neck to waist and dress length, if necessary, alter the pattern. Lengthening and shortening lines are indicated.
1. **TO LENGTHEN:** Cut pattern between printed lines and place paper underneath. Spread pattern the required amount and pin to paper.
 2. **TO SHORTEN:** Fold at the printed lines to form a pleat half the amount to be shortened, ie 1/2" (1.3cm) deep to shorten 1" (2.5cm).
- Study Your Pattern Markings**
3. **STRAIGHT GRAIN:** Place an even distance from selvage or a straight thread.
 4. **FOLD:** Place on fold of fabric.
 5. **LENGTHENING AND SHORTENING LINES.**
 6. **SEAM ALLOWANCE:** 5/8" (1.5cm) unless otherwise stated.
 7. **NOTCHES:** Match notches.
 8. **CUTTING LINES:** Multi patterns have different cutting lines for different sizes.
 9. **TAILOR-TACKS:** With double thread make two loose stitches forming loop through fabric layers and pattern leaving long ends. Cut loop to remove pattern. Snip thread between fabric layers. Leave tufts.

Cutting Layouts

- Cutting Directions**
- FOR FOLDED AND DOUBLE LAYER FABRIC - Place fabric with right side inside and pin pattern on wrong side of fabric.
- FOR SINGLE LAYER - Pin pattern on right side of fabric.
- NOTE: Pattern pieces may interlock more closely for smaller sizes. Cut notches out from cutting line.
- BEFORE removing pattern from fabric, transfer all pattern markings using tailor tacks or dressmaking tracing paper.
10. KEY: pattern printed side down
 11. KEY: pattern printed side up
 12. KEY: Cut out all pieces except pieces that extend beyond folded fabric, then open out fabric and on RIGHT side of fabric, cut in positions as shown.
 13. KEY: For with and without nap layouts ensure fabric is placed with nap or design running in same direction.
- Before pinning to fabric, press tissue pattern with a warm dry iron to remove creases.

Sewing Directions

- Fabric Key: Right Side, Wrong Side, Interfacing, Lining
- Sew garment following **Sewing Directions**.
PIN or machine-baste seams matching notches.
STITCH 5/8" (1.5cm) seams unless otherwise stated.
PRESS seams open unless otherwise indicated, clipping when necessary so seams will lie flat.
14. **EASE-STITCH** or **GATHER** - Loosen needle tension slightly. With RIGHT side up, stitch 5/8" (1.5cm) from cut edge using a long stitch. Stitch again 1/4" (6mm) away in the seam allowance.
 15. **EDGE FINISH** - Neaten raw edges of seams, hems and facings using one of the following methods.
 15. Stitch 1/4" (6mm) from edge, turn under along stitching and stitch.
 16. Zig-zag or overlock raw edges.
 17. **INTERFACING** - Pin interfacing to WRONG side of fabric. Cut across corners that will be enclosed with seams. Machine-baste 1/2" (1.3cm) from cut edge. (Shown only on first illustration). Trim interfacing close to machine-basting. For FUSIBLE interfacing, follow manufacturer's directions.
 18. **STAY-STITCH** - Stitch 1/2" (1.3cm) from cut edge, in direction of arrows: (Shown only in the first illustration).
- LAYERING** - Trim seam allowance in layers.
19. Layer enclosed seams
 20. Trim corners
 21. Clip inner curves
 22. Notch outer curves
23. **UNDERSTITCH** - Press facing away from garment; press seam toward facing. Facing side up, understitch close to seam through facing and seam allowances.

Sign-up for our free newsletter today at [simplicity.com](http://www.simplicity.com)

Cutting Layouts

A,B,C,D LINING



INTERFACING

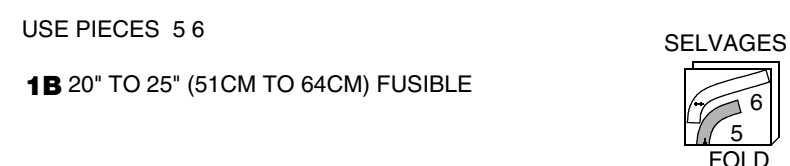

A,B

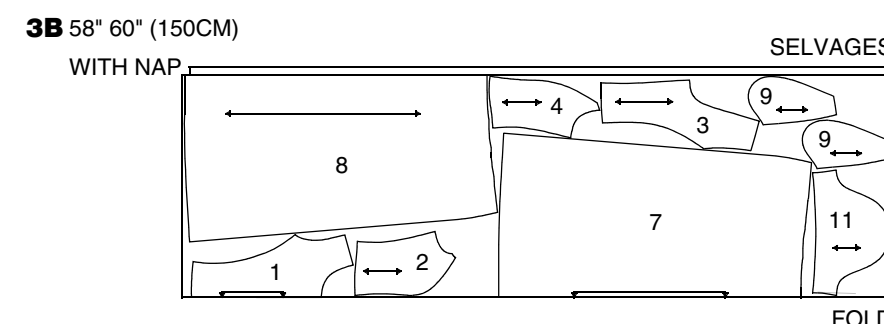
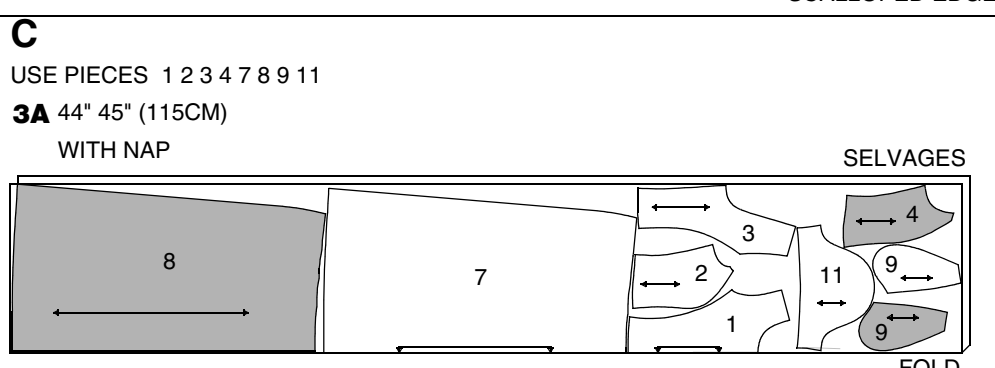
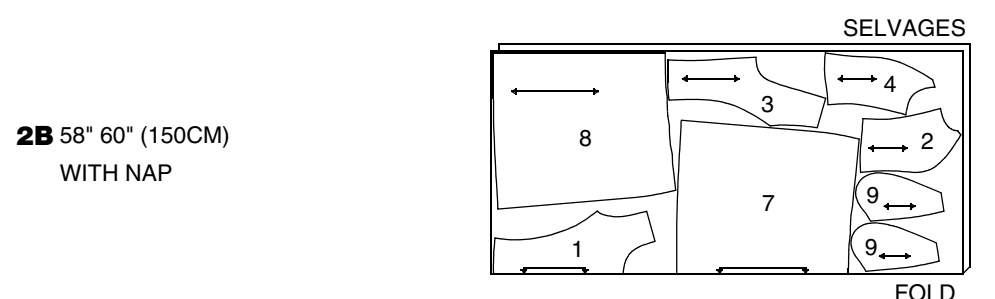
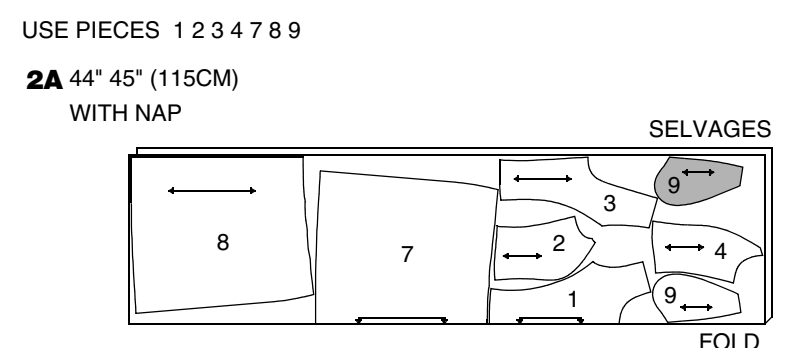

NOTE: SINCE THERE IS NO OPPORTUNITY TO CHANGE THE LENGTH OF GARMENT ONCE IT HAS BEEN CUT AND SEWN, IT WILL BE NECESSARY TO MAKE LENGTH ADJUSTMENTS TO PATTERN PIECES BEFORE CUTTING.

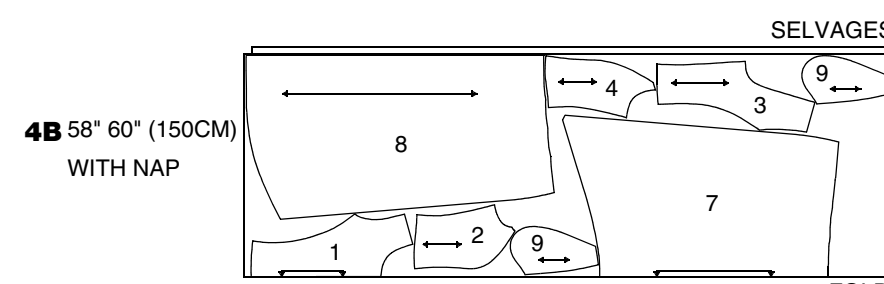
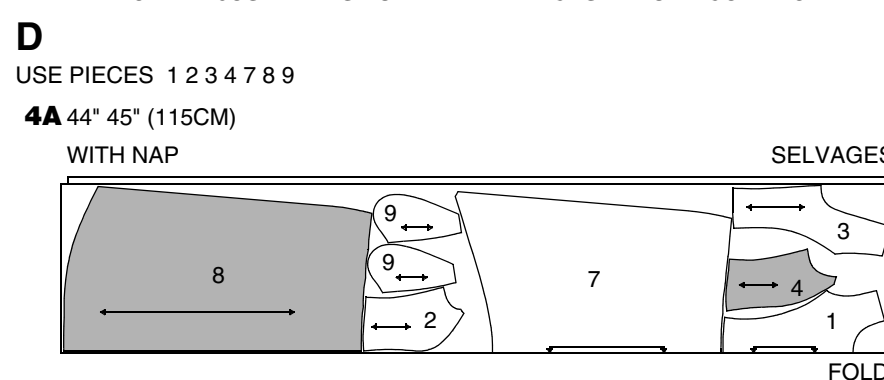

Español

A,B,C,D FORRO
USE LAS PIEZAS 1 2 3 4
1A 44" 45" (115CM) SIN PELUSA

ENTRETELA
USE LAS PIEZAS 5 6
1B 20" A 25" (51CM A 64CM) ADHESIVA

A,B USE LAS PIEZAS 1 2 3 4 7 8 9
2A 44" 45" (115CM) CON PELUSA
2B 58" 60" (150CM) CON PELUSA

COLOQUE EL BORDE SUPERIOR DE LA PIEZA 10 Y EL BORDE INFERIOR DE LA PIEZA 11 A LO LARGO DE LA EZQUINA INTERIOR DEL BORDE AFESTONADO

B INCRUSTACION DE LA ESPALDA Y MANGAS - CORTADA A LO ANCHO
USE LAS PIEZAS 10 11
2C 44" 45" O 58" 60" (115CM O 150CM) CON PELUSA

C USE LAS PIEZAS 1 2 3 4 7 8 9 11
3A 44" 45" (115CM) CON PELUSA
3B 58" 60" (150CM) CON PELUSA

NOTA: YA QUE NO ES POSIBLE CAMBIAR EL LARGO DE LA PRENDA UNA VEZ ESTE TERMINADA, SERÁ NECESARIO AJUSTAR EL LARGO EN LAS PIEZAS DEL PATRÓN ANTES DE CORTAR

D USE LAS PIEZAS 1 2 3 4 7 8 9
4A 44" 45" (115CM) CON PELUSA
4B 58" 60" (150CM) CON PELUSA

SELVAGES= ORILLAS
FOLD= DOBLEZ
CROSSWISE FOLD= DOBLEZ TRANSVERSAL
SCALLOPED EDGE= BORDE AFESTONADO

6341

2 / 4

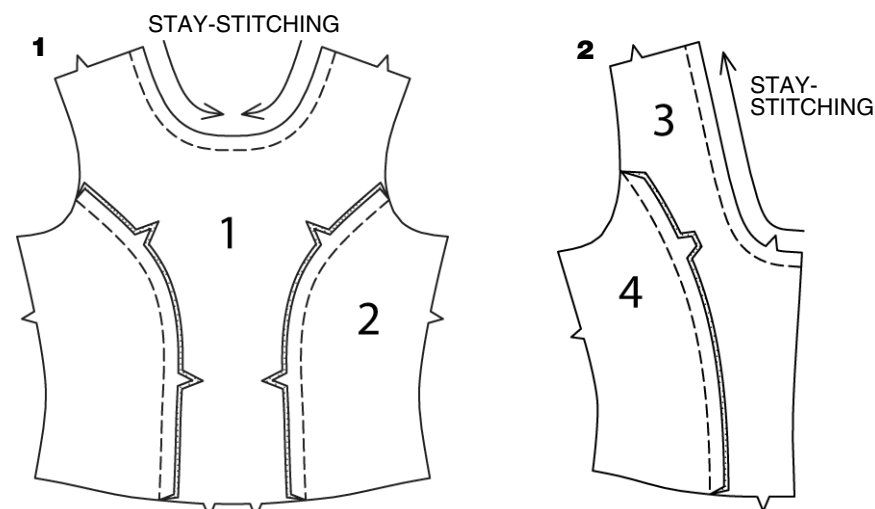

PATTERN PIECES WILL BE IDENTIFIED BY NUMBERS THE FIRST TIME THEY ARE USED.

DRESS A, B, C, D

- 1. STAY-STITCH** neck edge of bodice front (1). With **RIGHT** sides together, pin bodice side front (2) sections to bodice front. Stitch. Press seams toward center.
- 2. STAY-STITCH** upper edge of bodice back (3). With **RIGHT** sides together, pin bodice side back (4) to bodice back. Stitch. Press seam toward center.

BODICE AND LINING A, D

- With **RIGHT** sides together, stitch bodice front to bodice back at shoulder seams.

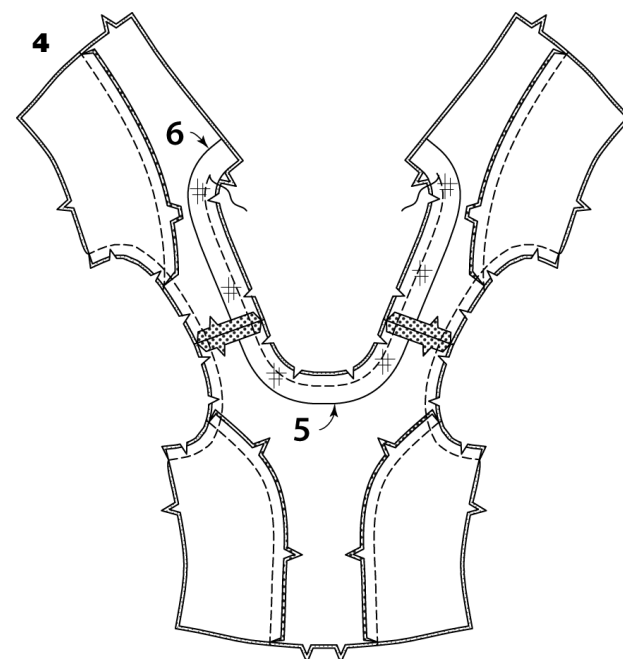
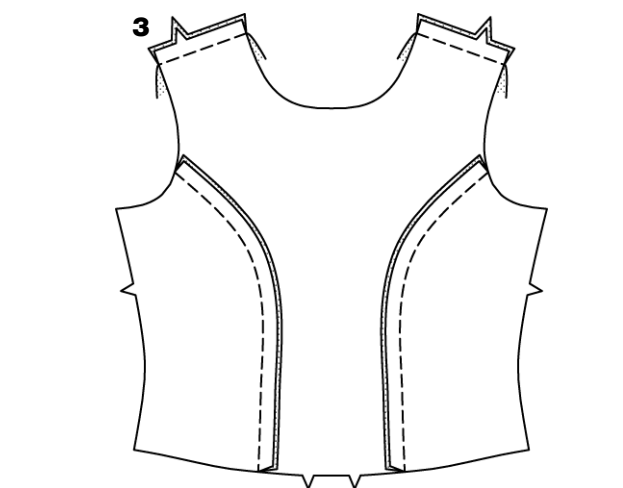

- Apply front **INTERFACING** (5) to bodice front lining and back **INTERFACING** (6) to bodice back lining. Stitch seams of bodice lining same as for bodice. With **RIGHT** sides together, pin lining to bodice, matching centers and shoulder seams, having raw edges even. Stitch neck and upper back edges between notches; back-stitch at notches to reinforce seam. Remaining upper edge of bodice back will be stitched after the zipper is inserted. Stitch armhole edges. **LAYER** seams. Do not trim the unstitched upper edge of bodice back.

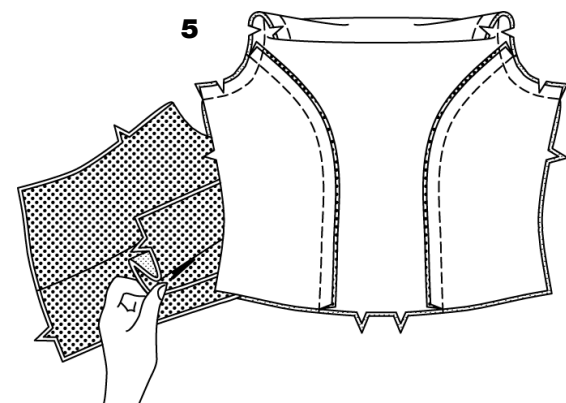

- Turn bodice **RIGHT** side out by pulling each back through front at shoulder seams.

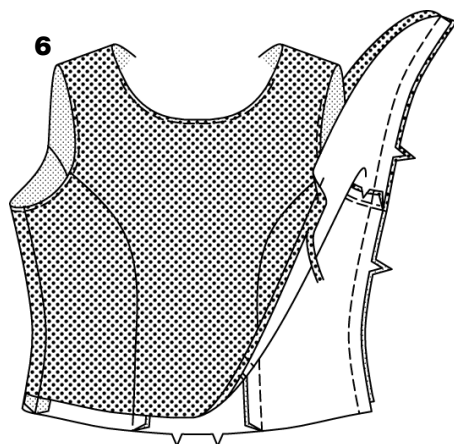

- UNDERSTITCH** lining as far as possible and to within 2" (5cm) of back edges. Open out lining at side edges. With **RIGHT** sides together, in one continuous stitching, stitch entire side seams from lower edge of bodice to edge of lining, matching seams. Turn lining back to **INSIDE**. Press, pressing under 5/8" (1.5cm) on lower edge of lining; trim to 1/4" (6mm).

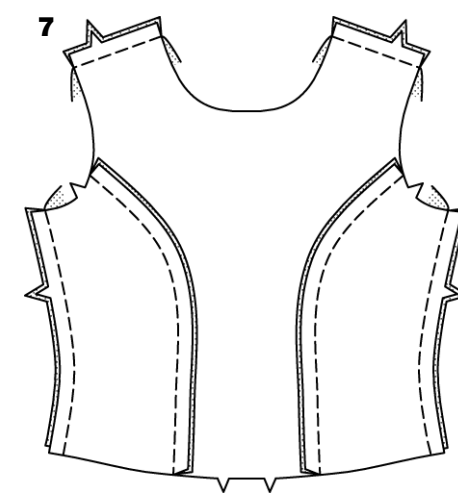

BODICE AND LINING B, C

- Stitch bodice front to bodice back at shoulder and side seams.

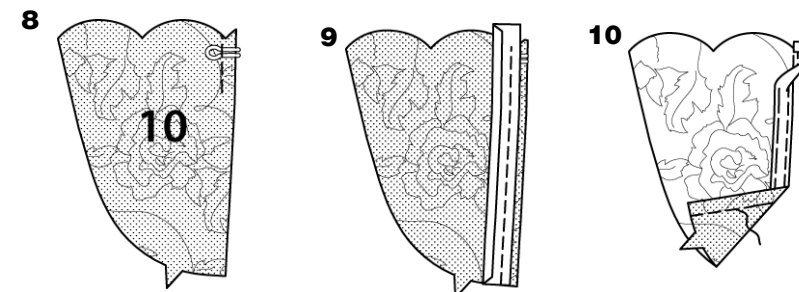

- FOR VIEW B-** Cut a piece of elastic cord to fit the size of the button, plus 3/4" (2cm) long. Fold cord in half, forming a loop. On **OUTSIDE**, pin loop 1/4" (6mm) below upper edge of **LEFT** back inset (10) at center back, having raw edges even. Stitch across end of loop.

- Open out one edge of single fold bias tape. With **RIGHT** sides together, pin tape to back edge of inset, having crease 3/8" (1cm) from raw edge and tape extending 3/8" (1cm) above upper edge. Stitch in 3/8" (1cm) seam. **LAYER** seam.

- UNDERSTITCH** tape. Turn tape to **INSIDE**, turning under ends at back opening. Press, pressing loop out. Baste close to inner edge of tape. On **OUTSIDE**, top-stitch as basted.

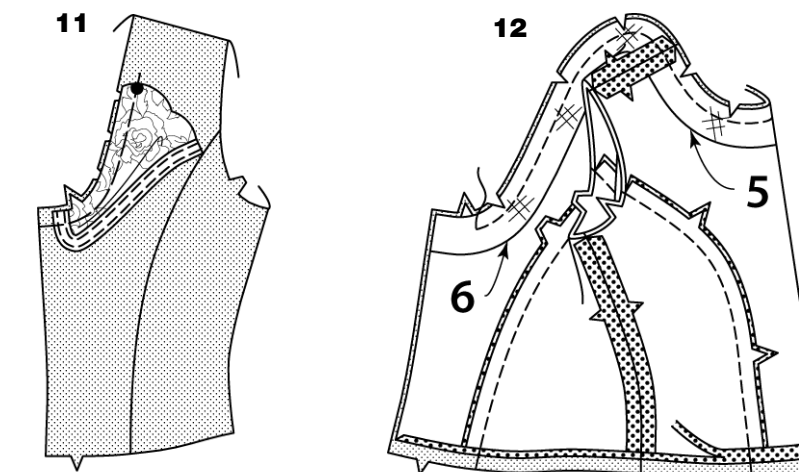

- Clip upper edge of bodice back to stay-stitching along curved edge. With **RIGHT** sides together, pin back inset to upper edge of bodice back, matching centers and notches, placing upper edge at large dot. Baste.

- FOR VIEWS B, C-** Apply front **INTERFACING** (5) to bodice front lining and back **INTERFACING** (6) to bodice back lining. Stitch seams of bodice lining same as for bodice. Press under 5/8" (1.5cm) on lower edge of lining; trim to 1/4" (6mm). With **RIGHT** sides together, pin lining to neck edge of bodice, matching centers and shoulder seams. Stitch neck and upper back edges between notches; back-stitch at notches to reinforce seam. Remaining upper edge of bodice back will be stitched after the zipper is inserted. **LAYER** seam. Do not trim the unstitched upper edge of bodice back.

- TIP FOR VIEW B-** Carefully stitch the back neck edge, keeping the inset flat along the curved neck edge as you sew. This will prevent getting folds in the inset.

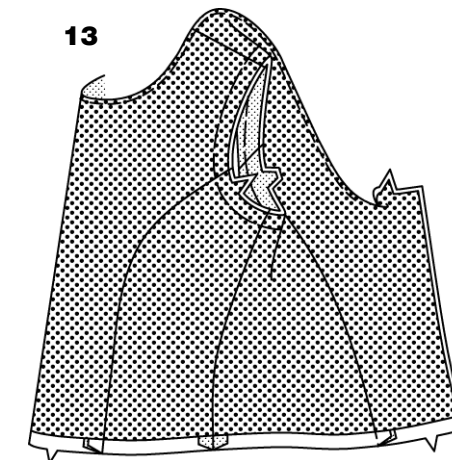

- UNDERSTITCH** lining to within 2" (5cm) of back edges. Turn lining to **INSIDE**; press. Machine-baste armhole edges together.



- FOR VIEW B- EASE-STITCH** top of sleeve (11) between notches. Stitch underarm seam. If you prefer, overlock/serge seam or stitch seam again 1/8" (3mm) from first stitching and trim close to stitching. Press seam to one side.



- FOR VIEW C- EASE-STITCH** top of sleeve (11) between notches. Stitch underarm seam. Press up hem. **EDGE FINISH** the raw edge. Slip-stitch hem in place.

6341

3 / 4

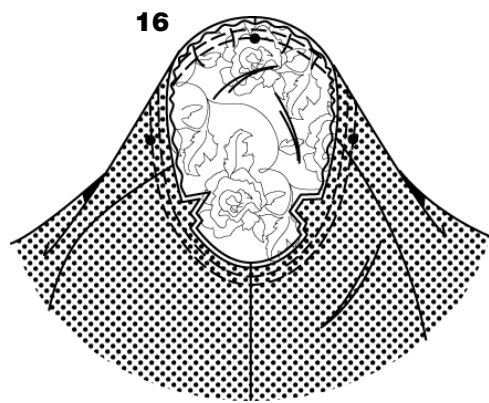

16. FOR VIEWS B, C- Turn sleeve RIGHT side out.

Hold garment WRONG side out with armhole toward you. With RIGHT sides together, pin sleeve to armhole edge with center small dot at shoulder seam, matching underarm seams, notches and remaining small dots. Pull up ease stitches to fit.

To distribute fullness evenly, slide fabric along bobbin threads until there are no puckers or tucks on the seam line. Baste. Stitch. Stitch again 1/8" (3mm) from first stitching. Trim seam below notches close to stitching. Press only the seam allowance, shrinking out fullness.

Press seam toward bodice for View B. If you prefer, tack armhole seam allowances to lining at seams.

CONTINUE AS FOLLOWS FOR ALL VIEWS

17. To make pleats in skirt front (7), on OUTSIDE, fold along solid lines.

Bring folds to broken lines; pin. Baste across entire upper edge.

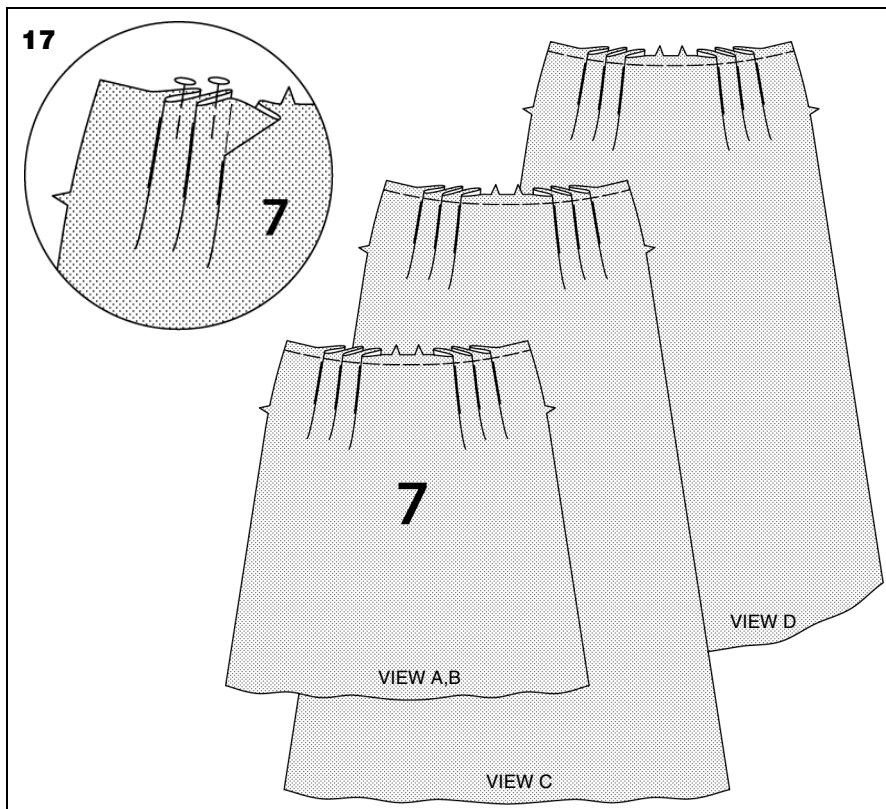

18. Make pleats in skirt back (8) same as for skirt front.

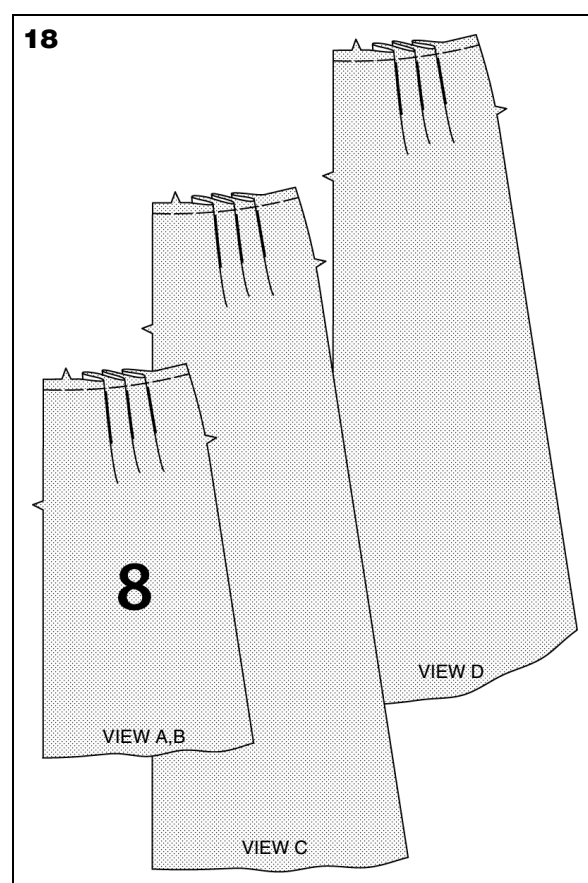

NOTE: Apply pockets to side edges of skirt front and skirt back as follows:

19. With RIGHT sides together, pin pocket (9) to skirt, matching large dots, having raw edges even. Stitch in 3/8" (1cm) seam.

20. Press seam toward pocket, pressing pocket out.

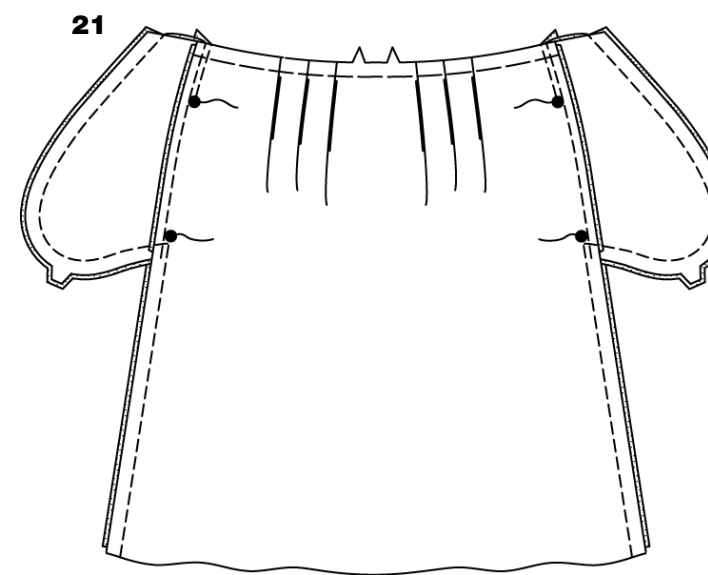
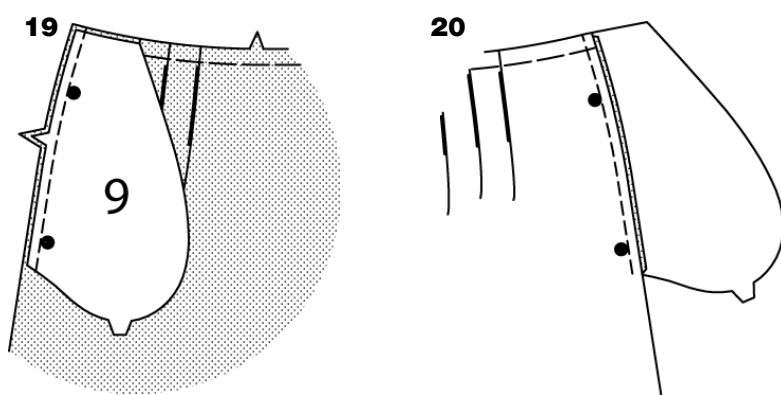

21. Pin front to back at side seams, matching large dots. Stitch side seams, leaving an opening between large dots; back-stitch at large dot to reinforce seam. Stitch pocket edges together from side seam to upper edge.

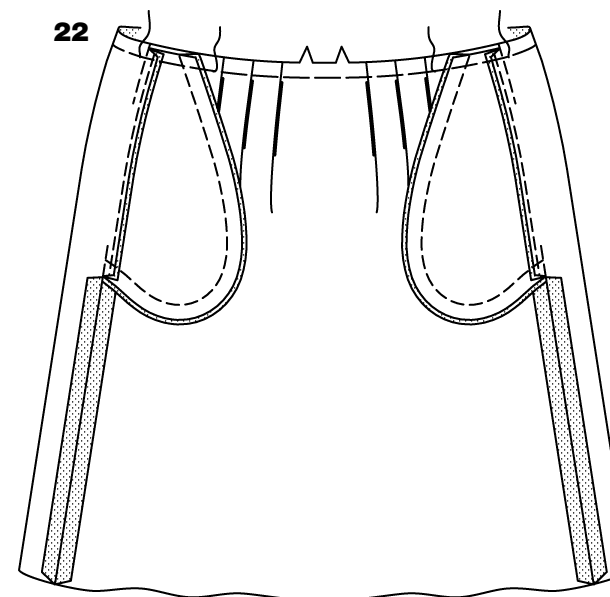

22. Clip skirt back seam allowance below end of pocket. Press seam open below clip. Press pocket toward front. Baste upper edge of pocket to front having raw edges even.

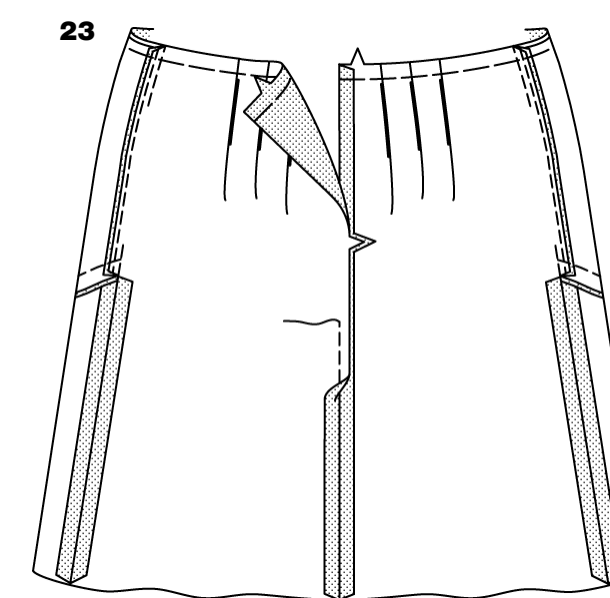

23. Stitch center back seam of skirt back from lower edge to within 3" (7.5cm) of notch; back-stitch at lower end of opening to reinforce seam.

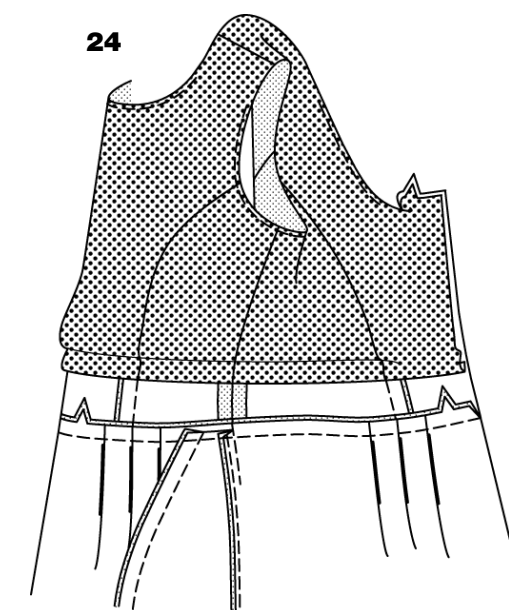

24. Open out bodice lining. With RIGHT sides together, stitch skirt to bodice at waistline seam, matching centers and side seams. Press seam toward bodice.

6341

4 / 4

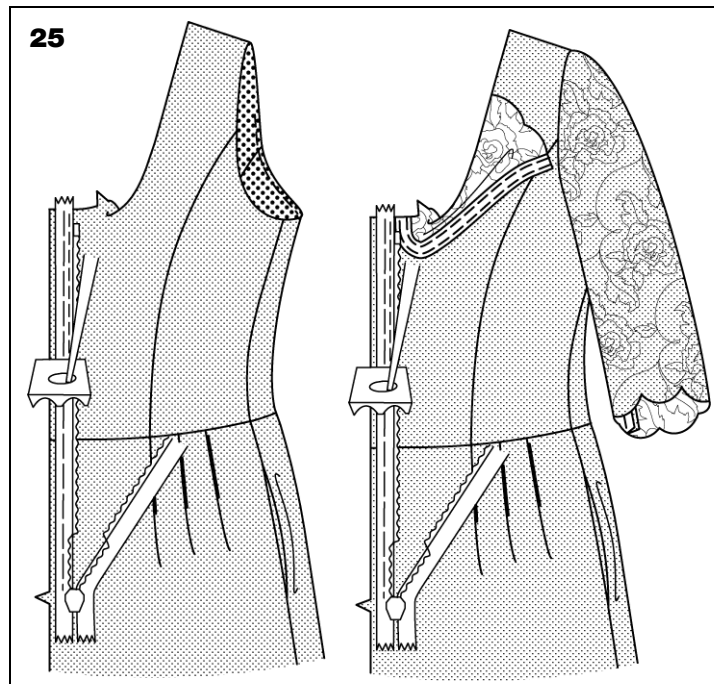

NOTE: *Stitch the invisible zipper using an invisible zipper foot. Before you begin, be sure to line up your needle with the center of the invisible zipper foot or you may break your needle. When the coils are to the LEFT of the raw edge use the LEFT groove and when the coils are to the RIGHT of the raw edge use the RIGHT groove.*

25. Keep free upper edges of bodice back lining out of the way. Open the zipper and press the tape flat on the **WRONG** side unrolling the coils. Do not press the coils. (Use a low iron setting.)

On **OUTSIDE**, pin **RIGHT** side of the zipper face down on the **RIGHT** side of the zipper opening. Have the coil along the seam line, the tape within the seam allowance and the top stop $3/4"$ (2cm) below upper edge, as shown. Hand-baste along center of the tape. Position zipper foot at the top of the zipper with **RIGHT** groove of the foot over coil. Stitch along tape to the notch. Back-stitch to reinforce.

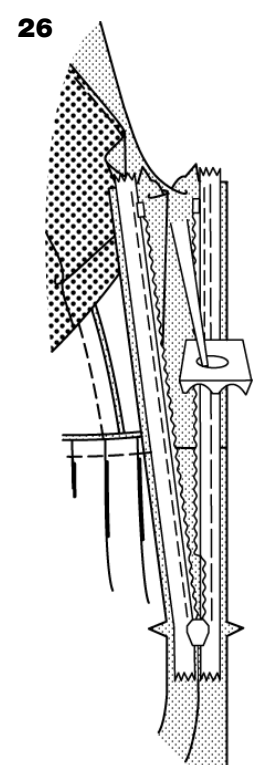

26. Pin the remaining half of the zipper to the **LEFT** side of the zipper opening in same manner. Make sure the upper edges of the dress are even and seams match. Hand-baste along the center of the tape. Position zipper foot at the top of the zipper with **LEFT** groove over the coil. Stitch along tape to the notch. Back-stitch to reinforce.

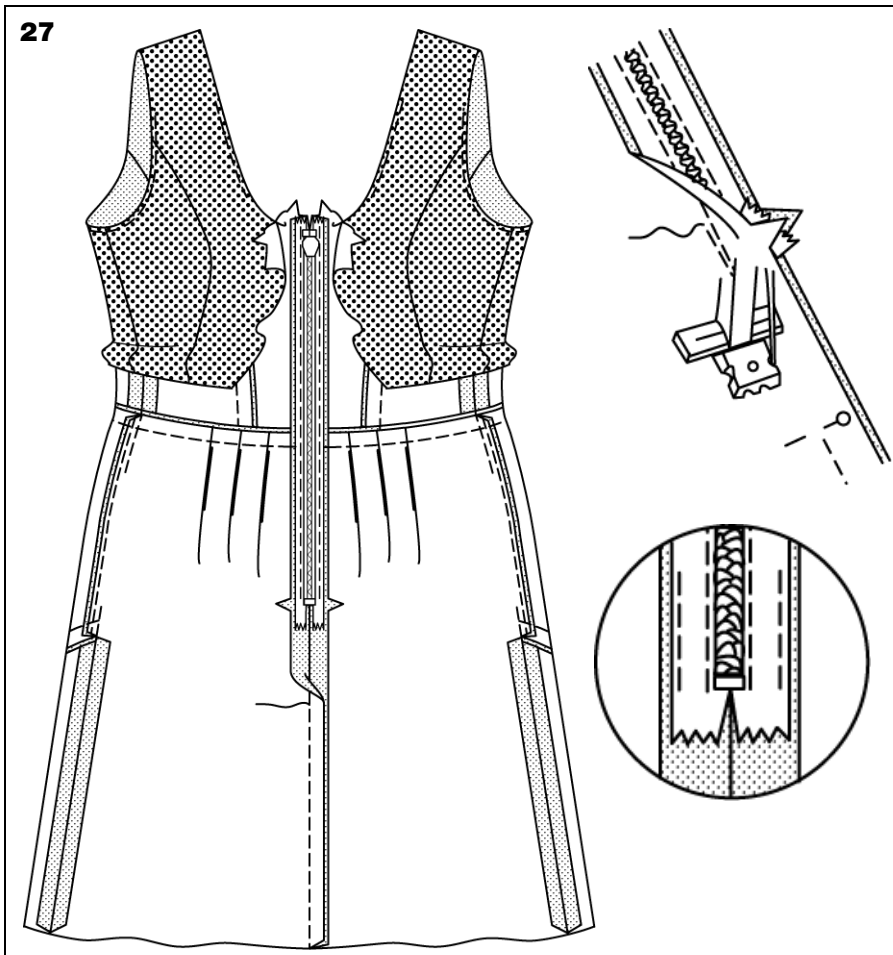

27. Close zipper and check that it is invisible from the **OUTSIDE**. Pull the free ends of the zipper tape away from the seam allowance. Pin remaining center back seam together below zipper. Position zipper foot all the way to the **LEFT** so the needle goes down through the outer notch of the foot. Start stitching seam $1/4"$ (6mm) above lowest stitch and slightly to the **LEFT**. Stitch remainder of seam connecting to previous stitching.

If you prefer, open out each seam allowance at end of zipper and stitch tape to seam allowance.

TIP- If you prefer, encase lower end of zipper with a piece of lining.

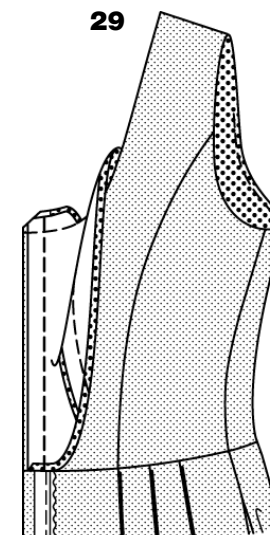
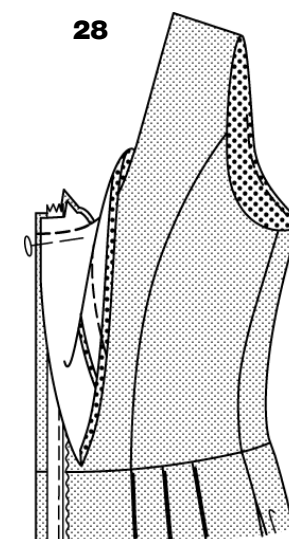

28. Open out back opening edges of dress, rolling the zipper teeth away from the opening edge. Turn bodice back lining to **OUTSIDE** and stitch remaining upper edges of bodice back and lining together, connecting to previous stitching. **LAYER** seam.

29. Pin back opening edges together. Stitch across lining $1/2"$ (1.3cm) from back edges, keeping zipper teeth free. Trim corners.

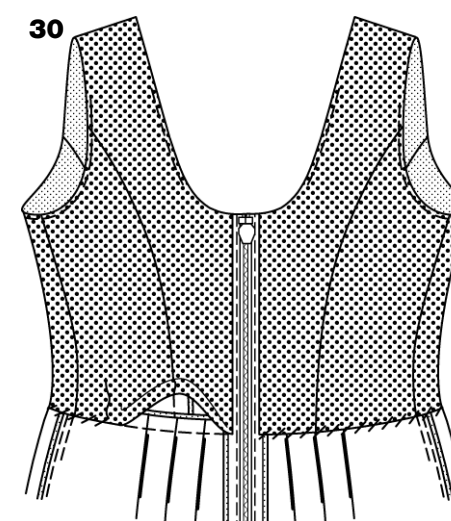

30. Turn lining and zipper tape to **INSIDE**, rolling zipper teeth back int place; press. Slip-stitch pressed edge of lining over waistline seam.

HEM A, B, C

31. Mark length.

Press up hem along marking.

Mark depth of hem; trim evenly.

EDGE FINISH the raw edge.

Slip-stitch hem in place.

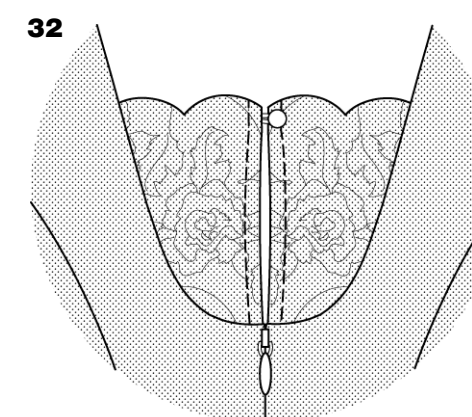
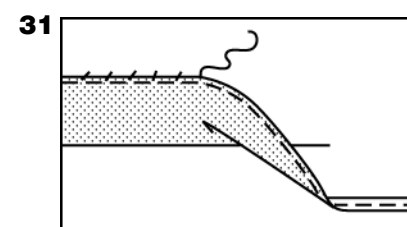

32. FOR VIEW B- On **OUTSIDE**, bring back opening edges together. Sew button under loop.

HEM D

33. Machine-baste $5/8"$ (1.5cm) from lower raw edge of dress.

Press up hem along basting.

To form narrow hem, tuck under raw edge to meet basting.

Press.

Stitch hem in place. Remove basting.

