

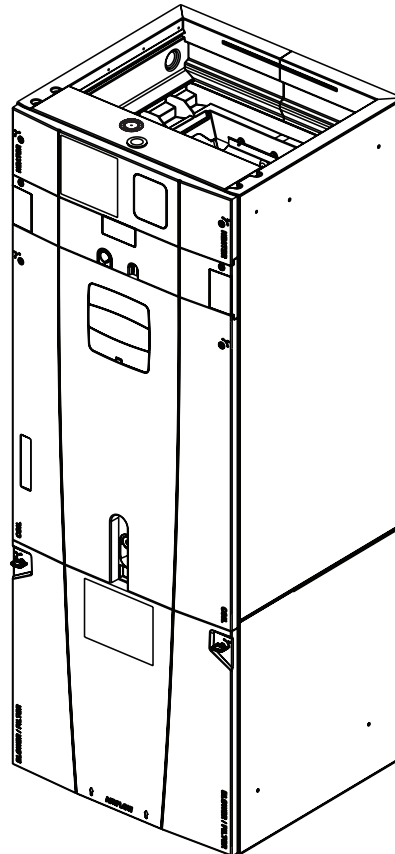

TRANE®

Modular Multi-position Air Handlers

**GAM5A0A18M11SA
GAM5A0A24M21SA
GAM5A0B30M21SA
GAM5A0B36M31SA
GAM5A0C42M31SA
GAM5A0C48M41SA
GAM5A0C60M51SA**



PUB. NO. 22-1845-08



Features and Benefits

- Unique Cabinet Design
 - Double Wall Foamed and Formed Cabinet System
 - Water Proof Cabinet Design
 - R-4.2 Insulating Value (Avg Insulating Value R-8.2)
 - Composite Foamed Cabinet Doors
 - Sweat Eliminating Cabinet Design
 - Loose Fiber Eliminating Cabinet Design
 - Smooth Cleanable Cabinet Design
 - 2% or Less air leakage
 - Precision Durable Door Seals
 - Modular Cabinet
- Multi-Position UP/Down Flow Horizontal Left /Right
- Phillips head door fasteners
- Side Return Option
- Refrigerant Connect
- Condensate Connect
- Premarked Conduit Connection Locations
- Alert Port to view Codes without door removal
- Vortica® Blower with Integrated Slide Deck for Easy Removal
- Polarized Plug connections on Blower
- Control Protection Pocket
- Aluminum Coil with Integrated Slide Deck for Easy Removal
- Polarized Plug connections on Coil EEV
- Slide in Electric Heaters with polarized plug connections (sold as accessory)
- Polarized Plug connections for Electric Heater
- UVC light kit with safety switch and polarized plug connections (sold as accessory)
- Labeled Panels and connections
- 1 1/4" to 1" And 3/4" to 1/2" Conduit connection on Left, Right and Top
- Molded in 1" Standard Filter rail
- Electronic Expansion Valve (EEV) With Low Ambient and Low Superheat Protection
- Dual Refrigerant Compatible as Shipped
- Low Voltage Terminal Connection Point
- 10 Alert Codes
- Enhanced Coil Fin Patented
- Blow Through Design
- High Efficiency ECM Motor
- Maximum Width of 23.5"
- Compact 20.8" depth with doors removed
- Integrated Horizontal Drain pans
- Soft start fan motor operation
- Built in fan delay modes
- Single Color
- Fused 24V Power
- Safety Door Switch
- **5 year warranty**
- **10-year warranty registered**
- **Optional extended warranty available**



Contents

Features and Benefits	2
Optional Equipment	4
Unique Cabinet Design Features and Benefits	5
General Data	6
GAM5A0A18M11SA	6
GAM5A0A24M21SA	6
GAM5A0B30M21SA	6
GAM5A0B36M31SA	6
GAM5A0C42M31SA	6
GAM5A0C48M41SA	7
GAM5A0C60M51SA	7
Performance Data	8
Electrical Data	15
Field Wiring	22
Convertibility	24
Dimensions	25



Optional Equipment

OPTIONAL EQUIPMENT FOR AIR HANDLERS

Accessory Number	Description	Fits Cabinet Size
BAYEAAC05BK1A	Electric Heater, 5kW, Breaker, 24V Control, 1 Ph	A to C
BAYEAAC05LG1A	Electric Heater, 5kW, Lugs, 24V Control, 1 Ph	A to C
BAYEAAC08BK1A	Electric Heater, 8kW, Breaker, 24V Control, 1 Ph	A to C
BAYEAAC08LG1A	Electric Heater, 8kW, Lugs, 24V Control, 1 Ph	A to C
BAYEAAC10BK1A	Electric Heater, 10kW, Breaker, 24V Control, 1 Ph	A to C
BAYEAAC10LG1A	Electric Heater, 10kW, Lugs, 24V Control, 1 Ph	A to C
BAYEAAC10LG3A	Electric Heater, 10kW, Lugs, 24V Control, 3 Ph	A to C
BAYEABC15BK1A	Electric Heater, 15kW, Breaker, 24V Control, 1 Ph	B to C
BAYEABC15LG3A	Electric Heater, 15kW, Lugs, 24V Control, 3 Ph	B to C
BAYEABC20BK1A	Electric Heater, 20kW, Breaker, 24V Control, 1 Ph	B to C
BAYEACC25BK1A	Electric Heater, 25kW, Breaker, 24V Control, 1 Ph	C
BAYSUPFLGAA	Supply Duct Flange A	A
BAYSUPFLGBA	Supply Duct Flange B	B
BAYSUPFLGCA	Supply Duct Flange C	C
BAYRETFLGAA	Return Duct Flange A	A
BAYRETFLGB	Return Duct Flange B	B
BAYRETFLGCA	Return Duct Flange C	C
TASB175SB	Plenum Stand with Integrated Sound Baffle A	A
TASB215SB	Plenum Stand with Integrated Sound Baffle B	B
TASB235SB	Plenum Stand with Integrated Sound Baffle C	C
MITISRKIT1620	Side Return Kit with 16" x 20" Filter	A to C
TASSBK175	Sound Baffle Kit 17.5" Cabinet	A
TASSBK215	Sound Baffle Kit 21.5" Cabinet	B
TASSBK235	Sound Baffle Kit 23.5" Cabinet	C
BAYSRKIT100A	Side Return Kit	A to C
BAYICSKIT01A	Internal Condensate Switch Kit	A to C
BAYHHKIT001A	Horizontal Hanger Kit	A to C
BAYUVCLK001A	UVC Lights	A to C
BAYLVKIT100A	Low Voltage Conduit Entry Kit	A to C
BAYSPEKT200A	Single Point Power Entry Kit	B to C
BAYWAAA05SC1AA	Hydronic heater, A cabinet, no control, slide-in	A
BAYWABB07SC1AA	Hydronic heater, B cabinet, no control, slide-in	B
BAYWACC08SC1AA	Hydronic heater, C cabinet, no control, slide-in	C
BAYWACC11SC1AA	Hydronic heater, C cabinet, no control, external	C



Unique Cabinet Design Features and Benefits

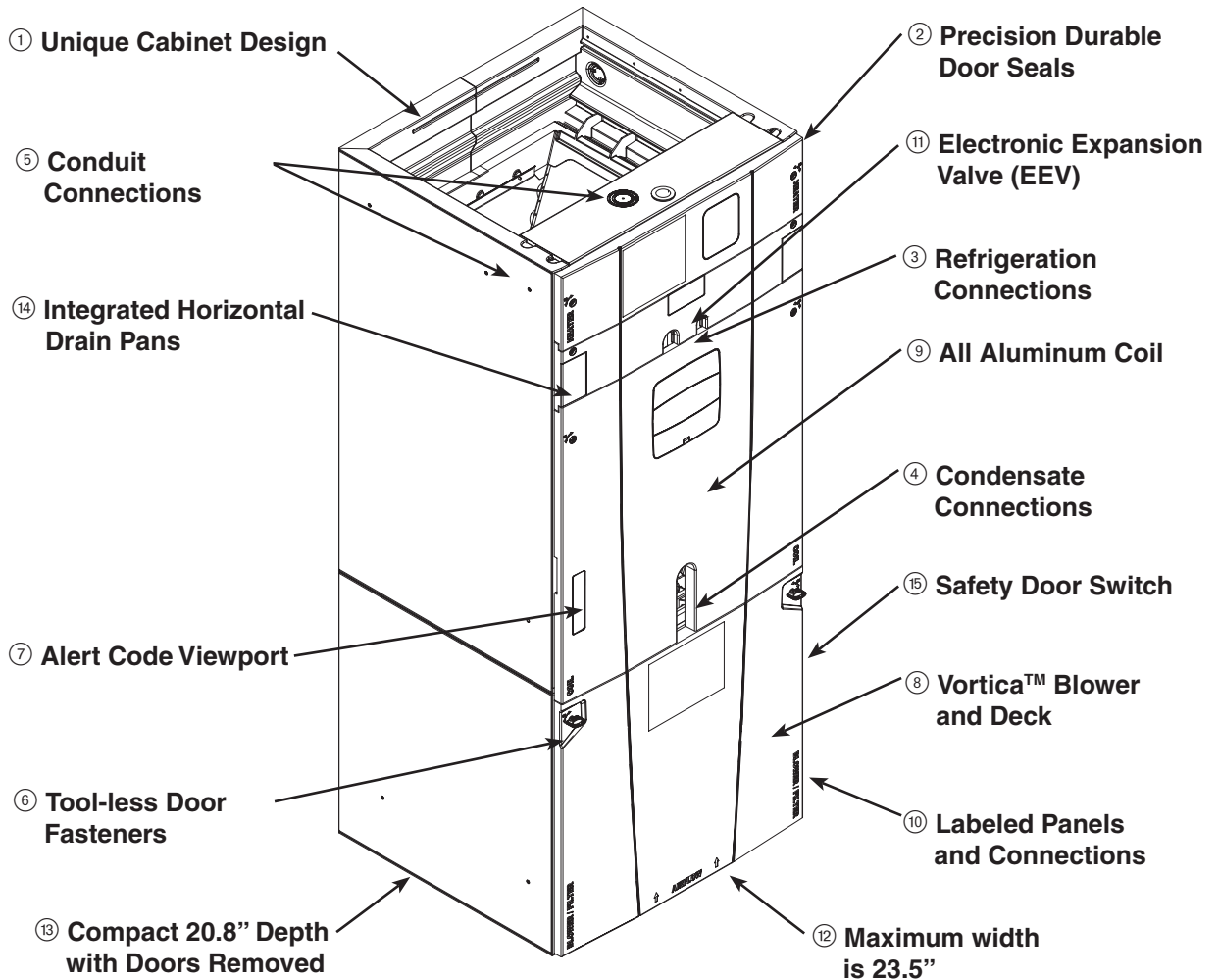

① Unique Cabinet Design

- Double wall foamed cabinet system
- Waterproof Cabinet Design
- R-4.2 Insulating Value (Avg Insulating Value R-8.2)
- Composite Foamed Cabinet Doors
- Sweat Eliminating Cabinet Design
- Loose Fiber Eliminating Design
- Smooth Cleanable Cabinet Design

② Precision Durable Door Seals

③ Refrigeration Connections

④ Condensate Connections

- ## ⑤ Conduit Connections
- Conduit Connections on Left, Right, and Top

⑥ Tool-less Door Fasteners

⑦ Alert Code Viewport

- Alert Codes can be Viewed Without Door Removal
- Control Protection Pocket

- ## ⑧ Vortica™ Blower and Deck
- Polarized Plug on Blower

⑨ All Aluminum Coil

- Integrated Slide Deck for Easy Removal
- Polarized Plug connections on Coil EEV
- Patented Enhanced Coil Fin

⑩ Labeled Panels and Connections

⑪ Electronic Expansion Valve (EEV)

- Low Ambient and Low Superheat Protection
- Dual Refrigerant Compatible as Shipped

⑫ Maximum width is 23.5"

⑬ Compact 20.8" Depth with Doors Removed

⑭ Integrated Horizontal Drain Pans

⑮ Safety Door Switch

- Fused 24V Power

⑯ Modular Cabinet



TRANE®

General Data

PRODUCT SPECIFICATIONS

MODEL	GAM5A0A18M11SA	GAM5A0A24M21SA	GAM5A0B30M21SA
RATED VOLTS/PH/HZ.	208-230/1/60	208-230/1/60	208-230/1/60
RATINGS ①	See O.D. Specifications	See O.D. Specifications	See O.D. Specifications
INDOOR COIL — Type	Plate Fin	Plate Fin	Plate Fin
Rows — F.P.I.	3 - 14	3 - 14	3 - 14
Face Area (sq. ft.)	3.67	3.67	4.13
Tube Size (in.)	3/8	3/8	3/8
Refrigerant Control	EEV	EEV	EEV
Drain Conn. Size (in.) ②	3/4 NPT	3/4 NPT	3/4 NPT
DUCT CONNECTIONS	See Outline Drawing	See Outline Drawing	See Outline Drawing
INDOOR FAN — Type	Centrifugal	Centrifugal	Centrifugal
Diameter-Width (In.)	11 X 8	11 X 8	11 X 10
No. Used	1	1	1
Drive - No. Speeds	Direct - 5	Direct - 5	Direct - 5
CFM vs. in. w.g.	See Fan Performance Table	See Fan Performance Table	See Fan Performance Table
No. Motors — H.P.	1 - 1/3	1 - 1/3	1 - 1/3
Motor Speed R.P.M.	1050	1050	1050
Volts/Ph/Hz	208-230/1/60	208-230/1/60	208-230/1/60
F.L. Amps	2.8	2.8	2.8
FILTER			
Filter Furnished?	No	No	No
Type Recommended	Throwaway	Throwaway	Throwaway
No.-Size-Thickness	1 - 16 X 20 - 1 in.	1 - 16 X 20 - 1 in.	1 - 20 X 20 - 1 in.
REFRIGERANT	R-410A	R-410A	R-410A
Ref. Line Connections	Brazed	Brazed	Brazed
Coupling or Conn. Size — in. Gas	3/4	3/4	3/4
Coupling or Conn. Size — in. Liq.	3/8	3/8	3/8
DIMENSIONS	H x W x D	H x W x D	H x W x D
Crated (In.)	51-3/8 x 20-1/2 x 25-3/4	51-3/8 x 20-1/2 x 25-3/4	53 x 24-1/4 x 25-3/4
Uncrated	49-7/8 x 17-1/2 x 21-3/4	49-7/8 x 17-1/2 x 21-3/4	51-1/2 x 21-1/4 x 21-3/4
WEIGHT			
Shipping (Lbs.)/Net (Lbs.)	126/120	126/120	140/132

PRODUCT SPECIFICATIONS

MODEL	GAM5A0B36M31SA	GAM5A0C42M31SA
RATED VOLTS/PH/HZ.	208-230/1/60	208-230/1/60
RATINGS ①	See O.D. Specifications	See O.D. Specifications
INDOOR COIL — Type	Plate Fin	Plate Fin
Rows — F.P.I.	3 - 14	4 - 14
Face Area (sq. ft.)	5.04	5.04
Tube (in.)	3/8	3/8
Refrigerant Control	EEV	EEV
Drain Conn. Size (in.) ②	3/4 NPT	3/4 NPT
DUCT CONNECTIONS	See Outline Drawing	See Outline Drawing
INDOOR FAN — Type	Centrifugal	Centrifugal
Diameter-Width (In.)	11 X 10	11 X 10
No. Used	1	1
Drive - No. Speeds	Direct - 5	Direct - 5
CFM vs. in. w.g.	See Fan Performance Table	See Fan Performance Table
No. Motors — H.P.	1 - 1/2	1 - 1/2
Motor Speed R.P.M.	1050	1050
Volts/Ph/Hz	208-230/1/60	208-230/1/60
F.L. Amps	4.1	4.1
FILTER		
Filter Furnished?	No	No
Type Recommended	Throwaway	Throwaway
No.-Size-Thickness	1 - 20 X 20 - 1 in.	1 - 22 X 20 - 1 in.
REFRIGERANT	R-410A	R-410A
Ref. Line Connections	Brazed	Brazed
Coupling or Conn. Size — in. Gas	7/8	7/8
Coupling or Conn. Size — in. Liq.	3/8	3/8
DIMENSIONS	H x W x D	H x W x D
Crated (In.)	57-1/4 x 24-1/4 x 25-3/4	58-1/2 x 27-1/2 x 25-3/4
Uncrated	55-3/4 x 21-1/4 x 21-3/4	56-7/8 x 23-1/2 x 21-3/4
WEIGHT		
Shipping (Lbs.)/Net (Lbs.)	150/142	163/153

① These Air Handlers are A.H.R.I. certified with various Split System Air Conditioners and Heat Pumps (AHRI STANDARD 210/240). Refer to the Split System Outdoor Unit Product Data Guides for performance data.

② 3/4" Male Plastic Pipe (Ref.: ASTM 1785-76)



TRANE®

General Data

PRODUCT SPECIFICATIONS		
MODEL	GAM5A0C48M41SA	GAM5A0C60M51SA
RATED VOLTS/PH/HZ.	208-230/1/60	208-230/1/60
RATINGS ①	See O.D. Specifications	See O.D. Specifications
INDOOR COIL — Type	Plate Fin	Plate Fin
Rows — F.P.I.	4 - 14	4 - 14
Face Area (sq. ft.)	5.96	5.96
Tube Size (in.)	3/8	3/8
Refrigerant Control	EEV	EEV
Drain Conn. Size (in.) ②	3/4 NPT	3/4 NPT
DUCT CONNECTIONS	See Outline Drawing	See Outline Drawing
INDOOR FAN — Type	Centrifugal	Centrifugal
Diameter-Width (In.)	11 X 10	11 X 10
No. Used	1	1
Drive - No. Speeds	Direct - 5	Direct - 5
CFM vs. in. w.g.	See Fan Performance Table	See Fan Performance Table
No. Motors — H.P.	1 - 3/4	1 - 1
Motor Speed R.P.M.	1050	1050
Volts/Ph/Hz	208-230/1/60	208-230/1/60
F.L. Amps	6.0	7.6
FILTER		
Filter Furnished?	No	No
Type Recommended	Throwaway	Throwaway
No.-Size-Thickness	1 - 22 X 20 - 1 in.	1 - 22 X 20 - 1 in.
REFRIGERANT	R-410A	R-410A
Ref. Line Connections	Brazed	Brazed
Coupling or Conn. Size — in. Gas	7/8	7/8
Coupling or Conn. Size — in. Liq.	3/8	3/8
DIMENSIONS	H x W x D	H x W x D
Crated (In.)	63-1/4 x 27-1/2 x 25-3/4	63-1/4 x 27-1/2 x 25-3/4
Uncrated	61-3/4 x 23-1/2 x 21-3/4	61-3/4 x 23-1/2 x 21-3/4
WEIGHT		
Shipping (Lbs.)/Net (Lbs.)	176/166	180/170

① These Air Handlers are A.H.R.I. certified with various Split System Air Conditioners and Heat Pumps (AHRI STANDARD 210/240). Refer to the Split System Outdoor Unit Product Data Guides for performance data.

② 3/4" Male Plastic Pipe (Ref.: ASTM 1785-76)



Performance Data

GAM5A0A18 AIRFLOW PERFORMANCE TABLE

AIRFLOW PERFORMANCE										
GAM5A0A18M11SA										
EXTERNAL STATIC (in w.g)	AIRFLOW (CFM)									
	Speed Taps - 230 VOLTS					Speed Taps - 208 VOLTS				
	5	4 †	3	2	1	5	4 †	3	2	1
0	1081	977	930	862	556	1078	974	927	858	553
0.1	1044	922	850	806	379	1038	916	844	800	373
0.2	995	880	787	702	202	987	871	778	693	193
0.3	956	830	738	621	-	944	819	727	610	-
0.4	914	788	692	562	-	900	774	677	548	-
0.5	872	749	646	502	-	855	732	629	485	-
0.6	838	707	590	445	-	819	687	570	425	-
0.7	802	650	528	389	-	779	628	505	367	-
0.8	755	598	478	327	-	730	573	453	302	-
0.9	708	539	420	-	-	680	512	392	-	-

NOTES:

1. Values are with wet coil and without filters.
2. Contact your particular filter manufacturer for pressure drop data.
3. Electric heater pressure drop is negligible and is included within the airflow data.
4. Tap 1 is a continuous fan speed tap.
5. † Factory Setting

GAM5A0A18M11SA MINIMUM HEATER AIRFLOW CFM		
Heater	Minimum Air Speed Tap	
	Without Heat Pump	With Heat Pump
BAYEAAC05BK1AA BAYEAAC05LG1AA	Tap 3	Tap 4
BAYEAAC08BK1AA BAYEAAC08LG1AA	Tap 3	Tap 4
BAYEAAC10BK1AA BAYEAAC10LG1AA	Tap 3 ①	Tap 5 ①
BAYEAAC10LG3AA	Tap 5	Tap 5 ②
BAYEABC15BK1AA	-	-
BAYEABC20BK1AA	-	-

① Heater not qualified for downflow installations
② Approved for 240 V only

Note: Heating and cooling speeds are the same, factory set at Speed Tap #4.

Note: A "G" only signal from the comfort control will run the blower at a lower speed, factory set at Speed Tap #1. See the Sequence of Operation for additional information.



Performance Data

GAM5A0A24 AIRFLOW PERFORMANCE TABLE

AIRFLOW PERFORMANCE										
GAM5A0A24M21SA										
EXTERNAL STATIC (in w.g)	AIRFLOW (CFM)									
	Speed Taps - 230 VOLTS					Speed Taps - 208 VOLTS				
	5	4 †	3	2	1	5	4 †	3	2	1
0	1081	977	937	928	579	1078	974	933	925	576
0.1	1044	922	868	844	418	1038	916	863	838	412
0.2	995	880	817	777	306	987	871	808	768	298
0.3	956	830	767	729	-	944	819	756	717	-
0.4	914	788	719	682	-	900	774	705	668	-
0.5	872	749	680	635	-	855	732	663	618	-
0.6	838	707	628	577	-	819	687	609	557	-
0.7	802	650	566	515	-	779	628	544	492	-
0.8	755	598	511	467	-	730	573	486	442	-
0.9	708	539	460	407	-	680	512	432	-	-

NOTES:

1. Values are with wet coil and without filters.
2. Contact your particular filter manufacturer for pressure drop data.
3. Electric heater pressure drop is negligible and is included within the airflow data.
4. Tap 1 is an continuous fan speed tap.
5. † Factory Setting

GAM5A0A24M21SA MINIMUM HEATER AIRFLOW CFM		
Heater	Minimum Air Speed Tap	
	Without HP	With HP
BAYEAAC05BK1AA BAYEAAC05LG1AA	Tap 3	Tap 4
BAYEAAC08BK1AA BAYEAAC08LG1AA	Tap 3	Tap 4
BAYEAAC10BK1AA BAYEAAC10LG1AA	Tap 3 ①	Tap 5 ①
BAYEAAC10LG3AA	Tap 5	Tap 5 ②
BAYEABC15BK1AA	-	-
BAYEABC20BK1AA	-	-

① Heater not qualified for downflow installations
② Approved for 240 V only

Note: Heating and cooling speeds are the same, factory set at Speed Tap #4.

Note: A "G" only signal from the comfort control will run the blower at a lower speed, factory set at Speed Tap #1. See the Sequence of Operation for additional information.



Performance Data

GAM5A0B30 AIRFLOW PERFORMANCE TABLE

AIRFLOW PERFORMANCE										
GAM5A0B30M21SA										
EXTERNAL STATIC (in w.g)	AIRFLOW (CFM)									
	Speed Taps - 230 VOLTS					Speed Taps - 208 VOLTS				
	5	4 †	3	2	1	5	4 †	3	2	1
0	1282	1150	979	856	678	1279	1146	976	853	675
0.1	1238	1094	931	797	482	1232	1088	925	791	476
0.2	1186	1047	863	725	285	1177	1039	854	716	276
0.3	1141	986	803	647	88	1130	975	791	636	77
0.4	1091	935	721	555	-	1076	921	707	540	-
0.5	1033	866	649	461	-	1016	849	632	444	-
0.6	977	799	554	388	-	958	779	534	369	-
0.7	914	732	490	318	-	892	710	468	296	-
0.8	846	646	429	-	-	821	621	404	-	-
0.9	771	587	376	-	-	743	560	348	-	-

NOTES:

1. Values are with wet coil and without filters.
2. Contact your particular filter manufacturer for pressure drop data.
3. Electric heater pressure drop is negligible and is included within the airflow data.
4. Tap 1 is a continuous fan speed tap.
5. † Factory Setting

GAM5A0B30M21SA MINIMUM HEATER AIRFLOW CFM		
Heater	Minimum Air Speed Tap	
	Without HP	With HP
BAYEAAC05BK1AA BAYEAAC05LG1AA	Tap 2	Tap 3
BAYEAAC08BK1AA BAYEAAC08LG1AA	Tap 3	Tap 4
BAYEAAC10BK1AA BAYEAAC10LG1AA	Tap 3	Tap 4
BAYEAAC10LG3AA	Tap 3 ①	Tap 4 ①
BAYEABC15BK1AA	Tap 4	Tap 5
BAYEABC15LG3AA	Tap 4	Tap 5
BAYEABC20BK1AA	-	-
BAYEACC25BK1AA	-	-

① 208 V not approved for upflow installations

Note: Heating and cooling speeds are the same, factory set at Speed Tap #4.

Note: A “G” only signal from the comfort control will run the blower at a lower speed, factory set at Speed Tap #1. See the Sequence of Operation for additional information.



Performance Data

GAM5A0B36 AIRFLOW PERFORMANCE TABLE

AIRFLOW PERFORMANCE										
GAM5A0B36M31SA										
EXTERNAL STATIC (in w.g)	AIRFLOW (CFM)									
	Speed Taps - 230 VOLTS					Speed Taps - 208 VOLTS				
	5	4 †	3	2	1	5	4 †	3	2	1
0	1438	1387	1197	1013	732	1435	1383	1194	1009	729
0.1	1394	1340	1143	945	552	1388	1334	1137	939	546
0.2	1350	1299	1090	892	413	1341	1291	1082	884	404
0.3	1301	1245	1031	817	305	1289	1233	1019	806	293
0.4	1253	1197	975	751	209	1239	1183	960	737	195
0.5	1205	1151	917	651	-	1188	1134	900	634	-
0.6	1155	1094	837	578	-	1136	1075	817	559	-
0.7	1099	1032	766	499	-	1077	1010	744	476	-
0.8	1039	972	691	453	-	1014	946	666	-	-
0.9	964	889	633	409	-	936	861	605	-	-

NOTES:

1. Values are with wet coil and without filters.
2. Contact your particular filter manufacturer for pressure drop data.
3. Electric heater pressure drop is negligible and is included within the airflow data.
4. Tap 1 is a continuous fan speed tap.
5. † Factory Setting

GAM5A0B36M31SA MINIMUM HEATER AIRFLOW CFM		
Heater	Minimum Air Speed Tap	
	Without HP	With HP
BAYEAAC05BK1AA BAYEAAC05LG1AA	Tap 2	Tap 3
BAYEAAC08BK1AA BAYEAAC08LG1AA	Tap 3	Tap 4
BAYEAAC10BK1AA BAYEAAC10LG1AA	Tap 4	Tap 5
BAYEAAC10LG3AA	Tap 4	Tap 5
BAYEABC15BK1AA	Tap 4	Tap 5
BAYEABC15LG3AA	Tap 4	Tap 5
BAYEABC20BK1AA	-	-
BAYEACC25BK1AA	-	-

Note: Heating and cooling speeds are the same, factory set at Speed Tap #4.

Note: A "G" only signal from the comfort control will run the blower at a lower speed, factory set at Speed Tap #1. See the Sequence of Operation for additional information.



Performance Data

GAM5A0C42 AIRFLOW PERFORMANCE TABLE

AIRFLOW PERFORMANCE										
GAM5A0C42M31SA										
EXTERNAL STATIC (in w.g)	AIRFLOW (CFM)									
	Speed Taps - 230 VOLTS					Speed Taps - 208 VOLTS				
	5	4 †	3	2	1	5	4 †	3	2	1
0	1644	1575	1401	1266	752	1641	1572	1398	1263	749
0.1	1596	1525	1346	1215	665	1590	1519	1340	1209	659
0.2	1550	1480	1300	1157	569	1542	1471	1291	1148	560
0.3	1509	1437	1252	1110	492	1497	1425	1241	1099	480
0.4	1463	1391	1205	1058	384	1449	1377	1191	1043	370
0.5	1420	1345	1151	980	327	1403	1328	1134	963	310
0.6	1376	1301	1085	917	259	1356	1282	1066	898	239
0.7	1332	1251	1020	865	-	1310	1228	998	842	-
0.8	1271	1179	969	813	-	1246	1154	944	788	-
0.9	1199	1119	924	747	-	1171	1091	897	719	-

NOTES:

1. Values are with wet coil and without filters.
2. Contact your particular filter manufacturer for pressure drop data.
3. Electric heater pressure drop is negligible and is included within the airflow data.
4. Tap 1 is a continuous fan speed tap.
5. † Factory Setting

GAM5A0C42M31SA MINIMUM HEATER AIRFLOW CFM		
Heater	Minimum Air Speed Tap	
	Without HP	With HP
BAYEAAC05BK1AA BAYEAAC05LG1AA	Tap 2	Tap 3
BAYEAAC08BK1AA BAYEAAC08LG1AA	Tap 2	Tap 3
BAYEAAC10BK1AA BAYEAAC10LG1AA	Tap 2	Tap 3
BAYEAAC10LG3AA	Tap 2	Tap 3
BAYEABC15BK1AA	Tap 3	Tap 4
BAYEABC15LG3AA	Tap 3	Tap 4
BAYEABC20BK1AA	-	-
BAYEACC25BK1AA	-	-

Note: Heating and cooling speeds are the same, factory set at Speed Tap #4.

Note: A "G" only signal from the comfort control will run the blower at a lower speed, factory set at Speed Tap #1. See the Sequence of Operation for additional information.



Performance Data

GAM5A0C48 AIRFLOW PERFORMANCE TABLE

AIRFLOW PERFORMANCE										
GAM5A0C48M41SA										
EXTERNAL STATIC (in w.g)	AIRFLOW (CFM)									
	Speed Taps - 230 VOLTS					Speed Taps - 208 VOLTS				
	5	4 †	3	2	1	5	4 †	3	2	1
0	1913	1770	1694	1593	866	1910	1767	1691	1590	863
0.1	1874	1730	1653	1547	791	1868	1724	1647	1541	785
0.2	1834	1690	1611	1505	699	1825	1681	1602	1496	690
0.3	1791	1646	1567	1456	620	1780	1635	1556	1445	609
0.4	1748	1600	1521	1410	537	1734	1586	1506	1396	522
0.5	1708	1556	1476	1367	453	1691	1539	1459	1350	437
0.6	1668	1516	1436	1326	370	1648	1496	1416	1306	351
0.7	1629	1475	1394	1283	-	1607	1452	1372	1260	-
0.8	1588	1435	1352	1236	-	1563	1410	1327	1211	-
0.9	1541	1390	1304	1183	-	1513	1362	1276	1156	-

NOTES:

1. Values are with wet coil and without filters.
2. Contact your particular filter manufacturer for pressure drop data.
3. Electric heater pressure drop is negligible and is included within the airflow data.
4. Tap 1 is an continuous fan speed tap.
5. † Factory Setting

GAM5A0C48M41SA MINIMUM HEATER AIRFLOW CFM		
Heater	Minimum Air Speed Tap	
	Without HP	With HP
BAYEAAC05BK1AA BAYEAAC05LG1AA	Tap 2	Tap 3
BAYEAAC08BK1AA BAYEAAC08LG1AA	Tap 2	Tap 3
BAYEAAC10BK1AA BAYEAAC10LG1AA	Tap 2	Tap 3
BAYEAAC10LG3AA	Tap 2	Tap 3
BAYEABC15BK1AA	Tap 3	Tap 4
BAYEABC15LG3AA	Tap 3	Tap 4
BAYEABC20BK1AA	Tap 3	Tap 4
BAYEACC25BK1AA	Tap 4	Tap 5

Note: Heating and cooling speeds are the same, factory set at Speed Tap #4.

Note: A "G" only signal from the comfort control will run the blower at a lower speed, factory set at Speed Tap #1. See the Sequence of Operation for additional information.



Performance Data

GAM5A0C60 AIRFLOW PERFORMANCE TABLE

AIRFLOW PERFORMANCE										
GAM5A0C60M51SA										
EXTERNAL STATIC (in w.g)	AIRFLOW (CFM)									
	Speed Taps - 230 VOLTS					Speed Taps - 208 VOLTS				
	5	4 †	3	2	1	5	4 †	3	2	1
0	2327	2020	1914	1819	1125	2324	2017	1910	1816	1122
0.1	2285	1980	1873	1780	990	2279	1974	1867	1774	984
0.2	2237	1944	1835	1740	831	2228	1935	1826	1731	822
0.3	2182	1908	1800	1705	600	2171	1896	1789	1693	589
0.4	2125	1869	1756	1659	331	2111	1854	1742	1645	317
0.5	2062	1830	1717	1620	249	2045	1813	1700	1603	232
0.6	1995	1747	1664	1575	187	1975	1727	1644	1555	168
0.7	1922	1707	1629	1540	-	1899	1685	1607	1518	-
0.8	1844	1673	1594	1502	-	1819	1648	1569	1477	-
0.9	1761	1629	1553	1464	-	1733	1601	1525	1436	-

NOTES:

1. Values are with wet coil and without filters.
2. Contact your particular filter manufacturer for pressure drop data.
3. Electric heater pressure drop is negligible and is included within the airflow data.
4. Tap 1 is an continuous fan speed tap.
5. If the air handler is applied in downflow or horizontal configurations, the airflow should not exceed 2000 CFM. Airflow above 2000 CFM could result in water blow-off.
6. † Factory Setting

GAM5A0C60M51SA MINIMUM HEATER AIRFLOW CFM		
Heater	Minimum Air Speed Tap	
	Without HP	With HP
BAYEAAC05BK1AA BAYEAAC05LG1AA	Tap 2	Tap 3
BAYEAAC08BK1AA BAYEAAC08LG1AA	Tap 2	Tap 3
BAYEAAC10BK1AA BAYEAAC10LG1AA	Tap 2	Tap 3
BAYEAAC10LG3AA	Tap 2	Tap 3
BAYEABC15BK1AA	Tap 3	Tap 4
BAYEABC15LG3AA	Tap 3	Tap 4
BAYEABC20BK1AA	Tap 3	Tap 4
BAYEACC25BK1AA	Tap 4	Tap 5 ①②

① If the air handler is applied in downflow or horizontal configurations, the airflow should not exceed 2000 CFM. Airflow above 2000 CFM could result in water blow-off.
 ② Tap 5 can be used but only when the external static pressure is .6" or above.

Note: Heating and cooling speeds are the same, factory set at Speed Tap #4.

Note: A "G" only signal from the comfort control will run the blower at a lower speed, factory set at Speed Tap #1. See the Sequence of Operation for additional information.



Electrical Data

WIRING DATA											
GAM5A0A18M11SA											
Heater Model No.	No. of Circuits	240 VOLT					208 VOLT				
		Capacity		Heater Amps per Circuit	Minimum Circuit Ampacity	Maximum Overload Protection	Capacity		Heater Amps per Circuit	Minimum Circuit Ampacity	Maximum Overload Protection
		kW	BTUH				kW	BTUH			
No Heater	-	-	-	2.8*	4	15	-	-	2.8*	4	15
BAYEAAC05BK1A BAYEAAC05LG1A	1	4.80	16400	20.0	29	30	3.60	12300	17.3	25	25
BAYEAAC08BK1A BAYEAAC08LG1A	1	7.68	26200	32.0	44	45	5.76	19700	27.7	38	40
BAYEAAC10BK1A ① BAYEAAC10LG1A ①	1	9.60	32800	40.0	54	60	7.20	24600	34.6	47	50
BAYEAAC10LG3A ②	1-3 PH	9.60	32800	23.1	32	35	7.20	24600	20.0	28	30

Note: * Motor Amps
 ① Heater not qualified for downflow installations
 ② Approved for 240 V only with Heat Pump

WIRING DATA											
GAM5A0A24M21SA											
Heater Model No.	No. of Circuits	240 VOLT					208 VOLT				
		Capacity		Heater Amps per Circuit	Minimum Circuit Ampacity	Maximum Overload Protection	Capacity		Heater Amps per Circuit	Minimum Circuit Ampacity	Maximum Overload Protection
		kW	BTUH				kW	BTUH			
No Heater	-	-	-	2.8*	4	15	-	-	2.8*	4	15
BAYEAAC05BK1A BAYEAAC05LG1A	1	4.80	16400	20.0	29	30	3.60	12300	17.3	25	25
BAYEAAC08BK1A BAYEAAC08LG1A	1	7.68	26200	32.0	44	45	5.76	19700	27.7	38	40
BAYEAAC10BK1A ① BAYEAAC10LG1A ①	1	9.60	32800	40.0	54	60	7.20	24600	34.6	47	50
BAYEAAC10LG3A ②	1-3 PH	9.60	32800	23.1	32	35	7.20	24600	20.0	28	30

Note: * Motor Amps
 ① Heater not qualified for downflow installations
 ② Approved for 240 V only with Heat Pump

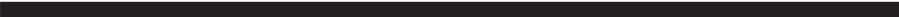

WIRING DATA											
GAM5A0B30M21SA											
Heater Model No.	No. of Circuits	240 VOLT					208 VOLT				
		Capacity		Heater Amps per Circuit	Minimum Circuit Ampacity	Maximum Overload Protection	Capacity		Heater Amps per Circuit	Minimum Circuit Ampacity	Maximum Overload Protection
		kW	BTUH				kW	BTUH			
No Heater	-	-	-	2.8*	4	15	-	-	2.8*	4	15
BAYEAAC05BK1A BAYEAAC05LG1A	1	4.80	16400	20.0	29	30	3.60	12300	17.3	25	25
BAYEAAC08BK1A BAYEAAC08LG1A	1	7.68	26200	32.0	44	45	5.76	19700	27.7	38	40
BAYEAAC10BK1A BAYEAAC10LG1A	1	9.60	32800	40.0	54	60	7.20	24600	34.6	47	50
BAYEAAC10LG3A	1-3 PH	9.60	32800	23.1	32	35	7.20	24600	20.0	28	30
BAYEABC15LG3A ①	1-3 PH	14.40	49200	34.6	46	50	10.80	36900	30.0	41	45
BAYEABC15BK1A - Circuit 1 ②	2	9.60	32800	40	54	60	7.20	24600	34.6	47	50
BAYEABC15BK1A - Circuit 2		4.80	16400	20	25	25	3.60	12300	17.3	22	25

Note: * Motor Amps
 ① 208 V not approved for upflow installations
 ② MCA and MOP for circuit 1 contains the motor amps

WIRING DATA											
GAM5A0B36M31SA											
Heater Model No.	No. of Circuits	240 VOLT					208 VOLT				
		Capacity		Heater Amps per Circuit	Minimum Circuit Ampacity	Maximum Overload Protection	Capacity		Heater Amps per Circuit	Minimum Circuit Ampacity	Maximum Overload Protection
		kW	BTUH				kW	BTUH			
No Heater	-	-	-	4.1*	5	15	-	-	4.1*	5	15
BAYEAAC05BK1A BAYEAAC05LG1A	1	4.80	16400	20.0	30	30	3.60	12300	17.3	27	30
BAYEAAC08BK1A BAYEAAC08LG1A	1	7.68	26200	32.0	45	45	5.76	19700	27.7	40	40
BAYEAAC10BK1A BAYEAAC10LG1A	1	9.60	32800	40.0	55	60	7.20	24600	34.6	48	50
BAYEAAC10LG3A	1-3 PH	9.60	32800	23.1	33	35	7.20	24600	20.0	30	30
BAYEABC15LG3A	1-3 PH	14.40	49200	34.6	48	50	10.80	36900	30.0	42	45
BAYEABC15BK1A - Circuit 1 ①	2	9.60	32800	40	55	60	7.20	24600	34.6	48	50
BAYEABC15BK1A - Circuit 2		4.80	16400	20	25	25	3.60	12300	17.3	22	25

Note: * Motor Amps
 ① MCA and MOP for circuit 1 contains the motor amps



Electrical Data

WIRING DATA											
GAM5A0C42M31SA											
Heater Model No.	No. of Circuits	240 VOLT					208 VOLT				
		Capacity		Heater Amps per Circuit	Minimum Circuit Ampacity	Maximum Overload Protection	Capacity		Heater Amps per Circuit	Minimum Circuit Ampacity	Maximum Overload Protection
		kW	BTUH				kW	BTUH			
No Heater	-	-	-	4.1*	5	15	-	-	4.1*	5	15
BAYEAC05BK1A BAYEAC05LG1A	1	4.80	16400	20.0	30	30	3.60	12300	17.3	27	30
BAYEAC08BK1A BAYEAC08LG1A	1	7.68	26200	32.0	45	45	5.76	19700	27.7	40	40
BAYEAC10BK1A BAYEAC10LG1A	1	9.60	32800	40.0	55	60	7.20	24600	34.6	48	50
BAYEAC10LG3A	1-3 PH	9.60	32800	23.1	33	35	7.20	24600	20.0	30	30
BAYEABC15LG3A	1-3 PH	14.40	49200	34.6	48	50	10.80	36900	30.0	42	45
BAYEABC15BK1A - Circuit 1 ^①	2	9.60	32800	40	55	60	7.20	24600	34.6	48	50
BAYEABC15BK1A - Circuit 2		4.80	16400	20	25	25	3.60	12300	17.3	22	25

Note: * Motor Amps
^① MCA and MOP for circuit 1 contains the motor amps



TRANE®

Electrical Data

WIRING DATA											
GAM5A0C48M41SA											
Heater Model No.	No. of Circuits	240 VOLT					208 VOLT				
		Capacity		Heater Amps per Circuit	Minimum Circuit Ampacity	Maximum Overload Protection	Capacity		Heater Amps per Circuit	Minimum Circuit Ampacity	Maximum Overload Protection
		kW	BTUH				kW	BTUH			
No Heater	-	-	-	6.0*	8	15	-	-	6.0*	8	15
BAYEAAAC05BK1A BAYEAAAC05LG1A	1	4.80	16400	20.0	33	35	3.60	12300	17.3	29	30
BAYEAAAC08BK1A BAYEAAAC08LG1A	1	7.68	26200	32.0	48	50	5.76	19700	27.7	42	45
BAYEAAAC10BK1A BAYEAAAC10LG1A	1	9.60	32800	40.0	58	60	7.20	24600	34.6	51	60
BAYEAAAC10LG3A	1-3 PH	9.60	32800	23.1	36	40	7.20	24600	20.0	32	35
BAYEABC15LG3A	1-3 PH	14.40	49200	34.6	50	50	10.80	36900	30.0	44	45
BAYEABC15BK1A - Circuit 1 ^①	2	9.60	32800	40	58	60	7.20	24600	34.6	51	60
BAYEABC15BK1A - Circuit 2		4.80	16400	20	25	25	3.60	12300	17.3	22	25
BAYEABC20BK1A - Circuit 1 ^①	2	9.60	32800	40	58	60	7.20	24600	34.6	51	60
BAYEABC20BK1A - Circuit 2		9.60	32800	40	50	50	7.20	24600	34.6	43	45
BAYEACC25BK1A - Circuit 1 ^①	3	9.60	32800	40	58	60	7.20	24600	34.6	51	60
BAYEACC25BK1A - Circuit 2		9.60	32800	40	50	50	7.20	24600	34.6	43	45
BAYEACC25BK1A - Circuit 3		4.80	16400	20	25	25	3.60	12300	17.3	22	25

Note: * Motor Amps
^① MCA and MOP for circuit 1 contains the motor amps



Electrical Data

WIRING DATA											
GAM5A0C60M51SA											
Heater Model No.	No. of Circuits	240 VOLT					208 VOLT				
		Capacity		Heater Amps per Circuit	Minimum Circuit Ampacity	Maximum Overload Protection	Capacity		Heater Amps per Circuit	Minimum Circuit Ampacity	Maximum Overload Protection
		kW	BTUH				kW	BTUH			
No Heater	-	-	-	7.6*	10	15	-	-	7.6*	10	15
BAYEAAC05BK1A BAYEAAC05LG1A	1	4.80	16400	20.0	35	35	3.60	12300	17.3	31	35
BAYEAAC08BK1A BAYEAAC08LG1A	1	7.68	26200	32.0	50	50	5.76	19700	27.7	44	45
BAYEAAC10BK1A BAYEAAC10LG1A	1	9.60	32800	40.0	60	60	7.20	24600	34.6	53	60
BAYEAAC10LG3A	1-3 PH	9.60	32800	23.1	37	40	7.20	24600	20.0	34	35
BAYEABC15LG3A	1-3 PH	14.40	49200	34.6	52	60	10.80	36900	30.0	46	50
BAYEABC15BK1A - Circuit 1 ^①	2	9.60	32800	40	60	60	7.20	24600	34.6	53	60
BAYEABC15BK1A - Circuit 2		4.80	16400	20	25	25	3.60	12300	17.3	22	25
BAYEABC20BK1A - Circuit 1 ^①	2	9.60	32800	40	60	60	7.20	24600	34.6	53	60
BAYEABC20BK1A - Circuit 2		9.60	32800	40	50	50	7.20	24600	34.6	43	45
BAYEACC25BK1A ^{②③} - Circuit 1 ^①	3	9.60	32800	40	60	60	7.20	24600	34.6	53	60
BAYEACC25BK1A - Circuit 2		9.60	32800	40	50	50	7.20	24600	34.6	43	45
BAYEACC25BK1A - Circuit 3		4.80	16400	20	25	25	3.60	12300	17.3	22	25

Note: * Motor Amps
^① MCA and MOP for circuit 1 contains the motor amps
^② If the air handler is applied in downflow or horizontal configurations, the airflow should not exceed 2000 CFM. Airflow above 2000 CFM could result in water blow-off. With Heat Pump.
^③ Tap 5 can be used but only when the external static pressure is .6" or above. With Heat Pump.



TRANE®

Electrical Data

GAM5 AIR HANDLER AND HEATER MATRIX - ALLOWABLE COMBINATIONS

APPROVED AIR HANDLER - HEATER COMBINATIONS											
AIR HANDLER	HEATER MODEL NUMBER BAYEA-										
MODEL NUMBER	AC05BK1AA 4.80 Kw BK	AC05LG1AA 4.80 Kw LG	AC08BK1AA 7.68 Kw BK	AC08LG1AA 7.68 Kw LG	AC10BK1AA 9.60 Kw BK	AC10LG1AA 9.60 Kw LG	AC10LG3AA 9.60 Kw LG	BC15BK1AA 14.40 Kw BK	AC15LG3AA 14.40 Kw LG	BC20BK1AA 19.20 Kw BK	CC25BK1AA 24.00 Kw BK
GAM5A0A18M11SA	Y	Y	Y	Y	Y ①	Y ①	Y ②	-	-	-	-
GAM5A0A24M21SA	Y	Y	Y	Y	Y ①	Y ①	Y ②	-	-	-	-
GAM5A0B30M21SA	Y	Y	Y	Y	Y	Y	Y ③	Y	Y	-	-
GAM5A0B36M31SA	Y	Y	Y	Y	Y	Y	Y	Y	Y	-	-
GAM5A0C42M31SA	Y	Y	Y	Y	Y	Y	Y	Y	Y	-	-
GAM5A0C48M41SA	Y	Y	Y	Y	Y	Y	Y	Y	Y	Y	Y
GAM5A0C60M51SA	Y	Y	Y	Y	Y	Y	Y	Y	Y	Y	Y ④⑤

① Heater is not qualified for downflow installations without Heat Pump or with Heat Pump.
 ② Approved for 240V only with Heat Pump.
 ③ 208V not approved for upflow installations without Heat Pump or with Heat Pump.
 ④ If the air handler is applied in downflow or horizontal configurations, the airflow should not exceed 2000 CFM. Airflow above 2000 CFM could result in water blow-off.
 ⑤ Tap 5 can be used but only when the external static pressure is .6" or above.



TRANE®

Electrical Data

WIRING DIAGRAM FOR GAM5 AIR HANDLERS

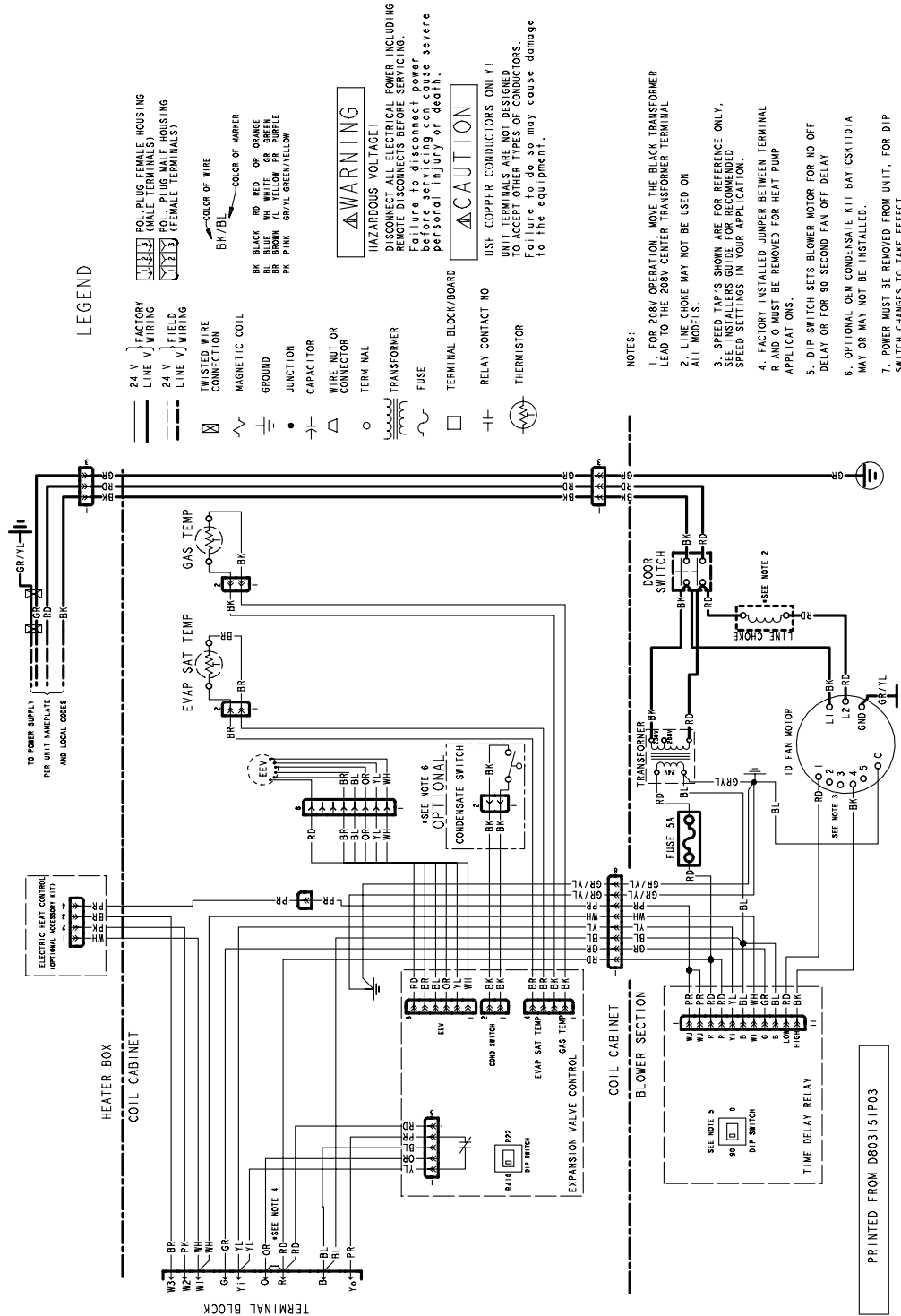

LEGEND

- 24 V } FACTORY WIRING
 - 24 V } FIELD WIRING
 - TWISTED WIRE CONNECTION
 - MAGNETIC COIL
 - GROUND
 - JUNCTION
 - CAPACITOR
 - WIRE NUT OR CONNECTOR
 - TERMINAL
 - TRANSFORMER
 - FUSE
 - TERMINAL BLOCK/BOARD
 - RELAY CONTACT NO
 - THERMISTOR
- POL-PLUG FEMALE HOUSING (MALE TERMINALS)
POL-PLUG MALE HOUSING (FEMALE TERMINALS)
- BK/BL — COLOR OF WIRE
- BK BLACK RD RED OR ORANGE
BL BLUE WH WHITE OR GREEN
GR GRN YL YELLOW
PK PINK GR/YL GREEN/YELLOW
- WARNING**
HAZARDOUS VOLTAGE!
DISCONNECT ALL ELECTRICAL POWER INCLUDING REMOTE DISCONNECTS BEFORE SERVICING.
Failure to disconnect power before servicing can cause severe personal injury or death.
- CAUTION**
USE COPPER CONDUCTORS ONLY!
UNIT TERMINALS ARE NOT DESIGNED TO ACCEPT OTHER TYPES OF CONDUCTORS.
Failure to do so may cause damage to the equipment.

NOTES:

- FOR 208V OPERATION, MOVE THE BLACK TRANSFORMER LEAD TO THE 208V CENTER TRANSFORMER TERMINAL
- LINE CHOKE MAY NOT BE USED ON ALL MODELS.
- SPEED TAP'S SHOWN ARE FOR REFERENCE ONLY, SEE INSTALLERS GUIDE FOR RECOMMENDED SPEED SETTINGS IN YOUR APPLICATION.
- FACTORY INSTALLED JUMPER BETWEEN TERMINAL R AND O MUST BE REMOVED FOR HEAT PUMP APPLICATIONS.
- DIP SWITCH SETS BLOWER MOTOR FOR NO OFF DELAY OR FOR 90 SECOND FAN OFF DELAY
- OPTIONAL OEM CONDENSATE PWT BAYKCSK101A MAY OR MAY NOT BE INSTALLED.
- POWER MUST BE REMOVED FROM UNIT, FOR DIP SWITCH CHANGES TO TAKE EFFECT.

PRINTED FROM D803151P03



TRANE®

Field Wiring

GAM5 AIR HANDLERS WITH SINGLE SPEED COOLING

Make connections per hookup diagrams.

Air Handler Hook-up Diagram Cooling

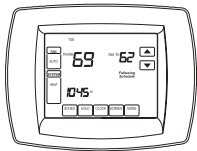

Comfort Control

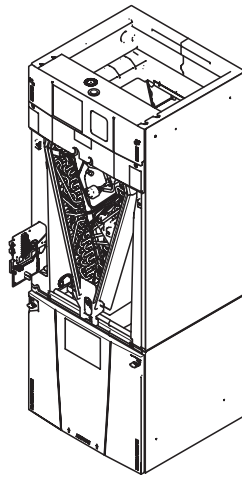

Air Handler

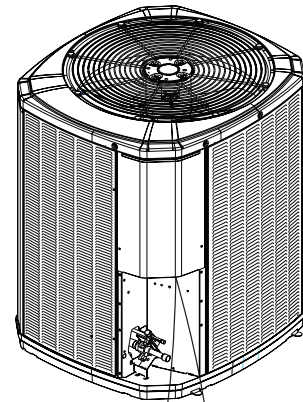

Air Conditioner

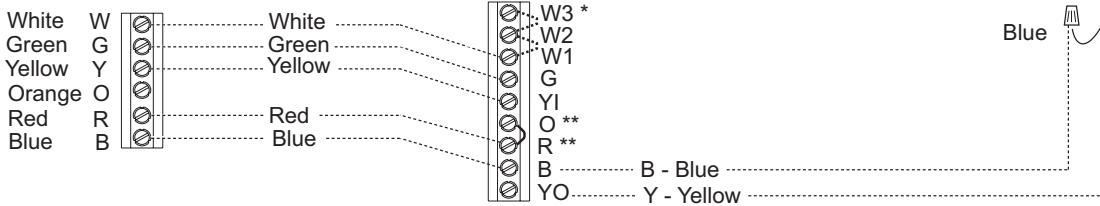

..... Field wiring

- * For multiple stages of electric heat, jumper W1, W2, and W3 together if comfort control has only one stage of heat.
- ** R to O jumper must be in place as shown for cooling only, non-heat pump systems for proper operation.
- Y1 and Y0 connections must be made as shown for freeze protection and internally mounted condensate overflow circuits to work properly.
- Internally mounted condensate switch is optional and must be ordered separately.
- If 3rd party condensate overflow switches are installed, they should be wired in series between and Y to the outdoor unit.

Field Wiring

GAM5 AIR HANDLERS WITH SINGLE SPEED HEAT PUMP

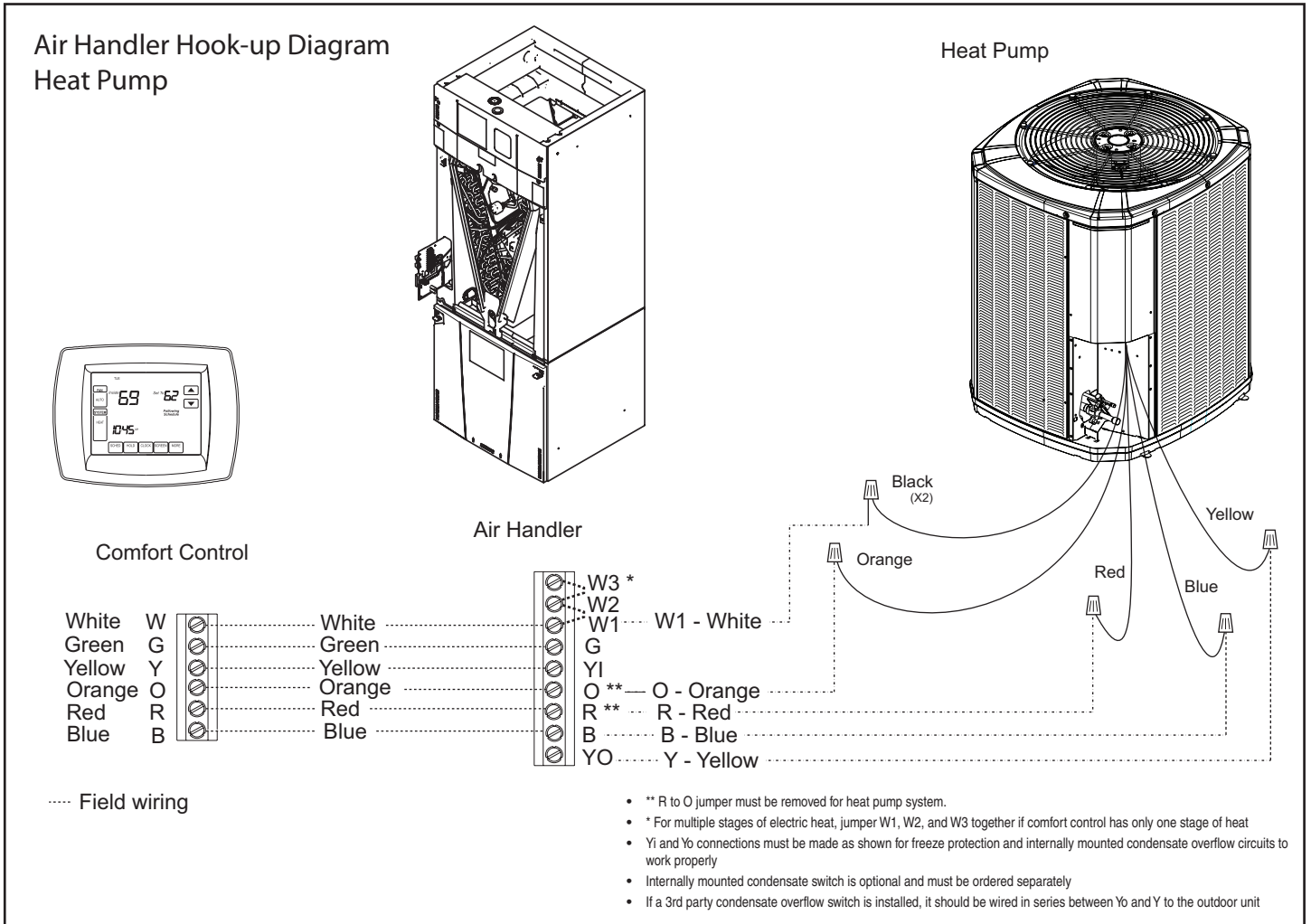



TRANE®

GAM5 Convertibility

* Note: No internal modifications required for any position.

① Badge rotation will keep brand in correct position

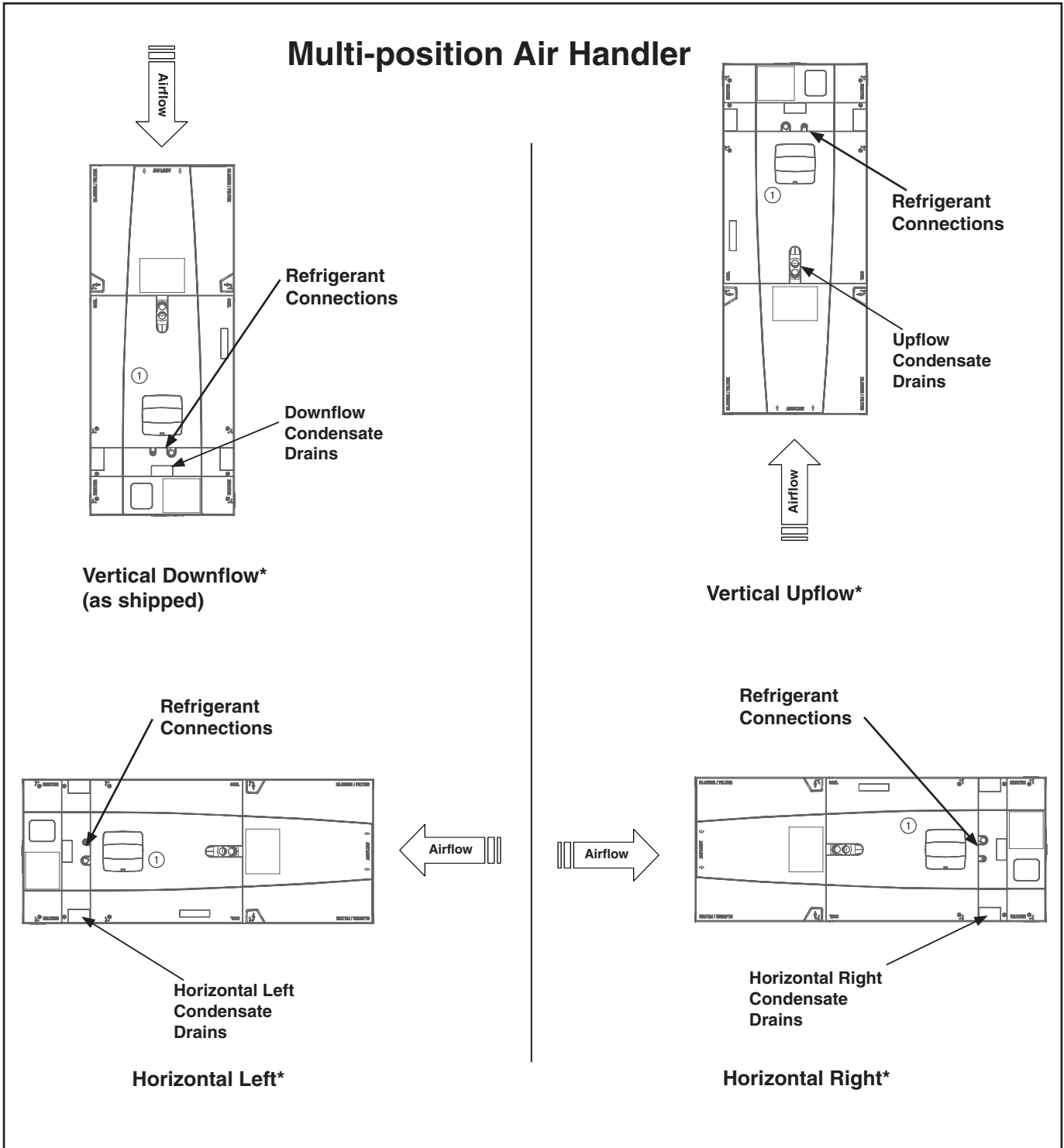

Dimensions

GAM5 AIR HANDLER DIMENSIONAL DATA

Model No.	H	W
GAM5A0A18	49.9	17.5
GAM5A0A24	49.9	17.5
GAM5A0B30	51.5	21.3
GAM5A0B36	55.7	21.3
GAM5A0C42	56.9	23.5
GAM5A0C48	61.7	23.5
GAM5A0C60	61.7	23.5

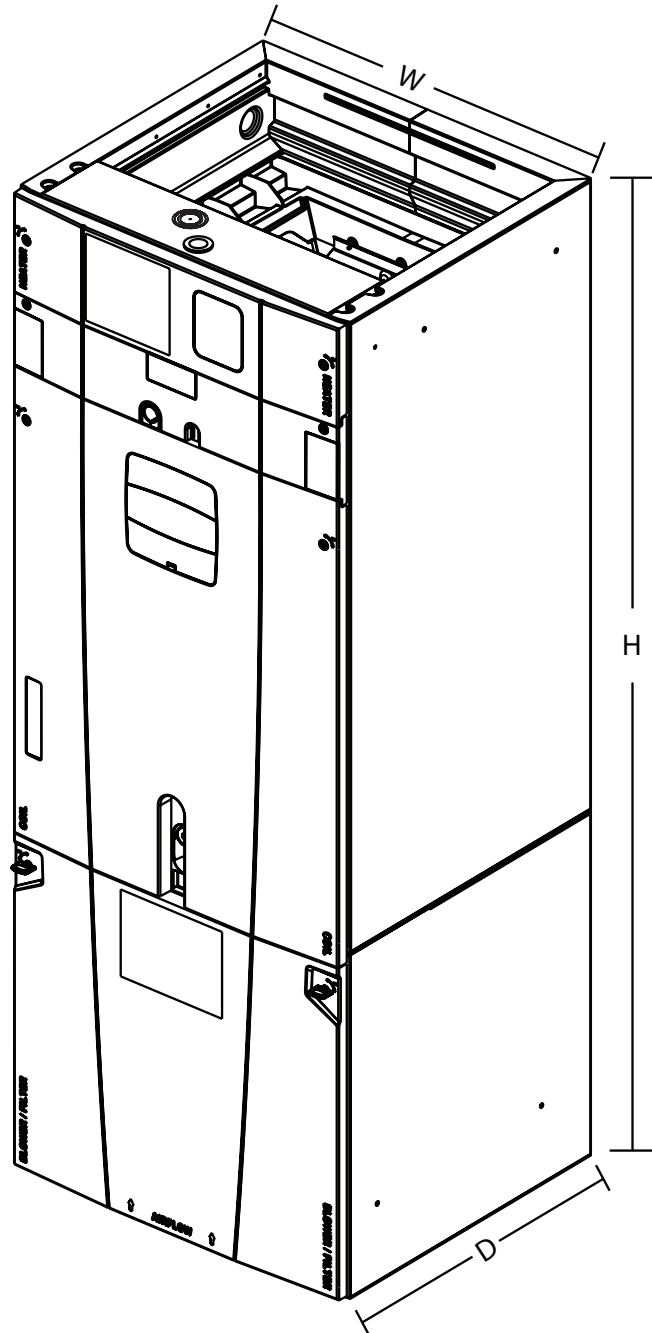

GAM5 AIR HANDLERS ARE ALL TWO PIECE CABINETS.

GAM5 OUTLINE DRAWING

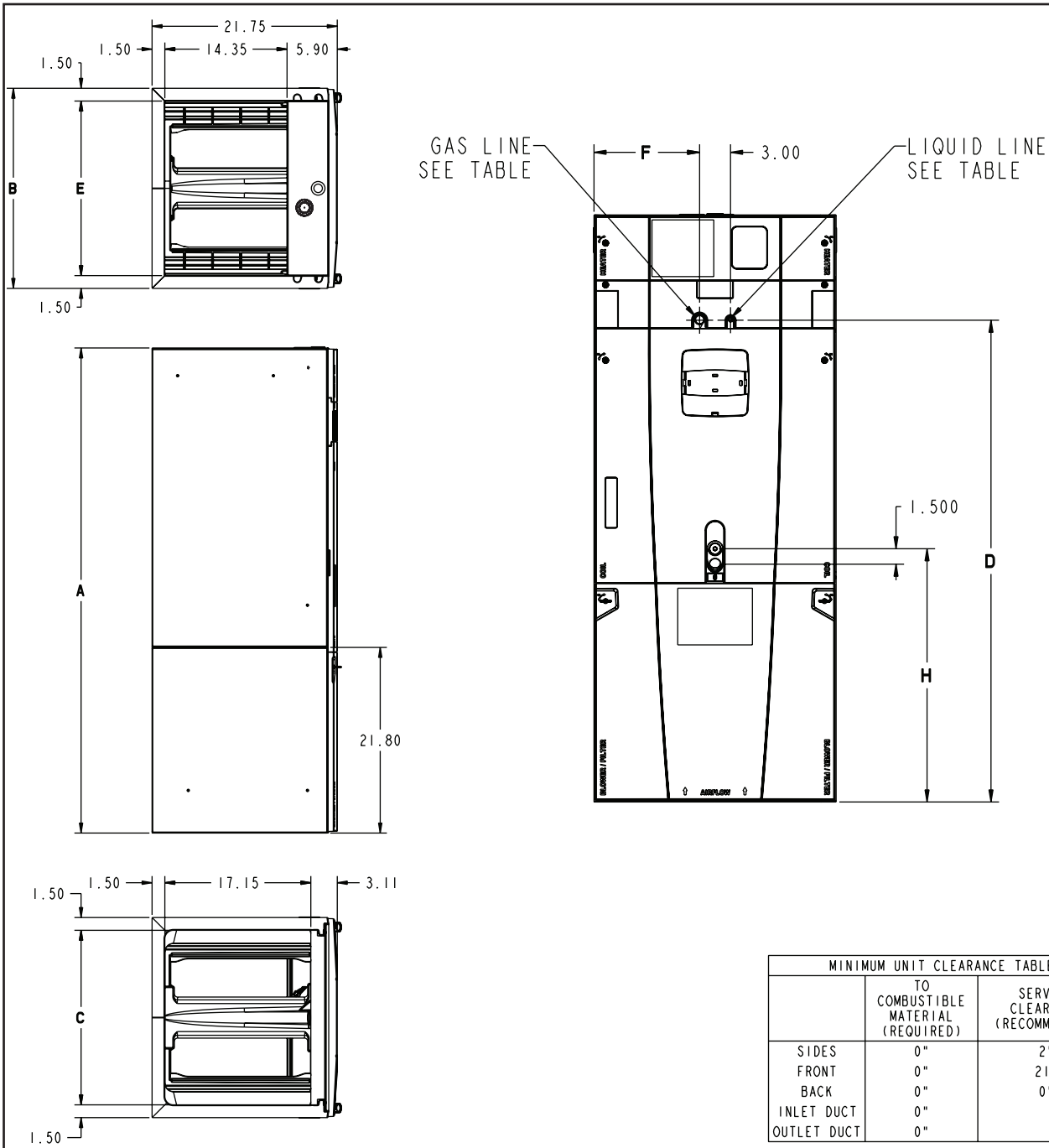

MINIMUM UNIT CLEARANCE TABLE		
	TO COMBUSTIBLE MATERIAL (REQUIRED)	SERVICE CLEARANCE (RECOMMENDED)
SIDES	0"	2"
FRONT	0"	21"
BACK	0"	0"
INLET DUCT	0"	
OUTLET DUCT	0"	

MODEL NO.	A	B	C	D	E	F	H	FLOW CONTROL	GAS LINE BRAZE	LIQ. LINE BRAZE
GAM5A0A18	49.9	17.5	14.5	39.6	14.5	7.3	24.4	EEV	3/4	3/8
GAM5A0A24	49.9	17.5	14.5	39.6	14.5	7.3	24.4	EEV	3/4	3/8
GAM5A0B30	51.5	21.3	18.4	41.2	18.4	9.2	24.8	EEV	3/4	3/8
GAM5A0B36	55.7	21.3	18.4	45.5	18.4	9.2	24.8	EEV	7/8	3/8
GAM5A0C42	56.9	23.5	20.5	46.7	20.5	10.3	24.5	EEV	7/8	3/8
GAM5A0C48	61.7	23.5	20.5	51.5	20.5	10.3	24.9	EEV	7/8	3/8
GAM5A0C60	61.7	23.5	20.5	51.5	20.5	10.3	24.9	EEV	7/8	3/8





02/12

Trane
6200 Troup Highway
Tyler, TX 75707
www.trane.com

The manufacturer has a policy of continuous product and product data improvement and it reserves the right to change design and specifications without notice.