

1  
AISC E&R Library



5434

B105

POCKET COMPANION

CONTAINING

USEFUL INFORMATION AND TABLES,

—PERTAINING TO THE USE OF—

STEEL,

AS MANUFACTURED BY

CARNEGIE STEEL COMPANY,

SUCCESSOR TO

THE CARNEGIE STEEL COMPANY, LIMITED,

PITTSBURG, PA.

FOR ENGINEERS, ARCHITECTS AND BUILDERS.

EDITED BY F. H. KINDL, C. E.

1900.

SM-C1

I

DIMEN

SAFE  
LOAD

PROP  
RTIES

OLS

L  
r

□  
□

↑

DECI  
MALS

AREA

WT.

ROCKET COMPANION  
SPECIAL INFORMATION MATTERS  
STEEL

---

Entered according to Act of Congress, in the year 1900, by  
THE CARNEGIE STEEL COMPANY, LIMITED,  
In the Office of the Librarian of Congress, at Washington.

---

STEVENSON & FOSTER Co.,  
PRINTERS, ENGRAVERS AND ELECTROTYPERS,  
WOOD ST., PITTSBURG, PA.

PRICE, \$2.00.

## CONTENTS.

	PAGES.
Sections of Shapes . . . . .	1-28
Method of Increasing Sectional Areas . . . . .	29
Dimensions and Weights of Bars . . . . .	30-32
Extreme Dimensions of Plates and Sheets . . . . .	33-34
Weights and Dimensions of Shapes . . . . .	35-49
Constructional Details . . . . .	50-56
Notes on Foundations . . . . .	57
Cantilevers . . . . .	58-59
Notes on Wind Bracing . . . . .	60
Girders in Buildings . . . . .	61
General Notes on Floors . . . . .	62-67
Explanation of Tables on Safe Loads and Spacing . . . . .	68-71
Deflection Coefficients for Carnegie Shapes . . . . .	72
Safe Loads for Carnegie Shapes . . . . .	73-84
Spacing of I-Beams for Different Loads . . . . .	85-92
Explanation of Tables of Properties . . . . .	93-96
General Formulae . . . . .	97-100
Tables of Properties of Carnegie Shapes . . . . .	101-124
Notes and Tables on Columns and Struts . . . . .	125-153
Moments of Inertia of Rectangles . . . . .	154
Beam Box and Riveted Plate Girders . . . . .	155-166
Beams in Foundations . . . . .	167-170
Buckled Plates . . . . .	171-172
Trough Plate Flooring . . . . .	173
Corrugated Plate Flooring . . . . .	174
Corrugated and Galvanized Sheets . . . . .	175-176
Notes on Roofs . . . . .	177-178
Steel Bearing Plates . . . . .	179
Standard Wall Anchors . . . . .	180
Standard Cast Iron Separators . . . . .	181
Standard Connections for Beams and Channels . . . . .	182-186
Connections for Constant Dimension Z-Bar Columns . . . . .	187-188

See Index for complete detail of contents.

CONTENTS.

(CONTINUED.)

	PAGES.
Conventional Signs for Riveting . . . . .	189
Lengths of Rivets for Variant Grips . . . . .	190
Notes and Tables on Rivets and Pins . . . . .	191-199
Table of Wood Screws . . . . .	198
Tables of Bolts and Nuts . . . . .	200-202
Upset Screw Ends . . . . .	203-204
Screw Threads . . . . .	205-206
Standard Steam, Gas and Water Pipe . . . . .	206
Tables of Spikes, Nails and Tacks . . . . .	207
Tables of Clevis and Sleeve Nuts . . . . .	208-209
Standard Eye Bar Heads . . . . .	210
Decimals of a Foot for each $\frac{1}{8}$ of an Inch . . . . .	211-212
Decimals of an Inch for each $\frac{1}{8}$ . . . . .	213
Table of Batters . . . . .	214
Standard Gauges . . . . .	215-216
Manufacturers Standard Specifications . . . . .	217-226
Standard Specifications for Steel Rails . . . . .	227-228
Standard Specifications for Rail Splice Bars . . . . .	229-230
Notes on Steel and Iron . . . . .	231
Safe Loads for Wooden Beams and Columns . . . . .	232-234
Strength of Materials . . . . .	235-237
Specific Gravity and Weight of Substances . . . . .	238-241
Linear Expansion of Substances by Heat . . . . .	242
Areas and Weights of Flat Steel, Square and Round Bars . . . . .	243-264
Weight of Iron, Steel, Copper and Brass Sheets . . . . .	265-266
Mensuration . . . . .	267-269
Weights and Measures . . . . .	270-271
Metric Tables . . . . .	272-278
Properties of Numbers . . . . .	279-298
Natural Tangents, Sines and Secants . . . . .	299-304

See Index for complete detail of contents.

## PREFACE.

---

EDITION OF 1900.

---

The present edition includes most of the data of the 1896 publication.

The safe transverse loads are now figured on the basis of 16,000 lbs. per square inch fiber stress for all rolled sections and 15,000 lbs. per square inch for riveted beam box and plate girders.

New standard connecting angles for beams and channels have been introduced also additional tables of standards used in detailing.

All bolts for separators will be  $\frac{3}{4}$ " diameter, except those for 3" beams.

Centers of the two-bolt separators will be made one-half the depth of the beams to which they belong.

The tables of properties of angles have been extended to include all thicknesses rolled, and new tables of safe loads for channel columns have been added.

## GENERAL NOTES.

The flanges of both I-Beams and Standard Channels have now a uniform slope of  $16\frac{2}{3}$  per cent., being equivalent to 2'' per foot. The small fillets on I-Beams and Standard Channels have been made to a radius of  $\frac{6}{10}$  of the minimum web thickness; the large fillets to a radius of the minimum web thickness plus  $\frac{1}{10}$  of an inch.

General (nearly straight line) formulae have been adopted for both I-Beams and Standard Channels to determine their dimensions and weights per foot so that similar sections designed hereafter have their dimensions and weights already determined.

The manner in which the weight of the various sections is increased is illustrated on page 29, figures 1, 2, 3, 4 and 5.

For Channels and I-Beams the enlargement of the section adds an equal amount to the thickness of web and the width of the flanges.

The effect on Angles of spreading the rolls is to slightly increase the length of the legs. Most of the sizes, however, are rolled in finishing grooves, whereby the exact dimensions are maintained for different thicknesses. Z-Bars are increased in thickness in the same manner as angles.

I-Beams and Channels should be ordered to weights given in the tables. Any weights ordered other than those shown in the tables will be furnished and charged for at the next higher weight. Sections of shapes shown correspond only to the minimum weight, excepting Z-Bars.

Channels having but one weight specified can be rolled only as shown. T-shapes do not admit of any variation and can be rolled only to the weight given.

All weights given are per lineal foot of the section.

A recapitulation of all rolled shapes is given on pages 1 to 28, inclusive.

In ordering designate weight or thickness wanted, but not both. Quicker deliveries can be obtained by ordering standard sections and weights.

All structural material will be cut to lengths with extreme variation not exceeding three-quarters of an inch, unless otherwise arranged.

In calculating the areas and weights of the various sections herein shown the fillets were disregarded, except in special cases.

THE CARNEGIE STEEL COMPANY, LIMITED.

# SHAPES

MANUFACTURED BY

THE CARNEGIE STEEL COMPANY, LIMITED,

PITTSBURG, PA.

I

DIMEN

SAFE  
LOAD

PROP  
ERTIES

COLS

$\frac{L}{r}$



T

DECI  
MALS

ARE

W



I - BEAMS.

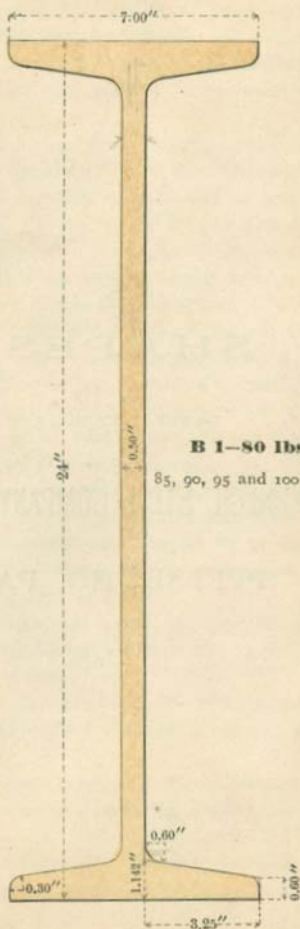

Weights in heavy print are standard, others are special.

I-BEAMS.

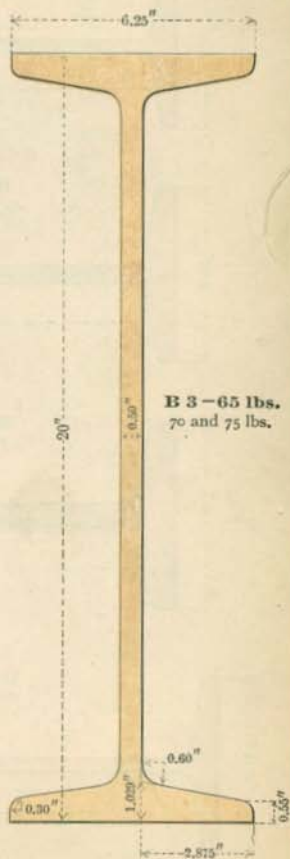
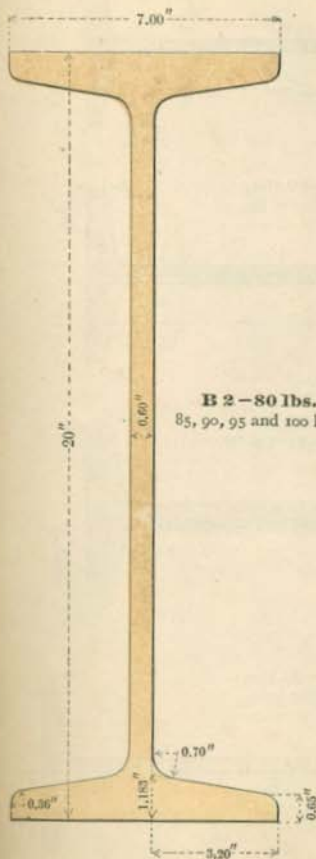

Weights in heavy print are standard, others are special.

I  
DIMEN  
SAFE  
LOAD  
PROP  
RTIES  
COLS  
L  
Y  
DEC  
MAL  
AR  
W

I-BEAMS.

**B 7 - 42 lbs.**  
45, 50 and 55 lbs.

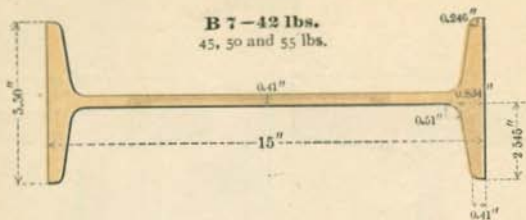

**B 5 - 60 lbs.**  
65, 70 and 75 lbs.

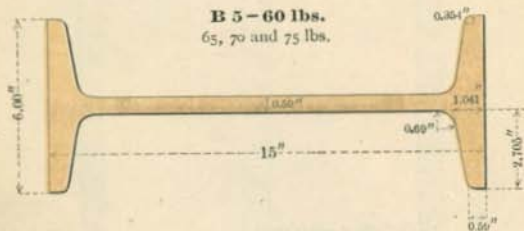

**B 4 - 80 lbs.**  
85, 90, 95 and 100 lbs.

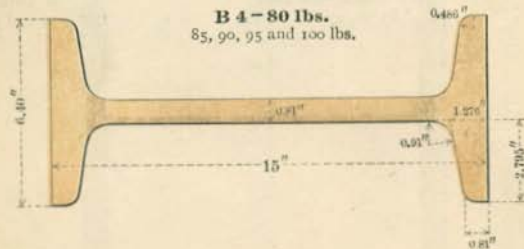

**B 80 - 55 lbs.**  
60, 65 and 70 lbs.

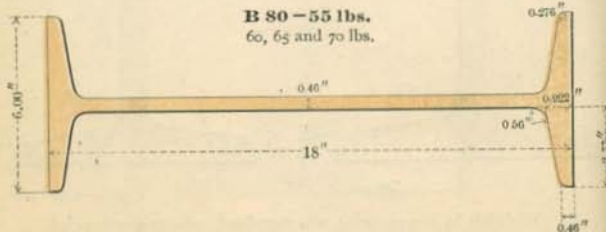

Weights in heavy print are standard, others are special.

I-BEAMS.

**B 13 - 21 lbs.**  
25, 30 and 35 lbs.

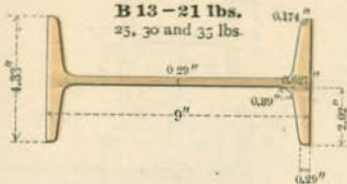

**B 11 - 25 lbs.**  
30, 35 and 40 lbs.

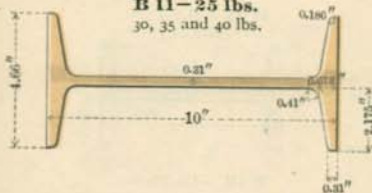

**B 9 - 31.5 lbs.**  
35 lbs.

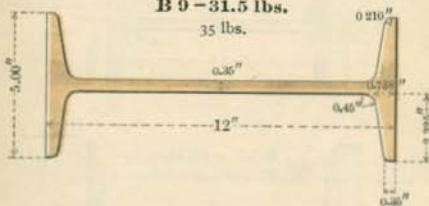

**B 8 - 40 lbs.**  
45, 50 and 55 lbs.

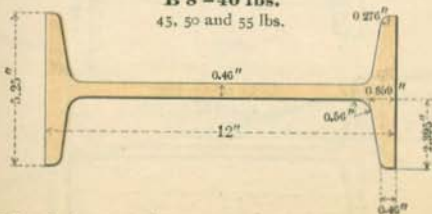

Weights in heavy print are standard, others are special.

DIMEN  
 SAFE  
 DAD  
 PROP  
 RTIES  
 COLS  
 L  
 r  
 DEC  
 MAL  
 ARE  
 W

I-BEAMS.

**B 77 - 5.5 lbs.**  
6.5 and 7.5 lbs.



**B 23 - 7.5 lbs.**  
5, 9.5 and 10.5 lbs.

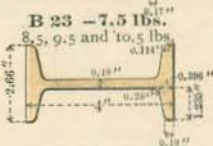

**B 21 - 9.75 lbs.**  
12.25 and 14.75 lbs.

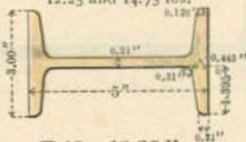

**B 19 - 12.25 lbs.**  
14.75 and 17.25 lbs.



**B 17 - 15 lbs.**  
17.5 and 20.0 lbs.

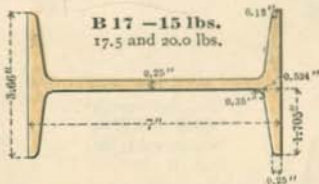

**B 15 - 18 lbs.**  
20.5, 23.0 and 25.5 lbs.

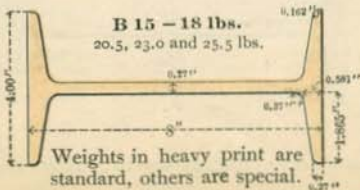

Weights in heavy print are standard, others are special.

DECK BEAMS.

B 105.

6" - 14.1 to 17.16 lbs.

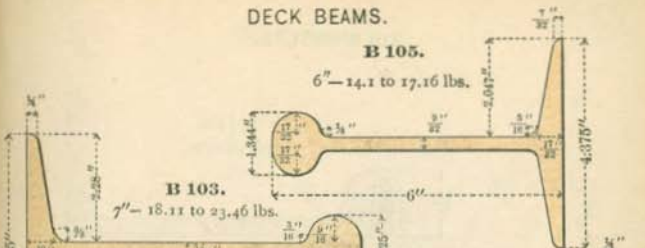

B 103.

7" - 18.11 to 23.46 lbs.

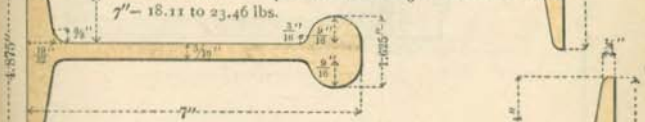

B 102.

8" - 20.15 to 24.48 lbs.

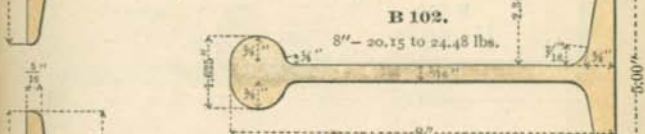

B 101.

9" - 26 to 30 lbs.

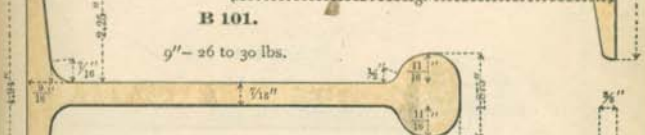

B 100.

10" - 27.23 to 35.70 lbs.

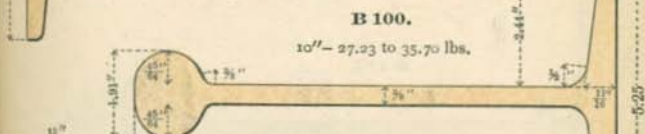

B 110.

11 1/2" - 32.2, 35 and 37 lbs.

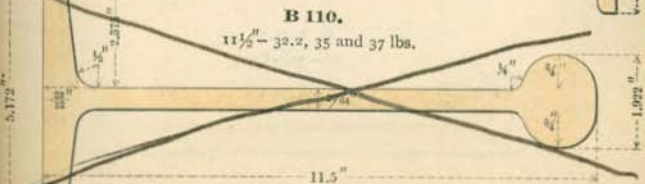

DIMEN  
 SAFE  
 LOAD  
 PROP  
 RTIES  
 COLS  
 L  
 Y  
 DEC  
 MAL  
 AR  
 W

BULB ANGLES.

**B 140.**

7" - 16.0 lbs.

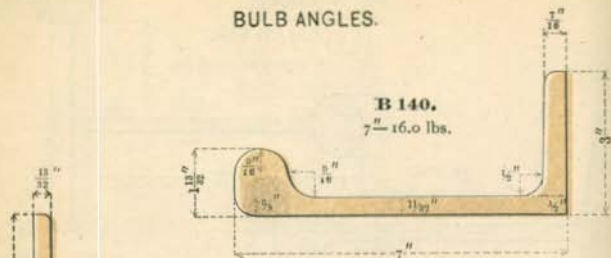

**B 132.**

8" - 19.23 lbs.

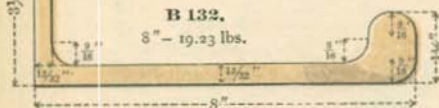

**B 131.**

9" - 21.8 lbs.

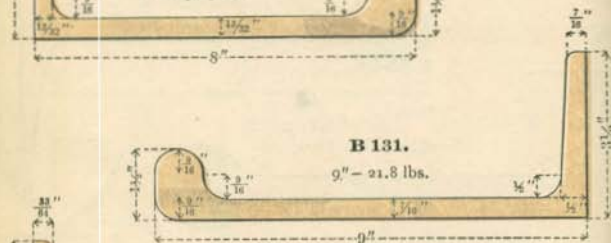

**B 130.**

10" - 26.5 lbs.

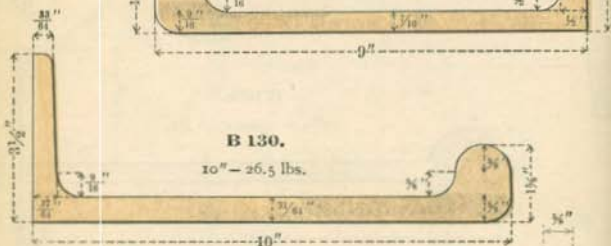

**B 130 a.**

10" - 32.0 lbs.

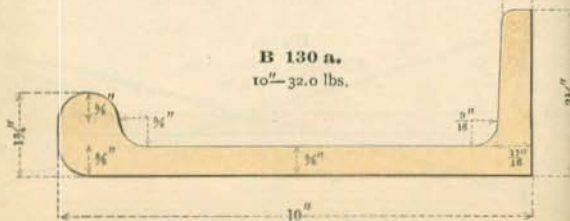

BULB ANGLES.

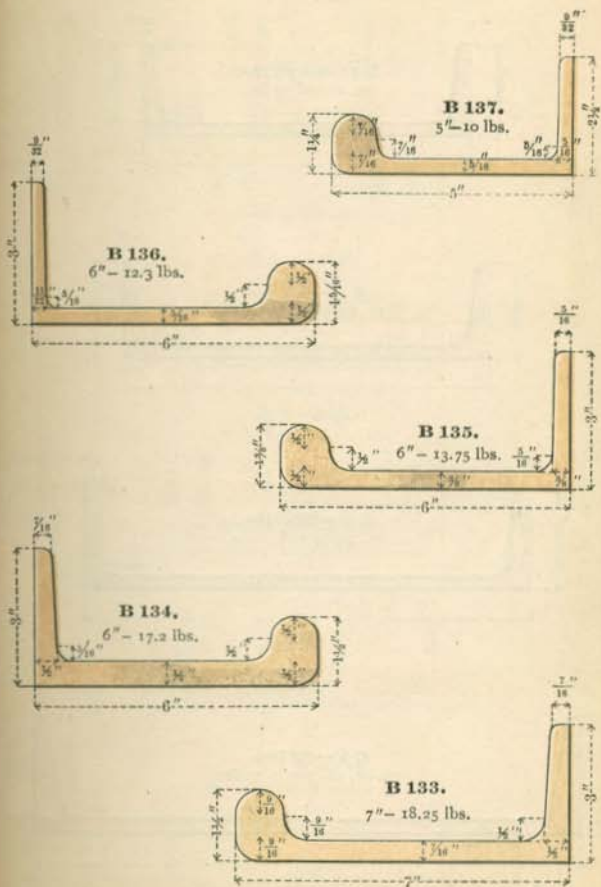

DIMEN  
SAFE  
LOAD  
PROP  
RTIES  
OLS  
L  
r  
DEC  
IMALS  
AREA  
WT.



CHANNELS.

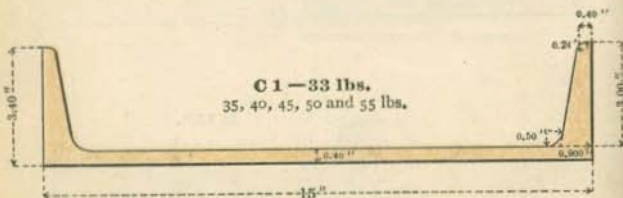
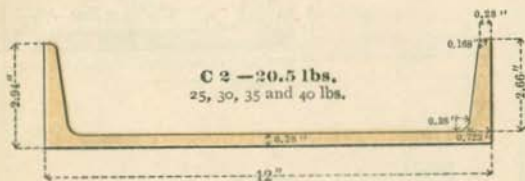
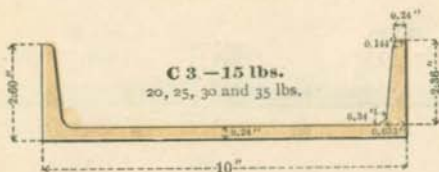
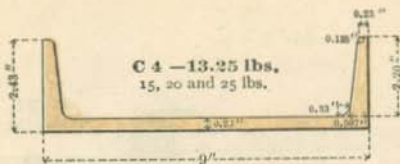

Weights in heavy print are standard, others are special.

CHANNELS.

**C 72** — 4 lbs.  
5 and 6 lbs.



**C 9** — 5.25 lbs.  
6.25 and 7.25 lbs.

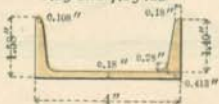

**C 8** — 6.5 lbs.  
9 and 11.5 lbs.

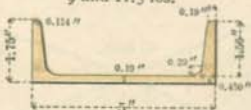

**C 7** — 8 lbs.  
10.5, 13.0 and 15.5 lbs.

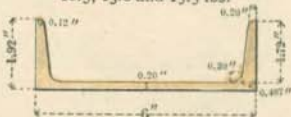

**C 6** — 9.75 lbs.  
12.25, 14.75, 17.25 and 19.75 lbs.

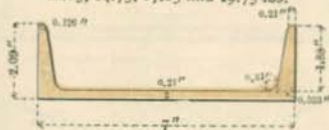

**C 5** — 11.25 lbs.  
13.75, 16.25, 18.75 and 21.25 lbs.



Weights in heavy print are standard, others are special.

CAR-TRUCK CHANNELS.

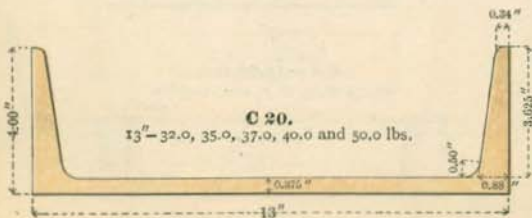
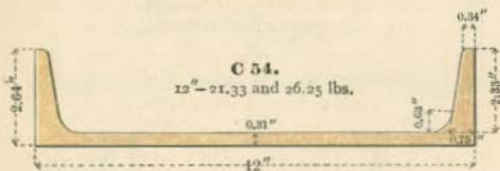
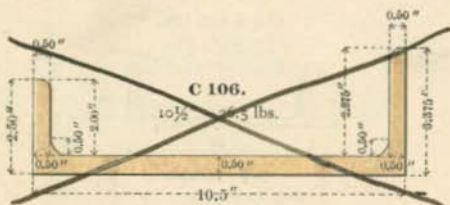
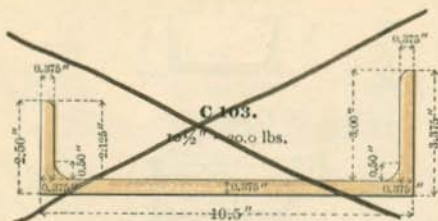

SHIP-BUILDING CHANNELS.

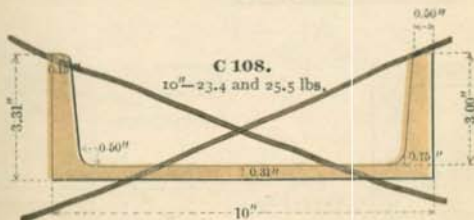
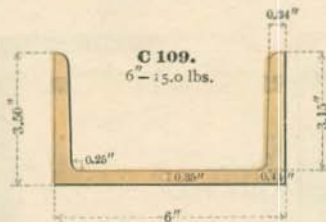
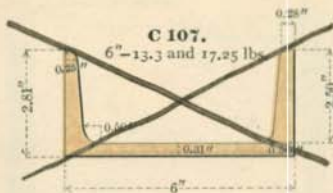

STANDARD Z-BARS.

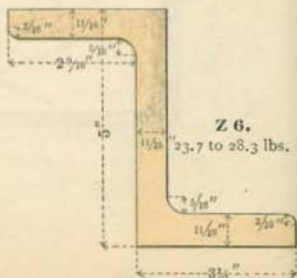
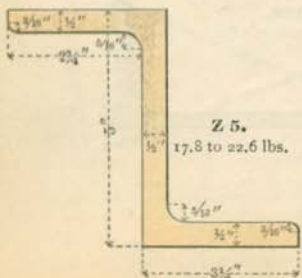
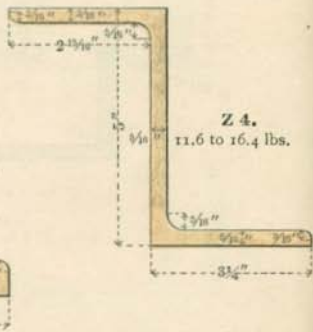
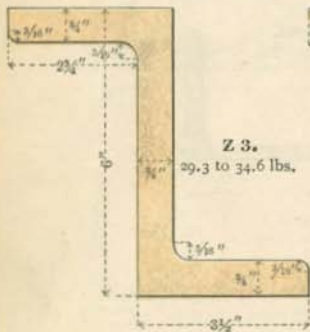
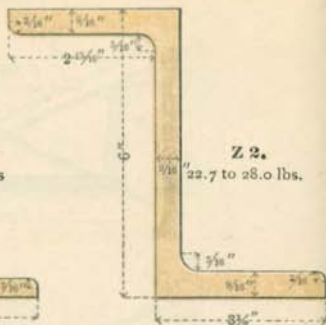
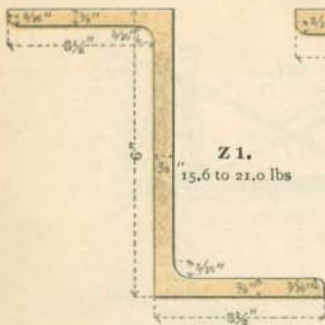

STANDARD Z-BARS.

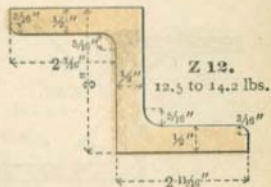
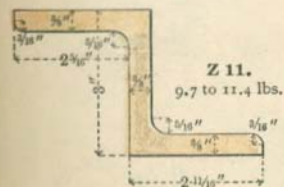
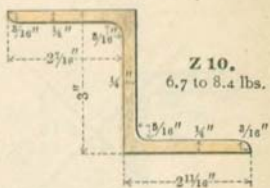
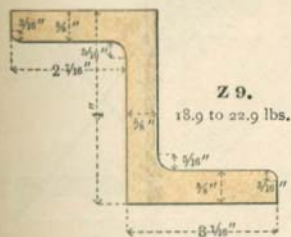
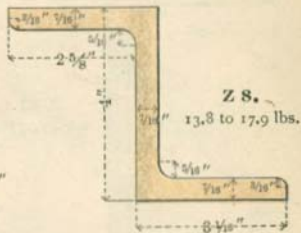
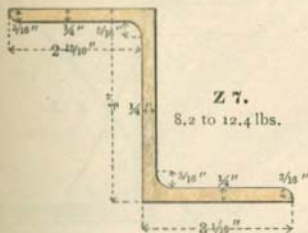

SPECIAL Z-BARS.

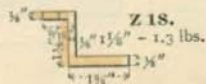
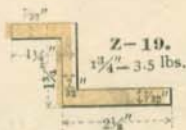
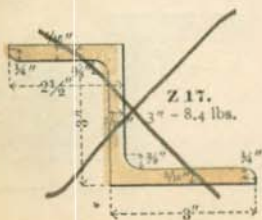
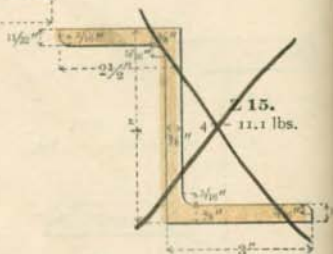
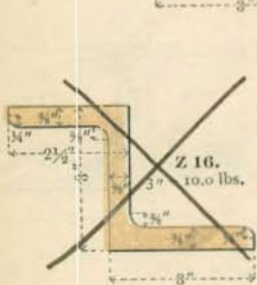
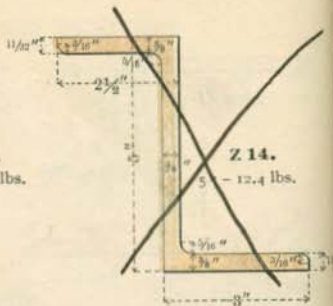
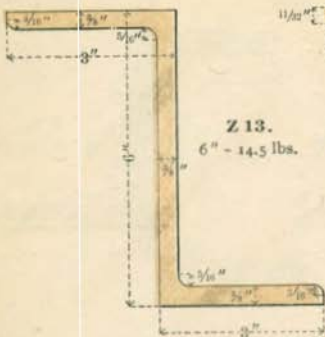

ANGLES WITH EQUAL LEGS.

Angles marked \* are special.

**A 103.**  
26.4 to 56.9 lbs.

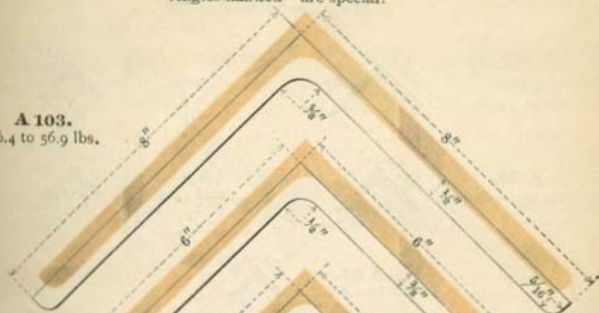

**A 88.**  
14.8 to 37.4 lbs.



**\* A 17.**  
12.3 to 30.6 lbs.

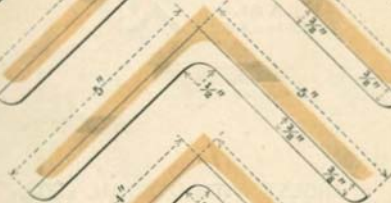

**A 90.**  
8.2 to 19.9 lbs.

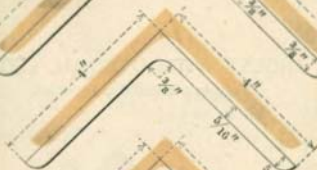

**A 99.**  
7.1 to 17.1 lbs.

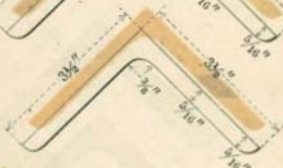

**A 40.**  
4.9 to 11.4 lbs.

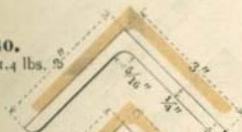

**\* A 101.**  
2.8 to 6.8 lbs.



**\* A 45.**  
4.5 to 8.5 lbs.



**A 60.**  
2.5 to 5.3 lbs.



**A 100.**  
3.1 to 7.7 lbs.



**A 65.**  
2.1 to 4.6 lbs.



DIMEN  
 SAFE  
 LOAD  
 PROP  
 RTIES  
 COLS  
 L  
 r  
 DEC  
 MAL  
 A



ANGLES WITH EQUAL LEGS.

Angles marked \* are special.

**A 102.**  
1.2 to 3.4 lbs.



**A 80.**  
0.8 to 1.5 lbs.



**A 73.**  
1.0 to 2.4 lbs.



**\*A 82.**  
0.7 and 1.0 lbs.



**A 84.**  
0.6 to 0.8 lbs.



ANGLES WITH UNEQUAL LEGS.

Angles marked \* are special.

**\*A 159.**  
15.0 to 32.3 lbs.



**A 168.**  
12.3 to 30.6 lbs.



**A 177.**  
11.7 to 28.9 lbs.



**\*A 186.**  
11.0 to 24.2 lbs.



ANGLES WITH UNEQUAL LEGS.

Angles marked \* are special.

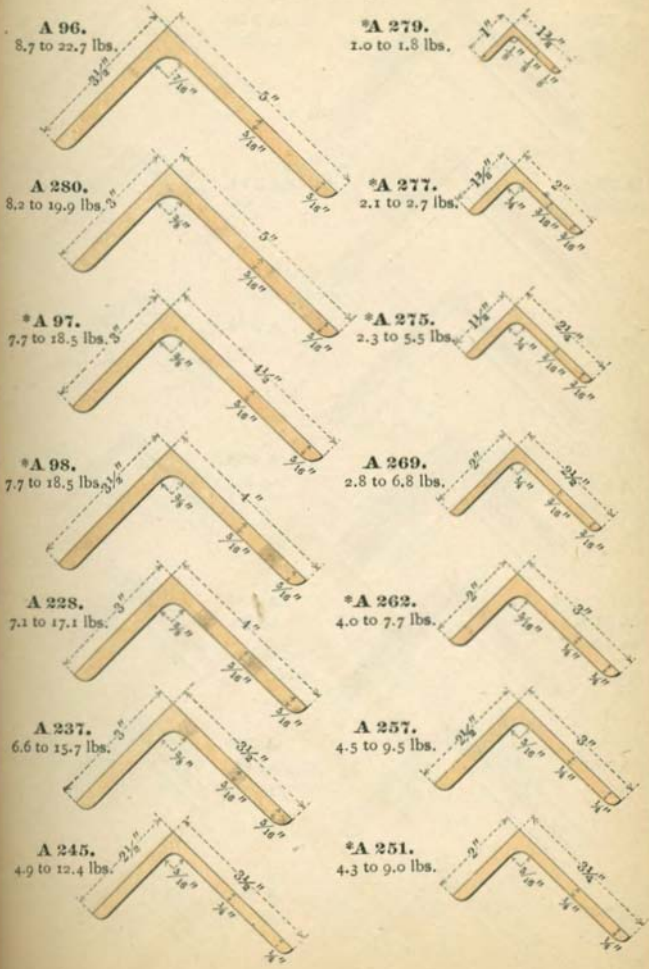

DIMEN  
 SAFE  
 LOAD  
 PROP  
 RTIES  
 COLS  
 L  
 Y  
 DE  
 MA  
 A

SPECIAL ANGLES - SQUARE ROOT.

**A 352.**  
15.7 lbs.



**A 370.**  
4.9 lbs.



**A 354.**  
12.8 lbs.

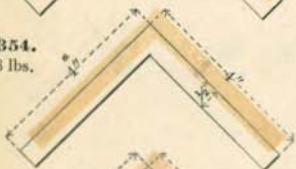

**A 374.**  
5.5 lbs.



**A 356.**  
9.7 lbs.



**A 378.**  
5.0 lbs.



**A 357.**  
16.0 lbs.



**A 379.**  
4.1 lbs.



**A 361.**  
11.0 lbs.



**A 385.**  
5.3 lbs.



**A 363.**  
8.5 lbs.



**A 386.**  
4.5 lbs.



**A 369.**  
6.0 lbs.



**A 387.**  
3.6 lbs.



SPECIAL ANGLES - SQUARE ROOT.

A 389.  
4.7 lbs.



A 402.  
1.5 lbs.



A 409.  
1.5 lbs.



A 390.  
3.9 lbs.



A 403.  
1.0 lbs.



A 410.  
1.1 lbs.



A 391.  
3.2 lbs.



A 404.  
1.8 lbs.



A 411.  
0.8 lbs.



A 395.  
2.8 lbs.

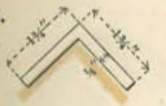

A 405.  
0.9 lbs.



A 413.  
0.7 lbs.



A 398.  
2.4 lbs.



A 406.  
1.7 lbs.



A 414.  
0.8 lbs.



A 399.  
1.9 lbs.



A 407.  
1.3 lbs.



A 415.  
0.6 lbs.



A 401.  
2.0 lbs.



A 430.  
1.1 lbs.



DIMEN  
 SAFE  
 LOAD  
 PROP  
 RTIES  
 COLS  
 L  
 T  
 DEC  
 MAL  
 AREA  
 WT.

ODD ANGLE SECTIONS.

COVER ANGLES.

OBTUSE ANGLES.

**A 452.**  
12.4 to 14.4 lbs.



**A 454.**  
10.4 to 12.4 lbs.



**A 457.**  
3.5 to 10.1 lbs.



**A 459.**  
6.8 to 8.5 lbs.



**A 460.**  
8.7 lbs.



**A 463.**  
2.1 to 8.2 lbs.



**A 466.**  
6.1 to 8.2 lbs.



**A 469.**  
6.1 to 8.4 lbs.

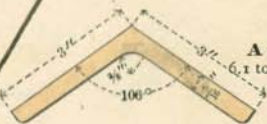

SAFE ANGLES.

**A 470.**  
4.2 lbs.

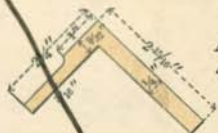

**A 471.**  
3.5 lbs.



TEES WITH EQUAL LEGS.

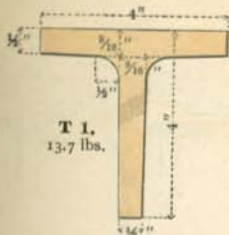

**T 1.**  
13.7 lbs.

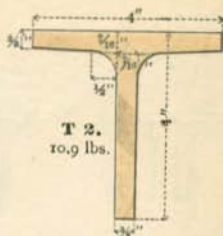

**T 2.**  
10.9 lbs.

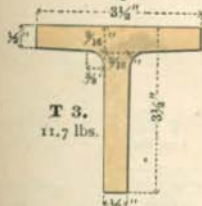

**T 3.**  
11.7 lbs.

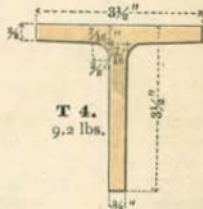

**T 4.**  
9.2 lbs.

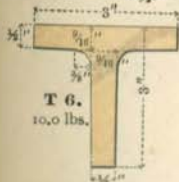

**T 6.**  
10.0 lbs.

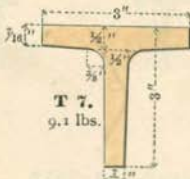

**T 7.**  
9.1 lbs.

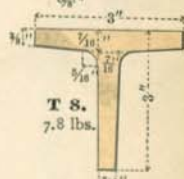

**T 8.**  
7.8 lbs.

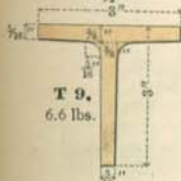

**T 9.**  
6.6 lbs.

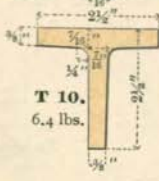

**T 10.**  
6.4 lbs.

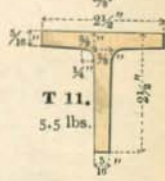

**T 11.**  
5.5 lbs.

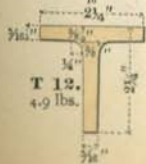

**T 12.**  
4.9 lbs.

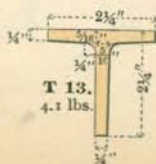

**T 13.**  
4.1 lbs.

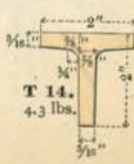

**T 14.**  
4.3 lbs.

DIMEN  
 SAFE  
 LOAD  
 PROP  
 RTIES  
 COLS  
 L  
 Y  
 DEC  
 MAL  
 AR  
 W

TEES WITH EQUAL LEGS.

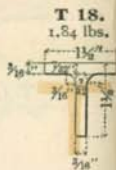
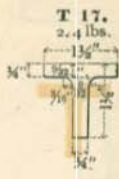
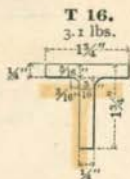
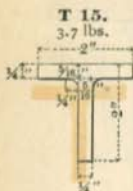

10.4

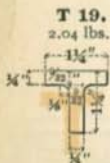

HAND-RAIL TEES.

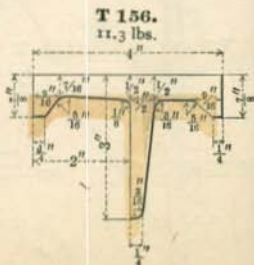
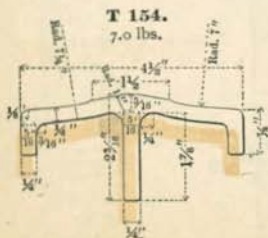

TEES WITH UNEQUAL LEGS.

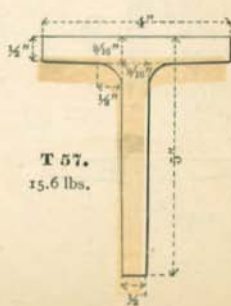
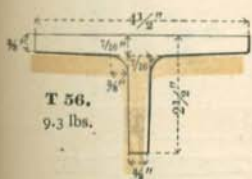
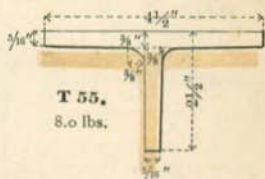
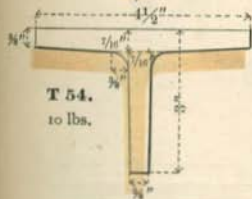
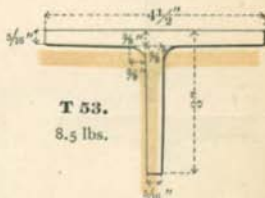
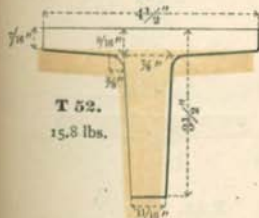
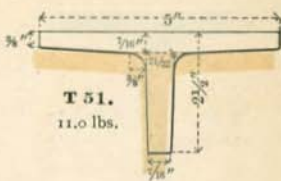
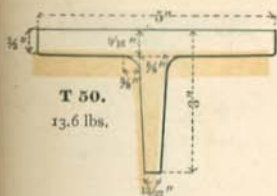



TEES WITH UNEQUAL LEGS.

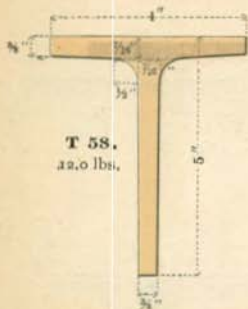

**T 58.**  
12.0 lbs.

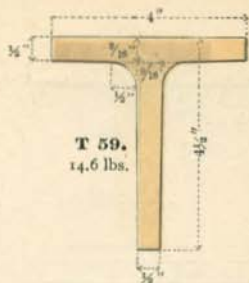

**T 59.**  
14.6 lbs.

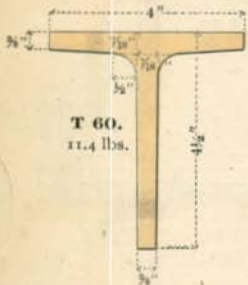

**T 60.**  
11.4 lbs.

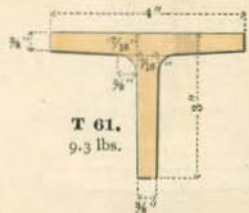

**T 61.**  
9.3 lbs.

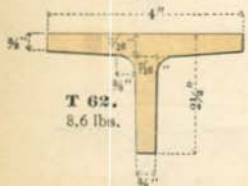

**T 62.**  
8.6 lbs.

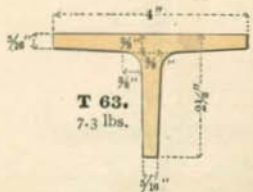

**T 63.**  
7.3 lbs.

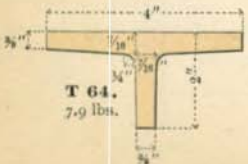

**T 64.**  
7.9 lbs.

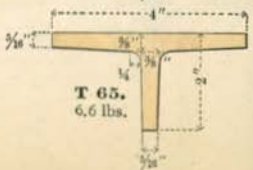

**T 65.**  
6.6 lbs.

TEES WITH UNEQUAL LEGS.

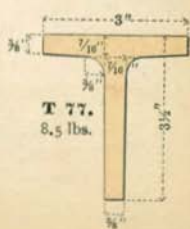
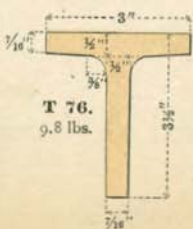
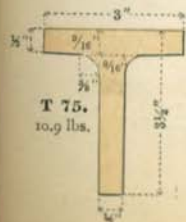
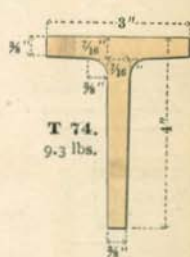
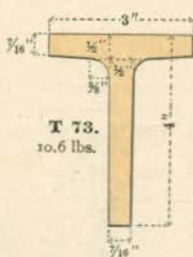
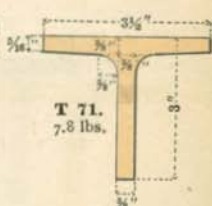
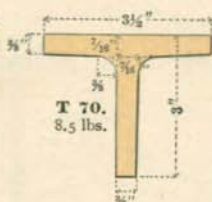
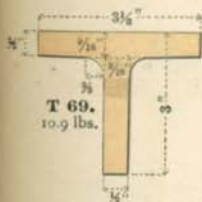
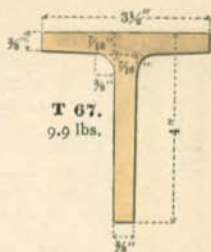
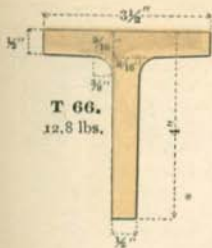

DIMEN  
 SAFE  
 LOAD  
 PROP  
 RTIES  
 COLS  
 L  
 7  
 DE  
 MA  
 A

TEES WITH UNEQUAL LEGS.

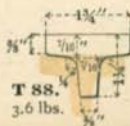
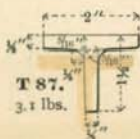
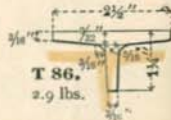
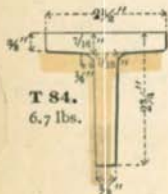
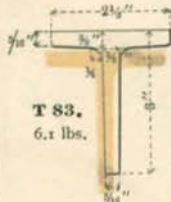
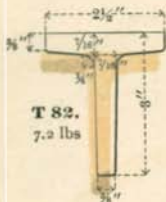
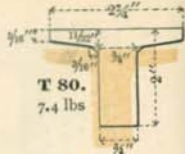
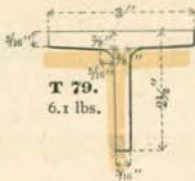
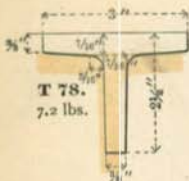

PLATES.  
TROUGH PLATE.

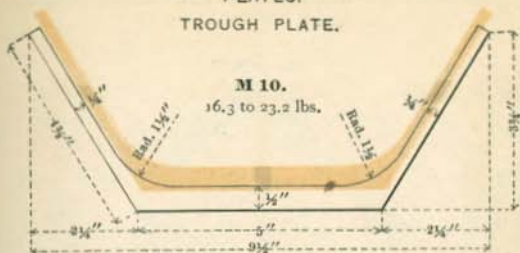

CORRUGATED PLATES.

**M 30.**

8.1 to 12.0 lbs.

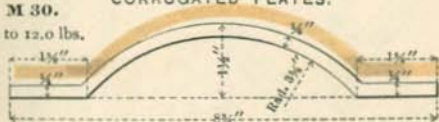

**M 33.**

17.75 to 23.67 lbs.



CHECKERED PLATE.

**M 51.**

Weight per sq. foot 13.8 to 21.4 lbs.

Maximum width 34".



METHOD OF INCREASING SECTIONAL AREAS.

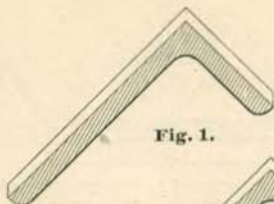

Fig. 1.

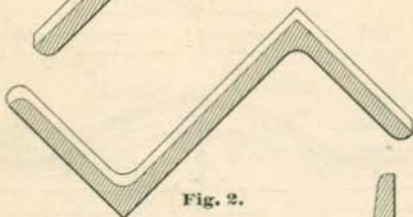

Fig. 2.

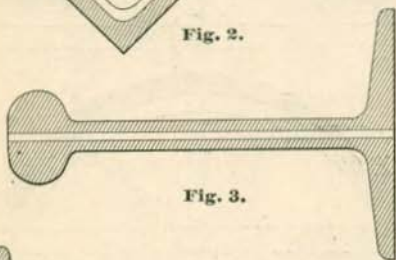

Fig. 3.

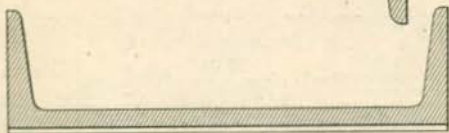

Fig. 4.

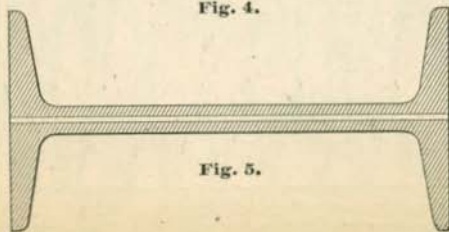

Fig. 5.

DIMENSIONS AND WEIGHTS OF  
CARNEGIE BARS.

ROUNDS.

Size. Inches.	Weight per foot. Lbs.	Size. Inches.	Weight per foot. Lbs.	Size. Inches.	Weight per foot. Lbs.	Size. Inches.	Weight per foot. Lbs.
1/4	.17	1 1/8	1.26	1 1/4	4.17	3	24.03
5/16	.21	1 1/4	1.38	1 3/8	4.60	3 1/8	26.08
3/8	.26	1 1/2	1.44	1 3/8	5.05	3 1/4	28.20
7/16	.32	1 3/4	1.50	1 7/8	5.52	3 3/8	30.42
1/2	.35	1 7/8	1.63	1 7/8	5.77	3 1/2	32.71
9/16	.38	2	1.76	1 1/2	6.01	3 5/8	35.09
5/8	.41	2 1/8	1.84	1 5/8	6.52	3 3/4	37.56
11/16	.44	2 1/4	1.91	1 5/8	7.05	3 7/8	40.10
3/4	.51	2 3/8	1.97	1 1/2	7.60	4	42.73
7/8	.55	2 1/2	2.04	1 3/4	8.18	4 1/4	48.24
1 1/8	.59	2 3/4	2.19	1 3/4	8.77	4 1/2	54.07
1 1/4	.63	3	2.35	1 7/8	9.39	4 3/4	60.25
1 1/2	.67	3 1/8	2.51	1 5/8	10.02	5	66.76
1 3/4	.71	3 1/4	2.59	2	10.68	5 1/4	73.60
1 7/8	.75	3 1/2	2.67	2 1/8	12.06	5 1/2	80.77
2	.80	3 3/8	2.84	2 1/4	13.52	5 3/4	88.29
2 1/8	.85	3 1/2	3.01	2 3/8	15.07	6	96.14
2 1/4	.94	3 3/4	3.19	2 1/2	16.69	6 1/4	104.30
2 3/8	.99	3 7/8	3.28	2 5/8	18.40	6 1/2	112.80
2 1/2	1.04	4	3.38	2 3/4	20.20	6 3/4	121.70
2 5/8	1.15	4 1/8	3.77	2 7/8	22.07		

SQUARES.

1/4	.21	7/8	2.60	1 1/2	7.65	2 1/4	17.22
5/16	.33	1 1/8	2.99	1 5/8	8.30	2 1/2	21.25
3/8	.48	1	3.40	1 5/8	8.98	2 3/4	25.00
7/16	.65	1 1/8	3.84	1 11/16	9.68	3	30.60
1/2	.85	1 1/4	4.30	1 3/4	10.41	3 1/4	35.92
5/8	1.08	1 3/8	4.80	1 3/4	11.17	3 1/2	41.65
11/16	1.33	1 1/2	5.31	1 7/8	11.95	3 3/4	47.82
3/4	1.61	1 5/8	5.86	1 11/16	12.76	4	54.40
7/8	1.91	1 3/4	6.43	2	13.60	4 1/2	68.85
1	2.25	1 7/8	7.03	2 1/8	15.35	5	85.00

DIMEN  
SAFE  
LOAD  
PROP  
ERTIE  
COL  
L  
r  
D  
M



DIMENSIONS AND WEIGHTS OF  
CARNEGIE BARS—Continued.

FLAT OVALS.

Size, Inches.	Weight per foot. Lbs.	Size, Inches.	Weight per foot. Lbs.	Size, Inches.	Weight per foot. Lbs.
1 $\frac{3}{4}$ x 1	5.22	1 $\frac{7}{8}$ x 1	5.65	2 x 1	6.07
1 $\frac{3}{4}$ x 1 $\frac{1}{8}$	6.18	1 $\frac{7}{8}$ x 1 $\frac{1}{8}$	6.44	2 x 1 $\frac{1}{8}$	6.73
1 $\frac{3}{4}$ x 1 $\frac{1}{4}$	7.14	1 $\frac{7}{8}$ x 1 $\frac{1}{4}$	7.24	2 x 1 $\frac{3}{8}$	8.06

ROUND OVALS.

Size, Inches.	Weight per foot. Lbs.	Size, Inches.	Weight per foot. Lbs.
2 x 1 $\frac{1}{2}$	8.01	2 $\frac{3}{16}$ x 1 $\frac{9}{16}$	9.12

ROUND EDGE FLATS.

Size, Inches.	Weight per foot. Lbs.	Size, Inches.	Weight per foot. Lbs.	Size, Inches.	Weight per foot. Lbs.	Size, Inches.	Weight per foot. Lbs.
1 x 1 $\frac{3}{16}$	.61	1 $\frac{3}{4}$ x 1 $\frac{7}{16}$	2.46	2 $\frac{1}{4}$ x 1 $\frac{7}{16}$	3.21	2 $\frac{3}{4}$ x 1 $\frac{7}{16}$	3.95
1 x 1 $\frac{1}{4}$	.81	1 $\frac{3}{4}$ x 1 $\frac{1}{2}$	2.79	2 $\frac{1}{4}$ x 1 $\frac{1}{2}$	3.65	2 $\frac{3}{4}$ x 1 $\frac{1}{2}$	4.50
1 x 1 $\frac{5}{16}$	.99	1 $\frac{3}{4}$ x 1 $\frac{9}{16}$	3.11	2 $\frac{1}{4}$ x 1 $\frac{9}{16}$	4.07	2 $\frac{3}{4}$ x 1 $\frac{9}{16}$	5.02
1 x 1 $\frac{3}{8}$	1.16	1 $\frac{3}{4}$ x 1 $\frac{5}{8}$	3.43	2 $\frac{1}{4}$ x 1 $\frac{5}{8}$	4.50	2 $\frac{3}{4}$ x 1 $\frac{5}{8}$	5.55
1 x 1 $\frac{7}{16}$	1.35	1 $\frac{3}{4}$ x 1 $\frac{11}{16}$	3.74	2 $\frac{1}{4}$ x 1 $\frac{11}{16}$	4.92	2 $\frac{3}{4}$ x 1 $\frac{11}{16}$	6.07
1 $\frac{1}{4}$ x 1 $\frac{3}{16}$	.77	1 $\frac{3}{4}$ x 1 $\frac{3}{4}$	4.05	2 $\frac{1}{4}$ x 1 $\frac{3}{4}$	5.33	2 $\frac{3}{4}$ x 1 $\frac{3}{4}$	6.60
1 $\frac{1}{4}$ x 1 $\frac{1}{4}$	1.02	1 $\frac{3}{4}$ x 1 $\frac{3}{8}$	4.35	2 $\frac{1}{4}$ x 1 $\frac{3}{8}$	5.74	2 $\frac{3}{4}$ x 1 $\frac{3}{8}$	7.10
1 $\frac{1}{4}$ x 1 $\frac{5}{16}$	1.25	1 $\frac{3}{4}$ x 1 $\frac{7}{8}$	4.65	2 $\frac{1}{4}$ x 1 $\frac{7}{8}$	6.14	2 $\frac{3}{4}$ x 1 $\frac{7}{8}$	7.61
1 $\frac{1}{4}$ x 1 $\frac{3}{8}$	1.49	1 $\frac{3}{4}$ x 1 $\frac{1}{2}$	4.94	2 $\frac{1}{4}$ x 1 $\frac{1}{2}$	6.53	2 $\frac{3}{4}$ x 1 $\frac{1}{2}$	8.11
1 $\frac{1}{4}$ x 1 $\frac{7}{16}$	1.71	1 $\frac{3}{4}$ x 1	5.23	2 $\frac{1}{4}$ x 1	6.92	2 $\frac{3}{4}$ x 1	8.62
1 $\frac{1}{2}$ x 1 $\frac{1}{4}$	1.23	2 x 1 $\frac{1}{4}$	1.66	2 $\frac{1}{2}$ x 1 $\frac{1}{4}$	2.08	3 x 1 $\frac{1}{4}$	2.50
1 $\frac{1}{2}$ x 1 $\frac{5}{16}$	1.52	2 x 1 $\frac{5}{16}$	2.04	2 $\frac{1}{2}$ x 1 $\frac{5}{16}$	2.58	3 x 1 $\frac{5}{16}$	3.11
1 $\frac{1}{2}$ x 1 $\frac{3}{8}$	1.81	2 x 1 $\frac{3}{8}$	2.45	2 $\frac{1}{2}$ x 1 $\frac{3}{8}$	3.08	3 x 1 $\frac{3}{8}$	3.72
1 $\frac{1}{2}$ x 1 $\frac{7}{16}$	2.09	2 x 1 $\frac{7}{16}$	2.83	2 $\frac{1}{2}$ x 1 $\frac{7}{16}$	3.58	3 x 1 $\frac{7}{16}$	4.31
1 $\frac{1}{2}$ x 1 $\frac{1}{2}$	2.37	2 x 1 $\frac{1}{2}$	3.22	2 $\frac{1}{2}$ x 1 $\frac{1}{2}$	4.07	3 x 1 $\frac{1}{2}$	4.91
1 $\frac{1}{2}$ x 1 $\frac{9}{16}$	2.64	2 x 1 $\frac{9}{16}$	3.59	2 $\frac{1}{2}$ x 1 $\frac{9}{16}$	4.55	3 x 1 $\frac{9}{16}$	5.50
1 $\frac{1}{2}$ x 1 $\frac{5}{8}$	2.90	2 x 1 $\frac{5}{8}$	3.96	2 $\frac{1}{2}$ x 1 $\frac{5}{8}$	5.02	3 x 1 $\frac{5}{8}$	6.09
1 $\frac{1}{2}$ x 1 $\frac{11}{16}$	3.16	2 x 1 $\frac{11}{16}$	4.32	2 $\frac{1}{2}$ x 1 $\frac{11}{16}$	5.49	3 x 1 $\frac{11}{16}$	6.67
1 $\frac{1}{2}$ x 1 $\frac{3}{4}$	3.41	2 x 1 $\frac{3}{4}$	4.69	2 $\frac{1}{2}$ x 1 $\frac{3}{4}$	5.97	3 x 1 $\frac{3}{4}$	7.25
1 $\frac{1}{2}$ x 1 $\frac{7}{8}$	3.65	2 x 1 $\frac{7}{8}$	5.04	2 $\frac{1}{2}$ x 1 $\frac{7}{8}$	6.42	3 x 1 $\frac{7}{8}$	7.80
1 $\frac{1}{2}$ x 1 $\frac{1}{2}$	3.90	2 x 1 $\frac{1}{2}$	5.39	2 $\frac{1}{2}$ x 1 $\frac{1}{2}$	6.87	3 x 1 $\frac{1}{2}$	8.36
1 $\frac{1}{2}$ x 1 $\frac{1}{2}$	4.14	2 x 1 $\frac{1}{2}$	5.73	2 $\frac{1}{2}$ x 1 $\frac{1}{2}$	7.32	3 x 1 $\frac{1}{2}$	8.91
1 $\frac{1}{2}$ x 1	4.37	2 x 1	6.07	2 $\frac{1}{2}$ x 1	7.77	3 x 1	9.47
1 $\frac{3}{4}$ x 1 $\frac{1}{4}$	1.45	2 $\frac{1}{4}$ x 1 $\frac{1}{4}$	1.87	2 $\frac{3}{4}$ x 1 $\frac{1}{4}$	2.29	.....	.....
1 $\frac{3}{4}$ x 1 $\frac{1}{8}$	1.79	2 $\frac{1}{4}$ x 1 $\frac{5}{16}$	2.31	2 $\frac{3}{4}$ x 1 $\frac{5}{16}$	2.84	.....	.....
1 $\frac{3}{4}$ x 1 $\frac{3}{8}$	2.13	2 $\frac{1}{4}$ x 1 $\frac{3}{8}$	2.76	2 $\frac{3}{4}$ x 1 $\frac{3}{8}$	3.40	.....	.....



LIST OF EXTREME SIZES OF RECTANGULAR PLATES ROLLED BY THE CARNEGIE STEEL COMPANY, LIMITED.

SHEARED PLATES.

Thickness Inches.	Width in Inches.															
	120	118	115	112	110	108	105	100	96	90	84	80	76	72	64	56
1/4								100	130	160	190	245	260	275	300	350
3/8							150	160	200	210	220	275	300	320	350	400
1/2						170	200	200	310	330	360	380	400	420	460	500
5/8				160	200	230	245	310	340	380	400	420	430	480	500	
3/4			160	170	200	220	240	290	330	360	370	390	410	450	500	
7/8		140	165	170	190	210	230	270	290	340	360	370	390	450	500	
1	130	135	140	160	160	180	200	220	240	260	300	310	330	350	400	480
1 1/8	130	135	150	155	160	180	190	200	220	240	260	280	310	330	380	430
1 1/4	125	130	150	155	160	180	190	200	210	220	250	280	300	320	360	410
1 1/2	125	130	140	150	150	170	180	190	200	215	245	260	280	300	340	380
1 3/4	125	125	130	135	140	160	170	180	190	205	220	230	260	270	320	360
1 7/8	120	120	125	125	130	150	160	170	180	195	215	230	240	250	290	330
2	120	120	120	120	120	140	145	150	160	175	190	210	220	230	260	300
2 1/8				112	110	120	125	140	145	155	175	185	195	205	230	265
2 1/4				112		110	120	140	145	155	175	185	195	200	225	260

Plates of greater dimensions than shown in the above table may be submitted for special consideration.

For intermediate widths not shown, use the dimensions of the next greatest width in the above table.

UNIVERSAL MILL PLATES.

Thickness Inches.	Width in Inches.									
	48-46 Inclu- sive.	45-41 Inclu- sive.	40-36 Inclu- sive.	35-31 Inclu- sive.	30-26 Inclu- sive.	25-21 Inclu- sive.	20-17 Inclu- sive.	16-15 Inclu- sive.	14-11 Inclu- sive.	10-7 Inclu- sive.
1/4						540	540	540	540	540
3/8					480	480	600	600	600	600
1/2	840	840	960	1080	1080	1200	1200	960	900	840
5/8	960	960	960	1080	1080	1200	1200	960	900	840
3/4	960	960	1080	1080	1140	1140	1140	1020	1020	840
7/8	960	960	1080	1080	1080	1080	1080	1020	1020	840
1	960	960	960	960	1020	1020	1020	1020	1020	840
1 1/8	780	780	780	780	780	900	960	960	900	840
1 1/4	600	600	600	600	720	840	960	960	900	840
1 1/2	420	420	480	540	600	780	900	960	900	840
1 3/4	360	360	420	480	480	720	780	780	840	840
1 7/8	324	324	360	420	480	600	720	780	840	840
2	324	300	300	360	360	540	600	780	840	840
2 1/8	300	300	300	300	360	480	600	720	840	840
2 1/4	240	240	240	240	300	300	300	660	840	840
2 1/2	240	240	240	240	300	300	300	240		
2 3/4	180	180	180	180	240	240	240	180		
3	180	180	180	180	240	240	240	180		

Plates of greater dimensions than shown in the above table may be submitted for special consideration.

Both Sheared and Universal Mill Plates of extreme dimensions, as shown in the above tables, are subject to special prices.

# SIZES OF SHEARED PLATES

Thickness	WIDTH IN INCHES												Heads, Diameter in Inches		
	24	30	36	40	50	60	70	80	90	100	105	110		115	118
$\frac{1}{8}$	180	180	168	156	156	204	180	240	180	144	120	180	144	120	80
$\frac{1}{4}$	300	300	300	300	228	360	264	240	240	216	180	228	216	204	105
$\frac{3}{8}$	360	360	360	360	360	360	300	300	240	240	240	240	216	216	110
$\frac{1}{2}$	420	420	480	540	540	480	360	300	240	240	240	240	240	216	122
$\frac{5}{8}$	420	420	480	540	540	480	360	300	240	240	240	240	240	216	122
$\frac{3}{4}$	420	420	480	480	480	360	336	300	240	240	240	240	240	216	122
$\frac{7}{8}$	420	420	480	480	420	360	300	300	240	240	240	240	216	216	122
1	420	420	420	420	360	300	264	264	240	240	240	240	216	180	120
$1\frac{1}{4}$	360	360	360	360	336	276	240	216	216	216	180	216	180	144	120
$1\frac{1}{2}$			300	300	240	240	216	216	216	180	144	144	120		
$1\frac{3}{4}$			264	264	240	240	216	216	180	144	120				
2			240	216	192	168	144	120	120	120					

## SIZES OF STEEL UNIVERSAL PLATES

Thickness in inches	WIDTH IN INCHES						
	7 to 10	10 to 15	15 to 20	20 to 25	25 to 30	30 to 36	36 to 42
	Length in feet	Length in feet	Length in feet	Length in feet	Length in feet	Length in feet	Length in feet
$\frac{1}{4}$	60	60	60	60	60	60	
$\frac{5}{16}$	70	70	70	70	60	60	
$\frac{3}{8}$	70	70	70	70	70	60	
$\frac{7}{16}$	70	70	70	70	70	60	45
$\frac{1}{2}$	70	70	70	70	70	60	50
$\frac{5}{8}$	70	70	60	60	50	45	40
$\frac{3}{4}$	70	70	55	55	50	40	36
$\frac{7}{8}$	60	60	50	40	40	35	30
1	60	60	50	40	35	30	25
$1\frac{1}{4}$	50	50	40	35	30	25	20
$1\frac{1}{2}$	40	35	30	25	20	20	18
$1\frac{3}{4}$	40	35	30	22	20	18	16
2	35	30	25	20	20	16	14
$2\frac{1}{4}$	30	30	20	18	15	12	

# Central L & L Co

## SIZES OF IRON UNIVERSAL PLATES

Thickness in inches	WIDTH IN INCHES					
	7 to 10	10 to 15	15 to 20	20 to 25	25 to 30	30 to 38
	Length in feet	Length in feet	Length in feet	Length in feet	Length in feet	Length in feet
$\frac{1}{4}$	60	60	60	60	60	
$\frac{3}{8}$	70	70	70	70	70	60
$\frac{1}{2}$	70	70	70	70	70	65
$\frac{3}{4}$	70	70	70	70	65	60
1	70	70	70	70	60	60
$1\frac{1}{4}$	70	70	60	55	50	40
$1\frac{1}{2}$	60	60	55	50	50	40
$1\frac{3}{4}$	60	60	50	50	40	35
2	50	50	45	40	35	30
$2\frac{1}{4}$	50	45	40	35	30	20
$2\frac{1}{2}$	40	35	30	25	20	15
$2\frac{3}{4}$	35	30	25	22	20	15
3	30	30	20	20	16	15
$3\frac{1}{2}$	25	25	20	18	15	

See p. <sup>221</sup>~~178~~ for overnight  
allowances

GRADES OF . . .

# CENTRAL

STEEL AND IRON

---

## STEEL

Locomotive Fire Box Steel.

Fire Box Steel.

Best Flange Steel.

Marine Steel.

Tank Steel.

## IRON

S. F. B. (Solid Fire Box).

Extra Flange.

C. H. No. 1 Flange.

C. H. No. 1 Shell.

Refined.

Tank.

---

UNIVERSAL MILL PLATES,

STEEL AND IRON

---



We have a just pride in the deservedly high reputation of all the grades in the foregoing lists.

LIST OF EXTREME SIZES OF RECTANGULAR  
STEEL SHEETS  $\frac{3}{16}$ " AND LIGHTER ROLLED  
BY THE CARNEGIE STEEL CO., LIMITED.

Thickness.	68 Inch. Width.	66 Inch. Width.	64 Inch. Width.	62 Inch. Width.	60 Inch. Width.	58 Inch. Width.	56 Inch. Width.	54 Inch. Width.
$\frac{3}{16}$	160	180	180	192	216	228	240	252
No. 8, B.W.G.	160	180	180	182	186	190	196	200
" 9, "	. . .	160	160	166	172	184	190	200
" 10, "	. . .	140	145	155	160	168	176	180
" 11, "	. . .	120	130	140	150	155	165	170
" 12, "	. . .	108	115	124	130	140	150	160

Thickness.	52 Inch. Width.	50 Inch. Width.	48 Inch. Width.	44 Inch. Width.	40 Inch. Width.	36 Inch. Width.	24 Inch. Width.	. . .
$\frac{3}{16}$	264	288	300	316	360	360	360	. . .
No. 8, B.W.G.	212	224	240	240	264	264	264	. . .
" 9, "	212	220	224	236	248	248	248	. . .
" 10, "	196	200	212	212	212	212	212	. . .
" 11, "	180	186	192	196	200	200	200	. . .
" 12, "	170	176	180	180	180	180	180	. . .

LIST OF EXTREME SIZES OF CIRCULAR  
PLATES ROLLED BY THE CARNEGIE  
STEEL CO., LIMITED.

Thickness in Inches.	Diameter in Inches.
$\frac{1}{4}$	102
$\frac{5}{16}$	108
$\frac{3}{8}$	110
$\frac{7}{16}$	112
$\frac{1}{2}$	112
$\frac{9}{16}$	112
$\frac{5}{8}$	112
$\frac{11}{16}$	112
$\frac{3}{4}$	112
$\frac{13}{16}$	112
$\frac{7}{8}$	112
1	112
$1\frac{1}{8}$	110
$1\frac{1}{4}$	110
$1\frac{1}{2}$	110

MINIMUM, MAXIMUM AND INTERMEDIATE WEIGHTS AND DIMENSIONS OF I-BEAMS.

Section Index.	Depth of Beam, Inches.	Weight per foot, Lbs.	Flange Width.		Web Thickness.		Page No. of Section.
			Inches and Decimal Parts.	Inches and Fractional Parts.	Decimal Parts of Inch.	Fractional Parts of Inch.	
B 1	24	100.00	7.254	7 $\frac{1}{4}$	0.754	3 $\frac{1}{4}$	1
		95.00	7.192	7 $\frac{1}{8}$	0.692	1 $\frac{1}{8}$	
		90.00	7.131	7 $\frac{1}{8}$	0.631	1 $\frac{1}{8}$	
		85.00	7.070	7 $\frac{1}{8}$	0.570	1 $\frac{1}{8}$	
		<b>80.00</b>	<b>7.000</b>	<b>7</b>	<b>0.500</b>	<b>1<math>\frac{1}{2}</math></b>	
B 2	20	100.00	7.284	7 $\frac{3}{8}$	0.884	7 $\frac{1}{8}$	2
		95.00	7.210	7 $\frac{1}{4}$	0.810	1 $\frac{1}{4}$	
		90.00	7.137	7 $\frac{1}{4}$	0.737	1 $\frac{1}{4}$	
		85.00	7.063	7 $\frac{1}{8}$	0.663	1 $\frac{1}{8}$	
		<b>80.00</b>	<b>7.000</b>	<b>7</b>	<b>0.600</b>	<b>1<math>\frac{1}{2}</math></b>	
B 3	20	75.00	6.399	6 $\frac{1}{2}$	0.649	1 $\frac{1}{2}$	2
		70.00	6.325	6 $\frac{1}{2}$	0.575	1 $\frac{1}{2}$	
		<b>65.00</b>	<b>6.250</b>	<b>6<math>\frac{1}{4}</math></b>	<b>0.500</b>	<b>1<math>\frac{1}{2}</math></b>	
B80	18	70.00	6.259	6 $\frac{1}{4}$	0.719	1 $\frac{1}{4}$	3
		65.00	6.177	6 $\frac{1}{4}$	0.637	1 $\frac{1}{4}$	
		60.00	6.095	6 $\frac{1}{8}$	0.555	1 $\frac{1}{8}$	
		<b>55.00</b>	<b>6.000</b>	<b>6</b>	<b>0.480</b>	<b>1<math>\frac{1}{2}</math></b>	
B 4	15	100.00	6.774	6 $\frac{3}{8}$	1.184	1 $\frac{3}{8}$	3
		95.00	6.675	6 $\frac{1}{4}$	1.085	1 $\frac{1}{4}$	
		90.00	6.577	6 $\frac{1}{4}$	0.987	1 $\frac{1}{4}$	
		85.00	6.479	6 $\frac{1}{4}$	0.889	1 $\frac{1}{4}$	
		<b>80.00</b>	<b>6.400</b>	<b>6<math>\frac{1}{2}</math></b>	<b>0.810</b>	<b>1<math>\frac{1}{2}</math></b>	
B 5	15	75.00	6.292	6 $\frac{1}{4}$	0.882	1 $\frac{1}{4}$	3
		70.00	6.194	6 $\frac{1}{8}$	0.784	1 $\frac{1}{8}$	
		65.00	6.096	6 $\frac{1}{8}$	0.686	1 $\frac{1}{8}$	
		<b>60.00</b>	<b>6.000</b>	<b>6</b>	<b>0.590</b>	<b>1<math>\frac{1}{2}</math></b>	
B 7	15	55.00	5.746	5 $\frac{1}{4}$	0.656	1 $\frac{1}{4}$	3
		50.00	5.648	5 $\frac{1}{8}$	0.558	1 $\frac{1}{8}$	
		45.00	5.550	5 $\frac{1}{8}$	0.460	1 $\frac{1}{8}$	
		<b>42.00</b>	<b>5.500</b>	<b>5<math>\frac{1}{2}</math></b>	<b>0.410</b>	<b>1<math>\frac{1}{2}</math></b>	
B 8	12	55.00	5.612	5 $\frac{3}{8}$	0.822	1 $\frac{3}{8}$	4
		50.00	5.489	5 $\frac{1}{4}$	0.699	1 $\frac{1}{4}$	
		45.00	5.366	5 $\frac{1}{8}$	0.576	1 $\frac{1}{8}$	
		<b>40.00</b>	<b>5.250</b>	<b>5<math>\frac{1}{4}</math></b>	<b>0.480</b>	<b>1<math>\frac{1}{4}</math></b>	
B 9	12	35.00	5.086	5 $\frac{3}{8}$	0.436	7 $\frac{1}{8}$	4
		<b>31.50</b>	<b>5.000</b>	<b>5</b>	<b>0.350</b>	<b>7<math>\frac{1}{8}</math></b>	
B11	10	40.00	5.099	5 $\frac{3}{8}$	0.749	3 $\frac{3}{4}$	4
		35.00	4.952	4 $\frac{1}{2}$	0.602	3 $\frac{1}{2}$	
		30.00	4.805	4 $\frac{1}{2}$	0.455	3 $\frac{1}{2}$	
		<b>25.00</b>	<b>4.660</b>	<b>4<math>\frac{3}{8}</math></b>	<b>0.310</b>	<b>3<math>\frac{1}{8}</math></b>	
B13	9	35.00	4.772	4 $\frac{1}{2}$	0.732	3 $\frac{1}{2}$	4
		30.00	4.609	4 $\frac{1}{2}$	0.569	3 $\frac{1}{2}$	
		25.00	4.446	4 $\frac{1}{2}$	0.406	3 $\frac{1}{2}$	
		<b>21.00</b>	<b>4.330</b>	<b>4<math>\frac{1}{2}</math></b>	<b>0.290</b>	<b>3<math>\frac{1}{2}</math></b>	
B15	8	25.50	4.271	4 $\frac{1}{2}$	0.541	3 $\frac{1}{2}$	5
		23.00	4.179	4 $\frac{1}{2}$	0.449	3 $\frac{1}{2}$	
		20.50	4.087	4 $\frac{1}{2}$	0.357	3 $\frac{1}{2}$	
		<b>18.00</b>	<b>4.000</b>	<b>4</b>	<b>0.270</b>	<b>3<math>\frac{1}{2}</math></b>	

Weights in heavy print are standard, others are special.

MINIMUM, MAXIMUM AND INTERMEDIATE WEIGHTS AND DIMENSIONS OF I - BEAMS—Continued.

Section Index.	Depth of Beam, Inches.	Weight per foot, Lbs.	Flange Width.		Web Thickness.		Page No. of Section.
			Inches and Decimal Parts.	Inches and Fractional Parts.	Decimal Parts of Inch.	Fractional Parts of Inch.	
B17	7	20.00	3.868	3 $\frac{7}{8}$	0.458	$\frac{1}{8}$	5
		17.50	3.763	3 $\frac{1}{2}$	0.353	$\frac{1}{4}$	
		<b>15.00</b>	<b>3.660</b>	<b>3<math>\frac{3}{4}</math></b>	<b>0.250</b>	$\frac{1}{4}$	
B19	6	17.25	3.575	3 $\frac{1}{2}$	0.475	$\frac{1}{8}$	5
		14.75	3.452	3 $\frac{1}{4}$	0.352	$\frac{1}{4}$	
		<b>12.25</b>	<b>3.330</b>	<b>3<math>\frac{1}{4}</math></b>	<b>0.230</b>	$\frac{1}{4}$	
B21	5	14.75	3.294	3 $\frac{1}{2}$	0.504	$\frac{1}{2}$	5
		12.25	3.147	3 $\frac{1}{4}$	0.357	$\frac{1}{4}$	
		<b>9.75</b>	<b>3.000</b>	<b>3</b>	<b>0.210</b>	$\frac{1}{4}$	
B23	4	10.50	2.880	2 $\frac{7}{8}$	0.410	$\frac{1}{8}$	5
		9.50	2.807	2 $\frac{1}{2}$	0.337	$\frac{1}{4}$	
		8.50	2.733	2 $\frac{1}{4}$	0.263	$\frac{1}{4}$	
B77	3	7.50	2.521	2 $\frac{3}{4}$	0.361	$\frac{1}{4}$	5
		6.50	2.423	2 $\frac{1}{4}$	0.263	$\frac{1}{4}$	
		<b>5.50</b>	<b>2.330</b>	<b>2<math>\frac{1}{4}</math></b>	<b>0.170</b>	$\frac{1}{4}$	

Weights in heavy print are standard, others are special.

MINIMUM AND MAXIMUM WEIGHTS AND DIMENSIONS OF CARNEGIE DECK BEAMS.

Section Index.	Depth of Beam, Inches.	Weight per foot, Lbs.		Flange Width, Inches.		Web Thickness, Inches.		Increase of Web and Flange for each lb. increase of weight.	Page No. of Section.
		Min.	Max.	Min.	Max.	Min.	Max.		
B110	11.5	32.20	37.00	5.17	5.30	.42	.55	.026	6
B100	10	27.23	35.70	5.25	5.50	.38	.63	.029	6
B101	9	26.00	30.00	4.94	5.07	.44	.57	.033	6
B102	8	20.15	24.48	5.00	5.16	.31	.47	.037	6
B103	7	18.11	23.46	4.88	5.10	.31	.54	.042	6
B105	6	14.10	17.16	4.38	4.53	.28	.43	.049	6

WEIGHTS AND DIMENSIONS OF CARNEGIE BULB ANGLES.

Section Index.	Depth of Angle, Inches.	Weight per foot, Lbs.	Flange Width, Inches.	Web Thickness, Inches.	Page No. of Section.
B130a	10	32.00	3.5	.63	7
B130	10	26.50	3.5	.48	7
B131	9	21.80	3.5	.44	7
B132	8	19.23	3.5	.41	7
B133	7	18.25	3.0	.44	7
B140	7	16.00	3.0	.34	8
B134	6	17.20	3.0	.50	8
B135	6	13.75	3.0	.38	8
B136	6	12.30	3.0	.31	8
B137	5	10.00	2.5	.31	8

DIMENSIONS  
 SAFE LOAD  
 PROP  
 ERTIE  
 COL  
 L  
 Y  
 H



MINIMUM, MAXIMUM AND INTERMEDIATE WEIGHTS AND DIMENSIONS OF CHANNELS.

Section Index.	Depth of Channel. Inches.	Weight per foot. Lbs.	Flange Width.		Web Thickness.		Page No. of Section.
			Inches and Decimal Parts.	Inches and Fractional Parts.	Decimal Parts of Inch.	Fractional Parts of Inch.	
C 1	15	55.00	3.818	3 <sup>11</sup> / <sub>16</sub>	0.818	5 <sup>1</sup> / <sub>16</sub>	9
		50.00	3.720	3 <sup>9</sup> / <sub>16</sub>	0.720	5 <sup>1</sup> / <sub>16</sub>	
		45.00	3.622	3 <sup>7</sup> / <sub>16</sub>	0.622	5 <sup>1</sup> / <sub>16</sub>	
		40.00	3.524	3 <sup>5</sup> / <sub>16</sub>	0.524	5 <sup>1</sup> / <sub>16</sub>	
		35.00	3.426	3 <sup>3</sup> / <sub>16</sub>	0.426	5 <sup>1</sup> / <sub>16</sub>	
		<b>33.00</b>	<b>3.400</b>	<b>3<sup>1</sup>/<sub>16</sub></b>	<b>0.400</b>	5 <sup>1</sup> / <sub>16</sub>	
C 2	12	40.00	3.418	3 <sup>1</sup> / <sub>16</sub>	0.758	4 <sup>1</sup> / <sub>16</sub>	9
		35.00	3.296	3 <sup>1</sup> / <sub>16</sub>	0.636	4 <sup>1</sup> / <sub>16</sub>	
		30.00	3.173	3 <sup>1</sup> / <sub>16</sub>	0.513	4 <sup>1</sup> / <sub>16</sub>	
		25.00	3.050	3 <sup>1</sup> / <sub>16</sub>	0.390	4 <sup>1</sup> / <sub>16</sub>	
		<b>20.50</b>	<b>2.940</b>	<b>2<sup>1</sup>/<sub>16</sub></b>	<b>0.280</b>	4 <sup>1</sup> / <sub>16</sub>	
C 3	10	35.00	3.183	3 <sup>1</sup> / <sub>16</sub>	0.823	4 <sup>1</sup> / <sub>16</sub>	9
		30.00	3.036	3 <sup>1</sup> / <sub>16</sub>	0.676	4 <sup>1</sup> / <sub>16</sub>	
		25.00	2.889	2 <sup>1</sup> / <sub>16</sub>	0.529	4 <sup>1</sup> / <sub>16</sub>	
		20.00	2.742	2 <sup>1</sup> / <sub>16</sub>	0.382	4 <sup>1</sup> / <sub>16</sub>	
		<b>15.00</b>	<b>2.600</b>	<b>2<sup>1</sup>/<sub>16</sub></b>	<b>0.240</b>	4 <sup>1</sup> / <sub>16</sub>	
C 4	8	25.00	2.815	2 <sup>1</sup> / <sub>16</sub>	0.615	3 <sup>1</sup> / <sub>16</sub>	9
		20.00	2.652	2 <sup>1</sup> / <sub>16</sub>	0.452	3 <sup>1</sup> / <sub>16</sub>	
		15.00	2.488	2 <sup>1</sup> / <sub>16</sub>	0.288	3 <sup>1</sup> / <sub>16</sub>	
		<b>13.25</b>	<b>2.430</b>	<b>2<sup>1</sup>/<sub>16</sub></b>	<b>0.230</b>	3 <sup>1</sup> / <sub>16</sub>	
C 5	8	21.25	2.622	2 <sup>1</sup> / <sub>16</sub>	0.582	3 <sup>1</sup> / <sub>16</sub>	10
		18.75	2.530	2 <sup>1</sup> / <sub>16</sub>	0.490	3 <sup>1</sup> / <sub>16</sub>	
		16.25	2.439	2 <sup>1</sup> / <sub>16</sub>	0.399	3 <sup>1</sup> / <sub>16</sub>	
		13.75	2.347	2 <sup>1</sup> / <sub>16</sub>	0.307	3 <sup>1</sup> / <sub>16</sub>	
		<b>11.25</b>	<b>2.260</b>	<b>2<sup>1</sup>/<sub>16</sub></b>	<b>0.220</b>	3 <sup>1</sup> / <sub>16</sub>	
C 6	7	19.75	2.513	2 <sup>1</sup> / <sub>16</sub>	0.633	3 <sup>1</sup> / <sub>16</sub>	10
		17.25	2.408	2 <sup>1</sup> / <sub>16</sub>	0.528	3 <sup>1</sup> / <sub>16</sub>	
		14.75	2.303	2 <sup>1</sup> / <sub>16</sub>	0.423	3 <sup>1</sup> / <sub>16</sub>	
		12.25	2.198	2 <sup>1</sup> / <sub>16</sub>	0.318	3 <sup>1</sup> / <sub>16</sub>	
		<b>9.75</b>	<b>2.090</b>	<b>2<sup>1</sup>/<sub>16</sub></b>	<b>0.210</b>	3 <sup>1</sup> / <sub>16</sub>	
C 7	6	15.50	2.283	2 <sup>1</sup> / <sub>16</sub>	0.563	3 <sup>1</sup> / <sub>16</sub>	10
		13.00	2.160	2 <sup>1</sup> / <sub>16</sub>	0.440	3 <sup>1</sup> / <sub>16</sub>	
		10.50	2.038	2 <sup>1</sup> / <sub>16</sub>	0.318	3 <sup>1</sup> / <sub>16</sub>	
		<b>8.00</b>	<b>1.920</b>	<b>1<sup>1</sup>/<sub>16</sub></b>	<b>0.200</b>	3 <sup>1</sup> / <sub>16</sub>	
C 8	5	11.50	2.037	2 <sup>1</sup> / <sub>16</sub>	0.477	3 <sup>1</sup> / <sub>16</sub>	10
		9.00	1.890	1 <sup>1</sup> / <sub>16</sub>	0.330	3 <sup>1</sup> / <sub>16</sub>	
		<b>6.50</b>	<b>1.750</b>	<b>1<sup>3</sup>/<sub>4</sub></b>	<b>0.190</b>	3 <sup>1</sup> / <sub>16</sub>	
C 9	4	7.25	1.725	1 <sup>1</sup> / <sub>16</sub>	0.325	3 <sup>1</sup> / <sub>16</sub>	10
		6.25	1.652	1 <sup>1</sup> / <sub>16</sub>	0.252	3 <sup>1</sup> / <sub>16</sub>	
		<b>5.25</b>	<b>1.580</b>	<b>1<sup>1</sup>/<sub>16</sub></b>	<b>0.180</b>	3 <sup>1</sup> / <sub>16</sub>	
C 72	3	6.00	1.602	1 <sup>1</sup> / <sub>16</sub>	0.362	3 <sup>1</sup> / <sub>16</sub>	10
		5.00	1.504	1 <sup>1</sup> / <sub>16</sub>	0.264	3 <sup>1</sup> / <sub>16</sub>	
		<b>4.00</b>	<b>1.410</b>	<b>1<sup>1</sup>/<sub>16</sub></b>	<b>0.170</b>	3 <sup>1</sup> / <sub>16</sub>	

Weights in heavy print are standard, others are special.

### MINIMUM AND MAXIMUM WEIGHTS AND DIMENSIONS OF CAR-TRUCK AND SHIP-BUILDING CHANNELS.

Section Index.	Depth of Channel. Inches.	Weight per foot. Lbs.		Flange Width. Inches.		Web Thickness. Inches.		Increase of Web and Flange for each lb. increase of weight.	Page No. of Section.
		Min.	Max.	Min.	Max.	Min.	Max.		
C 20	13.0	32.00	50.0	4.00	4.42	.38	.80	.023	11
C 54	12.0	21.33	26.25	2.64	2.76	.31	.43	.025	11
C 108	10.0	23.40	25.50	3.31	3.37	.31	.87	.029	12
C 109	6.0	15.00	.....	3.50	.....	.35	.....	.....	12
C 107	6.0	13.30	17.25	2.812	3.006	.312	.506	.049	12
C 103	10.5	20.00	.....	2.50	3.375	.375	.....	.....	11
C 106	10.5	26.50	.....	2.50	3.375	.50	.....	.....	11

### MINIMUM, MAXIMUM AND INTERMEDIATE WEIGHTS AND DIMENSIONS OF STANDARD Z-BARS.

Section Index.	Size in Inches.			Thickness of Metal. Inches.	Weight per foot. Lbs.	Page No. of Section.
	Flange.	Web.	Flange.			
Z 1	3 1/2	6	3 1/2	3/8	15.6	13
	3 1/8	6 1/8	3 9/16	7/8	18.3	
	3 5/8	6 3/8	3 5/8	1/2	21.0	
Z 2	3 1/2	6	3 1/2	9/16	22.7	13
	3 1/8	6 1/8	3 9/16	5/8	25.4	
	3 5/8	6 3/8	3 5/8	1 1/8	28.0	
Z 3	3 1/2	6	3 1/2	3/4	29.3	13
	3 1/8	6 1/8	3 9/16	1 1/8	32.0	
	3 5/8	6 3/8	3 5/8	7/8	34.6	
Z 4	3 1/4	5	3 1/4	5/8	11.6	13
	3 1/8	5 1/8	3 5/16	3/8	13.9	
	3 3/8	5 1/8	3 3/8	1/2	16.4	
Z 5	3 1/4	5	3 1/4	1/2	17.8	13
	3 1/8	5 1/8	3 5/16	9/16	20.2	
	3 3/8	5 1/8	3 3/8	5/8	22.6	
Z 6	3 1/4	5	3 1/4	1 1/16	23.7	13
	3 1/8	5 1/8	3 5/16	3/4	26.0	
	3 3/8	5 1/8	3 3/8	1 1/8	28.3	

SAFE LOAD

PROP  
ERTIES

COLS

L  
Y

H

D  
M

MINIMUM, MAXIMUM AND INTERMEDIATE WEIGHTS AND DIMENSIONS OF STANDARD Z-BARS—Continued.

Section Index.	Size in Inches.			Thickness of Metal. Inches.	Weight per foot. Lbs.	Page No. of Section.
	Flange.	Web.	Flange.			
Z 7	$3\frac{1}{16}$	4	$3\frac{1}{16}$	$\frac{1}{4}$	8.2	14
	$3\frac{3}{8}$	$4\frac{1}{16}$	$3\frac{3}{8}$	$\frac{1}{8}$	10.3	
	$3\frac{3}{8}$	$4\frac{1}{8}$	$3\frac{3}{8}$	$\frac{3}{8}$	12.4	
Z 8	$3\frac{1}{16}$	4	$3\frac{1}{16}$	$\frac{7}{16}$	13.8	14
	$3\frac{3}{8}$	$4\frac{1}{16}$	$3\frac{3}{8}$	$\frac{1}{2}$	15.8	
	$3\frac{3}{8}$	$4\frac{1}{8}$	$3\frac{3}{8}$	$\frac{9}{16}$	17.9	
Z 9	$3\frac{1}{16}$	4	$3\frac{1}{16}$	$\frac{5}{8}$	18.9	14
	$3\frac{3}{8}$	$4\frac{1}{16}$	$3\frac{3}{8}$	$\frac{11}{16}$	20.9	
	$3\frac{3}{8}$	$4\frac{1}{8}$	$3\frac{3}{8}$	$\frac{3}{4}$	22.9	
Z 10	$2\frac{11}{16}$	3	$2\frac{11}{16}$	$\frac{1}{4}$	6.7	14
	$2\frac{3}{4}$	$3\frac{1}{16}$	$2\frac{3}{4}$	$\frac{5}{16}$	8.4	
Z 11	$2\frac{11}{16}$	3	$2\frac{11}{16}$	$\frac{3}{8}$	9.7	14
	$2\frac{3}{4}$	$3\frac{1}{16}$	$2\frac{3}{4}$	$\frac{7}{16}$	11.4	
Z 12	$2\frac{11}{16}$	3	$2\frac{11}{16}$	$\frac{1}{2}$	12.5	14
	$2\frac{3}{4}$	$3\frac{1}{16}$	$2\frac{3}{4}$	$\frac{9}{16}$	14.2	

WEIGHTS AND DIMENSIONS OF SPECIAL Z-BARS.

Section Index.	Size in Inches.			Thickness of Metal. Inches.	Weight per foot. Lbs.	Page No. of Section.
	Flange.	Web.	Flange.			
Z 13	3	6	3	$\frac{3}{8}$	14.5	15
Z 14	$2\frac{1}{2}$	5	3	$\frac{3}{8}$	12.4	15
Z 15	$2\frac{1}{2}$	4	3	$\frac{3}{8}$	11.1	15
Z 16	$2\frac{1}{2}$	3	3	$\frac{3}{8}$	10.0	15
Z 17	$2\frac{1}{2}$	3	3	$\frac{5}{16}$	8.4	15
Z 18	$\frac{9}{16}$	$1\frac{3}{8}$	$1\frac{3}{8}$	$\frac{1}{8}$	1.3	15
Z 19	$1\frac{1}{4}$	$1\frac{3}{4}$	$2\frac{1}{8}$	$\frac{7}{16}$	3.5	15

MINIMUM, MAXIMUM AND INTERMEDIATE WEIGHTS AND DIMENSIONS OF ANGLES.

EQUAL LEGS.

Section Index.	Size. Inches.	Thickness of Metal.	Weight per foot. Lbs.	Area. Sq. In.	Section Index.	Size. Inches.	Thickness of Metal.	Weight per foot. Lbs.	Area. Sq. In.
A113	8 x8	1 1/8	56.9	16.73	A 18	4 x4	1 3/8	19.9	5.84
A112	8 x8	1 1/16	54.0	15.87	A 19	4 x4	3/4	18.5	5.44
A111	8 x8	1	51.0	15.00	A 20	4 x4	1 1/16	17.1	5.03
A110	8 x8	3/8	48.0	14.12	A 21	4 x4	5/8	15.7	4.61
A109	8 x8	7/8	45.0	13.23	A 22	4 x4	9/16	14.3	4.18
A108	8 x8	1 1/16	42.0	12.34	A 23	4 x4	1/2	12.8	3.75
A107	8 x8	3/4	38.9	11.44	A 24	4 x4	7/8	11.3	3.31
A106	8 x8	1 1/8	35.8	10.53	A 25	4 x4	3/8	9.8	2.86
A105	8 x8	5/8	32.7	9.61	A 90	4 x4	1/8	8.2	2.40
A104	8 x8	1 1/16	29.5	8.68					
A103	8 x8	1/2	26.4	7.75	A 26	3 1/2 x3 1/2	1 3/8	17.1	5.03
A 86	6 x6	1	37.4	11.00	A 27	3 1/2 x3 1/2	3/4	16.0	4.69
A 87	6 x6	1 1/16	35.3	10.37	A 28	3 1/2 x3 1/2	1 1/16	14.8	4.34
A 1	6 x6	7/8	33.1	9.74	A 29	3 1/2 x3 1/2	5/8	13.6	3.98
A 2	6 x6	1 1/8	30.9	9.09	A 30	3 1/2 x3 1/2	9/16	12.3	3.62
A 3	6 x6	3/4	28.7	8.44	A 31	3 1/2 x3 1/2	1/2	11.1	3.25
A 4	6 x6	1 1/16	26.5	7.78	A 32	3 1/2 x3 1/2	7/8	9.8	2.87
A 5	6 x6	5/8	24.2	7.11	A 33	3 1/2 x3 1/2	3/8	8.5	2.48
A 6	6 x6	9/16	21.9	6.43	A 99	3 1/2 x3 1/2	5/16	7.1	2.09
A 7	6 x6	1 1/2	19.6	5.75	A 34	3 x3	5/8	11.4	3.36
A 8	6 x6	7/8	17.2	5.06	A 35	3 x3	9/16	10.4	3.06
A 88	6 x6	3/8	14.8	4.36	A 36	3 x3	1/2	9.4	2.75
*A 94	5 x5	1	30.6	9.00	A 37	3 x3	7/8	8.3	2.43
*A 95	5 x5	1 1/16	28.9	8.50	A 38	3 x3	3/8	7.2	2.11
*A 9	5 x5	7/8	27.2	7.99	A 39	3 x3	5/8	6.1	1.78
*A 10	5 x5	1 1/8	25.4	7.46	A 40	3 x3	1/4	4.9	1.44
*A 11	5 x5	3/4	23.6	6.94	*A 41	2 3/4 x2 3/4	1/2	8.5	2.50
*A 12	5 x5	1 1/16	21.8	6.42	*A 42	2 3/4 x2 3/4	7/8	7.6	2.22
*A 13	5 x5	5/8	20.0	5.86	*A 43	2 3/4 x2 3/4	3/8	6.6	1.92
*A 14	5 x5	9/16	18.1	5.31	*A 44	2 3/4 x2 3/4	1/8	5.5	1.62
*A 15	5 x5	1 1/2	16.2	4.75	*A 45	2 3/4 x2 3/4	1/4	4.5	1.31
*A 16	5 x5	7/8	14.3	4.18					
*A 17	5 x5	3/8	12.3	3.61					

Angles marked \* are special.

SAFE LOAD

PROPERTIES

COLS

L  
r

D  
M

MINIMUM, MAXIMUM AND INTERMEDIATE  
WEIGHTS AND DIMENSIONS OF  
ANGLES—Continued.

EQUAL LEGS.

Section Index.	Size. Inches.	Thickness of Metal.	Weight per foot. Lbs.	Area. Sq. In.	Section Index.	Size. Inches.	Thickness of Metal.	Weight per foot. Lbs.	Area. Sq. In.
A 45	2 1/2 x 2 1/2	1/2	7.7	2.25	A 66	1 1/2 x 1 1/2	3/8	3.4	0.99
A 47	2 1/2 x 2 1/2	7/16	6.8	2.00	A 67	1 1/2 x 1 1/2	5/16	2.9	0.84
A 48	2 1/2 x 2 1/2	3/8	5.9	1.73	A 68	1 1/2 x 1 1/2	1/4	2.4	0.69
A 49	2 1/2 x 2 1/2	5/16	5.0	1.47	A 69	1 1/2 x 1 1/2	3/16	1.8	0.53
A 50	2 1/2 x 2 1/2	1/4	4.1	1.19	A102	1 1/2 x 1 1/2	1/8	1.2	0.36
A100	2 1/2 x 2 1/2	3/16	3.1	0.90					
*A 51	2 1/4 x 2 1/4	1/2	6.8	2.00	A 70	1 1/4 x 1 1/4	5/16	2.4	0.69
*A 52	2 1/4 x 2 1/4	7/16	6.1	1.78	A 71	1 1/4 x 1 1/4	1/4	1.9	0.56
*A 53	2 1/4 x 2 1/4	3/8	5.3	1.55	A 72	1 1/4 x 1 1/4	3/16	1.5	0.43
*A 54	2 1/4 x 2 1/4	5/16	4.5	1.31	A 73	1 1/4 x 1 1/4	1/8	1.0	0.30
*A 55	2 1/4 x 2 1/4	1/4	3.7	1.06					
*A101	2 1/4 x 2 1/4	3/16	2.8	0.81					
A 56	2 x 2	7/16	5.3	1.56	A 78	1 x 1	1/4	1.5	0.44
A 57	2 x 2	3/8	4.7	1.36	A 79	1 x 1	5/16	1.2	0.34
A 58	2 x 2	5/16	4.0	1.15	A 80	1 x 1	3/8	0.8	0.24
A 59	2 x 2	1/4	3.2	0.94					
A 60	2 x 2	3/16	2.5	0.72					
					*A 81	7/8 x 7/8	3/16	1.0	0.29
					*A 82	7/8 x 7/8	1/8	0.7	0.21
A 61	1 3/4 x 1 3/4	7/16	4.6	1.30					
A 62	1 3/4 x 1 3/4	3/8	4.0	1.17					
A 63	1 3/4 x 1 3/4	5/16	3.4	1.00					
A 64	1 3/4 x 1 3/4	1/4	2.8	0.81	A 83	3/4 x 3/4	3/16	0.8	0.25
A 65	1 3/4 x 1 3/4	3/16	2.1	0.62	A 84	3/4 x 3/4	1/8	0.6	0.17

Angles marked \* are special.

MINIMUM, MAXIMUM AND INTERMEDIATE WEIGHTS AND DIMENSIONS OF ANGLES.

UNEQUAL LEGS.

Section Index.	Size. Inches.	Thickness of Metal.	Weight per foot. Lbs.	Area. Sq. In.	Section Index.	Size. Inches.	Thickness of Metal.	Weight per foot. Lbs.	Area. Sq. In.
*A150	7 x 3 1/2	1	32.3	9.50	*A178	5 x 4	7/8	24.2	7.11
*A151	7 x 3 1/2	1 1/8	30.5	8.97	*A179	5 x 4	1 1/8	22.6	6.65
*A152	7 x 3 1/2	7/8	28.7	8.42	*A180	5 x 4	3/4	21.1	6.19
*A153	7 x 3 1/2	1 1/8	26.8	7.87	*A181	5 x 4	1 1/8	19.5	5.72
*A154	7 x 3 1/2	3/4	24.9	7.31	*A182	5 x 4	5/8	17.8	5.23
*A155	7 x 3 1/2	1 1/8	23.0	6.75	*A183	5 x 4	1 1/8	16.2	4.75
*A156	7 x 3 1/2	5/8	21.0	6.17	*A184	5 x 4	1/2	14.5	4.25
*A157	7 x 3 1/2	1 1/8	19.0	5.59	*A185	5 x 4	1 1/8	12.8	3.75
*A158	7 x 3 1/2	1/2	17.0	5.00	*A186	5 x 4	3/8	11.0	3.23
*A159	7 x 3 1/2	1 1/8	15.0	4.40					
A 89	6 x 4	1	30.6	9.00	A187	5 x 3 1/2	7/8	22.7	6.67
A 91	6 x 4	1 1/8	28.9	8.50	A188	5 x 3 1/2	1 1/8	21.3	6.25
A160	6 x 4	7/8	27.2	7.99	A189	5 x 3 1/2	3/4	19.8	5.81
A161	6 x 4	1 1/8	25.4	7.47	A190	5 x 3 1/2	1 1/8	18.3	5.37
A162	6 x 4	3/4	23.6	6.94	A191	5 x 3 1/2	5/8	16.8	4.92
A163	6 x 4	1 1/8	21.8	6.41	A192	5 x 3 1/2	1 1/8	15.2	4.47
A164	6 x 4	5/8	20.0	5.86	A193	5 x 3 1/2	1/2	13.6	4.00
A165	6 x 4	1 1/8	18.1	5.31	A194	5 x 3 1/2	7/8	12.0	3.53
A166	6 x 4	1/2	16.2	4.75	A195	5 x 3 1/2	5/8	10.4	3.05
A167	6 x 4	1 1/8	14.3	4.18	A 96	5 x 3 1/2	1 1/8	8.7	2.56
A168	6 x 4	3/8	12.3	3.61	A196	5 x 3	1 1/8	19.9	5.84
					A197	5 x 3	3/4	18.5	5.44
					A198	5 x 3	1 1/8	17.1	5.03
					A199	5 x 3	5/8	15.7	4.61
A 92	6 x 3 1/2	1	28.9	8.50	A200	5 x 3	1 1/8	14.2	4.18
A 93	6 x 3 1/2	1 1/8	27.3	8.03	A201	5 x 3	1 1/2	12.8	3.75
A169	6 x 3 1/2	7/8	25.7	7.55	A202	5 x 3	1 1/8	11.3	3.31
A170	6 x 3 1/2	1 1/8	24.0	7.06	A203	5 x 3	3/8	9.8	2.86
A171	6 x 3 1/2	3/4	22.3	6.56	A280	5 x 3	1 1/8	8.2	2.40
A172	6 x 3 1/2	1 1/8	20.6	6.06					
A173	6 x 3 1/2	5/8	18.9	5.55	*A204	4 1/2 x 3	1 1/8	18.5	5.43
A174	6 x 3 1/2	1 1/8	17.1	5.03	*A205	4 1/2 x 3	3/4	17.2	5.06
A175	6 x 3 1/2	1 1/2	15.3	4.50	*A206	4 1/2 x 3	1 1/8	15.9	4.68
A176	6 x 3 1/2	7/8	13.5	3.97	*A207	4 1/2 x 3	5/8	14.6	4.30
A177	6 x 3 1/2	1 1/8	11.7	3.42	*A208	4 1/2 x 3	1 1/8	13.3	3.90

Angles marked \* are special.

SAFE  
LOAD  
PROF  
ERTIE

COL  
L  
r

MINIMUM, MAXIMUM AND INTERMEDIATE  
WEIGHTS AND DIMENSIONS OF  
ANGLES—Continued.

UNEQUAL LEGS.

Section Index.	Size. Inches.	Thickness of Metal.	Weight per foot. Lbs.	Area. Sq. In.	Section Index.	Size. Inches.	Thickness of Metal.	Weight per foot. Lbs.	Area. Sq. In.
*A209	4 1/2 x 3	1/2	11.9	3.50	A238	3 1/2 x 2 1/2	1 1/8	12.4	3.65
*A210	4 1/2 x 3	7/16	10.5	3.09	A239	3 1/2 x 2 1/2	5/8	11.4	3.36
*A211	4 1/2 x 3	3/8	9.1	2.67	A240	3 1/2 x 2 1/2	9/16	10.4	3.06
*A 97	4 1/2 x 3	5/16	7.7	2.25	A241	3 1/2 x 2 1/2	1/2	9.4	2.75
					A242	3 1/2 x 2 1/2	7/16	8.3	2.43
*A212	4 x 3 1/2	1 3/16	18.5	5.43	A243	3 1/2 x 2 1/2	3/8	7.2	2.11
*A213	4 x 3 1/2	3/4	17.2	5.06	A244	3 1/2 x 2 1/2	5/16	6.1	1.78
*A214	4 x 3 1/2	1 1/16	15.9	4.68	A245	3 1/2 x 2 1/2	1/4	*4.9	1.44
*A215	4 x 3 1/2	5/8	14.6	4.30					
*A216	4 x 3 1/2	9/16	13.3	3.90	*A246	3 1/4 x 2	9/16	9.0	2.64
*A217	4 x 3 1/2	1/2	11.9	3.50	*A247	3 1/4 x 2	1/2	8.1	2.38
*A218	4 x 3 1/2	7/16	10.5	3.09	*A248	3 1/4 x 2	7/16	7.2	2.11
*A219	4 x 3 1/2	3/8	9.1	2.67	*A249	3 1/4 x 2	3/8	6.2	1.83
*A 98	4 x 3 1/2	5/16	7.7	2.25	*A250	3 1/4 x 2	5/16	5.3	1.54
					*A251	3 1/4 x 2	1/4	4.3	1.25
A220	4 x 3	1 3/16	17.1	5.03					
A221	4 x 3	3/4	16.0	4.69	A252	3 x 2 1/2	9/16	9.5	2.78
A222	4 x 3	1 1/16	14.8	4.34	A253	3 x 2 1/2	1/2	8.5	2.50
A223	4 x 3	5/8	13.6	3.98	A254	3 x 2 1/2	7/16	7.6	2.22
A224	4 x 3	9/16	12.3	3.62	A255	3 x 2 1/2	3/8	6.6	1.92
A225	4 x 3	1/2	11.1	3.25	A256	3 x 2 1/2	5/16	5.5	1.62
A226	4 x 3	7/16	9.8	2.87	A257	3 x 2 1/2	1/4	4.5	1.31
A227	4 x 3	3/8	8.5	2.48					
A228	4 x 3	5/16	7.1	2.09					
					*A258	3 x 2	1/2	7.7	2.25
A229	3 1/2 x 3	1 3/16	15.7	4.62	*A259	3 x 2	7/16	6.8	2.00
A230	3 1/2 x 3	3/4	14.7	4.31	*A260	3 x 2	3/8	5.9	1.73
A231	3 1/2 x 3	1 1/16	13.6	4.00	*A261	3 x 2	5/16	5.0	1.47
A232	3 1/2 x 3	5/8	12.5	3.67	*A262	3 x 2	1/4	4.0	1.19
A233	3 1/2 x 3	9/16	11.4	3.34					
A234	3 1/2 x 3	1/2	10.2	3.00					
A235	3 1/2 x 3	7/16	9.1	2.65	A264	2 1/2 x 2	1/2	6.8	2.00
A236	3 1/2 x 3	3/8	7.8	2.30	A265	2 1/2 x 2	7/16	6.1	1.78
A237	3 1/2 x 3	5/16	6.6	1.93	A266	2 1/2 x 2	3/8	5.3	1.55

Angles marked \* are special.

MINIMUM, MAXIMUM AND INTERMEDIATE WEIGHTS AND DIMENSIONS OF ANGLES—Continued.

UNEQUAL LEGS.

Section Index.	Size. Inches.	Thickness of Metal.	Weight per foot. Lbs.	Area. Sq. In.	Section Index.	Size. Inches.	Thickness of Metal.	Weight per foot. Lbs.	Area. Sq. In.
A267	2 1/2 x 2	5/16	4.5	1.31					
A268	2 1/2 x 2	3/4	3.7	1.06	*A276	2 x 1 3/8	1/4	2.7	0.78
A269	2 1/2 x 2	1/2	2.8	0.81	*A277	2 x 1 3/8	3/8	2.1	0.60
*A270	2 1/4 x 1 1/2	1/2	5.5	1.63					
*A271	2 1/4 x 1 1/2	7/16	5.0	1.45					
*A272	2 1/4 x 1 1/2	3/8	4.3	1.27	*A278	1 3/8 x 1	1/4	1.8	0.53
*A273	2 1/4 x 1 1/2	5/16	3.7	1.07	*A279	1 3/8 x 1	3/8	1.0	0.28
*A274	2 1/4 x 1 1/2	3/4	3.0	0.88					
*A275	2 1/4 x 1 1/2	1/2	2.3	0.67					

Angles marked \* are special.

ODD ANGLE SECTIONS.

These Sections will only be rolled by Special Agreement.

Section Index.	Size. Inches.	Thickness of Metal. Inches.	Weight per foot. Lbs.	Section Index.	Size. Inches.	Thickness of Metal. Inches.	Weight per foot. Lbs.
A450	3 x 3	1 1/8	14.4	A461	2 1/2 x 2 1/2	1/2	8.2
A451	3 x 3	3/4	13.4	A462	2 1/2 x 2 1/2	7/16	7.1
A452	3 x 3	1 1/4	12.4	A463	2 1/2 x 2 1/2	3/8	6.1
A453	3 x 3	5/8	11.4	A464	3 1/4 x 2	1/2	8.2
A454	3 x 3	9/16	10.4	A465	3 1/4 x 2	7/16	7.1
A455	2 1/2 x 2 1/2	1 1/4	10.1	A466	3 1/4 x 2	3/8	6.1
A456	2 1/2 x 2 1/2	5/8	9.3	A467	3 x 3	7/8	8.4
A457	2 1/2 x 2 1/2	9/16	8.5	A468	3 x 3	3/8	7.2
A458	2 1/2 x 2 1/2	1/2	7.7	A469	3 x 3	5/16	6.1
A459	2 1/2 x 2 1/2	7/16	6.8	A470	2 1/2 x 2 1/4	1/4	4.2
A460	2 1/2 x 2 1/4	3/4 x 1/2	8.7	A471	2 1/4 x 2 1/4	1/4	3.5



MINIMUM, MAXIMUM AND INTERMEDIATE  
WEIGHTS AND DIMENSIONS OF  
SPECIAL ANGLES.

SQUARE ROOT.

Section Index.	Size. Inches.	Thickness of Metal. Inches.	Weight per foot. Lbs.	Section Index.	Size. Inches.	Thickness of Metal. Inches.	Weight per foot. Lbs.
A350	4 x4	$\frac{3}{4}$	18.5	A387	2 $\frac{1}{4}$ x2 $\frac{1}{4}$	$\frac{1}{4}$	3.6
A351	4 x4	$\frac{11}{16}$	17.1	A388	2 x2	$\frac{7}{16}$	5.3
A352	4 x4	$\frac{5}{8}$	15.7	A389	2 x2	$\frac{3}{8}$	4.7
A353	4 x4	$\frac{9}{16}$	14.3	A390	2 x2	$\frac{5}{16}$	3.9
A354	4 x4	$\frac{1}{2}$	12.8	A391	2 x2	$\frac{1}{4}$	3.2
A355	4 x4	$\frac{7}{16}$	11.3	A392	1 $\frac{3}{4}$ x1 $\frac{3}{4}$	$\frac{7}{16}$	4.5
A356	4 x4	$\frac{3}{8}$	9.7	A393	1 $\frac{3}{4}$ x1 $\frac{3}{4}$	$\frac{3}{8}$	4.0
A357	3 $\frac{1}{2}$ x3 $\frac{1}{2}$	$\frac{3}{4}$	16.0	A394	1 $\frac{3}{4}$ x1 $\frac{3}{4}$	$\frac{5}{16}$	3.4
A358	3 $\frac{1}{2}$ x3 $\frac{1}{2}$	$\frac{11}{16}$	14.8	A395	1 $\frac{3}{4}$ x1 $\frac{3}{4}$	$\frac{1}{4}$	2.8
A359	3 $\frac{1}{2}$ x3 $\frac{1}{2}$	$\frac{5}{8}$	13.6	A396	1 $\frac{1}{2}$ x1 $\frac{1}{2}$	$\frac{3}{8}$	3.4
A360	3 $\frac{1}{2}$ x3 $\frac{1}{2}$	$\frac{9}{16}$	12.3	A397	1 $\frac{1}{2}$ x1 $\frac{1}{2}$	$\frac{5}{16}$	2.9
A361	3 $\frac{1}{2}$ x3 $\frac{1}{2}$	$\frac{1}{2}$	11.0	A398	1 $\frac{1}{2}$ x1 $\frac{1}{2}$	$\frac{1}{4}$	2.4
A362	3 $\frac{1}{2}$ x3 $\frac{1}{2}$	$\frac{7}{16}$	9.8	A399	1 $\frac{1}{2}$ x1 $\frac{1}{2}$	$\frac{3}{16}$	1.9
A363	3 $\frac{1}{2}$ x3 $\frac{1}{2}$	$\frac{3}{8}$	8.5	A400	1 $\frac{1}{4}$ x1 $\frac{1}{4}$	$\frac{5}{16}$	2.4
A364	3 x3	$\frac{5}{8}$	11.4	A401	1 $\frac{1}{4}$ x1 $\frac{1}{4}$	$\frac{1}{4}$	2.0
A365	3 x3	$\frac{9}{16}$	10.4	A402	1 $\frac{1}{4}$ x1 $\frac{1}{4}$	$\frac{3}{16}$	1.5
A366	3 x3	$\frac{1}{2}$	9.4	A403	1 $\frac{1}{4}$ x1 $\frac{1}{4}$	$\frac{1}{8}$	1.0
A367	3 x3	$\frac{7}{16}$	8.3	A404	1 $\frac{3}{8}$ x $\frac{7}{8}$	$\frac{1}{4}$	1.8
A368	3 x3	$\frac{3}{8}$	7.2	A405	1 $\frac{3}{8}$ x $\frac{7}{8}$	$\frac{1}{8}$	0.9
A369	3 x3	$\frac{5}{16}$	6.0	A406	1 $\frac{1}{8}$ x1 $\frac{1}{8}$	$\frac{1}{4}$	1.7
A370	3 x3	$\frac{1}{4}$	4.9	A407	1 $\frac{1}{8}$ x1 $\frac{1}{8}$	$\frac{3}{16}$	1.3
A371	2 $\frac{3}{4}$ x2 $\frac{3}{4}$	$\frac{1}{2}$	8.6	A408	1 $\frac{1}{8}$ x1 $\frac{1}{8}$	$\frac{1}{8}$	0.9
A372	2 $\frac{3}{4}$ x2 $\frac{3}{4}$	$\frac{7}{16}$	7.6	A430	1 $\frac{1}{16}$ x $\frac{1}{8}$	$\frac{3}{16}$	1.1
A373	2 $\frac{3}{4}$ x2 $\frac{3}{4}$	$\frac{3}{8}$	6.6	A409	1 x1	$\frac{1}{4}$	1.5
A374	2 $\frac{3}{4}$ x2 $\frac{3}{4}$	$\frac{5}{16}$	5.5	A410	1 x1	$\frac{3}{16}$	1.1
A375	2 $\frac{1}{2}$ x2 $\frac{1}{2}$	$\frac{1}{2}$	7.7	A411	1 x1	$\frac{1}{8}$	0.8
A376	2 $\frac{1}{2}$ x2 $\frac{1}{2}$	$\frac{7}{16}$	6.8	A412	$\frac{7}{16}$ x $\frac{7}{8}$	$\frac{3}{16}$	1.0
A377	2 $\frac{1}{2}$ x2 $\frac{1}{2}$	$\frac{3}{8}$	5.9	A413	$\frac{7}{16}$ x $\frac{7}{8}$	$\frac{1}{8}$	0.7
A378	2 $\frac{1}{2}$ x2 $\frac{1}{2}$	$\frac{5}{16}$	5.0	A414	$\frac{3}{4}$ x $\frac{3}{4}$	$\frac{3}{16}$	0.8
A379	2 $\frac{1}{2}$ x2 $\frac{1}{2}$	$\frac{1}{4}$	4.1	A415	$\frac{3}{4}$ x $\frac{3}{4}$	$\frac{1}{8}$	0.6
A383	2 $\frac{1}{4}$ x2 $\frac{1}{4}$	$\frac{1}{2}$	6.8				
A384	2 $\frac{1}{4}$ x2 $\frac{1}{4}$	$\frac{7}{16}$	6.0				
A385	2 $\frac{1}{4}$ x2 $\frac{1}{4}$	$\frac{3}{8}$	5.3				
A386	2 $\frac{1}{4}$ x2 $\frac{1}{4}$	$\frac{5}{16}$	4.5				

WEIGHTS AND DIMENSIONS OF CARNEGIE  
TEES.

EQUAL LEGS.

Section Index.	Size in Inches.		Thickness of Metal in Inches.		Weight per foot. Lbs.	Page No. of Section.
	Flange.	Stem.	Flange.	Stem.		
T 1	4	4	$\frac{1}{2}$ to $\frac{9}{16}$	$\frac{1}{2}$ to $\frac{9}{16}$	13.7	22
T 2	4	4	$\frac{3}{8}$ to $\frac{7}{16}$	$\frac{3}{8}$ to $\frac{7}{16}$	10.9	22
T 3	$3\frac{1}{2}$	$3\frac{1}{2}$	$\frac{1}{2}$ to $\frac{9}{16}$	$\frac{1}{2}$ to $\frac{9}{16}$	11.7	22
T 4	$3\frac{1}{2}$	$3\frac{1}{2}$	$\frac{3}{8}$ to $\frac{7}{16}$	$\frac{3}{8}$ to $\frac{7}{16}$	9.2	22
T 6	3	3	$\frac{1}{2}$ to $\frac{9}{16}$	$\frac{1}{2}$ to $\frac{9}{16}$	10.0	22
T 7	3	3	$\frac{7}{16}$ to $\frac{1}{2}$	$\frac{7}{16}$ to $\frac{1}{2}$	9.1	22
T 8	3	3	$\frac{3}{8}$ to $\frac{7}{16}$	$\frac{3}{8}$ to $\frac{7}{16}$	7.8	22
T 9	3	3	$\frac{5}{16}$ to $\frac{3}{8}$	$\frac{5}{16}$ to $\frac{3}{8}$	6.6	22
T 10	$2\frac{1}{2}$	$2\frac{1}{2}$	$\frac{3}{8}$ to $\frac{7}{16}$	$\frac{3}{8}$ to $\frac{7}{16}$	6.4	22
T 11	$2\frac{1}{2}$	$2\frac{1}{2}$	$\frac{5}{16}$ to $\frac{3}{8}$	$\frac{5}{16}$ to $\frac{3}{8}$	5.5	22
T 12	$2\frac{1}{4}$	$2\frac{1}{4}$	$\frac{5}{16}$ to $\frac{3}{8}$	$\frac{5}{16}$ to $\frac{3}{8}$	4.9	22
T 13	$2\frac{1}{4}$	$2\frac{1}{4}$	$\frac{1}{4}$ to $\frac{5}{16}$	$\frac{1}{4}$ to $\frac{5}{16}$	4.1	22
T 14	2	2	$\frac{5}{16}$ to $\frac{3}{8}$	$\frac{5}{16}$ to $\frac{3}{8}$	4.3	22
T 15	2	2	$\frac{1}{4}$ to $\frac{5}{16}$	$\frac{1}{4}$ to $\frac{5}{16}$	3.7	23
T 16	$1\frac{3}{4}$	$1\frac{3}{4}$	$\frac{1}{4}$ to $\frac{5}{16}$	$\frac{1}{4}$ to $\frac{5}{16}$	3.1	23
T 17	$1\frac{1}{2}$	$1\frac{1}{2}$	$\frac{1}{4}$ to $\frac{9}{32}$	$\frac{1}{4}$ to $\frac{9}{32}$	2.4	23
T 18	$1\frac{1}{2}$	$1\frac{1}{2}$	$\frac{3}{16}$ to $\frac{7}{32}$	$\frac{3}{16}$ to $\frac{7}{32}$	1.84	23
T 19	$1\frac{1}{4}$	$1\frac{1}{4}$	$\frac{1}{4}$ to $\frac{9}{32}$	$\frac{1}{4}$ to $\frac{9}{32}$	2.04	23
T 20	$1\frac{1}{4}$	$1\frac{1}{4}$	$\frac{3}{16}$ to $\frac{7}{32}$	$\frac{3}{16}$ to $\frac{7}{32}$	1.53	23
T 21	1	1	$\frac{3}{16}$ to $\frac{7}{32}$	$\frac{3}{16}$ to $\frac{7}{32}$	1.23	23
T 22	1	1	$\frac{1}{8}$ to $\frac{5}{32}$	$\frac{1}{8}$ to $\frac{5}{32}$	0.87	23

WEIGHTS AND DIMENSIONS OF CARNEGIE  
TEES.

UNEQUAL LEGS.

Section Index.	Size in Inches.		Thickness of Metal in Inches.		Weight per foot. Lbs.	Page No. of Section.
	Flange.	Stem.	Flange.	Stem.		
T 50	5	3	$\frac{1}{2}$ to $\frac{9}{16}$	$\frac{11}{16}$ to $\frac{3}{8}$	13.6	24
T 51	5	2½	$\frac{3}{8}$ to $\frac{7}{16}$	$\frac{7}{16}$ to $\frac{3}{16}$	11.0	24
T 52	4½	3½	$\frac{7}{16}$ to $\frac{9}{16}$	$\frac{1}{4}$ to $\frac{3}{8}$	15.8	24
T 53	4½	3	$\frac{5}{16}$ to $\frac{3}{8}$	$\frac{5}{16}$ to $\frac{3}{8}$	8.5	24
T 54	4½	3	$\frac{3}{8}$ to $\frac{7}{16}$	$\frac{3}{8}$ to $\frac{7}{16}$	10.0	24
T 55	4½	2½	$\frac{5}{16}$ to $\frac{3}{8}$	$\frac{5}{16}$ to $\frac{3}{8}$	8.0	24
T 56	4½	2½	$\frac{3}{8}$ to $\frac{7}{16}$	$\frac{3}{8}$ to $\frac{7}{16}$	9.3	24
T 57	4	5	$\frac{1}{2}$ to $\frac{9}{16}$	$\frac{1}{2}$ to $\frac{9}{16}$	15.6	24
T 58	4	5	$\frac{3}{8}$ to $\frac{7}{16}$	$\frac{3}{8}$ to $\frac{7}{16}$	12.0	25
T 59	4	4½	$\frac{1}{2}$ to $\frac{9}{16}$	$\frac{1}{2}$ to $\frac{9}{16}$	14.6	25
T 60	4	4½	$\frac{3}{8}$ to $\frac{7}{16}$	$\frac{3}{8}$ to $\frac{7}{16}$	11.4	25
T 61	4	3	$\frac{3}{8}$ to $\frac{7}{16}$	$\frac{3}{8}$ to $\frac{7}{16}$	9.3	25
T 62	4	2½	$\frac{3}{8}$ to $\frac{7}{16}$	$\frac{3}{8}$ to $\frac{7}{16}$	8.6	25
T 63	4	2½	$\frac{5}{16}$ to $\frac{3}{8}$	$\frac{5}{16}$ to $\frac{3}{8}$	7.3	25
T 64	4	2	$\frac{3}{8}$ to $\frac{7}{16}$	$\frac{3}{8}$ to $\frac{7}{16}$	7.9	25
T 65	4	2	$\frac{5}{16}$ to $\frac{3}{8}$	$\frac{5}{16}$ to $\frac{3}{8}$	6.6	25
T 66	3½	4	$\frac{1}{2}$ to $\frac{9}{16}$	$\frac{1}{2}$ to $\frac{9}{16}$	12.8	26
T 67	3½	4	$\frac{3}{8}$ to $\frac{7}{16}$	$\frac{3}{8}$ to $\frac{7}{16}$	9.9	26
T 69	3½	3	$\frac{1}{2}$ to $\frac{9}{16}$	$\frac{1}{2}$ to $\frac{9}{16}$	10.9	26
T 70	3½	3	$\frac{3}{8}$ to $\frac{7}{16}$	$\frac{3}{8}$ to $\frac{7}{16}$	8.5	26
T 71	3½	3	$\frac{5}{16}$ to $\frac{3}{8}$	$\frac{3}{8}$	7.8	26
T 72	3	4	$\frac{1}{2}$ to $\frac{9}{16}$	$\frac{1}{2}$ to $\frac{9}{16}$	11.8	26
T 73	3	4	$\frac{7}{16}$ to $\frac{1}{2}$	$\frac{7}{16}$ to $\frac{1}{2}$	10.6	26

WEIGHTS AND DIMENSIONS OF CARNEGIE  
TEES—Continued.

UNEQUAL LEGS.

Section Index.	Size in Inches.		Thickness of Metal in Inches.		Weight per foot. Lbs.	Page No. of Section.
	Flange.	Stem.	Flange.	Stem.		
T 74	3	4	$\frac{3}{8}$ to $\frac{7}{16}$	$\frac{3}{8}$ to $\frac{7}{16}$	9.3	26
T 75	3	$3\frac{1}{2}$	$\frac{1}{2}$ to $\frac{9}{16}$	$\frac{1}{2}$ to $\frac{9}{16}$	10.9	26
T 76	3	$3\frac{1}{2}$	$\frac{7}{16}$ to $\frac{1}{2}$	$\frac{7}{16}$ to $\frac{1}{2}$	9.8	26
T 77	3	$3\frac{1}{2}$	$\frac{3}{8}$ to $\frac{7}{16}$	$\frac{3}{8}$ to $\frac{7}{16}$	8.5	26
T 78	3	$2\frac{1}{2}$	$\frac{3}{8}$ to $\frac{7}{16}$	$\frac{3}{8}$ to $\frac{7}{16}$	7.2	27
T 79	3	$2\frac{1}{2}$	$\frac{1}{8}$ to $\frac{3}{8}$	$\frac{1}{8}$ to $\frac{3}{8}$	6.1	27
T 80	$2\frac{3}{4}$	2	$\frac{5}{16}$ to $\frac{11}{32}$	$\frac{3}{4}$	7.4	27
T 82	$2\frac{1}{2}$	3	$\frac{3}{8}$ to $\frac{7}{16}$	$\frac{3}{8}$ to $\frac{7}{16}$	7.2	27
T 83	$2\frac{1}{2}$	3	$\frac{1}{8}$ to $\frac{3}{8}$	$\frac{1}{8}$ to $\frac{3}{8}$	6.1	27
T 84	$2\frac{1}{2}$	$2\frac{3}{4}$	$\frac{3}{8}$ to $\frac{7}{16}$	$\frac{3}{8}$ to $\frac{7}{16}$	6.7	27
T 85	$2\frac{1}{2}$	$2\frac{3}{4}$	$\frac{1}{8}$ to $\frac{3}{8}$	$\frac{1}{8}$ to $\frac{3}{8}$	5.8	27
T 86	$2\frac{1}{2}$	$1\frac{1}{4}$	$\frac{3}{8}$ to $\frac{9}{32}$	$\frac{1}{8}$ to $\frac{1}{8}$	2.9	27
T 87	2	$1\frac{1}{2}$	$\frac{1}{4}$ to $\frac{5}{16}$	$\frac{1}{4}$ to $\frac{5}{16}$	3.1	27
T 88	$1\frac{3}{4}$	$1\frac{1}{4}$	$\frac{3}{8}$ to $\frac{7}{16}$	$\frac{3}{8}$ to $\frac{7}{16}$	3.6	27

HAND-RAIL TEES.

Section Index.	Size. Inches.	Weight per foot. Lbs.	Page No. of Section.	Section Index.	Size. Inches.	Weight per foot. Lbs.	Page No. of Section.
T 154	$4\frac{1}{2} \times 2\frac{3}{16}$	7.00	23	T 156	4 x 3	11.30	23

SAFE  
LOAD  
PROF  
ERTIE

COL

L  
r

H

D

M

WEIGHTS AND DIMENSIONS OF CARNEGIE  
MISCELLANEOUS SHAPES.

TROUGH PLATES.

Section Index.	Size. Inches.	Thickness of Metal. Inches.	Weight per foot. Lbs.	Page No. of Section.
M 10	$9\frac{1}{2} \times 3\frac{3}{4}$	$\frac{1}{2}$	16.3	28
M 11	$9\frac{1}{2} \times 3\frac{3}{4}$	$\frac{9}{16}$	18.0	. . .
M 12	$9\frac{1}{2} \times 3\frac{3}{4}$	$\frac{5}{8}$	19.7	. . .
M 13	$9\frac{1}{2} \times 3\frac{3}{4}$	$\frac{11}{16}$	21.4	. . .
M 14	$9\frac{1}{2} \times 3\frac{3}{4}$	$\frac{3}{4}$	23.2	. . .

CORRUGATED PLATES.

Section Index.	Size. Inches.	Thickness of Metal. Inches.	Weight per foot. Lbs.	Page No. of Section.
M 30	$8\frac{3}{4} \times 1\frac{1}{2}$	$\frac{1}{4}$	8.1	28
M 31	$8\frac{3}{4} \times 1\frac{9}{16}$	$\frac{5}{16}$	10.1	. . .
M 32	$8\frac{3}{4} \times 1\frac{5}{8}$	$\frac{3}{8}$	12.0	. . .
M 33	$12\frac{3}{16} \times 2\frac{3}{4}$	$\frac{3}{8}$	17.75	28
M 34	$12\frac{5}{16} \times 2\frac{1}{2}$	$\frac{7}{16}$	20.71	. . .
M 35	$12\frac{5}{16} \times 2\frac{7}{8}$	$\frac{1}{2}$	23.67	. . .

CHECKERED PLATES.

Section Index.	Width. Inches.	Thickness of Metal. Inches.	Weight per square foot. Lbs.	Page No. of Section.
M 51	34	$\frac{5}{16}$	13.8	28
M 52	34	$\frac{3}{8}$	16.3	. . .
M 53	34	$\frac{7}{16}$	18.9	. . .
M 54	34	$\frac{1}{2}$	21.4	. . .

CONSTRUCTIONAL DETAILS.

Fig. 1.

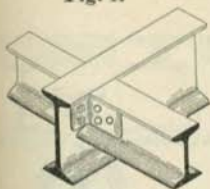

Fig. 2.

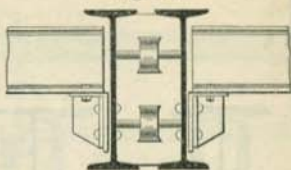

Fig. 3.



Fig. 4.

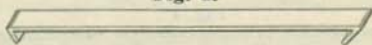

Fig. 5.

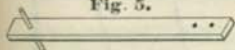

Fig. 6.

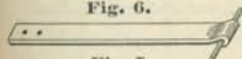

Fig. 7.



Fig. 8.

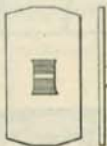

Fig. 9.

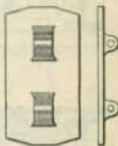

Fig. 10.

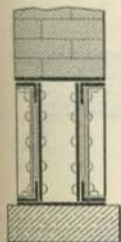

Fig. 11.

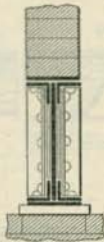

Fig. 12.

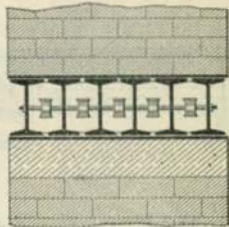

Fig. 13.



Fig. 14.



Fig. 15.



Fig. 16.



FIRE PROOF FLOORS

Fig. 1



Fig. 2

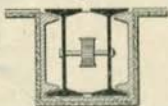

Fig. 3



Fig. 4

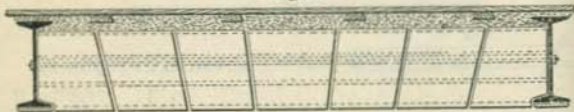

Fig. 5

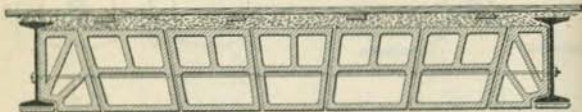

Fig. 6

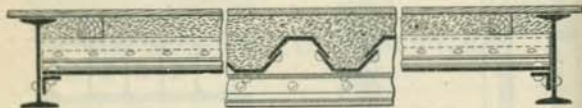
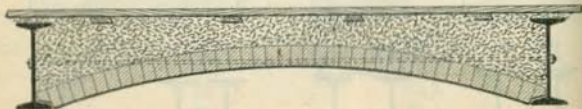

Fig. 7



FIRE-PROOF FLOORS, SUSPENDED CEILINGS AND PARTITIONS.

Fig. 1



Fig. 2

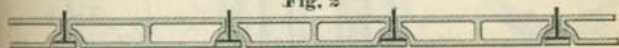

Fig. 3

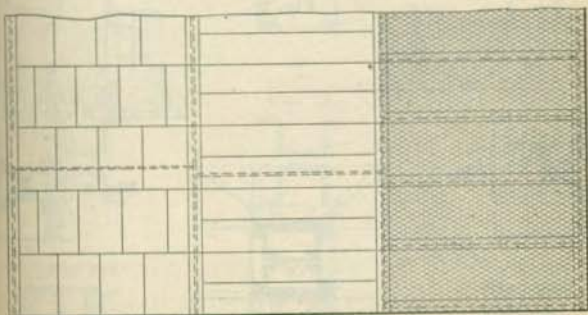
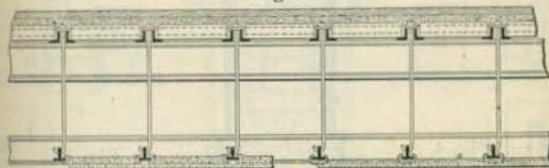
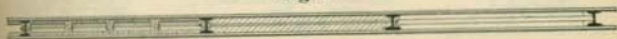

Fig. 4



SAFE  
LOAD  
PROP  
ERTIE

COL  
L  
R



DETAILS SHOWING FIRE-PROOFING AND BASES  
FOR Z-BAR COLUMNS.



Fig. 2

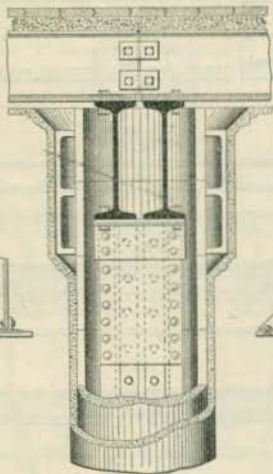

Fig. 1



Fig. 3

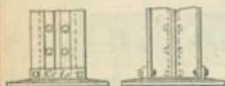

Fig. 4

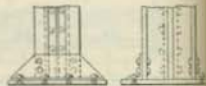

Fig. 7

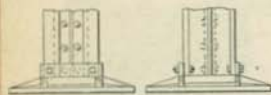
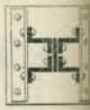

Fig. 5

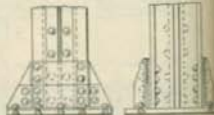

Fig. 8

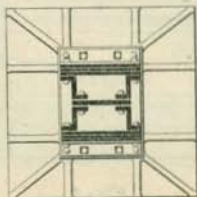
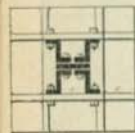
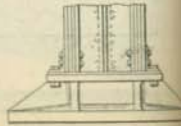
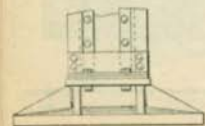

Fig. 6



BUILT COLUMN SECTIONS.

Fig. 1.



Fig. 2.



Fig. 3.



Fig. 4.



Fig. 5.



Fig. 6.

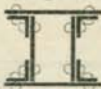

Fig. 7.



Fig. 8.



Fig. 9.



Fig. 10.



Fig. 11.



Fig. 12.



Fig. 13.



Fig. 14.



Fig. 15.



Fig. 16.



Fig. 17.



Fig. 18.



Fig. 19.



SAFE  
LOAD  
PROP  
ERTIE

COL

L  
r

TYPES OF CANTILEVERS.

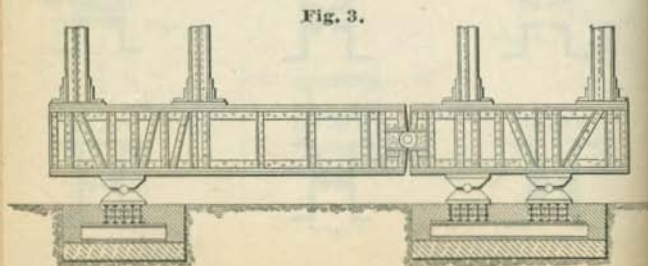
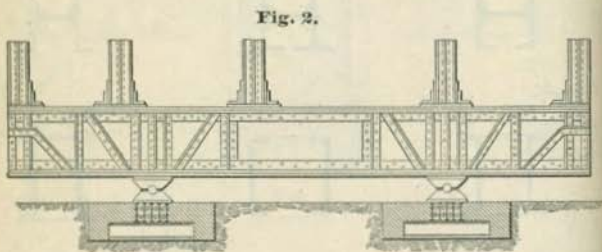
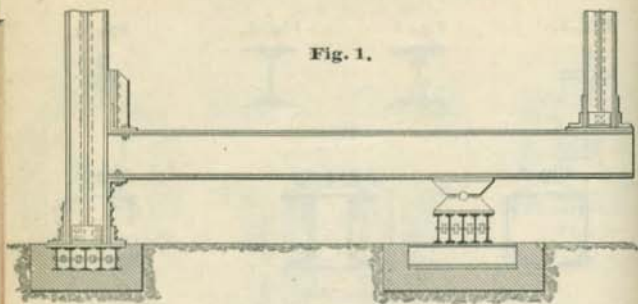

TYPES OF WIND BRACING.

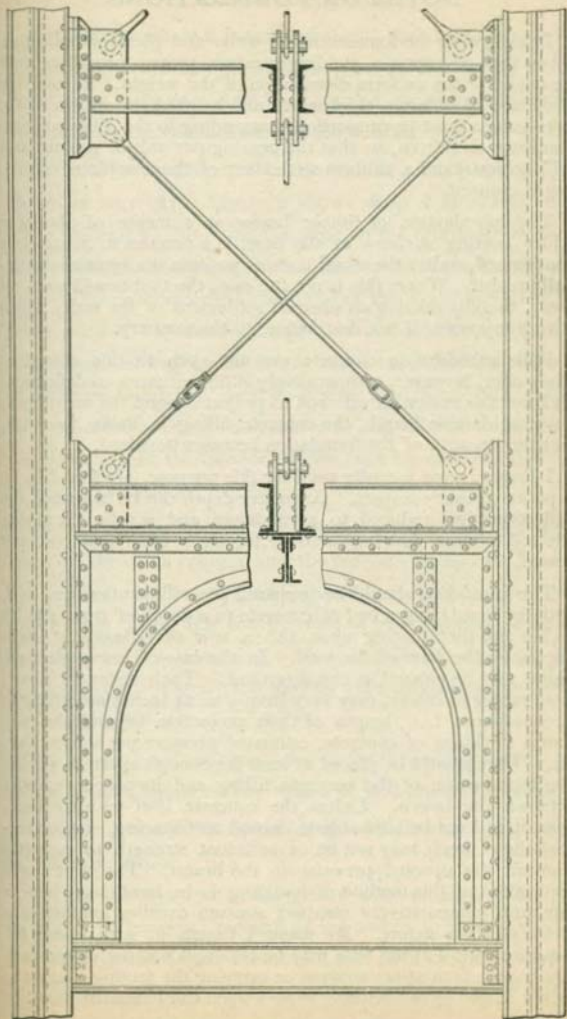

SAFE  
LOAD

PROP  
ERTIES

COLS

$\frac{L}{r}$

$\frac{H}{r}$

D  
M

## NOTES ON FOUNDATIONS.

In designing the foundations of walls and piers of buildings, when they rest upon a yielding stratum, proper provision must be made for the uniform distribution of the weight. In case the walls are of different thicknesses and heights, the widths of the foundations must be proportioned according to the different loads resulting therefrom, so that the bearing per unit of ground-area will be equal and a uniform settlement of the completed structure is ensured.

The introduction of timber beams as a means of obtaining wider bearing surfaces at the base, is a practice to be strongly condemned, unless the wood is in a position to remain continually moist. Where this is not the case, the timber will soon rot away, thereby causing an unequal settlement of the walls which is very injurious, if not destructive, to the masonry.

Rails imbedded in concrete are not open to this objection. They offer, however, comparatively little resistance to deflection, and for this reason, if allowed to project beyond the masonry to any considerable length, the concrete filling is liable to crack, and the strength of the foundation becomes impaired.

I-Beams, more recently used for this purpose, are found to be superior in every respect. A greater depth can be adopted, the deflection thus reduced to a minimum and a sufficient saving effected to more than compensate for their additional cost per pound.

The foundation should be prepared (see illustration pp. 168, 170) by first laying a bed of concrete to a depth of from 4 to 12 inches and then placing upon this a row of I-Beams at right angles to the face of the wall. In the case of heavy piers the beams may be crossed in two directions. Their distances apart, from center to center, may vary from 9 to 24 inches according to circumstances, *i. e.*, length of their projection beyond the masonry, thickness of concrete, estimated pressure per square foot, etc. They should be placed at least far enough apart to permit the introduction of the concrete filling and its proper tamping between the beams. Unless the concrete is of unusual thickness, it will not be advisable to exceed 20" spacing, since otherwise the concrete may not be of sufficient strength to properly transmit the upward pressure to the beams. The most useful application of this method of founding is in localities where a thin and comparatively compact stratum overlies another of a more yielding nature. By using I-Beams in such cases, the requisite spread at the base may be obtained without either penetrating the firm upper stratum or carrying the footing-courses to such a height as to encroach unduly upon the basement-room.

## CANTILEVERS.

In buildings where it is not desirable to undermine the adjoining property, or where the building laws do not permit of the foundations being carried under the same, cantilever girders are used to carry the columns next to the building line.

Three different designs of cantilevers, as actually applied, are shown on page 55. Figure 1 shows deep steel beams, used when the load on the columns resting on the cantilever produces such bending moments as can be taken up by the beams; it also shows a connection for the other end of the cantilever to an interior column. Evidently, the product obtained by multiplying the load on the interior column by the distance from its center to the fulcrum foundation must be greater than that of the load on the wall column times its distance to the fulcrum foundation. Should it be less, the interior column must be anchored down to an especially designed foundation.

The load on the fulcrum foundation is equal to the sum of the loads on the wall column and the reaction of the cantilever at the interior column. Figure 2 shows a method of cantilever construction where it is not desirable to have a separate foundation under each column and a heavy box girder of suitable design is used to transmit the various column loads to two independent foundations.

The reaction on foundations due to the different column loads can be quickly determined by means of well known formulae.

In figure 3 is shown a special design which avoids the use of a continuous girder.

The stresses in a continuous girder with supports fixed can be readily determined; but as it is impossible to fix the supports *i. e.* to prevent unequal settlement, this form of girder should be avoided if possible. There are, however, conditions which

SAFE  
LOADPROP  
ERTIES

COLS

L  
r

M

I  
M

make their application desirable. On the other hand, a simple cantilever admits of easy calculation and adapts itself to any slight settlements that may occur without materially affecting the reactions on the foundations or changing the stresses in the girder.

An important feature in connection with cantilever construction is to adopt a pin support in place of resting the cantilever beam directly on the top course of the foundation beams. For, if the cantilever rests directly upon the upper course of foundation beams without a pin support, the outer beam nearest the wall column will be strained more than any of the others, and thus the center of pressure will not be exactly in the middle of the foundation as it should be.

The extra cost involved in the two shoes and pin is very small as compared to the desirability of having the center of pressure in the center of the foundation.

The shoes for ordinary loads and conditions are made solid of cast iron and the pin of steel. The height of each shoe should not be less than 6" and the pin  $2\frac{1}{2}$ " diameter. Each individual case should be figured by itself.

The pin need be figured for bearing only, as it extends through the whole length of the casting. A clearance of  $\frac{1}{2}$ " to 1" is given between the cast shoes, which are always faced, and the hole bored to suit the pin.

## NOTES ON WIND BRACING.

On page 56 are shown two types of wind bracing used in buildings. The upper one shows the method of bracing usually applied where no openings such as doors and windows occur. This construction has adjustable diagonals properly fastened to the adjacent columns in the building. The horizontal components of the stresses in the diagonals are taken up by means of two latticed channel bars located in the floor system of the different floors. The vertical components are taken up by the columns themselves and must be added to the other loads to which the columns are subjected. In this calculation care should be taken to provide for such design as to avoid eccentric stresses on the columns. Should the design be such as to cause these stresses, the columns must be figured accordingly.

If desirable, the diagonals may run through one floor and attach to the columns at the floors above and below the intermediate floor; thus in some instances passage ways can be obtained.

The other type of wind bracing shows what is known as portal bracing. This arch design recommends itself for use in buildings where the diagonal system cannot be applied on account of lack of room. It is usually placed between adjacent columns in halls or passage ways and extends from the foundations up, from floor to floor, to such a height that the stability of the building itself is sufficient to resist the assumed wind pressure. In general, wind bracing should be placed, if the building is square or nearly so, close to the corners; if of a parallelogram shape, in the direction parallel with the least width and at such points as to equally divide the stresses in all the panels. In case neither of the above methods can be applied, brackets should be used at each floor level or a continuous deep beam or girder carried all around the building. In either case the number of rivets fastening the columns and girders should be carefully figured, as upon the value of the resistance of these rivets, as well as the girders and brackets, depends the stability of the structure. In the last two mentioned methods the columns will all be subject to a bending stress which should be added to the other loads of the columns. Besides this they will be subject to vertical loads resulting from the resistance they offer to the overturning moment of the wind against the structure.

SAFE  
LOADPROP  
ERTIES

COL

L  
r



## GIRDERS IN BUILDINGS.

In the design of a building, cases may occur where a single I-Beam girder will not answer. It may be found desirable to increase the length of the spans so as to reduce the number of supporting columns to a minimum, or perhaps heavy concentrated loads, such as columns, brick walls, etc., will render single I-Beam girders inadequate. On page 50, Figs. 10 to 16 inclusive, are shown various forms of girders that may be used in such cases. Where the ends of the girders rest upon the wall, steel bearing plates (Figs. 11 and 12) should be used to distribute the pressure over a greater surface and thereby prevent the crushing of the material in the wall directly under the girder. A table of standard wall plates is given on page 179. In some cases a large, tough stone will answer without the plates (Fig. 10), but where the pressure is heavy, both plates and stone should be used (Fig. 12).

The allowed pressure per square foot for first class brick work should not exceed eleven tons and for ordinary masonry eighteen tons.

For spanning openings in brick walls, girders composed of two or more I-Beams connected by bolts and separators (Figs. 12 and 15, page 50) are most commonly used.

Where the bricks have been laid regularly, the probable line of rupture, if the girder should fail, will be found to be inside of the sides of an isosceles triangle whose base is the span and whose height is  $\frac{1}{3}$  of the span. In order to be entirely on the safe side, the weight of wall between vertical lines directly over the girder for a height equal to that of the triangle is frequently adopted as the load to be carried. It should be noted, however, that for green walls or walls having openings this rule does not apply.

Placing the weight of brick work at 112 lbs. per cubic foot, the weights per superficial foot for different walls are as follows:

For 9" wall . . . . .	84 lbs.
" 13 " . . . . .	121 "
" 18 " . . . . .	168 "
" 22 " . . . . .	205 "
" 26 " . . . . .	243 "

## GENERAL NOTES ON FLOORS.

Examples of floor joists and their connections of common occurrence are shown on page 50, Figures 1 and 2. Girders consisting of two I-Beams or more, side by side, as in Figures 12 and 15, should be connected by means of bolts and cast-iron separators fitting closely between the flanges of the beams. The office of these separators is, in a measure, to hold in position the compression flanges of the beams, preventing side deflection or buckling and to unite the two beams so as to cause them to act in unison as regards vertical deflection. Separators should be provided near the supports and at points where heavy loads are imposed, otherwise at regular intervals of from 5 to 6 feet; these are shown in Figures 8 and 9. Complete tables for the weights of separators for I-Beams are given on page 181.

On page 50, Figures 1 and 2 show different methods of connecting beams with each other. Figure 1 represents the floor beam coped to the girder and joined to it by the means of a pair of connecting angles, which are usually riveted to the floor beam and bolted to the girder. Notes on standard sizes of these connecting angles and the number of bolts and rivets required for all sizes of I-Beams and Channels are given with illustrations on pages 182 and 183. Figure 2 shows the floor beam resting on shelf angles riveted to the girder. Stiffening angles are usually placed under these shelf angles to take up the bending in the same and should contain a sufficient number of rivets to take up the end reaction of the floor beam. This method is usually adopted to facilitate the work of erection when the girders are composed of two or more beams and of sufficient depth to allow the floor beam to abut against the girder without being coped.

The old method of constructing fire-proof floors in buildings is by means of brick arches. These usually consist of a single 4''

SAFE  
LOADPROP  
ERTIE

COL

L  
Y

course of brick with a rise at the center of 3 or 4 inches and resting on the lower flanges of the I-Beams against brick skew-backs. This method of construction is illustrated on page 51, Figure 7. In case the floor is designed for very heavy loads, several courses of brick should be used. The floor beams should be placed about 5 or 6 feet, center to center. A convenient device for centering the arches consists of wooden frames, called centers, suspended by iron hooks from the lower flanges of the beams and detachable on one side so that they may be shifted at pleasure as the work progresses. The space above the arches is filled with concrete in which are embedded wooden strips for securing the flooring. To finish the ceiling below plaster is generally applied on the bottom of the arches directly to the brick work. The horizontal thrust of the arches is provided for by the use of tie rods from  $\frac{5}{8}$ " to  $\frac{7}{8}$ " diameter spaced along the center line of the beams, or a little below, at regular intervals of from 5 to 7 feet. The thrust of these arches per lineal foot can be found

by the formula  $T = \frac{1.5WL^2}{R}$  in which W is equal to the load per square foot, R the rise of the arch in inches and L the span in feet. The tie rods in the arch abutting against the wall are securely anchored to the wall; an angle, channel or simply a wall plate can be used to support the arch and to properly distribute the load upon the wall. The weight of a fire-proof floor of this description, that is of 4" brick arches, concrete and flooring, exclusive of the weight of the beams, will average about 70 pounds per square foot.

Corrugated sheets may be used instead of the brick arches. They are placed against the lower flanges of the I-Beams and thus securely held in position, while the space above is filled with grouting. Tie rods are used the same as in the previous case. The distance between beams should be limited to 5 or 6 feet.

The corrugated sheets are usually left exposed below to form the ceiling, and are thus open to the objection that the moisture in the atmosphere may condense upon the surface of the sheets in sufficient quantities to drop into the room below. Ceilings of this kind should therefore be restricted in their use, or the sheets properly protected from contact with the air.

Two modern types of fire-proof floor constructions which have grown in favor so rapidly as to be used now almost to the exclusion of all others are illustrated on page 51, Figures 4 and 5. The arches in this case are formed of hollow blocks consisting of burnt fire-clay or similar refractory material. These are furnished by the manufacturers in a great variety of patterns and of a strength to meet the desired requirements.

In regard to their composition, there may be said to exist two distinct varieties.

In the first, known as hollow pottery, the material consists of burnt fire-clay and differs from the second variety, called "porous earthenware," in being thinner, harder and more compact.

In the second variety, the clay before it is burnt is mixed with sawdust and finely cut straw which, being consumed during the process of burning, leaves the material in a finely honeycombed state.

Figures 4 and 5 on page 51 show two methods of construction of hollow pottery and porous earthenware arches. The method illustrated by Figure 4 is the later and better.

From tests recently made it appears that this latter construction gives the best results in regard to strength. This is evidently due to the fact that the full section of the material is placed in its most advantageous position to take the direct pressure coming thereon.

SAFE  
LOADPROP  
ERTIES

COLS

L  
Y

When used in floor construction both varieties of arches are backed to the depth of several inches with concrete in which are embedded wooden strips to which the floor planking is secured. The joints should be made radial and the blocks should be thoroughly cemented together. They are made to project about 1 inch below the bottom flange of the I-Beams, which are further protected by the insertion of a thin strip of tile. The weight and cost of both hollow pottery and porous earthenware are about the same, and through their superior lightness they possess an important advantage over the brick arch. The saving in weight amounts to from 40 to 50 per cent., thus warranting more economical proportions for the steel framing, while in other respects the cost of this construction is about the same. The weight of these arches per square foot of floor without plastering, concrete or flooring is about as follows :

12'' arches used for warehouses	45 lbs.
10'' " " " theatres	36 lbs.
8'' " " " office buildings	30 lbs.
6'' " " " light purposes	22 lbs.

It is to be noted that such fire-proof floors, as fill the spaces between the floor beams, together with the tie rods forming a thoroughly braced floor, are better suited to meet the conditions of a high structure than if the spaces between the beams are not braced, as it is through this stiffness that wind stresses are more equally distributed to all the columns.

Horizontal bracing by means of diagonal rods or bars laid in the floor system should be avoided on account of difficult details of connections. This is not necessary if a proper fire-proof floor, as outlined above, is adopted.

Fig. 6, page 51, shows a type of fire-proof floor composed of Carnegie trough sections ; this style of floor is used in buildings

where extremely heavy loads must be sustained and also for railway bridges.

The following are the usual assumptions made in good practice for superimposed loads :

Floors of dwellings and offices	70 lbs. per sq. ft.
“ “ churches, theatres and ball rooms	125 lbs. “ “ “
“ “ warehouses	200 to 250 lbs. “ “ “
“ for heavy machinery	250 to 400 lbs. “ “ “

The building laws of many of our large cities have recently fixed superimposed loads for floors in buildings depending upon the purpose for which the building is to be used, and it is for these loads that the floors must be designed. In general they compare favorably with the above.

Where girders extend below bottom of floor beams they are made fire-proof by surrounding them with hollow earthenware blocks especially made to fit the bottom of the beams, as shown on page 51, Figures 1, 2 and 3.

Examples of fire-proof tile construction, as applied to ceilings and roofs, are given on page 52. In Figure 2 the Tees are suspended from the lower flanges of the I-Beams at intervals of 12" or 15" and support a layer of very thin tile, weighing about 5 pounds per square foot, to which the plastering is applied. For roofs somewhat heavier Tees are used, resting on the top flanges of the I-Beams and spaced about 18" apart. The tiling, weighing about 10 lbs. per square foot, may be covered with concrete, then with a layer of felt and gravel, or in the case of slate roofs, the slate may be nailed directly to the tiling.

In Figure 3 is shown a new type of suspended ceiling which recommends itself for easy erection. Upon the rafter beams are placed light purlin angles between which are hung rods for supporting the ceiling Tees.

SAFE  
LOAD

PROP  
ERTIE

COL

L  
r

H

Between the purlin angles are laid tile, then a course of concrete to level up and two coats of asphalt. Upon the ceiling Tees are placed like tiles; or metal lath can be wired directly to them on which the plastering is applied.

A semi-fire-proof construction which may be used to advantage in dwellings is shown on page 52, Figure 1, and consists of angles resting on the top of the floor beams and supporting wooden strips. The finished floor can be directly nailed on these latter, which are spaced from 12 to 16 inches apart. The ceiling is composed of wire lathing, which is fastened to Tees suspended from the floor beams and spaced about 16" apart. The plastering is applied directly to the wire lathing, and thus a level ceiling is obtained.

Wire lathing can also be used to good advantage in fire-proofing columns and girders, and has shown itself to be of great utility in many instances where hollow pottery could not be used.

On page 52, Figure 4, is given an elevation and section of three methods used in the construction of fire-proof partitions. One consists of the ordinary fire-proof square blocks, set with broken joints and held at intervals with light I-Beams, which take the place of wood studding.

In the second method, the space between the I-Beams is filled with a material called plaster boards. The third method consists of wire lathing attached to the flanges of the I-Beams and stiffened at intervals of 2 feet with angles. In all these methods plastering is applied directly to the surfaces in the usual manner.

## EXPLANATION OF TABLES ON SAFE LOADS AND SPACING FOR CARNEGIE SECTIONS.

PAGES 72 to 92 INCLUSIVE.

The tables on pages 73 to 75 for I-Beams give the loads which a beam will carry safely (distributed uniformly over its length) for the distances between supports indicated. These loads include the weight of the beam which must be deducted in order to arrive at the *net load* which the beam will carry. On pages 76 to 84 will also be found the safe loads for other sections.

For beams of heavier sections than those calculated in the tables, a separate column of corrections is given for each size, stating the proper increase of safe load for every additional pound in the weight per foot of beam. The values given are based on a maximum fiber stress of 16,000 lbs. per square inch.

It has been assumed in these tables that proper provision is made for preventing the compression flanges of the beams from deflecting sideways. They should be held in position at distances not exceeding twenty times the width of the flange, otherwise the stress allowed should be reduced as per table, page 71.

In some instances, *deflection* rather than *absolute strength* may become the governing consideration in determining the size of beam to be used. For beams carrying plastered ceilings, for example, it has been found by practical tests that, if the deflection exceeds  $\frac{1}{360}$ th of the distance between supports, or  $\frac{1}{360}$ th of an inch per foot of this distance, there is danger of the ceiling cracking.

A table of deflections of Carnegie sections is given on page 72. It may generally be assumed both for rolled and built

SAFE  
LOADPROP  
ERTIES

COLS

L  
r

M

I  
A



beams that this limit is not exceeded so long as the depth of the beam is not less than  $\frac{1}{20}$ th of the distance between supports ( $\frac{5}{8}$  inch per foot). This limit is indicated in the following tables by cross lines beyond which the beams should not be used, if intended to carry plastered ceilings, unless the allowable loads given in the tables are reduced. There is an element of safety not taken into account in the tables, viz., the fact that the dead load of the floor is carried by the beams before the plaster is applied; consequently, only the deflection due to the live load is liable to cause damage to the plaster. The following method can be used to obtain the reduced loads:

*Multiply the load given immediately above the cross line by the square of the corresponding span and divide by the square of the required span; the result will be the required load. See example III., page 71.*

Inasmuch as the carrying capacity of beams increases largely with their depth and it is, therefore, economical to use the greatest depth of beam consistent with the other conditions to which it is necessary to conform (as clear height, etc.), the above cases of extreme deflection will rarely be met with in practice.

The tables on pages 85 to 92 inclusive for I-Beams give the proper spacing, center to center of beams, for loads varying from 100 to 175 lbs. per square foot and for spans ranging in length from 5 to 30 feet. The spacing of beams is inversely proportionate to the loads; therefore, for a load not given in the table, as for instance 200 lbs. per square foot, divide the spaces given for 100 lbs. per square foot by 2, etc.

## EXAMPLES.

I. What will be the most economical arrangement of floor beams and girders for carrying a load of 150 lbs. including weight of floor, assuming floor to be supported by brick arches resting between the beams and carrying a plastered ceiling below?

*Answer:* The spacing of floor beams for brick arches, as stated above, should not exceed 6 feet. Referring to pages 89 and 90 we find the *deepest* I-Beam corresponding to this space (above horizontal cross lines) to be a 9'' I 21.0 lbs. with a length of span of 15 feet. The girders to which the floor beams are framed should, therefore, be spaced 15 feet apart, and from the table we find that either a 20'' I 65 lbs. 23 feet long, or a 15'' I 42 lbs. 16 feet long will answer. By using the former the number of supporting columns will be reduced, but the weight of the girders increased. The relative cost must be determined by the circumstances of the case, *i. e.*, length of columns, etc. The headroom required may render it necessary to use a double girder of shallower beams, say 2—10'' I-Beams 25 lbs. 15 feet long.

II. What size and weight of beam 19' 6'' long in clear between walls and, therefore, 20' 0'' long between centers of supports will be required to carry safely a uniformly distributed load of 17 tons, the weight of the beam included?

*Answer:* From the table of safe loads of I-Beams a 15'' I 42 lbs. will carry safely for a span of 20 feet 15.71 tons, or 1.29 tons less than required in this case. From the next column we find that for every pound increase in weight of beam we may add 0.20 tons to the load. Hence, for 1.29 tons we must increase the weight per foot of beam by  $1.29 \div .20 = 6.4$  lbs. *i. e.*, the beam required should weigh  $42 + 6.4 = 48.4$  lbs. per

SAFE  
LOADPROP  
ERTIES

COL

L  
r

foot, but as this weight is not rolled the beam to be used should weigh 50 lbs.

III. What load uniformly distributed, including its own weight, will a 15" I-Beam weighing 60.0 lbs. per foot carry for a span of 30 feet without deflecting sufficiently to endanger a plastered ceiling?

*Answer:* From the table for safe loads of I-Beams, we find at the limit indicated for plastered ceilings that a 15" 60.0 lb. beam will carry safely a uniform load of 17.32 tons over a span of 25 feet. In order not to give rise to undue deflection, the safe load for a 30 foot span, according to the rule given on page 69, will be  $\frac{17.32 \times 25^2}{30^2} = 12.03$  tons.

BEAMS WITHOUT LATERAL SUPPORT.

Length of Beam,	Proportion of Tabular Load Forming Greatest Safe Load.
20 times flange width.	Whole tabular load.
30 " " "	$\frac{9}{10}$ " "
40 " " "	$\frac{8}{10}$ " "
50 " " "	$\frac{7}{10}$ " "
60 " " "	$\frac{6}{10}$ " "
70 " " "	$\frac{5}{10}$ " "

DEFLECTION COEFFICIENTS FOR CARNEGIE SHAPES GIVEN IN 64ths OF AN INCH.

Coefficient Index.	Distance between Supports in Feet.								
	6	8	10	12	14	16	18	20	22
C. S. .	38.1	67.8	105.9	152.5	207.6	271.2	343.2	423.7	512.7
C' S. .	29.8	53.0	82.8	119.2	162.2	211.8	268.1	331.0	400.5

Coefficient Index.	Distance between Supports in Feet.								
	24	26	28	30	32	34	36	38	40
C. S. .	610.2	716.1	830.5	953.4	1085.0	1225.0	1373.0	1530.	1695.
C' S. .	476.6	559.4	648.8	744.8	847.4	956.6	1073.0	1195.	1324.

Figures given opposite C. S. and C' S. are the deflection coefficients for steel shapes, subject to transverse strain for varying spans under their maximum uniformly distributed safe loads, derived from a fiber stress of 16,000 and 12,500 respectively; the modulus of elasticity being taken at 29,000,000.

To find the deflection of any symmetrical shape used as a Beam under its corresponding safe load divide the coefficients given in the above tables by the depth of the Beam. This applies to such shapes as I-Beams, Channels, Z-Bars, etc. For those Beams having unsymmetrical axes, such as Tees, Angles, etc., divide by twice the greatest distance of the neutral axis from the outside fiber.

EXAMPLE :—Required the deflection of a 12" I-Beam 31.5 lbs. 20 ft. span under its maximum uniformly distributed safe load of 9.59 tons, as given on page 74. The above tables give 423.7 as the deflection coefficient; dividing this by 12 gives 35.3 as the required deflection in 64ths of an inch.

For deflections due to different systems of loading see page 98.

SAFE LOAD

PROP  
ERTIC

COL

L  
Y

SAFE LOADS UNIFORMLY DISTRIBUTED  
FOR STANDARD AND SPECIAL  
I-BEAMS.

IN TONS OF 2,000 LBS.

Distance between Supports in feet.	24" I		20" I		Add for every lb. increase in weight.	18" I		15" I			Add for every lb. increase in weight.
	80 lbs.	Add for every lb. increase in weight.	80 lbs.	65 lbs.		55 lbs.	Add for every lb. increase in weight.	80 lbs.	60 lbs.	42 lbs.	
12	77.33	.53	65.18	51.98	.44	39.29	.39	47.14	36.09	26.18	.33
13	71.38	.48	60.16	47.98	.40	36.27	.36	43.51	33.31	24.17	.30
14	66.28	.45	55.87	44.56	.37	33.68	.34	40.40	30.93	22.44	.28
15	61.86	.42	52.14	41.59	.35	31.43	.31	37.71	28.87	20.94	.26
16	58.00	.39	48.88	38.99	.33	29.47	.29	35.35	27.07	19.63	.24
17	54.58	.37	46.01	36.69	.31	27.74	.28	33.27	25.47	18.48	.23
18	51.56	.35	43.45	34.66	.29	26.19	.26	31.42	24.06	17.45	.22
19	48.84	.33	41.17	32.83	.28	24.82	.25	29.77	22.79	16.53	.21
20	46.40	.32	39.11	31.19	.26	23.58	.24	28.28	21.65	15.71	.20
21	44.19	.30	37.24	29.70	.25	22.45	.22	26.94	20.62	14.96	.19
22	42.18	.29	35.55	28.35	.24	21.43	.21	25.71	19.68	14.28	.18
23	40.35	.27	34.01	27.12	.23	20.50	.20	24.59	18.83	13.66	.17
24	38.67	.26	32.59	25.99	.22	19.65	.20	23.57	18.04	13.09	.16
25	37.12	.25	31.29	24.95	.21	18.86	.19	22.63	17.32	12.57	.16
26	35.69	.24	30.08	23.99	.20	18.14	.18	21.76	16.66	12.08	.15
27	34.37	.23	28.97	23.10	.19	17.46	.17	20.95	16.04	11.64	.14
28	33.14	.23	27.93	22.28	.19	16.84	.17	20.20	15.47	11.22	.14
29	32.00	.22	26.97	21.51	.18	16.26	.16	19.51	14.93	10.83	.13
30	30.93	.21	26.07	20.79	.17	15.72	.16	18.86	14.43	10.47	.13
31	29.94	.20	25.23	20.12	.17	15.21	.15	18.25	13.97	10.13	.13
32	29.00	.20	24.44	19.49	.16	14.73	.15	17.68	13.53	9.82	.12
33	28.12	.19	23.70	18.90	.16	14.29	.14	17.14	13.12	9.52	.12
34	27.29	.19	23.00	18.35	.15	13.87	.14	16.64	12.74	9.24	.11
35	26.51	.18	22.35	17.82	.15	13.47	.13	16.16	12.37	8.98	.11
36	25.78	.18	21.73	17.33	.15	13.10	.13	15.71	12.03	8.73	.11

Safe loads given include weight of beam. Maximum fiber stress  
16,000 lbs. per square inch.

THE CARNEGIE STEEL COMPANY, LIMITED.

**SAFE LOADS UNIFORMLY DISTRIBUTED  
FOR STANDARD AND SPECIAL  
I-BEAMS.**

IN TONS OF 2,000 LBS.

Distance between Supports in feet.	12" I		Add for every lb. increase in weight.	10" I	Add for every lb. increase in weight.	9" I	Add for every lb. increase in weight.	Distance between Supports in feet.	8" I	Add for every lb. increase in weight.
	40 lbs.	31.5 lbs.		25 lbs.		21 lbs.			18 lbs.	
12	19.92	15.99	.26	10.85	.22	8.39	.20	5	15.17	.42
13	18.39	14.76	.24	10.02	.20	7.74	.18	6	12.64	.35
14	17.08	13.70	.23	9.30	.19	7.19	.17	7	10.84	.30
15	15.94	12.79	.21	8.68	.17	6.71	.16	8	9.48	.26
16	14.94	11.99	.20	8.14	.16	6.29	.15	9	8.43	.23
17	14.06	11.29	.19	7.65	.15	5.92	.14	10	7.59	.21
18	13.28	10.66	.18	7.24	.14	5.59	.13	11	6.90	.19
19	12.58	10.10	.17	6.86	.14	5.30	.12	12	6.32	.18
20	11.95	9.59	.16	6.51	.13	5.03	.12	13	5.83	.16
21	11.38	9.14	.15	6.20	.12	4.79	.11	14	5.42	.15
22	10.87	8.72	.14	5.92	.12	4.58	.11	15	5.06	.14
23	10.39	8.34	.14	5.66	.11	4.38	.10	16	4.74	.13
24	9.96	7.99	.13	5.43	.11	4.19	.10	17	4.46	.12
25	9.56	7.67	.13	5.21	.10	4.03	.09	18	4.21	.12
26	9.19	7.38	.12	5.01	.10	3.87	.09	19	3.99	.11
27	8.85	7.11	.12	4.82	.10	3.73	.09	20	3.79	.11
28	8.54	6.85	.11	4.65	.09	3.59	.08	21	3.61	.10
29	8.24	6.62	.11	4.49	.09	3.47	.08	.	.	.
30	7.97	6.40	.11	4.34	.09	3.36	.08	.	.	.

Safe loads given include weight of beam. Maximum fiber stress 16,000 lbs. per square inch.

SAFE LOAD

PROP  
ERTIES

COLS

L  
r

H

D  
M

SAFE LOADS UNIFORMLY DISTRIBUTED  
FOR STANDARD AND SPECIAL  
I-BEAMS.

IN TONS OF 2,000 LBS.

Distance between Supports in feet.	7" I		6" I		5" I		4" I.		3" I	
	15 lbs.	Add for every lb. increase in weight.	12.25 lbs.	Add for every lb. increase in weight.	9.75 lbs.	Add for every lb. increase in weight.	7.5 lbs.	Add for every lb. increase in weight.	5.5 lbs.	Add for every lb. increase in weight.
5	11.04	.36	7.75	.31	5.16	.26	3.18	.21	1.76	.16
6	9.20	.30	6.46	.26	4.30	.22	2.65	.18	1.47	.13
7	7.89	.26	5.54	.22	3.69	.19	2.27	.15	1.26	.11
8	6.90	.23	4.84	.19	3.23	.16	1.99	.13	1.10	.10
9	6.13	.20	4.31	.17	2.87	.14	1.77	.12	0.98	.09
10	5.52	.18	3.88	.16	2.58	.13	1.59	.11	0.88	.08
11	5.02	.16	3.52	.14	2.35	.12	1.45	.10	0.80	.07
12	4.60	.15	3.23	.13	2.15	.11	1.33	.09	0.73	.07
13	4.25	.14	2.98	.12	1.98	.10	1.22	.08	0.68	.06
14	3.94	.13	2.77	.11	1.84	.09	1.14	.08	0.63	.06
15	3.68	.12	2.58	.10	1.72	.09	1.06	.07	0.59	.05
16	3.45	.11	2.42	.10	1.61	.08	0.99	.07	0.55	.05
17	3.25	.11	2.28	.09	1.52	.08	0.94	.06	0.52	.05
18	3.07	.10	2.15	.09	1.43	.07	0.88	.06	0.49	.04
19	2.91	.09	2.04	.08	1.36	.07	0.84	.06	0.46	.04
20	2.76	.09	1.94	.08	1.29	.07	0.80	.05	0.44	.04
21	2.63	.09	1.85	.07	1.23	.06	0.76	.05	0.42	.04

Safe loads given include weight of beam. Maximum fiber stress  
16,000 lbs. per square inch.

## SAFE LOADS UNIFORMLY DISTRIBUTED FOR STANDARD AND SPECIAL CHANNELS.

IN TONS OF 2,000 LBS.

Distance between Supports in feet.	15" C	Add for every lb. increase in weight.	12" C	Add for every lb. increase in weight.	10" C	Add for every lb. increase in weight.	9" C	Add for every lb. increase in weight.
	33 lbs.		20.5 lbs.		15 lbs.		13.25 lbs.	
10	22.23	.39	11.39	.32	7.14	.26	5.61	.24
11	20.20	.35	10.35	.29	6.49	.24	5.10	.21
12	18.52	.33	9.49	.26	5.95	.22	4.68	.20
13	17.10	.30	8.76	.24	5.49	.20	4.32	.18
14	15.87	.28	8.14	.23	5.10	.19	4.01	.17
15	14.82	.26	7.59	.21	4.76	.17	3.74	.16
16	13.89	.24	7.12	.20	4.46	.16	3.51	.15
17	13.07	.23	6.70	.18	4.20	.15	3.30	.14
18	12.35	.22	6.33	.18	3.96	.14	3.12	.13
19	11.70	.21	5.99	.17	3.76	.14	2.95	.12
20	11.11	.20	5.70	.16	3.57	.13	2.81	.12
21	10.58	.19	5.42	.15	3.40	.12	2.67	.11
22	10.10	.18	5.18	.14	3.24	.12	2.55	.11
23	9.66	.17	4.95	.14	3.10	.11	2.44	.10
24	9.26	.16	4.75	.13	2.97	.11	2.34	.10
25	8.89	.16	4.56	.13	2.85	.10	2.24	.09
26	8.55	.15	4.38	.12	2.74	.10	2.16	.09
27	8.23	.14	4.22	.12	2.64	.10	2.08	.09
28	7.94	.14	4.07	.11	2.55	.09	2.00	.08
29	7.66	.13	3.93	.11	2.46	.09	1.93	.08
30	7.41	.13	3.80	.11	2.38	.09	1.87	.08

Safe loads given include weight of channel. Maximum fiber stress 16,000 lbs. per square inch.

PROP  
ERTIES

COLS

L  
Y

H

D  
M



SAFE LOADS UNIFORMLY DISTRIBUTED  
FOR STANDARD AND SPECIAL  
CHANNELS.

IN TONS OF 2,000 LBS.

Distance between Supports in feet.	8" C		7" C		6" C		5" C		4" C		3" C	
	11.25 lbs.	Add for every lb. increase in weight.	9.75 lbs.	Add for every lb. increase in weight.	8 lbs.	Add for every lb. increase in weight.	6.5 lbs.	Add for every lb. increase in weight.	5.25 lbs.	Add for every lb. increase in weight.	4 lbs.	Add for every lb. increase in weight.
5	8.61	.42	6.68	.36	4.62	.31	3.16	.26	2.02	.21	1.16	.16
6	7.18	.35	5.57	.30	3.85	.26	2.63	.22	1.68	.18	.97	.13
7	6.15	.30	4.77	.26	3.30	.22	2.26	.19	1.44	.15	.83	.11
8	5.38	.26	4.18	.23	2.89	.19	1.98	.16	1.26	.13	.73	.10
9	4.78	.23	3.71	.20	2.57	.17	1.76	.14	1.12	.12	.64	.09
10	4.31	.21	3.34	.18	2.31	.16	1.58	.13	1.01	.11	.58	.08
11	3.91	.19	3.04	.16	2.10	.14	1.44	.12	.92	.10	.53	.07
12	3.59	.18	2.78	.15	1.93	.13	1.32	.11	.84	.09	.48	.07
13	3.31	.16	2.57	.14	1.78	.12	1.22	.10	.78	.08	.45	.06
14	3.08	.15	2.39	.13	1.65	.11	1.13	.09	.72	.08	.41	.06
15	2.87	.14	2.23	.12	1.54	.10	1.05	.09	.67	.07	.39	.05
16	2.69	.13	2.09	.11	1.44	.10	.99	.08	.63	.07	.36	.05
17	2.53	.12	1.96	.11	1.36	.09	.93	.08	.59	.06	.34	.05
18	2.39	.11	1.86	.10	1.28	.09	.88	.07	.56	.06	.32	.04
19	2.27	.11	1.76	.09	1.22	.08	.83	.07	.53	.06	.31	.04
20	2.15	.11	1.67	.09	1.16	.08	.79	.07	.51	.05	.29	.04
21	2.05	.10	1.59	.09	1.10	.07	.75	.06	.48	.05	.28	.04
22	1.96	.10	1.52	.08	1.05	.07	.72	.06	.46	.05	.26	.04
23	1.87	.09	1.45	.08	1.00	.07	.69	.06	.44	.05	.25	.03
24	1.79	.09	1.39	.08	.96	.06	.66	.05	.42	.04	.24	.03
25	1.72	.08	1.34	.07	.92	.06	.63	.05	.40	.04	.23	.03

Safe loads given include weight of channel. Maximum fiber stress  
16,000 lbs. per square inch.

## SAFE LOADS IN TONS OF 2,000 POUNDS UNIFORMLY DISTRIBUTED FOR STANDARD Z-BARS.

Size, Inches.	Thickness of Metal.	Distance between Supports in Feet.									
		4	5	6	7	8	9	10	12	14	16
6	$\frac{3}{8}$	11.25	9.00	7.50	6.43	5.63	5.00	4.50	3.75	3.21	2.81
$6\frac{1}{8}$	$\frac{7}{16}$	13.11	10.48	8.73	7.48	6.55	5.82	5.24	4.37	3.74	3.28
$6\frac{1}{2}$	$\frac{1}{2}$	14.96	11.97	9.97	8.55	7.48	6.65	5.99	4.99	4.28	3.74
6	$\frac{9}{16}$	15.40	12.32	10.27	8.80	7.70	6.84	6.16	5.13	4.40	3.85
$6\frac{1}{8}$	$\frac{5}{8}$	17.09	13.67	11.40	9.76	8.55	7.60	6.84	5.70	4.88	4.27
$6\frac{1}{2}$	$\frac{11}{16}$	18.80	15.04	12.53	10.74	9.40	8.36	7.52	6.27	5.37	4.70
6	$\frac{3}{4}$	18.72	14.98	12.48	10.70	9.36	8.32	7.49	6.24	5.35	4.68
$6\frac{1}{8}$	$\frac{13}{16}$	20.29	16.23	13.53	11.59	10.15	9.02	8.12	6.76	5.80	5.07
$6\frac{1}{2}$	$\frac{7}{8}$	21.86	17.49	14.57	12.49	10.93	9.72	8.75	7.29	6.25	5.47
5	$\frac{5}{8}$	7.12	5.70	4.75	4.07	3.56	3.17	2.85	2.37	2.03	1.78
$5\frac{1}{8}$	$\frac{3}{4}$	8.52	6.82	5.68	4.87	4.26	3.79	3.41	2.84	2.43	2.13
$5\frac{1}{2}$	$\frac{7}{8}$	9.92	7.94	6.62	5.67	4.96	4.41	3.97	3.31	2.83	2.48
5	$\frac{1}{2}$	10.24	8.19	6.83	5.85	5.12	4.55	4.09	3.41	2.92	2.56
$5\frac{1}{8}$	$\frac{9}{16}$	11.49	9.19	7.66	6.56	5.75	5.11	4.60	3.83	3.28	2.87
$5\frac{1}{2}$	$\frac{5}{8}$	12.76	10.21	8.51	7.29	6.38	5.67	5.11	4.25	3.65	3.19
5	$\frac{11}{16}$	12.63	10.10	8.42	7.21	6.32	5.61	5.05	4.21	3.61	3.16
$5\frac{1}{8}$	$\frac{3}{4}$	13.79	11.03	9.19	7.88	6.89	6.13	5.52	4.60	3.94	3.45
$5\frac{1}{2}$	$\frac{13}{16}$	14.94	11.95	9.96	8.54	7.47	6.64	5.97	4.98	4.27	3.73
4	$\frac{1}{4}$	4.19	3.35	2.79	2.39	2.09	1.86	1.68	1.40	1.20	1.05
$4\frac{1}{8}$	$\frac{5}{8}$	5.21	4.17	3.48	2.98	2.60	2.32	2.08	1.74	1.49	1.30
$4\frac{1}{2}$	$\frac{3}{8}$	6.22	4.98	4.15	3.56	3.11	2.77	2.49	2.08	1.78	1.56
4	$\frac{7}{8}$	6.44	5.15	4.29	3.68	3.22	2.86	2.57	2.15	1.84	1.61
$4\frac{1}{8}$	$\frac{1}{2}$	7.33	5.87	4.89	4.19	3.67	3.26	2.93	2.44	2.09	1.83
$4\frac{1}{2}$	$\frac{9}{16}$	8.24	6.59	5.49	4.71	4.12	3.66	3.29	2.75	2.35	2.06
4	$\frac{5}{8}$	8.06	6.45	5.37	4.61	4.03	3.58	3.23	2.69	2.31	2.01
$4\frac{1}{8}$	$\frac{11}{16}$	8.86	7.09	5.91	5.06	4.43	3.95	3.55	2.96	2.53	2.21
$4\frac{1}{2}$	$\frac{3}{4}$	9.68	7.74	6.45	5.53	4.84	4.30	3.87	3.23	2.76	2.42
3	$\frac{1}{4}$	2.56	2.05	1.71	1.46	1.28	1.14	1.03	0.85	0.73	0.64
$3\frac{1}{8}$	$\frac{5}{8}$	3.17	2.54	2.12	1.81	1.58	1.41	1.27	1.06	0.91	0.79
3	$\frac{3}{8}$	3.44	2.74	2.28	1.96	1.72	1.52	1.37	1.14	0.98	0.86
$3\frac{1}{8}$	$\frac{7}{8}$	3.97	3.18	2.65	2.27	1.98	1.77	1.59	1.32	1.13	0.99
3	$\frac{1}{2}$	4.08	3.26	2.72	2.33	2.04	1.81	1.63	1.36	1.17	1.02
$3\frac{1}{8}$	$\frac{9}{16}$	4.57	3.66	3.05	2.62	2.28	2.03	1.83	1.52	1.31	1.14

Safe loads given include weight of Z-bar. Maximum fiber stress 16,000 lbs. per square inch.

SAFE LOADS IN TONS OF 2,000 POUNDS  
UNIFORMLY DISTRIBUTED FOR STANDARD  
AND SPECIAL ANGLES WITH  
EQUAL LEGS.

Size of Angle.	Distance between Supports in Feet.									
	1	2	3	4	5	6	7	8	9	10
8 x8 x1 $\frac{1}{8}$	93.49	46.74	31.16	23.37	18.70	15.58	13.36	11.69	10.39	9.35
8 x8 x $\frac{1}{2}$	44.64	22.32	14.88	11.16	8.93	7.44	6.38	5.58	4.96	4.46
6 x6 x1	45.72	22.86	15.24	11.43	9.14	7.62	6.53	5.72	5.08	4.57
6 x6 x $\frac{3}{8}$	18.82	9.41	6.27	4.70	3.76	3.14	2.69	2.35	2.09	1.88
*5 x5 x1	30.91	15.45	10.30	7.73	6.18	5.15	4.42	3.86	3.43	3.09
*5 x5 x $\frac{3}{8}$	12.91	6.45	4.30	3.23	2.58	2.15	1.84	1.61	1.43	1.29
4 x4 x1 $\frac{3}{8}$	16.05	8.03	5.35	4.01	3.21	2.68	2.29	2.01	1.78	1.61
4 x4 x $\frac{5}{16}$	6.88	3.44	2.29	1.72	1.38	1.15	0.98	0.86	0.76	0.69
3 $\frac{1}{2}$ x3 $\frac{1}{2}$ x1 $\frac{3}{8}$	12.00	6.00	4.00	3.00	2.40	2.00	1.71	1.50	1.33	1.20
3 $\frac{1}{2}$ x3 $\frac{1}{2}$ x $\frac{5}{16}$	5.20	2.60	1.73	1.30	1.04	0.87	0.74	0.65	0.58	0.52
3 x3 x $\frac{5}{8}$	6.93	3.47	2.31	1.73	1.39	1.16	0.99	0.87	0.77	0.69
3 x3 x $\frac{1}{4}$	3.09	1.55	1.03	0.77	0.62	0.52	0.44	0.39	0.34	0.31
*2 $\frac{3}{4}$ x2 $\frac{3}{4}$ x $\frac{1}{2}$	4.75	2.37	1.58	1.19	0.95	0.79	0.68	0.59	0.53	0.47
*2 $\frac{3}{4}$ x2 $\frac{3}{4}$ x $\frac{1}{4}$	2.56	1.28	0.85	0.64	0.51	0.43	0.37	0.32	0.28	0.26
2 $\frac{1}{2}$ x2 $\frac{1}{2}$ x $\frac{1}{2}$	3.89	1.95	1.29	0.97	0.78	0.65	0.56	0.49	0.43	0.39
2 $\frac{1}{2}$ x2 $\frac{1}{2}$ x $\frac{3}{16}$	1.61	0.81	0.54	0.40	0.32	0.27	0.23	0.20	0.18	0.16
*2 $\frac{1}{4}$ x2 $\frac{1}{4}$ x $\frac{1}{2}$	3.09	1.55	1.03	0.77	0.62	0.52	0.44	0.39	0.34	0.31
*2 $\frac{1}{4}$ x2 $\frac{1}{4}$ x $\frac{3}{16}$	1.30	0.65	0.43	0.32	0.26	0.22	0.19	0.16	0.14	0.13
2 x2 x1 $\frac{7}{16}$	2.13	1.07	0.71	0.53	0.43	0.36	0.30	0.27	0.24	0.21
2 x2 x $\frac{3}{16}$	1.01	0.51	0.34	0.25	0.20	0.17	0.14	0.13	0.11	0.10
1 $\frac{3}{4}$ x1 $\frac{3}{4}$ x $\frac{7}{16}$	1.60	0.80	0.53	0.40	0.32	0.27	0.23	0.20	0.18	0.16
1 $\frac{3}{4}$ x1 $\frac{3}{4}$ x $\frac{3}{16}$	0.75	0.37	0.25	0.19	0.15	0.12	0.11	0.093	0.083	0.075
1 $\frac{1}{2}$ x1 $\frac{1}{2}$ x $\frac{3}{8}$	1.01	0.51	0.34	0.25	0.20	0.17	0.14	0.130	0.110	0.100
1 $\frac{1}{2}$ x1 $\frac{1}{2}$ x $\frac{1}{8}$	0.38	0.19	0.13	0.096	0.077	0.064	0.055	0.048	0.043	0.038
1 $\frac{1}{4}$ x1 $\frac{1}{4}$ x $\frac{5}{16}$	0.58	0.29	0.19	0.150	0.120	0.097	0.083	0.073	0.065	0.058
1 $\frac{1}{4}$ x1 $\frac{1}{4}$ x $\frac{1}{8}$	0.26	0.13	0.087	0.065	0.052	0.044	0.037	0.033	0.029	0.026
1 x1 x $\frac{1}{4}$	0.30	0.15	0.100	0.075	0.060	0.050	0.043	0.037	0.033	0.030
1 x1 x $\frac{1}{8}$	0.17	0.083	0.055	0.041	0.033	0.028	0.024	0.021	0.018	0.017
* $\frac{7}{8}$ x $\frac{7}{8}$ x $\frac{3}{16}$	0.18	0.088	0.059	0.044	0.035	0.029	0.025	0.022	0.020	0.018
* $\frac{7}{8}$ x $\frac{7}{8}$ x $\frac{1}{8}$	0.12	0.061	0.041	0.031	0.025	0.020	0.018	0.015	0.014	0.012
$\frac{3}{4}$ x $\frac{3}{4}$ x $\frac{3}{16}$	0.13	0.064	0.043	0.032	0.026	0.021	0.018	0.016	0.014	0.013
$\frac{3}{4}$ x $\frac{3}{4}$ x $\frac{1}{8}$	0.091	0.045	0.030	0.023	0.018	0.015	0.013	0.011	0.010	0.009

Safe loads given include weight of Angle. Maximum fiber stress 16,000 lbs. per square inch. Neutral axis through center of gravity parallel to one leg. Angles marked \* are special.

**SAFE LOADS IN TONS OF 2,000 POUNDS  
UNIFORMLY DISTRIBUTED FOR STANDARD  
AND SPECIAL ANGLES WITH  
UNEQUAL LEGS.  
LONG LEG VERTICAL.**

Size of Angle.	Distance between Supports in Feet.									
	1	2	3	4	5	6	7	8	9	10
*7 x 3½ x 1	56.43	28.21	18.81	14.11	11.29	9.40	8.06	7.05	6.27	5.64
*7 x 3½ x 7/16	26.72	13.36	8.91	6.68	5.34	4.45	3.82	3.34	2.97	2.67
6 x 4 x 1	42.77	21.39	14.26	10.69	8.55	7.13	6.11	5.35	4.75	4.28
6 x 4 x 3/8	17.71	8.85	5.90	4.43	3.54	2.95	2.53	2.21	1.97	1.77
6 x 3½ x 1	41.76	20.88	13.92	10.44	8.35	6.96	5.97	5.22	4.64	4.18
6 x 3½ x 3/8	17.33	8.67	5.78	4.33	3.47	2.89	2.48	2.17	1.93	1.73
*5 x 4 x 3/8	26.61	13.31	8.87	6.65	5.32	4.44	3.80	3.33	2.96	2.66
*5 x 4 x 3/8	12.48	6.24	4.16	3.12	2.50	2.08	1.78	1.56	1.39	1.25
5 x 3½ x 3/8	26.03	13.01	8.68	6.51	5.21	4.34	3.72	3.25	2.89	2.60
5 x 3½ x 1/8	10.35	5.18	3.45	2.59	2.07	1.73	1.48	1.29	1.15	1.04
5 x 3 x 1/8	23.73	11.87	7.91	5.93	4.75	3.96	3.39	2.97	2.64	2.37
5 x 3 x 1/8	10.08	5.04	3.36	2.52	2.02	1.68	1.44	1.26	1.12	1.01
*4½ x 3 x 1/8	19.31	9.65	6.44	4.83	3.86	3.22	2.76	2.41	2.15	1.93
*4½ x 3 x 1/8	8.21	4.11	2.74	2.05	1.64	1.37	1.17	1.03	0.91	0.82
*4 x 3½ x 1/8	15.57	7.79	5.19	3.89	3.11	2.60	2.22	1.95	1.73	1.56
*4 x 3½ x 1/8	6.72	3.36	2.24	1.68	1.34	1.12	0.96	0.84	0.75	0.67
4 x 3 x 1/8	15.31	7.65	5.10	3.83	3.06	2.55	2.19	1.91	1.70	1.53
4 x 3 x 1/8	6.56	3.28	2.19	1.64	1.31	1.10	0.94	0.82	0.73	0.66
3½ x 3 x 1/8	11.73	5.87	3.91	2.93	2.35	1.96	1.68	1.47	1.30	1.17
3½ x 3 x 1/8	5.12	2.56	1.71	1.28	1.02	0.85	0.73	0.64	0.57	0.51
3½ x 2½ x 1/8	9.87	4.93	3.29	2.47	1.97	1.64	1.41	1.23	1.10	0.99
3½ x 2½ x 1/4	4.00	2.00	1.33	1.00	0.80	0.67	0.57	0.50	0.44	0.40
*3¼ x 2 x 1/8	6.93	3.47	2.31	1.73	1.39	1.16	0.99	0.87	0.77	0.69
*3¼ x 2 x 1/4	3.36	1.68	1.12	0.84	0.67	0.56	0.48	0.42	0.37	0.34
3 x 2½ x 1/8	6.13	3.07	2.04	1.53	1.23	1.02	0.88	0.77	0.68	0.61
3 x 2½ x 1/4	2.99	1.50	1.00	0.75	0.60	0.50	0.43	0.37	0.33	0.30
*3 x 2 x 1/2	5.33	2.67	1.78	1.33	1.07	0.89	0.76	0.67	0.59	0.53
*3 x 2 x 1/4	2.88	1.44	0.96	0.72	0.58	0.48	0.41	0.36	0.32	0.29
2½ x 2 x 1/2	3.73	1.87	1.24	0.93	0.75	0.62	0.53	0.47	0.41	0.37
2½ x 2 x 1/8	1.55	0.77	0.52	0.39	0.31	0.26	0.22	0.19	0.17	0.16
*2¼ x 1½ x 1/2	3.15	1.57	1.05	0.79	0.63	0.52	0.45	0.39	0.35	0.32
*2¼ x 1½ x 1/8	1.23	0.61	0.41	0.31	0.25	0.21	0.18	0.15	0.14	0.12
*2 x 1¾ x 1/4	1.23	0.61	0.41	0.31	0.25	0.21	0.18	0.15	0.14	0.12
*2 x 1¾ x 1/8	0.96	0.48	0.32	0.24	0.19	0.16	0.14	0.12	0.11	0.10
*1¾ x 1 x 1/4	0.48	0.24	0.16	0.12	0.10	0.08	0.07	0.06	0.05	0.05
*1¾ x 1 x 1/8	0.32	0.16	0.11	0.08	0.06	0.05	0.05	0.04	0.04	0.03

Safe loads given include weight of Angle. Maximum fiber stress 16,000 lbs. per square inch. Neutral axis through center of gravity parallel to short leg. Angles marked \* are special.

SAFE LOADS IN TONS OF 2,000 POUNDS  
UNIFORMLY DISTRIBUTED FOR STANDARD  
AND SPECIAL ANGLES WITH  
UNEQUAL LEGS.  
SHORT LEG VERTICAL.

Size of Angle.	Distance between Supports in Feet.									
	1	2	3	4	5	6	7	8	9	10
*7 x3 1/2 x1	15.79	7.89	5.26	3.95	3.16	2.63	2.26	1.97	1.75	1.58
*7 x3 1/2 x 1/10	7.84	3.92	2.61	1.96	1.57	1.31	1.12	0.98	0.87	0.78
6 x4 x1	20.21	10.11	6.74	5.05	4.04	3.37	2.89	2.53	2.25	2.02
6 x4 x 3/8	8.53	4.27	2.84	2.13	1.71	1.42	1.22	1.07	0.95	0.85
6 x3 1/2 x1	15.47	7.74	5.16	3.87	3.09	2.58	2.21	1.93	1.72	1.55
6 x3 1/2 x 3/8	6.56	3.28	2.19	1.64	1.31	1.09	0.94	0.82	0.73	0.66
*5 x4 x 7/8	17.65	8.83	5.88	4.41	3.53	2.94	2.52	2.21	1.96	1.77
*5 x4 x 3/8	8.37	4.19	2.79	2.09	1.67	1.40	1.20	1.05	0.93	0.84
5 x3 1/2 x 7/8	13.44	6.72	4.48	3.36	2.69	2.24	1.92	1.68	1.49	1.34
5 x3 1/2 x 5/16	5.44	2.72	1.81	1.36	1.09	0.91	0.78	0.68	0.60	0.54
5 x3 x 1 1/8	9.28	4.64	3.09	2.32	1.86	1.55	1.33	1.16	1.03	0.93
5 x3 x 1/8	4.00	2.00	1.33	1.00	0.80	0.67	0.57	0.50	0.44	0.40
*4 1/2 x3 x 1 1/8	9.12	4.56	3.04	2.28	1.82	1.52	1.30	1.14	1.01	0.91
*4 1/2 x3 x 5/16	4.05	2.03	1.35	1.01	0.81	0.68	0.58	0.51	0.45	0.41
*4 x3 1/2 x 1 1/8	12.27	6.13	4.09	3.07	2.45	2.05	1.75	1.53	1.36	1.23
*4 x3 1/2 x 1/8	5.39	2.69	1.80	1.35	1.08	0.90	0.77	0.67	0.60	0.54
4 x3 x 1 1/8	8.96	4.48	2.99	2.24	1.79	1.49	1.28	1.12	1.00	0.90
4 x3 x 5/16	3.95	1.97	1.32	0.99	0.79	0.66	0.56	0.49	0.44	0.39
3 1/2 x3 x 1 1/8	8.80	4.40	2.93	2.20	1.76	1.47	1.26	1.10	0.98	0.88
3 1/2 x3 x 5/16	3.84	1.92	1.28	0.96	0.77	0.64	0.55	0.48	0.43	0.38
3 1/2 x2 1/2 x 1 1/8	5.28	2.64	1.76	1.32	1.06	0.88	0.75	0.66	0.59	0.53
3 1/2 x2 1/2 x 1/4	2.19	1.09	0.73	0.55	0.44	0.36	0.31	0.27	0.24	0.22
*3 1/4 x2 x 1 1/8	2.83	1.41	0.94	0.71	0.57	0.47	0.40	0.35	0.31	0.28
*3 1/4 x2 x 1/4	1.39	0.69	0.46	0.35	0.28	0.23	0.20	0.17	0.15	0.14
3 x2 1/2 x 1/8	4.37	2.19	1.46	1.09	0.87	0.73	0.62	0.55	0.49	0.44
3 x2 1/2 x 1/4	2.13	1.07	0.71	0.53	0.43	0.36	0.30	0.27	0.24	0.21
*3 x2 x 1/2	2.51	1.25	0.84	0.63	0.50	0.42	0.36	0.31	0.28	0.25
*3 x2 x 1/4	1.33	0.67	0.44	0.33	0.27	0.22	0.19	0.17	0.15	0.13
2 1/2 x2 x 1/2	2.45	1.23	0.82	0.61	0.49	0.41	0.35	0.31	0.27	0.25
2 1/2 x2 x 1/8	1.07	0.53	0.36	0.27	0.21	0.18	0.15	0.13	0.12	0.11
*2 1/4 x1 1/2 x 1/2	1.39	0.69	0.46	0.35	0.28	0.23	0.20	0.17	0.15	0.14
*2 1/4 x1 1/2 x 1/8	0.59	0.29	0.20	0.15	0.12	0.10	0.08	0.07	0.07	0.06
*2 x1 3/8 x 1/4	0.64	0.32	0.21	0.16	0.13	0.11	0.09	0.08	0.07	0.06
*2 x1 3/8 x 1/8	0.48	0.24	0.16	0.12	0.10	0.08	0.07	0.06	0.05	0.05
*1 3/8 x1 x 1/4	0.27	0.13	0.09	0.07	0.05	0.04	0.04	0.03	0.03	0.03
*1 3/8 x1 x 1/8	0.16	0.08	0.05	0.04	0.03	0.03	0.02	0.02	0.02	0.02

Safe loads given include weight of Angle. Maximum fiber stress 16,000 lbs. per square inch. Neutral axis through center of gravity parallel to long leg. Angles marked \* are special.

**SAFE LOADS IN TONS OF 2,000 POUNDS  
UNIFORMLY DISTRIBUTED FOR  
CARNEGIE TEES.**

Size. Flange by Stem.	Weight per foot.	Distance between Supports in Feet.									
		1	2	3	4	5	6	7	8	9	10
5 x3	13.6	6.29	3.15	2.10	1.57	1.26	1.05	0.90	0.79	0.70	0.63
5 x2½	11.0	4.59	2.29	1.53	1.15	0.92	0.76	0.66	0.57	0.51	0.46
4½ x3½	15.8	11.36	5.68	3.79	2.84	2.27	1.89	1.62	1.42	1.26	1.14
4½ x3	8.5	4.32	2.16	1.44	1.08	0.86	0.72	0.62	0.54	0.48	0.43
4½ x3	10.0	5.01	2.51	1.67	1.25	1.00	0.84	0.72	0.63	0.56	0.50
4½ x2½	8.0	2.99	1.49	0.96	0.75	0.60	0.48	0.43	0.37	0.32	0.30
4½ x2½	9.3	3.47	1.73	1.16	0.87	0.69	0.58	0.50	0.43	0.39	0.35
4 x5	15.6	16.53	8.27	5.51	4.13	3.31	2.76	2.36	2.07	1.84	1.65
4 x5	12.0	12.96	6.48	4.32	3.24	2.59	2.16	1.85	1.62	1.44	1.30
4 x4½	14.6	13.60	6.80	4.53	3.40	2.72	2.27	1.94	1.70	1.51	1.36
4 x4½	11.4	10.56	5.28	3.52	2.64	2.11	1.76	1.51	1.32	1.17	1.06
4 x4	13.7	10.77	5.39	3.59	2.69	2.15	1.80	1.54	1.35	1.20	1.08
4 x4	10.9	8.75	4.37	2.92	2.19	1.75	1.46	1.25	1.09	0.97	0.87
4 x3	9.3	4.69	2.35	1.56	1.17	0.94	0.78	0.67	0.59	0.52	0.47
4 x2½	8.6	3.31	1.65	1.10	0.83	0.66	0.55	0.47	0.41	0.37	0.33
4 x2½	7.3	2.93	1.47	0.98	0.73	0.59	0.49	0.42	0.37	0.33	0.29
4 x2	7.9	2.13	1.07	0.71	0.53	0.43	0.36	0.30	0.27	0.24	0.21
4 x2	6.6	1.81	0.91	0.60	0.45	0.36	0.30	0.26	0.23	0.20	0.18
3½ x4	12.8	10.56	5.28	3.52	2.64	2.11	1.76	1.51	1.32	1.17	1.06
3½ x4	9.9	8.27	4.13	2.76	2.07	1.65	1.38	1.18	1.03	0.92	0.83
3½ x3½	11.7	8.11	4.05	2.70	2.03	1.62	1.35	1.16	1.01	0.90	0.81
3½ x3½	9.2	6.35	3.17	2.12	1.59	1.27	1.06	0.91	0.79	0.71	0.63
3½ x3	10.9	6.03	3.01	2.01	1.51	1.21	1.00	0.86	0.75	0.67	0.60
3½ x3	8.5	4.69	2.35	1.56	1.17	0.94	0.78	0.67	0.59	0.52	0.47
3½ x3	7.8	3.84	1.92	1.28	0.96	0.77	0.64	0.55	0.48	0.43	0.38
3 x4	11.8	10.35	5.17	3.45	2.59	2.07	1.72	1.48	1.29	1.15	1.03
3 x4	10.6	9.49	4.75	3.16	2.37	1.90	1.58	1.36	1.19	1.05	0.95
3 x4	9.3	8.37	4.19	2.79	2.09	1.67	1.40	1.20	1.05	0.93	0.84
3 x3½	10.9	7.95	3.97	2.65	1.99	1.59	1.32	1.14	0.99	0.88	0.79
3 x3½	9.8	7.31	3.65	2.44	1.83	1.46	1.22	1.04	0.91	0.81	0.73
3 x3½	8.5	6.45	3.23	2.15	1.61	1.29	1.08	0.92	0.81	0.72	0.65
3 x3	10.0	5.87	2.93	1.96	1.47	1.17	0.98	0.84	0.73	0.65	0.59

Safe loads given include weight of Tee. Maximum fiber stress  
16,000 lbs. per square inch.

SAFE LOADS IN TONS OF 2,000 POUNDS  
UNIFORMLY DISTRIBUTED FOR  
CARNEGIE TEES.

Size. Flange by Stem.	Weight per foot.	Distance between Supports in Feet.									
		1	2	3	4	5	6	7	8	9	10
3 x3	9.1	5.39	2.69	1.80	1.35	1.08	0.90	0.77	0.67	0.60	0.54
3 x3	7.8	4.59	2.29	1.53	1.15	0.92	0.76	0.66	0.57	0.51	0.46
3 x3	6.6	3.95	1.97	1.32	0.99	0.79	0.66	0.56	0.49	0.44	0.39
3 x2½	7.2	3.20	1.60	1.07	0.80	0.64	0.53	0.46	0.40	0.36	0.32
3 x2½	6.1	2.77	1.39	0.92	0.69	0.55	0.46	0.40	0.35	0.31	0.28
2¾ x2	7.4	4.00	2.00	1.33	1.00	0.80	0.67	0.57	0.50	0.44	0.40
2½ x3	7.2	4.64	2.32	1.55	1.16	0.93	0.77	0.66	0.58	0.52	0.46
2½ x3	6.1	4.05	2.03	1.35	1.01	0.81	0.68	0.58	0.51	0.45	0.41
2½ x2¾	6.7	3.89	1.95	1.30	0.97	0.78	0.65	0.56	0.49	0.43	0.39
2½ x2¾	5.8	3.20	1.60	1.07	0.80	0.64	0.53	0.46	0.40	0.36	0.32
2½ x2½	6.4	3.15	1.57	1.05	0.79	0.63	0.52	0.45	0.39	0.35	0.31
2½ x2½	5.5	2.67	1.33	0.89	0.67	0.53	0.44	0.38	0.33	0.30	0.27
2½ x1¼	2.9	0.48	0.24	0.16	0.12	0.10	0.08	0.07	0.06	0.05	0.05
2¼ x2¼	4.9	2.24	1.12	0.75	0.56	0.45	0.37	0.32	0.28	0.25	0.22
2¼ x2¼	4.1	1.71	0.85	0.57	0.43	0.34	0.28	0.24	0.21	0.19	0.17
2 x2	4.3	1.76	0.88	0.59	0.44	0.35	0.29	0.25	0.22	0.20	0.18
2 x2	3.7	1.33	0.67	0.44	0.33	0.27	0.22	0.19	0.17	0.15	0.13
2 x1½	3.1	0.80	0.40	0.27	0.20	0.16	0.13	0.11	0.10	0.09	0.08
1¾ x1¾	3.1	1.01	0.51	0.34	0.25	0.20	0.17	0.14	0.13	0.11	0.10
1¾ x1¾	3.6	0.80	0.40	0.27	0.20	0.16	0.13	0.11	0.10	0.09	0.08
1½ x1½	2.4	0.75	0.37	0.25	0.19	0.15	0.12	0.11	0.09	0.08	0.07
1½ x1½	1.84	0.59	0.29	0.20	0.15	0.12	0.10	0.08	0.07	0.07	0.06
1¼ x1¼	2.04	0.53	0.27	0.18	0.13	0.11	0.09	0.08	0.07	0.06	0.05
1¼ x1¼	1.53	0.37	0.19	0.12	0.09	0.07	0.06	0.05	0.05	0.04	0.04
1 x1	1.23	0.27	0.13	0.09	0.07	0.05	0.04	0.04	0.03	0.03	0.03
1 x1	0.87	0.16	0.08	0.05	0.04	0.03	0.03	0.02	0.02	0.02	0.02

Safe loads given include weight of Tee. Maximum fiber stress  
16,000 lbs. per square inch.

T Spacing

THE CARNEGIE STEEL COMPANY, LIMITED

SAFE LOADS IN TONS OF 2,000 POUNDS  
UNIFORMLY DISTRIBUTED FOR  
CARNEGIE DECK BEAMS.

Depth of Section, Inches.	Weight per foot.	Distance between Supports in Feet.									
		5	6	7	8	9	10	12	14	16	18
11 1/2	37.00	32.65	27.21	23.32	20.40	18.14	16.32	13.60	11.66	10.20	9.07
11 1/4	32.20	29.47	24.56	21.05	18.42	16.37	14.74	12.28	10.53	9.21	8.19
10	35.70	27.41	22.84	19.58	17.13	15.23	13.71	11.42	9.79	8.57	7.61
10	27.23	22.61	18.84	16.15	14.13	12.56	11.31	9.42	8.08	7.07	6.28
9	30.00	20.85	17.37	14.89	13.03	11.59	10.43	8.69	7.45	6.52	5.79
9	26.00	18.91	15.76	13.51	11.81	10.51	9.45	7.88	6.75	5.91	5.25
8	24.48	15.01	12.51	10.72	9.39	8.35	7.51	6.25	5.36	4.69	4.17
8	20.15	12.98	10.82	9.27	8.11	7.21	6.49	5.41	4.64	4.06	3.61
7	23.46	12.46	10.38	8.90	7.79	6.92	6.23	5.19	4.45	3.89	3.46
7	18.11	10.30	8.58	7.36	6.44	5.72	5.15	4.29	3.68	3.22	2.86
6	17.16	7.68	6.40	5.48	4.80	4.27	3.84	3.20	2.75	2.40	2.14
6	14.10	6.51	5.42	4.65	4.07	3.62	3.25	2.71	2.33	2.04	1.81

PROP  
ERTIES  
COLS  
L  
r

SAFE LOADS IN TONS OF 2,000 POUNDS  
UNIFORMLY DISTRIBUTED FOR  
CARNEGIE BULB ANGLES.

Depth of Section, Inches.	Weight per foot.	Distance between Supports in Feet.									
		5	6	7	8	9	10	12	14	16	18
10	32.00	23.00	19.16	16.43	14.37	12.78	11.50	9.58	8.21	7.19	6.39
10	26.50	21.17	17.64	15.12	13.24	11.76	10.59	8.83	7.56	6.61	5.88
9	21.80	15.42	12.85	11.01	9.64	8.57	7.71	6.43	5.51	4.82	4.28
8	19.23	12.48	10.40	8.92	7.80	6.93	6.24	5.20	4.45	3.89	3.47
7	18.25	10.23	8.52	7.31	6.39	5.68	5.11	4.27	3.65	3.20	2.84
7	16.00	9.28	7.73	6.63	5.80	5.15	4.64	3.87	3.31	2.90	2.58
6	17.20	8.05	6.71	5.75	5.03	4.48	4.03	3.36	2.88	2.52	2.24
6	13.75	7.04	5.87	5.03	4.40	3.91	3.52	2.93	2.52	2.20	1.96
6	12.30	6.04	5.03	4.32	3.77	3.36	3.01	2.52	2.16	1.89	1.68
5	10.00	4.33	3.61	3.09	2.71	2.41	2.16	1.80	1.55	1.36	1.20

Safe loads given include weight of Section. Maximum fiber stress 16,000 lbs. per square inch.



SPACING OF STANDARD I-BEAMS FOR  
UNIFORM LOAD OF 100 LBS.  
PER SQUARE FOOT.

Proper Distance in Feet Center to Center of Beams.

Distance between Supports in feet.	24" I.		20" I.		18" I.	15" I.			12" I.		10" I.
	80 lbs.	80 lbs.	65 lbs.	55 lbs.	55 lbs.	80 lbs.	60 lbs.	42 lbs.	40 lbs.	31.5 lbs.	25 lbs.
12	128.9	108.6	86.6	65.5	78.6	60.1	43.6	33.2	26.6		18.1
13	109.8	92.6	73.8	55.8	67.0	51.3	37.2	28.3	22.7		15.4
14	94.7	79.8	63.7	48.1	57.7	44.2	32.1	24.4	19.6		13.3
15	82.5	69.5	55.5	41.9	50.3	38.5	27.9	21.3	17.1		11.6
16	72.5	61.1	48.7	36.8	44.2	33.8	24.5	18.7	15.0		10.2
17	64.2	54.1	43.2	32.6	39.2	30.0	21.7	16.5	13.3		9.0
18	57.3	48.3	38.5	29.1	34.9	26.7	19.4	14.8	11.8		8.0
19	51.4	43.3	34.6	26.1	31.3	24.0	17.4	13.2	10.6		7.2
20	46.4	39.1	31.2	23.6	28.3	21.7	15.7	12.0	9.6		6.5
21	42.1	35.5	28.3	21.4	25.7	19.6	14.2	10.8	8.7		5.9
22	38.4	32.3	25.8	19.5	23.4	17.9	13.0	9.9	7.9		5.4
23	35.1	29.6	23.6	17.8	21.4	16.4	11.9	9.0	7.3		4.9
24	32.2	27.2	21.7	16.4	19.6	15.0	10.9	8.3	6.7		4.5
25	29.7	25.0	20.0	15.1	18.1	13.9	10.1	7.7	6.1		4.2
26	27.5	23.1	18.5	13.9	16.7	12.8	9.3	7.1	5.7		3.9
27	25.5	21.5	17.1	12.9	15.5	11.9	8.6	6.6	5.3		3.6
28	23.7	20.0	15.9	12.0	14.4	11.0	8.0	6.1	4.9		3.3
29	22.1	18.6	14.8	11.2	13.5	10.3	7.5	5.7	4.6		3.1
30	20.6	17.4	13.9	10.5	12.6	9.6	7.0	5.3	4.3		2.9

For load of 200 lbs. per square foot divide the spacing given by 2.  
Maximum fiber stress 16,000 lbs. per square inch.

## THE CARNEGIE STEEL COMPANY, LIMITED.

SPACING OF STANDARD I-BEAMS FOR  
UNIFORM LOAD OF 100 LBS.  
PER SQUARE FOOT.

Proper Distance in Feet Center to Center of Beams.

Distance between Supports in feet.	9" I.	8" I.	7" I.	6" I.	5" I.	4" I.	3" I.
	21 lbs.	18 lbs.	15 lbs.	12.25 lbs.	9.75 lbs.	7.5 lbs.	5.5 lbs.
5	80.5	60.7	44.2	31.0	20.6	12.7	7.0
6	55.9	42.1	30.7	21.5	14.3	8.8	4.9
7	41.1	31.0	22.5	15.8	10.5	6.5	3.6
8	31.5	23.7	17.3	12.1	8.1	5.0	2.8
9	24.9	18.7	13.6	9.6	6.4	3.9	2.2
10	20.1	15.2	11.1	7.8	5.2	3.2	1.8
11	16.6	12.5	9.1	6.4	4.3	2.6	1.5
12	14.0	10.5	7.7	5.4	3.6	2.2	1.2
13	11.9	9.0	6.5	4.6	3.1	1.9	1.0
14	10.3	7.7	5.6	4.0	2.6	1.6	0.9
15	9.0	6.7	4.9	3.4	2.3	1.4	. .
16	7.9	5.9	4.3	3.0	2.0	1.2	. .
17	7.0	5.3	3.8	2.7	1.8	1.1	. .
18	6.2	4.7	3.4	2.4	1.6	.98	. .
19	5.6	4.2	3.1	2.2	1.4	. .	. .
20	5.0	3.8	2.8	1.9	1.3	. .	. .
21	4.6	3.4	2.5	1.8	1.2	. .	. .
22	3.8	3.1	2.3	1.6	1.1	. .	. .

For load of 200 lbs. per square foot divide the spacing given by 2.  
Maximum fiber stress 16,000 lbs. per square inch.

SPACING OF STANDARD I-BEAMS FOR  
UNIFORM LOAD OF 125 LBS.  
PER SQUARE FOOT.

Proper Distance in Feet Center to Center of Beams.

Distance between Supports in feet.	24" I.		20" I.		18" I.	15" I.			12" I.		10" I.
	80 lbs.	80 lbs.	65 lbs.	55 lbs.	80 lbs.	60 lbs.	42 lbs.	40 lbs.	31.5 lbs.	25 lbs.	
12	103.1	86.9	69.3	52.4	62.9	48.1	34.9	26.6	21.3	14.5	
13	87.8	74.1	59.0	44.6	53.6	41.0	29.8	22.6	18.2	12.3	
14	75.8	63.8	51.0	38.5	46.2	35.4	25.7	19.5	15.7	10.6	
15	66.0	55.6	44.4	33.5	40.2	30.8	22.3	17.0	13.7	9.3	
16	58.0	48.9	39.0	29.5	35.4	27.0	19.6	15.0	12.0	8.2	
17	51.4	43.3	34.6	26.1	31.4	24.0	17.4	13.2	10.6	7.2	
18	45.8	38.6	30.8	23.3	27.9	21.4	15.5	11.8	9.4	6.4	
19	41.1	34.6	27.7	20.9	25.0	19.2	13.9	10.6	8.5	5.8	
20	37.1	31.3	25.0	18.9	22.6	17.4	12.6	9.6	7.7	5.2	
21	33.7	28.4	22.6	17.1	20.6	15.7	11.4	8.6	7.0	4.7	
22	30.7	25.8	20.6	15.6	18.7	14.3	10.4	7.9	6.3	4.3	
23	28.1	23.7	18.9	14.3	17.1	13.1	9.5	7.2	5.8	3.9	
24	25.8	21.8	17.4	13.1	15.7	12.0	8.7	6.6	5.4	3.6	
25	23.8	20.0	16.0	12.1	14.5	11.1	8.1	6.2	4.9	3.4	
26	22.0	18.5	14.8	11.2	13.4	10.2	7.4	5.7	4.6	3.1	
27	20.4	17.2	13.7	10.3	12.4	9.5	6.9	5.3	4.2	2.9	
28	19.0	16.0	12.7	9.6	11.5	8.8	6.4	4.9	3.9	2.6	
29	17.7	14.9	11.8	9.0	10.8	8.2	6.0	4.6	3.7	2.5	
30	16.5	13.9	11.1	8.4	10.1	7.7	5.6	4.2	3.4	2.3	

For load of 250 lbs. per square foot divide the spacing given by 2.  
Maximum fiber stress 16,000 lbs. per square inch.

**SPACING OF STANDARD I-BEAMS FOR  
UNIFORM LOAD OF 125 LBS.  
PER SQUARE FOOT.**

Proper Distance in Feet Center to Center of Beams.

Distance between Supports in feet.	9" I.	8" I.	7" I.	6" I.	5" I.	4" I.	3" I.
	21 lbs.	18 lbs.	15 lbs.	12.25 lbs.	9.75 lbs.	7.5 lbs.	5.5 lbs.
5	64.4	48.6	35.4	24.8	16.5	10.2	5.6
6	44.7	33.7	24.6	17.2	11.4	7.1	3.9
7	32.9	24.8	18.0	12.6	8.4	5.2	2.9
8	25.2	19.0	13.8	9.7	6.4	4.0	2.2
9	19.9	15.0	10.9	7.7	5.1	3.2	1.7
10	16.1	12.2	8.9	6.2	4.1	2.5	1.4
11	13.3	10.0	7.3	5.1	3.4	2.1	1.2
12	11.2	8.4	6.1	4.3	2.9	1.8	1.0
13	9.5	7.2	5.2	3.7	2.4	1.5	0.8
14	8.2	6.2	4.5	3.2	2.1	1.3	. .
15	7.2	5.4	3.9	2.8	1.8	1.1	. .
16	6.3	4.7	3.4	2.4	1.6	1.0	. .
17	5.6	4.2	3.1	2.1	1.4	. .	. .
18	5.0	3.7	2.7	1.9	1.3	. .	. .
19	4.5	3.4	2.4	1.7	1.1	. .	. .
20	4.0	3.0	2.2	1.6	1.0	. .	. .
21	3.7	2.8	2.0	1.4	0.9	. .	. .
22	3.3	2.5	1.8	1.3	. .	. .	. .

For load of 250 lbs. per square foot divide the spacing given by 2.  
Maximum fiber stress 16,000 lbs. per square inch.

SPACING OF STANDARD I-BEAMS FOR  
UNIFORM LOAD OF 150 LBS.  
PER SQUARE FOOT.

Proper Distance in Feet Center to Center of Beams.

Distance between Supports in feet.	24" I.			20" I.		18" I.	15" I.			12" I.		10" I.
	80 lbs.	80 lbs.	65 lbs.	55 lbs.	80 lbs.	60 lbs.	42 lbs.	40 lbs.	31.5 lbs.	25 lbs.		
12	85.9	72.4	57.7	43.7	52.4	40.1	29.1	22.1	17.7	12.1		
13	73.2	61.7	49.2	37.2	44.7	34.2	24.8	18.9	15.1	10.3		
14	63.1	53.2	42.5	32.1	38.5	29.5	21.4	16.3	13.1	8.9		
15	55.0	46.3	37.0	27.9	33.5	25.7	18.6	14.2	11.4	7.7		
16	48.3	40.7	32.5	24.5	29.5	22.5	16.3	12.5	10.0	6.8		
17	42.8	36.1	28.8	21.7	26.1	20.0	14.5	11.0	8.9	6.0		
18	38.2	32.2	25.7	19.4	23.3	17.8	12.9	9.9	7.9	5.3		
19	34.3	28.9	23.1	17.4	20.9	16.0	11.6	8.8	7.1	4.8		
20	30.9	26.1	20.8	15.7	18.9	14.5	10.5	8.0	6.4	4.3		
21	28.1	23.7	18.9	14.3	17.1	13.1	9.5	7.2	5.8	3.9		
22	25.6	21.5	17.2	13.0	15.6	11.9	8.7	6.6	5.3	3.6		
23	23.4	19.7	15.7	11.9	14.3	10.9	7.9	6.0	4.9	3.3		
24	21.5	18.1	14.5	10.9	13.1	10.0	7.3	5.5	4.5	3.0		
25	19.8	16.7	13.3	10.1	12.1	9.3	6.7	5.1	4.1	2.8		
26	18.3	15.4	12.3	9.3	11.1	8.5	6.2	4.7	3.8	2.6		
27	17.0	14.3	11.4	8.6	10.3	7.9	5.7	4.4	3.5	2.4		
28	15.8	13.3	10.6	8.0	9.6	7.3	5.3	4.1	3.3	2.2		
29	14.7	12.4	9.9	7.5	9.0	6.9	5.0	3.8	3.1	2.1		
30	13.7	11.6	9.3	7.0	8.4	6.4	4.7	3.5	2.9	1.9		

For load of 300 lbs. per square foot divide the spacing given by 2.  
Maximum fiber stress 16,000 lbs. per square inch.

SPACING OF STANDARD I-BEAMS FOR  
UNIFORM LOAD OF 150 LBS.  
PER SQUARE FOOT.

Proper Distance in Feet Center to Center of Beams.

Distance between Supports in feet.	9'' I.	8'' I.	7'' I.	6'' I.	5'' I.	4'' I.	3'' I.
	21 lbs.	18 lbs.	15 lbs.	12.25 lbs.	9.75 lbs.	7.5 lbs.	5.5 lbs.
5	53.7	40.5	29.5	20.7	13.7	8.5	4.7
6	37.3	28.1	20.5	14.3	9.5	5.9	3.3
7	27.4	20.7	15.0	10.5	7.0	4.3	2.4
8	21.0	15.8	11.5	8.1	5.4	3.3	1.8
9	16.6	12.5	9.1	6.4	4.3	2.6	1.5
10	13.4	10.1	7.4	5.2	3.4	2.1	1.2
11	11.1	8.3	6.1	4.3	2.8	1.8	1.0
12	9.3	7.0	5.1	3.6	2.4	1.5	0.8
13	7.9	6.0	4.4	3.1	2.0	1.3	. .
14	6.9	5.2	3.8	2.6	1.8	1.1	. .
15	6.0	4.5	3.3	2.3	1.5	0.9	. .
16	5.2	4.0	2.9	2.0	1.4	. .	. .
17	4.7	3.5	2.6	1.8	1.2	. .	. .
18	4.1	3.1	2.3	1.6	1.1	. .	. .
19	3.7	2.8	2.0	1.4	1.0	. .	. .
20	3.4	2.5	1.8	1.3	. .	. .	. .
21	3.0	2.3	1.7	1.2	. .	. .	. .
22	2.8	2.1	1.5	1.1	. .	. .	. .

For load of 300 lbs. per square foot divide the spacing given by 2.  
Maximum fiber stress 16,000 lbs. per square inch.

PROP  
ERTIES

COLS

$\frac{L}{r}$

DE  
MA

SPACING OF STANDARD I-BEAMS FOR  
UNIFORM LOAD OF 175 LBS.  
PER SQUARE FOOT.

Proper Distance in Feet Center to Center of Beams.

Distance between Supports in feet.	24" I.			20" I.		18" I.		15" I.			12" I.		10" I.
	80 lbs.	80 lbs.	65 lbs.	55 lbs.	80 lbs.	60 lbs.	42 lbs.	40 lbs.	31.5 lbs.	25 lbs.			
12	73.7	62.1	49.5	37.4	44.9	34.3	24.9	19.0	15.2	10.3			
13	62.7	52.9	42.2	31.9	38.3	29.3	21.3	16.2	13.0	8.8			
14	54.1	45.6	36.4	27.5	33.0	25.3	18.3	13.9	11.2	7.6			
15	47.1	39.7	31.7	23.9	28.7	22.0	15.9	12.2	9.8	6.6			
16	41.4	34.9	27.8	21.0	25.3	19.3	14.0	10.7	8.6	5.8			
17	36.7	30.9	24.7	18.6	22.4	17.1	12.4	9.4	7.6	5.1			
18	32.7	27.6	22.0	16.6	19.9	15.3	11.1	8.5	6.7	4.6			
19	29.4	24.7	19.8	14.9	17.9	13.7	9.9	7.5	6.1	4.1			
20	26.5	22.3	17.8	13.5	16.2	12.4	9.0	6.9	5.5	3.7			
21	24.1	20.3	16.2	12.2	14.7	11.2	8.1	6.2	5.0	3.4			
22	21.9	18.5	14.7	11.1	13.4	10.2	7.4	5.7	4.5	3.1			
23	20.1	16.9	13.5	10.2	12.2	9.4	6.8	5.1	4.2	2.8			
24	18.4	15.5	12.4	9.4	11.2	8.6	6.2	4.7	3.8	2.6			
25	17.0	14.3	11.4	8.6	10.3	7.9	5.8	4.4	3.5	2.4			
26	15.7	13.2	10.6	8.0	9.5	7.3	5.3	4.1	3.3	2.2			
27	14.6	12.3	9.8	7.4	8.9	6.8	4.9	3.8	3.0	2.1			
28	13.5	11.4	9.1	6.9	8.2	6.3	4.6	3.5	2.8	1.9			
29	12.6	10.6	8.5	6.4	7.7	5.9	4.3	3.3	2.6	1.8			
30	11.8	9.9	7.9	6.0	7.2	5.5	4.0	3.0	2.5	1.7			

For load of 350 lbs. per square foot divide the spacing given by 2.  
Maximum fiber stress 16,000 lbs. per square inch.

SPACING OF STANDARD I-BEAMS FOR  
UNIFORM LOAD OF 175 LBS.  
PER SQUARE FOOT.

Proper Distance in Feet Center to Center of Beams.

Distance between Supports in feet.	9" I.	8" I.	7" I.	6" I.	5" I.	4" I.	3" I.
	21 lbs.	18 lbs.	15 lbs.	12.25 lbs.	9.75 lbs.	7.5 lbs.	5.5 lbs.
5	46.0	34.7	25.3	17.7	11.8	7.3	4.0
6	32.0	24.1	17.5	12.3	8.2	5.1	2.8
7	23.5	17.7	12.9	9.0	6.0	3.7	2.1
8	18.0	13.5	9.9	6.9	4.6	2.8	1.6
9	14.2	10.7	7.8	5.5	3.6	2.3	1.2
10	11.5	8.7	6.3	4.4	3.0	1.8	1.0
11	9.5	7.1	5.2	3.7	2.4	1.5	0.8
12	8.0	6.0	4.4	3.1	2.1	1.3	0.7
13	6.8	5.1	3.7	2.6	1.7	1.1	. .
14	5.9	4.4	3.2	2.3	1.5	0.9	. .
15	5.1	3.9	2.8	2.0	1.3	0.8	. .
16	4.5	3.4	2.5	1.7	1.2	. .	. .
17	4.0	3.0	2.2	1.5	1.0	. .	. .
18	3.6	2.7	2.0	1.4	. .	. .	. .
19	3.2	2.4	1.8	1.3	. .	. .	. .
20	2.9	2.2	1.6	1.1	. .	. .	. .
21	2.6	2.0	1.4	1.0	. .	. .	. .
22	2.4	1.8	1.3	0.9	. .	. .	. .

For load of 350 lbs. per square foot divide the spacing given by 2.  
Maximum fiber stress 16,000 lbs. per square inch.



## EXPLANATION OF TABLES

On the Properties of Standard and Special I-Beams and Channels,  
Standard and Special Angles, Carnegie Deck Beams, Bulb  
Angles, Z-Bars, Tees, Trough and Corrugated Plates

## AND STANDARD RAIL SECTIONS.

(Pages 101 to 124 inclusive.)

The tables on I-Beams, Channels and Angles are calculated for all weights to which each pattern is rolled. The table for Deck Beams is calculated for the minimum and maximum weights of the various shapes, while the properties of Z-Bars are given for thicknesses differing by  $\frac{1}{8}$  inch.

For Tees, each shape can be rolled to one weight only.

Columns 12 and 13 in the tables for I-Beams and Channels and columns 11 and 13 for Deck Beams and Bulb Angles give coefficients by the help of which the safe, uniformly distributed load may be readily and quickly determined. To do this, it is only necessary to divide the coefficient given by the span or distance between supports in feet. If the weight of the Deck Beam is intermediate between the minimum and maximum weights given, add to the coefficient for the minimum weight the value given in columns 12 or 14 (for one pound increase of weight) multiplied by the number of pounds the section is heavier than the minimum.

If a section is to be selected, (as will usually be the case) intended to carry a certain load for a length of span already determined on, it will only be necessary to ascertain the coefficient which this load and span will require and refer to the table for a section having a coefficient of this value. The coefficient is obtained by multiplying the load in pounds uniformly distributed by the span length in feet.

In case the load is not uniformly distributed, but is concentrated at the middle of the span, multiply the load by 2 and then

consider it as uniformly distributed. The deflection will be  $\frac{8}{10}$ ths of the deflection for the latter load.

For other cases of loading obtain the bending moment in ft. lbs. (the most common cases are given on page 98); this multiplied by 8 will give the coefficient required.

If the loads are quiescent, the coefficients for a fiber stress of 16,000 lbs. per square inch for steel may be used; but if moving loads are to be provided for, the coefficient for 12,500 lbs. should be taken. Inasmuch as the effects of impact may be very considerable (the stresses produced in an unyielding inelastic material by a load suddenly applied being double those produced by the same load in a quiescent state), it will sometimes be advisable to use still smaller fiber stresses than those given in the tables. In such cases the coefficients can readily be determined by proportion. Thus, for a fiber stress of 8,000 lbs. per square inch, the coefficient will equal the coefficient for 16,000 lbs. fiber stress divided by 2.

The section moduli are used to determine the fiber stress per square inch in a beam or other shape, subjected to bending or transverse stresses, by simply dividing the same into the bending moment expressed in inch-pounds.

The table on the properties of Carnegie T-shapes is modeled after the foregoing and will, therefore, scarcely require explanation. The horizontal portion of the T is called the flange and the vertical portion the stem. In the case of the neutral axis parallel to the flange, there will be two section moduli and the smaller is given. The fiber stress calculated from it will, therefore, give the larger of the two stresses in the extreme fibers, since these stresses are equal to the bending moment divided by the section modulus of the section.

For Carnegie Z-Bars complete tables of moments of inertia, section moduli, radii of gyration and values of the coefficients (C) are given on pages 107 and 108 for thicknesses varying by  $\frac{1}{8}$  inch. These coefficients may be applied, as explained above, for cases where the Z-Bars are subjected to transverse loading, as, for example, in the case of roof-purlins. A table of safe loads of Z-Bars is given on page 78.

For angles, there will be two section moduli for each position of the neutral axis, since the distance between the neutral axis and the extreme fibers has a different value on one side of the axis from what it has on the other. The section modulus given in the table is the smaller of these two values.

Column 14 in the table of the "Properties of Beams" gives the distance c. t. c. of beams making the radii of gyration equal for both axes.

The length of a beam used as a strut should not exceed 125 times its least radius of gyration.

Column 14 in the table of the "Properties of Standard Channels" gives the distances which the channels should be placed back to back to make the radii of gyration equal for both axes. Column 15 in the same table can be used to obtain the radius of gyration for struts consisting of two channels when the distance back to back varies from that given in the table.

These tables have all been prepared with great care. No approximations have entered into any of the calculations so that the figures given may be relied upon as accurate.

#### EXAMPLES.

I. What section of I-Beam will be required to carry 40,000 lbs. uniformly distributed, including its own weight, over a span of 16 feet between supports, allowing a fiber stress of 16,000 lbs. per square inch?

*Answer:* The coefficient (C) required =  $40,000 \times 16 = 640,000$ .

In table of Properties of I-Beams, page 102, look in Column 12 for the nearest number corresponding to 640,000 which is 648,200. Therefore the beam to be used is 15'' 45 lbs.

II. What load uniformly distributed will a 6'' Z-Bar carry, weighing 18.3 lbs. per foot and measuring 12 feet between supports with a maximum fiber stress of 12,000 lbs.?

*Answer:* From table on page 108 the coefficient (C') for a 6'' Z-Bar 18.3 lbs. = 78,600. Hence the safe load =  $78,600 \div 12 = 6,550$  lbs. including weight of Z-Bar.

III. A light 4" × 3" angle weighing 7.1 lbs. per foot, spanning 4 feet, is loaded with 1,000 lbs. at center. What will be the maximum fiber stress, if the 4" flange is in a vertical position?

*Answer:* Bending moment = 12,000 inch-pounds.

From table, section modulus = 1.23. Therefore maximum fiber stress =  $\frac{12,000}{1.23}$  or 9,756 lbs. which is the stress furthest from the neutral axis, *i. e.*, at the end of the long flange.

### SPECIAL CASES OF LOADING.

I. Beam loaded by a single load  $P$  at a point distant "b" feet from the left hand and "a" feet from the right hand support.  
 $l$  = length of beam between supports =  $a + b$ .

*Pressure or Reaction* at left hand support =  $P \frac{a}{l}$  and at right hand support =  $P \frac{b}{l}$

*Maximum bending moment* neglecting dead weight of beam occurs at point of application of the load and =  $\frac{Pab}{l}$ .

$P$  = load given in tables pages 73 to 84  $\times \frac{l^2}{8ab}$ .

When  $a = b = \frac{1}{2} l$ :

*Reaction* =  $\frac{P}{2}$ ; *maximum bending moment* =  $\frac{Pl}{4}$  and  $P$  = load given in tables  $\times \frac{1}{2}$ .

II. Beam fixed at one end and unsupported at the other,  $l$  representing the length of beam from end to support.

If loaded by a uniformly distributed load  $W$ :

*Maximum bending moment* occurs at support and =  $\frac{Wl}{2}$ .

$W$  = load given in tables pages 73 to 84  $\times \frac{1}{4}$ .

If loaded with a single load  $P$  at its extremity:

*Maximum bending moment* occurs at support and =  $Pl$ .

$P$  = load given in tables  $\times \frac{1}{8}$ .

GENERAL FORMULÆ ON THE FLEXURE OF BEAMS  
OF ANY CROSS-SECTION.

- Let  $A$  = area of section in square inches,  
 $l$  = length of span in inches,  
 $W$  = load uniformly distributed in lbs.,  
 $M$  = bending moment in inch pounds,  
 $h$  = height of cross-section, out to out, in inches,  
 $n$  = distance of center of gravity of section, from top or from bottom, in inches,  
 $f$  = stress per square inch in extreme fibers of beam, either top or bottom, in lbs. according as  $n$  relates to distance from top or from bottom of section,  
 $D$  = maximum deflection in inches,  
 $I$  = moment of inertia of section neutral axis through center of gravity,  
 $I''$  = moment of inertia of section neutral axis parallel to above, but not through center of gravity,  
 $d$  = distance between these neutral axes,  
 $S$  = section modulus,  
 $r$  = radius of gyration in inches.  
 $E$  = modulus of elasticity for steel 29,000,000 ;

$$\text{Then : } S = \frac{I}{n}, \quad r = \sqrt{\frac{I}{A}}$$

$$M = \frac{f I}{n} = f S,$$

$$f = \frac{M n}{I} = \frac{M}{S},$$

$$W = \frac{8 f I}{l n} = \frac{8 f}{l} S,$$

$$f = \frac{W l n}{8 I} = \frac{W l}{8 S},$$

$$I'' = I + A d^2,$$

$$D = \frac{5 W l^3}{384 E I} \text{ for beam supported at both ends and uniformly loaded,}$$

$$D = \frac{P l^3}{48 E I} \text{ for beam supported at both ends and loaded with a single load } P \text{ at middle,}$$

$$D = \frac{W l^3}{8 E I} \text{ for beam fixed at one end and unsupported at the other and uniformly loaded,}$$

$$D = \frac{P l^3}{3 E I} \text{ for beam fixed at one end and unsupported at the other and loaded with a single load } P \text{ at the latter end.}$$

BENDING MOMENTS AND DEFLECTIONS OF BEAMS UNDER VARIOUS SYSTEMS OF LOADING.

$W$ —total load.

$l$ —length of beam.

$I$ —moment of Inertia.

$E$ —modulus of elasticity.

- (1.) Beam fixed at one end and loaded at the other.

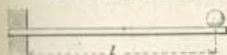

Safe load— $\frac{1}{8}$  that given in tables.  
 Maximum bending moment at point of support— $Wl$ .  
 Maximum shear at point of support— $W$ .  
 Deflection— $\frac{Wl^3}{3EI}$ .

- (2.) Beam fixed at one end and uniformly loaded.

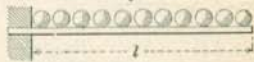

Safe load— $\frac{1}{4}$  that given in tables.  
 Maximum bending moment at point of support— $\frac{Wl}{2}$ .  
 Maximum shear at point of support— $W$ .  
 Deflection— $\frac{Wl^3}{8EI}$ .

- (3.) Beam supported at both ends, single load in the middle.



Safe load— $\frac{1}{2}$  that given in tables.  
 Maximum bending moment at middle of beam— $\frac{Wl}{4}$ .  
 Maximum shear at points of support— $\frac{1}{2}W$ .  
 Deflection— $\frac{Wl^3}{48EI}$ .

- (4.) Beam supported at both ends and uniformly loaded.

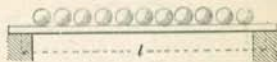

Safe load—that given in tables.  
 Maximum bending moment at middle of beam— $\frac{Wl}{8}$ .  
 Maximum shear at points of support— $\frac{1}{2}W$ .  
 Deflection— $\frac{Wl^3}{76.8EI}$ .

- (5.) Beam supported at both ends, single unsymmetrical load.

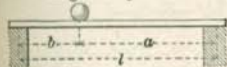

Safe load—that given in tables  $\times \frac{l^2}{8ab}$ .  
 Maximum bending moment under load— $\frac{Wab}{l}$ .  
 Maximum shears: at support near  $a = \frac{Wb}{l}$ ; at other support— $\frac{Wa}{l}$ .  
 Max. Deflec.— $\frac{Wab(2l-a)}{9EI} \sqrt{\frac{1}{3}a(2l-a)}$ .

- (6.) Beam supported at both ends, two symmetrical loads.

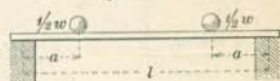

Safe load—that given in tables  $\times \frac{l}{4a}$ .  
 Maximum bending moment between loads— $\frac{1}{2}Wa$ .  
 Maximum shear between load and nearer support— $\frac{1}{2}W$ .  
 Max. Deflection— $\frac{Wa}{48EI} (3l^2 - 4a^2)$ .

PROP  
ERTIES

COLS

L  
Y

VALUES OF MOMENTS OF INERTIA FOR  
CARNEGIE STANDARD SHAPES.

$I$  = Moment of Inertia neutral axis parallel to flange.  
 $I'$  = " " " " " " " " web.

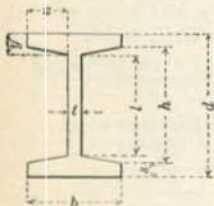

$$\text{Area} = A = dt + (s+y)2z.$$

$$I = \frac{1}{12} [bd^3 - \frac{3}{4}(h^4 - t^4)].$$

$$I' = \frac{1}{12} [b^3(d-h) + lt^3 + \frac{1}{2}(b^4 - t^4)].$$

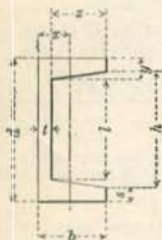

$$\text{Area} = A = dt + (s+y)z.$$

$$x = [b^2s + \frac{1}{2}ht^2 + \frac{1}{8}(b-t)^2(b+2t)] \div A.$$

$$I = \frac{1}{12} [bd^3 - \frac{3}{4}(h^4 - t^4)].$$

$$I' = \frac{1}{12} [2sb^3 + lt^3 + \frac{1}{2}(b^4 - t^4)] - Ax^2.$$

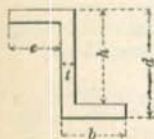

$$\text{Area} = A = (d+2c)t.$$

$$I = \frac{1}{12} [bd^3 - 8c(h - \frac{d}{2})^3].$$

$$I' = \frac{1}{12} [d(b+c)^3 - 2hc^3 - 6hcb^2].$$

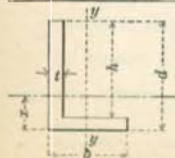









$$\text{Area} = A = (b+d-t)t.$$

$$x = \frac{t(2h+b) + h^2}{2(h+b)}.$$

$$I = \frac{1}{12} [bx^3 + t(d-x)^3 - (b-t)(x-t)^3].$$

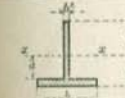
VALUES OF I (Moment of Inertia) AND S (Section Modulus)  
FOR USUAL SECTIONS.

SECTIONS,	I	S
	$I = \frac{bh^3}{12}$	$\frac{bh^2}{6}$
	$I' = \frac{bh^3}{3}$	
	$I = \frac{bh^3}{36}$	Min. $\frac{bh^2}{24}$
	$I' = \frac{bh^3}{12}$	
	$I = \frac{\pi d^4}{64}$ $= 0.0491 d^4$	$\frac{\pi d^3}{32}$ $= 0.0982 d^3$
	$I = \frac{bh^3 - b'h'^3}{12}$	$\frac{I}{0.5h}$
	$I = 0.0491 (d^4 - d'^4)$	$0.0982 \left( d^3 - \frac{d'^4}{d} \right)$
	$I = \frac{b'n^3 + bn'^3 - (b-b')a^3}{3}$	Min. $\frac{I}{n}$
	$I = \frac{bh^3 - 2b'h'^3}{12}$	$\frac{I}{0.5h}$

X X Denotes position of neutral axis.



PROPERTIES OF

1	2	3	4	5	6	7	8	9
Section Index.	Depth of Beam.	Weight per foot.	Area of Section.	Thickness of Web.	Width of Flange.	Mom. of Inertia neutral axis perpendicular to web at center.	Mom. of Inertia neutral axis coincident with center line of web.	Radius of Gyration neutral axis perpendicular to web at center.
	Ins.	Lbs.	Sq. In.	Inches.	Inches.	I	I'	r
B 1	24	100.00	29.41	0.754	7.254	2380.3	48.56	9.00
		95.00	27.94	0.692	7.192	2309.6	47.10	9.09
		90.00	26.47	0.631	7.131	2239.1	45.70	9.20
		85.00	25.00	0.570	7.070	2168.6	44.35	9.31
		<b>80.00</b>	<b>23.32</b>	<b>0.500</b>	<b>7.000</b>	<b>2087.9</b>	<b>42.86</b>	<b>9.46</b>
B 2	20	100.00	29.41	0.884	7.284	1655.8	52.65	7.50
		95.00	27.94	0.810	7.210	1606.8	50.78	7.58
		90.00	26.47	0.737	7.137	1557.8	48.98	7.67
		85.00	25.00	0.663	7.063	1508.7	47.25	7.77
		<b>80.00</b>	<b>23.73</b>	<b>0.600</b>	<b>7.000</b>	<b>1466.5</b>	<b>45.81</b>	<b>7.86</b>
B 3	20	75.00	22.06	0.649	6.399	1268.9	30.25	7.58
		70.00	20.59	0.575	6.325	1219.9	29.04	7.70
		<b>65.00</b>	<b>19.08</b>	<b>0.500</b>	<b>6.250</b>	<b>1169.6</b>	<b>27.86</b>	<b>7.83</b>
B 80	18	70.00	20.59	0.719	6.259	921.3	24.62	6.69
		65.00	19.12	0.637	6.177	881.5	23.47	6.79
		60.00	17.65	0.555	6.095	841.8	22.38	6.91
		<b>55.00</b>	<b>15.93</b>	<b>0.460</b>	<b>6.000</b>	<b>795.6</b>	<b>21.19</b>	<b>7.07</b>
B 4	15	100.00	29.41	1.184	6.774	900.5	50.98	5.53
		95.00	27.94	1.085	6.675	872.9	48.37	5.59
		90.00	26.47	0.987	6.577	845.4	45.91	5.65
		85.00	25.00	0.889	6.479	817.8	43.57	5.72
		<b>80.00</b>	<b>23.81</b>	<b>0.810</b>	<b>6.400</b>	<b>795.5</b>	<b>41.76</b>	<b>5.78</b>
B 5	15	75.00	22.06	0.882	6.292	691.2	30.68	5.60
		70.00	20.59	0.784	6.194	663.6	29.00	5.68
		65.00	19.12	0.686	6.096	636.0	27.42	5.77
		<b>60.00</b>	<b>17.67</b>	<b>0.590</b>	<b>6.000</b>	<b>609.0</b>	<b>25.96</b>	<b>5.87</b>
B 7	15	55.00	16.18	0.656	5.746	511.0	17.06	5.62
		50.00	14.71	0.558	5.648	483.4	16.04	5.73
		45.00	13.24	0.460	5.550	455.8	15.09	5.87
		<b>42.00</b>	<b>12.48</b>	<b>0.410</b>	<b>5.500</b>	<b>441.7</b>	<b>14.62</b>	<b>5.95</b>
B 8	12	55.00	16.18	0.822	5.612	321.0	17.46	4.45
		50.00	14.71	0.699	5.489	303.3	16.12	4.54
		45.00	13.24	0.576	5.366	285.7	14.89	4.65
		<b>40.00</b>	<b>11.84</b>	<b>0.460</b>	<b>5.250</b>	<b>268.9</b>	<b>13.81</b>	<b>4.77</b>
B 9	12	35.00	10.29	0.436	5.086	228.3	10.07	4.71
		<b>31.50</b>	<b>9.26</b>	<b>0.350</b>	<b>5.000</b>	<b>215.8</b>	<b>9.50</b>	<b>4.83</b>
B 11	10	40.00	11.76	0.749	5.099	158.7	9.50	3.67
		35.00	10.29	0.602	4.952	146.4	8.52	3.77
		30.00	8.82	0.455	4.805	134.2	7.65	3.90
		<b>25.00</b>	<b>7.37</b>	<b>0.310</b>	<b>4.660</b>	<b>122.1</b>	<b>6.89</b>	<b>4.07</b>
B 13	9	35.00	10.29	0.732	4.772	111.8	7.31	3.29
		30.00	8.82	0.569	4.609	101.9	6.42	3.40
		25.00	7.35	0.406	4.446	91.9	5.65	3.54
		<b>21.00</b>	<b>6.31</b>	<b>0.290</b>	<b>4.330</b>	<b>84.9</b>	<b>5.16</b>	<b>3.67</b>

L=Safe Load in lbs. uniformly distributed; l=Span in feet.

M'=Moment of forces in foot lbs.; C and C'==Coefficients given on opp. page.

Weights in heavy print are standard, others are special.

I-BEAMS.

10	11	12	13	14	15
Radius of Gyration neutral axis coincident with center line of web.	Section Modulus neutral axis perpendicular to web at center.	Coefficient of Strength for fiber stress of 16,000 lbs. per sq. in. Used for Buildings.	Coefficient of Strength for fiber stress of 22,500 lbs. per sq. in. Used for Bridges.	Distance center to center required to make Radii of Gyration equal.	Section Index.
1.28	198.4	2115800	1653000	17.82	
1.30	192.5	2052900	1603900	17.99	
1.31	186.6	1990300	1554900	18.21	B 1
1.33	180.7	1927600	1505900	18.43	
<b>1.36</b>	<b>174.0</b>	<b>1855900</b>	<b>1449900</b>	<b>18.72</b>	
1.34	165.6	1766100	1379800	14.76	
1.35	160.7	1713900	1339000	14.92	
1.36	155.8	1661600	1298100	15.10	B 2
1.37	150.9	1609300	1257200	15.30	
<b>1.39</b>	<b>146.7</b>	<b>1564300</b>	<b>1222100</b>	<b>15.47</b>	
1.17	126.9	1353500	1057400	14.98	
1.19	122.0	1301200	1016600	15.21	B 3
<b>1.21</b>	<b>117.0</b>	<b>1247600</b>	<b>974700</b>	<b>15.47</b>	
1.09	102.4	1091900	853000	13.20	
1.11	97.9	1044800	816200	13.40	
1.13	93.5	997700	779500	13.63	B 80
<b>1.15</b>	<b>88.4</b>	<b>943000</b>	<b>736700</b>	<b>13.95</b>	
1.31	120.1	1280700	1000600	10.75	
1.32	116.4	1241500	969900	10.86	
1.32	112.7	1202300	939300	10.99	B 4
1.32	109.0	1163000	908600	11.13	
<b>1.32</b>	<b>106.1</b>	<b>1131300</b>	<b>883900</b>	<b>11.25</b>	
1.18	92.2	983000	768000	10.95	
1.19	88.5	943800	737400	11.11	B 5
1.20	84.8	904600	706700	11.29	
<b>1.21</b>	<b>81.2</b>	<b>866100</b>	<b>676600</b>	<b>11.49</b>	
1.02	68.1	726800	567800	11.05	
1.04	64.5	687500	537100	11.27	
1.07	60.8	648200	506400	11.54	B 7
<b>1.08</b>	<b>58.9</b>	<b>628300</b>	<b>490800</b>	<b>11.70</b>	
1.04	53.5	570600	445800	8.65	
1.05	50.6	539200	421300	8.83	
1.06	47.6	507900	396800	9.06	B 8
<b>1.08</b>	<b>44.8</b>	<b>478100</b>	<b>373500</b>	<b>9.29</b>	
0.99	38.0	405800	317000	9.21	B 9
<b>1.01</b>	<b>36.0</b>	<b>383700</b>	<b>299700</b>	<b>9.45</b>	
0.90	31.7	338500	264500	7.12	
0.91	29.3	312400	244100	7.32	
0.93	26.8	286300	223600	7.57	B 11
<b>0.97</b>	<b>24.4</b>	<b>260500</b>	<b>203500</b>	<b>7.91</b>	
0.84	24.8	265000	207000	6.36	
0.85	22.6	241500	188700	7.58	
0.88	20.4	217900	170300	6.86	B 13
<b>0.90</b>	<b>18.9</b>	<b>201300</b>	<b>157300</b>	<b>7.12</b>	

$$L = \frac{C \text{ or } C'}{1}$$

$$M' = \frac{C \text{ or } C'}{8}$$

$$C \text{ or } C' = L - 8M' - \frac{8 f S}{12}$$

PROP  
ERTIES

COLS

$\frac{L}{r}$

D  
M

PROPERTIES OF

1	2	3	4	5	6	7	8	9
Section Index.	Depth of Beam. Ins.	Weight per foot. Lbs.	Area of Section. Sq. In.	Thickness of Web. Inches.	Width of Flange. Inches.	Mom. of Inertia neutral axis perpendicular to web at center. I	Mom. of Inertia neutral axis coincident with center line of web. I'	Radius of Gyration neu- tral axis per- pendicular to web at center. r
B 15	8	25.50	7.50	0.541	4.271	68.4	4.75	3.02
		23.00	6.76	0.449	4.179	64.5	4.39	3.09
		20.50	6.03	0.357	4.087	60.6	4.07	3.17
		<b>18.00</b>	<b>5.33</b>	<b>0.270</b>	<b>4.000</b>	<b>56.9</b>	<b>3.78</b>	<b>3.27</b>
B 17	7	20.00	5.88	0.458	3.868	42.2	3.24	2.68
		17.50	5.15	0.353	3.763	39.2	2.94	2.76
		<b>15.00</b>	<b>4.42</b>	<b>0.250</b>	<b>3.660</b>	<b>36.2</b>	<b>2.67</b>	<b>2.86</b>
B 19	6	17.25	5.07	0.475	3.575	26.2	2.36	2.27
		14.75	4.34	0.352	3.452	24.0	2.09	2.35
		<b>12.25</b>	<b>3.61</b>	<b>0.230</b>	<b>3.330</b>	<b>21.8</b>	<b>1.85</b>	<b>2.46</b>
B 21	5	14.75	4.34	0.504	3.294	15.2	1.70	1.87
		12.25	3.60	0.357	3.147	13.6	1.45	1.94
		<b>9.75</b>	<b>2.87</b>	<b>0.210</b>	<b>3.000</b>	<b>12.1</b>	<b>1.23</b>	<b>2.05</b>
B 23	4	10.50	3.09	0.410	2.880	7.1	1.01	1.52
		9.50	2.79	0.337	2.807	6.7	0.93	1.55
		8.50	2.50	0.263	2.733	6.4	0.85	1.59
		<b>7.50</b>	<b>2.21</b>	<b>0.190</b>	<b>2.660</b>	<b>6.0</b>	<b>0.77</b>	<b>1.64</b>
B 77	3	7.50	2.21	0.361	2.521	2.9	0.60	1.15
		6.50	1.91	0.263	2.423	2.7	0.53	1.19
		<b>5.50</b>	<b>1.63</b>	<b>0.170</b>	<b>2.330</b>	<b>2.5</b>	<b>0.46</b>	<b>1.23</b>

Weights in heavy print are standard, others are special.

PROPERTIES OF CARNEGIE TROUGH PLATES.

Section Index.	Size.	Thickness, Inches.	Weight per foot. Lbs.	Area of Section. Sq. In.	Moment of Inertia neutral axis parallel to length. I	Section Modulus, axis as before. S	Radius of Gyration, axis as before. r
	Inches.						
M 10	9 $\frac{1}{2}$ x 3 $\frac{3}{4}$	$\frac{1}{2}$	16.3	4.8	3.68	1.38	0.91
M 11	9 $\frac{1}{2}$ x 3 $\frac{3}{4}$	$\frac{1}{2}$	18.0	5.3	4.13	1.57	0.91
M 12	9 $\frac{1}{2}$ x 3 $\frac{3}{4}$	$\frac{5}{8}$	19.7	5.8	4.57	1.77	0.90
M 13	9 $\frac{1}{2}$ x 3 $\frac{3}{4}$	$\frac{1}{2}$	21.4	6.3	5.02	1.96	0.90
M 14	9 $\frac{1}{2}$ x 3 $\frac{3}{4}$	$\frac{3}{4}$	23.2	6.8	5.46	2.15	0.90

I-BEAMS—Continued.

10	11	12	13	14	15
Radius of Gyration neutral axis coincident with center line of web.	Section Modulus neutral axis perpendicular to web at center.	Coefficient of Strength for fiber stress of 16,000 lbs. per sq. in. Used for Buildings.	Coefficient of Strength for fiber stress of 12,500 lbs. per sq. in. Used for Bridges.	Distance center to center required to make to Radii of Gyration equal.	Section Index.
$r$	$S$	$C$	$C$		
0.80	17.1	182500	142600	5.82	
0.81	16.1	172000	134400	5.96	
0.82	15.1	161600	126200	6.12	B 15
<b>0.84</b>	<b>14.2</b>	<b>151700</b>	<b>118500</b>	<b>6.32</b>	
0.74	12.1	128600	100400	5.15	
0.75	11.2	119400	93300	5.31	B 17
<b>0.78</b>	<b>10.4</b>	<b>110400</b>	<b>86300</b>	<b>5.50</b>	
0.68	8.7	93100	72800	4.33	
0.69	8.0	85300	66600	4.49	B 19
<b>0.72</b>	<b>7.3</b>	<b>77500</b>	<b>60500</b>	<b>4.70</b>	
0.63	6.1	64600	50500	.....	
0.63	5.4	58100	45400	.....	B 21
<b>0.65</b>	<b>4.8</b>	<b>51600</b>	<b>40300</b>	.....	
0.57	3.6	38100	29800	.....	
0.58	3.4	36000	28100	.....	B 23
0.58	3.2	33900	26500	.....	
<b>0.59</b>	<b>3.0</b>	<b>31800</b>	<b>24900</b>	.....	
0.52	1.9	20700	16200	.....	
0.52	1.8	19100	15000	.....	B 77
0.53	1.7	17600	13800	.....	

PROPERTIES OF CARNEGIE CORRUGATED PLATES.

Section Index.	Size.	Thickness.	Weight per foot.	Area of Section.	Moment of Inertia neutral axis parallel to length.	Section Modulus, axis as before.	Radius of Gyration, axis as before.
	Inches.	Inches.	Lbs.	Sq. In.	$I$	$S$	$r$
M 30	8 $\frac{3}{4}$ x 1 $\frac{1}{2}$	$\frac{1}{4}$	8.1	2.4	0.64	0.80	0.52
M 31	8 $\frac{3}{4}$ x 1 $\frac{9}{8}$	$\frac{5}{16}$	10.1	3.0	0.95	1.13	0.57
M 32	8 $\frac{3}{4}$ x 1 $\frac{7}{8}$	$\frac{3}{8}$	12.0	3.5	1.25	1.42	0.62
M 33	12 $\frac{3}{8}$ x 2 $\frac{3}{4}$	$\frac{3}{8}$	17.75	5.2	4.79	3.33	0.96
M 34	12 $\frac{3}{8}$ x 2 $\frac{1}{2}$	$\frac{7}{16}$	20.71	6.1	5.81	3.90	0.98
M 35	12 $\frac{3}{8}$ x 2 $\frac{7}{8}$	$\frac{1}{2}$	23.67	7.0	6.82	4.46	0.99

PROPERTIES OF

1	2	3	4	5	6	7	8	9
Section Index.	Depth of Channel.	Weight per foot.	Area of Section.	Thickness of Web.	Width of Flange.	Mom. of Inertia neutral axis perpendicular to web at center.	Mom. of Inertia neutral axis parallel with center line of web.	Radius of Gyration neutral axis perpendicular to web at center.
	Ins.							
C 1	15	55.00	16.18	0.818	3.818	430.2	12.19	5.16
		50.00	14.71	0.720	3.720	402.7	11.22	5.23
		45.00	13.24	0.622	3.622	375.1	10.29	5.32
		40.00	11.76	0.524	3.524	347.5	9.39	5.43
		35.00	10.29	0.426	3.426	320.0	8.48	5.58
		<b>33.00</b>	<b>9.90</b>	<b>0.400</b>	<b>3.400</b>	<b>312.6</b>	<b>8.23</b>	<b>5.62</b>
C 2	12	40.00	11.76	0.758	3.418	197.0	6.63	4.09
		35.00	10.29	0.636	3.296	179.3	5.90	4.17
		30.00	8.82	0.513	3.173	161.7	5.21	4.28
		25.00	7.35	0.390	3.050	144.0	4.53	4.43
		<b>20.50</b>	<b>6.03</b>	<b>0.280</b>	<b>2.940</b>	<b>128.1</b>	<b>3.91</b>	<b>4.61</b>
C 3	10	35.00	10.29	0.823	3.183	115.5	4.66	3.35
		30.00	8.82	0.676	3.036	103.2	3.99	3.42
		25.00	7.35	0.529	2.889	91.0	3.40	3.52
		20.00	5.88	0.382	2.742	78.7	2.85	3.66
		<b>15.00</b>	<b>4.46</b>	<b>0.240</b>	<b>2.600</b>	<b>66.9</b>	<b>2.30</b>	<b>3.87</b>
C 4	9	25.00	7.35	0.615	2.815	70.7	2.98	3.10
		20.00	5.88	0.452	2.652	60.8	2.45	3.21
		15.00	4.41	0.285	2.488	50.9	1.95	3.40
		<b>13.25</b>	<b>3.89</b>	<b>0.230</b>	<b>2.430</b>	<b>47.3</b>	<b>1.77</b>	<b>3.49</b>
		21.25	6.25	0.582	2.622	47.8	2.25	2.77
C 5	8	18.75	5.51	0.490	2.530	43.8	2.01	2.82
		16.25	4.78	0.399	2.439	39.9	1.78	2.89
		13.75	4.04	0.307	2.347	36.0	1.55	2.98
		<b>11.25</b>	<b>3.35</b>	<b>0.220</b>	<b>2.260</b>	<b>32.3</b>	<b>1.33</b>	<b>3.11</b>
		19.75	5.81	0.633	2.513	33.2	1.85	2.39
C 6	7	17.25	5.07	0.528	2.408	30.2	1.62	2.44
		14.75	4.34	0.423	2.303	27.2	1.40	2.50
		12.25	3.60	0.318	2.198	24.2	1.19	2.59
		<b>9.75</b>	<b>2.85</b>	<b>0.210</b>	<b>2.090</b>	<b>21.1</b>	<b>0.98</b>	<b>2.72</b>
		15.50	4.56	0.563	2.283	19.5	1.28	2.07
C 7	6	13.00	3.82	0.440	2.160	17.3	1.07	2.13
		10.50	3.09	0.318	2.038	15.1	0.88	2.21
		<b>8.00</b>	<b>2.38</b>	<b>0.200</b>	<b>1.920</b>	<b>13.0</b>	<b>0.70</b>	<b>2.34</b>
		11.50	3.38	0.477	2.037	10.4	0.82	1.75
		9.00	2.65	0.330	1.890	8.9	0.64	1.83
C 8	5	<b>6.50</b>	<b>1.95</b>	<b>0.190</b>	<b>1.750</b>	<b>7.4</b>	<b>0.48</b>	<b>1.95</b>
		7.25	2.13	0.325	1.725	4.6	0.44	1.46
		6.25	1.84	0.252	1.652	4.2	0.38	1.51
		<b>5.25</b>	<b>1.55</b>	<b>0.180</b>	<b>1.580</b>	<b>3.8</b>	<b>0.32</b>	<b>1.56</b>
		6.00	1.76	0.362	1.602	2.1	0.31	1.08
C72	3	5.00	1.47	0.264	1.504	1.8	0.25	1.12
		<b>4.00</b>	<b>1.19</b>	<b>0.170</b>	<b>1.410</b>	<b>1.6</b>	<b>0.20</b>	<b>1.17</b>

L=Safe Load in lbs. uniformly distributed; l=Span in feet.  
 M'=Moment of forces in foot lbs.; C and C'=Coefficients given on opp. page.  
 Weights in heavy print are standard, others are special.

CHANNELS.

10	11	12	13	14	15	16
Radius of Gyration neutral axis parallel with center line of web. $r$	Section Modulus neutral axis perpendicular to web at center. $S$	Coefficient of Strength for fiber stress of 10,000 lbs. per sq. in. Used for Buildings. $C$	Coefficient of Strength for fiber stress of 12,500 lbs. per sq. in. Used for Bridges. $C$	Distance required to make Radii of Gyration equal. $D$	Distance of Center of Gravity from outside of web. $X$	Section Index.
.868	57.4	611900	478000	8.53	0.823	
.873	53.7	572700	447400	8.71	0.803	
.882	50.0	533500	416800	8.92	0.788	C 1
.893	46.3	494200	386100	9.15	0.783	
.908	42.7	455000	355500	9.43	0.789	
<b>.912</b>	<b>41.7</b>	<b>444500</b>	<b>347300</b>	<b>9.50</b>	<b>0.794</b>	
.751	32.8	350200	273600	6.60	0.722	
.757	29.9	318800	249100	6.81	0.694	
.768	26.9	287400	224500	7.07	0.677	C 2
.785	24.0	256100	200000	7.36	0.678	
<b>.805</b>	<b>21.4</b>	<b>227800</b>	<b>178000</b>	<b>7.67</b>	<b>0.704</b>	
.672	23.1	246400	192500	5.17	0.695	
.672	20.6	220300	172100	5.40	0.651	
.680	18.2	194100	151700	5.67	0.620	C 3
.696	15.7	168000	131200	5.97	0.609	
<b>.718</b>	<b>13.4</b>	<b>142700</b>	<b>111500</b>	<b>6.33</b>	<b>0.639</b>	
.637	15.7	167600	130900	4.84	0.615	
.646	13.5	144100	112600	5.12	0.585	
.665	11.3	120500	94200	5.49	0.590	C 4
<b>.674</b>	<b>10.5</b>	<b>112200</b>	<b>87600</b>	<b>5.63</b>	<b>0.607</b>	
.600	11.9	127400	99500	4.23	0.587	
.603	11.0	116900	91300	4.38	0.567	
.610	10.0	106400	83200	4.54	0.556	C 5
.619	9.0	96000	75000	4.72	0.557	
<b>.630</b>	<b>8.1</b>	<b>86100</b>	<b>67300</b>	<b>4.94</b>	<b>0.576</b>	
.565	9.5	101100	79000	3.48	0.583	
.564	8.6	92000	71800	3.64	0.555	
.568	7.8	82800	64700	3.80	0.535	C 6
.575	6.9	73700	57500	3.99	0.528	
<b>.586</b>	<b>6.0</b>	<b>66800</b>	<b>52200</b>	<b>4.22</b>	<b>0.546</b>	
.529	6.5	69500	54300	2.91	0.546	
.529	5.8	61600	48100	3.09	0.517	C 7
.534	5.0	53800	42000	3.28	0.503	
<b>.542</b>	<b>4.3</b>	<b>46200</b>	<b>36100</b>	<b>3.52</b>	<b>0.517</b>	
.493	4.2	44400	34700	2.34	0.508	
.493	3.5	37900	29600	2.56	0.481	C 8
<b>.498</b>	<b>3.0</b>	<b>31600</b>	<b>24700</b>	<b>2.79</b>	<b>0.489</b>	
.455	2.3	24400	19000	1.85	0.463	
.454	2.1	22300	17400	1.96	0.458	C 9
<b>.453</b>	<b>1.9</b>	<b>20200</b>	<b>15800</b>	<b>2.06</b>	<b>0.464</b>	
.421	1.4	14700	11500	1.07	0.459	
.415	1.2	13100	10300	1.19	0.443	C72
<b>.409</b>	<b>1.1</b>	<b>11600</b>	<b>9100</b>	<b>1.31</b>	<b>0.443</b>	

$$L = \frac{C \text{ or } C'}{I};$$

$$M' = \frac{C \text{ or } C'}{8};$$

$$C \text{ or } C' = L - 8 M' = \frac{8 f S}{12}$$

PROPERTIES OF

1 Section Index.	2 Depth of Web. Ins.	3 Width of Flange. Ins.	4 Thickness of Metal. Ins.	5 Weight per foot. Lbs.	6 Area of Section. Sq. In.	7 8 Moments of Inertia.	
						I	
						Neutral axis through center of gravity perpendicular to web.	Neutral axis through center of gravity coincident with web.
Z 1	6	3 1/2	3/8	15.6	4.59	25.32	9.11
	6 1/8	3 1/8	7/16	18.3	5.39	29.80	10.95
	6 1/2	3 5/8	1/2	21.0	6.19	34.36	12.87
Z 2	6	3 1/2	9/16	22.7	6.68	34.64	12.59
	6 1/8	3 1/8	5/8	25.4	7.46	38.86	14.42
	6 1/2	3 5/8	1 1/16	28.0	8.25	43.18	16.34
Z 3	6	3 1/2	3/4	29.3	8.63	42.12	15.44
	6 1/8	3 1/8	13/16	32.0	9.40	46.13	17.27
	6 1/2	3 5/8	7/8	34.6	10.17	50.22	19.18
Z 4	5	3 1/4	5/8	11.6	3.40	13.36	6.18
	5 1/8	3 1/8	3/8	13.9	4.10	16.18	7.65
	5 1/2	3 3/8	7/8	16.4	4.81	19.07	9.20
Z 5	5	3 1/4	1/2	17.8	5.25	19.19	9.05
	5 1/8	3 1/8	9/16	20.2	5.94	21.83	10.51
	5 1/2	3 3/8	5/8	22.6	6.64	24.53	12.06
Z 6	5	3 1/4	1 1/16	23.7	6.96	23.68	11.37
	5 1/8	3 1/8	3/4	26.0	7.64	26.16	12.83
	5 1/2	3 3/8	1 1/16	28.3	8.33	28.70	14.36
Z 7	4	3 1/8	1/4	8.2	2.41	6.28	4.23
	4 1/8	3 1/2	5/16	10.3	3.03	7.94	5.46
	4 1/2	3 1/8	3/8	12.4	3.66	9.63	6.77
Z 8	4	3 1/8	7/16	13.8	4.05	9.66	6.73
	4 1/8	3 1/2	1/2	15.8	4.66	11.18	7.96
	4 1/2	3 1/8	9/16	17.9	5.27	12.74	9.26
Z 9	4	3 1/8	5/8	18.9	5.55	12.11	8.73
	4 1/8	3 1/2	1 1/16	20.9	6.14	13.52	9.95
	4 1/2	3 1/8	3/4	22.9	6.75	14.97	11.24
Z10	3	2 1/8	1/4	6.7	1.97	2.87	2.81
	3 1/8	2 3/4	7/16	8.4	2.48	3.64	3.64
Z11	3	2 1/8	3/8	9.7	2.86	3.85	3.92
	3 1/8	2 3/4	1/2	11.4	3.36	4.57	4.75
Z12	3	2 1/8	1/2	12.5	3.69	4.59	4.85
	3 1/8	2 3/4	9/16	14.2	4.18	5.26	5.70

STANDARD Z-BARS.

9		10		11		12		13		14		15		16	
Section Moduli. <i>S</i>		Radii of Gyration. <i>r</i>						Coefficient of Strength. <i>C</i>				Section Index.			
Neutral axis through center of gravity perpendicular to web.	Neutral axis through center of gravity coincident with web.	Neutral axis through center of gravity perpendicular to web.	Neutral axis through center of gravity coincident with web.	Least radius, neutral axis diagonal.	For fiber stress of 16,000 lbs. per sq. in., axis perpendicular to web at center.	For fiber stress of 12,000 lbs. per sq. in., axis perpendicular to web at center.									
8.44	2.75	2.35	1.41	0.83	90000	67500					Z 1				
9.83	3.27	2.35	1.43	0.84	104800	78600									
11.22	3.81	2.36	1.44	0.84	119700	89500									
11.55	3.91	2.28	1.37	0.81	123200	92400					Z 2				
12.82	4.43	2.28	1.39	0.82	136700	102600									
14.10	4.98	2.29	1.41	0.84	150400	112800									
14.04	4.94	2.21	1.34	0.81	149800	112300					Z 3				
15.22	5.47	2.22	1.36	0.82	162300	121800									
16.40	6.02	2.22	1.37	0.83	174900	131200									
5.34	2.00	1.98	1.35	0.75	57000	42700					Z 4				
6.39	2.45	1.99	1.37	0.76	68200	51100									
7.44	2.92	1.99	1.38	0.77	79400	59500									
7.68	3.02	1.91	1.31	0.74	81900	61400					Z 5				
8.62	3.47	1.91	1.33	0.75	91900	69000									
9.57	3.94	1.92	1.35	0.76	102100	76600									
9.47	3.91	1.84	1.28	0.73	101000	75800					Z 6				
10.34	4.37	1.85	1.30	0.75	110300	82700									
11.20	4.84	1.86	1.31	0.76	119500	89600									
3.14	1.44	1.62	1.33	0.67	33500	25100					Z 7				
3.91	1.84	1.62	1.34	0.68	41700	31300									
4.67	2.26	1.62	1.36	0.69	49800	37400									
4.83	2.37	1.55	1.29	0.66	51500	38600					Z 8				
5.50	2.77	1.55	1.31	0.67	58700	44000									
6.18	3.19	1.55	1.33	0.69	65900	49400									
6.05	3.18	1.48	1.25	0.66	64500	48400					Z 9				
6.65	3.58	1.48	1.27	0.67	70900	53200									
7.26	4.00	1.49	1.29	0.69	77400	58100									
1.92	1.10	1.21	1.19	0.55	20500	15400					Z10				
2.38	1.40	1.21	1.21	0.56	25400	19000									
2.57	1.57	1.16	1.17	0.55	27400	20600									
2.98	1.88	1.17	1.19	0.56	31800	23800					Z11				
3.06	1.99	1.12	1.15	0.55	32600	24500					Z12				
3.43	2.31	1.12	1.17	0.56	36600	27400									

COLS

$\frac{L}{r}$

D  
M



THE CARNEGIE STEEL COMPANY, LIMITED.

PROPERTIES OF

1	2	3	4	5	6	7	8	9
Section Index.	Depth of Beam.	Weight per foot.	Area of Section.	Thickness of Web.	Width of Flange.	Increase of Thickness of Web for each lb. increase of wt.	Moment of Inertia, neutral axis perpendicular to web.	Section Modulus, neutral axis as before.
	Inches.							
B110	11.5	37.00	10.9	.55	5.30		194.7	30.6
B110	11.5	32.20	9.5	.42	5.17	.026	178.7	27.6
B100	10	35.70	10.5	.63	5.50		139.9	25.7
B100	10	27.23	8.0	.38	5.25	.029	118.4	21.2
B101	9	30.00	8.8	.57	5.07		93.2	19.6
B101	9	26.00	7.6	.44	4.94	.033	85.2	17.7
B102	8	24.48	7.2	.47	5.16		62.8	14.1
B102	8	20.15	5.9	.31	5.00	.037	55.6	12.2
B103	7	23.46	6.9	.54	5.10		45.5	11.7
B103	7	18.11	5.3	.31	4.87	.042	38.8	9.7
B105	6	17.16	5.0	.43	4.53		24.4	7.2
B105	6	14.10	4.1	.28	4.38	.049	21.6	6.1

PROPERTIES OF

B130a	10	32.00	9.41	.63	3.5		116.0	21.6
B130	10	26.50	7.80	.48	3.5		104.2	19.9
B131	9	21.80	6.41	.44	3.5		69.3	14.5
B132	8	19.23	5.66	.41	3.5		48.8	11.7
B133	7	18.25	5.37	.44	3.0		34.9	9.6
B140	7	16.00	4.71	.34	3.0		32.2	8.7
B134	6	17.20	5.06	.50	3.0		23.9	7.6
B135	6	13.75	4.04	.38	3.0		20.1	6.6
B136	6	12.30	3.62	.31	3.0		18.6	5.7
B137	5	10.00	2.94	.31	2.5		10.2	4.1

PROPERTIES OF

1	2	3	4	5	6	7
Section Index.	Size. Flange by Stem.	Weight per foot.	Area of Section.	Distance of Center of Gravity from outside of flange.	Moment of Inertia, neutral axis through center of gravity parallel to flange.	Least Section Modulus, neutral axis as before.
	Inches					
T50	5 × 3	13.6	3.99	0.75	2.6	1.18
T51	5 × 2 1/2	11.0	3.24	0.65	1.6	0.86
T52	4 1/2 × 3 1/2	15.8	4.65	1.11	5.1	2.13
T53	4 1/2 × 3	8.5	2.55	0.73	1.8	0.81
T54	4 1/2 × 3	10.0	3.00	0.75	2.1	0.94
T55	4 1/2 × 2 1/2	8.0	2.40	0.58	1.1	0.56
T56	4 1/2 × 2 1/2	9.3	2.79	0.60	1.2	0.65
T57	4 × 5	15.6	4.56	1.56	10.7	3.10
T58	4 × 5	12.0	3.54	1.51	8.5	2.43
T59	4 × 4 1/2	14.6	4.29	1.37	8.0	2.55
T60	4 × 4 1/2	11.4	3.36	1.31	6.3	1.98
T 1	4 × 4	13.7	4.02	1.18	5.7	2.02
T 2	4 × 4	10.9	3.21	1.15	4.7	1.64

CARNEGIE DECK BEAMS.

10	11	12	13	14	15	16
Radius of Gyration, neutral axis as before. r	Coefficient of Strength for fiber stress of 16,000 lbs. per sq. in. Used for Buildings. C	Add to coefficient for every lb. increase in weight of beam. C	Coefficient of Strength for fiber stress of 12,000 lbs. per sq. in. Used for Bridges. C'	Add to coefficient for every lb. increase in weight of beam. C'	Mom. of Inertia neutral axis coincident with center line of web. I'	Radius of Gyration, neutral axis as before. r'
4.23	326500		244800		6.60	0.78
4.34	294700	6080	221000	4560	6.06	0.80
3.64	274100		205800		7.41	0.84
3.83	226100	4900	169600	3700	6.12	0.87
3.25	208500		156400		5.18	0.75
3.35	189100	4500	141800	3300	4.61	0.76
3.97	150100		112600		4.45	0.79
3.08	129800	4000	97400	3000	3.90	0.82
3.57	124600		93400		4.30	0.79
2.70	103000	3400	77300	2600	3.55	0.82
2.20	76800		57600		2.66	0.73
2.28	65100	3000	48800	2200	2.22	0.72

CARNEGIE BULB ANGLES.

3.51	230000		172500			
3.66	211700		158800			
3.33	154200		115700			
2.95	124800		93600			
2.56	102300		76700			
2.61	92800		69600			
2.16	80500		60400			
2.21	70400		52800			
2.28	60400		45300			
1.86	43300		32500			

CARNEGIE T SHAPES.

8	9	10	11	12	13
Radius of Gyration, neutral axis as before. r	Mom. of Inertia, neutral axis through ctr. of gravity coincident with center line of stem. I'	Section Modulus, neutral axis as before. S'	Radius of Gyration, neutral axis as before. r'	Coefficient of Strength for fiber stress of 16,000 lbs. per square inch, neutral axis through ctr. of gravity parallel to flange. C	Coefficient of strength for fiber stress of 12,000 lbs. per square inch, neutral axis as before. C'
0.82	5.6	2.22	1.19	12550	9410
0.71	4.3	1.70	1.16	9200	6900
1.04	3.7	1.65	0.90	22690	17020
0.87	2.6	1.16	1.03	8650	6490
0.86	3.1	1.38	1.04	10050	7540
0.69	2.6	1.16	1.07	6030	4520
0.68	3.1	1.38	1.08	6950	5220
1.54	2.8	1.41	0.79	33070	24800
1.56	2.1	1.06	0.78	25880	19410
1.37	2.8	1.41	0.81	27200	20400
1.38	2.1	1.06	0.80	21120	15840
1.20	2.8	1.40	0.84	21550	16170
1.23	2.2	1.09	0.84	17470	13100

## PROPERTIES OF

1	2	3	4	5	6	7
Section Index.	Size, Flange by Stem, Inches.	Weight per foot, Lbs.	Area of Section, Sq. In.	Distance of Center of Gravity from outside of flange, Inches.	Moment of Iner- tia, neutral axis through center of gravity par- allel to flange, I	Least Section Modulus, neutral axis as before, S
T61	4 × 3	9.3	2.73	0.78	2.0	0.88
T62	4 × 2 <sup>1</sup> / <sub>2</sub>	8.6	2.52	0.63	1.2	0.62
T63	4 × 2 <sup>1</sup> / <sub>2</sub>	7.3	2.16	0.60	1.0	0.55
T64	4 × 2	7.9	2.31	0.48	0.6	0.40
T65	4 × 2	6.6	1.95	0.51	0.54	0.34
T66	3 <sup>1</sup> / <sub>2</sub> × 4	12.8	3.75	1.25	5.5	1.98
T67	3 <sup>1</sup> / <sub>2</sub> × 4	9.9	2.91	1.19	4.3	1.55
T 3	3 <sup>1</sup> / <sub>2</sub> × 3 <sup>1</sup> / <sub>2</sub>	11.7	3.45	1.06	3.7	1.52
T 4	3 <sup>1</sup> / <sub>2</sub> × 3 <sup>1</sup> / <sub>2</sub>	9.2	2.70	1.01	3.0	1.19
T69	3 <sup>1</sup> / <sub>2</sub> × 3	10.9	3.21	0.88	2.4	1.13
T70	3 <sup>1</sup> / <sub>2</sub> × 3	8.5	2.49	0.83	1.9	0.88
T71	3 <sup>1</sup> / <sub>2</sub> × 3	7.8	2.28	0.78	1.6	0.72
T72	3 × 4	11.8	3.48	1.32	5.2	1.94
T73	3 × 4	10.6	3.12	1.32	4.8	1.78
T74	3 × 4	9.3	2.73	1.29	4.3	1.57
T75	3 × 3 <sup>1</sup> / <sub>2</sub>	10.9	3.21	1.12	3.5	1.49
T76	3 × 3 <sup>1</sup> / <sub>2</sub>	9.8	2.88	1.11	3.3	1.37
T77	3 × 3 <sup>1</sup> / <sub>2</sub>	8.5	2.49	1.09	2.9	1.1
T 6	3 × 3	10.0	2.94	0.93	2.3	1.10
T 7	3 × 3	9.1	2.67	0.92	2.1	1.01
T 8	3 × 3	7.8	2.28	0.88	1.8	0.86
T 9	3 × 3	6.6	1.95	0.86	1.6	0.74
T78	3 × 2 <sup>1</sup> / <sub>2</sub>	7.2	2.10	0.71	1.1	0.60
T79	3 × 2 <sup>1</sup> / <sub>2</sub>	6.1	1.80	0.68	0.94	0.52
T80	2 <sup>3</sup> / <sub>4</sub> × 2	7.4	2.16	0.53	1.1	0.75
T82	2 <sup>1</sup> / <sub>2</sub> × 3	7.2	2.10	0.97	1.8	0.87
T83	2 <sup>1</sup> / <sub>2</sub> × 3	6.1	1.80	0.92	1.6	0.76
T84	2 <sup>1</sup> / <sub>2</sub> × 2 <sup>3</sup> / <sub>4</sub>	6.7	1.98	0.87	1.4	0.73
T85	2 <sup>1</sup> / <sub>2</sub> × 2 <sup>3</sup> / <sub>4</sub>	5.8	1.71	0.83	1.2	0.60
T10	2 <sup>1</sup> / <sub>2</sub> × 2 <sup>3</sup> / <sub>4</sub>	6.4	1.89	0.76	1.0	0.59
T11	2 <sup>1</sup> / <sub>2</sub> × 2 <sup>1</sup> / <sub>2</sub>	5.5	1.62	0.74	0.87	0.50
T86	2 <sup>1</sup> / <sub>2</sub> × 1 <sup>1</sup> / <sub>4</sub>	2.9	0.84	0.29	0.094	0.09
T12	2 <sup>1</sup> / <sub>4</sub> × 2 <sup>1</sup> / <sub>4</sub>	4.9	1.44	0.69	0.66	0.42
T13	2 <sup>1</sup> / <sub>4</sub> × 2 <sup>1</sup> / <sub>4</sub>	4.1	1.20	0.66	0.51	0.32
T14	2 × 2	4.3	1.26	0.63	0.45	0.33
T15	2 × 2	3.7	1.08	0.59	0.36	0.25
T87	2 × 1 <sup>1</sup> / <sub>2</sub>	3.1	0.90	0.42	0.16	0.15
T16	1 <sup>3</sup> / <sub>4</sub> × 1 <sup>3</sup> / <sub>4</sub>	3.1	0.90	0.54	0.23	0.19
T88	1 <sup>3</sup> / <sub>4</sub> × 1 <sup>1</sup> / <sub>4</sub>	3.6	1.05	0.91	0.12	0.15
T17	1 <sup>1</sup> / <sub>2</sub> × 1 <sup>1</sup> / <sub>2</sub>	2.4	0.75	0.42	0.15	0.14
T18	1 <sup>1</sup> / <sub>2</sub> × 1 <sup>1</sup> / <sub>2</sub>	1.84	0.54	0.44	0.11	0.11
T19	1 <sup>1</sup> / <sub>4</sub> × 1 <sup>1</sup> / <sub>4</sub>	2.04	0.60	0.40	0.08	0.10
T20	1 <sup>1</sup> / <sub>4</sub> × 1 <sup>1</sup> / <sub>4</sub>	1.53	0.45	0.38	0.06	0.07
T21	1 × 1	1.23	0.36	0.32	0.03	0.05
T22	1 × 1	0.87	0.26	0.29	0.02	0.03

CARNEGIE T SHAPES—Continued.

8	9	10	11	12	13
Radius of gyration, neutral axis as before. <i>r</i>	Mom. of inertia, neutral axis through ctr. of gravity coincident with center line of stem. <i>I'</i>	Section Modulus, neutral axis as before. <i>S'</i>	Radius of gyration, neutral axis as before. <i>r'</i>	Coefficient of Strength for fiber stress of 16,000 lbs. per square inch, neutral axis through ctr. of gravity parallel to flange. <i>C</i>	Coefficient of strength for fiber stress of 12,000 lbs. per square inch, neutral axis as before. <i>C'</i>
0.86	2.1	1.05	0.88	9430	7070
0.69	2.1	1.05	0.92	6640	4980
0.70	1.8	0.88	0.91	5850	4380
0.52	2.1	1.05	0.96	4250	3180
0.51	1.8	0.88	0.95	3600	2700
1.21	1.89	1.08	0.72	21150	15870
1.22	1.42	0.81	0.70	16510	12380
1.04	1.89	1.08	0.74	16210	12160
1.05	1.42	0.81	0.73	12710	9530
0.87	1.88	1.08	0.77	12070	9050
0.88	1.41	0.81	0.75	9390	7040
0.89	1.18	0.68	0.76	7720	5790
1.23	1.21	0.81	0.59	20650	15480
1.25	1.09	0.72	0.60	19030	14270
1.26	0.93	0.62	0.59	16720	12540
1.06	1.20	0.80	0.62	15880	11910
1.08	1.31	0.88	0.68	14650	10990
1.09	0.93	0.62	0.61	12910	9680
0.88	1.20	0.80	0.64	11710	8780
0.90	1.08	0.72	0.64	10810	8110
0.90	0.90	0.60	0.63	9200	6900
0.90	0.75	0.50	0.62	7870	5900
0.72	0.89	0.60	0.66	6400	4800
0.73	0.75	0.50	0.65	5470	4100
0.71	0.62	0.45	0.54	3000	6000
0.92	0.54	0.43	0.51	9280	6960
0.94	0.44	0.35	0.51	8150	6110
0.84	0.66	0.53	0.58	7810	5860
0.83	0.44	0.35	0.51	6440	4830
0.74	0.52	0.42	0.53	6270	4700
0.74	0.44	0.35	0.52	5330	4000
0.31	0.29	0.23	0.58	950	710
0.68	0.33	0.30	0.48	4480	3360
0.67	0.25	0.22	0.47	3450	2600
0.60	0.23	0.23	0.43	3480	2610
0.60	0.18	0.18	0.42	2670	2000
0.42	0.18	0.18	0.45	1600	1200
0.51	0.12	0.14	0.37	2050	1540
0.33	0.19	0.22	0.41	1560	1170
0.49	0.08	0.10	0.34	1530	1150
0.45	0.06	0.07	0.31	1150	860
0.36	0.05	0.07	0.27	1010	760
0.37	0.03	0.05	0.26	750	560
0.29	0.02	0.04	0.21	490	370
0.29	0.01	0.02	0.21	320	240

**PROPERTIES OF  
ANGLES WITH UNEQUAL LEGS.**

1 Section Index.	2		3 Thickness, Inches.	4 Weight per foot, lbs.	5 Area of Section, Sq. In.	6 Perpendicular Distances from center of gravity to back of flanges.		7
	Size.					To back of longer flange.	To back of shorter flange.	
	Inches.							
*A150	7	x3 1/2	1	32.3	9.50	0.96	2.71	
*A151	7	x3 1/2	1 1/10	30.5	8.97	0.94	2.69	
*A152	7	x3 1/2	7/8	28.7	8.42	0.92	2.67	
*A153	7	x3 1/2	1 1/10	26.8	7.87	0.89	2.64	
*A154	7	x3 1/2	3/4	24.9	7.31	0.87	2.62	
*A155	7	x3 1/2	1 1/10	23.0	6.75	0.85	2.60	
*A156	7	x3 1/2	3/8	21.0	6.17	0.82	2.57	
*A157	7	x3 1/2	1 9/16	19.0	5.59	0.80	2.55	
*A158	7	x3 1/2	1/2	17.0	5.00	0.78	2.53	
*A159	7	x3 1/2	1 7/8	15.0	4.40	0.75	2.50	
A 89	6	x4	1	30.6	9.00	1.17	2.17	
A 91	6	x4	1 5/16	28.9	8.50	1.14	2.14	
A160	6	x4	7/8	27.2	7.99	1.12	2.12	
A161	6	x4	1 3/8	25.4	7.47	1.10	2.10	
A162	6	x4	3/4	23.6	6.94	1.08	2.08	
A163	6	x4	1 1/8	21.8	6.41	1.06	2.06	
A164	6	x4	5/8	20.0	5.86	1.03	2.03	
A165	6	x4	1 9/16	18.1	5.31	1.01	2.01	
A166	6	x4	1/2	16.2	4.75	0.99	1.99	
A167	6	x4	7/8	14.3	4.18	0.96	1.96	
A168	6	x4	1 3/8	12.3	3.61	0.94	1.94	
A 92	6	x3 1/2	1	28.9	8.50	1.01	2.26	
A 93	6	x3 1/2	1 5/16	27.3	8.03	0.99	2.24	
A169	6	x3 1/2	7/8	25.7	7.55	0.97	2.22	
A170	6	x3 1/2	1 5/16	24.0	7.06	0.95	2.20	
A171	6	x3 1/2	3/4	22.3	6.56	0.93	2.18	
A172	6	x3 1/2	1 1/8	20.6	6.06	0.90	2.15	
A173	6	x3 1/2	3/8	18.9	5.55	0.88	2.13	
A174	6	x3 1/2	1 9/16	17.1	5.03	0.86	2.11	
A175	6	x3 1/2	1/2	15.3	4.50	0.83	2.08	
A176	6	x3 1/2	7/8	13.5	3.97	0.81	2.06	
A177	6	x3 1/2	3/8	11.7	3.42	0.79	2.04	
*A178	5	x4	7/8	24.2	7.11	1.21	1.71	
*A179	5	x4	1 1/8	22.6	6.65	1.18	1.68	
*A180	5	x4	3/4	21.1	6.19	1.16	1.66	

Angles marked \* are special.

STANDARD AND SPECIAL ANGLES.

ANGLES WITH UNEQUAL LEGS.

8	9	10	11	12	13	14	15
Moments of Inertia. I		Section Moduli. S		Radii of Gyration. r			Section Index.
Neutral axis parallel to longer flange.	Neutral axis parallel to shorter flange.	Neutral axis parallel to longer flange.	Neutral axis parallel to shorter flange.	Neutral axis parallel to longer flange.	Neutral axis parallel to shorter flange.	Least Radius.	
7.53	45.37	2.96	10.58	0.89	2.19	0.88	A150*
7.18	43.13	2.80	10.00	0.89	2.19	0.88	A151*
6.83	40.82	2.64	9.42	0.90	2.20	0.88	A152*
6.46	38.45	2.48	8.82	0.91	2.21	0.88	A153*
6.08	35.99	2.31	8.22	0.91	2.22	0.88	A154*
5.69	33.47	2.14	7.60	0.92	2.23	0.89	A155*
5.28	30.86	1.97	6.97	0.93	2.24	0.89	A156*
4.86	28.18	1.80	6.33	0.93	2.25	0.89	A157*
4.41	25.41	1.62	5.68	0.94	2.25	0.89	A158*
3.95	22.56	1.47	5.01	0.95	2.26	0.89	A159*
10.75	30.75	3.79	8.02	1.09	1.85	0.85	A 89
10.26	29.26	3.59	7.59	1.10	1.86	0.85	A 91
9.75	27.73	3.39	7.15	1.11	1.86	0.86	A160
9.23	26.15	3.18	6.70	1.11	1.87	0.86	A161
8.88	24.51	2.97	6.25	1.12	1.88	0.86	A162
8.11	22.82	2.76	5.78	1.13	1.89	0.86	A163
7.52	21.07	2.54	5.31	1.13	1.90	0.86	A164
6.91	19.26	2.31	4.83	1.14	1.90	0.87	A165
6.27	17.40	2.08	4.33	1.15	1.91	0.87	A166
5.60	15.46	1.85	3.83	1.16	1.92	0.87	A167
4.90	13.47	1.60	3.32	1.17	1.93	0.88	A168
7.21	29.24	2.90	7.83	0.92	1.85	0.74	A 92
6.88	27.84	2.74	7.41	0.93	1.86	0.74	A 93
6.55	26.38	2.59	6.98	0.93	1.87	0.75	A169
6.20	24.89	2.43	6.55	0.94	1.88	0.75	A170
5.84	23.34	2.27	6.10	0.94	1.89	0.75	A171
5.47	21.74	2.11	5.65	0.95	1.89	0.75	A172
5.08	20.08	1.94	5.19	0.96	1.90	0.75	A173
4.67	18.37	1.77	4.72	0.96	1.91	0.75	A174
4.25	16.59	1.59	4.24	0.97	1.92	0.76	A175
3.81	14.76	1.41	3.75	0.98	1.93	0.76	A176
3.34	12.86	1.23	3.25	0.99	1.94	0.77	A177
9.23	16.42	3.31	4.99	1.14	1.52	0.84	A178*
8.74	15.54	3.11	4.69	1.15	1.53	0.84	A179*
8.23	14.60	2.90	4.37	1.15	1.54	0.84	A180*

Angles marked \* are special.

**PROPERTIES OF  
ANGLES WITH UNEQUAL LEGS.**

1 Section Index.	2 Size.		3 Thickness, Inches.	4 Weight per foot, Lbs.	5 Area of Section, Sq. In.	6 Perpendicular Distances from center of grav- ity to back of flanges.		7
	Inches.					To back of longer flange.	To back of shorter flange.	
*A181	5	x4	$\frac{11}{16}$	19.5	5.72	1.14	1.64	
*A182	5	x4	$\frac{5}{8}$	17.8	5.23	1.12	1.62	
*A183	5	x4	$\frac{9}{16}$	16.2	4.75	1.10	1.60	
*A184	5	x4	$\frac{1}{2}$	14.5	4.25	1.07	1.57	
*A185	5	x4	$\frac{7}{16}$	12.8	3.75	1.05	1.55	
*A186	5	x4	$\frac{3}{8}$	11.0	3.23	1.03	1.53	
A187	5	x3½	$\frac{7}{8}$	22.7	6.67	1.04	1.79	
A188	5	x3½	$\frac{13}{16}$	21.3	6.25	1.02	1.77	
A189	5	x3½	$\frac{3}{4}$	19.8	5.81	1.00	1.75	
A190	5	x3½	$\frac{11}{16}$	18.3	5.37	0.97	1.72	
A191	5	x3½	$\frac{5}{8}$	16.8	4.92	0.95	1.70	
A192	5	x3½	$\frac{9}{16}$	15.2	4.47	0.93	1.68	
A193	5	x3½	$\frac{1}{2}$	13.6	4.00	0.91	1.66	
A194	5	x3½	$\frac{7}{16}$	12.0	3.53	0.88	1.63	
A195	5	x3½	$\frac{3}{8}$	10.4	3.05	0.86	1.61	
A 96	5	x3½	$\frac{5}{16}$	8.7	2.56	0.84	1.59	
A196	5	x3	$\frac{13}{16}$	19.9	5.84	0.86	1.86	
A197	5	x3	$\frac{3}{4}$	18.5	5.44	0.84	1.84	
A198	5	x3	$\frac{11}{16}$	17.1	5.03	0.82	1.82	
A199	5	x3	$\frac{5}{8}$	15.7	4.61	0.80	1.80	
A200	5	x3	$\frac{9}{16}$	14.2	4.18	0.77	1.77	
A201	5	x3	$\frac{1}{2}$	12.8	3.75	0.75	1.75	
A202	5	x3	$\frac{7}{16}$	11.3	3.31	0.73	1.73	
A203	5	x3	$\frac{3}{8}$	9.8	2.86	0.70	1.70	
A280	5	x3	$\frac{5}{16}$	8.2	2.40	0.68	1.68	
*A204	4½	x3	$\frac{13}{16}$	18.5	5.43	0.90	1.65	
*A205	4½	x3	$\frac{3}{4}$	17.2	5.06	0.88	1.63	
*A206	4½	x3	$\frac{11}{16}$	15.9	4.68	0.85	1.60	
*A207	4½	x3	$\frac{5}{8}$	14.6	4.30	0.83	1.58	
*A208	4½	x3	$\frac{9}{16}$	13.3	3.90	0.81	1.56	
*A209	4½	x3	$\frac{1}{2}$	11.9	3.50	0.79	1.54	
*A210	4½	x3	$\frac{7}{16}$	10.5	3.09	0.76	1.51	
*A211	4½	x3	$\frac{3}{8}$	9.1	2.67	0.74	1.49	
*A 97	4½	x3	$\frac{5}{16}$	7.7	2.25	0.72	1.47	

Angles marked \* are special.

THE CARNEGIE STEEL COMPANY, LIMITED.

STANDARD AND SPECIAL ANGLES—Continued.

ANGLES WITH UNEQUAL LEGS.

8		9		10		11		12		13		14		15	
Moments of Inertia. I				Section Moduli. S				Radii of Gyration. r				Section Index.			
Neutral axis parallel to longer flange.		Neutral axis parallel to shorter flange.		Neutral axis parallel to longer flange.		Neutral axis parallel to shorter flange.		Neutral axis parallel to longer flange.		Neutral axis parallel to shorter flange.					
7.70	13.62	2.69	4.05	1.16	1.54	0.84	A181*								
7.14	12.61	2.48	3.73	1.17	1.55	0.84	A182*								
6.56	11.55	2.26	3.39	1.18	1.56	0.85	A183*								
5.96	10.46	2.04	3.05	1.18	1.57	0.85	A184*								
5.32	9.32	1.81	2.70	1.19	1.58	0.85	A185*								
4.67	8.14	1.57	2.34	1.20	1.59	0.86	A186*								
6.21	15.67	2.52	4.88	0.96	1.53	0.75	A187								
5.89	14.81	2.37	4.58	0.97	1.54	0.75	A188								
5.55	13.92	2.22	4.28	0.98	1.55	0.75	A189								
5.20	12.99	2.06	3.97	0.98	1.56	0.75	A190								
4.83	12.03	1.90	3.65	0.99	1.56	0.75	A191								
4.45	11.03	1.73	3.32	1.00	1.57	0.75	A192								
4.05	9.99	1.56	2.99	1.01	1.58	0.75	A193								
3.63	8.90	1.39	2.64	1.01	1.59	0.76	A194								
3.18	7.78	1.21	2.29	1.02	1.60	0.76	A195								
2.72	6.60	1.02	1.94	1.03	1.61	0.76	A 96								
3.71	13.98	1.74	4.45	0.80	1.55	0.64	A196								
3.51	13.15	1.63	4.16	0.80	1.55	0.64	A197								
3.29	12.28	1.51	3.86	0.81	1.56	0.64	A198								
3.06	11.37	1.39	3.55	0.82	1.57	0.64	A199								
2.83	10.43	1.27	3.23	0.82	1.58	0.65	A200								
2.58	9.45	1.15	2.91	0.83	1.59	0.65	A201								
2.32	8.43	1.02	2.58	0.84	1.60	0.65	A202								
2.04	7.37	0.89	2.24	0.84	1.61	0.65	A203								
1.75	6.26	0.75	1.89	0.85	1.61	0.66	A280								
3.60	10.33	1.71	3.62	0.81	1.38	0.64	A204*								
3.40	9.73	1.60	3.38	0.82	1.39	0.64	A205*								
3.19	9.10	1.49	3.14	0.83	1.39	0.64	A206*								
2.98	8.44	1.37	2.89	0.83	1.40	0.64	A207*								
2.75	7.75	1.25	2.64	0.85	1.41	0.64	A208*								
2.51	7.04	1.13	2.37	0.85	1.42	0.65	A209*								
2.25	6.29	1.01	2.10	0.85	1.43	0.65	A210*								
1.98	5.50	0.88	1.83	0.86	1.44	0.66	A211*								
1.73	4.69	0.76	1.54	0.88	1.44	0.66	A 97*								

Angles marked \* are special.

COLS

L  
r

D  
M



PROPERTIES OF  
ANGLES WITH UNEQUAL LEGS.

1 Section Index.	2 Size. Inches.	3 Thickness. Inches.	4 Weight per foot. Lbs.	5 Area of Section. Sq. In.	6 Perpendicular Distances from center of grav- ity to back of flanges.		7
					To back of longer flange.	To back of shorter flange.	
*A212	4 x 3 1/2	1 1/8	18.5	5.43	1.11	1.36	
*A213	4 x 3 1/2	3/4	17.2	5.06	1.09	1.34	
*A214	4 x 3 1/2	1 1/8	15.9	4.68	1.07	1.32	
*A215	4 x 3 1/2	5/8	14.6	4.30	1.04	1.29	
*A216	4 x 3 1/2	1 1/8	13.3	3.90	1.02	1.27	
*A217	4 x 3 1/2	1/2	11.9	3.50	1.00	1.25	
*A218	4 x 3 1/2	7/8	10.5	3.09	0.98	1.23	
*A219	4 x 3 1/2	3/8	9.1	2.67	0.96	1.21	
*A 98	4 x 3 1/2	5/16	7.7	2.25	0.93	1.18	
A220	4 x 3	1 1/8	17.1	5.03	0.94	1.44	
A221	4 x 3	3/4	16.0	4.69	0.92	1.42	
A222	4 x 3	1 1/8	14.8	4.34	0.89	1.39	
A223	4 x 3	5/8	13.6	3.98	0.87	1.37	
A224	4 x 3	1 1/8	12.3	3.62	0.85	1.35	
A225	4 x 3	1/2	11.1	3.25	0.83	1.33	
A226	4 x 3	7/8	9.8	2.87	0.80	1.30	
A227	4 x 3	3/8	8.5	2.48	0.78	1.28	
A228	4 x 3	5/16	7.1	2.09	0.76	1.26	
A229	3 1/2 x 3	1 1/8	15.7	4.62	0.98	1.23	
A230	3 1/2 x 3	3/4	14.7	4.31	0.96	1.21	
A231	3 1/2 x 3	1 1/8	13.6	4.00	0.94	1.19	
A232	3 1/2 x 3	5/8	12.5	3.67	0.92	1.17	
A233	3 1/2 x 3	1 1/8	11.4	3.34	0.90	1.15	
A234	3 1/2 x 3	1/2	10.2	3.00	0.88	1.13	
A235	3 1/2 x 3	7/8	9.1	2.65	0.85	1.10	
A236	3 1/2 x 3	3/8	7.8	2.30	0.83	1.08	
A237	3 1/2 x 3	5/16	6.6	1.93	0.81	1.06	
A238	3 1/2 x 2 1/2	1 1/8	12.4	3.65	0.77	1.27	
A239	3 1/2 x 2 1/2	5/8	11.4	3.36	0.75	1.25	
A240	3 1/2 x 2 1/2	1 1/8	10.4	3.06	0.73	1.23	
A241	3 1/2 x 2 1/2	1/2	9.4	2.75	0.70	1.20	
A242	3 1/2 x 2 1/2	7/8	8.3	2.43	0.68	1.18	
A243	3 1/2 x 2 1/2	3/8	7.2	2.11	0.66	1.16	
A244	3 1/2 x 2 1/2	5/16	6.1	1.78	0.64	1.14	
A245	3 1/2 x 2 1/2	1/4	4.9	1.44	0.61	1.11	

Angles marked \* are special.

STANDARD AND SPECIAL ANGLES—Continued.  
 ANGLES WITH UNEQUAL LEGS.

8	9	10	11	12	13	14	15
Moments of Inertia. I		Section Moduli. S		Radii of Gyration. r			Section Index.
Neutral axis parallel to longer flange.	Neutral axis parallel to shorter flange.	Neutral axis parallel to longer flange.	Neutral axis parallel to shorter flange.	Neutral axis parallel to longer flange.	Neutral axis parallel to shorter flange.	Least Radius.	
5.49	7.77	2.30	2.92	1.01	1.19	0.72	A212*
5.18	7.32	2.15	2.75	1.01	1.20	0.72	A213*
4.86	6.86	2.00	2.56	1.02	1.21	0.72	A214*
4.52	6.37	1.84	2.35	1.03	1.22	0.72	A215*
4.17	5.86	1.68	2.15	1.03	1.23	0.72	A216*
3.79	5.32	1.52	1.93	1.04	1.23	0.72	A217*
3.40	4.76	1.35	1.72	1.05	1.24	0.72	A218*
2.99	4.18	1.18	1.50	1.06	1.25	0.73	A219*
2.59	3.56	1.01	1.26	1.07	1.26	0.73	A 98*
3.47	7.34	1.68	2.87	0.83	1.21	0.64	A220
3.28	6.93	1.57	2.68	0.84	1.22	0.64	A221
3.08	6.49	1.46	2.49	0.84	1.22	0.64	A222
2.87	6.03	1.35	2.30	0.85	1.23	0.64	A223
2.66	5.55	1.23	2.09	0.86	1.24	0.64	A224
2.42	5.05	1.12	1.89	0.86	1.25	0.64	A225
2.18	4.52	0.99	1.68	0.87	1.25	0.64	A226
1.92	3.96	0.87	1.46	0.88	1.26	0.64	A227
1.65	3.38	0.74	1.23	0.89	1.27	0.65	A228
3.33	4.98	1.65	2.20	0.85	1.04	0.62	A229
3.15	4.70	1.54	2.05	0.85	1.04	0.62	A230
2.96	4.41	1.44	1.91	0.86	1.05	0.62	A231
2.76	4.11	1.33	1.76	0.87	1.06	0.62	A232
2.55	3.79	1.21	1.61	0.87	1.07	0.62	A233
2.33	3.45	1.10	1.45	0.88	1.07	0.62	A234
2.09	3.10	0.98	1.29	0.89	1.08	0.62	A235
1.85	2.72	0.85	1.13	0.90	1.09	0.62	A236
1.58	2.33	0.72	0.96	0.90	1.10	0.63	A237
1.72	4.13	0.99	1.85	0.67	1.06	0.53	A238
1.61	3.85	0.92	1.71	0.69	1.07	0.53	A239
1.49	3.55	0.84	1.56	0.70	1.08	0.53	A240
1.36	3.24	0.76	1.41	0.70	1.09	0.53	A241
1.23	2.91	0.68	1.26	0.71	1.09	0.54	A242
1.09	2.56	0.59	1.09	0.72	1.10	0.54	A243
0.94	2.19	0.50	0.93	0.73	1.11	0.54	A244
0.78	1.80	0.41	0.75	0.74	1.12	0.54	A245

Angles marked \* are special.

COLS

L

r

H

D

M

PROPERTIES OF  
ANGLES WITH UNEQUAL LEGS.

1 Section Index.	2 Size.  Inches.	3 Thickness.  Inches.	4 Weight per foot.  Lbs.	5 Area of Section.  Sq. In.	6 Perpendicular Distances from center of grav- ity to back of flanges.		7  To back of shorter flange.
					To back of longer flange.	To back of shorter flange.	
*A246	3 1/4 x 2	9/16	9.0	2.64	0.59	1.21	
*A247	3 1/4 x 2	1/2	8.1	2.38	0.57	1.19	
*A248	3 1/4 x 2	7/8	7.2	2.11	0.54	1.17	
*A249	3 1/4 x 2	3/8	6.2	1.83	0.52	1.15	
*A250	3 1/4 x 2	5/8	5.3	1.54	0.50	1.12	
*A251	3 1/4 x 2	1/4	4.3	1.25	0.48	1.09	
A252	3 x 2 1/2	9/16	9.5	2.78	0.77	1.02	
A253	3 x 2 1/2	1/2	8.5	2.50	0.75	1.00	
A254	3 x 2 1/2	7/8	7.6	2.22	0.73	0.98	
A255	3 x 2 1/2	3/8	6.6	1.92	0.71	0.96	
A256	3 x 2 1/2	5/8	5.5	1.62	0.68	0.93	
A257	3 x 2 1/2	1/4	4.5	1.31	0.66	0.91	
*A258	3 x 2	1/2	7.7	2.25	0.58	1.08	
*A259	3 x 2	7/8	6.8	2.00	0.56	1.06	
*A260	3 x 2	3/8	5.9	1.73	0.54	1.04	
*A261	3 x 2	5/8	5.0	1.47	0.52	1.02	
*A262	3 x 2	1/4	4.0	1.19	0.49	0.99	
A264	2 1/2 x 2	1/2	6.8	2.00	0.63	0.88	
A265	2 1/2 x 2	7/8	6.1	1.78	0.60	0.85	
A266	2 1/2 x 2	3/8	5.3	1.55	0.58	0.83	
A267	2 1/2 x 2	5/8	4.5	1.31	0.56	0.81	
A268	2 1/2 x 2	1/4	3.7	1.06	0.54	0.79	
A269	2 1/2 x 2	3/8	2.8	0.81	0.51	0.76	
*A270	2 1/4 x 1 1/2	1/2	5.5	1.63	0.48	0.86	
*A271	2 1/4 x 1 1/2	7/8	5.0	1.45	0.46	0.83	
*A272	2 1/4 x 1 1/2	3/8	4.3	1.27	0.44	0.81	
*A273	2 1/4 x 1 1/2	5/8	3.7	1.07	0.42	0.79	
*A274	2 1/4 x 1 1/2	1/4	3.0	0.88	0.39	0.77	
*A275	2 1/4 x 1 1/2	3/8	2.3	0.67	0.37	0.75	
*A276	2 x 1 3/8	1/4	2.7	0.78	0.37	0.69	
*A277	2 x 1 3/8	3/8	2.1	0.60	0.35	0.66	
*A278	1 3/8 x 1	1/4	1.8	0.53	0.29	0.48	
*A279	1 3/8 x 1	3/8	1.0	0.28	0.26	0.44	

Angles marked \* are special.

STANDARD AND SPECIAL ANGLES—Continued.  
ANGLES WITH UNEQUAL LEGS.

8	9	10	11	12	13	14	15
Moments of Inertia. I		Section Moduli. S		Radii of Gyration. r			Section Index.
Neutral axis parallel to longer flange.	Neutral axis parallel to shorter flange.	Neutral axis parallel to longer flange.	Neutral axis parallel to shorter flange.	Neutral axis parallel to longer flange.	Neutral axis parallel to shorter flange.	Least Radius.	
0.75	2.64	0.53	1.30	0.53	1.00	0.44	A246*
0.69	2.42	0.48	1.17	0.54	1.01	0.44	A247*
0.62	2.18	0.43	1.05	0.54	1.02	0.44	A248*
0.55	1.92	0.37	0.91	0.55	1.02	0.44	A249*
0.48	1.65	0.32	0.77	0.56	1.03	0.45	A250*
0.40	1.36	0.26	0.63	0.57	1.04	0.45	A251*
1.42	2.28	0.82	1.15	0.72	0.91	0.52	A252
1.30	2.08	0.74	1.04	0.72	0.91	0.52	A253
1.18	1.88	0.66	0.93	0.73	0.92	0.52	A254
1.04	1.66	0.58	0.81	0.74	0.93	0.52	A255
0.90	1.42	0.49	0.69	0.74	0.94	0.53	A256
0.74	1.17	0.40	0.56	0.75	0.95	0.53	A257
0.67	1.92	0.47	1.00	0.55	0.92	0.43	A258*
0.61	1.73	0.42	0.89	0.55	0.93	0.43	A259*
0.54	1.53	0.37	0.78	0.56	0.94	0.43	A260*
0.47	1.32	0.32	0.66	0.57	0.95	0.43	A261*
0.39	1.09	0.25	0.54	0.57	0.95	0.43	A262*
0.64	1.14	0.46	0.70	0.56	0.75	0.42	A264
0.58	1.03	0.41	0.62	0.57	0.76	0.42	A265
0.51	0.91	0.36	0.55	0.58	0.77	0.42	A266
0.45	0.79	0.31	0.47	0.58	0.78	0.42	A267
0.37	0.65	0.25	0.38	0.59	0.78	0.42	A268
0.29	0.51	0.20	0.29	0.60	0.79	0.43	A269
0.26	0.82	0.26	0.59	0.40	0.71	0.39	A270*
0.24	0.68	0.23	0.48	0.41	0.69	0.39	A271*
0.21	0.61	0.20	0.42	0.41	0.69	0.39	A272*
0.19	0.53	0.17	0.36	0.42	0.70	0.40	A273*
0.16	0.44	0.14	0.30	0.42	0.71	0.40	A274*
0.12	0.34	0.11	0.23	0.43	0.72	0.40	A275*
0.12	0.37	0.12	0.23	0.39	0.63	0.30	A276*
0.09	0.24	0.09	0.18	0.40	0.63	0.31	A277*
0.04	0.09	0.05	0.09	0.27	0.41	0.22	A278*
0.02	0.05	0.03	0.06	0.29	0.44	0.22	A279*

Angles marked \* are special.

PROPERTIES OF STANDARD AND SPECIAL ANGLES.

ANGLES WITH EQUAL LEGS.

1	2	3	4	5	6	7	8	9	10
Section Index.	Size.  Inches.	Thickness.  Ins.	Weight per foot.  Lbs.	Area of Section.  Sq. In.	Distance of center of gravity from back of flange.  Inches.	Moment of Inertia, neutral axis through center of gravity parallel to flange.	Section Modulus, neutral axis as before.	Radius of Gyration, neutral axis as before.	Least Radius of Gy- ration, neutral axis through center of gravity at angle of 45° to flanges.
						I	S	r	
A113	8 x8	1 1/8	56.9	16.73	2.41	97.97	17.53	2.42	1.55
A112	8 x8	1 1/8	54.0	15.87	2.39	93.53	16.67	2.43	1.56
A111	8 x8	1	51.0	15.00	2.37	88.98	15.80	2.44	1.56
A110	8 x8	15/16	48.0	14.12	2.34	84.33	14.91	2.44	1.56
A109	8 x8	7/8	45.0	13.23	2.32	79.58	14.01	2.45	1.57
A108	8 x8	13/16	42.0	12.34	2.30	74.71	13.11	2.46	1.57
A107	8 x8	3/4	38.9	11.44	2.28	69.74	12.18	2.47	1.57
A106	8 x8	11/16	35.8	10.53	2.25	64.64	11.25	2.48	1.58
A105	8 x8	5/8	32.7	9.61	2.23	59.42	10.30	2.49	1.58
A104	8 x8	9/16	29.5	8.68	2.21	54.09	9.34	2.50	1.58
A103	8 x8	1/2	26.4	7.75	2.19	48.63	8.37	2.50	1.58
A 86	6 x6	1	37.4	11.00	1.86	35.46	8.57	1.80	1.16
A 87	6 x6	15/16	35.3	10.37	1.84	33.72	8.11	1.80	1.16
A 1	6 x6	7/8	33.1	9.74	1.82	31.92	7.64	1.81	1.17
A 2	6 x6	13/16	30.9	9.09	1.80	30.06	7.15	1.82	1.17
A 3	6 x6	3/4	28.7	8.44	1.78	28.15	6.66	1.83	1.17
A 4	6 x6	11/16	26.5	7.78	1.75	26.19	6.17	1.83	1.17
A 5	6 x6	5/8	24.2	7.11	1.73	24.16	5.66	1.84	1.18
A 6	6 x6	9/16	21.9	6.43	1.71	22.07	5.14	1.85	1.18
A 7	6 x6	1/2	19.6	5.75	1.68	19.91	4.61	1.86	1.18
A 8	6 x6	7/16	17.2	5.06	1.66	17.68	4.07	1.87	1.19
A 88	6 x6	3/8	14.8	4.36	1.64	15.39	3.53	1.88	1.19
*A 94	5 x5	1	30.6	9.00	1.61	19.64	5.80	1.48	0.96
*A 95	5 x5	15/16	28.9	8.50	1.59	18.71	5.49	1.48	0.96
*A 9	5 x5	7/8	27.2	7.99	1.57	17.75	5.17	1.49	0.96
*A 10	5 x5	13/16	25.4	7.46	1.55	16.77	4.85	1.50	0.97
*A 11	5 x5	3/4	23.6	6.94	1.52	15.74	4.53	1.51	0.97
*A 12	5 x5	11/16	21.8	6.42	1.50	14.68	4.20	1.51	0.97
*A 13	5 x5	5/8	20.0	5.86	1.48	13.58	3.86	1.52	0.97
*A 14	5 x5	9/16	18.1	5.31	1.46	12.44	3.51	1.53	0.98
*A 15	5 x5	1/2	16.2	4.75	1.43	11.25	3.15	1.54	0.98
*A 16	5 x5	7/16	14.3	4.18	1.41	10.02	2.79	1.55	0.98
*A 17	5 x5	3/8	12.3	3.61	1.39	8.74	2.42	1.56	0.99
A 18	4 x4	13/16	19.9	5.84	1.29	8.14	3.01	1.18	0.77
A 19	4 x4	3/4	18.5	5.44	1.27	7.67	2.81	1.19	0.77

Angles marked \* are special.

PROPERTIES OF STANDARD AND SPECIAL ANGLES—Continued.

ANGLES WITH EQUAL LEGS.

1	2	3	4	5	6	7	8	9	10	
Section Index.	Size.		Thickness.	Weight per foot.	Area of Section.	Distance of center of gravity from back of flange.	Moment of Inertia, neutral axis through center of gravity parallel to flange.	Section Modulus, neutral axis as before.	Radius of Gyration, neutral axis as before.	Least Radius of Gyration, neutral axis through center of gravity at angle of 45° to flanges.
	Inches.	Ins.								
A 20	4	x4	1 1/8	17.1	5.03	1.25	7.17	2.61	1.19	0.77
A 21	4	x4	3/8	15.7	4.61	1.23	6.66	2.40	1.20	0.77
A 22	4	x4	1 1/8	14.3	4.18	1.21	6.12	2.19	1.21	0.78
A 23	4	x4	1/2	12.8	3.75	1.18	5.56	1.97	1.22	0.78
A 24	4	x4	1 1/8	11.3	3.31	1.16	4.97	1.75	1.23	0.78
A 25	4	x4	3/8	9.8	2.86	1.14	4.36	1.52	1.23	0.79
A 90	4	x4	1 1/8	8.2	2.40	1.12	3.71	1.29	1.24	0.79
A 26	3 1/2	x3 1/2	1 1/8	17.1	5.03	1.17	5.25	2.25	1.02	0.67
A 27	3 1/2	x3 1/2	3/4	16.0	4.69	1.15	4.96	2.11	1.03	0.67
A 28	3 1/2	x3 1/2	1 1/8	14.8	4.34	1.12	4.65	1.96	1.04	0.67
A 29	3 1/2	x3 1/2	3/8	13.6	3.98	1.10	4.33	1.81	1.04	0.67
A 30	3 1/2	x3 1/2	1 1/8	12.3	3.62	1.08	3.99	1.65	1.05	0.68
A 31	3 1/2	x3 1/2	1/2	11.1	3.25	1.06	3.64	1.49	1.06	0.68
A 32	3 1/2	x3 1/2	1 1/8	9.8	2.87	1.04	3.26	1.32	1.07	0.68
A 33	3 1/2	x3 1/2	3/8	8.5	2.48	1.01	2.87	1.15	1.07	0.69
A 99	3 1/2	x3 1/2	1 1/8	7.1	2.09	0.99	2.45	0.98	1.08	0.69
A 34	3	x3	5/8	11.4	3.36	0.98	2.62	1.30	0.88	0.57
A 35	3	x3	1 1/8	10.4	3.06	0.95	2.43	1.19	0.89	0.58
A 36	3	x3	1/2	9.4	2.75	0.93	2.22	1.07	0.90	0.58
A 37	3	x3	1 1/8	8.3	2.43	0.91	1.99	0.95	0.91	0.58
A 38	3	x3	3/8	7.2	2.11	0.89	1.76	0.83	0.91	0.58
A 39	3	x3	1 1/8	6.1	1.78	0.87	1.51	0.71	0.92	0.59
A 40	3	x3	1/4	4.9	1.44	0.84	1.24	0.58	0.93	0.59
*A 41	2 3/4	x2 3/4	1/2	8.5	2.50	0.87	1.67	0.89	0.82	0.52
*A 42	2 3/4	x2 3/4	1 1/8	7.6	2.22	0.85	1.51	0.79	0.82	0.53
*A 43	2 3/4	x2 3/4	3/8	6.6	1.92	0.82	1.33	0.69	0.83	0.53
*A 44	2 3/4	x2 3/4	1 1/8	5.5	1.62	0.80	1.15	0.59	0.84	0.54
*A 45	2 3/4	x2 3/4	1/4	4.5	1.31	0.78	0.93	0.48	0.85	0.55
A 46	2 1/2	x2 1/2	1/2	7.7	2.25	0.81	1.23	0.73	0.74	0.47
A 47	2 1/2	x2 1/2	1 1/8	6.8	2.00	0.78	1.11	0.65	0.74	0.48
A 48	2 1/2	x2 1/2	3/8	5.9	1.73	0.76	0.98	0.57	0.75	0.48
A 49	2 1/2	x2 1/2	1 1/8	5.0	1.47	0.74	0.85	0.48	0.76	0.49
A 50	2 1/2	x2 1/2	1/4	4.1	1.19	0.72	0.70	0.40	0.77	0.49
A100	2 1/2	x2 1/2	1 1/8	3.1	0.90	0.69	0.55	0.30	0.78	0.49

Angles marked \* are special.

PROPERTIES OF STANDARD AND SPECIAL ANGLES—Continued.

ANGLES WITH EQUAL LEGS.

1	2	3	4	5	6	7	8	9	10
Section Index.	Size. Inches.	Thickness. Ins.	Weight per foot. Lbs.	Area of Section. Sq. In.	Distance of center of gravity from back of flange. Inches.	Moment of Inertia, neutral axis through center of gravity parallel to flange.	Section Modulus, neutral axis as before.	Radius of Gyration, neutral axis as before.	Least Radius of Gyration, neutral axis through center of gravity at angle of 45° to flanges.
						I	S	r	r'
*A 51	2 1/4 x 2 1/4	1/2	6.8	2.00	0.74	0.87	0.58	0.66	0.43
*A 52	2 1/4 x 2 1/4	5/8	6.1	1.78	0.72	0.79	0.52	0.67	0.43
*A 53	2 1/4 x 2 1/4	3/8	5.3	1.55	0.70	0.70	0.45	0.67	0.43
*A 54	2 1/4 x 2 1/4	1/2	4.5	1.31	0.68	0.61	0.39	0.68	0.44
*A 55	2 1/4 x 2 1/4	3/4	3.7	1.06	0.66	0.51	0.32	0.69	0.44
*A101	2 1/4 x 2 1/4	1/2	2.8	0.81	0.63	0.39	0.24	0.70	0.44
A 56	2 x 2	7/8	5.3	1.56	0.66	0.54	0.40	0.59	0.39
A 57	2 x 2	3/8	4.7	1.36	0.64	0.48	0.35	0.59	0.39
A 58	2 x 2	5/8	4.0	1.15	0.61	0.42	0.30	0.60	0.39
A 59	2 x 2	1/4	3.2	0.94	0.59	0.35	0.25	0.61	0.39
A 60	2 x 2	5/8	2.5	0.72	0.57	0.28	0.19	0.62	0.40
A 61	1 3/4 x 1 3/4	7/8	4.6	1.30	0.59	0.35	0.30	0.51	0.33
A 62	1 3/4 x 1 3/4	3/8	4.0	1.17	0.57	0.31	0.26	0.51	0.34
A 63	1 3/4 x 1 3/4	1/2	3.4	1.00	0.55	0.27	0.23	0.52	0.34
A 64	1 3/4 x 1 3/4	1/4	2.8	0.81	0.53	0.23	0.19	0.53	0.34
A 65	1 3/4 x 1 3/4	5/8	2.1	0.62	0.51	0.18	0.14	0.54	0.35
A 66	1 1/2 x 1 1/2	3/8	3.4	0.99	0.51	0.19	0.19	0.44	0.29
A 67	1 1/2 x 1 1/2	5/8	2.9	0.84	0.49	0.16	0.162	0.44	0.29
A 68	1 1/2 x 1 1/2	1/4	2.4	0.69	0.47	0.14	0.134	0.45	0.29
A 69	1 1/2 x 1 1/2	5/8	1.8	0.53	0.44	0.11	0.104	0.46	0.29
A102	1 1/2 x 1 1/2	3/8	1.2	0.36	0.42	0.08	0.070	0.46	0.30
A 70	1 1/4 x 1 1/4	5/8	2.4	0.69	0.42	0.09	0.109	0.36	0.23
A 71	1 1/4 x 1 1/4	3/4	1.9	0.56	0.40	0.077	0.091	0.37	0.24
A 72	1 1/4 x 1 1/4	1/2	1.5	0.43	0.38	0.061	0.071	0.38	0.24
A 73	1 1/4 x 1 1/4	3/8	1.0	0.30	0.35	0.044	0.049	0.38	0.25
A 78	1 x 1	1/4	1.5	0.44	0.34	0.037	0.056	0.29	0.19
A 79	1 x 1	5/8	1.2	0.34	0.32	0.030	0.044	0.30	0.19
A 80	1 x 1	1/8	0.8	0.24	0.30	0.022	0.031	0.31	0.20
*A 81	7/8 x 7/8	1/2	1.0	0.29	0.29	0.019	0.033	0.26	0.18
*A 82	7/8 x 7/8	1/8	0.7	0.21	0.26	0.014	0.023	0.26	0.19
A 83	3/4 x 3/4	5/8	0.8	0.25	0.26	0.012	0.024	0.22	0.16
A 84	3/4 x 3/4	1/8	0.6	0.17	0.23	0.009	0.017	0.23	0.17

Angles marked \* are special.

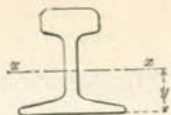

WEIGHTS AND DIMENSIONS OF AMERICAN STANDARD RAIL SECTIONS.

Section Index.	Weight Per Yard in Pounds.	Area in sq. in.	Width of base and height in inches.	Web in inches.	Width of head in inches.	Height of Center of Gravity above base in inches.	AXIS <i>x-x</i> .		
							Moment of Inertia. I	Section Modulus. S	Radius of Gyration. r
100A	100	9.8	5 $\frac{3}{4}$	$\frac{9}{16}$	2 $\frac{3}{4}$	2.8	43.8	14.6	2.13
95A	95	9.3	5 $\frac{9}{16}$	$\frac{9}{16}$	2 $\frac{11}{16}$	2.7	38.6	13.3	2.06
90A	90	8.8	5 $\frac{5}{8}$	$\frac{9}{16}$	2 $\frac{5}{8}$	2.5	34.0	12.0	1.97
85A	85	8.3	5 $\frac{3}{16}$	$\frac{9}{16}$	2 $\frac{9}{16}$	2.5	30.0	11.0	1.90
80A	80	7.8	5	$\frac{3}{4}$	2 $\frac{1}{2}$	2.4	26.2	10.0	1.83
75A	75	7.4	4 $\frac{11}{16}$	$\frac{11}{16}$	2 $\frac{11}{16}$	2.4	22.9	9.3	1.78
70A	70	6.9	4 $\frac{5}{8}$	$\frac{3}{4}$	2 $\frac{7}{16}$	2.2	19.6	8.2	1.70
65A	65	6.4	4 $\frac{7}{16}$	$\frac{1}{2}$	2 $\frac{3}{16}$	2.2	16.9	7.4	1.63
60A	60	5.9	4 $\frac{1}{4}$	$\frac{3}{4}$	2 $\frac{3}{8}$	2.1	14.5	6.7	1.58
55A	55	5.4	4 $\frac{1}{16}$	$\frac{11}{16}$	2 $\frac{1}{4}$	2.0	11.9	5.8	1.49
50A	50	4.9	3 $\frac{7}{8}$	$\frac{7}{16}$	2 $\frac{1}{8}$	1.9	9.8	4.9	1.42
45A	45	4.4	3 $\frac{11}{16}$	$\frac{3}{4}$	2	1.8	8.0	4.2	1.35
40A	40	3.9	3 $\frac{1}{2}$	$\frac{3}{4}$	1 $\frac{7}{8}$	1.7	6.6	3.6	1.30
35A	35	3.4	3 $\frac{1}{4}$	$\frac{3}{4}$	1 $\frac{3}{4}$	1.6	4.8	2.8	1.19
30A	30	3.0	3	$\frac{3}{4}$	1 $\frac{5}{8}$	1.4	3.5	2.3	1.11
25A	25	2.5	2 $\frac{3}{4}$	$\frac{11}{16}$	1 $\frac{1}{2}$	1.3	2.4	1.7	.99
20A	20	2.0	2 $\frac{1}{2}$	$\frac{11}{16}$	1 $\frac{3}{8}$	1.2	1.7	1.3	.92
16A	16	1.6	2 $\frac{1}{4}$	$\frac{11}{16}$	1 $\frac{1}{4}$	1.1	1.1	0.97	.84



## COLUMNS IN FIRE-PROOF BUILDINGS.

The subject of fire-proof construction is steadily growing in importance. The need of fire-proof buildings in the business centers of our great cities has been well demonstrated, and their superiority has become so generally recognized that at present but few structures of any size or importance are designed which are not more or less of this type. This change has been facilitated in no small measure by a number of signal improvements made of late in the art of fire-proof construction, ensuring not only a higher degree of efficiency, but a considerable reduction in cost, compared with methods formerly practiced.

The old style of solid brick arch, once so prevalent in floor-construction, has been almost wholly supplanted by the more modern forms of hollow tile and terra cotta arches. The important advantages of the latter have been already pointed out in these pages. Roofs, ceilings and partition walls are now also largely constructed of these light refractory materials.

The substitution of steel for iron in beams may be cited as a radical improvement in this direction and, simultaneously, the introduction by this firm of new patterns for its steel beams. These patterns are of more convenient shape and much more economical of material than the old forms.

Another change which is gradually taking place is the substitution of steel for cast iron in the composition of columns. Cast iron is a material so uncertain in character that its use has long since been abandoned in bridge construction. In buildings the loads are generally quiescent and the liability to sudden shocks is more remote than in bridges; yet, on the other hand, the columns seldom receive their loads as favorably as in bridges; in most cases there exists considerable eccentricity, that is, the loads on one side of the column are heavier than those on the other side, and the bending strains arising therefrom increase the strains from direct compression materially.

The following are some of the contingencies which may arise

in the manufacture of castings and which preclude anything approaching uniformity in the product.

In the case of hollow cast iron columns, while the metal is yet in a molten state, the buoyancy of the central core tends to cause it to rise, thereby reducing the thickness of the metal above and increasing it below. When columns are of such a length as to make it necessary to pour the metal into the mould from both ends, it sometimes occurs that the iron becomes too much chilled on the surface to properly mix and unite, thus creating a weak seam at the very point where the greatest strength will be needed. The presence of confined air, producing "blow holes" and "honey-comb" and the collection of impurities at the bottom of the mould may be further mentioned as frequent sources of weakness in cast iron.

The most critical condition, however, is that due to the unequal contraction of the metal during the process of cooling, thereby giving rise to initial stresses, at times of sufficient force to produce rupture in the column or in its lugs on the slightest provocation. In many cases the trouble can be ascribed to faulty designing or carelessness in the execution of the work, yet even under favorable conditions, it is so difficult to secure equal radiation from the moulds in all directions that castings entirely exempt from inherent shrinkage strains are probably seldom produced.

As a protection against these contingencies resort must be had either to the crude and uncertain expedient of a high safety factor, not less than eight or ten, or a material, such as rolled steel must be adopted of a more uniform and reliable character than cast iron.

STEEL COLUMNS fail either by deflecting bodily out of a straight line, or by the buckling of the metal between rivets or other points of support. Both actions may take place at the same time, but if the latter occurs alone, it may be an indication that the rivet spacing or the thickness of the metal is insufficient.

The rule has been deduced from actual experiments upon wrought iron columns that the distance between centers of rivets should not exceed in the line of strain sixteen times the thickness of metal of the parts joined, and that the distance between

rivets or other points of support at right angles to the line of strain should not exceed thirty-two times the thickness of the metal.

On page 54, sections are shown of some of the most common forms of built columns. Figs. 6, 13 and 19 belong to the type known as "Closed Columns." As it is impracticable to repaint the inner surfaces of such columns, they should preferably be used only for interior work, where the changes in temperature are not considerable, and the air is comparatively dry. In places exposed to extremes of temperature and unprotected from the rain, the paint on the inner surface of the column will, sooner or later, cease to be a protection; corrosion will set in, and, once begun, is apt to continue as long as there is unoxidized metal left in the column.

The remaining figures on the same page represent types of columns with open sections, which readily admit of repainting, and are, therefore, suitable for out-door work.

Of these, figures 14, 15, 16, 17 and 18, which are known as Z-bar columns, have been shown by extended use to be particularly well adapted to many purposes in construction.

In the use of columns of the types shown in figures 5, 7, 8, 9, 10 and 12, care should be taken in designing, that the flanges are placed sufficiently far apart to permit machine driving of the rivets.

The Z-bar and channel columns are particularly well adapted for buildings, owing to their facility for effecting connections with floor beams and girders.

The advantage of the constant dimension Z-bar column lies in the quicker preparation of plans and subsequent shop details, the outside dimensions being the same throughout the successive stories of the structure; making a guide for the architect in dimensioning walls and pillars, and facilitating the work of the engineer in the preparation of shop details, which are the same for all typical floors.

Standard bases, which can be adapted to any section of column, are shown on page 53, figures 4, 5 and 6 showing cast iron, and figures 7 and 8 the built up type.

Connections for floor beams to constant dimension Z-bar columns, detailed on pages 187 and 188, were designed to fairly

cover the range of ordinary practice. For other types of columns, the makeup of these details should be altered to suit the conditions governing, but, in a general way, they indicate the standard practice.

When the maximum loads in tons, as assumed for each case, are exceeded, the connections must be correspondingly strengthened by using longer vertical angles for the brackets, or by other suitable detail that will provide for the correct number of rivets. In proportioning these connections the shearing stress on rivets was assumed of a maximum intensity of 10,000 pounds per square inch.

In buildings, as a rule, the columns are permanently encased in a fire-proofing composition. On page 53, figures 1, 2 and 3, are shown designs of fire-proofing for Z-bar columns, giving the latter a cylindrical, or a rectangular finish with rounded corners as may be preferred. Similar casings can be used for any other type of built up column; the air space between the tiling and the metal adding to the protection of the latter in the event of fire.

Complete tables of dimensions and safe loads in tons for columns of different lengths are given on pages 131 to 140, inclusive, covering the constant dimension as well as the other type of Z-bar columns, and on pages 141 to 146 covering plate and channel and latticed channel columns.

We believe the variety given in these tables will cover a large majority of the cases presenting themselves in ordinary practice.

## COLUMNS AND STRUTS.

## EXPLANATION OF TABLES, PAGES 131 TO 153 INCLUSIVE.

The tables of safe loads for steel Z-bar and channel columns are compiled on the basis of an allowable stress per square inch of 12,000 pounds (factor of safety of 4) for lengths of 90 radii and under, and an allowable stress deduced from the formula

$$17,100 - 57 \frac{l}{r} \text{ for lengths greater than this limit.}$$

Complete dimensions of the Z-bar columns are given opposite their tables of safe loads.

The steel used in these columns is known as "medium" steel, containing a comparatively low percentage of carbon.

The values given in these tables should be used only for cases in which the loads are for the most part statical, and equal, or nearly so, on opposite sides of the column. When there is much eccentricity of loading, or the loads are subject to a sudden change, the tabulated values should be reduced according to circumstances.

The table on the "Ultimate Strength of Columns," page 147, gives the stress per square inch of section at which columns will fail for various proportions of length, in feet, to least radius of gyration, in inches. This table is based on Gordon's Formula changed for the use of steel. The table on page 151, showing the radii of gyration for round and square columns, will be found useful in connection with this table.

If the column or strut is a single rolled beam, channel or other shape, the radius of gyration will be found in the foregoing tables on page 101 to 123 inclusive.

If the column is composed of two channels latticed, the channels are usually placed far enough apart so that the column will be weakest in the direction of the web, i. e., with neutral axis at right angles to the web, for which case the radius of gyration of the column is the same as that of the single channel. In the table of "Properties of Standard Channels" page 106, are given the distances back to back of channels, which make the radii equal about both axes.

A common form of column or strut, to be recommended for comparatively light loads is that formed of two angles back to back, or four angles united either with a single course of lattice bars or a central web plate, as in Fig. 1, page 54.

The radii of gyration for such struts are tabulated on pages 148, 149 and 150. They are given for the neutral axis parallel to either flange and for Minimum and Maximum Sizes of all Standard and Special Angle Bars. In cases where four angles are used, the two pairs should be spaced far enough apart to

make the column weakest about a neutral axis parallel to the central web or latticing. The radius of gyration will then be the same as that given in the tables for a single pair of angles, since the moment of inertia of the web plate about such an axis is so small that it may be disregarded entirely.

The table on "Ultimate Strength of Hollow Cast Iron Columns" and that on "Safe Loads for Hollow Round Cast Iron Columns" were computed by Gordon's formula and cover a range of lengths that will seldom be exceeded in practice.

A column is *square bearing* when it has square ends which butt against or are firmly connected with an immovable surface, such as the floor of a building; it is *pin and square bearing* when one end only is square bearing and the other presses against a close-fitting pin; and it is *pin bearing* when both ends are thus pin-jointed with the axis of the pins in parallel directions (for example, the posts in pin-connected bridges).

#### EXAMPLES.

I. What size of constant dimension Z-Bar column 24 feet long with square bearing-ends will be required to carry a load of 300 tons, using a safety factor of 4?

*Answer:* From the table on page 139, it will be seen that for the length given  $4Z^8 4\frac{1}{8} \times 3\frac{3}{4} \times \frac{3}{4}$  with 2 web plates  $8 \times 1\frac{1}{2}$  will sustain 306.0 tons which is 6 tons in excess of that required, or referring to table on Channel Columns, page 143, 2-10" Channels 35 lbs. and 2 side plates  $12 \times 1\frac{1}{4}$  will be found sufficiently strong.

II. A strut 16 feet long, fixed rigidly at both ends is needed for supporting a load of 80,000 lbs. It is to be composed of two pairs of angles united with a single line of  $\frac{1}{4}$ " lattice bars along the central plane. What weight of angles will be required with a safety factor of 5?

*Answer:* We will assume 4-3"  $\times$  4" angles and determine the thickness of metal required. The angles must be spread  $\frac{1}{2}$ " in order to admit the latticing. From the table on page 150 we find the radius of gyration of a pair of 3"  $\times$  4"  $\times$   $\frac{3}{16}$ " angles with the 3" legs parallel and  $\frac{1}{2}$ " apart to be 1.97". Hence the value of  $\frac{l}{r} = \frac{16}{1.97} = 8.1$  for which the ultimate strength as per table on page 147 = 39,600 lbs.

The allowable strain per square inch with a safety factor of 5 will therefore be  $39,600 \div 5 = 7,920$  lbs. and the area of the required cross-section  $80,000 \div 7,920 = 10.10$  square inches, or 2.52 square inches for each angle. Hence the weight per foot of each angle will be  $2.52 \times 3.4 = 8.6$  lbs. This weight will be found to agree nearly with a thickness of  $\frac{7}{16}$  inch for a 4"  $\times$  3" angle.

SAFE LOADS IN TONS OF 2,000 LBS.

Z-BAR COLUMNS.

SQUARE ENDS.

Allowed stresses per square inch; { 12,000 lbs. for lengths of 90 radii or under.  
safety factor 4. { 17,100-57 $\frac{1}{2}$  for lengths over 90 radii.

6" Z-BAR COLUMNS.

Section: 4 Z-Bars 3" deep and one Web Plate 5 $\frac{3}{4}$ " x thickness of Z-Bars.

Length of Column in feet.	$\frac{3}{4}$ " Metal—31.7 lbs.—9.31 sq. in. r (min.)—1.86.	$\frac{5}{8}$ " Metal—39.8 lbs.—11.7 sq. in. r (min.)—1.90.	$\frac{3}{4}$ " Metal—46.2 lbs.—13.6 sq. in. r (min.)—1.88.	$\frac{7}{8}$ " Metal—54.3 lbs.—15.0 sq. in. r (min.)—1.93.	$\frac{1}{2}$ " Metal—59.9 lbs.—17.6 sq. in. r (min.)—1.90.	$\frac{9}{8}$ " Metal—67.9 lbs.—20.0 sq. in. r (min.)—1.95.
12 and under	55.9	70.3	81.6	95.8	105.7	119.8
14	55.7	70.3	81.6	95.8	105.7	119.8
16	52.3	66.5	76.6	91.3	99.9	114.6
18	48.8	62.3	71.7	85.6	93.6	107.8
20	45.4	58.1	66.7	79.9	87.2	100.8
22	42.0	53.9	61.8	74.3	80.9	93.8
24	38.6	49.7	56.9	68.6	74.6	86.8
26	35.2	45.5	51.9	63.0	68.2	79.8
28	31.7	41.3	47.0	57.3	61.9	72.8
30	28.3	37.1	42.0	51.7	55.5	65.8

8" Z-BAR COLUMNS.

Section: 4 Z-Bars 4" deep and 1 Web Plate 6 $\frac{1}{2}$ " x thickness of Z-Bars.

Length of Column in feet.	$\frac{3}{4}$ " Metal—38.3 lbs.—11.3 sq. in. r (min.)—2.47.	$\frac{5}{8}$ " Metal—48.1 lbs.—14.1 sq. in. r (min.)—2.52.	$\frac{3}{4}$ " Metal—58.0 lbs.—17.1 sq. in. r (min.)—2.57.	$\frac{7}{8}$ " Metal—64.7 lbs.—19.0 sq. in. r (min.)—2.49.	$\frac{1}{2}$ " Metal—74.4 lbs.—21.9 sq. in. r (min.)—2.55.	$\frac{9}{8}$ " Metal—84.1 lbs.—24.8 sq. in. r (min.)—2.60.	$\frac{5}{4}$ " Metal—89.2 lbs.—26.3 sq. in. r (min.)—2.52.	$\frac{1}{2}$ " Metal—98.3 lbs.—29.0 sq. in. r (min.)—2.58.	$\frac{3}{4}$ " Metal—108.4 lbs.—31.9 sq. in. r (min.)—2.63.
18 and under	67.5	84.8	102.4	114.2	131.2	148.5	157.5	174.3	191.2
20	65.0	82.5	100.5	110.5	128.2	146.4	153.3	171.3	189.6
22	61.9	78.7	95.9	105.3	122.4	139.9	146.2	163.5	181.3
24	58.8	74.8	91.3	100.1	116.5	133.4	139.1	155.8	173.0
26	55.7	71.0	86.8	94.8	110.6	126.9	132.0	148.1	164.7
28	52.6	67.1	82.3	89.6	104.7	120.3	124.8	140.4	156.4
30	49.4	63.3	77.7	84.4	98.8	113.8	117.7	132.7	148.2
32	46.3	59.5	73.2	79.2	93.0	107.3	110.6	125.0	139.9
34	43.2	55.6	68.7	74.0	87.1	100.8	103.5	117.3	131.6
36	40.1	51.8	64.1	68.7	81.2	94.3	96.4	109.6	123.3
38	37.0	48.0	59.6	63.5	75.3	87.8	89.4	101.9	115.0
40	33.9	44.1	55.0	58.3	69.5	81.3	82.2	94.2	106.7

To the above weights of column shafts add the weight of rivets.

Z-BAR COLUMN DIMENSIONS.

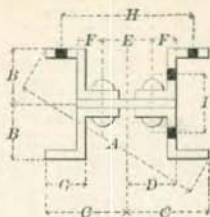

6" COLUMNS.

4 Z-Bars 3-3 1/8" deep.

1 Web Plate 5 3/4" x thickness of Z-Bars.

Diameter of Bolt or Rivet, 3/4".	Thickness of Metal.	A	B	C	D	E	F	G	H	I
		1/4	12 5/8	3 1/8	5 5/8	2 7/8	2 1/2	1 3/8	2 1/8	8 1/2
5/16	12 3/8	3 3/8	5 5/8	2 7/8	2 1/2	1 3/8	2 3/4	8 3/8	3 3/8	
3/8	12 1/8	3 5/8	5 5/8	2 7/8	2 1/2	1 3/8	2 1/8	8 1/4	3 3/8	
7/8	12 1/4	3 7/8	5 5/8	2 7/8	2 1/2	1 3/8	2 3/4	8 1/8	3 1/2	
1/2	12	3 1/4	5 1/8	2 7/8	2 1/2	1 3/8	2 1/8	8	3 1/2	
5/16	12 1/8	3 1/8	5 1/8	2 7/8	2 1/2	1 3/8	2 3/4	7 7/8	3 5/8	

8" COLUMNS.

4 Z-Bars 4-4 1/8" deep.

1 Web Plate 6 1/2" x thickness of Z-Bars.

Diameter of Bolt or Rivet, 3/4".	Thickness of Metal.	A	B	C	D	E	F	G	H	I
		1/4	14 1/8	4 1/8	6 1/8	3 1/4	3	1 3/4	3 1/8	9 1/2
5/16	14 3/4	4 3/8	6 1/8	3 1/4	3	1 3/4	3 1/8	9 3/8	4 3/8	
3/8	14 1/8	4 5/8	6 1/8	3 1/4	3	1 3/4	3 3/8	9 1/4	4 1/2	
7/8	14 1/2	4 7/8	5 7/8	3 1/4	3	1 3/4	3 1/8	9 1/8	4 7/8	
1/2	14 5/8	4 5/8	5 7/8	3 1/4	3	1 3/4	3 1/8	9	4 9/8	
5/16	14 3/8	4 3/8	5 7/8	3 1/4	3	1 3/4	3 3/8	8 7/8	4 1 1/2	
3/8	14 1/4	4 5/8	5 1 1/8	3 1/4	3	1 3/4	3 1/8	8 3/4	4 5/8	
7/8	14 1/2	4 7/8	5 1 1/8	3 1/4	3	1 3/4	3 1/8	8 5/8	4 3/4	
1/2	14 3/8	4 1/2	5 1 1/8	3 1/4	3	1 3/4	3 3/8	8 1/2	4 7/8	



SAFE LOADS IN TONS OF 2,000 LBS.

Z-BAR COLUMNS.

SQUARE ENDS.

Allowed stresses per square inch;  $\left\{ \begin{array}{l} 12,000 \text{ lbs. for lengths of 90 radii or under.} \\ 17,100-57\frac{1}{r} \text{ for lengths over 90 radii.} \end{array} \right.$   
safety factor 4.

10" Z-BAR COLUMNS.

Section: 4 Z-Bars 5" deep and one Web Plate 7"  $\times$  thickness of Z-Bars.

Length of Column in feet.	$\frac{5}{8}$ " Metal—53.7 lbs.—15.8 sq. in. r (min.)—3.08.		$\frac{7}{8}$ " Metal—64.7 lbs.—19.0 sq. in. r (min.)—3.13.		$\frac{7}{8}$ " Metal—75.8 lbs.—22.3 sq. in. r (min.)—3.18.		$\frac{1}{2}$ " Metal—83.3 lbs.—24.5 sq. in. r (min.)—3.10.		$\frac{3}{4}$ " Metal—94.2 lbs.—27.7 sq. in. r (min.)—3.15.		$\frac{5}{8}$ " Metal—105.2 lbs.—30.9 sq. in. r (min.)—3.21.		$\frac{3}{4}$ " Metal—111.0 lbs.—32.7 sq. in. r (min.)—3.13.		$\frac{3}{4}$ " Metal—121.8 lbs.—35.8 sq. in. r (min.)—3.18.		$\frac{1}{2}$ " Metal—132.6 lbs.—39.0 sq. in. r (min.)—3.22.	
	22 and under	94.7	114.2	133.9	147.0	166.2	185.6	196.0	214.9	234.0	242.8	261.9	281.0	299.9	318.8	337.7	356.6	375.5
24	92.8	112.6	133.1	144.6	164.8	185.3	193.6	213.9	233.0	241.8	260.9	279.8	298.7	317.6	336.5	355.4	374.3	393.2
26	89.3	108.6	129.3	139.2	159.7	178.7	186.5	206.8	225.6	234.4	253.7	272.6	291.5	310.4	329.3	348.2	367.1	386.0
28	85.8	104.4	123.5	133.8	152.7	172.1	179.5	199.5	218.2	227.0	246.7	265.4	284.1	302.8	321.5	340.2	358.9	377.6
30	82.3	100.2	118.7	128.4	146.7	165.5	172.2	192.8	211.4	220.2	239.9	258.6	277.3	296.0	314.7	333.4	352.1	370.8
32	78.8	96.1	113.8	123.0	140.7	158.9	165.0	183.1	202.0	210.8	230.7	249.6	268.5	287.4	306.3	325.2	344.1	363.0
34	75.3	91.9	109.1	117.6	134.7	152.3	157.9	175.4	193.8	202.6	222.7	241.6	260.5	279.4	298.3	317.2	336.1	355.0
36	71.8	87.8	104.3	112.2	128.7	145.7	150.7	167.8	185.8	194.6	214.9	233.8	252.7	271.6	290.5	309.4	328.3	347.2
38	68.3	83.6	99.5	106.8	122.7	139.1	143.6	160.0	177.4	186.2	206.8	225.6	244.4	263.2	282.0	300.8	319.6	338.4
40	64.8	79.4	94.7	101.4	116.7	132.5	136.5	152.3	170.1	179.0	199.9	218.8	237.7	256.6	275.5	294.4	313.3	332.2
42	61.3	75.3	89.9	96.0	110.6	125.9	129.4	144.6	160.9	170.0	191.1	210.0	228.9	247.8	266.7	285.6	304.5	323.4
44	57.7	71.1	85.1	90.6	104.6	119.3	122.2	136.9	153.8	163.0	184.3	203.2	222.1	241.0	259.9	278.8	297.7	316.6
46	54.2	67.0	80.3	85.2	98.6	112.7	115.1	129.2	146.8	156.2	177.7	196.6	215.5	234.4	253.3	272.2	291.1	310.0
48	50.7	62.8	75.5	79.8	92.6	106.1	107.9	121.5	139.6	149.2	171.0	190.0	208.9	227.8	246.7	265.6	284.5	303.4
50	47.2	58.6	70.7	74.4	86.6	99.5	100.8	113.8	132.9	143.6	165.8	185.0	204.1	223.2	242.3	261.4	280.5	299.6

12" Z-BAR COLUMNS.

Section: 4 Z-Bars 6" deep and 1 Web Plate 8"  $\times$  thickness of Z-Bars.

Length of Column in feet.	$\frac{5}{8}$ " Metal—72.7 lbs.—21.4 sq. in. r (min.)—3.67.		$\frac{7}{8}$ " Metal—85.2 lbs.—25.0 sq. in. r (min.)—3.72.		$\frac{7}{8}$ " Metal—97.8 lbs.—28.8 sq. in. r (min.)—3.77.		$\frac{1}{2}$ " Metal—106.2 lbs.—31.2 sq. in. r (min.)—3.70.		$\frac{5}{8}$ " Metal—118.5 lbs.—34.8 sq. in. r (min.)—3.75.		$\frac{3}{4}$ " Metal—130.9 lbs.—38.5 sq. in. r (min.)—3.73.		$\frac{3}{4}$ " Metal—137.8 lbs.—40.5 sq. in. r (min.)—3.68.		$\frac{3}{4}$ " Metal—149.9 lbs.—44.1 sq. in. r (min.)—3.66.		$\frac{1}{2}$ " Metal—162.1 lbs.—47.7 sq. in. r (min.)—3.64.	
	26 and under	128.3	150.3	172.6	187.3	209.1	231.0	243.0	264.5	286.1	295.0	316.5	338.0	359.5	381.0	402.5	424.0	445.5
28	127.0	149.7	172.5	186.0	208.9	230.3	240.8	261.4	282.1	291.0	312.5	334.0	355.5	377.0	398.5	420.0	441.5	463.0
30	123.0	145.1	167.6	180.2	202.5	223.3	233.2	253.8	274.6	283.5	304.3	325.1	345.9	366.7	387.5	408.3	429.1	449.9
32	119.0	140.5	162.4	174.5	196.1	216.3	225.7	245.0	264.2	273.1	293.6	314.1	334.6	355.1	375.6	396.1	416.6	437.1
34	115.1	135.9	157.2	168.7	189.8	209.2	218.2	236.7	255.2	264.1	284.8	304.3	323.8	343.3	362.8	382.3	401.8	421.3
36	111.1	131.3	152.0	162.9	183.4	202.1	210.6	228.4	246.3	255.2	275.3	294.2	313.1	332.0	350.9	369.8	388.7	407.6
38	107.1	126.7	146.8	157.1	177.0	195.1	203.1	220.2	237.3	246.2	266.5	284.6	302.7	320.8	338.9	357.0	375.1	393.2
40	103.1	122.1	141.5	151.4	170.7	188.0	195.6	211.9	228.3	237.2	257.8	275.9	294.0	312.1	330.2	348.3	366.4	384.5
42	99.1	117.5	136.3	145.5	164.4	180.9	188.0	203.7	219.4	228.3	249.3	267.4	285.5	303.6	321.7	339.8	357.9	376.0
44	95.1	112.9	131.1	139.8	158.0	173.9	180.5	195.5	210.4	219.3	240.7	258.8	276.9	295.0	313.1	331.2	349.3	367.4
46	91.2	108.3	126.2	134.0	151.6	166.8	172.9	187.2	201.4	210.3	232.1	250.2	268.3	286.4	304.5	322.6	340.7	358.8
48	87.2	103.6	120.7	128.2	145.3	159.8	165.4	179.0	192.4	201.3	223.5	241.6	259.7	277.8	295.9	314.0	332.1	350.2
50	83.2	99.1	115.5	122.4	138.9	152.7	157.9	170.7	183.1	192.0	214.5	232.6	250.7	268.8	286.9	305.0	323.1	341.2

To the above weights of column shafts add the weight of rivets.

Z-BAR COLUMN DIMENSIONS.

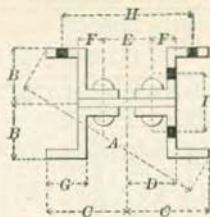

10" COLUMNS.

4 Z-Bars 5-5<sup>1</sup>/<sub>8</sub>" deep.

1 Web Plate 7" x thickness of Z-Bars.

Diameter of Bolt or Rivet, <sup>3</sup> / <sub>4</sub> ".	Thickness of Metal.	A	B	C	D	E	F	G	H	I
	<sup>5</sup> / <sub>16</sub>	16 <sup>1</sup> / <sub>2</sub>	5 <sup>5</sup> / <sub>8</sub>	6 <sup>7</sup> / <sub>16</sub>	3 <sup>1</sup> / <sub>2</sub>	3 <sup>1</sup> / <sub>4</sub>	1 <sup>7</sup> / <sub>8</sub>	3 <sup>1</sup> / <sub>4</sub>	10 <sup>1</sup> / <sub>8</sub>	5 <sup>5</sup> / <sub>16</sub>
<sup>3</sup> / <sub>8</sub>	16 <sup>9</sup> / <sub>16</sub>	5 <sup>1</sup> / <sub>4</sub>	6 <sup>7</sup> / <sub>16</sub>	3 <sup>1</sup> / <sub>2</sub>	3 <sup>1</sup> / <sub>4</sub>	1 <sup>7</sup> / <sub>8</sub>	3 <sup>1</sup> / <sub>4</sub>	10	5 <sup>7</sup> / <sub>16</sub>	
<sup>7</sup> / <sub>16</sub>	16 <sup>3</sup> / <sub>8</sub>	5 <sup>1</sup> / <sub>2</sub>	6 <sup>7</sup> / <sub>16</sub>	3 <sup>1</sup> / <sub>2</sub>	3 <sup>1</sup> / <sub>4</sub>	1 <sup>7</sup> / <sub>8</sub>	3 <sup>3</sup> / <sub>8</sub>	9 <sup>7</sup> / <sub>8</sub>	5 <sup>9</sup> / <sub>16</sub>	
<sup>1</sup> / <sub>2</sub>	16 <sup>3</sup> / <sub>8</sub>	5 <sup>1</sup> / <sub>4</sub>	6 <sup>1</sup> / <sub>4</sub>	3 <sup>1</sup> / <sub>2</sub>	3 <sup>1</sup> / <sub>4</sub>	1 <sup>7</sup> / <sub>8</sub>	3 <sup>1</sup> / <sub>4</sub>	9 <sup>3</sup> / <sub>4</sub>	5 <sup>1</sup> / <sub>2</sub>	
<sup>9</sup> / <sub>16</sub>	16 <sup>7</sup> / <sub>8</sub>	5 <sup>1</sup> / <sub>2</sub>	6 <sup>1</sup> / <sub>4</sub>	3 <sup>1</sup> / <sub>2</sub>	3 <sup>1</sup> / <sub>4</sub>	1 <sup>7</sup> / <sub>8</sub>	3 <sup>5</sup> / <sub>16</sub>	9 <sup>5</sup> / <sub>8</sub>	5 <sup>5</sup> / <sub>8</sub>	
<sup>5</sup> / <sub>8</sub>	16 <sup>1</sup> / <sub>2</sub>	5 <sup>1</sup> / <sub>2</sub>	6 <sup>1</sup> / <sub>4</sub>	3 <sup>1</sup> / <sub>2</sub>	3 <sup>1</sup> / <sub>4</sub>	1 <sup>7</sup> / <sub>8</sub>	3 <sup>5</sup> / <sub>16</sub>	9 <sup>1</sup> / <sub>2</sub>	5 <sup>3</sup> / <sub>4</sub>	
<sup>1</sup> / <sub>1</sub>	16 <sup>9</sup> / <sub>16</sub>	5 <sup>1</sup> / <sub>2</sub>	6 <sup>1</sup> / <sub>4</sub>	3 <sup>1</sup> / <sub>2</sub>	3 <sup>1</sup> / <sub>4</sub>	1 <sup>7</sup> / <sub>8</sub>	3 <sup>1</sup> / <sub>4</sub>	9 <sup>3</sup> / <sub>8</sub>	5 <sup>1</sup> / <sub>16</sub>	
<sup>1</sup> / <sub>1</sub>	16 <sup>3</sup> / <sub>4</sub>	5 <sup>1</sup> / <sub>2</sub>	6 <sup>1</sup> / <sub>4</sub>	3 <sup>1</sup> / <sub>2</sub>	3 <sup>1</sup> / <sub>4</sub>	1 <sup>7</sup> / <sub>8</sub>	3 <sup>5</sup> / <sub>16</sub>	9 <sup>1</sup> / <sub>4</sub>	5 <sup>1</sup> / <sub>16</sub>	
<sup>1</sup> / <sub>1</sub>	16 <sup>5</sup> / <sub>8</sub>	5 <sup>1</sup> / <sub>2</sub>	6 <sup>1</sup> / <sub>4</sub>	3 <sup>1</sup> / <sub>2</sub>	3 <sup>1</sup> / <sub>4</sub>	1 <sup>7</sup> / <sub>8</sub>	3 <sup>5</sup> / <sub>16</sub>	9 <sup>1</sup> / <sub>8</sub>	5 <sup>1</sup> / <sub>16</sub>	

12" COLUMNS.

4 Z-Bars 6-6<sup>1</sup>/<sub>8</sub>" deep.

1 Web Plate 8" x thickness of Z-Bars.

Diameter of Bolt or Rivet, <sup>3</sup> / <sub>4</sub> ".	Thickness of Metal.	A	B	C	D	E	F	G	H	I
	<sup>3</sup> / <sub>8</sub>	18 <sup>7</sup> / <sub>8</sub>	6 <sup>3</sup> / <sub>8</sub>	7 <sup>1</sup> / <sub>8</sub>	4	4	2	3 <sup>1</sup> / <sub>2</sub>	11 <sup>1</sup> / <sub>4</sub>	6 <sup>3</sup> / <sub>8</sub>
<sup>7</sup> / <sub>16</sub>	18 <sup>1</sup> / <sub>0</sub>	6 <sup>3</sup> / <sub>8</sub>	7 <sup>1</sup> / <sub>8</sub>	4	4	2	3 <sup>9</sup> / <sub>16</sub>	11 <sup>1</sup> / <sub>8</sub>	6 <sup>1</sup> / <sub>2</sub>	
<sup>1</sup> / <sub>2</sub>	19	6 <sup>3</sup> / <sub>8</sub>	7 <sup>1</sup> / <sub>8</sub>	4	4	2	3 <sup>3</sup> / <sub>8</sub>	11	6 <sup>5</sup> / <sub>8</sub>	
<sup>9</sup> / <sub>16</sub>	18 <sup>1</sup> / <sub>0</sub>	6 <sup>3</sup> / <sub>8</sub>	6 <sup>1</sup> / <sub>2</sub>	4	4	2	3 <sup>1</sup> / <sub>2</sub>	10 <sup>7</sup> / <sub>8</sub>	6 <sup>9</sup> / <sub>16</sub>	
<sup>5</sup> / <sub>8</sub>	18 <sup>3</sup> / <sub>4</sub>	6 <sup>3</sup> / <sub>8</sub>	6 <sup>1</sup> / <sub>2</sub>	4	4	2	3 <sup>1</sup> / <sub>2</sub>	10 <sup>3</sup> / <sub>4</sub>	6 <sup>1</sup> / <sub>16</sub>	
<sup>1</sup> / <sub>1</sub>	18 <sup>1</sup> / <sub>0</sub>	6 <sup>3</sup> / <sub>8</sub>	6 <sup>1</sup> / <sub>2</sub>	4	4	2	3 <sup>5</sup> / <sub>8</sub>	10 <sup>5</sup> / <sub>8</sub>	6 <sup>1</sup> / <sub>8</sub>	
<sup>1</sup> / <sub>1</sub>	18 <sup>9</sup> / <sub>16</sub>	6 <sup>3</sup> / <sub>8</sub>	6 <sup>3</sup> / <sub>4</sub>	4	4	2	3 <sup>1</sup> / <sub>2</sub>	10 <sup>1</sup> / <sub>2</sub>	6 <sup>3</sup> / <sub>4</sub>	
<sup>1</sup> / <sub>1</sub>	18 <sup>5</sup> / <sub>8</sub>	6 <sup>3</sup> / <sub>8</sub>	6 <sup>3</sup> / <sub>4</sub>	4	4	2	3 <sup>9</sup> / <sub>16</sub>	10 <sup>3</sup> / <sub>8</sub>	6 <sup>7</sup> / <sub>8</sub>	
<sup>7</sup> / <sub>8</sub>	18 <sup>1</sup> / <sub>1</sub>	6 <sup>3</sup> / <sub>8</sub>	6 <sup>3</sup> / <sub>4</sub>	4	4	2	3 <sup>5</sup> / <sub>8</sub>	10 <sup>1</sup> / <sub>4</sub>	7	

SAFE LOADS IN TONS OF 2,000 POUNDS.  
Z-BAR COLUMNS.  
SQUARE ENDS.

Allowed stresses per square inch; } 12,000 lbs. for lengths of 90 radii or under.  
safety factor 4. } 17,100-57 $\frac{1}{2}$  for lengths over 90 radii.

14" Z-BAR COLUMNS.

Section: 4 Z-Bars 6 $\frac{1}{2}$ " $\times$ 1 $\frac{1}{2}$ ". 1 Web Plate 8" $\times$ 1 $\frac{1}{2}$ ". 2 Side Plates 14" wide.

Length of Column in feet.	4x $\frac{3}{8}$ Plates—166.6 lbs.—49.0 sq. in. r (min.)—3.80.		4x $\frac{7}{8}$ Plates—172.6 lbs.—50.8 sq. in. r (min.)—3.81.		4x $\frac{1}{2}$ Plates—178.5 lbs.—52.5 sq. in. r (min.)—3.82.		4x $\frac{9}{16}$ Plates—184.5 lbs.—54.3 sq. in. r (min.)—3.82.		4x $\frac{5}{8}$ Plates—190.4 lbs.—56.0 sq. in. r (min.)—3.83.		4x $\frac{1}{2}$ Plates—196.4 lbs.—57.8 sq. in. r (min.)—3.84.		4x $\frac{3}{4}$ Plates—202.3 lbs.—59.5 sq. in. r (min.)—3.85.		4x $\frac{1}{2}$ Plates—208.4 lbs.—61.3 sq. in. r (min.)—3.85.		4x $\frac{7}{8}$ Plates—214.2 lbs.—63.0 sq. in. r (min.)—3.85.	
	28 and under	294.0	304.5	315.0	325.5	336.0	346.5	357.0	367.5	378.0	286.6	297.2	307.7	318.3	328.9	339.5	350.0	360.4
30	277.8	288.1	298.3	308.6	318.9	329.2	339.4	349.5	359.7	269.0	278.9	289.2	299.9	308.6	318.2	328.6	338.6	348.6
32	260.1	269.8	279.5	289.2	298.9	308.6	318.2	327.5	337.4	251.3	260.7	270.1	279.5	289.0	298.3	307.6	316.8	326.2
34	242.5	251.6	260.7	269.7	278.9	288.0	297.0	306.0	315.0	233.7	242.5	251.3	260.1	269.0	277.8	286.4	295.1	303.8
36	224.9	233.3	241.9	250.4	258.9	267.4	275.8	284.2	292.6	216.0	224.3	232.4	240.7	249.0	257.2	265.2	273.3	281.5
38	207.2	215.1	223.0	230.9	238.9	246.9	254.6	262.4	270.3	198.4	206.0	213.6	221.3	229.0	236.5	244.0	251.5	259.1
40	198.4	206.0	213.6	221.3	229.0	236.5	244.0	251.5	259.1									

14" Z-BAR COLUMNS.

Section: 4 Z-Bars 6" $\times$ 3/4". 1 Web Plate 8" $\times$ 3/4". 2 Side Plates 14" wide.

Length of Column in feet.	4x $\frac{3}{8}$ Plates—173.4 lbs.—51.0 sq. in. r (min.)—3.75.		4x $\frac{7}{8}$ Plates—179.4 lbs.—52.8 sq. in. r (min.)—3.76.		4x $\frac{1}{2}$ Plates—185.3 lbs.—54.5 sq. in. r (min.)—3.77.		4x $\frac{9}{16}$ Plates—191.3 lbs.—56.3 sq. in. r (min.)—3.78.		4x $\frac{5}{8}$ Plates—197.2 lbs.—58.0 sq. in. r (min.)—3.79.		4x $\frac{1}{2}$ Plates—203.2 lbs.—59.8 sq. in. r (min.)—3.80.		4x $\frac{3}{4}$ Plates—209.1 lbs.—61.5 sq. in. r (min.)—3.80.		4x $\frac{1}{2}$ Plates—215.1 lbs.—63.3 sq. in. r (min.)—3.81.		4x $\frac{7}{8}$ Plates—221.0 lbs.—65.0 sq. in. r (min.)—3.82.	
	28 and under	306.0	316.5	327.0	337.5	348.0	358.5	369.0	379.5	390.0	296.7	307.2	317.8	328.3	338.9	349.4	359.9	370.5
30	287.4	297.6	307.9	318.2	328.4	338.7	348.9	359.1	369.4	278.1	288.0	298.0	308.0	318.0	327.9	337.8	347.8	357.8
32	268.8	278.4	288.2	297.9	307.4	317.2	326.8	336.4	346.1	259.5	268.8	278.3	287.7	297.0	306.4	315.7	325.1	334.5
34	250.2	259.3	268.4	277.5	286.5	295.6	304.7	313.7	322.8	240.9	249.7	258.5	267.3	276.1	284.8	293.6	302.4	311.2
36	231.6	240.1	248.6	257.1	265.6	274.1	282.5	291.0	299.6	222.4	230.5	238.7	246.9	255.1	263.4	271.5	279.7	287.9
38	213.0	220.9	228.8	236.8	244.7	252.6	260.4	268.3	276.2	203.7	211.3	219.0	226.6	234.2	241.8	249.4	257.0	264.6
40	203.7	211.3	219.0	226.6	234.2	241.8	249.4	257.0	264.6									

To the above weights of column shafts add the weight of rivets.

Z-BAR COLUMN DIMENSIONS.

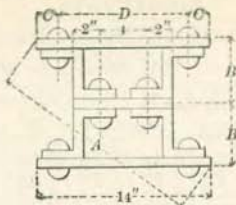

14" COLUMNS.

- 4 Z-Bars  $6\frac{1}{8}'' \times \frac{11}{16}''$ .  
 1 Web Plate  $8'' \times \frac{11}{16}''$ .  
 2 Side Plates 14" wide.

Diameter of Bolt or Rivet, $\frac{7}{8}''$ .	Thickness of Side Plates.	A	B	C	D
	$\frac{3}{8}$		$19\frac{9}{16}$	$6\frac{7}{16}$	$1\frac{1}{16}$
$\frac{7}{16}$		$19\frac{11}{16}$	$6\frac{9}{16}$	$1\frac{1}{16}$	$10\frac{5}{8}$
$\frac{1}{2}$		$19\frac{3}{4}$	$6\frac{11}{16}$	$1\frac{1}{16}$	$10\frac{5}{8}$
$\frac{9}{16}$		$19\frac{7}{8}$	$7\frac{1}{16}$	$1\frac{1}{16}$	$10\frac{5}{8}$
$\frac{5}{8}$		$19\frac{15}{16}$	$7\frac{3}{16}$	$1\frac{1}{16}$	$10\frac{5}{8}$
$\frac{11}{16}$		$20\frac{1}{16}$	$7\frac{5}{16}$	$1\frac{1}{16}$	$10\frac{5}{8}$
$\frac{3}{4}$		$20\frac{1}{8}$	$7\frac{7}{16}$	$1\frac{1}{16}$	$10\frac{5}{8}$
$\frac{13}{16}$		$20\frac{1}{4}$	$7\frac{9}{16}$	$1\frac{1}{16}$	$10\frac{5}{8}$
$\frac{7}{8}$		$20\frac{3}{8}$	$7\frac{11}{16}$	$1\frac{1}{16}$	$10\frac{5}{8}$

14" COLUMNS.

- 4 Z-Bars  $6'' \times \frac{3}{4}''$ .  
 1 Web Plate  $8'' \times \frac{3}{4}''$ .  
 2 Side Plates 14" wide.

Diameter of Bolt or Rivet, $\frac{7}{8}''$ .	Thickness of Side Plates.	A	B	C	D
	$\frac{3}{8}$		$19\frac{7}{16}$	$6\frac{3}{4}$	$1\frac{3}{4}$
$\frac{7}{16}$		$19\frac{1}{2}$	$6\frac{13}{16}$	$1\frac{3}{4}$	$10\frac{1}{2}$
$\frac{1}{2}$		$19\frac{5}{8}$	$6\frac{7}{8}$	$1\frac{3}{4}$	$10\frac{1}{2}$
$\frac{9}{16}$		$19\frac{3}{4}$	$6\frac{15}{16}$	$1\frac{3}{4}$	$10\frac{1}{2}$
$\frac{5}{8}$		$19\frac{11}{16}$	7	$1\frac{3}{4}$	$10\frac{1}{2}$
$\frac{11}{16}$		$19\frac{7}{8}$	$7\frac{1}{16}$	$1\frac{3}{4}$	$10\frac{1}{2}$
$\frac{3}{4}$		20	$7\frac{1}{8}$	$1\frac{3}{4}$	$10\frac{1}{2}$
$\frac{13}{16}$		$20\frac{1}{16}$	$7\frac{3}{16}$	$1\frac{3}{4}$	$10\frac{1}{2}$
$\frac{7}{8}$		$20\frac{1}{8}$	$7\frac{1}{4}$	$1\frac{3}{4}$	$10\frac{1}{2}$

SAFE LOADS IN TONS OF 2,000 POUNDS.  
Z-BAR COLUMNS.  
SQUARE ENDS.

allowed stresses per square inch; { 12,000 lbs. for lengths of 90 radii or under.  
safety factor 4. } 17,100-57  $\frac{1}{r}$  for lengths over 90 radii.

14" Z-BAR COLUMNS.

Section: 4 Z-Bars 6  $\frac{1}{2}$ "  $\times$   $\frac{1}{2}$ "  $\times$   $\frac{1}{2}$ ". 1 Web Plate 8"  $\times$   $\frac{1}{2}$ ". 2 Side Plates 14" wide.

Length of Column in feet.	14 $\frac{3}{8}$ " Plates—185.5 lbs.—54.6 sq. in. r (min.)—3.73.		14 $\frac{1}{2}$ " Plates—191.5 lbs.—56.3 sq. in. r (min.)—3.74.		14 $\frac{5}{8}$ " Plates—197.5 lbs.—58.1 sq. in. r (min.)—3.75.		14 $\frac{7}{8}$ " Plates—203.4 lbs.—59.8 sq. in. r (min.)—3.76.		14 $\frac{9}{8}$ " Plates—209.4 lbs.—61.6 sq. in. r (min.)—3.77.		14 $\frac{1}{2}$ " Plates—215.3 lbs.—63.3 sq. in. r (min.)—3.78.		14 $\frac{3}{4}$ " Plates—221.3 lbs.—65.1 sq. in. r (min.)—3.78.		14 $\frac{1}{4}$ " Plates—227.2 lbs.—66.8 sq. in. r (min.)—3.79.		14 $\frac{7}{16}$ " Plates—233.2 lbs.—68.6 sq. in. r (min.)—3.80.	
	26 and under	327.5	333.0	348.5	359.0	369.5	380.0	390.5	401.0	411.5	326.7	337.5	348.5	359.0	369.5	380.0	390.5	401.0
28	316.7	327.2	337.7	348.3	358.9	369.5	380.0	390.6	401.1	306.6	318.0	327.2	337.4	347.7	358.0	368.2	378.5	388.8
30	296.6	306.6	316.6	326.5	336.5	346.5	356.4	366.4	376.4	286.7	296.4	306.0	315.7	325.3	335.0	344.7	354.3	364.0
32	276.7	286.0	295.4	304.8	314.2	323.6	332.9	342.3	351.7	266.6	275.7	284.8	293.9	303.0	312.1	321.2	330.3	339.3
40	256.6	265.5	274.3	283.0	291.8	300.6	309.4	318.2	327.0	246.6	255.2	263.6	272.2	280.6	289.2	297.6	306.1	314.6
42	236.6	244.9	253.0	261.3	269.5	277.7	285.8	294.0	302.3	226.7	234.6	242.5	250.4	258.3	266.2	274.1	282.0	290.0
44	216.6	224.3	231.9	239.5	247.1	254.8	262.3	269.9	277.6	206.6	214.3	221.9	229.5	237.1	244.8	252.3	259.9	267.6

14" Z-BAR COLUMNS.

Section: 4 Z-Bars 6  $\frac{1}{2}$ "  $\times$   $\frac{7}{8}$ ". 1 Web Plate 8"  $\times$   $\frac{7}{8}$ ". 2 Side Plates 14" wide.

Length of Column in feet.	14 $\frac{3}{8}$ " Plates—197.8 lbs.—58.2 sq. in. r (min.)—3.71.		14 $\frac{1}{2}$ " Plates—203.8 lbs.—59.9 sq. in. r (min.)—3.72.		14 $\frac{5}{8}$ " Plates—209.7 lbs.—61.7 sq. in. r (min.)—3.73.		14 $\frac{7}{8}$ " Plates—215.7 lbs.—63.4 sq. in. r (min.)—3.74.		14 $\frac{9}{8}$ " Plates—221.6 lbs.—65.2 sq. in. r (min.)—3.75.		14 $\frac{1}{2}$ " Plates—227.6 lbs.—66.9 sq. in. r (min.)—3.76.		14 $\frac{3}{4}$ " Plates—233.5 lbs.—68.7 sq. in. r (min.)—3.77.		14 $\frac{1}{4}$ " Plates—239.5 lbs.—70.4 sq. in. r (min.)—3.77.		14 $\frac{7}{16}$ " Plates—245.4 lbs.—72.2 sq. in. r (min.)—3.78.	
	26 and under	349.1	359.6	370.1	380.6	391.1	401.6	412.1	422.6	433.1	347.4	358.3	369.1	380.0	390.9	401.6	412.1	422.6
28	336.7	347.2	357.9	368.4	378.9	389.5	400.1	410.7	421.2	326.0	336.3	346.6	356.8	367.1	377.3	387.6	397.9	408.2
30	315.3	325.2	335.2	345.2	355.1	365.2	375.2	385.1	395.1	304.5	314.2	324.0	333.8	343.3	353.0	362.7	372.4	382.0
32	293.8	303.2	312.6	322.0	331.4	340.8	350.2	359.6	369.0	283.1	292.2	301.3	310.4	319.5	328.6	337.7	346.8	355.9
40	272.3	281.2	290.0	298.8	307.6	316.4	325.2	334.0	342.8	261.6	270.2	278.7	287.2	295.7	304.2	312.7	321.2	329.8
42	250.9	259.1	267.4	275.6	283.8	292.1	300.3	308.5	316.7	240.2	248.1	256.1	264.0	272.0	279.8	287.8	295.7	303.6
44	229.5	237.1	244.8	252.4	260.0	267.6	275.3	283.0	290.6	229.5	237.1	244.8	252.4	260.0	267.6	275.3	283.0	290.6

To the above weights of column shafts add the weight of rivets.

Z-BAR COLUMN DIMENSIONS.

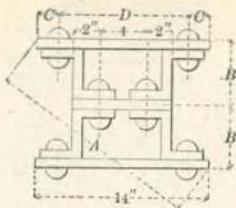

14" COLUMNS.

- 4 Z-Bars  $6\frac{1}{8}'' \times 1\frac{3}{8}''$ .  
 1 Web Plate  $8'' \times 1\frac{3}{8}''$ .  
 2 Side Plates 14" wide.

Diameter of Bolt or Rivet, $\frac{7}{8}''$ .	Thickness of Side Plates.	A	B	C	D
	$\frac{3}{8}$		$19\frac{9}{16}$	$6\frac{7}{16}$	$1\frac{1}{16}$
$\frac{7}{16}$		$19\frac{3}{8}$	$6\frac{1}{2}$	$1\frac{1}{16}$	$10\frac{3}{8}$
$\frac{1}{2}$		$19\frac{3}{4}$	$6\frac{1}{2}$	$1\frac{1}{16}$	$10\frac{3}{8}$
$\frac{9}{16}$		$19\frac{7}{8}$	$7\frac{1}{16}$	$1\frac{1}{16}$	$10\frac{3}{8}$
$\frac{5}{8}$		$19\frac{1}{2}$	$7\frac{3}{16}$	$1\frac{1}{16}$	$10\frac{3}{8}$
$\frac{11}{16}$		$20\frac{1}{16}$	$7\frac{5}{16}$	$1\frac{1}{16}$	$10\frac{3}{8}$
$\frac{3}{4}$		$20\frac{1}{8}$	$7\frac{7}{16}$	$1\frac{1}{16}$	$10\frac{3}{8}$
$\frac{13}{16}$		$20\frac{3}{8}$	$7\frac{9}{16}$	$1\frac{1}{16}$	$10\frac{3}{8}$
$\frac{7}{8}$		$20\frac{1}{4}$	$7\frac{11}{16}$	$1\frac{1}{16}$	$10\frac{3}{8}$

14" COLUMNS.

- 4 Z-Bars  $6\frac{1}{8}'' \times \frac{7}{8}''$ .  
 1 Web Plate  $8'' \times \frac{7}{8}''$ .  
 2 Side Plates 14" wide.

Diameter of Bolt or Rivet, $\frac{7}{8}''$ .	Thickness of Side Plates.	A	B	C	D
	$\frac{3}{8}$		$19\frac{3}{4}$	$6\frac{1}{2}$	$1\frac{7}{8}$
$\frac{7}{16}$		$19\frac{13}{16}$	7	$1\frac{7}{8}$	$10\frac{1}{4}$
$\frac{1}{2}$		$19\frac{7}{8}$	$7\frac{1}{16}$	$1\frac{7}{8}$	$10\frac{1}{4}$
$\frac{9}{16}$		20	$7\frac{1}{8}$	$1\frac{7}{8}$	$10\frac{1}{4}$
$\frac{5}{8}$		$20\frac{1}{16}$	$7\frac{3}{16}$	$1\frac{7}{8}$	$10\frac{1}{4}$
$\frac{11}{16}$		$20\frac{1}{8}$	$7\frac{1}{4}$	$1\frac{7}{8}$	$10\frac{1}{4}$
$\frac{3}{4}$		$20\frac{1}{4}$	$7\frac{5}{16}$	$1\frac{7}{8}$	$10\frac{1}{4}$
$\frac{13}{16}$		$20\frac{5}{16}$	$7\frac{3}{8}$	$1\frac{7}{8}$	$10\frac{1}{4}$
$\frac{7}{8}$		$20\frac{7}{16}$	$7\frac{7}{16}$	$1\frac{7}{8}$	$10\frac{1}{4}$

SAFE LOADS IN TONS OF 2,000 POUNDS.  
CONSTANT DIMENSION Z-BAR COLUMNS.  
SQUARE ENDS.

Allowed stresses per square inch; { 12,000 lbs. for lengths of 90 radii or under.  
safety factor 4. { 17,100-57; for lengths over 90 radii.

Section: 4 Z-Bars 4" deep with tie plates.

Length of Column in feet.	4 1/2" x 3 1/2" x 1/2" 9.64 sq. in. 32.8 lbs. r min. 4.0952.	4 7/8" x 3 1/2" x 1/2" 12.12 sq. in. 41.2 lbs. r min. 4.0714.	4 7/8" x 3 3/8" x 1/2" 14.64 sq. in. 49.6 lbs. r min. 4.0478.	4 7/8" x 3 1/2" x 7/8" 16.20 sq. in. 55.2 lbs. r min. 3.9949.	4 7/8" x 3 1/2" x 1" 18.64 sq. in. 63.2 lbs. r min. 3.9712.	4 7/8" x 3 3/8" x 1" 21.08 sq. in. 71.6 lbs. r min. 3.9473.	4 7/8" x 3 1/2" x 1 1/8" 22.20 sq. in. 75.6 lbs. r min. 3.8949.	4 7/8" x 3 3/8" x 1 1/8" 24.50 sq. in. 83.6 lbs. r min. 3.8715.	4 7/8" x 3 3/8" x 1 1/4" 27.00 sq. in. 91.6 lbs. r min. 3.8478.
28 and under	169.2	175.2	181.2	187.2	193.2	205.2	217.2	229.2	241.2
28	166.4	171.5	176.6	181.7	186.8	196.8	207.8	218.8	229.8
30	161.1	166.0	170.9	175.6	180.4	189.9	199.3	208.7	218.0
32	155.8	160.4	165.0	169.5	174.1	183.1	192.0	200.6	209.3
34	150.4	154.8	159.1	163.5	167.7	176.2	184.7	193.0	201.3
36	145.1	149.2	153.3	157.4	161.4	169.4	177.3	185.1	192.9
38	139.8	143.6	147.5	151.3	155.1	162.6	170.0	177.3	184.5
40	134.4	138.1	141.7	145.3	148.8	155.7	162.6	169.4	176.1

Section: 4 Z-Bars 4" deep 4" x 3 1/2" x 1/2" with web plates.

Length of Column in feet.	2 Pl's 8" x 3 3/8" x 1/2" 28.20 sq. in. 99.4 lbs. r min. 3.6163.	2 Pl's 8" x 1 1/2" x 7/8" 29.20 sq. in. 99.4 lbs. r min. 3.5794.	2 Pl's 8" x 1 1/2" x 1" 30.20 sq. in. 103.8 lbs. r min. 3.5447.	2 Pl's 8" x 1 1/2" x 1 1/8" 31.20 sq. in. 108.2 lbs. r min. 3.5118.	2 Pl's 8" x 1 1/2" x 1 1/4" 32.20 sq. in. 109.6 lbs. r min. 3.4807.	2 Pl's 8" x 3" x 1/2" 34.2 sq. in. 116.3 lbs. r min. 3.4233.	2 Pl's 8" x 1 1/2" x 1 1/2" 36.2 sq. in. 123.1 lbs. r min. 3.3714.	2 Pl's 8" x 1" x 1" 38.2 sq. in. 129.9 lbs. r min. 3.3242.	2 Pl's 8" x 1 1/2" x 1 1/4" 40.2 sq. in. 136.7 lbs. r min. 3.2811.
28 and under	169.2	175.2	181.2	187.2	193.2	205.2	217.2	229.2	241.2
28	166.4	171.5	176.6	181.7	186.8	196.8	207.8	218.8	229.8
30	161.1	166.0	170.9	175.6	180.4	189.9	199.3	208.7	218.0
32	155.8	160.4	165.0	169.5	174.1	183.1	192.0	200.6	209.3
34	150.4	154.8	159.1	163.5	167.7	176.2	184.7	193.0	201.3
36	145.1	149.2	153.3	157.4	161.4	169.4	177.3	185.1	192.9
38	139.8	143.6	147.5	151.3	155.1	162.6	170.0	177.3	184.5
40	134.4	138.1	141.7	145.3	148.8	155.7	162.6	169.4	176.1

Section: 4 Z-Bars 4" deep 4 1/2" x 3 3/8" x 1/2" with web plates.

Length of Column in feet.	2 Pl's 8" x 7" x 1/2" 41 sq. in. 139.4 lbs. r min. 3.4017.	2 Pl's 8" x 1" x 1" 43 sq. in. 146.2 lbs. r min. 3.3587.	2 Pl's 8" x 1 1/2" x 1" 45 sq. in. 153 lbs. r min. 3.3192.	2 Pl's 8" x 1 1/2" x 1 1/8" 47 sq. in. 159.8 lbs. r min. 3.2825.	2 Pl's 8" x 1 1/2" x 1 1/4" 49 sq. in. 166.6 lbs. r min. 3.2485.	2 Pl's 8" x 1 1/2" x 1 1/2" 51 sq. in. 173.4 lbs. r min. 3.2169.	2 Pl's 8" x 1 1/2" x 1 3/4" 53 sq. in. 180.2 lbs. r min. 3.1873.	2 Pl's 8" x 1 1/2" x 2" 55 sq. in. 187 lbs. r min. 3.1597.	2 Pl's 8" x 1 1/2" x 2 1/4" 57 sq. in. 193.8 lbs. r min. 3.1337.
22 and under	246.0	258.0	270.0	282.0	294.0	306.0	318.0	330.0	342.0
24	243.4	253.8	264.2	274.5	284.8	295.1	305.3	315.5	325.6
26	235.1	245.1	254.9	264.7	274.5	284.2	293.9	303.6	313.2
28	226.9	236.8	245.7	254.9	264.2	273.3	282.6	291.7	300.7
30	218.7	227.5	236.4	245.2	253.9	262.6	271.2	279.8	288.3
32	210.4	218.8	227.1	235.4	243.6	251.7	259.8	267.8	275.9
34	202.2	210.0	217.8	225.6	233.2	240.9	248.4	255.9	263.4
36	193.9	201.3	208.6	215.8	222.9	230.0	237.1	244.0	251.0
38	185.7	192.5	199.3	206.0	212.6	219.2	225.7	232.1	238.5
40	185.7	192.5	199.3	206.0	212.6	219.2	225.7	232.1	238.5

CONSTANT DIMENSION Z-BAR COLUMNS.

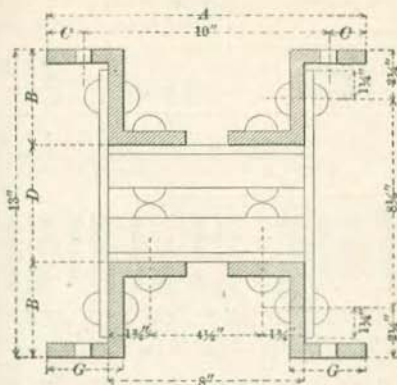

Constant dimensions are given on the sketch above for all columns.

Variable dimensions see below. All rivets  $\frac{3}{4}$ " dia. Open holes for  $\frac{3}{4}$ " rivets or bolts.

Web tie plates  $9' \times \frac{5}{16}" \times 0' - 8"$   
 Flange tie plates  $9' \times \frac{5}{16}" \times 0' - 11"$  } for all columns less than  $\frac{5}{8}"$  metal.

For all columns  $\frac{5}{8}"$  metal and over, tie plates are  $\frac{3}{8}"$  thick.

All tie plates spaced about 3'-0" center to center.

Sizes of Z Bars.	A	B	C	D	G
$4' \times 3\frac{1}{8}" \times \frac{1}{4}"$	$13\frac{5}{8}"$	4"	$1\frac{1}{8}"$	5"	$3\frac{1}{8}"$
$4\frac{1}{8}" \times 3\frac{1}{8}" \times \frac{5}{16}"$	$13\frac{5}{8}"$	$4\frac{1}{8}"$	$1\frac{1}{8}"$	$4\frac{7}{8}"$	$3\frac{1}{8}"$
$4\frac{1}{8}" \times 3\frac{3}{8}" \times \frac{3}{8}"$	$13\frac{5}{8}"$	$4\frac{1}{8}"$	$1\frac{1}{8}"$	$4\frac{3}{4}"$	$3\frac{3}{8}"$
$4' \times 3\frac{1}{8}" \times \frac{7}{16}"$	$13\frac{1}{4}"$	4"	$1\frac{5}{8}"$	5"	$3\frac{1}{8}"$
$4\frac{1}{8}" \times 3\frac{1}{8}" \times \frac{1}{2}"$	$13\frac{1}{4}"$	$4\frac{1}{8}"$	$1\frac{5}{8}"$	$4\frac{7}{8}"$	$3\frac{1}{8}"$
$4\frac{1}{8}" \times 3\frac{3}{8}" \times \frac{9}{16}"$	$13\frac{1}{4}"$	$4\frac{1}{8}"$	$1\frac{5}{8}"$	$4\frac{3}{4}"$	$3\frac{3}{8}"$
$4' \times 3\frac{1}{8}" \times \frac{9}{8}"$	$12\frac{7}{8}"$	4"	$1\frac{7}{16}"$	5"	$3\frac{1}{8}"$
$4\frac{1}{8}" \times 3\frac{1}{8}" \times \frac{11}{16}"$	$12\frac{7}{8}"$	$4\frac{1}{8}"$	$1\frac{7}{16}"$	$4\frac{7}{8}"$	$3\frac{1}{8}"$
$4\frac{1}{8}" \times 3\frac{3}{8}" \times \frac{3}{4}"$	$12\frac{7}{8}"$	$4\frac{1}{8}"$	$1\frac{7}{16}"$	$4\frac{3}{4}"$	$3\frac{3}{8}"$



**SAFE LOADS IN TONS OF 2,000 POUNDS.  
6" CHANNEL COLUMNS.  
SQUARE ENDS.**

Allowed stresses per square inch;  $\left\{ \begin{array}{l} 12,000 \text{ lbs. for lengths of 90 radii or under} \\ 17,100-57\frac{1}{r} \text{ for lengths over 90 radii.} \end{array} \right.$

Sections:  $\left\{ \begin{array}{l} 2-6'' \text{ Channels—lattice, or} \\ 2-6'' \text{ Channels and 2 side plates } 8'' \text{ wide.} \end{array} \right.$

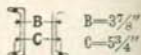

Weight of Channels.	Length of Col. in ft.	Plates								
		Lat. 16.0 lbs. r=2.33.	$\frac{1}{4}$ Pl. 29.6 lbs. r=2.32.	$\frac{5}{16}$ Pl. 33.0 lbs. r=2.32.	$\frac{3}{8}$ Pl. 36.4 lbs. r=2.32.	$\frac{7}{16}$ Pl. 39.8 lbs. r=2.32.	$\frac{1}{2}$ Pl. 43.2 lbs. r=2.32.	$\frac{5}{8}$ Pl. 46.6 lbs. r=2.32.	$\frac{3}{4}$ Pl. 50.0 lbs. r=2.32.	$\frac{7}{8}$ Pl. 53.4 lbs. r=2.32.
8 Lbs.	16	28.6	52.6	58.6	64.6	70.6	76.6	82.6	88.6	94.6
	18	28.1	51.7	57.5	63.4	69.3	75.2	81.1	87.0	92.9
	20	26.7	49.1	54.7	60.3	65.8	71.4	77.0	82.6	88.2
	22	25.3	46.5	51.8	57.1	62.4	67.7	73.0	78.2	83.5
	24	23.9	43.9	48.9	53.9	58.9	63.9	68.9	73.9	78.9
10.5 Lbs.	Lat. 21.0 lbs. r=2.20.	$\frac{1}{4}$ Pl. 34.6 lbs. r=2.24.	$\frac{5}{16}$ Pl. 38.0 lbs. r=2.25.	$\frac{3}{8}$ Pl. 41.4 lbs. r=2.25	$\frac{7}{16}$ Pl. 44.8 lbs. r=2.26.	$\frac{1}{2}$ Pl. 48.2 lbs. r=2.26.	$\frac{5}{8}$ Pl. 51.6 lbs. r=2.27.	$\frac{3}{4}$ Pl. 55.0 lbs. r=2.27.	$\frac{7}{8}$ Pl. 58.4 lbs. r=2.27.	
	16	37.1	61.1	67.1	73.1	79.1	85.1	91.1	97.1	103.1
	18	35.5	59.1	65.0	70.9	76.8	82.7	88.5	94.4	100.3
	20	33.6	56.0	61.6	67.2	72.8	78.4	84.0	89.5	95.1
	22	31.7	52.9	58.2	63.5	68.8	74.1	79.4	84.7	90.0
13 Lbs.	Lat. 26.0 lbs. r=2.09.	$\frac{5}{16}$ Pl. 43.0 lbs. r=2.18.	$\frac{3}{8}$ Pl. 46.4 lbs. r=2.19.	$\frac{7}{16}$ Pl. 49.8 lbs. r=2.20.	$\frac{1}{2}$ Pl. 53.2 lbs. r=2.21.	$\frac{5}{8}$ Pl. 56.6 lbs. r=2.21.	$\frac{3}{4}$ Pl. 60.0 lbs. r=2.22.	$\frac{7}{8}$ Pl. 63.4 lbs. r=2.22.	$\frac{15}{8}$ Pl. 66.8 lbs. r=2.23.	
	14	45.8	.....	.....	.....	.....	.....	.....	.....	
	16	45.3	75.8	81.8	87.8	93.8	99.8	105.8	111.8	117.8
	18	42.8	72.4	78.3	84.2	90.1	96.0	101.9	107.8	113.7
	20	40.3	68.4	74.1	79.7	85.2	90.8	96.4	102.0	107.6
22	37.8	64.5	69.8	75.1	80.4	85.7	91.0	96.3	101.6	
15.5 Lbs.	Lat. 31.0 lbs. r=2.00.	$\frac{3}{8}$ Pl. 48.0 lbs. r=2.12.	$\frac{5}{8}$ Pl. 51.4 lbs. r=2.13.	$\frac{7}{8}$ Pl. 54.8 lbs. r=2.14.	$\frac{1}{2}$ Pl. 58.2 lbs. r=2.15.	$\frac{5}{8}$ Pl. 61.6 lbs. r=2.16.	$\frac{3}{4}$ Pl. 65.0 lbs. r=2.17.	$\frac{7}{8}$ Pl. 68.4 lbs. r=2.18.	$\frac{15}{8}$ Pl. 71.8 lbs. r=2.18.	
	14	54.7	84.7	90.7	.....	.....	.....	.....	.....	
	16	53.0	84.2	90.4	96.7	102.7	108.7	114.7	120.7	126.7
	18	49.9	79.7	85.6	91.5	97.4	103.3	109.2	115.1	121.0
	20	46.8	75.1	80.7	86.4	92.0	97.6	103.2	108.8	114.4
22	.....	70.5	75.9	81.2	86.5	91.8	97.1	102.5	107.8	

To the above weights of column shafts add the weight of rivets and lattice bars.

The safe loads given in this and the following tables on channel columns range

in value from  $\frac{1}{r} = 90$  to about  $\frac{1}{r} = 125$ .

The size and spacing of lattice bars should be proportioned to the sections composing the column. They should not be less than  $1\frac{1}{2} \times \frac{5}{16}$  inches for 6 inch channels;  $1\frac{3}{4} \times \frac{5}{16}$  inches for 7 and 8 inch channels;  $2 \times \frac{5}{16}$  inches for 9 and 10 inch channels;  $2 \times \frac{3}{8}$  inches for 12 inch channels.

THE CARNEGIE STEEL COMPANY, LIMITED.

SAFE LOADS IN TONS OF 2,000 POUNDS.  
7" CHANNEL COLUMNS.  
SQUARE ENDS.

Allowed stresses per square inch; { 12,000 lbs. for lengths of 90 radii or under.  
safety factor 4. { 17,100-57<sup>1</sup>/<sub>r</sub> for lengths over 90 radii.

Sections: { 2-7" Channels—latticed, or  
2-7" Channels and 2 side plates 9" wide.

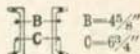

Weight of Channel.	Length of Col. in ft.	Section								
		Lat. 19.5 lbs. r=2.72.	1/4 Pl. 34.8 lbs. r=2.67.	5/8 Pl. 38.6 lbs. r=2.67.	3/8 Pl. 42.5 lbs. r=2.66.	7/8 Pl. 46.3 lbs. r=2.66.	1 1/2 Pl. 50.1 lbs. r=2.65.	2 Pl. 53.9 lbs. r=2.65.	5/8 Pl. 57.8 lbs. r=2.64.	1 1/8 Pl. 61.6 lbs. r=2.64.
9.75 Lbs.	18	.....	.....	.....	74.7	81.5	88.2	94.9	101.7	108.5
	20	34.2	61.2	67.9	74.4	81.1	87.8	94.4	101.1	107.8
	22	32.8	58.5	65.0	71.2	77.6	84.0	90.3	96.7	103.1
	24	31.4	55.9	62.0	68.0	74.1	80.2	86.2	92.3	98.4
	26	30.1	53.3	59.1	64.8	70.6	76.4	82.1	87.9	93.7
	28	28.7	.....	.....	.....	.....	.....	.....	.....	.....
12.25 Lbs.	18	43.2	70.2	76.9	83.7	90.5	97.2	103.9	110.7	117.5
	20	42.5	69.3	75.9	82.6	89.3	95.9	102.6	109.2	115.9
	22	40.6	66.2	72.6	79.0	85.3	91.7	98.0	104.4	110.8
	24	38.7	63.2	69.2	75.3	81.4	87.4	93.5	99.5	105.6
	26	36.8	60.1	65.8	71.6	77.4	83.2	88.9	94.7	100.5
	28	.....	.....	.....	.....	.....	.....	.....	.....	.....
14.75 Lbs.	18	52.1	79.1	85.8	92.6	99.4	106.1	112.8	119.6	126.4
	20	50.5	77.2	83.8	90.5	97.2	103.8	110.5	117.2	123.9
	22	48.1	73.7	80.0	86.4	92.8	99.1	105.5	111.8	118.2
	24	45.7	70.1	76.2	82.3	88.3	94.4	100.4	106.5	112.6
	26	43.3	66.6	72.3	78.1	83.9	89.7	95.4	101.2	107.0
	28	.....	.....	.....	.....	.....	.....	.....	.....	.....
17.25 Lbs.	18	60.8	94.6	101.3	108.1	114.8	121.6	128.3	135.1	141.8
	20	58.1	91.4	98.2	104.8	111.5	118.1	124.8	131.5	138.1
	22	55.3	87.1	93.5	99.9	106.3	112.6	119.0	125.4	131.7
	24	52.4	82.8	88.9	95.0	101.1	107.1	113.2	119.3	125.3
	26	.....	78.5	84.3	90.1	95.8	101.6	107.4	113.2	118.9
	28	.....	.....	.....	.....	.....	.....	.....	.....	.....
19.75 Lbs.	16	69.7	.....	.....	.....	.....	.....	.....	.....	.....
	18	68.9	103.4	110.2	117.0	123.7	130.4	137.2	144.0	150.7
	20	65.5	99.0	105.7	112.4	119.0	125.7	132.4	139.1	145.7
	22	62.2	94.2	100.6	107.0	113.3	119.6	126.1	132.4	138.8
	24	58.8	89.3	95.4	101.5	107.6	113.6	119.7	125.8	131.9
	26	.....	.....	.....	.....	.....	.....	.....	.....	.....

To the above weights of column shafts add the weight of rivets and lattice bars.

THE CARNEGIE STEEL COMPANY, LIMITED.

SAFE LOADS IN TONS OF 2,000 POUNDS.  
8" CHANNEL COLUMNS.  
SQUARE ENDS.

Allowed stresses per square inch: { 12,000 lbs. for lengths of 90 radii or under.  
safety factor 4. { 17,100-57<sup>1</sup>/<sub>r</sub> for lengths over 90 radii.

Sections: { 2-8" Channels—latticed, or  
2-8" Channels and 2 side plates 10" wide.



Weight of Channels.	Length of Col. in ft.	Lat.	1/4 Pl.	3/8 Pl.	1/2 Pl.	5/8 Pl.	3/4 Pl.	7/8 Pl.	1 1/8 Pl.	1 1/4 Pl.
		22.5 lbs. r=3.11.	39.5 lbs. r=3.03.	43.7 lbs. r=3.02.	48.0 lbs. r=3.01.	52.3 lbs. r=3.00.	56.5 lbs. r=2.99.	60.8 lbs. r=2.98.	65.0 lbs. r=2.98.	69.2 lbs. r=2.97.
1.1.25 Lbs.	22	40.2	70.2	77.7	85.2	92.7	100.2	107.7	115.2	122.7
	24	39.6	68.4	75.5	82.7	89.8	97.0	104.1	111.2	118.4
	26	38.1	65.7	72.6	79.4	86.3	93.1	100.0	106.8	113.7
	28	36.6	63.1	69.7	76.2	82.8	89.3	95.9	102.4	109.0
	30	35.2	60.5	66.7	73.0	79.2	85.5	91.8	98.0	104.2
1.3.75 Lbs.	22	48.5	86.0	93.5	101.0	108.5	116.0	123.5	131.0	138.5
	24	46.8	82.9	90.1	97.2	104.3	111.5	118.6	125.7	132.9
	26	45.0	79.6	86.5	93.3	100.1	107.0	113.8	120.7	127.5
	28	43.1	76.3	82.9	89.4	96.0	102.5	109.0	115.6	122.1
	30	41.3	73.0	79.3	85.5	91.8	98.0	104.3	110.5	116.8
1.6.25 Lbs.	20	57.4	102.4	109.9	117.4	124.9	132.4	139.9	147.4	154.9
	22	56.8	101.9	109.3	116.7	124.2	131.6	139.0	146.4	153.9
	24	54.6	97.9	105.0	112.1	119.3	126.4	133.5	140.7	147.8
	26	52.3	93.9	100.7	107.5	114.4	121.2	128.0	134.9	141.7
	28	50.1	89.9	96.4	102.9	109.5	116.0	122.6	129.1	135.7
1.8.75 Lbs.	20	66.1	118.6	126.1	133.6	141.1	148.6	156.1	163.6	171.1
	22	64.8	117.3	124.7	132.1	139.5	147.0	154.4	161.8	169.3
	24	62.1	112.6	119.7	126.8	133.9	141.1	148.2	155.3	162.5
	26	59.5	107.8	114.7	121.5	128.3	135.2	142.0	148.8	155.7
	28	56.8	103.1	109.7	116.2	122.8	129.3	135.8	142.4	148.9
2.1.25 Lbs.	20	75.0	135.0	142.5	150.0	157.5	165.0	172.5	180.0	187.5
	22	72.9	132.6	140.0	147.5	154.9	162.3	169.8	177.2	184.7
	24	69.8	127.2	134.3	141.5	148.6	155.7	162.9	170.0	177.1
	26	66.7	121.7	128.6	135.4	142.3	149.1	155.9	162.8	169.6
	28	63.7	116.3	122.9	129.4	136.0	142.5	149.0	155.6	162.1

To the above weights of column shafts add the weight of rivets and lattice bars.

THE CARNEGIE STEEL COMPANY, LIMITED.

SAFE LOADS IN TONS OF 2,000 POUNDS.

9" CHANNEL COLUMNS.

SQUARE ENDS.

Allowed stresses per square inch;  $\left\{ \begin{array}{l} 12,000 \text{ lbs. for lengths of 90 radii or under.} \\ 17,100 - 57 \frac{1}{r} \text{ for lengths over 90 radii.} \end{array} \right.$   
 safety factor 4.

Sections:  $\left\{ \begin{array}{l} 2-9'' \text{ Channels - latticed, or} \\ 2-9'' \text{ Channels and 2 side plates } 11'' \text{ wide.} \end{array} \right.$

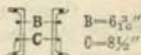

Weight of Channel.	Length of Col. in ft.	Weights of Column Shafts								
		Lat.	1/4 Pl.	5/16 Pl.	3/8 Pl.	7/16 Pl.	1/2 Pl.	5/8 Pl.	3/4 Pl.	1 1/8 Pl.
		26.5 lbs. r=3.49.	45.2 lbs. r=3.40.	49.9 lbs. r=3.38.	54.6 lbs. r=3.36.	59.2 lbs. r=3.35.	63.9 lbs. r=3.33.	68.5 lbs. r=3.32.	73.3 lbs. r=3.31.	77.9 lbs. r=3.31.
13.25 lbs.		24	79.7	88.0	96.2	104.4	112.7	121.0	129.2	137.4
		26	46.7	78.8	86.7	94.6	102.5	110.5	118.4	126.3
		28	45.2	76.1	83.8	91.4	99.0	106.6	114.3	121.9
		30	43.6	73.4	80.8	88.1	95.4	102.8	110.1	117.4
		32	42.1	70.8	77.8	84.9	91.9	98.9	106.0	113.0
		34	40.6	68.1	74.9	81.6	88.3	95.1	101.8	108.5
			Lat.	1/4 Pl.	5/16 Pl.	3/8 Pl.	7/16 Pl.	1/2 Pl.	5/8 Pl.	3/4 Pl.
			30.0 lbs. r=3.40.	48.7 lbs. r=3.36.	53.4 lbs. r=3.34.	58.1 lbs. r=3.33.	62.7 lbs. r=3.32.	67.4 lbs. r=3.31.	72.0 lbs. r=3.30.	76.8 lbs. r=3.29.
10 lbs.		24	52.9	85.9	94.2	102.4	110.6	118.9	127.2	135.4
		26	52.3	84.5	92.5	100.4	108.3	116.2	124.1	132.0
		28	50.6	81.6	89.3	96.9	104.5	112.1	119.7	127.4
		30	48.8	78.7	86.1	93.4	100.7	108.0	115.4	122.7
		32	47.0	75.8	82.8	89.9	96.9	103.9	111.0	118.0
		34	45.2	72.9	79.6	86.4	93.1	99.8	106.6	113.3
			Lat.	3/8 Pl.	7/16 Pl.	1/2 Pl.	5/8 Pl.	3/4 Pl.	1 1/8 Pl.	1 1/4 Pl.
			40.0 lbs. r=3.21.	68.1 lbs. r=3.25.	72.7 lbs. r=3.25.	77.4 lbs. r=3.24.	82.0 lbs. r=3.24.	86.8 lbs. r=3.23.	91.4 lbs. r=3.23.	96.1 lbs. r=3.23.
20 lbs.		24	70.6	120.1	128.3	136.6	144.8	153.1	161.3	169.6
		26	68.0	116.3	124.2	132.1	140.1	148.0	155.8	163.8
		28	65.5	112.1	119.7	127.3	135.0	142.6	150.1	157.8
		30	63.0	107.9	115.2	122.5	129.9	137.2	144.5	151.8
		32	60.5	103.7	110.7	117.7	124.8	131.8	138.8	145.8
			Lat.	5/8 Pl.	3/4 Pl.	7/8 Pl.	1 1/8 Pl.	1 1/4 Pl.	1 1/2 Pl.	1 3/4 Pl.
			50.0 lbs. r=3.10.	92.0 lbs. r=3.17.	96.8 lbs. r=3.17.	101.4 lbs. r=3.17.	106.1 lbs. r=3.17.	110.8 lbs. r=3.17.	115.4 lbs. r=3.17.	120.1 lbs. r=3.17.
25 lbs.		22	88.2	162.5	170.7	178.9	187.2	195.5	203.7	211.9
		24	86.8	161.5	169.6	177.8	186.0	194.3	202.4	210.6
		26	83.5	155.6	163.5	171.4	179.3	187.2	195.1	203.0
		28	80.3	149.8	157.4	164.9	172.6	180.2	187.8	195.4
		30	77.0	143.9	151.2	158.5	165.9	173.2	180.5	187.8
		32	73.8	138.1	145.1	152.1	159.1	166.2	173.2	180.2

To the above weights of column shafts add the weight of rivets and lattice bars.

THE CARNEGIE STEEL COMPANY, LIMITED.

SAFE LOADS IN TONS OF 2,000 POUNDS.  
10" CHANNEL COLUMNS.

SQUARE ENDS.

Allowed stresses per square inch; ( 12,000 lbs. for lengths of 90 radii or under.

safety factor 4. \* ( 17,100-57<sup>1</sup>/<sub>r</sub> for lengths over 90 radii.

Sections: { 2-10" Channels—lattice, or  
2-10" Channels and 2 side plates 12" wide.

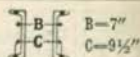

Weight of Channels.	Length of Col. in ft.	Weight of Channels									
		Lat. 30.0 lbs. r=3.87.	<sup>1</sup> / <sub>8</sub> Pl. 55.5 lbs. r=3.74.	<sup>3</sup> / <sub>8</sub> Pl. 60.6 lbs. r=3.72.	<sup>1</sup> / <sub>2</sub> Pl. 65.7 lbs. r=3.70.	<sup>3</sup> / <sub>4</sub> Pl. 70.8 lbs. r=3.68.	<sup>7</sup> / <sub>8</sub> Pl. 75.9 lbs. r=3.67.	<sup>1</sup> / <sub>2</sub> Pl. 81.0 lbs. r=3.65.	<sup>3</sup> / <sub>4</sub> Pl. 86.1 lbs. r=3.64.	<sup>1</sup> / <sub>2</sub> Pl. 91.2 lbs. r=3.63.	<sup>3</sup> / <sub>4</sub> Pl. 96.3 lbs. r=3.62.
15 Lbs.	26	.....	.....	107.5	116.5	125.5	134.5	143.5	152.5	161.5	
	28	53.5	98.5	107.0	115.7	124.4	133.1	141.8	150.5	159.2	
	30	52.6	95.3	103.7	112.2	120.5	128.9	137.3	145.7	154.2	
	32	51.0	92.3	100.4	108.6	116.7	124.8	132.9	141.0	149.1	
	34	49.5	89.3	97.1	105.0	112.8	120.6	128.4	136.2	144.0	
	36	47.9	86.3	93.8	101.4	108.9	116.4	123.9	131.4	139.0	
	38	46.3	83.3	90.5	97.8	105.0	112.2	119.4	126.7	133.9	
40	44.7	.....	.....	.....	.....	.....	.....	.....	.....		
20 Lbs.	26	Lat. 40.0 lbs. r=3.66.	<sup>1</sup> / <sub>8</sub> Pl. 75.7 lbs. r=3.64.	<sup>3</sup> / <sub>8</sub> Pl. 80.8 lbs. r=3.63.	<sup>1</sup> / <sub>2</sub> Pl. 85.9 lbs. r=3.62.	<sup>3</sup> / <sub>4</sub> Pl. 91.0 lbs. r=3.61.	<sup>7</sup> / <sub>8</sub> Pl. 96.1 lbs. r=3.60.	<sup>1</sup> / <sub>2</sub> Pl. 101.2 lbs. r=3.59.	<sup>3</sup> / <sub>4</sub> Pl. 106.3 lbs. r=3.59.	<sup>1</sup> / <sub>2</sub> Pl. 111.4 lbs. r=3.58.	
	28	70.6	133.6	142.6	151.6	160.6	169.6	178.6	187.6	196.6	
	28	69.8	131.7	140.4	149.1	157.8	166.4	175.1	183.8	192.5	
	30	67.6	127.5	135.9	144.3	152.7	161.1	169.5	177.9	186.2	
	32	65.4	123.3	131.4	139.5	147.6	155.7	163.8	171.9	180.0	
	34	63.2	119.1	126.9	134.7	142.5	150.3	158.1	165.9	173.7	
	36	61.0	114.9	122.4	129.9	137.5	145.0	152.5	160.0	167.5	
38	58.8	.....	.....	.....	.....	.....	.....	.....	.....		
25 Lbs.	26	Lat. 50.0 lbs. r=3.52.	<sup>1</sup> / <sub>8</sub> Pl. 95.9 lbs. r=3.56.	<sup>3</sup> / <sub>8</sub> Pl. 101.0 lbs. r=3.55.	<sup>1</sup> / <sub>2</sub> Pl. 106.1 lbs. r=3.55.	<sup>3</sup> / <sub>4</sub> Pl. 111.2 lbs. r=3.55.	<sup>7</sup> / <sub>8</sub> Pl. 116.3 lbs. r=3.54.	<sup>1</sup> / <sub>2</sub> Pl. 121.4 lbs. r=3.54.	<sup>3</sup> / <sub>4</sub> Pl. 126.5 lbs. r=3.54.	<sup>1</sup> / <sub>2</sub> Pl. 131.6 lbs. r=3.53.	
	28	88.2	169.2	178.2	187.2	196.2	205.2	214.2	223.2	232.2	
	28	85.7	165.3	173.9	182.6	191.3	200.0	208.7	217.3	226.0	
	30	82.8	159.8	168.2	176.6	185.0	193.4	201.8	210.1	218.5	
	32	80.0	154.4	162.5	170.6	178.7	186.8	194.9	202.9	211.0	
	34	77.1	149.0	156.8	164.6	172.3	180.2	188.0	195.8	203.5	
	36	74.3	143.6	151.1	158.5	166.0	173.6	181.1	188.6	196.1	
30 Lbs.	24	Lat. 60.0 lbs. r=3.42.	<sup>1</sup> / <sub>8</sub> Pl. 116.1 lbs. r=3.50.	<sup>3</sup> / <sub>8</sub> Pl. 121.2 lbs. r=3.50.	<sup>1</sup> / <sub>2</sub> Pl. 126.3 lbs. r=3.49.	<sup>3</sup> / <sub>4</sub> Pl. 131.4 lbs. r=3.49.	<sup>7</sup> / <sub>8</sub> Pl. 136.5 lbs. r=3.49.	<sup>1</sup> / <sub>2</sub> Pl. 141.6 lbs. r=3.49.	<sup>3</sup> / <sub>4</sub> Pl. 146.7 lbs. r=3.49.	<sup>1</sup> / <sub>2</sub> Pl. 151.8 lbs. r=3.49.	
	26	105.8	.....	.....	.....	.....	.....	.....	.....	.....	
	26	105.0	204.8	213.8	222.8	231.8	240.8	249.8	258.8	267.8	
	28	101.4	198.4	207.1	215.8	224.5	233.2	241.8	250.2	258.5	
	30	97.9	191.8	200.2	208.5	216.9	225.3	233.7	242.0	250.2	
	32	94.4	185.1	193.2	201.3	209.3	217.4	225.5	233.5	241.7	
	34	90.9	178.4	186.2	194.0	201.8	209.6	217.4	225.2	232.9	
36	.....	171.7	179.2	186.7	194.2	201.7	209.2	216.7	224.2		
35 Lbs.	24	Lat. 70.0 lbs. r=3.35.	<sup>1</sup> / <sub>8</sub> Pl. 136.3 lbs. r=3.45.	<sup>3</sup> / <sub>8</sub> Pl. 141.4 lbs. r=3.45.	<sup>1</sup> / <sub>2</sub> Pl. 146.5 lbs. r=3.45.	<sup>3</sup> / <sub>4</sub> Pl. 151.6 lbs. r=3.45.	<sup>7</sup> / <sub>8</sub> Pl. 156.7 lbs. r=3.45.	<sup>1</sup> / <sub>2</sub> Pl. 161.8 lbs. r=3.45.	<sup>3</sup> / <sub>4</sub> Pl. 166.9 lbs. r=3.45.	<sup>1</sup> / <sub>2</sub> Pl. 172.0 lbs. r=3.45.	
	26	123.5	240.5	249.5	258.5	267.5	276.5	285.5	294.5	303.5	
	26	121.3	239.3	248.2	257.2	266.2	275.1	284.1	292.9	301.8	
	28	117.1	231.3	240.0	248.7	257.3	265.9	274.7	283.2	291.7	
	30	112.9	223.3	231.7	240.1	248.5	256.9	265.2	273.6	281.9	
	32	108.7	215.4	223.5	231.6	239.6	247.6	255.6	263.5	271.4	
	34	104.5	207.4	215.2	223.0	230.8	238.6	246.3	254.0	261.7	
36	.....	199.5	207.0	214.5	222.0	229.5	237.0	244.5	252.0		

To the above weights of column shafts add the weight of rivets and lattice bars.

SAFE LOADS IN TONS OF 2,000 POUNDS.  
12" CHANNEL COLUMNS.

SQUARE ENDS.

Allowed stresses per square inch;  $\left\{ \begin{array}{l} 12,000 \text{ lbs. for lengths of 90 radii or under.} \\ 17,100-57\frac{1}{r} \text{ for lengths over 90 radii.} \end{array} \right.$   
safety factor 4.

Sections:  $\left\{ \begin{array}{l} 2-12'' \text{ Channels - latticed, or} \\ 2-12'' \text{ Channels and 2 side plates } 14'' \text{ wide.} \end{array} \right.$

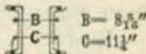

Weight of Channel, Length of Col. in ft.	Square Ends									
	Lat. 41.0 lbs. r=4.61.	$\frac{1}{4}$ Pl. 70.8 lbs. r=4.40.	$\frac{3}{8}$ Pl. 76.7 lbs. r=4.38.	$\frac{1}{2}$ Pl. 82.6 lbs. r=4.35.	$\frac{5}{8}$ Pl. 88.6 lbs. r=4.33.	$\frac{3}{4}$ Pl. 94.6 lbs. r=4.32.	$\frac{7}{8}$ Pl. 100.5 lbs. r=4.30.	$1\frac{1}{8}$ Pl. 106.4 lbs. r=4.29.	$1\frac{1}{4}$ Pl. 112.4 lbs. r=4.27.	
30.0 lbs.	32	124.9	135.4	145.9	156.4	166.9	177.4	187.9	198.4	
	34	72.4	123.0	133.0	142.9	152.9	162.8	172.8	182.8	
	36	70.9	119.7	129.4	139.1	148.8	158.4	168.1	177.8	
	38	69.1	116.5	125.9	135.3	144.6	154.0	163.4	172.8	
	40	67.3	113.3	122.4	131.5	140.5	149.6	158.7	167.8	
	42	65.5	110.0	118.8	127.6	136.4	145.2	154.0	162.8	
	44	63.7	106.8	115.3	123.8	132.3	140.8	149.3	157.8	
		Lat. 50.6 lbs. r=4.43.	$\frac{1}{4}$ Pl. 91.6 lbs. r=4.30.	$\frac{3}{8}$ Pl. 97.6 lbs. r=4.29.	$\frac{1}{2}$ Pl. 103.6 lbs. r=4.27.	$\frac{5}{8}$ Pl. 109.5 lbs. r=4.26.	$\frac{3}{4}$ Pl. 115.4 lbs. r=4.25.	$\frac{7}{8}$ Pl. 121.4 lbs. r=4.24.	$1\frac{1}{8}$ Pl. 127.3 lbs. r=4.23.	$1\frac{1}{4}$ Pl. 133.3 lbs. r=4.22.
30.0 lbs.	30	.....	.....	.....	193.2	203.7	214.2	224.7	235.2	
	32	88.2	161.7	172.2	182.7	192.6	202.9	213.1	223.3	
	34	87.1	157.6	167.6	177.5	187.5	197.4	207.3	217.3	
	36	84.8	153.3	163.0	172.6	182.3	191.9	201.6	211.2	
	38	82.6	149.1	158.4	167.8	177.1	186.5	195.8	205.2	
	40	80.3	144.8	153.8	162.9	172.0	181.0	190.1	199.1	
	42	78.0	140.5	149.3	158.0	166.8	175.5	184.3	193.1	
	44	75.7	136.2	144.7	153.2	161.6	170.1	178.6	187.0	
35 lbs.		Lat. 60.0 lbs. r=4.28.	$\frac{1}{4}$ Pl. 113.6 lbs. r=4.23.	$\frac{3}{8}$ Pl. 119.5 lbs. r=4.22.	$\frac{1}{2}$ Pl. 125.4 lbs. r=4.21.	$\frac{5}{8}$ Pl. 131.4 lbs. r=4.20.	$\frac{3}{4}$ Pl. 137.3 lbs. r=4.20.	$\frac{7}{8}$ Pl. 143.3 lbs. r=4.19.	$1\frac{1}{8}$ Pl. 149.3 lbs. r=4.18.	$1\frac{1}{4}$ Pl. 155.2 lbs. r=4.18.
35 lbs.	30	.....	200.3	210.8	221.3	231.8	242.3	252.8	263.3	
	32	105.8	199.1	209.3	219.5	229.8	240.0	250.2	260.5	
	34	102.9	193.7	203.6	213.5	223.5	233.4	243.3	253.3	
	36	100.1	188.3	197.9	207.5	217.2	226.8	236.5	246.1	
	38	97.3	182.9	192.2	201.5	210.9	220.2	229.6	238.9	
	40	94.4	177.5	186.5	195.5	204.6	213.6	222.7	231.8	
	42	91.6	172.0	180.8	189.5	198.3	207.1	215.8	224.6	
		Lat. 70.0 lbs. r=4.17.	$\frac{1}{4}$ Pl. 135.4 lbs. r=4.17.	$\frac{3}{8}$ Pl. 141.4 lbs. r=4.16.	$\frac{1}{2}$ Pl. 147.3 lbs. r=4.16.	$\frac{5}{8}$ Pl. 153.3 lbs. r=4.15.	$\frac{3}{4}$ Pl. 159.3 lbs. r=4.15.	$\frac{7}{8}$ Pl. 165.2 lbs. r=4.14.	$1\frac{1}{8}$ Pl. 171.1 lbs. r=4.14.	$1\frac{1}{4}$ Pl. 177.1 lbs. r=4.13.
35 lbs.	30	123.5	239.0	249.5	260.0	270.5	281.0	291.5	302.0	
	32	121.9	235.9	246.2	256.4	266.6	276.8	287.1	297.3	
	34	118.6	229.4	239.3	249.2	259.2	269.1	279.0	289.0	
	36	115.2	222.9	232.5	242.1	251.7	261.4	271.0	280.6	
	38	111.8	216.3	225.7	235.0	244.3	253.7	263.0	272.3	
	40	108.4	209.8	218.8	227.8	236.9	245.9	255.0	264.1	
	42	105.1	203.2	212.0	220.7	229.5	238.2	247.0	255.8	
		Lat. 80.0 lbs. r=4.09.	$\frac{1}{4}$ Pl. 157.3 lbs. r=4.12.	$\frac{3}{8}$ Pl. 163.3 lbs. r=4.11.	$\frac{1}{2}$ Pl. 169.3 lbs. r=4.11.	$\frac{5}{8}$ Pl. 175.2 lbs. r=4.11.	$\frac{3}{4}$ Pl. 181.1 lbs. r=4.10.	$\frac{7}{8}$ Pl. 187.0 lbs. r=4.10.	$1\frac{1}{8}$ Pl. 192.9 lbs. r=4.10.	$1\frac{1}{4}$ Pl. 198.8 lbs. r=4.09.
40 lbs.	30	141.1	277.6	288.1	298.6	309.1	319.6	330.1	340.6	
	32	138.2	272.6	282.8	293.0	303.2	313.7	324.1	334.6	
	34	134.2	264.9	274.8	284.8	294.7	304.5	314.5	324.4	
	36	130.3	257.2	266.8	276.5	286.1	295.4	304.6	313.9	
	38	126.3	249.5	258.8	268.2	277.5	286.2	294.9	303.5	
	40	122.4	241.8	250.9	259.9	268.9	277.0	285.1	293.2	
	42	118.5	234.1	242.9	251.6	260.3	267.8	275.3	282.8	

To the above weights of column shafts add the weight of rivets and lattice bars.

ULTIMATE STRENGTH OF COLUMNS.  
MEDIUM STEEL.

For different proportions of length in feet ( $-l$ )  
To least radius of gyration in inches ( $-r$ ).

Ultimate Strength in lbs. per square inch :

Column Square Bearing : 50000	Column Pin and Square Bearing : 50000	Column Pin Bearing : 50000
$1 + \frac{(12l)^2}{36000 r^2}$ ;	$1 + \frac{(12l)^2}{24000 r^2}$ ;	$1 + \frac{(12l)^2}{18000 r^2}$

To obtain Safe Resistance :

For quiescent loads, as in buildings, divide by 4.

For moving loads, as in bridges, divide by 5.

Ultimate Strength in Lbs. per square inch.			Ultimate Strength in Lbs. per square inch.			
$\frac{l}{r}$	Square.	Pin and Square.	$\frac{l}{r}$	Square.	Pin and Square.	Pin.
3.0	48260	47440	8.4	38990	35130	31960
3.2	48030	47110	8.6	38590	34630	31410
3.4	47790	46760	8.8	38180	34140	30870
3.6	47540	46390	9.0	37760	33650	30340
3.8	47270	46010	9.2	37350	33160	29810
4.0	46990	45620	9.4	36940	32680	29290
4.2	46710	45210	9.6	36530	32200	28780
4.4	46410	44800	9.8	36120	31720	28280
4.6	46100	44370	10.0	35710	31250	27780
4.8	45780	43930	10.2	35310	30780	27290
5.0	45460	43480	10.4	34900	30320	26810
5.2	45120	43020	10.6	34500	29870	26330
5.4	44780	42560	10.8	34090	29420	25870
5.6	44430	42080	11.0	33690	28970	25410
5.8	44070	41600	11.2	33290	28530	24960
6.0	43710	41120	11.4	32900	28090	24510
6.2	43340	40630	11.6	32510	27670	24080
6.4	42960	40140	11.8	32110	27240	23650
6.6	42580	39640	12.0	31730	26820	23230
6.8	42200	39140	12.2	31340	26410	22820
7.0	41810	38640	12.4	30960	26010	22420
7.2	41410	38140	12.6	30580	25610	22030
7.4	41020	37640	12.8	30210	25210	21640
7.6	40620	37130	13.0	29830	24830	21260
7.8	40210	36630	13.2	29460	24450	20890
8.0	39810	36130	13.5	28930	23890	20350
8.2	39400	35630	13.8	28380	23340	19810

ULTIMATE STRENGTH OF COLUMNS—Continued.

14.0	28030	22980	19470	17.5	22480	17630	14490
14.2	27680	22630	19130	17.8	22050	17240	14150
14.5	27180	22110	18650	18.0	21780	16980	13920
14.8	26650	21610	18170	18.2	21510	16740	13700
15.0	26320	21280	17860	18.5	21100	16380	13380
15.2	25990	20950	17550	18.8	20720	16020	13060
15.5	25500	20490	17110	19.0	20460	15790	12860
15.8	25020	20020	16680	19.2	20210	15570	12660
16.0	24700	19720	16400	19.5	19840	15240	12360
16.2	24390	19420	16130	19.8	19470	14920	12090
16.5	23940	18990	15740	20.0	19230	14710	11910
16.8	23490	18560	15350	20.2	19000	14500	11730
17.0	23190	18290	15100	20.5	18650	14200	11460
17.2	22900	18020	14850	20.8	18310	13910	11210

RADII OF GYRATION FOR TWO ANGLES PLACED BACK TO BACK.  
ANGLES WITH EQUAL LEGS.

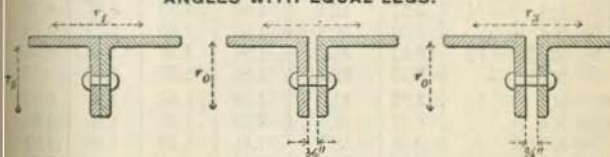

Radii of Gyration given correspond to directions indicated by arrow heads.

Size. Inches.	Thickness. Inches.	Area of single angle. Sq. In.	Weight per foot of single angle. Lbs.	Radii of Gyration.			
				$r_0$	$r_1$	$r_2$	$r_3$
8 × 8	1/2	7.75	26.4	2.50	3.32	3.49	3.58
8 × 8	1 1/8	16.73	56.9	2.42	3.42	3.60	3.69
6 × 6	3/8	4.36	14.8	1.88	2.49	2.67	2.76
6 × 6	1	11.00	37.4	1.80	2.59	2.77	2.87
*5 × 5	3/8	3.61	12.3	1.56	2.09	2.26	2.35
*5 × 5	1	9.00	30.6	1.48	2.19	2.38	2.48
4 × 4	5/16	2.40	8.2	1.24	1.67	1.85	1.94
4 × 4	1/2	5.84	19.9	1.18	1.75	1.94	2.04
3 1/2 × 3 1/2	5/16	2.09	7.1	1.08	1.47	1.65	1.74
3 1/2 × 3 1/2	1/2	5.03	17.1	1.02	1.55	1.74	1.85
3 × 3	1/4	1.44	4.9	0.93	1.25	1.43	1.53
3 × 3	5/8	3.36	11.4	0.88	1.32	1.51	1.62
*2 3/4 × 2 3/4	1/4	1.31	4.5	0.85	1.15	1.34	1.44
*2 3/4 × 2 3/4	1/2	2.50	8.5	0.82	1.19	1.39	1.49
2 1/2 × 2 1/2	3/8	0.90	3.1	0.78	1.04	1.22	1.32
2 1/2 × 2 1/2	1/2	2.25	7.7	0.74	1.10	1.29	1.40
*2 1/4 × 2 1/4	3/8	0.81	2.8	0.70	0.94	1.12	1.23
*2 1/4 × 2 1/4	1/2	2.00	6.8	0.66	0.99	1.19	1.30

Angles marked \* are special.



RADI OF GYRATION FOR TWO ANGLES PLACED BACK TO BACK.

ANGLES WITH UNEQUAL LEGS.

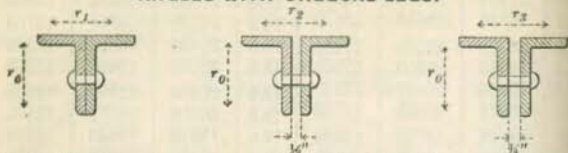

Radii of Gyration given correspond to directions indicated by arrow heads.

Size. Inches.	Thickness. Inches.	Area of single angle. Sq. In.	Weight per foot of single angle. Lbs.	Radii of Gyration.				
				$r_0$	$r_1$	$r_2$	$r_3$	
*7	$\times 3\frac{1}{2}$	$\frac{7}{16}$	4.40	15.0	2.26	1.21	1.39	1.47
*7	$\times 3\frac{1}{2}$	1	9.50	32.3	2.19	1.31	1.50	1.60
6	$\times 4$	$\frac{3}{8}$	3.61	12.3	1.93	1.50	1.67	1.76
6	$\times 4$	1	9.00	30.6	1.85	1.60	1.79	1.89
6	$\times 3\frac{1}{2}$	$\frac{3}{8}$	3.42	11.7	1.94	1.26	1.43	1.53
6	$\times 3\frac{1}{2}$	1	8.50	28.9	1.85	1.37	1.56	1.67
*5	$\times 4$	$\frac{3}{8}$	3.23	11.0	1.59	1.58	1.75	1.85
*5	$\times 4$	$\frac{7}{8}$	7.11	24.2	1.52	1.66	1.85	1.95
5	$\times 3\frac{1}{2}$	$\frac{5}{16}$	2.56	8.7	1.61	1.33	1.50	1.59
5	$\times 3\frac{1}{2}$	$\frac{7}{8}$	6.67	22.7	1.53	1.42	1.61	1.71
5	$\times 3$	$\frac{5}{16}$	2.40	8.2	1.61	1.09	1.26	1.35
5	$\times 3$	$\frac{1}{2}$	5.84	19.9	1.55	1.18	1.37	1.47
*4 $\frac{1}{2}$	$\times 3$	$\frac{5}{16}$	2.25	7.7	1.44	1.13	1.31	1.40
*4 $\frac{1}{2}$	$\times 3$	$\frac{1}{2}$	5.43	18.5	1.38	1.25	1.46	1.54
*4	$\times 3\frac{1}{2}$	$\frac{5}{16}$	2.25	7.7	1.26	1.42	1.60	1.69
*4	$\times 3\frac{1}{2}$	$\frac{1}{2}$	5.43	18.5	1.19	1.50	1.69	1.79
4	$\times 3$	$\frac{5}{16}$	2.09	7.1	1.27	1.17	1.35	1.44
4	$\times 3$	$\frac{1}{2}$	5.03	17.1	1.21	1.25	1.45	1.55
3 $\frac{1}{2}$	$\times 3$	$\frac{5}{16}$	1.93	6.6	1.10	1.22	1.40	1.49
3 $\frac{1}{2}$	$\times 3$	$\frac{1}{2}$	4.62	15.7	1.04	1.30	1.50	1.60
3 $\frac{1}{2}$	$\times 2\frac{1}{2}$	$\frac{1}{4}$	1.44	4.9	1.12	0.96	1.13	1.23
3 $\frac{1}{2}$	$\times 2\frac{1}{2}$	$\frac{1}{2}$	3.65	12.4	1.06	1.03	1.23	1.33
*3 $\frac{1}{4}$	$\times 2$	$\frac{1}{4}$	1.25	4.3	1.04	0.74	0.92	1.02
*3 $\frac{1}{4}$	$\times 2$	$\frac{9}{16}$	2.64	9.0	1.00	0.79	0.99	1.10
3	$\times 2\frac{1}{2}$	$\frac{1}{4}$	1.31	4.5	0.95	1.00	1.18	1.28
3	$\times 2\frac{1}{2}$	$\frac{9}{16}$	2.78	9.5	0.91	1.05	1.25	1.35
*3	$\times 2$	$\frac{1}{4}$	1.19	4.0	0.96	0.75	0.93	1.03
*3	$\times 2$	$\frac{1}{2}$	2.25	7.7	0.92	0.80	1.00	1.10
2 $\frac{1}{2}$	$\times 2$	$\frac{5}{16}$	0.81	2.8	0.79	0.79	0.97	1.07
2 $\frac{1}{2}$	$\times 2$	$\frac{1}{2}$	2.00	6.8	0.75	0.84	1.04	1.15

Angles marked \* are special.

RADII OF GYRATION FOR TWO ANGLES  
PLACED BACK TO BACK.

ANGLES WITH UNEQUAL LEGS.

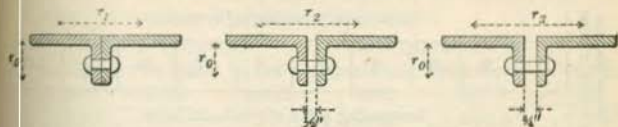

Radii of Gyration given correspond to directions indicated by arrow heads.

Size, Inches.	Thickness, Inches.	Area of single angle, Sq. In.	Weight per foot of single angle, Lbs.	Radii of Gyration.			
				$r_0$	$r_1$	$r_2$	$r_3$
*7 × 3½	¾	4.40	15.0	0.95	3.37	3.56	3.66
*7 × 3½	1	9.50	32.3	0.89	3.48	3.68	3.78
6 × 4	¾	3.61	12.3	1.17	2.74	2.92	3.01
6 × 4	1	9.00	30.6	1.09	2.85	3.04	3.14
6 × 3½	¾	3.42	11.7	0.99	2.81	3.00	3.10
6 × 3½	1	8.50	28.9	0.92	2.93	3.13	3.23
*5 × 4	¾	3.23	11.0	1.20	2.20	2.38	2.48
*5 × 4	¾	7.11	24.2	1.14	2.29	2.48	2.58
5 × 3½	¾	2.56	8.7	1.03	2.26	2.44	2.54
5 × 3½	¾	6.67	22.7	0.96	2.36	2.55	2.65
5 × 3	¾	2.40	8.2	0.85	2.33	2.51	2.61
5 × 3	¾	5.84	19.9	0.80	2.42	2.62	2.72
*4½ × 3	¾	2.25	7.7	0.88	2.06	2.24	2.34
*4½ × 3	¾	5.43	18.5	0.81	2.15	2.35	2.45
*4 × 3½	¾	2.25	7.7	1.07	1.73	1.91	2.00
*4 × 3½	¾	5.43	18.5	1.01	1.81	2.01	2.11
4 × 3	¾	2.09	7.1	0.89	1.79	1.97	2.07
4 × 3	¾	5.03	17.1	0.83	1.88	2.08	2.18
3½ × 3	¾	1.93	6.6	0.90	1.52	1.71	1.80
3½ × 3	¾	4.62	15.7	0.85	1.61	1.81	1.91
3½ × 2½	¾	1.44	4.9	0.74	1.58	1.76	1.86
3½ × 2½	¾	3.65	12.4	0.67	1.66	1.86	1.96
*3¼ × 2	¾	1.25	4.3	0.57	1.51	1.70	1.80
*3¼ × 2	¾	2.64	9.0	0.53	1.57	1.77	1.88
3 × 2½	¾	1.31	4.5	0.75	1.31	1.50	1.59
3 × 2½	¾	2.78	9.5	0.72	1.37	1.56	1.66
*3 × 2	¾	1.19	4.0	0.58	1.38	1.56	1.66
*3 × 2	¾	2.25	7.7	0.55	1.42	1.62	1.73
2½ × 2	¾	0.81	2.8	0.60	1.10	1.28	1.39
2½ × 2	¾	2.00	6.8	0.56	1.16	1.35	1.46

Angles marked \* are special.

RADI OF GYRATION FOR ROUND COLUMNS.

Outside Diameter of Column in Inches.	Thickness in Inches Varying by Tenths.									
	.1	.2	.3	.4	.5	.6	.7	.8	.9	1.0
	Corresponding Radius of Gyration in Inches.									
2	.67	.64	.61	.58	.56	.54	.52	.51	.50	.50
3	1.03	.99	.96	.93	.90	.88	.85	.83	.81	.79
4	1.38	1.35	1.31	1.28	1.25	1.22	1.19	1.16	1.14	1.12
5	1.73	1.70	1.66	1.63	1.60	1.57	1.54	1.51	1.48	1.46
6	2.08	2.05	2.02	1.98	1.95	1.92	1.89	1.86	1.83	1.80
7	2.43	2.40	2.36	2.33	2.30	2.27	2.24	2.21	2.18	2.15
8	2.79	2.76	2.72	2.69	2.66	2.62	2.59	2.56	2.53	2.50
9	3.15	3.11	3.08	3.04	3.01	2.97	2.94	2.91	2.88	2.85
10	3.51	3.47	3.44	3.40	3.37	3.33	3.30	3.27	3.23	3.20
11	3.86	3.82	3.79	3.75	3.72	3.68	3.65	3.62	3.58	3.55
12	4.21	4.18	4.15	4.11	4.08	4.04	4.01	3.97	3.94	3.90

RADI OF GYRATION FOR SQUARE COLUMNS.

Outer Diameter Across Flats in Inches.	Thickness in Inches Varying by Tenths.									
	.1	.2	.3	.4	.5	.6	.7	.8	.9	1.0
	Corresponding Radius of Gyration in Inches.									
2	.78	.74	.71	.68	.65	.63	.61	.59	.58	.58
3	1.18	1.14	1.11	1.08	1.04	1.01	.98	.96	.93	.91
4	1.59	1.55	1.51	1.47	1.44	1.41	1.38	1.35	1.32	1.29
5	2.00	1.96	1.92	1.89	1.85	1.81	1.78	1.75	1.71	1.68
6	2.41	2.37	2.33	2.29	2.25	2.21	2.18	2.15	2.11	2.08
7	2.82	2.78	2.74	2.70	2.66	2.62	2.58	2.55	2.51	2.48
8	3.23	3.19	3.15	3.11	3.07	3.03	2.99	2.96	2.92	2.89
9	3.63	3.59	3.55	3.51	3.48	3.44	3.40	3.36	3.32	3.29
10	4.04	4.00	3.96	3.92	3.88	3.84	3.80	3.77	3.73	3.70
11	4.45	4.41	4.37	4.33	4.29	4.25	4.21	4.17	4.13	4.10
12	4.86	4.82	4.78	4.74	4.70	4.66	4.62	4.58	4.54	4.51

ULTIMATE STRENGTH OF HOLLOW ROUND  
AND HOLLOW RECTANGULAR CAST  
IRON COLUMNS.

Ultimate Strength in Pounds per Square Inch :

ROUND COLUMNS.

RECTANGULAR COLUMNS.

ROUND COLUMNS.			RECTANGULAR COLUMNS.		
Square Bearing:	Pin & Square:	Pin Bearing:	Square Bearing:	Pin & Square:	Pin Bearing:
80000	80000	80000	80000	80000	80000
$1 + \frac{(12l)^2}{800 d^2}$	$1 + \frac{3(12l)^2}{1600 d^2}$	$1 + \frac{(12l)^2}{400 d^2}$	$1 + \frac{3(12l)^2}{3200 d^2}$	$1 + \frac{9(12l)^2}{6400 d^2}$	$1 + \frac{3(12l)^2}{1600 d^2}$

l=Length of Column in feet,

d=External diameter or least side of rectangle in inches.

$\frac{l}{d}$	ROUND COLUMNS.			RECTANGULAR COLUMNS.		
	Ultimate Strength in lbs. per sq. in.			Ultimate Strength in lbs. per sq. in.		
	Square Bearing.	Pin and Square.	Pin Bearing.	Square Bearing.	Pin and Square.	Pin Bearing.
1.0	67800	62990	58820	70480	66520	62990
1.1	65690	60300	55730	68790	64260	60300
1.2	63530	57600	52690	67000	61940	57600
1.3	61340	54930	49740	65140	59600	54960
1.4	59140	52310	46900	63260	57270	52320
1.5	56940	49770	44200	61350	54960	49760
1.6	54760	47300	41630	59450	52680	47300
1.7	52620	44940	39210	57550	50460	44960
1.8	50530	42670	36930	55670	48300	42670
1.9	48490	40510	34790	53800	46230	40510
2.0	46510	38460	32790	51940	44200	38460
2.1	44600	36520	30920	50160	42260	36520
2.2	42750	34680	29180	48400	40400	34680
2.3	40980	32940	27540	46670	38630	32950
2.4	39280	31310	26030	44990	36930	31310
2.5	37650	29770	24620	43390	35310	29760
2.6	36090	28320	23300	41820	33770	28320
2.7	34600	26950	22070	40320	32310	26950
2.8	33180	25670	20930	38870	30920	25670
2.9	31820	24460	19860	37470	29600	24460
3.0	30530	23320	18870	36120	28340	23320
3.1	29310	22250	17940	34830	27150	22250
3.2	28140	21250	17070	33580	26030	21250
3.3	27030	20300	16260	32390	24960	20300
3.4	25970	19410	15500	31240	23940	19410

THE CARNEGIE STEEL COMPANY, LIMITED

Safe Loads in Tons of 2,000 Lbs. for Hollow Round Cast Iron Columns.

Out-side diam. Ins.	Thickness of Metal.	Length of Columns in Feet.									Sectional Area. Ins.	Wght. lbs. of columns per foot of length.
		8	10	12	14	16	18	20	22	24		
		Tons.	Tons.	Tons.	Tons.	Tons.	Tons.	Tons.	Tons.	Tons.		
6	1/2	26.2	23.0	20.1	17.5	15.2	13.2	11.5	. .	. .	8.6	26.95
6	3/4	37.5	33.0	28.8	25.0	21.7	18.9	16.5	. .	. .	12.4	38.59
6	7/8	42.7	37.6	32.8	28.5	24.7	21.5	18.8	. .	. .	14.1	43.96
6	1	47.6	41.9	36.5	31.8	27.6	24.0	21.0	. .	. .	15.7	49.01
6	1 1/8	52.2	46.0	40.1	34.8	30.2	26.3	23.0	. .	. .	17.2	53.76
7	3/4	47.7	43.1	38.5	34.3	30.4	26.9	23.9	21.2	18.9	14.7	45.96
7	1	61.1	55.2	49.3	43.8	38.9	34.4	30.6	27.1	24.2	18.9	58.90
7	1 1/8	67.2	60.8	54.3	48.3	42.8	37.9	33.7	29.9	26.7	20.8	64.77
8	3/4	57.9	53.3	48.6	44.1	39.7	35.8	32.2	28.9	26.1	17.1	53.29
8	1	74.6	68.7	62.5	56.7	51.1	46.0	41.4	37.3	33.6	22.0	68.64
8	1 1/4	89.9	82.8	75.5	68.4	61.7	55.5	49.9	44.9	40.5	26.5	82.71
9	3/4	68.1	63.6	58.9	54.2	49.6	45.2	41.2	37.5	34.1	19.4	60.65
9	1	88.0	82.3	76.2	70.0	64.1	58.4	53.2	48.4	44.1	25.1	78.40
9	1 1/4	106.6	99.6	92.2	84.8	77.6	70.8	64.4	58.7	53.4	30.4	94.94
9	1 1/2	123.8	115.7	107.1	98.5	90.1	82.2	74.8	68.1	62.0	35.3	110.26
9	1 3/4	139.6	130.5	120.8	111.1	101.6	92.7	84.4	76.8	69.9	39.9	124.36
10	1	101.4	95.9	89.8	83.6	77.4	71.5	65.8	60.5	55.5	28.3	88.23
10	1 1/4	123.3	116.5	109.1	101.6	94.1	86.8	79.9	73.4	67.5	34.4	107.23
10	1 1/2	143.7	135.8	127.3	118.5	109.7	101.2	93.2	85.6	78.7	40.1	124.99
10	1 3/4	162.7	153.8	144.1	134.1	124.2	114.6	105.5	97.0	89.1	45.4	141.65
11	1	114.8	109.4	103.5	97.3	91.0	84.8	80.2	73.1	67.7	31.4	98.03
11	1 1/4	139.9	133.3	126.1	118.6	110.9	103.3	97.8	89.4	82.5	38.3	119.46
11	1 1/2	163.5	155.9	147.5	138.6	128.7	120.8	114.3	104.1	96.4	44.8	139.68
11	1 3/4	185.7	177.1	167.5	157.5	147.3	137.2	129.8	118.3	109.5	50.9	158.68
11	2	206.6	196.9	186.3	175.1	163.8	152.6	144.4	131.5	121.8	56.6	176.44
12	1	128.0	122.9	117.2	111.0	104.7	98.4	92.2	86.1	80.4	34.6	107.51
12	1 1/4	156.4	150.1	143.1	135.7	127.9	120.2	112.6	105.2	98.2	42.2	131.41
12	1 1/2	183.3	175.9	167.7	159.0	149.9	140.9	132.0	123.3	115.1	49.5	154.10
12	1 3/4	208.7	200.4	191.0	181.1	170.7	160.4	150.3	140.5	131.1	56.4	175.53
12	2	232.7	223.4	213.0	201.9	190.4	178.9	167.6	156.6	146.1	62.8	195.75
13	1	141.2	136.3	130.7	124.7	118.5	112.1	105.8	99.5	93.5	37.7	117.53
13	1 1/4	172.8	166.8	160.0	152.7	145.0	137.2	129.4	121.8	114.4	46.1	143.86
13	1 1/2	203.0	195.9	187.9	179.3	170.3	161.1	152.0	143.1	134.3	54.2	168.98
13	1 3/4	231.6	223.6	214.5	204.7	194.4	183.9	173.5	163.3	153.3	61.9	192.88
13	2	258.9	249.9	239.7	228.7	217.3	205.5	193.9	182.5	171.3	69.1	215.56
14	1	154.3	149.6	144.3	138.5	132.3	125.9	119.5	113.1	106.8	40.8	127.60
14	1 1/4	189.2	183.4	176.9	169.7	162.2	154.4	146.5	138.6	131.0	50.1	156.31
14	1 1/2	222.6	215.8	208.1	199.7	190.8	181.7	172.3	163.1	154.1	58.9	183.67
14	1 3/4	254.4	246.7	237.9	228.3	218.1	207.6	197.0	186.5	176.2	67.4	210.00
14	2	284.8	276.2	266.4	255.6	244.2	232.4	220.6	208.8	197.2	75.4	235.12
15	1	167.4	162.9	157.8	152.1	146.0	139.7	133.3	126.8	120.4	44.0	137.28
15	1 1/4	205.5	200.0	193.7	186.7	179.3	171.5	163.6	155.7	147.9	54.0	168.48
15	1 1/2	242.1	235.7	228.2	220.0	211.2	202.1	192.8	183.5	174.2	63.6	198.74
15	1 3/4	277.2	269.8	261.3	251.9	241.9	231.4	220.7	210.1	199.5	72.9	227.45
15	2	310.8	302.5	293.0	282.5	271.2	259.5	247.5	235.5	223.6	81.7	254.90

MOMENTS OF INERTIA OF RECTANGLES.

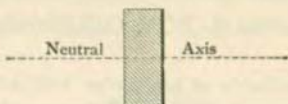

Depth in inches.	Width of Rectangle in Inches.						
	$\frac{1}{4}$	$\frac{5}{16}$	$\frac{3}{8}$	$\frac{7}{16}$	$\frac{1}{2}$	$\frac{9}{16}$	$\frac{5}{8}$
6	4.50	5.63	6.75	7.88	9.00	10.13	11.25
7	7.15	8.93	10.72	12.51	14.29	16.08	17.86
8	10.67	13.33	16.00	18.67	21.33	24.00	26.67
9	15.19	18.98	22.78	26.58	30.38	34.17	37.97
10	20.83	26.04	31.25	36.46	41.67	46.87	52.08
11	27.73	34.66	41.59	48.53	55.46	62.39	69.32
12	36.00	45.00	54.00	63.00	72.00	81.00	90.00
13	45.77	57.21	68.66	80.10	91.54	102.98	114.43
14	57.17	71.46	85.75	100.04	114.33	128.63	142.92
15	70.31	87.89	105.47	123.05	140.63	158.20	175.78
16	85.33	106.67	128.00	149.33	170.67	192.00	213.33
17	102.35	127.94	153.53	179.12	204.71	230.30	255.89
18	121.50	151.88	182.25	212.63	243.00	273.38	303.75
19	142.90	178.62	214.34	250.07	285.79	321.52	357.24
20	166.67	208.33	250.00	291.67	333.33	375.00	416.67
21	192.94	241.17	289.41	337.64	385.88	434.11	482.34
22	221.83	277.29	332.75	388.21	443.67	499.13	554.58
23	253.48	316.85	380.22	443.59	506.96	570.33	633.70
24	288.00	360.00	432.00	504.00	576.00	648.00	720.00
25	325.52	406.90	488.28	569.66	651.04	732.42	813.80
26	366.17	457.71	549.25	640.79	732.33	823.88	915.42
27	410.06	512.58	615.09	717.61	820.13	922.64	1025.16
28	457.33	571.67	686.00	800.33	914.67	1029.00	1143.33
29	508.10	635.13	762.16	889.18	1016.21	1143.23	1270.26
30	562.50	703.13	843.75	984.38	1125.00	1265.63	1406.25
31	620.65	775.81	930.97	1086.13	1241.30	1396.46	1551.62
32	682.67	853.33	1024.00	1194.67	1365.33	1536.00	1706.67
33	748.69	935.86	1123.03	1310.20	1497.38	1684.55	1871.72
34	818.83	1023.54	1228.25	1432.96	1637.67	1842.38	2047.08
35	893.23	1116.54	1339.84	1563.15	1786.46	2009.76	2233.07
36	972.00	1215.00	1458.00	1701.00	1944.00	2187.00	2430.00
37	1055.27	1319.09	1582.90	1846.72	2110.54	2374.35	2638.17
38	1143.17	1428.96	1714.75	2000.54	2286.33	2572.13	2857.92
39	1235.81	1544.77	1853.72	2162.67	2471.62	2780.58	3089.53
40	1333.33	1666.67	2000.00	2333.33	2666.67	3000.00	3333.33

## EXPLANATION OF TABLES ON BEAM BOX GIRDERS.

An economical style of box girder well adapted for short spans is one composed of a pair of I-Beams with top and bottom flange plates. Such girders are commonly used for supporting interior walls in buildings. The tables are prepared to conform to standard sizes of I-Beams.

The values given in the tables are founded upon the moments of inertia of the various sections. Deductions were made for the rivet holes in both flanges. The maximum stress in extreme fibers was limited to 15,000 lbs. per square inch, while in the tables on rolled steel beams a fiber stress of 16,000 lbs. was used. This reduction was made in order to amply compensate for the deterioration of the metal around the rivet holes from punching.

Box girders should not be used in damp or exposed places, since the interior surfaces do not readily admit of repainting.

### EXAMPLE.

A 13'' brick wall 16 feet high is to be built over an opening of 25 feet. What will be the section of the girder required?

*Answer:*—Assuming 26 feet as the distance center to center of bearings the weight of the wall will be  $26 \times 16 \times 121 = 50,336$  lbs. or 25.17 tons.

On page 157 we find that a girder composed of two 12'' beams each weighing 31.5 lbs. per foot and two 14''  $\times$  1/2'' flange plates will carry safely for a span of 26 feet a uniformly distributed load of 25.37 tons including its own weight. Subtracting the latter, 1.48 tons given in the next column, we find 23.89 tons for the value of the safe net load which is 1.28 tons less than required. From the following column we find that by increasing the thickness of the flange plates 1/8'' we may add 1.68 tons to the allowable load. This will more than cover the difference. Hence, the required section will be two 12'' beams 31.5 lbs. per foot and two 14''  $\times$  5/8'' cover plates.

BEAM BOX GIRDERS.

SAFE LOADS IN TONS UNIFORMLY DISTRIBUTED.

2-10" I-Beams and 2 Plates 12" x 1/2".

2 Plates  
12 x 1/2



10"  
I-Beams  
25.0 lbs.  
per foot.

Distance center to center of bearing in feet.	Safe load uniformly distributed (including weight of girder) in tons of 2,000 lbs.	Weight of girder (including rivet heads) in tons of 2,000 lbs.	Increase in safe load for 1/8" increase in thickness of flange plates.	Increase of weight of girder for 1/8" increase in thickness of flange plates.
10	45.00	0.47	3.06	0.02
11	40.92	0.52	2.78	0.03
12	37.50	0.56	2.55	0.03
13	34.62	0.61	2.35	0.03
14	32.15	0.66	2.18	0.03
15	30.00	0.70	2.04	0.04
16	28.13	0.75	1.90	0.04
17	26.47	0.80	1.80	0.04
18	25.00	0.84	1.70	0.04
19	23.69	0.89	1.60	0.05
20	22.50	0.94	1.53	0.05
21	21.43	0.99	1.45	0.05
22	20.46	1.03	1.38	0.05
23	19.57	1.08	1.32	0.06
24	18.75	1.13	1.28	0.06
25	18.00	1.17	1.22	0.06
26	17.31	1.22	1.18	0.06
27	16.67	1.27	1.13	0.07
28	16.07	1.31	1.10	0.07
29	15.52	1.36	1.05	0.07
30	15.00	1.41	1.02	0.07
31	14.52	1.45	0.99	0.08
32	14.07	1.50	0.96	0.08
33	13.64	1.55	0.92	0.08
34	13.23	1.59	0.90	0.08
35	12.85	1.64	0.88	0.09
36	12.50	1.69	0.85	0.09
37	12.16	1.74	0.83	0.09
38	11.84	1.78	0.81	0.09
39	11.54	1.83	0.78	0.10



Above values are based on maximum fiber stress of 15,000 lbs. per sq. in.; 1/8" rivet holes in both flanges deducted. Weights of girders correspond to lengths center to center of bearings.



BEAM BOX GIRDERS.

SAFE LOADS IN TONS UNIFORMLY DISTRIBUTED.

2-12" I-Beams and 2 Plates 14" x 1/2".

2 Plates 14x1/2				2 Plates 14x1/2			
		12" I-Beams 40.0 lbs. per foot.				12" I-Beams 31.5 lbs. per foot.	
Distance center to center of bearings in feet.	Safe load uniformly distributed (including weight of girder) in tons of 2,000 lbs.	Weight of girder (including rivet heads) in tons of 2,000 lbs.	Increase in safe load for 1/8" increase in thickness of flange plates.	Safe load uniformly distributed (including weight of girder) in tons of 2,000 lbs.	Weight of girder (including rivet heads) in tons of 2,000 lbs.	Increase in safe load for 1/8" increase in thickness of flange plates.	Increase in weight of girder for 1/8" increase in thickness of flange plates.
10	73.33	0.65	4.33	65.97	0.57	4.40	0.03
11	66.67	0.72	3.93	59.98	0.63	3.99	0.03
12	61.11	0.78	3.61	54.98	0.68	3.66	0.03
13	56.40	0.85	3.33	50.75	0.74	3.38	0.04
14	52.37	0.91	3.09	47.12	0.80	3.14	0.04
15	48.89	0.98	2.88	43.98	0.85	2.93	0.04
16	45.83	1.05	2.70	41.23	0.91	2.75	0.05
17	43.13	1.11	2.55	38.80	0.97	2.58	0.05
18	40.73	1.18	2.40	36.65	1.02	2.45	0.05
19	38.60	1.24	2.27	34.72	1.08	2.31	0.05
20	36.67	1.31	2.17	32.99	1.14	2.19	0.06
21	34.92	1.37	2.07	31.42	1.19	2.09	0.06
22	33.33	1.44	1.97	29.99	1.25	2.00	0.06
23	31.88	1.50	1.88	28.68	1.31	1.92	0.07
24	30.55	1.57	1.80	27.48	1.36	1.83	0.07
25	29.33	1.63	1.73	26.39	1.42	1.75	0.07
26	28.20	1.70	1.66	25.37	1.48	1.68	0.08
27	27.16	1.76	1.60	24.44	1.53	1.63	0.08
28	26.19	1.83	1.55	23.56	1.59	1.57	0.08
29	25.28	1.89	1.49	22.75	1.65	1.51	0.08
30	24.44	1.96	1.44	21.99	1.70	1.47	0.09
31	23.65	2.02	1.40	21.28	1.76	1.42	0.09
32	22.92	2.09	1.35	20.62	1.81	1.37	0.09
33	22.22	2.16	1.32	20.00	1.87	1.33	0.10
34	21.57	2.22	1.27	19.41	1.93	1.29	0.10
35	20.95	2.29	1.23	18.85	1.99	1.26	0.10
36	20.37	2.35	1.20	18.32	2.05	1.22	0.10
37	19.82	2.42	1.17	17.83	2.10	1.19	0.11
38	19.29	2.48	1.14	17.37	2.16	1.15	0.11
39	18.81	2.55	1.11	16.92	2.21	1.13	0.11

Above values are based on maximum fiber stress of 15,000 lbs. per sq. in.; 1/8" rivet holes in both flanges deducted. Weights of girders correspond to lengths center to center of bearings.

BEAM BOX GIRDERS.

SAFE LOADS IN TONS UNIFORMLY DISTRIBUTED.

2-15" I-Beams and 2 Plates 14" x 5/8".



15" I-Beams  
80.0 lbs.  
per foot.

2 Plates 14" x 5/8"



15" I-Beams  
60.0 lbs.  
per foot.

2 Plates 14" x 5/8"



15" I-Beams  
42.0 lbs.  
per foot.

2 Plates 14" x 5/8"

	2-15" I-Beams and 2 Plates 14" x 5/8" (6 1/2" flange)			2-15" I-Beams and 2 Plates 14" x 5/8" (6 1/2" flange)			2-15" I-Beams and 2 Plates 14" x 5/8" (6" flange)				
Distance center to center of bearings in feet.	Safe load uniformly distributed (including weight of girder) in tons of 2,000 lbs.	Weight of girder (including rivet heads) in tons of 2,000 lbs.	Increase in safe load for 1/8" increase in thickness of flange plates.	Safe load uniformly distributed (including weight of girder) in tons of 2,000 lbs.	Weight of girder (including rivet heads) in tons of 2,000 lbs.	Increase in safe load for 1/8" increase in thickness of flange plates.	Safe load uniformly distributed (including weight of girder) in tons of 2,000 lbs.	Weight of girder (including rivet heads) in tons of 2,000 lbs.	Increase of safe load for 1/8" increase in thickness of flange plates.	Increase in weight of girder for 1/8" increase in thickness of flange plates.	
10	146.00	1.11	5.17	124.86	0.91	5.33	106.08	0.73	5.47	0.03	
11	132.73	1.22	4.70	113.50	1.00	4.85	96.44	0.81	4.97	0.03	
12	121.66	1.34	4.30	104.05	1.10	4.44	88.41	0.88	4.56	0.03	
13	112.30	1.45	3.98	96.05	1.19	4.10	81.60	0.95	4.21	0.04	
14	104.28	1.56	3.69	89.18	1.28	3.81	75.77	1.03	3.91	0.04	
15	97.34	1.67	3.45	83.24	1.37	3.55	70.73	1.10	3.65	0.04	
16	91.25	1.78	3.23	78.03	1.46	3.33	66.30	1.18	3.43	0.05	
17	85.88	1.89	3.05	73.44	1.55	3.14	62.40	1.25	3.22	0.05	
18	81.12	2.00	2.87	69.37	1.64	2.97	58.94	1.32	3.05	0.05	
19	76.85	2.11	2.72	65.71	1.73	2.80	55.83	1.39	2.88	0.05	
20	73.00	2.23	2.58	62.43	1.83	2.67	53.04	1.47	2.73	0.06	
21	69.52	2.34	2.46	59.46	1.92	2.54	50.52	1.54	2.61	0.06	
22	66.37	2.45	2.35	56.76	2.01	2.42	48.22	1.61	2.49	0.06	
23	63.47	2.56	2.25	54.29	2.10	2.32	46.12	1.68	2.38	0.07	
24	60.83	2.67	2.16	52.03	2.19	2.23	44.20	1.76	2.28	0.07	
25	58.40	2.78	2.07	49.94	2.28	2.13	42.44	1.83	2.19	0.07	
26	56.16	2.89	1.98	48.02	2.37	2.05	40.80	1.90	2.10	0.08	
27	54.07	3.00	1.92	46.25	2.46	1.97	39.29	1.98	2.03	0.08	
28	52.14	3.12	1.85	44.60	2.56	1.90	37.89	2.05	1.95	0.08	
29	50.34	3.23	1.78	43.05	2.65	1.83	36.59	2.12	1.89	0.08	
30	48.67	3.34	1.72	41.62	2.74	1.78	35.37	2.20	1.82	0.09	
31	47.10	3.45	1.67	40.28	2.83	1.72	34.22	2.27	1.77	0.09	
32	45.62	3.56	1.62	39.02	2.92	1.66	33.15	2.34	1.71	0.09	
33	44.24	3.67	1.57	37.83	3.01	1.62	32.15	2.42	1.66	0.10	
34	42.95	3.78	1.52	36.73	3.10	1.57	31.20	2.49	1.62	0.10	
35	41.71	3.89	1.48	35.68	3.19	1.52	30.31	2.56	1.57	0.10	
36	40.56	4.01	1.43	34.68	3.29	1.48	29.47	2.64	1.52	0.10	
37	39.46	4.12	1.40	33.75	3.38	1.44	28.67	2.71	1.48	0.11	
38	38.42	4.23	1.36	32.86	3.47	1.41	27.92	2.78	1.44	0.11	
39	37.43	4.34	1.33	32.02	3.56	1.36	27.20	2.86	1.42	0.11	

Above values are based on maximum fiber stress of 15,000 lbs. per sq. in.; 1/8" rivet holes in both flanges deducted. Weights of girders correspond to lengths center to center of bearings.

BEAM BOX GIRDERS.

SAFE LOADS IN TONS UNIFORMLY DISTRIBUTED.

Distance center to center of bearings in feet.	18" I-Beams 55 lbs. per foot.				20" I-Beams 80 lbs. per foot.			
	Safe load uniformly distributed (including weight of girder) in tons of 2,000 lbs.	Weight of girder (including rivet heads) in tons of 2,000 lbs.	Increase in safe load for $\frac{1}{8}$ " increase in thickness of flange plates.		Safe load uniformly distributed (including weight of girder) in tons of 2,000 lbs.	Weight of girder (including rivet heads) in tons of 2,000 lbs.	Increase in safe load for $\frac{1}{8}$ " increase in thickness of flange plates.	Increase in weight of girder for $\frac{1}{8}$ " increase in thickness of flange plates.
10	194.53	0.98	7.52		231.98	1.22	8.32	0.08
11	176.84	1.08	6.84		210.89	1.35	7.56	0.04
12	162.10	1.18	6.27		193.33	1.47	6.93	0.04
13	149.64	1.27	5.78		178.44	1.59	6.39	0.04
14	138.95	1.37	5.38		165.70	1.71	5.94	0.05
15	129.67	1.47	5.02		154.65	1.83	5.55	0.05
16	121.58	1.57	4.70		144.99	1.96	5.19	0.05
17	114.43	1.66	4.42		136.47	2.08	4.89	0.06
18	108.07	1.76	4.18		128.87	2.20	4.62	0.06
19	102.38	1.86	3.96		122.10	2.32	4.37	0.08
20	97.26	1.96	3.76		116.00	2.45	4.15	0.07
21	92.63	2.06	3.58		110.47	2.57	3.96	0.07
22	88.42	2.15	3.42		105.45	2.69	3.78	0.07
23	84.58	2.25	3.27		100.87	2.81	3.61	0.08
24	81.06	2.35	3.14		96.67	2.94	3.46	0.08
25	77.82	2.45	3.01		92.79	3.06	3.32	0.08
26	74.82	2.55	2.90		89.23	3.18	3.20	0.09
27	72.05	2.64	2.78		85.92	3.30	3.08	0.09
28	69.47	2.74	2.69		82.85	3.42	2.97	0.09
29	67.07	2.84	2.60		80.01	3.55	2.87	0.10
30	64.85	2.94	2.50		77.33	3.67	2.77	0.10
31	62.75	3.03	2.42		74.84	3.79	2.69	0.10
32	60.78	3.13	2.35		72.51	3.91	2.60	0.11
33	58.95	3.23	2.28		70.29	4.04	2.52	0.11
34	57.21	3.33	2.22		68.24	4.16	2.45	0.11
35	55.58	3.43	2.15		66.28	4.28	2.38	0.12
36	54.03	3.52	2.09		64.45	4.40	2.31	0.12
37	52.57	3.62	2.03		62.70	4.53	2.25	0.12
38	51.18	3.72	1.98		61.05	4.65	2.19	0.13
39	49.88	3.82	1.93		59.49	4.77	2.13	0.13

Above values are based on maximum fiber stress of 15,000 lbs. per sq. in.;  $\frac{1}{8}$ " rivet holes in both flanges deducted. Weights of girders correspond to lengths center to center of bearings.

BEAM BOX GIRDERS.

SAFE LOADS IN TONS UNIFORMLY DISTRIBUTED.

2  
Plates  
16x3/4



20"  
I-Beams  
65.0 lbs.  
per foot.

2  
Plates  
18x3/4



24"  
I-Beams  
80.0 lbs.  
per foot.

Distance center to center of bearings in feet.	Safe load uniformly distributed (including weight of girder) in tons of 2,000 lbs.	Weight of girder (including rivet heads) in tons of 2,000 lbs.	Increase in safe load for 1/8" increase in thickness of flange plates.	Increase of weight in girder for 1/8" increase in thickness of flange plates.	Distance center to center of bearings in feet.	Safe load uniformly distributed (including weight of girder) in tons of 2,000 lbs.	Weight of girder (including rivet heads) in tons of 2,000 lbs.	Increase in safe load for 1/8" increase in thickness of flange plates.	Increase in weight of girder for 1/8" increase in thickness of flange plates.
10	205.88	1.07	8.47	0.03	14	211.98	1.78	8.28	0.05
11	187.15	1.18	7.70	0.04	15	197.86	1.91	7.73	0.06
12	171.57	1.29	7.06	0.04	16	185.49	2.04	7.25	0.06
13	158.37	1.39	6.52	0.04	17	174.58	2.17	6.82	0.06
14	147.06	1.50	6.05	0.05	18	164.88	2.29	6.45	0.07
15	137.25	1.61	5.64	0.05	19	156.21	2.42	6.10	0.07
16	128.68	1.72	5.30	0.05	20	148.40	2.55	5.80	0.08
17	121.11	1.82	4.98	0.06	21	141.32	2.68	5.53	0.08
18	114.31	1.93	4.71	0.06	22	134.91	2.80	5.27	0.08
19	108.36	2.04	4.45	0.06	23	129.04	2.93	5.04	0.09
20	102.93	2.15	4.23	0.07	24	123.66	3.06	4.83	0.09
21	98.05	2.25	4.03	0.07	25	118.72	3.19	4.64	0.09
22	93.58	2.36	3.85	0.07	26	114.15	3.31	4.47	0.10
23	89.52	2.47	3.68	0.08	27	109.91	3.44	4.29	0.10
24	85.78	2.58	3.53	0.08	28	105.99	3.57	4.14	0.11
25	82.36	2.68	3.39	0.08	29	102.33	3.69	4.00	0.11
26	79.19	2.79	3.25	0.09	30	98.93	3.82	3.87	0.11
27	76.25	2.90	3.14	0.09	31	95.73	3.95	3.74	0.12
28	73.52	3.00	3.02	0.09	32	92.75	4.08	3.62	0.12
29	71.00	3.11	2.92	0.10	33	89.93	4.20	3.53	0.12
30	68.63	3.22	2.83	0.10	34	87.29	4.33	3.42	0.13
31	66.42	3.33	2.73	0.10	35	84.80	4.46	3.31	0.13
32	64.34	3.43	2.64	0.11	36	82.44	4.59	3.22	0.14
33	62.39	3.54	2.56	0.11	37	80.22	4.71	3.14	0.14
34	60.55	3.65	2.49	0.11	38	78.10	4.84	3.06	0.14
35	58.82	3.76	2.42	0.12	39	76.10	4.97	2.98	0.15
36	57.18	3.86	2.35	0.12	40	74.19	5.10	2.90	0.15
37	55.64	3.97	2.28	0.12	41	72.39	5.22	2.83	0.16
38	54.17	4.08	2.23	0.13	42	70.66	5.35	2.76	0.16
39	52.80	4.18	2.17	0.13	43	69.02	5.48	2.70	0.16
....	.....	.....	.....	.....	44	67.45	5.61	2.64	0.17
....	.....	.....	.....	.....	45	65.95	5.73	2.57	0.17

Above values are based on maximum fiber stress of 15,000 lbs. per sq. in.; rivet holes in both flanges deducted. Weights of girders correspond to lengths center to center of bearings.

EXPLANATION OF TABLES ON RIVETED  
PLATE GIRDERS.

Riveted girders are used where rolled beams are insufficient to carry the load. On page 50 of the lithograph plates will be found illustrations of various forms of riveted girders. The sections with single webs are more economical than those with double webs, but the latter are stiffer laterally and should always be used where great length of span requires a wide top flange. If the girder is not held in position sideways, the proportion of length of span to width of flange should not exceed twenty without making provision for such increase by an addition of metal in the compression flange beyond that required by the table.

The web of the girder must be made of such thickness that there will be no tendency to buckle and that the vertical shearing stress per square inch will not exceed 10,000 pounds. This shearing stress is greatest near the supports and is obtained by dividing half the load upon the girder (provided the load is symmetrically applied) by the web section. The first condition (security against buckling) is attained when this shearing stress

does not exceed  $\frac{12,000}{1 + \frac{d^2}{3,000t^2}}$  in which  $d$  represents the

depth of girder out to out of flange angles and  $t$  the thickness of one web plate in inches. Ordinarily this formula gives a lower stress per square inch than 10,000 pounds, so that both conditions are usually attained when the first is. Instead of increasing the thickness of the web it may be stiffened by means of vertical angles riveted to it at proper intervals. These latter should always be less than the depth of the girder, at least near the ends, but toward the middle of the girder the stiffeners may be placed further apart or entirely omitted. Stiffeners should always be used at or near the supports and at any other point where there is a concentration of heavy loads. The duty of these stiffeners in such cases is twofold; first, to prevent buckling of the web; second, to transmit the shear to the web by means of the abutting areas and the rivets, both of which must be sufficient for the purpose.

The rivets generally should be  $\frac{3}{4}$ " and the spacing in flanges ought not to exceed six inches and should be closer for heavy flanges; but in all cases it should be close at the ends, say three inches for a distance equal to the depth of the girder. Where loads are great especial calculation for rivet spacing should be made.

The unsupported width of flange plates subjected to compression should not exceed 32 times their thickness, nor should the

flange plates extend beyond the outer line of rivets more than five inches, nor more than eight times their thickness.

The term "flange," as applied to the riveted girders, embraces all the metal in top or bottom of girder exclusive of web plate; or, in the case of a rolled beam or channel with top and bottom plates, all the metal exclusive of that part of the web between fillets.

Girders intended to carry plastering should be limited in depth from out to out to  $\frac{1}{80}$  of the span length ( $\frac{5}{8}$ " per foot); otherwise the deflection is liable to cause the plastering to crack.

The following pages, Nos. 163 to 166 inclusive, furnish a ready means of determining the sections of plate or box girders necessary to carry specified loads for spans varying from 20 to 40 feet, center to center of bearings.

The "Safe Loads" are given for the section shown and in columns headed "Increase in Safe Load" is given the increase in safe load for each  $\frac{1}{16}$ " increase in thickness of flange plates. The flange plates may be altered in width and thickness, provided the section remains the same as that required in the table and the conditions in regard to unsupported width be fulfilled.

### EXAMPLE.

A 30' box girder is to carry a load of 80 tons over a clear span of 30 feet. What section of girder is required? The span from center to center of bearings we will assume to be 31 feet.

In the table, page 165, the safe load for this span and for the girder shown is found to be 72.65 tons including weight of girder, which latter, according to the table, may be assumed at about 3.5 tons. The total load to be carried is, therefore, 83.5 tons. The increase in safe load for  $\frac{1}{16}$ " increase in thickness of flange plate given in the table is 4.27 tons. The thickness of the flange plate is then obtained as follows: 83.5 tons—72.65 tons=10.85 tons. This  $\div$  4.27 tons is very nearly 3. Each flange plate, therefore, must be increased by  $\frac{3}{16}$ ", making a total thickness of flange plate of  $\frac{9}{16}$ ".

The section of the girder is then composed of two 30'  $\times$   $\frac{1}{2}$ " web plates, two 16'  $\times$   $\frac{9}{16}$ " flange plates (which could be made 18'  $\times$   $\frac{1}{2}$ " or 20'  $\times$   $\frac{7}{16}$ ", etc.—see previous note) and four 3 $\frac{1}{2}$ "  $\times$  3 $\frac{1}{2}$ "  $\times$   $\frac{1}{2}$ " flange angles. The shear in one web is  $\frac{83.5 \times 2,000}{2 \times 2 \times 30 \times \frac{1}{2}}$  or 2,785 pounds per square inch which is also safe

against buckling, since it is less than  $\frac{12,000}{1 + \frac{d^2}{3,000t^2}}$  which, in this case, is 5,454 pounds.

PLATE GIRDERS.

SAFE LOADS IN TONS UNIFORMLY DISTRIBUTED.

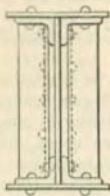
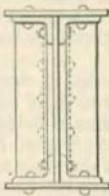
Distance Center to Center of Bearings in Feet.								
	Safe Load including weight of girder.	Weight of girder.	Increase in safe load for $\frac{1}{16}$ " increase in thickness of flange plates.	Increase in weight of girder for $\frac{1}{16}$ " increase in thickness of flange plates.	Safe Load including weight of girder.	Weight of girder.	Increase in safe load for $\frac{1}{16}$ " increase in thickness of flange plates.	Increase in weight of girder for $\frac{1}{16}$ " increase in thickness of flange plates.
20	93.67	1.62	4.62	.05	105.82	1.70	5.08	.05
21	89.22	1.69	4.38	.05	100.78	1.77	4.85	.05
22	85.15	1.76	4.19	.06	96.20	1.84	4.62	.06
23	81.46	1.86	4.00	.06	92.01	1.95	4.42	.06
24	78.07	1.93	3.83	.06	88.18	2.02	4.23	.06
25	74.94	2.01	3.68	.06	84.65	2.09	4.06	.06
26	72.06	2.07	3.54	.07	81.39	2.17	3.91	.07
27	69.40	2.14	3.42	.07	78.38	2.24	3.76	.07
28	66.91	2.21	3.29	.07	75.58	2.31	3.63	.07
29	64.60	2.31	3.17	.07	72.98	2.42	3.50	.07
30	62.45	2.38	3.07	.08	70.55	2.49	3.39	.08
31	60.44	2.45	2.97	.08	68.26	2.56	3.29	.08
32	58.55	2.52	2.88	.08	66.14	2.64	3.17	.08
33	56.77	2.59	2.79	.08	64.13	2.71	3.08	.08
34	55.11	2.66	2.70	.09	62.24	2.78	2.99	.09
35	53.53	2.73	2.63	.09	60.46	2.85	2.91	.09
36	52.04	2.83	2.56	.09	58.79	2.96	2.83	.09
37	50.63	2.90	2.49	.09	57.20	3.03	2.75	.09
38	49.30	2.97	2.42	.10	55.70	3.11	2.67	.10
39	48.03	3.04	2.37	.10	54.27	3.18	2.60	.10
40	46.83	3.11	2.31	.10	52.90	3.25	2.55	.10

The above values are founded on the moments of inertia of the sections using a maximum fiber stress of 15,000 lbs. per square inch;  $\frac{13}{16}$ " rivet holes in both flanges deducted. Weights of girders correspond to lengths center to center of bearings and include rivet heads, stiffeners and fillers.

PLATE GIRDERS.

SAFE LOADS IN TONS UNIFORMLY DISTRIBUTED.

Distance Center to Center of Bearings  
In Feet.

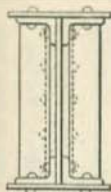

36" x 3/2" Web Plate.  
12" x 3/8" Flange Plates.  
5" x 3 1/2" x 1/2" Angles.

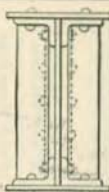

42" x 5/8" Web Plate.  
14" x 3/8" Flange Plates.  
6" x 8" x 5/8" Angles.

Distance Center to Center of Bearings In Feet.	Girder with 36" x 3/2" Web Plate and 12" x 3/8" Flange Plates				Girder with 42" x 5/8" Web Plate and 14" x 3/8" Flange Plates			
	Safe Load including weight of girder.	Weight of girder.	Increase in safe load for 1/8" increase in thickness of flange plates.	Increase in weight of girder for 1/8" increase in thickness of flange plates.	Safe Load including weight of girder.	Weight of girder.	Increase in safe load for 1/8" increase in thickness of flange plates.	Increase in weight of girder for 1/8" increase in thickness of flange plates.
20	118.35	1.77	5.54	.05	176.01	2.72	7.74	.06
21	112.70	1.85	5.28	.05	167.63	2.84	7.37	.06
22	107.57	1.92	5.04	.06	160.02	2.95	7.03	.07
23	102.90	2.04	4.82	.06	153.06	3.12	6.73	.07
24	98.61	2.17	4.63	.06	146.68	3.24	6.44	.07
25	94.66	2.19	4.44	.06	140.82	3.36	6.18	.07
26	91.02	2.26	4.27	.07	135.39	3.48	5.95	.08
27	87.65	2.34	4.11	.07	130.38	3.59	5.73	.08
28	84.53	2.41	3.96	.07	125.73	3.71	5.52	.08
29	81.61	2.53	3.82	.07	121.38	3.88	5.34	.09
30	78.89	2.60	3.70	.08	117.35	4.00	5.17	.09
31	76.34	2.68	3.58	.08	113.56	4.12	4.98	.09
32	73.96	2.75	3.46	.08	110.01	4.23	4.85	.10
33	71.72	2.82	3.36	.08	106.67	4.35	4.70	.10
34	69.61	2.89	3.27	.09	103.55	4.47	4.55	.10
35	67.62	2.98	3.17	.09	100.58	4.59	4.42	.10
36	65.75	3.09	3.07	.09	97.78	4.76	4.30	.11
37	63.97	3.16	2.99	.09	95.15	4.87	4.18	.11
38	62.28	3.24	2.91	.10	92.64	4.99	4.07	.11
39	60.69	3.31	2.85	.10	90.27	5.11	3.97	.12
40	59.14	3.39	2.77	.10	88.00	5.23	3.87	.12

The above values are founded on the moments of inertia of the sections using a maximum fiber stress of 15,000 lbs. per square inch ; 1/4" rivet holes in both flanges deducted. Weights of girders correspond to lengths center to center of bearings and include rivet heads, stiffeners and fillers.



BOX GIRDERS.

SAFE LOADS IN TONS UNIFORMLY DISTRIBUTED.

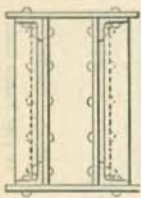
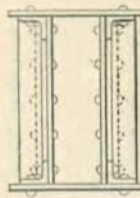
Distance Center to Center of Bearings in Feet.								
	Safe Load including weight of girder.	Weight of girder.	Increase in safe load for 1/8 inch increase in thickness of flange plates.	Increase in weight of girder for 1/8 inch increase in thickness of flange plates.	Safe Load including weight of girder.	Weight of girder.	Increase in safe load for 1/8 inch increase in thickness of flange plates.	Increase in weight of girder for 1/8 inch increase in thickness of flange plates.
20	112.60	2.13	6.61	.07	150.2	2.44	9.17	.09
21	107.24	2.23	6.30	.07	143.1	2.55	8.75	.09
22	102.37	2.32	6.00	.08	136.5	2.66	8.33	.09
23	97.92	2.45	5.75	.08	130.6	2.80	7.96	.10
24	93.83	2.54	5.52	.08	125.2	2.91	7.64	.10
25	90.08	2.64	5.30	.09	120.1	3.03	7.33	.11
26	86.62	2.74	5.09	.09	115.5	3.14	7.06	.11
27	83.41	2.83	4.90	.09	111.2	3.25	6.80	.12
28	80.42	2.93	4.73	.10	107.3	3.36	6.54	.12
29	77.65	3.06	4.57	.10	103.6	3.50	6.32	.12
30	75.07	3.16	4.41	.10	100.2	3.61	6.10	.13
31	72.65	3.25	4.27	.11	96.9	3.72	5.92	.13
32	70.38	3.35	4.13	.11	93.9	3.83	5.73	.14
33	68.24	3.50	4.02	.11	91.0	3.95	5.56	.14
34	66.23	3.54	3.90	.12	88.4	4.06	5.39	.14
35	64.34	3.64	3.78	.12	85.8	4.17	5.23	.15
36	62.56	3.76	3.67	.12	83.4	4.31	5.09	.15
37	60.87	3.86	3.57	.13	81.2	4.41	4.96	.16
38	59.26	3.95	3.48	.13	79.0	4.53	4.82	.16
39	57.74	4.05	3.39	.13	77.0	4.65	4.70	.17
40	56.31	4.15	3.30	.14	75.1	4.76	4.58	.17

The above values are founded on the moments of inertia of the sections using a maximum fiber stress of 15,000 lbs. per square inch; 1 1/8 inch rivet holes in both flanges deducted. Weights of girders correspond to lengths center to center of bearings and include rivet heads, stiffeners and fillers.

BOX GIRDERS.

SAFE LOADS IN TONS UNIFORMLY DISTRIBUTED.

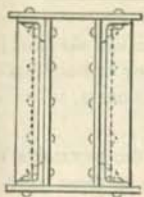
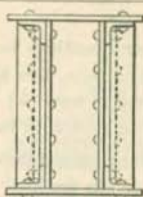
Distance Center to Center of Bearings in Feet.	 <p>36" x 1/2" Web Plates, 24" x 1/2" Flange Plates, 4" x 3 1/2" x 1/2" Angles.</p>				 <p>42" x 1/2" Web Plates, 30" x 1/2" Flange Plates, 5" x 3 1/2" x 1/2" Angles.</p>			
	Safe Load including weight of girder.	Weight of girder.	Increase in safe load for 1/8" increase in thickness of flange plates.	Increase in weight of girder for 1/8" increase in thickness of flange plates.	Safe Load including weight of girder.	Weight of girder.	Increase in safe load for 1/8" increase in thickness of flange plates.	Increase in weight of girder for 1/8" increase in thickness of flange plates.
20	213.3	2.92	12.22	.10	329.2	3.74	18.29	.13
21	203.3	3.06	11.65	.11	313.5	3.91	17.41	.13
22	194.1	3.19	11.12	.11	299.2	4.09	16.63	.14
23	185.5	3.36	10.64	.12	286.2	4.30	15.90	.15
24	177.9	3.49	10.20	.12	274.3	4.48	15.24	.15
25	170.8	3.63	9.78	.13	263.3	4.65	14.63	.16
26	164.3	3.76	9.44	.13	253.2	4.83	14.07	.17
27	158.1	3.89	9.06	.14	243.8	5.00	13.55	.17
28	152.4	4.03	8.73	.14	235.2	5.17	13.06	.18
29	147.2	4.15	8.43	.15	227.0	5.39	12.61	.19
30	142.3	4.33	8.15	.15	219.5	5.57	12.18	.19
31	137.7	4.45	7.88	.16	212.3	5.74	11.79	.20
32	133.4	4.60	7.65	.16	205.7	5.91	11.42	.20
33	129.3	4.74	7.42	.17	199.5	6.08	10.08	.21
34	125.5	4.87	7.20	.17	193.6	6.25	10.75	.22
35	122.0	5.00	6.99	.18	188.1	6.43	10.45	.22
36	118.6	5.17	6.81	.18	182.9	6.65	10.15	.23
37	115.4	5.31	6.62	.19	177.9	6.82	9.89	.24
38	112.4	5.44	6.44	.19	173.2	6.90	9.62	.24
39	109.5	5.58	6.28	.20	168.8	7.16	9.38	.25
40	106.7	5.71	6.12	.20	164.5	7.34	9.14	.26

The above values are founded on the moments of inertia of the sections using a maximum fiber stress of 15,000 lbs. per square inch; 1/4" rivet holes in both flanges deducted. Weights of girders correspond to lengths center to center of bearings and include rivet heads, stiffeners and fillers.

## I-BEAMS AS USED IN FOUNDATIONS. METHOD OF CALCULATION.

The known quantities in this calculation are the load (L) on the column in tons, the allowable bearing capacity per square foot of ground in tons (b) and the projections p, p', p'' in feet for the various tiers of beams.

Figure the separate areas covered by the successive tiers of beams and divide the load on the column by these areas. The quotients will give their respective pressures b, b', b'' per square foot. Assume any spacing in inches, generally greatest for the lowest tier of beams and about 9'' for the top course.

Find the corresponding figure for such spacing and pressure in the table and multiply it by the corresponding projection. This product will give the modulus M.

In the table of moduli find the beam corresponding to this product.

For any other spacing or pressure than those given find M from the formula  $M = p \sqrt{\frac{sb}{12}}$ .

### EXAMPLE.

Let L=588 tons. } Assume p=3'-6'', p'=5'-3'', p''=1'-9''.  
Let b= 3 tons. } Then b'=6 tons and b''=24 tons.

Use 15'' spacing for lowest tier of beams.

“ 12'' “ “ 2d “ “ “

“ 9'' “ “ 3d “ “ “

Now using the above method of calculation we have for the respective tiers :

$3.5 \times 1.937 = 6.78 =$  Modulus corresponding to 12'' 31.5 lb. beam.

$5.25 \times 2.450 = 12.86 =$  Modulus corresponding to 20'' 75 lb. beam.

$1.75 \times 4.243 = 7.43 =$  Modulus corresponding to 12'' 40 lb. beam

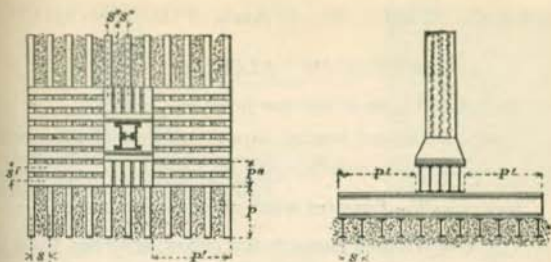

TABLES GIVING THE SIZE AND WEIGHT OF BEAMS FOR s-9-12-15-18-24 INCHES, b-1 TO 50 TONS PER SQUARE FOOT AND p-VARIABLE IN FEET.

Depth of beam in inches.	Weight per foot.	Moduli.	Depth of beam in inches.	Weight per foot.	Moduli.	Tons per square foot.	SPACING OF I-BEAMS.				
							9"	12"	15"	18"	24"
24	100	16.263	12	50.00	8.210	1	0.866	1.000	1.118	1.225	1.414
24	90	15.772	12	40.00	7.730	2	1.225	1.414	1.581	1.732	2.000
24	80	15.231	12	35.00	7.122	3	1.500	1.732	1.937	2.121	2.450
20	100	14.858	12	31.50	6.925	5	1.732	2.000	2.236	2.450	2.829
20	90	14.412	10	40.00	6.505	7	1.936	2.236	2.500	2.738	3.162
20	80	13.983	10	30.00	5.982	8	2.121	2.450	2.739	3.000	3.464
20	75	13.007	10	25.00	5.706	9	2.291	2.646	2.958	3.240	3.742
20	65	12.488	9	35.00	5.755	10	2.450	2.828	3.162	3.463	4.000
18	70	11.683	9	25.00	5.220	11	2.598	3.000	3.354	3.674	4.243
18	60	11.168	9	21.00	5.016	12	2.738	3.162	3.536	3.872	4.472
18	55	10.857	8	25.50	4.776	13	2.872	3.317	3.708	4.061	4.690
15	100	12.653	8	20.50	4.494	14	3.000	3.464	3.873	4.242	4.899
15	90	12.259	8	18.00	4.354	15	3.122	3.606	4.031	4.415	5.099
15	80	11.892	7	20.00	4.009	16	3.240	3.743	4.184	4.582	5.292
15	75	11.085	7	15.00	3.715	17	3.354	3.873	4.331	4.743	5.477
15	70	10.862	6	17.25	3.412	18	3.464	4.000	4.472	4.898	5.657
15	60	10.405	6	12.25	3.112	19	3.571	4.123	4.610	5.050	5.831
15	55	9.532	5	14.75	2.842	20	3.674	4.243	4.744	5.196	6.000
15	50	9.270	5	9.75	2.539	21	3.775	4.359	4.874	5.338	6.164
15	42	8.861	4	10.50	2.182	22	3.873	4.472	5.000	5.477	6.325
12	55	8.445	4	7.50	1.994	23	3.969	4.583	5.124	5.612	6.481
						24	4.062	4.690	5.244	5.744	6.633
						25	4.153	4.796	5.362	5.873	6.783
						26	4.243	4.899	5.477	6.000	6.928
						27	4.330	5.000	5.591	6.123	7.071
						28	4.415	5.100	5.707	6.245	7.215
						29	4.500	5.200	5.825	6.367	7.359
						30	4.583	5.300	5.943	6.489	7.503
						31	4.667	5.400	6.061	6.611	7.647
						32	4.750	5.500	6.179	6.733	7.791
						33	4.833	5.600	6.297	6.855	7.935
						34	4.917	5.700	6.415	6.977	8.079
						35	5.000	5.800	6.533	7.099	8.223
						36	5.083	5.900	6.651	7.221	8.367
						37	5.167	6.000	6.769	7.343	8.511
						38	5.250	6.100	6.887	7.465	8.655
						39	5.333	6.200	7.005	7.587	8.799
						40	5.417	6.300	7.123	7.709	8.943
						41	5.500	6.400	7.241	7.831	9.087
						42	5.583	6.500	7.359	7.953	9.231
						43	5.667	6.600	7.477	8.075	9.375
						44	5.750	6.700	7.595	8.197	9.519
						45	5.833	6.800	7.713	8.319	9.663
						46	5.917	6.900	7.831	8.441	9.807
						47	6.000	7.000	7.949	8.563	9.951
						48	6.083	7.100	8.067	8.685	10.095
						49	6.167	7.200	8.185	8.807	10.239
						50	6.250	7.300	8.303	8.929	10.383

## I-BEAMS USED IN WALL FOUNDATIONS.

## METHOD OF CALCULATION.

Let  $L$  = Weight of wall per lineal foot in tons

and  $b$  = Assumed bearing capacity of ground per square foot (usually from 1 to 3 tons);

then  $\frac{L}{b} = W$  = Required width of foundation in feet.

$w$  = Width of lowest course of footing-stones.

$p$  = Projection of beams beyond masonry in feet.

$s$  = Spacing of beams center to center in feet.

Evidently the size of beams required will depend upon their strength as cantilevers of a length " $p$ " sustaining the upward reaction, which may be regarded as a uniformly distributed load.

Thus  $p b$  = uniformly distributed load (in tons) on cantilevers per lineal foot of wall

and  $p b s$  = uniform load in tons on each beam.

The table on the following page gives the safe lengths " $p$ " for the various sizes and weights of beams for  $s=1$  foot and " $b$ " ranging from 1 to 5 tons per square foot. For other values of " $s$ ", say 15" or 1 $\frac{1}{4}$ ", the table may be used by simply considering " $b$ " increased in the same ratio as " $s$ " (see example below). As regards the weight of beams, it is advantageous to assign to " $s$ " as great a value as is warranted by the other considerations which obtain.

## EXAMPLE.

The weight of a brick wall together with the load it must support is 40 tons per lineal foot. The width of the lowest footing-course of masonry is 6 feet. Allowing a pressure of 2 tons per square foot on the foundation, what size and length of I-Beams 18" center to center will be required?

*Answer:*  $L=40$ ,  $b=2$ ,  $w=6$ ,  $s=1\frac{1}{2}$ .

Therefore  $W=40 \div 2=20$  feet, the required length of beams. The projection " $p$ " =  $\frac{1}{2} (20-6)=7$  feet.

In order to apply the table (calculated for  $s=1'$ ) we must consider " $b$ " increased in the same ratio as " $s$ ," *i. e.*,  $b=2 \times 1\frac{1}{2}=3$  tons.

In the column for 3 tons we find the length 7 feet to agree with 20" I-Beams 65 0 lbs. per foot.

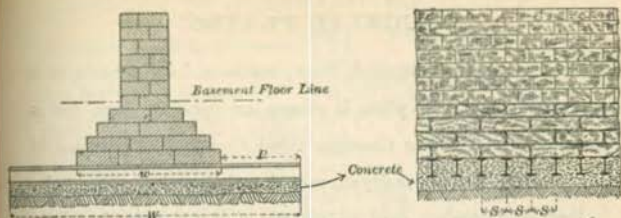

TABLE GIVING SAFE LENGTHS OF PROJECTIONS "p" IN FEET (SEE ILLUSTRATION) FOR "s"—1 FOOT AND VALUES OF "b" RANGING FROM 1 TO 5 TONS.

Depth of beam in inches.	Weight per foot.	b (TONS PER SQUARE FOOT).										
		1	1¼	1½	2	2¼	2½	3	3¾	4	4½	5
24	80.00	15.231	13.61	12.43	10.77	10.16	9.63	8.79	8.14	7.62	7.18	6.81
20	80.00	13.983	12.50	11.41	9.89	9.32	8.84	8.07	7.47	6.99	6.59	6.25
20	65.00	12.488	11.16	10.20	8.82	8.33	7.90	7.21	6.68	6.24	5.89	5.58
18	55.00	10.857	9.71	8.86	7.68	7.23	6.87	6.27	5.80	5.43	5.12	4.86
15	80.00	11.892	10.63	9.71	8.41	7.93	7.52	6.86	6.36	5.95	5.61	5.32
15	60.00	10.405	9.30	8.49	7.36	6.94	6.58	6.01	5.56	5.20	4.90	4.65
15	42.00	8.861	7.92	7.23	6.27	5.91	5.60	5.12	4.74	4.43	4.18	3.96
12	40.00	7.730	6.91	6.31	5.47	5.15	4.89	4.46	4.13	3.87	3.64	3.46
12	31.50	6.925	6.19	5.65	4.90	4.55	4.33	4.00	3.70	3.46	3.26	3.10
10	25.00	5.706	5.10	4.66	4.03	3.80	3.61	3.29	3.05	2.85	2.69	2.55
9	21.00	5.016	4.48	4.09	3.55	3.34	3.17	2.90	2.68	2.51	2.36	2.24
8	18.00	4.354	3.89	3.55	3.08	2.90	2.75	2.51	2.33	2.18	2.05	1.95
7	15.00	3.715	3.32	3.03	2.63	2.48	2.35	2.14	1.98	1.86	1.75	1.66
6	12.25	3.112	2.78	2.54	2.20	2.07	1.97	1.80	1.66	1.56	1.47	1.39
5	9.75	2.589	2.27	2.07	1.80	1.69	1.61	1.47	1.36	1.27	1.20	1.14
4	7.50	1.994	1.78	1.63	1.41	1.33	1.26	1.15	1.07	1.00	0.94	0.89

The size of beam for any other pressure is found by multiplying the projection by the square root of the assumed pressure and finding the beam having a projection corresponding to this product under the one ton column.

## BUCKLED PLATES.

A new form of Buckled Plate, made in long lengths with several buckles to the plate, is shown on opposite page and is manufactured by The Carnegie Steel Company, Limited. In this form the plate is usually supported at the two long edges only.

Buckled plates are used for the floors of fire-proof buildings and bridges. They are usually covered with concrete or asphalt and stone paving, etc. They are generally made in length and width from 3' to 4'-6'' and in thicknesses of  $\frac{1}{4}$ '' to  $\frac{3}{8}$ ''; they are very strong, as indicated by the following table. In order to allow for some deterioration by corrosion they are, however, rarely made thinner than  $\frac{1}{4}$ '', while  $\frac{5}{16}$ '' is a usual thickness for bridge floors.

There has not yet been a reliable formula devised from which the strength of buckled plates can be figured, but from experiments on plates 3'-0'' square, arched 2'' and well bolted down on all sides, the following table of quiescent safe loads uniformly distributed has been deduced.

Thickness.	Approximate Weight of one plate. Lbs.	Safe Load (one-fourth of ultimate load). Lbs.	Per square foot. Lbs.
$\frac{1}{4}$ ''	93.0	10080	1120
$\frac{5}{16}$ ''	116.5	13888	1544
$\frac{3}{8}$ ''	139.5	20160	2240

The resistance of buckled plates bolted or riveted down all around is double the resistance of the same plate merely supported all around and if the two opposite sides are unsupported, the resistance is reduced in the proportion of 8 to 5.

DIMENSIONS OF STANDARD BUCKLED PLATES.

No. of Plates.	Size of Buckle.		Rise "1" of Buckle.	Radii of Buckle—R.		Number of Buckles in one Plate.	Widths of Flanges and Fillets.			No. of con'tn holes per buckle.	
	Side L.	Side W.		For L.	For W.		End Flgs. 11 and 13.	Fillets 12.	Side Flgs. W1 & W2	For L.	For W.
1	3'-11"	4'-6"	3 1/2	6'-8 1/2"	8'-9 1/2"	1 to 7				8	9
2	4'-6"	3'-11"	3 1/2	8'-9 1/2"	6'-8 1/2"	1 to 6				9	8
3	3'-11"	3'-6"	3 3/8	7'-9 1/2"	6'-3"	1 to 7				8	7
4	3'-6"	3'-11"	3 3/8	6'-3"	7'-9 1/2"	1 to 8				7	8
5	3'-9"	3'-9"	3 3/8	7'-17 1/2"	7'-17 1/2"	1 to 8				8	8
6	3'-1"	3'-9"	3 3/8	4'-10 3/8"	7'-17 1/2"	1 to 9				7	8
7	3'-9"	3'-1"	3 3/8	7'-17 1/2"	4'-10 3/8"	1 to 8				8	7
8	3'-8"	3'-8"	2 1/2	10'-2"	10'-2"	1 to 8				8	8
9	2'-8"	3'-8"	2 1/2	5'-5"	10'-2"	1 to 10				8	8
10	3'-8"	2'-8"	2 1/2	10'-2"	5'-5"	1 to 8				8	8
11	2'-2"	3'-8"	2 1/2	3'-7 1/4"	10'-2"	1 to 10				5	5
12	3'-8"	2'-2"	2 1/2	10'-2"	3'-7 1/4"	1 to 8				8	8
13	3'-0"	3'-0"	2 1/2	8'-10"	6'-10 3/4"	1 to 9				6	6
14	2'-9"	2'-9"	2 1/2	3'-10 7/8"	3'-10 7/8"	1 to 10				6	6
15	2'-6"	2'-9"	2 1/2	3'-10 7/8"	4'-7 1/2"	1 to 10				5	5
16	2'-9"	2'-6"	2 1/2	4'-7 1/2"	3'-10 1/4"	1 to 10				5	5
17	2'-6"	2'-6"	2 1/2	3'-10 1/4"	3'-10 1/4"	1 to 10				5	5
18	3'-5"	3'-8"	3 1/2	5'-11 1/2"	6'-3 3/4"	1 to 8				7	7
19	3'-6"	3'-5"	3 3/8	6'-3 3/8"	5'-11 1/8"	1 to 8				7	7
20	3'-6"	3'-9"	3 3/8	6'-3 3/8"	7'-17 1/2"	1 to 8				7	8
21	3'-9"	3'-6"	3 3/8	7'-17 1/2"	6'-3 3/8"	1 to 8				8	7
22	3'-2"	3'-1"	3 3/8	5'-13 1/2"	4'-10 5/8"	1 to 9				7	7
23	3'-1"	3'-2"	3 3/8	4'-10 5/8"	5'-13 1/2"	1 to 9				7	7
24	3'-0"	3'-1"	3 3/8	4'-7 1/2"	4'-10 5/8"	1 to 9				6	7
25	3'-1"	3'-0"	3 3/8	4'-10 5/8"	4'-7 1/2"	1 to 9				7	6
26	2'-0"	2'-0"	2 1/2	3'-10 1/2"	2'-6 1/2"	1 to 10				5	4
27	2'-0"	2'-6"	2 1/2	2'-6 1/2"	3'-10 1/2"	1 to 15				4	5
28	5'-6"	3'-6"	3 1/2	13'-1 1/2"	5'-4 3/4"	1 to 5				11	7
29	3'-6"	5'-6"	3 1/2	5'-4 3/4"	13'-1 1/2"	1 only.				7	11
30	4'-0"	4'-0"	3 1/2	8'-1 1/2"	8'-1 1/2"	1 to 7				8	8

Letters L, 11, 12 and 13 refer to dimensions in length of plate.  
 Letters W, W1 and W2 refer to dimensions in width of plate.  
 The line between buckle and flange or fillet is not sharply defined on plates.  
 Plates are made of steel and may be either 1/4, 3/8 or 5/8 inch thick.  
 If plates of greater length than given in the table are required, they may be made by splicing with bars, angles or tees.  
 Connection holes are made either for 5/8" or 3/4" diameter bolts or rivets, but all holes in plate must be same size, as holes of different diameters in the same plate will increase the cost of the plate.  
 Buckles of different lengths (L) and widths (W) may be used in the same plate, but that will increase the cost of the plate.  
 Buckles of other dimensions than given in this table may be made, but the making of new dies will be at an additional cost.

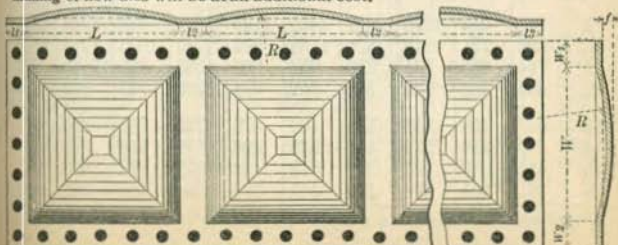



## TROUGH-PLATE FLOORING.

The trough and corrugated plate sections shown on page 28 are used for floors of bridges and fire proof buildings, as shown Fig. 6, page 51.

The following tables give weights per lineal foot of each rolled section and per square foot of floor surface for thicknesses varying by  $\frac{1}{8}$  inch; also the section modulus for one foot in width and the safe loads per square foot for spans of different lengths using fiber stresses of 12,000 and 10,000 lbs.

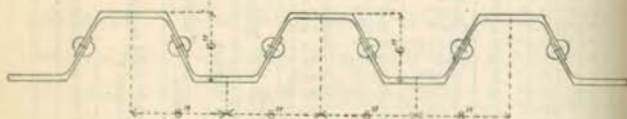

### PROPERTIES OF TROUGH SECTION.

Section index . . . . .	M10	M11	M12	M13	M14
Thickness of base . . . . .	$\frac{1}{2}$	$\frac{3}{8}$	$\frac{5}{8}$	$\frac{11}{8}$	$\frac{3}{4}$
Weight per lineal foot . . . . .	16.3	18.0	19.7	21.4	23.2
Weight per square foot . . . . .	25.00	28.15	31.31	34.48	37.74
Section Modulus for 1' in width . . . . .	11.56	13.06	14.57	16.12	17.67

### SAFE LOADS IN POUNDS PER SQUARE FOOT OF FLOOR FOR SPANS OF DIFFERENT LENGTHS.

Span in feet.	M10		M11		M12		M13		M14	
	12,000 lbs.	10,000 lbs.	12,000 lbs.	10,000 lbs.	12,000 lbs.	10,000 lbs.	12,000 lbs.	10,000 lbs.	12,000 lbs.	10,000 lbs.
5	3699	3083	4179	3483	4662	3885	5158	4298	5654	4712
6	2569	2141	2902	2418	3238	2698	3582	2985	3927	3272
7	1887	1573	2132	1777	2379	1983	2632	2193	2885	2404
8	1445	1204	1633	1361	1821	1517	2015	1679	2209	1841
9	1142	952	1290	1075	1439	1199	1592	1327	1745	1454
10	925	771	1045	871	1166	972	1290	1075	1414	1178
11	764	637	864	720	963	803	1066	888	1168	973
12	642	535	726	605	809	674	896	747	982	818
13	547	456	618	515	690	575	763	636	836	697
14	472	393	533	444	595	496	658	548	721	601
15	411	343	464	387	518	432	573	478	628	523
16	361	301	408	340	455	379	504	420	552	460

Safe loads given include weight of section.

CORRUGATED PLATE FLOORING.

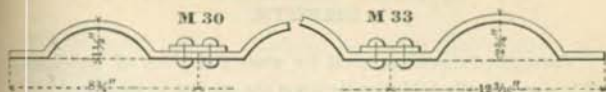

PROPERTIES OF CORRUGATED PLATE.

Section index . . . . .	M30	M31	M32	M33	M34	M35
Thickness of metal . . .	$\frac{1}{4}$	$\frac{5}{16}$	$\frac{3}{8}$	$\frac{3}{8}$	$\frac{7}{16}$	$\frac{1}{2}$
Weight per lineal foot . .	8.1	10.1	12.0	17.75	20.71	23.67
Weight per square foot	11.05	13.78	16.50	17.47	20.39	23.30
Section Modulus for 1' in width . . . . .	1.10	1.55	1.95	3.28	3.84	4.39

SAFE LOADS IN LBS. PER SQUARE FOOT OF FLOOR.

Span in Feet.	M30		M31		M32	
	12,000 lbs.	10,000 lbs.	12,000 lbs.	10,000 lbs.	12,000 lbs.	10,000 lbs.
5	352	293	496	413	624	520
6	244	203	345	287	433	361
7	180	150	253	211	318	265
8	138	115	194	162	244	203
9	109	91	153	128	193	161
10	88	73	124	103	156	130
11	73	61	103	86	129	108
12	61	51	86	72	108	90
13	52	43	73	61	92	77
14	45	38	63	53	80	67
15	39	33	55	46	69	58
16	35	29	49	41	61	51

Span in Feet.	M33		M34		M35	
	12,000 lbs.	10,000 lbs.	12,000 lbs.	10,000 lbs.	12,000 lbs.	10,000 lbs.
5	1049	874	1228	1023	1404	1170
6	728	607	853	711	975	813
7	535	446	627	523	717	598
8	410	342	480	400	549	458
9	324	270	379	316	433	361
10	262	218	307	256	351	293
11	217	181	254	212	290	242
12	182	152	213	178	244	203
13	155	129	182	152	208	173
14	134	112	157	131	179	149
15	117	98	136	113	156	130
16	103	86	120	100	137	114

Safe loads given include weight of section.

Weight per square foot given does not include weight of splice plate.

CORRUGATED AND GALVANIZED  
SHEETS.

Corrugated sheets are used for roofs and sides of buildings. They are usually laid directly upon the purlins in roofs and held in place by means of clips of hoop iron, which encircle the purlin and are placed in distances of about twelve inches apart. Special care must be taken that the projecting edges of the corrugated sheets at the eaves and gable ends of the roof are well secured, otherwise the wind will loosen the sheets and fold them up.

The corrugations are made of various sizes; the smaller present a more pleasing appearance to the eye, while the larger are stiffer and will span a greater distance, thereby permitting the purlins to be placed further apart. The sizes of sheets generally used for both roofing and siding are Nos. 20 and 22, B. W. G.

By one corrugation is meant the double curve between corresponding points, and by depth of corrugation the greatest deviation from the straight line measured between the concave surfaces of the corrugated sheet.

The corrugations are 2.425'' long measured on the straight line; they require a length of sheet of 2.725'' to make one corrugation and the depth of corrugation is  $\frac{3}{8}\frac{1}{2}$ '' . One corrugation is allowed for lap in the width of the sheet and 6'' in the length for the usual pitch of roof of two to one. Sheets can be corrugated of any length not exceeding ten feet. The most advantageous width is  $30\frac{1}{2}$ '' which (allowing  $\frac{1}{2}$ '' for irregularities) will make eleven corrugations= $30$ '', or making allowance for laps will cover  $24\frac{1}{4}$ '' of the surface of the roof.

By actual trial it is found that corrugated sheet No. 20 spanning 6 feet will begin to give a permanent deflection for a load of 30 lbs. per square foot, and that it will collapse with a load of 60 lbs. per square foot. The distance between centers of purlins should therefore not exceed 6 feet and preferably be less than this.

CORRUGATED SHEETS.

The following table is calculated for sheets 30½" wide before corrugating.

No. by Birmingham Gauge.	Thickness. Inch.	Weight per square foot Flat. Lbs.	Weight per square foot Corrugated. Lbs.	Weight per Square of 100 square feet when laid, allowing 6" lap in length and 2½" or one corrugation in width of sheet for sheet length of:						Weight per square foot Flat, Galvanized. Lbs.
				5'	6'	7'	8'	9'	10'	
16	.065	2.61	3.28	365	358	353	350	348	346	2.95
18	.049	1.97	2.48	275	270	267	264	262	261	2.31
20	.035	1.40	1.76	196	192	190	188	186	185	1.74
22	.028	1.12	1.41	156	154	152	150	149	148	1.46
24	.022	.88	1.11	123	121	119	118	117	117	1.22
26	.018	.72	.91	101	99	97	97	96	95	1.06

NOTE.—For weights per square laid with one and one-half lap add to above 5 per cent. For weights per square laid with two laps add to above 10 per cent.

TRANSVERSE STRENGTH.

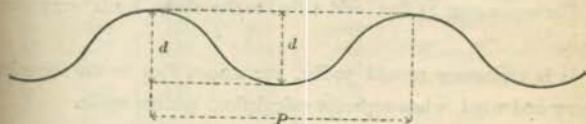

l=Unsupported length of sheet in inches.

t=Thickness of sheet in inches.

b=Width of sheet in inches.

d=Depth of corrugations in inches.

W=Breaking weight distributed in tons.

w= " " " " pounds.

$$W = \frac{49.95 \text{ t. b. d.}}{l}$$

$$w = \frac{99900 \text{ t. b. d.}}{l}$$

NOTES ON ROOFS AND LOADS FOR SAME.

Angles of roofs as commonly used.

Proportion of rise to span.	Angle.		Length of rafter to rise.	Proportion of rise to span.	Angle.		Length of rafter to rise.
	Deg.	Min.			Deg.	Min.	
$\frac{1}{2}$	45	..	1.4142	$\frac{1}{4}$	26	34	2.2361
$\frac{1}{3}$	33	41	1.8028	$\frac{1}{5}$	21	48	2.6926
$\frac{1}{2 \sqrt{3}}$	30	..	2.0000	$\frac{1}{6}$	18	26	3.1623

APPROXIMATE LOADS PER SQUARE FOOT FOR ROOFS OF SPANS UNDER 75 FEET INCLUDING WEIGHT OF TRUSS.

Roof covered with corrugated sheets, unboarded	-	8 pounds.
Roof covered with corrugated sheets, on boards	- -	11 "
Roof covered with slate, on laths	- - -	13 "
Same, on boards $1\frac{1}{4}$ " thick	- - -	16 "
Roof covered with shingles, on laths	- - -	10 "
Add to above, if plastered below rafters	- - -	10 "
Snow, light, weighs per cubic foot	- - -	5 to 12 "

For spans over 75 feet add 4 lbs. to the above loads per square foot.

It is customary to add 30 lbs. per square foot to the above for snow and wind when separate calculations are not made.

PRESSURE OF WIND ON ROOFS (Unwin).

a—Angle of surface of roof with direction of wind.

F—Force of wind in lbs. per square foot.

A—Pressure normal to surface of roof— $F \sin. a^{1.84} \cos. a-1$ .

B—Pressure perpendicular to direction of wind— $F \cot. a \sin. a^{1.84} \cos. a$ .

C—Pressure parallel to direction of wind— $F \sin. a^{1.84} \cos. a$ .

Angle of roof—a	5°	10°	20°	30°	40°	50°	60°	70°	80°	90°
A—F×	.125	.24	.45	.66	.83	.95	1.00	1.02	1.01	1.00
B—F×	.122	.24	.42	.57	.64	.61	.50	.35	.17	.00
C—F×	.01	.04	.15	.33	.53	.73	.85	.96	.99	1.00

## ROOF TRUSSES.

Tables for finding stresses in members for roof trusses of the different types and pitches as given below and of any span.

RULE.—To find the stress in any member multiply the coefficient given for that member by total dead load carried by truss (=span in feet  $\times$  distance between trusses in feet  $\times$  weight per square foot). If the truss is acted upon by wind forces, or other unsymmetrical loading, the stresses in the members must be calculated accordingly and combined with the dead load stresses as found below.

Member of Truss.	PITCH. (Depth to Span.)			
	$\frac{1}{3}$	$30^\circ$	$\frac{1}{4}$	$\frac{1}{5}$
Fig. 1.				
Aa	.675	.750	.838	1.010
Bb	.537	.625	.726	.917
Ca	.563	.650	.750	.938
Cc	.375	.433	.500	.625
ab	.208	.217	.224	.232
bc	.188	.217	.250	.313
Fig. 2.				
Aa	.750	.833	.930	1.120
Bb	.589	.666	.757	.928
Cc	.568	.666	.783	.995
Da	.625	.721	.833	1.042
Dd	.375	.433	.500	.625
ab	.155	.167	.180	.202
bc	.155	.167	.180	.202
cd	.250	.288	.333	.417
Fig. 3.				
Aa	.788	.874	.978	1.178
Bb	.718	.812	.922	1.131
Cc	.649	.750	.866	1.085
Dd	.580	.687	.810	1.038
Ea	.655	.758	.875	1.094
Ef	.562	.650	.750	.938
Eg	.375	.433	.500	.625
ab	.104	.108	.112	.116
bc	.093	.108	.125	.156
cd	.208	.216	.224	.232
de	.093	.108	.125	.156
ef	.104	.108	.112	.116
fg	.187	.217	.250	.313
gd	.280	.325	.375	.469

NOTE.—Heavy lines denote compression and light lines tension members. Loads are considered as concentrated at the joints.

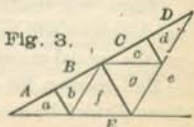
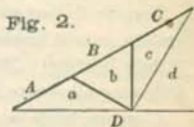
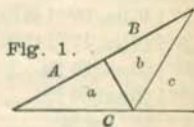

STANDARD WALL BEARING PLATES FOR  
I-BEAMS AND CHANNELS.

STANDARD STEEL WALL BEARING PLATES.

Depth of Beam or Channel.	Bearing on Wall.	Plates.		Safe Bearing Values in Tons for Plates Resting on			Weights, Lbs.
		Size.	Thickness.	Common Brickwork.	First Class Brickwork.	Ordinary Masonry.	
3", 4", 5" and 6"....	6"	6" x 6"	$\frac{1}{4}$ "	1.8	2.7	4.5	4
3", 4", 5" and 6"....	6"	6" x 6"	$\frac{1}{2}$ "	1.8	2.7	4.5	5
7" and 8".....	8"	8" x 8"	$\frac{1}{4}$ "	3.2	4.8	8.0	9
7" and 8".....	8"	8" x 8"	$\frac{1}{2}$ "	3.2	4.8	8.0	14
9" and 10".....	8"	8" x 12"	$\frac{1}{4}$ "	4.8	7.2	12.0	14
9" and 10".....	8"	8" x 12"	$\frac{1}{2}$ "	4.8	7.2	12.0	20
12" I 31.5 lbs.....	12"	12" x 12"	$\frac{1}{4}$ "	7.2	10.8	18.0	20
12" I 31.5 lbs.....	12"	12" x 12"	$\frac{1}{2}$ "	7.2	10.8	18.0	31
12" I 40 lbs., 15" I 42 lbs.	12"	12" x 16"	$\frac{1}{4}$ "	9.6	14.4	24.0	41
12" I 40 lbs., 15" I 42 lbs.	12"	12" x 16"	1 "	9.6	14.4	24.0	54
15" I 60 and 80 lbs....	12"	12" x 18"	$\frac{1}{4}$ "	10.8	16.2	27.0	46
15" I 60 and 80 lbs....	12"	12" x 18"	1 "	10.8	16.2	27.0	61
18", 20" and 24"....	16"	16" x 16"	1 "	12.8	19.2	32.0	73

Use the thicker plate for bearing values exceeding those given under common brickwork.

Safe bearing values given in above table are figured on the following allowable loads per square inch :

Common brick work 100 lbs. First class brickwork 150 lbs. Ordinary masonry 250 lbs.

When end reaction exceeds the above safe bearing values special plates will be provided. 20" and 24" beams will usually require special calculations.

End reaction for uniformly distributed load equals load on beam divided by 2.

Bearing area in square inches equals end reaction in pounds divided by the allowable bearing per square inch.

STANDARD WALL ANCHORS FOR BEAMS AND CHANNELS.

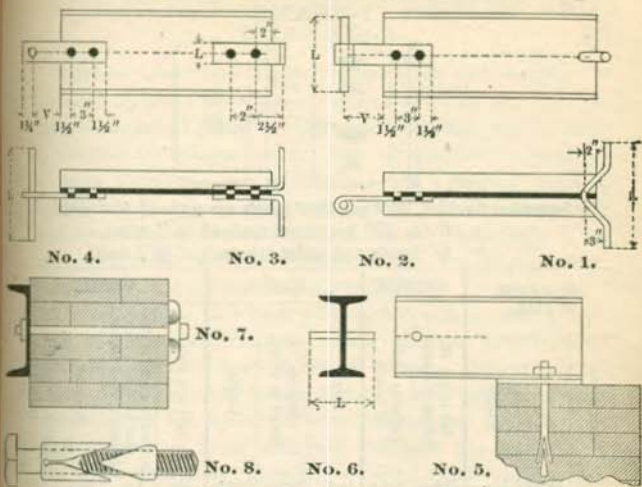

No. of Anchor.	Depth of Beam or Channel in Inches.	Size of Bar or Angles in Inches.	Length L in Inches.	Weight in Pounds.	No. of Anchor.	Depth of Beam or Channel in Inches.	Size of Bar or Angles in Inches.	Length L in Inches.	Weight in Pounds.
1	3 to 9	$\frac{3}{4}$	15	$2\frac{3}{4}$	4	3 to 5	$2\frac{3}{4} \times \frac{3}{4}$	12	V
	10 to 24		18	$2\frac{3}{4}$		6 to 10	$3 \times \frac{3}{4}$	12	
2	3 to 5	$2\frac{3}{4} \times \frac{3}{4}$	6	V	10 to 24	$3 \times \frac{3}{4}$	15		
	6 to 10	$3 \times \frac{3}{4}$	6		6	3 to 9	$\frac{3}{4}$	15	
3	12 to 24	$3 \times \frac{3}{4}$	12	6		10 to 24	$\frac{3}{4}$	18	All weights and dimensions marked V are variable, as are also other figures where not given.
	3 to 5	$6 \times 4 \times \frac{3}{4}$	$2\frac{3}{4}$		6				
	6 to 10	$6 \times 6 \times \frac{3}{4}$	3		8				
	12 to 24	$6 \times 6 \times \frac{3}{4}$	3	11					

All material for anchors steel, except Nos. 7 and 8 parts of which may be cast or malleable iron. All anchors are shipped loose and riveted or bolted to beams in the field; and in order to avoid two size holes in the same piece anchors should be so selected that holes for them and their connections may be  $\frac{1}{8}$ ". The weights given above include the bolts or rivets for field connections.

Anchors Nos. 1, 2, 3, 4 and 6 are common in building construction; the split anchor bolts No. 5, with or without wedges are mostly used for bridge work and column foundations; the washer for No. 7 on outside of wall may be either a cast iron star or a steel plate; expansion bolts No. 8 are of use in repair work to fasten channels, etc., to brick walls.



STANDARD CAST IRON SEPARATORS FOR I-BEAMS.

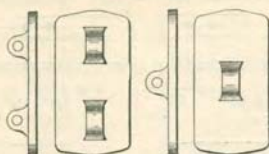

Separators for 18", 20" and 24" beams are made of  $\frac{5}{8}$ " metal.  
 " " 6" to 15" beams are made of  $\frac{1}{2}$ " metal.  
 " " 5" beams and under are made of  $\frac{3}{8}$ " metal.

DESIGNATION OF BEAM.			DISTANCES.		BOLTS.			WEIGHTS.			
Shape Index.	Depth.	Weight.	Out to out of flanges of beams.	Center to center of beams.	Size.	Distance center to center.	Length.	Bolts and Nuts.	Increase in weight of separator bolts for 1 inch additional spread of beams.	Separator.	Increase in weight of separator for 1 inch additional spread of beams.

SEPARATORS WITH TWO BOLTS.

B 1	24	80.	14 $\frac{3}{4}$	7 $\frac{3}{4}$	$\frac{3}{4}$	12	9 $\frac{1}{4}$	3.41	.250	32.	5.50
B 2	20	80.	14 $\frac{3}{4}$	7 $\frac{3}{4}$	$\frac{3}{4}$	10	9 $\frac{1}{4}$	3.41	"	28.	3.10
B 3	20	65.	13 $\frac{1}{4}$	7	$\frac{3}{4}$	10	8 $\frac{1}{2}$	3.23	"	25.	3.10
B80	18	55.	12 $\frac{3}{4}$	6 $\frac{3}{4}$	$\frac{3}{4}$	9	8 $\frac{1}{4}$	3.16	"	16.	2.75
B 4	15	80.	13 $\frac{5}{8}$	7 $\frac{1}{4}$	$\frac{3}{4}$	7 $\frac{1}{2}$	9	3.35	"	15.	1.75
B 5	15	60.	12 $\frac{3}{4}$	6 $\frac{3}{4}$	$\frac{3}{4}$	7 $\frac{1}{2}$	8 $\frac{1}{2}$	3.23	"	15.	1.75
B 7	15	42.	11 $\frac{3}{4}$	6 $\frac{1}{4}$	$\frac{3}{4}$	7 $\frac{1}{2}$	7 $\frac{1}{2}$	2.98	"	15.	1.75
B 8	12	40.	11 $\frac{1}{4}$	6	$\frac{3}{4}$	6	7 $\frac{1}{2}$	2.98	"	11.	1.50
B 9	12	31.5	10 $\frac{3}{4}$	5 $\frac{3}{4}$	$\frac{3}{4}$	6	7 $\frac{1}{4}$	2.92	"	11.	1.50

SEPARATORS WITH ONE BOLT.

B 8	12	40.0	11 $\frac{1}{4}$	6	$\frac{3}{4}$	..	7 $\frac{1}{2}$	1.49	.125	10.	1.50
B 9	12	31.5	10 $\frac{3}{4}$	5 $\frac{3}{4}$	$\frac{3}{4}$	..	7 $\frac{1}{4}$	1.46	"	10.	1.50
B11	10	25.0	10 $\frac{1}{8}$	5 $\frac{1}{2}$	$\frac{3}{4}$	..	6 $\frac{3}{4}$	1.40	"	8.	1.25
B13	9	21.0	9 $\frac{5}{16}$	5	$\frac{3}{4}$	..	6 $\frac{1}{4}$	1.34	"	7.	1.20
B15	8	18.0	8 $\frac{1}{2}$	4 $\frac{1}{2}$	$\frac{3}{4}$	..	5 $\frac{3}{4}$	1.28	"	6.	1.00
B17	7	15.0	7 $\frac{7}{8}$	4 $\frac{1}{4}$	$\frac{3}{4}$	..	5 $\frac{1}{2}$	1.25	"	4.	.75
B19	6	12.25	7 $\frac{5}{16}$	4	$\frac{3}{4}$	..	5 $\frac{1}{4}$	1.22	"	4.	.60
B21	5	9.75	6 $\frac{1}{2}$	3 $\frac{1}{2}$	$\frac{3}{4}$	..	4 $\frac{3}{4}$	1.16	"	3.	.50
B23	4	7.50	5 $\frac{7}{8}$	3 $\frac{1}{4}$	$\frac{3}{4}$	..	4 $\frac{1}{2}$	1.13	"	3.	.40
B77	3	5.50	5 $\frac{5}{16}$	3	$\frac{5}{8}$	..	4 $\frac{1}{4}$	0.70	.09	2.	.25

## NOTES ON STANDARD CONNECTION ANGLES FOR CARNEGIE I-BEAMS AND CHANNELS.

Standard connection angles for all sizes and weights of Standard I-Beams and Channels manufactured by The Carnegie Steel Company, Limited are illustrated on page 183. These connections are designed on the basis of an allowable shearing stress of 10,000 lbs. per square inch and a bearing stress of 20,000 lbs. per square inch on rivets or bolts, corresponding with extreme fiber stresses of 16,000 lbs. per square inch. The number of rivets or bolts required is found to be dependent, in most instances, on their bearing values.

The connections have been proportioned with a view to covering most cases occurring in ordinary practice with the usual relations of depth of beam to length of span. In extreme instances, however, where beams of short relative span lengths are loaded to their full capacity or when beams frame opposite each other into another beam with web thickness less than  $\frac{9}{16}$ "', it may be found necessary to make provision for additional strength in the connections. The limiting span lengths, at and above which the standard connection angles may be used with perfect safety, are given in the following table :

Table of Minimum Spans of I-Beams for which Standard Connection  
Angles may be Safely Used with Beams Loaded  
to their Full Capacity.

Designation of Beam.	Minimum Safe Span in feet.	Designation of Beam.	Minimum Safe Span in feet.	Designation of Beam.	Minimum Safe Span in feet.
24''-80. lbs.	21.0	15''-42. lbs.	10.5	7''-15. lbs.	5.0
20''-80. "	18.0	12''-40. "	9.0	6''-12.25 "	6.0
" 65. "	17.0	" 31.5 "	7.5	5''- 9.75 "	4.0
18''-55. "	14.0	10''-25. "	9.5	4''- 7.5 "	3.0
15''-80. "	16.0	9''-21. "	8.0	3''- 5.5 "	2.0
" 60. "	12.5	8''-18. "	6.5		

STANDARD CONNECTION ANGLES  
FOR I-BEAMS AND CHANNELS.

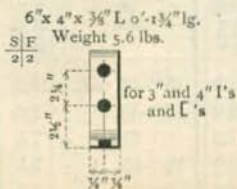
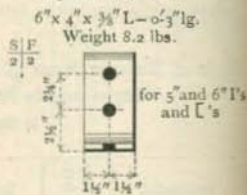
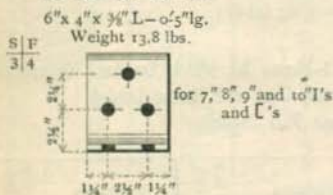
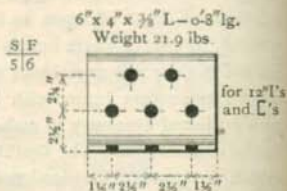
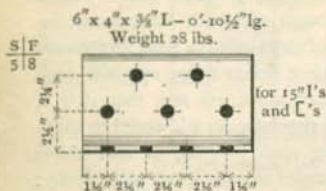
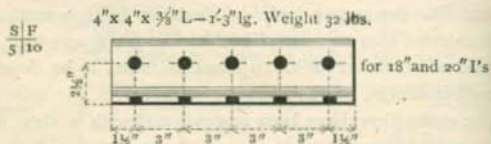
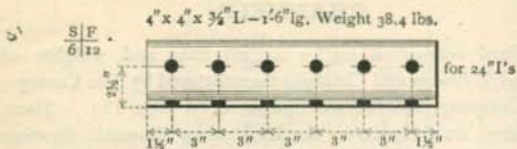

$\frac{S}{F}$   
Shop | Field

Rivets  
or  
Bolts.

All holes for  $\frac{3}{4}$ " Bolts or Rivets.

The weights of connections include shop and field rivets.  
2 1/2" gauge on all 4" legs.

CONNECTIONS FOR DIFFERENT DEPTHS  
OF BEAMS FRAMING OPPOSITE.

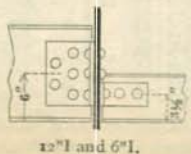
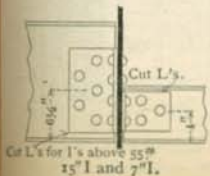
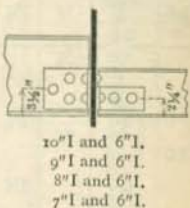
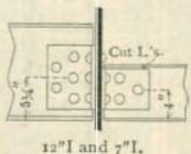
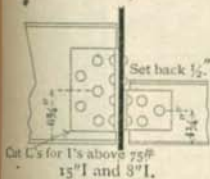
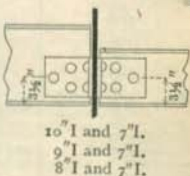
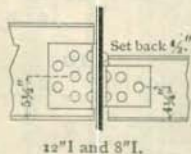
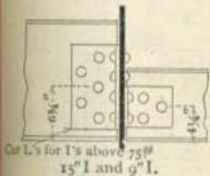
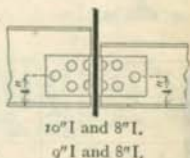
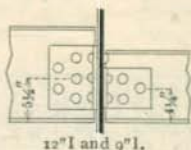
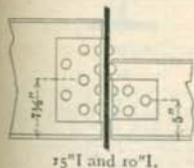
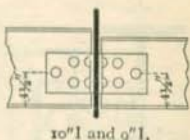
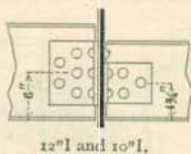
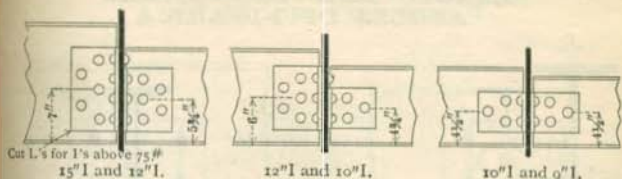

Standard connection angles to be used on larger beams unless gauge exceeds  $2\frac{3}{4}$ " on special angles of smaller beams.

STANDARD SPACING AND DIMENSIONS OF RIVET AND BOLT HOLES THROUGH FLANGES AND CONNECTION ANGLES OF I-BEAMS.

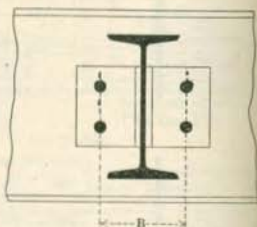
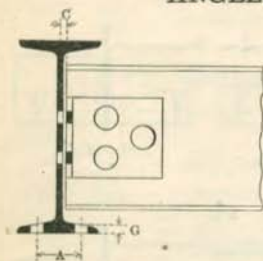

Depth in inches.	Weight per foot.	Max. Size Bolt or Rivet in Flanges.	Gauge A in inches.	Std. Conn. B Spacing.	Distance C in inches.	Grip G in inches.	Depth in inches.	Weight per foot.	Max. Size Bolt or Rivet in Flanges.	Gauge A in inches.	Std. Conn. B Spacing.	Distance C in inches.	Grip G in inches.
24	100	1	4	5 1/4	1 1/8	1 1/2	12	45	3/4	3	5 1/4	1 1/8	1 1/2
	95			5 1/2	1 1/8			5 1/2			1 1/8		
	90			5 3/4	1 1/8			5 3/4			1 1/8		
	85			5 7/8	1 1/8			5 7/8			1 1/8		
	80			5 7/8	1 1/8			5 7/8			1 1/8		
20	100	3/8	4	5 1/4	1 1/8	1 1/2	10	40	3/4	2 3/4	5 1/4	1 1/8	1 1/2
	95			5 1/2	1 1/8			5 1/2			1 1/8		
	90			5 3/4	1 1/8			5 3/4			1 1/8		
	85			5 7/8	1 1/8			5 7/8			1 1/8		
	80			5 7/8	1 1/8			5 7/8			1 1/8		
18	75	3/8	3 1/2	5 1/4	1 1/8	1 1/2	9	35	3/4	2 1/2	5 1/4	1 1/8	1 1/2
	70			5 1/2	1 1/8			5 1/2			1 1/8		
	65			5 3/4	1 1/8			5 3/4			1 1/8		
	60			5 7/8	1 1/8			5 7/8			1 1/8		
	55			5 7/8	1 1/8			5 7/8			1 1/8		
15	100	3/8	3 3/4	6 1/4	1 1/8	1 1/2	8	25.5	3/4	2 1/4	5 3/8	1 1/8	1 1/2
	95			6 1/4	1 1/8			6 1/4			1 1/8		
	90			6 1/4	1 1/8			6 1/4			1 1/8		
	85			6 1/4	1 1/8			6 1/4			1 1/8		
	80			6 1/4	1 1/8			6 1/4			1 1/8		
12	75	3/4	3	5 1/4	1 1/8	5/8	7	20	5/8	2 1/4	5 1/4	1 1/8	1 1/2
	70			5 1/2	1 1/8			5 1/2			1 1/8		
	65			5 3/4	1 1/8			5 3/4			1 1/8		
	60			5 7/8	1 1/8			5 7/8			1 1/8		
	55			5 7/8	1 1/8			5 7/8			1 1/8		

Weights in heavy print are standard, others are special.  
All holes for connections to be for 3/4" rivets or bolts.

STANDARD SPACING AND DIMENSIONS OF RIVET AND BOLT HOLES THROUGH FLANGES AND CONNECTION ANGLES OF CHANNELS.

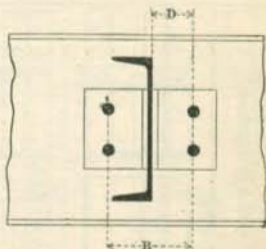
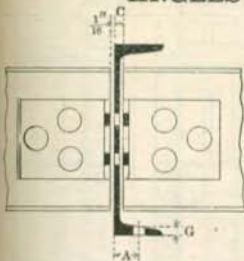

Depth in inches.	Weight per foot.	Max. Size Bolt or Rivet in Flanges.	Gauge A in inches.	Std. Conn. B Spacing.	Distance C in inches.	Grip G in inches.
15	56 45 40 36 <b>33</b>	3/4	2 1/4	5 1/2 5 1/4 5 1/8 5 1/8 5 1/8	7 1/2 7 1/8 7 1/8 7 1/8 7 1/8	5
12	40 35 30 25 <b>20.5</b>	3/4	2	5 1/2 5 1/4 5 1/8 5 1/8 5 1/8	7 1/2 7 1/8 7 1/8 7 1/8 7 1/8	3 1/2
10	35 30 25 20 15	3/4	2	5 1/2 5 1/4 5 1/8 5 1/8 5 1/8	7 1/2 7 1/8 7 1/8 7 1/8 7 1/8	3
9	25 20 15 <b>13.25</b>	3/4	1 3/4	5 1/2 5 1/4 5 1/8 5 1/8 5 1/8	7 1/2 7 1/8 7 1/8 7 1/8 7 1/8	3
8	21.25 18.75 16.25 13.75 <b>11.25</b>	3/4	1 1/2	5 1/2 5 1/4 5 1/8 5 1/8 5 1/8	7 1/2 7 1/8 7 1/8 7 1/8 7 1/8	3
7	19.75 17.25 14.75 12.25 <b>9.75</b>	5/8	1 1/2	5 1/2 5 1/4 5 1/8 5 1/8 5 1/8	7 1/2 7 1/8 7 1/8 7 1/8 7 1/8	3
6	15.5 13.0 10.5 8.0	5/8	1 3/8	5 1/2 5 1/4 5 1/8 5 1/8 5 1/8	7 1/2 7 1/8 7 1/8 7 1/8 7 1/8	3 1/2

STANDARD AND SPECIAL ANGLES.		
Depth of Leg in inches.	Maximum Diameter of Bolt or Rivet.	Gauge in inches. D
8	1	Variable.
7	1	"
6	1	"
5	1	"
4 1/2	1	"
4	1	"
3 1/2	1	"
3 1/4	7/8	2
3	5/8	1 3/4
2 3/4	5/8	1 3/4
2 1/2	5/8	1 3/4
2 1/4	5/8	1 3/4
2	5/8	1 3/4
1 3/4	5/8	1 3/4
1 1/2	5/8	1 3/4
1 1/4	5/8	1 3/4
1	5/8	1 3/4
3/4	5/8	1 3/4

Weights in heavy print are standard, others are special.  
All holes for connections to be for 3/4" rivets or bolts.

## CONNECTIONS FOR CONSTANT DIMENSION Z-BAR COLUMNS.

The number of tons indicated denote the end reactions of load on beams for columns of  $\frac{3}{16}$ " metal and above. For  $\frac{1}{4}$ " metal reduce them by 15 per cent.

Sketch of Connections.				
	Reaction. 4.4 Tons.	8.8 Tons.	17.7 Tons.	26.5 Tons.
	Size and weight of material used for connections.			
	Bill of Material for one Conn't'n. 2L <sup>o</sup> 3 $\frac{1}{2}$ x 3 $\frac{3}{8}$ 1'-1" 4 rivets $\frac{3}{4}$ " dia.	1L 3 $\frac{1}{2}$ x 3 $\frac{3}{8}$ 1'-1" 1L 6 x 3 $\frac{1}{2}$ x 3 $\frac{3}{8}$ 1'-1" 6 rivets $\frac{3}{4}$ " dia.	1L 3 $\frac{1}{2}$ x 3 $\frac{3}{8}$ 1'-1" 1L 6 x 3 $\frac{1}{2}$ x 3 $\frac{3}{8}$ 1'-1" 2L <sup>o</sup> 3 x 3 $\frac{3}{8}$ 0'-11 $\frac{1}{2}$ " 2 Fills 3 x 3 $\frac{3}{8}$ 0'-5 $\frac{3}{4}$ " 10 rivets $\frac{3}{4}$ " dia.	1L 3 $\frac{1}{2}$ x 3 $\frac{3}{8}$ 1'-1" 1L 6 x 3 $\frac{1}{2}$ x 3 $\frac{3}{8}$ 1'-1" 2L <sup>o</sup> 3 x 3 $\frac{3}{8}$ 1'-5 $\frac{3}{4}$ " 2 Fills 3 x 3 $\frac{3}{8}$ 0'-11 $\frac{1}{2}$ " 14 rivets $\frac{3}{4}$ " dia.
Weight.	19 lbs.	24 lbs.	44 lbs.	63 lbs.
Sketch of Connections.				
	Reaction. 4.4 Tons.	8.8 Tons.	17.7 Tons.	26.5 Tons.
	Size and weight of material used for connections.			
	Bill of Material for one Conn't'n. 2L <sup>o</sup> 3 $\frac{1}{2}$ x 3 $\frac{3}{8}$ 0'-11" 4 rivets $\frac{3}{4}$ " dia.	1L 3 $\frac{1}{2}$ x 3 $\frac{3}{8}$ 0'-11" 1L 6 x 3 $\frac{1}{2}$ x 3 $\frac{3}{8}$ 0'-11" 6 rivets $\frac{3}{4}$ " dia.	1L 3 $\frac{1}{2}$ x 3 $\frac{3}{8}$ 0'-11" 1L 6 x 3 $\frac{1}{2}$ x 3 $\frac{3}{8}$ 0'-11" 2L <sup>o</sup> 3 x 3 $\frac{3}{8}$ 0'-11 $\frac{1}{2}$ " 2 Fills 3 x 3 $\frac{3}{8}$ 0'-5 $\frac{3}{4}$ " 10 rivets $\frac{3}{4}$ " dia.	1L 3 $\frac{1}{2}$ x 3 $\frac{3}{8}$ 0'-11" 1L 6 x 3 $\frac{1}{2}$ x 3 $\frac{3}{8}$ 0'-11" 2L <sup>o</sup> 6 x 3 $\frac{1}{2}$ x 3 $\frac{3}{8}$ 1'-5 $\frac{3}{4}$ " 2 Fills 3 x 3 $\frac{3}{8}$ 0'-11 $\frac{1}{2}$ " 17 rivets $\frac{3}{4}$ " dia.
Weight.	18 lbs.	21 lbs.	40 lbs.	68 lbs.

DETAILS OF SPLICES AND CONNECTIONS FOR  
I-BEAMS TO CONSTANT DIMENSION  
Z-BAR COLUMNS.

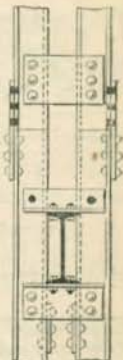
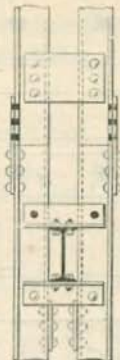

$\frac{5}{16}$ " Metal and above 4.4 tons.

$\frac{5}{16}$ " Metal and above 8.8 tons.

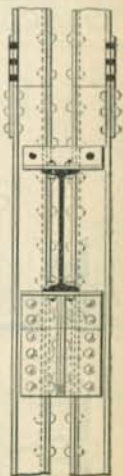
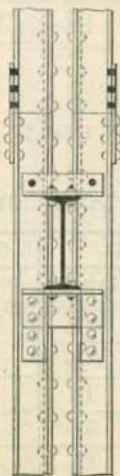

$\frac{3}{16}$ " Metal and above 17.7 tons.

$\frac{5}{16}$ " Metal and above 26.5 tons.

For description of other details see page 140.

Rivets and bolts  $\frac{3}{4}$ " diameter.

Splice plates 13' by thickness of Z<sup>n</sup> by 1' 6" long.

↑  
DEC  
MALS  
ARE  
W



CONVENTIONAL SIGNS FOR RIVETING.

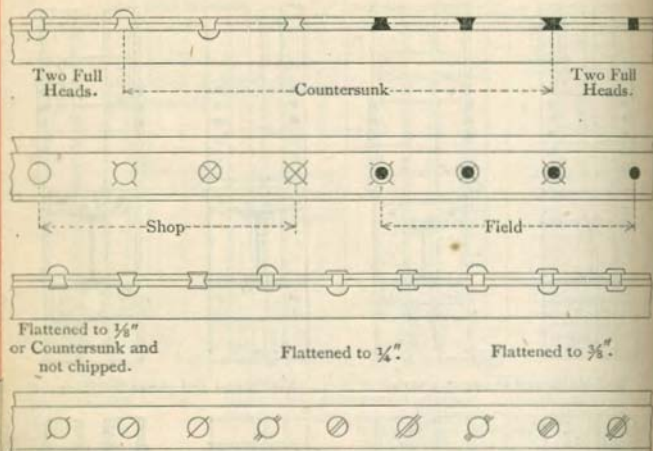

SIZES OF RIVET HEADS  
AND  
CLEARANCES FOR MACHINE DRIVING.

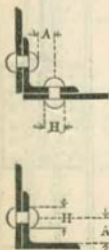

SIZE.	HEAD.		COUNTER SUNK.	
	Diam.	Height.	Depth.	Diam.
$\frac{1}{2}$	$\frac{3}{8}$	$\frac{7}{8}$	$\frac{1}{4}$	$\frac{3}{4}$
$\frac{5}{8}$	$\frac{11}{16}$	$1\frac{1}{8}$	$\frac{5}{16}$	1
$\frac{3}{4}$	$\frac{9}{16}$	$1\frac{1}{4}$	$\frac{3}{8}$	$1\frac{1}{8}$
$\frac{7}{8}$	$\frac{7}{8}$	$1\frac{7}{8}$	$\frac{7}{16}$	$1\frac{3}{8}$
1	$\frac{3}{4}$	$1\frac{5}{8}$	$\frac{1}{2}$	$1\frac{9}{16}$

A must not be less than  $\frac{1}{4}'' + \frac{1}{2} H$ .

LENGTHS OF RIVETS FOR VARIANT GRIPS.

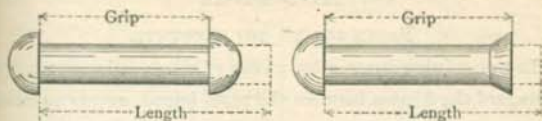

Grip in inches.	Diameter in Inches.					Diameter in Inches.					Grip in inches.
	1/2	5/8	3/4	7/8	1	1/2	5/8	3/4	7/8	1	
	Length in Inches.					Length in Inches.					
1/8	1 1/2	1 3/4	1 7/8	2	2 1/8	1 1/8	1 1/4	1 1/2	1 3/4	1 3/8	1/4
1/4	1 1/2	1 3/4	1 7/8	2	2 1/8	1 1/4	1 1/2	1 3/4	1 3/4	1 3/8	1/2
3/8	1 1/2	1 3/4	1 7/8	2	2 1/8	1 1/2	1 1/2	1 3/4	1 3/4	1 3/8	3/4
1/2	2	2 1/4	2 1/2	2 3/4	3	1 5/8	1 3/4	1 3/4	1 7/8	1 7/8	1
3/4	2	2 1/4	2 1/2	2 3/4	3	1 5/8	1 3/4	1 3/4	1 7/8	1 7/8	1 1/4
1	2	2 1/4	2 1/2	2 3/4	3	1 5/8	1 3/4	1 3/4	1 7/8	1 7/8	1 1/2
1 1/8	2	2 1/4	2 1/2	2 3/4	3	2	2 1/4	2 1/4	2 1/4	2 1/4	1 1/2
1 1/4	2	2 1/4	2 1/2	2 3/4	3	2	2 1/4	2 1/4	2 1/4	2 1/4	1 3/4
1 1/2	2	2 1/4	2 1/2	2 3/4	3	2	2 1/4	2 1/4	2 1/4	2 1/4	1 3/4
1 3/4	2	2 1/4	2 1/2	2 3/4	3	2	2 1/4	2 1/4	2 1/4	2 1/4	1 3/4
2	3	3 1/4	3 1/2	3 3/4	4	2 5/8	2 3/4	2 7/8	2 7/8	3	2
2 1/8	3	3 1/4	3 1/2	3 3/4	4	2 5/8	2 3/4	2 7/8	2 7/8	3	2 1/8
2 1/4	3	3 1/4	3 1/2	3 3/4	4	2 5/8	2 3/4	2 7/8	2 7/8	3	2 1/4
2 1/2	3	3 1/4	3 1/2	3 3/4	4	2 5/8	2 3/4	2 7/8	2 7/8	3	2 1/2
2 3/4	3	3 1/4	3 1/2	3 3/4	4	2 5/8	2 3/4	2 7/8	2 7/8	3	2 3/4
3	4	4 1/4	4 1/2	4 3/4	5	3 1/2	3 1/2	3 3/4	3 3/4	3 3/8	3
3 1/8	4	4 1/4	4 1/2	4 3/4	5	3 1/2	3 1/2	3 3/4	3 3/4	3 3/8	3 1/8
3 1/4	4	4 1/4	4 1/2	4 3/4	5	3 1/2	3 1/2	3 3/4	3 3/4	3 3/8	3 1/4
3 1/2	4	4 1/4	4 1/2	4 3/4	5	3 1/2	3 1/2	3 3/4	3 3/4	3 3/8	3 1/2
3 3/4	4	4 1/4	4 1/2	4 3/4	5	3 1/2	3 1/2	3 3/4	3 3/4	3 3/8	3 3/4
4	5	5 1/4	5 1/2	5 3/4	6	4 1/2	4 1/2	4 3/4	4 3/4	4 3/8	4
4 1/8	5	5 1/4	5 1/2	5 3/4	6	4 1/2	4 1/2	4 3/4	4 3/4	4 3/8	4 1/8
4 1/4	5	5 1/4	5 1/2	5 3/4	6	4 1/2	4 1/2	4 3/4	4 3/4	4 3/8	4 1/4
4 1/2	5	5 1/4	5 1/2	5 3/4	6	4 1/2	4 1/2	4 3/4	4 3/4	4 3/8	4 1/2
4 3/4	5	5 1/4	5 1/2	5 3/4	6	4 1/2	4 1/2	4 3/4	4 3/4	4 3/8	4 3/4
5	6	6 1/4	6 1/2	6 3/4	7	5 1/4	5 1/4	5 3/4	5 3/4	5 3/8	5

## EXPLANATION OF TABLES ON RIVETS AND PINS.

PAGES 193 TO 197 INCLUSIVE.

In transmitting stresses by means of rivets, it is customary to disregard the friction between the parts joined, as too uncertain an element to be relied upon to any extent. The rivets must then be proportioned for the entire stress which is to be transmitted from one plate or group of plates to the other, and they must be of sufficient size and number to present ample resistance to shearing and afford sufficient bearing area so as not to cause a crushing of the metal at the rivet holes. This latter condition, while generally observed for pins, is very often entirely overlooked in riveted work. Its observance, in most cases of riveted girders with single webs, determines the size and number of rivets to be used and frequently makes it necessary to adopt a greater thickness of web than would otherwise be required. Thus, if the web is  $\frac{5}{16}$ " thick, the rivets connecting the same, with the flange angles have a bearing value of only 3,520 lbs. for a  $\frac{3}{4}$ " rivet, while their shearing value is  $= 2 \times 3,310 = 6,620$  lbs. per rivet, the rivets being in double shear. Consequently, while the usual thickness of web of floor beams for railway bridges is  $\frac{3}{8}$ ", it sometimes becomes necessary for shallow floor beams to increase this thickness to  $\frac{1}{2}$ " and even  $\frac{5}{8}$ ", in order that the pressure of the rivets upon the semi-intrados of the rivet holes be not excessive between the points of support of floor beam and of application of the load (in which space the transmission of strain from web to flanges takes place).

Pins must be calculated for shearing, bending and bearing stresses, but one of the latter two only in almost every case determines the size to be used. The stress allowed upon pin-bearing in bridges proportioned to a factor of safety of five is usually 12,000 lbs. and the maximum fiber stress by bending

15,000 lbs. per square inch. When groups of bars are connected to the same pin, as in the lower chords of truss bridges, the sizes of bars must be so chosen and the bars so placed that at no point on the pin will there be an excessive bending stress, on the presumption that all the bars are strained equally per square inch.

The following is the formula for flexure applied to pins :

$$M = \frac{f \pi d^3}{32} \quad \text{or} \quad = \frac{f A d}{8}$$

M—moment of forces for any section through pin.

f—stress per square inch in extreme fibers of pin at that section.

A—area of section ; d—diameter ;  $\pi=3.14159$ .

The forces are assumed to act in a plane passing through the axis of the pin.

The tables on pages 195 and 196 give the values of M for different diameters of pin and for different values of f.

The following examples will illustrate the use of the tables :

I. A pin in the bolster or end shoe of a bridge has to carry a load of 40,000 lbs. between two points of support ; what size of pin is required, assuming the distance between points (*i. e.*, centers) of support of bolster plates and centers of pressure of end post plates =  $2\frac{1}{2}$ " ?

*Answer*:—Bending moments =  $20,000 \text{ lbs.} \times 2\frac{1}{2} = 50,000$  inch lbs., therefore,  $3\frac{1}{4}$ " pin required for 15,000 lbs. fiber stress, since the allowed moment for  $3\frac{1}{4}$ " = 50,600 as per table.

II. Required the thickness of metal in the top chord or in a post of a bridge that will give sufficient bearing area to a  $3\frac{3}{8}$ " pin, having to transmit a stress of 60,700 lbs.; the allowed pressure per square inch on bearing being 12,000 lbs. maximum.

The bearing value of a  $3\frac{3}{8}$ " pin for 1" thickness of plate = 40,500 lbs., therefore, the thickness of metal required =  $\frac{60,700}{40,500} = 1\frac{1}{2}$ ", or each of the two plates in the chord or post will have to be  $\frac{3}{4}$ " thick.

SHEARING AND BEARING VALUE OF RIVETS.

ALL DIMENSIONS IN INCHES.

Diameter of Rivet.		Area in square inches.	Single Shear at 6,000 lbs.	BEARING VALUE FOR			
Inches.				$\frac{1}{4}$	$\frac{5}{16}$	$\frac{3}{8}$	$\frac{7}{16}$
Fraction.	Decimal.						
$\frac{3}{8}$	.375	.1104	660	1130	1410	1690	..
$\frac{1}{2}$	.500	.1963	1180	1500	1880	2250	2630
$\frac{5}{8}$	.625	.3068	1840	1880	2340	2810	3280
$\frac{3}{4}$	.750	.4418	2650	2250	2810	3380	3940
$\frac{7}{8}$	.875	.6013	3610	2630	3280	3940	4590
1	1.000	.7854	4710	3000	3750	4500	5250

Diameter of Rivet.		Area in square inches.	Single Shear at 7,500 lbs.	BEARING VALUE FOR			
Inches.				$\frac{1}{4}$	$\frac{5}{16}$	$\frac{3}{8}$	$\frac{7}{16}$
Fraction.	Decimal.						
$\frac{3}{8}$	.375	.1104	830	1410	1760	2110	..
$\frac{1}{2}$	.500	.1963	1470	1880	2340	2810	3280
$\frac{5}{8}$	.625	.3068	2300	2340	2930	3520	4100
$\frac{3}{4}$	.750	.4418	3310	2810	3520	4220	4920
$\frac{7}{8}$	.875	.6013	4510	3280	4100	4920	5740
1	1.000	.7854	5890	3750	4690	5620	6560

Diameter of Rivet.		Area in square inches.	Single Shear at 10,000 lbs.	BEARING VALUE FOR			
Inches.				$\frac{1}{4}$	$\frac{5}{16}$	$\frac{3}{8}$	$\frac{7}{16}$
Fraction.	Decimal.						
$\frac{3}{8}$	.375	.1104	1100	1880	2340	2810	..
$\frac{1}{2}$	.500	.1963	1960	2500	3130	3750	4380
$\frac{5}{8}$	.625	.3068	3070	3130	3910	4690	5470
$\frac{3}{4}$	.750	.4418	4420	3750	4690	5630	6560
$\frac{7}{8}$	.875	.6013	6010	4380	5470	6570	7660
1	1.000	.7854	7850	5000	6250	7500	8750

Diameter of Rivet.		Area in square inches.	Single Shear at 12,000 lbs.	BEARING VALUE FOR			
Inches.				$\frac{1}{4}$	$\frac{5}{16}$	$\frac{3}{8}$	$\frac{7}{16}$
Fraction.	Decimal.						
$\frac{3}{8}$	.375	.1104	1320	2350	2930	3520	..
$\frac{1}{2}$	.500	.1963	2360	3130	3910	4690	5470
$\frac{5}{8}$	.625	.3068	3680	3910	4880	5860	6840
$\frac{3}{4}$	.750	.4418	5300	4690	5860	7030	8210
$\frac{7}{8}$	.875	.6013	7220	5470	6840	8210	9580
1	1.000	.7854	9430	6250	7820	9380	10940

In above tables all bearing values above or to right of upper zigzag lines are greater than double shear. Values between upper and lower zigzag lines are less than double and greater than single shear.

SHEARING AND BEARING VALUE OF RIVETS.

ALL DIMENSIONS IN INCHES.

DIFFERENT THICKNESSES OF PLATE IN INCHES AT 12,000 LBS. PER SQUARE INCH.

$\frac{1}{8}$	$\frac{9}{16}$	$\frac{5}{8}$	$\frac{11}{16}$	$\frac{3}{4}$	$\frac{13}{16}$	$\frac{7}{8}$	$\frac{15}{16}$	1
..	..	..	..	..	..	..	..	..
3000	..	..	..	..	..	..	..	..
3750	4220	4690	..	..	..	..	..	..
4500	5060	5630	6190	6750	..	..	..	..
5250	5910	6560	7220	7880	8530	9190	9840	..
6000	6750	7500	8250	9000	9750	10500	11250	12000

DIFFERENT THICKNESSES OF PLATE IN INCHES AT 15,000 LBS. PER SQUARE INCH.

$\frac{1}{8}$	$\frac{9}{16}$	$\frac{5}{8}$	$\frac{11}{16}$	$\frac{3}{4}$	$\frac{13}{16}$	$\frac{7}{8}$	$\frac{15}{16}$	1
..	..	..	..	..	..	..	..	..
3750	..	..	..	..	..	..	..	..
4690	5280	5860	..	..	..	..	..	..
5630	6330	7030	7720	8440	..	..	..	..
6560	7380	8200	9030	9850	10670	11480	12300	..
7500	8440	9380	10310	11250	12190	13130	14060	15000

DIFFERENT THICKNESSES OF PLATE IN INCHES AT 20,000 LBS. PER SQUARE INCH.

$\frac{1}{8}$	$\frac{9}{16}$	$\frac{5}{8}$	$\frac{11}{16}$	$\frac{3}{4}$	$\frac{13}{16}$	$\frac{7}{8}$	$\frac{15}{16}$	1
..	..	..	..	..	..	..	..	..
5000	..	..	..	..	..	..	..	..
6250	7030	7810	..	..	..	..	..	..
7500	8440	9380	10310	11250	..	..	..	..
8750	9840	10940	12030	13130	14220	15310	16410	..
10000	11250	12500	13750	15000	16250	17500	18750	20000

DIFFERENT THICKNESSES OF PLATE IN INCHES AT 25,000 LBS. PER SQUARE INCH.

$\frac{1}{8}$	$\frac{9}{16}$	$\frac{5}{8}$	$\frac{11}{16}$	$\frac{3}{4}$	$\frac{13}{16}$	$\frac{7}{8}$	$\frac{15}{16}$	1
..	..	..	..	..	..	..	..	..
6250	..	..	..	..	..	..	..	..
7810	8790	9770	..	..	..	..	..	..
9380	10550	11720	12890	14060	..	..	..	..
10940	12310	13670	15040	16410	17770	19140	20510	..
12500	14060	15630	17190	18750	20320	21880	23440	25000

Values below and to left of lower zigzag lines are less than single shear.

DECI  
MALS

ARE

W

## MAXIMUM BENDING MOMENTS OF PINS WITH EXTREME FIBER STRESSES

VARYING FROM 15,000 TO 25,000 POUNDS PER SQUARE INCH.

Diameter of Pin in inches.	Area of Pin in square inches.	MOMENTS IN INCH-POUNDS FOR FIBER STRESSES OF				
		15,000 lbs. per sq. inch.	18,000 lbs. per sq. inch.	20,000 lbs. per sq. inch.	22,500 lbs. per sq. inch.	25,000 lbs. per sq. inch.
1	0.785	1470	1770	1960	2210	2450
1 $\frac{1}{8}$	0.994	2100	2520	2800	3140	3500
1 $\frac{1}{4}$	1.227	2880	3450	3830	4310	4790
1 $\frac{3}{8}$	1.485	3830	4590	5100	5740	6380
1 $\frac{1}{2}$	1.767	4970	5960	6630	7460	8280
1 $\frac{5}{8}$	2.074	6320	7580	8430	9480	10500
1 $\frac{3}{4}$	2.405	7890	9470	10500	11800	13200
1 $\frac{7}{8}$	2.761	9710	11600	12900	14600	16200
2	3.142	11800	14100	15700	17700	19600
2 $\frac{1}{8}$	3.547	14100	17000	18800	21200	23600
2 $\frac{1}{4}$	3.976	16800	20100	22400	25200	28000
2 $\frac{3}{8}$	4.430	19700	23700	26300	29600	32900
2 $\frac{1}{2}$	4.909	23000	27600	30700	34500	38400
2 $\frac{5}{8}$	5.412	26600	32000	35500	40000	44400
2 $\frac{3}{4}$	5.940	30600	36800	40800	45900	51000
2 $\frac{7}{8}$	6.492	35000	42000	46700	52500	58300
3	7.069	39800	47700	53000	59600	66300
3 $\frac{1}{8}$	7.670	44900	53900	59900	67400	74900
3 $\frac{1}{4}$	8.296	50600	60700	67400	75800	84300
3 $\frac{3}{8}$	8.946	56600	67900	75500	84900	94400
3 $\frac{1}{2}$	9.621	63100	75800	84200	94700	105200
3 $\frac{5}{8}$	10.321	70100	84200	93500	105200	116900
3 $\frac{3}{4}$	11.045	77700	93200	103500	116500	129400
3 $\frac{7}{8}$	11.793	85700	102800	114200	128500	142800
4	12.566	94200	113100	125700	141400	157100
4 $\frac{1}{8}$	13.364	103400	124000	137800	155000	172300
4 $\frac{1}{4}$	14.186	113000	135700	150700	169600	188400
4 $\frac{3}{8}$	15.033	123300	148000	164400	185000	205500
4 $\frac{1}{2}$	15.904	134200	161000	178900	201300	223700
4 $\frac{5}{8}$	16.800	145700	174800	194300	218500	242800
4 $\frac{3}{4}$	17.721	157800	189400	210400	236700	263000
4 $\frac{7}{8}$	18.665	170600	204700	227500	256000	284400
5	19.635	184100	220900	245400	276100	306800
5 $\frac{1}{8}$	20.629	198200	237900	264300	297300	330400
5 $\frac{1}{4}$	21.648	213100	255700	284100	319600	355200
5 $\frac{3}{8}$	22.691	228700	274400	304900	343000	381100
5 $\frac{1}{2}$	23.758	245000	294000	326700	367500	408300
5 $\frac{5}{8}$	24.850	262100	314500	349500	393100	436800
5 $\frac{3}{4}$	25.967	280000	335900	373300	419900	466600
5 $\frac{7}{8}$	27.109	298000	358300	398200	447900	497700

MAXIMUM BENDING MOMENTS OF PINS

WITH EXTREME FIBER STRESSES

VARYING FROM 15,000 TO 25,000 POUNDS PER SQUARE INCH.

Diameter of Pin in inches.	Area of Pin in square inches.	MOMENTS IN INCH-POUNDS FOR FIBER STRESSES OF				
		15,000 lbs. per sq. inch.	18,000 lbs. per sq. inch.	20,000 lbs. per sq. inch.	22,500 lbs. per sq. inch.	25,000 lbs. per sq. inch.
6	28.274	318100	381700	424100	477100	530200
6 <sup>1</sup> / <sub>8</sub>	29.465	338400	406100	451200	507600	564000
6 <sup>1</sup> / <sub>4</sub>	30.680	359500	431400	479400	539300	592200
6 <sup>3</sup> / <sub>8</sub>	31.919	381500	457800	508700	572300	635900
6 <sup>1</sup> / <sub>2</sub>	33.183	404400	485300	539200	606600	674000
6 <sup>5</sup> / <sub>8</sub>	34.472	428200	513800	570900	642300	713700
6 <sup>3</sup> / <sub>4</sub>	35.785	452900	543500	603900	679400	754800
6 <sup>7</sup> / <sub>8</sub>	37.122	478500	574200	638000	717800	797500
7	38.485	505100	606100	673500	757700	841900
7 <sup>1</sup> / <sub>8</sub>	39.871	532700	639200	710200	799000	887800
7 <sup>1</sup> / <sub>4</sub>	41.282	561200	673400	748200	841800	935300
7 <sup>3</sup> / <sub>8</sub>	42.718	590700	708900	787600	886100	984500
7 <sup>1</sup> / <sub>2</sub>	44.179	621300	745500	828400	931900	1035400
7 <sup>5</sup> / <sub>8</sub>	45.664	652900	783400	870500	979300	1088100
7 <sup>3</sup> / <sub>4</sub>	47.173	685500	822600	914000	1028200	1142500
7 <sup>7</sup> / <sub>8</sub>	48.707	719200	863000	958900	1078800	1198700
8	50.265	754000	904800	1005300	1131000	1256600
8 <sup>1</sup> / <sub>8</sub>	51.849	789900	947900	1053200	1184800	1316500
8 <sup>1</sup> / <sub>4</sub>	53.456	826900	992300	1102500	1240300	1378200
8 <sup>3</sup> / <sub>8</sub>	55.088	865100	1038100	1153400	1297600	1441800
8 <sup>1</sup> / <sub>2</sub>	56.745	904400	1085200	1205800	1356600	1507300
8 <sup>5</sup> / <sub>8</sub>	58.426	944900	1133800	1259800	1417300	1574800
8 <sup>3</sup> / <sub>4</sub>	60.132	986500	1183800	1315400	1479800	1644200
8 <sup>7</sup> / <sub>8</sub>	61.862	1029400	1235300	1372500	1544100	1715700
9	63.617	1073500	1288200	1431400	1610300	1789200
9 <sup>1</sup> / <sub>8</sub>	65.397	1118900	1342700	1491900	1678400	1864800
9 <sup>1</sup> / <sub>4</sub>	67.201	1165500	1398600	1554000	1748300	1942500
9 <sup>3</sup> / <sub>8</sub>	69.029	1213400	1456100	1617900	1820100	2022300
9 <sup>1</sup> / <sub>2</sub>	70.882	1262600	1515100	1683400	1893900	2104300
9 <sup>5</sup> / <sub>8</sub>	72.760	1313100	1575700	1750800	1969600	2188500
9 <sup>3</sup> / <sub>4</sub>	74.662	1364900	1637900	1819600	2047400	2274900
9 <sup>7</sup> / <sub>8</sub>	76.590	1418100	1701700	1890800	2127100	2363500
10	78.54	1472600	1767100	1963500	2208900	2454400
10 <sup>1</sup> / <sub>4</sub>	82.52	1585900	1903000	2114500	2378800	2643100
10 <sup>1</sup> / <sub>2</sub>	86.59	1704700	2045700	2273000	2557100	2841200
10 <sup>3</sup> / <sub>4</sub>	90.76	1829400	2195300	2439300	2744200	3049100
11	95.03	1960100	2352100	2613400	2940100	3266800
11 <sup>1</sup> / <sub>4</sub>	99.40	2096800	2516100	2795700	3145200	3494800
11 <sup>1</sup> / <sub>2</sub>	103.87	2239700	2687600	2986300	3359500	3732800
12	113.10	2544700	3053600	3392900	3817000	4241200

DECI  
MALS  
ARE  
W



BEARING VALUES OF PINS  
FOR ONE INCH THICKNESS OF PLATE.

(=Diameter of Pin×1"× Stress per Square Inch.)

Diameter of Pin, inches.	Area of Pin, sq. in.	Bearing Value at 12,000 Lbs. Per sq. in. lbs.	Bearing Value at 15,000 Lbs. Per sq. in. lbs.	Diameter of Pin, inches.	Area of Pin, sq. in.	Bearing Value at 12,000 Lbs. Per sq. in. lbs.	Bearing Value at 15,000 Lbs. Per sq. in. lbs.
1	.785	12000	15000	4½	15.90	54000	67500
1¼	.994	13500	16900	4¾	16.80	55500	69400
1½	1.227	15000	18800	4¾	17.72	57000	71300
1¾	1.485	16500	20600	4¾	18.67	58500	73100
1½	1.767	18000	22500	5	19.64	60000	75000
1¾	2.074	19500	24400	5¼	20.63	61500	76900
1¾	2.405	21000	26300	5¼	21.65	63000	78800
1¾	2.761	22500	28100	5¾	22.69	64500	80600
2	3.142	24000	30000	5½	23.76	66000	82500
2¼	3.547	25500	31900	5¾	24.85	67500	84400
2¼	3.976	27000	33800	5¾	25.97	69000	86300
2¾	4.430	28500	35600	5¾	27.11	70500	88100
2½	4.909	30000	37500	6	28.27	72000	90000
2¾	5.412	31500	39400	6¼	29.46	73500	91900
2¾	5.940	33000	41300	6¼	30.68	75000	93800
2¾	6.492	34500	43100	6¾	31.92	76500	95600
3	7.069	36000	45000	6½	33.18	78000	97500
3¼	7.670	37500	46900	6¾	34.47	79500	99400
3¼	8.296	39000	48800	6¾	35.79	81000	101300
3¾	8.946	40500	50600	6¾	37.12	82500	103100
3½	9.621	42000	52500	7	38.48	84000	105000
3¾	10.32	43500	54400	7½	44.18	90000	112500
3¾	11.05	45000	56300	8	50.27	96000	120000
3¾	11.79	46500	58100	8½	56.75	102000	127500
4	12.57	48000	60000	9	63.62	108000	135000
4¼	13.36	49500	61900	10	78.54	120000	150000
4¼	14.19	51000	63800	11	95.03	132000	165000
4¾	15.03	52500	65600	12	113.10	144000	180000

STANDARD PIN-NUTS.

PINS.		PIN-NUTS.						PINS.		PIN-NUTS.					
Diam. of Pin.	Diam. of Screw.	Threads per inch.	Short Diameter.	Long Diameter.	Thick-ness.	Weight.	Diam. of Pin.	Diam. of Screw.	Threads per inch.	Short Diameter.	Long Diameter.	Thick-ness.	Weight.		
1 3/8	1 1/4	8	2 1/4	2 5/8	7/8	0.85	3 7/8	3 1/4	6	5	5 3/4	1 1/4	4.74		
2 1/8	1 1/2	8	2 1/2	2 7/8	3 1/2	1.03	4 1/8	3 1/2	6	5 1/2	6 3/8	1 1/4	6.19		
2 1/4	1 5/8	8	2 1/2	2 7/8	1	0.97	4 3/8	3 1/2	6	5 1/2	6 3/8	1 1/4	6.19		
2 3/8	1 3/4	8	3	3 1/2	1	1.50	4 5/8	3 3/4	6	5 1/2	6 3/8	1 1/4	5.87		
2 1/2	1 7/8	8	3	3 1/2	1	1.37	4 7/8	4	6	6	6 1 5/8	1 1/4	6.63		
2 5/8	2	8	3 1/2	4	1	2.06	5 1/8	4	6	6	6 1 5/8	1 1/4	6.63		
2 3/4	2 1/8	8	3 1/2	4	1	1.96	5 3/8	4 1/4	6	6	6 1 5/8	1 1/4	5.82		
2 7/8	2 1/4	8	4	4 5/8	1 1/4	3.38	5 5/8	4 1/2	6	6 3/4	7 1 3/8	1 1/4	8.53		
3	2 3/8	8	4	4 3/8	1 1/4	3.22	5 7/8	4 3/4	6	6 3/4	7 1 3/8	1 1/4	7.59		
3 1/8	2 1/2	8	4 1/4	4 7/8	1 1/4	3.63	6 1/8	4 3/4	6	6 3/4	7 1 3/8	1 1/4	7.59		
3 1/4	2 5/8	8	4 1/4	4 7/8	1 1/4	3.41	6 3/8	5	6	8	9 1/4	1 1/4	13.06		
3 3/8	2 3/4	6	4 1/2	5 1 1/8	1 1/4	4.09	6 5/8	5 1/4	6	8	9 1/4	1 1/2	14.86		
3 1/2	2 7/8	6	4 3/4	5 1/2	1 1/4	4.63	6 7/8	5 1/2	6	8	9 1/4	1 1/2	14.00		
3 5/8	3	6	5	5 3/4	1 1/4	5.25	7 1/8	5 3/4	6	8	9 1/4	1 1/2	13.10		

All dimensions given above are in inches. Weights refer to untapped nuts.

WOOD SCREWS.

Diameter=number  $\times$  0.01325 + 0.056.

No.	Diam.	No.	Diam.	No.	Diam.	No.	Diam.	No.	Diam.
0	.056	6	.135	12	.215	18	.293	24	.374
1	.069	7	.149	13	.228	19	.308	25	.387
2	.082	8	.162	14	.241	20	.321	26	.401
3	.096	9	.175	15	.255	21	.334	27	.414
4	.109	10	.188	16	.268	22	.347	28	.427
5	.122	11	.201	17	.281	23	.361	29	.440
								30	.453

DECI  
MALS

ARE

W

WEIGHT OF RIVETS AND ROUND HEADED  
BOLTS WITHOUT NUTS PER 100.  
STEEL.

Length. Inches.	$\frac{3}{8}$ " Dia.	$\frac{1}{2}$ " Dia.	$\frac{5}{8}$ " Dia.	$\frac{3}{4}$ " Dia.	$\frac{7}{8}$ " Dia.	1" Dia.	$1\frac{1}{8}$ " Dia.	$1\frac{1}{4}$ " Dia.
1 $\frac{1}{4}$	5.5	12.8	22.0	29.3	43.9	66.6	93.3	127.
1 $\frac{1}{2}$	6.3	14.2	24.1	32.4	48.2	72.1	100.	136.
1 $\frac{3}{4}$	7.0	15.5	26.3	35.5	52.5	77.7	107.	145.
2	7.9	16.9	28.5	38.7	56.7	83.3	114.	158.
2 $\frac{1}{4}$	8.7	18.3	30.7	41.8	61.0	88.8	121.	162.
2 $\frac{1}{2}$	9.4	19.7	32.8	44.9	65.2	94.4	128.	171.
2 $\frac{3}{4}$	10.2	21.1	35.0	48.0	69.5	100.	136.	179.
3	11.0	22.5	37.2	51.1	73.7	105.	143.	188.
3 $\frac{1}{4}$	11.7	23.9	39.3	54.3	78.0	111.	150.	197.
3 $\frac{1}{2}$	12.6	25.3	41.5	57.4	82.3	116.	157.	205.
3 $\frac{3}{4}$	13.4	26.7	43.7	60.5	86.5	122.	164.	214.
4	14.1	28.1	45.9	63.6	90.8	128.	170.	223.
4 $\frac{1}{4}$	14.9	29.4	48.0	66.7	95.0	134.	177.	231.
4 $\frac{1}{2}$	15.7	30.8	50.2	69.9	99.3	139.	185.	240.
4 $\frac{3}{4}$	16.5	32.2	52.4	73.0	104.	145.	192.	249.
5	17.2	33.6	54.5	76.1	108.	150.	199.	258.
5 $\frac{1}{4}$	18.1	35.0	56.7	79.2	112.	156.	206.	266.
5 $\frac{1}{2}$	18.8	36.4	58.9	82.3	116.	161.	213.	275.
5 $\frac{3}{4}$	19.6	37.8	61.1	85.5	120.	166.	220.	284.
6	20.4	39.2	63.2	88.6	124.	172.	227.	292.
6 $\frac{1}{2}$	21.9	42.0	67.6	95.1	133.	184.	241.	310.
7	23.5	44.7	71.9	101.	142.	195.	255.	327.
7 $\frac{1}{2}$	25.1	47.5	76.1	108.	150.	206.	269.	345.
8	26.6	50.3	80.6	114.	159.	217.	284.	362.
8 $\frac{1}{2}$	28.2	53.1	85.0	120.	167.	227.	298.	379.
9	29.8	55.9	89.3	126.	176.	239.	312.	397.
9 $\frac{1}{2}$	31.3	58.7	93.7	133.	185.	250.	325.	414.
10	32.8	61.4	98.0	139.	193.	261.	340.	431.
10 $\frac{1}{2}$	34.5	64.2	103.	145.	202.	272.	354.	449.
11	36.0	67.0	107.	151.	210.	284.	368.	466.
11 $\frac{1}{2}$	37.6	69.8	111.	158.	218.	295.	382.	484.
12	39.2	72.5	115.	164.	227.	306.	396.	501.
Heads.	1.8	5.8	11.1	13.6	22.6	39.0	58.0	83.5

WEIGHT OF 100 BOLTS WITH SQUARE HEADS AND NUTS.

Length under head to point.	DIAMETER OF BOLTS.								
	1/4 in.	5/16 in.	3/8 in.	7/16 in.	1/2 in.	5/8 in.	3/4 in.	7/8 in.	1 in.
	lbs.	lbs.	lbs.	lbs.	lbs.	lbs.	lbs.	lbs.	lbs.
1 1/4	4.0	7.0	10.5	15.2	22.5	39.5	63.0	....	...
1 3/4	4.4	7.5	11.3	16.3	23.8	41.6	66.0	....	...
2	4.8	8.0	12.0	17.4	25.2	43.8	69.0	109.0	163
2 1/4	5.2	8.5	12.8	18.5	26.5	45.8	72.0	113.3	169
2 3/4	5.5	9.0	13.5	19.6	27.8	48.0	75.0	117.5	174
3	5.8	9.5	14.8	20.7	29.1	50.1	78.0	121.8	180
3 1/2	6.3	10.0	15.0	21.8	30.5	52.3	81.0	126.0	185
4	7.0	11.0	16.5	24.0	33.1	56.5	87.0	134.3	196
4 1/2	7.8	12.0	18.0	26.2	35.8	60.8	93.1	142.5	207
5	8.5	13.0	19.5	28.4	38.4	65.0	99.1	151.0	218
5 1/2	9.3	14.0	21.0	30.6	41.1	69.3	105.2	159.6	229
6	10.0	15.0	22.5	32.8	43.7	73.5	111.3	168.0	240
6 1/2	10.8	16.0	24.0	35.0	46.4	77.8	117.3	176.6	251
7	....	....	25.5	37.2	49.0	82.0	123.4	185.0	262
7 1/2	....	....	27.0	39.4	51.7	86.3	129.4	193.7	273
8	....	....	28.5	41.6	54.3	90.5	135.0	202.0	284
9	....	....	30.0	43.8	59.6	94.8	141.5	210.7	295
10	....	....	....	46.0	64.9	103.3	153.6	227.8	317
11	....	....	....	48.2	70.2	111.8	165.7	244.8	339
12	....	....	....	50.4	75.5	120.3	177.8	261.9	360
13	....	....	....	52.6	80.8	128.8	189.9	278.9	382
14	....	....	....	....	86.1	137.3	202.0	296.0	404
15	....	....	....	....	91.4	145.8	214.1	313.0	426
16	....	....	....	....	96.7	154.3	226.2	330.1	448
17	....	....	....	....	102.0	162.8	238.3	347.1	470
18	....	....	....	....	107.3	171.0	250.4	364.2	492
19	....	....	....	....	112.6	179.5	262.6	381.2	514
20	....	....	....	....	117.9	188.0	274.7	398.3	536
Per inch additional.	1.1	2.1	3.1	4.2	5.5	8.5	12.3	16.7	21.8

WEIGHTS OF NUTS AND BOLT-HEADS IN POUNDS

For Calculating the Weight of Longer Bolts.

Diameter of Bolt in Inches.		1/4	3/8	1/2	5/8	3/4	7/8
Weight of Hexagon Nut and Head.....	.....	.017	.057	.128	.267	.43	.73
Weight of Square Nut and Head.....	.....	.021	.069	.161	.320	.55	.88
Diameter of Bolt in Inches.	1	1 1/4	1 1/2	1 3/4	2	2 1/2	3
Weight of Hexagon Nut and Head.....	1.10	2.14	3.78	5.6	8.75	17.0	28.8
Weight of Square Nut and Head.....	1.31	2.56	4.42	7.0	10.5	21.0	36.4

DIMENSIONS AND WEIGHTS OF HOT PRESSED SQUARE NUTS.

The sizes are the usual manufacturers' not the Franklin Institute Standard. Both weights and sizes are for the unfinished Nut.

Size of Bolt.	Weight of 100 Nuts.	Rough Hole.	Thickness of Nut.	Side of Square.	Diagonal.	No. of Nuts in 100 lbs.
$\frac{1}{4}$	1.5	$\frac{7}{8}$	$\frac{1}{4}$	$\frac{1}{2}$	.71	6800
$\frac{1}{8}$	2.9	$\frac{9}{8}$	$\frac{5}{8}$	$\frac{3}{8}$	.88	3480
$\frac{3}{8}$	4.9	$\frac{11}{8}$	$\frac{3}{8}$	$\frac{1}{4}$	1.06	2050
$\frac{7}{8}$	7.7	$\frac{13}{8}$	$\frac{7}{8}$	$\frac{7}{8}$	1.24	1290
$\frac{1}{2}$	8.6	$\frac{7}{8}$	$\frac{1}{2}$	$\frac{7}{8}$	1.24	1170
$\frac{1}{2}$	11.8	$\frac{7}{8}$	$\frac{1}{2}$	1	1.41	850
$\frac{9}{8}$	16.7	$\frac{1}{2}$	$\frac{9}{8}$	$1\frac{1}{8}$	1.59	600
$\frac{5}{8}$	17.7	$\frac{9}{8}$	$\frac{5}{8}$	$1\frac{1}{8}$	1.59	570
$\frac{5}{8}$	22.8	$\frac{9}{8}$	$\frac{5}{8}$	$1\frac{1}{4}$	1.77	440
$\frac{3}{4}$	32.3	$\frac{21}{8}$	$\frac{3}{4}$	$1\frac{3}{8}$	1.94	310
$\frac{3}{4}$	39.8	$\frac{21}{8}$	$\frac{3}{4}$	$1\frac{1}{2}$	2.12	251
$\frac{7}{8}$	53.	$\frac{21}{8}$	$\frac{7}{8}$	$1\frac{3}{8}$	2.30	190
$\frac{7}{8}$	63.	$\frac{21}{8}$	$\frac{7}{8}$	$1\frac{3}{4}$	2.47	159
1	68.	$\frac{7}{8}$	1	$1\frac{3}{4}$	2.47	146
1	94.	$\frac{7}{8}$	1	2	2.83	106
$1\frac{1}{8}$	103.	$\frac{15}{8}$	$1\frac{1}{8}$	2	2.83	97
$1\frac{1}{8}$	137.	$\frac{15}{8}$	$1\frac{1}{8}$	$2\frac{1}{4}$	3.18	73
$1\frac{1}{4}$	145.	$1\frac{1}{8}$	$1\frac{1}{4}$	$2\frac{1}{4}$	3.18	69
$1\frac{1}{4}$	186.	$1\frac{1}{8}$	$1\frac{1}{4}$	$2\frac{1}{2}$	3.54	54
$1\frac{3}{8}$	247.	$1\frac{3}{8}$	$1\frac{3}{8}$	$2\frac{3}{4}$	3.89	41
$1\frac{1}{2}$	319.	$1\frac{5}{8}$	$1\frac{1}{2}$	3	4.24	31.3
$1\frac{5}{8}$	400.	$1\frac{7}{8}$	$1\frac{5}{8}$	$3\frac{1}{4}$	4.60	24.8
$1\frac{3}{4}$	500.	$1\frac{9}{8}$	$1\frac{3}{4}$	$3\frac{1}{2}$	4.95	19.9
$1\frac{7}{8}$	620.	$1\frac{11}{8}$	$1\frac{7}{8}$	$3\frac{3}{4}$	5.30	16.2
2	750.	$1\frac{13}{8}$	2	4	5.66	13.4
$2\frac{1}{8}$	780.	$1\frac{7}{8}$	$2\frac{1}{8}$	4	5.66	12.8
$2\frac{1}{4}$	930.	2	$2\frac{1}{4}$	$4\frac{1}{4}$	6.01	10.7
$2\frac{3}{8}$	960.	$2\frac{1}{8}$	$2\frac{3}{8}$	$4\frac{1}{4}$	6.01	10.4
$2\frac{1}{2}$	1130.	$2\frac{1}{4}$	$2\frac{1}{2}$	$4\frac{1}{2}$	6.36	8.9
$2\frac{3}{4}$	1370.	$2\frac{7}{8}$	$2\frac{3}{4}$	$4\frac{3}{4}$	6.72	7.3
3	1610.	$2\frac{11}{8}$	3	5	7.07	6.2
$3\frac{1}{4}$	2110.	$2\frac{13}{8}$	$3\frac{1}{4}$	$5\frac{1}{2}$	7.78	4.7
$3\frac{1}{2}$	2750.	$3\frac{1}{8}$	$3\frac{1}{2}$	6	8.49	3.6

DIMENSIONS AND WEIGHTS OF HOT  
PRESSED HEXAGON NUTS.

The sizes are the usual manufacturers' not the Franklin Institute Standard. Both weights and sizes are for the unfinished Nut.

Size of Bolt.	Weight of 100 Nuts.	Rough Hole.	Thickness of Nut.	Short Diameter.	Long Diameter.	No. of Nuts in 100 lbs.
$\frac{1}{4}$	1.3	$\frac{7}{32}$	$\frac{1}{4}$	$\frac{1}{2}$	.58	8000
$\frac{5}{16}$	2.4	$\frac{9}{32}$	$\frac{5}{16}$	$\frac{5}{8}$	.72	4170
$\frac{3}{8}$	4.1	$\frac{11}{32}$	$\frac{3}{8}$	$\frac{3}{4}$	.87	2410
$\frac{7}{16}$	6.8	$\frac{13}{32}$	$\frac{7}{16}$	$\frac{7}{8}$	1.01	1460
$\frac{1}{2}$	7.1	$\frac{7}{16}$	$\frac{1}{2}$	$\frac{7}{8}$	1.01	1410
$\frac{1}{2}$	9.8	$\frac{7}{16}$	$\frac{1}{2}$	1	1.15	1020
$\frac{9}{16}$	14.0	$\frac{1}{2}$	$\frac{9}{16}$	$1\frac{1}{8}$	1.30	710
$\frac{5}{8}$	14.7	$\frac{9}{16}$	$\frac{5}{8}$	$1\frac{1}{8}$	1.30	680
$\frac{5}{8}$	19.1	$\frac{9}{16}$	$\frac{5}{8}$	$1\frac{1}{4}$	1.44	520
$\frac{5}{8}$	22.9	$\frac{1}{2}$	$\frac{3}{4}$	$1\frac{1}{4}$	1.44	440
$\frac{3}{4}$	27.2	$2\frac{1}{16}$	$\frac{3}{4}$	$1\frac{3}{8}$	1.59	370
$\frac{3}{4}$	39.	$2\frac{1}{16}$	$\frac{7}{8}$	$1\frac{1}{2}$	1.73	256
$\frac{7}{8}$	44.	$2\frac{1}{16}$	$\frac{7}{8}$	$1\frac{5}{8}$	1.88	226
$\frac{7}{8}$	50.	$2\frac{1}{16}$	1	$1\frac{5}{8}$	1.88	198
1	57.	$\frac{7}{8}$	1	$1\frac{3}{4}$	2.02	176
1	64.	$\frac{7}{8}$	$1\frac{1}{8}$	$1\frac{3}{4}$	2.02	156
$1\frac{1}{8}$	96.	$1\frac{5}{16}$	$1\frac{1}{4}$	2	2.31	104
$1\frac{1}{4}$	134.	$1\frac{1}{16}$	$1\frac{3}{8}$	$2\frac{1}{4}$	2.60	75
$1\frac{3}{8}$	180.	$1\frac{3}{16}$	$1\frac{1}{2}$	$2\frac{1}{2}$	2.89	56
$1\frac{1}{2}$	235.	$1\frac{9}{16}$	$1\frac{5}{8}$	$2\frac{3}{4}$	3.18	42
$1\frac{5}{8}$	300.	$1\frac{7}{16}$	$1\frac{3}{4}$	3	3.46	33.4
$1\frac{3}{4}$	370.	$1\frac{9}{16}$	$1\frac{7}{8}$	$3\frac{1}{4}$	3.75	26.7
$1\frac{7}{8}$	460.	$1\frac{11}{16}$	2	$3\frac{1}{2}$	4.04	21.5
2	450.	$1\frac{13}{16}$	2	$3\frac{1}{2}$	4.04	22.4
$2\frac{1}{8}$	560.	$1\frac{7}{8}$	$2\frac{1}{8}$	$3\frac{3}{4}$	4.33	18.0
$2\frac{1}{4}$	560.	2	$2\frac{1}{4}$	$3\frac{3}{4}$	4.33	17.7
$2\frac{3}{8}$	680.	$2\frac{1}{8}$	$2\frac{3}{8}$	4	4.62	14.7
$2\frac{1}{2}$	810.	$2\frac{1}{4}$	$2\frac{1}{2}$	$4\frac{1}{4}$	4.91	12.3
$2\frac{3}{4}$	980.	$2\frac{7}{16}$	$2\frac{3}{4}$	$4\frac{1}{2}$	5.20	10.2
3	1150.	$2\frac{11}{16}$	3	$4\frac{3}{4}$	5.48	8.7
$3\frac{1}{4}$	1340.	$2\frac{15}{16}$	$3\frac{1}{4}$	5	5.77	7.5
$3\frac{1}{2}$	1580.	$3\frac{1}{8}$	$3\frac{1}{2}$	$5\frac{1}{4}$	6.06	6.3

DECI  
MALS

ARC

W

UPSET SCREW ENDS FOR ROUND AND SQUARE BARS.

Dia. of Round or Side of Square Bar. Inches.	ROUND BARS.				SQUARE BARS.			
	Dia. of Upset Screw End. Inches.	Dia. of Screw at Root of Thread. Inches.	Threads per inch. No.	Excess of Effective Area of Screw End over Bar. Per Cent.	Dia. of Upset Screw End. Inches.	Dia. of Screw at Root of Thread. Inches.	Threads per inch. No.	Excess of Effective Area of Screw End over Bar. Per Cent.
$\frac{1}{2}$	$\frac{3}{4}$	.620	10	54	$\frac{3}{4}$	.620	10	21
$\frac{1}{16}$	$\frac{3}{4}$	.620	10	21	$\frac{7}{8}$	.731	9	33
$\frac{3}{8}$	$\frac{7}{8}$	.731	9	37	1	.837	8	41
$\frac{1}{8}$	1	.837	8	48	1	.837	8	17
$\frac{3}{4}$	1	.837	8	25	$1\frac{1}{8}$	.940	7	23
$\frac{1}{8}$	$1\frac{1}{8}$	.940	7	34	$1\frac{1}{4}$	1.065	7	35
$\frac{7}{8}$	$1\frac{1}{4}$	1.065	7	48	$1\frac{3}{8}$	1.160	6	38
$\frac{1}{8}$	$1\frac{1}{4}$	1.065	7	29	$1\frac{3}{8}$	1.160	6	20
1	$1\frac{3}{8}$	1.160	6	35	$1\frac{1}{2}$	1.284	6	29
$1\frac{1}{16}$	$1\frac{3}{8}$	1.160	6	19	$1\frac{5}{8}$	1.389	$5\frac{1}{2}$	34
$1\frac{1}{8}$	$1\frac{1}{2}$	1.284	6	30	$1\frac{5}{8}$	1.389	$5\frac{1}{2}$	20
$1\frac{1}{8}$	$1\frac{1}{2}$	1.284	6	17	$1\frac{3}{4}$	1.490	5	24
$1\frac{1}{4}$	$1\frac{5}{8}$	1.389	$5\frac{1}{2}$	23	$1\frac{7}{8}$	1.615	5	31
$1\frac{1}{8}$	$1\frac{3}{4}$	1.490	5	29	$1\frac{7}{8}$	1.615	5	19
$1\frac{3}{8}$	$1\frac{3}{4}$	1.490	5	18	2	1.712	$4\frac{1}{2}$	22
$1\frac{7}{8}$	$1\frac{7}{8}$	1.615	5	26	$2\frac{1}{8}$	1.837	$4\frac{1}{2}$	28
$1\frac{1}{2}$	2	1.712	$4\frac{1}{2}$	30	$2\frac{1}{8}$	1.837	$4\frac{1}{2}$	18
$1\frac{9}{8}$	2	1.712	$4\frac{1}{2}$	20	$2\frac{1}{4}$	1.962	$4\frac{1}{2}$	24
$1\frac{3}{8}$	$2\frac{1}{8}$	1.837	$4\frac{1}{2}$	28	$2\frac{3}{8}$	2.087	$4\frac{1}{2}$	30
$1\frac{1}{16}$	$2\frac{1}{8}$	1.837	$4\frac{1}{2}$	18	$2\frac{3}{8}$	2.087	$4\frac{1}{2}$	20
$1\frac{3}{4}$	$2\frac{1}{4}$	1.962	$4\frac{1}{2}$	26	$2\frac{1}{2}$	2.175	4	21
$1\frac{1}{8}$	$2\frac{1}{4}$	1.962	$4\frac{1}{2}$	17	$2\frac{5}{8}$	2.300	4	26
$1\frac{7}{8}$	$2\frac{3}{8}$	2.087	$4\frac{1}{2}$	24	$2\frac{5}{8}$	2.300	4	18
$1\frac{1}{8}$	$2\frac{1}{2}$	2.175	4	26	$2\frac{3}{4}$	2.425	4	23
2	$2\frac{1}{2}$	2.175	4	18	$2\frac{7}{8}$	2.550	4	28
$2\frac{1}{16}$	$2\frac{3}{8}$	2.300	4	24	$2\frac{7}{8}$	2.550	4	20
$2\frac{1}{8}$	$2\frac{5}{8}$	2.300	4	17	3	2.629	$3\frac{1}{2}$	20
$2\frac{1}{8}$	$2\frac{3}{4}$	2.425	4	23	$3\frac{1}{8}$	2.754	$3\frac{1}{2}$	24

UPSET SCREW ENDS.

(CONTINUED.)

Dia. of Round or Side of Square Bar. Inches.	ROUND BARS.				SQUARE BARS.			
	Dia. of Upset Screw End. Inches.	Dia. of Screw at Root of Thread. Inches.	Threads per inch. No.	Excess of Effective Area of Screw End over Bar. Per Cent.	Dia. of Upset Screw End. Inches.	Dia. of Screw at Root of Thread. Inches.	Threads per inch. No.	Excess of Effective Area of Screw End over Bar. Per Cent.
2¼	2⅞	2.550	4	28	3⅛	2.754	3½	18
2⅝	2⅞	2.550	4	22	3¼	2.879	3½	22
2⅞	3	2.629	3½	23	3⅜	3.004	3½	26
2⅞	3⅛	2.754	3½	28	3⅜	3.004	3½	19
2½	3⅛	2.754	3½	21	3½	3.100	3¼	21
2⅞	3¼	2.879	3½	26	3⅝	3.225	3¼	24
2⅝	3¼	2.879	3½	20	3⅝	3.225	3¼	19
2½	3⅜	3.004	3½	25	3¾	3.317	3	20
2¾	3⅜	3.004	3½	19	3⅞	3.442	3	23
2½	3½	3.100	3¼	22	3⅞	3.442	3	18
2⅞	3⅝	3.225	3¼	26	4	3.567	3	21
2½	3⅝	3.225	3¼	21	4⅛	3.692	3	24
3	3¾	3.317	3	22	4⅛	3.692	3	19
3⅛	3⅞	3.442	3	21	4⅜	3.923	2⅞	24
3¼	4	3.567	3	20	4½	4.028	2¾	21
3⅞	4⅛	3.692	3	20	4⅝	4.153	2¾	19
3½	4¼	3.798	2⅞	18	. .	. .	. .	. .
3⅝	4½	4.028	2¾	23	. .	. .	. .	. .
3¾	4⅝	4.153	2¾	23	. .	. .	. .	. .
3⅞	4¾	4.255	2⅝	21	. .	. .	. .	. .

REMARKS.—As upsetting reduces the strength, bars having the same diameter at root of thread as that of the bar invariably break in the screw end when tested to destruction, without developing the full strength of the bar. It is therefore necessary to make up for this loss in strength by an excess of metal in the upset screw ends over that in the bar.

The above table is the result of numerous tests on finished bars made by The Carnegie Steel Company, Limited, and gives proportions that will cause the bar to break in the body in preference to the upset end.

The screw threads in above table are the Franklin Institute standard.

To make one upset end for 5" length of thread allow 6" length of rod additional.

DECI  
MALS

ARE

W



STANDARD SCREW THREADS, NUTS AND BOLT HEADS.—Recommended by the Franklin Institute.

SCREW THREADS.

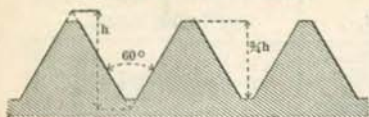

Angle of Thread 60°. Flat at Top and Bottom— $\frac{1}{8}$  of pitch.

Dia. of Screw, inches.	Dia. at Root of Thread, inches.	Threads per inch. No.
$\frac{1}{4}$	.185	20
$\frac{5}{16}$	.240	18
$\frac{3}{8}$	.294	16
$\frac{7}{8}$	.344	14
$\frac{1}{2}$	.400	13
$\frac{9}{16}$	.454	12
$\frac{5}{8}$	.507	11
$\frac{3}{4}$	.620	10
$\frac{7}{8}$	.731	9
1	.837	8
$1\frac{1}{8}$	.940	7
$1\frac{1}{4}$	1.065	7
$1\frac{3}{8}$	1.160	6
$1\frac{1}{2}$	1.284	6
$1\frac{5}{8}$	1.389	$5\frac{1}{2}$
$1\frac{3}{4}$	1.490	5
$1\frac{7}{8}$	1.615	5
2	1.712	$4\frac{1}{2}$
$2\frac{1}{4}$	1.962	$4\frac{1}{2}$
$2\frac{1}{2}$	2.175	4
$2\frac{3}{4}$	2.425	4
3	2.629	$3\frac{1}{2}$
$3\frac{1}{4}$	2.879	$3\frac{1}{2}$
$3\frac{1}{2}$	3.100	$3\frac{1}{4}$
$3\frac{3}{4}$	3.317	3
4	3.567	3
$4\frac{1}{4}$	3.798	$2\frac{7}{8}$
$4\frac{1}{2}$	4.028	$2\frac{3}{4}$
$4\frac{3}{4}$	4.255	$2\frac{5}{8}$
5	4.480	$2\frac{1}{2}$
$5\frac{1}{4}$	4.730	$2\frac{1}{2}$
$5\frac{1}{2}$	4.953	$2\frac{3}{8}$
$5\frac{3}{4}$	5.203	$2\frac{3}{8}$
6	5.423	$2\frac{1}{4}$

Nuts and Bolt Heads are determined by the following rules which apply to both Square and Hexagon Nuts:

Short diameter of rough nut  
 —  $1\frac{1}{2} \times$  dia. of bolt —  $\frac{1}{8}$  in.

Short diameter of finished nut  
 —  $1\frac{1}{2} \times$  dia. of bolt —  $1-16$  in.

Thickness of rough nut  
 — diameter of bolt.

Thickness of finished nut  
 — diameter of bolt— $1-16$  in.

Short diameter of rough head  
 —  $1\frac{1}{2} \times$  dia. of bolt —  $\frac{1}{8}$  in.

Short dia. of finished head  
 —  $1\frac{1}{2} \times$  dia. of bolt —  $1-16$  in.

Thickness of rough head  
 —  $\frac{1}{2}$  short dia. of head.

Thickness of finished head  
 — dia. of bolt —  $1-16$  in.

The long diameter of a hexagon nut may be obtained by multiplying the short diameter by 1.155 and the long diameter of a square nut by multiplying the short diameter by 1.414.

The above standards for screw threads, nuts and bolt heads were recommended by the Franklin Institute in Dec. 1864. The standard for screw threads has been very generally adopted in the United States, but the proportions recommended for nuts and bolt heads have not found general acceptance because of the odd sizes of bar—not usually rolled by the mills—required to make the nut.

**WHITWORTH'S STANDARD ANGULAR  
SCREW THREADS.**

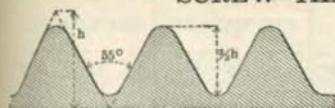

Angle of thread 55°.  
Depth of thread = pitch  
of screw.  
1/8 of depth is rounded off  
at top and bottom.

Number of threads to the inch in square threads = 1/2 the number in angular threads.

Dia. of Screw. In.	Threads to the inch. No.	Dia. of Screw. In.	Threads to the inch. No.	Dia. of Screw. In.	Threads to the inch. No.	Dia. of Screw. In.	Threads to the inch. No.
1/4	20	1	8	2	4 1/2	4	8
5/16	18	1 1/8	7	2 1/4	4	4 1/4	2 7/8
3/8	16	1 1/4	7	2 1/2	4	4 1/2	2 7/8
7/16	14	1 3/8	6	2 3/4	3 1/2	4 3/4	2 3/4
1/2	12	1 1/2	6	3	3 1/2	5	2 3/4
5/8	11	1 5/8	5	3 1/4	3 1/4	5 1/4	2 5/8
3/4	10	1 3/4	5	3 1/2	3 1/4	5 1/2	2 5/8
7/8	9	1 7/8	4 1/2	3 3/4	3	5 3/4	2 1/2
						6	2 1/2

**STANDARD STEAM, GAS AND WATER PIPE,**  
As manufactured by the National Tube Works Co.

DIAMETER IN INCHES.			Thickness. inches.	Length of Pipe containing one cubic foot.	Nominal Weight per foot. pounds.	Number of Threads per inch of screw.
Nominal Internal.	Actual External.	Actual Internal.				
3/8	.405	.27	.068	2513.	0.24	27
1/4	.54	.364	.088	1383.3	0.42	18
5/16	.675	.494	.091	751.2	0.56	18
3/8	.84	.623	.109	472.4	0.84	14
1/2	1.05	.824	.113	270.	1.12	14
3/4	1.315	1.048	.134	166.9	1.67	11 1/2
1	1.66	1.38	.140	96.25	2.24	11 1/2
1 1/4	1.9	1.611	.145	70.66	2.68	11 1/2
2	2.375	2.067	.154	42.91	3.61	11 1/2
2 1/2	2.875	2.468	.204	30.1	5.74	8
3	3.5	3.067	.217	19.5	7.54	8
3 1/2	4.	3.548	.226	14.57	9.00	8
4	4.5	4.026	.237	11.31	10.66	8
4 1/2	5.	4.508	.246	9.02	12.49	8
5	5.563	5.045	.259	7.2	14.50	8
6	6.625	6.065	.280	4.98	18.76	8
7	7.625	7.023	.301	3.72	23.27	8
8	8.625	7.982	.322	2.88	28.18	8
9	9.625	8.937	.344	2.29	33.70	8
10	10.75	10.019	.366	1.82	40.00	8

DECI  
MALS  
ARE  
W

SPIKES, NAILS AND TACKS.

STANDARD STEEL WIRE NAILS.						STEEL WIRE SPIKES.			COMMON IRON NAILS.		
Size.	Length.	Common.		Finishing.		Length.	Diam. inches.	No. per pound.	Size.	Length.	No. per pound.
		Diam. inches.	No. per pound.	Diam. inches.	No. per pound.						
2d	1"	.0524	1060	.0453	1558	3"	.1620	41	2d	1"	800
3d	1 1/4"	.0588	640	.0508	913	3 1/2"	.1819	30	3d	1 1/4"	400
4d	1 1/2"	.0720	380	.0508	761	4"	.2043	23	4d	1 1/2"	300
5d	1 3/4"	.0764	275	.0571	500	4 1/2"	.2294	17	5d	1 3/4"	200
6d	2"	.0808	210	.0641	350	5"	.2576	13	6d	2"	150
7d	2 1/4"	.0858	160	.0641	315	5 1/2"	.2893	11	7d	2 1/4"	120
8d	2 1/2"	.0935	115	.0720	214	6"	.2893	10	8d	2 1/2"	85
9d	2 3/4"	.0963	93	.0720	195	6 1/2"	.2249	7 1/2	9d	2 3/4"	75
10d	3"	.1082	77	.0808	137	7"	.2249	7	10d	3"	60
12d	3 1/4"	.1144	60	.0808	127	8"	.3648	5	12d	3 1/4"	50
16d	3 1/2"	.1285	48	.0907	90	9"	.3648	4 1/2	16d	3 1/2"	40
20d	4"	.1620	31	.1019	62				20d	4"	20
30d	4 1/2"	.1819	22						30d	4 1/2"	16
40d	5"	.2043	17						40d	5"	14
50d	5 1/2"	.2294	13						50d	5 1/2"	11
60d	6"	.2576	11						60d	6"	8

TACKS.

Title. oz.	Length. in.	Number per pound.	Title. oz.	Length. in.	Number per pound.	Title. oz.	Length. in.	Number per pound.
1	1/8	16000	4	7/8	4000	14	1 1/8	1143
1 1/2	1 1/8	10666	6	1 1/8	2666	16	7/8	1000
2	1/4	8000	8	3/8	2000	18	1 1/8	888
2 1/2	1 1/8	6400	10	1 1/8	1600	20	1	800
3	3/8	5333	12	3/4	1333	22	1 1/8	727
						24	1 3/8	666

WROUGHT SPIKES.

Number to a keg of 150 lbs.

Length. in.	1/4 inch. No.	5/8 inch. No.	3/4 inch. No.	Length. in.	1/4 inch. No.	5/8 inch. No.	3/4 inch. No.	1 1/8 inch. No.	1 1/2 inch. No.
3	2250			7	1161	662	482	445	306
3 1/2	1890	1208		8		635	455	384	256
4	1650	1135		9		573	424	300	240
4 1/2	1464	1064		10			391	270	222
5	1380	930	742	11				249	203
6	1292	868	570	12				236	180

STANDARD CLEVIS NUTS.

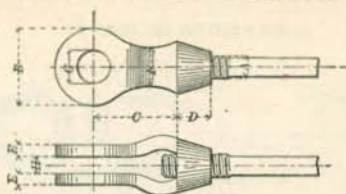

Distance H can be made to suit connections.

Diameter of Round Bar.	A	Side of Square Bar.	A	B	C	D	E	F	G
	Upset Screw End for Round Bar.		Upset Screw End for Square Bar.	Diameter of Eye.	Length of Fork.	Length of Thread.	Thickness of Bar in Fork.	Width of Bar in Fork.	Diameter of Pin.
1 1/4 *	1 5/8	1 1/8	1 5/8	4 3/4	5 1/2	2	5/8	2 1/2	1 7/8
1 1/2	1 3/4	1 1/8	1 3/4	5 7/8	6 1/2	2 1/2	3/4	3 1/8	2 1/4
1 3/8	1 3/4	1 1/4	1 7/8	5 7/8	6 1/2	2 1/2	3/4	3 1/8	2 1/4
1 7/8	1 7/8	1 5/8	1 7/8	5 7/8	6 1/2	2 1/2	3/4	3 1/8	2 1/4
1 1/2	2	1 3/8	2	5 7/8	6 1/2	2 1/2	3/4	3 1/8	2 1/4
1 9/16	2	1 7/8	2 1/8	5 7/8	6 1/2	2 1/2	3/4	3 1/8	2 1/4
1 3/8	2 1/8	.	.	5 7/8	6 1/2	2 1/2	3/4	3 1/8	2 1/4
1 1/2	2 1/8	1 1/2	2 1/8	6 5/8	7	2 7/8	7/8	3 1/8	2 5/8
1 3/4	2 1/4	1 9/16	2 1/4	6 5/8	7	2 7/8	7/8	3 1/8	2 5/8
1 11/16	2 1/4	1 5/8	2 3/8	6 5/8	7	2 7/8	7/8	3 1/8	2 5/8
1 7/8	2 3/8	1 11/16	2 3/8	6 5/8	7	2 7/8	7/8	3 1/8	2 5/8
1 11/8	2 1/2	1 3/4	2 1/2	7 7/8	8	3 1/2	1 1/8	3 7/8	3 1/8
2	2 1/2	1 13/16	2 5/8	7 7/8	8	3 1/2	1 1/8	3 7/8	3 1/8
2 1/16	2 5/8	1 7/8	2 5/8	7 7/8	8	3 1/2	1 1/8	3 7/8	3 1/8
2 1/8	2 5/8	1 15/16	2 3/4	7 7/8	8	3 1/2	1 1/8	3 7/8	3 1/8
2 1/4	2 7/8	.	.	7 7/8	8	3 1/2	1 1/8	3 7/8	3 1/8
2 5/16	2 7/8	2 1/16	2 7/8	9	8 1/2	4	1 1/4	4 1/8	3 5/8
2 3/8	3	2 1/8	3	9	8 1/2	4	1 1/4	4 1/8	3 5/8
2 7/16	3 1/8	2 3/16	3 1/8	9	8 1/2	4	1 1/4	4 1/8	3 5/8
2 1/2	3 1/8	2 1/4	3 1/8	9	8 1/2	4	1 1/4	4 1/8	3 5/8
2 9/16	3 1/4	2 1/16	3 1/4	9	8 1/2	4	1 1/4	4 1/8	3 5/8
2 5/8	3 1/4	2 3/8	3 3/8	9	8 1/2	4	1 1/4	4 1/8	3 5/8
2 11/16	3 3/8	.	.	9	8 1/2	4	1 1/4	4 1/8	3 5/8
2 3/4	3 3/8	2 7/16	3 3/8	9 3/4	9	4 1/4	1 5/8	5 1/4	3 7/8
2 13/16	3 1/2	2 1/2	3 1/2	9 3/4	9	4 1/4	1 5/8	5 1/4	3 7/8
2 7/8	3 5/8	2 15/16	3 5/8	9 3/4	9	4 1/4	1 5/8	5 1/4	3 7/8
2 15/16	3 5/8	2 5/8	3 5/8	9 3/4	9	4 1/4	1 5/8	5 1/4	3 7/8

\* This Clevis used for all smaller Bars.

STANDARD SLEEVE NUTS.

DIMENSIONS IN INCHES.

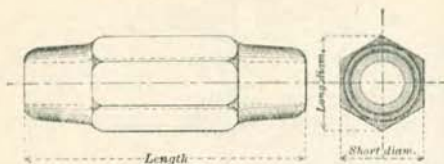

RODS.				NUT.			RODS.				NUT.				
Diam. of Round.	Side of Square.	Diam. of Upset.	Length of Upset.	Length of Nut.	Long Diam.	Short Diam.	Weight of Nut.	Diam. of Round.	Side of Square.	Diam. of Upset.	Length of Upset.	Length of Nut.	Long Diam.	Short Diam.	Weight of Nut.
5/8	1 0/8	3/4	4	6 1/2	2.02	1 3/4	2 3/4	2 1/8	2 1/2	3 1/2	6 1/2	12 3/4	6.35	5 1/2	51 1/2
1 1/8	1 5/8	1	4	6 1/2	2.02	1 3/4	2 1/2	2 7/8	2 1/8	3 5/8	7	13 3/8	6.78	5 7/8	63 1/2
1 1/8	1 3/4	1 1/8	4	7 1/8	2.45	2 1/8	4 1/4	3	2 1/8	3 3/4	7	13 3/8	6.78	5 7/8	62
3/8	1 1/8	1 1/4	4	7 1/8	2.45	2 1/8	4	3 1/8	2 3/4	3 7/8	7	14	7.22	6 1/4	75
1	1 3/8	1 3/8	4 1/2	7 3/4	2.89	2 1/2	6 1/2	3 1/4	2 7/8	4	7	14	7.22	6 1/4	73 1/2
1 1/8	1	1 1/2	4 1/2	7 3/4	2.89	2 1/2	6 1/4	3 3/8	2 1/8	4 1/8	7 1/2	14 5/8	7.65	6 5/8	88
1 1/4	1 1/8	1 5/8	5	8 3/8	3.32	2 7/8	9 1/2	3 1/2	..	4 1/4	7 1/2	14 5/8	7.65	6 5/8	86
1 5/8	1 1/8	1 3/4	5	8 3/8	3.32	2 7/8	9 1/4	..	3 1/8	4 3/8	7 1/2	15 1/4	8.08	7	102 1/2
1 7/8	1 1/4	1 7/8	5	9	3.75	3 1/4	13	3 5/8	3 1/4	4 1/2	7 1/2	15 1/4	8.08	7	100 1/2
1 1/2	1 3/8	2	5	9	3.75	3 1/4	12 1/2	3 3/4	3 3/8	4 5/8	8	15 7/8	8.52	7 3/8	118 1/2
1 5/8	1 7/8	2 1/8	5 1/2	9 5/8	4.19	3 5/8	17 1/2	3 7/8	..	4 3/4	8	15 7/8	8.52	7 3/8	116 1/2
1 3/4	1 1/8	2 1/4	5 1/2	9 5/8	4.19	3 5/8	17	..	..	4 7/8	8	16 1/2	8.95	7 3/4	135 1/2
1 7/8	1 5/8	2 3/8	5 1/2	10 1/4	4.62	4	22	..	..	5	8	16 1/2	8.95	7 3/4	133
1 1/8	1 3/4	2 1/2	5 1/2	10 1/4	4.62	4	22	..	..	5 1/8	8 1/2	17 1/8	9.38	8 1/8	154 1/2
2 1/8	1 1/8	2 5/8	6	10 7/8	5.05	4 3/8	28 1/2	..	..	5 1/4	8 1/2	17 1/8	9.38	8 1/8	152
2 3/8	1 1/8	2 3/4	6	10 7/8	5.05	4 3/8	27 1/2	..	..	5 3/8	8 1/2	17 3/4	9.82	8 1/2	175 1/2
2 1/4	2	2 7/8	6	11 1/2	5.48	4 3/4	35 1/2	..	..	5 1/2	8 1/2	17 3/4	9.82	8 1/2	173
2 3/8	2 1/8	3	6	11 1/2	5.48	4 3/4	35	..	..	5 5/8	9	18 3/8	10.25	8 7/8	197
2 7/8	2 1/8	3 1/8	6 1/2	12 1/8	5.92	5 1/8	44	..	..	5 3/4	9	18 3/8	10.25	8 7/8	194
2 1/8	2 5/8	3 1/4	6 1/2	12 1/8	5.92	5 1/8	42 1/2	..	..	5 7/8	9	19	10.68	9 1/4	222
2 1/2	2 3/8	3 3/8	6 1/2	12 3/4	6.35	5 1/2	52	..	..	6	9	19	10.68	9 1/4	218 1/2

Above weights are approximate.



THE CARNEGIE STEEL COMPANY, LIMITED.

DECIMALS OF A FOOT FOR EACH  $\frac{1}{16}$  OF AN INCH.

Inch.	0"	1"	2"	3"	4"	5"	6"	7"	8"	9"	10"	11"
0	0	.0833	.1667	.2500	.3333	.4167	.5000	.5833	.6667	.7500	.8333	.9167
$\frac{1}{16}$	.0013	.0846	.1680	.2513	.3346	.4180	.5013	.5846	.6680	.7513	.8346	.9180
$\frac{2}{16}$	.0026	.0859	.1693	.2526	.3359	.4193	.5026	.5859	.6693	.7526	.8359	.9193
$\frac{3}{16}$	.0039	.0872	.1706	.2539	.3372	.4206	.5039	.5872	.6706	.7539	.8372	.9206
$\frac{4}{16}$	.0052	.0885	.1719	.2552	.3385	.4219	.5052	.5885	.6719	.7552	.8385	.9219
$\frac{5}{16}$	.0065	.0898	.1732	.2565	.3398	.4232	.5065	.5898	.6732	.7565	.8398	.9232
$\frac{6}{16}$	.0078	.0911	.1745	.2578	.3411	.4245	.5078	.5911	.6745	.7578	.8411	.9245
$\frac{7}{16}$	.0091	.0924	.1758	.2591	.3424	.4258	.5091	.5924	.6758	.7591	.8424	.9258
$\frac{8}{16}$	.0104	.0937	.1771	.2604	.3437	.4271	.5104	.5937	.6771	.7604	.8437	.9271
$\frac{9}{16}$	.0117	.0951	.1784	.2617	.3451	.4284	.5117	.5951	.6784	.7617	.8451	.9284
$\frac{10}{16}$	.0130	.0964	.1797	.2630	.3464	.4297	.5130	.5964	.6797	.7630	.8464	.9297
$\frac{11}{16}$	.0143	.0977	.1810	.2643	.3477	.4310	.5143	.5977	.6810	.7643	.8477	.9310
$\frac{12}{16}$	.0156	.0990	.1823	.2656	.3490	.4323	.5156	.5990	.6823	.7656	.8490	.9323
$\frac{13}{16}$	.0169	.1003	.1836	.2669	.3503	.4336	.5169	.6003	.6836	.7669	.8503	.9336
$\frac{14}{16}$	.0182	.1016	.1849	.2682	.3516	.4349	.5182	.6016	.6849	.7682	.8516	.9349
$\frac{15}{16}$	.0195	.1029	.1862	.2695	.3529	.4362	.5195	.6029	.6862	.7695	.8529	.9362
$\frac{16}{16}$	.0208	.1042	.1875	.2708	.3542	.4375	.5208	.6042	.6875	.7708	.8542	.9375
$\frac{17}{16}$	.0221	.1055	.1888	.2721	.3555	.4388	.5221	.6055	.6888	.7721	.8555	.9388
$\frac{18}{16}$	.0234	.1068	.1901	.2734	.3568	.4401	.5234	.6068	.6901	.7734	.8568	.9401
$\frac{19}{16}$	.0247	.1081	.1914	.2747	.3581	.4414	.5247	.6081	.6914	.7747	.8581	.9414
$\frac{20}{16}$	.0260	.1094	.1927	.2760	.3594	.4427	.5260	.6094	.6927	.7760	.8594	.9427
$\frac{21}{16}$	.0273	.1107	.1940	.2773	.3607	.4440	.5273	.6107	.6940	.7773	.8607	.9440
$\frac{22}{16}$	.0286	.1120	.1953	.2786	.3620	.4453	.5286	.6120	.6953	.7786	.8620	.9453
$\frac{23}{16}$	.0299	.1133	.1966	.2799	.3633	.4466	.5299	.6133	.6966	.7799	.8633	.9466
$\frac{24}{16}$	.0312	.1146	.1979	.2812	.3646	.4479	.5312	.6146	.6979	.7812	.8646	.9479
$\frac{25}{16}$	.0326	.1159	.1992	.2826	.3659	.4492	.5326	.6159	.6992	.7826	.8659	.9492
$\frac{26}{16}$	.0339	.1172	.2005	.2839	.3672	.4505	.5339	.6172	.7005	.7839	.8672	.9505
$\frac{27}{16}$	.0352	.1185	.2018	.2852	.3685	.4518	.5352	.6185	.7018	.7852	.8685	.9518
$\frac{28}{16}$	.0365	.1198	.2031	.2865	.3698	.4531	.5365	.6198	.7031	.7865	.8698	.9531
$\frac{29}{16}$	.0378	.1211	.2044	.2878	.3711	.4544	.5378	.6211	.7044	.7878	.8711	.9544
$\frac{30}{16}$	.0391	.1224	.2057	.2891	.3724	.4557	.5391	.6224	.7057	.7891	.8724	.9557
$\frac{31}{16}$	.0404	.1237	.2070	.2904	.3737	.4570	.5404	.6237	.7070	.7904	.8737	.9570
$\frac{32}{16}$	.0417	.1250	.2083	.2917	.3750	.4583	.5417	.6250	.7083	.7917	.8750	.9583

THE CARNEGIE STEEL COMPANY, LIMITED.

DECIMALS OF A FOOT FOR EACH  $\frac{1}{4}$  OF AN INCH.

Inch.	0"	1"	2"	3"	4"	5"	6"	7"	8"	9"	10"	11"
.0417	.1250	.2083	.2917	.3750	.4583	.5417	.6250	.7083	.7917	.8750	.9583	
.0430	.1263	.2096	.2930	.3763	.4596	.5430	.6263	.7096	.7930	.8763	.9596	
.0443	.1276	.2109	.2943	.3776	.4609	.5443	.6276	.7109	.7943	.8776	.9609	
.0456	.1289	.2122	.2956	.3789	.4622	.5456	.6289	.7122	.7956	.8789	.9622	
.0469	.1302	.2135	.2969	.3802	.4635	.5469	.6302	.7135	.7969	.8802	.9635	
.0482	.1315	.2148	.2982	.3815	.4648	.5482	.6315	.7148	.7982	.8815	.9648	
.0495	.1328	.2161	.2995	.3828	.4661	.5495	.6328	.7161	.7995	.8828	.9661	
.0508	.1341	.2174	.3008	.3841	.4674	.5508	.6341	.7174	.8008	.8841	.9674	
.0521	.1354	.2188	.3021	.3854	.4688	.5521	.6354	.7188	.8021	.8854	.9688	
.0534	.1367	.2201	.3034	.3867	.4701	.5534	.6367	.7201	.8034	.8867	.9701	
.0547	.1380	.2214	.3047	.3880	.4714	.5547	.6380	.7214	.8047	.8880	.9714	
.0560	.1393	.2227	.3060	.3893	.4727	.5560	.6393	.7227	.8060	.8893	.9727	
.0573	.1406	.2240	.3073	.3906	.4740	.5573	.6406	.7240	.8073	.8906	.9740	
.0586	.1419	.2253	.3086	.3919	.4753	.5586	.6419	.7253	.8086	.8919	.9753	
.0599	.1432	.2266	.3099	.3932	.4766	.5599	.6432	.7266	.8099	.8932	.9766	
.0612	.1445	.2279	.3112	.3945	.4779	.5612	.6445	.7279	.8112	.8945	.9779	
.0625	.1458	.2292	.3125	.3958	.4792	.5625	.6458	.7292	.8125	.8958	.9792	
.0638	.1471	.2305	.3138	.3971	.4805	.5638	.6471	.7305	.8138	.8971	.9805	
.0651	.1484	.2318	.3151	.3984	.4818	.5651	.6484	.7318	.8151	.8984	.9818	
.0664	.1497	.2331	.3164	.3997	.4831	.5664	.6497	.7331	.8164	.8997	.9831	
.0677	.1510	.2344	.3177	.4010	.4844	.5677	.6510	.7344	.8177	.9010	.9844	
.0690	.1523	.2357	.3190	.4023	.4857	.5690	.6523	.7357	.8190	.9023	.9857	
.0703	.1536	.2370	.3203	.4036	.4870	.5703	.6536	.7370	.8203	.9036	.9870	
.0716	.1549	.2383	.3216	.4049	.4883	.5716	.6549	.7383	.8216	.9049	.9883	
.0729	.1562	.2396	.3229	.4062	.4896	.5729	.6562	.7396	.8229	.9062	.9896	
.0742	.1575	.2409	.3242	.4075	.4909	.5742	.6575	.7409	.8242	.9075	.9909	
.0755	.1588	.2422	.3255	.4088	.4922	.5755	.6588	.7422	.8255	.9088	.9922	
.0768	.1602	.2435	.3268	.4102	.4935	.5768	.6602	.7435	.8268	.9102	.9935	
.0781	.1615	.2448	.3281	.4115	.4948	.5781	.6615	.7448	.8281	.9115	.9948	
.0794	.1628	.2461	.3294	.4128	.4961	.5794	.6628	.7461	.8294	.9128	.9961	
.0807	.1641	.2474	.3307	.4141	.4974	.5807	.6641	.7474	.8307	.9141	.9974	
.0820	.1654	.2487	.3320	.4154	.4987	.5820	.6654	.7487	.8320	.9154	.9987	
												1.0000

DECI  
MALS

ARE

W



THE CARNEGIE STEEL COMPANY, LIMITED.

DECIMALS OF AN INCH FOR EACH  $\frac{1}{4}$ th.

$\frac{1}{2}$ ds.	$\frac{1}{4}$ ths.	Decimal.	Fraction.	$\frac{1}{2}$ ds.	$\frac{1}{4}$ ths.	Decimal.	Fraction.
	1	.015625			33	.515625	
1	2	.03125		17	34	.53125	
	3	.046875			35	.546875	
2	4	.0625	1-16	18	36	.5625	9-16
	5	.078125			37	.578125	
3	6	.09375		19	38	.59375	
	7	.109375			39	.609375	
4	8	.125	1-8	20	40	.625	5-8
	9	.140625			41	.640625	
5	10	.15625		21	42	.65625	
	11	.171875			43	.671875	
6	12	.1875	3-16	22	44	.6875	11-16
	13	.203125			45	.703125	
7	14	.21875		23	46	.71875	
	15	.234375			47	.734375	
8	16	.25	1-4	24	48	.75	3-4
	17	.265625			49	.765625	
9	18	.28125		25	50	.78125	
	19	.296875			51	.796875	
10	20	.3125	5-16	26	52	.8125	13-16
	21	.328125			53	.828125	
11	22	.34375		27	54	.84375	
	23	.359375			55	.859375	
12	24	.375	3-8	28	56	.875	7-8
	25	.390625			57	.890625	
13	26	.40625		29	58	.90625	
	27	.421875			59	.921875	
14	28	.4375	7-16	30	60	.9375	15-16
	29	.453125			61	.953125	
15	30	.46875		31	62	.96875	
	31	.484375			63	.984375	
16	32	.5	1-2	32	64	1.	1

THE CARNEGIE STEEL COMPANY, LIMITED.

TABLE OF BATTERS.



1:2			1:2.5			1:6			1:8		
a	b	c	a	b	c	a	b	c	a	b	c
1/8	3/4"	1/8"	1/8	3/4"	3/4"	1/8	1/8"	3/4"	1/8	1/8"	3/4"
1/4	3/2"	1/8"	1/4	3/4"	3/4"	1/4	1/4"	3/4"	1/4	1/4"	3/4"
3/8	3/4"	3/8"	3/8	3/2"	5/2"	3/8	3/8"	1/8"	3/8	3/8"	3/4"
1/2	1/8"	1/4"	1/2	3/4"	3/4"	1/2	1/2"	3/4"	1/2	1/2"	1/8"
5/8	3/4"	5/8"	5/8	3/4"	1/4"	5/8	3/4"	3/2"	5/8	5/8"	3/4"
3/4	3/2"	3/8"	3/4	3/4"	3/4"	3/4	3/4"	1/8"	3/4	3/4"	3/2"
7/8	3/4"	7/8"	7/8	1/8"	3/2"	7/8	3/4"	3/4"	7/8	7/8"	3/4"
1"	1/8"	1/2"	1"	1/8"	3/2"	1"	1/8"	3/4"	1"	1"	1/8"
2"	2/8"	1"	2"	2/8"	3/4"	2"	2/8"	3/4"	2"	2/8"	1/4"
3"	3/8"	1 1/2"	3"	3/8"	1 1/2"	3"	3/8"	1/2"	3"	3/8"	3/8"
4"	4/8"	2"	4"	4/8"	1 3/2"	4"	4/8"	3/4"	4"	4/8"	1/2"
5"	5/8"	2 1/2"	5"	5/8"	2"	5"	5/8"	3/4"	5"	5/8"	5/8"
6"	6/8"	3"	6"	6/8"	2 3/2"	6"	6/8"	1"	6"	6/8"	3/4"
7"	7/8"	3 1/2"	7"	7/8"	2 3/2"	7"	7/8"	1 1/4"	7"	7/8"	7/8"
8"	8/8"	4"	8"	8/8"	3 1/2"	8"	8/8"	1 1/2"	8"	8/8"	1"
9"	10 1/8"	4 1/2"	9"	9 1/8"	3 3/2"	9"	9 1/8"	1 1/2"	9"	9 1/8"	1 1/8"
10"	11 3/8"	5"	10"	10 3/8"	4"	10"	10 3/8"	1 3/2"	10"	10 3/8"	1 1/4"
11"	12 5/8"	5 1/2"	11"	11 5/8"	4 1/2"	11"	11 5/8"	1 3/2"	11"	11 5/8"	1 3/8"
12"	1' - 1 1/4"	6"	12"	12 7/8"	4 3/2"	12"	12 7/8"	2"	12"	12 3/2"	1 1/2"
2'	2' - 2 3/4"	1'	2'	2' - 1 1/4"	9 1/2"	2'	2' - 0 3/4"	4"	2'	2' - 0 3/8"	3"
3'	3' - 4 1/4"	1' - 6"	3'	3' - 2 3/4"	1' - 2 3/4"	3'	3' - 0 1/2"	6"	3'	3' - 0 3/2"	4 1/2"
4'	4' - 5 3/4"	2' - 0"	4'	4' - 3 5/4"	1' - 7 1/4"	4'	4' - 0 3/4"	8"	4'	4' - 0 3/8"	6"
5'	5' - 7 1/4"	2' - 6"	5'	5' - 4 5/8"	2' - 0"	5'	5' - 0 5/4"	10"	5'	5' - 0 1/2"	7 1/2"
6'	6' - 8 1/2"	3' - 0"	6'	6' - 5 3/4"	2' - 4 1/4"	6'	6' - 0 3/4"	12"	6'	6' - 0 1/8"	9"
7'	7' - 9 3/4"	3' - 6"	7'	7' - 6 3/2"	2' - 9 1/2"	7'	7' - 1 3/2"	1' - 2"	7'	7' - 0 3/2"	10 1/2"
8'	8' - 11 1/4"	4' - 0"	8'	8' - 7 3/4"	3' - 2 3/2"	8'	8' - 1 1/4"	1' - 4"	8'	8' - 0 3/4"	1'
9'	10' - 0 3/4"	4' - 6"	9'	9' - 8 5/8"	3' - 7 1/4"	9'	9' - 1 3/4"	1' - 6"	9'	9' - 0 3/2"	1' - 1 1/2"
10'	11' - 2 1/4"	5' - 0"	10'	10' - 9 1/4"	4' - 0"	10'	10' - 1 3/4"	1' - 8"	10'	10' - 0 1/2"	1' - 3"
15'	16' - 9 1/4"	7' - 6"	15'	16' - 1 5/4"	6' - 0"	15'	15' - 2 3/4"	2' - 6"	15'	15' - 1 1/2"	1' - 10 1/2"
20'	22' - 4 3/4"	10' - 0"	20'	21' - 6 3/4"	8' - 0"	20'	20' - 3 1/8"	3' - 4"	20'	20' - 1 7/8"	2' - 6"
25'	27' - 11 3/4"	12' - 6"	25'	26' - 11 7/8"	10' - 0"	25'	25' - 4 3/4"	4' - 2"	25'	25' - 2 1/2"	3' - 1 1/2"
30'	33' - 6 1/2"	15' - 0"	30'	32' - 3 3/2"	12' - 0"	30'	30' - 4 3/2"	5' - 0"	30'	30' - 2 1/8"	3' - 9"
35'	39' - 1 3/4"	17' - 6"	35'	37' - 8 1/2"	14' - 0"	35'	35' - 5 1/4"	5' - 10"	35'	35' - 3 3/2"	4' - 4 1/2"
40'	44' - 8 1/4"	20' - 0"	40'	43' - 0 3/4"	16' - 0"	40'	40' - 6 5/8"	6' - 8"	40'	40' - 3 3/4"	5' - 0"
45'	50' - 3 3/4"	22' - 6"	45'	48' - 5 1/2"	18' - 0"	45'	45' - 7 3/4"	7' - 6"	45'	45' - 4 3/2"	5' - 7 1/2"
50'	55' - 10 3/4"	25' - 0"	50'	53' - 10 1/2"	20' - 0"	50'	50' - 8 3/2"	8' - 4"	50'	50' - 4 1/8"	6' - 3"

Intermediate lengths and lengths above those given in the table can be found by interpolation.

THE CARNEGIE STEEL COMPANY, LIMITED.

UNITED STATES STANDARD GAUGE  
FOR SHEET AND PLATE IRON AND STEEL.

Adopted as Standard by  
American Railway Master Mechanics Association  
and Association of American Steel Manufacturers.

Number of Gauge.	Approximate thickness in fractions of an inch.	Approximate thickness in decimal parts of an inch.	Approximate thickness in millimeters.	Weight per square foot in pounds avoirdupois, Iron.	Weight per square foot in pounds avoirdupois, Steel.	Weight per square meter in kilograms, Steel.	Number of Gauge.
0000000	1—2	.5	12.70	20.00	20.4	99.601	0000000
000000	15—32	.46875	11.91	18.75	19.125	93.376	000000
00000	7—16	.4375	11.11	17.50	17.85	87.151	00000
0000	13—32	.40625	10.32	16.25	16.575	80.926	0000
000	3—8	.375	9.53	15.	15.30	74.701	000
00	11—32	.34375	8.73	13.75	14.025	68.476	00
0	5—16	.3125	7.94	12.50	12.75	62.251	0
1	9—32	.28125	7.14	11.25	11.475	56.026	1
2	17—64	.265625	6.75	10.625	10.8375	52.913	2
3	1—4	.25	6.35	10.	10.2	49.800	3
4	15—64	.234375	5.95	9.375	9.5625	46.688	4
5	7—32	.21875	5.56	8.75	8.925	43.575	5
6	13—64	.203125	5.16	8.125	8.2875	40.463	6
7	3—16	.1875	4.76	7.5	7.65	37.350	7
8	11—64	.171875	4.37	6.875	7.0125	34.238	8
9	5—32	.15625	3.97	6.25	6.375	31.125	9
10	9—64	.140625	3.57	5.625	5.7375	28.013	10
11	1—8	.125	3.18	5.	5.1	24.900	11
12	7—64	.109375	2.78	4.375	4.4625	21.788	12
13	3—32	.09375	2.38	3.75	3.825	18.675	13
14	5—64	.078125	1.98	3.125	3.1875	15.563	14
15	9—128	.0703125	1.79	2.8125	2.86875	14.006	15
16	1—16	.0625	1.59	2.5	2.55	12.450	16
17	9—160	.05625	1.43	2.25	2.295	11.205	17
18	1—20	.05	1.27	2.	2.04	9.960	18
19	7—160	.04375	1.11	1.75	1.765	8.715	19
20	3—80	.0375	0.953	1.50	1.53	7.470	20
21	11—320	.034375	0.873	1.375	1.4025	6.848	21
22	1—32	.03125	0.794	1.25	1.275	6.225	22
23	9—320	.028125	0.714	1.125	1.1475	5.603	23
24	1—40	.025	0.635	1.	1.02	4.980	24
25	7—320	.021875	0.556	.875	.8925	4.358	25
26	3—160	.01875	0.476	.75	.765	3.735	26
27	11—640	.0171875	0.437	.6875	.70125	3.424	27
28	1—64	.015625	0.397	.625	.6375	3.113	28
29	9—640	.0140625	0.357	.5625	.57375	2.801	29
30	1—80	.0125	0.318	.5	.51	2.490	30
31	7—640	.0109375	0.278	.4375	.44625	2.179	31
32	13—1280	.01015625	0.258	.40625	.414375	2.023	32
33	3—320	.009375	0.238	.375	.3825	1.868	33
34	11—1280	.00859375	0.218	.34375	.350625	1.712	34
35	5—640	.0078125	0.198	.3125	.31875	1.556	35
36	9—1280	.00703125	0.179	.28125	.286875	1.401	36
37	17—2560	.006640625	0.169	.265625	.2709375	1.323	37
38	1—160	.00625	0.159	.25	.255	1.245	38

THE CARNEGIE STEEL COMPANY, LIMITED.

STANDARD GAUGES.

No. of Gauge.	THICKNESS IN DECIMALS OF AN INCH.						No. of Gauge.	
	Birmingham	Browne & Sharpe.	United States Standard Plate Iron and Steel.	British Imperial.	Washburn & Moen Co.	Trenton Iron Co.		Stubs Steel Wire.
7			.500	.500				7
6			.46875	.464				6
5			.4375	.432				5
4	.454	.46	.40625	.400	.3938	.45		4
3	.425	.40964	.375	.372	.3625	.40		3
2	.380	.3648	.34375	.348	.3310	.36		2
1	.340	.32486	.3125	.324	.3065	.33		1
0	.300	.2893	.28125	.300	.2830	.305		0
2	.284	.25763	.265625	.276	.2625	.285	.227	2
3	.259	.22942	.25	.252	.2437	.265	.219	3
4	.238	.20431	.234375	.232	.2253	.245	.212	4
5	.220	.18194	.21875	.212	.2070	.225	.207	5
6	.203	.16202	.203125	.192	.1920	.205	.204	6
7	.180	.14428	.1875	.176	.1770	.190	.201	7
8	.165	.12849	.171875	.160	.1620	.175	.199	8
9	.148	.11443	.15625	.144	.1483	.160	.197	9
10	.134	.10189	.140625	.128	.1350	.145	.194	10
11	.120	.090742	.125	.116	.1205	.130	.191	11
12	.109	.080808	.109375	.104	.1055	.1175	.188	12
13	.095	.071961	.09375	.092	.0915	.1050	.185	13
14	.083	.064084	.078125	.080	.0800	.0925	.182	14
15	.072	.057068	.0703125	.072	.0720	.0800	.180	15
16	.065	.05082	.0625	.064	.0625	.0700	.178	16
17	.058	.045257	.05625	.056	.0540	.0610	.175	17
18	.049	.040303	.05	.048	.0475	.0525	.172	18
19	.042	.03589	.04375	.040	.0410	.0450	.168	19
20	.035	.031961	.0375	.036	.0348	.0400	.164	20
21	.032	.028462	.034375	.032	.03175	.0350	.161	21
22	.028	.025347	.03125	.028	.0286	.0310	.157	22
23	.025	.022571	.028125	.024	.0258	.0280	.155	23
24	.022	.0201	.025	.022	.0230	.0250	.153	24
25	.020	.0179	.021875	.020	.0204	.0225	.151	25
26	.018	.01594	.01875	.018	.0181	.0200	.148	26
27	.016	.014195	.0171875	.0164	.0173	.0180	.146	27
28	.014	.012641	.015625	.0148	.0162	.0170	.143	28
29	.013	.011257	.0140625	.0136	.0150	.0160	.139	29
30	.012	.010025	.0125	.0124	.0140	.0150	.134	30
31	.010	.008928	.0109375	.0116	.0132	.0140	.127	31
32	.009	.00795	.01015625	.0108	.0128	.0130	.120	32
33	.008	.00708	.009375	.0100	.0118	.0120	.115	33
34	.007	.006304	.00859375	.0092	.0104	.0110	.112	34
35	.005	.005614	.0078125	.0084	.0095	.0100	.110	35
36	.004	.005	.00703125	.0076	.0090	.0095	.108	36
37	.....	.004453	.006640625	.0068	.....	.0090	.106	37
38	.....	.003965	.00625	.0060	.....	.0085	.103	38
39	.....	.003531	.....	.....	.....	.0080	.101	39
40	.....	.003144	.....	.....	.....	.0075	.099	39
						.0070	.097	40

MANUFACTURERS

STANDARD SPECIFICATIONS.

STRUCTURAL STEEL.

PROCESS OF MANUFACTURE. 1. Steel may be made by either the Open-hearth or Bessemer process.

TESTING. 2. All tests and inspections shall be made at place of manufacture prior to shipment.

TEST PIECE. 3. The tensile strength, limit of elasticity and ductility shall be determined from a standard test piece cut from the finished material. The standard shape of the test piece for sheared plates shall be as shown by the following sketch :

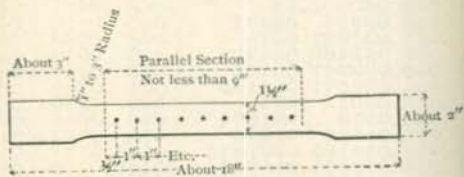

Piece to be of same thickness as the plate.

On tests cut from other material the test piece may be either the same as for plates or it may be planed or turned parallel throughout its entire length. The elongation shall be measured on an original length of 8 inches, except when the thickness of the finished material is 5-16 inch or less,

## THE CARNEGIE STEEL COMPANY, LIMITED.

in which case the elongation shall be measured in a length equal to sixteen times the thickness; and except in rounds of 5-8 inch or less in diameter, in which case the elongation shall be measured in a length equal to eight times the diameter of section tested. Two test pieces shall be taken from each melt or blow of finished material, one for tension and one for bending.

### ANNEALED TEST PIECES

4. Material which is to be used without annealing or further treatment is to be tested in the condition in which it comes from the rolls. When material is to be annealed or otherwise treated before use, the specimen representing such material is to be similarly treated before testing.

### MARKING.

5. Every finished piece of steel shall be stamped with the blow or melt number, and steel for pins shall have the blow or melt number stamped on the ends. Rivet and lacing steel, and small pieces for pin plates and stiffeners, may be shipped in bundles securely wired together, with the blow or melt number on a metal tag attached.

### FINISH.

6. Finished bars must be free from injurious seams, flaws or cracks, and have a workmanlike finish.

### CHEMICAL PROPERTIES.

7. Steel for  
Railway Bridges. } Maximum Phosphorus .08 per cent.

Steel for Buildings,  
Train Sheds,  
Highway Bridges  
and similar structures. } Maximum Phosphorus .10 per cent.

### PHYSICAL PROPERTIES.

8. Steel shall be of three grades, RIVET, SOFT and MEDIUM.

- RIVET STEEL.** 9. Ultimate strength, 48,000 to 58,000 pounds per square inch.
- Elastic limit, not less than one-half the ultimate strength.
- Elongation, 26 per cent.
- Bending test, 180 degrees flat on itself, without fracture on outside of bent portion.
- SOFT STEEL.** 10. Ultimate strength, 52,000 to 62,000 pounds per square inch.
- Elastic limit, not less than one-half the ultimate strength.
- Elongation, 25 per cent.
- Bending test, 180 degrees flat on itself, without fracture on outside of bent portion.
- MEDIUM STEEL.** 11. Ultimate strength, 60,000 to 70,000 pounds per square inch.
- Elastic limit, not less than one-half the ultimate strength.
- Elongation, 22 per cent.
- Bending test, 180 degrees to a diameter equal to thickness of piece tested, without fracture on outside of bent portion.
- PIN STEEL.** 12. Pins made from either of the above mentioned grades of steel shall, on specimen test pieces cut at a depth of one inch from surface of finished material, fill the physical requirements of the grade of steel from which they are rolled, for ultimate strength, elastic limit, and bending, but the required elongation shall be decreased 5 per cent.
- EYE-BAR STEEL.** 13. Eye-bar material,  $1\frac{1}{2}$  inches and less in thickness, made of either of the above-mentioned grades of steel, shall, on test pieces cut from finished material, fill the requirements of the grade of steel from which it is rolled. For thicknesses greater than  $1\frac{1}{2}$  inches, there will be allowed a reduction in the percentage of elongation of 1 per cent. for each  $\frac{1}{8}$  of an inch

increase of thickness, to a minimum of 20 per cent. for medium steel and 22 per cent. for soft steel.

FULL SIZE TEST  
OF STEEL  
EYE-BARS.

14. Full size test of steel eye-bars shall be required to show not less than 10 per cent. elongation in the body of the bar, and tensile strength not more than 5,000 pounds below the minimum tensile strength required in specimen tests of the grade of steel from which they are rolled. The bars will be required to break in the body, but should a bar break in the head, but develop 10 per cent. elongation and the ultimate strength specified, it shall not be cause for rejection, provided not more than one-third of the total number of bars tested break in the head; otherwise the entire lot will be rejected.

VARIATION IN  
WEIGHT.

15. The variation in cross-section or weight of more than  $2\frac{1}{2}$  per cent. from that specified will be sufficient cause for rejection, except in the case of sheared plates which will be covered by the following permissible variations:

*a.* Plates  $12\frac{1}{2}$  lbs. or heavier, when ordered to weight, shall not average more variation than  $2\frac{1}{2}$  per cent., either above or below the theoretical weight.

*b.* Plates from 10 to  $12\frac{1}{2}$  lbs., when ordered to weight, shall not average a greater variation than the following:

Up to 75 inches wide,  $2\frac{1}{2}$  per cent. either above or below the theoretical weight.

75 inches and over, 5 per cent. either above or below the theoretical weight.

*c.* Plates under 10 lbs. down to 5 lbs. when ordered to weight, shall not average more variation than 3 per cent. above or 5 per cent. below the theoretical weight.

*d.* Plates under 5 lbs. when ordered to weight, shall not average more variation than 5 per cent. either above or below the theoretical weight.

*e.* For all plates ordered to gauge, there will be permitted an average excess of weight over that corresponding to the dimensions on the order equal in amount to that specified in the following table:



TABLE OF ALLOWANCES FOR OVERWEIGHT  
FOR RECTANGULAR PLATES WHEN  
ORDERED TO GAUGE.

THE WEIGHT OF 1 CUBIC INCH OF ROLLED STEEL IS ASSUMED TO BE  
.2833 POUNDS.

PLATES  $\frac{1}{4}$ " AND OVER IN THICKNESS.

THICKNESS OF PLATE.	WIDTH OF PLATE.		
	Up to 75 in.	75 in. to 100 in.	Over 100 in.
$\frac{1}{4}$ inch	10 per cent.	14 per cent.	18 per cent.
$\frac{5}{16}$ "	8 "	12 "	16 "
$\frac{3}{8}$ "	7 "	10 "	13 "
$\frac{7}{16}$ "	6 "	8 "	10 "
$\frac{1}{2}$ "	5 "	7 "	9 "
$\frac{9}{16}$ "	4 $\frac{1}{2}$ "	6 $\frac{1}{2}$ "	8 $\frac{1}{2}$ "
$\frac{5}{8}$ "	4 "	6 "	8 "
Over $\frac{5}{8}$ "	3 $\frac{1}{2}$ "	5 "	6 $\frac{1}{2}$ "

PLATES UNDER  $\frac{1}{4}$ " IN THICKNESS.

THICKNESS OF PLATE.	WIDTH OF PLATE.	
	Up to 50 in.	50 in. and above.
$\frac{1}{8}$ up to $\frac{5}{32}$	10 per cent.	15 per cent.
$\frac{5}{32}$ " $\frac{3}{16}$	8 $\frac{1}{2}$ "	12 $\frac{1}{2}$ "
$\frac{3}{16}$ " $\frac{1}{4}$	7 "	10 "

STRUCTURAL CAST IRON.

1. Except where chilled iron is specified, all castings shall be tough gray iron, free from injurious cold-shuts or blow-holes, true to pattern, and of a workmanlike finish. Sample pieces, one inch square, cast from the same heat of metal in sand moulds, shall be capable of sustaining on a clear span of 4 feet 8 inches, a central load of 500 pounds when tested in the rough bar.

# Schedule of Standard Permissible Variations

IN THE WEIGHT OF

## Sheared Plates

FOR

Structural Steel for Bridges and Ships,  
Structural Steel for Buildings, and  
O. H. Boiler Plate Steel.

---

Adopted by the Association of American Steel Manufacturers on August 9, 1895. Revised July 17, 1896, October 23, 1896, February 15, 1901, and April 19, 1902. And since formally approved by the following companies:

American Steel Hoop Co.  
American Steel and Wire Co.  
Cambria Steel Company.  
Carbon Steel Company.  
Carnegie Steel Company.  
Central Iron and Steel Co.  
The Cleveland Steel Co.  
The Colorado Fuel & Iron Co.  
Crucible Steel Co. of America.  
Glasgow Iron Company.  
Illinois Steel Company.

Inland Steel Company.  
Jones & Laughlins, Ltd.  
Lukens Iron & Steel Co.  
National Steel Company.  
The Otis Steel Co., Ltd.  
The Passaic Rolling Mill Co.  
The Pennsylvania Steel Co.  
Republic Iron and Steel Co.  
Tenn. Coal, Iron and R.R. Co.  
Tidewater Steel Company.  
Worth Brothers Company.

---

COMPLIMENTS OF

LUKENS IRON AND STEEL CO.,  
COATESVILLE, PA.

# Schedule for Sheared Plates when Ordered by Weight

## VARIATION IN WEIGHT.

The variation in cross-section or weight of more than  $2\frac{1}{2}$  per cent. from that specified will be sufficient cause for rejection, except in the case of sheared plates, which will be covered by the following permissible variations.

Plates  $12\frac{1}{2}$  pounds per square foot or heavier, up to 100 inches wide, when ordered to weight, shall not average more than  $2\frac{1}{2}$  per cent. variation above or  $2\frac{1}{2}$  per cent. below the theoretical weight. When 100 inches wide and over 5 per cent. above or 5 per cent. below the theoretical weight.



Plates under  $12\frac{1}{2}$  pounds per square foot, when ordered to weight, shall not average a greater variation than the following :

Up to 75 inches wide,  $2\frac{1}{2}$  per cent. above or  $2\frac{1}{2}$  per cent. below the theoretical weight. 75 inches wide up to 100 inches wide, 5 per cent. above or 3 per cent. below the theoretical weight. When 100 inches wide and over, 10 per cent. above or 3 per cent. below the theoretical weight.

# Schedule for Sheared Plates when Ordered to Gauge

For all plates ordered to gauge, there will be permitted an average excess of weight over that corresponding to the dimensions on the order equal in amount to that specified in the following table.

## TABLE OF ALLOWANCES FOR OVERWEIGHT FOR RECTANGULAR PLATES WHEN ORDERED TO GAUGE.

Plates will be considered up to gauge if measuring not over  $\frac{1}{100}$  inch less than the ordered gauge.

The weight of one cubic inch of rolled steel is assumed to be 0.2833 pound.

### PLATE $\frac{1}{4}$ INCH AND OVER IN THICKNESS.

Thickness of Plate. Inch.	WIDTH OF PLATE.			
	Up to 75 Inches. Per Cent.	75 to 100 Inches. Per Cent.	Over 100 to 115 Inches. Per Cent.	Over 115 Inches. Per Cent.
$\frac{1}{4}$	10	14	18	...
$\frac{5}{16}$	8	12	16	...
$\frac{3}{8}$	7	10	13	17
$\frac{7}{16}$	6	8	10	13
$\frac{1}{2}$	5	7	9	12
$\frac{9}{16}$	4½	6½	8½	11
$\frac{5}{8}$	4	6	8	10
Over $\frac{5}{8}$	3½	5	6½	9

### PLATE UNDER $\frac{1}{4}$ INCH IN THICKNESS.

Thickness of Plate. Inch.	WIDTH OF PLATE.		
	Up to 50 Inches. Per Cent.	50 to 70 Inches. Per Cent.	Over 70 Inches. Per Cent.
$\frac{1}{8}$ up to $\frac{5}{32}$	10	15	20
$\frac{5}{32}$ up to $\frac{3}{16}$	8½	12½	17
$\frac{3}{16}$ up to $\frac{1}{4}$	7	10	15



## SPECIAL OPEN-HEARTH PLATE AND RIVET STEEL.

**TESTING AND INSPECTION.** 1. All tests and inspections shall be made at place of manufacture prior to shipment.

**TEST PIECES.** 2. The tensile strength, limit of elasticity and ductility, shall be determined from a standard test piece cut from the finished material. The standard shape of the test piece for sheared plates shall be as shown by the following sketch:

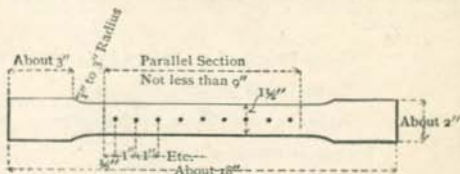

Piece to be of same thickness as the plate.

On tests cut from other material the test piece may be either the same as for plates, or it may be planed or turned parallel throughout its entire length. The elongation shall be measured on an original length of 8 inches, except when the thickness of the finished material is 5-16 inch or less, in which case the elongation shall be measured in a length equal to sixteen times the thickness; and except in rounds of  $\frac{5}{8}$  inch or less in diameter, in which case the elongation shall be measured in a length equal to eight times the diameter of section tested. Four test pieces shall be taken from each melt of finished material; two for tension and two for bending.

**ANNEALED TEST PIECES.** 3. Material which is to be used without annealing or further treatment is to be tested in the condition in which it comes from the rolls. When material is to be annealed or otherwise treated before use, the specimen representing such material is to be similarly treated before testing.

**MARKING.** 4. Every finished piece of steel shall be stamped with the melt number. Rivet steel may be shipped in bundles securely wired together, with the melt number on a metal tag attached.

**FINISH.** 5. All plates shall be free from surface defects and have a workmanlike finish.

**THE CARNEGIE STEEL COMPANY, LIMITED.**

CHEMICAL PROPERTIES.	6. Extra soft and Fire Box Steel. } Flange or Boiler or Steel. } Boiler Rivet Steel. }	Maximum Phosphorus " Sulphur " Phosphorus " Sulphur " Phosphorus " Sulphur	.04 per cent.	.04	"	"
			.06	"	"	"
			.04	"	"	"
PHYSICAL PROPERTIES.	7. Steel shall be of four grades—EXTRA SOFT, FIRE BOX, FLANGE or BOILER, and BOILER RIVET STEEL.					
	EXTRA SOFT STEEL.	8. Ultimate strength, 45,000 to 55,000 pounds per square inch. Elastic limit, not less than one-half the ultimate strength Elongation, 28 per cent. Cold and Quench bends, 180 degrees flat on itself, without fracture on outside of bent portion.				
FIRE BOX STEEL.		9. Ultimate strength, 52,000 to 62,000 pounds per square inch. Elastic limit, not less than one-half the ultimate strength. Elongation, 26 per cent. Cold and Quench bends, 180 degrees flat on itself, without fracture on outside of bent portion.				
	FLANGE OR BOILER STEEL.	10. Ultimate strength, 52,000 to 62,000 pounds per square inch. Elastic limit, not less than one-half the ultimate strength. Elongation, 25 per cent. Cold and Quench bends, 180 degrees flat on itself, without fracture on outside of bent portion.				
BOILER RIVET STEEL.		11. Steel for boiler rivets shall be made of the extra soft quality specified in paragraph No. 8.				
VARIATION WHEN ORDERED TO GAUGE.	12. For all plates ordered to gauge, there will be permitted an average excess of weight over that corresponding to the dimensions on the order equal in amount to that specified in the following table, provided no plate shall be rejected for light gauge measuring .01" or less, below the ordered thickness :					

TABLE OF ALLOWANCES FOR OVERWEIGHT  
FOR RECTANGULAR PLATES WHEN  
ORDERED TO GAUGE.

THE WEIGHT OF 1 CUBIC INCH OF ROLLED STEEL IS ASSUMED TO BE  
.2833 POUNDS.

PLATES  $\frac{1}{4}$ " AND OVER IN THICKNESS.

THICKNESS OF PLATE.	WIDTH OF PLATE.		
	Up to 75 in.	75 in. to 100 in.	Over 100 in.
$\frac{1}{4}$ inch	10 per cent.	14 per cent.	18 per cent.
$\frac{5}{16}$ "	8 "	12 "	16 "
$\frac{3}{8}$ "	7 "	10 "	13 "
$\frac{7}{16}$ "	6 "	8 "	10 "
$\frac{1}{2}$ "	5 "	7 "	9 "
$\frac{9}{16}$ "	4 $\frac{1}{2}$ "	6 $\frac{1}{2}$ "	8 $\frac{1}{2}$ "
$\frac{5}{8}$ "	4 "	6 "	8 "
Over $\frac{5}{8}$ "	3 $\frac{1}{2}$ "	5 "	6 $\frac{1}{2}$ "

PLATES UNDER  $\frac{1}{4}$ " IN THICKNESS.

THICKNESS OF PLATE.	WIDTH OF PLATE.	
	Up to 50 in.	50 in. and above.
$\frac{1}{8}$ up to $\frac{5}{16}$	10 per cent.	15 per cent.
$\frac{5}{16}$ " $\frac{3}{8}$	8 $\frac{1}{2}$ "	12 $\frac{1}{2}$ "
$\frac{3}{8}$ " $\frac{1}{2}$	7 "	10 "

VARIATION  
WHEN ORDERED  
TO WEIGHT.

13. Plates 12 $\frac{1}{2}$  lbs. or heavier, when ordered to weight, shall not average more variation than 2 $\frac{1}{2}$  per cent., either above or below the theoretical weight.

Plates from 10 to 12 $\frac{1}{2}$  lbs., when ordered to weight, shall not average a greater variation than the following:

Up to 75 inches wide, 2 $\frac{1}{2}$  per cent. either above or below the theoretical weight.

75 inches and over, 5 per cent. either above or below the theoretical weight.

Plates under 10 lbs. down to 5 lbs. when ordered to weight, shall not average more variation than 3 per cent. above or 5 per cent. below the theoretical weight.

Plates under 5 lbs. when ordered to weight shall not average more variation than 5 per cent. either above or below the theoretical weight.



## SPECIFICATIONS FOR WORKMANSHIP.

**INSPECTION.** 1. Inspection of work shall be made as it progresses, and at as early a period as the nature of the work permits.

2. All workmanship must be first-class. All abutting surfaces of compression members, except flanges of plate girders where the joints are fully spliced, must be planed or turned to even bearings so that they shall be in such contact throughout as may be obtained by such means. All finished surfaces must be protected by white lead and tallow.

3. The rivet holes for splice plates of abutting members shall be so accurately spaced that when the members are brought into position the holes shall be truly opposite before the rivets are driven.

4. Rollers must be finished perfectly round and roller-beds planed.

**RIVETS.** 5. The pitch of rivets in all classes of work shall never exceed 6 inches, nor 16 times the thinnest outside plate, nor be less than 3 diameters of the rivet. The rivets used shall generally be  $\frac{5}{8}$ ,  $\frac{3}{4}$  and  $\frac{7}{8}$  inch diameter. The distance between the edge of any piece and the center of a rivet hole must never be less than  $1\frac{1}{4}$  inches, except for bars less than  $2\frac{1}{2}$  inches wide. When practicable it shall be at least two diameters of the rivet. Rivets must completely fill the holes, have full heads concentric with the rivet, of a height not less than .6 the diameter of the rivet, and in full contact with the surface, or be countersunk when so required, and machine-driven wherever practicable.

**PUNCHING.** 6. The diameter of the punch shall not exceed by more than 1-16 inch the diameter of the rivets to be used, and all holes must be clean cuts without horn or ragged edges. Rivet holes must be accurately spaced; the use of drift pins will be allowed only for bringing together the several parts forming a member, and they must not be driven with such force as to disturb the metal about the holes.

7. Built members must, when finished, be true and free from twists, kinks, buckles, or open joints between the component pieces.

EYE-BARS AND  
PIN-HOLES.

8. All pin-holes must be accurately bored at right angles to the axis of the members, unless otherwise shown in the drawings, and in pieces not adjustable for length no variation of more than 1-32 of an inch will be allowed in the length between centers of pin-holes; the diameter of the pin-holes shall not exceed that of the pins by more than 1-32 inch, nor by more than 1-50 inch for pins under  $3\frac{1}{2}$  inches diameter. Eye-bars must be straight before boring; the holes must be in the center of the heads, and on the center line of the bars. Whenever eye-bars are to be packed more than  $\frac{1}{8}$  of an inch to the foot of their length out of parallel with the axis of the structure, they must be bent with a gentle curve until the head stands at right angles to the pin in their intended positions before being bored. All eye-bars belonging to the same panel, when placed in a pile, must allow the pin at each end to pass through at the same time without forcing. No welds will be allowed in the body of the bar of eye-bars, laterals or counters, except to form the loops of laterals, counters and sway rods; eyes of laterals, stirrups, sway rods and counters must be bored; pins and lateral bolts must be finished perfectly round and straight, and the party contracting to erect the work must provide pilot nuts where necessary to preserve the threads while the pins are being driven. Thimbles or washers must be used whenever required to fill the vacant spaces on pins or bolts.

PILOT NUTS.

ANNEALING.

9. In all cases where a steel piece in which the full strength is required has been partially heated the whole piece must be subsequently annealed. All bends in steel must be made cold, or if the degree of curvature is so great as to require heating, the whole piece must be subsequently annealed.

PAINTING.

10. All surfaces inaccessible after assembling must be well painted or oiled before the parts are assembled.

11. The decision of the engineer shall control as to the interpretation of drawings and specifications during the execution of work thereunder, but this shall not deprive the contractor of his right to redress, after the completion of the work, for an improper decision.

AREA

WT

## STANDARD SPECIFICATIONS FOR STEEL RAILS.

(January 1st, 1899.)

CHEMICAL COMPOSITION.	1.	50 LBS. UP	50 LBS. UP	70 LBS. UP
		TO 60 LBS.	TO 70 LBS.	TO 80 LBS.
	Carbon .....	.35 to .45	.38 to .48	.40 to .50
	Phosphorus.....	not over .10	not over .10	not over .10
	Silicon.....	not over .20	not over .20	not over .20
	Manganese .....	.70 to 1.00	.70 to 1.00	.75 to 1.05
		80 LBS. UP	80 LBS. UP	
		TO 90 LBS.	TO 100 LBS.	
	Carbon .....	.43 to .53	.45 to .55	
	Phosphorus.....	not over .10	not over .10	
	Silicon.....	not over .20	not over .20	
	Manganese .....	.80 to 1.10	.80 to 1.10	

**SECTION.** 2. Unless otherwise specified, the section of rail shall be the American Standard, recommended by the American Society of Civil Engineers, and shall conform, as accurately as possible, to the templet furnished by the Railroad Company, consistent with Clause No. 3, relative to specified weight. An allowance in height of  $\frac{1}{8}$  of an inch under and  $\frac{1}{2}$  of an inch over, will be permitted. A perfect fit of the Splice Bars, however, shall be maintained at all times.

**WEIGHT.** 3. The weight of the rails shall be maintained as near as possible, after complying with Clause No. 2, to that specified in contract. A variation of  $\frac{1}{2}$  of one per cent. for an entire order will be allowed. Rails shall be accepted and settled for according to actual weight.

**LENGTH.** 4. The standard length of rails shall be 30 feet. Ten per cent. of the entire order will be accepted in shorter lengths, varying by even feet down to 24 feet. A variation of  $\frac{1}{4}$  inch in length from the lengths specified will be allowed.

## THE CARNEGIE STEEL COMPANY, LIMITED.

- BRANDING.** 5. The name of the maker and the month and year of manufacture shall be rolled in raised letters on the side of the web, and the number of the heat shall be stamped on each rail.
- DRILLING.** 6. Circular holes for splice bars shall be drilled in accordance with specifications of purchaser. They shall be accurate to drawing and dimensions furnished in every respect, and free from burrs.
- FINISHING.** 7. Rails to be straightened while cold, to be smooth on head, to be sawed square at ends, and, prior to shipment, to have the burr occasioned by the saw cutting, removed, and to have ends made clean. They are to be free from injurious defects and flaws of all kinds.
- INSPECTION.** 8. The inspector, representing the purchaser, shall have free access to the works of the manufacturer at all times, while his contract is being executed, and shall have all reasonable facilities afforded to satisfy him that the rails are being made in accordance with specifications. The manufacturer shall furnish the inspector, daily, with carbon determinations of each heat, and a complete chemical analysis every twenty-four hours, representing the average of the other elements contained in the steel.
- NO. 2 RAILS.** 9. Rails which possess any injurious physical defects, or for any other cause are not suitable for first quality, shall be considered No. 2 Rails.

STANDARD SPECIFICATIONS  
FOR  
STEEL SPLICE BARS.

(January 1st, 1899.)

CHEMICAL  
COMPOSITION.

1. Carbon.....not to exceed.....0.15 per cent.
- Phosphorus .....not to exceed.....0.10 per cent.
- Manganese.....0.40 to 0.60 per cent.

PHYSICAL  
PROPERTIES.

2. Test pieces cut from head of Splice Bar must show :
  - a. Ultimate Strength, 54,000 to 64,000 pounds per square inch.
  - b. Elastic Limit, not less than one-half the Ultimate Strength.
  - c. Elongation, not less than 25 per cent. measured in 8 inches. (203 Millimeters.)
  - d. Bending test, 180 degrees flat on itself without fracture on outside of bent portion.

FINISH.

3. All Splice Bars shall be smoothly rolled and true to templet. The name of maker and year of manufacture shall be rolled in raised letters on the side of the bar. The bars shall be sheared accurately to lengths and free from fins or cracks, and shall be perfect fit to the rails for which they are intended.

THE CARNEGIE STEEL COMPANY, LIMITED.

WORKMANSHIP. 4. The punching and notching of Splice Bars must be accurate in every respect to drawing and dimensions furnished.

INSPECTION. 5. The Inspector, representing the purchaser, shall have free access to the works of the manufacturer at all times while his contract is being executed, and shall have all reasonable facilities afforded to satisfy him that Splice Bars are being made in accordance with specifications.

NOTES ON STEEL AND IRON.

1. The average weight of wrought iron is 480 lbs. per cubic foot. A bar 1 inch square and 3 feet long weighs, therefore, exactly 10 lbs. Hence:

To find the sectional area, given the weight per foot:

Multiply by  $\frac{1}{10}$ .

To find the weight per foot, given the sectional area:

Multiply by  $\frac{1}{10}$ .

2. The weight of steel is 2 per cent. greater than that of wrought iron.

To find sectional area, given weight per foot:

Divide by 3.4.

To find weight per foot, given sectional area:

Multiply by 3.4.

3. The center load, at which a bar of wrought iron 1 inch square and 12 inches center to center of points of support will give way, is very nearly *one ton* (of 2,240 lbs.)

4. Within the elastic limit, the extension and compression of wrought iron is very nearly  $\frac{1}{10000}$  of its length for a stress of *one ton* (of 2,240 lbs.) per square inch.

For cast iron this ratio is  $\frac{1}{5000}$  for tension, but becomes variable for compression.

5. The contraction or expansion of wrought iron under changes of temperature is about  $\frac{1}{10000}$  of its length, for a variation of 15° Fahrenheit.

The stress thus induced, if the ends are held rigidly fixed, will be about *one ton* (of 2,240 lbs.) per square inch of cross-section.

6. The coefficient of expansion of wrought iron, for 100° Fahrenheit, is 0.000686. Therefore, for a variation in temperature of 125°, a bar of wrought iron 100 feet long will expand or contract 1.029 inches.

*Conversely:* A change in length of 1 inch per hundred feet would be produced by a variation in temperature of 121.5° Fahrenheit.

7. The melting point of iron and steel is about as follows:

Wrought iron, . . . . . 3,000° Fahrenheit.

Cast iron, . . . . . 2,000° "

Steel, . . . . . 2,400° "

8. The welding heat of wrought iron is 2,733° Fahrenheit.

MISCELLANEOUS NOTES.

1. Thrust of arch per lineal foot:

$$T = \frac{1.5 w l^2}{r}, \text{ in which } w = \text{load per square foot, } r =$$

rise in arch in inches, and  $l =$  span in feet.

2. Approximately the radius of gyration for a box section is  $\frac{1}{10}$  the least side.

**SAFE LOADS UNIFORMLY DISTRIBUTED FOR  
RECTANGULAR SPRUCE OR WHITE  
PINE BEAMS ONE INCH THICK.**

The following table has been calculated for extreme fiber stresses of 750 lbs. per square inch corresponding to the following values for Moduli of Rupture recommended by Prof. Lanza, viz :

- Spruce and white pine.....3,000 lbs.
- Oak.....4,000 "
- Yellow pine.....5,000 "

For oak increase values in table by  $\frac{1}{3}$ . For yellow pine increase values in table by  $\frac{2}{3}$ .

The safe load for any other values per sq. inch is found by increasing or decreasing the loads given in the table in the same proportion as the increased or decreased fiber stress.

Span in feet.	DEPTH OF BEAM.										
	6"	7"	8"	9"	10"	11"	12"	13"	14"	15"	16"
5	600	820	1070	1350	1670	2020	2400	2820	3270	3750	4270
6	500	680	890	1120	1390	1680	2000	2350	2730	3120	3560
7	430	580	760	960	1190	1440	1710	2010	2330	2680	3050
8	380	510	670	840	1040	1260	1500	1760	2040	2340	2670
9	330	460	590	750	930	1120	1330	1560	1810	2080	2370
10	300	410	530	670	830	1010	1200	1410	1630	1880	2130
11	270	370	490	610	760	920	1090	1280	1490	1710	1940
12	250	340	440	560	690	840	1000	1180	1360	1560	1780
13	230	310	410	520	640	780	930	1080	1260	1440	1640
14	210	290	380	480	590	720	860	1010	1170	1340	1530
15	200	270	360	450	560	670	800	940	1090	1250	1420
16	190	260	330	420	520	630	750	880	1020	1180	1330
17	180	240	310	400	490	590	710	830	960	1100	1260
18	170	230	290	370	460	560	670	780	910	1040	1190
19	160	210	280	360	440	530	630	740	860	990	1130
20	150	200	270	340	420	510	600	710	820	940	1070
21	140	190	260	320	390	480	570	670	780	890	1020
22	140	190	240	310	380	460	540	640	740	850	970
23	130	180	230	290	360	440	520	610	710	810	920
24	130	170	220	280	350	420	500	590	680	780	890
25	120	160	210	270	330	410	480	560	660	750	860
26	110	160	210	260	320	390	460	540	630	720	820
27	110	150	200	250	310	370	440	520	610	690	790
28	110	140	190	240	300	360	430	500	580	670	760
29	110	140	180	230	290	350	410	490	560	640	740

To obtain the safe load for any thickness : Multiply values for 1 inch by thickness of beam.

To obtain the required thickness for any load : Divide by safe load for 1 inch.

AREA  
WT.



SAFE LOADS FOR RECTANGULAR  
WOODEN PILLARS.

(SEASONED.)

$l$ —length of pillar in inches.

$d$ —width of smallest side in inches.

Yellow Pine. (Southern). 1125 $1 - \frac{l^2}{1100 d^2}$	White Oak. 925 $1 - \frac{l^2}{1100 d^2}$	White Pine and Spruce. 800 $1 - \frac{l^2}{1100 d^2}$
---	---	--

These formulæ give safe loads of one-fourth the ultimate strength for short pillars decreasing to one-fifth the ultimate for long pillars.

Ratio of Length to Least Side. $\frac{l}{d}$	Safe Loads in lbs. per square inch of Section.		
	Yellow Pine. (Southern).	White Oak.	White Pine and Spruce.
12	995	818	707
14	955	785	679
16	913	750	649
18	869	715	618
20	825	678	587
22	781	642	556
24	738	607	525
26	697	575	495
28	657	541	467
30	619	509	440
32	583	479	414
34	549	451	390
36	516	425	367
38	487	400	346
40	458	377	326

SAFE LOADS IN TONS OF 2,000 LBS.  
FOR  
SQUARE WOODEN PILLARS.

Unsupported length of Column in Feet.	Size of Pillar in Inches.						
	6×6	8×8	9×9	10×10	12×12	14×14	16×16
<b>WHITE PINE OR SPRUCE.</b>							
6	12.80						
8	11.70	22.7	29.6				
10	10.60	21.3	28.0	35.5			
12	9.54	19.8	26.3	33.7	51.1		
14	8.46	18.4	24.7	31.9	49.0	69.6	
16	7.38	17.0	23.1	30.1	46.8	67.0	91.0
18		15.5	21.5	28.3	44.7	64.5	88.0
20		14.1	19.8	26.5	42.5	62.0	85.2
22			18.2	24.7	40.3	59.5	82.3
24				22.9	38.2	57.0	79.4
<b>WHITE OAK.</b>							
6	14.80						
8	13.50	26.2	34.0				
10	12.20	24.6	32.4	41.0			
12	11.00	22.7	30.4	39.1	59.1		
14	9.73	21.1	28.4	36.7	56.9	80.4	
16	8.64	19.5	26.5	34.6	54.0	77.8	105.0
18		17.8	24.7	32.4	51.1	74.5	102.0
20		16.3	22.7	30.5	49.0	71.3	98.5
22			21.1	28.2	46.1	68.3	94.7
24				26.4	43.9	65.5	90.9
<b>YELLOW PINE. (SOUTHERN.)</b>							
6	18.0						
8	16.4	32.0	41.6				
10	14.9	29.9	39.4	50.0			
12	13.3	27.8	36.9	47.6	72.0		
14	11.9	25.8	34.7	44.7	69.1	98.0	132.0
16	10.4	23.7	32.3	42.3	65.5	94.6	128.0
18		21.8	30.0	39.5	62.6	90.7	124.0
20		19.8	27.8	37.0	59.8	86.9	120.0
22			25.7	34.6	56.2	83.6	115.0
24				32.2	53.3	80.0	111.0

AREA

WT.

## STRENGTH OF MATERIALS.

## ULTIMATE RESISTANCE TO TENSION

IN LBS. PER SQUARE INCH.

## METALS AND ALLOYS.

	AVERAGE.
Aluminum Bronze,	
10 per cent. Al. and 90 per cent. Copper, .	85000
1¼ " " " 98¾ " " "	28000
Brass, cast, . . . . .	18000
" wire, . . . . .	49000
Bronze or gun metal, . . . . .	36000
Copper, cast, . . . . .	19000
" sheet, . . . . .	30000
" bolts, . . . . .	36000
" wire, (annealed), . . . . .	60000
Iron, cast, 13,400 to 29,000, . . . . .	16500
" wire, black or annealed, . . . . .	56000
" " bright hard drawn, . . . . .	78400
Lead, sheet, . . . . .	3300
Steel, . . . . .	45000 to 120000
" Aluminum, 2½ per cent. Aluminum, . . . . .	70000
" Copper, .35 per cent. Copper, . . . . .	60000
" Nickel, 3¼ per cent. Nickel, . . . . .	86000
" cast, wire, crucible, . . . . .	224000
" " Bessemer, . . . . .	89600
" " high carbon, . . . . .	179200
" " Mild, O. H., . . . . .	134000
The modulus of elasticity of steel from recent tests is from 27,000,000 to 31,000,000. Average, 29,000,000.	
Tin, cast, . . . . .	4600
Zinc, . . . . .	7000 to 8000

**STRENGTH OF MATERIALS.—Continued.**

**TIMBER, SEASONED AND OTHER ORGANIC FIBER.**

Taken largely from Trautwine's pocket book (edition of 1891).

	AVERAGE.
Ash, English, . . . . .	16000
“ American, . . . . .	16500
Beech, English, . . . . .	11500
Birch, . . . . .	15000
Cedar of Lebanon, . . . . .	11400
“ American, red, . . . . .	10300
Fir or Spruce, . . . . .	10000
Hempen Ropes, . . . . .	12000 to 18000
Hickory, American, . . . . .	11000
Mahogany, . . . . .	8000
Oak, American, white, . . . . .	10000
“ European, . . . . .	10000
Pine, American, white, red and pitch, Memel, Riga, . . . . .	10000
“ “ long leaf yellow, . . . . .	12600 to 19200
Poplar, . . . . .	7000
Silk fiber, . . . . .	20000
Walnut, black, . . . . .	8000

**STONE, NATURAL AND ARTIFICIAL.**

Brick and Cement, . . . . .	280 to 300
Glass, . . . . .	2560
Slate, . . . . .	2400 to 4800
Mortar, ordinary lime, . . . . .	10 to 20

**ULTIMATE RESISTANCE TO COMPRESSION.**

**METALS.**

Brass, cast, . . . . .	10300
Iron, “ . . . . .	85000 to 125000
Steel, . . . . .	45000 to 120000

AREA  
WT.

## STRENGTH OF MATERIALS.—Continued.

TIMBER, SEASONED, COMPRESSED IN THE  
DIRECTION OF THE GRAIN.

Taken largely from Trautwine's pocket book (edition of 1891).

	AVERAGE.
Ash, American, . . . . .	6800
Beech, " . . . . .	7000
Birch, . . . . .	8000
Cedar of Lebanon, . . . . .	5900
" American, red, . . . . .	6000
Chestnut, . . . . .	5300
Deal, red, . . . . .	6500
Fir or Spruce, . . . . .	5000
Hickory, . . . . .	8000
Oak, American, white, . . . . .	7000
" British, . . . . .	10000
" Dantzig, . . . . .	7700
Pine, American, white, . . . . .	5400
" " long leaf yellow, . . . . .	8500
Walnut, black, . . . . .	8000

## STONE, NATURAL AND ARTIFICIAL.

Brick, weak, . . . . .	550 to 800
" strong, . . . . .	1100
" fire, . . . . .	1700
Brick work, ordinary, in cement, . . . . .	300 to 600
" best, . . . . .	1000
Glass, . . . . .	30000
Granite, . . . . .	5000 to 18000
Limestone, . . . . .	4000 to 16000
Sandstone, ordinary, . . . . .	2500 to 10000

## ULTIMATE RESISTANCE TO SHEARING.

## METALS.

Iron, cast, . . . . .	25000
Steel, . . . . .	50000

## TIMBER, SEASONED, ALONG THE GRAIN.

White Pine, Spruce, Hemlock, . . . . .	250 to 500
Yellow Pine, long leaf, . . . . .	300 to 600
Oak, . . . . .	400 to 700

SPECIFIC GRAVITY  
OF VARIOUS SUBSTANCES.

NAMES OF SUBSTANCES.	Specific Gravity.	NAMES OF SUBSTANCES.	Specific Gravity.
Aluminum { cast . . . . .	2.60	Magnesium . . . . .	1.74
{ hammered . . . . .	2.75	Mahogany . . . . .	0.56-1.09
Amber . . . . .	1.08	Maple, dry . . . . .	0.70
Anthracite . . . . .	1.40-1.70	Marble . . . . .	2.52-2.85
Asphaltum . . . . .	1.10-1.20	Masonry, stone, dry . . . . .	2.00-2.55
Beech . . . . .	0.85	"    brick, " . . . . .	1.50-1.60
Brass { cast . . . . .	8.40-8.70	Mercury, at 32° Fah . . . . .	13.596
{ rolled . . . . .	8.57	Mica . . . . .	2.80
Brick, common hard . . . . .	1.53-2.30	Oak, dry . . . . .	0.69-1.03
Cement, ground, loose . . . . .	1.85	Petroleum, at 59° Fah . . . . .	0.80
Charcoal . . . . .	0.44	Pine . . . . .	0.35-0.60
Cherry, dry . . . . .	0.76-0.84	Platinum { cast . . . . .	21.15
Clay, dry . . . . .	1.80-2.60	{ hammered . . . . .	21.3-21.5
Coal, bituminous . . . . .	1.20-1.50	Quartz . . . . .	2.5-2.80
Coke, loose . . . . .	0.55	Saltpetre, Chili . . . . .	2.26
Concrete . . . . .	2.47	"    Kali . . . . .	1.95-2.08
Copper { cast . . . . .	8.79	Sand, fine, dry . . . . .	1.40-1.65
{ rolled . . . . .	8.78-9.00	"    wet . . . . .	1.90-2.05
Diamond . . . . .	3.52	"    coarse . . . . .	1.40-1.50
Earth, humus . . . . .	1.30-1.80	Sandstone . . . . .	2.20-2.50
Glass, common window . . . . .	2.64	Silver { cast . . . . .	10.48
Gneiss, common . . . . .	2.40-2.70	{ hammered . . . . .	10.62
Gold { cast, pure or 24 . . . . .	19.28	Slate . . . . .	2.60-2.70
{ carat . . . . .	19.33	Snow, freshly fallen . . . . .	0.19
{ pure, hammered . . . . .	19.33	Steel . . . . .	7.26-7.86
Granite . . . . .	2.50-3.00	Sulphur . . . . .	1.93-2.07
Gypsum, cast, dry . . . . .	0.97	Sodium . . . . .	0.978
Hornblende . . . . .	3.00	Tin { cast . . . . .	7.20
Ice . . . . .	0.88-0.92	{ rolled . . . . .	7.30
Iron { cast . . . . .	7.10-7.50	Water { pure rain or di-	
{ wrought . . . . .	7.79	{ stilled, at 39° Fah . . . . .	1.00
Ivory . . . . .	1.82	"    sea . . . . .	1.03
Lead . . . . .	11.37	Walnut, dry . . . . .	0.60-0.81
Lime . . . . .	2.30-3.20	Wax . . . . .	0.95-0.98
Lime, slacked . . . . .	1.30-1.40	Zinc { cast . . . . .	6.90
Limestones . . . . .	2.46-2.84	{ rolled . . . . .	7.20

AREA

WT.

WEIGHT OF A CUBIC FOOT OF SUB-  
STANCES.

NAMES OF SUBSTANCES.	Average Weight, Lbs.
Aluminum, . . . . .	162
Anthracite, solid, of Pennsylvania, . . . . .	93
"    broken, loose, . . . . .	54
"    "    moderately shaken, . . . . .	58
"    heaped bushel, loose, . . . . .	(80)
Ash, American white, dry, . . . . .	38
Asphaltum, . . . . .	87
Brass, (Copper and Zinc), cast, . . . . .	504
"    rolled, . . . . .	524
Brick, best pressed, . . . . .	150
"    common hard, . . . . .	125
"    soft, inferior, . . . . .	100
Brickwork, pressed brick, . . . . .	140
"    ordinary, . . . . .	112
Cement, hydraulic, ground, loose, American, Rosendale, . . . . .	56
"    "    "    "    "    Louisville, . . . . .	50
"    "    "    "    English, Portland, . . . . .	90
Cherry, dry, . . . . .	42
Chestnut, dry, . . . . .	41
Clay, potters', dry, . . . . .	119
"    in lump, loose, . . . . .	63
Coal, bituminous, solid, . . . . .	84
"    "    broken, loose, . . . . .	49
"    "    heaped bushel, loose, . . . . .	(74)
Coke, loose, of good coal, . . . . .	26.3
"    "    heaped bushel, . . . . .	(40)
Copper, cast, . . . . .	542
"    rolled, . . . . .	548
Earth, common loam, dry, loose, . . . . .	76
"    "    "    "    moderately rammed, . . . . .	95
"    as a soft flowing mud, . . . . .	108
Ebony, dry, . . . . .	76
Elm, dry, . . . . .	35
Flint, . . . . .	162

## WEIGHT OF SUBSTANCES—Continued.

NAMES OF SUBSTANCES.	Average Weight, Lbs.
Glass, common window, . . . . .	157
Gneiss, common, . . . . .	168
Gold, cast, pure, or 24 carat, . . . . .	1204
“ pure, hammered, . . . . .	1217
Grain at 60 lbs. per bushel, . . . . .	48
Granite, . . . . .	170
Gravel, about the same as sand, which see.	
Gypsum (plaster of paris), . . . . .	142
Hemlock, dry, . . . . .	25
Hickory, dry, . . . . .	53
Hornblende, black, . . . . .	203
Ice, . . . . .	58.7
Iron, cast, . . . . .	450
“ wrought, purest, . . . . .	485
“ “ average, . . . . .	480
Ivory, . . . . .	114
Lead, . . . . .	711
Lignum Vitae, dry, . . . . .	83
Lime, quick, ground, loose, or in small lumps, . . . . .	53
“ “ “ “ thoroughly shaken, . . . . .	75
“ “ “ “ per struck bushel, . . . . .	(66)
Limestones and Marbles, . . . . .	168
“ “ “ loose, in irregular fragments, . . . . .	96
Magnesium, . . . . .	109
Mahogany, Spanish, dry, . . . . .	53
“ Honduras, dry, . . . . .	35
Maple, dry, . . . . .	49
Marbles, see Limestones.	
Masonry, of granite or limestone, well dressed, . . . . .	165
“ “ mortar rubble, . . . . .	154
“ “ dry “ (well scabbled), . . . . .	138
“ “ sandstone, well dressed, . . . . .	144
Mercury, at 32° Fahrenheit, . . . . .	849
Mica, . . . . .	183
Mortar, hardened, . . . . .	103
Mud, dry, close, . . . . .	80 to 110

AREA

WT.



## WEIGHT OF SUBSTANCES—Continued.

NAMES OF SUBSTANCES.	Average Weight, Lbs.
Mud, wet, fluid, maximum, . . . . .	120
Oak, live, dry, . . . . .	59
" white, dry, . . . . .	50
" other kinds, . . . . .	32 to 45
Petroleum, . . . . .	55
Pine, white, dry, . . . . .	25
" yellow, Northern, . . . . .	34
" " Southern, . . . . .	45
Platinum, . . . . .	1342
Quartz, common, pure, . . . . .	165
Rosin, . . . . .	69
Salt, coarse, Syracuse, N. Y., . . . . .	45
" Liverpool, fine, for table use, . . . . .	49
Sand, of pure quartz, dry, loose, . . . . .	90 to 106
" well shaken, . . . . .	99 to 117
" perfectly wet, . . . . .	120 to 140
Sandstones, fit for building, . . . . .	151
Shales, red or black, . . . . .	162
Silver, . . . . .	655
Slate, . . . . .	175
Snow, freshly fallen, . . . . .	5 to 12
" moistened and compacted by rain, . . . . .	15 to 50
Spruce, dry, . . . . .	25
Steel, . . . . .	490
Sulphur, . . . . .	125
Sycamore, dry, . . . . .	37
Tar, . . . . .	62
Tin, cast, . . . . .	459
Turf or Peat, dry, unpressed, . . . . .	20 to 30
Walnut, black, dry, . . . . .	38
Water, pure rain or distilled, at 60° Fahrenheit, . . . . .	62 $\frac{1}{3}$
" sea, . . . . .	64
Wax, bees, . . . . .	60.5
Zinc or Spelter, . . . . .	437.5

Green timbers usually weigh from one-fifth to one-half more than dry.

LINEAR EXPANSION OF SUBSTANCES BY HEAT.

To find the increase in the length of a bar of any material due to an increase of temperature, multiply the number of degrees of increase of temperature by the coefficient for 100 degrees and by the length of the bar and divide by 100.

NAME OF SUBSTANCE.	Coefficient for 100° Fahrenheit.	Coefficient for 180° Fahrenheit, or 100° Centigrade.
Baywood, (in the direction of the grain, dry,) - - - - -	.00026	.00046
	TO	TO
	.00031	.00057
Brass, (cast,) - - - - -	.00104	.00188
“ (wire,) - - - - -	.00107	.00193
Brick, (fire,) - - - - -	.0003	.0005
Cement, (Roman,) - - - - -	.0008	.0014
Copper, - - - - -	.0009	.0017
Deal, (in the direction of the grain, dry,) - - - - -	.00024	.00044
Glass, (English flint,) - - - - -	.00045	.00081
“ (French white lead,) - - - - -	.00048	.00087
Gold, - - - - -	.0008	.0015
Granite, (average,) - - - - -	.00047	.00085
Iron, (cast,) - - - - -	.0006	.0011
“ (soft forged,) - - - - -	.0007	.0012
“ (wire,) - - - - -	.0008	.0014
Lead, - - - - -	.0016	.0029
Marble, (Carrara,) - - - - -	.00036	.00065
	TO	TO
	.0006	.0011
Mercury, - - - - -	.0033	.0060
Platinum, - - - - -	.0005	.0009
Sandstone, - - - - -	.0005	.0009
	TO	TO
	.0007	.0012
Silver, - - - - -	.0011	.002
Slate, (Wales,) - - - - -	.0008	.001
Water, (varies considerably with the temperature,) - - - - -	.0086	.0155

AREA  
WT.

## AREAS OF FLAT ROLLED STEEL.

For Thicknesses from  $\frac{1}{8}$  in. to 2 in. and Widths from 1 in. to  $12\frac{3}{4}$  in.

Thickness in inches.	1''	1 $\frac{1}{4}$ ''	1 $\frac{1}{2}$ ''	1 $\frac{3}{4}$ ''	2''	2 $\frac{1}{4}$ ''	2 $\frac{1}{2}$ ''	2 $\frac{3}{4}$ ''	12''
$\frac{1}{8}$	.063	.078	.094	.109	.125	.141	.156	.172	.750
$\frac{1}{4}$	.125	.156	.188	.219	.250	.281	.313	.344	1.50
$\frac{3}{8}$	.188	.234	.281	.328	.375	.422	.469	.516	2.25
$\frac{1}{2}$	.250	.313	.375	.438	.500	.563	.625	.688	3.00
$\frac{5}{8}$	.313	.391	.469	.547	.625	.703	.781	.859	3.75
$\frac{3}{4}$	.375	.469	.563	.656	.750	.844	.938	1.03	4.50
$\frac{7}{8}$	.438	.547	.656	.766	.875	.984	1.09	1.20	5.25
1	.500	.625	.750	.875	1.00	1.13	1.25	1.38	6.00
$1\frac{1}{8}$	.563	.703	.844	.984	1.13	1.27	1.41	1.55	6.75
$1\frac{1}{4}$	.625	.781	.938	1.09	1.25	1.41	1.56	1.72	7.50
$1\frac{1}{2}$	.688	.859	1.03	1.20	1.38	1.55	1.72	1.89	8.25
$1\frac{3}{4}$	.750	.938	1.13	1.31	1.50	1.69	1.88	2.06	9.00
$1\frac{5}{8}$	.813	1.02	1.22	1.42	1.63	1.83	2.03	2.23	9.75
$1\frac{3}{4}$	.875	1.09	1.31	1.53	1.75	1.97	2.19	2.41	10.50
$1\frac{7}{8}$	.938	1.17	1.41	1.64	1.88	2.11	2.34	2.58	11.25
1	1.00	1.25	1.50	1.75	2.00	2.25	2.50	2.75	12.00
$1\frac{1}{8}$	1.06	1.33	1.59	1.86	2.13	2.39	2.66	2.92	12.75
$1\frac{1}{4}$	1.13	1.41	1.69	1.97	2.25	2.53	2.81	3.09	13.50
$1\frac{3}{8}$	1.19	1.48	1.78	2.08	2.38	2.67	2.97	3.27	14.25
$1\frac{1}{2}$	1.25	1.56	1.88	2.19	2.50	2.81	3.13	3.44	15.00
$1\frac{5}{8}$	1.31	1.64	1.97	2.30	2.63	2.95	3.28	3.61	15.75
$1\frac{3}{4}$	1.38	1.72	2.06	2.41	2.75	3.09	3.44	3.78	16.50
$1\frac{7}{8}$	1.44	1.80	2.16	2.52	2.88	3.23	3.59	3.95	17.25
$1\frac{1}{2}$	1.50	1.88	2.25	2.63	3.00	3.38	3.75	4.13	18.00
$1\frac{9}{8}$	1.56	1.95	2.34	2.73	3.13	3.52	3.91	4.30	18.75
$1\frac{5}{4}$	1.63	2.03	2.44	2.84	3.25	3.66	4.06	4.47	19.50
$1\frac{11}{8}$	1.69	2.11	2.53	2.95	3.38	3.80	4.22	4.64	20.25
$1\frac{3}{4}$	1.75	2.19	2.63	3.06	3.50	3.94	4.38	4.81	21.00
$1\frac{7}{8}$	1.81	2.27	2.72	3.17	3.63	4.08	4.53	4.98	21.75
$1\frac{1}{2}$	1.88	2.34	2.81	3.28	3.75	4.22	4.69	5.16	22.50
$1\frac{9}{8}$	1.94	2.42	2.91	3.39	3.88	4.36	4.84	5.33	23.25
2	2.00	2.50	3.00	3.50	4.00	4.50	5.00	5.50	24.00

THE CARNEGIE STEEL COMPANY, LIMITED.

AREAS OF FLAT ROLLED STEEL.

(CONTINUED.)

Thickness in inches.	3''	3¼''	3½''	3¾''	4''	4¼''	4½''	4¾''	12''
1/16	.188	.203	.219	.234	.250	.266	.281	.297	.750
1/8	.375	.406	.438	.469	.500	.531	.563	.594	1.50
3/16	.563	.609	.656	.703	.750	.797	.844	.891	2.25
1/4	.750	.813	.875	.938	1.00	1.06	1.13	1.19	3.00
5/16	.938	1.02	1.09	1.17	1.25	1.33	1.41	1.48	3.75
3/8	1.13	1.22	1.31	1.41	1.50	1.59	1.69	1.78	4.50
7/16	1.31	1.42	1.53	1.64	1.75	1.86	1.97	2.08	5.25
1/2	1.50	1.63	1.75	1.88	2.00	2.13	2.25	2.38	6.00
9/16	1.69	1.83	1.97	2.11	2.25	2.39	2.53	2.67	6.75
5/8	1.88	2.03	2.19	2.34	2.50	2.66	2.81	2.97	7.50
11/16	2.06	2.23	2.41	2.58	2.75	2.92	3.09	3.27	8.25
3/4	2.25	2.44	2.63	2.81	3.00	3.19	3.38	3.56	9.00
13/16	2.44	2.64	2.84	3.05	3.25	3.45	3.66	3.86	9.75
7/8	2.63	2.84	3.06	3.28	3.50	3.72	3.94	4.16	10.50
15/16	2.81	3.05	3.28	3.52	3.75	3.98	4.22	4.45	11.25
1	3.00	3.25	3.50	3.75	4.00	4.25	4.50	4.75	12.00
1 1/16	3.19	3.45	3.72	3.98	4.25	4.52	4.78	5.05	12.75
1 1/8	3.38	3.66	3.94	4.22	4.50	4.78	5.06	5.34	13.50
1 1/4	3.56	3.86	4.16	4.45	4.75	5.05	5.34	5.64	14.25
1 3/8	3.75	4.06	4.38	4.69	5.00	5.31	5.63	5.94	15.00
1 1/2	3.94	4.27	4.59	4.92	5.25	5.58	5.91	6.23	15.75
1 5/8	4.13	4.47	4.81	5.16	5.50	5.84	6.19	6.53	16.50
1 3/4	4.31	4.67	5.03	5.39	5.75	6.11	6.47	6.83	17.25
1 7/8	4.50	4.88	5.25	5.63	6.00	6.38	6.75	7.13	18.00
2	4.69	5.08	5.47	5.86	6.25	6.64	7.03	7.42	18.75
1 1/2	4.88	5.28	5.69	6.09	6.50	6.91	7.31	7.72	19.50
1 1/4	5.06	5.48	5.91	6.33	6.75	7.17	7.59	8.02	20.25
1 1/8	5.25	5.69	6.13	6.56	7.00	7.44	7.88	8.31	21.00
1 1/16	5.44	5.89	6.34	6.80	7.25	7.70	8.16	8.61	21.75
1 1/8	5.63	6.09	6.56	7.03	7.50	7.97	8.44	8.91	22.50
1 5/8	5.81	6.30	6.78	7.27	7.75	8.23	8.72	9.20	23.25
2	6.00	6.50	7.00	7.50	8.00	8.50	9.00	9.50	24.00

AREA

WT.

## AREAS OF FLAT ROLLED STEEL.

(CONTINUED.)

Thickness in inches.	5"	5¼"	5½"	5¾"	6"	6¼"	6½"	6¾"	12"
$\frac{1}{16}$	.313	.328	.344	.359	.375	.391	.406	.422	.750
$\frac{1}{8}$	.625	.656	.688	.719	.750	.781	.813	.844	1.50
$\frac{3}{16}$	.938	.984	1.03	1.08	1.13	1.17	1.22	1.27	2.25
$\frac{1}{4}$	1.25	1.31	1.38	1.44	1.50	1.56	1.63	1.69	3.00
$\frac{5}{16}$	1.56	1.64	1.72	1.80	1.88	1.95	2.03	2.11	3.75
$\frac{3}{8}$	1.88	1.97	2.06	2.16	2.25	2.34	2.44	2.53	4.50
$\frac{7}{16}$	2.19	2.30	2.41	2.52	2.63	2.73	2.84	2.95	5.25
$\frac{1}{2}$	2.50	2.63	2.75	2.88	3.00	3.13	3.25	3.38	6.00
$\frac{9}{16}$	2.81	2.95	3.09	3.23	3.38	3.52	3.66	3.80	6.75
$\frac{5}{8}$	3.13	3.28	3.44	3.59	3.75	3.91	4.06	4.22	7.50
$1\frac{1}{16}$	3.44	3.61	3.78	3.95	4.13	4.30	4.47	4.64	8.25
$\frac{3}{4}$	3.75	3.94	4.13	4.31	4.50	4.69	4.88	5.06	9.00
$1\frac{1}{8}$	4.06	4.27	4.47	4.67	4.88	5.08	5.28	5.48	9.75
$1\frac{1}{4}$	4.38	4.59	4.81	5.03	5.25	5.47	5.69	5.91	10.50
$1\frac{3}{8}$	4.69	4.92	5.16	5.39	5.63	5.86	6.09	6.33	11.25
1	5.00	5.25	5.50	5.75	6.00	6.25	6.50	6.75	12.00
$1\frac{1}{16}$	5.31	5.58	5.84	6.11	6.38	6.64	6.91	7.17	12.75
$1\frac{1}{8}$	5.63	5.91	6.19	6.47	6.75	7.03	7.31	7.59	13.50
$1\frac{1}{4}$	5.94	6.23	6.53	6.83	7.13	7.42	7.72	8.02	14.25
$1\frac{3}{8}$	6.25	6.56	6.88	7.19	7.50	7.81	8.13	8.44	15.00
$1\frac{5}{8}$	6.56	6.89	7.22	7.55	7.88	8.20	8.53	8.86	15.75
$1\frac{3}{4}$	6.88	7.22	7.56	7.91	8.25	8.59	8.94	9.28	16.50
$1\frac{7}{8}$	7.19	7.55	7.91	8.27	8.63	8.98	9.34	9.70	17.25
$2$	7.50	7.88	8.25	8.63	9.00	9.38	9.75	10.13	18.00
$1\frac{9}{8}$	7.81	8.20	8.59	8.98	9.38	9.77	10.16	10.55	18.75
$1\frac{5}{4}$	8.13	8.53	8.94	9.34	9.75	10.16	10.56	10.97	19.50
$1\frac{11}{8}$	8.44	8.86	9.28	9.70	10.13	10.55	10.97	11.39	20.25
$1\frac{3}{4}$	8.75	9.19	9.63	10.06	10.50	10.94	11.38	11.81	21.00
$1\frac{7}{8}$	9.06	9.52	9.97	10.42	10.88	11.33	11.78	12.23	21.75
$1\frac{15}{8}$	9.38	9.84	10.31	10.78	11.25	11.72	12.19	12.66	22.50
$1\frac{13}{8}$	9.69	10.17	10.66	11.14	11.63	12.11	12.59	13.08	23.25
2	10.00	10.50	11.00	11.50	12.00	12.50	13.00	13.50	24.00

## AREAS OF FLAT ROLLED STEEL.

(CONTINUED.)

Thickness in inches.	7''	7 $\frac{1}{4}$ ''	7 $\frac{1}{2}$ ''	7 $\frac{3}{4}$ ''	8''	8 $\frac{1}{4}$ ''	8 $\frac{1}{2}$ ''	8 $\frac{3}{4}$ ''	12''
$\frac{1}{16}$	.438	.453	.469	.484	.500	.516	.531	.547	.750
$\frac{3}{16}$	.875	.906	.938	.969	1.00	1.03	1.06	1.09	1.50
$\frac{1}{8}$	1.31	1.36	1.41	1.45	1.50	1.55	1.59	1.64	2.25
$\frac{3}{8}$	1.75	1.81	1.88	1.94	2.00	2.06	2.13	2.19	3.00
$\frac{5}{16}$	2.19	2.27	2.34	2.42	2.50	2.58	2.66	2.73	3.75
$\frac{3}{8}$	2.63	2.72	2.81	2.91	3.00	3.09	3.19	3.28	4.50
$\frac{1}{2}$	3.06	3.17	3.28	3.39	3.50	3.61	3.72	3.83	5.25
$\frac{5}{8}$	3.50	3.63	3.75	3.88	4.00	4.13	4.25	4.38	6.00
$\frac{3}{4}$	3.94	4.08	4.22	4.36	4.50	4.64	4.78	4.92	6.75
$\frac{7}{8}$	4.38	4.53	4.69	4.84	5.00	5.16	5.31	5.47	7.50
$1\frac{1}{16}$	4.81	4.98	5.16	5.33	5.50	5.67	5.84	6.02	8.25
$1\frac{1}{8}$	5.25	5.44	5.63	5.81	6.00	6.19	6.38	6.56	9.00
$1\frac{1}{4}$	5.69	5.89	6.09	6.30	6.50	6.70	6.91	7.11	9.75
$1\frac{3}{8}$	6.13	6.34	6.56	6.78	7.00	7.22	7.44	7.66	10.50
$1\frac{1}{2}$	6.56	6.80	7.03	7.27	7.50	7.73	7.97	8.20	11.25
1	7.00	7.25	7.50	7.75	8.00	8.25	8.50	8.75	12.00
$1\frac{1}{16}$	7.44	7.70	7.97	8.23	8.50	8.77	9.03	9.30	12.75
$1\frac{1}{8}$	7.88	8.16	8.44	8.72	9.00	9.28	9.56	9.84	13.50
$1\frac{1}{4}$	8.31	8.61	8.91	9.20	9.50	9.80	10.09	10.39	14.25
$1\frac{3}{8}$	8.75	9.06	9.38	9.69	10.00	10.31	10.63	10.94	15.00
$1\frac{5}{8}$	9.19	9.52	9.84	10.17	10.50	10.83	11.16	11.48	15.75
$1\frac{3}{4}$	9.63	9.97	10.31	10.66	11.00	11.34	11.69	12.03	16.50
$1\frac{7}{8}$	10.06	10.42	10.78	11.14	11.50	11.86	12.22	12.58	17.25
$1\frac{1}{2}$	10.50	10.88	11.25	11.63	12.00	12.38	12.75	13.13	18.00
$1\frac{9}{8}$	10.94	11.33	11.72	12.11	12.50	12.89	13.28	13.67	18.75
$1\frac{5}{4}$	11.38	11.78	12.19	12.59	13.00	13.41	13.81	14.22	19.50
$1\frac{11}{8}$	11.81	12.23	12.66	13.08	13.50	13.92	14.34	14.77	20.25
$1\frac{3}{4}$	12.25	12.69	13.13	13.56	14.00	14.44	14.88	15.31	21.00
$1\frac{13}{8}$	12.69	13.14	13.59	14.05	14.50	14.95	15.41	15.86	21.75
$1\frac{7}{4}$	13.13	13.59	14.06	14.53	15.00	15.47	15.94	16.41	22.50
$1\frac{15}{8}$	13.56	14.05	14.53	15.02	15.50	15.98	16.47	16.95	23.25
2	14.00	14.50	15.00	15.50	16.00	16.50	17.00	17.50	24.00

Wt.

## AREAS OF FLAT ROLLED STEEL.

(CONTINUED.)

Thickness in inches.	9''	9¼''	9½''	9¾''	10''	10¼''	10½''	10¾''	12''
$\frac{1}{8}$	.563	.578	.594	.609	.625	.641	.656	.672	.750
$\frac{1}{4}$	1.13	1.16	1.19	1.22	1.25	1.28	1.31	1.34	1.50
$\frac{3}{8}$	1.69	1.73	1.78	1.83	1.88	1.92	1.97	2.02	2.25
$\frac{1}{2}$	2.25	2.31	2.38	2.44	2.50	2.56	2.63	2.69	3.00
$\frac{5}{8}$	2.81	2.89	2.97	3.05	3.13	3.20	3.28	3.36	3.75
$\frac{3}{4}$	3.38	3.47	3.56	3.65	3.75	3.84	3.94	4.03	4.50
$\frac{7}{8}$	3.94	4.05	4.16	4.27	4.38	4.48	4.59	4.70	5.25
1	4.50	4.63	4.75	4.88	5.00	5.13	5.25	5.38	6.00
$\frac{9}{8}$	5.06	5.20	5.34	5.48	5.63	5.77	5.91	6.05	6.75
$\frac{5}{4}$	5.63	5.78	5.94	6.09	6.25	6.41	6.56	6.72	7.50
$\frac{11}{8}$	6.19	6.36	6.53	6.70	6.88	7.05	7.22	7.39	8.25
$\frac{3}{2}$	6.75	6.94	7.13	7.31	7.50	7.69	7.88	8.06	9.00
$\frac{13}{8}$	7.31	7.52	7.72	7.92	8.13	8.33	8.53	8.73	9.75
$\frac{7}{4}$	7.88	8.09	8.31	8.53	8.75	8.97	9.19	9.41	10.50
$\frac{15}{8}$	8.44	8.67	8.91	9.14	9.38	9.61	9.84	10.08	11.25
1	9.00	9.25	9.50	9.75	10.00	10.25	10.50	10.75	12.00
$1\frac{1}{8}$	9.56	9.83	10.09	10.36	10.63	10.89	11.16	11.42	12.75
$1\frac{1}{4}$	10.13	10.41	10.69	10.97	11.25	11.53	11.81	12.09	13.50
$1\frac{3}{8}$	10.69	10.98	11.28	11.58	11.88	12.17	12.47	12.77	14.25
$1\frac{1}{2}$	11.25	11.56	11.88	12.19	12.50	12.81	13.13	13.44	15.00
$1\frac{5}{8}$	11.81	12.14	12.47	12.80	13.13	13.45	13.78	14.11	15.75
$1\frac{3}{4}$	12.38	12.72	13.06	13.41	13.75	14.09	14.44	14.78	16.50
$1\frac{7}{8}$	12.94	13.30	13.66	14.02	14.38	14.73	15.09	15.45	17.25
$1\frac{1}{2}$	13.50	13.88	14.25	14.63	15.00	15.38	15.75	16.13	18.00
$1\frac{9}{8}$	14.06	14.45	14.84	15.23	15.63	16.02	16.41	16.80	18.75
$1\frac{5}{4}$	14.63	15.03	15.44	15.84	16.25	16.66	17.06	17.47	19.50
$1\frac{11}{8}$	15.19	15.61	16.03	16.45	16.88	17.30	17.72	18.14	20.25
$1\frac{3}{4}$	15.75	16.19	16.63	17.06	17.50	17.94	18.38	18.81	21.00
$1\frac{13}{8}$	16.31	16.77	17.22	17.67	18.13	18.58	19.03	19.48	21.75
$1\frac{7}{4}$	16.88	17.34	17.81	18.28	18.75	19.22	19.69	20.16	22.50
$1\frac{15}{8}$	17.44	17.92	18.41	18.89	19.38	19.86	20.34	20.83	23.25
2	18.00	18.50	19.00	19.50	20.00	20.50	21.00	21.50	24.00

## AREAS OF FLAT ROLLED STEEL.

(CONTINUED.)

Thickness in inches.	11''	11 $\frac{1}{4}$ ''	11 $\frac{1}{2}$ ''	11 $\frac{3}{4}$ ''	12''	12 $\frac{1}{4}$ ''	12 $\frac{1}{2}$ ''	12 $\frac{3}{4}$ ''
$\frac{1}{16}$	.688	.703	.719	.734	.750	.766	.781	.797
$\frac{1}{8}$	1.38	1.41	1.44	1.47	1.50	1.53	1.56	1.59
$\frac{3}{16}$	2.06	2.11	2.16	2.20	2.25	2.30	2.34	2.39
$\frac{1}{4}$	2.75	2.81	2.88	2.94	3.00	3.06	3.13	3.19
$\frac{5}{16}$	3.44	3.52	3.59	3.67	3.75	3.83	3.91	3.98
$\frac{3}{8}$	4.13	4.22	4.31	4.41	4.50	4.59	4.69	4.78
$\frac{7}{16}$	4.81	4.92	5.03	5.14	5.25	5.36	5.47	5.58
$\frac{1}{2}$	5.50	5.63	5.75	5.88	6.00	6.13	6.25	6.38
$\frac{9}{16}$	6.19	6.33	6.47	6.61	6.75	6.89	7.03	7.17
$\frac{5}{8}$	6.88	7.03	7.19	7.34	7.50	7.66	7.81	7.97
$1\frac{1}{16}$	7.56	7.73	7.91	8.08	8.25	8.42	8.59	8.77
$1\frac{1}{8}$	8.25	8.44	8.63	8.81	9.00	9.19	9.38	9.56
$1\frac{3}{8}$	8.94	9.14	9.34	9.55	9.75	9.95	10.16	10.36
$1\frac{1}{2}$	9.63	9.84	10.06	10.28	10.50	10.72	10.94	11.16
$1\frac{5}{8}$	10.31	10.55	10.78	11.02	11.25	11.48	11.72	11.95
1	11.00	11.25	11.50	11.75	12.00	12.25	12.50	12.75
$1\frac{1}{16}$	11.69	11.95	12.22	12.48	12.75	13.02	13.28	13.55
$1\frac{1}{8}$	12.38	12.66	12.94	13.22	13.50	13.78	14.06	14.34
$1\frac{3}{16}$	13.06	13.36	13.66	13.95	14.25	14.55	14.84	15.14
$1\frac{1}{4}$	13.75	14.06	14.38	14.69	15.00	15.31	15.63	15.94
$1\frac{5}{16}$	14.44	14.77	15.09	15.42	15.75	16.08	16.41	16.73
$1\frac{3}{8}$	15.13	15.47	15.81	16.16	16.50	16.84	17.19	17.53
$1\frac{7}{16}$	15.81	16.17	16.53	16.89	17.25	17.61	17.97	18.33
$1\frac{1}{2}$	16.50	16.88	17.25	17.63	18.00	18.38	18.75	19.13
$1\frac{9}{16}$	17.19	17.58	17.97	18.36	18.75	19.14	19.53	19.92
$1\frac{5}{8}$	17.88	18.28	18.69	19.09	19.50	19.91	20.31	20.72
$1\frac{11}{16}$	18.56	18.98	19.41	19.83	20.25	20.67	21.09	21.52
$1\frac{3}{4}$	19.25	19.69	20.13	20.56	21.00	21.44	21.88	22.31
$1\frac{7}{8}$	19.94	20.39	20.84	21.30	21.75	22.20	22.66	23.11
$1\frac{15}{16}$	20.63	21.09	21.56	22.03	22.50	22.97	23.44	23.91
$1\frac{1}{2}$	21.31	21.80	22.28	22.77	23.25	23.73	24.22	24.70
2	22.00	22.50	23.00	23.50	24.00	24.50	25.00	25.50

The areas for 12'' width are repeated on each page to facilitate making the additions necessary to obtain the areas of plates wider than 12''. Thus, to find the area of 15 $\frac{1}{4}$ '' $\times$ 7 $\frac{1}{8}$ '', add the areas to be found in the same line for 3 $\frac{1}{4}$ '' $\times$ 7 $\frac{1}{8}$ ' and 12'' $\times$ 7 $\frac{1}{8}$ '—2.84+10.50=13.34 square inches.



## WEIGHTS OF FLAT ROLLED STEEL.

PER LINEAL FOOT.

1 Cubic Foot weighing 489.6 lbs.

Thickness in inches.	1''	1¼''	1½''	1¾''	2''	2¼''	2½''	2¾''	3''
⅜	.688	.797	.957	1.11	1.28	1.44	1.59	1.75	7.65
¼	.850	1.06	1.28	1.49	1.70	1.91	2.12	2.34	10.20
⅜	1.06	1.33	1.59	1.86	2.12	2.39	2.65	2.92	12.75
⅜	1.28	1.59	1.92	2.23	2.55	2.87	3.19	3.51	15.30
⅜	1.49	1.86	2.23	2.60	2.98	3.35	3.72	4.09	17.85
½	1.70	2.12	2.55	2.98	3.40	3.83	4.25	4.67	20.40
⅝	1.92	2.39	2.87	3.35	3.83	4.30	4.78	5.26	22.95
⅝	2.12	2.65	3.19	3.72	4.25	4.78	5.31	5.84	25.50
⅝	2.34	2.92	3.51	4.09	4.67	5.26	5.84	6.43	28.05
¾	2.55	3.19	3.83	4.47	5.10	5.75	6.38	7.02	30.60
⅞	2.76	3.45	4.14	4.84	5.53	6.21	6.90	7.60	33.15
⅞	2.98	3.72	4.47	5.20	5.95	6.69	7.44	8.18	35.70
⅞	3.19	3.99	4.78	5.58	6.38	7.18	7.97	8.77	38.25
1	3.40	4.25	5.10	5.95	6.80	7.65	8.50	9.35	40.80
1 ⅛	3.61	4.52	5.42	6.32	7.22	8.13	9.03	9.93	43.35
1 ⅛	3.83	4.78	5.74	6.70	7.65	8.61	9.57	10.52	45.90
1 ⅛	4.04	5.05	6.06	7.07	8.08	9.09	10.10	11.11	48.45
1 ¼	4.25	5.31	6.38	7.44	8.50	9.57	10.63	11.69	51.00
1 ⅝	4.46	5.58	6.69	7.81	8.93	10.04	11.16	12.27	53.55
1 ⅝	4.67	5.84	7.02	8.18	9.35	10.52	11.69	12.85	56.10
1 ⅝	4.89	6.11	7.34	8.56	9.78	11.00	12.22	13.44	58.65
1 ½	5.10	6.38	7.65	8.93	10.20	11.48	12.75	14.03	61.20
1 ⅞	5.32	6.64	7.97	9.30	10.63	11.95	13.28	14.61	63.75
1 ⅞	5.52	6.90	8.29	9.67	11.05	12.43	13.81	15.19	66.30
1 ⅞	5.74	7.17	8.61	10.04	11.47	12.91	14.34	15.78	68.85
1 ¾	5.95	7.44	8.93	10.42	11.90	13.40	14.88	16.37	71.40
1 ⅞	6.16	7.70	9.24	10.79	12.33	13.86	15.40	16.95	73.95
1 ¾	6.38	7.97	9.57	11.15	12.75	14.34	15.94	17.53	76.50
1 ⅞	6.59	8.24	9.88	11.53	13.18	14.83	16.47	18.12	79.05
2	6.80	8.50	10.20	11.90	13.60	15.30	17.00	18.70	81.60

## WEIGHTS OF FLAT ROLLED STEEL.

PER LINEAL FOOT.

(CONTINUED.)

Thickness in inches.	3"	3¼"	3½"	3¾"	4"	4¼"	4½"	4¾"	12"
⅜	1.91	2.07	2.23	2.39	2.55	2.71	2.87	3.03	7.65
¼	2.55	2.76	2.98	3.19	3.40	3.61	3.83	4.04	10.20
⅝	3.19	3.45	3.72	3.99	4.25	4.52	4.78	5.05	12.75
⅜	3.83	4.15	4.47	4.78	5.10	5.42	5.74	6.06	15.30
⅞	4.46	4.83	5.20	5.58	5.95	6.32	6.70	7.07	17.85
½	5.10	5.53	5.95	6.38	6.80	7.22	7.65	8.08	20.40
⅝	5.74	6.22	6.70	7.17	7.65	8.13	8.61	9.09	22.95
⅜	6.38	6.91	7.44	7.97	8.50	9.03	9.57	10.10	25.50
⅞	7.02	7.60	8.18	8.76	9.35	9.93	10.52	11.11	28.05
¾	7.65	8.29	8.93	9.57	10.20	10.84	11.48	12.12	30.60
⅞	8.29	8.98	9.67	10.36	11.05	11.74	12.43	13.12	33.15
⅝	8.93	9.67	10.41	11.16	11.90	12.65	13.39	14.13	35.70
⅞	9.57	10.36	11.16	11.95	12.75	13.55	14.34	15.14	38.25
1	10.20	11.05	11.90	12.75	13.60	14.45	15.30	16.15	40.80
1⅛	10.84	11.74	12.65	13.55	14.45	15.35	16.26	17.16	43.35
1⅜	11.48	12.43	13.39	14.34	15.30	16.26	17.22	18.17	45.90
1⅝	12.12	13.12	14.13	15.14	16.15	17.16	18.17	19.18	48.45
1⅞	12.75	13.81	14.87	15.94	17.00	18.06	19.13	20.19	51.00
1⅝	13.39	14.50	15.62	16.74	17.85	18.96	20.08	21.20	53.55
1⅜	14.03	15.20	16.36	17.53	18.70	19.87	21.04	22.21	56.10
1⅞	14.66	15.88	17.10	18.33	19.55	20.77	21.99	23.22	58.65
1½	15.30	16.58	17.85	19.13	20.40	21.68	22.95	24.23	61.20
1⅞	15.94	17.27	18.60	19.92	21.25	22.58	23.91	25.24	63.75
1⅝	16.58	17.96	19.34	20.72	22.10	23.48	24.87	26.25	66.30
1⅞	17.22	18.65	20.08	21.51	22.95	24.38	25.82	27.26	68.85
1¾	17.85	19.34	20.83	22.32	23.80	25.29	26.78	28.27	71.40
1⅞	18.49	20.03	21.57	23.11	24.65	26.19	27.73	29.27	73.95
1⅝	19.13	20.72	22.31	23.91	25.50	27.10	28.69	30.28	76.50
1⅞	19.77	21.41	23.06	24.70	26.35	28.00	29.64	31.29	79.05
2	20.40	22.10	23.80	25.50	27.20	28.90	30.60	32.30	81.60

Wt.

THE CARNEGIE STEEL COMPANY, LIMITED.

WEIGHTS OF FLAT ROLLED STEEL.

PER LINEAL FOOT.

(CONTINUED.)

Thickness in inches.	5''	5¼''	5½''	5¾''	6''	6¼''	6½''	6¾''	12''
$\frac{3}{16}$	3.19	3.35	3.51	3.67	3.83	3.99	4.14	4.30	7.65
$\frac{1}{4}$	4.25	4.46	4.67	4.89	5.10	5.31	5.53	5.74	10.20
$\frac{5}{16}$	5.31	5.58	5.84	6.11	6.38	6.64	6.90	7.17	12.75
$\frac{3}{8}$	6.38	6.69	7.02	7.34	7.65	7.97	8.29	8.61	15.30
$\frac{7}{16}$	7.44	7.81	8.18	8.56	8.93	9.29	9.67	10.04	17.85
$\frac{1}{2}$	8.50	8.93	9.35	9.77	10.20	10.63	11.05	11.48	20.40
$\frac{9}{16}$	9.57	10.04	10.52	11.00	11.48	11.95	12.43	12.91	22.95
$\frac{5}{8}$	10.63	11.16	11.69	12.22	12.75	13.28	13.81	14.34	25.50
$1\frac{1}{16}$	11.69	12.27	12.85	13.44	14.03	14.61	15.20	15.78	28.05
$\frac{3}{4}$	12.75	13.39	14.03	14.67	15.30	15.94	16.58	17.22	30.60
$1\frac{1}{8}$	13.81	14.50	15.19	15.88	16.58	17.27	17.95	18.65	33.15
$\frac{7}{8}$	14.87	15.62	16.36	17.10	17.85	18.60	19.34	20.08	35.70
$1\frac{1}{4}$	15.94	16.74	17.53	18.33	19.13	19.92	20.72	21.51	38.25
1	17.00	17.85	18.70	19.55	20.40	21.25	22.10	22.95	40.80
$1\frac{1}{8}$	18.06	18.96	19.87	20.77	21.63	22.58	23.48	24.39	43.35
$1\frac{3}{8}$	19.13	20.08	21.04	21.99	22.95	23.91	24.87	25.82	45.90
$1\frac{5}{8}$	20.19	21.20	22.21	23.22	24.23	25.23	26.24	27.25	48.45
$1\frac{3}{4}$	21.25	22.32	23.38	24.44	25.50	26.56	27.62	28.69	51.00
$1\frac{5}{8}$	22.32	23.43	24.54	25.66	26.78	27.90	29.01	30.12	53.55
$1\frac{7}{8}$	23.38	24.54	25.71	26.88	28.05	29.22	30.39	31.56	56.10
$1\frac{9}{8}$	24.44	25.66	26.88	28.10	29.33	30.55	31.77	32.99	58.65
$1\frac{1}{2}$	25.50	26.78	28.05	29.33	30.60	31.88	33.15	34.43	61.20
$1\frac{9}{16}$	26.57	27.89	29.22	30.55	31.88	33.20	34.53	35.86	63.75
$1\frac{5}{8}$	27.63	29.01	30.39	31.77	33.15	34.53	35.91	37.29	66.30
$1\frac{7}{8}$	28.69	30.12	31.55	32.99	34.43	35.86	37.30	38.73	68.85
$1\frac{3}{4}$	29.75	31.24	32.73	34.22	35.70	37.19	38.68	40.17	71.40
$1\frac{1}{2}$	30.81	32.35	33.89	35.43	36.98	38.52	40.05	41.60	73.95
$1\frac{5}{8}$	31.87	33.47	35.06	36.65	38.25	39.85	41.44	43.03	76.50
$1\frac{7}{8}$	32.94	34.59	36.23	37.88	39.53	41.17	42.82	44.46	79.05
2	34.00	35.70	37.40	39.10	40.80	42.50	44.20	45.90	81.60

THE CARNEGIE STEEL COMPANY, LIMITED.

WEIGHTS OF FLAT ROLLED STEEL.

PER LINEAL FOOT.

(CONTINUED.)

Thickness in inches.	7"	7¼"	7½"	7¾"	8"	8¼"	8½"	8¾"	12"
$\frac{3}{16}$	4.46	4.62	4.78	4.94	5.10	5.26	5.42	5.58	7.65
$\frac{1}{4}$	5.95	6.16	6.36	6.58	6.80	7.01	7.22	7.43	10.20
$\frac{5}{16}$	7.44	7.70	7.97	8.23	8.50	8.76	9.03	9.29	12.75
$\frac{3}{8}$	8.93	9.25	9.57	9.88	10.20	10.52	10.84	11.16	15.30
$\frac{7}{16}$	10.41	10.78	11.16	11.53	11.90	12.27	12.64	13.02	17.85
$\frac{1}{2}$	11.90	12.32	12.75	13.18	13.60	14.03	14.44	14.87	20.40
$\frac{9}{16}$	13.39	13.86	14.34	14.82	15.30	15.78	16.26	16.74	22.95
$\frac{5}{8}$	14.87	15.40	15.94	16.47	17.00	17.53	18.06	18.59	25.50
$\frac{11}{16}$	16.36	16.94	17.53	18.12	18.70	19.28	19.86	20.45	28.05
$\frac{3}{4}$	17.85	18.49	19.13	19.77	20.40	21.04	21.68	22.32	30.60
$\frac{13}{16}$	19.34	20.03	20.72	21.41	22.10	22.79	23.48	24.17	33.15
$\frac{7}{8}$	20.83	21.57	22.32	23.05	23.80	24.55	25.30	26.04	35.70
$\frac{15}{16}$	22.32	23.11	23.91	24.70	25.50	26.30	27.10	27.89	38.25
1	23.80	24.65	25.50	26.35	27.20	28.05	28.90	29.75	40.80
$1\frac{1}{16}$	25.29	26.19	27.10	28.00	28.90	29.80	30.70	31.61	43.35
$1\frac{1}{8}$	26.78	27.73	28.68	29.64	30.60	31.56	32.52	33.47	45.90
$1\frac{3}{16}$	28.26	29.27	30.28	31.29	32.30	33.31	34.32	35.33	48.45
$1\frac{1}{4}$	29.75	30.81	31.88	32.94	34.00	35.06	36.12	37.20	51.00
$1\frac{5}{16}$	31.23	32.35	33.48	34.59	35.70	36.81	37.93	39.05	53.55
$1\frac{3}{8}$	32.72	33.89	35.06	36.23	37.40	38.57	39.74	40.91	56.10
$1\frac{7}{16}$	34.21	35.44	36.66	37.88	39.10	40.32	41.54	42.77	58.65
$1\frac{1}{2}$	35.70	36.98	38.26	39.53	40.80	42.08	43.35	44.63	61.20
$1\frac{9}{16}$	37.19	38.51	39.84	41.17	42.50	43.83	45.16	46.49	63.75
$1\frac{5}{8}$	38.67	40.05	41.44	42.82	44.20	45.58	46.96	48.34	66.30
$1\frac{11}{16}$	40.16	41.59	43.03	44.47	45.90	47.33	48.76	50.20	68.85
$1\frac{3}{4}$	41.65	43.14	44.63	46.12	47.60	49.09	50.58	52.07	71.40
$1\frac{7}{8}$	43.14	44.68	46.22	47.76	49.30	50.84	52.38	53.92	73.95
$1\frac{7}{8}$	44.63	46.22	47.82	49.40	51.00	52.60	54.20	55.79	76.50
$1\frac{15}{16}$	46.12	47.76	49.41	51.05	52.70	54.35	56.00	57.64	79.05
2	47.60	49.30	51.00	52.70	54.40	56.10	57.80	59.50	81.60

## WEIGHTS OF FLAT ROLLED STEEL.

PER LINEAL FOOT.

(CONTINUED.)

Thickness in inches.	9"	9¼"	9½"	9¾"	10"	10¼"	10½"	10¾"	12"
⅜	5.74	5.90	6.06	6.22	6.38	6.54	6.70	6.86	7.65
¼	7.65	7.86	8.08	8.29	8.50	8.71	8.92	9.14	10.20
⅜	9.56	9.83	10.10	10.36	10.62	10.89	11.16	11.42	12.75
⅜	11.48	11.80	12.12	12.44	12.75	13.07	13.39	13.71	15.30
⅜	13.40	13.76	14.14	14.51	14.88	15.25	15.62	15.99	17.85
½	15.30	15.73	16.16	16.58	17.00	17.42	17.85	18.28	20.40
⅝	17.22	17.69	18.18	18.65	19.14	19.61	20.08	20.56	22.95
⅝	19.13	19.65	20.19	20.72	21.25	21.78	22.32	22.85	25.50
⅞	21.04	21.62	22.21	22.79	23.38	23.96	24.54	25.13	28.05
¾	22.96	23.59	24.23	24.86	25.50	26.14	26.78	27.42	30.60
⅞	24.86	25.55	26.24	26.94	27.62	28.32	29.00	29.69	33.15
¾	26.78	27.52	28.26	29.01	29.75	30.50	31.24	31.98	35.70
⅞	28.69	29.49	30.28	31.08	31.88	32.67	33.48	34.28	38.25
1	30.60	31.45	32.30	33.15	34.00	34.85	35.70	36.55	40.80
1⅛	32.52	33.41	34.32	35.22	36.12	37.03	37.92	38.83	43.35
1⅛	34.43	35.38	36.34	37.29	38.25	39.21	40.17	41.12	45.90
1⅜	36.34	37.35	38.36	39.37	40.38	41.39	42.40	43.40	48.45
1¼	38.26	39.31	40.37	41.44	42.50	43.56	44.63	45.69	51.00
1⅝	40.16	41.28	42.40	43.52	44.64	45.75	46.86	47.97	53.55
1⅝	42.08	43.25	44.41	45.58	46.75	47.92	49.08	50.25	56.10
1⅞	44.00	45.22	46.44	47.66	48.88	50.10	51.32	52.54	58.65
1½	45.90	47.18	48.45	49.73	51.00	52.28	53.55	54.83	61.20
1⅞	47.82	49.14	50.48	51.80	53.14	54.46	55.78	57.11	63.75
1⅝	49.73	51.10	52.49	53.87	55.25	56.63	58.02	59.40	66.30
1⅞	51.64	53.07	54.51	55.94	57.38	58.81	60.24	61.68	68.85
1¾	53.56	55.04	56.53	58.01	59.50	60.99	62.48	63.97	71.40
1⅞	55.46	57.00	58.54	60.09	61.62	63.17	64.70	66.24	73.95
1⅝	57.38	58.97	60.56	62.16	63.75	65.35	66.94	68.53	76.50
1⅞	59.29	60.94	62.58	64.23	65.88	67.52	69.18	70.83	79.05
2	61.20	62.90	64.60	66.30	68.00	69.70	71.40	73.10	81.60

THE CARNEGIE STEEL COMPANY, LIMITED.

WEIGHTS OF FLAT ROLLED STEEL.

PER LINEAL FOOT.

(CONTINUED.)

Thickness in inches.	11"	11 $\frac{1}{4}$ "	11 $\frac{1}{2}$ "	11 $\frac{3}{4}$ "	12"	12 $\frac{1}{4}$ "	12 $\frac{1}{2}$ "	12 $\frac{3}{4}$ "
$\frac{3}{16}$	7.02	7.17	7.32	7.49	7.65	7.82	7.98	8.13
$\frac{1}{4}$	9.34	9.57	9.78	10.00	10.20	10.42	10.63	10.84
$\frac{5}{16}$	11.68	11.95	12.22	12.49	12.75	13.01	13.28	13.55
$\frac{3}{8}$	14.03	14.35	14.68	14.99	15.30	15.62	15.94	16.26
$\frac{7}{16}$	16.36	16.74	17.12	17.49	17.85	18.23	18.60	18.97
$\frac{1}{2}$	18.70	19.13	19.55	19.97	20.40	20.82	21.25	21.67
$\frac{9}{16}$	21.02	21.51	22.00	22.48	22.95	23.43	23.90	24.39
$\frac{5}{8}$	23.38	23.91	24.44	24.97	25.50	26.03	26.56	27.09
$1\frac{1}{16}$	25.70	26.30	26.88	27.47	28.05	28.64	29.22	29.80
$1\frac{1}{8}$	28.05	28.68	29.33	29.97	30.60	31.25	31.88	32.52
$1\frac{3}{16}$	30.40	31.08	31.76	32.46	33.15	33.83	34.53	35.22
$\frac{7}{8}$	32.72	33.47	34.21	34.95	35.70	36.44	37.19	37.93
$1\frac{1}{8}$	35.06	35.86	36.66	37.46	38.25	39.05	39.84	40.64
1	37.40	38.25	39.10	39.95	40.80	41.65	42.50	43.35
$1\frac{1}{16}$	39.74	40.64	41.54	42.45	43.35	44.25	45.16	46.06
$1\frac{1}{8}$	42.08	43.04	44.00	44.94	45.90	46.86	47.82	48.77
$1\frac{3}{8}$	44.42	45.42	46.44	47.45	48.45	49.46	50.46	51.48
$1\frac{1}{4}$	46.76	47.82	48.88	49.94	51.00	52.06	53.12	54.19
$1\frac{5}{8}$	49.08	50.20	51.32	52.44	53.55	54.67	55.78	56.90
$1\frac{3}{8}$	51.42	52.59	53.76	54.93	56.10	57.27	58.44	59.60
$1\frac{7}{8}$	53.76	54.99	56.21	57.43	58.65	59.87	61.10	62.32
$1\frac{1}{2}$	56.10	57.37	58.65	59.93	61.20	62.48	63.75	65.03
$1\frac{9}{8}$	58.42	59.76	61.10	62.43	63.75	65.08	66.40	67.74
$1\frac{5}{8}$	60.78	62.16	63.54	64.92	66.30	67.68	69.06	70.44
$1\frac{11}{8}$	63.10	64.55	65.98	67.42	68.85	70.29	71.72	73.15
$1\frac{3}{4}$	65.45	66.93	68.43	69.92	71.40	72.90	74.38	75.87
$1\frac{7}{8}$	67.80	69.33	70.86	72.41	73.95	75.48	77.03	78.57
$1\frac{5}{8}$	70.12	71.72	73.31	74.90	76.50	78.09	79.69	81.28
$1\frac{11}{8}$	72.46	74.11	75.76	77.41	79.05	80.70	82.34	83.99
2	74.80	76.50	78.20	79.90	81.60	83.30	85.00	86.70

The weights for 12" width are repeated on each page to facilitate making the additions necessary to obtain the weights of plates wider than 12". Thus to find the weight of 15 $\frac{1}{8}$ " x  $\frac{7}{8}$ ", add the weights to be found in the same line for 3 $\frac{3}{4}$ " x  $\frac{7}{8}$ " and 12" x  $\frac{7}{8}$ " — 10.41 + 35.70 = 46.11 lbs.

THE CARNEGIE STEEL COMPANY, LIMITED.

WEIGHTS OF FLAT ROLLED STEEL.

PER LINEAL FOOT.

(CONTINUED.)

Thickness in inches.	13''	14''	15''	16''	17''	18''	19''	20''	21''
$\frac{3}{16}$	8.28	8.92	9.56	10.20	10.84	11.48	12.10	12.76	13.40
$\frac{1}{4}$	11.06	11.90	12.75	13.60	14.44	15.30	16.16	17.00	17.84
$\frac{5}{16}$	13.81	14.88	15.94	17.00	18.06	19.12	20.20	21.24	22.32
$\frac{3}{8}$	16.58	17.86	19.14	20.40	21.68	22.96	24.24	25.50	26.78
$\frac{7}{16}$	19.34	20.82	22.32	23.80	25.28	26.79	28.28	29.75	31.24
$\frac{1}{2}$	22.10	23.80	25.50	27.20	28.89	30.60	32.31	34.00	35.70
$\frac{9}{16}$	24.86	26.78	28.70	30.60	32.52	34.44	36.34	38.27	40.16
$\frac{5}{8}$	27.62	29.74	31.88	34.00	36.12	38.25	40.37	42.50	44.64
$1\frac{1}{8}$	30.39	32.72	35.06	37.40	39.72	42.08	44.42	46.74	49.08
$\frac{3}{4}$	33.16	35.71	38.26	40.80	43.36	45.92	48.46	51.00	53.56
$1\frac{1}{8}$	35.91	38.67	41.43	44.20	46.96	49.72	52.48	55.25	58.01
$\frac{7}{8}$	38.68	41.65	44.62	47.60	50.60	53.56	56.52	59.50	62.49
$1\frac{1}{8}$	41.44	44.63	47.82	51.00	54.20	57.38	60.57	63.76	66.96
1	44.20	47.60	51.00	54.40	57.80	61.20	64.60	68.00	71.40
$1\frac{1}{8}$	46.96	50.57	54.20	57.80	61.40	65.02	68.64	72.25	75.85
$1\frac{3}{8}$	49.72	53.55	57.37	61.20	65.04	68.85	72.68	76.50	80.33
$1\frac{1}{2}$	52.48	56.52	60.56	64.60	68.64	72.68	76.72	80.75	84.79
$1\frac{3}{4}$	55.25	59.50	63.76	68.00	72.26	76.50	80.74	85.00	89.26
$1\frac{5}{8}$	58.02	62.47	66.95	71.40	75.86	80.33	84.80	89.28	93.72
$1\frac{3}{8}$	60.77	65.45	70.12	74.80	79.48	84.15	88.83	93.50	98.17
$1\frac{7}{8}$	63.54	68.42	73.32	78.20	83.08	88.00	92.88	97.75	102.65
$1\frac{1}{2}$	66.30	71.40	76.51	81.60	86.70	91.80	96.90	102.00	107.10
$1\frac{9}{8}$	69.06	74.38	79.69	85.00	90.31	95.63	100.94	106.25	111.56
$1\frac{5}{8}$	71.83	77.35	82.88	88.40	93.93	99.45	104.98	110.50	116.03
$1\frac{11}{8}$	74.59	80.33	86.06	91.80	97.54	103.28	109.01	114.75	120.49
$1\frac{3}{4}$	77.35	83.30	89.25	95.20	101.15	107.10	113.05	119.00	124.95
$1\frac{13}{8}$	80.11	86.28	92.44	98.60	104.76	110.93	117.09	123.25	129.41
$1\frac{7}{8}$	82.88	89.25	95.63	102.00	108.38	114.75	121.13	127.50	133.88
$1\frac{15}{8}$	85.64	92.23	98.81	105.40	111.99	118.58	125.16	131.75	138.34
2	88.40	95.20	102.00	108.80	115.60	122.40	129.20	136.00	142.80

THE CARNEGIE STEEL COMPANY, LIMITED.

WEIGHTS OF FLAT ROLLED STEEL.

PER LINEAL FOOT.

(CONTINUED.)

Thickness in inches.	22''	23''	24''	25''	26''	27''	28''	29''	30''
$\frac{3}{16}$	14.04	14.64	15.32	15.96	16.56	17.20	17.84	18.48	19.12
$\frac{1}{4}$	18.69	19.56	20.40	21.26	22.12	22.96	23.80	24.64	25.50
$\frac{5}{16}$	23.36	24.44	25.52	26.56	27.62	28.68	29.76	30.80	31.88
$\frac{3}{8}$	28.06	29.36	30.60	31.88	33.16	34.44	35.72	37.00	38.28
$\frac{7}{16}$	32.72	34.24	35.72	37.20	38.68	40.17	41.65	43.14	44.64
$\frac{1}{2}$	37.40	39.10	40.80	42.50	44.20	45.92	47.60	49.28	51.00
$\frac{9}{16}$	42.04	44.00	45.92	47.80	49.73	51.64	53.56	55.48	57.40
$\frac{5}{8}$	46.76	48.88	51.00	53.12	55.24	57.37	59.49	61.60	63.76
$\frac{11}{16}$	51.40	53.76	56.12	58.44	60.78	63.11	65.44	67.77	70.13
$\frac{3}{4}$	56.10	58.66	61.20	63.76	66.32	68.88	71.42	73.97	76.53
$\frac{13}{16}$	60.79	63.53	66.29	69.06	71.82	74.58	77.34	80.10	82.86
$\frac{7}{8}$	65.44	68.43	71.40	74.38	77.36	80.33	83.30	86.29	89.24
$\frac{15}{16}$	70.13	73.32	76.50	79.68	82.88	86.07	89.26	92.44	95.64
1	74.80	78.20	81.60	85.00	88.40	91.80	95.20	98.60	102.00
$1\frac{1}{16}$	79.48	83.08	86.70	90.32	93.92	97.54	101.14	104.75	108.38
$1\frac{1}{8}$	84.16	88.00	91.80	95.64	99.44	103.26	107.10	110.92	114.74
$1\frac{1}{4}$	88.83	92.88	96.92	100.92	104.96	109.01	113.05	117.09	121.13
$1\frac{3}{4}$	93.52	97.76	102.00	106.24	110.50	114.76	119.00	123.24	127.51
$1\frac{5}{8}$	98.16	102.64	107.12	111.56	116.04	120.50	124.94	129.40	133.89
$1\frac{3}{4}$	102.84	107.52	112.20	116.88	121.54	126.22	130.90	135.58	140.24
$1\frac{7}{8}$	107.52	112.42	117.30	122.20	127.08	131.96	136.84	141.76	146.64
$1\frac{1}{2}$	112.20	117.30	122.40	127.50	132.60	137.72	142.80	147.92	153.02
$1\frac{9}{16}$	116.88	122.19	127.50	132.81	138.13	143.44	148.75	154.06	159.38
$1\frac{5}{8}$	121.55	127.08	132.60	138.13	143.65	149.18	154.70	160.23	165.75
$1\frac{11}{16}$	126.23	131.96	137.70	143.44	149.18	154.91	160.65	166.39	172.13
$1\frac{3}{4}$	130.90	136.85	142.80	148.75	154.70	160.65	166.60	172.55	178.50
$1\frac{13}{16}$	135.58	141.74	147.90	154.06	160.23	166.39	172.55	178.71	184.88
$1\frac{7}{8}$	140.25	146.63	153.00	159.38	165.75	172.13	178.50	184.88	191.25
$1\frac{15}{16}$	144.93	151.51	158.10	164.69	171.28	177.86	184.45	191.04	197.63
2	149.60	156.40	163.20	170.00	176.80	183.60	190.40	197.20	204.00



THE CARNEGIE STEEL COMPANY, LIMITED.

WEIGHTS OF FLAT ROLLED STEEL.

PER LINEAL FOOT.

(CONTINUED.)

Thickness in inches.	31''	32''	33''	34''	35''	36''	38''	40''	42''
$\frac{3}{16}$	19.75	20.40	21.04	21.68	22.32	22.96	24.20	25.52	26.80
$\frac{1}{4}$	26.36	27.20	28.04	28.88	29.72	30.59	32.32	34.00	35.68
$\frac{5}{16}$	32.94	34.00	35.04	36.12	37.16	38.24	40.39	42.48	44.64
$\frac{3}{8}$	39.54	40.80	42.08	43.36	44.64	45.92	48.48	51.00	53.56
$\frac{7}{16}$	46.12	47.60	49.08	50.57	52.07	53.58	56.56	59.50	62.48
$\frac{1}{2}$	52.70	54.40	56.10	57.78	59.50	61.20	64.62	68.00	71.40
$\frac{9}{16}$	59.32	61.22	63.12	65.04	66.96	68.88	72.68	76.54	80.32
$\frac{5}{8}$	65.88	68.00	70.13	72.24	74.36	76.50	80.74	85.00	89.28
$\frac{11}{16}$	72.48	74.80	77.12	79.44	81.79	84.15	88.84	93.48	98.16
$\frac{3}{4}$	79.08	81.61	84.16	86.72	89.28	91.84	96.92	102.00	107.12
$\frac{13}{16}$	85.62	88.39	91.15	93.91	96.68	99.44	104.96	110.50	116.02
$\frac{7}{8}$	92.20	95.20	98.20	101.20	104.16	107.12	113.04	119.00	124.98
$\frac{15}{16}$	98.82	102.00	105.20	108.40	111.59	114.76	121.14	127.52	133.92
1	105.40	108.80	112.20	115.60	119.00	122.40	129.20	136.00	142.80
$1\frac{1}{16}$	112.00	115.59	119.20	122.80	126.42	130.04	137.28	144.50	151.70
$1\frac{1}{8}$	118.56	122.40	126.24	130.08	133.90	137.70	145.36	153.00	160.66
$1\frac{1}{4}$	125.16	129.21	133.24	137.28	141.32	145.36	153.44	161.50	169.58
$1\frac{3}{8}$	131.76	136.00	140.28	144.52	148.76	153.00	161.48	170.00	178.52
$1\frac{5}{8}$	138.36	142.81	147.24	151.72	156.20	160.66	169.60	178.56	187.44
$1\frac{3}{4}$	144.92	149.60	154.28	158.96	163.62	168.30	177.66	187.00	196.34
$1\frac{7}{8}$	151.52	156.40	161.28	166.16	171.08	176.00	185.75	195.50	205.29
$1\frac{1}{2}$	158.11	163.20	168.32	173.40	178.51	183.60	193.80	204.00	214.20
$1\frac{9}{16}$	164.69	170.00	175.31	180.63	185.94	191.25	201.88	212.50	223.13
$1\frac{5}{8}$	171.28	176.80	182.33	187.85	193.38	198.90	209.95	221.00	232.05
$1\frac{11}{16}$	177.86	183.60	189.34	195.08	200.81	206.55	218.03	229.50	240.98
$1\frac{3}{4}$	184.45	190.40	196.35	202.30	208.25	214.20	226.10	238.00	249.90
$1\frac{13}{16}$	191.04	197.20	203.36	209.53	215.69	221.85	234.18	246.50	258.88
$1\frac{7}{8}$	197.63	204.00	210.38	216.75	223.13	229.50	242.25	255.00	267.75
$1\frac{15}{16}$	204.21	210.80	217.39	223.98	230.56	237.15	250.33	263.50	276.68
2	210.80	217.60	224.40	231.20	238.00	244.80	258.40	272.00	285.60

THE CARNEGIE STEEL COMPANY, LIMITED.

WEIGHTS OF FLAT ROLLED STEEL.

PER LINEAL FOOT.

(CONTINUED.)

Thickness in inches.	44''	46''	48''	50''	52''	54''	56''	58''	60''
$\frac{3}{16}$	28.08	29.29	30.64	31.92	33.12	34.40	35.68	36.96	38.24
$\frac{1}{4}$	37.38	39.11	40.80	42.52	44.24	45.92	47.60	49.28	51.00
$\frac{5}{16}$	46.72	48.88	51.04	53.12	55.24	57.36	59.51	61.60	63.76
$\frac{3}{8}$	56.12	58.71	61.20	63.76	66.32	68.88	71.44	74.00	76.56
$\frac{7}{16}$	65.44	68.47	71.44	74.40	77.37	80.34	83.30	86.28	89.28
$\frac{1}{2}$	74.80	78.20	81.60	85.00	88.40	91.84	95.20	98.56	102.00
$\frac{9}{16}$	84.09	88.00	91.84	95.60	99.46	103.28	107.12	110.96	114.80
$\frac{5}{8}$	93.52	97.76	102.00	106.24	110.48	114.74	118.98	123.20	127.52
$\frac{11}{16}$	102.81	107.53	112.24	116.88	121.56	126.22	130.88	135.54	140.26
$\frac{3}{4}$	112.20	117.31	122.40	127.52	132.64	137.76	142.85	147.94	153.06
$\frac{13}{16}$	121.56	127.06	132.58	138.12	143.64	149.16	154.68	160.20	165.72
$\frac{7}{8}$	130.89	136.86	142.80	148.76	154.72	160.66	166.60	172.58	178.48
$\frac{15}{16}$	140.27	146.64	153.00	159.36	165.76	172.15	178.52	184.88	191.28
1	149.60	156.40	163.20	170.00	176.80	183.60	190.40	197.20	204.00
$1\frac{1}{16}$	158.96	166.16	173.40	180.64	187.84	195.08	202.28	209.50	216.76
$1\frac{1}{8}$	168.32	175.99	183.60	191.28	198.88	206.52	214.20	221.84	229.48
$1\frac{3}{16}$	177.66	185.76	193.84	201.84	209.92	218.02	226.10	234.18	242.26
$1\frac{1}{4}$	187.04	195.52	204.00	212.48	221.00	229.52	238.00	246.48	255.02
$1\frac{5}{16}$	196.32	205.28	214.24	223.12	232.08	241.00	249.88	258.80	267.78
$1\frac{3}{8}$	205.68	215.04	224.40	233.76	243.08	252.44	261.80	271.16	280.48
$1\frac{7}{16}$	215.04	224.84	234.60	244.40	254.16	263.92	273.68	283.52	293.28
$1\frac{1}{2}$	224.40	234.60	244.80	255.00	265.20	275.44	285.60	295.84	306.04
$1\frac{9}{16}$	233.75	244.38	255.00	265.63	276.25	286.88	297.50	308.13	318.75
$1\frac{5}{8}$	243.10	254.15	265.20	276.25	287.30	298.35	309.40	320.45	331.50
$1\frac{11}{16}$	252.45	263.93	275.40	286.88	298.35	309.83	321.30	332.78	344.25
$1\frac{3}{4}$	261.80	273.70	285.60	297.50	309.40	321.30	333.20	345.10	357.00
$1\frac{13}{16}$	271.15	283.48	295.80	308.13	320.45	332.78	345.10	357.43	369.75
$1\frac{7}{8}$	280.50	293.25	306.00	318.75	331.50	344.25	357.00	369.75	382.50
$1\frac{15}{16}$	289.85	303.03	316.20	329.38	342.55	355.73	368.90	382.08	395.25
2	299.20	312.80	326.40	340.00	353.60	367.20	380.80	394.40	408.00

THE CARNEGIE STEEL COMPANY, LIMITED.

WEIGHTS AND AREAS OF SQUARE AND ROUND BARS AND CIRCUMFERENCES OF ROUND BARS.

One cubic foot of steel weighing 489.6 pounds.

Thickness or Diameter in inches.	Weight of $\square$ Bar one foot long.	Weight of $\circ$ Bar one foot long.	Area of $\square$ Bar in sq. inches.	Area of $\circ$ Bar in sq. inches.	Circumference of $\circ$ Bar in inches.
0					
$\frac{1}{16}$	.013	.010	.0039	.0031	.1963
$\frac{1}{8}$	.053	.042	.0156	.0123	.3927
$\frac{3}{16}$	.119	.094	.0352	.0276	.5890
$\frac{1}{4}$	.212	.167	.0625	.0491	.7854
$\frac{5}{16}$	.333	.261	.0977	.0767	.9817
$\frac{3}{8}$	.478	.375	.1406	.1104	1.1781
$\frac{7}{16}$	.651	.511	.1914	.1503	1.3744
$\frac{1}{2}$	.850	.667	.2500	.1963	1.5708
$\frac{9}{16}$	1.076	.845	.3164	.2485	1.7671
$\frac{5}{8}$	1.328	1.043	.3906	.3068	1.9635
$\frac{11}{16}$	1.608	1.262	.4727	.3712	2.1598
$\frac{3}{4}$	1.913	1.502	.5625	.4418	2.3562
$\frac{13}{16}$	2.245	1.763	.6602	.5185	2.5525
$\frac{7}{8}$	2.603	2.044	.7656	.6013	2.7489
$\frac{15}{16}$	2.989	2.347	.8789	.6903	2.9452
1	3.400	2.670	1.0000	.7854	3.1416
$1\frac{1}{16}$	3.838	3.014	1.1289	.8866	3.3379
$1\frac{1}{8}$	4.303	3.379	1.2656	.9940	3.5343
$1\frac{3}{16}$	4.795	3.766	1.4102	1.1075	3.7306
$1\frac{1}{4}$	5.312	4.173	1.5625	1.2272	3.9270
$1\frac{5}{16}$	5.857	4.600	1.7227	1.3530	4.1233
$1\frac{3}{8}$	6.428	5.049	1.8906	1.4849	4.3197
$1\frac{7}{16}$	7.026	5.518	2.0664	1.6230	4.5160
$1\frac{1}{2}$	7.650	6.008	2.2500	1.7671	4.7124
$1\frac{9}{16}$	8.301	6.520	2.4414	1.9175	4.9087
$1\frac{5}{8}$	8.978	7.051	2.6406	2.0739	5.1051
$1\frac{11}{16}$	9.682	7.604	2.8477	2.2365	5.3014
$1\frac{3}{4}$	10.41	8.178	3.0625	2.4053	5.4978
$1\frac{13}{16}$	11.17	8.773	3.2852	2.5802	5.6941
$1\frac{7}{8}$	11.95	9.388	3.5156	2.7612	5.8905
$1\frac{15}{16}$	12.76	10.02	3.7539	2.9483	6.0868

G4080VM1208

CARNEGIE STEEL COMPANY  
PITTSBURG, PENNA.

---

SUPPLEMENT No. 11

TO

SHAPE BOOK, 1903

---

JANUARY, 1909

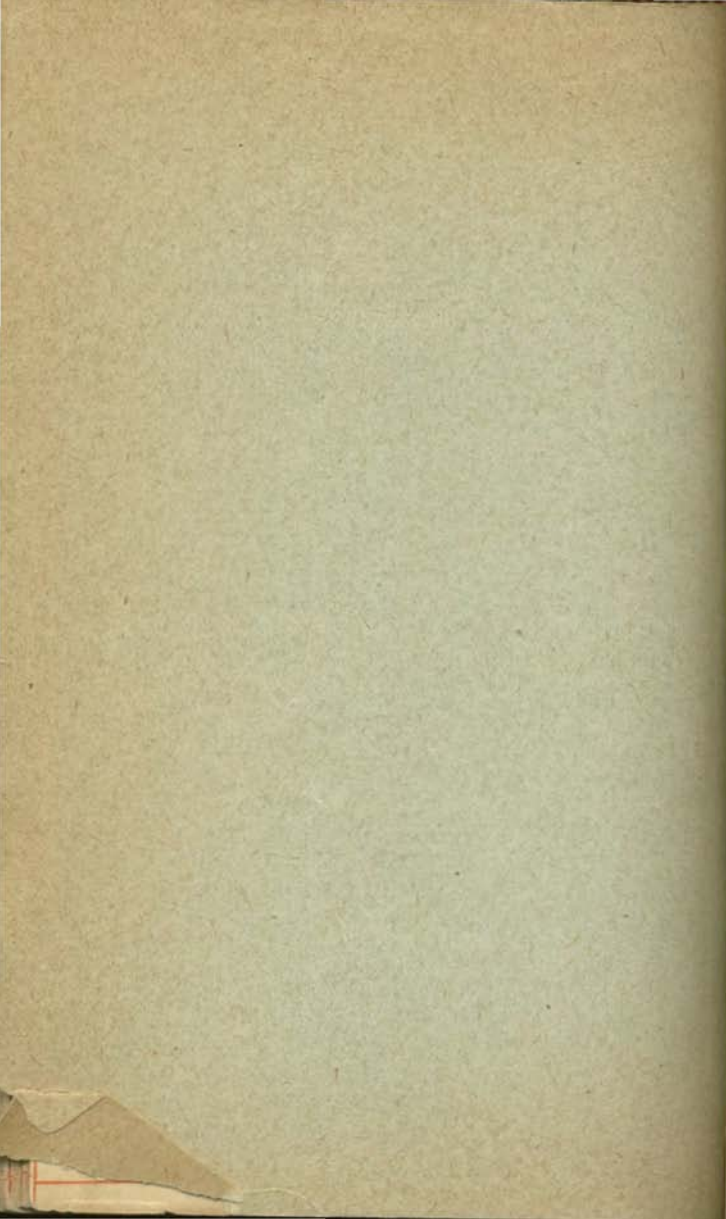

# SUPPLEMENT No. 11

TO

## SHAPE BOOK, 1903

---

JANUARY, 1909

Supplement No. 11 supersedes and cancels all previous Supplements.

This Pamphlet refers only to the original Shape Book—edition of 1903, and therefore ANY CHANGES OR ADDITIONS HERETOFORE MADE BUT NOT MENTIONED IN THIS SUPPLEMENT ARE VOID.

**Part I.** deals only with changes in and additions to data already published in the Shape Book.

**Part II.** embodies all new Sections for which rolls have been prepared since the publication of the Shape Book ; also several tables of weights not appearing in the original book.

PART I.

Corrections in data published in Shape Book, 1903.

- Page 1 — A-100 can also be rolled 1/2" thick, 11.30 lbs.
- Page 2 — A-100 can also be rolled 3/4" thick, 11.30 lbs.
- Page 3 — A-100 can also be rolled 1" thick, 11.30 lbs.
- Page 4 — A-100 can also be rolled 1 1/4" thick, 11.30 lbs.
- Page 5 — A-100 can also be rolled 1 1/2" thick, 11.30 lbs.
- Page 6 — A-100 can also be rolled 1 3/4" thick, 11.30 lbs.
- Page 7 — A-100 can also be rolled 2" thick, 11.30 lbs.
- Page 8 — A-100 can also be rolled 2 1/4" thick, 11.30 lbs.
- Page 9 — A-100 can also be rolled 2 1/2" thick, 11.30 lbs.
- Page 10 — A-100 can also be rolled 2 3/4" thick, 11.30 lbs.
- Page 11 — A-100 can also be rolled 3" thick, 11.30 lbs.
- Page 12 — A-100 can also be rolled 3 1/4" thick, 11.30 lbs.
- Page 13 — A-100 can also be rolled 3 1/2" thick, 11.30 lbs.
- Page 14 — A-100 can also be rolled 3 3/4" thick, 11.30 lbs.
- Page 15 — A-100 can also be rolled 4" thick, 11.30 lbs.
- Page 16 — A-100 can also be rolled 4 1/4" thick, 11.30 lbs.
- Page 17 — A-100 can also be rolled 4 1/2" thick, 11.30 lbs.
- Page 18 — A-100 can also be rolled 4 3/4" thick, 11.30 lbs.
- Page 19 — A-100 can also be rolled 5" thick, 11.30 lbs.



## CORRECTIONS IN SHAPE BOOK, 1903.

- Page 7 —C- 9—Radius at toe of section should read 0.108".
- Page 8 —C-20 can also be rolled to 40.0, 45.0 and 50.0 lbs., but flanges of these sections will not be full.  
C-20—Radius at toe of section to be 0.1875".
- Page 9— C-170 can be rolled to a minimum weight of 35.0 lbs. and a maximum weight of 50.0 lbs., making minimum flange width and web thickness 3.773" and 0.473" respectively.  
C-160—We now have rolls for this formerly "Proposed Shipbuilding Channel" with a minimum weight of 30.0 lbs. and a maximum weight of 40.0 lbs., making minimum flange width and web thickness 3.797" and 0.447" respectively.
- Page 12 —Z-510 can also be rolled to 2.4 lbs.
- Page 13 —A- 90 can also be rolled  $\frac{1}{4}$ " thick, 6.60 lbs.  
A- 99 can also be rolled  $\frac{1}{4}$ " thick, 5.80 lbs.  
A-103 can also be rolled  $1\frac{1}{4}$ " thick, 62.70 lbs.
- Page 14 —A-102 can also be rolled  $\frac{3}{32}$ " thick, 0.92 lbs.  
A-140 can also be rolled  $\frac{1}{2}$ " thick, 18.70 lbs.
- Page 15 —A-228 can also be rolled  $\frac{1}{4}$ " thick, 5.80 lbs.  
A-601 can also be rolled  $\frac{1}{4}$ " thick, 4.90 lbs.  
A-603 can also be rolled  $\frac{1}{4}$ " thick, 4.50 lbs.  
A-607—canceled.
- Page 16 —A-269 can also be rolled  $\frac{1}{8}$ " thick, 1.86 lbs.  
A-612 can also be rolled  $\frac{3}{8}$ " thick, 4.62 lbs.  
A-616 can also be rolled  $\frac{1}{8}$ " thick, 1.43 lbs.  
A-616 can also be rolled  $\frac{3}{8}$ " thick, 4.00 lbs.  
A-617—canceled.
- Page 17 —A-374 can also be rolled  $\frac{1}{4}$ " thick, 4.47 lbs.
- Page 18 —A-391 can also be rolled  $\frac{3}{16}$ " thick, 2.43 lbs.  
A-395 can also be rolled  $\frac{3}{16}$ " thick, 2.11 lbs.
- Page 19 —A-700 can also be rolled  $\frac{9}{16}$ " thick, 11.30 lbs.

- Page 21 —T-500, see revised section, page 35 of this Supplement.
- Page 25 —T-602—canceled.  
T-603—See revised section, page 34 of this Supplement.
- Page 27 —C-500—Change flange and web to  $\frac{1\frac{1}{8}}{84}$ " and  $\frac{7}{64}$ " respectively, add minimum weight 0.25 lbs.  
C-501—Change web thickness to  $\frac{5}{84}$ " and weights to read 0.224 to 0.25 lbs.  
C-502—Change flange and web to  $\frac{5}{16}$ " and No. 13, respectively, also dimension at root of flange from  $\frac{3}{4}$ " to  $\frac{5}{32}$ " and give one weight of 0.36 lbs. only.  
C-504—Change weight to 0.47 lbs.  
C-507, C-509, C-512, C-514, C-515, C-517, C-521, C-526—canceled.  
C-508—reinstated.  
C-510—Change weights to 0.69 lbs. and 1.06 lbs.  
C-511—Change dimensions at toe and root of flange to  $\frac{3}{32}$ " and  $\frac{3}{16}$ ", respectively, also weight to 0.73 lbs.  
C-523—Change minimum weight to 0.91 lbs.  
C-525—Change maximum weight to 1.49 lbs.
- Page 28 —C-530, C-533, C-540—canceled.  
C-532—Change minimum flange and web to  $\frac{7}{16}$ " and  $\frac{3}{16}$ ", respectively, also minimum weight to 1.43 lbs.  
C-535—Add minimum weight of 1.47 lbs.
- Page 29 —C-550, C-555—canceled.
- Page 30 —C-600, C-601, C-602, are now rolled to the following weights per foot:  
C-600, 0.51 lbs.  
C-601, 0.67 lbs.  
C-602, 0.79 lbs.
- Page 31 —C-702—See revised section, page 49 of this Supplement.
- Page 32 —U-572, U-578, C-562—canceled.

- Page 33 —B-500—Change maximum widths of head and web from  $\frac{3}{16}$ " and  $\frac{5}{16}$ " to  $\frac{5}{8}$ " and  $\frac{3}{8}$ ", respectively, also maximum weight to 2.58 lbs.  
 B-506—Change weight to 1.60 lbs.  
 B-507—Canceled.
- Page 34 —P-501 can now be rolled to a minimum weight of 5.02 lbs. and a maximum of 8.21 lbs. Minimum section has web thickness of  $\frac{3}{8}$ ".  
 P-3—Change minimum weight to 8.1 lbs.
- Page 37 —M-680, M-681, M-682, M-687, M-688—canceled.  
 M-685—Change maximum weight to 3.67 lbs., omitting  $\frac{1}{8}$ " thickness.
- Page 38 —M-715 can also be rolled  $\frac{3}{16}$ ",  $\frac{5}{8}$ " and  $\frac{3}{4}$ " thick, making 3.90 lbs. maximum weight.  
 M-716 can also be rolled  $\frac{3}{16}$ " thick, 2.70 lbs.
- Page 40 —M-890—canceled.
- Page 41 —M-902—canceled.
- Page 42 —M-921, M-922, M-923, M-924, M-926, M-928—canceled.
- Page 43 —M-931, M-932, M-933, M-934—canceled.
- Page 44 —M-936, M-937, M-939, M-940—canceled.
- Page 45 —M-942—canceled.
- Page 46 —M-950, M-951—canceled.
- Pages 48, 49 —**I-Beams, Special I-Beams**, for new sections see page 40, of this Supplement.
- Pages 50, 51 —**Channels, Special Channels**, for new sections see pages 42 and 43 of this Supplement.
- Page 50 —C-8 can also be rolled to 7.52 lbs.  
 C-5 can also be rolled to 22.60 lbs.
- Page 51 —C-170—Change as follows:
- |                       |             |           |      |
|-----------------------|-------------|-----------|------|
| Minimum weight        | . . . . .   | to 35.0   | lbs. |
| Maximum               | " . . . . . | to 50.0   | "    |
| Minimum flange width  | . . . . .   | to 3.773" |      |
| Maximum               | " . . . . . | to 4.14"  |      |
| Minimum web thickness | . . . . .   | to 0.473" |      |
| Maximum               | " . . . . . | to 0.84"  |      |

Page 51 C-160—Change as follows :

Minimum weight . . . to 30.0 lbs.

Maximum " . . . to 40.0 "

Minimum flange width . to 3.797''

Maximum " " . to 4.091''

Minimum web thickness to 0.447''

Maximum " " to 0.741''

C- 20—Flanges for sections weighing over 37.0 lbs. will not be full.

Pages 51, 52 —**Z-Bars, Special Z-Bars**, for new sections see page 33, of this Supplement.

Page 52 —Z-510 can also be rolled to 2.4 lbs.

Pages 53 to 65, incl. **Angles, Special and Odd Angles**, for new sections see pages 29 to 33, inclusive, of this Supplement.

A-103 can also be rolled 1¼'' thick, 62.70 lbs.

Page 57 —A-140 can also be rolled ½'' thick, 18.7 lbs.

Page 61 —A-607, A-617—canceled.

Pages 66 to 68, incl. **Tees, Special and Hand Rail Tees**, for new sections see pages 34 and 35 of this Supplement.

Page 68 —T-602—canceled.

T-603—Change as follows: Weight 0.88 lbs.; thickness of flange No. 9; thickness of stem ⅝'' to No. 7.

Pages 70 to 75, incl. **Special Channel Bars, Odd Channels**, for new sections see pages 42 and 43 of this Supplement.

Page 70 —C-500—Add ½'' x ⅝'' x ⅜'' x 0.25 lbs.

C-501—Change to ½'' x ⅝'' x ⅜'' x 0.224 lbs. and to ½'' x ¼'' x ⅜'' x 0.25 lbs.

Cancel ½'' x ¼'' Full x No. 12 x 0.27 lbs.

C-502—Change to ⅝'' x ⅝'' x No. 13 x 0.36 lbs.

Cancel ⅝'' x ⅝'' Full x No. 14 x 0.33 lbs.

C-507, C-509, C-512, C-514, C-515, C-517—canceled.

C-508—reinstated.

C-510—Change weights to 0.69 and 0.87 lbs. and add ⅜'' x ⅝'' x ¼'' x 1.06 lbs.

C-511—Change to ⅜'' x ½'' x ⅝'' x 0.73 lbs.

- Page 71 —C-521, C-526, C-530, C-533—canceled.  
 C-523—Add  $1\frac{1}{4}'' \times \frac{7}{16}'' \times \frac{1}{8}'' \times 0.91$  lbs.  
 C-525—Add  $1\frac{3}{8}'' \times \frac{1}{2}'' \times \frac{1}{4}'' \times 1.49$  lbs.  
 C-532—Add  $1\frac{3}{4}'' \times \frac{7}{16}'' \times \frac{3}{16}'' \times 1.43$  lbs.  
 C-535—Add  $2'' \times \frac{1}{2}'' \times \frac{1}{8}'' \times 1.47$  lbs. and  
 $2'' \times \frac{9}{16}'' \times \frac{3}{16}'' \times 1.89$  lbs.
- Page 72 —C-550, C-540—canceled.
- Page 73 —C-555—canceled.
- Page 73 —**Standard Rubber Tire Channels**, C-600, C-601, C-602, are now rolled to the following weights:  
 C-600, 0.51 lbs., Web thickness,  $\frac{3}{32}''$ , Flange width,  $\frac{1}{2}''$ .  
 C-601, 0.67 lbs., Web thickness,  $\frac{1}{8}''$ , Flange width,  $\frac{7}{16}''$ .  
 C-602, 0.79 lbs., Web thickness,  $\frac{1}{8}''$ , Flange width,  $\frac{3}{4}''$ .  
 C-612—Flange width should be  $\frac{1}{2}''$  instead of  $\frac{3}{4}''$ .
- Page 74 —**Trolley Track**.  
 C-702—See revised section, page 49 of this Supplement.
- Page 75 —C-562—canceled.  
**U Bars**, for new sections see page 45, of this Supplement.  
 U-572, U-578—canceled.
- Pages 76, 77—**Agricultural Beams, Cultivator, Harrow and Plow Beams**, for new sections see page 41 of this Supplement.
- Page 76 —B-500—Add  $1\frac{1}{2}'' \times \frac{5}{8}'' \times \frac{3}{8}'' \times 2.58$  lbs.  
 B-506—Change weight to 1.60 lbs.  
 B-507—Canceled.
- Page 77 —P-501—Additional sizes can now be rolled as follows:  
 $2\frac{1}{2}'' \times \frac{7}{8}'' \times \frac{3}{8}'' \times 5.02$  lbs.       $2\frac{1}{2}'' \times 1\frac{1}{16}'' \times \frac{9}{16}'' \times 6.61$  lbs.  
 $2\frac{1}{2}'' \times \frac{1}{2}'' \times \frac{7}{16}'' \times 5.55$  lbs.       $2\frac{1}{2}'' \times 1\frac{3}{16}'' \times \frac{1}{16}'' \times 7.68$  lbs.  
 $2\frac{1}{2}'' \times 1'' \times \frac{1}{2}'' \times 6.08$  lbs.       $2\frac{1}{2}'' \times 1\frac{1}{4}'' \times \frac{3}{4}'' \times 8.21$  lbs.
- P-3—Change minimum weight to 8.1 lbs.
- Page 78 —**Bevel Nose Sections**, for new sections see page 28 of this Supplement.

Pages 79 to 82, incl. **Bevel Edge Sections**, for new sections see pages 26 and 27 of this Supplement.

Page 81—Make the following substitutions under corresponding Section Numbers :

Section Index	d Inches	a Inches	b Inches	t Gauge	Weight per foot Pounds
M 596	1 3/4	1 3/5	9/32	No. 10	0.72
	1 3/4	1 3/5	9/32	No. 11	0.64
	1 3/4	1 3/5	9/32	No. 12	0.58
	1 3/4	1 3/5	9/32	No. 13	0.49
M 598	2	1 5/8	11/16	No. 12	0.68
	2	1 5/8	11/16	No. 13	0.59
	2	1 5/8	11/16	No. 14	0.51
M 600	2	1 3/4	11/16	No. 10	0.76
	2	1 3/4	11/16	No. 11	0.67
	2	1 3/4	11/16	No. 12	0.60
M 603	2 1/4	1 3/4	1/4	No. 12	0.79
	2 1/4	1 3/4	1/4	No. 13	0.69
	2 1/4	1 3/4	1/4	No. 14	0.60

Page 82—Make the following substitutions under corresponding Section Numbers :

Section Index	d Inches	a Inches	b Inches	t Gauge	Weight per foot Pounds
M 612	2 1/2	1 7/8	4 1/4	No. 10	0.97
	2 1/2	1 7/8	4 1/4	No. 11	0.85
	2 1/2	1 7/8	4 1/4	No. 12	0.76
M 614	2 5/8	1 7/8	3/8	No. 10	1.03
	2 5/8	1 7/8	3/8	No. 11	0.90
	2 5/8	1 7/8	3/8	No. 12	0.80
M 615	2 5/8	2	5/16	No. 10	1.05
	2 5/8	2	5/16	No. 11	0.93
	2 5/8	2	5/16	No. 12	0.83

Pages 83, 84—**Round Bevel Edge Sections**, for new sections see pages 54 and 55 of this Supplement.

- Page 84 —M-680, M-681, M-682, M-687, M-688—canceled.  
M-685, cancel  $1\frac{1}{8}$ " thickness.
- Page 85 —**Special Bevels**, for new sections see pages 52 and 53 of this Supplement.
- Page 86 —M-715—Add 3 sizes as follows:  
 $1\frac{1}{2}$ " x  $\frac{9}{16}$ " x 2.92 lbs.       $1\frac{1}{2}$ " x  $\frac{5}{8}$ " x 3.24 lbs.  
 $1\frac{1}{2}$ " x  $\frac{3}{4}$ " x 3.90 lbs.  
 M-716—Add  $1\frac{1}{2}$ " x  $\frac{9}{16}$ " x 2.70 lbs.
- Pages 86, 87—**Crescents, Special Crescents, Concave Convex, Crescent Hame, Beveled Hame, Pole Cap Sections**, for new sections see page 45 of this Supplement.
- Page 88 —**Special Half Oval, Grooved Half Oval**, for new sections see pages 48 and 56 of this Supplement.
- Page 89 —**Star Sections**, for new sections see page 49 of this Supplement.  
M-902, M-890—canceled.
- Page 90 —**Can Ring Sections**, for new sections see page 47 of this Supplement.
- Page 92 —M-921, M-922, M-923, M-924—canceled.
- Page 93 —M-926, M-928, M-931, M-932, M-933, M-934—canceled.
- Page 94 —M-936, M-937, M-939, M-940—canceled.
- Page 95 —M-942—canceled.
- Page 96 —**Axle Clip, Special Nut Sections**, for new sections see pages 46 and 47 of this Supplement.  
M-950, M-951—canceled.
- Page 97 —**Concord Hame Strap**, for new sections see page 24 of this Supplement.  
M-1023—reinstated.
- Page 98 —**Bevel Edge Clip**.  
M-1069, M-1073, M-1074—reinstated.  
M-1061, change length, b and c, to read:  
 $5\frac{1}{8}$ " +  $5\frac{9}{16}$ ".

Page 99 —**Half Oval Clip**, for new sections see page 24 of this Supplement.

M-1112—reinstated.

M-1129, M-1131, M-1133, change dimensions as given on page 24 of this Supplement.

Page 100 —**Box Strap**.

See Revised Table, page 25 of this Supplement.

Page 101 —**Bit Mouth Steel**, for new sections see page 24 of this Supplement.

Page 102 —**Rounds**.

See Revised Table, page 13 of this Supplement.

**Squares**.

See Revised Table, page 13 of this Supplement.

Page 103 —**Ovals**—See Revised Table showing also weights of Ovals on page 59 of this Supplement.

For Special Ovals see page 55 of this Supplement.

Page 104 —**Half Ovals**—See Revised Table showing also weights of Half Ovals on pages 60 and 61 of this Supplement.

For Special Half Ovals, see page 56 of this Supplement.

**Hexagons**—See Revised Table showing also weights of Hexagons on page 58 of this Supplement.

Pages 105, 106—**Hoops and Bands**.

See Revised Tables, page 15 of this Supplement.

**Square Edge Flats**.

See Revised Table, page 13 of this Supplement.



- Page 107 —**Round Edge Flats**—See Revised Tables, page 14 of this Supplement and table showing weights of Round Edge Flats on pages 62 and 63 of this Supplement.
- Page 108 —**Rectangular Plates**, sheared and universal. See Revised Tables of extreme sizes, pages 16 and 17 of this Supplement.
- Page 109 —**Circular Plates**—See Revised Tables of extreme sizes, pages 16 and 17 of this Supplement.
- Page 112 —Change weight of  $1\frac{3}{16}$ " x No. 19 to .1696.
- Page 114 —Change weight of  $2\frac{1}{8}$ " x No. 3 to 1.8713.
- Page 116 —Change weight of  $2\frac{3}{4}$ " x No. 10 to 1.2529.
- Page 133 —Change weight of  $30$ " x  $1\frac{3}{4}$ " to 178.50.
- Page 140 —Circumference for  $9\frac{1}{8}$ " should read 31.220.
- Page 143 —**Table of Standard Gauges**—See Revised Table, page 18 of this Supplement.
- Page 146 —By an error in printing, the halves of table shown on pages 146 and 147 are reversed ; portion on page 146 should appear on page 147.
- Page 147 —This portion of table should replace that on page 146.

**SQUARES**

$\frac{3}{16}$ " to 2", inclusive, advancing by  $\frac{1}{64}$ "  
 $2\frac{1}{16}$ " to  $3\frac{1}{16}$ ", inclusive, advancing by  $\frac{1}{16}$ "  
 $3\frac{1}{8}$ " to  $5\frac{1}{2}$ ", inclusive, advancing by  $\frac{1}{8}$ "

**ROUNDS**

$\frac{7}{32}$ " to  $1\frac{3}{4}$ ", inclusive, advancing by  $\frac{1}{64}$ "  
 $1\frac{1}{8}$ " to  $6\frac{1}{8}$ ", inclusive, advancing by  $\frac{1}{16}$ "  
 $6\frac{1}{4}$ " to 7", inclusive, advancing by  $\frac{1}{8}$ "

**HALF ROUNDS**

$\frac{5}{16}$ " to 1", inclusive, advancing by  $\frac{1}{64}$ "  
 $1\frac{1}{8}$ ",  $1\frac{1}{4}$ ",  $1\frac{3}{8}$ ",  $1\frac{1}{2}$ ",  $1\frac{3}{4}$ ", 2",  $2\frac{1}{2}$ ", 3"

**SQUARE EDGE FLATS**

$\frac{1}{4}$ " to  $3\frac{1}{4}$ ", inclusive, wide, by any thickness,  $\frac{1}{8}$ " up to width.

Over  $3\frac{1}{4}$ " to 5", inclusive, wide, by any thickness,  $\frac{1}{4}$ " up to 3", inclusive.

Over 5" to 6", inclusive, wide, by any thickness  $\frac{1}{4}$ " up to 2", inclusive.

Sizes not shown in above list will be considered.

**NUT STEEL**

All sizes of Nut Steel within the range of Square Edge Flats can be furnished.

### ROUND EDGE FLATS FACE MEASUREMENTS

$\frac{3}{8}$ "	and	$\frac{7}{16}$ "	wide, by No. 12 to	$\frac{1}{4}$ "
$\frac{1}{2}$ "	to	$\frac{11}{16}$ "	wide, by No. 12 to	$\frac{5}{16}$ "
$\frac{3}{4}$ "	and	$\frac{13}{16}$ "	wide, by No. 12 to	$\frac{1}{2}$ "
$\frac{7}{8}$ "	to	1 "	wide, by No. 12 to	$\frac{3}{4}$ "
$1\frac{1}{16}$ "	to	$1\frac{1}{2}$ "	wide, by	$\frac{1}{8}$ " to $\frac{3}{4}$ "
$1\frac{9}{16}$ "	to	3 "	wide, by	$\frac{1}{8}$ " to 1 "
$3\frac{1}{16}$ "	to	$3\frac{1}{2}$ "	wide, by	$\frac{3}{16}$ " to $1\frac{1}{4}$ "
$3\frac{9}{16}$ "	to	4 "	wide, by	$\frac{1}{4}$ " to $1\frac{1}{4}$ "
$4\frac{1}{16}$ "	to	6 "	wide, by	$\frac{5}{16}$ " to 1 "

The widths given above are face measurements.

The over-all measurements of the above sizes are determined by adding to face measurements:

$\frac{1}{2}$ " thickness, for all sizes  $\frac{1}{8}$ " to  $\frac{1}{2}$ ", inclusive, in thickness.

$\frac{5}{16}$ " for all sizes over  $\frac{1}{2}$ " to  $\frac{3}{4}$ ", inclusive, in thickness.

$\frac{3}{8}$ " for all sizes over  $\frac{3}{4}$ " in thickness.

Sizes not shown in above list will be considered.

### ROUND EDGE SPRING STEEL FLATS

#### OVER-ALL MEASUREMENTS

$\frac{3}{4}$ "	wide, by	$\frac{1}{8}$ "	to	$\frac{1}{2}$ "		
$\frac{7}{8}$ "	wide, by	$\frac{1}{8}$ "	to	$\frac{3}{4}$ "		
1 "	to	$1\frac{1}{2}$ "	wide, by	$\frac{1}{8}$ "	to	$\frac{3}{4}$ "
$1\frac{9}{16}$ "	to	5 "	wide, by	$\frac{1}{4}$ "	to	1 "
$5\frac{1}{16}$ "	to	6 "	wide, by	$\frac{1}{4}$ "	to	$\frac{1}{2}$ "

### ROUND EDGE CONCAVE OR VEHICLE SPRING STEEL

#### OVER-ALL MEASUREMENTS

1 "	and	$1\frac{1}{8}$ "	wide, by No. 6 to No. 1
$1\frac{1}{4}$ "	to	$2\frac{1}{4}$ "	wide, by No. 6 to No. 0
$2\frac{1}{2}$ "	to	$3\frac{1}{2}$ "	wide, by No. 3 to $\frac{3}{8}$ "

Sizes not shown in above list will be considered.

### ROUND EDGE BABY BUGGY SPRING STEEL

#### OVER-ALL MEASUREMENTS

$\frac{1}{2}$ "	and	$\frac{9}{16}$ "	wide, by No. 13 to	$\frac{3}{16}$ "
$\frac{5}{8}$ "	to	$1\frac{1}{16}$ "	wide, by No. 13 to	$\frac{1}{4}$ "

Sizes not shown in above list will be considered.

HOOPS AND BANDS

Minimum Width, Inches	Thickness, Inches	Maximum Width, Inches	Recogging, Minimum Width
3/8	3/16	9 5/8	.....
3/8	1/4	9 5/8	.....
3/8	5/16	9 5/8	.....
3/8	3/8	9 5/8	.....
3/8	9/16	9 5/8	.....
3/8	1/2	8 5/8	.....
3/8	7/8	8 5/8	.....
3/8	1	8 5/8	.....
3/8	5/8	8 5/8	.....
3/8	3/4	7	.....
3/8	1/2	6	.....
3/8	3/8	4 1/2	.....
3/8	1/4	3	.....

Minimum Width, Inches	Thickness, B. W. Gauge	Maximum Width, Inches	Recogging, Minimum Width
3/8	1	6 1/4	.....
3/8	2	6 1/4	.....
3/8	3	6 1/4	.....
3/8	4	9 5/8	.....
3/8	5	9 5/8	.....
3/8	6	9 5/8	.....
3/8	7	9 5/8	.....
3/8	8	9 5/8	.....
3/8	9	9 5/8	.....
3/8	10	9 5/8	.....
3/8	11	8 5/8	.....
3/8	12	8 5/8	.....
3/8	13	8 5/8	.....
3/8	14	8 5/8	.....
3/8	15	6 3/4	.....
3/8	16	6	.....
3/8	17	5	.....
3/8	18	4 1/2	.....
7/16	19	4 1/2	3/8"
1/2	20	4	3/8"
1/2	21	3	3/8"
1/2	22	2 3/4	3/8"
1/2	23	2 1/4	3/8"
5/8	24	1	1/2"

ABOVE REPLACES TABLES OF HOOPS AND BANDS, APPEARING IN SHAPE BOOK, 1903, PAGES 105 AND 106.

## RECTANGULAR AND CIRCULAR PLATES EXTREME SIZES ROLLED BY CARNEGIE STEEL COMPANY

### SHEARED PLATES, ONE-FOURTH INCH AND OVER

Thickness, Inches	Wt. Per Sq. Ft. Pounds	Widths and Lengths in Inches										Diam. of Head
		132	126	120	114	108	102	96	90	84	78	
$\frac{1}{4}$	10.20					150	200	210	250	280	300	110
$\frac{3}{8}$	12.75			180	200	230	260	275	300	325	380	120
$\frac{1}{2}$	15.30		200	220	250	265	310	350	400	440	460	126
$\frac{5}{8}$	17.85	190	200	240	265	290	350	380	440	465	475	132
$\frac{3}{4}$	20.40	220	230	260	280	300	360	400	450	475	500	132
$1$	22.95	220	230	260	290	300	380	400	450	475	500	132
$1\frac{1}{8}$	25.50	220	230	270	300	320	360	380	420	440	480	134
$1\frac{1}{4}$	28.05	220	230	270	300	320	350	380	420	440	480	134
$1\frac{3}{8}$	30.60	220	230	270	290	320	350	380	420	440	480	134
$1\frac{1}{2}$	33.15	220	230	270	290	320	350	380	420	440	480	134
$1\frac{3}{4}$	35.70	220	230	260	280	320	350	380	420	440	480	134
$2$	40.80	220	230	250	270	300	320	350	380	400	430	134
$2\frac{1}{8}$	45.90	200	220	230	250	280	300	320	350	370	405	132
$2\frac{1}{4}$	51.00	190	200	210	230	255	275	295	325	340	360	132
$2\frac{3}{8}$	61.20	180	190	200	210	240	250	275	300	315	340	132
$2\frac{1}{2}$	71.40	175	180	190	200	225	240	260	285	300	320	132
$2\frac{3}{4}$	81.60	165	170	180	190	210	230	245	270	280	300	130
$3$	91.80	132	145	150	160	170	190	200	230	240	260	130
		72	66	60	54	50	48	42	36	30	24	
$\frac{1}{4}$	10.20	350	350	380	400	400	430	400	400	380	380	110
$\frac{3}{8}$	12.75	380	400	450	460	460	500	450	450	400	400	120
$\frac{1}{2}$	15.30	490	500	540	540	540	540	500	500	480	480	126
$\frac{5}{8}$	17.85	520	560	560	560	560	560	550	550	530	530	132
$\frac{3}{4}$	20.40	525	560	560	560	560	560	550	550	530	530	132
$1$	22.95	525	560	560	560	560	560	550	550	530	530	132
$1\frac{1}{8}$	25.50	520	560	560	560	560	560	560	560	530	500	134
$1\frac{1}{4}$	28.05	500	530	540	540	560	560	560	540	530	500	134
$1\frac{3}{8}$	30.60	490	500	540	540	560	560	560	540	530	500	134
$1\frac{1}{2}$	33.15	480	500	520	540	540	540	560	540	520	480	134
$1\frac{3}{4}$	35.70	480	500	520	520	520	530	530	530	500	480	134
$2$	40.80	460	480	500	520	520	520	500	480	470	460	134
$2\frac{1}{8}$	45.90	430	450	470	480	480	500	480	480	470	450	132
$2\frac{1}{4}$	51.00	380	400	420	430	430	450	460	460	450	440	132
$2\frac{3}{8}$	61.20	360	380	400	420	430	440	440	420	420	420	132
$2\frac{1}{2}$	71.40	340	360	380	400	420	430	400	380	380	360	132
$2\frac{3}{4}$	81.60	320	340	360	380	400	400	360	350	350	320	130
$3$	91.80	280	300	320	340	350	330	300	300	250	200	130

Plates 48" wide and under can also be rolled on Universal Mills. For greater length and Universal Mill sizes, see Universal Mill plate table.

Plates of greater dimensions than shown in above tables may be submitted for special consideration.

**ABOVE REPLACES TABLES IN SHAPE BOOK, 1903,  
PAGES 108 AND 109.**

**RECTANGULAR AND CIRCULAR PLATES  
EXTREME SIZES ROLLED BY CARNEGIE STEEL  
COMPANY**

**SHEARED PLATES, THREE-SIXTEENTHS INCH AND UNDER**

Gauge, Inches, B. W. G.	Wt. Per Sq. Ft., Pounds	Widths and Lengths in Inches								Diam. of Head	
		74	72	70	68	66	64	62	60		58
$\frac{3}{16}$	7.65	200	220	240	250	270	290	310	320	330	77
No. 8	6.73		200	210	210	220	240	250	260	270	74
No. 9	6.04			160	170	180	200	200	220	230	70
No. 10	5.47				140	160	170	170	190	200	68
$\frac{1}{8}$	5.10					140	150	150	160	170	66
No. 11	4.89					140	150	150	160	170	66
No. 12	4.45					120	130	130	140	150	64
		56	54	52	50	48	42	36	30	24	
$\frac{3}{16}$	7.65	340	350	360	370	360	360	360	360	360	77
No. 8	6.73	270	280	280	290	290	290	290	290	290	74
No. 9	6.04	230	240	240	250	250	250	250	250	250	70
No. 10	5.47	220	220	230	230	230	230	230	230	230	68
$\frac{1}{8}$	5.10	180	190	190	195	195	200	200	200	200	66
No. 11	4.89	180	190	190	195	195	200	200	200	200	66
No. 12	4.45	160	160	170	176	180	180	180	180	180	64

**RECTANGULAR UNIVERSAL PLATES  
EXTREME SIZES ROLLED BY CARNEGIE STEEL  
COMPANY**

**UNIVERSAL MILL PLATES, ONE-FOURTH INCH AND OVER**

Thickness, Inches	Wt. Per Sq. Ft., Pounds	Widths and Lengths in Inches										
		48-46	45-41	40-36	35-31	30-26	25-20	19-17	16-15	14-12	11	10-7
$\frac{1}{4}$	10.20						780	780	780	780	540	540
$\frac{3}{8}$	12.75	600	600	600	660	720	840	840	840	840	600	600
$\frac{1}{2}$	15.30	840	840	960	1140	1140	1140	1080	1080	1080	900	840
$\frac{5}{8}$	17.85	960	960	960	1140	1140	1200	1080	1080	1080	900	840
$\frac{3}{4}$	20.40	960	960	1080	1200	1200	1200	1080	1080	1080	1020	840
$\frac{7}{8}$	22.95	960	960	1080	1200	1200	1200	1080	1080	1080	1020	840
1	25.50	960	960	1020	1200	1200	1200	1020	1080	1080	1020	840
$1\frac{1}{8}$	30.60	840	840	960	1080	1080	1080	1020	1020	1020	900	840
$1\frac{1}{4}$	35.70	780	840	840	960	960	960	960	960	960	900	840
$1\frac{3}{8}$	40.80	720	720	720	840	840	840	900	960	960	900	840
$1\frac{1}{2}$	45.90	600	600	660	708	720	780	780	900	900	840	840
$1\frac{3}{4}$	51.00	540	540	600	660	660	660	720	840	840	840	840
$1\frac{7}{8}$	56.10	480	528	540	600	600	600	660	780	840	840	840
2	61.20	480	504	528	540	540	540	600	720	780	840	840
$2\frac{1}{8}$	66.30	480	480	480	480	480	480	540	660	720	840	840
$2\frac{1}{4}$	71.40	420	420	432	420	420	420	480	600	660		
$2\frac{3}{8}$	76.50	420	420	432	420	420	420	480	540	600		
$2\frac{1}{2}$	81.60	420	420	420	408	408	408	420	480	540		

Plates of greater dimensions than shown in above tables may be submitted for special consideration.

**ABOVE REPLACES TABLES IN SHAPE BOOK, 1903  
PAGES 108 AND 109.**

## STANDARD GAUGES

REPLACES TABLE IN SHAPE BOOK, 1903, PAGE 143

No. of Gauge	THICKNESS IN DECIMALS OF AN INCH.						No. of Gauge
	Birmingham Wire Gauge (B. W. G.) also known as Stubs (Wire) Gauge	United States Standard Sheet and Plate Gauge	Standard Birmingham Sheet and Hoop Gauge (B. G.)	American Steel & Wire Co.'s Gauge, Formerly Washburn & Moen Gauge	British Standard Wire Gauge (S. W. G.)	Browne & Sharpe's Gauge American (Wire) Gauge	
7 <sup>0</sup>	.....	.500	.....	.4900	.500	.....	7 <sup>0</sup>
6 <sup>0</sup>	.....	.46875	.....	.4615	.464	.580000	6 <sup>0</sup>
5 <sup>0</sup>	.....	.4375	.....	.4305	.432	.516500	5 <sup>0</sup>
4 <sup>0</sup>	.454	.40625	.....	.3938	.400	.460000	4 <sup>0</sup>
3 <sup>0</sup>	.425	.375	.5000	.3625	.372	.409642	3 <sup>0</sup>
2 <sup>0</sup>	.380	.34375	.4452	.3310	.348	.364796	2 <sup>0</sup>
0	.340	.3125	.3964	.3065	.324	.324861	0
1	.300	.28125	.3532	.2830	.300	.289297	1
2	.284	.265625	.3147	.2625	.276	.257627	2
3	.259	.25	.2804	.2437	.252	.229423	3
4	.238	.234375	.2500	.2253	.232	.204307	4
5	.220	.21875	.2225	.2070	.212	.181940	5
6	.203	.203125	.1981	.1920	.192	.162023	6
7	.180	.1875	.1764	.1770	.176	.144285	7
8	.165	.171875	.1570	.1620	.160	.128490	8
9	.148	.15625	.1398	.1483	.144	.114423	9
10	.134	.140625	.1250	.1350	.128	.101897	10
11	.120	.125	.1113	.1205	.116	.090742	11
12	.109	.109375	.0991	.1055	.104	.080808	12
13	.095	.09375	.0882	.0915	.092	.071962	13
14	.083	.078125	.0785	.0800	.080	.064084	14
15	.072	.0703125	.0699	.0720	.072	.057068	15
16	.065	.0625	.0625	.0625	.064	.050821	16
17	.058	.05625	.0556	.0540	.056	.045257	17
18	.049	.05	.0495	.0475	.048	.040303	18
19	.042	.04375	.0440	.0410	.040	.035890	19
20	.035	.0375	.0392	.0348	.036	.031961	20
21	.032	.034375	.0349	.03175	.032	.028462	21
22	.028	.03125	.03125	.0286	.028	.025346	22
23	.025	.028125	.02782	.0258	.024	.022572	23
24	.022	.025	.02476	.0230	.022	.020101	24
25	.020	.021875	.02204	.0204	.020	.017900	25
26	.018	.01875	.01961	.0181	.018	.015941	26
27	.016	.0171875	.01745	.0173	.0164	.014195	27
28	.014	.015625	.015625	.0162	.0148	.012641	28
29	.013	.0140625	.0139	.0150	.0136	.011257	29
30	.012	.0125	.0123	.0140	.0124	.010025	30
31	.010	.0109375	.0110	.0132	.0116	.008928	31
32	.009	.01015625	.0098	.0128	.0108	.007950	32
33	.008	.009375	.0087	.0118	.0100	.007080	33
34	.007	.00859375	.0077	.0104	.0092	.006305	34
35	.006	.0078125	.0069	.0095	.0084	.005615	35
36	.004	.00703125	.0061	.0090	.0076	.005000	36
37	.....	.006640625	.0054	.0085	.0068	.004453	37
38	.....	.00625	.0048	.0080	.0060	.003965	38
39	.....	.....	.....	.0075	.0052	.003531	39
40	.....	.....	.....	.0070	.0048	.003144	40

## PART II.

New sections for which rolls have been prepared.

Tables showing weights of Hexagons, Round Edge Flats, Ovals and Half Ovals.



## FROG FILLERS

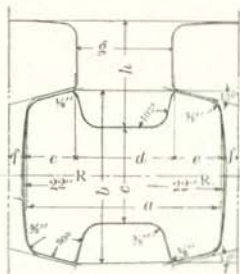

Section Index	Filler Section	Weight per Foot, Pounds	DIMENSIONS IN INCHES							Rail Section A.S.C.E.	
			a	b	c	d	e	f	g		h
M 201	F 10001c	39.15	4 1/2	3 3/4	2 1/8	2 1/8	3/4	3/4	2	2 3/4	100
M 202	F 10001b	38.24	3 3/4	3 3/4	2 1/8	1 1/2	3/4	3/4	1 7/8	2 3/4	100
M 203	F 10001a	37.34	3 3/4	3 3/4	2 1/8	1 1/2	3/4	3/4	1 3/4	2 3/4	100
M 204	F 9001c	34.46	3 3/4	3 1/2	1 7/8	2 1/8	3/4	3/4	2	2 1/2	90
M 205	F 9001b	33.67	3 3/4	3 1/2	1 7/8	1 1/2	3/4	3/4	1 7/8	2 1/2	90
M 206	F 9001a	32.80	3 3/4	3 1/2	1 7/8	1 1/2	3/4	3/4	1 3/4	2 1/2	90
M 207	F 8501c	33.00	3 3/4	3 1/4	1 1/2	2 1/8	3/4	3/4	2	2 1/2	85
M 208	F 8501b	32.23	3 3/4	3 1/4	1 1/2	1 1/2	3/4	3/4	1 7/8	2 1/2	85
M 209	F 8501a	31.48	3 3/4	3 1/4	1 1/2	1 1/2	3/4	3/4	1 3/4	2 1/2	85
M 210	F 8001c	31.35	3 3/4	3 3/4	1 3/4	2 1/8	3/4	3/4	2	1 1/2	80
M 211	F 8001b	30.57	3 3/4	3 3/4	1 3/4	1 1/2	3/4	3/4	1 7/8	1 1/2	80
M 212	F 8001a	29.80	3 1/2	3 3/4	1 3/4	1 1/2	3/4	3/4	1 3/4	1 1/2	80
M 213	F 7501c	30.32	3 3/4	3 1/8	1 1/2	2 1/8	3/4	1/2	2	1 3/4	75
M 214	F 7501b	29.57	3 3/4	3 1/8	1 1/2	1 1/2	3/4	1/2	1 7/8	1 3/4	75
M 215	F 7501a	28.80	3 1/2	3 1/8	1 1/2	1 1/2	3/4	1/2	1 3/4	1 3/4	75
M 216	F 7001c	29.29	3 3/4	2 3/4	1 5/8	2 1/8	3/4	3/4	2	1 1/2	70
M 217	F 7001b	28.60	3 3/4	2 3/4	1 5/8	1 1/2	3/4	3/4	1 7/8	1 1/2	70
M 218	F 7001a	27.89	3 1/2	2 3/4	1 5/8	1 1/2	3/4	3/4	1 3/4	1 1/2	70
M 219	F 6501c	29.12	3 1/2	2 7/8	1 3/4	2 1/8	3/8	3/4	2	1 1/2	65
M 220	F 6501b	28.48	3 1/2	2 7/8	1 3/4	1 1/2	3/8	3/4	1 7/8	1 1/2	65
M 221	F 6501a	27.81	3 1/8	2 7/8	1 3/4	1 1/2	3/8	3/4	1 3/4	1 1/2	65
M 222	F 6001c	27.68	3 1/2	2 3/4	1 5/8	2 1/8	3/8	3/8	2	1 1/2	60
M 223	F 6001b	27.06	3 1/2	2 3/4	1 5/8	1 1/2	3/8	3/8	1 7/8	1 1/2	60
M 224	F 6001a	26.45	3 1/8	2 3/4	1 5/8	1 1/2	3/8	3/8	1 3/4	1 1/2	60

## THIRD RAIL FROG FILLERS

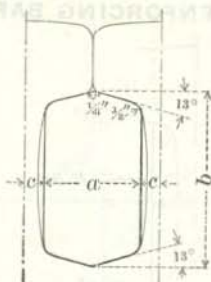

Section Index	Weight per Foot, Pounds	a Inches	b Inches	c Inches	Rail Section A. S. C. E.
M 1417	23.16	$2\frac{1}{2}$	$3\frac{3}{4}$	$\frac{2}{4}$	100 A
M 1416	20.17	$1\frac{7}{8}$	$3\frac{3}{4}$	$\frac{3}{8}$	90 A
M 1415	19.42	$1\frac{7}{8}$	$3\frac{1}{2}$	$\frac{1}{2}$	85 A
M 1414	17.93	$1\frac{1}{2}$	$3\frac{3}{4}$	$\frac{3}{4}$	80 A
M 1413	17.25	$1\frac{1}{2}$	$3\frac{1}{8}$	$\frac{3}{4}$	75 A
M 1411	16.84	$1\frac{1}{2}$	$2\frac{3}{4}$	$\frac{5}{16}$	70 A
M 1412	14.21	$1\frac{1}{2}$	$2\frac{1}{4}$	$\frac{1}{8}$	70 H
M 1410	16.11	$1\frac{1}{2}$	$2\frac{7}{8}$	$\frac{1}{4}$	65 A

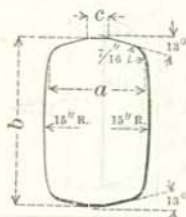

Section Index	Weight per Foot, Pounds	a Inches	b Inches	c Inches	Rail Section A. S. C. E.
M 1418	20.00	$1\frac{5}{8}$	$3\frac{3}{4}$	$\frac{3}{8}$	100 A
M 1419	16.65	$1\frac{1}{2}$	$3\frac{1}{8}$	$\frac{1}{4}$	90 A
M 1420	15.85	$1\frac{1}{2}$	$3\frac{1}{16}$	$\frac{1}{4}$	85 A
M 1421	15.15	$1\frac{1}{2}$	$3\frac{1}{8}$	$\frac{1}{4}$	80 A
M 1422	14.76	$1\frac{1}{2}$	$2\frac{3}{4}$	$\frac{1}{4}$	75 A
M 1423	14.40	$1\frac{1}{2}$	$2\frac{3}{4}$	$\frac{1}{4}$	70 A
M 1424	13.60	$1\frac{1}{2}$	$2\frac{1}{4}$	$\frac{1}{4}$	65 A
M 1425	13.00	$1\frac{1}{2}$	$2\frac{1}{4}$	$\frac{1}{4}$	60 A

## REINFORCING BARS

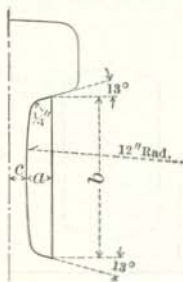

Section Index	Weight per Foot, Pounds	a Inches	b Inches	c Inches	Rail Section A. S. C. E.
M 1386	4.02	$3\frac{1}{2}$	$3\frac{1}{2}$	$\frac{9}{8}$	100 A
M 1385	3.71	$3\frac{1}{2}$	$3\frac{1}{4}$	$\frac{3}{2}$	90 A
M 1384	3.65	$3\frac{1}{2}$	$3\frac{3}{4}$	$\frac{3}{2}$	85 A
M 1383	3.47	$3\frac{1}{2}$	$2\frac{3}{4}$	$1\frac{3}{8}$	80 A
M 1382	3.35	$3\frac{1}{2}$	$2\frac{3}{4}$	$1\frac{3}{8}$	70 A

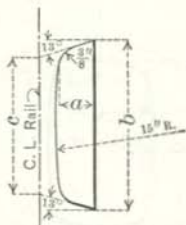

Section Index	Weight per Foot, Pounds	a Inches	b Inches	c Inches	Rail Section A. S. C. E.
M 1461	8.78	$3\frac{1}{4}$	$3\frac{3}{4}$	$3\frac{5}{8}$	100 A
M 1462	8.29	$3\frac{1}{4}$	$3\frac{3}{4}$	$2\frac{3}{4}$	90 A
M 1463	7.88	$3\frac{1}{4}$	$3\frac{1}{2}$	$2\frac{3}{4}$	85 A
M 1464	7.56	$3\frac{1}{4}$	$3\frac{3}{4}$	$2\frac{5}{8}$	80 A
M 1465	7.38	$3\frac{1}{4}$	$3\frac{1}{2}$	$2\frac{3}{4}$	75 A
M 1466	7.18	$3\frac{1}{4}$	$2\frac{3}{4}$	$2\frac{1}{2}$	70 A
M 1467	6.72	$3\frac{1}{4}$	$2\frac{3}{4}$	$2\frac{3}{8}$	65 A
M 1468	6.48	$3\frac{1}{4}$	$2\frac{3}{4}$	$2\frac{1}{4}$	60 A

REENFORCING BARS—CONTINUED

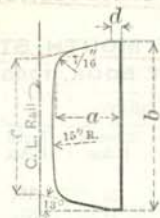

Section Index	Weight per Foot, Pounds	a Inches	b Inches	c Inches	d Inches	Rail Section A. S. C. E.
M 1453	15.30	1 1/4	3 3/4	3 5/4	1/8	100 A
	16.84	1 3/8			1/4	
	18.51	1 1/2			5/8	
M 1454	14.26	1 1/4	3 1/2	2 5/4	1/8	90 A
	15.79	1 3/8			1/4	
	17.34	1 1/2			5/8	
M 1455	13.79	1 1/4	3 1/4	2 3/4	1/8	85 A
	15.26	1 3/8			1/4	
	16.79	1 1/2			5/8	
M 1456	13.24	1 1/4	3 1/4	2 5/8	1/8	80 A
	14.67	1 3/8			1/4	
	16.12	1 1/2			5/4	
M 1457	12.83	1 1/4	3 1/4	2 3/4	1/8	75 A
	14.23	1 3/8			1/4	
	15.63	1 1/2			5/4	
M 1458	12.49	1 1/4	3 3/8	2 3/4	1/8	70 A
	13.86	1 3/8			1/4	
	15.22	1 1/2			5/8	
M 1459	12.08	1 1/4	3 3/8	2 3/8	1/8	65 A
	13.41	1 3/8			1/4	
	14.73	1 1/2			5/8	
M 1460	11.61	1 1/4	2 3/4	2 1/4	1/4	60 A
	12.88	1 3/8			1/4	
	14.15	1 1/2			5/8	

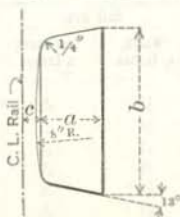

Section Index	Weight per Foot, Pounds	a Inches	b Inches	c Inches	Rail Section
M 1387	9.56	1 1/8	2 3/4	1 7/8	70 H, 60 EI

**BIT MOUTH STEEL**  
SEE SHAPE BOOK, 1903, PAGE 101

Section Index	Round	Hollow Half Oval		Length		
	Diameter, Inches	Width, Inches	Thickness, Inches	Round, Inches	Hollow Half Oval, Inches	Total, Inches
M 1034	$\frac{7}{16}$	$\frac{3}{8}$	$\frac{1}{4}$	$5\frac{3}{4}$	$1\frac{3}{8} + 1\frac{3}{8}$	$9\frac{3}{8}$
M 1035	$\frac{7}{16}$	$\frac{3}{8}$	$\frac{1}{4}$	$5\frac{7}{8}$	$1\frac{3}{4} + 1\frac{3}{4}$	$9\frac{3}{8}$
M 1036	$\frac{7}{16}$	$\frac{3}{8}$	$\frac{1}{4}$	$6\frac{1}{16}$	$1\frac{3}{8} + 1\frac{3}{8}$	$9\frac{3}{8}$

**CONCORD HAME STRAP**  
SEE SHAPE BOOK, 1903, PAGE 97

Section Index.	Flat		Half Oval		Lengths		
	Width, g, Inches	Thickness, e, Inches	Width, f, Inches	Thickness, d, Inches	Flat, c, Inches	Half Oval, b, Inches	Total, a, Inches
M 1021a	$\frac{3}{4}$	$\frac{1}{4}$	$\frac{3}{4}$	$\frac{3}{8}$	18	$12\frac{3}{4}$	$28\frac{3}{4}$
M 1022a	$\frac{3}{4}$	$\frac{1}{4}$	$\frac{3}{4}$	$\frac{3}{8}$	$16\frac{3}{4}$	$13\frac{3}{8}$	$29\frac{7}{8}$
M 1024a	$\frac{3}{4}$	$\frac{1}{4}$	$\frac{3}{4}$	$\frac{3}{8}$	$17\frac{7}{8}$	14	$31\frac{7}{8}$
M 1033	$\frac{7}{8}$	$\frac{1}{8}$	$1\frac{1}{8}$	$\frac{3}{8}$	$17\frac{1}{2}$	14	$31\frac{1}{2}$
M 1025a	$\frac{7}{8}$	$\frac{1}{4}$	$\frac{7}{8}$	$\frac{3}{8}$	$17\frac{7}{8}$	$14\frac{1}{2}$	$32\frac{1}{2}$
M 1026a	1	$\frac{1}{4}$	1	$\frac{3}{8}$	19	15	34

**HALF OVAL CLIP**  
SEE SHAPE BOOK, 1903, PAGE 99

Section Index	Round	Half Oval		Length	
	Diameter, d, Inches	Width, e, Inches	Thickness, t, Inches	Round, a, Inches	Half Oval, b and c, Inches
M 1133	$\frac{1}{8}$	$\frac{1}{2}$	$\frac{1}{4}$	$3\frac{7}{8}$	$3 + 6\frac{1}{4}$
M 1148	$\frac{1}{8}$	$\frac{1}{2}$	$\frac{1}{4}$	$3\frac{1}{4}$	$3 + 6\frac{1}{4}$
M 1131	$\frac{3}{8}$	$\frac{1}{8}$	$\frac{3}{8}$	$3\frac{3}{8}$	$3 + 6\frac{1}{8}$
M 1129	$\frac{1}{2}$	$\frac{1}{8}$	$\frac{1}{4}$	3	$4\frac{1}{2} + 4\frac{1}{2}$
M 1149	$\frac{1}{2}$	$\frac{1}{2}$	$\frac{1}{8}$	$3\frac{1}{2}$	$3\frac{1}{2} + 8\frac{3}{8}$
M 1150	$\frac{1}{8}$	$\frac{1}{2}$	$\frac{3}{8}$	$3\frac{1}{8}$	$3\frac{1}{8} + 3\frac{1}{8}$
M 1151	$\frac{1}{2}$	$\frac{3}{8}$	$\frac{1}{2}$	$4\frac{1}{2}$	$8\frac{7}{8} + 4\frac{7}{8}$

## SPECIAL HALF OVAL CLIP

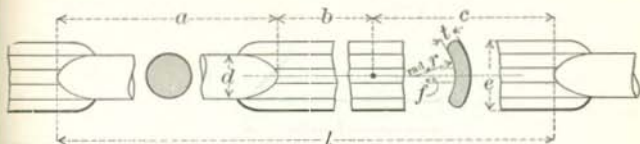

Section Index	Round	Concave-Convex				Length		
	Diameter d, Inches	Width e, Inches	Thickness t, Inches	Radius r, Inches	Flat f, Inches	Round a, Inches	Concave-Convex b + c, Inches	Total l, Inches
M1159	$\frac{1}{2}$	1	$\frac{3}{16}$	$\frac{1}{4}$	$\frac{1}{4}$	5	5 + 10	20
M1160	$\frac{1}{2}$	1	$\frac{5}{32}$	$\frac{7}{16}$	$\frac{5}{32}$	$4\frac{11}{32}$	$4\frac{7}{16} + 8\frac{7}{16}$	$17\frac{7}{32}$
M1160a	$\frac{1}{2}$	$\frac{3}{4}$	$\frac{5}{32}$	$\frac{7}{16}$	$\frac{11}{32}$	$4\frac{11}{32}$	5 + $10\frac{1}{4}$	$19\frac{11}{32}$

## BOX STRAP

\* REPLACES TABLE IN SHAPE BOOK, 1903, PAGE 100.

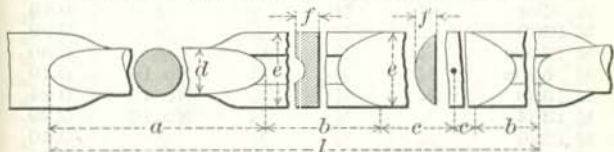

Section Index	Round	Grooved Flat		Half Oval		Length			
	Diameter d, Inches	Width e, Inches	Thickness f, Inches	Width e, Inches	Thickness f, Inches	Round a, Inches	Grooved Flat b, Inches	Half Oval c, Inches	Total l, Inches
M 1200	$\frac{1}{2}$	$\frac{1}{8}$	$\frac{7}{32}$	$\frac{1}{8}$	$\frac{7}{32}$	$7\frac{1}{8}$	$2\frac{5}{16}$	$7\frac{7}{8}$	28
M 1201	$\frac{9}{16}$	$\frac{7}{8}$	$\frac{1}{4}$	$\frac{7}{8}$	$\frac{1}{4}$	$7\frac{3}{8}$	$3\frac{1}{16}$	$7\frac{3}{4}$	$29\frac{1}{2}$
M 1202	$\frac{9}{16}$	$\frac{7}{8}$	$\frac{1}{4}$	$\frac{7}{8}$	$\frac{1}{4}$	$7\frac{3}{8}$	$2\frac{3}{8}$	$9\frac{7}{8}$	$31\frac{7}{8}$
M 1203	$\frac{9}{16}$	$\frac{7}{8}$	$\frac{1}{4}$	$\frac{7}{8}$	$\frac{1}{4}$	$6\frac{1}{8}$	$2\frac{5}{16}$	$8\frac{9}{32}$	28
M 1204	$\frac{5}{8}$	1	$\frac{1}{4}$	1	$\frac{1}{4}$	$7\frac{5}{8}$	2	$8\frac{3}{4}$	28
M 1205	$\frac{5}{8}$	1	$\frac{1}{4}$	1	$\frac{1}{4}$	$6\frac{1}{8}$	$2\frac{1}{8}$	$10\frac{11}{32}$	$31\frac{3}{8}$
M 1206	$\frac{5}{8}$	1	$\frac{1}{4}$	1	$\frac{1}{4}$	7	$2\frac{1}{4}$	$12\frac{1}{4}$	36
M 1207	$\frac{5}{8}$	$\frac{3}{32}$	$\frac{9}{32}$	$\frac{3}{32}$	$\frac{9}{32}$	$7\frac{3}{8}$	$2\frac{5}{8}$	$4\frac{7}{16}$	$21\frac{1}{2}$
M 1208	$\frac{5}{8}$	$\frac{3}{32}$	$\frac{9}{32}$	$\frac{3}{32}$	$\frac{9}{32}$	$7\frac{5}{8}$	3	$5\frac{3}{16}$	24
M 1211	$\frac{9}{16}$	$\frac{7}{8}$	$\frac{1}{4}$	$\frac{7}{8}$	$\frac{1}{4}$	$6\frac{3}{8}$	$2\frac{3}{8}$	$6\frac{1}{8}$	$23\frac{3}{8}$

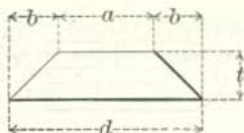

SEE SHAPE BOOK, 1903, PAGE 79

BEVEL EDGE, INCLUDING BEVEL SHAFT, WAGON  
BOX AND TONGUE CAP

Section Index	d Inches	a Inches	b Inches	t B. W. Gauge and Inches	Weight per foot, Pounds
M 624	$\frac{3}{8}$	$\frac{11}{16}$	$\frac{3}{16}$	$\frac{1}{16}$	0.48
M 1300	$\frac{5}{8}$	$\frac{3}{4}$	$\frac{1}{16}$	$\frac{1}{8}$	0.23
M 1300a	$\frac{5}{8}$	$\frac{3}{4}$	$\frac{1}{16}$	$\frac{3}{16}$	0.30
M 525a	$\frac{3}{4}$	$\frac{1}{8}$	$\frac{3}{16}$	No. 14	0.19
M 1333	$\frac{3}{4}$	$\frac{1}{2}$	$\frac{1}{4}$	No. 12	0.24
M 1334	$\frac{3}{4}$	$\frac{1}{2}$	$\frac{1}{4}$	No. 10	0.29
M 1320	$\frac{3}{4}$	$\frac{1}{2}$	$\frac{1}{8}$	$\frac{1}{8}$	0.40
M 977	$\frac{3}{4}$	$\frac{1}{2}$	$\frac{1}{8}$	$\frac{3}{8}$	0.80
M 1370	$\frac{3}{4}$	$\frac{1}{8}$	$\frac{3}{16}$	$\frac{3}{8}$	0.84
M 1332	$\frac{7}{8}$	$\frac{1}{2}$	$\frac{1}{8}$	$\frac{1}{8}$	0.29
M 1376	1	$\frac{1}{2}$	$\frac{1}{4}$	$\frac{1}{8}$	1.12
M 1330	1	$\frac{1}{8}$	$\frac{3}{16}$	$\frac{1}{8}$	1.16
M 1302	1	$\frac{1}{4}$	$\frac{3}{16}$	$\frac{1}{8}$	0.90
M 1377	$1\frac{1}{8}$	$\frac{5}{8}$	$\frac{1}{4}$	$\frac{3}{8}$	1.12
M 1328	$1\frac{1}{8}$	$\frac{5}{8}$	$\frac{1}{4}$	$\frac{1}{8}$	1.30
M 1327	$1\frac{1}{8}$	$\frac{3}{4}$	$\frac{1}{16}$	$\frac{1}{8}$	1.34
M 1303	$1\frac{1}{8}$	$\frac{1}{4}$	$\frac{3}{16}$	$\frac{1}{8}$	1.03
M 1329	$1\frac{1}{8}$	$\frac{3}{4}$	$\frac{1}{8}$	$\frac{3}{8}$	1.20
M 1371	$1\frac{1}{8}$	$\frac{3}{4}$	$\frac{1}{16}$	$\frac{1}{8}$	1.37
M 1326	$1\frac{1}{4}$	$\frac{5}{8}$	$\frac{1}{8}$	$\frac{1}{8}$	1.40
M 1305	$1\frac{1}{4}$	$\frac{1}{2}$	$\frac{3}{16}$	$\frac{1}{8}$	1.10
M 1321	$1\frac{1}{4}$	$\frac{3}{4}$	$\frac{1}{4}$	$\frac{3}{8}$	1.38
M 1339	$1\frac{1}{4}$	$\frac{1}{2}$	$\frac{3}{16}$	$\frac{1}{8}$	0.70
M 620	$1\frac{1}{16}$	$\frac{1}{2}$	$\frac{1}{8}$	$1\frac{1}{16}$	4.07

BEVEL EDGE, INCLUDING BEVEL SHAFT, WAGON  
BOX AND TONGUE CAP

CONTINUED

Section Index	d Inches	a Inches	b Inches	t B. W. Gauge and Inches	Weight per foot, Pounds
M 1306	1 $\frac{3}{8}$	1 $\frac{1}{2}$	$\frac{11}{16}$	$\frac{1}{8}$	0.52
M 1322	1 $\frac{3}{8}$	1 $\frac{1}{2}$	$\frac{11}{16}$	$\frac{3}{8}$	1.54
M 1323	1 $\frac{1}{2}$	$\frac{3}{4}$	$\frac{11}{16}$	$\frac{1}{2}$	1.58
M 1378	1 $\frac{1}{2}$	$\frac{7}{8}$	$\frac{1}{2}$	$\frac{1}{8}$	2.27
M 1366	1 $\frac{1}{2}$	1	$\frac{1}{4}$	$\frac{1}{4}$	1.08
M 1307	1 $\frac{1}{2}$	1 $\frac{1}{2}$	$\frac{11}{16}$	$\frac{1}{8}$	0.56
M 623	1 $\frac{1}{16}$	1 $\frac{1}{8}$	$\frac{1}{2}$	$\frac{1}{8}$	0.86
M 1308	1 $\frac{3}{4}$	$\frac{7}{8}$	$\frac{1}{16}$	$\frac{1}{2}$	0.79
M 1324	1 $\frac{3}{4}$	$\frac{7}{8}$	$\frac{1}{16}$	$\frac{1}{8}$	0.84
M 1331	1 $\frac{3}{4}$	1 $\frac{1}{16}$	$\frac{1}{2}$	$\frac{3}{8}$	1.87
M 1309	2	1 $\frac{3}{8}$	$\frac{1}{16}$	No. 10	0.71
M 1368	2	1 $\frac{1}{4}$	$\frac{3}{8}$	$\frac{3}{8}$	2.09
M 1310	2	1 $\frac{1}{16}$	$\frac{11}{16}$	$\frac{1}{8}$	0.71
M 1367	2	1 $\frac{3}{8}$	$\frac{1}{16}$	$\frac{1}{8}$	1.81
M 1311	2 $\frac{1}{4}$	1	$\frac{3}{8}$	$\frac{1}{8}$	1.17
M 619	2 $\frac{1}{4}$	1 $\frac{1}{4}$	$\frac{1}{2}$	$\frac{1}{4}$	0.75
M 1342	2 $\frac{1}{4}$	1 $\frac{5}{8}$	$\frac{1}{16}$	$\frac{1}{8}$	2.06
M 1369	2 $\frac{1}{8}$	1 $\frac{5}{8}$	$\frac{11}{16}$	$\frac{1}{16}$	2.11
M 626	2 $\frac{1}{2}$	1 $\frac{1}{2}$	$\frac{1}{2}$	$\frac{1}{2}$	1.50
M 625	2 $\frac{1}{2}$	1 $\frac{5}{8}$	$\frac{1}{16}$	$\frac{1}{2}$	1.54
M 618	3	2 $\frac{1}{16}$	$\frac{11}{16}$	No. 12	0.96



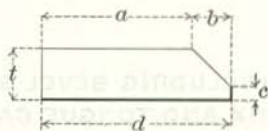

SEE SHAPE BOOK, 1903, PAGE 78

## BEVEL NOSE

Section Index	d Inches	a Inches	b Inches	t B.W. Gauge and Inches	c Inches	Weight per foot, Pounds
M 988	$\frac{3}{4}$	$1\frac{7}{8}$	$\frac{7}{8}$	$\frac{5}{8}$	$\frac{1}{2}$	0.85
M 979	$\frac{3}{4}$	$1\frac{5}{8}$	$\frac{3}{4}$	$\frac{3}{8}$	$1\frac{1}{8}$	0.22
M 965	$1\frac{3}{8}$	$\frac{5}{8}$	$\frac{3}{8}$	$\frac{3}{8}$	$\frac{1}{4}$	0.20
M 959	$\frac{7}{8}$	$1\frac{1}{8}$	$\frac{3}{8}$	$\frac{3}{8}$	$\frac{1}{4}$	0.22
M 978	$1\frac{1}{4}$	$1\frac{3}{8}$	$\frac{7}{8}$	$\frac{1}{8}$	$\frac{1}{8}$	0.49
M 976	$1\frac{3}{4}$	$1\frac{1}{4}$	$\frac{1}{2}$	$\frac{3}{8}$	$\frac{5}{8}$	1.98
M 990	$2\frac{1}{4}$	$1\frac{1}{4}$	1	$\frac{1}{4}$	$\frac{1}{8}$	1.70
M 966	$2\frac{1}{4}$	$1\frac{3}{4}$	$\frac{1}{2}$	$\frac{1}{4}$	$\frac{1}{8}$	1.73
M 967	$2\frac{1}{4}$	$1\frac{3}{4}$	$\frac{1}{2}$	$\frac{1}{4}$	$\frac{1}{8}$	1.75
M 991	$2\frac{1}{2}$	$1\frac{1}{4}$	$1\frac{1}{4}$	$\frac{1}{4}$	$\frac{3}{8}$	1.79
M 968	$2\frac{1}{2}$	$1\frac{3}{8}$	$1\frac{1}{8}$	$\frac{5}{16}$	$\frac{1}{8}$	2.30
M 994	$2\frac{1}{2}$	$1\frac{3}{4}$	$\frac{3}{4}$	$\frac{1}{2}$	$\frac{1}{8}$	3.13
M 969	3	$2\frac{1}{2}$	$\frac{1}{2}$	$\frac{1}{2}$	$\frac{1}{4}$	1.54
M 970	3	$2\frac{3}{4}$	$\frac{1}{4}$	$\frac{1}{4}$	$\frac{1}{8}$	2.47
M 971	3	$1\frac{3}{4}$	$1\frac{1}{4}$	$\frac{5}{16}$	$\frac{1}{8}$	2.79
M 972	3	$1\frac{3}{4}$	$1\frac{1}{4}$	$\frac{3}{8}$	$\frac{1}{8}$	3.29
M 992	3	$1\frac{1}{2}$	$1\frac{1}{2}$	$\frac{1}{4}$	$\frac{3}{8}$	2.15
M 998	3	$2\frac{1}{4}$	$\frac{3}{4}$	$\frac{1}{2}$	$\frac{1}{8}$	3.67
M 973	$3\frac{1}{4}$	2	$1\frac{1}{4}$	$\frac{3}{16}$	$\frac{1}{16}$	1.81
M 974	$3\frac{1}{4}$	$2\frac{1}{16}$	$1\frac{3}{16}$	$\frac{3}{16}$	$\frac{1}{16}$	1.82
M 989	$3\frac{1}{2}$	$2\frac{1}{2}$	1	$\frac{5}{8}$	$\frac{1}{8}$	5.53

ODD ANGLES

A 930

1.53 lbs.

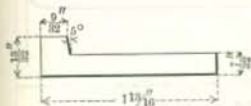

A 820

0.50 lbs.

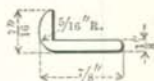

HALF SIZE

RAIL GUARD ANGLE

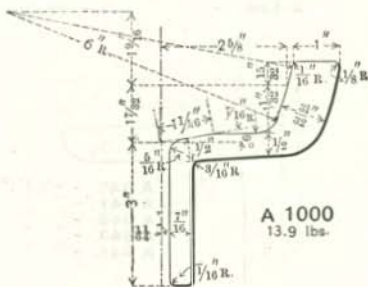

A 1000

13.9 lbs.

TRIMMER ANGLE

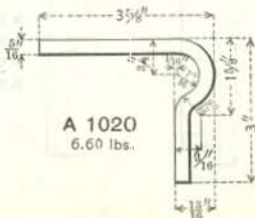

A 1020

6.60 lbs.

QUARTER SIZE

## ANGLES

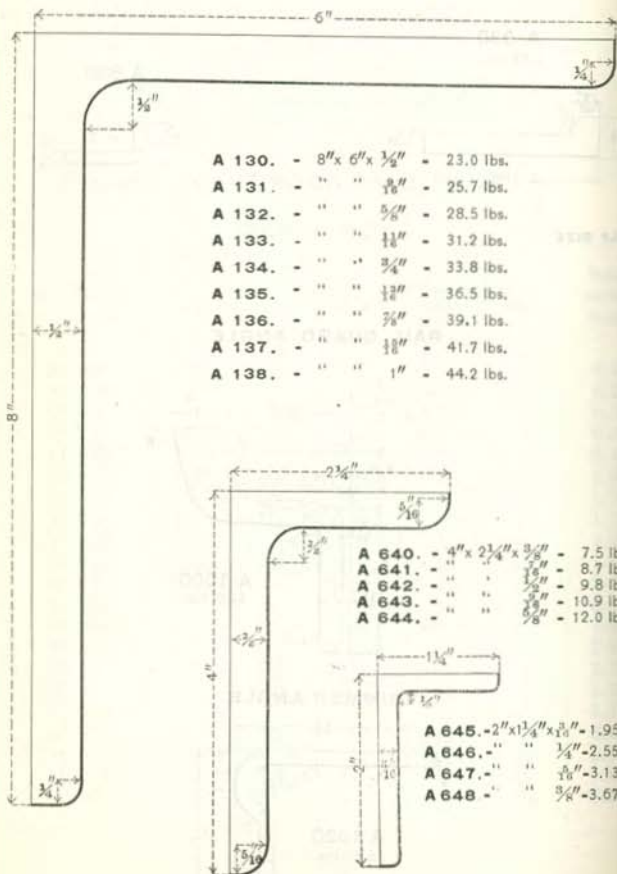

ANGLES, Continued

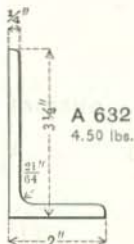
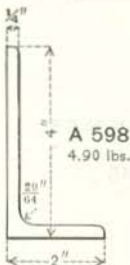
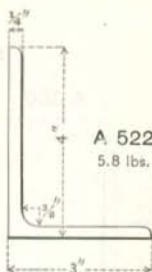
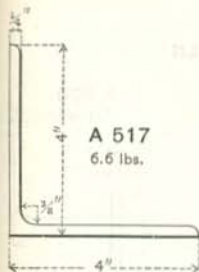

A 523  
1.86 lbs.

A 524  
4.62 lbs.

A 631  
4.00 lbs.

A 525  
1.43 lbs.

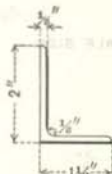
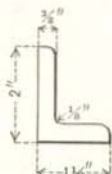
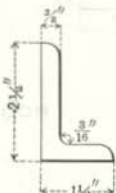
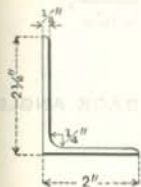

A 519  
0.92 lbs.

A 74  
1.48 lbs.

A 960  
0.85 lbs.

A 526  
0.42 lbs.

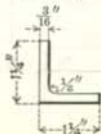
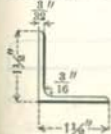

QUARTER SIZE

## ANGLES, Continued

## SQUARE ROOT ANGLES

A 380

4.47 lbs.

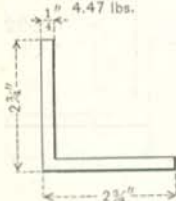

QUARTER SIZE

A 521

2.43 lbs.

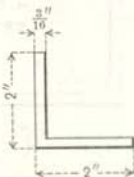

A 520

2.11 lbs.

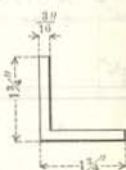

## SPECIAL ANGLES

A 940

0.96 lbs.

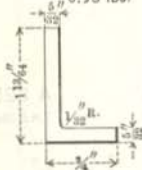

HALF SIZE

A 945

0.91 lbs.

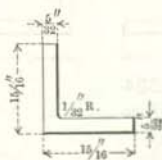

A 950

0.61 lbs.

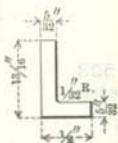

## ROUND BACK ANGLE

A 480

9.8 lbs.

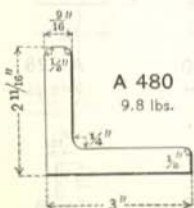

QUARTER SIZE

A 481

10.1 lbs.

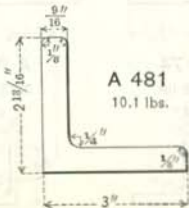

A 701

11.3 lbs.

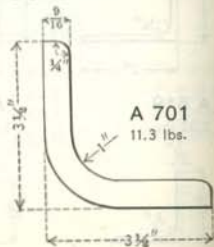

ROUND BACK ANGLES

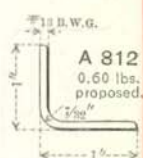
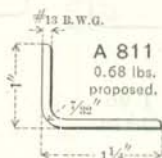

HALF SIZE

ZEE'S

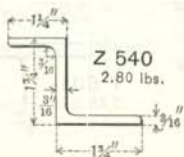
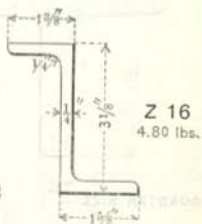
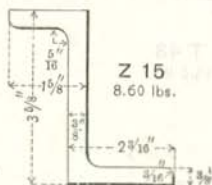
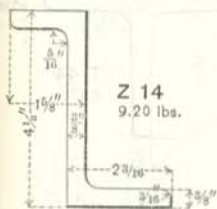

QUARTER SIZE

SEE FIG. 1

## TEES

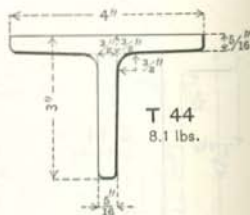
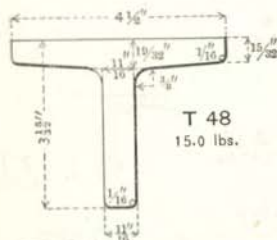
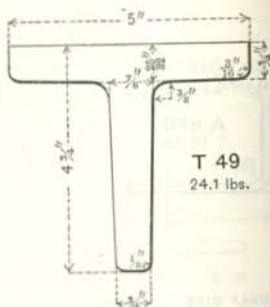
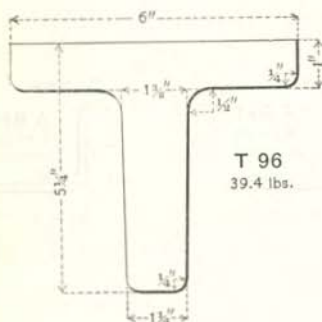

## QUARTER SIZE

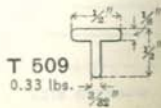
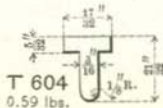
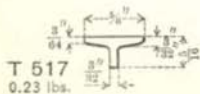
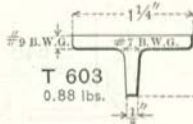
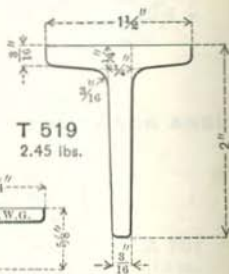
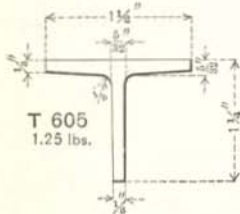

## HALF SIZE

TEES, Continued

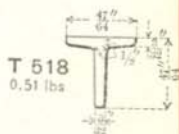
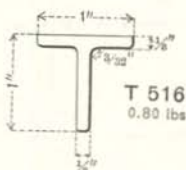
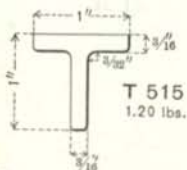
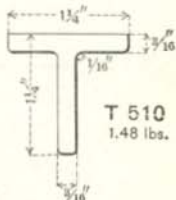
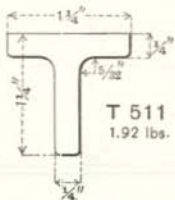
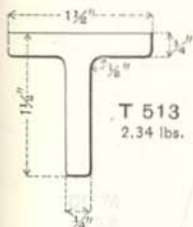
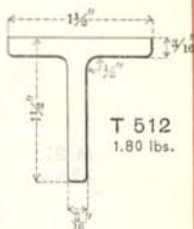
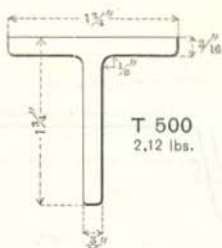
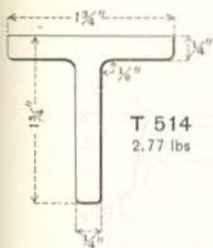

HALF SIZE

CONDUCTOR RAIL TEES

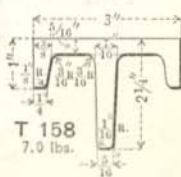
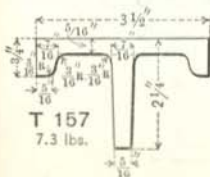

QUARTER SIZE



## CROSS TIES,

M 27  
9.0 lbs.

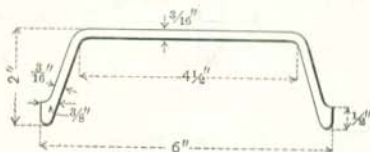
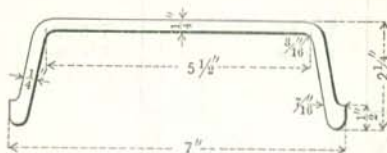

M 20  
6.0 lbs.

M 26  
3.2 lbs.

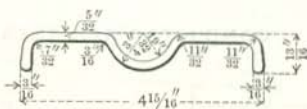

## CROSS TIES Continued

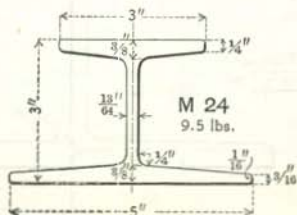
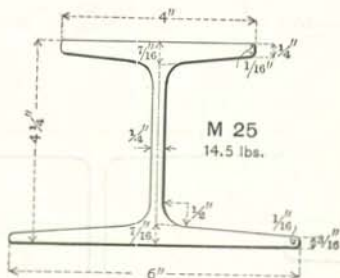
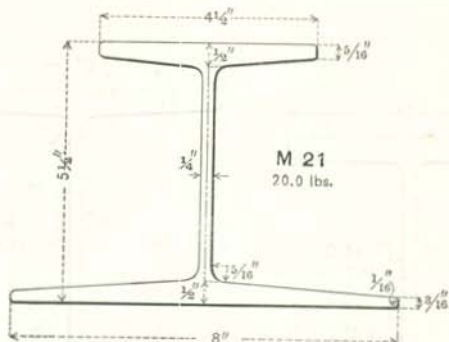

## H-SECTIONS

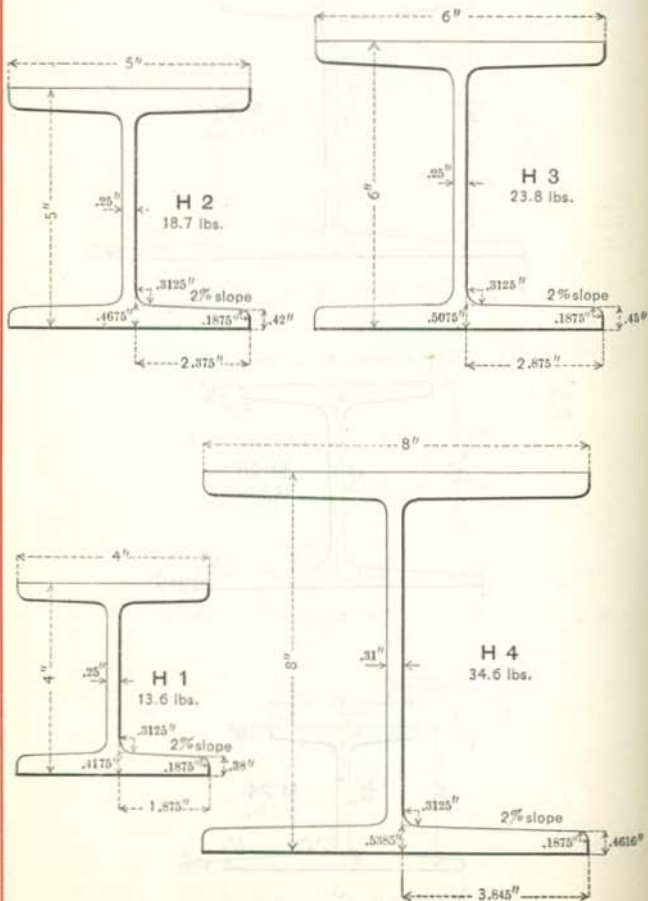

QUARTER SIZE

UNITED STATES STEEL SHEET PILING

CLASS I

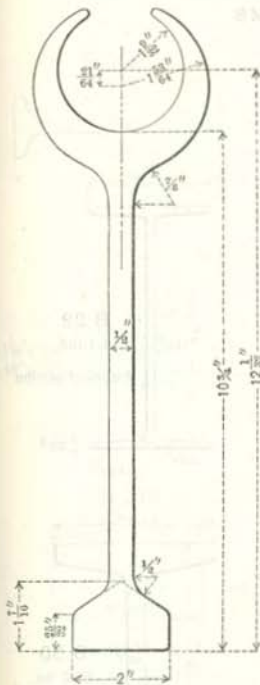

**M 102**  
12" x 40 lbs.

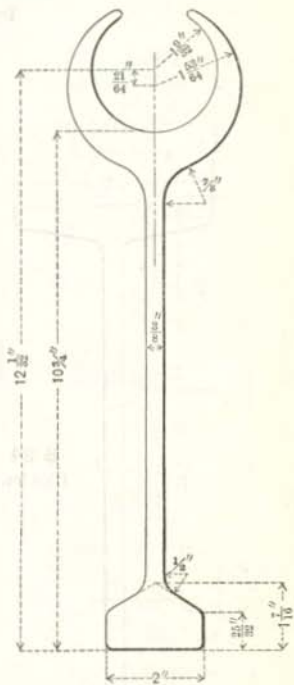

**M 101**  
12" x 35 lbs.



**M 100**  
6" x 11 lbs.

QUARTER SIZE

## I-BEAMS



EIGHTH SIZE

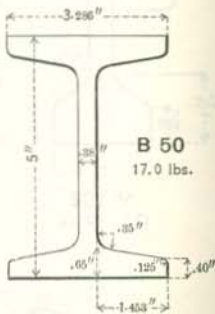
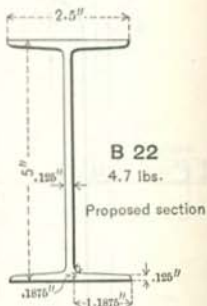

QUARTER SIZE

CULTIVATOR BEAMS

B 508

1.41 lbs.

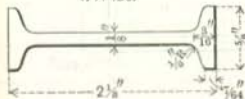

B 509

1.58 lbs.

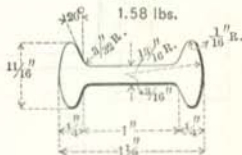

B 515

$2 \times \frac{7}{16} \times \frac{3}{16}$  - 1.95 lbs.  
 $2 \times \frac{1}{2} \times \frac{1}{4}$  - 2.38 lbs.

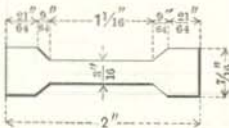

B 511

1.84 lbs.

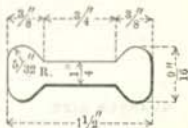

B 510

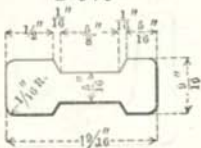

$1\frac{9}{16} \times \frac{3}{16} \times \frac{3}{16}$  - 2.39 lbs  
 $1\frac{9}{16} \times \frac{5}{8} \times \frac{3}{8}$  - 2.72 lbs

B 582

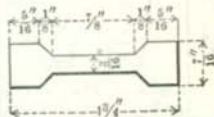

$1\frac{3}{4} \times \frac{7}{16} \times \frac{3}{16}$  - 1.75 lbs.  
 $1\frac{3}{4} \times \frac{1}{2} \times \frac{1}{4}$  - 2.12 lbs.

B 580

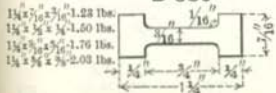

$1\frac{3}{4} \times \frac{7}{16} \times \frac{3}{16}$  - 1.23 lbs.  
 $1\frac{3}{4} \times \frac{3}{4} \times \frac{1}{4}$  - 1.60 lbs.  
 $1\frac{3}{4} \times \frac{5}{16} \times \frac{5}{16}$  - 1.76 lbs.  
 $1\frac{3}{4} \times \frac{3}{4} \times \frac{3}{8}$  - 2.03 lbs.

B 590

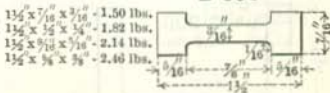

$1\frac{3}{8} \times \frac{7}{16} \times \frac{3}{16}$  - 1.50 lbs.  
 $1\frac{3}{8} \times \frac{3}{4} \times \frac{1}{4}$  - 1.82 lbs.  
 $1\frac{3}{8} \times \frac{9}{16} \times \frac{7}{16}$  - 2.14 lbs.  
 $1\frac{3}{8} \times \frac{3}{4} \times \frac{3}{8}$  - 2.46 lbs.

## SHIP-BUILDING CHANNELS

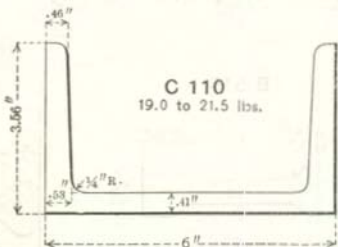
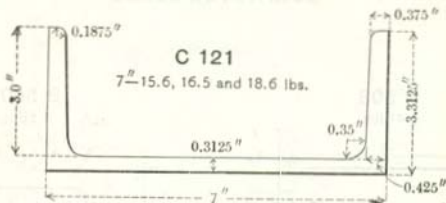

QUARTER SIZE

## BRAKE BEAM CHANNELS

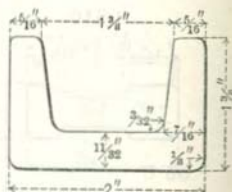
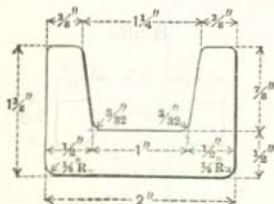

C 567—6.0 lbs.

C 578—4.97 lbs.

HALF SIZE

## SPECIAL CHANNELS

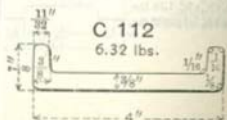
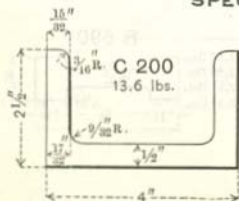

QUARTER SIZE

SPECIAL CHANNELS, Continued

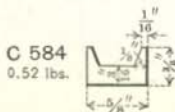
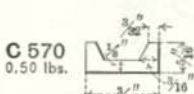
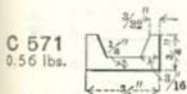
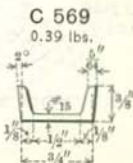
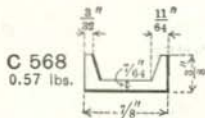
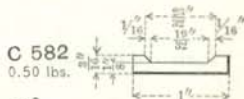
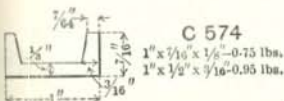
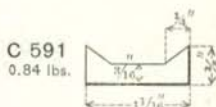
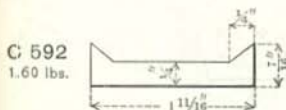
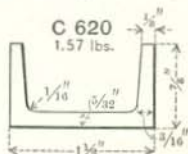
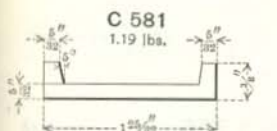
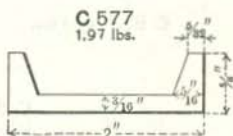
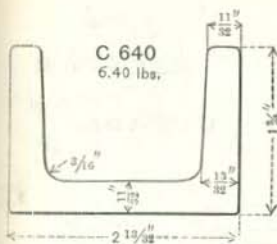



## CHANNEL TIRES

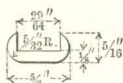

C 559 -0.33 lbs.

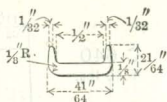

C 558 -0.32 lbs.

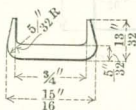
C 557  
0.55 lbs.

## 1" CUSHION TIRE

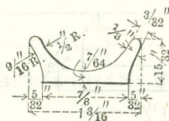
C 1000  
0.75 lbs.

## FENDER CHANNEL

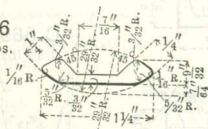
C 546  
0.68 lbs.

## DASH CHANNEL

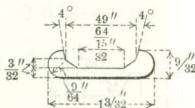
C 545  
0.52 lbs.

**CRESCENTS**

**M 733** -0.16 lbs.



**M 736**

0.27 lbs.



**M 732** -0.23 lbs.



**M 728**

0.20 lbs.

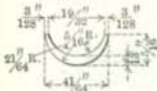

**M 731**

0.24 lbs.

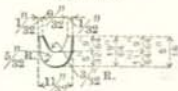

**M 729**

0.14 lbs.

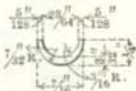

**M 734**

.20 lbs.



**M 741**

0.22 lbs.

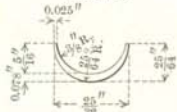

**M 737**

0.20 lbs.



**POLE CAP**

**M 814**

0.75 lbs.

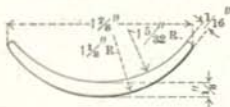

**BEVELED HAME**

**M 796**

0.20 lbs.

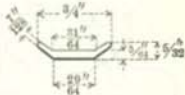

**U-BAR**

**U 579**

1.69 lbs.

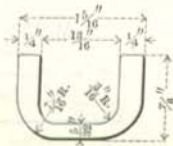

**CONCAVE CONVEX**

**M 774**

0.68 lbs.

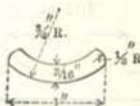

## VEHICLE SPRING CLIPS

M 1315

1.39 lbs.

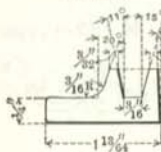

M 1316

1.36 lbs.

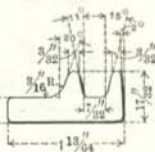

M 1317

1.46 lbs.

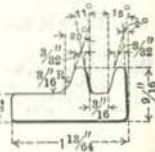

M 1318

1.84 lbs.

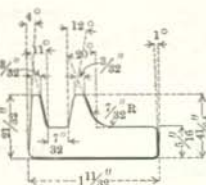

M 1319

1.92 lbs.

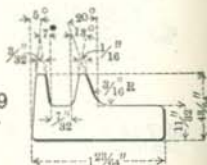

## AXLE CLIPS

M 956

2.50 lbs.

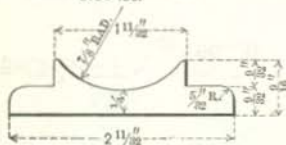

M 957

2.76 lbs.

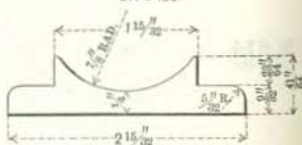

M 1230

2.12 lbs.

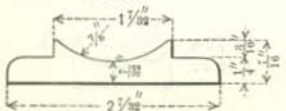

M 955

1.41 lbs.



CAN RING SECTIONS

M 914

0.78 lbs.

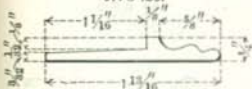

M 949

1.61 lbs.

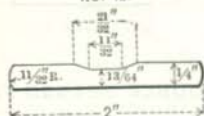

M 1280

1.25 lbs.

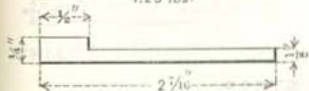

M 929

0.98 lbs.

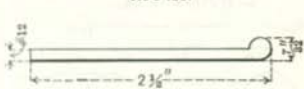

M 958

1.20 lbs.

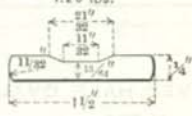

M 1281

1.12 lbs.

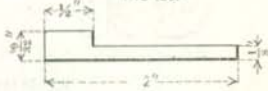

SPECIAL NUT SECTIONS

M 897-1.98 lbs.

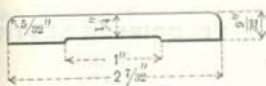

M 894

1.87 lbs.

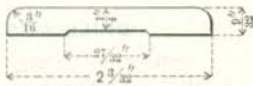

M 893

1.75 lbs.



M 963

2.35 lbs.

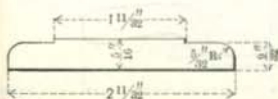

M 964

2.48 lbs.



**DOUBLE BEADED BAR**

C 579-4.45 lbs.

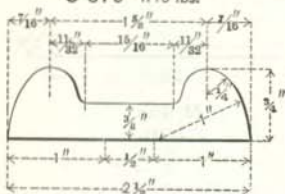
**GROOVED FLAT**

M 852

2.65 lbs.

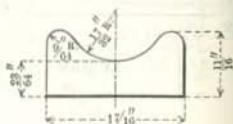
**GROOVED HALF OVAL**

M 851

1.30 lbs.

**DOUBLE BEADED FLAT**

M 1400

0.87 lbs.

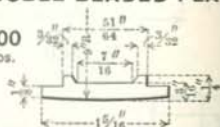
**HAMMER STRAP**

M 1312

1.45 lbs.

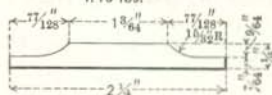
**DRILL POST****VELOCIPEDA SECTION**

M 995

2.80 lbs.

HALF SIZE

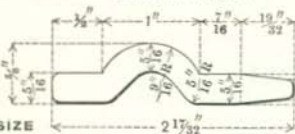

M 880

.32 lbs.

**THIMBLE SECTION**

M 40

18.1 lbs.

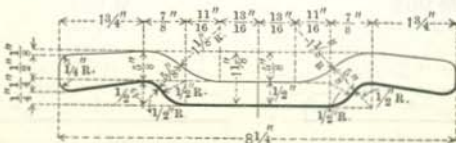

QUARTER SIZE.

SASH BAR

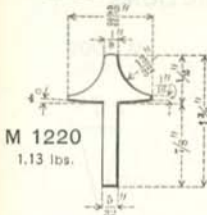

RAIL BAR

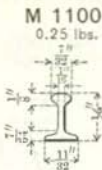

KEY SECTION

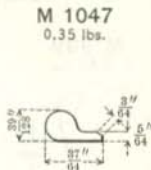

SPECIAL CONCAVE BEVELS

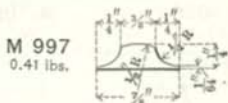
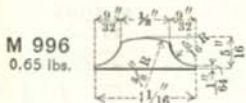

TRIANGULAR SECTION

M 895 - 0.23 lbs.



STAR SECTIONS

M 1390  
0.26 lbs.



M 1391  
0.49 lbs.



AX SECTION

M 1037  
0.70 lbs.

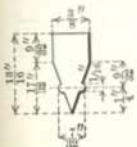

CHAIN SECTION

M 1045  
.67 lbs.



HAME BAR

M 797  
0.57 lbs.

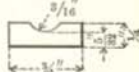

TROLLEY TRACK

C 702

1.70 lbs.

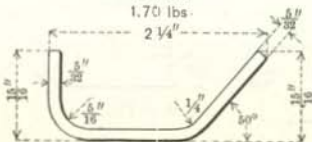

## SHARP TOE CALK SECTIONS

M 999

0.44 lbs.

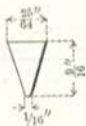

M 1001

0.53 lbs.

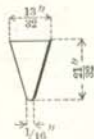

M 1002

0.68 lbs.

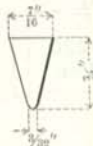

M 1003

0.82 lbs.

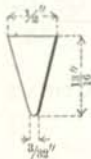

M 1004

1.05 lbs.

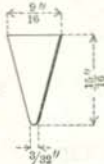

M 1005

1.17 lbs.

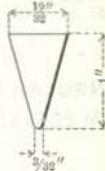

M 1006

1.30 lbs.

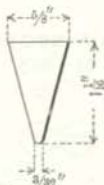

HALF SIZE

M 1381

2.17 lbs.

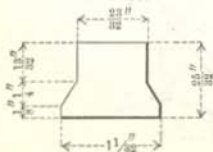

HALF SIZE

M 1340

1.16 lbs.

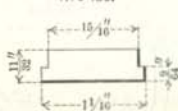

STEP BAR

M 1190

0.28 lbs.

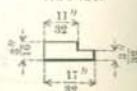

BEVELED SKELP

M 1348

1.83 lbs.

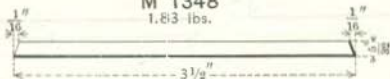

M 1347

3.22 lbs.

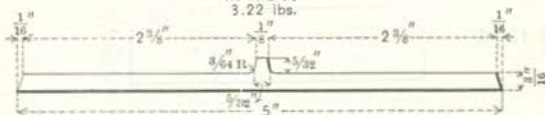

M 1341

4.30 lbs.

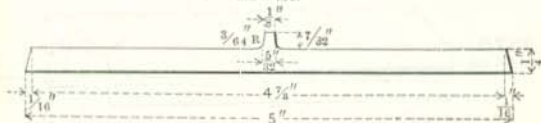

M 1345

6.00 lbs.

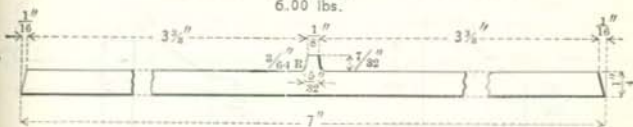

M 1346

7.48 lbs.

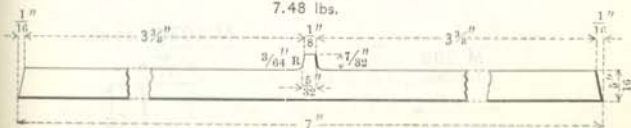



## SPECIAL BEVELS

M 1372

5.02 lbs.

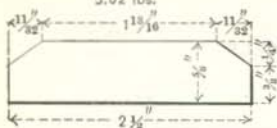

M 1373

6.06 lbs.

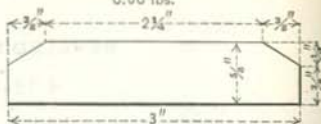

M 1374

7.29 lbs.



M 1375

6.9 to 8.4 lbs.

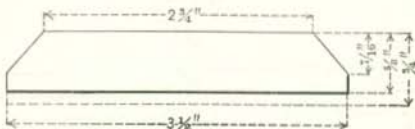

M 1083-3.34 lbs.

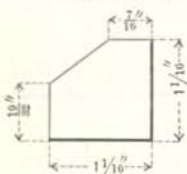

M 1084-2.54 lbs.

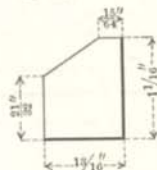

M 898

1.20 lbs.

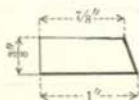

M 1039-1.30 lbs.

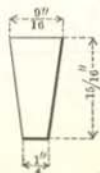

SPECIAL BEVELS, Continued

M 300

8.74 lbs

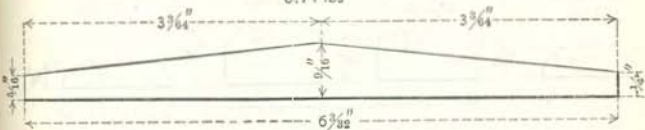

M 621- 6.70 lbs. to 9.25 lbs.

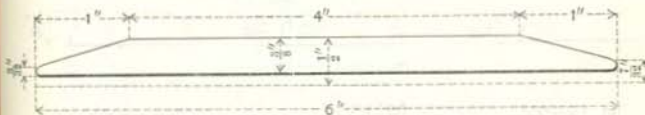

M 824- 6.46 lbs.



M 666- 6.25 lbs. to 8.20 lbs.

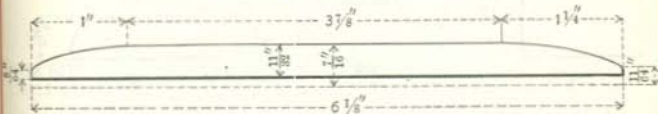

M 1038- 6.59 lbs.

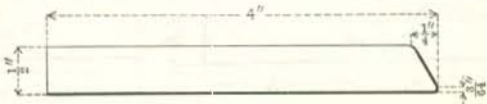

DOUBLE BEVELED SECTION

M 1304- 3.19 lbs. and 4.15 lbs.

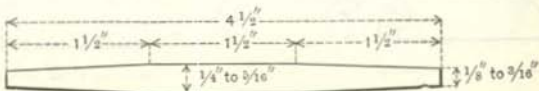

## ROUND BEVEL EDGE AND CYLINDER LAG

M 1362

.90 lbs.



M 1350

1.65 lbs.

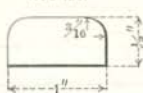

M 1351

2.01 lbs.



M 1344

0.87 lbs.

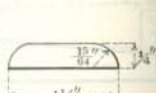

M 1349

1.08 lbs.

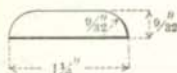

M 1365

1.28 lbs.

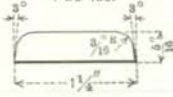

M 1338

1.29 lbs.

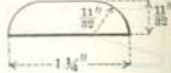

M 1352

1.98 lbs.

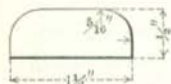

M 1353

2.51 lbs.

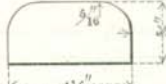

M 1354

3.05 lbs.



M 1355

3.60 lbs.



M 1356

1.10 lbs.

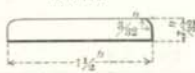

M 1357

2.03 lbs.

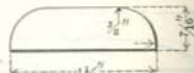

M 1359

2.98 lbs.



M 1358

2.50 lbs.

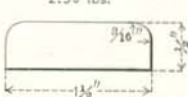

M 1360

3.02 to 3.65 lbs.

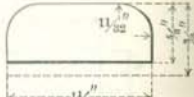

M 1363

2.72 lbs.

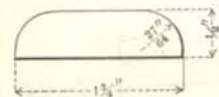

M 1337

1.52 lbs.



ROUND BEVEL EDGE, Continued

M 1361

5.55 lbs.

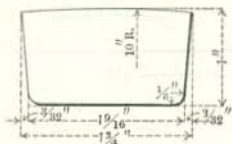

FOLLOWER PLATE

M 1379

39.34 lbs.

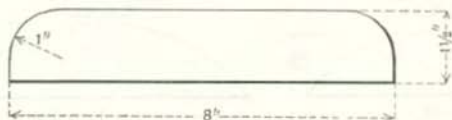

SPECIAL OVALS

M 861  
0.92 lbs.

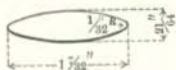

M 862  
1.43 lbs.

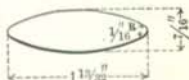

M 863  
1.52 lbs.

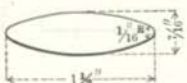

M 864  
1.73 lbs.

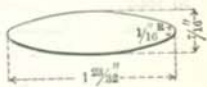

M 867  
1.76 lbs.



M 869  
2.13 lbs.

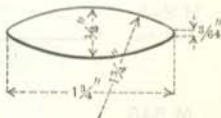

M 868  
2.67 lbs.

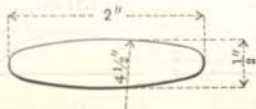

M 860  
1.00 lbs.

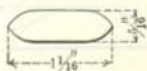

## SPECIAL HALF OVALS

M 838 - 3.01 lbs.

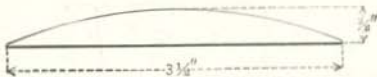

M 839

2.93 lbs.

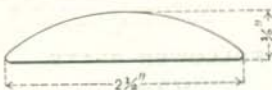

M 841

3.72 lbs.



M 842

5.35 lbs.

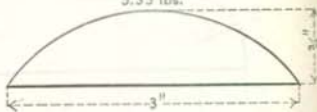

M 843

2.78 lbs.

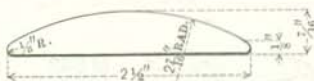

M 844

3.31 lbs.

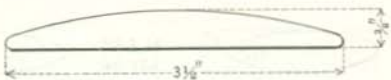

M 845

3.73 lbs.



M 846

1.72 lbs.

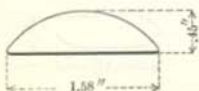

M 847

1.33 lbs.

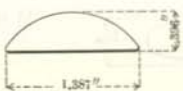

M 848

1.73 lbs.

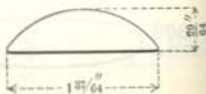

HALF SIZE

**SPECIAL ROUND EDGE BARS**

**M 1700**  
4.64 lbs.

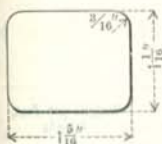

**M 1701**  
4.19 lbs.

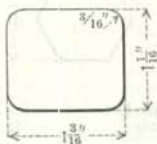

**M 1702**  
3.34 lbs.

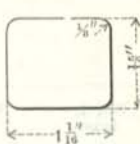

**SPECIAL HEXAGON**

**M 1240**  
5.30 lbs.

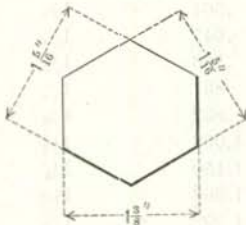

**SPECIAL ROUND EDGE FLAT**

**M 694**  
1.84 lbs.

HALF SIZE

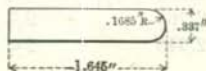

## HEXAGONS



Size, h, Inches	Weight per Foot, Pounds	Size, h, Inches	Weight per Foot, Pounds
$\frac{1}{4}$	.184	1	2.945
$\frac{3}{8}$	.233	$1\frac{1}{8}$	3.324
$\frac{5}{16}$	.288	$1\frac{1}{4}$	3.727
$\frac{11}{32}$	.348	$1\frac{3}{8}$	4.152
$\frac{3}{8}$	.414	$1\frac{1}{2}$	4.601
$\frac{13}{32}$	.486	$1\frac{5}{8}$	5.072
$\frac{7}{16}$	.564	$1\frac{3}{4}$	5.567
$\frac{15}{32}$	.647	$1\frac{7}{8}$	6.085
$\frac{1}{2}$	.736	$1\frac{1}{2}$	6.625
$\frac{17}{32}$	.831	$1\frac{9}{8}$	7.189
$\frac{9}{16}$	.932	$1\frac{5}{4}$	7.775
$\frac{19}{32}$	1.038	$1\frac{11}{8}$	8.385
$\frac{5}{8}$	1.150	$1\frac{3}{4}$	9.018
$\frac{21}{32}$	1.268	$1\frac{13}{8}$	9.673
$\frac{11}{16}$	1.392	$1\frac{7}{8}$	10.352
$\frac{23}{32}$	1.521	$1\frac{15}{8}$	11.053
$\frac{3}{4}$	1.656	2	11.778
$\frac{25}{32}$	1.897	$2\frac{1}{8}$	12.525
$\frac{13}{16}$	1.944	$2\frac{1}{4}$	13.296
$\frac{27}{32}$	2.096	$2\frac{3}{8}$	14.089
$\frac{7}{8}$	2.254	$2\frac{1}{2}$	14.907
$\frac{29}{32}$	2.418	$2\frac{5}{8}$	15.746
$\frac{15}{16}$	2.588	$2\frac{3}{4}$	16.609
$\frac{31}{32}$	2.763	$2\frac{7}{8}$	17.494
1	2.945	$2\frac{1}{2}$	18.403

OVALS

Width, Inches	Thickness, B. W. G. and Inches	Weight per Foot, Pounds	Width, Inches	Thickness, B. W. G. and Inches	Weight per Foot, Pounds	Width, Inches	Thickness, B. W. G. and Inches	Weight per Foot, Pounds
	No. 12	0.094		$\frac{1}{8}$	0.179	$\frac{3}{32}$	$\frac{1}{32}$	1.073
$\frac{3}{8}$	$\frac{1}{8}$	0.109		$\frac{3}{16}$	0.270		$\frac{1}{32}$	0.873
	$\frac{5}{32}$	0.137		$\frac{13}{64}$	0.294		$\frac{3}{8}$	1.029
	$\frac{3}{16}$	0.167		$\frac{1}{4}$	0.365		$\frac{7}{16}$	1.188
	$\frac{1}{4}$	0.230	$\frac{5}{8}$	$\frac{5}{16}$	0.464	1	$\frac{1}{2}$	1.522
	No. 10	0.135		$\frac{3}{8}$	0.568		$\frac{5}{8}$	1.696
$\frac{7}{16}$	$\frac{5}{32}$	0.159		$\frac{7}{16}$	0.677		$\frac{11}{16}$	1.878
	$\frac{3}{16}$	0.227		$\frac{1}{2}$	0.792		$\frac{3}{4}$	2.260
$\frac{1}{2}$	$\frac{3}{16}$	0.205		$\frac{9}{16}$	0.914		$\frac{7}{8}$	2.620
	$\frac{1}{8}$	0.143	$\frac{1}{2}$	$\frac{7}{32}$	0.348		$\frac{1}{2}$	1.324
	$\frac{3}{16}$	0.218		$\frac{11}{32}$	0.562	$\frac{1}{8}$	$\frac{9}{16}$	1.504
	$\frac{1}{4}$	0.257		$\frac{5}{16}$	0.549		$\frac{3}{8}$	1.688
	$\frac{5}{16}$	0.297		$\frac{3}{8}$	0.668	$\frac{1}{4}$	$\frac{3}{4}$	2.073
	$\frac{3}{8}$	0.380	$\frac{3}{4}$	$\frac{7}{16}$	0.792		$\frac{7}{8}$	2.482
	$\frac{1}{2}$	0.470		$\frac{1}{2}$	0.921	$1\frac{1}{2}$	$\frac{3}{4}$	0.919
$\frac{1}{2}$	$\frac{9}{32}$	0.357		$\frac{9}{16}$	1.056		$\frac{1}{4}$	0.714
	$\frac{3}{16}$	0.244	$\frac{1}{2}$	$\frac{13}{32}$	0.784		$\frac{3}{8}$	1.082
	$\frac{3}{16}$	0.287		$\frac{7}{16}$	0.851	$1\frac{1}{4}$	$\frac{1}{2}$	1.461
	$\frac{1}{4}$	0.331		$\frac{5}{16}$	0.635		$\frac{5}{8}$	1.855
	$\frac{9}{32}$	0.376		$\frac{3}{8}$	0.770		$\frac{11}{16}$	2.061
$\frac{9}{16}$	$\frac{5}{16}$	0.423		$\frac{7}{16}$	0.910		$\frac{3}{4}$	2.271
	$\frac{3}{8}$	0.517	$\frac{7}{8}$	$\frac{1}{2}$	1.054		$\frac{7}{8}$	2.708
	$\frac{1}{2}$	0.622		$\frac{9}{16}$	1.203	$1\frac{1}{2}$	$\frac{7}{8}$	1.421
	$\frac{9}{16}$	0.395		$\frac{5}{8}$	1.358	$1\frac{1}{2}$	$\frac{7}{8}$	1.512
$\frac{1}{2}$	$\frac{3}{16}$			$\frac{3}{4}$	1.687	$1\frac{3}{4}$	$\frac{7}{8}$	1.727
			$\frac{1}{2}$	$\frac{15}{32}$	1.044	$1\frac{3}{4}$	$\frac{7}{8}$	1.757

BLUNT OVALS

Width, Inches	Thickness, B. W. G. and Inches	Weight per Foot, Pounds	Width, Inches	Thickness, B. W. G. and Inches	Weight per Foot, Pounds	Width, Inches	Thickness, B. W. G. and Inches	Weight per Foot, Pounds
$\frac{3}{8}$	No. 12	0.109	$\frac{1}{2}$	$\frac{1}{8}$	0.167		$\frac{3}{16}$	0.313
	$\frac{1}{8}$	0.125		$\frac{3}{16}$	0.250	$\frac{5}{8}$	$\frac{13}{64}$	0.339
	No. 10	0.157		$\frac{1}{4}$	0.282		$\frac{1}{4}$	0.417
$\frac{7}{16}$	$\frac{3}{16}$	0.219	$\frac{9}{16}$	$\frac{3}{16}$		$1\frac{1}{8}$	$\frac{3}{16}$	0.402
	$\frac{3}{16}$	0.256				$1\frac{3}{4}$	$\frac{1}{2}$	2.110
						2	$\frac{1}{2}$	2.670





**HALF OVALS**

Width, Inches	Thickness B. W. G. and Inches	Weight per Foot, Pounds	Width, Inches	Thickness B. W. G. and Inches	Weight per Foot, Pounds	Width, Inches	Thickness B. W. G. and Inches	Weight per Foot, Pounds
3/8	No. 15	0.063	1 5/8	9/32	0.342	1 1/2	1/8	0.427
	5/32	0.084					5/32	0.536
	1/8	0.115					1/8	0.645
1 1/8	5/32	0.150	1	1/8	0.249	1 1/2	5/32	0.756
	7/32	0.106					1/4	0.869
	No. 15	0.073					5/32	0.983
7/16	5/32	0.096	1	5/32	0.514	1 1/2	5/16	1.098
	1/8	0.131					1/4	1.216
	No. 14	0.096					3/8	1.337
1/2	No. 12	0.128	1 1/8	5/16	0.761	1 5/8	1 1/2	1.712
	1/8	0.149					3/8	1.723
	5/32	0.190					No. 12	5/32
7/32	0.235	1/8	0.322					
No. 14	0.108	5/32	0.404					
9/16	No. 12	0.143	1 1/8	5/16	0.488	1 5/8	5/32	0.580
	1/8	0.166					1/8	0.698
	5/32	0.211					5/16	0.817
1 1/16	7/32	0.259	1 1/4	7/32	0.574	1 5/8	7/32	0.938
	No. 14	0.119					1/4	0.498
	No. 12	0.158					5/16	0.624
5/8	1/8	0.183	1 1/4	9/32	0.844	1 3/4	5/32	0.751
	5/32	0.232					1/8	0.878
	5/16	0.284					5/16	1.008
1 1/16	7/32	0.349	1 1/4	7/32	0.635	1 3/4	7/32	1.138
	1/4	0.396					1/4	1.271
	No. 14	0.142					5/16	1.405
1 1/8	No. 12	0.188	1 1/4	7/32	0.730	1 3/4	1 1/2	1.541
	1/8	0.217					1/4	0.828
	5/32	0.275					5/16	0.928
3/4	5/16	0.334	1 1/4	1 1/2	1.030	1 7/8	3/8	0.803
	7/32	0.396					1 1/2	1.077
	1/4	0.461					3/8	1.357
1 1/4	No. 12	0.219	1 3/8	1/8	0.392	2	3/8	1.644
	1/8	0.252					5/32	0.492
	5/32	0.318					3/16	0.593
7/8	5/16	0.385	1 3/8	7/32	0.695	2	5/16	1.444
	7/32	0.455					1/4	1.747
	1/4	0.527					9/32	2.058
1 1/2	9/32	0.602	1.387	.396	1.323	2	7/16	2.376
	5/16	0.679					1/2	

**HALF OVALS—CONTINUED**

Width, Inches	Thickness, B. W. G. and Inches	Weight per Foot, Pounds	Width, Inches	Thickness, B. W. G. and Inches	Weight per Foot, Pounds	Width, Inches	Thickness, B. W. G. and Inches	Weight per Foot, Pounds
2 $\frac{1}{8}$	$\frac{3}{16}$	0.909	2 $\frac{1}{2}$	$\frac{1}{4}$	1.428	2 $\frac{7}{8}$	$\frac{1}{4}$	1.639
	$\frac{1}{4}$	1.217		$\frac{5}{16}$	1.793		$\frac{5}{16}$	2.056
	$\frac{5}{16}$	1.531		$\frac{3}{8}$	2.163		$\frac{3}{8}$	2.477
	$\frac{3}{8}$	1.851		$\frac{7}{16}$	2.539		$\frac{1}{4}$	1.710
2 $\frac{1}{4}$	$\frac{3}{16}$	0.962	2 $\frac{3}{8}$	$\frac{1}{2}$	2.922	3	$\frac{5}{16}$	2.144
	$\frac{1}{4}$	1.287		$\frac{2}{16}$	3.313		$\frac{3}{8}$	2.582
	$\frac{5}{16}$	1.618		$\frac{3}{8}$	3.713		$\frac{7}{16}$	3.025
	$\frac{3}{8}$	1.954		$\frac{1}{4}$	1.495		$\frac{1}{2}$	3.475
2 $\frac{3}{8}$	$\frac{3}{8}$	1.954	2 $\frac{3}{4}$	$\frac{5}{16}$	1.880	3 $\frac{1}{2}$	$\frac{5}{16}$	3.930
	$\frac{1}{4}$	1.858		$\frac{3}{8}$	2.268		$\frac{3}{8}$	4.395
	$\frac{5}{16}$	1.705		$\frac{1}{4}$	1.569		$\frac{11}{16}$	4.866
	$\frac{3}{8}$	2.058		$\frac{5}{16}$	1.968		$\frac{3}{4}$	5.347
2 $\frac{3}{8}$	$\frac{3}{8}$	2.058	2 $\frac{3}{4}$	$\frac{3}{8}$	2.371	4	$\frac{3}{8}$	3.002
	$\frac{5}{16}$	1.705		$\frac{5}{16}$	1.968		$\frac{5}{8}$	2.848
	$\frac{3}{8}$	2.058		$\frac{3}{8}$	2.371		$\frac{3}{8}$	3.424

**BLUNT HALF OVALS**

Width, Inches	Thickness, B. W. G. and Inches	Weight per Foot, Pounds	Width, Inches	Thickness, B. W. G. and Inches	Weight per Foot, Pounds	Width, Inches	Thickness, B. W. G. and Inches	Weight per Foot, Pounds
2 $\frac{1}{2}$	$\frac{7}{16}$	2.780	3 $\frac{1}{2}$	$\frac{3}{8}$	3.300	4	$\frac{3}{8}$	3.720

## ROUND EDGE FLATS.—WEIGHTS IN POUNDS PER LINEAL FOOT

Face Measure, Inches	THICKNESS IN INCHES																Face Measure, Inches	
	1/8	1/4	3/8	1/2	5/8	3/4	7/8	1	1 1/8	1 1/4	1 1/2	1 3/4	1 7/8	2	2 1/4	2 1/2		
1/8	0.178	0.281	0.393															1/8
1/4	0.205	0.321	0.446															1/4
3/8	0.251	0.361	0.490	0.647														3/8
1/2	0.258	0.400	0.552	0.714														1/2
5/8	0.284	0.440	0.605	0.780														5/8
3/4	0.311	0.480	0.659	0.847														3/4
7/8	0.337	0.520	0.712	0.913	1.123	1.343	1.572											7/8
1	0.364	0.500	0.765	0.979	1.203	1.436	1.678											1
1 1/8	0.390	0.600	0.818	1.046	1.283	1.529	1.785											1 1/8
1 1/4	0.417	0.639	0.871	1.112	1.362	1.622	1.891											1 1/4
1 1/2	0.444	0.679	0.924	1.179	1.442	1.715	1.997											1 1/2
1 3/4	0.470	0.719	0.977	1.245	1.522	1.808	2.103											1 3/4
1 7/8	0.497	0.759	1.030	1.311	1.601	1.901	2.210											1 7/8
2	0.523	0.799	1.084	1.378	1.681	1.994	2.316											2
2 1/8	0.550	0.839	1.137	1.444	1.761	2.087	2.422											2 1/8
2 1/4	0.576	0.879	1.190	1.511	1.840	2.180	2.528											2 1/4
2 1/2	0.603	0.918	1.243	1.577	1.920	2.273	2.635											2 1/2
2 3/4	0.630	0.958	1.296	1.643	2.000	2.366	2.741											2 3/4
3	0.656	0.998	1.349	1.710	2.080	2.459	2.847											3
3 1/8	0.683	1.038	1.402	1.776	2.159	2.552	2.953											3 1/8
3 1/4	0.709	1.078	1.455	1.843	2.239	2.645	3.060											3 1/4
3 1/2	0.736	1.118	1.509	1.909	2.319	2.738	3.166											3 1/2
3 3/4	0.762	1.157	1.562	1.975	2.398	2.831	3.272											3 3/4
4	0.789	1.197	1.615	2.042	2.478	2.924	3.378											4
4 1/8	0.815	1.237	1.668	2.108	2.558	3.016	3.485											4 1/8
4 1/4	0.842	1.277	1.721	2.175	2.637	3.109	3.591											4 1/4
4 1/2	0.869	1.317	1.774	2.241	2.717	3.202	3.697											4 1/2
4 3/4	0.895	1.357	1.827	2.307	2.797	3.295	3.803											4 3/4
5	0.922	1.396	1.880	2.374	2.876	3.388	3.910											5
5 1/8	0.948	1.436	1.933	2.440	2.956	3.481	4.016											5 1/8
5 1/4	0.975	1.476	1.987	2.507	3.036	3.574	4.122											5 1/4
5 1/2	1.001	1.516	2.040	2.573	3.115	3.667	4.228											5 1/2
5 3/4	1.028	1.556	2.093	2.639	3.195	3.760	4.335											5 3/4
6	1.055	1.596	2.146	2.709	3.275	3.853	4.441											6
6 1/8	1.083	1.636	2.199	2.772	3.355	3.946	4.547											6 1/8

—See opposite—

—See opposite—

**THICKNESS IN INCHES**

Face Measure, Inches	1/8	1/4	3/8	1/2	5/8	3/4	7/8	1	1 1/8	1 1/4	1 1/2	1 3/4	1 7/8	2	Face Measure, Inches
2 5/8	1.134	1.715	2.305	2.905	3.514	4.132	4.760	5.442	6.043	6.643	7.243	7.971	8.580	9.189	9.798
2 3/4	1.187	1.785	2.412	3.038	3.673	4.318	4.972	5.681	6.308	6.935	7.562	8.316	8.952	9.587	10.223
2 5/8	1.240	1.875	2.518	3.171	3.833	4.504	5.185	5.920	6.574	7.227	7.880	8.602	9.323	9.986	10.648
3	1.294	1.954	2.624	3.304	3.992	4.690	5.397	6.159	6.839	7.519	8.199	9.007	9.695	10.384	11.073
3 1/8	2.034	2.730	3.436	4.151	4.876	5.610	6.368	7.105	7.811	8.518	9.352	10.077	10.783	11.498	12.214
3 1/4	2.114	2.857	3.569	4.311	5.062	5.822	6.638	7.371	8.104	8.897	9.682	10.439	11.181	11.923	12.666
3 3/8	2.193	2.943	3.702	4.470	5.248	6.035	6.877	7.636	8.396	9.156	10.043	10.811	11.580	12.348	13.117
3 1/2	2.273	3.049	3.855	4.630	5.434	6.247	7.116	7.902	8.688	9.474	10.388	11.183	11.978	12.773	13.569
3 5/8	3.155	3.968	4.789	5.620	6.460	7.355	8.167	9.082	9.793	10.733	11.555	12.376	13.198	14.020	14.843
3 3/4	3.262	4.100	4.948	5.806	6.672	7.594	8.433	9.272	10.112	11.079	11.927	12.775	13.623	14.472	15.321
3 3/8	3.368	4.233	5.108	5.991	6.885	7.833	8.699	9.565	10.431	11.424	12.298	13.173	14.048	14.924	15.799
4	3.474	4.366	5.267	6.177	7.097	8.072	8.964	9.857	10.749	11.709	12.670	13.572	14.473	15.375	16.277
4 1/8	4.499	5.426	6.363	7.310	8.311	9.230	10.149	11.068	12.115	13.042	13.970	14.898	15.826	16.754	17.682
4 1/4	4.632	5.586	6.549	7.522	8.550	9.496	10.441	11.387	12.400	13.414	14.390	15.323	16.256	17.189	18.122
4 3/8	4.764	5.745	6.735	7.795	8.789	9.761	10.733	11.706	12.805	13.786	14.767	15.748	16.729	17.710	18.691
4 1/2	4.897	5.905	6.921	7.947	9.028	10.027	11.025	12.024	13.151	14.158	15.166	16.173	17.181	18.189	19.197
4 5/8	5.030	6.064	7.107	8.160	9.267	10.292	11.317	12.343	13.496	14.530	15.564	16.598	17.632	18.666	19.700
4 3/4	5.163	6.223	7.293	8.372	9.506	10.558	11.610	12.662	13.841	14.902	15.962	17.023	18.083	19.144	20.204
4 5/8	5.296	6.383	7.479	8.585	9.745	10.824	11.902	12.981	14.187	15.273	16.361	17.448	18.535	19.622	20.709
5	5.429	6.542	7.665	8.797	9.984	11.089	12.194	13.299	14.532	15.645	16.759	17.873	18.986	20.099	21.212
5 1/8	5.561	6.701	7.851	9.010	10.223	11.355	12.486	13.618	14.877	16.017	17.158	18.298	19.439	20.580	21.720
5 1/4	5.694	6.861	8.037	9.222	10.463	11.621	12.779	13.937	15.222	16.380	17.538	18.696	19.854	21.012	22.170
5 3/8	5.827	7.020	8.223	9.434	10.702	11.896	13.071	14.256	15.568	16.761	17.955	19.148	20.341	21.534	22.727
5 1/2	5.960	7.180	8.409	9.647	10.941	12.152	13.363	14.574	15.913	17.133	18.353	19.573	20.793	22.013	23.233
5 5/8	6.093	7.339	8.595	9.890	11.180	12.417	13.656	14.958	16.258	17.505	18.751	19.998	21.245	22.492	23.739
5 3/4	6.225	7.498	8.781	10.072	11.419	12.683	13.947	15.212	16.604	17.877	19.150	20.423	21.696	22.969	24.242
5 5/8	6.358	7.658	8.967	10.285	11.658	12.949	14.240	15.531	16.949	18.248	19.548	20.848	22.148	23.448	24.748
6	6.491	7.817	9.152	10.497	11.897	13.214	14.582	15.849	17.294	18.620	19.947	21.273	22.600	23.927	25.254

TO OBTAIN WIDTH OVER ALL, FOR ANY THICKNESS, ADD TO FACE MEASURE OF FLATS THE INCREMENT GIVEN FOR THAT THICKNESS IN TABLE BELOW.

**THICKNESS IN INCHES**

Face Measure, Inches	1/8	1/4	3/8	1/2	5/8	3/4	7/8	1	1 1/8	1 1/4	1 1/2	1 3/4	1 7/8	2	Face Measure, Inches
1/8	1/8	1/8	1/8	1/8	1/8	1/8	1/8	1/8	1/8	1/8	1/8	1/8	1/8	1/8	1 1/8
1/4	1/4	1/4	1/4	1/4	1/4	1/4	1/4	1/4	1/4	1/4	1/4	1/4	1/4	1/4	1 1/4
3/8	3/8	3/8	3/8	3/8	3/8	3/8	3/8	3/8	3/8	3/8	3/8	3/8	3/8	3/8	1 3/8
1/2	1/2	1/2	1/2	1/2	1/2	1/2	1/2	1/2	1/2	1/2	1/2	1/2	1/2	1/2	1 1/2
5/8	5/8	5/8	5/8	5/8	5/8	5/8	5/8	5/8	5/8	5/8	5/8	5/8	5/8	5/8	1 5/8
3/4	3/4	3/4	3/4	3/4	3/4	3/4	3/4	3/4	3/4	3/4	3/4	3/4	3/4	3/4	1 3/4
7/8	7/8	7/8	7/8	7/8	7/8	7/8	7/8	7/8	7/8	7/8	7/8	7/8	7/8	7/8	1 7/8
1	1	1	1	1	1	1	1	1	1	1	1	1	1	1	2

FOR LIST OF SIZES OF ROUND EDGE FLATS, SEE PAGE 14 OF THIS SUPPLEMENT

## CARNEGIE STEEL COMPANY

---

### GENERAL OFFICES:

**Pittsburg, Carnegie Building.**

### DISTRICT OFFICES:

**Birmingham, Woodward Building,**

**Boston, Telephone Building,**

**Buffalo, Ellicott Square Building,**

**Chicago, Commercial National Bank Building,**

**Cincinnati, Union Trust Building,**

**Cleveland, Rockefeller Building,**

**Denver, Equitable Building,**

**Detroit, Union Trust Building,**

**New Orleans, Maison Blanche,**

**New York, Hudson Terminal, 30 Church Street,**

**Philadelphia, Pennsylvania Building,**

**Pittsburg, Carnegie Building,**

**Portland, Wells, Fargo Building,**

**San Francisco, Crocker Building,**

**St. Louis, Third National Bank Building,**

**St. Paul, Pioneer Press Building.**

SQUARE AND ROUND BARS.

(CONTINUED.)

Thickness or diameter in inches.	Weight of □ Bar one foot long.	Weight of ○ Bar one foot long.	Area of □ Bar in sq. inches.	Area of ○ Bar in sq. inches.	Circumference of ○ Bar in inches.
2	13.60	10.68	4.0000	3.1416	6.2832
$2\frac{1}{16}$	14.46	11.36	4.2539	3.3410	6.4795
$2\frac{1}{8}$	15.35	12.06	4.5156	3.5466	6.6759
$2\frac{1}{4}$	16.27	12.78	4.7852	3.7583	6.8722
$2\frac{3}{8}$	17.22	13.52	5.0625	3.9761	7.0886
$2\frac{1}{2}$	18.19	14.28	5.3477	4.2000	7.2649
$2\frac{5}{8}$	19.18	15.07	5.6406	4.4301	7.4613
$2\frac{3}{4}$	20.20	15.86	5.9414	4.6664	7.6576
$2\frac{7}{8}$	21.25	16.69	6.2500	4.9087	7.8540
$3$	22.33	17.53	6.5664	5.1572	8.0503
$3\frac{1}{16}$	23.43	18.40	6.8906	5.4119	8.2467
$3\frac{1}{8}$	24.56	19.29	7.2227	5.6727	8.4430
$3\frac{1}{4}$	25.	20.20	7.5625	5.9396	8.6394
$3\frac{3}{8}$	26.90	21.12	7.9102	6.2126	8.8357
$3\frac{1}{2}$	28.10	22.07	8.2656	6.4918	9.0321
$3\frac{5}{8}$	29.34	23.04	8.6289	6.7771	9.2284
3	30.60	24.03	9.0000	7.0686	9.4248
$3\frac{1}{16}$	31.89	25.04	9.3789	7.3662	9.6211
$3\frac{1}{8}$	33.20	26.08	9.7656	7.6699	9.8175
$3\frac{1}{4}$	34.55	27.13	10.160	7.9798	10.014
$3\frac{3}{8}$	35.92	28.20	10.563	8.2958	10.210
$3\frac{1}{2}$	37.31	29.30	10.973	8.6179	10.407
$3\frac{5}{8}$	38.73	30.42	11.391	8.9462	10.603
$3\frac{3}{4}$	40.18	31.56	11.816	9.2806	10.799
$3\frac{7}{8}$	41.65	32.71	12.250	9.6211	10.996
$4$	43.14	33.90	12.691	9.9678	11.192
$4\frac{1}{16}$	44.68	35.09	13.141	10.321	11.388
$4\frac{1}{8}$	46.24	36.31	13.598	10.680	11.585
$4\frac{1}{4}$	47.82	37.56	14.063	11.045	11.781
$4\frac{3}{8}$	49.42	38.81	14.535	11.416	11.977
$4\frac{1}{2}$	51.05	40.10	15.016	11.793	12.174
$4\frac{5}{8}$	52.71	41.40	15.504	12.177	12.370





## SQUARE AND ROUND BARS.

(CONTINUED.)

Thickness or Diameter in inches.	Weight of □ Bar one foot long.	Weight of ○ Bar one foot long.	Area of □ Bar in sq. inches.	Area of ○ Bar in sq. inches.	Circumference of ○ Bar in inches.
4	54.40	42.73	16.000	12.566	12.566
$\frac{1}{16}$	56.11	44.07	16.504	12.962	12.763
$\frac{1}{8}$	57.85	45.44	17.016	13.364	12.959
$\frac{3}{16}$	59.62	46.83	17.535	13.772	13.155
$\frac{1}{4}$	61.41	48.24	18.063	14.186	13.352
$\frac{5}{16}$	63.23	49.66	18.598	14.607	13.548
$\frac{3}{8}$	65.08	51.11	19.141	15.033	13.744
$\frac{7}{16}$	66.95	52.58	19.691	15.466	13.941
$\frac{1}{2}$	68.85	54.07	20.250	15.904	14.137
$\frac{9}{16}$	70.78	55.59	20.816	16.349	14.334
$\frac{5}{8}$	72.73	57.12	21.391	16.800	14.530
$\frac{11}{16}$	74.70	58.67	21.973	17.257	14.726
$\frac{3}{4}$	76.71	60.25	22.563	17.721	14.923
$\frac{13}{16}$	78.74	61.84	23.160	18.190	15.119
$\frac{7}{8}$	80.81	63.46	23.766	18.665	15.315
$\frac{15}{16}$	82.89	65.10	24.379	19.147	15.512
5	85.00	66.76	25.000	19.635	15.708
$\frac{1}{16}$	87.14	68.44	25.629	20.129	15.904
$\frac{1}{8}$	89.30	70.14	26.266	20.629	16.101
$\frac{3}{16}$	91.49	71.86	26.910	21.135	16.297
$\frac{1}{4}$	93.72	73.60	27.563	21.648	16.493
$\frac{5}{16}$	95.96	75.37	28.223	22.166	16.690
$\frac{3}{8}$	98.23	77.15	28.891	22.691	16.886
$\frac{7}{16}$	100.5	78.95	29.566	23.221	17.082
$\frac{1}{2}$	102.8	80.77	30.250	23.758	17.279
$\frac{9}{16}$	105.2	82.62	30.941	24.301	17.475
$\frac{5}{8}$	107.6	84.49	31.641	24.850	17.671
$\frac{11}{16}$	110.0	86.38	32.348	25.406	17.868
$\frac{3}{4}$	112.4	88.29	33.063	25.967	18.064
$\frac{13}{16}$	114.9	90.22	33.785	26.535	18.261
$\frac{7}{8}$	117.4	92.17	34.516	27.109	18.457
$\frac{15}{16}$	119.9	94.14	35.254	27.688	18.653

SQUARE AND ROUND BARS.

(CONTINUED.)

Thickness or Diameter in inches.	Weight of  Bar one foot long.	Weight of  Bar one foot long.	Area of  Bar in sq. inches.	Area of  Bar in sq. inches.	Circumference of  Bar in inches.
6	122.4	96.14	36.000	28.274	18.850
$1\frac{1}{8}$	125.0	98.14	36.754	28.866	19.046
$1\frac{1}{4}$	127.6	100.2	37.516	29.465	19.242
$1\frac{3}{8}$	130.2	102.2	38.285	30.069	19.439
$1\frac{1}{2}$	132.8	104.3	39.063	30.680	19.635
$1\frac{5}{8}$	135.5	106.4	39.848	31.296	19.831
$1\frac{3}{4}$	138.2	108.5	40.641	31.919	20.028
$1\frac{7}{8}$	140.9	110.7	41.441	32.548	20.224
$1\frac{1}{2}$	143.6	112.8	42.250	33.183	20.420
$1\frac{5}{8}$	146.5	114.9	43.066	33.824	20.617
$1\frac{3}{4}$	149.2	117.2	43.891	34.472	20.813
$1\frac{7}{8}$	152.1	119.4	44.723	35.125	21.009
$1\frac{1}{2}$	154.9	121.7	45.563	35.785	21.206
$1\frac{5}{8}$	157.8	123.9	46.410	36.450	21.402
$1\frac{3}{4}$	160.8	126.2	47.266	37.122	21.598
$1\frac{7}{8}$	163.6	128.5	48.129	37.800	21.795
7	166.6	130.9	49.000	38.485	21.991
$1\frac{1}{8}$	169.6	133.2	49.879	39.175	22.187
$1\frac{1}{4}$	172.6	135.6	50.766	39.871	22.384
$1\frac{3}{8}$	175.6	137.9	51.660	40.574	22.580
$1\frac{1}{2}$	178.7	140.4	52.563	41.282	22.777
$1\frac{5}{8}$	181.8	142.8	53.473	41.997	22.973
$1\frac{3}{4}$	184.9	145.3	54.391	42.718	23.169
$1\frac{7}{8}$	188.1	147.7	55.316	43.445	23.366
$1\frac{1}{2}$	191.3	150.2	56.250	44.179	23.562
$1\frac{5}{8}$	194.4	152.7	57.191	44.918	23.758
$1\frac{3}{4}$	197.7	155.2	58.141	45.664	23.955
$1\frac{7}{8}$	200.9	157.8	59.098	46.415	24.151
$1\frac{1}{2}$	204.2	160.3	60.063	47.173	24.347
$1\frac{5}{8}$	207.6	163.0	61.035	47.937	24.544
$1\frac{3}{4}$	210.8	165.6	62.016	48.707	24.740
$1\frac{7}{8}$	214.2	168.2	63.004	49.483	24.936



SQUARE AND ROUND BARS.

(CONTINUED.)

Thickness or Diameter in inches.	Weight of $\square$ Bar one foot long.	Weight of $\circ$ Bar one foot long.	Area of $\square$ Bar in sq. inches.	Area of $\circ$ Bar in sq. inches.	Circumference of $\circ$ Bar in inches.
8	217.6	171.0	64.000	50.265	25.133
$1\frac{1}{8}$	221.0	173.6	65.004	51.054	25.329
$1\frac{1}{4}$	224.5	176.3	66.016	51.849	25.525
$1\frac{3}{8}$	228.0	179.0	67.035	52.649	25.722
$1\frac{1}{2}$	231.4	181.8	68.063	53.456	25.918
$1\frac{5}{8}$	234.9	184.5	69.098	54.269	26.114
$1\frac{3}{4}$	238.5	187.3	70.141	55.088	26.311
$1\frac{7}{8}$	242.0	190.1	71.191	55.914	26.507
$1\frac{1}{2}$	245.6	193.0	72.250	56.745	26.704
$1\frac{5}{8}$	249.3	195.7	73.316	57.583	26.900
$1\frac{3}{4}$	252.9	198.7	74.391	58.426	27.096
$1\frac{7}{8}$	256.6	201.6	75.473	59.276	27.293
$1\frac{1}{2}$	260.3	204.4	76.563	60.132	27.489
$1\frac{5}{8}$	264.1	207.4	77.660	60.994	27.685
$1\frac{3}{4}$	267.9	210.3	78.766	61.862	27.882
$1\frac{7}{8}$	271.6	213.3	79.879	62.737	28.078
9	275.4	216.3	81.000	63.617	28.274
$1\frac{1}{8}$	279.3	219.3	82.129	64.504	28.471
$1\frac{1}{4}$	283.2	222.4	83.266	65.397	28.667
$1\frac{3}{8}$	287.0	225.4	84.410	66.296	28.863
$1\frac{1}{2}$	290.9	228.5	85.563	67.201	29.060
$1\frac{5}{8}$	294.9	231.5	86.723	68.112	29.256
$1\frac{3}{4}$	298.9	234.7	87.891	69.029	29.452
$1\frac{7}{8}$	302.8	237.9	89.066	69.953	29.649
$1\frac{1}{2}$	306.8	241.0	90.250	70.882	29.845
$1\frac{5}{8}$	310.9	244.2	91.441	71.818	30.041
$1\frac{3}{4}$	315.0	247.4	92.641	72.760	30.238
$1\frac{7}{8}$	319.1	250.6	93.848	73.708	30.434
$1\frac{1}{2}$	323.2	253.9	95.063	74.662	30.631
$1\frac{5}{8}$	327.4	257.1	96.285	75.622	30.827
$1\frac{3}{4}$	331.6	260.4	97.516	76.589	31.023
$1\frac{7}{8}$	335.8	263.7	98.754	77.561	31.220

## SQUARE AND ROUND BARS.

(CONTINUED.)

Thickness or Diameter in inches.	Weight of □ Bar one foot long.	Weight of ○ Bar one foot long.	Area of □ Bar in sq. inches.	Area of ○ Bar in sq. inches.	Circumference of ○ Bar in inches.
10	340.0	267.0	100.00	78.540	31.416
$\frac{1}{16}$	344.3	270.4	101.25	79.525	31.612
$\frac{1}{8}$	348.5	273.8	102.52	80.516	31.809
$\frac{3}{16}$	352.9	277.1	103.79	81.513	32.005
$\frac{1}{4}$	357.2	280.6	105.06	82.516	32.201
$\frac{5}{16}$	361.6	284.0	106.35	83.525	32.398
$\frac{3}{8}$	366.0	287.4	107.64	84.541	32.594
$\frac{7}{16}$	370.4	290.9	108.94	85.562	32.790
$\frac{1}{2}$	374.9	294.4	110.25	86.590	32.987
$\frac{9}{16}$	379.4	297.9	111.57	87.624	33.183
$\frac{5}{8}$	383.8	301.4	112.89	88.664	33.379
$\frac{11}{16}$	388.3	305.0	114.22	89.710	33.576
$\frac{3}{4}$	392.9	308.6	115.56	90.763	33.772
$\frac{7}{8}$	397.5	312.2	116.91	91.821	33.968
$\frac{15}{16}$	402.1	315.8	118.27	92.886	34.165
1	406.8	319.5	119.63	93.956	34.361
11	411.4	323.1	121.00	95.033	34.558
$\frac{1}{16}$	416.1	326.8	122.38	96.116	34.754
$\frac{1}{8}$	420.9	330.5	123.77	97.205	34.950
$\frac{3}{16}$	425.5	334.3	125.16	98.301	35.147
$\frac{1}{4}$	430.3	337.9	126.56	99.402	35.343
$\frac{5}{16}$	435.1	341.7	127.97	100.51	35.539
$\frac{3}{8}$	439.9	345.5	129.39	101.62	35.736
$\frac{7}{16}$	444.8	349.4	130.82	102.74	35.932
$\frac{1}{2}$	449.6	353.1	132.25	103.87	36.128
$\frac{9}{16}$	454.5	357.0	133.69	105.00	36.325
$\frac{5}{8}$	459.5	360.9	135.14	106.14	36.521
$\frac{11}{16}$	464.4	364.8	136.60	107.28	36.717
$\frac{3}{4}$	469.4	368.6	138.06	108.43	36.914
$\frac{7}{8}$	474.4	372.6	139.54	109.59	37.110
$\frac{15}{16}$	479.5	376.6	141.02	110.75	37.306
1	484.5	380.6	142.50	111.92	37.503

THE CARNEGIE STEEL COMPANY, LIMITED.

WEIGHT OF SHEETS OF WROUGHT IRON, STEEL, COPPER AND BRASS. (From Haswell.)

Weights per Square Foot. Thickness by Birmingham Gauge.

No. of Gauge.	Thickness in inches.	Iron.	Steel.	Copper.	Brass.
0000	.454	18.22	18.46	20.57	19.43
000	.425	17.05	17.28	19.25	18.19
00	.38	15.25	15.45	17.21	16.26
0	.34	13.64	13.82	15.40	14.55
1	.3	12.04	12.20	13.59	12.84
2	.284	11.40	11.55	12.87	12.16
3	.259	10.39	10.53	11.73	11.09
4	.238	9.55	9.68	10.78	10.19
5	.22	8.83	8.95	9.97	9.42
6	.203	8.15	8.25	9.20	8.69
7	.18	7.22	7.32	8.15	7.70
8	.165	6.62	6.71	7.47	7.06
9	.148	5.94	6.02	6.70	6.33
10	.134	5.38	5.45	6.07	5.74
11	.12	4.82	4.88	5.44	5.14
12	.109	4.37	4.43	4.94	4.67
13	.095	3.81	3.86	4.30	4.07
14	.083	3.33	3.37	3.76	3.55
15	.072	2.89	2.93	3.26	3.08
16	.065	2.61	2.64	2.94	2.78
17	.058	2.33	2.36	2.63	2.48
18	.049	1.97	1.99	2.22	2.10
19	.042	1.69	1.71	1.90	1.80
20	.035	1.40	1.42	1.59	1.50
21	.032	1.28	1.30	1.45	1.37
22	.028	1.12	1.14	1.27	1.20
23	.025	1.00	1.02	1.13	1.07
24	.022	.883	.895	1.00	.942
25	.02	.803	.813	.906	.856
26	.018	.722	.732	.815	.770
27	.016	.642	.651	.725	.685
28	.014	.562	.569	.634	.599
29	.013	.522	.529	.589	.556
30	.012	.482	.488	.544	.514
31	.01	.401	.407	.453	.428
32	.009	.361	.366	.408	.385
33	.008	.321	.325	.362	.342
34	.007	.281	.285	.317	.300
35	.005	.201	.203	.227	.214
Specific Gravity,		7.704	7.806	8.698	8.218
Weight Cubic Foot,		481.75	487.75	543.6	513.6
" " Inch,		.2787	.2823	.3146	.2972

THE CARNEGIE STEEL COMPANY, LIMITED.

WEIGHT OF SHEETS OF WROUGHT IRON,  
STEEL, COPPER AND BRASS. (From Haswell.)  
Weights per Sq. Foot. Thickness by American (Browne & Sharpe's) Gauge.

No. of Gauge.	Thickness in inches.	Iron.	Steel.	Copper.	Brass.
0000	.46	18.46	18.70	20.84	19.69
000	.4096	16.44	16.66	18.56	17.53
00	.3648	14.64	14.83	16.53	15.61
0	.3249	13.04	13.21	14.72	13.90
1	.2893	11.61	11.76	13.11	12.38
2	.2576	10.34	10.48	11.67	11.03
3	.2294	9.21	9.33	10.39	9.82
4	.2043	8.20	8.31	9.26	8.74
5	.1819	7.30	7.40	8.24	7.79
6	.1620	6.50	6.59	7.34	6.93
7	.1443	5.79	5.87	6.54	6.18
8	.1285	5.16	5.22	5.82	5.50
9	.1144	4.59	4.65	5.18	4.90
10	.1019	4.09	4.14	4.62	4.36
11	.0907	3.64	3.69	4.11	3.88
12	.0808	3.24	3.29	3.66	3.46
13	.0720	2.89	2.93	3.26	3.08
14	.0641	2.57	2.61	2.90	2.74
15	.0571	2.29	2.32	2.59	2.44
16	.0508	2.04	2.07	2.30	2.18
17	.0453	1.82	1.84	2.05	1.94
18	.0403	1.62	1.64	1.83	1.73
19	.0359	1.44	1.46	1.63	1.54
20	.0320	1.28	1.30	1.45	1.37
21	.0285	1.14	1.16	1.29	1.22
22	.0253	1.02	1.03	1.15	1.08
23	.0226	.906	.918	1.02	.966
24	.0201	.807	.817	.911	.860
25	.0179	.718	.728	.811	.766
26	.0159	.640	.648	.722	.682
27	.0142	.570	.577	.643	.608
28	.0126	.507	.514	.573	.541
29	.0113	.452	.458	.510	.482
30	.0100	.402	.408	.454	.429
31	.0089	.358	.363	.404	.382
32	.0080	.319	.323	.360	.340
33	.0071	.284	.288	.321	.303
34	.0063	.253	.256	.286	.270
35	.0056	.225	.228	.254	.240

As there are many gauges in use differing from each other and even the thicknesses of a certain specified gauge, as the Birmingham, are not assumed the same by all manufacturers, orders for sheets and wire should always state the weight per square foot, or the thickness in thousandths of an inch.

MENSURATION.

LENGTH.

Circumference of circle = diameter  $\times$  3.1416.

Diameter of circle = circumference  $\times$  0.3183.

Side of square of equal periphery as circle = diameter  $\times$  0.7854.

Diameter of circle of equal periphery as square = side  $\times$  1.2732.

Side of an inscribed square = diameter of circle  $\times$  0.7071.

Length of arc = No. of degrees  $\times$  diameter  $\times$  0.008727.

Circumference of circle whose diameter is 1 =

$$\pi = 3.14159265.$$

$$\log. \pi = 0.4971499.$$

$$\sqrt{\pi} = 1.772454.$$

$$\pi^2 = 9.869604.$$

$$r = \frac{v^2 + \frac{c^2}{4}}{2v}$$

$$\text{or very nearly} = \frac{c^2}{8v}.$$

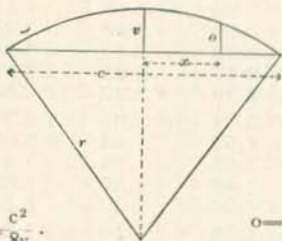

$$\frac{1}{\pi} = 0.318310.$$

$$\frac{1}{\pi^2} = 0.101321.$$

$$\sqrt{\frac{1}{\pi}} = 0.564190.$$

$$v = \sqrt{r^2 - \frac{c^2}{4}} - (r - v).$$

$$v = r - \sqrt{r^2 - \frac{c^2}{4}} \text{ or very nearly } = \frac{c^2}{8r}.$$

AREA.

Triangle = base  $\times$  half perpendicular height.

Parallelogram = base  $\times$  perpendicular height.

Trapezoid = half the sum of the parallel sides  $\times$  perpendicular height.

Trapezium, found by dividing into two triangles.

Circle = diameter squared  $\times$  0.7854; or,

= circumference squared  $\times$  0.07958.

Sector of circle = length of arc  $\times$  half radius.

MENSURATION—Continued.

Segment of circle = area of sector less triangle; also for

$$\text{flat segments very nearly} = \frac{4v}{3} \sqrt{0.388v^2 + \frac{c^2}{4}}$$

Side of square of equal area as circle = diameter  $\times$  0.8862;  
also = circumference  $\times$  0.2821.

Diameter of circle of equal area as square = side  $\times$  1.1284.

Parabola = base  $\times$   $\frac{2}{3}$  height.

Ellipse = long diameter  $\times$  short diameter  $\times$  0.7854.

Regular polygon = sum of sides  $\times$  half perpendicular distance from center to sides.

Surface of cylinder = circumference  $\times$  height + area of both ends.

Surface of sphere = diameter squared  $\times$  3.1416;  
also = circumference  $\times$  diameter.

Surface of a right pyramid or cone = periphery or circumference of base  $\times$  half slant height.

Surface of a frustrum of a regular right pyramid or cone = sum of peripheries or circumferences of the two ends  $\times$  half slant height + area of both ends.

The following formulæ are used to obtain the areas of irregular plane surfaces which are bounded by a base line "cc" and two ordinates "a" and "b" as per figure.

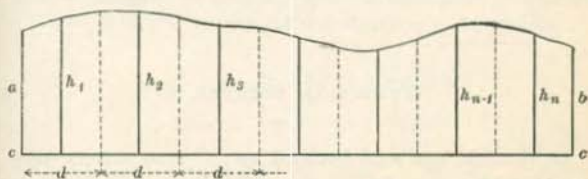

The formulæ are given in the order of their accuracy beginning with the most accurate

The surface is divided into any number ( $n$ ) of parallel strips having the same widths  $d$  and whose middle ordinates are represented by  $h_1$   $h_2$   $h_3$  .....  $h_{n-1}$   $h_n$ .

## MENSURATION—Continued.

$$\text{I. Area} = d \times \sum h + \frac{d}{72} (8a + h - 9h) + \frac{d}{72} (8b + h - 9h).$$

(Francke's rule.)

$$\text{II. Area} = d \times \sum h + \frac{d}{12} (a - h) + \frac{d}{12} (b - h).$$

(Poncelet's rule.)

$$\text{III. Area} = d \times \sum h.$$

These formulae are more convenient for use than Simpson's rule and I and II give generally and III sometimes more accurate results.

$\sum$  stands for *sum of*.

## SOLID CONTENTS.

Prism, right or oblique = area of base  $\times$  perpendicular height.

Cylinder, right or oblique = area of section at right angles to sides  $\times$  length of side.

Sphere = diameter cubed  $\times$  0.5236;  
also = surface  $\times$   $\frac{1}{6}$  diameter.

Pyramid or cone, right or oblique, regular or irregular, = area of base  $\times$   $\frac{1}{3}$  perpendicular height.

## PRISMOIDAL FORMULA.

A prismoid is a solid bounded by six plane surfaces only two of which are parallel.

To find the contents of a prismoid, add together the areas of the two parallel surfaces and four times the area of a section taken midway between and parallel to them, and multiply the sum by  $\frac{1}{6}$ th of the perpendicular distance between the parallel surfaces.

WEIGHTS AND MEASURES.

AVOIRDUPOIS OR ORDINARY COMMERCIAL WEIGHT.

UNITED STATES AND BRITISH.

Gross Ton.	Cwts.	Pounds.	Ounces.
1.	20.	2240.	35840.
0.050	1.	112.	1792.
	0.0089	1.	16.
		0.0625	1.

1 pound = 27.7 cubic inches of distilled water at its maximum density (39° Fahrenheit).

LONG MEASURE.

UNITED STATES AND BRITISH.

Miles.	Rods.	Yards.	Feet.	Inches.
1.	320.	1760.	5280.	63360.
0.003125	1.	5.5	16.5	198.
0.000568	0.1818	1.	3.	36.
0.0001894	0.0606	0.3333	1.	12.
0.0000158	0.005051	0.02778	0.08333	1.

The British measures are shorter than those of the U. S. by about 1 part in 17230 or 3.677 inches in a mile.

A fathom = 6 feet. A Gunter's surveying chain = 66 feet or 4 rods, 80 chains making a mile.

SQUARE OR LAND MEASURE.

UNITED STATES AND BRITISH.

Sq. Miles.	Acres.	Sq. Rods.	Sq. Yards.	Sq. Feet.	Sq. Inches.
1.	640.	102400.	3097600.	27878400.	
	1.	160.	4840.	43560.	6272640.
		1.	30.25	272.25	39204.
		0.0331	1.	9.0	1296.
			0.111	1.	144.
				0.00694	1.



## WEIGHTS AND MEASURES—Continued.

## CUBIC OR SOLID MEASURE.

## UNITED STATES AND BRITISH.

1728 cubic inches = 1 cubic foot.

27 cubic feet = 1 cubic yard.

A cord of wood =  $4' \times 4' \times 8'$  = 128 cubic feet.

A perch of masonry =  $16.5' \times 1.5' \times 1'$  = 24.75 cubic feet, but is generally assumed at 25 cubic feet.

## DRY MEASURE.

## UNITED STATES ONLY.

Struck Bush.	Pecks.	Quarts.	Pints.	Gallons.	Cubic Inch.
1	4	32.	64	8.	2150.
	1	8.	16	2.	537.6
		1.	2	0.25	67.2
		0.5	1	0.125	33.6
		4.	8	1.	268.8

A gallon of liquid measure = 231 cubic inches.

A heaped bushel =  $1\frac{1}{4}$  struck bushels. The cone in a heaped bushel must be not less than 6 inches high.

A barrel of U. S. hydraulic cement = 300 to 310 lbs. usually and of genuine Portland cement = 425 lbs.

To reduce U. S. dry measures to British imperial of the same name divide by 1.032.

## NAUTICAL MEASURE.

A nautical or sea mile is the length of a minute of longitude of the earth at the equator at the level of the sea. It is assumed at 6086.07 feet = 1.152664 statute or land miles by the United States Coast Survey.

3 nautical miles = 1 league.

METRIC SYSTEM.

Linear Measures.			Measures of Surface.		
Denomination.	Abbr.	Value.	Denomination.	Abbr.	Value.
Myriameter .....		10000 m.	Sq. Kilometer .	km <sup>2</sup> .	1000000 m <sup>2</sup> .
Kilometer .....	km.	1000 "	Hektare .....	ha.	10000 "
Hectometer .....		100 "	Are .....	a.	100 "
Dekameter .....		10 "	{ Centare .....		1 "
Meter .....	m.	1 "	{ Sq. Meter....	m <sup>2</sup> .	1 "
Decimeter.....	dm.	.1 "	Sq. Decimeter.	dm <sup>2</sup> .	.01 "
Centimeter .....	cm.	.01 "	Sq. Centimeter.	cm <sup>2</sup> .	.0001 "
Millimeter.....	mm.	.001 "	Sq. Millimeter.	mm <sup>2</sup> .	.000001 "
Measures of Volume.			Measures of Mass.		
Denomination.	Abbr.	Value.	Denomination.	Abbr.	Value.
{ Kiloliter.....		1000 l.	{ Millier .....		1000 kg.
{ Stere .....	s.	1000 "	{ Tonneau .....		1000 "
{ Cubic Meter..	m <sup>3</sup> .	1000 "	{ Metric Ton..	t.	1000 "
Hectoliter .....	hl.	100 "	Quintal .....	q.	100 "
Dekaliter .....	dal.	10 "	Myriagram.....		10 "
{ Cu. Decimeter	dm <sup>3</sup> .	1 "	{ Kilogram....	kg.	1000 g.
{ Liter .....	l.	1 "	{ Kilo.....		1000 "
Deciliter .....	dl.	.1 "	Hectogram ...		100 "
Centiliter ...	cl.	.01 "	Dekagram .....		10 "
{ Cu. Centimeter	cm <sup>3</sup> .	.001 "	Gram .....	g.	1 "
{ Milliliter .....	ml.	.001 "	Decigram ....	dg.	.1 "
Cubic Millimeter	mm <sup>3</sup>	.000001 "	Centigram.....	cg.	.01 "
Microliter .....	λ.	.001 ml.	Milligram .....	mg.	.001 "
			Microgram ....	y.	.001 mg.

## INTERCHANGEABLE TABLES BETWEEN UNITED STATES AND METRIC SYSTEMS.

1 Meter = 39.37 inches. (Act of Congress.)

### LONG MEASURE.

No.	64ths of an inch to Millimeters.	Millimeters to 64ths of an Inch.	Inches to Centimeters.	Centimeters to Inches.
1	0.3969	2.5197	2.54	0.3937
2	0.7938	5.0394	5.08	0.7874
3	1.1906	7.5590	7.62	1.1811
4	1.5875	10.0787	10.16	1.5748
5	1.9844	12.5984	12.70	1.9685
6	2.3813	15.1181	15.24	2.3622
7	2.7781	17.6378	17.78	2.7559
8	3.1750	20.1574	20.32	3.1496
9	3.5719	22.6771	22.86	3.5433
No.	Meters to Feet.	Feet. to Meters.	Kilometers to Miles.	Miles to Kilometers.
1	3.2808	0.3048	0.62137	1.60935
2	6.5617	0.6096	1.24274	3.21869
3	9.8425	0.9144	1.86411	4.82804
4	13.1233	1.2192	2.48548	6.43739
5	16.4042	1.5240	3.10685	8.04674
6	19.6850	1.8288	3.72822	9.65608
7	22.9658	2.1336	4.34959	11.26543
8	26.2467	2.4384	4.97096	12.87478
9	29.5275	2.7432	5.59233	14.48412

INTERCHANGEABLE TABLES BETWEEN  
UNITED STATES AND METRIC SYSTEMS.

SQUARE MEASURE.

No.	Square Inches to Square Centimeters.	Square Centimeters to Square Inches.	Square Feet to Square Meters.	Square Meters to Square Feet.	Square Yards to Square Meters.	Square Meters to Square Yards.
1	6.4516	0.155	0.0929	10.7639	0.8361	1.196
2	12.9032	0.310	0.1858	21.5278	1.6722	2.392
3	19.3548	0.465	0.2787	32.2917	2.5084	3.588
4	25.8064	0.620	0.3716	43.0556	3.3445	4.784
5	32.2581	0.775	0.4645	53.8194	4.1806	5.980
6	38.7097	0.930	0.5574	64.5833	5.0167	7.176
7	45.1613	1.085	0.6503	75.3472	5.8528	8.372
8	51.6129	1.240	0.7432	86.1111	6.6890	9.568
9	58.0645	1.395	0.8361	96.8750	7.5251	10.764

No.	Acres to Hectares.	Hectares to Acres.	Square Miles to Square Kilometers.	Square Kilometers to Square Miles.	Square Miles to Hectares.	Hectares to Square Miles.
1	0.4047	2.471	2.59	0.3861	259.00	0.00386
2	0.8094	4.942	5.18	0.7722	518.00	0.00772
3	1.2141	7.413	7.77	1.1583	777.01	0.01158
4	1.6188	9.884	10.36	1.5444	1036.01	0.01544
5	2.0235	12.355	12.95	1.9305	1295.02	0.01930
6	2.4282	14.826	15.54	2.3166	1554.02	0.02317
7	2.8329	17.297	18.13	2.7027	1813.03	0.02703
8	3.2376	19.768	20.72	3.0887	2072.03	0.03089
9	3.6422	22.239	23.31	3.4748	2331.04	0.03475

INTERCHANGEABLE TABLES BETWEEN  
UNITED STATES AND METRIC SYSTEMS.

1 Kilogram—2.2046 pounds. (Act of Congress.)

WEIGHTS.

No.	Kilograms to Ounces Troy.	Troy Ounces to Grams.	Grains to Milligrams.	Grams to Grains.	Gross Tons to Metric Tons.	Metric Tons to Gross Tons.
1	32.1507	31.1035	64.8004	15.432	1.0161	0.9842
2	64.3015	62.2070	129.6008	30.864	2.0321	1.9684
3	96.4522	93.3104	194.4012	46.296	3.0482	2.9526
4	128.6030	124.4139	259.2017	61.728	4.0642	3.9368
5	160.7537	155.5174	324.0021	77.160	5.0803	4.9210
6	192.9045	186.6209	388.8025	92.592	6.0963	5.9052
7	225.0552	217.7244	453.6029	108.024	7.1124	6.8894
8	257.2059	248.8278	518.4033	123.456	8.1285	7.8736
9	289.3567	279.9313	583.2037	138.888	9.1445	8.8578
No.	Avoirdupois Ounces to Grams.	Kilograms to Ounces Avoirdupois.	Avoirdupois Pounds to Kilograms.	Kilograms to Pounds Avoirdupois.	Net Tons to Metric Tons.	Metric Tons to Net Tons.
1	28.3495	35.274	0.4536	2.2046	0.9072	1.1023
2	56.6990	70.548	0.9072	4.4092	1.8144	2.2046
3	85.0485	105.822	1.3608	6.6138	2.7216	3.3069
4	113.3980	141.096	1.8144	8.8184	3.6288	4.4092
5	141.7475	176.370	2.2680	11.0230	4.5360	5.5115
6	170.0970	211.644	2.7216	13.2276	5.4432	6.6138
7	198.4464	246.918	3.1752	15.4322	6.3504	7.7161
8	226.7959	282.192	3.6288	17.6368	7.2576	8.8184
9	255.1454	317.466	4.0824	19.8414	8.1647	9.9207

THE CARNEGIE STEEL COMPANY, LIMITED.

INTERCHANGEABLE TABLES BETWEEN UNITED STATES AND METRIC SYSTEMS.

1 Liter = 1.0567 Quarts—Liquid Measure.  
 " " " " —Dry Measure. (Act of Congress.)

LIQUID AND DRY MEASURE.

No.	Liters to Quarts.		Quarts to Liters.		Liters to Gallons. Liquid.	Gallons to Liters. Liquid.
	Liquid.	Dry.	Liquid.	Dry.		
1	1.0567	0.908	0.9463	1.1013	0.2642	3.7854
2	2.1134	1.816	1.8927	2.2026	0.5284	7.5707
3	3.1701	2.724	2.8390	3.3040	0.7925	11.3561
4	4.2268	3.632	3.7854	4.4053	1.0567	15.1415
5	5.2835	4.540	4.7317	5.5066	1.3209	18.9268
6	6.3402	5.448	5.6781	6.6079	1.5851	22.7122
7	7.3969	6.356	6.6244	7.7093	1.8492	26.4976
8	8.4536	7.264	7.5707	8.8106	2.1134	30.2830
9	9.5103	8.172	8.5171	9.9119	2.3776	34.0683

No.	Cubic Meters to Gallons. Liquid.	Gallons to Cubic Meters. Liquid.	Hectoliters to Bushels. Dry.	Bushels to Hectoliters. Dry.
1	264.17	0.0038	2.8375	0.3524
2	528.34	0.0076	5.6750	0.7048
3	792.51	0.0114	8.5125	1.0573
4	1056.68	0.0151	11.3500	1.4097
5	1320.85	0.0189	14.1875	1.7621
6	1585.02	0.0227	17.0250	2.1145
7	1849.19	0.0265	19.8625	2.4670
8	2113.36	0.0303	22.7000	2.8194
9	2377.53	0.0341	25.5375	3.1718

INTERCHANGEABLE TABLES BETWEEN  
UNITED STATES AND METRIC SYSTEMS.

CUBIC, HORSE POWER AND TON MEASURES.

No.	Cubic Centimeters to Cubic Inches.	Cubic Inches to Cubic Centimeters.	Cubic Meters to Cubic Feet.	Cubic Feet to Cubic Meters.	Cubic Meters to Cubic Yards.	Cubic Yards to Cubic Meters.
1	0.061	16.3934	35.316	0.0283	1.308	0.7645
2	0.122	32.7869	70.632	0.0566	2.616	1.5291
3	0.183	49.1803	105.948	0.0849	3.924	2.2936
4	0.244	65.5738	141.264	0.1133	5.232	3.0581
5	0.305	81.9672	176.580	0.1416	6.540	3.8226
6	0.366	98.3607	211.896	0.1699	7.848	4.5872
7	0.427	114.7541	247.212	0.1982	9.156	5.3517
8	0.488	131.1475	282.528	0.2265	10.464	6.1162
9	0.549	147.5410	317.844	0.2548	11.772	6.8807

No.	Horsepower Metric to U. S.	Horsepower U. S. to Metric.	Foot-Pounds to Kilogram-meters.	Kilogram-meters to Foot-Pounds.	Gross Tons per Sq. Foot to Metric Tons per Sq. Meter.	Metric Tons per Sq. Meter to Gross Tons per Sq. Foot.
1	0.986	1.014	0.1383	7.2329	10.937	0.091
2	1.973	2.028	0.2765	14.4659	21.873	0.183
3	2.959	3.042	0.4148	21.6988	32.810	0.274
4	3.945	4.056	0.5530	28.9317	43.747	0.366
5	4.932	5.069	0.6913	36.1646	54.684	0.457
6	5.918	6.083	0.8295	43.3976	65.620	0.549
7	6.904	7.097	0.9678	50.6305	76.557	0.640
8	7.890	8.111	1.1061	57.8634	87.494	0.731
9	8.877	9.125	1.2443	65.0963	98.431	0.823

INTERCHANGEABLE TABLES BETWEEN  
UNITED STATES AND METRIC SYSTEMS.

## MISCELLANEOUS.

No.	Kilo. per Meter to Pounds per foot.	Pounds per foot to Kilo. per Meter.	Kilo. per Square Meter to Pounds per Square Foot.	Pounds per Square Foot to Kilo. per Square Meter.
1	0.6720	1.4882	0.2048	4.8825
2	1.3439	2.9764	0.4096	9.7649
3	2.0159	4.4645	0.6144	14.6474
4	2.6879	5.9527	0.8193	19.5299
5	3.3598	7.4409	1.0241	24.4123
6	4.0318	8.9291	1.2289	29.2948
7	4.7037	10.4172	1.4337	34.1773
8	5.3757	11.9054	1.6385	39.0597
9	6.0477	13.3936	1.8433	43.9422

No.	Kilo. per Cubic Meter to Pounds per Cubic Foot.	Pounds per Cubic Foot to Kilo. per Cubic Meter.	Kilo. per Square Centimeter to Pounds per Square Inch.	Pounds per Square Inch to Kilo. per Square Centimeter.
1	0.0624	16.0192	14.2232	0.0703
2	0.1248	32.0385	28.4465	0.1406
3	0.1873	48.0577	42.6697	0.2109
4	0.2497	64.0769	56.8929	0.2812
5	0.3121	80.0962	71.1161	0.3515
6	0.3745	96.1154	85.3394	0.4218
7	0.4370	112.1346	99.5626	0.4922
8	0.4994	128.1539	113.7858	0.5625
9	0.5618	144.1731	128.0090	0.6328



THE CARNEGIE STEEL COMPANY, LIMITED.

SQUARES, CUBES, SQUARE ROOTS, CUBE ROOTS, LOGARITHMS,  
RECIPROCAL, CIRCUMFERENCES AND CIRCULAR  
AREAS OF NOS. FROM 1 TO 1000.

No.	Square.	Cubs.	Sq. Root.	Cube Root.	Log.	1000xRecip.	No. - Dia.	
							Circum.	Area.
1	1	1	1.0000	1.0000	0.00000	1000.000	3.142	0.7854
2	4	8	1.4142	1.2599	0.30103	500.000	6.283	3.1416
3	9	27	1.7321	1.4422	0.47712	333.333	9.425	7.0686
4	16	64	2.0000	1.5874	0.60206	250.000	12.566	12.5664
5	25	125	2.2361	1.7100	0.69897	200.000	15.708	19.6350
6	36	216	2.4495	1.8171	0.77815	166.667	18.850	28.2743
7	49	343	2.6458	1.9129	0.84510	142.857	21.991	38.4845
8	64	512	2.8284	2.0000	0.90309	125.000	25.133	50.2655
9	81	729	3.0000	2.0801	0.95424	111.111	28.274	63.6173
10	100	1000	3.1623	2.1544	1.00000	100.000	31.416	78.5398
11	121	1331	3.3166	2.2240	1.04139	90.9091	34.558	95.0332
12	144	1728	3.4641	2.2894	1.07918	83.3333	37.699	113.097
13	169	2197	3.6056	2.3513	1.11394	76.9231	40.841	132.732
14	196	2744	3.7417	2.4101	1.14613	71.4286	43.982	153.938
15	225	3375	3.8730	2.4662	1.17609	66.6667	47.124	176.715
16	256	4096	4.0000	2.5198	1.20412	62.5000	50.265	201.062
17	289	4913	4.1231	2.5713	1.23045	58.8235	53.407	226.980
18	324	5832	4.2426	2.6207	1.25527	55.5556	56.549	254.469
19	361	6859	4.3589	2.6684	1.27875	52.6316	59.690	283.529
20	400	8000	4.4721	2.7144	1.30103	50.0000	62.832	314.150
21	441	9261	4.5826	2.7589	1.32222	47.6190	65.973	346.361
22	484	10648	4.6904	2.8020	1.34242	45.4545	69.115	380.133
23	529	12167	4.7958	2.8439	1.36173	43.4783	72.257	415.476
24	576	13824	4.8990	2.8845	1.38021	41.6667	75.398	452.389
25	625	15625	5.0000	2.9240	1.39794	40.0000	78.540	490.874
26	676	17576	5.0990	2.9625	1.41497	38.4615	81.681	530.929
27	729	19683	5.1962	3.0000	1.43136	37.0370	84.823	572.555
28	784	21952	5.2915	3.0366	1.44716	35.7143	87.965	615.752
29	841	24389	5.3852	3.0723	1.46240	34.4828	91.106	660.520
30	900	27000	5.4772	3.1072	1.47712	33.3333	94.248	706.858
31	961	29791	5.5678	3.1414	1.49136	32.2581	97.389	754.768
32	1024	32768	5.6569	3.1748	1.50515	31.2500	100.531	804.248
33	1089	35937	5.7446	3.2075	1.51851	30.3030	103.673	855.299
34	1156	39304	5.8310	3.2396	1.53148	29.4118	106.814	907.920
35	1225	42875	5.9161	3.2711	1.54407	28.5714	109.956	962.113
36	1296	46656	6.0000	3.3019	1.55630	27.7778	113.097	1017.88
37	1369	50653	6.0828	3.3322	1.56820	27.0270	116.239	1075.21
38	1444	54872	6.1644	3.3620	1.57978	26.3158	119.381	1134.11
39	1521	59319	6.2450	3.3912	1.59106	25.6410	122.522	1194.59
40	1600	64000	6.3246	3.4200	1.60206	25.0000	125.66	1256.64
41	1681	68921	6.4031	3.4482	1.61278	24.3902	128.81	1320.25
42	1764	74088	6.4807	3.4760	1.62325	23.8095	131.95	1385.44
43	1849	79507	6.5574	3.5034	1.63347	23.2558	135.09	1452.20
44	1936	85184	6.6332	3.5303	1.64345	22.7273	138.23	1520.53
45	2025	91125	6.7082	3.5569	1.65321	22.2222	141.37	1590.43
46	2116	97336	6.7823	3.5830	1.66276	21.7391	144.51	1661.90
47	2209	103823	6.8557	3.6088	1.67210	21.2766	147.65	1734.94
48	2304	110592	6.9282	3.6342	1.68124	20.8333	150.80	1809.56
49	2401	117649	7.0000	3.6593	1.69020	20.4082	153.94	1885.74

THE CARNEGIE STEEL COMPANY, LIMITED.

SQUARES, CUBES, SQUARE ROOTS, CUBE ROOTS, LOGARITHMS,  
 RECIPROCAL, CIRCUMFERENCES AND CIRCULAR  
 AREAS OF NOS. FROM 1 TO 1000.

No.	Square.	Cube.	Sq. Root.	Cube Root.	Log.	1000xRecip.	No. - Dia.	
							Circum.	Area.
50	2500	125000	7.0711	3.6840	1.69897	20.0000	157.08	1963.50
51	2601	132651	7.1414	3.7084	1.70757	19.6078	160.22	2042.82
52	2704	140608	7.2111	3.7325	1.71600	19.2308	163.36	2123.72
53	2809	148877	7.2801	3.7563	1.72428	18.8679	166.50	2206.18
54	2916	157464	7.3485	3.7798	1.73239	18.5185	169.65	2290.22
55	3025	166375	7.4162	3.8030	1.74036	18.1818	172.79	2375.83
56	3136	175616	7.4833	3.8259	1.74819	17.8571	175.93	2463.01
57	3249	185193	7.5498	3.8485	1.75587	17.5439	179.07	2551.76
58	3364	195112	7.6158	3.8709	1.76343	17.2414	182.21	2642.08
59	3481	205379	7.6811	3.8930	1.77085	16.9492	185.35	2733.97
60	3600	216000	7.7460	3.9149	1.77815	16.6667	188.50	2827.43
61	3721	226981	7.8102	3.9365	1.78533	16.3934	191.64	2922.47
62	3844	238328	7.8740	3.9579	1.79239	16.1290	194.78	3019.07
63	3969	250047	7.9373	3.9791	1.79934	15.8730	197.92	3117.25
64	4096	262144	8.0000	4.0000	1.80618	15.6250	201.06	3216.99
65	4225	274625	8.0623	4.0207	1.81291	15.3846	204.20	3318.31
66	4356	287496	8.1240	4.0412	1.81954	15.1515	207.35	3421.19
67	4489	300793	8.1854	4.0615	1.82607	14.9254	210.49	3525.65
68	4624	314432	8.2462	4.0817	1.83251	14.7059	213.63	3631.68
69	4761	328509	8.3066	4.1016	1.83885	14.4928	216.77	3739.28
70	4900	343000	8.3666	4.1213	1.84510	14.2857	219.91	3848.45
71	5041	357911	8.4261	4.1408	1.85126	14.0845	223.05	3959.19
72	5184	373248	8.4853	4.1602	1.85733	13.8880	226.19	4071.50
73	5329	389017	8.5440	4.1793	1.86332	13.6966	229.34	4185.39
74	5476	405224	8.6023	4.1983	1.86923	13.5135	232.48	4300.84
75	5625	421875	8.6603	4.2172	1.87506	13.3333	235.62	4417.86
76	5776	438976	8.7178	4.2358	1.88081	13.1579	238.76	4536.46
77	5929	456533	8.7750	4.2543	1.88649	12.9870	241.90	4656.63
78	6084	474552	8.8318	4.2727	1.89209	12.8205	245.04	4778.36
79	6241	493039	8.8882	4.2908	1.89763	12.6582	248.19	4901.67
80	6400	512000	8.9443	4.3089	1.90309	12.5000	251.33	5026.55
81	6561	531441	9.0000	4.3267	1.90849	12.3457	254.47	5153.00
82	6724	551368	9.0554	4.3445	1.91381	12.1951	257.61	5281.02
83	6889	571787	9.1104	4.3621	1.91908	12.0482	260.75	5410.61
84	7056	592704	9.1652	4.3795	1.92428	11.9048	263.89	5541.77
85	7225	614125	9.2195	4.3968	1.92942	11.7647	267.04	5674.50
86	7396	636056	9.2736	4.4140	1.93450	11.6279	270.18	5808.80
87	7569	658503	9.3274	4.4310	1.93952	11.4943	273.32	5944.68
88	7744	681472	9.3808	4.4480	1.94448	11.3636	276.46	6082.12
89	7921	704969	9.4340	4.4647	1.94939	11.2360	279.60	6221.14
90	8100	729000	9.4868	4.4814	1.95424	11.1111	282.74	6361.73
91	8281	753571	9.5394	4.4979	1.95904	10.9890	285.88	6503.88
92	8464	778688	9.5917	4.5144	1.96379	10.8696	289.03	6647.61
93	8649	804357	9.6437	4.5307	1.96848	10.7527	292.17	6792.91
94	8836	830584	9.6954	4.5468	1.97313	10.6383	295.31	6939.78
95	9025	857375	9.7468	4.5629	1.97772	10.5263	298.45	7088.22
96	9216	884736	9.7980	4.5789	1.98227	10.4167	301.59	7238.23
97	9409	912673	9.8489	4.5947	1.98677	10.3093	304.73	7389.81
98	9604	941192	9.8995	4.6104	1.99123	10.2041	307.88	7542.96
99	9801	970299	9.9499	4.6261	1.99564	10.1010	311.02	7697.69

□  
 ✓  
 IND

THE CARNEGIE STEEL COMPANY, LIMITED.

SQUARES, CUBES, SQUARE ROOTS, CUBE ROOTS, LOGARITHMS,  
 RECIPROCAL, CIRCUMFERENCES AND CIRCULAR  
 AREAS OF NOS. FROM 1 TO 1000.

No.	Square.	Cube.	Sq. Root.	Cube Root.	Log.	1000xRecip.	No. = Dia.	
							Circum.	Area.
100	10000	1000000	10.0000	4.6416	2.00000	10.0000	314.16	7853.98
101	10201	1030301	10.0499	4.6570	2.00432	9.90090	317.30	8011.85
102	10404	1061208	10.0995	4.6723	2.00860	9.80392	320.44	8171.28
103	10609	1092727	10.1489	4.6875	2.01284	9.70874	323.58	8332.29
104	10816	1124864	10.1980	4.7027	2.01708	9.61538	326.73	8494.87
105	11025	1157625	10.2470	4.7177	2.02119	9.52381	329.87	8659.01
106	11236	1191016	10.2956	4.7326	2.02531	9.43396	333.01	8824.73
107	11449	1225043	10.3441	4.7475	2.02938	9.34579	336.15	8992.02
108	11664	1259712	10.3923	4.7622	2.03342	9.25926	339.29	9160.88
109	11881	1295029	10.4403	4.7769	2.03743	9.17431	342.43	9331.32
110	12100	1331000	10.4881	4.7914	2.04139	9.09091	345.58	9503.32
111	12321	1367631	10.5357	4.8059	2.04532	9.00901	348.72	9676.89
112	12544	1404928	10.5830	4.8203	2.04922	8.92857	351.86	9852.03
113	12769	1442897	10.6301	4.8346	2.05308	8.84956	355.00	10028.7
114	12996	1481544	10.6771	4.8488	2.05690	8.77193	358.14	10207.0
115	13225	1520875	10.7238	4.8629	2.06070	8.69565	361.28	10386.9
116	13456	1560896	10.7703	4.8770	2.06446	8.62060	364.42	10568.3
117	13689	1601613	10.8167	4.8910	2.06819	8.54701	367.57	10751.3
118	13924	1643032	10.8628	4.9049	2.07188	8.47458	370.71	10935.9
119	14161	1685159	10.9087	4.9187	2.07555	8.40336	373.85	11122.0
120	14400	1728000	10.9545	4.9324	2.07918	8.33333	376.99	11309.7
121	14641	1771561	11.0000	4.9461	2.08279	8.26446	380.13	11499.0
122	14884	1815848	11.0454	4.9597	2.08636	8.19672	383.27	11689.9
123	15129	1860867	11.0905	4.9732	2.08991	8.13008	386.42	11882.3
124	15376	1906624	11.1355	4.9866	2.09342	8.06452	389.56	12076.3
125	15625	1953125	11.1803	5.0000	2.09691	8.00000	392.70	12271.8
126	15876	2000376	11.2250	5.0133	2.10037	7.93651	395.84	12469.0
127	16129	2048383	11.2694	5.0265	2.10380	7.87402	398.98	12667.7
128	16384	2097152	11.3137	5.0397	2.10721	7.81250	402.12	12868.0
129	16641	2146689	11.3578	5.0528	2.11059	7.75194	405.27	13069.8
130	16900	2197000	11.4018	5.0658	2.11394	7.69231	408.41	13273.2
131	17161	2248091	11.4455	5.0788	2.11727	7.63359	411.55	13478.2
132	17424	2299968	11.4891	5.0916	2.12057	7.57576	414.69	13684.8
133	17689	2352637	11.5326	5.1045	2.12385	7.51880	417.83	13892.9
134	17956	2406104	11.5758	5.1172	2.12710	7.46269	420.97	14102.6
135	18225	2460375	11.6190	5.1299	2.13033	7.40741	424.12	14313.9
136	18496	2515456	11.6619	5.1426	2.13354	7.35294	427.26	14526.7
137	18769	2571353	11.7047	5.1551	2.13672	7.29927	430.40	14741.1
138	19044	2628072	11.7473	5.1676	2.13988	7.24638	433.54	14957.1
139	19321	2685619	11.7898	5.1801	2.14301	7.19424	436.68	15174.7
140	19600	2744000	11.8322	5.1925	2.14613	7.14286	439.82	15393.8
141	19881	2803221	11.8743	5.2048	2.14922	7.09220	442.96	15614.5
142	20164	2863288	11.9164	5.2171	2.15229	7.04225	446.11	15836.8
143	20449	2924207	11.9583	5.2293	2.15534	6.99301	449.25	16060.6
144	20736	2985984	12.0000	5.2415	2.15836	6.94444	452.39	16286.0
145	21025	3048625	12.0416	5.2536	2.16137	6.89655	455.53	16513.0
146	21316	3112136	12.0830	5.2656	2.16435	6.84932	458.67	16741.5
147	21609	3176523	12.1244	5.2776	2.16732	6.80272	461.81	16971.7
148	21904	3241792	12.1655	5.2896	2.17026	6.75676	464.96	17203.4
149	22201	3307949	12.2066	5.3015	2.17319	6.71141	468.10	17436.6

THE CARNEGIE STEEL COMPANY, LIMITED.

SQUARES, CUBES, SQUARE ROOTS, CUBE ROOTS, LOGARITHMS,  
 RECIPROCAL, CIRCUMFERENCES AND CIRCULAR  
 AREAS OF NOS. FROM 1 TO 1000.

No.	Square.	Cube.	Sq. Root.	Cube Root.	Log.	1000xRecip.	No.-Dia.	
							Circum.	Area.
150	22500	3375000	12.2474	5.3133	2.17609	6.00067	471.24	17671.5
151	22801	3442051	12.2882	5.3251	2.17898	6.02252	474.38	17907.9
152	23104	3511808	12.3288	5.3368	2.18184	6.057895	477.52	18145.8
153	23409	3581577	12.3693	5.3485	2.18469	6.09595	480.66	18385.4
154	23716	3652264	12.4097	5.3601	2.18752	6.140351	483.81	18626.5
155	24025	3723875	12.4499	5.3717	2.19033	6.45161	486.95	18869.2
156	24336	3796416	12.4900	5.3832	2.19312	6.41026	490.09	19113.4
157	24649	3869893	12.5300	5.3947	2.19590	6.36943	493.23	19359.3
158	24964	3944312	12.5698	5.4061	2.19866	6.32911	496.37	19606.7
159	25281	4019679	12.6095	5.4175	2.20140	6.28931	499.51	19855.7
160	25600	4096000	12.6491	5.4288	2.20412	6.25000	502.65	20106.2
161	25921	4173281	12.6886	5.4401	2.20683	6.21118	505.80	20358.3
162	26244	4251528	12.7279	5.4514	2.20952	6.17284	508.94	20612.0
163	26569	4330747	12.7671	5.4626	2.21219	6.13497	512.08	20867.2
164	26896	4410944	12.8062	5.4737	2.21484	6.09756	515.22	21124.1
165	27225	4492125	12.8452	5.4848	2.21748	6.06061	518.36	21382.5
166	27556	4574296	12.8841	5.4959	2.22011	6.02410	521.50	21642.4
167	27889	4657463	12.9228	5.5069	2.22272	5.98802	524.65	21904.0
168	28224	4741632	12.9615	5.5178	2.22531	5.95238	527.79	22167.1
169	28561	4826809	13.0000	5.5288	2.22789	5.91716	530.93	22431.8
170	28900	4913000	13.0384	5.5397	2.23045	5.88235	534.07	22698.0
171	29241	5000211	13.0767	5.5505	2.23300	5.84795	537.21	22965.8
172	29584	5088448	13.1149	5.5613	2.23553	5.81395	540.35	23235.2
173	29929	5177717	13.1529	5.5721	2.23805	5.78035	543.50	23506.2
174	30276	5268024	13.1909	5.5828	2.24055	5.74713	546.64	23778.7
175	30625	5359375	13.2288	5.5934	2.24304	5.71429	549.78	24052.8
176	30976	5451776	13.2666	5.6041	2.24551	5.68182	552.92	24328.5
177	31329	5545233	13.3041	5.6147	2.24797	5.64972	556.06	24605.7
178	31684	5639752	13.3417	5.6252	2.25042	5.61798	559.20	24884.6
179	32041	5735339	13.3791	5.6357	2.25285	5.58659	562.35	25164.9
180	32400	5832000	13.4164	5.6462	2.25527	5.55556	565.49	25446.9
181	32761	5929741	13.4536	5.6567	2.25768	5.52486	568.63	25730.4
182	33124	6028568	13.4907	5.6671	2.26007	5.49451	571.77	26015.5
183	33489	6128487	13.5277	5.6774	2.26245	5.46448	574.91	26302.2
184	33856	6229504	13.5647	5.6877	2.26482	5.43478	578.05	26590.4
185	34225	6331625	13.6015	5.6980	2.26717	5.40541	581.19	26880.3
186	34596	6434856	13.6382	5.7083	2.26951	5.37634	584.34	27171.6
187	34969	6539203	13.6748	5.7185	2.27184	5.34759	587.48	27464.6
188	35344	6644672	13.7113	5.7287	2.27416	5.31915	590.62	27759.1
189	35721	6751269	13.7477	5.7388	2.27646	5.29101	593.76	28055.2
190	36100	6859000	13.7840	5.7489	2.27875	5.26316	596.90	28352.9
191	36481	6967871	13.8203	5.7590	2.28103	5.23560	600.04	28652.1
192	36864	7077888	13.8564	5.7690	2.28330	5.20833	603.19	28952.9
193	37249	7189057	13.8924	5.7790	2.28556	5.18135	606.33	29255.3
194	37636	7301384	13.9284	5.7890	2.28780	5.15464	609.47	29559.2
195	38025	7414875	13.9642	5.7989	2.29003	5.12821	612.61	29864.8
196	38416	7529536	14.0000	5.8088	2.29226	5.10204	615.75	30171.9
197	38809	7645373	14.0357	5.8186	2.29447	5.07614	618.89	30480.5
198	39204	7762392	14.0712	5.8285	2.29667	5.05051	622.04	30790.7
199	39601	7880599	14.1067	5.8383	2.29885	5.02513	625.18	31102.6

IND

THE CARNEGIE STEEL COMPANY, LIMITED.

SQUARES, CUBES, SQUARE ROOTS, CUBE ROOTS, LOGARITHMS,  
RECIPROCAL, CIRCUMFERENCES AND CIRCULAR  
AREAS OF NOS. FROM 1 TO 1000.

No.	Square.	Cube.	Sq. Root.	Cube Root.	Log.	1000xRecip.	No. = Dia.	
							Circum.	Area.
200	40000	8000000	14.1421	5.8480	2.30103	5.00000	628.32	31415.9
201	40401	8120601	14.1774	5.8578	2.30320	4.97512	631.46	31730.9
202	40804	8242408	14.2127	5.8675	2.30535	4.95050	634.60	32047.4
203	41209	8365427	14.2478	5.8771	2.30750	4.92611	637.74	32365.5
204	41616	8489664	14.2829	5.8868	2.30963	4.90196	640.89	32685.1
205	42025	8615125	14.3178	5.8964	2.31175	4.87805	644.03	33006.4
206	42436	8741816	14.3527	5.9059	2.31387	4.85437	647.17	33329.2
207	42849	8869743	14.3875	5.9155	2.31597	4.83092	650.31	33653.5
208	43264	8998912	14.4222	5.9250	2.31806	4.80769	653.45	33979.5
209	43681	9129329	14.4568	5.9345	2.32015	4.78469	656.59	34307.0
210	44100	9261000	14.4914	5.9439	2.32222	4.76190	659.73	34636.1
211	44521	9393931	14.5258	5.9533	2.32428	4.73934	662.88	34966.7
212	44944	9528128	14.5602	5.9627	2.32634	4.71698	666.02	35298.9
213	45369	9663597	14.5945	5.9721	2.32838	4.69484	669.16	35632.7
214	45796	9800344	14.6287	5.9814	2.33041	4.67290	672.30	35968.1
215	46225	9938375	14.6629	5.9907	2.33244	4.65116	675.44	36305.0
216	46656	10077696	14.6969	6.0000	2.33445	4.62963	678.58	36643.5
217	47089	10218313	14.7309	6.0092	2.33646	4.60829	681.73	36983.6
218	47524	10360232	14.7648	6.0185	2.33846	4.58716	684.87	37325.3
219	47961	10503459	14.7986	6.0277	2.34044	4.56621	688.01	37668.5
220	48400	10648000	14.8324	6.0368	2.34242	4.54545	691.15	38013.3
221	48841	10793861	14.8661	6.0459	2.34439	4.52489	694.29	38359.6
222	49284	10941048	14.8997	6.0550	2.34635	4.50450	697.43	38707.6
223	49729	11089567	14.9332	6.0641	2.34830	4.48431	700.58	39057.1
224	50176	11239424	14.9666	6.0732	2.35025	4.46429	703.72	39408.1
225	50625	11390625	15.0000	6.0822	2.35218	4.44444	706.86	39760.8
226	51076	11543176	15.0333	6.0912	2.35411	4.42478	710.00	40115.0
227	51529	11697083	15.0665	6.1002	2.35603	4.40529	713.14	40470.8
228	51984	11852352	15.0997	6.1091	2.35793	4.38596	716.28	40828.1
229	52441	12008989	15.1327	6.1180	2.35984	4.36681	719.42	41187.1
230	52900	12167000	15.1658	6.1269	2.36173	4.34783	722.57	41547.6
231	53361	12326391	15.1987	6.1358	2.36361	4.32900	725.71	41909.6
232	53824	12487168	15.2315	6.1446	2.36549	4.31034	728.85	42273.3
233	54289	12649337	15.2643	6.1534	2.36736	4.29185	731.99	42638.5
234	54756	12812904	15.2971	6.1622	2.36922	4.27350	735.13	43005.3
235	55225	12977875	15.3297	6.1710	2.37107	4.25532	738.27	43373.6
236	55696	13144256	15.3623	6.1797	2.37291	4.23729	741.42	43743.5
237	56169	13312053	15.3948	6.1885	2.37475	4.21941	744.56	44115.0
238	56644	13481272	15.4272	6.1972	2.37658	4.20168	747.70	44488.1
239	57121	13651919	15.4596	6.2058	2.37840	4.18410	750.84	44862.7
240	57600	13824000	15.4919	6.2145	2.38021	4.16667	753.98	45238.9
241	58081	13997521	15.5242	6.2231	2.38202	4.14938	757.12	45616.7
242	58564	14172488	15.5563	6.2317	2.38382	4.13223	760.27	45996.1
243	59049	14348907	15.5885	6.2403	2.38561	4.11523	763.41	46377.0
244	59536	14526784	15.6205	6.2488	2.38739	4.09836	766.55	46759.5
245	60025	14706125	15.6525	6.2573	2.38917	4.08163	769.69	47143.5
246	60516	14886936	15.6844	6.2658	2.39094	4.06504	772.83	47529.2
247	61009	15069223	15.7162	6.2743	2.39270	4.04858	775.97	47916.4
248	61504	15253092	15.7480	6.2828	2.39445	4.03226	779.12	48305.1
249	62001	15438549	15.7797	6.2912	2.39620	4.01606	782.26	48695.5

THE CARNEGIE STEEL COMPANY, LIMITED.

SQUARES, CUBES, SQUARE ROOTS, CUBE ROOTS, LOGARITHMS, RECIPROCAL, CIRCUMFERENCES AND CIRCULAR AREAS OF NOS. FROM 1 TO 1000.

No.	Square.	Cube.	Sq. Root.	Cube Root.	Log.	1000xRecip.	No. = Dia.	
							Circum.	Area.
250	62500	15625000	15.8114	6.2906	2.39794	4.00000	785.40	49087.4
251	63001	15813251	15.8430	6.3080	2.39967	3.98406	788.54	49480.9
252	63504	16003008	15.8745	6.3164	2.40140	3.96825	791.68	49875.9
253	64009	16194277	15.9060	6.3247	2.40312	3.95257	794.82	50272.6
254	64516	16387064	15.9374	6.3330	2.40483	3.93701	797.96	50670.7
255	65025	16581375	15.9687	6.3413	2.40654	3.92157	801.11	51070.5
256	65536	16777216	16.0000	6.3496	2.40824	3.90625	804.25	51471.9
257	66049	16974593	16.0312	6.3579	2.40993	3.89105	807.39	51874.8
258	66564	17173512	16.0624	6.3661	2.41162	3.87597	810.53	52279.2
259	67081	17373979	16.0935	6.3743	2.41330	3.86100	813.67	52685.3
260	67600	17576000	16.1245	6.3825	2.41497	3.84615	816.81	53092.9
261	68121	17779581	16.1555	6.3907	2.41664	3.83142	819.96	53502.1
262	68644	17984728	16.1864	6.3988	2.41830	3.81679	823.10	53912.9
263	69169	18191447	16.2173	6.4070	2.41996	3.80228	826.24	54325.2
264	69696	18399744	16.2481	6.4151	2.42160	3.78788	829.38	54739.1
265	70225	18609625	16.2788	6.4232	2.42325	3.77358	832.52	55154.6
266	70756	18821096	16.3095	6.4312	2.42488	3.75940	835.66	55571.6
267	71289	19034163	16.3401	6.4393	2.42651	3.74532	838.81	55990.3
268	71824	19248832	16.3707	6.4473	2.42813	3.73134	841.95	56410.4
269	72361	19465109	16.4012	6.4553	2.42975	3.71747	845.09	56832.2
270	72900	19683000	16.4317	6.4633	2.43136	3.70370	848.23	57255.5
271	73441	19902511	16.4621	6.4713	2.43297	3.69004	851.37	57680.4
272	73984	20123648	16.4924	6.4792	2.43457	3.67647	854.51	58106.9
273	74529	20346417	16.5227	6.4872	2.43616	3.66300	857.66	58534.9
274	75076	20570824	16.5529	6.4951	2.43775	3.64964	860.80	58964.6
275	75625	20796875	16.5831	6.5030	2.43933	3.63636	863.94	59395.7
276	76176	21024576	16.6132	6.5108	2.44091	3.62319	867.08	59828.5
277	76729	21253933	16.6433	6.5187	2.44248	3.61011	870.22	60262.8
278	77284	21484952	16.6733	6.5265	2.44404	3.59712	873.36	60698.7
279	77841	21717639	16.7033	6.5343	2.44560	3.58423	876.50	61136.2
280	78400	21952000	16.7332	6.5421	2.44716	3.57143	879.65	61575.2
281	78961	22188041	16.7631	6.5499	2.44871	3.55872	882.79	62015.8
282	79524	22425768	16.7929	6.5577	2.45025	3.54610	885.93	62458.0
283	80089	22665187	16.8226	6.5654	2.45179	3.53357	889.07	62901.8
284	80656	22906304	16.8523	6.5731	2.45332	3.52113	892.21	63347.1
285	81225	23149125	16.8819	6.5808	2.45484	3.50877	895.35	63794.0
286	81796	23393656	16.9115	6.5885	2.45637	3.49650	898.50	64242.4
287	82369	23639903	16.9411	6.5962	2.45788	3.48432	901.64	64692.5
288	82944	23887872	16.9706	6.6039	2.45939	3.47222	904.78	65144.1
289	83521	24137569	17.0000	6.6115	2.46090	3.46021	907.92	65597.2
290	84100	24389000	17.0294	6.6191	2.46240	3.44828	911.06	66052.0
291	84681	24642171	17.0587	6.6267	2.46389	3.43643	914.20	66508.3
292	85264	24897088	17.0880	6.6343	2.46538	3.42466	917.35	66966.2
293	85849	25153757	17.1172	6.6419	2.46687	3.41297	920.49	67425.6
294	86436	25412184	17.1464	6.6494	2.46835	3.40136	923.63	67886.7
295	87025	25672375	17.1756	6.6569	2.46982	3.38983	926.77	68349.3
296	87616	25934336	17.2047	6.6644	2.47129	3.37838	929.91	68813.5
297	88209	26198073	17.2337	6.6719	2.47276	3.36700	933.05	69279.2
298	88804	26463592	17.2627	6.6794	2.47422	3.35570	936.19	69746.5
299	89401	26730899	17.2916	6.6869	2.47567	3.34448	939.34	70215.4

THE CARNEGIE STEEL COMPANY, LIMITED.

SQUARES, CUBES, SQUARE ROOTS, CUBE ROOTS, LOGARITHMS,  
RECIPROCAL, CIRCUMFERENCES AND CIRCULAR  
AREAS OF NOS. FROM 1 TO 1000.

No.	Square.	Cube.	Sq. Root.	Cube Root.	Log.	1000xRecip.	No.-Dia.	
							Circum.	Area.
300	90000	27000000	17.3205	6.6943	2.47712	3.33333	942.48	70685.8
301	90001	27270901	17.3494	6.7018	2.47857	3.32226	945.62	71157.9
302	91204	27543008	17.3781	6.7092	2.48001	3.31126	948.76	71631.5
303	91809	27818127	17.4069	6.7166	2.48144	3.30033	951.90	7213.6
304	92416	28094464	17.4356	6.7240	2.48287	3.28947	955.04	72583.4
305	93025	28372025	17.4642	6.7313	2.48430	3.27860	958.19	73061.7
306	93636	28652616	17.4929	6.7387	2.48572	3.26779	961.33	73541.5
307	94249	28935443	17.5214	6.7460	2.48714	3.25733	964.47	74023.0
308	94864	29218112	17.5499	6.7533	2.48855	3.24675	967.61	74506.0
309	95481	29503629	17.5784	6.7606	2.48996	3.23625	970.75	74990.6
310	96100	29791000	17.6068	6.7679	2.49136	3.22581	973.89	75476.8
311	96721	30080231	17.6352	6.7752	2.49276	3.21543	977.04	75964.5
312	97344	30371328	17.6635	6.7824	2.49415	3.20513	980.18	76453.8
313	97969	30664297	17.6918	6.7897	2.49554	3.19489	983.32	76944.7
314	98596	30959144	17.7200	6.7969	2.49693	3.18471	986.46	77437.1
315	99225	31255875	17.7482	6.8041	2.49831	3.17460	989.60	77931.1
316	99856	31554496	17.7764	6.8113	2.49969	3.16456	992.74	78426.7
317	100489	31855013	17.8045	6.8185	2.50106	3.15457	995.88	78923.9
318	101124	32157432	17.8326	6.8256	2.50243	3.14465	999.03	79422.6
319	101761	32461759	17.8606	6.8328	2.50379	3.13480	1002.2	79922.9
320	102400	32768000	17.8885	6.8399	2.50515	3.12500	1005.3	80424.8
321	103041	33076161	17.9165	6.8470	2.50651	3.11527	1008.5	80928.2
322	103684	33386248	17.9444	6.8541	2.50786	3.10559	1011.6	81433.2
323	104329	33698267	17.9722	6.8612	2.50920	3.09598	1014.7	81939.8
324	104976	34012224	18.0000	6.8683	2.51055	3.08642	1017.9	82448.0
325	105625	34328125	18.0278	6.8753	2.51188	3.07692	1021.0	82957.7
326	106276	34645976	18.0555	6.8824	2.51322	3.06749	1024.2	83469.0
327	106929	34965783	18.0831	6.8894	2.51455	3.05810	1027.3	83981.8
328	107584	35287552	18.1108	6.8964	2.51587	3.04878	1030.4	84496.3
329	108241	35611289	18.1384	6.9034	2.51720	3.03951	1033.6	85012.3
330	108900	35937000	18.1659	6.9104	2.51851	3.03030	1036.7	85529.9
331	109561	36264691	18.1934	6.9174	2.51983	3.02115	1039.9	86049.0
332	110224	36594368	18.2209	6.9244	2.52114	3.01205	1043.0	86569.7
333	110889	36926037	18.2483	6.9313	2.52244	3.00300	1046.2	87092.0
334	111556	37259704	18.2757	6.9382	2.52375	2.99401	1049.3	87615.9
335	112225	37595375	18.3030	6.9451	2.52504	2.98507	1052.4	88141.3
336	112896	37933056	18.3303	6.9521	2.52634	2.97619	1055.6	88668.3
337	113569	38272753	18.3576	6.9590	2.52763	2.96736	1058.7	89196.9
338	114244	38614472	18.3848	6.9658	2.52892	2.95858	1061.9	89727.0
339	114921	38958219	18.4120	6.9727	2.53020	2.94985	1065.0	90258.7
340	115600	39304000	18.4391	6.9795	2.53148	2.94118	1068.1	90792.0
341	116281	39651821	18.4662	6.9864	2.53275	2.93255	1071.3	91326.9
342	116964	40001688	18.4932	6.9932	2.53403	2.92398	1074.4	91863.3
343	117649	40353607	18.5203	7.0000	2.53529	2.91545	1077.6	92401.3
344	118336	40707584	18.5472	7.0068	2.53656	2.90698	1080.7	92940.9
345	119025	41063625	18.5742	7.0136	2.53782	2.89855	1083.8	93482.0
346	119716	41421736	18.6011	7.0203	2.53908	2.89017	1087.0	94024.7
347	120409	41781923	18.6279	7.0271	2.54033	2.88184	1090.1	94569.0
348	121104	42144192	18.6548	7.0338	2.54158	2.87356	1093.3	95114.9
349	121801	42508549	18.6815	7.0406	2.54283	2.86533	1096.4	95662.3

THE CARNEGIE STEEL COMPANY, LIMITED.

SQUARES, CUBES, SQUARE ROOTS, CUBE ROOTS, LOGARITHMS, RECIPROCAL, CIRCUMFERENCES AND CIRCULAR AREAS OF NOS. FROM 1 TO 1000.

No.	Square.	Cube.	Sq. Root.	Cube Root.	Log.	1000xRecip.	No. = Dia.	
							Circum.	Area.
350	122500	42875000	18.7083	7.0473	2.54407	2.85714	1099.6	96211.3
351	123201	43249551	18.7350	7.0540	2.54531	2.84900	1102.7	96761.8
352	123904	43614208	18.7617	7.0607	2.54654	2.84091	1105.8	97314.0
353	124609	43988977	18.7883	7.0674	2.54777	2.83286	1109.0	97867.7
354	125316	44363864	18.8149	7.0740	2.54900	2.82486	1112.1	98423.0
355	126025	44738875	18.8414	7.0807	2.55023	2.81690	1115.3	98979.8
356	126736	45118016	18.8680	7.0873	2.55145	2.80899	1118.4	99538.2
357	127449	45499293	18.8944	7.0940	2.55267	2.80112	1121.5	100098
358	128164	45882712	18.9209	7.1006	2.55388	2.79330	1124.7	100660
359	128881	46268279	18.9473	7.1072	2.55509	2.78552	1127.8	101223
360	129600	46656000	18.9737	7.1138	2.55630	2.77778	1131.0	101788
361	130321	47045881	19.0000	7.1204	2.55751	2.77008	1134.1	102354
362	131044	47437928	19.0263	7.1269	2.55871	2.76243	1137.3	102922
363	131769	47832147	19.0526	7.1335	2.55991	2.75482	1140.4	103491
364	132496	48228544	19.0788	7.1400	2.56110	2.74725	1143.5	104062
365	133225	48627125	19.1050	7.1466	2.56229	2.73973	1146.7	104635
366	133956	49027896	19.1311	7.1531	2.56348	2.73224	1149.8	105209
367	134689	49430863	19.1572	7.1596	2.56467	2.72480	1153.0	105785
368	135424	49836032	19.1833	7.1661	2.56585	2.71739	1156.1	106362
369	136161	50243409	19.2094	7.1726	2.56703	2.71003	1159.2	106941
370	136900	50653000	19.2354	7.1791	2.56820	2.70270	1162.4	107521
371	137641	51064811	19.2614	7.1855	2.56937	2.69542	1165.5	108103
372	138384	51478848	19.2873	7.1920	2.57054	2.68817	1168.7	108687
373	139129	51895117	19.3132	7.1984	2.57171	2.68097	1171.8	109272
374	139876	52313624	19.3391	7.2048	2.57287	2.67380	1175.0	109858
375	140625	52734375	19.3649	7.2112	2.57403	2.66667	1178.1	110447
376	141376	53157376	19.3907	7.2177	2.57519	2.65957	1181.2	111036
377	142129	53582633	19.4165	7.2240	2.57634	2.65252	1184.4	111628
378	142884	54010152	19.4422	7.2304	2.57749	2.64550	1187.5	112221
379	143641	54439939	19.4679	7.2368	2.57864	2.63852	1190.7	112815
380	144400	54872000	19.4936	7.2432	2.57978	2.63158	1193.8	113411
381	145161	55306341	19.5192	7.2495	2.58093	2.62467	1196.9	114009
382	145924	55742968	19.5448	7.2558	2.58206	2.61780	1200.1	114608
383	146689	56181887	19.5704	7.2622	2.58320	2.61097	1203.2	115209
384	147456	56623104	19.5959	7.2685	2.58433	2.60417	1206.4	115812
385	148225	57066625	19.6214	7.2748	2.58546	2.59740	1209.5	116416
386	148996	57512456	19.6469	7.2811	2.58659	2.59067	1212.7	117021
387	149769	57960603	19.6723	7.2874	2.58771	2.58398	1215.8	117628
388	150544	58411072	19.6977	7.2936	2.58883	2.57732	1218.9	118237
389	151321	58863869	19.7231	7.2999	2.58995	2.57069	1222.1	118847
390	152100	59319000	19.7484	7.3061	2.59106	2.56410	1225.2	119459
391	152881	59776471	19.7737	7.3124	2.59218	2.55755	1228.4	120072
392	153664	60236288	19.7990	7.3186	2.59329	2.55102	1231.5	120687
393	154449	60698457	19.8242	7.3248	2.59439	2.54453	1234.6	121304
394	155236	61162984	19.8494	7.3310	2.59550	2.53807	1237.8	121922
395	156025	61629875	19.8746	7.3372	2.59660	2.53165	1240.9	122542
396	156816	62099136	19.8997	7.3434	2.59770	2.52525	1244.1	123163
397	157609	62570773	19.9249	7.3496	2.59879	2.51889	1247.2	123786
398	158404	63044792	19.9499	7.3558	2.59988	2.51256	1250.4	124410
399	159201	63521199	19.9750	7.3619	2.60097	2.50627	1253.5	125036



THE CARNEGIE STEEL COMPANY, LIMITED.

SQUARES, CUBES, SQUARE ROOTS, CUBE ROOTS, LOGARITHMS,  
RECIPROCAL, CIRCUMFERENCES AND CIRCULAR  
AREAS OF NOS. FROM 1 TO 1000.

No.	Square.	Cube.	Sq. Root.	Cube Root.	Log.	1000xRecip.	No. - Dia.	
							Circum.	Area.
400	160000	64000000	20.0000	7.3681	2.60206	2.50000	1256.6	125664
401	160801	64481201	20.0250	7.3742	2.60314	2.49377	1259.8	126203
402	161604	64964808	20.0499	7.3803	2.60423	2.48756	1262.9	126723
403	162409	65450827	20.0749	7.3864	2.60531	2.48139	1266.1	127256
404	163216	65939264	20.0998	7.3925	2.60638	2.47525	1269.2	127800
405	164025	66430125	20.1246	7.3986	2.60746	2.46914	1272.3	128325
406	164836	66923416	20.1494	7.4047	2.60853	2.46305	1275.5	128862
407	165649	67419143	20.1742	7.4108	2.60959	2.45700	1278.6	130100
408	166464	67917312	20.1990	7.4169	2.61066	2.45098	1281.8	130741
409	167281	68417929	20.2237	7.4229	2.61172	2.44499	1284.9	131382
410	168100	68921000	20.2485	7.4290	2.61278	2.43902	1288.1	132025
411	168921	69426531	20.2731	7.4350	2.61384	2.43309	1291.2	132670
412	169744	69934528	20.2978	7.4410	2.61490	2.42718	1294.3	133317
413	170569	70444997	20.3224	7.4470	2.61595	2.42131	1297.5	133965
414	171396	70957944	20.3470	7.4530	2.61700	2.41546	1300.6	134614
415	172225	71473375	20.3715	7.4590	2.61805	2.40964	1303.8	135265
416	173056	71991296	20.3961	7.4650	2.61909	2.40385	1306.9	135918
417	173889	72511713	20.4206	7.4710	2.62014	2.39808	1310.0	136572
418	174724	73034632	20.4450	7.4770	2.62118	2.39234	1313.2	137228
419	175561	73560059	20.4695	7.4829	2.62221	2.38664	1316.3	137885
420	176400	74088000	20.4939	7.4889	2.62325	2.38095	1319.5	138544
421	177241	74618461	20.5183	7.4948	2.62428	2.37530	1322.6	139205
422	178084	75151448	20.5426	7.5007	2.62531	2.36967	1325.8	139867
423	178929	75686967	20.5670	7.5067	2.62634	2.36407	1328.9	140531
424	179776	76225024	20.5913	7.5126	2.62737	2.35849	1332.0	141196
425	180625	76765625	20.6155	7.5185	2.62839	2.35294	1335.2	141863
426	181476	77308776	20.6398	7.5244	2.62941	2.34742	1338.3	142531
427	182329	77854483	20.6640	7.5302	2.63043	2.34192	1341.5	143201
428	183184	78402752	20.6882	7.5361	2.63144	2.33645	1344.6	143872
429	184041	78953589	20.7123	7.5420	2.63246	2.33100	1347.7	144545
430	184900	79507000	20.7364	7.5478	2.63347	2.32558	1350.9	145220
431	185761	80062991	20.7605	7.5537	2.63448	2.32019	1354.0	145896
432	186624	80621568	20.7846	7.5595	2.63548	2.31482	1357.2	146574
433	187489	81182737	20.8087	7.5654	2.63649	2.30947	1360.3	147254
434	188356	81746504	20.8327	7.5712	2.63749	2.30415	1363.5	147934
435	189225	82312875	20.8567	7.5770	2.63849	2.29885	1366.6	148617
436	190096	82881856	20.8806	7.5828	2.63949	2.29358	1369.7	149301
437	190969	83453453	20.9045	7.5886	2.64048	2.28833	1372.9	149987
438	191844	84027672	20.9284	7.5944	2.64147	2.28311	1376.0	150674
439	192721	84604519	20.9523	7.6001	2.64246	2.27790	1379.2	151363
440	193600	85184000	20.9762	7.6059	2.64345	2.27273	1382.3	152053
441	194481	85766121	21.0000	7.6117	2.64444	2.26757	1385.4	152745
442	195364	86350888	21.0238	7.6174	2.64542	2.26244	1388.6	153439
443	196249	86938307	21.0476	7.6232	2.64640	2.25734	1391.7	154134
444	197136	87528384	21.0713	7.6289	2.64738	2.25225	1394.9	154830
445	198025	88121125	21.0950	7.6346	2.64836	2.24719	1398.0	155528
446	198916	88716536	21.1187	7.6403	2.64933	2.24215	1401.2	156228
447	199809	89314623	21.1424	7.6460	2.65031	2.23714	1404.3	156930
448	200704	89915392	21.1660	7.6517	2.65128	2.23214	1407.4	157633
449	201601	90518849	21.1896	7.6574	2.65225	2.22717	1410.6	158337

THE CARNEGIE STEEL COMPANY, LIMITED.

SQUARES, CUBES, SQUARE ROOTS, CUBE ROOTS, LOGARITHMS,  
 RECIPROCAL, CIRCUMFERENCES AND CIRCULAR  
 AREAS OF NOS. FROM 1 TO 1000.

No.	Square.	Cube.	Sq. Root.	Cube Root.	Log.	1000xRecip.	No. - Dia.	
							Circum.	Area.
450	202500	91125000	21.2132	7.6631	2.65321	2.22222	1413.7	150043
451	203401	91733851	21.2368	7.6688	2.65418	2.21730	1416.9	150751
452	204304	92345408	21.2603	7.6744	2.65514	2.21239	1420.0	160460
453	205209	92959677	21.2838	7.6801	2.65610	2.20751	1423.1	161171
454	206116	93576664	21.3073	7.6857	2.65706	2.20264	1426.3	161883
455	207025	94196375	21.3307	7.6914	2.65801	2.19780	1429.4	162597
456	207936	94818816	21.3542	7.6970	2.65896	2.19298	1432.6	163313
457	208849	95443993	21.3776	7.7026	2.65992	2.18818	1435.7	164030
458	209764	96071912	21.4009	7.7082	2.66087	2.18341	1438.9	164748
459	210681	96702579	21.4243	7.7138	2.66181	2.17865	1442.0	165468
460	211600	97336000	21.4476	7.7194	2.66276	2.17391	1445.1	166190
461	212521	97972181	21.4709	7.7250	2.66370	2.16920	1448.3	166914
462	213444	98611128	21.4942	7.7306	2.66464	2.16450	1451.4	167639
463	214369	99252847	21.5174	7.7362	2.66558	2.15983	1454.6	168365
464	215296	99897344	21.5407	7.7418	2.66652	2.15517	1457.7	169093
465	216225	100544625	21.5639	7.7473	2.66745	2.15054	1460.8	169823
466	217156	101194696	21.5870	7.7529	2.66839	2.14592	1464.0	170554
467	218089	101847563	21.6102	7.7584	2.66932	2.14133	1467.1	171287
468	219024	102503232	21.6333	7.7639	2.67025	2.13675	1470.3	172021
469	219961	103161709	21.6564	7.7695	2.67117	2.13220	1473.4	172757
470	220900	103823000	21.6795	7.7750	2.67210	2.12766	1476.5	173494
471	221841	104487111	21.7025	7.7805	2.67302	2.12314	1479.7	174234
472	222784	105154048	21.7255	7.7860	2.67394	2.11864	1482.8	174974
473	223729	105823817	21.7486	7.7915	2.67486	2.11417	1486.0	175716
474	224676	106496424	21.7715	7.7970	2.67578	2.10971	1489.1	176460
475	225625	107171875	21.7945	7.8025	2.67669	2.10526	1492.3	177205
476	226576	107850176	21.8174	7.8079	2.67761	2.10084	1495.4	177952
477	227529	108531333	21.8403	7.8134	2.67852	2.09644	1498.5	178701
478	228484	109215352	21.8632	7.8188	2.67943	2.09205	1501.7	179451
479	229441	109902239	21.8861	7.8243	2.68034	2.08768	1504.8	180203
480	230400	110592000	21.9089	7.8297	2.68124	2.08333	1508.0	180956
481	231361	111284641	21.9317	7.8352	2.68215	2.07900	1511.1	181711
482	232324	111980168	21.9545	7.8406	2.68305	2.07469	1514.3	182467
483	233289	112678587	21.9773	7.8460	2.68395	2.07039	1517.4	183225
484	234256	113379904	22.0000	7.8514	2.68485	2.06612	1520.5	183984
485	235225	114084125	22.0227	7.8568	2.68574	2.06186	1523.7	184745
486	236196	114791256	22.0454	7.8622	2.68664	2.05761	1526.8	185508
487	237169	115501303	22.0681	7.8676	2.68753	2.05339	1530.0	186272
488	238144	116214272	22.0907	7.8730	2.68842	2.04918	1533.1	187038
489	239121	116930169	22.1133	7.8784	2.68931	2.04499	1536.2	187805
490	240100	117649000	22.1359	7.8837	2.69020	2.04082	1539.4	188574
491	241081	118370771	22.1585	7.8891	2.69108	2.03666	1542.5	189345
492	242064	119095488	22.1811	7.8944	2.69197	2.03252	1545.7	190117
493	243049	119823157	22.2036	7.8998	2.69285	2.02840	1548.8	190890
494	244036	120553784	22.2261	7.9051	2.69373	2.02429	1551.9	191665
495	245025	121287375	22.2486	7.9105	2.69461	2.02020	1555.1	192442
496	246016	122023936	22.2711	7.9158	2.69548	2.01613	1558.2	193221
497	247009	122763473	22.2935	7.9211	2.69636	2.01207	1561.4	194000
498	248004	123505992	22.3159	7.9264	2.69723	2.00803	1564.5	194782
499	249001	124251499	22.3383	7.9317	2.69810	2.00401	1567.7	195565

THE CARNEGIE STEEL COMPANY, LIMITED.

SQUARES, CUBES, SQUARE ROOTS, CUBE ROOTS, LOGARITHMS,  
RECIPROCAL, CIRCUMFERENCES AND CIRCULAR  
AREAS OF NOS. FROM 1 TO 1000.

No.	Square.	Cube.	Sq. Root.	Cube Root.	Log.	1000xRecip.	No. - Dia.	
							Circum.	Area.
500	250000	125000000	22.3607	7.9370	2.69897	2.00000	1570.8	196350
501	251001	125751501	22.3830	7.9423	2.69984	1.99901	1573.9	197136
502	252004	126506008	22.4054	7.9476	2.70070	1.99203	1577.1	197923
503	253009	127263527	22.4277	7.9528	2.70157	1.98807	1580.2	198713
504	254016	128024064	22.4499	7.9581	2.70243	1.98413	1583.4	199504
505	255025	128787625	22.4722	7.9634	2.70329	1.98020	1586.5	200296
506	256036	129554216	22.4944	7.9686	2.70415	1.97629	1589.7	201090
507	257049	130323843	22.5167	7.9739	2.70501	1.97239	1592.8	201886
508	258064	131096512	22.5389	7.9791	2.70586	1.96850	1595.9	202683
509	259081	131872229	22.5610	7.9843	2.70672	1.96464	1599.1	203482
510	260100	132651000	22.5832	7.9896	2.70757	1.96078	1602.2	204282
511	261121	133432831	22.6053	7.9948	2.70842	1.95695	1605.4	205084
512	262144	134217728	22.6274	8.0000	2.70927	1.95312	1608.5	205887
513	263169	135005687	22.6495	8.0052	2.71012	1.94932	1611.6	206692
514	264196	135796744	22.6716	8.0104	2.71096	1.94553	1614.8	207499
515	265225	136590875	22.6936	8.0156	2.71181	1.94175	1617.9	208307
516	266256	137388096	22.7156	8.0208	2.71265	1.93798	1621.1	209117
517	267289	138188413	22.7376	8.0260	2.71349	1.93424	1624.2	209928
518	268324	138991832	22.7596	8.0311	2.71433	1.93050	1627.3	210741
519	269361	139798359	22.7816	8.0363	2.71517	1.92678	1630.5	211556
520	270400	140608000	22.8035	8.0415	2.71600	1.92308	1633.6	212372
521	271441	141420761	22.8254	8.0466	2.71684	1.91939	1636.8	213189
522	272484	142236648	22.8473	8.0517	2.71767	1.91571	1639.9	214008
523	273529	143055667	22.8692	8.0569	2.71850	1.91205	1643.1	214829
524	274576	143877824	22.8910	8.0620	2.71933	1.90840	1646.2	215651
525	275625	144703125	22.9129	8.0671	2.72016	1.90476	1649.3	216475
526	276676	145531576	22.9347	8.0723	2.72099	1.90114	1652.5	217301
527	277729	146363183	22.9565	8.0774	2.72181	1.89753	1655.6	218128
528	278784	147197952	22.9783	8.0825	2.72263	1.89394	1658.8	218956
529	279841	148035889	23.0000	8.0876	2.72346	1.89036	1661.9	219787
530	280900	148877000	23.0217	8.0927	2.72428	1.88679	1665.0	220618
531	281961	149721201	23.0434	8.0978	2.72509	1.88324	1668.2	221452
532	283024	150568768	23.0651	8.1028	2.72591	1.87970	1671.3	222287
533	284089	151419437	23.0868	8.1079	2.72673	1.87617	1674.5	223123
534	285156	152273304	23.1084	8.1130	2.72754	1.87266	1677.6	223961
535	286225	153130375	23.1301	8.1180	2.72835	1.86916	1680.8	224801
536	287296	153990656	23.1517	8.1231	2.72916	1.86567	1683.9	225642
537	288369	154854153	23.1733	8.1281	2.72997	1.86220	1687.0	226484
538	289444	155720872	23.1948	8.1332	2.73078	1.85874	1690.2	227329
539	290521	156590819	23.2164	8.1382	2.73159	1.85529	1693.3	228175
540	291600	157464000	23.2379	8.1433	2.73239	1.85185	1696.5	229022
541	292681	158340421	23.2594	8.1483	2.73320	1.84843	1699.6	229871
542	293764	159220088	23.2809	8.1533	2.73400	1.84502	1702.7	230722
543	294849	160103007	23.3024	8.1583	2.73480	1.84162	1705.9	231574
544	295936	160989184	23.3238	8.1633	2.73560	1.83824	1709.0	232428
545	297025	161878625	23.3452	8.1683	2.73640	1.83486	1712.2	233283
546	298116	162771336	23.3666	8.1733	2.73719	1.83150	1715.3	234140
547	299209	163667323	23.3880	8.1783	2.73799	1.82815	1718.5	234998
548	300304	164566592	23.4094	8.1833	2.73878	1.82482	1721.6	235858
549	301401	165469149	23.4307	8.1882	2.73957	1.82149	1724.7	236720

THE CARNEGIE STEEL COMPANY, LIMITED.

SQUARES, CUBES, SQUARE ROOTS, CUBE ROOTS, LOGARITHMS,  
 RECIPROCAL, CIRCUMFERENCES AND CIRCULAR  
 AREAS OF NOS. FROM 1 TO 1000.

No.	Square.	Cube.	Sq. Root.	Cube Root.	Log.	1000xRecip.	No.-Dia.	
							Circum.	Area.
550	302500	166375000	23.4521	8.1932	2.74036	1.81818	1727.9	2375.83
551	303601	167284151	23.4734	8.1982	2.74115	1.81488	1731.0	2384.48
552	304704	168196608	23.4947	8.2031	2.74194	1.81159	1734.2	2393.14
553	305800	169112377	23.5160	8.2081	2.74273	1.80832	1737.3	2401.82
554	306916	170031464	23.5372	8.2130	2.74351	1.80505	1740.4	2410.51
555	308025	170953875	23.5584	8.2180	2.74429	1.80180	1743.6	2419.22
556	309136	171879616	23.5797	8.2229	2.74507	1.79856	1746.7	2427.95
557	310249	172808693	23.6008	8.2278	2.74586	1.79533	1749.9	2436.69
558	311364	173741112	23.6220	8.2327	2.74663	1.79211	1753.0	2445.45
559	312481	174676879	23.6432	8.2377	2.74741	1.78891	1756.2	2454.22
560	313600	175616000	23.6643	8.2426	2.74819	1.78571	1759.3	2463.01
561	314721	176558481	23.6854	8.2475	2.74896	1.78253	1762.4	2471.81
562	315844	177504328	23.7065	8.2524	2.74974	1.77936	1765.6	2480.63
563	316969	178453547	23.7276	8.2573	2.75051	1.77620	1768.7	2489.47
564	318096	179406144	23.7487	8.2621	2.75128	1.77305	1771.9	2498.32
565	319225	180362125	23.7697	8.2670	2.75205	1.76991	1775.0	2507.19
566	320356	181321496	23.7908	8.2719	2.75282	1.76678	1778.1	2516.07
567	321489	182284263	23.8118	8.2768	2.75358	1.76367	1781.3	2524.97
568	322624	183250432	23.8328	8.2816	2.75435	1.76056	1784.4	2533.88
569	323761	184220009	23.8537	8.2865	2.75511	1.75747	1787.6	2542.81
570	324900	185193000	23.8747	8.2913	2.75587	1.75439	1790.7	2551.76
571	326041	186169411	23.8956	8.2962	2.75664	1.75131	1793.9	2560.72
572	327184	187149248	23.9165	8.3010	2.75740	1.74825	1797.0	2569.70
573	328329	188132517	23.9374	8.3059	2.75815	1.74520	1800.1	2578.69
574	329476	189119224	23.9583	8.3107	2.75891	1.74216	1803.3	2587.70
575	330625	190109375	23.9792	8.3155	2.75967	1.73913	1806.4	2596.72
576	331776	191102976	24.0000	8.3203	2.76042	1.73611	1809.6	2605.76
577	332929	192100033	24.0208	8.3251	2.76118	1.73310	1812.7	2614.82
578	334084	193100552	24.0416	8.3300	2.76193	1.73010	1815.8	2623.89
579	335241	194104539	24.0624	8.3348	2.76268	1.72712	1819.0	2632.98
580	336400	195112000	24.0832	8.3396	2.76343	1.72414	1822.1	2642.08
581	337561	196122941	24.1039	8.3443	2.76418	1.72117	1825.3	2651.20
582	338724	197137368	24.1247	8.3491	2.76492	1.71821	1828.4	2660.33
583	339889	198155287	24.1454	8.3539	2.76567	1.71527	1831.6	2669.48
584	341056	199176704	24.1661	8.3587	2.76641	1.71233	1834.7	2678.65
585	342225	200201625	24.1868	8.3634	2.76716	1.70940	1837.8	2687.83
586	343396	201230056	24.2074	8.3682	2.76790	1.70649	1841.0	2697.01
587	344569	202262003	24.2281	8.3730	2.76864	1.70358	1844.1	2706.24
588	345744	203297472	24.2487	8.3777	2.76938	1.70068	1847.3	2715.47
589	346921	204336469	24.2693	8.3825	2.77012	1.69779	1850.4	2724.71
590	348100	205379000	24.2899	8.3872	2.77085	1.69492	1853.5	2733.97
591	349281	206425071	24.3105	8.3919	2.77159	1.69205	1856.7	2743.25
592	350464	207474688	24.3311	8.3967	2.77232	1.68919	1859.8	2752.54
593	351649	208527857	24.3516	8.4014	2.77305	1.68634	1863.0	2761.84
594	352836	209584584	24.3721	8.4061	2.77379	1.68350	1866.1	2771.17
595	354025	210644875	24.3926	8.4108	2.77452	1.68067	1869.3	2780.51
596	355216	211708736	24.4131	8.4155	2.77525	1.67785	1872.4	2789.86
597	356409	212776173	24.4336	8.4202	2.77597	1.67504	1875.5	2799.23
598	357604	213847192	24.4540	8.4249	2.77670	1.67224	1878.7	2808.62
599	358801	214921799	24.4745	8.4296	2.77743	1.66945	1881.8	2818.02

THE CARNEGIE STEEL COMPANY, LIMITED.

SQUARES, CUBES, SQUARE ROOTS, CUBE ROOTS, LOGARITHMS,  
RECIPROCALLS, CIRCUMFERENCES AND CIRCULAR  
AREAS OF NOS. FROM 1 TO 1000.

No.	Square.	Cube.	Sq. Root.	Cube Root.	Log.	1000xRecip.	No.-Dia.	
							Circum.	Area.
600	360000	216000000	24.4949	8.4343	2.77815	1.66667	1885.0	2827.43
601	361201	217081801	24.5153	8.4390	2.77887	1.66389	1888.1	283687
602	362404	218167208	24.5357	8.4437	2.77960	1.66113	1891.2	284631
603	363609	219256227	24.5561	8.4484	2.78032	1.65837	1894.4	285578
604	364816	220348864	24.5764	8.4530	2.78104	1.65563	1897.5	286526
605	366025	221445125	24.5967	8.4577	2.78176	1.65289	1900.7	287475
606	367236	222545016	24.6171	8.4623	2.78247	1.65017	1903.8	288426
607	368449	223648543	24.6374	8.4670	2.78319	1.64745	1907.0	289379
608	369664	224755712	24.6577	8.4716	2.78390	1.64474	1910.1	290333
609	370881	225866529	24.6779	8.4763	2.78462	1.64204	1913.2	291289
610	372100	226981000	24.6982	8.4809	2.78533	1.63934	1916.4	292247
611	373321	228099131	24.7184	8.4856	2.78604	1.63666	1919.5	293206
612	374544	229220928	24.7386	8.4902	2.78675	1.63399	1922.7	294166
613	375769	230346397	24.7588	8.4948	2.78746	1.63132	1925.8	295128
614	376996	231475544	24.7790	8.4994	2.78817	1.62866	1928.9	296092
615	378225	232608375	24.7992	8.5040	2.78888	1.62602	1932.1	297057
616	379456	233744896	24.8193	8.5086	2.78958	1.62338	1935.2	298024
617	380689	234885113	24.8395	8.5132	2.79029	1.62075	1938.4	298992
618	381924	236029032	24.8596	8.5178	2.79099	1.61812	1941.5	299962
619	383161	237176659	24.8797	8.5224	2.79169	1.61551	1944.7	300934
620	384400	238328000	24.8998	8.5270	2.79239	1.61290	1947.8	301907
621	385641	239483061	24.9199	8.5316	2.79309	1.61031	1950.9	302882
622	386884	240641848	24.9399	8.5362	2.79379	1.60772	1954.1	303858
623	388129	241804367	24.9600	8.5408	2.79449	1.60514	1957.2	304836
624	389376	242970624	24.9800	8.5453	2.79518	1.60256	1960.4	305815
625	390625	244140625	25.0000	8.5499	2.79588	1.60000	1963.5	306796
626	391876	245314376	25.0200	8.5544	2.79657	1.59744	1966.6	307779
627	393129	246491883	25.0400	8.5590	2.79727	1.59490	1969.8	308763
628	394384	247673152	25.0599	8.5635	2.79796	1.59236	1972.9	309748
629	395641	248858189	25.0799	8.5681	2.79865	1.58983	1976.1	310736
630	396900	250047000	25.0998	8.5726	2.79934	1.58730	1979.2	311725
631	398161	251239591	25.1197	8.5772	2.80003	1.58479	1982.4	312715
632	399424	252435968	25.1396	8.5817	2.80072	1.58228	1985.5	313707
633	400689	253636137	25.1595	8.5862	2.80140	1.57978	1988.6	314700
634	401956	254840104	25.1794	8.5907	2.80209	1.57729	1991.8	315696
635	403225	256047875	25.1992	8.5952	2.80277	1.57480	1994.9	316692
636	404496	257259456	25.2190	8.5997	2.80346	1.57233	1998.1	317689
637	405769	258474853	25.2389	8.6043	2.80414	1.56986	2001.2	318689
638	407044	259694072	25.2587	8.6088	2.80482	1.56740	2004.3	319692
639	408321	260917119	25.2784	8.6132	2.80550	1.56495	2007.5	320696
640	409600	262144000	25.2982	8.6177	2.80618	1.56250	2010.6	321699
641	410881	263374721	25.3180	8.6222	2.80686	1.56006	2013.8	322705
642	412164	264609288	25.3377	8.6267	2.80754	1.55763	2016.9	323713
643	413449	265847707	25.3574	8.6312	2.80821	1.55521	2020.0	324722
644	414736	267089984	25.3772	8.6357	2.80889	1.55280	2023.2	325733
645	416025	268336125	25.3969	8.6401	2.80956	1.55039	2026.3	326745
646	417316	269586136	25.4165	8.6446	2.81023	1.54799	2029.5	327759
647	418609	270840023	25.4362	8.6490	2.81090	1.54559	2032.6	328775
648	419904	272097792	25.4558	8.6535	2.81158	1.54321	2035.8	329792
649	421201	273359449	25.4755	8.6579	2.81224	1.54083	2038.9	330810

THE CARNEGIE STEEL COMPANY, LIMITED.

SQUARES, CUBES, SQUARE ROOTS, CUBE ROOTS, LOGARITHMS,  
RECIPROCAL, CIRCUMFERENCES AND CIRCULAR  
AREAS OF NOS. FROM 1 TO 1000.

No.	Square.	Cube.	Sq. Root.	Cube Root.	Log.	1000xRecip.	No. - Dia.	
							Circum.	Area.
650	422500	274625000	25.4951	8.6624	2.81201	1.53846	2042.0	331831
651	423801	275894451	25.5147	8.6668	2.81358	1.53610	2045.2	332853
652	425104	277167808	25.5343	8.6713	2.81425	1.53374	2048.3	333876
653	426409	278445077	25.5539	8.6757	2.81491	1.53139	2051.5	334901
654	427716	279726264	25.5734	8.6801	2.81558	1.52905	2054.6	335927
655	429025	281011375	25.5930	8.6845	2.81624	1.52672	2057.7	336955
656	430336	282300416	25.6125	8.6890	2.81690	1.52439	2060.9	337985
657	431649	283593393	25.6320	8.6934	2.81757	1.52207	2064.0	339016
658	432964	284890312	25.6515	8.6978	2.81823	1.51976	2067.2	340049
659	434281	286191179	25.6710	8.7022	2.81889	1.51745	2070.3	341084
660	435600	287496000	25.6905	8.7066	2.81954	1.51515	2073.5	342119
661	436921	288804781	25.7099	8.7110	2.82020	1.51286	2076.6	343157
662	438244	290117528	25.7294	8.7154	2.82086	1.51057	2079.7	344196
663	439569	291434247	25.7488	8.7198	2.82151	1.50830	2082.9	345237
664	440896	292754944	25.7682	8.7241	2.82217	1.50602	2086.0	346279
665	442225	294079625	25.7876	8.7285	2.82282	1.50376	2089.2	347323
666	443556	295408296	25.8070	8.7329	2.82347	1.50150	2092.3	348368
667	444889	296740963	25.8263	8.7373	2.82413	1.49925	2095.4	349415
668	446224	298077632	25.8457	8.7416	2.82478	1.49701	2098.6	350464
669	447561	299418309	25.8650	8.7460	2.82543	1.49477	2101.7	351514
670	448900	300763000	25.8844	8.7503	2.82607	1.49254	2104.9	352565
671	450241	302111711	25.9037	8.7547	2.82672	1.49031	2108.0	353618
672	451584	303464448	25.9230	8.7590	2.82737	1.48810	2111.2	354673
673	452929	304821217	25.9422	8.7634	2.82802	1.48588	2114.3	355730
674	454276	306182024	25.9615	8.7677	2.82866	1.48368	2117.4	356788
675	455625	307546875	25.9808	8.7721	2.82930	1.48148	2120.6	357847
676	456976	308915776	26.0000	8.7764	2.82995	1.47929	2123.7	358908
677	458329	310288733	26.0192	8.7807	2.83059	1.47711	2126.9	359971
678	459684	311665752	26.0384	8.7850	2.83123	1.47493	2130.0	361035
679	461041	313046839	26.0576	8.7893	2.83187	1.47275	2133.1	362101
680	462400	314432000	26.0768	8.7937	2.83251	1.47059	2136.3	363168
681	463761	315821241	26.0960	8.7980	2.83315	1.46843	2139.4	364237
682	465124	317214568	26.1151	8.8023	2.83378	1.46628	2142.6	365308
683	466489	318611987	26.1343	8.8066	2.83442	1.46413	2145.7	366380
684	467856	320013504	26.1534	8.8109	2.83506	1.46199	2148.9	367453
685	469225	321419125	26.1725	8.8152	2.83569	1.45985	2152.0	368528
686	470596	322828856	26.1916	8.8194	2.83632	1.45773	2155.1	369605
687	471969	324242703	26.2107	8.8237	2.83696	1.45560	2158.3	370684
688	473344	325660672	26.2298	8.8280	2.83759	1.45349	2161.4	371764
689	474721	327082769	26.2488	8.8323	2.83822	1.45138	2164.6	372845
690	476100	328509000	26.2679	8.8366	2.83885	1.44928	2167.7	373928
691	477481	329939371	26.2869	8.8408	2.83948	1.44718	2170.8	375013
692	478864	331373888	26.3059	8.8451	2.84011	1.44509	2174.0	376099
693	480249	332812557	26.3249	8.8493	2.84073	1.44300	2177.1	377187
694	481636	334255384	26.3439	8.8536	2.84136	1.44092	2180.3	378276
695	483025	335702375	26.3629	8.8578	2.84198	1.43885	2183.4	379367
696	484416	337153536	26.3818	8.8621	2.84261	1.43678	2186.6	380459
697	485809	338608873	26.4008	8.8663	2.84323	1.43472	2189.7	381554
698	487204	340068392	26.4197	8.8706	2.84386	1.43267	2192.8	382649
699	488601	341532099	26.4386	8.8748	2.84448	1.43062	2196.0	383746

THE CARNEGIE STEEL COMPANY, LIMITED.

SQUARES, CUBES, SQUARE ROOTS, CUBE ROOTS, LOGARITHMS,  
RECIPROCAL, CIRCUMFERENCES AND CIRCULAR  
AREAS OF NOS. FROM 1 TO 1000.

No.	Square.	Cube.	Sq. Root.	Cube Root.	Log.	1000xRecip.	No. - Dia.	
							Circum.	Area.
700	490000	343000000	26.4575	8.8790	2.84510	1.42857	2190.1	3848.45
701	491401	344472101	26.4764	8.8883	2.84572	1.42853	2202.3	3859.45
702	492804	345948408	26.4953	8.8875	2.84634	1.42450	2205.4	3870.47
703	494209	347428927	26.5141	8.8917	2.84696	1.42248	2208.5	3881.51
704	495616	348913664	26.5330	8.8959	2.84757	1.42046	2211.7	3892.56
705	497025	350402625	26.5518	8.9001	2.84819	1.41844	2214.8	3903.63
706	498436	351895816	26.5707	8.9043	2.84880	1.41643	2218.0	3914.71
707	499849	353393243	26.5895	8.9085	2.84942	1.41443	2221.1	3925.80
708	501264	354894912	26.6083	8.9127	2.85003	1.41243	2224.3	3936.92
709	502681	356400829	26.6271	8.9169	2.85065	1.41044	2227.4	3948.05
710	504100	357911000	26.6458	8.9211	2.85126	1.40845	2230.5	3959.19
711	505521	359425431	26.6646	8.9253	2.85187	1.40647	2233.7	3970.35
712	506944	360944128	26.6833	8.9295	2.85248	1.40449	2236.8	3981.53
713	508369	362467097	26.7021	8.9337	2.85309	1.40253	2240.0	3992.72
714	509796	363994344	26.7208	8.9378	2.85370	1.40056	2243.1	4003.93
715	511225	365525875	26.7395	8.9420	2.85431	1.39860	2246.2	4015.15
716	512656	367061696	26.7582	8.9462	2.85491	1.39665	2249.4	4026.39
717	514089	368601813	26.7769	8.9503	2.85552	1.39470	2252.5	4037.65
718	515524	370146232	26.7955	8.9545	2.85612	1.39276	2255.7	4048.92
719	516961	371694959	26.8142	8.9587	2.85673	1.39082	2258.8	4060.20
720	518400	373248000	26.8328	8.9628	2.85733	1.38888	2261.9	4071.50
721	519841	374805361	26.8514	8.9670	2.85794	1.38696	2265.1	4082.82
722	521284	376367048	26.8701	8.9711	2.85854	1.38504	2268.2	4094.16
723	522729	377933067	26.8887	8.9752	2.85914	1.38313	2271.4	4105.50
724	524176	379503424	26.9072	8.9794	2.85974	1.38122	2274.5	4116.87
725	525625	381078125	26.9258	8.9835	2.86034	1.37931	2277.7	4128.25
726	527076	382657176	26.9444	8.9876	2.86094	1.37741	2280.8	4139.65
727	528529	384240583	26.9629	8.9918	2.86153	1.37552	2283.9	4151.06
728	529984	385828352	26.9815	8.9959	2.86213	1.37363	2287.1	4162.48
729	531441	387420489	27.0000	9.0000	2.86273	1.37174	2290.2	4173.93
730	532900	389017000	27.0185	9.0041	2.86332	1.36986	2293.4	4185.39
731	534361	390617891	27.0370	9.0082	2.86392	1.36799	2296.5	4196.86
732	535824	392223168	27.0555	9.0123	2.86451	1.36612	2299.7	4208.35
733	537289	393832837	27.0740	9.0164	2.86510	1.36426	2302.8	4219.86
734	538756	395446904	27.0924	9.0205	2.86570	1.36240	2305.9	4231.38
735	540225	397065375	27.1109	9.0246	2.86629	1.36054	2309.1	4242.93
736	541696	398688256	27.1293	9.0287	2.86688	1.35870	2312.2	4254.48
737	543169	400315553	27.1477	9.0328	2.86747	1.35685	2315.4	4266.04
738	544644	401947272	27.1662	9.0369	2.86806	1.35501	2318.5	4277.62
739	546121	403583419	27.1846	9.0410	2.86864	1.35318	2321.6	4289.22
740	547600	405224000	27.2029	9.0450	2.86923	1.35135	2324.8	4300.84
741	549081	406869021	27.2213	9.0491	2.86982	1.34953	2327.9	4312.47
742	550564	408518488	27.2397	9.0532	2.87040	1.34771	2331.1	4324.12
743	552049	410172407	27.2580	9.0572	2.87099	1.34590	2334.2	4335.78
744	553536	411830784	27.2764	9.0613	2.87157	1.34409	2337.3	4347.46
745	555025	413493625	27.2947	9.0654	2.87216	1.34228	2340.5	4359.16
746	556516	415160936	27.3130	9.0694	2.87274	1.34048	2343.6	4370.87
747	558009	416832723	27.3313	9.0735	2.87332	1.33869	2346.8	4382.59
748	559504	418508992	27.3496	9.0775	2.87390	1.33690	2349.9	4394.33
749	561001	420189749	27.3679	9.0816	2.87448	1.33511	2353.1	4406.09

THE CARNEGIE STEEL COMPANY, LIMITED.

SQUARES, CUBES, SQUARE ROOTS, CUBE ROOTS, LOGARITHMS,  
 RECIPROCAL, CIRCUMFERENCES AND CIRCULAR  
 AREAS OF NOS. FROM 1 TO 1000.

No.	Square.	Cube.	Sq. Root.	Cube Root.	Log.	1000rRecip.	No.-Dia.	
							Circum.	Area.
750	502500	421875000	27.3861	9.0856	2.87506	1.33333	2356.2	441780
751	564001	423564751	27.4044	9.0896	2.87504	1.33156	2359.3	442065
752	565504	425250008	27.4226	9.0937	2.87502	1.32979	2362.5	444146
753	567009	426935777	27.4408	9.0977	2.87500	1.32802	2365.6	445328
754	568516	428621004	27.4591	9.1017	2.87737	1.32626	2368.8	446511
755	570025	430306875	27.4773	9.1057	2.87795	1.32450	2371.9	447697
756	571536	432012116	27.4955	9.1098	2.87852	1.32275	2375.0	448883
757	573049	433728003	27.5136	9.1138	2.87910	1.32100	2378.2	450072
758	574564	435453512	27.5318	9.1178	2.87967	1.31926	2381.3	451262
759	576081	437245479	27.5500	9.1218	2.88024	1.31752	2384.5	452453
760	577600	439070000	27.5681	9.1258	2.88081	1.31579	2387.6	453646
761	579121	440911081	27.5862	9.1298	2.88138	1.31406	2390.8	454841
762	580644	442768728	27.6043	9.1338	2.88196	1.31234	2393.9	456037
763	582169	444642947	27.6225	9.1378	2.88252	1.31062	2397.0	457234
764	583696	446533744	27.6405	9.1418	2.88309	1.30890	2400.2	458434
765	585225	448440125	27.6586	9.1458	2.88366	1.30719	2403.3	459635
766	586756	449450006	27.6767	9.1498	2.88423	1.30548	2406.5	460837
767	588289	451217603	27.6948	9.1537	2.88480	1.30378	2409.6	462042
768	589824	452984832	27.7128	9.1577	2.88536	1.30208	2412.7	463247
769	591361	454750000	27.7308	9.1617	2.88593	1.30039	2415.9	464454
770	592900	456533000	27.7489	9.1657	2.88649	1.29870	2419.0	465663
771	594441	458333011	27.7669	9.1696	2.88705	1.29702	2422.2	466873
772	595984	460099648	27.7849	9.1736	2.88762	1.29534	2425.3	468085
773	597529	461889917	27.8029	9.1775	2.88818	1.29366	2428.5	469298
774	599076	463684824	27.8209	9.1815	2.88874	1.29199	2431.6	470513
775	600625	465484375	27.8388	9.1855	2.88930	1.29032	2434.7	471730
776	602176	467288576	27.8568	9.1894	2.88986	1.28866	2437.9	472948
777	603729	469097433	27.8747	9.1933	2.89042	1.28700	2441.0	474168
778	605284	470910952	27.8927	9.1973	2.89098	1.28535	2444.2	475389
779	606841	472729139	27.9106	9.2012	2.89154	1.28370	2447.3	476612
780	608400	474552000	27.9285	9.2052	2.89209	1.28205	2450.4	477836
781	609961	476379541	27.9464	9.2091	2.89265	1.28041	2453.6	479062
782	611524	478211768	27.9643	9.2130	2.89321	1.27877	2456.7	480290
783	613089	480048687	27.9821	9.2170	2.89376	1.27714	2459.9	481519
784	614656	481890304	28.0000	9.2209	2.89432	1.27551	2463.0	482750
785	616225	483736625	28.0179	9.2248	2.89487	1.27389	2466.2	483982
786	617796	485587656	28.0357	9.2287	2.89542	1.27226	2469.3	485216
787	619369	487443403	28.0535	9.2326	2.89597	1.27065	2472.4	486451
788	620944	489303872	28.0713	9.2365	2.89653	1.26904	2475.6	487688
789	622521	491169069	28.0891	9.2404	2.89708	1.26743	2478.7	488927
790	624100	493039000	28.1069	9.2443	2.89763	1.26582	2481.9	490167
791	625681	494913671	28.1247	9.2482	2.89818	1.26422	2485.0	491409
792	627264	496793088	28.1425	9.2521	2.89873	1.26263	2488.1	492652
793	628849	498677257	28.1603	9.2560	2.89927	1.26103	2491.3	493897
794	630436	500566184	28.1780	9.2599	2.89982	1.25945	2494.4	495143
795	632025	502459875	28.1957	9.2638	2.90037	1.25786	2497.6	496391
796	633616	504358336	28.2135	9.2677	2.90091	1.25628	2500.7	497641
797	635209	506261573	28.2312	9.2716	2.90146	1.25471	2503.8	498892
798	636804	508169592	28.2489	9.2755	2.90200	1.25313	2507.0	500145
799	638401	510082399	28.2666	9.2793	2.90255	1.25156	2510.1	501399

INDEX  
 METRIC MEASUREMENTS



**THE CARNEGIE STEEL COMPANY, LIMITED.**

**SQUARES, CUBES, SQUARE ROOTS, CUBE ROOTS, LOGARITHMS,  
RECIPROCAL, CIRCUMFERENCES AND CIRCULAR  
AREAS OF NOS. FROM 1 TO 1000.**

No.	Square.	Cube.	Sq. Root.	Cube Root.	Log.	1000xRecip.	No. - Dia.	
							Circum.	Area.
800	640000	512000000	28.2843	9.2832	2.90309	1.25000	2513.3	502655
801	641601	513922401	28.3019	9.2870	2.90363	1.24844	2516.4	503912
802	643204	515849608	28.3196	9.2909	2.90417	1.24688	2519.6	505171
803	644809	517781627	28.3373	9.2948	2.90472	1.24533	2522.7	506432
804	646416	519718464	28.3549	9.2986	2.90526	1.24378	2525.8	507694
805	648025	521660125	28.3725	9.3025	2.90580	1.24224	2529.0	508958
806	649636	523606616	28.3901	9.3063	2.90634	1.24069	2532.1	510223
807	651249	525557943	28.4077	9.3102	2.90687	1.23916	2535.3	511490
808	652864	527514112	28.4253	9.3140	2.90741	1.23762	2538.4	512758
809	654481	529475129	28.4429	9.3179	2.90795	1.23609	2541.5	514028
810	656100	531441000	28.4605	9.3217	2.90849	1.23457	2544.7	515300
811	657721	533411731	28.4781	9.3255	2.90902	1.23305	2547.8	516573
812	659344	535387328	28.4956	9.3294	2.90956	1.23153	2551.0	517848
813	660969	537367797	28.5132	9.3332	2.91009	1.23001	2554.1	519124
814	662596	539353144	28.5307	9.3370	2.91062	1.22850	2557.3	520402
815	664225	541343375	28.5482	9.3408	2.91116	1.22699	2560.4	521681
816	665856	543338496	28.5657	9.3447	2.91169	1.22549	2563.5	522962
817	667489	545338513	28.5832	9.3485	2.91222	1.22399	2566.7	524245
818	669124	547343432	28.6007	9.3523	2.91275	1.22249	2569.8	525529
819	670761	549353259	28.6182	9.3561	2.91328	1.22100	2573.0	526814
820	672400	551368000	28.6356	9.3599	2.91381	1.21951	2576.1	528102
821	674041	553387661	28.6531	9.3637	2.91434	1.21803	2579.2	529391
822	675684	555412248	28.6705	9.3675	2.91487	1.21655	2582.4	530681
823	677329	557441767	28.6880	9.3713	2.91540	1.21507	2585.5	531973
824	678976	559476224	28.7054	9.3751	2.91593	1.21359	2588.7	533267
825	680625	561515625	28.7228	9.3789	2.91645	1.21212	2591.8	534562
826	682276	563559976	28.7402	9.3827	2.91698	1.21065	2595.0	535858
827	683929	565609283	28.7576	9.3865	2.91751	1.20919	2598.1	537157
828	685584	567663552	28.7750	9.3902	2.91803	1.20773	2601.2	538456
829	687241	569722789	28.7924	9.3940	2.91855	1.20627	2604.4	539758
830	688900	571787000	28.8097	9.3978	2.91908	1.20482	2607.5	541061
831	690561	573856191	28.8271	9.4016	2.91960	1.20337	2610.7	542365
832	692224	575930368	28.8444	9.4053	2.92012	1.20192	2613.8	543671
833	693889	578009537	28.8617	9.4091	2.92065	1.20048	2616.9	544979
834	695556	580093704	28.8791	9.4129	2.92117	1.19904	2620.1	546288
835	697225	582182875	28.8964	9.4166	2.92169	1.19760	2623.2	547599
836	698896	584277056	28.9137	9.4204	2.92221	1.19617	2626.4	548912
837	700569	586376253	28.9310	9.4241	2.92273	1.19474	2629.5	550226
838	702244	588480472	28.9482	9.4279	2.92324	1.19332	2632.7	551541
839	703921	590589719	28.9655	9.4316	2.92376	1.19189	2635.8	552858
840	705600	592704000	28.9828	9.4354	2.92428	1.19048	2638.9	554177
841	707281	594823321	29.0000	9.4391	2.92480	1.18906	2642.1	555497
842	708964	596947688	29.0172	9.4429	2.92531	1.18765	2645.2	556819
843	710649	599077107	29.0345	9.4466	2.92583	1.18624	2648.4	558142
844	712336	601211584	29.0517	9.4503	2.92634	1.18483	2651.5	559467
845	714025	603351125	29.0689	9.4541	2.92686	1.18343	2654.6	560794
846	715716	605495736	29.0861	9.4578	2.92737	1.18203	2657.8	562122
847	717409	607645423	29.1033	9.4615	2.92788	1.18064	2660.9	563452
848	719104	609800192	29.1204	9.4652	2.92840	1.17925	2664.1	564783
849	720801	611960049	29.1376	9.4689	2.92891	1.17786	2667.2	566116

THE CARNEGIE STEEL COMPANY, LIMITED.

SQUARES, CUBES, SQUARE ROOTS, CUBE ROOTS, LOGARITHMS, RECIPROCAL, CIRCUMFERENCES AND CIRCULAR AREAS OF NOS. FROM 1 TO 1000.

No.	Square.	Cube.	Sq. Root.	Cube Root.	Log.	1000xRecip.	No. = Dia.	
							Circum.	Area.
850	722500	614125000	29.1548	9.4727	2.92942	1.17647	2670.4	567450
851	724201	616295051	29.1719	9.4764	2.92993	1.17509	2673.5	568786
852	725904	618470208	29.1890	9.4801	2.93044	1.17371	2676.6	570124
853	727609	620650477	29.2062	9.4838	2.93095	1.17233	2679.8	571463
854	729316	622835864	29.2233	9.4875	2.93146	1.17096	2682.9	572803
855	731025	625026375	29.2404	9.4912	2.93197	1.16959	2686.1	574146
856	732736	627222016	29.2575	9.4949	2.93247	1.16822	2689.2	575490
857	734449	629422793	29.2746	9.4986	2.93298	1.16686	2692.3	576835
858	736164	631628712	29.2916	9.5023	2.93349	1.16550	2695.5	578182
859	737881	633839779	29.3087	9.5060	2.93399	1.16414	2698.6	579530
860	739600	636050900	29.3258	9.5097	2.93450	1.16279	2701.8	580880
861	741321	638277381	29.3428	9.5134	2.93500	1.16144	2704.9	582232
862	743044	640503928	29.3598	9.5171	2.93551	1.16009	2708.1	583585
863	744769	642735647	29.3769	9.5207	2.93601	1.15875	2711.2	584940
864	746496	644972544	29.3939	9.5244	2.93651	1.15741	2714.3	586297
865	748225	647214625	29.4109	9.5281	2.93702	1.15607	2717.5	587655
866	749956	649461896	29.4279	9.5317	2.93752	1.15473	2720.6	589014
867	751689	651714363	29.4449	9.5354	2.93802	1.15340	2723.8	590375
868	753424	653972032	29.4618	9.5391	2.93852	1.15207	2726.9	591738
869	755161	656234909	29.4788	9.5427	2.93902	1.15075	2730.0	593102
870	756900	658503000	29.4958	9.5464	2.93952	1.14943	2733.2	594468
871	758641	660776311	29.5127	9.5501	2.94002	1.14811	2736.3	595835
872	760384	663054848	29.5296	9.5537	2.94052	1.14679	2739.5	597204
873	762129	665338617	29.5466	9.5574	2.94101	1.14548	2742.6	598575
874	763876	667627624	29.5635	9.5610	2.94151	1.14416	2745.8	599947
875	765625	669921875	29.5804	9.5647	2.94201	1.14286	2748.9	601320
876	767376	672221376	29.5973	9.5683	2.94250	1.14155	2752.0	602696
877	769129	674526133	29.6142	9.5719	2.94300	1.14025	2755.2	604073
878	770884	676836152	29.6311	9.5756	2.94349	1.13895	2758.3	605451
879	772641	679151439	29.6479	9.5792	2.94399	1.13766	2761.5	606831
880	774400	681472000	29.6648	9.5828	2.94448	1.13636	2764.6	608212
881	776161	683797841	29.6816	9.5865	2.94498	1.13507	2767.7	609595
882	777924	686128968	29.6985	9.5901	2.94547	1.13379	2770.9	610980
883	779689	688465387	29.7153	9.5937	2.94596	1.13250	2774.0	612366
884	781456	690807104	29.7321	9.5973	2.94645	1.13122	2777.2	613754
885	783225	693154125	29.7489	9.6010	2.94694	1.12994	2780.3	615143
886	784996	695506456	29.7658	9.6046	2.94743	1.12867	2783.5	616534
887	786769	697864103	29.7825	9.6082	2.94792	1.12740	2786.6	617927
888	788544	700227072	29.7993	9.6118	2.94841	1.12613	2789.7	619321
889	790321	702595369	29.8161	9.6154	2.94890	1.12486	2792.9	620717
890	792100	704969000	29.8329	9.6190	2.94939	1.12360	2796.0	622114
891	793881	707347971	29.8496	9.6226	2.94988	1.12233	2799.2	623513
892	795664	709732288	29.8664	9.6262	2.95036	1.12108	2802.3	624913
893	797449	712121957	29.8831	9.6298	2.95085	1.11982	2805.4	626315
894	799236	714516984	29.8998	9.6334	2.95134	1.11857	2808.6	627718
895	801025	716917375	29.9166	9.6370	2.95182	1.11732	2811.7	629124
896	802816	719323136	29.9333	9.6406	2.95231	1.11607	2814.9	630530
897	804609	721734273	29.9500	9.6442	2.95279	1.11483	2818.0	631938
898	806404	724150792	29.9666	9.6477	2.95328	1.11359	2821.2	633348
899	808201	726572699	29.9833	9.6513	2.95376	1.11235	2824.3	634760

THE CARNEGIE STEEL COMPANY, LIMITED.

SQUARES, CUBES, SQUARE ROOTS, CUBE ROOTS, LOGARITHMS,  
RECIPROCAL, CIRCUMFERENCES AND CIRCULAR  
AREAS OF NOS. FROM 1 TO 1000.

No.	Square.	Cube.	Sq. Root.	Cube Root.	Log.	1000xRecip.	No. = Dia.	
							Circum.	Area.
900	810000	729000000	30.0000	9.6549	2.95424	1.11111	2827.4	636173
901	811801	731432701	30.0167	9.6585	2.95472	1.10888	2830.6	637587
902	813604	733870808	30.0333	9.6620	2.95521	1.10865	2833.7	639003
903	815409	736314327	30.0500	9.6656	2.95569	1.10742	2836.9	640421
904	817216	738763264	30.0666	9.6692	2.95617	1.10619	2840.0	641840
905	819025	741217625	30.0832	9.6727	2.95665	1.10497	2843.1	643261
906	820836	743677416	30.0998	9.6763	2.95713	1.10375	2846.3	644683
907	822649	746142643	30.1164	9.6799	2.95761	1.10254	2849.4	646107
908	824464	748613312	30.1330	9.6834	2.95809	1.10132	2852.6	647533
909	826281	751089429	30.1496	9.6870	2.95856	1.10011	2855.7	648960
910	828100	753571000	30.1662	9.6905	2.95904	1.09890	2858.8	650388
911	829921	756058031	30.1828	9.6941	2.95952	1.09769	2862.0	651818
912	831744	758550528	30.1993	9.6976	2.95999	1.09649	2865.1	653250
913	833569	761048497	30.2159	9.7012	2.96047	1.09529	2868.3	654684
914	835396	763551944	30.2324	9.7047	2.96095	1.09409	2871.4	656118
915	837225	766060875	30.2490	9.7082	2.96142	1.09290	2874.6	657555
916	839056	768575296	30.2655	9.7118	2.96190	1.09170	2877.7	658993
917	840889	771095213	30.2820	9.7153	2.96237	1.09051	2880.8	660433
918	842724	773620632	30.2985	9.7188	2.96284	1.08932	2884.0	661874
919	844561	776151559	30.3150	9.7224	2.96332	1.08814	2887.1	663317
920	846400	778688000	30.3315	9.7259	2.96379	1.08696	2890.3	664761
921	848241	781229961	30.3480	9.7294	2.96426	1.08578	2893.4	666207
922	850084	783777448	30.3645	9.7329	2.96473	1.08460	2896.5	667654
923	851929	786330467	30.3809	9.7364	2.96520	1.08342	2899.7	669103
924	853776	788889024	30.3974	9.7400	2.96567	1.08225	2902.8	670554
925	855625	791453125	30.4138	9.7435	2.96614	1.08108	2906.0	672006
926	857476	794022776	30.4302	9.7470	2.96661	1.07991	2909.1	673460
927	859329	796597983	30.4467	9.7505	2.96708	1.07875	2912.3	674915
928	861184	799178752	30.4631	9.7540	2.96755	1.07759	2915.4	676372
929	863041	801765089	30.4795	9.7575	2.96802	1.07643	2918.5	677831
930	864900	804357000	30.4959	9.7610	2.96848	1.07527	2921.7	679291
931	866761	806954491	30.5123	9.7645	2.96895	1.07411	2924.8	680752
932	868624	809557568	30.5287	9.7680	2.96942	1.07296	2928.0	682216
933	870489	812166237	30.5450	9.7715	2.96988	1.07181	2931.1	683680
934	872356	814780504	30.5614	9.7750	2.97035	1.07066	2934.2	685147
935	874225	817400375	30.5778	9.7785	2.97081	1.06952	2937.4	686615
936	876096	820025856	30.5941	9.7819	2.97128	1.06838	2940.5	688084
937	877969	822656953	30.6105	9.7854	2.97174	1.06724	2943.7	689555
938	879844	825293672	30.6268	9.7889	2.97220	1.06610	2946.8	691028
939	881721	827936019	30.6431	9.7924	2.97267	1.06496	2950.0	692502
940	883600	830584000	30.6594	9.7959	2.97313	1.06383	2953.1	693978
941	885481	833237621	30.6757	9.7993	2.97359	1.06270	2956.2	695455
942	887364	835896888	30.6920	9.8028	2.97405	1.06157	2959.4	696934
943	889249	838561807	30.7083	9.8063	2.97451	1.06045	2962.5	698415
944	891136	841232384	30.7246	9.8097	2.97497	1.05932	2965.7	699897
945	893025	843908625	30.7409	9.8132	2.97543	1.05820	2968.8	701380
946	894916	846590536	30.7571	9.8167	2.97589	1.05708	2971.9	702865
947	896809	849278123	30.7734	9.8201	2.97635	1.05597	2975.1	704352
948	898704	851971392	30.7896	9.8236	2.97681	1.05485	2978.2	705840
949	900601	854670349	30.8058	9.8270	2.97727	1.05374	2981.4	707330

THE CARNEGIE STEEL COMPANY, LIMITED.

SQUARES, CUBES, SQUARE ROOTS, CUBE ROOTS, LOGARITHMS,  
RECIPROCAL, CIRCUMFERENCES AND CIRCULAR  
AREAS OF NOS. FROM 1 TO 1000.

No.	Square.	Cube.	Sq. Root.	Cube Root	Log.	1000xRecip.	No. - Dia.	
							Circum.	Area.
950	902500	857375000	30.8221	9.8305	2.97772	1.05263	2984.5	708822
951	904401	860085351	30.8383	9.8339	2.97818	1.05152	2987.7	710315
952	906304	862801408	30.8545	9.8374	2.97864	1.05042	2990.8	711809
953	908209	865523177	30.8707	9.8408	2.97909	1.04932	2993.9	713306
954	910116	868250664	30.8869	9.8443	2.97955	1.04822	2997.1	714803
955	912025	870983875	30.9031	9.8477	2.98000	1.04712	3000.2	716303
956	913936	873722816	30.9192	9.8511	2.98046	1.04603	3003.4	717804
957	915849	876467493	30.9354	9.8546	2.98091	1.04493	3006.5	719306
958	917764	879217912	30.9516	9.8580	2.98137	1.04384	3009.6	720810
959	919681	881974079	30.9677	9.8614	2.98182	1.04275	3012.8	722316
960	921600	884736000	30.9839	9.8648	2.98227	1.04167	3015.9	723823
961	923521	887503681	31.0000	9.8683	2.98272	1.04058	3019.1	725332
962	925444	890277128	31.0161	9.8717	2.98318	1.03950	3022.2	726842
963	927369	893056347	31.0322	9.8751	2.98363	1.03842	3025.4	728354
964	929296	895841344	31.0483	9.8785	2.98408	1.03734	3028.5	729867
965	931225	898632125	31.0644	9.8819	2.98453	1.03627	3031.6	731382
966	933156	901428696	31.0805	9.8854	2.98498	1.03520	3034.8	732899
967	935089	904231063	31.0966	9.8888	2.98543	1.03413	3037.9	734417
968	937024	907039232	31.1127	9.8922	2.98588	1.03306	3041.1	735937
969	938961	909853200	31.1288	9.8956	2.98633	1.03199	3044.2	737458
970	940900	912673000	31.1448	9.8990	2.98677	1.03093	3047.3	738981
971	942841	915498611	31.1609	9.9024	2.98722	1.02987	3050.5	740506
972	944784	918330048	31.1769	9.9058	2.98767	1.02881	3053.6	742032
973	946729	921167317	31.1929	9.9092	2.98811	1.02775	3056.8	743559
974	948676	924010424	31.2090	9.9126	2.98856	1.02669	3059.9	745088
975	950625	926859375	31.2250	9.9160	2.98900	1.02564	3063.1	746619
976	952576	929714176	31.2410	9.9194	2.98945	1.02459	3066.2	748151
977	954529	932574833	31.2570	9.9227	2.98989	1.02354	3069.3	749685
978	956484	935441352	31.2730	9.9261	2.99034	1.02249	3072.5	751221
979	958441	938313739	31.2890	9.9295	2.99078	1.02145	3075.6	752758
980	960400	941192000	31.3050	9.9329	2.99123	1.02041	3078.8	754296
981	962361	944076141	31.3209	9.9363	2.99167	1.01937	3081.9	755837
982	964324	946966168	31.3369	9.9396	2.99211	1.01833	3085.0	757378
983	966289	949862087	31.3528	9.9430	2.99255	1.01729	3088.2	758922
984	968256	952763904	31.3688	9.9464	2.99300	1.01626	3091.3	760466
985	970225	955671625	31.3847	9.9497	2.99344	1.01523	3094.5	762013
986	972196	958585256	31.4006	9.9531	2.99388	1.01420	3097.6	763561
987	974169	961504803	31.4166	9.9565	2.99432	1.01317	3100.8	765111
988	976144	964430272	31.4325	9.9598	2.99476	1.01215	3103.9	766662
989	978121	967361669	31.4484	9.9632	2.99520	1.01112	3107.0	768214
990	980100	970299000	31.4643	9.9666	2.99564	1.01010	3110.2	769769
991	982081	973242271	31.4802	9.9700	2.99607	1.00908	3113.3	771325
992	984064	976191488	31.4960	9.9733	2.99651	1.00806	3116.5	772882
993	986049	979146657	31.5119	9.9766	2.99695	1.00705	3119.6	774441
994	988036	982107784	31.5278	9.9800	2.99739	1.00604	3122.7	776002
995	990025	985074875	31.5436	9.9833	2.99782	1.00503	3125.9	777564
996	992016	988047936	31.5595	9.9866	2.99826	1.00402	3129.0	779128
997	994009	991026973	31.5753	9.9900	2.99870	1.00301	3132.2	780693
998	996004	994011992	31.5911	9.9933	2.99913	1.00200	3135.3	782260
999	998001	997002999	31.6070	9.9967	2.99957	1.00100	3138.5	783828

INDEX  
MISCELLANEOUS

THE CARNEGIE STEEL COMPANY, LIMITED.

Degrees.	TANGENT.							
	0'	10'	20'	30'	40'	50'	60'	
0	0.00000	0.00201	0.00582	0.00873	0.01164	0.01455	0.01746	89
1	0.01746	0.02036	0.02328	0.02619	0.02910	0.03201	0.03492	88
2	0.03492	0.03783	0.04075	0.04366	0.04658	0.04949	0.05241	87
3	0.05241	0.05533	0.05824	0.06116	0.06408	0.06700	0.06993	86
4	0.06993	0.07285	0.07578	0.07870	0.08163	0.08456	0.08749	85
5	0.08749	0.09042	0.09335	0.09629	0.09923	0.10216	0.10510	84
6	0.10510	0.10805	0.11099	0.11394	0.11688	0.11983	0.12278	83
7	0.12278	0.12574	0.12869	0.13165	0.13461	0.13758	0.14054	82
8	0.14054	0.14351	0.14648	0.14945	0.15243	0.15540	0.15838	81
9	0.15838	0.16137	0.16435	0.16734	0.17033	0.17333	0.17633	80
10	0.17633	0.17933	0.18233	0.18534	0.18835	0.19136	0.19438	79
11	0.19438	0.19740	0.20042	0.20345	0.20648	0.20952	0.21256	78
12	0.21256	0.21560	0.21864	0.22169	0.22475	0.22781	0.23087	77
13	0.23087	0.23393	0.23700	0.24008	0.24316	0.24624	0.24933	76
14	0.24933	0.25242	0.25552	0.25862	0.26172	0.26483	0.26795	75
15	0.26795	0.27107	0.27419	0.27732	0.28046	0.28360	0.28675	74
16	0.28675	0.28990	0.29305	0.29621	0.29938	0.30255	0.30573	73
17	0.30573	0.30891	0.31210	0.31530	0.31850	0.32171	0.32492	72
18	0.32492	0.32814	0.33136	0.33460	0.33783	0.34108	0.34433	71
19	0.34433	0.34758	0.35085	0.35412	0.35740	0.36068	0.36397	70
20	0.36397	0.36727	0.37057	0.37388	0.37720	0.38053	0.38386	69
21	0.38386	0.38721	0.39055	0.39391	0.39727	0.40065	0.40403	68
22	0.40403	0.40741	0.41081	0.41421	0.41763	0.42105	0.42447	67
23	0.42447	0.42791	0.43136	0.43481	0.43828	0.44175	0.44523	66
24	0.44523	0.44872	0.45222	0.45573	0.45924	0.46277	0.46631	65
25	0.46631	0.46985	0.47341	0.47698	0.48055	0.48414	0.48773	64
26	0.48773	0.49134	0.49495	0.49858	0.50222	0.50587	0.50953	63
27	0.50953	0.51320	0.51688	0.52057	0.52427	0.52798	0.53171	62
28	0.53171	0.53545	0.53920	0.54296	0.54673	0.55051	0.55431	61
29	0.55431	0.55812	0.56194	0.56577	0.56962	0.57348	0.57735	60
30	0.57735	0.58124	0.58513	0.58905	0.59297	0.59691	0.60086	59
31	0.60086	0.60483	0.60881	0.61280	0.61681	0.62083	0.62487	58
32	0.62487	0.62892	0.63299	0.63707	0.64117	0.64528	0.64941	57
33	0.64941	0.65355	0.65771	0.66189	0.66608	0.67028	0.67451	56
34	0.67451	0.67875	0.68301	0.68728	0.69157	0.69588	0.70021	55
35	0.70021	0.70455	0.70891	0.71329	0.71769	0.72211	0.72654	54
36	0.72654	0.73100	0.73547	0.73996	0.74447	0.74900	0.75355	53
37	0.75355	0.75812	0.76272	0.76733	0.77196	0.77661	0.78129	52
38	0.78129	0.78598	0.79070	0.79544	0.80020	0.80498	0.80978	51
39	0.80978	0.81461	0.81946	0.82434	0.82923	0.83415	0.83910	50
40	0.83910	0.84407	0.84906	0.85408	0.85912	0.86419	0.86929	49
41	0.86929	0.87441	0.87955	0.88473	0.88992	0.89515	0.90040	48
42	0.90040	0.90569	0.91099	0.91633	0.92170	0.92709	0.93252	47
43	0.93252	0.93797	0.94345	0.94896	0.95451	0.96008	0.96569	46
44	0.96569	0.97133	0.97700	0.98270	0.98843	0.99420	1.00000	45
	60'	50'	40'	30'	20'	10'	0'	Degrees.

COTANGENT.

THE CARNEGIE STEEL COMPANY, LIMITED.

Degrees.	COTANGENT.							Degrees.
	0'	10'	20'	30'	40'	50'	60'	
0	∞	343.77371	171.88540	114.58805	85.93979	68.75000	57.28996	89
1	57.28996	49.10388	42.96408	38.18846	34.36777	31.24158	28.63625	88
2	28.63625	26.43160	24.54176	22.90377	21.47040	20.20555	19.08114	87
3	19.08114	18.07498	17.16934	16.34986	15.60478	14.92442	14.30067	86
4	14.30067	13.72674	13.19688	12.70621	12.25051	11.82617	11.43005	85
5	11.43005	11.05943	10.71191	10.38540	10.07803	9.78817	9.51436	84
6	9.51436	9.25530	9.00983	8.77689	8.55555	8.34496	8.14435	83
7	8.14435	7.95302	7.77035	7.59575	7.42871	7.26873	7.11537	82
8	7.11537	6.96823	6.82694	6.69116	6.56055	6.43484	6.31375	81
9	6.31375	6.19703	6.08444	5.97576	5.87080	5.76937	5.67128	80
10	5.67128	5.57638	5.48451	5.39552	5.30928	5.22566	5.14455	79
11	5.14455	5.06584	4.98940	4.91516	4.84300	4.77286	4.70463	78
12	4.70463	4.63825	4.57363	4.51071	4.44942	4.38969	4.33148	77
13	4.33148	4.27471	4.21933	4.16530	4.11256	4.06107	4.01078	76
14	4.01078	3.96165	3.91364	3.86671	3.82083	3.77595	3.73205	75
15	3.73205	3.68900	3.64705	3.60588	3.56557	3.52609	3.48741	74
16	3.48741	3.44951	3.41236	3.37594	3.34023	3.30521	3.27085	73
17	3.27085	3.23714	3.20406	3.17159	3.13972	3.10842	3.07768	72
18	3.07768	3.04749	3.01783	2.98869	2.96004	2.93189	2.90421	71
19	2.90421	2.87700	2.85023	2.82391	2.79802	2.77254	2.74748	70
20	2.74748	2.72281	2.69853	2.67462	2.65109	2.62791	2.60509	69
21	2.60509	2.58261	2.56046	2.53865	2.51715	2.49597	2.47509	68
22	2.47509	2.45451	2.43422	2.41421	2.39449	2.37504	2.35585	67
23	2.35585	2.33693	2.31826	2.29984	2.28167	2.26374	2.24604	66
24	2.24604	2.22857	2.21132	2.19430	2.17749	2.16090	2.14451	65
25	2.14451	2.12832	2.11233	2.09654	2.08094	2.06553	2.05030	64
26	2.05030	2.03526	2.02039	2.00569	1.99116	1.97680	1.96261	63
27	1.96261	1.94858	1.93470	1.92098	1.90741	1.89400	1.88073	62
28	1.88073	1.86760	1.85462	1.84177	1.82906	1.81649	1.80405	61
29	1.80405	1.79174	1.77955	1.76749	1.75556	1.74375	1.73205	60
30	1.73205	1.72047	1.70901	1.69766	1.68643	1.67530	1.66428	59
31	1.66428	1.65337	1.64256	1.63185	1.62125	1.61074	1.60033	58
32	1.60033	1.59002	1.57981	1.56969	1.55966	1.54972	1.53987	57
33	1.53987	1.53010	1.52043	1.51084	1.50133	1.49190	1.48256	56
34	1.48256	1.47330	1.46411	1.45501	1.44598	1.43703	1.42815	55
35	1.42815	1.41934	1.41061	1.40195	1.39336	1.38484	1.37638	54
36	1.37638	1.36800	1.35968	1.35142	1.34323	1.33511	1.32704	53
37	1.32704	1.31904	1.31110	1.30323	1.29541	1.28764	1.27994	52
38	1.27994	1.27230	1.26471	1.25717	1.24969	1.24227	1.23490	51
39	1.23490	1.22758	1.22031	1.21310	1.20593	1.19882	1.19175	50
40	1.19175	1.18474	1.17777	1.17085	1.16398	1.15715	1.15037	49
41	1.15037	1.14363	1.13694	1.13029	1.12369	1.11713	1.11061	48
42	1.11061	1.10414	1.09770	1.09131	1.08496	1.07864	1.07237	47
43	1.07237	1.06613	1.05994	1.05378	1.04766	1.04158	1.03553	46
44	1.03553	1.02952	1.02355	1.01761	1.01170	1.00583	1.00000	45
	60'	50'	40'	30'	20'	10'	0'	

TANGENT.

INDEX

THE CARNEGIE STEEL COMPANY, LIMITED.

Degrees.	SINE							
	0'	10'	20'	30'	40'	50'	60'	
0	0.00000	0.00291	0.00582	0.00873	0.01164	0.01454	0.01745	89
1	0.01745	0.02036	0.02327	0.02618	0.02908	0.03199	0.03490	88
2	0.03490	0.03781	0.04071	0.04362	0.04653	0.04943	0.05234	87
3	0.05234	0.05524	0.05814	0.06105	0.06395	0.06685	0.06976	86
4	0.06976	0.07266	0.07556	0.07846	0.08136	0.08426	0.08716	85
5	0.08716	0.09005	0.09295	0.09585	0.09874	0.10164	0.10453	84
6	0.10453	0.10742	0.11031	0.11320	0.11609	0.11898	0.12187	83
7	0.12187	0.12476	0.12764	0.13053	0.13341	0.13629	0.13917	82
8	0.13917	0.14205	0.14493	0.14781	0.15069	0.15356	0.15643	81
9	0.15643	0.15931	0.16218	0.16505	0.16792	0.17078	0.17365	80
10	0.17365	0.17651	0.17937	0.18224	0.18509	0.18795	0.19081	79
11	0.19081	0.19366	0.19652	0.19937	0.20222	0.20507	0.20791	78
12	0.20791	0.21076	0.21360	0.21644	0.21928	0.22212	0.22495	77
13	0.22495	0.22778	0.23062	0.23345	0.23627	0.23910	0.24192	76
14	0.24192	0.24474	0.24756	0.25038	0.25320	0.25601	0.25882	75
15	0.25882	0.26163	0.26443	0.26724	0.27004	0.27284	0.27564	74
16	0.27564	0.27843	0.28123	0.28402	0.28680	0.28959	0.29237	73
17	0.29237	0.29515	0.29793	0.30071	0.30348	0.30625	0.30902	72
18	0.30902	0.31178	0.31454	0.31730	0.32006	0.32282	0.32557	71
19	0.32557	0.32832	0.33106	0.33381	0.33655	0.33929	0.34202	70
20	0.34202	0.34475	0.34748	0.35021	0.35293	0.35565	0.35837	69
21	0.35837	0.36108	0.36379	0.36650	0.36921	0.37191	0.37461	68
22	0.37461	0.37730	0.37999	0.38268	0.38537	0.38805	0.39073	67
23	0.39073	0.39341	0.39608	0.39875	0.40142	0.40408	0.40674	66
24	0.40674	0.40939	0.41204	0.41469	0.41734	0.41998	0.42262	65
25	0.42262	0.42525	0.42788	0.43051	0.43313	0.43575	0.43837	64
26	0.43837	0.44098	0.44359	0.44620	0.44880	0.45140	0.45399	63
27	0.45399	0.45658	0.45917	0.46175	0.46433	0.46690	0.46947	62
28	0.46947	0.47204	0.47460	0.47716	0.47971	0.48226	0.48481	61
29	0.48481	0.48735	0.48989	0.49242	0.49495	0.49748	0.50000	60
30	0.50000	0.50252	0.50503	0.50754	0.51004	0.51254	0.51504	59
31	0.51504	0.51753	0.52002	0.52250	0.52498	0.52745	0.52992	58
32	0.52992	0.53238	0.53484	0.53730	0.53975	0.54220	0.54464	57
33	0.54464	0.54708	0.54951	0.55194	0.55436	0.55678	0.55919	56
34	0.55919	0.56160	0.56401	0.56641	0.56880	0.57119	0.57358	55
35	0.57358	0.57596	0.57833	0.58070	0.58307	0.58543	0.58779	54
36	0.58779	0.59014	0.59248	0.59482	0.59716	0.59949	0.60182	53
37	0.60182	0.60414	0.60645	0.60876	0.61107	0.61337	0.61566	52
38	0.61566	0.61795	0.62024	0.62251	0.62479	0.62706	0.62932	51
39	0.62932	0.63158	0.63383	0.63608	0.63832	0.64056	0.64279	50
40	0.64279	0.64501	0.64723	0.64945	0.65166	0.65386	0.65606	49
41	0.65606	0.65825	0.66044	0.66262	0.66480	0.66697	0.66913	48
42	0.66913	0.67129	0.67344	0.67559	0.67773	0.67987	0.68200	47
43	0.68200	0.68412	0.68624	0.68835	0.69046	0.69256	0.69466	46
44	0.69466	0.69675	0.69883	0.70091	0.70298	0.70505	0.70711	45
	60'	50'	40'	30'	20'	10'	0'	

COSINE

Degrees.

THE CARNEGIE STEEL COMPANY, LIMITED.

Degrees.	COSINE.							Degrees.
	0'	10'	20'	30'	40'	50'	60'	
0	1.00000	1.00000	0.99908	0.99996	0.99993	0.99989	0.99985	89
1	0.99985	0.99979	0.99973	0.99966	0.99958	0.99949	0.99939	88
2	0.99969	0.99929	0.99917	0.99905	0.99892	0.99878	0.99863	87
3	0.99863	0.99847	0.99831	0.99813	0.99795	0.99776	0.99756	86
4	0.99756	0.99736	0.99714	0.99692	0.99668	0.99644	0.99619	85
5	0.99619	0.99594	0.99567	0.99540	0.99511	0.99482	0.99452	84
6	0.99452	0.99421	0.99390	0.99357	0.99324	0.99290	0.99255	83
7	0.99255	0.99219	0.99182	0.99144	0.99106	0.99067	0.99027	82
8	0.99027	0.98986	0.98944	0.98902	0.98858	0.98814	0.98769	81
9	0.98769	0.98723	0.98676	0.98629	0.98580	0.98531	0.98481	80
10	0.98481	0.98430	0.98378	0.98325	0.98272	0.98218	0.98163	79
11	0.98163	0.98107	0.98050	0.97992	0.97934	0.97875	0.97815	78
12	0.97815	0.97754	0.97692	0.97630	0.97566	0.97502	0.97437	77
13	0.97437	0.97371	0.97304	0.97237	0.97169	0.97100	0.97030	76
14	0.97030	0.96959	0.96887	0.96815	0.96742	0.96667	0.96593	75
15	0.96593	0.96517	0.96440	0.96363	0.96285	0.96206	0.96126	74
16	0.96126	0.96046	0.95964	0.95882	0.95799	0.95715	0.95630	73
17	0.95630	0.95545	0.95459	0.95372	0.95284	0.95195	0.95106	72
18	0.95106	0.95015	0.94924	0.94832	0.94740	0.94646	0.94552	71
19	0.94552	0.94457	0.94361	0.94264	0.94167	0.94068	0.93969	70
20	0.93969	0.93869	0.93769	0.93667	0.93565	0.93462	0.93358	69
21	0.93358	0.93253	0.93148	0.93042	0.92935	0.92827	0.92718	68
22	0.92718	0.92609	0.92499	0.92388	0.92276	0.92164	0.92050	67
23	0.92050	0.91936	0.91822	0.91706	0.91590	0.91472	0.91355	66
24	0.91355	0.91236	0.91116	0.90996	0.90875	0.90753	0.90631	65
25	0.90631	0.90507	0.90383	0.90259	0.90133	0.90007	0.89879	64
26	0.89879	0.89752	0.89623	0.89493	0.89363	0.89232	0.89101	63
27	0.89101	0.88968	0.88835	0.88701	0.88566	0.88431	0.88295	62
28	0.88295	0.88158	0.88020	0.87882	0.87743	0.87603	0.87462	61
29	0.87462	0.87321	0.87178	0.87036	0.86892	0.86748	0.86603	60
30	0.86603	0.86457	0.86310	0.86163	0.86015	0.85866	0.85717	59
31	0.85717	0.85567	0.85416	0.85264	0.85112	0.84959	0.84805	58
32	0.84805	0.84650	0.84495	0.84339	0.84182	0.84025	0.83867	57
33	0.83867	0.83708	0.83549	0.83389	0.83228	0.83066	0.82904	56
34	0.82904	0.82741	0.82577	0.82413	0.82248	0.82082	0.81915	55
35	0.81915	0.81748	0.81580	0.81412	0.81242	0.81072	0.80902	54
36	0.80902	0.80730	0.80558	0.80386	0.80212	0.80038	0.79864	53
37	0.79864	0.79688	0.79512	0.79335	0.79158	0.78980	0.78801	52
38	0.78801	0.78622	0.78442	0.78261	0.78079	0.77897	0.77715	51
39	0.77715	0.77531	0.77347	0.77162	0.76977	0.76791	0.76604	50
40	0.76604	0.76417	0.76229	0.76041	0.75851	0.75661	0.75471	49
41	0.75471	0.75280	0.75088	0.74896	0.74703	0.74509	0.74314	48
42	0.74314	0.74120	0.73924	0.73728	0.73531	0.73333	0.73135	47
43	0.73135	0.72937	0.72737	0.72537	0.72337	0.72136	0.71934	46
44	0.71934	0.71732	0.71529	0.71325	0.71121	0.70916	0.70711	45
	60'	50'	40'	30'	20'	10'	0'	

SINE.

INDEX

MISCELLANEOUS



THE CARNEGIE STEEL COMPANY, LIMITED.

Degrees.	SECSANTS.							
	0'	10'	20'	30'	40'	50'	60'	
0	1.00000	1.00001	1.00002	1.00004	1.00007	1.00011	1.00015	89
1	1.00015	1.00021	1.00027	1.00034	1.00042	1.00051	1.00061	88
2	1.00061	1.00072	1.00083	1.00095	1.00108	1.00122	1.00137	87
3	1.00137	1.00153	1.00169	1.00187	1.00205	1.00224	1.00244	86
4	1.00244	1.00265	1.00287	1.00309	1.00333	1.00357	1.00382	85
5	1.00382	1.00408	1.00435	1.00463	1.00491	1.00521	1.00551	84
6	1.00551	1.00582	1.00614	1.00647	1.00681	1.00715	1.00751	83
7	1.00751	1.00787	1.00825	1.00863	1.00902	1.00942	1.00983	82
8	1.00983	1.01024	1.01067	1.01111	1.01155	1.01200	1.01247	81
9	1.01247	1.01294	1.01342	1.01391	1.01440	1.01491	1.01543	80
10	1.01543	1.01595	1.01649	1.01703	1.01758	1.01815	1.01872	79
11	1.01872	1.01930	1.01989	1.02049	1.02110	1.02171	1.02234	78
12	1.02234	1.02298	1.02362	1.02428	1.02494	1.02562	1.02630	77
13	1.02630	1.02700	1.02770	1.02842	1.02914	1.02987	1.03061	76
14	1.03061	1.03137	1.03213	1.03290	1.03368	1.03447	1.03528	75
15	1.03528	1.03609	1.03691	1.03774	1.03858	1.03944	1.04030	74
16	1.04030	1.04117	1.04206	1.04295	1.04385	1.04477	1.04569	73
17	1.04569	1.04663	1.04757	1.04853	1.04950	1.05047	1.05146	72
18	1.05146	1.05246	1.05347	1.05449	1.05552	1.05657	1.05762	71
19	1.05762	1.05869	1.05976	1.06085	1.06195	1.06306	1.06418	70
20	1.06418	1.06531	1.06645	1.06761	1.06878	1.06995	1.07115	69
21	1.07115	1.07235	1.07356	1.07479	1.07602	1.07727	1.07853	68
22	1.07853	1.07981	1.08109	1.08239	1.08370	1.08503	1.08636	67
23	1.08636	1.08771	1.08907	1.09044	1.09183	1.09323	1.09464	66
24	1.09464	1.09606	1.09750	1.09895	1.10041	1.10189	1.10338	65
25	1.10338	1.10488	1.10640	1.10793	1.10947	1.11103	1.11260	64
26	1.11260	1.11419	1.11579	1.11740	1.11903	1.12067	1.12233	63
27	1.12233	1.12400	1.12568	1.12738	1.12910	1.13083	1.13257	62
28	1.13257	1.13433	1.13610	1.13789	1.13970	1.14152	1.14335	61
29	1.14335	1.14521	1.14707	1.14896	1.15085	1.15277	1.15470	60
30	1.15470	1.15667	1.15861	1.16059	1.16259	1.16460	1.16663	59
31	1.16663	1.16868	1.17075	1.17283	1.17493	1.17704	1.17918	58
32	1.17918	1.18133	1.18350	1.18569	1.18790	1.19012	1.19236	57
33	1.19236	1.19463	1.19691	1.19920	1.20152	1.20386	1.20622	56
34	1.20622	1.20859	1.21099	1.21341	1.21584	1.21830	1.22077	55
35	1.22077	1.22327	1.22579	1.22833	1.23089	1.23347	1.23607	54
36	1.23607	1.23869	1.24134	1.24400	1.24669	1.24940	1.25214	53
37	1.25214	1.25489	1.25767	1.26047	1.26330	1.26615	1.26902	52
38	1.26902	1.27191	1.27483	1.27778	1.28075	1.28374	1.28676	51
39	1.28676	1.28980	1.29287	1.29597	1.29909	1.30223	1.30541	50
40	1.30541	1.30861	1.31183	1.31509	1.31837	1.32168	1.32501	49
41	1.32501	1.32838	1.33177	1.33519	1.33864	1.34212	1.34563	48
42	1.34563	1.34917	1.35274	1.35634	1.35997	1.36363	1.36733	47
43	1.36733	1.37105	1.37481	1.37860	1.38242	1.38628	1.39016	46
44	1.39016	1.39409	1.39804	1.40203	1.40606	1.41012	1.41421	45
	60'	50'	40'	30'	20'	10'	0'	
	COSECANTS.							

Degrees.

THE CARNEGIE STEEL COMPANY, LIMITED.

COSECANTS.

Degrees.	COSECANTS.							Degrees.
	0'	10'	20'	30'	40'	50'	60'	
0	∞	343.77516	171.88831	114.59801	85.94561	68.75736	57.29869	89
1	57.29869	49.11406	42.97571	38.20155	34.38232	31.25758	28.65371	88
2	28.65371	26.45051	24.50212	22.92559	21.49368	20.23028	19.10732	87
3	19.10732	18.10262	17.19843	16.38041	15.63679	14.95788	14.33559	86
4	14.33559	13.76312	13.23472	12.74550	12.29125	11.80837	11.47371	85
5	11.47371	11.10455	10.75849	10.43343	10.12752	9.83912	9.56677	84
6	9.56677	9.30917	9.06515	8.83367	8.61379	8.40466	8.20551	83
7	8.20551	8.01565	7.83443	7.66130	7.49571	7.33719	7.18530	82
8	7.18530	7.03962	6.89979	6.76547	6.63633	6.51208	6.39245	81
9	6.39245	6.27719	6.16607	6.05886	5.95536	5.85539	5.75877	80
10	5.75877	5.66533	5.57493	5.48740	5.40263	5.32049	5.24084	79
11	5.24084	5.16359	5.08863	5.01585	4.94517	4.87649	4.80973	78
12	4.80973	4.74482	4.68167	4.62023	4.56041	4.50216	4.44541	77
13	4.44541	4.39012	4.33622	4.28366	4.23239	4.18238	4.13357	76
14	4.13357	4.08591	4.03938	3.99393	3.94952	3.90613	3.86370	75
15	3.86370	3.82223	3.78166	3.74198	3.70315	3.66515	3.62796	74
16	3.62796	3.59154	3.55587	3.52094	3.48671	3.45317	3.42030	73
17	3.42030	3.38808	3.35649	3.32551	3.29512	3.26531	3.23607	72
18	3.23607	3.20737	3.17920	3.15155	3.12440	3.09774	3.07155	71
19	3.07155	3.04584	3.02057	2.99574	2.97135	2.94737	2.92380	70
20	2.92380	2.90063	2.87785	2.85545	2.83342	2.81175	2.79043	69
21	2.79043	2.76945	2.74881	2.72850	2.70851	2.68884	2.66947	68
22	2.66947	2.65040	2.63162	2.61313	2.59491	2.57698	2.55930	67
23	2.55930	2.54190	2.52474	2.50784	2.49119	2.47477	2.45859	66
24	2.45859	2.44264	2.42692	2.41142	2.39614	2.38107	2.36620	65
25	2.36620	2.35154	2.33708	2.32282	2.30875	2.29487	2.28117	64
26	2.28117	2.26766	2.25432	2.24116	2.22817	2.21535	2.20269	63
27	2.20269	2.19019	2.17786	2.16568	2.15366	2.14178	2.13005	62
28	2.13005	2.11847	2.10704	2.09574	2.08458	2.07356	2.06267	61
29	2.06267	2.05191	2.04128	2.03077	2.02039	2.01014	2.00000	60
30	2.00000	1.98998	1.98008	1.97029	1.96062	1.95106	1.94160	59
31	1.94160	1.93226	1.92302	1.91388	1.90485	1.89591	1.88708	58
32	1.88708	1.87834	1.86990	1.86116	1.85271	1.84435	1.83608	57
33	1.83608	1.82790	1.81981	1.81180	1.80388	1.79604	1.78829	56
34	1.78829	1.78062	1.77303	1.76552	1.75808	1.75073	1.74345	55
35	1.74345	1.73624	1.72911	1.72205	1.71506	1.70815	1.70130	54
36	1.70130	1.69452	1.68782	1.68117	1.67460	1.66809	1.66164	53
37	1.66164	1.65526	1.64894	1.64268	1.63648	1.63035	1.62427	52
38	1.62427	1.61825	1.61229	1.60639	1.60054	1.59475	1.58902	51
39	1.58902	1.58333	1.57771	1.57213	1.56661	1.56114	1.55572	50
40	1.55572	1.55036	1.54504	1.53977	1.53455	1.52938	1.52425	49
41	1.52425	1.51918	1.51415	1.50916	1.50422	1.49933	1.49448	48
42	1.49448	1.48967	1.48491	1.48019	1.47551	1.47087	1.46628	47
43	1.46628	1.46173	1.45721	1.45274	1.44831	1.44391	1.43956	46
44	1.43956	1.43524	1.43096	1.42672	1.42251	1.41835	1.41421	45
	60'	50'	40'	30'	20'	10'	0'	

SECANTS.

INDEX

# THE CARNEGIE STEEL COMPANY, LIMITED,

MANUFACTURER OF

BESSEMER AND OPEN HEARTH BASIC STEEL

OF ALL GRADES,

OWNS AND OPERATES THE FOLLOWING WORKS:—

Edgar Thomson Furnaces,	- -	Bessemer,
Duquesne Furnaces,	- - -	Duquesne,
Lucy Furnaces,	- - - - -	Pittsburg,
Carrie Furnaces,	- - - - -	Rankin,
Edgar Thomson Steel Works,	-	Bessemer,
Duquesne Steel Works,	- -	Duquesne,
Homestead Steel Works,	- -	Munhall,
Keystone Bridge Works,	- - -	Pittsburg,
Upper Union Mills,	- - - -	Pittsburg,
Lower Union Mills,	- - -	Pittsburg,
Howard Axle Works,	- - -	Homestead,
Larimer Coke Works,	- - - -	Larimer,
Youghiogheny Coke Works,	-	Douglass.

**THE CARNEGIE STEEL COMPANY, LIMITED.**

**—AT WHICH ARE PRODUCED:—**

Armor Plate.

Billets (1½" up), Blooms, Slabs, Coke.

Ferro Manganese, Spiegel-eisen, Pig Iron.

Forgings, such as Axles, Arch Bars, Links, Pins and other Car Forgings, Connecting Rods, Crank Shafts, Locomotive Frames, Eye Bars.

Plates for Boilers, Bridges, Ships and Tanks.

Rails, Steel, 25 to 100 lbs. per yd.; Steel Splice Bars, (plain and angle), for all sections of Rails.

Rolled Structural Shapes, such as Angles, Rounds, Flats, Squares, Ovals, I-Beams, Channels, Bulb Angles, Deck Beams, Tees, Zees, etc.

Structural Work, such as Bridges, Buildings, Elevated Railroads, Girders, Columns, etc.

**—ADDRESS:—**

**GENERAL OFFICES:**

Pittsburg; Carnegie Building.

**SALES OFFICES:**

Atlanta; Equitable Building.

Boston; Telephone Building.

Buffalo; German Insurance Building.

Chicago; Marquette Building.

Cincinnati; Neave Building.

Cleveland; Perry-Payne Building.

Denver; Peoples Bank Building.

Detroit; Hammond Building.

Minneapolis; Guaranty Loan Building.

New York; Empire Building.

Philadelphia; Harrison Building.

St. Louis; Chemical Building.

San Francisco; 258 Market Street.

Washington; National Safe Deposit Building.

**FOREIGN SALES OFFICES:**

London (Eng.); 71 and 72 King William Street.

Montreal (Canada); Bell Telephone Building.

Mexico; 924 Apartado, City of Mexico.



INDEX.

	PAGE.
ANCHORS . . . . .	180
ANGLES . . . . .	109-110
" bulb, properties of . . . . .	84
" safe loads for . . . . .	7-8
" shapes of . . . . .	36
" weights and dimensions of . . . . .	113-123
properties of standard and special . . . . .	148-150
radii of gyration for, used as struts . . . . .	79-81
safe loads for standard and special . . . . .	21
shapes of cover . . . . .	21
" " obtuse . . . . .	21
" " safe . . . . .	19-20
" " square root . . . . .	16-17
" " standard and special, equal legs . . . . .	17-18
" " standard and special, unequal legs . . . . .	183-186
standard connection, details of . . . . .	182
" " notes on . . . . .	183-186
" gauges for punching . . . . .	44
weights and dimensions of odd . . . . .	45
" " " " square root . . . . .	40-41
" " " " standard and special, equal legs . . . . .	42-44
" " " " " " " " unequal legs . . . . .	62-72
ARCHES . . . . .	51-52
notes on . . . . .	279-298
types of fire-proof . . . . .	243-248
AREAS . . . . .	259-264
of circles . . . . .	29
of flat rolled steel . . . . .	259-264
of square and round bars . . . . .	29
sectional, method of increasing . . . . .	259-264
BARS . . . . .	31
circumferences of round . . . . .	32
dimensions and weights of flat . . . . .	31
" " " " flat oval . . . . .	31
" " " " half round . . . . .	31
" " " " oval . . . . .	30
" " " " round . . . . .	32
" " " " round edge flat . . . . .	32
" " " " round oval . . . . .	30
" " " " square . . . . .	210
standard eye . . . . .	259-264
weights and areas of square and round . . . . .	53
BASES . . . . .	214
for columns . . . . .	180
BATTERS . . . . .	155
tables of . . . . .	156-160
BEAM . . . . .	180
anchors, details, weights and dimensions of . . . . .	155
box girders, explanation of tables on . . . . .	156-160
" " safe loads for . . . . .	156-160

INDEX

MISCELLANEOUS

THE CARNEGIE STEEL COMPANY, LIMITED.

	PAGE.
BEAMS . . . . .	bending moments, shears and deflections of . . . . . 98
	cast iron separators for . . . . . 181
	deck, properties of . . . . . 109-110
	“ safe loads for . . . . . 84
	“ shapes of . . . . . 6
	“ weights and dimensions of . . . . . 36
	distance center to center, for equal radii . . . . . 95, 102, 104
	in foundations, notes on . . . . . 57
	in foundations, tables for . . . . . 167-170
	properties of standard and special . . . . . 101-104
	safe lengths of, used as struts . . . . . 95
	safe loads for standard and special . . . . . 73-75
	safe loads on wooden . . . . . 232
	shapes of standard . . . . . 1-5
	spacing tables for standard . . . . . 85-92
	standard connections for . . . . . 182-186
	standard gauges for punching . . . . . 185
	weights and dimensions of standard and special . . . . . 35-36
	without lateral support, proportion of safe loads of . . . . . 71
BEARING . . . . .	plates, notes on . . . . . 61
	“ steel, weights and dimensions of . . . . . 179
	values of pins . . . . . 197
	“ rivets . . . . . 193-194
	“ safe, of brick-work and masonry . . . . . 179
BENDING . . . . .	moments of pins . . . . . 195-196
BOLT . . . . .	heads, standard dimensions of . . . . . 205
BOLTS . . . . .	weights of . . . . . 199-200
BRACING . . . . .	details of types of wind . . . . . 56
	notes on wind . . . . . 60
BRASS . . . . .	weights of sheets of . . . . . 265-266
BRICK . . . . .	arches in floors . . . . . 63
	-work, safe bearing values of . . . . . 179
	-work, weight of . . . . . 61
BUCKLED . . . . .	plates . . . . . 171-172
BULB . . . . .	angles, properties of . . . . . 109-110
	“ safe loads for . . . . . 84
	“ shapes of . . . . . 7-8
	“ weights and dimensions of . . . . . 36
CANTILEVERS . . . . .	notes on . . . . . 58-59
	types of . . . . . 55
CAST IRON . . . . .	columns, notes on . . . . . 125-126
	“ safe loads for round . . . . . 153
	“ ultimate strength of . . . . . 152
	notes on . . . . . 231
	separators . . . . . 181

THE CARNEGIE STEEL COMPANY, LIMITED.

	PAGE.
CAST IRON . . . specifications for . . . . .	221
CEILINGS . . . details of suspended . . . . .	52
	notes on fire-proof and suspended . . . . . 66-67
CHANNEL . . . columns, radii of gyration for . . . . .	141-146
	" safe loads for . . . . . 141-146
	" weights and dimensions of . . . . . 141-146
CHANNELS . . . distance back to back, in columns for equal radii . . . . .	95, 106, 129
	properties of standard and special . . . . . 105-106
	safe loads for standard and special . . . . . 76-77
	shapes of car-truck and ship-building . . . . . 11-12
	shapes of standard . . . . . 9-10
	standard connections for . . . . . 182-186
	standard gauges for punching . . . . . 186
	weights and dimensions of car-truck and ship-building . . . . . 38
	" " " " standard and special . . . . . 37
CHECKERED . . . plates, shapes of . . . . .	28
	" weights and dimensions of . . . . . 49
CIRCLES . . . areas and circumferences of . . . . .	279-298
CIRCULAR . . . plates, extreme dimensions of . . . . .	34
CIRCUMFERENCES . . . of round bars . . . . .	259-264
CLEARANCES . . . for machine driven rivets . . . . .	189
CLEVIS . . . nuts, standard . . . . .	208
COEFFICIENTS . . . of deflection . . . . .	72
COLUMNS . . . and struts, notes on . . . . .	129-130
	bases for . . . . . 53
	connections for constant dimension zee-bar . . . . . 187-198
	details of built sections of . . . . . 54
	" " fire-proofing of . . . . . 53
	equal radii of gyration for channel . . . . . 95, 106, 129
	in fire-proof buildings . . . . . 125-128
	radii of gyration for channel . . . . . 141-146
	" " " " round and square . . . . . 151
	" " " " zee-bar . . . . . 131-140
	safe loads for channel . . . . . 141-146
	" " " round cast iron . . . . . 153
	" " " zee-bar . . . . . 131-140
	standard spacing for rivets in zee-bar . . . . . 132-140
	ultimate strength of cast iron . . . . . 152
	" " " medium steel . . . . . 147-148
	weights and dimensions for channel . . . . . 141-146
	" " " " zee-bar . . . . . 131-140
COMPRESSION . . . ultimate resistance of material to . . . . .	236-237
CONCRETE . . . in foundations . . . . .	57
CONNECTION . . . angles, standard, for beams and channels . . . . .	182-186
CONNECTIONS . . . for constant dimension zee-bar columns . . . . .	187-188
CONSTRUCTIONAL . . . details . . . . .	50-56
CONVENTIONAL . . . signs for riveting . . . . .	189



THE CARNEGIE STEEL COMPANY, LIMITED.

	PAGE.
COPPER . . . weights of sheets of . . . . .	265-266
CORRUGATED . . . plate flooring . . . . .	174
plates, properties of . . . . .	104
" shapes of . . . . .	28
" weights and dimensions of . . . . .	49
sheets in flooring . . . . .	63-64
" notes on . . . . .	175-176
COSECANTS . . . cosines and cotangents . . . . .	299-304
COVER . . . . angles, shapes of . . . . .	21
" weights and dimensions of . . . . .	44
CUBES . . . . and cube roots of numbers . . . . .	279-298
DECIMALS . . . of a foot for each $\frac{1}{2}$ of an inch . . . . .	211-212
of an inch for each $\frac{1}{64}$ . . . . .	213
DECK . . . . beams, properties of . . . . .	109-110
" safe loads for . . . . .	84
" shapes of . . . . .	6
" weights and dimensions of . . . . .	36
DEFLECTION . . . coefficients . . . . .	72
limit of safe . . . . .	69
DETAILS . . . . constructional . . . . .	50-56
of built column sections . . . . .	54
" fire-proofing floors and columns . . . . .	51-53
" partitions . . . . .	52
" suspended ceilings . . . . .	52
" types of cantilevers . . . . .	55
" " " wind bracing . . . . .	56
DIMENSIONS . . . extreme of circular plates . . . . .	34
" " rectangular plates . . . . .	33
" " " sheets . . . . .	34
of angles, odd . . . . .	44
" " square root . . . . .	45
" " standard and special, equal legs . . . . .	40-41
" " " " " unequal legs . . . . .	42-44
" bars, flat . . . . .	31
" " flat oval . . . . .	32
" " half round . . . . .	31
" " oval . . . . .	31
" " round . . . . .	30
" " round edge flat . . . . .	32
" " round oval . . . . .	32
" " square . . . . .	30
" beams, standard and special . . . . .	35-36
bulb angles . . . . .	36
" channel columns . . . . .	141-146
" channels, car-truck and ship-building . . . . .	38

THE CARNEGIE STEEL COMPANY, LIMITED.

	PAGE.
DIMENSIONS . . . of channels, standard and special . . . . .	37
" checkered plates . . . . .	49
" corrugated plates . . . . .	49
" deck beams . . . . .	36
" miscellaneous shapes . . . . .	49
" rails, American standard . . . . .	124
" tees, equal legs . . . . .	46
" " hand-rail . . . . .	48
" " unequal legs . . . . .	47-48
" trough plates . . . . .	49
" zee-bar columns . . . . .	131-140
" zee-bars, special . . . . .	39
" " standard . . . . .	38-39
DISTANCE . . . back to back of channels to make radii equal . . . . .	95, 106, 129
center to center of beams for equal radii . . . . .	95, 102, 104
EXPANSION . . . linear, of substances by heat . . . . .	242
EXPLANATION . . . of tables on beam box girders . . . . .	155
" " " pins and rivets . . . . .	191-192
" " " plate girders . . . . .	161-162
" " " properties of Carnegie shapes . . . . .	93-96
" " " safe loads and spacing . . . . .	68-71
EXTREME . . . dimensions of circular plates . . . . .	34
" " rectangular plates . . . . .	33
" " " sheets . . . . .	34
EYE-BAR . . . heads, standard . . . . .	210
FIRE-PROOF . . . buildings, columns in . . . . .	125-128
ceilings, notes on . . . . .	66-67
partitions, notes on . . . . .	67
FIRE-PROOFING . . . of floors and columns, details of . . . . .	51-53
" girders and columns, notes on . . . . .	66-67
FLAT . . . . . bars, dimensions and weights of . . . . .	31
oval bars, dimensions and weights of . . . . .	32
rolled steel, areas of . . . . .	243-248
" " weights of . . . . .	249-258
FLOORS . . . . . details of fire-proofing . . . . .	51-52
general notes on . . . . .	62-67
FLOORING . . . . . corrugated plate . . . . .	174
trough plate . . . . .	173
FORMULAE . . . . . general . . . . .	97-100
FOUNDATIONS . . . beams used in . . . . .	167-170
cantilevers in . . . . .	58-59
notes on . . . . .	57
FUNCTIONS . . . . . natural trigonometrical . . . . .	299-304

**THE CARNEGIE STEEL COMPANY, LIMITED.**

	PAGE.
<b>GAS PIPE</b> . . . standard .....	206
<b>GAUGES</b> . . . standard, for punching angles, beams and channels .....	183-186
"      for sheets and wire .....	215, 216, 265, 266
<b>GENERAL</b> . . . formulae .....	97-100
<b>GIRDERS</b> . . . explanation of tables on beam box .....	155
"      "      "      "      riveted plate .....	161-162
in buildings, notes on .....	61-62
safe loads for beam box .....	156-160
"      "      "      riveted plate .....	163-166
<b>GRAVITY</b> . . . specific, of substances .....	238
<b>GRIPS</b> . . . lengths of rivets for variant .....	190
<b>HALF ROUND</b> . . . bars, dimensions and weights of .....	31
<b>HAND-RAIL</b> . . . tees, shapes of .....	23
<b>HEAT</b> . . . linear expansion of substances by .....	242
<b>I-BEAMS</b> . . . (see beams.)	
<b>INCREASING</b> . . . sectional areas, method of .....	29
<b>INERTIA</b> . . . moments of, for Carnegie standard shapes .....	99
"      "      "      rectangles .....	154
"      "      "      usual shapes .....	100
<b>INTERCHANGEABLE</b> tables between U. S. and metric system .....	273-278
<b>IRON</b> . . . notes on .....	231
weights of sheets of .....	215, 265, 266
<b>LIMIT</b> . . . of safe deflection .....	69
<b>LINEAR</b> . . . expansion of substances by heat .....	242
<b>LINTELS</b> . . . notes on .....	61
<b>LOADS</b> . . . per square foot on floors .....	66
"      "      "      "      roofs .....	177
safe (see safe loads)	
<b>LOGARITHMS</b> . . . of numbers .....	279-298
<b>MANUFACTURERS</b> standard specifications .....	217-226
<b>MASONRY</b> . . . safe bearing values of .....	61, 179
<b>MATERIALS</b> . . . strength of .....	235-237
<b>MEASURES</b> . . . and weights .....	270-271
<b>MENSURATION</b> .....	267-269
<b>METHOD</b> . . . of increasing sectional areas .....	29
<b>METRIC SYSTEM</b> . . . tables of .....	272-278
<b>MISCELLANEOUS</b> . . . shapes, weights and dimensions of .....	49

	PAGE.
MOMENTS . . . bending, of beams . . . . .	98
"    "    pins . . . . .	195-196
of inertia for Carnegie standard shapes . . . . .	99
"    "    rectangles . . . . .	154
"    "    usual shapes . . . . .	100
NAILS . . . spikes and tacks . . . . .	207
NATURAL . . . trigonometrical functions . . . . .	299-304
NUMBERS . . . properties of . . . . .	279-298
NUTS . . . standard clevis . . . . .	208
"    dimensions of . . . . .	205
"    pin . . . . .	198
"    sleeve . . . . .	209
weights and dimensions of . . . . .	200-202
OBTUSE . . . angles, shapes of . . . . .	21
"    weights and dimensions of . . . . .	44
OVAL . . . bars, weights and dimensions of . . . . .	31
PARTITIONS . . . details of fire-proof . . . . .	52
notes on fire-proof . . . . .	67
PILLARS . . . safe loads for wooden . . . . .	233-234
PIN-NUTS . . . standard . . . . .	198
PINS . . . bearing values of . . . . .	197
bending moments of . . . . .	195-196
explanation of tables on . . . . .	191-192
PIPE . . . standard steam, gas and water . . . . .	206
PLATE-GIRDERS . . . explanation of tables on . . . . .	161-162
safe loads for . . . . .	163-166
PLATES . . . buckled . . . . .	171-172
extreme dimensions of circular . . . . .	34
"    "    rectangular . . . . .	33
flooring of corrugated . . . . .	174
"    "    trough . . . . .	173
properties of corrugated . . . . .	104
"    "    trough . . . . .	103
shapes of checkered . . . . .	28
"    "    corrugated . . . . .	28
"    "    trough . . . . .	28
standard gauges for . . . . .	215-216
steel bearing . . . . .	179
PROPERTIES . . . explanation of tables on . . . . .	93-96
of angles, standard and special . . . . .	113-123
"    beams, standard and special . . . . .	101-104
"    bulb angles . . . . .	109-110

THE CARNEGIE STEEL COMPANY, LIMITED.

	PAGE.
PROPERTIES . . . . .	
of channels, standard and special . . . . .	105-106
" corrugated plates . . . . .	104
" deck beams . . . . .	109-110
" numbers . . . . .	279-298
" rails, American standard . . . . .	124
" tees . . . . .	109-112
" trough plates . . . . .	103
" zee-bars, standard . . . . .	107-108
PROPORTION . . . . .	
of safe loads for beams without lateral support . . . . .	71
<b>RADII</b> . . . . .	
of gyration, equal, for beams used as struts . . . . .	95, 102, 104
" " " " channel columns . . . . .	95, 106, 129, 141-146
" " " for columns, notes on . . . . .	129
" " " round and square columns . . . . .	151
" " " two angles, back to back, used as struts . . . . .	148-150
" " " zee-bar columns . . . . .	131-140
RAILS . . . . .	
in foundations . . . . .	57
properties of American standard . . . . .	124
specifications for . . . . .	227-228
" " splice bars used for . . . . .	229-230
weights and dimensions of American standard . . . . .	124
RECIPROCALLS . . . . .	
of numbers . . . . .	279-298
RECTANGLES . . . . .	
moments of inertia of . . . . .	154
RECTANGULAR . . . . .	
columns, ultimate strength of cast-iron . . . . .	152
plates, extreme dimensions of . . . . .	33
sheets, extreme dimensions of . . . . .	34
RIVETS . . . . .	
clearances for machine driven . . . . .	189
conventional signs for . . . . .	189
explanation of tables on . . . . .	191-192
heads, dimensions of . . . . .	189
lengths of, for variant grips . . . . .	190
shearing and bearing values of . . . . .	193-194
weights of . . . . .	199
ROOFS . . . . .	
notes on . . . . .	177
ROOF TRUSSES . . . . .	
diagrams and notes on . . . . .	178
ROUND . . . . .	
bars, dimensions and weights of . . . . .	30
" weights, areas and circumferences of . . . . .	259-264
columns, radii of gyration for . . . . .	151
" safe loads for cast iron . . . . .	153
" ultimate strength of cast iron . . . . .	152
edge flat bars, dimensions and weights of . . . . .	32
oval bars, dimensions and weights of . . . . .	32
<b>SAFE</b> . . . . .	
angles, shapes of . . . . .	21
" weights and dimensions of . . . . .	44
bearing values of brick-work and masonry . . . . .	61, 179

THE CARNEGIE STEEL COMPANY, LIMITED.

	PAGE.
SAFE . . . .	deflection, limit of . . . . . 69
	length of beams used as struts . . . . . 95
SAFE LOADS . . . .	explanation of tables on . . . . . 68-71
	for angles, standard and special . . . . . 79-81
	“ beam box girders . . . . . 156-160
	“ beams, standard and special . . . . . 73-75
	“ beams without lateral support, proportion of . . . . . 71
	“ bulb angles . . . . . 84
	“ channels, standard and special . . . . . 76-77
	“ columns, channel . . . . . 141-146
	“ “ round cast iron . . . . . 153
	“ “ zee-bar . . . . . 131-140
	“ corrugated plate flooring . . . . . 174
	“ deck beams . . . . . 84
	“ plate girders . . . . . 163-166
	“ tees . . . . . 82-83
	“ trough plate flooring . . . . . 173
	“ wooden beams and pillars . . . . . 232-234
	“ zee-bars, standard . . . . . 78
SCREW . . . .	ends, upset . . . . . 203-204
	threads, standard . . . . . 205-206
SCREWS . . . .	wood . . . . . 198
SECANTS . . . .	and cosecants . . . . . 303-304
SECTIONAL . . . .	areas, method of increasing . . . . . 29
SECTIONS . . . .	of built columns, notes on . . . . . 127-128
	“ “ “ types of . . . . . 54
SEPARATORS . . . .	cast iron . . . . . 181
SHAPES . . . .	angles, cover . . . . . 21
	“ obtuse . . . . . 21
	“ safe . . . . . 21
	“ square root . . . . . 19-20
	“ standard and special, equal legs . . . . . 16-17
	“ “ “ “ unequal legs . . . . . 17-18
	beams, standard . . . . . 1-5
	bulb angles . . . . . 7-8
	channels, car-truck and ship-building . . . . . 11-12
	“ standard . . . . . 9-10
	checkered plates . . . . . 28
	corrugated plates . . . . . 28
	deck beams . . . . . 6
	miscellaneous . . . . . 28
	tees, equal legs . . . . . 22-23
	“ hand-rail . . . . . 23
	“ unequal legs . . . . . 24-27
	trough plates . . . . . 28
	zee-bars, special . . . . . 15
	“ “ standard . . . . . 13-14

THE CARNEGIE STEEL COMPANY, LIMITED.

	PAGE.
SHEARING . . .	ultimate resistance of materials to..... 237
	values of rivets..... 193-194
SHEETS . . .	corrugated ..... 175-176
	extreme dimensions of rectangular ..... 34
	standard gauges for ..... 215-216
	weights of iron and steel ..... 215
	“ “ iron, steel, copper and brass ..... 265-266
SINES . . .	and cosines ..... 301-302
SLEEVE NUTS . . .	standard ..... 209
SPACING . . .	of beams for standard cast iron separators..... 181
	“ holes for standard connections ..... 184-186
	tables, explanation of..... 68-71
	“ for standard beams..... 85-92
SPECIFICATIONS . . .	for steel rails..... 227-228
	“ splice bars..... 229-230
	manufacturers' standard..... 217-226
SPECIFIC . . .	gravity of substances..... 238
SPIKES . . .	nails and tacks ..... 207
SPLICE BARS . . .	for rails, specifications for..... 229-230
SQUARE . . .	bars, dimensions and weights of..... 30
	“ weights and areas of..... 259-264
	columns, radii of gyration for..... 151
SQUARES . . .	and square roots of numbers..... 279-298
STREAM . . .	pipe, standard ..... 206
STEEL . . .	areas of flat rolled ..... 243-248
	bearing plates..... 179
	notes on..... 231
	standard specifications for..... 217-226
	weights of flat rolled..... 249-258
	“ “ sheets of..... 215, 265, 266
STRENGTH . . .	of corrugated sheets..... 176
	“ materials ..... 235-237
	ultimate, of cast iron columns..... 152
	“ “ medium steel columns ..... 147-148
STRUTS . . .	and columns, notes on..... 129-130
	distance center to center of beams for equal radii ..... 95, 102, 104
	radii of gyration for two angles, back to back ..... 148-150
	safe lengths of beams used as..... 95
SUBSTANCES . . .	linear expansion of, by heat..... 242
	specific gravity of..... 238
	weights per cubic foot of..... 239-241
SUSPENDED . . .	ceilings, details of..... 52
	“ notes on..... 66-67
TACKS . . .	nails and spikes..... 207
TANGENTS . . .	and cotangents..... 299-300

	PAGE.
TEES . . . . .	properties of . . . . . 109-112
	safe loads for . . . . . 82-83
	shapes of, equal legs . . . . . 22-23
	"    " hand-rail . . . . . 23
	"    " unequal legs . . . . . 24-27
	weights and dimensions of equal legs . . . . . 46
	"    "    "    " hand-rail . . . . . 48
	"    "    "    " unequal legs . . . . . 47-48
TENSION . . . . .	ultimate resistance of materials to . . . . . 235-236
TERRA-COTTA . . . . .	arches in floors . . . . . 64-65
THREADS . . . . .	standard screw . . . . . 205-206
TIE-RODS . . . . .	in floors . . . . . 63-64
TRIGONOMETRICAL	functions, natural . . . . . 299-304
TROUGH . . . . .	plate flooring . . . . . 173
	plates in fire-proof floors . . . . . 66
	" properties of . . . . . 103
	" shapes of . . . . . 28
	" weights and dimensions of . . . . . 49
TRUSSES . . . . .	roof . . . . . 178
ULTIMATE . . . . .	strength of columns, cast iron . . . . . 152
	"    "    " medium steel . . . . . 147-148
	"    " materials . . . . . 235-237
UNITS . . . . .	of metric system . . . . . 272
UPSETS . . . . .	allowance for . . . . . 204
	for screw ends . . . . . 203-204
WALL ANCHORS . . . . .	standard . . . . . 180
WATER . . . . .	pipe, standard . . . . . 206
WEIGHTS . . . . .	and measures . . . . . 270-271
	of angles, odd . . . . . 44
	"    " square root . . . . . 45
	"    " standard and special, equal legs . . . . . 40-41
	"    "    "    " unequal legs . . . . . 42-44
	" bars, flat . . . . . 31
	"    " flat oval . . . . . 32
	"    " half-round . . . . . 31
	"    " oval . . . . . 31
	"    " round . . . . . 30
	"    " round edge flat . . . . . 32
	"    " round oval . . . . . 32
	"    " square . . . . . 30
	"    " square and round . . . . . 259-264
	" beams, standard and special . . . . . 35-36
	" bearing plates, standard steel . . . . . 179
	" brick-work . . . . . 61
	" bulb angles . . . . . 36



THE CARNEGIE STEEL COMPANY, LIMITED.

	PAGE.
WEIGHTS . . . . .	
of channel columns . . . . .	141-146
" channels, car-truck and ship-building . . . . .	38
" " standard and special . . . . .	37
" checkered plates . . . . .	49
" corrugated plates . . . . .	49
" " sheets . . . . .	176
" deck beams . . . . .	36
" flat rolled steel . . . . .	249-258
" miscellaneous shapes . . . . .	49
" rails, American standard . . . . .	124
" rivets and bolts . . . . .	199-200
" separators, standard cast iron . . . . .	181
" sheets of iron and steel . . . . .	215
" " " " steel, copper and brass . . . . .	265-266
" sleeve nuts . . . . .	209
" spikes, nails and tacks . . . . .	207
" substances per cubic foot . . . . .	239-241
" superimposed floor loads . . . . .	66
" tees, equal legs . . . . .	46
" " hand-rail . . . . .	48
" " unequal legs . . . . .	47-48
" terra-cotta arches in floors . . . . .	65
" trough plates . . . . .	49
" zee-bar columns . . . . .	131-140
" zee-bars, special . . . . .	39
" " " standard . . . . .	38-39
WIND . . . . .	
bracing, details of types of . . . . .	56
" notes on . . . . .	60
pressure on roofs . . . . .	177
WOODEN . . . . .	
beams in foundations . . . . .	57
" safe loads for . . . . .	232
pillars, safe loads for . . . . .	233-234
WOOD SCREWS . . . . .	198
WORKMANSHIP . . . . .	225-226
<b>ZEE-BAR</b> . . . . .	
columns connections for constant dimension . . . . .	187-188
" radii of gyration for . . . . .	131-140
" safe loads for . . . . .	131-140
" standard spacing for rivets and bolts in . . . . .	131-140
" weights and dimensions of . . . . .	131-140
ZEE-BARS . . . . .	
properties of standard . . . . .	107-108
safe loads for standard . . . . .	78
shapes of special . . . . .	15
" " standard . . . . .	13-14
weights and dimensions of special . . . . .	39
" " " " standard . . . . .	38-39

SECTIONS CUT OUT BY ONE RIVET-

Thickness of Plate.	Diameter of Rivet-			
	1/2"	5/8"	3/4"	7/8"
1/8"				
3/16"	.11	.14	.16	.19
1/4"	.15	.19	.22	.25
5/16"	.19	.23	.27	.31
3/8"	.23	.28	.33	.38
7/16"	.26	.33	.38	.44
1/2"	.30	.38	.44	.50
9/16"	.34	.42	.49	.56
5/8"	.38	.46	.54	.63
11/16"	.41	.52	.60	.69
3/4"	.45	.56	.66	.75
13/16"	.49	.60	.71	.81
7/8"	.53	.65	.76	.88
15/16"	.57	.70	.82	.94

— WATER —

1 CU. FT. = 62.4 lb.  
 = 7.48 gals.  
 1 Gallon = 8.34 lb.  
 = 231.0 CU. IN.  
 = 0.13368 CU. FT.

U.S. Meas.

— WEIGHTS IN POUNDS —

	Cast Iron	Wrot. Iron.	Steel.
1 Cu. Ft.	450.0		
1 Sq. Ft. 1" Thick	37.5		
1 Cu. Inch.	0.26		
1 Lineal Ft. 1" Sq.	3.125		
1 Pound. = Cu. In.	3.84		

— BRICK WALLS —

Thickness	Wt. per. $\square'$	Thickness	Wt. per. $\square'$
4"	38.	20"	192.
8"	76.	24"	230.
12"	115.	28"	268.
16"	153.	32"	306.

— PARTITIONS —

HOLLOW BRICK		POROUS TERRA COTTA.	
Thickness	Wt. per $\square'$	Thickness	Wt. per. $\square'$
3"	14.	3"	12.
4"	18.	4"	17.
5"	23.	5"	23.
6"	25.	6"	27.
7"	31.	7"	31.
8"	34.	8"	36.

FURRING, ROOFING ETC.

Description	Wt. $\square'$	Description	Wt. $\square'$
Porous.T.C. Furring 2"	8.	Por. T.C. Ceiling 2"	11.
" " Roofing 2"	12.	" " " 3"	15.
" " " 3"	16.	" " " 4"	20.
" " " 4"	20.	Hollow Clay Furring 2"	12.

WEIGHTS OF ARCHES.

ORDINARY FLAT.

6" deep = 29. lb.	7" deep = 33.
8" " = 37.	9" " = 40.
10" " = 43.	12" " = 48.

END CONSTRUCTION

8" deep = 30. lb.	9" deep = 32. lb.
10" " = 34.	12" " = 37.

ROEBLING CONSTRUCTION



Min. Depth. "D"	Max. Spacing "S"	Wt. per sq' of Concrete & Wire.
8"	4'-0"	33. lb.
9"	4'-6"	34.
10"	5'-0"	36.
12"	6'-0"	41.
15"	7'-6"	47.

Sizes of Tiles (Maurer)  
for Roofs & Ceilings.

- 12" x 16" x 2"
- 12" x 18" x 3"
- 12" x 20" x 3"
- 12" x 24" x 3"
- 12" x 24" x 4"

## SECTION MODULUS FOR WRO'T. IRON PIPE

Nominal Size	Inside Diam.	Outside Diam.	Thickness	Sec. Mod. "S"
12"	12.00	12.75	3/8"	43.8
"	11.75	"	1/2"	54.3
"	11.50	"	5/8"	
10"	10.00	10.75	3/8"	30.6
"	9.75	"	1/2"	39.5
"	9.50	"	5/8"	
8"	7.98	8.62	.32"	16.7
"	7.50	"	.56"	26.8
"	6.87	"	.87"	
6"	6.06	6.62	.28"	8.45
"	5.75	"	.43"	12.30
"	4.87	"	.87"	
4 1/2"	4.50	5.00	.25"	4.2
"	4.25	"	.35"	5.9

Weight of One cast iron Separator,  
Including bolts for same.

to	24"	20"	18"	15"	12"	10"	9"	8"	7"	6"
4"							9	7	6	<u>6</u>
5"						10	<u>10</u>	<u>8</u>	<u>7</u>	7
6"			23	20	<u>17</u>	<u>12</u>	12	10	9	8
7"	36	<u>28</u>	<u>26</u>	<u>23</u>	20	13	13	11	10	10
8"	<u>41</u>	32	30	26	22	15	15	13	12	11
9"	46	35	33	29	25	17	17	14	13	12
10"	50	39	36	32	27	19	18	16	14	13
11"	55	42	40	35	30	20	20	17	16	15
12"	60	46	43	38	32	22	21	18	17	16
13"	65	50	46	41	35	24	23	20	18	17
14"	69	53	50	44	37	25	25	21	19	18
15"	73	57	53	46	40	27	27	23	20	19
16"	78	60	56	52	43	29				
18"	87	64	60							



# CAST IRON LINTELS

THE CARNEGIE STEEL COMPANY, LIMITED.

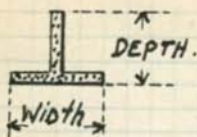

COEF. of STRENGTH.  
IN TONS of 2000 lbs.

Max. Tension 3000<sup>lb.</sup>

Width	Depth	Thickness of Metal					No. of Webs
		3/4"	7/8"	1"	1 1/8"	1 1/4"	
28"	6"	59.5	65.	70.	75.	78.	2
"	8"	95.5	106.	115.	123.	131.	2
"	10"	140.5	151.	165.	176.	192.	2
"	12"	171.4	197.	216.	236.	257.	2
"	16"	235.8	273.	307.	342.	375.	2
24"	6"	53.	57.	63.	67.	70.	2
"	8"	84.	93.	102.	110.	117.	2
"	10"	116.	130.	144.	156.	168.	2
"	12"	150.	169.	190.	207.	223.	2
"	16"	225	257	286.	317.	345.	2
20"	6"	47.	51.	55.	59.	62.	2
"	8"	73.	85.	90.	96.	103.	2
"	10"	101.	113.	125.	136.	147.	2
"	12"	123.	142.	158.	175.	190.	2
"	16"	196.	225.	251.	277.	302.	2
16"	6"	33.	35.	38.	40.	42.	1
"	8"	52.	58.	63.	67.	72.	1
"	10"	72.	81.	90.	97.	104.	1
"	12"	92.	106.	118.	129.	139.	1
"	16"	139.	159.	178.	196.	214.	1
12"	6"	26.	29.	31.	33.	35.	1
"	8"	42.	47.	51.	55.	58.	1
"	10"	58.	65.	72.	78.	84.	1
"	12"	75.	84.	95.	104.	112.	1
8"	6"	20.	22.	23.	25.	26.	1
"	8"	31.	34.	38.	41.	43.	1
"	10"	43.	48.	53.	58.	63.	1
"	12"	55.	62.	70.	77.	84.	1

"C" = W x L



3/4" Rivets 10,000 lb. or less  
 20,000 lb. Bearing

	Single Skear <sup>T</sup>	1/4" Pl.	5/16" Pl.	3/8" Pl.
1 Riv.	2.21	1.87		
2 "	4.42	3.74		
3 "	6.63	5.61		
4 "	8.84	7.48		
5 "	11.05	9.35		
6 "	13.26	11.22		
7 "	15.47	13.09		
8 "	17.68	14.96		























