

ACEPER

TARIFA PRECIOS
PRICE BOOK
LISTE PRIX



octubre **2021**

FABRICA Y DELEGACIONES · FACTORY & BRANCH OFFICES
L'USINE ET DÉLÉGATIONS



OURENSE
Parque Tecnológico de Galicia
C/ Vigo Nº 2
32901 - SAN CIBRAO DAS VIÑAS
OURENSE

aceper@aceper.es



BARCELONA
C/ Gorcs Llado, 104 - 110 Nave 2
Pol. Ind. Can Salvatella
08210 - BARBERA DEL VALLES
BARCELONA
barcelona@aceper.es



FABRICA · FACTORY · L'USINE
Rioseco
Paderne de Allariz
32111 OURENSE

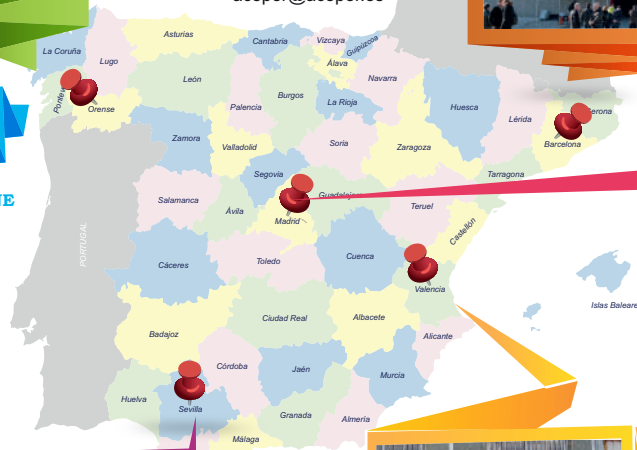

MADRID
C/ Puerto Navacerrada, 101
Pol. Ind. Las Nieves
28935 - MÓSTOLES
MADRID
madrid@aceper.es

SEVILLA
C/La Red Doce, 9
Pol. Ind. La Red
41500 - ALCALÁ DE GUADAIRA
SEVILLA
sevilla@aceper.es



VALENCIA
C/Central, 21
Pol. Ind. El Oliveral - Fase 3
46190 - RIBARROJA DEL TURIA
VALENCIA
valencia@aceper.es

RELACIONES INTERNACIONALES · INTERNATIONAL AFFAIRS
INTERNATIONALISATION



· Países en los que estamos presentes / Where we are / Nous sommes présent ici
· Próximos proyectos / Coming soon / Prochains projects

www.aceper.es



En el grupo Aceper llevamos 30 años ofreciendo soluciones a nuestros clientes en el ámbito de la protección solar, sistemas de persianas, toldos y decoración interior.

Nuestro amplio catálogo de productos ofrece alternativas eficaces e innovadoras a nuestros clientes nacionales e internacionales.

The company Aceper has been providing solutions in the sector of solar protection, roller shutter systems, awnings and interior desing for 30 years.

Our wide selection of products offers efficient and innovatives to our national and international clients.

Ça fait 30 ans que le groupe Aceper offre les solutions aux clients dans le secteur de la protection solaire, système de volet roulant, stores d'extérieur et protection solaire d'intérieur.

Notre vaste gamme de produits offre des solutions efficaces et innovation à nos clients nationaux et internationaux.



Bajo la marca Aceper fabricamos toda la gama de accesorios para sistemas de persianas, lamas y cajones.

Under the name Aceper, we manufacture any kind of accesories for roller shutters, aluminium and PVC foam filled slats and roller shutter casings.

Sous la marque Aceper nous fabriquons la gamme complète d'accessoires pour les systèmes des volets roulants, lames et caissons avec volets roulants.



POLÍTICA MEDIOAMBIENTAL · ENVIRONMENTAL POLICY POLITIQUE ENVIRONNEMENTALE



En el grupo Aceper creemos que el crecimiento empresarial va de la mano con la sostenibilidad del planeta, por eso nuestros sistemas de fabricación cumplen todas las normativas medioambientales de reutilización de residuos.

Trabajamos con circuitos cerrados de agua y nuestros residuos plásticos y metálicos no reutilizables se trasladan a plantas de reciclado para su correspondiente uso.

The group Aceper believes that business growth goes hand and with the sustainability of the planet, so our manufacturing systems meet all environmental and waste recycling legislation.

We work with closed circuit water and our non-reusable plastic and metal waste is shipped to recycling plants for its corresponding use.

Dans le groupe Aceper nous croyons que la croissance des entreprises va de pair avec le développement durable de la planète, afin que nos systèmes de fabrication répondent toutes les lois de recyclage de l'eau en circuit fermé et de notre plastique non réutilisables et les déchets métalliques sont expédiés à des usines de recyclage pour son utilisation.

CONDICIONES GENERALES DE VENTA
TERMS OF SALE / CONDITIONS GÉNÉRALES DE VENTE

PEDIDOS / ORDERS /COMMANDES

- Para evitar posibles errores, los pedidos han de ser por correo electrónico o fax.
To avoid any mistake, the orders should be made by e-mail or fax.
Afin d'éviter de possibles erreurs, les commandes doivent être réalisées par e-mail ou par fax.

PORTES / TRANSPORT / FRAIS DE PORT

- La mercancía que se sirva por medios ajenos a nuestro transporte se enviará a portes debidos.
The goods served by foreign companies will always be sent with freight collect.
La marchandise qui soit livrée par un autre transporteur sera envoyée à charge du client.

ARTÍCULOS / GOODS / ARTICLES

- Todas las medidas expresadas en esta tarifa salvo indicación contraria son en mm.
All the measurements of this book, unless contrary indications, are in mm.
Toutes les mesures exprimées dans ce catalogue sont en millimètres (sauf indication contraire).
- Las características y descripciones de los artículos de ACEPER, S.L., pueden verse modificados sin previo aviso.
All characteristics and description of the goods of ACEPER S.L. are subject to change without notice.
Les caractéristiques et descriptions des articles d'ACEPER S.L. peuvent subir des modifications sans avis préalable.

GARANTÍAS / WARRANTY / GARANTIES

- Los productos comercializados por ACEPER, S.L. disponen de las mismas condiciones de garantía que las ofrecidas por el fabricante de origen.
The products distributed by ACEPER S.L. have the same warranty conditions than the original manufacturer
Les produits commercialisés par ACEPER S.L. disposent des mêmes conditions de garantie que les offres par le fabricant d'origine.
- ACEPER, S.L. ofrece una garantía para sus motores de 5 años, contando dicho periodo desde la fecha de fabricación.
La responsabilidad de ACEPER, S.L. está limitada a la reparación o sustitución gratuita de las partes reconocidas como defectuosas por parte de nuestro servicio técnico. Quedarán excluidos de esta garantía todos los componentes que resulten dañados debido a un uso incorrecto, negligencia o mala instalación, los daños causados cuando no se han respetado las instrucciones de selección del motor, las consecuencias de catástrofes naturales o accidente fortuito, los gastos del desmontaje o montaje.
ACEPER S.L. gives 5 years of guaranty to his motors, starting this one in the date of manufacture.
The responsibility of ACEPER S.L. shall only be extended to the material's repair or replacement that our technical department deems necessary. No compensation can be claimed with reference to: misuse, wrong installation, problems derivate from a incorrect use, natural disasters and the costs sustained in replacing the material.
ACEPER S.L. garantie ses moteurs cinq ans à compter de la date de fabrication.
La responsabilité d'ACEPER S.L. est limiter à la réparation ou substitution gratuite des parties reconnues comme défectueuses par notre service technique.
Seront exclus de cette garantie tous les composants qui se voient endommagés par un usage incorrect, une négligence, une mauvaise installation ainsi que les dégâts causés par non-respect des instructions d'installation du moteur, pour cause de catastrophe naturelle ou tout autres accidents ou les frais liés au montage ou au démontage.

EXCLUSIONES DE LA GARANTIA / EXCLUDED FROM WARRANTY / EXCLUSIONS DE LA GARANTIE

Quedan excluidos de la garantía las averías, daños y gastos producidos por una incorrecta manipulación, instalación o aplicación de los productos vendidos por ACEPER, S.L. así como los ocasionados como consecuencia de catástrofes naturales, agentes atmosféricos, casos fortuitos o fuerzas mayores.

Following cases are excluded from warranty: failures, expense and damage due to a improper installation on the products sold hy ACEPER, S.L. as well as a result of natural disasters, atmospheric agents, foruitous events or force majeure.

Seront exclus de la garantie les pannes, les dommages, et les dégâts produits par une mauvaise manipulation, ou tout autre problème d'installation des produits vendus par ACEPER S.L.

Aussi, Aceper exclut de sa garantie les conséquences liées à une catastrophe naturelle, agents atmosphériques ou cas de force majeure.

CONDICIONES GENERALES DE VENTA
TERMS OF SALE / CONDITIONS GÉNÉRALES DE VENTE

PRECIOS / PRICES / PRIX

- Los precios de los artículos de ACEPER, S.L. en vigor, están sujetos a cambios, sin previo aviso, motivados por la alteración del coste o materias primas.
Prices of ACEPER items may be modified at any time without prior notice due to the change in the price of raw materials.
Les prix des articles d'ACEPER S.L. en vigueur sont soumis à des changements sans avis préalable, motivé par l'altération du coût des matières premières.
- Cualquier descuento facilitado sobre la tarifa será aplicado sólo a las cajas completas.
Any discount applied only refers to whole boxes, not single items.
Toutes les remises sur les tarifs vous seront effectuées sur les paquets complets.
- Para pedidos de unidades sueltas el precio será siempre el de tarifa sin descuento.
No discount will be applied to single-unit orders.
Pour les commandes de produits à l'unité, le prix sera celui du tarif sans réduction possible.
- El I.V.A. será a cargo del comprador.
The buyer will be in charge of VADs payments and other taxes.
La TVA sera à la charge de l'acheteur.

RECLAMACIONES / COMPLAINTS / RÉCLAMATIONS

- No se admitirán reclamaciones sobre la mercancía, pasadas 48 horas desde la fecha de recepción de la misma. El comprador debe verificar las cantidades y el estado del material a su recepción, haciendo constar la oportuna reclamación en el albarán de entrega. La mercancía recibida por agencia tiene un plazo de reclamación de 24 horas después de su recepción. En caso contrario ACEPER, S.L. declina cualquier responsabilidad.
No claims will be accepted after 48 hours from the delivery day. The buyer must check the quantity and condition of the goods and establish the claim in the delivery note. In case of receiving the items from a freight company, the buyer must establish the claim within 24 hours after the reception. Otherwise, ACEPER, S.L. won't be held responsible.
L'acheteur devra vérifier les quantités et l'état du matériel dès sa réception et dès lors noter les réclamations sur le bordereau de livraison.
Nous n'admettons pas de réclamation concernant cette marchandise passer 48 heures à compter de la date de livraison par nos soins.
Les réclamations concernant la marchandise livrée par une agence de transports externes devront être faite dans les 24 heures à compter de sa réception. Au-delà ACEPER S.L. décline toute responsabilité.

DEVOLUCIONES / REFUNDS / RETOURS

- No se admitirán devoluciones de mercancía no autorizada previamente por ACEPER, S.L.
No refunds will be accepted without the previous authorization from ACEPER S.L.
Nous n'admettons pas de retour de marchandise sans une autorisation préalable par ACEPER, S.L.

JURISDICCIÓN / JURISDICTION / JURIDICTION

- Cualquier litigio derivado de las ventas efectuadas por ACEPER, S.L. será competencia de los Tribunales y Juzgados de la ciudad de OURENSE.
In case of dispute, the case will be taken under the jurisdiction of the Court of Ourense (subjected to the Spanish law).
Les litiges en relation avec la marchandise d'ACEPER S.L. seront réglés par les tribunaux de la ville d'Ourense (Espagne).

LEYENDA DE ICONOS · ICON LEGEND

LÉGENDE DES ICÔNES

- | | |
|--|--|
|  Descripción / Description / Description |  Color / Colour / Couleur |
|  Código / Code / Code |  Color cinta / Strap colour / Sangle colour |
|  Precio / Price / Prix |  Medidas / Measure / Dimensions |
|  Unidades bulto / Unit per packet / Unites par paquet |  Modelo / Model / Modèle |

ACCESORIOS / ACCESSORIES / ACCESSOIRES POUR VOLETS ROULANTS

RECOGEDORES STRAP COILERS / ENROULEURS	Pág. 9
CAJETINES - FRENTES BOX FOR STRAP COILER - COVER PLATE / BOÎTIERS - PLAQUES	Pág. 21
GUÍA-CINTAS STRAP GUIDES / GUIDE SANGLES	Pág. 23
POLEAS PULLEYS / POULIES	Pág. 26
CONTERAS CAPS / EMBOUTS	Pág. 27
SOPORTES Y RODAMIENTOS BRACKETS AND BALL BEARING / SUPPORTS ET ROULEMENTS	Pág. 29
EMBUDOS - ESPIGAS SET OF END GUIDE - DRIVE / PAIRE DE TULIPES - TENON	Pág. 30
TOPES STOPPERS / BUTÉES.....	Pág. 31
TESTEROS DE ALUMINIO SET OF END CAPS IN ALUMINIUM / PAIRE DE JOUE D'ALUMINIUM	Pág. 32
PLACAS DE CONTENCIÓN METÁLICAS SAFETY PLATES / FLASQUES	Pág. 37
TESTEROS DE ABS SET OF END CAPS ABS / PAIRE DE JOUE D'ABS	Pág. 38
CINTAS STRAP / SANGLE	Pág. 39
EJES TUBES / AXES	Pág. 40
VARIOS OTHERS / DIVERS	Pág. 41
TORNOS ROPE WINCH / TREUIL	Pág. 42
CARDAN GEAR BOX / MÉCANISME POUR CARDAN	Pág. 45
 LAMAS / SLATS / LAMES	
ESPECIFICACIONES LAMAS Y BAJERAS DE PVC SPECIFICATIONS PVC SLATS AN PVC END SLATS / SPECIFICATIONS LAMES ET LAMES FINALES EN PVC.....	Pág. 48
ESPECIFICACIONES LAMAS Y BAJERAS DE ALUMINIO PERFILADO SPECIFICATIONS ALUMINIUM SLATS AND ALUMINIUM PVC SLTAS / SPECIFICATIONS LAMES ET LAMES FINALES EN ALUMINIUM	Pág. 50
COLOR LAMAS SLAT COLOR / COULEUR LAME	Pág. 52
ENROLLAMIENTOS TOTAL DIAMETER / ENROULEMENT	Pág. 53

ACCESORIOS ACCESSORIES / ACCESSOIRES	Pág. 55
PRECIO LAMAS Y BAJERAS PRICE SLATS AND END SLATS / PRIX LAMES ET LAMES FINALE	Pág. 56
PRODUCTOS CERTIFICADOS CE CERTIFIED PRODUCTS CE / PRODUITS CERTIFIÉS CE	Pág. 57
MOTORIZACIÓN / MOTORS / MOTEURS	
TABLAS DE SELECCIÓN MOTOR SELECTION TABLE / TABLEAUX DE SELECTION DE MOTEUR	Pág. 60
MOTORES K/KRE Ø35 MOTORS K/KRE Ø35 / MOTEURS K/KRE Ø35	Pág. 61
SOPORTES PARA MOTORES Ø35 BRACKET FOR MOTORS Ø35 / SUPPORTS POUR MOTEURS Ø35	Pág. 63
MOTORES K/KE/KC/KRE/KRET Ø45 MOTORS K/KE/KC/KRE/KRET Ø45 MOTEURS K/KE/KC/KRE/KRET Ø45	Pág. 64
SOPORTES PARA MOTORES K/KE/KC/KRE/KRET Ø45 BRACKET FOR K/KE/KC/KRE/KRET Ø45 SUPPORTS POUR MOTEUR K/KE/KC/KRE/KRET Ø45	Pág. 68
MOTOR KMM Ø45 MOTOR KMM Ø45 / MOTEUR KMM Ø59	Pág. 69
SOPORTES Y ACCESORIOS PARA MOTOR KMM Ø45 BRACKET AND ACCESSOIRES FOR KMM Ø45 / SUPPORT ET ACCESSOIRES POUR MOTEUR KMM Ø45	Pág. 70
ADAPTACIONES PARA MOTORES K/KE/KMM/KRE/KRET Ø45 ADAPTERS FOR K/KE/KMM/KRE/KRET Ø45 ADAPTIONS À MOTEUR K/KE/KMM/KRE/KRET Ø45	Pág. 71
MOTORES K/KRE/KRET Ø59 MOTORS K/KRE/KRET Ø59 / MOTEURS K/KRE/KRET Ø59	Pág. 72
SOPORTES Y ADAPTACIONES MOTORES K Ø59 BRACKET AND ADAPTERS FOR K Ø59 / SUPPORTS ET ADAPTATIONS À MOTEUR K Ø59	Pág. 75
MOTOR KMM Ø59 MOTOR KMM Ø59 / MOTEUR KMM Ø59	Pág. 76
SOPORTES , ACCESORIOS Y ADAPTACIONES MOTORES KMM Ø59 BRACKET, ACCESSOIRES AND ADAPTERS FOR K Ø59 SUPPORTS, ACCESSOIRES ET ADAPTATIONS À MOTEUR K Ø59	Pág. 77
EMISORES PARA MOTORES KRE/KRET TRANSMITTERS AND CONTROL UNITS FOR KRE/KRET ÉMETTEURS RADIO POUR LES MOTEURS KRE/KRET	Pág. 78
CENTRALES DE MANDO CONTROL UNITS / CENTRALE DE CONTRÔLE	Pág. 79
ACCESORIOS ACCESSORIES / ACCESSOIRES	Pág. 80
PROGRAMACIÓN PROGRAMMING / PROGRAMMATION	Pág. 81

RECOGEDOR MIÑO C-14 (Frente de *poliamida* - Cajetín *sin pivote*)
STRAP COILER MIÑO C-14 (Polyamide cover plate - Non screw cavity box)
ENROULEUR MIÑO C-14 (Plaque de couverture de polyamide - Sans pivot)



MIÑO BLANCO MIÑO WHITE / MIÑO BLANC	14	Pintas White & Grey Blanche et Grise	4211701	6,00 €	50 uds.
	14	Gris Grey Grise	4211301	6,00 €	50 uds.
MIÑO GRIS MIÑO GREY / MIÑO GRIS	14	Pintas White & Grey Blanche et Grise	4213701	6,00 €	50 uds.
	14	Gris Grey Grise	4213301	6,00 €	50 uds.
MIÑO MARRÓN MIÑO BROWN / MIÑO MARRON	14	Marrón Brown Marron	4214401	6,00 €	50 uds.
MIÑO NEGRO MIÑO BLACK / MIÑO NOIR	14	Negra Black Noire	4216601	6,00 €	50 uds.
MIÑO VERDE MIÑO GREEN / MIÑO VERT	14	Pintas White & Grey Blanche et Grise	4218701	6,00 €	50 uds.

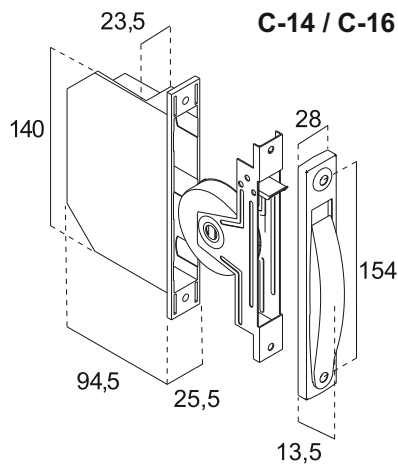

RECOGEDOR MIÑO C-16 (Frente de *poliamida* - Cajetín *sin pivote*)
STRAP COILER MIÑO C-16 (Polyamide cover plate - Non screw cavity box)
ENROULEUR MIÑO C-16 (Plaque de couverture de polyamide - Sans pivot)



MIÑO BLANCO MIÑO WHITE / MIÑO BLANC	16	Pintas White & Grey Blanche et Grise	4271701	4,57 €	50 uds.
	16	Gris Grey Grise	4271301	4,57 €	50 uds.
MIÑO GRIS MIÑO GREY / MIÑO GRIS	16	Pintas White & Grey Blanche et Grise	4273701	4,57 €	50 uds.
	16	Gris Grey Grise	4273301	4,57 €	50 uds.
MIÑO MARRÓN MIÑO BROWN / MIÑO MARRON	16	Marrón Brown Marron	4274401	4,57 €	50 uds.
MIÑO NEGRO MIÑO BLACK / MIÑO NOIR	16	Negra Black Noire	4276601	4,57 €	50 uds.
MIÑO VERDE MIÑO GREEN / MIÑO VERT	16	Pintas White & Grey Blanche et Grise	4278701	4,57 €	50 uds.

RECOGEDOR PLANO ULLA C-16 FRENO INOX (Frente de *poliamida* - Cajetín *sin pivote*)
STRAP COILER FLAT ULLA C-16 INOX STOPPER (Polyamide cover plate - Non screw cavity box)
ENROULEUR PLAN ULLA C-16 FREIN INOX (Plaque de couverture de polyamide - Sans pivot)



PLANO ULLA BLANCO FLAT ULLA WHITE PLAN ULLA BLANC	16	Pintas White & Grey Blanche et Grise	42817A	6,63 €	25 uds.
	16	Gris Grey Grise	42813A	6,63 €	25 uds.
PLANO ULLA GRIS FLAT ULLA GREY PLAN ULLA GRIS	16	Pintas White & Grey Blanche et Grise	42837A	6,63 €	25 uds.
	16	Gris Grey Grise	42833A	6,63 €	25 uds.
PLANO ULLA MARRÓN FLAT ULLA BROWN PLAN ULLA MARRON	16	Marrón Brown Marron	42844A	6,63 €	25 uds.
PLANO ULLA NEGRO FLAT ULLA BLACK PLAN ULLA NOIR	16	Negra Black Noire	42866A	6,63 €	25 uds.
PLANO ULLA VERDE FLAT ULLA GREEN PLAN ULLA VERT	16	Pintas White & Grey Blanche et Grise	42887A	6,63 €	25 uds.

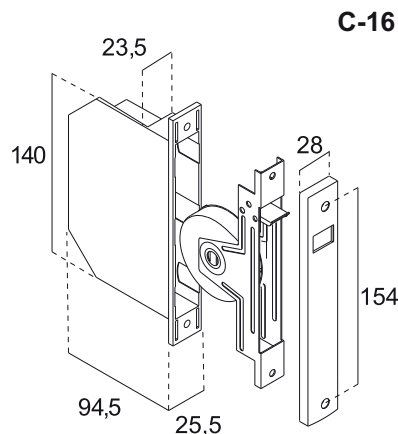

RECOGEDOR MIÑO C-18 (Frente de **poliamida** - Cajetín **sin pivote**)
STRAP COILER MIÑO C-18 (Polyamide cover plate - Non screw cavity box)
ENROULEUR MIÑO C-18 (Plaque de couverture de polyamide - Sans pivot)

MIÑO BLANCO MIÑO WHITE / MIÑO BLANC	18	Pintas White & Grey Blanche et Grise	4241701	4,60 €	50 uds.
	18	Gris Grey Grise	4241301	4,60 €	50 uds.
MIÑO GRIS MIÑO GREY / MIÑO GRIS	18	Pintas White & Grey Blanche et Grise	4243701	4,60 €	50 uds.
	18	Gris Grey Grise	4243301	4,60 €	50 uds.
MIÑO MARRÓN MIÑO BROWN / MIÑO MARRON	18	Marrón Brown Marron	4244401	4,60 €	50 uds.
MIÑO NEGRO MIÑO BLACK / MIÑO NOIR	18	Negra Black Noire	4246601	4,60 €	50 uds.
MIÑO VERDE MIÑO GREEN / MIÑO VERT	18	Pintas White & Grey Blanche et Grise	4248701	4,60 €	50 uds.

RECOGEDOR MIÑO C-18 (Frente de **poliamida** - Cajetín **con pivote**)
STRAP COILER MIÑO C-18 (Polyamide cover plate - Box with screw cavity)
ENROULEUR MIÑO C-18 (Plaque de couverture de polyamide - Avec pivot)

MIÑO BLANCO MIÑO WHITE / MIÑO BLANC	18	Pintas White & Grey Blanche et Grise	4241700	4,60 €	50 uds.
	18	Gris Grey Grise	4241300	4,60 €	50 uds.
MIÑO GRIS MIÑO GREY / MIÑO GRIS	18	Pintas White & Grey Blanche et Grise	4243700	4,60 €	50 uds.
	18	Gris Grey Grise	4243300	4,60 €	50 uds.
MIÑO MARRÓN MIÑO BROWN / MIÑO MARRON	18	Marrón Brown Marron	4240400	4,60 €	50 uds.
MIÑO NEGRO MIÑO BLACK / MIÑO NOIR	18	Negra Black Noire	4246600	4,60 €	50 uds.
MIÑO VERDE MIÑO GREEN / MIÑO VERT	18	Pintas White & Grey Blanche et Grise	4248700	4,60 €	50 uds.

RECOGEDOR NAVIA C-18 (Frente de **poliamida** - Cajetín **con pivote extraíble**)
STRAP COILER NAVIA C-18 (Polyamide cover plate - Box with removable screw cavity)
ENROULEUR NAVIA C-18 (Plaque de couverture de polyamide - Avec pivot extractible)

NAVIA BLANCO NAVIA WHITE / NAVIA BLANC	18	Pintas White & Grey Blanche et Grise	42217L11	4,60 €	50 uds.
	18	Gris Grey Grise	42213L11	4,60 €	50 uds.
NAVIA GRIS NAVIA GREY / NAVIA GRIS	18	Pintas White & Grey Blanche et Grise	42237L11	4,60 €	50 uds.
	18	Gris Grey Grise	42233L11	4,60 €	50 uds.
NAVIA MARRÓN NAVIA BROWN / NAVIA MARRON	18	Marrón Brown Marron	42244L11	4,60 €	50 uds.
NAVIA NEGRO NAVIA BLACK / NAVIA NOIR	18	Negra Black Noire	42266L11	4,60 €	50 uds.
NAVIA VERDE NAVIA GREEN / NAVIA VERT	18	Pintas White & Grey Blanche et Grise	42287L11	4,60 €	50 uds.

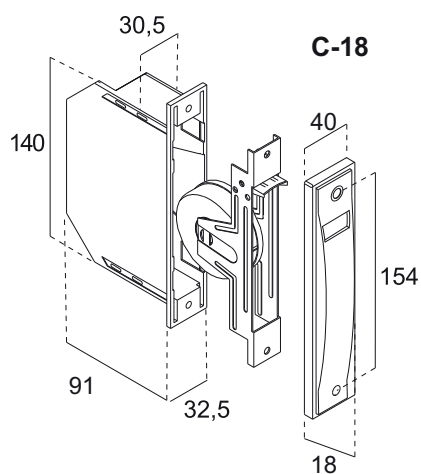
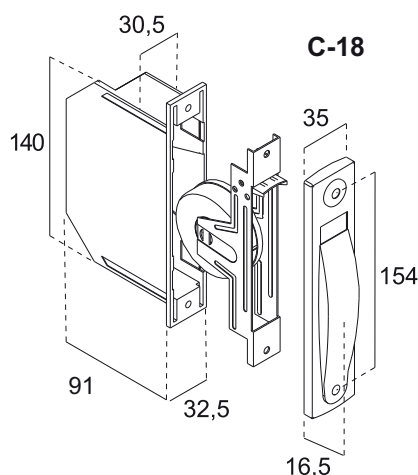

RECOGEDOR MIÑO C-20 (Frente de **poliamida** - Cajetín **sin pivote**)
STRAP COILER MIÑO C-20 (Polyamide cover plate - Non screw cavity box)
ENROULEUR MIÑO C-20 (Plaque de couverture de polyamide - Sans pivot)



MIÑO BLANCO MIÑO WHITE / MIÑO BLANC	20	Pintas White & Grey Blanche et Grise	4231701	4,70 €	50 uds.
	20	Gris Grey Grise	4231301	4,70 €	50 uds.
MIÑO GRIS MIÑO GREY / MIÑO GRIS	20	Pintas White & Grey Blanche et Grise	4233701	4,70 €	50 uds.
	20	Gris Grey Grise	4233301	4,70 €	50 uds.
MIÑO MARRÓN MIÑO BROWN / MIÑO MARRON	20	Marrón Brown Marron	4234401	4,70 €	50 uds.
MIÑO NEGRO MIÑO BLACK / MIÑO NOIR	20	Negra Black Noire	4236601	4,70 €	50 uds.
MIÑO VERDE MIÑO GREEN / MIÑO VERT	20	Pintas White & Grey Blanche et Grise	4238701	4,70 €	50 uds.

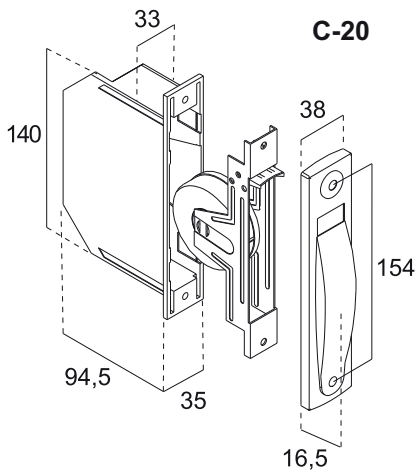

RECOGEDOR MIÑO C-20 (Frente de **poliamida** - Cajetín **con pivote**)
STRAP COILER MIÑO C-20 (Polyamide cover plate - Box with screw cavity)
ENROULEUR MIÑO C-20 (Plaque de couverture de polyamide - Avec pivot)



MIÑO BLANCO MIÑO WHITE / MIÑO BLANC	20	Pintas White & Grey Blanche et Grise	4231700	4,70 €	50 uds.
	20	Gris Grey Grise	4231300	4,70 €	50 uds.
MIÑO GRIS MIÑO GREY / MIÑO GRIS	20	Pintas White & Grey Blanche et Grise	4233700	4,70 €	50 uds.
	20	Gris Grey Grise	4233300	4,70 €	50 uds.
MIÑO MARRÓN MIÑO BROWN / MIÑO MARRON	20	Marrón Brown Marron	4234400	4,70 €	50 uds.
MIÑO NEGRO MIÑO BLACK / MIÑO NOIR	20	Negra Black Noire	4236600	4,70 €	50 uds.
MIÑO VERDE MIÑO GREEN / MIÑO VERT	20	Pintas White & Grey Blanche et Grise	4238700	4,70 €	50 uds.

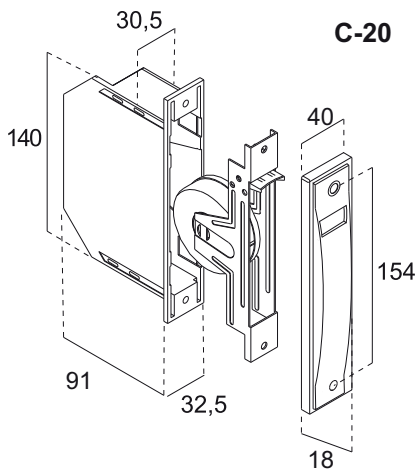

RECOGEDOR NAVIA C-20 (Frente de **poliamida** - Cajetín **con pivote extraíble**)
STRAP COILER NAVIA C-20 (Polyamide cover plate - Box with removable screw cavity)
ENROULEUR NAVIA C-20 (Plaque de couverture de polyamide - Avec pivot extractible)



NAVIA BLANCO NAVIA WHITE / NAVIA BLANC	20	Pintas White & Grey Blanche et Grise	42317L11	4,70 €	50 uds.
	20	Gris Grey Grise	42313L11	4,70 €	50 uds.
NAVIA GRIS NAVIA GREY / NAVIA GRIS	20	Pintas White & Grey Blanche et Grise	42337L11	4,70 €	50 uds.
	20	Gris Grey Grise	42333L11	4,70 €	50 uds.
NAVIA MARRÓN NAVIA BROWN / NAVIA MARRON	20	Marrón Brown Marron	42344L11	4,70 €	50 uds.
NAVIA NEGRO NAVIA BLACK / NAVIA NOIR	20	Negra Black Noire	42366L11	4,70 €	50 uds.
NAVIA VERDE NAVIA GREEN / NAVIA VERT	20	Pintas White & Grey Blanche et Grise	42387L11	4,70 €	50 uds.

RECOGEDOR MIÑO C-14 FRENO INOX (Frente de *poliamida* - Cajetín *sin pivote*)
STRAP COILER MIÑO C-14 INOX STOPPER (Polyamide cover plate - Non screw cavity box)
ENROULEUR MIÑO C-14 FREIN INOX (Plaque de couverture de polyamide - Sans pivot)



MIÑO BLANCO MIÑO WHITE / MIÑO BLANC	14	Pintas White & Grey Blanche et Grise	4251701	6,20 €	50 uds.
	14	Gris Grey Grise	4251301	6,20 €	50 uds.
MIÑO GRIS MIÑO GREY / MIÑO GRIS	14	Pintas White & Grey Blanche et Grise	4253701	6,20 €	50 uds.
	14	Gris Grey Grise	4253301	6,20 €	50 uds.
MIÑO MARRÓN MIÑO BROWN / MIÑO MARRON	14	Marrón Brown Marron	4250401	6,20 €	50 uds.
MIÑO NEGRO MIÑO BLACK / MIÑO NOIR	14	Negra Black Noire	4256601	6,20 €	50 uds.
MIÑO VERDE MIÑO GREEN / MIÑO VERT	14	Pintas White & Grey Blanche et Grise	4258701	6,20 €	50 uds.

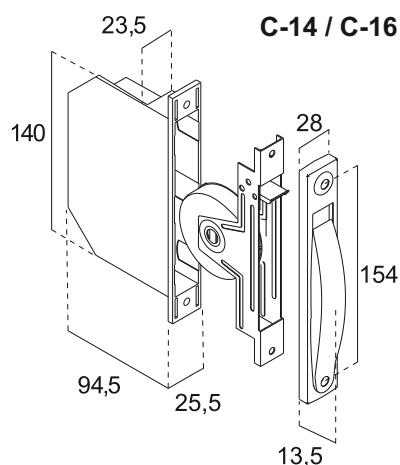

RECOGEDOR MIÑO C-16 FRENO INOX (Frente de *poliamida* - Cajetín *sin pivote*)
STRAP COILER MIÑO C-16 INOX STOPPER (Polyamide cover plate - Non screw cavity box)
ENROULEUR MIÑO C-16 FREIN INOX (Plaque de couverture de polyamide - Sans pivot)



MIÑO BLANCO MIÑO WHITE / MIÑO BLANC	16	Pintas White & Grey Blanche et Grise	4281701	4,57 €	50 uds.
	16	Gris Grey Grise	4281301	4,57 €	50 uds.
MIÑO GRIS MIÑO GREY / MIÑO GRIS	16	Pintas White & Grey Blanche et Grise	4283701	4,57 €	50 uds.
	16	Gris Grey Grise	4283301	4,57 €	50 uds.
MIÑO MARRÓN MIÑO BROWN / MIÑO MARRON	16	Marrón Brown Marron	4284401	4,57 €	50 uds.
MIÑO NEGRO MIÑO BLACK / MIÑO NOIR	16	Negra Black Noire	4286601	4,57 €	50 uds.
MIÑO VERDE MIÑO GREEN / MIÑO VERT	16	Pintas White & Grey Blanche et Grise	4288701	4,57 €	50 uds.

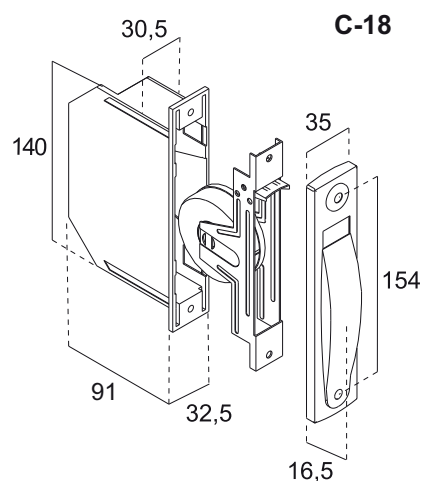

RECOGEDOR MIÑO C-18 FRENO INOX (Frente de *poliamida* - Cajetín *sin pivote*)
STRAP COILER MIÑO C-18 INOX STOPPER (Polyamide cover plate - Non screw cavity box)
ENROULEUR MIÑO C-18 FREIN INOX (Plaque de couverture de polyamide - Sans pivot)



MIÑO BLANCO MIÑO WHITE / MIÑO BLANC	18	Pintas White & Grey Blanche et Grise	42417011	4,70 €	50 uds.
	18	Gris Grey Grise	42413011	4,70 €	50 uds.
MIÑO GRIS MIÑO GREY / MIÑO GRIS	18	Pintas White & Grey Blanche et Grise	42437011	4,70 €	50 uds.
	18	Gris Grey Grise	42433011	4,70 €	50 uds.
MIÑO MARRÓN MIÑO BROWN / MIÑO MARRON	18	Marrón Brown Marron	42404011	4,70 €	50 uds.
MIÑO NEGRO MIÑO BLACK / MIÑO NOIR	18	Negra Black Noire	42466011	4,70 €	50 uds.
MIÑO VERDE MIÑO GREEN / MIÑO VERT	18	Pintas White & Grey Blanche et Grise	42487011	4,70 €	50 uds.

RECOGEDOR MIÑO C-18 FRENO INOX (Frente de *poliamida* - Cajetín *con pivote*)
STRAP COILER MIÑO C-18 INOX STOPPER (Polyamide cover plate - Box with screw cavity)
ENROULEUR MIÑO C-18 FREIN INOX (Plaque de couverture de polyamide - Avec pivot)

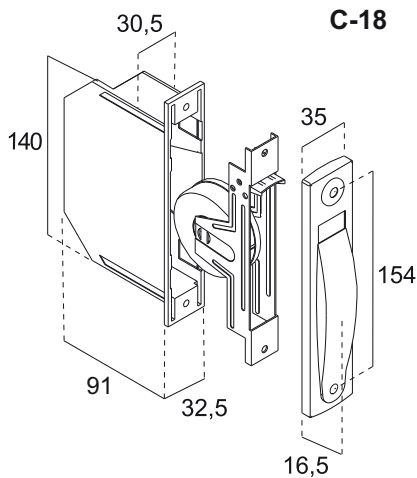

MIÑO BLANCO MIÑO WHITE / MIÑO BLANC	18	Pintas White & Grey Blanche et Grise	42417001	4,70 €	50 uds.
	18	Gris Grey Grise	42413001	4,70 €	50 uds.
MIÑO GRIS MIÑO GREY / MIÑO GRIS	18	Pintas White & Grey Blanche et Grise	42437001	4,70 €	50 uds.
	18	Gris Grey Grise	42433001	4,70 €	50 uds.
MIÑO MARRÓN MIÑO BROWN / MIÑO MARRON	18	Marrón Brown Marron	42404001	4,70 €	50 uds.
MIÑO NEGRO MIÑO BLACK / MIÑO NOIR	18	Negra Black Noire	42466001	4,70 €	50 uds.
MIÑO VERDE MIÑO GREEN / MIÑO VERT	18	Pintas White & Grey Blanche et Grise	42487001	4,70 €	50 uds.

RECOGEDOR MIÑO C-20 FRENO INOX (Frente de *poliamida* - Cajetín *sin pivote*)
STRAP COILER MIÑO C-20 INOX STOPPER (Polyamide cover plate - Non screw cavity box)
ENROULEUR MIÑO C-20 FREIN INOX (Plaque de couverture de polyamide - Sans pivot)

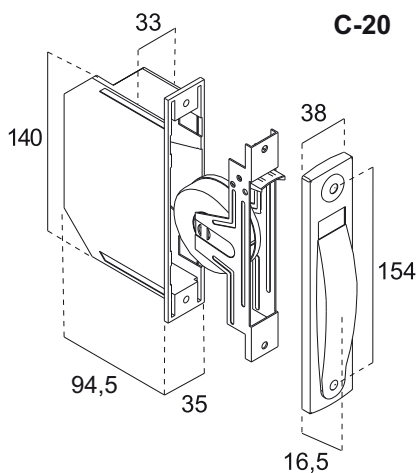

MIÑO BLANCO MIÑO WHITE / MIÑO BLANC	20	Pintas White & Grey Blanche et Grise	42617011	4,80 €	50 uds.
	20	Gris Grey Grise	42613011	4,80 €	50 uds.
MIÑO GRIS MIÑO GREY / MIÑO GRIS	20	Pintas White & Grey Blanche et Grise	42637011	4,80 €	50 uds.
	20	Gris Grey Grise	42633011	4,80 €	50 uds.
MIÑO MARRÓN MIÑO BROWN / MIÑO MARRON	20	Marrón Brown Marron	42604011	4,80 €	50 uds.
MIÑO NEGRO MIÑO BLACK / MIÑO NOIR	20	Negra Black Noire	42666011	4,80 €	50 uds.
MIÑO VERDE MIÑO GREEN / MIÑO VERT	20	Pintas White & Grey Blanche et Grise	42687011	4,80 €	50 uds.

RECOGEDOR MIÑO C-20 FRENO INOX (Frente de *poliamida* - Cajetín *con pivote*)
STRAP COILER MIÑO C-20 INOX STOPPER (Polyamide cover plate - Box with screw cavity)
ENROULEUR MIÑO C-20 FREIN INOX (Plaque de couverture de polyamide - Avec pivot)



MIÑO BLANCO MIÑO WHITE / MIÑO BLANC	20	Pintas White & Grey Blanche et Grise	42617001	4,80 €	50 uds.
	20	Gris Grey Grise	42613001	4,80 €	50 uds.
MIÑO GRIS MIÑO GREY / MIÑO GRIS	20	Pintas White & Grey Blanche et Grise	42637001	4,80 €	50 uds.
	20	Gris Grey Grise	42633001	4,80 €	50 uds.
MIÑO MARRÓN MIÑO BROWN / MIÑO MARRON	20	Marrón Brown Marron	42604001	4,80 €	50 uds.
MIÑO NEGRO MIÑO BLACK / MIÑO NOIR	20	Negra Black Noire	42666001	4,80 €	50 uds.
MIÑO VERDE MIÑO GREEN / MIÑO VERT	20	Pintas White & Grey Blanche et Grise	42687001	4,80 €	50 uds.

Los recogedores Miño C-20 están disponibles con pivote extraíble.
In the strap coiler Miño C-20 there is available a portable screw cavity.
Les enrouleurs Miño C-20 sont disponibles avec pivot.

RECOGEDORES DE EMPOTRAR

INSIDE BOX STRAP COILERS / ENROULEUR À ENCASTRÉ

RECOGEDOR MIÑO C-18 (Frente de aluminio- Cajetín sin pivote) STRAP COILER MIÑO C-18 (Aluminium cover plate - Non screw cavity box) ENROULEUR MIÑO C-18 (Plaque de couverture d'aluminium - Sans pivot)



MIÑO BLANCO MIÑO WHITE / MIÑO BLANC	18	Pintas White & Grey Blanche et Grise	4221711	5,40 €	50 uds.
	18	Gris Grey Grise	4221311	5,40 €	50 uds.
MIÑO GRIS MIÑO GREY / MIÑO GRIS	18	Pintas White & Grey Blanche et Grise	4223711	5,40 €	50 uds.
	18	Gris Grey Grise	4223311	5,40 €	50 uds.
MIÑO BRONCE MIÑO BRONZE / MIÑO BRONZE	18	Marrón Brown Marron	4225411	5,40 €	50 uds.
MIÑO NEGRO MIÑO BLACK / MIÑO NOIR	18	Negra Black Noire	4226611	5,40 €	50 uds.
MIÑO VERDE 6009 MIÑO GREEN 6009 / MIÑO VERT 6009	18	Pintas White & Grey Blanche et Grise	4228711	5,40 €	50 uds.
MIÑO ORO MIÑO GOLD / MIÑO DORÉE	18	Pintas White & Grey Blanche et Grise	4222711	6,20 €	50 uds.
MIÑO MADERA CLARO MIÑO CLEAR WOOD / MIÑO BOIS CLAIR	18	Pintas White & Grey Blanche et Grise	4227711	14,20 €	50 uds.
MIÑO MADERA OSCURO MIÑO DARK WOOD / MIÑO BOIS FONCÉ	18	Marrón Brown Marron	4229411	14,20 €	50 uds.

RECOGEDOR MIÑO C-18 (Frente de aluminio- Cajetín con pivote) STRAP COILER MIÑO C-18 (Aluminium cover plate - Box with screw cavity) ENROULEUR MIÑO C-18 (Plaque de couverture d'aluminium - Avec pivot)



MIÑO BLANCO MIÑO WHITE / MIÑO BLANC	18	Pintas White & Grey Blanche et Grise	4221710	5,40 €	50 uds.
	18	Gris Grey Grise	4221310	5,40 €	50 uds.
MIÑO GRIS MIÑO GREY / MIÑO GRIS	18	Pintas White & Grey Blanche et Grise	4223710	5,40 €	50 uds.
	18	Gris Grey Grise	4223310	5,40 €	50 uds.
MIÑO BRONCE MIÑO BRONZE / MIÑO BRONZE	18	Marrón Brown Marron	4225410	5,40 €	50 uds.
MIÑO NEGRO MIÑO BLACK / MIÑO NOIR	18	Negra Black Noire	4226610	5,40 €	50 uds.
MIÑO VERDE 6009 MIÑO GREEN 6009 / MIÑO VERT 6009	18	Pintas White & Grey Blanche et Grise	4228710	5,40 €	50 uds.
MIÑO ORO MIÑO GOLD / MIÑO DORÉE	18	Pintas White & Grey Blanche et Grise	4222710	6,20 €	50 uds.
MIÑO MADERA CLARO MIÑO CLEAR WOOD / MIÑO BOIS CLAIR	18	Pintas White & Grey Blanche et Grise	4227710	14,20 €	50 uds.
MIÑO MADERA OSCURO MIÑO DARK WOOD / MIÑO BOIS FONCÉ	18	Marrón Brown Marron	4229410	14,20 €	50 uds.

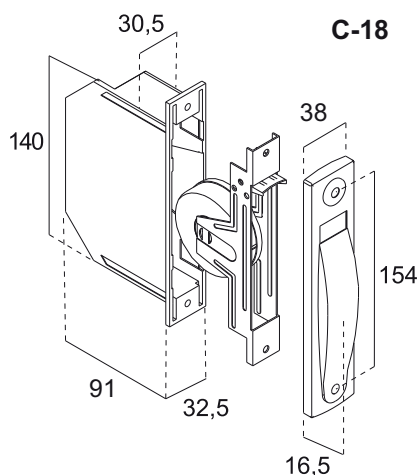

NOTA : Otros colores consultar precio y plazo de entrega.
NOTE: Another colour demand request price and delivery time.
NOTE: Pour toute autre couleur, consulter prix et délais de livraison.

RECOGEDOR MIÑO C-20 (Frente de aluminio- Cajetín *sin pivote*)
STRAP COILER MIÑO C-20 (Aluminium cover plate - Non screw cavity box)
ENROULEUR MIÑO C-20 (Plaque de couverture d'aluminium - Sans pivot)



MIÑO BLANCO MIÑO WHITE / MIÑO BLANC	20	Pintas White & Grey Blanche et Grise	4231711	5,50 €	50 uds.
	20	Gris Grey Grise	4231311	5,50 €	50 uds.
MIÑO GRIS MIÑO GREY / MIÑO GRIS	20	Pintas White & Grey Blanche et Grise	4233711	5,50 €	50 uds.
	20	Gris Grey Grise	4233311	5,50 €	50 uds.
MIÑO BRONCE MIÑO BRONZE / MIÑO BRONZE	20	Marrón Brown Marron	4235411	5,50 €	50 uds.
MIÑO NEGRO MIÑO BLACK / MIÑO NOIR	20	Negra Black Noire	4236611	5,50 €	50 uds.
MIÑO VERDE 6009 MIÑO GREEN 6009 / MIÑO VERT 6009	20	Pintas White & Grey Blanche et Grise	4238711	5,50 €	50 uds.
MIÑO ORO MIÑO GOLD / MIÑO DORÉE	20	Pintas White & Grey Blanche et Grise	4232711	6,20 €	50 uds.
MIÑO MADERA CLARO MIÑO CLEAR WOOD / MIÑO BOIS CLAIR	20	Pintas White & Grey Blanche et Grise	4237711	15,00 €	50 uds.
MIÑO MADERA OSCURO MIÑO DARK WOOD / MIÑO BOIS FONCÉ	20	Marrón Brown Marron	4239411	15,00 €	50 uds.

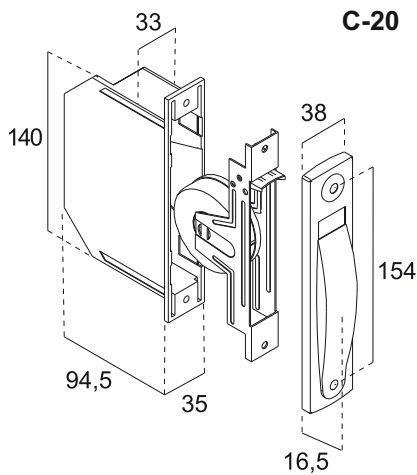

RECOGEDOR MIÑO C-20 (Frente de aluminio- Cajetín *con pivote*)
STRAP COILER MIÑO C-20 (Aluminium cover plate - Box with screw cavity)
ENROULEUR MIÑO C-20 (Plaque de couverture d'aluminium - Avec pivot)



MIÑO BLANCO MIÑO WHITE / MIÑO BLANC	20	Pintas White & Grey Blanche et Grise	4231710	5,50 €	50 uds.
	20	Gris Grey Grise	4231310	5,50 €	50 uds.
MIÑO GRIS MIÑO GREY / MIÑO GRIS	20	Pintas White & Grey Blanche et Grise	4233710	5,50 €	50 uds.
	20	Gris Grey Grise	4233310	5,50 €	50 uds.
MIÑO BRONCE MIÑO BRONZE / MIÑO BRONZE	20	Marrón Brown Marron	4235410	5,50 €	50 uds.
MIÑO NEGRO MIÑO BLACK / MIÑO NOIR	20	Negra Black Noire	4236610	5,50 €	50 uds.
MIÑO VERDE 6009 MIÑO GREEN 6009 / MIÑO VERT 6009	20	Pintas White & Grey Blanche et Grise	4238710	5,50 €	50 uds.
MIÑO ORO MIÑO GOLD / MIÑO DORÉE	20	Pintas White & Grey Blanche et Grise	4232710	6,20 €	50 uds.
MIÑO MADERA CLARO MIÑO CLEAR WOOD / MIÑO BOIS CLAIR	20	Pintas White & Grey Blanche et Grise	4237710	15,00 €	50 uds.
MIÑO MADERA OSCURO MIÑO DARK WOOD / MIÑO BOIS FONCÉ	20	Marrón Brown Marron	4239410	15,00 €	50 uds.

Los recogedores Miño C-20 están disponibles con pivote extraíble.
In the strap coiler Miño C-20 there is available a portable screw cavity.
Les enrouleurs Miño C-20 sont disponibles avec pivot removable.

RECOGEDOR MIÑO C-18 FRENO INOX (Frente de aluminio- Cajetín *sin* pivote)
STRAP COILER MIÑO C-18 INOX STOPPER (Aluminium cover plate - Non screw cavity box)
ENROULEUR MIÑO C-18 FREIN INOX (Plaque de couverture d'aluminium - Sans pivot)



MIÑO BLANCO MIÑO WHITE / MIÑO BLANC	18	Pintas White & Grey Blanche et Grise	42217111	5,50 €	50 uds.
	18	Gris Grey Grise	42213111	5,50 €	50 uds.
MIÑO GRIS MIÑO GREY / MIÑO GRIS	18	Pintas White & Grey Blanche et Grise	42237111	5,50 €	50 uds.
	18	Gris Grey Grise	42233111	5,50 €	50 uds.
MIÑO BRONCE MIÑO BRONZE / MIÑO BRONZE	18	Marrón Brown Marron	42254111	5,50 €	50 uds.
MIÑO NEGRO MIÑO BLACK / MIÑO NOIR	18	Negra Black Noire	42266111	5,50 €	50 uds.
MIÑO VERDE 6009 MIÑO GREEN 6009 / MIÑO VERT 6009	18	Pintas White & Grey Blanche et Grise	42287111	5,50 €	50 uds.
MIÑO ORO MIÑO GOLD / MIÑO DORÉE	18	Pintas White & Grey Blanche et Grise	42227111	6,20 €	50 uds.
MIÑO MADERA CLARO MIÑO CLEAR WOOD / MIÑO BOIS CLAIR	18	Pintas White & Grey Blanche et Grise	42277111	14,20 €	50 uds.
MIÑO MADERA OSCURO MIÑO DARK WOOD / MIÑO BOIS FONCÉ	18	Marrón Brown Marron	42294111	14,20 €	50 uds.

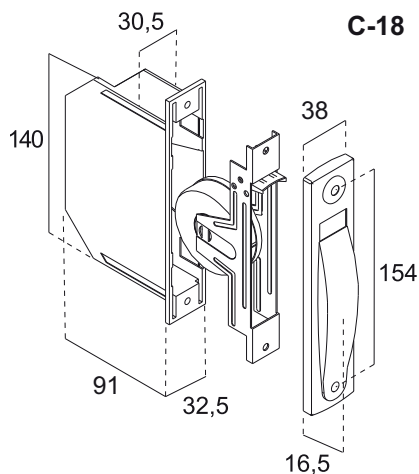

RECOGEDOR MIÑO C-18 FRENO INOX (Frente de aluminio- Cajetín *con* pivote)
STRAP COILER MIÑO C-18 INOX STOPPER (Aluminium cover plate - Box with screw cavity)
ENROULEUR MIÑO C-18 FREIN INOX (Plaque de couverture d'aluminium - Avec pivot)



MIÑO BLANCO MIÑO WHITE / MIÑO BLANC	18	Pintas White & Grey Blanche et Grise	42217101	5,50 €	50 uds.
	18	Gris Grey Grise	42213101	5,50 €	50 uds.
MIÑO GRIS MIÑO GREY / MIÑO GRIS	18	Pintas White & Grey Blanche et Grise	42237101	5,50 €	50 uds.
	18	Gris Grey Grise	42233101	5,50 €	50 uds.
MIÑO BRONCE MIÑO BRONZE / MIÑO BRONZE	18	Marrón Brown Marron	42254101	5,50 €	50 uds.
MIÑO NEGRO MIÑO BLACK / MIÑO NOIR	18	Negra Black Noire	42266101	5,50 €	50 uds.
MIÑO VERDE 6009 MIÑO GREEN 6009 / MIÑO VERT 6009	18	Pintas White & Grey Blanche et Grise	42287101	5,50 €	50 uds.
MIÑO ORO MIÑO GOLD / MIÑO DORÉE	18	Pintas White & Grey Blanche et Grise	42227101	6,20 €	50 uds.
MIÑO MADERA CLARO MIÑO CLEAR WOOD / MIÑO BOIS CLAIR	18	Pintas White & Grey Blanche et Grise	42277101	14,20 €	50 uds.
MIÑO MADERA OSCURO MIÑO DARK WOOD / MIÑO BOIS FONCÉ	18	Marrón Brown Marron	42294101	14,20 €	50 uds.

NOTA: Otros colores consultar precio y plazo de entrega.
NOTE: Another colour demand request price and delivery time.
NOTE: Pour toute autre couleur, consulter prix et délais de livraison.

RECOGEDOR MIÑO C-20 FRENO INOX (Frente de **aluminio- Cajetín sin pivote**)
STRAP COILER MIÑO C-20 INOX STOPPER (Aluminium cover plate - Non screw cavity box)
ENROULEUR MIÑO C-20 FREIN INOX (Plaque de couverture d'aluminium - Sans pivot)



MIÑO BLANCO MIÑO WHITE / MIÑO BLANC	20	Pintas White & Grey Blanche et Grise	42317111	5,60 €	50 uds.
	20	Gris Grey Grise	42313111	5,60 €	50 uds.
MIÑO GRIS MIÑO GREY / MIÑO GRIS	20	Pintas White & Grey Blanche et Grise	42337111	5,60 €	50 uds.
	20	Gris Grey Grise	42333111	5,60 €	50 uds.
MIÑO BRONCE MIÑO BRONZE / MIÑO BRONZE	20	Marrón Brown Marron	42354111	5,60 €	50 uds.
MIÑO NEGRO MIÑO BLACK / MIÑO NOIR	20	Negra Black Noire	42366111	5,60 €	50 uds.
MIÑO VERDE 6009 MIÑO GREEN 6009 / MIÑO VERT 6009	20	Pintas White & Grey Blanche et Grise	42387111	5,60 €	50 uds.
MIÑO ORO MIÑO GOLD / MIÑO DORÉE	20	Pintas White & Grey Blanche et Grise	42327111	6,20 €	50 uds.
MIÑO MADERA CLARO MIÑO CLEAR WOOD / MIÑO BOIS CLAIR	20	Pintas White & Grey Blanche et Grise	42377111	15,00 €	50 uds.
MIÑO MADERA OSCURO MIÑO DARK WOOD / MIÑO BOIS FONCÉ	20	Marrón Brown Marron	42394111	15,00 €	50 uds.

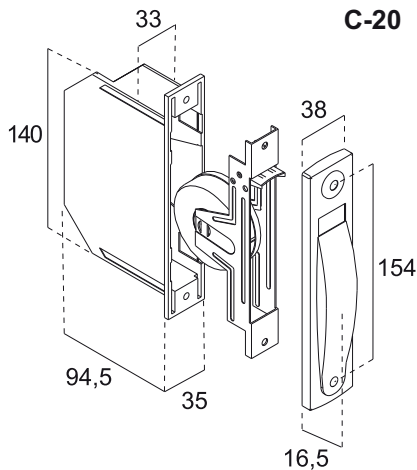

RECOGEDOR MIÑO C-20 FRENO INOX (Frente de **aluminio- Cajetín con pivote**)
STRAP COILER MIÑO C-20 INOX STOPPER (Aluminium cover plate - Box with screw cavity)
ENROULEUR MIÑO C-20 FREIN INOX (Plaque de couverture d'aluminium - Avec pivot)



MIÑO BLANCO MIÑO WHITE / MIÑO BLANC	20	Pintas White & Grey Blanche et Grise	42317101	5,60 €	50 uds.
	20	Gris Grey Grise	42313101	5,60 €	50 uds.
MIÑO GRIS MIÑO GREY / MIÑO GRIS	20	Pintas White & Grey Blanche et Grise	42337101	5,60 €	50 uds.
	20	Gris Grey Grise	42333101	5,60 €	50 uds.
MIÑO BRONCE MIÑO BRONZE / MIÑO BRONZE	20	Marrón Brown Marron	42354101	5,60 €	50 uds.
MIÑO NEGRO MIÑO BLACK / MIÑO NOIR	20	Negra Black Noire	42366101	5,60 €	50 uds.
MIÑO VERDE 6009 MIÑO GREEN 6009 / MIÑO VERT 6009	20	Pintas White & Grey Blanche et Grise	42387101	5,60 €	50 uds.
MIÑO ORO MIÑO GOLD / MIÑO DORÉE	20	Pintas White & Grey Blanche et Grise	42327101	6,20 €	50 uds.
MIÑO MADERA CLARO MIÑO CLEAR WOOD / MIÑO BOIS CLAIR	20	Pintas White & Grey Blanche et Grise	42377101	15,00 €	50 uds.
MIÑO MADERA OSCURO MIÑO DARK WOOD / MIÑO BOIS FONCÉ	20	Marrón Brown Marron	42394101	15,00 €	50 uds.

Los recogedores Miño C-20 están disponibles con pivote extraíble.
In the strap coiler Miño C-20 there is available a portable screw cavity.
Les enrouleurs Miño C-20 sont disponibles avec pivot removable.

ABATIBLE (CINTA 14)
OUTSIDE STRAP COILER (STRAP 14)
PIVOTANT (SANGLE 14)

			€/ud.	
Blanco White / Blanc	Blanco White / Blanche	21111	5,00 €	25 uds.
	Gris Grey / Grise	21113	5,00 €	25 uds.
	Pintas White&Grey / Blanche et Grise	21117	5,00 €	25 uds.
Marfil Ivory / Ivoire	Marfil Ivory / Ivoire	21122	5,00 €	25 uds.
	Gris Grey / Grise	21123	5,00 €	25 uds.
Gris Grey / Gris	Gris Grey / Grise	21133	5,00 €	25 uds.
Marrón Brown / Marron	Marrón Brown / Marron	21144	5,00 €	25 uds.
Negro Black / Noir	Negro Black / Noire	21166	5,00 €	25 uds.

ABATIBLE (CINTA 18)
OUTSIDE STRAP COILER (STRAP 18)
PIVOTANT (SANGLE 18)

			€/ud.	
Blanco White / Blanc	Blanco White / Blanche	21211	5,50 €	25 uds.
	Gris Grey / Grise	21213	5,50 €	25 uds.
	Pintas White&Grey / Blanche et Grise	21217	5,50 €	25 uds.
Marfil Ivory / Ivoire	Marfil Ivory / Ivoire	21222	5,50 €	25 uds.
	Gris Grey / Grise	21223	5,50 €	25 uds.
Gris Grey / Gris	Gris Grey / Grise	21233	5,50 €	25 uds.
	Pintas White&Grey / Blanche et Grise	21237	5,50 €	25 uds.
Marrón Brown / Marron	Marrón Brown / Marron	21244	5,50 €	25 uds.
Negro Black / Noir	Negro Black / Noire	21266	5,50 €	25 uds.

ABATIBLE SIN CINTA (CINTA 14)
OUTSIDE STRAP COILER (STRAP 14) WITHOUT STRAP
PIVOTANT (SANGLE 14) SANS SANGLE

			€/ud.	
Marfil Ivory / Ivoire		21020	4,32 €	25 uds.
Blanco White / Blanc		21021	4,32 €	25 uds.

ABATIBLE SIN CINTA (CINTA 22)
OUTSIDE BOX STRAP COILER (STRAP 22) WITHOUT STRAP
PIVOTANT (SANGLE 22) SANS SANGLE

			€/ud.	
Blanco White / Blanc		01901	7,00 €	20 uds.
Marfil Ivory / Ivoire		01902	7,00 €	20 uds.

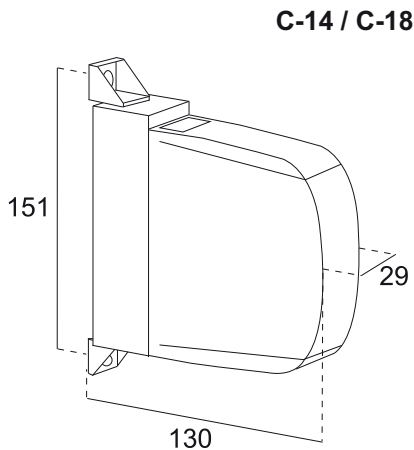

C-14 / C-18

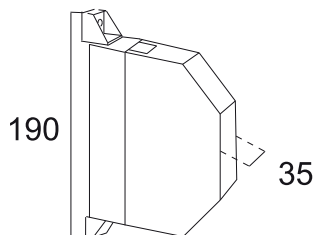

C-22

ABATIBLE SIL (CINTA 20)
OUTSIDE STRAP COILER SIL (STRAP 20)
PIVOTANT SIL (SANGLE 20)

C-20

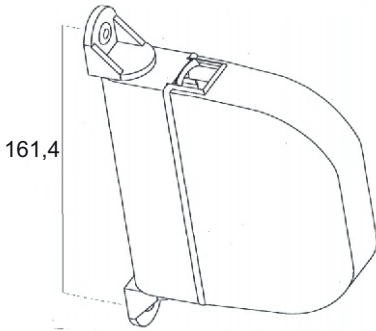

Blanco White / Blanc	Pintas White&Grey / Blanche et Grise	21617	5,80 €	20 uds.
	Gris Grey / Grise	21613	5,80 €	20 uds.
Marfil Ivory / Ivoire	Marfil Ivory / Ivoire	21622	5,80 €	20 uds.
Gris Grey / Gris	Pintas White&Grey / Blanche et Grise	21637	5,80 €	20 uds.
	Gris Grey / Grise	21633	5,80 €	20 uds.
Marrón Brown / Marron	Marrón Brown / Marron	21644	5,80 €	20 uds.
Negro Black / Noir	Negro Black / Noire	21666	5,80 €	20 uds.

ABATIBLE ESPECIAL (CINTA 20)
ESPECIAL OUTSIDE STRAP COILER (STRAP 20)
PIVOTANT SPÉCIAL (SANGLE 20)

C-20

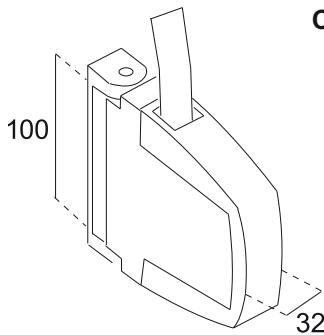

Blanco White / Blanc	Pintas White&Grey / Blanche et Grise	21317	9,00 €	20 uds.
Marfil Ivory / Ivoire	Marfil Ivory / Ivoire	21322	9,00 €	20 uds.
Gris Grey / Gris	Pintas White&Grey / Blanche et Grise	21337	9,00 €	20 uds.
Marrón Brown / Marron	Marrón Brown / Marron	21344	9,00 €	20 uds.

ABATIBLE CORDÓN 3 mm. CON MANETA
OUTSIDE STRAP COILER CORD 3 mm. WITH LEVER
PIVOTANT DE CORDON 3 mm. AVEC POIGNÉE

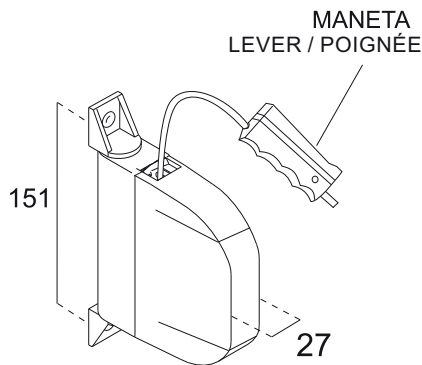

Blanco White / Blanc		21901	9,00 €	20 uds.
Marfil Ivory / Ivoire		21902	9,00 €	20 uds.
Marrón Brown / Marron		21904	9,00 €	20 uds.
Gris Grey / Gris		21905	9,00 €	20 uds.

ABATIBLE CORDÓN 5 mm. SIN MANETA
OUTSIDE STRAP COILER CORD 5 mm. WITHOUT LEVER
PIVOTANT DE CORDON 5 mm. SANS POIGNÉE

21901



Blanco White / Blanc		21911	10,00 €	25 uds.
Marfil Ivory / Ivoire		21912	10,00 €	25 uds.
Marrón Brown / Marron		21914	10,00 €	25 uds.
Gris Grey / Gris		21913	10,00 €	25 uds.



CORDÓN 3 mm CORD 3 mm CORDON 3 mm	Blanco White / Blanc	21917	0,73 €	300 ml.
	Marfil Ivory / Ivoire	21907	0,54 €	300 ml.
CORDÓN 5 mm CORD 5 mm CORDON 5 mm	Blanco White / Blanc	21919	0,75 €	300 ml.
	Marfil Ivory / Ivoire	21909	0,57 €	300 ml.

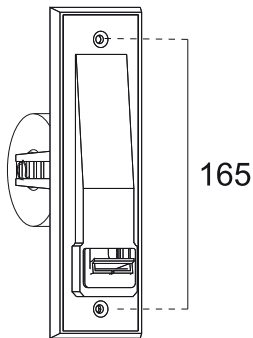

RECOGEDOR PLÁSTICO GRANDE (CINTA 22)
BIG PLASTIC STRAP COILER (STRAP 22)
ENROULEUR GRAND EN PLASTIQUE (SANGLE 22)

Blanco White / Blanc		01101	3,94 €	50 uds.
Marfil Ivory / Ivoire		01102	3,94 €	50 uds.
Gris Grey / Gris		01103	3,94 €	50 uds.
Marrón Brown / Marron		01104	3,94 €	50 uds.
Natural Natural / Naturelle		01108	3,94 €	50 uds.

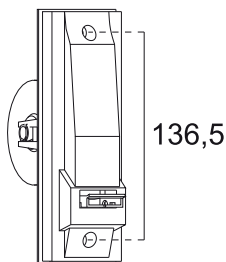

RECOGEDOR PLÁSTICO PEQUEÑO (CINTA 22)
SMALL PLASTIC COILER (STRAP 22)
ENROULEUR PETIT EN PLASTIQUE (SANGLE 22)

Blanco White / Blanc		01111	3,94 €	50 uds.
Marfil Ivory / Ivoire		01112	3,94 €	50 uds.
Gris Grey / Gris		01113	3,94 €	50 uds.
Marrón Brown / Marron		01114	3,94 €	50 uds.
Natural Natural / Naturelle		01118	3,94 €	50 uds.

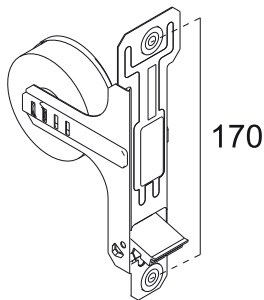

RECOGEDOR METÁLICO DOS PATILLAS (CINTA 22)
TWO ARMS METAL COILER (STRAP 22)
METAL ENROULEUR DEUX TIGES (SANGLE 22)

Cincado Zinc / Zinc		01120	5,00 €	50 uds.
Blanco White / Blanc		01121	5,00 €	50 uds.
Bronce Bronze / Bronze		01125	5,00 €	50 uds.

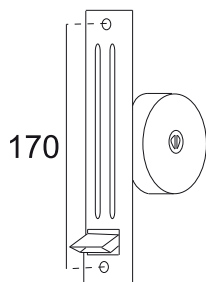

RECOGEDOR METÁLICO UNA PATILLA (CINTA 22)
ONE ARM METAL COILER (STRAP 22)
METAL ENROULEUR UNE TIGE (SANGLE 22)

Cincado Zinc / Zinc		01140	3,30 €	50 uds.
Blanco White / Blanc		01141	3,30 €	50 uds.
Bronce Bronze / Bronze		01145	3,30 €	50 uds.
Oro Gold / Dorée		01146	3,30 €	50 uds.



CAJETÍN PLÁSTICO GRANDE para recogedor plástico grande y metálico dos patillas
BIG BOX FOR STRAP COILER for big plastic strap coiler and two arms
BOÎTIER GRAND EN PLASTIQUE pour enrouleur grande et enrouleur avec deux tiges

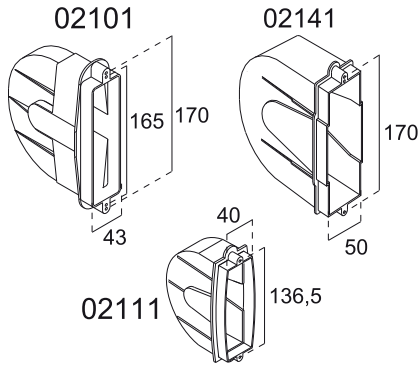

02101	1,97 €	50 uds.
-------	--------	---------

CAJETÍN PLÁSTICO PEQUEÑO para recogedor plástico pequeño
SMALL BOX FOR STRAP COILER for small plastic strap coiler
BOÎTIER PETIT EN PLASTIQUE pour enrouleur petit en plastique et enrouleur avec deux tiges

02111	1,21 €	100 uds.
-------	--------	----------

CAJETÍN PLÁSTICO GRANDE para recogedor metálico una patilla
BIG BOX FOR STRAP COILER for one arms metal strap coiler
BOÎTIER GRAND EN PLASTIQUE pour metal enrouleur une tige

02141	1,77 €	50 uds.
-------	--------	---------

FRENTE DE ALUMINIO espesor 0,5 mm. para recogedor metálico dos patillas
ALUMINIUM COVER PLATE thickness 0,5 mm. for two arms metal strap coiler
PLAQUE D'ALUMINIUM épaisseur 0,5 mm. pour metal enrouleur avec deux tiges

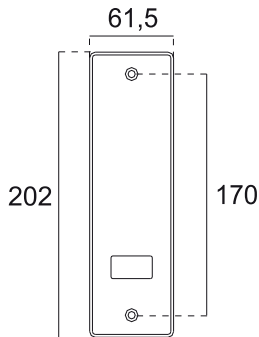

Blanco White / Blanche	01131	0,90 €	50 uds.
Bronce Bronze / Bronze	01135	0,90 €	50 uds.
Oro Gold / Dorée	01136	0,90 €	50 uds.
Natural Natural / Naturelle	01138	0,90 €	50 uds.

FRENTE LATÓN para recogedor metálico dos patillas
BRASS COVER PLATE for two arms metal strap coiler
PLAQUE DE LAITON pour metal enrouleur avec deux tiges

Latón Brass / Laiton	01137	29,40 €	
-------------------------	-------	---------	--

FRENTE ACERO INOXIDABLE espesor 0,5 mm. para recogedor metálico dos patillas
STAINLESS STEEL COVER PLATE thickness 0,5 mm. for two arms metal strap coiler
PLAQUE DE INOX épaisseur 0,5 mm. pour metal enrouleur avec avec deux tiges

Inoxidable Inox / Inox	01139	1,53 €	50 uds.
---------------------------	-------	--------	---------

FRENTE ALUMINIO espesor 0,5 mm. para recogedor metálico una patilla
ALUMINIUM COVER PLATE thickness 0,5 mm. for one arm metal strap coiler
PLAQUE D'ALUMINIUM épaisseur 0,5 mm. pour metal enrouleur avec une tige

Blanco White / Blanche	01171	1,35 €	50 uds.
Bronce Bronze / Bronze	01175	3,71 €	50 uds.
Natural Natural / Naturelle	01178	1,36 €	50 uds.

FRENTE ALUMINIO espesor 0,5 mm. ancho especial para recogedor metálico una patilla
ALUMINIUM COVER PLATE thickness 0,5 mm. for special width for one arm metal strap coiler
PLAQUE D'ALUMINIUM épaisseur 0,5 mm. pour large spécial pour metal enrouleur avec une tige

Blanco White / Blanche	01172	1,28 €	50 uds.
Bronce Bronze / Bronze	01173	3,61 €	50 uds.

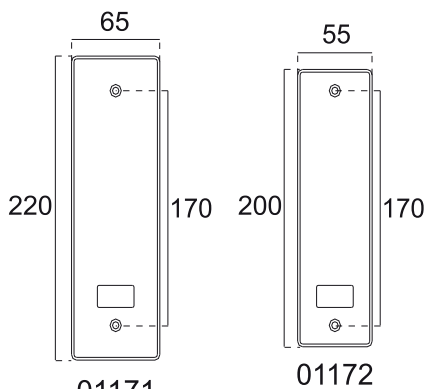

01171
01181
01190

Para recogedor una patilla
For one arm strap coiler
Pour enrouleur avec une tige

FRENTE ALUMINIO espesor 1 mm. para recogedor metálico una patilla
ALUMINIUM COVER PLATE thickness 1 mm. for one arm metal strap coiler
PLAQUE D'ALUMINIUM épaisseur 1 mm. pour metal enrouleur avec une tige

Blanco White / Blanche	01181	2,54 €	50 uds.
Bronce Bronze / Bronze	01185	4,75 €	50 uds.
Natural Natural / Naturelle	01188	2,37 €	50 uds.

FRENTE ACERO INOXIDABLE espesor 1 mm. para recogedor metálico una patilla
STAINLESS STEEL COVER PLATE thickness 1 mm. for one arm metal strap coiler
PLAQUE D'INOX épaisseur 1 mm. pour metal enrouleur avec une tige

Inoxidable Inox / Inox	01190	2,11 €	50 uds.
---------------------------	-------	--------	---------

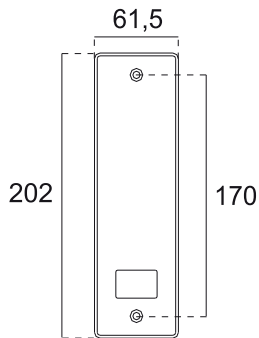

Para recoger una patilla
For one arm strap coiler
Pour enrouleur avec une tige

FRENTE ALUMINIO ESPECIAL espesor 0,5 para recogedor una patilla

SPECIAL ALUMINIUM COVER PLATE thickness 0,5 for one arm strap coiler

PLAQUE SPÉCIAL D'ALUMINIUM épaisseur 0,5 pour enrouleur avec une tige

Blanco White / Blanche		01951	0,97 €	50 uds.
Gris Grey / Grise		01953	1,05 €	50 uds.
Bronce Bronze / Bronze		01955	1,05 €	50 uds.
Negro Black / Noire		01956	1,05 €	50 uds.
Oro Gold / Dorée		01957	1,05 €	50 uds.
Natural Natural / Naturelle		01958	0,97 €	50 uds.

FRENTE ACERO INOXIDABLE ESPECIAL para recogedor una patilla

SPECIAL STAINLESS STEEL COVER PLATE for one arm strap coiler

PLAQUE D'INOX SPÉCIAL pour enrouleur avec une tige

Inoxidable Inox / Inox		01959	0,97 €	50 uds.
---------------------------	--	-------	--------	---------

FRENTE ALUMINIO PARA RECOGEDOR MIÑO colores estándar

ALUMINIUM COVER PLATE FOR STRAP COILER MIÑO standar colour

PLAQUE D'ALUMINIUM POUR ENROULEUR MIÑO couleur standard

Blanco White / Blanche		01201	0,77 €
Gris Grey / Grise		01203	0,77 €
Bronce Bronze / Bronze		01205	0,77 €
Negro Black / Noire		01206	0,77 €
Verde 6009 Green 6009 / Verte 6009		01208	0,77 €
Oro Gold / Dorée		01209	0,77 €

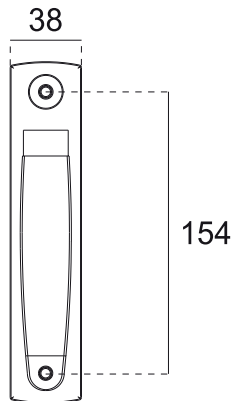
**FRENTE ALUMINIO PARA RECOGEDOR MIÑO colores especiales**

ALUMINIUM COVER PLATE FOR STRAP COILER MIÑO special colour

PLAQUE D'ALUMINIUM POUR ENROULEUR MIÑO couleur spécial

Madera clara Clear wood / Bois clair		01217	12,29 €
Madera oscura Dark wood / Bois foncé		01214	13,18 €
COLORES ESPECIALES SPECIAL COLOURS / COULEURS SPÉCIAUX		CONSULTAR CONSULT / CONSULTER	

FRENTE DE POLIAMIDA PARA RECOGEDOR MIÑO 38 mm.

POLYAMIDE COVER PLATE FOR STRAP COILER MIÑO 38 mm.

POLYAMIDE PLAQUE POUR ENROULEUR MIÑO 38 mm.

Blanco White / Blanche		42381	0,87 €
Gris Grey / Grise		42383	0,87 €
Marrón Brown / Marron		42384	0,87 €
Verde Green / Verte		42388	0,87 €
Negro Black / Noire		42386	0,87 €
COLORES ESPECIALES SPECIAL COLOURS / COULEURS SPÉCIAUX		CONSULTAR CONSULT / CONSULTER	

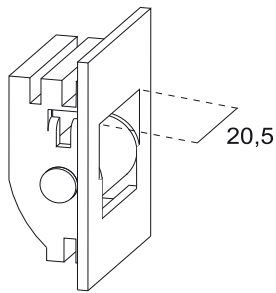

GUIA-CINTA DOS RANURAS PARA CAJÓN ALUMINIO (CINTA 18 Y 20) RODILLO METÁLICO STRAP GUIDES FOR ALUMINIUM BOX (STRAP 18 AND 20) METAL ROLLER GUIDE SANGLE CAISSON ALUMINIUM (SANGLE 18 ET 20) ROULEU MÉTALLIQUE	Blanco White / Blanche	43401	1,00 €	500 uds.
	Marfil Ivory / Ivoire	43402	1,00 €	500 uds.
	Gris Grey / Gris	43403	1,00 €	500 uds.
	Marrón Brown / Marron	43404	1,00 €	500 uds.
	Bronce Bronze / Bronze	43405	1,00 €	500 uds.
	Negro Black / Noire	43406	1,00 €	500 uds.
	Verde* Green* / Verte*	43408	1,00 €	500 uds.

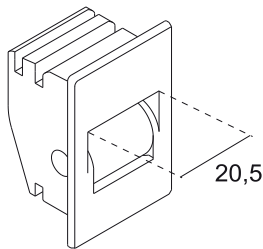

GUÍA - CINTA DOBLE TABIQUE (CINTA 18 Y 20) RODILLO METÁLICO STRAP GUIDES PVC BOX (STRAP 18 AND 20) METAL ROLLER GUIDE SANGLE CAISSON PVC (SANGLE 18 ET 20) ROULEU MÉTALLIQUE	Blanco White / Blanche	43501	0,75 €	500 uds.
	Marfil Ivory / Ivoire	43502	0,75 €	500 uds.
	Gris Grey / Grise	43503	0,75 €	500 uds.
	Marrón Brown / Marron	43504	0,75 €	500 uds.
	Bronce Bronze / Bronze	43505	0,75 €	500 uds.
	Negro Black / Noire	43506	0,75 €	500 uds.
	Verde* Green* / Verte*	43508	0,75 €	500 uds.

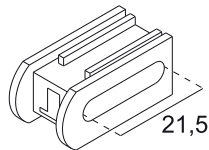

GUÍA - CINTA INFERIOR DOBLE TABIQUE (CINTA 18 Y 20) BELLOW STRAP GUIDE PVC BOX (STRAP 18 AND 20) GUIDE SANGLE INFÉRIEUR (SANGLE 18 ET 20)	Blanco White / Blanche	43241	0,18 €	500 uds.
	Gris Grey / Grise	43243	0,18 €	500 uds.
	Marrón Brown / Marron	43244	0,18 €	500 uds.
	Bronce Bronze / Bronze	43245	0,18 €	500 uds.
	Negro Black / Noire	43246	0,18 €	500 uds.

* Tonalidad similar al RAL 6009

Hue similar to the RAL 6009 / * Tonalité similaire à RAL 6009

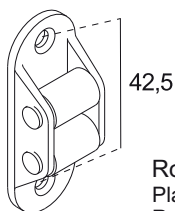
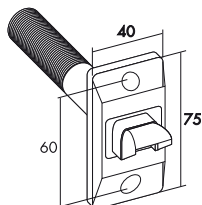
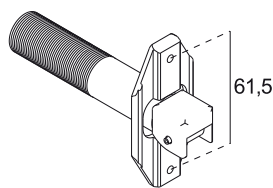

Rodillos Plásticos
Plastic rollers
Rouleaux plastiques

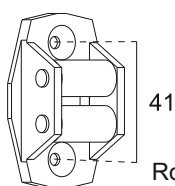
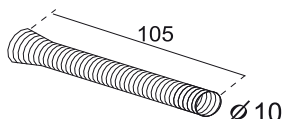
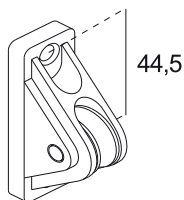

Rodillos Plásticos
Plastic rollers
Rouleaux plastiques

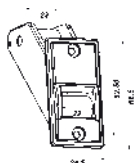

			€/ud	
GUÍA - CINTA OSCILANTE CON MUELLE (CINTA 14) STRAP GUIDES WITH SPRING (STRAP 14) GUIDE SANGLE AVEC RESSORT (SANGLE 14)	Blanco White / Blanche	23101	1,12 €	250 uds.
	Marfil Ivory / Ivoire	23102	1,12 €	250 uds.
	Gris Grey / Grise	23103	1,12 €	250 uds.
	Marrón Brown / Marron	23104	1,12 €	250 uds.
GUÍA - CINTA OSCILANTE CON MUELLE (CINTA 18) STRAP GUIDES WITH SPRING (STRAP 18) GUIDE SANGLE AVEC RESSORT (SANGLE 18)	Blanco White / Blanche	23112	1,90 €	200 uds.
	Marfil Ivory / Ivoire	23114	1,90 €	200 uds.
	Gris Grey / Grise	23113	1,90 €	200 uds.
	Marrón Brown / Marron	23115	1,90 €	200 uds.
GUÍA - CINTA MINI DOS RODILLOS (CINTA 14) MINI STRAP GUIDES TWO ROLLERS (STRAP 14) MINI GUIDE SANGLE DEUX ROULEAUX (SANGLE 14)	Blanco White / Blanche	23121	0,45 €	500 uds.
	Marfil Ivory / Ivoire	23122	0,45 €	500 uds.
	Gris Grey / Grise	23123	0,45 €	500 uds.
	Marrón Brown / Marron	23124	0,45 €	500 uds.
	Bronce Bronze / Bronze	23125	0,45 €	500 uds.
GUÍA CORDÓN CORD GUIDES GUIDE CORDON	Blanco White / Blanche	23131	2,18 €	250 uds.
	Marrón Brown / Marron	23134	2,18 €	250 uds.
MUELLE PARA CORDÓN SPRING FOR CORD RESSORT POUR GUIDE CORDON		23141	0,88 €	200 uds.
GUÍA - CINTA PLÁSTICA DOS RODILLOS (CINTA 22) PLASTIC STRAP GUIDES TWO ROLLERS (STRAP 22) GUIDE SANGLE PLASTIQUE DEUX ROULEAUX (SANGLE 22)	Blanco White / Blanche	03101	0,68 €	500 uds.
	Marfil Ivory / Ivoire	03102	0,68 €	500 uds.
	Gris Grey / Grise	03103	0,68 €	500 uds.
	Marrón Brown / Marron	03104	0,68 €	500 uds.
	Bronce Bronze / Bronze	03105	0,68 €	500 uds.
GUÍA - CINTA PARA EMPOTRAR EN GUÍA PLASTIC STRAP GUIDES TO ADAPT IN THE GUIDE GUIDE SANGLE POUR ENCASTRER EN GUIDE	Blanco White / Blanche	03181	3,91 €	100 uds.
	Gris Grey / Grise	03183	3,91 €	100 uds.
	Negro Black / Noire	03186	3,91 €	100 uds.

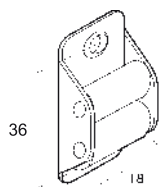

GUÍA - CINTA METÁLICA DOS RODILLOS POLIAMIDA (CINTA 14) METAL STRAP GUIDE TWO ROLLERS POLYAMIDE (STRAP 14) GUIDE SANGLE DE METAL DEUX ROULEAUX DE POLYAMIDE (SANGLE 14)	03110	0,71 €	1000 uds.
--	-------	--------	-----------

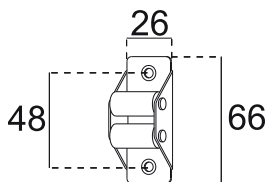

GUÍA - CINTA LATÓN DOS RODILLOS POLIAMIDA (CINTA 22) BRASS STRAP GUIDE TWO ROLLERS POLYAMIDE (STRAP 22) GUIDE SANGLE DE LAITON DEUX ROULEAUX DE POLYAMIDE (SANGLE 22)	03107	15,84 €	
--	-------	---------	--

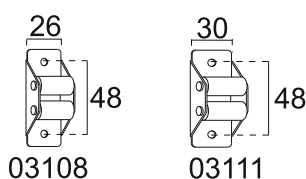

GUÍA - CINTA METÁLICA DOS RODILLOS POLIAMIDA (CINTA 22) METAL STRAP GUIDE TWO ROLLERS POLYAMIDE (STRAP 22) GUIDE SANGLE DE METAL DEUX ROULEAUX POLYAMIDE (SANGLE 22)	03108	0,84 €	500 uds.
	03111	0,95 €	500 uds.

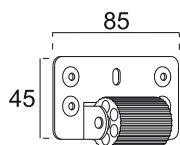

RODILLO SEPARADOR SEPARATOR ROLLER SÉPARATEUR AVEC ROULEAU PLASTIQUE	03120	1,64 €	100 uds.
---	-------	--------	----------

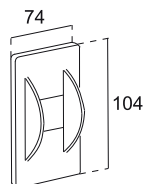

EMBELLECEDOR PLÁSTICO PARA GUÍA-CINTA METÁLICA 03111 TAP FOR METAL TRAP GUIDE 03111 CARCASSE EN PLASTIQUE POUR GUIDE SANGLE DE METAL 03111	Blanco White / Blanche	03121	0,68 €	200 uds.
---	---------------------------	-------	--------	----------

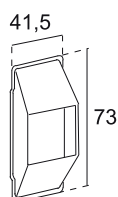

EMBELLECEDOR ALUMINIO PARA GUÍA-CINTA METÁLICA 03111 ALUMINIUM TAP FOR METAL TRAP GUIDE 03111 COUVERCLE EN ALUMINIUM POUR GUIDE SANGLE DE METAL 03111	Blanco White / Blanche	03131	1,05 €	500 uds.
--	---------------------------	-------	--------	----------

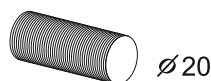

MUELLE GUÍA - CINTA OSCILANTE (CINTA 14) SPRING STRAP (GUIDE 14) RESSORT SANGLE (SANGLE 14)	23142	1,25 €	200 uds.
--	-------	--------	----------

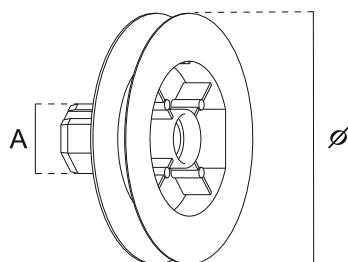

POLEA PLÁSTICA PARA RODAMIENTO (CINTA 18) PLASTIC PULLEY FOR BALL BEARING (STRAP 18) POULIE DE PLASTIQUE POUR ROULEMENT (SANGLE 18)	Ø120 A = 42 oct 45101	0,47 €	150 uds.
	Ø140 A = 42 oct 45102	0,55 €	100 uds.

POLEA PLÁSTICA CON RODAMIENTO INCLUIDO DE 12 (CINTA 18) PLASTIC PULLEY WITH BEARING INCLUDED 12 (STRAP 18) POULIE DE PLASTIQUE AVEC ROULEMENT INCLUS DE 12 (SANGLE 18)	Ø120 A = 42 oct 45186	1,27 €	150 uds.
	Ø140 A = 42 oct 45183	0,75 €	100 uds.

POLEA PLÁSTICA PARA RODAMIENTO (CINTA 20) PLASTIC PULLEY FOR BALL BEARING (STRAP 20) POULIE DE PLASTIQUE POUR ROULEMENT (SANGLE 20)	Ø120 A = 42 oct 45107	0,52 €	150 uds.
	Ø140 A = 42 oct 45109	0,60 €	100 uds.

POLEA PLÁSTICA CON RODAMIENTO INCLUIDO DE 12 (CINTA 20) PLASTIC PULLEY WITH BEARING INCLUDED 12 (STRAP 20) POULIE DE PLASTIQUE AVEC ROULEMENT INCLUS DE 12 (SANGLE 20)	Ø120 A = 42 oct 45202	0,73 €	150 uds.
	Ø140 A = 42 oct 45204	0,81 €	100 uds.

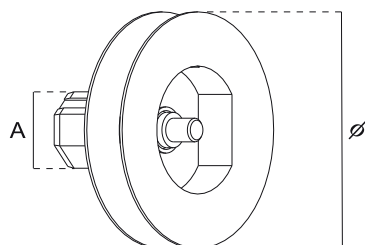

POLEA PLÁSTICA CON ESPIGA METÁLICA DE 12 (CINTA 18) PLASTIC PULLEY WITH METAL DRIVE 12 (STRAP 18) POULIE DE PLASTIQUE AVEC TETON MÉTALLIQUE INTERNE DE 12 (SANGLE 18)	Ø120 A = 42 oct 25101	1,25 €	150 uds.
	Ø140 A = 42 oct 25102	1,38 €	100 uds.

POLEA PLÁSTICA CON ESPIGA METÁLICA DE 12 (CINTA 20) PLASTIC PULLEY WITH METAL DRIVE 12 (STRAP 20) POULIES DE PLASTIQUE AVEC TETON MÉTALLIQUE INTERNE DE 12 (SANGLE 20)	Ø120 A = 42 oct 25123	1,39 €	150 uds.
	Ø140 A = 42 oct 25124	1,95 €	100 uds.

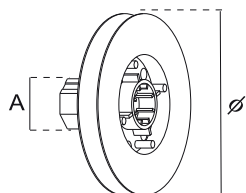

POLEA POLIAMIDA PARA RODAMIENTO (CINTA 14 Y 16) POLYAMIDE PULLEY FOR BALL BEARING (STRAP 14 AND 16) POULIE DE POLYAMIDE POUR ROULEMENT (SANGLE 14 ET 16)	Ø120 A = 42 oct 45104	1,27 €	50 uds.
	Ø140 A = 42 oct 45105	1,52 €	25 uds.

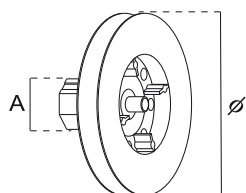

POLEA POLIAMIDA CON ESPIGA PLÁSTICA DE 10 (CINTA 14 Y 16) POLYAMIDE PULLEY WITH DRIVE PLASTIC 10 (STRAP 14 AND 16) POULIE DE POLYAMIDE AVEC TENON INTERNE DE 10 (SANGLE 14 ET 16)	Ø120 A = 42 oct 25111	1,86 €	50 uds.
	Ø140 A = 42 oct 25112	2,30 €	25 uds.

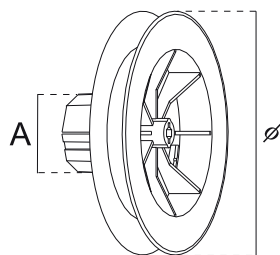

**POLEA PLÁSTICA SIN ESPIGA
PARA ESPIGA MACIZA (CINTA 22)**

PLASTIC PULLEY WITH LODGING FOR
DRIVE (STRAP 22)

POULIE PLASTIQUE SANS TENON
(SANGLE 22)

Ø130 A = 42 oct	05121	1,39 €	20 uds.
Ø160 A = 42 oct	05122	1,55 €	20 uds.
Ø140 A = 60 oct	05101	1,87 €	20 uds.
Ø160 A = 60 oct	05100	1,97 €	20 uds.
Ø180 A = 60 oct	05102	2,25 €	20 uds.
Ø160 A = 70 oct	05105	1,89 €	20 uds.
Ø180 A = 70 oct	05106	2,26 €	20 uds.

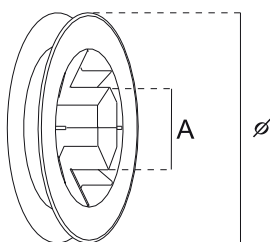

**POLEA PLÁSTICA PASANTE
(CINTA 22)**

SLIDING PLASTIC PULLEY (STRAP 22)

POULIE RÉGLABLE DE PLASTIQUE
(SANGLE 22)

Ø160 A = 60 oct	05133	2,26 €	20 uds.
-----------------	-------	--------	---------

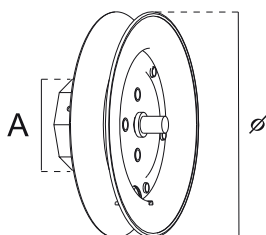

**POLEA METÁLICA CON ESPIGA
METÁLICA DE 12 (CINTA 22)**

METALLIC PULLEY WITH DRIVE 12
(STRAP 22)

POULIE MÉTALLIQUE AVEC TENON
INTERNE DE 12 (SANGLE 22)

Ø150 A = 60 oct	05134	4,21 €	25 uds.
Ø180 A = 60 oct	05135	4,24 €	25 uds.

(*) Ver poleas para torno en página 43

Pag. 43 Pulleys for crank mechanism / Pag 43 Voir poulies pour treuil.

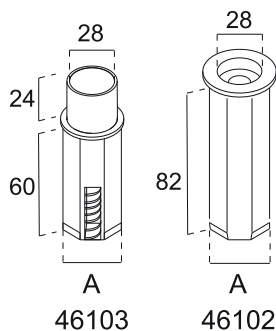

**CONTERA PLÁSTICA CON
MUELLE PARA RODAMIENTO**

PLASTIC RETRACTABLE CAP FOR
BEARING

EMBOUT TÉLESCOPIQUE DE
PLASTIQUE POUR ROULEMENT

A = 42 oct	46103	0,72 €	200 uds.
------------	-------	--------	----------

**CONTERA PLÁSTICA FIJA PARA
RODAMIENTO**

PLASTIC CAP WITH LODGING HOLL
BEARING

EMBOUT DE PLASTIQUE POUR
ROULEMENT

A = 42 oct	46102	0,23 €	200 uds.
------------	-------	--------	----------

**CONTERA PLÁSTICA FIJA CON
RODAMIENTO INCLUIDO DE 12**

PLASTIC CAP WITH BEARING
INCLUDED 12

EMBOUT DE PLASTIQUE AVEC
ROULEMENT INCLUS DE 12

A = 42 oct	46123	0,43 €	200 uds.
------------	-------	--------	----------

CONTERAS
CAPS / EMBOUTS

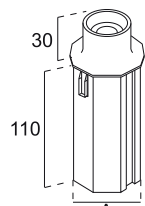

06125

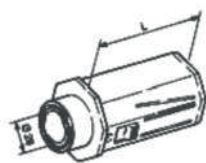

06119



CONTERA POLIAMIDA LARGA 60 PARA RODAMIENTO	A = 60 oct	06125	0,64 €	50 uds.
LARGE POLYAMIDE CAP WITH LODGING FOR BALL BEARING				
EMBOUT LONG DE POLYAMIDE POUR ROULEMENT	A = 60 oct imbac	06119	1,17 €	50 uds.

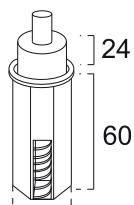

26104

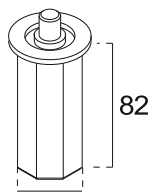

26105

CONTERA POLIAMIDA CON MUELLE ESPIGA 12	A = 42 oct	26104	0,94 €	200 uds.
POLYAMIDE RETRACTABLE CAP DRIVE 12				
EMBOUT TÉLESCOPIQUE DE POLYAMIDE AVEC TENON 12				
CONTERA PLÁSTICA 42 CON ESPIGA METÁLICA 12	A = 42 oct	26105	1,08 €	50 uds.
PLASTIC CAP DRIVE 12				
EMBOUT 42 DE PLASTIQUE AVEC TENON 12				

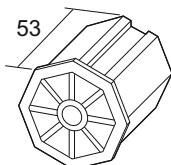
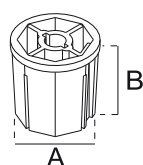

CONTERA PLÁSTICA SIN ESPIGA PARA ESPIGA MACIZA	A = 42 oct B = 45	26101	0,69 €	200 uds.
	A = 60 oct B = 45	06101	1,44 €	100 uds.
	A = 60 oct imbac B = 45	06103	0,91 €	200 uds.
	A = 70 oct B = 50	06102	1,19 €	50 uds.
PLASTIC ROLLER CAP WITH ROUND HOLE FOR DRIVE				
EMBOUT DE PLASTIQUE SANS TENON				

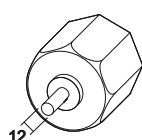
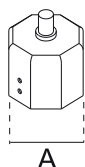

CONTERA METÁLICA CON ESPIGA METÁLICA 12	A = 42 oct	26102	1,74 €	50 uds.
GALVANIZED STEEL EXTERIOR GAP WITH ROUND DRIVE 12	A = 60 oct	06115	1,38 €	100 uds.
EMBOUT DE METAL AVEC TENON 12	A = 60 oct imbac	06130	1,51 €	100 uds.

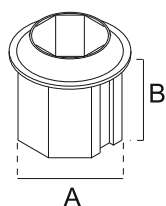

VALIDA PARA / VALID FOR / POUR CODE
26104, 26105, 46102, 46103

ADAPTACIÓN A EJE 60 OCT. PARA CONTERA DE 42	A = 60 oct B = 45	06117	1,33 €	40 uds.
COUPLING FOR 60 OCT. AXLE WITH CAPS OF 42 AXLE				
ADAPTATION D'AXE 60 OCT. POUR EMBOUT 42				
ADAPTACIÓN A EJE 60 IMBAC PARA CONTERA DE 42	A = 60 oct imbac B = 45	46104	1,87 €	100 uds.
COUPLING FOR 60 IMBAC AXLE WITH CAPS OF 42 AXLE				
ADAPTATION D'AXE 60 IMBAC POUR EMBOUT 42				
ADAPTACIÓN A EJE 52 OCT. PARA CONTERA DE 42	A = 52 oct B = 45	06123	0,63 €	100 uds.
COUPLING FOR 52 OCT. AXLE WITH CAPS OF 42 AXLE				
ADAPTATION D'AXE 52 OCT. POUR EMBOUT 42				

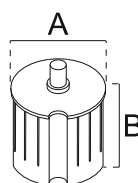

06122

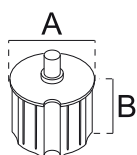

06120

CONTERA METÁLICA PARA EJE CON OJIVA DE 70 Y 78 ESPIGA DE 12	A = 70 B = 50	06120	3,98 €	
ROUND CAP OF 70 AND 78 mm WITH DRIVE 12				
EMBOUT DE METAL POUR AXE 70 ET 78 AVEC OGIVE TENON 12	A = 78 B = 60	06122	4,52 €	

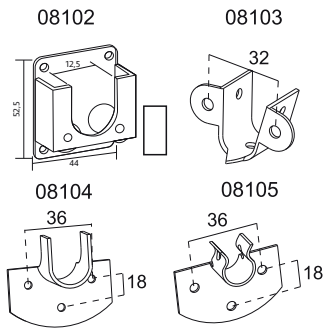

			€/ud	
SOPORTE BRACKET SUPPORT	Rodillos Rollers / Rouleau	08102	1,63 €	150 uds.
	Pincho Spike / Pointe	08103	0,22 €	500 uds.
	Estampado abierto Open stamp Ouvert	08104	0,38 €	250 uds.
	Estampado cerrado Close stamp Fermé	08105	0,41 €	250 uds.

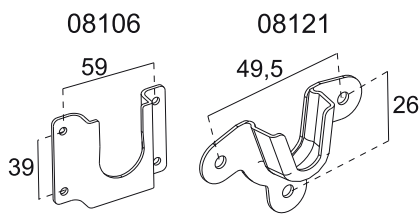

SOPORTE PARA RODAMIENTO (SIN RODAMIENTO) BRACKET FOR BALL BEARING (WITHOUT BALL BEARING) SUPPORT POUR ROUEMENT (SANS ROUEMENT)	Super Sper Super	08106	1,60 €	100 uds.
	Normal Normal Normal	08121	0,47 €	400 uds.
	Super imbac Super imbac Super imbac	08111	1,50 €	200 uds.

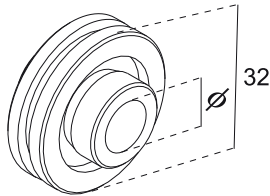

RODAMIENTO SUPER BALL BEARING SUPER ROUEMENT SUPER	Ø 10	08129	3,90 €	100 uds.
	Ø 12	08130	3,90 €	100 uds.
	imbac	08144	0,85 €	100 uds.

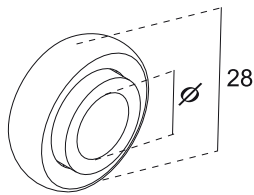

RODAMIENTO NORMAL BALL BEARING NORMAL ROUEMENT NORMAL	Ø 10	08122	0,26 €	400 uds.
	Ø 12	08123	0,20 €	400 uds.

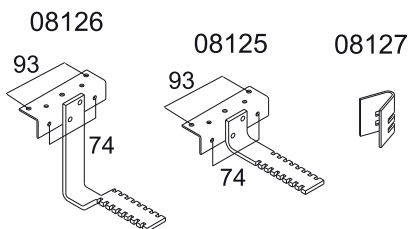

SOPORTE CATALUÑA SQUARE BRACKET CATALUÑA SUPPORT CATALUÑA	Juego* Kit* / Ensemble*	08124	4,92 €	25 uds.
	Sin soldar Whithout welding Sans soudeé	08128	4,92 €	
	Corto Short / Court	08125	1,77 €	
	Largo Large / Long	08126	1,94 €	
	"U"	08127	0,49 €	
SOPORTE ESPECIAL CATALUÑA REGULABLE AJUSTABLE SQUARE BRACKET CATALUÑA SUPPORT SPÉCIAL CATALUÑA RÉGLABLE	Largo Large / Long	08132	7,83 €	25 uds.
	Corto Short / Court	08133	5,62 €	50 uds.
	"U"	08134	0,76 €	200 uds.

(* Incluye un soporte largo, uno corto y dos "U".

(* Includes large bracket, a short bracket and two "U" / (*) Comprend un support long, un curt et deux "U"

EMBUDOS

SET OF END GUIDE / PAIRE DE TULIPES

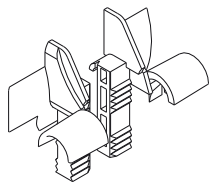

EMBUDO SIN RODILLO PARA CAJÓN DE ALUMINIO (Juego) SET OF END GUIDE FOR ALUMINIUM BOX (COUPLE) PAIRE DE TULIPES CAISSON ALUMINIUM	Blanco White Blanche	44101	0,58 €	400 jgos.	
	Negro Black Noir	44106	0,57 €	400 jgos.	

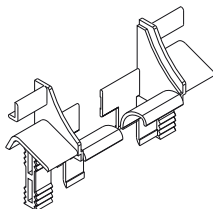

EMBUDOS ENRASADOS SIN RODILLO (Juego) SET OF END GUIDE FOR PVC BOX (COUPLE) PAIRE DE TULIPES CAISSON PVC SANS ROULEAU	Blanco White Blanche	44111	0,86 €	200 jgos.
	Gris Grey Grise	44110	0,37 €	200 jgos.

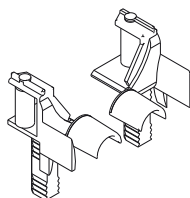

EMBUDO CON RODILLO (Juego) SET OF END GUIDE WITH ROLLER FOR STRAP ALUMINIUM BOX (COUPLE) PAIRE DE TULIPES CAISSON ALUMINIUM AVEC ROULEAU	Blanco White Blanche	30101	1,52 €	250 jgos.
	Negro Black Noir	30106	1,78 €	250 jgos.

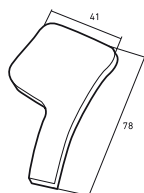

EMBUDO CHAPA GUÍA DE ALUMINIO (Juego) SET OF END GUIDE WITH ROLLER FOR STRAP ALUMINIUM BOX (COUPLE) PAIRE DE TULIPES CAISSON ALUMINIUM AVEC ROULEAU	Blanco White Blanche	30110	2,02 €	500 jgos.
--	----------------------------	-------	--------	-----------

ESPIGAS

DRIVE / TENON

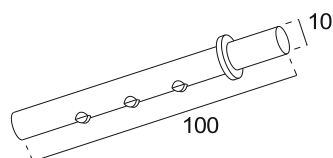

ESPIGA MACIZA DRIVE TENON	Ø 10 X 100	07101	0,57 €	200 uds.	



<p>TOPE 40 STOPPER 40 BUTÉE 40 L = 40</p>	Blanco White / Blanche	04101	0,20 €	1000 uds.
	Marfil Ivory / Ivoire	04102	0,20 €	1000 uds.
	Gris Grey / Grise	04103	0,20 €	1000 uds.
	Marrón Brown / Marron	04104	0,20 €	1000 uds.
	Bronce Bronze / Bronze	04105	0,20 €	1000 uds.
	Negro Black / Noire	04106	0,20 €	1000 uds.
	Marrón claro Clear Brown / Marron clair	04107	0,20 €	1000 uds.
	Verde Green / Verte	04108	0,20 €	1000 uds.
	Burdeos Bordeaux / Bordeaux	04109	0,20 €	1000 uds.

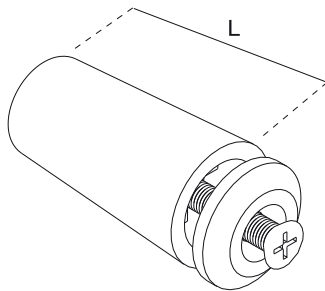

<p>TOPE 40 TORNILLO INOXIDABLE STOPPER 40 INOX SCREW BUTÉE 40 VIS INOX L = 40</p>	Blanco White / Blanche	04131	0,65 €	1000 uds.
	Marfil Ivory / Ivoire	04132	0,65 €	1000 uds.
	Gris Grey / Grise	04133	0,65 €	1000 uds.
	Marrón Brown / Marron	04134	0,65 €	1000 uds.
	Bronce Bronze / Bronze	04135	0,65 €	1000 uds.
	Negro Black / Noire	04136	0,65 €	1000 uds.

<p>TOPE 25 STOPPER 25 BUTÉE 25 L = 25</p>	Blanco White / Blanche	04111	0,59 €	1000 uds.
	Marfil Ivory / Ivoire	04112	0,59 €	1000 uds.
	Gri Grey / Grise	04113	0,59 €	1000 uds.
	Marrón Brown / Marron	04114	0,59 €	1000 uds.
	Bronce Bronze / Bronze	04115	0,59 €	1000 uds.

<p>TOPE 60 STOPPER 60 BUTÉE 60 L = 60</p>	Blanco White / Blanche	04121	0,51 €	500 uds.
	Marfil Ivory / Ivoire	04122	0,51 €	500 uds.
	Gri Grey / Grise	04123	0,51 €	500 uds.
	Marrón Brown / Marron	04124	0,51 €	500 uds.
	Bronce Bronze / Bronze	04125	0,51 €	500 uds.
	Negro Black / Noire	04126	0,51 €	500 uds.

TESTEROS DE ALUMINIO

SET OF END CAPS IN ALUMINIUM / PAIRE DE JOUE D'ALUMINIUM

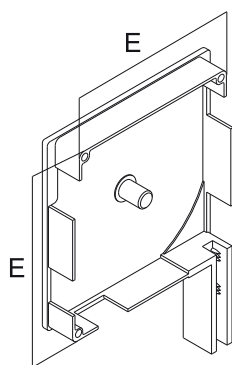

**TESTEROS 137
CAJÓN DE ALUMINIO 90°
(JUEGO)**

SET OF END CAP 137
ALUMINIUM BOX 90°

PAIRE DE JOUE 137
CAISSON ALUMINIUM 90°

E = 137

**TESTEROS 165
CAJÓN DE ALUMINIO 90°
(JUEGO)**

SET OF END CAP 165
ALUMINIUM BOX 90°

PAIRE DE JOUE 165
CAISSON ALUMINIUM 90°

E = 165

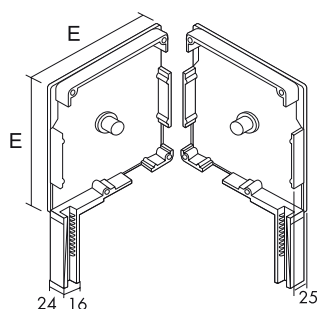

**TESTEROS 180
CAJÓN DE ALUMINIO 90°
(JUEGO)**

SET OF END CAP 180
ALUMINIUM BOX 90°

PAIRE DE JOUE 180
CAISSON ALUMINIUM 90°

E = 180

Blanco White / Blanche	48101	6,70 €	25 jgos.
Marfil ¹⁰¹³ Ivory / Ivoire	48102	6,70 €	25 jgos.
Gris ⁷⁰⁴⁰ Grey / Grise	48103	6,70 €	25 jgos.
Marrón ⁸⁰¹⁴ Brown / Marron	48104	6,70 €	25 jgos.
Bronce ⁷⁰¹³ Bronze / Bronze	48105	6,70 €	25 jgos.
Marrón claro ¹⁰⁰² Clear Brown / Marron clair	48106	6,70 €	25 jgos.
Burdeos ³⁰⁰⁵ Bordeaux / Bordeaux	48901	7,14 €	25 jgos.
Verde ⁶⁰⁰⁹ Green / Verte	48902	7,14 €	25 jgos.
Brut Brut / Sans laquer	48201	6,70 €	25 jgos.
Negro Black / Noire	48904	7,14 €	25 jgos.
Blanco White / Blanche	48111	8,47 €	25 jgos.
Marfil ¹⁰¹³ Ivory / Ivoire	48112	8,47 €	25 jgos.
Gris ⁷⁰⁴⁰ Grey / Grise	48113	8,47 €	25 jgos.
Marrón ⁸⁰¹⁴ Brown / Marron	48114	8,47 €	25 jgos.
Bronce ⁷⁰¹³ Bronze / Bronze	48115	8,47 €	25 jgos.
Marrón claro ¹⁰⁰² Clear Brown / Marron clair	48116	8,47 €	25 jgos.
Burdeos ³⁰⁰⁵ Bordeaux / Bordeaux	48921	8,88 €	25 jgos.
Verde ⁶⁰⁰⁹ Green / Verte	48922	8,88 €	25 jgos.
Brut Brut / Sans laquer	48211	8,47 €	25 jgos.
Negro Black / Noire	48924	8,88 €	25 jgos.
Blanco White / Blanche	48121	11,47 €	20 jgos.
Marfil ¹⁰¹³ Ivory / Ivoire	48122	11,47 €	20 jgos.
Gris ⁷⁰⁴⁰ Grey / Grise	48123	11,47 €	20 jgos.
Marrón ⁸⁰¹⁴ Brown / Marron	48124	11,47 €	20 jgos.
Bronce ⁷⁰¹³ Bronze / Bronze	48125	11,47 €	20 jgos.
Marrón claro ¹⁰⁰² Clear Brown / Marron clair	48126	11,47 €	20 jgos.
Burdeos ³⁰⁰⁵ Bordeaux / Bordeaux	48941	12,00 €	20 jgos.
Verde ⁶⁰⁰⁹ Green / Verte	48942	12,00 €	20 jgos.
Brut Brut / Sans laquer	48221	11,47 €	20 jgos.
Negro Black / Noire	48944	12,00 €	20 jgos.

Nota: Otros colores consultar precio y plazo de entrega

Note: Another colour demand request price and delivery / **Note:** Pour toute autre couleur, consulter prix et délais de livraison

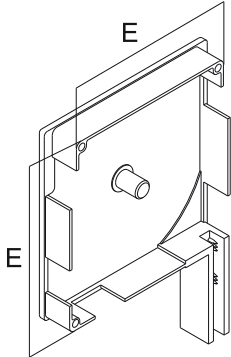

TESTEROS 205 CAJÓN DE ALUMINIO 90° (JUEGO) SET OF END CAP 205 ALUMINIUM BOX 90° PAIRE DE JOUE 205 CAISSON ALUMINIUM 90° E = 205					
Blanco	White / Blanche	48301	13,55 €	15 jgos.	
Gris	Grey / Grise	7040 48127	13,55 €	15 jgos.	
Marrón	Brown / Marron	8014 48304	13,55 €	15 jgos.	
Bronce	Bronze / Bronze	7013 48305	13,55 €	15 jgos.	
Brut	Brut / Sans laquer	48308	13,55 €	15 jgos.	
Negro	Black / Noire	48306	13,55 €	15 jgos.	
<hr/>					
TESTEROS 250 CAJÓN DE ALUMINIO 90° (JUEGO) SET OF END CAP 250 ALUMINIUM BOX 90° PAIRE DE JOUE 250 CAISSON ALUMINIUM 90° E = 250					
Blanco	White / Blanche	48311	19,22 €	10 jgos.	
Gris	Grey / Grise	7040 48313	19,22 €	10 jgos.	
Marrón	Brown / Marron	8014 48314	19,22 €	10 jgos.	
Bronce	Bronze / Bronze	7013 48315	19,22 €	10 jgos.	
Brut	Brut / Sans laquer	48320	19,22 €	10 jgos.	
Negro	Black / Noire	48316	19,22 €	10 jgos.	

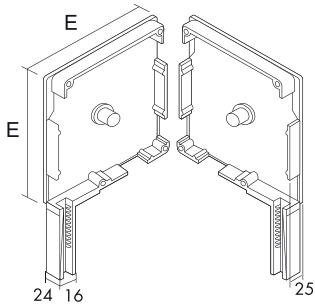

TESTEROS CENTRALES CAJÓN DE ALUMINIO 90° (JUEGO) SET OF CENTRAL END CAP ALUMINIUM BOX 90° PAIRE DE JOUE CENTRAL CAISSON ALUMINIUM 90°					
137	Brut	48131	6,94 €	25 jgos.	
	Brut / Sans laquer				
165	Brut	48133	8,01 €	25 jgos.	
	Brut / Sans laquer				
180	Brut	48134	9,43 €	20 uds.	
	Brut / Sans laquer				
205	Brut	48300	21,73 €	15 uds.	
	Brut / Sans laquer				
250	Brut	48319	28,69 €	10 uds.	
	Brut / Sans laquer				

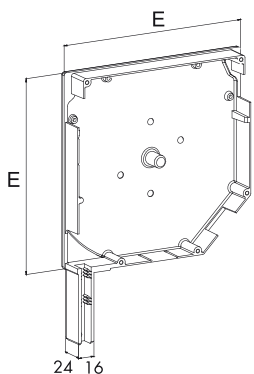

TESTEROS 137 CAJÓN DE ALUMINIO 45° (JUEGO) SET OF END CAP 137 ALUMINIUM BOX 45° PAIRE DE JOUE 137 CAISSON ALUMINIUM 45° E = 137					
Blanco	White / Blanche	48541	9,85 €	25 jgos.	
Gris	Grey / Grise	7040 48543	9,85 €	25 jgos.	
Marrón	Brown / Marron	8014 48544	9,85 €	25 jgos.	
Bronce	Bronze / Bronze	7013 48545	9,85 €	25 jgos.	
Brut	Brut / Sans laquer	48550	9,85 €	25 jgos.	
Negro	Black / Noire	48546	9,85 €	25 jgos.	
<hr/>					
TESTEROS 165 CAJÓN DE ALUMINIO 45° (JUEGO) SET OF END CAP 165 ALUMINIUM BOX 45° PAIRE DE JOUE 165 CAISSON ALUMINIUM 45° E = 165					
Blanco	White / Blanche	48551	10,68 €	25 jgos.	
Gris	Grey / Grise	7040 48553	10,68 €	25 jgos.	
Marrón	Brown / Marron	8014 48554	10,68 €	25 jgos.	
Bronce	Bronze / Bronze	7013 48555	10,68 €	25 jgos.	
Brut	Brut / Sans laquer	48560	10,68 €	25 jgos.	
Negro	Black / Noire	48556	10,68 €	25 jgos.	

Nota: Otros colores consultar precio y plazo de entrega

Note: Another colour demand request price and delivery / **Note:** Pour toute autre couleur, consulter prix et délais de livraison

TESTEROS DE ALUMINIO

SET OF END CAPS IN ALUMINIUM / PAIRE DE JOUE D'ALUMINIUM

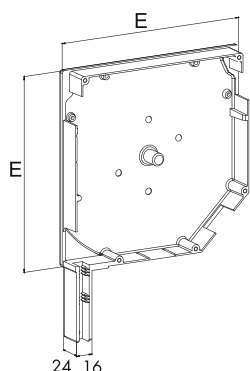

<p>TESTEROS 180 CAJÓN DE ALUMINIO 45° (JUEGO)</p> <p>SET OF END CAP 180 ALUMINIUM BOX 45°</p> <p>PAIRE DE JOUE 180 CAISSON ALUMINIUM 45°</p> <p>E = 180</p>	Blanco White / Blanche	48561	12,25 €	20 jgos.
	Gris 7040 Grey / Grise	48563	12,25 €	20 jgos.
	Marrón 8014 Brown / Marron	48564	12,25 €	20 jgos.
	Bronce 7013 Bronze / Bronze	48565	12,25 €	20 jgos.
	Brut Brut / Sans laquer	48570	12,25 €	20 jgos.
	Negro Black / Noire	48566	12,25 €	20 jgos.
<p>TESTEROS 205 CAJÓN DE ALUMINIO 45° (JUEGO)</p> <p>SET OF END CAP 205 ALUMINIUM BOX 45°</p> <p>PAIRE DE JOUE 205 CAISSON ALUMINIUM 45°</p> <p>E = 205</p>	Blanco White / Blanche	48571	14,64 €	15 jgos.
	Gris 7040 Grey / Grise	48573	14,64 €	15 jgos.
	Marrón 8014 Brown / Marron	48574	14,64 €	15 jgos.
	Bronce 7013 Bronze / Bronze	48575	14,64 €	15 jgos.
	Brut Brut / Sans laquer	48580	14,64 €	15 jgos.
	Negro Black / Noire	48576	14,64 €	15 jgos.
<p>TESTEROS 250 CAJÓN DE ALUMINIO 45° (JUEGO)</p> <p>SET OF END CAP 250 ALUMINIUM BOX 45°</p> <p>PAIRE DE JOUE 250 CAISSON ALUMINIUM 45°</p> <p>E = 250</p>	Blanco White / Blanche	48581	29,30 €	8 jgos.
	Gris 7040 Grey / Grise	48583	29,30 €	8 jgos.
	Marrón 8014 Brown / Marron	48584	29,30 €	8 jgos.
	Bronce 7013 Bronze / Bronze	48585	29,30 €	8 jgos.
	Brut Brut / Sans laquer	48350	26,20 €	8 jgos.
	Negro Black / Noire	48586	29,30 €	8 jgos.
<p>TESTEROS 300 CAJÓN DE ALUMINIO 45° (JUEGO)</p> <p>SET OF END CAP 300 ALUMINIUM BOX 45°</p> <p>PAIRE DE JOUE 300 CAISSON ALUMINIUM 45°</p> <p>E = 300</p>	Blanco White / Blanche	48591	37,46 €	6 jgos.
	Gris 7040 Grey / Grise	48593	37,46 €	6 jgos.
	Marrón 8014 Brown / Marron	48594	37,46 €	6 jgos.
	Bronce 7013 Bronze / Bronze	48595	37,46 €	6 jgos.
	Brut Brut / Sans laquer	48599	37,46 €	6 jgos.
	Negro Black / Noire	48596	37,46 €	6 jgos.

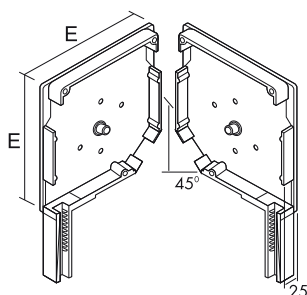

<p>TESTEROS CENTRALES CAJÓN DE ALUMINIO 45° (JUEGO)</p> <p>SET OF CENTRAL END CAP ALUMINIUM BOX 45°</p> <p>PAIRE DE JOUE CENTRAL CAISSON ALUMINIUM 45°</p>	137 Brut Brut / Sans laquer	48549	14,21 €	25 jgos.
	165 Brut Brut / Sans laquer	48559	15,91 €	25 jgos.
	180 Brut Brut / Sans laquer	48569	17,09 €	20 jgos.
	205 Brut Brut / Sans laquer	48579	19,50 €	15 jgos.
	250 Brut Brut / Sans laquer	48589	28,69 €	8 jgos.
	300 Brut Brut / Sans laquer	48598	35,33 €	6 jgos.

Nota: Otros colores consultar precio y plazo de entrega

Note: Another colour demand request price and delivery / **Note:** Pour toute autre couleur, consulter prix et délais de livraison

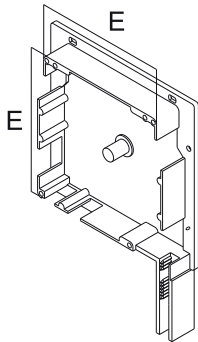

TESTEROS 155 ENRASADO CAJÓN DE PVC (JUEGO) SET OF END CAP 155 LEVELNESS PVC BOX PAIRE DE JOUE 155 ALIGNÉE CAISSON PVC E = 137				
Blanco White / Blanche	48161	8,50 €	25 jgos.	
Marfil ¹⁰¹³ Ivory / Ivoire	48160	8,50 €	25 jgos.	
Gris ⁷⁰⁴⁰ Grey / Grise	48163	8,50 €	25 jgos.	
Marrón ⁸⁰¹⁴ Brown / Marron	48168	8,50 €	25 jgos.	
Bronce ⁷⁰¹³ Bronze / Bronze	48165	8,50 €	25 jgos.	
Burdeos ³⁰⁰⁵ Bordeaux / Bordeaux	48169	8,50 €	25 jgos.	
Verde ⁶⁰⁰⁹ Green / Verte	48162	8,50 €	25 jgos.	
Brut Brut / Sans laquer	48170	8,50 €	25 jgos.	
Gris ⁷⁰¹¹ Grey / Grise	48164	8,50 €	25 jgos.	
Negro Black / Noire	48166	8,50 €	25 jgos.	
TESTEROS 185 ENRASADO CAJÓN DE PVC (JUEGO) SET OF END CAP 185 LEVELNESS PVC BOX PAIRE DE JOUE 185 ALIGNÉE CAISSON PVC E = 165				
Blanco White / Blanche	48171	10,63 €	20 jgos.	
Marfil ¹⁰¹³ Ivory / Ivoire	48190	10,63 €	20 jgos.	
Gris ⁷⁰⁴⁰ Grey / Grise	48173	10,63 €	20 jgos.	
Marrón ⁸⁰¹⁴ Brown / Marron	48178	10,63 €	20 jgos.	
Bronce ⁷⁰¹³ Bronze / Bronze	48175	10,63 €	20 jgos.	
Burdeos ³⁰⁰⁵ Bordeaux / Bordeaux	48179	10,63 €	20 jgos.	
Verde ⁶⁰⁰⁹ Green / Verte	48172	10,63 €	20 jgos.	
Brut Brut / Sans laquer	48180	10,63 €	20 jgos.	
Gris ⁷⁰¹¹ Grey / Grise	48174	10,63 €	20 jgos.	
Negro Black / Noire	48176	10,63 €	20 jgos.	

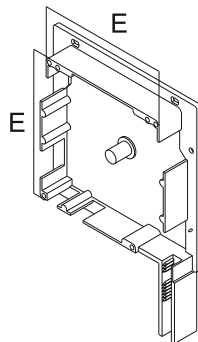

TESTEROS 200 ENRASADO CAJÓN DE PVC (JUEGO) SET OF END CAP 200 LEVELNESS PVC BOX PAIRE DE JOUE 200 ALIGNÉE CAISSON PVC E = 180				
Blanco White / Blanche	48991	12,50 €	15 jgos.	
Gris ⁷⁰⁴⁰ Grey / Grise	48988	12,50 €	15 jgos.	
Marrón ⁸⁰¹⁴ Brown / Marron	48993	12,50 €	15 jgos.	
Bronce ⁷⁰¹³ Bronze / Bronze	48989	12,50 €	15 jgos.	
Marrón claro ¹⁰⁰² Clear Brown / Marron Clair	48995	12,50 €	15 jgos.	
Burdeos ³⁰⁰⁵ Bordeaux / Bordeaux	48987	12,50 €	15 jgos.	
Verde ⁶⁰⁰⁹ Green / Verte	48985	12,50 €	15 jgos.	
Brut Brut / Sans laquer	48990	12,50 €	15 jgos.	
Gris ⁷⁰¹¹ Grey / Grise	48752	12,50 €	15 jgos.	
Negro Black / Noire	48756	12,50 €	15 jgos.	

Nota: Otros colores consultar precio y plazo de entrega

Note: Another colour demand request price and delivery / **Note:** Pour toute autre couleur, consulter prix et délais de livraison

TESTEROS DE ALUMINIO

SET OF END CAPS IN ALUMINIUM / PAIRE DE JOUE D'ALUMINIUM

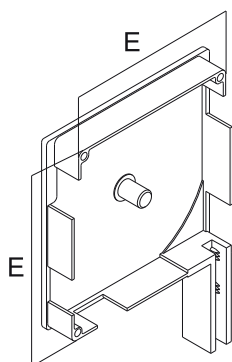
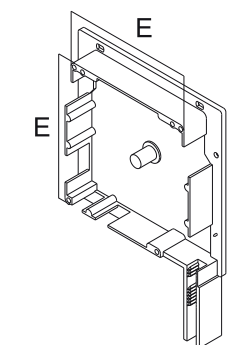
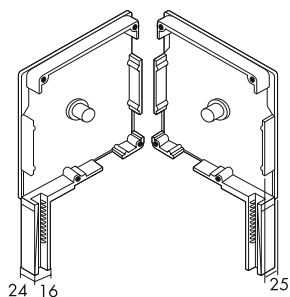

<p>TESTEROS CENTRALES ENRASADO (JUEGO)</p> <p>SET OF END CAP LEVELNESS PVC BOX (COUPLE)</p> <p>PAIRE DE JOUE ALIGNÉE CAISSON PVC (JEU)</p>	155	Brut Brut Sans laquer	48136	6,57 €	25 jgos.
	185	Brut Brut Sans laquer	48135	8,19 €	20 jgos.
	200	Brut Brut Sans laquer	48981	8,64 €	15 jgos.

<p>TESTEROS 170 ENRASADO CAJÓN DE PVC Nº4 (JUEGO)</p> <p>SET OF END CAP 170 LEVELNESS PVC BOX Nº4</p> <p>PAIRE DE JOUE 170 ALIGNÉE CAISSON PVC Nº4</p> <p>E = 170</p>	Blanco White / Blanche	48971	13,26 €	20 jgos.
	Marfil Ivory / Ivoire	1013 48402	16,95 €	20 jgos.
	Gris Grey / Grise	7040 48403	16,95 €	20 jgos.
	Marrón Brown / Marron	8014 48404	16,95 €	20 jgos.
	Bronce Bronze / Bronze	7013 48405	16,95 €	20 jgos.
	Brut Brut / Sans laquer	48401	16,95 €	20 jgos.
	Negro Black / Noire	48406	16,95 €	20 jgos.

<p>TESTEROS 155 CAJÓN DE PVC CURVO Nº 1 (JUEGO)</p> <p>SET OF END CAP 155 PVC BOX CURVE Nº 1</p> <p>PAIRE DE JOUE 155 CAISSON PVC COURBE Nº 1</p> <p>E = 137</p>	Blanco White / Blanche	48866	10,14 €	20 jgos.
	Gris Grey / Grise	7040 48803	12,96 €	20 jgos.
	Marrón Brown / Marron	8014 48805	12,96 €	20 jgos.
	Bronce Bronze / Bronze	7013 48811	12,96 €	20 jgos.
	Brut Brut / Sans laquer	48813	12,96 €	20 jgos.
	Negro Black / Noire	48815	12,96 €	20 jgos.

<p>TESTEROS 185 CAJÓN DE PVC CURVO Nº 1 (JUEGO)</p> <p>SET OF END CAP 185 PVC BOX CURVED Nº 1</p> <p>PAIRE DE JOUE 185 CAISSON PVC COURBE Nº 1</p> <p>E = 165</p>	Blanco White / Blanche	48889	12,07 €	15 jgos.
	Gris Grey / Grise	7040 48804	14,89 €	15 jgos.
	Marrón Brown / Marron	8014 48806	14,89 €	15 jgos.
	Bronce Bronze / Bronze	7013 48812	14,89 €	15 jgos.
	Brut Brut / Sans laquer	48814	14,89 €	15 jgos.
	Negro Black / Noire	48816	14,89 €	15 jgos.

Nota: Otros colores consultar precio y plazo de entrega

Note: Another colour demand request price and delivery / **Note:** Pour toute autre couleur, consulter prix et délais de livraison



Espesor
Thickness = 0,5
Épaisseur

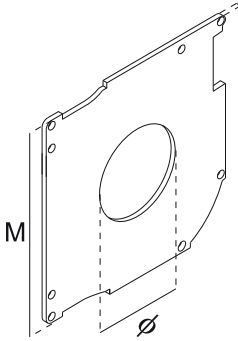

	M = 137	49137	0,65 €	200 uds.
PLACA DE CONTECIÓN 90° (UNIDAD)	M = 165	49165	0,86 €	200 uds.
SAFETY PLATE 90° (UNIT)	M = 180	49180	1,01 €	200 uds.
FLASQUE 90° (UNITÉ)	M = 205	49205	2,41 €	100 uds.
Ø 55	M = 250	49207	5,73 €	50 uds.

M = 137	49357	1,25 €	150 uds.	
PLACA DE CONTECIÓN 45° (UNIDAD)	M = 165	49359	1,49 €	150 uds.
SAFETY PLATE 45° (UNIT)	M = 180	49360	1,73 €	150 uds.
FLASQUE 45° (UNITÉ)	M = 205	49361	2,29 €	80 uds.
Ø 55	M = 250	49362	6,37 €	50 uds.
	M = 300	49363	7,96 €	36 uds.

Espesor
Thickness = 0,5
Épaisseur

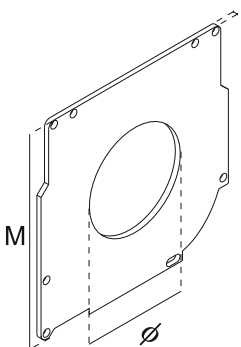

M = 137	49192	0,81 €	150 uds.	
PLACA DE CONTECIÓN 90° (UNIDAD)	M = 165	49193	1,06 €	150 uds.
SAFETY PLATE 90° (UNIT)	M = 180	49190	1,61 €	150 uds.
FLASQUE 90° (UNITÉ)	M = 205	49191	2,29 €	100 uds.
Ø 72	M = 250	49195	6,29 €	50 uds.

M = 137	49281	1,44 €	150 uds.	
PLACA DE CONTECIÓN 45° (UNIDAD)	M = 165	49282	1,51 €	150 uds.
SAFETY PLATE 45° (UNIT)	M = 180	49283	1,80 €	150 uds.
FLASQUE 45° (UNITÉ)	M = 205	49284	2,41 €	100 uds.
Ø 72	M = 250	49285	5,93 €	50 uds.
	M = 300	49286	8,32 €	36 uds.

TESTEROS DE ABS

SET OF END CAPS ABS / PAIRE DE JOUE D'ABS

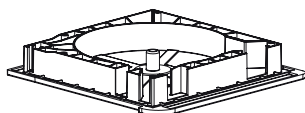
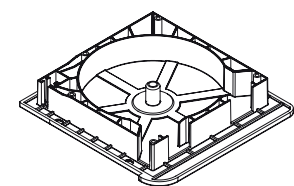

TESTERO ABS 155 BLANCO (ESPIGA 12 mm.) SET OF END CAPS ABS 155 WHITE (METAL DRIVE 12 mm.) PAIRE DE JOUE D'ABS 155 BLANCHE (TETON 12 mm.) E = 137	90 °	48001	4,67 €	25 jgos.	
	Decorativo 1	48081	4,59 €	25 jgos.	
	Decorativo 2	48083	4,68 €	25 jgos.	
TESTERO ABS 185 BLANCO (ESPIGA 12 mm.) SET OF END CAPS ABS 185 WHITE (METAL DRIVE 12 mm.) PAIRE DE JOUE D'ABS 185 BLANCHE (TETON 12 mm.) E = 165	90 °	48011	6,13 €	20 jgos.	
	Decorativo 1	48082	5,77 €	15 jgos.	
	Decorativo 2	48084	6,35 €	15 jgos.	

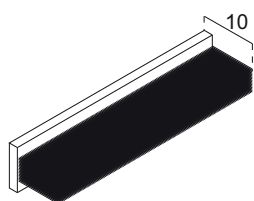
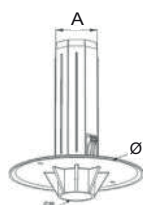

POLEA LATERAL PARA RODAMIENTO LATERAL PULLEY FOR BALL BEARING POULIE LATÉRAL POUR ROULEMENT	Ø120 A = 42 oct	46141	2,12 €	100 uds.	
	Ø140 A = 42 oct	46142	2,31 €	100 uds.	
	Ø120 A = 50 oct	46143	2,67 €	100 uds.	
	Ø140 A = 50 oct	46144	2,81 €	100 uds.	
BURLETE PARA TESTERO DECORATIVO AUTOADHESIVO BOX GUIDE FOR SET OF END CAPS DECORATIVE SELF-ADHESIVE JOINTS BROSSES POUR PAIRE DE JOUE AUTOADHÉSIF DÉCORATIF	3x14	99153	1,27 €	50 jgos.	

EMBUDOS CON PATA PARA TESTEROS DE ABS

SET OF END GUIDE WITH LEG FOR SET OF END CAPS ABS
 PAIRE DE TULIPES AVEC PIEDS POUR PAIRE DE JOUES D'ABS

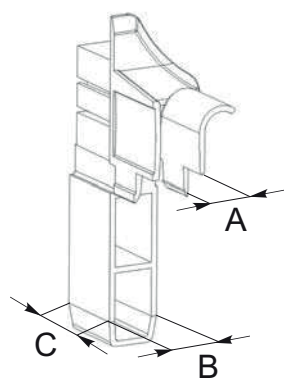

SIN ENRASAR (JUEGO) NO LEVELNESS (COUPLE) SANS AJUSTER (JEU)	A=12 B=16 C=24	44112	1,85 €	100 jgos.	
ENRASADO (JUEGO) LEVELNESS (COUPLE) ALIGNÉ (JEU)	A=12 B=16 C=24	44113	1,86 €	100 jgos.	
PARA GUÍA DE KOMMERLING (JUEGO) FOR KOMMERLING GUIDE (COUPLE) POUR KOMMERLING GUIDE (JEU)	A=12 B=36 C=32	44114	2,43 €	100 jgos.	
PARA GUÍA DE AP (JUEGO) FOR AP GUIDE (COUPLE) POUR AP GUIDE (JEU)	A=13 B=16 C=24,5	44120	2,76 €	100 jgos.	
PARA GUÍA DE LV 30x60 (JUEGO) FOR LV 30x60 GUIDE (COUPLE) POUR LV 30x60 GUIDE (JEU)	A=12 B=17,5 C=30,5	44119	2,99 €	100 jgos.	
PARA GUÍA DE LV 45x60 (JUEGO) FOR LV 45x60 GUIDE (COUPLE) POUR LV 45x60 GUIDE (JEU)	A=14 B=17 C=30	44117	2,97 €	100 jgos.	
PARA GUÍA DE CEUNIK (JUEGO) FOR CEUNIK GUIDE (COUPLE) POUR CEUNIK GUIDE (JEU)	A=12 B=17,5 C=26	44121	2,05 €	100 jgos.	



CINTA 14 STRAP 14 SANGLE 14	Blanco White / Blanche	10101	0,26 €	50 mts.
	Marfil Ivory / Ivoire	10102	0,26 €	50 mts.
	Gris Grey / Grise	10103	0,26 €	50 mts.
	Marrón Brown / Marron	10104	0,26 €	50 mts.
	Pintas White&Grey Blanche et Grise	10107	0,26 €	50 mts.
CINTA 16 STRAP 16 SANGLE 16	Marrón Brown / Marron	10164	0,32 €	50 mts.
	Pintas White&Grey Blanche et Grise	10167	0,32 €	50 mts.
	Gris Grey / Grise	10163	0,32 €	50 mts.
CINTA 18 STRAP 18 SANGLE 18	Blanco White / Blanche	10201	0,32 €	50 mts.
	Marfil Ivory / Ivoire	10202	0,32 €	50 mts.
	Gris Grey / Grise	10203	0,32 €	50 mts.
	Marrón Brown / Marron	10204	0,32 €	50 mts.
	Negro Black / Noire	10206	0,32 €	50 mts.
	Pintas White&Grey Blanche et Grise	10207	0,32 €	50 mts.
CINTA 20 STRAP 20 SANGLE 20	Blanco White / Blanche	10301	0,34 €	50 mts.
	Marfil Ivory / Ivoire	10302	0,34 €	50 mts.
	Gris Grey / Grise	10303	0,34 €	50 mts.
	Marrón Brown / Marron	10304	0,34 €	50 mts.
	Negro Black / Noire	10306	0,34 €	50 mts.
	Pintas White&Grey Blanche et Grise	10307	0,34 €	50 mts.
CINTA 22 C-1 STRAP 21 C-1 SANGLE 22 C-1	Marfil cantos blancos Ivory wite edges Ivoire avec bords blancs	10402	0,67 €	50 mts.
	Gris cantos blancos Grey wite edges Grise avec bords blancs	10403	0,67 €	50 mts.
CINTA 22 C-2 STRAP 21 C-2 SANGLE 22 C-2	Pintas White&Grey Blanche et Grise	10407	0,55 €	50 mts.
	Marfil cantos blancos Ivory wite edges Ivoire avec bords blancs	10422	0,40 €	50 mts.
	Gris cantos blancos Grey wite edges Grise avec bords blancs	10423	0,40 €	50 mts.
CINTA TIRANTE STRAP LOCK SANGLE TENDUE		10400	0,20 €	50 mts.

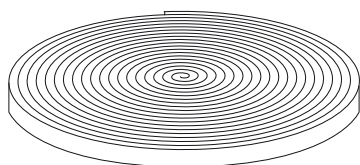

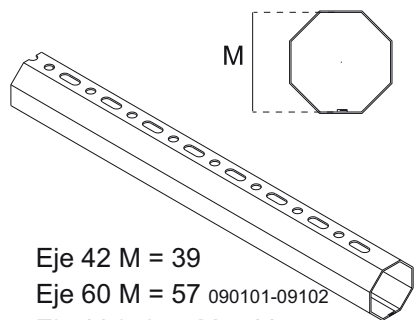

Eje 42 M = 39
Eje 60 M = 57 090101-09102
Eje 60 imbac M = 60
Eje 70 M = 64,5

M= medida aproximada
approximate measure / mesure approximative

			€/m.	
EJE OCTOGONAL OCTOGONAL TUBE AXE OCTOGONALE	42x0,4	09121	3,37 €	72 mts.
	42x0,7	09122	5,74 €	48 mts.
	50x0,4	09133	4,96 €	36 mts.
	50x0,8	09134	8,68 €	18 mts.
	60x0,4	09101	4,67 €	36 mts.
	60x0,7	09102	8,06 €	36 mts.
	60x0,4 imbac	60542	4,99 €	36 mts.
	60x0,6 imbac	60535	8,04 €	36 mts.
	60x0,8 imbac	60539	9,79 €	18 mts.
	70x1,2 imbac	09113	18,16 €	6 mts.

EJE REDONDO ROUND TUBE AXE ROND	50x1,5	60530	31,66 €	6 mts.
--	--------	-------	---------	--------

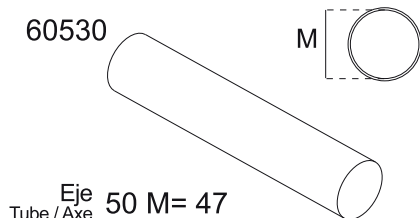

Eje
Tube / Axe 50 M= 47

M= medida aproximada
approximate measure / mesure approximative

EJE CON OJIVA TUBE WITH OGIVE AXE AVEC OGIVE	70x0,8	60537	9,41 €	7 mts.
	78x1	60538	22,01 €	7 mts.

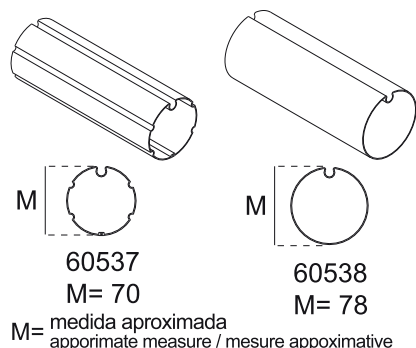

60537
M= 70

60538
M= 78

M= medida aproximada
approximate measure / mesure approximative

NOTA: Una jaula de 42 x 0,4 (09121) lleva 3.456 mts. (48 atados)

Una jaula de 60 x 0,4 (09101) lleva 1.620 mts. (45 atados)

El eje octogonal cortado a medida, llevará un recargo de 0,15 € corte NETO.

El eje redondo o con ojiva cortado a medida, llevará un recargo de 1,24 € corte NETO.

NOTE: A cage 42 x 0,4 (09121) leads 3.456 meters. (48 packet)

A cage 60 x 0,4 (09102) leads 1.620 meters. (45 packet)

Cut the octogonal tube with a different measurement increases the unit price 0,15 € (net)

Round tube and Round axe with ogive with a different measurement increases the unit price 1,24 € (net)

NOTE: Une complète cage du 42 x 0,4 (09121) conduit 3.456 mètres. (48 paquets)

Une complète cage du 60 x 0,4 (06101) conduit 1.620 mètres. (45 paquets)

Couper l'axe octogonal portera une prime de 0,15€ (net)

Couper l'axe round ou axe avec ogive portera une prime de 1,24 € (net)

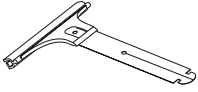
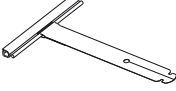
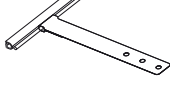
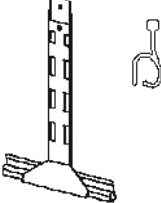
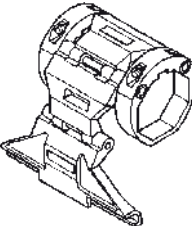
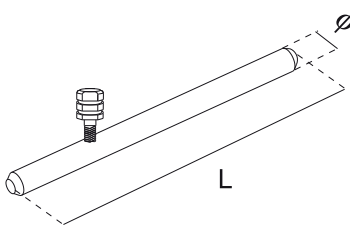
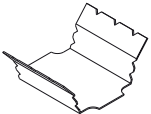
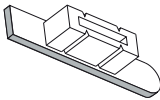
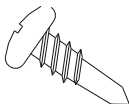

	TIRANTE MIXTO AUTOANCLAJE COVERED MIXED SPRING LOCK ATTACHE TABLIER MIXTE GAINÉ	99120	0,75 €	500 uds.
	TIRANTE ABIERTO METÁLICO METAL OPEN SPRING LOCK ATTACHE POINTE FLÈCHE MÉTALLIQUE	99102	0,62 €	500 uds.
	TIRANTE CERRADO METÁLICO CLOSE SPRING LOCK ATTACHE TABLIER POINTE FLÈCHE PERFORÉE MÉTALLIQUE	99103	0,62 €	500 uds.
	TIRANTE ABIERTO MIXTO MAXI LACADO L-190 MAXI OPEN SPRING LOCK LACQUERED L-190 ATTACHE POINTE FLÈCHE LAQUÉE MIXTE L-190	99130	2,87 €	500 uds.
	TIRANTE MIXTO ABIERTO CD/100-300 OPEN MIXED SPRING LOCK CD/100-300 ATTACHE TABLIER MIXTE FLÈCHE CD/100-300	99134	1,63 €	500 uds.
	TIRANTE BLOQUEO EJE 60 3 ELEMENTOS IMBAC BLOCKING SPRING LOCK TUBE 60 3 ELEMENTS IMBAC ATTACHE POINTE VERROU AXE 60 3 ELEMENTS IMBAC	65111	22,98 €	25 uds.
	TIRANTE BLOQUEO EJE 60 4 ELEMENTOS IMBAC BLOCKING SPRING LOCK TUBE 60 4 ELEMENTS IMBAC ATTACHE POINTE VERROU AXE 60 4 ELEMENTS IMBAC	65115	38,32 €	25 uds.
	CERROJILLO BAJERA BAR LOCKING VERROU DE SÉCURITÉ L = 150 Ø = 6,5	99105	1,42 €	250 uds.
	CERROJILLO BAJERA BAR LOCKING VERROU DE SÉCURITÉ L = 80 Ø = 6,5	99106	0,80 €	250 uds.
	CERROJILLO BAJERA BAR LOCKING VERROU DE SÉCURITÉ L = 80 Ø = 5,5	99126	0,69 €	250 uds.
	GRAPA GUÍA RECUBRIMIENTO GUIDE CRAMP BRACKET FOR ALUMINIUM GUIDES	99109	0,88 €	500 uds.
	TAPÓN LATERAL LAMA DE SEGURIDAD PL - 45 LATERAL CAP SLAT SECURITY FOR PL - 45 EMBOUT LATÉRAL LAME SÉCURITÉ PL - 45	99110	0,35 €	100 uds.
	TORNILLO PUNTA ROSCA SCREW WITH DRILL POINT VIS POINTE FILET	99119	0,11 €	1.000 uds.

VARIOS
OTHERS / DIVERS

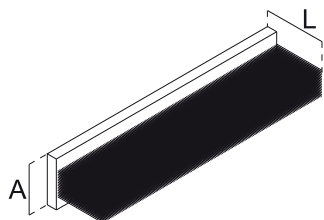
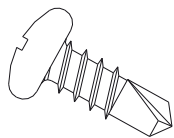

			€/ud.	
TORNILLO AUTORROSCANTE SELF-TAPPING SCREW VIS AUTOPERCEUSE	Blanco White / Blanc	99112	0,11 €	5.000 uds.
	Bronce Bronze / Bronze	99114	0,18 €	5.000 uds.
	Natural Natural / Naturelle	99117	0,05 €	5.000 uds.
BURLETE COMPACTO NEGRO BOX GUIDE BRUSH JOINTS BROSSES POUR GUIDE DE CAISSON A = 7 L = 6		99150	0,33 €	1.300 ml.
BURLETE GUÍA RECUBRIMIENTO NEGRO GUIDE BRUSH JOINTS BROSSES POUR GUIDE A = 4 L = 6		99155	0,33 €	1.600 ml.

TORNOS
ROPE WINCH / TREUIL

40 KG

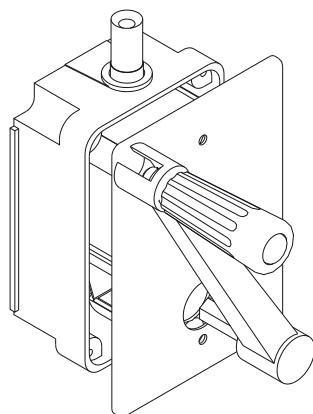

			€/ud.	
TORNO EMPOTRAR (PLACA BLANCA) INSIDE ROPE WINCH (WHITE COVER) TREUIL À CÂBLE POUR ENCASTRER (PLAQUE BLANCHE)	Blanco White / Blanche	50102	34,00 €	20 uds.
TORNO EMPOTRAR (PLACA BRONCE) INSIDE ROPE WINCH (BRONZE COVER) TREUIL À CÂBLE POUR ENCASTRER (PLAQUE BRONZE)	Negro Black / Noire	50105	34,00 €	20 uds.
TORNO EMPOTRAR (PLACA GRIS) INSIDE ROPE WINCH (GREY COVER) TREUIL À CÂBLE POUR ENCASTRER (PLAQUE GRISE)	Negro Black / Noire	50108	34,00 €	20 uds.
TORNO EMPOTRAR (PLACA NEGRA) INSIDE ROPE WINCH (BLACK COVER) TREUIL À CÂBLE POUR ENCASTRER (PLAQUE NOIRE)	Negro Black / Noire	50109	34,00 €	20 uds.

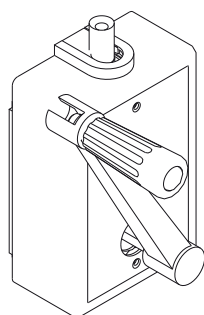

40 KG

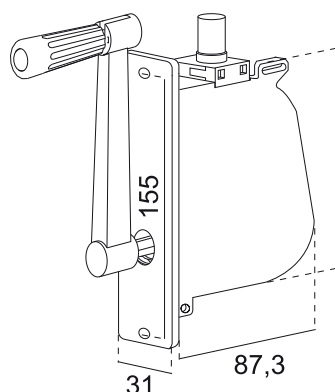

136,5

31

87,3

TORNO EXTERIOR (PLACA BLANCA) OUTSIDE ROPE WINCH (WHITE COVER) TREUIL À CÂBLE EXTÉRIEUR (PLAQUE BLANCHE)		Blanco White / Blanche	50112	34,00 €	20 uds.
TORNO EXTERIOR (PLACA BRONCE) OUTSIDE ROPE WINCH (BRONZE COVER) TREUIL À CÂBLE EXTÉRIEUR (PLAQUE BRONZE)		Negro Black / Noire	50115	34,00 €	20 uds.
TORNO COMPACTO (PLACA BLANCA) ROPE WINCH FOR ALUMINIUM GUIDE (WHITE COVER) TREUIL COMPACT (PLAQUE BLANCHE)		Blanco White / Blanche	50126	34,00 €	20 uds.
TORNO COMPACTO (PLACA BRONCE) ROPE WINCH FOR ALUMINIUM GUIDE (BRONZE COVER) TREUIL COMPACT (PLAQUE BRONZE)		Negro Black / Noire	50128	34,00 €	20 uds.
TORNO COMPACTO (PLACA GRIS) ROPE WINCH FOR ALUMINIUM GUIDE (GREY COVER) TREUIL COMPACT (PLAQUE GRISE)		Negro Black / Noire	50129	34,00 €	20 uds.
TORNO COMPACTO (PLACA NEGRO) ROPE WINCH FOR ALUMINIUM GUIDE (BLACK COVER) TREUIL COMPACT (PLAQUE NOIRE)		Negro Black / Noire	50127	34,00 €	20 uds.

ACCESORIOS TORNO
CRANK HANDLE / ACCESSOIRES TREUIL

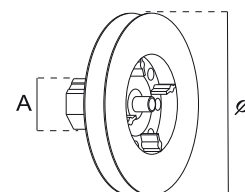
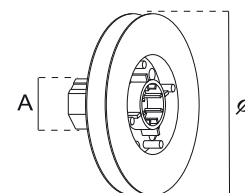
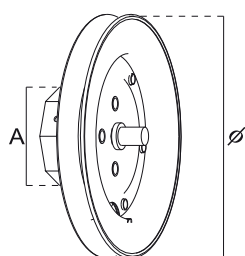

POLEA METÁLICA TORNO CON ESPIGA METÁLICA DE 12 mm. METAL PULLEY FOR WINCH 12 mm. ROUND PIVOT POULIE EN METAL POUR TREUIL AVEC TETON MÉTALLIQUE 12 mm:	Ø160 A = 60 oct	50081	8,35 €	25 uds.	
	Ø180 A = 60 oct	50082	9,82 €	25 uds.	
POLEA POLIAMIDA PARA RODAMIENTO (CINTA 14 Y 16) POLYAMIDE PULLEY FOR BALL BEARING (STRAP 14 AND 16) POULIE DE POLYAMIDE POUR ROULEMENT (SANGLE 14 ET 16)	Ø120 A = 42 oct	45104	1,27 €	50 uds.	
	Ø140 A = 42 oct	45105	1,52 €	25 uds.	
POLEA POLIAMIDA CON ESPIGA PLÁSTICA DE 10 (CINTA 14 Y 16) POLYAMIDE PULLEY WINCH DRIVE (STRAP 14 AND 16) POULIE DE POLYAMIDE AVEC TETON INTERNE DE 10 (SANGLE 14 ET 16)	Ø120 A = 42 oct	25111	1,86 €	50 uds.	
	Ø140 A = 42 oct	25112	2,30 €	25 uds.	



ACCESORIOS TORNO

CRANK HANDLE / ACCESSOIRES TREUIL

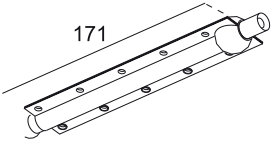
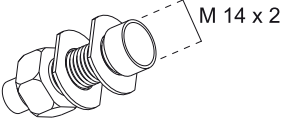
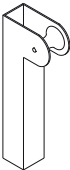
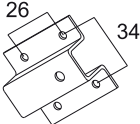
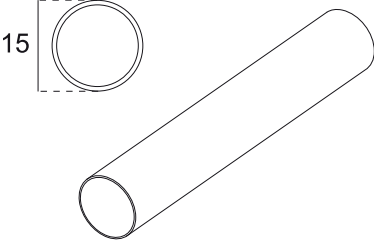
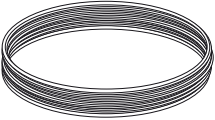
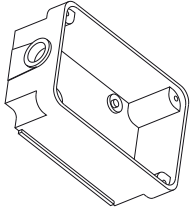

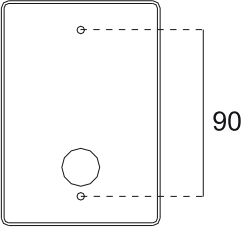
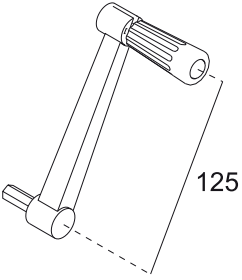
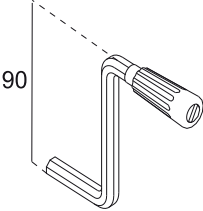
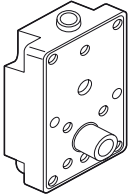
 <p>171</p>	<p>GUÍA CABLE METÁLICO DE EMPOTRAR METAL INSIDE CABLE GUIDE GUIDE CÂBLE MÉTALLIQUE À ENCASTRER</p>	<p>50090 2,78 € 200 uds.</p>
 <p>M 14 x 2</p>	<p>GUÍA POLIAMIDA CON TUERCA PARA TORNO EXTERIOR POLYAMIDE OUTSIDE CABLE GUIDE GUIDE CÂBLE DE POLYAMIDE AVEC ÉCROU</p>	<p>50531 1,17 € 250 uds.</p>
	<p>GUÍA CABLE DE ROLDANA ROLLER CABLE GUIDE GUIDE CÂBLE DE GALET</p>	<p>50532 3,51 € 200 uds.</p>
 <p>26 34</p>	<p>ABRAZADERA GUIA CABLE DE ROLDANA ROLLER CABLE GUIDE BRACKET BRIDE GUIDE CÂBLE DE GALET</p>	<p>50533 0,72 € 200 uds.</p>
 <p>15</p>	<p>TUBO PVC PARA TORNO EMPOTRAR 1,5 mts. PVC TUBE FOR INSIDE WINCH 1,5 mts. TUBE DE PVC POUR TREUIL À ENCASTRER 1,5 mts.</p>	<p>50095 1,37 €</p>
	<p>TUBO ALUMINIO PARA TORNO EXTERIOR 1,5 mts. ALUMINIUM TUBE FOR OUTSIDE WINCH 1,5 mts. TUBE D'ALUMINIUM POUR TREUIL EXTÉRIEUR 1,5 mts.</p>	<p>Blanco White Blanc 50542 9,04 €</p> <p>Natural Natural Naturelle 50543 11,25 €</p> <p>Bronce Bronze Bronce 50544 10,69 €</p>
	<p>CABLE TORNO CABLE WINCH CÂBLE TREUIL</p>	<p>50501 104,00 € 200 mts.</p> <p>50502 52,00 € 100 mts.</p> <p>50070 3,19 € 5 mts.</p> <p>50071 3,74 € 6 mts.</p>
<p>Espesor = 2 Thickness = 2 / Épaisseur = 2</p> 		
 <p>40 KG</p>	<p>CAJA DE EMPOTRAR TORNO INSIDE BOX WINCH BOÎTIER TREUIL À ENCASTRER</p>	<p>50701 8,50 €</p>
	<p>TORNO COMPLETO SIN CAJA WINCH WITHOUT BOX TREUIL SANS BOÎTIER</p>	<p>Blanco White Blanc 50702 29,85 € 20 uds.</p>

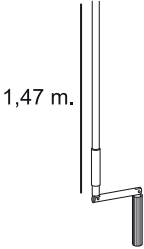
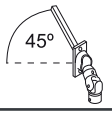
	PLACA TORNO EMPOTRAR COVER PLATE FOR WINCH PLAQUE POUR TREUIL À ENCASTRE	Blanco White Blanche	50703	1,28 €	
		Natural Natural Naturelle	50704	1,28 €	
		Bronce Bronze Bronze	50705	1,28 €	
		Oro Gold Dorée	50717	1,92 €	
	MANIVELA TORNO CON POMO ABATIBLE DE 125 TWO POSITION CRANK OF 125 MANIVELLE À TREUIL PIVOTANT DE 125	Blanco White Blanche	50706	8,00 €	
		Gris Grey Grise	50707	8,00 €	
		Bronce Bronze Bronze	50708	8,00 €	
	MANIVELA TORNO FIJA CORTA DE 90 NATURAL 90 CRANK NATURAL MANIVELLE NATURELLE FIXE DE 90 À TREUIL NATURELLE	Blanco White Blanche	50711	12,33 €	
		Negro Black Noire	50714	12,33 €	
	BOLSA TORNILLOS PARA TORNO SCREW KIT FOR WINCH SAC AVEC VIS POUR MONTAGE TREUIL	Blanco White Blanche	50709	0,91 €	
	MECANISMO TORNO EMPOTRAR INSIDE ROPE WINCH MECHANISM MÉCANISME TREUIL À ENCASTER		50130	17,89 €	35 uds.

	TUBO MANIVELA SIN MONTAR CRANK TUBE NO MADE TUBE MANIVELLE SANS MONTER	Blanco White Blanc	50820	28,98 €	
		Gris Grey Gris	50823	30,68 €	
		Negro Black Noir	50821	30,68 €	
	SNODO 45° 2 TALADROS SNODO 45° 2 SCREW SNODO 45° DOUBLE TROU		50825	34,68 €	
	SNODO 90° 2 TALADROS SNODO 90° 2 SCREW SNODO 90° DOUBLE TROU		50826	53,65 €	

ACCESORIOS TORNO - CARDAN

CRANK HANDLE - GEAR BOX/ ACCESSOIRES TREUIL - MECHANISME POUR TREUIL

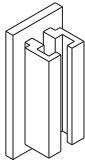
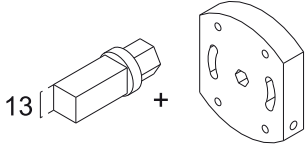
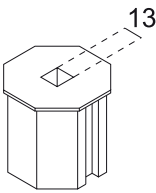
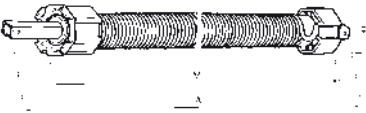
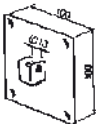
	<p>FIJACIÓN PLÁSTICA PARA MANIVELA PLASTIC HANDLE LOCK SUPPORT DE PLASTIQUE FIXATION MANIVELLE</p>	<p>Blanco White Blanc</p> <p>50839 0,52 €</p> <p>Negro Black Noir</p> <p>50838 0,51 €</p> <p>Gris Grey Gris</p> <p>50840 0,48 €</p>
	<p>MECANISMO CARDAN CON ADAPTACIÓN CONTRA GEAR BOX MÉCANISM POUR TREUIL AVEC PIVOT</p>	<p>13 kgs. 50801 30,78 €</p> <p>30 kgs. 50803 41,95 €</p>
	<p>CONTERA PLÁSTICA PLASTIC CAP EMBOUT DE PLASTIQUE</p> <p>CONTERA ZAMAK ZAMAK CAP EMBOUT DE ZAMAK</p>	<p>A = 42 oct 50806 0,86 €</p> <p>A = 60 oct 50807 4,47 €</p> <p>A = 42 oct 50808 4,75 €</p>
	<p>MUELLE COMPENSACIÓN 40 OCT 120 ESP D 1.8 SPRING 40 OCT 120 ROUND DRIVE D1.8 RESSORT DE COMPENSATION 40 OCT 120 TIGE D 1.8</p> <p>MUELLE COMPENSACIÓN 40 OCT 17 KGS SPRING 40 OCT 120 17 KGS RESSORT DE COMPENSATION 40 OCT 17 KGS</p> <p>MUELLE COMPENSACIÓN 60 IMBAC 140 ESP D5 SPRING 60 IMBAC 140 ROUND DRIVE D5 RESSORT DE COMPENSATION 60 IMBAC 140 TIGE D5</p> <p>MUELLE COMPENSACIÓN 40 OCT 180 ESPIGA D 3,0 SPRING 40 OCT 180 ROUND DRIVE D3 RESSORT DE COMPENSATION 40 OCT 180 TIGE D 3.0</p>	<p>4 kgs. 99183 35,74 € 10 uds.</p> <p>17 kgs. 99184 36,11 € 10 uds.</p> <p>62 kgs. 99190 70,57 € 5 uds.</p> <p>24 kgs. 99191 38,95 € 10 uds.</p>
	<p>SOPORTE 100X100 P/MUELLE COMPENSACIÓN SPRING'S BRACKET 100X100 SUPPORT 100X100 P/RESSOR DE COMPENSATION</p>	<p>99186 8,20 € 100 uds.</p>

ACEPER

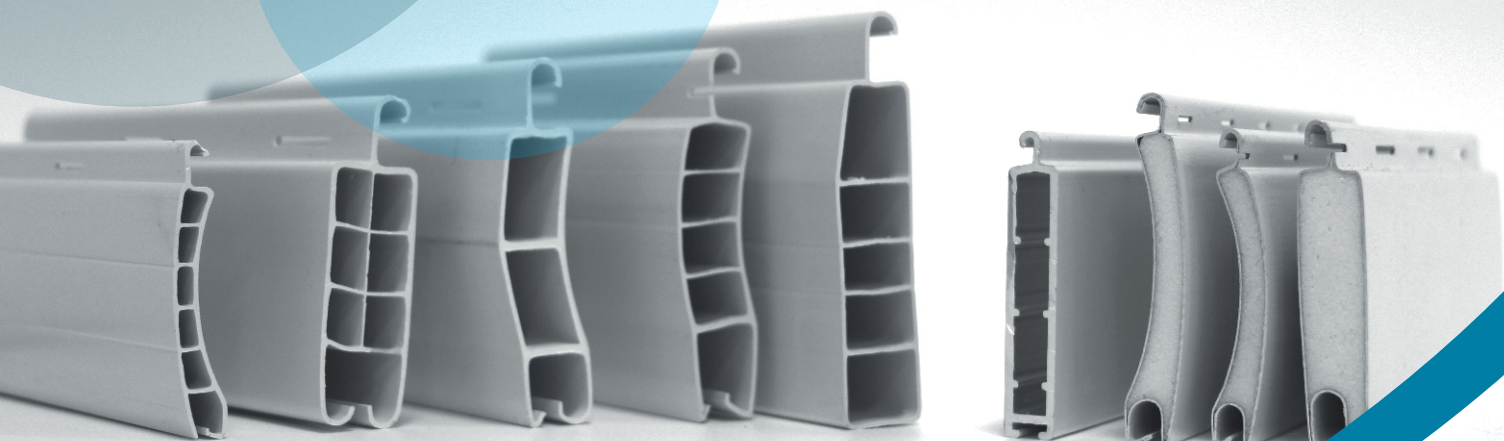

LAMAS · SLATS · LAMES

LAMAS DE PVC
PVS SLATS - LAMES EN PVC

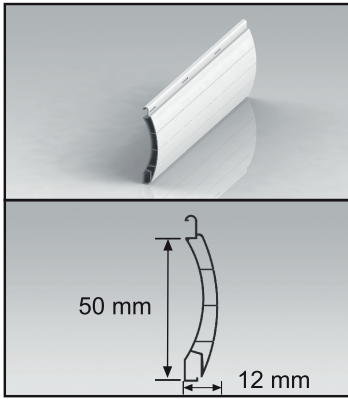

T5

ALTURA ÚTIL HIGH COVER / HAUTEUR UTILE PROFIL	50 mm
ESPEJOR NOMINAL NOMINAL THICKNESS / EPAISSEUR DU PROFIL	12 mm
LAMAS POR METRO DE ALTURA NUMBER OF SLATS PER METER / PROFILS PAR METRE	20 uds
PESO APROX. POR m² APPROX. WEIGHT PER m ² / POIDS APPROX. PAR m ²	3,6 kg/m ²
EMBALAJE PACKING / EMBALLAGE	120 ml
LARGO PRODUCCIÓN ESTÁNDAR STANDARD LENGTH / LONGUEUR DE PRODUCTION	6 m

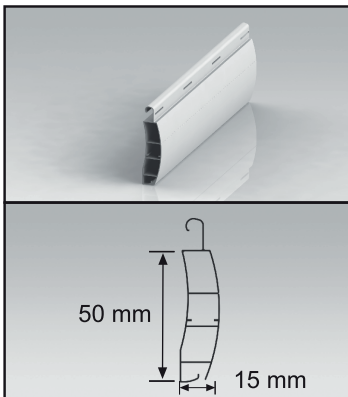

F50

ALTURA ÚTIL HIGH COVER / HAUTEUR UTILE PROFIL	50 mm
ESPEJOR NOMINAL NOMINAL THICKNESS / EPAISSEUR DU PROFIL	15 mm
LAMAS POR METRO DE ALTURA NUMBER OF SLATS PER METER / PROFILS PAR METRE	20 uds
PESO APROX. POR m² APPROX. WEIGHT PER m ² / POIDS APPROX. PAR m ²	3,7 kg/m ²
EMBALAJE PACKING / EMBALLAGE	120 ml
LARGO PRODUCCIÓN ESTÁNDAR STANDARD LENGTH / LONGUEUR DE PRODUCTION	6 m

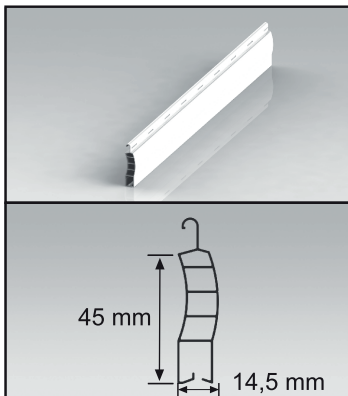

F4

ALTURA ÚTIL HIGH COVER / HAUTEUR UTILE PROFIL	45 mm
ESPEJOR NOMINAL NOMINAL THICKNESS / EPAISSEUR DU PROFIL	14,5 mm
LAMAS POR METRO DE ALTURA NUMBER OF SLATS PER METER / PROFILS PAR METRE	23 uds
PESO APROX. POR m² APPROX. WEIGHT PER m ² / POIDS APPROX. PAR m ²	4,9 kg/m ²
EMBALAJE PACKING / EMBALLAGE	120 ml
LARGO PRODUCCIÓN ESTÁNDAR STANDARD LENGTH / LONGUEUR DE PRODUCTION	6 m

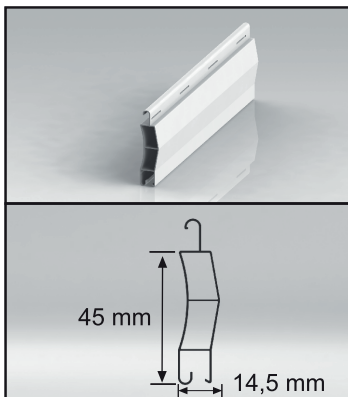

FC

ALTURA ÚTIL HIGH COVER / HAUTEUR UTILE PROFIL	45 mm
ESPEJOR NOMINAL NOMINAL THICKNESS / EPAISSEUR DU PROFIL	14,5 mm
LAMAS POR METRO DE ALTURA NUMBER OF SLATS PER METER / PROFILS PAR METRE	23 uds
PESO APROX. POR m² APPROX. WEIGHT PER m ² / POIDS APPROX. PAR m ²	3,7 kg/m ²
EMBALAJE PACKING / EMBALLAGE	120 ml
LARGO PRODUCCIÓN ESTÁNDAR STANDARD LENGTH / LONGUEUR DE PRODUCTION	6 m

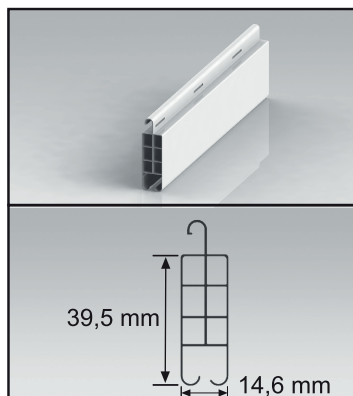

FA

ALTURA ÚTIL HIGH COVER / HAUTEUR UTILE PROFIL	39,5 mm
ESPEJOR NOMINAL NOMINAL THICKNESS / EPAISSEUR DU PROFIL	14,6 mm
LAMAS POR METRO DE ALTURA NUMBER OF SLATS PER METER / PROFILS PAR METRE	26 uds
PESO APROX. POR m² APPROX. WEIGHT PER m ² / POIDS APPROX. PAR m ²	3,6 kg/m ²
EMBALAJE PACKING / EMBALLAGE	120 ml
LARGO PRODUCCIÓN ESTÁNDAR STANDARD LENGTH / LONGUEUR DE PRODUCTION	6 m

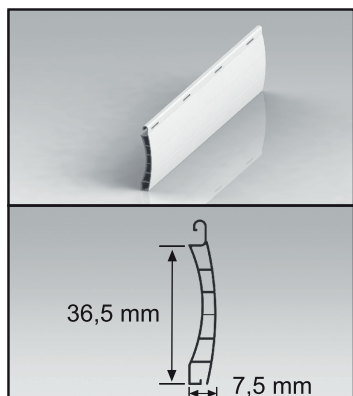

MINI

ALTURA ÚTIL HIGH COVER / HAUTEUR UTILE PROFIL	36,5 mm
ESPEJOR NOMINAL NOMINAL THICKNESS / EPAISSEUR DU PROFIL	7,5 mm
LAMAS POR METRO DE ALTURA NUMBER OF SLATS PER METER / PROFILS PAR METRE	28 uds
PESO APROX. POR m² APPROX. WEIGHT PER m ² / POIDS APPROX. PAR m ²	3 kg/m ²
EMBALAJE PACKING / EMBALLAGE	240 ml
LARGO PRODUCCIÓN ESTÁNDAR STANDARD LENGTH / LONGUEUR DE PRODUCTION	6 m

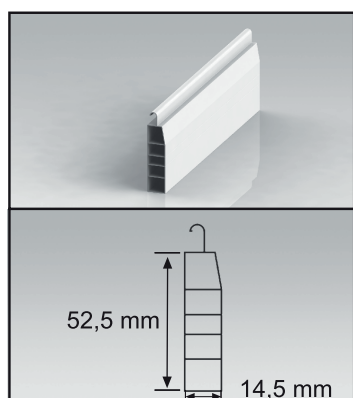

BAJERA DE OBRA / PVC END SLAT / LAME FINALE

ALTURA ÚTIL HIGH COVER / HAUTEUR UTILE PROFIL	52,5 mm
ESPEJOR NOMINAL NOMINAL THICKNESS / EPAISSEUR DU PROFIL	14,5 mm
PESO APROX. POR ml APPROX. WEIGHT PER ml / POIDS APPROX. PAR ml	0,2 kg/ml
EMBALAJE PACKING / EMBALLAGE	200 ml
LARGO PRODUCCIÓN ESTÁNDAR STANDARD LENGTH / LONGUEUR DE PRODUCTION	6 m
COMPATIBLE CON: SUITABLE / PROPICE:	T 5, F 50, F 4, F C y F A

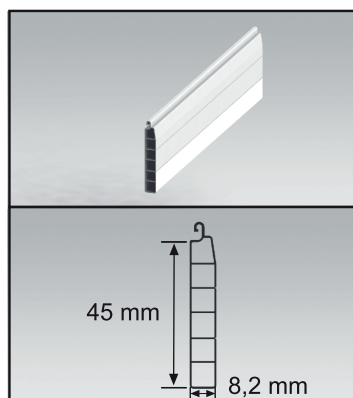

BAJERA MINI / MINI PVC END SLAT / LAME FINALE MINI

ALTURA ÚTIL HIGH COVER / HAUTEUR UTILE PROFIL	45 mm
ESPEJOR NOMINAL NOMINAL THICKNESS / EPAISSEUR DU PROFIL	8,2 mm
PESO APROX. POR ml APPROX. WEIGHT PER ml / POIDS APPROX. PAR ml	0,2 kg/ml
EMBALAJE PACKING / EMBALLAGE	200 ml
LARGO PRODUCCIÓN ESTÁNDAR STANDARD LENGTH / LONGUEUR DE PRODUCTION	6 m
COMPATIBLE CON: SUITABLE / PROPICE:	MINI

Colores: Blanco, Marfil, Gris y Marrón. Otros colores consultar.

Colors: White, Ivory, Gray and Brown. Other colors on request. / **Couleurs:** Blanc, Ivoire, Gris et Brun. Autres couleurs sur demande.

LAMAS DE ALUMINIO PERFILADO
ALUMINIUM SLATS - LAMES EN ALUMINIUM

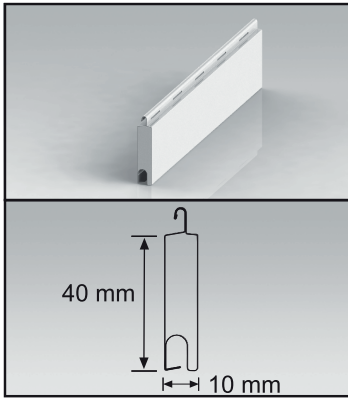

40 PLANA / FLAT / PLAT

ALTURA ÚTIL HIGH COVER / HAUTEUR UTILE PROFIL	40 mm
ESPEJOR NOMINAL NOMINAL THICKNESS / EPAISSEUR DU PROFIL	10 mm
LAMAS POR METRO DE ALTURA NUMBER OF SLATS PER METER / PROFILS PAR METRE	25 uds
PESO APROX. POR m² APPROX. WEIGHT PER m ² / POIDS APPROX. PAR m ²	3,5 kg/m ²
EMBALAJE PACKING / EMBALLAGE	288 ml
LARGO PRODUCCIÓN ESTÁNDAR STANDARD LENGTH / LONGUEUR DE PRODUCTION	6 m
ESPEJOR DEL ALUMINIO SIN PINTURA ALUMINIUM THICKNESS WITHOUT PAINTING EPAISSEUR D'ALUMINIUM PEINTURE	0,27 mm

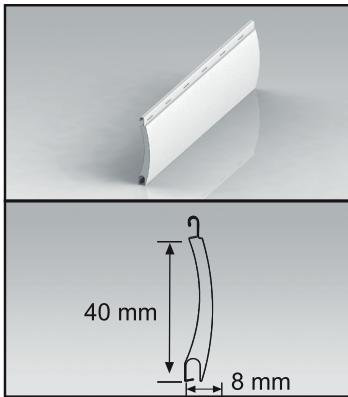

40 CURVA / CURVE / CURVE

ALTURA ÚTIL HIGH COVER / HAUTEUR UTILE PROFIL	40 mm
ESPEJOR NOMINAL NOMINAL THICKNESS / EPAISSEUR DU PROFIL	8 mm
LAMAS POR METRO DE ALTURA NUMBER OF SLATS PER METER / PROFILS PAR METRE	25 uds
PESO APROX. POR m² APPROX. WEIGHT PER m ² / POIDS APPROX. PAR m ²	2,6 kg/m ²
EMBALAJE PACKING / EMBALLAGE	384 ml
LARGO PRODUCCIÓN ESTÁNDAR STANDARD LENGTH / LONGUEUR DE PRODUCTION	6 m
ESPEJOR DEL ALUMINIO SIN PINTURA ALUMINIUM THICKNESS WITHOUT PAINTING EPAISSEUR D'ALUMINIUM PEINTURE	0,27 mm

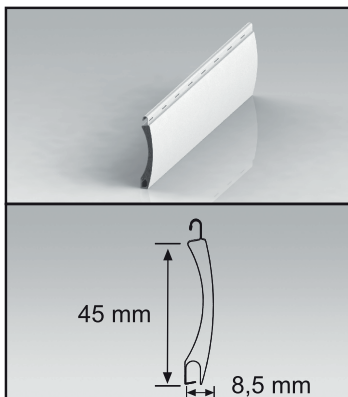

45 CURVA / CURVE / CURVE

ALTURA ÚTIL HIGH COVER / HAUTEUR UTILE PROFIL	45 mm
ESPEJOR NOMINAL NOMINAL THICKNESS / EPAISSEUR DU PROFIL	8,5 mm
LAMAS POR METRO DE ALTURA NUMBER OF SLATS PER METER / PROFILS PAR METRE	23 uds
PESO APROX. POR m² APPROX. WEIGHT PER m ² / POIDS APPROX. PAR m ²	2,8 kg/m ²
EMBALAJE PACKING / EMBALLAGE	288 ml
LARGO PRODUCCIÓN ESTÁNDAR STANDARD LENGTH / LONGUEUR DE PRODUCTION	6 m
ESPEJOR DEL ALUMINIO SIN PINTURA ALUMINIUM THICKNESS WITHOUT PAINTING EPAISSEUR D'ALUMINIUM PEINTURE	0,27 mm

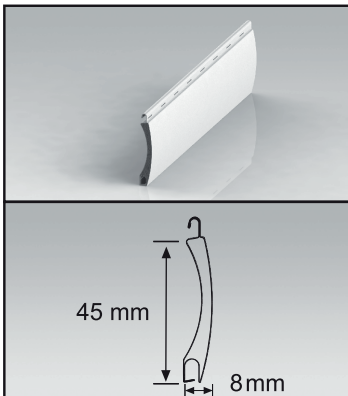

EO 45

ALTURA ÚTIL HIGH COVER / HAUTEUR UTILE PROFIL	45 mm
ESPEJOR NOMINAL NOMINAL THICKNESS / EPAISSEUR DU PROFIL	8 mm
LAMAS POR METRO DE ALTURA NUMBER OF SLATS PER METER / PROFILS PAR METRE	23 uds
PESO APROX. POR m² APPROX. WEIGHT PER m ² / POIDS APPROX. PAR m ²	2,2 kg/m ²
EMBALAJE PACKING / EMBALLAGE	384 ml
LARGO PRODUCCIÓN ESTÁNDAR STANDARD LENGTH / LONGUEUR DE PRODUCTION	6 m
ESPEJOR DEL ALUMINIO SIN PINTURA ALUMINIUM THICKNESS WITHOUT PAINTING EPAISSEUR D'ALUMINIUM PEINTURE	0,23 mm

Nota: Se puede fabricar la lama ciega (sin troquelado).

Note: We can manufacture blind aluminium slats.

Note: Nous pouvons fabriquer des lames en aluminium aveugles.

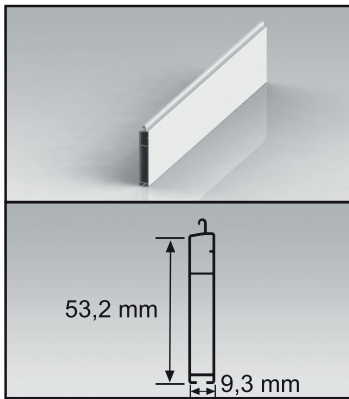

BAJERA DE 50 de aluminio de extrusión

50 END SLAT / LAME FINALE EN 50

ALTURA ÚTIL
HIGH COVER / HAUTEUR UTILE PROFIL 53,2 mm

ESPESOR NOMINAL
NOMINAL THICKNESS / EPAISSEUR DU PROFIL 9,3 mm

PESO APROX. por ml
APPROX. WEIGHT ml / POIDS APPROX. ml 0,4 kg/ml

EMBALAJE
PACKING / EMBALLAGE 60m

LARGO PRODUCCIÓN ESTÁNDAR
STANDARD LENGTH / LONGUEUR DE PRODUCTION 6,5 m

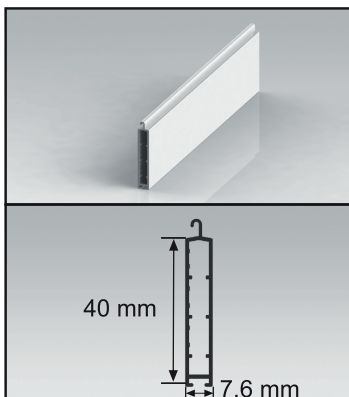

BAJERA DE 40 de aluminio de extrusión

40 END SLAT / LAME FINALE EN 40

ALTURA ÚTIL
HIGH COVER / HAUTEUR UTILE PROFIL 40 mm

ESPESOR NOMINAL
NOMINAL THICKNESS / EPAISSEUR DU PROFIL 7,6 mm

PESO APROX. por ml
APPROX. WEIGHT ml / POIDS APPROX. ml 0,3 kg/ml

EMBALAJE
PACKING / EMBALLAGE 60 m

LARGO PRODUCCIÓN ESTÁNDAR
STANDARD LENGTH / LONGUEUR DE PRODUCTION 6 m

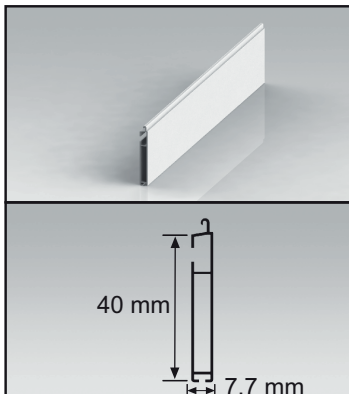

BAJERA DE 40 PARA CERROJILLOS

40 END SLAT BAR LOCKING / LAME FINALE EN 40 POUR VERROU DE SÉCURITÉ

ALTURA ÚTIL
HIGH COVER / HAUTEUR UTILE PROFIL 40 mm

ESPESOR NOMINAL
NOMINAL THICKNESS / EPAISSEUR DU PROFIL 7,7 mm

PESO APROX. por ml
APPROX. WEIGHT ml / POIDS APPROX. ml 0,3 kg/ml

EMBALAJE
PACKING / EMBALLAGE 60 m

LARGO PRODUCCIÓN ESTÁNDAR
STANDARD LENGTH / LONGUEUR DE PRODUCTION 6 m

COLOR LAMA
SLAT COLOR - COULEUR LAME

Cada color de lama tiene asociado un color único de bajera de extrusión.

Each slat has an unique associated aluminium end slat color. / Chaque lame finale en aluminium a une couleur associée de lame finale.

COLOR LAMA SLAT COLOR / COULEUR LAME	CODIGO COLOR COLOR CODE / CODE COULEUR	CODIGO BAJERA / COLOR END SLAT / CODE LAME FINALE	
		50	40
BLANCO WHITE / BLANC	001	AG200011200	AG100011200
MARFIL IVORY / IVOIRE	115	AG201151200	AG101151200
BURDEOS05 BORDEAUX05/ BORDEAUX05	305	AG203051200	AG103051200
VERDE05 GREEN05 / VERT05	605	AG206051200	AG106051200
VERDE09 GREEN09 / VERT09	609	AG206091200	AG106091200
GRIS11 GREY11 / GRIS11	711	AG207111200	AG107111200
GRIS16 GREY16 / GRIS16	716	AG207161200	AG107161200
NATURAL NATURAL / NATUREL	720	AG207201200	AG107201200
MARRÓN14 BROWN14 / BRUN 14	814	AG208141200	AG108141200
MARRÓN17 BROWN 8017 / BRUN 8017	817	AG208171200	AG108171200
BRONCE BRONZE / BRONZE	907	AG209071200	AG109071200
NEGRO BLACK / NOIR	911	AG209111200	AG109111200
GRIS SABLE * GREY SABLE * / GRIS SABLE *	935	AG209351200	AG109351200
GRIS MOTEADO GREY SPOTTED / GRIS POIS	937	AG209201200	AG109201200
INOX INOX / INOX	938	AG209381200	AG109381200

* Disponible en P40 y C45 / Available in P40 and C45 / Disponibles dans P40 et C45

Nota: Se puede fabricar en cualquier color de la carta Ral.

Note: We can manufacture in any Ral colour. / Note: Pouvons fabriquer dans n'importe quelle couleur Ral.

COLOR LAMA SLAT COLOR / COULEUR LAME	CODIGO COLOR COLOR CODE / CODE COULEUR	CODIGO BAJERA / COLOR END SLAT / CODE LAME FINALE	
		50	40
MADERA 120 WOOD 120 / BOIS 120	948	AG209481200	AG109481200
MADERA 170 WOOD 170 / BOIS 170	949	AG209491200	AG109491200

* Disponible en C40 / Available in C40 / Disponibles dans C40

TABLAS DE ENROLLAMIENTO PARA LAMAS DE ALUMINIO PERFILADO
ALUMINIUM SLATS DIAMETER TABLE / LAMES EN ALUMINIUM TABLEAU ENROULEMENT

	PLANA 40 FLAT 40 / PLAT 40	CURVA 40 CURVE 40 / CURVE 40	CURVA 45 CURVE 45 / CURVE 45	EO 45
ALTO (mm) HIGH / HATEAUR	EJE DE 60 / DIÁMETRO (mm) AXLE 60 / DIAMETER // AXE 60 / DIAMETRE			
1000	160	125	125	117
1200	170	130	135	128
1400	185	135	145	132
1600	195	140	150	140
1800	200	145	155	144
2000	210	155	160	150
2200	220	160	165	155
2400	230	165	175	159
2600	230	170	180	163
2800	240	175	185	166
3000	245	180	190	177

Nota: Estas medidas son orientativas.

Note: These measures are approximate.

Note: Ces mesures sont approximatives.

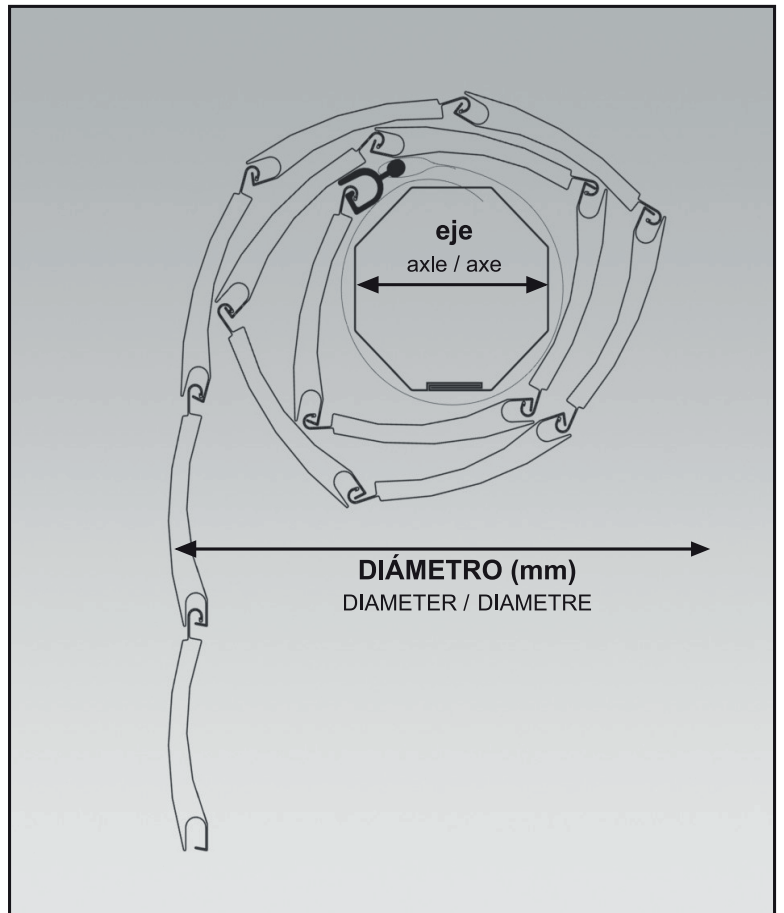

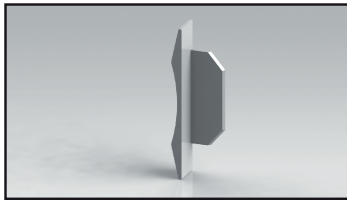

TAPONES LATERALES PARA LAMA DE ALUMINIO P40	
ALUMINIUM SLATS LATERAL STOPPER P40	
LAMES EN ALUMINIUM BOUCHON VOLET P40	
Código / Code / Code	AM619994000
Precio Ud. / Unit price / Prix unitaire	0,23 €
Embalaje / Packing / Embalaje	1000 uds.



TAPONES LATERALES PARA LAMA DE ALUMINIO C40	
ALUMINIUM SLATS LATERAL STOPPER C40	
LAMES EN ALUMINIUM BOUCHON VOLET C40	
Código / Code / Code	AM609994000
Precio Ud. / Unit price / Prix unitaire	0,07 €
Embalaje / Packing / Embalaje	1000 uds.



TAPONES LATERALES PARA LAMA DE ALUMINIO C45 / EO 45	
ALUMINIUM SLATS LATERAL STOPPER C45 / EO 45	
LAMES EN ALUMINIUM BOUCHON VOLET C45 / EO 45	
Código / Code / Code	AM609994500
Precio Ud. / Unit price / Prix unitaire	0,07 €
Embalaje / Packing / Embalaje	1000 uds.

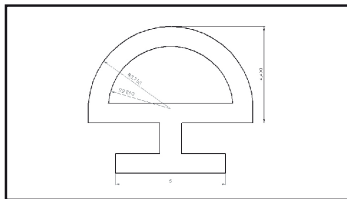

GOMA BAJERA 40	
RUBBER PROTECTION 40	
CAOUTCHOUC FINITION 40	
Código / Code / Code	Am909990000
Precio Ud. / Unit price / Prix unitaire	0,72 €
Embalaje / Packing / Embalaje	300 ml.

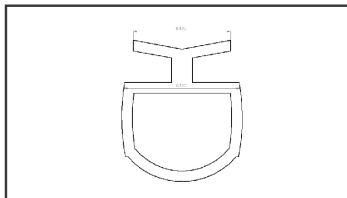

GOMA BAJERA 50	
RUBBER PROTECTION 50	
CAOUTCHOUC FINITION 50	
Código / Code / Code	Am909990002
Precio Ud. / Unit price / Prix unitaire	1,20 €
Embalaje / Packing / Embalaje	250 ml.

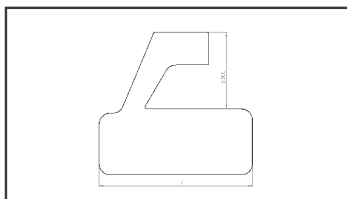

JUNQUILLO ULTIMA LAMA	
RUBBER LAST SLAT	
CAOUTCHOUC DERNIER LAME	
Código / Code / Code	Am909990001
Precio Ud. / Unit price / Prix unitaire	0,67 €
Embalaje / Packing / Embalaje	300 ml.

TABLAS DE ENROLLAMIENTO PARA LAMAS DE PVC
PVC SLATS DIAMETER TABLE / LAMES EN PVC TABLEAU ENROULEMENT

	T5	F50	FC / F4	FA	MINI
ALTO (mm) HIGH / HATEAUR	EJE DE 60 / DIÁMETRO (mm) AXLE 60 / DIAMETER // AXE 60 / DIAMETRE				
1000	125	160	160	175	120
1200	135	175	175	195	130
1400	145	185	185	200	135
1600	155	195	195	210	145
1800	165	210	210	225	155
2000	175	220	220	240	165
2200	180	225	225	245	175
2400	190	235	235	250	190
2600	195	245	245	265	200
2800	205	260	260	275	210
3000	210	270	270	285	220

TABLAS DE ENROLLAMIENTO PARA LAMAS DE ALUMINIO PERFILADO
ALUMINIUM SLATS DIAMETER TABLE / LAMES EN ALUMINIUM TABLEAU ENROULEMENT

	PLANA 40 FLAT 40 / PLAT 40	CURVA 40 CURVE 40 / CURVE 40	CURVA 45 CURVE 45 / CURVE 45	EO 45
ALTO (mm) HIGH / HATEAUR	EJE DE 42 / DIÁMETRO (mm) AXLE 42 / DIAMETER // AXE 42 / DIAMETRE			
1000	149	111	119	114
1200	156	121	127	121
1400	168	132	139	125
1600	173	137	146	133
1800	177	141	149	138
2000	192	144	153	146
2200	198	153	155	149
2400	209	159	168	156
2600	210	160	170	163
2800	222	170	179	165
3000	229	177	194	173

Nota: Estas medidas son orientativas.

Note: These measures are approximate.

Note: Ces mesures sont approximatives.

PRECIO LAMAS DE PVC
PRICE PVC SLATS / PRIX LAMES EN PVC

T5	F50	F4	FC	FA	MINI	BAJERA OBRA PVC END SLAT LAME FINALE	BAJERA MINI MINI PVC END SLAT LAME FINALE MINI
1,38 €/ml.	1,17 €/ml.	1,35 €/ml.	1,17 €/ml.	1,38 €/ml.	0,72 €/ml.	1,36 €/ml.	0,92 €/ml.

PRECIO LAMAS DE ALUMINIO PERFILADO
PRICE ALUMINIUM SLATS / PRIX LAMES EN ALUMINIUM

	DENSIDAD DENSITY / DENSITÉ	BASE	GRUPO 1	GRUPO 2	GRUPO 3
P40	100	1,82 €/ml.	1,95 €/ml.	1,98 €/ml.	2,11 €/ml.
C40	80	1,36 €/ml.	1,46 €/ml.	1,49 €/ml.	1,62 €/ml.
C45	80	1,62 €/ml.	1,69 €/ml.	1,79 €/ml.	1,88 €/ml.
EO 45	80	1,33 €/ml.	1,40 €/ml.	1,46 €/ml.	1,56 €/ml.

En stock / in stock / en stock.

	DENSIDAD DENSITY / DENSITÉ	BASE	GRUPO 1	GRUPO 2	GRUPO 3
C40	180	1,56 €	1,88 €	1,92 €	1,95 €
C45	180	1,95 €	2,01 €	2,05 €	2,18 €
P40	180	2,27 €	2,31 €	2,44 €	2,60 €

Fabricación bajo pedido / on request / sur demande.

PRECIO BAJERAS DE ALUMINIO DE EXTRUSIÓN
PRICE ALUMINIUM END SLATS / PRIX LAMES FINALE EN ALUMINIUM

	BRUT	BASE	GRUPO 1-2 GROUP 1-2 / GROUPE 1-2	GRUPO 3 GROUP 3 / GROUPE 3
40	4,90 €/ml.	6,24 €/ml.	6,24 €/ml.	7,50 €/ml.
50	6,51 €/ml.	8,02 €/ml.	8,02 €/ml.	8,75 €/ml.

Precio bajeras foliadas (imitación madera) consultar / Wooden effect end slats ask for / Prix lames finales faux bois consulter.

PRECIO BAJERAS DE ALUMINIO DE EXTRUSIÓN PARA CERROJILLOS
PRICE ALUMINIUM END SLATS BAR LOCKING / PRIX LAMES FINALE EN ALUMINIUM POUR VERROU DE SÉCURITÉ

40	4,90 €/ml.	6,24 €/ml.	6,24 €/ml.	7,50 €/ml.
-----------	------------	------------	------------	------------

GRUPO COLORES PARA LAMAS
COLOR GROUP FOR SLATS / GROUPE COULEURS POUR LAMES

- BASE:** Blanco y Marfil.
- GRUPO 1:** Burdeos 3005, Verde 6005, Verde 6009, Natural, Marrón 8014, Marrón 8017, Negro y Gris 7011.
- GRUPO 2:** Bronce, Gris 7016, Sable 935 y 937.
- GRUPO 3:** Moteados, Inox, Madera oscuro, Madera 120, Madera 170 y Winchester.
- BASE:** White and Ivory.
- GROUP 1:** Bordeaux 3005, Green 6005, Green 6009, Natural, Brown 8014, Brown 8017, Black and Grey7011.
- GROUP 2:** Bronze, Grey 7016, Sable 935 and 937.
- GROUP 3:** Spotted, Inox, Dark Wood, Wood 120, Wood 170 and Winchester.
- BASE:** Blanc et Ivoire.
- GROUPE 1:** Bordeaux 3005, Vert 6005, Vert 6009, Naturel, Brun 8014, Brun 8017, Noir et Gris7011.
- GROUPE 2:** Bronze, Gris7016, Sable 935 et 937.
- GROUPE 3:** Pois, Inox, Bois foncé, Bois 120, Bois 170 et Winchester.

Clasificación según UNE-EN 13659:2015

Classification according to the UNE-EN 13659:2015 / Classement selon UNE- EN 13659:2015

CLASES DE RESISTENCIA AL VIENTO							
CLASSES OF WIND RESSISTANCE / CLASSES DE RÉSISTANCE AU VENT							
Clase Class / Classe	0	1	2	3	4	5	6
Presión nominal (p(N/m²)) Nominal pressure (p(N/m ²)) Pression nominale (p(N/m ²))	<50	50	70	100	170	270	400

Resultados de ensayos realizados según Norma UNE-EN 1932:2013

Wind resistance test according to the UNE-EN 1932:2013 / Résultats des essais réalisés selon la Règle UNE-EN 1932:2013

Modelo Model / Modèle	Medidas ensayadas Tested sizes / Mesures testées	Clase Class / Classe	Tipo de Lama Type of Slat / Type de Lame
C 40	2300x2300 mm	4	Laminada de aluminio 40x8 (Poliuretano inyectado) Profiled aluminium 40x8 (Insulated with poliurethane foam) Laminée d'aluminium 40x8 (Polyuréthane injecté)
C 45	2400x2300 mm	4	Laminada de aluminio 45x8.5 (Poliuretano inyectado) Profiled aluminium 45x8.5 (Insulated with poliurethane foam) Laminée d'aluminium 45x8.5 (Polyuréthane injecté)
EO 45	2100x2300 mm	4	Laminada de aluminio 45x8 (Poliuretano inyectado) Profiled aluminium 45x8 (Insulated with poliurethane foam) Laminée d'aluminium 45x8 (Polyuréthane injecté)
P 40	2700x2300 mm	4	Laminada de aluminio 40x10 (Poliuretano inyectado) Profiled aluminium 40x10 (Insulated with poliurethane foam) Laminée d'aluminium 40x10 (Polyuréthane injecté)

Aceper S.L. declara bajo su responsabilidad, que el/los siguiente/s productos son conformes a los anexos ZA de la/s norma/s armonizadas de aplicación y por tanto cumple/n con los requisitos de la Directiva 89/106/CEE de Productos de la Construcción. Transposición a la legislación española en el R.D.1630.1992

Aceper S.L. declares that these products fulfil the provisions of annex ZA concerning to the harmonised rules and therefore fulfills the essential requirements of the Construction Products Directive 89/106/CEE. Transposition into spanish law in the R.D. 1630.1992

Aceper S.L. déclare sous sa responsabilité, que les produits sont conformes aux annexes ZA des normes d'application et, par conséquent, remplissent les conditions requises de la Directive 89/106/CEE de Produits de la Construction. Transposition à la législation espagnole dans le R.D.1630.1192

ACEPER



Motores y automatismos para persianas y toldos

Motors and automation for rolling shutters and sun awnings

Moteurs et automatismes pour volets roulants et stores

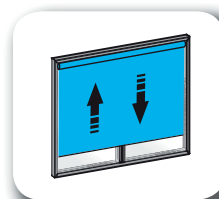

TABLAS DE SELECCIÓN DEL MOTOR

MOTOR SELECTION TABLE / TABLEAUX DE SELECTION DE MOTEUR

Ø35: Peso levantado (kg) según el eje / Lifted weight according to the tube / Poids soulevé (kg) selon l'axe					
POTENCIA TORQUE / PUISSANCE	Eje 42 TUBE 42 / AXE 42	Eje 50 TUBE 50 / AXE 50	Eje 60 TUBE 60 / AXE 60	Eje 70 TUBE 70 / AXE 70	Eje 78 TUBE 78 / AXE 78
5 Nm	10	-	-	-	-
10 Nm	20	-	-	-	-
13 Nm	25	-	-	-	-

Ø45: Peso levantado (kg) según el eje / Lifted weight according to the tube / Poids soulevé (kg) selon l'axe					
POTENCIA TORQUE / PUISSANCE	Eje 42 TUBE 42 / AXE 42	Eje 50 TUBE 50 / AXE 50	Eje 60 TUBE 60 / AXE 60	Eje 70 TUBE 70 / AXE 70	Eje 78 TUBE 78 / AXE 78
6 Nm	-	14	12	9	-
10 Nm	-	20	17	15	-
20 Nm	-	41	35	31	-
30 Nm	-	61	52	46	28
40 Nm	-	82	70	61	37
50 Nm	-	102	87	76	46

Ø59: Peso levantado (kg) según el eje / Lifted weight according to the tube / Poids soulevé (kg) selon l'axe					
POTENCIA TORQUE / PUISSANCE	Eje 42 TUBE 42 / AXE 42	Eje 50 TUBE 50 / AXE 50	Eje 60 TUBE 60 / AXE 60	Eje 70 TUBE 70 / AXE 70	Eje 78 TUBE 78 / AXE 78
80 Nm	-	-	-	129	93
120 Nm	-	-	-	182	139

CARACTERÍSTICAS GENERALES DE TODOS LOS MOTORES K

GENERAL CHARACTERISTICS OF OUR MOTORS K

CARACTÉRISTIQUES GÉNÉRALES DE TOUS LES MOTEURS K

- Longitud del cable: **2,5 m.** / Cable length: **2,5 m.** / Longueur du câble: **2,5 m.**
- Tiempo límite de funcionamiento (antes de saltar la protección térmica): **4 minutos**
Operation time limit (Before security protection works): **4 minutes**
Temp de fonctionnement minimum (Avant de mise en marche la protection thermique): **4 minutes**
- Grado de protección: **IP44** / International protection marking: **IP44** / Protection de type **IP 44**
- Tensión de entrada: **220/230 V** / Motor supplied: **220/230 V** / Tension d'entrée: **220/230 V**
- Facilidad de montaje / Easy setting / Facilité de montage.

K Ø35: motores para persianas y stores enrollables

suitable for rolling shutters and screens / Moteur pour volets et stores enroulables.

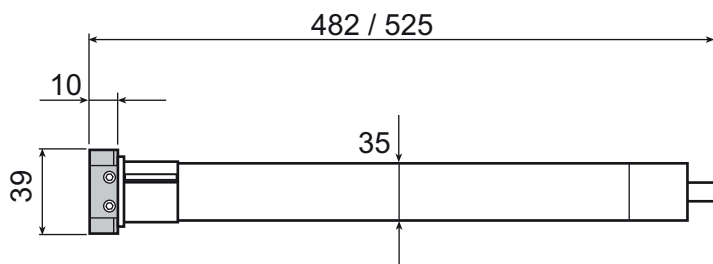
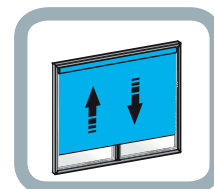
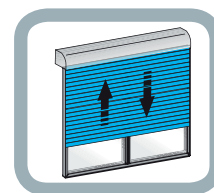

- Final de carrera mecánico y accionamiento mediante inversor.

Wired mechanical end limit switch and work by contact breaker

Fin de course mécanique et mis en marche avec interrupteur

- Dimensiones muy reducidas

Small size /Dimensions réduites



64504	K 05/28	169,20 €	1 ud.
64505	K 05/28	125,33 €	10 uds.
64509	K 09/16	163,59 €	1 ud.
64510	K 09/16	121,18 €	10 uds.
64514	K 13/10	156,60 €	1 ud.
64515	K 13/10	116,00 €	10 uds.

CARACTERÍSTICAS TÉCNICAS / TECHNICAL FEATURES / CARACTÉRISTIQUES TECHNIQUES

MOTOR MOTOR MOTEUR	LONGITUD LENGTH LONGUEUR	CONSUMO CONSUMPTION CONSUMMATION	PAR NOMINAL TORQUE COUPLE MOTEUR	VUELTAS POR MINUTO SPEED TOURS PAR MINUTE	VUELTAS FINAL DE CARRERA LS ROUNDS FIN DE COURSE
K 05/28	525 mm	123 W	4 Nm	28 rpm	38
K 09/16	482 mm	123 W	10 Nm	16 rpm	38
K 13/10	525 mm	135 W	13 Nm	10 rpm	38

* Ver soportes y adaptaciones en página 63.

Refer to page 63 for bracket information and adapter information / Voir supports et adaptations page 63.

KRE Ø35: motores para persianas y stores enrollables

suitable for rolling shutters and screens / Moteur pour volets roulants et stores enroulables.

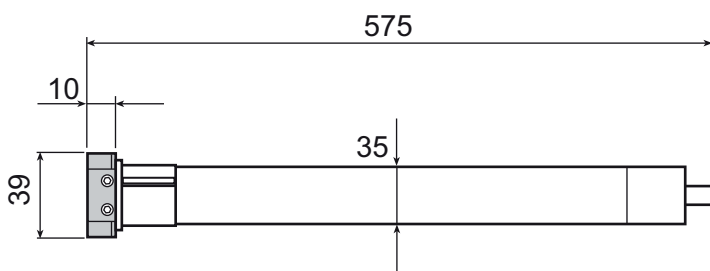
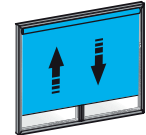
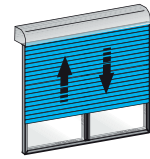

- Final de carrera electrónico y receptor radio integrado.
Electronic end limit switch & built in radio and built in radio receiver.
Fin de course électronique et récepteur radio intégré.
- Fácil ajuste del final de carrera desde el mando a distancia.
Easy end limits adjustment by the transmitter.
Facile regulation à l'aide de la télécommande.
- Facilidad para la agrupación de motores.
Easy group controls adjustment.
Facile groupement de moteurs.



64601	KRE 05/28	217,87 €	1 ud.
64602	KRE 09/12	203,35 €	1 ud.
64603	KRE 13/12	154,01 €	1 ud.

CARACTERÍSTICAS TÉCNICAS / TECHNICAL FEATURES / CARACTÉRISTIQUES TECHNIQUES

MOTOR MOTOR MOTEUR	LONGITUD LENGTH LONGUEUR	CONSUMO CONSUMPTION CONSUMMATION	PAR NOMINAL TORQUE COUPLE MOTEUR	VUELTAS POR MINUTO SPEED TOURS PAR MINUTE	VUELTAS FINAL DE CARRERA LS ROUNDS FIN DE COURSE
KRE 05/28	575 mm	123 W	4 Nm	28 rpm	térmico warming / thermique
KRE 09/12	575 mm	123 W	10 Nm	12 rpm	térmico warming / thermique
KRE 13/12	575 mm	135 W	13 Nm	12 rpm	térmico warming / thermique

SOPORTES PARA MOTORES K Ø35

BRACKETS FOR K Ø35 / SUPPORTS POUR MOTEUR K Ø35

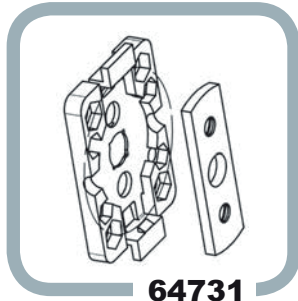

64731

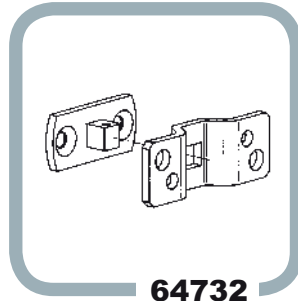

64732

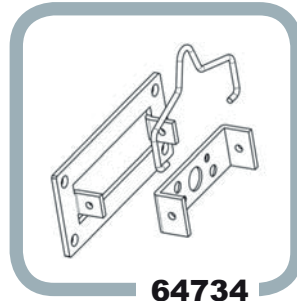

64734



64731	Soporte PVC Ø35 / PVC bracket Ø35 / Support en PVC Ø35	6,43 €
64732	Soporte obra Ø35 / Bracket with pin / Support Ø35	7,33 €
64733	Soporte plano metálico taladro / Minimum dimensions bracket / support plat métallique perçage	4,98 €

ADAPTACIONES PARA MOTORES K Ø35

Adapters for K Ø35 / Adaptations pour moteur K Ø35

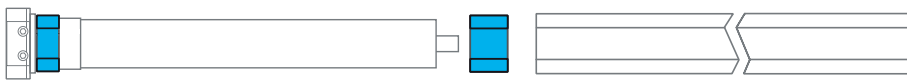

42 oct.

64706

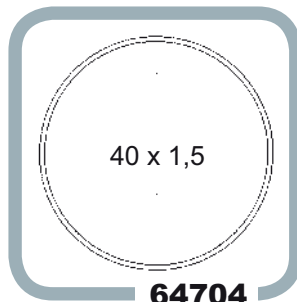

40 x 1,5

64704



64706	Rueda y corona para eje de 42 oct. Adapters for 42 oct. / Roue et couronne pour axe 42 oct.	2,49 €
64704	Rueda y corona para eje de 40 x 1,5 Adapters for 40x1,5. / Roue et couronne pour axe 40x1,5.	2,53 €

K Ø45: motores para persianas y toldos

suitable for rolling shutters and sun awnings / Moteur pour volets roulants et stores banners

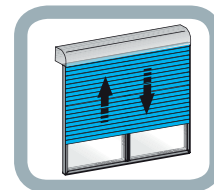
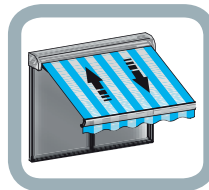
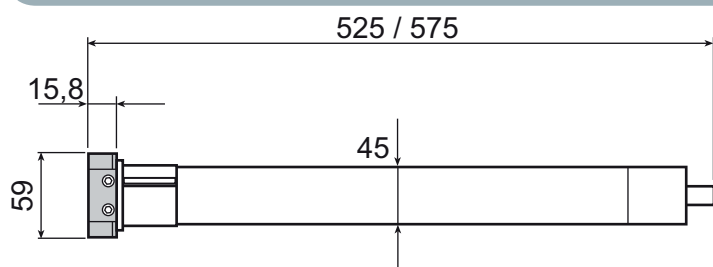

- Final de carrera mecánico y accionamiento mediante inversor.

Wired mechanical end limit switch and work by contact breaker.

Fin de course mécanique et mis en marche avec interrupteur.

- Amplia gama de potencias disponibles.

Wide range of power classes.

Vaste gamme de puissances disponibles.



64519	K 06/17	107,57 €	1 ud.
64520	K 06/17	79,68 €	10 uds.
64523	K 10/17	112,05 €	1 ud.
64525	K 10/17	83,00 €	10 uds.
64529	K 20/17	131,66 €	1 ud.
64530	K 20/17	97,53 €	10 uds.
64534	K 30/17	156,87 €	1 ud.
64535	K 30/17	116,20 €	10 uds.
64537	K 40/17	168,07 €	1 ud.
64540	K 40/17	124,50 €	10 uds.
64543	K 50/12	190,48 €	1 ud.
64545	K 50/12	141,10 €	10 uds.

CARACTERÍSTICAS TÉCNICAS / TECHNICAL FEATURES / CARACTÉRISTIQUES TECHNIQUES

MOTOR MOTOR MOTEUR	LONGITUD LENGTH LONGUEUR	CONSUMO CONSUMPTION CONSUMMATION	PAR NOMINAL TORQUE COUPLE MOTEUR	VUELTAS POR MINUTO SPEED TOURS PAR MINUTE	VUELTAS FINAL DE CARRERA LS ROUNDS FIN DE COURSE
K 06/17	575 mm	130 W	6 Nm	17 rpm	28
K 10/17	525 mm	130 W	10 Nm	17 rpm	28
K 20/17	575 mm	160 W	20 Nm	17 rpm	28
K 30/17	575 mm	210 W	30 Nm	17 rpm	28
K 40/17	575 mm	270 W	40 Nm	17 rpm	28
K 50/12	575 mm	270 W	50 Nm	12 rpm	28

* Ver soportes en página 68 y adaptaciones en página 71.

Refer to page 68 for bracket information and page 71 for adapter information / Voir supports page 68 et adaptations page 71.

KC Ø45: motores para persianas.
suitable for rolling shutters / Moteur pour volets roulants

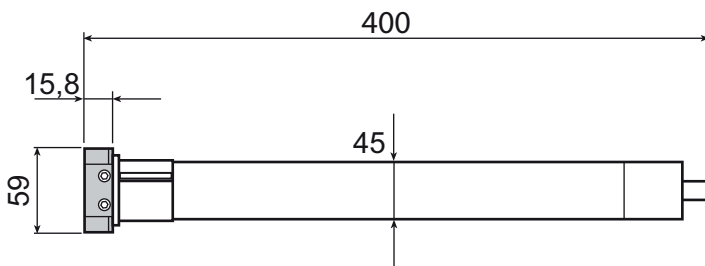

- Final de carrera electrónico con nuevo sistema de regulación.
Wired mechanical end limit switch with new end limits adjuntement.
Fin de course electronique avec nouveau système de regulation.
- Nuestro motor más corto, permite la instalación en huecos reducidos.
Our shortest motor, suitable for the smallest rolling shutters.
Notre plus petit moteur permet l'installation dans espaces réduits.
- Permite conexión en paralelo.
Parallel wiring allowed.
Permet une connexion parallèle.

64605	KC 6/17	176,60 €	1 ud.

CARACTERÍSTICAS TÉCNICAS / TECHNICAL FEATURES / CARACTÉRISTIQUES TECHNIQUES					
MOTOR MOTOR MOTEUR	LONGITUD LENGTH LONGUEUR	CONSUMO CONSUMTION CONSUMMATION	PAR NOMINAL TORQUE COUPLE MOTEUR	VUELTAS POR MINUTO SPEED TOURS PAR MINUTE	VUELTAS FINAL DE CARRERA LS ROUNDS FIN DE COURSE
KC 6/17	400 mm	105 W	6 Nm	17 rpm	térmico warming / thermique

* Ver soportes en página 68 y adaptaciones en página 71.
Refer to page 68 for bracket information and page 71 for adapter information / Voir supports page 68 et adaptations page 71.

KRE Ø45: motores para persianas y toldos

suitable for rolling shutters and sun awnings / Moteur pour volets et stores banners

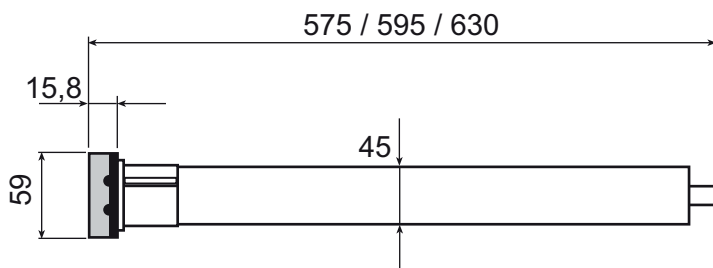
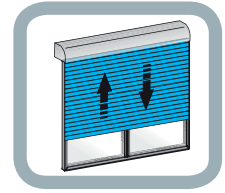
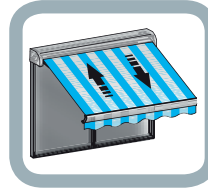

- Final de carrera electrónico y receptor radio integrado.
Electronic end limit switch & built in radio and built in radio receiver.
Fin de course électronique et récepteur radio intégré.
- Fácil ajuste del final de carrera desde el mando a distancia.
Easy end limits adjustment by the transmitter.
Facile système de regulation à l'aide de la télécommande.
- Facilidad para la agrupación de motores.
Easy group controls adjustment.
Facile groupement de moteurs.



64607	KRE 10/17	219,83 €	1 ud.
64609	KRE 10/17	162,84 €	10 uds.
64613	KRE 20/17	242,19 €	1 ud.
64614	KRE 20/17	179,40 €	10 uds.
64619	KRE 30/17	275,72 €	1 ud.
64620	KRE 30/17	204,24 €	10 uds.
64624	KRE 40/17	212,52 €	1 ud.
64630	KRE 50/12	223,56 €	1 ud.

CARACTERÍSTICAS TÉCNICAS / TECHNICAL FEATURES / CARACTÉRISTIQUES TECHNIQUES

MOTOR MOTOR MOTEUR	LONGITUD LENGTH LONGUEUR	CONSUMO CONSUMTION CONSUMMATION	PAR NOMINAL TORQUE COUPLE MOTEUR	VUeltas POR MINUTO SPEED TOURS PAR MINUTE	VUeltas FINAL DE CARRERA LS ROUNDS FIN DE COURSE
KRE 10/17	575 mm	130 W	10 Nm	17 rpm	térmico warming / thermique
KRE 20/17	595 mm	160 W	20 Nm	17 rpm	térmico warming / thermique
KRE 30/17	630 mm	210 W	30 Nm	17 rpm	térmico warming / thermique
KRE 40/17	630 mm	270 W	40 Nm	17 rpm	térmico warming / thermique
KRE 50/12	630 mm	270 W	50 Nm	12 rpm	térmico warming / thermique

* Ver soportes en página 68 y adaptaciones en página 71.

Refer to page 68 for bracket information and page 71 for adapter information / Voir supports page 68 et adaptations page 71.

KRET Ø45: motores específicos para toldos cofre

suitable for box sun awnings / Moteur pour stores bannes coffre

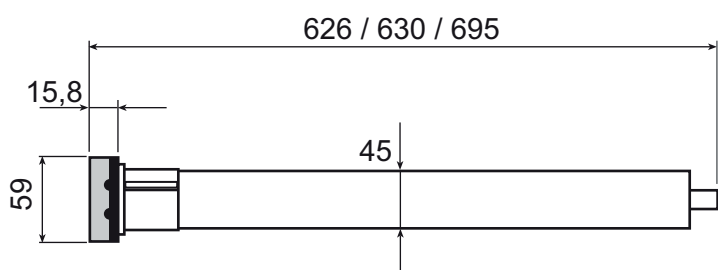
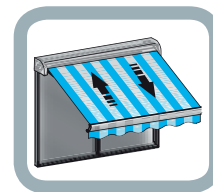

- Final de carrera electrónico y receptor radio integrado.

Electronic end limit switch & built in radio and built in radio receiver.

Fin de course électronique et récepteur radio intégré.

- Específico para toldos cofre.

Specific to box awnings.

Spécifique pour stores bannes coffre.

- Facilidad para la agrupación de motores.

Easy group controls adjustment.

Facile groupement de moteurs.



64645	KRET 10/17	240,33 €	1 ud.
64650	KRET 10/17	178,02 €	10 uds.
64653	KRET 20/17	248,67 €	1 ud.
64655	KRET 20/17	184,92 €	10 uds.
64657	KRET 30/17	283,17 €	1 ud.
64660	KRET 30/17	209,76 €	10 uds.
64665	KRET 40/17	218,04 €	1 ud.
64670	KRET 50/12	226,32 €	1 ud.

CARACTERÍSTICAS TÉCNICAS / TECHNICAL FEATURES / CARACTÉRISTIQUES TECHNIQUES

MOTOR	LONGITUD LENGTH LONGUEUR	CONSUMO CONSUMPTION CONSUMMATION	PAR NOMINAL TORQUE COUPLE MOTEUR	VUeltas POR MINUTO SPEED TOURS PAR MINUTE	VUeltas FINAL DE CARRERA LS ROUNDS FIN DE COURSE
KRET 10/17	626 mm	130 W	10 Nm	17 rpm	térmico warming / thermique
KRET 20/17	695 mm	160 W	20 Nm	17 rpm	térmico warming / thermique
KRET 30/17	630 mm	210 W	30 Nm	17 rpm	térmico warming / thermique
KRET 40/17	630 mm	270 W	40 Nm	17 rpm	térmico warming / thermique
KRET 50/12	630 mm	270 W	50 Nm	12 rpm	térmico warming / thermique

* Ver soportes en página 68 y adaptaciones en página 71.

Refer to page 68 for bracket information and page 71 for adapter information / Voir supports page 68 et adaptations page 71.

SOPORTES PARA MOTORES K / KE / KC / KRE / KRET Ø45

BRACKET FOR K / KE / KRE / KRET Ø45

SUPPORTS POUR MOTEUR K / KE / KRE / KRET Ø45

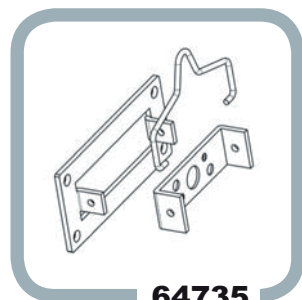

64735

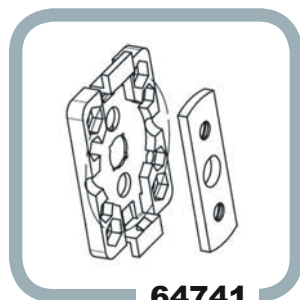

64741

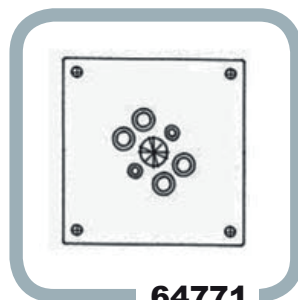

64771

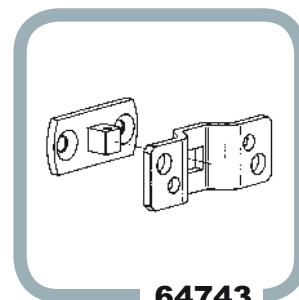

64743

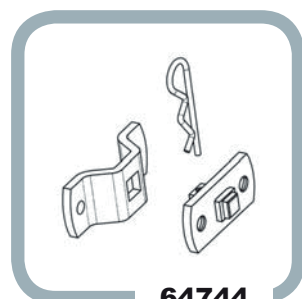

64744

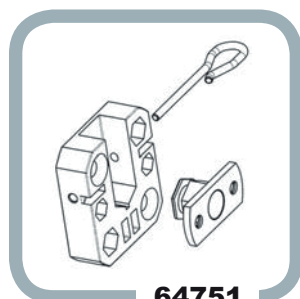

64751



64752



64760

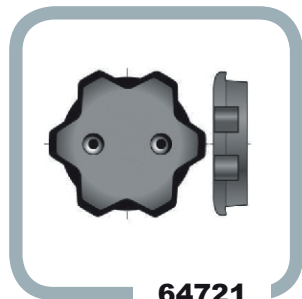

64721

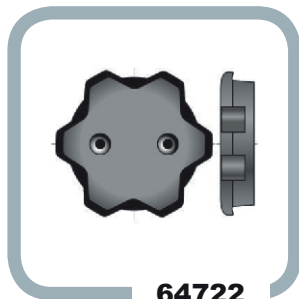

64722



64735	Soporte plano metálico taladro / Minimum dimensions bracket / Support plat métallique perçage	8,30 €
64741	Soporte PVC Ø45 (máx. 30 Nm) / PVC bracket Ø 45 / Support en pvc Ø 45	3,05 €
64771	Soporte placa 100x100 / 100x100 bracket plate / Support plaque 100x100	22,78 €
64743	Soporte obra Ø45 / Bracket with pin Ø 45 / Support Ø 45	7,33 €
64744	Soporte obra Ø45 roscado / Bracket with pin Ø 45 threaded / Support ouvre Ø 45 fileté	7,76 €
64751	Soporte toldo / Sun awning Bracket / Support store	12,54 €
64752	Soporte Uni / Bracket Uni / Support Uni	10,54 €
64760	Soporte Penta / Penta Bracket / Support Penta	6,43 €
64721	Adaptador soporte universal motor K / Coupling bracket Uni motor K / Embout support Uni moteur K	3,40 €
64722	Adaptador soporte universal motor KRE / Coupling bracket Uni motor KRE / Embout support Uni moteur KRE	3,40 €

KMM Ø45: motores con mando auxiliar de manivela para persianas y toldos
 motor with manual override suitable for rolling shutters and sun awning
 moteur avec manœuvre auxiliaire de manivelle pour volets roulants et stores

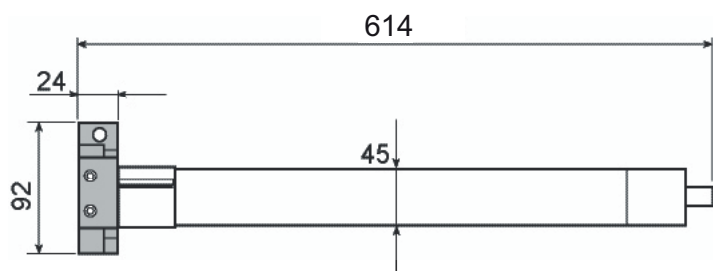
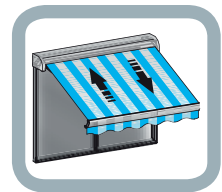
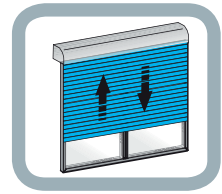

- Accionamiento de emergencia mediante
mediante inversor.
Wired mechanical end limit switch and work by contact
breaker.
Manœuvre d'urgence avec interrupteur.
- Final de carrera mecánico y accionamiento
mediante manivela
Emergency manual override with handle crank
Fin de course mécanique et mis en marche avec manivelle

↔	📄	€/ud.	📦
64550	KMM 30/17	278,47 €	1 ud.
64555	KMM 50/12	339,70 €	1 ud.

CARACTERÍSTICAS TÉCNICAS / TECHNICAL FEATURES / CARACTÉRISTIQUES TECHNIQUES					
MOTOR MOTOR MOTEUR	LONGITUD LENGTH LONGUEUR	CONSUMO CONSUMPTION CONSUMMATION	PAR NOMINAL TORQUE COUPLE MOTEUR	VUELTAS POR MINUTO SPEED TOURS PAR MINUTE	VUELTAS FINAL DE CARRERA LS ROUNDS FIN DE COURSE
KMM 30/17	614 mm	210 W	30 Nm	17 rpm	28
KMM 50/12	614 mm	270 W	50 Nm	12 rpm	28

SOPORTES PARA MOTORES KMM Ø45 BRACKETS FOR KMM MOTORS Ø45 / SUPPORTS POUR MOTEUR KMM Ø45

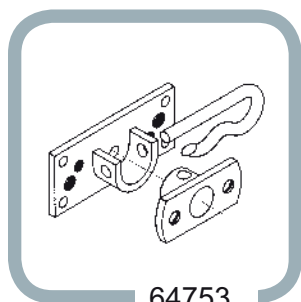

64753

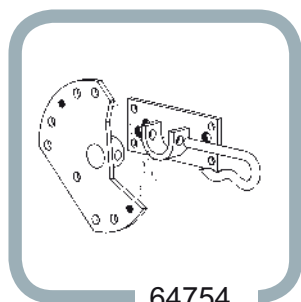

64754

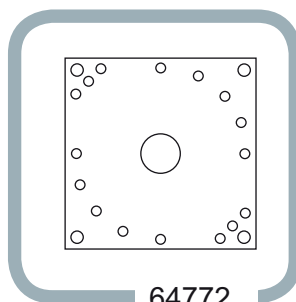

64772



64753	Soporte con espigo redondo Bracket with two position round pin / Support à deux positions de tenon ronde	15,77 €
64754	Soporte con espigo redondo para mando manual Revolving bracket with two position round pin / Support à deux positions tenon ronde pour télécommande manuelle	37,14 €
64772	Soporte placa 100x100 para mando manual 100x100 bracket plate / Support plaque 100x100 pour télécommande manuelle	22,78 €

ACCESORIOS PARA MOTORES KMM Ø45 ACCESSOIRES FOR KMM MOTOR Ø45 / ACCESSORIES KMM Ø45

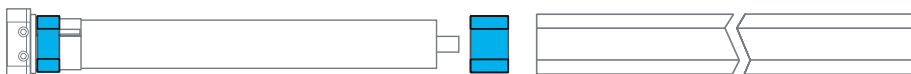

64761

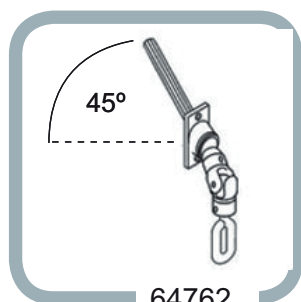

64762

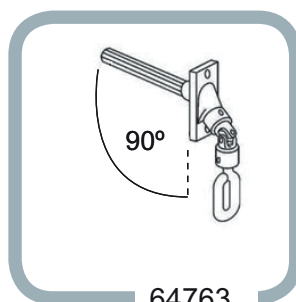

64763



64764 / 64765



64761	Varilla con cáncamo / Square joint with short eye / Tige avec anneau	9,08 €
64762	Snodo 45° con cáncamo / 45° joint with eye / Snodo 45° avec anneau	26,12 €
64763	Snodo 90° con cáncamo / 90° joint with eye / Snodo 90° avec anneau	43,53 €
64764	Manivela 1500 mm blanca / White 1500 mm. handle / Manivelle 1500 mm. blanche	24,70 €
64765	Manivela 1500 mm negra / Black 1500 mm. handle / Manivelle 1500 mm. noire	28,34 €

ADAPTACIONES PARA MOTORES K / KE / KMM / KRE / KRET Ø45
ADAPTERS FOR K / KE / KMM / KRE / KRET Ø45
ADAPTIONS À MOTEUR K / KE / KMM / KRE / KRET Ø45

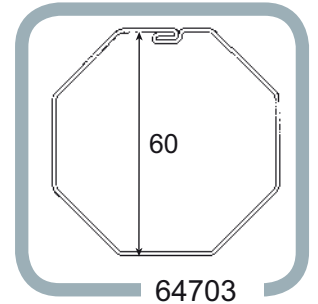
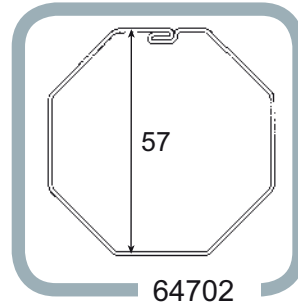
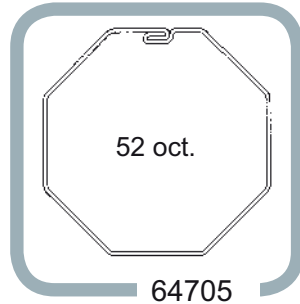
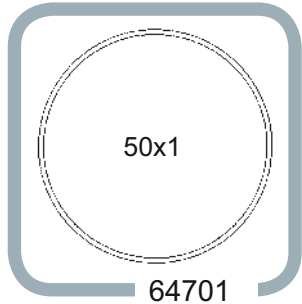
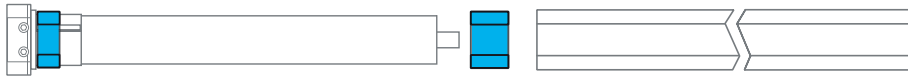

64701	Rueda para eje de 50 redondo 50X1 Adapter for rolling tube / Roue et couronne pour axe 50 ronde	3,82 €
64705	Rueda y corona para eje de 52 oct. Adapters for 52 octagonal axis / Roue et couronne pour axe 52 oct.	7,80 €
64702	Rueda y corona para eje de 60 oct. Adapters for 60 octagonal axis / Roue et couronne pour axe 60 oct.	4,15 €
64703	Rueda y corona para eje de 60 IMBAC Adapters for 60 IMBAC / Roue et couronne pour axe 60 IMBAC	3,53 €
64707	Rueda y corona para eje de 70 con ojiva Adapters (plastic wheel) for 70 with groove rolling tube / Roue et couronne pour axe 70 avec ogive	9,05 €
64708	Rueda y corona para eje de 78 con ojiva Ø45 Adapters for 78 with groove rolling tube Ø45/ Roue et couronne pour axe 78 avec ogive Ø45	9,05 €

K Ø59: motores para persianas y toldos

suitable for rolling shutters and sun awnings / Moteur pour volets roulants et stores banners

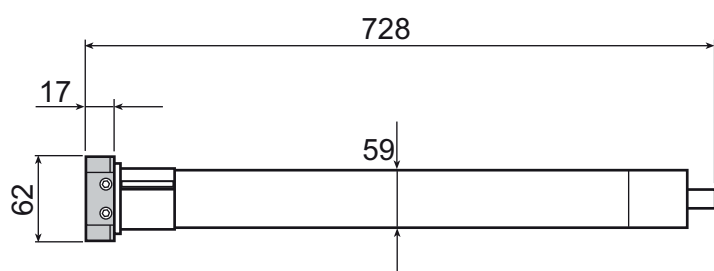
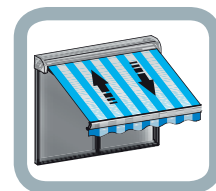
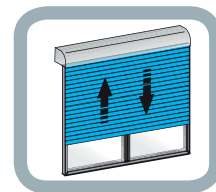

- Final de carrera mecánico y accionamiento mediante inversor.

Wired mechanical end limit switch and work by contact breaker

Fin de course mécanique et mis en marche avec interrupteur.

- Elevada potencia para grandes pesos

The strongest motor, suitable for heavy weights.

Grande puissance pour poids lourds.



64570	K 80/12	260,41 €	1 ud.
64575	K 120/12	329,93 €	1 ud.

CARACTERÍSTICAS TÉCNICAS / TECHNICAL FEATURES / CARACTÉRISTIQUES TECHNIQUES

MOTOR MOTOR MOTEUR	LONGITUD LENGTH LONGUEUR	CONSUMO CONSUMPTION CONSUMMATION	PAR NOMINAL TORQUE COUPLE MOTEUR	VUeltas POR MINUTO SPEED TOURS PAR MINUTE	VUeltas FINAL DE CARRERA LS ROUNDS FIN DE COURSE
K 80/12	728 mm	385 W	80 Nm	12 rpm	23
K 120/12	728 mm	385 W	120 Nm	12 rpm	23

* Ver soportes y adaptaciones en página 75.

Refer to page 75 for bracket information and adapter information / Voir supports et adaptations page 75.

KRE Ø59: motores para persianas y toldos

suitable for rolling shutters and sun awnings / Moteur pour volets et stores banners

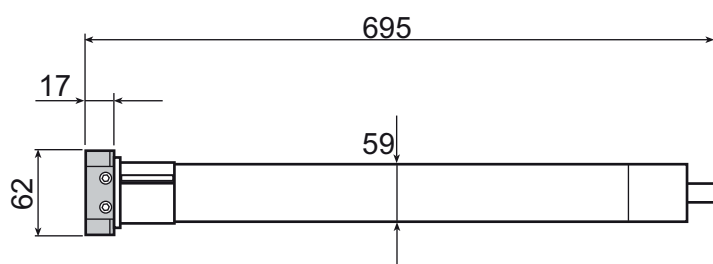
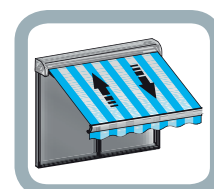
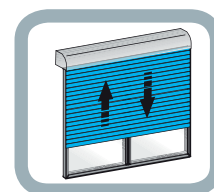

- Final de carrera electrónico y receptor radio integrado.
Electronic end limit switch & built in radio and built in radio receiver.
Fin de course électronique et récepteur radio intégré.
- Fácil ajuste del final de carrera desde el mando a distancia.
Easy end limits adjustment by the transmitter.
Facile régulation à l'aide de la télécommande.
- Elevada potencia para grandes pesos.
The strongest motor, suitable for heavy weighis.
Grande puissance pour poids lourds.



64635	KRE 80/12	294,65 €	1 ud.
64640	KRE 120/12	327,85 €	1 ud.

CARACTERÍSTICAS TÉCNICAS / TECHNICAL FEATURES / CARACTÉRISTIQUES TECHNIQUES

MOTOR MOTOR MOTEUR	LONGITUD LENGTH LONGUEUR	CONSUMO CONSUMTION CONSUMMATION	PAR NOMINAL TORQUE COUPLE MOTEUR	VUeltas POR MINUTO SPEED TOURS PAR MINUTE	VUeltas FINAL DE CARRERA LS ROUNDS TOURS POUR LE FIN DE COURSE
KRE 80/12	695 mm	385 W	80 Nm	12 rpm	térmico warning / thermique
KRE 120/12	695 mm	385 W	120 Nm	12 rpm	térmico warning / thermique

KRET Ø59: motores para persianas y toldos

suitable for rolling shutters and sun awnings / Moteur pour volets roulants et stores banners

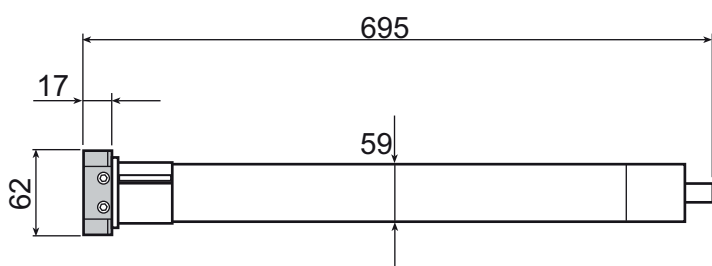
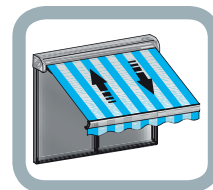
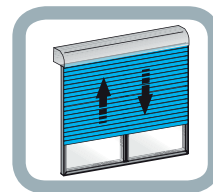

- Final de carrera electrónico y receptor radio integrado.
Electronic end limit switch & built in radio and built in radio receiver.
Fin de course électronique et récepteur radio intégré.
- Fácil ajuste del final de carrera desde el mando a distancia.
Easy end limits adjustment by the transmitter.
Facile regulation à l'aide de la télécommande.
- Elevada potencia para grandes pesos
The strongest motor, suitable for heavy weights.
Grande puissance pour poids lourds.



64675	KRET 80/12	318,72 €	1 ud.
64680	KRET 120/12	352,75 €	1 ud.

CARACTERÍSTICAS TÉCNICAS / TECHNICAL FEATURES / CARACTÉRISTIQUES TECHNIQUES

MOTOR MOTOR MOTEUR	LONGITUD LENGTH LONGUEUR	CONSUMO CONSUMTION CONSUMMATION	PAR NOMINAL TORQUE COUPLE MOTEUR	VUeltas POR MINUTO SPEED TOURS PAR MINUTE	VUeltas FINAL DE CARRERA LS ROUNDS TOURS POUR LE FIN DE COURSE
KRET 80/12	695 mm	385 W	80 Nm	12 rpm	térmico warming / thermique
KRET 120/12	695 mm	385 W	120 Nm	12 rpm	térmico warming / thermique

SOPORTES PARA MOTORES K Ø59 BRACKETS FOR MOTORS Ø59 / SUPPORTS POUR MOTEUR Ø59

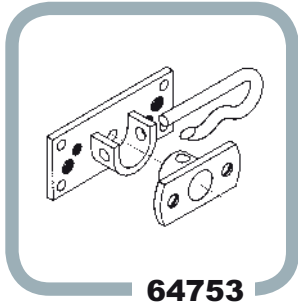

64753



64771



64753	Soporte con espigo redondo Bracket with two position round pin / Support deux positions tenon rounde	15,77 €
64771	Soporte placa 100x100 100x100 bracket plate / Support plaque 100x100	22,78 €

ADAPTACIONES PARA MOTORES K Ø59 ADAPTERS FOR MOTORS K Ø59 / ADAPTIIONS À MOTEUR K Ø59

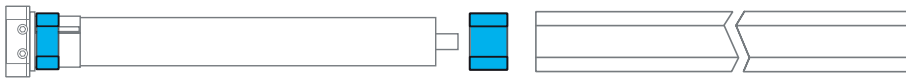

78 con ojiva
78 with ogive
78 avec ogive

64709

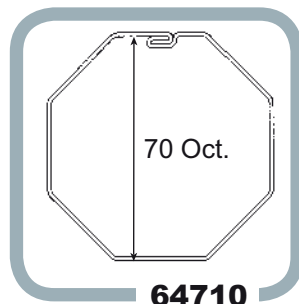

70 Oct.

64710



64709	Rueda y corona para eje de 78 con ojiva para motor Ø59 Adapters for 78 with groove rolling tub for Ø59 motor Roue et couronne pour axe 78 avec ogive pour moteur Ø59	22,41 €
64710	Rueda y corona para eje de 70 oct. para motor Ø59 Adapters for 70 octagonal axis rolling tub for Ø59 Roue et couronne pour axe 70 oct. pour moteur Ø59	15,41 €

KMM Ø59: motores con mando auxiliar de manivela para persianas y toldos

motor with manual override suitable for rolling shutters and awnings

moteur avec commande auxiliaire de manivelle pour volets roulants et stores

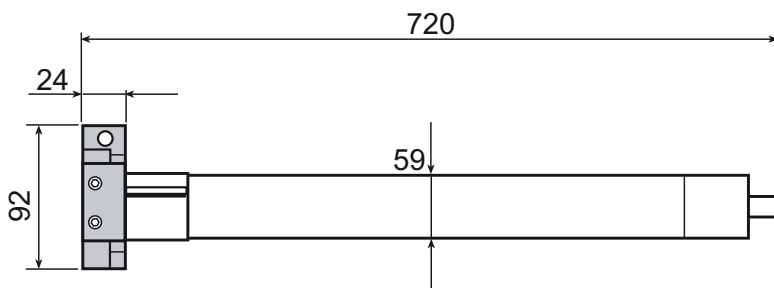
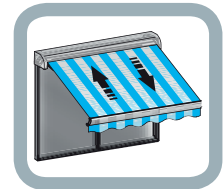
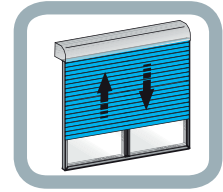

Accionamiento de emergencia mediante manivela y accionamiento mediante inversor.

Wired mechanical end limit switch and work by contact breaker.

Manoeuvre d'urgence avec télécommande.

Final de carrera mecánico y accionamiento manivela.

Emergency manual override with handle crank.

Fin de course mécanique et manœuvre à l'aide d'une manivelle.

Elevada potencia para grandes pesos.

The strongest motor suitable for heavy weights.

Grande puissance pour poids lourds.



64560



KMM 120/12



540,75 €



1 uds.

CARACTERÍSTICAS TÉCNICAS / TECHNICAL FEATURES / CARACTÉRISTIQUES TECHNIQUES

MOTOR MOTOR MOTEUR	LONGITUD LENGTH LONGUEUR	CONSUMO CONSUMPTION CONSUMMATION	PAR NOMINAL TORQUE COUPLE MOTEUR	VUELTAS POR MINUTO SPEED TOURS PAR MINUTE	VUELTAS FINAL DE CARRERA LS ROUNDS FIN DE COURSE
KMM 120/12	720 mm	365 W	120 Nm	12 rpm	27

SOPORTES PARA MOTORES KMM Ø59

BRACKETS FOR KMM MOTORS Ø59 / SUPPORTS POUR MOTEUR KMM Ø59

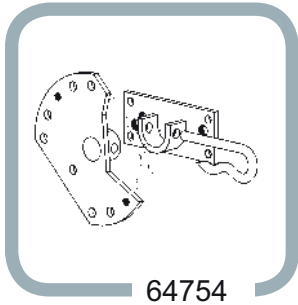

64754

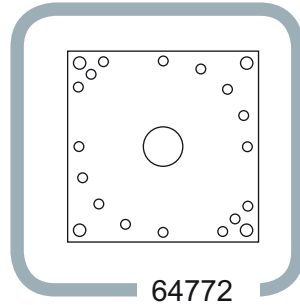

64772



64754	Soporte con espigo redondo para mando manual Revolving bracket with two position round pin / Support deux positions tenon ronde pour commande manuelle	37,14 €
64772	Soporte placa 100x100 para mando manual 100x100 bracket plate / Support plateau 100x100 pour commande manuelle	22,78 €

ACCESORIOS PARA MOTORES KMM Ø59

ACCESSORIES FOR KMM MOTOR Ø59 / ACCESSOIRES POUR KMM Ø59

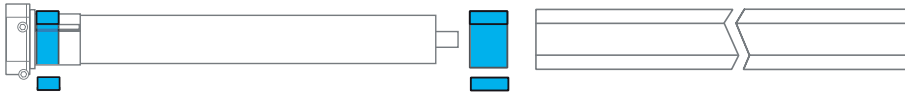

64761

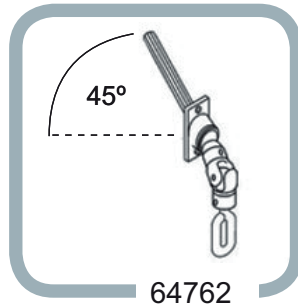

64762

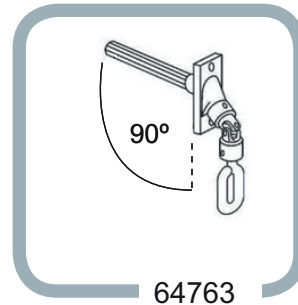

64763



64764 / 64765



64761	Varilla con cáncamo / Square joint with short eye / Tige avec anneau	9,08 €
64762	Snodo 45° con cáncamo / 45° joint with eye / Snodo 45° avec anneau	26,12 €
64763	Snodo 90° con cáncamo / 90° joint with eye / Snodo 90° avec anneau	43,53 €
64764	Manivela 1500 mm blanca / White 1500 mm. handle / Manivelle 1500 mm. blanche	24,70 €
64765	Manivela 1500 mm negra / Black 1500 mm. handle / Manivelle 1500 mm. noire	28,34 €

ADAPTACIONES PARA MOTORES K Ø59

ADAPTERS FOR MOTORS K Ø57 / ADAPTIIONS POUR MOTEUR K Ø59



78 con ojiva
78 with ogive
78 avec ogive

64709

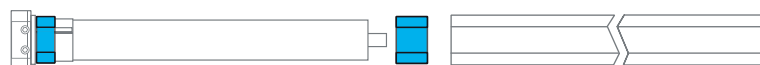

64709	Rueda y corona para eje de 78 con ojiva para motor Ø59 Adapters wheel for 78 with groove rolling tub for Ø59 motor Roue et coronne pour axe 78 avec ogive pour moteur Ø59	22,41 €
-------	---	---------

EMISORES PARA MOTORES KRE / KRET

TRANSMITTERS AND CONTROL UNITS FOR KRE / KRET

ÉMETTEUR RADIO POUR LES MOTEURS KRE / KRET

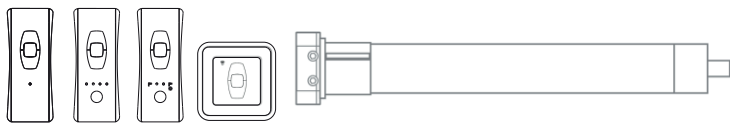

Tecnología Rolling Code

Rolling Code Technology
Technologie Rolling Code

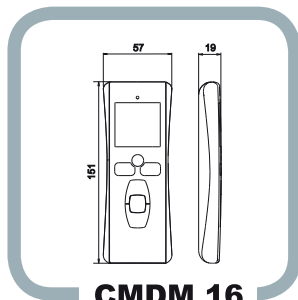
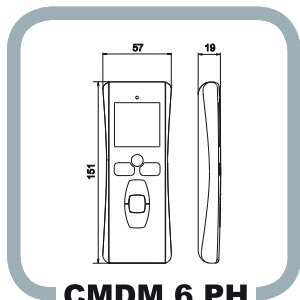
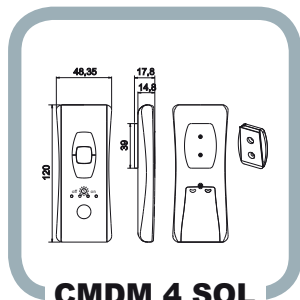
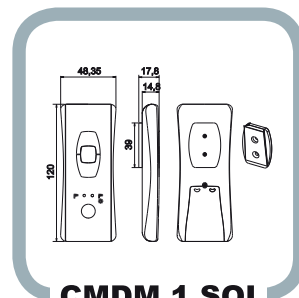
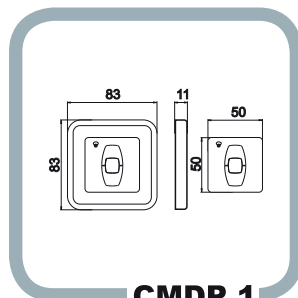
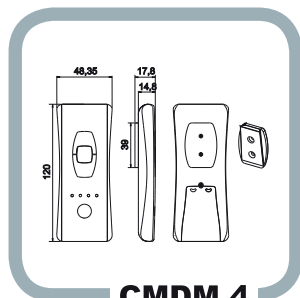
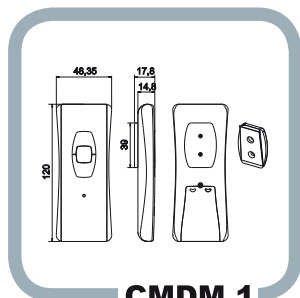
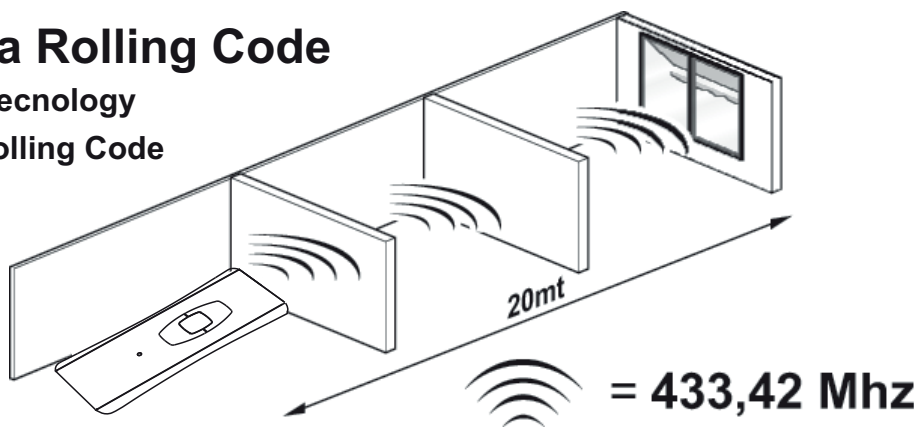

64802	CMDM 1 - Emisor de 1 canal / 1 Channel transmitter / Télécommande 1 canal	37,35 €
64809	CMDM 4 - Emisor de 4 canales / 4 Channel transmitter / Télécommande 4 canaux	70,59 €
64816	CMDP 1 - Emisor de pared/ Wall swich transmitter/ Émetteur mural	66,73 €
64812	CMDM1 SOL - Emisor viento/sol / CMDM1 - Sun & wind sensor transmitter / CMDM1 - Émetteur vent / soleil	65,99 €
64803	CMDM 4 SOL- Emisor viento/sol blanco / CMDM4 - Sun & wind sensor transmitter white / CMDM4 - Émetteur vent/soleil blanc	82,50 €
64804	CMDM 4 SOL- Emisor viento/sol negro / CMDM4 - Sun & wind sensor transmitter black / CMDM4 - Émetteur vent/soleil noir	82,50 €
64814	CMDM 6 PH - Programador horario 6 canales / 6 chanel with clock / Programmeur horaire 6 canaux	328,33 €
64819	CMDM 16 - Emisor de 16 canales / 16 Channel transmitter / Télécommande 16 canaux	296,73 €

CENTRALES DE MANDO

CONTROL UNITS / CENTRALE DE CONTRÔLE

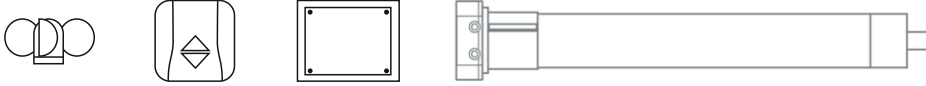

Automatismos para motores radio

Automation for radio motors / Automatismes pour moteur rádio

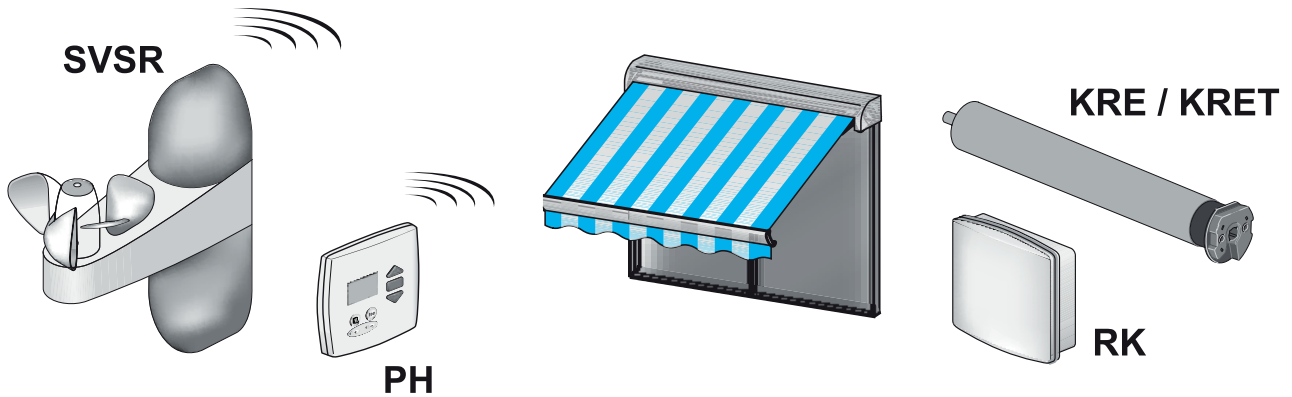

64820	SVSR - Sensor viento y sol vía radio / Radio sensor for sun and wind / Capteur radio vent et soleil	150,50 €
64830	RK - Receptor radio / External radio receiver / Récepteur radio	118,28 €
64831	RK para persiana - Receptor radio External radio receiver for roller shutters / Récepteur radio pour volets roulant	103,00 €
64821	SMR - Sensor de movimiento K radio / Radio sensor for wind / Capteur radio du mouvement	161,85 €
64822	SSR - Sensor de Sol y Temperatura radio para interior Sun and temperature inside radio sensor / Capteur radio soleil et température pour intérieur	161,85 €

ACCESORIOS / ACCESSORIES / ACCESSOIRES

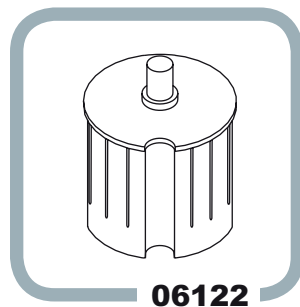
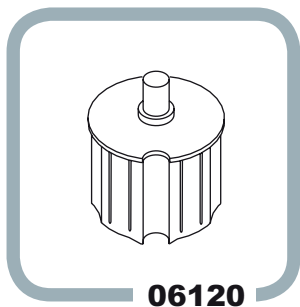
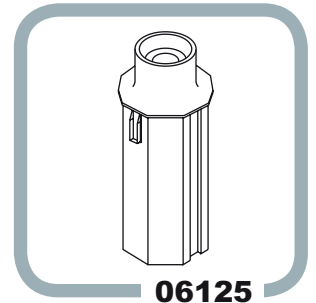
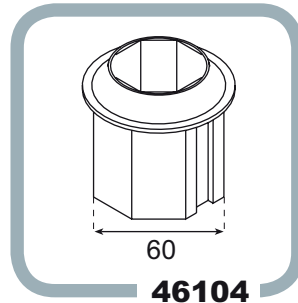
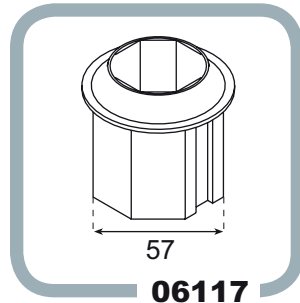
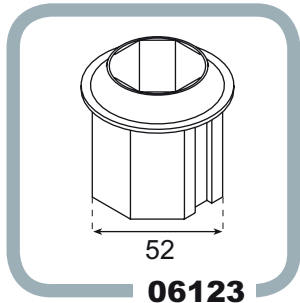

06123	Adaptación a eje de 52 oct. para contera de 42 Coupling for 52 oct. axle with caps of 42 axle / Adaptation de axe 52 oct. pour embout 42	0,63 €
06117	Adaptación a eje de 60 oct. para contera de 42 Coupling for 60 oct. axle with caps of 42 axle / Adaptation de axe 60 oct. pour embout 42	1,33 €
46104	Adaptación a eje de 60 IMBAC para contera de 42 Coupling for 60 IMBAC axle with caps of 42 axle / Adaptation de axe 60 IMBAC pour embout 42	1,87 €
06125	Contera poliamida larga de 60 para rodamiento Large polyamide cap with lodging for ball bearing / Embout long 60 de polyamide pour roulement	0,64 €
06120	Contera metálica para eje de 70 c/ojiva espiga de 12 Round cap of 70 with round pivot 12/ Embout de metal pour axe 70 avec ogive tenon 12	3,98 €
06122	Contera metálica para eje de 78 c/ojiva espiga de 12 Round cap of 78 with round pivot 12 / Embout de metal pour axe 78 avec ogive tenon 12	4,52 €
64910	Varilla reglaje Adjusting rod / Tige réglage	0,80 €

PROGRAMACIÓN KRE Y KRET Ø45

KRE AND KRET Ø45 PROGRAMMING / PROGRAMMATION DE KRE ET KRET Ø45

¡ATENCIÓN! La programación del motor consta de dos fases: la primera donde se le especifica al motor el sentido de giro, y una segunda donde se regulan los finales de carrera. Siempre se deberá seguir este orden.

¡WARNING! Programming consist of two diferent parts: The first one where the motor learn how to turn (what is up and down) and the second one where the motor learn where are his limit switch. Should always be in that order.

¡ATTENTION! La programmation du moteur se compose de deux phases : la première où le sens de tour est spécifié au moteur, et la deuxième où les fins de course sont réglées. Il faudra toujours suivre cet ordre.

¡ATENCIÓN! Durante la fase de programación, el motor funcionará en modo "Hombre Presente", es decir, habrá que mantener pulsado el botón de accionamiento para que el motor continúe girando.

En el funcionamiento normal "Use Mode", el motor tendrá un funcionamiento "por impulsos", es decir, una vez activado un movimiento, el motor se parará sólo cuando se active el pulsador Stop o cuando se alcance el fin de carrera programado.

¡WARNING! The motor will run in "Man Present" mode during the programming phase. During a normal operation (Use Mode), the motor will have "impulse" operation, so once a movement is started, the motor stops only by pressing the STOP button or when the set limit switch point is reached.

¡ATTENTION! Pendant la phase de programmation le moteur marchera en mode « homme présent », c'est-à-dire, il faudra appuyer en continu sur le bouton de déclenchement pour que le moteur continue à tourner. Dans le fonctionnement normal « use mode », le moteur aura un fonctionnement par impulsions, c'est-à-dire, une fois le mouvement activé, le moteur s'arrêtera seulement en activant la touche de Stop ou quand on obtient la fin de course programmée.

- **¡ATENCIÓN!** Para el procedimiento de **REGULACIÓN DE LOS FINALES DE CARRERA** siempre se debe respetar el orden indicado, por lo que, el primer final de carrera memorizado debe ser **SIEMPRE** el inferior .

Si se produce algún error durante la programación, sólo hay que cortar la alimentación del motor antes de que termine el procedimiento, para que el motor vuelva a tener la configuración de fábrica. Luego, volver a comenzar la programación.

¡WARNING! The programming procedure must **ABSOLUTELY** follow the indicated order. The first limit switch stored must be the bottom one (Closed).

If a mistake happen during the programming phasse, cutting out the power of the motor before the procedure is completed, will restore the motor back to the factory configuration. Then you can start again the progamming.

ATTENTION! Pour la procédure de **RÉGULATION DES FINS DE COURSE** il faut toujours respecter l'ordre indiqué, pair que, la première fin de course mémorisé doit **TOUJOURS** être l'inférieure. Si un erreur se produit pendant la programmation, il faut seulement couper l'alimentation du moteur avant que le processus finis, pour que le moteur obtienne à nouveau la configuration d'usine. Tout de suite, recommencez la programmation.

REGULACIÓN DEL SENTIDO DE GIRO

DIRECTION OF ROTATION ADJUSTMENT

Réglage du sens de rotation

REGULACIÓN DE LOS FINALES DE CARRERA

A. Primer final de carrera.

B. Segundo final de carrera. (NO NECESARIO EN MOTOR KRET)

LIMIT SWITCH ADJUSTMENT

A. First limit switch

B. Second limit switch. (NO NECESARY IN MOTOR KRET)

RÉGLAGE DE FINS DE COURSES

A. Premier fins de courses

B. Deuxième fin de cours. (IL N'EST PAS NÉCESSAIRE AVEC MOTEUR KRET)

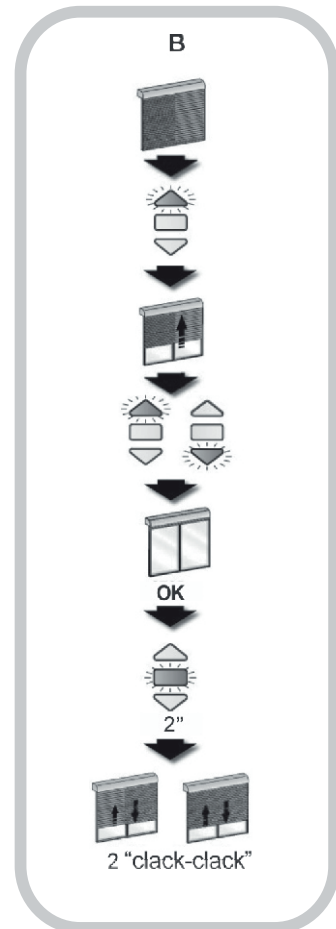
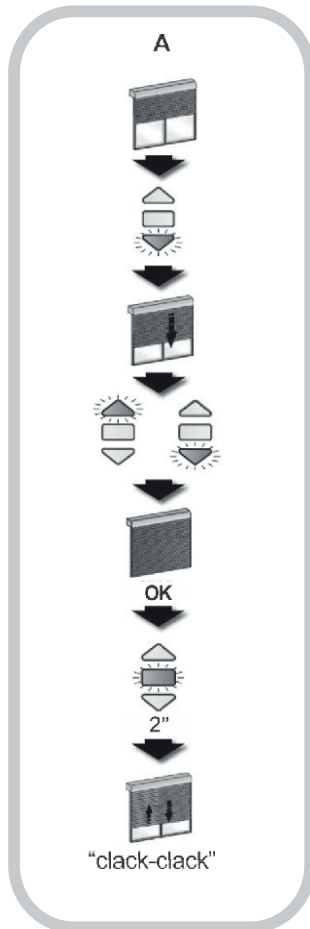
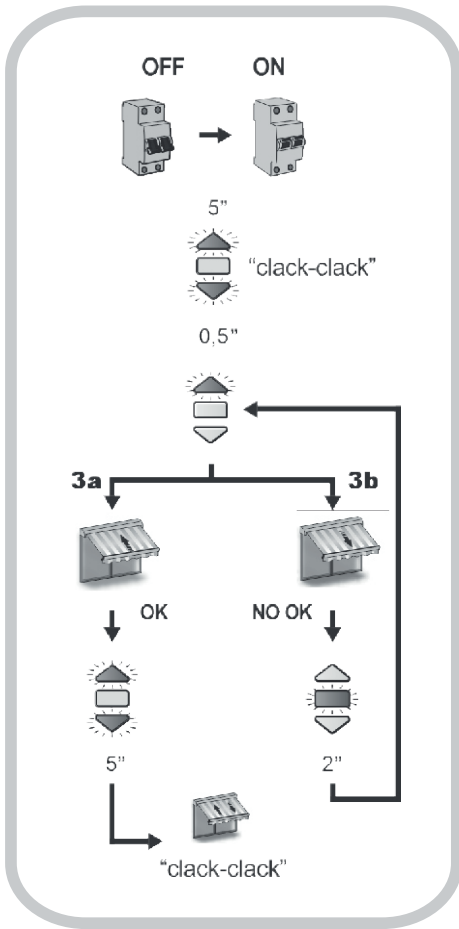

PROGRAMACIÓN ADICIONALES KRE Y KRET

KRE AND KRET EXTRA PROGRAMMING / PROGRAMMATIONS ADDITIONNELS KRE ET KRET

AÑADIR O BORRAR UN TRANSMISOR

A. Nº 1 / Mantener pulsado el botón PROG de un mando ya programado, el motor hará un movimiento de confirmación.

B. Nº 2 / Pulsar el botón PROG del mando que queremos añadir/borrar (Indicador luminoso parpadea), el motor hará un movimiento de confirmación.

¡ATENCIÓN! Antes de hacer un copiado o borrado de un mando es necesario que el motor esté completamente programado con otro mando.

ADD OR REMOVE A TRANSMITTER

A. Nº 1 / Press on the PROG / Feedback key: LED "ON" short movement of awning/roller shutter.

B. Nº 2 / Press on the PROG / Feedback key: LED blinks, short movement of awning/roller shutter.

WARNING: the motor must have been previously programmed by another single transmitter or a single channel of the same transmitter.

AJOUTER OU EFFACER UN ÉMETTEUR

A. Nº 1 / Maintenir appuyé le bouton PROG d'une commande déjà programmée le moteur fera un mouvement de confirmation.

B. Nº 2 / Appuyer sur le bouton PROG de la télécommande que l'on veut programmer (signale lumineuse qui clignote), le moteur fera un mouvement de confirmation.

ATTENTION, avant de faire une copie ou d'effacer la télécommande vérifiez que le moteur soit complètement programmé avec une autre télécommande.

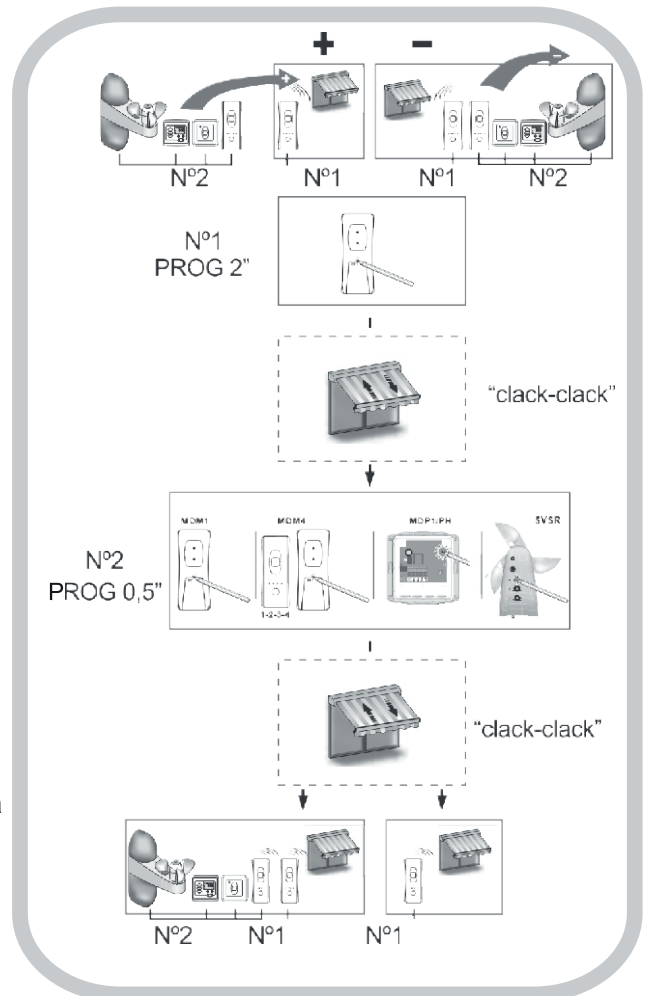

BORRADO TOTAL DE LA MEMORIA DEL MOTOR

ERASING THE MOTOR'S MEMORY (RESET)

EFFACEMENT TOTAL DE LA MEMOIRE DU MOTEUR

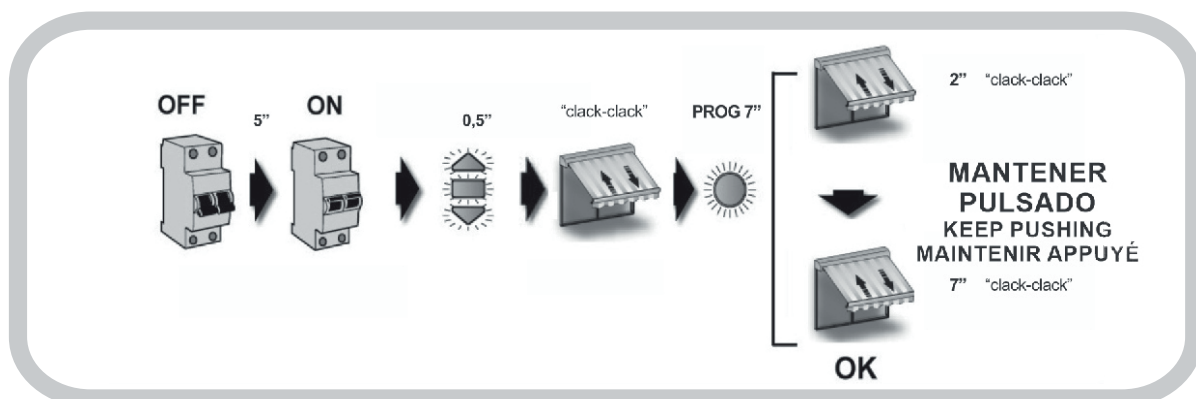

SUSTITUCIÓN DE UN TRANSMISOR PERDIDO REPLACING A LOST TRANSMITTER / SUBSTITUTION D'UN ÉMETTEUR PERDU

¡ATENCIÓN! Si se efectúan estos pasos el resto de los transmisores se borrarán de la memoria del motor. Sin embargo, los puntos de final de carrera programados se conservan.

¡WARNING! Performing this procedure erases all other transmitters from the motor's memory. The set limit switch points will however be saved.

¡ATTENTION! Si on fait ces étapes pour le reste des émetteurs on effacera LA MÉMOIRE DU MOTEUR. Ce pendant les points de fin de course resteront programmés.

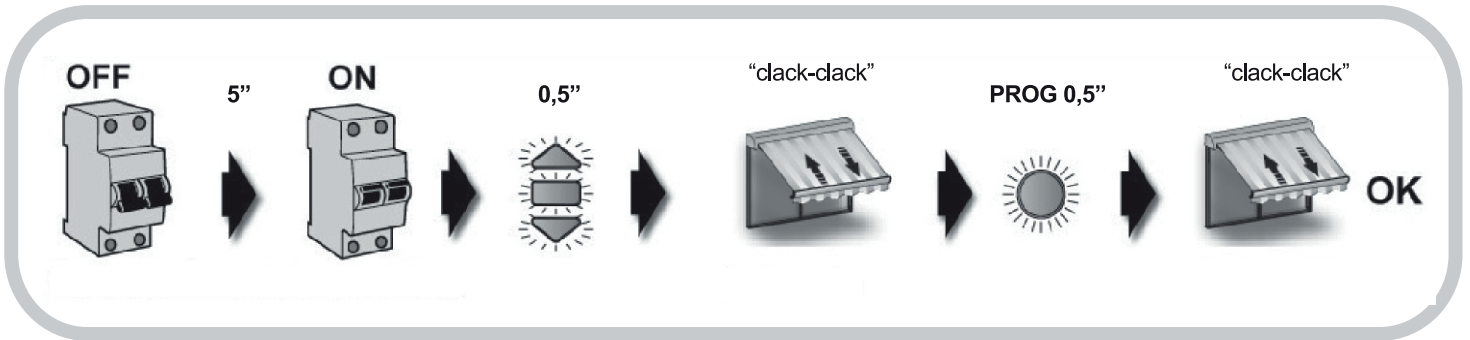

MODIFICACIÓN DE UN FINAL DE CARRERA REPLACING THE END LIMIT ADJUSTMENT MODIFICATION D'UN FIN DE COURSE

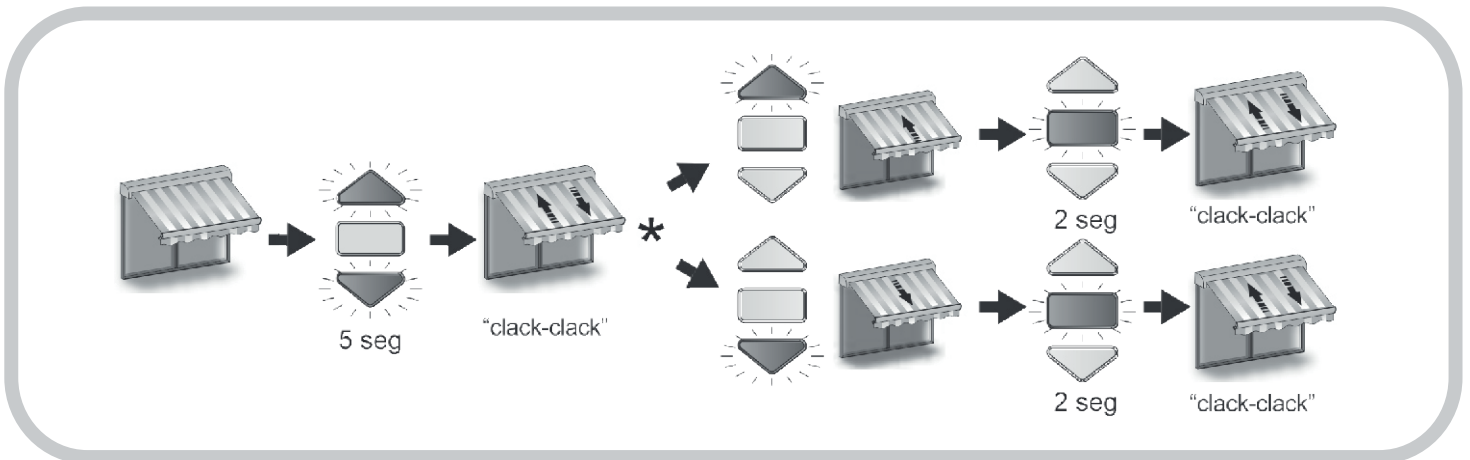

PROGRAMACIÓN KC KC PROGRAMMING / PROGRAMMATION DE KC

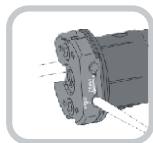

- 1. Colocar la varilla magnética en el regulador PROG.**
Position the magnetic key inside the seat PROG.
Placer la tige magnétique dans le régulateur PROG.

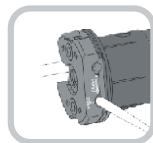

- 6. Colocar la varilla magnética en el regulador PROG.**
Position the magnetic key inside the seat PROG.
Placer la tige magnétique dans le régulateur PROG.

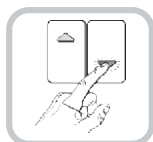

- 2. Pulsar Bajada hasta aproximar al final de carrera inferior**
Go to the desired bottom limit switch point by pressing the down button.
Appuyer descendre jusqu'à approcher la fin de course inférieure.



- 7. Pulsar Subida hasta aproximar al final de carrera superior.**
Go to the desired top limit switch point by pressing the high up button.
Appuyez "monter" jusqu'à l'approche de la fin de course supérieure.

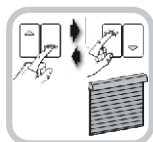

- 3. Ajustar la posición deseada de bajada.**
Use down and up buttons for a fine adjustment.
Ajuster la position désirée de descendre.

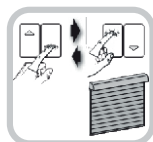

- 8. Ajustar la posición deseada de subida.**
Use up and down buttons for a fine adjustment.
Ajuster la position désirée de montée.

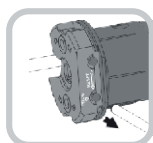

- 4. Retirar la varilla magnética.**
Remove the magnetic key
Retirer la tige magnétique.

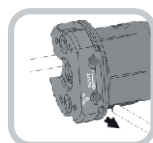

- 9. Retirar la varilla magnética.**
Remove the magnetic key
Retirer la tige magnétique.



- 5. Confirmar el punto de final de carrera inferior presionando el pulsador de bajada (2 seg)**
Confirm the bottom limit switch point by pressing the down button (2 sec)
Confirmer le point de fin de course inférieure en appuyant le bouton de descendre (2 seg)



- 10. Confirmar el punto de final de carrera inferior presionando el pulsador de subida (2 seg)**
Confirm the bottom limit switch point by pressing the up button (2 sec)
Confirmer le point de fin de course supérieure en appuyant le bouton de monter (2 seg)



BORRADO DE MEMORIA MOTOR KC.

ERASING THE MOTOR'S MEMORY KC.

EFFACEMENT DE MÉMOIRE MOTEUR KC.

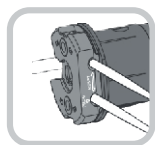

1. Introducir los dos extremos de la varilla magnética en los dos reguladores RESET.

Insert the two ends of the magnetic key into the two seats RESET.

Introduire les deux extrémités de la tige magnétique dans les deux régulateurs RESET.



2. Pulsar BAJADA ó SUBIDA durante dos segundos.

Hold down one of the two keys up or down for about two seconds.

Jouer "Baisse" ou "Montée" pendant deux seconds.



OFICINAS CENTRALES

Parque Tecnológico de Galicia
C/ Vigo Nº 2
32901 - SAN CIBRAO DAS VIÑAS
OURENSE

Telf: 988 38 38 24
aceper@aceper.es

FÁBRICA

Rioseco
32111 - SAN CIPRIÁN DE VIÑAS
OURENSE

DELEGACIÓN SEVILLA

C/La Red Doce, 9
Pol. Ind. La Red
41500 - ALCALÁ DE GUADAIRA
SEVILLA

Telf: 95 563 06 08
sevilla@aceper.es

DELEGACIÓN BARCELONA

C/ Gorcs Llado, 104 - 110 Nave 2
Pol. Ind. Can Salvatella
08210 - BARBERA DEL VALLES
BARCELONA

Telf: 93 719 75 64
barcelona@aceper.es

DELEGACIÓN VALENCIA

C/Central, 21
Pol. Ind. El Oliveral - Fase 3
46190 - RIBARROJA DEL TURIA
VALENCIA

Telf: 96 166 68 58
valencia@aceper.es

DELEGACIÓN MADRID

C/ Puerto Navacerrada, 99
Pol. Ind. Las Nieves
28935 - MÓSTOLES
MADRID

Telf: 91 665 70 77
madrid@aceper.es

www.aceper.es

ACEPER