

# Personal Computer

FULL  
OSBORNE 1  
BENCHTEST

Canada \$2.75/US \$2.00/FF 8.80/FL 4.00/SFr 7.20/IR £1.07/  
BFr 87/SKr 13.55/DKr 21.00/Lire 3000/DM 5.50

World November 1981 75p

BRITAIN'S LARGEST SELLING MICRO MAGAZINE



**THE JOLLY GIANT DELIVERS THE GOODS**  
World exclusive Benchtest of IBM's Personal Computer

## Cromemco System Three



If you've already recognised the superiority of Cromemco products, or even if you're still evaluating alternative systems, it's worthwhile visiting MicroCentre.

Here's our promise. Ask to see anything in the Cromemco catalogue, and we'll demonstrate it for you. Nobody else in the UK carries a wider range of Cromemco demonstration systems and stock. We'll show you all the Cromemco computers, of course. From System Zero to System Three; the Z-2H Hard Disk system; high performance colour graphics; and the adaptable SCC single card computer.

Then we'll show you quality Cromemco peripherals; a choice of operating

systems—single user and multi-user; and a wide range of software, including compilers, data base management, word processing, and Cromemco's integrated business packages.

At MicroCentre we pride ourselves in taking care of all the important details that make up a complete service . . . like stocking the complete library of Cromemco documentation; arranging leasing and maintenance agreements; supplying continuous stationery, ribbons, floppy disks, print thimbles, etc.

So if you're interested in Cromemco systems don't miss out a visit to MicroCentre. We're Cromemco's top dealers in Europe—and proud of it!

# For Cromemco...call the experts

**MicroCentre**  
Tel: 031-556 7354

**LEADING UK  
DISTRIBUTORS**

**Complete Micro Systems Ltd.,**  
30 Dundas Street  
Edinburgh EH3 6JN



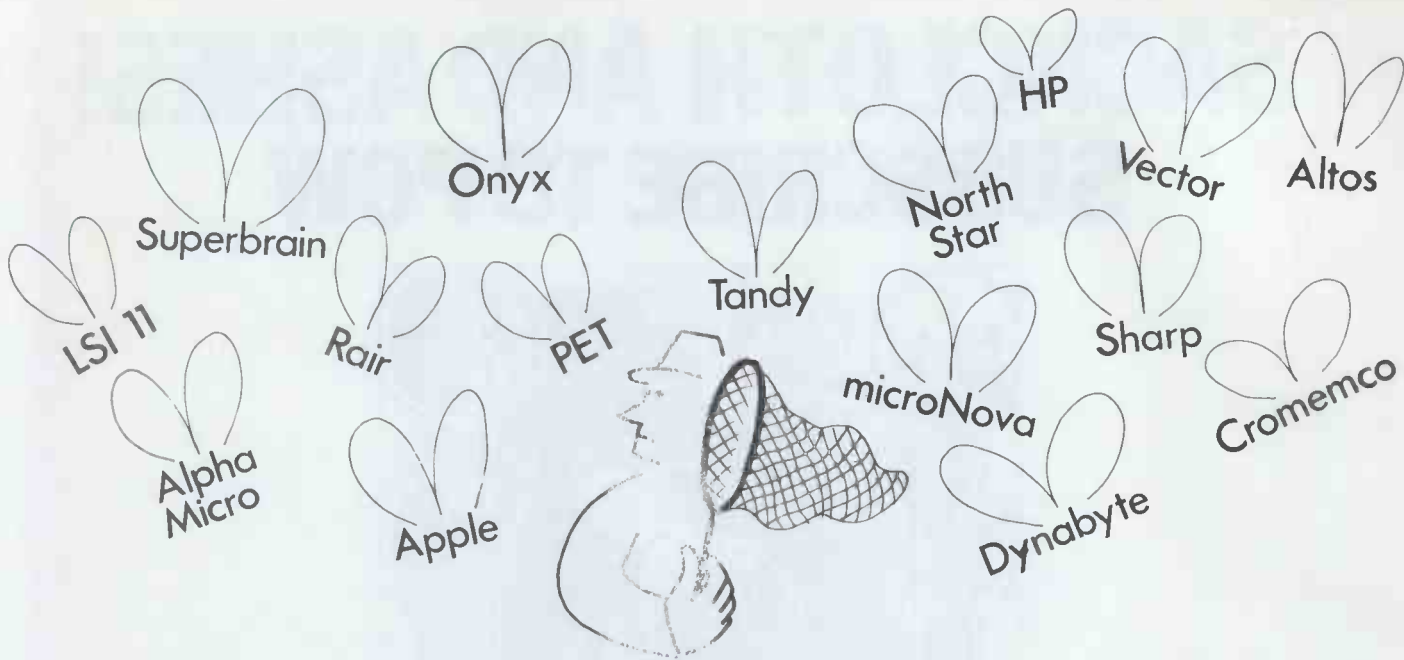

# If only choosing a microcomputer was as simple as using one

Just look at the advertisements in this magazine. When can you find time to digest them all?

There are millions of chips, thousands of boards and hundreds of peripherals, software systems and application packages. How do you pick the right ones to meet your requirements?

And put them together? And make them work? And add the specials you want?

## Professional Services

At Digitus we have computer professionals working full-time putting systems together. Absorbing information. Testing equipment and software. Writing programs. Training users.

At one stop you can commission a complete system to fit your requirements.

## Working Systems

In the last two years we have supplied systems for: number processing, word processing, data processing, information management, graphics and many creative applications. Advised accountants, surveyors, archaeologists and engineers. Helped DP departments and small business men. Developed software for personnel, insurance, incomplete records, order processing, business games, linear programming, process control and terminal emulation. And were retained by other computer companies to advise on micros.

## Proven Experience

This year we can put over 200 man years computer experience to work so that you can benefit from micro technology ... in comfort.

Come and see us. Spend a few hours discussing your requirements. Attend a training course. Select a machine. Test some software packages.

Solve the micro puzzle. Buy an operational system that fits your needs.

Call for an appointment or return the slip and we will call you.

**Digitus Ltd 10-14 Bedford Street  
Covent Garden London WC2  
Tel 01- 379 6968**

# Digitus

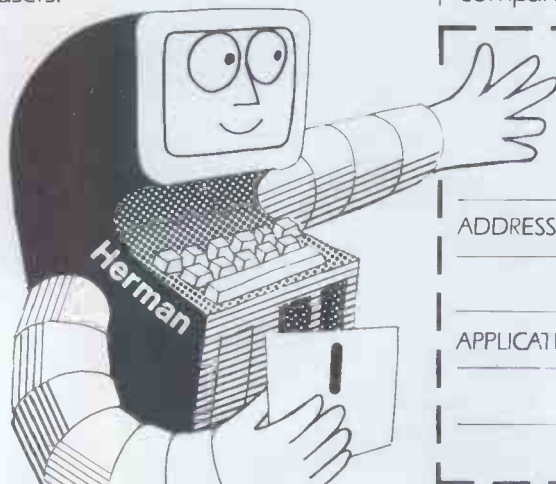

NAME \_\_\_\_\_

POSITION \_\_\_\_\_

COMPANY \_\_\_\_\_

ADDRESS \_\_\_\_\_

TELEPHONE \_\_\_\_\_

APPLICATION \_\_\_\_\_

# INSIDE

# PCW

Volume 4 No 11 November 1981



Illustration by Richard Dunn

**54 NEWSPRINT:** Guy Kewney reports the latest micro-happenings.

**69 BANKS' STATEMENT:** Martin Banks looks at the likely effects of the big companies moving into micros.

**70 COMMUNICATIONS:** Your chance to have your say.

**75 CTUK! NEWS:** Latest happenings around the 'Towns.

**77 COMAL-80:** Could this be the replacement for Basic?

**81 CONTROL YOUR OWN SUBSTATION:** D E Graham concludes his article on interfacing the ZX80/81.

**93 PATTERNS:** Alan Sutcliffe ponders randomness.

**100 2nd EURO MICRO CHESS CHAMPIONSHIP:** A full report on the winning games.

**105 BENCHTEST:** David Tebbutt brings the first ever full test of the Osborne O1.

**114 CHECKOUT:** Sharp's new pocket translator, the IQ3100.

**116 BENCHTEST:** A world exclusive — a full test of IBM's Personal Computer.

**123 EURO MICRO-MOUSE '81:** Robin Bradbeer reports on the recent finals in Paris.



**127 COMPUTER ANSWERS:** Your queries answered by Sheridan Williams and friends.

**131 BOOKFARE:** Malcolm Peltu reviews the latest printed words.

**139 INTERRUPT:** Jeff Taylor continues his look at computer literacy projects in the US.

**145 CALCULATOR CORNER:** Dick Pountain reviews the Casio fx702p.

**147 BENCHMARK SUMMARY:** A roundup of our Benchmark tests and a listing of the programs we use.

**148 TJ'S WORKSHOP:** More hints and tips for popular micros.

**153 YOUNG COMPUTER WORLD:** Especially for our younger readers.

**155 NEWCOMERS START HERE:** Our quick intro for those new to the micro world.

**156 PCW SHOW:** A report on Britain's most successful micro show.

**159 DIRECT ACCESS:** With Packages, full User

Groups, Transaction File, Network News and Diary Data.

**172 PCW SUB SET:** More useful assembler language subroutines.

**178 LEISURE LINES:** J J Clessa poses another problem for your micro.

**178 PROGRAMS:** Our readers' latest listings.

**183 BLUDNERS:** Red-face time!

**184 BACK ISSUES:** Catch up with what you've missed.

**239 CHIP CHAT:** All the gossip from the Show!

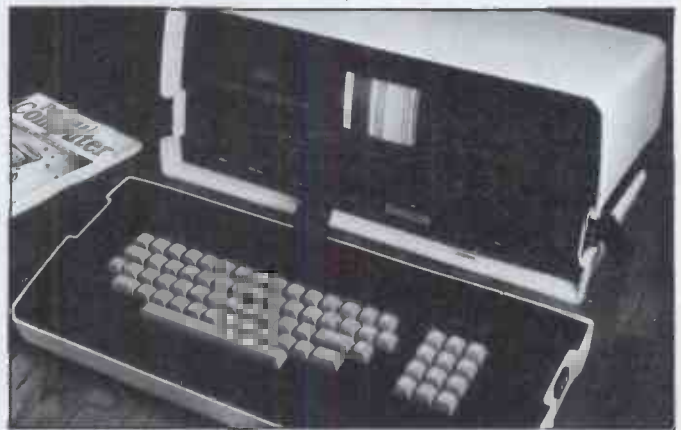

Founder  
Angelo Zgorelec  
Managing Editor  
Dick Pountain

Editor  
Peter Rodwell  
Editorial Assistant  
Maggie Burton

Consultant Editor  
David Tebbutt

Sub Editor  
Jon Wall

Art Director  
Paul Carpenter

Art Editor  
Phoebe Creswell-  
Evans

Typesetter  
Jane Hammell  
Advertisement  
Director  
Stephen England

Advertisement  
Manager  
Patrick Dolan

Assistant  
Advertisement  
Manager  
Claire Fullerton

Advertisement  
Executive  
(Micromart)  
Marianne  
McNicholas

Publicity/  
Press Relations  
Penny Flood  
(01-995 1548)

Production  
Manager  
Stephen Rowe

Advertisement  
Production  
Vic Lime  
Anna Williamson

Subscriptions  
Manager  
Alexandra James

Subscription rates  
UK: £10.00  
Overseas: £17.00

Address  
14 Rathbone  
Place, London  
W1P 1DE

01-631 1433  
(10am - 6pm)

Published by  
Sportscene  
Publishers (PCW)  
Ltd, 14 Rathbone  
Place, London  
W1P 1DE, England.  
Tel: 01-631 1433  
Telex: 8954139  
BUNCH G London

Copyright notice  
Personal Computer  
World is published  
by Sportscene  
Publishers (PCW)  
Ltd. 1981 Felden  
Productions. No

material may be  
reproduced in  
whole or part  
without written  
consent from the  
copyright holders.

Printed by  
Riverside Press,  
Whitstable  
Distributed by  
Seymour Press  
334 Brixton Road  
London SW9  
Tel: 01-733 4444

ABC



On the edge of the atmosphere, space shuttle Columbia was about to lose all contact with Earth: for 21 agonising minutes, touch-down would be touch-and-go. As the world held its breath, the £4½ billion project relied on a £165 hand-held calculator, small enough to live in the pocket of Robert Crippen's flight suit. The Hewlett-Packard HP-41C. Unmodified. Just as you buy it today...

# Astronaut quality. Everyday simplicity. The HP-41C. £165<sup>inc</sup> VAT\*

Sooner or later, a basic calculator is too basic.

Suddenly you need to 'compute' – but with a 'computer' that's as simple and pocketable as a hand-held calculator. And, as NASA found, that means an HP-41C.

Today, a broad-ranging companion to an A-level course. Tomorrow, a fully-fledged, advanced programmable system for the businessman, analyst, researcher, technician, engineer or scientist.

Whatever your job, here's a calculator that will grow with you and your needs step-by-step into a complete calculating system – yet will always stay simple, manageable and portable.

## The friendly calculator with power in reserve.

As a straightforward calculator, the HP-41C is a masterpiece of compact power.

It gives you read-out in letters, as well as figures and symbols, so the display can talk to you in an easy, simple way

Yet, inside, it has the effortless, problem-solving power normally associated with computers.

Among other things, that means the HP-41C is fully programmable. You can feed its built-in 400-line memory with ready-made programs or develop your own. Its friendly style makes it surprisingly easy. And, because the memory is continuous, what you put into it stays in – even when you switch off.

But that's not the end of the story by any means. Because, unlike any other advanced programmable calculator you are likely to see, the HP-41C has behind it a highly developed package of software support representing many years of heavy investment by Hewlett-Packard. So when you buy the HP-41C you don't just own a powerful system; you can put it powerfully to work.



The HP-41C hand-held 'computer' in a box. £165 brings you the calculator, a comprehensive 270-page manual, owner's handbook, and programming guide, a standard applications handbook, customising overlays, HP Users' Library membership reply card, free one year's subscription to HP's User's Newsletter, batteries, carrying pouch and 12 months' full guarantee.



## Proven software support – at your fingertips.

Here, the HP-41C really comes into its own with an unrivalled range of software support.

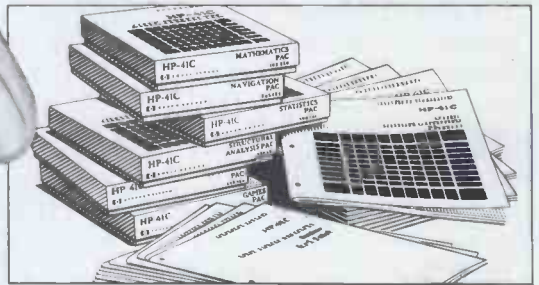

**17 Application Modules** – miniature plug-in solutions: maths, electrical engineering, financial decisions, games...

**29 Solutions Books** – each with up to 15 programs drawn from the best of 10,000 user-submitted programs. Each book provided with Bar Codes – for instant program entry with the HP wand.

**11 Application Pacs** – pre-recorded magnetic cards covering over 2,000 programs, entered through the card reader.

All software and peripherals are optional extras.

\*Price correct at time of going to press.

## Two ways to make your system grow...



**Snap-in more memory.** A single module will double the memory available. A quad module adds no fewer than 256 registers at once. Suddenly you've got over 1800 lines of memory at your command.

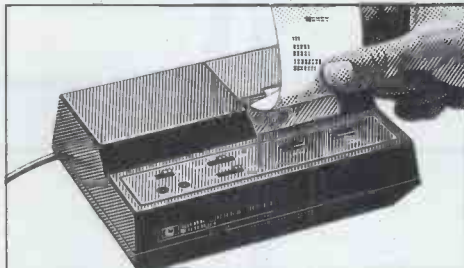

**Plug-in a printer.** The HP-41C printer handles upper and lower case, in alpha, numeric and graph-plotting modes. Use it for final hard copy, or to follow program execution.

## Four ways to program your HP-41C...

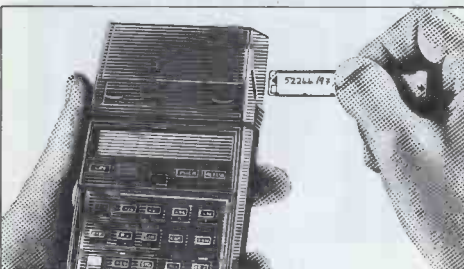

**Card reader.** This reads pre-programmed magnetic cards. It can also record and read your own programs and data.

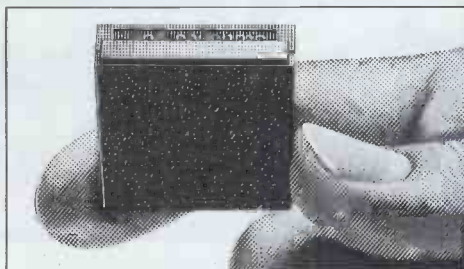

**Application modules.** These are plug-in modules each containing a whole range of ready-made programs on your chosen subject.



**Bar code reader.** A quick and easy way of loading any one of the software packages. The wand simply 'lifts' the coded program straight off the page of your HP-41C solution books.

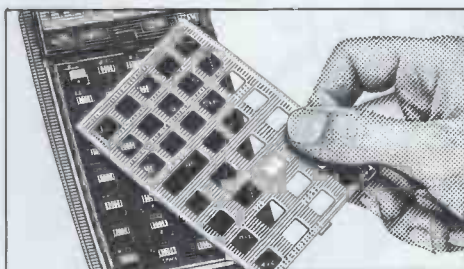

**Keyboard customising.** Develop your own programs and enter them through the keyboard. You can assign any function or program to any key and mark them on your own customising overlay.

## Thousands of easy ways to solve problems.

Think of a problem! As an HP-41C owner you won't have far to look for the solution - or long to wait before it's locked in your system's memory. Any of HP's hundreds of pre-programmed solutions can be easily entered in any of the four ways we illustrate above. You'll certainly want to devise your own solutions, too. The guidance manual in your basic pack tells you how. If you develop an original one you could submit it to the HP-41C Users' Library. It already contains thousands of tested programs which 10,000 users worldwide are happy for you to share.

## Quality from HP - the big computer manufacturer.

The HP-41C is made from the chip upwards by Hewlett-Packard, a world leader in computers. And you can tell! By the detail like the permanent inlaid key notations, tough ABS case, and gold-plated port contacts. By the elegant simplicity designed into the HP-41C's operating style. By the sort of software support only a computer giant would be capable of. By the utter reliability that is the HP hallmark throughout the world of computers.



## See the HP-41C at Comet, Xerox Stores, Wilding, Sumlock-Bondain, Landau or these other Appointed Dealers:

Aberdeen Tyseal Office Equipment.  
 Bath Wilding Office Equipment.  
 Belfast Cardiac Services Company.  
 Birmingham John Mabon Associates; Research Micro System.  
 Bolton Wilding Office Equipment.  
 Bournemouth South Coast Business Machines.  
 Brighton Office Machinery Engineering Co.  
 Bristol Decimal Business Machines; Wilding Office Equipment.  
 Bromley Wilding Office Equipment.  
 Cambridge W. Heffer & Sons; Wilding Office Equipment.  
 Canterbury R. E. Typewriters.  
 Cardiff Sigma Systems (Calculators).  
 Carlisle Thos. Hill International.  
 Colchester Wilding Office Equipment.  
 Croydon Wilding Office Equipment. Derby Office Machines.  
 Dundee Tayside Office Equipment.  
 Edinburgh Business & Electronic Machines; Holdene; Robox.  
 Folkestone R. E. Harding. Glasgow Robox.  
 Gloucester Wilding Office Equipment.  
 Gravesend Wilding Office Equipment.  
 Grimsby Teesdale Office Equipment.  
 High Wycombe Wilding Office Equipment.  
 Hornchurch Wilding Office Equipment.  
 Ilford Wilding Office Equipment.  
 Ipswich Anglia Business Machines; Wilding Office Equipment.  
 Kingston-upon-Thames Wilding Office Equipment.  
 Leeds Holdene; Wilding Office Equipment.  
 Leicester A. C. Barratt & Co.; Sumlock Services.  
 Lichfield Anglo American Computing.  
 Liverpool Rockliff Brothers.  
 London AEC - 2 Shoreditch High Street; City Business Machines - 57 Houndsditch, Bethnal Green Road; Concept Business Systems; Dixons Photographic - 123 Holborn, 64 New Bond Street; Euro-Calc - 128-132 Curtain Road, 224 Tottenham Court Road, 55 High Holborn; Landau Calculators - Bourne's Oxford Street, 227 Tottenham Court Road; McDonald Stores - 78 Oxford Street; Metyclean - 137 The Strand, 92 Victoria Street; Mountandene - 22 Cowper Street; Sumlock-Bondain - 263-269 City Road, 360 Euston Road, Cannon Street Station; Wallace-Heaton - 127 New Bond Street; Wilding Office Equipment - 7 The Arcade Hoe Street, 21 Thomas Street, 120 The Broadway, Wimbledon; 199 Parrock Street, Gravesend. The Xerox Store Piccadilly - 76 High Holborn, 110 Moorgate.  
 Luton Wilding Office Equipment.  
 Maidstone Wilding Office Equipment.  
 Manchester Automated Business Equipment; Holdene; Wilding Office Equipment. Matlock Derby Office Machines.  
 Middlesbrough Thos. Hill International.  
 Newcastle Thos. Hill International.  
 Northampton A. C. Barratt & Co.  
 Norwich Leamons Office Machines; Sumlock-Bondain.  
 Nottingham Bennett's (Typewriter & Office Suppliers); Trent Office Equipment. Oxford Reid's Office Equipment; Science Studio. Plymouth JAD Integrated Services.  
 Reading Central Southern Equipment; Reid's Office Equipment; Caversham, 38 Market Place, Reading.  
 Romford Wilding Office Equipment. Royston Herts Electroplan.  
 Sheffield Butlers Office Equipment.  
 Slough Wilding Office Equipment.  
 Southampton Leicester Typewriters.  
 Southend Wilding Office Equipment.  
 Sunderland Thos. Hill International.  
 Sutton Landau Calculators.  
 Swindon Wilding Office Equipment.  
 Waltham Cross Wilding Office Equipment.  
 Watford Automatic & Electronic Calculators; Wilding Office Equipment.  
 Worthing Office Machinery Engineering Co.  
**CHANNEL ISLANDS:** Guernsey A. E. S. Ltd.  
 Jersey A. E. S. Ltd. **EIRE:** Dublin Abacus Systems.  
 All UK Comet branches.

# What would I do with a computer?

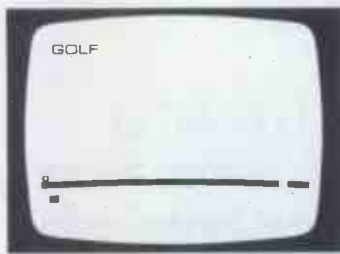

Play golf. Estimate your drive force on the fairway.

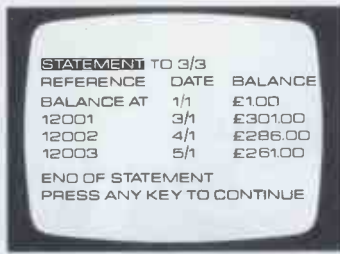

\*Flummox your Bank Manager by keeping your finances at your finger tips.



\*Keep the rundown on friends, everything from their telephone numbers to birthdays.



Play Orbit and captain a spacecraft.

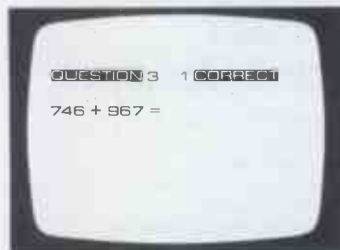

Teach the children maths from Division to Volume.

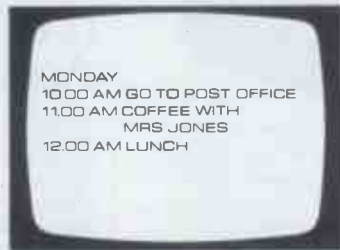

\*Keep a diary of future appointments and past events.



\*Catalogue all your collections from coins to stamps.

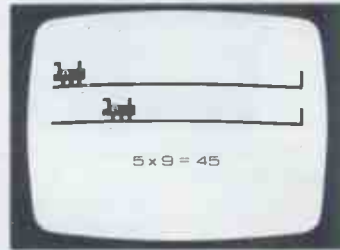

\*Teach the children multiplication and play trains at the same time.



Or within a week you can write your own complex programs.



All you need to know for £14.95.



And a great range of books...



...and magazines to help you become an expert.

## The first personal computer that only adds up to £69.95

You'll be surprised how much you can do with a personal computer and even more surprised at how little it costs.

We made it our business to find not only the best-value-for-money computer on the market, but also the best books to enable you to progress from a beginner to an advanced user. And W.H. Smith is the only retail chain where you can buy the incredible ZX81.

The Sinclair ZX81 is a masterpiece of design. Which is why it can carry out programs you'd normally expect from more expensive computers.

Although the ZX81 is fast and powerful, it's also simple to use. Within hours you can learn to run programs and within a week you could be writing your own complex programs. All you need is your own TV (any model that receives BBC2) and a cassette player when using pre-programmed cassettes. And W.H. Smith have a range available from £3.95 each.

So take your first steps in computing at W.H. Smith and make your life easier to run.



16K RAM pack expands the memory capability by 16 times. £49.95. \*These programs require this unit.

# WHSMITH



Prices correct at time of going to press.



Available at these branches only:- Altrincham · Basildon · Bedford · Birkenhead · Birmingham · Bolton · Bournemouth · Bracknell · Bradford Broadway · Bradford Kirkgate · Brent Cross · Brighton · Bristol Broadmead · Bromley · Burgess Hill · Burnley · Cambridge Lion Yard · Canterbury · Cardiff · Carlisle · Chatham · Chelmsford · Chester · Chichester · Chippenham · Colchester · Coventry · Crawley · Croydon · Darlington · Derby · Doncaster · Ealing Broadway · Eastbourne · Edinburgh · Eltham · Exeter · Gloucester · Guildford · Hammersmith · Hanley · Harrogate · Hartlepool · Hemel Hempstead · Holborn Circus · Hull · Ilford · Ipswich · Kensington · Kidderminster · King's Lynn · Kingsway · Leamington Spa · Leeds · Leicester · Leitchworth · Lewisham · Lincoln · Liverpool · Loughborough · Lowestoft · Luton · Macclesfield · Maidenhead · Maidstone · Manchester · Middlesbrough · Milton Keynes · Newcastle · Newton Abbot · Northampton · Norwich · Nottingham Listergate · Nottingham Victoria · Orpington · Oxford · Peterborough · Plymouth · Pontefract · Poole · Portsmouth · Putney · Reading · Richmond · Romford · Salisbury · Sheffield · Slough · Solihull · Southampton · Southend · Stafford · Staines · Stevenage · Stockport · Stockton · Stratford East · Streatham · Sunderland · Sutton Coldfield · Swindon · Taunton · Telford · Watford · Winchester · Woking · Wolverhampton · Wood Green · Woolwich · Worcester · Worthing · Wrexham · York.



# MICRODIGITAL

PRICES OCTOBER/NOVEMBER 1981

## APPLE ★

Two year guarantee

	NET	V.A.T.	TOTAL
● Apple II + 48K, B & W Modulator		Ring for Latest Price!	
● Disk Drive Plus Controller (3.3)	375.00	56.25	431.25
● Disk Drive	295.00	44.25	339.25
Programmer's Aid	26.00	3.90	29.90
Autostart Rom Pack	33.00	4.95	37.95
Graphics Tablet	485.00	72.75	557.75
● Silentype	195.00	29.25	224.25
Apple Tel System	575.00	86.25	661.25
Black and White Modulator	14.00	2.10	16.10
Pascal Language System	245.00	36.75	281.75
Applesoft Firmware Card	95.00	14.25	109.25
Integer Card	95.00	14.25	109.25
● 16K Ram Card (48K → 64K)	95.00	14.25	109.25
Language Card	97.50	14.63	112.13
Apple Pilot	79.00	11.85	90.85
Apple Fortran	105.00	15.75	120.75
Apple Prototype/Hobby Card	12.00	1.80	13.80
Vero Prototype/Hobby Card	10.00	1.50	11.50
Parallel Printer Interface Card	87.50	13.13	100.63
Communications Card	103.00	15.45	118.45
High Speed Serial Interface Card	94.75	14.21	108.96
Centronics Card	103.00	15.45	118.45
Controller Card	100.00	15.00	115.00
● Eurocolour Card	69.00	10.35	79.35
B/W Modulator	14.00	2.10	16.10
IEEE-488 Interface	230.00	34.50	264.50
Thermal Paper for Silentype	2.75	.41	3.16
Vinyl Carrying Case	16.00	2.40	18.40
Apple Ties	6.00	.90	6.90
<b>AIF</b>			
MC1 - 9 Voice	99.00	14.85	113.85
MC16 - 3 Voice	123.00	18.45	141.45
10-1-17 Timing Mode Input	11.30	1.70	13.00
<b>Heuristics</b>			
Speech Lab	135.00	20.25	155.25
Controller 70	60.00	9.00	69.00
Speechlink 2000	185.00	27.75	212.75
<b>Mountain Hardware</b>			
Clock/Calander	173.00	25.95	198.95
Supertalker	185.00	27.75	212.75
Romplus + Keyboard Filter	127.00	19.05	146.05
Rom Writer	105.00	15.75	120.75
Music System Complete	330.00	49.50	379.50
Copyplus Rom	34.00	5.10	39.10
AD + DA 16 Channel	210.00	31.50	241.50
● CPS Card	160.00	24.00	184.00
<b>Other Items</b>			
● Omnivision	150.00	22.50	172.50
Numeric Keypad	85.00	12.75	97.75
Sup 'R' Terminal	195.00	29.25	224.25
Z80 Softcard	179.00	26.85	205.85
<b>Interactive Structures</b>			
AO-03/4 Analog Output 4 Chan	195.00	29.25	224.25
AO-03/8 Analog Output 8 Chan	299.00	44.85	343.85
A1-02 Data Acquisition	210.00	31.50	241.50
D1-09 Digital Interface	235.00	32.25	270.25
● AI-13 Analog Input 16 Chan	395.00	59.25	454.25
<b>March Communications</b>			
Micro-Clock	49.95	7.49	57.44
Micro-Port	49.95	7.49	57.44
Micro-Synth	49.95	7.49	57.44
Micro-Talker 1	85.00	12.75	97.75

## APPLESOFTWARE

● Micro Modeller	425.00	63.75	488.75
● Visicalc (3.3)	105.00	15.75	120.75
Visidex	110.00	16.50	126.50

# MICRODIGITAL

The Microcomputer Specialists



★ Send for free 24 page book brochure

	NET	V.A.T.	TOTAL
Visiplot	98.00	14.70	112.70
Visi Trend/Plot	140.00	21.00	161.00
Visi Term	82.00	12.30	94.30
Desktop Plan II	110.00	16.50	126.50
CCA Datamanagement	56.00	8.40	64.40
Apple Writer	39.00	5.85	44.85
Apple Plot	38.00	5.70	43.70
Data Plot (Muse)	33.00	4.95	37.95
Data Base Management	47.00	7.05	54.05
Data Master	47.00	7.05	54.05
Information Master	67.00	10.05	77.05
● D.B. Master V.2.4	105.00	15.75	120.75
The Address Book	27.00	4.05	31.05
Magic Window Text Editor	49.00	7.35	56.35
Easywriter (80 Col.)	155.00	23.25	178.25
Mailmerge (80 Col.)	68.50	10.28	78.78
Applesoft Basic Compiler	111.00	16.65	127.65
Full Lisa 4-part Package	66.00	9.90	75.90
● Lisa Interactive Assembler	35.00	5.25	40.25
Bill Budge 3D Graf Tutor	21.70	3.26	24.96
E-Z Draw 3.3	22.50	3.38	25.88
Animation Pac	31.00	4.65	35.65
Saturn Navigator	15.00	2.25	17.25
Higher Graphics II	20.50	3.08	23.58
Higher Text	20.50	3.08	23.58
3-D Super Graphics	22.25	3.34	25.59
Apple World	33.00	4.95	37.95
Memory Management System	25.25	3.79	29.04
● Programming Aids 3.3	43.50	6.53	50.03

## 9 Shops Nationwide & Mail Order!

### BIRMINGHAM MICRODIGITAL

19/21 Corporation Street, Birmingham, B2 4LP. Tel: 021-632 6303.  
Manager: Peter Stallard. 300 yards from Bullring Centre (within Laskys).

### BRISTOL MICRODIGITAL

16/20 Penn Street, Bristol, BS1 3AN. Tel: 0272 20421.  
Opening 16th October. Between Holiday Inn and C. & A. (within Laskys).

### CHESTER MICRODIGITAL

The Forum, Northgate Street, Chester, CH1 2BZ. Tel: 0244 317667.  
Manager: Jeremy Ashcroft. Next to the Town Hall (within Laskys).

### EDINBURGH MICRODIGITAL

4 St. James Centre, Edinburgh, EH1 3SR. Tel: 031-556 2914.  
Manager: Colin Draper. East end of Princes Street, St. James Centre (within Laskys).

### KINGSTON MICRODIGITAL

38/40 Eden Street, Kingston, KT1 1EP. Tel: 01-546 1271.  
Opposite Main Post Office (within Laskys)

### LIVERPOOL MICRODIGITAL

33 Dale Street, Liverpool, L2 2HF. Tel: 051-236 2828  
Manager: Mark Butler. Between the Town Hall and Magistrates Courts. (within Laskys).

### MANCHESTER MICRODIGITAL

12/14 St. Mary's Gate, Market Street, Manchester, M1 1PX. Tel: 061-832 6087.  
Manager: Lesly Jacobs. Corner of Deansgate (within Laskys).

### NOTTINGHAM MICRODIGITAL

1/4 Smithy Row, Nottingham, NG1 2DU. Tel: 0602 415150.  
Manager: Alistair Hawkes  
Within Market Square, Exchange Buildings, Nottingham (within Laskys)

### SHEFFIELD MICRODIGITAL

58 Leopold Street, Sheffield, S1 2GZ. Tel: 0742 750971.  
Manager: Justin Rowles. Top of the Moor, opposite Town Hall (within Laskys).

### Mail Order

If you are unable to get to a Microdigital shop then you can buy your requirements from our Mail Order department at:

**Microdigital Limited**, FREEPOST (No stamp required), Liverpool L2 2AB

# SHARP

## 117-80K SPECIAL OFFER!

A proper full size microcomputer for less than the real cost of a toy microcomputer. The Sharp comes with 48k of RAM and the screen and cassette are built in, instead of being expensive extras.

Nett VAT Total  
347.00 52.00 399.00

2 year  
parts and labour  
guarantee on all  
Sharp products  
supplied by  
Microdigital

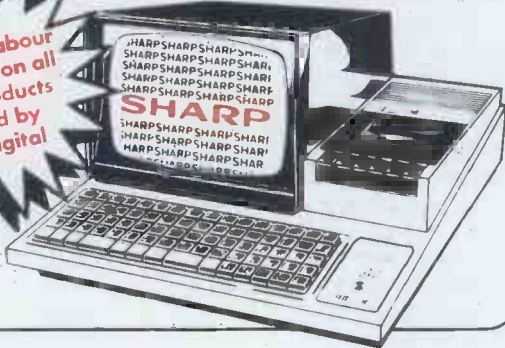

### APPLE BOOKS

	NETT	V.A.T.	TOTAL
Apple II Reference Manual.....	10.00	-	10.00
6502 Hardware Manual.....	11.00	-	11.00
Apple II Basic Program Manual.....	3.00	-	3.00
Applesoft II Reference Manual.....	5.00	-	5.00
DOS 3.2 Manual.....	5.00	-	5.00
Apple II Basic Tutorial Manual.....	5.00	-	5.00
Fortran Reference Manual.....	14.00	-	14.00
Pascal Reference Manual (1.1).....	11.00	-	11.00
Pascal Operating Manual.....	13.00	-	13.00
Graphics Tablet Manual.....	5.00	-	5.00
Silentype Manual.....	1.00	-	1.00
DOS 3.3 Manual.....	5.00	-	5.00
Pilot Language Reference Manual.....	10.00	-	10.00
Pilot Editors Manual.....	8.00	-	8.00
6502 Software Manual.....	11.00	-	11.00

### HEWLETT PACKARD

HP 83 Computer.....	1340.00	201.00	1541.00
HP 85 Computer.....	1935.70	290.36	2226.06
16K Memory Module.....	175.70	26.36	202.06
ROM Drawer.....	26.80	4.02	30.82
Mass Storage ROM.....	86.36	12.95	99.31
Plotter/Printer ROM.....	86.36	12.95	99.31
Input/Output ROM.....	175.70	26.36	202.06
Matrix ROM.....	86.36	12.95	99.31
● Assembler ROM.....	175.70	26.36	202.06
HP-IB Interface.....	235.26	35.29	270.55
Serial Interface Female.....	235.26	35.29	270.55
Serial Interface Male.....	235.26	35.29	270.55
Serial Interface No Connector.....	235.26	35.29	270.55
GP I/O Interface.....	294.82	44.22	339.04
B.C.D. Interface.....	294.82	44.22	339.04
Centronics Interface.....	175.70	26.36	202.06
HP-IB Cable 1/2M.....	41.51	6.23	47.74
HP-IB Cable 1M.....	41.51	6.23	47.74
HP-IB Cable 2M.....	44.48	6.67	51.15
HP-IB Cable 4M.....	50.41	7.56	57.97
Plotter.....	1435.70	215.36	1651.06
Personality Module.....	439.50	65.93	505.43
O'Head Transp. Kit.....	58.06	8.71	66.77
Digitising Sight.....	21.07	3.16	24.23

	NETT	V.A.T.	TOTAL
Plotter Carrying Case.....	140.64	21.10	161.74
100 Sheets English.....	4.21	.63	4.84
100 Sheets Metric.....	4.21	.63	4.84
50 Sheets Blank EF.....	1.81	.27	2.08
50 Sheets Blank A4.....	1.81	.27	2.08
4 Colour Pen PAC.....	3.82	.57	4.39
5 Red Pens.....	3.82	.57	4.39
5 Blue Pens.....	3.82	.57	4.39
5 Green Pens.....	3.82	.57	4.39
5 Black Pens.....	3.82	.57	4.39
100 Transp. Films.....	12.97	1.95	14.92
Transp. Solvent.....	2.35	.35	2.70
Transp. Pens BRBG.....	5.00	.75	5.75
Transp. Pens BOBV.....	5.00	.75	5.75
Transp. Pens BRBG Wide.....	5.00	.75	5.75
Transp. Pens BOBV Wide.....	5.00	.75	5.75
● Printer HP 82905A.....	597.00	89.55	686.55
Printer HP 2631B.....	2314.70	347.21	2661.91
Printer Stand.....	169.94	25.49	195.43
Paper Rack.....	31.06	4.66	35.72
Sound Cover.....	61.53	9.23	70.76
Wire Paper Basket.....	31.06	4.66	35.72
Printer Ribbon (Pack of 3).....	36.92	5.54	42.46
Tape Cartridge (Pack of 5).....	55.67	8.35	64.02
Thermal Paper Blue (Box 2).....	18.06	2.71	20.77
Thermal Paper Black (Box 6).....	54.17	8.13	62.30
Cartridge Manual Holder.....	6.02	.90	6.92
HP 83/85 Carrying Case.....	72.23	10.83	83.06
3 Ring System Binder.....	6.02	.90	6.92
Dust Cover.....	9.03	1.35	10.38
Owners Manual HP 83/85.....	15.05	-	15.05
Pocket Guide.....	3.01	-	3.01
Mass Storage ROM Manual.....	6.02	-	6.02
Plotter Printer ROM Manual.....	6.02	-	6.02
I/O ROM Manual.....	18.05	-	18.05
Matrix ROM Manual.....	6.02	-	6.02
Assembler ROM Manual.....	12.04	-	12.04
Flexible Disk Operating Manual.....	6.02	-	6.02
HP-IB Manual.....	6.02	-	6.02
Serial Installation Manual.....	6.02	-	6.02
GP-I/O Manual.....	6.02	-	6.02
BCD Manual.....	6.02	-	6.02
Centronics Manual.....	6.02	-	6.02
Standard PAC.....	56.58	8.49	65.07
Basic Training.....	56.58	8.49	65.07
General Statistics.....	56.58	8.49	65.07
Finance.....	56.58	8.49	65.07
Maths.....	56.58	8.49	65.07
Circuit Analysis.....	56.58	8.49	65.07
Games.....	56.58	8.49	65.07
Linear Programming.....	56.58	8.49	65.07
Text Editing.....	56.58	8.49	65.07
Wave Form Analysis.....	56.58	8.49	65.07
Basic Stat and Data.....	56.58	8.49	65.07
Regression Analysis.....	56.58	8.49	65.07
Graphics Presentation.....	119.12	17.87	136.99
● Visicalc Plus.....	119.12	17.87	136.99
● Information Management.....	119.12	17.87	136.99
Surveying.....	119.12	17.87	136.99
Dual Master 5 1/4" (540K).....	1489.00	223.35	1712.35
Dual Add on 5 1/4" (540K).....	1310.32	196.55	1506.87
Single Master 5 1/4" (270K).....	893.40	134.01	1027.41
Single Add on 5 1/4" (270K).....	774.28	116.14	890.42
Dual Master 8" (2400K).....	4002.33	600.35	4602.68
Dual Add on 8" (2400K).....	3387.03	508.05	3895.08
Single Master 8" (1200K).....	2924.14	438.62	3362.76
Single Add on 8" (1200K).....	2308.84	346.33	2655.17
Flexible Disk 5 1/4" (Pack 10).....	43.30	6.50	49.80
Flexible Disk 8" (Pack 10).....	61.53	9.23	70.76
Graphics Tablet.....	1201.30	180.20	1381.50

★ Send for free 24 page book brochure



# MICRODIGITAL

The Microcomputer Specialists

# SHARP ★ Two year guarantee

	NETT	V.A.T.	TOTAL
● PC1211 Computer.....	80.00	12.00	92.00
CE121 Cassette Interface.....	11.00	1.65	12.65
CE122 Printer Interface.....	60.00	9.00	69.00
CSR 700 Paper Rolls (40).....	5.00	.75	5.75
EA 800R Ink Ribbons.....	1.80	.27	2.07
● MZ80K Computer 48K.....	347.00	52.00	399.00
MZ80 I/O Expansion Interface.....	96.00	14.40	110.40
MZ80 F.D. Dual Disks.....	560.00	84.00	644.00
MZ80 F I/O Disk Interface.....	52.00	7.80	59.80
MZ80 FMD Master Disk and Manual.....	20.00	3.00	23.00
MZ80 F15 Disk Cable.....	8.00	1.20	9.20
MZ80 FOS Extra Disk Cable.....	7.00	1.05	8.05
MZ80 P3 Dot Matrix Printer.....	365.00	54.75	419.75
MZ80 T20C Machine Language.....	18.00	2.70	20.70
MZ80 TU Assembler.....	36.00	5.40	41.40
● MZ80 T40E Pascal.....	40.00	6.00	46.00
MZ80 I/O-1 Universal Interface Card.....	40.00	6.00	46.00
● MZ80B Computer 64K.....	Ring for Latest Price!		
MZ80 FI Disk Interface.....	94.00	14.10	108.10
MZ80 MDB Master Disk and Manual.....	30.00	4.50	34.50
MZ80 BJC Disk Cable Joiner.....	15.00	2.25	17.25
MZ80 EU Expansion Interface.....	47.00	7.05	54.05
MZ80 P5 Dot Matrix Printer.....	387.00	58.05	445.05
MZ80 GMK Graphics Option.....	112.00	16.80	128.80
MZ80 I/O-2 Universal Interface Card.....	40.00	6.00	46.00
MZ80 T10C K → B Converter.....	7.00	1.05	8.05

## Sharp Cassette Software

Towering Inferno.....	5.85	.88	6.73
Block Kuzushai.....	5.85	.88	6.73
Head-On.....	5.85	.88	6.73
Asteroids.....	5.85	.88	6.73
Escape from Colditz.....	8.45	1.27	9.72

## The Memory PRICE WAR

Guaranteed quality - thousands already supplied. Any faulty chips should be returned to us within 12 months of purchase with proof of purchase for replacement by return of post.

**4116** 200 nanoseconds **87 pence + VAT each.**

**2114 low power** 300 nanoseconds **130 pence + VAT each.**

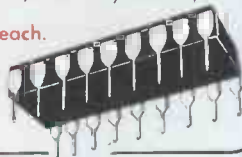

## ATARI

400 16K Computer.....	300.00	45.00	345.00
800 16K Computer.....	560.87	84.13	645.00
410 Tape Recorder.....	43.48	6.52	50.00
810 Disk Drive.....	300.00	45.00	345.00
822 Thermal Printer.....	230.43	34.57	265.00
825 80 Column Printer.....	478.26	71.74	550.00
850 RS232 Interface.....	117.39	17.61	135.00
16K RAM Upgrade.....	56.52	8.48	65.00
Light Pen.....	39.13	5.87	45.00
Pair Paddles.....	10.43	1.57	12.00
Pair Joysticks.....	10.43	1.57	12.00
I/O Cable.....	8.26	1.24	9.50
Printer Cable.....	24.78	3.72	28.50
Interface Cable.....	20.43	3.07	23.50
RS 232 Cable.....	20.43	3.07	23.50
Monitor Cable.....	20.43	3.07	23.50
Thermal Paper.....	3.48	.52	4.00
Master Disk.....	13.91	2.09	16.00
5 Blank Disks.....	13.91	2.09	16.00
Word Processor.....	73.91	11.09	85.00
Inv. Prog. 1.....	10.39	1.56	11.95
Conversational French.....	28.26	4.24	32.50
Conversational German.....	28.26	4.24	32.50

	NETT	V.A.T.	TOTAL
Conversational Spanish.....	28.26	4.24	32.50
Conversational Italian.....	28.26	4.24	32.50
Music Composer ROM.....	28.26	4.24	32.50
Touchtype.....	13.00	1.95	14.95
Calc/Tor.....	14.74	2.21	16.95
Graphit.....	10.39	1.56	11.95
Statistics.....	10.39	1.56	11.95
Eng. Czar.....	7.78	1.17	8.95
Hangman.....	7.78	1.17	8.95
Kingdom.....	7.78	1.17	8.95
States and Capitals.....	7.78	1.17	8.95
States Europe.....	7.78	1.17	8.95
Scram.....	11.26	1.69	12.95
Telelink ROM.....	13.00	1.95	14.95
Asteroids ROM.....	26.04	3.91	29.95
Basket/Ball ROM.....	21.30	3.20	24.50
Blackjack.....	7.78	1.17	8.95
Chess ROM.....	21.30	3.20	24.50
Miss. Conid ROM.....	26.04	3.91	29.95
Space Inv. ROM.....	21.30	3.20	24.50
Space Inv.....	11.26	1.69	12.95
● Star Raiders ROM.....	26.04	3.91	29.95
Super Breakout ROM.....	21.30	3.20	24.50
Assembler Editor ROM.....	30.00	4.50	34.50
Pilot ROM.....	43.04	6.46	49.50
Microsoft Basic.....	43.04	6.46	49.50
Technical Notes.....	14.74	-	14.74
Operating System Lists.....	9.52	-	9.52
DOS Lists.....	2.61	-	2.61
DOS 2 Manual.....	6.04	-	6.04

## VIDEO GENIE

Video Genie Computer.....	279.00	41.85	320.85
EG3013 Expander.....	185.00	27.75	212.75
EG3013 Expander + RS232.....	215.00	32.25	247.25
32K Memory Board S100.....	105.00	15.75	120.75
Single Disk Drive.....	215.00	32.25	247.25
Dual Disk Drive (40 Track).....	410.00	61.50	471.50
2 Drive Cable.....	17.00	2.55	19.55
4 Drive Cable.....	32.00	4.80	36.80
Printer Cable.....	17.00	2.55	19.55
Parallel Interface EG3016.....	33.00	4.95	37.95
Sound Kit.....	10.00	1.50	11.50
Fitting Above.....	5.00	.75	5.75
Lower Case Kit.....	33.00	4.95	37.95
Fitting Above.....	5.00	.75	5.75
Keyboard Update Kit.....	3.00	.45	3.45
RS232 Interface.....	52.00	7.80	59.80

## Video Genie Cassette Software

Space Invaders.....	13.00	1.95	14.95
Asteroids.....	8.75	1.31	10.06
Golden Baton.....	8.75	1.31	10.06
Lost in Space.....	8.75	1.31	10.06
Space Eye.....	8.75	1.31	10.06

## Books for Video Genie

Learning Level II BASIC by David Lien.....			12.40
Microsoft™ BASIC by Knecht.....			8.95
Video Genie System Service Manual.....			5.00
The easy way to programming in BASIC using the Video Genie System by John and Judy Deane.....			5.00

## PRINTERS

### Epson

MX80 T Newtype 2.....	415.00	62.26	477.25
MX80 FT/1.....	399.00	59.85	458.85
● MX80 FT Newtype 2.....	465.00	69.75	534.75
MX82.....	389.00	58.35	447.35
MX100.....	575.00	86.25	661.25
● MX130.....	Ring for Latest Price!		

# Terms & Conditions

## Microdigital Limited

Microdigital Limited is part of the retail division of the Ladbroke Group of companies and is registered in England. Registered Number: 319646437  
Registered Office: Chancel House, Neasden Lane, London NW10  
Directors: P. M. George, P. Klein, G. W. Raiph, D. J. Sate, T. Edmundson  
Ultimate Holding Company: Ladbroke Group Limited. VAT Number: 240 1132 31

## Our Conditions of Business

In addition to cash we accept Access, Barclaycard, Stereo Club, American Express, Diners Club and cheques covered by a bankers card.

Official orders over £50 are welcome, with normal 30 days credit extended to bona-fide commercial and government organisations. All prices, specifications and terms are subject to change without notice at the discretion of the management. Offers subject to availability.

All previous Microdigital Advertisements are superseded by this. Not all stores carry every advertised item. Prices correct at time of going to press. E & OE

## Computer Retailers Association

We are founder members of the Computer Retailers Association, a voluntary organisation of leading micro-computer dealers and service organisations.

The purpose of the Association is to maintain and improve standards of trading and customer support within the industry and to present the industry's case to the outside world. The Association also acts as a forum where members can discuss common problems.

## A Better Guarantee

Microdigital Ltd. warrants the products it sells against defects in material and workmanship for a period of one year from the date of purchase, two years for Apple and Sharp products.

During the warranty period, the company will repair (or at its own option, replace) at no charge, components that prove defective. This is provided the product is returned, shipping prepaid, or by person, stating when it was bought and enclosing proof of purchase.

This warranty does not apply if, in the opinion of the company, the product has been damaged by accident, misuse or misapplication.

## Lasky's Stereo Club

The handy way to buy, from Microdigital. Multiply your monthly payment to 24 to find out your credit limit. For instance, for the minimum monthly payment of £5 you would get credit up to £120. In some cases you may be able to get instant credit by paying a deposit of 10% of a purchase price. Current Stereo Club interest rate is 2.5% monthly - equivalent to an APR of 34.8%. Rates may vary.

If you pay by Bankers' Order, apart from the extra convenience, you'll enjoy a LOWER INTEREST RATE - currently 2.2% monthly, equivalent to an APR of 29.8%.

As a Stereo Club member we'll send you regular news and literature from Lasky's and Microdigital. Lasky's Stereo Club is probably the best thing that's happened to Microcomputers since the invention of the chip!

## Mail Order

If you are unable to get to a Microdigital shop then you can buy your requirements from our Mail Order Department at:

**Microdigital Limited, FREEPOST (No stamp required), Liverpool, L2 2AB**

The Conditions of Business are the same as the shops except:

1. Allow one week for personal cheques to clear.
2. Add £1 p&p to orders under £10
3. Carriage free on orders over £10 within Mainland U.K. Overseas add 15%

## Telephone Orders

Just give your credit card number and requirements on our 24 hour 7 day

Answerphone Service 051-236 0707 Mail Order Manageress - Lyn Major

## Head Office

Accounts, administration and engineering are at:

**Microdigital Limited, 14 Castle Street, Liverpool L2 0TA Telephone 051-227 2535**

General Manager: Bruce Evans, Operations Manager: Graham Jones

## Epson Interfaces

	NETT	V.A.T.	TOTAL
Epson/Sharp Cassette	65.00	9.75	74.75
Epson/Sharp Disk	120.00	18.00	138.00
Epson/RS232	45.00	6.75	51.75
Epson/RS232 + 2K FIFO	98.00	14.70	112.70
Epson/Apple	85.00	12.75	97.75
Epson/TRS 80 Bus	59.00	8.85	67.85
Epson/TRS 80 Expansion	25.00	3.75	28.75
Epson Ribbons	7.00	1.05	8.05
Epson MX100, MX130 Ribbons	8.50	1.28	9.78
<b>Microline 80</b>	<b>295.00</b>	<b>44.25</b>	<b>339.25</b>
Microline 80 Tractor	45.00	6.75	51.75
Diplomat Card (Apple-Microline)	85.00	12.75	97.75
Microline Ribbons	2.25	.34	2.59
Paper Tiger 445	560.00	84.00	644.00
Paper Tiger 460	690.00	103.50	793.50
● Paper Tiger 560	<b>850.00</b>	<b>127.50</b>	<b>977.50</b>
445, 460, 560 Ribbons	8.50	1.28	9.78
Centronics 737	390.00	58.50	448.50
Centronics 739	485.00	72.75	557.75
737/739 Ribbons	6.00	.90	6.90
● Seikosha GP80	<b>195.00</b>	<b>29.25</b>	<b>224.25</b>

## Seikosha Interfaces

Seiko/Apple	59.00	8.85	67.85
Seiko/Pet	59.00	8.85	67.85
Seiko/Video Genie (EG3016)	33.00	4.95	37.95
Seiko/RS232	79.00	11.85	90.85
Seiko/TTL Serial	43.00	6.45	49.45
Seiko/IEEE 488	59.00	8.85	67.85
Seiko/Sharp (Disk)	59.00	8.85	67.85
Seiko/Tandy	30.00	4.50	34.50
Seiko Ribbons	4.00	.60	4.60
Seiko Paper 8 1/2" x 11" 2000 Sheets	12.00	1.80	13.80
Paper 9 1/2" x 11" 2000 Sheets	12.00	1.80	13.80
Paper Delivery	3.00	.45	3.45

## VIDEO MONITORS

BM12E 12" Green	180.00	27.00	207.00
VM129 12" B/W	183.00	27.45	210.45
VM906 9" HI-RES B/W	150.00	22.50	172.50
VM910 9" B/W	125.00	18.75	143.75
10" B/W Monitor	85.00	12.75	97.75
Cables	5.00	.75	5.75

## Colour Monitors 14" New!

● MP 14N (NTSC) TTL, RGB	285.00	42.75	327.75
● MP 14P (PAL) TTL, RGB	285.00	42.75	327.75

## SUNDRIES

QED Mains Suppressor 3 amp	12.80	1.92	14.72
QED Mains Suppressor 6 amp	17.30	2.60	19.90
Mini Floppy Head Cleaning Kit	19.50	2.93	22.43
C15 Cassette	.80	.12	.92
C15 Cassettes Box 10	5.20	.78	5.98
C15 Cassettes Box 50	25.00	3.75	28.75
C15 Cassettes Box 100	45.00	6.75	51.75
● C15 Cassettes Box 1000	<b>370.00</b>	<b>55.50</b>	<b>425.50</b>
Mini Floppy SS/DD	2.50	.38	2.88
Mini Floppy SS/DD x 10	20.00	3.00	23.00
Mini Floppy SS/DD x 50	87.50	13.13	100.63
Mini Floppy SS/DD x 100	150.00	22.50	172.50
Mini Floppy DS/DD	4.00	.60	4.60
Mini Floppy DS/DD x 10	33.00	4.95	37.95
Mini Floppy DS/DD x 50	150.00	22.50	172.50
Mini Floppy DS/DD x 100	275.00	41.25	316.25
● 4116, 200 N.S.	.87	.13	1.00
● 2114, 300 N.S.	1.30	.20	1.50
TI Programmer Calc	45.00	6.75	51.75
Paper 8 1/2" x 11" 2000 Sheets	12.00	1.80	13.80
Paper 9 1/2" x 11" 2000 sheets	12.00	1.80	13.80
Paper Delivery	3.00	.45	3.45

## Microdigital Mail Order Form

MAIL TO: Microdigital Limited, Freeport, Liverpool L2 2AB

Office Use only	Goods required	Price
	1	
	2	
	3	
	4	
	5	
	6	
VAT in this ad has been calculated at the rate of 15% current at the time of writing. Please allow for any changes.		Add £1 P & P to orders under £10
		<b>Total</b>

If you require a Stereo Club application form tick this box

Access: 5224

Barclaycard: 4929

American Express/Diners Club/Stereo Club No

Expiry date:

Name:

Address:

Post Code:

Tel: (day)



PCW 11/81

★ Send for free 24 page book brochure



# MICRODIGITAL

The Microcomputer Specialists

# SIX TOUGH QUESTIONS YOU SHOULD ASK BEFORE BUYING A MICRO.

1. Is it easy to use?
2. Are the programs versatile?
3. Is it absolutely reliable?
4. Does it have a national network of distributors and dealers offering full service and support?
5. Is it competitively priced?
6. Can you see proof of performance?

With the new Adler Alphatronic the answer is 'yes' to all these questions. Because Alphatronic is the micro that was specially designed for the small businessman. To cut paperwork, cope with accounts, payroll, stock control, VAT — and generally make business, and cash, flow more smoothly. When it comes to versatility, price, reliability and performance, Alphatronic is outstanding value.

The Alphatronic P1 costs £1600\* and includes a 2000 character screen, keyboard, integral double density floppy disk unit and CP/M† disk and manual. Alphatronic P2 complete includes 2000 character screen, keyboard, two integral double density floppy disk units together with a dot-matrix printer, CP/M† disk and manual and costs £2345.\*

\* Prices exclusive of VAT. † Trade mark of Digital Research Corp.

**FREE**  
 With model P1: a two disk basic teach-in course worth £85.  
 With model P2: a two disk data retrieval program worth £120.  
 Send back the coupon and we'll tell you how Alphatronic could be the answer — your answer.



**ADLER'S NEW £1600 MICRO. BRILLIANTLY SIMPLE ALPHATRONIC.**

Alphatronic Division, **TRIUMPH ADLER (UK) LTD.**  
 (formerly Adler Business Systems Ltd.)  
 27 Goswell Road, London EC1M 7AJ. Tel: 01-250 1717.

Please send me further details on the Adler Alphatronic.

Name.....  
 Company.....  
 Address.....  
 Telephone.....

PCW/11/81

Printer not included on P1 model at £1600.

IBS 81 October 20-29. Hall 4 Stand 321.

# INNOVATIVE

# TRS-80 SOFTWARE

## FROM THE PROFESSIONALS



Extended Basic from Snapp Inc. is, in our opinion, the best add on utility to the Basic Interpreters for the Model III and Model II TRS-80 machines that is available on the market at the moment. It incorporates into the Interpreter, commands which hitherto have had to be loaded in separate utilities, indeed some of the commands, to the best of our knowledge, are not even available in other utilities. What must be emphasised is that these modifications to the Interpreter are entirely transparent to the user, they literally patch the Interpreter and become an integral part of it. The enhancements unfortunately are too lengthy to explain in detail in this advertisement, but briefly they add the following functions:

**Single keystroke commands to:**

- List first line of program
- List last line of program
- List previous line of program
- List next line of program
- Edit current line
- List current line

**Ten single keystroke abbreviations are provided for the Basic commands:**

AUTO	CLS	DELETE	EDIT	KILL
LIST	MERGE	NEW	LLLIST	SAVE

**Cross Reference**

A complete cross reference utility with output either to the screen or to the printer listing all line numbers in which numeric or string variables are held. The reference may be to all variables or individual ones.

**Dump Utility**

A dump utility to direct to the display or printer the variables used in the program *together with their current values.*

**Renumbering**

A renumber utility. This is a sophisticated renumbering facility permitting not only renumbering, but also the relocation and duplication of blocks of code. It also has a higher speed execution than the present renumbering routine in the Interpreter.

**String or Keyword Cross Reference**

This utility will find and cross reference all keywords (commands) in the program together with, and probably most importantly, strings. That is to say, it is possible to find the whereabouts of specific words in the text of the program. Output is to the screen or to the printer.

**Compression Utility**

This utility takes a Basic program and compresses it in a number of different ways including merging multiple statements into single lines. Compressed programs typically will occupy 30-40% less memory space and run 7-10% faster.

In addition to the above, the Model III version adds single step entry into Basic (similar to LDOS or NEWDOS) together with the ability to recover accidentally "deleted" Basic programs.

Model III ... .. £67.50

Model II ... .. £94.50

Both exclusive of V.A.T. No P. & P.

TRS-80 & VIDEO GENIE SOFTWARE CATALOGUE £1.00 [refundable] plus 50p postage.



## MOLIMERX LTD.

A. J. HARDING (MOLIMERX)

1 BUCKHURST ROAD, TOWN HALL SQUARE,  
BEXHILL-ON-SEA, EAST SUSSEX.

TEL: [0424] 220391/223636

TELEX 86736 SOTEX G



# INNOVATIVE

# TRS-80 SOFTWARE

## FROM THE PROFESSIONALS

# LDOS

First there were the TRSDOS's, 2.0, 2.1, 2.2 and 2.3. Then came Newdos +, essentially a patched version of the TRSDOS's but with a number of very useful commands and utilities added. Then VTOS 3.0 and VTOS 4.0. These constituted a departure from the earlier DOS's and featured Device Independence so that devices such as the keyboard, printer, VDU and disk drives could interact directly together. Then came Newdos80 which is a rewrite of Newdos +, adding new utilities and new Basic commands, its main features being the ability to mix different capacity drives on the same cable and the ability to use variable length records. Now from LOBO International comes LDOS, the fifth generation disk operating system for the TRS-80 microcomputer. It combines most of the advantages of the preceding disk operating systems and unlike some of them, is accompanied by a complete and readable set of documentation, which includes a Technical Section containing relevant addresses.

It is impossible to describe all of the features of LDOS in an advertisement. For instance it includes no less than 35 library commands as follows:—

APPEND	COPY	DEVICE	DIR	DO	FILTER	KILL
LIB	LINK	LIST	LOAD	MEMORY	RENAME	RESET
ROUTE	RUN	SET	SPOOL	ATTRIB	AUTO	BOOT
BUILD	CLOCK	CREATE	DATE	DEBUG	DUMP	FREE
PROT	PURGE	SYSTEM	TIME	TRACE	VERIFY	XFER

All of the useful abbreviations in Newdos are included and the System Commands in Basic (CMD) now number eleven. A program called LBASIC/FIX is included, with which the normal TRSDOS Disk Basic may be patched to include a number of new commands and features. A Job Control Language is included and in fact is one of the most powerful features of LDOS. It allows the user to compile a sequence of commands or key strokes for later execution as a chain, with or without user intervention. There are too many new features to list them herein, but examples are: The ability to provide an audible signal, output through the cassette port. To flash or blink a one line message on the video display. A WAIT feature is included so that the machine can be put into a "sleep" state until such time as the system clock matches the time specified. And so on!

Hard disks in addition to single/double density, single/double sided, 8" and 5 1/4" floppies are supported although they may, of course, require hardware modifications. Utilities included in the package are:

BACKUP	COMMAND FILE	FORMAT	LCOMM
PATCH	RS232	KEY STROKE/MULTIPLIER	PRINTER FILTER

A Basic Renumber facility is included, as is a Basic Cross Reference function. Both are similar to the ones in Newdos + and Newdos80. Most of the utilities are library commands which were existent in the previous DOS's, have been improved with the addition of new functions or facilities.

The prime development team of LDOS consisted of no less than 8 first rank programmers and they had the support and advice of six other well known programmers. They have done an excellent job to bring to the user what must be the best disk operating system so far produced for a microcomputer, which is destined to become the Standard DOS.

LDOS is totally upward compatible with TRSDOS, that is to say LDOS will be able to copy files and programs from TRSDOS disks onto LDOS formatted disks. As they are competitive disk operating systems, it is not surprising that the manual states that disks created under Newdos are not guaranteed to be compatible with LDOS, but we have not experienced any difficulty. We have done some work on investigating the compatibility of LDOS and the Video Genie and at the time of going to press we have found no incompatibilities. LDOS appears to run on the Video Genie without any problems at all. LDOS is compatible with either the Tandy or Electric Pencil lowercase modifications and Scripsit. LDOS is available for the Model I and Model III. A Model II version will be available shortly.

LDOS .....£85.00 plus VAT and £1.50 P&P.

TRS-80 & VIDEO GENIE SOFTWARE CATALOGUE £1.00 [refundable] plus 50p postage.



## MOLIMERX LTD.

### A. J. HARDING (MOLIMERX)

1 BUCKHURST ROAD, TOWN HALL SQUARE,  
BEXHILL-ON-SEA, EAST SUSSEX.

TEL: [0424] 220391/223636

TELEX 86736 SOTEX G



# A complete, portable computer system from Hewlett-Packard. What more can we add?



## Business sense!

You'll recognise the unmistakably compact lines of the HP-85 – the friendly, typewriter-sized personal computer with built-in printer, VDU and tape drive. And you'd be excused for thinking you're looking at an exceptionally comprehensive, but ultimately limited, standalone computer. You'd be wrong! For even more remarkable than the capability Hewlett-Packard have built *into* the HP-85 is the business system they've built *around* it.

Here's the HP personal computer system with the business sense you need to help you to a better-informed management control and a higher personal productivity.

**First, choose your personal computer** – either the well established HP-85 or the new low-cost HP-83. Both form the ideal nucleus of an affordable, expandable personal business system.

**Next, start building your system** – Add HP's full-scale, compatible peripherals: flexible disc drives to provide you with fast access into large volumes of data; an impact printer, a full-colour graphics plotter... And, if you ever need more power, simply plug it in with add-on ROMs and modules.

**Now, give your system the business sense you need** – by selecting from Hewlett-Packard's comprehensive and still growing range of professional software. For planning budgets, creating forecasts, modifying projections, financial planning, organising data and even generating mailing lists. Software packages such as VisiCalc<sup>®</sup> PLUS allow dynamic and immediate analysis of data and projections using the "what if" facility as well as automatic and fast recalculation capabilities... Like the Series 80 Graphics Presentation Pac, which lets you prepare professional, presentation-standard graphs, charts and overhead transparencies straight off the computer... Like the HP Information Management Pac, a complete, powerful and flexible system for managing your data files.

When you build your complete personal business system around an HP computer, you can promise yourself not only the long-term reliability for which Hewlett-Packard are renowned, but the assurance that your entire system can be serviced and cared for on site by the same business computer professionals who designed it.

HP personal computers, and the business sense that goes with them, are available now from your HP dealer. Ask him for a demonstration.

\*VisiCalc is a trademark of Personal Software Inc.



**HEWLETT  
PACKARD**

## Contact your nearest dealer for a demonstration:

Aberdeen Tyseal Office Equipment Ltd, Tel: 29019. Belfast Cardiac Services, Tel: 625566. Birmingham John Mabon Assoc, Tel: 643 6351. Microdigital, Tel: 632 6303. Bournemouth South Coast Computers, Tel: Wimborne 893040. Brighton Office Machinery Engineering, Tel: 689682. Bristol Decimal Business Machines, Tel: 214093. Cambridge Cambridge Computer Store, Tel: 65334. Hi-Tek Distribution Ltd, Tel: 81996. Chester Microdigital, Tel: 317667. Dublin Abacus Systems, Tel: 711966. Edinburgh Business & Electronic Machines, Tel: 226 4294. Robox Office Equipment Ltd, Tel: 225 3871. Holdene, Tel: 668 2727. Glasgow Robox, Tel: 221 8413/4. Leeds Holdene, Tel: 459459. Leicester Sumlock Services, Tel: 29673. Leighton Buzzard Co-ordinated Computer Systems, Tel: Heath & Reach 581/2. Lichfield Anglo-American, Tel: 481042. Liverpool Microdigital, Tel: 227 2535/6/7. Rockliff Brothers, Tel: 521 5830. London Euro-Calc, Tel: 739 6484, 636 8161, 405 3113; Sumlock-Bondain, Tel: 250 0505, 626 0487, 388 5702; The Xerox Store, Tel: 405 5659, 629 0694, 588 1531. Manchester Automated Business Equipment, Tel: 432 0708. Holdene, Tel: Wilmslow 529486. Microdigital, Tel: 832 6087. Newcastle Thos Hill International, Tel: 739261. Newport Micromedia Systems, Tel: 59276. Reading CSE Computers, Tel: 61492; Sintrom Electronics, Tel: 85464. Royston (Herts) Electroplan, Tel: 41171. Sheffield Microdigital, Tel: 750977. Slough Crellon Electronics Ltd, Tel: Burnham 4300. Southampton South Coast Business Machines, Tel: 22958. Sunderland Thos Hill International, Tel: 42447. Tunbridge Wells D. J. Herriott, Tel: 22443/4. Wallingford Midas Advisory Services, Tel: 36773. Watford Automatic & Electronic Calculators, Tel: 31571. Woking Petallect Electronic Services, Tel: 69032. Worthing Office Machinery Engineering, Tel: 207292. CHANNEL ISLANDS: Absolute Electronic Systems, Tel: Jersey 77070.



# COBOL the language of business.

## The language of Micro Focus

# CIS COBOL

Our CIS COBOL product family brings you the most successful business programming tool ever devised, COBOL, in a form optimized for today's most cost effective hardware, the microcomputer. Standard COBOL as defined by ANSI X3.23-1974.

The reliability and performance of CIS COBOL are strongly emphasized by its' continued qualification for U.S. government contracts. In January 1981 CIS COBOL entered its 2nd year of G.S.A. certification.

CIS COBOL is powerful but simple to use. Its screenhandling, dynamic module loading and fast ISAM let you take full benefit from micro computer facilities.

Our FORMS-2 utility is a COBOL source code generator to help you build interactive applications with ease. Using our unique demonstration "How to create a COBOL program in 20 minutes," you can quickly try out new application ideas.

And if you are developing software for resale, the variety of systems running CIS COBOL offers you a very large available market.

WITH FORMS-2

CIS COBOL and FORMS-2 are available through our dealers and distributors for many 8080, Z80 and LSI-11 systems including Apple II with Softcard and CP/M.

For OEM purchase on 8086, PDP-11, UNIX and other order codes approach us direct. Our system transfer technology has made CIS COBOL first on a number of processors and enabled us to interface to 30 different operating systems.

For more information about CIS COBOL fill in the coupon below.

To: Micro Focus Ltd, David Murray John Tower,  
Brunel Centre, Swindon, Wilts., SN1 1NB.  
Tel: 0793 695891 (Sales Dept.)

Please send me

- A brochure on CIS COBOL
- A brochure on FORMS-2
- A set of Applications Notes

..... (Qty) CIS COBOL manual(s) at £37.50  
(inc. p+p) for which I enclose a cheque  
for £.....

My chief interest is in; (please tick box)

- 8080
- 8086
- UNIX
- Apple II

Name .....

Position .....

Company .....

Address .....

Tel No.....

 **MICRO  
FOCUS**

CIS COBOL and FORMS-2 are trademarks of Micro Focus. 8080 is a trademark of Intel Corp, Z80 of Zilog, LSI-11 and PDP-11 of Digital Equipment Corp, Apple II of Apple Computer, Softcard of Microsoft Consumer Products, CP/M of Digital Research and UNIX of Bell Laboratories.

# If you prefer the better things in life then you're going to like the new

## Micro

# 8

Epson MX80 New Type 2 £465 + VAT



BMC 14" Green Screen  
£180 + VAT

RGB Colour version available

Micro 8 (keyboard unit)  
£995 + VAT

*The Micro-8 is a new generation of microcomputer incorporating the very latest in technology. Based on the new 8 bit 6809 microprocessor (utilises 16 bit internal architecture and Micro-8 uses 2 of them!) along with its Z80 microprocessor (CP/M capability) and high resolution colour graphics the Micro-8 is ideal for all those discerning users, business, educational and hobbyist alike. Just look at all these STANDARD features which for most micros are expensive add on's or even just not available:-*

*\*Utilises 2 x 6809 MPU \*64k RAM \*Comp Video & RGB output \*High Resolution Colour Graphics 640 x 200 \*48k Video RAM \*Mixable high & low res. screens \*Soft select 40 column or 80 column screen \*10 user defined function keys \*Duplex RS232 port \*Parallel printer port \*Real Time clock/interrupt timer \*Comprehensive cursor and edit control keys \*Graphics cursor Draw and plot with Cartesian card o/p \*Z80 MPU.*

*Utilises 32k extended Microsoft Basic with all the standard commands plus the following:- AUTO, RENUM, MERGE, TROFF, TRON, EXEC, HARDC, BUBINI, DEFFN, DEFUSR, DEFINT, IF-THEN-ELSE (Multiple), ON ERROR GOTO, RESUME, UNLIST, PAIN, CIRCLE, CONNECT, SYMBOL, GCURSOR, PRINTUSING, DSKOs, BUBO, BUBI, KEYLIST, FIX, CSNG, POINT, VARPTR, TIMES, DAT Es, DSKs, ANPORT, HEXs, FEFTs, OCTs, STRs, STRINGs, XOR IMP MOD, ON TIME GOSUB, IN INTERVAL GOSUB, CSNG, CDBL, CINT.*

*Operating systems include:- UCSD PASCAL, FLEX, CP/M, running, Basic, Fortran, Pascal.*

*Future expansions include:- \*BUBBLE MEMORY \*MODEM \*SOUND SYNTH. and many more.*

# Micro 8 Ltd.

56 Queens Road, Basingstoke, Hants.

Tel: 0256 54057/56417 (4 lines)

To: Micro 8 Ltd., 56 Queens Road, Basingstoke, Hampshire.  
Please send me details of the amazing new Micro 8.

Name..... Company .....

Address .....

..... PCW11

# NEW books from Prentice-Hall International

Seamus Dunn and Valerie Morgan

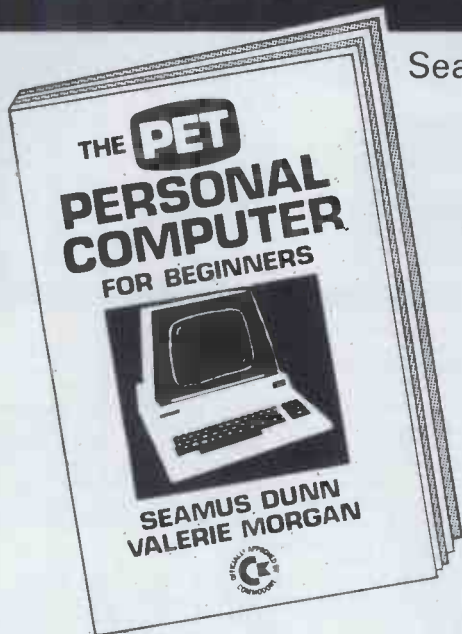

## THE PET PERSONAL COMPUTER FOR BEGINNERS

Written for beginners with no experience of computers, this complete introduction to the Commodore PET gives a very clear explanation of how to operate the PET and make full use of this versatile machine. Eleven compact, carefully sequenced chapters provide detailed descriptions of the PET's different facilities. Each step required to operate the PET is illustrated with sample programs and screen responses. The book is suitable for all versions of the PET, from the original 2001 to the new 8032 SuperPET.

A Commodore Approved Product



- £7.50 hardback 256 pages 13-661835-9  
 £4.95 paperback 13-661827-8 October 1981

Ramon Zamora, William Scarvie and Bob Albrecht  
**PET BASIC 1**

Creative graphics, open page formats and interesting small programs are among the topics covered in this new handbook.

- £13.45 hardback 224 pages 8359-5525-7  
 £9.70 paperback 8359-5524-9 August 1981

Howard Berenbon  
**Mostly BASIC: Applications for Your PET**

Full chapters are included on real-time applications, educational programs, business investment and home applications.

- £7.65 paperback 160 pages 672-21790-2  
 March 1981

Mac Ogelsby  
**PET Games and Recreation**

The activities in this book range from the simple to complex games of deductive reasoning, games of chance, and word and number games.

- £13.45 hardback 248 pages 8359-5530-3  
 £9.70 paperback 8359-5529-X September 1981

J. Downey and S. Rogers  
**PET Interfacing**

This practical book explains how specialised interfaces can be built and used with the PET. Three types of interfacing are covered: the user port, the memory expansion port, and the IEEE 488 port.

- £11.85 paperback 262 pages 672-21795-3  
 July 1981

Richard Gauthier  
**Using the UNIX System**

A full description of the UNIX System, which was designed for both program development and software applications, is given in this book. Topics discussed include a hierarchical file system, asynchronous processing, over 100 sub-systems and utilities, and languages such as FORTRAN 77, FORTRAN VI, PASCAL, BASIC and C.

- £14.20 hardback 298 pages 8359-8164-9  
 October 1981

Prices are correct at the time of going to press but may be subject to change.

### Book Orders:

These books can be ordered from your bookseller or in case of difficulty from Department 30, Prentice-Hall International, 66 Wood Lane End, Hemel Hempstead, Hertfordshire HP2 4RG, England.

Please mark the number of books you wish to order in the boxes beside each title and return the advertisement to the address above with your payment.

Name \_\_\_\_\_

Address \_\_\_\_\_

I enclose a cheque/P.O. for £ \_\_\_\_\_

Please add 55p per book for postage and packing. Payment should be made out to International Book Distributors. Please allow 28 days for delivery.

PCW11

Prentice Hall



International

# GW Computers Ltd

CALLERS BY APPOINTMENT ONLY  
LONDON WC1, TEL NO. 636 8210/631 4818

## SUPERBRAIN



**Intelligent Video Terminal Systems  
350K or 700K of Disk Storage**  
SuperBrain's CP/M operating system boasts an overwhelming amount of available software in BASIC, FORTRAN, COBOL and APL. Whatever your application' ... General Ledger, Accounts Receivable, Payroll, Inventory or Word Processing, SuperBrain is top in its class. And the SuperBrain QD boasts the same powerful performance but also features a double-sided drive system to render more than 700K bytes of disk storage and a full 64K or RAM. All standard!

## COMPUSTAR™



### Functional characteristics

The CompuStar 10 megabyte Disk Storage System (DSS) consists of read/write and control electronics, read/write heads, a track positioning mechanism, a spindle drive mechanism, dual disks, an air filtration system, and our exclusive 255 user controller - all packaged in a compact desktop enclosure. Although designed primarily to accommodate multiple CompuStar Video Processing Units (described at left), the unit can easily be connected to a single SuperBrain Video Computer System to facilitate additional disk storage. When used with CompuStar VDUs, however, the integral Z80 based controller will permit up to 255 users to "share" the resources of the disk with minimal CPU response degradation.

### Read/Write Heads and Disks

The recording media consists of a lubricated thin magnetic oxide coating on a 200mm diameter aluminium substrate. This coating formulation, together with the low load force/low mass Winchester type flying heads, permits reliable contact start/stop operation. Data on each disk surface is read by one read/write head, each of which accesses 256 tracks.

\*\*\* D/SIM \*\*\*

### (DETERMINISTIC SIMULATOR)

01=FILE RELATED TASKS	06=VOCABULARY SECTION
02=FUNCTION TABLES	07=SET RECORD FORMS
03=MATHEMATICS	08=FIELD ATTRIBUTES
04=COMPUTE FUNCTIONS	09=PRINT FORMAT
05=AUTOMATIC PROCESSES	10=DISK SWAP
SELECT ?	

A NEW MODELLING PROGRAM. TOTALLY IN CORE. PROVIDES THE ABILITY TO TABULATE FINANCIAL (AS WELL AS OTHER) DATA AND THEN PROCESS THE DATA UNDER CERTAIN ALTERNATIVE CONDITIONS. SET-UP INITIAL CONDITIONS OF A GIVEN SITUATION AND EVALUATE THE CONSEQUENCES UNDER A GIVEN LOGICAL MODEL. ALTER THE CONDITIONS AND EVALUATE POSSIBLE ALTERNATIVE CONSEQUENCES BEFORE TAKING ACTION.

PRICE (195.00) MAIL ORDER OR 250.00 WITH TRAINING. (MANUAL 20.00)

GRAMA (WINTER) LTD/G.W. COMPUTERS LTD. ARE THE PRODUCERS OF THIS PACKAGE WHICH IS UNEQUALLED FOR ITS LEVEL OF TOTAL INTEGRATION, LINGUISTIC FLEXIBILITY AND MAXIMISED DISK/MEMORY CONSERVATION.

AUTHOR TONY WINTER (M.D.;B.A.LIT;B.A. HON. PHIL;AND LECTURER)

### TWO TYPICAL PACKAGE DEALS.

	NORMALLY
01-SUPERBRAIN 64K RAM 320 K	1950.00
02-EPSON MX80 FT (OR SIMILAR)	450.00
03-CABLE	25.00
04-12 MONTH WARRANTY	235.00
05-DELIVERY IN U.K.	40.00
06-TRAINING SESSION	50.00
07-CPM HANDBOOK	8.75
08-50 BASIC EXERCISES	8.75
09-BOX PAPER (2000 SHEETS)	20.00
10-DBMS (DATABASE)	475.00
11-WORD-STAR (ELSEWHERE 250)	190.00
12-MBASIC-80	150.00
13-SUPER CALC	125.00
14-40 MEMOREX DISKETTES	114.00
15-DOS+ AND DIAGNOSTICS	125.00
16-MSORT & DSORT	75.00
17-RECOVER (ERASED FILES)	25.00
18-INSTANT BASIC	9.00

(NOT INC VAT)

=====  
4075.50

OUR PRICE \*\*\* 2950.00

	NORMALLY
01-SUPERBRAIN 64K RAM 700K	2395.00
02-NEC 5510 (OR SIMILAR)	1695.00
03-CABLE ADAPTER	25.00
04-12 MONTH WARRANTY	410.00
05-DELIVERY IN U.K.	50.00
06-TRAINING SESSION	50.00
07-CPM HANDBOOK	8.75
08-50 BASIS EXERCISES	8.75
09-BOX PAPER (2000 SHEETS)	20.00
10-DBMS (DATABASE)	475.00
11-WORD STAR (ELSEWHERE 250)	190.00
12-MBASIC-80	150.00
13-SUPER CALC	125.00
14-25 DYSAN D/SIDE DISKETTES	150.00
15-DOS+ AND DIAGNOSTICS	125.00
16-MSORT & DSORT	75.00
17-RECOVER (ERASED FILES)	25.00
18-INSTANT BASIC	9.00

(NOT INC VAT)

=====  
5985.50

OUR PRICE \*\*\* 4850.00

WARRANTY NOTE: WE HANDLE ALL REPAIRS OURSELVES. WARRANTY COVERS FREE REPLACEMENT EQUIPMENT IF DEFECTIVE IN FIRST THREE WEEKS. THEREAFTER UP TO 12 MONTHS THE COVER PROVIDES INSURANCE ON ALL SPARE PARTS AND LABOUR COSTS (EXCLUDING CARRIAGE). CALL OUT MAINTAINANCE IS ALSO AVAILABLE AT 25.00 MINIMUM (LONDON) 50.00 MINIMUM ELSEWHERE IN U.K. PLUS MILEAGE.

CORRESPONDENCE ADDRESS ONLY: 55 BEDFORD COURT MANSIONS, BEDFORD AVENUE, LONDON WC1,

**\*\*\* BUS \*\*\***  
**(BUSINESS EFFICIENCY)**

**WIDELY USED IN UK/France/USA AND ENGLISH SPEAKING COUNTRIES FOR ITS  
OVERALL FLEXIBILITY AS A COMPLETE BUSINESS PACKAGE.**

Includes Inventory, Database, Management, Invoicing, Mailing Addresses, Statements, Sales/Purchase Ledger  
with or without Auto Stock Update and Double Entry Journals including Nominal Ledger; plus A/C Receivable  
and Payable making Auto Bank entries.

01= NAMES AND ADDRESS	07=BANK UPDATE	13=STATEMENTS	19=DIARY REMINDER
02=STOCK CONTROL	08=USER DATABASE AREA	14= TAX REPORTS	20=COMPUTE FUNCTIONS (+)
03=OPEN SALES LEDGER	09=INVOICE CREATION	15=AGED ANALYSIS	21=FILE MAINTAINANCE
04=OPEN PURCHASE LEDGER	10=ORDER FILES	16=MANAGEMENT ANALYSIS	22=CALL OTHER PROGRAMS
05=GENERAL SALES LEDGER	11=TEXT FILES	17=CASHFLOW FORECAST	23=AUTOMATIC DRIVE (+)
06=GENERAL PURCHASE LEDGER	12=EMPLOYEE FILES	18=PARAMETER SECTION	24=DISK SWAP/EXIT SYSTEM

**WHICH OPTION**

SUB-MENU EXAMPLES:

- >Quit or .Random or .Sequential or .Key sorted field or .Other functions
- >Quit or .All or .Part or .Specific
- >Quit or .Fast screen or .Slow screen or .Rapid print or .Pausing print
- >Quit or .Continue or .Amend or .Delete or .Print
- >Quit or .Double entry or .Alter filename or .Echo input or .Print options
- >Quit or .Mail ticket or .Columnated or .Raw data line
- >Quit or .Add or .Subtract or .Multiply or .Divide
- >Quit or .Greater or .Smaller or .Cross refer two files

(LEVEL 8.00 @ 975.00)  
(LEVEL 9.00 @ 1075.00)

++++++ SUPER - BUS ++++++ A NEW HIGHER LEVEL OF THE ABOVE PACKAGE. . . . HAS BEEN REDUCED IN SIZE BY  
50 PER CENT TO A SINGLE 15K BASIC PROGRAM, MAKING ALL FILE RETRIEVALS A MATTER OF NANOSECONDS. WORKS  
UNDER M/PM AND COMPUSTAR FOR COMMON DATA RETRIEVAL LEVEL 10.00 . . . . \*\*\*\*\* 1475.00 \*\*\*\*\*

DBMS (DATABASE) HAS 01=.02=.04=.06=.07=.08=.17=.18=.21=.24=. PRICE 475.00

DATABASE FEATURES ARE: . . . . . FOR ANY SIZE RECORD UP TO TWENTY FOUR FIELDS FILE ARCHITECTURES CAN BE DESIGNED  
WITH COMPLETE FREEDOM OVER THE LINGUISTIC CONVENTIONS ASSIGNED TO EACH FIELD. THE FILE THEN CAN STORE 32000  
RECORDS WHICH CAN BE SEARCHED BY THE RANDOM ACCESS NUMBER (RETRIEVED IN LESS THAN ONE SECOND) OR 'KEY'  
RANDOM ACCESS ON SPECIFIED FIELD OR SEQUENTIALLY COMPARING FOR LEFT FIELD PARTS, FIELD-INKEYS, OR PARTS OF  
RECORD, AND THEN CHANGED, PRINTED, DELETED, SKIPPED.

GRAMA (WINTER) LTD/G.W. COMPUTERS LTD. ARE THE PRODUCERS OF THIS PACKAGE WHICH IS UNEQUALLED FOR ITS LEVEL OF  
TOTAL INTEGRATION, LINGUISTIC FLEXIBILITY AND MAXIMISED DISK/MEMORY CONSERVATION.  
AUTHOR TONY WINTER (M.D.;B.A.LIT;B.A.HON.PHIL;AND LECTURER)

**DUE TO LONG TERM CONTRACTUAL COMMITMENTS, WE ARE ONLY GIVING RESTRICTED  
DEMONSTRATIONS BY APPOINTMENT AT ONE OF OUR LONDON OFFICES. WE EXPORT TO ALL  
COUNTRIES, TAKE AMEXCO, ACCESS AND BARCLAYCARD.  
CONTACT TONY WINTER ON 01.636.8210 OR 01.631.4818 AND IF UNAVAILABLE THEN LEAVE A  
CALL-BACK MESSAGE (CLEARLY STATING YOUR TELEPHONE NUMBER AND NAME) ON THE  
24-HOUR ANSWER-PHONE, WE CALL BACK ANYWHERE IN THE WORLD.**

**IMPORTANT!!! No hardware is any value without the software, and our software is unequalled. We give you a  
discount to set you going. Just decide on the system you intend purchasing, and take 10% of its value off the price  
you would have to pay for the software. You could get the software free with the hardware if you choose the best  
system we sell.**

SUPERBRAIN * SUPERBRAIN		/ COMPUSTAR * COMPUSTAR		/ PRINTER * PRINTER	
64K + 320 K DISK	1950.00	/ 64K MDL 10 VPU	1695.00	/ OKI MICRO-80	425.00
64K + 700 K DISK	2395.00	/ 64K MDL 15 PRNT	1595.00	/ OKI MICRO-83	795.00
64K + 6.3 M DISK	4595.00	/ 64K MDL 20 VPU	2495.00	/ EPSON MX80F/T	450.00
EMULATOR TERML	495.00	/ 64K MDL 30 VPU	2695.00	/ TEXAS 810	1395.00
INTERTUBE III TML	495.00	/ 64K MDL 40 VPU	2995.00	/ DIABLO 630	1595.00
5 MEG CORVUS. DISK	2250.00	/ 10 MEG INTERTEC	2950.00	/ NEC 5530	1595.00
11 MEG CORVUS	3250.00	/ 32 MEG INTERTEC	7950.00	/ NEC 5510	1695.00
CORDLESS PHONES	135.00	/ 96 MEG INTERTEC	8500.00	/ NEC 5525	1895.00
HIGH RES S/B GRAPH	750.00	/ BUS PROGRAM	975.00	/ QUME 5/55	1950.00
TRACTORS	150.00	/ BUS MANUAL	9.00	/ SHEET FEED	850.00
SHUGART 5 MEG DSK	1250.00	/ S100 CONTROLLER	750.00	/ C.P.M (TM)	FREE.00
SYSTEM 1	2750.00	/ SYSTEM 2	4595.00	/ SYSTEM 3	5750.00
64K+750 K DISK		/ 64K + 6.3 MEG CORVUS		/ 64K + 10 MEG	
CRT AND S100 BUS		/ MICRO-WINCHESTER & CRT		/ CRT AND TWIN 5"	
IN 1 'ARCHIVES' UNIT		/ IN 1 'SUPERBRAIN' UNIT		/ IN 1 MODEL 30 UNIT	
MBASIC 80	150.00	/ FORTRAN-80	200.00	/ COBOL-80	320.00
CIS COBOL	420.00	/ PASCAL UCSD	275.00	/ WORD-STAR	195.00
MAIL MERGE	55.00	/ SUPER SORT	120.00	/ CBASIC	75.00
DATASTAR	190.00	/ BASCOMPILER	190.00	/ MAGIC WAND	175.00
DBMS (DATABASE)	195.00	/ SUPER CALC (CPM)	125.00	/ T/MAKER	150.00
DBMS (EXTENDED)	475.00	/ BUS VER 8.00	975.00	/ BUS.VER 9.00	1075.00
MSORT & DSORT	75.00	/ LETTERIGHT	100.00	/ UTILITIES	75.00

OUR PRICE INCLUDES FREE:

- |                           |                          |                      |
|---------------------------|--------------------------|----------------------|
| TRAINING SESSION          | / 10% ALLOWANCES AGAINST | / ANY SOFTWARE ABOVE |
| CABLES                    | / DELIVERY               | / 5-50 DISKS *****   |
| EXTENDED WARRANTY IF REQD | / 6/12 MTH WARRANTY      | / 24/48 HOUR REPAIR  |
| CPM HANDBOOK              | / RIBBONS & THIMBLES     | / MANUALS            |
|                           | / BASIC MANUAL           | / 2000 SHEETS PAPER  |

IF YOU WISH TO MAKE THE WARRANTY TO 1 YEAR THEN ADD 5% OF HARDWARE COST. OTHERWISE NO MAINTENANCE  
SCHEDULE, SIMPLY AD-HOC CHARGES AFTER WARRANTY EXPIRATION, SAME QUALITY SERVICE.

DOS + AND DIAGNOSTICS FOR SUPERBRAIN SPECIAL . . . . 125.00 . . . . . REPEAT KEY AUTO-LOAD, RAM CHIP TEST,  
FAST FORMAT BOTH DRIVES, FAST COPY TRACK TO TRACK TPU TEST, RS232 TEST, SCREEN TEST, DISK TEST (VARI-  
OUS), DISK I/O TEST.

MAIL ADDRESS G.W. COMPUTERS LTD. 55 BEDFORD COURT MANS. BEDFORD AVENUE. W.C.1.

**DUE TO LONG TERM CONTRACTUAL COMMITMENTS WE ARE ONLY ABLE TO GIVE RESTRICTED  
APPOINTMENTS AT ONE OF OUR LONDON OFFICES. CONTACT TONY WINTER ON TELS 01.636.8210  
AND 01.631.4818. ALSO 24 HOUR ANSWERPHONE. IF YOU JUST WANT LITERATURE THEN CLEARLY  
STATE YOUR NAME AND ADDRESS, WE WILL MAIL YOU A STANDARD INFORMATION PACK.**

# GW Computers Ltd

CALLERS BY APPOINTMENT ONLY  
LONDON WC1. TEL NO. 636 8210/631 4818

\*\*\* Introducing the new Bus10.00/Dbms2 \*\*\*

If you are interested enough to study this section of our new manual, then you are probably in need of a program embodying such features. If you understand the text, that is, if at least its meaning is a touchstone that fires your imagination towards grasping it with the mind then you and it are converging.

## \*\*\* MULTIPLE FIELD SEARCHES \*\*\*

### dbms2 and bus10.00

The following trajectory of a file interrogation may be set up and found to be both complex and of considerable power. Try a Sequential search that is Slow and on Multiple fields within a range say of record '1 to 30'. Notice that the cursor prompter will move to the first field in the record form. You will be able to ask any of the following types of questions on each field. When you set the question against that field; if the carriage return is not enabled by the fact that you hit the right-hand-field-bracket, then hit (cr).

There are five types of questions you may ask against a permutation of up to sixteen fields. (Think about them).

**1=straight text identity (P=P)** which is to say that you can enter TONY in a name search where the record may look like TONY WINTER or WINTER TONY. the 'TONY' text is sought for in any part of the field.

**2=Greater than identity (P>Q)** which is to say that you may first enter the symbol > followed by a numeric value (say 100) where the records may possess different ranges of numbers in that field, and you only want 100 upwards.

**3=Smaller than identity (P<Q)** as '2=' above in reverse using <.

**4=Not identical (P<>Q)** which is to say that all records found on other criteria must not possess the stated attribute. (ie: all records with TONY but not in W.C.1.). You must first enter the symbol ~ followed by the criteria that is to be excluded from the comparison.

**5=Either or identity (P~Q)** which is to say that you may search for either TONY or someone in W.C.1. or telephones with a 01 in their number. Note: that only one match of those disjunctive premisses is sufficient to provide the truth condition establishing a match. That is to say you may find records of TONY in Birmingham and FRED in W.C.1. You must first enter the symbol ~ followed by the text. A multiple example is shown below.

Field 01=number	( )	) The question is: ?
Field 02=name	(TONY	) straight text (cr)
Field 03=postcode	(~W.C.1.	) one or
Field 04=town	(~London	) other
Field 05=income	(>5000 )	greater 5000
Field 06=age	(<40 )	younger than 40
Field 07=sex	(~female )	not female

02-025

## \*\*\* MULTIPLE FIELD ATTRIBUTES \*\*\*

### dbms2 and bus10.00

The following is a list of the field attribute arithmetic functions that may be set up against up to 16 fields per record and found to be both complex and of considerable power.

fn1=Multiply one field against another and total per record/file. fn3=Divide one field from another and total per record/file.

fn2=Add one field against another and total per record/file. fn4=Subtract one field by another and total per record/file.

fn5=Total vertical columns within a file of records. The result per record and per file.

fn6=Calculate a percentage of the value of one field and if the toggle is set to 1 then add that result to the field; whereas if the toggle is set to -1 then simply store the result.

Example:

record.5 . . . . . computed values . . . . .  
record . . . . . file . . . . .

Field 01=number	(5 )		
Field 02=number	(MICRO )		
Field 03=quantity	(50 )	[ 50,000.00 ]	[ 70,000.00 ]
Field 04=s.price	(1000.00 )	[ 150.00 ]	[ 170.00 ]
Field 05=profit	(250.00 )	[ .25 ]	[ .27 ]
Field 06=cost	(800.00 )	[ 1,000.00 ]	[ 1,145.00 ]
Field 07=allocated	(20 )	[ 30.00 ]	[ 450.00 ]

The two results to the right of the record show the use of several of the functions listed above.

Field 03 function 1 (03 \* 04) has a value of 50,000.00 pounds worth of 'MICROS' for the number '5' and 70,000.00 pounds worth of for all such records so far scanned.

Field 04 functions 6 'toggle -1' (04 \* .15) has the increase that is required to raise the price of record '5' by 15%, and so on averaging for all such records.

Field 05 function 3 (05 / 04) has the value of itself divided by the value found in field 04, for the record and all such records scanned. (profit margin ?).

Field 06 function 6 'toggle 1' (06 \* 1.25) has the value of record '5' as if it were subject to an increase of 25%, and all such records scanned.

Field 07 functions 4 (03 - 07) has the quantity remaining in stock after allocations are subtracted.

You have a combination of multiple field searches of 5 TYPES and multiple compute functions of 10 TYPES against up to 16 fields, using words you choose and printing only those columns in the order you desire in one SINGLE CORE PROGRAM.

02-026

contact:

G.W. COMPUTERS LTD.

55 BEDFORD COURT MANSIONS, BEDFORD AVENUE LONDON W.C.1.

TEL. 01-636 8210 / 01-631 4818 TELEX 892031 TWC G

Also incorporated in Boston U.S.A.

BUS PROGRAM MANUAL VERSION 8.00-10.00 AND DBMS (SUBSET OF ABOVE)

AUTHOR: TONY WINTER B.A.LIT:B.A.HON.PHIL. AND LECTURER

GRAMA WINTER CALLERS BY APPOINTMENT ONLY  
LONDON WC1. TEL NO. 636 8210/631 4818

## WIDEBAND SPEAKEASY



- Speech output for any Micro can be used with the Acorn, Pet, ZX81, Apple, NSH etc.
- Uses Phoneme Access to produce clear and true speech
- Has INFINITE Vocabulary
- Comes complete with PSU and speaker
- Software and Manual included

only **£89** + VAT

Cable **£9.50** + VAT

Extra Dictionary **£2.50** + VAT P + P **£4.50** + VAT

*Votrax*

## TYPE 'N TALK

text to speech synthesizer. Connects into any RS232 line between a computer and terminal and speaks any English text with unlimited vocabulary permitting VDU and speech data on a single channel. It has 750 char. buffer and micro processor. Ideal for voice response business systems, games, computer aided learning, terminals for the blind.

## IA SMALL ARM ROBOT



- Low cost Robot Arm
- Wrist, hand, elbow, shoulder movement
- Can be used with any micro
- Parallel input
- Suitable for Pet User Port etc.
- Ideal for Education, Industrial Training, developing robot control software etc.

Only **£349** + VAT

Cable **£9.50** P + P **£15** + VAT

## WIDEBAND CONTROLLER

Controller Card capable of driving six stepping motors and 3 solenoids

- Parallel input
- Suitable for Pet user port etc
- Six 16-volt outputs
- 3, 1 amp solenoid outputs
- own integral power supply

Only **£148** + VAT Cable **£9.50**

**Intelligent Artefacts Limited**

Cambridge Road, Orwell, Royston, Herts. SG8 5QD  
Tel: CAMBRIDGE (0223) 207689

# **“If it wasn’t for me, the Russians would have invaded Poland last night?”**

Whether your kind of fun is saving Europe in a war game, sharpening your chess strategy or piloting a 747, computer games reach new levels of exhilaration in terms of excitement, intellect and dexterity.

And, to help you get the most fun out of your computer, there’s a brand new monthly magazine: Computer & Video Games.

It brings the best entertainment out of all types of computer, from personal Sinclairs, Ataris, Tandys, VICs, Apples and PETs right up to mainframe IBMs.

Every issue’s packed with pages of games listings for you to program. And you don’t have to be a computer expert.

Each month there’s reviews of new computer and video games, regular pages on chess, bridge and mainframe games. Brush up or learn programming with our regular workshop, and discover the fun of creating graphics and adding sound to the games you invent yourself. There’s also regular brain teasers (some with prizes) plus the secrets of beating arcade video machines.



Computer & Video Games is packed with new levels of stimulation for people who get fun out of computers.

The first great issue is out today at all good newsagents. And, on the front cover you'll find some free brain torture in the form of the most tantalising little puzzle since Rubik's cube.

It *can* be solved mathematically so you should be able to write the program. But if you fail, you've got four whole weeks of frustration because the solution's not available till the second issue.

I would like to take out an annual subscription. I enclose a cheque/P.O. for £10, (£20 overseas) for twelve issues. Computer & Video Games, Bretton Court, Bretton, Peterborough PE3 8DZ.

Name \_\_\_\_\_

Address \_\_\_\_\_

PCW1

**Computer  
& Video Games.**  
The magazine that makes computers fun.

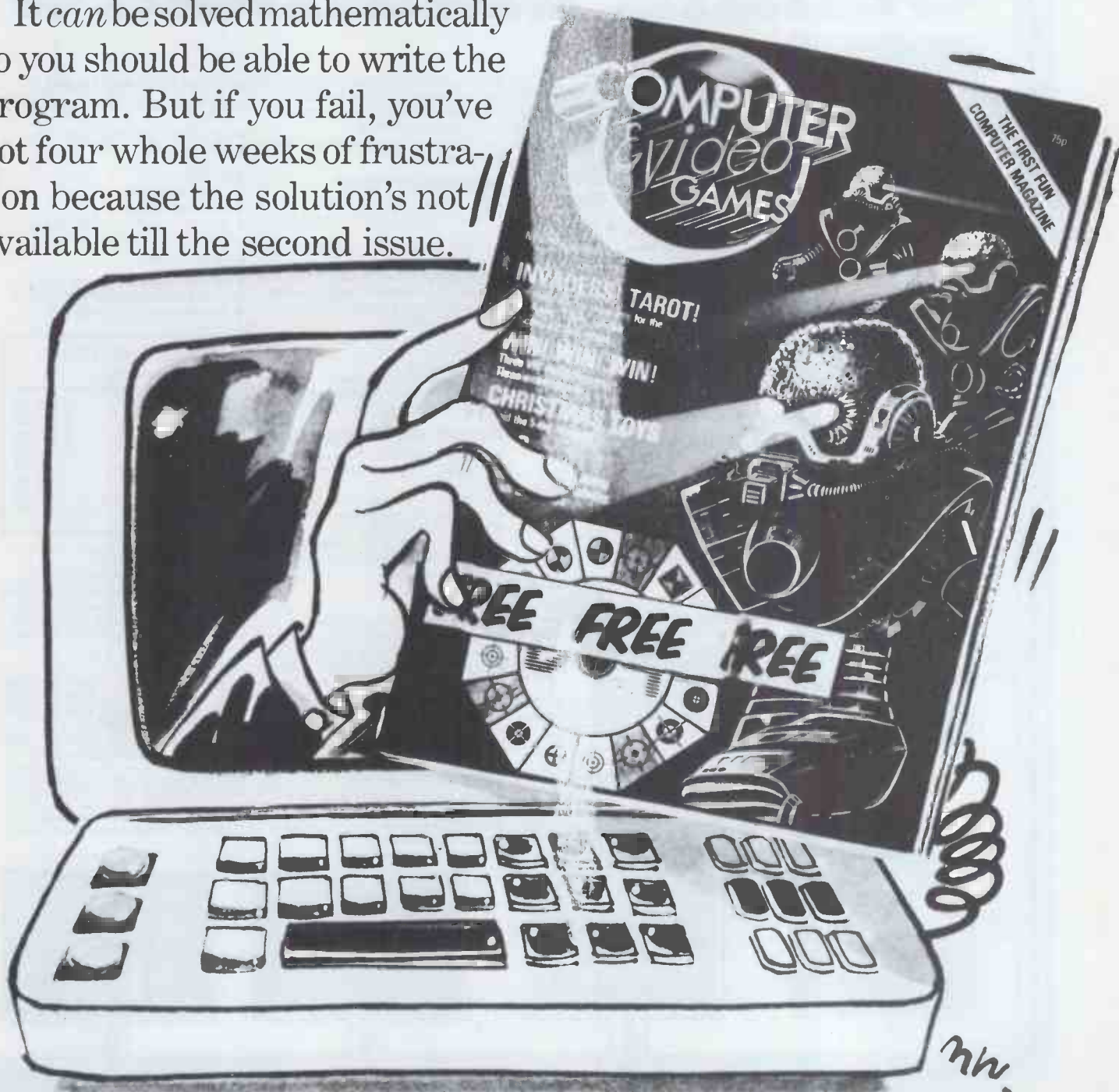

The first issue is at your newsagent now.

# MicroValue

# New British Microsystem. Gemini MultiBoard



● Eight boards available NOW ● 8" x 8" board modules ● Z80A CPU board ● Z80A Video board ● 64K RAM ● Built and tested

Developed by one of the most experienced micro board design teams in the UK, Gemini MultiBoard\* is the ultimate modular board system. Unlike most systems of its kind, virtually nothing is made redundant when you expand it. And for those who want expansion this can be immediate, for we are launching eight boards simultaneously. No other system has offered so much so soon.

All MultiBoard modules are Nasbus† and Gemini 80-BUS\* compatible and can be used in a wide spectrum of application, e.g. educational, personal, business, system development and process/production control.

MultiBoard modules are built and tested to the highest standards. And offer enormous computing power and potential at astonishingly low cost.

## MultiBoard Modules available now

### Z80A CPU

**Processor:** Z80A CPU at 4MHz. Optional wait-states. Reset jump to any 4K boundary.

**Parallel I/O:** 8 bit ASCII keyboard socket. Uncommitted Z80A PIO giving two 8 bit bi-directional ports with handshake.

**Serial I/O:** 8250 UART with programmable baud rates and software selectable between RS232 or 1200 baud CUTS cassette interfaces.

**Memory:** 4 'ByteWide' sockets to accept EPROM/ROM/RAM. Memory switched in/out of memory map under software control.

**Software:** Comprehensive monitor. Optional 12K Microsoft BASIC (ROM). Standard configuration PROM provides decodes for 4 x 2732 (4K x 8) EPROMs.

The CPU Board is fully buffered to the Gemini 80-BUS standard.

### INTELLIGENT VIDEO

- Z80A microprocessor controlled.
- 80 x 25 display controlled by 6845 CRTG chip.
- Adjustable dot clock for alternative screen formats.
- Character set: 128 in EPROM + 128 in RAM which can be defined as the video inverse of the main set or as block graphics with 160 x 75 resolution.
- I/O port communication with host computer.
- Light pen socket.
- 8-bit input port allowing several video boards (each with its own keyboard) to be connected to a single CPU board.

### FLOPPY DISK CONTROLLER

- Controls: Pertec FD250 5.25in 48 TPI, Micropolis 1015 5.25in 96 TPI, Pertec FD650 8in.
- Controls up to 4 drives of same type.
- Single/double density software selectable.
- Single or double sided.
- Western Digital FD1797 controller.
- Up to 8 drives (2 boards) can be used in the same system.

### 64K RAM

- Runs at 4MHz with no wait-states.
- 4 banks of 16K dynamic RAM, each bank locatable on any 4K address boundary.
- Page Mode supplied as standard allowing up to 4 memory boards to be addressed.
- All the memory can be used by switching out on-board CPU memory, e.g. in disk environment.

### EPROM/ROM BOARD

- Accepts up to 40K of firmware.
- 4 banks of 4 sockets.
- Banks can be mixed between 2708 or 2716.
- 24-pin ROM socket.
- Wait-state generator.
- Supports Page Mode scheme.

### EPROM PROGRAMMER

- Programs multi-rail 2708 or single rail 2716.
- Connects to PIO on CPU board.
- Software provided on tape.

### 3A PSU

- Supplies 4/5 boards.
- LED on each output.
- +5V at 3A; +12 at 1A; -5V at 1A; -12V at 80mA.

### KEYBOARD

- Full alpha-numeric ● 59-keys ASCII encoded ● Exclusively designed for Gemini
- Auto repeat ● Cursor control keys

### MULTIBOARD PRICES

(excl VAT)

(All built and tested except where marked)	
CPU (G811).....	£125.00
Video (G812).....	£140.00
64K RAM (G802).....	£140.00
FDC (G809).....	£140.00
EPROM/ROM (G803).....	£ 70.00
EPROM PROG. (G808) Kit.....	£ 29.50
3A PSU (G807).....	£ 40.00
Keyboard (G613).....	£ 57.50

### FLOPPY DISK UNIT

Gemini unit suitable for MultiBoard. Holds one or two 5 1/4 in double sided, double density Pertec drives. Integral power supply. Price £375 plus VAT for one drive, £575 plus VAT for two drives. CP/M2.2 and documentation £90 plus VAT.

KENILWORTH CASE for MultiBoard .....	£49.50 + VAT
5-Card Support Kit.....	£19.50 + VAT
VERO Frame.....	£32.50 + VAT
(also suitable for Nascom)	
PSU Enclosure Kit .....	£24.50 + VAT
KEYBOARD enclosures available soon.	

MultiBoard Modules are available from the MicroValue dealers listed on facing page.

\* Trademarks of Gemini Microcomputers Limited  
† Trademarks of Nascom Microcomputers Division of Lucas Logic

‡ Trademarks of Digital Research Inc.

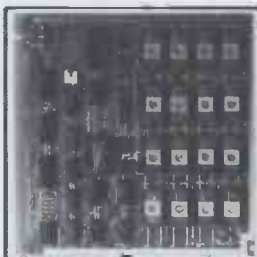
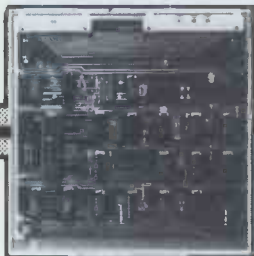
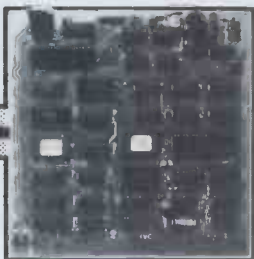

# MicroValue

## COMPATIBLE Nasbus products from your MicroValue Dealers

### GEMINI G805 FLOPPY DISK SYSTEM FOR NASCOM-1 & 2

It's here at last. A floppy disk system and CP/M CP/M SYSTEM. The disk unit comes fully assembled complete with one or two 5 1/4" drives (FD250 double sided, single density) giving 160K per drive, controller card, power supply, interconnects from Nascom-1 or 2 to the FDC card and a second interconnect from the FDC card to two drives, CP/M 1.4 on diskette plus manual, a BIOS EPROM and a new N2MD PROM. All in a stylish enclosure.

Single drive system ..... **£450 + VAT**  
Double drive system ..... **£640 + VAT**  
Additional FD250 drives ..... **£205 + VAT**

**D-DOS SYSTEM.** The disk unit is also available without CP/M to enable existing Nas-Sys software to be used. Simple read, write routines are supplied in EPROM. The unit plugs straight into the Nascom PIO. Single drive system **£395 + VAT**

**DCS-DOS** A greatly enhanced version of D-DOS, running under Nas-Sys. Gives named files in BASIC, ZEAP, NAS-PEN and machine code programs ..... **£50 + VAT**

### DISKPEN

The powerful text editor written for the Nascom is now available on a 5 1/4 inch floppy disk with a number of new features. **Price £43.25 + VAT.**

### NASCOM COMPUTERS

NASCOM-2 Microcomputer Kit

**£225 + VAT**

NASCOM-1 Microcomputer Kit

**£125 + VAT**

Built and tested **£140 + VAT**

16K RAM KIT ..... **£100 + VAT**

3A PSU KIT ..... **£32.50 + VAT**

### KENILWORTH CASE FOR NASCOM-2

The Kenilworth case is a professional case designed specifically for the Nascom-2 and up to four additional 8" x 8" cards. It has hardwood slide panels and a plastic coated steel base and cover. A fully cut back panel will accept a fan, UHF and video connectors and up to 8 D-type connectors. The basic case accepts the N2 board, PSU and keyboard. Optional support kits are available for 2 and 5 card expansion.

Kenilworth case ..... **£49.50 + VAT**

2-card support kit ..... **£7.50 + VAT**

5-card support kit ..... **£19.50 + VAT**

### CASSETTE ENHANCING UNIT

The Castle interface is a built and tested add-on unit which lifts the Nascom-2 into the class of the fully professional computer. It mutes spurious output from cassette recorder switching, adds motor control facilities, automatically switches output between cassette and printer, simplifies 2400 baud cassette operating and provides true RS232C handshake.

Castle Interface Unit ..... **£17.50 + VAT**

STOP PRESS · STOP PRESS · STOP PRESS · STOP PRESS · STOP PRESS · STOP PRESS

### Exclusive MicroValue Money Savers

#### SAVE £200

Sharp MZ80K + Prog. Character Generator  
+ 5 Quantum games tapes

- Normal price £645 + VAT  
MicroValue price **£445 + VAT**

#### SAVE £156

Nascom Imp printer + Imprint text editor

- Normal price £355 + VAT  
MicroValue price **£199 + VAT**

#### SAVE £110

Epson MX80 F/T1 + High Res. Graphics

- Normal price £460 + VAT  
MicroValue Price **£350 + VAT**

#### SAVE £97.50

Nascom 2 + Nas-Sys 3 + Programmers Aid

- Normal price £392.50 + VAT  
MicroValue price **£295 + VAT**

### A-D CONVERTER

For really interesting and useful interactions with the 'outside world' the Milham analogue to digital converter is a must. This 8-bit converter is multiplexed between four channels - all software selectable. Sampling rate is 4KHz. Sensitivity is adjustable. Typical applications include temperature measurement, voice analysis, joystick tracking and voltage measurement. It is supplied built and tested with extensive software and easy connection to the Nascom PIO. Milham A-D Converter (built and tested) ..... **£49.50 + VAT**

### PROGRAMMER'S AID

For Nascom ROM BASIC running under Nas-Sys. Supplied in 2 x 2708 EPROMs. Features include: auto line numbering; intelligent renumbering; program appending; line deletion; hexadecimal conversion; recompression of reserved words; auto repeat; and printer handshake routines. When ordering please state whether this is to be used with Nas-Sys 1 or 3. **Price £28 + VAT.**

### GEMINI 'SUPERMUM'

12 x 8 piggy-back board for Nascom-1 offering five-slot motherboard, quality 5A power supply and reliable buffering with reset jump facility. **Kit Price £85 + VAT.**

### CENTRONICS 737 MICRO PRINTER

A high performance, low price, dot-matrix printer that runs at 80cps (proportional) and 50cps (monospaced). This new printer gives text processing quality print. And can print subscripts and superscripts. It has 3-way paper handling and parallel interface as standard. Serial interface is optional. **Price £375 + VAT.** Fanfold paper (2000 sheets) **£18 + VAT.**

### BITS & PC's PCG

5 x 4 board which plugs straight into Nascom-2. Operates on cell structure of 128 dots, producing 64 different cells. Once defined, each cell may be placed anywhere, any number of times on screen simultaneously. Max screen capacity: 768 cells. Dot resolution: 384 x 256 98304. Many other features including intermixing of alpha-numeric characters and pixels. **Price (kit) £60 + VAT.**

### PORT PROBE

Allows monitoring of input and output of Nascom PIO. This board can generate interrupts and simulate handshake control. **Price (kit) £17.50 + VAT.**

All prices are correct at time of going to press and are effective 1st July 1981.

### HEX & CONTROL KEYPADS

Hexadecimal scratchpad keyboard kit for N1/2. **Price £34 + VAT.**

As above but including (on the same board) a control keypad kit to add N2 control keys to N1. **Price £40.50 + VAT.**

### BASIC PROGRAMMER'S AID

Supplied on tape for N1/2 running Nas-Sys and Nascom ROM BASIC. Features include auto line number, full cross-reference listing, delete lines, find, compacting command, plus a comprehensive line re-numbering facility. **Price £13 + VAT.**

### 'SCREENPLUS'

Screenplus enables a programmer to blank or display in reverse video, selected words, letters or areas of the screen under program control. Suitable for use with either Nascom 1 or 2. 'Screenplus' (built and tested) ..... **£40.00 + VAT.**

### DUAL MONITOR BOARD

A piggy-back board that allows N1 users to switch rapidly between two separate operating systems. **Price (kit) £6.50 + VAT.**

### YOUR LOCAL MICROVALUE DEALER

All the products on these two pages are available while stocks last from the MicroValue dealers listed below. (Mail order enquiries should telephone for delivery dates and post and packing costs.) Access and Barclaycard welcome.

**BITS & PC'S**  
4 Westgate, Wetherby, W. Yorks.  
Tel: (0937) 63774.

**BUSINESS & LEISURE  
MICROCOMPUTERS**  
16 The Square, Kenilworth, Warks.  
Tel: (0926) 512127.

**ELECTROVALUE LTD.**  
680 Burnage Lane, Burnage,  
Manchester M19 1NA.  
Tel: (061) 432 4945.  
28 St Judes, Englefield Green,  
Egham, Surrey TW20 0HB.  
Tel: (0784) 33603. Tlx: 264475.



**TARGET ELECTRONICS**  
16 Cherry Lane, Bristol BS1 3NG.  
Tel: (0272) 421196.

**INTERFACE COMPONENTS LTD.**  
Oakfield Corner, Sycamore Road,  
Amersham, Bucks.  
Tel: (02403) 22307. Tlx: 837788.

**HENRY'S RADIO**  
404 Edgware Road, London W2.  
Tel: (01) 402 6822.  
Tlx: 262284 (quote ref: 1400).

# Pete & Pam Computers



APPLE SYSTEM SALES AND SERVICE  
IN BOTH LONDON AND LANCASHIRE

Competitive Quotes and Personal Service

Ring Chris Gillard in London — Pete or Pam Fisher in Lancashire

We welcome dealer enquiries. All the products we advertise are available from your local dealer

<b>RAMCARD</b> A 16K Expansion card for your Apple. It will provide additional memory for Visicalc, load integer from a System Master and is fully compatible with Apple's Pascal System. The only board with Neon Read/Write indicators. The only card with data bus lines for faster data retrieval.	<b>£99.95</b>
<b>Z-80 SOFTCARD</b> A Z-80 microprocessor for Apple. Comes with CP/M operating system and Microsoft Basic 5. Free until January 1st — Olympic Decathlon game disk — value £13.95 with every card.	<b>£195.00</b>
<b>COBOL 80</b>	<b>£299.00</b>
<b>FORTRAN 80</b>	<b>£109.95</b>
<b>BASIC COMPILER</b>	<b>£199.00</b>
<b>ASSEMBLY LANGUAGE DEVELOPMENT</b>	<b>£79.00</b>
<b>80 COLUMN BOARDS</b> Take your pick —	
<b>SUP-B-TERMINAL</b>	<b>£195.00</b>
<b>VIDEX</b>	<b>£185.00</b>
<b>PASCAL JOB CONTROL SYSTEM — From High Technology.</b>	<b>£205.00</b>
A fast, sophisticated job control/costing system able to control costs on 400 jobs, providing useful reports and maintaining 50 cost centres with 500 sub cost centres. Worth its weight in gold!	
<b>DB MASTER</b> The Data Base with 100 fields operating on multi-diskette files for large capacity.	<b>£129.95</b>
<b>DB MASTER Utility Pack No. 1</b> Links DB master with Apple Text Files and Visicalc 3.3. Add, delete or change existing DB Master fields and more.	<b>£60</b>
<b>DB MASTER for Corvus available soon</b>	<b>£295</b>
<b>INFORMATION MASTER — Data Base</b> A dream to use, has advanced facilities such as global change and calculator mode of entering figures. A system that a novice can use with ease.	<b>£79.00</b>
<b>DATA MASTER</b> A utility for use with Information Master. Allows the splitting of a data base system selectively change of field types and transfer of print formats.	<b>£55.00</b>
<b>TRANSIT</b> A utility that enables you to link Information Master to many files including those created by Visicalc.	<b>£29.00</b>
<b>VISICALC 3.3</b> At last — Visicalc on 16 sector DOS 3.3 with 12 additional commands. Enhanced Manual is included.	<b>Our Price £105.00</b>
<b>VISIDEX</b> New from Personal Software. Type in whatever key words. Phase dates or numbers you want the info to be associated with and store it away.	<b>£105.00</b>
<b>VISITERM</b> Allows your computer to communicate with larger computers or other personal computers. Link your personal computer with your company's mainframe.	<b>£79.00</b>
<b>VISIPILOT</b> Automatically creates high resolution graphs and charts. Visualise data in six different formats and six different colours. Data can be directly entered or data files loaded from Visicalc 3.3.	<b>£85.00</b>
<b>VISITREND</b> Allows you to perform sophisticated math operations on time series data such as stock prices or production figures. Includes Multi line regress, cumulative total, percent change, lead/lag moving averages, smoothing and various transformations which let you create new time series. This package also includes Visipilot.	<b>£129.00</b>
<b>WORDSTAR for Apple</b> If you want the best in word processing for Apple then Wordstar is the answer. Very well documented and great to use. Require the installation of a Z-80 Softcard.	<b>£179.00</b>
<b>MAILMERGE</b> Allows you to maintain name and address lists and merge fields into text to form personalised letters etc.	<b>£69.00</b>
<b>Z TERM</b> Software that allows you to emulate the terminal of your choice whilst using Apple with a Z-80 Softcard.	<b>£59.95</b>
<b>THE MILL</b> A 6809 plug-in board for Apple can run at full speed whilst the 6502 runs at 20%. Comes with either a Pascal speed-up kit to increase the speed of execution of Apple's U65D Pascal or a 6809 assembler.	<b>£249.95</b>
<b>DAKIN 5 PROG AIDS 3.3</b> 12 Utility Programmes in one pack.	<b>£49.00</b>
<b>APPLE HOW TO</b> Requires Int Basic or 16K Expansion Card — teaches calculating and programming.	<b>£29.95</b>
<b>APPLE MUSIC MEMORY</b>	<b>£29.95</b>
<b>RAMEX 16</b> UK entrant to the expansion card market — does not need to be ribboned to the memory area.	<b>£89.95</b>
<b>ECHO II Speech Synthesizer</b> Based on TMS 5200 chip from TI — type in speech direct from the keyboard.	<b>£139.95</b>
<b>EXPANSION CHASSIS</b> Long awaited — here at last. More slots for your Apple.	<b>£399.00</b>
<b>MOUNTAIN CPS — multi-function card</b> A bi-directional serial interface — parallel port and clock/calendar card — all on one board. Can be made to use phantom slots.	<b>£159.95</b>
<b>MEMORY MANAGEMENT SYSTEM</b> A utility that moves DOS onto a 16K expansion card — freeing motherboard Ram space for larger programs.	<b>£29.00</b>
<b>VERSA WRITER</b> Superb graphics tablet from Versa Computing. You don't have to go to the expense of an Apple graphics tablet for graphics capability.	<b>£149.95</b>
<b>VERSA EXPANSION SOFTWARE</b> Auxiliary Pack for the Versawriter includes the ability to draw in fine detail using magnification mode.	<b>£20.95</b>
<b>VERSA EXPANDER PORT</b> An expansion cable and ZIP socket for the Apple game I/O socket allows zero insertion force of peripherals requiring connection to game socket.	<b>£12.95</b>
<b>GRAPPLER FROM ORANGE MICRO</b> An interface for the Epson MX 80 and 100 that obeys Apple protocols and has a graphics dump programme in ROM producing 2 sizes of picture and 360 degrees rotation with positive or negative image.	<b>£99.00</b>
<b>OLYMPIA SCRIPIA ESW K8P-100</b> Daisywheel printer with keyboard. A little slow (17 characters per second) but with excellent print quality.	<b>£950.00</b>
<b>EPSON MX-80 F/T</b> 9 x 9 matrix printer with friction and tractor feed.	<b>£398.00</b>
<b>EPSON MX-80 T</b> Tractor feed only.	<b>£349.00</b>
<b>INTERFACE AND CABLE</b> For the above (non-graphic).	<b>£65.00</b>
<b>AIO INTERFACE FROM SSM</b> A parallel and serial interface on one board.	<b>£119.95</b>
<b>MACHINE COVERS</b> only the best material used	
Apple only	<b>£5.95</b>
Single disk	<b>£2.95</b>
2 stacked disks	<b>£4.95</b>
Apple, 2 disks and 9" monitor or Apple and 12" monitor	<b>£8.95</b>
Apple and 2 disk	<b>£7.95</b>
EPSON MX 70/80	<b>£5.45</b>

## High Technology

We make our competition obsolete

with Information Master,<sup>TM</sup> Data Master,<sup>TM</sup> and Transit.<sup>TM</sup>

Information Master is clearly the best information management software available for your Apple II,\* and it's the easiest to use.

Here are two very useful companions that add even more power to Information Master.

- Data Master — Alter the file layout of existing Information Master files without re-entering data. Add, omit, change fields, subdivide and append files selectively.
- Transit — Convert VisiCalc\* files (and almost any other files you may have) into Information Master files.

See your computer dealer today for all the details.

\* VisiCalc is a trademark of Personal Software, Inc. Apple II is a trademark of Apple Computer, Inc.

<b>ABT NUMERICAL KEYPAD</b>	<b>£74.95</b>
<b>SOFTKEY</b> (Basic or Pascal versions available) A 15 key programmable keypad	<b>£99.00</b>
<b>SENSIBLE SOFTWARE UTILITIES</b> Applesoft programme optimiser	<b>£12.95</b>
Multi Disk III	<b>£14.95</b>
Super Disk Copy III	<b>£17.95</b>
DOS Plus	<b>£17.95</b>
Disk Organiser II	<b>£17.95</b>
Disk Recovery	<b>£17.95</b>
Applesoft Plus Structured Basic	<b>£14.95</b>
<b>BENEATH APPLE DOS (no VAT)</b> An excellent book on Apple DOS	<b>£12.95</b>
<b>NEC GREEN SCREEN MONITOR</b>	<b>£169.00</b>
<b>BASF Disks (for 10)</b>	<b>£18.50</b>
<b>OLYMPIC DECLATHLON from Microsoft</b> Superb Hi-Res Graphics — Winner of this year's WCCF prize for creative programming	<b>£12.95</b>
<b>FLIGHT SIMULATOR by Sub-Logic</b> So realistic — you might feel airsick! — be warned!	Disk <b>£19.95</b> Cassette <b>£14.95</b>
<b>DRAGON FIRE from Dakin Corp.</b>	<b>£29.95</b>
<b>WIZARDRY from Sir-Tech</b> PASCAL ADVENTURE needing only 48K	<b>£20.95</b>
Apple Galaxian — Galaxy Wars — Head-On — Galactic Revolution — Galactic Trader — Galactic Empire — Mystery House — Bridge Partner — Checker King — Gammon Gambler — Roulette — Craps — Apple 21 — Puckman — Global War — Space Warrior — Apple Typhoon — Apple Panic — Sneakers — Galactic Attack — Gorgon by Nasir	<b>All at £15.95</b>
Microsoft Adventure — ABM — Dog Fight — Phantoms Five — Orbitron — Pulsar — Microchess 2.0 — Odyssey — La Land Monopoly — Morloc's Tower — Rescue at Rigel — Space Eggs — Trilogy of Games — The Prisoner — Raster Blaster — Autobahn — Space Raiders — Tawala's Last Redoubt — Gamma Goblins — Apple Panic	<b>All at £15.95</b>
Computer Conflict — Computer Quarterback — Carels and Cuthroats — Space Album — Bill Budge 3D Graphics Tutor — Cyber Strike — 3 Mile Island — Adventure 123 — Adventure 456 — Adventure 789 — Hi-Res Soccer — Temples of Apsah — Hellfire Warrior — Zork	<b>All at £20.95</b>
Buy any five games and you can deduct 10% off the total price!	
<b>Authorised Apple Sales and Service</b>	
<b>LONDON RETAIL</b> , 98, Moyer Road, London, SW16 6SH Tel: 01-677 2052/7341	 
<b>MAIL ORDER AND DISTRIBUTION</b> , Watnagte Lodge, Watnagte Close Rossendale, Lancs. BB4 7SO Tel: Rossendale (0706) 227011	
Prices do not include VAT. Please add 15% VAT to your remittance. Postage and packing FREE	



## 74LS SERIES I.C.S

74LS00	0.20	74LS75	0.36	74LS164	0.90	74LS279	0.90
74LS02	0.20	74LS76	0.45	74LS165	1.40	74LS283	1.80
74LS03	0.22	74LS83a	0.70	74LS168	2.00	74LS290	1.10
74LS04	0.20	74LS85	0.80	74LS169	2.00	74LS293	1.10
74LS05	0.30	74LS86	0.40	74LS170	2.50	74LS295a	1.20
74LS08	0.25	74LS90	0.40	74LS173	1.00	74LS298	1.60
74LS09	0.25	74LS92	0.70	74LS174	0.90	74LS299	2.40
74LS10	0.22	74LS93	0.60	74LS175	1.10	74LS323	4.00
74LS11	0.35	74LS95b	0.86	74LS181	3.20	74LS365	0.48
74LS13	0.40	74LS109	0.80	74LS190	1.00	74LS366	0.70
74LS14	0.50	74LS112	1.00	74LS191	1.00	74LS367	0.70
74LS15	0.45	74LS113	0.90	74LS192	1.00	74LS368	1.00
74LS20	0.22	74LS114	0.45	74LS193	1.00	74LS373	1.50
74LS21	0.45	74LS123	0.80	74LS194a	1.20	74LS374	1.50
74LS22	0.45	74LS125a	0.60	74LS195a	1.40	74LS375	1.20
74LS26	0.50	74LS126	0.60	74LS196	1.20	74LS377	1.60
74LS27	0.38	74LS132	0.95	74LS197	1.20	74LS378	2.00
74LS28	0.40	74LS133	0.30	74LS240	1.75	74LS379	1.00
74LS30	0.22	74LS136	0.65	74LS241	1.75	74LS390	1.20
74LS32	0.27	74LS138	0.65	74LS242	1.70	74LS393	1.20
74LS33	0.27	74LS139	0.75	74LS243	1.70	74LS395	1.10
74LS37	0.36	74LS151	1.00	74LS244	1.50	74LS490	1.00
74LS38	0.36	74LS153	0.60	74LS245	2.50	74LS670	2.80
74LS40	0.40	74LS154	2.00	74LS251	1.40		
74LS42	0.70	74LS155	0.90	74LS253	1.40		
74LS47	0.75	74LS156	0.90	74LS256	1.20		
74LS51	0.26	74LS157	0.60	74LS257	1.20		
74LS54	0.33	74LS158	0.90	74LS258	1.60		
74LS55	0.50	74LS160	1.30	74LS259	1.60		
74LS73	0.50	74LS161	0.80	74LS260	0.85		
74LS74	0.27	74LS162	1.40	74LS266	0.80		
74LS74a	0.40	74LS163	1.00	74LS273	1.75		

## MAKE YOUR MICRO TALK TO YOU

WITH

'ELEKTOR' SPEECH SYNTHESISER BOARD. IN CONJUNCTION WITH TEXAS INSTRUMENTS LTD. THIS PROJECT AS FEATURED IN ELEKTOR HAS A LIBRARY OF 400 WORDS WITH FURTHER EXPANSION AVAILABLE. EASILY INTERFACED TO YOUR MICRO KIT OF PARTS INC PCB AND REPRINT OF ARTICLE ONLY £75.90

READY BUILT & TESTED £93.15p

NOTE ALL OUR PRICES

INCLUDE VAT

Send cheque or postal order to Crestway Electronics Ltd., write or ring with your Access/Barclaycard account no. (do not send your card). Please add 40p to all U.K. orders for postage and packing.



### COMPLETE SYSTEM FOR £1190

- 48K Apple II Plus
- \* Disc Drive w/controller
- \* Visicalc or Magic window
- \* Video Monitor
- \* Plus 12 months warranty.

AUTHORISED APPLE SALES AND LEVEL I SERVICE CENTRE

### VERBATIM FLOPPY DISKS

- 5 1/4" 55.5 Density £1.99
- REDUCE ERROR RATE. Use cleaning kit. £16.95
- LOW LOW PRICES



Adventures: Alien Rain - Asteroid - Galaxian - Mystery House - Snoggle All at £9.95

Tarturian - Creature Venture - Apple Panic - STAR Mines - Draw Poker - All at £14.95

Soft-Porn Adventure - The Wizard & The Princess - Space Eggs - Trilogy of Games, Missile Defence

All at £17.95

Hi-Res Soccer ) Wrap Factor - Three Mile Island

at £20.95

VACANCY: Young sales engineer required.

Add 15% VAT DELIVERY IS PAID AT COST

DEANS Of Kensington

191, KENSINGTON HIGH STREET, LONDON W.8.  
Tel. 01-937 7896 Ext. 3.



- MZ-80K, 20K . . . . £389
- PC1211 Computer . . £ 75
- CE121 Interface . . . £ 13
- CE122 Printer . . . . £ 65

PC 1211



Programs in BASIC 1.9k  
Random Access Memory  
"QWERTY" Alphabetic  
Keyboard Long Battery Life

## ATARI

- Atari 400 with 8K RAM - £225
- Atari 400 with 16K RAM - £295
- Atari 800 with 16K RAM - £625

## PRINTERS

### CENTRONICS 737

This versatile printer provides consistently excellent standard print for routine applications. Furthermore, under software control, it will also generate proportionally spaced high density matrix characters of correspondence quality.

- 80 CPS - Proportional Spaced Mode
- 50 CPS - Monospaced Mode
- Proportional Spacing, Plus 10 CP1 and 16.7 CP1
- Nx9 (Proportional) or 7x8 (Monospaced) Dot Matrix
- 3 Way Paper Handling System
- 96 Character ASC11 plus 6 European character sets
- Microprocessor Electronics
- Expanded Print
- Right Margin Justification

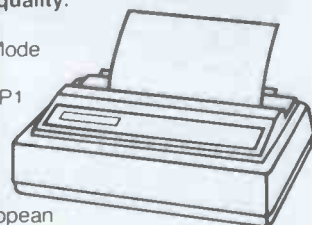

£ 345

+VAT

### EPSON

A FINE RANGE OF PRINTERS WITH ASCII AND GRAPHICS

MX70T, MX80T, MX80FT, MX100FT

+VAT

The VIDEO GENIE SYSTEM EG3003

16K RAM, 12K Microsoft BASIC in ROM  
TRS-80 Level II software compatible.

£ 277

+VAT



LR.COMPUTERS

CHURCHILL CHAMBERS  
92 GEORGE LANE LONDON E18 1JJ 01-989-3259



**TODAY'S BEST  
PRICE/PERFORMANCE  
RATIO FROM  
A MICRO  
COMPUTER**

**£1695**

Standard Model 64K RAM/320 DISK

**ALTERNATIVE MODELS**  
 'QD' 700K DISK £1995  
 'S' 800K DISK plus  
 Function Keys etc £2095

# SUPERBRAIN PACKAGES

The efficient business system consists of standard Superbrain Microline 80 Printer

**£2045**

Complete word processing system - including 'Word Star' and 'Mailmerge', standard Superbrain, Diablo 630 printer and training.

**£3495**



Individual Price: £395 (inc. serial interface)



Microline 80

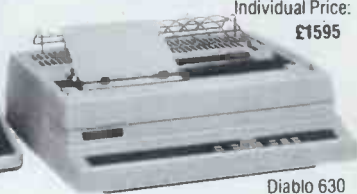

Individual Price: £1595

Diablo 630

**Software Options:** we market a full supporting range of standard languages, including, BASIC @ £175, FORTRAN @ £225, PASCAL @ £225, and CIS COBOL @ £425. We have a growing and comprehensive library of software programmes available:

**Incomplete Records for Practising Accountants @ £750**

**Graphics - Hardware @ £435 with Software from £80**

**Integrated Accounting System - Stock Control @ £350, Order Entry and Invoicing @ £350, Sales Ledger @ £450, Purchase Ledger @ £450, General/Nominal @ £400, Name & Address @ £250, Complete Package so far @ £1650 plus Payroll @ £500.**

**Financial Modelling - T/Maker @ £155 and Micromodeller @ £645.**

**Data Base Management - DMS @ £400 Word Processing - Wordstar @ £250 and Mailmerge @ £75.**

Also available - Form Creation, Debugging etc. Alternatively we will design and implement software packages to suit your specific needs

# KGB

**MICROS LIMITED**

**KGB Micros Ltd., 14 Windsor Road, Slough, Berks. SL1 2EJ Tel: Slough 38581**

Prices exclude V A T and are subject to fluctuation please phone for an up-to-the-minute quote

# MAPLIN for ATARI

AUTHORISED DEALER



## The World-beating ATARI PERSONAL COMPUTERS

3 consoles available

**Atari 400 with 16K RAM (AF36P) £345**

**Atari 400 with 32K RAM (AF37S) £395**

**Atari 800 with 16K RAM (AFO2C) £645**  
(expandable to 48K)

All consoles when connected to a standard UK colour (or black and white) TV set can generate the most amazing graphics you've ever seen.

### Look at what you get:

- \* Background colour, plotting colour, text colour and border colour settable to any one of 16 colours with 8 levels of illuminance!
- \* Video display has upper and lower case characters with true descenders, double and quad size text and inverse video.
- \* 57-Key keyboard (touch type on Atari 400) and four function keys.
- \* Full screen editing and four-way cursor control.
- \* 29 keystroke graphics and plottable points up to 320 x 192 (160 x 96 only with 8K RAM).
- \* 40 character by 24 line display.
- \* Extended graphics control and high speed action using a DMA chip with its own character set.
- \* Player missile graphics.
- \* Four programmable sound generators can be played individually or together and each has 1785 possible sounds playable at any one of eight volume settings, for game sounds or music.
- \* Full software control of pitch, timbre and duration of notes in 4-octave range.
- \* Four joystick or paddle ports, sounds output to TV.
- \* BASIC cartridge and 10K ROM operating system and full documentation.



Atari 400 Console



Atari 800 Console (with cover removed)

### MORE HARDWARE

- Atari 410 Cassette Recorder (AF28P) £50
- Atari 810 Disk Drive (AF06G) £345
- Atari 822 40-column Thermal Printer (AF04E) £265
- Atari 850 Interface (AF29G) £135
- Joystick Controllers (AC37S) £13.95
- Paddle Controllers (AC29G) £13.95
- 16K RAM Memory Module (AF08J) £65

**MUCH MORE FOR ATARI COMING SOON SOFTWARE**  
SEND S.A.E. NOW FOR OUR LEAFLET (XH52G)

\* \* \* \* \*  
**STOP PRESS ROAD SHOWS**  
 \* \* \* \* \*

- Friday 25th September  
Newcastle Centre Hotel
- Saturday 26th September  
Grosvenor Centre Hotel, Edinburgh
- Sunday 27th September  
Portland Hotel, Manchester
- Monday 28th September  
Birmingham Centre Hotel
- Tuesday 29th September  
Hotel Nelson, Norwich

\* \* \* \* \*  
 For further details phone 0702 554155  
 \* \* \* \* \*

### SPECIAL PACKAGE OFFER

Disk-based system for £725 with Le Stick  
 The Atari 400 Console  
 Special 32K RAM Module  
 Atari 810 Disk Drive  
 Disk Operating System  
 Documentation  
 Interconnecting Leads  
 Everything in "Look at what you get" list.  
 Can any other computer on the market offer all this at anything like this price?

### VERSAWRITER

12½ x 8in. drawing board. Drawing on board is reproduced on TV via Atari with 32K RAM and Disk Drive. Closed areas may be filled in with one of 3 colours. Text may be added in any one of 4 fonts. Paint brush mode: select size of brush and paint away. Air brush mode: shade in your drawing - colour and density is up to you. Plus many more features. S.a.e. for price and further details.

### LE STICK

For Atari Computer or Video Game  
 Replaces standard joystick, but much easier to use. Internal motion detectors sense hand movements. Large pushbutton on top of Stick. Squeeze Stick to freeze motion. A MUST for SPACE INVADERS, STAR RAIDERS & ASTEROIDS.  
**ONLY £24.95 (AC45Y)**

DEALER ENQUIRIES WELCOME



Maplin Electronic Supplies Ltd  
 P.O. Box 3, Rayleigh, Essex.  
 Tel: Southend (0702) 552911/554155

Note: Order codes shown in brackets. Prices firm until 14th November, 1981 and include VAT and Postage and Packing. (Errors excluded).

Demonstrations at our shops NOW  
 See Atari at 284 London Road,  
 Westcliff-on-Sea, Essex.  
 Tel: (0702) 554000 and at  
 159-161 King St., Hammersmith W6.  
 Tel: 01-748 0926

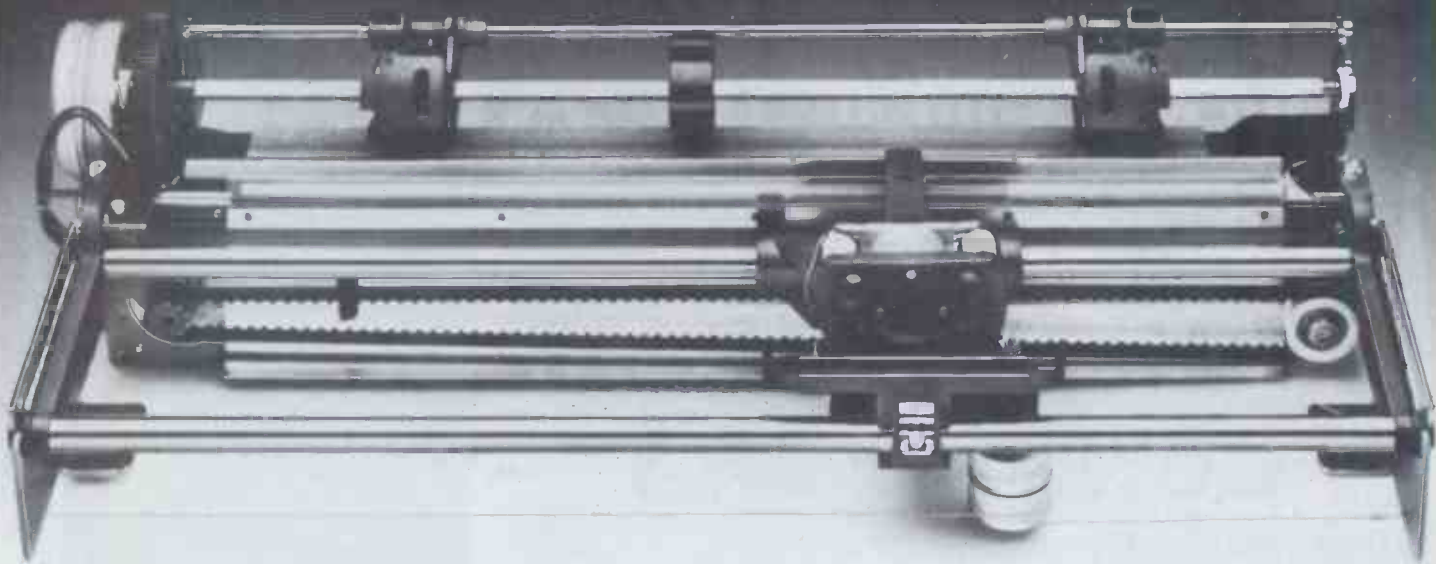

# Straightforward linear design: the secret of the Honeywell Printers' long life.

The rational simplification of the mechanical part maximizes use over long periods, thus reducing the possibility of breakdown to a minimum and at the same time ensuring greater reliability.

The simplification, straightforwardness of design, is a logical consequence of Honeywell's sophisticated technology, a technology born out of many years of experience

in the development of data systems, guaranteeing only the highest quality in Honeywell Printers.

Depending on their utilization, there are Honeywell printing systems capable of 180 cps optimized bidirectional printing with parallel or serial interface of up to 9,600 bps for the best use of the computer.

Easy to service and flexible, Honeywell Printers can easily be adapted to all specific application requirements.

**O.E.M.  
Products**

If you are interested and would like to know more about Honeywell's products please complete the attached form and mail to:

**Honeywell Information Systems Italia**  
Via Tazzoli, 6 - 20154 Milano  
Tel. (02) 6570312 - 6570592 - 6977 - 1  
Telex Milano 311308 HISI

Name \_\_\_\_\_

Position \_\_\_\_\_

Company \_\_\_\_\_

Address \_\_\_\_\_

Tel. \_\_\_\_\_

## Honeywell

Honeywell Information Systems Italia

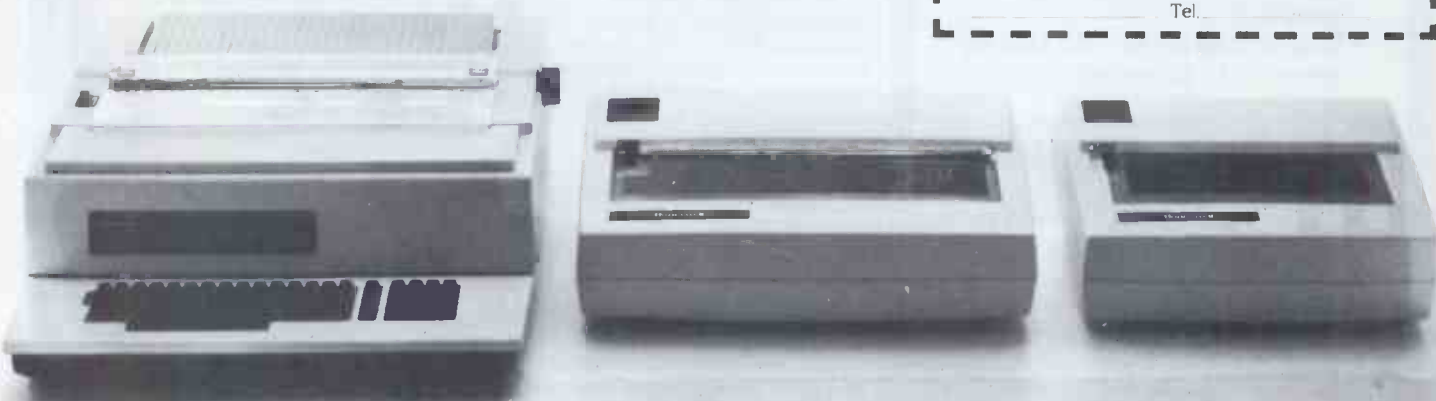



# PIXELPLOTTER™ graphics

— graphics packages for microcomputers and  
intelligent terminals

in service worldwide in industry, science, education and commerce

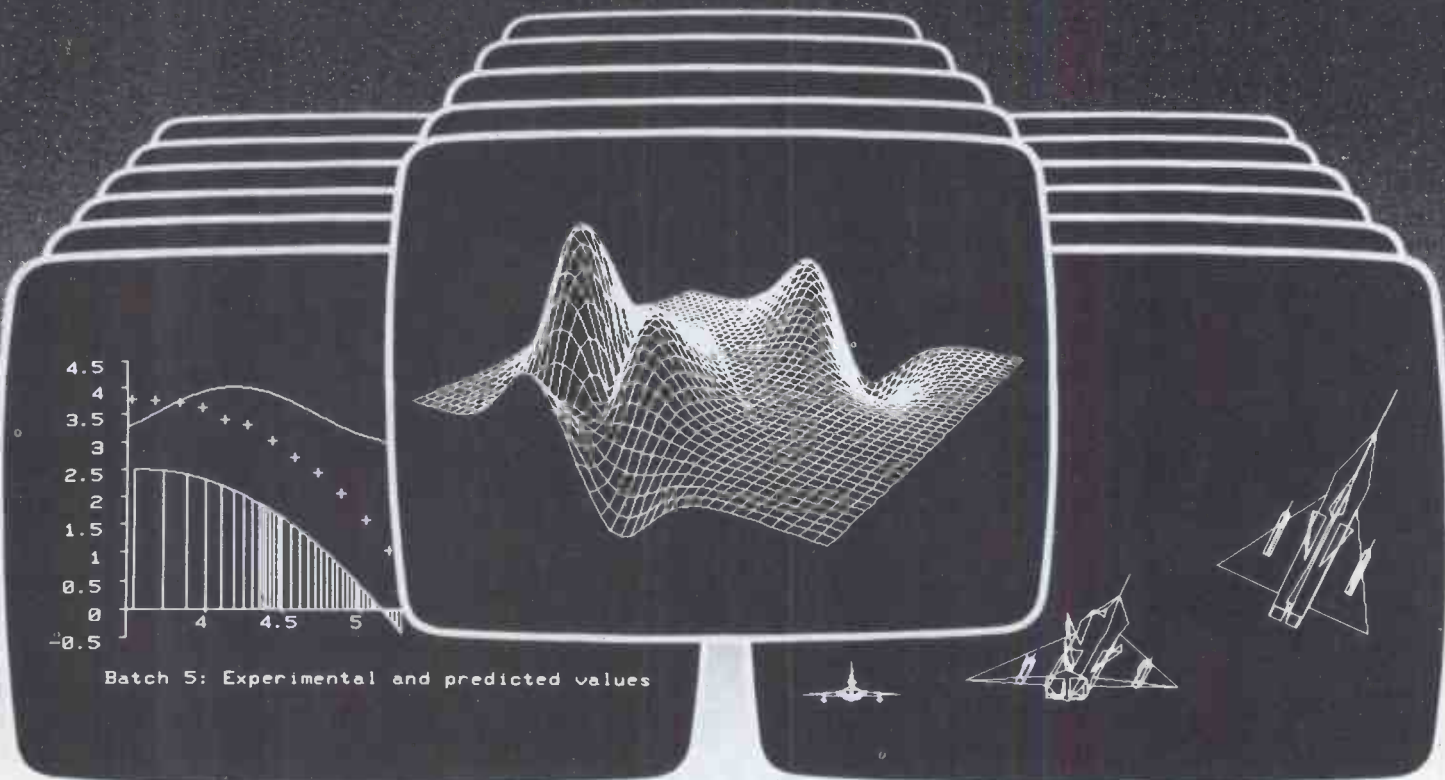

## A choice of hardware ...

A wide range of PIXELPLOTTER raster graphics display generators for microcomputers and intelligent terminals which can be specified as an option on your new machine or simply retro-fitted in the field ● Intertec Superbrain DD, QD and HD

● Heath/Zenith Z19 and Z89 ● Televideo ● Ampex ● screens from 512 x 256 pixels to 1024 x 512 pixels depending on model ● all packages easily installed ● screen hardcopy output ● digitiser pad input ● Prices from £435.00

UK: Encotel Systems 01-686-9687 ● Heath/Zenith 0452-29451 ● Helistar Systems 0296-630364 ● Icarus Computer Systems ● KGB Micros 0753-38581 ● distributors supported by an extensive dealer network.

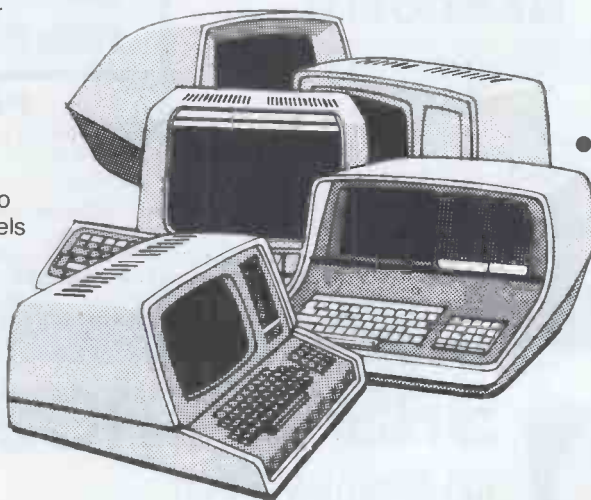

## A choice of software ...

A comprehensive suite of packages for use in industry, science, education and commerce ● Symbol Generator Graph Plotter ● 3-D with true-perspective ● Surface Plotter ● ACUSOFT routines supplied in library form for use with compilers, interpreters and assemblers using Microsoft parameter passing under Digital Research CP/M 2.2 ● Tektronix 4010-series Graphics Terminal Emulator for use with microcomputers and intelligent terminals ● Prices from £80.00

USA & Canada: Maxtek, Inc. XCEL graphics (213) 320-6604 (manufacturing licensee for Micronex PIXELPLOTTER graphics products). Distributor and OEM enquiries: Micronex Ltd. (027 589) 3042.

**MICRONEX**  
SYSTEMS GROUP

# No experience required to shop here!

We fully understand that to the uninitiated the first look at the Micro Computer world can be somewhat confusing, to say the least. But of course, to the experienced operator or programmer it's all plain—Kilobyte! Well, you don't have to be experienced to shop at SRS, we try to keep things as simple as possible and cater for everyone's needs. The businessman thinking about a small computer for the office or the advanced hobbyist requiring all the extra accessories for the micro system at home. We'll be pleased to give you all the help you need, advising you, in plain English, and plan the system that's just right for your needs—not one 32K RAM Module more! And at the end of the day, with our LOW PRICES and all the bits you were advised NOT to buy, we'll have almost certainly have saved you a great deal of money too! Call in and see us soon.



## ATARI for the HOME & OFFICE

The advanced electronics of the ATARI 400 and 800 systems make them simple to use, even if you've never used a computer before. Yet, for the sophisticated user, they offer full user-programmability. In BASIC or Assembly Language. Connects to any TV. You simply attach them to any home television set, causing no interference to TV reception. And entertainment programs turn your television set into an entertainment centre for the whole family. Call in and find out more about these exciting new Micro Computers.

### Model 400



**16K  
RAM  
£300**

Cassette recorder . . . . . £43.48  
Disc drive . . . . . £300.00  
Thermal printer . . . . . £230.43

### Model 800



**16K  
RAM  
£560**

Plain paper printer . . . £478.00  
Printer interface . . . . . £117.39  
16 Plug-in RAM . . . . . £56.50



**APPLE II 48K . . . . . £807**  
**Disc Drive with controller . . £383**  
**Additional Disc Drive . . . . . £299**  
**Video Monitor . . . . . £127**

### PART EXCHANGE

Considering a new computer? You might be surprised what we offer you (we might be surprised what you offer us!)



### Model MZ80K

**In stock shortly.  
Please phone for details  
or call in.**

### NASCOM II

This excellent single board Micro Computer is supplied ready built and tested with keyboard but no memory

**£265**

Power supply . . . . . £32.50  
4 x 4118 Memory chips (4K) . . . . . £20.00  
48K RAM Board . . . . . P.O.A.

Call in and see us for: Printers, video monitors, software, computing books, discs, tapes etc. Many new items coming along soon.

**ACCESS & BARCLAYCARD WELCOME – HIRE PURCHASE AVAILABLE  
FREE SECURICOR DELIVERY ON ORDER OVER £100**

All prices shown are excluding V.A.T. E. & O. E.

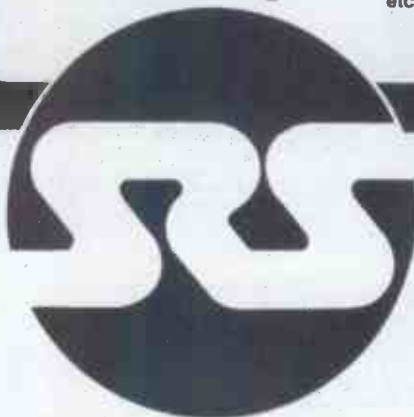

## SRS MICROSYSTEMS

161 Bramley Road,  
Oakwood, London N14 4XA

Telephone: 01-363 8060  
(Closed Monday)





# COMPUTER WAREHOUSE

**NOW OPEN**  
**MONDAY-SATURDAY**  
**9.30-5.30**

## RAM AND EPROM NEW LOW VAT INCLUSIVE PRICES

2716 5v Rail	£7.50	4116	200 NS 16KX1 DYN.	8 for £19.95
2716 3 Rail	£8.50	2114L-3	300 NS 1KX4 ST.	8 for £22.50
2708 40 NS	£4.50	2102L-3	650 NS 1KX1 ST.	8 for £ 5.50
2708 Ex Equip	£2.25	TMS4030JL	300 NS 4KX1 DYN.	8 for £ 9.95

All devices full spec. and guaranteed. Bulk enquiries welcome.

In stock now test equipment, microprocessors, teletypes, transformers, power supplies, scopes, sig. gen's, motors, peripheral equipment, I.C.'s, tools, components, variacs, keyboards, transistors, microswitches, V.D.U's sub-assemblies + thousands of other stock lines. Just a mere fraction of our vast range, is displayed below: 100's of bargains for callers.

## TELETYPE ASR33 I/O TERMINALS

## ICL TERMIPRINTER 300 BAUD TERMINALS

## SCOOP PURCHASE 12" VIDEO MONITORS

## EX STOCK SOFTY

### EPROM BLOWER

Software development system invaluable tool for designers, hobbyists, etc. Enables open heart surgery on 2716, 2708 etc. Blows, copies, reads EPROMS or emulates EPROM/ROM/RAM in situ whilst displaying contents on domestic TV receiver. Many other features. **£115 + carr. + VAT.** Optional 2716, 2716 Function Card £40 + VAT. PSU £20 + £1.50 carr. + VAT. Write or phone for more details.

## JUST IN

Secondhand chassis 9" Blue-boost mains powered, video monitors, composite video input with inbuilt 5v 3 amp DC P.S.U. Tested, but unguaranteed.

**£39.99 + £7.50 carriage**  
Complete with circuit.

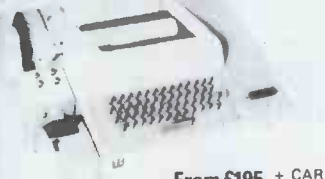

From **£195 + CAR + VAT**

Fully fledged industry standard ASR33 data terminal. Many features including: ASCII keyboard and printer for data I/O, auto data detect circuitry, RS232 serial interface, 110 baud, 8 bit paper tape punch and reader for off line data preparation and ridiculously cheap and reliable data storage. Supplied in good condition and in working order. Options: Floor stand **£12.50 + VAT** Sound proof enclosure **£25.00 + VAT**



**PRICES REDUCED**

**ONLY £295 + CAR + VAT**

Made under licence from the world famous GE Co. The ICL Termiprinter is a small attractive unit with so many features it is impossible to list them in the space available! Brief spec. as follows: RS232 serial interface, switchable baud rates 110, 150, 300, (30 cps), upper and lower case correspondence type face, standard paper, almost silent running, form feed, electronic tab settings, suited for word processor applications plus many more features. Supplied in good condition and in working order. Limited quantity.



**CONNECT DIRECT TO YOUR MICRO**

Made by the "BALL MIRATEL" CORPORATION USA the CD12 is a self contained, mains powered chassis professional monitor. All controls are inbuilt on a single PCB with exception of the brightness control which can be brought out for external use. Many features such as composite video, quoted bandwidth of 19 Mhz, superb linearity and definition make this a brand for any MICRO/CCTV application. Brand new and boxed only **+ carriage £7.50 + VAT. £97.50 + VAT** Input harness, brightness pot and connector **£2.50 + VAT.** Dimensions 9" H x 11" D x 11 1/2" W

**HURRY WHILE STOCKS LAST**

## EQUIPMENT CASES



**GIVE YOUR M.P.U. A HOME ONLY £9.95 + 1.85 pp**

Superb professional fully enclosed, made for the G.P.O. to the highest standard, offered at a fraction of their original cost they feature aluminium sides, hinged removable front panel, which can be secured by 2 screws to prevent prying fingers. All are finished in two tone G.P.O. grey and although believed brand new may have minor scuff marks/scratches due to bad storage. Dimensions 16" D x 6 1/2" H x 14 3/4" W

## NATIONAL MA1012 LED CLOCK MODULE

- ★ 12 HOUR
- ★ ALARM
- ★ 50/60 HZ



The same module as used in most ALARM/CLOCK radios today, the only difference is our price! All electronics are mounted on a PCB measuring only 3" x 1 1/2" and by addition of a few switches and 5/16 volts AC you have a multi function alarm clock at a fraction of cost. Other features include snooze timer, am pm, alarm set, power fail indicator, flashing seconds cursor, modulated alarm output etc. Supplied brand new with full data only Suitable transformer **£1.75. £5.25**

## SEMICONDUCTOR 'GRAB BAGS'

Amazing value mixed semiconductors, include transistors, digital, linear I.C.'s, triacs, diodes, bridge recs. etc. etc. All devices guaranteed brand new, full spec. with manufacturers markings, fully guaranteed. **50 + BAG £2.95 100 + BAGS £5.15**

## MUFFIN FANS

Keep your equipment Cool and Reliable with our tested ex-equipment "Muffin Fans" almost silent running and easily mounted. Available in two voltages. 110 V.A.C. £5.05 + pp 90p OR 240V A.C. £6.15 + pp 90p DIMENSIONS 4 1/2" x 4 1/2" x 1 1/2"

ELECTRONIC COMPONENTS & EQUIPMENT

**66% DISCOUNT**

Due to our massive bulk purchasing programme which enables us to bring you the best possible bargains, we have thousands of I.C.'s, Transistors, Relays, Cap's, P.C.B.'s, Sub-assemblies, Switches, etc. etc. surplus to our requirements. Because we don't have sufficient stocks of any one item to include in our ads., we are packing all these items into the "BARGAIN PARCEL OF A LIFETIME" Thousands of components at giveaway prices! Guaranteed to be worth at least 3 times what you pay plus we always include something from our ads. for unbeatable value!! Sold by weight

2.5kts **£ 4.75 + pp £1.25** 5kts **£ 6.75 + pp £1.80**  
10kts **£11.75 + pp £2.25** 20kts **£19.99 + pp £4.75**

## THE PRINTER SCOOP OF THE YEAR THE LOGABAX Z80 MICROPROCESSOR CONTROLLED LX180L MATRIX PRINTER

SAVE OVER £1400



A massive bulk purchase enables us to offer you this superb professional printer at a fraction of its recent cost of over £2000. Utilising the very latest in microprocessor technology, it features a host of facilities with all electronics on one plug in P.C.B. Just study the specification and you will instantly realise it meets all the requirements of the most exacting professional or hobbyist user.

**STANDARD FUNCTIONS** ★ Full ASCII character set ★ Standard ink ribbon ★ RS232/V24 serial interface - 7 xtal controlled baud rates up to 9600 ★ 194 characters per line ★ Parallel interface ★ Handshakes on serial and parallel ports ★ 4 Type fonts, italic script, double width, italic large, standard ★ Internal buffer ★ Internal self test ★ 170 CPS ★ Variable paper tractor up to 17.5" wide ★ Solid steel construction ★ All software in 2708 eeproms easily reconfigured for custom fonts etc.

All this and more, not refurbished but **BRAND NEW** At Only **£525 + VAT** + carriage and ins. **£18.00 + VAT** **OPTIONAL EXTRAS** ★ Lower case **£25.00** ★ 16K buffer **£30.00** ★ Second tractor for simultaneous dual forms **£85.00** ★ Logabax maintenance, P.O.A.

## MAJOR SAVINGS HARD DISK DRIVES

Another major purchase allows us to bring you the professional technology of hard disk drives at a price you can now afford. Just imagine absolutely masses of correct data transferred by your system by the time your finger leaves the carriage return key!! All drives offered are made to the highest professional standard by the DRE Co., which are the largest of UK OEM peripheral manufacturers. All components are batch selected to obtain the utmost reliability and after having run two series 30 and a 4000 drive continuously 24 hours a day for over a year without a single read/write error we can most certainly vouch for the quality. **DIABLO/DRE series 30.** Fully refurbished this 2.5 MB drive accepts 2315 exchangeable (via removing top cover) disk cartridges. Sectoring is a feature of the disk pack and may range from 8-48. Fully DEC RK05, Nova, Texas, system compatible. Requires + 8 -15v DC Supply. **Series 30 Drive £475 + VAT Series 30 Front Loader £695 + VAT** **DC Power Supply £125 + VAT** **DRE 4000 B Series.** Model 4044. Technology at its finest, this drive currently manufactured by DRE features 10 MBs of on line storage split into two disk platters, 1.5 MB fixed and 1 top load 5 MB type 5440 exchangeable cartridge. Features, OC drive motor, built in air conditioning system, write protect, mains powered, etc. Supplied Brand New and Boxed complete with Manual and Rack Slides. **Manufacturers current price £3100, our price £1495 + VAT**

\*For DEC compatibility or alternate sectoring please enquire. Xylogics DEC LSI 11 controller for 4 S30 or 2 4000 drives **£850 + VAT** Newton Labs S100 controller for 4 S30 or 2 4000 **£625 + VAT** Controller for TRS80, PET, APPLE, price to be announced. **NEW 2315 12 sector disk packs £40 + VAT** **NEW 5440 any sector packs £48 + VAT** **ORDER NOW!!** These prices may never be repeated. Specialist carriage S30 **£15.00 + VAT** 4000 £20 + VAT.

## STEP INTO THE 80's WITH TOMORROW'S WORLD TECHNOLOGY TODAY

## THE TANTEL PRESTEL-VEWDATA ADAPTOR

At last this amazing piece of micro technology is available at a price you can afford. Just connect to the aerial socket of any colour or black and white domestic TV receiver and to your Post Office installed jack socket and you are into the exciting world of PRESTEL. Via simple push button use you are able to view a staggering 170,000 pages of up to the minute information on many services and utilities, order goods from companies, even play games!! All this and more without ever leaving your armchair!

**ONLY £170 + £1.75 carr. + VAT**  
**SEND £197.51**

## RCA FULLY CASED ASCII CODED KEYBOARDS



**IDEAL - TANGERINE, OHIO ETC.**

Straight from the U.S.A. made by the world famous R.C.A. Co., the VP600 Series of cased freestanding keyboards meet all requirements of the most exacting user, right down to the price! Utilising the latest in switch technology, Guaranteed in excess of 5 million operations. The keyboard has a host of other features including full ASCII 128 character set, user definable keys, upper/lower case, rollover protection, single 5V rail, keyboard impervious to liquids and dust, TTL or CMOS outputs, even an on-board tone generator for keypad feedback and a 1 year full R.C.A. backed guarantee.

VP601 7 bit fully coded output with delayed strobe, etc.	<b>£43.95</b>
VP611 Same as VP601 with numeric pad.	<b>£54.95</b>
VP606 Serial, RS232, 20MA and TTL output, with 6 selectable Baud Rates.	<b>£60.95</b>
VP616 Same as VP606, with numeric pad, Plug and cable for VP601, VP611	<b>£72.50</b>
Plug for VP606, VP616	<b>£2.10</b>

Post, Packing and Insurance. **£1.95**  
ORDER NOW OR SEND FOR DETAILS.

## 5v D.C. POWER SUPPLIES

Following the recent "SELL OUT" demand for our 5v 3 amp P.S.U. we have managed to secure a large quantity of ex-computer systems P.S.U.'s with the following spec.: 240 or 110v A.C. input. Outputs of 5v @ 3-4 amps, 7.2v @ 3 amps and 6.5v @ 1 amp. The 5v and 7.2v outputs are fully regulated and adjustable with variable current limiting on the 5v supply. Unit is self contained on a P.C.B. measuring only 12" x 5" x 3". The 7.2v output is ideal for feeding "on board" regulators or a further 3 amp LM323K regulator to give an effective 5v @ 7 amp supply. Supplied complete with circuit at only **£10.95 + £1.75 pp.** Believed working but untested, unguaranteed.



Dept. PC.W. 64-66 Melfort Rd., Thornton Heath, Croydon, Surrey. Tel: 01-689 7702 or 01-689 6800  
MAIL ORDER INFORMATION  
Unless otherwise stated all prices inclusive of V.A.T. Cash with order. Minimum order value £2.00. Prices and Postage quoted for UK only. Where post and packing not indicated please add 60p per order. Bona Fida account orders minimum £10.00. Export and trade enquiries welcome. Orders despatched same day where possible. Access and Barclaycard Visa welcome.

# LONDON COMPUTER CENTRE

**RADIO SHACK DAISYWHEEL PRINTER II £950**  
 60 CHARACTERS PER SECOND — THE FASTEST DAISYWHEEL PRINTER  
 \* EXCELLENT PRINT QUALITY — SUPERIOR TO MOST FAMOUS  
 MAKES \* BUILT IN PROPORTIONAL SPACING \* LOOK AHEAD LOGIC  
 \* USES RICOH RP-1600 DAISYWHEELS

Heavy duty commercial daisywheel printer, with high quality printout, coupled with low noise necessary for office environment \* 124 chrs \* upper/lower case \* 10/12 chrs per inch giving 126 & 163 columns \* 15 inch wide friction platten \* bolding \* underline and a host of other features.

\* Centronics type Parallel interface as standard. \* Options: Series interface £60, PET Interface £65, APPLE interface £75.

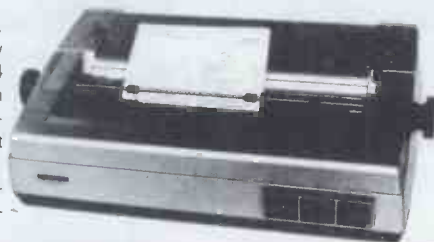

OPTIONAL BI-DIRECTIONAL TRACTOR FOR RICOH

RP-1600

**RADIO SHACK DAISYWHEEL II £95**

## Other Daisywheel Printers

<b>QUME RO</b>	<b>£1550</b>
<b>QUME KSR</b>	<b>£1795</b>
<b>NEC RO</b>	<b>£1795</b>
<b>RP-1600S</b>	<b>£1500</b>

**SUPERBRAIN WITH NEW EXTRA FEATURES FROM £1795\***



- \* 16% Greater Disc Capacity
- \* Faster disc Access
- \* Auto Repeat on all Keys
- \* 18 Programmable Keys

Now with multi-coloured dedicated keys for Magic Wand and Wordstar; the ultimate word processors.

\* £ = \$1.80

## CP/M SOFTWARE WORD PROCESSORS

WORDSTAR	£275
WORDSTAR WITH DEDICATED KEYS	£340
WORDSTAR MAIL-MERGE	£65
MAGIC WAND	£185
MAGIC WAND WITH DEDICATED KEYS	£250
SPELLBINDER	£185
SPELLBINDER WITH DEDICATED KEYS	£250

## DATA BASE SYSTEMS

DBASE II RELATIONAL DATA BASE	£375
CONDOR	£250
TIM	£75

## CRITICAL PATH ANALYSIS

MILESTONE	£250
-----------	------

## EPSON DUAL MODE PRINTERS

LETTER QUALITY & STANDARD DOT MATRIX IN ONE LOW COST UNIT

LETTER LIKE PRINT QUALITY  
 3 WAY PAPER HANDLING  
 1. Letterheads or A4  
 2. Fanfold  
 3. Paper Rolls  
 LOW NOISE  
 132 COLUMNS PER LINE  
 JAPANESE RELIABILITY  
 MX-80 F/T2 £425  
 MX-100 F/T £575



The only full 15" width platten printer with dual print modes & built in dot matrix & built in hi-res. graphics.

Full specification as the MX-80 F/T.

## AUTHORISED TANDY DEALERS

### COMPLETE MODEL I 48K SYSTEM

SPECIAL OFFER: LIMITED PERIOD 48K System — 16K keyboard, 32K Expansion Interface, dual Disc Drives, Green VDU, complete with all cables. £999  
 16K keyboard with UHF Modulator £375  
 16K System with VDU & Cassette £475  
 32K Expansion Interface £289  
 Dual Disc Drives £399



### MODEL II

from £1999 including CP/M

State-of-the-art generation computer. Over 10,000 already sold in USA. 8 slot bus ensures expansion to hard discs and other peripherals. 76 key professional keyboard. Self test on power up. CP/M 2.2, TRSDOS & Level III BASIC are standard. CP/M 2.2 enables a vast range of CP/M software to be used on the MODEL II.

### MODEL III

From £550  
 16K without disc drives £550  
 48K without disc drives £599  
 48K with disc drives £1399  
 With Epson MX-80 and Scripsit for Wordprocessing £1799

### TRS-80 MODEL I SOFTWARE

ELECTRIC PENCIL (DISC)	£60
SCRIPSIT (DISC)	£61
SCRIPSIT (CASSETTE)	£25
MAIL-MERGE FOR PENCIL & SCRIPSIT	£45
VAT AID PROGRAMME	£45
CCA DATA MANAGEMENT SYSTEM	£125
<b>FINANCIAL PLANNER/ MODELLING</b>	
T/MAKER	£175
TARGET	£250
MINI-MODELLER	£350

### THE SPECIAL LCC APPLE SYSTEM

48K Apple, Dual 40 Track Disc Drives & 12 Green Screen Monitor	£1395
Double Vision 80x24 Card	£170
CP/M Softcard	£175
16K RAM (Integer) Card	£95
Centronics Parallel Card	£75
Serial Printer/Communications Card	£85

**ALL PRICES ARE EXCLUSIVE OF VAT AND DELIVERY  
 DEALER ENQUIRIES INVITED ON ALL PRODUCTS**

43 GRAFTON WAY, LONDON W1P 5LA (Opposite Maples)  
 OPENING HOURS: 11-7 MON-FRI 12-4 SA1 Tel: 388 6991/2  
 24 hour answer phone: 01-388 5721

# The model of good business.



## Tuscan – the all-British microcomputer

With a proven record of steady development behind it, the Tuscan S100 now goes a step forward, solving the problem of effective backup storage.

The Tuscan S100, Britain's first S100 computer on a single board, is now available with designed-in mini-Winchester drive for better performance, shorter access time and higher transfer rate. All this from Britain's own home-grown micro manufacturer.

Systems with printer, screen and CP/M start at £2125 with twin floppies, and at £3625 with one floppy and one 5-meg. mini-Winchester.

**SOFTWARE.** Business accounts packages start at £800 when purchased with the Tuscan system. Word processing packages start at £315; Database packages start at £100.

**HARDWARE.** Flexibility is the key feature of all Tuscan systems. A choice of storage capacity, video format and graphics is available. The Tuscan S100 can read and write in sixteen different disk formats, with a choice of 5¼" or 8" drives.

**SUPPORT.** The Tuscan S100, designed and built in Britain, is backed by Transam's substantial experience in electronics plus a dedicated hardware and software team. National third party maintenance is available at ten per cent of hardware costs.

**BUSINESS SYSTEM DEALERS.** Business Equipment Centre, 10 Edge Lane, Liverpool.

Tel: 263 5783. Contact: Rod Crofts.

Purley Computers, 21 Bartholomew Street, Newbury, Berkshire. Tel: 41784. Contact: Ron Smith.

**FURTHER INFORMATION.** Two new catalogues covering "systems and peripherals" and "CP/M Software" are available, giving details of our systems and services. Call or write for yours.

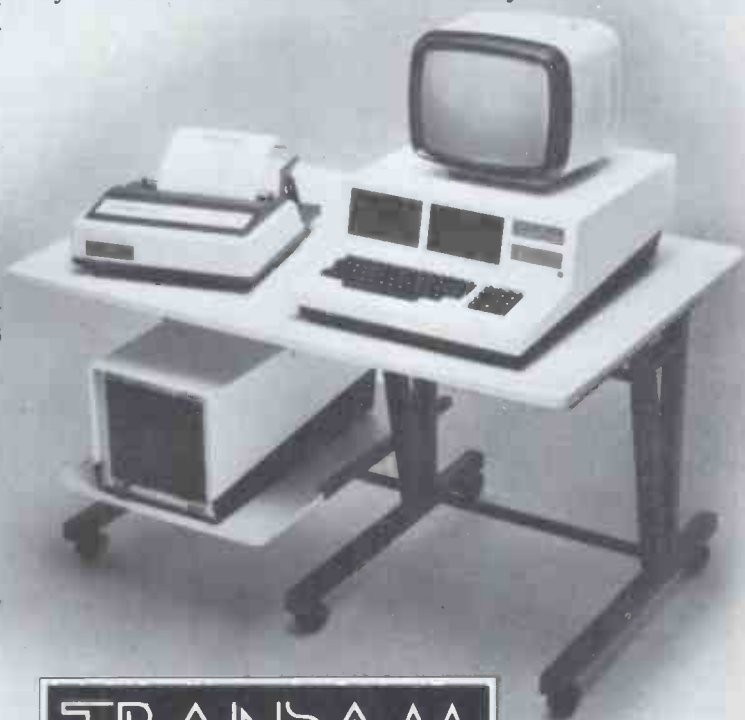

## TRANSAM

TRANSAM COMPONENTS LIMITED  
59/61 THEOBALD'S ROAD, LONDON WC1  
Tel: 01-405 5240/2113. Telex: 24224 (Ref. 1422)

# MICROCOMPUTER PRODUCTS

# MPI

INTERNATIONAL LTD.

ROOM PCW 8 CAMBRIDGE HOUSE, CAMBRIDGE ROAD, BARKING, ESSEX IG11 8NT, ENGLAND

Telephone: 01-591 6511 Telex: 892395

EUROPE'S LARGEST SELECTION OF MICROCOMPUTER SOFTWARE, BOOKS AND MAGAZINES FOR THE HOBBYIST, EDUCATIONALIST, PROFESSIONAL AND RETAILER

## BOOKS

### BY OSBORNE

Introduction to Microcomputer Series  
 Vol 0: Beginners Book £6.50  
 Vol 1: BASIC Concepts £9.00  
 Vol 2: Some Real Microprocessors £20.85  
 Vol 2: Updating supplement set Nos. 1 - 6 £20.85  
 Vol 3: Some Real Support Devices £13.00  
 Vol 3: Updating supplement set Nos. 1 - 6 £20.85  
 1 Updating supplement (Specify for Vol 2 or 3) £4.50

PET and the IEEE 488 (GPIB) Bus £10.95  
 8080 Programming for Logic Design £6.30  
 Z80 Programming for Logic Design £6.30  
 Z80 Assembly Language Programming £11.85  
 Z8000 Assembly Language Programming £14.85  
 6502 Assembly Language Programming £11.85  
 6800 Assembly Language Programming £7.95  
 6809 Assembly Language Programming £13.50  
 Accounts Payable and Accounts Receivable £14.85  
 Payroll with Cost Accounting £14.85  
 General Ledger £14.85  
 Some Common BASIC Programs £9.85  
 Practical BASIC Programs £10.25  
 8089 1/0 Processor Handbook £4.95  
 The CRT Controller Handbook £4.95  
 The 68000 Microprocessor Handbook £4.50  
 Apple II Users' Guide £11.50  
 CP/M User's Guide £10.10  
 16 Bit Microprocessor Handbook £15.95  
 4 and 8 Bit Microprocessor Handbook £15.95  
 8086 Book £13.50

### GENERAL

See Magazines and Subscriptions!  
 Microprocessors from Chips to Systems  
 Microprocessor Interfacing Techniques  
 IC OP-AMP Cookbook £9.85  
 RTL Cookbook £4.25  
 Ciarcias Circuit Cellar £6.00  
 Buyers Guide to Microsoftware £2.40  
 Calculating with BASIC £4.95  
 Computer Programs that Work (in BASIC) £3.95  
 Dr Dobbs Journal Volume 1 £15.50  
 Dr Dobbs Journal Volume 2 £15.50  
 Dr Dobbs Journal Volume 3 £15.50  
 Scelbi BYTE Primer £8.95  
 Best of Creative Computing, Vol. 1 £6.95  
 Best of Creative Computing, Vol. 2 £6.95  
 Program Design £4.75  
 Programming Techniques: Simulation £4.75  
 Numbers in Theory and Practice £6.00  
 PIMS—A Database Management System £6.50  
 Best of Interface Age—Software £9.95  
 Programming the Z8000 £11.60  
 CPM Handbook £12.10  
 CPM Primer £8.45  
 K2 FDOS £15.50

Microsoft BASIC University Software Inc., Listings: Home and Economics Programs £16.50  
 Education and Scientific Programs 23.00

### FOR THE Z80

See Osborne Books!  
 Z80 Instruction Handbook (Wadsworth) £3.50  
 Programming the Z80 (Zacs) £11.50  
 Z80 Software Gourmet Guide and Cookbook £10.25  
 32 BASIC Programs for the TRS-80 (Level II) 16K £11.10  
 Introduction to the T-Bug £4.95  
 (Guide to TRS-80 Machine Language Monitor) £6.95  
 30 Programs for the Sinclair ZX80 £6.95  
 Cambridge Collection for the ZX81 £4.95

### CONCERNING LANGUAGE

A Practical Introduction to PASCAL £4.95  
 The PASCAL Handbook £11.50  
 Introduction to PASCAL (Including UCSD PASCAL) £9.10  
 SCALBAL—BASIC Language Interpreter (Source Code) £10.00  
 BASIC BASIC £7.15  
 Advanced BASIC £6.60  
 Users Guide to North Star BASIC £10.00  
 Microsoft BASIC (a guide) £7.15  
 Secret Guide to Computers £4.00  
 Fifty BASIC Exercises £10.25  
 PASCAL Programs for Scientists & Engineers £12.70

### FOR THE 6502

See Magazines and Subscriptions!  
 Best of Micro, Vol 2 £5.50  
 Programming the 6502 (Zacs) £10.25  
 6502 Applications £10.25  
 6502 Instruction Handbook £3.50  
 The PET Revealed £10.00  
 Library of PET Subroutines £10.00  
 32 BASIC Programs for the PET £11.10  
 First Book of KIM £7.00  
 PET/CBM Personal Computer Guide (2nd edition) £11.00

### FOR THE 8080

See Osborne Books!  
 8080 Hex Code Card £2.30  
 8080 Octal Code Card £2.30  
 8080 Software Gourmet Guide and Cookbook £7.15  
 8080/8085 Software Design £6.75  
 8080 Standard Monitor £8.95  
 8080 Standard Assembler £8.95  
 8080 Standard Editor £8.95  
 8080 Special Package: Monitor, Editor, Assembler £20.00  
 BASEX: A Simple Language and Compiler for the 8080 £6.00

### FOR THE 6800

See Magazines See Osborne Books!  
 6800 Software Gourmet Guide and Cookbook £7.85  
 6800 Tracer—An aid to 6800 Program Debugging £4.50  
 Tiny Assembler £6.30  
 RA 6800 ML—An M6800 Relocatable Macro Assembler £17.50  
 Link 68—An M6800 Linking Loader £6.00  
 MONDEB—An Advanced M6800 Monitor Debugger £3.85

### FOR FUN

8080 Galaxy Game £6.95  
 SUPER-WUMPUS—A Game in 6800 Assembler Code & BASIC £4.25  
 Computer Music Book £6.75  
 Computer Rage (a Board Game) £6.95  
 Introduction to TRS-80 Graphics £6.30  
 Take My Computer Please... (Fiction) £3.25  
 Introduction to Low Resolution Graphics for PET, Apple TRS-80 £6.00  
 Starship Simulation £4.50  
 Microsoft BASIC: University Software Inc., Listings:  
 Fun and Games Programs 1 £10.45  
 Fun and Games Programs 2 £10.45  
 6502 Games £10.25  
 Inside BASIC Games £9.45

### FOR THE NOVICE

See Magazines See Osborne Books!  
 Getting Down to Business with Your Microcomputer £5.50  
 Getting Involved with Your Own Computer £5.50  
 How to Profit from Your Personal Computer £6.50  
 Microcomputer Potpourri £1.95  
 Hobby Computers are Here £3.00  
 New Hobby Computers £3.00  
 Understanding Microcomputers and Small Computer Systems £7.50  
 Understanding Microcomputers and Small Computer Systems and Audio Cassette £9.25  
 From the Counter to the Bottom Line £10.00  
 Buying a Business Computer £9.75  
 You Just Bought a Personal What? £8.75  
 How to Make Money with Your Microcomputer £7.00

### MAGAZINE BACK ISSUES

Micro 6502 Journal £1.95  
 Personal Computing £2.15  
 Interface Age £3.25  
 Dr Dobbs Journal £2.15  
 Computer Music Journal £3.75  
 Recreational Computing £2.15  
 BYTE £3.60  
 Creative Computing £2.15  
 Calculators and Computers £1.95  
 Keyboard Microcomputing £3.60  
 Compute—for the 6502 £2.50  
 68 Micro £2.15  
 80-Microcomputing £3.60  
 On Computing £1.95  
 S-100 Microsystems £2.15  
 Magazine Storage Box (holds 12) £2.15

### BYTE NIBBLE REPRINTS:

a) A TMS-9900 Monitor £3.50  
 b) BASIC Cross-Reference Generator £1.25  
 c) A Micro Word Processor £4.50  
 d) Tiny PASCAL in 8080 Assembly Language ('e needed to use this) £13.00  
 e) A Tiny PASCAL Compiler £13.50  
 f) An APL Interpreter in PASCAL £13.00  
 g) Computer Assisted Flight Planning £2.35  
 h) Computerized Wine Cellar £2.00  
 i) The Design of an M6800 Lisp Interpreter £13.00

### ORDER INFORMATION

MAGAZINES: Magazine back issues that are not currently in stock are often difficult to obtain. For unavailable back issues there is a photocopying service of £0.15 per page plus p-p plus VAT.

BOOKS: Most books are published in the USA and stocked in Britain by Microcomputer Products Ltd. We aim to keep all of these books in stock and as a result of this, most prepaid orders are despatched by return of post. Please add £0.75 (plus 15% VAT) towards postage for EACH book purchased. If purchasing more than 5 books at any one time, please add £0.15 for each extra title (over the 5).

PAYMENT: All payment must be in sterling and drawn against a UK Bank. Send cash, cheques, postal orders, IMO, Access or Barclaycard No. 10: Microcomputer Products International Ltd., Room PCW, 8 Cambridge House, Cambridge Road, Barking, Essex IG11 8NT. Prices subject to change due to fluctuations in the dollar rate.

Retailer and OEM terms available

MAIL ORDER TELEPHONE CREDIT CARD ORDER

\* VISIT \*

Full descriptive Catalogue: available £1—deductible from first purchase

Trade Enquiries Welcome

# DEVELOPMENT

**EPROM-PROGRAMMER  
ROMULATOR**



**2716  
2732  
2532  
etc.**

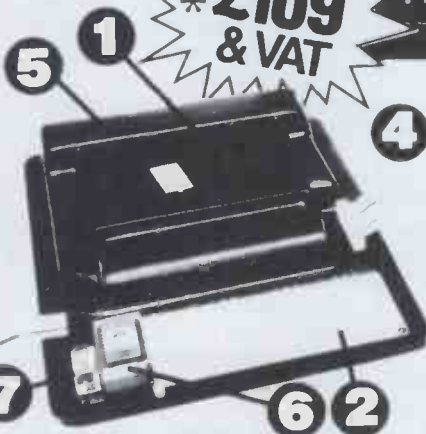

**\*£169  
& VAT**

- 1** MONITOR or TV output (625 line UHF). Data contents of memory visible — A WINDOW IN THE CHIP.
- 2** 28-KEY, 2-LEVEL KEYPAD with HEX ENTRY and EDITING CAPABILITY. (BYTES and BLOCKS of code can be changed, inserted, deleted, shifted around etc.).
- 3** INPUT and OUTPUT: SERIAL (RS232) and PARALLEL (Centronics) routines provide ready interface with computer or printer.
- 4** EMULATION of PROGRAM MEMORY in-circuit is performed by plugging SOFTY into the ROM SOCKET. A lead with a 24 pin DIL PLUG is supplied.
- 5** CASSETTE INTERFACE.
- 6** EPROM-PROGRAMMER: an EPROM may be copied or reprogrammed at the press of a key.
- 7** PERSONALITY SWITCH selects 2716, 2532, 2732.

**SOFTY is used as an EPROM-PROGRAMMER, a production ROM CHECKER and for the DEVELOPMENT and PRODUCTION of PRODUCTS which contain MICRO-PROCESSORS and use EPROM for program storage.**

\*Price is for a BUILT and TESTED SOFTY (No kits) including POWER SUPPLY, TV LEAD, ROMULATOR LEAD, 90 DAY WARRANTY and 14 day money-back guarantee.  
£169.00 + £25.35 (VAT 15%) = £194.35.

**DATAMAN DESIGNS,**  
Lombard House, Dorchester, Dorset DT1 1RX  
Dorchester (0305) 68066 (UK Sales)  
Maiden Newton (0300) 20700 (Export)

# TEACHING

**Z80-ASSEMBLER  
MICRO-CONTROLLER**

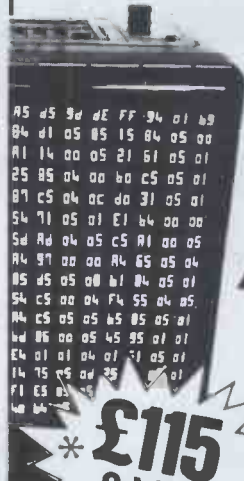

# MENTA



**\*£115  
& VAT**

- 1** MONITOR or TV output (625 line UHF). PROGRAM, STACK and REGISTER contents visible.
- 2** 40-KEY, 3-LEVEL KEYPAD with Z80 ASSEMBLER MNEMONICS and HEX. PROGRAM-EDIT, STEP, RUN etc.
- 3** 24 bits of I/O can control external machinery, indicators etc.
- 4** CASSETTE INTERFACE.
- 5** BEEPER gives entry and error feedback.
- 6** LED gives prompt and page number.

**MENTA was designed to fulfil request of Schools Council's Modular Courses in Technology Project for "Microelectronics Teaching Devices" for use in a module which is now being tested in schools in Bromley. Inquiries are invited from Companies and Institutions with commitment to train students in SYSTEM DESIGN. MENTA is from the same stable as the SOFTY development systems.**

\*Price is for a SAMPLE UNIT with POWER SUPPLY and TV LEAD. £115 + £17.25 (15% VAT) = £132.25.

**DATAMAN DESIGNS,**  
Lombard House, Dorchester, Dorset DT1 1RX  
Dorchester (0305) 68066 (UK sales)  
Maiden Newton (0300) 20700 (Export)

# COMPUTECH for



# ITT

COMPEC  
'81  
17-20 NOV  
OLYMPIA

Come and see us on Stand 1230 Ground Floor Grand Hall  
NEW! A Mailing, Merging Document Processor  
CHAIN MAIL - only £45

## COMPUTECH SOFTWARE & HARDWARE IS WIDELY ACCLAIMED - WHY?

Companies like Shell UK Oil, Grindlays Bank, W.H. Smith, government departments and hundreds of firms from multinational corporations to sole traders and small businesses have licensed Computech software. Why?

Thirty years experience of business fifteen years experience of computing and dedication to serving the users' interests economically must be major contributions. By the time this advertisement appears about 1000 business software packages will have been installed and supported by us. Note other features which appeal to our customers - no special equipment, all configurations of Apple systems supported, no extra charge for lifetime support, hot-line service, economical use of hardware resources, program code supplied, modifications allowed, full validation, all accountancy requirements satisfied, all data written to disk and recoverable on demand, very simple operation, emulation of traditional manual methods, comprehensive manuals with sample reports, reliable operation, advisory bulletins and free fixing of bugs, (which is fortunately rare). Reduced licence fee for new versions with extra features. As approved dealers of Apple products and actual manufacturers of compatible hardware we combine the knowledge of hardware and software so essential for the application of microcomputers.

## COMPUTECH SOFTWARE AND HARDWARE INCLUDES:

**Payroll** for 350 employees, 100 departments, all pay periods, printed payslips, approved year end documents, very quick and easy to use, **£375**. **Sales, Purchases** and **General Ledgers** **£295** each, detailed statements. **Job Costing** and **Group Consolidation** are amongst many and various applications of the **General Ledger** package, which supports values to totals of one thousand million accurate to a penny! Our **Utilities Disk** available like other packages in 13 sector or 16 sector format, is widely used for reliable, error checking, copying, including single drive, and the renowned **DPATCH** program beloved of programmers for **£20**. We have developed a **Terminal Utilities** package which enables Apple to Apple and Apple to mainframe communications with local processing and storage as well as Apple to host communications from the amazingly low price of **£130**. Our **Graphics Utilities** program for use with the **Microline** and **Epson** families of printers enable the plain paper production on low cost printers of high resolution screen pictures, graphs etc. - free with **Microlines** or **£30** separately. **Keyboard Driver** enables the use of our **Lower Case** adaptor with BASIC programs and **Applewriter Patches** supplied **FREE** with our character generator package (total cost **£50**) is separately available on disk with documents for **£10**. At the same price **CAI** (convert Apple pictures for ITT) makes binary high resolution picture files display properly on the ITT 2020. We sell the famous **Visicalc** for **£125** and have delivered systems using it to do amazing things like production control, shipping accounts and stocks and shares valuations! The versatile **Applewriter** word-processing package at only **£42**, especially employed with our **Lower Case Character Generator** is widely used by people who cannot type to produce word-perfect copy! Experience with Apple systems has led to the design and manufacture of compatible products with enhanced features at very favourable prices to satisfy users' needs. These include the **Diplomat Serial Interface** which has handshaking capability and switchable options (**£80**), the **Diplomat Parallel Interface** which enables the direct use of text and graphics with the **Microline** and **Epson** printers and is a complete 'plug in and go' item with gold-plated edge-connector at **£80** and has optional direct connection for **Centronics 730/737** printers. Our new **Diplomat Communications Card** at **£95** is a sophisticated peripheral especially suitable for Apple to mainframe communications at high speeds in full duplex mode with switch selectable bit rates and other options. The **Lower Case** adaptor is available for Apples (revision 7 and earlier) as well as ITT 2020, complete with diskette software for **£50**. It offers true descenders on screen and the £ sign. We also have an **Optional Character Generator** for the ever popular **Microline M80** at **£15**. This provides £ sign and improved digits and lower case characters with USASCII special symbols. Our price for the **Microline M80**, with graphics, 40, 80 and 132 characters per line, friction, sprocket and teleprinter feed, is only **£345**, amazing for this small, quiet reliable 'look alike' printer. Tractor option is **£40** and **Serial Adaptor** **£80**. The **Microline M82**, bidirectional printer with both parallel and serial input is only **£525**, it can have an optional 2K buffer, while the **Microline M83** full width adjustable tractor 120 cps printer with similar specification is only **£775**. Then for all computer users there is the unique **Micromux** which from **£800** provides up to 16 ports for simultaneous independent serial asynchronous communications! Telephone for data sheets or to arrange a demonstration or for the address of our nearest dealer. Please hurry - the demand for our products has been such that some have been temporarily out of stock. We offer the effective low cost solutions you need. **Prices exclude V.A.T., carriage and packing.**

# COMPUTECH SYSTEMS

168, Finchley Road, London NW3 6HP. Tel: 01-794 0202

AGENTS THROUGHOUT THE UK AND OVERSEAS



# Changes an apple into an orchard

## The Beeblebox-at £3950



**PHONE JANNETTE BROOKS**  
**on 0925-810828 or**  
**SEND COUPON**  
**AND GET THE FACTS—**  
**NOW!**

### Expands capacity 20 times!

### The Beeblebox gives you:

- 10 megabytes of plug-in Winchester storage for Apple systems
  - integral Shugart® floppy disc drive for fast back-up
- plug-in e-x-p-a-n-s-i-o-n capability, via revolutionary Apple Host adapter
  - switch on and go operation...adapted operating system included!
- full guarantee and service back-up
  - host adaptors shortly to be available for all popular makes of micros

**DEALERSHIP ENQUIRIES  
WELCOME**

To: Lisiar Computers Ltd.,  
 Genesis Birchwood Science Park South,  
 Risley, Warrington, Cheshire, WA13 7BH.

Please send full details of the low-cost,  
 Apple-enhancing Beeblebox

Please tick:

I am an existing Apple user

I own another micro system

(State name) \_\_\_\_\_

I am interested  
 in learning about dealerships

Name \_\_\_\_\_

Address \_\_\_\_\_

Telephone \_\_\_\_\_

Reliability assured with SHUGART® Technology.

# THE MEMORABLE 64k STATIC BOARD

**Exported, not imported.  
The ultimate in reliability.**

A new high technology product from Transam, the ME3 64K static S100 memory board is the first standard S100 card to hold a full 64K of static RAM (low power CMOS 200nS parts). It has the added advantage of doubling as an EPROM card for 2516 EPROMs, and is suitable for all S100 computers.

Designed and manufactured in the UK and available now.

- Expandable from 0-64k of RAM or EPROM in 2k blocks, one chip at a time.
- Maskable in 8k boundaries and selectable in 8k blocks (FFFF to E000 selectable in 2k blocks).
- Phantom disable implemented.
- RAM and EPROM can be resident on the same card.

ME3 assembled  
with 16k RAM

**£162** excl. VAT

Dealer and OEM enquiries welcome. For further details please contact:

**TRANSAM**

TRANSAM COMPONENTS LIMITED  
59/61 THEOBALD'S ROAD  
LONDON WC1  
Tel: 01-405 5240/2113  
Telex: 24224 (Ref. 1422)

**TRANSAM  
MADE IN U.K.**



LSI-11/23 128Kb MOS  
96Mb Disk Drive  
VT100-AB  
RT-11 License  
**Cost £15,950\***



# we add more to DEC<sup>®</sup> at lower cost

## TSX-Plus

Provides functionality of the DEC<sup>®</sup> RT-11 operating system for up to 12 terminals. Increase productivity of RT-11 systems. Contains no RT-11 emulator.

**Cost £1,250**

## TSX-Net

Allows implementation of business and scientific applications requiring distributed processing networks of TSX-Plus/RT-11 systems. Allows multiple systems to share resources.

**Cost £750**

® Registered trade mark  
Digital Equipment Co. Ltd.

**Wilkes  
Computing**

\* Price is for fully supported system excluding V.A.T.

Bush House, 72 Prince Street, Bristol BS1 4HU  
Tel (0272) 25921 Telex 449205

IF YOU DON'T WANT A WORD PROCESSING DOCUMENT  
THAT LOOKS LIKE THIS.

YOU NEED A PRINTER THAT PRINTS LIKE THIS.

The more your system can do, the better your terminal should be. That's why, if you're adding text editing capability to your data processing system, you should also think about adding a quality daisywheel terminal to replace the matrix terminal you're using now. And the best-quality terminal you can buy is one by Qume.

**A printer for every application.**

No matter what application you choose, Qume makes a printer to fit it.

Like our Sprint 5® KSR and RO, which have achieved the reputation for being the easy-to-use leader in letter-perfect terminals. You can have 50 different typestyles to use with it, including APL, scientific symbols and international character sets.

And there's the Sprint 5 Wide-Track™ with RS-232C interface. The first character printer data terminal in the world capable of handling paper up to 28 inches wide. That's a full 264-column printing area. Sprint 5 Wide-Track adds an entirely new dimension to the printed word.

**The best backup in the business.**

Not only do we make the best printers, but we also provide the best support to back up

what we sell. That means excellent service to the OEM and the end user, and one of the best supplies programs in the business.

So if you're getting ready to upgrade your system, then it's time you upgraded your printer as well. To a Qume.

Ask about the NEW Sprint 7 and 9 models.

For more information  
contact your

**Qume** [UK]  
AUTHORISED  
DISTRIBUTOR

AT COMPEC '81  
Stand 5144-6143

ACCESS DATA COMMUNICATIONS LTD.,  
Eskdale Road, Uxbridge Industrial Estate,  
Uxbridge, Middlesex UB8 2RT. Tel: (0895) 30831.

BYTECH LIMITED, Suttons Industrial Park,  
London Rd, Earley, Reading RG6 1AZ. Tel: (0734) 61031.

DAISY TERMINALS LIMITED, Bridge Road,  
Haywards Heath, West Sussex. Tel: (0444) 57546.

FACIT, Maidstone Road, Rochester, Kent.  
Tel: (0634) 401721.

ISG DATA SALES LIMITED, Unit 9, Fairacres Ind. Estate,  
Dedworth Road, Windsor, Berkshire. Tel: (07535) 57955.

ROHAN COMPUTING LIMITED, 52 Coventry Street,  
Southam, Warwickshire. Tel: (092681) 4045.

**Qume**®

Qume (UK) Limited Tel: (0734) 584646. Telex: 849706.

A British Company of ITT

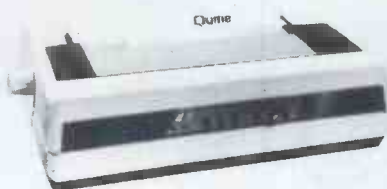

The NEW Sprint 9

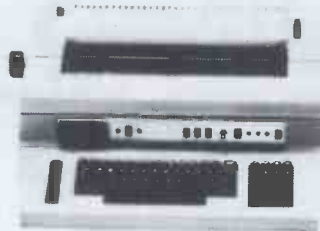

# Step by step with the computer system designed for tomorrow.

- ★ 6502 Microprocessor
- ★ 2K Monitor TANBUG
- ★ Intelligent socket accepts keypad or full ASCII Keyboard
- ★ Chunky Graphics and Lower Case Options
- ★ Connects to unmodified B/W or Colour TV

For the first time buyer or experienced user, Microtan 65 is a superb route into personal computing. If you are looking for a sophisticated machine with the capability of expansion into a professional system, then this is the



computer for you. Step by step with the computer system designed for tomorrow. . . .

## 6502 Microprocessor

Probably the most popular CPU (central processing unit) for personal computers, having a powerful instruction set and architecture.

## 2K Monitor TANBUG

The built-in 'mind' of the machine, TANBUG controls all system functions and gives comprehensive machine-code facilities. Functions include:- set and clear breakpoints, single step through program, execute program, copy block of memory, modify memory locations and much more.

## Intelligent keyboard socket

For absolute beginners we can supply an easy to use 20-way Hex keypad; for the more experienced user there is a full typewriter style ASCII keyboard. Either way, Microtan will work out exactly which type you are using and act appropriately.

## Chunky Graphics Options

For drawing simple lines and graphs, or for animated games, Chunky Graphics is a low cost answer. This set of chips plug into the Microtan board

## Microtan 65

£79.00 Ready +VAT Built

£69.00 Kit +VAT

and allow graphics to be built up on the screen at a resolution of 64 rows by 64 columns.

### Lower Case Option

To extend the character set to 128 characters, allows for real descenders on lower case characters and a set of extra symbols and characters for simple graphics.

### Microtan Accessories

20-way Hex keypad MPS 1 Basic power supply

Aerial connector lead

Full ASCII Keyboard

MPS 2 Full system

power supply

Mini — motherboard

Microtan is available

ready-built or as a kit.

We recommend that

you should have some

soldering experience

before attempting the

Microtan Kit, although

if you do run into

problems you can

make use of our "Get

you Going" service

(telephone for details).

### TANEX

- ★ 7K Static Ram
- ★ 10K Microsoft Basic
- ★ 32 Parallel I/O lines
- ★ 1 Serial I/O port
- ★ XBUG
- ★ Cassette Interface

The first step in expanding your system. Tanex provides the extra facilities necessary for the serious programmer. Memory expansion: Tanex has provisions for up to 7K of static RAM and up to 14K of EPROM using 2716 or 2732 chips.

### XBUG and BASIC

XBUG is a 2K extension to TANBUG that contains a mnemonic assembler and disassembler and cassette firmware running at 300 Baud-CUTS, standard or high speed, 2400 Baud Tangerine standard with 6 character filenames. Tangerine have taken out a full O.E.M. licence for Microsoft BASIC, the microcomputer industry standard, this is a full feature implementation with interrupt and machine code handling, and a superb program editor.

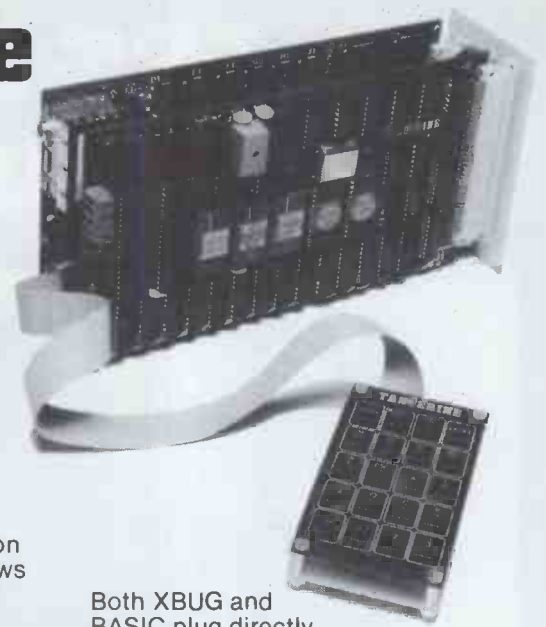

Both XBUG and BASIC plug directly into Tanex and are supplied with comprehensive user manuals.

### Parallel I/O

When fully expanded Tanex includes two V.I.A.s (Versatile Interface Adaptors) which implement the cassette interface and the parallel I/O ports. Software in TANBUG V2.3 enables you to plug in and use a Centronics type printer. The two V.I.A.s also contain counter timers that can be used for a variety of applications enhanced by the use of the integral handshake facilities.

### Serial I/O

Also on the expanded board is a serial I/O port that can be used to interface RS232 or 20Ma loop terminals or VDU's, again all controlled by TANBUG V2.3.

Whether Tanex is purchased in a minimum or maximum configuration, Tanex will buffer the data bus and configure the system memory map for maximum expansion.

To complete Tanex, a comprehensive user guide is supplied which contains full constructional details. This manual is also available separately.

### TANEX options

- 10K extended MICROSOFT BASIC
- Serial I/O Kit
- Extra RAM (2114s)
- XBUG
- 6522 V.I.A.
- 2716 EPROM for your own software

Tanex (Min Config) Kit £50.95 inc VAT and P & P  
 Tanex (Min Config) Assembled £62.45 inc VAT and P & P  
 Expanded Tanex Kit £104.66 inc VAT and P & P  
 Expanded Tanex Assembled £116.16 inc VAT and P & P

tangerine  
 computer systems ltd  
 Forehill Works, Ely,  
 Cambs. CB7 4AE.

# TRS 80 MODEL III DUAL DENSITY DISK DRIVES



## INTERNAL DRIVE PRICES

1 x 40 TRACK DRIVE	£420
2 x 40 TRACK DRIVES	£599
1 x 80 TRACK DRIVE	£490
2 x 80 TRACK DRIVES	£729

INTERNAL DRIVE PRICES INCLUDE DISK CONTROLLER BOARD, POWER SUPPLY UNIT AND ALL CABLES AND CONNECTORS REQUIRED FOR INSTALLATION.

## EXTERNAL DRIVE PRICES

1 x 40 TRACK DRIVE	£236
2 x 40 TRACK DRIVES	£440
1 x 80 TRACK DRIVE	£299
2 x 80 TRACK DRIVES	£569
EXTERNAL 2 DRIVE CABLE	15.50

EXTERNAL DRIVES ARE DIRECTLY COMPATIBLE WITH THE TRS 80 MODEL I AND VIDEO GENIE EXPANSION INTERFACES.

**Call your nearest dealer for more information:**

**RADIO SHACK LTD.**,  
188, Broadhurst Gardens,  
London NW6  
Tel: 01-624-7174

**COMP SHOP LTD.**,  
14, Station Road,  
New Barnet, Herts.  
Tel: 01-441-2922

**COMP SHOP LTD.**,  
311, Edgware Road,  
London W2  
Tel: 01-262-0387

**COMP SHOP LTD.**,  
19, Herbert Street,  
Dublin 2  
Tel: 604165

**LONDON COMPUTER CENTRE**, 43, Grafton Way, London W1.  
Tel: 01-388-5721

**N.I.C.**,  
61, Broad Lane,  
London N15.  
Tel: 01-808-0377

**CROYDON COMPUTER CENTRE**, 29a, Brigstock Road, Thornton Heath, Surrey.  
Tel: 01-689-1280

**P J EQUIPMENT LTD.**,  
3, Bridge Street,  
Guildford  
Tel: 0483-504801

**R.D.S. ELECTRICAL LTD.**, 157-161, Kingston Road, Portsmouth  
Tel: 0705-812478

**TANDY HASTINGS LTD.**, 48, Queens Road, Hastings.  
Tel: 0424-431849

**MICROWARE COMPUTING SERVICES**, 57, Queen Charlotte Street, Bristol  
Tel: 0272-279560

**BLANDFORD COMPUTERS**, Higher Shaftsbury Road, Blandford Forum  
Tel: 0258-53737

**TAPE SHOP**,  
32, Vraduct Road,  
Brighton  
Tel: 0273-609099

**PARWEST LTD.**,  
18 St. Mary Street,  
Chippenham.  
Tel: 0249-2131

**COMPUTER SHACK**,  
14, Pittville Street,  
Cheltenham.  
Tel: 0242-584343

**ENSIGN**,  
13-19, Millford Street,  
Swindon, Wilts.  
Tel: 0793-42615

**TANDY GLOUCESTER**,  
13, Clarence Street,  
Gloucester  
Tel: 0452-31323

**CONSERVE**,  
98, Tavistock Street,  
Bedford.  
Tel: 0234-216749

**CLEARTONE COMPUTERS**, Prince of Wales Ind. Estate, Abercarn, Gwent.  
Tel: 0495-244555

**EMPRISE LTD.**,  
58, East Street,  
Colchester,  
Tel: 0206-865926

**MAGNUS MICRO-COMPUTERS**,  
139 The Moors,  
Kidlington, Oxford.  
Tel: 08675-6703

**CAMBRIDGE COMPUTER STORE**,  
1, Emmanuel Street,  
Cambridge.  
Tel: 0223-65334

**I.C. ELECTRONICS**,  
Flagstones,  
Stede Quarter,  
Biddenden, Kent.  
Tel: 0508-291816

**MICRO CHIP SHOP**,  
190, Lord Street,  
Fleetwood, Lancs.  
Tel: 03917-79511

**MICRO CHIP SHOP**,  
197, Waterloo Road,  
Blackpool.  
Tel: 0253-403122

**MICRO CHIP SHOP**,  
93, Friargate,  
Preston, Lancs.  
Tel: 0772-22669

**HARDEN MICRO-SYSTEMS**, 28-30, Back Lord Street, Blackpool.  
Tel: 0253-27590

**NORTH WEST COMPUTER CONSULTANTS LTD.**,  
214 Market Street,  
Hyde, Cheshire  
Tel: 061-366-8624

**HEWART MICRO-ELECTRONICS**,  
95, Blakelow Road,  
Macclesfield.  
Tel: 0625-22030

**KARADAWN LTD.**,  
2 Forest Way,  
Great Sankey,  
Warrington.  
Tel: 0925-572668

**PHOTO-ELECTRICS**,  
459 London Road,  
Sheffield.  
Tel: 0742-53865

**BRIARWOOD COMPUTER SERVICES**,  
Briarwood House,  
Preston Street,  
Bradford.  
Tel: 0274-306018

**THOMAS WRIGHT LTD.**,  
Thorite House,  
Laisterdyke,  
Bradford.  
Tel: 0274-663471

**GNOMIC LTD.**,  
46, Middle Street,  
Blackhall,  
Hartlepool.  
Tel: 0783-863871

**BRIERS COMPUTER SERVICES**, 1, King Edward Square, Middlesbrough, Cleveland.  
Tel: 0642-242017

**3 LINE COMPUTING**,  
36, Clough Road, Hull.  
Tel: 0482-445496

**H.C. COMPUTER SALES LTD.**, 182, Earlsway, Team Valley Trading Estate, Gateshead.  
Tel: 0632-874811

**EWL COMPUTERS LTD.**,  
8, Royal Crescent,  
Glasgow.  
Tel: 041-332-7642

**CUMANA LTD** 35 Walnut Tree Close, Guildford, Surrey, GU1 4UN.  
Telephone: (0483) 503121.

*Please add VAT to all prices.  
Delivery at cost will be advised  
at time of order.*

# WATFORD ELECTRONICS

33/35, CARDIFF ROAD, WATFORD, HERTS, ENGLAND  
Tel Watford (0923) 40588. Telex: 8956095

ALL DEVICES BRAND NEW FULL SPEC. AND FULLY GUARANTEED ORDERS DESPATCHED BY RETURN OF POST. TERMS OF BUSINESS CASH/CHEQUE/P.O.s OR BANKERS DRAFT WITH ORDER. GOVERNMENT AND EDUCATIONAL INSTITUTIONS OFFICIAL ORDERS ACCEPTED (TELEPHONE ORDERS BY ACCESS NOW ACCEPTED (Minimum £10.00 please) TRADE AND EXPORT INQUIRY WELCOME. P&P ADD 50p TO ALL ORDERS UNDER £10.00 NETT

**VAT** Export orders on V.A.T. Applicable to UK Customers only. Unless stated otherwise all prices are exclusive of VAT. Please add 15% to the total cost incl. p&p.

We stock many more items. It pays to visit us. We are behind Watford Football ground Nearest Underground/Br Rail Station Watford High St. Open Monday to Saturday 9am. - 6pm. Ample Free Car Parking space available.

COMPUTER ICs:	7438	27	LS14	48	LS373	75	CRYSTALS	
1702	325	7440	17	LS15	15	LS374	100KHz	290
1802	720	7441	38	LS20	15	LS375	200KHz	370
2101-2	250	7442	38	LS21	15	LS377	455KHz	370
2112-2	250	7443	90	LS22	15	LS378	1.0MHz	295
2114-450n	99	7444	90	LS26	18	LS379	1.008MHz	392
2114L-300n	110	7445	65	LS27	15	LS385	1.28MHz	323
2114L-200n	130	7446	65	LS28	20	LS386	1.6MHz	323
2532-450n	725	7447	50	LS30	15	LS390	1.8MHz	240
2708	225	7448	50	LS32	15	LS392	1.8432MHz	240
2716-5V	250	7472	30	LS33	16	LS393	2.0MHz	240
2732-450n	725	7473	30	LS37	16	LS395	2.4576MHz	300
4027	240	7474	25	LS38	16	LS396	3.2768MHz	240
4116-3	90	7475	40	LS40	16	LS398	3.57954M	150
4118-250n	530	7476	30	LS42	35	LS445	3.6864M	300
4315CMOS	995	7480	48	LS47	40	LS447	4.0MHz	240
4334-3	325	7481	120	LS48	80	LS471	4.032MHz	290
4864-3	£12	7484	80	LS49	60	LS472	4.19430M	270
6116	£11	7485	95	LS51	15	LS473	4.433619M	120
6502CPU	495	7486	25	LS54	15	LS474	5.0MHz	240
6503	850	7489	205	LS55	30	LS475	5.185MHz	300
6505	795	7490	28	LS56	150	LS476	5.24288M	390
6520PIA	325	7492	30	LS73	25	LS477	6.0MHz	240
6522VIA	495	7493	30	LS75	28	LS478	6.144MHz	240
6530PRIOT	1310	74100	85	LS76	20	LS479	6.5536MHz	290
6532PRIOT	795	74110	40	LS78	24	LS480	7.0MHz	290
6545CRCT	1450	74111	55	LS78	24	LS481	7.168MHz	290
6551ACIA	785	74112	170	LS83	50	LS482	7.680MHz	300
6592PC	£26	74116	88	LS85	70	LS483	8.0MHz	240
6802	375	74118	80	LS86	38	LS484	8.08333M	362
6803	1350	74119	90	LS90	35	LS485	8.67237M	240
6808	520	74121	75	LS91	80	LS486	9.375MHz	323
6809	£13	74122	45	LS92	36	LS487	10.0MHz	240
6810	175	74123	50	LS93	36	LS488	10.7MHz	270
6821	175	74124	42	LS93	36	LS489	12.0MHz	290
6840	1459	74126	40	LS96	120	LS490	14.31818M	275
6845	£12	74136	35	LS107	43	LS491	16.0MHz	290
6847	795	74143	250	LS109	30	LS492	18.432M	240
6850	225	74144	250	LS112	30	LS493	19.968MHz	300
6852	450	74145	70	LS113	35	LS494	20.0MHz	323
8085A	550	74147	95	LS124	105	LS495	26.0MHz	383
81LS95	115	74148	75	LS125	30	LS496	26.69MHz	290
81LS96	115	74150	80	LS126	30	LS497	27.145MHz	323
81LS97	210	74151	45	LS127	35	LS498	27.648MHz	240
8212	425	74153	45	LS133	45	LS499	38.6667M	290
8214	200	74154	75	LS136	28	LS500	48.0MHz	270
8216	400	74155	75	LS138	35	LS501	100.0MHz	323
8253	795	74156	60	LS139	39	LS502	116.0MHz	300
8255	800	74157	95	LS145	75	LS503		
8257	800	74159	99	LS147	199	LS504		
826A	90	74160	60	LS148	99	LS505		
8T28A	90	74161	60	LS151	39	LS506		
8T31A	350	74162	62	LS153	99	LS507		
8T95N	160	74163	64	LS155	39	LS508		
8T97N	90	74164	64	LS156	39	LS509		
AY-3-1015	395	74165	65	LS157	35	LS510		
AY-5-1013	750	74166	85	LS158	36	LS511		
AY-5-2376	350	74170	168	LS161	41	LS512		
MC1488	62	74172	200	LS162	41	LS513		
MC1489	62	74173	65	LS163	41	LS514		
MC14411	895	74174	72	LS164	48	LS515		
MC14412	800	74175	72	LS165	145	LS516		
RO-3-2513U	600	74176	55	LS166	85	LS517		
RO-3-2513L	850	74177	75	LS170	110	LS518		
SFF96364E	950	74178	95	LS173	72	LS519		
IM6402	420	74179	68	LS174	72	LS520		
SFC71301	820	74180	58	LS177	68	LS521		
TMS3716-3V	875	74182	140	LS181	130	LS522		
TMS4027	240	74183	75	LS183	275	LS523		
TMS5011	365	74184	99	LS190	58	LS524		
TMS9900J	£36	74185	99	LS191	58	LS525		
TMS9900A	£20	74188	290	LS192	58	LS526		
Z80CPU2M	390	74190	70	LS193	65	LS527		
Z80CPU4M	550	74191	70	LS194	40	LS528		
Z80PIA	400	74192	70	LS195	40	LS529		
Z80PIA	440	74193	65	LS196	58	LS530		
Z80CTC	440	74194	75	LS196	58	LS531		
Z80SIO-1	£15	74195	65	LS197	85	LS532		
Z80A SIO	£23	74196	85	LS200	345	LS533		
Z800ART	726	74197	65	LS202	120	LS534		
Z80A DART	776	74198	99	LS221	41	LS535		
ZN423	195	74199	99	LS240	165	LS536		
ZN425	325	74201	80	LS241	96	LS537		
ZN427	625	74202	150	LS242	85	LS538		
ZN428	478	74203	150	LS243	85	LS539		
ZN429	210	74204	150	LS244	80	LS540		
ZN1034	200	74205	80	LS245	118	LS541		
ZN1040	685	74206	85	LS248	68	LS542		
		74207	160	LS249	40	LS543		
		74279	90	LS251	40	LS544		
		74280	90	LS252	40	LS545		
		74281	99	LS253	40	LS546		
		74282	199	LS258	85	LS547		
		74283	195	LS259	85	LS548		
		74284	199	LS261	195	LS549		
		74285	125	LS266	25	LS550		
		74286	105	LS267	25	LS551		
		74287	236	LS273	290	LS552		
		74288	14	LS275	88	LS553		
		74289	55	LS279	88	LS554		
		74290	55	LS280	250	LS555		
		74291	55	LS283	45	LS556		
		74292	55	LS285	45	LS557		
		74293	99	LS290	57	LS558		
		74294	99	LS293	215	LS559		
		74295	115	LS295	40	LS560		
		74296	120	LS298	130	LS561		
		74297	120	LS299	420	LS562		
		74298	120	LS300	270	LS563		
		74299	120	LS302	175	LS564		
		74300	120	LS303	175	LS565		
		74301	13	LS320	270	LS566		
		74302	12	LS323	270	LS567		
		74303	12	LS324	320	LS568		
		74304	12	LS325	330	LS569		
		74305	14	LS326	315	LS570		
		74306	15	LS327	315	LS571		
		74307	15	LS328	315	LS572		
		74308	15	LS329	315	LS573		
		74309	15	LS330	315	LS574		
		74310	15	LS331	315	LS575		
		74311	15	LS332	315	LS576		
		74312	15	LS333	315	LS577		
		74313	15	LS334	315	LS578		
		74314	15	LS335	315	LS579		
		74315	15	LS336	315	LS580		
		74316	15	LS337	315	LS581		
		74317	15	LS338	315	LS582		
		74318	15	LS339	315	LS583		
		74319	15	LS340	315	LS584		
		74320	15	LS341	315	LS585		
		74321	15	LS342	315	LS586		
		74322	15	LS343	315	LS587		
		74323	15	LS344	315	LS588		
		74324	15	LS345	315	LS589		
		74325	15	LS346	315	LS590		
		74326	15	LS347	315	LS591		
		74327	15	LS348	315	LS592		
		74328	15	LS349	315	LS593		
		74329	15	LS350	315	LS594		
		74330	15	LS351	315	LS595		

# Xitan South Coast Leaders in Microcomputer Support Application and Service



## **Xitan – First for Business & Commercial Systems**

Xitan's specialised Administrative and Operational Microcomputer Systems provide cost effective computer support for wide ranging business organisations; from low entry level, stand alone systems for the smaller business, to integrated multiuser/multitasking systems to meet the more specific needs of the larger business enterprise.

## **Xitan – First in Science and Research**

Xitan support the more personalised requirements of the scientific and research users universities and colleges, and in government and independent research establishments with comprehensive practical experience embracing hardware, system, and applicational software.

## **Xitan – First in Industry**

Xitan's depth in microcomputer experience is playing an increasing role in the rapidly developing industrial applications for production and process control, and in product and production development operations.

## **Xitan – First for Service**

Xitan's local reputation is founded securely on Service – both in system development – software and hardware support, and service in the field.

# **XITAN** SYSTEMS

Xitan Systems Ltd 23 Cumberland Place Southampton SO1 2BB Tel: 0703 38740

**Cromemco SHARP North Star Horizon comart**





# MICRO NETWORKS

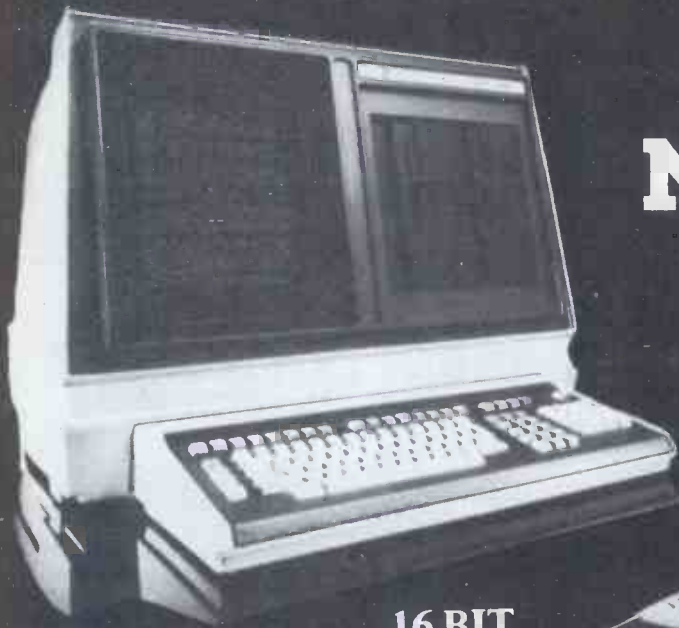

## PM 1000 16 BIT CP/M86\*\*

The PM100 is remarkably low in cost

it offers one of the highest performance-to-price ratios of any "truly intelligent" terminal available today. It boasts a full page display. Up to 66 lines of 80 characters. Unique proprietary word processing software and split-screen display for comparing related documents. Best of all, you receive your PIICEON terminals when they are promised, no excuses.

### Languages:

BASIC (Microsoft)

CIS COBOL (Micro Focus)

Future: PASCAL

**LOW LOW PRICES**



## PM 2010

An 8086 based CPU. Built on a single easily accessible PC Board with 32K of RAM standard. The Model 2010 is plug compatible with any computer supporting standard ASCII terminals and is capable of going well beyond this via the most complete set of ANSI standard terminal control functions available in the industry.

A CORVUS computer disk system provides 6.11 or 20 million Bytes of unformatted storage.

The price includes:

A single enclosure that contains

A Winchester disk drive.

A power supply and an intelligent controller.

An interface card with a 5 foot cable for the specific computer.

System software and installation manual mirror back-up to V.C.R.

Networking and Multiplexors.

## CORVUS DISK SYSTEMS



## NEC SPINWRITERS



The new NEC 3500, 5500 and 7700 Series of Spinwriter™ are top quality printers setting new standards for today's most demanding office printing tasks.

## DIABLO PRINTERS

- \* Print speed up to 40 cps.
- \* RS-232-C and CCITT V.24 serial interface.
- \* Full 128 ASCII Character set: 96 printable.
- \* More than 120 print wheel type styles and fonts are available.
- \* Full word processing capability.

**FULL RANGE OF SYSTEM APPLICATION SOFTWARE AVAILABLE**

*It's faster and more thorough than classroom learning: you pace yourself and answer questions on each new aspect as you go. This gives rare satisfaction - you know that you are really learning and without mindless drudgery. With a good self-instruction course you become your own best teacher.*

## Understand Digital Electronics

In the years ahead digital electronics will play an increasing part in your life. Calculators and digital watches mushroomed in the 1970's - soon we will have digital car instrumentation, cash cards, TV messages from friends and electronic mail.

After completing these books you will have broadened your career prospects and increased your knowledge of the fast-changing world around you.

### DIGITAL COMPUTER LOGIC AND ELECTRONICS £8.50

This course is designed as an introduction to digital electronics and is written at a pace that suits the raw beginner. No mathematical knowledge is assumed other than the use of simple arithmetic and decimals and no electronic knowledge is expected at all. The course moves painstakingly through all the basic concepts of digital electronics in a simple and concise fashion: questions and answers on every page make sure that the points are understood.

Everyone can learn from it - students, engineers, hobbyists, housewives, scientists. Its four A4 volumes consist of:

**Book 1** Binary, octal and decimal number systems; conversion between number systems; conversion of fractions; octal-decimal conversion tables.

**Book 2** AND, OR gates; inverters; NOR and NAND gates; truth tables; introduction to Boolean algebra.

**Book 3** Positive ECL; De Morgans Laws; designing logic circuits using NOR gates; dual-input gates.

**Book 4** Introduction to pulse driven circuits; R-S and J-K flip flops; binary counters; shift registers; half-adders.



### DESIGN OF DIGITAL SYSTEMS £14.00

This course takes the reader to real proficiency. Written in a similar question and answer style to Digital Computer Logic and Electronics, this course moves at a much faster pace and goes into the subject in greater depth. Ideally suited for scientists or engineers wanting to know more about digital electronics, its six A4 volumes lead step by step through number systems and Boolean algebra to memories, counters and arithmetic circuits and finally to an understanding of calculator and computer design.

**Book 1** Octal, hexadecimal and binary number systems; conversion between number systems; representation of negative numbers; complementary systems; binary multiplication and division.

**Book 2** OR and AND functions; logic gates; NOT, exclusive-OR, NAND, NOR and exclusive-NOR functions; multiple input gates; truth tables; De Morgans Laws; canonical forms; logic conventions; karnaugh mapping; three state and wired logic.

**Book 3** Half adders and full adders; subtractors; serial and parallel adders; processors and arithmetic logic units (ALUs); multiplication and division systems.

**Book 4** Flip flops; shift registers; asynchronous and synchronous counters; ring, Johnson and exclusive-OR feedback counters; random access memories (RAMs) and read only memories (ROMs).

**Book 5** Structure of calculators; keyboard encoding; decoding display data; register systems; control unit; program ROM; address decoding; instruction sets; instruction decoding; control programme structure.

**Book 6** Central processing unit (CPU); memory organization; character representation; program storage; address modes; input/output systems; program interrupts; interrupt priorities; programming; assemblers; computers; executive programs; operating systems and time sharing.



## Flow Charts and Algorithms

are the essential logical procedures used in all computer programming and mastering them is the key to success here as well as being a priceless tool in all administrative areas - presenting safety regulations, government legislation, office procedures etc.

### THE ALGORITHM WRITER'S GUIDE £4.00

explains how to define questions, put them in the best order and draw the flow chart, with numerous examples.

## Microcomputers are coming - ride the wave! Learn to program.

Millions of jobs are threatened but millions more will be created. Learn BASIC - the language of the small computer and the most easy-to-learn computer language in widespread use. Teach yourself with a course which takes you from complete ignorance step-by-step to real proficiency with a unique style of graded hints. In 60 straightforward lessons you will learn the five essentials of programming: problem definition, flowcharting, coding the program, debugging, clear documentation. Harder problems are provided with a series of hints so you never sit glassy-eyed with your mind a blank. You soon learn to tackle really tough tasks such as programs for graphs, cost estimates, compound interest and computer games.

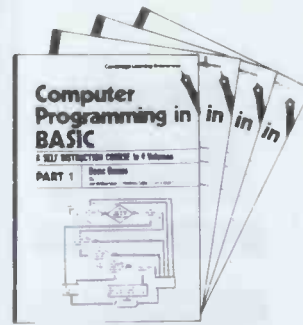

### COMPUTER PROGRAMMING IN BASIC £10.50

**Book 1** Computers and what they do well: READ, DATA, PRINT powers, brackets, variable names; LET errors; coding simple programs.

**Book 2** High and low level languages; flowcharting, functions; REM and documentation; INPUT, IF...THEN, GO TO; limitations of computers, problem definition.

**Book 3** Compilers and interpreters; loops, FOR...NEXT, RESTORE; debugging; arrays; bubble sorting; TAB.

**Book 4** Advanced BASIC; subroutines; string variables; files; complex programming; examples; glossary.

### THE BASIC HANDBOOK £14.50

This best-selling American title usefully supplements our BASIC course with an alphabetical guide to the many variations that occur in BASIC terminology. The dozens of BASIC 'dialects' in use today mean programmers often need to translate instructions so that they can be RUN on their system. The BASIC Handbook is clear, easy to use and should save hours of your time and computer time. **NEW COMPLETELY REVISED EDITION**

### A.N.S. COBOL £5.90

The indispensable guide to the world's No. 1 business language. After 25 hours with this course, one beginner took a consulting job, documenting oil company programs and did invaluable work from the first day. Need we say more?

## ORDER FORM

Please send me the following books:-

..... Digital Computer Logic & Electronics @ £8.50

..... Design of Digital Systems @ £14.00

..... Algorithm Writer's Guide @ £4.00

..... Computer Programming in BASIC @ £10.50

..... BASIC Handbook @ £14.50

..... ANS COBOL @ £5.90

..... Your Booklist (Free)

I enclose a cheque/PO payable to Cambridge Learning Ltd.

for £..... (\*delete where applicable)

Please charge my:

\* Access/American Express/Barclaycard/Diners Club/ Visa/  
Mastercharge/Trustcard

Exp. Date. . . . . Credit Card No. . . . .

Signature . . . . .

Telephone orders from credit card holders accepted on 0480 67446 (Ansafone).

Overseas customers (incl. Eire) should send a bank draft in sterling drawn on a London bank, or quote credit card number.

Name . . . . .

Address . . . . .

Cambridge Learning Limited, Unit 78, Rivermill Site,  
FREEPOST, St. Ives, Huntingdon, Cambs PE17 4BR, England.  
(Registered in England, No. 1328762)

### GUARANTEE No risk to you.

If you are not completely satisfied, your money will be refunded upon return of the books in good condition.

**CAMBRIDGE LEARNING LIMITED, UNIT 78**  
RIVERMILL SITE, FREEPOST, ST. IVES, HUNTINGDON,  
CAMBS., PE17 4BR, ENGLAND.  
TELEPHONE: ST. IVES (0480) 67446

All prices include worldwide postage (airmail is extra - please ask for prepayment invoice).

Please allow 28 days for delivery in U.K.

# Your search for the right price stops here.



## Pet

Well known for making short work of accounting, word processing, mailing lists. A great buy from NSC.



## Apple

You know what the Apple system will do but you don't know the deal we're offering. Come and see for yourself.



## Rair

The exciting new 3/30 system offering 5 mb of fixed disc storage on brand new 5 1/4" Winchester drives. 64K Machine £4,313 incl. VAT. Full range of black box systems available. Rental terms available.



## Cromemco

We can now supply the Cromix operating system for single and multi user working. The first big system operating system to be offered on a small system—the only system which offers up to 63K memory space per user.



## Acorn Atom

Now available ex-stock. Special offer to ZX80 owners: We will take your ZX80 in part exchange for an Atom.

Used Bargain: Second hand ZX80's from £50.



## North Star Horizon

A complete word processing system extendible from 32K-56K RAM, with up to four mini disc drives, 4MHz Z80A processor, serial and parallel I/O ports and extended BASIC. Full range of accounting packages available. You can lease this very popular system for as little as £25 per week.

## Bargain Offers

We have recently been appointed agents for the Commodore VIC 20, why not call in for a demonstration. Order by post, only £199.95 including VAT.

## After Sales Service

When you buy from NSC Computer Shops you have the opportunity to take advantage of a special service contract on favourable terms.

## Order by post with confidence

Instead of calling personally at NSC Computer Shops you can send cash with order. Orders are despatched by carrier, please telephone for details of delivery charges.

BOOKS: Send s.a.e. for our full price list, or call in at our shop to see our wide range of publications.

Most of our prices are heavily discounted and therefore payment must accompany the order. Credit card payments will be accepted. Please quote credit card number and type of card.

**WE WILL NOT BE KNOWINGLY UNDERSOLD.**

# NSC COMPUTER SHOPS

Computing to suit your size.

NSC Computer Shops, 29 Hanging Ditch, Manchester M4 3ES. Ring 061-832 2269 for further information.

NSC 24a

The new flexible multi-user system

# The Vector Graphic 5005 from Almarc

with 5 megabyte Winchester, 630k floppy disc

The new Vector 5005 is a multiple-user, multi-tasking hard disc system for general business and word processing applications.

It is a low priced system with highly rated capabilities.

It supports up to a maximum of 5 users and gives 5 megabytes of high-speed totally reliable Winchester disc technology with Vector's automatic error correction feature. It is also MP/M compatible.

Total flexibility means that the VG 5005's terminals can work independently which permits the widest possible range of usage. One user could use Execuplan for financial planning whilst the second user is entering sales information with accounting software and the third may run correspondence simultaneously with Vector's Memorite III word processing software. Each user gets a full 56k bytes of RAM and most other standard CP/M

compatible applications software will run on the system e.g. COBOL, FORTRAN, PASCAL, BASIC COMPILER, ALGOL, PL/I and other statistical and data based management packages.

The Vector Graphic 5005 is ideal for application packages, such as accounts, stock control, payroll, word processing, financial modelling and solicitors packages, all available from Almarc.

For further information on the VG 5005 write or telephone Almarc. Complete sales and servicing facilities are available throughout the U.K.

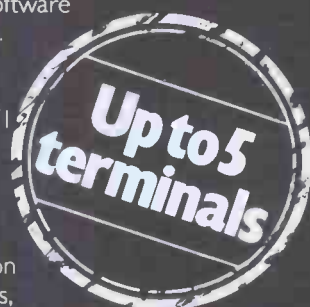

## Almarc

DATA SYSTEMS

Almarc Data Systems Limited,  
Great Freeman Street,  
Nottingham NG3 1FR.  
Tel: (0602) 52657.  
Telex: 37407 Almarc/G.

Also at:  
Green Street,  
High Wycombe,  
Bucks. HP11 2RF.  
Tel: (0494) 23804.



## APPLE AND S100 USERS: A 5 1/4 " WINCHESTER DISK SUBSYSTEM

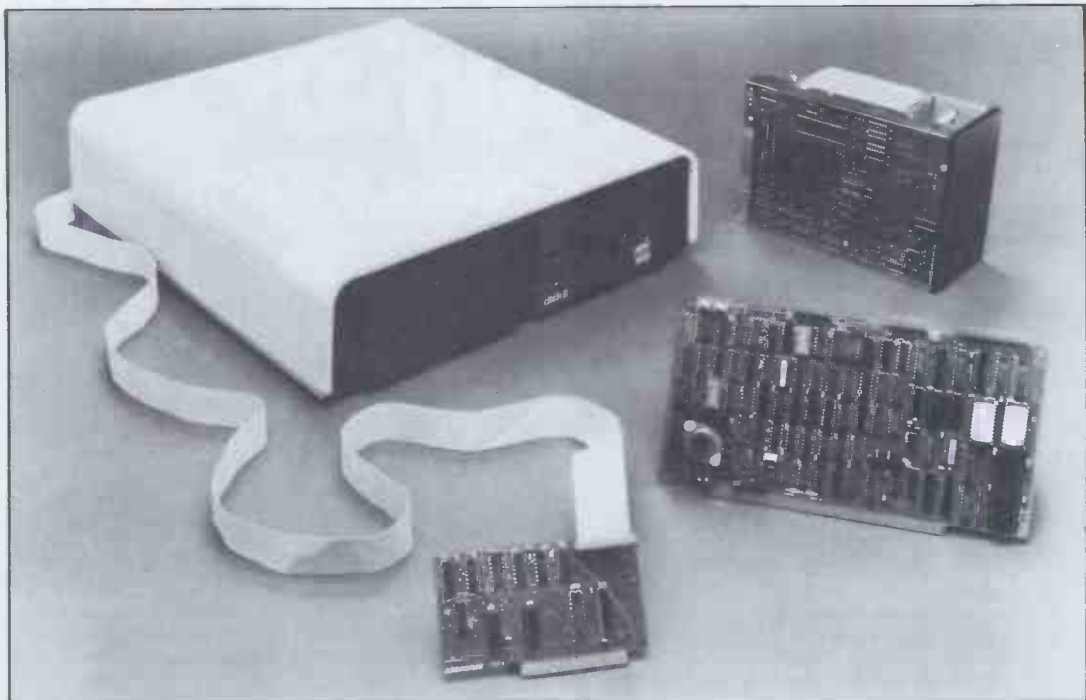

- \* UP TO 12.6 MBYTE FORMATTED (256 BYTE SECTORS) CAPACITY PER DRIVE
- \* OPTIMISED SEEKTIMES (DRIVE HAS ON BOARD MICROPROCESSOR)
- \* CABINET & POWER SUPPLY SUPPORTS 2 WINCHESTER DRIVES OR MIX OF 5 1/4" FLOPPY + WINCHESTER
- \* DRIVES AVAILABLE SEPARATELY
- \* SUB-SYSTEM INCLUDES: CONTROLLER, CABLES, DRIVE, CABINET AND SOFTWARE TO SUPPORT YOUR SYSTEM.

**PRICES FROM: £1560 FOR COMPLETE SUBSYSTEM**

**COMPLETE S100 BUS COMPUTER SYSTEM (Z80, 64K,  
1 x 5 1/4" MINI FLOPPY, 1 x 5 1/4" WINCHESTER, 6.3 MBYTE FORMATTED) £3240**

### **CROMEMCO SYSTEMS & SOFTWARE**

CP/M 2.2    £150

MP/M 1.1 -    £350

### **CALIFORNIA COMPUTER SYSTEMS:**

S100 BOARDS & SYSTEMS

64K DYNAMIC RAM BANK SELECT - £380

**EPSON: MX80    £395**

**MX80 F/T + HIGH RES. GRAPHICS £455**

**NEW: MX100 - 15" CARRIAGE**

**PLUS HIGH RES. GRAPHICS £575**

### **TELEVIDEO:**

**910, 920, 950 FROM £425**

**WORDSTAR/CUSTOMISING OPTIONS**

ALL PRICES  
EXCLUDE VAT

END USER & OEM ENQUIRIES TO: ASHFORD (STD 07842) 47271  
INDEPENDENT COMPUTER ENGINEERING LIMITED  
16/18 LITTLETON ROAD, ASHFORD, MIDDLESEX, TW15 1UQ

TELEX:  
8952042

# CHROMASONIC electronics

48 JUNCTION ROAD, ARCHWAY, LONDON N19 5RD 100 yds from Archway Station & 9 bus routes  
TELEPHONE 01-263 9493 01-263 9495

YOUR SOUNDEST CONNECTION IN THE WORLD OF COMPONENTS AND COMPUTERS

V  
I  
C  
2  
0

## PET



NEW 12" Green Screen with end of line bleep  
4016 16K RAM  
4032 32K RAM  
4040 Dual Drive Disk  
402280 column tracks feed. as 4008 8k RAM etc.  
4022 80 column tracks feed.  
3023 80 column friction feed.  
C2N Cassett Unit.  
For the business man we stock the 8000 range inc. 8032 and 8050 with daisy wheel printers coming soon.

PHONE FOR MOST COMPETITIVE PRICES  
WORD PROCESSING AND 32K SYSTEMS  
PHONE FOR DETAILS

## UK 101

UK101 Kit inc 8K memory £125  
Ready Built inc 8K memory £175  
Complete in case £199  
4K Expansion 8x2114 £14  
New Memory Expansion kit 32k

### PRICE ON APPLICATION

Printer Interface  
Sound generator plus PIO kit £29.95

Cases £24.50

NEW Chromasonics Sound £24.95

Colour Kit £84.95

Inc. Demo Tape & Full

Documentation Send for details

## VIDEO GENIE

£279 EG3003



Utilises Z80, 12 K level II Basic, Integral Cassette Deck, UHF0/P, 16K RAM, all TRS80 features. Simply plugs into monitor or UHF TV, With V.U. Meter.

PARALLEL PRINTER INTERFACE INC CABLE. . . . 33.00  
CHROMASONICS PROGRAMABLE SOUND KIT. . . . 24.95  
SOUND KIT (FITTING EXTRA). . . . 7.00  
LOWER CASE KIT (FITTING EXTRA). . . . 27.50  
COLOUR KIT (FIT) . . . . .  
COLOUR KIT (FITTING EXTRA). . . . . 34.95  
EXPANSION BOX WITH/WITHOUT RS232 . . . . .215/185  
16K/32K RAM CARD . . . . . 94/129

## APPLE

### APPLE II PLUS

Complete Systems

48K Machines £595.00



DISK DRIVE WITH CONTROLLER £349.00

DISK DRIVE WITHOUT CONTROLLER £299.00

ACCESSORY CARDS, SOFTWARE ALL AVAILABLE - PHONE FOR DETAILS

## PRINTERS



EPSON MX80 £359

Dot-matrix printer with Pet graphics interface. Centronics parallel and serial. Pet and Apple compatible. True bidirectional, 80 cps.

EPSON MX80 FT/1 £399

Dual single sheet friction and tractor, 9 wire head, true descenders.

INTERFACES AND CABLES FOR APPLE II, PET, TRS80, RS232, UK 101, SHARP SUPERBOARD ALL AVAILABLE  
EPSON MX80 FT/2 £449  
An FT/1 with high resolution graphics.  
EPSON MX70 £259  
Tractor feed, 7 wire head high resolution graphics.  
SEIKOSHA GP80A £199  
Dot matrix 5 x 7, 80 columns 30 cps. graphics, double width characters.

JUST PHONE FOR FURTHER DETAILS

## MONITORS

Green monitor 9" (illustr) £95.00

MONI 9" (illustr.) B & W £82.00

Hitachi professional monitors

9" Black & White £99.95

12" Black & White £149.00



## VIC20 - £165

CASSETTE DECK £34.95

### Colours

24 total. 8 for characters, 8 for border, 16 for screen mixed as you wish. Basic colours on program keys are black, white, red, blue, light blue, green, yellow, and purple.

### Sound

3 Tone Generator for music  
"White Noise" Generator for language and sound effects

Each Generator gives 3 octaves.  
Reproduction is through tv speaker.

### Character/Line Display

22 Characters by 23 lines  
64 ASCII characters, pet-type graphic character set

### Keyboard

DIN typewriter keyboard with 8 programmable function possibilities via 4 special function keys. Colours are directly addressable from the keyboard.

### Peripherals/Accessories

VIC Datacassette with special interface to guarantee high reliability read/write quality (PET/CBM compatible).

VIC 1515 - Low cost VIC DOT Matrix printer (July Release)

VIC 1540 - Single disk unit with 170k Byte capacity (July Release)



£165

## TANTEL

### PRESTEL BY TANTEL

COMMUNICATION AT YOUR FINGER TIPS FOR BUSINESS & HOME. UP TO DATE INFO

180,000 pages of information on Travel, News, Investment, Holidays, Hotels Etc., Etc.,

£170

TANTEL IS POST OFFICE APPROVED. SEND FOR DETAILS.  
DEMONSTRATION AVAILABLE AT OUR SHOWROOM



Please add VAT 15% to all prices. Postage on computers, printers and cassette decks charged at cost, all other items, P&P 30p. Place your order using your Access or Barclaycard (Min. tel order, £5). Trade and export enquiries welcome. Official orders welcome.



Guy Kewney, editor of Datalink, presents the latest micro news.

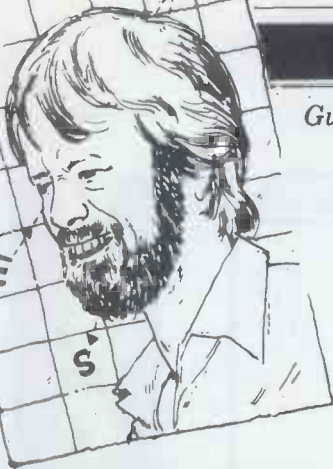

## BBC micro -part 94

The new BBC machine, despite all the criticism there has been, is going to have to work very hard to fail, as anyone will have to admit who saw the first models, as promised, at the PCW Show.

Mind you, you had to be pretty clever to actually see it. If it is possible to imagine a worse crush of spectators than surrounded the Wembley Online show's Micromouse heats, all you have to imagine is the Acorn/BBC stand at the PCW Show with more space to fit the crush into.

Into the crowd I marched, elbows hard at work, until I got into sight of John Coll, who was answering all questions with positive and confident ease.

John Coll is Acorn's education expert. He was one of the first teachers in the country to really push the micro as an essential item for schools and one of the few experts who is also well-informed. Criticism from Coll goes deep and his accusations that virtually everything I'd written about the BBC micro were misguided, hurt. Nonetheless, the only thing he really picked me up on was the report that the new machine would include, in its Basic interpreter, the unusual Basic that is contained in the Atom. This, said Coll, is absolutely not true.

Exactly why it isn't true, I'm still not sure. All its more admirable features are there, (such as the ability to run machine code routines just by entering assembler language into the program) in improved and standardised syntax versions; strings, for instance, are given the way the rest of the world does it, as AS rather than SA but upgrades and improvements of Atom Basic aren't the same as dropping it. I suppose 'retaining' Atom Basic sounds a bit too much like retaining

its more difficult features, which, it seems, have all been tackled.

Anyway, the biggest flea John Coll could have put in my ear still wouldn't have stopped me falling in love with the machine, for two reasons.

First, it looks nice; neat and flat with a good keyboard and a square table on which to place a television of monitor, and lots of special keys on the keyboard so that you can have special functions built into your program. Its output looked nice, too. Ominous rumblings from the trade that the ultra-high resolution graphics would just make a television freak out turned out to be plain rubbish.

The more important reason for liking the machine, the one that should impress the business user, is that it is designed for a long future.

Inside, it has a design feature called The Tube. This, as we mentioned when first writing about the Proton design from Acorn (the Proton has become the BBC micro) lets you connect the computer to a second, usually more powerful machine, for which it handles all human activities. By May next year, the BBC micro will have a second, add-on processor, a Zilog Z80, running CP/M as its operating system. Some time after that (say when Motorola gets the memory management problems straightened out), a system using the Motorola 68000 will be produced, again ready to use the Proton as its front end.

The front end will handle all the housekeeping chores. It will watch the users at their key-pressing, it will watch the disks spin round, and the printer zip along, and it will listen to the phone and the television for piped or broadcast software. When it has a message worth passing on to the main processor, it

will do this, as far as possible without interrupting it, through The Tube, some four kbytes of internal software.

The only serious objection to the BBC machine, the fact that it uses the obsolete and dead-end 6502 processor, is thus destroyed. As a pre-processor and operating machine, the 6502 is more than adequate for any task it is ever likely to meet in the next decade. And as a teaching machine for the next two years or so, the BBC micro is going to be enhanced, not handicapped, by the amount of educational software being generated for the Acorn Atom, much of which will transfer quite easily.

Looking at price, if a full, expandable-with-colour BBC machine costs £335 and the disk controller £70 and disks £500, the extra Z80 and CP/M board only needs to cost £300 to provide a CP/M system (without video) of roughly the same cost as the Osborne 1 and with a much more 'luxurious' specification as far as disk capacity and display quality are concerned.

The only thing that could hurt the machine is the way it is sold. It is true that nobody could afford to boost the BBC micro the way the BBC will do and that using a specialist mail-order outfit should make sure that anybody who wants one can get one. But the computer trade can see no obvious way to make money out of it, because they can't handle it.

This puzzles me a bit. Apparently it arises from the Beeb's desire to appear whiter than white and not to take too large a step into the private industry sector. But the fact is that there is no trade discount on the BBC machine. It costs £235 for the basic model, £325 for the advanced version and that is that.

Obviously there is nothing to stop enterprising shops from buying them in and flogging them at (say) £300 and £400, but for the fact that few people will want to buy them this way unless they can jump the queue. And if the retail trade can't stock the machine, will it sell software to run on it? Won't it rather denigrate

it and push the virtues of the VICs and Ataris, where profits can be made on both hard and software?

## Murphy strikes again

Some software has no defence against Murphy's law and can fail at any time. The time is chosen in accordance with Murphy's law, that is to say, when loading it from tape or disk, which is why people like to have a spare disk or tape of their favourite programs.

That, naturally enough, is why people like Apple Orchard sell programs designed to let users copy programs that normally cannot be copied because they deliberately deceive the operating system into mis-copying them.

Apple Orchard's Copy II Plus runs on the 48k Apple II Plus, costs £40 under DOS 3.3, and can be used to copy itself. 'Unlike most other copy devices,' notes Orchard, 'further copies cannot be made from a copy.' That stops people giving a friend a copy and then watching that friend make a copy for another friend. It doesn't stop one person making a lot of copies and giving them away, of course. But on a large scale, that would be a tedious lot of work unless you were charging for the service. And not too many people would be grateful for a program which can't be copied (see Murphy's Law above) so the only likely prospect for that crime would be the sort of unscrupulous dealer who sells you an Apple at the same price as anyone else, with a 'free' set of software which he's ripped off. You buy from such a pirate at your own risk unless he guarantees to support the programs under normal guarantee terms — but he won't.

If your conscience bothers you about using a copying program, because you have read in the *Wall Street Journal* that piracy costs the publishers £6 million a year, ignore such figures as entirely spurious. Most people copy programs, most do it for



reasons other than back-up, and almost none of these copy programs which they would otherwise have paid for. And an equally unmeasurable number go on to buy a program which they wouldn't have considered buying without the judgment learned from the first. Apple Orchard is on (0908) 53595.

## Compiler collection

Without giving too much away, Professor Peter Brown of the University of Kent wants it known that he is working on the answer to the problem of compilers.

The problem with compilers, he says, is that 'typically, they are too big to fit onto many computers, they operate slowly, they require frequent and lengthy maintenance to bring them up to date with new developments in computer programming and that the compilers on any two computers are often different from one another.'

Professor Brown and his colleague Peter Welch expect to solve many of these problems by putting specialist compiling machines onto their local computer network, so that the central compiling machine does all the compiling work, for all languages used around the net and for all machines used on the net.

Brown and Welch aren't saying too much about how they will do this but they are keen to hear from compiler-users, in the hope that these unfortunate people will say what's wrong with the things, and then Brown and Welch can think up solutions.

Let us hope that compiler non-users also get in touch. The reasons why someone avoids a compiler are probably at least as revealing as the reasons for using them; perhaps more revealing, since they will ask for things that compiler users have resigned themselves to doing without.

For instance, most micro users would want to sit down at the keyboard and start developing a program creatively there and then. Most professional programmers, accustomed to compilers, have developed the discipline of sitting down at a desk and designing the program first, on a piece of paper. They learned their trade, most of them, when there just weren't enough computers around to use the beasts to help the programmers but that isn't true today. Brown and Welch are on Canterbury (0227) 66822 ext 636 or 629.

## Sauron strikes

Originally, Sauron was a semi-deity of the Wotan type:

one-eyed, treacherous, consorter of crows and assisted by flying harpies who haunted battlefields while he tried to rule the world with the assistance of a Balrog called Loki.

This Sauron is obviously designed for the purposes of bucket print shops, since it can go a fair way towards being a typesetting tool — and at £8000 plus including VAT, just being a black word-processor wouldn't be enough.

The Sauron's desire to interfere with the life of its slaves seems to be limited to a 'program generator' which dealers will use, in order to convince customers that they are getting bespoke software 'as would be expected of a system of this calibre,' says its builder, CPS Data Systems, righteously.

It is based on the British-built Cifer 2683 intelligent terminal, with detachable keyboard with colour-coded function keys and the system has 2.4 megabytes on two floppies (quite a lot) and the Sanders Media 12/7 printer, which can change type size and style letter by letter. 'With an ordinary 60 characters per second daisy wheel printer, the cost is reduced by £1000,' notes CPS. Oh, and it has a spelling correction program. Or, as some prefer to call it, a misprint detector.

Its main claims to fame, apart from all that, are error-correcting communications from one Sauron to another (presumably through Palantir modules) down a phone line and its masses of black steel. Details on 021-707 3866.

## Hard work

There is, at last, some evidence that hard disks are pretty reliable devices. There is also evidence that they're pretty hard to fix. Take a product — any product — and you'll find that the man who makes it boasts of how reliable it is and the man who makes a business repairing it ruins the show by boasting how fast he can fix the hundred and one faults it suffers from and this includes hard winchester disks.

The big thing about winchesters is the fact that they can store an enormous amount of data and save or regurgitate it much faster than floppies can. And the big thing about mini-winchesters is that they are built to fit into the same box that an eight-inch floppy fits in. And the big thing about micro-winchesters is that they fit into the volume of a minifloppy, so manufacturers just whip out the old floppy and bang in the new winchester.

Almost a year ago, I heard stories suggesting that not all winchester disks were perfectly reliable. Mostly, the stories were about one particular drive, but since that was the most common drive, it wasn't surprising that most reports (of any kind) were about it.

Now, after a year's nervous silence, the suppliers have been hopelessly let down by a reasoned, calm and detailed account of how hard it was to fix the things. Kode Services in Wiltshire has got itself the contract to fix them all over Britain and Europe.

John May, managing director, doesn't paint a bad picture of reliability; in fact he expects around three percent of hard disks installed to fail in any one year and suggests that the figure could (possibly) be as low as one percent.

May's company has, at last, been given a contract by three of the leading makers of hard disks — IMI, Kennedy and Seagate Technology — to maintain their products in Europe. At first, he recalls, the US makers weren't too keen. 'Two years ago,' he told journalists at a recent announcement, 'we

approached a selection of US based winchester disk makers and suggested that we should become their repair agents in Europe. Initially the interest we aroused was lukewarm.' At the time, this was reasonable, says May, because they had spare production capacity. They could merely swap a faulty disk for a good one and save up all the faulty ones until the time came when they had enough to send them down the factory production line and fix them on a mass production basis. But today, this spare capacity doesn't exist and the number of disks installed is so large that even if it did, it wouldn't be enough. The result was that users were having to wait enormous times for repairs. 'European users,' he notes, 'have the additional expense and delay of shipping drives to the States.'

But setting up a repair centre isn't just a question of marking off a laboratory area. You need a clean room, a frightfully expensive thing to build and normally only attempted for making microchips. Dust is the cause.

'As you probably appreciate,' May said, 'in winchester disks, the gap



*In 10 years' time, any electronic device coming onto the market will automatically keep track of what goes wrong with itself. When the engineer phones it up (it will, naturally be connectable to the phone system) it will report not only the permanent breakdowns ('photo-cell not generating current, transistors burned out on chip 27, voltage too low from stage five') but intermittent ones as well ('on Tuesday, at 6.45, when the phone rang, 17 bits of a message to the video were corrupted by interference picked up from channel six of the analogue server' or 'disk number four mis-read four tracks over the past three weeks, on a non-random basis').*

*Until self-diagnosis is a lot cheaper and cleverer than today, however, devices such as the Oasis, which can put any electronic computer peripheral through all its paces, are going to be essential aids to the engineer.*

*The Oasis, from Hal computers of Weybridge, has software which will let it test several different computer peripherals — software called a Peripheral ALgorithm Module, or PALM — and the engineer just plugs in the right module, connects your apparently faulty peripheral, and can soon find out what it won't do. It works in the US, too, on US power supplies of 115 volts at 60 Hz. Details on Reading (0734) 586802.*

# CHOOSING A COMPUTER MADE SIMPLE

**FOR  
BUSINESS**

Made simple...

**FOR WORD  
PROCESSING**

Made simple...

**FOR  
EDUCATION**

Made simple...

**ADVICE**

Made simple...

**SERVICE  
AND  
BACK-UP**

Made simple...

**IMPROVING  
ON PET**

Not so simple

**Choosing a computer is . . .** Choosing a computer is more than just choosing a computer. That is, it's a lot more than just hardware. Mind you, PET stacks up very well when it comes to the computer itself. Because at Commodore we've been involved with microcomputers for over 20 years – in fact, many other manufacturers pay us the compliment of using our microchip for their own computers.

So, when you choose PET you know you have a microcomputer that everyone in the business admires and respects.

**. . . choosing software . . .** Our software programs live up to the quality of our computer. The range, from both Commodore and specialist suppliers, covers everything from word processing, stock control and payroll to accounting and information processing. As well as specialist applications for education and the sciences.

For light relief, we've a pretty impressive range of games and other brain-teasing packages.

**. . . choosing value . . .** Our computers start at under £200 and go through to £3000 – which will buy you a complete business system. The extent of our range makes sure that you'll easily be able to choose the right computer for your individual needs.

**. . . choosing a dealer . . .** As you can see, you do get nationwide dealer back-up with Commodore.

What's more, many of our dealers have specific expertise – which means they can advise on anything from business systems to specialist technical applications. So, if your particular problem is of a highly specialised nature, it may be best to contact our Information Department direct.

They will then recommend the dealers who understand – and who speak your kind of language.

**. . . choosing your computer . . .** It all adds up. By choosing a PET you're getting the kind of systems and service that you'd expect from Britain's biggest selling microcomputer.



Send to: Commodore Information Services, P.O. Box 109, Baker Street, High Wycombe, Tel: Slough 79292.

I'd like to know how a Commodore PET will make choosing a computer simple for me.

Name.....  
 Company.....  
 Address.....  
 Tel:.....

24PC2

**COMMODORE PET**  
 Quite simply, Britain's biggest  
 selling microcomputer

**LONDON AREA**  
 Adda Computers Ltd  
 W13, 01-579 5845  
 Byteshop Computerland  
 NW1, 01-387 0505  
 Capital Computer Systems Ltd  
 W1, 01-636 3863 & 637 5551  
 Centralex - London Ltd  
 SE13, 01-318 4213-7  
 Chromasonic Electronics  
 N19, 01-263 9493/9495  
 Healey Management Services Ltd  
 E1, 01-247 2858/3149  
 Home and Business Computers  
 E12, 01-472 5107  
 Logic Box Ltd  
 SW1, 01-222 1122/5492  
 Merchant Systems Limited  
 EC4, 01-583 6774  
 Metyclean Ltd  
 EC4, 01-236 2000  
 Micro Computation  
 N14, 01-882 5104  
 Micro Computer Centre  
 SW14, 01-878 7044-7  
 Sumlock Bondain Ltd  
 EC1, 01-250 0505  
 The Computer Shop (City) Ltd  
 EC1, 01-628 3531

**HOME COUNTIES**  
 Millhouse Designs Ltd  
 ALTON, 84517  
 The Computer Shop (Banbury) Ltd  
 BANBURY, 3477  
 H.S.V. Ltd  
 BASINGSTOKE, 62444  
 M.M.S. Limited  
 BEDFORD, 40601/2  
 Bracknell Computers  
 BRACKNELL, 52929  
 D.D.M. Direct Data Marketing Ltd  
 BRENTWOOD, 229379 & 230480  
 Amplicon Micro Systems Limited  
 BRIGHTON, 562163 & 608331  
 T & V Johnson (Microcomputers Etc) Ltd  
 CAMBERLEY, 20446  
 Wego Computers Ltd  
 CATERHAM, 49235  
 The Computer Shop (Caversham) Ltd  
 CAVERSHAM, 481555  
 Dataview Ltd  
 COLCHESTER, 865835  
 DaVinci Computers Ltd  
 EDGWARE, 01-952 0526  
 Micro-Facilities Ltd  
 HAMPTON HILL, 01-979 4546  
 Cream Computer Shop  
 HARROW, 01-863 0833  
 L & J Computers  
 HARROW, 01-204 7525  
 South East Computers Ltd  
 HASTINGS, 426844  
 Bromwall Data Services Ltd  
 HATFIELD, 60980/67111  
 Alpha Business Systems  
 HERTFORD, 57425  
 Commonsense Business Systems Ltd  
 HIGH WYCOMBE, 40116  
 Kingsley Computers Ltd  
 HIGH WYCOMBE, 449749  
 Computer Sales & Software Centre Ltd  
 ILFORD, 01-554 3344  
 H.B. Computers Ltd  
 KETTERING, 520910  
 H.B. Computers (Luton) Ltd  
 LUTON, 426887/416892  
 South East Computers Ltd  
 MAIDSTONE, 681263  
 Photo Acoustics Ltd  
 NEWPORT PAGNELL, 610625  
 WATFORD, 32006 & 40698  
 Sumlock Bondain (East Anglia) Ltd  
 NORWICH, 26259 & 614302  
 The Computer Shop (Oxford) Ltd  
 OXFORD, 722872  
 T & V Johnson (Microcomputers Etc) Ltd  
 OXFORD, 721461  
 Arden Data Processing  
 PETERBOROUGH, 49577 & 67831  
 H.S.V. Ltd  
 SOUTHAMPTON, 331422  
 Sumlock Tabdown Ltd  
 SOUTHAMPTON, 26647  
 D.D.M. Direct Data Marketing Ltd  
 SOUTHBEND-ON-SEA, 65787 & 64589  
 Scan Computers Ltd  
 STORRINGTON, (09066) 5432  
 The Computer Room  
 TONBRIDGE, 355962  
 Orchard Computer Services  
 WALLINGFORD, 35529  
 Microchips  
 WINCHESTER, 68085  
 P.P.M. Ltd  
 WOKING, (04867) 80111  
 Petallect Limited  
 WOKING, (04862) 69032 & 21776

**MIDLANDS**  
 Byteshop Computerland  
 BIRMINGHAM, 021-622 7149  
 C.P.S. (Data Systems) Limited  
 BIRMINGHAM, 021-707 3866  
 Camden Electronics Limited  
 BIRMINGHAM, 021-773 8240  
 Joseph Ware Associates Ltd  
 BIRMINGHAM, 021-643 8033  
 Marchant Business Systems Ltd  
 BIRMINGHAM, 021-706 8232  
 Micro Associates  
 BIRMINGHAM, 021-328 4574  
 Peach Data Services  
 BURTON-ON-TRENT, 44968  
 Catlands Information Systems  
 CHESTER, 46327  
 PEG Associates (Computer Systems) Ltd  
 COVENTRY, 20246  
 Davison-Richards Ltd  
 DERBY, 365803  
 Taylor Wilson Systems Ltd  
 DORRIDGE, (05645) 6192  
 Caddis Computer Systems Ltd  
 HINCKLEY, 613544

Arden Data Processing  
 LEICESTER, 22255  
 Roger Clark Business Systems Ltd  
 LEICESTER, 20455  
 A.J.R. Ltd  
 NOTTINGHAM, 206647  
 Betos (Systems) Ltd  
 NOTTINGHAM, 48108  
 Byteshop Computerland  
 NOTTINGHAM, 40576  
 PEG Associates (Computer Systems) Ltd  
 RUGBY, 65756  
 Synchro Computing Ltd  
 STOKE-ON-TRENT, 825391  
 Walters Computer Systems Ltd  
 STOURBRIDGE, 70811  
 The Computer Shop (Swindon) Ltd  
 SWINDON, 694061  
 McDowell, Knaggs & Associates Limited  
 WORCESTER, 28466

**YORKS AND HUMBERSIDE**  
 Ackroyd Typewriter & Adding Machine Co. Ltd  
 BRADFORD, 31835 & 32243  
 Allen Computers  
 GRIMSBY, 40568  
 Microprocessor Services  
 HULL, 23146  
 Microware Computers Ltd  
 HULL, 562107  
 Holdene Ltd  
 LEEDS, 459459  
 Yorkshire Electronics Services Ltd  
 MORLEY, 522181  
 Computer Centre (Sheffield) Ltd  
 SHEFFIELD, 53519/588731  
 Holbrook Business Systems Ltd  
 SHEFFIELD, 484466  
 Estate Computer Systems  
 SLEAFORD, 305637  
 Mitrefinch Ltd  
 YORK, 52995

**NORTH EAST**  
 Currie & Maughan  
 GATESHEAD, 774540  
 Dyson Instruments  
 HETTON, 260452  
 Key Computer Services Ltd  
 NEWCASTLE-UPON-TYNE, 815157  
 Intex Datalog Ltd  
 STOCKTON-ON-TEES, (0642) 781193

**MANCHESTER AREA**  
 Byteshop Computerland  
 MANCHESTER, 061-236 4737  
 Computastore Limited  
 MANCHESTER, 061-832 4761  
 Cytek (UK) Limited  
 MANCHESTER, 061-872 4682  
 Executive Reprographic Ltd  
 MANCHESTER, 061-228 1637  
 D. Kipping Ltd  
 MANCHESTER, 061-834 6367  
 Professional Computer Services Ltd  
 OLDHAM, 061-624 4065  
 Catlands Information Systems Ltd  
 STOCKPORT, 061-477 6699  
 Catlands Information Systems Ltd  
 WILMSLOW, 527166

**LIVERPOOL**  
 Stack Computer Services Ltd  
 BOOTLE, 051-933 5511  
 Aughton Microsystems  
 KIRKBY, 051-548 7788  
 Rockcliff Micro Computers  
 LIVERPOOL, 051-521 5830  
 The Computer Shop (Southport) Ltd  
 SOUTHPORT, 77783

**NORTH WEST**  
 B & B (Computers) Limited  
 BOLTON, 26644  
 Tharstern Limited  
 BURNLEY, 38481  
 Preston Computer Centre  
 PRESTON, 57684

**WEST COUNTRY**  
 Radan Computational Ltd  
 BATH, 318483  
 Calculator Services & Sales (Bristol) Ltd  
 BRISTOL, 779452/3  
 Sumlock Tabdown Ltd  
 BRISTOL, 276685  
 T & V Johnson (Microcomputers Etc) Ltd  
 BRISTOL, 422061

**A.C. Systems**  
 EXETER, 71718  
 South Coast Business Machines Ltd  
 FERNDOWN, 893040  
 Milequip Ltd  
 GLOUCESTER, 411010  
 Devon Computers  
 PAIGNTON, 526303  
 A.C. Systems  
 PLYMOUTH, 260861  
 JAD Integrated Services (Plymouth) Ltd  
 PLYMOUTH, 662616 & 29038  
 J.M. Computer Services Ltd  
 TRURO, 71626

**WALES**  
 Sumlock Tabdown Ltd  
 CARDIFF, 41361  
 Sigma Systems Ltd  
 CARDIFF, 34869 & 21515  
 Reeves Computers Limited  
 CARMARTHEN, 32441/2  
 Computer Supplies (Swansea)  
 SWANSEA, 290047

**SCOTLAND**  
 MacMicro Ltd  
 BEAULY, 046-371 2774  
 Holdene Microsystems Ltd  
 EDINBURGH, 031-668 2727  
 Byteshop Computerland  
 GLASGOW, 041-221 7409  
 Gate Microsystems Limited  
 GLASGOW, 041-221 9372-4  
 Robox Ltd  
 GLASGOW, 041-221 8413/4  
 Ayrshire Office Computers  
 KILMARNOCK, 42972

**NORTHERN IRELAND**  
 Northern Ireland Computer Centre Limited  
 HOLYWOOD, (02317) 6548

# NEWSPRINT

between the read-write head and the surface of the magnetic disk itself is minute. Currently, the gap is around 18 to 20 micro-inches and a typical particle of cigarette smoke is many times wider. Smoke in a winchester would plough along the highly-polished magnetic surface, destroying data. So winchesters are air-sealed, dust-free environments and opening them up for repairs can only be done in a similarly dust-free room. Not easy, when you consider that the human body gives off five million dust particles per minute just walking along, and when you consider that the next generation of winchesters will have the heads only two-thirds of the distance away, to record more bits per inch.

Kode expects to have plenty of customers, however. 'With a few exceptions, turnaround times for repair, once the disks have reached an American plant, are now well in excess of 10 weeks,' he announced. By contrast, Kode guarantees a fortnight now and a week as soon as this can be managed.

The end result of all this is to convince me, at last, to take winchesters seriously. With reliable products available, and reasonable service, many of the horror stories currently circulating will vanish and sales resistance will become a thing of the past. And if sales boom, prices will come down, and sales will boom even more.

I anticipate that by the end of 1982, Kode will be supporting a base of more than 100,000 disk drives in Europe. This figure refers only to those made by the three companies I have mentioned; May added. He is in Calne, Wilts, on 0249 813771.

## Prestel cutback

The decision to reduce drastically the number of British Telecom computers running Prestel (because nobody was using them) proves just how much power the Press doesn't have.

Despite endless stories about viewdata, Prestel and the Information Providers, people have failed to buy their automatic money-takers and those who bought them don't use them enough. Optimists still maintain that the move is premature and that one day it will have to be reversed.

Similarly, Michael Marshall MP went on record shortly before he vanished from his post as Parliamentary Under Secretary of State (junior minister to you) for Industry, saying that the vaguely similar teletext invention (the BBC and ITA sending

pages of text through decoders inside normal TVs) would have a remarkable future success. Marshall predicted a million teletext sets by the end of next year, then he vanished from the Department of Industry.

Even counting the undoubtedly large numbers of people using the BBC micro to get programs off the air through Ceefax, this sounds pretty optimistic. If you're not loading Basic, what good is Ceefax, anyway?

## Short words

In computers as in speech, it is possible to reduce the amount of unproductive storage and communication time by a judicious reduction in the packaging density of the information medium. Or, it is quicker to explain if you use short words.

Using this method, Sage de Gale (a consultancy) reckons it can double the capacity of your floppy disk — by using shorter words. It notes that most information on a disk uses many more bits than is really needed. For instance, 400 spaces may be vital to a program but if they come together, all you need is a code for 'spaces' and another for '400' — say three bytes. De Gale reckons that it has refined this sort of technique to the point where its Archive software can pack data into half the normal space. Details from Patrick de Gale, on 086 733 529.

## The other Gemini

Looking at the nice machines around today which weren't around a year ago, it is worth recalling the widespread predictions by industry pundits that this wouldn't be much of a year for new machines. Examples to prove the predictions wrong include the Chris Shelton Sig-Net, the Gemini, the Osborne, the BBC micro, and the IBM offering.

The Gemini, most frustratingly, is the best-looking bargain around the UK, which isn't all surprising since its father is John Marshall, who originally gave us the ultra-cheap Nascom. Frustratingly, because Marshall is selling all the machines he and his partner (printed circuit king Manas Heghoyan) can make, into Europe. The Gemini 80 is a strange machine. It is more a consolidation of past machines than a really new one and it owes its origins to the long gap between the collapse of Nascom and its eventual revival at Lucas Logic. History explains the sequence of events: the Nascom actually has a standard bus on which, it was intended by its designer, people could fasten odd bits

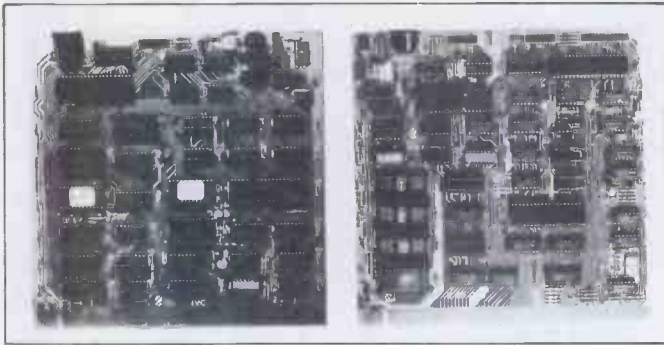

and pieces such as speech synthesiser circuits, remote control boards, extra memory, disk controllers, and so on. It's a fairly old trick in the computer business and it works pretty well: it means that people can have a big computer but can start off with a cheap one.

All the companies that moved into the Nascom market did so by designing a special add-on for the Nascom bus, or Nasbus. When Nascom went bust, their annoyance (that there would be no more Nascom customers to sell to) was very much tempered by relief (that Nascom would not be competing in their specialist areas). And very soon, they got together, to sell products in co-operation, and to plot to produce a new computer that would look enough like a Nascom that it could use their special add-ons, but little enough like that they wouldn't face legal reprisals from Nascom itself.

The Gemini is part of the result: its Gemini 80 bus is very similar to the Nasbus. However there are a lot of boards for the Nasbus that won't easily attach to the Gemini (too big, wrong shape) and for them, Gemini and the other add-on merchants have devised a sort of British answer to the S100 bus. It's called the Multiboard, and two boards in the range are shown elsewhere on this page; they can be fitted into a standard Vero case, or a special Kenilworth case.

Dealers who make compatible add-ons (they call themselves the Microvalue Group) include: Business & Leisure of Kenilworth; Electrovalue of Egham and Manchester; Target Electronics in Bristol; Henry's Radio, London; Bits & PCs, Wetherby; and of course, John Marshall's own components shop, Interface of Amersham.

Putting a system together this way is not the cheapest possible method of starting, though it can be very useful for building a system exactly the way you want it. Nonetheless, paying some £850 (inc VAT) for CPU, video board, 64k RAM, disk controller, keyboard, power supply and program memory is far from top whack. Details: (02403) 22307.

## HO 'No' to data protection

The Home Office has upset people who reckon that computers can be a threat to privacy by insisting that it can look after all our interests.

Considering that the Home Office's computers and those of the police who are nominally responsible to it, are often regarded as one of the greatest such threats, this attitude can only be regarded as suspicious. So, at least, said a lot of people at the British Medical Association conference on the subject of data protection.

The BMA is concerned that people will be afraid to tell doctors things, unless there is some guarantee that the information can't be simply, automatically and rapidly transferred into publicly accessible data banks. They want a data protection authority to deal with the problem.

Not possible, the Home Office minister, Timothy Raison told the BMA. A data protection authority would create new crimes, not covered by the courts but by the authority, an unacceptable extension of the law. To me this sounds like ignoring the new crimes that actually exist, created by the mass processing power of multiple computers but I'm sure the Home Office knows best, the way it did on Citizens Band Radio....

## Rair upgrade

Whatever Rair says, it isn't the first microcomputer company to offer its users the option of 'state of the art' high speed 64 kbit dynamic RAM chips for memory. But at least Rair is one of the first and it is offering a 256 kbyte board (that's got at least 32 of the little things inside) for its Black Box micro at a cost of £1250.

## NS Advantage

It is entirely the wrong time for North Star to launch a nice new micro costing less than \$4000 when David Broad in Britain has just pro-

duced new versions of his Communicator. On its own, there is nothing to say that Comart's boss has easy opposition from America in the new Horizon. It's just that his own look-alike doesn't have to fight its way through a falling pound, whereas the Horizon would have cost £2000 in April and will cost at least £3000 now, before the import cost is added.

The new Horizon is the Advantage; unlike older Horizon machines, it has a built-in screen and very good-looking graphics. And, of

course, another new feature: a keyboard. Two disks are built in, as before and both old and new versions of the machine can be linked (one day) into multi-user, local networks.

The rubbing sound you will hear if you ring Broad up to ask about the Advantage will be his hands, gleefully being wrong over the rise of the dollar and how well his Communicator will do as a result. Don't let him gloat: details from North Star in California on (415) 357 8500.



## ACT starts

The biggest supplier of business software for micro users is ACT. This is the opinion of ACT, at any rate, which says that games are out and sales are three times what they were.

According to a recent announcement, some £4.75 million worth of off-the-shelf personal computer programs will come off the shelves during 1981. There are other fascinating statistics. ACT has found, for instance that, 'there are now 450 computer stores offering programs of a business nature, plus a smaller number who offer games programs.' There is also a growing number of software consultants, says ACT, 'consultants who undertake "tailoring" in addition to various micro-software houses and publishers selling by mail order.'

ACT says it expects 'a dramatic increase in the number of outlets handling the less sophisticated programs this winter, with the arrival both of a new generation of low-cost personal computers and of cartridge programs, — referring to Atari, Texas, VIC and so on. But from ACT's point of view, the more interesting development will not be the toys and the move of multiples such as WH Smith into selling cartridges for the toys; it will be the arrival of the rest of the 'real' computer industry.

The ACT study pointed to the 'steady improvement' in the quality of business software available, in the judgement of dealers at least. And it predicted the

increasing involvement of the more experienced dealers in the bigger 'minicomputers', dealers who call themselves original equipment manufacturers, or OEMs because they disguise other people's original equipment with software and badges of their own.

'Many of these companies have been working with mainframe and minicomputers,' says the ACT report. 'They cannot afford not to be in the micro market place and our study suggests that their involvement is causing an all round improvement in professionalism and support for the customer.'

And after all that ACT says you can get its catalogue from its offices at Shenstone House, Dudley Road, Halesowen, West Midlands, or phone 021-501 2284.

## Intel's analogue

The most unusual computer ever to appear for under £1000 must be the new analogue computer kit from Intel. It is built round the analogue signal processor Intel released a year or more ago and which caused wild excitement in high places where people know what an analogue signal processor is.

Normally, analogue signal processors are a trial-and-error sort of magic, where you work out component values, twiddle the adjustable bits and watch the output to see if it does what you want. The Intel device changes its internal (on chip) values

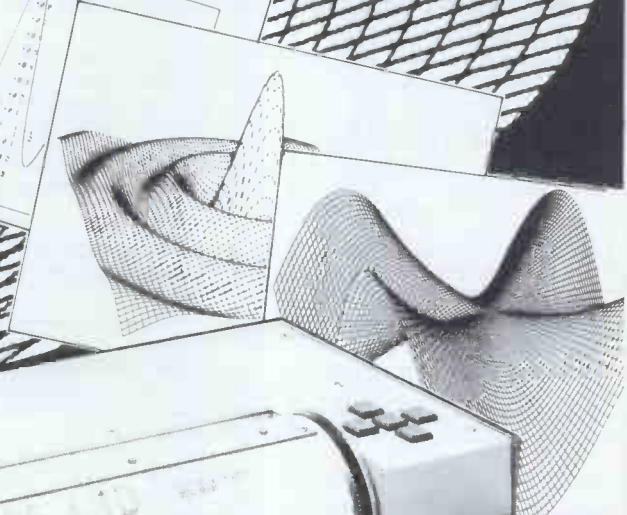
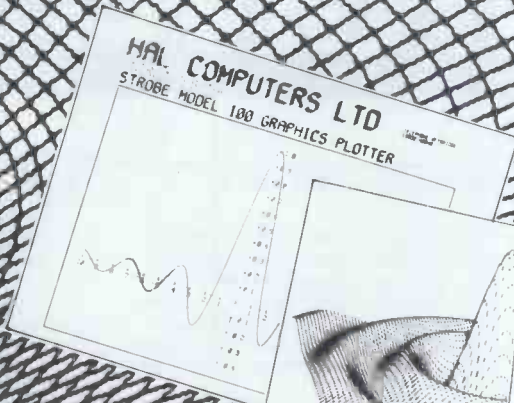

# VECTOR PLOTTING, MICRO PRICE

The new Strobe Model 100 drum-type plotter gives you real vector plotting, interfacing to your computer hardware and system software, from only £690\*

- \* High resolution — 0.1mm at 7.6cm/sec. \* A4 paper capacity. \* Will plot in most colours, uses off-the-shelf felt tip pens. \* Precise operator control. \* Interactive input of coordinates.

## Driver Routines

The Strobe Model 100 can be interfaced to any computer through two parallel 8-bit output ports and one 8-bit input port. Optional interfaces for TRS-80\*, Apple II\*, PET\*, and S-100 bus computers are currently available. Source listings of the assembly language motor drivers and vector plot routines for use on 8080, Z80, and 6502 microprocessors are supplied with Model 100. Flow charts of these routines simplify modifications of drivers for custom machine level software.

- \* Unit price for plotter ex-delivery and ex-VAT
- \* TRS-80, APPLE II, and PET are trademarks of Tandy Corp., Apple Computer Co., and Commodore Business Machines Inc., respectively.

**HAL Computers Limited**  
 57 Woodham Lane New Haw  
 Weybridge Surrey KT15 3ND  
 Telephone: Weybridge 48346/7



SEE US  
 ON STAND  
 9043 AT  
 COMPEC

DEALER  
 ENQUIRIES  
 INVITED

# LOOKING FOR 5%

## EP4000 EPROM Programmer/Emulator — Not just a programmer.

Programs a wide range of EPROMs without personality cards. Video output for editing and LED display for stand alone operation. Standard interfaces include RS232C, 20mA, TTL, cassette, printer and DMA. In EMULATION MODE EP4000 replaces your in-circuit PROMs for program development and makes changes, entries, edits simple. Accessories include Bipolar programming modules, multi EPROM simulator adaptors, buffer pods, ERASERS, Monitors, 2764/2564 programming satellite, printer and production gang programmers.

EP4000 programmer/simulator £545.00 P4000 production programmer £545.00 (9 sockets) Eraser £78.00 Monitor £88.00 Printer £395.00

## Microtek MT80

Probably the most reliable small matrix printer. To coincide with the move into our new factory we are offering these at clearance prices. 9 x 7 matrix, upper and lower case — one only ARABIC —, extended print, 40,80,132 column, 125 CHARACTERS PER SECOND.

Parallel MT80P £395.00 Serial MT80S £445.00

Cables available for all of the popular micros.

## DYSAN DISKETTES. Indisputably the best you can buy.

30,000 diskettes in stock. As well as the standard range of diskettes for Apple, PET, TRS-80, etc, we also supply pre-formatted for: CPT 8000, Micom/1P5002, all IBM, AES/Lanier, Atari, Nexos 2200, Wang, Zenith and P2000. For immediate delivery call our HOTLINE... Weybridge 48346/7

## The Revolutionary New 8" Thinline

Tandon's revolutionary new 8 inch floppy disc drive is only half the thickness of earlier drives so that you can pack twice the storage into the same space. In addition a new method of construction allows the drive to constantly compensate for changes in temperature and humidity so that real capacities of up to 4.M.bytes are now achievable in the usual 8 inch floppy disc drive envelope size. The TM800 series drives require only D.C. power (5v and 24v) so that they run cool and no changing of pulleys and belts is needed for manufacturers who want to ship products abroad.

Our new low profile packaging, designed and built in the U.K., complete with power supplies makes incorporation into, or addition to, existing systems simple.

## APPLE II & TRS-80 COMPATIBLE MINI FLOPPIES

This is our popular TM 100 series mini floppy... Tandon make 40,000 of these a month. Available as bare drives and packaged in single and dual cabinets with power supplies. Capacities from 100K.bytes to 1 Mbyte per drive! Compatible with TRS-80, Video Genie, SUPERBRAIN, Horizon, Zenith, SWTP, Heathkit etc., and supplied as the standard drive with many of these systems.

TRS-80 compatible (in cabinet with power supply)	DUAL UNITS	40 track	£399.00
		80 track	£549.00
	SINGLE UNITS	40 track	£219.00
		80 track	£289.00

APPLE II Compatible	Single disc	£249.00
	Dual disc	£488.00

APPLE Controller board DOS 3.3 £POA

Prices exclude VAT and delivery charges.

## SPARE PARTS SERVICE AND TRAINING

We carry a complete stock of emergency spare parts for Tandon disc drives and we can fix any drive on a short turn-round. All final testing is carried out on an in-house ATE drive testing system which can run 73 separate diagnostic programs to ensure that your drive leaves us in absolutely first class condition. A less complex calibration service is also available. Full product support exists for genuine OEM customers and we run single day training courses at regular intervals. Call our service engineering department for further information.

We carry the full range of Dysan alignment diskettes and a staff of Sales Engineers will be pleased to help you with any queries.

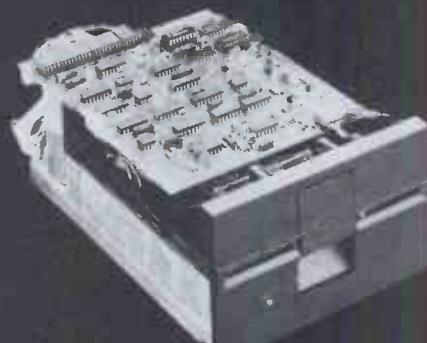

**HAL Computers Limited**  
**57 Woodham Lane New Haw**  
**Weybridge Surrey KT15 3ND**  
**Telephone: Weybridge 48346/7**

# WINCHESTERS?

I've got just what  
you're looking for....

Our new Micro Winchester gives you from 5 to 20 M.bytes of hard disc storage from as little as £1425.00 for a complete ready-to-go, plug-in system with software.

Floppies and larger more expensive hard discs are no match for our new drives which pack enough data to run serious business or technical applications software into a mini-floppy size 5¼" unit. Your data is protected in the sealed enclosure making diskette handling problems a thing of the past. The disc is fast — 40 times faster transfer rate than a mini-floppy — yet fits into the same space and so can be used as a replacement or an enhancement.

## Controllerbility

Our controller comes with a range of adaptors to plug on to most popular micros and there are more adaptors on the way. It supports two discs with ease and while others are struggling with less stable analog data separators and speed-eating error correction circuits, we use a high performance digital design which literally locks into the data stream and stays there. Incidentally we also sell digital data separator cards to OEMs. Real time and multi-tasking applications benefit from the controller's interrupt capability and macro level command structure and the OEM version features a simple software interface and CP/M 2.2 BIOS with extensive development aids. The software comes on either 5¼" or 8" diskettes together with Boot PROMs.

## Service and Support

If you are impressed with the specifications so far, there is more to come. Our packaged sub-systems are assembled in-house and they carry a full one year parts and labour warranty. Our controllers are built completely from TTL logic — there are no fancy chips — so we can fix them if they ever break down. Dozens of floppy disc drives go through our workshops every month and we are well known within the industry both for our training courses and our heavy investment in computer based disc test equipment. If your Winchester ever stops working you can depend on us to fix it.

SEE US  
STAND  
043 AT  
COMPEC

For:  
SUPERBRAIN,  
S-100, APPLE II,  
HEATH H89,  
TRS-80.

**DEALER  
ENQUIRIES  
INVITED**

under software control. The only trouble is that before this latest kit, you needed a hefty chunk of expensive hardware to get the software in. With this kit, you need a hefty chunk of ingenuity but at least the thing only costs £655. The dealer who told me about this is Rapid Recall, on (0494) 35634, but I dare say other Intel distributors have the SDK 2920 too.

## Selling well

When Microsense first offered the Apple computer which it distributes in the UK to schools, it offered a first-time discount. And all the dealers who got their Apples from Microsense raised a huge fuss because this meant that the teachers got their computers direct, and the local agent lost out.

Well, it looks as if the local men didn't lose out all that much. Partly as a result of that promotion, Microsense can now point to 1000 Apples in UK schools, despite the Government's choice of the BBC micro and Research Machines' 380Z as official education machines.

And another 1000 says Microsense, are in universities.

## War mag

Until now, there has been no magazine devoted to games software for domestic

microcomputers. Now there is: it's called *The War Machine*. As the title rather betrays, it is into combat games and claims that readers 'came to microcomputers from a background in hexagon wargaming, and others are fantasy role-playing gamers.' Not for Space Invaders freaks, then. It costs £1 for the first issue, and they hope to publish it every two months. Details and postal order to MW Costello, 17 Langbank Avenue, Rise Park, Nottingham NG5 5BU.

## Serial switch

On the back of many modern micros is a port labelled 'RS232' and KGB Micros has noticed that several people have more than one printer, or video display, or modem but only one socket to plug it into. To circumvent this awkward problem, the company is offering a Softswitch which allows people to plug three devices into the one socket.

The Softswitch can do nothing about those irritating systems designers, such as Triumph Adler, who have redesigned the RS232 interface. But assuming that your video and printer have sufficiently similar RS232 plugs, you may be able to adjust your software to con you into thinking that you have two or three sockets. 'Softswitch works by sensing a user-defined two-character

code, which precedes data being transferred,' explains KGB. 'This code switches the data to the appropriate output port' and the actual switch can be as quick as you can send the code, it continues.

At the time of writing, I don't know how to change applications software to operate the switch, or what restrictions are likely to result but a small bet that changes and restrictions will occur might attract me. Details on Slough (0753) 38310.

## Faster not cheaper

'Going faster' is a concept attracting several micro-computer makers who have satisfied themselves that they can't win the fight for 'going cheaper' with the BBC micro, Osborne and Gemini around.

Frankly, with the IBM machine on the horizon, 'going faster' with a Z80-based system looks like a short-term grab for glory to me and it certainly does make for vastly expensive machinery, like the MC Computers' Quasar QDP-100, costing £3380. You get a lot of disk capacity (two megabytes) and some slots to plug in \$100 cards, but otherwise it's a bog-standard CP/M system without screen or keyboard, rather like the Cromemco.

I'm slightly more impressed with Paul Joyce's new machine at Graham-Dorian; he's brought in the Performance machine from MicroPro. It was designed by MicroPro, who designed the best-selling Wordstar word processor and it was designed to run Wordstar at its best, with high speed and lots of extra features and a big disk but it costs the best part of £7000. Quasar is in Northampton on (0604) 858011. Graham Dorian is in Reading on (0734) 664 345.

## Golden turkey

This time they've gone too far. The Americans, I mean, with their obsession for trademarking every normal word in the English language.

Remember how Zilog earned widespread ridicule when it tried to trademark the letter 'Z'? Now somebody has trademarked 'English' as the name of a computer language.

That somebody is an outfit called Microdata Corporation in California (where else?) which has taken to advertising its business system, the Reality a silly enough name, if

ever I heard one. I quote from Microdata's advert in the 24 August edition of *Fortune*: 'Microdata's Reality computer system speaks your language: English', etc, etc. At the bottom there's the line: 'Reality and English are registered trademarks of Microdata Corporation, Irvine, CA'.

Starting as of now, we're going to award an annual Golden Turkey trophy for the silliest marketing/advertising ideas in the micro-computer industry. At the moment, as usual, Britain is lagging seriously behind the Americans in this, and it's about time we got our act together. So, if you spot anything that could rival the Reality ad (and that's far ahead of anything else in the Golden Turkey ratings right now), let us know at PCW.

## Taped tips

'Oh, you know about computers, do you? I'm thinking of getting one of these new micros: tell me, do you think I could put all my customers on one, and should I use an Apple or a PET?'

People at parties who ask this question while you're trying to pour straight can now be dealt with more kindly than with the usual beer-on-trousers diversionary gimmick. You can instead refer them to the National Computing Centre, which has released a cassette tape on 'How to choose your small business computer' which gives checklists, jobs to do before you get the system, jobs after, sources of advice, book lists, and glossary of jargon terms.

Tape and booklet cost a mere £10 from The Microsystems Centre, 11 New Fetter Lane, London EC4A 1PU or from Manchester NCC headquarters.

## Whaa?

It's difficult to be sure but I think the new Uniquad is an 'ideal prototyping printed circuit card.' It is, I think, designed to allow circuit designers to put prototype boards together and know that some of the important design criteria that normally only appear in the production version, are there from the start.

If you think I must be pretty feeble not to be sure, remember first that my phone bill can't be pushed to infinite lengths, nor can I spend all week talking to everyone who puzzles me with an announcement that looks worth running.

Listen to this: 'Introduction. The Uniquad was developed as a flexible prototyping board for in-



Do I have to tell anyone that Uncle Clive has finally launched his £50 ZX printer? Surely everyone knows? You do? Great! Bet you didn't know that Sinclair sales are now running at £20 million per year, though, did you? And I'll tell you what: bet you can't get a printer yet, either.

The amazing enthusiasm of Sinclair users for their machines never ceases to amaze me, even though I think I recall saying that a high-volume sales machine like the ZX8X series would generate just such self-help enthusiasts. Latest to come to my attention is G A Bobker of 29 Chadderton Drive, Unsworth, Bury, Lancs, who produces a sort of quarterly called ZX-Guaranteed with lots of free software and circuit ideas, not all of which are fully recommended by the author. Bobker is a dissident; that is to say, he is rude about Uncle Clive. If that sort of thing offends you, don't write to ask his price. Phone him instead on 061-766 5712.





*The Apple II may be less than a year away from death as the company's biggest money spinner and there may be three new machines just waiting for it to flag. But as long as people build musical instruments like this around it, Apples will continue to change hands. This is the new alphaSyntauri synthesiser, with a new operating system that lets musicians go beyond performing and recording what they played; it adds such a wide range of sound manipulations and storage options that I'm not going to try listing them or explaining them here. Suffice it to say the new system is available on the old alpha by adding a new disk of software and full details are available direct from Syntauri Corporation at 3506 Waverley Street, Palo Alto, CA 94306.*

house use. Its prerequisites were low cost and minimal wiring overhead for the development of a networking microsystem in respect of memory, processor, and global/local bus buffer PCBs.

'From this objective, the concept of a flexible board for production use arose, leading to considerable savings in general inventory and stock control.'

There is more amiable waffle of this sort, totally opaque to me, followed by a row of asterisks and the statement: 'THE UNIQRD IN CONTEXT', which includes paragraphs such as: '4) Plated Through & Non-plated Through Holes. A combination (mainly plated through) achieve inherent topology and afford user-defined circuit extensions by simple through hole link.'

I can only agree. For details, contact Wessex Micro-computers (0063-22-402) in Somerset. I'm fairly sure this is something clever but for the life of me, I can't work out what.

## Cunning stunt

Admire, if you will, the use of the word 'conversion' by ACT for the process of getting the Micromodeller, which some say is like Visicalc but nicer (and much pricier) to run on the modified PET. The difference is that ACT supplies a Stunt Box with the software on it.

Details from ACT Micro-soft on 021-501 2284.

## Zak's view

Rodnay Zaks, a name all of you will recognise from the computer book stalls, reckons that computer makers are slowing down the growth of the micro market.

Zaks released his analysis of the microworld at the recent PCW Show. And gave us several statistics, previously published, to show just how huge the micro market was going to be. His opinion is 'that it could be many times larger than these figures show.' What is slowing us all up, said Zaks, is the fact that both customers and technology are way ahead of the personal computer market.

Most of today's best sellers are deeply rooted in the past, he noted. Bright new chips like the Motorola 68000, the Z8000 and the Intel 8086 are not to be found in any common machine. Indeed, they are hardly to be found even in any available machine and certainly in no cheap machine, despite the fact, Zaks observed, that the Intel 8086 is now cheaper than the Z80. And the Intel 8086 has some chance of running a more modern operating system like Unix, where the eight-bit micros of today's systems, cannot.

'Unix may be all that its proponents say and be a step forward,' said Zaks (I'm paraphrasing somewhat) 'but the suppliers just don't understand that to the user, all these wonderful features and

protection are useless if the machine takes 10 seconds to interpret his commands. And today's eight-bit micros are just too slow to run Unix'. So we have the old Apple II, the creaking TRS-80 (Model I banned in America, Model II very pricey, Model III still not really supported) and the PET which is strong only in Europe and has made a real mess of things in the US and is no more modern except for the MicroMainframe. On all this rather outdated hardware, we have Visicalc, Wordstar and CP/M, of which only Visicalc has any real future to it.

While the chip makers have the most amazing technology waiting, the customers are equally far ahead, he noted. 'We used to have to explain what a computer can do. Nowadays, by contrast, the customer knows what he wants. He wants indexing, forecasting, word processing, database, and other things and the machinery just can't deliver. There is a tremendous market pressure building up, waiting for the right products to emerge,' Zaks said.

I think he's right about the possibility of selling many millions — even billions-worth of micros by 1985. I'll also add my opinion that the more powerful machines won't be widely available until they are cheaply available. Who needs powerful minis, anyway? We've got those already, with masses of software already written. When powerful minis cost £335, it's a different prospect, however.

## Z8000 module

One good sign that the Z8000 may be turning into a widely available chip is the release, by its designer (Zilog) of a cheap development module for engineers to play with.

It's called the Z8001 Development Module. It has some minimal monitor soft-

ware, a segmented Z8000 capable of driving eight megabytes of memory but with only 16k words on the board and some input and output ports. Details from Zilog in Maidenhead on (0628) 36131.

## Electronic mailbox

In the September issue of US magazine *Microcomputing*, editor Wayne Green devotes his 'Publisher's Remarks' column to the need for, and the megabucks to be made from, an electronic mailbox system, ie, a system for sending text over the phone line via a microcomputer, stored for perusal at leisure by the recipient's computer.

If we skip over the issue of whether or not 'The Source' and other such networks are to be counted (Wayne doesn't mention them), then for once the little old UK is ahead of the game. Prestel called a press conference on 23 September to launch its Mailbox service. Available initially only to subscribers in London and the SE who have access to the Enterprise computer, the facility will be extended to the other computers of the Prestel network in early 1983 once PANDA is in operation.

The sender calls up a would-be recipient's account no. and then accesses a 'mailbox frame' on the Prestel computer. If he/she has an alphanumeric keyboard he/she may deposit therein a screenful of message; if only a numeric pad, then a variety of preformatted messages may be left, such as 'Order acknowledged', 'Booking confirmed', 'Congratulations' and 'Get well soon'. The latter include wonderfully artless graphics, such as a glass of champagne or a basket of flowers! The cost will be 5p per frame but is on free trial offer until January 1982.

The recipient will be noti-

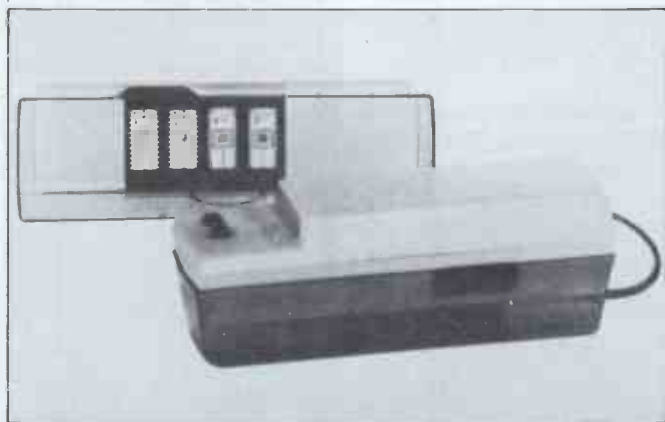

*This is an ultraviolet box and it costs just £45; don't try to get a suntan with it, or you'll be disappointed (it'll blind you if you manage to jimmy the safety interlock system) but for erasing erasable memories, it could be a bargain. Details from Hi-Tek Distribution in Cambridge, tel 0954 81996.*

fied that a message is waiting the next time Prestel is accessed; a directory of users will be available, obviously enough, on Prestel. With first class post now at 14p it only requires a modest Fortran program to calculate how many words your message needs to be before you break-even on such a deal. You didn't forget to add the connection charge and price of the phone call did you? Hardware permitting, though, at least your message will get there in less than four days via Prestel.

## Computer cosmetics I

Ashamed of your ZX80/81s scrawny physique? Bullies will no longer kick sand in its video interface if you conceal it completely within a Fuller FD81. This is a case/keyboard/power supply unit into which the Sinclair PCB fits; Fuller Designs claims all Sinclair peripherals are accommodated, and that its own motherboard and 16k RAM board will follow. In kit form or assembled, from £18.95 (keyboard kit), details are available from Fuller Designs Ltd, Sandfield Park East, Liverpool L12 9HP (state whether ZX80 or 81).

## Computer cosmetics II

If on the other hand you are inordinately proud of the number of Apple add-on cards you have amassed, then a transparent lid called 'Appleview' will allow the neighbours to ogle them. Such exhibitionism will set you back £17.50 plus VAT. Should your neighbour be inflamed to covet them, you can deny him/her access by adding an 'Applelock' for a further £12.00 plus VAT (also adds to standard lid). Show-offs should contact Datron Micro Centre, 2 Abbeydale Road, Sheffield. Tel: 0742 585490.

## In brief

On the subject of gaming and pecuniary reward... Ingersoll announces that Missile Command and Asteroids are now available for the Atari Video Computer System. Several of our staff could be saved from destitution in the pubs and arcades of the West End; but only if they release Battle Zone as well.

On the other hand Tantus Microsystems announces successful trials with a 'leading bookmaker' of a new terminal which allows direct entry of telephone bets into a computer. Advantages include 'low cost bet checking, setting and accounting'. Why not a terminal which directly debits a punters bank account without the tedious business of betting at all...?

## Toshiba launch

Toshiba's new T-200 Small Business Computer is being launched by Office International at the International Business Show (20 October). The T-200 is to be marketed as an integrated system, which includes 80x24 screen, 560k of twin double side/double density disk, RS232C interface, a detached keyboard and an 80character 125 cps dot matrix printer with 132 character option. 64k RAM is standard and Toshiba Business Basic which is said to include 'the main utility programmes' completes the package; the press release carefully claims 'the ability to operate in CP/M 2.2' which is not the same as claiming that it's available yet. On the other hand, invoicing, ledger and payroll software are to be available on launch.

The hardware looks very neat in the picture. The package price of £2995 is not far off the mark for that spec (check a Superbrain with a comparable printer), so with Office International's 130 outlets and adequate software support, it could do well.



Contrary to this evidence, you don't have to have a double-barrelled name to use Prestel (see 'Electronic mailbox').



Toshiba's T-200 system. Green screen VDU plus obstructive hairstyle are said to reduce operator fatigue (see 'Toshiba launch').

## And now, the micro you can run a truck over

What has 144k of non-volatile CMOS RAM, a Z-80 compatible processor, Basic in ROM, is hand-held, British-designed and -manufactured

and can be run over by a truck with impunity?

Yes, it does exist and no, I hadn't heard of it either until recently. It's called the



Conceal your ZX81 (see Computer cosmetics I)



Reveal your Apple (see Computer cosmetics II)



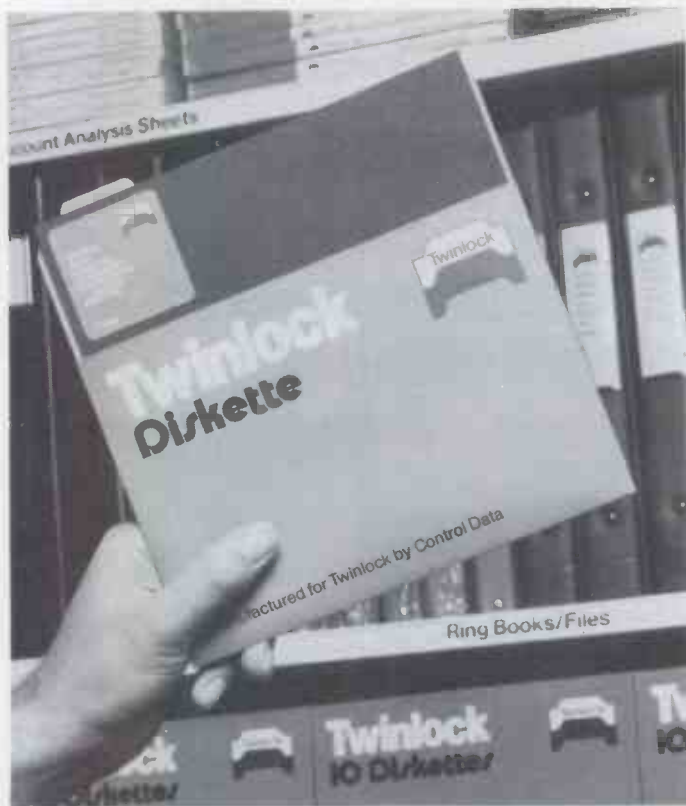

all major manufacturers' equipment, with typical uses including mini-computers, word processing, data entry/retrieval, intelligent terminals, and auxiliary storage for large main frames, amongst many other applications.

Additionally, Twinlock Diskettes cover all common types of Diskette, both 8" and 5¼", and come packed in tens, conveniently available through better local office stationery and equipment suppliers.

The result? With Twinlock Diskettes you get the quality you want, but only buy the quantity you need.

For details of Twinlock Diskettes and also our comprehensive Diskette Filing

# Twinlock Diskettes. The quality you want, in the quantity you need.

Until now when you wanted Diskettes, you had to buy many more than you actually needed. Not only that, but you invariably had to spend valuable time visiting specialist suppliers to get the quality you required – an altogether inconvenient and expensive business.

But not now.

Because Twinlock, Britain's leading supplier of office equipment, are proud to announce the introduction of Twinlock Diskettes, specially manufactured by Control Data, one of the world's leading names in high quality magnetic media.

Twinlock error-free Diskettes exceed ANSI, ECMA, ISO, IBM and Shugart industry standards and are fully compatible with

and Storage range, please write to us at the address below.

Twinlock UK Ltd, Marketing Services Dept, 36 Croydon Road, Beckenham, Kent, BR3 4BH. (01-658 5931).



**Business would be lost without us.**



Husky 144 (rugged, outdoor, geddit?) and it is the work of DVW Microelectronics, a subsidiary of AID (Allied International Designers Ltd). DVW has developed the Husky to a full working prototype and a first batch of virtually hand-made machines (the alloy case is sand cast and machined) will soon be available at a necessarily high £1000+ price. But AID, who are aggressively and refreshingly market orientated, are quite clear that volume production with an ABS plastic case and a PET/Apple-competitive price on both sides of the Atlantic is the ultimate aim. The first machines, though, will go to public utilities, such as the Severn-Trent Water Board, in collaboration with whom the Husky was developed. They intend to use it for complex on-site water-flow calculations.

The machine has a very impressive specification indeed. The processor is the NSC800, a relatively new chip which uses the 8085 bus and is Z-80 compatible. The 144k of non-volatile CMOS RAM (also NSC) is paged and automatically managed to



*The Husky 144, perhaps the most powerful hand-held computer to date; you can run a truck over it, but don't drop it on your foot.*

appear to the user as a continuous block.

The display, of Japanese origin (Epson?), is a large-scale LCD, with four lines

of 128 characters total; the first LCD of such size to be marketed in a computer product, but not the last. The keyboard is a sealed touch-sensitive job with a central numeric keypad, QWERTY and cursor/scrolling keys. 8k Basic is in ROM, a DVW implementation on the prototype, probably Microsoft on the production machines. The whole shebang is cased in a rugged alloy case, which is to a military hardware specification which includes being waterproof, shock resistant and 'Arcticised'. It weighs in at a chunky 2kg at present and is meant to be carried on a shoulder strap. Power is by 1000 hour alkaline cells with eight hour reserve cells as back up. An RS232 interface allows a printer, VDU or acoustic coupler to be connected.

The firmware has obviously received much thought; perhaps the nicest touch is that the instruction

manual is held in 8k of ROM and accessed via a HELP key, which selects the page appropriate to the current activity, though you can scroll backwards and forwards through it at will. A real time clock can automatically log data with entry time and date.

As if this were not enough, DVW has set itself the heroic task of designing an outdoor-proof disk drive, also battery operated, so that the Husky can support CP/M!

Altogether a product which deserves to succeed, though the transition from 'hand made' to volume production and a keener price will not be easy to achieve, judged by the experience of some previous British bright ideas. We hope to Benchtest the Husky very soon.

Enquiries to David Viewing, DVW Microelectronics, 10 The Quadrant, Coventry CV1 2EL. Tel: 0203 56580/27535.



*This squishy typewriter, the Maltron, is normally completely useless to typists. First, it has all the keys in the wrong place (designed to be much more easily operated but in the wrong place for a fast typist who can use a qwerty machine) and second, it normally isn't attached to a typewriter; it's normally just an electronic keyboard.*

Both these objections have been overcome by Ergonics, a company which has produced a qwerty version of the keyboard for dinosaur typists like me and has built it into a typewriter (illustrated) which can be expanded into a microsystem. Details on Oxford (0865) 55921.

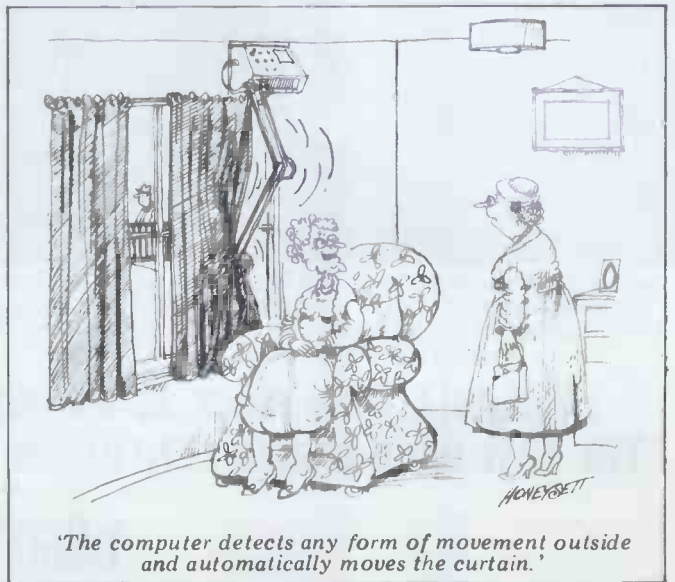

*'The computer detects any form of movement outside and automatically moves the curtain.'*

# DESK TOP COMPUTING

**A COMPREHENSIVE GUIDE TO SUCCESSFUL  
BUSINESS AND PROFESSIONAL MICROCOMPUTING**

We live in an age of cheap computing power. For the first time the cost of a computer is within the reach of the small businessman, the professional person or the private citizen. And in the present economic climate the pressure is on to increase productivity and efficiency using these electronic aids.

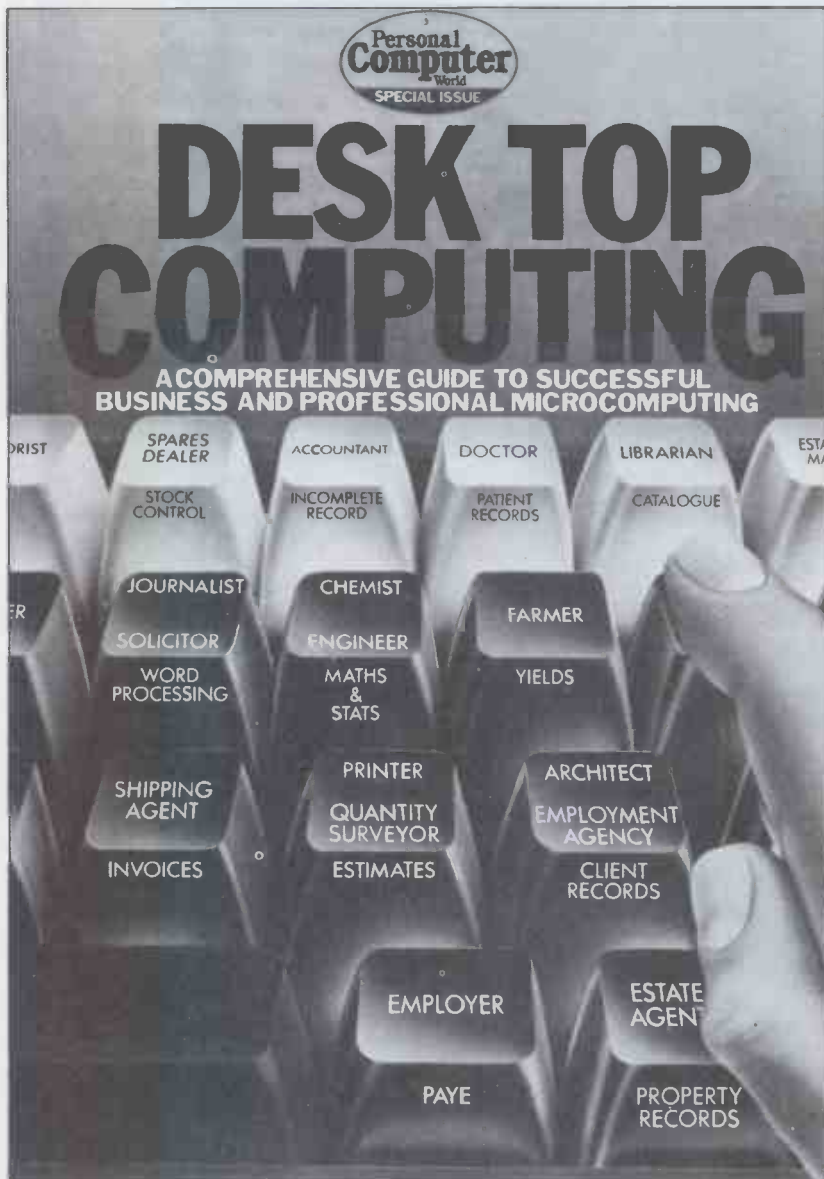

But will your desk top computer be a boon or a curse? Will it increase your profits or disrupt your workplace? Will you be misled by salesmen's patter, baffled by programmers' jargon and find yourself the unhappy owner of a totally unsuitable system?

Success in computer installation depends on taking a logical approach to your task — the *Systems Approach*; the side of the microcomputing revolution they didn't tell you about. This book, from the publishers of PERSONAL COMPUTER WORLD, Britain's largest-selling micro magazine, tells you.

Lyn Antill explains, in language plain enough for the most non-technical user, the secrets of Systems Analysis, the key to obtaining the computer system you need. Step by step, this book tells you how to:-

- Define exactly what tasks you wish your computer to undertake.
- Interpret those tasks in a way the computer can handle.
- Choose the right machine for present and future needs.
- Buy off-the-peg software.
- Hire and supervise a programmer when necessary.
- Write program specifications tailored to *your* staff and working methods.
- Test programs and introduce them into your business smoothly with minimal disruption.
- Maintain and modify programs.

Also included are several case studies covering the installation of desk top computers in small businesses and for professional use together with a comprehensive listing of virtually every hardware and software system currently available in the UK.

**AVAILABLE NOW PRICE £1.95 FROM YOUR PCW NEWSAGENTS,  
THE PCW BACK ISSUES CENTRE OR BY MAIL ORDER**



# BANKS' STATEMENT

## LAUNCHED LEVIATHANS, MANGLED MINNOWS

*Martin Banks looks at the effects on the micro industry as the big companies move in.*

Imagine the scene. Ex-Hollywood B-movie actors mix nonchalantly with the ageing Florida blue-rinses on a harbour wall somewhere near Boca Raton as the most important VIP, a man with ne'er a Cary in the world, takes up the champagne bottle in his hand and says those immortal words: 'I name this ship "The IBM Personal Computer". May God bless her, and send my love to the competition.'

As 'The IBM Personal Computer' begins to glide out into its future life of tracking its manufacturer's previously uncharted waters, a wit in the crowd yells, 'Hey, that baby's heavy. I'd hate to be a minnow and have that land on my head.'

Well, there you go. I have managed to start by writing nonsense again. And even though it is nonsense, it has a potential ring of truth about it, a ring of truth that possibly bodes well for some and ill for others.

As mentioned before in *PCW* (and, doubtless, a million other places), that ultimate leviathan of the computer industry, IBM, has been threatening to launch a new baby system aimed directly at the market and users developed by the likes of Apple, Commodore, *et al.* Well, of course, it has now been and gone and done it, and by initial appearances it would seem to have done it rather well.

It is only the first of the majors to launch a full-blown tilt at this business, and there are no doubt many surprises yet to come from other companies. These will be added to the recent product introductions from such not-quite-leviathan-but-very-significant companies as Hewlett-Packard, Data General and Digico.

All of these must be added to the introductions that have come from the Japanese, with Sharp's PC-3201 being followed by NEC (itself a corporate leviathan, though not in that class through computers alone) launching its PC8000 range. Then again, there is Kalamazoo muscling in on the act. The company is better known for man-powered administration systems but, by the time you read this, it will have launched its own baby computer system with 'Made in Britain' written right through it.

All of these companies have taken due note of the direction the mass of users have, in fact, followed, rather than the direction they were expected to follow. When the original microcomputer

manufacturers started to set themselves up, they were predominantly run by computer freaks. Their first customers were also computer freaks. It maybe seemed logical to suppose that every other customer would also be a freak.

Not so, of course, for the small business fraternity latched on pretty quickly to the things. As the technology improved, so these users could do more wondrous, and usable, things with them. They grew into a significant market.

More importantly, perhaps, they started to mark a more long-term direction for the whole computer industry, a move away from reliance on mainframes and minis, and a move away from the traditional manual methods of small business administration. Now, for a company that manufactured mainframes or minis, or manual business administration systems, this was a fact worth noting and acting upon.

### IBM

Acted they now have, with the jolly blue leviathan IBM well up towards centre stage. It is perhaps on the performance of IBM's personal computer, more than any other company's, that the fate of the existing microcomputer manufacturers now hangs. If IBM gets it as right as it might at first appeared to have done, then some of these companies could be in for a rough ride. Some indeed may not make it.

I don't intend to waste too much space writing about the actual IBM machine here, for others will no doubt partake of that sport. And excellent sport it should be, for the company seems to have produced a technically advanced box of hardware based around Intel's 8088 processor. This is an interesting choice, for while not being truly *avant garde*, it provides a sound compromise between sensible engineering and the provision of advanced capabilities. There is a great deal of scope for future expansion with this beast.

On the software side, the optional CP/M 86 is also a sound move. More significant, perhaps, is the optional Pascal p-code software. This can be used, in the hands of a knowledgeable programmer, to greatly extend the applications capability of the machine.

It matters little, however, especially in the shorter term, how wonderful the system is. It could be the ultimate better mouse trap, but it won't mean a

light if the company fails to market and sell it properly.

The fact that IBM is for the first time using externally provided systems software on a new product is just one indication that the company has thought long and hard about these very subjects and maybe has come up with the right answers. Looking at the system from a marketing point of view, the use of the 8088 processor falls into perspective. It is a sensible choice because it is available in reasonable and reliable quantities and at tolerable prices. This means that IBM can be sure (or as sure as anyone can in manufacturing) of a continuous supply of essential parts at good prices. It is also 'adventurous', for the processor is powerful enough to allow notable processing performance.

Put the two together and IBM becomes one of the first companies to produce a single system that gets close to the utopian 'all-purpose' machine. It can be produced cheaply enough to be directly price-competitive at the low end and it is powerful enough to be performance competitive at the high end. Add, as the jam to this substantial dollop of bread and butter, communications facilities such as the optional IBM 3270 emulator and the company is seen to cover more bases in one go than any company before it.

Given that, the potential sales volume could be enormous, so how is the company going to tackle the selling of the system?

Move number one has been restrictive, on the surface at least. Initially, the Personal Computer will only be available in the US and Canada. This again is probably a sensible move, for a variety of reasons. Not least among these is the fact that it is a market that accounts for around 50 percent of all world sales. Equally important, however, is the fact that it has the most homogenous distribution and sales network.

### Four-pronged attack

IBM has chosen a four-pronged attack, and the homogenous nature of North American distribution makes this a far easier task to manage. This is particularly important for a company that has not played the microcomputer game before.

*GOTO page 183*

# COMMUNICATIONS

PCW welcomes correspondence from its readers but we must warn that it tends to be one way! Please be as brief as possible and add 'not for publication' if your letter is to be kept private. Please note that we are unable to give advice about the purchase of computers or other hardware/software -- these questions must be addressed to Sheridan Williams (see 'Computer Answers' page). Address letters to: 'Communications', Personal Computer World, 14 Rathbone Place, London W1P 1DE.

## Info on BBC micro

I am sure most of your readers will have heard about the BBC television series on computers, 'The Computer Programme', which starts next January. There is already tremendous interest in the BBC Microcomputer itself and we believe that the series will do a great deal to stimulate further interest in all aspects of computers and computing. Many viewers will want to follow up the series by discovering what is available in their area in the way of courses, computer clubs or centres offering 'hands-on' experience. One way of finding out this information will be through the Computer Referral Service run by Broadcasting Support Services as part of the Computer Literacy Project.

Our address will be given at the end of each programme and anyone wanting further information can write in. To be able to answer all the enquiries we need to hear about what is going on locally. Some of the information we already have, but what we are particularly keen to learn more about are computer clubs. Clubs will have a major role to play as they can be an ideal source of informal advice and 'hands-on' experience for people who don't want to go on a formal course or who aren't quite sure what they want to do yet.

Ideally, what we would like to be able to say to people is 'here is your nearest computer club, this is when they meet, why not go along and talk to them see if this is what you want?' To do this, though, we need to know which clubs are willing to help out in this way. If any clubs are interested, could they write to us at the Computer Referral Service, P O Box 7, London W3 6XJ. David Highton, Broadcasting Support Services, London W3

## Bridge bidding

Seeing David Levy's interesting article in the May issue on how to program a computer to perform the difficult task of bidding bridge hands, I realised that he (quite understandably) was unaware of the fact that this task has already been successfully completed.

David, and maybe some of

your readers as well, might be interested in knowing that my bidding system, 'Cobra' (for Computer Oriented Bridge Analysis), has been in existence for several years and will be published in book form by Victor Gollancz in November 1981. Torbjorn Lindelof, Geneva, Switzerland

## Memorite memo

I'm glad to see Vector Graphic getting a bit of publicity in your pages last month with your very full review of VG's own word processing software, Memorite. As a daily Mem3 user since it first came out at the end of last year I noticed one or two blunders and oversights.

1. Dating documents isn't compulsory. Your article doesn't make clear that you simply enter the date into the system on powering up with Memorite. Thereafter, all documents will be dated (creation or revision date) by the system. But if you don't want a file title to carry a date, or for some reason you're shy about letting the system know what day it is, you can always save documents with the WR R (Write to Disk, Raw) command

2. Spell operates on an algorithm rather than a dictionary and there are, as you say, some surprising oversights -- like Memorite not being able to spell its own name! You've described the temporary dictionary Spell creates so that it won't query a word you've already marked as acceptable. What you don't mention is that this temporary dictionary can then be converted into a permanent file, which you either append to your own dictionary or save as a subsidiary dictionary for (say) proof-reading specialist documents. Once the word 'Memorite', for example, has been included in such a file, the word will never be queried whenever the file name is appended to the end of the command string, as: SPELL < document-name > < dictionary-name >

3. The latest version of Memorite will write to a dot matrix printer. There are also extensive provisions for providing jump tables to customise both the key to screen-character and screen-character to print-character mapping. Different jump tables can be pulled in from inside Memorite, so one can to switch from, say, an

English to a French character set *tres facilement*.

4. Backing up onto floppies isn't quite as tough as you suggest. Floppies aren't the best medium for this -- though of course they're better than nothing -- and database files that exceed the capacity of a floppy are a particular problem. But the 3003 comes with a pair of programs, Store and Restore, that allow large files to be written onto a set of floppies and then joined up again if they ever need to be shunted back to the hard disk.

5. The hard disk operates as a logical pair of drives (A: and B:) in one of its configurations; an alternative configuration sets it as a single drive.

6. The floppy drive is single-sided in one of its configurations, which gives it, as you say, a capacity of around a quarter k. But this is only to provide compatibility with Vector Graphic's earlier Micropolis drives. The Tandon drive in the 3003 is chiefly intended to operate in double-sided mode, which appears to the system as a single logical drive of around 600k capacity.

The foregoing is mostly a mopping-up operation after a very thorough and fair review and I'm really only butting in because the software (and its predecessor MEM2) has done a lot of good work for me and has already paid for itself many times over. Incidentally, I don't share your doubts about its suitability for the author/journalist. I use Mem3 for my TV scriptwriting, technical writing and journalism, and the best thing about it, as you've spotted, is the file-handling, which means you can go back to a disk months later and just by looking at the dictionary identify every file on it, as well as know each file's date of creation and last revision. Word-processing systems that don't provide this sort of chest-of-drawers for document files aren't much use to me professionally.

I agree with you that it's a pity document length should be limited to the size of the work-area. To some extent this is alleviated by a command that links files together for printing, but the real thing would be nice. The absence of full on-screen formatting is occasionally something of a problem: MEM3 will tell you where pages will break, but not where lines end, so if you want to move a page break it has to be to the beginning of a paragraph or you run the

risk of introducing an unintended short line. But on the whole I much prefer the way Mem3 makes the maximum use of the screen area and lets hard-copy formatting take care of itself according to imbedded format commands. Chris Bidmead, London NW3

## ACC at PCW show

Please may I put on record as soon as possible after the event how much the Amateur Computer Club appreciated the offer to attend and organise the amateur side of the PCW Show. All the user groups and clubs present have also voiced their thanks.

The show was an obvious success and I like to think that the clubs contributed towards it by giving impartial advice and replying to technical enquiries which would be difficult for even the manufacturers to answer!

I would also like to thank the staff at Montbuild, the show's organisers, who could not have been more helpful and friendly.

Dr David Annal,  
ACC Exhibition Organiser.

## Beating Gomoku

No doubt many readers have discovered ways of beating the Gomoku program (PCW, August '81). Here are a couple of ways I have found:

Playing first: 35, 36, 56, 24, 47, 42, 64, 52, 65, 37, 38 - win next move.

Playing second: 44, 53, 42, 65, 62, 73, 72, 71, 74 - win next move.

As the program contains a random element, these plays guarantee a win.

By the way, I see from 'Chip Chat' that someone has adopted 'Othello' as a trade mark. What's his name -- Shakespeare?  
J Aughton, Southport.

## Computopia

We were very interested, though a little puzzled, to read the comments in September's PCW concerning Micro-Sci disk drives, under the title 'Apple Crush'.

One of the impressions gained from the editorial was that these drives, and their users, apparently suffer great problems when trying to read ordinary Apple disks.

In our experience this is not so. The 40-track Micro-



Sci drives (A40) will boot and/or read ordinary Apple disks (35 track) with high reliability and increased speed. The additional 20k of storage is gained by accessing more tracks towards the centre of the disk. So an A40 can be considered as a standard Apple drive if desired, or the extra space can be accessed by using the modified DOS provided. The 70-track drives (A70) have twice the number of tracks of an Apple drive and require a modified DOS to take advantage of the extra storage. This DOS is capable of reading 35, 40, or 70 track disks, thus allowing the A70 to read ordinary Apple disks — but not boot them — unless the software has been transferred to the A70 DOS.

There are some programs that will not boot on either drive type, typically those using half-track security methods. Incidentally, Visicalc will run on A40 drives, although it only makes use of 35 tracks.

Pascal and CP/M, provided you wish to ignore the extra storage available, can be run unchanged on an A40, but it obviously makes sense to take advantage of the extra tracks by using the utilities available to modify each system.

In conclusion, the A40 drive can be used as Apple drive substitutes (with certain software specific exceptions), but more storage is available if required. The A70 drives can read/run ordinary Apple data/software, using the A70 DOS, but are mainly intended as higher storage devices (1/4 Megabyte).

We hope this clarifies the issue of compatibility and shows that the situation is nowhere near as dire as may have appeared from previous comments. C Sunderland, Managing Director, Computopia Ltd.

## Puzzler solved

I suspect that the problem is due to inaccuracies of floating point arithmetic. From test runs on my ZX81 it appears that numbers less than 1 ( $2^0$ ) in decimal notation, with the exception of other powers of 2, eg 0.125 ( $2^{-3}$ ), convert to an approximate binary form. This approximation tends to build up as an inaccuracy as calculation are made.

Although the decimal form appears to be correct when printed out, presumably the relational operator testing for equality (=) uses binary numbers. Due to the different approximation of the two numbers being compared, equality will never be satisfied as the binary forms are not identical.

A solution is to modify the program, eg by multi-

plying through by 10 to remove the figures after the decimal point if you suspect that the answer is not an exact power of 2. (It is interesting to note that the test for equality does however work when using steps of exact powers of 2. Try 0.00048828125 ( $2^{-11}$ ) in an appropriate program). J G Taylor, Dartford, Kent

## North Star GT

The excellent article on HMSOS in your September issue highlights once more the problem of using fully the limited 64k address space in an 8-bit micro-computer. North Star, like many other companies, 'waste' 8k of this on their popular Horizon computer largely because of the way in which the floppy disk system is addressed. This effectively limits actual Basic program and data space to about 32k which is proving restrictive as program size inevitably increases.

After overcoming many teething troubles, a way has been found to overcome this. A special S100 card is used to automatically switch in and out the top 8k of RAM as required by the program and the operating system. This permits the full use of the 64k address range under DOS and up to 63k under CP/M. No modifications to existing programs are necessary.

If anyone is running out of program space on their Horizon and wants details of how to do this, telephone me on 01-788 5054. Derek Eldridge, Tantus Microsystems, Putney.

## Tandy warranty

As secretary of the North West TRS-80 Users Group, I feel that the public and prospective microcomputer purchasers should be informed of a recent problem that one of our members has experienced, with Tandy, in relation to after sales service.

It was pointed out to our member, by Tandy's Burnley store manager, that because his CPU was six months old, it was no longer within Tandy's warranty and that Tandy does not give more than 90 days' warranty on its computers.

Firstly I should like to bring to the attention of prospective purchasers that TRS-80s purchased from sources other than Tandy, of which there are many, often come with a full 12 months warranty.

Secondly, the apparent attitude of Tandy on after-sales service seems to have gone full circle. In the past, I personally have had very

good after sales service, but with Tandy's recent attitude this seems to have disappeared.

On behalf of our group and the member mentioned above, I am taking steps to find out whether Tandy has the legal right, under the Sale of Goods Act, to actually reduce a purchaser's rights to a 90-day period. If Tandy's 90-day warranty stands in a court of law, prospective purchasers of a TRS-80 can decide for themselves where to make their purchase. Melvyn Franklin, Group Secretary, TRS-80 Users' Group.

## Subscriber solution

Alan Sutcliffe mentioned in his article 'Patterns' (PCW, Aug) that subscripts in the DAI, 'even though they may be typed in as integers, are always listed — and presumably stored — as floating point numbers'. The solution to this problem is to change the default for all numeric information from floating point format (to which it is automatically set on power up) to integer format. This is done using the following command: IMP INT. Obviously when the default is changed to integer, any floating point variables required will have to be explicitly defined using the IMP command.

To eliminate the floating point subscripts from Mr Sutcliffe's program the first few lines should be altered as follows:

```
IMP INT
IMP FPT A-H
IMP FPT Q-Z
Clear 10000
Etc.
Michael Coughlan, The
National Institute for
Higher Education, Limerick,
Eire
```

## Illogical shift

I refer to the Sinclair advertisement on page 137 of the September issue of PCW.

Does 'Uncle Clive' know something about the British weather that no-one else knows, since his printer, will be available in 'Summer 81'?

As I write in late August, is this perhaps a late Spring in the Sinclair 'timeshifted' year?

J Farrall, Leek, Staffs.

## ZX81 points

Here are a few points about the ZX81:

- 1) GOTOs can be followed not only by line numbers, but also variable and arithmetic expressions (in effect the ON statement).
- 2) It is possible to have a type

of FOR...WHILE loop by using:  
'IF (condition) THEN NEXT'  
If the condition is true, the loop continues and if not the computer goes on to the next line.

3) When the memory is nearly full, the computer will not allow the EDIT function to be used which means a lot of unnecessary typing has to be done. This can be avoided by:

- a) positioning the cursor on the required line;
  - b) typing CLEAR;
  - c) When the display goes to 0/0 then press the EDIT key.
- 4) The Meteors program on the cassette can be shortened (and improved) by:
- a) deleting lines 135, 210, 230, 310, 315;
  - b) moving lines 220 to 265 and 240 to 295;
  - c) replacing the PAUSE and POKE statements by a FOR . . . NEXT loop (FOR 1 to 20 should provide a reasonable delay);
  - d) Changing lines: 130 LET X=12, 250 PRINTAT 1,31,"", 270 IF PEEK (33+P+K) . . . etc.

The game is run in the slow mode.

A Barrett, Wembley

## Flying high

As a poverty-stricken, low-time private pilot recently introduced to micro-computing, I would be very interested to know if there is any software available for the simulation of instrument flying (as distinct from VMC flying) on a micro.

If there is, who sells it and what machine(s) does it run on?

B M Neary, Coventry

*If any readers have the answer to this question, they could let us know through communications — Ed.*

## Let's get together

I am a lecturer in chemistry and have recently taken an interest in computing. With the rapid increase in the number of schools and colleges possessing their own microcomputers, I was surprised to find the lack of good educational software available. Programs written for GCE and lower school work appear to have been written by computer buffs rather than specialist subject teachers and consequently do not relate too well to their subject (rather like a badly written textbook), mathematics being the exception, of course.

At Brooklands we have three PETs in this department and are starting to build a library of educational programs, some written by our own lecturers (including

# The Printer People

**OKI does it faster - by half...**

With 120 character per second  
bidirectionally

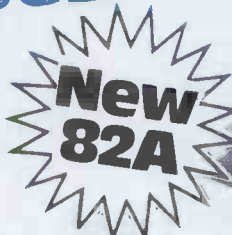

**...and better**

Now with  
9 x 9 matrix  
and true descenders

## The Microline 82A

Microline printers are again setting the quality standard for the entire industry. Built on a cast aluminium base and driven by two motors, these rugged units will run all day with no duty cycle limitations. The head warranty, equivalent to 200,000,000 characters, is unmatched in the industry.

**We don't need to offer a replacement print head!**

The Microline 82A prints bidirectionally at 120 characters per second and includes a short line seeking logic that can increase throughput by 80% over equivalent unidirectional printers. A dense 9 x 9 dot pattern is used to produce crisp, clean copies, first copy to last.

In addition to normal upper and lower case, ten character per inch printing, the 82A prints both double width and condensed characters at six or eight lines per inch. Font selection, character pitch and line spacing are all standard and program-controlled.

CHARACTER DENSITIES:

10 CPI: ABCDEFGHIJKLMNOPQRSTUVWXYZ abcdefghijklmnopqrstuvwxyz

5 CPI: ABCDEFGHIJKLMNOPQRSTUVWXYZ

8.3 CPI: ABCDEFGHIJKLMNOPQRSTUVWXYZ

### Graphics

Microline users can generate charts, graphs and illustrations and explain them with captions of double width characters. The Microline 82A prints 64 block shapes in addition to the full character ASCII set.

### Three Printers in One

Microline 82A users do not have to purchase different models for different forms. The standard platen accommodates friction and pin feed forms and optional tractors snap in place and adjust to suit form width. The Microline 82A provides versatile forms controls including vertical tab, top of form and a vertical format unit that provides switch and program selection for up to ten form lengths.

### Interfaces

The Microline 82A is offered with both Centronics-compatible parallel and RS232C serial interfaces as standard equipment and TRS-80™, APPLE® and other popular small computers. IEEE 488 parallel and current loop interfaces are also available.

### Standard Features

- 120 cps
- 9 x 9 matrix
- Bidirectional
- Short line seeking
- 80 columns with standard characters
- 132 columns with condensed characters
- Graphics
- Dual interfaces
- Operates with TRS-80™, APPLE®, PET and others
- Plain paper - up to 4 parts
- Full 96 character ASCII set
- Double width characters
- 6 and 8 lines per inch
- Paper tear bar

**NORTHAMBER LIMITED**  
3 and 4 Dawes Court, Esher, Surrey  
Phone: Esher (0372) 62071 or 66398

Importers Distributors & Wholesalers of quality computer products.

**If you want a Printer tomorrow call us today**

Full details on request.

Phone **0372 62071 / 66398**

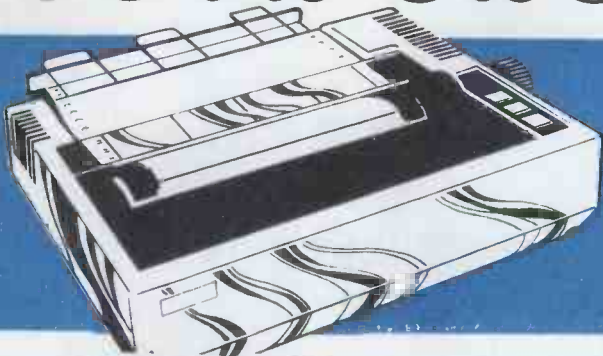

## EPSON

- Built in dependability with an extensive range of features.
- Unbelievable quality from the world's largest print head manufacturer



### TEC STARTWRITER

- Suitable for micro/mini computers
- Centronics or RS232 Interface
- Easy change 96 character daisy wheel

### TYMAC (Not illustrated)

Universal Centronics type printer board complete with cable and connector for Apple Computers.



### TVI 910, 912C, 920C, 950

- Fully intelligent Terminal with 24 x 80 display and dual intensity, blinking, reversed, underline & protect fields
- ASCII characters etc.

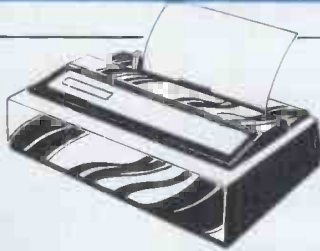

### CENTRONICS 737-739

- Correspondence quality print
- Nx9 dot matrix in proportional spacing mode
- 7x8 dot matrix at 10 and 16.7 cpi monospace mode

### NEC SPINWRITER 5510-RS232, 5530 Centronics 8 bit par

- 5 copies
- Friction of Tractor End
- 55 characters per second

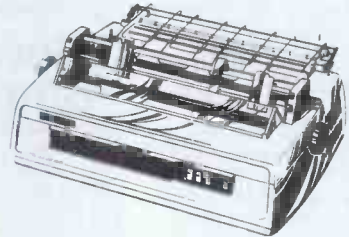

### QANTEX

- Series 6000/6010 printers
- X on/X off
- Parallel or serial interfaces
- 150 characters per second

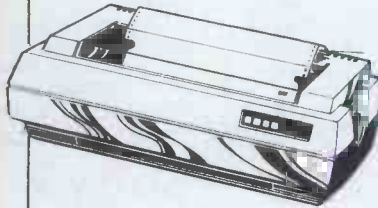

**Unbeatable Discounts From Your Ex-stock Wholesaler**

**Wholesale, Education and OEM enquiries welcome**

**Delivered by Securicor (24 hours)**

### ASF 160 and 560 SERIES AUTOMATIC SHEET FEEDER

- Feeds up to 250 single sheets or letterheads automatically – no more handfeeding!
- Easily attached or removed in seconds

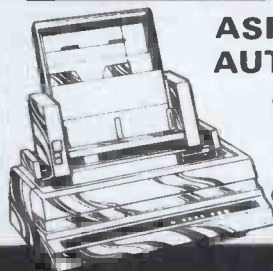

# NORTHAMBER LIMITED

3 and 4 Dawes Court, Esher, Surrey  
Phone: Esher (0372) 62071 or 66398

Importers Distributors & Wholesalers of quality computer products.

**Now stocking:  
Ricoh RP1600 Flowriter  
and Qume Sprint 9**

myself) and some by teachers of local schools with whom we have exchanged programs. At present they are limited to mainly scientific subjects including chemistry, biology, physics, geology, geography and environmental science but we are hoping to add English and French to the range.

I would like to hear from other teachers and lecturers with whom we might exchange ideas and programs. Although we would prefer exchange, we are quite happy to send listings to any educational establishment. Our own programs are written for 'O' and 'A' levels. Michael Gilford, Brooklands Technical College, Heath Rd, Weybridge, KT13 8TT

## Big brother

I am writing to tell you of my amazement at the procedure required to visit your exhibition on 10 September. After paying the requisite sum of £2, I was required to give my name and address, business interests, and spare time activities *before* I was allowed to enter the show.

The young lady at the reception desk insisted that I would not be given a coloured disk unless I filled out the details of the entry ticket. The attendant at the entrance to the show would not allow me into the hall unless I had a coloured disk on my entry ticket. All this fuss after paying the entrance fee! Despite my objections to providing the personal information demanded, both were adamant.

Having in my possession a copy of every issue of *PCW*, I have over a period of time formed the conclusion that yours is a responsible publication concerned, among other things, with the confidential nature of material in data collection systems. The events referred to above have caused me to revise my conclusion. It was unnecessary for you to know any of the details demanded on the entry ticket. A request for information would have been met in a different spirit but with no different end result.

To avoid further alteration, I completed the card with completely false data which, strangely enough, seemed to satisfy everybody. So some of the information that you have from the show is wrong and I wonder what use you will make of it. How many other visitors gave wrong information is hard to assess, but I am sure that I was not the only one to object to giving personal information in these circumstances. I do not object to giving personal information if there is a 'need to know' but this was not one of those instances.

The future of a police-controlled, or similar, state

draws closer every time that an unnecessary demand for personal information is made. I see a future (and 1984 is near) where the processors of the police, Ministry of Transport, National Health Service, Social Services, Inland Revenue, banks, credit cards, credit rating bureaux and market research organisations are all linked. Free access to such data will be the norm. In your small way you have tended to assist this process and I, hopefully, have foiled you.

J Turner, London E11

*Thanks for giving us your real name and address, Mr Turner — we'll add it to our database, ready for the day we go online to the Thought Police computer.*

*We can assure everyone who filled in registration forms correctly that the information will be used solely for planning next year's show and will most certainly not be passed to any outside organisations — Ed.*

## More Gomoku

Reader B E Newson, ('Communications' *PCW* Oct) claims he has a winning line as black against Bob Chappell's Gomoku program (Aug *PCW*).

Unfortunately, move 15 (see diagram) is illegal in all but the ancient Chinese versions of the game: Black is not allowed to make simultaneously two open threes (a row of three stones capable of being converted to an open four, which is a row of four capable of being converted to a row of five in two ways). The open threes here are 9-15-13 and 15-7-11.

I can't say much about the program but it can't be much cop if it doesn't point out illegal moves and as far as being 'unbeatable', there would be many people in Japan willing to take Black, with the proper rules and stake a lot of money on winning. They still tell a story there of a Danish professor of computing who claimed his algorithm made him world champion.

Challenged by low-grade Renju professionals, he was ground into the board by some ridiculous margin.

Incidentally the name 'Gomoku' used by American computer hobbyists is quite incorrect but if prospective Gomoku programmers want alternative names they can choose from the Japanese Gomoku-narabe, Go-narabe, Goren, Goseki, Kakugo, Gogo, Gocho, Gorengo, Miyako-go, etc. There are also many Chinese and Western names for the game: the Chinese Wu-tzu-ch'i and the Western Go-bang and Pegity. More importantly,

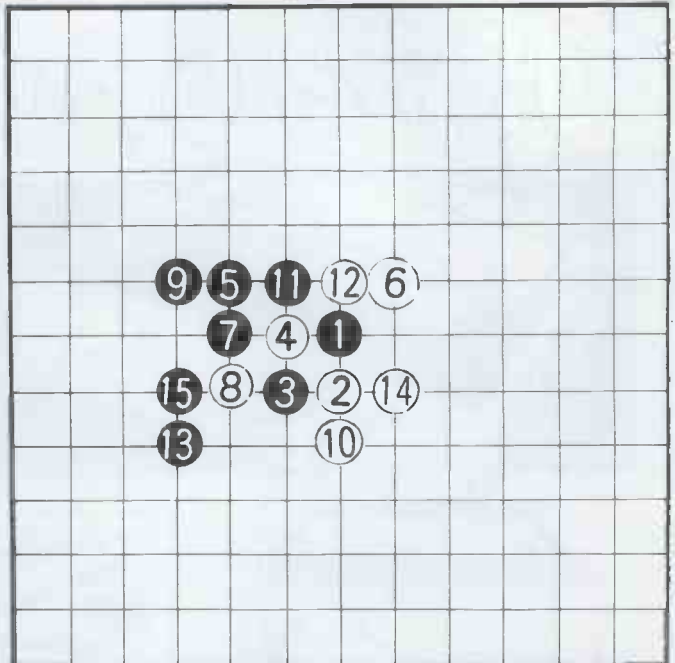

they should get the rules right (I know of no accurate source in English) and realise there are several versions.

Also, in the series 'Computer Games', *PCW* has perpetrated the error that Renju is the same as Gomoku. It isn't, though it is a derivative. Renju is a far better game, played professionally in Japan, but again there are no correct rules in English.

If enough readers want the complete rules of both games you can write to me care of *PCW*, enclosing a large SAE. John Fairbairn, Harrow

## Softy 2

I have just read the 'Checkout' on Softy 2 (*PCW*, Oct) and frankly it doesn't please me much. Neil Cryer doesn't seem very happy about Softy but he is obviously not an engineer and has no use for such equipment.

Much of Neil's criticism is valid only for the prototype sample we sent you so that you could get into print while the subject was still news. There are several errors of fact in the text and much of Softy's capability has escaped mention.

Firstly the 'flimsy plastic case'. Early samples of the case, for photos etc, were taken straight from the wooden model in 0.8mm ABS. Later production is in 1.6mm ABS and you can stand on the case. Then, in the paragraph dealing with operation, a reference is made to the MOVE command allowing a block of 110 hex bytes to be moved from one position to another — it should be 127 bytes. A bug worked its way into the article later on, with reference to the checking of any program using the screen of the host system as a

window and Softy in ROM emulator mode. Finally the last paragraph is a misdirection. There is no 'more sophisticated system' that will do the same tasks that Softy does.

The idea that Softy is useful only to impoverished enthusiasts willing to program in Hex at the lowest level is quite untrue. In system developments of even modest complexity there is no substitute for an assembler. Softy forms the link between the assembler and the nascent product. Most development systems are costly and not portable in any sense of the word. I like to think that Softy was designed to suits its purpose exactly and is not thoughtless or substandard in any way. Soft is actually *meant* to be small and light and cheap to fit the engineer's pocket or briefcase. The keyboard isn't meant for continuous use nor for continual hexadecimal entry of programs. In most applications this is unnecessary. Efforts have been made to keep cost and weight down — the 'improvements' you seem to think necessary would, in fact, ruin the product. It is most unusual for any of the engineers who are our customers to be less than delighted with the facilities of their Softy. Barry Savage, Dataman Designs, Dorchester

*Dr Cryer is in fact a physicist with extensive computing experience. And it was not made clear to us that the machine supplied for review was a prototype sample. Wherever possible we try to review only production — quality items and we assume that this is what we receive unless we're told otherwise — Ed.*



# NEWS

David Tebbutt brings you the latest update.

## THANET START-UP

Do you live in the Thanet area? If you do you'll be delighted to hear that a ComputerTown is about to open in Broadstairs public library. Opening day is 16 October and the show will run from 5 to 8 pm. Peter Kiff is the man responsible for getting this one off the ground and he and his band of helpers will be there every Friday from the 16th onwards. Well done Peter and all your anonymous colleagues. This month we've also been hearing rumours of a 'Town starting in Harrow but I'm still waiting for a letter with the details.

It's silly isn't it, but I'm almost disappointed at only hearing from one new ComputerTown this month — perhaps everyone was too busy getting along to the PCW Show to get their new 'Towns off the ground. Were you there? Wasn't it busy? We're going to need Olympia next year the way things are going. The ComputerTown stand was a roaring success, with lots of very serious interest shown as well as a lot of fun being had by all. Our sincere thanks go to Ingersoll who supplied all those Atari machines and to the brave band of volunteers who helped out on the stand. I've started getting enquiries already as a result of the show and that finished only a few days ago.

One of the problems all ComputerTowns face is lack of machines and lack of volunteers. I get the feeling that there are a lot of people out there with machines who'd thoroughly enjoy themselves if they came along to a 'Town night from time to time. It's no good saying to yourself 'They won't want me, I don't know enough about computers' — if you use one then you know quite enough to help out. No-one is looking for experts, just interested people willing to share their knowledge and experience (and computers). It's no good either saying to yourself 'They've probably got all the help they need, what would they want with me' — the fact is we're all short of people and every new volunteer lightens the load for everyone else. If you feel you'd like to help with ComputerTown then please don't hang back, we'd love to see you and if you're in an area without a ComputerTown, why not start one yourself? I'll send you some guidelines if you send me an SAE to the address in the box.

Last month I mentioned that I'd received a couple of letters from the Beeb. Well, this month I received a couple more. One you'll find reproduced in the 'Communications' section of the magazine this month and the other one asked me to invite all the

ComputerTowns to participate in the Beebs referral scheme. The idea is that every time someone contacts the Beeb for information about computers, it can put them on to local clubs, colleges, ComputerTowns or what-have-you. I wrote an appropriate letter for the Beeb to send to all 'Towns and gave them a mailing list as well. If you've not heard yet and you'd like to be involved then drop a line to David Highton, Broadcasting Support Services, 252 Western Avenue, London W3 6XJ. I'd suggest you turn to 'Communications' first for a fuller idea of what this is all about.

The funniest letter this month came from someone asking us to send details to them *urgently* in the enclosed SAE; a) There was no SAE; b) There was no address on the letter; and c) we couldn't read the person's signature! So if you're wondering why it's taking so long for me to write to you then you may be the guilty party. Incidentally, the urgency was stressed because this particular enquirer was leaving the country for Israel a few days after writing to me. Ho hum.

A number of people have written expressing a willingness to start ComputerTowns in their own areas. Here are their names and addresses. If you'd like to help out then I'm sure they'd love to hear from you: Francis Glenister, 13 Pridmouth Road, Withington, Manchester M20 9GN; P P Bartlett, 273 Kings Drive, Eastbourne, East Sussex BN21 2UR; Miss S Beckett, 7 Lingmoor Rise, Kendal, Cumbria LA9 7NP; John Byfield, 'Moonrakers', The Rutts, Bushey Heath, Herts WD2 1LH; Tabassam Kayani, SOBAT Computer Club, 12 Calderon Road, London E11 4EV; Wing Commander

Brian Carroll RAF, The Cottage, Manor Road, Aldershot, Hants; L M Symonds, 14 The Quay, Appledore, Bideford, North Devon, EX39 1QS.

The Scottish Microelectronics Development Programme is a very active group when it comes to micro-computing and they've (inevitably) got to hear about ComputerTown. If any of you read their periodical, *Phase Two*, then keep your eyes peeled for an article about ComputerTown. They've kindly asked us if they can reprint parts of our Guidelines document.

Finally, here are the areas from which we've received letters this month: Stirchley, London (N1, N20, SW11), Bury, Cranleigh, Naunton Beauchamp, Cults, Withington, Lydiate, Wembley, Sheffield and Blackwater.

ComputerTown UK! is an ever-growing network of computer literacy centres, where members of the public are given free access to micro-computers, courtesy of those willing to volunteer their time and equipment. ComputerTowns might be found anywhere: in a church hall, a library or maybe in a school after hours. The emphasis is on making computing enjoyable and non-threatening and, because Computer Town is entirely non-commercial, overt axe-grinding of any sort is banned. Guidelines are available for those interested in setting up their own 'Towns: Write to CTUK!, 7 Collins Drive, Eastcote, Middlesex HA4 9EL and remember to enclose a large SAE (A4 would be fine) for your reply. Please don't try to telephone PCW for information because this project is entirely a spare-time activity.

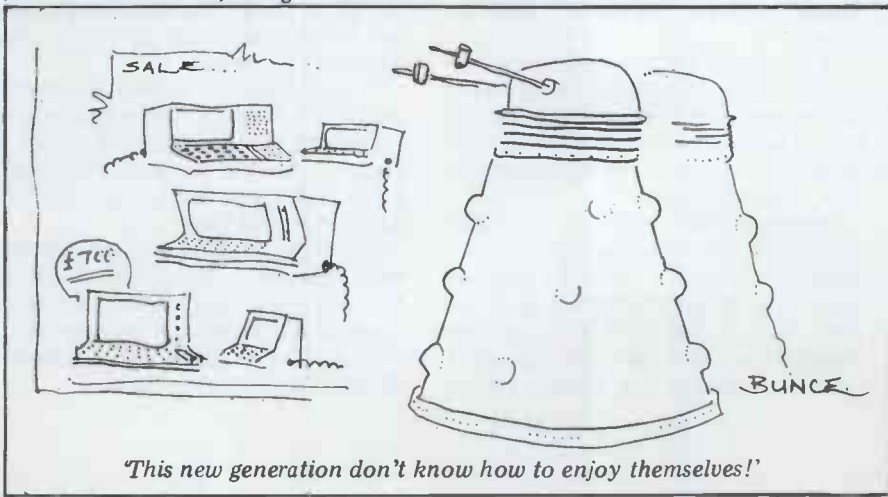

**The Sinclair ZX80 is innovative and powerful.  
Now there's a magazine to help you get  
the most out of it.**

# Get in sync



SYNC magazine is different from other personal computing magazines. Not just different because it is about a unique computer, the Sinclair ZX80 (and kit version, the MicroAce). But different because of the creative and innovative philosophy of the editors.

## A Fascinating Computer

The ZX80 doesn't have memory mapped video. Thus the screen goes blank when a key is pressed. To some reviewers this is a disadvantage. To our editors this is a challenge. One suggested that games could be written to take advantage of the screen blanking. For example, how about a game where characters and graphic symbols move around the screen while it is blanked? The object would be to crack the secret code governing the movements. Voila! A new game like Mastermind or Black Box uniquely for the ZX80.

We made some interesting discoveries soon after setting up the machine. For instance, the CHR\$ function is not limited to a value between 0 and 255, but cycles repeatedly through the code. CHR\$(9) and CHR\$(265) will produce identical values. In other words, CHR\$ operates in a MOD 256 fashion. We found that the "=" sign can be used several times on a single line, allowing the logical evaluation of variables. In the Sinclair, LET X=Y=Z=W is a valid expression.

Or consider the TL\$ function which strips a string of its initial character. At first, we wondered what practical value it had. Then someone suggested it would be perfect for removing the dollar sign from numerical inputs.

Breakthroughs? Hardly. But indicative of the hints and kinds you'll find in every issue of SYNC. We intend to take the Sinclair to its limits and then push beyond, finding new tricks and tips, new applications, new ways to do what couldn't be done before. SYNC functions

on many levels, with tutorials for the beginner and concepts that will keep the pros coming back for more. We'll show you how to duplicate commands available in other Basics. And, perhaps, how to do things that can't be done on other machines.

Many computer applications require that data be sorted. But did you realize there are over ten fundamentally different sorting algorithms? Many people settle for a simple bubble sort perhaps because it's described in so many programming manuals or because they've seen it in another program. However, sort routines such as heapsort or Shell-Metzner are over 100 times as fast as a bubble sort and may actually use less memory. Sure, 1K of memory isn't a lot to work with, but it can be stretched much further by using innovative, clever coding. You'll find this type of help in SYNC.

## Lots of Games and Applications

Applications and software are the meat of SYNC. We recognize that along with useful, pragmatic applications, like financial analysis and graphing, you'll want games that are fun and challenging. In the charter issue of SYNC you'll find several games. Acey Ducey is a card game in which the dealer (the computer) deals two cards face up. You then have an option to bet depending upon whether you feel the next card dealt will have a value between the first two.

In Hurdle, another game in the charter issue, you have to find a happy little Hurdle who is hiding on a 10 X 10 grid. In response to your guesses, the Hurdle sends our a clue telling you in which direction to look next.

One of the most ancient forms of arithmetical puzzle is called a "boomerang." The oldest recorded example is that set down by Nicomachus in his *Arithmetica* around 100 A.D. You'll find a computer version of this puzzle in SYNC.

## Hard-Hitting, Objective Evaluations

By selecting the ZX80 or MicroAce as your personal computer you've shown that you are an astute buyer looking for good performance, an innovative design and economical price. However, selecting software will not be easy. That's where SYNC comes in. SYNC evaluates software packages and other peripherals and doesn't just publish manufacturer descriptions. We put each package through its paces and give you an in-depth, objective report of its strengths and weaknesses.

SYNC is a Creative Computing publication. Creative Computing is the number 1 magazine of software and applications with nearly 100,000 circulation. The two most popular computer games books in the world, *Basic Computer Games* and *More Basic Computer Games* (combined sales over 500,000) are published by Creative Computing. Creative Computing Software manufactures over 150 software packages for six different personal computers.

Creative Computing, founded in 1974 by David Ahl, is a well-established firm committed to the future of personal computing. We expect the Sinclair ZX80 to be a highly successful computer and correspondingly, SYNC to be a respected and successful magazine.

## Order SYNC Today

Right now we need all the help we can get. First of all, we'd like you to subscribe to SYNC. Subscriptions are posted by air directly from America and cost just £10 for one year (6 issues), £18 for two years (12 issues) or, if you really want to beat inflation, £25 for three years (18 issues). SYNC is available only by subscription; it is not on newstands. We guarantee your satisfaction or we will refund the unfulfilled portion of your subscription.

Needless to say, we can't fill up all the pages without your help. So send in your programs, articles, hints and tips. Remember, illustrations and screen photos make a piece much more interesting. Send in your reviews of peripherals and software too—but be warned: reviews must be in-depth and objective. We want you to respect what you read on the pages of SYNC so be honest and forthright in the material you send us. Of course we pay for contributions—just don't expect to retire on it.

The exploration has begun. Join us.

The magazine for Sinclair ZX80 users

# SYNC

27 Andrew Close  
Stoke Golding

Nuneaton CV13 6EL, England

# COMAL-80

*With the launch of the BBC Microcomputer, the subject of structured extensions to Basic has come very much into the news. Here Borge Christensen, its inventor, discusses COMAL the first and arguably the best of such extended Basics.*

In the July issue of *PCW* Jonathan Palmer from Currie, Midlothian, wrote about Basic and Pascal. In many ways his letter was a very sensible one that hit an amazing lot of important points in a few lines. I am sure that his point of view is shared by thousands of people who use Basic but at the same time feel that this language is beginning to be left behind by the development of both hardware and software. My special concern is about his final statement 'So what should be done? A structured Basic seems the best idea so that one can progress from simple Basic to structured Basic without the need to learn a whole new language. After all, we do want people to use computers, don't we?' In what follows, I would like to tell Jonathan and his thousands of fellow partisans how we solved that problem in Denmark six years ago, and at the same time I shall comment on some of the items in his letter.

Before coming to the main part of my story I would like to sort out a few facts and concepts, however. It is my impression that in very many letters in *PCW* and elsewhere about Basic versus Pascal and interpreters as opposed to compilers, the languages and their operational environments are mixed up. To illustrate the problem we can take a look at one of the most user friendly Pascal systems, viz, UCSD Pascal.

The version referred to in the following is distributed by SofTech Microsystems, and I run it on a micro-computer with 64kB RAM storage and two mini diskette stations. It takes about 45 seconds to load the system and during that period of time I have to manipulate correctly three diskettes. Having been successfully loaded, the Pascal system proclaims its attendance by displaying the so-called 'Prompt Line':

Command: E(dit, R(un, F(ile, C(ompile, X(ecute,...

and a few more items. Well, okay, let us start to write a Pascal program; it is claimed to be good for your health! The first line of the small sample program I have dug out of some highly recommended textbook goes like this:

PROGRAM FOR1;  
Since "PROGRAM" begins with a "P", I'd better press the "P" key. Now what happens? The screen flickers for a split second and the Prompt Line is restored. But my "P" seems to have suffered the same fate as some of the odd particles in nuclear physics that only live for a fraction of a second. What's wrong? Why, of course! I have to switch to *Edit mode* first. This is done by pressing the "E" key — "E" for "Edit" — so that's what I do. After

about five seconds the following is displayed:

>Edit: A(djst C(py D(lete F(ind I(nsr. followed by a printout of some other person's program!! Since I am not interested in other persons' inferior programs, I try to type NEW, which ought to help. As soon as the "N" has been pressed the system answers with a loud BEEP, but my poor "N" has become the innocent victim of the same brutal treatment as the "P" above. By pressing "Q" and answering correctly to a menu of suggested actions, I am sent back to *command mode*. I type "F" for "File" and the *File* comes in saluting me:

File: G(et, S(ave, W(hat, N(ew, L(dir,...

Ah, there it is! I press the "N" key, and the system asks me to confirm that I really want to throw away the workfile. I do, oh, I do.

Then back to the editor, where it appears that I have to press "I" to be allowed to *Insert* the program, "D" to be able to *Delete* one or more characters in it, "X" to *eXchange* parts of it, and — *not to forget* — after each of these operations I must press a certain key to finish it and come back to *edit command mode*.

## Writing to Aunt Agatha

During all this I do not get the faintest hint from the system to tell me whether the statements of my program have got a reasonable Pascal syntax or not. As far as the editor is concerned, I might just as well be writing a letter to Aunt Agatha reporting the latest family reunion instead of a sensible Pascal program.

Whether it is one or the other is not revealed until I come back to *command mode* and order the system to *compile* the text that I have written. It appears that I have forgotten to put a semicolon after the name of the program, whereupon it takes several seconds to reload the editor, have the site of the bug pointed out and named, and then again several seconds to get the editor into *insertion mode*. Having inserted the semi-colon I have to *Quit* the editor, *Update* the workfile — several seconds — and *invoke* the compiler to start anew on my program. Even with a beginner's tiny sixliner program all this "system ping-pong" may take several minutes, and as mentioned by Jonathan Palmer, it can take more than two minutes to catch and kill a completely trivial bug.

In the second example a system that contrasts favourably with the former will be used, viz. CBM COMAL-80 — Commodore's new Structured

Basic. Disk station 0 is loaded with a diskette and the SHIFT-RUN/STOP keys of the CBM are depressed. After 15 seconds the system reports its presence and willingness to work with COMAL 80 rev 00.11

You may start typing at once:

10 W\$="HEAP\*"

20 S =W

It is obvious that a bug has been introduced in line 20, and the system answers with a beep and displays the following:

type conflict

20 S =W

with the cursor marking the place where the bug has been detected. You only have to press the "\$" key and then the RETURN key to be allowed to go on with your program.

After having entered the program you may have it executed *immediately* by typing the usual command RUN. An *extremely fast prerun* is first performed by the system. During this prerun *structural bugs* — such as FOR without NEXT — are discovered and reported, and you are sent back to *edit mode* automatically, thus being given the chance to mend your program and rehabilitate yourself. After a program has been approved by the prerun, only run-time errors may still hide in it. It is not unusual that small beginners' programs run flawlessly at the first trial. And if they do not, it is always a very straightforward affair to come back to *edit mode* and correct the program using line numbers as references.

## Easy to get started

Let us try to analyse what it is that makes Basic programming so easy compared to Pascal programming. In Basic, lines can be entered in any order and are automatically placed in the correct sequence. *Syntax checking* takes place on a line-by-line basis as program statements are typed; thus it is not possible to store or list an invalid line of Basic. Run-time errors identify the offending statement directly by means of its line number. It is extremely easy to "get started" in Basic. Having logged on it is only necessary to type

10 PRINT "HI, THERE"

RUN

to see your first program live. Most other language systems perform badly on this test.

In Pascal you have to learn how to use a text editor to input or change programs; in Basic line numbers are used to replace and delete program statements as well as to sequence them.

# COMAL-80

If your Basic system has a screen editor at its disposal it is easy to "walk around" on the screen and make minor modifications, adjusting printouts, etc. In Pascal you also need to learn a separate Operating System command language to manipulate programs and files or to specify input or output devices. Basic has its own set of simple commands (LIST, RUN, SAVE, etc) which refer in an obvious way to the user's current program, etc.

In Basic at the end of program execution, control returns *automatically* to the terminal and the program remains unaltered in the user's "workspace". It can be changed and rerun in a simple fashion, or the values of specific variables can be displayed. Many Basic systems allow particular statements (eg, assignments) to be executed in "immediate mode", ie, as commands, followed by restarting the program.

Though the features mentioned above seem to comprise genuine advantages of Basic over Pascal, they do in fact not relate to the programming languages as such, but rather to the operating environment in which they are used. The normal use of an interpreter rather than a compiler for Basic makes many of the user aids described above much easier to provide, and the lack of compiled code is not a significant problem for most reasonably small programs, although it can become so as Basic is used for more and more ambitious projects. The use of line numbers for program input and editing is an especially valuable feature. Naturally, a Basic-like environment could be built around Pascal, but surprisingly this has not been done.

Though Basic may live in very convenient operating environments it is still a very poor language, far inferior to Pascal. But what can be done about that? The practical difficulties associated with the abandoning of an established language make a powerful argument against "revolutionary" changes. The alternative option of an evolutionary approach, ie, *improving Basic rather than replacing it*, is an attractive one. However in choosing this option it is essential not to lose sight of the original objectives of the language, as an easy-to-learn, easy-to-use, straightforward language (or system) aimed particularly at the beginner and non-computer specialist.

## Comal is born

In 1974 we faced that problem here at the States Training College, Tonder, Denmark. We had been using Basic for about two years by then to teach our maths students elementary computer science. At first everything seemed just fine. As already mentioned, Basic is easy to learn, and both the students and I wrote a lot of programs — most of them with mathematical themes — and they ran irreproachably. However, as programs grew bigger, errors became more frequent. Very often I had to sit for quite some time to find out where a student had made a mistake, and it began to irritate me that I often found it difficult to read

even relatively small programs written in Basic.

I found two main reasons for that: *variable names are much too short* to give any information about what they represent, and *the exclusive use of GOTO makes it difficult to identify the structures of the program*. I discussed the problems with Benedict Loefstedt, one of the lecturers at the Institute of Computer Science, University of Aarhus, and together we designed a set of extensions of Basic in order to produce more readable and safer programs. As a model we used the algorithmic structures from Pascal —

which was not a very well known language at that time — and allowed identifier names of up to eight characters. After we had designed the extensions, two students of mine, Knud Christensen and Per Christiansen, began to modify our Basic interpreter, and in 1975 we had the first version running. We called it COMAL (COMMon Algorithmic Language). At that time Basic had become such a nuisance that we wanted to get rid of the name altogether. Today we admit that it was a structured Basic we designed and implemented.

Over the years the first version — COMAL-75 — has been substantially

```
0010 DIM COLOR$ OF 10, GUESS$ OF 10
0020 DIM ANSW$ OF 3, LEGAL$ OF 30
0030 LEGAL$=" .RED.YELLOW.GREEN.BLUE."
0040 REPEAT
0050 EXEC BET
0060 EXEC WHEEL
0070 EXEC RESULT
0080 UNTIL HALT
0090 //
0100 PROC WHEEL
0110 OUTCOME:=RND(1,15)
0120 CASE OUTCOME OF
0130 WHEN 1,3,6,9,12,15
0140 COLOR$="RED"
0150 FACTOR:=1.5
0160 WHEN 2,5,8,11,14
0170 COLOR$="YELLOW"
0180 FACTOR:=2
0190 WHEN 4,10,13
0200 COLOR$="GREEN"
0210 FACTOR:=3
0220 WHEN 7
0230 COLOR$="BLUE"
0240 FACTOR:=9
0250 ENDCASE
0260 PRINT "***** ",COLOR$," WINS *****"
0270 ENDPROC WHEEL
0280 //
0290 PROC BET
0300 PRINT "WHAT COLOR",
0310 INPUT GUESS$
0320 WHILE NOT ("."+GUESS$+"." IN LEGAL$) DO
0330 PRINT "ONLY (RED,YELLOW,GREEN,BLUE) ALLOWED!"
0340 PRINT "NOW, WHAT DO YOU PICK OUT",
0350 INPUT GUESS$
0360 ENDWHILE
0370 PRINT "HOW MUCH DO YOU WANT TO BET",
0380 INPUT STAKE
0390 WHILE STAKE<10 DO
0400 PRINT "DON'T BE MEAN, MAN!"
0410 PRINT "NOT LESS THAN 10 PENCE"
0420 PRINT "MAY WE ASK FOR YOUR BET",
0430 INPUT STAKE
0440 ENDWHILE
0450 ENDPROC BET
0460 //
0470 PROC RESULT
0480 IF GUESS$=COLOR$ THEN
0490 PRINT "HURRAY, YOU WIN."
0500 PRINT "YOU HAVE STAKED ",STAKE," PENCE,"
0510 PRINT "SO YOU GET ",STAKE*FACTOR," PENCE."
0520 ELSE
0530 PRINT "SORRY, YOU HAVE LOST ",STAKE," PENCE."
0540 PRINT "BETTER LUCK NEXT TIME."
0550 ENDIF
0560 INPUT "PLAY AGAIN (Y/N)? ": ANSW$
0570 HALT:=ANSW$="N"
0580 ENDPROC RESULT
0590 //
0600 //END OF PROGRAM: WHEEL//
0610 //WRITTEN IN CBM COMAL-80//
0620 //BY BORGE R. CHRISTENSEN//
0630 //FOR PERSONAL COMPUTER WORLD//
0640 //JULY 2, 1981//
```



improved, and in 1979 I defined a new version of COMAL — COMAL-80 — which was finally further improved by a working group of academics and representatives of several manufacturers of microcomputers. In 1980 COMAL-80 was fully implemented by Commodore to run on the 4032 and 8032 microcomputers. This task was undertaken by Mogens Kjaer, Copenhagen, Denmark. Mogens Kjaer wrote the whole thing for Commodore in about four months, and even though he is a very talented programmer, you can see that the task of turning Basic into a useful modern language is not an impossible venture. In what follows I shall survey the major features of COMAL-80, and I am quite confident that Jonathan Palmer and like-minded persons will fully approve of what they come to see. The sample program I shall refer to is in no way sensational, but it demonstrates the most important facilities of COMAL-80 quite well. Please refer to the program listing while reading the following (list on page 78).

## Sample program

In lines 10, 20 and 110 long identifier names are demonstrated. In COMAL-80 a variable name may hold up to 16 characters, all of which are significant. The first character must be a letter, the following may be letters or digits. Most versions of COMAL-80 also allow an extra character to be introduced in an identifier name, such as the underscore or the quote. In CBM COMAL-80 the quote may be part of a name, eg, NUMBER 'OF' ITEMS is a legal identifier name.

The IF...ELSE...ENDIF branching is displayed in line 480-550. In the IF statement the keyword IF is as usual followed by a Boolean expression. If this expression is evaluated to TRUE the block of statements between the IF statement and the ELSE statement is executed, whereas if it returns a value of FALSE, the block of statements between ELSE and ENDIF is processed. Sequential processing is then resumed with the statement following the ENDIF statement. Program structures of all types may be nested to any depth in COMAL-80.

The REPEAT..UNTIL loop is used in line 40-80. Notice that the *Boolean variable* (the flag) HALT is assigned a truth value in line 570. The difference between the assignment token (:=) and the relational operator (=) is clearly demonstrated in that line. This is the one point where I do not agree with Jonathan Palmer. It is very important to teach beginners to distinguish between the assignment *instruction* and a relational *operator*. The assignment contained in line 570 may, however, be entered thus:  
 HALT:=ANSW\$="N"

or even:  
 LET HALT =ANSW\$="N"

The COMAL-80 interpreter automatically converts either of the two strings into the one displayed in the program list.

WHILE..ENDWHILE loops are demonstrated in line 320-360 and 390-440. The IN operator in the Boolean expression following WHILE in line 320 returns a value of TRUE if the first operand is a substring of the

second operand; otherwise it outputs a value of FALSE. This is the closest we can come to *sets* in COMAL-80.

Procedures (subroutines) are named in COMAL. As is seen from line 100 a procedure head consists of the keyword PROC followed by the name of the procedure. The block of statements that constitute the body of the procedure is executed only if it is called by means of an EXEC (EXECute) statement. Three such statements are found in line 50-70. If you happen to stumble over a procedure during simple sequential processing it is skipped. Though it is not demonstrated in the program, the call of procedures in COMAL-80 allows passing of parameters called by value as well as called by reference. GOSUB "linenumber" should not be used in COMAL; you never know what is going on when you have nothing but an anonymous linenumber to look at. There is no doubt that GOTO "linenumber" and GOSUB "linenumber" are the two most foolish control statements that were ever invented. I am sure they will remain a disgrace to the history of computer science long after Basic has been consigned to Limbo.

A multi-branching structure is found in line 120-250. If the value of the expression following the CASE keyword matches the value of one of the expressions lined up after a WHEN keyword, the block of statements following that WHEN statement is executed. When the block is finished, sequential processing is resumed with the statement following the ENDCASE statement. The keyword OTHERWISE may be used to initiate a default case which is then inserted immediately before the terminating ENDCASE statement.

The indentations to indicate the blocks of statements are of course done automatically by the system on the listing.

COMAL-80 also includes a very simple yet versatile file handling system, offering loading, saving and merging of programs and sequential as well as random access files.

## Linking the structures

As a CBM COMAL-80 program is

typed in it is, as mentioned before, syntactically analysed. If accepted by the scanner it is not just stored but converted into reverse polish notation. The prun links the structures of the program, such that, for example, a WHILE statement contains the address of its ENDWHILE statement and vice versa, and an EXEC statement knows where to find the procedure it is calling. This means that a long COMAL program is processed much faster than the equivalent Basic program. All identifiers are converted into tokens internally, such that they occur only once in the storage. A rather nasty program has been written that will erase the symbol table (which is only used in the listing) from a program. The reader can guess what happens when an unauthorised person tries to list such a program!

After having used COMAL for more than six years now I can confirm that it is a good idea to implement a structured Basic. But if you do so, you must ensure the *generality of the structures*. We took our structures from Pascal, because we realised that better ones would hardly be designed for the next 500 years. In the meantime, Pascal has become very popular, and it is easy for one of our students who chooses to become a professional programmer to learn to use Pascal. Not long ago I got a paper called "BBC Basic" from a friend of mine in England. It describes one of the most pathetic attempts to extend Basic that I have ever seen. If that incoherent jumble is what BBC plans to use to bring the English into the Computer Age I sincerely hope you will be able to pump oil out of the North Sea for many, many years to come!

You can get more detailed information about CBM COMAL-80 by contacting Nick Green at Commodore's headquarters in Slough. A very good paper entitled "COMAL 80 — adding structure to Basic" has been written by Max Bramer at the Open University, Walton Hall, Milton Keynes, MK7 6AA (CAL Research Group Technical Report No. 3). COMAL-80 has been implemented on some Danish built microcomputer systems too. Information about one of them, the RC PICCOLO, may be obtained from Roy Atherton, Bulmershe College, Woodlands Ave, Reading RG6 1HY.

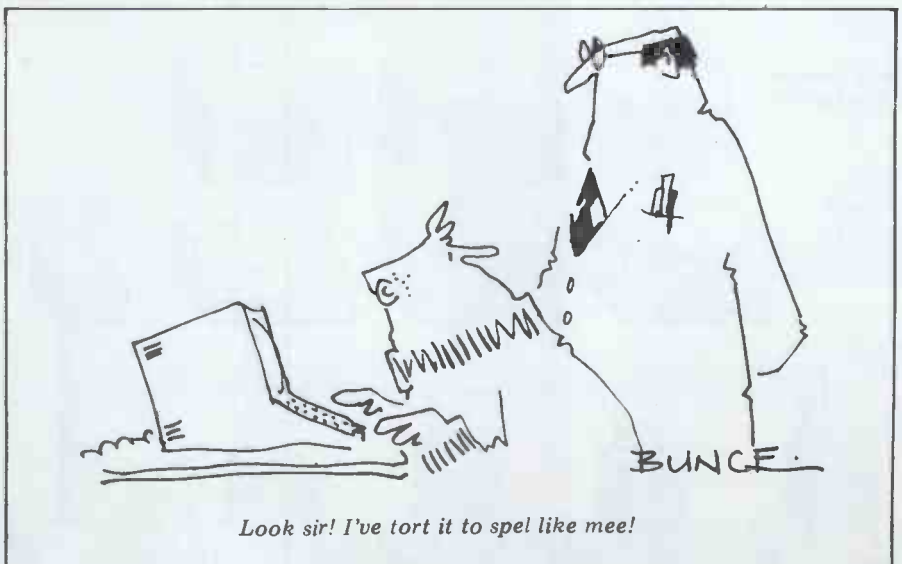

# UNLEASH THE POWER OF YOUR MICRO WITH THE CORVUS 5Mb HARD DISC SYSTEM It can add up to a Miracle.

Corvus systems will change your whole way of thinking on microcomputer performance.

You can forget the small data storage capacity and slow access times of traditional floppy-based systems when you add on from 5Mb of Corvus hard-disc capacity. Corvus technology enables a microcomputer to handle up to 600 times more data than normal, and with 5, 10 and 18Mb versions available, they can be chosen to exactly meet your data storage requirements.

True, they cost more than floppies, but for the price of eight single density floppies you can get a 10Mb Corvus disc which has the capacity of 67 floppies. Plus greatly increased speed and convenience.

But that's just the start of a Miracle. When 2-64 micros share up to 72Mb of Corvus hard disc through a Constellation host multiplexer, a Miracle network brings you all the economies of low-cost microcomputers sharing expensive peripherals. With his own dedicated computer and associated memory, each Miracle user has interference-free access to a central database, and he can communicate with like computers in the network.

## How a Miracle system works

Each Constellation host multiplexer links 2-8 micros in star configuration to 5, 10 or 18Mb of Corvus hard-disc drive. Up to 8 host multiplexers can be connected together, allowing up to 64 micros to use four disc drives for a total system capacity of 72Mb.

Inexpensive back-up for the hard-disc system is provided by the unique Corvus Mirror. It interfaces the data signals on the disc with a 100Mb capacity video tape system.



**Available for Apple, PET, Superbrain, S100, Tandy, Vector Graphic—and more to come!**

## Applications software

Miracle makes use of a comprehensive range of languages, from BASIC, COBOL and FORTRAN to PASCAL, ALGOL and APL. Applications software packages include: Accounting Systems, Payroll and Stock Control (fully integrated with order processing/invoice generator), Addressing/

Mailing, Database Management, Incomplete Records, Job Costing, Time Records, Graphics and Critical Path Analysis.

Phone now for a demonstration or complete and return the coupon below.

**London 01-236 5682/3/4  
Nottingham 0602 412777**

## Typical five-user Miracle system

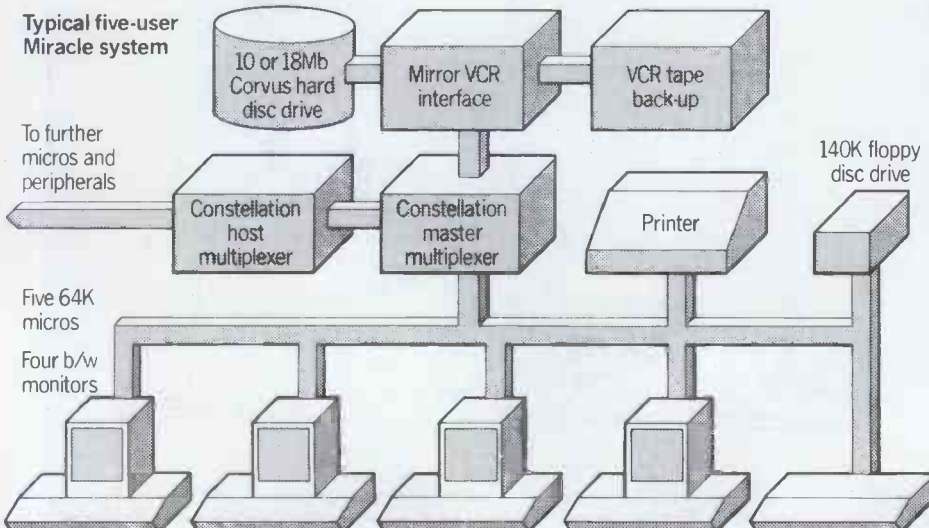

**Keen Computers**



Please send me details of: K1  
Miracle with the following micros

Applications software packages  
(please state) \_\_\_\_\_

Name \_\_\_\_\_

Position \_\_\_\_\_

Company/Establishment \_\_\_\_\_

Address \_\_\_\_\_

Tel \_\_\_\_\_

Please post to Keen Computers,  
Marketing Department,  
5 Giltspur Street, London EC1A 9DE

# CONTROL YOUR OWN SUBSTATION!

D E Graham describes further ways in which your ZX80/81 can control things in the outside world.

## Audio output

Sound output from the ZX80 and ZX81 can be achieved in a variety of different ways with the 80/81 port board. The simplest, using a solid state buzzer, was dealt with briefly last month. Here we will have a look at two methods which allow a variable frequency note to be output to a loudspeaker. This is most simply achieved by connecting a fairly high impedance loudspeaker — a 65 ohm 2in variety was used in the prototype — directly to channel zero of the output port (see Figure 1). A succession of zeros and ones can then be POKEd to the port to produce an audio tone of quite good volume. The following programs achieve this:

```
10 REM ZX80 AUDIO
20 FOR A = 1 TO 100
30 POKE 25000, 1
40 POKE 25000, 0
50 NEXT A
```

```
10 REM ZX81 AUDIO
15 FAST
20 FOR A = 1 TO 100
30 POKE 11000, 1
40 POKE 11000, 0
50 NEXT A
```

The duration of the tone is determined by the length of the FOR loop in line 20 and its frequency by the time the ZX takes to execute each cycle of the loop. This is limited by the speed of the Basic interpreter to a couple of hundred hertz or so; while the bleep produced is useful as an audio cue, it is no use in more sophisticated applications. To extend the attainable frequency range, it is necessary to resort to a machine code subroutine which may be accessed from Basic with a USR call.

## Full range audio

Reproduced below is an assembler listing of a 27-byte machine code pro-

gram that may be used on the ZX80 or 81 to produce audio outputs over the frequency range 200 Hz to 25 kHz. It makes use of a number of counting loops, set up on registers B, C, and D of the ZX80 to achieve an audio output of a duration which is independent of note frequency. The differences between the implementation on the ZX80 and 81 lie mainly in where the program is to be stored within the 1k available memory.

The problem of storage is most easily resolved on the 81, and we will deal with this first. The method chosen is to store the code within a REM statement on program line 1. This has the dual advantage that it may be stored on tape with a normal SAVE command and that it is not shifted around by the ZX81's extremely busy operating system.

```
1 REM AAAAAAAAAAAAAAAAAAAAAA-
  AAAAAAAAAAAAAAAAAAAAAA
10 FOR A=16515 TO 16541
20 PRINT A; " ";
30 INPUT B
40 PRINT B
50 POKE A,B
60 NEXT A
```

To fill the REM statement with the appropriate code, the program below may be used. This sets up the REM statement on line one, and allocates sufficient space for it, and then allows it to be filled with data received from a looped INPUT statement. The 27 bytes of data to be entered are as follows: 62, 0, 14, 100, 5, 194, 143, 64, 13, 202, 157, 64, 21, 194, 135, 64, 22, 255, 238, 1, 50, 0, 42, 195, 135, 64, 201. When the program stops because the screen has filled, execute CONT and continue. If you list the program after it has been run, you should find that the contents of the REM statement in line 1 have taken on a peculiar aspect.

It might be as well to test the audio routine at this stage. This may be achieved by plugging in the loudspeaker

(wired as in Figure 1), and executing LET X = USR 16515. A bleep of about 1/2 sec duration should be heard. If not, check the contents of the 27 locations from 16515 to 16541 using the PEEK function to verify that you have entered all the data correctly. When all is functioning well, erase all of the program lines but the first, by entering empty line numbers. What remains is the single REM statement containing the audio subroutine. This should now be saved to tape, and may be reloaded and incorporated in any programs that you wish. Before treating applications of the routine, we will look at how it may be loaded on the ZX80.

It is unfortunately not possible to store the machine code audio routine in a REM statement on the ZX80, because the machine's interpreter actually checks the contents of REM statements for an end-of-line character, and will unceremoniously hang up when it finds certain unexpected data there. One way around this is to store the program in a section of memory somewhere below the stack, beginning at 17000. The data is not automatically saved to tape, but even this can be easily circumvented. Below is a program in Basic which contains the audio subroutine, and which loads it into memory when RUN is executed:

```
10 REM ZX80 MACHINE CODE
  AUDIO
20 LET A$ = "3E000E6405C-
  2744200CA824215C26C4216FFE-
  E01320060C36C42C9"
```

Line 20 contains the hex code for the 27 bytes of machine code, and the remainder of the program reads off pairs

```

;ZX80 AUDIO SUBROUTINE
STT: LD A,0
      LD C,100 ;DURATION
      DEC B
      JP NZ,ONE
      DEC C
      JP Z,OUT
      DEC D
      JP NZ,STT
      LD D,255 ;FREQUENCY
      XOR 1
      LD (PORT),A ;PORT = 25000 FOR ZX80
      JP STT ;PORT = 11000 FOR ZX81
OUT: RET

```

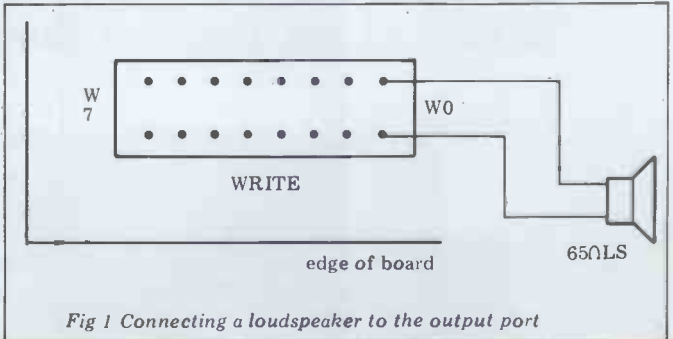
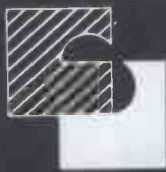

Fig 1 Connecting a loudspeaker to the output port



# CompUtopia

Introduce

**U-SCI**

disk drive

**WHY  
MICRO SCI  
FOR  
YOUR  
APPLE  
II?**

reduced  
**COST**  
increased  
**CAPACITY**  
high  
**RELIABILITY**  
genuine  
**COMPATIBILITY**  
improved  
**SPEED**  
efficient  
**CONTROLLER**

**U-SCI**



For further information contact your local APPLE dealer or COMPUTOPIA direct at  
**30 Lake Street, Leighton Buzzard. Bedfordshire. Tel:0525-376600**



# CONTROL YOUR OWN SUBSTATION!

of these from left to right, converts them to decimal, and POKEs them to the appropriate locations, ie, 17000 onwards.

Once the program has been run, it may be tested by executing LET Z = USR (17000). This should again produce a bleep on the loudspeaker. If all is well the program should be saved in its entirety, and may be incorporated into any programs requiring audio output.

## Using the audio generator

Both the frequency and duration of audio output from the generator program may be varied by using two POKE commands before executing the USR call. On the ZX80, the two locations are 17003 and 17017 for duration and frequency respectively, while for the '81 the locations are 16518 and 16532. Any integer between 1 and 255 may be POKEd to these addresses, with low numbers producing short durations or high frequencies. The test program below allows both durations and frequencies to be entered using INPUT statements before making the USR call.

```
150 PRINT "DURATION 1-255"
160 INPUT D
170 PRINT "FREQUENCY 1-255" Variations for the ZX81:
180 INPUT F
190 CLS
200 POKE 17003,D          POKE 16518,D
210 POKE 17017,F          POKE 16532,F
220 LET X = USR(17000)    LET X = USR 16515
230 GO TO 150
```

The machine code audio subroutine offers one further facility. As things stand, once the USR call has been made, the signal levels on channels 1-7 of the output port will all be reset to zero. This is obviously inconvenient if they are being used simultaneously for some other purpose. To get around this problem, a POKE command may be executed to address 17001 for the ZX80 or 16516 for the ZX81 just before executing the USR call. The data POKEd in this command should be the same as the last data POKEd to the output port. Thus, suppose a program were required to turn on a relay on channel two of the output port by POKeing the value 4 to the port, and at the same time needed to access the audio routine, POKeing 17001 or 16516 with the value 4 would ensure that when the USR call was made it would leave the relay in the ON position.

## Sound effects

A wide range of sound effects may be produced using the audio subroutine and these may be used to add life to games and more serious programs. Here are one or two examples of effects produced by rapidly varying the output frequency using a series of FOR loops to create noises of the kind that Invader machines are fond of producing.

```
500 REM ZX80 SOUND EFFECTS
510 PRINT "DURATION 3-255"
520 INPUT D
530 CLS
```

```
540 POKE 17003,D
550 FOR A = 1 TO 10
560 POKE 17017,(255/A)
570 LET X = USR(17000)
580 NEXT A
590 GO TO 550
```

```
500 REM ZX81 SOUND EFFECTS
510 PRINT "DURATION 3-255"
520 INPUT D
530 CLS
540 POKE 16518,D
550 FOR A = 1 TO 10
560 POKE 16532,INT(255/A)
570 LET X = USR 16515
580 NEXT A
590 GO TO 550
```

These program lines should of course be entered on top of the relevant audio generating subroutines described above. To halt sound output press the BREAK key, though in real applications a further FOR loop may be inserted to exit the routine when required. The sound effect produced by the above routines may be altered considerably by changing line 550 to: FOR A = 10 TO 1 STEP -1. Also, inserting the two lines:

```
573 POKE 17017,255
575 LET X = USR(17000)
```

```
573 POKE 16532,255
575 LET X = USR 16515
```

will also change the sound produced.

## Random 'music'

The following short routines, which again access the machine code audio subroutine, allow the ZX to play an infinite (though repeating) series of notes chosen randomly using its RND function. The RANDOMISE function might additionally be incorporated at some point, though this will not greatly increase the probability that the machine will hit upon Beethoven's Ninth, given long enough.

```
500 REM ZX80 RANDOM PLAYER
510 POKE 17003,100
520 POKE 17017,(15+RND(240))
530 LET X = USR(17000)
540 GO TO 520
```

```
500 REM ZX81 RANDOM PLAYER
510 POKE 16518,100
520 POKE 16532,(240*RND+15)
530 LET X = USR 16515
540 GO TO 520
```

## Keyboard organ

If you want to play tunes for yourself, that can also be arranged, though it is a little harder with the ZX80, since it has no INKEY\$ function for detecting keyboard presses without stopping the program with an INPUT statement. Here firstly is the ZX81 version:

```
199 REM ZX81 ORGAN-USES M/C
ROUTINE IN REM
200 IF INKEY$ < ">" THEN
GO TO 200
205 LET QS = INKEY$
207 IF QS = "" THEN GO TO 205
210 LET W = VAL QS
215 IF W = 0 THEN GO TO 300
220 POKE 16532,INT(255/W)
230 LET X = USR 16515
240 GO TO 205
```

```
300 PRINT "ENTER NEW PERIOD
1-255"
310 INPUT Z
320 IF Z < 1 OR Z > 255 THEN GO
TO 300
330 POKE 16518,Z
340 CLS
350 GO TO 200
```

Keyboard numbers 1 - 9 play nine different notes and, if zero is pressed, the playing routine is exited so that the note duration may be altered. Values of about 100 give good results, with lower values producing a tremolo effect.

To implement the organ on the ZX80, a machine code patch could be used to implement the INKEY\$ function, but here we will use a set of push buttons connected to the lowest four channels of the input port (R0-R3) using the circuit of Figure 9 of last month. The program below can play up to 15 different notes with this arrangement, depending on which combination of the four buttons are pressed. There is at present no facility for altering the duration of the note, but this may be easily added in such a way that pressing a button on say channel four initiates an appropriate INPUT routine.

```
140 REM ZX80 PUSH BUTTON
ORGAN
145 REM USE WITH M/C ROUTINE
150 LET A = PEEK(25000)
160 IF A = 0 THEN GO TO 150
170 POKE 17017,(15 + A*15)
180 LET X = USR(17000)
190 GO TO 150
```

Some interesting effects can be obtained using the program with LDR photo-resistors substituted for the push buttons, as in Figure 12 last month. This arrangement transforms visual patterns into audio tones.

## Hardwired audio

An alternative way to produce audio output from the ZX is to use a separate audio generator IC such as the NE555, which costs only 20p. The advantage of this approach is that, since the audio is actually generated by the NE555 and not by the microprocessor chip itself, the ZX can get on with other things during sound output. This means that with the ZX81 in the slow mode, for example, TV output may continue during the production of sounds. Figure 2 shows the circuit for such a generator. As may be seen, it occupies four of the 80/81 board's output channels to achieve a repertoire of eight notes. In fact, channels 0, 1 and 2 actually control the frequency generated, while channel 3 decides whether the output is on or off. Output is enabled when channel 3 is high, so that data in the range 8 to 15 produces audio output. To alter the range of frequencies produced, C may be changed. Larger values give a lower frequency, and vice versa.

To produce audio with the generator, simply POKE a value between 8 and 15 to the output port (25000 on the '80, 11000 on the '81). To stop the flow of sound, POKE 0 to the port.

As suggested above, one advantage of the hardwired audio approach is that (at the cost of an extra three output channels) audio can be output

# "COPY-WRITE" A most complete bit copier for Apple programmes

"COPY-WRITE" disk backup system copies virtually all Apple programmes. SPREEBOND believes "COPY-WRITE" is the most sophisticated disk backup system available. Do not be misled by our advertised competitors. Their programmes may not copy all the latest protection formats employed by manufacturers to frustrate the software buyer from making needed backup copies of his vital business, accounting, data base, and modelling programmes.

## FEATURES OF "COPY-WRITE"

- **AUTOMATICALLY COPIES HALF TRACKS.** Apple disks only use 35 tracks, or every other one of the 70 available on a 5¼ inch disk. Many protection techniques place some data on the alternate or half-tracks which normal copy programmes cannot read or copy. "COPY-WRITE" automatically searches and reads both full tracks and half-tracks and then writes the data found to the destination disk.
- **COPIES SYNCHRONIZED TRACKS.** Some disks align all tracks in the same pattern as on track 00. "COPY-WRITE" writes these sectors in the same pattern as found on the original disk. Most other copy programmes cannot.
- **PROVIDES "STATUS FIELD DISPLAY".** "COPY-WRITE" supplies the operator with a track by track progress report as the programme reads, aligns, verifies, and writes each track.
- **PERMITS PARAMETER CHANGES.** "COPY-WRITE" not only recognizes the usual DOS 3.2, 3.3, Pascal, CP/M, etc. formats, it will also change parameters to adjust to abnormal or

foreign DOS techniques designed to frustrate making of backup copies.

These parameter changes can be made with "COPY-WRITE's" special and unique state-of-the-art utility called MDDS (Memory Dumper/Disk Searcher). MDDS enables the user to look at each track in ASCII or HEX and determine whether the usual FF sync-bytes have changed to some abnormal permutation.

- **FILE PROGRAMMES.** Once unusual parameters have been identified by MDDS, "COPY-WRITE" allows the user to save to disk each set of parameters for future use with similarly encoded disk formats.
- **FLEXIBLE.** "COPY-WRITE" is the only bit copier with flexible parameters and filer programmes that enable it to respond to new encoding techniques developed by manufacturers. SPREEBOND'S subscription maintenance service will provide parameters that update the programme to match new encoding techniques. No other copy programme is as versatile.
- **TUTORIAL MANUAL.** "COPY-WRITE's" 21 page tutorial manual provides instructions for use of the programme.

## HOW TO GET "COPY-WRITE"

- "COPY-WRITE" is available for £50 + VAT.

Orders may be placed by mail or by telephone. Personal cheques are accepted, as are VISA and ACCESS cards.

**Spreebond Limited**

Telephone: (0622) 683-866  
Dealer enquiries welcome

Unit 7, Haslemere,  
Parkwood Estate,  
Sutton Road,  
Maidstone,  
Kent. ME15 9NE.

# APPLE II & CP/M

Apple II Europlus 48k	£595
Z-80 Softcard with CP/M & Microsoft Basic	£160
Videx 80-column card	£175
16k Expansion RAM Card	£95
Wordstar	£190
Mailmerge	£70
Visicalc 3.3	£110
D.B. Master	£120
Olympia Scripta ESW 100 KSR	£975
Centronics 737	£375
Epson Printers at reduced prices	P.O.A.

Ring for latest price list  
Add 15% VAT

GRANATA COMPUTER SYSTEMS  
CENTURY HOUSE, HAVELOCK ROAD  
SOUTHALL, MIDDLESEX  
01-843 1971

SCOOP ONLY  
£29.95  
+VAT

- BRITISH MADE
- 52 KEY 7 BIT ASCII CODED
- POSITIVE STROBE +5V - 12V
- FULL ASCII CHARACTERS
- PARALLEL OUTPUT WITH STROBE
- POWER LIGHT ON CONTROL

The 'CHERRY' Computer Keyboard



- CHIP BY GENERAL INSTRUMENT (G.I.)
- TTL OUTPUT
- SUPERBLY MADE SIZE 13 x 5.5 x 1.5 ins.
- BLACK KEYS WITH WHITE LEDGERS

- ESCAPE SHIFT RETURN & RESET KEYS
  - CONTROL REPEAT & BELL
- Complete with DATA

Ideal for use with TANGERINE, TRITON, TUSCAN, APPLE and most computers. Ex-Stock from HENRY'S  
This is definitely the BEST BUY FULLY GUARANTEED Supplied BRAND NEW in manufacturers original packing. Just post remittance total £35.95 (incl. V.A.T. & Post)

## The 'Apple' Power Supply

A PROFESSIONAL BUILT & TESTED, CASED & VENTILATED POWER UNIT WITH BUILT IN OVERLOAD & CUT OUT PROTECTION CIRCUITS

**SPECIFICATIONS**  
Input voltage: 210-250v  
Supply voltages: +5.0, +11.8, -12.0, -5.2  
Power consumption: 60 watts max. (full load)  
Full load power output  
+5v: 2.5 amp. -5v: 250ma.  
+12v: 1.5 amp. -12v: 250ma.  
Size: 10" x 3 1/2" x 2 1/2"  
Weight: (Approx) 3 lbs

Complete with full data & information - Supplied brand new

The Apple Power Supply is a high-voltage "switching" power supply. While most other power supplies use a large transformer with many windings to convert the input voltage into many lesser voltages and then rectify and regulate these lesser voltages, the Apple Power Supply first converts the AC line voltage into a DC voltage, and then uses this DC voltage to drive a high-frequency oscillator. The output of this oscillator is fed into a small transformer with many windings. The voltages on the secondary windings are then regulated.

PREVENTS DAMAGE & RETURNS UNIT TO NORMAL WORKING CONDITIONS

Suitable for use with most computers



LIST PRICE £60  
OUR PRICE £32.50 +VAT  
Just post remittance £39.50 (incl. VAT post & packing) for delivery by return



## I.T.T. 2020 CABINET

Complete PROFESSIONAL Case beautifully constructed with cut out for one 'CHERRY' keyboard, plus ample room to house a COMPLETE SYSTEM, and our power supply complete with fittings. (Case top detachable). Unit is silver-grey in colour. Robust construction. Sloping front with side ventilation.

Ideal for NASCOM, ACORN, TANGERINE or your own system.  
Size 18" x 15 1/2" x 4 1/2" (Front sloped)

A snap at £39.95 incl. VAT post free



## 'CHERRY' ADD-ON KEYPAD

'CHERRY' ADD-ON KEYPAD  
A compact 12 button keypad suitable for use with Cherry keyboard to extend its functions plus four extra keys.  
Supplied brand new with data.  
A 3 x 4 non-encoded single mode keyboard in sloped format

£7.95 +VAT

**HENRY'S**

COMPERKIT DIVISION  
404 Edgware Road, London, W2, England  
Telephone: 01-402 6822  
Telex: 262284 Mono Transonics



# CONTROL YOUR OWN SUBSTATION!

when the ZX is occupied elsewhere. In the case of the ZX81, sound effects can be produced under Basic control, while the ZX maintains the screen display. The program below illustrates this.

```

10 REM ZX81 HARDWIRED AUDIO EFFECT
20 SLOW
30 PRINT "SIMULTANEOUS AUDIO AND SCREEN SUPPORT"
40 FOR A = 1 TO 8
50 FOR B = 8 TO 16
60 POKE 11000,B
70 NEXT B
80 NEXT A
  
```

Of course, faster changing audio effects can be produced in the FAST mode, but screen support will be lost in the process.

## Polling a keypad

The 80/81 port board provides eight input and eight output channels which will be sufficient for many applications. If more are required for a particular task, it is often possible to increase the effective number of channels by using a few hardware tricks.

The so-called polled keyboard is a case in point. Last month the use of an 8-button keypad was discussed. This employs one push button on each of the eight input channels. It is possible, however, to economise on this set-up by using a polling technique. Suppose that a hex keypad (containing 16 switches) is to be used for data input at the 80/81 port, and on top of this we want to leave four of the eight input channels free for other devices. The circuit of Figure 3 achieves this.

It does so by grouping the 16 switches into four rows by four columns (and in fact hex keypads are often manufactured prewired in this way). The individual columns are connected to the lowest four bits of the input port (R0-R3), while the four rows are each

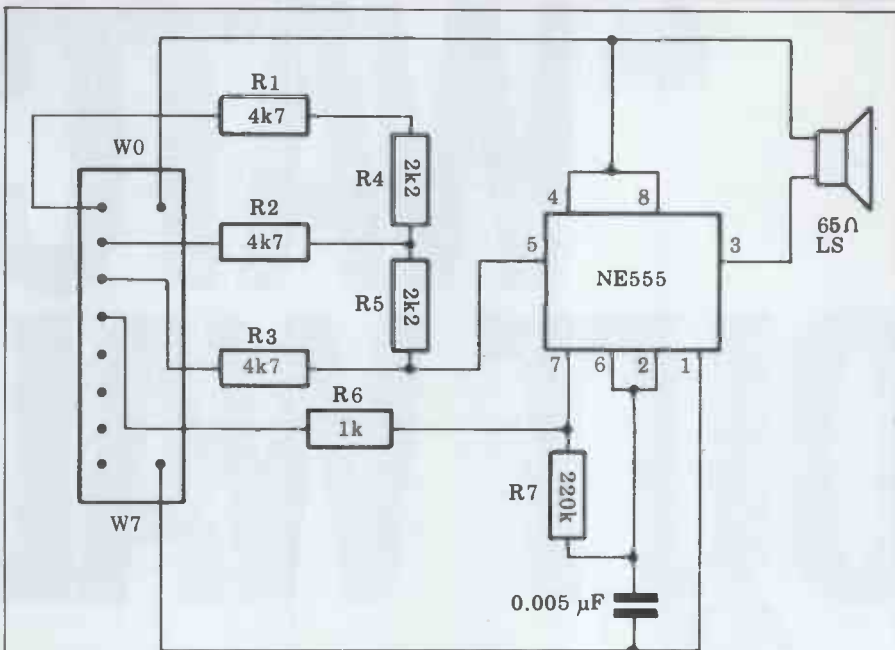

Fig 2 Hardwired audio generator. For accurate conversion, R1, R2 & R3 should be 4k 1% and R4 & R5 should be 2k 1%.

connected to one bit of the output port (W0-W3). A short software routine may then be used to read the state of the keyboard row by row. To poll the top row, a high output is set up on row one by POKing the value 1 to the output port. The input port is then PEEKed to see whether any of R0-R3 are in a high state. If so, it means that the corresponding button on the top row has been pressed. Next W1 can be made high, and the input port re-read to test the state of the keys in the second row, and so on. The principle used here is very commonly employed in microcomputer systems, and is in fact used on the keyboards of the ZX80 and 81; although of course in such cases the polling is executed by the computer's machine code operating system, rather than in Basic, which would prove somewhat slow for rapid key response.

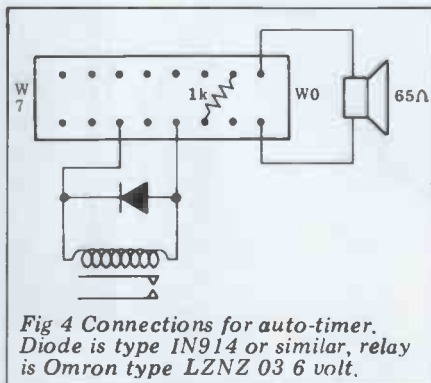

Fig 4 Connections for auto-timer. Diode is type IN914 or similar, relay is Omron type LZNZ 03 6 volt.

## Auto-timer

Since the output port on the 80/81 board is capable of supporting both relay and audio output at the same time, it is possible to implement a chiming timer. In the simplest case, a program to accomplish this might request a time duration to be input and when the given time has elapsed it could switch on or off any desired device connected to a relay on the output port. It might at the same time count off the seconds with an audible bleep. The program below achieves this when used in conjunction with the circuit of Figure 4. The loudspeaker is connected to channel zero of the output port, and the relay switching the device to be timed is driven from channel one using the on-board buffer amplifier. The program first requests a time delay in seconds (though a small software change would allow it to cope with minutes or even hours). It then switches on the relay and begins counting.

```

10 REM ZX80 TIMER/CONTROLLER
20 POKE 25000,0
30 PRINT "ZX80 TIMER"
40 PRINT "TIME IN SECS?"
50 INPUT C
60 LET B = 1
70 POKE 25000,2
100 FOR A = 1 TO 440
110 NEXT A
  
```

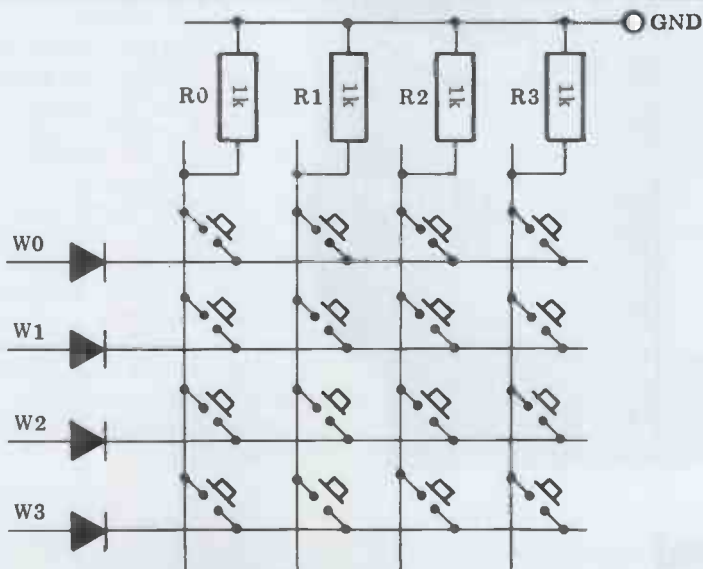

Fig 3 software polled Hex Keypad. D = IN914 or similar. W0 = channel 0 of output port = pin 1 of WRITE plug etc. R0 = channel 0 of input port = pin 1 of READ plug etc. Connect the ground on each resistor to pin 9 of the READ plug.

# “WATCH OUT WALLS.”



Are you running a successful business? Then, more than likely your ambition is to expand and make it even more prosperous.

And you can't do that if you're spending all your time on book-keeping, worrying about invoices, statements, stock levels or filling in the VAT return.

So why not leave all that to the remarkable BOSS. The new desk-top computer from Olympia.

It's been specially designed with your needs in mind.

It's small enough to fit on top of your desk. Yet it's big enough to handle all your everyday jobs quickly and efficiently.

Both now and in the future.

It will automatically print out your invoices and statements.

It will pick up overdue accounts, so chasing bad payers is easier. It'll even print a warning letter.

All of which means a better cash flow. And it'll give your latest profit picture whenever you want.

With the BOSS you can make fast, accurate decisions today and plan ahead for tomorrow.

And all at a price of less than a company car.

You don't need specialist training. Just plug in the BOSS and see how easy it is to operate.

Maintenance is not a problem.

Olympia have a nationwide service network just a telephone call away.

So don't waste any more time. Simply fill in the coupon below.

 **Olympia International**  
Microcomputers to help you mind your own business

Write to Phil Fencott, Olympia International, FREEPOST, Olympia House, 199/205 Old Marylebone Road, London NW1 5QS or ring: 01-262 6788. Please send me details on how the Olympia BOSS can help me in:

Business  Educational, Scientific, Technical applications

Name

Business Address

Tel No

PCW6



# CONTROL YOUR OWN SUBSTATION!

```

130 IF B = C THEN GO TO 400
140 GO SUB 300
150 LET B = B + 1
160 GO TO 100
300 FOR D = 1 TO 10
310 POKE 25000,3
320 POKE 25000,2
330 NEXT D
340 RETURN
400 FOR E = 1 TO 100
410 POKE 25000,1
420 POKE 25000,0
430 NEXT E
440 GO TO 50
    
```

Timing is carried out using the loop at line 100 which may be adjusted in length to achieve an accuracy of about one part in 400. Every second a short beep is produced on the loudspeaker (using a Basic routine rather than machine code). And after the pre-determined delay the relay is switched off and a one-second beep is produced to signal this. To run the program on the ZX81, change all 25000s to 11000 and use the FAST mode. Some correction will also be required to the length of the FOR loop in line 100 since the ZX81's Basic runs slower than that of the '80. Although this example has been kept fairly simple, one could envisage much more complex timers being implemented using similar techniques. These might, for example, use a number of relays to control a series of different devices at different times.

## Logic analyser

When checking digital circuits, or even when trying to follow the operation of a particular IC, it is very useful to be able to test logic states at any point. That is to say, to test whether any point in the circuit is at a logical high or low. The logic tester to be described here does this and more. It allows the simultaneous monitoring of the logic states of up to eight separate points and also allows the results to be printed on to the screen. In this respect it will also prove useful in testing the states of switches, pushbuttons, and photocells used in experiments described in these articles.

The circuit for the analyser is given in Figure 5. As may be seen, it is extremely simple, requiring only nine pieces of wire and, for the deluxe version, nine crocodile clips or similar. The program for running it on the ZX80 is given below. For the ZX81 just alter all 25000s to 11000.

```

100 REM ZX80 LOGIC ANALYSER
110 PRINT TAB 4; "CHAN:";TAB 10
120 FOR A = 0 TO 7
130 PRINT 7-A;" ";
140 NEXT A
150 PRINT
160 INPUT Z
170 LET X = PEEK (25000)
180 PRINT TAB 5; X; TAB 10;
190 FOR L = 0 TO 7
195 LET Y = 7-L
200 LET P = 0
210 LET X = X - 2**Y
220 IF X > -1 THEN LET P = 1
    
```

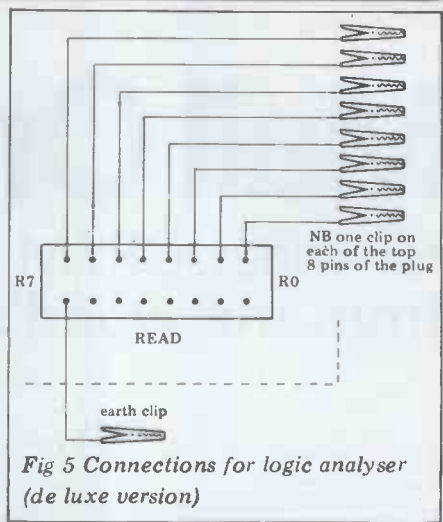

Fig 5 Connections for logic analyser (de luxe version)

```

230 IF X < 0 THEN LET X = X + 2**Y
240 PRINT P;" ";
250 NEXT L
260 PRINT
270 GO TO 160
    
```

When the program is run, each time that NEW LINE is pressed the input port will be read and a printout of 1s and 0s will be produced, representing the states of the eight channels. This takes the following form:

```

CHAN: 7 6 5 4 3 2 1 0
17      0 0 0 1 0 0 0 1
145     1 0 0 1 0 0 0 1
    
```

In this example, at the first test, channels 4 and 0 were high, while in

# PROGRAM POWER

# NASCOM 1 & 2

Keys of Kraal (24K/B/G) — superb adventure game PLUS exciting graphics. Fight the monsters & demons in real time. Swords flash, arrows fly & spells home-in. Endless hours of enjoyment. £8.95

Vortex (MC) — Speed up your display of pixel graphics. 29 routines called from BASIC. Manipulate 2 screen images & then update your VDU. Changes appear instantaneous. Extensive examples and instructions supplied. State 16, 32 or 48K. £8.95

Serpent (MC/G) — 8K of incredible M/C code. An interactive game 'par excellence'. Torpedo the moving snake-like sea serpents & the marauding killer whales. Five levels & special missions with almost infinite skill settings. £5.95

Galaxian Attack (MC/G) — Fast machine code space game, featuring diving Galaxian spacecraft. 10 speeds from good to impossible. No barriers for protection. Highest score displayed. £8.95

MICROPOWER MAGAZINE — Devoted to NASCOM. Issues 1/2 now available (3/4 November/December). Featured and Series articles, news from clubs, schools, etc. Send now to secure your copies. Only 95p each (inc. p&p).

\*\* NASCOM 1 — Cottis Blandford cassette interface — for N2 format, reliability and fast load. £14.90

WRITTEN ANY PROGRAMS? WE PAY HANDSOME ROYALTIES!

Please add 55p/order P&P + VAT @ 15% or Sae for FULL catalogue (over 60 items)

All programs supplied on cassette in Kansas City/CUTS format (listings available)

PROGRAM POWER  
5 Wensley Road  
Leeds LS7 2LX  
Tel. (0532) 683186

# PROGRAM POWER

# MORE NEW PROGRAMS FOR ACORN ATOM

\*\* Special Offer \*\*  
Deduct £1/cassette when ordering 2 or more  
QUALITY SPACE GAMES

ASTROBIRDS (5K \* + 6Kgr) — incredible GALAXIAN type program, fantastic sound effects! Screaming missiles, swooping birds. £8.95  
LUNAR LANDER (5K \* + 6K gr) — superb version of arcade game incl long & short range scans. £8.95  
INVADER FORCE (5K \* + 6K gr) — 4 invader types, mother ship, sound, hi-score, 6 skill levels. £8.95  
3D ASTEROIDS (3K \* + 2K gr) — Steer through the rolling, hurtling asteroids. Excellent real life graphics. £6.95  
ALIEN MAZE (5K \* + 2K gr) — Escape the 3D labyrinth before being eaten. £5.95  
SPACE STORM (4K \*) — Survive amid the raging comets & space debris. £4.95  
STAR TREK (5K \* + fl. pt.) — 8x8 galaxy, starbases, torpedoes etc. £6.95  
MUSIC BOX (5K \* + VIA) — Make music with your Atom. Compose tunes or key in old favourites. Hours of enjoyment. £8.95  
REVERSI (5K \* + 2K gr) — trad board game, 5 levels of skill, many options, superb version, action replay. £5.95  
HI-STATS (5K + 6K gr + fl. pt.) — Statistical analysis & graphical rep. of file of input values. £7.95  
DEMON DUNGEON (5K \*) — Find the treasure, the way out & escape the demons. £6.95  
SKETCH PAD (3K \*) — Draw in black on white & vice versa. Many options incl choice of gr. modes & save & recover routines. £5.95  
DISASSEMBLER (3K \*) — Lists object code & assembler mnemonics. £6.95  
DAMBUSTERS (3K \* + 2K gr) — Realistic bombing raids, bouncing bombs etc. £4.95  
ZOMBIES (Real Time) + DEMOVADERS + LASER FIGHT (3K \*) £6.95  
LABYRINTH + SLOT RACER (5K \* + 6K gr) £6.95  
MINEFIELD + SNAKE + AWARI (2K \*) £5.95  
TERRITORY + AZTEC (3K \* + 2K gr) £5.95  
EXTRA MEMORY 2 x 2114 Low power chips. £3.75

WRITTEN ANY PROGRAMS? — WE PAY 20% ROYALTIES!

Please add 55p/order P&P + VAT @ 15%.  
Send Sae for catalogue.

PROGRAM POWER  
5 Wensley Road,  
Leeds LS7 2LX.  
Tel (0532) 683186

# Mail Order Software

for most CP/M systems – a selection of products from the world's leading microsoftware supplier

Software with Manual / Manual Alone

Software with Manual / Manual Alone

Software with Manual / Manual Alone

## DIGITAL RESEARCH

- CP/M\* FOOS – Diskette Operating System complete with Text Editor, Assembler, Debugger, File Manager and system utilities. Available for wide variety of disk systems from £75/£15
- CP/M for Apple 11\* Softcard with Z80 Microsoft BASIC - 80 with high resolution graphics ..... £250/£15
- MP/M for Intel MOS single density ..... £195/£25
- MAC – 8080 Macro Assembler. Full Intel macro definitions. Pseudo Ops include RPC, IRP, REPT, TITLE, PAGE, and MACLIB. Z-80 library included. Produces Intel absolute hex output plus symbols file for use by SID (see below) ..... £55/£10
- SID – 8080 symbolic debugger. Full trace, pass count and break-point program testing system with back-trace and histogram utilities. When used with MAC, provides full symbolic display of memory labels and equated values ..... £45/£10
- ZSID Includes Z80 mnemonics, requires Z80 CPU ..... £50/£10
- TEX – Text formatter to create paginated, page-numbered and justified copy from source text files, directable to disk or printer ..... £45/£10
- DESPOOL – Program to permit simultaneous printing of data from disk while user executes another program from the console ..... £30/£1

- BSTAM – Utility to link one computer to another also equipped with BSTAM. Allows file transfers at full data speed (no conversion to hex), with CRC block control check for very reliable error detection and automatic retry. We use it! It's great! Full wildcard expansions to send \*.COM, etc. 9600 baud with wire, 300 baud with phone connection. Both ends need one. Standard and M versions can talk to one another ..... £75/£5

- BSTMS – Intelligent terminal program for CP/M systems. Permits communication between micros and mainframes. Sends character data files to remote computers under complete control. System can record character data sent from remote computer systems and data banks. Includes programs to EXPAND and COMPRESS binary files for transmission. This software requires a knowledge of assembler language for installation ..... £115/£10

- PLINK\* – Two pass disk-to-disk linkage editor/loader which can produce re-entrant, ROMable code. Can link programs that are larger than available memory for execution targeted on another machine. Full library capabilities. Input can be PSA Relocatable Binary Module, TDL Object Module or Microsoft REL files Output can be a COM file, Intel hex file, TDL Object Module or PSA Relocatable file ..... £75/£15

- RECLAIM – A utility to validate media under CP/M. Program tests a diskette or hard diskette or hard disk surface for errors, reserving the imperfections in invisible files, and permitting continued usage of the remainder. Essential for any hard disk. Requires CP/M version 2. .... £40/£5

- IBM/CPM Utility Package – has full range of functions to create or re-name an IBM 3741 volume, display directory information and edit the data set contents. Provides full file transfer facilities between 3741 volume data sets and CP/M files ..... £125/£7

- Z80 Development Package – Consists of (1) disk file line editor, with global Inter and intra-line facilities; (2) Z80 relocating assembler, Zilog Mostek mnemonics, conditional assembly and cross reference table capabilities; (3) linking loader producing absolute Intel hex disk file for CP/M LOAD, DDT or SID facilities ..... £50/£12

- ZDT – Z80 Debugger to trace, break and examine registers with standard Zilog/Mostek mnemonic disassembly displays. Facilities similar to DDT £20 when ordered with Z80 Development Package ..... £30/£7

## MICROSOFT

- BASIC-80 – Disk Extended BASIC Interpreter Version 5, ANSI compatible with long variable names, WHILE/WEND, chaining, variable length file records ..... £155/£15
- BASIC Compiler – Language compatible with Version 5 Microsoft interpreter and 3-10 times faster execution. Produces standard Microsoft relocatable binary output. Includes Macro-80. Also linkable to FORTRAN-80 or COBOL-80 code modules ..... £195/£15
- FORTRAN 80 – ANSI '66 (except for COMPLEX) plus many extensions. Includes relocatable object compiler, linking loader, library with manager. Also includes MACRO-80 (see below) ..... £205/£15
- COBOL-80 – ANSI '74 Relocatable object output. Format same as FORTRAN-80 and MACRO-80 modules. Complete ISAM. Interactive ACCEPT DISPLAY, COPY, EXTEND ..... £325/£15
- MACRO-80 – 8080/Z80 Macro Assembler. Intel and Zilog mnemonics supported. Relocatable linkable output. Loader, Library Manager and Cross Reference List utilities included ..... £75/£10

## SOFTWARE SYSTEMS

- CBASIC-2 Disk Extended BASIC – Non-interactive BASIC with pseudo-code compiler and runtime interpreter. Supports full file control, chaining, integer and extended precision variables etc. .... £75/£10

- PASCAL/M – Compiler generates P code from extended language implementation of standard PASCAL. Supports overlay structure through additional procedure calls and the SEGMENT procedure type. Provides convenient string handling capability with the added variable type STRING. Untyped files allow memory image I/O. Requires 56K CP/M ..... £95/£20

- PASCALZ – Z80 native code PASCAL compiler. Produces optimised portable reentrant code. All interfacing to CP/M is through the support library. The package includes compiler companion macro assembler and source for the library. Requires 56K and Z80 CPU. Version 3 includes all of Jensen/Wirth ..... £205/£15

- PASCAL/MT – Subset of standard PASCAL. Generates ROMable 8080 machine code. Symbolic debugger included. Supports interrupt procedures, CP/M file I/O and assembly language interface. Real variables can be BCD, software floating point, or AMD 9511 hardware floating point. Version 3 includes Sets, Enumeration and Record data types. Manual explains BASIC to PASCAL conversion. Source for the run time package requires MAC (See under Digital Research). Requires 32K. .... £135/£20

- WHITESMITHS' C COMPILER – The ultimate in systems software tools. Produces faster code than Pascal with more extensive facilities. Conforms to the full UNIX Version 7 C language, described by Kernighan and Ritchie, and makes available over 75 functions for performing I/O, string manipulation and storage allocation. Compiler output in A-Natural source. Supplied with A-Natural. Requires 60K CP/M ..... £325/£20

- MAGSAM III – Sophisticated keyed access file support system. Supports random, sequential, and generic retrieval by key. Also, multiple secondary keys. Dynamic allocation and extension of files with automatic free space reclamation. Interactive tutorial included to get the user started. Complete with documentation and quick reference card. Specify CBASIC or Microsoft BASIC version. Requires 48K system ..... £75/£15

- MAGSAM IV – High speed machine code version of MAGSAM III for CBASIC only. Distributed as pre-loaded modules and Microsoft relocatable object modules ..... £185/£15

## MICROPRO

- SUPER-SORT 1 – Sort, merge, extract utility as absolute executable program or linkable module in Microsoft format. Sorts fixed or variable records with data in binary, BCD, Packed Decimal, EBCCDIC, ASCII, floating, fixed point, exponential, field justified, etc. etc. Even variable number of fields per record! ..... £125/£15

- WORD-MASTER Text Editor – In one mode has super-set of CP/M's ED commands including global searching and replacing, forward and backwards in file. In video mode, provides full screen editor for users with serial addressable-cursor terminal ..... £75/£15

- WORD-STAR – Menu driven visual word processing system for use with standard terminals. Text formatting performed on screen. Facilities for text paginate, page number, justify, center, underscore and PRINT. Edit facilities include global search and replace, read/write to other text files, block move, etc. Requires CRT terminal with addressable cursor positioning ..... £255/£15

- WORD-STAR/MAIL-MERGE – As above with option for production mailing of personalised documents with mail list from Datasat or NAD ..... £315/£15

- DATASTAR – Professional forms control entry and display system for key-to-disk data capture. Menu driven with built-in learning aids. Input field verification by length, mask, attribute (i.e. uppercase, lowercase, numeric, auto dup., etc.). Built-in arithmetic capabilities using keyed data, constants and derived values. Visual feedback for ease of forms design. Files compatible with all CP/M-MP/M supported languages. Requires 32K CP/M ..... £195/£25

- CBS – Configurable Business System is a comprehensive set of programmes for defining custom data files and application systems without using programming language such as BASIC, FORTRAN, etc. Multiple key fields for each data file are supported. Set-up program customizes system to user's CRT and printer. Provides fast and easy interactive data entry and retrieval with transaction processing. Report generator program does complex calculations with stored and derived data, record selection with multiple criteria, and custom formats. Sample inventory and mailing list system included. No support language required ..... £185/£20

- MAGIC WAND\* – Word processing system with simple, easy to use full screen text editor and powerful print processor. Editor has all standard editing functions including text insert and delete, global search and replace, block move and library files for boiler plate text. Print processor formatting commands include automatic margins, pagination, heading & footings, centred and justified text. Also prints with true proportional spacing, merges with data files for automatic form letters, and performs run-time conditional testing for varied output. Requires 32K CP/M and CRT terminal with addressable cursor. .... £185/£20

- TIMAKER – Powerful new tool for preparing management reports with tabular data. Makes financial modeling projects easy. Do you want a weekly profitability report? Set up the table and compute. Just change the sales figures for next week and compute. You have a new report! TIMAKER includes a full screen editor for setting up tables which pages left, right, up and down. Compute includes standard arithmetic, percents, exponents, common transcendental functions, averages, maxima, minima, projections, etc. Requires 48K CP/M and CBASIC-2. .... £155/£15

- SELECTOR III-C2 – Data Base Processor to create and maintain multi Key data bases. Prints formatted, sorted reports with numerical summaries or mailing labels. Comes with sample applications including Sales Activity, Inventory, Payables, Receivables, Check Register, and Client/Patient Appointments, etc. Requires CBASIC Version 2. Supplied in source code. .... £185/£12

## AND MANY OTHERS

Call us for:  
A complete catalogue  
Further details of products  
Information on new products  
Ordering information  
Disc format list

Modified version available for use with CP/M as implemented on Heath and TRS-80 Model 1 computers

User license agreement for this product must be signed and returned to Lifeboat Associates before shipment may be made.

\*CP/M is a trademark of Digital Research  
\*\*Z80 is a trademark of Zilog Inc.  
UNIX is a trademark of Bell Laboratories.  
Trs-80 is a trademark of Tandy Corp.  
Pascal M is a trademark of Sorcim.  
PLINK is a trademark of Phoenix Software Associates Ltd.  
MAGIC WAND is a trademark of Small Business Application Inc.

EFFECTIVE JUNE 1981

The Software Supermarket is a trademark of Lifeboat Associates.



Lifeboat Associates P.O. Box 125 London WC2H 9LU 01-836 9028/9

# CONTROL YOUR OWN SUBSTATION!

the second, 7, 4 and 0 were high. The decimal equivalent of the combined input is also printed out — 17 and 145 respectively.

The FOR loop in this program, running from line 190 to 260, performs the task of actually identifying which of the input channels are high and which low and of producing a series of 1s and 0s accordingly.

In many applications of the input port it is useful to be able to treat each channel as a separate entity and to be able to take action on the basis of the state of any given channel irrespective of the state of the remainder. Below is a generalised routine which permits this.

```

100 REM ZX80 INPUT SEPARATOR
ROUTINE
110 DIM D(8)
120 LET D = PEEK (25000)
[use 11000 for the '81]
130 FOR E = 0 TO 7
135 LET F = 7 - E
140 LET D(F + 1) = 0
150 LET D = D - 2**F
160 IF D > -1 THEN LET D(F + 1)
= 1
170 IF D < 0 THEN LET D = D + 2**F
180 NEXT E
    
```

An array D(n) is first set up and the input port is PEEKed. The routine then sets each of the eight array variables to 1 if the corresponding channel of the port is high and to 0 if it is not. The resultant data for channel 7 is held in D(8), channel 6 in D(7) and so on. Thus to discover the state of channel 4 of the input port irrespective of the states of the other channels, execute the above program followed by a test for the value of D(3). If D(3) = 0, channel 3 was low. If it is = 1, then it was high.

## Burglar alarms and train controllers

The provision of eight input and eight output channels on the ZX port is sufficient to allow the ZX to be used as a systems controller in a number of different applications. The essential feature of such a control system is the collection of data from a variety of sensors and, after due processing, the control of a number of devices in response. A burglar alarm system and a model train controller both provide examples of such an application and may be implemented using the ZX port board.

In the case of the burglar alarm, sensors of many different kinds could be employed — from magnetic reed switches to detect door openings, to photocells and pressure switches. Each of the port's eight input channels could be used to monitor a group of sensors wired together, and the ZX could be programmed to indicate not only when activity had been detected on a particular group of sensors, but which group had been activated. The input separator routine discussed above should prove useful in this respect. A range of re-

sponses to detector stimulation could easily be implemented on such a system to initiate low-level warning lamps or high-level alarm switching, depending on what sequence of detectors had been activated, and under what circumstances.

In the case of the model train layout, the data to be input would consist mainly of indications as to the train's whereabouts. This could be achieved with a number of microswitches, or by light-dependent resistors mounted below the track, and facing upwards. The passage of the train could be arranged to obscure the photocell sufficiently for detection to occur. The output port could then be used to control the direction of travel of the train, the position of the points, and the state of signals around the track. In a fairly simple set-up, two relays could be used to provide stop/start and forward/reverse control, while each of the six remaining output channels could control a set of points or signals. Thus an unextended port could support up to eight position detectors, plus three sets of points and three independent signals, as well as engine control. This would be sufficient for quite complex train manoeuvres — especially if the RND function on the ZX were employed to vary the routes taken and the stops made. Using the ZX81 in the slow mode, it might even be possible to run a video timetable display, or a screen train position indicator.

## Speech synthesis

The inputs and outputs of the ZX port are what is called TTL compatible. This means that they may be used to interface some of the many proprietary devices which use this logic standard. By way of illustration we will look at how a speech synthesis unit may be run from the board. The unit concerned is produced by Modus Systems Ltd, and has a fixed vocabulary of from 24 to 64 words. The vocabulary of the standard version is given in Figure 6 together with its digital value.

The Modus speech board has a six-line data bus plus three control lines labelled Latch, Start and Busy. To generate speech, the unit requires the following sequence of events to occur: data must first be put on the board's six data lines to select the word required; the Latch line must then be taken from low to high, so as to store the data presented; the Start line must then be taken from high to low to initiate

speech output.

To satisfy these conditions the ZX port output socket may be connected as in Figure 7. That is to say, lines W0 to W5 are connected to the Latch and Start lines respectively. Software is then used to place the data on the bus and manipulate the state of the two control lines. In fact, by cutting one or two corners, the whole thing can be executed in two lines of ZX Basic — as may be seen from the following, which causes the word 'Three' to be spoken:

```

10 POKE 25000, (3 + 128)
20 POKE 25000, (3 + 64)
    
```

(Use 11000 instead of 25000 on the ZX81)

The first command puts the value 3 on the speech board's data bus and at the same time sets the Start line high, and the Latch line low. The second maintains the value 3 on the bus and takes Start low and Latch high, thus simultaneously latching the data and initiating speech output. The program is of course easily generalised to permit any word from the board's vocabulary to be output:

```

10 REM SPOKEN VOCABULARY
20 PRINT "ENTER A NUMBER 0-23"
30 INPUT W
40 POKE 25000, (W + 128)
50 POKE 25000, (W + 64)
60 GO TO 20
    
```

(Use 11000 instead of 25000 for the ZX81)

The speech board provides one further control line that has not yet been discussed: the Busy line. This is controlled by the speech board itself and is used to inform the host computer when it has finished outputting a word. This is a useful facility, since it avoids the computer having to guess when each word has been completed, during the output of a string of words, before

data	word	data	word
0	oh	12	percent
1	one	13	low
2	two	14	over
3	three	15	root
4	four	16	em (M)
5	five	17	times
6	six	18	point
7	seven	19	overflow
8	eight	20	minus
9	nine	21	plus
10	times-minus	22	clear
11	equals	23	swap

Fig 6 Speech board vocabulary



Proof that it can be done: a ZX81 controlling a model train set.

# Flexibility at the heart of your system.

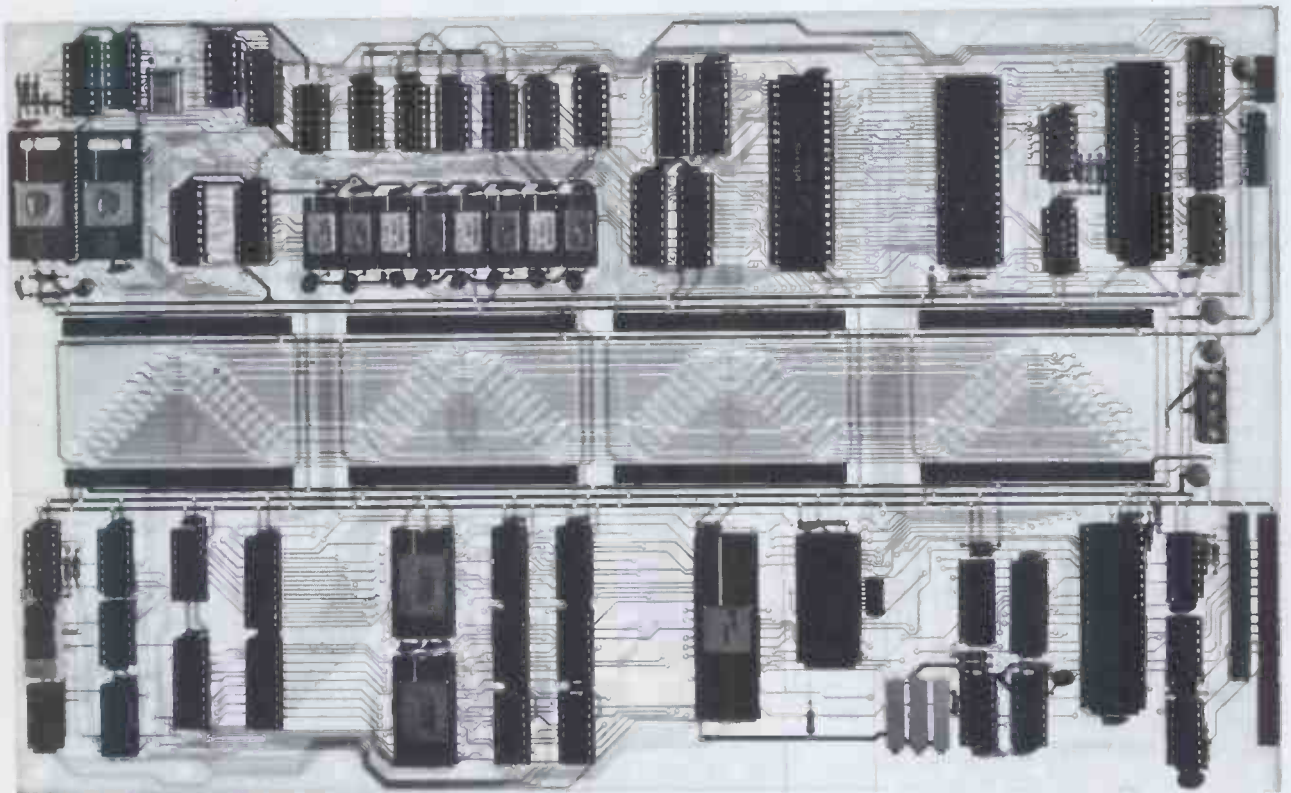

The RADER single board computer has been developed and tailormade to offer the user a combination of economy by using the most up-to-date techniques of microprocessor technology coupled with the built in facilities of ultimate expandability and flexibility.

The board is ideally suited as the basis for small to medium business machines, games machines, industrial control machines, research and development equipment.

## standard features

- 64K RAM
- 4 MHZ Z80A CPU
- 5¼" or 8" Disk Interface, single/double /sided density
- Z80A CTC (clock/timer/counter)
- DMA Controller
- Memory Mapped Video Display
- Memory Mapped RAM Character Generator
- Programmable Video Controller
- 8 Expansion Connectors

## add on option boards

- Dual Parallel Ports
- Dual Serial Ports
- Cassette Interface
- RAM Expansion Board – Capacity 192K, in 64K Increments
- External ROM Board
- User Prototyping Board
- Hard Disk Interface
- Real time clock with battery back-up

- Full Custom software development support available
- Sample evaluation board £350 + VAT
- CP/M DOS available Send for complete technical specification

**Rade Systems Ltd., 53-55 Ballards Lane, London N3 1XP**  
**Telephone 01-349 4714 Telex 46523 Simsys G.**

# RADE

## Dedicated Intelligence

# CONTROL YOUR OWN SUBSTATION!

starting the next. Without this information the computer would either run the longer words into each other, or leave too long a gap between the shorter ones.

The Busy line may be connected directly to the input port on channel 7, as in Figure 7. In this way its state can be monitored by PEEKing the port before outputting the next word. The program below uses this facility to endlessly speak through the whole vocabulary of the board at an even pace.

```

10 REM ZX81 COMPLETE VOCAB
20 REM OF SPEECH BOARD BOARD
30 LET A = 11000
40 FOR B = 0 TO 23
50 GO SUB 100
60 FOR C = 1 TO 10
70 NEXT C
80 NEXT B
90 GO TO 30
100 POKE A, (B + 128)
110 POKE A, (B + 64)
120 IF PEEK A < 128 THEN GO TO 120
130 RETURN
    
```

The Busy line is monitored in program line 120, and the program loops here until it is clear. The short delay in line 60 provides a small equal separation space between each word. To implement the program on the ZX80, change line 30 to allocate A to 25000, and bracket A in line 120. Of course a

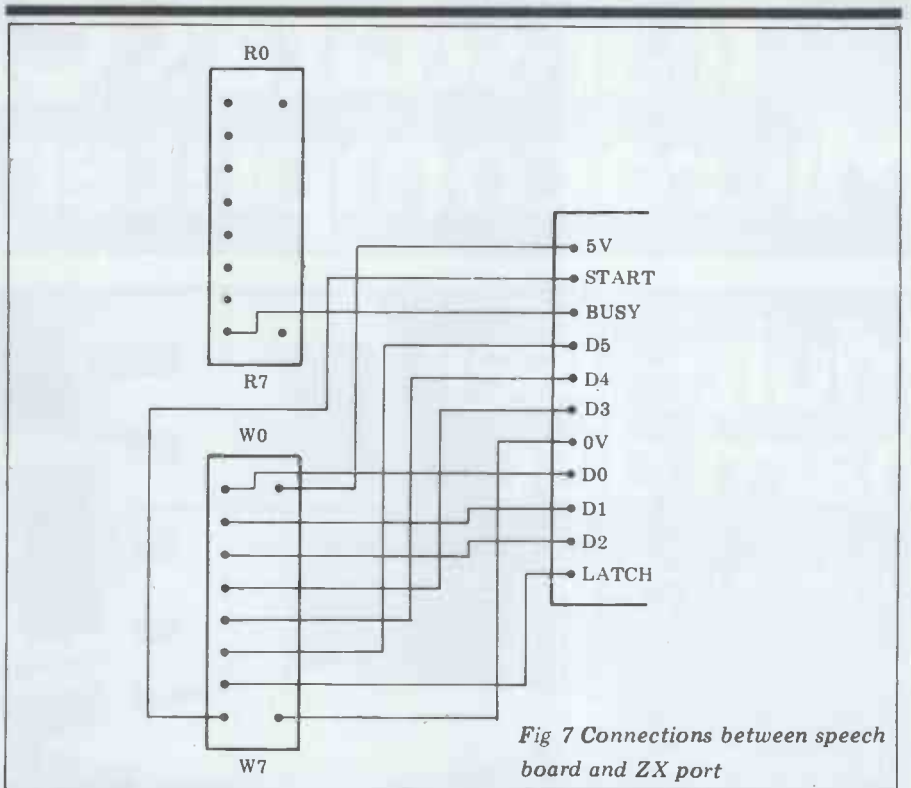

Fig 7 Connections between speech board and ZX port

speech board can be programmed to do much more than just speak sequentially through its vocabulary. And with the principles illustrated here it should be possible to program a number of interesting applications on the ZX, from speaking calculators and speaking clock to spoken games' scores.

This concludes treatment of the

ZX port, but by no means exhausts its possible applications. If you develop a novel working application of the port that you think may interest readers, then write in to the Editor giving full details.

The ZX port kit may be obtained from Technomatic Ltd at £11.50 + P&P + VAT.

# GET THE AMAZING VIC20 HOME COMPUTER FOR CHRISTMAS!

## from Petalect

This is one present all the family could use. The VIC 20 is a fully fledged computer that simply plugs into your television receiver and it comes at an incredibly low price (well under £200).

It can help the children with their computer studies, handle business and home budgeting or you can relax and play space invaders or one of the many video games soon to be available. So to make sure you're one of the first owners of the VIC 20 fill in the coupon below to ORDER TODAY or give us a ring on Woking 63901.



I would like to order a VIC 20 Home Computer. (Qty.....)

Name \_\_\_\_\_

Address \_\_\_\_\_

Post Code \_\_\_\_\_

**PETALECT**  
MICROCOMPUTERS

Showroom: 32 Chertsey Rd., Woking, Surrey. GU21 5BG

Petalect Microcomputers.  
33/35 Portugal Rd., Woking, Surrey. GU21 5JE

# Transdata's Cx500 Microcomputer Family

## Multi-user hard disc

## Single-user floppy disc



The Transdata Cx 500 family of Business and Scientific Microcomputers features upgrade potential from the Cx 502 single user 8" floppy disc system to the Cx 504 multi-user hard disc system. All Cx 500 systems feature an advanced multi-processor architecture which results in higher performance with simple expansion.

Experienced End Users, Computer Professionals and Distributors will value the quality, reliability and after sales support offered with these advanced U.K. manufactured microcomputers.

### **Cx 500 Features & Expansion**

- Z80A Master Processor 4 MHz
- 64Kb RAM, ROM BOOTSTRAP
- Four V24 Serial Interfaces
- 8" IBM compatible floppy disc
- 20 Megabytes Winchester Hard Disc
- Cartridge Tape Back-up
- Extended memory with bank switching

### **Cx 500 The Complete Family**

- Cx 502** - Dual 8" Floppy Disc System
- Cx 503** - Winchester Hard Disc System with 8" Floppy
- Cx 504** - Hard Disc System with Cartridge Tape Backup & 8" Floppy

### **Operating Systems**

SINGLE USER choose either CP/M or MicroCobol BOS  
MULTI-USER choose MP/M or MBOS

### **Proven Software**

Wide choice of languages for CP/M and MP/M including BASIC, FORTRAN, COBOL and APL.  
Quality Commercial Accounting packages for BOS and MBOS.

COMSPAK: Transdata's Communications Software Package for connecting Cx 500 Systems to most remote computers (The modem interface is a standard feature of all configurations).

NETWORKING: Connect Cx 500's and share resources.

### **System Upgrade**

The Cx 500 family offers upgrade potential with compatible software.

### **Customer Support**

Cx 500 Systems are fully supported in the field by Transdata's own Field Service Division - not a third party organisation.

### **Peripherals**

Choose from our range of VDU's, Printers and Paper-tape equipment to complete your Cx 500 configuration.

OEM Discounts Available.  
Dealer and Distributor enquiries welcome.

## Cx 500 Microcomputers - The Problem Solvers

**TRANSDATA LIMITED**

DATA TERMINALS AND COMMUNICATION SYSTEMS  
Sales and Marketing Division Telephone: 01 403 5115  
Battlebridge House, 87-95 Tooley Street, LONDON, SE1 2RA.

Please send me more information about your Cx 500 Family of Microcomputers

Name \_\_\_\_\_  
Company \_\_\_\_\_  
Address \_\_\_\_\_  
Tel \_\_\_\_\_

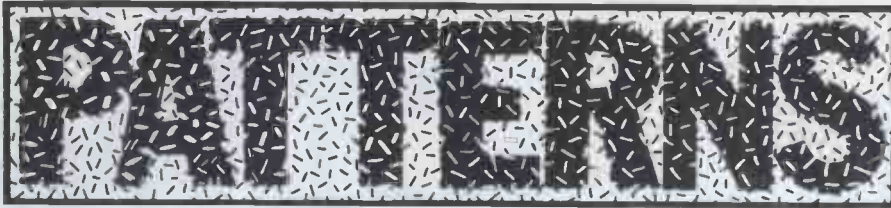

# HOW RANDOM IS RANDOM?

Alan Sutcliffe continues his series with thoughts on accurate randomness

Standards for randomness is, at first sight, an odd topic for this column on patterns. Patterns are inherently interesting: they are what we pick out from the flux of our environment. To be random is to be without pattern.

The early tables of random numbers for use by statisticians were produced by someone writing down digits 'at random' until some tendency to a pattern began to emerge, say a fondness for 7 or too few occurrences of 0. Then the imbalance would be restored, the pattern destroyed. Even so, it seems likely that there were not enough of the freak patterns that do happen in random sequences. After all, if you spin a coin 1000 times it is likely that somewhere along the way it will come up heads nine or 10 times in succession, without indicating any bias in the coin.

But if a coin came up heads 12 times with no tails in such a test, would that be significant? How about 14 times? These are the kinds of question that statistics was developed to answer — and the kind of answer that can be given is that such and such a thing should only happen once in 20 tests, or once in 100 tests. A statistical test can never show something beyond all possible doubt. After all, if you deal a pack of cards for whist, each player will get a complete suit about once in every 2,235, 197,406,895,366,368,301,560,000 times. And every other particular distribution is just as unlikely. Yet the cards have to be distributed somehow, however improbable that distribution is. If the same combination turns up twice in the same day (or even twice on the same planet) you would have some grounds for suspecting an irregularity.

Why we don't see the outcome of every deal of cards as an extraordinary freak is that we don't see the precise and complete pattern of it — 3 and Q of Hearts, 8 of Clubs and so on — but abstract from it a higher level pattern, two Hearts, one of them high, one Club, and so on.

As for standards, that sounds like a pretty dull subject, conjuring up images of smoked-filled rooms of worthy people endlessly debating this or that detail of a feature of a language or an interface. But that is the subject I have chosen this month: a review of some programs that test systems for conformity with the US National Bureau of

Standards (NBS) standard for Minimal Basic, and a review of how my DAI computer fared with some of these test programs, particularly those for the Random function.

## Minimal Basic

The American National Standard for Minimal Basic (ANSI X3.60-1978) is just what its name suggests. It is so minimal that I cannot imagine anyone producing a system now which had only the facilities stated: single letter variable names, LET required in assignments, lines to be input strictly in numerical order. But the standard is not meant to specify a complete language, rather a common core and standards for extensions to that core. Many of the test programs deal specifically with common extensions and contain the following words:

'This is a test for a non-standard feature of minimal Basic. To pass this test, the processor must either:

1. Accept the program and be accompanied by documentation accurately describing the features' interpretation by the processor, or
2. Reject the program with an appropriate error message.'

This approach, with the rest of the philosophy adopted by the authors of the test programs, is given in detail in the first volume of *NBS Minimal Basic Test Programs — Version 2, User's Manual* while the second volume is devoted to the text of the 208 test programs, with sample output from each one.

## Test programs

Many of the programs are verbose and simple to the point of triviality. Seated at your own small machine, you hardly need a 30-line program to find out what the processor does with a line number containing a space; it is enough to type in one such line. But the programs were written to be called up at a terminal from a file and each one is fully self-documenting. It is easy to miss out the repetitious bits if you want to test your own computer and I think you will find it very interesting to run many of these tests.

If you are a supplier of Basic systems which may be sold to the US federal government or any of its many agencies,

then you will find it more than interesting. It is proposed that sometime before the end of 1982 any such system will have to conform to the ANSI standard. That is why these test programs have been developed by the NBS, which is part of the Department of Commerce.

There are various kinds of test. There are those for simple conformity, like PRINT does print a blank line, and PRINT "A" does print A. Then there are tests for how the system reacts to common errors like an array subscript out of range. There are tests, as already mentioned, for some of the usual extensions to Basic. Another group of test programs is concerned with the accuracy of computations, particularly those for the built-in functions such as SQR and COS. These tests are informative only, since the standard does not lay down limits for accuracy. Similar to these tests for accuracy, and a shade more problematical, is a group that allow an investigation of the behaviour of the RND function.

The Documentation volume makes it clear that even taken as a whole these programs do not amount to an algorithm that can prove conformity with the standard, although one failure easily shows non-conformity. Rather, they should be seen as test data for the Basic processor, probing any weakness it may have, but never able to show it is entirely free of faults.

This is particularly true of the tests for randomness. There is no algorithm that establishes a sequence or a process as random, only tests that find patterns indicating departure from randomness and estimates of how likely such departures are in a random sequence. First of all, there is no such thing as a random number; every number is a particular number. There is certainly no such thing as a random person; any individual, however randomly chosen, will be male or female, a specific age and weight. There is not even such a thing as a typical person, for the same reasons.

But returning to numbers, even suppose a range is specified, such as 0 to 1, as for the RND function, no single number is random. Look at 0.6249, for example. Nothing very special about it, apparently, just an ordinary looking fraction, not the square of anything interesting or a simple function of pi. But suppose your random number generator gave the value 0.6249 every time. Then you might not be too happy to accept it as random. In any case, I cheated, since  $\tan 32^\circ = 0.6249$  approximately.

Donald Knuth, in his book on semi-numerical algorithms, *The Art of Computer Programming*, Vol 2, takes this line of thought further to argue that there is no such thing as a random sequence: there are only particular sequences. Another problem in our relation of randomness is our natural tendency to see patterns. Take a random distribution in nature, the stars in the night sky, leaving aside the clustering of the Milky Way. What people through the ages have seen in this is not the randomness but patterns, the constellations. The same seven stars are picked out in almost every civilisation and seen as a Bear or a Plough or seven wise men.

By the way, Knuth also discusses in this book the use of the Fibonacci

# VIC Computing

**The 'how-to' magazine all about  
Commodore's VIC computer**

*VIC Computing* is a great new magazine for users of the VIC. Each issue is packed with valuable programming hints, software reviews, 'how-to' articles and program listings.

You don't have to be an expert to enjoy *VIC Computing*. It is written in straightforward English for beginners – not computer experts.

Features in the first colour packed issue included: "Anyone can Program", an article to teach you to program in one hour; "But What Can It Do?", an introduction to VIC's capabilities; "Expansion of the VIC", a guided tour of its add-on capabilities; "Using Graphics" covering programming in colour; "Converting Software for VIC" – how to convert PET programs; "VIC Sound", data sheet on sound generation; plus "Dear VIC", "Beginners Queries" and "VIC hints".

It costs just £6 a year to subscribe to *VIC Computing*. Can you afford not to?



**To:** Printout Publications, PO Box 48, Newbury RG16 0BD

Please enter my subscription to *VIC Computing*.

I enclose a cheque/Postal Order for [ ] £6 UK [ ] £1R8.50 Eire  
[ ] £9 Europe [ ] \$20 USA Surface [ ] \$30 USA Air  
[ ] £9 Rest of World Surface [ ] £16 Rest of World Air  
or Charge my Access/Mastercharge/Eurocard or Barclaycard/Visa card  
No: .....

NAME: .....

ADDRESS: .....

POSTCODE: .....

# VIC Computing



# PATTERNS

series as a way of generating random sequences and gives a brief history of the topic. I wrote about this in my last article, and could have given Knuth as a reference. While he writes about using the rule that the next term is the sum of the two preceding ones to generate fractions, I was concerned with it for sequences of integers.

But the main reason for mentioning Knuth's book here is that the NBS test programs for randomness are based on his work, and a detailed understanding can be got from reading it. To emphasise the importance of theory in this subject, Knuth relates how many of the random generators developed during the 1970s are seriously faulty because they were designed to pass a test which was itself wrong! So you could get some surprises from running these tests on your system.

## Testing the DAI

Program A tests the average value of the numbers generated by RND. It is reproduced exactly as it appears in the NBS book, together with its sample output. The program is self-documenting: the statistical theory is not explained but the result of the test is unambiguously clear: PASS or FAIL. This is at the expense of some prolixity and to run this test on your own machine you hardly need to type in the first 18 lines — it is enough to read them.

I have run this program on my DAI, which is a good machine for testing these tests since it has both a hardware and a software random number generator. The software one is called in the normal way, while the hardware generator is activated by giving a zero parameter in the call, that is RND(0). Table 1 gives the results from four tests with each one.

As has been said, no statistical test is completely conclusive but these results are reassuring. In every case the amount of deviation was within the limit set by the program. A failure should be expected from about one case in 20. In relation to this, the results look reasonably spaced, the highest being about two-thirds of the limit. One failure would not indicate a high probability of bias, but it should cause the test to be repeated a few times: it would be a cause for some suspicion, a possible clue.

While each of these NBS programs was designed as a simple go/no-go test, I think it is much more sensible to run them several times and in some cases to modify them, as I shall show later — to think of them as tools for an investigation rather than as tests to pass or fail. This is important in any statistical test, and leads to a criticism of the NBS programs.

Printing and using the value for the limit to six significant figures might lead someone to think that there is a sharp dividing line between pass and fail. It would be much better to give only three significant figures as a reminder that results near the limit are in a grey area, a shoulder of doubt between staying on

```
10 PRINT "PROGRAM FILE 132: AVERAGE OF RANDOM NUMBERS APPROXIMATES 0.5"
15 PRINT "      AND 0 <= RND < 1."
20 PRINT "      ANSI STANDARD 8.4"
30 PRINT
40 PRINT "SECTION 132.1: AVERAGE OF RANDOM NUMBERS APPROXIMATES 0.5"
50 PRINT "      AND 0 <= RND < 1."
60 PRINT
70 PRINT "THIS PROGRAM TESTS WHETHER THE AVERAGE OF A SERIES OF RANDOM"
80 PRINT "NUMBERS IS SIGNIFICANTLY FAR FROM THE IDEAL OF 0.5. IF SO,"
90 PRINT "THIS RESULT INDICATES NON-UNIFORM DISTRIBUTION AND THE TEST"
100 PRINT "FAILS. ALSO, IF ANY OF THE NUMBERS IS OUTSIDE THE ALLOWABLE"
110 PRINT "RANGE, AN IMMEDIATE FAILURE IS REPORTED."
120 PRINT
130 PRINT "      BEGIN TEST"
140 PRINT
150 REM N=8754 BASED ON SIGNIFICANCE LEVEL OF .05 AND 0.1 CHANCE OF
160 REM NOT FINDING A DIFFERENCE OF AT LEAST .01 FROM STANDARD
170 REM AVERAGE OF 0.5, AND STANDARD DEVIATION OF 1/(2*SQR(3))
180 LET N=8754
190 LET S1=0
200 LET S2=0
210 FOR I=1 TO N
220   LET X=RND
230   IF X<0 THEN 490
240   IF X>=1 THEN 510
250   LET S1=S1+X
260   LET S2=S2+(X*X)
270 NEXT I
280 LET S = SQR((N*S2) - (S1*S1)) / N
290 LET X1=S1/N
300 PRINT "AVERAGE", "STD. DEV."
310 PRINT "THEORETICAL:", ".5, 1/(2*SQR(3))"
320 PRINT "ACTUAL:", X1, S
330 LET A1=ABS(X1-0.5)
340 REM 1.96 BASED ON SIGNIFICANCE LEVEL OF .05 AND INFINITE D.F.
350 LET A2=(1.96*S)/SQR(N)
360 PRINT
370 PRINT "ALLOWABLE DEVIATION: ";A2
380 PRINT "ACTUAL DEVIATION: ";A1
390 PRINT
400 IF A1>A2 THEN 430
410 PRINT "**** TEST PASSED ****"
420 GOTO 440
430 PRINT "**** TEST FAILED ****"
440 PRINT
450 PRINT "      END TEST"
460 PRINT
470 PRINT "END PROGRAM 132"
480 STOP
490 PRINT "RND#";I;" < 0: ";X
500 GOTO 430
510 PRINT "RND#";I;" >= 1: ";X
520 GOTO 430
530 END
```

### Program A

```
PROGRAM FILE 132: AVERAGE OF RANDOM NUMBERS APPROXIMATES 0.5
      AND 0 <= RND < 1.
      ANSI STANDARD 8.4
```

```
SECTION 132.1: AVERAGE OF RANDOM NUMBERS APPROXIMATES 0.5
      AND 0 <= RND < 1.
```

```
THIS PROGRAM TESTS WHETHER THE AVERAGE OF A SERIES OF RANDOM
NUMBERS IS SIGNIFICANTLY FAR FROM THE IDEAL OF 0.5. IF SO,
THIS RESULT INDICATES NON-UNIFORM DISTRIBUTION AND THE TEST
FAILS. ALSO, IF ANY OF THE NUMBERS IS OUTSIDE THE ALLOWABLE
RANGE, AN IMMEDIATE FAILURE IS REPORTED.
```

```
BEGIN TEST
```

	AVERAGE	STD. DEV.
THEORETICAL:	.5	.288675
ACTUAL:	.494921	.288053

```
ALLOWABLE DEVIATION: 6.03429E-3
ACTUAL DEVIATION: 5.07560E-3
```

```
*** TEST PASSED ***
```

```
END TEST
```

```
END PROGRAM 132
```

# YOU DESERVE AN EASIER WAY TO STAY ON TOP OF YOUR RECORDS.

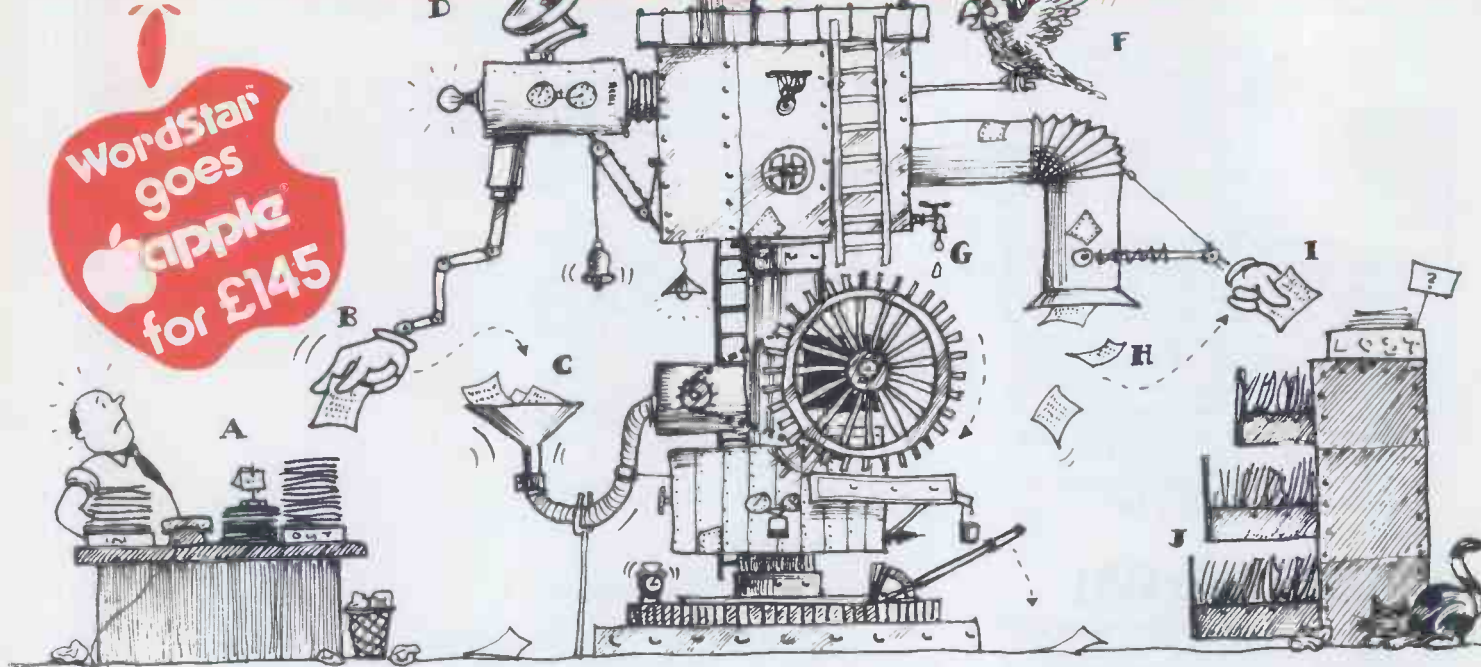

**DataStar** is an easy to learn, yet professionally powerful, comprehensive data entry, retrieval and update system for microcomputer systems. DataStar handles record keeping applications from initial design through updating, addition/deletion, and search/retrieval of records — quickly and easily, even for complex operations. DataStar is a powerful program that can be used for an extremely wide range of possible applications by experienced programmers or systems analysts as well as inexperienced first-time users. Application examples: Order entry and invoicing, name and address lists etc.

**MailMerge** is a powerful file merging tool permitting up to eight levels of nested file references as well as chaining. As variable data is merged with text MailMerge automatically reforms paragraphs as required to conform to the margin settings and justification used in the original document resulting in accurately formed and marginated documents that look as though each received special attention, all without special intervention, consideration or calculation required by the operator.

**SpellStar** is an optional addition to WordStar, already the most powerful and versatile word processing software on the market. SpellStar compares your text with its 20,000 word dictionary. It flags every word not in its dictionary, giving you three choices. You can either change the word, leave it as it is, or leave it and add it to the dictionary, and it won't get flagged again. You can put it in the main dictionary, or just as easy, create your own supplemental dictionaries on other disks for such things as specialised terms and names. SpellStar actually operates within the WordStar program and lets you see each word in context before taking action.

**SuperSort** combines performance and flexibility in sorting, merging and selecting information from data files. It can sort and merge up to 32 files into a single file, at the rate of 560 records per minute. And new records can be integrated into a master file in one simple and efficient operation. SuperSort is a star at sorting. It will accept just about any kind of record you can imagine. The data can be justified, or include floating decimals, exponential notation, or upper and lower case letters; it can even be in several standard formats, such as binary, bcd, ASCII, etc. You won't have to waste time and money translating your records for the computer. And you can have fixed or variable length records and fields. In fact, you can have a different number of fields in each record.

**WordStar** is a powerful, screen-oriented, integrated word processing package for CP/M systems. Advanced features include: simultaneous printing and editing, multiple levels of user-selectable help messages, word-wrap, page break display, hyphen help, and extensive print enhancements, including boldface, underline, sub and super script, variable line height and character pitch. Comprehensive screen prompts allow for easy insertion and deletion of words, lines, paragraphs and pages. Gives true screen image of what your print-out will look like, before you print. Use in conjunction with MailMerge to automatically insert variable text either from console or data files into standard forms, such as circulars etc.

DataStar	—	Software*/Manual**	£160/£25
WordStar	—	Software*/Manual**	£205/£25
MailMerge	—	Software*/Manual**	£ 60/£15
SuperSort 1	—	Software*/Manual**	£110/£20
SpellStar	—	Software*/Manual**	£125/£25
Apple WordStar	—	Software*/Manual**	£145/£25
Apple MailMerge	—	Software*/Manual**	£ 50/£15
Apple SuperSort 1	—	Software*/Manual**	£ 85/£20

\*Price of software includes manual

\*\*100% credit if software is purchased later

TRADE ENQUIRIES  
WELCOME



Prices and specifications subject to change without prior notice.

CP/M is a trademark of Digital Research Wordstar, DataStar, SuperSort and MailMerge are trademarks of MicroPro Inc.

Please write or phone for free 16-page brochures and flyers.

MAIN UK DISTRIBUTOR:

INTERAM COMPUTER SYSTEMS LTD.,  
46 BALHAM HIGH RD., LONDON SW12 9AQ  
Tel: 01 - 675 5325/6/7 Telex: 925859

# THE SHARP MZ-80K HAS GOT IT ALL

**NOW ONLY**  
**£460** R.R.P.  
 +Vat  
**48K**



STOP PRESS... NOW AVAILABLE  
 BASIC COMPILER  
 PASCAL (CASSETTE BASED)  
 DOUBLE PRECISION DISC BASIC

Since its introduction the Sharp MZ-80K has proved to be one of the most successful and versatile microcomputer systems around. Sharp now have a comprehensive range of products ready to make the powerful MZ-80K with its Printer and Disc Drives even more adaptable.

Products include: - Universal Interface Card, Machine Language and Z-80 Assembler packages, CP/M\* plus a comprehensive range of software.

\*Trade mark of Digital Research Ltd.

You'll find all the help and advice you need about the MZ-80K at your Specialist Sharp Dealer in the list below.

If there is no dealer in your area, or if you require any further information write to: - Computer Division, Sharp Electronics (UK) Ltd., Sharp House, Thorp Road, Newton Heath, Manchester M10 9BE.

## GET IT ALL HERE...

**AVON**  
 BCG Shop Equipment Ltd.,  
 Bristol. Tel: 0272 425338  
 Decimal Business M/Cs Ltd.,  
 Bristol. Tel: 0272 294591  
**BERKSHIRE**  
 Computer 100,  
 Bray. Tel: 0628 35619  
 Newbear Computing Store Ltd.,  
 Newbury. Tel: 0635 30505  
**BIRMINGHAM**  
 Camden Electronics,  
 Small Heath. Tel: 021 773 8240  
 Electronic Business Systems Ltd.,  
 Birmingham. Tel: 021 384 2513  
 Jax Rest Ltd.,  
 Birmingham. Tel: 021 350 5247  
 Newbear Computing Store Ltd.,  
 Birmingham 526.  
 Tel: 021 707 7170  
**BUCKINGHAMSHIRE**  
 Curry's Microsystems,  
 High Wycombe. Tel: 0494 40262  
 Interface Components Ltd.,  
 Amersham. Tel: 02403 22307  
**CAMBRIDGE**  
 The Avery Computing Co Ltd.,  
 Bar Hill. Tel: 0954 80391  
**CHESHIRE**  
 Bellard Electronics Ltd.,  
 Chester. Tel: 0244 380123  
 Charlesworth of Crewe Ltd.,  
 Crewe. Tel: 0270 56342  
 Chandos Products,  
 New Mills. Tel: New Mills 44344  
 CR Technical Services,  
 Chester. Tel: 0244 317549  
 Fletcher Worthington Ltd.,  
 Hale. Tel: 061 928 8928  
 Newbear Computing Store Ltd.,  
 Stockport. Tel: 061 491 2290

Ors Group Ltd.,  
 Warrington. Tel: 0925 67411  
**Sumlock Software**,  
 Warrington. Tel: 0925 574593  
**CLEVELAND**  
 Hunting Computer Services Ltd.,  
 Stockton-on-Tees. Tel: 0642 769709  
 Intex Datalog Ltd.,  
 Stockton-on-Tees. Tel: 0642 781193  
**DERBYSHIRE**  
 Lowe Electronics Ltd.,  
 Matlock. Tel: 0629 2817  
**DEVON**  
 Crystal Electronics Ltd.,  
 Torquay. Tel: 0803 22699  
**PLYMOUTH**  
 Plymouth Computers,  
 Plymouth. Tel: 0752 23042  
**DURHAM**  
 Neecos (DP) Ltd.,  
 Darlington. Tel: 0325 69540  
**ESSEX**  
 Prorate Ltd.,  
 Westcliff-on-Sea. Tel: 0702 335298  
 Wilding Office Equipment,  
 Ilford. Tel: 01 514 1525  
**GLOUCESTERSHIRE**  
 Gloucestershire Shop  
 Equipment Ltd.,  
 Gloucester. Tel: 0452 36012  
 The Computer Shack,  
 Cheltenham. Tel: 0242 584343  
**HAMPSHIRE**  
 Advanced Business Concepts,  
 New Milton. Tel: 0425 618181  
 Xitan Systems Ltd.,  
 Southampton. Tel: 0703 39890  
**HEREFORD**  
 BMP,  
 Little Dewchurch. Tel: 021 643 3832

**HUMBERSIDE**  
 Commercial Systems Ltd.,  
 Hull. Tel: 0482 20500  
 Silicon Chip Centre,  
 Gmsby. Tel: 0472 45353  
**KENT**  
 Technolink Europa Ltd.,  
 Tunbridge Wells. Tel: 0892 32116  
 Video Services (Bromley) Ltd.,  
 Bromley. Tel: 01 460 8833  
**LANCASHIRE**  
 Nelson Computer Services,  
 Rawtenstall. Tel: 0706 229125  
 Sumita Electronics Ltd.,  
 Preston. Tel: 0772 51686  
 The Micro Chip Shop,  
 Blackpool. Tel: 0253 403122  
**LEICESTERSHIRE**  
 Gilbert Computers,  
 Lubeham. Tel: 0858 65894  
 G.W. Cowling Ltd.,  
 Leicester. Tel: 0533 553232  
 Leicester Computing Centre,  
 Leicester. Tel: 0533 556268  
 Mays Hi-Fi,  
 Leicester. Tel: 0533 22212  
**UNCOLNSHIRE**  
 Howes Elect & Autom. Servs.,  
 Lincoln. Tel: 0522 32379  
 Z.R. Business Consultants,  
 Lincoln. Tel: 0522 31621  
**LONDON**  
 Bridgewater Accounting,  
 Whetstone. Tel: 01 446 0320  
 Bi 'al-Comco Ltd.,  
 Hendon. Tel: 01 202 0262  
 Central Calculators Ltd.,  
 London EC2. Tel: 01 729 5588  
 Deans,  
 London W8. Tel: 01 937 7896

Digital Design and Development,  
 London W1. Tel: 01 387 7388  
 Euro-Calc Ltd.,  
 London EC2. Tel: 01 729 4555  
 Lion Computing Shops Ltd.,  
 London W1. Tel: 01 637 1601  
 Scope Ltd.,  
 London EC2. Tel: 01 729 3035  
 Sumlock Bondain Ltd.,  
 London EC1. Tel: 01 253 2447  
**MANCHESTER**  
 The Byte Shop,  
 Manchester M1. Tel: 061 236 4737  
 Sumlock Electronic Services Ltd.,  
 Manchester M3. Tel: 061 834 4233  
**MERSEYSIDE**  
 Microdigital Ltd.,  
 Liverpool. Tel: 051 227 2535  
**NORFOLK**  
 Sumlock Bondain (East Anglia),  
 Norwich. Tel: 0603 26259  
**NORTHAMPTONSHIRE**  
 Computer Supermarket,  
 Corby. Tel: 05366 62571  
**NORTHERN IRELAND**  
 Bromac (UK),  
 Co. Antrim. Tel: 023831 3394  
 O & M Systems,  
 Belfast. Tel: 0232 49440  
**NOTTINGHAMSHIRE**  
 Mansfield Business M/C Ltd.,  
 Mansfield. Tel: 0623 26610  
**OXFORDSHIRE**  
 Oxford Computer Centre,  
 Oxford. Tel: 0865 45172  
**REPUBLIC OF IRELAND**  
 O'Connor Computers Ltd.,  
 Galway. Tel: 0009 61173  
 Sharptext,  
 Dublin 2. Tel: 0001 764511  
 Tommorrow's World Ltd.,  
 Dublin 2. Tel: 0001 776861

**SALOP**  
 Computer Corner,  
 Shrewsbury. Tel: 0743 59788  
**SCOTLAND**  
 A & G Knight,  
 Aberdeen. Tel: 0224 630526  
 Business and Electronics M/Cs,  
 Edinburgh. Tel: 031 226 5454  
 Esco Computing Ltd.,  
 Glasgow. Tel: 041 204 1811  
 Micro Centre,  
 Edinburgh. Tel: 031 556 7354  
 Micro Change,  
 Glasgow. Tel: 041 554 7621  
 Microforth,  
 Dunfermline. Tel: 0383 34954  
 Moray Instruments Ltd.,  
 Elgin. Tel: 0343 3747  
 Pointer Business Equipment Ltd.,  
 Glasgow. Tel: 041 332 3621  
**SOMERSET**  
 Norset Office Supplies Ltd.,  
 Cheddar. Tel: 0934 742184  
**STAFFORDSHIRE**  
 W.B. Computer Services,  
 Cannock. Tel: 0543 75555  
**SUFFOLK**  
 C.J.R. Microtek Co. Ltd.,  
 Ipswich. Tel: 0473 50152  
**SURREY**  
 3D Computers,  
 Surbiton. Tel: 01 337 4317  
 Microlines Ltd.,  
 Kingston. Tel: 01 546 9944  
 Petaltek,  
 Woking. Tel: 04862 69032  
 R.M.B. Ltd.,  
 Croydon. Tel: 01 684 1134  
 Saradan Electronic Services,  
 Wallington. Tel: 01 669 9483

**SUSSEX**  
 Crown Business Centre,  
 Eastbourne. Tel: 0323 639983  
**Gamer**,  
 Brighton. Tel: 0273 698424  
 M & H Office Equipment  
 Brighton. Tel: 0273 697231  
**WALES**  
 Limrose Electronics Ltd.,  
 Wrexham. Tel: 097 883 5555  
 Morrison Computer Centre,  
 Swansea. Tel: 0792 795817  
 Sigma Systems Ltd.,  
 Cardiff. Tel: 0222 21515  
**WARWICKSHIRE**  
 Business & Leisure  
 Microcomputers,  
 Kenilworth. Tel: 0926 512127  
**WILTSHIRE**  
 Everyman Computers,  
 Westbury. Tel: 0373 823764  
**YORKSHIRE**  
 Bits & P.C.'s  
 Wetherby. Tel: 0937 63744  
 Datron Micro-Centre Ltd.,  
 Sheffield. Tel: 0742 585490  
 Huddersfield Computer Centre,  
 Huddersfield. Tel: 0484 20774  
 Omega,  
 Leeds. Tel: 0532 704499  
 Ram Computer Services Ltd.,  
 Bradford. Tel: 0274 391166  
 Superior Systems Ltd.,  
 Sheffield. Tel: 0742 755005

Also at selected Lasky's and Wildings Office Equipment Branches

# YOU WILL FIND WHAT WE DID!!

## Specifications BM-12E

Input Signal:  $1.0 \pm 0.2V$  P-P  
composite Video sync.  
negative, fully compatible.  
Input Impedance: 75 ohms  
CRT: 12", 90° deflection  
CRT Color: Green P31 phosphor  
Video Amplifier Bandwidth: 18 MHz  
Display Format: 25 lines of 80 characters  
Scan Frequency: Horizontal-15.75KHz Vertical -60 Hz  
Power Requirement: AC 117/230 volts 50/60 Hz  
Size: 11¼" high x 12½" wide x 12" deep  
Weight: 16 Lbs

### BMC 12-INCH GREEN MONITOR DISPLAY

CRT WITH PHOSPHOR P-31 (GREEN) MAKES  
VIEWING MUCH EASIER AND SHADOW SCREEN  
COVER DISPLAYS IT MUCH SHARPER  
ALLOWS 80 CHARACTERS WITH 25 LINES  
SURE BOTH CHARACTERS AND GRAPHICS  
PLUG-IN COMPATIBLE TO ALMOST ALL SYSTEM  
JITTER AND GHOST FREE IMAGE  
SO,,,,,A COMPUTER WITH  
BMC DISPLAY DOES IT MUCH BETTER!!!



**BMC ELEKTRONIK**

CAPIM CENTER, ROßMARKT 15,  
6000 FRANKFURT AM MAIN 1, F.R. OF GERMANY.  
TELEFON (0611) 1344105 TELEX 412889 CAPIM D.

**BMC INTERNATIONAL**

NO. 27, 5-CHOME, TANIMACHI, HIGASHI-KU,  
OSAKA 540, JAPAN CABLE "BMCINT" OSAKA  
PHONE: OSAKA 768-7791 TELEX: 64930 NISEMIC

# PATTERNS

the hard conforming carriageway and going off the road into very unlikely countryside. If the test is run once and the result is near the limit, whether just inside or just outside, the action should be the same: run it again.

One rule of thumb in any such test is that the effect of altering just one of the values in the test sequence cannot be significant. In this case it would be silly to think that if just one of the 8754 values had been near 1 instead of near 0 this could affect the result. One such change would increase the average by about 0.0001. So the fourth figure in the average can hardly matter, and the fifth and sixth figures, as given in the NBS results, are irrelevant. It's called spurious precision and should be avoided, as I have tried to do in Table 1. I leave it as a programming exercise for you to devise a routine to print the value of a Basic variable to three significant places.

This is a surprising deficiency for a National Bureau of Standards. It is compounded by the use of a constant in the computation correct only to three figures. In line 350 the value 1.96 is only approximate, like calling pi 3.14. Actually it is a little better because I think the true value is 1.960-something. It is the number of standard deviations within which 95 percent of the normal curve lies.

Notice, too, that a slightly different figure is given for the standard deviation, and therefore for the limit, for each run of the test. But since the limit is always around 0.00600 to 0.00602 this refinement hardly matters and may again suggest a precision that is irrelevant.

There is just the suspicion of something amiss in the figure in Table 1. The deviations from the hardware generator are somewhat higher than those from the software one, although they overlap. The standard deviations from the hardware are all higher than those from the software. This suggests that while the average values from the hardware are about right, they may vary away from the average, up and down, more than they should. The next test shows this dramatically.

Remember, in looking at these results, that too many values from repeated tests very near 0.5, that is, too many results with very low actual deviation, can indicate a fault just as much as too much can — a distribution that is too well behaved. An extreme example would be if the random generator produced exactly 0.5 every time. Such a generator would pass this test with zero deviation (and zero standard deviation, too). Over a long series of tests the actual deviations should have a normal distribution, with an average of 0.5 and a standard deviation of about 0.0031. But always remember that the outsider might just come up. There is a chance of 1 in  $10^{8754}$  that all the values will be less than 0.1 in a test. If that happens, with an otherwise sound generator, let me know. It is of the same order of chance of a miracle happening without divine intervention: say a bullet passing through someone's body

	Average	Standard Deviation	Allowed Deviation	Actual Deviation
Theoretical	0.5	0.288	0.00605	—
Software 1	0.50239	0.287	0.00600	0.00239
2	0.49704	0.291	0.00610	0.00296
3	0.50031	0.291	0.00609	0.00031
4	0.49977	0.289	0.00606	0.00023
Hardware 1	0.50411	0.294	0.00617	0.00411
2	0.50060	0.293	0.00613	0.00060
3	0.50116	0.294	0.00615	0.00116
4	0.49692	0.295	0.00619	0.00308

Table 1 Results from NBS program 132 on the DAI computer random generators.

```

100 PRINT "NBS PROGRAM MODIFIED BY ALAN SUTCLIFFE"
110 PRINT "CHI-SQUARE UNIFORMITY TEST FOR RND FUNCTION"
120 PRINT
130 PRINT "INPUT NUMBER OF SLOTS"
140 INPUT M
150 DIM Y(M)
160 P1=50*M
170 REM ABOUT 50 VALUES PER SLOT EXPECTED
180 PRINT "INPUT NUMBER OF EXPERIMENTS"
190 INPUT N
192 PRINT "EXPT", "CHI-SQUARE"
200 REM CARRY OUT N EXPERIMENTS
210 FOR E=1 TO N
220 REM ZERO SLOT COUNTS
230 FOR I=1 TO M
240 Y(I)=0
250 NEXT I
260 REM OBTAIN FREQUENCY COUNTS
270 FOR I=1 TO P1
280 X=RND(1)
290 REM USE RND(0) FOR THE DAI HARDWARE GENERATOR
300 R=INT(M*X)+1
310 Y(R)=Y(R)+1
320 NEXT I
330 REM COMPUTE CHI*SQUARE STATISTIC
340 S=0
350 FOR I=1 TO M
360 S=S+M*Y(I)*Y(I)
370 NEXT I
380 V1=(S/P1)-P1
390 PRINT E, V1
400 NEXT E
410 COMPUTE AND PRINT CHI-SQUARE LIMITS FOR M SLOTS
420 Q1=SQR(M+M-3)
430 Q2= 2.32*Q1
440 R1=M+1.75-Q2
450 R4=M+2.08+Q2
460 Q2=1.645*Q1
470 R2=M+0.14-Q2
480 R3=M+0.14+Q2
490 PRINT
500 PRINT "CHI-SQUARE LIMITS"
510 PRINT " 1%",R1
520 PRINT " 5%",R2
530 PRINT "95%",R3
540 PRINT "99%",R4
550 END

```

Program B

without doing any harm because none of the atoms collided.

## Testing distribution

Having looked at the average, it is natural to look at the distribution of values in the allowed range 0 to 1; Program B enables you to do this. It is based on the NBS program, but I have modified it to allow any number of slots. The range 0 to 1 is divided into a number of equal slots and there is a count for each slot which is increased by one whenever a value occurs within the range of that slot.

At the end of a run the distribution of the values of these counts is checked using the X-square test. There is no space here to explain this standard statistical method, any more than I have

explained standard deviation or normal distribution. If you are not familiar with these terms, refer to any introduction to statistics, such as *Facts from Figures* by M J Moronéy (Penguin).

The NBS program works only for 21 slots and gives the values of X-square only for this case. I have therefore added a subroutine that calculates it for any number of slots. But beware — this routine gives inaccurate values for cases with fewer than 10 slots, so for these cases you should look in a book of statistical tables for X-square.

Table 2 shows the results of 10 tests with Program B for the DAI software and hardware generators. In each test there were 100 slots and 5000 samples, that is, random numbers. The chi-square limits indicate how many of the results are expected to lie below the

# PATTERNS

quoted values. For example, from Table 2, only 1 percent of the tests should have a result below 69.2, while only 1 percent should be above 134.6.

The software generator is again well behaved, with all the results well within the limits. But the results from the hardware generator are very high, with half the values above the 99 percent limit, indicating a big departure from uniform distribution.

To check this further, I next ran a simple test on each generator. 200,000 samples were distributed among 70 slots and the totals in each slot displayed on the screen as a bar chart; 70 was chosen so that the results would fit conveniently on the screen in low resolution mode.

The software generator behaves as it should, with a nice even distribution of values. Figure 1 shows a plot of the results from one test photographed from the screen and Figure 2 shows the corresponding results from the hardware generator. You don't have to know a thing about statistics to see what is happening. At the extremes of the range, near 0 and 1, there are far more values than there should be. There is also a lesser peak in the middle and some other minor peaks in between. I could not have asked for a better example to illustrate this article.

I don't want to spoil your fun too much by giving away the rest of the story, because I think you should buy or borrow this book of programs and run some of them. All I will say is that some of the other tests for randomness have intriguing names: the Komolgorov-Smirnov test for uniformity, the serial test and the gap test for randomness, the poker test and the coupon collector test for the RND function, among others.

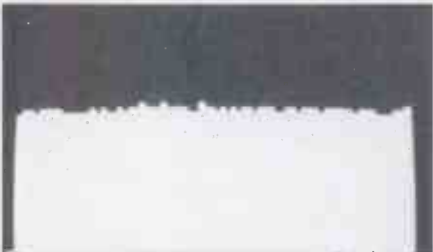

Figure 1



Figure 2

## Crossword composition

The Computer Journal is not noted for articles of popular interest; more usually it is devoted to technical topics such as the 'Determination of Eigenvalues of

Expt	Software	Hardware
1	91.3	129.4
2	102.1	172.3
3	92.6	119.7
4	92.4	140.6
5	84.5	152.4
6	98.7	138.5
7	97.2	143.3
8	103.4	110.4
9	96.0	131.1
10	104.6	110.1

### Chi-Square Limits

1%	69.2
5%	77.1
95%	123.2
99%	134.6

Table 2 Result of tests of distribution of random numbers from the DAI computer, with 100 slots and 5000 samples in each test.

Symmetric Quindagonal Matrices'. But the May 1981 issue has a fascinating description by P D Smith and S Y Steen of their Prototype Crossword Compiler.

Input to the compiler is a diagram of blank and blocked-in squares of the usual kind. The program then attempts to fill the blank squares with words looked up in a dictionary of nearly 8000 words held on disk. The use of bit lists and heuristic tree searching allows non-trivial puzzles to be composed in reasonable time, anything from six to 600 processor seconds on an ICL 1904S. To ensure a fair trial, input diagrams were taken from puzzles in daily papers.

That still leaves the clues to be composed and the authors think that the simple type of multiple-definition would be easy to generate (Utensil god = PAN), but see no prospect of making up cryptic clues by program. A dictionary of anagrams could be computed once and for all. The methods described could be adapted to run on a small machine.

## Further study

The City University in London is running several evening courses this winter on computing and related subjects. The list below shows the starting dates, some of the shorter classes being run twice.

Elementary Programming in Fortran, January; Introduction to Basic, October and January; Pascal and Structured Programming, October and January; Computer Music, October; Business Programming in Cobol, October.

For more information contact: Adult Education, Centre for Arts and Related Studies, City University, Northampton Square, London EC1V 0HB, telephone 01-253 4399 ext 496.

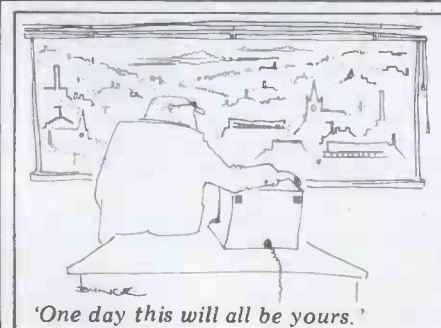

# CHESS FINAL '81

For the second year running the Personal Computer World Show played host to the European Microcomputer Chess Championship. The accommodation provided, namely a discreet suite well removed from the howling mobs, seemed somehow more in keeping with the spirit of the game than last year's site next to the bar.

Twelve programs found their way into the finals: Advance 2.0 (Dave Wilson, Mike Johnson); Albatross 3.0 (Michael J Parker); Caesar (John Lowe); Chess Champion (Sci Sys-W Ltd: David Broughton, M Johnson, D Levy, KO'Connell, M Taylor); Chessnut (Geoffrey J Bulmer); Cyrus (Richard Lang); Gambiet 81 (Microtrend Ltd: Wim Rens); Logichess (Kaare Danielsen); Microtrend Experimental (Microtrend Ltd: Wim Rens); Philidor Experimental (Philidor Software: D Broughton, D Levy, K O'Connell, M Taylor); Philidor (Philidor Software: D Broughton, D Levy, K O'Connell, M Taylor); White Knight (Philidor Software: M Bryant).

Of these entries I had only heard of the Philidor before the event and, considering the claims the programmers had made about it, it seemed natural that it would win quite easily. In the absence of the Great Game Machine (with the Granfeld and Morphy Cartridges) and other well known machines such as the Mephisto and the Sensory Voice Challenger (the winner of the 1st Official World Championship for micro-computers last year), surely there could be no doubt.

The final result was very surprising. The non-commercial entries scored very well.

As a very keen chess player, I am much more interested in the quality of the games than the bare results. Many of the games were decided, in my view, in a most random manner — but this was not the case with the games played by Cyrus. Cyrus played such good games I would have been quite pleased had I played them myself. Only in the first round did Cyrus get into a diffi-

cult position. Philidor Experimental won material and then insisted on a continual attack on Cyrus's pieces while ignoring the defence of its own king which Cyrus finally managed to checkmate.

For the remainder of the tournament Cyrus played remarkable chess and I have chosen two games for comments although all five are well worth publication.

Philidor-Cyrus: round 3

1	d2-d4	d7-d5
2	c2-c4	d5xc4
3	e2-e4	e7-e5
4	Ng1-f3	e5xd4
5	Bf1xc4	Nb8-C6

Both programs are now out of their book openings. Instead of Cyrus's last move, the recommended move is Bf8-b4+6 00 Ng8-f6.

'Knights before Bishops' is an often-quoted recipe for use in opening play. The reason is that it's rarely clear which are the best squares to develop bishops, whereas knights nearly always belong as near to the centre as possible.

7	e4-e5	Nf6-e4
8	Qd1-e2	Ne4-Cs
9	Bc1-g5	Bf8-e7
10	Bg5xe7	Qd8 x e7
11	b2-b4	

The Levy *et al* programs seem to play this move a lot in different types of positions. Here it is easily understandable in that after the exchange of Philidor's b-pawn for Cyrus's d-pawn, White will have made a small gain in position. Central pawns tend to be worth more than the outer pawns because of their influence over the central squares (although this tends to be reversed as the end game approaches and outside passed pawns become very important).

11	... Nc6 x b4	
12	Nf3 x d4	Bc8-e6
13	Nd4 x e6	Nc5 x e6
14	Nb1-c3	00-0 (Ke8-c8)

This seems a most unusual decision. A human player would think twice before castling in front of so many open files. However, in this position, this move is a very good idea for several reasons: Had Cyrus played 14...00 (Ke8-g8) then Philidor could have generated a strong attacking position with moves such as f2-f4, f5-f6, Nc3-e4 and so on. Further, if (after 14...000) Philidor attempts to attack on the Queen-side, the active Black pieces should easily be able to defend. Lastly, Cyrus can now contemplate a King-side attack. The trouble with the above ideas is that they are all plans which can materialise over, let's say, six to 10 moves (12 - 20 ply). Now, for a machine to analyse six to 10 moves ahead, it would require a considerable length of time. In this tournament the machines had to play at a time rate of 30 moves by each player per hour of that player's time, so, there is no way these long range ideas could have been considered. Yet, amazingly, Cyrus castled Queen-side, easily defended its own King and successfully attacked Philidor's King!

15	a2-a3	Nb4-c6
16	Nc3-d5	Qe7-c5
17	Rf1-d1	Nc6-d4
18	Qe2-a2	C7-c6
19	Nd5-e3	Qc5 x e5
20	Ra1	h7-h5

I like to imagine Cyrus's last move as the inauguration of a King-side attack, although it was played simply to increase the scope of the Rook on h8.

21	Bc4-d5	Kc8-b8
22	Bd5-C4	h5-h4

Philidor's last two moves show a common weakness of chess programs. A strong human player would not consider placing a piece on a bad

	Rnd 1	Rnd 2	Rnd 3	Rnd 4	Rnd 5		
1	Cyrus	W5	W7	W4	W2	W6	5
2	Advance 2.0	W12	W3	W9	L1	W4	4
3	Logichess	W9	L2	W5	L4	W8	3
4	Philidor	W10	W8	L1	W3	L2	3
5	Philidor Expl.	L1	W11	L3	W9	W10	3
6	Caesar	D8	L10	W12	W7	L1	2½
7	Gambiet 81	W11	L1	D10	L6	W12	2½
8	Microtrend Expl.	D8	L4	W11	W10	L3	2½
9	Ch. Champ Mk V	L3	W12	L2	L5	W11	2
10	White Knight	L10	W6	D7	L8	L5	1½
11	Chessnut	L7	L5	L8	W12	L9	1
12	Albatross 3.0	L2	L9	L6	L11	L7	0

Table 1 Results

square in order to make a random attack if, after a straightforward defensive move, that piece is forced to withdraw to the position from which it came. Philidor's last two moves did nothing to improve its own position, while Cyrus uses in effect the extra two moves very constructively.

Another weakness of chess programs is that they do not 'learn' from their mistakes, so Philidor makes the same error with its next two moves.

23	Ne3-g4	Qe5-g5
24	Ng4-e3	Nd4-f3+
25	Kg1-h1	Rd8xd1+
26	Rc1xd1	Nf3-d4
27	Rd1-b1	h4-h3
28	Qa2-b2	h3xg2+
29	Ne3xg2	b7-b5
30	h2-h4	Nf3xh4

This is the only move in the game which disappointed me. I would have liked to have seen Cyrus play 31... Qg5-g4 with the threat of check mate next move. Only delaying moves such as Qb2-e5+ would prolong the game but then only for a few moves. The move chosen by Cyrus is still very strong, and indeed wins a lot of material, but Philidor lasts a lot longer than necessary.

and Cyrus delivered checkmate on move 53.

Finally, the game that essentially decided the tournament. After three rounds only two programs, Advance 2.0 and Cyrus, had won all their games. They now had to play each other.

Advance 2.0 - Cyrus: round 4

1	e2-e4	c7-c5
2	Ng1-f3	Nb8-c6
3	d2-d4	c5xd4
4	Nf3xd4	Ng8-f6
5	Nb1-c3	d7-d6
6	Bc1-g5	

This is a standard opening variation known as the Sicilian Richter-Rauzer. Cyrus now goes its own way and by accident transposes into an extremely popular variation called the Sicilian Svesnikov!

6	... e7-e5	
7	Nd4-b5	a7-a6

Advance 2.0 should have played the attacked knight to f5. Now the opening has become a Sicilian Svesnikov.

8	Bg5xf6	g7xf6
9	Nb5-a3	Bc8-e6
10	Bf1-c4	

Generally 10 Na3-c4 is considered the best move here but I'm sure most computers would give more weight to developing an unmoved piece rather than spend time improving the position of a piece already developed.

10	... Qd8-b6	
11	Bc4xe6	F7xe6
12	a3-c4	Qb6-b4
13	Qd1-e2	d6-d5!

Cyrus begins a tactical phase, resulting in the gain of material and

finally checkmate. In several of its games Cyrus initiated a sequence of simple tactics, which resulted in the gain of material, but only after building up its position to the point where the tactics were justified. The significant point to consider here is that it is in exactly this manner that the majority of games between strong human players are decided. Both players will manoeuvre until one player gains the greater freedom of action for his pieces. Then, using this freedom, the player creates a sequence of threats which usually force a sudden deterioration in his opponent's position, often resulting in the gain of material. 'As usual, tactics flow from a positionally superior game.' (Bobby Fischer.)

14 Qe2-h5+ Ke8-e7  
Rather dynamic play this! Yet completely in tune with the nature of the opening variation.

15	e4xd5	Nc6-d4
16	Nc4-e3	Qb4xb2
17	d5-d6+	Ke7-d8
18	Ke1-d2	

Forced to avoid the loss of a piece. But now the White king is rapidly executed.

18	... Ra8-c8	
19	Nc3-e4	Nd4Xc2
20	Ne3Xc2	Qb2-c2+
21	Kd2-e3	Rc8-c4
22	Qh5-h4	Bf8-h6+!

One of those moves any human player would have found extremely pleasant to play. If the bishop is captured, Cyrus mates in three moves. After the move played it's mate in 4.

23	Ke3-f3	Qc2-d3+
24	Kf3-g4	Qd3xe4+
25	Kg4-g3	

and the operators of Advance 2.0 resigned.

The last round was a bit of an anti-climax as Cyrus had already disposed of its main rivals. Yet again Cyrus won a nice game after Caesar managed to get a knight trapped among Cyrus's pawns.

What strikes me most about the games played by Cyrus, compared with those played by the other programs, is that Cyrus seems to co-ordinate its pieces. It gets them working well together then begins an attack for which it is well prepared.

Richard Lang kindly provided some information about his program, part of which I reproduce here.

Cyrus has seven levels of play; the levels correspond to the number of ½ moves (ply) that Cyrus looks ahead (the search is automatically made deeper in the end-game and for checks at the top ply). The most useful levels are 3,4 and 5 which have average response times of about six seconds, 40 seconds and 1 minute 45 seconds respectively.

Cyrus occupies just over 7k of memory, of which about 1.25k is a table of 450 opening moves. In addition, level 5 needs a 2k workspace and level 7 needs 2.5k.

Cyrus uses depth-first alpha-beta



in association with Kent Barlow Information Associates  
present

# Eagle Eye<sup>®</sup>



## The Database Management and Information Retrieval System For CP/M\* Microsystems

- Mainframe retrieval power at micro cost using internationally accepted EURONET Command Language.
- Sets new standards in clarity of instructions. Entire system is menu driven to make it really friendly to users, experienced or otherwise.
- Design and update your own database with over 50 searchable terms and relocate any record by any combination of terms.
- Each record can be up to 472 characters. Each database up to 8 megabytes. Typical retrieval time is 6 seconds using any term in 10,000 records.

Search results can be viewed, printed or filed for subsequent processing into any format which makes Eagle Eye ideal for custom built information systems, mailing lists, personnel records, cataloguing, market research, sales management, medical and veterinary records, correspondence filing, customer profiles, product lists, price lists, project research, insurance client records, legal research, enquiry services for libraries, museums, sales promotion, recruitment etc., etc., etc.

Eagle Eye is available from Leading Software Dealers or direct from

SOLE UK DISTRIBUTOR  
KATOTEK SYSTEMS DESIGN LTD  
21/25 GOLDHAWK RD LONDON W12

Recommended Retail Price **£310** (excluding VAT)  
Dealer enquiries welcome.

\* CP/M is a trademark of Digital Research.



# THIS IS THE ONE YOU'VE ALL BEEN WAITING FOR!! YOU WOULDN'T BELIEVE IT WAS POSSIBLE

## 64K RAM, DUAL 5¼ DRIVES, CP/M 2.2 FOR ONLY £1299



**SIG/NET 202S – Z80A CPU, 64K RAM, 2 FAST STEPPING 5¼" DRIVES (400K, Superbrain compatible format), 2 SERIAL RS232 PORTS, CP/M 2.2**  
**EPSON MX80 F/T PRINTER – BIDIRECTIONAL, LOGIC SEEKING, GRAPHICS, SERIAL INTERFACE**  
**TELEVIDEO TVI-910 VDU**  
**ALL THE ABOVE SYSTEM AS ILLUSTRATED FOR JUST £2145 !!!**

The SHELTON SIG/NET 200 series computer is a high performance stand alone computer system using the Z80A microprocessor. The system is based on a new revolutionary design concept which achieves low cost flexibility through the simple interconnection of functional modules via the SIG/NET "ring".

The CPU-RAM module houses the Z80A processor, 64K RAM, 2K ROM, a Z80 counter/timer circuit and the SIG/NET ring interface. The FDC-5 disk controller module which interfaces up to four mini-floppy disk drives to the SIG/NET ring can be modified to support eight inch drives. The design of this module incorporates the latest suite of disk controller chips which provide advanced features such as phase locked loop data separation and write precompensation – essential for reliable disk performance. The third module which completes the basic 200 series configuration is the 2SER dual serial interface. This provides two independent RS232 serial channels – one for the VDU and one for a serial printer. Baud rate and serial line parameters are fully software controllable for maximum flexibility in use.

The SIG/NET Resident Operating System (ROS) resides in 2K EPROM, and includes a bootstrap loader and a simple system monitor.

The SIG/NET 200 series uses the popular Tandon Magnetics disk drives (either single or double-sided) with a storage capacity of 200K per side.

The modular design of the SIG/NET provides a low cost system, yet offers a greater expansion potential than bus-based systems. Multi-user and network configurations are possible and together with the addition of a hard disk make the SIG/NET range extremely powerful.

SYSTEMS	
SIG/NET 202S – 2 Single sided drives (400K)	£1299.00
SIG/NET 202D – 2 Double sided drives (800K)	£1649.00
SIG/NET 202Q – 2 Double sided 96tpi drives (1920K)	£1999.00

MODULES	
CPU-RAM (Z80 + 64K)	£299.50
FDC-5 (Floppy disk controller)	£159.50
2SER (2 RS232 serial ports)	£89.50
3PAR (3 parallel ports)	£59.50
RING-RING (Interface module)	£69.50

SOFTWARE	
Microsoft MBASIC-80 Interpreter	£155/£18
Microsoft MBASIC-80 Compiler	£195/£18
Microsoft FORTRAN-80 Compiler	£205/£18
MMike's BaZic (Z80 North Star BASIC compatible)	£95/£25

MICROPRO SOFTWARE	
WordStar – Word-processing Package	£205/£25
SpellStar – Dictionary Program for above	£125/£25
DataStar – Database Management System	£160/£25
SuperSort 1 – CP/M File Sort Utility	£110/£20
MailMerge – Mailing list for WordStar	£60/£15

PERIPHERALS	
Televideo TVI-910 VDU	£460.00
Televideo TVI-920 VDU	£595.00
Televideo TVI-920 Customised for WordStar	£695.00
Televideo TVI-950 Detachable Keyboard, Many Features	£750.00
Epson MX80 Printer	£350.00
Anadex DP9500L Printer 150cps	£795.00
Anadex DP9500 Printer 150cps. Graphics	£895.00
TEC Starwriter Daisy Wheel Printer	£995.00
NEC Spinwriter RO Letter Quality Printer	£1695.00

SIG/NET is a trademark of Shelton Instruments Ltd.  
 CP/M is a trademark of Digital Research Corp.

**TRADE AND OEM ENQUIRIES WELCOME**

All prices exclude VAT and are subject to change without notice  
 All specifications are approximate only

**Sole Distributor for South/S. East**  
**INTERAM COMPUTER SYSTEMS LTD.**  
 46 Balham High Rd  
 London SW12 9AQ  
 Tel: 01-675 5325/6/7 Telex: 925859



## WHY PEOPLE BUY THEIR APPLE COMPUTER FROM A CRA MEMBER



The Computer Retailers Association is a voluntary organisation of leading microcomputer dealers and service organisations.

The purpose of the Association is to maintain and improve standards of trading and customer support within the industry, and to present the industry's case to the outside world. The Association also acts as a forum where members can discuss common problems.

Membership is open only to those reputable organisations within the industry who are willing to subscribe to the Association's Code of Practice, and who meet the Conditions of Membership.

### Member Apple Dealers subscribing to this advertisement:

**B & B Computers Ltd**  
Suite 1  
124 Newport Street  
Bolton  
Tel: 0204 26644

**Business Office Links Ltd**  
73 Albany Road  
Coventry CV5 6JR  
Tel: 0203 78651

**ByteShop Computerland**  
324 Euston Road  
London NW1  
Tel: 01-387 0505

**Camden Electronics Ltd**  
462 Coventry Road  
Small Heath  
Birmingham B10 0UG  
Tel: 021-773 8240

**DBM Systems & Software**  
58 Victoria Street  
Bristol 1 Avon  
Tel: 0272 214093

**Datron Micro Centre**  
2 Abbeydale Road  
Sheffield S7 1FD  
Tel: 0742 585490

**Ferguson Computers Ltd**  
4 Byrford Road  
West Byfleet Surrey KT14 62S  
Tel: 09323/45330

**Great Northern Computer Svcs Ltd**  
116 Low Lane  
Horsforth Leeds  
Tel: 0532 589980

**Johnson Microcomputers**  
Johnson House,  
75-79 Park Street, Camberley  
Surrey  
Tel: 0276 20446

**Keen Computers Ltd**  
Minerva House  
Spanniel Row Nottingham  
Tel: 0602 412777

**Lion Microsystems**  
Lion House  
227 Tottenham Court Road  
London W1P 0HX  
Tel: 01-636 9613

**Micro Facilities**  
129 High Street  
Hampton Hill  
Middlesex, TW12 1NJ  
Tel: 01-979 4546

**Micro Management**  
32 Princes Street  
Ipswich Suffolk  
Tel: 0473 57871

**Newbear Computing Store**  
40 Bartholomew Street  
Newbury Berks  
Tel: 0635 30505

**Vlasak Computer Systems**  
Vlasak House, Stuart Rd  
High Wycombe  
Bucks, HP13 6AG  
Tel: 0494 448633

# COMPUTER RETAILERS ASSOCIATION



## Your Guarantee of Satisfaction

## OSBORNE 01



*When we heard that Adam Osborne was in town and that he had his Osborne 1 computer with him we tracked him down to a party near the Embankment. Hearing that we were prepared to work all night and most of the next day on the evaluation, he kindly handed it over. David Tebbutt takes up the tale.*

Well, after years of telling everyone else what to do and handing out White Elephant Awards to those who satisfied his idea of what is excellent in the microcomputer industry, Adam Osborne has put his neck on the block and come up with an interesting hardware/software package which, with typical modesty, he calls the Osborne 1. It is a portable microcomputer comprising a keyboard, a built-in video monitor, two floppy disk drives and a whole bunch of useful software. In fact, in America, the cost of the software if purchased separately would be around \$1500. The Osborne 1 including all this software sells over there for \$1795, a theoretical hardware cost of just \$295! Nor is the software gratui-

tous rubbish — it comprises CP/M, MBasic, CBasic, Wordstar, Mailmerge and Supercalc. CP/M is just about the industry standard operating system, which means that a wide range of existing and new software products will be quickly made available for the Osborne 1. MBasic and CBasic must be the most widely used Basic implementations; one is interpreted, the other compiled. At the risk of oversimplification, this means that MBasic is easier to use whereas CBasic programs run faster. Wordstar must be one of the best word processing packages around, although my personal preference (bias?) is for Spellbinder, and it comes with Mailmerge, which enables you to maintain and use mailing lists and merge

details from the lists into standard letters and the like. Finally, Supercalc is what the Americans would call an electronic spreadsheet. It allows you to enter numbers, formulae or descriptions on a large matrix of rows and columns. Any cell on the grid whose value is derived from other values within the grid displays a fresh result every time that one of its component values is changed. It is similar to Visicalc but, according to people who've used both, it's also better.

So there you have it; at £1200 the Osborne 1 appears to be the answer to every would-be computerist's prayer. It does have one major drawback though — the screen is *very* small — 5in — and that's its *diagonal* measure-

# Unique accessories to PET/CBM add more power

## Software

### PET-FORTH

A unique, extensible programming language that in many cases has cut program development time to a fraction of the normal. FORTH allows you to program any type of application, thanks to its extensible nature. FORTH programs are modular, structured, extremely fast, and compact. PET-FORTH is a full, extended, standard FORTH, and includes a virtual memory facility, an interpreter and compiler, a resident editor, as well as a resident macro assembler, all which fits in 8.5K – simultaneously.

A comprehensive manual of more than 320 pages, which also is an exhaustive tutorial, is included. For production purposes we can supply a special **Target Compiler**, that will produce code suitable for placement in ROM, enabling you to write programs for control of digital machines etc. We use FORTH ourselves for business, data base and process control applications. PET-FORTH includes a life-time guarantee. For 8032 only.

Price: **PET-FORTH, including manual** £ 195  
**PET-FORTH, only manual** £ 20  
**Target compiler** £ 500  
**PET-FORTH** £ 500



### PET-TERM

A program that turns your PET/CBM 8032 into an intelligent terminal. Supports three different interfaces: the PET-COM, the SCIP or the CBM 8010 acoustic coupler. You may communicate at up to 9600 baud, with selectable framing and parity. PET-TERM will also translate and transmit Word-Pro files. Data may be printed on the printer or saved on disk. PET-TERM includes a life-time guarantee.

Price: **PET-TERM, including manual** £ 90  
**PET-TERM, only manual** £ 10



**Dealers are invited.**

## Hardware

### PET-SWITCH

At a sensational price of £ 75 per unit, PET-SWITCH enables you to connect up to 16 PET/CBM computers to one disk drive and one printer. You can mix all models of PET/CBM in the same system (2001, 3032, 8032 etc). PET-SWITCH is technically superior to most of its competitors—no priority problems for example.

Price: **PET-SWITCH, mother unit** £ 125  
**PET-SWITCH, daughter unit** £ 75



### SCIP

A Serial Communication Interface that supplies both RS-232 and Current Loop. Programmable baudrate. Addressed as an IEEE device. 50 character internal buffer. Selectable ASCII translation.



Price: £ 240

### PET-COM – RS-232C interface for PET

A bidirectional RS-232C interface that connects to PET via the memory expansion port. The baud rates range from 50 to 9600, and the number of data bits and stop bits is selectable. You may also set even, odd, or no parity.

Price: £ 72



### PET IEEE to Centronics Interface

This IEEE => Centronics interface is especially constructed for the PET. It is fully addressable and translates from PET-ASCII to Standard ASCII in two different modes, corresponding to PET's graphic and upper/lower case modes. This is available through a built-in switch.

Price: £ 48



### Country specific Character Generator for the 4022 and 3022 printers

By using this board you can have Greek, French, German, or any other special characters in your printer, at a very low cost. It is already used in all Nordic countries, and several other countries have requested it.

Price: £ 20

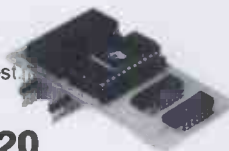

*Datatronic AB is since 1978 sole Swedish distributor of the Commodore computer product line, and is now market leading in microcomputer technology in Scandinavia. Datatronic AB has a long experience in both hardware and software; today Datatronic has used more than 150.000 man-hours in software and hardware development for the PET. All non-Commodore products are produced and tested in-house. The Datatronic-group, which is the fastest growing electronics group in Scandinavia, has a turnover of approximately \$ 30.000.000, and employs over 200 people.*

For further information contact Datatronic AB,  
 Box 42094, S-126 12 Stockholm, Sweden.  
 Phone 8-744 59 20  
 or your nearest Commodore dealer.

**datatronic ab**

Box 42094 · S-126 12 STOCKHOLM · Sweden  
 Phone: 8-744 59 20 · Telex: PET S 17828

# OSBORNE 01

ment! To overcome this, those who really need one can buy a separate 12in monitor. In America this costs \$250. Of course the machine is then less convenient to carry around. Perhaps the answer is to have the large screen situated wherever you use the machine most.

Adam Osborne neither makes nor sells the Osborne 1. He assembles it and tests it from supplied components and he puts most of the selling emphasis on the software available. In other words he's selling solutions to problems and he couples this with the sinister suggestion that you won't be able to compete in your profession without an Osborne 1. Of course such comments apply to all computers, but to read the sales literature you'd think that the Osborne was the only route to salvation. He even claims that the Osborne 1 marks the advent of the Personal Business Computer. If that's the case, I wonder how he would describe machines like the SuperBrain and Apple.

If you think you'd like one, a number of UK dealers will be getting demonstration machines in October but orders will take from three to six months to fulfil. This is expected to come down to a month or less by next summer. Adam is only authorising dealers who can demonstrate a willingness and ability to support their customers. This means that you're unlikely to find these machines in discount stores or with flaky dealers.

## Hardware

The Osborne 1 comes in a cream vacuum-formed plastic case with a carrying handle at the back and a keyboard clipped on the front. A groove runs along each side of the case rather like that along the side of some Rover cars. Unlike the cars, this groove makes the Osborne easy to pick up. It's a bit of an odd shape when the keyboard is clamped in place. In fact when you stand it on end the whole thing tilts alarmingly due to the fact that the keyboard unit is designed to slope down towards the user. Although the present case is vacuum-formed, there are plans afoot for a new design using injection-moulded plastic foam. I'll be mentioning that later in the review.

When the machine is opened, you find a black bezel (front) and a grey keyboard set in a black keyplate. The



The O-1 in carrying mode.



The keyboard detaches completely — apart from the ribbon cable, of course.

machine weighs in at 26.5lbs according to my bathroom scales but Adam tells me it should weigh 24. If he's right then my scales are wrong and I'm actually my ideal weight. (*Hysterical laughter — Ed.*) With the keyboard clipped in place the effect is not unlike my wife's sewing machine except of course the O-1 is much lighter.

A disk drive is located on either side of the small 5in monitor and beneath each drive is a pocket capable of holding up to 15 disks. I had a nasty moment during the review when I thought I'd lost all the disks. I searched high and low for them and after 10 minutes of sheer panic I glanced at the machine and there they were, nicely tucked up in one of the pockets!

Along the bezel and below the monitor and disk pockets are a number of sockets and controls. Working from right to left this is what you'll find: battery socket, reset button, external video socket, contrast and brightness controls, keyboard socket, IEEE-488/Centronic parallel socket (software switchable), serial RS232C socket and a modem socket. I quite like the idea of being able to see what you've got plugged into the machine without having to grovel round the back. Quite how it looks when all the various leads are in place I can't imagine. The keyboard lead is a flat cable enclosed in a plastic braid. I presume this is to prevent the wires getting pinched when the keyboard is clamped on the front. I didn't have anything connected anywhere else. The brightness and contrast controls I found essential for getting the display just right; unless it is right it can be very tiring to use. The reset button wipes out the memory and returns you to a monitor command telling you to insert a disk and type RETURN. This then drops you into a master menu or CP/M, depending which disk you've loaded.

The review machine had almost silent Siemens' disk drives. They worked perfectly and I could only really hear them when the house went quiet in the early hours. Around three o'clock in the morning I thought I heard a budgie hopping around — it was the disk drives. I decided that I'd had enough and grabbed a couple of hours' sleep. MPI drives are installed on some Osbornes and these are just as reliable — the doors

are slightly more robust but, according to Osborne they sound like 'a sack of marbles'!

The screen is interesting because it allows two display intensities plus optional underlining. If you're technical you might be wondering how Adam manages this with just eight bits per character. The answer is that he doesn't — he uses nine for the characters to be displayed. Bits 0-6 are used for the ASCII code, bit 7 for underline and bit 8 for intensity. The matrix is an unusual 8 x 10 which gives true descenders, 32 graphics characters plus the underlining mentioned just now. Another fascinating feature of the display is the lateral and vertical scrolling. The vertical didn't work on the review machine, incidentally, so I don't know whether it would be smooth or not. One thing's certain, the lateral scrolling was perfectly smooth. The screen can display 24 lines of 52 characters at a time. The screen memory can hold 32 lines of 128 characters so, using certain control keys, you can move the 'window' to any part of the screen memory. If, for example, you had completely filled the screen memory and you decided to scroll sideways, the effect would be rather like watching a cylinder revolving, because the whole screen scrolls, not just the current line.

The major disadvantage of the screen is that it's too darned small. Adam tells me that he uses it for hours on end without any trouble. I knew then just how Mandy Rice-Davies came to utter those immortal words when the judge told her that Lord Astor had denied any 'goings-on' between them: 'Well, he would, wouldn't he?' said Mandy. I digress. I did ask Adam if he'd considered putting a fresnel lens in front of the screen. He had, and the result was so much distortion that he felt it better to forget it. Here's a money-spinning opportunity for someone — invent a device that fits into one of the diskette pockets when not in use and which magnifies the screen without unacceptable distortion. Of course, if you'd like to make me rich too for tipping you off then that's just fine by me!

The keyboard is nicely laid out, with both typewriter and calculator-style keypads. A few things are on the Osborne that you perhaps wouldn't expect on a budget machine — a caps lock, a '£' sign on British versions

# OSBORNE 01

and a pimple on the 5 on the numeric keypad so you know where you are without looking. The keys automatically repeat after being held down for a second or so. My only criticism of the layout is that you need two hands to scroll the screen — one to hold the control key and the other to operate the 'arrow' key. I mentioned this to Adam and he told me that he was faced with the choice of giving the user single-handed cursor movement when creating text or single-handed operation when scrolling (reading) text. At least Adam's way means you can keep your place on an input document with one hand while operating the cursor controls with the other. I wish I'd thought of asking him why the control key wasn't placed next to the arrow keys. Another way of scrolling the screen is to use the control key in conjunction with the 1, 2 or 3 keys. CTRL-1 displays columns 1 to 52, CTRL-2 columns 53 to 104 and CTRL-3 columns 105 back round to 28.

Moving round the back, there's a little recess which contains the on/off switch and a circuit breaker reset button. This is where you stow the cable and plug when carting the machine around. A plastic cover is 'velcroed' over the recess to hold everything in place. The review machine didn't have appropriate slots for the UK type of plug so I had to disconnect it to make the photos look okay. Adam tells me that this won't be a problem on the UK versions of the O-1. Also at the back is the quaintest carrying handle you ever did see. It's like those leather handles you get on the old-fashioned cardboard suitcases. Adam is a firm believer that if something does a job adequately then that's just fine. To risk boring you with another quote, he says 'Better is the enemy of good, adequacy is sufficient and everything else is irrelevant.' This maybe explains the 5in screen too and it certainly explains his approach to software authorisation, which you'll be reading about later on.

To get inside the machine it is necessary to remove the bezel, which is attached by four screws, and the brightness and contrast knobs. The screws were easy but the knobs needed a very small Allen key. Once inside, you can only see the first inch or two of the various components since they all disappear into the depths of the case. I felt as if I was peering into a rather full bucket. What I could see looked clean and well made. The only noticeable thing out of place was a jumper wire from one part of the single board computer to another. Adam tells me that there were design faults on some of the earlier boards and that this must have been one of them. The front edge of the board contained all the ports and controls mentioned earlier. Ah yes, that reminds me, the serial port connection should have protruded from the bezel. As it was on the review machine it would have been difficult to attach a printer connector, for example. Once again Adam says that is being attended to. A closer examination would have involved a lot of time literally pulling the machine apart and, really, it just wasn't worth it. I had a peek inside the

keyboard unit and it, too, was well made, comprising a metal keyplate in a vacuum-formed plastic shell. The keyboard itself was quite firm and I noticed that a couple of metal channels ran from end to end underneath. I presume that these were attached for rigidity.

Everything connected with the Osborne 1 has got 'Osborne' plastered all over it, even the disk sleeves. I'm not sure whether this is simply sound publicity or an ego trip by Adam. I must say I find the private man far more pleasant than the public version.

Each disk can hold up to 102,400 bytes of information. That's the equivalent of about three times the length of this Benchtest. The disks are soft sectored with 40 tracks, each comprising 10 sectors. A sector on this machine is 256 bytes. I suspect there must be some sort of software fudge to make CP/M think that the tracks are 20 sectors of 128 bytes. Adam tells me that double-density drives will be available soon, which must be good news for those with high volumes of data to process. Although Adam gets his disks from several sources, he tells me that Dysan is the major supplier. Since I use them exclusively, I was pleased to hear this. I have heard that the oxide coating is less stable on some other disks, the 'no-name' ones being the worst offenders.

## Software

Adam Osborne has collected together a very good range of software which he supplies with the machine at no extra cost. This is sometimes referred to in the trade as 'bundled' software. Adam knew what the most popular applications were and he knew that it would be wise to stick to industry standard system software so he went ahead and wrapped up an entire package which would satisfy most people's immediate requirements and still give them the opportunity to buy other programs as their needs developed. In my view a decent database package would have rounded everything off just nicely but Adam is sticking to a few 'authorised' databases for which the customer pays extra.

Let's comment on each piece of software in turn. If you're an old hand at this game, you'll be able to skip the next four paragraphs without losing too much information.

First of all, CP/M: the name is on everyone's lips, but how many people actually know what it is? The initials stand for Control Program for Microprocessors and it was designed to facilitate the writing of programs for Z80, 8080 and 8085 processors. Although the processors in different microcomputers are the same, the bits and pieces that surround them are very different. Keyboards use different keys, printers vary, screens have different layouts, disks come in an alarming number of shapes and sizes and I/O ports have different addresses. CP/M comes between the program and these different devices and it handles transfers of information between them and the memory. Since CP/M takes care of the information transfer beyond the program and the memory, all the

program has to do is to pass the information to CP/M together with some instruction on what it wants done with it. The program then just sits back and waits for CP/M to tell it that the job's been done. This all means that a program written for use with CP/M rather than for a specific machine will be widely used, provided it's worth using in the first place. All that has to be done to ensure that this will happen is that the machine supplier usually 'configures' CP/M to suit the peculiarities of your piece of equipment. By providing CP/M with the Osborne, a whole world of software opens up immediately.

You also get a few other things with CP/M. You get a whole pile of disk utilities which enable you to format, examine, copy, and generally mess around with information on your disks. The most common uses are to initialise new disks — this means writing the tracks and sectors on them and encoding a certain amount of control information for use by CP/M — and to make back-up copies of files so that you can recover from spilling beer on your master disk, for example. Another useful facility allows you to find out how much space is left on a disk. CP/M is often called an operating system and there are lots of manufacturers around who claim that their operating system is better than CP/M. Better they may be, but the fact is that on 8-bit machines, CP/M is the *de facto* standard and you'd be wise to check the availability of the packages you need before going for a different operating system.

And I've not finished yet. CP/M also includes a couple of programs of great interest to keen programmers, or programmers who want to make their programs run faster. The programs provided are an editor (ED), an assembler (ASM) and a debugging tool (DDT). The editor is an absolute dog and should only be used if you have to create programs in assembler language prior to assembling them into machine code using the assembler. ASM checks your program as it tries to translate it into machine code and if it finds anything wrong it tells you so. It can't detect errors in your program design, only in your coding. Finally, if your program doesn't work as planned then you can use the Dynamic Debugging Tool to examine the contents of various parts of memory and the registers as you step through the program. The assembler and DDT are absolutely fine, but most word

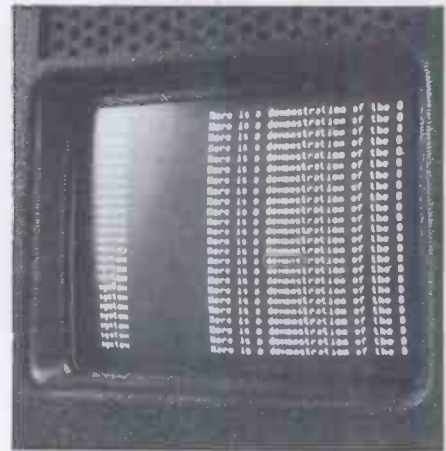

The tiny screen is the O-1's big drawback.

processing packages will allow you to edit program files a darned sight more easily than using ED.

Sticking with system software for the moment, you get CBasic and MBasic with the O-1. There are pretty much the same language except that you can execute one as soon as you've finished typing the program and, if it doesn't work, quickly amend it and have another go. The current buzz-phrase for this approach is 'quick and dirty'. If you write a Basic program using the other version then you have to compile the program using a Basic compiler. This takes longer and you can't really change the code generated by the compiler. You have to go back to your Basic code, change that and then recompile the program. The compilation process is similar to, but not the same as, the assembly process mentioned earlier. Why, you might ask, should you go to all that trouble? The answer is that the resulting program will run faster than an interpreted version and you can also embed identifying information which could trap a copyist because (s)he is most unlikely to find it. I ran the Benchmark programs on MBasic (interpreted) and they were faster than most machines we've tested. CBasic of course would have been faster still. Don't get too excited by these findings unless you are heavily into number crunching. The fact is that, in normal processing, the speed of the machine is completely nullified by the enormous time it takes for the operator to respond to the machine's promptings.

There is another tiny system program tucked in the disk which allows you to enter certain constants from time to time. The first is the speed at which you set the serial port — 300 or 1200 baud. The second allows you to change the screen size — 52, 128 or user-defined. The third allows you to enter the date and time. The time is accurate to within a few minutes per day.

That's taken care of the system programs provided, now let's look at the application programs. First of all, Wordstar and Mailmerge. Wordstar is one of the best word processing packages on the market. On the Osborne it is a little strange to use, mainly because of the small screen — see my earlier comments. Adam has wisely had the package modified so that it automatically scrolls sideways as you are typing text in. He has yet to do that with the Basic packages but he promises me that he will. If you're unfamiliar with word processing there's not a lot I can say here except that it will either increase your throughput of typed material or it will improve the quality of what you write, simply because it is so easy to 'craft' your words until you get them right. If you really want to get into word processing, I suggest you read the April 1981 PCW where we ran an introductory article on the subject.

Associated with most of the good word processors is a mailing list facility which enables you to create and maintain a mailing list. Wordstar is no exception to this and it allows you to incorporate names and addresses in documents and letters so that they look as if they were prepared especially for the person receiving them. Lists can be sorted and names and addresses extrac-

ted according to your own chosen criteria. This is all done using the Mailmerge facilities.

Finally we come to Supercalc. You've probably heard of Visicalc, which is one of the biggest-selling microcomputer packages. Well, Adam couldn't get hold of Visicalc for the Osborne 1 so he decided to plump for Supercalc instead. The program makes good use of the O-1's 'shadow' mode, in which the screen characters can be displayed at half intensity. The spreadsheet grid is displayed in shadow while the entries are all in full intensity. It looks very good. Anyone who messes around with 'what-if' calculations will find this product an absolute boon. Also, are you one of those people who makes lots of calculations and at the end you realise that somewhere, way back, you'd got something wrong which messed up every figure derived since? Using Supercalc, you don't have to worry, you just change the offending number and all the others come right instantly. An interesting bonus is that the data file generated by Supercalc can be edited using Wordstar. I'm sure that's useful but I'm not too sure how useful.

Now on to the ones you pay money for. I mentioned earlier that a database would be my next choice of product. Well, Adam thinks it important too and he recommends three: DBMS, Condor and Datastar. Condor and Datastar are on his approved software list which means that Osborne will be packaging and selling them. DBMS you will have to get direct from your supplier.

Talking of Osborne-approved products, the company will be maintaining three lists: one for the USA, one for the UK and an international one. If you're a software writer and you think you'd like to get your product on to the Osborne 1 then Adam would like to receive your documentation first; then, if he approves, you send him four disks with the program on. It will be carefully examined and any comments made. You will then have to bring it up to the required standard and Osborne will then take over the entire production and marketing effort for the Osborne 1 version. You just sit back and wait for the royalty cheques to drop through the letterbox. Adam tells me that the royalties start high and reduce as sales increase. His justification for this approach is that the higher the sales the more it is due to the efforts of the Osborne Corporation. In general, Adam is not too interested in 'better' versions of what he's already selling because, apart from anything else, it dissipates the marketing effort and, if the first one was adequate for the job, is it really worth the extra hassle? I'm not sure how he equates that attitude with the fact that he'll be handling two database packages, unless they're very different.

I used almost all of the programs supplied and most of them worked just fine for the limited time I could try them. I did run into trouble once or twice when I keyed something in; it was echoed on the screen but then the most odd things occurred. The only example that I reproduced was that I'd get into MBasic, type AUTO in order to get automatic line numbering and it

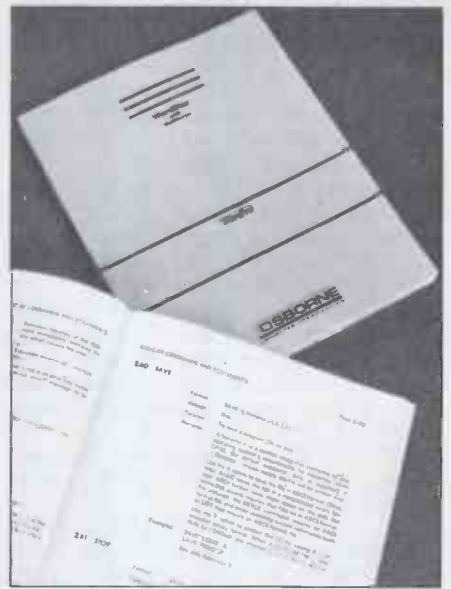

Documentation is of good quality.

would give me SYNTAX ERROR. I'd try for the third time and it would do what it should have done all along and type 10 on the screen. The problem may be in the MBasic implementation or, more likely, I'd got myself a hardware fault. Adam did say that there were a few problems with the review machine's keyboard. Another problem I had, and this time I think it was the MBasic, was that I couldn't read programs which I'd previously saved using the 'A' suffix. It behaved as if I'd saved a null file. Even CP/M's TYPE command couldn't throw any light on this one. Adam thought I must have had a duff version of the software.

## Documentation

Since Adam Osborne started to make his way in the world with books, you should expect a high standard of documentation. And indeed the manuals are very well presented. Unfortunately the almost obligatory glitches had appeared in the books he supplied me. I don't think I encountered a really serious error — they were things like leaving out the key symbols when describing the various key functions or saying that k=1024 then claiming that the disks were 102k — they're not, they're 100k. When I pointed this out, Adam told me that 'all the manuals are undergoing scrutiny and finalisation right now'. All the books will be in a large paperback format with a glossy cover and very neat, readable typesetting inside. True to form, Adam couldn't resist the occasional homily which I found very refreshing. On the first page of his Users Reference Guide he talked about the incompatibility of the various machines on the market. He then goes on in brackets — well he printed the first bracket anyway — 'This is a deliberate marketing strategy on the part of the manufacturers. It is designed to prevent you shopping around for programs, accessories or additional computers once you've made an initial commitment to one of these products.' Later on he mentions the CP/M editor that I dislike so much — 'This editor is primitive and should not be used. Wordstar is capable of perfor-

# OSBORNE 01

ming the same task and is easier to use. If you really must use the editor, consult one of the books now available on CP/M.' Dead right, squire.

Adam has tried very hard to pitch the documentation at the first-time user. In one place he gave the very sensible advice, 'Do not try to get the plastic disk out of the cardboard envelope or you will destroy the disk'. Don't laugh, I've heard of people doing it. Here's another one: 'The door on the drive is closed and opened in the same way as you would open and close an overhead garage door.' Isn't that nice? He's actually remembered his most likely audience, the person who's never used a machine before.

Every package is fully documented, sometimes in the User Reference Guide, otherwise in its own separate manual. The only thing that was missing that interested me was a full technical specification of the Osborne 1. You don't need it to use the machine but it would be of interest to the curious, or to Benchtesters like me. The CP/M overview section of the User Reference book is clearer than most books on the subject although it doesn't try to go too deep with some of the more obscure facilities. I picked up a tip that I suppose I should have realised but didn't — you shouldn't use SAVE more than once since memory contents can be changed as a result of SAVEing.

The MBasic manual has simply been reset because Adam is obliged to retain the original wording until the end of this year. He'll then look at it and change it where necessary. This manual is not at all bad, though, so it shouldn't be a problem. In general, all the documentation will be brought up to the company's house style before publication.

Incidentally, I should give you the address of Osborne Computers: Osborne Computer Corporation, 26500 Corporate Avenue, Hayward, California 94545, telephone (415) 887 8080.

## Users

Who'd use it? My guess is anyone who is taking computing a bit seriously and who either doesn't mind a small screen or who is prepared to forgo a little portability in favour of a separate monitor. The price is good, the facilities offered are more than adequate and, because he's plumped for CP/M, plenty of packages will be quickly available. The sort of dealers that Adam is encouraging are the sort that traditionally sell to the professionals and these are exactly the sort of people that the machine is aimed at. In fact, Adam defines the users as 'professional people using it in the course of their daily work'. It certainly isn't a fun and games machine, although I'm sure that a lot of games will sneak their way onto O-1s. The easiest way for me to describe the market is anyone other than the fun and games, colour and hi-res graphics brigades. I must admit I'm not too sure about number crunching, speed and accuracy either. You'll have to check this out for yourself.

## Prices and delivery

The only price we have in the UK is 'not more than £1200' (excluding VAT) for the Osborne 1 with all its standard software (CP/M, CBasic, MBasic, Wordstar, Mailmerge and Supercalc). The price will be reviewed every three months to take account of the exchange rate between the pound and the dollar. With a bit of luck the price should only go down.

In the USA the monitor costs \$250 and the Osborne \$1795. If the same ratio pertains this would make the monitor £170 in the UK. Delivery at present is between three and six months; Adam says this should improve to between off-the-shelf and 30 days by next summer. I'd say this rather depends on demand.

At the moment a 90-day warranty is offered but Osborne realises that this will have to be a year for the UK market so it will be changed. In the USA, 90 days is standard.

The UK dealerships that I know of are: Rank Xerox, Datron, Crystal Electronics, Cambridge Computer Store, Comart/ Xitan/ Byte Shop/ Computerland, Adda Computers, Lion House and Microdigital. Other decisions are pending and we'll let you know as soon as we're told.

Adam plans to open a UK office with a UK person in charge. I know one of the people being considered and, if he's anything to go by, it will be a very professional organisation. The staff will be mainly British and they'll be given a lot of autonomy. We'll keep you posted on these developments as well.

## Future plans

In early 1982 we should be seeing a new case. This time it will be made of injection-moulded plastic foam in a 'clam shell' arrangement. This means that the inside will be much more accessible for engineers and nosey users. The quaint carrying handle will disappear to be replaced by one moulded into the case. The machine will be lower as a result of having a thinner keyboard unit and it's expected to weigh about a pound less. The bezel is expected to be prettier too.

A battery pack is currently under development and the most likely arrangement will be a large flat unit which forms a false bottom to the Osborne 1. Adam expects this to be available by January or February 1982.

Dual-density disk drives should be announced in November or December and communication facilities in six months or so for the UK. An 80-column screen with user-defined graphics and a 52-column option is also likely to appear in the near future.

Finally, don't just expect upgrades to be up. Adam is well aware of the potential mass market opportunities for small domestic machines. He hinted at smaller Osbornes as well as bigger ones.

## Conclusion

I suppose I've said it all in the Users'

section. The machine is well made, offers more facilities than any other machine at the price and suffers one enormous drawback: the screen measures just 5in diagonally. This isn't a problem for occasional use — an hour or two even — but I'd hate to use it continuously. To overcome this problem, a 12in monitor is available and I would suggest that you keep this where you'd use the machine most. Making such a sophisticated machine portable was a really neat idea. I think, though, that there will be a lot of wives up and down the country who'll roundly curse Adam Osborne for what he's done.

Getting the thing going is a doddle — easier than filling a kettle and plugging it in. You'll need a printer — most people I know use the Epson MX-80 and it offers excellent value at far less than £500. Adam Osborne also uses the same printer on his machine, so it would seem ideal. You'll also need disks and stationery to get under way. And then you're in business. I recommend that you consider this machine very seriously among your options.

## Benchmark timings

There is nothing wrong with the Osborne's performance on our standard Benchmarks. It came out faster overall than most other machines we've tested. You must remember though that these tests relate mainly to the computer's numerical processing speed and take no account of accuracy, string handling or disk handling. The other thing to bear in mind is that computers spend most of their time waiting for information to be transferred between themselves and their peripheral devices. Timings were made using MBasic. CBasic would have returned still faster times.

All times in seconds.

BM1	1.4
BM2	4.4
BM3	11.7
BM4	11.6
BM5	12.3
BM6	21.9
BM7	34.9
BM8	6.1

## Memory map

0000	System read only space; part switches to ROM in shadow mode
4000	Post processing sequence & data buffer RAM
EA00	CBIOS entry points
F000	Memory-mapped video RAM
FFFF	Top of memory

In shadow mode the memory up to 4000H isn't available when CBIOS is operating. To get into and out of shadow memory mode you need to OUT 0 or 1 coupled with a change to location EF08H making that 0 or 1 too. These routines must be above location 4000H.



**DON'T FORGET XMAS ORDER NOW**

# SUPER INVASION ON YOUR ZX80 & ZX81

**1K**

## TOTALLY FLICKER FREE ● 3 LEVELS OF PLAY IN EACH GAME

Absolutely no flicker. You don't need to press any thing for the display to move!

From easy to dangerously difficult — you'll find it hard to resist the challenge time after time!

## MOVING GRAPHICS ● MACHINE LANGUAGE

No hardware modifications are necessary to get moving graphics. Just follow the instructions for cassette loading and off you go, no extra memory needed.

These programs are written in the computer's own language — only this way is it possible for continuous, flicker free action to occur.

## ALL PROGRAMS ON CASSETTE ● FITS 1K BASIC MACHINE

Loads just like any other program on cassette. Each tape contains instructions on how best to load the cassette.

Amazing as it is, all these moving graphics programs fit into your basic 1K Sinclair!

### SUPER INVASION

is the machine language game you and your Sinclair have been waiting for. Cruel and crafty invaders have been spotted in battle formation ready to attack with your ship just below them! Quickly and skilfully you shift right and left as you carefully fire your lasers at them. But watch out — they are accurate! 3 levels from easy to almost impossible to beat.

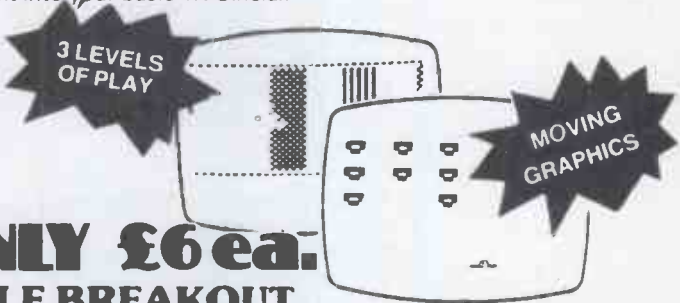

**ONLY £6 ea. DOUBLE BREAKOUT**

You'll be amazed to see how difficult it is for you to break through the ZX80 DOUBLE BREAKOUT and even more astonished to see the exciting game fit into your 1K Sinclair. Try your skill on the easiest level because even with the most skilful bat control you'll find it hard to catch at the fastest level! Breaking through the first barricade is easy but don't be fooled for the second — it's much harder than you think! Two ball angles and curved bat will keep the excitement going for hours!

THE ESSENTIAL SOFTWARE COMPANY  
47 BRUNSWICK CENTRE LONDON WC1N 1AF

I have a ZX80 Old ROM  New ROM  ZX81

Please send me ..... copies SUPER INVADERS and ..... copies DOUBLE BREAKOUT.

I enclose cheque/postal order for ..... plus 50p post and pack

Name .....

Address .....

Access accepted for Mail Order or phone 01-837 3154



### Video Genie TRS 80

Your fighter appears below a convoy of Aliens! If you destroy them another set appears who seem to be slightly cleverer than before! Soon your space station nears but before you can dock the station comes under attack! Survival is up to you! The excitement is just beginning!!

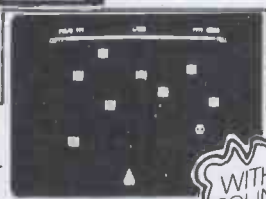

**COSMIC FIGHTER**

WITH SOUND

TRS 80 Levels I & II 16K Tape £10  
Video Genie 16K Tape £10

Dodge the alien Ramships and fire missiles to destroy them before they get you. The alien Flagship uses his deadly laser bolt to transform a Ramship into another Flagship or into your ship's double. Look out! Destroy your double and you could destroy yourself.

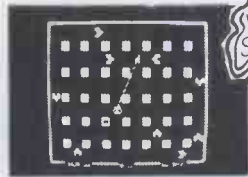

**ATTACK FORCE**

WITH SOUND

TRS 80 Level I & II 16K Tape £10  
Video Genie EG3003 16K Tape £10

## COMPUTING CAN BE FUN

QUALITY PROGRAMS CHOSEN FOR THEIR SUPERB GRAPHICS AND SMOOTH ACTION

### GALAXY INVASION

The newest and most exciting invaders type game yet! Cruel and crafty aliens attack Earth. You are the sole defender. As you fire your laser at the aliens they swoop down and bomb you. Exciting use of graphics! Must be seen.

TRS 80 Level I & II 16K Tape £10  
Video Genie 16K Tape £10

Now the amazing ASTEROIDS arcade game for your TRS 80! Your ship is floating in the middle of an asteroid belt! Your only escape is to destroy them and the crafty alien spacecraft! Blast them with your laser, thrust, rotate or hit hyperspace to survive!



TRS 80 Levels I & II 16K Tape £10  
Video Genie 16K Tape £10

**ASTEROID NOVA**

## LABYRINTH & DEATHMAZE

A must for all adventure addicts!

Walk down corridors depicted in full 3-D graphics. Look around to find the objects you need to survive. But beware! Monsters and Incredible Obstacles can lurk round every corner!

**NEW!**  
for TRS 80 LEVEL II 16K

LABYRINTH TAPE £10  
DEATHMAZE TAPE £10



THE ESSENTIAL SOFTWARE COMPANY  
(Viscounti Ltd.) 01-837 3154  
47 Brunswick Centre, London WC1N 1AF

I have a ..... microcomputer.

Please send me your software catalogue. I enclose a stamped self addressed envelope.

Please send me .....  
I enclose a cheque/postal order for £ ..... (plus 50p post & packing)

Signature .....

Name .....

Address .....

Postcode .....

My ACCESS No/s .....

# The first ITT developed software The 2020 Accountant

The 2020 Accountant is a comprehensive Accounting software package designed to run on the ITT 2020 Micro computer. It performs the functions of:- Sales Ledger, Purchase Ledger, General Ledger, VAT, Sales Analysis, Transaction Recording, Age Debt Analysis and Name and Address Recording.

All of the items are fully integrated and the system can run a set of up to 10 ledgers concurrently.

The main application areas for this software are seen as:- Small Businesses, Practising Accountants, Incomplete Records, Managing Estate Agents, Time Recording/Job Control and Contract Control. In addition, its comprehensive detailed transaction recording and audit capability will make it suitable for use as a 'stand alone' system within the Cost Centres of large companies.

## HARDWARE

The hardware requirement for the system is as follows:- 48K ITT 2020 Micro Computer, 3 ITT 2020 Disc Drives, Monitor, Printer, 16K Memory Extension Card, 2020 Accountant Diskettes, 2020 Accountant User Manual.

# ITT

World-wide Technology

ITT Consumer Products (UK) Ltd.,  
Chester Hall Lane, Basildon, Essex.  
Tel: Basildon 3040 Ext. 196-198



PUT SOME  
**COLOUR**  
 INTO YOUR PERSONAL COMPUTING

WITH THE NEW

**OKI *if*800**  
*model 20*

The **OKI *if*800** brings a new and colourful dimension to personal computing. Now you can enjoy extensive multicolour graphics facilities and a CP/M\* environment on the same machine!

Just look at some of the features and facilities uniquely offered by the new **OKI *if*800** ... a truly versatile fully integrated computer system!

Features:

- Powerful Z80A 4MHz Processor.
- High resolution multi-colour graphics CRT.
- CP/M\*
- Versatile OKI BASIC.
- Twin set of programmable function keys.
- Integral 80cps OKI printer.
- 560K bytes mini floppy disks.

Options:

- External twin 8 inch floppy disk drives (1M byte).
- ROM cartridge.
- RS 232C Interface.
- Audio cassette.
- Light pen.
- Centronics parallel interface.
- Instrument interface IEEE 488.
- Analogue-digital and digital-analogue convertor.

*DISTRIBUTOR AND DEALER ENQUIRIES INVITED.*

PRICED AROUND £4,750 (+ VAT)

**OEM Systems**

COMPUTERS

Copse Road, St. Johns, Woking, Surrey GU34 1SX Telephone: Woking (04862) 23411 Telex: 85952



Please send me full details of **OKI *if*800** today!

Name: .....

Company: .....

Address: .....

Tel: .....

\*CP/M is a registered trade mark of Digital Research

## SHARP IQ3100 MICROTRANSLATOR

*John Fairbairn tests the latest in pocket translators.*

As a professional linguist, I am usually assumed to pour scorn on phrase-books or their silicon-chip equivalents. But I, and especially my stomach, have frightful memories of a stay in Hungary, the one country I have been to where I did not have at least a smattering of the language. The only word I knew was for ice-cream — and that is the only thing I was given that was edible. I soon acquired an image of Hungary as a surly and depressing place, and I couldn't wait to get over the border to Czechoslovakia and "civilisation".

I have no doubt now that I am being unfair to a beautiful country, but to me civilisation is based on communication and anything that helps that along is a blessing. For example, the Sharp IQ3100 Microtranslator.

After testing this new machine for a month round the tourist haunts of London, I am happy to say it's fun and it works and it's the best around. At about £70 plus £18 for each language module it's not exactly cheap, unless you can set it against tax, but it's certainly a novel way to chat up the opposite sex.

First impressions of the IQ3100 were highly favourable: sleek, robust, and genuinely pocket-sized. Those feelings soon changed to abject terror after I read the first five pages of the otherwise satisfactory instruction book. To paraphrase them: unless you handle the tiny language modules with the skill of a brain surgeon, that's £18 up the spout. I managed to get two modules, the maximum, into the machine safely but put that down to the clove of garlic in my back pocket. But once the modules were in, the machine confirmed its robust impression, even when rammed into a shoulder bag on a crowded tube train.

### In use

Then it was idiot's test time: press every button in sight and see what happens. The machine responded at once — but not in the obvious way. To get the thing to translate anything you have to read the instruction book; which means you can't accost a stranger, tap out a question for him, and then pass the machine to him for a reply — a serious design fault with no obvious solution.

Other design niggles were the alphabetically ordered keyboard (though, of course, it has to be that way for other countries), the wrist strap which surely should be at the top right corner, and the display, which is the liquid crystal type seen in the Sharp PC-1211 pocket computer (24 characters, 7x5 dot matrix, all upper case). This display is attractive, especially when it rotates to show long sentences (using the DSP key). However, at certain angles it looks blank and if you point the machine at someone in the street in bright sunlight you are apt (I speak from experience) to get some very funny looks.

Another difficulty with the display is that letter 'O' and number '0' are not differentiated (they are only slightly so on the keyboard). But the box of tricks inside *does* differentiate, and if you ask for a DOCTOR with zeroes instead of vowels you might be dead before you realise why it won't translate.

Once the machine is powered up (using the non-rechargeable one-year battery provided), you choose the languages to work in. English is built in and you can add one or two of the eight other languages so far available: Dutch, French, German, Italian, Japanese (in romanised or kana forms),

Portuguese, Spanish or Swedish. The modules are easy to change — provided you take care!

You press the LNG key repeatedly until arrows point to the two languages you want (little stickers are provided for two vacant slots after SPA for the rare languages), then press the double-arrow key to alternate the arrows on the display pointing 'from' and 'to' a language.

You then have a choice of typing in a word or sequence of words and translating that (pressing TRN), or of pressing the SNT/WRD key to set the machine to a category mode. In that mode you can choose sentences or words (by one or two presses of SNT/WRD). The category most appropriate, one of 14 clearly labelled round the outside (plane, Customs, transport, hotel, restaurant, sightseeing, amusement, shopping, direction, business, service, conversation, doctor, emergency) is chosen by pressing the key next to the symbol. For example, using sentences, pressing S (restaurant) brings the display DO YOU HAVE A (BAR)?

You can accept this sentence or search through all the sentences in that category (11 in this case) by pressing SCH. Stepping through SCH in this category gives next:

I DO NOT HAVE A RESERVATION  
I WANT (A TABLE) FOR (7)

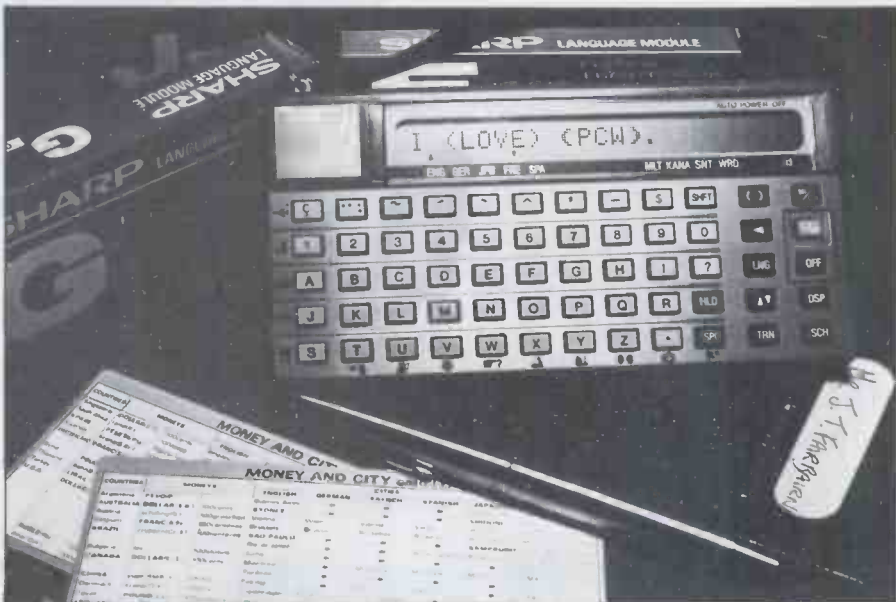

*The IQ3100*

# CHECKOUT

## WHAT DO YOU RECOMMEND? PLEASE GIVE ME (A GIN FIZZ)

You can change any word in brackets (if there are two sets of brackets, use the key  $\langle \rangle$  to alternate between them) simply by typing in the new word, as the first key-stroke wipes out what was in brackets and the replacement letters are displayed inside them. This business can be made to work smoothly, but consider first one of the worst cases: you want a book. You find the gin-fizz phrase, which takes about 25 seconds after switching on, then type in A BOOK (at least 10 seconds), press TRN, wait for five seconds and, hey presto, you get **DONNEZ-MOI (UN(UNE) LIVRE(LIRE)) S.V.P. from the French**



module. If this silly attempt to avoid saying 'give me a pound' instead of 'give me a book' could be justified on the grounds of avoiding arrest for vagrancy in Paris, good enough; but I think the excessive preoccupation with the problem of multiple meanings or genders betrays the conceit of the linguists behind the modules. The problem is there and has to be met, particularly because it is the commonest words that tend to have multiple meanings, but it seems reasonable to allow a fair measure of ambiguity, even more so when I tell you that you can't use plurals or other noun declensions or decline verbs or change tenses — in short, you get a pretty peculiar output, anyway. But it still works — so why worry about one more peculiarity?

If you made a mistake and didn't want to ask for a book, but had already typed that, it would take you about 30 seconds to step round back to the gin-fizz phrase. I'm sure you realise by this time that you have to be pretty familiar

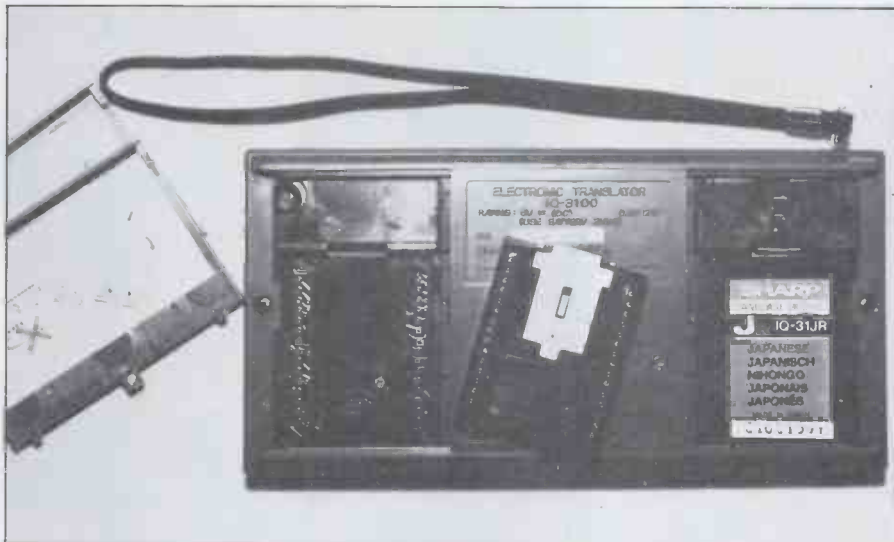

The language modules plug in at the back.

with the whereabouts of all these phrases.

Why not just type in your request straight off, without going through the category mode? Answer: input **GIVE ME A NEWSPAPER** gives output **DONNER ME UN(UNE) NEWSPAPER**. This is because it will translate literally word for word or set-phrase for set-phrase only, with no attempt to change word order or to make any other grammatical concessions. And if you try a word that's not in the 2000 or so words of the memory that word is left untranslated, usually with the addition of '!!' — and always in the case of rude words.

The box of tricks is, therefore, little more than a program for retrieving data from a file. Some idea of how this works can be inferred from another



feature, the dictionary search. Type in an initial letter or letters and by pressing **SCH** you can step through all the words in the memory that begin that way. Until these machines become as familiar in use as calculators are, almost the only way to find out what a foreigner is saying is to try to pick out the first letter of the most important word (the one he keeps repeating or shouting), type that in, then point the machine at him while you step through the dictionary, hoping what he's saying is in there.

I said earlier that all this can work quite smoothly, but you probably don't believe me. The point is, you use these



machines in a spirit of fun or desperation, but at any rate time or egg-on-face will not be your main worries, and it is amazing how much you can murder a language and still be understood. You do become familiar with the machine, and learn what kinds of sentences or words it will find digestible (a sort of basic English). The selection of words in the memory bank is excellent, apart from a few words like gin-fizz and Americanisms. To take one category, Customs: I asked Customs officers at Heathrow what they thought of the sentences and words relating to their work, and they thought they were very apt. No one has yet tried a machine on them.

Above all, don't forget that the IQ3100 can be used as a back-up when you already know a little of the language. It is an invaluable dictionary (and very fast when used exclusively that way), with the 2000 words being far in excess of the 800-odd words that were used successfully to render *Chambers Dictionary of Science* into basic English, and not too much below the *specialist* dictionaries of around 3000 words used in many mainframe machine-translation projects.

## Conclusion

Sharp's IQ3100 is by no means the first pocket electronic phrase-book, nor are

GOTO page 182

# BENCHTEST

# IBM PERSONAL COMPUTER

*The much-rumoured IBM Personal Computer was finally announced last month and, just to make sure it really exists, PCW sent David Tebbutt to Florida to conduct the world's first Benchtest and to meet the people who made it happen.*

With more than a little help from its friends, IBM has come up with a real stunner of a personal computer and, much to PCW's delight, it has named it the IBM Personal Computer, which must surely remove any lingering doubts about this magazine's title. The system has much to commend it both for serious and fun applications since it can grow from a fairly expensive cassette-based configuration to a full-blown twin disk/colour graphics machine which offers the competition a fair run for its money. It almost goes without saying that the computer is well made, keeping up IBM's almost legendary reputation for quality.

After watching the growing personal computer industry very carefully, IBM finally cranked its own Personal Computer project into action around 14 months ago. The public was becoming aware of the usefulness of these machines and prices were dropping to an affordable level; this was enough for the grey giant and it made its move. By swearing certain key people and companies to utter secrecy, IBM was able to discuss its plans and listen to those who already knew what the microcomputer game was all about. Microsoft, for example, was involved right from the beginning and was able to give a lot of help, particularly with the graphics and sound facilities. Later on, once a design was fairly clear, ComputerLand became involved and advised on aspects of dealer support and training. Sears, Roebuck was approached, too, and was particularly helpful when it came to packaging the products for the retail outlet.

The machine will be sold in America through IBM's own Products Centres, through sales offices within its Data Processing Division (DPD), through ComputerLand's existing network of some 170 shops and through Sears' about-to-be-opened business machine stores. At the moment the system will only be sold in the USA and Canada and IBM will not say when, if ever, it will come to Britain. Since demand is bound to be very high in North America, IBM will clearly have to gear up its manufacturing and distribution quite significantly before we will see any systems in this country.

## Hardware

The minimum configuration Personal Computer comes in two parts: a



System Unit, which houses the memory, processor, loudspeaker, power supply and expansion slots and a keyboard, which is connected to the system unit with a six-foot coiled flex terminating in a DIN plug. One or two 5¼in disk drives can be installed in the front of the system unit and up to five optional enhancement cards can be plugged into the slots. A monitor or domestic television is needed and, for those without disks, a domestic tape recorder with a DIN connection will be necessary too. IBM supplies an Epson printer as its standard listing device although there's no reason why you shouldn't attach a printer of your own choosing. In use, the monitor would probably sit on the System Unit while the keyboard could be used on a table or on your lap. Two little lugs allow the keyboard to tilt when on a flat surface and they tuck away if you're using it on your lap. The whole design is very pleasing and all the parts clearly belong together.

Everything about the IBM system is designed with a first-time user in mind. The company has gone overboard to make the system as easy as possible to configure and use with one of the main aims presumably being to minimise IBM and dealer post-sale involvement. Two screws secure the top of the system unit and, once removed, it is a simple matter to add memory, plug-in boards or even disk drives. IBM supplies a monochrome monitor with a very steady,

clear display of 25 rows of 80 characters or you may prefer to buy your own colour monitor or even use the domestic TV, each of which gives an option of 24 rows of either 40 or 80 characters. The graphics resolution is not as good in colour as it is on the IBM display. In fact, each character is 7 x 7 dots in an 8 x 8 box compared with 7 x 9 in a 9 x 14 box for the monochrome display. IBM does issue a warning that certain televisions and monitors (not its own) can cause data errors on disk transfers. It suggests the solution is to have the screen at least 12in away from the system unit. In order to drive these colour devices you would need to plug a colour/graphics monitor adaptor into one of the spare expansion slots. This board supports colour graphics — up to 16 colours in text mode, up to four in medium resolution graphics (320 x 200) and black and white in high resolution mode (640 x 200); it also allows you to define 128 graphics characters of your own when using either of the graphics modes. The board is also designed to handle a light pen. Composite and direct drive video outputs are provided to drive a colour monitor but for your domestic TV you'd have to buy an RF modulator as well.

The IBM monochrome monitor is a very high quality 11½in green phosphor device with an anti-glare screen. It gives a rock-steady display with no trace of flickering or that high-pitched whistling

which sometimes occurs. The steadiness is achieved by using a high-persistence phosphor coating which takes a fraction of a second longer to clear than most screens, although I can think of one or two machines which are far, far worse. In normal use it's doubtful that you'd even notice it. The screen displays 25 lines of 80 characters and each character is beautifully formed thanks to the high resolution mentioned earlier. IBM has taken advantage of all eight bits of the character code by adding a ninth bit for parity checking. This means that 255 different characters are offered, ranging from little faces through the standard ASCII set to special characters for foreign currency, mathematics and graphics. A separate byte associated with each screen character is used to describe the character's status — whether it is underlined, enhanced, flashing, non-displayed or reversed. An interesting feature of the character set is that the business graphics — the ones used to display forms on the screen — comprise a mixture of single and double line shapes which makes for very neat and compact form layouts.

The monitor plugs into a monochrome display and the printer adaptor, which occupies one of the expansion slots. If you're using the Epson printer then you won't need to buy an extra card to drive it as it plugs into this same card. If you'd gone for colour then you'd need a separate printer adaptor. There's no reason why you shouldn't drive a variety of displays, or even a variety of printers if you feel so inclined. The standard device is the Epson MX-80 tractor feed machine which has had some soundproofing installed and the wire paper guide sprayed in the official IBM colour. It offers 12 different character styles and (according to the documentation) 64 graphic characters plus nine special characters as well as the standard 96 character ASCII set. It will handle multi-part (up to three, anyway) forms between 4in and 10in wide. You can buy an optional printer stand which is a very neat smoky perspex unit which can store an inch or two deep stack of continuous stationery. It does have the slight disadvantage of amplifying the printer noise so you'd have to trade off noise against neatness. The stand is a rectangular piece of perspex bent back on itself, each half being separated by plastic pillars 3in or so high. This simple design was cooked up by an IBM engineer who felt that the programmers' own design of three or four bricks was somewhat less than elegant. One thing you'll notice from the price list is that the printer comes without a cable — you have to buy it separately at \$55.

The 'typomatic' keyboard is a work of art. Offering tactile feedback and automatic repeating on certain keys, it contains every key you could ever imagine using, all in a well-designed unit which clearly owes a lot to IBM's experience in typewriter design. The only thing I disliked was that the shift keys were hard to find because they are located above a couple of other keys. To a non-typist this wouldn't cause the slightest problem but anyone used to a keyboard may experience some difficulty at first. Apart from the standard typewriter keys, it has 10 function keys, some assorted control

keys and a separate numeric/editing keypad — 83 keys in all. The keyboard is a low, flat unit which weighs a surprising six pounds. I found out later that IBM actually put a heavy metal plate in purely to stop it sliding around. It's that kind of attention to detail that characterises the design of this machine.

A numeric lock and a caps lock do exactly what you might suspect but when the numeric pad is not locked it acts as an editing keypad with insert, delete, cursor left, right, up and down, page up and down, home and end functions. A touch on the control key and the character functions operate on whole word instead. You will have probably gathered from this that full screen editing is standard. The mathematical symbols appear in their normal places as well as on separate keys so that they can be accessed without the need to use a shift key. Tabbing can be both forward and backward and a 'Prtscr' key allows you to dump text from the screen to the printer. When programming in Basic, you can print most of the commonly used commands by hitting a single key with the 'ALT' key depressed. The 10 function keys are defined to give single stroke facilities such as SAVE and LOAD and you may redefine them by using the KEY command in Basic. By judicious use of the shift, alt and control keys it is possible to access 40 facilities from the function keys. A mysterious key called 'Scroll Lock' doesn't actually do anything.

The Benchtest systems each had two

disk drives horizontally mounted in the front of the system unit. These looked suspiciously like the drives in my Super-Brain although IBM wouldn't confirm or deny this other than to say that it might obtain disk drives from more than one source. Each disk has a capacity of 160 kbytes held in 40 tracks each of 8 x 512-byte sectors. The drives are quite accessible even when the keyboard is pushed up close. A sensible feature is that the disk drives automatically switch off when they haven't been accessed for a second or two.

Tucked away inside the system unit is an 8088 processor which has an internal 16-bit structure, 8-bit data transfer and a 20-bit memory addressing capability. The 8-bit data bus means that the 8088 is compatible with the popular 8080/8085 processors' support circuits while the 20-bit addressing means that the processor is capable of accessing up to one megabyte of memory. An interesting gap on the processor board tells me that the IBM can accommodate an auxiliary processor — a floating point arithmetic processor or a mass memory/large scale communications handler perhaps?

The Personal Computer gives the user from 16k to 256k of RAM plus 4k or 16k of display memory on the adapter card, depending on whether it's for monochrome or colour. Up to 64k is held on the processor board and additional memory in 32k or 64k plug-in expansion boards. Since only five slots are available it would pay to go

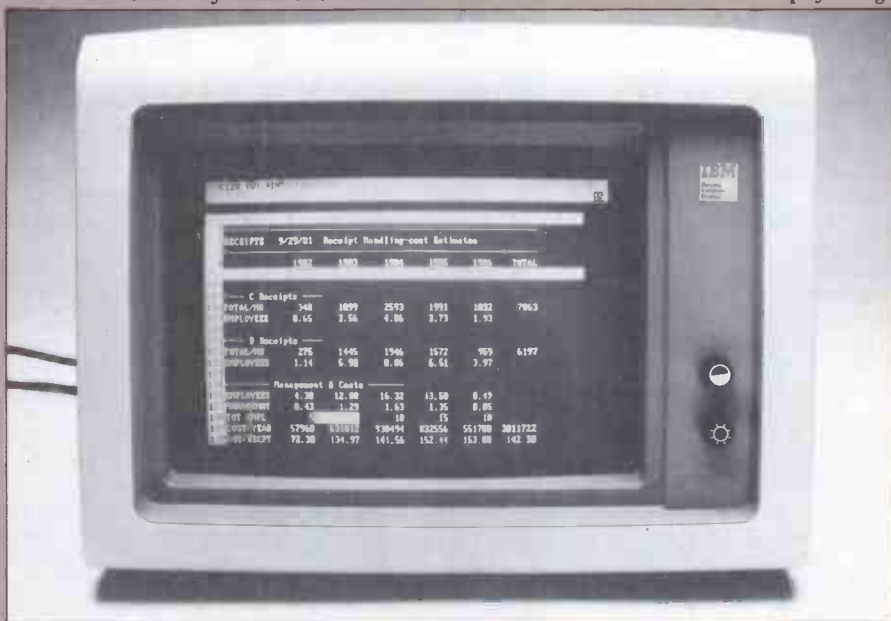

The IBM's display: '... each character is beautifully formed ...'



Rear view of the System Unit

# IBM PERSONAL COMPUTER

for the 64k upgrades if at all possible. I wouldn't be at all surprised if one of the early announcements isn't an external expansion box to take more plug-in option cards.

Other cards currently available are a game control adaptor and an asynchronous communications adaptor. The game controller will accept two joysticks or four paddles which you'll have to buy from outside. The communications adaptor seems to me to be a complicated way of describing an RS232C/current loop interface which can be driven at speeds between 50 and 9600 baud. IBM intends to provide a subset of full 3270 emulation capability which should excite the odd DP manager here and there.

Working through a typical configuration, we find that a colour/graphics card takes one slot, the printer another and the disk drives another. This leaves two slots free for games, communications and extra memory (up to 64k can be on the processor board and another 16k is on the graphics adaptor). I'd say that this package will suit 99.9 percent of intending purchasers' requirements. The remaining 0.1 percent will have to compromise, buy another machine or wait for an announcement of an expansion box.

Microsoft's Cassette Basic interpreter is contained in 40k of ROM with some fundamental I/O routines and is standard in every Personal Computer sold. Basic enhancements and the Disk Operating System (DOS) are loaded from disk.

Every peripheral is interrupt-driven, which means that when a particular device is not doing anything, it is ignored. Once it has something to say then it interrupts the processor to demand attention. The processor then finishes whatever it happens to be doing at that instant, serves the interrupting device and then gets back to whatever it was doing before. This makes programming much easier and also makes the machine run significantly faster by avoiding 'waiting time'. The Benchmark timings weren't designed to highlight this sort of activity so, although they're fast, they're nothing extraordinary.

Somewhere between hardware and software lies the firmware which is the stuff that gives the Personal Computer its native intelligence before any programs have been loaded from outside. What follows is a bit of a pot-pourri of facilities thus offered.

The first thing the system does at switch-on is to run its own internal diagnostic routines to make sure that everything is working okay. Once complete, the machine 'peeps' through the loudspeaker and allows you to load programs or whatever. It is also internally programmed to react to certain key combinations. For example, if you want to 're-boot' the DOS, the system will recognise a simultaneous depression of the ESC, ALT and DEL keys. CTL with Numlock is a toggle which suspends and restarts program execution while CTL with Prtscr is another toggle which causes an echo to the printer. The keyboard has a 16-character buffer which is

pretty exciting when using the word processor — you have to keep a careful count of the number of times you hit the delete key! This buffer size can be changed but I'm assured that it's a 'non-trivial' exercise.

## Software

The IBM Personal Computer is supplied with a Cassette Basic developed by Microsoft and all the other packages are sold as extras. IBM will divide its software packages into the following groups: Professional, Business, Word Processing, Entertainment, Personal, Education, Computer Languages and Software Series. Each is coded with a pleasant colour, mainly pastel shades with the exception of Entertainment which is black. The colour is used on all documentation and packaging for products within that particular theme. While I was Benchmarking the machine, the only products actually available were Disk Basic, Advanced Basic, DOS, EasyWriter, VisiCalc, Adventure, General Ledger, Accounts Payable (Purchase Ledger), Accounts Receivable (Sales Ledger) and (I think) the Communications Package and Pascal Compiler. I didn't actually get to see either of the last two packages in action.

IBM didn't see any point in starting software development from scratch so it went to those companies whose products and people best met its own criteria and together they produced the IBM versions of the packages. Microsoft published the Basics, the Pascal compiler, the DOS and the Adventure game, Personal Software published Visicalc, Information Unlimited Software published Easywriter, Peachtree Software was responsible for the ledger packages and it looks as if IBM devised the communications software. I'll deal with the application programs first.

Visicalc is a hotted-up version of the program we've grown to know and love. It now allows you to edit parts of fields, handle tables and move around much faster than on the previous versions I'd seen. You can also choose between a 40-column or an 80-column display. On the domestic TV you'd almost certainly have to go for the 40-column display.

Easywriter is an interesting word processing package because it is entirely memory resident. This means that individual text files can't exceed 18,500 characters (this Benchmark so far is around 15,000 characters) but to comp-

ensate for this, a linking function allows Easywriter to treat a number of separate files as a single file for reporting purposes. Once I got the hang of it, I found this package quite pleasant to use and I think that many people will find it offers all the facilities they're likely to need. It is possible to move blocks of text around, to do word counts and even to undelete stuff provided you haven't moved the cursor since the delete took place. Even my lovely Spell-Binder doesn't offer the last two functions.

Adventure is the standard Microsoft game in which you have to overcome obstacles in an underground network of caves while collecting as much treasure as you can manage. At the moment the game is entirely textual, which is unfortunate, but I suspect that within the next few years it will be on video disks and, boy, will we have some fun then!

The ledgers are all designed for the American market and are therefore of little use here. All I'll say is that they've been professionally produced and give a good indication of the software standards that IBM is going for.

## Basic

The built-in cassette Basic is a superset of Microsoft's Basic-80. It allows you to use all 256 characters, to plot in medium or high resolution graphics, play sounds through the loudspeaker and control light pens and joysticks as well as doing all the things that Basic-80 does. It can handle up to 17-digit precision, full floating — point arithmetic. It does borrow 4k of user memory to operate. If you move on to the Disk Basic you'll find that it uses 24k of memory plus an extra 1.5k if you want to use the communications facilities as well. In addition to everything offered by Cassette Basic, this version allows you to handle disk-based files, to keep track of the date and time, to handle two additional printers and to drive an RS232 port.

The Advanced Basic pinches 29k of user memory, again with an extra 1.5k if you're into communications, and it offers everything the Disk Basic does plus some additional features. This is the one that allows you to handle interrupts from the function keys, a joystick button, the light pen or the communications line. It also includes a graphics macro language which offers statements such as CIRCLE, PUT, GET, PAINT and DRAW. A music macro lan-



The keyboard has just about every key you might ever need.



guage allows you to create music and sound effects quite easily through PLAY statements and musical notation written in English. Since the functions within the macro languages are all written in machine code they operate at very high speeds. The only Basic overhead is the execution of the single statement calling the routine. Some neat effects can be achieved using the graphics macros GET and PUT which handle the transfer of arrays to and from the screen. The trick is to define a shape on the screen, imagine a box around it and define this as a two-dimensional array to be saved. A GET saves the array and a PUT will redisplay it wherever you like. If you PUT an array to the same position twice using an XOR argument this removes the array image and restores the original background. The sequence for animation then becomes PUT to the screen with XOR, calculate the new position, PUT to the screen at the old location (using XOR) and then repeat the process for the new location. Another neat trick can be played if you're in text mode. You can define an active page and a visual page. This means that one screen can be on display while your program is busily changing another page ready for display. Sound, too, offers some potential because, having initiated the playing process, the system gets on with it while you do something else. This means that if you want to play a musical background to a game, for example, then you can, regardless of what is happening on the screen and keyboard.

The first 40 characters of all variable names are significant. This means that the novice programmer can describe the variables in full. After a while, of course, he'll realise how much space is being gobbled up and will then either have to cut down on eloquent names or buy more memory. With 256k I don't suppose that long variable names would be a problem.

Since Microsoft Basic is pretty well the standard these days I think I'll leave you with those few tantalising glimpses of the extra facilities and move on to the DOS.

## DOS

No, this isn't the same DOS as on the IBM mainframes. Some people call it PC-DOS just to differentiate but I'll stick to DOS for this article. Not surprisingly, it is similar to CP/M in its range of facilities but to the user it is a whole lot more friendly. For example, if you want to copy files in CP/M, you have to load the PIP facility and then give the necessary instruction to PIP. In DOS you simply type COPY, the file to be copied and the new file name. In PIP it's back-to-front — you have to start with the new file name and follow with the old file name.

Other DOS functions allow you to copy a whole disk, compare the contents of two files or a pair of disks, erase files, rename files, format a disk, list the contents of a disk, type the contents of a file and put the DOS on to another disk. Nothing unusual about that I hear you say. Well, that's true except that all the instructions are near enough in English, eg DISKCOPY.

But then we come to the other facilities: you can invoke batch files,

issue messages and prompts (for DATE and TIME) while they are running and even pause and restart their operation. MODE allows you to define screen and printer characteristics and if you don't like the position of the display on the screen, you can scroll it sideways a column at a time until it suits your monitor or TV. CHKDSK examines the chosen disk and gives a status report. If you name a file AUTO-EXEC. BAT it will be executed on boot-up and it can be either a program or a job stream (batch).

DOS will work on a single disk drive system, issuing appropriate prompts for the user to change disks when necessary. Other programs available on the DOS disk are a relocatable module linker, an editor and a debugger. IBM refuses to comment on the likelihood of an Assembler. I saw enough clues to make me think it's a strong possibility very soon. A diagnostic disk is available which allows the user to run his own diagnostic routines, the results of which he can analyse from the descriptions given in the manual. Although I've not covered the DOS in detail, you can see that it provides everything that a user is likely to need.

Looking at it from the programmer's point of view was a little difficult without an assembler. The FCB is in two parts — the first seven bytes act as a prefix to a 35-byte FCB. The first 11 bytes of the main FCB tally with the CP/M version but after that either the terminology differs or the actual contents are different — I can't be sure. They do actually look different to me although they're the same length. I was told that although the DOS has its own entry points, it is possible to use all the CP/M calls as well. It looks as if IBM is making it as easy as possible to convert from CP/M to DOS on the Personal Computer. It will be interesting to see what CP/M-86 has to offer when it comes along.

## Documentation

All the IBM documentation is excellent. It comes in a series of colour-coded, cloth-bound three ring binders which fit into matching cloth-covered boxes. If you buy a game or a package which doesn't justify the full treatment, then you get a plastic wallet, four of which just happen to fit into one of the boxes I just mentioned. Each box, which can be bought separately, measures about 8in x 2in x 9½in high. In the seven or eight hours I spent reading the manuals, I only found one error and that was in the dealer's product guide. Considering that IBM has only been working on the project for 14 months, I think it's a remarkable achievement. Mind you, I do wonder how many staff it's had beavering away — no one would tell me.

The manuals are very well written, and IBM must have really thought about the target audience before writing each document because they start off talking about 4096 chars but by the time you reach the Basic manual it cheerfully uses 4k, knowing that you must have grown accustomed to some of the jargon by then. All the manuals are very clear and seem to cover all the ground necessary. They have indexes and tables of contents and appendices to save you

diving around all over the show if all you need is a quick reference. Error messages are clearly explained with the appropriate actions suggested.

A 'Guide to Operations' and a Basic manual are supplied with the machine. The 'Guide to Operations' includes sections on setting up the machine, operating it, 'Problem Determination', installation of options and how to move it from one location to another. Another example of IBM's attention to detail is the fact it supplies its disks with reinforcing rings and some don't have notches so that you can't accidentally overwrite them.

## Who'd use it?

The television advertisement uses a Charlie Chaplin look-alike, presumably to hook every viewer. The emphasis is on simplicity, ease of installation and fun. The music and the voice-over reminded me of the Disney wild-life films where the music changes according to the screen activity and throughout a very friendly voice explains what's going on. In the beginning there's 'Charlie' sitting on a white chair at a white table with a room-sized white box gradually shrinking before his eyes. The narrator says things like 'Once upon a time a computer was the size of a room' and, as it shrinks, he describes how IBM kept making them smaller until you could pick them up. At this point 'Charlie' picks up the machine and takes it over to his table where he unpacks it, assembles it and starts tapping the keyboard. All this is done with grossly exaggerated gestures of course. The final shot is of this rather nice machine sitting on the table next to a vase containing a single rose. Very warm, very friendly, very simple and a bit of fun too. More evidence of IBM's seriousness and attention to detail. There's not a threatening moment in the whole ad.

IBM sees its Personal Computer being used in the home, the office, the laboratory and the school. It goes further and defines its users as small businesses, the self-employed, departmental users, home users and hobbyists. It seems they've covered just about everyone there, doesn't it? I'm not too sure about the hobbyist being able to afford the machine at the moment. All the hobbyists I know are beavering away on low budget equipment with half the fun being to make these puny systems really perform. I'm not sure they'd even be happy with everything done for them. Middle class homes and all the other categories are bang on target as far as I can tell, although in Britain I suspect it would be more likely to sell to businesses, with bulk orders coming from those companies already well into data processing.

All the dealers appointed by IBM will have had to sign a strict agreement which tells them the sort of behaviour that IBM expects of them. They agree not to exaggerate the capabilities of the equipment nor to disparage other people's products. They have to agree to do warranty work regardless of where the machine was bought and they must send two sales and two engineering staff on IBM-run courses. And IBM has the right at any time to inspect the premises and interview the staff to ensure that

### Commodore VIC-20

A fully-fledged, fully expandable, computer with large typewriter-style keyboard, programmable function keys, PET compatible. Gives 24 colours and sound, (to the degree that it can be used to compose music). High resolution graphics module available as extra. Speaks BASIC. Easy-to-use, even for beginners. New VIC-20 material is available and more is on the way. Supplied with easy-to-read, easy-to-use manual, suitable for beginners and children. Programs can be stored on optional VIC tape recorder. Commodore approved supplier.

### Texas Instruments TI-99/4 (PAL colour TV compatible)

Usable literally within minutes of unpacking. Anyone can use it without previous computer experience or programming knowledge. Powerful 16K. BASIC language. Special features: high resolution graphics let you create animated displays, charts, graphs; built-in music synthesizer allows you to build notes and chords; equation calculator for maths solutions. Designed for home management, educational and entertainment use. Large amount of educational software available on modules for youngsters. Programs can also be stored using good quality tape recorder. Texas Instruments approved supplier.

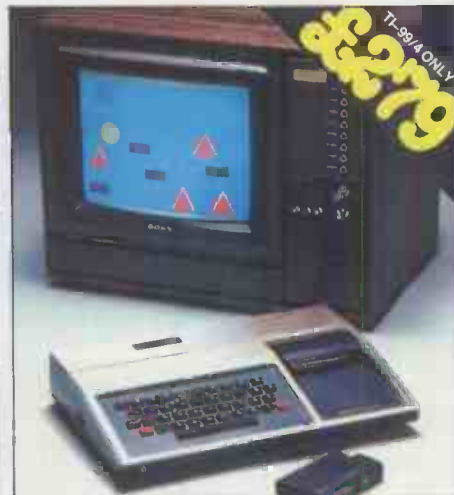
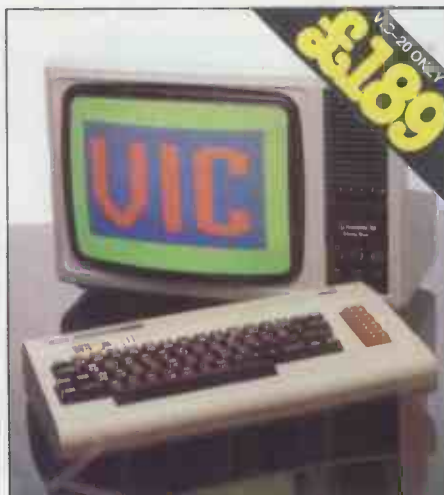

# Trust the unique Computer Supermarket to be first with the unique new personal computers.

Four new-technology computers bring you colour, sound, high resolution graphics. All with plug-in program modules. All at unique Computer Supermarket prices.

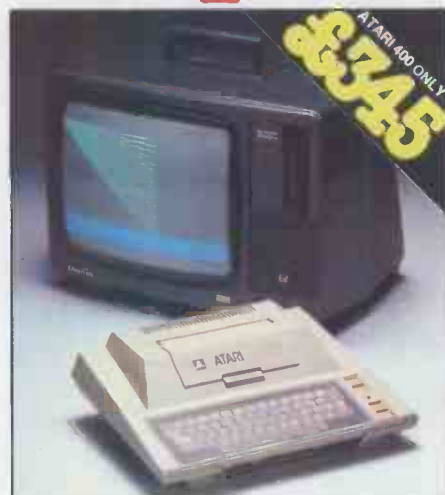

#### Atari 400

Brings the family music, art, education, entertainment. A general purpose personal computer that's easy to operate and offers 16 colours, each with 8 intensities; high resolution graphics; 4 sound synthesizers; 57 key alphanumeric keyboard with upper/lower case, inverse video, full screen editing, four-way cursor control, 29 graphics keys. Programming languages: BASIC, ASSEMBLER, PILOT. Programs can be stored on optional Atari tape recorder. Atari approved supplier.

#### Atari 800

Top-of-the-line personal computer. Advanced peripheral components, comprehensive software library. Modular design precludes obsolescence. 16 colours (8 intensities), 4 sound synthesizers; 57 keys with upper/lower case, inverse video, full screen editing, four-way cursor control, 29 graphics keys. Programming languages: BASIC, EXTENDED BASIC, ASSEMBLER, PILOT, PASCAL. Programs can be stored on optional Atari tape recorder. Atari approved supplier.

**THESE EXCITING NEW PERSONAL COMPUTERS CONNECT TO VIRTUALLY ANY COLOUR OR MONO TV.** Full range of peripherals will be available for each computer. All units are complete and ready to use. 13 amp plug fitted. Thorn colour TV's can be supplied for use with these computers. Details on application.

**Prices include VAT. P&p & insurance £3.50**

Your remittance should be made payable to 'Computer Supermarket Ltd', and shall remain your money until the goods have been despatched to you at the address specified. All goods offered are subject to Computer Supermarket conditions of sale, copies available on request. Registered in England No. 2646589.

**PRESTEL SERVICE** Prestel subscribers can obtain further details on these computers - and place orders for them - through the Prestel service. PRESTEL No. 400400

To Computer Supermarket Ltd, Douglas House, Queens Square, Corby, Northants.

Please send me

- Commodore VIC-20 at £192.50
- Texas Instruments TI-99/4 at £282.50
- Atari 400 at £348.50
- Atari 800 at £648.50
- Hardware/Software list
- Atari tape recorder at £45 inc. VAT, p&p
- VIC tape recorder at £40 inc. VAT, p&p

I enclose my cheque for £  
Or debit my Access/Barclaycard/Diners Card No.

--	--	--	--	--	--	--	--	--	--	--

(Cardholders may telephone orders to 05366 61587/8)

Signature \_\_\_\_\_

Name \_\_\_\_\_

Address \_\_\_\_\_

\_\_\_\_\_

(BLOCK CAPITALS PLEASE) PCW-11

# COMPUTER SUPERMARKET

COMPUTER SUPERMARKET LTD, DOUGLAS HOUSE, QUEENS SQUARE, CORBY, NORTHANTS. TELEPHONE 05366 61587/8 AND 62571



# CHOOSE ATOM POWER

At work or play - everything you need in a personal computer

The Atom is a machine to be used. Every day, day after day. It's a full function machine - check the specification against others. It's rugged, easy to operate built to last and features a full-size typewriter keyboard.

Just look at some of the features!

- More hardware support than any other microcomputer
- Superfast BASIC - can be updated to BBC BASIC if required
- High resolution and comprehensive graphics ideal for games programmers and players\*
- Integral printer connection\*
- Software available for games, education, maths, graphs, business, word processing, etc.
- Other languages: Pascal, FORTH, LISP
- I/O port for control of external devices
- Built-in loudspeaker
- Cassette interface
- Full service/repair facility
- Users club

\* Expanded version only

## Optional Extras

- Network facility with Econet
- Disk
- PAL UHF colour encoder
- Add-on cards include 32K memory, analogue to digital, viewdata VDU, disk controller, daisywheel printer, plus many, many more!
- Power supply

## FREE MANUAL

The Atom's highly acclaimed manual comes free with every Atom and leaves nothing out. In just a while you'll be completely at ease with your new machine! Within hours you'll be writing your own programs.



## YOU AND YOUR CHILDREN

More and more schools are buying Atoms. More and more children will learn on an Atom. You can give them that extra familiarity with an Atom in the home.



4a Market Hill,  
CAMBRIDGE CB2 3NJ

When you order your Atom we will include full details of all software packs and the optional hardware.

To: Acorn Computer Limited, 4A Market Hill, Cambridge CB2 3NJ.

I enclose a cheque/postal order for £.....

Please debit my Access/

Barclaycard No .....

Signature .....

Name (please print) .....

Address .....

Telephone Number .....

Registered No. 1403810 VAT No. 215 400 220

Quantity	Item	Item price inc. VAT + P&P	Totals
	Atom Kit 8K ROM + 2K RAM	@ £140.00	
	Atom Assembled 8K ROM + 2K RAM	@ £174.50	
	Atom Assembled 12K ROM + 12K RAM	@ £289.50	
	Power Supply	@ £ 10.20	
	TOTAL		

## Dealers or Mail Order

Computer stores are stocking Atoms - there's a list below, but if you have any problems getting hold of one just fill in the coupon and we'll rush one to you within 28 days. If the machine isn't all you expected, or all we've told you, just return it within 14 days for a full refund.

MOM, Aberdeen 22863. Broadway Electronics, Bedford. Owl Computers, Bishops Stortford, 52682. Eltec Services, Bradford 491371. Gamer, Brighton 698424. Electronic Information Systems, Bristol 774564. Cambridge Comp Store, Cambridge 65334. Cardiff Micros, Cardiff 373072. Emprise, Colchester 865926. Silicon Centre, Edinburgh 332 5277. Esco Computing, Glasgow 204 1811. Control Universal, Harlow 31604. Unitron Electronics, Haslington. Castle Electronics, Hastings 437875. Currys Micro Systems, High Wycombe. Microdigital, Liverpool 236 0707. Barrie Electronics, London 488 3316. Off Records, SW12. Technomatic, NW10 452 1500. H.C.C.S., Low Fell 821924. NSC Comp Shops, Manchester 832 2269. Compshop, New Barnet 441 2922. Newbear Comp Store, Newbury 30505. Newcastle Comp Services, Newcastle 615325. Anglia Comp Store, Norwich 29652. Leaslink Viewdata, Nottingham 396976. Customized Elect, Redcar 481460. Computers for All, Romford 751906. Intelligent Artefacts, Royston, Arrington 689. Quadruphenia, Sheffield 77824. Q-TEK Systems, Stevenage 65385. 3D Computers, Surbiton (01) 337 4317. Computer Supplies, Swansea 290047. Abacus Micro Comp, Tonbridge, Paddock Wood 3861. Northern Comp, Warrington 601683.

# IBM PERSONAL COMPUTER

the standards are being maintained.

So, dealers, and readers, if the IBM Personal Computer ever comes to Britain, you now have some idea of what to expect. I hope it happens, but don't hold your breath waiting for it.

## Future plans

It's just about impossible to discuss IBM's future plans because they won't tell you anything intentionally. I suspect that an Assembler is on the way and that, if it appears, it's 99 percent certain to come from Microsoft since they've written the editor and debug facilities. The only things I know for sure are that CP/M-86 is undergoing final testing right now and IBM will be looking at the dealer situation again in December to see whether it will be able to supply new dealers if they are taken on board. IBM's attitude is that it's better not to appoint new dealers until it can be sure of keeping them supplied.

Incidentally, CP/M-86 will cost considerably more than DOS and I'm not at all sure that it will be able to support the Microsoft Basics and Pascal which were written to run under DOS.

## Prices

Just as a guide, here are some extracts from the IBM price list. ComputerLand stores will almost certainly charge different prices and not necessarily less than IBM.

System Unit (16k) with keyboard	\$1265
Monochrome display	\$345
Matrix printer	\$755
Printer cable	\$55
Printer stand	\$55
Monochrome display and printer adaptor	\$355
Colour/graphics monitor adaptor	\$300
Printer adaptor	\$150
Memory expansions	
16k kit	\$90
32k option board	\$325
64k option board	\$540
(64k must be on-board before adding plug-in memory options)	
Disk drive adaptor	\$220
Disk drive	\$570
RS232	\$150
Game adaptor	\$50
DOS + Basic extensions	\$40



Pascal Compiler	\$300
Comms support	\$40
VisiCalc	\$200
Easywriter	\$175
Adventure	\$40
Ledgers	each \$595

I've worked out that a typical 64k, twin disk, RS232 system with a monochrome display and a printer would cost \$4575 — around £2500 in our money. This price includes the DOS and the Basic enhancements.

## Conclusions

It's all been said really. This is probably the most professionally put together system I have seen. Lots of them look good then you find they fall over, or the manual is unintelligible; neither is the case with this Personal Computer. The only thing missing at the moment is a wide selection of packages, but I

rather feel that the whole world and its grandmother will be frantically trying to fill that particular gap.

IBM has paid great attention to the details of the hardware, the software, the documentation, the distribution and support. In a word it's a knock-out. I wish it was on sale here.

## Benchmark timings

All timings in seconds.

BM1	1.5
BM2	5.2
BM3	12.1
BM4	12.6
BM5	13.6
BM6	23.5
BM7	37.4
BM8	3.5

## Technical specifications

CPU	Intel 8088, 4.77 MHz
RAM	16.256k, plus 4k or 16k video RAM
ROM	40k
Disks	Up to 2 drives, each 160k
Cassette	Accepts user's own cassettes
Ports	Joystick/Paddles, RS232
Screens	Monochrome (green) 25 x 80, Colour 24 x 40 or 80, up to 16 foreground and 8 background colours, 320 x 200 and 640 x 200 graphics. Will drive monitor or domestic TV with appropriate RF modulator.
Keyboard	83 key typamatic. Tactile feedback. Auto repeat. 10 function keys (40 functions programmable). Single stroke Basic keywords. Numeric keypad.

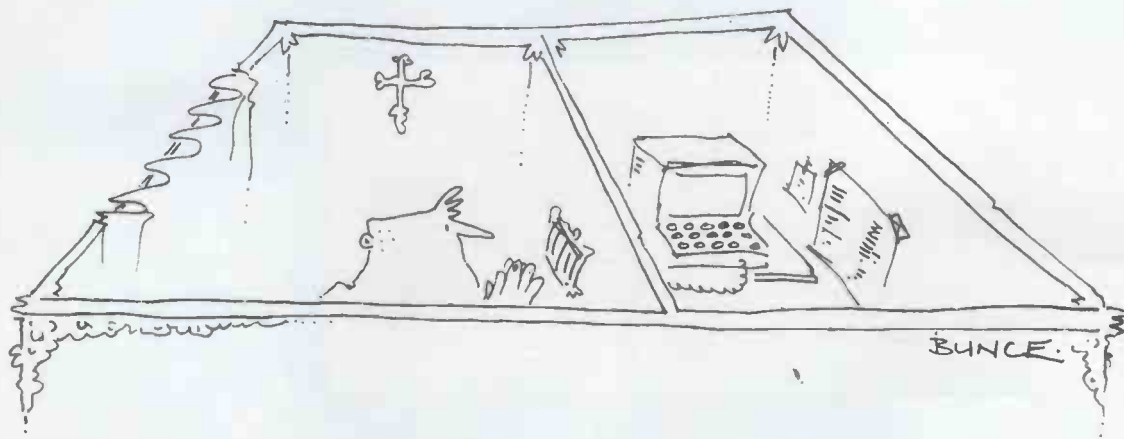

# EURO MICROMOUSE '81

*Robin Bradbeer brings us his observations on the European Micromouse finals, held in Paris during the Euromicro Conference in September.*

The object of a Micromouse competition is to design a robot that will negotiate a maze constructed of 3in high walls. The 'mice' are allowed 15 minutes to 'learn' the quickest way to the centre and the maze is designed to stop 'wall followers' from getting to the middle.

There had been a couple of trial heats during the previous months — one in London in July, and the other in Paris. The European contest was based on the now defunct American competition run by the Institute of Electrical and Electronic Engineers. It was resurrected by John Billingsley, a lecturer at Portsmouth Polytechnic last year. In the 1981 contest a British designed mouse — Sterling Mouse by Nick Smith — beat all the competition; this was taken as a great challenge by a number of countries, especially the Finns and the French.

Something like 15 mice turned up for the trials at the beginning of the conference. These had a couple of days to get 'tuned up' and then an elimination contest was held to decide the top seven to enter the final, along with Sterling Mouse which was there as champion.

The line-up in the trials reflected the level of interest in each participating country. There were three Finnish, two French, two German, eight British... and one Japanese! The latter came all the way to Europe to get a taste of the competition.

The difference in construction of each mouse also reflected the level of sponsorship available. Lorthocogitante, designed by Marc Rempauville of Paris, was constructed from bits of Fischer Technik and took him about four weekends to build. It was lacking in intelligence and Marc brought the mouse along to compare notes. Similarly, Dave Buckley from West Hampstead had a home-built mouse called Questor which was not fully operational but Dave, like Marc, wanted the experience. Both belonged to computer clubs — Marc to a small (three members!) robotics club and Dave to the 250+ members North London Hobby Computer Club. Another Club-based mouse came from Hayes Manor, a school electronics club supported by a local firm, LB Electronics of Hillingdon. Two of the schoolboys — Bob Taylor and Ralph Allen — were in Paris to represent the many in Hayes Manor School who contributed to the construction of Die Fledermaus #2. This mouse is based on a cut-down tank kit with an aluminium body to replace the original plastic. It performed at Wembley in July but was still a few weeks away from being able to complete the course in Paris.

## A different story

Another non-starter was Speedy Gonzales. This German mouse was altogether a different story.



*Setting up the maze for the Finals in the Palais de la Decouverte.*



*A swarm of Micronice.*

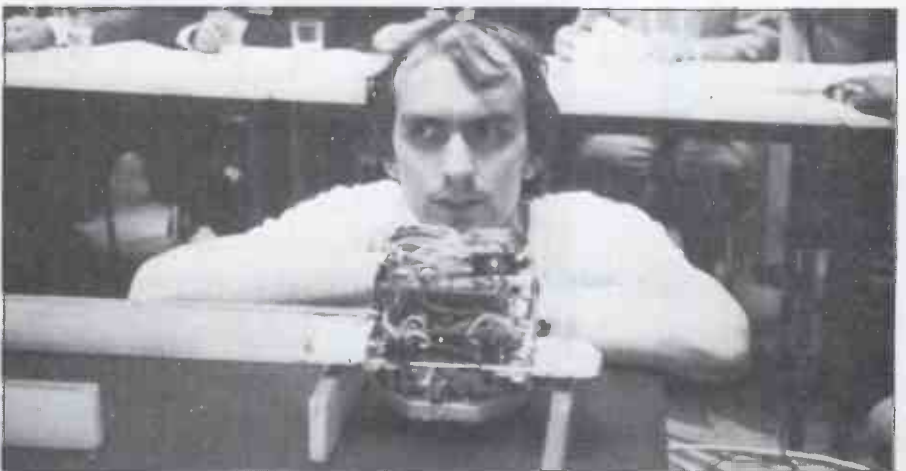

*Nick Smith with Sterling Mouse.*

Speedy Gonzales cost nearly DM10,000(!) and was designed and constructed as a project over two years by electronics students from

Dortmund University. It used two 8085 processors in a complicated arrangement, one controlling the motors and sensors the other solving the labyrinth

# FERGUSSON COMPUTERS LIMITED



apple computer



SALES AND SERVICE

## SALES

- \* Authorised Apple Dealer
- \* Full range of equipment
- \* on demonstration

## AFTER SALES

- \* Full support services
- \* Installation
- \* Staff Training
- \* Consultancy

## MAINTENANCE

- \* Apple Level I Service Centre
- \* ITT Repair and Maintenance
- \* On-Site contracts
- \* Ad-hoc repairs
- \* Workshop Services
- \* Collection from Red Star

## AGENTS FOR: HARDWARE

- \* Qume
- \* Anadex
- \* Epson
- \* NEC

## ACCOUNTING

- \* Systematics
- \* Vlasak
- \* Computech
- \* Tabs

## FINANCIAL

- \* Visicalc
- \* Micromodeller
- ...and many others

Come and see us for a demonstration  
or telephone for an appointment

**4 PYRFORD ROAD, WEST BYFLEET, SURREY**  
**TELEPHONE (09323) 45330/41810**



## Turn your Apple into the world's most versatile personal computer.

**The SoftCard™ Solution.** SoftCard turns your Apple into two computers. A Z-80 and a 6502. By adding a Z-80 microprocessor and CP/M to your Apple, SoftCard turns your Apple into a CP/M based machine. That means you can access the single largest body of microcomputer software in existence. Two computers in one. And, the advantages of both.

**Plug and go.** The SoftCard system starts with a Z-80 based circuit card. Just plug it into any slot (except 0) of your Apple. No modifications required. SoftCard supports most of your Apple peripherals, and, in 6502-mode, your Apple is still your Apple.

**CP/M for your Apple.** You get CP/M on disk with the SoftCard package. It's a powerful and simple-to-use operating system. It supports more software than any other microcomputer operating system. And that's the key to the versatility of the SoftCard/Apple.

**BASIC included.** A powerful tool, BASIC-80 is included in the SoftCard package. Running under CP/M, ANSI Standard BASIC-80 is the most powerful microcomputer BASIC available. It includes extensive disk I/O statements, error trapping, integer variables, 16-digit precision, extensive EDIT commands and string functions, high and low-res Apple graphics, PRINT USING, CHAIN and COMMON, plus many additional commands. And, it's a BASIC you can compile with Microsoft's BASIC Compiler.

**More languages.** With SoftCard and CP/M, you can add Microsoft's ANSI Standard COBOL, and FORTRAN, or

Basic Compiler and Assembly Language Development System. All, more powerful tools for your Apple.

**Seeing is believing.** See the SoftCard in operation at your Microsoft or Apple dealer. We think you'll agree that the SoftCard turns your Apple into the world's most versatile personal computer.

**Complete information?** It's at your dealer's now. Or, we'll send it to you and include a dealer list. Write us. Call us.

SoftCard is a trademark of Microsoft, Inc. Apple II and Apple II Plus are registered trademarks of Apple Computer Inc. Z-80 is a registered trademark of Zilog, Inc. CP/M is a registered trademark of Digital Research, Inc.

**MICROSOFT**  
CONSUMER PRODUCTS

Microsoft Consumer Products, 400 108th Ave. N.E.,  
Bellevue, WA 98004, U.S.A. (206) 454-1315



**Pete & Pam Computers**

Waingate Lodge,  
Waingate Close,  
Rossendale, Lancs, BB4 7SQ  
Telephone Rossendale (0706) 227011

## EURO MICROMOUSE '81

algorithms. This mouse was also a non-starter.

The main organised opposition to the British came from the Finns. They had a competition in Finland last month and only one out of five mice which entered actually finished. However, such is the dedication of most mouse-freaks that three made it to Paris and all succeeded in the trials.

The slowest mouse in the trials was Thezeus, built by Alan Dibley of Cheddar, Somerset, and based around a ZX80. Unfortunately, Thezeus blundered about so much during its first run — it took over 11 minutes — that there was no time left for subsequent runs. Superlite, another German mouse built by Klaus Waldsmidt, also from Dortmund, had a final run of 3m 6s. Next was Alan Dibley's second entry Son of Thezeus, also based on a ZX80, which took 2m 49s.

Two Finnish mice were next in line, Midnight Sun Junior and Jukka. The former was built by students from Tampere University and took 2m 36s. The latter, nicknamed Jack the Rat, was also built by students, this time from Oulu University and took 2m 32s.

In third place came the sole working French mouse, KIM, which was constructed by Te Vin Huor from Bandoufle. It took 1m 43s. The third Finnish mouse, Minitaurus, from Tampere University, took 1m 27s with the fastest trial run of 1m 15s being made by Thumper. This was the winner of the London competition and was built by three people from Wolverhampton, Andrew Keatley, Dave Woodfield and Arthur White. Thumper was one of the two mice in the competition (the other was Minitaurus) that had speech synthesis. As it moved about the maze, cries of 'West', 'East', 'There's a cat in this maze', etc could be heard among the motors' whirrings.

## The final

And so the final, held in the Palais de la Decouverte, the Parisian equivalent of the Science Museum. The entrance hall is a large rotunda and about 200 people turned up to watch. Discussions between the judging panel and the organisers meant that the maze in the final was slightly different to that in the trials. It was basically designed to sort the 'blunderers' out from the 'thinkers'. It seems incredible, but all those people sat for nearly two hours watching pieces of metal trying to find their way into the middle of the maze! That shows you how enthralling micromouse competitions are.

The mice went in reverse order of best trial time with Sterling Mouse going third from last. John Billingsley did a marvellous job compering the whole thing in English and near-perfect French. (In some ways this did more to enhance the feeling that Britain was finally a part of Europe than anything else!) However, even John refused to translate 'up a creek without a paddle' when one of the contenders got stuck at a dead end.

First away was Superlite from Germany (Thezeus bowed out so that Sterling Mouse could enter). After 15

minutes it still hadn't got anywhere near the middle and the German challenge faded. Son of Thezeus, waving a small Union Jack, conked out after a couple of minutes and was allowed to withdraw temporarily. On his return later in the event Alan, who only had 10 minutes left, found that the program had got corrupted. It was instructive to compare the use of sophisticated equipment at Intel's headquarters in Paris to debug some of the software on one of the Intel distributor-sponsored Finnish mice to the use of a portable TV/cassette recorder and detached ZX80 keyboard, with Alan writing Z-80 code from his head! So Son of Thezeus retired.

## The Finnish challenge

The first Finnish challenge was from Midnight Sun Junior, who could have had more than 15 minutes if it wanted to as the clock — on a PET — broke down. It got so close to the middle but its batteries ran out: exit one Finn! The next Finnish challenger, Jukka, just would not work properly and was retired. A big cheer greeted the sole French entry, KIM, with the crowd being goaded to patriotic fervour by John Billingsley at the microphone. (The French were so convinced that a native mouse would win the earlier French heats, that the prize computer did not have any export documents. As it was won by Sterling Mouse, Nick Smith had some problems later!) Unfortunately, all KIM would do was to go around in circles!

By now the crowd was beginning to get a bit restless as nothing much was happening to inspire confidence in these strange creatures. Some were even beginning to mutter about the whole thing being a bit of a con! But enter Sterling Mouse to a big cheer. On its first run it got to the middle in 3m 45s, on the second 1m 53s and on the third and final run, 1m 8s. Confidence had been restored and the battle looked alive again.

The Minitaurus team now took the centre of the arena. If you can imagine eight, six-foot high, blonde Finns all wearing Minitaurus tee shirts, then you can envisage the impressive sight presented to the crowd. Minitaurus, which was only 12 seconds behind Thumper in the trials, had been carefully 'tweaked' by its creators to win. The Finns were so determined that their seriousness rather worried the more

phlegmatic Britons present. However, all Minitaurus could achieve was to move very quickly everywhere — except to the middle. It eventually got there in 6m 7s and then promptly refused to do anything more! The rather annoyed Finnish team had to retire to the corner to prepare their mouse for its *piece de resistance* later in the programme.

Finally Thumper entered, with John giving it quite a build-up. Its first run took just 1m 59s, the second 1m 44s and the third only 44s! It then repeated this time, with the team not having any more runs. Thumper received a standing ovation, especially after John had translated its mutterings into French.

Once the maze had been conquered so successfully, Minitaurus took the stage again. A large sheet of white paper was attached to a board that covered the maze and Minitaurus began its 'dance'. While playing a whole selection of synthesised music from classical to rock, the mouse wrote its name in a circle on the paper using a pen attached to one of its 'arms'. This won the Finns at least a consolation prize for the best virtuoso performance.

The presentations themselves were rather chaotic, in the most endearing Gallic way: Thumper won its makers an MZ-80K while Sterling Mouse's creator won an HP5036 computer. All the finalists got prizes, even if it was a free subscription to a couple of French personal computer magazines.

## What of the future?

After that convincing show of British-make-do-and-mend — what of the future? So far we know of five events next year. First are some London Trials, being sponsored by the Association of London Computer Clubs, at the London Computer Fair in April. Although primarily a chance for mice being built by members of ALCC clubs, these are open to anybody — the Japanese have expressed an interest. Following that in July, at the Micro-computer Show, are the British Finals, to decide who goes through to the European Finals in early September. The French Finals will be held in Paris, also in July. The European Finals will be held at the Euromicro Conference in Haifa, Israel. Finally(!) there is hope that a World Finals will be held at next year's Personal Computer World Show, also in September. If all goes to plan,

GOTO page 182

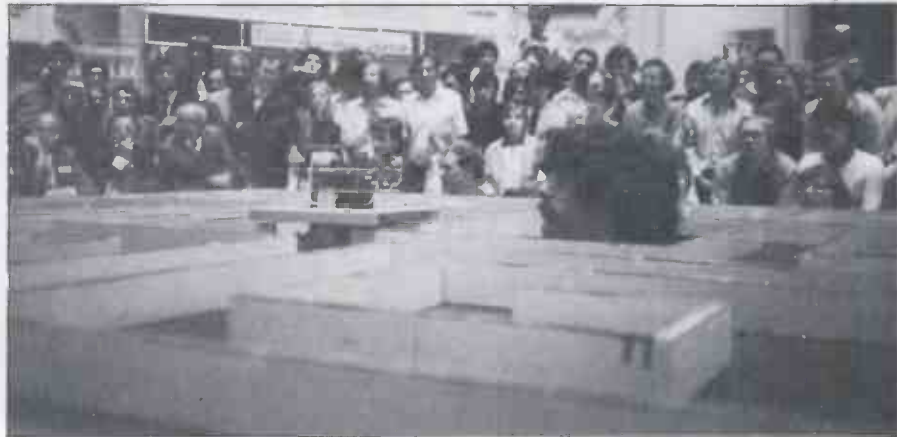

Andrew Keatley keeping a close eye on Thumper as it approaches the centre of the maze.



# COMPUTER ANSWERS

Send your queries to: Sheridan Williams, 35 St Julian's Road, St Albans, Herts.  
Please note that Sheridan can no longer answer questions on an individual basis, so please don't send an SAE with your query.

mathematics and statistics. Stick to data processing type programs. Stock control, survey analysis, information retrieval, computer dating and estate agents' housing lists are just some examples that may sound complicated but are not, provided you keep things simple. Ask your parents or relations what they would like a computer to do in their companies. Part of the idea of a project is that you should be able to think up a project for yourself.

Program documentation is vitally important. Most students spend 95 per cent of the course writing the program and leave the documentation until too late. A better ratio is to allow at least 25 per cent of the time for the documentation. After all, the only way the examiner can tell how good your project is is to read your documentation. Documentation should provide three major items: making the program *easy to use*, *easy to understand*, and *easy to modify*. Think about each one of these carefully, and if your documentation doesn't fulfil them then you'll know what to do. A good idea is to come to an agreement with another student on the course who is doing a different project. Swap your write-ups and see if you can understand what the other is doing, be vicious and scathing with each other's documentation but be sure to leave enough time to get over the shock and re-write it.

SW

## Feedback

In the August 81 'Computer Answers' there was a query from P G Upton regarding programs for survey data entry and analysis. I have received letters from two companies who both offer such packages. I have not tried them, so I cannot give any recommendations. Both run under CP/M and so would be of wide use. Suppliers are: Systematica, 112 Strand, London WC2R 0AA (01-836 9379); Arithmos, 59 Bancroft House, Bramlands Close, London SW11 (01-228 2452) and 2 Jubilee Road, Walkersburn, Peebleshire EH43 6AJ (089687 583).

Another previous query from R Jones requested information about running programs direct from cassette on the Acorn Atom. I have been notified of a new Utility ROM for the Atom: a program can be saved using the new command BSAVE, and only the filename need be specified. The program can then be run direct from cassette using the standard RUN

command. The ROM provides an additional 17 commands, including renumber, string search, auto line numbers, etc. For further details, send an SAE to: Willow Software, PO Box 6, Crediton, Devon EX17 1DL. Again, I haven't tested this so cannot give any recommendations.

## Fuzzy puzzle

Why is it that when a TRS-80 (with a modulator) or a Video Genie is connected to an ordinary TV, the display is so fuzzy? I can barely distinguish between 8 and 3! How do I make the figures as sharp as those on a ZX80?

T D Edwards, Chalfont St Giles

There is no easy solution to your problem — it will be present as long as you use a TV instead of a monitor!

Any computer which produces video output for a TV has extra links in the chain connecting the two — the computer modulator and the TV tuner and demodulator. This introduces some signal degradation and affects picture quality.

The TV circuitry is not designed to cope with the bandwidth of the signals the computer feeds to it. This means that it is also designed for a lower screen definition than a video monitor. The video circuitry can produce smaller individual points on the screen than the TV and this means the characters it produces are better defined.

The Sinclair ZX80 achieves its picture quality by producing inverse characters — ie black on white, rather than the normal white on black. This overcomes some of the loss of definition. This can be done on the TRS-80, but only at the loss of your guarantee!

The American magazine *80 Microcomputing* published in May 1981 a three chip modification which will produce inverse characters. Graphics boards such as the Programma will also produce inverse video characters.

Dr N Robinson

## Which printer?

I want to buy a printer for my TRS80 which costs less than £500 (plus VAT) and has tractor and friction feed.

T G Wright, Ruwi, Sultanate of Oman

One of the biggest recent areas of growth in the computer market has been that for better and cheaper matrix

printers. The new generation of printers has features which were formerly the province of the golfball and daisywheel printers. These include double density printing, superscripts, proportional spacing, variable print size, and underlining.

These features are controlled by control codes from the computer, either direct from the keyboard, or incorporated into a program.

Printers such as the Micro-line 80, (£300), Epson MX-80F/T (£399) and Centronics 737 (£349) — all prices plus VAT — have these features, as well as a choice of tractor or friction feed.

These enhanced printing capabilities are not accessible by the most popular TRS-80 word-processing programs, Electric Pencil and Scripsit. However, a program available from A J Harding Ltd, called Superscript allows any printer capabilities to be accessed from within Scripsit.

If money is short, then the Tandy Line Printer VII (a custom version of the Seikosha GP 80A) is only £200 (inc VAT). It is tractor feed only but single sheets can be taped to the continuous paper and fed through.

A final word of warning — dealers tend to charge about £30 (plus VAT) for the two plugs and three feet of cable which connect the printer to the computer! You can make one yourself for £5 or so.

Dr N Robinson

## Tuscan change

Owing to the lack of commercial software for my standard Tuscan 2, I would like to dispense with the TCL Basic ROMs and install an EPROM board with a better served system (eg TRS-80 Level 2). Could this be made to work with the Tuscan configuration?

P A Janies, Chepstow

The problem with your interesting suggestion is that a ROM-based interpreter has not only to convert from the high-level language into machine code but it must also provide the interfacing between the programs and the screen, VDU terminal, printer, etc. Thus, while the Tuscan Basic interpreter is closely based on the interpreter Transam already had available for their Triton computer, it was still necessary for the I/O portion to be re-written for the Tuscan.

One way out of your problem, although an expensive one, would be to

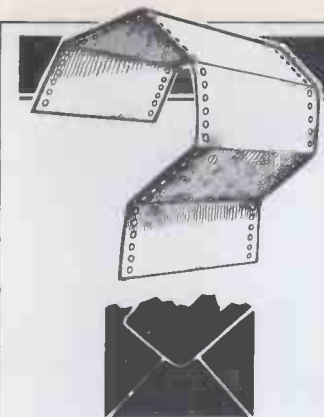

## Open question

Could you tell me the principles involved in writing an INFILL or PAINT routine to block in an area bounded by a line or number of lines? It is easy to deal with simple shapes like rectangles but a routine to deal with weird shapes is defeating me. Some examples are:

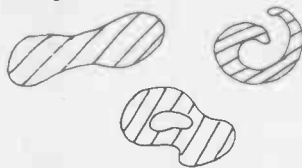

Please send your answers directly to J Sharp, 11 Portrea Close, Davenport, Stockport, Cheshire. The best answer will receive a small prize.

SW

## Project problem

I am about to start an O level/A level course in computer science. I am worried because I do not know what project to do. I am also unsure what to include in the project write-up (documentation).

H Singh, Birmingham

Yes, this is the time to discuss such matters, although by the time this appears in *PCW* it will probably be too late — I am writing this in August (1981!).

Well, you will get far more details from the teacher concerned at your school/college, but you should bear in mind what you are doing this project for. It is not for fun, or just something for the examiners to mark, it is to show that you have an aptitude for programming. Future employers may wish to see your project if they are employing you in a computer-related field. For that reason alone it is best to reject a games-playing program. Choose something that you can research, like a payroll program. That will give you an insight into pay that virtually no one else has and will enable you easily to work out whether you are paying too much tax when you start work. Scientific programs are usually too trivial, unless you have a good knowledge of

# Make the most of your Sinclair ZX Computer... Sinclair ZX software on cassette. £3.<sup>95</sup> per cassette.

The unprecedented popularity of the ZX Series of Sinclair Personal Computers has generated a large volume of programs written by users.

Sinclair has undertaken to publish the most elegant of these on pre-recorded cassettes. Each program is carefully vetted for interest and quality, and then grouped with other programs to form a single-subject cassette.

Each cassette costs £3.95 (including VAT and p&p) and comes complete with full instructions.

Although primarily designed for the Sinclair ZX81, many of the cassettes are suitable for running on a Sinclair ZX80 - if fitted with a replacement 8K BASIC ROM.

Some of the more elaborate programs can be run only on a Sinclair ZX Personal Computer augmented by a 16K-byte add-on RAM pack.

This RAM pack and the replacement ROM are described below. And the description of each cassette makes it clear what hardware is required.

## 8K BASIC ROM

The 8K BASIC ROM used in the ZX81 is available to ZX80 owners as a drop-in replacement chip. With the exception of animated graphics, all the advanced features of the ZX81 are now available on a ZX80 - including the ability to run much of the Sinclair ZX Software.

The ROM chip comes with a new keyboard template, which can be overlaid on the existing keyboard in minutes, and a new operating manual.

## 16K-BYTE RAM pack

The 16K-byte RAM pack provides 16-times more memory in one complete module. Compatible with the ZX81 and the ZX80, it can be used for program storage or as a database.

The RAM pack simply plugs into the existing expansion port on the rear of a Sinclair ZX Personal Computer.



## Cassette 1 - Games

For ZX81 (and ZX80 with 8K BASIC ROM)

**ORBIT** - your space craft's mission is to pick up a very valuable cargo that's in orbit around a star.

**SNIPER** - you're surrounded by 40 of the enemy. How quickly can you spot and shoot them when they appear?

**METEORS** - your starship is cruising through space when you meet a meteor storm. How long can you dodge the deadly danger?

**LIFE** - J.H. Conway's 'Game of Life' has achieved tremendous popularity in the computing world. Study the life, death and evolution patterns of cells.

**WOLFPACK** - your naval destroyer is on a submarine hunt. The depth charges are armed, but must be fired with precision.

**GOLF** - what's your handicap? It's a tricky course but you control the strength of your shots.

## Cassette 2 - Junior Education: 7-11-year-olds

For ZX81 with 16K RAM pack

**CRASH** - simple addition - with the added attraction of a car crash if you get it wrong.

**MULTIPLY** - long multiplication with five levels of difficulty. If the answer's wrong - the solution is explained.

**TRAIN** - multiplication tests against the computer. The winner's train reaches the station first.

**FRACTIONS** - fractions explained at three levels of difficulty. A ten-question test completes the program.

**ADDSUB** - addition and subtraction with three levels of difficulty. Again, wrong answers are followed by an explanation.

**DIVISION** - with five levels of difficulty. Mistakes are explained graphically, and a running score is displayed.

**SPELLING** - up to 500 words over five levels of difficulty. You can even change the words yourself.

## Cassette 3 - Business and Household

For ZX81 (and ZX80 with 8K BASIC ROM) with 16K RAM pack

**TELEPHONE** - set up your own computerised telephone directory and address book. Changes, additions and deletions of up to 50 entries are easy.

**NOTE PAD** - a powerful, easy-to-run system for storing and



retrieving everyday information. Use it as a diary, a catalogue, a reminder system, or a directory.

**BANK ACCOUNT** - a sophisticated financial recording system with comprehensive documentation. Use it at home to keep track of 'where the money goes,' and at work for expenses, departmental budgets, etc.

## Cassette 4 - Games

For ZX81 (and ZX80 with 8K BASIC ROM) and 16K RAM pack

**LUNAR LANDING** - bring the lunar module down from orbit to a soft landing. You control attitude and orbital direction - but watch the fuel gauge! The screen displays your flight status - digitally and graphically.

**TWENTYONE** - a dice version of Blackjack.

**COMBAT** - you're on a suicide space mission. You have only 12 missiles but the aliens have unlimited strength. Can you take 12 of them with you?

**SUBSTRIKE** - on patrol, your frigate detects a pack of 10 enemy subs. Can you depth-charge them before they torpedo you?

**CODEBREAKER** - the computer thinks of a 4-digit number which you have to guess in up to 10 tries. The logical approach is best!

**MAYDAY** - in answer to a distress call, you've narrowed down the search area to 343 cubic kilometers of deep space. Can you find the astronaut before his life-support system fails in 10 hours time?

## Cassette 5 - Junior Education: 9-11-year-olds

For ZX81 (and ZX80 with 8K BASIC ROM)

**MATHS** - tests arithmetic with three levels of difficulty, and gives your score out of 10.

**BALANCE** - tests understanding of levers/fulcrum theory with a series of graphic examples.

**VOLUMES** - 'yes' or 'no' answers from the computer to a series of cube volume calculations.

**AVERAGES** - what's the average height of your class? The average shoe size of your family? The average pocket money of your friends? The computer plots a bar chart, and distinguishes MEAN from MEDIAN.

**BASES** - convert from decimal (base 10) to other bases of your choice in the range 2 to 9.

**TEMP** - Volumes, temperatures - and their combinations.

## How to order

Simply use the order form below, and either enclose a cheque or give us the number of your Access, Barclaycard or Trustcard account. Please allow 28 days for delivery. 14-day money-back option.

# sinclair ZX SOFTWARE

Sinclair Research Ltd,  
6 Kings Parade, Cambridge,  
Cams., CB2 1SN. Tel: 0276 66104.

To: Sinclair Research, FREEPOST 7, Cambridge, CB2 1YY

Please print

Please send me the items I have indicated below.

Qty	Code	Item	Item price	Total
	21	Cassette 1 - Games	£3.95	
	22	Cassette 2 - Junior Education	£3.95	
	23	Cassette 3 - Business and Household	£3.95	
	24	Cassette 4 - Games	£3.95	
	25	Cassette 5 - Junior Education	£3.95	
	17	*8K BASIC ROM for ZX80	£19.95	
	18	*16K RAM pack for ZX81 and ZX80	£49.95	
		*Post and packing (if applicable)	£2.95	
			Total £	

\*Please add £2.95 to total order value only if ordering ROM and/or RAM.

I enclose a cheque/PO to Sinclair Research Ltd for £

Please charge my Access\*/Barclaycard/Trustcard no.

\*Please delete as applicable.

Name: Mr/Mrs/Miss

Address:

PCW 11

# COMPUTER ANSWERS

upgrade your Tuscan to take a disk drive. As you know, the Tuscan is specifically designed to make this upgrade easy. Once you have a disk it will be possible to use the CP/M operating system, which will allow you to load any of a wide variety of Basic (and other language) interpreters and compilers. If you were to use Microsoft Basic, for example, you would find a wide variety of software available. Indeed, there is a wide variety of commercial software on the market designed to run under CP/M, including machine code programs such as the well-known WordStar word processing program.

A second solution would be to learn enough about programming in Basic to be able to convert purchased programs to the TCL version of Basic. (You would need to make sure the programs you bought were in source code, not compiled into machine code, and could be LISTed). David Lien's *Basic Handbook* would be very useful here, as it gives details of the differences between many dialects of Basic and help with how to convert between them.

P L McIlmoyle

## Micro RTTY

I intend to purchase a small computer to encode and decode amateur RTTY. The problem is interfacing the transceiver with the computer ports.

Does the UK101 have a suitable port? Are there other suitable models, eg ZX81 or Nascom? Can you suggest a book that would help in writing the routine for checking the port status? Is it possible to record the incoming data onto cassette while the program is decoding it?

G Caselton, Orpington

Nowhere do things move so fast as in electronics and computing! You can now buy an RTTY transceiver with built-in micro for decoding for about £300, thus solving the interfacing problem at a stroke, and not spending much more than the computer would have been. A receive-only unit is about £160. Further details of these MM 4000 and MM 2000 units can be obtained from: Catronics Ltd, Wallington Square, Wallington, Surrey. Both units work in both Murray and ASCII codes.

If you particularly want to use a separate computer then I believe that suitable combinations of hardware and software are available for the Video Genie at about £150.

A guide in doing it all yourself you could well start with 'How to Program Micro-computers' by William Barden Jr (H W Sams & Co

Inc). Chapter 23 gives a lot of useful information on I/O formatting. See also the article in PCW Vol 4 No. 6, July 1981.

P L McIlmoyle

## List block

I have become interested in computers since the school purchased a 32k PET last September. Ever since we began programming my friends and I have been looking for a 'list block' to prevent listing but without success. Can you help?

D Waterman, Gt Dunmow, Essex

There is no simple answer to this one — no magic POKE which will render a program unLISTable. None of the software security methods known to be in use today would defeat a determined expert, knowledgeable about how Basic works, how the Charget routine operates, and able to delve into the machine code, particularly if equipped with one of the powerful machine code aids such as IPUG South East's Basmon ROM. However there are various tricks which are appropriate in various circumstances, which will give limited degrees of security within those circumstances.

Maybe you just want to leave a program running unattended at a school exhibition, and wish to prevent fiddling by practical jokers. You could cause the program to disable the STOP key and write it so that it would not crash under any conceivable circumstances. Obviously, it could not then be LISTed or modified.

There is also a program called Locksmith, recently released as a puzzle by Jim Butterfield, which may be used to treat another program so that it cannot be just LOAded; it will only LOAD and RUN. If the program disables the STOP key, then a similar security is achieved. In both cases, the PET concerned must not have a warm reset button.

The same end might be achieved in a more amusing fashion by incorporating into the program a short program called Protect. You may leave your program unattended after you have started it, as it will then respond to LIST with the statement: FOR DETAILS OF THIS AND OTHER SOFTWARE PLEASE CONTACT D WATERMAN.

If you wish to prevent the program from being LISTed, or even RUN, except by you or your agent, then you could alter one of the Basic lines to point elsewhere than to the following lines. Only a person who knows the secret POKE could then use or LIST the program. This method is discussed briefly in *The*

*PET Revealed* by Nick Hampshire. Once the program had been POKEd, it would be as vulnerable as ever and could not be left unattended.

The most promising areas in which to experiment with a view to producing non-standard modes of operation of the PET are line linkage, as mentioned above, and the Charget routine, which may readily be modified to generate new commands and to detect additional control characters.

To obtain a free copy of Protect and Locksmith, which are public domain programs, contact the writer on Biggin Hill 71742.

B J Biddles

A simple command like POKE 1025,1 has an interesting anti-listing effect.

SW

## Light pen

Do you know of a currently available light pen for the Atom.

Adrian Pegg, Benfleet, Essex

I am not aware of a light pen for the Atom. It should be possible to use a light sensor to latch the address present on the VDG address lines and read this address. The easiest way of doing this on an experimental basis would be to obtain A1-A8 from IC40, configure the VIA so that port A was in latched input mode, connect the eight address lines to PA and latch the input when the sensor detected the extra brightness present on the TV screen when the electron beam refreshes the phosphor. Using A1-A8 will result in an error of u-1 in the horizontal resolution and using one of the VDU RAM sockets to obtain the address lines will limit the use of the Atom to graphics modes 0-3.

When the system has been developed the address lines can be permanently connected to two latches with tristate outputs and the sensors will then latch the address lines and generate an interrupt. Intel 8212 chips would be appropriate for this latching. It would be necessary to develop suitable software to identify the character at the specified address.

The Atom VDU board has a light pen facility and can be inserted at 0400H and 0800H. However, it would then be necessary to write new software to print on the screen.

Robin Lewis

## Expanded Atom

Do you know of any business software for the Atom? Would it be possible to run a disk system. What advantages would installing an

acoustic coupler bring to talk 'intelligently' to a main-frame. Will the Proton's peripherals and software be compatible with the Atom? Lastly, will there be a Last One version for the Acorn Atom?

J Neill, Bangor, Co Down

I am not aware of any business software for the Atom. The recent announcement of floppy disks from Control Universal should encourage its development, though.

It would, theoretically, be possible to use an Atom as an intelligent terminal but it would be necessary to write suitable software to handle the mainframe's communications protocol and extra hardware would be needed to generate and receive transmissions.

I do not know what upward compatibility there will be to the Proton, we will have to wait and see. Finally, I doubt if there will be a 'Last One' for the Atom.

Robin Lewis

## PET upgrade

We are trying to upgrade a 'new ROM' 2001 PET from 16k to 32k by replacing the RAMs but are unable to access more than 16k even after changing the top-of-memory pointer. Are there some hardware links we should change?

A Dobbie, Caerphilly, Mid Glamorgan

In a word, yes. This is because there are two types of RAM chip used on dynamic RAM PETs, the 4116 and the 4108. The 4108 is in fact a 4116 that only has its top or bottom half working when tested. The addressing of the top or bottom halves is controlled by two wire links, together with two others that enable the machine to work with either 4116 or 4108 RAMs.

There are also other links to indicate how much memory is present on the mother board, allowing the rest to be addressed from the memory expansion port.

A suitable configuration — one I used myself when upgrading from 8k to 32k — is as follows:

LINK	STATE
A	open
B	open
C	closed
E	open
F	closed
G	closed
H	closed
I	closed
L	oper
M	open

The table only lists the links concerned with on-board memory. For a more detailed understanding you may find the electronic circuit diagrams in *The PET Revealed* to be helpful.

Julian Bane

# GUESS WHAT?

THE MONTHLY COMPETITION FROM GUESTEL



Two items in the above photograph have changed from the last issue. We know the two apple disc drives have gone, they're being snapped up at **£595** a pair.

It's the other item that you can win if your entry is the first to be drawn on December 14th at our Brighton office.

Send your entry to Dept PCW at the Brighton office.

Guestel provide Sales, Service and an in depth knowledge of Apple systems at the most competitive prices.

**24 HOUR CALL OUT SERVICE**

**COMPUTER RENTAL SERVICE**

# GUESTEL

## EXPANSION THROUGH EFFICIENCY

For mail order and free advice on your systems requirements contact:

### BRIGHTON OFFICE

15 Grand Parade Brighton  
East Sussex BN2 2QB  
Telephone 0273 695264

OPEN ALL DAY SATURDAY

### LONDON OFFICE

8-12 New Bridge Street  
London EC4V 6AL  
Telephone 01-583 2255

### BRISTOL OFFICE

41/43 Baldwin Street  
Bristol 1

NEW OFFICE

**AUTHORISED APPLE DEALER  
AND LEVEL 1 SERVICE CENTRE**



All prices ex VAT and P&P

All items subject to availability

*This week Malcolm Peltu reviews a new crop of introductions to micros in business applications.*

## A GUIDE TO THE GUIDES

The small business is the apple of everyone's eye at the moment. The government looks to small businesses as the generators of jobs, entrepreneurial spirit, etc. The computer systems vendor views the small business with the same relish that whales look at plankton.

Book publishers, providers of educational courses, even polytechnics and universities also hope to get a bit of juice out of the small business person. Explaining technology and selling technology to the end user/naive user/punter/small businessman is booming — small business is Big Business.

This month a couple of cassette tapes and a book aimed at explaining small business systems and word processors have caught my eye and ear. Before reviewing each item, I would like to provide some guidance on how to choose an introductory small business book.

Although you can't judge a book just by looking at the cover, it is possible to get a good idea of the level and style of the book and the amount of detail provided by flipping through. (The inability to do this with a tape is one disadvantage of audio material.)

By its nature, introductory material is generalised. This is a good thing. So if you see lots of detail about specific products or technology, its probably better to leave the book to a second course, after you have savoured the hors d'oeuvre.

Generalisations need not be waffle, although they are frequently couched in consultantese to give them a touch of unwarranted grandeur. Consultantese is the language developed by highly paid consultants in order to make their reports and documentation as fat as their fees.

It is said that a consultant is a person who borrows your watch to tell you the time. Many consultants, of course, have had a great deal of experience which makes their services worthwhile. The trouble is that 'good advice' can sound like just common sense. In fact, it is common sense to someone with experience.

Typical consultantese are phrases like, 'in regard to the proposition' and 'given that the theory has been complied with'. Anywhere where five words are used instead of one and where bland platitudes seal off the whiff of reality.

If such consultantese litters the pages, avoid the book like the plague. The language used should be the language of the real business world.

On the other hand, an attempt must be made to explain jargon. You can tell this by looking at the index or glossary. *Word Processing* by Richard Morgan and Brian Wood has a good index because it indicates the page where the word is first defined. The index strikes the right level of necessary jargon. And so does the book.

Two attitudes of jargon should be avoided — the 'you don't need to know any jargon other than hardware or software' brigade or the 'bits, bytes and Basic' merchants.

A cassette tape by Olivetti on choosing a business system uses the line about needing to know only 'hardware' and 'software' as jargon words and then goes on to mention things like VDUs, floppy disks, parameter-driven software, etc.

This de-emphasising of jargon was a natural antidote to the jargon-soaked image which computing has had in the past. Yet it is wrong to pretend that computing can be comprehended without learning some new terms.

In any case, one man's jargon is another's natural language. Word processing jargon like wraprounds, scrolling and windows sounds more 'English' than bytes, RAMs and VDUs — but it is still jargon.

The alternative approach is to get bogged down in unnecessary jargon. I have frequently lamented the type of book called *Introduction to Computing* which begins with binary logic, computer architecture, etc, rather than with the uses of the systems.

The style and mood of the book is another vital ingredient in choosing one. To me it is the poetic quality of the author which is of particular significance in raising life out of a dead topic.

By 'poetic', I mean the imagery, the analogies, the examples. I have often thought that it would be nice to bring out a book of computer analogies. 'A computer is like...' is how many sentences begin, before sliding down a precipice of despairing clichés and metaphors.

On this test, the tape 'How to choose your small business computer' by J Mike Eaton gets high marks. His analogy for a computer system is a barn.

Roughly (and he emphasises that it is only a rough image), the bigger the barn, the more you pay. The barn is the place where information is stored. The keyboard is equivalent to a door marked IN; the printer to a door marked OUT. The VDU screen is a window for looking into the databarn. Disks and storage are equivalent to shelves, filing cabinets, etc.

Then you need someone to rush around inside doing calculations and moving information around. This (in a not very good analogy) is the processor, says Eaton.

The barn image, however, is apt because he is trying to point out that the size of your data requirement plays a dominant role in determining the size and cost of the system.

The Olivetti tape, however, uses some corny imagery. Computers are like motor vehicles. You can get a motorcycle at a cheap price or a Rolls-Royce at a higher price. This analogy is misleading. Computers are not as

single-purpose as vehicles and the difference between a Roller and a Honda tells you nothing about the factors which distinguish one computer from another. Eaton's barn, however, has the characteristic of actually being a storage area, which helps to clarify and enliven the description of a computer.

Another element of style is how the witticisms, asides, jokes and general personality of the author(s) appeal. Morgan and Wood, for example have a touch of literary class. They start with a quote from Omar Khayyam: *The Moving Finger writes;*

*and having writ  
Moves on; nor all thy Piety or Wit  
Shall lure it back to cancel half a line,  
Nor all thy Tears wash out a Word of it.*

'The typewriter emulates the Moving Finger, but, because unlike the finger, it was mechanical, it was reasonable to ask if more mechanism might accomplish what Piety, Wit and Tears were powerless to do.'

They have another erudite reference when explaining macros: 'Macros is the Greek for "long" and one of the early kings of Persia was nicknamed Macrocheir or "longhand" because his reach extended to all parts of his large dominions,' they comment.

Tit-bits like this add little to an understanding of the technology but they make a great deal of difference in making the newcomer to computers feel at ease.

The key to appeal is style rather than uniqueness of content. On his tape, Mike Eaton makes a trenchant point about buying a computer: it does not really matter what computer you buy, provided it does what you want. 'If you have some irrational desire to buy a particular computer, get it,' he says. Of course, the system must have the required capabilities and the supplier should provide adequate support. But there are a multitude of systems which can do the job, and selecting one system rather than another is unlikely to make much real difference.

In the same way, I believe that a small business person (or any other newcomer to computing) should choose whichever book, course or tape appeals most and with which he or she feels at ease.

Although I have been critical of many introductory books, I cannot remember any that were actually *wrong* in what they say. The worst crimes are to be out of date, to miss out important aspects of information technology and to over-emphasise the technology rather than the uses. But when you are wanting something that gives an insight into computing potential, none of these faults are disastrous. What is important is that the essential messages get through. That is why I have emphasised factors like general feel of the book (or sound of the tape); style; wit and relevance of the imagery.

In assessing introductory material, it is important to be aware of what I call the Roots And Branches culture

# DTL-BASIC COMPILER

The only BASIC Compiler fully compatible with the full range of Commodore Microcomputers.

- ★ Up to 20 times faster when compiled
- ★ More compact object code e.g. a 24K program when compiled would run on a 16K machine
- ★ Available now on 3000, 4000 & 8000 Series machines
- ★ DTL-BASIC handles full arithmetic expressions
- ★ The compiler copes with nested loops, handles arrays and variables dynamically and accepts extensions to Basic
- ★ Thoroughly supported by a comprehensive manual and full back-up from Dataview.

Unique new security system for compiled programs for use by Software Houses — ring us for details — Colchester (0206) 865835

**£360.00** + VAT  
special prices for education

Dataview Ltd, Portreeves House, East Bay, Colchester, Essex.

 **Dataview**

# The best diskette for your system

- \* All IBM formats
- \* AES/Lanier
- \* Apple II
- \* Atari
- \* CPT 8000
- \* Diamond

  
**Dysan**  
DISKETTES — AND DISC PACKS

- \* Nexos 2200
- \* P2000
- \* P5002/Micom
- \* Wang
- \* Zenith
- \* — among others

We keep stocks of 30,000 for immediate delivery to dp and wp users

FOR YOUR RECORDS THE DYSAN HOTLINE IS: WEYBRIDGE 48346/7

**HAL Computers Limited**  
57 Woodham Lane New Haw  
Weybridge Surrey KT15 3ND  
Telephone: Weybridge 48346/7



gaps. Information technology has its roots in many different activities — large-scale commercial data processing, hobbyist personal computing, automatic typewriters, telephone exchanges, etc. From each of these roots, the technology has branched out. Data processing has sent its tentacles into office automation. Word processors grow into small business computers. Personal computers are sold for data processing and word processing tasks rather than for home use.

The branches intertwine and merge until you cannot see the join. But the people who have grown up in one of these cultures tends to view the world from their own cultural perspective.

A traditional DP man sees the information world in terms of databases, online terminals, communications networks, etc. Word processor buffs are into editing facilities, ergonomics of workstations, text processing and letter-quality printers with data processing and communications seen as adjuncts or as some future extensions of word processing.

Both DP and WP (word processing) experts tend to look down on personal computers as toys. On the other hand, to the personal computerist, life is a bowl of Apples, CP/Ms, VisiCales and WordStars, with DP and WP regarded as cumbersome old-fashioned dinosaurs. Provided the newcomer is aware of these cultural differences and makes allowances for them, little harm can be done. The newcomer will grow individual roots from his or her own 'cultural' background. The small business person will relate the technology to small businesses. The solicitor or accountant will relate it to soliciting or accounting. The community organiser will relate it to community organising. From a base of knowledge of one activity, branches will grow and the merging of information technologies will become clear.

Just remember that the label is irrelevant. Word processors, giant mainframes, intelligent terminals, personal computers are all manifestations of computing power. Do not dismiss or ignore any system because of its label. Look at what it actually does, the manufacturer's support, software availability, costs and all the other good bits of advice.

With introductory material, it is much more important to get stuck into something you enjoy reading or listening to and which you understand than to worry whether it is the ideal, most comprehensive, most updated book or tape. None of them are. But there is a lot of extremely good and useful material available.

Now for a closer look at the tapes and books I have already mentioned.

## Top of my pops

Mike Eaton's tape *How To Choose Your Small Business Computer* does everything just about right. My main reservations lie with the medium, not the message.

The tape lasts about an hour. It consists primarily of Eaton talking, although it is interspersed with a female voice and snatches of muzak as chapter

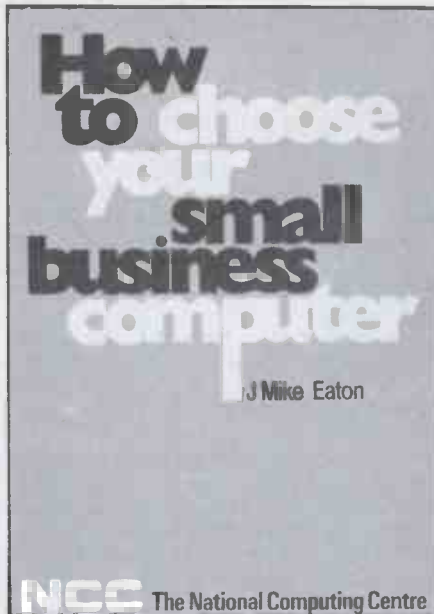

headings. In addition there is a very useful little booklet with practical checklists.

These checklists give a flavour of the straightforward, practical common sense and advice given by Eaton. He gives guidelines, for example, on how to estimate file sizes. Multiply the number of customers and suppliers each by 150. Multiply items supplied to customers by 90 and actual stock items by 50. Each of these numbers is a typical number of characters needed to describe the relevant item. Add all these figures together, multiply by three for safety and future growth and the result, very roughly, is the amount of disk storage you might need. He stresses the roughness of these figures. But by offering this rule of thumb, it at least offers a feel for the size and cost of a system.

Other checklists cover how to define minimum requirements in more detail (invoices, stock items, financial analysis, payroll and special factors, like seasonal workloads), how to evaluate a software package, how to minimise risks and what to do before and after the computer arrives.

Eaton's approach is laced with the fruits of experience. As far as possible, he has no special 'computer cultural' bias. He includes the 'top end of the personal computer range'. Although his main emphasis is on data processing, he has a special section on word processors. His analogies are generally good (although I don't like his comparison of an operating system with the instinctive genetic inheritance in human beings!). In fact, for the market aimed at, I find the content almost faultless.

But whether or not you find this your cup of tea depends on your attitudes to tapes in general and to the particular production techniques used on this one in particular. With a tape, you can get on with other things while listening. On the other hand you cannot read it on a train journey or in front of the telly. A voice can be more expressive than text on a page, but it is difficult to linger over a particular item on tape and impossible to flick through as you might with a book, although you could note the timings at which parti-

cular words are spoken.

These reservations and advantages apply to any tape. In producing this tape, the National Computing Centre has gone for the single-voice lecture format. Eaton gives a relaxed and fluent talk but having a single voice becomes hypnotic and a bit boring at times. In places I found myself drifting off, then realising a chunk had passed me by without anything registering.

The Olivetti tape (see below) is much livelier because it has more voices. But, despite the reservations, I think the Eaton tape plus booklet are excellent value for money.

## Sales talk

The Olivetti *Guide to Buying a Business Computer* has two advantages over the Eaton tape: it is free and it is easier on the ear. But it is nowhere near as good as Eaton's offering.

To be fair, it doesn't really pretend to rival Eaton's scope. And it is something more than just a straight sales pitch. It makes a neat complement to Eaton's views as its general drift is the same: software and support are more important than hardware.

Instead of having one person read the text, Olivetti has used a team from LBC, London's commercial news radio station. Douglas Cameron, Douglas Moffat and Anna Barrie present the information like a news report.

Anna acts as the news reporter providing information on a survey conducted by Olivetti of businessmen's attitudes to computers. The two Dougases comment on the fears expressed by the businessmen and give details of some Olivetti products. As the tape comes from the business computer side of Olivetti, there is an emphasis on data processing, stock control and financial and accounting management rather than on word processing. Although the LBC team raise all the right points, they are a bit too glib in dismissing problems; in some cases much too glib.

For example, the Olivetti study found that people were worried about the reorganisation needed if you install a computer. 'In fact a computer can be installed with no disruption whatsoever,' is the bland answer. This is rubbish. Every computer system leads to some form of work and job reorganisation. It is no good pretending it doesn't. The tape also summarily and incorrectly dismisses fears about system breakdowns and 'hidden costs'. But the fact that the tape is a freebie from a manufacturer will naturally alert the listener to any soft or hard sell. By showing what can be done with audio presentation and by talking much commonsense as well as much sales spiel, this is an imaginative and useful piece of sales material.

## The moving cursor writes

Morgan and Wood's *Word Processing* suffers from the 'culture gap' problem. When it sticks to describing what word processors do, it is excellent both in content and style. But it begins to

## WORD PROCESSING WORD PROCESSING WORD PROCESSING

RICHARD MORGAN  
AND BRIAN WOOD

become ragged when trying to relate word processing to other computing and communications developments.

The first three chapters are particularly good: What is a word processor; hardware; and software. But it loosened the tight grip of these chapters in the next one, which contains a ragbag of capabilities under the title 'machine layout'.

It has some skimpy and disappointing material on staff and the future and doesn't really deal adequately with the relationship between WP and other information technologies. Local networks, which are of great significance in office automation, are mentioned only towards the end, *en passant*. But it has some sensible material on choosing and implementing systems. The culture gap problem means that it views the world primarily down the barrel of a word processor. As an introduction to the roots of word processing, this book is a very good starting point, provided you are aware that later you will have to branch out into other subjects.

### An aptitude for it

Wood and Morgan treat office staff problems primarily as an extension of computer systems development. They also focus on workstation ergono-

mics for operators (VDUs and eyestrain in particular). But the office provides a unique and complex environment, with many more new staff challenges to be faced.

As part of its general consultancy and research services, Urwick Nexos has produced an interesting report called *Staff Attitudes and Aptitudes* by Emma Bird which examines some of these new challenges. The first part examines staff reactions to change, ergonomics, training and the role of trade unions. Her message is clear: 'To obtain maximum productivity from the new system it is essential to have staff support and the key to gaining this support is to involve staff in the change process from the start.'

The second part examines initial results from an Urwick Nexos study into identifying the skills and attributes which determine whether or not an individual will be proficient and contented when working with electronic office systems.

The main characteristics identified in the study were good skills in English, problem solving ability, interest in information technology, accurate and fast typing, and logical thinking.

The report is pricey for what it is, but it is meant to be viewed as part of a spectrum of publications and research activity into office systems, not just as a one-off publication. When more results of the aptitude study become available, more meat will be available to flesh out what is still a skeletal theory.

Anyone in office automation should be aware of the factors highlighted by Emma Bird. Some managers will disagree with her recommendation for more industrial democracy. But to ignore the human factor is to set the scene for strife, and will probably lead to inhumanity in the systems developed.

Management has a right to manage. But staff have a right to be treated like human beings. This report is a useful contribution to making this point.

### Cryptic primer

Data encryption is an important method of protecting data. A book which describes itself as the 'first accessible step-by-step guide to both theory and applications' sounds welcoming.

*Cryptography - A Primer* by Alan G

Konheim unfortunately fails to live up to the blurb. It is more a textbook of cryptography than an 'accessible guide'. It has about 400 pages stacked with equations. As such it is of use to anyone who is prepared to delve into the subject in depth.

Konheim says the book is an introductory one because it doesn't attempt to cover all methods of encipherment. This may be true but it is still a pretty detailed and comprehensive book.

Publishers should be more careful about the way they describe books like this, particularly when the price is clearly aimed at a specialist market.

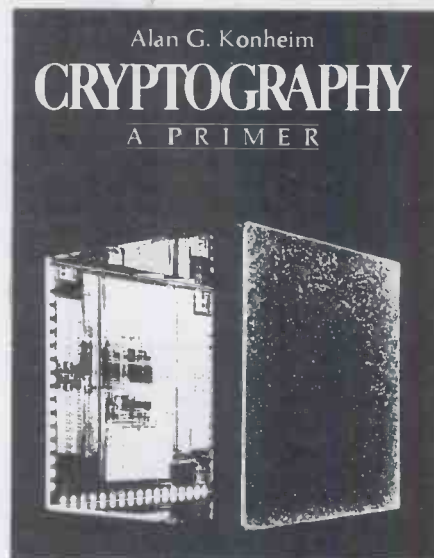

This month's Bookfare included:  
*How to Choose your Small Business Computer* by J Mike Eaton (National Computing Centre, cassette tape and booklet,  
*The Olivetti Guide to Buying a Business Computer* (British Olivetti Ltd, 30 Berkeley Square, London W1X 6AH, cassette tape, free to business people.)  
*Word Processing* by Richard Morgan and Brian Wood (Oyez Publishing, £9.95)  
*Staff Attitudes and Aptitudes* by Dr Emma Bird (Urwick Nexos, Farnham Common, £15.00)  
*Cryptography - A Primer* by Alan G Konheim (Wiley-Interscience, £23.40)

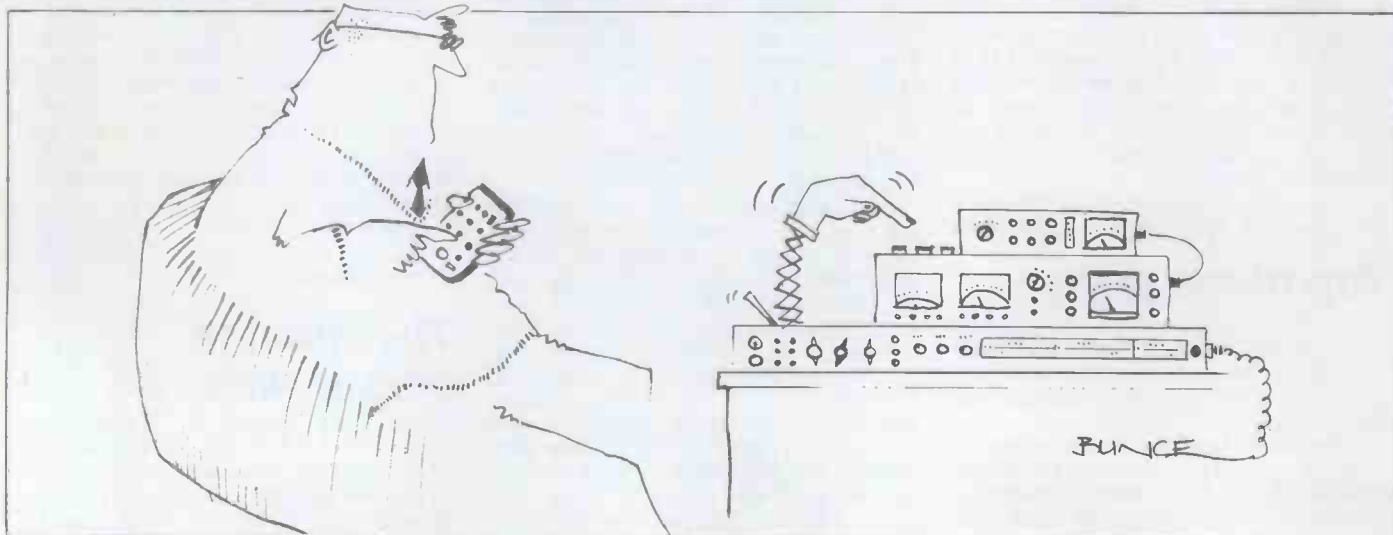



# sinclair ZX81 PERSONAL COMPUTER



# Sinclair ZX81 Personal Computer the heart of a system that grows with you.

1980 saw a genuine breakthrough – the Sinclair ZX80, world's first complete personal computer for under £100. Not surprisingly, over 50,000 were sold.

In March 1981, the Sinclair lead increased dramatically. For just £69.95 the Sinclair ZX81 offers even more advanced facilities at an even lower price. Initially, even we were surprised by the demand – over 50,000 in the first 3 months!

Today, the Sinclair ZX81 is the heart of a computer system. You can add 16-times more memory with the ZX RAM pack. The ZX Printer offers an unbeatable combination of performance and price. And the ZX Software library is growing every day.

## Lower price: higher capability

With the ZX81, it's still very simple to teach yourself computing, but the ZX81 packs even greater working capability than the ZX80.

It uses the same micro-processor, but incorporates a new, more powerful 8K BASIC ROM – the 'trained intelligence' of the computer. This chip works in decimals, handles logs and trig, allows you to plot graphs, and builds up animated displays.

And the ZX81 incorporates other operation refinements – the facility to load and save named programs on cassette, for example, and to drive the new ZX Printer.



New BASIC manual

Every ZX81 comes with a comprehensive, specially-written manual – a complete course in BASIC programming, from first principles to complex programs.

## Kit: £49.<sup>95</sup>

## Higher specification, lower price – how's it done?

Quite simply, by design. The ZX80 reduced the chips in a working computer from 40 or so, to 21. The ZX81 reduces the 21 to 4!

The secret lies in a totally new master chip. Designed by Sinclair and custom-built in Britain, this unique chip replaces 18 chips from the ZX80!

## New, improved specification

- Z80A micro-processor – new faster version of the famous Z80 chip, widely recognised as the best ever made.
- Unique 'one-touch' key word entry: the ZX81 eliminates a great deal of tiresome typing. Key words (RUN, LIST, PRINT, etc.) have their own single-key entry.
- Unique syntax-check and report codes identify programming errors immediately.
- Full range of mathematical and scientific functions accurate to eight decimal places.
- Graph-drawing and animated-display facilities.
- Multi-dimensional string and numerical arrays.
- Up to 26 FOR/NEXT loops.
- Randomise function – useful for games as well as serious applications.
- Cassette LOAD and SAVE with named programs.
- 1K-byte RAM expandable to 16K bytes with Sinclair RAM pack.
- Able to drive the new Sinclair printer.
- Advanced 4-chip design: micro-processor, ROM, RAM, plus master chip – unique, custom-built chip replacing 18 ZX80 chips.



## Built: £69.<sup>95</sup>

## Kit or built – it's up to you!

You'll be surprised how easy the ZX81 kit is to build: just four chips to assemble (plus, of course the other discrete components) – a few hours' work with a fine-tipped soldering iron. And you may already have a suitable mains adaptor – 600 mA at 9 V DC nominal unregulated (supplied with built version).

Kit and built versions come complete with all leads to connect to your TV (colour or black and white) and cassette recorder.



# ter-



## Available now - the ZX Printer for only £49.<sup>95</sup>

Designed exclusively for use with the ZX81 (and ZX80 with 8K BASIC ROM), the printer offers full alphanumerics and highly sophisticated graphics.

A special feature is COPY, which prints out exactly what is on the whole TV screen without the need for further instructions.

**How to order your ZX81**  
 BY PHONE – Access, Barclaycard or Trustcard holders can call 01-200 0200 for personal attention 24 hours a day, every day.  
 BY FREEPOST – use the no-stamp-needed coupon below. You can pay

At last you can have a hard copy of your program listings – particularly useful when writing or editing programs.

And of course you can print out your results for permanent records or sending to a friend.

Printing speed is 50 characters per second, with 32 characters per line and 9 lines per vertical inch.

The ZX Printer connects to the rear of your computer – using a stackable connector so you can plug in a RAM pack as well. A roll of paper (65 ft long x 4 in wide) is supplied, along with full instructions.

by cheque, postal order, Access, Barclaycard or Trustcard.  
 EITHER WAY – please allow up to 28 days for delivery. And there's a 14-day money-back option. We want you to be satisfied beyond doubt – and we have no doubt that you will be.

## 16K-byte RAM pack for massive add-on memory.

Designed as a complete module to fit your Sinclair ZX80 or ZX81, the RAM pack simply plugs into the existing expansion port at the rear of the computer to multiply your data/program storage by 16!

Use it for long and complex programs or as a personal database. Yet it costs as little as half the price of competitive additional memory.

With the RAM pack, you can also run some of the more sophisticated ZX Software – the Business & Household management systems for example.

To: Sinclair Research Ltd, FREEPOST 7, Cambridge, CB21 1YY.				Order
Qty	Item	Code	Item price £	Total £
	Sinclair ZX81 Personal Computer kit(s). Price includes ZX81 BASIC manual, excludes mains adaptor.	12	49.95	
	Ready-assembled Sinclair ZX81 Personal Computer(s). Price includes ZX81 BASIC manual and mains adaptor.	11	69.95	
	Mains Adaptor(s) (600 mA at 9 V DC nominal unregulated).	10	8.95	
	16K-BYTE RAM pack.	18	49.95	
	Sinclair ZX Printer.	27	49.95	
	8K BASIC ROM to fit ZX80.	17	19.95	
	Post and Packing.			2.95

Please tick if you require a VAT receipt

TOTAL £.....

\*I enclose a cheque/postal order payable to Sinclair Research Ltd, for £.....

\*Please charge to my Access/Barclaycard/Trustcard account no.

\*Please delete/complete as applicable.

Please print.

Name: Mr/Mrs/Miss \_\_\_\_\_

Address: \_\_\_\_\_

FREEPOST – no stamp needed.

PCW 11

# sinclair ZX81

6 Kings Parade, Cambridge, Cambs., CB2 1SN.  
 Tel: (0276) 66104 & 21282.

# How the ZX81 compares with other personal computers

SYSTEM IDENTIFICATION		ZX81	ZX80	ACORN ATOM	APPLE II PLUS	PET 2001	TRS 80 LEVEL I	TRS 80 LEVEL II
ROM		8K	4K	8K	8K	14K	4K	12K
GUIDE PRICE	Basic unit - inc. VAT	£70	£100	£175	£630	£435	£290	£375
	Unit plus 16K RAM (*12K RAM)	£120	£150	£285*	£630	£530	£360	£375
COMMANDS	LIST, LOAD, NEW, RUN, SAVE	●	●	●	●	●	●	●
STATEMENTS	PRINT, INPUT, LET, GOTO, GOSUB/RETURN, FOR/NEXT IF/THEN	●	●	●	●	●	●	●
	STEP	●		●	●	●	●	●
	TAB	●			●	●	●	●
ARITHMETIC FUNCTIONS	ABS, RND	●	●	●	●	●	●	●
	INT	●			●	●	●	●
	ATN, COS, EXP, LOG, SGN, SIN, SQR, TAN	●			●	●		●
STRING FUNCTIONS	ARCSIN, ARCOS	●						
	CHR\$	●	●		●	●		●
	LEN	●		●	●	●		●
NUMBERS	ASC(CODE), STR\$, VAL, INKEY\$	●				●		●
	FLOATING PT ±10 <sup>-38</sup>	●			●	●	●	●
	INTEGERS		●	●	●	●		●
NUMERIC VARIABLES	A-Z			●			●	
	AA-ZØ				●	●		●
	An-Zn, n= any alphanumeric string	●	●					
STRING VARIABLES	A\$ & B\$						●	
	A\$ to Z\$	●	●	●				
	An\$ to Zn\$, n= any alphanumeric character				●	●		●
NUMERIC ARRAYS	SINGLE DIMENSIONAL		●	●			●	
	MULTI DIMENSIONAL	●			●	●		●
DISPLAY	ROWS	24	24	16	24	25	16	16
	COLUMNS	32	32	32	40	40	64	64
	LOW RES GRAPHICS (<7000 pixels)	●	●	●	●	●	●	●
	HI RES GRAPHICS (>40000 pixels)			●	●			
SPECIAL FEATURES	USR (CALL, LINK)	●	●	●	●	●		●
	PEEK, POKE (OR EQUIV)	●	●	●	●	●		●

## Sinclair software on cassette.



The unprecedented popularity of the ZX Series of Sinclair Personal Computers has generated a large volume of programs written by users.

Sinclair has undertaken to publish the most elegant of these on pre-recorded cassettes. Each program is carefully vetted for interest and quality, and then grouped with others to form single-subject cassettes.

Software currently available includes games, junior education, and business/household management systems. You'll receive a Sinclair ZX Software catalogue with your ZX81 - or see our separate advertisement in this magazine.

## The ultimate course in ZX81 BASIC programming.



Some people prefer to learn their programming from books. For them, the ZX81 BASIC manual is ideal.

But many have expressed a preference to learn *on the machine, through the machine*. Hence the new cassette-based ZX81 Learning Lab.

The package comprises a 160-page manual and 8 cassettes. 20 programs, each demonstrating a particular aspect of ZX81 programming, are spread over 6 of the cassettes. The other two are blank practice cassettes.

Full details with your Sinclair ZX81.

## If you own a Sinclair ZX80...

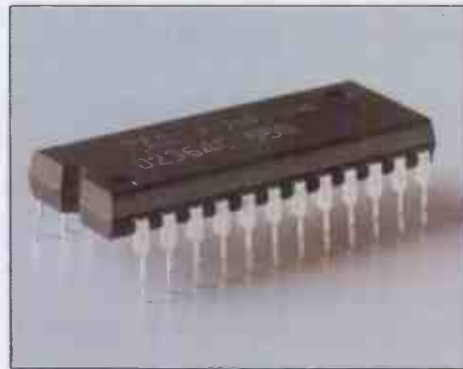

The new 8K BASIC ROM used in the Sinclair ZX81 is available to ZX80 owners as a drop-in replacement chip. (Complete with new keyboard template and operating manual.)

With the exception of animated graphics, all the advanced features of the ZX81 are now available on your ZX80 - including the ability to drive the Sinclair ZX Printer.

# sinclair

## ZX81

6 Kings Parade, Cambridge, Cambs., CB2 1SN.  
Tel: (0276) 66104 & 21282.

# NOT-SO-OPEN SESAME

*Jeff Taylor continues his look at US computer literacy projects.*

Sesame Place has the largest collection of educational computers in the country, or so claim its founders in their publicity material. A joint venture of Children's Television Workshop and Busch Entertainment Group, Sesame Place is located near Oxford Valley Mall, a wealthy suburb north of Philadelphia. As Dennis Sullivan, chief software designer for the park, points out, CTW has been subsidised by grants for the past ten years; these funds are now drying up and it needs new sources of revenue. Sesame Place represents the vanguard of CTW's new commercial interests, which will be cloned in six other sites around the country. As Sullivan states, the software, designed primarily to entertain but with secondary educational value, will soon be offered for sale to the exploding home computer market: 'We took academic subjects and built games around key concepts. The educational concept came first.' (Joyce Hakansson, SP's computer games co-ordinator, in *Recreational Computing*, May-June, 1981.)

Once the park entrance fee of \$5.45 is paid, tokens are available for using the computers at a cost of three for a dollar, each one worth four minutes of computer time. The token gives one access to nearly 70 Apple computers, linked in a Nestar network and bullet-proofed in heavy metal with touch-sensitive screens. Despite educational overtones, arcade mercantilism prevails, so that when four minutes are up the game is over, whether or not the user is left halfway through, frustrated by this new 'learning' experience. Whether designed to entertain or to educate, the games are disappointing on both counts, and lurking in the wings of the Computer Gallery are the old faithfuls, Space Invaders and Asteroids, to lure and satiate the addicted.

Sesame Place is, in part, aspiring to fulfil a hands-on science education function, modelled on the Exploratorium in San Francisco and on the Lawrence Hall of Science in Berkeley, from where its key staff have emerged. Yet it provides precious little education about computers, much less about the microrevolution. There is nothing to inform the visitor that the machines from which they are being fed canned CAI trivia are in fact microcomputers, that they are not just terminals to a manframe. As an afterthought, tucked away on a side wall is a cryptic and untitled display of Apple circuit boards, with inscrutable descriptions of functions. I observed no one being distracted from spending money on the machines in order to try to decipher this free attraction. Nowhere is there,

for example, a microscope with a chip to gaze at and by which to be amazed into beginning to fathom just how potentially fundamental and pervasive is this new technology. Nowhere is there a small library in which to browse through books and journals that might be concerned with the social implications of the technology, or even a casually displayed bibliography to such. Nor are there updated newsclippings and longer articles displayed that might begin to make relevant this new technology to parents whose children are being so obsessively entertained by it. Not even a video is in evidence, on which could be shown offerings such as 'Now the Chips are Down' to the uninformed. At least, one would think, one machine could be spared to offer an educational program that begins to inform about another recent technology: the simulation of Three-Mile Island now available for the Apple.

Although I may be overcritical of Sesame Place, especially when it is seen in context with other amusement parks that offer only passive experiences built around thrill rides, it is clear that, as a commercial venture, it is designed primarily to please and entertain rather than to provoke and educate. Its commercial ties with Busch, the hand from which it is fed, prevent its presenting contentious material, although there seems little excuse, beyond lack of awareness among staff, for missing so many opportunities to demystify the technology. In fact, the Gallery can be seen to have the opposite effect; instead of exploiting the educational opportunity when a machine is down by informing passers-by that the computer is a fallible mechanism, it is chosen to display the anthropomorphic message: 'Computer is resting'.

On the positive side, Sesame Place is beginning to offer special workshops for teachers and pupils; one is called 'Meet the Playful Computer', and aims to teach how computers work and 'what they can and can't do', rather than concentrating on programming. In a very limited sense, it is beginning to offer public access to computers and to education about them. However, the cost of frequently entering the park and paying for computer time ensures accessibility to only the advantaged, a fact I was to encounter throughout my tour.

## Franklin Institute

It is not so much that the Franklin Institute in Philadelphia would not like to educate about microtechnology, as one of its staff explained, as it is a lack of funds. Yet, the Institute has nine Apple computers buried in exhibits,

none of which inform the visitor that they are computer-driven. It would seem an important opportunity missed not to sacrifice at least one exhibit in order to use a microcomputer to facilitate education about itself. One likely candidate, an 8ft tall plywood box with screen and keypad with which the visitor interacts in order to obtain a 'personalised' suggested tour of the Institute, might seem obviously to be a computer, reminiscent of popular mythology of what computers are supposed to look like. Yet, sitting behind the box on a shelf, invisible to the public, is a microcomputer; the remaining space is empty. The Franklin Institute cannot afford to begin to educate the public about the technology that will dominate civilisation to the end of the century, yet it can afford to perpetuate myths about the technology before an unsophisticated audience.

## The CCM

The Capital Children's Museum, in a Washington DC ghetto, has just been donated 30 Atari computers, Warner-Amex being eager to publicise and dominate the personal computer market. The Museum now considers itself the largest public computer access utility on the East Coast, discounting Sesame Place which the Museum considers an arcade. The Museum is delightfully inexpensive to enter and it must be a cultural education for many of its economically-advantaged visitors to venture into a ghetto neighbourhood to reach it. The Museum is also in the genre of exciting hands-on facilities for children, and will be using the computers in its exhibit 'Communications' to open later this year, in existing exhibits, and in the 'Future Center', a computer classroom that has just begun running courses in learning how to 'play' with computers as well as how to program.

The museum is sensitive to the 'further disenfranchisement of the poor', as Executive Director Ann Lewin describes the major problem that will be exacerbated by the proliferation of computers; she sees the Museum's role as one of addressing this by providing a public-access computer centre in an area accessible to the 'permanent underclass'. Yet, in outlining the objectives for a computer activity at the Museum, staff have not included the spread of awareness concerning such social implications among the ten listed.

The 'Communications' exhibit (yet to open) sounds promising in its attempt to reveal computer applications such as graphics, robotics, text editing, electronic mail, simulations,

# Over the last two year's



more than 1,000 completely non-technical users in the UK alone used one British program to keep student records, personnel files, mailing lists, sales records, parrot breeding records, man hole cover records, electoral roll records, blood donor records, pharmacy records, patient records, stock records, library lists, dating agency files, parts files, exchange rate files, employment files, accountant and solicitors records, farm records, garage records etc, etc.

## How could YOU use Compssoft's DMS\* (Data Management System) this year?

**\*Available on CP/M with link to Wordstar or Commodore machines linking to Wordcraft, Wordpro, and Visicalc.**

Designed with the non-computer expert in mind, DMS users, ranging from those in the smallest to those in the largest multi-national companies, have followed the simple screen instructions to create their own file, store, amend, sort and search for information.

Searching on multiple parameters is easy, and these pre-selected batches of records can then be processed (e.g. update all my prices by 5% and recalculate the new inventory value), displayed, passed to the report generator, or merged with other files.

Batches of data may be deleted, and the space automatically re-used. Most importantly the file structure can be amended, adding or deleting lines as required, while still retaining existing data.

Screen layouts (as many per file as you like and all password protected), calculations and print layouts can be stored on disk for future use.

DMS can store up to 1,000 characters per record, and is backed up by its own British authors from Compssoft's base in Guildford, Surrey. We are always happy to discuss your applications or arrange demonstrations with your area dealers.

DMS will run on Equinox, PET (including 96K), Rair, Cromemco, Superbrain (including double tracking machines), Apple, Cifer, Heath, North Star, Dynabyte, Vectorgraphic, Shelton, SD. In fact on any CPM-based system with floppy or hard disks.

**You can contact us at**

**Compssoft Ltd, Great Tangley Manor Farm, Wonerish,  
Guildford, Surrey GU5 0PT.**

**Telephone: Guildford 0483 505918/39665.**

games, an electronic library and musical composition, and one hopes there will be no surcharge to have access to this exhibit.

Finally, despite Museum efforts to redress potential imbalance by providing more equal access to computing, the unfortunate decision has been taken by them to charge a fee of \$7 per session for classroom instruction, which must certainly exclude the 'permanent underclass' in whose neighbourhood the Museum is located, and give crucial extra advantage to the already advantaged who can afford to become computer literate.

## Oakridge

Oakridge, Tennessee, infamous as the birthplace of nuclear power, is home of the Museum of Science and Energy. Formerly known as the Atomic Energy Museum, the establishment is controlled by the Department of Energy, which decided to change the name as a public relations move following Three-Mile Island. The new title is a misnomer, since, although concerned with energy, the Museum is not concerned with Science and certainly not with scientific objectivity *per se*. In 'educating' the public with regard to energy issues, the Museum offers one of the country's largest public accesses to computers. It is DOE policy deliberately *not* to educate about computers but, rather, *with*, and the reasons are not merely bureaucratic. Already the Museum is primarily concerned with presenting a clear image of what is to many of the public a blemished technology (nuclear). Computers have proven effective as a means for holding public attention at museum exhibits, so that to actively point out to the public that the machines they are using are in fact computers, a technology for which many of the public is blemished as well, may prove counterproductive.

For most of the people I interviewed at the Museum, this was their first time 'touching' a computer and half of them didn't realise that the machines were computers. Here is a case of free public access to computers, yet without the crucial educational point being made that these machines are manifestations of a new technology that will dominate the rest of their lives (that is, unless the technology about which the computers are being used to educate doesn't first bring mankind to a hasty end!).

As with the Franklin Institute, Sesame Place and the Capital Children's Museum, it is partly a case of not being aware of the potential social implications, and therefore not including anything to contribute towards a more informed public. Yet a new motive begins to appear here: conflicts of interest. In a sense it could be predicted that, even if aware of the need to stimulate public education concerning the social implications of microtechnology, at Sesame Place and the Capital Children's Museum the threatening and political nature of such material might be offensive to some and thereby jeopardise funding, as happens with American television.

It is interesting to note a further computer-related conflict of interest at the Oakridge Museum. The 'Energy Van' that brings the museum presentation to outlying areas has Apples on board, one of which was originally programmed to continually collect and graph data concerning the public's feelings on nuclear and other energies, so that people could access the data and add their views to the bank. Sensing that the dissemination of such information could be counterproductive to its aims, the DOE put an abrupt halt to this form of computer and energy education, claiming that the availability of such information could prejudice people. (It is a similarly elitist argument that seems to suppress information concerning the social implications of microtechnology.) The program exists on computer inside the Museum now, soon to be retired, yet only graphs visitors' responses for a given day, clearing its memory when the machine is shut off at night. The DOE sees no value in compiling a profile of data on what people actually feel about energy issues, and visitors to the museum are so illiterate of the technology and its potential social use and misuse that they would not think to question why this opportunity for democratisation is being diluted.

## Three school projects

A brief stop in each of three schools en route to California yielded data that contributes to this travelogue of missed opportunities in micro-related education.

In nearby Knoxville, Mike Moshel is sponsored by the NSF to develop a Pascal teaching system using graphics. I had the opportunity to see the system field-tested in a classroom of 12 students, of whom four were women. This programming class, to run a term, attempts to operate around the limitations of having only two machines in a classroom. Students work in groups of three and the idea is that when two groups are at the machines, the rest are working at their seats on solving set problems, or on their required projects. This and another class that was testing the material had lost six students, all female. The graphics mode is meant to motivate the students to learn programming, so that typical projects are the construction of state maps, or arcade-like combat simulations. Yet, this motivation wears off quickly after the first three sessions when the hard work begins, according to teacher Bill Baird, so that in the session I observed (the eighth), few students at their seats were involved with their work but were rather passing time. The classroom itself was barren, with no windows, and there was certainly no effort to make the students aware of the microrevolution by providing books, journals, a collection of newspaper clippings to which they could contribute, etc. I engaged some students in conversations concerning home banking via computer which a local banking firm in Knoxville had just

undertaken to promote in a big way. They were keen to contribute to this discussion, eager to speculate on the motives of the bank, yet it would not normally have been part of their experience in this programming class.

Not only was the opportunity missed to educate these students more widely concerning the social implications of microelectronics, but such exposure could prove motivating for some who otherwise might not see the relevance to their lives of learning programming. Issues such as the exploitation of Third World women by the semiconductor industry, or the threat of automation to their own future jobs (since women, the itinerant workforce, are the first to go) might have struck a responsive chord with these otherwise unmotivated female students.

The philosophy of Lamplighter School is displayed in tasteful lettering on the wall adjoining its pleasant visitors' reception: 'Not a Vessel to be Filled, but rather a Lamp to be Lighted'. A private, open-plan elementary school in wealthy North Dallas, Lamplighter is a test-bed and showcase for nearby Texas Instruments' version of Logo, a computing language developed by Seymour Papert, Professor at MIT, and author of *Mindstorms*. Papert based much of his research here among advantaged children, developing this system which purports to put the child in control of the computer rather than vice versa, which he sees as the relationship reinforced by most CAI (computer-aided instruction). Drill and practice CAI, formerly in evidence at Lamplighter, has been discreetly dropped from the curriculum in favour of the discovery-based Logo.

I was struck here by the children's obvious motivation to use Logo, and by the missed opportunity of building upon this motivation to expose these children to the possible futures with microtechnology: either the potential for a caring society, a resurgence of Ancient Athens with microtechnology the slave; or for an even more polarised and divided society, with the shrinking number of jobs going to those advantaged enough to gain access to computing skills at this early stage, and with the gulf between the haves and have-nots (the knows and the know-nots) growing ever wider. It would be an ideal opportunity to facilitate empathy in these extremely advantaged children for the present and potential future condition of the disadvantaged. Such a chord struck early could ring through these children's lives and would at last represent some effort at redressing the inequity that arises from giving children such as those at Lamplighter still further advantage through their access to computing.

Outside Albuquerque, Judith Hakes has a National Science Foundation grant to develop software to teach the Pueblo Indian schoolchildren science and maths-related concepts, using the traditional Pueblo storytelling techniques and other cultural links in the programs. I visited a school in Acoma, 60 miles west of Albuquerque, where the field development work was taking place in

a fifth-grade class. Using animated graphics, a story is told about the sun and rain, after which children in pairs play at catching raindrops from clouds, using a paddle to manipulate an electronic bucket on the screen, after which the results are graphed on paper. The idea of catching is engrained in Pueblo culture, since there is an annual feast day when gifts are thrown from the rooftops and children catch them. It represents a more humanistic use of the medium to reinforce catching rather than shooting down.

Prior to visiting the school, I had the opportunity to speak to a young Indian at the Institute of American Indian Art in Sante Fe to gauge his feelings concerning this integration of Pueblo culture into schools. His response was vehemently opposed to what he saw as outsiders using Pueblo children as guinea pigs. I retorted that, if successful, this software could validate Pueblo storytelling technique as an educational method that could be used elsewhere, and in a sense be a medium for widely disseminating traditional Pueblo values.

His response was still more vehement: Pueblo children relating to computers rather than to the wisdom of their elders, the traditional storytellers, will completely decimate this dying culture which has clung so long to its traditions.

After my visit to the school, my conversation with the Sante Fe Indian came back to me. I had learned that all but three of the school's teachers, most of whom are white, commute the 60 miles from Albuquerque, and it occurred to me that if indeed the traditional storytelling technique was so highly valued by the NSF project, would it not be far more sensible to use humans to tell the stories, preferably the local elders, who are otherwise unemployed? Unemployment is extremely high among the locals, whose dwellings appear devastatingly poor in comparison to the Westernised and well-equipped school. Most young people move off to Albuquerque for industrial work when they are old enough, and one can empathise with the short-term needs of Indians to gain Western skills to leave their traditional homes in order to make a decent living wage. Yet, in the not so long-term, these jobs will be automated anyway and the Pueblo will be left with no culture. The micro-revolution could make it advantageous to the Pueblo that their culture be resurrected, that their arts once again flourish. Facilitating awareness of the micro-revolution, of its possible social impact among the Pueblo, could provide a means to motivate them to re-investigate their own culture.

The plight of the Pueblo reflects some more general implications of microtechnology for the Third World. The vital difference is that when Western automation brings to a sharp halt economic development in the Third World by undercutting costs of even cheap labour there and stealing back recently acquired markets, nuclear proliferation allows them a potent threat of retaliation.

This is not to say that computers are not an appropriate technology in

Pueblo schools. Computer literacy could enhance employment skills in jobs that will not be so quickly automated and, as mentioned, could facilitate questioning about the implications of micro-technology for the Pueblo. But in automating traditions, the NSF project is merely attempting to foist onto the Pueblo a more palatable CAI, offering Western video values that put the computer rather than the child in control, just the kind of CAI that advantaged schools such as Lamplighter are booting out. This disturbing pattern is becoming more evident, as dedicated non-programmable machines coming onto the market threaten to find their way into disadvantaged schools in order to reinforce basic skills and improve minimal competency test scores. This in itself would not be so bad, if it were not that these systems will be bought up by poorer schools *instead of* programmable systems that can offer access to work-related computer literacy. The ironic implications are that the poor may become literate in traditional skills but in doing so will be cut out from computer-related work.

## In California

From the Lawrence Hall of Science in Berkeley has emerged a handful of key personnel who are involved with other access-to-computing initiatives, such as Sesame Place and the Capital Children's Museum. After paying a \$2.00 entrance fee, one has free hands-on access to six terminals and two microcomputers, programmed with specific routines, such as stockmarket games, an animal guessing game, and Joseph Weizenbaum's famous Eliza program. The nearby bookshop is filled with over 20 books to do with computing, only one of which involves itself with wider social issues, Weizenbaum's classic *Human Judgement and Computer Reason*. In style it is a book geared to an academic audience, although his arguments are extremely relevant to vital issues. There was no other material in the Hall that the average person could obtain to begin to be informed about the social implications of the technology which surrounds him at Lawrence.

The cruellest irony is that what gains mass access in the Hall is the program Eliza, which Weizenbaum developed to mimic a Rogerian psychotherapist in order to prove his important points concerning the dangers and limitations of artificial intelligence. Yet the Lawrence Hall of Science doesn't even see fit to at least place above the computer a modest placard briefly mentioning Weizenbaum's intentions and warnings about Eliza, and directing the interested to Weizenbaum's book for further information.

Downstairs at Lawrence are to be found rooms full of Apples, Ataris, PETs and Plato terminals. For \$3 per hour you can rent time on Plato, and classes are given regularly on the microcomputers at \$5 per hour. Atop a hill overlooking Berkeley and the San Francisco Bay, the Hall is accessible only by bus or car. Prices are continually rising, which further limits access.

Hopes are expressed by staff, as they were at the Capital Children's Museum in Washington, that eventually the Hall can afford to subsidise access for disadvantaged people. However, I would argue that the immediate future will be the crucial time for gaining access to computers, to ensure one's foothold in the diminishing job market. As Art Luehrmann, past computer research director at the Hall and computer literacy advocate, notes, 75 per cent of the jobs by 1985 will require skills in computing. Any delay in making equal access available now is critical.

Incidentally, Luehrmann was instrumental in the establishment of the Hall's computer van, which gives wider access to computing by travelling to outlying schools. Yet, even this noble initiative does little toward balancing the equity problem since only the better schools can afford its fee of \$250 per visit.

Across the Bay in affluent Marin County, Dave and Annie Fox have established what undoubtedly represents the crest of a wave of public access facilities to be set up by enterprising individuals. Housed in one section of a former school, individuals can book time on machine (\$3 per hour), arrange 'computer birthday parties' in which party games are computer games, or attend classes in programming. Classes run about \$5 per hour (\$30 for four 1½-hour sessions). Books, periodicals and software are also available for sale.

Such an enterprise is established to cater for demand and it was bold foresight by the Foxes to predict this demand and borrow \$50,000 from a bank four years ago to finance the operation. The advantaged and educated public of Marin County is quickly realising the importance of computer-related skills for their children's, and their own, future employability, and at present that is interpreted to mean programming. The Foxes have never needed to advertise the Center since this aware public quickly learned of its existence. The American free enterprise system ensures that privately-run computing centres will be springing up around the country in all areas where people are informed about upcoming skill needs and can afford to pay for this kind of service, to fill the need that schools and other public institutions are leaving unmet. Such are the consequences of *laissez faire* control of a vital resource, information, that a whole segment of the population will ensure its dominance at the expense of the rest.

A further consequence is that organisations such as the Marin County Computing Center are not in business to inform people about the social implications of new technology. Indeed, some of the implications are critical of their business and threatening to the clientele they serve. If clients demanded such information it would be different, but the product the public has been led to believe it needs is a streamlined computer literacy: programming. So yet another opportunity is missed to begin to redress the

GOTO page 182



**Comart Approved  
Dealers**

**Aberdeen**

MOM Offshore  
21 Bon Accord Street  
Tel: 0224 22863

**Belfast**

O & M Systems  
95 Dublin Road  
Tel: 0232 49440

**Birmingham**

Byteshop Computerland  
94/96 Hurst Street  
Tel: 021 622 7149

**Bristol**

Senton  
27 Nicholas Street  
Tel: 0272 276132

**Cambridge**

Toltec  
24 Thompson Lane  
Tel: 0223 312347

**Cheshire**

Holdene  
82a Water Lane  
Wilmslow  
Tel: 0625 529486

**Dublin**

Lendac Data Systems  
8 Dawson Street  
Tel: 0001 372052

**Edinburgh**

Holdene Micro Systems  
Bristo Street  
Tel: 031 668 2727

**Glasgow**

Byteshop Computerland  
61 Waterloo Street  
Tel: 041 221 7409

**Leeds**

Holdene Micro Systems  
11/12 Rampart Road  
Tel: 0532 459459

**London**

Byteshop Computerland  
324 Euston Road, W1  
Tel: 01-387 0505

**Digitus**

9 Macklin Street, WC2  
Tel: 01-405 6761

**Jarogate**

67 Tulsemere Road, SE17  
Tel: 01-670 3674

**Manchester**

Byteshop Computerland  
Piccadilly Station Approach  
Tel: 061 236 4737

**NSC Computers**

29 Hanging Ditch  
Tel: 061 832 2269

**Newbury**

Newbear Computing Store  
40 Bartholomew Street  
Tel: 0635 30505

**Nottingham**

Byteshop Computerland  
92a Upper Parliament Street,  
NG1 6LF  
Tel: 0602 40576

**Sheffield**

Hallam Computer Systems  
451 Eccleshall Road  
Tel: 0742 663125

**Southampton**

Xitan Systems  
23 Cumberland Place  
Tel: 0703 38740

**Suffolk**

Eurotec Consultants  
Little Walsingham,  
Sudbury  
Tel: 0787 247959

**Surrey**

Gemlines  
184 London Road, KT2 6OU  
Tel: 01-546 9944

**Warwicks**

Business & Leisure  
Microcomputers  
Kenilworth  
Tel: 0926 512127

**Watford**

Lux Computer Services  
108 The Parade,  
WD11 2AW  
Tel: 0923 29513

**Worthing**

Ace Computing Services  
1-11 Bridge Road  
Tel: 0903 35411

**Comart Ltd.**

St. Neots, Cambs.  
Tel (0480) 215005  
Telex 32514 Comart G.

# comart communicator

## The clean simplicity outside...



**NOW WITH 5 MEGABYTE  
HARD DISK DRIVE**

## ...conceals the pedigree inside.

First came the Communicator CP100, a British designed, British made Microcomputer; Z80A processing power, Twin Floppy Disk Drives, S100Bus Construction, CP/M operating system, neat compact styling, and a standard of engineering reliability uncommon in such a new system.

In just a few short months Communicator was the focal point of a new range of Microcomputers.

It offered floppy disk drive options, double density, quad capacity, and 80 track quad capacity. It offered floppy disk and S100 bus expansions. It had a 20 Megabyte Hard Disk Sub System and Cassette Back up.

Now there is Communicator CP500, a dedicated system within a System. CP500

provides over 5 Megabytes of on-line data storage with its integral 5 MegaByte 5" Winchester Technology Hard Disk and very high capacity floppy disk drive.

To the user, CP500 means greatly improved utility. It will support larger scale computer operations at several times the speed and commence of the conventional floppy disk systems. And it offers greater application flexibility, with reduced operator involvement in diskette management routines.

Find out more about the Communicator range today.

# comart

SPECIALISTS IN MICROCOMPUTERS

A member of the Comart  Group of Companies.

# Paper Tigers - still the best, now even more versatile

It's now possible to feed single-sheet non-perforated paper through Europe's favourite matrix printers. Our single sheet feed device is simple, reliable and low in cost – just one more reason to buy a Paper Tiger.

And here's another – our new PET interface card. For a few pounds, this plug-in, micro-processor P.C.B. card marries the striking advantages of Paper

Tiger printing with Europe's best-selling micro.

Find out today about Paper Tiger – just phone or write for full details.



Teleprinter Equipment Limited –  
*the peripheral people*

70-82 Akeman Street, Tring, Herts. HP23 6AJ. U.K.  
Tel. Tring (0442 82) 4011/9 & 5551/9.  
Telex: 82362 BATECO G.

**NEW**  
LOW PRICES  
check with your  
dealer for  
details

Model 445 – rugged and reliable printing mechanism, raster graphics and 198 c.p.s. print speed.

Model 460 – features a nine wire staggered head for enhanced print quality.



Model 560 – All the features of the 460 plus the ability to handle full size 132 column paper.

Please send details of Paper Tiger 445  460  560  all

Name \_\_\_\_\_  
Company \_\_\_\_\_  
Address \_\_\_\_\_  
Tel. \_\_\_\_\_

# CALCULATOR CORNER

Compiled by Dick Pountain.

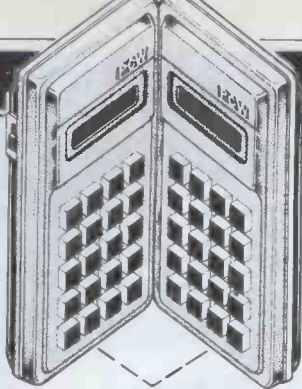

## Casio fx702p - a Sharp contest

The arrival of the 702p marks the introduction to the UK market of a second real pocket computer, the Sharp PC1211/Tandy being the first. Next year should see Panasonic's contender enter this expanding arena, where the border between calculators and micro-computers grows indistinct. Just to add to the confusion, Casio have called the 702p a programmable calculator, which at least allows me to Benchtest it in Calculator Corner without receiving rude letters, as I have done from Sharp owners, saying 'Hands off — it's a computer!' as if some ego threat was being posed.

Since only two machines exist at present in this niche, it seems logical to compare them in this review, not to say which is 'better', since each has features the other lacks, but to orient prospective buyers toward the machine more suited to their need.

## Hardware

The 702p comes in an ABS plastic case with a brushed-aluminium facing, the Casio 'house style', and, at 80x165mm, is rather dumber or squarer than the Sharp but the same thickness. Unlike the Sharp, its travelling case is of the soft pouch type. The batteries (two Cr2032 lithium cells) are in a slide top compartment in the back and give approx 240 hours' continuous use. This same compartment contains a large, suggestive space with an edge connector which is obviously designed to receive ROM and/or RAM modules at a later date.

The keyboard is an ABCD, rather than QWERTY as on the Sharp, and has 65 keys, rather larger than those of the 502/602p but with a similar feel. There are two shift keys, F1 and F2, so that all the alpha keys support three functions while the numeric/calculator keys support two. This gives sufficient functions for the whole of the Basic command set to be implemented by single key strokes, Sinclair fashion, which is a nice facility. No lower case alphas are available and the symbols are limited to punctuation and arithmetic plus '#', '\$' and 'π'. The keyboard is more convenient than the Sharp's in that often-used punctuation symbols such as ",:;\$ and # are not shifted functions.

The display is grey 5x7 dot matrix LCD with the unique, if useless, addition of a rotary contrast control. Though the display is slightly longer than that of the Sharp, it displays only

20 characters to Sharp's 24, the remaining space being occupied by a 'Steps Remaining' counter which is shown during program entry and editing. The now familiar Casio mode annunciators are present with the addition of TRACE and PRT (PRINT), the latter referring to the FP-2 peripheral printer which will be available soon.

## Firmware

Casio has wisely carried over many of the functions and features of the 502/602p machines into the 702. These include the excellent ergonomic features of dividing the program memory into 10 registers, each of which can be executed separately by pressing P0-P9. The Basic will accept P0-P9 as a GOSUB destination in addition to line number addresses and programs can be executed either by a RUN instruction or by the relevant P button. The set of scientific functions is extensive, including hyperbolic, random number, factional, polar to rectangular and vice versa, linear regression and standard deviation in addition to all the standard Basic maths routines. Angular modes are DEG, RAD and GRAD, and INT and FRAC are both supported. A key called ANS recalls the result of the last calculation performed, rather like LAST x on HP calculators. Calculations are over the standard calculator range  $10^{\pm 9}$  with 10 digit accuracy (12 digit internal). Numeric formats catered for are RND (round) to a power of 10, eg  $10^{-2}$ , SET number of significant figures or decimal places, or may be specified in a PRINT statement by, for example, ###.##, as on the Sharp, although using it is not necessary. The arithmetic is true algebraic with 20 levels of parenthesis.

Program entry is performed in WRT mode. Line numbering is not automatic but the Basic is fully tokenised, one instruction corresponding to one step with the number remaining being dis-

played. Editing is performed by a cursor which goes into fast stepping when the ← or → key is depressed for more than a second. Overwrite is automatic with a backspace delete and an insert which is, annoyingly, the shift of delete. Unlike the Sharp, the 702 doesn't have a cursor up or down key. Vertical movement through the program is downward (to higher line numbers) by pressing EXE (the equivalent of ENTER or RETURN), or access to a particular line by LIST n. LIST also works in RUN mode but then it automatically scrolls down from the start and editing is not possible. I personally think the Sharp system is more convenient, since going to the next lowest line on the Casio requires you to list the line, involving at least four key strokes.

Debugging is facilitated by a TRACE mode which executes one line at a time, displaying the program register and line number. Pressing CONT steps to the next line.

The PASSWORD protection system has been incorporated, like that on the 602p. A protected program cannot be listed, deleted or edited without knowing the password.

## Memory

Unlike the Sharp, which has automatic memory management, Casio has chosen a user-defined partition similar to that on the 602p. The starting position is 26 registers (or variables) and 1680 program steps; extra variables are selectable in blocks of 10 via the DEFM n command up to 226 variable and 80 program steps. This represents 256 bytes more memory than the Sharp, 1888 user bytes in all. Memory is, of course, non-volatile. Attempting to select more variables than the program spaces allow results in a memory overflow ERROR message and doesn't complete the program.

GOTO page 181



**Comart Approved  
Dealers**

**Aberdeen**

MOM Offshore  
21 Bon Accord Street  
Tel: 0224 22863

**Belfast**

O & M Systems  
95 Dublin Road  
Tel: 0232 49440

**Birmingham**

Byteshop Computerland  
94/96 Hurst Street  
Tel: 021 622 7149

**Bristol**

Senton  
27 Nicholas Street  
Tel: 0272 276132

**Cambridge**

Toltec  
24 Thompson Lane  
Tel: 0223 312347

**Cheshire**

Holdene  
82a Water Lane  
Wilmslow  
Tel: 0625 529486

**Dublin**

Lendac Data Systems  
8 Dawson Street  
Tel: 001 372052

**Edinburgh**

Holdene Micro Systems  
48 Great King Street  
Tel: 031 557 4060

**Glasgow**

Byteshop Computerland  
61 Waterloo Street  
Tel: 041 221 7409

**Leeds**

Holdene Micro Systems  
11/12 Rampart Road  
Tel: 0532 459459

**London**

Byteshop Computerland  
324 Euston Road, W1  
Tel: 01-387 0505

**Digitus**

9 Macklin Street, WC2  
Tel: 01-405 6761

**Jarogate**

67 Tulsemere Road, SE17  
Tel: 01-670 3674

**Manchester**

Byteshop Computerland  
Piccadilly Station Approach  
Tel: 061 236 4737

**NSC Computers**

29 Hanging Ditch  
Tel: 061 832 2269

**Newbury**

Newbear Computing Store  
40 Bartholomew Street  
Tel: 0635 30505

**Nottingham**

Byteshop Computerland  
92a Upper Parliament Street,  
NG1 6LF  
Tel: 0602 40576

**Sheffield**

Hallam Computer Systems  
451 Eccleshall Road  
Tel: 0742 663125

**Southampton**

Xitan Systems  
23 Cumberland Place  
Tel: 0703 38740

**Suffolk**

Eurotec Consultants  
Little Waldingfield,  
Sudbury  
Tel: 0787 247959

**Surrey**

Gemlines  
184 London Road, KT2 6QU  
Tel: 01-546 9944

**Warwick**

Business & Leisure  
Microcomputers  
Kenilworth  
Tel: 0926 512127

**Watford**

Lux Computer Services  
108 The Parade,  
WD11 2AW  
Tel: 0923 29513

**Worthing**

Ace Computing Services  
1-11 Bridge Road  
Tel: 0903 35411

**Comart Ltd,**

St. Neots, Cambs.  
Tel (0480) 215005  
Telex 32514 Comart G.

# Trust Comart to turn a new ADVANTAGE



## into a major benefit.

ADVANTAGE is the exciting new, packaged high performance desk top computer with integral video screen. It brings the proven reliability, so long the hallmark of NORTH STAR products, into new and broader fields of application.

Add the established Comart technical, software, and service support and the ADVANTAGE becomes a major benefit to users looking for a low cost, yet versatile, dedicated system. NOW!

Just look at the benefits.

ADVANTAGE is economical: A complete integrated accounting system and word processing system will cost around £4500 depending on the printer and software used.

ADVANTAGE is versatile: You have the benefit of application software that is already available and proven on NORTH STAR Systems.

ADVANTAGE is new: It's Business Graphics can convert data into bar charts, pie charts, graphs, and 3D representations instantly. And, what you can see on the screen, you can print.

For the technically minded, Advantage is a 4MHz, Z80A based microcomputer with 64K dynamic RAM, a 20K Byte display dedicated RAM, plus 2K Boot PROM.

An auxiliary 8035 processor provides keyboard and disk control. It has a 12" green screen, and integrated twin quad capacity 5" disk drives providing 720K Bytes of data storage. It has a 87 key Selectric® style keyboard with 9 control keys, 14 key numeric/cursor control pad, 15 programmable function keys, and 49 conventional character keys.

ADVANTAGE comes complete with Business graphics, self diagnostic software and graphics demo software. Its G-Basic/G-DOS, and Graphics CP/M® are supersets of the industry standards. They enhance ADVANTAGE'S Graphic and Character Mode capabilities, and provide a consistent operating environment for development and application programs written in any other CP/M compatible language.

To see more of the benefits of the ADVANTAGE ask your Comart Dealer, or send now for further information.



# comart

SPECIALISTS IN MICROCOMPUTERS

A member of the Comart Group of Companies.

# BENCHMARKS SUMMARY

We have received a large number of requests for details of the Benchmark programs used in our Benchtests so we're reprinting them here. You'll also find the timings for machines Benchtested since October last year.

The Benchmark programs, originally published in *Kilobaud*, are fairly self-explanatory and provide a rough rule-of-thumb guide to the efficiency of the machines' Basic interpreters and, to a lesser extent, to the efficiency of certain aspects of hardware design. They should be interpreted as such, and not used as absolute guides to which machine is 'better' than another; this is a decision which involves a great many factors and which can only be arrived at by studying the full Benchtests and by forming a clear idea of which machine is best suited to the purpose to which you intend to put it.

The disk Benchmark timings which were introduced last year have not been listed, and neither have the disk timings been reproduced here as they do not apply to all machines. As different dialects of Basic have such widely different disk I/O formats, we cannot provide listings of a specific suite of programs which can run unaltered on any machine. Here, however, is a summary of what the disk tests do:

- Test 1 OPEN a new file, then immediately CLOSE it.
- Test 2 Using a FOR . . . NEXT loop, fill two strings, A\$ and B\$ with 128 As each; OPEN an existing file; using a FOR . . . NEXT loop, fill each of the 100 records, each of which contains two fields of 128 characters, with A\$ and B\$ in ascending order; CLOSE the file.
- Test 3 Identical to Test 2 except that the records are written in reverse order.
- Test 4 OPEN the file; read records 1 to 100 into A\$ and B\$; CLOSE the file.
- Test 5 Identical to Test 4 except that the records are read in reverse order.

Machine	BM1	BM2	BM3	BM4	BM5	BM6	BM7	BM8
SBS-8000	1.8	9.4	29.0	29.0	31.6	44.0	82.5	11.2
Transam Tuscan	2.3	13.0	26.0	27.0	32.0	48.0	68.0	6.0
Vector Graphic VIP (int)	1.0	3.0	10.9	10.7	11.6	18.2	27.1	3.4
VG VIP (S/prec)	1.0	3.8	10.9	10.7	11.6	20.5	32.7	3.4
VG VIP (D/prec)	—	4.9	39.1	39.9	40.5	49.5	61.1	3.4
ABC 24 integer	1.2	4.0	16.0	15.0	16.0	25.0	38.0	8.0
ABC 24 double prec	—	7.0	54.0	55.0	56.0	68.0	86.0	8.0
Pasca 640	2.0	7.0	19.0	18.0	20.0	36.0	57.0	10.0
NEC PC8000	1.7	83.	18.1	17.8	18.6	29.5	49.2	7.0
Sharp PC-3201	4.0	13.5	35.5	35.5	38.5	67.0	108.0	25.0
TRS-80 III ROM Basic	2.7	10.4	24.3	25.3	47.4	72.5	10.5	—
TRS-80 III disk Basic	2.7	10.5	24.6	25.6	48.3	73.8	10.8	—
TRS-80 Col	2.0	11.3	22.2	23.9	27.0	41.5	61.1	13.0
VIC-20	1.4	8.3	15.5	17.1	18.3	27.2	42.7	9.9
Oki if800	2.2	6.4	16.8	16.8	17.9	31.8	50.7	5.7

Int = Integer Basic      S/prec = Single precision      All timings in seconds.  
F/P = Floating point Basic      D/prec = Double precision

<b>BM1</b>	300 PRINT "S" 400 FOR K=1 TO 1000 500 NEXT K 700 PRINT "E" 800 END	<b>BM6</b>	300 PRINT "S" 400 K=0 430 DIM M(5) 500 K=K+1 510 A=K/2*3+4-5 520 GOSUB 820 530 FOR L=1 TO 5 540 NEXT L 600 IF K<1000 THEN 500 700 PRINT "E" 800 END 820 RETURN
<b>BM2</b>	300 PRINT "S" 400 K=0 500 K=K+1 600 IF K<1000 THEN 500 700 PRINT "E" 800 END	<b>BM7</b>	300 PRINT "S" 400 K=0 430 DIM M(5) 500 K=K+1 510 A=K/2*3+4-5 520 GOSUB 820 530 FOR L=1 TO 5 535 M(L)=A 540 NEXT L 600 IF K<1000 THEN 500 700 PRINT "E" 800 END 820 RETURN
<b>BM3</b>	300 PRINT "S" 400 K=0 500 K=K+1 510 A=K/K*K*K-K-K 600 IF K<1000 THEN 500 700 PRINT "E" 800 END	<b>BM8</b>	300 PRINT "S" 400 K=0 500 K=K+1 530 A=K↑2 540 B=LOG(K) 550 C=SIN(K) 600 IF K<100 THEN 500 700 PRINT "E" 800 END
<b>BM4</b>	300 PRINT "S" 400 K=0 500 K=K+1 510 A=K/2*3+4-5 600 IF K<1000 THEN 500 700 PRINT "E" 800 END		
<b>BM5</b>	300 PRINT "S" 400 K=0 500 K=K+1 510 A=K/2*3+4-5 520 GOSUB 820 600 IF K<1000 THEN 500 700 PRINT "E" 800 END 820 RETURN		

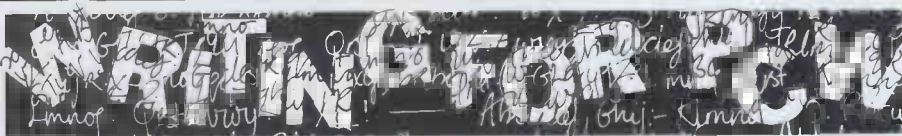

PCW welcomes approaches from would-be writers, even those who may never have appeared in print before. In this game it is often those with practical experience who have important things to say so we don't mind too much if their prose is less than perfect. Providing that submissions have a sensible structure and follow a logical sequence, we can take care of the polishing. Here are some tips:

If the article is already written, simply send it in, making sure that your name, address and 'phone number appear on both the article and the

covering letter. If you have submitted the same work to other magazines you should tell us — it would be embarrassing (to say the least) if the same article appeared in more than one.

If you have an idea for an article or a series, write us a letter outlining your ideas. A one or two page synopsis giving the proposed structure, sequence and content will give us a sound basis for discussion. Please give us a daytime 'phone number if possible.

If you have nothing specific in mind but feel qualified to conduct case studies, Benchtests or whatever then

drop us a line saying what you'd like to do and why you think you're qualified to do it. We're not particularly looking for strings of academic qualifications — experience carries just as much weight.

Dick Pountain is always on the lookout for interesting calculator features and we wouldn't mind seeing one or two readers getting on their soapboxes but remember: even articles such as this need a structure.

Reading PCW will give you a good idea of the style we prefer. You may notice that we try to avoid pomposity at one extreme and flippancy at the other (except in 'Chip Chat', that is).

Finally, have a look through back issue indexes and try not to re-invent any wheels. Oh, we almost forgot — PCW does pay for all published work.

# TJ's WORKSHOP

Our monthly pot-pourri of hardware and software tips for the popular micros. If you have a favourite tip, to pass on, send it to: 'TJ's Workshop', PCW, 14 Rathbone Place, London W1P 1DE.

## LOOPY SHARP

I have come across a baffling problem concerning an MZ-80K Basic program containing a series of consecutive loops contained within two nested loops. During the course of writing, the program was saved on tape and loaded back later for further work. More work was done, including the deletion of one of the consecutive loops. The program worked and was saved on tape. When later loaded back, the outer loop of the group refused to increment, giving a syntax error

on the line 'NEXT J'. I spent many hours trying to find out what had happened, and it became evident that to edit a once-saved program within such a loop system is courting disaster. Rewriting the whole section does not help, and neither does replacing the deleted loop. The only way to cure this if you wish to retain the outer FOR...NEXT loop as such is to rewrite the entire program. Luckily there is a way round this by altering the form of the outermost

loop. Listing 1 is an example of the enclosed consecutive loops. After deleting loop 3, J refused to increment, so the following cure was effected:

There seems no way of knowing whether editing within a loop system is going to produce this odd effect or not, but once it has happened the above two remedies appear to be the only ones. Whether this is a peculiarity of Sharp Basic I do not know. In his book, *Basic Basic*, James S Coan hints at this in the summary to Chapter 3-2: 'Caution is urged against inadvertently changing the loop variable within the loop...' although he does not enlarge further. I would be very glad to know whether this effect can be prevented, or if it can be predicted from the sort of editing one has in mind.

Now, RUN the following program:

```
10 FOR X = 3.1 TO 2.1 STEP -.5
20 IF X = 3.1 GOTO 100
30 IF X = 2.6 GOTO 110
40 IF X = 2.1 GOTO 120
50 PRINT "50",X: NEXT X
100 PRINT "100",X: NEXT X
110 PRINT "110",X: NEXT X
120 PRINT "120",X: END
```

You will get:

```
100 3.1
110 2.6
120 2.1
```

as you would expect. Now, alter line 10 to read:

```
10 FOR X = 3.1 to 2.5 STEP -.3
and alter lines 30 and 40 to:
30 IF X = 2.8 GOTO 110
```

```
40 IF X = 2.5 GOTO 120
RUN this and you will get:
100 3.1
50 2.8
50 2.5
100 2.2
```

SYNTAX ERROR IN 100

There are countless sets of numbers which will run with no trouble, and just as many which will not. It appears to be a fundamental requirement of Sharp Basic that in a statement as at line 10 FOR X = a TO b STEP C, a and b should be integers, but c need not be. The MZ-80K manual is misleading in that it says that the initial value and final value (ie, a and b) may be variables, constants or equations.

I am grateful to Paul Streeter of Sharp UK who referred the problem to Japan; their way round this one is, using the second example values above, to change lines 20 to 40:

```
20 IF INT(X*10) = 31 GOTO 100
30 IF INT(X*10) = 28 GOTO 110
40 IF INT(X*10) = 25 GOTO 120
```

In this form the program works whatever the value of a and b. It is interesting to note that, if only a printout of the results is needed without the GOTO direction, which is obtained by altering line 20 to: 20 PRINT X: NEXT X: END, the program will again work with any values of a and b. The above can also be demonstrated on a PET.

G Hayward

```
480 FOR J=1 TO H
490 FOR C=1 TO 25: PPS = MIDS(NBS(J),C,1): XS = PPS
500 FOR D=1 TO 37: PS = MIDS(A$,D,1)
510 IF XS = PS THEN G=D: GOTO 530
520 NEXT D
530 QS = MIDS(B$,G,1) Loop 1
```

Thence to two more consecutive loops 2 and 3

```
650 NEXT C
```

```
750 NEXT J
```

Listing 1

```
470 J=1 (added line)
480 IF J > H THEN GOTO 760 (rewritten)
Then as before
750 J=J+1: GOTO 480 (rewritten)
760 — program continues from 480
```

## LOWER CASE LISTER

This PET program will let you produce listings with lower-case characters. You have to store the program as an ASC data file on tape, using OPEN 1,1,1:CMD 1:LIST to save it on cassette 1. Close the file with PRINT 1:CLOSE 1 and then use this program to translate the tape file to the printer. The program also allows a doubled character title to be used, as well as allowing double-spaced lines

and splitting the listing into pages, which prevents program lines being printed on perforations.

M Clampitt

```
100 rem lists on printer a programme saved in asc form on tape
110 poke 59468,14
120 print chr$(147)
130 input "Name of programme":z$
140 print:input "Double (d) or single (s) spacing":y$
150 if len(y$)>1 then y$=left$(y$,1)
160 open 1,1,0
170 open 4,4
180 print#4,chr$(14):z$
190 get#1,a$
200 if st=64 or st=128 then close 1:close 4:end
210 a=asc(a$)
220 if a>64 and a<91 then a=a+32
230 if a>192 and a<219 then a=a-128
240 if a=13 or a=141 then a$=chr$(13)+chr$(10):z=z+1:goto 270
250 if a<32 or a>126 then 190
260 a$=chr$(a)
270 if a$=chr$(13)+chr$(10) and y$<>"s" then a$=a$a$
280 print#4,a$
285 if z>58 or (z>29 and y$<>"s") then z=0:print#4,chr$(12)
290 goto 190
```

# ATOM + SEIKOSHA = GRAPHICS

The Seikosha GP-80A is a good low-cost printer which would be a useful extension to an Acorn Atom micro-computer. The Atom has the necessary output port, edge connector and inbuilt driving software to use the printer without a special interface. However, it is necessary to put in one extra link within the Atom case. The reason for this is that the Seikosha printer has a graphics facility which requires an eight-bit ASCII input whereas the Atom only outputs seven bits. No internal alteration is required to the printer.

The link should be connected from bit 3 of the output port C, from the 8255 PIA (location #B8002) to the DATAB line on the printer connector. The DATAB line is on pin 17 of the connector in the fifth row of solder pins away from the edge of the board; it's the fifth from the left as you look over the board. The 8255 bit 3 output line is conveniently located on pin 7 of the cassette DIN connector (SK2). As you look over the board you see two rows of four pins soldered in SK2. It is the leftmost pin on the row nearest the edge of the board. A 74LS244 buffer must be positioned in the IC50 socket and the printer edge connector fitted. ICI, the 6522 VIA, is used.

When the Atom is reset (as at switch-on) bit 3 of Port C is set low which is as required for normal character use of the printer. When graphics are needed this bit should be set high. For full instructions as to the required printer control

codes for graphics see the GP-80A manual. Bit 3 is also used by the colour board, so when the graphics bit is set the display colour may change and vice versa. The Atom routines for outputting data to the printer are located at #FEFB. These recognise the control codes to turn the printer on and off and also send the character code contained in location #FE.

As an example of the use of Seikosha in graphics mode, here's a program to dump the Atom's high resolution graphics screen onto the printer. It also surrounds the display with a border. Also shown is an example of its printout. The general slowish speed of the printer, together with its strange way of dealing with graphics data, results in each plot taking approximately four minutes.

I have found it best to assemble the hi-res dump program at #2800. It takes up #B4 bytes, so it will not overwrite any Basic program (assuming it starts at #2900) but will destroy most floating-point values. The best practice is to save the program on tape (\*SAVE "HIRES" 2800 2865 2800) so that you can run it easily. So, if one types (CNTRL U) before doing the hi res display and then types (ESC) once when the plot is done, followed by \*RUN "HIRES" (without text display) the entire screen can be printed out without any extra 'text' being added onto the screen.

The program has to output the 256\*192 display as a set of 28 lines of seven bits. Any

particular byte is displayed normally as a horizontal line. However, the printer requires the information in vertical lines seven bits long. Thus, the program takes in seven 'horizontal bytes' and shifts the bits out to the printer. As the horizontal resolution is 256 points, the number of bytes to be shifted in each line is  $256/8 = 32$ . In addition, the program includes several mask words to avoid redundant information past the end of the

graphics display and to add on a border.

*Christopher Cant*

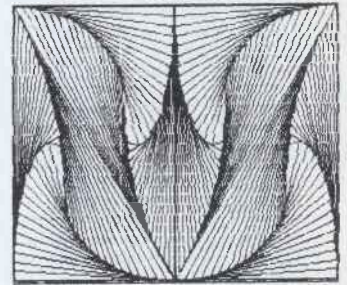

```

50DIM L10
10IN, "ASSEMBLE TO"
12IN, "LIST"
10F, I=0TO10:LLI=Q:N.
10P, #21
20F, I=0TO1
30P=0
100C
110 LL0 LDA #2
120 JSR #FEFB START PRINTER
130 LDA #8
140 JSR #FEFB ENTER GRAPHICS MODE
150 LDA #27F
160 STA #8A MASK1
170 LDA #27F
180 STA #81 HI RES
190 LDA #E0D POINTER
200 STA #80
210 LDA #0
220 STA #8D BLKCNT
230 LDX #1
240 STY #8E MASK2
300:LL1 LDY #0 blk
310 STY #89 LCOUNT
320 LDA #21B [
330 JSR #FEFB ESC [
340 LDA #210 [
350 JSR #FEFB POS [ TAB
360 LDA #0 [
370 JSR #FEFB HP [
380 LDA #270 [
390 JSR #FEFB LP [
392 LDA #8002 SET
394 ORA #3 GRAPHICS
396 STA #8002 BIT
397 LDA #27F
398 AND #8A (MASK1)
399 JSR #FF10 PRINT LEFT MARGIN
400:LL2 LDX #7 line
460 CLC
500:LL3 LDA (#80),Y xfer
510 STA #81.X
520 TYA MOVE FROM
530 ADC #20 GRAPHICS
540 TAY MEMORY TO
550 DEX ZERO PAGE.
560 BNE LL3
580 LDY #5
600:LL4 LDX #7 loop0
610:LL5 ASL #81.X loop1
620 ROR A
630 DEX SHIFT OUT
640 BNE LL5 7 BITS
650 ROR A AND PRINT.
655 ORA #8B MASK2
660 AND #8A (MASK1)
670 JSR #FF10 (PRINT)
680 DEY
690 BNE LL4 (LOOP0)
700 INC #89
710 LDY #89 LCOUNT
730 CPY #32 BLOCK DONE?
740 BNE LL2
800 LDA #0
810 STA #8B MASK2
820 LDA #27F
825 AND #8A (MASK1)
830 JSR #FEFB PRINT RIGHT MARGIN
840 LDA #8002
850 AND #27F EXIT
860 STA #8002 GRAPHICS
870 LDA #13
880 JSR #FEFB (CR)
900 LDA #224 (7*32)
910 CLC
920 ADC #80 INCREMENT
930 STA #80 HI RES
940 LDA #0 POINTER
950 ADC #81
960 STA #81
1000 INC #8D BLKCNT
1010 LDA #8D
1020 CMP #27 ALL DONE?
1030 BMI LL5 (BACK)
1040 BNE LL7 (END)
1050 LDA #23F
1060 STA #8A MASK BOTTOM LINE
1070 LDA #20
1080 STA #8B MASK2
1090 JSR #FF10 back
1100:LL7 LDA #27F end
1110 JSR #FEFB CHAR MODE
1120 LDA #3
1130 JSR #FEFB STOP PRINTING
1140 RTS
4000J
4010IFL P.#5
4020N.
4030P.#6, #0" -> "AP"
4040E.
5000P.CLEAR4.MOVE0.1.DRAW255.190.DRAW0.
190.DRAW255.1
5050DRAW0.1
5100LINKL0.E.

```

## AUTO ATOM

This is a short Basic program which will automatically number the lines of a Basic program as it is being typed in. The lines can be incremented by any value and can be started from any value. There is also a check in the program

in case the size of the program exceeds the amount of memory the user has and a check for the line number being too large (ie, over 32767).

The program should be typed into the Atom exactly as in the listing but keywords can be shortened as usual (ie, PRINT becomes P). The program should be loaded into the

lower text part of the VDU (#8200) and run. It will automatically place the program you are typing in the memory from #2900 onwards. The program is halted by typing a (cr) after a line number is printed; it will then tidy up by setting top and placing you where the program is. You will then set the prompt and the

program may be listed and changed as usual. To place the program in a different memory area you must change line 50 from C = #2900 to C = #XXXXX.

*Andrew Smith*

```

10 REM ANDREW B. SMITH
20 REM (C) 1981
30 REM
40 DIM T(60)
50 C=#2900: @=5
60 ?C=#0D: C=C+1
70 INPUT "START AT LINE " F
80 INPUT "STEP" S
90 FOR L=F TO 32767 STEP S
100 PRINT L
110 !C=L
120 B=?C(C+1)
130 ?(C+1)=?C
140 ?C=B
150 C=C+2
160 INPUT $T
170 IF $T="" THEN GOSUB 270: END
180 FOR J=0 TO LEN(T)
190 ?C=T?J
200 IF ?C<>T?J THEN PRINT "NO MEMORY LEFT!" : END
210 C=C+1
220 NEXT J
230 NEXT L
240 PRINT "NO MORE LINE NUMBERS LEFT!"
250 GOSUB 270
260 END
270 ?C=#20
280 C=C+1
290 ?C=#0D
300 C=C+1
310 ?C=#FF
320 C=C+1
330 ?18=#29
340 !#0D=C
350 RETURN

```

# Programs for Programmers from Leicester Computer Centre



THE APPLESOFT COMPILER FROM THE APPLE II UTILITY SPECIALISTS

Speed Star is a full-function Applesoft compiler designed to quickly and easily convert your programs to fast and efficient 6502 machine language. This means a dramatic increase in the operating speed of your programs. No knowledge of assembly or machine language is necessary. Speed Star offers full support for DOS commands, Error Messages, Hi-Res and Lo-Res Graphics. In addition, Speed Star can make your programs "control-C" proof, thus only RESET will interrupt a program while running. Speed Star is also the only compiler that allows you to pass variables directly from an Applesoft program to a compiled program. This means you can use compiled modules as subroutines from standard Applesoft programs. Compiled programs are generally larger than the original, restricting the maximum size of program that most compilers can handle.

With Speed Star you need only compile the routines you require to run faster or protect from listing or modification. Therefore no program is too large to benefit from Speed Star. P.O.A.

## List Master

by Ted Birkhead and Roger Wagner

An excellent companion to APPLE-DOC, LIST-MASTER provides a number of utilities for performing large scale changes to your program listings. This means tremendous savings in program development time, and helps assure logical and usable listings at all stages of your program's development. It also means you can produce a final version which operates in a minimum of space and at an optimum speed.

APPLESPEED takes any Applesoft program and optionally removes REMarks, shortens variable names, combines lines, and renumbers by 1's. Each of these steps can considerably reduce the length of a program, and altogether the reduction can be as much as 25-50%. Speed of operation typically increases as well.

The SMART RENUMBER program is the finest in renumber utilities. SMART RENUMBER gives you the option of preserving the logical blocks of line numbers that you establish for the various routines in a program. This means that the renumbered version will still retain the logic and workability of the original. If you've ever tried to work on a program after you've blindly renumbered the entire thing by 10's, you'll appreciate this feature.

COMP-LIST will compare any two Applesoft or Integer programs and list out any lines added, deleted, or changed. This is often handy after you have changed a program and wish to list out the alterations. P.O.A.

### SUPER DISK COPY III

48K & DISK II required, APPLE II or APPLE II PLUS SDC is a menu-driven programme that allows manipulation of all types of files under DOS 3.1, 3.2 and 3.3. SDC is the only disk utility available for the APPLE that combines these features: COPY single files (Integer, Applesoft, Binary, or Text), COPY DOS, COPY entire disk, UNDELETE deleted files, LOCK or UNLOCK files, PLOT of disk usage, and optional rearrangement of files so that they occupy contiguous sectors for improved access times. SDC supports the wlldcard character "=" in file specifications. SDC makes the conversion to DOS 3.3 less painful (than MUFFIN) and also allows files to be transferred back to DOS 3.2 since both 13 and 16 sectored disks can be accessed at the same time. £24.95 + VAT



**LEICESTER**  
computer centre limited

Dept. P11, 67 Regent Road, Leicester LE1 6YF.  
Tel: 0533 556268

# CROMWELL COMPUTING

presents, for the Sharp MZ-80K:

**GALACTIC  
ATTACK**  
(6k)

How long can you survive against dive-bombing aliens?

**TORNADO**  
(20k)

Fly an RAF Tornado at a Russian column. A DEADLY accurate game!

**DOOM  
MOUNTAIN**  
(34k)

Pass through misty catacombs in your search for treasure. Each room graphically depicted!

**BOWLING  
+  
LASER  
DEFENCE**  
(6k)

Two great games on one cassette! Both feature superb sound and graphics.

**\* ALL AT ONLY £5 EACH !! \***

\*Special introductory offer:

After first program, further programs are only £4 each!

\*FREE with orders over £10:

CANYON BOMBER — An exciting game!!

\*PRICES INCLUDE POST & PACKING!

Cheques payable to Cromwell Computing, please.

Ring for details of new releases. Got any SHARP creations? Ring for details on royalties.

## CROMWELL COMPUTING

CROMWELL HOUSE CROMWELL GARDENS,  
MARLOW, BUCKS. SL7 1BG (Tel (06284) 6136 (after 5 o'clock))

## SHARP PC3201 PAYROLL

Up to 500 employees All Tax and NHI codes Monthly and weekly paid with full coin analysis, full end of year printout. Complex Bonus calculations, voluntary deductions 3 overtime rates.

All output, payslips etc on PLAIN PAPER Full support and updates available. Personalisation undertaken

£275.00

## CP/M REVIVE

Ever erased a file by mistake? Revive enables you to recover all erased files on a disc! You must have REVIVE if you use CP/M, fully menu driven

**ONLY £20**

## PC3201 now with choice of PRINTERS

The Latest **MZ80B** on display.

Phone Chris Robinson on (0473) 50152

**MICROTEK** IPSWICH

15 Lower Brook St Ipswich Suffolk





# TJ's WORKSHOP

## SHARP TIPS

Here's a selection of tips for the Sharp MZ-80K.

PEEK (17828) allows continuous input from the keyboard with only one key press. In other words, if in, say, a game, you want to move the cursor across the screen, continually PEEKing this location will return the ASCII value of the key for as long as it's pressed. You must first POKE 10167,1 to allow access to non-video RAM, then GET a string from the keyboard (but don't wait for it with an IF... THEN statement). Decide whether the right key has been pressed with IF PEEK (17828)=n THEN... where n is the ASCII value of the right key. Here's an example:

```
30 GET R$
40 IF PEEK(17828)=65
   THEN 60
50 GOTO 30
60 REM CONT WITH
   PROG
```

This checks to see if 'A' has been pressed and loops back if it hasn't. Note that this is for SP-5025 Basic only, not disk Basic.

If you accidentally type NEW, you can still save your Basic program onto tape with the USR calls 33 and 36.

Now a bumper bundle of PEEKs and POKEs. The following disables the BREAK key during a program: POKE 6636,0: POKE 8767,0: POKE 8768,0: POKE 8769,0. To re-enable the BREAK key, use POKE 6636,205: POKE 8767,218: POKE 8768,133: POKE 8769,19. This will prevent a user from BREAKing

a program and copying it, as the only way to exit then is to reset the machine. POKEing 10682,1 before you SAVE makes the program run automatically on reloading, and POKE 4360,0: POKE 10680,0 disables SAVE and LIST. If you POKE 10681,0 before SAVEing, the reloaded program won't SAVE or LIST (unless re-POKED). POKE 18440,0: POKE 18441,0 will change line number 1 to 0 with the result that the line can't be deleted or altered without renumbering the program or re-POKEing the number. Useful for copyright notices, etc.

POKE 59555,0 switches off the CTR; POKEing a 1 into the same location switches it on again. POKE 4464,1 changes to lower case, and a 0 reverts to upper. POKE 57347,4 changes the LED from green to red and POKEing a 5 to the same location reverts it to green. POKE 4465,x (where x is from 1 to 40) moves the cursor x places across the screen and POKE 4466,y (with y from 1 to 24) moves it down x lines.

Finally, if you want to fit a reset switch to your MZ-80K, there's a socket on the main PCB marked 'RESET SW'. The centre pair of holes in the socket are dummies but you can wire a small push-to-make switch across either of the other two pairs. Pressing the switch will put the machine back into the monitor without clearing the memory.

*Phil Clark*

## TRS-80 INVERSE VIDEO

Several readers have pointed out that the TRS-80 mod in last month's 'TJ's' could overload Z24 by connecting its

output to its own input, causing it to oscillate. This can be overcome by using an SPDT switch, as shown below.

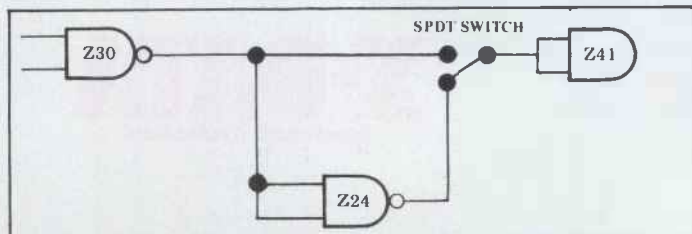

## TRS-80 LIFESAVER

This program is an invaluable utility to any disk-based TRS-80 owner who uses either 'Electric Pencil' or 'Scripsit'.

Should an error occur in saving text to disk or should there be any software or hardware failure, the user could be in a situation of having valuable text in the memory of the computer with no means of recovering it.

In the majority of cases RESCUE will transfer this

text to disk; there is however a possibility that the latter part of a relatively large block of text could become degraded by Basic's string storage and stack. As an alternative there is a machine language program called HELP which is guaranteed to save all 'Pencil' or 'Scripsit' text after a reboot, DOS error or disk crash.

*Laurie Shields*

### TRSS00 SCRIPSIT & ELECTRIC PENCIL =====

RECOVERY OF TEXT FROM MEMORY AFTER A REBOOT  
DOS OR HARDWARE FAILURE

```
5 REM COPYRIGHT (C) 1981 LAURIE SHIELDS
10 ON ERROR GOTO 90
20 CLS:
   PRINT:
   PRINT "F I L E   R E S C U E"
30 PRINT:
   INPUT "SCRIPSIT OR PENCIL"; A$
40 IF LEFT$(A$, 1) = "S" THEN N = 32610 ELSE
   IF LEFT$(A$, 1) = "P" THEN N = 27650 ELSE 30
50 LINEINPUT "FILESPEC ? "; A$:
   OPEN "0", 1, A$
60 IF N > 32767 THEN N = N - 65536
70 C = PEEK(N):
   PRINT CHR$(C)::
   PRINT#1,CHR$(C)::
   N = N + 1:
   IF C <> 0 THEN 60 ELSE
   FOR N = 1 TO 256:
   PRINT#1, " ";:
   NEXT:
   GOTO 90
90 CMD"E"
90 CLOSE:
   END
```

### PROCEEDURE: =====

1. DON'T SWITCH OFF.
2. RE-BOOT DOS WITH WITH ENTER KEY DOWN
3. FORMAT NEW DATA DISC IF NECESSARY.
4. ACTIVATE BASIC.  
(BUT WITH ONLY 1 FILE IF IT WAS PENCIL TEXT)
5. DO NOT USE ANY NEWDOS TYPE CMD COMMANDS.
6. RUN "RESCUE"
7. ORDER 'HELP/CMD' BEFORE IT HAPPENS AGAIN.



# We've raised the standard but not the price.

The new Microline 82A raises X-Data's price/performance standard higher than ever. At no extra cost.

Based on Oki's superb engineering tradition, the Microline 82A is the result of a continuous development program aimed at providing highest performance at lowest cost.

Unbelievably at the same price as its best-selling predecessor, the Microline 82, it offers:

- Speed - 120cps
- Clarity - 9 x 9 matrix
- Throughput - enhanced logic seeking
- Style - true descenders
- Convenience - rear and bottom paper feed

The Microline 82A will challenge any other printer available in this price range. With Oki engineering to give total reliability.

And it has a sister — the wide-carriage Microline 83A — which offers all the facilities of the Microline 82A with a full 136-column carriage.

Plus lower cost. We've reduced the price by 15 per cent compared with the Microline 83.

Price/performance is X-Data's winning theme. Ring Jane Lindsay at Slough (0753) 49117 for further details and prices or the name of your nearest dealer.

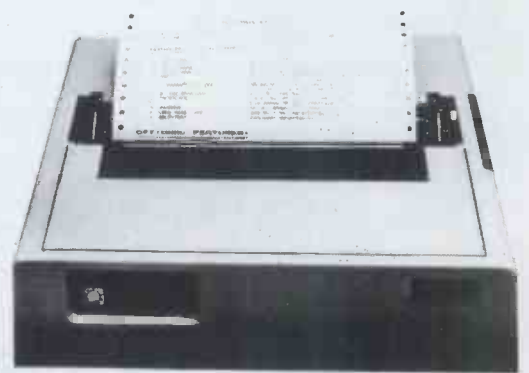

X-Data Limited, Marish Wharf, St Mary's Road  
Langley, Slough, Berks SL4 1HE  
Tel: Slough 49117. Telex: 847728.

**X-DATA**  
Equipment Wholesalers

# YOUR

## COMPUTER WORLD

Compiled by Derrick Daines

### Illogicality

There's a lot of illogicality in the world, isn't there? Only a month before writing this, various self-styled experts were widely criticising teachers because of the spate of lamentable city riots. It was said that discipline in the schools was nonexistent and that this was a contributory factor in causing the riots.

My young friend Stewart Sargaison of Berkhamsted has prompted these thoughts in a lively correspondence we've been having. In writing about the effect on employment of new technology in general and computers in particular, he writes, '... I can't see the point in the "right to work" ... People look forward to retiring, but shy away from redundancy ...'

At first, one is inclined to nod and think that this is another example of illogicality that Stewart has pointed out, but is it? Are people being illogical in not wanting to be thrown out of work? I remember my father telling me off in very strong terms for being an idle layabout and I remember how furious he was when I got sacked from my first job. Being reared in a society that considered work to be the right and proper function of man, even today I find extreme difficulty in sitting down to do nothing in particular. I always experience a vague feeling of guilt if I spend an evening watching television, for instance — I always think of the million other things that I should be doing.

Stewart would probably say that this is a function of my upbringing and he would be right in part, but I suspect that it goes much deeper than that. I suspect that it is a part of what I perceive as my worth as a person. I actually believe that the need to be up and doing something — exploring and manipulating the environment — is something that is an inbuilt part of mankind, going back to the origin of the species. As for retirement, any doctor will tell you that the person who retires from active life is dead very soon afterwards. For a long retirement, you have to keep working — which sounds daft, but really means that when you retire you have to find something else to do — gardening, bowls, or something.

When I retire — which won't be for a long time yet (*who are you kidding?* — Ed) — I'm going to spend days on the golf course and evenings computing, which brings me round to the thought that the DHSS could do a lot worse than give all unemployed youngsters a small computer instead of unemployment benefit one week!

It won't happen of course — there

are far too many difficulties in the way — but just think of the benefits! Not only would we be keeping folks mentally stimulated, but we would have enormous spin-offs. Production of machines would soar — with increased trade generally — and countless people would be fitting themselves for a computing future once the recession lifts. Besides, I simply cannot imagine any computer nut lifting his nose from the keyboard long enough to be aware that there was a riot going on, let alone wanting to go and join in! What do you think?

I would be very interested to hear from any unemployed reader who is managing to keep sane because of an interest in computing, or who has found employment through his own efforts in that field. We hear so much of gloom and doom that it would be nice to publicise the 'get-up-and-go' that I know young folks are capable of.

### Too much

In another piece of correspondence, a writer wanted to know why I was in favour of Space Wars at first and have now turned against it. I wouldn't say that I've turned against it exactly, but it does remind me of a story of a young bride who tearfully said to her husband of one week, 'I can't understand you! You liked baked beans on Monday, Tuesday, Wednesday, Thursday, Friday and Saturday, and now suddenly on Sunday, you don't like them any more!'

So please — no more Star Wars or similar shooting games, OK?

Daniel Haywood of Ormskirk very

kindly wrote to say that he agreed with my definition of a good computer game (July 1981 PCW) and added that he thought that different skill levels are 'a good thing'. He's right, of course. He says, 'I think it's great knowing you have mastered one skill level and are good enough to go up to the next.' I couldn't put it better myself.

He also asks if Acorn will be likely to provide a new ROM for the Atom. There are a lot of people interested in this question, Daniel, and it all depends on how the Acorn people add up their sums. If they think that there's money to be made out of it, they will. Personally, I think that they'd be silly not to, but they might consider that they can get more folk to buy the Proton by withholding the ROM from us Atom users. They'd be wrong because I suspect that other folks will be ready to provide 'BBC-compatible' ROMs for all sorts of machines, including the Atom. The trick for Acorn will be to offer their ROM at the right time to maximise their profits and 'wrong-foot' the 'cowboy' suppliers.

### Programs received

Obstacle Course & Drawing Board (ZX80) by Stephen Bootes (10) of Hartwell, Wumpus, Breakout & Super-Meteor (TRS-80) by Andrew Bennett of Southam, Warwick, Snake Winder, Zap!, Spacey Shoot, Moonlander, Missile Shoot and Rebound by Daniel Haywood (14) of Ormskirk Lanes, Quadratic Equation Roots (ICL 1900) by Jon Harvey (16) of Prestwich.

### Mugtraps

The supply of Mugtraps appears to be drying up, so we'll call a halt to that particular correspondence, if you don't mind. A reader in Bolton wanted to 'punish' a wrong-user by putting the machine in an infinite loop, which was not quite what I had in mind when I started this thing off.

Stewart Sargaison (again!) had a similar idea when he sent this one, and I'll let him have the last word:-

```
10 INPUT "YOUR NAME", NS
20 IF NS = "DERRICK DAINES"
    THEN CRASH
    (Sniff!)
```

## ZX80 Obstacle Course by Stephen Bootes

The object of this program is to reach the top left-hand corner of the board by travelling on the black squares only. To start, type '5' and then move using the arrow keys. When there isn't a path for you to follow, or you want to give up, type '1'. At the end of the game the computer tells you how many moves you have made.

```
10 LET A=1
20 LET Z=296
30 FOR Q=1 TO 386
40 LET C=RND(3)
50 IF C=1 THEN PRINT CHR$(9);
53 IF C=2 THEN PRINT CHR$(128);
55 IF C=3 THEN PRINT CHR$(128);
57 NEXT Q
60 GO SUB 110
70 LET A=PEEK(16396)+PEEK(16397)*256
80 POKE A+Z,148
```

```
90 GO TO 60
100 STOP
110 INPUT K
115 LET T=1
120 IF Z=33 THEN GO TO 200
123 IF K=1 THEN GO TO 300
125 POKE A+7,9
130 IF K=8 THEN LET Z=Z+1
140 IF K=5 THEN LET Z=Z-1
150 IF K=6 THEN LET Z=Z+33
160 IF K=7 THEN LET Z=Z-33
170 LET T=T+1
180 RETURN
190 STOP
200 CLS
210 PRINT "CONGRATULATIONS - "
220 PRINT "YOU COMPLETED THE OBSTACLE"
230 PRINT "COURSE IN ";T;" GOES"
240 STOP
300 CLS
310 PRINT "GOOD TRY BUT YOU DID NOT"
320 PRINT "COMPLETE THE OBSTACLE COURSE."
330 PRINT "YOU MADE ";T;" MOVES"
340 STOP
```

# WEIGH US UP

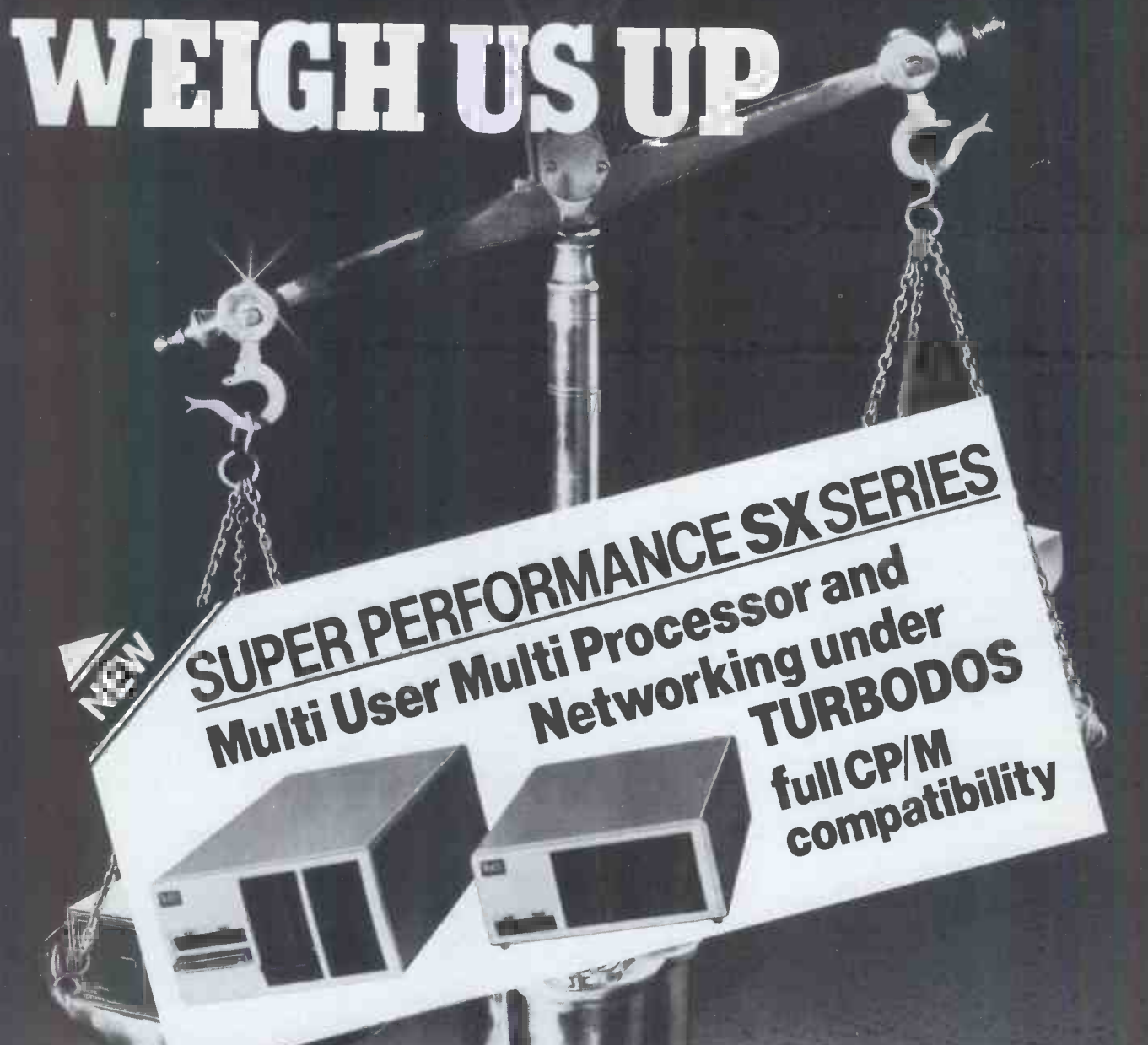

**NEW**  
**SUPER PERFORMANCE SX SERIES**  
**Multi User Multi Processor and**  
**Networking under**  
**TURBODOS**  
**full CP/M**  
**compatibility**

## Our advantages: —

- S-100
- 12 slots
- Z80A Microprocessor
- Real time clock
- Interrupt driven hardware
- Double density, single or double sided 5" and 8" floppy disc drives
- 5" and 8" Winchester drives (option)
- Tape back-up (option)
- Cartridge disc drives (Equinox 200)
- 64KB Dynamic RAM with parity
- Static RAM (option)
- Up to 384KB RAM (option)
- Two serial ports
- Additional serial and parallel ports (option)
- CAP Microcobol
- CP/M, CP/NET, MP/M
- TURBOCHARGER II for greater disc capacity and performance for your CP/M software
- BASIC, COBOL, FORTRAN, PASCAL, C, LISP, APL, FORTH
- Word Processing
- Information Management
- Powerful Utilities-Z80 Assembler, Editor, Debugger and linker
- Analog/Digital and Digital/Analog interfaces
- Prestel/Viewdata
- Mainframe/Micro Communication
- Networking
- CCTA Approved Systems

*Built to high quality standards by IMS International*

**And consider the price — from £1750**



## **EQUINOX**

**COMPUTER SYSTEMS LIMITED**  
Specialists in Multi-user Microsystems

Kleeman House, 16 Anning Street, New Inn Yard.  
London EC2A 3HB. Tel: 01-739 2387 & 01-729 4460  
Telex: 27341

# NEWCOMERS START HERE

*This is our unique quick-reference guide, reprinted every month to help our readers pick their way through the most important pieces of (necessary) jargon found in PCW. While it's in no way totally comprehensive, we trust you'll find it a useful introduction. Happy microcomputing!*

Welcome to the confusing world of the microcomputer. First of all, don't be fooled; there's nothing complicated about this business, it's just that we're surrounded by an immense amount of necessary jargon. Imagine if we had to continually say 'numbering system with a radix of 16 in which the letters A to F represent the values ten to 15' when instead we can simply say 'hex'. No doubt soon many of the words and phrases we are about to explain will eventually fall into common English usage. Until that time, PCW will be publishing this guide — every month.

We'll start by considering a microcomputer's functions and then examine the physical components necessary to implement these functions.

The microcomputer is capable of receiving information, processing it, storing the results or sending them somewhere else. All this information is called **data** and it comprises numbers, letters and special symbols which can be read by humans. Although the data is accepted and output by the computer in 'human' form, inside it's a different story — it must be held in the form of an electronic code. This code is called **binary** — a system of numbering which uses only 0s and 1s. Thus in most micros each character, number or symbol is represented by eight binary digits or **bits** as they are called, ranging from 00000000 to 11111111.

To simplify communication between computers, several standard coding systems exist, the most common being **ASCII** (American Standard Code for Information Interchange). As an example of this standard, the number five is represented as 00110101 — complicated for humans, but easy for the computer! This collection of eight bits is called a **byte** and computer freaks who spend a lot of time messing around with bits and bytes use a half-way human representation called **hex**. The hex equivalent of a byte is obtained by giving each half a single character code (0—9, A—F): 0=0000, 1=0001, 2=0010, 3=0011, 4=0100, 5=0101 . . . . E=1110 and F=1111. Our example of 5 is therefore 35 in hex. This makes it easier for humans to handle complicated collections of 0s and 1s. The machine detects these 0s and 1s by recognising different voltage levels.

The computer processes data by reshuffling, performing arithmetic on, or by comparing it with other data. It's the latter function that gives a computer its apparent 'intelligence' — the ability to make decisions and to act upon them. It has to be given a set of rules in order to do this and, once again, these rules are stored in **memory** as bytes. The rules are called **programs** and while they can be input in binary or hex (**machine code programming**), the usual method is to have a special program which translates English or near-English into machine code. This speeds programming considerably; the nearer the programming language is to English, the faster the programming time. On the other hand, program execution speed tends to be slower.

The most common microcomputer language is **Basic**. Program instructions are typed in at

the keyboard, to be coded and stored in the computer's memory. To run such a program the computer uses an interpreter which picks up each English-type instruction, translates it into machine code and then feeds it into the processor for execution. It has to do this each time the same instruction has to be executed.

Two strange words you will hear in connection with Basic are **PEEK** and **POKE**. They give the programmer access to the memory of the machine. It's possible to read (**PEEK**) the contents of a byte in the computer and to modify a byte (**POKE**).

Moving on to **hardware**, this means the physical components of a computer system as opposed to **software** — the programs needed to make the system work.

At the heart of a microcomputer system is the central processing unit (**CPU**), a single microprocessor chip with supporting devices such as **buffers**, which 'amplify' the CPU's signals for use by other components in the system. The packaged chips are either soldered directly to a printed circuit board (**PCB**) or are mounted in sockets.

In some microcomputers, the entire system is mounted on a single, large, PCB; in others a **bus system** is used, comprising a long PCB holding a number of interconnected sockets. Plugged into these are several smaller PCBs, each with a specific function — for instance, one card would hold the CPU and its support chips. The most widely-used bus system is called the **S100**.

The CPU needs memory in which to keep programs and data. Microcomputers generally have two types of memory, **RAM** (Random Access Memory) and **ROM** (Read Only Memory). The CPU can read information stored in RAM — and also put information into RAM. Two types of RAM exist — **static** and **dynamic**; all you really need know is that dynamic RAM uses less power and is less expensive than static, but it requires additional, complex, circuitry to make it work. Both types of RAM lose their contents when power is switched off, whereas ROM retains its contents permanently. Not surprisingly, manufacturers often store interpreters and the like in ROM. The CPU can only read the ROM's contents and cannot alter them in any way. You can buy special ROMs called **PROMs** (Programmable ROMs) and **EPROMs** (Erasable PROMs) which can be programmed using a special device; EPROMs can be erased using ultraviolet light.

Because RAM loses its contents when power is switched off, **cassettes** and **floppy disks** are used to save programs and data for later use. Audio-type tape recorders are often used by converting data to a series of audio tones and recording them; later the computer can listen to these same tones and re-convert them into data. Various methods are used for this, so a cassette recorded by one make of computer won't necessarily work on another make. It takes a long time to record and play back information and it's difficult to locate one specific item among a whole mass of information on a cassette; therefore, to overcome these problems, **floppy disks** are

used on more sophisticated systems.

A floppy disk is made of thin plastic, coated with a magnetic recording surface rather like that used on tape. The disk, in its protective envelope, is placed in a disk drive which rotates it and moves a **read/write head** across the disk's surface. The disk is divided into concentric rings called **tracks**, each of which is in turn subdivided into **sectors**. Using a program called a **disk operating system**, the computer keeps track of exactly where information is on the disk and it can get to any item of data by moving the head to the appropriate track and then waiting for the right sector to come round. Two methods are used to tell the computer where on a track each sector starts: **soft sectoring** where special signals are recorded on the surface and **hard sectoring** where holes are punched through the disk around the central hole, one per sector.

Half-way between cassettes and disks is the **stringy floppy** — a miniature continuous loop tape cartridge, faster than a cassette but cheaper than a disk system. **Hard disk** systems are also available for micro-computers; they store more information than floppy disks, are more reliable and information can be transferred to and from them much more quickly.

You, the user, must be able to communicate with the computer and the generally accepted minimum for this is the visual display unit (**VDU**), which looks like a TV screen with a typewriter-style **keyboard**; sometimes these are built into the system, sometimes they're separate. If you want a written record (**hard copy**) of the computer's output, you'll need a **printer**.

The computer can send out and receive information in two forms — **parallel** and **serial**. Parallel input/output (**I/O**) requires a series of wires to connect the computer to another device, such as a printer, and it sends out data a byte at a time, with a separate wire carrying each bit. Serial I/O involves sending data one bit at a time along a single piece of wire, with extra bits added to tell the receiving device when a byte is about to start and when it has finished. The speed that data is transmitted is referred to as the **baud rate** and, very roughly, the baud rate divided by ten equals the number of bytes being sent per second.

To ensure that both receiver and transmitter link up without any electrical horrors, standards exist for serial interfaces; the most common is **RS232** (or **V24**) while, for parallel interfaces to printers, the **Centronics** standard is popular.

Finally, a **modem** connects a computer, via a serial interface, to the telephone system allowing two computers with modems to exchange information. A modem must be wired into the telephone system and you need British Telecom's permission; instead you could use an **acoustic coupler**, which has two obscene-looking rubber cups into which the handset fits, and which has no electrical connection with the phone system — British Telecom isn't so uppity about the use of these.

# THE PCW SHOW 1981



*NOT the Royal Wedding Presents. . .*



*David Ahls of Creative Computing in newsvendor mode.*

# OUT OF THE GHETTO!



*Tim Jones receives prize from Judith Hann, aided by 3rd arm.*

Being acutely aware of PCW's dramatic increase in circulation since 1980 we, in our wisdom, allowed for twice as many visitors as last year. Imagine our embarrassment when the first day dawned to a queue approximately ¼-mile long, stretching around the corner and out of sight. Only by gradually jettisoning the more time-consuming of the registration procedures and opening a second entrance could we get the eager throng in fast enough to prevent mayhem on the streets of Hammersmith. Such mass activity soon attracted *The Times*, *Guardian* and ITN News to the scene; as David Tebbutt remarked to me on the first day, 'We've reached critical mass!'; in other words, microcomputing in the UK has emerged from the ghetto and into the limelight.

Inside the hotel the two floors were packed almost beyond endurance; only the enthusiasm and goodwill of visitors and exhibitors kept it manageable. The hotel's air conditioning struggled hard to keep the temperature only sub-tropical. Several American visitors remarked that there was more action than at the West Coast Faire, which we grudgingly accepted as a compliment.

It's not possible to identify a single biggest attraction, as there were at least eight among the 72 exhibitors.

Acorn had the prototype BBC Micro on display with some impressive graphics. The waiting time to see it, unless you had tungsten elbows like Guy Kewney, was on a par with that for the Royal Wedding presents.

Atari's large stand offered the public its first view of the neat 400 and 800 and the disk drives. The Thorn-EMI games software attracted a pullulating swarm of schoolboys to the stand, despite the fact that it was ostensibly on the upstairs 'business' floor. It's easy to see why: their darts game has quite the best colour graphics I've seen on a micro.

The Last One had over 6000 visitors to their stand and dispensed over 10,000 order forms (see 'Chip Chat' for amusing anecdote). They seemed happy.

NEC officially launched its PC8000 and several mouthwatering peripherals at the Show. The most intriguing of these was a neat digital plotter which scuttles across at intervals to pick up a different coloured pen from a stack of about ten. At their reception, high-up Japanese execs made plain that they're after the business market; no doubt wise, but, if they made it UK TV-compatible, the PC8000 could eat into the hobby market as well.

Sinclair had their long-awaited ZX81 printer on show and took orders indecently fast. They also sold all the '81s they had brought; rather charming to see people walking away from a computer show with one under their arm (smacks of 'sell 'em cheap and pile 'em high).

Least seen but most requested item was the Osborne 1. If I had a pound for every enquiry, etc. . . The machine (there only being one in the country — the one tested in this issue) made a brief appearance on Microtrend's stand on Thursday afternoon.

Personal Computers' stand boasted the Alpha Centauri synthesiser lashed up to an Apple II. Proper keyboard, and an impressive range of sounds and effects was broadcast far and very wide

through a NAD/A&R hi-fi rig. Never did pluck up courage to play some Booker T for them instead of those curious teatime muzak tunes. . .

An event witnessed by ITN and BBC but not the public at large was the award of a DAI computer by Judith Hann of 'Tomorrow's World' to Tim Jones, winner of the IYDP competition. Tim's robot arm was by far the most lifelike seen so far; as a student of industrial design and engineering he produced a strikingly professional effort using vacuum-formed plastic shells and ingenious pneumatic powered 'muscles', all controlled by an Acorn card via solenoids and air valves. In addition to its potential as an aid for the disabled, Tim is developing the arm (in conjunction with a fashion firm) for animated window dummies, in order to be self-financing. Perhaps there is still some hope for Britain in microtechnology. . .

It was rather surprising but heartening to see mini-makers Digico with their own stand, bearing their new Prince micro. With a spec and price quite similar to SuperBrain, this machine could make a dent in the business market if marketed aggressively, particularly if Digico can extend mini standards of after-sales support into the long-suffering micro market.

The activity on the club/hobby floor is covered below by Rupert Steele. Suffice to say that there was a lot of it.

To all the exhibitors, thanks for exhibiting.

To the 16,500 visitors who came, thanks for coming. To Montbuild, the organisers, thanks for organising. To the rest of the computer press, thanks from the Catering Manager (Alcoholic Beverages Div). Next year 50,000 at Olympia?

*Dick Pountain*

## Conglomeration of clubs

Certainly an overwhelming majority of visitors to the home and hobbyist area of the show will have noticed or stopped at the ACC stand. For the benefit of those who didn't, the ACC itself distributed the space among various local clubs and user groups. Thanks must go to Dr David Annal of the ACC for his excellent work in administering the whole operation.

A database was run on the stand which had details of all the user groups and clubs known to the ACC. Visitors

were able to ask for details of their nearest club and a printout of the information was given to them. However, the ACC's records do seem to have some gaps — notably in Cambridgeshire and Shropshire.

Advice to bewildered newcomers was easily forthcoming from the enquiry desk. One good suggestion was that people join a club before buying a computer, thereby learning a little more about which machine would suit them best.

If you have a club and have not been in touch with the ACC before, drop them a line care of Vernon Gifford (ACC), 111 Selhurst Road, London SE25 6LH. Information can also be updated in this way. ACC details are available from Rupert Steele, St John's College, Oxford.

Finally, for all of you who weren't there, here's a run-down of what the computer clubs had to offer. The TRS-80 Level 1 User Group was demonstrating a Tiny Pascal which attracted much interest. According to the Atom User Group, existing Atom users will be able to get a PROM to mimic the BBC machine. The National ZX80/81 User Group found that, instead of being deluged with complaints about failed hardware or late delivery, folks were exchanging software ideas. The Association of London Computer Clubs attracted crowds with a robot arm and a micromouse (Questor) just back from Paris. They are organising a national Robotics and Micromouse conference at Imperial College on Saturday 28 November. Vernon Gifford (address as before) will have details, and the registration fee is £9.50.

*Rupert Steele*



*Mummy, what's a syntax error?*



*PCW/Microdigital Competition winner J.C. Haines (left) receives prize from Bruce Everiss of Microdigital. Editor Rodwell presses flesh.*



# L&J COMPUTERS

192 HONEYPOT LANE, QUEENSBURY, STANMORE, MIDDX HA7 1EE. 01-204 7525

## THE "PET" SPECIALISTS



### COMPETITIVE CBM PET PRICES!!

4032	40 Col. PET	585.00*
8032	80 Col. PET	755.00*
4040	347K Disk	585.00*
8050	1M Byte Disk	755.00*
4022	Printer	357.00*
8024*	Printer	975.00*

**PRICE BREAKTHROUGH!!!**

**TRY US!  
YOU WILL NOT BE  
DISAPPOINTED**

**CASH & CARRY  
PRICES ONLY**

<b>EXT CASSETTE DECKS (INC COUNTER &amp; SOUNDBOX) £55*</b>	
Printers	Disk Drives
CBM 4022	CBM 8050
Centronic 779	CBM 4040
Centronic 737	CBM 3040
Splnwriter 5510	COMPU/K 800K
CBM 8026 & 8027	
Interfaces:	Sundries
Disks:	C12 Cassettes
Paper:	Library Cases
Labels:	(roll & tractor feed)
	Dust covers

### SOFTWARE

As well as a full range of Petsoft and Commodore Software, we have some highly reliable "Home-Brewed" programs available.

<b>STOCK CONTROL &amp; INVOICING</b>	£60
(Handles up to 500 items — 32K) (180 on 16K). Stock depleted on invoicing, search etc. Cassette, disk (& print option).	
3000 item: 4040/8050	£125
<b>CASH BOOK</b>	£90
Enter daily/weekly amounts — printout and totals, weekly/monthly analysis, totals and balances.	
<b>STOCK TAKING</b>	£240
Cuts out all the hard work	
<b>OUTSIDE SERVICES (For Mini-Cabs Etc)</b>	£220

Sae for free software booklet

Visicalc "OZZ"	Commodore Business Programs
Compsoft DMSV	Bristol Trader, Item & Monitor
Anagram Ledgers	Superpay Word Processing.

**SPECIALISED SOFTWARE APPLICATIONS  
UNDERTAKEN. RING FOR DETAILS**

**TOOL KITS (BASIC 2 & 4), SUPERCHIPS,  
.....AND ALL SORTS OF OTHER CHIPS.....  
UPGRADE YOUR PET EVEN MORE!!**

**THE "MUPETS" ARE HERE!  
3 TO 8 PETs ONLY NEED 1 DISK DRIVE...  
Daily demonstrations: Ring for details.**



**COMPLETE SYSTEMS  
FROM £1700!!**

**THE SYSTEMS WE SUPPLY & INSTALL ARE COMPLETE:  
ESTIMATES GIVEN FREE WITH NO HIDDEN EXTRAS:  
FULL BACK-UP: GUARANTEED EXPERTISE.**

\* PRICES DO NOT INCLUDE VAT

**PERSONAL SHOPPERS WELCOME  
Phone & Mail Orders accepted.**

**COME AND SEE THE NEW** **VIC-20** **at £189 (inc VAT)**

**FULLY WORKING AND OPERATIONAL  
ASK US ABOUT ALL THE ADD-ON-GOODIES  
THAT GO WITH THE VIC.....!**

**ALL GOODS SENT SAME DAY WHEREVER POSSIBLE  
LARGE S.A.E. FOR LISTS ETC.**



## FROM THE PUBLISHERS OF THE BEST SELLING BOOKS FOR THE SINCLAIR COMES:

**Not Only But Also...**  
PROGRAMS FOR THE  
SINCLAIR ZX81...1K

Probably the **LARGEST** range  
of ZX 81 Software  
in the **WORLD**

**Not Only** ...does this book contain over  
30 fully debugged and exciting programs,  
every one of which will fit into the basic 1K  
memory of your Sinclair ZX81 — including  
programs such as **STAR WARS, LUNAR  
LANDER, BLACKJACK, MINI ADVENTURE,  
DRAUGHTS, BREAKOUT.**

**But Also**  
\* Detailed explanation of how  
these programs were written.  
\* Lots of hints on how  
you can write exciting  
programs for your  
ZX81.  
\* Numerous space  
saving techniques —  
obviously invaluable to  
the ZX81 owner.  
\* **PEEKs and POKEs**  
and all the other  
'complicated' func-  
tions are clearly  
explained.  
\* **MUCH, MUCH  
MORE...**



**£6-95**

**£8-95**

**PLUS SPECIAL SECTION:  
HOW TO USE MACHINE CODE  
ROUTINES IN YOUR  
BASIC PROGRAMS**

### Understanding Your ZX81 ROM

**Plus special section:** How to use machine code routines in your BASIC programs. by DR. I. LOGAN.  
Dr Logan was the first person to disassemble the Sinclair ZX80 Monitor and was the co-author of the ZX80 COMPANION.  
In UNDERSTANDING YOUR ZX81 ROM Dr. Logan illustrates all the facilities of the ZX81 Monitor, how it works and how you can use it in your own programs. A special section shows you how you can squeeze more power into your ZX81, by using machine language and machine language subroutines.  
An essential book for those who really want to understand the full working of the SINCLAIR ZX81.

Published by MELBOURNE HOUSE PUBLISHERS LTD.  
Send Stamped, self-addressed envelope for FREE catalogue.

THE ESSENTIAL SOFTWARE COMPANY (Visconti Ltd)  
47 Brunswick Centre, London W1CN 1AF (01-837 3154)

Please rush me NOT ONLY 30 PROGRAMS FOR THE SINCLAIR ZX81 1K: at £6.95 each

Please also rush UNDERSTANDING YOUR ZX81 ROM by Dr. I. Logan at £8.95

I enclose a cheque/postal order for £..... +50p post and pack.

Name .....

Address .....



# PACKAGES

**DIRECT ACCESS**

PCW's 'Packages' section is produced bi-monthly, alternating with our 'In Store' hardware guide. We have confined coverage to business packages which are available and supported at national level and which have been in use for at least six months in a minimum of five sites. Producers of packages which fall within these constraints should send details or updates to: Dick Olney, PCW, 14 Rathbone Place, London W1P 1DE.

The layout has been designed to allow you to discover which packages are available for the application you have in mind and to show you which packages are available for your computer if you already have a machine. In either case the code enables you to look up the supplier's name and telephone number in the table below.

All details published are the latest made available — some may have changed since this issue went to press.

Code	Company	Telephone	H4	Supplier	Telephone
A1	ACT/Peisoft	021-501 2284	H4	Hipposoft	0337 76023127
A2	Arden Data Processing	0533 22255	I1	Intereurope Software Design	0734 786644
B1	B + B Computer Ltd.	0204 26644	I2	Intex Datalog Ltd	0642 781193
B2	Beam Business Centre	061-831-7292	J1	T.V. Johnson	0276 20446
B3	Benchmark Computer Systems	0726 61000	K2	Keen Computers	0602 412777
B4	Bristol Software Factory	0272 23430	L1	Lifeboat Associates	01-836 9028
B5	ByteSoft Systems Ltd	0533 531441	L2	Liveport (Exidy Sorcerer Firmware)	0736 798157
C1	CAP-CPP Products Ltd.	01-404 0911	L3	Ludhouse (Computing) Ltd.	01-679 4321
C2	Commodore	01-388 5702	M1	Micro Computer Applications Ltd.	0734 470425
C3	Compsoft	0483 39665	M2	Microteck	Orpington 26803
C4	Comput-a-crop	0507-604271	M3	Microsys Ltd	051 426 7271
C5	Computastore Ltd.	061-832-4761	P1	Padmede Computer Services	02514 21892
C6	CompuTech	01-794 0202	P2	Personal Computers Ltd.	01-626 8121
C7	Compass	Standish 426252	R1	Rockliff	051-521 5830
D1	Data Bank	0509 217671	S1	SMG Micro Computers	0474 55813
E1	Engineering Sciences	01-437-4894	S2	The Softwarehouse	01-637 2108
G1	Grafcom Systems Ltd.	01-727 5561	S3	Stage One Software	0202 23570
G2	Gramma (Winter) Ltd.	01-636 8210	S4	Systematics International	0440 61121
G3	Great Northern	0532 589980	S5	Sumlock Bondain	01-250 0505
G4	Alan Greenhalgh Ltd	01-520-0218	S6	Stemmos	01 602 6242
H1	A.J. Harding	0424 220391	S7	Software Aids Int	01-204 9396
H2	Hartford Software	0606 76265	T1	Tridata Micros Ltd.	021 622 6085
H3	H.B. Computers	0536 83922	V1	Viasak Electronics Ltd.	0494-448633
			X1	Xetal	061 682 7555

## Applications

Machine	Application	Price	Code
Appointments planner	Commodore/Computhink/Challenger	£100 £25	S3 C7
Assembler dev	PET/CBM	£50	L2
Bank accounts	Apple II Commodore/Computhink ITT 2020 PET	£10 £100 £10 £10	D1 S3 D1 D1
Bill of materials	CP/M	£500	B5
Bonds/pension quotations	Commodore/Computhink	£100	S3
Budgeting package	MCZ Zilog Apple/Apple II	£500 + £125	I1 P2
Bureau de change	CBM	£8	H3
Cash flow	Apple II Apple II CP/M CP/M PET	£125 £80 £250 £95 £8	P2 V1 L3 B5 A1
Cash register	Apple II ITT 2020 PET	£10 £10 £10	D1 D1 D1
CBasic	Tandy Model II	£70	M1
Company secretary	CP/M	£450	C4
Conference organiser	MCZ Zilog	£500 +	I1
Contract costing	Apple II CP/M	£500 £2000	P1 L3
CP/M & utilities	Tandy Model II	£150	M1
Credit control	Apple II PET	£98 £650	P2 B4
Customer file	Famos	£1000	M2
Database management/Information retrieval	ACT800 Apple Apple Apple Apple Apple II Apple II/ITT 2020 Commodore/Computhink CP/M CP/M Cromemco Famos North Star Horizon PET PET PET PET PET/CBM PET/CBM PET/CBM PET/CBM Superbrain Tandy Model I TRS-80 TRS-80 TRS-80 8000 Series	£225 £150 £150 £60-140 £150 £75 £100 £45-250 £150-750 £100 £250 £1500 £250 £170 £325 £225 £75 £50-150 £150 £150 £300 £25-80 £60 £150 £32.50 POR	H4 A2 K2 S2 S5 P2 S4 S3 C4 G3 B3 M2 B3 C3 A1 H4 B1 C2 J1 G2 S6 M1 S2 J1 H1 C2
Disk operating system	PET/CBM	£150	B1
Estate agent	Apple Apple Apple Apple II	£850 £850 £850 £175	A2 S5 K2 P2

Apple II/ITT 2020	£750	S4
CBM	£30	H3
Commodore/Computhink	£250	S3
CP/M	£750	C4
North Star	£750	B5
Horizon		
PCC 2000		
Simplex Triton 3	£350	B3
PET	£25	A1
Superbrain	£600	S6
Equipment lease/rent/HP	CP/M	£400 G1
Financial modelling	CP/M	£400 G1
Apple/Apple II	£450 P2	
CP/M	£95 B5	
Financial planning	Apple II/ITT2020	£250 S4
General ledger/NL	Apple	£300 A2
Apple	£300 S5	
Apple	£300 K2	
Apple II	£455 P2	
Apple II	£225 V1	
Apple II	£295 C6	
CBM	£200 H3	
Commodore/Computhink	POR S3	
CP/M	£500 L3	
CP/M	£375 L1	
CP/M	£500 C4	
CP/M	£400 G1	
CP/M	£400 M3	
CP/M	£200 B5	
CP/M	£275 S6	
CP/M	£275 S7	
Cromemco	£250 B3	
ITT 2020	£295 C6	
ITT 2020/Apple II	£250P S4	
North Star		
Horizon	£250 B3	
North Star		
Horizon	£400 M3	
PCC 2000		
Simplex Triton 3	£350 B2	
PET/CBM	£200 C2	
Sharp PC3201	£450 P2	
Superbrain	£400 M3	
Superbrain	£400 S6	
Tandy Model I	£90 M1	
Tandy Model II	£90 M1	
TRS-80	£225 H1	
TRS-80 I	£225/325 T1	
TRS-80 II	£425 T1	
Vector	£400 C5	
8080/Z80	£357 L1	
8080/Z80	£275 G3	
Hire purchase	Cromemco	£400 + B3
Incomplete records	Apple	£250 S2
Apple	POR K2	
Apple II	£425 P2	
Apple II	£450 P1	
Commodore/Computhink	£750 S3	
CP/M	£750 M3	
CP/M	£250 B5	
North Star		
Horizon	£750 M3	
Superbrain	£750 M3	
Tandy Model I	£40 M1	
TRS-80	£40 H1	
Industry/Factory loading	Apple	£360 X1
CP/M	£360 X1	
PET	£300 X1	
Industry work study	Apple	£990 X1
CP/M	£990 X1	
PET	£750 X1	

Integrated accs	Altos (CP/M, MP/M)	£300 B1
	Apple II	£450 P1
	Apple II	£300 P2
	Apple II	£855 V1
Commodore/Computhink	POR	S3
CP/M	£950	L1
CP/M	£1500	C4
CP/M	£1100	G1
CP/M	£990	M3
CP/M	£690	B5
CP/M	£850	S7
Cromemco	£950	B3
Famos	£2000	M2
ITT 2020	£450	P1
MZ-80K	£150	P2
North Star		
Horizon	£950	B3
PET/CBM	£300	B1
North Star		
Horizon	£990	M3
PET/CBM	£(50)	C2
PET/CBM	£650	J1
PET/CBM	£650	G2
Superbrain	£990	M3
Superbrain	£1200	S6
Tandy Model I	£350	M1
Tandy Model II	£350	M1
TRS-80	£75	J1
Vector	£1000	C5
8000 Series	POR	C2
8080/Z80	£950	L1
8080/Z80	£995	G3
Investment portfolio	TRS-80	£20 S2
Invoicing	Apple	£295 S2
	Apple II	£300 P1
	Apple II	£300 P2
	Apple II	£140 V1
	Challenger	£25 C7
Commodore/Computhink	POR	S3
CP/M	£325	L1
CP/M	£150-350	C4
CP/M	£250	M3
CP/M	£150	S7
Cromemco	£100	B3
North Star		
Horizon	£100	B3
North Star		
Horizon	£250	M3
PET	£350	A1
PET/CBM	£25-50	B1
PET/CBM	POR	J1
Superbrain	£250	M3
Superbrain	£150	S6
Tandy Model I	£90	M1
Tandy Model II	£90	M1
TRS-80	£25	H1
TRS-801	£75	T1
TRS-8011	£125	T1
8080/Z80	£325	L1
ITT 2020	£300	P1
Job costing	Apple II	£300 P1
Apple	£990 X1	
CP/M	£700 C4	
CP/M	£350 M3	
CP/M	£990 X1	
ITT 2020	£300 P1	
North Star		
Horizon	£350 M3	
PET	£750 X1	
Superbrain	£350 M3	
Tandy Model I	POR M1	
Tandy Model II	POR M1	
Job order control	8080/Z80	£275 G3
Leasing	Cromemco	£400 + B3
Legal precedents	CP/M	£1100 C4
Letter writer	Apple II	£80 V1
CP/M	£150 M3	
North Star		
Horizon	£150 M3	
Superbrain	£150 M3	
Lisp	PET/CBM	£75 C2
Lotteries	PET	£45 H2
Mailing List	Altos (CP/M, MP/M)	£75 B1
	Apple	£300 A2
	Apple	£50-150 S2
	Apple	£300 S5
	Apple	£300 K2
	Apple II	£40 P2
	Apple II	£50 D1
	Apple II/ITT 2020	£100 S4
	CBM	£35 H3
	Commodore/Computhink	£100 S3
	CP/M	£50-150 C4
	CP/M	£250 G1
	ITT 2020	£50 D1
	PET	£45 H2
	PET	£50 D1
	PET	£15 A1
	PET/CBM	£75 B1
	PET/8032	£75/150 S1
	Tandy Model I	£40 M1
	Tandy Model II	£75 M1
	TRS-80	£50-150 S2
	TRS-80	£25/38/55 H1
Mail shot	Apple	£14 S2
	Apple II	£40 P2
	Challenger	£25 C7
	Commodore/Computhink	£125 S3
	CP/M	£200-360 C4

# SELECT THE BEST

## DIABLO 630

LETTER QUALITY PRINTING AT REALISTIC PRICES



- Interchangeable Metal/Plastic Print Wheels
- Automatic Bi-directional Printing
- Word Processing Options
- Diablo Quality and Reliability
- Paper Handling Accessories

FOR INNOVATIVE DISTRIBUTION TO OEMs



## DRE Series 8000

HIGH QUALITY BUSINESS SYSTEM PRINTERS



- Full Range of Models with High Parts Commonality
- Bi-Directional Logic Seeking and Efficient Paper Handling
- Operator Changeable, Long Life 9 Wire Print Head
- Cartridge Ribbon and Red Black Option
- Optional Keyboards
- Models 8820 (150cps), 8830 (180 cps), 8840 (240 cps)
- Models 8910 8920, 160cps Correspondence, 240cps WP Draft

FOR INNOVATIVE DISTRIBUTION TO OEMs



## AMPEX VDU

INTERACTIVE VIDEO DISPLAY TERMINAL



- Low Cost, Full Feature VDU
- Conversational or Block Mode
- Transmission Rates to 19200 Bauds
- 20 Programmable Function Keys
- Detached Full ASCII Keyboard
- Standard Serial Printer Interface
- 2 Page Display & Optional 2 Pages
- Line Graphics
- Switch Selectable Status Line
- Full Tabs

FOR INNOVATIVE DISTRIBUTION TO OEMs

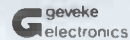

Geveke Electronics Ltd., RMC House, Vale Farm Rd., Woking Tel: 04862 71337

## DO YOU USE AN APPLE SYSTEM IN YOUR BUSINESS?

## LOOKING AFTER IT IS OURS

## PHONE NOW FOR PRICES AND BROCHURE

- ★ COMPLETE SYSTEM COVER
- ★ FAST RESPONSE
- ★ COMPETITIVE RATES
- ★ FULLY TRAINED PERSONNEL
- ★ OVER 600 SATISFIED CUSTOMERS



★ OUR AREA

ON-SITE MAINTENANCE TEL. 0268-710292

FROM

**COMMERCIAL DATA SYSTEMS LTD**

HEAD OFFICE

DOWNHAM ROAD RAMSDEN HEATH BILLERICAY ESSEX

AUTHORISED  
SERVICE  
CENTRE

CORVUS  
APPLE



**PACKAGES**

Application	Machine	Price	Code
	CP/M	£90	M3
	CP/M	£75	S7
	MCZ Zilog	£250	I1
	North Star		
	Horizon	£90	M3
	PCC 2000		
	Simpelec Triton 3	£450	B2
	Superbrain	£90	M3
	Tandy Model I	£75 +	G4
	Tandy Model II	£75	M1
	Tandy Model II	£75 +	G4
Membership acctg	Apple/Apple II	£75	P2
	PET	£85	H2
Motor Dealer	Famos	£5000	M2
Order entry/invoicing	CP/M	£350	G1
Order processing	CP/M	£550	L1
	8080/Z80	£550	L1
Office admin	Apple II/ITT 2020	£100	S4
Packages		£1	
Pad to plotter systems	Apple II	£250	P2
Pascal	Apple/Apple II	£299	P2
	PET/CBM	£120	C2
Payroll	Apple	POR	A2
	Apple	£200	S2
	Apple	POR	S5
	Apple	POR	K2
	Apple II	£200	P2
	Apple II	£375	V1
	Apple II	£375	C6
	Apple II	£10	D1
	Apple II/ITT 2022	£250P	S4
	Challenger	£25	C7
	CBM	£10	H3
	CP/M	£450	L3
	CP/M	£475	L1
	CP/M	£495	C4
	CP/M	£500	G1
	CP/M	£390	M3
	CP/M	£500	B5
	Cromemco	£350	B3
	Famos	£1500	M2
	ITT 2020	£375	C6
	ITT 2020	£10	D1
	North Star		
	Horizon	£350	B3
	North Star		
	Horizon	£390	M3
	PET	£200/350	C5
	PET	£50/25	
	PET	195	A1
	PET	£50/195	I2
	PET	£10	D1
	PET/CBM	£150	G2
	PET/CBM	£150	J1
	PET/CBM	£150	C2
	PET/CBM	£150	L2
	Scorecer	£250	M3
	Superbrain	£390	M3
	Superbrain	£400	S6
	Tandy Model I	£249	M1
	TRS-80	£200	H1
	TRS-801	£218	T1
	TRS-801	£218	T1
	TRS-801	£218	T1
	TRS-801	£375	T1
	TRS-801	£225	C2
	8000 Series	£475	L1
	8080/Z80	£275	G3
	PET/CBM	£150	G2
	PET/CBM	£150	J1
	PET/CBM	£150	C2
	PET/CBM	£250	L2
	Scorecer	£249	M1
	Tandy Model I	£249	M1
	TRS-80	£200	H1
	TRS-801	£218	K1
	TRS-801	£218	T1
	TRS-801	£218	T1
	TRS-801	£375	T1
	8000 Series	£250	C2
	8080/Z80	£475	L1
	8080/Z80	£275	G3
Personnel records	Apple II	£98	P2
	CP/M	£450	C4
	MCZ Zilog	£500 +	I1
	PET	£85	H2
Petaid report generator	Commodore/Computhink	£125	S3
Petsoft programs	PET/CBM	£160	J1
Planning/Maintenance	PET/8032	£595	S1
Postal advertising response package	Apple	£350	S2
PR/advertising package	Commodore/Computhink	£1000	S3
Price lister	CBM	£12	H3
Printers job control	Commodore/Computhink	£250	S3
Production analysis	Apple II	£75	P2
	CP/M	£700	C4
	PET/CBM	£300	B1
Prof appts groups	8080/Z80	£275	G3
Prof appts individ	8080/Z80	£220	G3
Prof client billing	8080/Z80	£330	G3
Programming aids	Apple II	£40	P2
Property management	CP/M	£450-1000	C4
	CP/M	£400	M3
	North Star		
	Horizon	£400	M3
	Superbrain	£400	M3
Purchase ledger	Apple	£300	A2

Application	Machine	Price	Code
	Apple	£300	S5
	Apple	£300	K2
	Apple II	£295	C6
	Apple II	£300	P1
	Apple II	£300	P2
	Apple II	£315	V1
	Apple II/ITT 2020	£250P	S4
	CBM	£350	H3
	Challenger	£25	C7
	Commodore/Computhink	POR	S3
	CP/M	£500	C4
	CP/M	£450	G1
	CP/M	£500	L3
	CP/M	£425	L1
	CP/M	£400	M3
	CP/M	£200	B5
	CP/M	£275	S7
	Cromemco	£250	B3
	ITT 2020	£295	C6
	ITT 2020	£300	P1
	North Star		
	Horizon	£250	B3
	North Star		
	Horizon	£400	M3
	Superbrain	£400	M3
	Superbrain	£300	S6
	PCC 2000		
	Simpelec Triton 3	£350	B2
	PET	£300	B4
	PET	£95/120/350	A1
	PET/CBM	£200	C2
	PET/CBM	POR	J1
	PET/8032	£395	S1
	Sharp PC3201	£300	P2
	Tandy Model I	£90	M1
	Tandy Model II	£90	M1
	TRS-80	£225	H1
	TRS-801	£225	T1
	TRS-801	£375	T1
	Vector	£400	C5
	8000 Series	£250	C2
	8080/Z80	£275	G3
	8080/Z80	£425	L1
Quotation estimating	Apple II	£300	P1
Revolving credit	Cromemco	£400 +	B3
Sales ledger	Apple	£300	A2
	Apple	£300	S5
	Apple	£300	K2
	Apple II	£295	C6
	Apple II	£300	P1
	Apple II	£300	P2
	Apple II	£315	V1
	Apple II/ITT 2020	£250P	S4
	CBM	£350	H3
	Challenger	£25	C7
	Commodore/Computhink	POR	S3
	CP/M	£500	C4
	CP/M	£450	G1
	CP/M	£500	L3
	CP/M	£425	L1
	CP/M	£400	M3
	CP/M	£200	B5
	CP/M	£275	S7
	Cromemco	£250	B3
	ITT 2020	£295	C6
	ITT 2020	£300	P1
	North Star		
	Horizon	£250	B3
	North Star		
	Horizon	£400	M3
	PCC 2000		
	Simpelec Triton 3	£350	B2
	PET	£300	B4
	PET	£800	C1
	PET	£95/350	A1
	PET/CBM	POR	J1
	PET/CBM	£200	C2
	PET/8032	£395	S1
	Sharp PC 3201	£300	P2
	Superbrain	£400	M3
	Superbrain	£300	S6
	Tandy Model I	£90	M1
	Tandy Model II	£90	M1
	TRS-80	£225	H1
	TRS-801	£225	T1
	TRS-801	£375	T1
	Vector	£400	C5
	8000 Series	£250	C2
	8080/Z80	£275	G3
	8080/Z80	£425	L1
Salesman	Apple II	£10	D1
	ITT 2020	£10	D1
	PET	£10	D1
Screen generator	MCZ Zilog	£75 +	I1
S/L, P/L & stock control	Apple/Apple II	£900	P2
	CP/M	£1000	L3
Solicitor's complete record accounting	Apple	£3000	S2
Solicitor's package	PET/8032	£750	S1
Statistics	Apple	£150	G3
	Apple II	£100-195	P2
	TRS-80	£45	S2
Stock control/recording	Altos (CP/M, MP/M)	£300	B1
	Apple	POR	A2
	Apple	POR	K2
	Apple	POR	S5
	Apple	£150	G3
	Apple	£80	S2
	Apple II	£75/300	P2
	Apple II	£10	D1
	Apple II	£285	V1

Application	Machine	Price	Code
	Apple II	£300	P1
	Apple II/ITT 2020	£500	S4
	CBM	£35/25	H3
	Challenger	£25	C7
	Commodore/Computhink	£100/250	S3
	CP/M	£325	L1
	CP/M	£500-1500	C4
	CP/M	£350	G1
	CP/M	£900	M3
	CP/M	£500	B5
	Cromemco	£450	B3
	Famos	£1500	M2
	ITT 2020	£10	D1
	ITT 2020	£300	P1
	MZ-80K	£150	P2
	North Star		
	Horizon	£450	B3
	North Star		
	Horizon	£900	M3
	PCC 2000		
	Simpelec Triton 3	£350	B2
	PET	£12/25/350	A1
	PET	£10	D1
	PET	£195	I2
	PET	£300	B4
	PET	£15	A2
	PET/CBM	£300	B1
	PET/CBM	£150	C2
	PET/CBM	£150	J1
	PET/CBM	£150	G2
	PET/Computhink	£250	R1
	PET/8032	£395	S1
	Sharp PC3201	£300	P2
	Superbrain	£900	M3
	Superbrain	£300	S6
	Tandy Model I	£30-50	M1
	Tandy Model II	£300	M1
	TRS-80	£48	S2
	TRS-80	£200	H1
	TRS-80	£115	J1
	TRS-801	£200	T1
	TRS-801	£375	T1
	8080/Z80	£275	G3
	8080/Z80	£325	L1
TAP business system	PET	£125	H2
Text file librarian	Apple II/ITT 2020	£125	S4
Time/cost recording	Apple	£450	S2
	Apple II	£300	P1
	Commodore/Computhink	POR	S3
	CP/M	£400	G1
	CP/M	£200	M3
	Cromemco	£250	B3
	ITT 2020	£300	P1
	North Star		
	Horizon	£250	B3
	North Star		
	Horizon	£200	M3
	PCC 2000		
	Simpelec Triton 3	£350	B2
	PET/CBM	£300	B1
	Superbrain	£200	M3
	Tandy Model I	POR	M1
	Tandy Model II	POR	M1
Travel agency accts	Superbrain	£800	S6
	Tandy Model I	£225	G4
	Tandy Model II	£225	G4
Travel Agents Dairy	Tandy Model I	£100	G4
	Tandy Model II	£100	G4
Travel Ticket Sales	Tandy Model I	£225	G4
	Tandy Model II	£225	G4
Utilities	Apple/Apple II	£40	P2
	Apple II	£20	C6
	ITT 2020	£20	C6
Utility set	CBM	£78	H3
Various engineering	Tektronix		E1
VAT	PET	£17.50	A1
VAT master	CBM	£25	H3
VAT register	TRS-80	£15	H1
Vet package	PET/8032	POR	S1
Video message	Apple	£200	G3
Warehousing	PET/8032	POR	S1
Word processing	ACT 800	£375	H4
	Apple	£60	S2
	Apple	£75	K2
	Apple	£75	S5
	Apple	£75	A2
	Apple II	£150-300	P2
	Apple II	£75	J1
	Apple II	£120	V1
	Apple II	£40	D1
	Apple II/ITT 2020	£180/95	S4
	CBM	£35	H3
	Commodore/Computhink	£120	S3
	CP/M	£150-260	C4
	CP/M	£400	G1
	CP/M	£250	M3
	Famos	£500	M2
	ITT 2020	£40	D1
	MCZ Zilog	£500 +	I1
	North Star		
	Horizon	£250	M3
	PET	£85/65/40/20	H2
	PET	£40	D1
	PET	£375	H4
	PET	£25/325	A1
	PET	£325	C5
	PET/CBM	£75/150	C2

**PACKAGES**

Application	Machine	Price	Code
	PET/CBM	£75/150	J1
	PET/CBM	£75/150	G2
	Superbrain	£250	M3
	Tandy Model I	£50/75	M1
	Tandy Model II	£175-240	M1
	TRS-80	£30/60/90	S2
	TRS-80	£45/95	J1
	TRS-80	£15	H1
	Vector	£400	C5
	8000 Series	£250	C2

**Machines**

Machine	Application	Price	Code
ACT 800	Database management/	£225	H4
	Word processing	£375	H4
Altos (CP/M, MP/M)	Integrated accts	£300	B1
	Mailing list	£75	B1
	Stock control/recording	£300	B1
Apple	Contract costing	£450	P1
	Database management/ information retrieval	£150	K2
	Database management/ information retrieval	£150	A2
	Database management/ information retrieval	£60-140	S2
	Database management/ information retrieval	£150	S5
	Database management	£75	P2
	Estate agent	£850	S5
	Estate agent	£850	A2
	Estate agent	£850	K2
	General ledger/NL	£300	K2
	General ledger/NL	£300	A2
	General ledger/NL	£450	P2
	General ledger/NL	£300	S5
	Incomplete records	POR	K2
	Incomplete records	£250	S2
	Incomplete records	£450	P1
	Incomplete records	£450	P2
	Industry factory loading	£360	X1
	Industry work study	£990	X1
	Invoicing	£295	S2
	Invoicing	£300	P2
	Job costing	£450	S2
	Job costing	£990	X1
	Mailing list	£300	K2
	Mailing list	£300	A2
	Mailing list	£40	P2
	Mailing list	£50-150	S2
	Mailing list	£300	S5
	Mail shot	£14	S2
	Payroll	POR	S5
	Payroll	POR	K2
	Payroll	POR	A2
	Payroll	£200	S2
	Postal advertising response package	£350	S2
	Purchase ledger	£300	K2
	Purchase ledger	£300	P2
	Purchase ledger	£300	A2
	Purchase ledger	£300	S5
	Quotation estimating	£300	P1
	Sales ledger	£300	A2
	Sales ledger	£300	K2
	Sales ledger	£300	S5
	Sales ledger	£300	P2
	Solicitor's complete record accounting	£3000	S2
	Statistics	£150	G3
	Statistics	£100/195	P2
	Stock control/recording	£150	G3
	Stock control/recording	POR	K2
	Stock control/recording	£300	P2
	Stock control/recording	POR	A2
	Stock control/recording	£80	S2
	Stock control/recording	POR	S5
	Time/cost recording	£450	S2
	Video message	£200	G3
	Word processing	£75	K2
	Word processing	£75	A2
	Word processing	£60	S2
	Word processing	£300	P2
	Word processing	£75	S5
	Apple II	Bank account	£10
Cash flow		£80	V1
Cash flow		£75	P2
Cash register		£10	D1
Database management/ information retrieval		£98	P2
General ledger/NL		£225	V1
General ledger/NL		£450	P2
General ledger/NL		£295	C6
Incomplete records		£300	P2
Integrated accts		£855	V1
Integrated accts		£450	P1
Integrated accts		£300	P2
Invoicing		£140	V1
Invoicing		£300	P1
Invoicing		£300	P2
Job costing		£300	P1
Letter writer		£80	V1
Mailing list		£50	D1
Mailing list		£40	P2
Mail shot		£225	P2
Pad to plotter system		£250	P2
Payroll		£375	V1
Payroll		£200	P2
Payroll		£375	C6
Payroll		£10	D1
Personnel records		£75	P2
Production analysis		£75	P2
Programming aids		£40	P2
Purchase ledger		£315	V1
Purchase ledger		£300	P1
Purchase ledger		£300	P2
Purchase ledger		£295	C6
Sales ledger		£315	V1

Machine	Application	Price	Code	
	Sales ledger	£300	P1	
	Sales ledger	£300	P2	
	Sales ledger	£295	C6	
	Salesman	£10	D1	
	Statistics	£100-195	P2	
	Stock control/recording	£285	V1	
	Stock control/recording	£300	P1	
	Stock control/recording	£300	P2	
	Stock control/recording	£10	D1	
	Time/cost recording	£300	P1	
	Utilities	£20	C6	
	Word processing	£120	V1	
	Word processing	£150-300	P2	
	Word processing	£40	D1	
	Word processing	£75	J1	
Apple II/ITT 2020	Database management/ information retrieval	£100	S4	
	Estate agent	£750	S4	
	Financial planning	£250	S4	
	General ledger/NL	£250P	S4	
	Mailing list	£100	S4	
	Office admin	£100	S4	
	Payroll	£250P	S4	
	Purchase ledger	£250P	S4	
	Sales ledger	£250P	S4	
	Stock control/recording	£500	S4	
	Text file librarian	£125	S4	
	Word processing	£180/95	S4	
	CBM	Bureau de change	£8	H3
		Estate agent	£30	H3
		General ledger/NL	£200	H3
Mailing list		£35	H3	
Payroll		£10	H3	
Price lister		£12	H3	
Purchase ledger		£350	H3	
Sales ledger		£350	H3	
Stock control/recording		£35/25	H3	
Utility set		£78	H3	
VAT master		£25	H3	
Word processing		£35	H3	
Challenger		Appointment Planner	£25	C7
		Invoicing	£25	C7
		Mail Shot	£25	C7
	Payroll	£25	C7	
	Purchase Ledger	£25	C7	
	Sales Ledger	£25	C7	
	Stock Control	£25	C7	
	Commodore/Computhink	Appointments planner	£100	S3
		Bank accounts	£100	S3
		Bonds/pension quotations	£100	S3
		Database management/ information retrieval	£45-250	S3
		Estate agent	£250	S3
		General ledger/NL	POR	S3
		Incomplete records	£750	S3
		Integrated accts	POR	S3
Invoicing		POR	S3	
Mailing list		£100	S3	
Mail shot		£125	S3	
Petaid report generator		£125	S3	
PR/advertising package		£1000	S3	
Printers job control		£250	S3	
Purchase ledger		POR	S3	
Sales ledger	POR	S3		
Stock control/recording	£100/250	S3		
Time/cost recording	POR	S3		
Word processing	£120	S3		
CP/M	Bill of materials	£500	B5	
	Cash flow	£250	L3	
	Cash flow	£95	B5	
	Company secretary	£450	C4	
	Contract costing	£2000	L3	
	Database management/ information retrieval	£150-750	C4	
	Database management/ information retrieval	£100	G3	
	Equipment lease/rent/HP	£400	G1	
	Estate agents	£750	C4	
	Financial modelling	£400	G1	
	Financial modelling	£95	B5	
	General ledger/NL	£500	L3	
	General ledger/NL	£500	C4	
	General ledger/NL	£400	G1	
	General ledger/NL	£375	L1	
	General ledger/NL	£200	B5	
	General ledger/NL	£275	S7	
	General ledger/NL	£400	M3	
	Incomplete Records	£250	B5	
	Incomplete Records	£750	M3	
	Industry factory loading	£360	X1	
	Industry work study	£990	X1	
	Integrated accts	£1500	C4	
	Integrated accts	£1100	G1	
	Integrated accts	£950	L1	
	Integrated accts	£690	B5	
	Integrated accts	£850	S7	
	Integrated accts	£990	M3	
	Invoicing	£325	L1	
	Invoicing	£150-350	C4	
	Invoicing	£150	S7	
	Invoicing	£250	M3	
	Job costing	£700	C4	
	Job costing	£990	X1	
	Job costing	£350	M3	
	Legal precedents	£1100	C4	
	Letter Writer	£150	M3	
	Mailing list	£50-150	C4	
	Mailing list	£250	G1	
	Mailing list	£75	S7	
	Mail shot	£200-360	G4	
	Mail shot	£90	M3	
	Order entry/invoicing	£350	G1	
	Order processing	£550	L1	
	Payroll	£450	L3	
Payroll	£495	C4		
Payroll	£500	G1		

Machine	Application	Price	Code	
	Payroll	£475	L1	
	Payroll	£500	B5	
	Payroll	£390	M3	
	Personnel records	£450	C4	
	Production analysis	£700	C4	
	Property management	£450-1000	C4	
	Property management	£400	M3	
	Purchase ledger	£500	L3	
	Purchase ledger	£450	G1	
	Purchase ledger	£425	L1	
	Purchase ledger	£500	C4	
	Purchase ledger	£200	B5	
	Purchase ledger	£275	S7	
	Purchase ledger	£400	M3	
	Sales ledger	£500	L3	
	Sales ledger	£500	C4	
	Sales ledger	£425	L1	
	Sales ledger	£200	B5	
	Sales ledger	£275	S7	
	Sales ledger	£400	M3	
	S/L, P/L + stock control	£1000	L3	
	Stock control/recording	£325	L1	
	Stock control/recording	£500-1500	C4	
	Stock control/recording	£350	G1	
	Stock control/recording	£500	B5	
	Stock control/recording	£900	M3	
	Time/cost recording	£400	G1	
	Time/cost recording	£200	M3	
	Word processing	£400	G1	
	Word processing	£150-260	C4	
	Word processing	£250	M3	
Cromemco	Database management/ information retrieval	£250	B3	
	General ledger/NL	£250	B3	
	Hire purchase	£400+	B3	
	Integrated accts	£950	B3	
	Invoicing	£100	B3	
	Leasing	£400+	B3	
	Purchase ledger	£250	B3	
	Revolving credit	£400+	B3	
	Sales ledger	£250	B3	
	Stock control/recording	£450	B3	
	Time/cost recording	£250	B3	
	Famos	Customer file	£1000	M2
		Data base	£1500	M2
		Integrated accts	£2000	M2
		Motor dealer	£5000	M2
Payroll		£1500	M2	
Stock control		£1500	M2	
Word processing		£500	M2	
ITT 2020		Bank account	£10	D1
		Cash register	£10	D1
		General ledger/NL	£295	C6
	Integrated accts	£450	P1	
	Invoicing	£300	P1	
	Job costing	£300	P1	
	Mailing list	£50	D1	
	Payroll	£10	D1	
	Payroll	£375	C6	
	Purchase ledger	£300	P1	
	Purchase ledger	£295	C6	
	Sales ledger	£300	P1	
	Sales ledger	£295	C6	
	Salesman	£10	D1	
	Stock control/recording	£10	D1	
Stock control/recording	£300	P1		
Time/cost recording	£300	P1		
Utilities	£20	C6		
Word processing	£40	D1		
MCZ Zilog	Budgeting package	£500+	I1	
	Conference organiser	£500+	I1	
	Mail shot	£200	I1	
	Personnel records	£500+	I1	
	Screen generator	£75+	I1	
	Word processing	£500+	I1	
	MZ-80K	Integrated accounts	£150	P2
		Stock control/recording	£150	P2
	North Star Horizon	Database management/ information retrieval	£250	B3
		Estate agent	£750	B5
General ledger/NL		£250	B3	
General ledger/NL		£400	M3	
Incomplete records		£750	M3	
Integrated accts		£950	B3	
Integrated accts		£990	M3	
Invoicing		£100	B3	
Invoicing		£250	M3	
Job costing		£350	M3	
Letter writer		£150	M3	
Mail shot		£90	M3	
Payroll		£350	B3	
Payroll		£390	M3	
Property Management		£400	M3	
Purchase ledger	£250	B3		
Purchase ledger	£400	M3		
Sales ledger	£250	B3		
Sales ledger	£400	M3		
Stock control/recording	£450	B3		
Stock control/recording	£900	M3		
Time/cost recording	£250	B3		
Time/cost recording	£200	M3		
Word processing	£250	M3		
PCC 2000 Simpelec Triton 3	Estate Agent	£350	B2	
	General ledger/NL	£350	B2	
	Mail Shot	£450	B2	
	Purchase ledger	£350	B2	
	Sales ledger	£350	B2	
	Stock control/recording	£350	B2	
	Time/cost recording	£350	B2	
	PET	Bank account	£10	D1
		Cash flow	£8	A1
		Cash register	£10	D1
Credit control		£650	B4	
Database management/ information retrieval		POR	C1	

**PACKAGES**

Machine	Application	Price	Code	Machine	Application	Price	Code	Machine	Application	Price	Code
	Database management/ information retrieval	£325	A1		Stock control/recording	£150	G2		Time/cost recording	POR	M1
	Database management/ information retrieval	£225	H4		Stock control/recording	£150	J1		Travel Agency Accts	£225	G4
	Database management/ information retrieval	£170	C3		Time/cost recording	£300	B1		Travel Agency Diary	£100	G4
	Estate agent	£25	A1		Word processing	£75/150	J1		Travel Ticket Sales	£225	G4
	General ledger/NL	£1000	C1		Word processing	£75/150	G2-		Word processing	£175-240	M1
	Industry factory loading	£300	X1	PET/ Computhink	Stock control/recording	£250	R1	Tektronix	Various engineering Packages		E1
	Industry work study	£750	X1	PET/8032	Mailing list	£75/150	S1	TRS-80	Database management/ information retrieval	£60	S2
	Invoicing	£350	A1		Planning maintenance	£595	S1		Database management/ information retrieval	£32.50	H1
	Invoicing	£400	C1		Purchase ledger	£395	S1		Database management/ information retrieval	£150	J1
	Job costing	£750	X1		Sales ledger	£395	S1		General ledger/NL	£225	H1
	Lotteries	£45	H2		Solicitor's package	£750	S1		Incomplete records	£40	H1
	Mailing list	£15	A1		Stock control/recording	£395	S1		Integrated accts	£75	J1
	Mailing list	£50	D1		Ver package	POR	S1		Investment portfolio	£20	S2
	Mailing list	£45	H2		Warehousing	POR	S1		Invoicing	£25	H1
	Membership accting	£85	H2	Sharp PC-3201	General ledger	£450	P2		Invoicing	£25/38/	H1
	Payroll	£50/195	I2		Sales ledger	£300	P2		Mailing list	£5	H1
	Payroll	£10	D1		Purchase ledger	£300	P2		Mailing list	£50-150	S2
	Payroll	£50/25/	A1		Stock control	£300	P2		Payroll	£200	H1
	Payroll	195	A1	Sorcerer	Payroll	£250	L2		Purchase ledger	£225	H1
	Payroll	£200/350	C1	Superbrain	Database	£300	S6		Sales ledger	£225	H1
	Personnel records	£85	H2		Estate agent	£800	S6		Statistics	£45	S2
	Purchase ledger	£95/120/	C5		General ledger	£400	M3		Stock control/recording	£200	H1
	Purchase ledger	350	A1		General ledger	£400	S6		Stock control/recording	£48	S2
	Purchase ledger	£1000	C1		General ledger	£400	S6		Stock control/recording	£115	J1
	Purchase ledger	£300	B4		Incomplete Records	£750	M3		Stock control/recording	£15	H1
	Sales ledger	£300	B4		Integrated Accts	£1200	S6		VAT register	£45/95	J1
	Sales ledger	£800	C1		Integrated Accts	£990	M3		Word processing	£15	H1
	Sales ledger	£95/350	A1		Invoicing	£250	M3		Word processing	£30/60/	S2
	Salesman	£10	D1		Invoicing	£150	S6	TRS-801	General ledger/NL	£225/325	T1
	Stock control/recording	£195	I2		Job costing	£150	M3		Invoicing	£75	T1
	Stock control/recording	£10	D1		Letter writer	£350	M3		Payroll	£218	T1
	Stock control/recording	£12/25/	A1		Mail shot	£90	M3		Purchase ledger	£225	T1
	Stock control/recording	350	A1		Payroll	£400	S6		Sales ledger	£225	T1
	Stock control/recording	£15	A2		Payroll	£390	M3		Stock control/recording	£200	T1
	Stock control/recording	£300	B4		Property management	£400	M3	TRS-8011	General ledger/NL	£425	T1
	TAP business system	£125	H2		Purchase ledger	£300	S6		Invoicing	£125	T1
	VAT	£17.50	A1		Purchase ledger	£400	M3		Payroll	£375	T1
	Word processing	£40	D1		Sales ledger	£300	S6		Purchase ledger	£375	T1
	Word processing	£85/65/	H2		Sales ledger	£400	M3		Sales ledger	£375	T1
	Word processing	40/20	H2		Stock control	£300	S6		Stock control/recording	£375	T1
	Word processing	£375	H4		Stock control	£900	M3	Vector	General ledger/NL	£400	C5
	Word processing	£25/325	A1		Time recording	£200	M3		Integrated accts	£1000	C5
	Word processing	325	C5		Travel agency accts	£250	M3		Purchase ledger	£400	C5
					Travel agency accts	£800	S6		Sales ledger	£400	C5
PET/CBM	Assembler dev	£50	C2	Tandy Model I	Database management/ information retrieval	£25-80	M1		Word processing	£40	C5
	Database management/ information retrieval	£75	B1		General ledger/NL	£90	M1	8000 Series	Database management/ information retrieval	POR	C2
	Database management/ information retrieval	£50/150	C2		Incomplete records	£40	M1		Integrated accts	POR	C2
	Database management/ information retrieval	£150	G2		Integrated accts	£350	M1		Payroll	£250	C2
	Database management/ information retrieval	£150	J1		Invoicing	£90	M1		Purchase ledger	£250	C2
	Disk operating system	£150	B1		Job costing	POR	M1		Sales ledger	£250	C2
	General ledger/NL	£200	C2		Mailing list	£40	M1		Word processing	£250	C2
	Integrated accts	£300	B1		Mail shot	£75 +	G4	8080/Z80	Database management/ information retrieval	POR	C2
	Integrated accts	£(50)	C2		Payroll	£249	M1		Integrated accts	POR	C2
	Integrated accts	£650	G2		Purchase ledger	£90	M1		Payroll	£250	C2
	Integrated accts	£650	J1		Sales ledger	£90	M1		Purchase ledger	£250	C2
	Invoicing	POR	J1		Stock control/recording	£30-50	M1		Sales ledger	£250	C2
	Invoicing	£25-50	B1		Travel Agency Accts	£225	G4		Word processing	£250	C2
	Lisp	£75	C2		Travel Agents Dairy	£100	G4		General ledger/NL	£275	G3
	Mailing list	£75	B1		Travel Ticket Sales	£225	G4		General ledger/NL	£375	L1
	Pascal	£120	C2		Time/cost recording	POR	M1		Integrated accts	£950	L1
	Payroll	£150	G2		Word processing	£50/75	M1		Integrated accts	£995	G3
	Payroll	£150	J1	Tandy Model II	CBasic	£70	M1		Invoicing	£325	L1
	Payroll	£150	C2		CP/M + utilities	£150	M1		Job order control	£257	G3
	Petsoft programs	£160	J1		General ledger/NL	£90	M1		Order processing	£550	L1
	Production analysis	£300	B1		Integrated accts	£350	M1		Payroll	£475	L1
	Purchase ledger	£200	C2		Invoicing	£90	M1		Payroll	£275	G3
	Purchase ledger	POR	J1		Job costing	POR	M1		Prof appts groups	£275	G3
	Sales ledger	POR	J1		Mailing list	£75	M1		Prof appts individ	£220	G3
	Sales ledger	£200	J1		Mail shot	£75	M1		Proficient billing	£330	G3
	Stock control/recording	£150	C2		Mail shot	£75 +	G4		Purchase ledger	£425	L1
	Stock control/recording	£300	B1		Purchase ledger	£90	M1		Purchase ledger	£275	G3
					Sales ledger	£90	M1		Sales ledger	£275	G3
					Stock control/recording	£300	M1		Sales ledger	£425	L1
									Stock control/recording	£325	L1
									Stock control/recording	£275	G3

**TRANSACTION FILE**

We charge a flat fee of £1 for one insertion of up to 30 words. Ads for this section are accepted only from non-commercial readers. Please type or write clearly. Send your ad plus PO or cheque for £1, payable to Sportscene Publishers (PCW) Ltd, to: Transaction File, PCW, 14 Rathone Place, London W1P 1DE

PET 3016... 16k, new ROM, large keyboard, green screen, cassette deck, soundbox, many games tapes, inc Invaders, Acrobat, startrek, beginners course, £500. 94 Coventry Rd, Exhall, Coventry, tel: Coventry (0203) 366505.

Atari Video Computer... all controller types, 22 cartridges inc Space Invaders, Soccer, Superman, Adventure, Casino, Indy 500, Bowling, Golf, Basketball, Circus, only £300, worth over £550. Tel: Tenterden 3830 eve.

UK101... 8k RAM, cased, 1 or 2 MHz, sound board and I/O port, doc software, £260 ono. Extra sound board, fully built and tested, £25. Tel: Leeds 561967.

Sharp Serial Printer Interface... made by 3D, interfaces MZ-80k to serial printers with either RS232C or 20mA loop, with circuit & components for hand-shake, £70. Tel: Whitaker, Retford 702608.

Acorn Atom... 8k + 5k, PSU, leads, 4 mnths old, manuals, Magic Book, user group newsletters, £185 or nearest. Tel: Great Bolas-432 (after 5pm).

Nascom II... 16k, graphics ROM, sound chip, fitted in attache case, £325. Tel: Matlock (0629) 3528.

Superboard Series II... 8k RAM, Wemom monitor, power supply unit, plus high speed cassette interface kit, a four tapes and user group newsletters, £160. Tel: Oxford (0865) 46823.

Acorn Atom... 12k RAM, 8k ROM. Basic and assemblr, Acorn built, tested, as new, all leads and manuals, needs external regulated PSU, £200. Write: Ian Paton, 39 Yates Street, Liverpool.

PET 32k... & cassette, h'ware reset switch, various progs, user manual, £550 the lot. Tel John, Colnbrook 3854 eve & wkend, or 01-250 1500 ext 245 day.

PET 8k... new ROMs, green screen, integral cassette deck, soundbox, some software, little used, as new cond. £395. Tel: Southampton 25621.

PET 8k... new ROM, external cassette etc, manuals, plenty of software, cover, superb condition, private use only, friendly help if needed, £400. Tel: Wyndham (Norfolk) 602951.

Nascom II... 16k RAM & board at 4MHz graphics ROM, 3 amp PSU, Vero case, £450 ono cash. Casio FX502P with wallet, program library and manual £40 ono cash. Ring 01-647 1541.

ZX81... yes 81! Factory built, 16k RAM, leads, manual and three Sinclair cassettes, only 12 weeks old. Sold to first offer of £110. Ring 0484 89 2837 after 7pm.

ZX81... factory built, only used twice, complete with leads, main adaptor, manual and cassette of Sinc games, £65 ono. Tel: 01-958 5931 after 5.

PET 8k... new ROM large keyboard, soundbox books, magazines also programs included, £400. Tel: Derby (0332) 371473.

# THE GREAT COVER-UP!

Not since the days of Watergate has there been a public scandal of such far-reaching implications.

It has recently come to the attention of the PCW Secret Police that certain regular readers have been storing their valuable back issues 'au naturelle'.

We consider this practise to be singularly lacking in dignity, and would therefore appeal to you in the name of common decency to please ensure that your

magazines are properly dressed at all times.

This may be achieved by the simple expedient of purchasing one or more of our sturdy yet colourful PCW binders.

So why not join in the great cover-up and preserve your precious PCW's in their original pristine perfection.

Just check the coupon at the foot of the page.



Please send me \_\_\_\_\_ PCW Binders at £3.25 each

NAME \_\_\_\_\_

ADDRESS \_\_\_\_\_

(Block capitals please)

I enclose cheque/P.O. for £\_\_\_\_\_ made payable to  
Sportscene Publishers Ltd.  
Send coupon to PCW (Binders),  
14 Rathbone Place, London  
W1P 1DE. Allow at least  
14 days for processing.

# TRANSACTION FILE

**PET 8k 2001...** owner upgrading, hence £350 ono. + PET manual + subroutines + strathclyde Basic + programs (statistics/home finance/games etc). Tel: Sharp-thorne 810006 eve, w/ends. Can deliver anywhere in South East.

**Triton...** with Basic, Pascal & Assembler, 16k RAM, 4800 baud interface, keyboard repeat & spare i/o ports, also Imp printer, all for less than half original cost. Tel: Dublin 854250.

**Free PET...** (not working), old ROM, with 24k expansion, programs and manuals, when you buy PET tractor printer 3022 ingood working order, little used, for £400 cash, buyer collects. J Tobin, Flat 3, 18 Acton Street, London WC1X 9ND.

**PET 16k...** new ROM, large keyboard, 40+programs, PET revealed, soundbox, magazines, blank tapes, original packing, will deliver in London, £450. Tel: 040 488-212 or 01-727 2476.

**Sharp MZ-80K...** 48k, extended Basic, programmers toolkit, games, manuals, virtually unused, £450. Tel: Bolton (0204) 493074.

**IBM 375...** golfball I/O typewriter complete with all solenoids & wiring, full upper & lower case keyboard, economical correspondence quality printer also usable as typewriter. Tel: 01-445 3000.

**Acorn Atom...** 12k RAM, floating point, built by Acorn, complete with manuals, leads, PSU and some software, little used £195. Tel: Paul, Much Hadham (027984) 2540.

**Phillips G7000...** games computer with 11 cartridges inc. programming, Othello, golf etc, owner going on to bigger things, £100 Tel: 0621 740075 (Essex).

**Apple Users...** Supertalker and Speechlabs Heuristics set (incl. 2 cards, 2 diskettes, 2 mics, cassette, full documentation), surplus to requirements, £180. Tel 0621 740075 (Essex).

**Exidy Sorcerer 32k...** with software worth over £200 inc Chess, Adventure, Disassembler, Debug etc, 2 years back numbers PCW, PC, £480. Quality printer £175. All cables, manuals inc Tel: 01-776 1705.

**Video Genie EG3003...** with 4th arrow and level meter and original box, only 3 months old, still under guarantee, lots of programs and bits and pieces, £299. Tel: 01-300 0657 (Sidecup).

**Intellivision...** with football and golf carts. With sound effects, seeing mine friends bougat, so I bought TRS-80, cost £219, sell for £175 (+ p&p), 6 months old, boxed. Tel: Colbrook (Berks) 2504.

**Challenger C2 computer...** cegmon monitor, 8k RAM, Microsoft Basic in 8k ROM, sound, D/A, video and RF outputs, cassette I/O, printer 20mA I/O, colour circuitry added. 64 x 32/32 x 32 screen res, £420 ono. TV/monitor, cassette, ASR33 available. Tel: Brighton 561670 after 6.

**Texas TI58 prog calc...** as new offer includes master module (inc labels) manuals, coding sheets, case and mains adaptor/charger, £45. Tel: Taunton (0823) 73915.

**Sharp MZ-80P printer...** with MZ80-I/O interface unit. Only 2 months old. Perfect cond, only £490 complete, quick sale. Tel: (0384) 232095.

**GE PTR66 paper tape reader** 150 CPS, a synchronous stepping, 8-hole, integral power supplies, £25, tel: 0494 28899.

**OKI dot matrix printer...** 80 char per line, 110 CPS, serial and parallel interface, RS232 up to 9600 baud, standard paper, £185, tel 0494 28899.

**Tandy Model I...** 16k, CPU and VDU plus lots of programs, £350 ono. 266 Poolstock Lane, Wigan, Lancs

**ZX80...** with 4k & new 8k ROMs. All leads, manual & PSU, 30 games on tape for 4k ROM. £50 ono. Tel Carlisle (0228) 35785 eve.

**Casio fx502p...** programmable calculator in wallet, as new, with overlay and instructions, hardly used. Owner now uses a micro, £50 ono. Telephone: 01-445 8507 (Finchley) after 7pm.

**Tandy...** 12in video monitor, green screen, 5 months old, rarely used, excellent condition. Cost £100, sell for £80 ono. Write to: Paul O'Neil, 187 Main St, Chapelhall, Airdrie, Scotland ML6 8SF.

**Video Genie...** 16k. Complete with manuals & leads exc cond. 8 months old. £300 ono. Tel: 01-561 4918.

**Apple II...** 48k, disk drive, manuals, word processing package, chess, invaders etc. £900. Decwriter IV 132 col. printer + serial interface card £400, or complete system £1,200. Tel: Coleshill 62875 (STD 0675).

**Video Genie...** Latest model with tab keys and VU meter, sound fitted, with documentation. Perfect condition, also commercial software retail value £120. Plus own software. Bargain, both for £300. Tel (0248) 712177.

**32K PET COMPUTER...** new ROM, large keyboard, cassette with sound and tapecontrol. Soundbox, toolkit, superchip. Games inc: microchess, invaders, acrobat, 3-D startrek, nightdrive and many others. Quick sale £495. Bracknell (0344) 51024.

**TRS-80 16k L2...** 5 months old, immaculate cond. With: Sargon, Temple of Asphai + more software, £340. Tel: 0922 30283 (after 5).

**ZX80...** 1k, factory built, all leads, PSU, manual, Tim Hartnell book. £60 ono. Tel: 01-360 8020 eves. to view London N21.

**For sale...** PET 2001, 8k old ROM, good cond, games programmes, £300. Telephone Wentworth 2181.

**Tangerine Microtan 65...** Latest Tandbug, chunky graphics Tanex with 10K Basic, XBug, 8k RAM. 12 slot motherboard keyboard, PSU £300 ono. Tel: 01-223 4496 between 10 to 12am Saturdays.

**Sharp MZ-80k 48k...** 6 months old, £100 worth of programs inc. machine language, space invaders, star trek and many other programs. Also dust cover. £530. Phone David (0702) 612921.

**ZX80...** As new with 16k RAM. Exc cond, PSU etc, lots of software, 2 exc. books - 30 progs for ZX80 + making most of ZX80, also tapes with games. All for £100. Tel: Clevedon 877523.

**TRS-80 Model II...** 16k complete system - VDU. CTR-80 cassette, keyboard with numeric keypad, latest ROM - keyboard needs no de-bouncing. Stacks of software: Invaders, Adventure, etc. Still under guarantee. £490. Tel: (0508) 470589 (Norfolk)

**Acorn Atom...** 12k+12k, leads, manual, 6522, colour board, power supply, many programs £250 ono. Tel: (0533) 712614 after 4.30pm.

**Nascom 1...** with NAS-SYS 1, 5 amp PSU, dual monitor board, blank EPROM and 2 cassettes of programs. All documentation £120. Also Casio fx501p and FA-I £50. Tel: Wargrave 4493.

**UK101 8k...** cased, new EPROM monitor, high speed cassette interface switchable 300/600/2400/4800 baud. RS232 printer interface with cables. Extended monitor, plus cassette player, over 30 professional games inc space invaders, real time startrek, £350 ono. Tel Brighthouse (0484) 717974, can deliver within reason.

**ZX81...** 1 1/2 months old, games tape, manual, leads for 1/recorder, PSU, any offers over £55 (inc p&p) tel: Bradford 566221 after 4.

**PET 32k...** large keyboard, external cassette recorder, toolkit, speaker, many progs (inc invader and microchess) documentation and original box etc. £500. Tel: William 01-550 4350 (buyer collects).

**Acorn Atom...** 12k ROM, 8k RAM, inc floating point ROM, power supply, all leads and documentation. Cassette recorder inc. £300 ono. Tel: Stonehouse 791940. Lanarkshire, Scotland.

**Video Genie...** perfect condition, new type keys, 16k RAM, 8 months old, inc: manuals, leads, some books, software inc - Adventures, Flying Saucers, Asteroids. Total cost new £440 sell £280. Phone: 053 718738.

**PET 8032 + 8050 + Epson MX80...** with Aculab PET interface + cassette + toolkit + cables + manuals etc. Mint cond, hardly used. Cost over £2,500, will accept £2150 ono. Chris Lawless. Tel: 01-903 1333 (work), 0442 40953 (home).

**TVI 921 video...** 24x80, character display, upper and lower case, numeric pad, with editing and formatting, RS232 interface, maintenance and operation handbooks. £330. 01-908 0501 eve Mon-Fri.

**TRS-80...** Model I, 48k, one disk, lower case, green screen, all Tandy's and few months old, £1000, but will add tons of software: Newdos/80, Scriptsit, Sargon, Edtasm etc. Tel: 06755 2745.

**4k UK101...** cased, very good cond. 3 monitors (wemon, compshot + exmon). Fully documented with PSU and some software. Worth £240 - sell for £190 ono. Tel: Wrexham 364188.

**ZX81...** 16K RAM, exc cond. Don't wait 6-8wks - have it now. Leads, manual, PSU, games cassette. A snip at £120. Tel: 01-607 3325 (w/ends only).

**ITT 2020...** 48k disk drive, D/S 232k and large quantity of software for sale. Computer £500, disk £375. 01-249 9895.

**Mk 14...** issue 5, revised monitor, psu, external keyboard, extra literature, £20. Tel: Belfast 671734.

**PET 32k...** model 2001, small keyboard, integral cassette manual plus some games, offers. Tel: 01-866 2532.

**A Centronic VCS...** with 14 cartridges, inc programmable cartridge turning the unit into a full computer, cost £280, will sell £150 ono. Phone 0329 42654.

**Sharp PC-1211...** pocket computer, 9 months old, cost £94, sell for £70, as supplied with 2yr guarantee, except box. David Leigh, 21 Broadmead, Parbold (02576) 3661 after 6.

**ZX80...** complete, Sinc built, in good working order, manual, all leads, and adaptor, £60 ono. Tel: 021-308 0851 L Hands.

**PET 8k...** old ROMs, integral cassette deck, recently serviced by Commodore agents, immaculate order with tapes, games, RAM test etc. Reluctantly accept first £315 ono. Chester 675717 most evenings.

**Bargain Price Computing...** Open University microprocessor £60, Sinc ZX80 computer £40, each complete with operating manuals and hardly ever used, will negotiate. Tel: Evenings, Ruislip 73455.

**Acorn Atom...** 12k + 12k, PSU, all leads, books, software, games, etc, Acorn built, 6 months old. Atom Club new-sheets, programs, etc, £235. Tel: Littlehampton 21676 eve & w/ends.

**TI-58...** calculator & PC100A printer, inc extra programs & leisure module, £120, or swap with Printer/ZX81 or ZX81 16k memory unit, S Gimblett, 79 Calderwood Crescent, Gateshead, Tyne & Wear.

**Pet 2001 32k...** (8k with expansion), getting married, therefore only £450 ono. Complete with invaders, PET revealed, monitor etc. Tel: Coventry (0203) 412141 after 5.

**Olivetti P652...** 4k RAM, plus 600 X-Y plotter, both in good working order, manuals, some software, numerous mag cards & printer rolls, £100 ono. Tel: 0282 867289

**Olivetti P652...** 4k RAM, + 600 X-Y plotter, both in good working order, manuals, some software, numerous mag. cards & printer rolls, £100 ono. Tel: 0282-867289 (Colne, Lans).

**UK101...** 24k, cased, Cegmon, toolkit & extended monitor in EPROM, 300/600 baud switchable + 4800 baud card, 48x32 screen, loads of software, £450 ono. Tel: 01- 950 6936.

**TRS-80 L2...** progs, approx 50 on tape, £25 ono, inc Space Invaders, some space games: 2 books of Basic games (approx 200), £7 ono; TRS-80 graphics, £1 ono. Buyer collects. Tel Adam, Northwood 27733.

**Centronics Microprinter P1...** inc 5 rolls paper, £175 (£170 you collect). Tel 068-45 4930 eve/w/ends.

**TRS-80 16k Level 2...** with lower case mod, green screen monitor, cass recorder and manual, 10 months old, very little used, £370. Tel: 01-778 8835.

**8k PET...** 24k expandamem, new Rom, external keyboard, toolkit, £450. Computink 400k dual disk drive, £450. Free with the above system over 300 PET programs. Phone 01-894 7149.

**UK101...** 8k, boxed, orig monitor, inc tapes, books, lots of magazines & electric typewriter, £300 ono. Tel: Newmarket 3185.

**PET 8k...** internal cassette, sound, software (16 cassettes) inc chess, invaders, acrobat, breakout, assemblers, etc, best offer, will also swap, phone Jeff Leighton Buzzard 384874 eve.

**Tangerine...** 8k RAM, 1/case, graphics, psu, ASCII keyboard, 10k Basic in Eprom, all in case, with full documentation, only 5 months old, accept £220. Tel Southend 545676.

**Casio fx502p...** library, manuals, overlays, wallet, December 1980, used but not exhausted, £50 ono. Tel: 01-947 1527.

**Videomaster...** Star Chess (boxed), galaxy invader + Binatone TV game (not boxed), all for £70 or exchange all for ZX80 (new ROM) or ZX81. Tel: Swansea (0792) 795391 after 6.

# TRANSACTION FILE

T158. . . Prog calc plus case, mains adaptor/charger, and manual, £30. Tel: (Hull) 0482 801428.

HP-41C. . . with battery pack, battery charger, 2 memory modules, games and maths packs, all perfect cond. with manuals, cost £250, accept £160 ono. Tel: 01-806 4831.

ZX81. . . plus 16k RAM, psu, leads and manual, many progs, only 2 months old, hardly used, £105 ono. Tel: Derby (0332) 752567.

Acorn Atom. . . 12k + 12k, superb cond, inc manual, mains adaptor, tapes (Invaders, Asteroids etc), UHF lead, load/save lead, boxed, £235 tel: Richard, Torquay 06332.

PET 3032. . . computer (32k, large keyboard), disk drive 3040 (343k) each, £500 ono. Cables, manuals and cassette supplied. Tel: Aldershot (0252) 317943 9am to 5pm or Leatherhead (03723) 79304 after 6.

Sinc ZX80. . . 6 months old, 1k RAM, ex cond, Sinc built, with adaptor and ZX80 manual, £55. Tel: Leatherhead 77073 eve or w/ends.

Tangerine. . . Microtan 65, latest Tanbug, graphics, keyboard, MPSI power supply with ± 12 volts, as new, £100. Watson, Tel: 01-903 4363.

32k pet 3032. . . CBM 3040 disk drive, CBM 3022 printer, C2N cassette deck, £1800 (or will split), plus a number of software packages. Tel: 07744 51425 (Lancs)

32k Sorcerer. . . all manuals, 2 motor-controlled cassette-cables/modem connection, working cassette, 3 adventures, Startrek, Space Invaders + various s/wre, £500 ono. Also Casio fx502p prog calc, case, full cond, £50 ono. All VGC 01-670 1828.

PET 2001. . . 8k integral cassette deck, calculator keyboard + documentation, etc, £300. For quick sale. Slough 77695 eve/w-ends.

TRS-80 L2 16k. . . VDU, cassette, manual & pro aid, software, Basic programming, Asteroid, attack force, etc, about £400. Tel: Floyd 01-802 1280, eve only.

Acorn Atom. . . 12k + 12k, power supply, lots of software, £210. James Morecroft, 01-789 9964.

Sharp MZ-80k (48k). . . 6 months old, + toolkit and assembler, manuals, large selection of games and programs, £450 ono, may deliver. Brighton (0273) 606876.

TRS-80 L2 16k. . . with c/recorder. VDU, power supply, manuals, cassettes with games and many other programs, like new condition Tel: Mon-Fri, 8-6 Winsford (06065) 3424 ask for Pollock.

Teletype KSR33. . . with floor stand etc in good cond. & full working order, £120 ono. Also KSR35 (very silent) in perfect cond, £200 ono. Contact J Harmer (0532) 502954 after 7.

ZX81. . . with Sinclair 16k RAM pack, Sinclair built, hardly used, inc all leads, PSU and manual, £100. Tel: Wylam (Northumberland) 06614 3629 after 5.

32k PET. . . Toolkit, Superchip, Picchip, many games on cassette, magazines (PCW, CT), mint cond, also desk, £620 ONO. 7 Barton St, Bath, Avon. Tel: Bath 66850 after 6-30.

PET 32k. . . 4016 professionally updated to 32k with cassette and dozens of tapes, as new with green screen and dust cover, £600. TX80 printer with IEEE card £280, 0442 41826.

Apple II + 48k. . . 2 disk drives with controller, Dos 3.3. System is unused and complete with all manuals and books, some disk software included ie editor assembler, games. £1325, May split. Tel: 01-450 5049 (eve)

ZX80. . . with 16k RAM, Sinc built, as new, cassette of games, 3 books on ZX80, vgc very good buy, £95. Tel: Brighton 415371 (eve).

ZX81. . . 16k RAM, complete, Sinc built, manual, 2 Sinc cassettes, £110. Phone 01-202 7203 eve or w/ends.

Structural engineering. . . s/ware for PET, top quality progs on cassette, for sale due to upgrade: Keypack -1, Analysis of rigidly jointed plane frames, Keypack -2: analysis of pin jointed plane frames, cost £600, bargain at £300 or £150 ea. Tel: 0752 51258 after 6.

Video Genie 16k. . . latest model, 8 colour board (fully software compatible), fitted by Lowe, exc cond, games & utility software, bargain at £270. Tel: 0272-603252.

ZX81. . . complete with mains adaptor, leads, manual and games tape, £68. Tel: Bishops Stortford (0279) 722098.

TRS80. . . 16k L2, boxed, perfect cond, hardly used, plus manuals, cover, games, level 2 course cassette, £325, buyer collects. Tel: Calne (0249) 813526 after 6.

UK101. . . cased, 12k RAM, Mono2, Cegmon, 300/600 baud, new power supply/transformer, fan, expansion board has room for additional 4k + 8k EPROM, new Ba53, £300 ono. Tel: Bromsgrove 71201.

ZX80. . . 1k, PSU, leads, manual, users club mags and cassette recorder, £60. Tel: Maidstone 76461 (day). Snodland 242-235 Mr Jefferys.

Video Genie 16k RAM. . . new version (eg 3003), 4 months old, as new, inc sound, joysticks, £150, worth games, dustcover, television, £400 ono. Tel: Leicester 866265.

Video Genie. . . contrl keys, sound, boxed with Edtasm, ZBug, zchess, pirate, apshai, trek, mags PCW, CT, PC, fow missing, TSR books, £310. Mr E Bamber, 206 Brook St, Preston

VDU. . . 80x24, separate numeric pad, RS232 C & C/loop, 2 page memory with scroll, loads of features, was £700 new, hardly used. C/W circuits, manual, spare CRT, £200 ono. Phone 0442-43659.

Video Genie. . . latest model, sound, manuals, £375 of progs you may wait forever for a bargain like this, £450. Tel: Hastings (0424) 427698.

Intel 8086. . . MPU + datasheet (x10), bought too many from USA supplier now must sell at loss as payment is due, will sell for £69 inc p+p, contact: Jonathan, tel: 01-223 7283.

48k Apple II. . . with disk drive + 3.3 controller, additional disk drive & B/W TV Mod £1295 inc spare disks. Centronic 737-2 printer + interface card £470

inc cable & paper. Tel Brian Cranwell, Sheffield 754322 day or 662746 eve.

Acorn 8k static. . . RAM board with 2 sockets for 4k ROMs, fully buffered with 64 pin plug, £80 ono. Tel: Todmorden (070 681) 4961.

HP41-C. . . calculator complete with 3 memory modules all in perfect cond, £227 value, yours for £145. Tel: 01-235 7010 ext 372 office hrs.

FX502P. . . perfect working order, in orig box with wallet, overlay and manuals, also several programs using novel display techniques inc Mastermind & Fighter Pilot, offers around £50 to: 061 761 5654.

Acorn Atom. . . 12k RAM, 8k ROM, PSU, leads and manual perfect working order, £179. Phone Poole 85180 eve or weekends.

ZX80. . . 16k RAM pack, Sinc built, leads, PSU, manual, two 5 program tapes & book, good cond, all worth £170. Sell for £100 ono. Tel: Bradford (0274) 594536 after 5.

Casio fx501P. . . prog calc, 128 program steps, 11 non-volatile memories, complete with manual and program library, £40 ono. Tel: (0803) 844229.

CBM 3032. . . Toolkit, Tensai deck with counter and sound, dustcover, books £525. PET 2008, Dustcover, books £275. Tel: 047483 493 S W Wiltshire.

Acorn Atom. . . 8k RAM, 8k ROM, new Acorn 8k RAM/ROM card, buffers, connectors, 3A PSU, new keyboard, £200/ offers, Stevens, Burnham-on-Sea (0278) 785504.

PET 4008. . . with manuals, Invaders, Jailbreak, Cosmiads, perfect cond, £395. Ring (0792) 781370.

ZX80. . . Making the Most of your ZX80 Linsac/Bug Byte cassettes, incompatible with my ZX81! (blush): 01-274 3205 after 5 w/days anytime w/ends, C Andrew, 19 Burbage Road, London SE24 9HJ.

ZX81. . . programmable character generator built & cased, £35, Repeating key module, £2.50, 3k memory expansion £15, (these would also work on ZX80) K Purkiss, 4 Asby Rd, Asby, Worthington, CA14 4RR.

Centronics. . . interface for PET and Toolkit to fit old 8k PET (mounted on separate PLB). D Johnston, 12 Balgillo Rd, Broughty Ferry, Dundee DD5 3LU.

IBM 3982. . . recond golfball printer, ex cond, inc Aculab 735p parallel interface, 3 golfballs & spare ribbons, need dot matrix for business, £500 ono. Tel Steward, 0642 315123 (home) 243370 (work)

Microtan 65. . . built to Micron standards, Tanex Basic in EPROM. Xbug, lower case, graphics, PSU, in superb case, Tangerine ASCII keyboard and case, hex keypad, manuals and many games and tapes inc. space invaders with sound effects, exc cond, £275 ono. Phone 0253 591805.

ZX81+16k RAM. . . Sinc built, 4 books, 2 tapes of software, executive carrying case, £140 ono. Also Videomaster Starchess TV game, hardly used, £40 ono. Contact David on 01-478 5249 after 21 Sept.

Nascom 2. . . 32k RAM, professionally built & boxed, Naspen, Zeap assembler, graphics ROM, revas disassembler (cassette), inc, tape recorder and games software, £450. View in Oxford or London. Tel Paul Hoggett, Oxford (0865) 727375 (work).

TRS80 4k LI. . . CPU, £190. Tel: Bath (0225) 310688.

Acorn Atom. . . 12k + 12k, inc PSU, leads & manual, software inc Invaders, Acornsoft packs 1, 3 & 4, plus lots more (inc books), £250 ono. Tel: 01-431 1493 (after 6.00), 01-435 0431 (8-5)

UK101. . . Wemon monitor for sale due to upgrading to 32x48 display, £16. Tel: Sedgley 74804.

Nascom 2. . . 32k RAM 4MHz no waits, Nas Sys 3, Zeap 2/ EPROM, Nas-Dis Debug/tape, Bits & PCs toolkit/EPROM, chess & space invaders, castle int, port probe, 3 D/N vero rack & case, fan, etc, £690 ono. Tel (0983) 402549.

HP67. . . programmable with maths and games packs, spare battery pack, etc, original cost over £300, £150 or part exchange for micro computr. 07554 2343 office hours.

Compukit UK101. . . ready built, cased, 8k RAM, new Wemon monitor, also manual, all leads, software inc sea battle, asteroid runner, also cassette recorder with tape counter, £220. Phone Buckingham 3796.

ZX81. . . Sinc built, inc PSU and manual plus cassette recorder, only £65. Phone (0706) 226907 eve (Lancs)

Casio fx502p. . . very good cond, manuals and extra programs, £60 ono. Tel: 0487 812812.

Sharp PC1211. . . with manuals overlays, cassette interface, accept £80. Also HP29C prog calc, continuous memory, 99 steps, 30 memories, manuals, accept £40. Martin Stabb, Tel Bristol 392428 423957w.

Video Genie 16k. . . extra keys ample socket, hardly used, + 12" portable TV, plus a fortune in programs, all for £275. Tel 01-904 8512, eve.

Vido Genie. . . 6 months old, as new in orig box, manuals, books, some programs inc space invaders and other games, £275. Tel: didcot 814656 after 6 or w/ends.

PET 8k. . . old ROMs, integral cassette, with the PET/CBM Guide +32 prog, £350. Tel: Dursley (Glos) 3532.

ZX81. . . Sinc built, all leads, manual, adaptor, and packaging, as new, £60 ono. Tel: Maidstone 51499 (eves)

## Wanted

Nascom computer, if possible with some expansion, anyone want to sell for around £160? contact David, 01-478 5249 after 21 Sept.

Superbrain (CP/M). . . programs wanted: games/business/programming, etc, anything to assist a newcomer to computing. 51 Burgess Rd, Bassett, Southampton SO1 7AP.

16k RAM. . . pack for ZX81. Tel 0795 521280 pm/w/ends.

Will pay. . . immediate cash for a neat metal cabinet with S100 motherboard and power supply, Z80 CPU, RAM and disk controller. Mr Back, Walton-on-Thames 44825, eve.

TCL Pascal. . . programs for CBM3032. Anyone interested in exchanging programs/games? Write: John Douglass, Gimmenenstr 1, CH6300, Zug, Switzerland.

Wanted. . . handbook circuits etc for ICL 7181 VDU. Buy or loan against deposit. Have several for sale. Mr Adamson, Woodend, Victoria Rd, Kingsdown, Deal, Kent. Tel: Deal 03045 3788.



# USER GROUPS INDEX

Once again, here is a revised listing of user groups and clubs. The next full listing will appear in March with updates in the issues between. Send entries to: 'USER GROUPS', Personal Computer World, 14, RATHBONE PLACE, LONDON W1P 1DE.

## INTERNATIONAL

**Apple Users Group Europe.** President: K Giese, Hackstucker 11, D-4320 Hattingen 15, West Germany. Tel 02324 52240.

**CP/M. IRL. Irish CP/M Users' Group.** Meets monthly in Dublin area, membership IR £5 pa. Newsletter: CP/M.MAG. Contact: Doug Notley, Gardner House, Ballsbridge, Dublin 4, tel: 01-686411.

**DENSPEP:** group specifically for exchange or original programs for MTU 200x320 dot matrix hi-res PET add-on. Send sample of your work or £2.50 (\$2.50) & receive sample in return plus newsletter sub & lists of available programs. Contact: DENSPEP, Rock House, Ballycrooy, Westport, Co Mayo, Eire.

**DAInamic:** European DAI personal computer users' club. Has over 500 members, publishes a bi-monthly newsletter with most articles in English. Contact: DAIInamic, Heide 98, 3171 Westmeerbeek, Belgium.

**Microcomputer Users Club:** recently established for program writing and exchange, emphasis on 6502/Z80 users. Contact c/o Synthetronics Microcomputers PO Box 151, 1322 Hoevik Norway.

**KAOS** — the official 6502 users' group of Australia. Has a range of projects within special interest groups: hardware, software, amateur radio, Pascal, education. Publishes monthly newsletter. Contact: Mr Ian Eyles, 10 Forbes St, Essendon, Victoria, Australia 3040.

**Group/380.** Recently established for information interchange on microsystems equivalent to IBM 360/370 main frames, newsletter, access to a computerised database listing relevant software. Annual sub: \$10 for individuals, \$25 for organisations. Contact: Mokurai Cherlin, PO Box 1131, Mount Shasta, CA96067, USA.

**Ithaca Intersystems and S100 Bus Users' Club.** Formed to 'organise the construction and design of software and hardware based on Ithaca or other S100 systems.' Contact: George Brooke, Sebastian Baverstrasse 20c, 8000 Munich 83, W Germany.

## NATIONAL

**6502 User's Club.** Holds regular meetings and welcomes new members. Contact: Walter Wallenborn, 21 Argyll Avenue, Luton, Beds or Joe Manifold, 16 Bunyan Close, Pirton, Hitchin, Herts.

**9900 Users Group.** Contact Chris Cadogan, Dept. Computer Science, University of Manchester, Manchester M13 9PL.

**Amateur Computer Club.** National organisation with seminars, local group meetings. Bi-monthly newsletter 'ACCUMULATOR'. 6800, Z-80, and 2650 libraries. Founded 1972. Fee £4.50 SAE Jim McDonald, 1 Carlton Court, Studley Grange Road, London, W7 2LU.

**Amateur Computer Club, 2650 Library.** 2650 related data and technical assistance only. No meetings, no newsletter. Contact Roger A Munt, 51 Beechwood Drive, Feniscowles, Blackburn, Lancs. BB2 5AT (0254 22341).

**Apple Music Synthesis Group.** Interested in ALF, Mountain Hardware, Alpha Syntauri and Soundchaser systems. Contact: Dr David Ellis, 22 Lennox Gardens, London SW1 enclosing an SAE.

**Atom User Group.** Quarterly newsletter, software library, technical help when possible. Some local groups. Membership £4 pa including newsletter. Contact Richard Meredith, Sheerwater, Yealm View Road, Newton Ferrers, S Devon, PL18 1AN.

**BASUG** — British Apple Systems User Group. Now incorporates the UK Apple User Group. Caters for all current and prospective Apple/ITT 2020 users. Publishes magazine called Hard Core, meets fortnightly at Park Street, just south of St Albans. Contact: Martin Perry, BASUG, PO Box 174, Watford WD2 6NF.

**Commodore Pet Users Group** publishes a monthly magazine — the official voice of Commodore. For membership details contact Margaret Gulliford on Slough 74111.

**Compucolor II User Group (UK).** Quarterly newsletter: Hardware and software advice: Program library and exchange; links with other CCI national groups. Contact: Bill Donkin, 19 Harwood Avenue, Bromley, Kent 01-460 2626 (eve).

**CP/M Users' Group (UK).** Annual sub £6. S/ware library, newsletters, meetings, 'help' service. Contact: 11 Sun Street, Finsbury Square, London EC2M 2PS, tel: 01-247 0691.

**EZUG: Educational ZX80/1 Users' Group.** Annual sub £2.50 (UK), £3 (rest of Europe), £6/£12 elsewhere. Bimonthly newsletter. Large SAE for sample newsletter (UK & Eire only). Contact: Eric Deeson, Highgate School, Balsall Heath Rd, Highgate, Birmingham B12 9DS

**FX500-P Users Association.** For Casio FX501-P & FX502-P users to communicate with each other and to work together. SAE to Max Francis, 38 Grymsdyke, Gt. Missenden, Bucks HP16 0LP.

**Ithaca Audio S-100 bus UK User Group.** Contact: Dave Weaver, 16 Etive Place, Bumbernauld, Glasgow. G67 4JE. Phone 02867 36570.

**MUSE** is an organisation for co-ordinating activity in schools and colleges. Meetings are held regionally and nationally. Full details from Muse, Freeport, Bromsgrove, Worcs B61 0JT.

**National Acorn Atom User Group.** Publishes monthly program magazine. For free copy and club details send large SAE (15½p) to Alan Carr, 105 Fairhole Avenue, Gidea Park, Romford, Essex.

**National RML User Group, c/o RML Ltd.,** PO Box 75, Oxford.

**National TRS-80 Users' Group.** Activities include a computerised bulletin board service (see 'Network News'). Contact: Brian Pain, National TRS-80 UG, 40A High Street, Stony Stratford, Milton Keynes, tel (0908) 566660 (office) 564271 (home).

**National ZX80 and ZX81 Users Club.** Publishes monthly magazine *Interface*. For free copy and club details send a large SAE (15½p) to 44-46 Earls Court Road, London W8 6EJ.

**Sharp PC-1211 Users Club for all PC-1211/TRS-80 Pocket Computer users.** Membership of £5 pa, includes newsletter containing programs etc. Contact: Johnathan Dakeyne, 281 Lidgett Lane, Leeds LS17 6PD.

**Sharp MZ-80 Users Club.** Free membership: Extensive library and facilities. Details on meetings & Newsletters (SAE please) from: Paul Chappell, Computer Centre, Yeovil College, Yeovil, Somerset. BA21 4AE.

**Sharp MZ-80k User Group.** Contact: Joe LP Seet, 16 Elmhurst Drive, Hornchurch, Essex RM11 1PE. Tel: 04024 42905.

**Sharp MZ-80K user group (and shortly PC3201/00 and 80B)** £3 per annum for three news letters. Send cheque/POs tips, articles and sales to Mr R Erdine, 271 Meadow Rd, Sheffield S8 7UN

**TI 99/4 Users Group** — TIHOME offers access to a software library and sends out a monthly newsletter. Contact: P M Dicks, 157 Bishopsford Road, Morden, Surrey.

**Transducer.** The club for those interested in robotics, micro's and micro hardware. Send 25p to D Stockqueler 66 Waterloo Rd, Penylan, Cardiff for sample newsletter and details.

**Tangerine Users Group (TUG),** 16 Iddesleigh Rd, Charminstre, Bournemouth, Dorset BH3 7JR. Tel: 0202 294393.

**TRS-80 Level 1 User Group.** Software library and quality newsletter (write for details and free copy), £5.00 pa. N Rushton (LIUG), 123 Roughwood Drive, Northwood, Kirkby, Merseyside L33 9UG.

**TRS-80 Medical & Laboratory Users Newsletter.** Free quarterly newsletter detailing interests, programs & applications. Send SAE & details of interests to: Dr N Robinson, The Residency, Northwick Park Hospital, Harrow, Middx.

**UK101/Superboard User Group (Computer User Aids).** Newsletter, software library and technical service. Membership £4.60 inc VAT per 6 months — £5.00 overseas. Apply to Adrian Waters, 9 Moss Lane, Romford, Essex — Romford 64954.

**UK Intel MDS Users Group.** Contact: Lewis Hard, Space Intelligence, The Old Coach House, Court Row, Upton Upon Severn, Worcestershire. WR8 0NS.

**UK Pilot Users Group** — SAE for fact sheet on Pilot versions available **Common Pilot Reference Manual** £5. Contact: Alec Wood, Wirral Grammar School for boys, Cross Lane, Bebington, Wirral, Merseyside L63 8AQ.

**National T158/9 Club:** bi-monthly newsletter, program exchange etc. Annual sub £5.50 or, if you include a program with your cheque then it's £3.50. Contact: R M Murphy, Dept. of Electronic Engineering, University College Swansea, S. Wales.

**CP/M Users' Group (UK).** Annual sub £5. S/ware library, newsletter, 'help' service. Contact: 11 Sun St, Finsbury Sq, London EC2M 22D.

**British Apple Systems User Group** For Apple II and ITT 2020 users. Meets 1st Tues eve & 3rd Sun afternoons monthly at The Old School, Branch Rd, Park St, St. Albans (on A5 about 2 miles south of city centre). Contact: John Sharp, Garston (09273) 75093 or David Bolton, Park Street (0727) 72917.

**Mk 14 Club.** Bi-monthly magazine called 'Complement and Add'. Contact: Geoff Phillips, 8 Podsford Rd, London NW9 6HP.

**Independent PET users Group** Contact: IPUG, 57 Clough Hall Rd, Kidsgrave, Stoke-on-Trent. Staffs.

**UK Apple Users Group.** Contact (Keen Computers) 5 The Poultry, Nottingham. Tel: 0602 583254/5/6.

**Cosmac Users Club (proposed).** For people using the RCA 1802, Cosmac ELF, ELFI, Super ELF etc. Those interested contact James Cunningham at 7 Harrowden Court, Harrowden Road, Luton LU2 0SR (enclosed sae, please).

**Ohio Scientific UK User Group.** Independent of OSI, an important role will be the disentangling of poor documentation. There will be regular newsletters and membership is at present £5 per year. The group will initially be concerned with the practical aspects and applications of OSI systems — rather than with games. Contact Tom Graves at: 19a West End, Somerset, BA16 0LQ.

**Compukit User Club.** Details, contact P. Crabb Esq., 21 Jones Close, Yatton, Avon (0934 834808).

**77/68 Users Group.** Quarterly Newsletter. Free membership for 1st year if you buy the 77/68 instruction manual, £1.50 thereafter. Contact: Newbury Computing Store, 40 Bartholomew St, Newbury, Berkshire.

**Compukit User Club.** Details contact S H Grisenor Esq., 11 Bernard Rd, Oldbury, Warley, West Midlands (021-422 3298)

**11s Users Group.** A sort of help service only. No meetings, no newsletter. Contact: Pete Harris, 119 Carpenter Way, Potters Bar, Herts, EN6 5QB. Tel: 0707 52091 or 01-248 8000 ext 7065.

**ZX80/81 National Software Association.** Annual sub £6, incs cassette of software. Bimonthly newsletter, software available on cassette. Send SAE for details. Contact: 15 Woodlands Rd, Wombourne, Staffs WV5 0JZ.

**Educational Users' Group for TRS-80 & Video Genie.** Offshoot of Nat TRS-80 UG, other TRS-80/Video Genie users welcome. Contact: D J Fatcher, Head Teacher Beaconsfield First & Middle School, Beaconsfield Rd, Southall, Middx.

## REGIONAL

**Central Scotland Computer Club.** Meets the first and third Thursdays each month in Falkirk College of Technology, Grange-mouth Road, Falkirk. Secretary, J Lyon, 78 Slamannan Rd, Falkirk, FK1 5NF 22430.

**East Anglian Computer Users' Group.** Meets: Crane Community Centre, Telegraph Lane East, Norwich. Contact: Gill Rijzl, 88 St Benedict's St, Norwich NR2 4AB, tel: (0603) 29652.

**Grampian Amateur Computer Society.** Meets 2nd Monday every month. New premises are in Thistle Lane, Aberdeen. Contact Alan Hird, 20 Harcourt Road, Aberdeen, Tel: 90224) 33102.

**IPUG South East.** Meet 7.30 3rd & 4th Thursday. Charles Darwin School, Jail Lane, Biggin Hill. Bi-monthly newsletter. Contact: M Ryan, 164 Chesterfield Drive, Sevenoaks. Tel: (0732) 53530.

**MACC (Midlands Amateur Computer Club)** meet every Friday evening 7.00pm onwards. . . no sub, no magazine. Contact: John or Roy Diamond Tel: Coventry (0203) 454061.

**Merseyside Nascom Users' Group.** Now independent, with 150 members. Meets 1st Mon monthly, 7.30pm at Mona Hotel, James Street, Liverpool. Contact: T Searle, 14 Hawkeshead Close, Maghull, Liverpool L31 9BT.



# NEW FROM SYBEX!

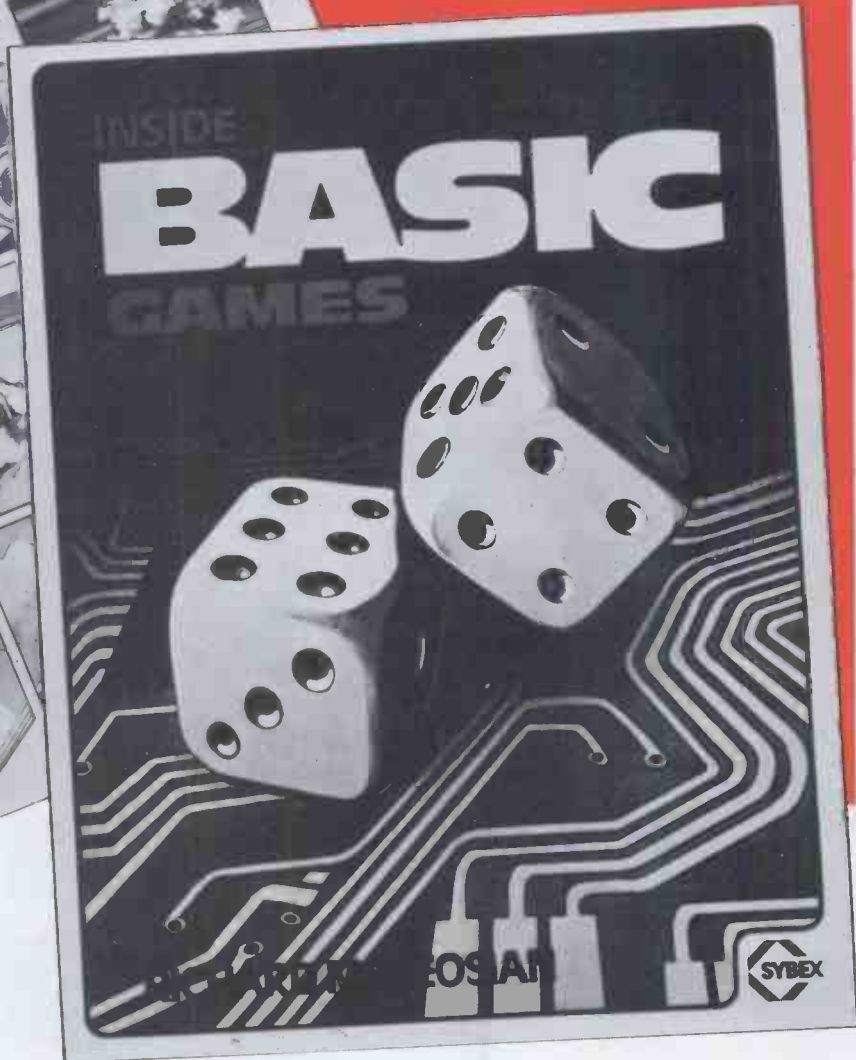
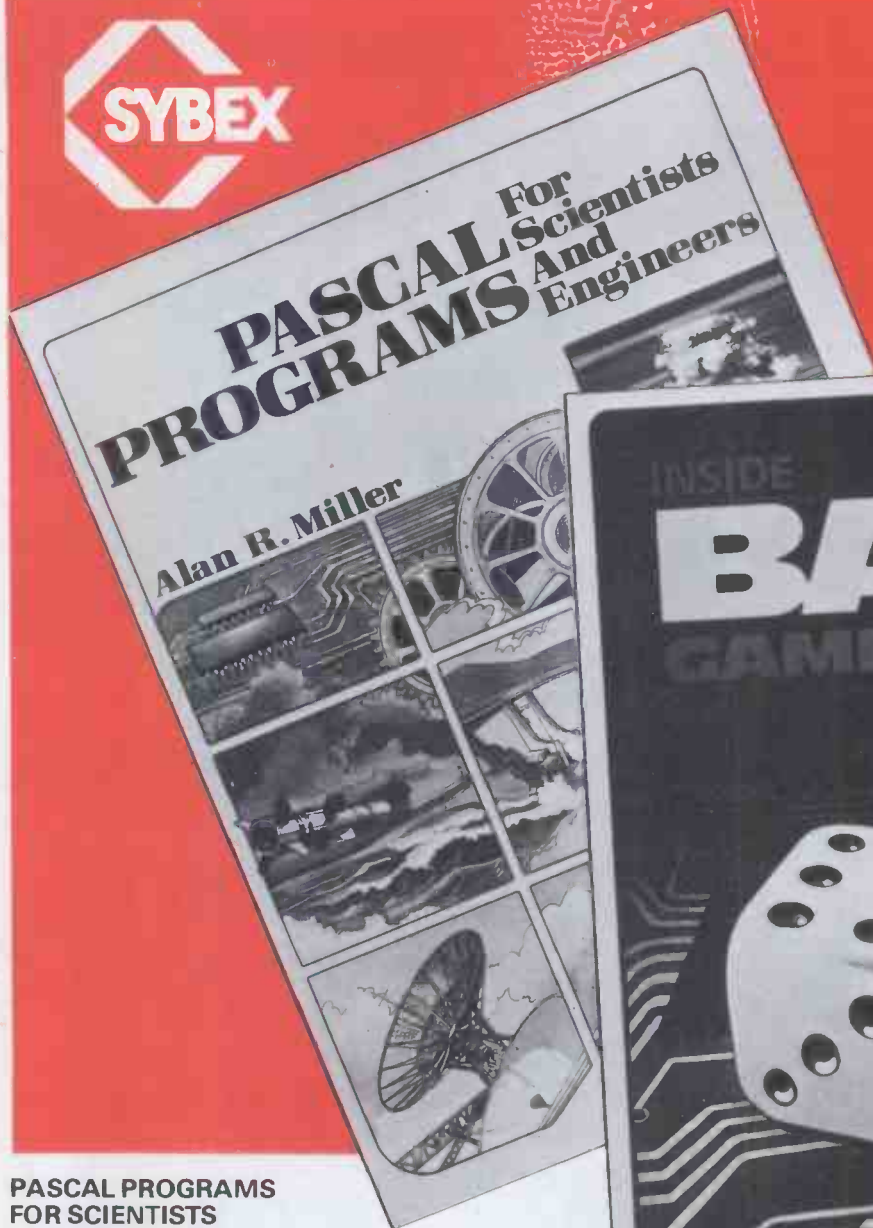

### PASCAL PROGRAMS FOR SCIENTISTS AND ENGINEERS

By Alan Miller

320 pages 120 illustrations

Price £12.70

### INSIDE BASIC GAMES

By Richard Mateosian

350 pages 120 illustrations

Price £10.85

### PASCAL PROGRAMS FOR SCIENTISTS & ENGINEERS

This book provides an immediately usable collection of Pascal programs for scientists and engineers. It contains over 60 of the most frequently used algorithms along with their program implementations in Pascal. Algorithms presented include curve fitting, vectors, matrices, approximations, random number generation and more.

Of major importance is the unique approach describing the pitfalls of writing scientific programs in current implementations of Pascal. The book provides programs to detect these pitfalls in any particular version of Pascal and explains general techniques for solving the problems once discovered. Specific hints for retaining accuracy in Pascal programs are included throughout.

### INSIDE BASIC GAMES

This book teaches you how to design error-free interactive BASIC programs including games and other "real-time" situations. Eight different kinds of computer games (a total of 14 games) are described in detail, then completely explained and analyzed in order to illustrate how the games were designed and developed in BASIC. All facets of game program design, including program structuring, cursor positioning, randomization and other concepts are discussed. Programs for games such as Hangman, Ten-Key Flicker and Taxman are coded in Microsoft BASIC and versions are provided for PET/CBM, APPLE II and TRS-80.

Get these invaluable books from your Local Bookshop or Micro Store - NOW!

In case of difficulty, send S.A.E. and we'll let you have the name of your nearest stockist.

The Computer Bookshop is the exclusive UK distributor for Sybex.

Dept. PCW

## The Computer Bookshop



30 Lincoln Road, Olton, Birmingham B27 6PA

# USER GROUPS INDEX

**DIRECT  
ACCESS**

Merseyside TRS-80/Video Genie Users' Group. Contact: Peter Tootill, 101 Swanside Rd, Liverpool L14 7NL, tel 051-220 9733.

Merseyside Microcomputer Group. Special interest groups: PET, Apple, 380Z, SC/MP. Education (Mr M Trotter, 051-652 1696). Contact: Fred Shaw, 14 Albany Avenue, Eccleston Park, Prescot, Merseyside L34 2QW tel: 051-426 5436.

TRS-80 - North West Group, (for 6 issues). Meetings last Wednesday monthly (not Dec) Contact: Melvyn D. Franklin, 40 Cowlees, Westthroughton, Bolton, BL5 3EG. Tel: 0942 812843.

380Z User Group Northern Home Counties: inc Herts, Cambs, Oxon. Contact: Sheridan Williams, 35 St Julian's Road, St Albans, Herts AL1 2AZ.

6502 User's Club (Southern Region). Welcomes all 6502 Users - Acorn, Aim, Apple, Atari, Atom, Kim, Microtan, PET, SYM, Superboard, UK101 etc. Regular Newsletter. Contact: Steve Cole, 70 Sydney Road, Gosport, Hants.

Northwest Computer Club. Fortnightly meetings 25p attendance fee. No subscriptions. Contact: John Lightfoot, 135 Ashton Drive, Frodsham, Warrington, Cheshire WA6 7PU. Tel: 0928-31519.

ACC (Merseyside 380Z Users Group). Contact: Alan Pope, Paal Enterprise, 37 Stuart Rd, Crosby, Liverpool L23 0QE.

Northeast PETs. Contact: Jim Cocalis, 20 Worcester Road, Newton Hall Estate, Durham. They meet the 2nd Monday of each month for software tuition and the 3rd Monday for hardware tuition (both in addition to normal activities). They start at 7.00 pm and meet in the PET Lab, Newcastle Polytechnic, Ellison Building, Newcastle upon Tyne.

A PET group is being formed on the Sussex/Surrey border, presently centered on Crawley & Horsham. Aims to meet monthly & produce a monthly newsletter. Contact: Richard Dyer, 33 Parham Rd, Ifield, Crawley RH11 0ET.

Southern Users of PETs Association, free membership, meet first Wed. each month, £1.50 for monthly newsletter. Contact 42 Compton Road, Brighton BN1 5AN.

North-East RML 380Z Users' Group. Meets monthly at Micro-Electronics Education Centre, The Polytechnic, Newcastle upon Tyne. Contact: M Hatfield or R Reed, Computer Unit, Northumberland Building, The Polytechnic, Newcastle-upon-Tyne NE1 8ST. Tel: 26002 ext. 268 office hours.

Manchester Computer Club (formerly the Amateur Computer Club (Northwest Group)). Meets 1st & 3rd Thursdays monthly at St Peter's Chaplaincy, Precinct Centre, Oxford Rd, Manchester. Contact: David Wade, 28 Hazel Rd, Altrincham, Cheshire WA14 1JL, tel 061-941 2486.

Anglia Computer User Group. Contact Jan Réjzl, 128 Templemere, Sprowston Rd, Norwich NR3 4EQ.

Pennine & District Computer Club. Open at both 26 and 51 Mill Hey, Haworth, W. Yorks. each Sat & Sun 10am to 10pm. Systems books, magazines, members shop. Contact: club at w/ends on Haworth 43007 or chairman, Douglas Bryant, on Bradford 569660.

Computer Education Society of Ireland. A voluntary organisation that consists of a national body and an expanding number of local branches. Their brief is to monitor computer education in Ireland. National CESI (£3pa) - Dairmuid McCarthy, 7 St Kevin's Pk.

Kilmacud, Blackrock, Co. Dublin. Cork branch (£1 extra) - Michael Moynihan, Colaiste an Spioraid Naomh, Bishopstown, Cork. Dublin branch (£1.50 extra) - Jim Walsh, CBS Naas, Co Kildare. Limerick branch (£1 extra) - Sr Lourda Keane, Convent FCJ, Laurel Hill, Limerick. Waterford branch (£1 extra) - Mr Hugh Dobbs, Newtown School, Waterford. Kilkenny branch (£1 extra) - Sr Helen Lenehan, Presentation Secondary School, Kilkenny.

Surrey Microprocessor Society. (SUMPS) Covering Surrey plus bits of South London and other adjacent counties. Anyone interested in joining, call Mike on 01-642 8362

Wirral Microcomputer Users' Group. Meets at Mons at Birkenhead Technical College. Contact: J Phillips, 14 Helton Close, Nocturum, Birkenhead, Merseyside L43 9HP. Tel 051-652 0268.

## COUNTY

Cornish Radio Amateur Club - Computer section meets on the second Monday of every month at the SWEB Social clubroom, Pool, Redruth. New members welcome - contact Bob Reason, 24 Mitchell Road, Camborne, Cornwall TR14 7JH.

South East Essex Computer Society, holds monthly informal computer evenings plus lectures. Open to anyone over 14. Contact R Knight at Southend-on-Sea 218456.

N Herts area CBM/PET/VIC users' group. Regular meetings, talks, affiliated to IPUG. Contact: P Moriboy 2 Spurr's Close, Hitchin, Herts SG4 9OE, tel: Hitchin (0462) 54435.

North Kent Amateur Computer Club. Meetings first Thursday of each month, usually in Biggin Hill. New members and visitors always welcome. Contact Barry Biddles (sec), Biggin Hill 71742.

PET Users' in West Lancs. Meetings on the third Thursday of each month at Arnold School, Blackpool. Contact: David W Jowett, 197 Victoria Road East, Thornton, Blackpool, FY5 3ST. Tel: Cleveleys 869108.

LPRINT is the newsletter of the East Midlands TRS-80/VG User Group. For a FREE sample copy send large SAE to: Mike Costello, 17 Langbank Avenue, Rise Park, Nottingham. NG5 5BH.

ACC (Merseyside 380Z and BBC Atom Users Group) Contact: Alan Pope, Paal Enterprise, 37 Stuart Road, Crosby, Liverpool L23 0QE.

Manchester area TRS-80 Users' Group Contact: Francis Glenister, 13 Pridmouth Road, Withington, Manchester M20 9GN, tel: 061-445 7191.

West Midlands Amateur CC. meet 2nd & 4th Tuesdays each month at Elmfield School, Love Lane, Stourbridge. Further details John Tracey, 100 Booth Close, Brierley Hill, West Mid. 0384 70097.

West Midlands RML User Group, c/o BECC, The Bordesley Centre, Camp Hill, Stratford Road, Birmingham B11 1AR.

South Yorkshire Personal Computing Group. Meets 7.30, second Wednesday each month. St George's Building, Mappin Street, Sheffield. Visitors always welcome. Contact: Paul Sanderson, 8 Vernon Road, Totley, Sheffield. Tel: 0742 351895.

Suffolk Microcomputer Club. Meets monthly, produces newsletter, sub £5 pa. Contact: Mr S Pratt, c/o Microtek, 15 Lower Brook St, Ipswich, Suffolk IP4 1AQ tel: 0473 50152.

Amateur Computer Club of North Staffordshire. Call or write to Mr M Turner (chairman) ACCNS, 542 Lightwood Rd, Lightwood, Stoke-on-Trent ST3 7EH (0782) 324639 eve.

Gwent Amateur Computer Club. Covering the Gwent and Cardiff areas, the club has its own computer room and technical library. Meetings are held once a week on Wednesdays at 10 Park Place, Newport. Contact Ian Hazell on 0633 277711 office hours.

Thames Valley Amateur Computer Club. Meetings 1st Tues monthly. From November on at the Southcote, Southcote Lane off the Bath Rd, Reading, Berks. Start 7.00pm. Contact Brian Quarm (Camberley 22186) or Brian Steer (Slough 20034)

Would anyone interested in setting up an Apple Users Group in the Bucks/Berks area contact: Steve Proffitt, tel 01-759 5511 ext 7298 day, or Marlow 73074 eve or w/ends.

The Leicestershire Personal Computer Club. Meetings held the 2nd Monday in each month, at Leicester University and Loughborough University alternately. They start 7pm. Membership is £2 per annum £1 for under 16s. Contact Ms Jill Olorenshaw (Club Secretary) c/o Arden Data Processing, Municipal Buildings, Charles Street, Leicester (0533 22255) OR Mr Dick Foden (club chairman) at 11 Gaddesby Lane, Rearsby, Leicester.

Lincolnshire Microprocessor Society. Various meeting places. For up-to-date information contact: Hon Sec. Mr Eric Booth, Senior Common Room, Bishop Grosseteste College, Newport, Lincoln.

MACRO (Medway Amateur Computer & Robotics Organisation). Meets monthly, sub £3. Contact: Ms Christine Webster, 13 Ladywood Rd, Cuxton, Rochester, Kent. Tel: 0634 78517.

Merseyside Microcomputer Group. Several sub-groups including: 380Z Users Group (Alan Pope on 051-924 2470); Computer Education Society (Mr M Trotter on 051-652 1596); SC/MP Special Interest Group (Bob Perrigo on 051-677 6716); PET Special Interest Group: 6800 and 77/68 Special Interest Group: Apple Special Interest Group: The secretary is John Stout of the Dept. of Architecture, Liverpool Polytechnic, 53 Victoria St, Liverpool L1 6EY (051-416 5536).

NE RML 380Z Users' Group. Meets monthly at MEC, Newcastle-upon-Tyne Polytechnic, Coach Lane Campus. Contact: M Hatfield or R Reed, tel: 26002 ext 268 (office hours)

North Lancs User Group, Contact John Robinson, 12 Harold Ave., Blackpool, Lancashire.

Oxford Microcomputer Club. £5.00 pa. Contact: S C Bird, 139 The Moors, Kidlington, Oxford OX5 2AF. Tel: Kidlington (08675) 6703.

Anyone interested in forming a Suffolk Computer Users' Club should contact Ian on Ipswich 831353 eve/w/ends.

South Shropshire: Ludlow & Dist Microcomputer Club. Meets 7.30 2nd Monday monthly at Diocesan Education Centre, Lower Galdeford, Ludlow. Contact: David Pauli. 32 High St, Leintwardine, Craven Arms, Shropshire, tel: 05473 287.

West Yorkshire Microcomputer Group. Formed following an inaugural meeting on Oct 23rd, a varied diary of events has been drawn up. For details contact the Chairman, Philip Clark, Care Computers Services, 15 Wellington St, Leeds LS1 4DL (0532 450667) OR the Secretary, Keith Knaggs, Price Waterhouse & Co., Leeds (0532 448741).

## TOWNS

Bedford Amateur Computer Club. Recently started, no further details as yet. Contact: Mr R Bird, 7a High Street, Great Barford, Bedford MK44 3LB, tel 0234 870763.

Bournemouth Area Computer Club. Meets monthly at the Kinson Community Centre. Contact: Peter Hills, 54 Runnymede Ave, Bournemouth, Dorset. BH11 9SE. Tel Northbourne 6547.

Brunel Computer Club: meets alternate Wednesdays, 1900-2200 hrs at St Werburgh's Community Centre. Contact: Mr R Sampson, 4 The Coots, Stockwood.

Bristol Computing Club. £4.00 pa. Meetings 3rd Wednesday monthly. Contact: Leo Wallis, 6 Kilbirnie Road, Bristol, BS14 0HY. Tel Bristol 832453

Cambridge Microcomputer Club. Meets 3rd Wednesday monthly at Portland Arms, Cambridge. Contact: Duncan Mackay, 4 High Street, Waterbeach, tel: 63137 (day).

Cheltenham Amateur Computer Club. Meetings 4th Wednesday monthly 7.30pm start. Contact: Mr M Pullin, 45 Merestone Drive, the Park, Cheltenham, GL50 2SU (Cheltenham 25617).

Derby & District Branch of IPUG meets monthly in Derby. For details contact Raymond Davies, 105 Normanton Road, Derby DE1 2GG. Tel (day) 41025 (eve) 514016.

Derby Microcomputer Society. Meets fortnightly at Derby Lonsdale College, Uttoxeter Road, Derby. Contact: Mike Riordan, 172 Blagreaves Lane, Littleover, Derby Tel (0332) 769440.

Exeter and District Amateur Computer Club. General meetings 2nd Tuesday monthly, specialist meetings 3rd or 4th Tuesday. £7.50 adults pa. Contact: Doug Bates, 2 Station Road, Pinhoe, Exeter, EX1 3SA.

Grimsby Computer Club. Meets fortnightly on Mondays at 7.30 pm. Contact: Jensen Lee, 29 Park View, Cleethorpes. Tel: 32559.

Harpenden Microcomputer Group - Informal meetings are held on alternate Monday evenings. Contact: David James, 5 Ox Lane, Harpenden, Herts. AL5 4HH. Tel: (05827) 5366 (eve).

Harrow Computer Group meets on alternate Wednesdays at 7pm in room G43 of Harrow College of Higher Education. Summer meetings in the 'Plough', Kenton. Contact B Butcher, 01-950 7068.

Hartlepool, Cleveland. Is anyone interested in starting a TRS-80 users group in this area? If so, please contact Ian Nicholson, 3 Thirk Grove, Hartlepool, Cleveland TS25 1LT.

IOW TRS-80 Users Club: Meets last Friday in every month at 7.30pm at the London Hotel, Ryde. Contact Mr M Collins, 11 Star Street, Ryde, Isle of Wight. Ryde 614589.

Leeds Microcomputer Users Group. Meets fortnightly on Thurs eve in Leeds, new members welcome. Contact: Paul O'Higgins, 20 Brudenell Mt, Leeds 6, tel (0532) 742347 after 6.

The SOBAT Computer Club (Leyton). Meets in first week of each month at 12 Calderon Road, London E11 4EU. Anyone (inc beginners) is welcome. Membership fee only £1 pa, inc newsletter. Specialised information, and access to several different kinds of microcomputers. Contact Mr T Kayani: 01-556 5423 eve.

**USER GROUPS INDEX**

**East London Computer Club.** Meets every Friday at 7.30 in term at North East London Polytechnic, Romford Rd Precinct, Stratford E15. Contact John Grieve, 01-553 4761.

**North London Hobby Computer Club.** Workshops four evenings a week during term time. General meetings open to all last Wednesday of each month. Contact Secretary DELE, Polytechnic of North London, Holloway Road, London N7 8DB. Communications Group — interfacing personal computers with Prestel/teletext and Networks like PC Net and The Source. Every Thursday 6.30 — 9. Room 2/5, Tower Block, Holloway Road. ZX81 User Group every Monday during term-time 6-9pm. Room 3/4. Tower Block, Holloway Road.

**Oxford University Microcomputer Society.** Meets weekly in Clarendon laboratory, Oxford, visiting speakers, micros available for programming. Contact: Richard Ash, Christchurch, Oxford.

**South Oxford Computer Club.** Covers Wantage, Abingdon, Didcot, Wallingford and Newbury. Meets 1st Tues monthly at The Star, East Ilsley. Contacts: Mike 0235 834402; Malcolm, 0235 816949; Paul, 0235 815305; Rocky, 0635 34456.

**SELMIC (South East London Microcomputer Club).** Meets fortnightly at Thames Polytechnic, Woolwich. Contact: Peter Philipps, 61 Craigerne Road, London SE3. Tel: 01-853 5829.

**Manchester Computer Club.** Meetings 1st and 3rd Thursday monthly in the Computer Science Building, Manchester University, Oxford Road. Contact D Wade, 28 Hazel Road, Altrincham, Cheshire, WA14 1JL. Tel: 061-941 2486.

**Medway Atom Users' Group.** Meets last Tues monthly during school terms at St John Fisher School, Ordinance St, Chatham. Contact: Clem Rutter, (0634) 42811 (day).

**Newcastle-upon-Tyne Personal Computer Society:** meets first Tues each month in Room D103, Newcastle Polytechnic. Over 60 members sub £5.00. Several sub-groups inc. PET, TRS-80 and S100 (Last one meets weekly). Contact Pete Scargill, Secretary on 0632 573905.

**Orpington ZX80/81 Computer Club.** Meeting each Friday. Contact: R A Pyatt, 23 Arundel Drive, Orpington, Kent BR6 9JF. Tel: 66 20281.

**Plymouth and District Amateur Computing Club.** Subscription £5.00 pa. Meetings last Wednesday monthly. Contact: Mr S A Bell, Secretary, Plymouth and District Amateur Computing Club, 31 Victoria Place, Stoke, Plymouth, Devon.

**Southampton Amateur Computer Club.** Meets 2nd Wed monthly, Medical Sciences Building, Bassett Crescent East, Southampton (alternative venue Aug & Sept). Contact: P Blitz, 'Gardenways', Chilworth Towers, Chilworth, Southampton, tel: 0703 766161.

Would anyone interested in forming a computer club in the Portsmouth area please contact Dave Cocker on Portsmouth 751156.

**Sunbury Computer Club,** meets last Tuesday each month. 40p/meeting £4pa (under 18½ price) enquire to: S N Taylor, 8 Priory Close, Sunbury-on-Thames TW16 5AB.

**Local IPUG Group** meet other PET users and make friends. Contact G Squibb initially. 108 Teddington Pk Rd, Teddington, Middx.

Would anyone interested in joining an informal Computer Club in the Tonbridge or Tunbridge Wells area please contact either Chris Wallwork (Tonbridge Wells 37682) or Ray Szatkowski (Tonbridge 355960).

**Worle Computer Club:** meets alternate Mondays 1900-22.30 at Woodsprings Inn Function Rooms, Contact: S Rabone, 18 Castle Rd, Worle, Weston-Super-Mare, Avon, tel: 0934 513068.

**Worcester & District Computer Club.** Meets 2nd Monday monthly at 8pm, Old Pheasant Inn, New Street, Worcester. Contact: D Stanton, 55 Vauxhall St, Rainbow Hill, Worcester. WR3 8PA.

**York Computer Club.** Meetings 8pm Mondays at Holgate WMC New Lane, Acomb, York. Further info K Thomas, York 38239.

**Croydon micro/small computer group.** Contact Vernon Gifford, 111 Selhurst Road, London SE25 6LH.

**East London Amateur Computer Club.** Meets 7-10pm on 2nd & 4th Tuesdays monthly at Harrow Green Library, Leytonstone, London E11. Contact: Fred Linger, 01-554 3288.

**Richmond Computer Club.** Meets 8.00 2nd Monday monthly, Richmond Community Centre. Contact: Bob Forster, 01-892 1873 (eve).

**TRS-80 Independent User Group.** Recently formed in Birmingham. Contact Mike Bayliss, 021-743 7197.

Anybody interested in forming a microcomputer users club in the Towcester (S. Northants) area, please contact R J Wellsted, 20 Hampton Court Close, Abbey Chase, Towcester, Tel: Towcester 51354 eves.

**Ashfield Computer Club.** Meets 1st & 3rd Thurs each month at Carsic Junior School, membership £3 pa. Contact Deric Ellerby, tel 0380 75376 or Derrick Daines tel 0380 56198

Anyone interested in forming a micro group in the Doncaster area, contact Mr P Flinders, tel Doncaster 78954 or Doncaster 868 379, 6-9pm.

**SALISBURY.** Is anyone interested in forming a microprocessor and computer society in this area? SAE to David Bone, Flat 2, 24 St Mark's Rd, Salisbury, Wilts.

**Shipleigh College Computer Group (Sorcerer/6800).** They meet Tuesdays (software) and Wednesdays (hardware/advanced) between 7.00 & 9.00 pm. Contact Paul Channell on Shipleigh 595731.

**Microsoc the Oxford University micro group** holds shared meetings with the Oxford Microcomputer Club. Contact: M. Bourla, St. John's College, Oxford.

**Scunthorpe & Dist Microprocessor Society.** Contact: G Hinch, 21 Old Crosby, Scunthorpe, S Humberside DN15 8PU.

**Sunbury Amateur Computer Club.** Meets 1st Friday monthly whenever possible, 20p per meeting. Contact: S Taylor, 8 Priory Close, Sunbury-on-Thames TW16 5AB, tel Sunbury 86649.

**Manchester Atom Users' Group.** Meets last Tues monthly during school terms at Abraham Moss Centre, Crescent Rd, Manchester 8. Contact: John Ashurst, 061-370 5121 ext 27 (day), 061-681 4962 (eves).

Anybody in the Warrington area interested in forming a Mattel Intellivision TV Game group to organise meetings, competitions and lay foundations for the forthcoming computer addition? Tel Warrington 62215 after 4 pm.

**BAUD (Bristol Apple Users and Dabblers).** Contact: Geoff Smythe, Datalink Microcomputer Systems Ltd, 10 Waring House, Redcliffe Hill, Bristol BS1 6TB, tel (0272) 213427.

**Brunel Technical College Computing Club.** The club divides into two sections... the "skilled" and the "not skilled". They share alternate Wednesdays at the College. Contact: S.W. Rabona at 18 Castle Road, Worle, Weston-Super-Mare, Avon, BS22 9JW (0934 513068).

Any one interested in forming a computer club in Cornwall, catering mainly for PET, ZX80 and UK 101 computers should contact: M F Grove, 35 Causeway Head, Penzance, Cornwall.

**Peterborough Computer Club.** Recently formed, meets on first and third Mondays each month at Adult Education Centre, Brook Street, Peterborough. Contact: T Marchant, tel Peterborough 76681 after 6 weekdays, anytime weekends.

**Computer Club. Business & Word Processor section** meets

Fridays 7.30, Scientific & Recreational Saturdays 10.00. Contact: L. Boxell, 8 Vane Terrace, Darlington. Tel: 0325 67766.

**Southgate Computer Club.** The club recently held its AGM and adopted a formal constitution. Annual subscription will be £2.50 from January 1981, including a club newsletter; full-time students under 18 pay half-cost. The club now has 83 members. Contact: Panos Koumi, Southgate Computer Club, 33 Chandos Avenue, London N14.

**West London Personal Computer Club.** Meets first Tues. each month at Willesden Technical College. Also visits, special int. groups, demos, problem surgeries. Contact: Graham Brain, 81 Rydal Cres, Perivale Middx, Tel: 01-997 8986

**TRS80 User Club (Chelmsford).** Now part of the National TRS80 User Club. Contact: Michael Dean, 22 Roughtons, Galleywood, Chelmsford, Essex.

A Crawley computer club has recently been formed, open to anyone interested in personal computing, with or without computing facilities. contact either Mr J. Fieldhouse, 18 Seaford Road, Broadfield, Crawley, West Sussex (Crawley 542509) — or — Mr J. M. Clarke, 31 Hyde Heath Court, Pound Hill, Crawley, West Sussex (Crawley 884207)

**Birmingham Computer Club.** To be formed shortly, catering for all micro users. Fortnightly meetings planned but venue not yet fixed. Contact: Dr M Bayliss, 021-743 7197.

**Southampton Amateur Computer Club.** Meets 8 pm 2nd Wed each month (not July — Sept) at Medical Science Building, Bassett Cres, East, Southampton. £3 pa, OAP, & students £2. Newsletter & special int. groups; 2 yrs old, 80 members soon setting up another club in Portsmouth area. Contact: P G Dorey, Dept Physiology, The University, Southampton SO9 3TU or Andy Low, Tel: (0703) 555 605 ext 34.

**Springfield Computer Club.** Special interest in Sorcerer but beginners and others welcome. Meetings 1st Friday monthly. Contact: Stephen Cousins, 1, Aldeburgh Way, Springfield, Chelmsford, Essex CM1 5PB. Tel: 0245 60165.

**TRS80 User Club (Chelmsford).** Now part of the National TRS80 User Club. Contact: Michael Dean, 22 Roughtons, Galleywood, Chelmsford, Essex.

**The Colchester Microprocessor Group.** Meetings held at the University of Essex on the second and fourth Wednesdays of each month — 7.30 pm start. Membership is open to all, on payments of £5 annual sub (£1 for full-time students). Contact: the Information Centre at the University on the evening of the meeting.

**NETWORK NEWS**

*Here is a list of all British (and one Dutch) personal computer networks. As more networks appear — and as more facilities are added to existing ones — we'll report them in this section, which appears monthly.*

**Forum-80 Hull.** . . Operator: Frederick Brown, tel 0482 856169. Facilities: electronic mail, software up/down loading, Forum-80 Users' Group, PET users' section, shopping list. Hours: 7 days/week, midnight-0800, Tues & Thurs 1900-2200, Sat & Sun 1300-2200.

**Forum-80 London.** . . Operator: Leon Jay, tel 01-286 6207. Facilities:

electronic mail, program downloading. Hours: Tues, Fri, Sat & Sun 1900-2300.

**80-NET** . . . Operators: Leon Heller & Brian Pain, National TRS-80 Users' Group, tel 0908 566660. Facilities: electronic mail, software for downloading, newsletter, TRS-80 information. Hours: 7 days/week, 1900-2200.

**CBBS London.** . . Operator: Peter Goldman, tel 01-399 2136. Facilities: electronic mail, program downloading. Hours: Wed 0700-0930 & 1900-2200, Fri 1900-2200, Sun 1600-2200.

**Forum-80 Holland.** . . Operator: Nico Karssemeyer, tel 010 313 512 533. Facilities: electronic mail, program up/downloading, shopping list. Hours: Tues-Sat 1800-0700 nightly, continuous from 1800 Sat — 0700 Tues.

# DIARY DATA

Readers are strongly advised to check details with exhibition organisers before making travel arrangements to avoid wasted journeys due to cancellations, printer's errors, etc.

Friedrichshafen, W Germany	Euro Congress for Word Proc-Interext. Contact: Int Bodensee-Messe, Meistershofener Str 25, 7790 Friedrichshafen.	21-25 Oct
Stuttgart, W Germany	Hobby Electronics & Minicomputers-Exbn. Contact: CES, 01-236 0911	21-25 Oct
London	(Bloomsbury Centre) Computer Graphics Exbn. Contact: Online, 09274 28211	27-29 Oct
London	(West Centre Hotel) Viewdata Exbn. Contact: IPC Exbns, 01-643 8040	4-6 Nov
Cologne (W Germany)	Business Communications Congress & Trade Fair. Contact: Int Trade Fair Agencies 01-409 0956	4-6 Nov
Mexico city	Technology for the People Int Fair. Contact: TRTP, Casa Postale 187, 1215 Geneva, Switzerland	6-12 Nov.
Madrid, Spain	Int Office Equip & Computers Exbn. Contact: CITEMA, Plaza de conde de valle Suchil 8, Madrid 15	13-20 Nov
London	(Olympia) Computer Peripherals & Small Computer Systems exbn & conf. Contact: IPC exbns 01-643 8040	17-20 Nov
China (Guangzhou)	Word Processing Machinery, Equip & Technology exbn. Contact: Industrial & Trade Fairs Ltd 021-705 6707	4-8 Dec

# CTUK! CENTRES

Here's an updated list of people organising Computer Towns. Don't forget to enclose an SAE if you write to your nearest 'Town' for details.

Lyn Antill,  
1 Defoe House,  
Barbican,  
London

Peter J Kiff,  
52 Stone Road,  
Broadstairs,  
Kent CT10 1DZ

Patrick Colley,  
52 Queensway,  
Caversham Park Village,  
Reading,  
Berks RG4 0SJ

Pete Shaw,  
15 St Vincent Road,  
Clacton-on-Sea,  
Essex CO15 1NA

Vernon Gifford,  
111 Selhurst Road,  
Croydon,  
London SE25 6LH

David Tebbutt,  
7 Collins Drive,  
Eastcote,  
Middx HA4 9EL

John Stephen Bone,  
2 Claremont Place,  
Gateshead,  
Tyne & Wear NE8 1TL

Mike Baker,  
5 Edinburgh Road,  
Hanwell,  
London W7 3JY

Pete Rowan,  
10 Lambton Road,  
Jesmond,  
Newcastle-on-Tyne NE2 4RX

Steve Haynes,  
5 Guinea Street,  
Kingsholm,  
Gloucester GL1 3BL

Ted Broadhead,  
27 Cardinal Road,  
Leeds LS11 8EY

Andrew Holyer,  
10 Masons Field,  
Mannings Heath,  
Horsham, Sussex RH13 6JP

Brigitte Gorton,  
18 Purbright Crescent,  
New Addington,  
Croydon CR0 0RT.

Steven Christian,  
51 Burnstones,  
West Denton,  
Newcastle-on-Tyne NE5 2DF

Vernon Quaintance,  
50 Beatrice Avenue,  
Norbury,  
London SW16 4UN

Bill Gibbings,  
3 Lougholme Road,  
Retford,  
Notts DN22 6TU

Philip Joy,  
130 Rush Green Road,  
Romford,  
Essex.

Richard Powell,  
22 Downham Court,  
South Shields,  
Tyne & Wear

Derrick Daines,  
18 Cuttings Avenue,  
Sutton in Ashfield,  
Notts

Keith Taylor,  
Carter Hydraulic Works,  
Thornbury,  
Bradford BD3 8HG

Alan S Waring,  
50 Drayton Gardens,  
Winchmore Hill,  
London N21 2NS

Alan Northcott,  
Rushmoor,  
464 Reading Road,  
Winnesh,  
Wokingham,  
Berks RG11 5ET

Alan Sutcliffe,  
4 Binfield Road,  
Wokingham,  
Berks RG11 1SL

Tony Cartmell,  
4 Foregate Street,  
Worcester WR1 1DX

Tom Graves,  
19a West End,  
Street,  
Somerset BA16 0LQ

## THE WAR MACHINE

The magazine of microcomputer wargaming,  
and fantasy science fiction gaming

Before spending money on expensive games software, wouldn't you like to read our independent reviews of the new, demanding games and simulations that are now coming onto the market?

Send just £1 for the latest issue of The War Machine, packed with reviews of the latest games for all popular brands of micro, news of developments in this exciting area, and hints on improving your own games programs. Cheques or P.O.'s payable to: M. W. Costello, 17 Langbank Avenue, Ruse Park, Nottingham NG5 5BU

## OHIO COMPUTERS

SUPERBOARDS FROM £135 + VAT C2s,  
C3s, and spare boards.

BOOKS:

NEW User Manuals - full of information re Superboard III/C1P/C4P/C8P. (state which)

SAMS SERVICING/MANUALS - Superboard III/C1P/C4P/C8P/C3. (state which)

VIP Book - Programs for Superboard/C1P/C4P.

WORKBOOK - Superboard III/C1P/C4P

FIRST and SECOND Books of OSI

65V PRIMER - machine code manual.

SETTING UP PROFESSIONAL COMPUTERS, BASIC Books etc.

CPM COMPUTERS

System 10 twin disk integral VDU 64K

PERIPHERALS

Printers, VDUs, Floppy Disks etc.

ALL FROM:  
CTS

31/33 Church Street  
Littleborough  
Lancs OL15 8DA

Tel: (0706) 74342/79332

## TRS-80 MODEL I ENHANCED VIDEO

- TANDY COMPATIBILITY mode (default) gives lower case without the need for switches.
- FULL MODE gives the FULL CHARACTER SET in POSITIVE and INVERTED VIDEO and all graphics characters.
- WHOLE SCREEN INVERSION including borders is independently controllable. Double width capability is not affected. Mode selection by port FE. Fits inside the keyboard case.
- Technical manual with software patches E6 Assembled and tested PCB, 2102 chip E26.45 Parts and manual ordered together E26.45
- The above prices include worldwide postage and United Kingdom VAT, Dealer discounts. Installation available, please enquire.

RHA (MINISYSTEMS) LTD., 83 GIDLEY WAY, HORSPTH, OXFORD OX9 1TQ.  
Tel. 08677-3625

## BUSINESS & COMPUTER SERVICES

292 Caledonian Rd, London N1 1BA  
Tel: 01-607 0157 (24-hour Answering Service)

We are  
Micro-computer Consultants  
& Programmers

— and specialise in industrial & commercial programs written to clients' specifications.

VAT & Post incl.

Cash Analyser £20.00  
Vehicle Cost Analyser £25.00  
Book Keeping (min 48k & 2 drives) £150.00

Please ask us for fuller details of the above. All are disk based for the TRS-80 Model I or III. Please state your DOS when ordering. Apple II versions soon.

## ZX81

### CASSETTE ONE

- \* REACT (m/c)
- \* INVADERS (m/c)
- \* PHANTOM ALIENS (m/c)
- \* MAZE OF DEATH (m/c)
- \* PLANET LANDER (m/c)
- \* BUG SPLAT (m/c)
- \* BOUNCING LETTERS (m/c)
- \* I CHING (basic)
- \* MASTERMIND (basic)
- \* BASIC HANGMAN (basic)
- \* ROBOTS (basic)

### PROG OF THE MONTH PHANTOM ALIENS

A very weird version of invaders. The phantom aliens move at different speeds, setting up strange defensive patterns, some disappearing and suddenly reappearing. Genuine pixel graphics for continuous movement. Continuous display of score.

All for 1K RAM, all on CASSETTE ONE (sent first class) for £3.80 from:

Michael Orwin  
26 BROWNLOW ROAD  
WILLESDEN LONDON  
NW10 9QL

(Quality programs wanted, please send sae for details)

### PET MACHINE LANGUAGE GUIDE

IF YOU ARE INTERESTED IN OR ARE ALREADY INTO MACHINE LANGUAGE PROGRAMMING ON THE PET, THEN THIS INVALUABLE GUIDE IS FOR YOU. MORE THAN 30 OF THE PET'S BUILT-IN ROUTINES ARE FULLY DETAILED SO THAT THE READER CAN IMMEDIATELY PUT THEM TO GOOD USE. £8.00

### THE BRAIN SURGEON (Apple)

This Diagnostic's package is designed to check every major area of your computer, detect errors and report any malfunctions. The Brain Surgeon will put your system through exhaustive, thorough procedures testing and reporting all findings. £30.00  
RS232 Serial Interface. £50.00  
Apple Serial I/O. £45.00  
PET TV Interface £35.00  
PET Soundbox. £22.50  
Disk Head Cleaning Kit £17.50  
PET IEEE/Parallel Interface (addressable). £80.00  
4-channel A/D Converter. £45.00  
8-channel programmable Relay Switching Unit £45.00

UART & BAUDRATE Generator £50.00 (converts parallel to serial and serial to parallel)  
Apple Action Adventure Games  
RED BARRON £14.95 BATTLE OF MIDWAY  
SUB ATTACK £14.95 £14.95  
Mail order welcome. Please send for catalogue.

### PEDRO COMPUTER SERVICES

65 Globe Crescent  
Kenton, Middx. HA3 9LB  
Tel. 01-204 9351

# PCW SUBSET

Alan Tootill presents more useful assembler — language subroutines.  
If you'd like to contribute your routines (for any of the popular processors), send them to:  
Sub Set, PCW, 14 Rathbone Place, London W1P 1DE.

## Extra 6500 instructions

Many general-purpose routines are written to meet a need for instructions not provided in a processor's instruction set. ROTREX, our first Datasheet this

month, from Dave Barrow of Hems-worth, offers no fewer than seven extra instructions to the 6502. Just think how many other useful instructions could be added to the 6502 and other popular processors! Then do it, and send the results to 'Sub Set'.

## Datasheet

= ROTREX — 6502 register rotate, transfer and exchange package.

CLASS: 1

TIME CRITICAL?: No

DESCRIPTION: TXY transfers index X to index Y.

EXAY exchanges the accumulator and index Y.

RRAXY rotates to the right the accumulator, index X and index Y.

TYX transfers index Y to index X.

EXAX exchanges the accumulator and index X.

RLAXY rotates to the left the accumulator, index X and index Y.

EXXY exchanges index X and index Y.

ACTION: TXY Y ← X or

EXAY A ↔ Y or

RRAXY [A → X → Y] or

TYX X ← Y or

EXAX A ↔ X or

RLAXY [A ← X ← Y] or

EXXY X ↔ Y

SUBr DEPENDENCE: None

INTERFACES: None

INPUT: None. A CALL is made to TXY, EXAY, RRAXY, TYX, EXAX, RLAXY or EXXY depending on the action required

OUTPUT: As shown in ACTION plus normal N and Z flag information output for transfers. P is unaltered by rotates and exchanges.

REGs USED: YP or AY or AX or XP or AX or AX or XY

STACK USE: 4 in all cases

LENGTH: 56

TIME STATES: 72 or 68 or 65 or 68 or 64 or 59 or 42

PROCESSOR: 6502

ROTREX EQU \$0100 ; for normal page one stack base.

TXY TAY ; Y ← A, A ← X, then A ↔ Y. A8

## FAST FOURIER TRANSFORM

for the PET and APPLE

A fast and accurate machine code implementation interfacing to BASIC and Pascal. £125

Details:

### STRUCTURED SOFTWARE

23 Redcar Drive,  
Eastham, Wirral,  
Merseyside. L62 8HE

Please specify PET BASIC,  
Apple BASIC or Apple Pascal.

## ZX81 goes REALTIME



with RD 8100 series Input/Output Modules.

Professionally designed units for use with ZX81 — with or without 16k RAM and Printer. Call using BASIC or Machine Code routines.

\* LOGIC OUTPUTS — switch lights, relays, etc.  
\* LOGIC INPUTS — realtime program branching  
\* ANALOGUE VOLTAGE I/O — datalogging, control plus LIGHT PEN, REALTIME CLOCK and others.

LOW Individual modules & Motherboard  
COST Send SAE for full details

R.E. Dickens (Dept W) 5 Kennedy Road, Dane End,  
Ware, Herts. SG12 0LU  
(Mail Order Only)

EXAY	TXA	:	8A
	PHP	:	08
	SEC	:	38
	.BYTE \$2C	:	2C
RRAXY	PHP	:	08
	CLC	:	18
	PHA	:	48
	PHA	:	48
	TXA	:	8A
	PHA	:	48
	TYA	:	98
	CLV	:	B8
	BVC	:	50 0C
TYX	TAX	:	AA
	TYA	:	98
EXAX	PHP	:	08
	CLC	:	18
	.BYTE \$2C	:	2C
RLAXY	PHP	:	08
	SEC	:	38
	PHA	:	48
	PHA	:	48
	TYA	:	98
	PHA	:	48
	TXA	:	8A
REPAST	TSX	:	BA
	INX	:	E8
	INX	:	E8
	INX	:	E8
	STA	:	9D 00 01
	BCC	:	90 0D
	PLA	:	68
XYAPO	TAX	:	AA
XYAP1	PLA	:	68
XYAP2	TAY	:	A8
XYAP3	PLA	:	68
	PLP	:	28
	RTS	:	60
EXXY	PHP	:	08
	PHA	:	48
	TYA	:	98
	PHA	:	48
	TXA	:	8A
	PHA	:	48
YXAPO	PLA	:	68
YXAP1	TAY	:	A8
YXAP2	PLA	:	68
YXAP3	TAX	:	AA
	PLA	:	68
	PLP	:	28
	RTS	:	60

; for XYAP restore.

; starts dummy instruction (BIT \$1808) to skip next 2 bytes

; for YXAP restore.

; put A A X on stack & Y into A.

X ← A, A ← Y, then A ↔ X.

; for YXAP restore.

; starts dummy instruction (BIT \$3808) to skip next 2 bytes

; for XYAP restore.

; make X index stack and point to first A pushed.

; replace stacked A by X or Y.

; jump if RRAXY or EXAX.

; restore X Y A P with X getting X or Y,

; Y getting A,

; A getting what X didn't.

; put P A Y X on stack and restore Y X A P.

; restore Y X A P

; X gets Y if EXXY

; X gets A if PRAXY or EXAX.

## Byte-misers treat

Take a good look at the fifth byte of the ROTREX package. Here the program wants to jump over the next two bytes and, since the carry has just been set anyway, could BCS +2 (BO 02). But that takes two bytes of code, so the single byte 2C is used instead. This, with the next two bytes, forms the BIT \$1808 instruction, which can alter the N, Z and Y flags of P without affecting

the routine. The same byte-saving trick is used again at the 20th byte.

There are other byte-saving techniques possible with other processors. Send in any you can think of to Sub Set and we will put them all together.

## Using Rotrex

Other useful 6502 'instructions' can be built up from the elementary functions in ROTREX. Dave Barrow sent

# ZX81 16K

## SOFTWARE

CHESS ADVENTURE  
OTHELLO  
AND MORE  
Send SAE for details

ABERSOFT

7 Maes Afallen, Bow St. Dyfed.

### Beneath Apple DOS

— a technical manual by Don Worth and Peter Lechner  
 \* If you have ever found that the Apple DOS manual ends where your problems begin then BENEATH APPLE DOS is for you.  
 \* If you have had compatibility problems with 3.2 or 3.3 disks, or if you have had disks which have "crashed" on you, then BENEATH APPLE DOS can help.  
 \* If you need to access your disk drives from assembler, you can't do without this manual.  
 \* If you want a complete lucid explanation of how your disks are formatted at "bit" level, how protection of disks is achieved, how data may be written between tracks, how the bootstrap procedure works, what every routine in DOS does, how to customise DOS to your needs.....  
 its all in BENEATH APPLE DOS £11.95 inclusive

### The Linker

by Don Worth — a sophisticated tool for use with assembler routines and programs  
 \* Subroutine library facilities: many routines supplied including complete DOS text file access (OPEN, CLOSE, POSN, READ, WRITE), line generation, and more.  
 \* Dynamic loading of subroutines, control over target location, optional packing of routines to force page alignment. No need for JMP vectors or re-assembly!!!  
 \* The Linker itself can be called as a subroutine to load programs at execution time, and to manage overlaying.  
 Boots under DOS 3.2 and 3.3. Needs min. 32K + 1 disk. £29.95 + VAT

### Cross-Ref

— a fast and compact machine language utility, co-resides with Applesoft!  
 \* Gives various cross-reference reports on variables and line numbers.  
 \* Global FIND & REPLACE functions for easy modifications of Applesoft programs.  
 Boots under DOS 3.2 and 3.3. Needs min. 32K + 1 disk. £14.95 + VAT

PROTOCOL COMPUTER PRODUCTS 01-460-2580  
 Apartment 3, 114 Widmore Road, Bromley, Kent BR1 3BE

# MICROMART

## Great products from Mutek Tiny PILOT

Mutek's Tiny PILOT (MTP) is a small-scale yet comprehensive implementation of the PILOT text-oriented programming language for OSI and UK101 computers.

Commands are: R: remark; T: type text (or graphics character); ?: accept name; A: accept answer (numeric or alphanumeric); M: match (full range of comparisons); J: jump to label; U: use subroutine at label; E: end subroutine; C: compute (26 single-character variables); I: input numeric value to variable; P: produce random number; S: stop (end program)  
 Numeric functions are performed in 16-bit unsigned form, giving a range 0-65535. A full line-editor is included in the package.

Note: MTP uses CEGMON facilities extensively and will not operate with non-standard monitors such as WEMON or MONUK02. MTP is available as a package with the relevant version of CEGMON at a special reduced price. This gives you the special facilities of CEGMON as well as the best use of MTP.

The EPROM package is available ex-stock, and comes complete with fitting instructions, manual and reference card.

PILOT package £17.50+VAT  
 PILOT/CEGMON  
 package £29.50+VAT

## StarLink

Communications package

A complete comms. package for OSI systems, including:

'Smart terminal' mode for link to external mainframe, mini or micro;  
 half-duplex/full-duplex operation;  
 transmit/receive prepared text or files (on-line/off-line preparation); direct upload/download of programs; 'indirect file' handling for transfer of programs/data between external computer, disk or ROM BASIC; full editing; and many other features

Available in EPROM in two versions: StarLink I for disk or ROM BASIC systems, and StarLink II for non-disk operation of Superboard Series II. Specify type required when ordering!

Starlink (either version) £17.50+VAT

### Coming shortly

Modem (acoustic coupler) for use with StarLink — c.£50 or less  
 High res (256x256) graphics for Superboard/C1 — bare board + instructions, software c.£35, ready-built c.£110

FigFORTH (full Forth Interest Group implementation) in ROM — c.£50, source listing c.£15

MUTEK Quarry Hill, Box, Wilts  
 Tel: Bath (0225) 743289

# MICROMART

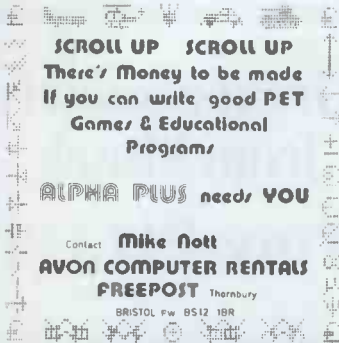
**SCROLL UP SCROLL UP**  
**There's Money to be made**  
**If you can write good PET**  
**Games & Educational**  
**Programs**  
  
**ALPHA PLUS needs YOU**  
  
 Contact **Mike Nott**  
**AVON COMPUTER RENTALS**  
**FREEPOST** Thurnbury  
 BRISTOL Pw 8512 1BR

## NASCOM USERS

**INVERSE GRAPHICS** without hardware mode. Two EPROMS to replace your A/N and NASGRA, plus driving routines and demo in BASIC. As characters are shifted down to centralise them in the character block, two versions are available. One for standard NASCOM 2 and one for 16 rows per character. State which required. £15

**CHARACTER BUILDER.** Design your own character sets with this BASIC programme. Displays character 16 times full size and stores result in format required to blow a graphics EPROM. Required 12K. £5

**PROM BLOWING, 2716** with copy of your taped character set. £5

SAE for further details to:

## SPIRAL SOFTWARE

19 Fairmile Close, Coventry CV3 2PS.

# SILVERSOFT

## 16K-ZX81 STARTREK

HIGH QUALITY PROGRAMS FOR 16K ZX81

**STARTREK:** Full graphics, 4-levels of play. 8x8 Galaxy, Starbases, Klingons, Romulans, etc.

**GAMES PACK 1:** Starwars, Hamurabi, Graphic Lander, Mastermind, Minefield.

PRICES: (Including documentation)  
 £4.95 EACH CASSETTE  
 £8.95 FOR BOTH

Send cheque/PO to:

**SILVERSOFT**

40 Empress Avenue, Ilford, Essex.

## SIMPLY WRITE!



Super Word Processor at a silly price!

All you'd expect for ten times the price, PLUS re-define keyboard, graphics printing, tape or disk files, old or new ROMs, PET or ASCII printers, AND 40 or 80 column (same tape or disk). We didn't believe it either! £37 tape (can save to disk); £40 disk (sample files etc). Manual £1 refundable. Specify drive.

'SIMPLY-FILE' database manager to match. Robust, versatile, self-calculating. £65 + VAT. Disk only. Specify drive.

**LIGHT PEN + SOFTWARE** plugs in. £22  
**PROGRAMMER'S TOOLKIT** - 16/32K new ROM: makes programming less like work! £28 (£30 4.0).  
**ADVENTURE 1 & 2:** authentic Scott Adams 24K classic games. Each £7 (both £13).  
**NEW! ASTEROIDS-81** Fast action £6

Add VAT to all prices please, but post/insurance included. Unconditional instant Refund Guarantee on hardware, also software if not up to description. Write for more details, more items, newsletter.

SIMPLE SOFTWARE LTD.  
 15 HAVELOCK ROAD  
 BRIGHTON SUSSEX BN1 6GL  
 (0273) 504879



three which, apart from the Z flag in the 16-bit case, return the correct status; something not done by the PHA, go-through-A, PLA method:

1) Transfer the stack pointer to index Y:  
 TSY JSR EXXY ; save X in Y.  
     TSX ; get SP  
     INX ; past return  
     INX ; address.  
     JMP EXXY ; restore X, move  
               SP to Y & return.  
  
 2) Increment A:  
 INCA JSR EXAX ; A to X preserving X.  
       INX ; A + 1 not altering Cy or V.  
       JMP EXAX ; restore A X & return.  
  
 3) Arithmetic shift left XY:  
 ASLXY JSR RRAYX ; rotate Y into A.  
        ASL A ; double it.  
        JSR RRAYX ; rotate X into A.  
        ROL A ; double + Cy from Y.  
        JMP RRAYX ; rotate to correct  
               registers & return.

## Now for M6800

Ron Yorston, from Reading, wanted instructions to push the index register onto the stack and pull it off again in

his M6800 system. These next Datasheets from him, PUSHX and PULLX, do this and affect no other registers or flags. This means that a subroutine may begin by saving the IX register contents on the stack and end by pulling them off again, but still pass results to the calling program in the flags.

To help readers not too familiar with the M6800 processor, I have added detailed ACTION sections to the documentation. These could be replaced to show only the net effect of the routines thus:

For PUSHX: ↓ (IXL)  
               SP ← (SP) - 1  
               ↓ (IXH)  
               SP ← (SP) - 1  
 For PULLX: SP ← (SP) + 1  
               ↑ IXH  
               SP ← (SP) + 1  
               ↑ IXL

## Datasheet

; = PUSHX - Push the IX register  
 ; CLASS: 2 (local RAM used fleetingly)  
 ; TIME CRITICAL?: No  
 ; DESCRIPTION: Pushes IX onto the stack without affecting other registers or flags.

ACTION:

SP →  
 ;  
 ; SP ← (SP) - 2  
 ; ↓ (ACCA)  
 ; SP ← (SP) - 1  
 ; ACCA ← (CC)  
 ; ↓ (ACCA)  
 ; SP ← (SP) - 1  
 ; I bit ← 1  
 ; Memory ← (IXH)  
 ; Memory + 1 ← (IXL)  
 ; IX ← (SP) + 1  
 ; ACCA ← (IX) + 4  
 ; IX + 2 ← (ACCA)  
 ; ACCA ← (IX) + 5  
 ; IX + 3 ← (ACCA)  
 ; ACCA ← (Memory)  
 ; IX + 4 ← (ACCA)  
 ; ACCA ← (Memory) + 1  
 ; IX + 5 ← (ACCA)  
 ; IXH - (IX) + 4  
 ; IXL - (IX) + 5  
 ; SP - (SP) + 1  
 ; ↑ ACCA  
 ; CC - (ACCA)  
 ; SP ← (SP) + 1  
 ; ↑ ACCA  
 ; SP ← (SP) + 1  
 ; ↑ PCH  
 ; SP ← (SP) + 1  
 ; ↑ PCL

SUBr DEPENDENCE: None

INTERFACES: Two bytes of RAM are needed fleetingly to store the original value of the IX register. The interrupt mask is set whilst this RAM is in use but a non-maskable interrupt could still affect the RAM. For PUSHX to be considered re-entrant, any NMI service

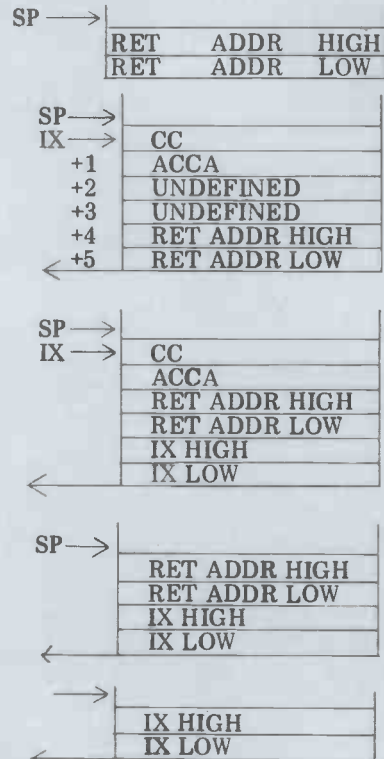

## SHARP MZ 80K

Special Programme Package  
25 PROGRAMMES FOR £25

HANGMAN. HOME BUDGET. BLOCKADE. SPACEPURSUIT. BOMBER. ELECTRONIC-ORGAN. GRAPHICS. HYPNO. MUSIC. POKER. OTHELLO. 3D MAZE. DUCK-SHOOT. STAMPOUT. WORLD TIME. PRIME NUMBERS. BREAKOUT. COLDITZ. SPACE-FIGHTERS. STARTREK. PAPERSTONES. COSMIC INVASION. SNAKE ISLAND CO-ORDIN WARS. ETERNAL CALENDAR.

LIMITED OFFER SEND CHEQUE FOR £25  
 TO STENMEAD, 42 BERECROFT,  
 HARLOW, ESSEX.

## TRS 80 L2

### VIDEO GENIE OWNERS

**COPY KITS:** Make a system 'back up' copy of your own SARGON 2 or Microchess 1.5 program. Full step by step instructions are supplied along with the necessary utility program on tape. Kits are £6.00 each or £10.0 for both. Special Copy Kits produced to order: £10.00. (program on tape must be sent).

**PRINTING SERVICE:** Program Listing. Basic Programs = of a penny per line. £2.00 minimum charge. Machine code programs eg. Invaders £5.00. Small chess program £10.00.

Send programs with instructions to:

CLEVELAND HOME COMPUTERS,  
 9 HAMBLETON SQ., BILINGHAM,  
 CLEVELAND TS23 2RZ.

(All business Mail Order Only CWO)



## UK101 PROGRAMS ON CASSETTE

**TAPE 1:** Startrek (8K), Robot Chase (4K), Maze (6K), Golf (4K), Space Invaders (4K), Chessboard (4K), Graphics (4K), Fourier Series (8K), Best fit Polynomial (4K), Hangman (8K), Docking a Space Ship (4K).

**TAPE 2:** Adventure (8K), King (8K), Moon Landing (6K), Simultaneous Equations (4K), Gunfight (4K), Hexapawn (6K), Dogfight (4K), The Tower of Brahma (4K), Nim (4K), Life (8K), Mugwump (4K).

**TAPE 3:** Real Time Startrek (8K), Mastermind (4K), Tank Battle (4K), Surround (4K), Integration (8K), Biorhythm (4K), Asteroid Shoot (4K), Breakout (4K), Graph Plotter (6K), Graphic Aid (4K), Space War (4K).

One tape: £6.00 two for £11.50, three for £16.00.

Machine Code Programs:  
Space Invaders, Asteroids  
(9 speeds, 5 difficulty levels)  
Life (128x128 board, 1.2sec per generation)  
Assembler  
£3.00 each, two for £5.00  
three for £7.00, all four for £8.00  
All programs are available for use with  
standard (48x16) or enhanced (48x32)  
V.D.U. display

Mr. M. WARD, 9 ST. ANDREWS AVENUE,  
CREWE, CHESHIRE CW2 6JJ.

## MZ-80 owners

Something for everyone  
this Christmas!

**CAROLS** (22K)

Festive music for all. Plays any of 18 traditional carols. Words & music.

**RHYMES** (10K)

A must for the youngsters! Plays 20 favourite nursery rhymes.

**MELODY** (22K)

Get the party going. Guess the tune from fragments of well-known show and film melodies. Three levels.

Cassettes £7 each incl. postage & VAT.

(Convertible to MZ-80B format using Sharp conversion tape.) Send s.a.e. for further details.

Also available from NewBear Computing Stores and Sharp dealers.

## Maris & Tresham

Software for personal computers  
19 Pytchley Way, Brixworth,  
Northampton NN6 9EF.

## ZX81 CHESS

A full feature program, written in machine code, offering 6 levels of play and a graphic display. All legal moves, including castling and en passant, are recognised and you can choose to alter the board whenever you wish. You can even exchange sides with your computer during a game.

You will need a ZX81 or ZX80 8k ROM, plus a 16k RAM pack.

Top quality tapes used, and all recordings verified before despatch. The price of £15 is fully inclusive of post, packing etc.

Send to:

A. LAWRIE (SOFTWARE)  
68 BINGLEY ROAD  
SUNBURY-ON-THAMES  
MIDDLESEX TW16 7RB.  
Strictly no callers please.

routine should not be allowed to affect the local RAM or call PUSHX.

INPUT: None

OUTPUT: The contents of IX are stored on the stack and the stack pointer is decremented twice.

REGs USED: None

STACK USE: 4

LENGTH: 35

TIME STATES: 95

PROCESSOR: M6800

PUSHX:	DES		; make space on stack.	34
	DES		;	34
	PSH	A	; preserve ACCA	36
	TPA		; and CC.	07
	PSH	A	;	36
	NOP		; to ensure SEI effected	01
	SEI		; turn off interrupts	OF
	STX	LRAM	; store X temporarily.	FF XX XX
	TSX		; point to stack with X.	30
	LDA	A 4, X	; move return	A6 04
	STA	A 2, X	; address	A7 02
	IDA	A 5, X	; on	A6 05
	STA	A 3, X	; stack.	A7 03
	LDA	A LRAM	; put	B6 XX XX
	STA	A 4, X	; X register	A7 04
	LDA	A LRAM + 1	; on	B6 XX XX
	STA	A 5, X	; stack.	A7 05
	LDX	4, X	; regain A and CC.	EE 04
	PUL A		;	32
	TAP		;	06
	PUL A		;	32
	RTS		;	39

## Datasheet

= PULLX - Pull the IX register

CLASS: 1

TIME CRITICAL?: No

DESCRIPTION: Pulls IX off the stack without affecting other registers or flags.

ACTION:

↓ (ACCA)	SP →	
SP ← (SP) - 1	IX →	CC
↓ (ACCB)	+1	ACCB
SP ← (SP) - 1	+2	ACCA
ACCA ← (CC)	+3	RET ADDR HIGH
↓ (ACCA)	+4	RET ADDR LOW
SP ← (SP) - 1	+5	IX HIGH
IX ← (SP) + 1	+6	IX LOW
ACCA ← (IX) + 3	←	
ACCB ← (IX) + 5	SP →	
IX + 5 ← (ACCA)	IX →	CC
IX + 3 ← (ACCB)	+1	ACCB
ACCA ← (IX) + 4	+2	ACCA
ACCB ← (IX) + 6	+3	IX HIGH
IX + 6 ← (ACCA)	+4	IX LOW
IX + 4 ← (ACCB)	+5	RET ADDR HIGH
IXH ← (IX) + 3	+6	RET ADDR LOW
IXL ← (IX) + 4	←	
SP ← (SP) + 1		
↑ ACCA		
CC ← (ACCA)		
SP ← (SP) + 1		
↑ ACCB		
SP ← (SP) + 1		
↑ ACCA		
SP ← (SP) + 3		
↑ PCH		

## ZX80 & ZX81 16K RAM & I.O. BOARD

Gives 16K of RAM and 3 x 8 bit program-able I.O. ports, complete.

Cased ..... £55.00  
Uncased ..... £48.00

4116-4 ..... £ 0.85  
23+23 edge conn ..... £ 3.20  
Apple keyboard ..... £28.00

All including P&P  
Access & Barclaycard (+6%)

Alfreda Avenue, Hullbridge  
Essex SS5 6LT.

Tel: Southend (0702) 230324.

Ground  
Control

## MICROTYPE



MODEL  
3 CASE

NEW  
LOW  
PRICE

READY CUT CASE FOR SUPERBIRD,  
UK101, NASCIM 2  
ALSO AVAILABLE WITH BLANK KEYBOARD  
(HIMEMREW, NASCIM 1 ETC.)

PRINTED IN BLACK ABS PLASTIC COMPLETE WITH SCREWS AND INSTRUCTIONS  
SPACE BAR EXPANSION, FORCE FEED BAR, NUMERIC PAD AND ADDITIONAL KEYS  
ONLY £19.95 + £1.50 p&h + VAT  
SEND CHEQUES OR PO'S FOR £29.97 (U.K.)  
MICROTYPE P.O. BOX 108, HEMEL HEMPSTEAD, HERTS HP2 70Z  
SAY FOR DETAILS DEALER & L.T. ENQUIRIES WELCOME

# MICROMART



RAMCARD - 16K expansion	£107.95
Z80 SOFTCARD +CP/M + M/Basic	£166.90
VIDEX 80 col. board + switchplate	£195.95
NEC P31 Green Screen Monitor	£162.45
Epson MX80 Printer (FT1) + I/Face	£391.00
Extra H/res Graphics Rom	£51.00
M/Hardware Expansion Chassis	£395.75
Software e.g. Visicalc 3.3	£92.15
Visitronic/Plot	£118.95

Full range also by M/soft, Muse, High Tech, Micropro, Quality S/ware, Sensible etc. Business Games, Utilities.

All prices plus 15% VAT. Carriage - FREE

For full details of above and other items contact:

**S-SYSTEMS**  
9 Goffs Close, Crawley, Sussex  
Tel: Crawley 515201

## MARTIAN ADVENTURE

In 1993 the orbiting Mars probe sighted an ancient building on the planet's surface, and a three-man lander was despatched to investigate. What the astronauts discovered represented both the greatest benefits and the greatest perils that humanity had ever encountered.

Martian Adventure is the most challenging 16K Adventure yet written. Like all good games of this type, it offers normal English commands, responses at machine-code speed, excellent displays and many rooms, treasures and threats. Beyond this, it introduces new ideas such as simultaneous control of three Agents, rather than one puppet figure. You must co-ordinate the actions of two or even three Agents; sometimes you may have to decide whether to risk sacrificing an Agent in a dangerous situation, to obtain information that might aid the others. Special data compaction techniques have been devised for the game, allowing the maximum amount of information to be crammed into 16K, and weeks of play lie ahead before you discover the secret of the Martians.

Martian Adventure is available on tape for the TRS-80 1/III and Video Genie, and is being rewritten for the ZX81 and other machines. Send a cheque/P.O. for £12 to: M. W. Costello, 17 Langbank Avenue, Rise Park, Nottingham NG5 5BU. Your order will be promptly fulfilled.

## NASCOM SOFTWARE

We offer the following quality software for NASCOM systems:

**NASPAS** - a 12K PASCAL compiler which produces Z80 code directly, i.e. no P-code. The compiler offers floating point and integer arithmetic, arrays, sets, strings and all major Pascal statements together with fully recursive functions and procedures with value and variable parameters. The object program runs very quickly. Price: £35.00.

**NASMON** - A new monitor for NASCOMs. Occupies 4K and includes a sophisticated screen editor, a 'front panel' mode, blocked and buffered tape routines and powerful debugging commands. Price £30.00 in EPROM

**BAS12K** - a 12K BASIC interpreter offering 11 digit precision arithmetic, PRINT USING, IF...THEN...ELSE and other advanced features. Price: £25.00

**NASGEN** - a fast 3K assembler generating a full symbol table and with many assembler directives and commands. Price: £15.00 on tape, £25.00 in EPROM.

**NASNEM** - a 2½K disassembler which interfaces to NASCOM's front panel to produce single step disassembly. Optionally it produces labels and o/p may be directed to a text buffer suitable for NASGEN. Price: £10.00 on tape, £15.00 in EPROM.

All the above software runs under NASMON except NASPAS which can run under NASMON or NAS-SYS. All prices are fully inclusive.

**FREE:** a free CHESS program with every order of NASMON.

**GEMINI DISK OWNERS:** HISOFT offer a Z80 development package to run under CP/M 1.4 on the Gemini Floppy Disk System. Included in the package are:

- a powerful screen editor.
- a fast Z80 assembler with conditional assembly.
- a debugger based on the Front Panel on NASMON together with a labelling Z80 disassembler. All this for the inclusive price of: £50! Send for details NOW.

Full details may be obtained from:

**HISOFT 60 HALLAM MOOR  
LIDEN, SWINDON, WILTSHIRE**

```

:/      SP ← (SP) + 1
:/      ↑ PCL
:/      SUBr DEPENDENCE: None
:/      INTERFACES: None
:/      INPUT: None
:/      OUTPUT: The IX register is loaded from the stack and the
:/              stack pointer is incremented twice.
:/      REGs USED: None
:/      STACK USE: 3
:/      LENGTH: 30
:/      TIME STATES: 95
:/      PROCESSOR: M6800
PULLX: PSH  A   ; save A B.          36
        PSH  B   ;                      37
        TPA   ; save condition codes. 07
        PSH  A   ;                      36
        TSX   ; point to stack with X. 30
        LDA  A 3,X ; switch IX, Ret addr on stack. A6 03
        LDA  B 5,X ;                      E6 05
        STA  A 5,X ;                      A7 05
        STA  B 3,X ;                      E7 03
        LDA  A 4,X ;                      A6 04
        LDA  B 6,X ;                      E6 06
        STA  A 6,X ;                      A7 06
        STA  B 4,X ;                      E7 04
        LDX  3,X  ;                      EE 03
        PUL  A   ; restore condition codes. 32
        TAP   ;                      06
        PUL  B   ; restore A B.          33
        PUL  A   ;                      32
        INS   ; fix                      31
        INS   ; stack                   31
        RTS   ;                          39
    
```

## Z80 improvements

One of the reasons for printing your routines is for others to try them out and suggest improvements. In the July issue, in the penultimate item, we gave a few lines of code, SAY, for allowing output messages to be set in the code at the place where they are invoked. This code has been criticised with some ferocity by Andrew Bain of Welwyn Garden City, for needlessly destroying the contents of HL and A. He suggests:

```

SAY:  EX  (SP),HL  E3
      PUSH AF    F5
SLP:  LD  A,(HL)  7E
      INC HL     23
      CP  ""\    FE 5C
      JR  Z,EXIT 28 05
      CALL OUT   CD XX XX
      JR  SLP    18 F5
EXIT: POP AF     F1
      EX  (SP),HL E3
      RET       C9
    
```

This merits documenting into a Data-sheet, but I am running out of space and so leave it to you.

To make the string match, CPSTR, in the same issue, position-independent, both David Yeomans of Halifax and Roger Hargrave of Crawley suggest:

```

CPSTR: LD  A,(DE) 1A
      INC DE     13
      CPI      ED A1
      RET  NZ    C0
      RET  PO    E0
      JR  CPSTR
    
```

Simon Sellick of Pershore thought a string length limit (in register B) of 256 bytes adequate, and gave this:

```

CPSTR: LD  A,(DE) 1A
      CP  (HL)  BE
      RET  NZ    C0
      INC HL    23
      DJNZ CPSTR 10 F9
      RET      C9
    
```

## CP/M file-name checks

Simon Sellick also sent a string compare routine, SUBP, which edits strings according to the following rules:

1. The first byte must be an ASCII upper-case letter.
2. Remaining bytes must be either ASCII digits or ASCII upper-case letters.
3. Trailing spaces are added to the string to the length specified.

This might seem to have rather limited application, but Simon finds it can be used to avoid CP/M's unhappy knack of allowing the creation of in-

## STOKE on TRENT

for  
TUSCAN  
and  
TANGERINE  
and  
VIC and NASCOM  
and  
VIDEO GENIE + SOFTWARE  
and  
BOOKS

**MICRO-PRINT Ltd.,**  
59 Church Street, Stoke on Trent  
(0782) 48348. Barclaycard and Access

## COMPUSENSE - 6800/9 THE SPECIALISTS

- COMPLETE 6809/6800 SYSTEMS FROM AROUND £800.00
- TWIN 5¼" DISKS + CONTROLLER £500.00 EXCL. VAT
- FULL RANGE OF SOFTWARE FOR 6809/6800
- FULL RANGE OF PRINTED CIRCUIT BOARDS

**Announcing TABULA RASA  
FINANCIAL MODELLING PACKAGE  
FOR 6800/6809 SYSTEMS IN BASIC.  
£100.00 + VAT**

DETAILS FROM: COMPUSENSE LTD.  
PO BOX 169 PALMERS GREEN  
LONDON N13 4HT. TEL: 01-882 0681

valid file names which cannot then be destroyed using CP/M because the name doesn't follow the above rules. Not all Z80 systems support CP/M (and disks) but the day might not be far off

when they will. I, for one, have applied for an increase in my Barclaycard credit limit, just in case there is any truth in these stories about Osborne's computer.

# MICROMART

## Datasheet

```

; = SUBP -- CP/M File Name Check
;/ CLASS: 1
;/ TIME CRITICAL: No
;/ DESCRIPTION: Tests that a string consists of a leading upper-
;/                case ASCII letter + a number of upper-case
;/                ASCII letters or digits and fills to the specified
;/                length with trailing spaces.
;/ ACTION: See listing comments.
;/ SUBr DEPENDENCE: None
;/ INTERFACES: None
;/ INPUT: HL points to the first byte of the string
;/         B contains the actual length of the string
;/         C contains the required string length
;/ OUTPUT: The result of the edit is in Z, C and HL.
;/         If the carry is set
;/         Then if the Z flag is set
;/             Then a character at (HL) is bad.
;/             Else B and C parameters are incompatible.
;/         Else the string at (HL) is good and space-filled.
;/         Endif
;/ REGs USED:   AF BC HL
;/ STACK USE:  2
;/ PROCESSOR: Z80

SUBP:  LD  A,C      ; return if          79
        CP  B       ; actual string length  B8
        RET C       ; < required length    D8
        PUSH HL     ; save string pointer.  E5
        LD  A,(HL)  ; get 1st byte.          7E
        JR  SBP2    ; jump to test for ASCII u.c. 18 09
SBP1:  LD  A,(HL)  ; get next byte.          7E
        CP  "0      ; jump out as error      FE 30
        JR  C,SBP7 ; if < 1st ASCII digit.    38 1C
        CP  "       ; jump to accept        FE 3A
        JR  C,SBP3 ; if last ASCII digit.    38 08
SBP2:  CP  "A       ; jump out as error      FE 41
        JR  C,SBP7 ; if < 1st ASCII u.c. letter. 38 14
        CP  "[      ; jump out as error      FE 5B
        JR  NC,SBP7; if > last ASCII u.c. letter. 30 10
SBP3:  INC HL      ; point to next byte.      23
        DEC C      ; decrement trailing space cnt.0D
        DJNZ SBP1 ; & edited bytes count until 0.10 EB
        INC C      ;
        LD  B,C     ; pre-decrement in          41
        JR  SBP5    ; case no spaces required. 18 03
SBP4:  LD  (HL),"   ; put space in next byte. 36 20
        INC HL     ;
        INC HL     ;
SBP5:  DJNZ SBP4  ; repeat until trailing space 10 FB
SBP6:  POP HL     ; count 0. Restore pointer.  E1
        OR  A      ; reset C.          B7
        RET       ;
        ;          ;
        ;          ;
SBP7:  INC SP     ; 'loose' saved pointer.      33
        INC SP     ; set Z to show bad character. AF
        XOR A      ; set C to show error.      37
        SCF       ;
        RET       ;
        ;          ;
        ;          ;

```

## ZX81

ZX81 QUALITY SOFTWARE  
— LOW PRICES —

- C1 RACETRACK, BULLETS, HANG-MAN, MUSIC; ALL 1K; RACETRACK 4K REDUCED TO £2.90.
- C2 VIDEO SQUASH GAME 1K AND 4K. £2.90.
- C3 INVADERS M/C 1K PLUS 4K VERSIONS ONLY £2.90.
- C4 BOMBER M/C 1K. FANTASTIC GAME, REALLY CHALLENGING ONLY £2.90.

ANY INDIVIDUAL 1K LISTINGS  
£1.00 (INC. M/C)

ATTENTION ALL PROGRAMMERS!  
Send in your m/c programs to JEM SOFTWARE, post free (listing or cassette) for inclusion in a new publication 'THE MACHINE CODE COLLECTION'. Royalties of up to 50p/copy to be paid monthly to all included. All programs to be received by NOVEMBER 15th.

SAE FOR FURTHER DETAILS  
JEM SOFTWARE  
2 THE GREEN, LILBOURNE,  
WARKS. CV23 0SR.

## Softcentre

OVER 1500 PROGRAMS  
FOR CBM/PET\*

NOW INCLUDING ENHANCED  
MICRO-POOLS PACKAGE  
(Sole UK Distributors)

PLUS  
HEAPS OF GEAR AT REASONABLE  
PRICES FROM CASSETTES TO  
COMPLETE SYSTEMS

WHATEVER YOU WANT/  
WHOEVER MAKES IT IT'S  
PROBABLY IN OUR MASSIVE  
RANGE & OUR CATALOGUE IS  
UPDATED ALMOST DAILY.

SEND 20p STAMP FOR YOUR  
FREE COPY!

MOST MICROS BOUGHT,  
SOLD, REPAIRED

Top Royalties paid on really  
ORIGINAL programs —  
send cassette

26 ALBANY ROAD  
RAYLEIGH ESSEX  
Callers strictly by appointment

(0268-774089) 1pm - 8pm Mon - Sat  
Dealer enquiries welcome.

O P P T E E L C O

## FASTER, FASTER, FASTER!

One way you can get your PET programs to run faster is to use machine code — in which case you'll need a good assembler, like our MIKRO assembler. In one 4k chip we've packed a powerful assembler/editor — and because MIKRO source is written as BASIC lines it's an easy way to start! Available for 3000, 4000 or 8000 machines, just £50 plus VAT.

Writing machine code isn't everybody's cup of tea. You could spend £300 on a compiler, but we think that for most purposes our new FASTER BASIC chip is the best solution. For just £30 plus VAT it'll speed up most Basic programs by 50-100%, sometimes more. If you don't have a disk unit then much of your time is spent waiting for programs to LOAD, SAVE, and VERIFY. The ARROW chip enables the standard CBM cassette deck to load, save, verify and append at 6 to 7 times normal speed. For £30 plus VAT you also get auto-repeat, a plot command, and a 'hexadecimal calculator' mode.

FASTER BASIC and ARROW are 2k chips which can be located in any vacant ROM area (as ordered). Each can also be combined in a 4k chip with one of our other 2k chips such as SUPERCHIP or PIC-CHIP. There is a 'customising' charge of £5 plus VAT.

OUR CURRENT CATALOGUE IS  
FREE TO PET OWNERS

**SUPERSOFT**

Dept P6, 10-14 Canning Road,  
Wealdstone, Harrow, Middlesex.  
Telephone: 01-861 1166



### NASPRINT for NASCOM II

A powerful companion to your NASPEN text processor. Features:

- \* Mail Merge
- \* Option to merge a heading onto each page
- \* Page numbering from 1 to 99 by single text character
- \* User set margin size
- \* User set paper size for software form feed after printing a NASPEN page
- \* Software form feed by single text character
- \* Option to stop print after each page
- \* User set Newline flyback time count
- \* Relocatable machine code program includes a useful screen processing routine.

All this only £11.50 inclusive

Available only for NAS-SY31 on 300 bps cassette. Mail order only please to:-

ZENTHOR SYSTEMS LIMITED  
5 CHALKPIT LANE,  
OXFORD, SURREY RH8 0NF.



From  
£120\*

Ex-stock  
\*Plus 15% VAT

ACORN PRODUCTS-ACCESSORIES-SOFTWARE  
REPAIR SERVICE AND SPARES  
ECONET COMMUNICATIONS INTERFACE

Please call or write for more  
information, lists, order forms etc.

2114L R.A.M. £1.25 each

D.A. Computers Ltd., 184 London Road

# LEICESTER

to Sell, Buy or Exchange  
Ring us for used bargains

## USED SOFTWARE

We will act as agents for sellers and buyers of used software.

Ring for huge savings

## EPSON

Complete stock of MX-70, MX-80 MX-100 Printers, Interface Cards, etc. in stock. Price £'s CALL. Maintenance Contract or leasing if required. We Know EPSON because we use EPSON.

## £'S CALL

### ACORN ATOM In Yorkshire

Kits or Built from £120

### ATOM SOFTWARE

Play against the computer.

### ATOMIC CHESS £10.99

(plays different levels)

### ATOMIC DRAUGHTS £4.99

(Both feature excellent graphics and play as a real opponent would) Both £14.99

### SUPERBOARD/UK101 ADD-ONS

(require soldering ability)

High Speed Cassette Interface Kit £14.99

300I/2400I/4800 switchable to suit recorder Enhanced Video Display. 48 x 32 display £14.99

Kit + 48 x 32 CEGMON £36.99

Kit + 48 x 32 NEWMON £27.99

Software for all Superboard/UK101 screen formats.

Chess 1.9, £9.99 Draughts £4.99 Both £13.99

N.B. All board games are fully interactive with complete instructions and excellent graphics.

## NORTHERN MICRO

29 Moorcroft Park, New Mill, Huddersfield  
Tel: Holmfirth (0484) 892062

Add 50p P + P and 15% VAT

Callers welcome by appointment.

# TRS-80 Compiler Work-Station

Model I and III, and Video Genie

## Speed up your Basic Program Development

EDIT — Full-screen BASIC editor with floating cursor and auto repeat. 30 commands and functions let you find, change, insert, delete, replicate, copy, or move BASIC text at the character, string, line, or block level. Improved program visibility, fewer errors. £17.50

EXEC — Command-list processor. Speeds up and simplifies repetitive procedures such as power-up, file reorganisation. £9.50

## Speed up your Basic Program Execution

ACCEL2 — Compiler for Model I and III BASIC (disk and non-disk). Execution speed-ups of 20-30 times for integer operations, 5-7 times for string handling, less if I/D limited. Very easy to use. Professionals note: Full instructions for selling derived code on tape or disk. No royalties! Ask for more details. £39.95

TSAVE — Writes compiled code to SYSTEM tape. Makes core-image backups of any machine-language programs. £4.95

**southern software**

PO Box 39, Eastleigh, Hants, England, SO5 5WQ

# LEISURE LINES

by J J Clessa

There was a very good response to the August puzzle — about 200 entries were received. Most of these had the correct answer. Many had used micros and calculators for solution but some had found analytical methods by which the problem could be solved. The correct answer, to the nearest second, is 142, ie 2m 22s.

The randomly-plucked winning entry came from Stephen Grant of Horsham in Sussex. Nice going, Stephen! Your prize will soon be winging its way to sunny Sussex.

## Quickie

No answer, no prizes. There is one word on this page which is not spelt correctly — can you find it?

## Prize puzzle

An exercise in logic this month.

1. There are eight pens, A to H as shown, and each pen contains either a cow, a horse, a pig or a sheep.

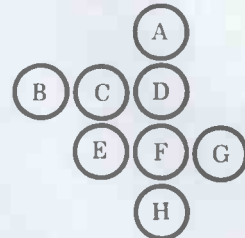

2. At least one of each type of animal is present.

3. At least the pig is penned between two cow pens.

4. Every horse is penned between two pig pens.

5. No cow is penned next to a horse.

6. There is only one sheep, and its pen is not next to that of a pig.

7. At least two pig pens are contiguous. Which pen is the sheep in?

Answers on *postcards*, please, to arrive not later than 30 November, to: November Prize Puzzle, Leisure Lines, PCW, 14 Rathbone place, London W1P 1DE.

# PROGRAMS

## TRS-80 Sheepdog Trial

by Simon Williams

This is written in Level II Basic and takes up about 8k of RAM. All the

instructions are contained within the program. Note that the '^' character denotes a space.

```

10 GOTO 200
19 *** MOVE SHEEPDOG
20 I=VAL(INKEY$): IF I<1 OR I>9 GOTO 20
30 DV=DX+DM(0,I-1):DW=DY+DM(1,I-1):DP=P+D+DV
40 L=-2: U=2: IF DM(1,I-1)=0 IF DM(0,I-1)-3 U=0 ELSE IF DM(0,I-1)=3 L=0
50 DF=0: FOR N=L TO U: IF PEEK(DP+N)>32 AND PEEK(DP+N)<128 DF=1
60 NEXT: IF DF=0 AND DV>1 AND DW<62 AND DN>0 AND DN<1024 PRINTDY+DX-2,B$;:
    PRINTDX+DV-2,D$;: DX=DV: DY=DM
99 *** MOVE SHEEP
100 FOR N=0 TO K: SD(N)=SQR((ABS(DX-SX(N))/3)^2+(ABS(DY-SY(N))/64)^2)
110 IF SD(N)>3 SD(N)=0: NEXT ELSE NEXT
120 IF SD(0)+SD(1)+SD(2)=0 C=C+1: IF C>5L AND S>0 S=20-(C-5L)/3: RETURN ELSE
    RETURN
130 IF SD(0)>SD(1) IF SD(0)>SD(2) M=0 ELSE M=2 ELSE IF SD(1)>SD(2) M=1 ELSE M=2
140 SX=SX(M)+SGN(DX-SX(M))*3: SY=SY(M)+SGN(DY-SY(M))*64: SP=P+SX+SY
150 L=-2: U=1: IF SY=SY(M) IF SX=SX(M)-3 U=0 ELSE IF SX=SX(M)+3 L=0
160 DF=0: FOR N=L TO U: IF PEEK(SP+N)>127 DF=1
170 NEXT: IF DF=0 AND SX>XL AND SX<59 AND SY>63 AND SY<960 PRINTSY(M)+SX(M)-2,
    B1$;: PRINTSY(SX-2,S$);: SX(M)-SX: SY(M)-SY
180 SD(M)=0: GOTO 120
199 *** INITIALISE
200 DEFINT A-Z: DIM DM(1,8),SD(2),SX(2),SY(2): FOR M=0 TO 1: FOR N=0 TO 8: READ
    DM(M,N): NEXT M,N
210 DATA -3,0,3,-3,0,3,3,0,3,64,6,-34,0,0,0,-64,-64,-64
220 B$="*****": B1$="*****": S$=CHR$(131)+CHR$(175)+CHR$(143)+C+(175)
230 D$=CHR$(131)+CHR$(173)+CHR$(140)+CHR$(156)+CHR$(129): P=15: L=K-0
299 *** TITLE GRAPHICS
300 CLS:FOR M=1 TO 40: READ X,Y,Z: FOR N=X TO Y: SET(N,Z): NEXT N,M
310 DATA 10,25,12,10,25,13,58,73,12,58,73,13,82,97,12,82,97,13,106,117,12,106,
    117,13,10,21,16,10,21,17,34,45,16,34,45,17,58,67,16,58,67,17,82,91,16,82,91,
    17,106,117,16,106,117,17,6,21,20,6,21,21,58,73,20,58,73,21,82,97,20,82,97,21
320 DATA 10,15,24,26,31,24,40,45,24,58,67,24,74,79,24,94,99,24,16,17,25,46,47,25
    44,47,28,74,79,28,94,99,28,16,17,31,12,15,32,26,31,32,40,45,32,108,115,32
330 FOR M=1 TO 30: READ X,Y,Z: FOR N=X TO Y: SET(2,N): SET(2+1,N): NEXT N,M
340 DATA 12,17,6,12,17,8,16,21,22,16,21,24,12,21,30,12,27,32,12,21,46,12,21,48,
    12,21,54,12,21,56,12,21,78,12,21,80,12,21,102,12,21,104,12,17,118,12,17,120
    
```

## Specialised electronic circuits

Do you have an idea for a circuit which you have difficulty in implementing?

We undertake all types of circuit design from initial concept through circuit diagram to completed board.



78 Willoughby Road  
Bourne  
Lincs.  
Tel: 0945 712741

## NATIONAL TRS-80 USERS GROUP

OFFER:  
MONTHLY NEWSLETTER  
(Back Issues Available)

80-US \* BOOKLETS ON ASSEMBLER

\* VIDEOGENIE SORTING

4-DAY COURSE IN DECEMBER

MEETINGS IN:

Cambridge, Oxford, Birmingham, London,

Manchester, Milton Keynes

FREE SOFTWARE LIBRARY

INDEPENDENT ADVICE AT ALL TIMES

Regional Sub-Groups \* Software & Article

Compilations

RING BRIAN PAIN

on 0908 566660(W) 564271(H)

Write: 40A High Street

Stoney Stratford, Milton Keynes

# PROGRAMS

```

350 DATA 24,32,10,26,30,18,25,31,24,25,31,32,25,31,38,29,31,46,25,32,62,24,32,
72,25,27,80,29,32,80,24,32,86,25,32,92,25,32,100,24,32,106
360 PRINT#723,"COPYRIGHT 1981, S.WILLIAMS"
370 SX(0)=47: SY(0)=128: DX=56: DY=128: I=4: FOR X=1 TO 7: GOSUB 30: NEXT
380 I=7: GOSUB 30: I=1: GOSUB 30: FOR X=207 TO 216: PRINT#X,"-": NEXT
390 K=2: C=0: FOR N=1 TO 1000: NEXT
399 *** INSTRUCTIONS
400 CLS: PRINT#25,"SHEEPDOG TRIAL"
410 FOR N=89 TO 102: PRINT#N,CHR$(131);: NEXT
420 PRINT#130,"THE IDEA OF THE GAME IS TO DIRECT A SHEEPDOG "D$ TO GUIDE↓
***THREE SHEEP "S$ THROUGH AND AROUND A SERIES OF OBSTACLES↓
***DEPICTED ON THE SCREEN. THE CONTROLS FOR THE SHEEPDOG ARE:
430 PRINT#130,"AS SHOWN WITH, FOR INSTANCE, THE '8' MOVING THE DOG↑↑8↑↑9↓
↑↑UP THE SCREEN AND THE '6' MOVING IT TO THE RIGHT.↑↑↑↑6↑↑↑↑6↑
↑↑THE '5' CAUSES THE DOG TO STAND STILL. THE SHEEP↑↑↑↑1↑↑↑↑3↑
440 PRINT#130,"WILL ONLY MOVE WHEN PROMPTED BY THE PROXIMITY OF THE DOG.↓
↑↑THE COURSE IS DIVIDED INTO 4 SECTIONS, EACH WITH AN OBSTACLE↓
↑↑TO GUIDE THE SHEEP THROUGH OR AROUND. POINTS ARE DEDUCTED FROM"
450 PRINT#130,"A MAXIMUM SCORE IN EACH SECTION FOR AN EXCESSIVE NUMBER OF↓
MOVES. THE COURSE IS SHOWN IN AN INSET IN THE TOP LEFT OF THE↓
↑↑SCREEN. AVOID CORNERS, ALTHOUGH THE SHEEP CAN ALWAYS BE"
460 PRINT#130,"RETRIEVED. GUIDE THEM INTO THE PEN TO FINISH.↓
↑↑↑↑↑↑↑↑↑↑PRESS SPACE BAR TO START";
470 IF INKEY$<>" " GOTO 470
480 *** SECTION 1
490 CLS: S=20: XL=19: SL=24
510 FOR M=0 TO 320 STEP 64: FOR N=0 TO 15: READ D: PRINT#M+N,CHR$(D);: NEXT N,M
520 DATA 51,150,179,179,179,147,137,144,32,32,160,140,140,32,49,170,32,149,72,
69,68,71,69,170,160,168,161,71,65,84,63,170,176,178,179,179,147,169,32,170,
32,130,164,176,176,144,32,170
530 DATA 70,79,82,68,130,164,133,170,84,82,69,69,42,162,132,170,52,80,69,78,136,
133,137,144,131,131,131,131,131,129,50,170,131,131,131,131,131,131,131,131,131,
131,131,131,131,131,131,131
540 PRINT#390,"SECTION 1";: PRINT#440,"SECTION SCORE"S;: PRINT#512,"RUNNING
SCOPE"PS;
550 DX=55: SX(0)=43: SX(1)=46: SX(2)=52: DT=128: SY(0)=128: SY(1)=256: SY(2)=720
560 PRINT#546,CHR$(152);CHR$(149);: PRINT#555,CHR$(152);CHR$(149)
570 PRINT#609,CHR$(191);CHR$(134);: PRINT#622,CHR$(191);CHR$(134)
580 PRINT#169,5$;: PRINT#300,5$;: PRINT#370,5$;: PRINT#181,D$;
590 GOSUB 20
600 FOR N=0 TO 2: IF SX(N)>34 AND SX(N)<46 AND SY(N)=576 AND S(N)=0 S(N)=1
610 NEXT: PRINT#461,5;
620 IF S(0)=0 OR S(1)=0 OR S(2)=0 OR SY(0)>768 OR SY(1)>768 OR SY(2)>768 OR DY<
640 GOTO 590
630 FOR N=1 TO 500: NEXT: C=0
635 *** SECTION 2
700 RS=5: S=20: SL=28: PRINT#398,"2";: PRINT#461,5;: PRINT#525,RS: STRING$(40,
32): PRINT
710 PRINT#DX+DY-2,B$;: DY=DY+640: PRINT#DX+DY-2,D$;
720 FOR N=0 TO 2: PRINT#SX(N)+SY(N)-2,B1$;: SY(N)=SY(N)+640: PRINT#SX(N)+SY(N)
-2,S$;: S(N)=0
730 FOR M=512 TO 704 STEP 64: FOR N=37 TO 42: READ D: PRINT#M+N,CHR$(D);: NEXT
N,M
740 DATA 32,176,164,164,136,144,138,152,187,185,155,166,32,130,32,191,32,129,32,
32,152,143,145,32
750 GOSUB 20
760 FOR N=0 TO 2: IF SX(N)=40 AND SY(N)>704 AND S(N)=0 S(N)=1
770 NEXT: PRINT#461,5;
780 IF S(0)=0 OR S(1)=0 OR S(2)=0 OR SY(0)>255 OR SY(1)>255 OR SY(2)>255 OR DY<
380 GOTO 750
790 FOR N=1 TO 500: NEXT: C=0
795 *** SECTION 3
800 RS=RS+5: S=20: SL=51: PRINT#398,"3";: PRINT#461,5;: PRINT#525,RS: STRING$(30,
32): PRINT: PRINT
810 PRINT#DX+DY-2,B$;: DY=DY+640: PRINT#DX+DY-2,D$;
820 FOR N=0 TO 2: PRINT#SX(N)+SY(N)-2,B1$;: SY(N)=SY(N)+640: PRINT#SX(N)+SY(N)
-2,S$;: S(N)=0: NEXT
830 FOR M=256 TO 320 STEP 64: FOR N=30 TO 49: READ D: PRINT#M+N,CHR$(D);: NEXT
N,M
840 DATA 150,158,166,154,166,166,166,172,139,178,166,165,153,153,155,158,178,
166,150,148,138,32,32,133,32,129,135,130,32,130,32,129,32,173,130,138,32,
133,130,32
850 GOSUB 20
860 FOR N=0 TO 2: IF SX(N)=40 AND SY(N)<256 AND S(N)=0 S(N)=1
870 NEXT: PRINT#461,5;
880 IF S(0)=0 OR S(1)=0 OR S(2)=0 OR SY(0)>768 OR SY(1)>768 OR SY(2)>768 OR DY<
640 GOTO 850
890 FOR N=1 TO 500: NEXT: C=0
895 *** SECTION 4
900 RS=RS+5: S=20: XL=7: SL=21: PRINT#398,"4";: PRINT#461,5;: PRINT#525,RS;:
PRINT#286,STRING$(20," ");: PRINT#300,STRING$(15," ");
910 PRINT#DX+DY-2,B$;: DY=DY+640: PRINT#DX+DY-2,D$;
920 FOR N=0 TO 2: PRINT#SX(N)+SY(N)-2,B1$;: SY(N)=SY(N)+640: PRINT#SX(N)+SY(N)
-2,S$;: S(N)=0: NEXT
930 FOR N=0 TO 9: READ D: PRINT#652+N,CHR$(D);: PRINT#908+N,CHR$(D);: NEXT
940 FOR N=723 TO 851 STEP 64: PRINT#N," ": NEXT: DATA 151,131,131,151,131,131,
151,131,131,149
950 FOR Y=33 TO 41: SET(24,Y): NEXT: PRINT#1007,CHR$(188);CHR$(176);
960 FOR X=34 TO 62 STEP 2: READ D: FOR Y=D TO D+2: SET(X,Y): SET(X+1,Y): NEXT
Y,X
970 FOR X=80 TO 92 STEP 2: READ D: FOR Y=D TO D+2: SET(X,Y): SET(X+1,Y): NEXT
Y,X
980 DATA 21,21,21,22,22,22,22,23,23,23,24,25,26,27,27,29,40,41,42,43,44,45
990 PRINT#672,"*";: PRINT#738,"*";: PRINT#805,"*";
1000 GOSUB 20

```

# MICROMART

## J.M.Pickard.

**MICRO COMPUTER SERVICES**  
PAPER: 11x9.5 inch 60g continuous plain with perforated sprockets. £10.00 per box of 2000 sheets.  
LABELS: 1.44x4 inch 2 across on web. £7.50 per 1000.  
FLOPPY DISKS: MD 525 01 £15.00 per box of 10  
MEMOREX £16.20 per box of 10

MAILING SERVICE: PERSONAL AND BUSINESS MAILING LISTS CREATED AND PRINTED. RING FOR A QUOTE.  
DON'T WORRY IF YOU CAN'T SEE WHAT YOU WANT. RING US AND WE WILL RING YOU BACK WITH A QUOTE.  
APPLE 48K EUROPLUS, 2 DRIVES AND 12 inch B/W MONITOR £1350.00  
APPLE SILENT TYPE PRINTER £189.00  
EPSON MX80T £299.00 MX80FT £325  
OTHERS - RING FOR A QUOTE  
VIDEO GENIE SYSTEM 48K, 2 DRIVES AND 12 inch B/W MONITOR  
THIS MONTH'S SPECIAL OFFER : £999.00  
VIDEO GENIE 16K £289... 32K £345  
12 inch B/W MONITOR £69.00.

POST AND PACKING AT COST ALL ITEMS PLUS VAT  
22 HOLLAND ROAD, CLACTON-ON-SEA ESSEX. TEL (0255) 29018.

## SHARP MZ-80K software

- E5 - DUST COVERS for MZ-80K COMPUTER or MZ-80P3 printer. Black, waterproof.
  - E6 - HEAD ON. Basic/machine code arcade game. Gobble up dots but avoid suicidal robot cars intent on your destruction! Very fast.
  - E5 - MOONLANDER. Complex real time lander. Superlative graphics/sound (10K RAM).
  - E5 - COMPOSER. Play tunes via the keyboard. Replay your compositions. Print music strings for future use.
  - E5 - CHASE. Excellent real time chase. Steal the gems but avoid the vicious dog!
  - E5 - MANIAC. Exhausting real time maniac drive. Run down strays, but don't crash. 81 skills.
  - E4 - BANK ACCOUNT. Input your regular income/outgoings. See the year's cash flow in monthly statements.
  - E4 - BANNER. Input your message and see it scroll up the screen in large graphics characters.
  - E4 EACH - BIORHYTHMS, MASTERMIND, FOX & GEESE, ADDRESS BOOK.
  - COMPUTER ASSISTED LEARNING. Superb suite of programs written by experts. Exclusive to us. E5 each - WORD MATCH, COUNT & ADD, PICTURE COUNT, E4 - CHARACTER MATCH.
- Write or phone for full catalogue. Cash with order, or ACCESS. All prices fully inclusive. Orders despatched by return. FREE machine code SPACE INVADERS with all orders of £15 and over.

## HIGHLIGHT SOFTWARE

3 Nether Court Halstead Essex CO9 2HE  
Telephone (0787) 475714

## TOP PET GAMES

Only the best games qualify for inclusion in SUPERSOFT's catalogue of programs for the PET.  
If you're a fan of arcade games then you'll love SUPER GLOOPER, ASTEROIDS, GIDDY GHOLS and METEORITES. They cost £8 each (plus VAT) and run on all 40-column PETs other than the original Old Rom machines.  
If you prefer an intellectual challenge, then THE HITCH-HIKERS GUIDE TO THE GALAXY will have you tearing your hair out (but you'll need a 32k machine - and £16 plus VAT). The ultimate adventure game is CATACOMBS (£27) but you must have disks. If you have got CBM drives, but prefer to take it easy then our latest adventure, GOBLIN TOWERS (£14) is a comparatively mild introduction to the world of adventure programs. Adventure addicts with Basic 4 and disks should consider WEIRD WOOD (£25); some people think it's better than CATACOMBS!  
Somewhere in between the extremes of arcade and adventure you'll find HALLOWS OF DEATH (£14) and WIZARD'S LAIR (£10) and if you write for a free copy of our latest catalogue you'll discover even more great games.  
Please add 15% VAT to all prices - Postage FREE.

**SUPERSOFT**  
Dept. P3, 10-14 Canning Road Wealdstone, Harrow, Middlesex  
Tel: 01-861 1166



### SIXTYFIVE ZX81 PROGRAMS

65 1K program listings for only £4.95  
Includes many games, Home Finance, Utility, Chequebook, Mortgage, and more. Includes Hints'n'Tips.

### BEGINNERS BASIC COURSE

Self-teach course in non technical language for use with/without a computer. Special sections for ZX81/PET. Full question/answer sections. Only £10.95. Barclaycard accepted.

### SUSSEX SOFTWARE

(DEPT PCW3) WALLSEND HOUSE  
PEVENSEY BAY, SUSSEX

### M & G SOFT

#### MZ 80K SOFTWARE

Z80 DISASSEMBLER  
MACHINE CODE-FULL MNEWMONIC WILL RUN WITH BASIC OR ZEN OR ALONE £10.00

MZ-80K MACHINE CODE MONITOR SIMPLE TO USE BUT VERY LARGE INSTRUCTION SET - SAVE - LOAD - VERIFY NAMED FILES - FULL ON SCREEN EDIT - WILL SAVE ANY PROGRAM - NO MEMORY LIMITS £9.95

SOUND EFFECTS GENERATOR A PACK OF THREE PROGRAMS MACHINE CODE GENERATOR +2 BASIC CONTROL PROGS. £5.95

18 LEGATE ROAD  
GYPSY BRIDGE, BOSTON, LINCS.

# MICROMART

## PETS

### PETS - We Sell Them

As authorised Commodore Dealers we stock and supply all PET Hardware, Computhink Discs, Oki Microline 80 Decwriter LA34, Texas 810, Qume Sprint 5 - all at competitive prices

### PETS - We Buy Them

Part Exchange is very welcome, we also buy for cash.

### PETS - We Hire Them

Our specialist hire service, with maintenance included for all Commodore equipment.  
- Complete systems for evaluation  
- Multiple units for educational courses  
- Single units for individual use

From 1 day upwards, all units available. Delivery by arrangement, anywhere in UK.

### PETS - Software

We are fully authorised BUSINESS SOFTWARE DEALERS for Commodore Software - COMPAY COMSTOCK, WORDPRO etc. Also PETSOFT, BRISTOL SOFTWARE, LANDSLER PAYROLL & HOTEL SYSTEM.

PLUS for ACCOUNTANTS, the unique CSM INCOMPLETE RECORDS PACKAGE - this is the best available.

### MAIL - ORDER

All Hardware and Software can be bought by Mail Order Delivery by Securicor, or Registered Post. Discounts for Cash & Carry or Mail-Order. Access accepted or by Leasing (subject to acceptance)

### MICRO-FACILITIES LTD

129 High Street, Hampton Hill, Middlesex, TW12 1NJ 01-979 4546 or 01-941 1197

# GAMER

SHARP MZ-80K (48K - £399 plus VAT)  
SHARP MZ-80B (£960 plus VAT)  
VIDEO GENIE (£289 plus VAT)  
ACORN ATOM (assembled - £150 plus VAT)  
ATARI 400 (16K - £285 plus VAT)  
ATARI 800 (16K - £525 plus VAT)  
TEXAS T199/4 (£242.50 plus VAT)  
Send large SAE for computer price list.

ATARI 400 £285 plus VAT  
ATARI 800 £525 plus VAT  
+ INTELIVISION + ACE TV GAMES  
+ CHESS COMPUTERS  
+ HAND HELD ELECTRONIC GAMES  
+ SF, FANTASY & WAR GAMES  
+ ALL KINDS OF GAMES & PUZZLES

**BRIGHTON** 18 SYDNEY STREET  
TEL 0273 698424

## io systems ltd.

VERY HIGH RESOLUTION FOR NASCOM 2  
380 x 220 individually addressable points

### FEATURES:

- fully bit mapped from dynamic RAM
- software controlled
- software supplied for point-plot, line-draw - block shading and display control
- mixed text and graphics
- real time plotting
- display size variable to suit memory available

Price . . . . £55 + 15% VAT (post free)

### EPROM PROGRAMMER FEATURES:

- programs: 3-rail 2708, 2716 2716, 2516 and single rail: 2758, 2508 2732, 2532
- EPROM type selected by plug-in modules - 3 modules supplied with simple wiring diagrams for all EPROM types
- driven from NASCOM 1 or 2 PIO
- powered from NASCOM and transformer supplied
- software supplied for READ/PROGRAM/VERIFY

### \*\* CAN BE USED WITH OTHER MACHINES WITH 2 PARALLEL PORTS

Price . . . . £63 + 15% VAT (post free)

All products built & fully tested supplied with comprehensive documentation and full instructions for simple installation

Send SAE for free data sheets

AVAILABLE NOW direct from:

6 Laleham Ave., Mill Hill London NW7 3HL  
Tel: 01-959 0106



# PROGRAMS

```

1010 FOR N=0 TO 2: IF SX(N)>14 AND SX(N)<20 AND SY(N)>639 AND SY(N)<896 AND S(N)
=C S(N)-1
1020 NEXT: PRINT@461,5;
1030 IF S(C)=0 OR S(1)=0 OR S(2)=0 GOTO 1000
1099 *** FINISH/REPLAY
1100 PRINT@97,"YOU HAVE COMPLETED THE COURSE":
1110 PRINT@164,"WITH A TOTAL OF"RS+S"POINTS.":
1120 PRINT@239,"AGAIN (Y OR N)?":
1130 IS=INKEYS: IF IS="N" CLS: END ELSE IF IS<>"Y" GOTO 1130
1140 RESTORE: FOR N=1 TO 228: READ D: NEXT: GOTO 500
    
```

## ZX81 Sun and Planets

by C Ward

This program calculates the day-by-day the Sun; day zero is 1 January 1980. positions of the inner planets relative to

```

10 LET A=327.95626
20 LET B=0
30 LET C=-258.47927
40 LET D=-135.14322
45 PLOT 30,20
46 PRINT "SUN"
50 PLOT 30+SIN(A/180*PI)*20,20
+COS(A/180*PI)*20
60 PRINT "MARS"
61 PLOT 30+SIN(B/180*PI)*13.180432,20
+COS(B/180*PI)*13.180432
65 PRINT "EARTH"
70 PLOT 30+SIN(C/180*PI)*9.5330396,20
+COS(C/180*PI)*9.5330396
75 PRINT "VENUS"
80 PLOT 30+SIN(D/180*PI)*5.1013216,20
+COS(D/180*PI)*5.1013216
85 PRINT "M"
90 LET A=A-0.5240327
100 LET B=B-0.98561
110 LET C=C-1.6021291
120 LET D=D-4.0923507
130 PAUSE 40
140 CLS
150 GOTO 45
    
```

## CHESS FINAL '81

Continued from page 101

search with the killer heuristic and employs selective 'pruning' of the tree. The amount of 'pruning' is increased in complex situations to keep the thinking time reasonably constant. Cyrus examines about 200 positions a second and includes an allowance for future captures in each assessment.

Cyrus is the result of about six months spare time work by its author. Version 2 is currently being planned and will be considerably stronger.

Three points are worth stressing here: firstly, Cyrus only uses around 7k whereas all the other computers use considerably more: Logichess 2.1 uses 26k for instance. Secondly, version 2 promises to be stronger. M Stean, one of England's International Grand Masters discussed Cyrus's games with the author, finding them most impressive. He estimated the strength of Cyrus to be around 170 on the BCF grading scale (equal to about 1960 on the international list). If Cyrus is really this strong now what will it be like when improved?

Finally, Cyrus is in fact a better player than its author!

Clearly most people would like to know how Cyrus would fare against the best commercially available computers and how it would stand up to human opposition. I am afraid we will have to wait a while before that can be answered. No doubt all the big names will be competing for the World Micro Computer Chess Championship (to be held in Hamburg, 21-29 September.) Unfortunately, Cyrus will not be taking part. Still, there is no doubt everyone interested in chess programs is going to hear a lot about Cyrus in the coming months.

Thanks must go to the organising committee, D Levy, K O'Connell, PCW, the tournament director, Peter Morrish, Stewart Reuben (FIDE International Arbiter) and Graham Lee. Kaane Danielsen would like to thank Dylan Harris and John John Jones of Thames Polytechnic for operating his program and Nascom for loaning the machine on which it ran. Thanks also to Cetronic for supplying the mains conditioners.

## SPECIAL LIMITED OFFER

for just one month only

THE EPSON MX100 for just £499

Yes, this popular 15 inch carriage 80 cps bi-directional printer which is ideal for APPLE, PET, SHARP, SUPERBRAIN, TANDY etc. is offered at this special price for 1 month only. Interfaces extra. Specify which micro on order. FULL 12 MONTH GUARANTEE

To claim your special offer send this advert together with your cash/cheque or bankers draft to:

ANDERLEE COMPUTING SERVICES  
17 ADELPHI CRES., HAYES PARK, MIDDX.  
PHONE: 01-841 1507

Offer is subject to product availability and will end on 30 November 1981.

## APPLE DOS 3.2 PERSONALISED DISKETTE SERVICE

Your own DOS commands to order  
Flashing Disk Volume to order  
Flashing Disk File to order  
Free Sector Count in DOS

## SIMPLE LETTER WRITER (Disk only)

for Apple/Paper Tiger Printer. Uses 9½" computer paper. Enhanced mode for Letter Heading. 96 character line.

Lower case with Lazer's I/c adaptor  
SAE for details

MAIL ORDER ONLY  
KWOKSONIC 27A ORCHARD ROAD  
BROMLEY KENT

# CALCULATOR CORNER

Continued from page 145

## Software

The Casio Basic is closer to 'normal' Basic than that used by the Sharp, which is both good and bad news since some of the more unorthodox features of the Sharp Basic, such as GOTO (string variable) and IF (string variable) are useful and attractive.

The 702 Basic has its high points too, though. One and two dimensional arrays (up to 200 elements) are catered for and they may be numeric or string arrays (or mixed if you can stay in control of your subscripts). Strings may be stored in the usual string variables A\$,B\$ etc (seven characters max) or in a special 30 character variable called \$. The string functions LEN() and MID() are supported, but MID(n,m) only works on the contents of \$. String addition is allowed.

No fewer than six sorts of variable names are allowed; A-Z are the 26 fixed registers, A0 to A9 through T0-9 are the 200 user assigned variables and A(n) is the form for array variables plus their string equivalents. Thus A(10) is the same register as B0, and A(18,7) is the same as S7. As on the Sharp, A and A\$ cannot be defined simultaneously.

'Key' is the equivalent of the keyboard GET; when used in a loop it waits for a character from the keyboard, which allows input to start execution without a return. Good news for interactive games fans! WAIT is a programmable pause which determines how long a PRINT statement will display its output - from 0.05 to 50 seconds.

CSR is equivalent to TAB and specifies the place in the display at which a printed result will appear. CSR and the PRT (PRINT) instruction with which it is used can both accept an expression for their argument, which is a nice touch allowing all sorts of dynamic displays to be set up.

GOTO and GSB may both take a numeric variable or any expression as argument to allow indirect jumps; both may also specify a P register. Subroutines are nestable to ten levels, and FOR...NEXT to eight. The conditional IF may be followed by THEN

and a line number (direct or indirect) or by ; and a command or assignment. The biggest omission in this otherwise remarkably comprehensive Basic is that no Boolean operators are included; the Sharp by contrast has full Boolean logic and advanced programmers may well miss them. You pay your money and takes your choice: string functions or Boolean operators.

## Bulk storage

The 702p stores onto cassette using the same adaptor (FA-2) as the 602. I don't have one and so cannot report directly on cassette storage. Programs are SAVED by filename; individual P registers can be saved and loaded. Chaining is automatic; a program can be chained or overlaid from tape by suitable choice of line numbers. Data is transferred by PUT and GET and individual blocks of variables may be saved. Remote control of a suitable recorder is provided for. All this is gleaned from the manual, which is no better than we have come to expect from Casio and quite unintelligible in places. The program library is the standard Casio issue, the same programs from the 502 and 602 libraries translated into Basic.

## Benchmarks and conclusions

I applied my new standard Benchmark (see Calc Corner, Sept) to the 702 and my earlier suspicion was confirmed: it is very fast, as fast, in fact, as the 602p which is my current record holder. This is quite remarkable, given that it uses interpreted Basic, and is in stark contrast to the Sharp. I print the full table of Benchmarks again, since I have now performed the Sharp test myself instead of using *Microcomputing's* figures.

To summarise, I liked this machine a lot. Only the fact that I had a broken wrist at the time of writing stopped me sitting up all night with it; the features are such that several months would be necessary to really plumb its depths. It has all the ergonomic features which

Machine	Time taken (secs)	Memory used	% of total memory
Texas T159	43	59 steps	10.3
HP-41C	37	41 bytes	15.6
Sharp PC1211	52	81 steps	5.9
Casio 602p	20	21 steps	4.1
Casio 702p	20	77 steps	4.6

# MICROMART

## UNDECIDED STRIKE NOW

PET	RRP	OUR PRICE
4008N 8K	£450	£382
4016 16K	£550	£467
4032 32K	£695	£590
8032 32K	£895	£760
DISK DRIVE		
4040 343K	£695	£590
8050 950K	£895	£760
PRINTERS		
4022 80COL	£395	£335
8024 132COL	£1160	£986
8026 DAISY	£995	£845

VAT to be added to the above figures.  
Carr. £5 P&P per item.

IF YOU KNOW WHAT YOU WANT WHY WAIT?  
THESE ARE THE PRICES YOU NEED.

ORCHARD COMPUTER SERVICES  
ORCHARD HOUSE,  
21 ST MARTINS STREET,  
WALLINGFORD, OXON.  
OPEN 6 DAYS PER WEEK  
Telephone - Wallingford 0491-35529



## VETS FOR PETS

Anita Electronic Services (London) Ltd. are specialists in the repair and service of Commodore Pets.

We offer a fast on-site service, or alternatively repairs can be carried out at our workshops should you wish to bring in your Pet.

Pet maintenance contracts are available at very competitive prices. Trade inquiries welcomed.

For further information, tel or write to:

John Meade  
Anita Electronic Services  
15 Clerkenwell Close, London EC1  
01-253 2444

We also specialise in the repair of all makes of office equipment.

## PET HI-RES

The new HR-40 board offers -

- 8K of its own RAM
- 64,000 individually addressable points
- 320 by 200 resolution
- machine code utility software in EPROM
- existing PET features unaffected
- easily fitted, no soldering necessary
- low price of £149 plus VAT

There's no limit to what you can do when you have the HR-40 board fitted to your PET. The single dot resolution allows you to draw smooth curves, accurate diagrams and much more. If you've got one of the new 4000 machines with a 12 inch screen then you'll need the HR-40B, but it won't cost a penny more.

The HR-80 board for the 8032 should be available soon - phone for details.

SUPERSOFT are PET/CBM software specialists. Other top quality products include MIKRO, the assembler in a chip (£50) and SUPERCHIP, the biggest selling British chip (£45).

Our catalogue is available free to PET owners.

## SUPERSOFT

Dept. P3, 10-14 Canning Road,  
Wealdstone, Harrow, Middlesex.  
Tel: 01-861 1166



ON THE MOVE WITH ZX SOFTWARE

PROGRAMS FOR THE ZX 80/81 INCLUDING:  
ZX CHESS - Machine Code Program £10.00  
ADVENTURES - From £7.00 To £9.00  
ZX BUG - Machine Code Debugging £7.00  
EDUCATIONAL GAMES For Children.

AND MANY OTHERS  
FOR A CATALOGUE GIVING DETAILS OF ALL PROGRAMS PLEASE SEND A S.A.E. TO:  
ARTIC COMPUTING,  
396, JAMES RECKITT AVENUE,  
HULL, HU80JA.

## PET UPGRADE

We can upgrade your large keyboard PET at a fraction of the 'New Price' difference.

8K to 16K ..... £44.00  
16K to 32K ..... from £56.00  
8K to 32K ..... £69.00

NO EXTRA CHARGE

If expansion area drilled with quarter inch holes . . .

All new RAMs fitted with sockets  
Fast 2 hours while you wait service.

Tel: Mick Bignell  
01-953 8385.

# MICROMART

## SINCLAIR ZX81 SOFTWARE

16K ADVENTURES      CASTLE  
REVERSI              DRAUGHTS  
EDUCATIONAL        ASTEROIDS  
ARCADE GAMES      GRAPHICS

Send an sae for the latest  
colour catalogue of software  
for the SINCLAIR ZX81.

CDS MICRO SYSTEMS  
10 Westfield Close, Tickhill  
Doncaster DN11 9LA  
Mail Order Only

## L&J COMPUTERS

192 HONEYPOT LANE, QUEENSBURY,  
MIDDX HA7 1EE. 01-204 7525

### BASIC PROGRAMMING

In response to many enquiries, we are running  
courses in Basic Programming during this winter.  
These courses are complete in themselves and  
comprise 2 evening sessions, each from 6 PM to  
10 PM. Dates available are as follows:

Tuesday/Wednesday 10/11th November 1981  
Tuesday/Wednesday 24/25th November 1981  
Wednesday/Thursday 9/10th December 1981  
Tuesday/Wednesday 12/13th January 1982

The courses are designed as a concentrated teach-  
teach-in with about 50% of the time being spent  
on practical work at the keyboard. Syntax,  
commands, algorithms, flowcharting will be  
covered.

Price (per 2 evening session) is £40.00 plus VAT  
(46.00 INCLUSIVE)

Further information, Programs and Application  
forms may be had by writing to the above  
address, or telephoning 01-204 7525 during  
normal business hours (10AM-6PM Mon-Fri;  
10AM-2PM Sat).

Numbers will be strictly limited to 10 per session  
so that the highest ratio of instructors to students  
can be maintained. Bookings will be made on a  
first come-first served basis.

### Quality support for; ATOM

#### ZX80 ACTION !

Flicker-free action games for your ZX80,  
need only 1K RAM and the original 4K ROM.

Cassette C80A: BRKOUT --- ACK-ACK £4.00  
Cassette C80B: SHELL GAME - INVADERS £4.00

The ZX80 Magic Book \*WITH 8K ROM/ZX81 SUPPLEMENT\*  
Games programs, computer music, converting programs  
written in other BASICS, improving the picture, RAM  
and I/O circuits, and much more. £4.75

Getting Acquainted with your ZX81 £4.95  
Mastering Machine Code on your ZX80/81 £5.95

23\*23 WAY ZX80/81 EDGE CONNECTOR SOCKET £3.50  
23\*23 WAY ZX80/81 GOLD PLATED PLUG EXTENSION £3.50

#### ATOM CASSETTES; £5 each

CAAA: BREAKOUT + CUPBALL + 3D MAZE + SIMON 2

CAAB: PINBALL + LETTERS + SPACEWAR + DRIVE

Both tapes need 1K VDU + 5K text RAM

#### The ATOM Magic Book

A wealth of games and other programs; storing speech  
in your ATOM, converting programs written in other  
BASICS, tape recording hints, plus many other useful  
hardware and software tips. £5.50

16/32K ATOM RAM Boards from £59.50  
Single Eurocard, can fit inside ATOM's case. Built &  
tested. Bare PCB only £23. S.a.e. for details.

ALL PRICES INCLUDE U.K. P&P + VAT WHERE APPLICABLE

TIMEDATA Ltd. 57 Swallowdale, Basildon, Essex

## CALCULATOR CORNER

made the 602 and 502 so pleasant to  
use, plus a good Basic, and all this with-  
out sacrificing speed. At around £119 it  
is good value, and, coupled with a  
cassette recorder and printer, it will not

be out of place on the laboratory bench  
or in the engineer's office; indeed it can  
do the job of a micro costing four times  
as much.

## EURO MICROMOUSE '81

Continued from page 126

the PCW Show competition will be  
attended by American mice. The state-  
of-play in America, as far as micromice  
are concerned, is not really too clear but  
maybe a well-sponsored event will bring  
some interest in the competition alive  
in its birthplace.

Some aspects of the competition  
will have to be amended. Mice are  
getting quite intelligent and very fast.  
Whether cross-overs will be allowed, or  
some restrictions on how they are built,  
or even cost-limits imposed is still up in

the air. What is clear, though, is that  
interest in this rather amusing aspect  
of robotics and artificial intelligence is  
growing and some of the spin-offs will  
probably be applicable to more serious  
situations in the home, with handi-  
capped people, and even in industry.

If you are interested in knowing  
more about the competition — or micro-  
mice in general — contact: John  
Billingsley, Department of Electronics,  
Portsmouth Poly, Anglesea Road,  
Portsmouth. For more information  
about the London Computer Fair Trials  
contact: Fred Linger, c/o East London  
Amateur Computer Club, 82 The Drive,  
Ilford, Essex.

## INTERRUPT

Continued from page 142

growing imbalance by at least inform-  
ing the haves about the potential plight  
of the have-nots, and of the further  
potential conflict that poses for the  
entire society, which the riots in Britain  
signal.

I have once again, as I did earlier for

Britain, painted a dismal scenario  
which seems to indicate that the present  
course of events is ensuring that, in its  
social impact, microtechnology will  
model itself after that fundamental  
technology, the development of  
writing, and will lead toward a more  
hierarchical and polarised society. Next  
month I shall investigate the origins of  
hope that ComputerTown UK! brought  
flickering from that earlier scene: the  
elusive ComputerTown USA!

## SHARP IQ3100 MICROTRANSLATOR

Continued from page 115

its features novel, but in my opinion it  
is streets ahead of the opposition, both  
in design and price. The Graig and  
Lexicon machines are not the sort of  
thing an executive wants to take onto  
an aeroplane, at least in the first-class  
section. Moreover, they and the Odd-  
pod, which is very similar to the IQ-  
3100, cost well over £100.

Finally, should you wait until  
machines that are cheaper/actually  
translate/play Space Invaders come  
along before you buy? I used to work  
on machine translation myself and now,  
as part of my normal job, I follow the

Japanese technical press, including  
personal computer magazines. Nothing I  
have gleaned leads me to believe there  
will be any drastic new developments in  
the near future — but as a linguist who's  
had to translate phrases like 'of the'  
at least a billion times, I'd love to be  
proved wrong.

A review of Graig and Lexicon  
machines appeared in PCW December  
1979. The only work on translation  
using personal computers that I know  
of was a French-English/English-French  
Dictionary program in Basic that  
appeared in Byte January 1980, pp.  
206-208. Thanks are due to Sharp in  
Manchester for the loan of the review  
IQ3100, but sets are at present only  
available from PHS Nelson Ltd of  
Burnley, who have bought the entire  
UK stock.

## S.WALES MICRO CENTRE

COMMODORE PETS

+  
APPLES

+  
SHARP

+  
COMPUTER BOOKS

+  
VIC-20 — ORDER NOW!!

SEND £35 DEPOSIT.

## SIGMA SYSTEMS

54 PARK PLACE CARDIFF 21515/34869

## RING ME LAST Ring ROGER MAY

on 0342 832244

before you make the final decision  
ring me and check the price. You'll  
find I am the cheapest for your  
computer equipment.

or save time ring now  
for best possible prices

Computertrade



# BANKS STATEMENT

Continued from page 69

The four prongs are constituted of both internal and external selling. Internally, special groups are being established within the company to sell the system direct to end users (this will presumably largely hinge around the system's 3270 emulation capacity as well as, in the longer term, the company's interest in local area networking). Not unnaturally, it is also selling the system through its own 'shops'.

Externally it has gone for two major retail chains. In the specialist computer area it has selected the Computerland chain, with some 160 outlets nationwide. The other is Sears, Roebuck & Co, one of the major chains (like Marks & Spencer with knobs on), which is setting up a business systems selling operation in selected stores. With this range of outlets, it should be able to sell to all potential users of such a widely applicable machine.

Another possible reason for restricting itself to the US only is that it may well not have the expertise yet to manage the European market. Unlike the US, European distribution is a mish-mash of local dealers and distributors, with no clear-cut national names like Computerland in the US (not here, there: to save D Broad suing me).

To penetrate this market, IBM will have to deal with the local dealers. Though it has its own shops, in the UK for example (all two of them), the individual retail companies will have to handle the system for IBM to achieve significant penetration. So, before it attacks Europe, the company can be expected to set up some form of internal distribution group or company to manage the operation. This, then, will deal with the dealers. The chosen few, at a guess between 30 and 50 of them

around the UK, will be getting the equivalent of a million Michelin stars.

But that is enough about IBM in particular, and the other leviathans in general. What is their collective entry liable to do to the 'minnows', the companies that started the whole goddam business in the first place? There are two generalised schools of thought here, and at present it is hard to choose between them. The first is that the 'credibility' they will give to the overall market will expand it considerably, and that all present will be able to take their share. The second is that the minnows will be effectively mangled and trodden underfoot.

In practice, there is liable to be a mixture of the two. Certainly there will be added credibility for the microcomputer market. Everyone has heard of IBM, even my Auntie Vera, and knows that they make computers (which do great harm to gas bills — and other horror stories). Some of the original manufacturers, however, are liable to suffer.

These will no doubt include some of the smaller companies, though if they are sensible, they will 'cherry pick' applications areas or provide other specialist reasons for users to keep them in business. The main sufferers could well be those companies that are now at the top of the microcomputer pile — companies like Apple, Tandy and Commodore. Apple could suffer because it is narrowly based, having been built up solely out of the micro business. It is, however, the darling of Wall Street, and the rumours about Apples IV and V show it is still developing new products. Tandy is, well Tandy, a very large and broadly based company.

But Commodore? Well, the PET is now long in the tooth, and it is significant that new PET-based products marketed by Commodore are not all developed by Commodore. They could be a favourite for something, which could range from a new system, via a takeover, to demise.

# BLUDNERS

An entire line seems to have fallen off the very bottom of page 54 last month's 'Newsprint' — the line (the last on the page) should have read: 'With the decision to sell. . .' And heavens knows

how, but the headlines in 'Leisure Lines' became Transposed so that what should have been the Quickie became the Prize Puzzle, and vice versa.

# SOFTWARE

WE WRITE PROGRAMS TO FIT YOUR REQUIREMENTS  
E.G. SCHOOL RECORDS



ARMBAM LTD  
KILN LANE  
LEIGH  
TONBRIDGE  
KENT TN11 8RT  
HILDENBOROUGH 832130

# Word Processing with WORDSTAR

Independent advice before purchase  
Expert training afterwards in your office  
Mayflower  
Computing Consultants  
6 Hardon Road, Parkfields  
Wolverhampton WV6 0HD  
0902-403010

# MICROMART

## ELCOMP BOOKS and SOFTWARE

For ATARI - PET/IBM - OSI - 6502

### 8K Microsoft BASIC Reference Manual

Authoritative reference for the original Microsoft 8K + 8K BASIC developed for Altair and later computers including OSI, PET and TRS-80.  
Order-No. 141 \$9.95

### Expansion Handbook for 6502 and 6502

S-44 Card Manual describes all of the 4.5 x 6.5 44-pin S-44 cards incl. schematics. A MUST for every KIM, SYM and AIM owner.  
Order-No. 152 \$9.95

### Microcomputer Application Notes

Reprint of Intel's most important application notes including 2708, 8085, 8255, 6251 chips. Very necessary for the hardware buff.  
Order-No. 153 \$9.95

### Complex Sound Generation

New revised applications manual for the Texas Instruments SN 76477 Complex Sound Generator. Circuit Board available (\$8.95).  
Order-No. 154 \$6.95

### Small Business Programs

Complete listings for the business user. Inventory, Invoice Writing, Mailing List and much more. Introduction to Business Applications.  
Order-No. 155 \$14.99

### The First Book of Ohio Scientific

Introduction to OSI computers. Diagrams, Hardware and software information not previously available in one compact source. 192 pages.  
Order-No. 157 \$7.95

### The Second Book of Ohio Scientific

Very valuable information about OSI microcomputer systems. Introduction to OS-65 D and OS-65U Networking, Hardware and Software hints and tips. Systems specifications. Business applications.  
Order-No. 158 \$7.95

### The Fourth Book of OHIO

Very Important Programs Many interesting programs for OSI computers. Sorting (Binary Tree), Differential Equations, Statistics, Astrology, Gas Consumption, Games 8.0  
Order-No. 160 \$9.95

### VIP Package - Above book plus a cassette with the programs.

Order-No. 160 A \$19.95

### Invoice Writing Program for OSI-CIPMF, C4P, Disk and Cassette, 8K RAM.

Order-No. 8234 \$29.99

### Mailing List for CIPMF or CIPMF 24K RAM

250 addresses incl. phone number and parameters on one 5 1/4 Disk  
Order-No. 8240 \$29.99

### Programs for the Challenger

C1/C2 8K  
Order-No. 2004 "Bare Bones" Wordprocessor \$9.95

Order-No. 2005, "Bare Bones" Mailing List \$9.95

### ATMONA-1 Machine Language Monitor for the ATARI 400/800

This powerful monitor provides you with the firmware support that you need to get the most out of your powerful system. ATMONA-1 comes on a bootable cassette. No cartridges required. Disassemble, Memory-Dump HEX + ASCII, (Change Memory Locations, Blocktransfer, Fill memory block, Save and Load Machine Language Programs, Start Watch, Lang. Progr. (Printer Optional).  
Order-No. 7022 \$19.95

### ATMONA-2 Supervisor

A very powerful Tracer to explore the ATARI ROM/RAM area. Stop at previously selected address. Opcode or operand.  
Order-No. 7080 Includes ATMONA-1 \$49.95

### EDITOR/ASSEMBLER for ATARI 800, 48K RAM

Extremely fast and powerful Editor/Assembler. (8K Source code in about 5 seconds) includes ATMONA-1.  
Order-No. 7088 \$49.95

### MACRO Assembler for ATARI-800, 48K RAM

Order-No. 7089 \$99.00

### Care and Feeding of the Commodore PET

Eight chapters exploring PET hardware. Includes repair and interfacing information. Programming tricks and schematics.  
Order-No. 150 \$9.95



ELCOMP Publishing, Inc.  
53 Redrock Lane, Pomona, CA 91766  
Phone: (714) 623-8314

Payment: Check, Money Order, VISA, MasterCard, Eurocheck, POSTPAID or PREPAID in USA. \$ 5.00 handling fee for C.D.D. All orders outside USA: ADD 15 % shipping. CA add 6 % sales tax. ATARI is a registered trademark of ATARI INC. PET/ACBII is a registered trademark of Commodore Business

# BACK ISSUES SERVICE

Here is a complete guide to all available back issues of PCW. A quick guide to their contents is shown below. Check the coupon overleaf for the issues you require.

ABC 24: Vol 4 No 4

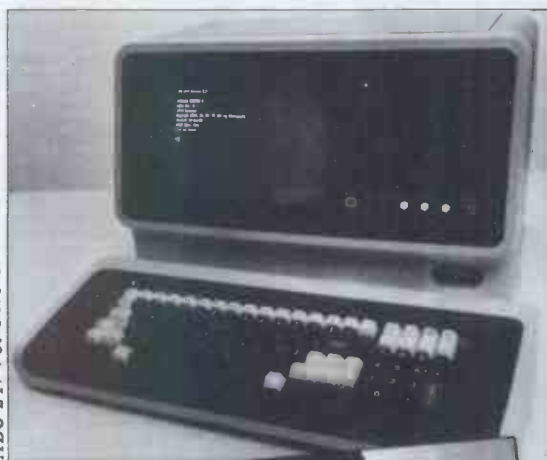

'SuperPET', /Programs: PET Dots & boxes, PET Bloopers, PET Demolition, Apple Showpiece, PEEK & POKE for Apple & Pascal, PET Giant Slalom, Speed & Acceleration.



Volume 3 No 10  
October 1980  
3-D graphics/Benchtest: Atari 400 & 800/Benchtest: DAI/Robotics/Benchmarks/Programs: PET Racer, PET Fighter Pilot, UK101 Graphics, Apple Plotting, UK101 Gunfight, PET Algebraic evaluation, ZX80 Breakout



Volume 3 No 12  
December 1980  
Benchtest: Microwriter/Printerfac: Series — Part 1/Sharp PC-1211 speed-up/Programs: TRS-80 Tarot, PET Gat & Mouse, PET Rebound, MZ-80K Alligator Swamp, PET Connect, UK101 Minefield, PET Simon



Volume 4 No 1  
January 1981  
Benchtest: Transam Tuscan/Real-time control using trains — part 1/Recover from a data tape disaster/PET Music/Multi-user systems — part 1/Programs: TRS80 Four in a row, TRS80 Target Practice, PET Convoy, PET Wire, PET Maze Chase, PET Android Attack, PET Anagram



Volume 4 No 2  
February 1981  
Benchtest: The Vector Graphics VIP/Patterns — Part 1/The last one/Real time control — part 2/Multi-user systems part 2/ZX80 Printer/Programs: PET Greenfingers, ZX80 Bumper Bundle (3 programs), PET Brick Stop



Volume 4 No 4  
April 1981  
Benchtest: ABC 24/Slow scan TV/IDPM/Word processing: Benchtests/ZX80 books/Commons report/Casio fx 3500p/Programs: ZX80 Maths Test, ZX80 Calendar, PET Link Index, ZX80 Moon Lander, TRS-80 Rocket Attack, TRS-80 Dropout, PET Giant Trap.



Volume 4 No 3  
March 1981  
Benchtest: Onyx C8002/Benchtest: Bigboard/Micro music software package/ALC circuit/Commons report/HP 34C/Programs: TRS80 Show Jumping, PET Grand Prix, PET Aircraft landing, PET Bouncy.



Volume 4 No 5  
May 1981  
Benchtest: Pasca 640/WP Benchtest: Magic Wand/PET colour/Low-cost digital tape system/Using calculator printers on micros/Apple music-making/Multi-user Benchtest: MVT-Famos/Programs: PET Grand Prix, PET Aircraft Landing, PET Bouncy.

Volume 1 No 1, 1978  
The 77-68/Practical hints on kit building/Nascom 1/Charity case study/Flowcharting/Pontoon flowchart

Volume 1 No 2, 1978  
Kit building/Basic — first steps/Case study — a software house/PET 2001/Research machines 380Z/School computing/E78 — Europa Bus.

Volume 1 No 3, 1978  
More efficient programs/Cosmac 1802/The PDP11 Part 1/Small business computing — an approach/The Z80/EPR0M programmer construction.

Volume 1 No 6  
October 1978  
Pilot/Assembly code programming/Small business case study/PET preening/Time tabling for schools.

Volume 1 No 8  
December 1978  
Microcomputer architecture/System design/Colossus/Medical interviewing machine/Hints for the business beginner/Cromemco Z2D/School computing/3rd Noughts & crosses/Low cost/High speed cassette interface

Volume 1 No 11  
March 1979  
SYM-1/Mk14/IEEE-488 Bus/Motorola 6809/Small computer networks/TMS-9900 homebrew.

Volume 2 No 1  
May 1979  
Chess programming/Using a small business computer Part 1/Smart 1/In defence of PET/3D Noughts & crosses.

Volume 2 No 2  
June 1979  
Different computer lan-

guages/(MSI) 6800/Using a small business computer Part II/Demonstrations using the Apple II Part I.

Volume 2 No 3  
July 1979  
Basic or Pascal?/The Sorcerer/Z8000/Chess programming/Graphics for the TRS-80/Apple- vision — part II/

Volume 2 No 4  
Apple medical application/North Star Horizon/Word processing/High speed cassette interface/Sorting/Buying a computer for a small business

Volume 2 No 5  
September 1979  
Benchtest: Compucolor II/Checkout: Heuristics Speech Lab/Testing Recognition/Pascal series — Part I/Programs: 6800 Time response, Apple memory test, Fx 201p spaceship, PET Orbit sim, PET digital clock, Acronyms.

Volume 3 No 6  
June 1980  
Benchtest: Tandy TRS-80 Model II/Benchtest: Sintrom Periflex 630/48 / Staff case study/Checkout: Softy Intelligent EPROM Programmer/Checkout: Exatron Stringy Floppy/Practical examples of the IEEE-488 bus use/Programs: Naming Nascom files, 380Z Pictures, Fuel tank calculations — PET, PET large numeral generator, PET tank battle, Basic string handling routines/Pascal: Final instalment.

Volume 3 No 9  
September 1980  
Benchtest: BASF 7120/Checkout: Hi-Tech S100 colour VDU board/Secrets of systems analysis — Part 1/Sub set part 1/Benchtest: CBM's



## Personal Computer



Volume 4 No 6  
June 1981  
Benchtest: NEC PC-8001/  
Multi-user Benchtest: MP/  
M/Benchtest: Sinclair  
ZX81/West Coast Faire  
report/Radio Teletype/  
WP Benchtest: Wordpro  
4 Plus/Budget tape inter-  
face/Further Casio quirks/  
Programs: UK101 Zor,  
PET Chords.  
Volume 4 No 7  
July 1981  
Benchtest: Sharp PC-3201/

## Personal Computer



Multi-user Benchtest: Acorn  
Ecqnet/ Case study:  
Accident investigation on  
TRS-80/Zilog Z8 family/  
WP Benchtest: Format-80/  
Pascal Benchmarks: readers  
letters/Quicker Casio com-  
putations/Programs: ZX80  
Sliding Letters, UK101 Car  
Rally, TRS-80 Calendar,  
UK101 m/c code to Basic  
converter, PET Exam  
Questions, MZ-80K  
Designer, ZX81 Sketch  
Pad.

## Personal Computer



Volume 4 No 8  
August 1981  
Benchtest: Tandy Model  
III/Viewdata update/WP  
Benchtest: Spellbinder/  
Printer survey/Micro-  
holism/Programs: ZX80  
Othello; Easter Sunday;  
Apple Mondrian; MZ-80K  
Duck Shoot; PET  
Gomoku; MZ-80K Foot-  
ball.

## Personal Computer



Vol 4 No 9  
September 1981  
Benchtests: Tandy Color  
Computer, Commodore  
VIC/Checkouts: Hi Tech  
Speakeasy, Tanel/ Multi-  
user Benchtest: HMSOS/  
WP Benchtest: Memorite  
III/Word proc program for  
PET/Apple dealership  
run by spastics/Printer-  
facinating extra/Calc Corner:  
Casio fx602p review/  
Programs: PET Arithmetic  
test, ZX80 Eldorado,  
380Z Memory test.

## Personal Computer



Volume 4 No 10  
October 1981  
Benchtest: OKI if-800/  
Checkouts: Heuristics  
speech link, Softy 2/Calc  
Corner: Texas T151-III/  
Jeff Taylor on computer  
literacy projects/Introduc-  
ing TJ's Workshop/ Control  
Your Own Substation  
pt 1/Programs: TRS-80  
Sailing

# BACK ISSUES CENTRE

We have a complete selection of all available PCW back numbers in our flashy new Back Issues Centre in the West End of London, just half a minute's walk from Oxford Street (close to Tottenham Court Road tube station). Of course, you could order them from our excellent mail order service using the coupon below, but by visiting in person you save on postage costs. The Back Issues Centre also often has back numbers of PCW on sale which we cannot offer through the mail order service because of shortage of stock. And any new issue is usually on sale in the Back Issues Centre several days before it reaches your local newsagent. Our receptionists will also be happy to sell you a set of binders or take your subscription. And there's a range of interesting computer books on sale as well. Drop by next time you're in the West End. We're open Monday to Friday, 10am to 6pm. The address is 14 Rathbone Place, London W1.

## COME UP AND SEE US..

**NOW OPEN SATURDAY!!**  
11.00AM-5.00PM /  
**MON-FRI**  
10.00AM-6.00PM

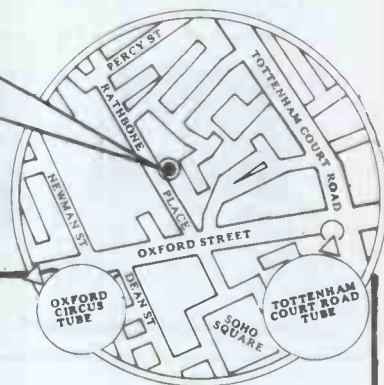

# DESK TOP COMPUTING

A COMPREHENSIVE GUIDE TO SUCCESSFUL BUSINESS AND PROFESSIONAL MICROCOMPUTING

Send £2.25 to Desk Top Computing Offer, 14 Rathbone Place, London W1P 1DE. Cheques should be made payable to *Personal Computer World*.

## PCW BINDERS

Strong, durable, attractive yellow PCW binders — £3.25 each, including postage and packing. See coupon below.

Any one issue £1.25; Any two issues £2.25; Any three issues £3.00; Any four issues £3.75. All additional issues @ 75p each. Binders @ £3.25. All prices include post and packing. Cheque or P.O. payable to (PCW) SportsScene Publishers Ltd., 14 Rathbone Place, London W1P 1DE. Please allow up

to 3 weeks for delivery and don't forget to state clearly your name and full address with your order. Please send me the following copies of PCW. I enclose a cheque/P.O. for £\_\_\_\_\_ Please tick appropriate boxes.

Volume 1	Volume 2	Volume 3	Volume 4
1 <input type="checkbox"/> 2 <input type="checkbox"/> 3 <input type="checkbox"/> 6 <input type="checkbox"/>	1 <input type="checkbox"/> 2 <input type="checkbox"/> 3 <input type="checkbox"/> 4 <input type="checkbox"/> 5 <input type="checkbox"/>	5 <input type="checkbox"/> 6 <input type="checkbox"/>	1 <input type="checkbox"/> 3 <input type="checkbox"/> 2 <input type="checkbox"/> 4 <input type="checkbox"/> 5 <input type="checkbox"/> 6 <input type="checkbox"/>
8 <input type="checkbox"/> 11 <input type="checkbox"/>	Binder <input type="checkbox"/> DTC <input type="checkbox"/>	9 <input type="checkbox"/> 10 <input type="checkbox"/> 11 <input type="checkbox"/> 12 <input type="checkbox"/>	7 <input type="checkbox"/> 8 <input type="checkbox"/> 9 <input type="checkbox"/> 10 <input type="checkbox"/>

Name \_\_\_\_\_ Address \_\_\_\_\_

# DON'T KICK THE TELLY!

GIVE IT A **VIC-20**

EARTH SHATTERING HARDWARE PRICES

\*\*\*\*\*

SAVE £100.00 ON COMMODORE BUSINESS MACHINES

CBM 8032 Computer	£795.00
CBM 8050 Disk Drive	£795.00
CBM 4032 Computer	£595.00
CBM 4040 Disk Drive	£595.00
+ All prices Ex. VAT.	

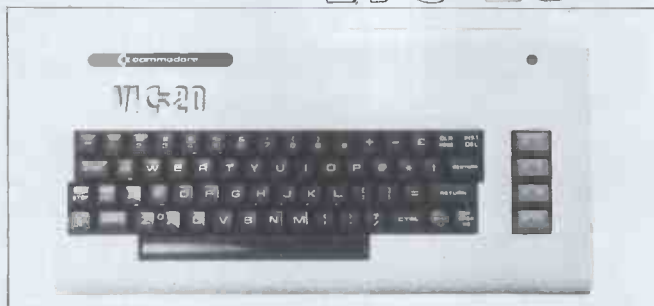

Video Genie EG3003 16K	£299.00
Superbrain 64K s/s	£1895.00
Superbrain 64K q/d	£2195.00
+ Plus a good selection of printers books and sundries.	



## MICRO COMPUTERS

TEL: GRAVESEND 55813 or 57433

39 WINDMILL STREET, GRAVESEND, KENT

# MORE POWER TO YOUR POCKET!

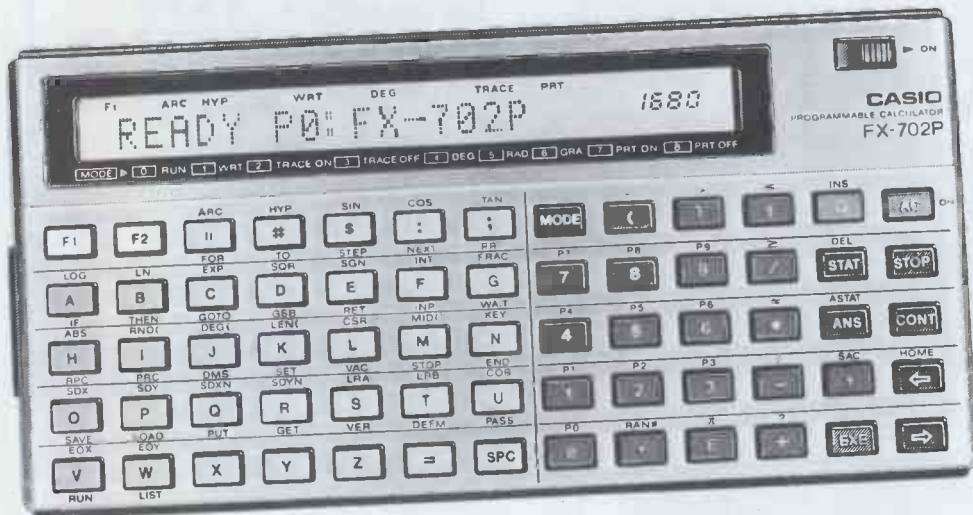

Hand held alphanumeric programmable-BASIC language-holds up to ten different programs simultaneously-subroutines nested up to ten levels-program looping up to eight levels-simplified program editing and debugging-variable programming capacity: between 1680 steps with 26 memories and 80 steps with 226 memories-55 single key routines including log, trig and hyperbolic-built-in routines include standard deviation (both types), regression analysis and correlation coefficient-all programs and memory data retained even when switched off. *Comprehensive library with over 70 program examples. Optional FA2 adaptor for program storage on cassette and FP10 printer.*

R.R.P. £134.95

**THE FX702P. A pocket computer that communicates in BASIC language.**

AVAILABLE AT SPECIALIST CASIO CALCULATOR OUTLETS.

**CASIO** WHAT WILL THEY THINK OF NEXT?

CASIO ELECTRONICS CO. LTD., SHAIBURN HOUSE, 28 SCRUTTON STREET, LONDON EC2A 4TY.

# DISKING



FREEPOST  
LIPHOOK  
HAMPSHIRE  
GU30 7BR  
ENGLAND  
Tel: (0428 722563)

## THE WORLD'S BEST 5 1/4" MINI DISKS

### and ACCESSORIES

Factory fresh & individually certified  
100% error free

### FREE

LIBRARY BOX with every  
TEN-PACK

**\*\*PLUS\*\***

NEW DISK DIRECTORY & DISK-  
WRITER when ordering two packs  
or more

**\*\*PLUS\*\***

BRUSHED CHROME PAPERMATE

PEN when ordering 5-9

TEN-PACKS

**\*\*PLUS\*\***

GOLD PLATED PAPERMATE PEN  
when ordering 10+ TEN-PACKS

#### DISKS VERBATIM

DATALIFE  
ARE  
DOUBLE  
DENSITY  
AND  
ALL  
HAVE  
HUB  
RING



EXC VAT

MD525 S/Sided ..... £17.35  
MD550 D/Sided ..... £26.04  
MD577 77 Track ..... £27.50  
10 & 16 Hard Sector at same prices

#### MINI DISK ACCESSORIES DISKING SUPERLUXE DISK LIBRARY

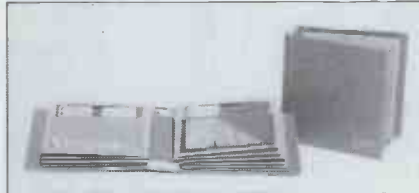

Manufactured exclu-  
sively for us to our own  
design, the SDL keeps  
your valuable disks flat  
& dust-free, while at  
the same time allowing

you instant visual  
selection of any single  
disk. The standard SDL  
holds 20 disks, while  
the SDLX holds 28 disks.  
The SDL may be uprated  
to an SDLX retrospectively.

SDL only ..... £8.65  
SDLX only ..... £10.39

#### DISKING DISKWRITERS

Ultrafine fibre tipped pens that write with mini-  
mum pressure - essential when labelling disks.  
DW only ..... 40p

#### PLASTIC LIBRARY BOXES

The genuine Egly Box that stores and protects  
your disks in tens - Unbeatable - (FREE with  
every ten disks ordered)  
LB only ..... £1.70

#### NEC SPINWRITER RIBBONS

Fabric only ..... £5.00 ten £45.00  
Multistrike only ..... £6.00 ten £50.00

#### SUPERBRAIN SOFTWARE

'DATAKING' coming soon: will mathematically  
massage any Dastar or Wordstar data file, and  
columnate with report writer. Instant Sales,  
Nominal or Purchase ledger or Comprehensive  
Sales/Purchase Reporting for Dastar users.

DATAKING only ..... £49.00  
DATAKING User Manual ..... £2.50

#### BASF

SUPERIOR  
QUALITY  
DATA  
STORAGE  
AT  
NEW  
LOW  
PRICES



EXC VAT

S/S S/Density ..... £17.35  
S/S D/Density ..... £20.85  
D/S D/Density ..... £25.61  
10 & 16 Hard Sector at same prices

#### DISK DRIVE HEAD CLEANING KITS

Prevent head crashes  
and ensure efficient  
error-free operation.  
Enough for 26 bi-  
monthly cleans & a lot  
cheaper than a service  
call!!  
CK5 only ..... £16.50



#### DISKING DISKMAILERS

This product also exclusively ours, is a strong  
plastic envelope for mailing one, two or three  
disks, in safety and comes complete with  
warning labels & address labels.  
DM only ..... 50p

#### ATTENTION THE TRADE

Please write to us on your letter headed paper,  
and ask for our special trade prices and offers.  
Give your software and ultimate in presentation.  
We can make the SDL and SDLX in your colour  
PVC, with your Logo. Sample plastics swatch  
available free by request.

#### NEW DISKING DISK DIRECTORIES

Our brand new Disk Directories now give you  
much more space to write down all your disk file  
information. You can really keep 'track' of what's  
on your disks. (FREE with every TEN-PACK,  
when ordering 20 disks or more).

DD only ..... 83p

ALL PRICES ARE EXCLUSIVE OF VAT  
PLEASE ADD 15%

#### ORDERING INFORMATION

POST TO:  
DISKING, FREEPOST, Liphook, Hants. GU30 7BR. England.

##### U.K. P&P RATES

##### NORMAL ORDERS

EXC VAT  
Disks (1-5 packs) each pack @ 95p  
Disks (6+ packs) each pack @ 65p  
SDL or SDLX @ 95p  
DM, DD or DW each @ 25p  
Tens @ 80p  
LB @ 45p  
CK5 @ 75p  
NEC Ribbons @ 50p  
DATAKING SOFTWARE post free  
DATAKING USER MANUAL post free  
DM's, DD's & DW's post free if free

We accept MOD orders over £50.00  
in value. All other customers cheques  
with order please payable to Disking.  
If you are a large establishment, and  
can not raise cheques without an  
invoice, please post or telephone us  
your order, and we will send a pro-  
forma invoice by return, for your  
accounts department to pay against.

##### URGENT ORDERS

##### CREDIT CARD ORDERS

Either post your cheque not forget-  
ting to stamp it first class, or tele-  
phone your order with credit card  
No., mentioning in either instance  
that your order is URGENT. You  
may then pay FIRST CLASS POST  
for your goods, if required.  
FIRST CLASS RATES EXC VAT  
First TEN-PACK £1.80  
Second & Subsequent £1.30

We accept Barclaycard and Access  
card, and make a small surcharge of  
6% on the total order value. You may  
write your c/card No. on your order  
or telephone the order day or night,  
365 days a year. You may speak for  
as long as you like, and don't forget  
to give full details of what you wish  
to purchase, your credit card num-  
ber, credit card holder's name &  
address, and delivery or invoice  
address if different.

#### ORDER FORM

PLEASE SEND ME:

QTY	DESCRIPTION	PRICE EXC VAT
		£
		£
		£
TOTAL GOODS VALUE EXC. VAT		£
TOTAL DELIVERY & INSURANCE		£
SUB TOTAL EXC. VAT		£
VAT		£
VALUE OF CHEQUE PAYABLE TO DISKING		£

Name \_\_\_\_\_

Address \_\_\_\_\_

Tel. No: \_\_\_\_\_

My Access/Barclaycard\* Number is: \_\_\_\_\_

# ZX81 or ZX80 ONLY JOIN ZX-GUARANTEED

(club is devoted exclusively to ZX80/81)

All games/progs guaranteed error-free. ZX-guaranteed is not just games, it is intended to be educational. Includes articles on Peek, Poke, how to make Sinclairs cassettes flicker-free, converting programs ZX80 to ZX81 to ZX80 etc, etc.

Membership £5 per year (SAE for details).

Please make cheques/P.O. payable to: ZX Guaranteed.

**G.A. BOBKER**

29 Chadderton Drive, Unsworth, Bury, Lancs.

Tel: 061-766 5712



## in CROYDON

APPLE II HARDWARE  
APPLE II SOFTWARE  
APPLE II PERIPHERALS  
APPLE II BESPOKE SOFTWARE

OPEN 9AM to 8PM 6 DAYS A WEEK  
SUNDAY DEMONSTRATIONS  
BY APPOINTMENT

IF WE DON'T HAVE IT WE WILL GET IT!  
CALL OR PHONE FOR PRICES & DETAILS

# SYMBIOTIC COMPUTER SYSTEMS

85/87 STATION RD, WEST CROYDON  
TEL: 01-680 8606



**CRAB SOFTWARE**  
(for the TRS-80,  
Level II)

\*Trademark of the Tandy Corporation

### CRAB ALGOL INTERPRETER

Based on ALGOL W (developed by Niklaus Wirth) CRAB ALGOL offers the best features of block structured, high level languages and as an interpreted language, CRAB ALGOL is an ideal tool for developing powerful programs. Included amongst the features of this extensive language are:

- Data modes; Integers (2-100 bytes length), logical, strings, ref (pointer), records (any number of fields), dynamic arrays.
- Functions and procedures; recursive definitions, any number of parameters (value, result & value-result)
- Statements; IF, REPEAT, WHILE, FOR, CASE etc.
  - all fully implemented
- m/c link & memory access; CALL, GET, PUT
- Standard functions; SIGN, ASC, RND, STR, INKEY etc.
- Full tape I/O; user definable I/O; multi-speed scrolling; repeating keyboard; definable cursor etc.

Send S.A.E. for further details £75.00

### CRAB MACHINE CODE DEVELOPMENT SOFTWARE: CRAB ASSEMBLER

Features all the usual assembler functions, but with compressed storage can assemble programs 40% longer than with EDTASM. Includes complete documentation for Z80 instruction set. £10.00

### CRAB DIS-ASSEMBLER

Fully comprehensive dis-assembler producing source tapes compatible with the CRAB ASSEMBLER. £6.00

Both above programs £14.00

All three programs above will run on the MODEL III

Make cheques/postal orders payable to: CRAB SOFTWARE. Orders, by post only, to: **CRAB SOFTWARE**

Prices are completely inclusive. 10% discount on orders over £15. **2, PONDWICK RD.**

Send S.A.E. for full software list. **HARPENDEN HERTS AL5 2HG**



# ZX81 AND ZX80 OWNERS

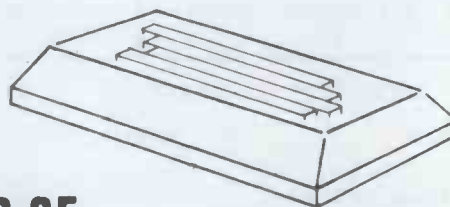

**£18.95** IN KIT FORM + 80p p&p  
**FD81 Keyboard**

End the frustration of tapping the tiny ZX keypad with our full size keyboard.

- Easy to build kit includes 40 keyswitches pcb ribbon cable and ledgens, case not included
- Keyboard built £24.95, ZX 80 installation £10
- Keyboard case £8.75, keyboard & ZX case £11.75
- Vdu driver board kit £4.95, Vdu's from £30+p&p

To Fuller Designs Ltd Sandfield Park East  
Liverpool L12 9HP tick ZX80  ZX81

Please send me

I enclose a cheque/po for

Name  
Address

# SHARP MZ80K

48K RAM £399.00 including VAT

SHARP MZ80 P3	80 Column Dot Matrix Printer	£395.00	EPSON MX80 F/T1	Dot Matrix Printer	£399.00
SHARP MZ80 FD	Dual Floppy Disc Unit Complete	£660.00	EPSON MX80 F/T2	Dot Matrix Printer	£499.00
SHARP MZ80 I/O	Interface Unit	£ 95.00	OLYMPIA ESW100-RO	Daisy Printer	£886.00
SHARP PC 1211	Pocket Computer	£ 80.00	SHARP	Interface and Cable	£ 75.00
SHARP CE 122	Printer/Cassette Interface	£ 63.00	SHARP (DISK)	Interface and Cable	£120.00

ALL PRICES INCLUDE VAT.

## LATEST SOFTWARE INCLUDES:

tiny C a structured programming language (cassette) ..... £57.00 inc. VAT

ASTEROIDS, COMMANDO, EMPIRE II, MUSIC COMPOSER – EDITOR, 15 GAME, ALDEBARAN, CRIBBAGE, OTHELO PACKAGE (32 page book 'Key to Othello' PLUS MZ80 OTH PLUS REPLAY OTH), HOME FINANCE PACKAGE (4 Programs Book – 1 Home Budget, 2 Bank Reconciliation, 3 Bank Loan, 4 Mortgage Amortization) MANY MORE, SEND STAMPED ADDRESSED ENVELOPE FOR COMPLETE LIST.

## USER NOTE No. 2 NOW AVAILABLE:

Annual subscription only £3.00 – Send 35p stamp for complete catalogue and subscription form, or send cheque for £3.00 and receive Issues No. 1 and 2.

TO:

# SHARPSOFT

Sharpsoft Limited – 86-90 Paul Street, London EC2A 4NE Telephone: 01-739 8559

# MACHINE LANGUAGE MADE SIMPLE ZX80 AND ZX81

This new book is a must for any **SINCLAIR** user who wants to make full use of his **SINCLAIR ZX80** and **ZX81**. Go beyond Basic into the world of **MACHINE LANGUAGE PROGRAMMING** and open computer horizons you never thought possible!

Learn how to use the **SINCLAIR** computer's own language and finally find out what PEEK and POKE is all about!

**MORE COMPUTING POWER IN LESS SPACE!**

**FASTER RUNNING PROGRAMS!**

Written for the complete beginner as well as for the experienced **SINCLAIR** user, **MACHINE LANGUAGE MADE SIMPLE** has over 120 pages packed with programming techniques, hints and tips.

**WRITE YOUR OWN MACHINE LANGUAGE PROGRAMS...**

★ USEFUL BASIC PROGRAM TO EDIT MACHINE LANGUAGE ★  
★ COMPLETE DESCRIPTION OF THE INSTRUCTIONS GROUPED BY SUBJECT AND BY USEFULNESS ★  
★ NUMEROUS SAMPLE MACHINE

★ LANGUAGE ROUTINES DESIGNED SPECIFICALLY FOR THE SINCLAIR 80 & 81 ★  
★ SIMPLE EASY TO USE LOOK UP TABLES.

**£8.95** (plus 50P p&p)

Please send me ..... copies **MACHINE LANGUAGE MADE SIMPLE FOR YOUR ZX80 & ZX81.**

NAME .....

ADDRESS .....

### MELBOURNE HOUSE PUBLISHERS

Orders to: 131 Trafalgar Rd. London SE10  
Correspondence: Glebe Cottage, Glebe House, Station Rd,  
Cheddington, Leighton Buzzard, Bedfordshire LU7.  
Please enclose cheque or P.O. for £9.45 per copy.  
Orders outside the UK £9.95.

## LOW - COST VDU's

### Hazeltine VDU's



H1000 The low, low priced teletypewriter-compatible video display terminal, offering your choice of transmission speeds up to 9600 baud as well as parity generation and checking. 12 x 80 display upper case ASCII, RS232 interface, choice of baud rates Standard baud rates either (a) 110/300 or (b) 300/1200. (£25 surcharge for other combinations up to 9600 baud).  
SUPER VALUE ..... **£199.00**



H2000 Superb spec. including full XY cursor addressing and edit facility, 27 x 74 display, upper case ASCII, RS232 interface, switch-selectable baud rates ..... **£299.00**



H2000C NOW ALSO AVAILABLE with 25 x 80 line format and C-MOS logic ..... **£375.00**

Modular One. Now with upper/lower case, XY cursor addressing, 24 x 80 line display, dual intensity detachable keyboard, choice of 8 transmission rates up to 9600 baud ..... **£399.00**

Also available from time to time  
Hazeltine 1500 from ..... **£575.00**  
Hazeltine 1510 from ..... **£650.00**

## NEW GP80 PRINTER

BRAND NEW — LOW COST MATRIX PRINTER IDEAL FOR MICROPROCESSOR USERS SUCH AS HOBBYISTS & EDUCATIONALISTS OR ANY LOW-BUDGET APPLICATION

### Selkoshia GP80

**NEW**



- ★ Full upper/lower case ASCII PLUS GRAPHIC Mode
- ★ 80-column printing with adjustable tractor feed
- ★ Standard and double-width characters (12 cpi and 6 cpi)
- ★ 30 cps print speed with 1-line buffer
- ★ Standard parallel (Centronics-type) interface
- ★ Optional interfaces available for RS232, IEEE488, Tandy, PET, Apple II
- ★ ONLY ..... **£199.00**

## TELETYPE OFFERS

Reconditioned ASR33 Teletype Terminals with paper tape punch and reader, even parity keyboard and RS232 interface.

SPECIAL OFFER — SEVEN DAY WARRANTY — CASH AND CARRY ONLY ..... **£295.00**

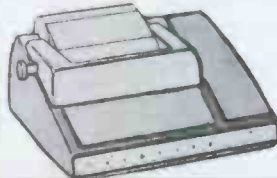

### Low Cost Printer offer.

Teletype 33 printer mechanism including case but no keyboard or electronics, 64 upper case ASCII, 10 cps, pinfeed platen, ideal for the electronic hobbyist ONLY ..... **£85.00**

## DEC SALE

Huge stocks of DEC processors, peripherals, disk drives, terminals, add-on memory, option modules, etc. etc. Send for latest list

**Electronic Brokers Limited**  
61/65 Kings Cross Road  
London WC1X 9LN England  
Telephone: 01-278 3461  
Telex: 298694 Elebro G

All items reconditioned unless otherwise stated.  
Hours of Business: 9a.m. - 5p.m. Mon-Fri. Closed lunch 1-2p.m.  
ADD 15% VAT TO ALL PRICES  
Carriage and Packing charge extra on all items unless otherwise stated. A copy of our Trading Conditions is available on request

# THE ZX 81 COMPANION

PRICE **£7.95**  
INCL. UK POSTAGE

ISBN 0 907211 01 1

The best-selling in-depth guide to useful applications of the Sinclair ZX81.

**Chapter 1: REAL TIME AND GRAPHICAL TECHNIQUES** including a full treatment of INKEY\$.

**Chapter 2: INFORMATION PROCESSING.** The ZX81 as an electronic filing system.

**Chapter 3: EDUCATIONAL APPLICATIONS** with several primary and secondary examples.

**Chapter 4: THE MONITOR** with disassembled listing and entry points.

Send cheque for £7.95 to:

**LINSAC** 68 Barker Road, Linthorpe,  
Middlesbrough, Co. Cleveland TS5 5ES

## Micro General

### MATRIX PRINTERS...

Please contact us for advice on printer selection

#### MICROLINE 80

Popular, robust printer with block graphics. New models 82A & 83A now available, 120 cps, true descenders, Serial/Parallel interfaces switch selectable.



**£285+VAT**

#### EPSON MX-SERIES

Remarkably versatile printers for many applications. Graphics models and full range of interfaces available.



FROM **£359+VAT**  
(FOR MX-80T)

#### CENTRONICS 737-2

Correspondence quality. Forward and reverse paper motion. Superscript and subscript etc. Nascom 2 driver routine supplied.



**£345+VAT**

**FREE DELIVERY** to UK Mainland.  
Listing paper £17.00+VAT per 2,000 sheets.  
**FREE INSTALLATION** within 30 miles of Reading.  
DAY or EVENING appointments welcome.

**MICRO GENERAL, 6 The Birchwoods, Tilehurst, Reading, Berks RG3 5UH. Tel: 0734 25226.**



# STARTTECH

## PRICES SPEAK FOR THEMSELVES

### HARDWARE

Computer Stop 16k Memory Expansion Card - New low price for this card of proven reliability. Can be used in place of language card for Pascal etc.	£75.00
Omnivision 80 column Card - Fully compatible with all the currently available Apple languages. True decoders on lower case. Now best value on market at Mountain Hardware C.P.S. Card. Three Cards in one both serial and parallel interfaces and a clock/calendar. Amazing phantom slot capability.	£120.00
Sup-R-Terminal	£195.00
Echo II speech Synthesiser	£139.95
SSM IEEE Card	£319.00
Vindex Videoterm	£185.00
Z-80 Softcard	£195.00
Astar Light Pen	£19.95

### SOFTWARE

Visicalc 3.3	£125	Visidex	£125
Visiterm	£100	Visiplot	£75
Starfleet Orion-Morlocks Tower-Galactic Empire-Galactic revolution-Demon Derby-Golden Mountain-Alien Typhoon-Space Warrior-Fender Bender-Torpedo Terror-Network-Windfall-Invasion Orion-Datestones of Ryn-The Dragons Eye-Galactic Trader-Galaxy Wars-Alien Rain (Galaxians)-Tank Command-3D Sking-Computer Bingo-Space II-A.B.M.-Mission Asteroids-Wizard and Princess-Gobblers-Checker King-Bridge Partner-Allan Lander-Both Barrals-Bloody Murder-A2 3D1 Enhancement-Wilderness Campaign-Doom Cavern & Sorc. Chall-Tank Attack-Global War-Mystery House-H/R Cribbage-Sabotage-Microchess 2.0-Gammon Gambler-Star Crusier-Tranquility Base-Flight Simulator-Saturn Navigator-Higher Fonts			

All at £13.95

Crush Crumble and Chomp-Trilogy of Games-Hyperspace Wars-Space-Rescue at Pigeon-Tawala's Last Redoubt-Apple panic-Raster Blaster-Appleoids-LA A Land Monopoly-Terrorist-The Prisoner-Painter Power-Missile Defence-HI-Res Soccer-Space Adventure-Phantoms Five-Autobahn-Orbitron-Galactic Attack-Micro Info System-Soft Porn Adventure-Retro Ball-Space eggs-Pulsar II-Gamma Goblins-Sneakers-Space Raiders

All at £15.95

Temple of Apshai-Hellfire Warrior-Snoggle-Akalabeth-Ultima-Home money Minder-Caves of Karkan-Star Warrior-Space album-3D Graphics-The Mail Room-Telestar I-Pool 1.5-Shuffle Board-Three Mile Island-The Voice-Threshold-Paddle Graphics-Gorgon-Epock-Micro Memo-Cartels and Cutthroats-President Elect-Linguist-Higher Graphics II-Higher Text II-Dogfight-Robot Wars-The Best of Muse-U-Draw II-Elementary Math-Cranston Manor-Monty Play Monopoly-Cyber Strike-Aristotles apple-Computer Conflict-The Warp Factor-Flight Simulator-Odyssey-Star Gasers Guide-Escape From Arcturus-Program Line Editor-Directory Manager

All from £20.95

### Software for Apple with Z-80 Softcard.

Dbase II - State of art data base just arrived from America. This is the most sophisticated piece of software for the Apple we have ever seen. We are still finding features in it. Programming will never be the same again.			
Supercalc	£179.00	Wordstar	£179.00
Basic Compiler	£256.00	Mailmerge	£75.00
Fortran 80	£109.00	Cobol 80	£299.00
ACT I Cross assembler	£83.00	Supersort I	£94.00

63 Lisburn Lane, Tuebrook, Liverpool L13 9AF. Tel: 051-256-8244.

# The Prince - a micro computer that offers you everything

### Everything?

Well, check it out for yourself and see if there's anything missing. But be warned, the Prince is not a plaything although the price might suggest it. Its a real business machine with full computer facilities.

### Keeping up with technology.

Digico Computers have enabled their users to keep pace with technology since 1966.

### Provides for growth

By linking you to powerful mini systems and permit you to develop a real big system capability.

### Maintenance for seven years.

Offering a seven year maintenance guarantee\* the Digico Prince provides the 'coming of age' seal to the micro industry.

### Backed In Britain.

Digico Computers have been in the business of computer hardware design, manufacture and maintenance for over fifteen years. With factories in Leeds and Stevenage, the Prince is fully supported in the United Kingdom.

### Rentals for low cost items.

Including maintenance, rentals start from way under £20 per week.

### Minimum Interruption Plan (MIP)

If your Prince goes down, we'll exchange it for a replacement to keep you running - all in the rental price!

### Starting from around £1,700

Start with the computer, visual display, diskette storage, add CP/M operating system plus languages and build up from there.

### Ready made accounting

No development cost - just buy proven packages covering sales, purchase and nominal ledgers plus stock control, order entry, payroll, word processing and full graphics.

### Ideal for new Computer users

Maximise your learning on a minimum investment and then link up to larger systems when you're fully familiar and ready to grow.

Well, have we offered you everything? We may have omitted to mention a demonstration first.



DIGICO Computers  
MICRO DIVISION  
Arena House  
46 Broadway  
Letchworth  
Herts SG6 3BX  
Tel: (04626) 78172

\*Providing there is a maintenance contract continuously from new.

# C.F.S. IS HERE

An economic, easy to use, reliable digital Cassette File Store - C.F.S. is available now for use with NASCOM 1 and 2 microcomputers.

## FEATURES

Sophisticated operating system provides a file handling capability superior to that of many floppy disc systems.

High reliability ensured by use of professional digital recorder and automatic data verification.

Fast data rate of 6000 b.p.s. equivalent to 1 Kbyte in 1.3 Secs.

Automatic storage and retrieval of Machine Code, BASIC, ZEAP and NASPEN.

Controls up to 24 individually named files.

96 Kbytes of storage on single digital mini-cassette.

Easy to install - connects to PIO port.

Supplied as self-contained unit in compact rugged case with its own integral power supply.

Low cost - complete system only £170 + VAT.

For full details S.A.E. to:

GRANGE ELECTRONICS LTD., (Dept. E), STONE LANE INDUSTRIAL ESTATE,  
WIMBORNE, DORSET BH21 1HD (Tel: 0202 884752)



**Commodore official distributors**

NEW DAISYWHEEL PRINTER IN STOCK  
NEW MATRIX PRINTER NOW IN STOCK  
THE RELIABLE VALUE FOR MONEY SYSTEM  
WITH FULL AFTER SALES SUPPORT.



4008/16/32  
8032 - 8050



48K £807.00  
DISK DRIVE £393.00  
DISC £299.00

FULL RANGE OF  
MONITORS  
B/W - GREEN OR  
COLOUR.  
PAPER TIGERS.

Apple authorised distributors  
The sophisticated quality system with  
a reputation for advanced design and  
innovation.

64K S/D £1750  
64K QD £2250  
64K +  
1.5 MEG £2850

FULLY  
INTERGRATED  
ACCOUNTS  
PACKAGE.

**SHARP**

Z80K

48K £395  
DISK DRIVES  
PRINTERS ETC.



The incredible computer system  
now available ex-stock including the  
New Duel Drive Double Sided Floppy Disk.



**CAMDEN ELECTRONICS LTD**

MICROCOMPUTER SYSTEMS

462 COVENTRY ROAD · SMALL HEATH · BIRMINGHAM B10 0UG  
Telephone: 021 773 8240 or 021-772 5718 · Telex: 335909 (Camden G)



AT  
LAST

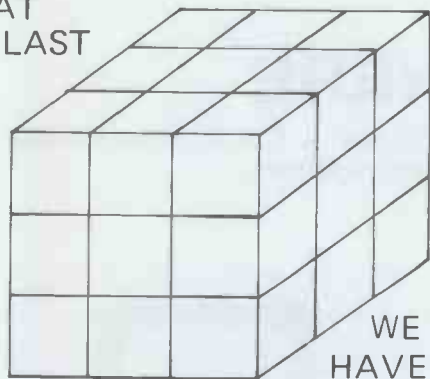

WE  
HAVE

**COMPUTER CUBE**

**TRS-80**

Following the craze that is sweeping the world  
we are pleased to introduce an innovation in  
computer puzzles. Computerized Rubiks Cube.  
This program gives graphical representation of  
twists, slices and rotations of the cube and with  
over 43 billion combinations it could take you  
a week or two (at least) to solve!

TRS-80 IbkII or Video Genie

**FREE**

As a seasonal good gesture we are  
giving away a free sound subroutine £10 inc  
with all orders that we receive before p & p  
Christmas



**TRS 80**  
and  
**VIDEO  
GENIE**

Our new ROM will . . .

- Completely debounce your keyboard!
- Give you lower-case software (includes keyboard inverter as typewriter - state if NOT required)
- Auto check if our new 'Feature' ROM(s) are installed
- New security feature installs your own security code for all to see (up to 19 characters) we suggest name and postcode

Send £14.95 + VAT (with your security code) for ROM and full fitting instructions (simply remove old and plug in new - as easy as childs play).

'Feature' ROMS . . .

A new series starting with the following . . .

- 'A'
- Gives a toggle feature for the keyboard inverter
- Auto repeat
- Single keystroke commands
- Machine code monitor and editor plus special features (details on request)

Kit £18.95 + VAT or fitted for £26.45 + VAT + carriage (£8 Securicor) including full simple instructions.

Lower Case Hardware

Kit gives full lower case and special characters . . .  
VIDEO GENIE - £19 + VAT ) Fitting £5 if required +  
TRS 80 - £10 + VAT ) VAT and return carriage  
Access and Barclaycard accepted

**General Northern Microcomputers (GNOMIC)**

46 Middle St, Blackhall, Hartlepool, Cleveland.  
Telephone: Peterlee 863871/860314

TELE  
SOFT

21 FFORDD ERYR, MOCHDRE  
COLWYN BAY, CLWYD LL28 5BN

# SALES - LEASE

and other services

64K

SUPERBRAIN

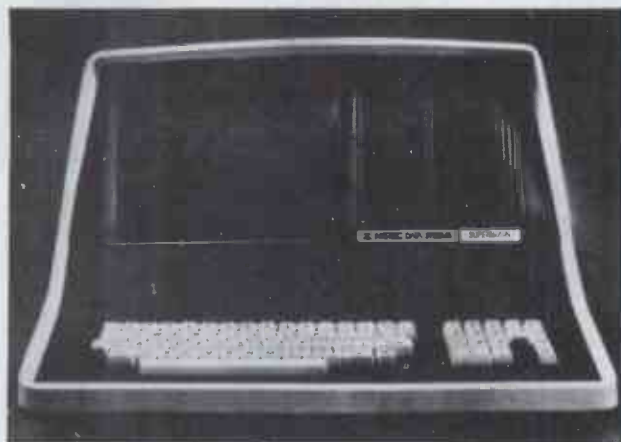

APPLE  
CPM  
Z80



## SUPERBRAIN 64K

- £1770 SUPERBRAIN STANDARD MODEL  
(350KB DOUBLE DENSITY DISK DRIVE)  
SUPERBRAIN QUAD MODEL  
£2070 (700KB QUAD DENSITY DISK DRIVE)  
SUPERBRAIN + PRINTER  
(BUSINESS SYSTEM CONFIGURATION)  
SUPERBRAIN + PRINTER  
+ 'WORD STAR' SOFTWARE PACKAGE  
(COMPLETE WORD PROCESSING SYSTEM)

## ALL CPM SOFTWARE P.O.A.

- |            |              |                    |
|------------|--------------|--------------------|
| PASCAL     | WORDSTAR     | INCOMPLETE RECORDS |
| FORTRAN    | MAGIC WAND   | INTEGR. ACCOUNTS   |
| CIS-COBOL  | SPELLBINDER  | SALES LEDGER       |
| COBOL 80   | MAILMERGE    | PURCHASE LEDGER    |
| FORTRAN 80 | DATASTAR     | NOMINAL LEDGER     |
| MBASIC     | SUPERSORT 1  | INVOICING          |
| CBASIC     | IBM 3780 EMU | PAYROLL            |
| APL        | STATIONERIES | STOCK CONTROL      |
| MPM        |              | DBMS               |
| PLI        |              |                    |

## EPSON

Unbelievable quality from the world's largest print head manufacturer.



**MX 80T**  
**MX80/FT**  
**MX100**



Qume  
£1395

\*Our own low cost maintenance 24 hrs. service

- |   |  |
|---|--|
| <p>20 HIGHER GRAPHICS<br/>95 APPLE DESK TOP PLAN<br/>60 CCA DATA MANAGEMENT SYSTEM<br/>12 MICROCHESS CHESS DISK<br/>10 DISC UTILITY PACK<br/>300 APPLE BUSINESS CONTROLLER PROGRAM<br/>25 APPLE POST PROGRAM<br/>10 APPLE BOWLING DISKETTE<br/>35 3.3 DISK OPERATING SYSTEM<br/>8 STELLAR INVADER<br/>100 APPLE FORTRAN PACKAGE<br/>100 VISIPLLOT VISI-TREND<br/>70 VISITERM<br/>16 ZORK<br/>15 GAMMON GAMBLER<br/>15 BRIDGE PARTNER<br/>100 VISICALC DISK &amp; BOOK COMPLETE 3.3<br/>50 MICROBASE MAILING LIST<br/>100 MICROCHASE STOCK CONTROL<br/>20 3D SUPER GRAPHICS</p> <p>DOCUMENTATION<br/>12 FORTRAN<br/>9 APPLE II REFERENCE MANUAL<br/>10 6502 HARDWARE MANUAL<br/>8 6502 SOFTWARE MANUAL<br/>3 APPLE II BASIC PROGRAM MANUAL<br/>4 APPLESOFT II REFERENCE MANUAL<br/>4 DOS 3.2 MANUAL 3.3<br/>4 APPLE II BASIC TUTORIAL MANUAL<br/>4 AUTOSTART ROM MANUAL<br/>11 PASCAL MANUALS<br/>14 BENEATH APPLE DOS</p> <p>GENERAL ACCESSORIES<br/>18 WIZARD AND THE PRINCESS<br/>20 (10) BLANK APPLE DISKETTES<br/>VINYL CARRYING CASE<br/>MINT DISC LIBRARY BOX<br/>DUST COVER FOR APPLE II<br/>DUST COVER FOR APPLE DISK DRIVE<br/>APPLE DESK TWO TIER<br/>PRINTER TABLE FOR APPLE<br/>PRINTER DESK ECONOMY RANGE<br/>TWO TIER DESK ECONOMY RANGE<br/>SINGLE TIER APPLE DESK<br/>ADD ON PRINTER STAND FOR APPS<br/>MONITOR SHELVE FOR APPS<br/>FREESTANDING MONITOR SHELF<br/>DATA DESK TWO TIER WORKSTATION<br/>DISCOFLEX FILING CASE MINI<br/>12 MISSION ASTEROIDS</p> <p>VIDEO MONITORS<br/>18 MYSTERY HOUSE<br/>100 9" HIGH RESOLUTION B/W MONITOR<br/>100 9" BLACK &amp; WHITE VIDEO MONITOR<br/>165 12" BLACK &amp; WHITE VIDEO MONITOR<br/>CABLE FOR VIDEO MONITOR<br/>150 12" VIDEO MONITOR GREEN DISPLAY<br/>MONITOR CABLE FOR VM12G<br/>120 VERSA WRITER GRAPH PORTABLE<br/>175 Z80 SOFTCARD<br/>POA TABS ACCOUNTS<br/>110 DB MASTER</p> | <p>HARDWARE<br/>600 APPLE 48K VIDEO OUTPUT ONLY<br/>260 DISC DRIVE WITHOUT CONTROLLER<br/>330 DISC DRIVE WITH CONTROLLER<br/>25 16K ADD ON</p> <p>CARDS &amp; ACCESSORIES<br/>120 ALF MUSIC SYNTHESIZER CARD<br/>10 TIMING MODE INPUT BOARD<br/>7 ALF MUSIC ALBUM 1<br/>7 ALF MUSIC ALBUM 2<br/>7 ALF MUSIC ALBUM 0 (CHRISTMAS)<br/>180 ANALOG OUTPUT BOARD 4 CHANNEL<br/>300 ANALOG OUTPUT BOARD 8 CHANNEL<br/>200 A1-02 DATA ACQUISITION CARD<br/>200 AD-DA<br/>11 PROTOTYPE/HOBBY CARD<br/>50 PARALLEL PRINTER INTERFACE CARD<br/>100 COMMUNICATIONS CARD<br/>80 HIGH SPEED SERIAL INTERFACE CARD<br/>90 LANGUAGE CARD<br/>50 CENTRONICS CARD<br/>90 RAM CARD<br/>95 EUROCOLOUR CARD<br/>120 SPEECH LAB<br/>380 GRAPHICS TABLET<br/>90 CONTROLLER CARD<br/>APPLETEL SYSTEM<br/>180 80-COL DISPLAY CARD FOR BASICS<br/>10 DISC TO CONVERT DV80 TO PASCAL<br/>200 APPLE JUICE<br/>5 APPLE BLACK &amp; WHITE MODULATOR<br/>58 HEURISTICS CONTROLLER 70<br/>145 HEURISTICS SPEECHLINK 2000<br/>110 IEEE INTERFACE<br/>160 CLOCK/CALENDAR CARD<br/>180 SUPERTALKER<br/>110 ROM-PLUS BOARD<br/>100 ROMWRITER<br/>30 COPYPLUS ROM<br/>320 MUSIC SYSTEM COMPLETE</p> <p>PRINTERS<br/>250 SILENTYPE 80-COL GRAPHICS PRINTER<br/>25 10 ROLLS THERMAL PAPER FOR A2M0034<br/>9 DUST COVER FOR SILENTYPE PRINTER<br/>380 CENTRONICS 737 PRINTER C/W ADAPTOR<br/>20 11x9.5" PAPER FOR CENT. 737<br/>32 11 ZIPPACK RIBBONS FOR CENT. 737<br/>9 DUST COVER FOR CENT. 737 PRINTER<br/>TEXAS OMNI 810 PRINTER<br/>T1810 PAPER 11x14.5" (2000)<br/>T1810 PAPER 11x15.5/16" (2000)<br/>TEXAS 810 RIBBON<br/>FULL UK ASCII<br/>DUST COVER FOR T1810 PRINTER<br/>540 PAPER TIGER PRINTER WITH GRAPHICS<br/>8 SERIAL CABLE FOR TIGER PRINTER<br/>18 GRAPHICS SOFTWARE FOR TIGER/G<br/>18 2000 SHEETS 11x9.5 PAPER 1 PART<br/>RE-INKING RIBBON &amp; ROLLER SET</p> |
|---|--|

\*All prices ex. VAT

## MICROCOMPUTER HIRE SERVICE

Superbrain with application packages  
Apple System  
PET Tandy Sorcerer Horizon Printers

A TRIAL PERIOD FOR YOUR COMPUTERISATION.  
A COMPREHENSIVE SERVICE FOR RENTALS

CENTRAL OFFICE: Microcomputer Spacedrome, 3 Westholm, London NW11. 01-458 5845

Promglow Ltd., 12 Dene Road, New Southgate. Tel 01-368 9002.

SELLING YOUR COMPUTER.  
UPGRADING – PART EXCHANGE YOUR SYSTEM.  
LOOKING FOR A NEW OR USED COMPUTER.  
SEARCHING FOR A SUITABLE SUPPLIER.

COMPUT A COMPUTER WITH  
**KELLYS COMPUTER MARKET**  
**01-659-7997**

New APPLE 48k £595  
Refurbished ITT2020  
Used 5¼ floppies

New ACORN ATOM – Ring for details  
Used Computers – printers – Peripherals etc.  
Software for all. Bespoke + off the shelf.

**NEW** ELECTRONIC TILL. Everything for the small BUSINESS. INSTANT STOCK UPDATE, Invoice printer, daybook, VAT Calculations, Posting, Accounts, Low Stock Warning, Reorder printing, Visual verification of Inputs, Transactions analysis, Remote keypad + VDU. INCLUDING PRINTER from £2700.

All prices exclude VAT and Carriage

PARAGON HOUSE, 46 KENT HOUSE LANE, Beckenham, KENT

## "COPY-WRITE" A most complete bit copier for Apple programmes

"COPY-WRITE" disk backup system copies virtually all Apple programmes. SPREBOND believes "COPY-WRITE" is the most sophisticated disk backup system available. Do not be misled by our advertised competitors. Their programmes may not copy all the latest protection formats employed by manufacturers to frustrate the software buyer from making needed backup copies of his vital business, accounting, data base, and modelling programmes.

### FEATURES OF "COPY-WRITE"

- **AUTOMATICALLY COPIES HALF TRACKS.** Apple disks only use 35 tracks, or every other one of the 70 available on a 5¼ inch disk. Many protection techniques place some data on the alternate or half-tracks which normal copy programmes cannot read or copy. "COPY-WRITE" automatically searches and reads both full tracks and half-tracks and then writes the data found to the destination disk.
- **COPIES SYNCHRONIZED TRACKS.** Some disks align all tracks in the same pattern as on track 00. "COPY-WRITE" writes these sectors in the same pattern as found on the original disk. Most other copy programmes cannot.
- **PROVIDES "STATUS FIELD DISPLAY".** "COPY-WRITE" supplies the operator with a track by track progress report as the programme reads, aligns, verifies, and writes each track.
- **PERMITS PARAMETER CHANGES.** "COPY-WRITE" not only recognizes the usual DOS 3.2, 3.3, Pascal, CP/M, etc. formats, it will also change parameters to adjust to abnormal or

foreign DOS techniques designed to frustrate making of backup copies.

These parameter changes can be made with "COPY-WRITE's" special and unique state-of-the-art utility called MDDS (Memory Dumper/Disk Searcher). MDDS enables the user to look at each track in ASCII or HEX and determine whether the usual FF sync-bytes have changed to some abnormal permutation.

- **FILER PROGRAMMES.** Once unusual parameters have been identified by MDDS, "COPY-WRITE" allows the user to save to disk each set of parameters for future use with similarly encoded disk formats.
- **FLEXIBLE.** "COPY-WRITE" is the only bit copier with flexible parameters and filer programmes that enable it to respond to new encoding techniques developed by manufacturers. SPREBOND'S subscription maintenance service will provide parameters that update the programme to match new encoding techniques. No other copy programme is as versatile.
- **TUTORIAL MANUAL.** "COPY-WRITE's" 21 page tutorial manual provides instructions for use of the programme.

### HOW TO GET "COPY-WRITE"

- "COPY-WRITE" is available for £50 + VAT.

Orders may be placed by mail or by telephone. Personal cheques are accepted, as are VISA and ACCESS cards.

**Spreebond Limited**

Telephone: (0622) 683-866  
Dealer enquiries welcome

Unit 7, Haslemere,  
Parkwood Estate,  
Sutton Road,  
Maidstone,  
Kent. ME15 9NE.

ALL PRE-PAID ORDERS POST FREE

404 EDGWARE RD. LONDON, W2 1ED TEL: 01-402 8822

### TANGERINE • TANGERINE • TANGERINE • TANGERINE • TANGERINE

## MICROTAN 65

Microtan 65 is the most advanced, powerful, expandable micro-computer available - it also happens to be the most cost effective!

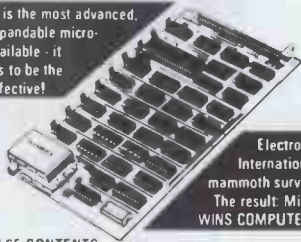

Electronic Today International held a mammoth survey of kits. The result: Microtan 65 WINS COMPUTER CLASS!

### MICROTAN 65 CONTENTS

High quality, plated thru hole printed circuit board, solder resist and silk screened component identification 6502 microprocessor 1K monitor TANBUG Now with 'V' Bug 1K RAM for user programme, stack and display memory VDU alphanumeric display of 16 rows by 32 characters MICROTAN 65 system life binder 136 page, bound, users hardware/software manual with constructional details and sample programmes Logic and discrete components to fully expand MICROTAN 65

The MICROTAN 65 kit has won widespread acclaim for its superb presentation. We pay attention to detail!

KIT FORM **£69.00** + £10 35 V.A.T. total £79 35

MICROTAN 65 assembled and tested, Specification as above, but assembled and fully bench tested by ourselves **£79.00** + £11 85 V.A.T. total £90 85

## MICROTAN 65 OPTIONS

### LOWER CASE PACK

Two integrated circuits which connect into locations on MICROTAN allowing 128 displayable characters

**£9.48** + £1 42. total £10 90

### MINI MOTHER BOARD

Used to connect Microtan to Tanex Built **£10.00** - VAT

### GRAPHICS PACK

Five integrated circuits which connect into locations on MICROTAN allowing the display of chunky graphics (64 x 64 pixels) What are chunky graphics? Well, imagine a piece of graph paper with 64 squares vertically and 64 squares horizontally, a total of 4096. Each square can be made black on white

**£6.52** + V.A.T. 98p, total £7 50

### 20 WAY KEYPAD

Inexpensive means of getting up and running. Uses 'Schoeller' key-switches, and connects to MICROTAN through a 16 pin D.I.L. plug on ribbon cable. Black anodised escutcheon, with TANGERINE legends, finishes off what must be the best value for money keypad available. Available assembled and tested

**£10.00** + V.A.T. £1 50, total £11 50.

\*Space Invaders game (for use with keypad only)

**£15.22** + V.A.T. £2 28 total £17 50

## POWER SUPPLIES

MPS 1 Input 120 or 240V AC Output 5 Volts at 3 Amps Regulated MPS 1 will power both MICROTAN and TANEX fully expanded. Built on the same size printed circuit board as MICROTAN etc. Available as a fully built and tested unit

**£23.00** - V.A.T. £3 45, total £26 45

X MPS2 +5V 6A, +12V, -5 and -12V switch mode system PSU

**£69.13** + V.A.T.

## MINI-SYSTEM RACK

We have produced a mini-system rack which accepts MICROTAN 65, TANEX and our mini-mother board. It has an integral power supply, just plug it into the mains and away you go! Finished in TANGERINE/BLACK, it gives your system the professional finish. Front panel access for I/O cables. AVAILABLE AS AN ASSEMBLED UNIT.

**£43.00** + V.A.T. £6 45, total £49 45

## FULL SYSTEM RACK

For the man that has everything! 19 inch wide system rack which accepts MICROTAN 65, TANEX, TANRAM, SEVEN FURTHER EXPANSION BOARDS, TANDOS and THE SYSTEM POWER SUPPLY. Available in many formats, e.g. individual front panels, full width hinged front panel, back panel with or without connectors

**£49.00** + V.A.T. £7 35, total £56 35.

## MICRON COMPUTER

FULLY BUILT, TESTED, and housed in ATTRACTIVE CASES.

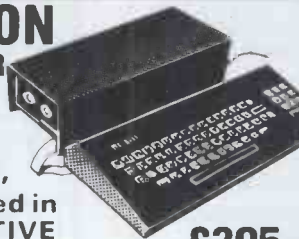

**£395**  
inc V.A.T. P&P

6502 based microcomputer VDU alpha numeric display. Powerful monitor TANBUG-8K RAM 32 parallel I/O lines 2 TTL serial I/O lines Four 16 Bit counter timers. Cassette interface. Data bus buffering. Memory mapping control. 71 key ASCII Keyboard, including numeric keypad. Includes power supply. Also includes the first '10K MICRO-SOFT BASIC' available in the U.K. All the usual BASIC commands

## TANRAM

AVAILABLE NOW TANRAM - 40K Bytes on one board! Single board of bulk memory offering 7K Static RAM (2114), and 32K Dynamic RAM (4116). Onboard refresh is totally transparent to CPU operation and is unaffected by normal OMA's. TANRAM fully expands the available address space of the 6502 microprocessor MICROTAN, TANEX and TANRAM together provide 16K RAM, 48K RAM, and 1K I/O - that's a lot of memory and a lot of I/O! Built and tested. TANRAM ASSEMBLED



40K RAM CARD with 16K DYNAMIC RAM **£76** - VAT

CONTENTS: High quality plated thru hole printed circuit board, solder resist and silk screened component identification. Full complement of I.C. sockets for maximum expansion. 64 way D.I.N. edge connector 1K RAM (2114). Data bus buffering. TANRAM users manual.

EXTRA RAM: 1K STATIC (2114) £2 95 each. 16K DYNAMIC (4116) £1 50 each.

MEMORIES - EXPAND YOUR SYSTEM WITH OUR TANGERINE APPROVED CHIPS.

Discounts 10% for 4, 15% for 8, 20% for 16.

2102 1K x 1 Static RAM - 80p	IM 6402 UART	£4.50
2708 £3.50	2114 1K x 4 Static RAM	£2.95
2716 - £6.50	8080A	£5.00
MK 4116 16K x 1 Dynamic RAM	4118 1K x 8 Static RAM	£7.50
£1.50	All plus VAT	

## MONITORS (PROFESSIONAL)

RECONDITIONED AND NEW - FROM £35.00 to **£129.95**

## CENTRONICS Ideal for Tangerine PRINTERS

SHEIKOSHA **£199** + V.A.T.

Model 730 **£350** + V.A.T.

Model 737 **£395** - V.A.T.



## NEW MICROTANTEL POST OFFICE APPROVED PRESTEL - VIEWDATA

• FULL COLOUR GRAPHICS • MICROTAN OWNERS CAN COMMUNICATE WITH EACH OTHER • CAN STORE PRESTEL • CAN BE USED AS AN EDITING TERMINAL • CAN BE INTERFACED WITH PET, APPLE etc.

Just connect to the aerial socket of any colour or black and white domestic TV receiver and to your Post Office installed jack socket and you are into the exciting world of PRESTEL. Via simple push button use you are able to view 170,000 pages of up to the minute information on many services, order goods from companies - all this without leaving your armchair!

**£170**  
+ V.A.T.

## NEW PRODUCTS

NOW AVAILABLE

HIGH DEFINITION GRAPHICS CONTROLLER CARD **£90.85** inc. V.A.T.

SERIAL I/O CARD (From) **£58.00** - V.A.T.

PARALLEL I/O CARD (From) **£47.50** - V.A.T.

ROM CARD (BUILT) LESS ROM **£47.50** - V.A.T.

ALM.KIM INTERFACE CARD **£59.00** - V.A.T.

SERIAL I/O KIT **£17.25** inc. V.A.T.

SYSTEM MOTHER BOARD WITH 4 SOCKETS FOR SYSTEM RACK **£39** - V.A.T.

SYSTEM MOTHER BOARD WITH 12 SOCKETS FOR SYSTEM RACK **£55** - V.A.T.

32K RAM CARD **£115** - V.A.T.

32K ROM CARD (LESS CHIPS) **£54.65** inc. V.A.T.

## TANEX £43.00

Minimum Config Kit. + V.A.T. £6 45, total £49 45.

### CONTENTS

High quality plated thru hole printed circuit board, solder resist and silk screened component identification 1C sockets for maximum expansion 64 Way D.I.N. edge connector 1K RAM, cassette interface, 16 parallel I/O lines, a TTL serial I/O port, two 16 bit counter timers, data bus buffering, memory mapping, logic and discrete components for maximum expansion. TANEX users manual. TANEX (Minimum configuration) Assembled **£53.00** + V.A.T. £7 95, total £60 95



## TANEX EXPANSION

Expanded, TANEX offers 7K RAM, locations for 4K EPROM (2716), locations for 10K extended MICROSOFT BASIC, 32 parallel I/O lines, two TTL serial I/O ports, a third serial I/O port with RS232/20mA loop, full modem control and 16 programmable baud rates, four 16 bit counter timers, cassette interface, data bus buffering, and memory mapping

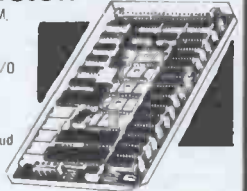

EXPANDED TANEX KIT (Excludes ROM, XBUG and BASIC) **£89.70** + V.A.T. £13 46, total £103 16

EXPANDED TANEX ASSEMBLED **£99.70** + V.A.T. £14 96, total £114 66

OPTIONS TO FULLY EXPANDED TANEX IN SIMPLE INEXPENSIVE STAGES.

10K Extended MICROSOFT BASIC in EPROM (with manual) **£49.00** + V.A.T. £7 35, total £56 35

Extra RAM 1K (2 x 2114) **£5.20** + V.A.T. 78p, total £5 98

SERIAL I/O KIT **£10.26** + V.A.T. £1 60, total £11 80

6522 VIA **£8.00** + V.A.T. £1 20, total £9 20

XBUG **£17 35** + V.A.T. £2 60, total £19 95

AS YOU CAN SEE THE PRICES OF OUR EXPANSION COMPONENTS ARE VERY, VERY COMPETITIVE!

## TANGERINE DISC SYSTEM

Z80 CONTROLLER CARD **£150.00** + V.A.T.

DOUBLE SIDED DOUBLE DENSITY DRIVE **£215.00** + V.A.T.

CP/M DISK OPERATING SYSTEM **£80** + V.A.T.

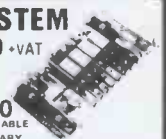

## 71 KEY ASCII KEYBOARD **£56.34** + V.A.T.

NO EXTRAS NEEDED

Uses gold crosspoint keys. Includes numeric keypad and ribbon cable. Available as fully assembled and tested.

SUPER METAL CABINET IN TANGERINE/BLACK

**£20.00** + V.A.T. £3 00, total £23 00



## PROFESSIONAL ASCII KEYBOARDS

Ideal for Tangerine

**£29.95** + V.A.T.



• 52 key 7 bit ASCII coded

• Positive strobe +5V-12V

• Full ASCII characters

• Parallel output with strobe

• Power light on control

• Chip by General Instrument (G1) TTL output

• Superbly made  
• Size 13 x 5.5 x 1.5 ins  
• Black keys with white legends  
• Escape shift return & reset keys  
• Cont of repeat & bell  
• Complete with DATA

## ADD-ON KEYPAD

A compact 12 button keypad suitable for use with above keyboard to extend its functions plus four extra keys. Supplied brand new with with data. A 4 x 4 non-encoded single mode keyboard

LIST PRICE £22 00  
OUR PRICE **£7.95** + V.A.T.

PLUS MANY NEW EXCITING PRODUCTS IN DEVELOPMENT AUTOMATICALLY AVAILABLE FROM US WHEN RELEASED BY TANGERINE LTD

All products are available

FULLY GUARANTEED \* BUY WITH CONFIDENCE

BRITISH DESIGN & MANUFACTURE AND ON DEMONSTRATION IN OUR COMPUTER DEPT

TANGERINE • TANGERINE • TANGERINE • TANGERINE • TANGERINE • TANGERINE • TANGERINE • TANGERINE • TANGERINE

Stockist Enquiries on headed notepaper to:  
COMPUTER KIT LTD. (Principal Distributors in U.K.)  
11/12 Paddington Green, London, W2. Tele: 01-723 5095  
Telex: 262284 Ref. 1400 TRANSONICS

All orders pre-paid and official advertised here to be forwarded DIRECTLY to:  
COMPUTER DEPT., 11/12 PADDINGTON GREEN, LONDON W2

SEND FOR FREE BROCHURE



## COMPUTERS in OXFORD

### HARDWARE

**VIDEO GENIE MICRO** only £299 with 12 month warranty. We supply the full Genie System, including single disc drive: -£215; Twin 40 track: -£395; Twin 80 track: -£545. 12" Monitor £65.00. (Free with every Genie, 120 page Software Catalogue).

### PRINTERS

Epson MX80 FT £399 (High Quality Bi-Directional)  
 Centronics 737 £349 (with proportional spacing)  
 Seikosha GP80A £210 (Economical Matrix Printer)  
 Microline 80 £229 (quiet and reliable).

### SUPERBRAIN-STATE OF THE ART BUSINESS

**MICRO** Tremendous Price/Performance Ratio. CP/M Based, Masses of Software. Lease a Superbrain from around £12 per week! or a complete Business system, including Software and 136 Column Printer from only £29 per week.

**TANTEL** We can now demonstrate the Tanel Adapter, giving access to over 180,000 pages of Data with any Television, only £169.00

### SOFTWARE (ask for full list)

#### FOR GENIE/TRS 80

Visicalc £65.00  
 Newdos 80 £69.00  
 L.Dos £85.00

#### SUPERBRAIN

Wordstar £215.00  
 Mailmerge £ 65.00  
 Dastar £170.00

Complete Integrated Business systems, from under £1000, Ask for details.

### GOOD RANGE OF ACCESSORIES AND COMPUTER

### BOOKS FINANCE LEASING AVAILABLE

Open 9.00 - 5.30 Monday - Friday

9.30 - 1.00 Saturday.

All prices VAT extra.

**MICRO BUSINESS SYSTEMS**

C.T. MADDISON LTD

EAGLE INDUSTRIAL ESTATE THE CROFTS

WITNEY OXFORD TEL: WITNEY (0993) 73145



# The Computer Company

CROYDON

THE SHARP MZ80K  
 48K SYSTEM



**£390**

### FOR COMMERCIAL APPLICATIONS

A COMPLETE SYSTEM INCLUDING 48K MZ80K.

DUAL FLOPPY DISK DRIVE, PRINTER

I/F CARDS & CABLES

**£1,450**

### + THE NEW SHARP MZ80R

BASIC SYSTEM

**£1,095**

COMPLETE SYSTEM INCLUDING 64K MZ80B.

DUAL FLOPPY DISK DRIVE WITH 680K

STORAGE, PRINTER, CP/M + WORDSTAR (OR

SOFTWARE OF COMPARABLE VALUE)

**£2,250**

WORSTAR	269	CIS COBOL	425	GREAT NORTHERN
MAILMERGE	82	FORMS 2	100	SOFTWARE
SPELLSTAR	136	BASIC-80	209	SALES LEDGER
DASTAR	190	BASIC COMPILER	236	OPEN ITEM
SUPERSORT 1	136	FORTRAN-80	299	SALES LEDGER
WORDMASTER	82	COBOL-80	448	PROFESSIONAL
PL/1 - 80	299	M/SORT	75	CLIENT BILLING
BT-80	120	MUMATH	149	PURCHASE LEDGER
MAC	54	EDIT-80	72	NOMINAL LEDGER
SID	45	MACRO-80	119	STOCK CONTROL
ZS1D	60	MAXELL MD2	36	DATAFLOW -
TEX	60	DSDD DISKETTES PER	36	DATABASE
DESPOOL	30	PACK		MANUFACTURERS -
				INVENTORY

MANUALS AVAILABLE SEPARATELY

DELIVERY - ANYWHERE IN THE U.K.

ADD VAT TO ALL PRICES.

78 LOWER ADDISCOMBE ROAD, CROYDON. TEL: 01-654 4147

WHY DON'T YOU PLAY A ROUND  
 WITH OUR NEW GAMES?



Now a whole world of skilled entertainment is at your fingertips. LEISURE GENIUS introduces games like EXPLOSION, DEATH, and WORMS to test your strategic ability and your dexterity. Unlike most other computer games, you can play these with partners and opponents and you can play WORMS against your own micro. Invented by some of Britain's brightest experts, they are a challenge you can't pass up or put down. Don't let all work and no play make computing a dull business!

Each game is available on floppy disk for only £15.00 plus VAT from most computer retailers or direct mail order from:

Leisure Genius, Suite 504, Albany House,  
 324 Regent Street, London W1R 5AA  
 Telephone: 01-580 6361

In U.S. write to:

Leisure Genius, 34-36 83rd Street, Jackson Heights, New York 11372

# Leisure Genius

# 'CFACC'

"THE BEST ACCOUNTS PROGRAMME ON THE MARKET\*" – £900

(FULLY TAILORED TO YOUR OWN REQUIREMENTS – £1200 IF YOU BUY THE HARDWARE FROM US, OTHERWISE £1500)

## MAIN MENU

- |                          |                                   |
|--------------------------|-----------------------------------|
| 1. ADDRESS PROGRAMME     | 16. BANK RECONCILIATION           |
| 2. SALES INVOICES        | 17. PURCHASE LEDGER               |
| 3. PURCHASE INVOICES     | 18. SALES LEDGER                  |
| 4. STOCK CONTROL         | 19. END OF MONTH PROCEDURE        |
| 5. ORDER CONTROL         | 20. VAT STATEMENTS                |
| 6. PAYROLL               | 21. JOB COST ANALYSIS             |
| 7. PAYMENTS MADE         | 22. PROFIT & LOSS ACCOUNT         |
| 8. PAYMENTS RECEIVED     | 23. BALANCE SHEET                 |
| 9. CREDITORS             | 24. CAPITAL ASSETS                |
| 10. DEBTORS              | 25. (JOB COST ANALYSIS)           |
| 11. SUPPLIER STATEMENTS  | 26. DISK DIRECTORIES              |
| 12. CUSTOMER STATEMENTS  | 27. ALTER IN CORRECT FILE ENTRIES |
| 13. AGENTS STATEMENTS    | 28. PRINT LEDGER CODES            |
| 14. PRINT CUSTOMER INDEX | 29. PRINT STOCK LIST              |
| 15. PRINT SUPPLIER INDEX | 30. FINISH USING 'CFACC'          |

PLEASE ENTER SELECTION NUMBER

## 'CFACC' ACCOUNTS PROGRAMME – COPYRIGHT COMPUTERS FOR ALL LTD

1. The Programme resides totally "in core" leaving BOTH DISKS FREE for files and enabling disks to be changed during use.
2. Every Programme issued is "PERSONALISED" with your Company's details. Our "After Sales Service" is positive, giving you constant access to the Author of "CFACC". We arrange Nationwide hardware support.
3. You need only enter invoices and other payments in and out and "CFACC" will produce all the DATA for the MENU Programmes (it will ask the user for any other information it needs).
4. All relevant information is stored for CUSTOMERS, SUPPLIERS, EMPLOYEES and Others.
5. Automatic VAT Calculations.
6. Automatic calculations of WAGES and SALARIES.
7. INVOICES can be produced automatically using Customers' names and addresses from file and Stock Items from file – all calculations are automatic.
8. INVOICES are automatically printed on plain paper or on your own stationery. Invoices entered are retained for automatic printing at the end of the day, lunchtime etc.
9. STOCK FILE is automatically UPDATED whenever a Purchase or Sales Invoice is entered and the User's attention is drawn to any item which has reached RE-ORDER LEVEL.
10. Customer and Supplier Statements printed on demand showing Current, 1 Month, 2 Months, and 3 Months and over figures. These are automatically updated as payments are entered. The User's attention is automatically drawn to any Customer exceeding his CREDIT LIMIT. REMITTANCE NOTES are produced of invoices selected for payment – CHEQUE PRINTING optional.
11. "Open Item" ledgers retain all invoices until they are paid (Purchase & Sales).
12. Outstanding Orders are retained on file until invoiced (Purchase & Sales).
13. Automatically calculates COMMISSION due to Agents and Salesmen.
14. DEBTOR and CREDITOR lists available on demand.
15. PROFIT & LOSS ACCOUNT, BALANCE SHEET and TRIAL BALANCE printouts on demand.
16. MANAGEMENT FINANCIAL REPORTS include:
  - i) GROSS PROFIT RATIO
  - ii) RATE OF STOCK TURNOVER
  - iii) NET PROFIT as a PERCENTAGE OF SALES
  - iv) INCOME STATEMENTS.
  - v) AGE OF DEPT ANALYSIS
17. CAPITAL ASSETS STATEMENT on demand.
18. INCOMES & EXPENDITURE is analysed into 70 ledger classifications and the amounts in any one of these can be called at any time.
19. ENVELOPES or ADDRESS labels can be printed from Address Files.
20. Full Random Access to any record in any file – No Limit on Record Lengths.
21. Ledgers are automatically updated after every transaction.
22. All sections of the Programme and files are fully integrated.
23. Some Programmes on the market claim to be easy to use with no need for a manual (BUT TO THE LAYMAN THEY SIMPLY ARE NOT). "CFACC" really is USER ORIENTATED – WE ARE PREPARED TO LET YOU PROVE THIS FOR YOURSELF. MONEY REFUNDED IN FULL IF YOU CAN SHOW US A BETTER MICROCOMPUTER ACCOUNTS PROGRAMME WITHIN 7 DAYS OF USE.
24. The PRICE makes "CFACC" the best VALUE FOR MONEY on the Market.
25. Fully tested and debugged. You will receive Free of Charge any Improvements or Modifications we make in the future.
26. All equipment is fully tested by us prior to installation – Normal Guarantees on all Equipment and we only recommend the most able. Service Contracts available. Finance and Leasing a speciality.
27. DELIVERY and INSTALLATION FREE of Complete Packages within the UK.
28. We have examples of other Accounts Programmes on the market which you are welcome to try and to compare them with 'CFACC'.
29. PETS, APPLEs and TANDYs taken in PART EXCHANGE against Complete Packages.

64K 'SUPERBRAIN' (350K DISK STORAGE) – DAISYWHEEL PRINTER – "CFACC" ACCOUNTS –  
"WORDSTAR" Word Processing.

\*\* ALL FOR £3,986.00 \*\*

Computers For All Ltd. Stratford on Avon (0789) 840064

24-Hour Service (not machine) on 021-236 1794 Ext. 224

# SUPERBRAIN<sup>®</sup> SERVICES

## IN ALL THE RIGHT PLACES

### FROM HELISTAR SYSTEMS

#### Repair and Maintenance

Your SuperBrain<sup>®</sup> repaired and maintained on-site through the Helistar contract maintenance service - our own engineers cover Central, North and West London, Bucks, Berks, Oxon, Herts, Northants, Beds, Glos, Warwicks. and Middx. Also repairs carried out at our workshop on a time and materials or contract basis.

#### Upgrades and Modifications

Have your SuperBrain disk system upgraded to QD (700Kb) or DQD (1.5Mb). Benefit from faster disk accessing and 40-track capacity with our FASTROM. Improve the character display with true descenders.

#### Add on Hardware

GRAPHICS - 512 x 256 high-resolution graphics with the Micronex PIXELPLOTTER<sup>®</sup>. PORT-BUFFER<sup>®</sup> - allows the connection of external devices to the internal Z80 address and data bus.

#### Software

Memory-mapped WORDSTAR. This version of WordStar is specially tailored to take advantage of the SuperBrain's memory-mapped video giving faster screen display and smoother scrolling.

Contact us today! Telephone Aylesbury (0296) 630364

Helistar Systems Ltd. 150 Weston Road, Aston Clinton, Aylesbury, Bucks. HP22 5EP

## Happy Memories

Part type	1 off	50-99	100 up
4116 200ns	.95	.85	.75
4116 250ns	.90	.80	.70
2114 200ns Low power	1.30	1.20	1.10
2114 450ns Low power	1.25	1.15	1.05
4118 250ns	3.50	3.15	2.95
6116 150ns CMOS	8.75	8.25	7.95
2708 450ns	1.95	1.75	1.65
2716 450ns 5 volt	2.25	2.05	1.95
2716 450ns three rail	7.40	7.00	6.75
2732 450ns Intel type	4.50	4.15	3.95
2532 450ns Texas type	4.95	4.60	4.40
Z80A-CPU	£5.25	Z80A-PIO	£4.75
Z80A-CTC	£4.75		

#### Low profile IC sockets:

Pins	8	14	16	18	20	22	24	28	40
Pence	9	10	11	14	15	18	19	25	33

#### Soft-sectored floppy discs per 10 in plastic library case:

5 inch SSDD	£17.00	5 inch DSDD	£21.00
8 inch SSSD	£21.00	8 inch SSDD	£26.65
8 inch DSSD	£31.75		

74LS series TTL, large stocks at low prices with DIY discounts starting at a mix of just 25 pieces. Write or 'phone for list.

Please add 30p post & packing to orders under £15 and VAT @ 15%. Access & Barclaycard accepted. 24hr service on (054 422) 618. Government & Educational orders welcome, £15 minimum. Trade accounts operated, phone or write for details. Prices are still tending to drop, 'phone for a quote before you buy.



Happy Memories (PCW),  
Gladestry, Kingston, Herefordshire,  
HR5 3NY  
Tel: (054 422) 618 or 628

## ★ NEW BROOM FOR EPROMS ★ TEX ERASER SWEEPS CLEAN!

*EPROMPT is Prompt Enough!*

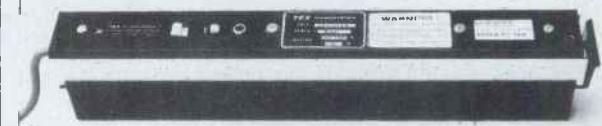

Eproms need careful treatment to survive their expected lifetime. Rushing it could burn their brains out. So cop-out of this helter-skelter world; take it easy the TEX way and give your chips a well-earned break. Cool, gentle and affordable; EPROMPT does it properly.

★ 16-chip basic economy EPROMPT EB: £32 nett; £39 c.w.o. ★  
★ 32-chip interlocked de-luxe EPROMPT GT: £40 nett; £49 c.w.o. ★



*TEXTIME  
is  
Tea-Break Time!*

Our EPROMPT needs just half-an-hour to finish its job; this is the proper erase time for all Eproms. While it's busy you may as well take a break yourself, but don't take too long without a timer on the job; over-erasing can shorten data storage time. So our TEXTIME will remember to turn out the light and your chips will forget nothing new.

★ 30-minute solid-state TEXTIME M30: £15 nett; £19 c.w.o. ★  
★ ★ ★ Special Offer EB + M30: £45 nett; £55 c.w.o. ★ ★ ★  
★ ★ ★ Special Offer GT + M30: £53 nett; £66 c.w.o. ★ ★ ★

TEX: Reliable quality at affordable prices. We manufacture in the U.K. and sell direct. All items ex-stock from St. Albans or Watford Electronics.

C.W.O. Prices include Carriage & VAT. Write post-free: **BOX 11;**  
**TEX MICROSYSTEMS LTD. FREEPOST**  
ST. ALBANS, HERTS. AL1 1BR ST. ALBANS 64077/TRING 4797 ANYTIME



# Your prayers have been answered.

If you own or use a micro-computer, then chances are that from time to time, you've wished that someone could simplify programming.

Because as useful as micro-computers are, they can only ever be as good as the programs they run.

Well then, how does this sound?

No more program-coding. No more debugging. And no more time wasting.

Arguably more comprehensive and advanced than anything else of its kind, The Last One is a computer program that writes computer programs. Programs that work first time, every time.

By asking you questions in plain English about what you want your program to do, The Last One uses your answers to generate a ready-to-use program in BASIC.

What's more, with The Last One, you can change or modify your program as often as you wish. Without effort, fuss or any additional cost. So as your requirements change, your programs can too.

And if, because of the difficulties and costs of buying, writing and customising software, you've put off purchasing a computer system up to now, you need delay no longer.

Available now.

The Last One costs £260 + £39 VAT and is now available from better computer stores.

For further information, write to D.J. 'AI' Systems Ltd.,  
Station Road,  
Ilminster,  
Somerset TA19 9BQ.  
Tel: 04605 4117.

## **THE LAST ONE**<sup>®</sup>

# THE NEW TEXAS T199/4 42K PERSONAL COMPUTER ONLY £275.00 +VAT

## LOOK AT THESE FEATURES

9900 16 BIT PROCESSOR 3.5 MHZ ● 26K ROM INCLUDING 14K BASIC ● 7.6K GRAPHICS LANGUAGE INTERPRETER ● 4.4K MONITOR ● 16K USER RAM (EXPANDABLE TO 48K) ● EQUATION CALCULATOR ● HI-RES GRAPHICS 192 x 256 ● 16 COLOURS WITH FORGROUND, MIDDLE, AND BACK GROUND ● FULL MEMORY MAPPED SCREEN ● 5 OCTAVES SOUND FROM 110Hz TO OVER 40000 ● 3 SIMULTANEOUS TONES + NOISE GENERATOR ● BUILT IN LOUDSPEAKER WITH VOLUME CONTROL ● PLUGS INTO ANY STD COLOUR TV (B/W GIVES SHADES OF GREY) ● INTERFACE TO CONTROL 2 CASSETTE PLAYERS (AUTO COPY AND UPDATE FROM ONE TO THE OTHER) PLUS MANY MORE SUPER FEATURES ● 12 MONTH GUARANTEE ● OPTIONS INCLUDE:- BIG RANGE OF SOLID STATE PLUG IN SOFTWARE ● RS232 INTERFACE ● THERMAL PRINTER ● DISK DRIVES ● SPEECH SYNTHESIZER ● JOYSTICKS ETC ETC.



Please send me  
T199/4 COMPUTERS (Inc.  
Power supply modulators  
and cass interface).  
Please send me details and price list.

Name \_\_\_\_\_

Address \_\_\_\_\_

Phone \_\_\_\_\_

I enclose cheque for \_\_\_\_\_ (£316.25 per computer including £41.25 VAT)

Please charge my Access/Diners Club Card.

Number \_\_\_\_\_

or telephone your card order during shop hours to:-  
Watford (0923) 40601.

Signed \_\_\_\_\_

Send to The Computer Centre, Watford, Ltd.  
150 High Street, Watford, Herts. WD1 2EN



## THE ZX81 POCKET BOOK

Also suitable for ZX80 with 8K ROM

- ADVENTURE  
- City of Alzan  
- Create your own
- TUNNELS & TROLLS
- BUCKET CATCHING
- JAWS
- BECOME AN ARTIST
- PRO-AM GOLF
- PUTTER
- ETCH-A-SKETCH
- FRUIT MACHINE  
*With hold*
- DIGITAL CLOCK
- DICE ROLLING  
plus 20 others

110 PAGE  
BOOK

**5.95** ★

CASSETTE  
& BOOK

**10.00** ★

**PLUS** Hints & tips on programming  
Reference Sections

The ZX80 Pocket Book still available, prices as above.

## ATOM BUSINESS

Suitable for the expanded Atom with floating point ROM

Each section contains:  
- Management Summary  
- Operating Instructions  
- Program notes  
- Source listing

ADDLIST  
LABEL PRODUCTION  
LEASE OR BUY DCF  
METRIC CONVERSION  
STANDARD DEVIATION  
BUDGET FACTORING

SALES GRAPH  
SALES RECORDS  
NOMINAL LEDGER  
QUEUEING  
SIMULATION  
EXPENSE CLAIMS

110 Page  
Book

**6.95** ★

Cassette  
& Book

**15.57** ★

## PHIPPS ASSOCIATES

3 DOWNS AVENUE EPSOM Surrey KT18 5HG  
Tel: Epsom (03727) 21215 quoting your credit  
card reference. 24 Hour phone service. Air Mail  
delivery in Europe add 50p, air mail elsewhere  
add £1.50 per book. Prices shown above include  
UK postage and VAT on cassettes

## Rent a Computer

Did you know you can rent a computer for as little as £2.76 per week (ACORN ATOM).

Minimum Rental 12 months. Written quotation on request. Please phone for details.

## ... Monitors & TV's ...

COLOUR TV'S by FERGUSON, JVC, MITSUBISHI, PANASONIC, TOSHIBA.



PANASONIC TC492 Colour TV 12"	£199.00
SHARP B/W 12" TV	£54.90
DECCA 14" COLOUR MONITORS	£250.00
9" O.P.C. GREEN	£95.00
9" APFB/W	£85.00
9" HITACHI B/W	£112.17
12" BMC	£180.00
12" NEC GREEN	£159.00
12" NEC COLOUR	£579.00

(Please add VAT to prices above)

## ..... Hardware .....

SYSTEMS BY ADLER, APPLE, ACORN, PANASONIC, SHARP, VIDEO GENIE.



SHARP PC1211 POCKET	£79.00
SHARP MZ80K (20K)	£390.00
SHARP MZ80K (48K)	£405.00
(Plus £25 worth of free Software)	
SHARP MZ80B (64K)	£999.00
ACORN ATOM KIT 8K ROM + 2K RAM	£123.00
ATOM ASSEMBLED 8K ROM + 2K RAM	£153.00
ATOM KIT 12K ROM + 12K RAM	£223.00
ATOM ASSEMBLED 12K ROM + 12K RAM	£253.00
POWERSUPPLY	£11.00
APPLE II (48K)	£695.00
ADLER SYSTEMS FROM VIDEO GENIE (16K)	£1850.00
COMMODORE VIC 20	£275.00
VIDEO GENIE Model 2	P.O.A. £356.00

ALL ABOVE PRICES INCLUSIVE OF P&P - Please add VAT.

## Mail Order Accessories

All items listed are available through our fast efficient mail order service. If you find our prices are not competitive than we will be pleased to match any genuine offer in this magazine.

P&P Rates: a 0.75 b 1.00 c 1.50 d 2.50

ACORN Colour Encoder	20.00 a
Floating Point Rom	20.00 a
Memory Chips	1.95 a
Magic Book	5.50 c
Printer Drive	9.00 a
Printer Buffer	2.50 a
Utility	10.00 a
VDU	10.00 a
Maths Pack	10.00 a
Games Packs 1 to 7	10.00 a
Word Pack Rom	26.00 a

APPLE (Please ring for software not listed)	
Visicalc (New 16 sector)	111.00 b
Visiplot	100.00 b
Visitrend/Visiplot	144.00 b
Visidex	111.00 b
Ciscobol	475.00 b
Desk Top Plan	65.00 b
Micro Modeller	425.00 b
APM	121.00 b
Writer	39.00 b
Magic Window	79.00 b

BOOKS (Send SAE for full list)	
Acorn Magic	5.50 c
Microsoft Basic	8.95 c
Basic Basic	8.25 c
Learning Level II	11.00 c
Basic Handbook	11.00 c
Introduction to Pascal	8.75 c
Programming in Pascal	6.95 c
CP/M Handbook	8.95 c
Programming & Interfacing 65 02	8.95 c
Programming the 65 02	9.10 c
Basic Computer Games	5.50 c
Basic A Unit for Secondary Schools	4.45 c
More Basic Computer Games	6.25 c
Making Most of ZX80	6.95 c
Machine Language from ground up	9.00 c

Getting Acquainted with your VIC 20	5.95 c
Getting Acquainted with your Acom Atom	7.95 c
ZX81 Companion	7.95 c
ZX81 Pocket Book	4.95 c

MEMORY CHIPS	
4116 (Apple, Sharp)	ea 1.50 a
2114 (Acorn)	ea 1.95 a
4027 (1/2 K Sharp)	ea 0.50 a

VIDEO GENIE Sound Mod	7.50 a
Colour Mod	39.46 b
Synthesiser	45.00 b
EG 3013 Expander	185.00 d
EG 3013/RS232	215.00 d
Lower Case	35.00 b
Dust Cover	5.55 a
Invaders	13.00 a
Biorhythm	7.50 a
Battle of Britain	13.50 a
Pinball	13.00 a
Pools	13.50 a
Imon	23.10 a
Sargon II chess	25.00 a
Star Trek	9.50 a
Z chess 3	14.50 a
Adventure Sampler	6.50 a
Adventure 1 to 9	8.75 a
Maniball	13.50 a
Android Nim	8.75 a
Tables	6.50 a

SHARP CE 121 Cassette	
Interface	11.50 b
CE 122 Printer	
Interface	63.90 b
Assembler Tapes & Manual	20.44 b
Machine Language tape & Manual	41.40 b
Speed Basic	10.00 a
Biorhythm	4.00 a
Autocross	4.00 a
Hanoi	4.00 a
Fox & Geese	4.00 a
Four in a Row	5.00 a
Moontender	5.00 a
Composer	4.00 a
Bank Account	5.00 a
Posidon	5.00 a
Address Book	4.00 a
Anagrams	3.00 a
Dust Cover	5.00 a

P3 Printer Dust Cover	5.00 a
Picture Count	5.00 a
Count & Add	5.00 a
Match the Word	5.00 a
Character Match	5.00 a
Head On	6.00 a

Getting Acquainted with your VIC 20	5.95 c
Getting Acquainted with your Acom Atom	7.95 c
ZX81 Companion	7.95 c
ZX81 Pocket Book	4.95 c

SUPERIOR SYSTEMS SOFTWARE	
SHARP Games Pack 1 (5 games on Cassette)	10.00 a
Games Pack 2 (5 games on Cassette)	10.00 a

CALCUBET - Complete Bookmaker Bet Calculation programme, various versions available. Phone for details.

APPLE Games Pack 1 (Disc 5 games)	12.50 a
Games Pack 2 (Disc 5 games)	12.50 a

VIDEO GENIE Games Pack (5 games on Cassette)	10.00 a
Education Pack 1 (3-6 year old on Cassette)	10.00 a

COMPUTER ACCESSORIES	
C12 Digital Cassettes. Box of 10	£7.90
5 1/4 Discs Single Sided Double Density. Box of 10	£20.00
5 1/4 Double Sided Double Density. Box of 10	£32.00
SHARP Speed Basic	£10.00

Please add P&P (75p) & VAT for above Accessories.

## Peripherals

### PRINTERS

SEIKOSHA GP80	£195.00
EPSON MX 70	£259.00
EPSON MX80F/T	£399.00
MICROLINE 83	£799.00
CENTRONICS 737	£395.00
SHARP MZ80P 3	£379.00
SHARP MZ80P 5	£415.00
EPSON MX 100	£575.00
EPSON MX 130	POA
EPSON MX80F/T2	£480.00



DISK DRIVES	
SHARP DUAL DRIVE	£580.00
VIDEO GENIE SINGLE DRIVE	£215.00
VIDEO GENIE DUAL DRIVE	£410.00

INTERFACE UNITS  
A WIDE RANGE OF INTERFACES ARE AVAILABLE EX-STOCK  
WESTRA COMPUTER STATION  
DESKS IN STOCK  
(Please add VAT to prices above)

Interest Free and Lease Purchasing Plan  
3 MONTHS INTEREST FREE CREDIT  
AVAILABLE ON ALL ITEMS OVER £300. PLEASE PHONE FOR DETAILS. LEASE PURCHASE SYSTEMS FOR AS LITTLE AS £10 PER WEEK!

# Superior Systems Ltd.



178, WEST STREET, SHEFFIELD S1 4ET TEL: 0742 755005  
ALSO AT: QUADRAPHENIA, 19 BRADFORD ROW, (HALLGATE) DONCASTER DN1 3NF TEL: 0302 21215

Business Hours: Sheffield Mon-Sat 9am-5.15pm Doncaster Mon-Sat 10am-5.00pm

# BITS & P.C.S.

COMPUTER PRODUCTS LTD

**The North's Leading Computer Specialist Service & Advice our Speciality**

**Quantum Micros**

**HIGH RESOLUTION GRAPHICS FOR MZ 80K**

**Available Now At £150 + VAT**

Resolution down to a single dot. User definable characters. Reverse Video. New Pixel graphics which actually join. Rotate Characters through 360°. High resolution plotting. Three dimensional drawing & high resolution rotates. Fixes internally and is fully compatible with all existing hardware & software. Comprehensive graphics editor with twenty commands. Fully built and tested units, easily installed or alternatively we will arrange for installation.

★ **Quantum MZ 80K High Res.** ★  
This is a Sharp MZ 80K (48K Version) already fitted with high resolution system.  
Only **£500 (Carriage £10) + VAT**

**SHARP MZ 80K ONLY £430 + VAT**

FULL RANGE OF EPSON PRINTERS AT COMPETITIVE PRICES.  
Interfacing details & Cords available for Nascom & Sharp.

Full Range of **NASCOM & GEMINI MULTIBOARD** products, see the **MICRO VALUE** Ads for details.

**Quantum Software for MZ80K £7.00 each**

- GAMES (1)** Star Trek, Spacefighter, Stock car, Labyrinth, Reverse, Test.
- GAMES (2)** Electric organ, Othello, Ambush, Fox & hounds, Metric conversions, Hangman, Shuffle.
- GAMES (3)** Ten pin, War, Swamp, Minefield, Biorythm, Scramble.
- GAMES (4)** Paper stone, Jumping balls, Bounce, Race, Calendar, Alarm clock, One armed bandit.
- GAMES (5)** Poker, Stamp, Obstacle, Battleships, Surround, Animal.

**PC1211 POCKET COMPUTER** £96.00 inc VAT  
**PC1211 POCKET COMPUTER PRINTER** £88.00 inc VAT  
**PC1211 CASS INTERFACE** £16.95 inc VAT

**BITS & P.C.s Computer Products Ltd.**  
4 Westgate, Wetherby, West Yorkshire  
LS22 4LL Tel: 0937 63744.  
SAE for details



# Dola Software

117 BLENHEIM ROAD, DEAL, KENT

**ATOM MUSIC!!!!** Supplied on tape. Graphics 6K. Program + tune storage 4½K. NO extra hardware so single note. Look at these features:- A powerful music 'processor' with high-res graphics display of notes (over 700). Tune entry with full editing. Linked notes, dotted notes and rests. KEY SIGNATURE, SPEED, TEMPO, PLAY, PLAYX, LIST, LISTX, FORWARD ONE, BACKWARD ONE, GO TO END OF STAVE, GO TO END OF TUNE, DELETE NOTE, INSERT NOTE, COPY SECTION, CHANGE, NORMALISE. All commands on direct interpretation — no need to go to a menu every time! Double sharp, double flat etc. Automatic stepping past either end of stave! DISPLAY tune, or not, when being played. Tune deletion double protected! INCLUDES an input to high-res graphics for clear interaction!! Marvellous for composing your own music — or just copying tunes. Demonstration music included. Sounds great. £10

**ATOM MATRICES.** Supplied on tape. Program 4½K. Graphics ½K. Matrix storage — the more the better. We use the upper text space and can deal with matrices up to 25x25.

This is FULLY interpretative (no menu) with a powerful extra (see below). MULTI-STATEMENT lines with semi-colon separation! Matrix functions:- MULTIPLY, ADD, SUBTRACT, INVERSE, PRINT, SACLAR MULTIPLY. All numbers may be floating point. All matrices are stored and may be used again at any time. FULL error checking. Also included in the Interpreted commands are:- PRINTER ON, PRINTER OFF, PRINTOUT FORMAT. POWERFUL EXTRA (included). Machine code floating point formatter!!  
1.00000000 becomes 1 Makes formatting EASY. Number of digits  
1.30000000E-1 becomes 0.13 required is software selectable. Simple indication if number doesn't fit format. £10

**UK101 FRONT PANEL.** Supplied on tape.

A powerful machine code program to display and change all the 6502 registers and memory locations. Each location is displayed in Hex, Decimal, Binary and Character (as for POKE). Full screen editing is used as with the monitor. The memory locations automatically move along when entering programs. This will be of great value to anyone writing machine code programs, and can co-exist with the extended monitor. As well as normal entry the front panel can also be entered by a break point in your program — giving a display of the present state of all registers. PLUS a facility for 'continue' after break! Great for debugging. As a BONUS a BASIC program is included which allows relocation of the front panel. Written for the new monitor and Cegmon (please specify). £10

All the rest of the Dola Software library will be sent on receipt of a large SAE.

## NORTH EAST

ACORN — VIDEO GENIE — SWIPC  
Acorn Atom . . . . From £120  
Video Genie . . . . From £299

PRINTERS  
Seikosha GP80 (with paper) . . . £199  
Epson, Anadex, Qume, & Others

MONITORS  
12" Green Phosphor . . . £79  
DISC DRIVES  
For All Micros

We supply components, cables, plugs, connectors, cassettes, discs & paper  
500 sheets 8" x 11" fanfold paper for  
Seikosha GP80 — £5.50

FULL maintenance service available  
All above prices exclude VAT to be applied at 15% — FREE delivery

FOR FULL DETAILS, INFORMATION & PRICES

CONTACT

**HCCS ASSOCIATES**  
533 DURHAM ROAD LOW FELL  
GATESHEAD TYNE & WEAR  
(0632) 821924

# DATA LINK

**MICROCOMPUTER SYSTEMS LIMITED**

Announce

## MICRO PLANNER

— the program that gives microcomputer users a mainframe capability  
— at a fraction of the cost.

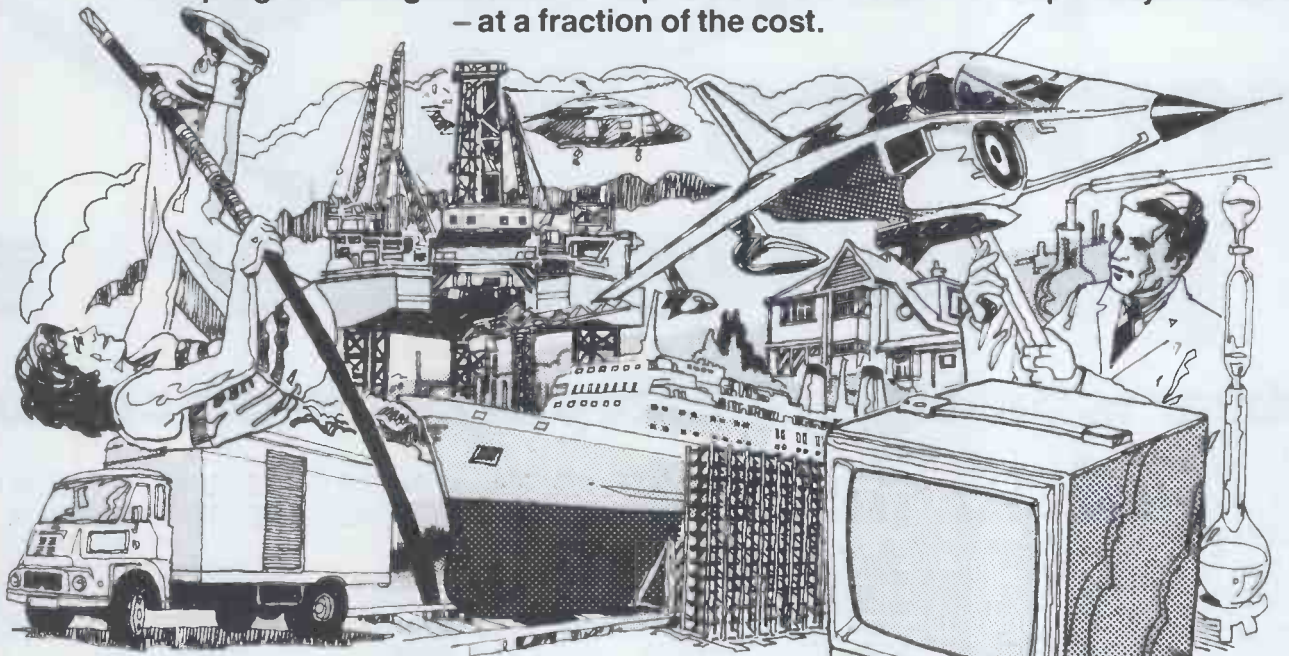

Specifically written for the Apple II, Micro Planner plans and controls projects which require accurate co-ordination of interdependent operations and inputs.

Micro Planner uses the powerful technique of Network Analysis (or P.E.R.T.) to enable operators with no previous computer experience to control complex projects on site.

**CONSTRUCTION** — private housing to oil rigs  
**EVENTS** — exhibitions, sports meetings, air displays.  
**NEW PRODUCT LAUNCHES**  
**RESEARCH and DEVELOPMENT**  
**SHIPPING** — building and refit.  
**MILITARY** — planning operations. ETC., ETC.

We believe that Micro Planner is a superb program which in many respects revolutionises the use of the microcomputer allowing it to achieve its maximum potential with an economy and flexibility unobtainable with larger systems.

# DATA LINK

Microcomputer Systems Limited  
10, Waring House, Redcliffe Hill,  
Bristol BS1 6TB. Tel: Bristol (0272) 213427

To: Datalink Microcomputer Systems Limited  
Please send me detailed information about Micro Planner

Name .....

Address .....

.....

Tel No. ....

# NewBear Limited

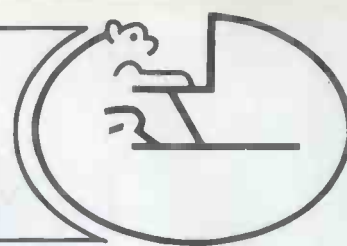

# sharp operators go to Newbear



**Newbear is the biggest Sharp dealer in the country.**

**FOR THE MZ-80K HARDWARE**

<b>MZ80-K 48K RAM</b>	<b>£410.00</b>
MZ80-K 48K RAM	£410.00
MZ80K-FD DUAL DISC UNIT	£589.00
M280K-P3 PRINTER	£385.00
MZ80K-105 SLOT I/O BOX	£87.00
BI-DIRECT. V24/RS232 CARD	£99.50
UNIVERSAL I/O CARD	£45.00
RS232 I/O BOX WITH PSU	£64.95
(SINGLE DIRECT NO I/O BOX REQD. O/P ONLY)	

**UTILITY PACKAGES**

APOLLO WORD PROCESSOR V1.9	— £24.95
ANIMATE	— £5.50
CASSETTE DATABASE	— £29.50
BASIC EXTENSIONS	— £13.00
ARDENSOFT TOOLKIT	— £35.00
CP/M (INCLUDES HARDWARE MOD., CP/M DISC & FULL DOCUMENTATION)	— £150.00
ZEN EDITOR/ASSEMBLER	— £19.50
SHARP EDITOR/ASSEMBLER	— £45.00
ZEN-DOS	— £37.50
SHARP MACHINE CODE TAPE & MANUAL	— £22.50

**DISSASSEMBLER (ZEN COMPATIBLE)**

CRYSTAL BASIC	— £10.50
SUPER COPY	— £40.00
PROGRAM FILING INDEX	— £5.50
MUSIC COMPOSER-EDITOR	— £10.50
DOUBLE PRECISION BASIC FOR THE MZ80K DISC SYSTEM	— £4.00
PASCAL SP4015 (CASSETTE)	— £50.00

**ACCESSORIES**

MZ80-K MANUALS	— £15.00
MONITOR LISTING (COMMENTED)	— £15.00
BASIC 5025 MANUAL	— £7.00
MZ80-K SERVICE MANUAL	— £7.50
MZ80-10 SERVICE MANUAL	— £5.00
MZ-80P3 SERVICE MANUAL	— £7.50
MZ-80FD SERVICE MANUAL	— £10.00
MZ80-K DUST COVER	— £9.95

**GAMES BOOKS. WORD PROCESSING. EDUCATION PRINTERS. DISCS. + THE LATEST MZ-80B!**

<b>GAMES</b>			
ANIMATE	— £5.50	GUESS WORD	— £5.50
BLOCKADE	— £5.50	GUN	— £5.50
BOMBER	— £5.50	HANGMAN	— £5.50
BREAKOUT	— £5.50	HEADON	— £5.50
CAMELOT	— £5.50	HOME BUDGET	— £5.50
CATCH 2000/INVADER	— £5.50	HUNTER KILLER	— £5.50
CHESS	— £10.50	INTRUDER	— £5.50
COMBAT	— £5.50	J.S. LINE 4	— £5.50
CONCENTRATION	— £5.50	LARGE DISPLAY	— £5.50
CRIBBAGE	— £10.50	LIFE	— £8.00
DONKEY DERBY	— £5.50	LUNAR	— £5.50
ELECTRONIC ORGAN	— £5.50	LUNAR LANDER	— £5.50
ENIGMA	— £5.50	MAP OF ENGLAND	— £5.50
EVASION	— £5.50	MASTERMIND	— £5.50
EXECUTIVE	— £8.00	MIZ MAZE	— £8.50
EXPLORING AFRICA	— £5.50	MONKEY CLIMB	— £5.50
FALL OUT	— £5.50	MORTAR ATTACK	— £5.50
FIREBALLS	— £5.50	PATIENCE	— £5.50
4 INAROW	— £5.50	POKER	— £5.50
FRUIT MACHINE	— £5.50	PONTOON	— £5.50
GRAPHICS/MUSIC PACK	— £5.50	PRINCESS & MONSTER	— £5.50
TYCOON	— £5.50	3D	— £5.50
		RACING	— £5.50
		RACETRACK	— £5.50
		RAIDER	— £5.50
		REACTOR	— £5.50
		ROAD HUNTER	— £8.00
		RHYMES	— £5.50
		SHAPEMATCH	— £5.50
		SHARP DEMO(GRAPHICS)	— £5.50
		SHDWJUMPING	— £5.50
		SNAKES & LADDERS	— £5.50
		SPACE BATTLE	— £5.50
		SPACE INVADERS	— £5.50
		SPACE PURSUIT	— £5.50
		STAR TREK	— £5.50
		STOMPER	— £5.50
		SUBMARINE	— £5.50
		SUPER FIRE	— £5.50
		SUPER SIMON	— £5.50
		SWORDMAN	— £8.00
		MAZE TANKWARP/WALL	— £5.50
		TEN PIN BOWLING	— £5.50
		TRADER SMITH	— £8.00
		U.F.O.	— £5.50

**SEND FOR FULL CATALOGUE**

**EDUCATIONAL PACKAGES**

TIMETABLING AID	— £19.50
CHILDRENS MATHS	— £5.50
PHONE FOR LATEST LIST	

**BUSINESS PACKAGES**

STOCK CONTROL (DISC)	— £95.00
MAILING LIST (DISC)	— £19.50
MAILING LIST (CASSETTE)	— £14.50

*Please add V.A.T. to all prices*

Newbear Limited. (Head Office) 40 Bartholomew St., Newbury, Berks.  
Tel: (0635) 30505. Telex: 848-507 NCS  
Newbear Limited. First Floor Offices: Tivoll Centre, Coventry Road, Birmingham.  
Tel: (021) 707-8255  
Newbear Limited. Stockport Road, Cheadle Heath, Manchester.  
Tel: (061) 491-2290

Please send me details of:

Name \_\_\_\_\_  
Company \_\_\_\_\_  
Address \_\_\_\_\_  
pcw



# New and popular Sams books

## Sams Books Stockists

Byteshop Computerland Ltd.  
P.O. Box 2  
St Neots  
Huntingdon  
Cambridgeshire

Cambridge Computer Store  
1 Emmanuel Street  
Cambridge

Datron Micro Centre  
2 Abbeydale Road  
Snettisham, S7 1FD

Micro-C  
5-11 Martineau Way  
Union Street  
Birmingham

Micro-C  
127 Charles Street  
Leicester

Micro-C  
19 Brown Street  
Manchester

Micro-C  
2 Wheeler Gate  
Nottingham

Newbear Computing Bookstore  
40 Bartholomew Street  
Newbury  
Berkshire

Silicon Centre  
Pictural Electronics Ltd  
21 Comely Bank Road  
Edinburgh 4

Tomorrow's World  
Grafton Arcade  
Grafton Street  
Dublin 2

J. Downey and S. Rogers

### PET Interfacing

This practical book explains how specialised interfaces can be built and used with the PET computer. It covers three types of interfacing: the user port, the memory expansion port, and the IEEE 488 port.  
£11.85 672-21795-3

Elmer C. Poe and James C. Goodwin, II  
**The S-100 and Other Micro Buses:  
2nd Edition**

21 of the most widely used bus systems are fully described, including their mechanical data, pinout designations and bus signal definitions, as well as various ways to convert different bus signals to S-100 signals. Expansion boards for the APPLE and the PET are also discussed.  
£6.95 672-21810-0

Stephen Murtha and Mitchell Waite

### CP/M™ Primer

£8.35 672-21791-0

Andrew C. Staugaard, Jr.

### How to Program and Interface the 6800

£11.15 672-21684-1

David Fox and Mitchell Waite

### Pascal Primer

£11.85 672-21793-7

Marvin L. De Jong

### Programming and Interfacing the 6502, with Experiments

£11.15 672-21651-5

Don Lancaster

### Son of Cheap Video

£6.25 672-21723-6

William Barden, Jr.

### Z-80 Microcomputer Handbook

£6.25 672-21500-4

*Prices are correct at the time of going to press but may be subject to change. All titles advertised are published as paperback books.*

## Dealer enquiries are welcome:

Please contact Roy Jones at the address below or telephone: Hemel Hempstead (0442) 58531.

Prentice-Hall  International

66 Wood Lane End, Hemel Hempstead,  
Hertfordshire HP2 4RG, England.

Exclusive distributors of Howard W. Sams  
books in the UK and Europe.

# APPLE :: PET :: TRS Software



## DUNJONQUEST Temple of Apshai

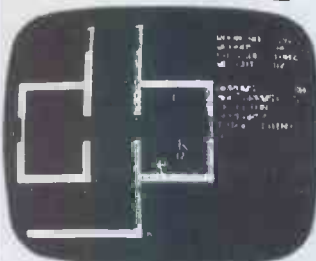

Temple of Apshai during play on the Apple computer.

**Graphics!**  
(Apple uses high-resolution & color!)  
**Real time!**  
A fantasy role-playing experience!  
For ages 10 through adult  
Complexity: Intermediate  
Playing time: 30 minutes to forever!  
For one player

Now, you can enter a universe in which quick wit, the strength of your sword arm and a talisman around your neck might be what separates you from a pharaoh's priceless treasure—or the death-grip mandibles of a giant mantis.

"Temple..." is a role-playing game (RPG) that catapults you into a world of magic and monsters—doomed cities and damsels in distress. More than a game, it's an alter-ego experience. In an RPG, complex factors that make up a human being are abstracted into a few basic characteristics: strength, constitution, dexterity, intelligence and ego. Via your role-playing character, you'll venture into an essentially unknown world, and be at home with the likes of skeletons, zombies, spiders and wraiths. You'll bargain with a tight-fisted innkeeper for the weapons and armor you'll need in the dunjon.

When you play the "Temple of Apshai," you'll be both a character within and a reader of the epic you're actually helping to create. In this labyrinth, the choice is always yours... fight or flee, parry or thrust, slay the monsters or see if they'll listen to reason.

After you've bargained for your sword, armor, shield and your bow and arrows, most of your time in the dunjon will be spent exploring the 200 rooms on four different levels... trying to find 80 types of treasures of priceless worth. But wait—the treasures are surrounded by traps—needles, daggers, flames and bottomless pits—closely guarded by monsters vile and noxious. Do you dare to thrust your broadsword at the giant leech, the skeletal bat, the zombies or the ghouls with mouths full of razor fangs?

We invite you to project yourself into the labyrinth. See and touch the treasures, hear and smell the creatures that inhabit the place. Discover for yourself the fantasy world of Apshai!

**TRSSB**  
16k LII;  
**PET 32k**  
Case  
**14.95**

**TRSDOS**  
32k;  
**APPLE**  
48k  
(Disk)  
**16.95**

All prices include p & p and V.A.T.



# ALGRAY

ALGRAY House, 33 Bradbury Street, Barnsley.  
South Yorkshire Tel: Barnsley (0226) 83199

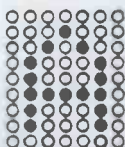

## For the best PET software...

COMMAND-O.....	For Basic IV CBM/PET, 39 functions with improved "Toolkit" commands	£59.95 + Vat
DISK-O-PRO....	For Basic II PET, adds 25 commands including Basic IV, in one 4K rom	£59.95 + Vat
KRAM.....	For any 32K PET/CBM for retrieving disk data by KEVED Random Access	£86.95 + Vat
SPACEMAKER IV	For any PET/CBM, mounts 1-4 roms in one rom slot, switch selection	£29.95 + Vat
USER I/O	For software selection of up to 8 roms, in any two Spacemaker Quads	£12.95 + Vat
FRONTO-PET....	Soft/hard reset for 40-column PETs	£9.99 + Vat

SUPERKRAM, REQUEST & KRAM PLUS will be available shortly

We are sole UK Distributors for these products, which are available from your local CBM dealer, or direct from us by mail or telephone order. To order by cheque write to: Calco Software, FREEPOST, Kingston-upon-Thames, Surrey KT2 7BR (no stamp required). For same-day Access/Barclaycard service, telephone 01-546-7256. Official orders accepted from educational, government & local authority establishments

## ... at the best prices!

WORDPRO IV PLUS	RRP £395 less £98.75 = £296.25!
WORDPRO III PLUS	RRP £275 less £68.75 = £206.25!
WORDPRO II PLUS	RRP £125 less £31.25 = £93.75!
VISICALC	RRP £125 less £25.00 = £100.00!
TOOLKIT Basic IV	RRP £34 less £9.50 = £24.50!
TOOLKIT Basic II	RRP £29 less £7.25 = £21.75!

The items above are available by mail or telephone order at our Special Offer Price when purchased with any one of our software products. This offer is for a LIMITED PERIOD only. UK - ADD 15% VAT. OVERSEAS airmail postage - add £3.00 (Europe), £5.00 (outside Europe).

## Calco Software

Lakeside House - Kingston Hill - Surrey - KT2 7QT Tel 01-546-7256

## Rumour has it that we sell microcomputers...

But we also supply:

- Complete Business Systems
- Wordprocessors
- Bespoke software
- Packaged software
- Printers
- Accessories
- Full after sales support
- Sound advice

Don't believe everything you read in the press though-

Find out for yourself.

THE AVERY  
COMPUTER COMPANY  
13 The Mall  
Bar Hill, Cambridge.  
Tel: Crafts Hill 80991



# EXPLORER 85 For Maximum flexibility

A thoroughly versatile S100 based computer

Arrange your own microsystem  
with the following fully  
assembled and tested modules

64K

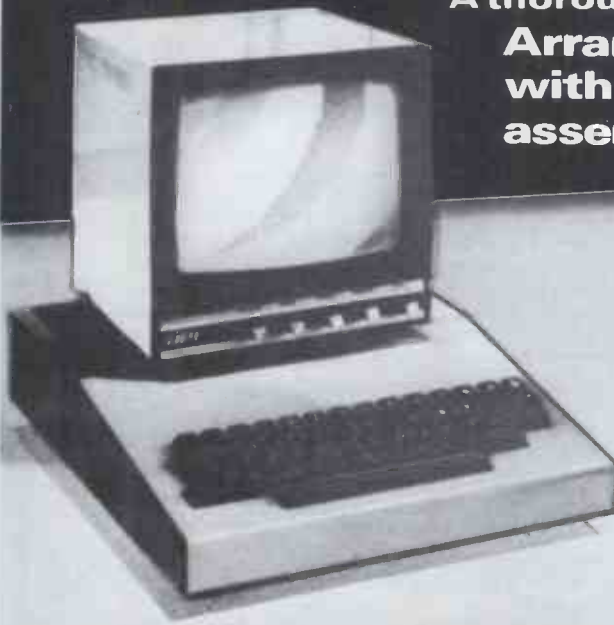

MOTHER BOARD 8085 cpu—3.5MHz 2K Monitor,  
Cassette Interface, S100 bus connectors and  
circuitry, provision for ROM/EPROM. . . . . £165.00  
AP-1 POWER SUPPLY UNIT 5AMP power supply. £35.00  
KEY BOARD TERMINAL Stand alone, cpu  
controlled 1K RAM, 64/32 x16 format, 128  
charecter upper & lower case, full cursor control. . £130.00  
64K DYNAMIC S-100 RAM CARD. . . . . £175.00  
FLOPPY DISK CONTROL CARD controls 4  
drives 2 serial I/O ports 2716 PROM socket. . . . . £165.00  
RUNS under resident 8K BASIC in ROM. . . . . £65.00  
or with Disk System under CP/M2.2. . . . . £95.00

## Monitors

**NEW** 12" Green screen monitor  
**£150**



- 10" Black & white monitor.
- Ideal for Apple, Nascom, UK 101 and more **£79.95**
- 10 MHZ band width
- Metal cabinet 9" x 9" x 9.5"
- Trade enquiries welcome.

## Expansion Cards

SJ64K S100 Dynamic Ram Card  
16K from £130 48K from £145  
32K from £160 64K from £175

S100 SS16K Board  
Add memory beyond the 64K limit  
Expand to a multi terminal system  
Bank selectable **£165**

ELECTRIC MOUTH S100  
"DIGITALK" cards. Give your  
computer a voice! Complete with  
loudspeaker. Versions also available  
for ELF11: APPLE: & TRS-80  
ASSEMBLED & TESTED. **£99.50**  
p&p £2.00

## Disks

8" Control Data Corporation  
Professional Drives

- LSI controller
- Single density 400K
- Double density 800K
- Access time 25 ns **£350**
- Controller I/O S100 card
- Up to 4 drives
- 1771 ALSI floppy disk controller
- On board data separation. IBM compatible
- 2716 PROM socket
- On board I/O Baud rate
- Two serial I/O ports **£165**
- Generates to 9600 Baud
- Disk drive cabinet P.S.U. **£79**
- Cable set **£19**
- Coming shortly. Hard disks.

## Printers



- **Oki Microline £299**
- Serial Interface £75 extra
- **Centronics 737-2 £399**
- **737-4 £429**
- Other models available

## ELF 11

A great beginner's computer  
for as little as **£49.95**

Ideal for controller systems  
Extra low power RCA Cosmac 1102

- For engineer and industry
- Learn to programme in machine code and really understand computer systems
- Expand it to meet your requirement up to 64k RAM working in basic level 111
- Starters pack - Elf 11 and RF modulator and T. Pitmans short course for **£56.70**
- Expansion Kits. Full Range available. Hardware. Firmware
- Software. Manuals. Send S.A.E. for literature

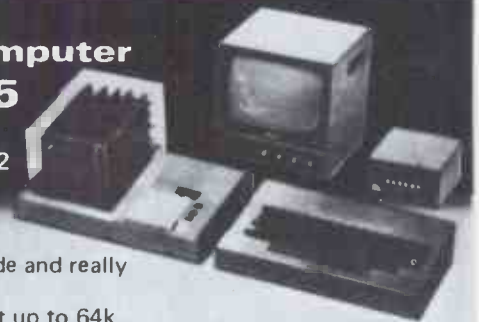

SEND SAE FOR COMPREHENSIVE BROCHURE



**NEWTRONICS**

255 ARCHWAY ROAD,  
LONDON, N.6 TEL: 01-348 3325

Please add VAT to all prices. P&P extra. Please make cheques and postal orders payable to NEWTRONICS or phone your order quoting BARCLAYCARD, ACCESS number.

We are open for demonstrations and Sales. Monday-Saturday 9.30 a.m.-6.30 p.m. Near Highgate Underground on main A1 into London.

# The latest and indeed the greatest of the Kansas Arcade series **ARCADE SCRAMBLE**

for TRS 80  
and  
Video Genie

Don't waste your time playing the simple starts to the Big Five games — get straight into the heavy action with this brand-new multi-action, home grown 'Arcade' game.

Yes, it's the famous one of the Arcades, and the first time it's ever been achieved on a computer.

Not that easy though, for without warning suddenly there's a squadron of enemy fighters heading straight at you hell bent on your destruction. Then comes the ack-ack flung at you from the ground batterles to add to your difficulties, and there's the cluster of blimps to make things even more difficult.

But the real nasties are the rockets, which the enemy blast at you, without warning, from the ground installations.

Even if you manage to out-shoot, out-fight, out-maneuver that little lot, you still have the mountains to negotiate which is a problem with the fighters streaming through the only available space.

But with this really unbelievable game, you have

no less than six different controls at your fingertips, being able to move your bomber forward, backward, up and down, whilst at the same time both firing your guns at the enemy and bombing the installations.

And not only do you have infinite control over the bomber, but the ground and enemy installations continuously unfold below, with valleys and mountains actually moving across the screen, giving an hitherto undreamed of realism.

The installations include rocket launch pads, ack-ack batteries, forts, munition dumps and fuel dumps. You do your damnest to destroy these as they unfold below, so building up your score.

The famed Mike Chalk who created Arcade Invaders and U-Boat Strike, has teamed up with Chris Smyth to create this fantastic machine language Arcade game.

There is so much happening it really is unbelievable with sound adding to the realism of this ultra-fast moving game.

IT'S ONLY FROM KANSAS £9.50

All prices VAT paid and post free. First class return post service. Barclay-card, Visa orders dispatched same day if phoned in by 3pm. Answering machine ordering service after 6pm and Sundays to allow use of cheap rate. Catalogue available on request.

# Kansas

Kansas City Systems, Unit 3, Sutton Springs Wood, Chesterfield, Derbys. Tel 0246 850357

**ATARI  
APPROVED  
DEALER**

**ATARI** PERSONAL  
COMPUTER  
SYSTEMS  
  
**ATARI**  
**400 & 800**

**IN MANCHESTER**

★ SOFTWARE ★ PERIPHERALS  
★ COMPUTER CHESS GAMES  
(FULL RANGE IN STOCK)

BARCLAYCARD  
**VISA**

ACCESS  
 Buy it with Access

**SPECIAL MAIL ORDER  
SERVICE WRITE OR  
PHONE FOR FULL DETAILS**

**GEMINI ELECTRONICS**  
 Dept. PCW, 50 Newton St., Off Piccadilly,  
 Manchester M1 2EA. Tel: 061-236 3083.

WE ARE AT THE CORNER NEWTON ST./ HILTON ST.

## MICRO SPEECH 2 DOES YOUR COMPUTER SPEAK TO YOU?

MICROSPEECH 2 is a stand alone speech synthesizing unit. It converts phonetic code or any ASCII text into a speech output. MICROSPEECH 2 may be interfaced to any computer system because all the computation necessary to synthesize speech is performed by its own dedicated microprocessor. Up to one thousand phonetic characters, representing about one minute of speech, may be assembled in the units internal buffer before it is commanded to speak.

### FEATURES

- Runs from phonetic code, giving unlimited vocabulary and simple operating software.
- Optional English to phonetics translator allows operation directly from ordinary text.
- Uses standard RS232C/V24 interface.
- Totally self contained with internal loudspeaker and power supply.
- No need to worry about complex interfacing or support software.

### PRICE

Phonetic model £875.00 + VAT  
 Phonetic model plus English to phonetics translator ..... £950.00 + VAT



COSTRONICS ELECTRONICS 13 Field Heath Avenue,  
 Hillingdon, Middlesex Uxbridge (89) 38791  
**TIM ORR DESIGN CONSULTANT**  
 55 Drive Mansions, Fulham Rd, London SW6  
 (01) 7312077

THE  
COMPUTER BOOK SHOP  
RUN BY PEOPLE WHO KNOW COMPUTERS

**LION MICRO COMPUTERS**  
*NEW*  
**COMPUTER BOOK SHOP**

(ALSO STOCKING HI-FI, VIDEO AND C/B BOOKS)

**LONDON'S LARGEST  
SELECTION OF COMPUTER  
BOOKS**

PLUS ALL THE HARD TO GET COMPUTER MAGAZINES

OPEN MONDAY to SATURDAY 9-6 *PLUS*  
THURSDAY LATE CLOSING 9-7

GROUND FLOOR  
LION HOUSE  
227 TOTTENHAM COURT ROAD  
LONDON W1  
*TEL: 01-580 7383*

SEND SAE FOR FULL CURRENT LIST – BETTER STILL, CALL IN.

# The Osborne Library of Microcomputer Books

We've reduced the prices of nearly all the great titles in the Osborne series. Now you can get the same standard of practical, accurate guidance you've come to expect from Osborne — but for less!

Our best selling titles include:—

44-6	CP/M User's Guide	£9.50
21-7	Z80 Assembly Language Programming	£11.95
27-6	6502 Assembly Language Programming	£11.95
55-1	PET/CBM Personal Computer Guide 2/e	£10.95
47-0	The Business System Buyer's Guide	£5.95
46-2	Apple II User's Guide	£10.95
34-9	An Introduction to Microcomputers: Vol 1 Basic Concepts 2/e	£9.50
42-X	Osborne 4 & 8-Bit Microprocessor Handbook	£14.50
43-8	Osborne 16-Bit Microprocessor Handbook	£14.50

All Osborne titles are available through your local bookseller, or direct from the publisher, so make the most of our price reductions and your computer today!

McGraw-Hill Book Company (UK) Limited, Shoppenhangers Road, Maidenhead, Berkshire, SL6 2QL.

## ...now even cheaper!

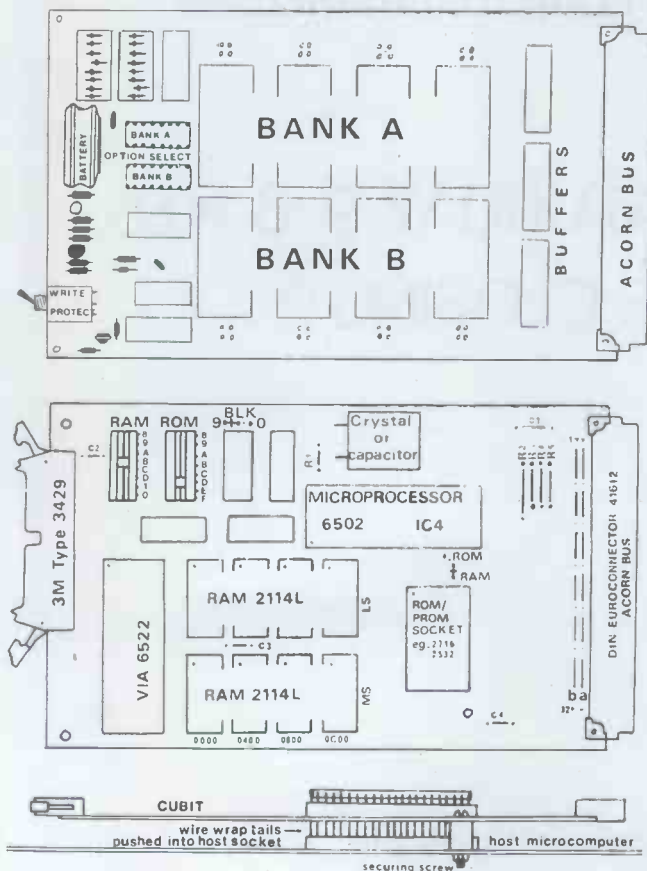

### CU-MEM — UNIVERSAL MEMORY

Up to 64K of byte-wide standard memory  
**NMOS RAM, battery-backed CMOS RAM,  
 ROM, EPROM, EEPROM**

CU-MEM has eight sockets arranged in two independent banks, each of which can be filled with 24 or 28 pin industry standard memory devices in 1K, 2K, 4K or 8K bytes sizes.

### CUBIT — VERSATILITY PLUS

This Eurocard carries 4K RAM, 4K ROM/EPROM, a VIA 6522 i/o chip and a DIN connector to the Acorn Euro-bus. It can be used:-

- ★ as a 6502-based single board microcomputer
- ★ as an extension to AIM 65 and similar computers
- ★ as a peripheral to a CUBIT or other computer

CUBIT and CU-MEM are fully compatible with the Acorn range of Eurocards (eg. VDU, disk, analog) Control Universal supply CUBIT, CU-MEM, and all Acorn and Rowell products.

**Control Universal Ltd, 11/15 Bush House,  
 Bush Fair, Harlow, Essex.  
 Tel: 0279 31604/412043.**

MICROTEK INTRODUCE THE  
**'MICOM 81'**  
THE 'STATE OF THE ART' MICRO-COMPUTER SYSTEM.



- \* 4 MHZ Z80A CPU!
- \* 18 Slot S100 Mainframe!
- \* 32 MB or 96 MB CMD Hard Disk Storage!
- \* Up to 768K Dynamic or 384K Static RAM with Bank Switching!
- \* 2, 4 or 8 port Serial and Parallel I/O boards!
- \* 8" Double Density Floppy Disk Drives, (optional)!
- \* IBM Compatible Communications!
- \* Rugged and Reliable Rack Housing!

The 'MICOM 81' system will run CPM, (if you really must!) or

## **'MVT FAMOS'**

The most powerful and versatile multi-tasking, multi-user 8-bit operating system currently available! You don't believe us? Well we have a large international bank using this system with 6 terminals and 2 printers in a 'Real Time' trading application!

Do you know of a UNIX, MPM, MBOS, OASIS or any other 8-bit 'multi-user' operating system, that you can get demonstrated doing the same? Well neither do we!

The 'MICOM 81' system is also currently being used in one of this country's leading universities, and in many other different types of industrial and commercial applications.

Prices start from as little as £7,000 and OEM enquiries are welcome.

For further details phone Orpington 26803/36228 or write to Microtek Computer Services, 50 Chislehurst Road, Orpington, Kent, BR5 ODJ.

# Brain Specialists

**Simplify all your accounting  
Sales, Purchases, Invoicing,  
Payrole, Stock control  
VAT Reports  
Even Trial ballances and  
P & L Accounts**

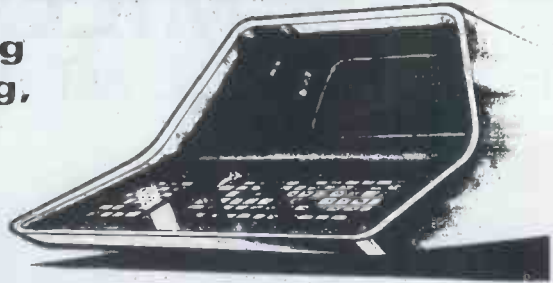

**SuperBrain can work as a word processor  
Provide All Tektronix type and graphics  
and even emulate a Tektronix terminal.**

- Communications to most mainframes and MINIS
- Runs IBM "BISYNC" protocol emulating 3270s or 2780s.
- Programming languages include PASCAL FORTRAN BASIC COBOL!
- Disk capacities from 360K to 10M bytes • Prices from **£1695** plus VAT
- Full range of C.P.M. software and peripherals
- NEC spinwriters. EPSON printer MICROPRO software
- **DEALERS BEST DISCOUNTS**
- We also sell CROMEMCO and North Star Hardware.

26 New Broadway, Ealing, London W5  
Telephone: 01-840 1926



**CONTACT :- S.B.D. SOFTWARE**

**15 Jocelyn Road, RICHMOND TW9 2TJ  
Tel : 01-948 0461**

Add 15% VAT, Postage & Packing Free.  
Write or phone for full catalogue.  
Dealer Enquiries Welcome.

<b>MAGIC WINDOW</b> will instantly convert your Apple system into a word-processor, no modifications or fancy gadgets to buy. Magic Window's 4-way scrolling allows you to type up to 80 CHARACTERS per line!! This allows you to see your letter exactly the way it will be printed. Inserting, deleting, centring, and justifying can be done on the screen without the need to print a work copy.	<b>£79.95</b>
<b>BASIC MAILER</b> is a mailing list merge system designed to take MAGIC WINDOW document files and replace names, addresses or any other section of the document with individual data, creating customized letters, invoices, etc. Basic Mailer will save you so much time with form letters for mailing that it is hard to believe.	<b>£49.95</b>
<b>DAN PAYMAR LCA-2</b> see true upper & lower case characters on the screen. It works with the Magic Window and other programs.	<b>£39.95</b>
<b>MAGIC WINDOW &amp; MAGIC MAILER</b>	<b>£115.00</b>
<b>MAGIC WINDOW, MAGIC MAILER &amp; DAN PAYMAR LCA-2</b>	<b>£145.00</b>
Microsoft 16K expansion card	<b>£95.00</b>
Andromeda 16K expansion card	<b>£95.00</b>
<b>VISICALC DOS 3.3</b> The upgraded version of the most popular program ever.	<b>£125.00</b>
<b>VISHDEX</b> A most useful cross-reference of information. Assign multiple keywords to the index. Vary the input format as you go. Swift retrieval & printing as required.	<b>£111.00</b>
<b>VISHPLOT</b> Plot your data onto high-res. graphs. 6 formats & 6 colours.	<b>£75.00</b>
<b>VISITREND/VISIPLOT</b> Use sophisticated trend analysis techniques on your graphs.	<b>£144.00</b>
<b>VISICALC DOS 3.2</b> Still available, the original Visicalc. Still as popular as ever.	<b>£75.00</b>
<b>BRAIN SURGEON</b> thoroughly test your Apple II. Diagnose that tricky fault.	<b>£30.00</b>
<b>DB MASTER (VERSION 3)</b> Computed fields, Statistical Analysis. Faster report printing.	<b>£130.00</b>
<b>UTILITIES</b>	
<b>EXPEDITER</b> At last you can compile your Applesoft program into machine code and watch it run 2-20 times faster.	<b>£75.00</b>
<b>CRAE - Co-Resident Applesoft Editor</b> Anyone Writing software on the Apple needs this editor. Global changes & finds, renumber, append, modify. 15 commands in all.	<b>£14.95</b>
<b>GRAE &amp; MCAT - Catalogue</b> We carry the full range of "Sensible Software" utilities.	<b>£19.95</b>
<b>SUPER DISK COPY III</b> The best most versatile copy program on the market. Initialize a diskette with or without the DOS sectors. Copy files one by one or the entire disk. View the catalogue & then see a display of the diskettes free & used sectors. Copy from DOS 3.2 to 3.3 & visa-versa. Many other commands.	<b>£24.95</b>
<b>APPLEGUARD</b> Protect your software!! PROTECT AGAINST BIT COPIERS.	<b>£200.00</b>
<b>AOPT - Applesoft OPTimizer</b> Optimize your Applesoft program, remove REM's, pack as many instructions as possible per line.	<b>£19.95</b>
<b>APLUS - Structured Basic</b> Write programs in a structured manner with your new additional commands and then compile into a regular Applesoft program.	<b>£19.95</b>
<b>DOS PLUS</b> 3 new Dos Commands built-in, 5 commands are user-definable. You can now FLIP easily between Dos 3.3/3.2 from within the program. Also Dos Command Editor. Edit the names of the Dos commands and initialize disks with your own DOS.	<b>£19.95</b>
<b>DISK RECOVERY "The Scanner"</b> Scan your disks and mark faulty tracks so they are not used. Also able to REDO VTOC which may recover your 'messed-up' disk.	<b>£24.95</b>
<b>BACK-IT-UP</b> Bit copier to back-up your protected software.	<b>£50.00</b>

## ARCADE GAMES

Snaice Warrior	£12.95
Alien Rain	£12.95
Snoggle	£12.95
Demon Derby	£12.95
Galaxy Wars	£12.95
Gobbler	£12.95

Star Cruiser	£12.95
Alien Typhoon	£13.95
Space Eggs	£14.95
Autobahn	£14.95
Star Mines	£14.95
Apple Panic	£14.95

Sneakers	£16.95
Raster Blaster	£16.95
Star Thief	£16.95
Missile Defense	£17.95
Epoch	£19.95

## ADVENTURE GAMES

Mission Asteroid	£ 9.95
Mystery House	£12.95
The Wizard & Princess	£17.95
Cranston Manor	£17.95

Oldorf's Revenge	£11.95
Tarturian	£14.95
Creature Venture	£14.95
Soft Porn Adventure	£17.95

## CARD GAMES & SPORTS GAMES

German Whist	£ 9.95
Crabage	£12.95
Draw Poker	£14.95

Pool 1.5	£18.95
American Football	£19.95
Hi-Res Soccer	£22.95

## STRATEGY GAMES

Galactic Empire I	£12.95
Galactic Trader II	£12.95
Galactic Revolution III	£12.95

Tawala's Last Redoubt	£14.95
Golden Mountain	£ 9.95
Kubik	£ 9.95

# PERINET

The multiuser, multiprocessor network system  
with Ethernet compatibility

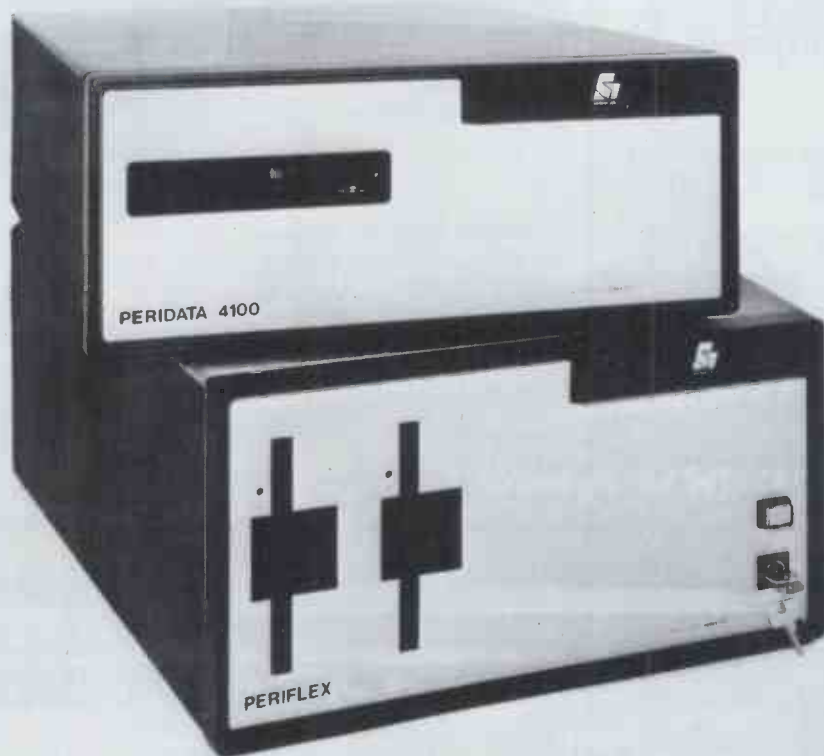

## OPERATIONAL BENEFITS

- Multiuser, multitasking, multiprocessor system
- CP/M compatible for programs and data
- Supports automatic print spooling
- Multi access file and record interlocks
- Password security and system usage

Now available from Sintrom is the **PERINET** Z-80 based multiprocessor networking system capable of providing mainframe power at a much lower cost.

**PERINET** is expandable — a minimal system may consist of just one user, but additional users can easily be accommodated by adding more S100 processor cards into the chassis. Once the full user capacity of **PERINET** has been reached, the system may be expanded to any size with hundreds of users if required by using the Ethernet networking system.

The system incorporates the **PERIFLEX 4000**

S100 microcomputer and can handle up to 16 users from a single chassis with each user having their own processor under the control of a master processor with 'bus-master' capability. Unlike some other multiuser systems, **PERINET** users are totally independent of the system crashes or resets of other system users.

Storage requirements are handled by the field proven **PERIDATA 4100** Winchester disc and cartridge back-up system.\*

\* Available separately as a standalone peripheral for other microcomputer systems



## Sintrom Electronics

Sintrom Electronics Ltd  
Arkwright Road, Reading, Berks RG2 0LS  
Tel: Reading (0734) 85464 Telex: 847395



DEALER ENQUIRIES WELCOME  
SEE US ON STANDS 3172  
& 4171 AT COMPEC 81

# Try Hunting in the North East

## SUPERBRAIN

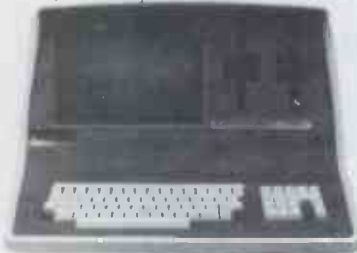

Full Accounts/Payroll System including Superbrain SD and Printer from only £4125  
Word Processing System from only £3348

FULL RANGE OF PRINTERS -  
ANADIX  
NEC SPINWRITER  
OLYMPIA SCRIPTA  
RICOH RP1600

MicroPro CP/M software -  
WordStar - MailMerge  
DataStar - SuperSort

Other CP/M packages - T/Maker -  
Target - Small Hotel System -  
Job Costing - Ductwork Estimating  
- Super Accounts - and now 'The  
Last One' the program that writes  
programs.

All prices exclude VAT and  
delivery.

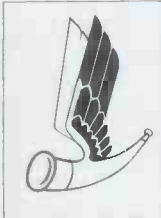

Established 1874

**Hunting Business Systems** (A Division of Hunting Computer Services Limited)

3 Brus House Mitchell Avenue Thornaby Town Centre Cleveland Tel: (0642) 769709

## SHARP

MZ-80K PERSONAL  
COMPUTER 48K RAM



For limited period  
only £425  
exc. VAT & delivery

Includes: Manual, BASIC  
language, cassette player/  
recorder, 10" VDU, clock,  
graphics, music, one year's  
guarantee. BEST VALUE

## BUSS STOP

PROP: PHOTO ACOUSTICS LTD

BUSS  
STOP

## Cash & Carry Prices

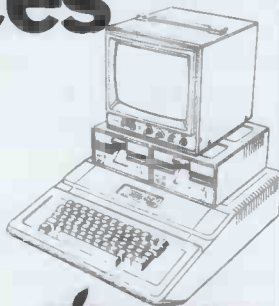

## PET

A FULL RANGE OF PERIPHERALS  
AND SOFTWARE AVAILABLE.  
RING NOW!!

58 HIGH ST  
NEWPORT PAGNELL  
BUCKS  
TEL: (0908) 610625

255a ST ALBANS RD  
WATFORD, HERTS  
(entrance in Judge St)  
TEL: 32006



Mail order  
credit charge



## Westwood Computers

117 TENNANT STREET, FIVE WAYS,  
BIRMINGHAM

SEE OUR COMPREHENSIVE range of microcomputers  
for business and personal use!

WORDPROCESSING, ACCOUNTING, FINANCIAL  
MODELLING. We give full software and technical  
support.

The APPLE II - many programs, accessories, graphics, etc.

The CIFER 2684 microcomputer - Excellent CP/M  
computer with ability to interface with mainframes.  
POWERFUL WORDPROCESSING program available  
with macro programming facilities.

The Z PLUS microcomputer range - Extends to 20MB  
hard disk multi-user system. CP/M, \$100 bus.

MATRIX PRINTERS: SEIKOSHA GP80, MPI, CEN-  
TRONICS 737, LEAR SIEGLER, ANADIX 9500.  
DAISYWHEELS: OLYMPIA SCRIPTA, DIABLO 630.

We have an extensive range of COMPUTER BOOKS,  
APPLE PROGRAMS, and are distributors for SCOTCH  
DISCS and TAPES.

VISIT OUR SHOWROOMS!

CONTINUOUS DEMONSTRATIONS - BROWSERS  
WELCOME!



021 632 5824  
On the street parking  
always available





# THE SEED SYSTEM 19



microcomputer products

A 6809 BASED SYSTEM SUPPORTING EITHER MINI-FLOPPY OR FLOPPY DISK MEMORY SYSTEM CHOICE OF TWO POWERFUL DISK OPERATING SYSTEMS

OS-9  
TRUE MULTI-TASKING/MULTI USER  
FAST BASIC INTERPRETER/COMPILER  
PASCAL  
EDITOR/ASSEMBLER  
STYLOGRAPH WORD PROCESSOR

DOS69  
SINGLE USER  
BASIC  
EDITOR/ASSEMBLER  
DOS 68 EQUIVALENT

WIDE RANGE OF TERMINALS PRINTERS AND ANCILLARY EQUIPMENT  
NATIONWIDE MAINTENANCE  
PERSONEL TRAINING  
RAM EXPANDABLE FROM 32K TO 1 MEGABYTE

PRICED FROM £2515

INTERESTED? THEN CALL US FOR YOUR DEMONSTRATION FREE OF OBLIGATION.

SEED

**STRUMECH**

PORTLAND HOUSE, COPPICE SIDE,  
BROWNHILLS, WALSALL, W. MIDLANDS.  
TEL 054 33 78151 TELEX 335243 SELG



**NEW!  
FOR PET**

Not just a light pen but a complete data entry and processing system for your PET. It can offer a much faster, more convenient and often better alternative to the keyboard in almost any program. In fact any task involving human participation in the office, lab or classroom can be carried out faster and with fewer errors. (Especially if you can't touch type!). Typical applications include: data input and selection, word processor enhancement, graphics handling, fast program writing and editing, computer assisted design, games etc. etc. This system is very easy to use. All complicated machine code is out of sight in a plug in ROM - just point the pen and touch the tip! The hardware includes a stainless steel light pen with precision optics, programmable touch switch and retractable cable. The 'pen-rest' houses the control electronics (including CB2 sound) which simply plugs into the USER PORT. The firmware supports both pic and track modes, auto cursor movement (better than repeat keys for editing!), single key instant screen reverse, high resolution (1 x 2 pixels) if needed, Coordinates and screen address returned as BASIC variables. All this and more is fully explained and documented in the comprehensive manual. There is not enough room in this ad to list all its features but literature is available on request. To order just send a cheque or phone (anytime) quoting your credit card number.

**ALTEK**

(C.W.) 1 Green Lane  
Walton-on-Thames Surrey

Order by post or phone (093 22) 44110 . . . 24 hours

Access or Visa accepted. . . Callers by appointment  
Selected dealers needed in U.K. and overseas.

**£170 +  
VAT**

# BUTEL-COMCO

## RP1600 Daisywheel Printer



**60 cps!**

- \* Serial V24/IEEE/Centronics interface
- \* Optional intelligent version includes
  - Qume/Diablo compatible commands
  - Auto bidirectional operation
  - 2 - 8K buffer

Write or call for further information:  
Butel Comco Limited  
Garrick Industrial Centre  
Garrick Road,  
London NW9 6AQ  
Telephone: 01 - 202 0262

**BUTEL**  
Technology for business

Trade / OEM discounts available.

## KNIGHTS SHARP MZ-80K OFFERS

48K Sharp with Basic and Pascal £399 48K with BASIC, PASCAL and machine code £409 48K with BASIC, PASCAL, FORTH, FORTRAN, and machine code £449 48K with all above languages, ASSEMBLER, and 100 programs £499

## MZ-80B OFFERS

Sharp MZ-80B with 20 programs £945 MZ-80B with BASIC, ASSEMBLER, DISASSEMBLER and 100 programs £1045

Write for our latest newsletters which detail the new PDOS, DISK COMMANDER, Double precision 16 digit BASIC, and the MZ-80DU colour intelligent terminal with 24 colours and 59,000 point definition. Please add VAT to the above prices and remember we guarantee to beat any currently advertised price on the spot. Remember only Knights have six languages for the K and only we have a tape based assembler for the B and masses of Sharp programs.

**Knights T.V. &  
COMPUTERS**

108 ROSEMOUNT PLACE ABERDEEN

Telephone 0224 630526 telex 739169

## APPLE SOFTWARE

Alien Rain (Galaxian) - Colour + hi-res version of pub game	£13.95	M48K
Alien Typhoon - A much more difficult version of Alien Rain.	£13.95	M48K
Apple Panic - Chase little apples up and down ladders.	£16.95	M48K
Autobahn - Road race game with sound and hi-res graphics.	£14.95	M48K
Both Barrels - 2 hi-res action games on one disk	£12.95	A48K
Cranston Manor - A new hi-res adventure like Wizard + the Princess.	£19.95	M48K
Cyber Strike - 3D hi-res action adventure in space	£19.95	M48K
Demon Derby (Hyper Head-on) - 4 skill level hi-res car race game.	£13.95	M32K
Expediter II - The Applesoft Compiler at a LOW, LOW, price.	£56.95	A48K
Galaxy Wars - Colour graphics + Sound effects + Hi-res.	£13.95	M32K
Gamma Goblins - Yet another superb hi-res action game.	£16.95	M48K
Gobbler - Eat up the dots but watch out for the Gobblers.	£13.95	M48K
Gorgon - Another superb pub game for your Apple.	£21.95	M48K
Hi-Res Cribbage - The title describes it. Even hear the pegs move.	£14.95	M48K
Hi-Res Soccer - English football for 1 or 2 players in hi-res.	£16.95	M48K
Missile Defense - Hi-res animation and sound arcade game.	£16.95	M48K
Mission:Asteroid - Hi-res adventure in 21 colours. Save the World!!	£10.95	M32K
Mystery House - Hi-res adventure using over 100 pictures.	£12.95	M48K
Oldorf's Revenge - Hi-res adventure with 100 rooms.	£11.95	A48K
Operation Apocalypse - Four computer simulations of World War II	£35.95	A48K
Orbitron - Fight off enemy forces and avoid meteor showers.	£14.95	M48K
Paddle Graphics - Draw your own pictures in 21 hi-res colours.	£12.95	A48K
Pool 1.5 - hi-res colour graphics pool table simulation. 4 games.	£19.95	M48K
Pulsar II - 2 superb hi-res games on one disk.	£14.95	M48K
Sneakers - Waves of little creatures attack you in hi-res.	£16.95	M48K
Snoggle (Puckman) - Hi-res maze of ghosts. Great fun.	£13.95	M48K
Space Eggs - Hi-res super fast arcade style game.	£14.95	M48K
Space Warrior - Hi-res pub game.	£13.95	M48K
SuperScribe - Word processor. True upper/lower case on screen.	£48.95	M48K
Tarturian (Wizard) - Another hi-res adventure with 160 rooms.	£14.95	A48K
The Shattered Alliance - Swords & Sorcery on a far-flung world.	£35.95	A48K
The Warp Factor - 1 or 2 player hi-res Star Trek/Space War game.	£23.95	A48K
The Wizard and the Princess - Hi-res adventure in 21 colours.	£18.95	M48K

A: Require Applesoft in ROM, M: Will run any any Apple. All software is available on disk only and boots under DOS 3.2 (Most software will also boot under DOS 3.3). Many of the games require paddles. PRICES INCLUDE VAT AT 15% UNLIKE MOST OTHER ADVERTISERS. Please add 50p P+P for orders under £30 totally. Please write for your free copy of our software list. DEALER INQUIRIES INVITED. MAIL ORDER ONLY

**SPIDER SOFTWARE**

98, AVONDALE ROAD, SOUTH CROYDON, SURREY.  
Tel: 01-661 1829

# THE Video Genie EG3000 Series

WITH \*16K user RAM plus extended 12K Microsoft BASIC in ROM \*Fully TRS-80 Level II software compatible \*Huge range of software already available \*Self contained, PSU, UHF modulator, and cassette \*Simply plugs into video monitor or UHF TV \*Full expansion to disks and printer \*Absolutely complete just fit into mains plug.



STILL ONLY  
**£299** + VAT  
16K

## GP80 The most compact 80 column impact graphic-dot printer available - at a very compact price

by seikosha

Graphics, Normal and Double-Width Characters can be printed on the same line. Pine Feed Tractor is equipped as standard.

Two Line-Feed Commands (1/6 and 1/9 inch)

Print on Plain Paper with two copies

Continuous Self-Inking Ribbon for easy handling

Centronics type Parallel Interface standard

Wide Range of Optional Interface Boards

Self-Test Programme standard



**£199** + VAT

### SUPERBRAIN

SuperBrain's CP/M operating system boasts an overwhelming amount of available software in BASIC, FORTRAN, COBOL, and APL. Whatever your application... General Ledger, Accounts Receivable, Payroll, Inventory or Word Processing, SuperBrain is tops in its class.

320K £1850 700K £2400  
1.5Mb £2750

### COMMODORE COMPUTERS

PET 8K £415  
PET 16K £525  
PET 32K £650  
PET 8032 £895

### DISK DRIVES

4040 £695

### PRINTERS

EPSON TX80B (inc. I/F & cable) £299  
EPSON MX80F/T £395  
ANADEX DP8000 £495  
ANADEX DP9500 £895  
ANADEX DP9501 £995

### VIDEO MONITORS

10" BLACK & WHITE £85  
10" GREEN SCREEN £95

## Aculab

Floppy Tape  
The tape that behaves like a disk.

Connects directly to TRS-80 level 2 keyboard. Operating and file handling software in ROM 8 commands add 12 powerful functions to level 2 BASIC. No buttons, switches or volume controls. Full control of all functions from keyboard or program. Maintains directory with up to 32 files on each tape.

for all TRS 80  
& Video Genie owners

TRS80 version: **£165**  
Video Genie: **£170**

Please add £10 Securicor delivery charge to all computers etc.  
Plus 15% VAT on all prices.

# Acorn Atom



AND available ready to go for **£150** PLUS VAT and cable

Unique in concept — the home computer that grows as you do!

Special features include  
\*FULL SIZED KEYBOARD  
\*ASSEMBLER AND BASIC  
\*TOP QUALITY MOULDED CASE  
\*HIGH RESOLUTION COLOUR GRAPHICS

Simple to build, simple to operate. A powerful, full facility computer with all the features you would expect.

Just connect the assembled computer to any domestic TV and power source and you are ready to begin.

Full-sized QWERTY keyboard  
6502 Microprocessor Rugged injection-moulded case  
2K RAM  
8K HYPER-ROM  
23 integrated circuits and sockets Audio

cassette interface UHF TV output Full assembly instructions

**£120** + VAT

## The Second Generation Personal Computer

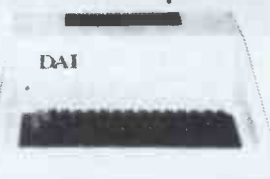

## Highest performance - lowest price

\*48K (8080A)  
\*16 Colours or shades of Grey  
\*Multiple High Resolution Graphics Modes (64 x 71, 129 x 159, 255 x 335)  
\*Character mode (60 x 24)  
\*Split Screen Modes

\*Full ASCII Upper & Lower Character Set  
\*Unique graphical — Sound Commands for Smooth Music, random frequencies & enveloped sound!

**DAI** Personal Computer

\*RS232 I/F at only **£595** + VAT

## Paper Tiger 460

The Paper Tiger 460 sets new standards by incorporating many features previously only available on units costing much more.

Features like a specially developed nine wire 'staggered column' head which overlaps the dots of each matrix character with just one pass of the printhead giving a dense, high quality print image without reducing the units 160 c.p.s. print speed

It also offers a bi-directional logic seeking device to enhance its print optimisation characteristics and wide range of 'print versatility' features such as mono or proportional spacing, automatic justification, programmable horizontal and vertical tabbing and 'fine' positioning for word processing applications.

## Paper Tiger 560

**£695** - VAT

The Paper Tiger 560 is the first printer which bridges the gap between conventional matrix and 'daisy wheel' types offering quality printing at a relatively low price.

Full 'width' 132 column printing at 160 c.p.s., a unique nine wire 'staggered' print head bi-directional printing, an inbuilt tractor feed and a host of selectable features set it apart from ordinary matrix printers.

Plus for even greater versatility a full dot plot graphics facility if supplied which includes a 2K buffer

**£895** VAT

## Books & bits

Books Manuals

Diskettes - ribbons - Paper chips (2114 x 2 1K) £4 pair.  
RS232 to Centronics interfaces £40 etc. etc.  
A variety of second-hand computer equipment usually available, spares, repairs and service.

# MicroStyle

Freepost, The Bath Computer Centre,  
29 Belvedere, Lansdown Road, BATH BA1 1FP.  
Tel: Bath (0225) 334659

**New Showroom now open**



The suppliers of the first Basic Compiler for the Pet,  
Oxford Computer Systems (Software), proudly announce:



# PETSPEED

the first of a new generation of Basic Compilers for Commodore systems. **PETSPEED** is a fully compatible, optimising Basic Compiler for Commodore Systems. Programs written in Pet Basic may be compiled **WITHOUT** alteration to give a highly efficient object program saved as a program file on disc.

**PETSPEED** supports advanced features previously only available on much larger systems:

- **OPTIMISATION** — this feature, previously provided only on large computers, results both in smaller programs and much faster code.
- **DATA** — in addition to **FLOATING POINT**, **STRING** and genuine **INTEGER** arithmetic, the Compiler uses extra internal data types. Although this is completely transparent to the user, it allows many operations which would otherwise be carried out in floating point to be executed in integer arithmetic. This means **FASTER** code and more efficient operation.
- **COMPATIBILITY** — any Pet Basic programme can be compiled.
- **LONG VARIABLE NAMES** — meaningful variable names can now be used in Basic programs allowing easier **DE-BUGGING** and maintenance.
- **SPEED** — Compiled programs run at up to **30 TIMES** the speed of Pet Basic.
- **PROGRAM SIZE** — the size of long programs is considerably reduced leaving room for extra code and data.
- **COMPILING SPEED** — **PETSPEED** is driven entirely in machine code giving a Compiling Speed of **2 LINES PER SECOND**.
- **USER SUPPORT** — in addition to the fully Comprehensive manual, a telephone and postal enquiry service is available to answer questions from users of **PETSPEED**.
- **AVAILABILITY** — use **PETSPEED** for all your 8000 series programming including the **NEW 8096**.

Also available from **OXFORD COMPUTER SYSTEMS (SOFTWARE)**:

**COMPILED INTEGER BASIC** — a very fast Integer Compiler for **ALL** Pet models. Compiled Basic is for those applications where the speed of the machine is required without the inconvenience of assembly level programming.

"admirably fast code . . ."  
"exciting extra commands . . ." *Printout*  
(the Pet users magazine)

Compiled basic is already widely used in education and research. It is ideal for applications that do not require floating point arithmetic e.g.

- **DISC HANDLING** — disc operations in Compiled Basic are much faster than in Pet basic. Compiled Basic provides a set of extra **IEEE** commands to speed up the process even further.
- **FAST INPUT/OUTPUT** — Compiled Basic is ideal for fast I/O such as Datalogging, driving fast peripherals etc.
- **POKING THE SCREEN** — poking to the screen is incredibly fast in Compiled Basic. This, together with the **PLOT** command makes Compiled Basic ideal for any graphics application.
- **SEARCHING and SORTING** — large quantities of data can be processed at real machine code speed.
- **SPEED** — Compiled Basic programs run at up to **150 TIMES** the speed of Pet Basic

## WHICH COMPILER IS SUITABLE FOR YOUR APPLICATION?

At Oxford Computer Systems we can advise on which Compiler is most suitable for you.

**PETSPEED** for 8000 series . . . . . £225.00    **COMPILED BASIC** . . . . . £150.00  
**PETSPEED** for 8096 series . . . . . £300.00    (for all Commodore Systems, including **COMPUTHINK** drives.)

★ **SPECIAL OFFER: PETSPEED** for 8000 series **PLUS COMPILED BASIC** for just £250.00  
(if your order is received before 25 September 1981)

For further details contact:

**Oxford Computer Systems (Software) Ltd.**

7 & 8 Park End Street, Oxford OX1 1HH

Telephone: Oxford (0865) 722872

# Cromemco

## Tomorrow's Computers Today.

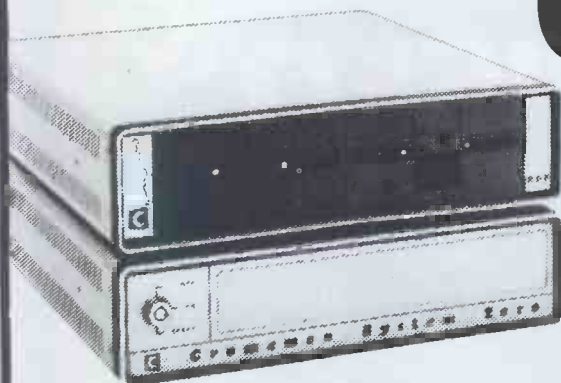

### CROMEMCO MODELS.

Unit	RAM	ROM	Disc
System Zero/D	64K	4K	2 x 390K
System 2	64K	4K	2 x 390K
System 3	64K	4K	2 x 1.2M
Hard Disc Z2-H	64K	4K	10M + 2 x 390K
Z2H Colour Graphics	64K	4K	10M + 2 x 390K

*Cromemco's none obsolescence policy protects your investment for years to come.*

DEALER ENQUIRIES WELCOME.



Wide range of languages, 16K and 32K Basic, Cobol, Rational Fortran and Fortran 1V, Lisp, RPG etc. Operating systems — Cromemco CDOS, CP/M Compatible or Cromix for Multi-User

*We are the Experts - Write or phone for FREE advice and catalogue, or allow us to arrange a demonstration.*

## DATRON MICRO CENTRE

2 Abbeydale Road, Sheffield S7 1FD.  
Telephone 0742-585490/585400.  
Telex 547151.

# The Newest Peripheral for your Microcomputer~ The Encyclopedia for the TRS 80

What's the key to getting the most from your TRS-80? No, it isn't disk drives or printers or joysticks. It's information. Without a continual supply of information and ideas, you can't realize the full potential of the TRS-80.

Our response to the clamour for additional information is the Encyclopedia for the TRS-80, a ten-volume reference work that is absolutely packed with programs and articles carefully selected to help you make the most of your microcomputer. You can consider the volumes of the Encyclopedia to be an extension of the documentation that came with your TRS-80. The articles and programs will be similar to those found in 80 Microcomputing. Each book is full of material on programming techniques, business, games, tutorials, education, utilities, interfacing... you name it.

Unlike conventional encyclopedias, the Encyclopedia for the TRS-80 will never become stale or out of date. That's because the volumes of the Encyclopedia are being issued one-at-a-time, over a period of months. This means that each new volume will reflect the latest developments and discoveries, making this a living encyclopedia for TRS-80 users.

Volume 1 will be out in September. It's more than 270 pages in length... that's 270 pages of solid information... no advertising.

### SPECIAL INTRODUCTORY OFFER

Order the entire set (the first ten volumes) of the Encyclopedia for the TRS-80 and receive the tenth volume FREE! PAY ONLY £53.91 for the first ten volumes — normally £59.90.

Beat inflation by buying the whole set now... we cannot guarantee these same single volume prices for future volumes. You cannot lose! Preview the first volume of the set and judge for yourself. If the Encyclopedia for the TRS-80 does not meet your needs or expectations, just return the first volume within ten days and we will refund the entire amount of your purchase. If at any time you are dissatisfied, you may cancel the remaining volumes. The books will be automatically sent to you every 6 weeks. Take advantage of this offer now! You can't afford to miss out on the newest peripheral — the Encyclopedia for the TRS-80. Telephone 021-632 6458 call your order in today or use the coupon below.

Send me a complete set of the first ten volumes of the Encyclopedia of the TRS-80 at your special introductory price of £53.91 including VAT and p & p

Send me Volume 1 priced £5.99 including VAT and p & p

Name \_\_\_\_\_  
Address \_\_\_\_\_

Phone \_\_\_\_\_ (Day/Evg)  
(Cheque enclosed/My credit card number is \_\_\_\_\_)

# CALISTO

## COMPUTERS LIMITED

SPECIALISTS IN MICROCOMPUTER HARDWARE/SOFTWARE  
119 John Bright Street  
Birmingham B1 1BE  
Phone: 021-632 6458



# TECPACS

The reliable technical programs for desktop computers

TECPACS are high-quality, technical software packages, written and tested by professionals for professionals. They can be used in your office, no large centralised computing facilities are needed, and computing experience is unnecessary. With TECPACS, designers and engineers can explore design alternatives with ease and confidence.

TECPACS offer such features as  
 Built-in high technical standard  
 Easy to use, friendly style

For further details,  
 of TECPACS available contact the:  
**Technical Software Centre**  
 BHRA Fluid Engineering  
 Cranfield, Bedford MK43 0AJ  
 England  
 or telephone Dr Eugene Sweeney on  
 0234 750 102

- Data checking facilities
- Trend facilities
- Choice of units
- High-quality presentation of results

Typical TECPACS available now include:

- FUNKIT-1, evaluates and plots any function (up to 100 characters long, any number of variables) £100
- POLYNOMIAL evaluation and analysis (root finding, integration etc) £80
- GRAPHKIT, graph plotting,

curve fitting, non-linear regression £80

- HISTOKIT, high resolution histograms, univariate statistics. £80

TECPACS add another professional to your team. In your office, or in the design office, just switch on, select your TECPAC program disk, and in minutes you have the answers you need.

Technical Software Centre  
**tecpac**

For use with PETS, APPLES and other machines.

## MICROCOMPUTER COMPONENTS LOWEST PRICES — FASTEST DELIVERY

CPU's		SUPPORT CHIPS		MEMORIES NEW LOW PRICES	
6502	4.95	6520	3.15	2114L200ns	1 1.28
6800	3.70	6522	4.95	(Low power)	25 1.19
6802	5.11	6532	7.95	2114L300ns	1 1.28
6803	11.90	6821	1.74	(Low power)	
6809	11.95	6840	4.20	for Acorn etc	25 1.19
8085A	5.50	68488P	9.11	2708 450ns	1 1.99
Z80CPU	4.00	6850	1.70	2716 450ns	25 1.86
Z80A CPU	4.82	682	6.91	2732 450ns	1 5.50
		6871(A)T	18.70	2732 450ns	25 5.31
CRT CONTROLLERS		6875L	4.18	4118 150ns	1 1.15
9364AP	5.94	6880	1.07	4116 200ns	25 1.06
9365	62.90	6887	0.80	4118 200ns	1 3.90
9366	62.90	8212	1.70	6116 200ns	1 10.95
6845	9.50	8216	1.70	2k 8	25 9.95
		8224	2.45	8264 200ns	1 12.00
DATA CONVERTERS		8228	3.95	64k 1	25 11.00
ZN425E	3.50	8251	3.95	REGULATORS	
ZN426E	3.00	8253	7.95	7805	0.50
ZN427E	6.28	8255	3.95	7812	0.50
ZN428E	4.78	AY-3-1015	3.90	7905	0.55
ZN429E	2.10	AY-5-1013	3.45	7912	0.55
ZN432	28.09	AY-5-2376	6.95		
ZN433	22.59	MC1488	0.64	DIL SOCKETS	
ZN433	56.63	MC1489	0.64	8pin	0.07
ZN440	7.61	MC14411	6.94	14pin	0.09
Data Converter H'book	1.00	MC14412	7.99	16pin	0.09
Data Converter Kit	29.95	RO-3-2513L	7.70	18pin	0.15
		RO-3-2513U	7.70	20pin	0.17
		Z80 CTC	4.00	22pin	0.21
BUFFERS		Z80A CTC	4.00	24pin	0.23
81LS95	0.90	Z80 DMA	11.52	28pin	0.25
81LS96	0.90	Z80A DMA	9.99	40pin	0.29
81LS97	0.90	Z80 DART	7.18		
81LS98	0.90	Z80A DART	7.18		
8T26A	1.50	Z80 PIO	3.78		
8T28A	1.50	Z80A PIO	3.78		
8T35N	1.50	Z80 SIO 0	13.95		
8T37N	1.50	Z80 SIO-1	13.95		
8T98	1.50	Z80 SIO-2	13.95		
		Z80A SIO-0	13.95		
CRYSTALS		Z80A SIO-1	13.95		
1 MHz	3.00	Z80A SIO-2	13.95		
1.8432 MHz	2.50				
2.4576 MHz	2.50				
4 MHz	1.65				

OFFICIAL ORDERS WELCOME — QUANTITY DISCOUNTS AVAILABLE

MIDWICH COMPUTER  
 COMPANY LIMITED

Dept PCW/I  
 Hewitt House, Northgate Street,  
 Bury St. Edmunds, Suffolk,  
 IP33 1HQ. Tel: (0284) 701321

All prices exclude Post and Packing,  
 (50p on orders under £10) and VAT.  
 All orders despatched on day of receipt  
 with full refund for out of stock items  
 if requested.

CREDIT CARD ORDERS WELCOME (ACCESS AND VISA)  
 24 HOUR TELEPHONE SERVICE



Colour  
 from  
**EuroApple**  
 without  
**'Colour Card'**

14" Colour Monitors  
 for Computer Application

Model AM 378I dedicated to EuroApple. £325.

No 'colour card' required

High Resolution Colour Graphics

80 Character Capability

Full Screen Text Window Display

Green or white text

Model TVTM 378I. USA Apple, Texas TI 99/4

Atari 800 etc, £325.

TV Programmes

American Standard Video, NTSC (3-58)

European Standard Video, PAL (4-43)

add 15% VAT

**PortaTel** Conversions Limited

25 Sunbury Cross Centre

Sunbury on Thames Middlesex

Tel. No. Sunbury (09327) 88972

VIDEO MODIFICATION SPECIALISTS





# COMPUTER SYSTEMS FOR THE HOME & BUSINESS ENTHUSIAST

## SHARP MZ 80K

Sharp MZ-80K 48K £434, Twin Disk Unit for MZ-80 £660, 80-Col. Printer for MZ-80 £399. \*A complete business system for less than £2000.00.

Now available Sharp MZ-80B P.O.A. ring for details of this outstanding system.

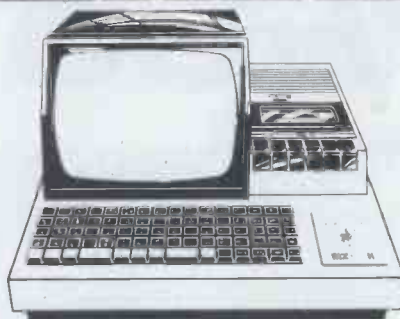

SHARP MZ 80K - £399



## ATARI 400/800

Atari 400 · 16K Ram expandable to 32K · Amazing graphics · amazing 3D games · the game computer of the future · must be

seen to be believed · programs in "Basic" "Assembler" "Pilot"

ATARI 400 - £335  
ATARI 800 - £625

## SHARP 3201

Business computer 64K Ram 32K Rom expandable to 112K Ram 72K Rom P.O.A.

SHARP 3201

## SHARP PC 1211 Pocket Comp

Sharp PC1211 Pocket computer • Programs in Basic • Qwerty Alphabetic Keyboard • 1.9K Ram • Long battery life with interface £105.00, Printer for SHARP PC 1211 - £93.00  
PC1211 £67.00

Phone for more details now



## GAME COMPUTERS

Atari 2600 plus Combat £95.45, Game cartridges from £15.45, Atari 2600 Space Invader Package plus Combat, 139 games only £119, Atari 2600 Asteroids package plus Combat, 93 games, only £125, \*\*\*Asteroids Launched\*\* game cartridge only £29.95, Philips G7000 Computer Game of the Future only £84, Game cartridges from £13.50, Matel Intellivision the most advanced computer game (3D graphics) an unbelievable £199.

**CREDIT FACILITIES AVAILABLE**

**SPECIAL DISCOUNTS FOR CASH & CARRY CUSTOMERS**

**MAIL ORDER AVAILABLE**

VIDEO SERVICES (BROMLEY)  
8 SUNDRIDGE PARADE  
PLAISTOW LANE BROMLEY KENT  
near Sunningdale Park Station

Prices include VAT  
& may change during month

TELEPHONE 01-460 4169/8833

# TEMPLEMAN SOFTWARE LIMITED

... Comprehensive packages for complete solutions to ...

- \* INVOICING
- \* PURCHASE LEDGER
- \* STOCK CONTROL/RE-ORDERING
- \* PALLET/WAREHOUSING
- \* WORD PROCESSING WITH ADDRESSING
- \* PAYROLL
- \* PRODUCTION CONTROL
- \* HI FI RETAILING
- \* GROCERY RETAILING
- \* WHOLESALING

SOFTWARE IS OUR MIDDLE NAME

TEMPLEMAN SOFTWARE LTD

STRATFORD-ON-AVON

WARWICKSHIRE

Tel 0789 66237

CREAM  
HAVE

## E-X-P-A-N-D-E-D

Cream, with its large modern shop centrally situated in Harrow (5 minutes from Harrow on the Hill Tube) has long been recognised as THE Computer Shop in North-West London to see and buy the latest in Apple and Commodore PET computer systems.

— NOW WE HAVE EXPANDED —

More professional demonstrators and consultants and AN EVEN GREATER PRODUCT RANGE!

### PROFESSIONAL SERVICES

- \* The best demonstrators in town.
- \* First class consultants to help identify your specific business needs.
- \* Programming expertise second to none for special software and tailoring.
- \* Full after sales service and training of your staff.

### PRODUCT RANGE

- \* THE Fullest range of Apple and Commodore Pet computers and the latest peripherals.
- \* MORE printers to choose from — Qumes, Okis, Epsoms, etc.
- \* Excellent business software.
- \* THE NEW VIC 20 personal computer with colour and sound — plugs straight into your TV — Just £189.95 inc VAT.
- \* Disks Tapes Books, Paper Ribbons.

FOR KEEN PRICES PROMPT DELIVERY AND THE BEST SERVICE IN TOWN —

## CREAM COMPUTER SHOP

380 STATION ROAD, HARROW, MIDDLESEX HA1 2DE.

Open Tuesday — Friday 10am — 5.30pm — Saturday 10am — 5.00pm Tel: 01-863 0833/4

ACCESS BARCLAYCARD and MAIL ORDERS WELCOMED.



# BREADBOARD '81

Wednesday 11th November 10 a.m.-6 p.m.  
 Thursday 12th November 10 a.m.-8 p.m.  
 Friday 13th November 10 a.m.-6 p.m.  
 Saturday 14th November 10 a.m.-6 p.m.  
 Sunday 15th November 10 a.m.-4 p.m.

COMPONENTS • DEMONSTRATIONS • SPECIAL OFFERS • MAGAZINES • BOOKS

ROYAL HORTICULTURAL SOCIETY'S  
 NEW HALL, GREYCOAT STREET,  
 WESTMINSTER, LONDON S.W.1.

## 17,000 PEOPLE CAN'T BE WRONG

For 5 days last year they packed the RHS halls for Breadboard '80. All the leading companies were there . . . .

. . . . and they're back again this year for BREADBOARD '81 . . . . with larger stands and wider gangways.

Whether you're buying or just browsing, BREADBOARD '81 has something to offer you. The top electronics magazines will be there.

If you're interested in kits, components or computing, BREADBOARD '81 covers it all . . . . books, bargains and demonstrations. It's all happening at BREADBOARD '81.

Cost of entry will be £2.00 for adults, and £1.00 for children under 14 yrs and O.A.P.s.

To avoid queueing, Advance tickets will be available from:  
 Advance Tickets BB '81,  
 Modmags Ltd, 145 Charing Cross Road,  
 London WC2H 0EE.

\*\*Special Advance Booking Price\*\*  
 Adults £1.75, Children under 14 yrs and O.A.P.s 80p

Please send . . . . . tickets @ £1.75 . . . . . tickets @ 80p

To . . . . .

I enclose PO/cheque for £ . . . . .  
 Advance tickets MUST be ordered BEFORE 20th October 1981.

## VIGIL FOR THE PET/CBM

VIGIL is an exciting, new interactive language for your PET/CBM. It's easy to learn and lets you quickly create games and graphics applications.

- More than 60 powerful commands for manipulating graphics figures
- Double density graphics give you 80 x 50 plot positions
- Large number displays, two timers and tone (with ext. speaker)
- LOADING and SAVING of VIGIL programs to cassette or diskette
- Nine complete programs included - Breakout, SpaceWar, AntiAircraft, U.F.O., SpaceBattle, Concentration, Maze, Kaleidoscope & FortuneTeller.
- Comprehensive 50+ page manual
- For OLD, NEW or 4.0 Doms



	U.S.	CANADA	FOREIGN
VIGIL for PET/CBM on cassette or diskette w/9 programs . . . . .	\$35	\$40	\$40
VIGIL User's Manual (refundable with software order) . . . . .	\$10	\$12	\$12
VIGIL Interpreter Listing (6502 Assembler Language) . . . . .	\$25	\$30	\$30
PET MACHINE LANGUAGE GUIDE (OLD, NEW, or 4.0 ROMS) . . . . .	\$9	\$11	\$11

## PET & APPLE II USERS TINY PASCAL

The TINY Pascal System turns your PET or APPLE II into a P-machine with:

- LINE EDITOR - creates, modifies and maintains source language
- COMPILER - produces P-code, the assembly language of the P-machine
- INTERPRETER - executes compiled P-code. Features built-in TRACE.
- STRUCTURED PROGRAMMING - CASE-OF, WHILE-DO, IF-THEN-ELSE, REPEAT-UNTIL, FOR-TO/DOWNTO, BEGIN-END, PROC, FUNC
- Graphics version has more - GRAPHICS, PLOT, POINT, TEXT, INKEY, ABS, SQRT, PET/CRM has double density plotting and APPLE II has LORES and HIRES (with ROM Applesoft) - COLOR, HGRAPHICS, HCOLOR, HPLLOT, PDL and TONE

	U.S.	CANADA	FOREIGN
TINY Pascal PLUS+ GRAPHICS VERSION includes manual . . . . .	\$50	\$60	\$60
PET 32K NEW/4.0 ROMS diskette . . . . .	\$55	\$65	\$65
PET 16K/32K NEW ROMS cassette . . . . .	\$40	\$50	\$50
APPLE II 48K and DOS 3.2/3.3 . . . . .	\$50	\$60	\$60
TINY Pascal NON-GRAPHICS VERSION includes manual . . . . .	\$35	\$45	\$45
PET 16K/32K NEW ROMS diskette . . . . .	\$35	\$45	\$45
PET 16K/32K NEW ROMS cassette . . . . .	\$40	\$50	\$50
APPLE II 32K and DOS 3.2/3.3 . . . . .	\$35	\$45	\$45
TINY Pascal User's Manual (refundable with software order) . . . . .	\$10	\$12	\$12
TINY Pascal 6502 Interpreter Listing-GRAPHICS version . . . . .	\$25	\$30	\$30
TINY Pascal 6502 Interpreter Listing-NON-GRAPHICS version . . . . .	\$15	\$20	\$20
PET MACHINE LANGUAGE GUIDE \$for OLD, NEW or 4.0 ROMS . . . . .	\$9	\$11	\$11

Plus +  
 GRAPHICS



ABACUS SOFTWARE  
 P. O. Box 7211  
 Grand Rapids, Michigan 49510  
 616 / 241-5510

Prices include postage.  
 Orders must be prepaid via check, money order or bankcard. Foreign orders may be paid for via international money order or bankcard. (Access, Eurocard, Barclaycard)

## PET & APPLE II USERS

### TINY PASCAL

Plus +  
 GRAPHICS

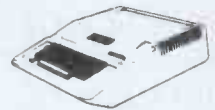

The TINY Pascal System turns your APPLE II or PET micro into a 16-bit P-machine. You too can learn the language that is slated to become the successor to BASIC. TINY Pascal offers the following:

- LINE EDITOR to create, modify and maintain source
- COMPILER to produce P-code, the assembly language of the P-machine
- INTERPRETER to execute the compiled P-code (has TRACE)
- Structured programmed constructs: CASE-OF-ELSE, WHILE-DO, IF-THEN-ELSE, REPEAT-UNTIL, FOR-TO/DOWNTO-DO, BEGIN-END, MEM, CONST, VAR ARRAY

Our new TINY Pascal PLUS+ provides graphics and other builtin functions: GRAPHICS, PLOT, POINT, TEXT, INKEY, ABS and SQRT. The PET version supports double density plotting on 40 column screen giving 80 x 50 plot positions. The APPLE II version supports LORES and for ROM APPLESOFT owners the HIRES graphics plus other features with: COLOR, HGRAPHICS, HCOLOR, HPLLOT, PDL and TONE. For those who do not require graphics capabilities, you may still order our original Tiny Pascal package.

PET BASIC 4.0 version also available

TINY Pascal Plus + GRAPHICS VERSION-includes manual . . . . .	\$65
PET 32K NEW RomS cassette . . . . .	\$60
PET 32K NEW RomS diskette . . . . .	\$60
APPLE II w/ROM Applesoft only w/DOS . . . . .	\$60

TINY Pascal NON-GRAPHICS VERSIONS-includes manual . . . . .	\$50
PET 16K/32K NEW RomS cassette . . . . .	\$45
PET 16K/32K NEW RomS diskette . . . . .	\$45
APPLE II w/ROM Applesoft 32K w/DOS . . . . .	\$45
APPLE II w/RAM Applesoft 48K w/DOS . . . . .	\$45

USER'S Manual (refundable with software order) . . . . .	\$12
6502 Assembly Listing of INTERPRETER-graphics . . . . .	\$30
non-graphics . . . . .	\$25

Includes Airmail Postage to Europe. Orders may be prepaid by bankcard (include card number and expiration date) Eurocard, Access, Barclaycard etc.



ABACUS SOFTWARE  
 P. O. Box 7211  
 Grand Rapids, Michigan 49510

# Professional Data Systems.



Carne House, Markland Hill,  
Chorley New Road, Bolton.

0204 493816

**LEVEL I APPLE ACCREDITED SERVICE  
DEALER ONE YEARS FULL WARRANTY  
ON ALL APPLE EQUIPMENT. DEALER  
ENQUIRIES WELCOMED.**

*RING FOR OUR COMPLETE CATALOGUE  
ALL PRICES SUBJECT TO 15% VAT +  
POSTAGE & PACKING CREDIT CARD  
SALES SUBJECT TO 5% CHARGE OVER  
ADVERTISED PRICE. WE NOW  
DISTRIBUTE FOR SIRIUS, MICROSOFT,  
STONEWARE HIGH TECHNOLOGY  
CREATIVE COMPUTING*

**APPLE 48K MICRO COMPUTER £710.50  
SEIKOSHA GP80 FRICTION/TRACTOR  
PRINTER £235.59**

**CENTRONICS 737 PRINTER £371.00**

**EPSON MX 80 FT/2 £392.44**

**ANADIX 9500 £783.13**

**16k RAMCARD £101.06**

**VIDEX VIDEOTERM 80 COL CARD £196.88**

**THE MILL WITH PASCAL KIT £238.88**

**PASCAL LANGUAGE SYSTEM £261.63**

**Z80 SOFTCARD £192.94**

**JOYSTICKS (NEW PRODUCT) £19.69**

**VERSAWRITER £130.38**

**NEC 12" GREEN/BLACK MONITOR £172.16**

**WORDSTAR £191.63**

**MAIL-MERGE £74.81**

**DB MASTER £116.81**

**VISIDEX £116.81**

**WATANABE DIGI-PLOTS £892.50**

**CORVUS 10 MEGABYTE HARD DISC £3753.75**

**PASCAL HANDBOOK £13.19**

**YOUR FIRST COMPUTER £8.27**

**BENEATH APPLE DOS £13.06**

**ANTI BALLISTIC MISSILE £15.65**

**HELL FIRE WARRIORS £23.49**

**STAR CRUISER £15.65**

**SPACE EGGS £15.68**

**CYBER STRIKE £16.41**

**COMPUTER NEPOLEONICS £31.43**

**SPACE INVADERS £11.91**

**TORPEDO FIRE £34.08**

**ROBOT WAR £23.49**

**NEW CATALOGUE NOW READY!**

**PLEASE RING!**

# COMMODORE PETS



8032 Computer  
8050 Floppy Disk  
8024 Matrix Printer  
8026 Daisy Printer Keyboard  
8027 Daisy Printer Read Only  
4032 Computer  
4040 Floppy Disk  
4022 Matrix Printer.

**\*Phone for latest prices \***

**\*\* VIC'S NOW IN \*\***

Second Hand Equipment Brought & Sold. Call now.

Other printers we supply are: Qume, Ricoh, Epson, Centronics.

We also supply software: Visicalc, Wordcraft, Incomplete Records, Payroll, Stock Control, Invoicing, Sales & Purchase, Time Recording, Ozz.

All accessories are available from us and our other services include installation & training and maintenance contracts.

Please phone for a quotation of our typing, work-processing and personalised mail shot services.



**DAVINCI COMPUTER SHOP**

65 High Street  
Edgware Midds

Mon-Fri. 9.00-4.30 Sat 9.30-5.00

or send for details.

Tel: 01-952 0526

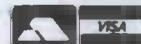

## Diskwise Ltd

25 Fore Street, Callington  
Cornwall, PL17 7AD.  
Tel: 05793 3780

# DEVON & CORNWALL

Computer enthusiasts look no further

**WE STOCK THE FOLLOWING PRODUCTS:**

APPLE II PLUS 48K ..... £807  
ADLER ALPHATRONIC FROM ..... £18.20  
VIDEO GENIE ..... £325  
TRANSAM TUSCAN KIT FROM ..... £235  
EPSON MX80 F/T ..... £425  
Plus extra for I/F to Pet, TRS80, etc.  
MICRO LINE 80 ..... £350  
OLYMPIA SCRIPTA  
DAISYWHEEL quality printers from ..... £838  
TANTEL PRESTEL ADAPTER ..... £170

*Above prices plus VAT*

Paper, Discs, Books and the largest range  
of **APPLE BUSINESS SOFTWARE** in the  
South West



**PLYMOUTH SHOP NOW OPEN AT:**

Deptford Place, North Hill Plymouth, Tel 267000

# The Currah Mini Digital Recorder is the fast and simple alternative to Disc

- High Read/Write speed - 6000 baud (10-20 times faster than audio cassette)
- High data integrity (error better than 1:10<sup>7</sup>)
- No keys - under software control - facilities normally only available with disc
- Uses proven Philips mechanism
- Large capacity - up to 120K bytes
- Additional RAM and ROM
- Firmware included
- Robust construction/ Attractive appearance
- Compatible with 6502 based computers including



**£195**  
+ postage and packing + VAT

DISTRIBUTORS REQUIRED IN SELECTED AREAS

**CURRAH**

COMPUTER COMPONENTS LIMITED

GRAYTHORP INDUSTRIAL ESTATE  
HARTLEPOOL, CLEVELAND TS25 2DF  
Telephone: (0429) 72996

SEND FOR FULL DATA NOW!

To Currah Computer Components Ltd.,  
Graythorp Industrial Estate, Hartlepool, Cleveland, TS25 2DF.  
Please send me

- 220m recorder £227.40 inc. P & P. and VAT
- Box (6) Cassettes £18.80 inc. P & P. and VAT
- Further Information

Money Back Guaranteed if returned in 7 days.

PCW



I enclose my cheque/postal order for £..... or debit my Access Barclaycard No.....

Name .....

Address .....

Signature .....

..... please allow 28 days for delivery

## WIN 128K BYTES EXPANSION FOR YOUR APPLE, PET, ATOM, VIDEO, GENIE, TRS, SINCLAIR ZX81

**SPECIAL OFFER!**



to encourage software development on the ATOM system.

Instead of making vague promises, we give a frank 'yes' in reply — because we have done it on our Ram expansion modules. We use the latest device from today's technology to offer you simplicity and flexibility — the Motorola MC 665-L20 64K bit on a chip, which consumes a mere 10mA/5V to retain your data, or the Hitachi HM 6116 2 x 8K CMOS RAM which can keep programs and data for weeks or months.

We have done our best to make it affordable for everyone — look at the prices below for example. First, however, take a look at the specifications.

(details of the competition in our leaflets)

If you intend to buy any Ram expansion for your system, you would probably ask the salesman some of the following questions:

- Is it fully compatible with the hardware on my system?
- Is it upgradable to a total Ram system?
- Is it easy to install, reliable and affordable?

Price List	16K byte	32K byte	64K bytes Total RAM system	64K bytes secondary memory	128K bytes secondary memory	CMOS language card
Apple	—	—	—	£80	£130	16K = £63
Pet	£39	£54	£87	£80	£130	20K = £75
UK 101	£39	£54	£87	£80	£130	16K = £63
Atom	£39	£54	Special offer	Special offer	Special offer	16K = £63
TRS80	£33	£43	—	£70	£120	
Video Genie	£33	£43	—	£70	£120	
ZX81 internal fitting	£33	£43	—	£70	£120	
ZX81 DRAMPACK	£36	£46	—	£73	£123	
ZX81 experimenter system	£31	£41	—	£68	£118	8K = £38

Most micros except new Pet & Videogenie need extra power supply for 16K and 32K expansion = 12V/400mA and -5V/10mA. We can supply PSV card at £8.00. All prices are quoted for kit package. Ready built — please add a unique charge at £8.00 to all prices. All components and documentation included — guarantee 3 months. We also sell bareboard and components separately, e.g.: MC6665 -L20 = £7.00 + VAT. HM 6116P = £6.00 + VAT. No VAT for all export orders.

For full details together with price list, please write or ring us on Southend (0702) 613081.

**AUDIO COMPUTERS 87 BOURNEMOUTH PARK ROAD SOUTHEND ON SEA ESSEX**  
Tel: (0702) 613081.

# FREE SOUND WITH VIDEO GENIE

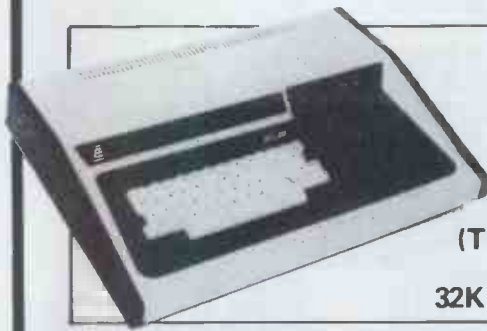

**NEW "SUPER GENIE"  
WITH UPPER/LOWER  
CASE AS STANDARD  
ONLY £299 INC. SOUND!  
(THIS IS THE LATEST MODEL  
NOT AN UPGRADE)  
32K EXPANSION BOX ONLY £279**

**\* GENIE II \*  
THE BUSINESSMAN'S  
MOST COST EFFECTIVE  
COMPUTER  
INCLUDING NUMERIC  
PAD AND SOUND  
ONLY £329**



## COMPUKIT UK101

**1K KIT £99.95  
8K KIT £119.00  
8K BUILT £159.00  
(8K BUILT WITH FREE  
SOUND)**

## EPSON PRINTERS

**MX80T — £329  
MX80F/T — £379**

**DISC DRIVES FOR  
VIDEO GENIE  
(40 TRACK)  
SINGLE — £195  
DUAL — £380**

**DISC CONTROLLER/24K  
EXPANSION  
FOR UK101/SUPERBOARD  
ONLY £189**

**SEIKOSHA  
PRINTER  
NOW ONLY £179**

**KRAM ELECTRONICS,  
VICTORIA HOUSE,  
17 HIGHCROSS ST.,  
LEICESTER.  
TEL. LEICESTER 27556**



# THE LONDON SORCERER CENTRE

**EMG MICROCOMPUTERS LTD.  
30 HEATHFIELD ROAD, CROYDON, SURREY CRO 1EU.  
TEL: 01-688 0088**

We are specialists in complete installations, tailor-made software for your business needs.

WORD PROCESSING SYSTEM	£14.99/WEEK
COMPLETE BUSINESS SYSTEM	£24.99/WEEK

Software includes customer and invoice system, leads and sales system, VAT outputs and debtors, insurance agents system, car sales program, order processing program.

We provide any printer to fit your Sorcerer e.g. Qume, Starwriter, Spinwriter, Centronics 737 and NEW Adcomp printer plotter matches '8.8 Graphics capability of Sorcerer to give complete graphics.

### ★ SPECIAL OFFER ★

Sorcerer 48K for only £595\*

- ★ Special Educational Discount
- ★ Demonstrations and Quotes given
- ★ Free Software and Hardware catalogue
- ★ 6 copies of Source magazine £6

ALL PRICES EXCLUDE VAT

AN EMG COMPANY

\*Subject to dollar surcharge.

## PRINTERS

Buy any of the below and get a free interface kit and word processor program for UK101 or Superboard. Base 2,800MST £250. Seikosha GP80 A £199. Centronics 737 £395. OKI Microline 80 £299. OKI Microline 82A £399. OKI Microline 82 £399. OKI Microline 83 £699. Epson MX70T £259. Epson MX80T £359. Epson MX80F/T1 £399. Epson MX80F/T2 £449. Epson MX100 £575.

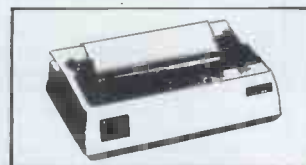

**SHARP COMPUTERS**  
MZ80K 20K £380, 36K £394,  
48K £408. PC1211 £82.

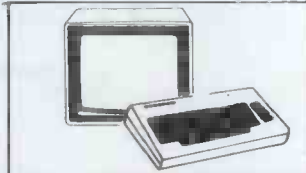

**VIC 20 COMPUTER £165**



**SWANLEY ELECTRONICS**  
Dept PCW, 32 Goldsel Rd,  
Swanley, Kent BR8 8EZ.  
Tel Swanley (0322) 64851

## OHIO SCIENTIFIC COMPUTERS

Superboard 3 poa. Series 2 challenger 4k poa, 8k poa. Power supply kit £11-95. Modulator £3-50. Guard band kit £10. 4k extra RAM £10-80. 16K memory expansion complete kit £50. built £58. 32K memory expansion kit £74, built £82. Case £27. Cegmon £22-50. Wemon £19-95. Assembler/Editor tape £25. Word processor program £10. Centronics interface kit £10. 610 expansion board poa. Cased mini-floppy disc drive with DOS and PSU poa. Cassette recorder £19. Colour adaptor board built £45.

**PET, ATOM, UK101  
MEMORY REVOLUTION**  
Memory expansion boards 16k kit £50, built £58. 32K kit £74, built £82.

**VIDEO GENIE £279**

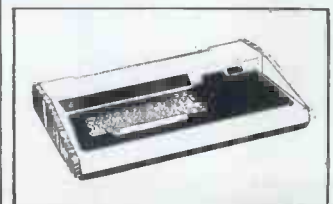

## 5V POWER KITS

Fully stabilised 5V computer and TTL power kits. Automatic current limiting and short circuit protection. Crowbar over-voltage protection. 1.5A £7.83, 3A £12-17, 6A £19-13.

Postage £3.50 on computers, £4.50 on printers and 45p on other orders. Lists 27p post free. Please add VAT to all prices. Official credit orders welcome.

# ZX81 owners

have you seen

*The Cambridge Collection*

A book of

## 30 PROGRAMS

For Only **£4.95**

### NO MEMORY EXPANSION NEEDED

Each program has been designed to fit into 1K of RAM

### TEACH YOURSELF PROGRAMMING

Comprehensive explanations of each listing will teach you many techniques of ZX81 programming.

### HOURS OF AMUSEMENT

With titles such as FORTRESS, BALLOON, and ODD MAN OUT, you could easily become a ZX81 addict. Plus, entirely new implementations of well-known favourites; LUNAR LANDING, MASTER CODE, ORBITAL INVADERS, and many others.

### CASSETTE AVAILABLE TOO!

If you order the book you can also buy the programs on a quality cassette for only £4.95 extra.

Please send me:

copies of the book at  
**£4.95 each**

copies of the book and  
cassette at **£9.90 pair**

Please send your orders  
with cheques/PO's to:

**Richard Francis, Dept PCW  
22 Foxhollow, Barhill,  
Cambridge, CB3 9EP.**

## CASCADE COMPUTERS OF NEWBURY

Telephone:  
**(0635) 201591**

for the full range of  
Apple products, Apple  
compatible peripherals

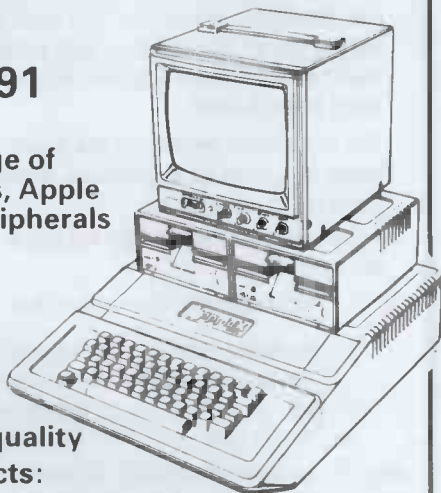

and these high quality  
software products:

- \* Financial modelling with Micro Modeller + Decision Modeller
- \* Decision Evaluation with VisiCalc, Desk Top, Visi Plant, Visi Trend, + Visi Decks.
- \* Integrated Accounts with TABS Accounting Business Systems.
- \* Word Processing with AppleWRiter and Word Star.
- \* Portable Software Development with CIS-COBOL and PASCAL.

*Apple Computer Specialists*

## Attention Atom Owners become WORD PERFECT WITH THE NEW ATOM WORD PACK

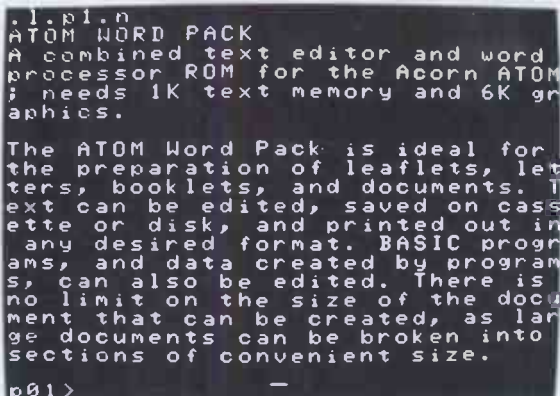

The ATOM word pack is ideal for the preparation of leaflets, letters, booklets and documents. Text can be edited, saved on cassette or disk and then printed out in any desired format. BASIC programs and data created by programs can also be edited. The Word Pack is a 4K ROM which simply plugs into the ATOM's utility ROM socket and adds EDIT and TEXT to the command set. Complete with a 16 page booklet giving full instructions and examples. Just £29.90 including post, packing and insurance.

### Also Available:

#### SOFT VDU

The soft VDU replaces the normal ATOM VDU, but provides 128 characters including upper and lower-case letters, and mathematical symbols. Program 1.5K, graphics 6K.

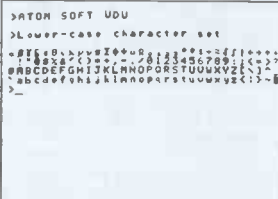

#### MATHS PACK 1

Plot A versatile graph-plotting package for research, accounting, schools and mathematics, or simply for amusement. Program 5K, graphics 6K. Simultaneous Solves a set of simultaneous equations, with integer or real coefficients. Program 2K, graphics ½K. Regression Calculates the best-fitting straight line to a specified set of data points, gives the equation and the correlation coefficient. Program 2K, graphics ½K.

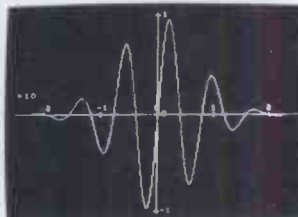

#### UTILITY PACK 1

Disassembler Lists machine code in standard ATOM assembler form, or stores the assembler text into memory. Graphics 2K. Fast Cos Modifies the ATOM's standard cassette-interface routines to operate at 1200 baud, or 4 times faster. Program 1K. Renumber A fast renumber for BASIC or assembler programs, gives display of the numbers for labelled lines. Program 1K.



### ORDER TODAY!

Just send a cheque or money order for only £11.50 per pack (£29.90 for the word pack) including VAT and post and packing. State which packs you want.

Or ring 0223 316039 or 01-930 1614 quoting your Access or Barclaycard number. Allow 14 days for delivery.

Or if you think you can wait for more details just write to  
**Acornsoft Limited, 4a Market Hill, Cambridge**

**ACORNSOFT**

# GATEPOST

Gate now sole UK Distributors for Strategic Simulations Inc!  
Quality Games for your Apple!

2 more great new games from Strategic Simulations  
Computer Quarterback & President Elect available now,  
from Gatepost — see below!

From Strategic Simulations, we can now offer:

**COMPUTER QUARTERBACK (48k-D)**. A real time strategy football game for 1 or 2 players. Pick your own team! £27.00

**PRESIDENT ELECT (48k-D)**. Change the course of history — rerun the last 2 elections — stand yourself! £27.00

**COMPUTER NAPOLEONICS (48k-D)**. Traditional wargame — 1 or 2 players — meticulous detail and realism £40.50

**COMPUTER BISMARCK (48k-D)**. Simulation of this historic ship's battle with British Home Fleet. 1 or 2 players. £40.50

**COMPUTER AMBUSH (48k-D)**. World War II man-to-man street fight in French town. 7 scenarios, 1 or 2 players. £40.50

**COMPUTER CONFLICT (48k-D)**. 2 Games for 1 or 2 players in HIRES graphics — modern warfare with tanks and infantry £27.00

**COMPUTER AIR COMBAT (48k-D)**. 36 famous World War II planes accurately simulated, HIRES graphics, 1 or 2 players £40.50

**OPERATION APOCALYPSE (48k-D)**. HIRES graphics, 4 scenarios of WWII. 1 or 2 players — recreate actual battles. £40.50

**TORPEDO FIRE (48k-D)**. 3-D graphics periscope view of fleet of 30 different WWII vessels. 1 or 2 players. £40.50

**THE WARP FACTOR (48k-D)**. 1 or 2 player strategy space game with 12 starship designs — light years ahead of the rest! £27.00

**CARTELS AND CUTTHROATS (48k-D)**. 1 to 6 player business strategy game. You select difficulty (advanced version will beat the boss!) — an accurate business simulation. £27.00

**THE SHATTERED ALLIANCE (48k-D)**. First in a new series — send for full details. £40.50

Of course we still stock the best from other software houses! Our most popular sellers are:-

**SARGON II (24k-D)**. The champion chess game for Apple £23.85

**A2-FS1 FLIGHT SIMULATOR (34k-D)**. Extended and improved version, including British Ace 3D Aerial Battle Game £23.60

**THE PRISONER (48k-D)**. A nightmare world of 1984 — very difficult — uses every trick, including subliminal techniques £21.00

**THE WIZARD AND THE PRINCESS (48k-D)**. This has to be the best HIRES adventure game. 100s of pictures. We're still trying to get past the giant! £23.00

**METEORIDS IN SPACE (32k-D)** improved version of asteroids in space. Watch out for debris — and aliens! £14.40

**SPACE (48k-D)**. Simulation of human life in space. You develop characters and games. £20.35

**SPACE EGGS (48k-D)**. Shoot down the aliens as they hatch — great arcade game £20.35

**ADVENTURELAND (32k-C)** An enchanted world of lost treasures, wild animals and magical beings. £10.15

**TEMPLE OF APSHA! (48k-D)** Mythical labyrinth with fearsome monsters and treasure. £27.15

**SAUCER WARS (24k-C)** One person game with 150 levels of difficulty. £11.55

**GOLF (20k-C)** 18 holes for 1 or 2 players — full choice of clubs and direction. £5.55

**AIR FLIGHT SIMULATION (16k-C) ONLY** £7.15

## NEW NEW NEW NEW NEW

**POOL 1.5 (48k-D)** Fantastic! 4 different games of pool. Fine tune shots for great accuracy. Great graphics £25.25

**3-D SKIING (48k-D)** Ski slalom with real time skiing! 3 course, ski jump and good graphics. Up to 4 players. £18.10

**SUPER SOUND (32k-D)** Allows you to produce a wide variety of noises to put in your own programmes £12.25

**CRANSTON MANOR (48k-D)** At last! The sequel to Wizard & Princess! Every bit as good — and difficult! £23.80

**Plain Brown Envelope Department**

**INTERLUDE (32k-D)** or (16k-C) Rediscover the playful, the erotic side to your relationships! VERY comprehensive manual! £12.25  
£14.50

**SOFTPORN ADVENTURE (48k-D)** On Line. Find and seduce 3 girls! Win the money to do this at the casino! You have to be creative in your approach! Not easy, this one! £21.60

**PORNOPOLY — Not yet in stock, but said to contain HIRES!** £21.60

Send large S.A.E. for our full list. (3rd Edition).

**DOS BOSS (32k-D)** Dos 3.3 Super value utility — change dos, rename commands, plus lots more! Loads of tips in manual. £16.25

**BEAGLE BROTHERS GAME PACKS (32k-D)** 4 different packs of super games — even includes magic tricks! Each pack £16.25

**GAMMA GOBLINS (48k-D)** Defend your body against all manner of intravenous nasties. Super HIRES arcade game £23.15

**GORGON (48k-D)** Gorgons materialise from air to steal your man. Defend him with your fighter. Beats space invaders out of sight for HIRES graphics and action. Easily worth £30.85

**PLUS LOTS MORE!!** Send large stamped addressed envelope for our full list.

All programmes listed above are written in Applesoft or machine code. C = on cassette, D = on diskette.

**ALL THE ABOVE PRICES ALREADY INCLUDE VAT!** Just add 50p for post & packing and send your order with cheque or PO to our address below.

Prices are subject to change in the event of dollar fluctuations.  
STOP PRESS STOP PRESS STOP PRESS STOP PRESS

## SERIOUS STUFF DEPARTMENT

**THE FAST ONE — no not LAST, FAST!**

**THE HAYDEN APPLESOFT COMPILER** We've Benchmarked it and amazed ourselves with the results! It's selling like hot cakes, and no wonder!

S.A.E. for details and benchmark, or for the full kit £125.00  
Dealer enquiries welcome. plus VAT and £1.00 p&p



**GATE MICROSYSTEMS LIMITED**  
The Nethergate Centre, 35 Yeaman Shore,  
Dundee.

# MASTER THE MIGHTY MICRO.

## RENT OR PURCHASE A MICRO

We supply micro wordprocessing and accountancy microcomputer systems for full home and office use. A complete micro system including printer with full wordprocessing is £12.50 a week.

## TAILOR MADE SOFTWARE

The micro should fit your company, not your company the micro. We produce programs and systems that do exactly what you want in your business.

## TRAINING COURSES

Training courses in wordprocessing, micro operating, micro computers, micro processing and micro data processing for executives, secretaries, businessmen, students, accountancy personnel and hobbyists. These short courses are attended week days, evenings and weekends and are all with 'hands on experience'.

TEL:  
01-730-8791  
TODAY



RETAIL ONLY

# THE LONDON MICRO CENTRE

An EMG Company.

47, Lower Belgrave St., London, SW1.

DEALERS

## THE WESTFARTHING SMALL BUSINESS SYSTEM

is almost the only integrated accounting and invoicing system specially written for the 1 to 10-man business and professional practice. It is user-modifiable (a main selling point), has been on sale for over a year, and no user has reported a bug over the last few months. The retail price is £500.

The program is written for the Apple, and versions are being prepared for Superbrain, Sharp, Tandy and sorcerer machines.

Applications are invited for exclusive rights to market the system:

- (1) for a specific micro, other than the above makes
- (2) for Apple or other computers in a foreign country — no need to re-apply if you are already in touch with us — In each case the financial outlay involved would be around £2,000.

Also (3) we welcome more U.K. dealers for the Apple version. No further payment than the kit charge is required before a sale is made.

An approval kit, consisting of demo disc, manual and sales literature costs £20 + VAT.



Westfarthing  
Computer Services Ltd.  
21 Wendron St. Helston, Cornwall.  
Tel: Helston [03265] 4098.



# Personal Computer Palace

## COMPUTERS FOR PEOPLE

Atari 400 computer £345  
WITH FREE JOYSTICKS

Atari 800 computer £625  
WITH FREE JOYSTICKS

Atari 410 cassette £45

Atari 810 disk drive £325

Atari 16k RAM module £63

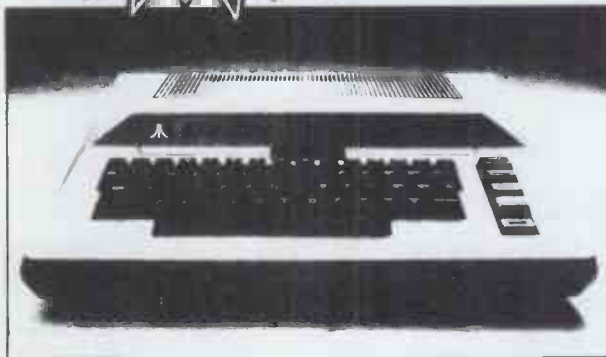

New generation micros for family entertainment and education. Amazing sound and graphics direct from your colour T.V. give you the best games available. Atari from Personal Computer Palace provides easy reliability at a price you can afford.

## video genie

We have the Video Genie in stock with free sound, lower case and dust cover at £367 inc. programs and manuals.



The Apple computer system is on show with a wide selection of software, supported by trained sales and engineering staff.

Centronics, Epson and Atari printers in stock at competitive prices, good service.

All our equipment is covered by the unique Personal Computer Palace Service, which provides free carriage, one year parts & labour guarantee and optional maintenance contracts.

Goods are despatched same day as order received. Please write your order carefully or phone us for information/order form. Callers welcome. Open 9.00-6.00 closed Wednesday.

6 Castle Street,  
Reading, Berkshire.  
Tel. (0734) 589249

### ATARI SOFTWARE

Cartridge	
Asteroids	£29.95
Basketball	£29.95
Chess	£29.95
Music Composer	£32.50
Star Raiders	£29.95
Super Breakout	£29.95

Cassette	
Blackjack	£8.95
Energy Czar	£8.95
Europe	£8.95
Graph It	£11.95
Hangman	£8.95
Scram	£12.95
Space Invaders	£12.95

## NASCOM SOFTWARE

We offer the following quality software for NASCOM systems:  
NASPAS — a 12k PASCAL compiler which produces Z80 code directly, i.e. no P-code. The compiler offers floating point and integer arithmetic, arrays, sets, strings and all major Pascal statements together with fully recursive functions and procedures with value and variable parameters. The object program runs very quickly.

Price: £35.00

NASMON — A new monitor for NASCOMs. Occupies 4k and includes a sophisticated screen editor, a 'front panel' mode, blocked and buffered tapa routines and powerful debugging commands. Price: £30.00 in EPROM

BAS12K — a 12K BASIC interpreter offering 11 digit precision arithmetic, PRINT USING, IF...THEN...ELSE and other advanced features. Price: £25.00

NASGEN — a fast 3K assembler generating a full symbol table and with many assembler directives and commands. Price: £15.00 on tape, £25.00 in EPROM.

NASNEM — a 2½K disassembler which interfaces to NASCOM's front panel to produce single step disassembly. Optionally it produces labels and o/p may be directed to a text buffer suitable for NASGEN. Price: £10.00 on tape, £15.00 in EPROM.

All the above software runs under NASMON except NASPAS which can run under NASMON or NAS-SYS. All prices are fully inclusive.

FREE: a free CHESS program with every order of NASMON.

GEMINI DISK OWNERS: HISOFT offer a Z80 development package to run under CP/M 1.4 on the Gemini Floppy Disk System. Included in the package are:

- a powerful screen editor.
- a fast Z80 assembler with conditional assembly.
- a debugger based on the Front Panel of NASMON together with a labelling Z80 disassembler. All this for the inclusive price of: £50!

Send for details NOW.

Full details may be obtained from:

**HISOFT 60 HALLAM MOOR,  
LIDEN, SWINDON, WILTSHIRE.**

# ZX81 VIC ATOM

Make the most of your microcomputer with our range of proven books:

- GETTING ACQUAINTED WITH YOUR VIC £5.95
- GETTING ACQUAINTED WITH YOUR ACORN ATOM £7.95
- GETTING ACQUAINTED WITH YOUR ZX81 £4.95  
(Each of the above contain around 80 programs)
- THE GATEWAY GUIDE TO THE ZX81 & ZX80 £5.95  
(ZX BASIC explained in detail, 60 programs)
- MASTERING MACHINE CODE ON YOUR ZX80 & ZX81 £4.95
- INTERFACE, monthly ZX81, ZX80 and Acorn Atom magazine. £8.50 for 12 copies, £1 for sample copy.

Send this ad., or a copy, with cheque to:

**INTERFACE, Dept PCW, 44 Earls Court Road,  
London W8 6EJ.**

## INTERFACE



# TRS-80 OWNERS!



Accounts Receivable .....	£90.00
Invoicing for above .....	£70.00
General Ledger	
includes Cash Journal .....	£90.00
Manuals for above (3) .....	£32.00
Complete Co-ordinated System	
with Manuals .....	£300.00

## LEVEL II CASSETTE GAMES

Adventures:	
Special Sampler*	£6.50
Adventureland*	£13.50
Pirates Adventure*	£13.50
Mission Impossible*	£13.50
Voodoo Castle*	£13.50
The Count*	£13.50
Strange Odyssey*	£13.50
Mystery Fun House*	£13.50
Pyramid of Doom*	£13.50
Krog Town*	£13.50
Kid Venture	£13.50
Savage Island*	£13.50
Crowley Manor*	£13.50
Air Raid*	£7.50
Air Traffic Control*	£8.50
Amazon Mazes	£5.50
Android NIM	£7.50
Attack Force*	£10.50
Backgammon	£6.50
Barricade*	£7.50
Battle Bastogne	£10.50
Battle St. Vlth	£10.50
BattleShip	£7.50
Bee Wary	£7.50
Bingo	£5.00
Bowling (Ten Pin)	£6.50
Bridge Partner	£13.50
Chess Partner*	£9.50
Cosmic Fighter*	£10.50
Cribbage	£6.50
Datestones of Ryn	£17.50
D-Day	£10.50
Death Dreadnaught*	£10.50
Duel & Droids	£10.50
The Empire Strikes	£10.50
End Zone II	£6.50
Fastgammon*	£14.00
Galactic Empire	£10.50
Galactic Revolution	£10.50
Galactic Trader	£10.50
Galaxy Invasion*	£10.50
Game of Life*	£6.50
Gammon Challenger*	£10.50
Gangster	£5.50
Hangman	£5.50
Hellfire Warrior	£20.50
I Ching	£6.50
Interlude*	£12.00
Invasion Orion	£17.50
Invaders from Space*	£10.50
Kamikaze	£6.50

## MODELS I & III

Kreigspiel II	£10.50	Direct Function Graph	£10.50
Labyrinth*	£10.50	Editor Assembler Plus*	£20.50
Life Two	£10.50	Electric Pencil*	£50.00
Lost Dutchman's Gold	£9.50	Electronics Assistant	£7.50
Lunar Lander*	£10.50	EMU 02* (requires TBUG)	£17.00
Mean Checkers*	£11.00	ESP Tester	£5.00
Meteor Mission*	£10.50	File Handling	£7.50
Morloc's Tower	£17.50	Finance Pack	£7.50
Noughts & Crosses	£5.00	Finplan	£35.00
Othello III	£6.50	Flight Simulator*	£17.00
Olympic Decathlon*	£20.50	Forth* (incl. Primer)	£42.00
Pentominos	£6.50	GFH*	£19.50
Pinball*	£10.50	General Accounting	£8.50
Pork Barrel	£6.50	Ham Radio	£7.50
Planetoids*	£10.50	Home Finance	£8.50
PR Dogfight	£6.50	Histogram/Scattergram	£6.50
Rescue at Rigel	£17.50	Infinite Basic*	£34.00
Reversi	£20.50	Infinite Business*	£20.50
Round The Horn	£6.50	Instant Calculator	£8.50
Safari	£6.50	Inventory Control	£11.00
Sargon II*	£20.50	Inventory 'S'	£17.00
Snake Eggs	£7.50	IRV*	£17.00
Space Battles	£7.50	Keyboard 80*	£7.50
Starfleet Orion	£14.00	KVP*	£10.50
Star Trek III.5	£10.50	Level III Basic*	£34.00
Super Nova*	£10.50	Linear Programming	£7.50
Taipan	£6.50	Magic Paper Calculator	£9.50
Temple of Asphai	£17.50	Mathdrill	£5.50
Time Trek*	£10.50	Maths Library I	£10.50
Trolls Gold	£4.50	Maths Library II	£10.50
Turret & Track	£7.50	Memdump*	£8.50
Up Periscope	£10.50	Mortgage Calculator	£5.00
Warfare I	£6.00	Pascal*	£26.00
Warpath	£10.50	Periodical X-REF	£10.50
X-Wing Fighter II	£7.50	Personal Finance	£7.50
		Pilot 2.2*	£10.50
		Pre-Flight	£10.50
		Remodel & Proload*	£25.00
		Remember*	£7.50
		RPN Calculator	£7.50
		RSM 2 Monitor*	£16.00
		SCRIPSIT*	£42.95
		Screen Hold*	£6.00
		Statistics	£6.50
		S.T.A.D.*	£17.00
		ST-80*	£34.00
		Super Pims Data Base	£10.50
		Super Simon	£7.50
		Super T-Legs*	£7.50
		T-Step*	£7.50
		System Copy*	£9.50
		T-Short*	£6.50
		T-Short**	£14.00
		Tarot Cards	£6.50
		Timser*	£10.50

Tiny Comp .....	£14.00
TRS80 Opera*	£7.50
Typing Tutor	£13.50
Ultra Mon*	£17.00
X-Ref*	£9.50
Y-Y Bar	£10.50
76 Basic Programs	£23.00
Manual for Above	£8.00
Library 100	£40.00

## DISK

Accounts Receivable II	£40.00
Advanced Personal Finance	£17.00
Amateur Radio System	£17.00
APL 80	£30.00
Auto Disk Directory	£10.50
Basic Compiler	£120.00
Cash Register + Inventory	£40.00
CCA Data Management	£52.50
Comproc	£13.50
Data Base II	£30.00
DCV-1	£9.50
Dosort	£25.00
Dynamic Data Base	£22.50
Electric Pencil	£75.00
File Manager 80	£30.00
Floppy Disk Diagnostic	£13.50
Forth (inc. Primer)	£45.00
Forth Databandler	£40.00
Forth Utilities Disk	£27.50
Inventory Control	£50.00
Inventory 'S'	£40.00
KVP Extender	£17.00
Mailist IV	£45.00
Mychess	£25.00
Newdos 80 V2.0	£97.50
Newdos +	£47.50
Office Accounting	£20.00
Pascal	£35.00
Penpatch	£11.00
Pencil PAL	£17.00
Roots	£17.00
RSM 2D Monitor	£20.00
Sargon II	£25.00
SCRIPSIT*	£65.00
Simplify It	£15.00
Space Intruders	£20.00
ST80D*	£45.00
ST80D III*	£95.00
SUPERSCRIP*	£20.50
Visicalc*	£65.00
Taranto & Associates Conversion of Osbourne & Associates Business Programmes	£90.00
Accounts Payable .....	£90.00

## MODEL II

CPM 2.2 X	£165.00
CBasic (CPM)	£80.00
Disk Sort Merge	£95.00
Development System	£80.00
G.S.F.	£35.00
Pascal	from £125.00
Reference II	£35.00
RM Cobol	from £350.00
RSM II Monitor	£35.00
Supersort III (CPM)	£90.00
Utility Package	£95.00
Hard Disk Operating Sys	£300.00

## WORD PROCESSORS

Electric Pencil II (CP/M)	£200.00
Electric Pencil II TRSDOS	£225.00
Magic Wand (CP/M)	£230.00
Wordstar (CP/M)	£275.00

## BUSINESS SYSTEMS

Accounting	from £150.00
Mailist	from £100.00
Medical	from £100.00
Property Analysis	£175.00

CP/M USERS GROUP	
23 Volumes	Each £12.00

ALL PRICES INCLUDE VAT AT 15%. PACKAGING & RETURN POSTAGE TO U.K. ADDRESSES. PRICES TO OVERSEAS ADDRESSES INCLUDE RETURN AIRMAIL. SEND £1.00 FOR NEW DESCRIPTIVE CATALOGUE.

\*Denotes Machine Language TRS-80 Trademark of Tandy Corp. CP/M Trademark of Digital Res. C-Basic Trademark of Compilizer Systems.

ALL PRICES SUBJECT TO CHANGE WITHOUT NOTICE

## MICROCOMPUTER APPLICATIONS

42A CHURCH STREET, CAVERSHAM, READING RG4 8AU, ENGLAND. TEL: (0734) 470425

# THE LONDON SUPERBRAIN CENTRE

47, Lower Belgrave St., London, SW1.

Visit the Superbrain centre to see wordprocessing systems and business systems with your own tailored software.

Software includes customer and invoice system, leads and sales system. VAT output and debtors, insurance agents system, car sales program, order processing program.

**SPECIAL OFFER!**  
**SUPERBRAIN FOR ONLY £1,550\***

\*Subject to dollar surcharge.

We provide any printer to fit the Superbrain e.g. Qume, Starwriter, Spinwriter, Centronics 737 etc.

- ★ Special Educational Discounts
- ★ Demonstrations and Quotes given
- ★ Free catalogues on request

TEL: 01-730-8791  
TODAY



47, Lower Belgrave Street, London, SW1.  
Tel: 01-730-8791

AN EMG COMPANY



Illustrated Paperback 160 pages  
216 x 138mm 0 408 00580 7 **£4.95**

## Practical Microprocessor Systems

Ian R. Sinclair

- ★ Describes the microprocessor as part of a system
- ★ Covers practical aspects

Illustrated Paperback 144 pages  
216 x 138mm 0 408 00496 7 **£4.95**

Order NOW - from your local bookseller

Particulars of other books on Computers available upon request or in case of difficulty send cash with order to Patricia Davies, Marketing Manager at the address below.

A division of Butterworths **Newnes Technical Books**  
Borough Green, Sevenoaks, Kent TN15 8PH (PCW/11.81)



**There's only one word for a boss who expects 200 letters by coffee break, 100 mailings by lunchtime, 250 price lists by teatime and a couple of complex documents before you leave...**

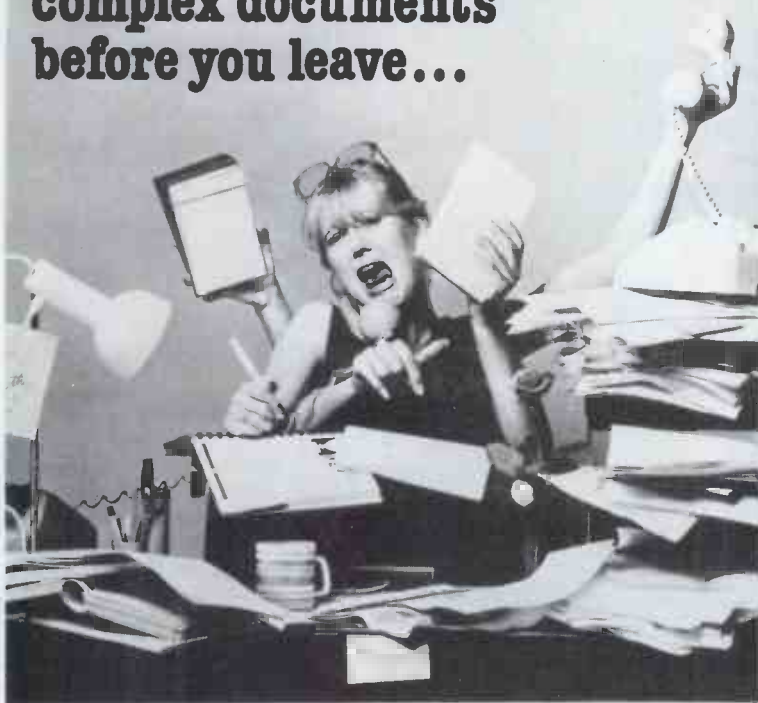

Wordcraft. It transforms your PET microcomputer into a word processor. But Wordcraft Software isn't just about producing large quantities of work.

Retyping becomes a thing of the past. Corrections can be done on the machine before the final copy is typed. Everything is stored in the memory so you can have as many perfect copies as you want, as and when you want them.

Commodore-approved Wordcraft takes advantage of today's 'daisywheel' printer's features. Just to make sure you get the kind of quality of typing you're used to. At very reasonable cost.

Finally, using Wordcraft doesn't affect the PET's equipment - so think how handy it could be in your business.

For further information:

M.M.S. LTD  
Bedford 0234 40601  
CAMDEN ELECTRONICS LTD  
Birmingham B10 0UG 021-773 8240  
CBS CONSULTANTS LTD  
Birmingham B9 4HW 021-772 8181  
CPS (DATA SYSTEMS) LTD  
Birmingham 021-707 3866  
CSM LTD  
Birmingham 021-382 4171  
MICRO ASSOCIATES  
Birmingham/Walsall 021-328 4574  
JOSEPH WARE & ASSOCIATES  
Birmingham B1 1LS 021-643 8033  
DIXON-MARTIN SYSTEMS LTD  
Birmingham B26 3NX 021-742 8771  
PEACH DATA SERVICES  
Burton-on Trent 0283 44968  
DAVIDSON RICHARDS LTD  
Derby 0332 366803  
DAVINCI COMPUTER SHDP  
Edgware 01-952 0526  
A.C. SYSTEMS  
Exeter 0392 71718  
MICROFACILITIES  
Hampton Hill 01-941 1197  
SOUTH EAST COMPUTERS  
Hastings 0424 426844

MICROPROCESSOR SERVICES  
Hull 0482 23146  
H.B. COMPUTERS  
Kettering 0536 520910  
ADDA COMPUTERS  
London W13 01-579 5845  
MERCHANT SYSTEMS LTD  
London EC4 01-583 6774  
MICRO COMPUTER CENTRE  
London SW14 01-878 7044  
LOGIC COMPUTER SYSTEMS  
London SW1 01-222 1122  
CYBERNETIC TEACHING SYSTEMS  
Long Eaton 0332 810639  
H.B. COMPUTERS (LUTON) LTD  
Luton 0582 416887  
CYTEK (UK) LTD  
Manchester 061-872 4682  
CLAREMONT CONTROLS  
Newcastle 0632 610210  
KEY COMPUTER SERVICES  
Newcastle 0632 815157  
C.S.E. (COMPUTERS)  
Reading 0734 61492  
COMPUTER CENTRE (SHEFFIELD) LTD  
Sheffield 0742 588731  
TAYLOR WILSON SYSTEMS LTD  
Solihiull 05645 6192  
INTEX DATALOG LTD  
Stockton-on-Tees 0642 781193

or contact  
Dataview, Portreeves House, East Bay,  
Colchester CO1 2XB Telephone Colchester (0206) 865835

**Dataview**  
The better business shop

# Does your microcomputer suffer from hiccups?

If so, quite often the cause of irregular performance or breakdown is very simple.

It's probably a high voltage spike in the electricity supply, called a transient, affecting the performance. Heavy electrical loads in the vicinity of your microcomputer (from domestic electrical appliances to office photo-copiers) can often cause voltage transients, which in turn, play havoc with both hardware and software.

The Reguvolt 'P' Model Constant Voltage Transformer provides the answer to a very simple yet aggravating problem, offering the following benefits to safeguard your supply sensitive computer and equipment.

- Transient suppression — gives software and hardware protection.
- Brownout protection — prevents micro interruptions and system crashes.
- Isolated secondary circuitry — gives complete electrical isolation between mains and computer.
- Fast voltage stabilisation — prevents VDU screen drift and complete system failure.

- Automatic overload current limited — protects equipment against damage during a fault condition.
- Low frequency mains harmonics removed, preventing VDU flicker and circuit overload.

The complete range of Reguvolt 'P' models, from 1/2 to 2 amp ratings (ie. 120VA to 500VA) are available from stock.

Should you require further details, please fill in the coupon, or, if you prefer, give us a call.

 **Cetronic Limited**  
Hoddesdon Road, Stanstead Abbots,  
Ware, Herts SG12 8EJ, England  
Tel Ware (0920) 871077 Telex 817293



**stand  
B55**

Please send me further information on your range of Reguvolt 'P' Model Constant Voltage Transformers.

Name .....

Company .....

Address .....

Telephone .....

# CAMBRIDGE COMPUTER SHOW

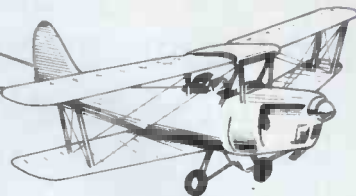

## Micros have really taken off in Cambridge!

- Apple II
- Hewlett-Packard HP-85
- Commodore Pet
- TRS-80 Model I, II & III
- Communicator
- North Star Horizon
- Daisy-Wheel printers
- Acorn Atom
- Commodore Vic
- UK 101 kit computer
- Sharp pocket computer
- WordStar/DataStar
- Plotters/Digitisers
- Electronic components

First time buyer or experienced user? See what's best in microcomputers today, all generally on demonstration and available from stock at:

### Cambridge Computer Store

1 Emmanuel Street Cambridge CB1 1NE  
Telephone (0223) 65335/4

Mon. - Fri. 9.00 to 12.30, 1.15 to 5.30  
Sat 9.00 to 5.30

## Compare & Save

**apple II**  
**euoplus**  
**48K**  
**£695 + VAT**



Complete 48K with Games  
Paddles manuals + 12  
Months Warranty  
Service available nationwide

**Epson**  
**MX-80 F/T2**  
**£399**  
**+ VAT**



The Best Buy in Printers Today  
9 - 9 Matrix with 40, 60, 80,  
132 Columns  
Friction & Tractor Feed With  
High Resolution Graphics

**apple**  
**Disk II**



With 3.3 Controller **£350**  
Without Controller **£279**

**Software**

3.3 VISICALC II	£99
VISILOT	£89
Visidex	£99
Desktop Plan	£99
D B Master (data base)	£109
Data Plot	£49
Apple Plot	£33
Musicomp	£21
Galactic Wars	£16
Anti-Ballistic Missiles	£17

**Hardware**

Apple Graphics Tablet	£413
Parallel Interface	£79
Apple Serial Interface	£89
Apple Centronics Interface	£99
Apple PRESTEL Interface	£536
12" Green Monitor/cable	£156
Epson MX100 Hi-Res Printer	£517
Paper Tiger 560 Printer	£795
Apple Silentype Printer	£170
Epson MX80F/T1 Printer	£359

**MICROSAVE**  
**68 Alma Road**  
**Bristol BS8 2DJ**  
**Mail Order Desk**  
**0272-37555**



PLEASE REMEMBER TO ADD 15% VAT

ALL PRICES ARE FOR MAIL ORDER ONLY. MAIL ORDER SALES AT SHOWROOM. WE TRY TO KEEP PRICES STABLE BUT THEY ARE LIABLE TO CHANGE WITHOUT NOTICE

## apple computer

Level 1 Service Centre  
Apple Software Experts:

## CESIL II

Barristers' Accounts  
Technical "Page" Database

## CARDIFF

## micro

## COMPUTERS

46 Charles Street

Tel: 373072

OPEN ALL DAY SATURDAYS

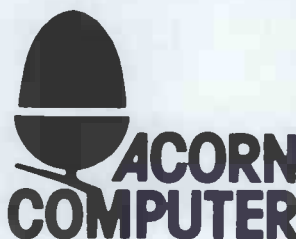

**ATOM**  
**IN**  
**STOCK**

# World's most powerfull BASIC pocket computer CASIO FX-702P

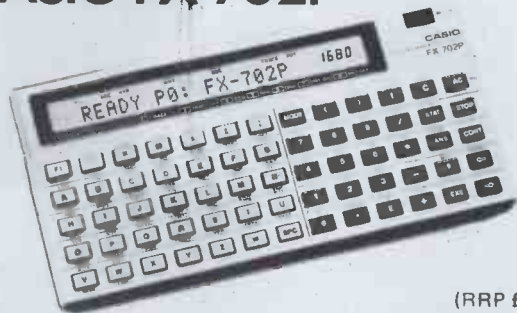

(RRP £134.95)  
**ONLY £119.95**

High-speed computer using BASIC Language, with program/data storage on cassette tape via optional FA-2 adaptor.  
AVAILABLE SOON: Plug-In ROM program modules and FP-10 Mini Printer for program/data printout.

LCD dot matrix scrolling display. Input can be varied from 1680 program steps, with 26 independent memories, to 80 program steps with 226 memories, all protected (non-volatile). Up to 10 programs (P0 to P9) can be stored.

Subroutines: 10 levels. FOR NEXT looping, 8 levels.

Debugging by tracing. Editing by moving cursor.

55 built-in functions including Regression Analysis and Correlation Coefficient all usable in programs. Program/data storage on cassette tape. Two lithium batteries give approximately 200 hours continuous use, with Auto Power Off after 6 mins. disuse.

Dimensions: 17x166x82mm (2/8 x 6 1/2" x 3 1/4"). Weight 180g (6.3oz).

**FX-602P** Advanced programmable. Up to 512 steps **£74.95**

\*\*\* **NEW** \*\*\* **FX-3600P** 38 program steps **£22.95**

# World's most versatile alarm chronograph watch CASIO AX-210



10 alternative displays  
Over 60 useful functions  
ANALOGUE display of time plus:-  
\* Digital time display, 12 or 24 hour system  
\* Digital date, month and year, plus day flag  
\* Full month calendar display, current month.  
\* Full month calendar display, next month.  
Auto calendar pre-programmed to the year 2029.  
Dual time modes.  
\* ANALOGUE display of local time, plus digital second time zone, 12 or 24 hour system.  
Alarm mode.  
\* ANALOGUE time with "Alarm Set" digital time. 24 hour system AM/PM and "alarm on" indicators.  
Buzzer for 20 seconds, or select "Dixieland" "Greensleeves" or "My Darling, Clementine."  
Hourly time signal.  
"Big Ben" chimes at noon. Easily switched on or off.

(RRP £34.95)  
**ONLY £29.95**

Countdown alarm timer mode

\* Amazing ANALOGUE display, plus digital countdown. Normal and net times from 1 to 60 minutes with automatic retrieval of pre-entered time.

Stopwatch mode

\* ANALOGUE counting, with digital timing of net, lap and first and second place times from 1/100 sec to 1 hour. Confirmation signal.

Easy setting of times and alarm with forward and backward stepping and rapid run facility. Dimensions: 9.25 x 35 x 36mm approx. Mineral glass. Long life lithium battery. Accuracy +/- 15 seconds/month.

SHORT FORM CATALOGUE ON REQUEST. 14p stamp appreciated.

Delivery normally by return of post. Prices include VAT and P&P. Send your cheque, P.O. or phone your ACCESS or B'CARD number to:

**THE LEADING U.K. SPECIALISTS**  
DEPT. PCW  
164/167 East Road, Cambridge CB1 1DB  
Telephone: 0223 312866

## INCOMPLETE RECORDS

**THE MOST COMPLETE SYSTEM AVAILABLE**

- HIGH SPEED, HIGH VOLUME DATA ENTRY.
- ALL REPORTS CAN BE DISPLAYED OR PRINTED.
- FINAL ACCOUNTS CAN BE SET OUT IN ANY DESIRED FORMAT.
- LIBRARY ROUTINES, TO ARCHIVE CLIENT DETAILS ON THE DISK.
- LINKS TO WORDSTAR OR ANY WORD PROCESSORS.
- HANDLES SOLE TRADERS, PARTNERSHIPS AND LIMITED COMPANIES.

FULL SYSTEM INCLUDING A MICRO WITH 400K DISKS, DAISY WHEEL PRINTER (600 cps), WORDSTAR AND SOFTWARE ABOVE PLUS TIME RECORDING .....£3700

INCOMPLETE RECORDS SOFTWARE ONLY .....£450

SOFTWARE & WORDSTAR .....£700

ALL PRICES EXCLUDE VAT

**BOOK KEEPING SYSTEM £395**  
(FOR RETAIL OR SMALL BUSINESSES)

INCLUDING MICRO COMPUTER AND EPSON PRINTER.....£2250

**INTEGRATED ACCOUNTS £400**  
(INVOICING, SALES, PURCHASE, NOMINAL AND STOCK RECORDING) INCLUDING MICRO COMPUTER AND EPSON PRINTER.....£2250

SOURCE PROGRAMS ARE AVAILABLE ON ALL SYSTEMS SHELTON SIC/NET AND KARADAWN MICRO COMPUTERS ON DISPLAY.









\*FOR MORE DETAILS PHONE OR WRITE TO:

## ANPAC SYSTEMS

92 CANAL LANE  
LOFTHOUSE GATE  
WAKEFIELD, W. YORKS.  
0924 826236



## THE magazine for Apple users

-  **MAKE** your Apple more powerful and your programs more exciting
-  **READ** in-depth analyses of the latest developments on the Apple scene
-  **LEARN** to make the most of Apple's remarkable high-resolution graphics
-  **GET TO GRIPS** with Apple's ever-growing music and speech capabilities
-  **PLAY** the newest Apple games and have fun with the help of our experts
-  **KEEP** in touch with Britain's growing army of Apple owners and users groups
-  **DISCOVER** how the Apple is scoring in business, industry and education
-  **FIND OUT** what's coming next in Apple-compatible hardware and software

Keep up to date with the rapidly changing world of the Apple



Please send me the next 12 issues of Windfall

I enclose  cash  cheque  postal order  credit card

Name .....

Address .....

Signed .....

Credit card name

No.



Post to: Windfall, Europa House, 68 Chester Road, Stockport SK7 5NY

PCW/11/81

### SID 1: THE COLOURFUL CARD

Full-resolution 8-colour S100 graph display card



For use with all S100 machines

8 colours at full (312 X 290) resolution

64 Kbytes of bit-mapped screen

RGB non-interlaced

Disc software for Dynabyte, North Star, Comart Communicator Cromemco, etc.

Only £389 + VAT

### HI-TECH ELECTRONICS

54 HIGH ROAD SWAYTHLING SOUTHAMPTON SO2 2JF  
TEL 0703 581555 TELEX NO 47388 HTL

## ZX81 VIC-20 ACORN ATOM SUPERB SOFTWARE

### ZX81 16K SOFTWARE

The following is a list of our 16K ZX81 Software (which fit into 11K)

Code and contents

AIR TRAFFIC CONTROL:

Details

An absorbing simulation of air traffic control over a busy airport. Animated display shows radar screen with moving aircraft with name tags and a list of call sign, height, speed, heading is displayed; by contacting the pilot you must bring in all the planes without them hitting the mountains or running out of fuel.

INVADERS + Self play vers:

A ZX81 implementation of the arcade game with full screen, and a self play version is supplied.

PHONE BOOK:

Now you can keep all your friends' and relatives' phone numbers on cassette, uses very fast data retrieval technique.

DATE 81:

Computer dating program... who will it pick for you?

16/81/2

ADVENTURE ATLANTIS:

You are shipwrecked in the middle of a terrific storm... in this game you can become very rich... or you may be marooned on a desert island for ever!

BREAKOUT + self play vers:

A ZX81 implementation of the arcade game with full screen, and a self play version is supplied.

TRANSL8R:

Translates any European language into any other! This program stores its vocabulary on cassette.

COMPUTAPUNT:

Keeps statistical records of horses' or dogs' performances in races - and will make predictions on future races.

both packs contain the four programs described; these programs come with user instructions and are loaded and ready to run. Pack: 16/81/1 and 16/81/2 are £4.95 each or £5.95 for both incl.

VIC20 5k RAM VOLKSCOMPUTER

Tapebook 15:15 VIC-20 programs at £3.95: Tapebook 30 = £5.95 incl.

See list of ZX81 Tapebooks for details!

ACORN ATOM (original ROM) f/p not required

Code

Contents

a/1

STAR TREK: sound effects, damage control, help, animated display + all features found on other versions available, requires 6K + 4K upper text area min.

PHONE BOOK: keep records on a data tape of useful phone nos, menu driven.

FRUIT MACHINE: 6K + mode3 graphics; £6.95 inc

GALAXIONS, PIANO, requires 6K + 6K £6.95 inc

a/2

Both a/1 and a/2 for £8.95

CONTROL TECHNOLOGY, 39 Gloucester Road, Gee Cross, Hyde, Cheshire SK14 5JG. 061-368 7558

# MARCH COMMUNICATIONS Ltd.

# MICRO CLOCK

The March Micro-Clock II is possibly the cheapest and smallest real time clock card for the APPLE II COMPUTER. The Micro-Clock II is designed to provide a useful and economical timing facility for incorporation within the users own programs. The unit provides a time count from tenths of seconds to months and years. Once initiated the count will continue without supervision and can be read at any time.

Possible uses include: micro-monitored experiments, micro-controlled processes, data logging, games and lots more. The comprehensive handbook contains the necessary software and applications programs required to make full use of the card.

**NOW AVAILABLE WITH BATTERY BACK-UP.**  
Available from most good Apple dealers or direct from March Communications Ltd.

**MARCH COMMUNICATIONS Ltd.**  
7, VICTORIA TERRACE  
LIVERPOOL L15 5BH  
Tel. 051-733 2618

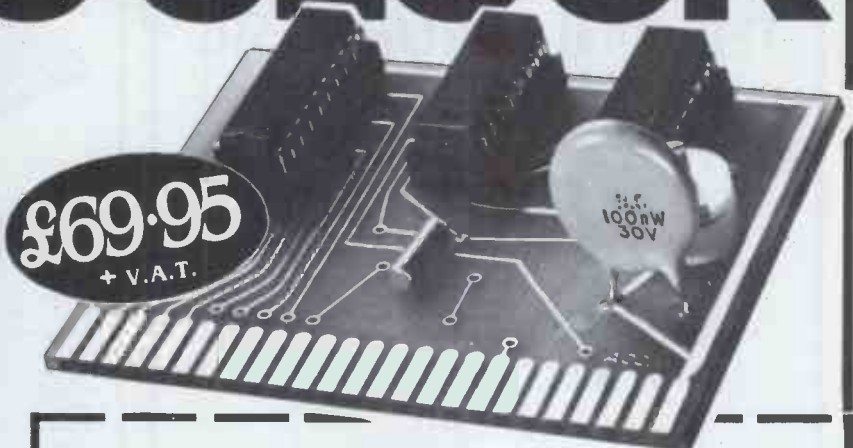

Send me ..... Micro-Clock II cards @ £69.95 plus V.A.T.  
Send details of the full range of March products.

I am paying by cheque/P.O./ Barclaycard/Access.

Barclaycard/Access No. ....

Name .....

Address .....

My present computer system is .....



## TESTED & ASSEMBLED PCB'S & KITS

6 MONTH GUARANTEE — REPAIR SERVICE

<b>I-8080 S-100 ENCLOSURE SHEET METAL KIT</b> Just like THE ORIGINAL IMSAI: Mainframe with blue cover, cardguides and hardware spaced for PS-28D Power Supply, up to 22 slot motherboard. <i>Kit of all metal parts and hardware with documentation.</i>	£120.00
<i>Thinker Toys Wunder Buss 20 for above w/o conn.</i>	£85.00
S-100 Connectors—each	£3.60
8015 Blank jump-start panel w/3 switches	£41.00
8035 Jump start panel for 2 SA-400	£95.00
<b>PS-28D POWER SUPPLY PARTS KIT</b> Mounts in the I-8080 enclosure, supplies + 8V @ 28A, +I- 16V @ 3A, kit includes board, transformer, documentation, and all components. Improved from original.	£180.00
KH1	£160.00
PIO 4-4 4 parallel inputs and outputs (8212)	£160.00
SIO 2-2 2 serial I/O ports, good to 9600 baud	£160.00
<b>VIO-F</b> Improved memory mapped video I/O board. Includes keyboard port, 256 character EPROM's, firmware, monitor. <i>Assembled &amp; Tested.</i>	£269.00
<b>DIO/CD</b> 2 board disk controller for 8" or 5 1/4"	£299.00
<b>CPM* 2.2</b> For DIO including documentation	£125.00
<b>CPA</b> Improved Imsai style front panel works with Z80, etc.	£249.00
<b>MPU-A</b> 8080 processor board—requires CPA	£129.00
<b>MPU-B</b> 8085 3MHz processor SBC w/serial plus parallel port, monitor	£249.00
<b>RAM III 64K MEMORY</b> 64K byte dynamic RAM board—Utilizes the Intel 3242 refresh controller and a single delay line for totally internal refresh. Uses time proven 4116 RAMS. memory mapped I/O boards are allowed to coexist by the use of phantom. Board select via A16 thru A20 extended address lines. <i>Assembled &amp; Tested.</i>	£349.00
<b>IKB-1</b> Intelligent keyboard uses 8035	£189.00
<b>MDX</b> Dual SA400 drive enclosure	£78.00
<b>DE 8</b> Dual 800R/801R horizontal style enclosure w/power supply and fan	£270.00
<b>VIO-X</b> New port mapped video I/O board w/8085 processor, 8275 CRT controller keyboard port, firmware. <i>Assembled &amp; Tested.</i>	£249.00
<b>IEEE 488 + 3P</b> New IEEE-488 I/O interface with 3 parallel ports. <i>Assembled &amp; Tested.</i>	£599.00



## COMPUTER SYSTEMS INSTALLATION — SOFTWARE PROGRAMMING — MAINTENANCE



<b>I-8080 SYSTEM</b> The basic 8080 based S-100 system. Includes CPA front panel, 20 slot 10 MHz motherboard (with all 20 connectors), MPU-A 8080 CPU board, PS-28D power supply (+ 8V @ 28A, +I- 16V @ 3A), and chassis. <i>Assembled &amp; Tested. With MPU-A.</i>	£706.00
<b>I-8015 BASIC SYSTEM</b> The complete 8085 system, includes MPU-B, 64K RAM 10 slot terminated motherboard, PS-28D, and jump start front panel. <i>Assembled &amp; Tested.</i>	£1035.00
<b>I-8025 COMPLETE BUSINESS SYSTEM</b> Includes I-8015 system and DS-8 Disk system w/CPM 2.2. <i>Assembled &amp; Tested.</i>	£2933.00
1.2 M byte 8" drive	£3017.00
2.4 M byte 8" drive	£2386.00
<b>I-8035</b> The 8085 computer system with twin 5 1/4" disk drives, DIO-D, MPU-b, 64K RAM, chassis, 10 slot motherboard and power supply. Includes CPM* 2.2.	£2686.00
180K store	£3186.00
360K store	
780K store	
<i>Assembled &amp; Tested.</i>	
<b>VDP-40</b> Desk-top 8085 micro-computer system with keyboard, 9" CRT display, 10 slot S-100 board, 64K RAM, twin 5 1/4" disk drives. <i>Assembled &amp; Tested.</i>	2820.00
<b>DS-8</b> Dual 801R horizontal style 8" disk enclosure w/power supply, fan, and 2 Shugart 801R drives. <i>Assembled &amp; Tested.</i>	£855.00
Above w/DIO-C & CPM 2.2	£1030.00
<b>DS-5</b> Dual 5 1/4" disk enclosure w/power supply, fan, and room for 2 drives	£189.80

ALL PRICES PLUS VAT



WIDE RANGE OF COMMERCIAL SOFTWARE AVAILABLE

# RING NOW

FOR FREE PRODUCT  
BROCHURE AND DETAILS  
OF OUR SUPPORT SERVICES  
& DEALERS



0245 357136  
0621 828763

Telex: 995411  
Export enquiries welcome

# Intex DATALOG LTD

MICROCOMPUTER HARDWARE/  
SOFTWARE & ACCESSORIES

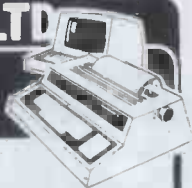

## PC-BASIC THE ONLY TRUE BASIC COMPILER WRITTEN IN MACHINE CODE TO PRODUCE MACHINE CODE

AVAILABLE NOW, for the  
CBM 3000, 4000 and 8000  
systems

- The code produced is REAL MACHINE CODE, NOT an intermediate PSEUDO language, like other so-called 'compilers'.
- This means SPEED, as the code produced does NOT need to be interpreted when the program is running.
- Completely re-written string handling for IMPROVED SPEED and LOWER storage requirements.

Test program timings:—

10 FOR A% = 1 TO 100:FORB% = 1 TO 10  
20 A\$ = A\$ + "1" + "2" + "3" + "4" + "5" + "6" + "7" + "8" + "9" + "0"  
30 NEXT B%:A\$ = "" :NEXT A%

Interpreted BASIC 26.23 Secs.  
PC-BASIC (COMPILED) 5.30 Secs.

ALSO:— 2000, 10 character strings occupy:  
BASIC 4 OVER 30,000 Bytes.  
PC-BASIC 24,000 Bytes.

- NO GARBAGE COLLECTION
- TRUE INTEGER arithmetic, usable where you want it. AND true integer arithmetic is FAST.

BUBBLE SORT of 100 integers from REVERSE order:—  
Interpreted BASIC 130.90 Secs.  
PC-BASIC 12.00 Secs.

- TRUE compiled ADDITIONS to BASIC. Not just to the interpreter for evaluation.
- FULL error reporting on both the screen and printer.

00010 IF A = 3 PRINT B

\*\*\*\*\* ERROR 04 at 005 IN 00010: THEN OR GOTO EXPECTED AFTER IF  
00020 IFA\$ < > THEN 100 AS  
\*\*\*\*\* WARNING 02 AT 012 IN 00020: SUPERFLUOUS  
CHARACTERS IGNORED

- The compiler is written COMPLETELY in MACHINE CODE for extremely fast compilation.
- Extra Commands built in:—

POP	POP return address from stack.
POPFOR	POP FOR LOOP (REAL).
POPI	POP FOR LOOP (INTEGER).
REM%	Convert all variables to integer, except those in a REM/REAL statement.
REM/REAL	X,Y
REM/INTEGER	A,B
REM/STRING	NAME,C,D
REM.LIST	Indented listing
REM.XREF	Cross ref. map of program
REM.STOP	Enable run/stop key
REM.GO	Auto run NULL input at an INPUT statement
INPUT\$ "PROMPT"	AS input any characters, including commas and quotes
INPUT # S	Input records from disk upto 255 characters long
DATA\$	Hexadecimal data

PRICE £300 plus VAT

ADDITIONAL RUN-TIME CHIPS £25.00 EACH

PLEASE QUOTE: EC 1081

Eaglecliffe Ind. Est. Stockton  
Cleveland TS16 0PN Tel: 0642 781193

# Intex

# MARCHCARDS

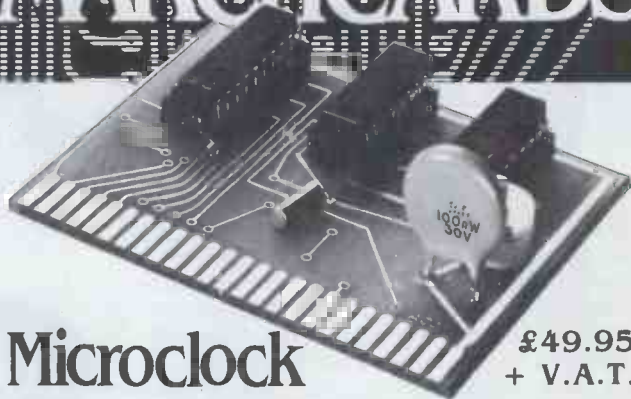

Microclock £49.95 + V.A.T.

The March Micro-Clock is possibly the cheapest and smallest real time clock card for the Apple II computer. The Micro-Clock is designed to provide a useful and economical timing facility for incorporation within the users own programs. The unit provides a time count from tenths of seconds to months and years. Once initiated the count will continue without supervision and can be read at any time without interfering in any way with the operation of Micro-Clock.

Possible uses include: micro-monitored experiments, micro-controlled processes, data logging, games and lots more.

Microtalker £84.95 + V.A.T.

The March Communications Micro-Talker I is designed for use with the Apple II computer and is based on the National Semiconductor Digitaltalker™ chip set. The basic vocabulary is in excess of 140 words. The speech system used involves digital compression of a REAL VOICE and thus Micro-Talker does not use animated robot-like phonetic generators. The result is a clearer and cleaner speech output than is usually achieved with conventional computer voice synthesis equipment.

The Micro-Talker I can be programmed from either low or high level languages with a minimum of software overhead. This then leaves maximum space available for user programs. Applications include verbal warning devices, process control and data monitoring, point of sale terminals.

Microport £49.95 + V.A.T.

In keeping with March Communications design philosophy of producing small low cost peripheral cards for the Apple II computer, we have developed a dual port card. Each port provides eight input/output lines and two handshake lines. The card is based on the Motorola MC 6821 peripheral interface adapter device. The TTL lines terminate in 20-way ribbon cable; connectors and suitable matching cables are supplied with the card.

Applications include process control, data monitoring, alarm systems, music systems, model railway control, etc.

Microsynth £49.95 + V.A.T.

The March Communications Micro-Synth produces complex sound waveforms under user program control. It consists of two AY-3-8910 programmable sound generator devices which enable the user to obtain both sound effects and music. Possible applications include games, music composing aid, electronic organs.

THE COMPREHENSIVE HANDBOOKS CONTAIN THE NECESSARY SOFTWARE AND APPLICATIONS PROGRAMS REQUIRED TO MAKE FULL USE OF THE CARDS.

MARCH COMMUNICATIONS Ltd.  
4 COMMUTATION ROW  
LIVERPOOL L1 1JB  
Tel. 051-207 7477

For details of the MARCHCARDS and a FREE copy of our comprehensive book list, fill in the coupon and post to:—  
March Communications Ltd., 4 Commutation Row,  
Liverpool L1 1JB

Name .....

Address .....

Telephone .....

# — ELFTON LIMITED —

## "APPLIED TECHNOLOGY"

Recession or no recession, you want a computer or you wouldn't be reading this. Right?

By streamlining our operation we have brought forward that magic moment for you.

Compare THESE prices! All products are brand new, boxed and fully guaranteed.

### COMMODORE

VIC 20	£165
4032N	£579
4016N	£459
8032	£749
8050	£749
C2N	£ 49

### APPLE

48K Europlus	£649
Disk Drive & Controller	£319
Disk Drive	£249
9" Monitor	£ 99

### ITT

48K 2020	£549
Full system:	
48K processor	
2 drives	
12" green monitor	£1199

HP and leasing may be possible, otherwise please send cheque with order, after adding VAT and £20 for Securicor delivery to: ELFTON Ltd. Mail Order Divn., Advance Chambers, Surtees Street, Hartlepool, Cleveland. Telephone: Hartlepool 61770. (Do not hesitate to check prices on any item not quoted here).

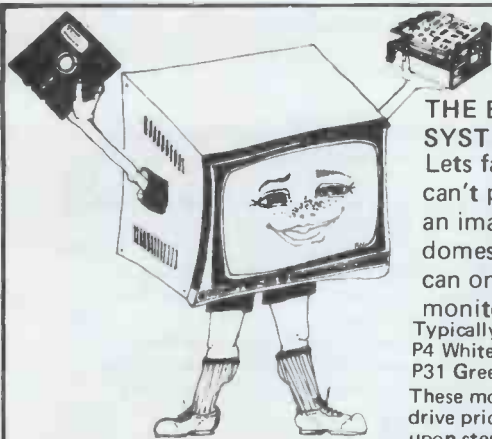

#### THE BODY OF ANY SYSTEM

Lets face it — you can't produce as crisp an image on a domestic T.V. as you can on a Crofton monitor.

Typically  
P4 White £64.97  
P31 Green £79.32  
These monitor/floppy disk drive prices are dependent upon sterling-dollar conversion rates. Please phone us for up-to-date prices.

#### SHUGART FLOPPY DISK DRIVES

No case, No Power Supply	
SA 400 5 1/4" S.S.S.D.	£149.05
SA 450 5 1/4" D.S.S.D.	£283.31
SA 800 8" S.S.S.D.	£340.52

#### FLOPPY DISKS — BOXES OF TEN

Single sided 35/40 Track	£ 26.45
Double sided 35/40 Track 5 1/4"	£ 37.95
Single sided 77 Track	£ 41.40
Double sided 77 Track 5 1/4"	£ 47.15
Single sided 8"	£ 40.25

CALLING ALL ZX81 USERS!  
CONVERT YOUR ZX81 TO FULL SIZE QUERTY  
KEYBOARD. ASK FOR DETAILS.  
SPECIAL OFFER

2 1/2" MINIATURE CCTV CAMERAS	£130
USED COMPUTER DESKS	£38

(Note: Personal Callers Only)

ALL THE ABOVE PRICES INCLUDE V.A.T. AND CARRIAGE



ALL MAJOR CREDIT CARDS  
ACCEPTED — Small surcharge



CROFTON ELECTRONICS LTD

35 Grosvenor Road, Twickenham, Middx TW1 4AD  
01-891 1923/1513

### NEW 64K RAMCARD FOR THE APPLE

for little more than you could pay for the old 16K RAMCARD. It will replace the 16K card as a LANGUAGE CARD. Uses bank selection similar to 16K card. Each APPLE can power up to 3 of these 64K cards plus 1 16K card giving an

#### INCREDIBLE 1/4 MEGABYTES OF RAM

64K cards only £189 each

16K RAMCARDS available at the much reduced price of £69.

Other Apple cards available:

EPROM PROGRAMMER	£58
Programs 5V EPROMS including the 2716, 2732 and the new 2764 64K-bit EPROM.	
EPROM EXPANSION CARD	£39
Holds six 5 Volt 2716's or 2516's (not included) for a total of 12K bytes of read only memory.	
SPEECH SYNTHESISER	£179
Uses Votrax SC-01 chip to give UNLIMITED VOCABULARY. Requires 10 bytes/sec for continuous speech. Demonstration software on disc.	
VIA BOARD	£38
Adds two 8-bit input/output ports, a serial port and 2 timers to your Apple.	
CLOCK SOFTWARE	£7/£8 on disc
Together with the VIABOARD will provide your Apple with a real-time clock.	
SINGLE CHANNEL ADC	£29
140 micro-second conversion time 8-bit ADC. Provides full 8-bit resolution between any two levels within 0— +5V range.	
16 CHANNEL ADC	£49
Less than 100 micro-second conversion time 8-bit ADC.	
SINGLE CHANNEL DAC	£28
8-bit adjustable 0— +10V full scale buffered voltage output DAC (settling time 500 mono-seconds).	
PET ADC'S AND DAC'S	
SINGLE CHANNEL ADC	£38
140 micro-second conversion time 8-bit ADC. Provides full 8-bit resolution between any two levels within 0— +5V range.	
SINGLE CHANNEL DAC	£36
8-bit adjustable 0— +10V full scale buffered voltage output DAC (settling time 500 mono-seconds)	

All prices inclusive of VAT and postage & packing  
Cheques or official orders to:

MERTON ELECTRONICS Dept. PW  
8 Rutlish Road Wimbeldon London, SW19  
TEL: 01-543 3533

# WE'LL PAY YOU TO PLAY WITH MICROS

Would you like to work on the very latest micro machinery in a soon-to-be-created Software Evaluation Department associated with *Personal Computer World* magazine?

Wide experience and a deep obsession with all aspects of microcomputing vital. Ability to write reports an asset but not essential.

Excellent salary negotiable appropriate with experience. Write (do not phone) in strict confidence, with full CV, to:

Managing Director  
Bunch Publishers Ltd  
14 Rathbone Place  
London W1P 1DE

## SPECIAL OFFERS TI 99/4

PERSONAL COMPUTER	ONLY
PLUS: SUITABLE RECORDER	<b>£260</b>
VALUE TI CASSETTE CABLE	£299
<b>£45</b> LIBRARY OF MIXED PROGS.	with vat

TI99/4 PLUS PROGS ONLY £243 (£279 with VAT)

ALSO:

DISCOUNTS ON ALL TI COMMAND MODULES

THE SUPERB 48K RAM PERSONAL  
**DAI** INCLUDING: COMPUTER

FREE WITH FIRST 10 ORDERS	SUITABLE RECORDER AND LIBRARY OF MIXED PROGRAMS	ONLY <b>£595</b> £684 WITH VAT
---------------------------	---	---

OUR MOBILE SHOWROOM IS  
AVAILABLE FOR VISITS ON REQUEST

ORDERS TO:

**COMPUTER CONTACT**

50 HEADINGLEY ROAD, RUSHDEN,  
NORTHANTS.

TEL: (09334) 56894 or 55673 (ANY TIME)

TI 99/4 P.C.	NAME:
SPECIAL OFFER £299	ADDRESS
TI 99/4 PLUS LIBRARY ONLY £279	
D.A.I. P.C.	
SPECIAL OFFER £684	
CHEQUE, ETC. FOR ENCLOSED	TEL: ( )

## ANGLIA COMPUTER CENTRE

MICROCOMPUTER SPECIALISTS  
FOR BUSINESS AND SCIENCE  
88 St Benedict's Street,  
Norwich NR2 4AB  
Telephone (0603) 29652



PROGRAMS FROM THE LARGEST EAST ANGLIAN  
MICROCOMPUTER & APPLE DISTRIBUTORS !!!



APPLE II	799
DIGI-PLOT	895
APPLE PAR. INT.	104
VISICALC	111
APPLE PLOT	37
GRAPH PLOTTING	105
TABLET PLOT	95
GRAPHICS TABLET	462

APPLE PLUS  
No. 1 + DIGI-PLOT  
Unique Graph plotting software is available to plot graphs from APPLE PLOT and VISICALC

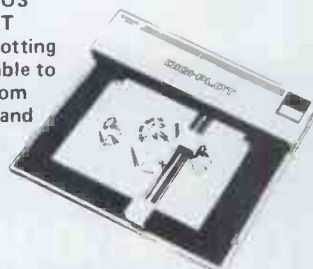

This GRAPH PLOTTING SOFTWARE is free when you purchase Digi-Plot from us!

No. 2 TABLET PLOT More unique software to interface the APPLE - GRAPHICS TABLET and DIGI-PLOT Free when you purchase either Digi-Plot or Tablet from us!

No. 3 Get the MOST VERSATILE and LOW COST printers for your APPLE II, and take advantage of its versatile character set from within APPLE WRITER



The EPSON/APPLE WRITER ADVANCED CHARACTER GENERATOR cost . . . £49

EPSON MX80 F/T	£399
" "	£450 (WITH GRAPHICS)
EPSON MX100	£575
EPSON MX130	£CALL
APPLE WRITER	£42

- No. 4 CASHBOOK PROGRAMME suitable for personal, Departmental, societies and institutional financial records. £95
- No. 5 COSTING your production of ASSEMBLED MENUS Includes Stock Control, Price Update and Sub Assembly Costs. Written in Pascal £650
- No. 6 PROPERTY RENTAL - all financial records & transactions for property renting - suitable for Estate Agents. In Pascal £295
- No. 7 EXAM TIME -- Save yourself time in preparing multiple choice questions and after exam tuition. Suitable schools, colleges and industry training. £49



APPLE 3 - STILL WAITING?  
then contact us immediately!!

OR ARE YOU STILL TRYING TO GRASP COMPUTING WITH ZX80/ZX81 ??

To help you we will trade your ZX80 for something better! Starting with ACORN ATOM We are full stockists of all ACORN HARDWARE & SOFTWARE plus our own unique ANGLIA ATOM ASSEMBLER: to help you see into the heart of machine code programming and computing itself . . . Cost £14.98 or FREE with EVERY ASSEMBLED ACORN ATOM purchased from us. Also stock GP80 printers and connecting cables. WE OFFER FAST DELIVERY.





# ADVERTISERS INDEX

Abacus	223	Datalink	203	Keen	80	Personal Computer	
Acorn	121,227	Dataman	37	Kelly's	194	Palace	229
Adda	47	Datatron	106	A&G Knight	216	Petalect	91
Adler	11	Dataview	132,231	Kram	226	Pete & Pam	26,125
Algray	206	Datron	220	L&J Computers	158	Phipps Associates	200
Almarc	51	Davinci	224	LSI	113	Photo Acoustics	214
Altek	216	Deans	27	Leicester	150	Portatel	221
Altwasser	227	Digico	191	Leisure Reference	27	Prentice-Hall	17,205
Anglia Comp Centre	238	Digitus	2	Lifeboat	88	Printout	94
Anpac	233	Disking	187	Linsac	190	Professional Data	
Audio Computers	225	Diskwise	224	Lion House	209	Systems	224
Avery Computer Co	206	Display	33	Lislar	39	Program Power	87
BHRA	221	Dola	202	Little Genius	196	Qume	42
BMC	98	EMAP	22,23	London Computer		Rade	90
Bit's & PC's	202	EMG	226,228,230	Centre	34	SBD Consultants	212
Bobker	188	Easicomp	218	MPI	36	SMG	186
Butel	216	Electronic Brokers	190	McGraw-Hill	210	SRS Microsystems	32
CRA Apple Dealer Group	104	Elfton	237	Maddison	196	ST Commercial	212
Calco	206	Equinox	154	Maplin	29	Sharp	97
Calisto	220	Essential Software	111,158	March		Sharpsoft	189
Cambridge Comp Store	232	Fergusson	124	Communications	235,236	Sinclair	128,135-138
Cambridge Learning	49	Fulcrum	235	Melbourne House	189	Sintrom	213
Cardiff Micros	232	Fuller	188	Merton Electronics	238	WH Smith	6
Cascade Computers	227	GW Computers	18,19,20	Microcentre	IFC	Spangrade	218
Casio	186	Gate	228	Microcomputer		Spider Software	216
Cetronics	231	Gemini	208	Applications	230	Spreebond	84,194
Chromasonic	53	General Northern	192	Microcomputer		Startech	191
Comart	143,146	Geveke	160	Spacedome	193	Strumech	215
Commercial Data Systems	160	Granata	84	Microdigital	7-10,65	Superior Systems	201
Commodore PET	56,57	Grange Electronics	191	Microfocus	15	Swanley	226
Comp Shop	240,IBC	Guestel	130	Microgeneral	190	Symbiotic	188
Compsoft	140	HCCS Associates	202	Micronetworks	48	Tangerine	43
Computech	38	Hal	59,60,61,132	Micronex	31	Technomatic	218
Computer Bookshop	168	Happy Memories	198	Microsave	232	Teleprinter Equipment	144
Computer Centre		Harding	12,13	Microstyle	217	Telesoft	192
(Watford)	200	Helistar	198	Microtek (Orpington)	211	Templeman Software	222
Computer Company	196	Henry's Radio	84,195	Microtek (Ipswich)	150	Tempus	233
Computer Contact	238	Hewlett Packard	4,5,14	Microvalue	24,25	Tex	198
Computers For All	197	Hisoft	229	Micro 8	16	Transam	35,40
Computer Supermarket	120	Hitech	234	Midwich	221	Transdata	92
Computopia	82	Honeywell	30	Modmags	223	Twinlock	66
Control Technology	234	Hunting Business		NSC	50	Video Services	
Control Universal	210	Systems	214	Newbear	204	(Bromley)	222
Crab	188	ITT	112	Newnes	230	Watford Electronics	45
Cream	222	Independent Comp Eng	52	Newtronics	207	Westfarthing	228
Creative Computing	76	Intelligent Artefacts	21	Northamber	72,73	Westwood	214
Crestway Electronics	27	Interam	96,103	Olympia	86	Wilkes	41
Crofton	237	Interface ZX80/81	229	Tim Orr Design	208	Windfall	234
Cromwell Computing	150	Intex	236	Oxford Computer		X-Data	152
Cumana	44	KGB Micros	28	Systems	219	Xitan	46
Currah	225	Kansas City Systems	208	Personal Computers	OBC		
DJ AI Systems	199	Katotek	102				

## ChipChat

Wow! Did we have a Show! Almost 16,500 of you turned up at the Cunard over the three days, making it the country's most successful micro show ever. . . Mike 'Hello Sailor' Sterland insisted on dressing his stand staff as Midshipman Hornblower look-alikes then spent the entire show explaining to everyone the obscure connection — the show was at the Cunard Hotel, geddit? (No — Ed) . . . 'Bumper' Harris dropped — or, rather, stumped — by the Acorn stand to see the BBC Micro and was amused to see an Acorn minion lift the machine's lid every ten minutes and spray the inside with an instant-ice aerosol. . . Winfried Hofacker of Elcomp showed us his Atari monitor. Very impressive, except that just as Winfried was explaining that the English was absolutely perfect, the word 'adress' appeared on the

screen. . . When Sinclair ran out of Barclaycard slips, people became so desperate that they started nicking them from nearby stands. . . Overheard in the coffee shop: one American asking another if he had any fragmentation grenades with which to clear a path to see the ZX Printer . . . Microsoft's Alan Boyd has at last found a use for the Sorcerer — as a paperweight . . . When asked 'Have you got an Apple?' one of the girls on the stand of a 'certain other micro magazine' rummaged in her handbag and said, 'No, but would you like some peanuts?' . . . An American couple joined the end of the Show queue and when, after a very long time, they reached the registration desk, asked for two single rooms. . . Until they met the luscious Susan Ben-David, The Last One's programmers thought that SBD stood for Silent But Deadly. . . The lovely Viv

Collins sold a ticket to one man and said 'Thank you, sir'. He replied, 'Actually, I'd rather be called Madam.' Closer inspection revealed that he was in fact wearing ladies' clothes. . . How's this for cheek: a punter sat down for a demo at The Last One's stand and, after being shown how it worked at great length, used it to produce a suite of business programs, which he listed out on a printer. Then he scuttled off around a corner where his client was waiting and sold the listings for £150! . . . And no, he wasn't from Comp Shop. . . Felix Dennis, our publisher, having ensured that 16,439 people paid for their tickets, finally gave in at 3.30 on the last day and told a man he could go in for free. Felix could hardly believe his luck when the man insisted on paying even though the show was closing in half an hour . . . Even Vince Cohen liked

the Show. . . And how about the two men who spotted a sign at the Show which said 'The Last One'. One turned to the other and said, 'What a pity, it seems to be going so well!'. . . The biggest disappointment was the failure of 'Legless' and 'Bumper' to perform their promised dance on the fly-over after the Show. 'Bumper' stalked off in a huff after 'Bogey' had failed to recognise him and 'Legless' was too, well, tired and emotional to oblige, despite the encouragement of the crowds blocking the flyover. . . Finally, our sincere thanks to all of you who braved the queues and the crush to help make the show a success; we hope we see you all again next year in a bigger (and better air-conditioned) location — Hyde Park, maybe?

**NOW IN STOCK**

**THE NEW & EXCITING TRS80 MODEL III**



48K £619 + VAT

The Radio Shack TRS-80™ Model III is a ROM-based computer system consisting of:

- A 12-inch screen to display results and other information
  - A 65-key console keyboard for inputting programs and data to the Computer
  - A Z-80 Microprocessor, the "brains" of the system
  - A Real-Time Clock
  - Read Only Memory (ROM) containing the Model III BASIC Language (fully compatible with most Model I BASIC programs)
  - Random Access Memory (RAM) for storage of programs and data while the Computer is on (amount is expandable from "16K" to "48K", optional extra)
  - A Cassette Interface for long-term storage of programs and data (requires a separate cassette recorder, optional/extra)
  - A Printer Interface for hard-copy output of programs and data (requires a separate line printer, optional/extra)
  - Expansion area for upgrading to a disk-based system (optional/extra)
  - Expansion area for an RS-232-C serial communications interface (optional/extra)
- All these components are contained in a single moulded case, and all are powered via one power cord.

Disc Drives Kit with 2x40 Track Drives — £599 + VAT  
 Disc Drives Kit with 2x80 Track Drives — £729 + VAT  
 Add £25 for Installation

EXTENDED GUARANTEE BY COMPU-CARE

**WE ARE NOW STOCKING THE APPLE II AT REDUCED PRICES**



**AUTOSTART EURO PLUS**  
 48K  
**£599**  
 + VAT

**Getting Started** APPLE II is faster, smaller, and more powerful than its predecessors. And it's more fun to use too because of built-in features like:

- **BASIC** — The Language that Makes Programming Fun.
- **High-Resolution Graphics** (in a 54,000-Point Array) for Finely-Detailed Displays.
- **Sound Capability** that Brings Programs to Life.
- **Hand Controls** for Games and Other Human-Input Applications.
- **Internal Memory Capacity** of 48K Bytes of RAM, 12K Bytes of ROM; for Big-System Performance in a Small Package.
- **Eight Accessory Expansion Slots** to let the System Grow With Your Needs.

You don't need to be an expert to enjoy APPLE II. It is a complete, ready-to-run computer. Just connect it to a video display and start using programs (or writing your own) the first day. You'll find that its tutorial manuals help you make it your own personal problem solver.

**APPLE DISC II 3.3 Dos**



Disc with Controller  
**£349 + VAT**  
 Additional Drives  
**£299 + VAT**

- **Powerful Disk Operating Software** Supports up to 6 drives
- **Name Access to Files** for Ease of Use
- **BASIC Program Chaining** to Link Software Together
- **Random or Sequential File Access** to Simplify Programming
- **Dynamic Disk Space Allocation** for Efficient Storage
- **Individual File Write-Protection** Eliminates Accidental File Alterations
- **Loads an 8K Byte Binary Image** in 6.5 sec. (1.2 sec. in Pascal)
- **Storage Capacity** of 116 Kilobytes (143K Bytes with Pascal) on Standard 5 1/4" Diskettes
- **Powered Directly From the APPLE** (Up to 6 Drives) for Convenience and High Reliability
- **Packaged in Heavy-Duty, Colour-Coordinated Steel Cabinet**

Colour Monitors for Apple — £295 + VAT

**NEW The PEDIGREE PETS**



RRP £795 for 32K

32K  
**ONLY £569**  
 + VAT

Very popular for home & business use. 8K Microsoft Basic in ROM. 32K with new improved keyboard. 12" screen. Cassette Deck £55 extra

EXTENDED GUARANTEE BY COMPU-CARE

**GET YOURSELF A NEW MX70 PRINTER AND SAVE A FORTUNE**



only **£249** + VAT

- 80 Column.
- Upper & lower case.
- Apple dot Graphics
- Centronics Parallel
- Uni-directional.
- TX80 — £249 + VAT

EXTENDED GUARANTEE BY COMPU-CARE

EX-STOCK

**NEW**

**ACORN ATOM**  
 UNIQUE IN CONCEPT — THE HOME COMPUTER THAT GROWS AS YOU DO



Fully Assembled **£149** + VAT

- Special features include
- Full Sized Keyboard
- Assembler and Basic
- Top Quality Moulded Case
- High Resolution Colour Graphics
- 6502 Microprocessor

EXTENDED GUARANTEE BY COMPU-CARE

**CASIO VL TONE**

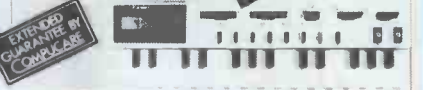

**£31.25** + VAT

It's a new kind of musical instrument. A computer controlled synthesiser that helps you create, play and arrange compositions that normally take years of musical training.

EXTENDED GUARANTEE BY COMPU-CARE

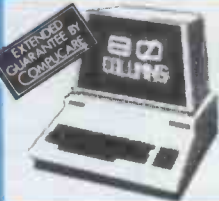

**8032**  
**80 COLUMN PET**  
 ONLY **£825** + VAT

The reliable value for money system with after sales support, instruction and training facilities and a wide range of programmes.

EXTENDED GUARANTEE BY COMPU-CARE

**SALE MEMORY UPGRADES**  
 16K (8 x 4116) **£15.90** + VAT  
 4K CompuKit (8 x 2114) **£15.90** + VAT

**COMMODORE VIC-20**

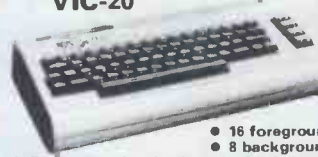

ONLY **£179** + VAT

- 16 foreground colours
- 8 background colours
- Real typewriter keyboard with full graphics
- Music in three voices and three octaves
- Language and sound effects

EXTENDED GUARANTEE BY COMPU-CARE

**TV GAME BREAK OUT**

Has got to be one of the world's greatest TV games. You really get hooked. As featured in ETI. Has also 4 other pinball games/and lots of options. Good kit for up-grading old amusement games.



**MINI KIT** — PCB, sound & vision modulator, memory chip and de-code chip. Very simple to construct. **£14.90** + VAT  
**OR PCB £2.90 MAIN LSI £8.50** Both plus VAT

EXTENDED GUARANTEE BY COMPU-CARE

**NEW**

**TANTEL**



ONLY **£169** + VAT

Demonstration available at our showroom

**PRESTEL by TANTEL** The greatest thing since television & telephones. Communications at your fingertips for business & home. 180,000 pages of up-to-date information on travel, news, investment, holidays, hotels etc etc. Ask Prestel a question and you have your answer in seconds in full colour on your own TV. Only requires a telephone jack socket available from the PO.

**CENTRONICS 737 DOT MATRIX PRINTER**



only **£369** + VAT including cables

- Standard Features**
- 80 CPS — Proportional Spaced Mode
- 50 CPS — Monospaced Mode
- Proportional Spacing. Plus 10 CP1 and 16.7 CP1
- N x 9 (Proportional) or 7 x 8 (Monospaced) Dot Matrix
- 7 x 8 Dot Matrix
- 3 Way Paper Handling System
- 96 Character ASCII plus 6 European character sets
- Microprocessor Electronics
- Expanded Print
- Right Margin Justification
- Print Underlining
- 9-Wire Free Flight Print Head
- Bidirectional Stepper Motor Paper Drive
- Full One Line Buffer
- 21 LPM With 80 Columns Printed
- 58 LPM With 20 Columns Printed
- 6 Lines Perch inch Vertical Spacing
- Paper Tear Bar
- Centronic Colours and Logo

EXTENDED GUARANTEE BY COMPU-CARE

**THE VIDEO GENIE SYSTEM**

Ideal for small businesses, schools, colleges, homes, etc. Suitable for the experienced, inexperienced, hobbyist, teacher, etc.

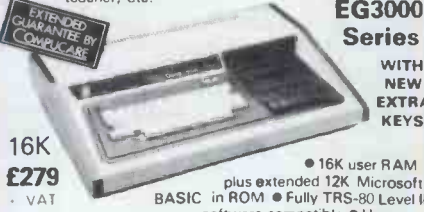

**EG3000 Series**  
 WITH NEW EXTRA KEYS!

- 16K user RAM plus extended 12K Microsoft BASIC in ROM
- Fully TRS-80 Level II software compatible
- Huge range of software already available
- Self contained, PSU, UHF modulator, and cassette
- Simply plugs into video monitor or UHF TV
- Full expansion to disks and printer
- Absolutely complete — just fit into mains plug
- The Video Genie is a complete computer system, requiring only connection to a domestic 625 line TV set to be fully operational; or if required a video monitor can be connected to provide the best quality display
- 51 key typewriter style keyboard, which features a 10 key rollover. Supplied with the following accessories:
  - BASIC demonstration tape;
  - Video lead;
  - Second cassette lead;
  - Users manual;
  - BASIC manual;
  - Beginners programming manual. Write useful programs in the BASIC computer language yourself.

16K **£279** + VAT

EXTENDED GUARANTEE BY COMPU-CARE

**HITACHI PROFESSIONAL MONITORS**



9" — **£129** **£99.95**  
 12" — **£199** **£149**

- **Reliability** Solid state circuitry using an IC and silicon transistors ensures high reliability.
- **500 lines horizontal resolution** Horizontal resolution in excess of 500 lines is achieved in picture center.
- **Stable picture** Even played back pictures of VTR can be displayed without jittering.
- **Looping video** Input Video input can be looped through with built-in termination switch.
- **External sync operation** (available as option for U and C types)
- **Compact construction** Two monitors are mountable side by side in a standard 19-inch rack.

EXTENDED GUARANTEE BY COMPU-CARE

**MICROLINE 80** **£299** + VAT

- 80 cps Uni-directional
- Small size: 342 (W) x 254 (D) x 108 (H) mm.
- 160 Characters, 96 ASCII and 64 graphics
- 3 Character sizes: 40, 80 or 132 chars/line
- Friction and Pin Feed
- Low noise: 65 dB
- Low weight: 6.5 kg

**MICROLINE 82** **£449** + VAT

- 80 cps Bi-directional logic seeking
- Small size: 360 (W) x 328 (D) x 130 (H) mm.
- 160 characters, 96 ASCII and 64 graphics, with 10 National character-set Variants.
- 4 Character sizes: 40, 66, 80 or 132 chars/line.
- Built-in parallel and serial interfaces.
- Friction and Pin Feed
- Low noise: 65dB
- Low weight: 8kg

**MICROLINE 83** **£779** + VAT

- 120 cps bi-directional logic seeking
- 136 column printing on up to 15in forms
- Small size: 512 (W) x 328 (D) x 130 (H) mm.
- 160 characters, 96 ASCII and 64 graphics with 10 National character-set variants
- 3 Character spacings: 5, 10 and 16.5 Char./in.
- Built-in parallel and serial interfaces
- Friction and Pin Feed
- Low noise 65dB
- Low weight: 13 kg

Microline 83 & 82 NOW IN STOCK

EXTENDED GUARANTEE BY COMPU-CARE

**VIDEO GENIE EXPANSION BOX**

Complete with RS232 interface and floppy disc controller. 0 memory. **£225** + VAT.  
 Memory expansion card (S100) 16K £110 32K £159 + VAT

EXTENDED GUARANTEE BY COMPU-CARE

# YOUR ZX80 IS NOW NO LONGER REDUNDANT

Upgrade your ZX80 to the full animated graphics of the ZX81. (No screen flicker).

FOR ONLY **£12.95** + VAT IN KIT FORM

Works only in conjunction with **NEW 8K ROM** from Sinclair (Not Included).

ZX81 part-exchanges accepted - **GOOD PRICES OFFERED**

## ATARI CARTRIDGES IN STOCK

Phone for availability

## COMP PRO MIXER

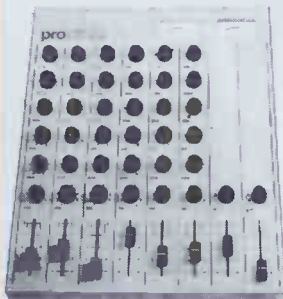

**Professional audio mixer that you can build yourself and save over £100.**

Only **£99.90** plus VAT for complete kit. Plus **FREE** power supply valued at £25.00



## TEAC DISK DRIVES

- TEAC FD-50A has 40 tracks giving 125K Bytes unformatted single density capacity.
- The FD-50A can be used in double density recording mode.
- The FD-50A is Shugart SA400 interface compatible.
- Directly compatible with Tandy TRS80 expansion interface.
- Also interfaces with Video Genie, SWTP, TRS80, North Star Horizon, Superbrain, Nascom, etc, etc.
- Address selection for Daisy chaining up to 4 Disks.
- Disks plus power supply housed in an attractive grey case.

**40 TRACK** Single Disk Drive **£225** + VAT Double Disk Drive **£389** + VAT  
**77 TRACK** Single Disk Drive **£299** + VAT Double Disk Drive **£499** + VAT

## FANTASTIC FOR FILE HANDLING ACULAB FLOPPY TAPE

The tape that behaves like a disc, for TRS-80 LEVEL 2. only **£169** + VAT  
 The Aculab Floppy Tape for the TRS-80 and Video Genie is a highly reliable digital storage system that provides many of the advantages of floppy disks at less cost. Automatic debounce routine for the Level 2 keyboard. Connects directly to TRS-80 Level 2 Keyboard. Operating and file handling software in ROM. 8 commands add 12 powerful functions to Level 2 BASIC.

**STOCKTAKE SALE NEVER TO BE REPEATED AT THIS PRICE UNTIL STOCKS LAST**

# EUROPE'S FASTEST SELLING ONE BOARD COMPUTER COMPUKIT UK101



**COMPUKIT WITH ALL THE FEATURES THAT MADE IT THE MOST PROFESSIONAL COMPUTER KIT ON THE MARKET. Now WITH FREE NEW MONITOR (a saving), which includes Flashing Cursor, Screen Editing, & Save Data on Tape.**

\*6502 based system — best value for money on the market. \*Powerful 8K Basic — Fastest around \*Full Qwerty Keyboard \*1K RAM Expandable to 8K on board. \*Power supply and RF Modulator on board. \*No Extras needed — Plug-in and go \*Kansas City Tape Interface on board. \*Free Sampler Tape including powerful Disassembler and Monitor with each Kit. \*If you want to learn about Micros, but didn't know which machine to buy then this is the machine for you.

Build, Understand and Program your own Computer for only a small outlay.

KIT ONLY **£99.95** + VAT Fully Assembled — **£149** + VAT

**NEW MONITOR IN ROM** — available separately at **£7.90** + VAT Improved Basic function — revised GARBAGE routine. Allows correct use of STRING ARRAYS **£4.90** This chip can be sold separately to existing CompuKit and Super board users. **£4.90** + VAT

**4K Upgrade Kit £15.90** + VAT

**FOR THE COMPUKIT** — Assembler Editor **£14.90**  
**GAME PACKS** — 1) Four Games **£5.00** 2) Four Games **£5.00** 3) Three Games 8K only **£5.00**  
 Super Space Invaders (8K) **£6.50** Chequers **£3.00** Realtime Clock **£3.00**  
 Case for CompuKit **£29.50** 40 pin Expansion Jumper Cable **£8.50** All Prices exclusive VAT

### TTL SALE

	Minimum	Order — £5
74LS00 <b>£0.10</b>	74LS86 <b>£0.30</b>	Z80 <b>£4.90</b>
74LS04 <b>£0.10</b>	74LS93 <b>£0.50</b>	ACIA 6850 <b>£1.90</b>
74LS05 <b>£0.15</b>	74LS157 <b>£0.60</b>	OP-AMP <b>£0.45</b>
74LS10 <b>£0.15</b>	74LS165 <b>£0.90</b>	CA3130 <b>£0.45</b>
74LS32 <b>£0.20</b>	74LS365 <b>£0.40</b>	REG. <b>£0.45</b>
74LS74 <b>£0.25</b>	74LS373 <b>£1.20</b>	7805 5V <b>£0.75</b>

**Low Profile Sockets**

14 PIN <b>£0.05</b>	18 PIN <b>£0.10</b>	24 PIN <b>£0.20</b>
16 PIN <b>£0.06</b>	20 PIN <b>£0.15</b>	40 PIN <b>£0.27</b>

## PANASONIC KX-T1520 AUTOMATIC TELEPHONE ANSWERING SYSTEM

**NOW AVAILABLE**

**£190** + VAT

One of the most technically advanced telephone answering units available, the KX-T1520 features a double cassette system, a C60 cassette for incoming calls, which can be limited to 30 secs each or recorded in their entirety, and a 20 sec continuous loop cassette for your outgoing messages which are recorded through the built-in microphone. Your telephone conversations can also be recorded after a bleep tone has notified your caller they are being taped. Incoming calls can be monitored and the ring control is adjustable.

The remote call-in pick-up with Playback/Reset/Repeat and Skip controls, activates the system to play back your messages to you over the phone wherever you are in the world.

## OUR NEW SUPER LOCATION IN IRELAND

**19 Herbert Street, Dublin 2. Telephone: Dublin 604165**  
**HEAR OUR ADS ON RADIO NOVA 88.1 VHF Stereo**

## NEC SPINWRITER

only **£1490** + VAT

NEC's high quality printer uses a print "thimble" that has less diameter and inertia than a daisy wheel, giving a quieter, faster, more reliable printer that can cope with plotting and printing (128 ASCII characters) with up to five copies, friction or tractor fed. The ribbon and thimble can be changed in seconds. 55 characters per second bidirectional printing — with red/black, bold, subscript, superscript, proportional spacing, tabbing, and much, much more.

8MHz Super Quality Modulators	<b>£4.90</b>
6MHz Standard Modulators	<b>£2.90</b>
C12 Computer Grade Cassettes	10 for <b>£4.00</b>
Anadex Printer Paper — 2000 sheets	<b>£15.00</b>
Floppy Discs 5 1/4" Hard and Soft Sector	<b>£2.90</b>
Floppy Disc Library Case 5 1/4"	<b>£3.50</b>
Ribbons DP8000	<b>£3.50</b>
DP9500/9501	<b>£12.50</b>

All Prices exclusive VAT

## WE HAVE ONE OF THE LARGEST COLLECTIONS OF COMPUTER BOOKS UNDER ONE ROOF, ALONG WITH RACKS OF SOFTWARE FOR THE GENIE AND TRS80.

## SHARP PC1211

**£79.90** + VAT

COMPUTER POWER THAT ONCE FILLED A ROOM CAN NOW BE CARRIED IN YOUR POCKET!

- Programs in BASIC • "QWERTY" Alphabetic Keyboard • 1.9K Random Access Memory • Long Battery Life.

We give a full one year's guarantee on all our products, which normally only carry 3 months guarantee.

## A SELECTION OF APPLE INTERFACES ARE NOW AVAILABLE AT OUR EDGWARE ROAD SHOWROOM

# COMP SHOP

"Europe's Largest Discount Personal Computer Stores"

Delivery is added at cost. Please make cheques and postal orders payable to **COMP SHOP LTD.**, or phone your order quoting **BARCLAYCARD, ACCESS, DINERS CLUB** or **AMERICAN EXPRESS** number. **CREDIT FACILITIES ARRANGED** — send S.A.E. for application form.

**MAIL ORDER AND SHOP:** 14 Station Road, New Barnet, Hertfordshire, EN5 1QW (Close to New Barnet BR Station — Moorgate Line). Telephone: 01-441 2922 (Sales) 01-449 6596 Telex: 298755 TELCOM G  
**OPEN (BARNET) — 10am - 7pm — Monday to Saturday**

**NEW WEST END SHOWROOM:** 311 Edgware Road, London W2. Telephone: 01-262 0387  
**OPEN (LONDON) — 10am - 6pm — Monday to Saturday**

★ IRELAND: 19 Herbert Street, Dublin 2. Telephone: Dublin 604155  
 ★ COMP SHOP USA, 1348 East Edinger, Santa Ana, California. Zip Code 92705. Telephone: 0101 714 5472526

**TELEPHONE SALES OPEN 24 hrs. 7 days a week 01-449 6596**



# BUYING THE HARDWARE IS ONLY HALF THE STORY...



Come & visit us



... bring your colleagues



... excellent demonstrations



... ex-stock items



... in the unlikely event,

## ... At Personal Computers we'll give it a happy ending.

Personal Computers Limited have been in the personal computing business right from the start — so we've got our values sorted out.

It's important for you to choose the right hardware and vital to select the right software.

To help you make the right choice we offer our highly-trained staff.

They know what makes computers whirr, and they know how to give you the right kind of support and maintenance.

### THE BEST AVAILABLE

We stock the best available hardware and software packages in the market.

Such as Apple and Sharp units, with the latest additions like 16K RAM card.

We have I.E.E.E. Interface, low cost serial, parallel interfaces, Doublevision 80 character card, numeric keypads, personal computer plotters, Paper Tiger printers, and much more besides.

Whatever you need in computing, we will satisfy your requirements.

### FROM PERSONAL COMPUTERS

- **Small Business/Accounting.** We provide low-cost invoicing, purchase, sales and general ledger systems.
- **Financial Planning.** Micromodeller or Visicalc for ad hoc or regular financial reporting.

- **Dow Jones & Prestel** (including I.P. Terminal) services to the city, plus access to city commodities data base.
- **Word Processing.** Our Format 80 system is recognised as the best of its kind.
- **Databases.** State-of-the-art products like Personal Filing Systems and Data Factory.
- **Graphics.** Pad to plotter software and low-cost plotter.
- **Technical Support.** Our knowledge of computer languages and application requirements is unrivalled. And we can supply either on-site or in-house maintenance.

*Once again ... Personal Computers Limited give the story a happy ending.*

*Computers are only as good as the people who use them ... and sell them. Think about that! Then give us a call.*

Personal Computers Limited  
Masters of Personal Computer Technology  
194/200 Bishopsgate London EC2M 4NR Tel: 01-626 8121