

TECHNICAL MANUAL

REVs 3.0, 3.1 & 3.2

**SEQUENTIAL
CIRCUITS INC**

MODEL 1000
S/N 1301 and Above
Revisions 3.0, 3.1 and 3.2
Manual No. TM1000D.2

PROPHET-5 SYNTHESIZER TECHNICAL MANUAL

SECOND EDITION

By STANLEY JUNGLEIB

Wine Country Productions, Inc.
1572 Park Crest Court, Suite #505
San Jose, California 95118 USA
Phone: (408) 265-2008 FAX (408) 266-6591
SEQUENTIAL *Product Specialists Since 1987*

**PROPHET-5 SYNTHESIZER
TECHNICAL MANUAL**

By Stanley Jungleib

Artwork: Denis Simard
Greg Armbruster

Second Edition
For Revisions 3.0, 3.1 and 3.2

Manual No. TM1000D.2
Issued: October, 1981

Copyright © 1981 by
SEQUENTIAL CIRCUITS, INC.
All rights reserved. Printed in USA.

The contents of this manual are the property
of SCI and are not to be copied or reproduced
without our prior written permission.

About This Manual and Servicing The Prophet

The Prophet is a sophisticated instrument and SCI issues its technical manual for use by qualified technicians only. Of course the manual will be read by Prophet owners and others interested in synthesizer design. And we realize it will also be used by some to develop modifications for the instrument. While we support this innovative attitude in spirit, we cannot support it financially: Modifications or unauthorized service void the Prophet's warranty. They also invariably extend service time (thus, cost) if factory repair is required. Familiarize yourself thoroughly with this manual before attempting any work on the Prophet. This will at least help you judge whether you should be working on it at all. If in doubt, please contact our Service Department.

This edition of the Technical Manual (TM1000D) documents Prophet-5s with serial numbers 1301 and above. Although great care was taken to ensure the changes would be transparent to players, technicians will find "Rev 3" quite a different instrument from its predecessors. Rev 2 (S/N 184-1299, see TM1000C) was a mere refinement of Rev 1 (S/N 1-182). Rev 3, however, uses new voltage-controlled ICs in the analog synthesizer and, in the microcomputer, a vastly different ADC, DAC and control voltage distribution scheme. Although the main purpose of the revision was to remove production limitations caused by inconsistent supply and quality of the previous synth "chip set," the hardware redesign encouraged the implementation of more sophisticated editing, tuning and maintenance software while improving servicability; the number of voice trimmers being reduced from 80 to 45.

The manual is organized as follows:

SECTION 1, MECHANICAL provides a physical introduction and directions for disassembling/assembling the Prophet.

SECTION 2, THEORY explains general function and circuit operation, referring to block diagrams and to the schematics for hardware details.

SECTION 3, DOCUMENTS contains schematics and pictorials identifying all components.

SECTION 4, SERVICE contains procedures for routine tests and trims.

SECTION 5, PARTS cross-references component designators to SCI stock numbers.

SECTION 6, GLOSSARY decodes abbreviations appearing on SCI documentation.

SECTION 7, APPENDIX contains selected data sheets.

Your response to the questionnaire on the next page will help us monitor our publication's usefulness.

About The Second Edition

In addition to the original revision 3.0 data (with a few corrections), the following material covering later refinements of the instrument has been added. The revisions occurred chiefly in the microcomputer's memory configuration, added PITCH and MOD CV inputs, and in the addition of a serial interface for communication with the Model 1005 Polyphonic Sequencer or Model 1001 Remote Keyboard.

SECTION 8, THEORY discusses the hardware changes comprising revisions 3.1 and 3.2.

SECTION 9, PROGRAMMING covers use of the serial interface.

SECTION 10, DOCUMENTS contains schematics and pictorials for revisions 3.1 and 3.2.

SECTION 11, SERVICE includes instructions for updating a 3.0 or 3.1 instrument to level 3.2, for using the diagnostic memory tests, and for an added adjustment on PCB 3.

SECTION 12, PARTS lists SCI stock numbers for 3.1 and 3.2-level assemblies.

Table of Contents

SECTION 1 MECHANICAL

1-0	GENERAL	1-1
1-1	PRECAUTIONS	1-1
1-2	SERVICE POSITION	1-1
1-3	PCB 4 VOICE BOARD	1-3
1-4	PCB 3 COMPUTER BOARD	1-4
1-5	PCB 1/2 CONTROL PANELS	1-5
1-6	KEYBOARD	1-6

SECTION 2 THEORY

2-0	GENERAL	2-1
2-1	SYNTHESIZER BACKGROUND	2-1
2-2	THE PROPHET	2-4
2-3	ANALOG SYNTHESIZER DESCRIPTION	2-7
2-4	OSCILLATOR A, B AND LFO	2-8
2-5	MIXER AND AMOUNT VCAS	2-9
2-6	FILTER	2-9
2-7	ENVELOPE GENERATORS	2-9
2-8	AUDIO OUTPUT	2-10
2-9	MICROCOMPUTER SYSTEM DESCRIPTION	2-10
2-10	MICROPROCESSOR, MEMORY, AND I/O INTERFACE	2-12
2-11	CONTROL MATRICES	2-15
2-12	ADC, DAC, AND CV OUTPUTS	2-16
2-13	TUNE AND A-440	2-19
2-14	SEQUENCER INTERFACE	2-20
2-15	CASSETTE INTERFACE	2-21

SECTION 3 DOCUMENTS

3-0	DOCUMENT LIST	3-1
3-1	DOCUMENT NOTES	3-1

SECTION 4 SERVICE

4-0	GENERAL	4-1
4-1	OSCILLATOR A TEST	4-3
4-2	OSCILLATOR B TEST	4-4
4-3	MIXER AND NOISE TEST	4-5
4-4	UNISON AND GLIDE TEST	4-5
4-5	FILTER TEST	4-6
4-6	AMPLIFIER TEST	4-6
4-7	LFO AND WHEEL-MOD TEST	4-7
4-8	POLY-MOD TEST	4-8
4-9	FINAL TEST	4-9
4-10	POWER SUPPLY TRIM	4-10
4-11	PITCH WHEEL TRIM	4-10
4-12	MASTER SUMMER OFFSET TRIM	4-10
4-13	WHEEL-MOD LFO VCA BALANCE	4-10
4-14	DAC GAIN, ADC GAIN, SEQ INTERFACE TRIM	4-11
4-15	WHEEL-MOD NOISE VCA BALANCE	4-11
4-16	VCO SCALE TRIM	4-12
4-17	POLY-MOD FILTER ENVELOPE VCA BALANCE	4-13
4-18	POLY-MOD OSCILLATOR B VCA BALANCE	4-13
4-19	FILTER ENVELOPE AMOUNT VCA BALANCE	4-14
4-20	FILTER TUNING	4-14
4-21	FINAL VCA BALANCE	4-16
4-22	VOICE VOLUME	4-16

SECTION 5 PARTS		
5-0	CHASSIS	5-1
5-1	PCB 1	5-1
5-2	PCB 2	5-1
5-3	PCB 3	5-2
5-4	PCB 4	5-4
5-5	PCB 5	5-8
5-6	BILL OF MATERIALS (TOTAL ITEMS)	5-9
SECTION 6 GLOSSARY		
SECTION 7 APPENDIX		
	CA3280 Dual Operational Transconductance Amplifier	
	CEM 3310 Voltage Controlled Envelope Generator	
	CEM 3320 Voltage Controlled Filter	
	CEM 3340/3345 Voltage Controlled Oscillator	
SECTION 8 THEORY		
8-0	INTRODUCTION	
8-1	REVISION 3.1 COMPUTER and POWER SUPPLY	8-1
8-2	REVISION 3.2 COMPUTER and USART	8-1
8-3	REVISION 3.2 ANALOG and POWER SUPPLY	8-2
		8-4
SECTION 9 PROGRAMMING		
9-0	INTRODUCTION	
9-1	Data Format	9-1
9-2	Error Checking	9-1
9-3	Status Bytes	9-2
9-4	STATUS 0: SEND KEYBOARD and PROGRAM	9-2
9-5	STATUS 1: ACK, RECEIVE KEYBOARD and PROGRAM	9-3
9-6	STATUS 2: TRANSPOSE ON	9-3
9-7	STATUS 3: SAVE TO TAPE	9-4
9-8	STATUS 4: LOAD FROM TAPE	9-4
9-9	STATUS 5: CLEAR TRANSPOSE	9-5
9-10	STATUS 6: INITIALIZE SEQ LOWER PROGRAM	9-5
9-11	STATUS 9: DISABLE TUNE	9-6
9-12	STATUS A: ENABLE TUNE	9-6
9-13	STATUS B: RECEIVE PROGRAM CHANGE	9-6
9-14	STATUS C: SYSTEM CONNECT	9-6
9-15	STATUS E: RECEIVE SHORT KEYBOARD DATA	9-6
		9-6
SECTION 10 DOCUMENTS		
10-0	DOCUMENT LIST	
		10-1
SECTION 11 SERVICE		
11-0	INTRODUCTION	
11-1	REVISION 3.2 RETROFIT KIT INSTRUCTIONS	11-1
11-2	REVISION 3.0 MEMORY TEST	11-1
11-3	REVISION 3.1 MEMORY TEST	11-4
11-4	REVISION 3.2 MEMORY TEST	11-4
11-5	WHEEL-MOD BALANCE TRIM	11-5
		11-6
SECTION 12 PARTS		
	REVISION 3.2 COMPONENTS	

SECTION 1

MECHANICAL

1-0 GENERAL

This section shows how to remove the Prophet's main assemblies. Not all of the procedures given here should be necessary at any one time. For some service situations you will only need to separate the top and bottom panel assemblies and arrange them as shown in Figure 1-0. This configuration, discussed in paragraph 1-2, allows access to all trimmers on PCB 4 and most trimmers on PCB 3. However, for some PCB 3 trims you will have to swing-out or completely remove PCB 4, as discussed in paragraph 1-3.

1-1 PRECAUTIONS

Observe the following precautions when working on the Prophet:

SWITCH POWER OFF AND CHECK 115/230V SWITCH ON BACK PANEL BEFORE CONNECTING PROPHET TO POWER OUTLET OR AMPLIFIER.

NEVER TOGGLE 115/230V SWITCH WITH POWER ON.

TRIMMING, OF COURSE, MUST BE PERFORMED WITH POWER ON. SO AVOID THE POWER SUPPLY PRIMARY CIRCUITRY, WHICH CONDUCTS LETHAL VOLTAGE.

SWITCH POWER OFF BEFORE DISCONNECTING OR CONNECTING ANY CIRCUITRY, OR REMOVING OR INSTALLING PCBs.

IMPORTANT! WHENEVER THE AUDIO CABLE IS DISCONNECTED, PCB 3 MUST BE GROUNDED TO THE BACK PACK PANEL.

DO NOT BEND OR STRAIN THE PCBs. OTHERWISE MAY CAUSE TINY BREAKS IN THE PRINTED-CIRCUIT TRACES WHICH WILL BE EXTREMELY DIFFICULT TO FIND.

TO REPLACE SOLDERED COMPONENTS SWITCH POWER OFF, REMOVE THE PCB COMPLETELY FROM THE INSTRUMENT AND DESOLDER FROM BOTH SIDES. USE A VACUUM SYRINGE OR DIP DESOLDERER. KEEP VACUUM SYRINGES CLEAN TO PREVENT THEM FROM SPRAYING MOLTEN SOLDER. DON'T OVERHEAT THE PADS. WORK CAREFULLY!

1-2 SERVICE POSITION

TO PREVENT DAMAGE TO THE TOP PANEL, KEYBOARD, OR WOODWORK, USE A CARPETTED OR SIMILARLY-COVERED WORK SURFACE WHEN OPENING THE BOX.

To set up the Prophet for service first switch power off, unplug power cord, and turn instrument over to expose bottom panel. Remove two large screws near front feet. Remove eleven screws around perimeter of bottom panel.

Holding top and bottom panel assemblies together, turn the Prophet right-side-up again. Remove four screws along top edge of back panel. Slowly slide the top panel assembly forward—about nine inches—so when raised the control panel will clear the large power supply capacitors.

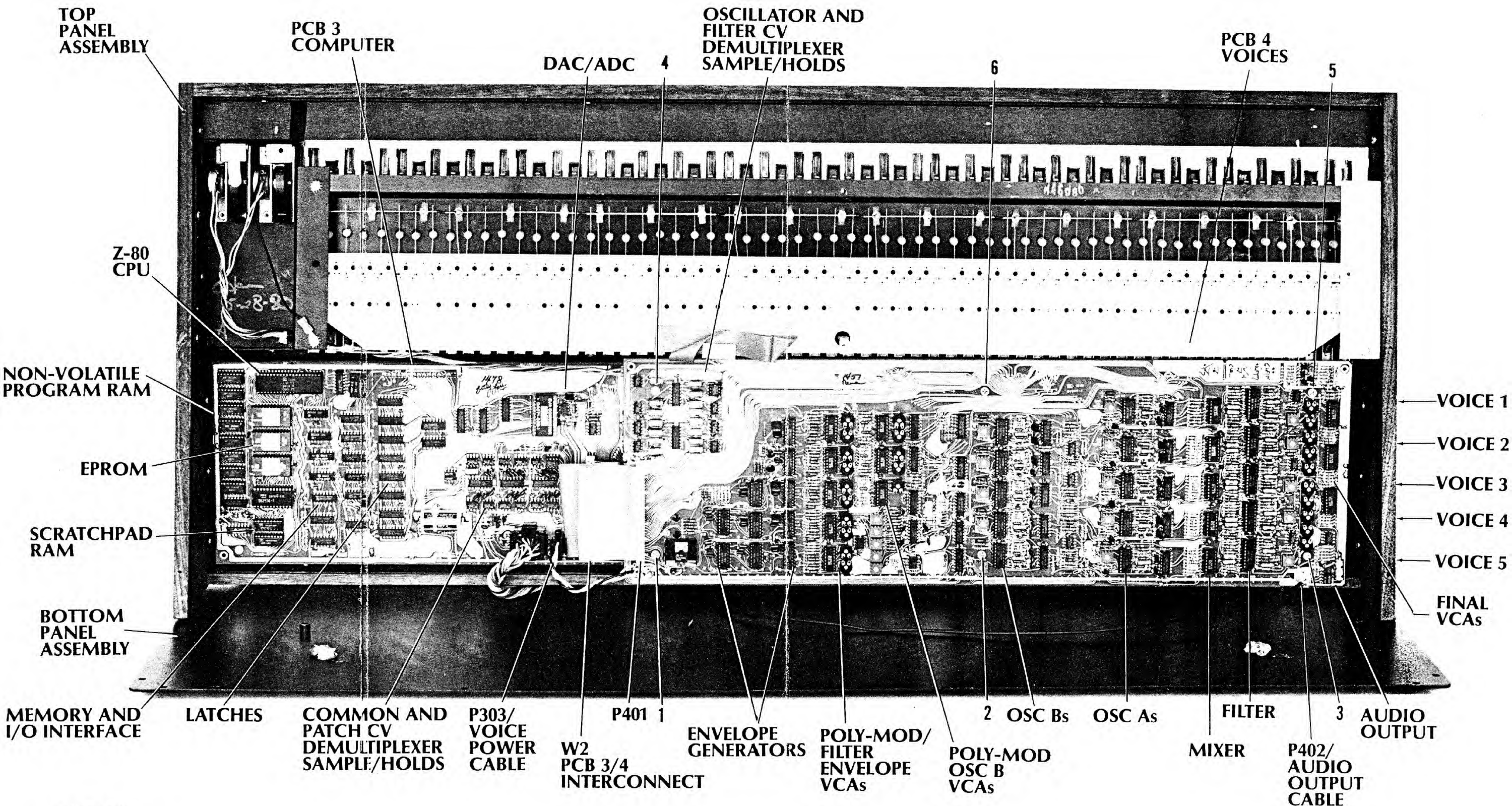

Figure 1-0
SERVICE POSITION

Raise the top panel assembly to service position shown. For best stability both top panel side back edges should rest on the bottom panel. Actually, the top panel upper edge rests on the back panel cable. This is normal; but a small (half-inch) prop may be added to improve stability.

The instrument can operate normally in this position. Of course its operating temperature will be far below normal. This may slightly affect adjustments or the performance of certain ICs.

REMEMBER THAT IN SERVICE POSITION THE TOP PANEL ASSEMBLY BALANCES ON ITS REAR EDGES. DON'T UPSET THIS BALANCE BY PUSHING TOO HARD WHEN PROBING OR TRIMMING.

When reassembling the Prophet, turn instrument over and first start two large screws near front feet. Then start bottom and back panel screws to obtain overall alignment before tightening all screws.

1-3 PCB 4 VOICE BOARD

PCB 4 may be swung-out and operated under power. For this set-up, switch power off, remove screws identified in Figure 1-0 in the order suggested, and position board on insulation as shown in Figure 1-1.

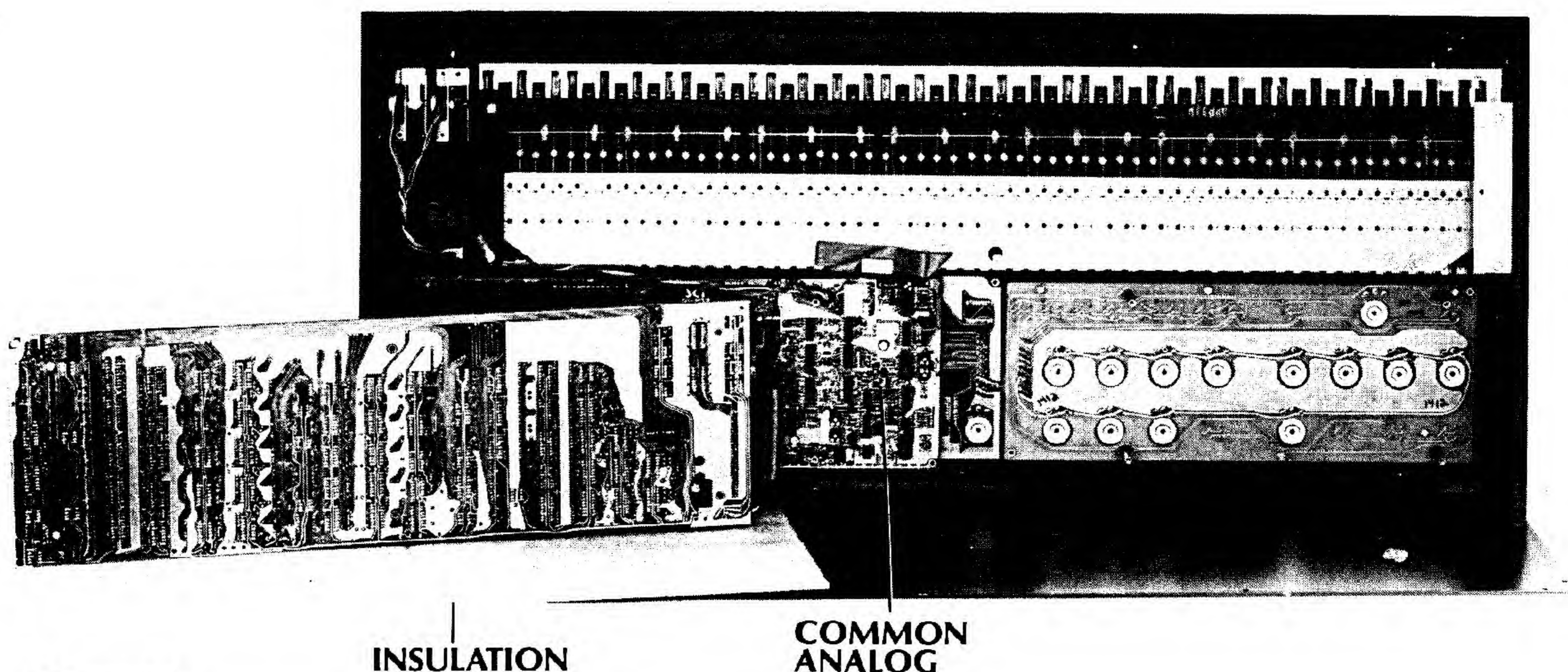

**Figure 1-1
PCB 4 SWINGOUT**

TO PREVENT GROUND LOOPS, PCB 3 IS GROUNDED ONLY THROUGH THE AUDIO CABLE TO THE BACK PANEL. THEREFORE, WHENEVER THE AUDIO CABLE IS DISCONNECTED, PCB 3 MUST BE TIED TO THE BACK PANEL.

CAREFUL! DON'T ALLOW PCB 4 TO SHORT AGAINST STANDOFFS FROM PCB 3 OR AGAINST THE BOTTOM PANEL.

To remove W2, completely switch power off and disconnect voice power cable at P303 on PCB 3 (see Figure 1-0). Also remove PCB 3/4 interconnect at P401 on PCB4, with a gentle "see-saw" motion. Detach audio output cable from P402.

When reconnecting voice power and audio output cables, be sure tabs interlock. Also be sure the PCB 3/4 interconnect is correctly mated and firmly seated at P304 and P401.

1-4 PCB 3 COMPUTER BOARD

PCB 3 is held by the screws identified in Figure 1-2, and by two direct connectors to PCB 2, behind it. To remove PCB 3 first remove PCB 4. Disconnect back panel cable from P302 and wheel cable from P301, remove screws, and pull while rocking the board to minimize stress.

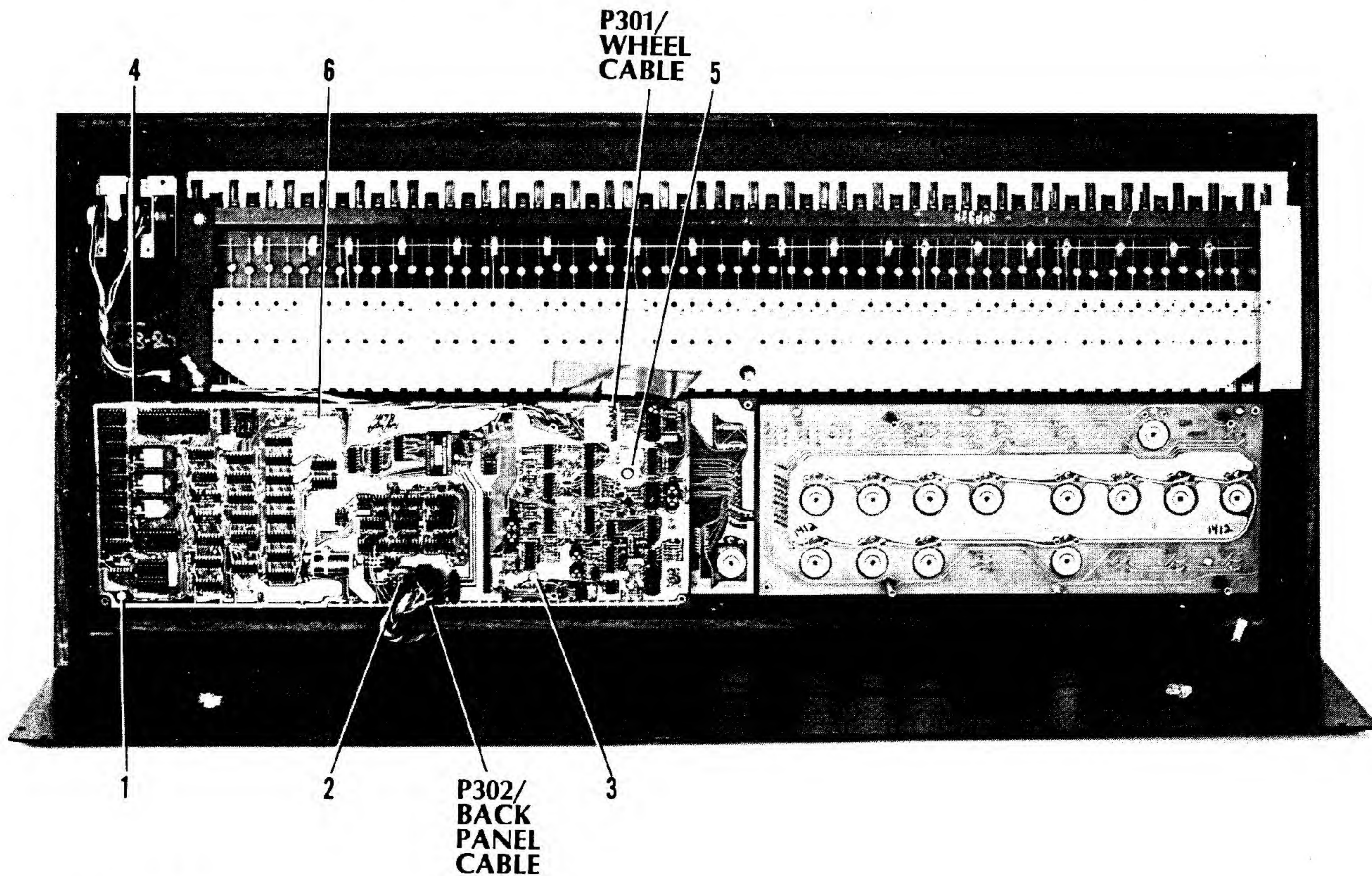

Figure 1-2
PCB 3 MOUNTING

When replacing be sure all connector pins are correctly mated with PCB 2 before fastening screws. Alignment is insured by machine screw holes with their standoffs. Remember to reconnect the wheel cable, too, before replacing PCB 4. When reconnecting wheel and back-panel cables, be sure tabs interlock.

1-5 PCB 1/2 CONTROL PANELS

Once PCB 3 and PCB 4 have been removed, control panel removal involves pulling off all knobs, unscrewing all potentiometer mounting nuts—using a half-inch nutdriver—and removing screws identified in Figure 1-3.

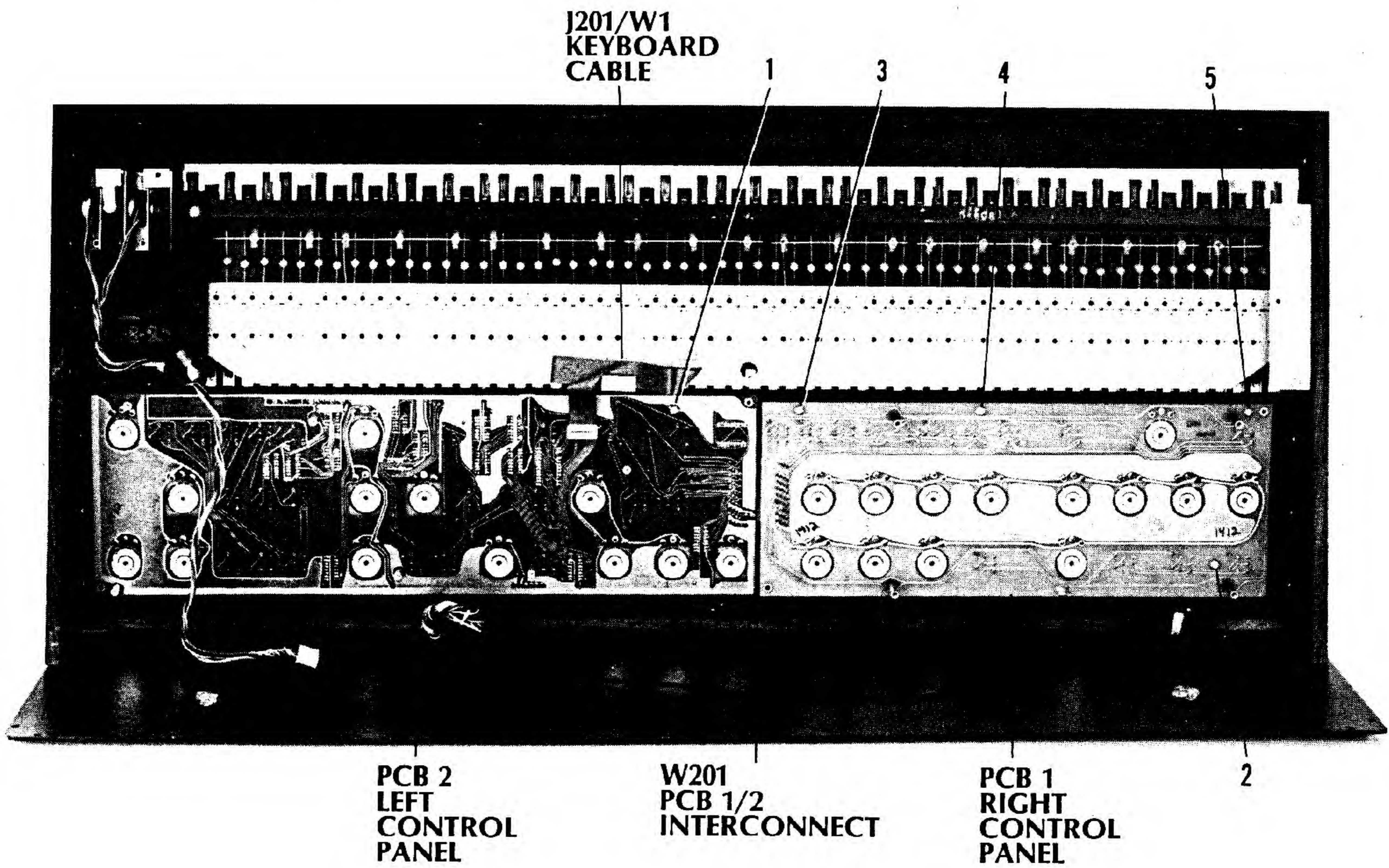

Figure 1-3
PCB 1/2 MOUNTING

When replacing, check keyboard cable, that all pots fit correctly through the front panel, and that switches operate freely before tightening pot nuts.

1-6 KEYBOARD

After removing PCB 3 and PCB 4, turn the top panel assembly over and disconnect keyboard cable at J201 (see Figure 1-3).

Figure 1-4 details keyboard mounting. At both ends, remove keyed supports by first removing keyed screws then rear keyboard mounting screws. Remove front keyboard mounting screws. The entire keyboard will slide out of the case—and back in—as shown in Figure 1-5.

CAREFUL! DURING THIS OPERATION THE J-WIRES FOR THE LOWEST AND HIGHEST KEYS ARE VULNERABLE TO DAMAGE FROM COLLISION WITH THE KEYBOARD MOUNTING BRACKETS. WHEN REPLACING CHECK J-WIRES AT EACH END OF KEYBOARD FOR CONTACT WITH BUS BAR.

Also, remember to attach the wheel ground lug.

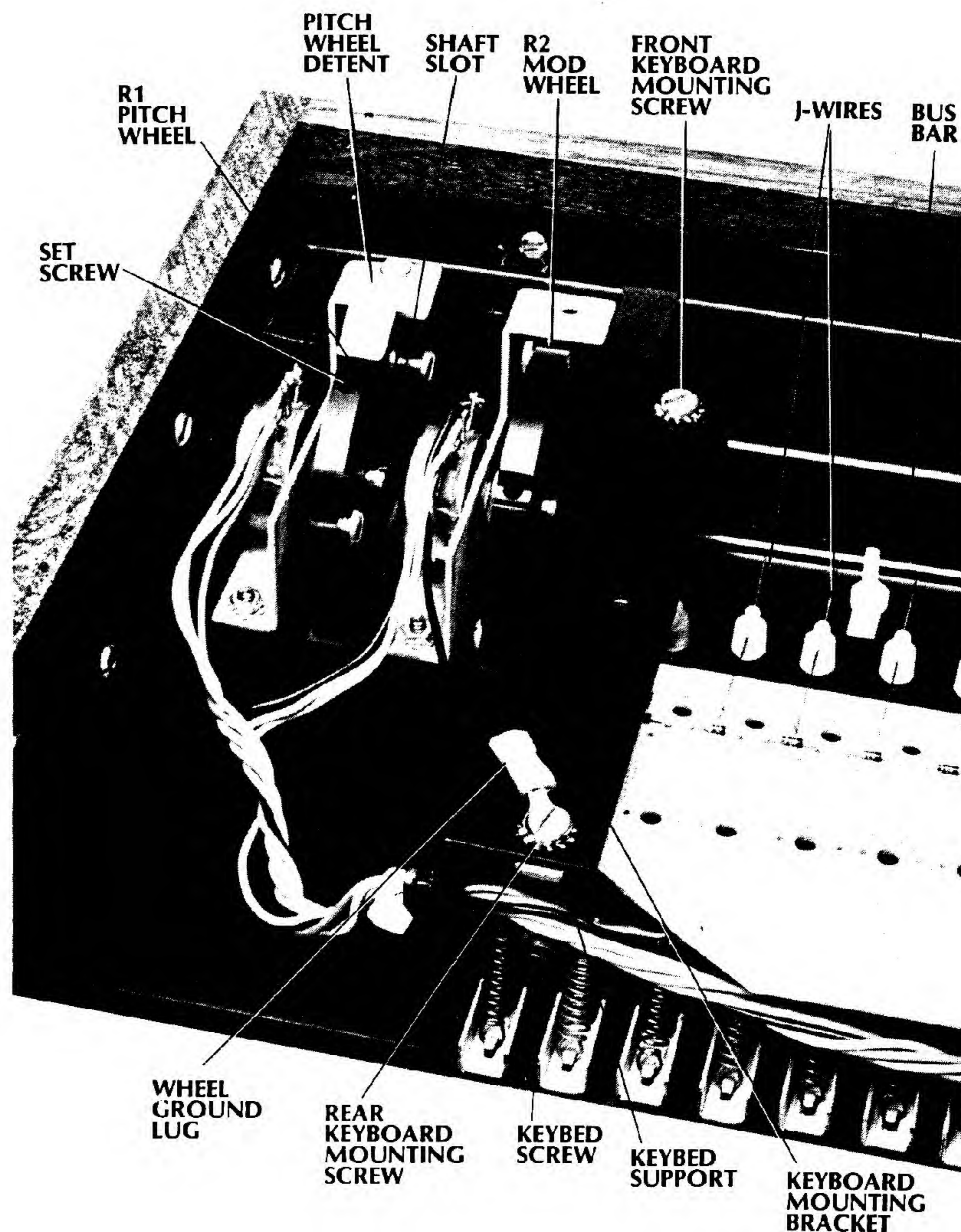

Figure 1-4
KEYBOARD MOUNTING

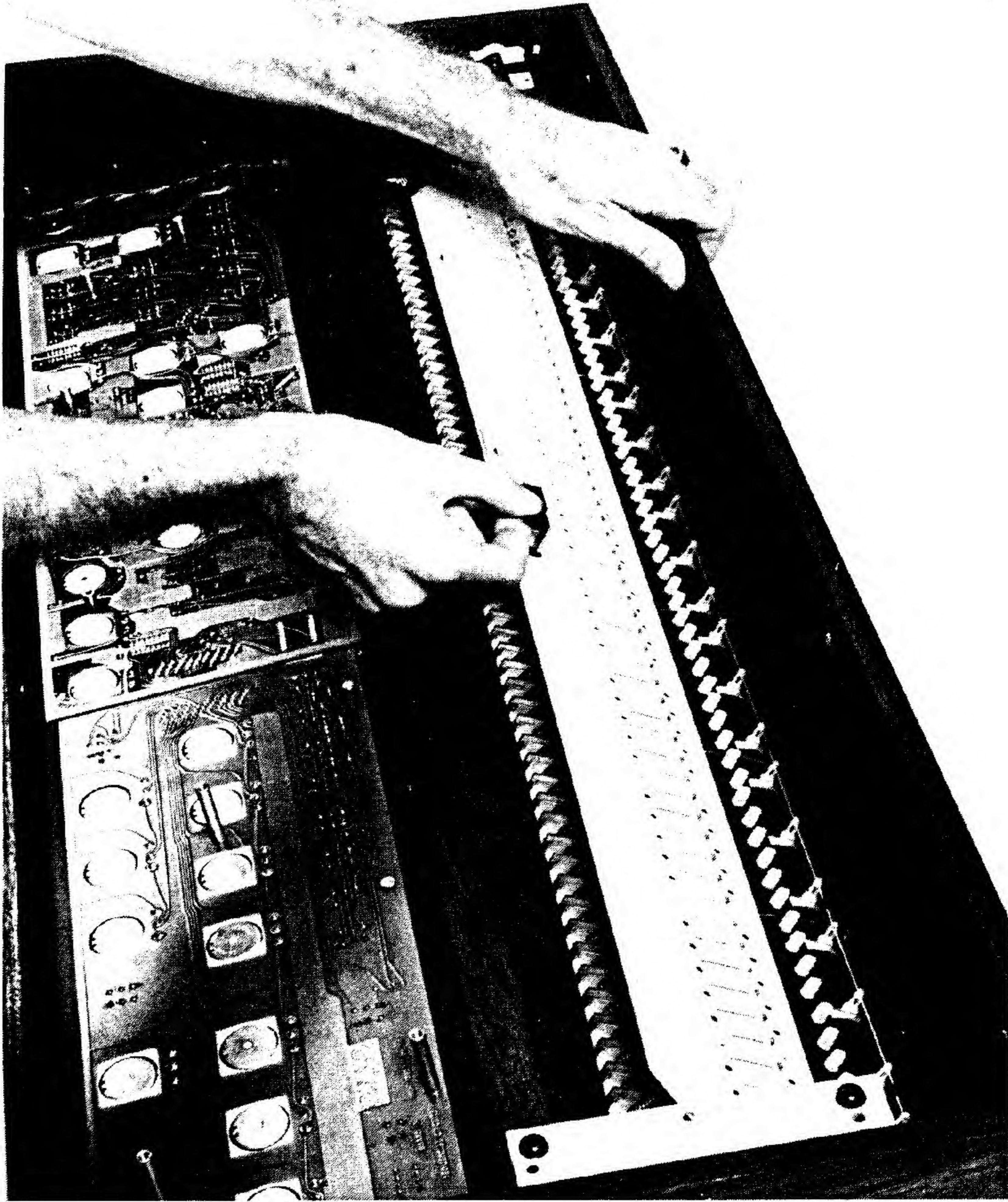

Figure 1-5
KEYBOARD REMOVAL

SECTION 2 THEORY

2-0 GENERAL

This section explains the Prophet's theory of operation. First a general description relates the Prophet to the basic analog synthesizer and introduces the concepts central to the Prophet's advances over conventional performance instruments: programmability and polyphony. Then the analog synth and microcomputer functions are covered and their sub-circuits detailed. Throughout it is assumed the reader is already familiar with Prophet-5 operation (see Operation Manual CM1000B).

2-1 SYNTHESIZER BACKGROUND

The synthesizer is a new instrument but the urge to set technology in search of music is quite old. Consider the pipe organ; of traditional instruments, most like the synthesizer. The organ achieved its broad dynamic, pitch and timbral ranges through intricate mechanical arrays; for generating steady wind, transferring key action to pneumatic valves for each note, activating ranks of pipes, and to couple pedalboards and keyboards. Later, the bellows tremolo and pedal-operated swell shutters were added for dynamic and timbral expression. As the organ expanded into larger halls pneumatic and hydraulic devices were developed to isolate the keyboard from the force required to key more pipes at higher wind pressure. With the advent of electricity the keyboard and drawknobs, formerly levers, became switches. Elaborate relay banks now drove solenoid valves for each pipe. More recently, electronic organs—in many variations—have relied on motor-driven tone generators or switch/relay banks for oscillator frequency division or waveform addition or shaping. Another influential technology, the tape recorder captured natural, instrumental, and electronic sounds for new uses and stimulated the idea of composing music not performable “in real time” on conventional instruments. A few keyboard instruments have been directly based on tape mechanisms.

Now, what is a synthesizer? It can be distinguished from the organ or tape recorder by reliance on electronic rather than mechanical devices to generate and modify sound. Except for performer's controls a synth need have no moving parts. (Even this exception may one day disappear.) Thus it is far more flexible and controllable than an organ. In contrast to organ or tape technology, voltage control (VC) allows the immediate and precise adjustment of the basic parameters of an audio stage such as oscillator (VCO) or filter (VCF) frequency, or amplifier (VCA) gain, by a signal from another VCO, an envelope generator (ENV GEN), keyboard (KBD) or sequencer (SEQ). Most music is analyzable into elements replicable by a few VC-modules. For example, if a synth imitates a drum or piano it is not by being a (mechanical) percussion instrument, but by simulating the dynamic envelope accompanying percussive sounds with a VCA under control of an ENV GEN.

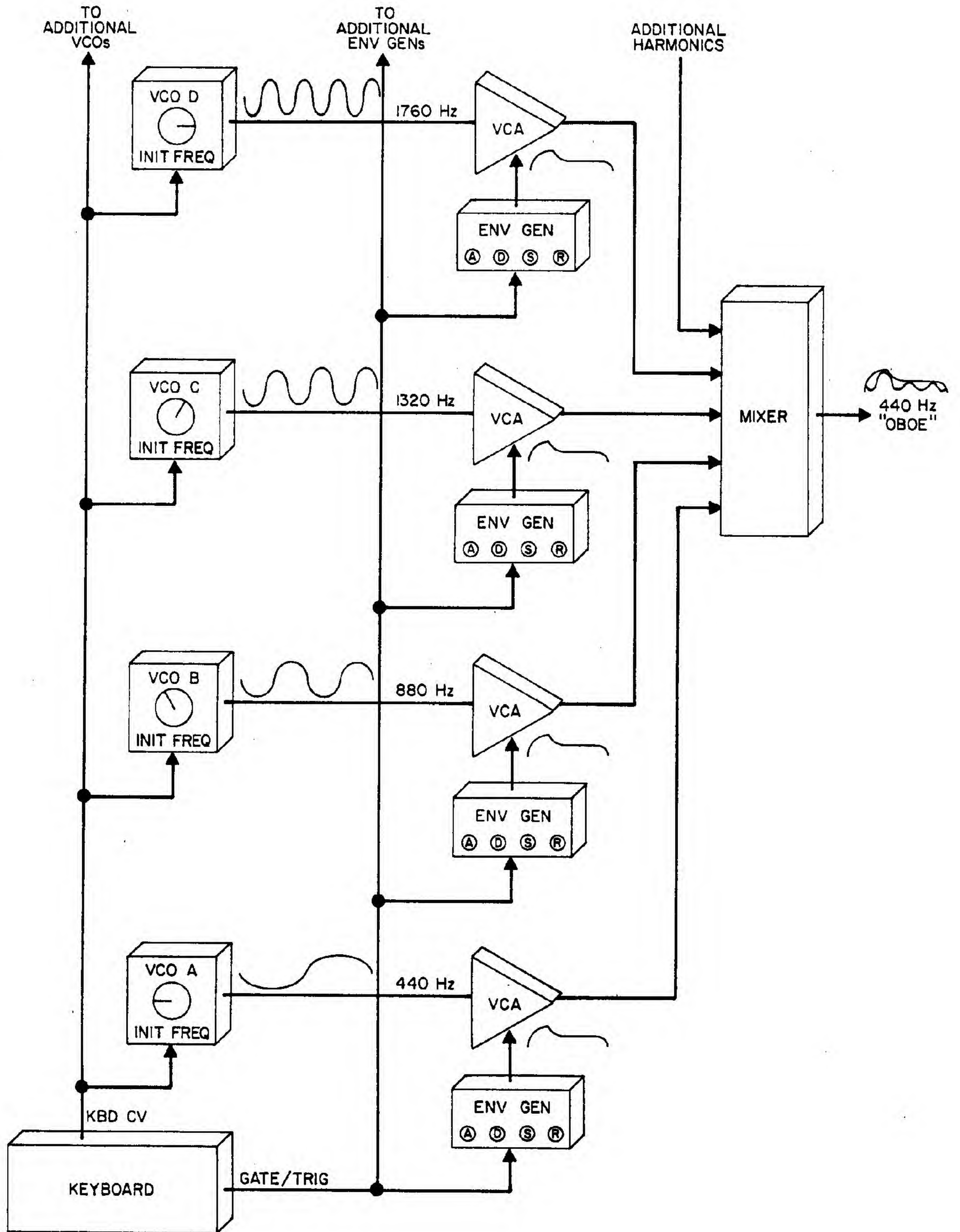

Figure 2-0
MONOPHONIC ADDITIVE SYNTHESIS

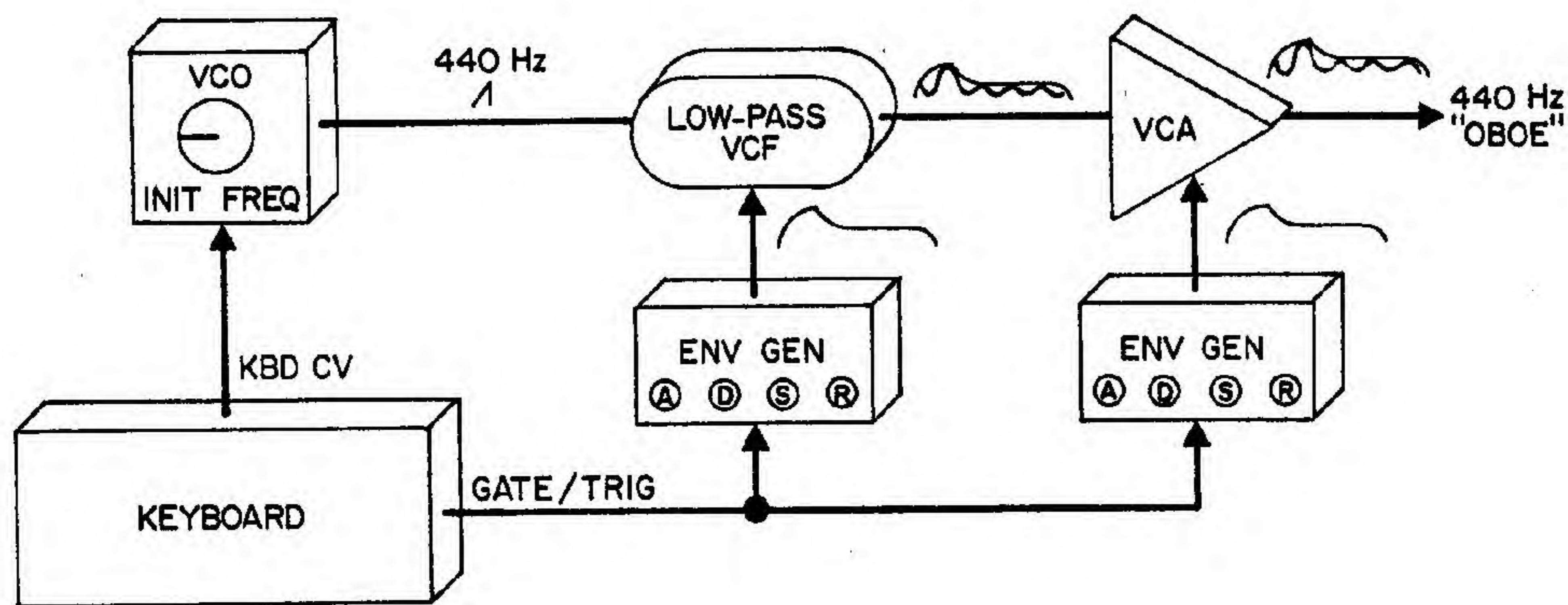

Figure 2-1
MONOPHONIC SUBTRACTIVE SYNTHESIS

Besides a dynamic envelope a musical voice usually has a pitch and timbre which consists of a fundamental and a number of harmonic frequencies—all of varying relative strengths. Pitch and timbre synthesis raises a distinction between two techniques, diagrammed in Figures 2-0 and 2-1. The first technique, additive synthesis, might create a timbre by summing the output of several sine-wave VCOs for the fundamental and each harmonic. In contrast, subtractive synthesis can start with one sawtooth-wave VCO generating the fundamental with extensive harmonics, then obtain the desired timbre by subtracting unwanted harmonics with a low-pass VCF.

The additive and subtractive techniques have encouraged the development of two types of instruments, roughly, "studio" and "performance." Actually most organs use additive synthesis, but since with a synth one can individually control the level of each harmonic over time additive synthesis may be potentially more accurate for synthesizing a particular sound. Whether additive or subtractive, studio synths may be configured from dozens of modules interconnected by patch cords. The modules have knobs to establish the initial settings of VC-parameters such as initial frequency (FREQ), pulse width (PW), and resonance (RES). But the flexibility and complexity of modular synths has discouraged their live use on stage because significant sound changes often require repatching modules and precisely checking knobs. Favorite, complex sounds take a long-time to create, and almost as long to recreate on a modular synth. So these monophonic (one-voice) synths instead feed multi-track recorders on which polyphonic interpretations or compositions are actually orchestrated.

A comparison of the number of modules and interconnections depicted in Figures 2-0 and 2-1 shows why the subtractive configuration has become the popular technique for performance synths. Subtractive synths may be smaller, so, more portable. Their patches will not be as elaborate, so, easier to change. Originally, performance synths were monophonic. Or they exploited organ technology so more than one note could be played at a time. "Preset" switches that select fixed patches supplanted many modular controls. Though one could certainly change sounds quickly by using them, many players have found preset synths unsatisfactory because they eliminate an essential part of synth musicianship—control of the sound itself. Some manufacturers have offered partially-programmable instruments. But before the Prophet appeared it was not possible for a keyboardist to instantly select his or her own customized synth sounds and play them polyphonically.

2-2 THE PROPHET

The Prophet is a subtractive, analog synthesizer suitable for performance or studio use. It provides instantaneous patch repeatability and polyphonic capability without the limitations of organ technology or fixed presets. The term "digital-analog hybrid" is often used to describe the Prophet. It means the digital computer controls the analog audio sources and modifiers. The computer itself generates no sound (except for the A-440 reference).

Figure 2-2 diagrams the Prophet at the most general level. Instead of controlling the synth directly, the keyboard and most controls are processed through a microcomputer system. The system provides a way to store all of the switch and knob settings which form a patch, and solves the problem of generating five sets of oscillator (OSC) and filter (FILT) CVs and GATEs from a single keyboard. The Common Analog circuitry mixes the few non-processed controls with processed signals for the voices. Although only one voice is depicted on the control panel, the black knobs and switches patch the five voices identically. This makes the voices homophonous—they sound alike—with pitch differences corresponding to (at most) five simultaneously-held keys.

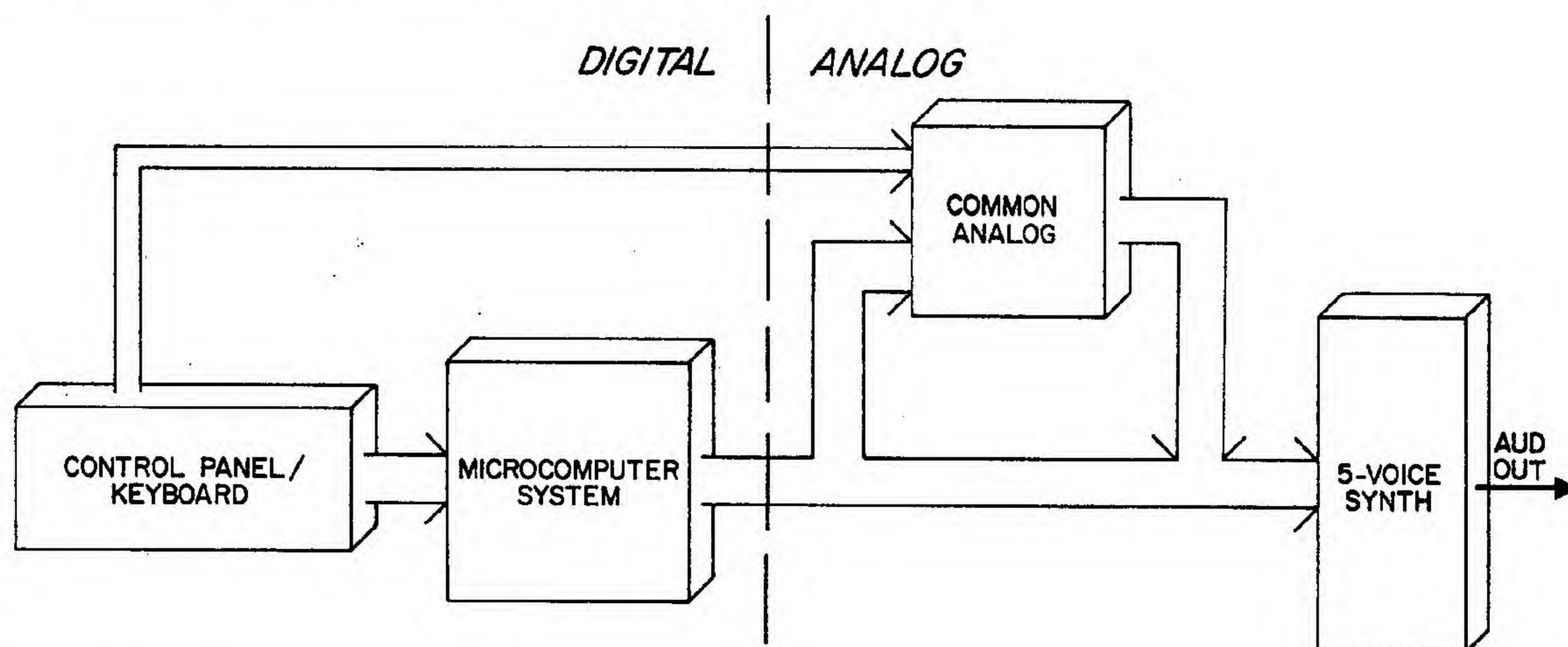

Figure 2-2
PROPHET GENERAL BLOCK DIAGRAM

Figure 2-3 shows the principle functions of the four main blocks. Beginning with AUDIO OUT, the voice outputs are combined and overall volume set by the VOL VCA controlled directly from the control panel. Each voice is a complete synthesizer with two VCOs, a MIXER, VCF, FINAL VCA, and two ENV GENs. Each of the ten VCOs has its own FREQ CV, which allows the computer to individually fine-tune them and allows the voices to follow separate keys. Each voice receives its own GATE, which triggers the two envelope generators with each keystroke.

All switch commands and most CVs are generated by the computer. Non-processed CVs include MASTER TUNE, PITCH-bend, and WHEEL-MODulation which are mixed in the Common Analog circuitry. The Common Analog circuitry also requires a few switch commands.

The microcomputer performs the task of voice assignment. It decides which held keys sound which voices through the OSC and FILT CVs and GATEs. Voice 1 is assigned to the first key hit, Voice 2 to the second key, and so on. After the five initial assignments the system is "last note priority." The earliest-used voice is reassigned to each new note played. Repeated notes key the same voice. For example, holding C, D, E, F, and G, sustains Voices 1, 2, 3, 4, 5, respectively. Adding A "steals" Voice 1 from the C-key, whose pitch disappears even though the key may still be held.

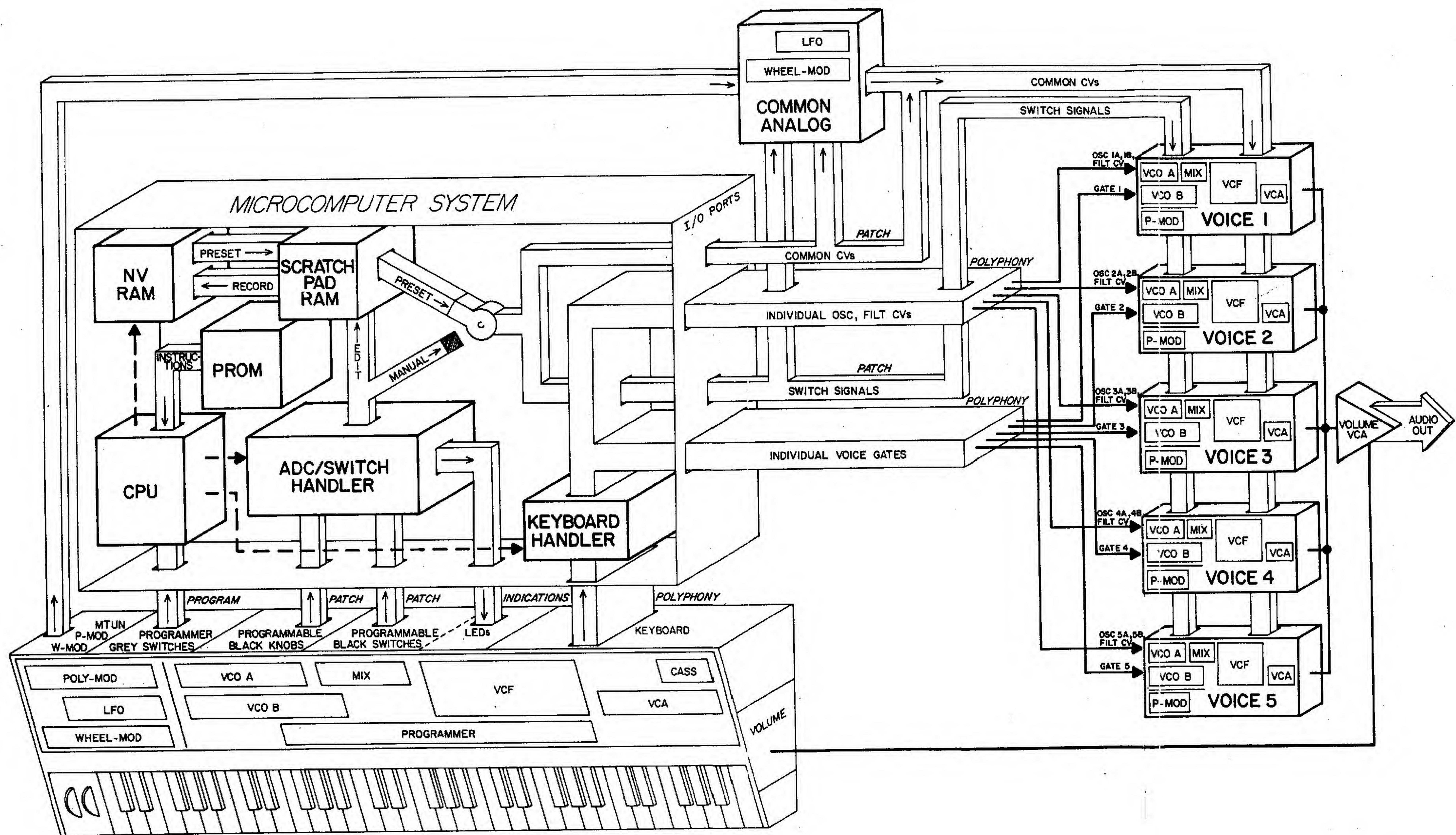

Figure 2-3
PROPHET FUNCTIONAL BLOCK DIAGRAM

COMMON ANALOG

VOICE 1
(VOICES 2-5 ARE SIMILAR)

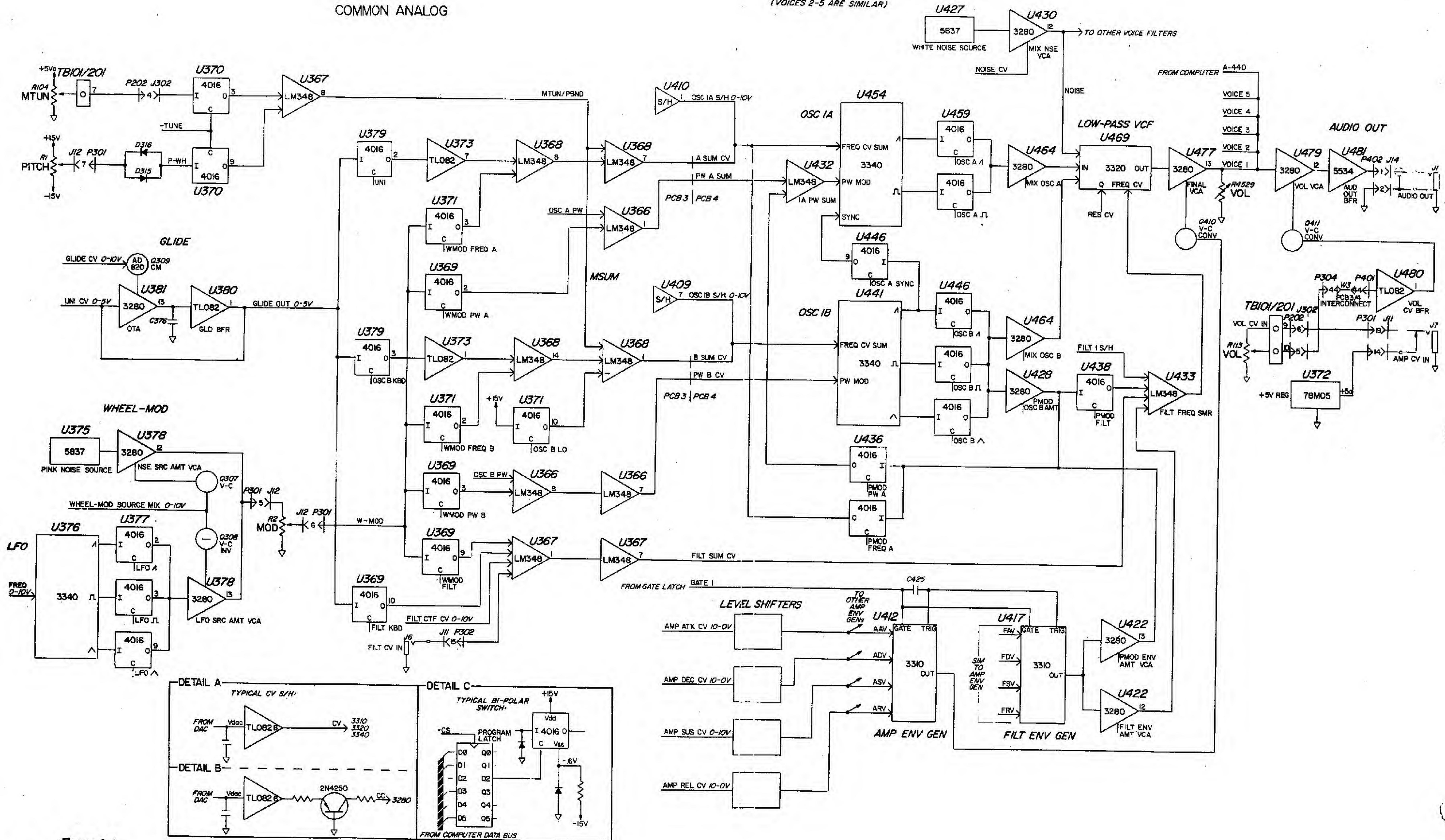

Figure 2-4
ANALOG SYNTH ABSTRACT SCHEMATIC

In UNISON (monophonic) mode a UNISON CV derived from the lowest note played on the keyboard becomes the main pitch control for all voices through the Common Analog circuitry. The five GATEs occur simultaneously, but the envelope generators only re-trigger if no keys are held.

The microcomputer system itself consists of the microprocessor or CPU, memory (MEM), and input/output (I/O) interface. The CPU executes the program permanently residing in the read-only memory (EPROM). This program determines how the various input devices—keyboards, switches, and knobs—are “read”, and how “data” generated by them is “processed” to control the synthesizer. The Scratchpad RAM is the CPU’s work area. It holds data representing the current status of the keyboard and all controls. Control status depends on the operational mode. In MANUAL mode the control data corresponds to the current settings of the black, programmable knobs and switches. If desired this data can be recorded from Scratchpad to the Non-Volatile Memory (NV RAM). Then, in PRESET mode, selecting recorded programs moves them from NV to Scratchpad, reprogramming the synthesizer for that sound. The EDIT feature allows one to alter individual control settings in Scratchpad, which can then be recorded to supplement or replace the original program in NV RAM.

The remainder of this section discusses the Prophet’s actual analog and microcomputer circuitry. Each sub-circuit is described functionally in relation to its block diagram. Principal ICs and any uncommon designs are explained. However the function of common linear, TTL, and MOS ICs is not covered because anyone contemplating technical work on the Prophet must already be familiar with, for example, combinational logic and op amp circuits.

2-3 ANALOG SYNTHESIZER DESCRIPTION

The definitions of the various CV and switch commands in the analog synthesizer must be clear before the Voice and Common Analog sub-circuits can be discussed. Referring to Figure 2-4, the Common Analog circuitry includes the master summers (MSUMs), Glide, and WHEEL-MOD circuits. The MSUMS produce five Common Analog output CVs: A SUM, B SUM, PW A SUM, PW B SUM, and FILT SUM CV. These enable simultaneous pitch control and modulation for the voices, as follows.

R104 MASTER TUNE (MTUN) and R1 PITCH wheel adjust OSC A and B frequency directly—that is, without computer processing—through A SUM CV and B SUM CV. To prevent interference with the TUNE routine (see paragraph 2-13), the switches shown disconnect these controls during the TUNE routine. In UNISON mode the KBD component of the FREQ CV appears through the UNISON CV. The OSC B KBD and FILT KBD switches are for keyboard tracking in UNISON mode. UNISON CV is processed through the Glide circuit which, essentially, delays quick changes in UNISON CV as GLIDE CV increases. The OSC B MSUM is similar to OSC A. FILT SUM CV mainly consists of the FILT CTF CV (which follows the FILT CUTOFF KNOB). An external FILT CV IN can be added through the back panel.

The W-MOD signal, switchable to any MSUM consists of pink noise or LFO output as determined by the W-MOD SOURCE MIX CV. CV inversion to the LFO VCA allows the NOISE and LFO levels to move in opposite directions for a single CV. The MOD wheel sets this mixture’s output level to selected MSUMs.

Besides the Common Analog output CVs there are two types of computer-output CVs which terminate at the voices. First, Patch CVs control all five voices identically. For example, all five Amplifier Envelope Generator attack times will be equal for any patch, so the Amplifier Envelope Generator ATK CV is wired to the same terminal on all five AMP ENV GENs. Other Patch CVs include MIX OSC A, P-MOD ENV AMT, and FILT RESONANCE. Second, the Individual CVs determine the frequency of a single VCO or VCF alone. Each voice has two OSC S/H CVs and one FILT S/H CV. These signals contain the polyphonic KBD component of the total FREQ CV applied to these devices. The ten OSC S/H CVs also contain INIT FREQ control—actually common to the OSC As or Bs—and the TUNE “biases”, which fine-tune each VCO.

All processed CVs originate from the computer at a separate Sample/Hold (S/H). This circuit is discussed in paragraph 2-12, but for introduction Figure 2-4, Detail A shows a typical S/H used with VC-devices. Detail B adds a voltage-to-current converter (V-C CONV) required to control the operational transconductance amplifiers (OTAs—see paragraph 2-5) used as “VCAs” in all places. Twenty-three S/Hs on PCB 3 supply the Common Analog and Patch CVs and fifteen S/Hs on PCB 4 supply the Individual OSC and FILT CVs.

Voice 1 is used for explanatory purposes, below. The five voices are functionally identical. See schematics SD431 and SD334.

2-4 OSCILLATOR A, B, AND LFO

The Prophet's eleven oscillators—two per voice, plus one LFO—are based on the CEM 3340 integrated VCO. The IC is scaled at 1V/octave. This means an overall CV change of exactly 1V ideally produces a pitch change of exactly one octave. So a CV change of 1/12V (83.3 mV) changes pitch by one semitone. In the voices the basic oscillator range is nine octaves; resulting from 0-5V supplied by the KBD and 0-4V supplied by the OSC FREQ knob through the OSC S/H CV (see Figure 2-4). While most CVs in the Prophet are quantized by only the most significant seven bits of a fourteen-bit DAC into 128 83.3-mV steps ($128 \times 0.0833V = 10.67V$), the OSC S/H CVs are quantized by the full fourteen bits into 16,384 651-uV steps ($16,384 \times 0.000651 = 10.67$). This finer resolution allows the TUNE circuitry to tune the oscillators to within 1/128 semitone. It also allows the SCALE MODE feature, where each note can be raised or lowered by up to a semitone. (For further information, see under DAC and TUNE, paragraphs 2-12 and 2-13). In UNISON mode the KBD CV is routed through the Glide circuit and the OSC MSUMs.

Additional OSC 1A FREQ control is created on Voice 1 itself through the POLY-MOD circuit. The P-MOD FREQ A switch applies a CV mixed from the P-MOD FILT ENV and P-MOD OSC B AMT VCAs to the OSC 1A CV SUM input. OSC 1A's pulse width is controlled by two CVs at the OSC A PW SUM. First PW A SUM CV originates in the Common Analog circuitry as the sum of OSC A PW and W-MOD PW A (if ON). Second, the P-MOD PW A switch can add a CV mixed from the FILT ENV GEN and/or OSC B. When on, the OSC A SYNC switch tunes OSC A to harmonic frequencies of OSC B or changes OSC A's timbre when the two are not in harmonic relation. This occurs independently of whatever OSC B waveforms are switched on.

OSC B is similar to OSC A except that besides being a pitch source it can be a modulation source through POLY-MOD, and can operate as an LFO with or without KBD control. In the OSC B MSUM, the OSC B LO FREQ switch adds a -7.5V offset through B SUM CV. To provide adequate control range, the INIT FREQ control doubles its range (to 9V) when OSC B LO FREQ is ON.

The LFO itself is not controlled by the keyboard, and its pulse width is fixed at 50% (square wave). Its output is a modulation CV effective through the five MSUMs.

Details of the 3340 and associated components can be found on its Data Sheet in the Appendix. All 3340 outputs are positive-going. But using the LFO and OSC B as a modulation source requires their triangle peaks travel as far negative as positive for smooth vibrato. On Voice 1, circuitry containing U451-1 (see SD431) shifts down the dc-level of the triangle to be symmetrical about ground.

While creating a symmetrical signal for modulation, the triangle level-shifting poses a slight problem for the 4016, which is basically designed to pass only positive voltages. Figure 2-4, Detail C shows the basic circuit used for switching all bipolar signals in the Prophet. Instead of being grounded, the Vss pin is biased slightly-negative, allowing the switch to pass slightly negative voltages. Diodes at each switch input protect the switch by clamping negative voltages to not exceed the diode drop, which is also the negative bias value (0.6V). Where a bipolar voltage (such as P-MOD OSC B with OSC B TRIANGLE on) is being switched, the level must be sharply attenuated. Where a current (such as all summing nodes) is being switched, the only voltage developed is by the 4016's ON resistance (300 ohm, typical) since the op amp node following the switch is a virtual ground.

2-5 MIXER AND AMOUNT VCAs

The Mixer on each voice sets the level of selected OSC A or B waveforms sent to the filter. Noise level is set in one place for all voices. All of the Prophet's VCA circuits use the RCA 3280 dual operational transconductance amplifier (OTA). The OTA is similar to the typical op amp in input and open-loop gain characteristics but the output is current rather than voltage. (So there must be a load to develop any significant voltage.) The magnitude of the output current is equal to the product of the transconductance (rather than the voltage gain) and the input voltage. The transconductance is adjusted by the amplifier bias current (I_{abc}) at pins 3 and 6 (see Appendix). A second terminal, I_d at pins 1 and 8 control the transfer characteristic (as shown on Data Sheet). In effect, I_d controls the input impedance of the OTA. For example, with I_d cut off, as at U464-1 MIX OSC A, U464-8 MIX OSC B and U428-1 P-MOD OSC B, Z_{in} ranges 100 Kohm. With I_d active, as at U477-1 FINAL VCA, U422-1 P-MOD ENV and U422-8 FILT ENV, Z_{in} ranges 600 ohm.

Since the 3280 is controlled by current, the term CV is not accurate in this context. All 3280 "CVs" are converted to control currents by a 2N4250 PNP transistor as shown in Figure 2-4, Detail B.

In most places, BALANCE trimmers cancel OTA dc-offset, ensuring that even with maximum I_{abc} , there is no output with no input signal.

The OTA is the central component in the Glide circuit, which also contains current mirror Q309 and voltage follower U380-1. GLIDE OUT CV is fed back to the OTA input so positive or negative current will flow if there is a difference between it and UNISON CV. When GLIDE CV is 0, I_{abc} will be maximum because the diode-connected current source biases the other transistor's emitter 0.6V above ground. Transconductance will therefore be maximum, so plenty of current is available to charge C376 and GLIDE OUT CV will follow UNISON CV very closely. However as GLIDE CV increases, I_{abc} decreases, reducing the rate of charge to C376. It will thus take longer for GLIDE OUT CV to approach UNISON CV. This creates a slew between the discrete voltage steps of the input UNISON CV.

2-6 FILTER

The Prophet's five low-pass filters are based on the CEM 3320 integrated VCF. Its scale matches the VCO scale of 1V/OCT, so is also adjusted in semitones by 83-mV DAC steps. Filter frequency is controlled by three CVs summed by U433-7 FILT FREQ SUM. FILT 1 S/H is the Individual CV, FILT SUM CV is the Common Analog output, and the P-MOD FILT switch can add a POLY-MOD CV. R4133 adjusts the FILT FREQ SUM gain.

Details of the 3320 and associated components can be found on its Data Sheet in the Appendix.

2-7 ENVELOPE GENERATORS

The FILT and AMP ENV GENs are based on the CEM 3310. Its output is a positive dc-voltage whose level changes over the time periods set by the input timing CVs. When applied to the VCF and FINAL VCA, the transient voltage determines the frequency and amplitude contours of the voice.

FILT ENV GEN output to the FILTER is controlled by the FILT ENV AMT VCA. (There is no comparable attenuator for the AMP ENV GEN.) Note the P-MOD FILT switch is a redundant path for the FILT ENV GEN output. The switch is provided for OSC B to modulate the FILTER.

Details of the 3310 and associated components can be found on its Data Sheet in the Appendix.

Note that the ATK, DEC, and REL times are controlled by 0 to -5V and the SUS level is set by 0 to +5V. Accordingly, the computer inverts its normal 0 to +10V output so +10V corresponds to minimum, and 0 corresponds to maximum time. The resistor network shown for the AMP ENV GEN (R415, R407, R402...R403) divides the 10-V range by two and performs the required negative level-shift. The FILT ENV GEN is controlled in the same way.

2-8 AUDIO OUTPUT

As shown in Figure 2-4, the VOL CV follows a long path from its source on PCB 3 to the back panel, up to the control panel, and back to PCB 4. If external dynamic control such as a footpedal is used, it (instead of U372) supplies VOL CV through R113. (When troubleshooting for no audio output, check J7).

R4545 in series with U481 minimizes the possibility of oscillation with capacitive loads. R4544 reduces hum resulting when the Prophet is switched off but left connected to an energized amplifier.

2-9 MICROCOMPUTER SYSTEM DESCRIPTION

A microcomputer system consists of electronic hardware and program "software." The microprocessor (or CPU) constantly reads the program instructions from read-only memory (EPROM) which directs the processing of inputs such as switch actions, knob settings and keystrokes into switch commands and CVs for the synth. This section concentrates on hardware functions associated with this processing. The assembly-language program itself is not covered in depth as it is proprietary. But knowledge of the program is not required either to learn how the Prophet operates or to service it. In fact a good deal about what the program must do can be inferred from a thorough understanding of what the hardware does.

See Figure 2-5. If you are unfamiliar with microcomputers you might find it helpful to focus on the Data Bus, to which the CPU, Memory, and all input/output (I/O) devices connect. All processing is communicated over this bus. But since the bus can signify only a byte (comprised of eight bits) at a time, data must be transferred sequentially, a byte at a time. Conflicts between data senders and receivers—actually, bus drivers and latches—are prevented by Chip Selects (CS) generated by the Memory Address, Input Port, and Output Port Decoders. Each memory device, bus driver or latch can only send or receive data when its CS is active, and no two CSs can occur at once. Each CS is decoded from a unique combination of Address and Control Bus signals. All memory devices have A0-A9 in common. These lines signify up to 1024 (1k) addresses. Individual memory devices are differentiated by decoding A10-A12 and -MREQ into CSs which select the appropriate 1-K block. The I/O Port Decoders share A0-A5 with Memory, but only issue CSs or CSOs when -IORQ goes low. While -MREQ and -IORQ indicate Memory or I/O can "converse" with the CPU, -WR and -RD indicate the direction of the transfer is from or to the CPU.

The Scratchpad RAM contains tables which represent the status of the switches, keyboard and knobs. In PRESET mode the Scratchpad's switch and knob tables are loaded by data from NV RAM when the current program is selected. NV RAM contains 40 such sets of programs. In PRESET pressing a switch or turning a knob is an EDIT operation which changes the Scratchpad tables, but has no effect on the original program in NV RAM unless the EDITed tables are specifically recorded (in place of the original program).

Paragraphs 2-11 and 2-12 detail how the input circuits generate data which controls the synth through the output circuits. Although it may take, for example, several thousand data bus operations to completely scan the keyboard and establish the appropriate oscillator CVs, you perceive no delay between a keystroke and the note produced because of the speed at which the program is executed. The basic program "loops" every 6 ms (166 times per second) to maintain the current status of the machine. Any status change such as a keystroke or control operation extends the loop time to about 11 ms.

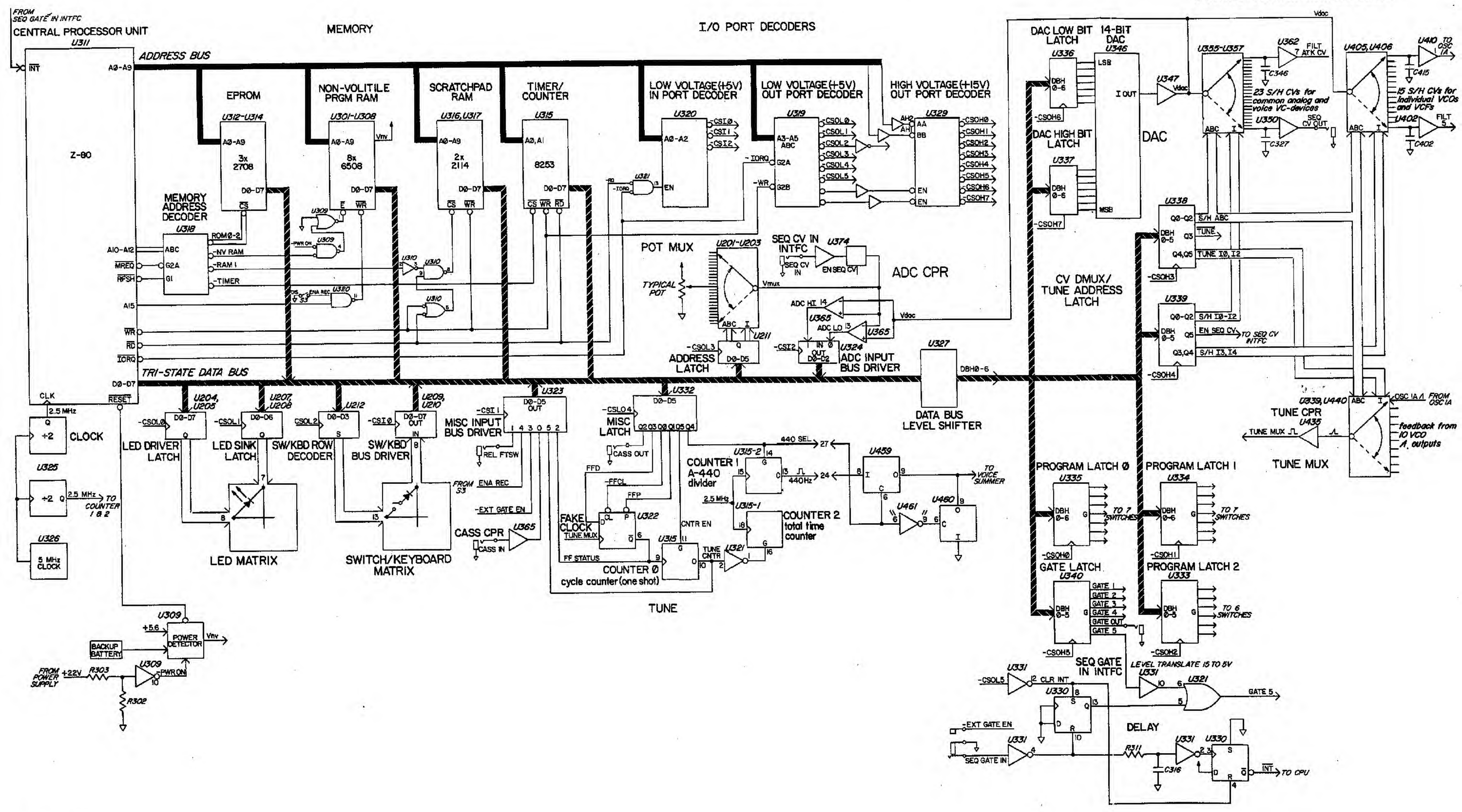

Figure 2-5 MICROCOMPUTER ABSTRACT SCHEMATIC

2-10 MICROPROCESSOR, MEMORY, AND I/O INTERFACE

Please see Figure 2-5 and schematic SD331. The Power Detector (PWR DET) circuit controls CPU start-up and shut-off through the Clock and -RESET signals. PWR DET also contains battery BT301 which provides back-up power, Vnv, for Non-Volatile (NV) RAM. The NV RAM's low current requirement allows the battery a ten-year life expectancy.

WARNING! BT301 MAY EXPLODE IF SHORTED FOR ANY LENGTH OF TIME, ALTHOUGH IT WILL USUALLY "JUST" VENT NOXIOUS GASES.

Vnv also powers U309, CMOS quad NOR gate. With power off, inverter-connected U309-10 is high. This high and that through D301 make U309-13 low holding the CPU -RESET. -RESET initializes the CPU and resets its program counter (PC) to execute the instruction in location 0000 once the Clock starts and -RESET goes high.

When power is switched on the CPU CLOCK starts immediately because the lower power supply voltages stabilize before the higher voltages. When power is switched off, the higher supply voltages decay more quickly. If the CPU is being clocked while power rises or falls, the EPROMs could conceivably cause spurious data to be written into NV RAM, since they operate on a higher voltage than the CPU (+12V as opposed to +5V). Accordingly, PWR DET immediately resets the CPU when power drops, and disables the NV RAM -CS (see below). Divider R303/R302 monitors the highest power supply voltage, which must achieve full value for U309-10 to go low. This discharges C303 through R3-1 so after about one second U309-3 goes high, starting the CPU. With the power on, D303 provides 5V for Vnv.

The Data, Address and Control Buses were basically described in the preceding paragraph. A0-A9 set up one out of 1024 addresses on all the memory chips, while the specific 1-K block CS is decoded from A10-A12, -MREQ, and -RFSH. -MREQ actually signifies the Address Bus indeed holds a valid address for a memory read or write operation. Intended for use with dynamic RAMs, -RFSH indicates the Address Bus instead holds a refresh address. Therefore to enable any memory, -MREQ must be low and -RFSH high.

A15, the most significant Address Bus line is gated with the ENABLE RECORD (ENA REC) signal through U320-11. ENA REC is pulled high by R308 unless grounded by the back-panel RECORD ENABLE/DISABLE switch which, of course, prevents unintended recording into NV RAM. Gating A15 in this way means that although NV RAM is read from memory addresses 0C00-0FFF(H), it is written into through addresses 8C00-8CFFF(H)—rather than just relying on the usual -RD and -WR signals.

-WR indicates the Data Bus holds valid data to be stored in the addressed memory or I/O device. -RD indicates the CPU wants to read data from memory or an I/O device. -IORQ indicates A0-A7 hold a valid address for an I/O operation. The -INT input is discussed in paragraph 2-15.

The Prophet's program is contained in three 2708 1024 x 8-bit ultra-violet erasable programmable read-only memories (EPROM) occupying addresses 000-03FF (ROM0), 0400-07FF (ROM1) and 0800-0BFF (ROM2). Since no write operations are performed into ROM, the appropriate CS is sufficient to place an instruction on the bus.

THE NV RAM which holds the patch programs is made from eight 6508 1024 x 1-bit CMOS static RAMs. Total current demand on the backup battery is 10 uA, or less. Many steps have been taken to protect NV, although cassette storage makes a catastrophic NV RAM failure unnecessary.

TECHNICIANS SHOULD BACK-UP PROGRAMS THROUGH THE CASSETTE INTERFACE BEFORE SERVICING. (IT TAKES ONLY TWO MINUTES.) PLAYERS SHOULD BE ENCOURAGED TO BACK-UP THEIR PROGRAMS ON CASSETTES AND/OR ON BLANK PANEL DIAGRAM (INCLUDED IN OPERATION MANUAL), SINCE IT IS ALWAYS POSSIBLE FOR PROGRAMS TO BE LOST THROUGH THE COURSE OF SERVICE.

NV RAM read and write operations are controlled by the gated A15 and the -NV CS which is only gated through U309-4 if power is on. -NV CS causes the RAM to latch the address bus and place the addressed data on the Data Bus. The CPU acknowledges receipt of the data by setting -NV CS high. For a memory write operation, -NV WR goes low to set "WRITE MODE," and the data is written when -NV CS returns to a high state.

Two 2114 1024 x 4-bit NMOS static RAMs comprise the Scratchpad RAM. The read and write logic for SPAD is similar to that for NV, with added gating ensuring -WR or -RD is low for the SPAD RAM -CS to appear at U310-8.

U315 is an 8253 Programmable Interval Timer (PIT) used in the TUNE and A-440 circuits. For discussion, see paragraph 2-13.

As mentioned above, the I/O Port Decoders issue chip selects which control input sources and output destinations. Table 2-0 shows how all CSs are specifically decoded. Eight of the fourteen Output -CS, undergo a voltage shift from 5-V to 15-V levels. The reason is that the analog switches for 10-V level waveforms in the synth must operate on +15V, therefore so must the latches which control the switches and, likewise, the decoder which controls the latches. Seven bits of the Data Bus itself are also shifted up, by U327, for compatibility with the high-voltage latches and DAC.

Table 2-0
CHIP SELECT DECODING

CS NAME	FUNCTION	-MREQ	-IORQ	-RD	-WR	-A10-A12	A0-A9
ROM 0	ROM 0	0	1	X	X	0	X
ROM 1	ROM 1	0	1	X	X	1	X
ROM 2	ROM 2	0	1	X	X	2	X
NV		0	1	X	X	3	X
RAM 1	SPAD	0	1	X	X	4	X
TIMER		0	1	X	X	6	X
CS10	KBD/SW	1	0	0	1	X	01(H)
CS11	CASS/MISC	1	0	0	1	X	02
CS12	ADC	1	0	0	1	X	04
CSOL0	LED DRVR	1	0	1	0	X	00
CSOL1	LED SINK	1	0	1	0	X	08
CSOL2	KBD/SW DRVR	1	0	1	0	X	10
CSOL3	POT MUX ADR	1	0	1	0	X	18
CSOL4	CASS/TUNE	1	0	1	0	X	20
CSOL5	CLEAR INT	1	0	1	0	X	28
CSOH0	PROG SW 0	1	0	1	0	X	30
CSOH1	PROG SW 1	1	0	1	0	X	31
CSOH2	PROG SW 2	1	0	1	0	X	32
CSOH3	S/H ABC/TUNE	1	0	1	0	X	33
CSOH4	S/H	1	0	1	0	X	38
CSOH5	GATES	1	0	1	0	X	39
CSOH6	DAC LSB	1	0	1	0	X	3A
CSOH7	DAC MSB	1	0	1	0	X	3B

1 = DIGITAL HIGH
0 = DIGITAL LOW
(H) = HEXADECIMAL
X = DON'T CARE

For troubleshooting, it should be emphasized that most computer malfunctions are caused by failures of devices connected to the Data Bus. For example, any shorted latch input can prevent an entire data line from ever being high. Shorts between data lines will also confuse the computer terribly. Shorts may occur within a device or between the PCB traces. If you suspect a data bus problem try to pick out the line(s) with questionable levels: low should be 0-500 mV, high 4-5V (3.5V min for CMOS), as shown in Waveform 2-0A. Readings of 1V or 1.8V, for example, indicate a failure. The general procedure is to first remove socketed PCB 3 devices: CPU, EPROM, SPAD RAM, and NV RAM—WHICH WILL CLEAR THE PROGRAM MEMORY! If this doesn't locate the problem you may have to cut traces. REMEMBER—SINCE THE COMPUTER WAS OBVIOUSLY RUNNING AT ONE TIME, THE SHORT IS MORE LIKELY TO BE DEVICE FAILURE THAN A PC-SHORT, SO BE SURE TO CHECK ALL POSSIBLY BAD COMPONENTS BEFORE CUTTING TRACES. The customary technique is to make the first cut at the electrical center of a bus line to isolate the problem to one half or the other. Then halve the trace again, and so on, until correct levels are restored. To prevent other malfunctions, cut traces should usually be repaired just after they have yielded information on the direction of the short. Note that a short on the high-voltage data bus (DBH) will not usually degrade computer operations since DBH is buffered from DB. However it will be easy to check DBH for malfunctioning switch bits, GATE bits, or S/H addresses.

A DBO, U311-14
B 2.5 MHz CLOCK

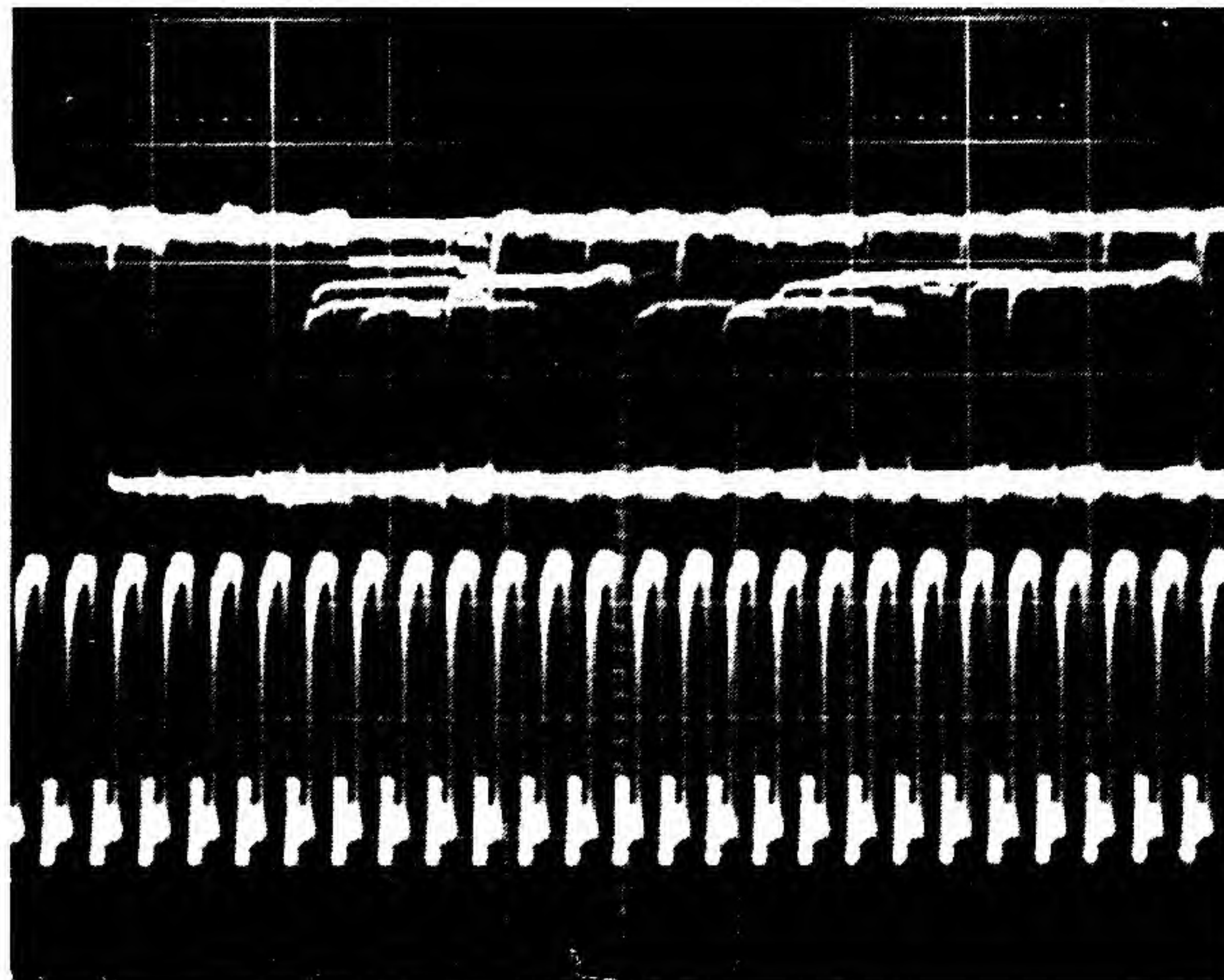

V: 2V/div
H: 1 us/div

Waveform 2-0
DATA BUS AND CLOCK

2-11 CONTROL MATRICES

This paragraph describes how the computer scans the control panel to learn what keys or switches have been pressed, and to light the LEDs imbedded in switches that are on. As input devices, switches and keys are scanned indentically. In both cases the microcomputer maintains tables in Scratchpad RAM which correspond to the status of the Switch/Keyboard Matrix (SW/KBD MTX). That is, each switch or key has a corresponding memory bit which is set (1) or reset (0) if the switch or key is on or off. Although similar in structure the switch and keyboard tables are interpreted quite differently. For example the W-MOD FREQ A switch bit causes a digital output to close or open a solid-state switch, and light or extinguish its LED. But a key bit is converted to a key number (1 - 61) which becomes an OSC FREQ CV through the DAC. In addition, the fact of a key going on or off must be stored for voice assignment and generation of the GATEs.

The SW and LED MTX are divided across PCBs 1 and 2; principal components being shown on schematic SD232. The keyboard is wired into the SW MTX through J201. The LED MTX includes all the elements of DS224 dual BANK-PROGRAM display; all seven-segment decoding being done by software.

The program scans the keyboard first. The basic procedure is to activate one matrix row of eight consecutive keys, then check the intercepting columns for the presence of a bit. The resulting data sent to the CPU by the column bus drivers uniquely identifies a combination of switch closures in each row.

Specifically, to scan the first eight keys the CPU sends the number 08(H) to the SW/KBD ROW DECODER by clocking -CSOL2. This selects S8 (U212-18), which holds the first matrix row high. If C0, E0, and G0 happen to be held, the number 10010001 (91H) will be sent to the CPU when it clocks the bus drivers with -CSI0. This number is then placed in Scratchpad; becoming the first byte in the keyboard table. To read the next key row the CPU increments the driver to set S9, and reads the second key table byte.

Switches are scanned to fill a Scratchpad RAM table in the same way when the CPU sets the driver S0-S4. The diodes wired throughout the SW/KBD MATRIX allow n-key rollover, which is the simultaneous pressing of any number of switches and keys. They prevent switched bits from returning through other closed switches on the same column, which would activate other rows.

For troubleshooting it must be emphasized that most keyboard problems are caused by dirty, bent, or broken J-wires. Dead notes not caused by J-wires usually occur in groups of eight, making it easy to isolate the problem row or column. If a switch does not function and its LED doesn't light, the problem must be in the SW MTX. Check other switches to isolate malfunctions to a single row or column. If the LED lights but the function is not enabled, the problem must be in the corresponding output latch, solid-state switch (4016), or analog circuitry.

The LED matrix operates on the same line-by-line technique used to scan the switches and keys. In fact, the LEDs are "mapped" similarly to the switches so the two tables will correspond. First a number from the Scratchpad LED table representing active LEDs in the first column is latched by the LED DRIVERS U204/5 as port -CSOL0. Then the first column is pulled low—causing current to flow through LEDs whose anodes are being pulled high—through U206-10 by latching data 01(H) to U207/08 LED SINK; port -CSOL1. To output the next column, the CPU sends the next LED table byte to the LED DRIVERS and rotates the LED SINK bit to pull the second-row cathodes low, and so on. The LEDs are therefore not constantly lit, they only seem so due to persistence effects accompanying our sight. Some owners may notice a slight difference in brightness between the BANK and PROGRAM numeric displays, or complain of them flickering while playing. Both effects are normal, resulting from different scan times for each display, and from the lengthening of the "loop" time with each new keystroke.

2-12 ADC, DAC, AND CV OUTPUTS

The DAC is the essential interface between the control potentiometers and microcomputer and between the microcomputer and the synthesizer. It is based on the 16-bit, integrated DAC-71-CSB-I. However, at most, 14 bits are used only for precisely controlling the oscillators while, normally, seven bits provide adequate resolution for all other computer-processed CVs. The DAC's full scale voltage is 10.67V, but most CVs are limited to 10V by the software.

For editing or manual operation, the DAC performs analog-to-digital conversion (ADC). This is done by outputting one of 24 entries from a Scratchpad RAM table of pot settings, at the same time the actual pot is being sampled through the ADC "window" comparator (ADC CPR). (Actually, the 10-V DAC range is divided by two for comparison with 5V-range pots.) The comparator signals ADC HI or ADC LO if the pot wiper is actually set below or above the value of the converted table entry. As long as the voltages don't match, the table value is decremented or incremented until they do match. Once all the pots have been checked, a few adjustments are made (depending on the mode of operation), and the DAC again converts the pot values, this time distributing them and the oscillator and filter CVs to the synth. Thus, the DAC output, V_{dac} , steps between 62 values (24 pots + 38 CVs) (during each 6-ms loop. The POT MUX output, V_{mux} , assumes the value of the settings of all 24 pots during the first part of each loop. This is shown in Waveform 2-1a. In Waveform 2-1b, V_{dac} is shown assuming the 24 comparative pot values and the 38 CVs.

A V_{MUX} , U365-9

B V_{DAC} , U364-7

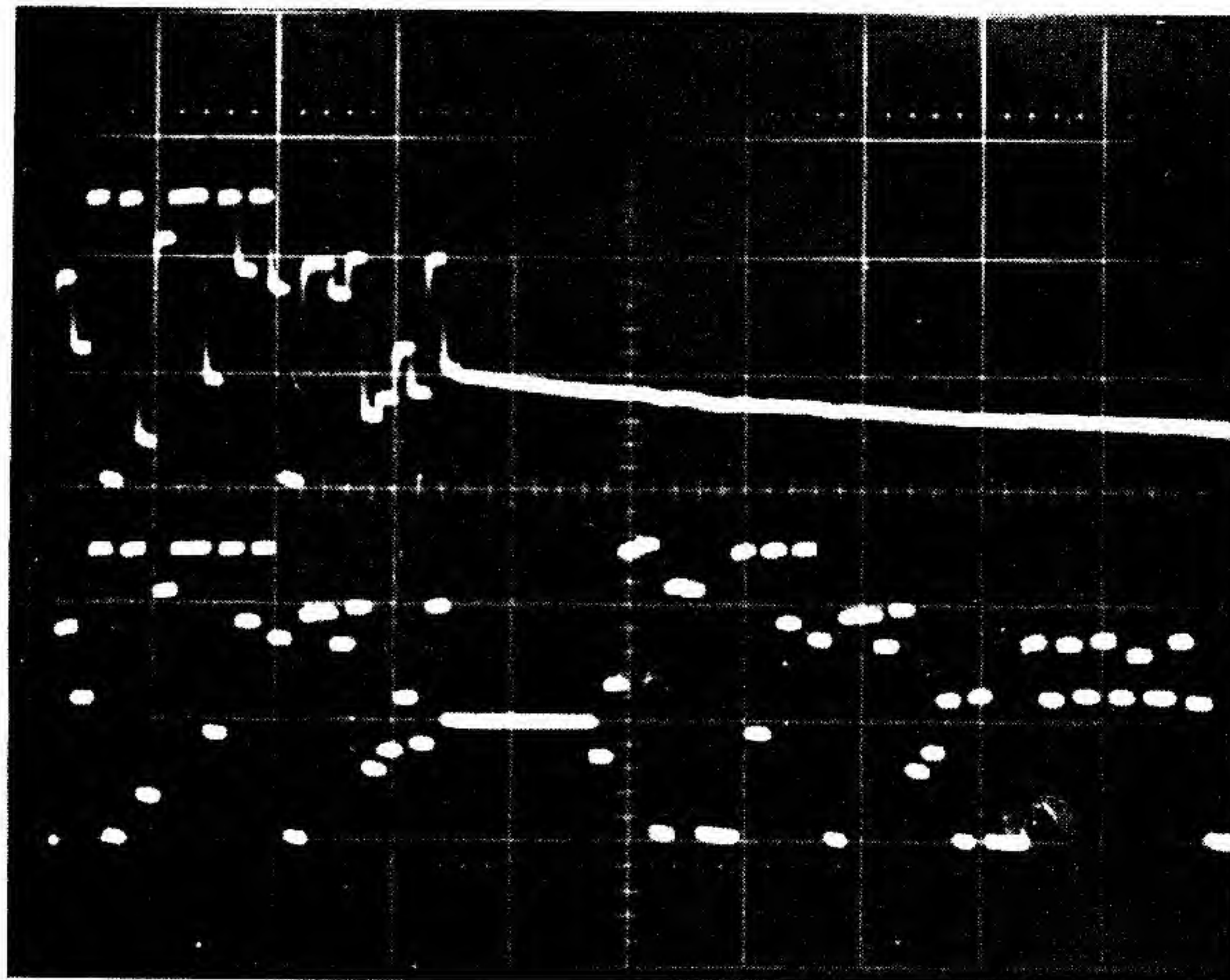

V: 2V/div
H: .5 ms/div
(approx.)

Waveform 2-1
 V_{MUX} AND V_{DAC}

The POT MUX is shown on SD231. Basically, data latched by U211 selects (or, addresses) one of 24 pots at a time, whose wiper voltage becomes the V_{mux} sent to the ADC comparator. The address latch bits Q0, Q1, Q5 have a decimal value 0-7. Waveform 2-2 shows Q0 toggling when clocked. Applied to the A, B, C, inputs of U201-03, these bits simultaneously select one of eight inputs on each 4051. When high the I inputs inhibit the 4051; so to select just one pot, Q2, Q3, or Q4 must be low.

A -CSOL3, U211-9

B Q0, U211-2

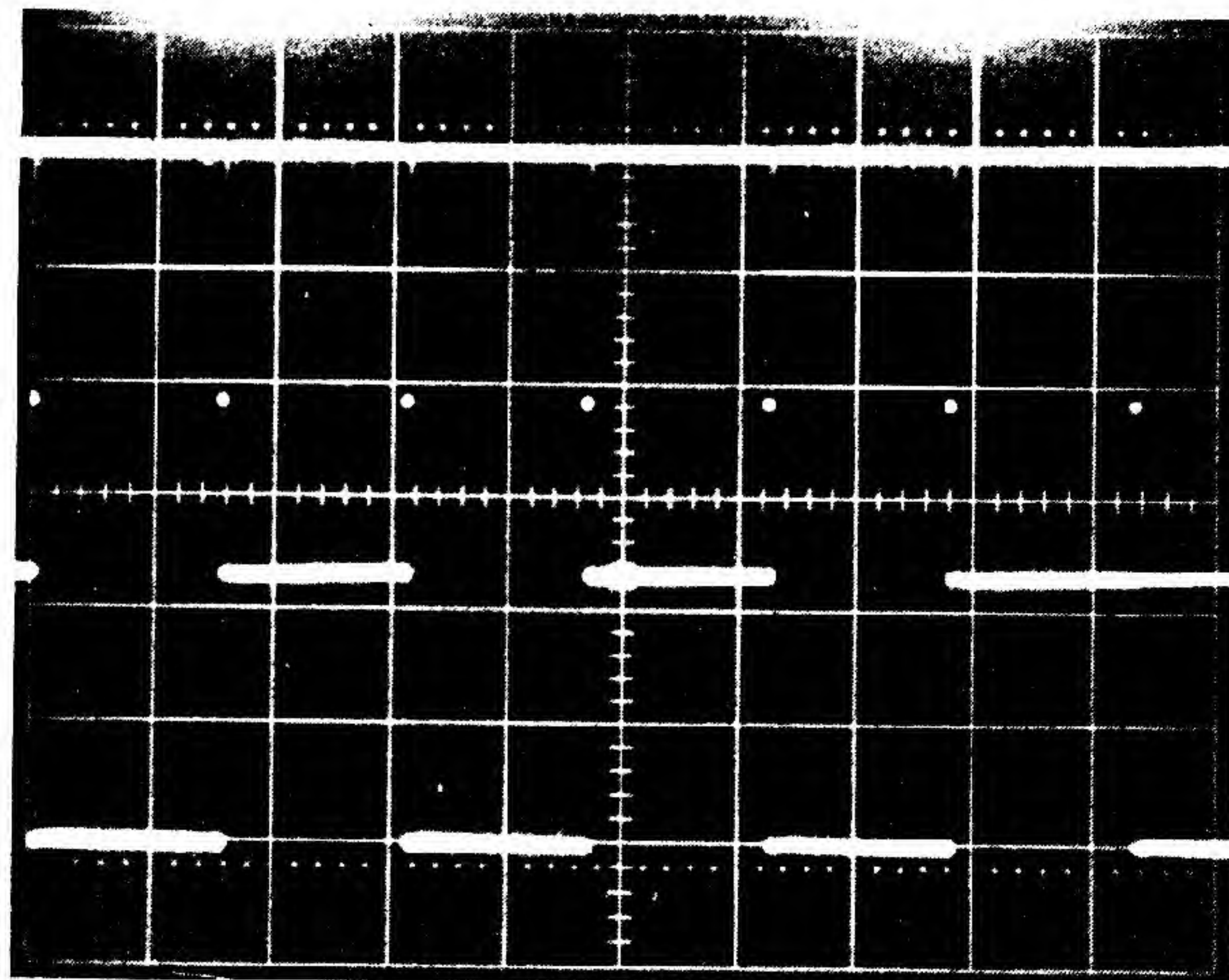

V: 2V/div
H: 50 us/div

Waveform 2-2
POT MUX LATCH

U211's state is undetermined on power-up, since the computer has not yet had time to initialize the POT MUX by setting all inhibits high. U211 might well "come up" with more than one low for Q2, Q3, and Q4. In such cases two or more pots would be connected together at V_{mux} . The current surge resulting from any significant potential difference between their settings would instantly destroy a 4051, were it not for R203/R206/R209.

To check the pots the CPU first places data 18H on the bus and clocks the POT MUX address latch with -CSOL3. This sets Q2 and Q4, inhibiting U201 and U202. With Q3 reset (0), U203 connects R105 FILT ATK wiper from pin 13 to 3. If the knob is set halfway, +2.5V (V_{mux}) will appear at the common input of the ADC CPR, U365-9/10 (see schematic SD332).

Next the CPU takes the first pot table byte from SPAD RAM, places it on the bus, and latches it to the DAC HI latch U337 (and U342-5), port -CSOH7. If we assume this pot has not changed position since the last loop, the converted data should compare with V_{mux} . Thus data 3C(H) pulls DAC bits 11, 12, 13, and 14 low through U344/45 inverters. The DAC has a current output which U347 converts to voltage, in this case 5V ($2.667 + 1.333 + 0.666 + 0.333V$). R334/35 and R336 divide by two so 2.5V appears at U364-7. Since this equals V_{mux} , neither comparator output goes high. The network containing D306/07, and R366-71 provide "hysteresis", such that the difference between $V_{dac}/2$ and V_{mux} must be more than 34 mV before the comparator will activate. Pot drift is also eliminated through software hysteresis which watches the direction of pot changes. A pot must move two steps in the same direction to qualify as a legitimate change. To check the remaining pots, the CPU latches data 19-1F, 28-2F, and 30-37(H) to port -CSOL3. When done, data 38(H) clears the POT MUX. Waveform 2-3 details V_{mux} .

Having updated its Scratchpad RAM tables of switch and key status and of pot values, the CPU is now ready to output the appropriate CVs. Certain adjustments need to be performed, such as figuring the tuning biases according to the notes to be sounded (see paragraph 2-13), and inverting the envelope generator timing voltages (see paragraph 2-7). If UNISON mode is on, the KBD CVs are removed from the OSC S/Hs. GLIDE CV is also switched on in UNISON.

VMUX, U201-3

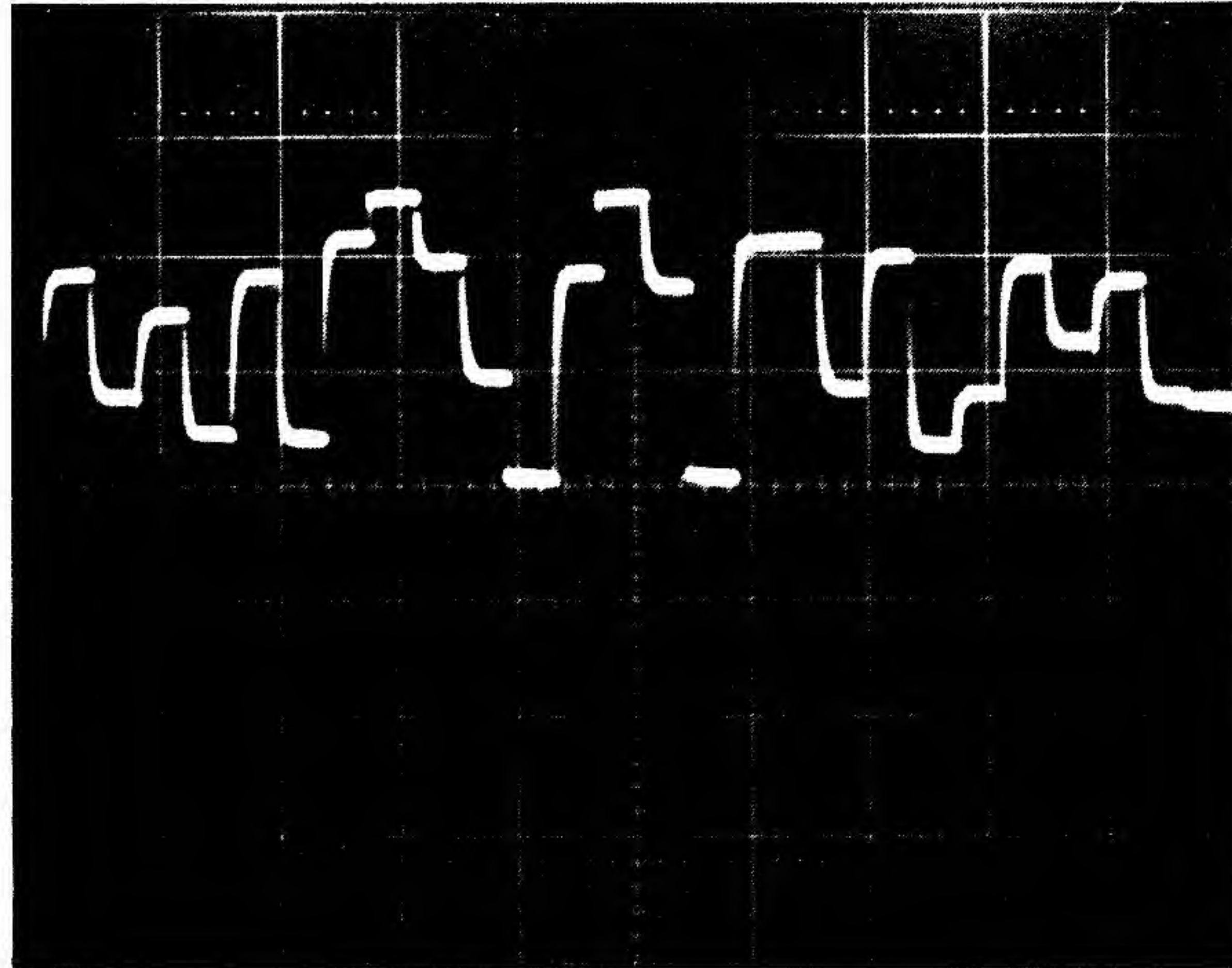

2V/div
.2 ms/div

Waveform 2-3
VMUX

The CV DMUX is the reciprocal of the POT MUX. In fact it uses the same 4051 devices, though wired so a single input can be routed to one of 38 destinations. As in the POT MUX, CV destinations are addressed by data latched from an output port. And since CV distribution is sequential, a short-term sample/hold (S/H) analog memory is provided at each destination to ensure the synth is isolated from the pulsing Vdac. Each S/H consists of a low-leakage capacitor in shunt with the non-inverting input of a TL082 JFET-input op amp (BIFET) voltage follower. The BIFET has extremely high input impedance—several thousand megohms. The computer-output process of strobing the S/Hs only allows a few microseconds for each S/H to acquire a specific value of Vdac. The S/H capacitor is large enough to hold this charge for 11 ms (the longest loop time) but low enough to quickly recharge to a higher or lower Vdac when next strobed. Between strobes, or whenever the 4051 is inhibited, the S/H output remains constant because there is no discharge path for the capacitor. As a practical matter S/H output can be expected to “droop” up to 1/2-mV over 7 ms. Droop greater than this is usually BIFET failure (input leakage). Of course capacitors can also leak, and if open, will make the S/H output pulse.

Using the FILT ATK example above, data 3C(H) is again sent to the DAC through port -CSOH7, producing a Vdac of 5V (Remember that the six ENV GEN timing CVs are inverted in software). Port -CSOH4 S/H STROBE latch U339 (see schematic SD333) sets S/H I0, I1, I2, I3, and I4 all high, inhibiting all DMUX 4051s. Port -CSOH 3 latches data 00. S/H I0 then goes low enabling U357 which strobes C346 and U362-7 with 5V. I0 returns to a high state, completing the first strobe. In short, the DMUX 4051s are always inhibited while Vdac is changing value.

To set oscillator pitch, first the most significant DAC bits are latched through -CSOH7, then the least significant DAC bits are latched through -CSOH6. The Individual CV DMUX is located on PCB 4, controlled by S/H A, B, C, I3, and I4 (see schematic SD430).

2-13 TUNE AND A-440

The synthesizer and microcomputer circuits employed for polyphony and programmability having been covered, this paragraph explains the third main feature resulting from the Prophet's A/D hybrid technology. The TUNE system has only been briefly mentioned before, but it is responsible for the entire performance of the instrument in the sense that without its corrective influence, the Prophet's ten voice oscillators could not be expected to stay in tune over their nine-octave range. The reasons for this are several.

There are two basic parameters to work with in tuning. One is initial frequency (INIT FREQ) that is, the specification that all ten oscillators sound the same pitch given the same, steady CV. The other is SCALE (or, V/OCT), which desires a predictable pitch change to accompany a specified CV change. INIT FREQ errors can be introduced by any of the many sources of oscillator control. While summing resistors in the Common Analog circuitry are precision-matched, errors may still result from the combination of MTUN, P-BND, W-MOD, UNISON, and FINE (on OSC B). In the voices the A SUM and OSC S/H CV summing resistors and P-MOD FREQ A circuits are error sources. SCALE errors generally occur in the VCO itself. For example, while a CV change from 1V to 2V may produce an exact octave interval, a change of 5V to 6V might cause a pitch change of greater or less than an octave. All VCOs have this error to some degree somewhere in their range. For an IC, its associated components, such as the SCALE trimmer, can contribute error. Chips age, and their parameters will change with changing temperature—although this effect is significantly reduced with on-chip temperature compensation circuitry (see Appendix).

Actually, TUNE has two stages, only the first of which occurs when the TUNE switch is pressed. In less than ten seconds the microcomputer samples each VCO frequency at octaves, while using successive-approximation to determine the exact 14-bit CV required to tune the VCO to a reference. The system measures the period of each oscillation in terms of CPU clock cycles. The difference between the ideal, 83mV-step CV which should produce the reference frequency and the 14-bit, 651-uV CV which actually does so is called bias. Biases for each oscillator are determined at the ten C's (C0 - C9) across the VCOs' full range. The biases are placed in a 200-byte table in Scratchpad RAM (1 bias/oct × 10 oct × 2 bytes/bias). The second stage of TUNE occurs while playing. Whenever an OSC S/H CV is to change in response to a keystroke, the computer determines the new note's position between octave bias-points, and calculates the exact bias for that semitone.

U433/40

The first stage functions as follows. First the CPU disables the PITCH wheel, MTUN, and UNI CV, by opening switches in their signal paths. The TUNE circuit consists of ~~U339/40~~ U435 TUNE MUX (see Figure 2-5 or schematic SD430), U435 TUNE CPR, and Counter (CNTR) 0 and 2 of U315, a three-section 8253 Programmable Interval Timer. (CNTR 1 is used for A-440, discussed below). When activated, the TUNE MUX sequentially connects each oscillator output to the TUNE CPR in the same way the POT MUX samples pots for the ADC CPR. The TUNE CPR converts the sawtooth to pulses. With no input at U435-3, R4158/R4159 hold U435-2 at 1.36V, so U435-7 is high. U435-3 increases with the positive-going sawtooth, so that when it crosses 1.36V, U435-7 goes low. R4170 feeds-back the transition to prevent oscillation (hysteresis).

The TUNE flip-flop (FF) must be explained in conjunction with the 8253. The PIT contains three independent, multi-mode, 16-bit presetable down-counters addressed as memory locations 1800-1802(H), plus a control word register at 1803(H). TIMER -CS must be low for all write or read operations. -WR or -RD indicate the CPU is writing a control word or count, or expecting a count. During initialization (on power-up) each counter's mode is programmed by a byte written into the control word register. CNTR 0 operates in "one-shot" mode. It is programmed to, at first, count one oscillator pulse. But the 8253 actually requires an extra clock pulse—which we call a "fake clock"—to accurately begin the count. Therefore each oscillator sampling is preceded by the fake clock pulse from the TUNE FF, under control of U332, port -CSLO4 (see schematic SD332). After the fake clock pulse, FFD goes high, allowing the TUNE FF to invert TUN MUX through -Q (U322-6). The TUNE FF is then constantly cleared in preparation for each new oscillator pulse.

With CNTR 0 enabled by CNTR EN at U332-5, OUT0 (U315-10) goes low at the first oscillator edge from the TUNE CPR. U321-1 inverts this to a high which gates CNTR 2. CNTR 2 is programmed to count CPU clock cycles, so it decrements at the rate of 2.5 MHz. When CNTR 0 reaches its terminal count, that is, when one pulse (in addition to the fake clock) has been counted, OUT0 goes high, stopping CNTR 2. CNTR 2's 16-bit register now represents the number of CPU clock cycles occurring during one period of OSC 1A's sawtooth. This number is compared to a reference. An oscillator that is too sharp will have a lower count than the reference, and vice versa. As long as the count and reference don't match, the CPU adjusts the OSC S/H CV and samples the sawtooth again. Successive approximation starts with the DAC MSB, setting each bit which does not cause the oscillator pitch to overshoot the reference.

After tuning OSC 1A at C3, the reference count is halved to tune C4, since one cycle at C4 should take exactly half the number of CPU clock cycles than at C3. For octaves C5 - C9, the cycle count in CNTR 0 is doubled instead (2, 4, 8...32). The C0 - C2 biases are actually extrapolated from the curve suggested by the C3 - C9 bias table, rather than found by direct measurement because counting such low-frequency pulses would take an inconvenient amount of time. The remaining oscillators are tuned in the same way.

When enabled by U332-12, CNTR 1 simply divides 2.5 MHz by 5682 to produce the 440-Hz square wave summed into the AUD OUT stage (see SD430). To prevent noise, the A-440 input is grounded by U460-9 when not in use, by inverter-connected U461-9.

2-14 SEQUENCER INTERFACE

The sequencer interface is intended for use with SCI's Model 800 Digital Sequencer, although the design is flexible enough to interface with many types and qualities of analog inputs. For sequence recording the Prophet outputs the keyboard CV and a trigger pulse for the most recently played note in polyphonic mode, and for the lowest note played in UNISON mode. To playback, the sequencer sends the same CV and trigger pattern to the Prophet, which digitizes the SEQ CV IN for control of Voice 5.

The Prophet's sequencer output (record) circuitry is the same as the synthesizer output circuitry. SEQ CV OUT appears at S/H U350-7 before buffering by voltage follower U348-6 (see schematic SD333). The SEQ TRIG OUT is a bit latched by port -CSOH5, U340-2.

The sequencer input (playback) circuitry is a bit more complex (see schematic SD332). Connecting SEQUENCER.GATE IN closes a switch on J3 grounding U323-10. When port CSI1 is input, this low notifies the computer to process the two SEQ inputs. SEQ CV IN is assumed to be an analog voltage which slews between its various values. The slew rate will vary with the type of sequencer (or other accessory). Ideally, the input device only produces its GATE once its CV output has fully stabilized. However, in the worst case some accessories will continue to slew after producing the GATE. For this reason the Prophet delays the SEQ GATE IN to allow SEQ CV IN time to settle, by using the interrupt (-INT) feature of the CPU.

During initialization the Z-80's interrupt mode is programmed so that a low on the -INT pin forces the program to restart at memory location 38(H) (when the interrupt has been software-enabled). This is the starting address of the SEQ HANDLER subroutine. Initialization also clears the -INT through port -CSOL5. U331-12 inverts this -CS to +CLR INT which resets U330-4, making -Q high. U330-13, Q remains low, being held reset by U331-4. When a GATE appears, U331-4 goes low and U331-2 goes high after a 2-ms delay through R311/C316. This high clocks U330-3, producing the -INT pulse at U330-2.

When it receives the -INT, the CPU completes its current instruction, placing the next instruction address and register statuses on the "stack", then enables the SEQ CV IN by latching EN SEQ through port -CSOH4, U339-2 (see schematic SD333). This bit closes switch U371-9, connecting the SEQ CV IN to the ADC CPR. The SEQ CV is then determined through successive-approximation and stored in a Scratchpad table for later addition to Voice 5. After the voltage is processed, the CPU again clears the interrupt. However, this time U330-13 goes high, gating voice 5, because U330-10 is being held low by the SEQ GATE IN through U331-4. When SEQ GATE IN turns off, U330-13 is again reset.

2-15 CASSETTE INTERFACE

The cassette interface hardware is simple (see schematic SD332). For storing on tape, bits are serially-latched out through MISC output port -CSOL4, U332-7, filtered by R324/C351, and ac-coupled to the recorder input by C352. For loading from tape, the pulses are ac-coupled by C361 and squared-up by the CASS CPR which, as a zero-crossing detector, is insensitive to phase or polarity variations between recorders. R343 and R344 form a divider parallel with divider R342, R430, R337, and R341, each having a threshold of about 0.9V. D305 clamps the pulses to not exceed -0.6V. Read bits are input through MISC input port -CSI1. Since allowance must also be made for speed variation, a technique of counting edges rather than identifying logic states must be used.

Organized as 40 24-byte programs, NV RAM contains 960 bytes. The least-significant seven bits of each byte represents a pot setting of 0 - 127 steps, while the MSB represents a switch setting (1=on, 0=off). (When selecting a program in PRESET mode, a set of twenty-four bytes is transferred to the Scratchpad, with the pot bits filling the pot table and the switch bits being regrouped into the switch status table.) Interface timing is based on a unit called a minim, which is equivalent to 232.4 us. Each bit is transmitted or received over a 12-minim period (2.8 ms), with a few microsecond space between them. To write, the interface simulates frequency-shift keying (FSK) by toggling the output latch every minim to indicate a 1, and every fourth minim to indicate a 0. These rates correspond to approximately 2151 Hz ($1/234 \text{ us} \times 1/2$) and 538 Hz ($2151 \text{ Hz}/4$). When reading from tape the interface counts the edges received and loads a 1 or 0 into NV RAM depending on whether the number of edges is greater or less than seven. The absolute number of edges need not be detected in any specific period, thus providing range to accommodate wow and flutter in the cassette deck.

SECTION 3 DOCUMENTS

3-0 DOCUMENT LIST

SHEET	DOC No.	TITLE	PAGE
	BD031	INTERCONNECTION	3-3
	PP131	PCB 1 PARTS ID	3-4
A	SD131	PCB 1 CONTROLS.....	3-5/3-6
	PP231	PCB 2 PARTS ID	3-7
B	SD231	PCB 2 POT MUX	3-8
C	SD232	PCB 2 CONTROL MATRICES	3-9
	PP331	PCB 3 PARTS ID	3-10
D	SD331	PCB 3 CPU, MEMORY, I/O INTERFACE	3-11
E	SD332	PCB 3 DAC, ADC, TUNE, SEQ, CASSETTE	3-12
F	SD333	PCB 3 CV DMUX, LATCHES	3-13
G	SD334	PCB 3 W-MOD, MASTER SUMMERS	3-14
H	SD430	PCB 4 CV DMUX, TUNE MUX, AUD OUT	3-15
	PP431	PCB 4 PARTS ID	3-16
I	SD431	PCB 4 VOICE 1	3-17
J	SD432	PCB 4 VOICE 2	3-18
K	SD433	PCB 4 VOICE 3	3-19
L	SD434	PCB 4 VOICE 4	3-20
M	SD435	PCB 4 VOICE 5	3-21
	PP531	PCB 5 PARTS ID	3-22
N	SD531	PCB 5 POWER SUPPLY	3-23/3-24

3-1 DOCUMENT NOTES

These notes explain component designation and the use of symbols on our documentation. For glossary of abbreviations, see Section 6.

Component designators include three items of information:

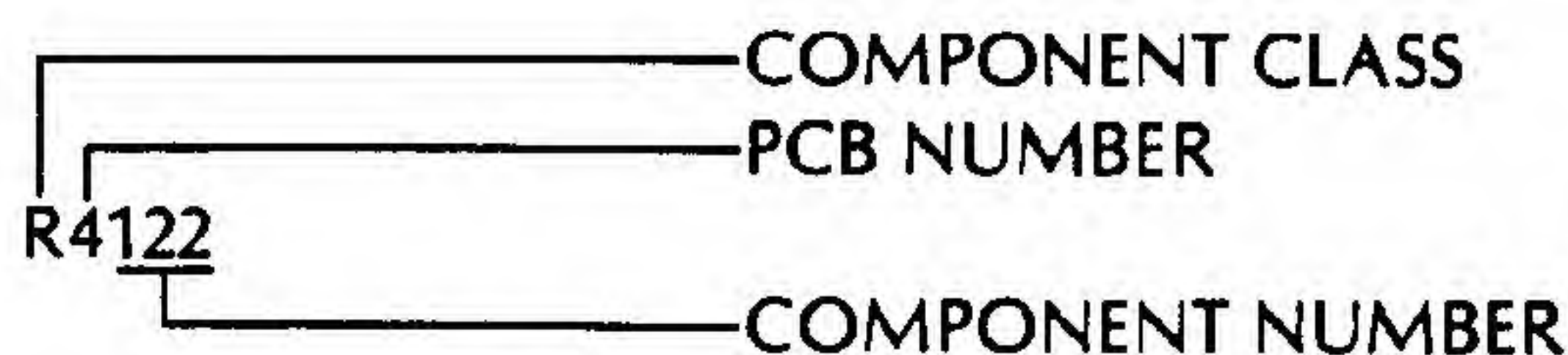

COMPONENT CLASS is symbolized by standard letters, for example, U for integrated circuit, RT for temperature-sensitive resistor, and DS for indicator.

PCB NUMBERS are:

- PCB 1 RIGHT CONTROL PANEL
- PCB 2 LEFT CONTROL PANEL
- PCB 3 COMPUTER BOARD
- PCB 4 VOICE BOARD
- PCB 5 POWER SUPPLY BOARD

No PCB NUMBER is given for chassis-mounted components.

COMPONENT NUMBERS are sequenced according to their position on the PCB.

We bus lines together to prevent long, confusing parallel runs. For example, DATA BUS lines are drawn as a single line, with individual lines symbolized DB0, DB1, DB2... where the bus "fans-in" or "fans-out" at a device. If there are no DB (or A, ADDRESS BUS) symbols, the bus lines are assumed to connect according to the device pin names.

Although bussing wires reduces the number of interrupted signals, some breaking of lines on a page or continuation of signals between pages cannot be avoided. At these points you will find symbols such as:

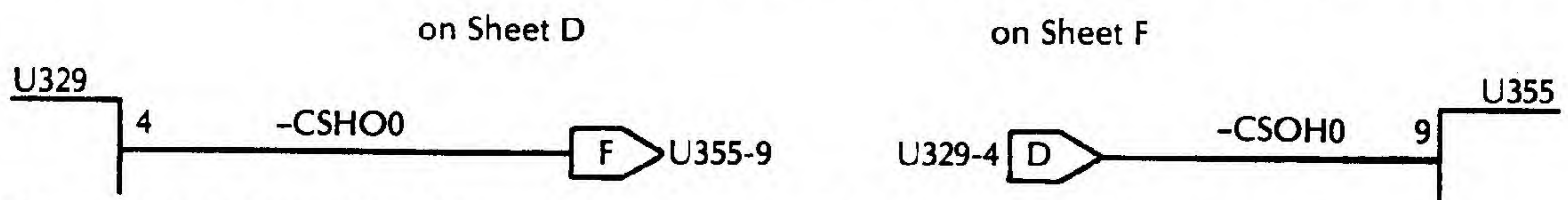

The pointers indicate signal flow. The sheet letter symbol is found in its margin.

Connectors are drawn according to whether the pins are male or female, so the arrows do not necessarily indicate signal flow.

Zeros are slashed (Ø) only where needed to prevent ambiguity.

Power and ground connections for multi-device packages have been shown on the first device in the package, except where the first device is not presently used.

Unless otherwise indicated resistances are in ohms and capacitances are in microfarads.

TOP PANEL ASSEMBLY

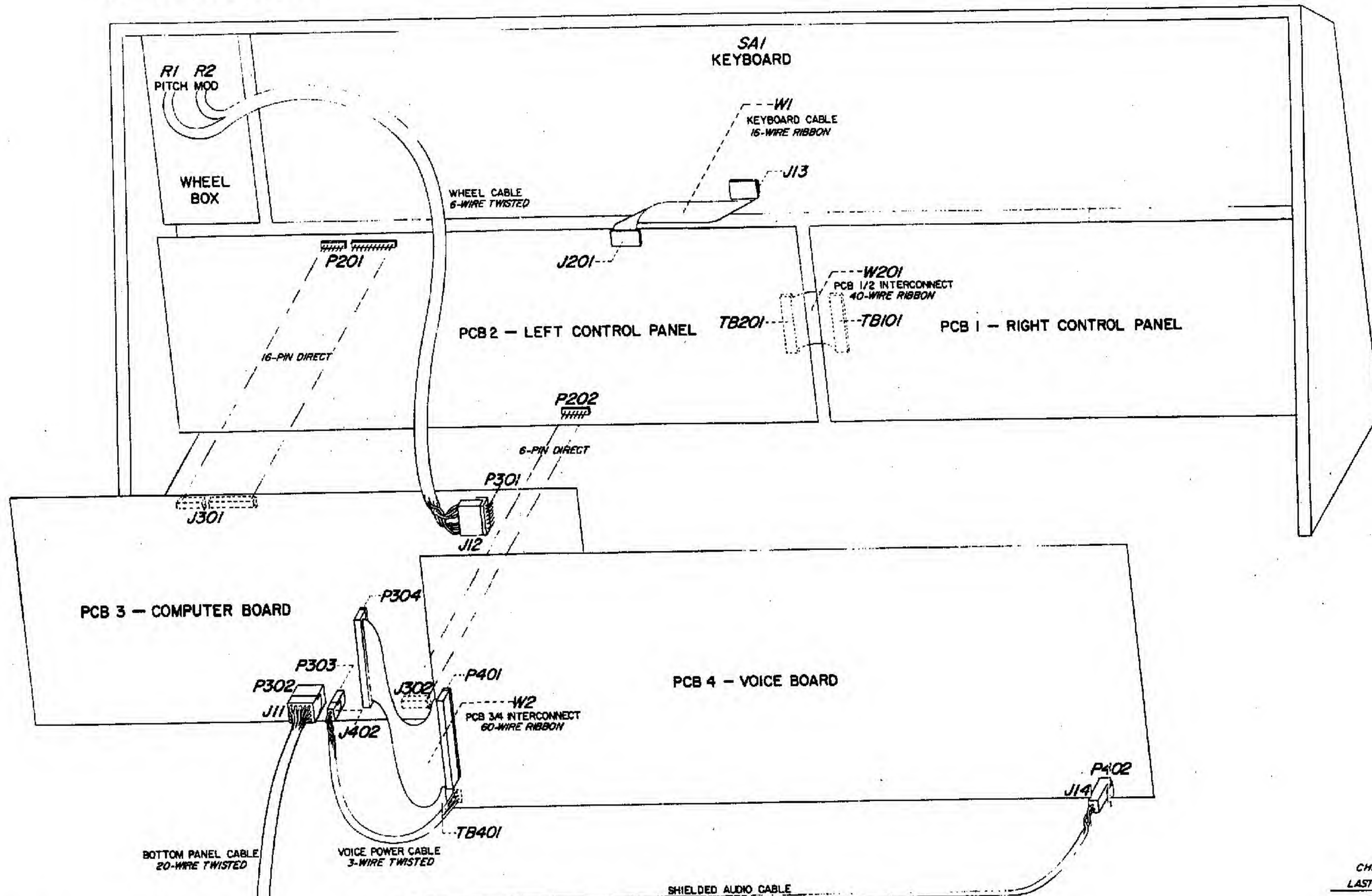

BOTTOM PANEL ASSEMBLY

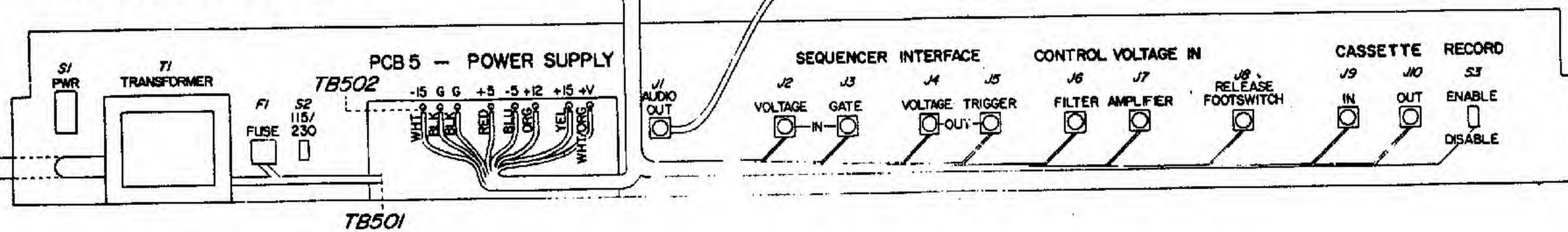

CHASSIS	
LAST	NOT USED
F1	
J4	
P1	
R2	
S3	
SA1	
T1	
W2	

SEQUENTIAL CIRCUITS INC	
TITLE INTERCONNECTION	
DESIGNER	DATE
APP	REV
DATE	REVISION
DOCUMENT NO. BD031	
SHEET 1 OF 1	

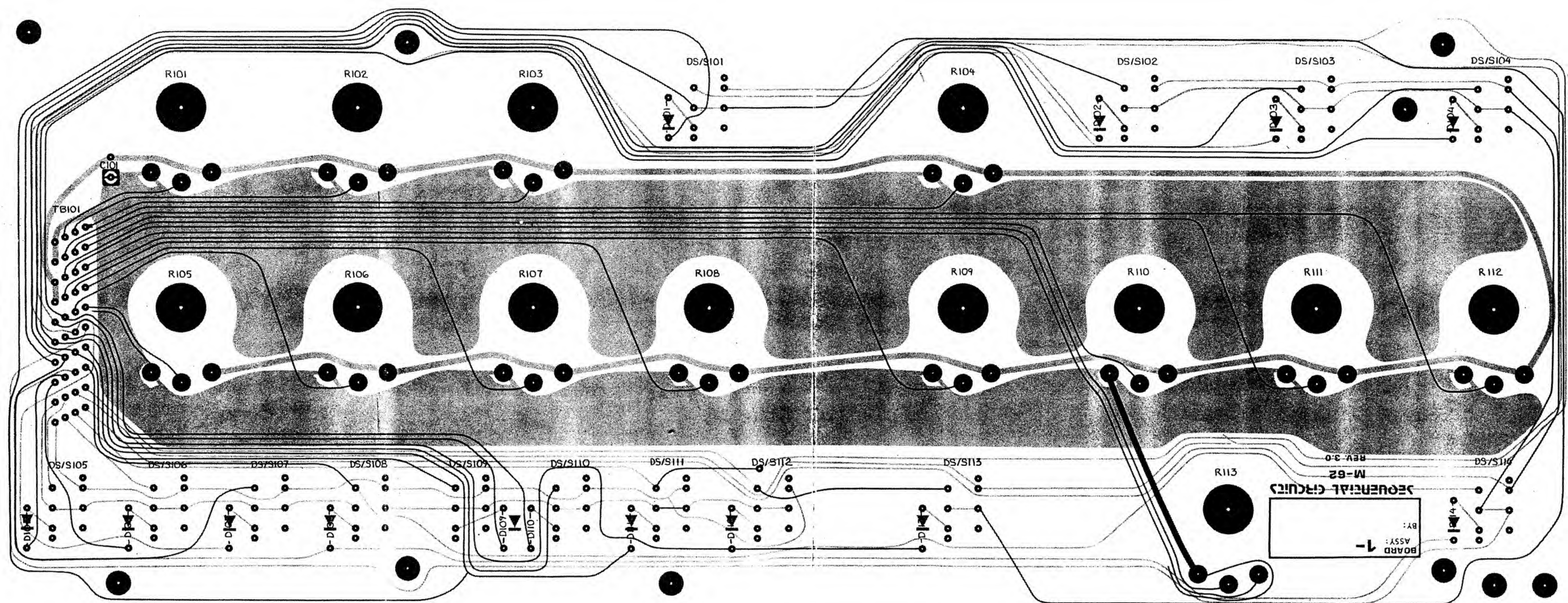

3-4

SEQUENTIAL CIRCUITS INC					
TITLE PCB1 PARTS ID					
DSN	DATE	REV	D	MODEL No	1000.3
DWN	7/17/60			DOCUMENT No.	PP 131
APP					
ISS	5	12/60			SHEET 1 OF 1

TB101/201

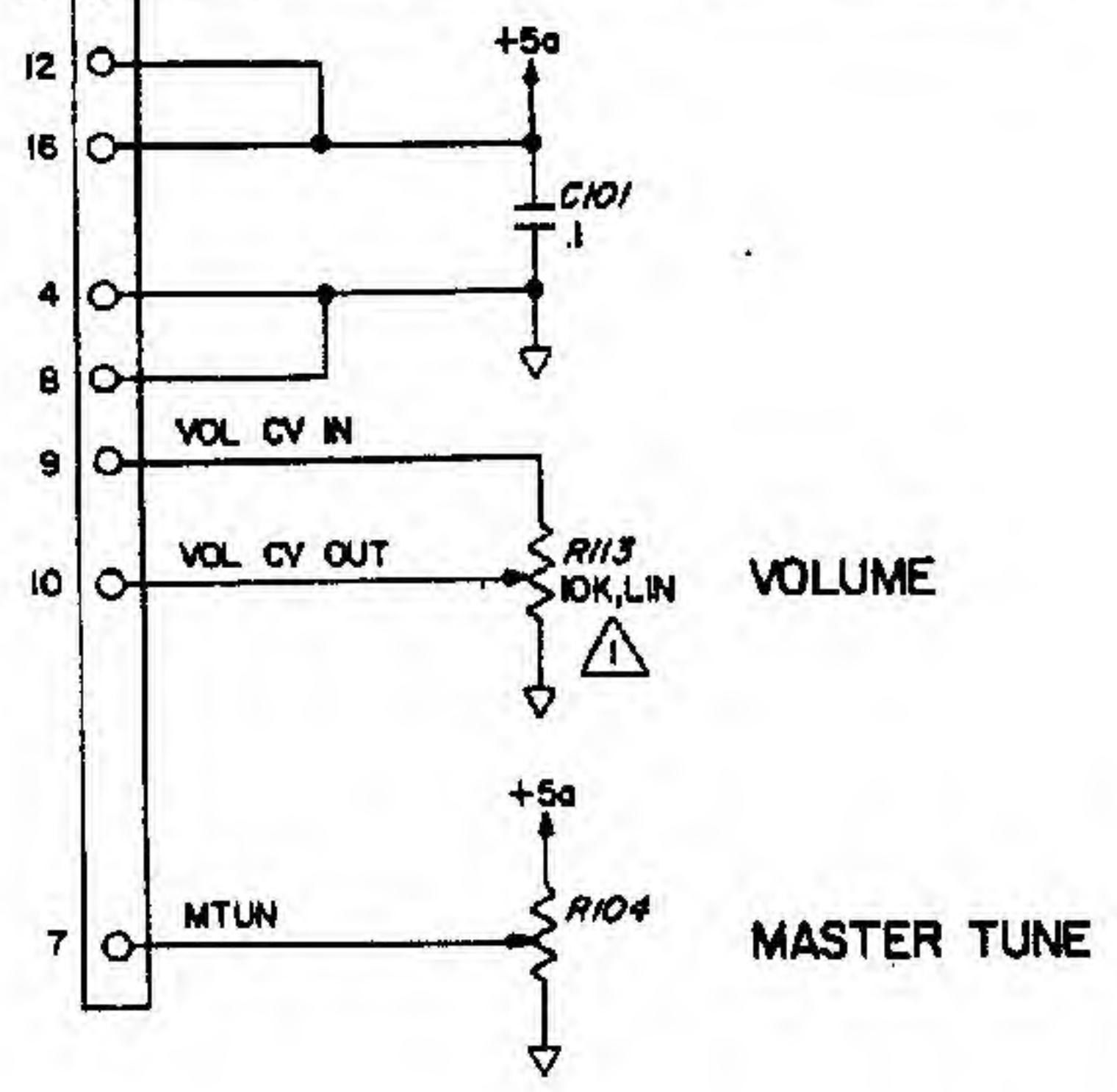
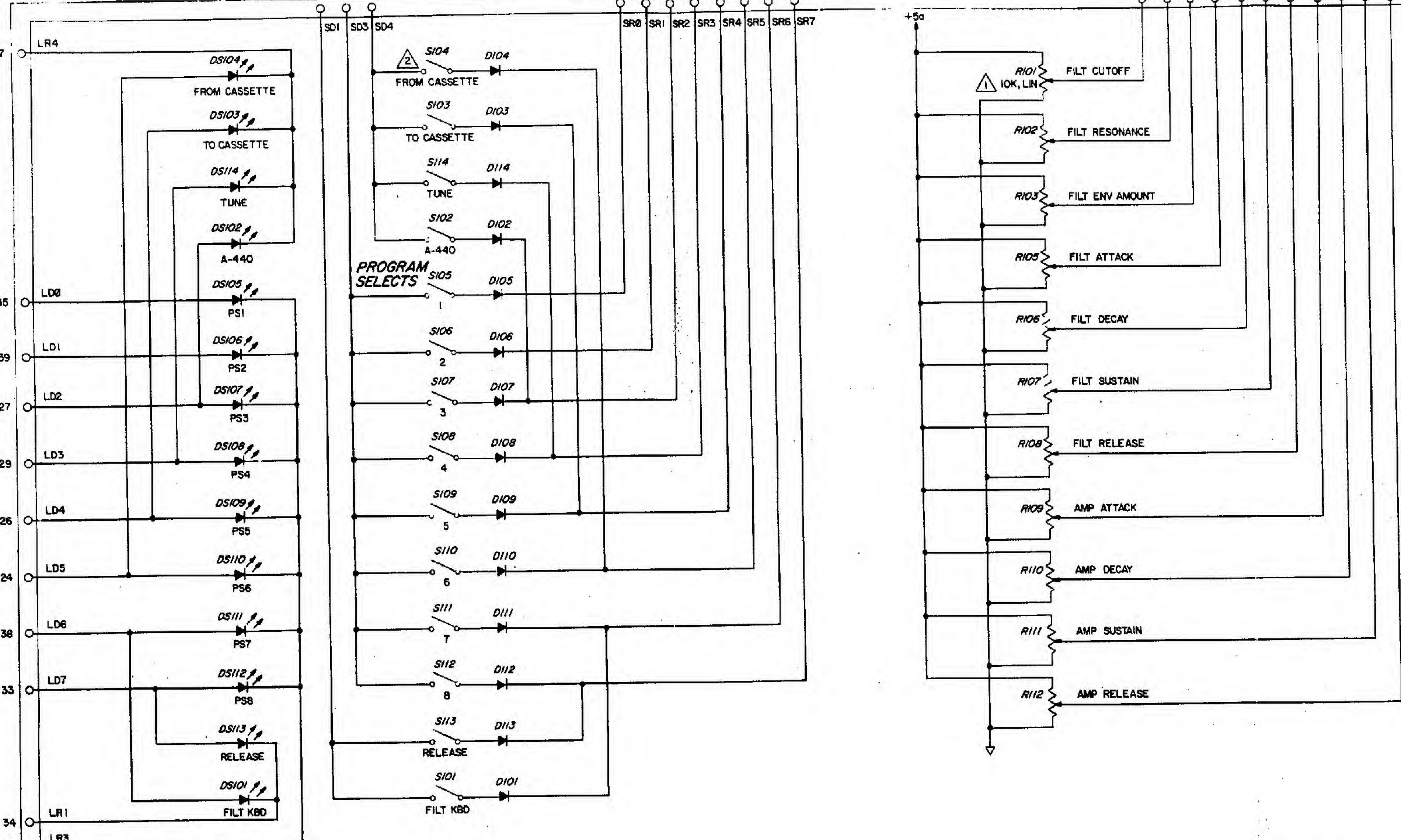

1 ALL POTS IOK, LIN
 2 S101/13 ARE BLACK
 S102-12 ARE GREY

LAST	NOT USED
C101	
D114	
DS114	
R113	
S114	
TB101	

3-5/3-6

SEQUENTIAL CIRCUITS INC			
TITLE PCB1 CONTROLS			
DESIGN	DATE	REV	NO. 1000.3
APP	DATE	REV	DOCUMENT NO.
SDI31			SHEET 1 OF 1

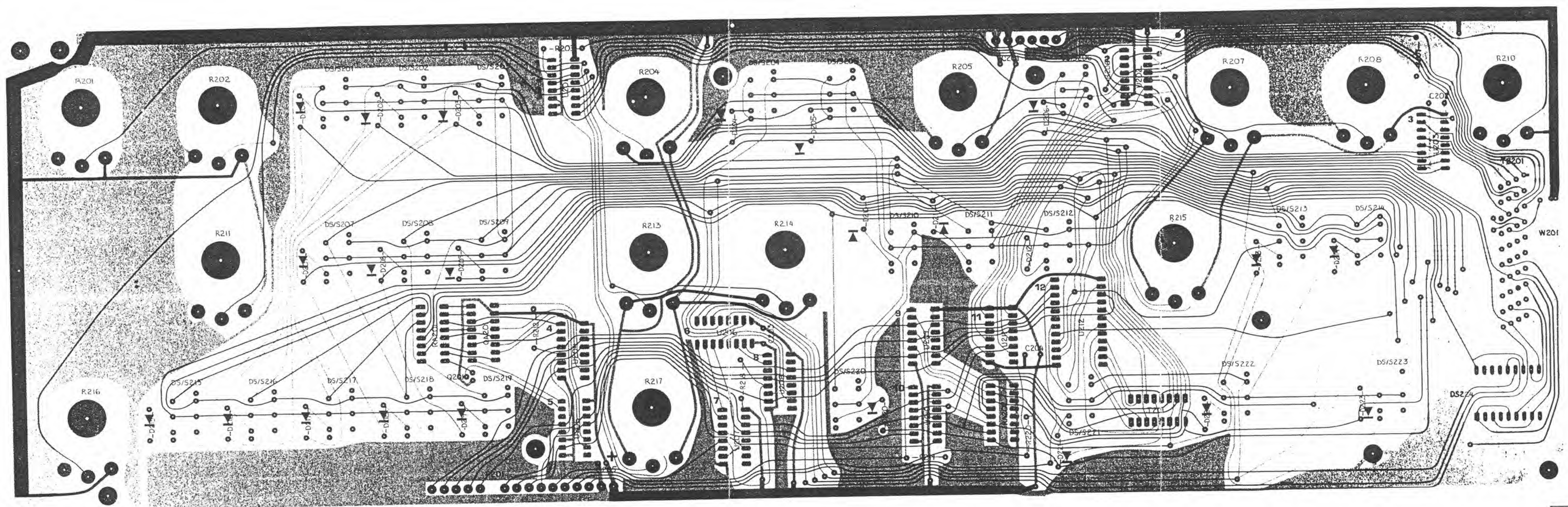

3-7

SEQUENTIAL CIRCUITS INC			
TITLE PCB 2 PARTS ID			
DESIGN	DATE	REV	REV E
DWH	7/17/60		
APP			
ISS	5/1/60		
DATE	REV	REVISION	DOCUMENT NO.
			PP 231
			SHEET 1 OF 1

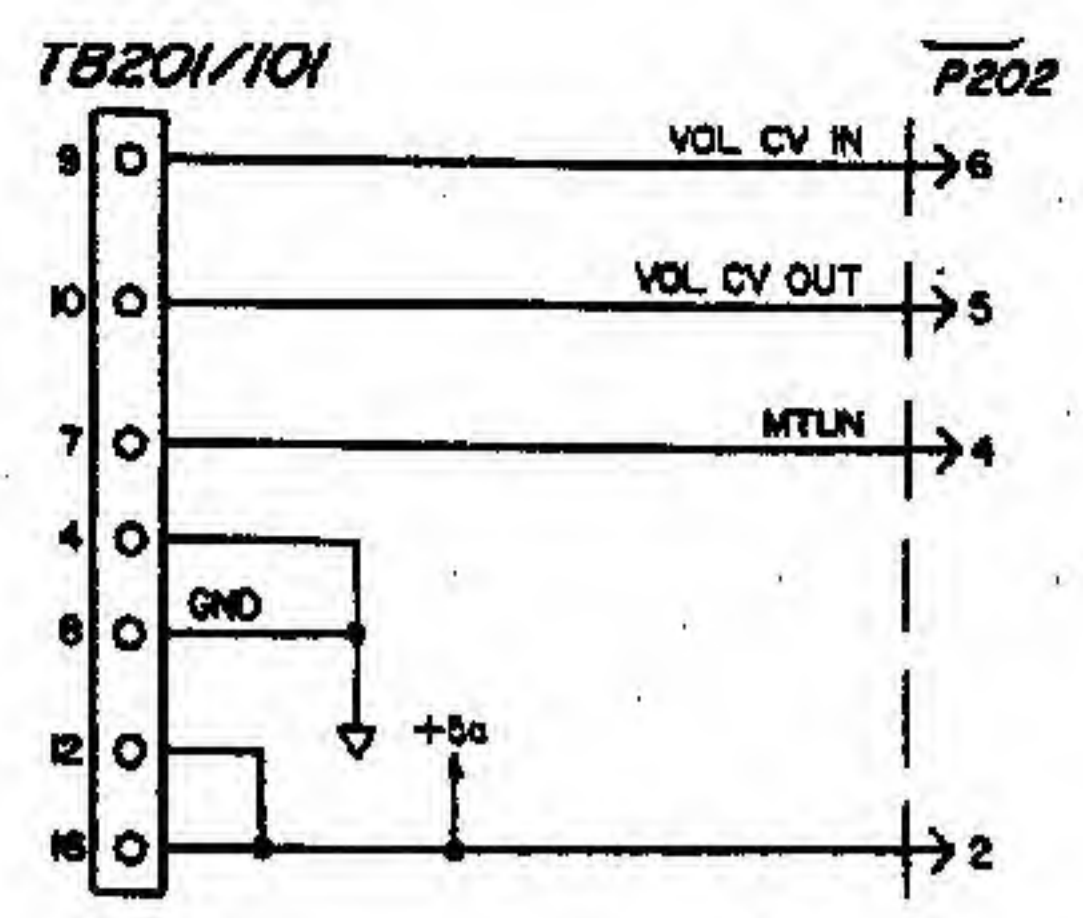
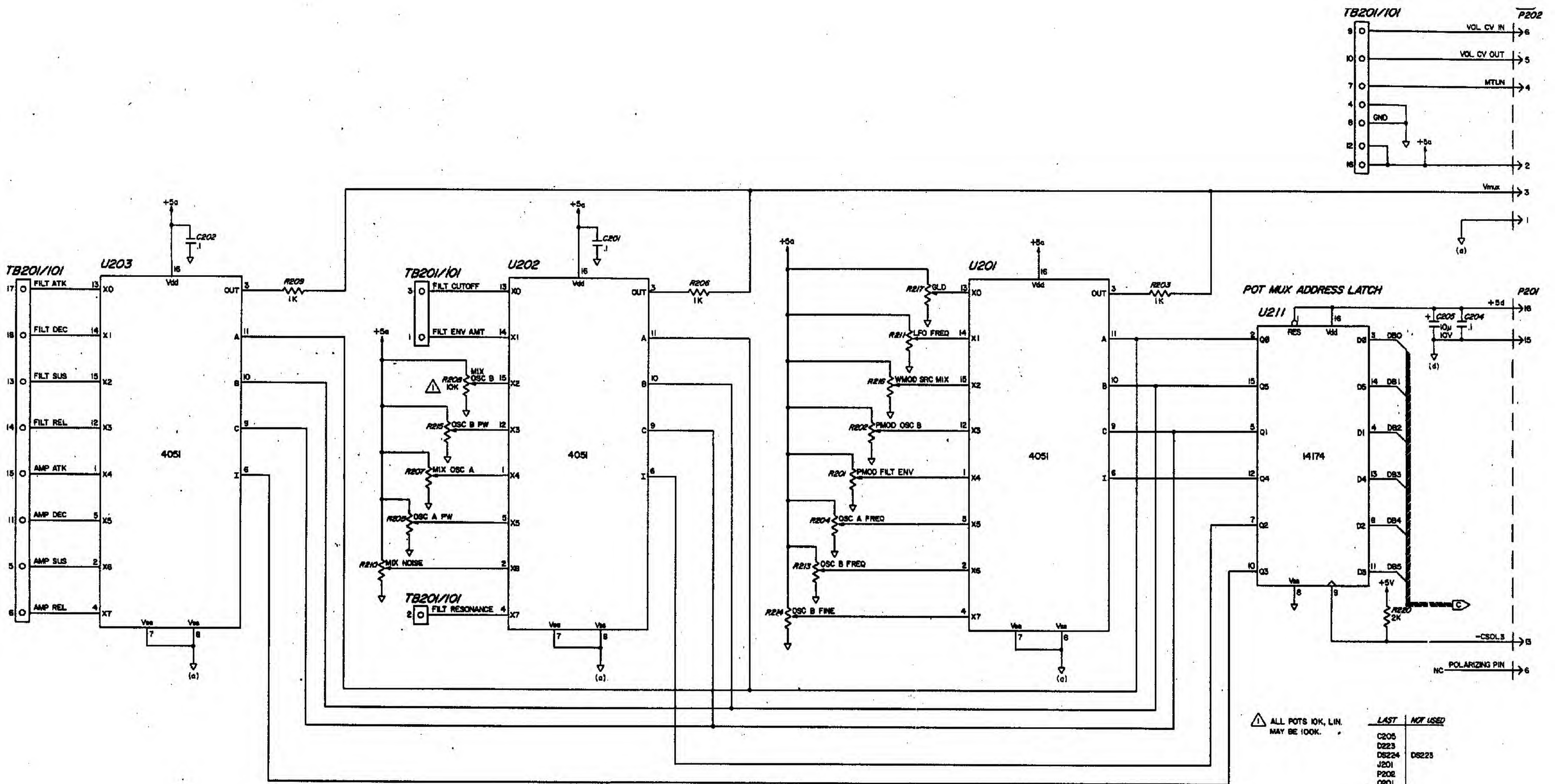

- ⚠ ALL POTS 10K, LIN. MAY BE 100K.
- | LAST | NOT USED |
|-------|----------|
| C205 | |
| D223 | |
| D8224 | |
| J201 | D8223 |
| P202 | |
| Q201 | |
| Q4201 | |
| R220 | |
| RA202 | |
| S223 | |
| U212 | |
| W201 | |

J		H		G		F		E		D		C		B		A	
SEQUENTIAL CIRCUITS INC																	
PCB2 POT MUX																	
D 08N																	
S 08N 1/2 1/2 1/2 1/2 1/2 1/2 1/2 1/2 1/2 1/2 1/2 1/2 1/2 1/2 1/2 1/2 1/2 1/2																	
A APP																	
DATE 1/1/80																	
DESIGNER 5/1/80																	
DRAWN 5/1/80																	
CHECKED 5/1/80																	
APPROVED 5/1/80																	
PART NO. 1000.3																	
REV. 1																	
SD231																	
SHEET 1 OF 2																	

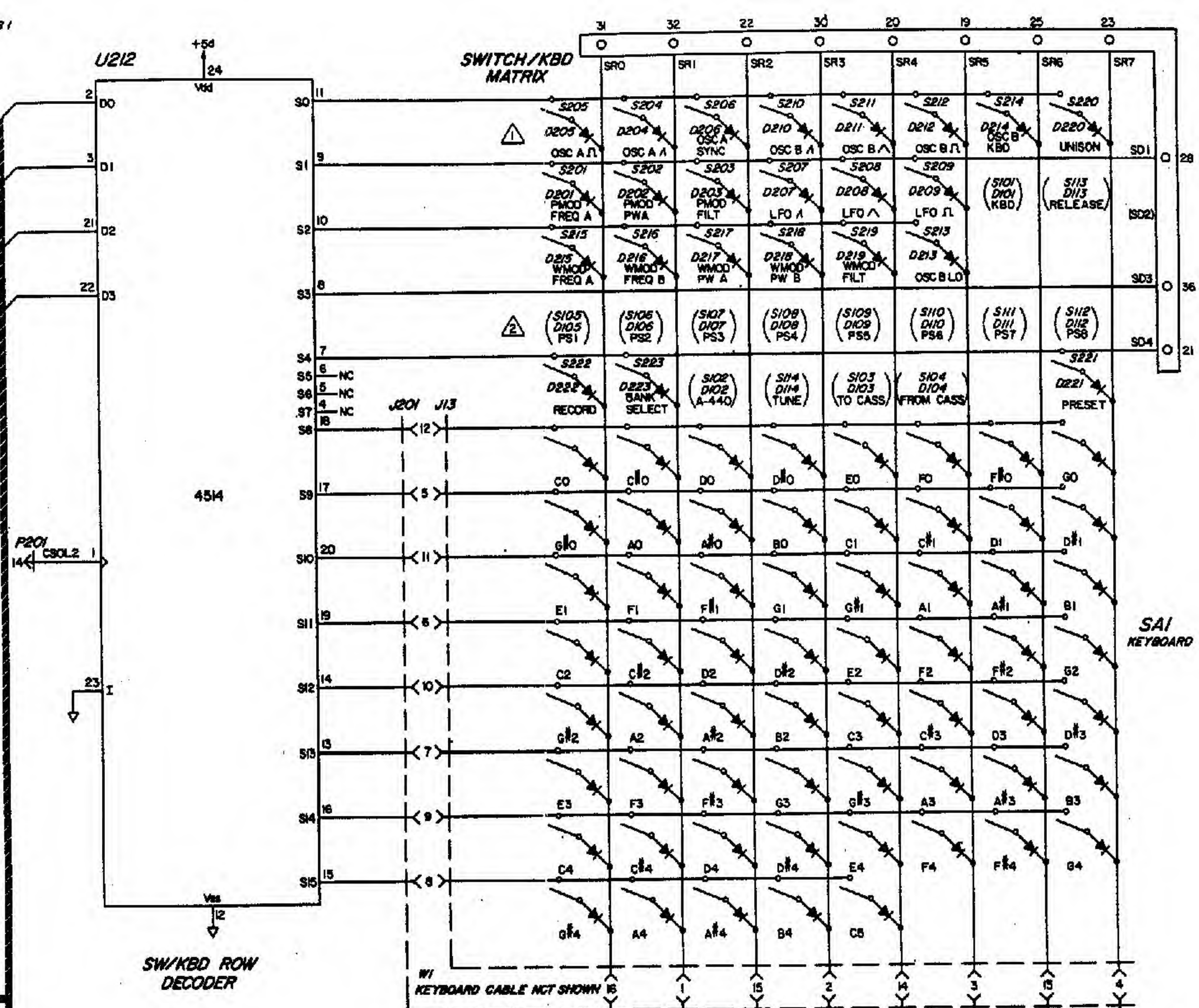
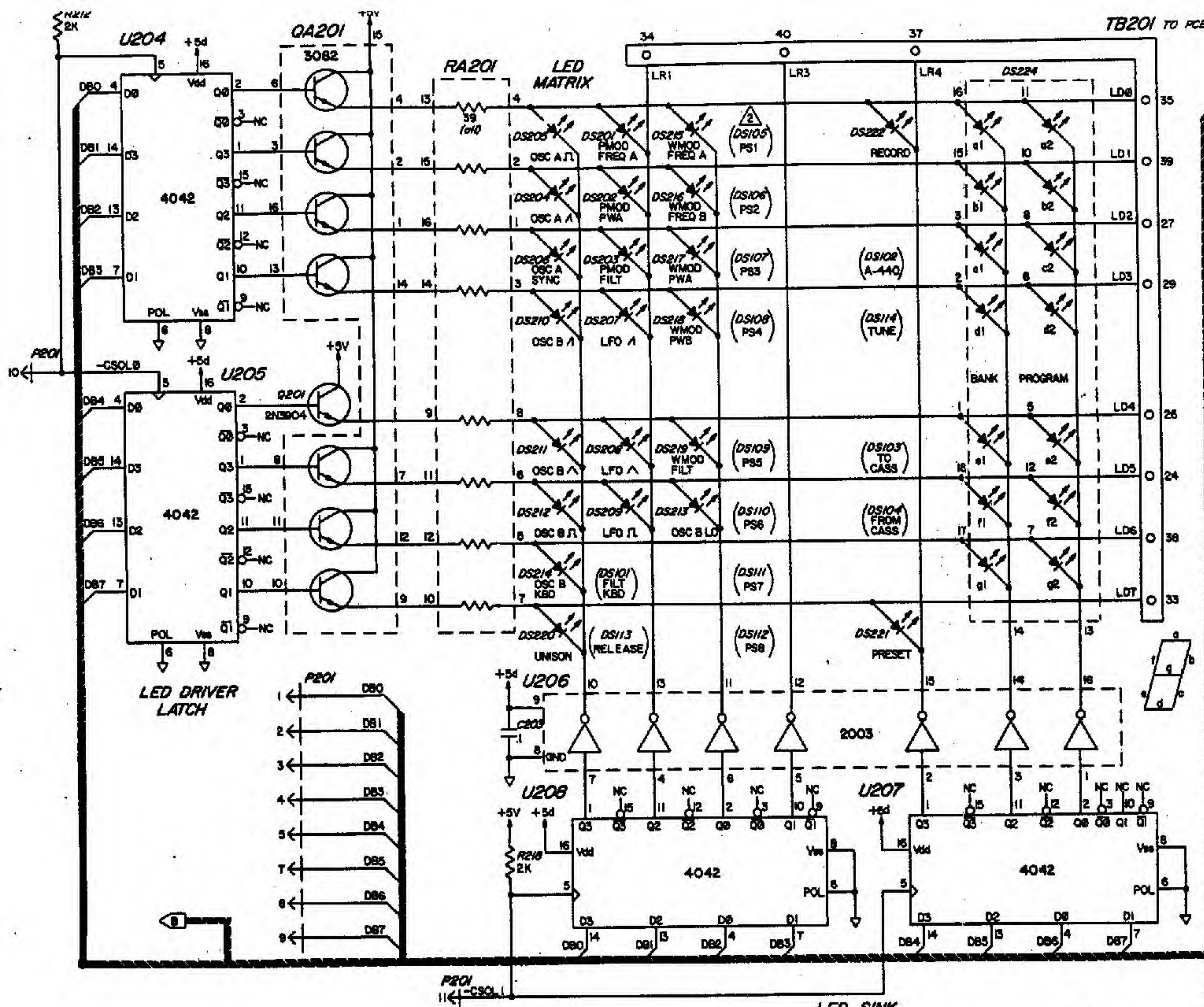

SPARES:

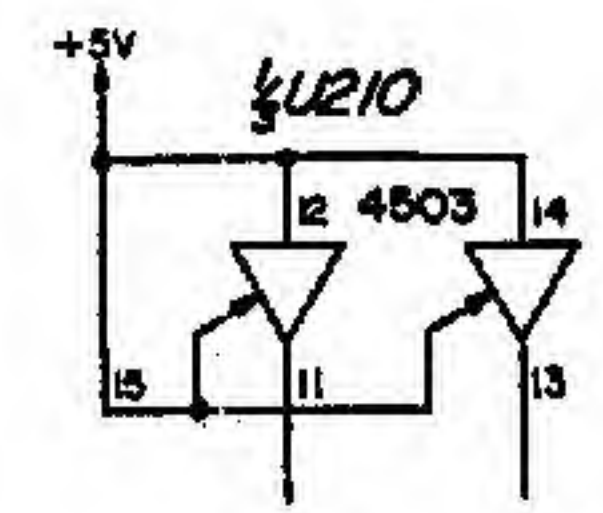
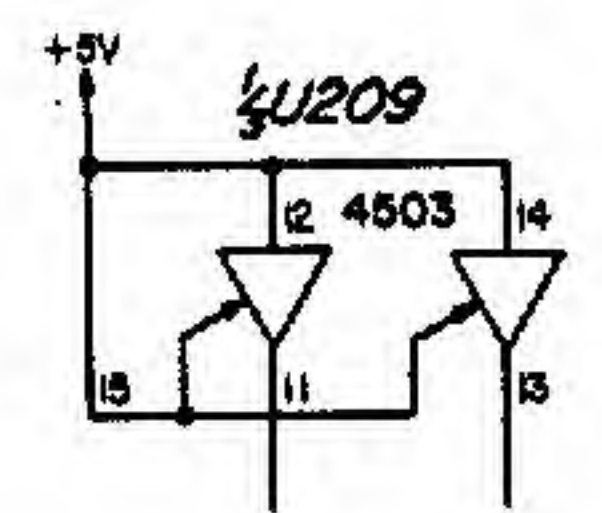
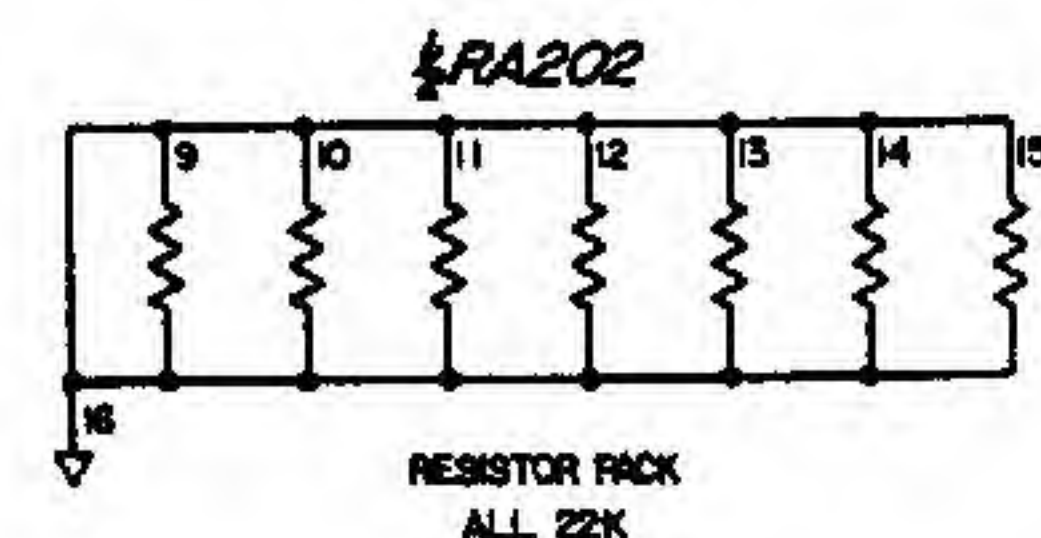

△ S201-21 ARE BLACK
 S222/24 ARE GREY
 S223 IS ORANGE
 △ CONTROLS IN PARENTHESES
 ARE ON PCB1

3-9	
SEQUENTIAL CIRCUITS INC	
PCB 2 CONTROL MATRICES	
REV	DATE
1	1000.3
2	
3	
4	
5	
6	
7	
8	
9	
10	
11	
12	
13	
14	
15	
16	
17	
18	
19	
20	
21	
22	
23	
24	
25	
26	
27	
28	
29	
30	
31	
32	
33	
34	
35	
36	
37	
38	
39	
40	
41	
42	
43	
44	
45	
46	
47	
48	
49	
50	
51	
52	
53	
54	
55	
56	
57	
58	
59	
60	
61	
62	
63	
64	
65	
66	
67	
68	
69	
70	
71	
72	
73	
74	
75	
76	
77	
78	
79	
80	
81	
82	
83	
84	
85	
86	
87	
88	
89	
90	
91	
92	
93	
94	
95	
96	
97	
98	
99	
100	

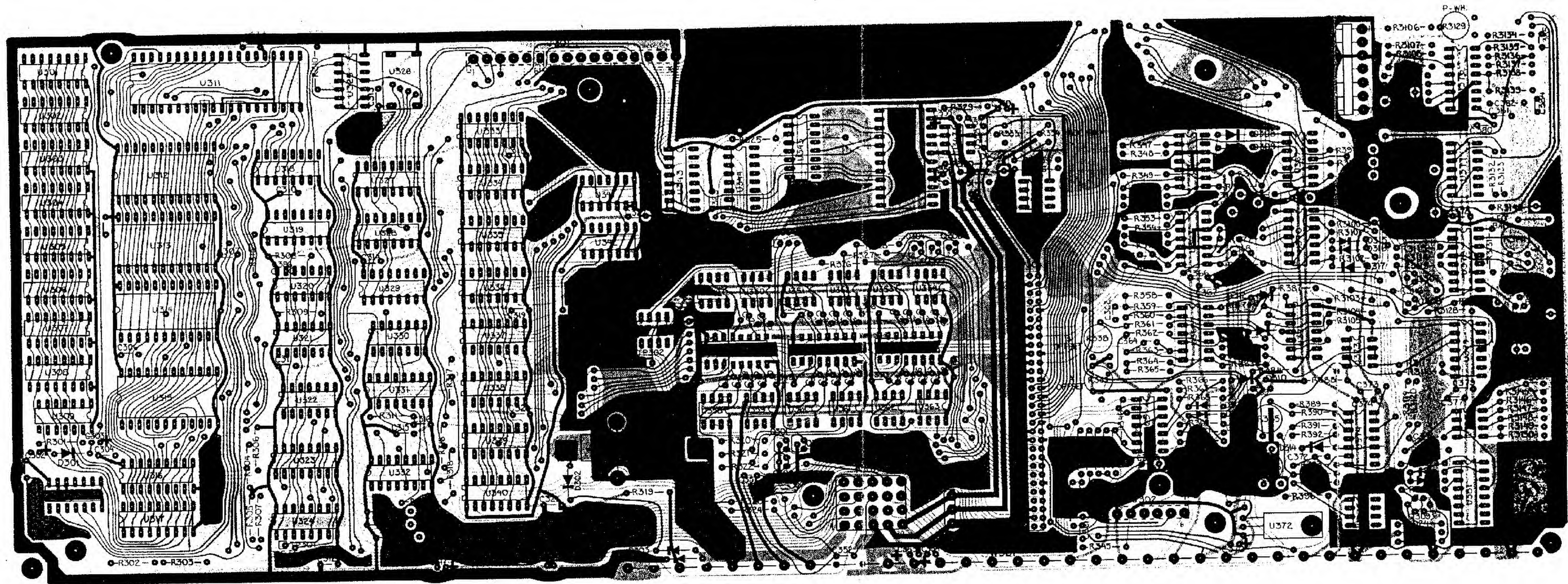

3-10

		SEQUENTIAL CIRCUITS INC	
		TITLE PCB 3 PARTS ID	
		DATE	REV D
		DESIGNER <i>J. J. [unclear]</i>	1000.3
		APP <i>[unclear]</i>	PP331
DATE	REV	REVISION	SHEET 1 OF 1

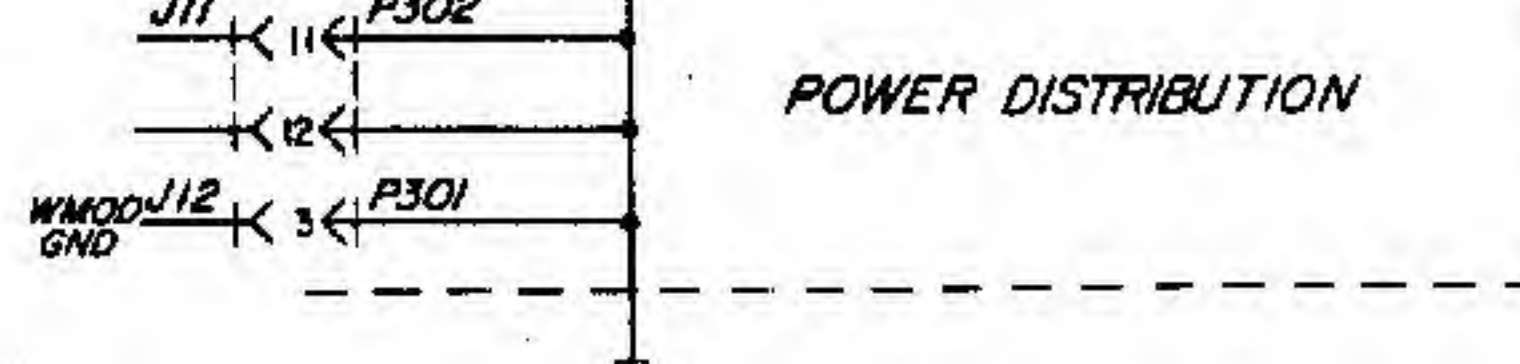
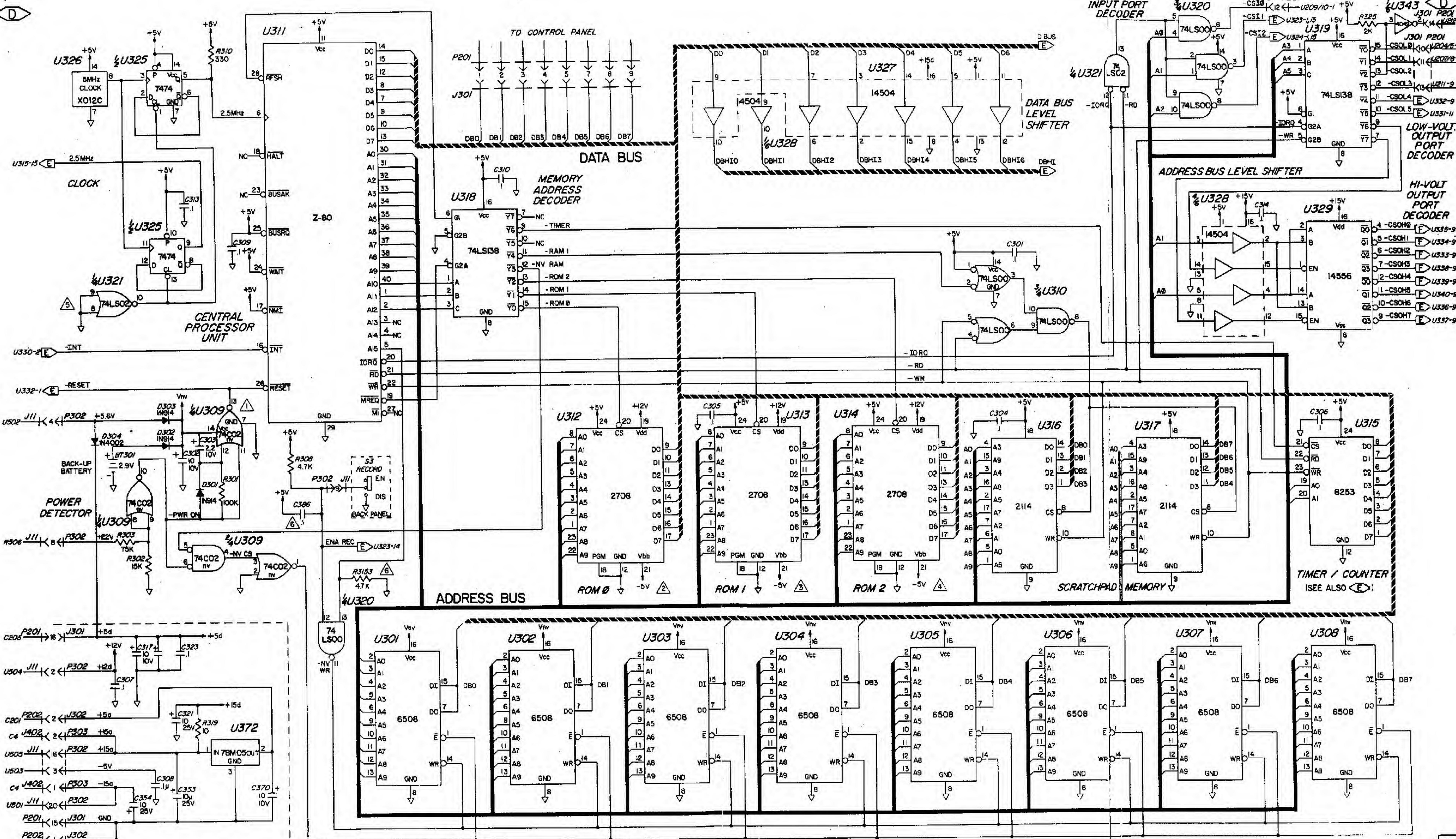

- NOTES:
- ▲ U309 IS POWERED BY BT301 WHEN POWER SUPPLY IS OFF
 - △ MAY BE A JUMPER
 - ▲ VERSION 0.V.8.2
 - △ MAY BE MOUNTED ON U320
 - ▲ VERSION 1.V.8.2
 - ▲ VERSION 2.V.8.2

LAST	NOT USED
BT301	
C386	
D319	
J302	
P304	
Q309	
R3153	
TP303	
U381	
W301	

NON-VOLATILE PROGRAM MEMORY

SEQUENTIAL CIRCUITS INC			
PCB 3 CPU, MEMORY, I/O INTFC			
REV	DATE	REV	DATE
1	8/13/80	1	1000.3
2	7/8/80	2	SD331
3	21	3	
4		4	
5		5	
6		6	
7		7	
8		8	
9		9	
10		10	
11		11	
12		12	
13		13	
14		14	
15		15	
16		16	
17		17	
18		18	
19		19	
20		20	
21		21	
22		22	
23		23	
24		24	
25		25	
26		26	
27		27	
28		28	
29		29	
30		30	
31		31	
32		32	
33		33	
34		34	
35		35	
36		36	
37		37	
38		38	
39		39	
40		40	
41		41	
42		42	
43		43	
44		44	
45		45	
46		46	
47		47	
48		48	
49		49	
50		50	
51		51	
52		52	
53		53	
54		54	
55		55	
56		56	
57		57	
58		58	
59		59	
60		60	
61		61	
62		62	
63		63	
64		64	
65		65	
66		66	
67		67	
68		68	
69		69	
70		70	
71		71	
72		72	
73		73	
74		74	
75		75	
76		76	
77		77	
78		78	
79		79	
80		80	
81		81	
82		82	
83		83	
84		84	
85		85	
86		86	
87		87	
88		88	
89		89	
90		90	
91		91	
92		92	
93		93	
94		94	
95		95	
96		96	
97		97	
98		98	
99		99	
100		100	

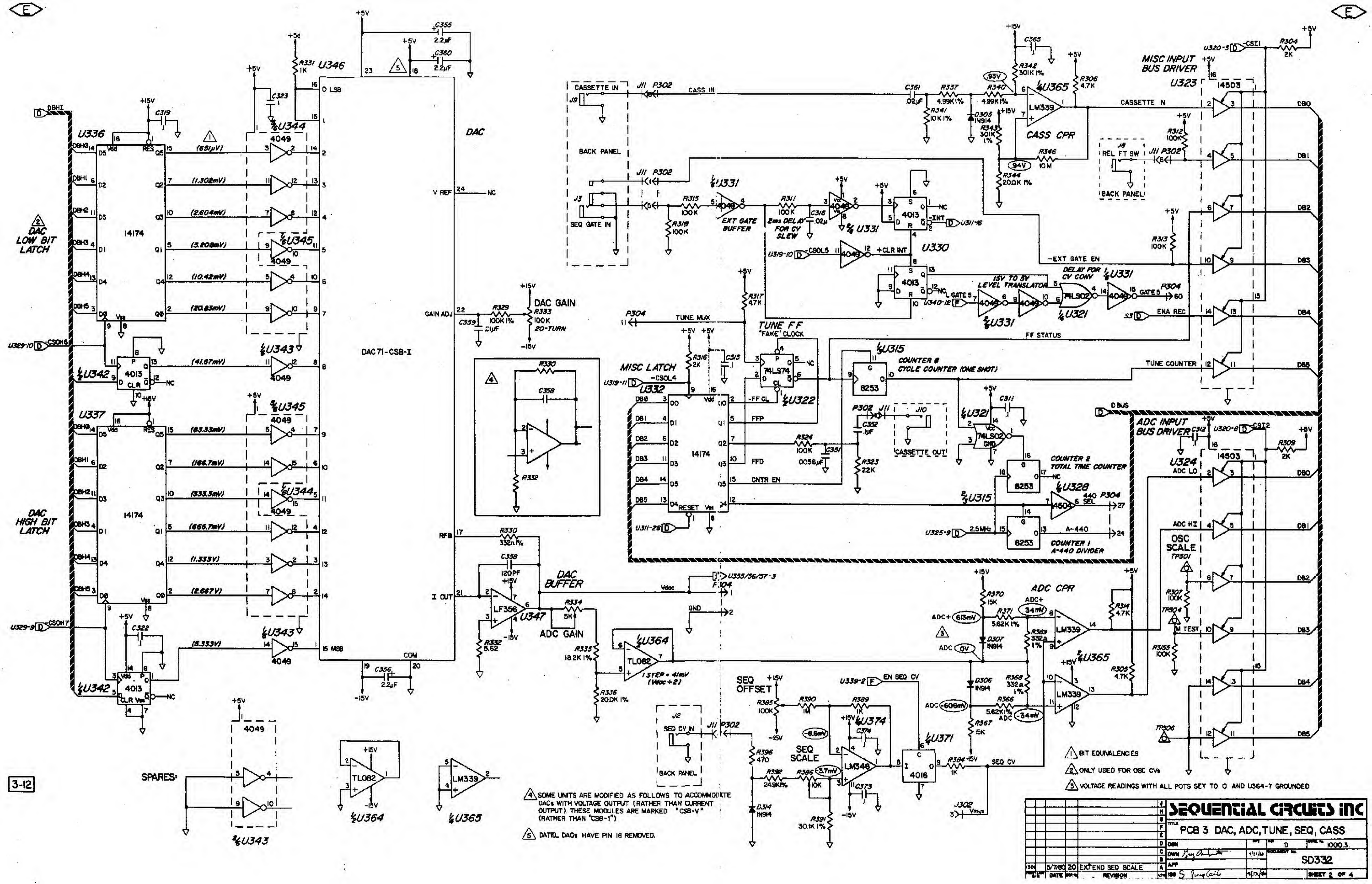

2
DAC LOW BIT LATCH

2
DAC HIGH BIT LATCH

3-12

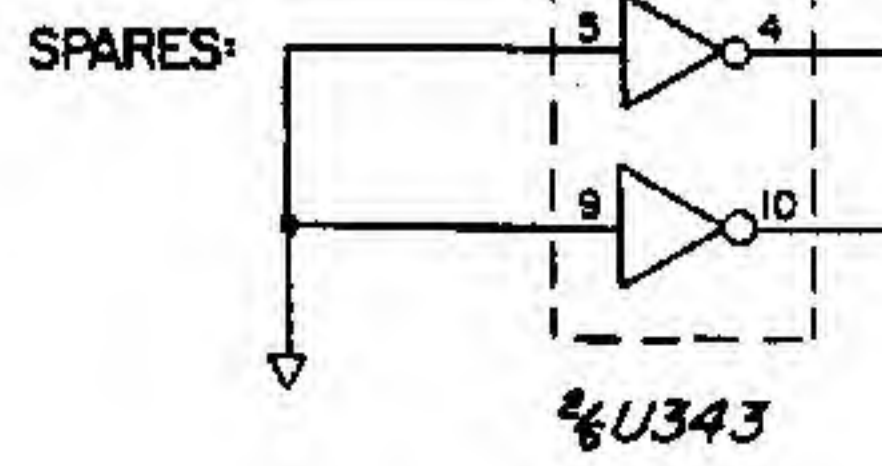

4 SOME UNITS ARE MODIFIED AS FOLLOWS TO ACCOMMODATE DACs WITH VOLTAGE OUTPUT (RATHER THAN CURRENT OUTPUT). THESE MODULES ARE MARKED "CSB-V" (RATHER THAN "CSB-1")

5 DATEL DACs HAVE PIN 18 REMOVED.

- 1 BIT EQUIVALENCIES
- 2 ONLY USED FOR OSC CVs
- 3 VOLTAGE READINGS WITH ALL POTS SET TO 0 AND U364-7 GROUNDED

SEQUENTIAL CIRCUITS INC PCB 3 DAC, ADC, TUNE, SEQ, CASS		REV	DATE	BY	CHKD	APP	DATE	BY	CHKD
		0							
SD332 SHEET 2 OF 4									

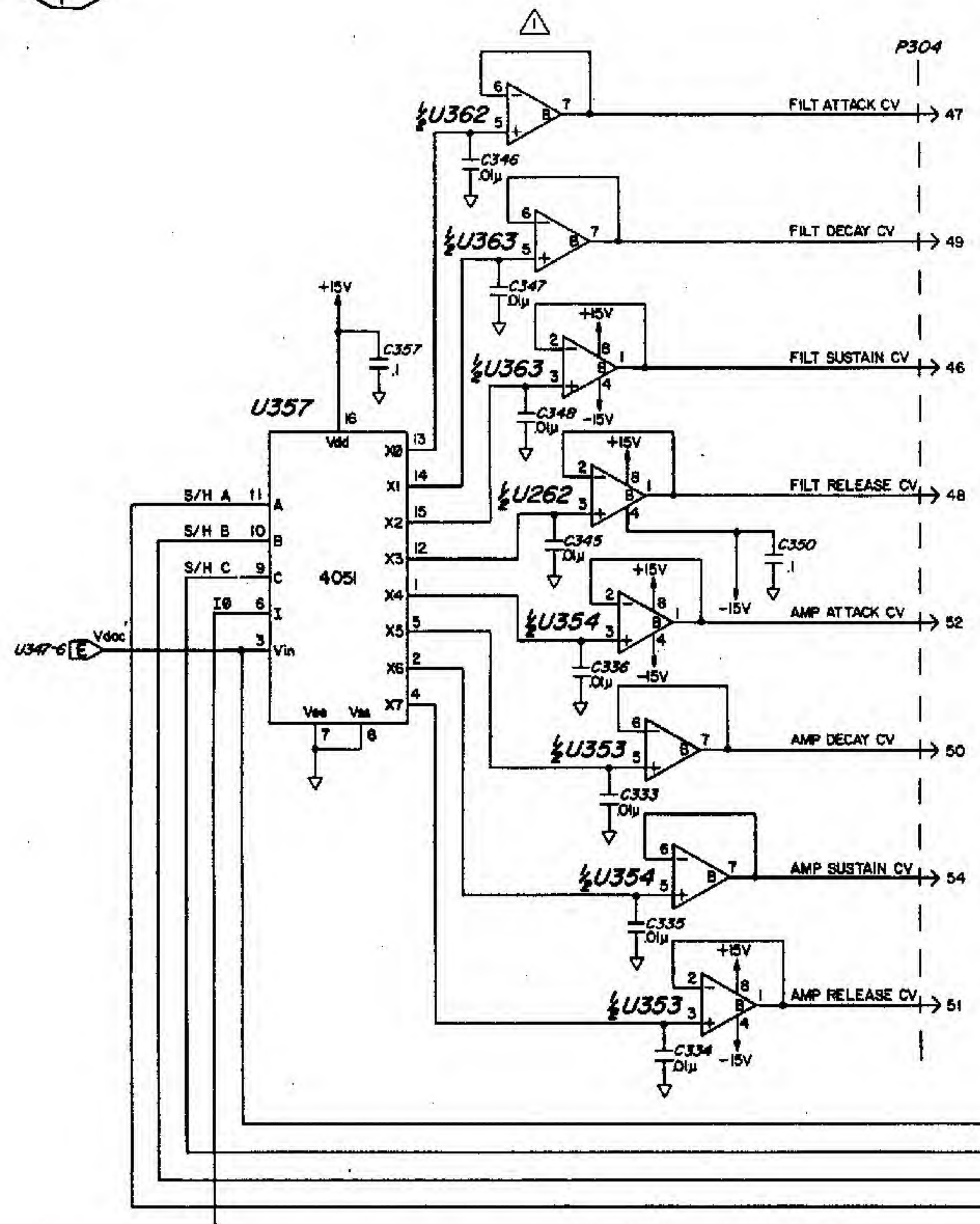

PATCH CV DEMULTIPLEXER (SAMPLE/HOLDS)

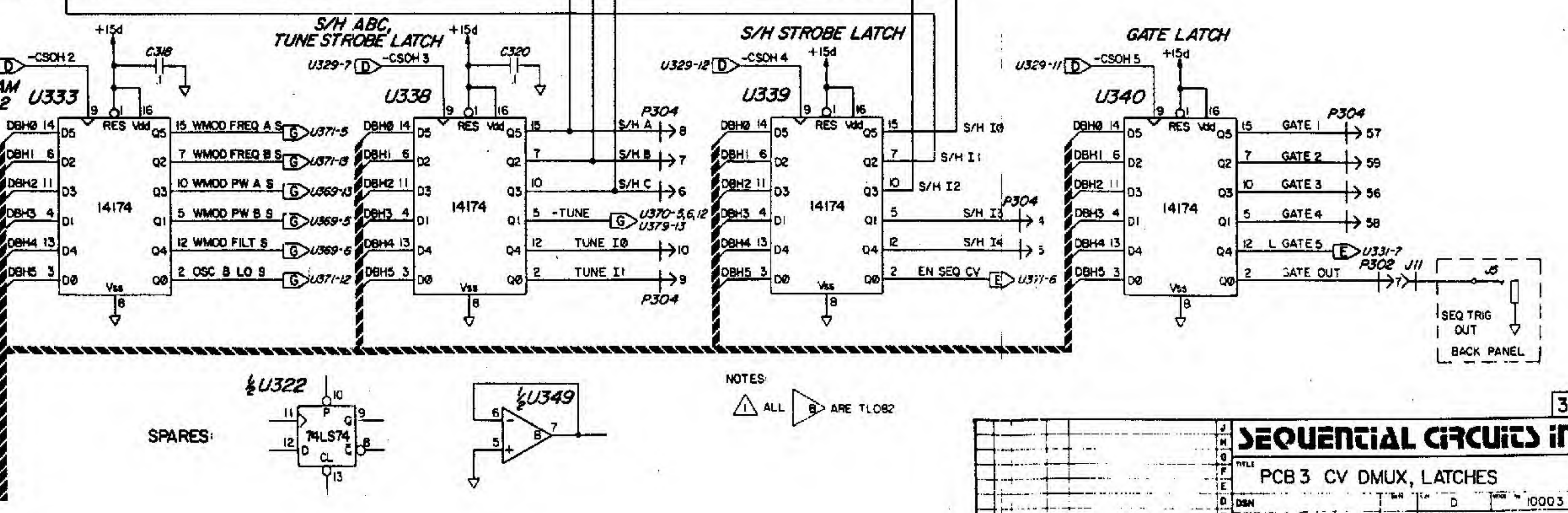
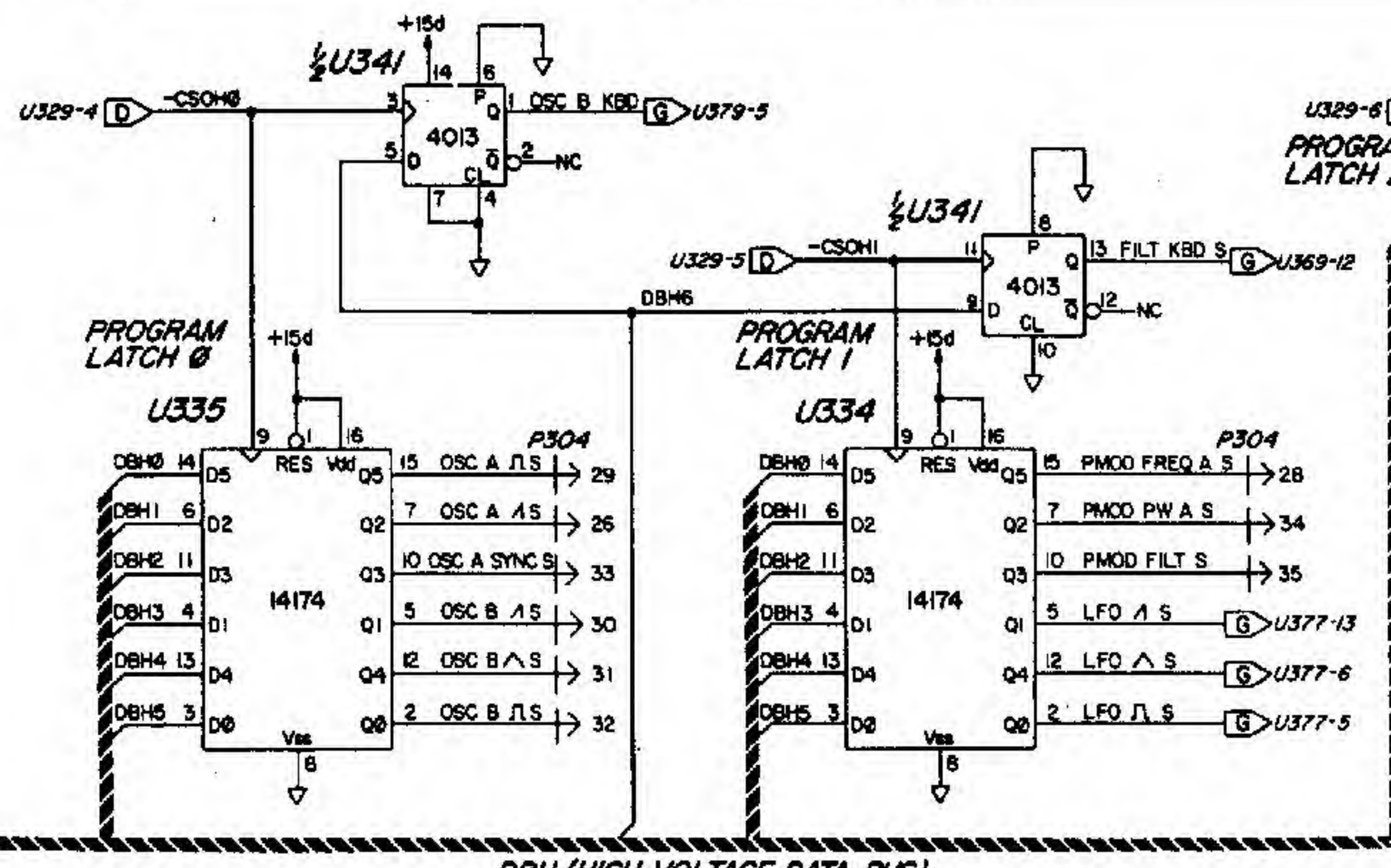
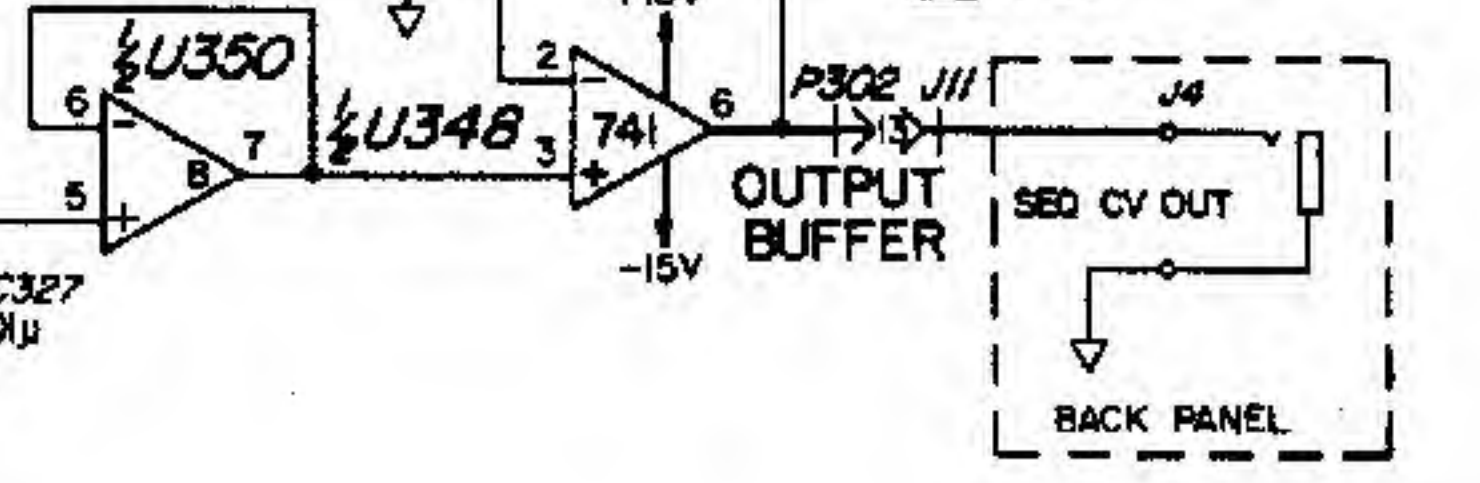
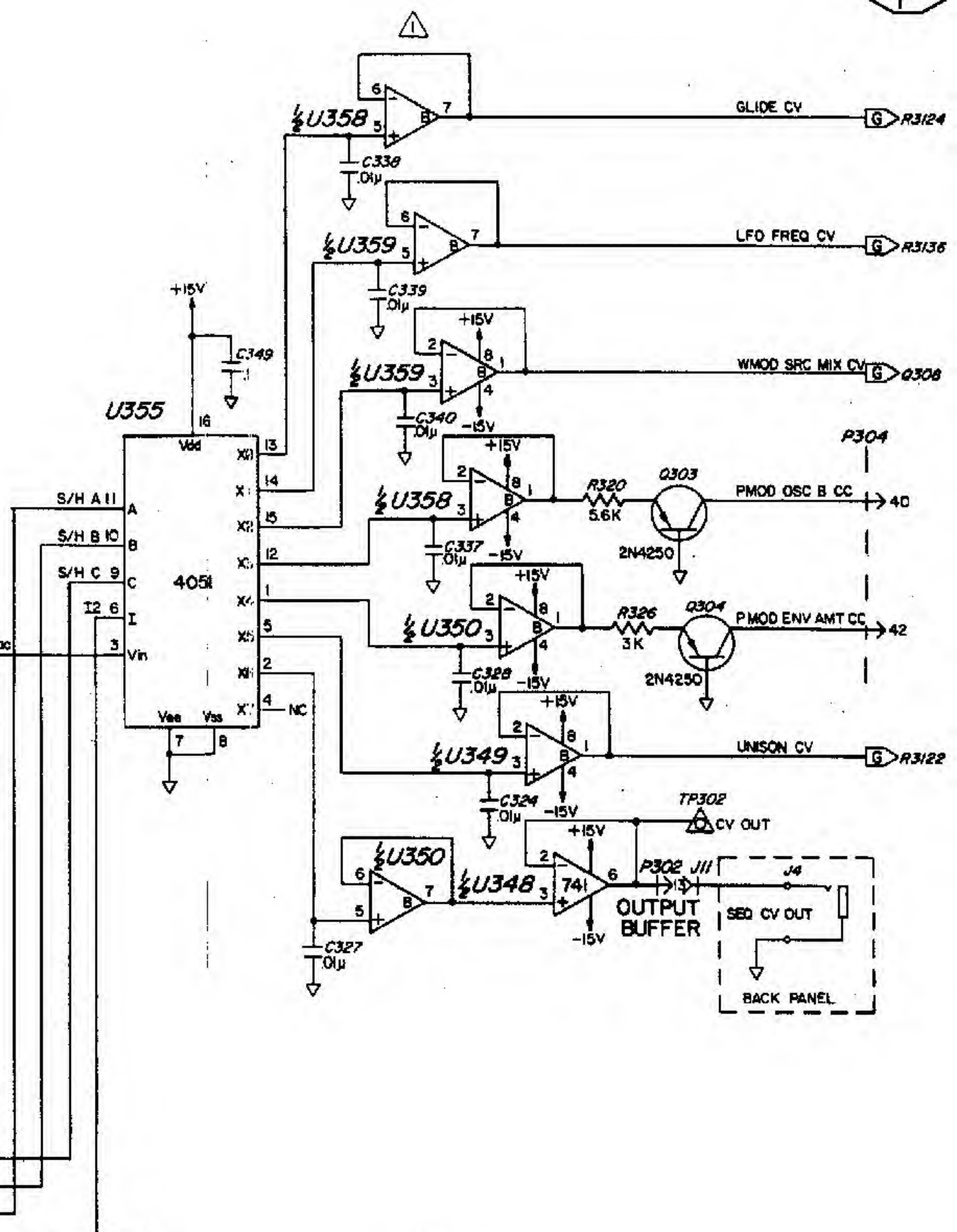
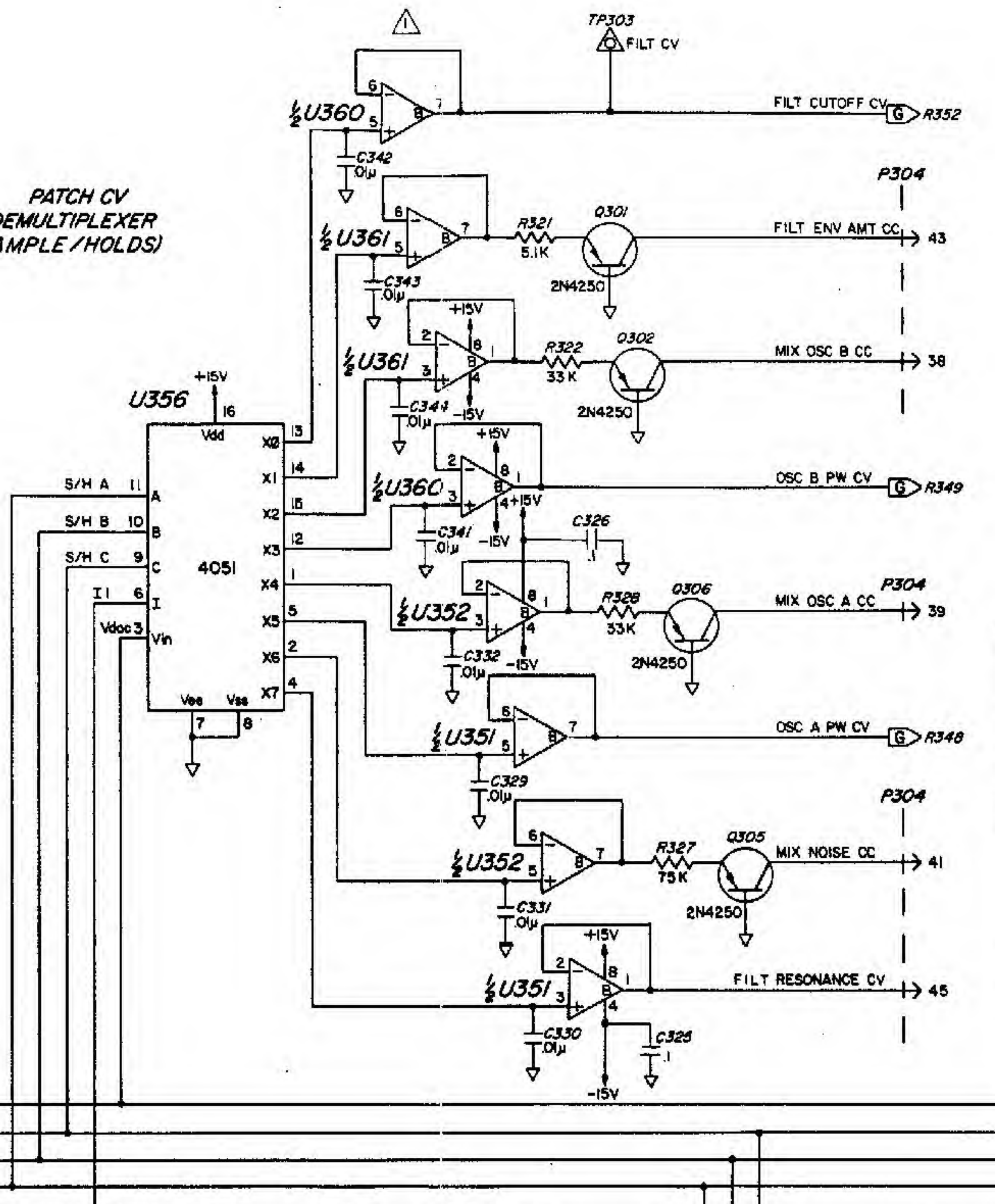

SPARES:

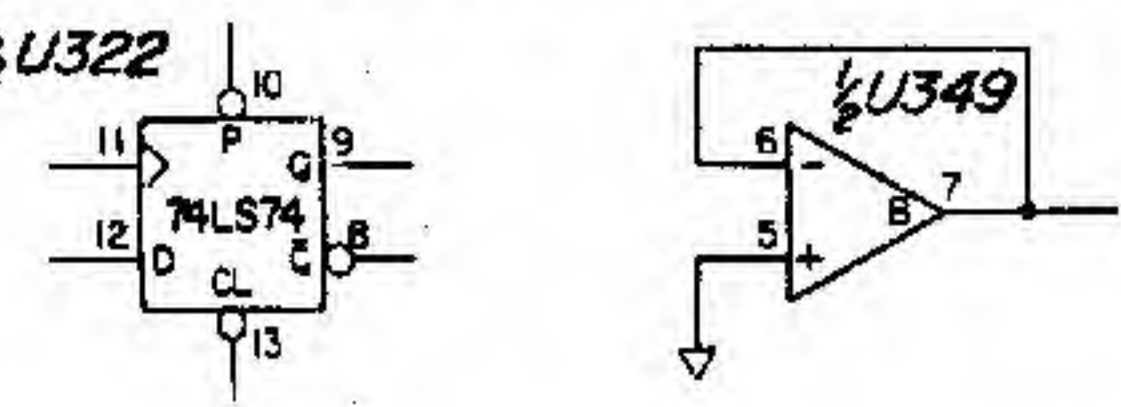

NOTES:
 1 ALL ARE TL082

DBH (HIGH VOLTAGE DATA BUS)

SEQUENTIAL CIRCUITS INC			
PCB 3 CV DMUX, LATCHES			
REV	DATE	BY	APP
0			
DOCUMENT NO. 10003			SD333
ISS	REV	DATE	SHEET 5 OF 4

SAMPLE AND HOLDS

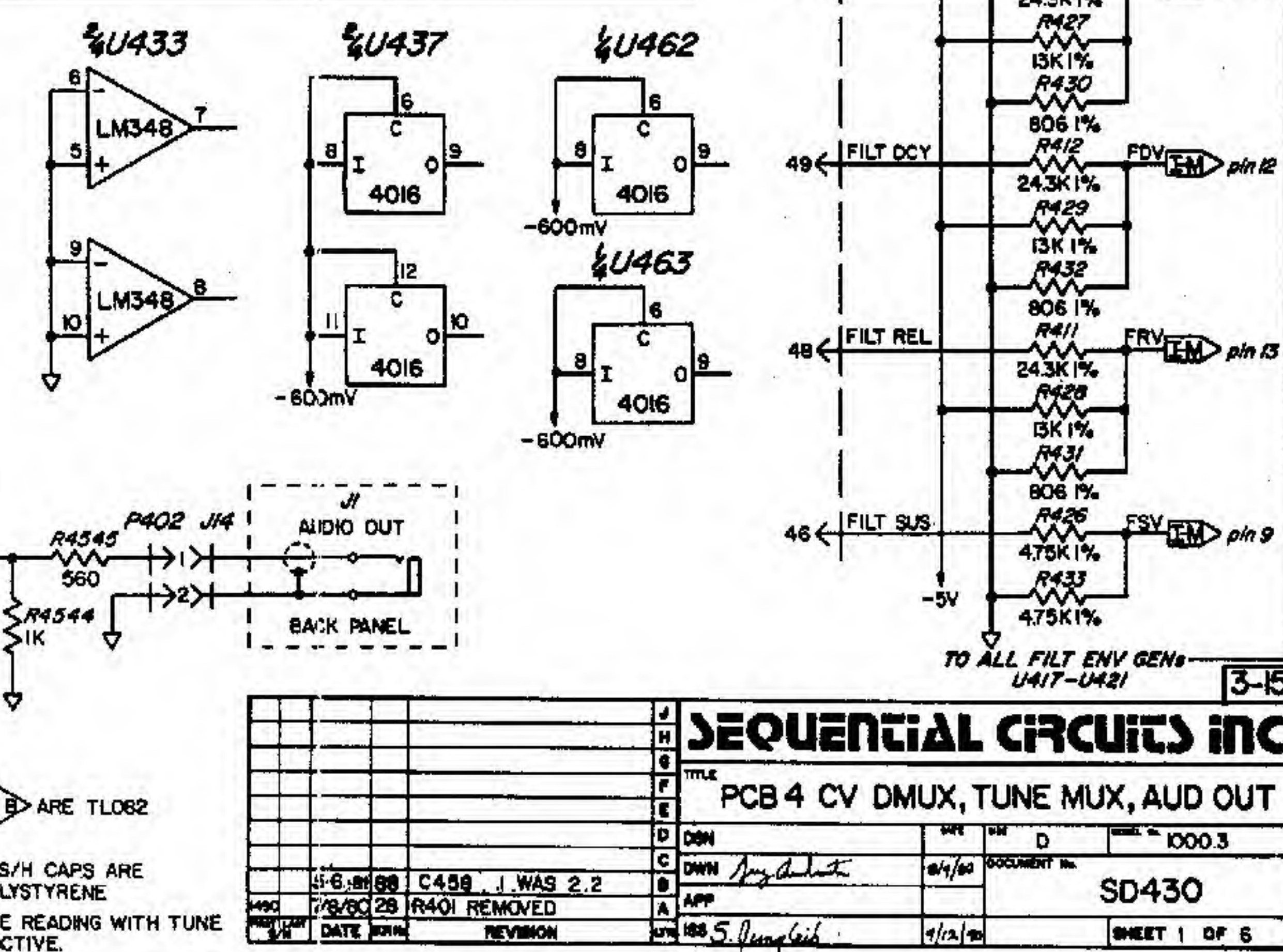
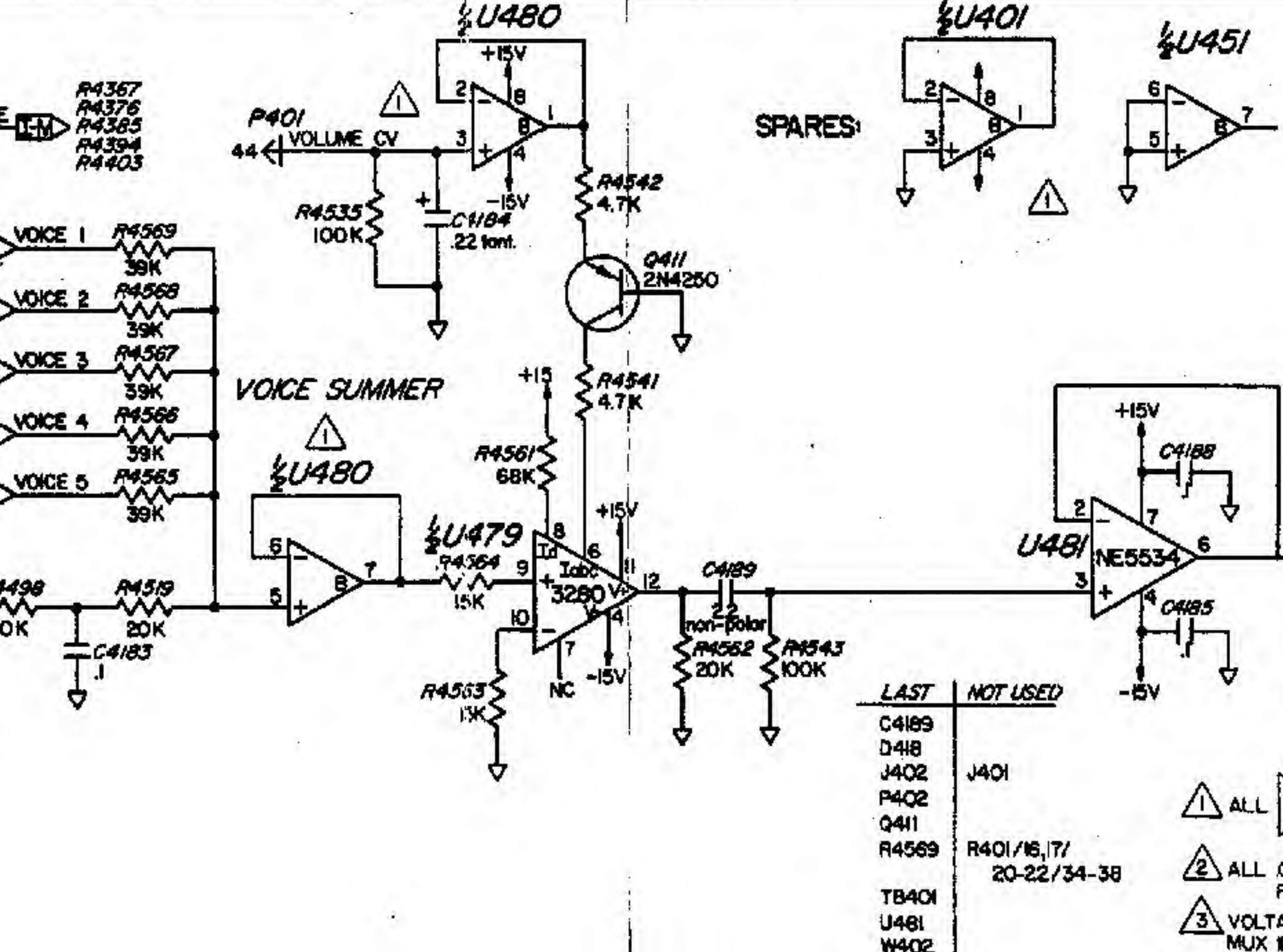
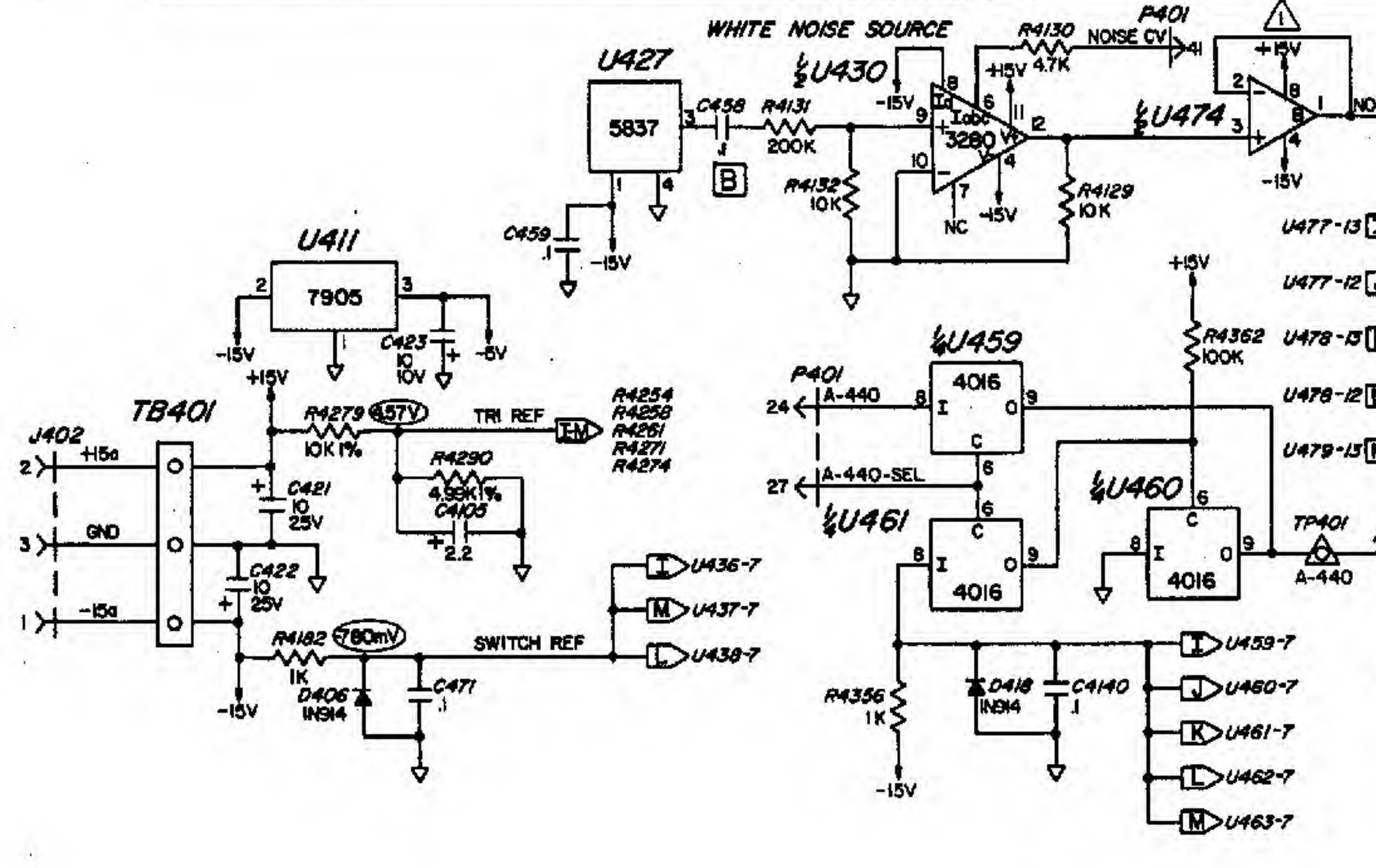
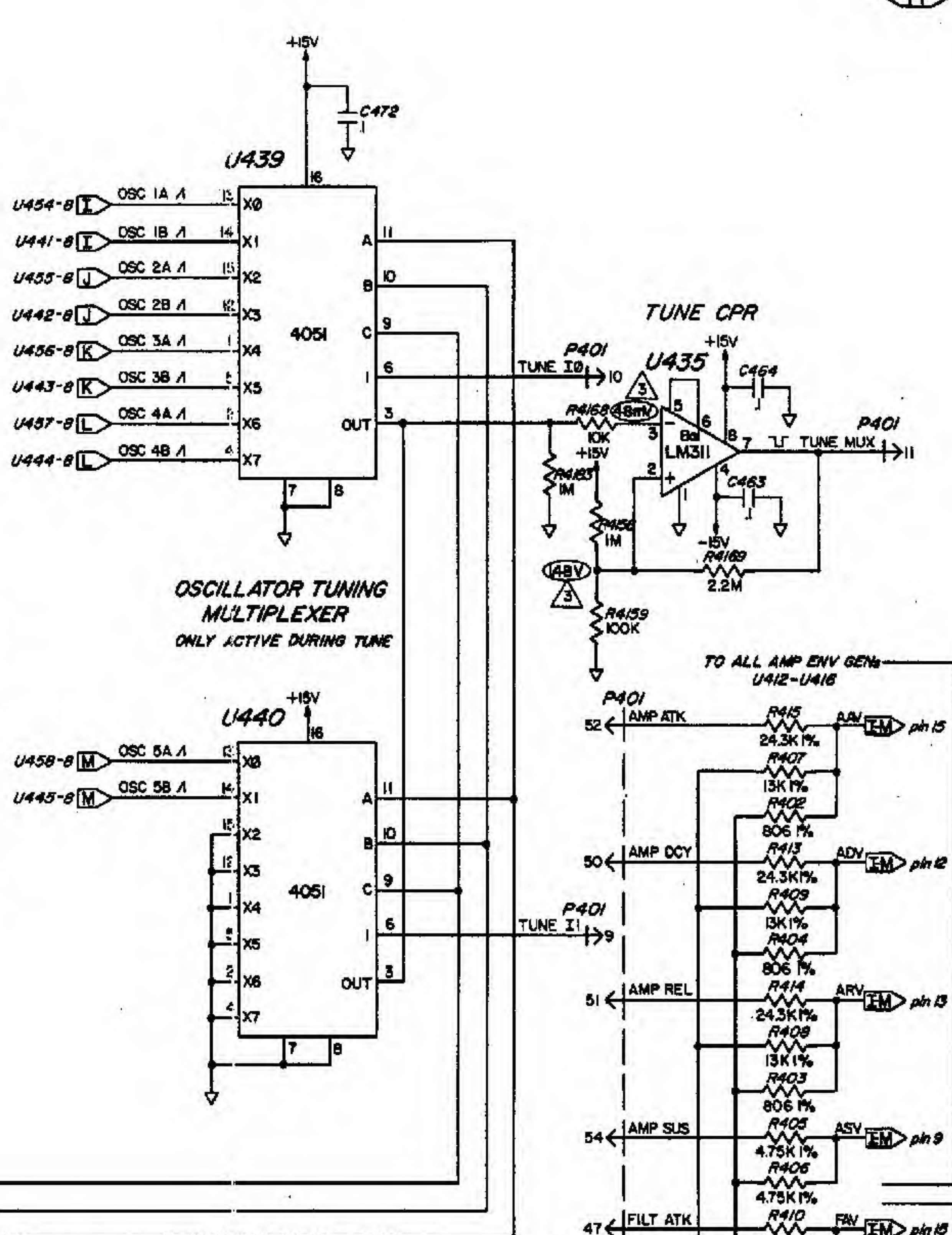
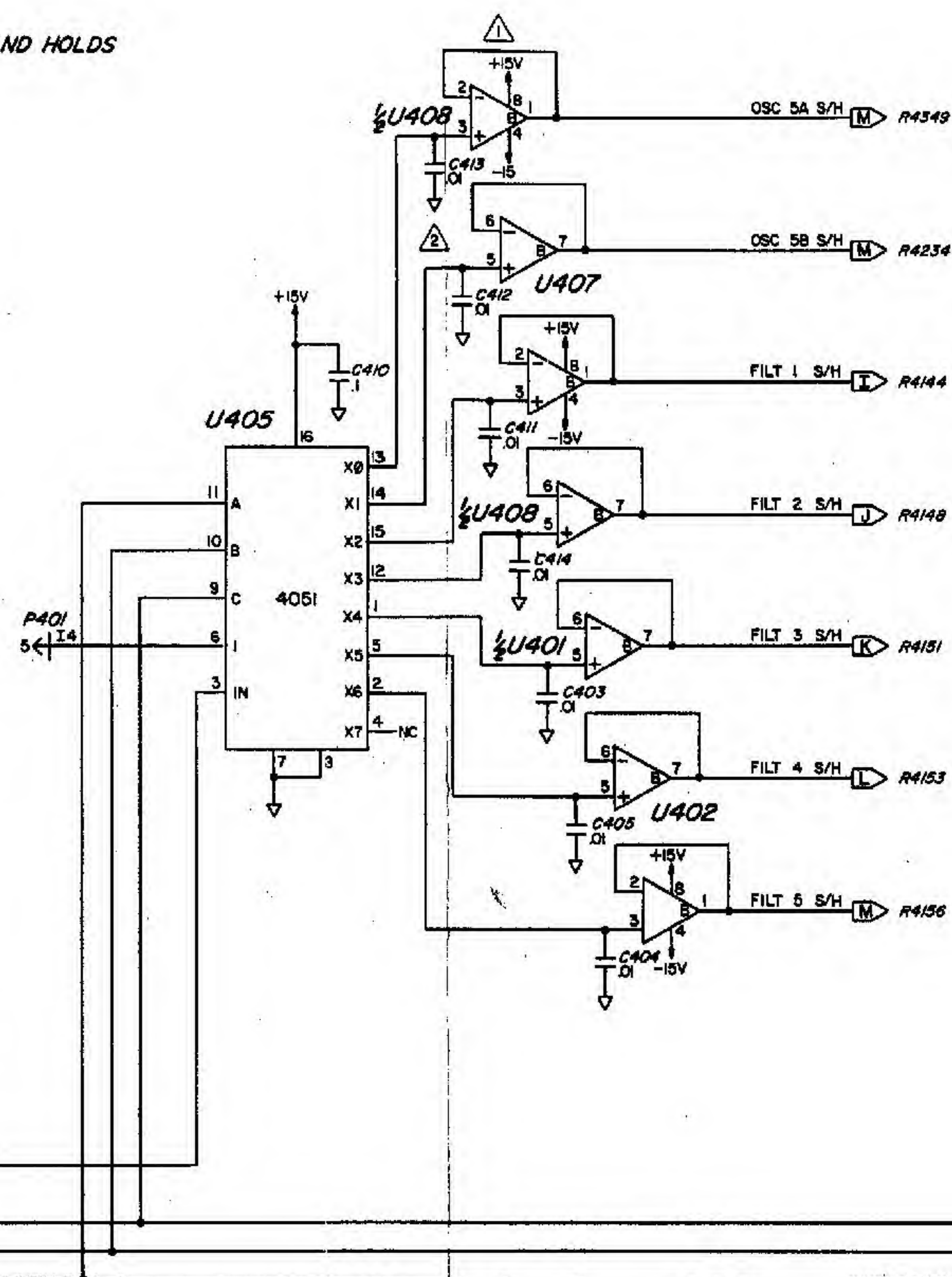
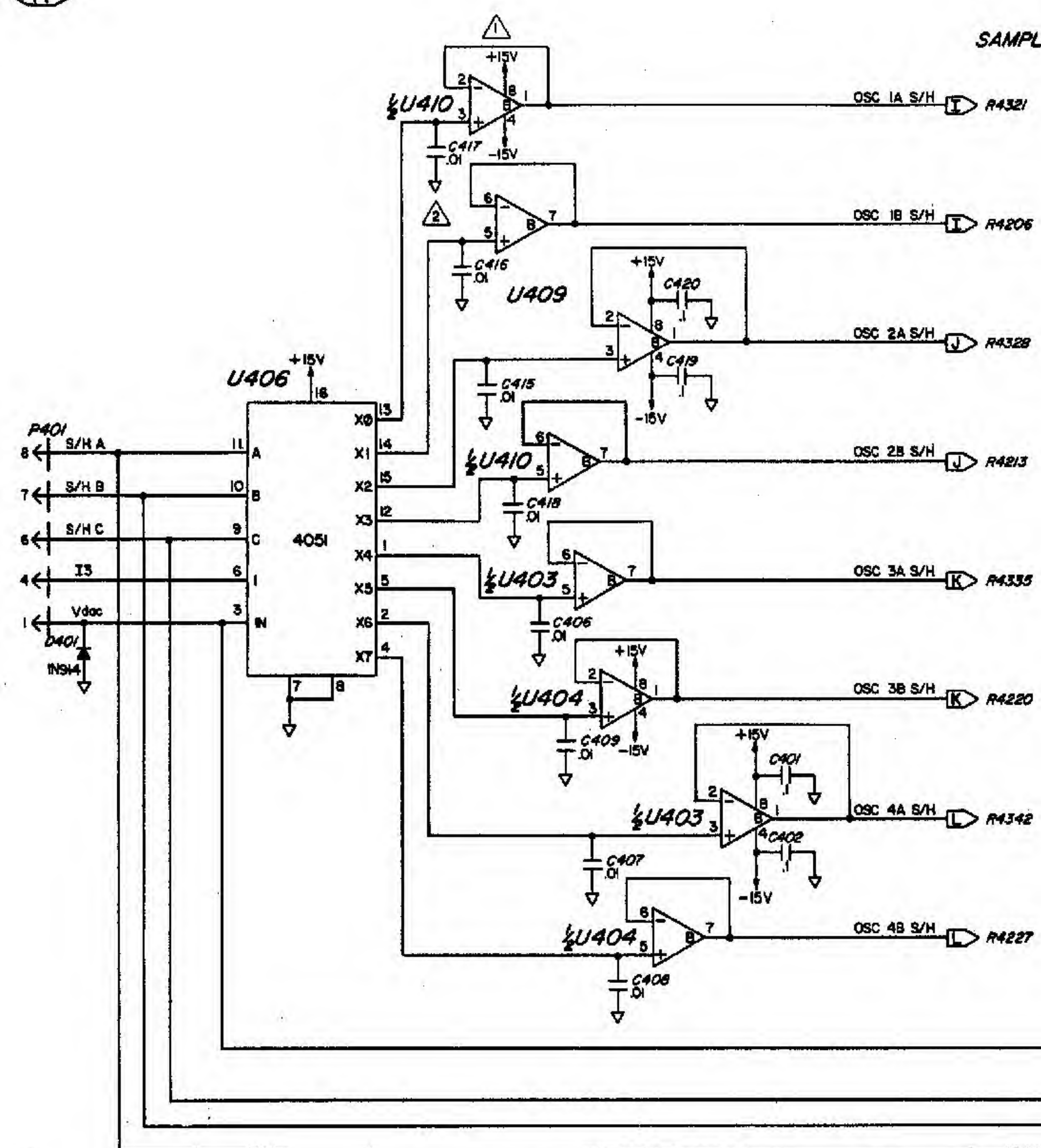

LAST	NOT USED
C4189	
D418	
J402	J401
P402	
Q411	
R4589	R401/16,17 20-22/34-38
TB401	
U481	
W402	

- ALL ARE TL082
- ALL O/S/H CAPS ARE POLYSTYRENE
- VOLTAGE READING WITH TUNE MUX INACTIVE.

SEQUENTIAL CIRCUITS INC

PCB 4 CV DMUX, TUNE MUX, AUD OUT

DATE: 8/1/80

REVISION: 1

SD430

SHEET 1 OF 6

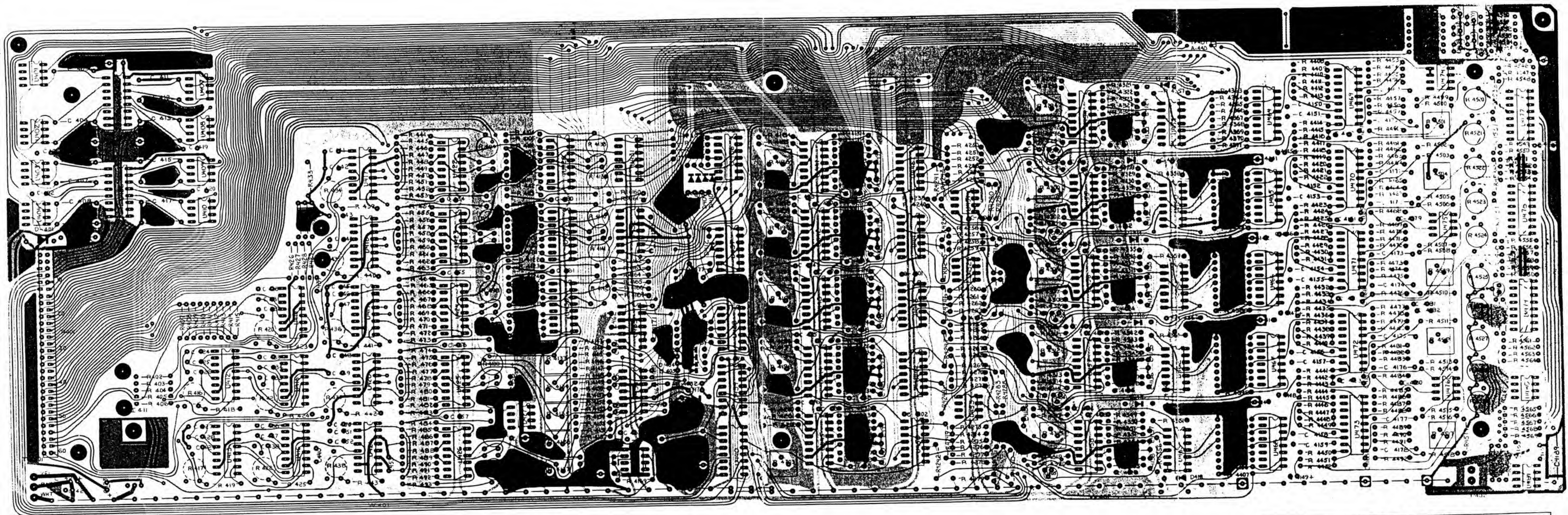

SEQUENTIAL CIRCUITS INC			
DATE	31	REVISION	
DESIGNED BY	S. J. Kelly	DATE	7/12/64
CHECKED BY		DOCUMENT NO.	PP431
APP'D			SHEET 1 OF 1
TITLE		PCB 4 PARTS ID	
DSN		1000.3	

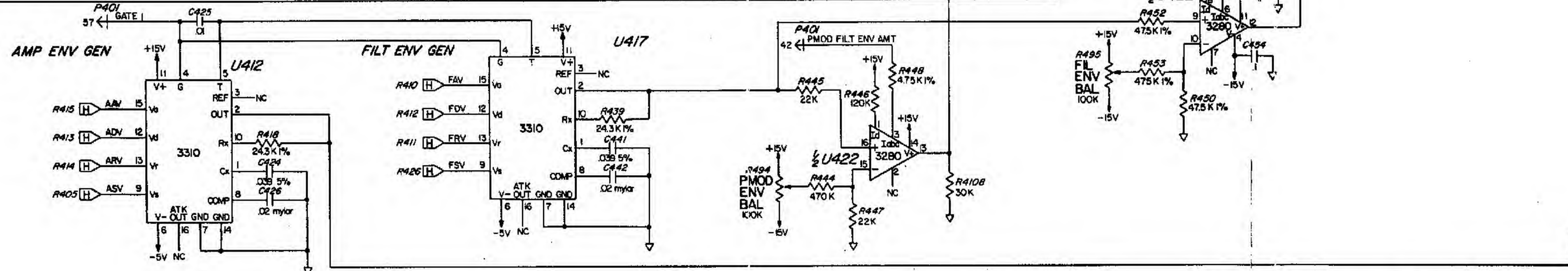
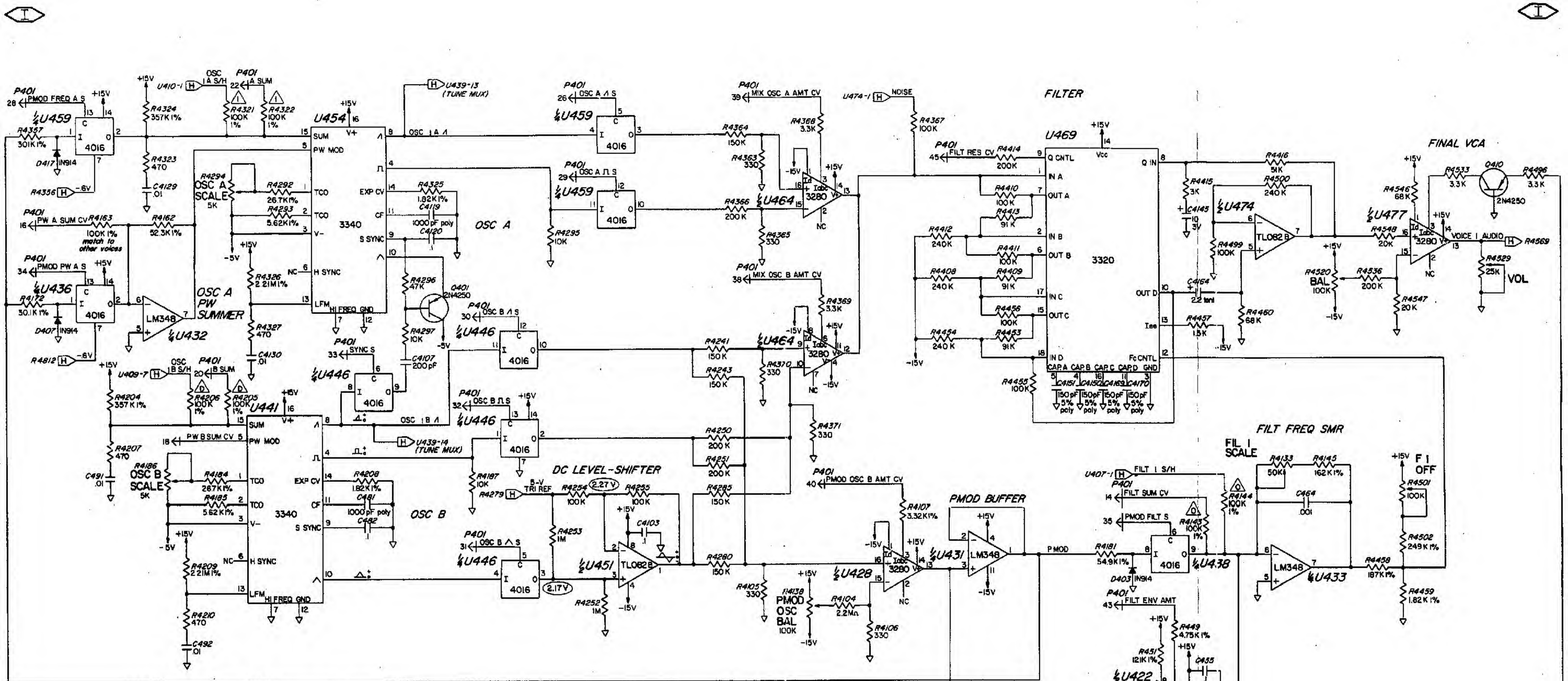

△ RESISTORS MATCHED TO .01%

SEQUENTIAL CIRCUITS INC PCB 4 VOICE I		DATE	REV	DESIGNED BY	DRAWN BY	DATE	REV	DOC NO	1000.3
		DATE	REV	DESIGNED BY	DRAWN BY	DATE	REV	DOC NO	SD431
DATE	REV	DESIGNED BY	DRAWN BY	DATE	REV	DESIGNED BY	DRAWN BY	DATE	REV
DATE	REV	DESIGNED BY	DRAWN BY	DATE	REV	DESIGNED BY	DRAWN BY	DATE	REV

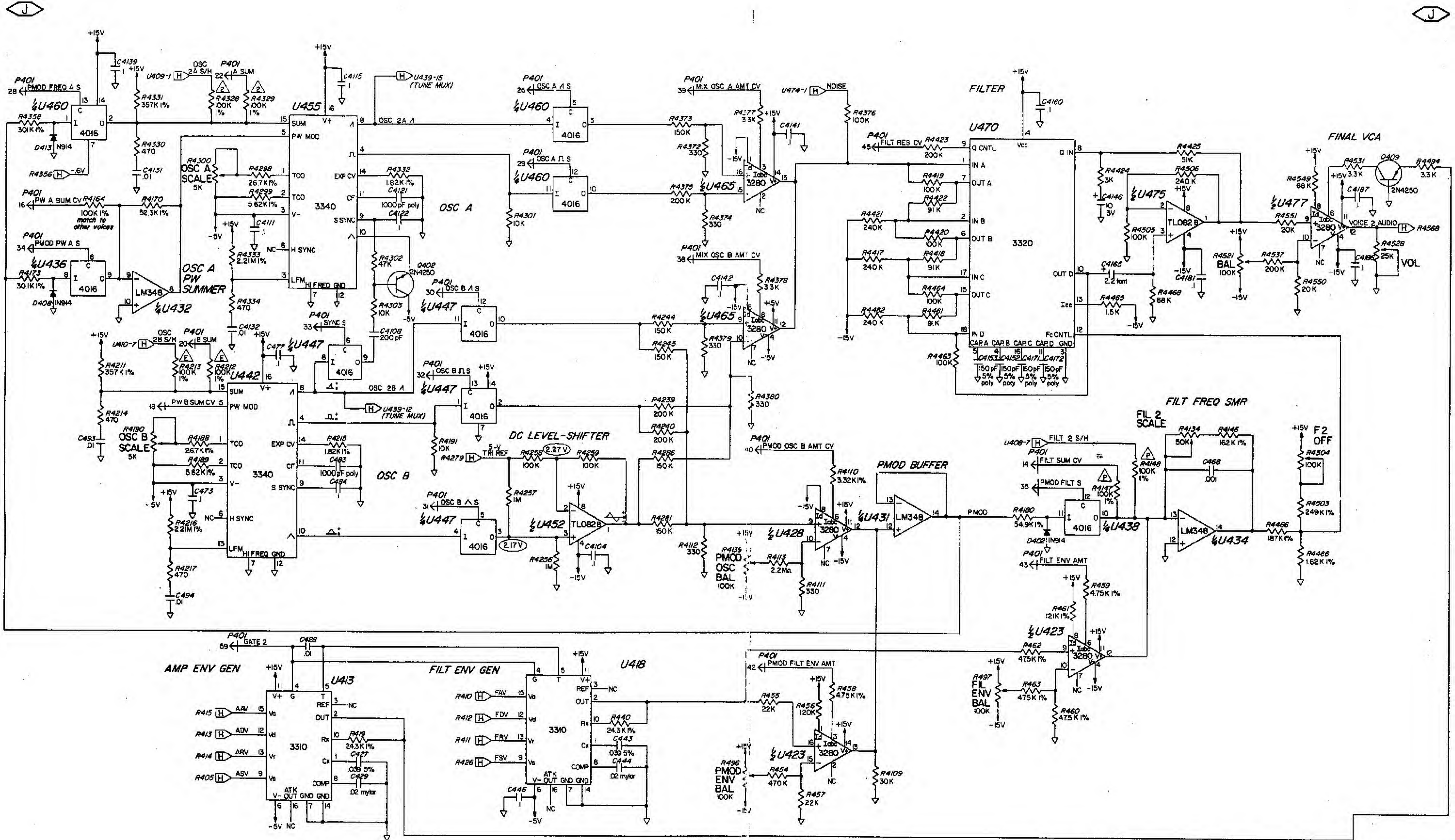

3-18

△ RESISTORS MATCHED TO .01%

SEQUENTIAL CIRCUITS INC			
PCB 4 VOICE 2			
DSN	REV	DATE	ISSUE
DWN	1/14	1/14	1000.3
APP			SD432
DATE	REV	ISS	SHEET 3 OF

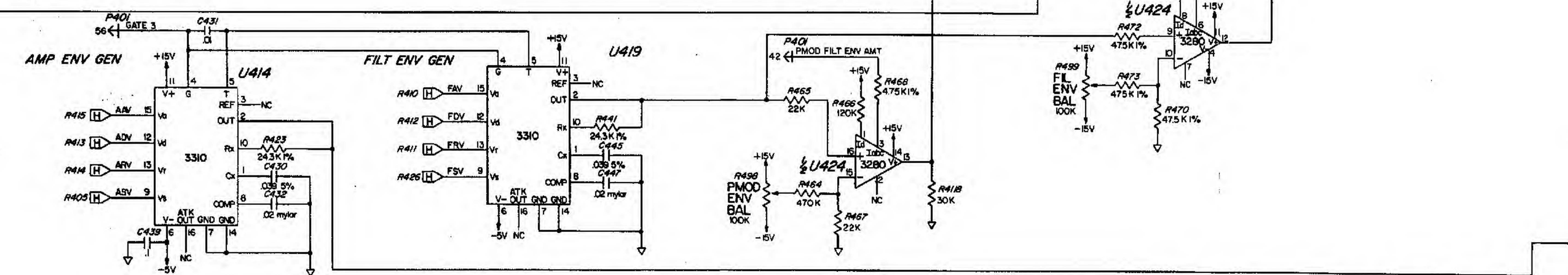
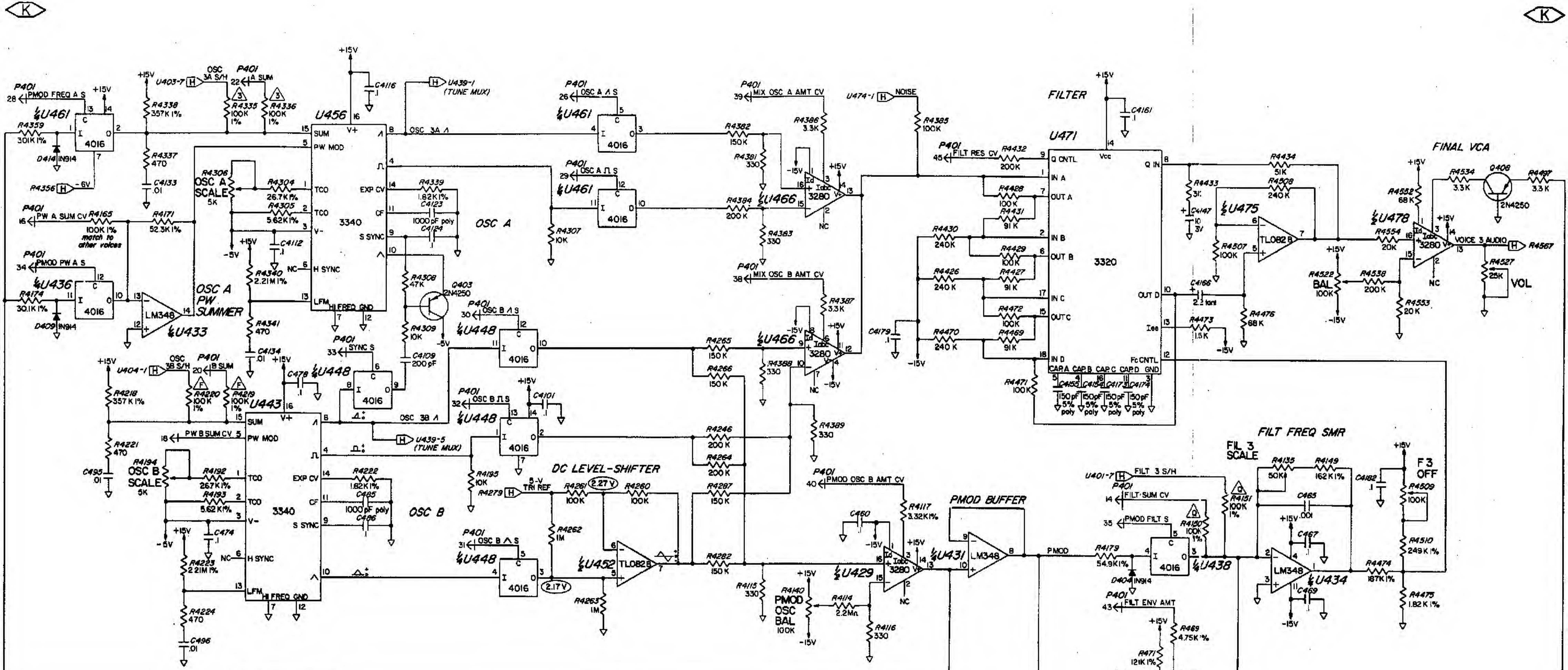

RESISTORS MATCHED TO 01%

3-19			
SEQUENTIAL CIRCUITS INC			
TITLE PCB 4 VOICE 3			
DESIGN	DATE	BY	REV. D
APP	DATE	BY	REV. 1000.3
DRAWN BY <i>John Smith</i>			DOCUMENT NO. SD433
DATE	REV	REVISION	SHEET 4 OF

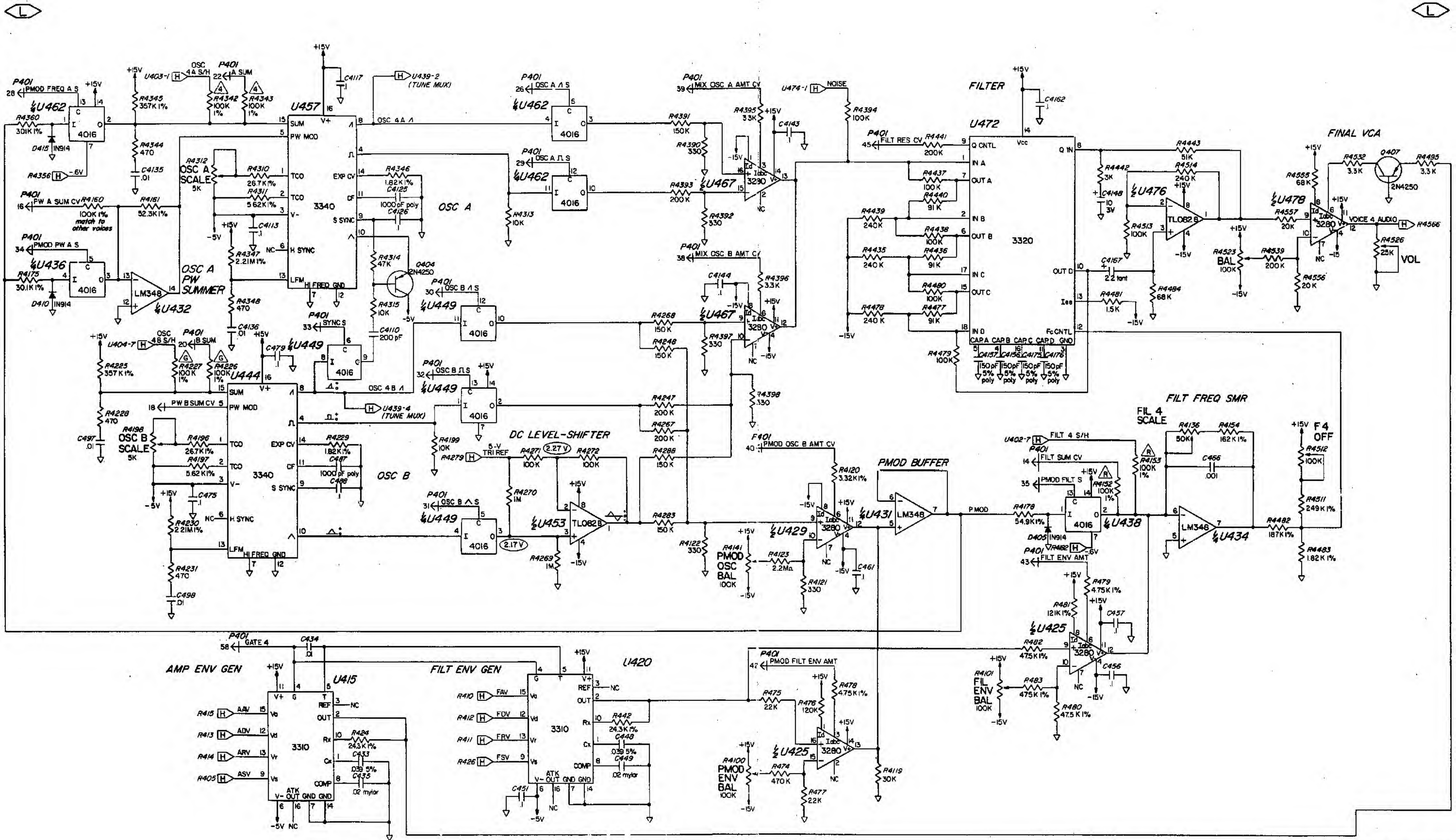

△ RESISTORS MATCHED TO 0.1%

SEQUENTIAL CIRCUITS INC			
PCB 4 VOICE 4			
D	DRN	REV	D
C	OWN	DATE	DECLARATION
B	APP		SD434
A			
DATE	REV	REVISION	
1985	5		
			SHEET 5 OF

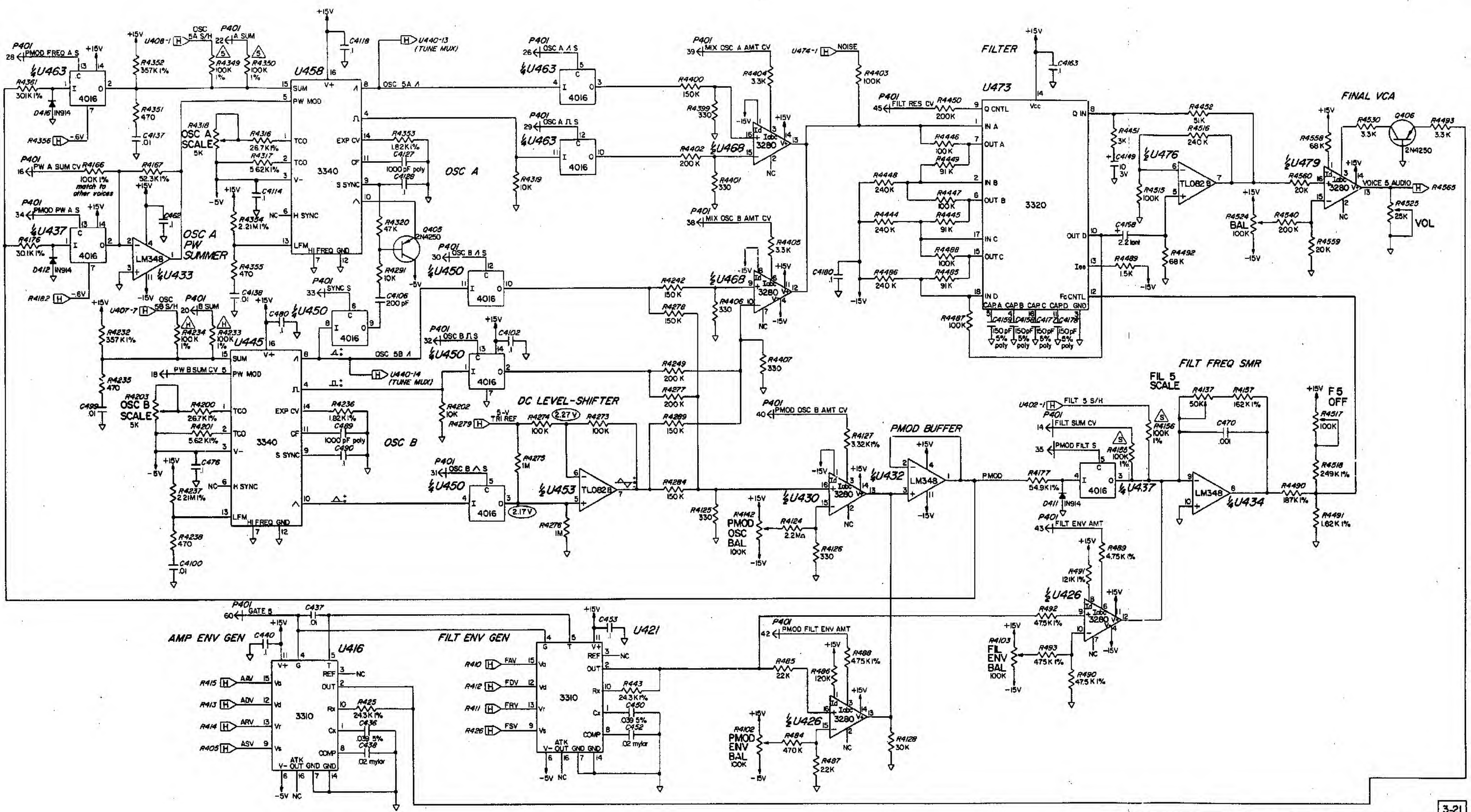

△ RESISTORS MATCHED TO .01%

J		K		L		M		N		O		P		Q		R		S		T		U		V		W		X		Y		Z	
SEQUENTIAL CIRCUITS INC																																	
PCB 4 VOICE 5																																	
DASH DATE D 1000.3																																	
OWN APP SD435																																	
REVISION DATE 1/1/68 SHEET 6 OF 6																																	

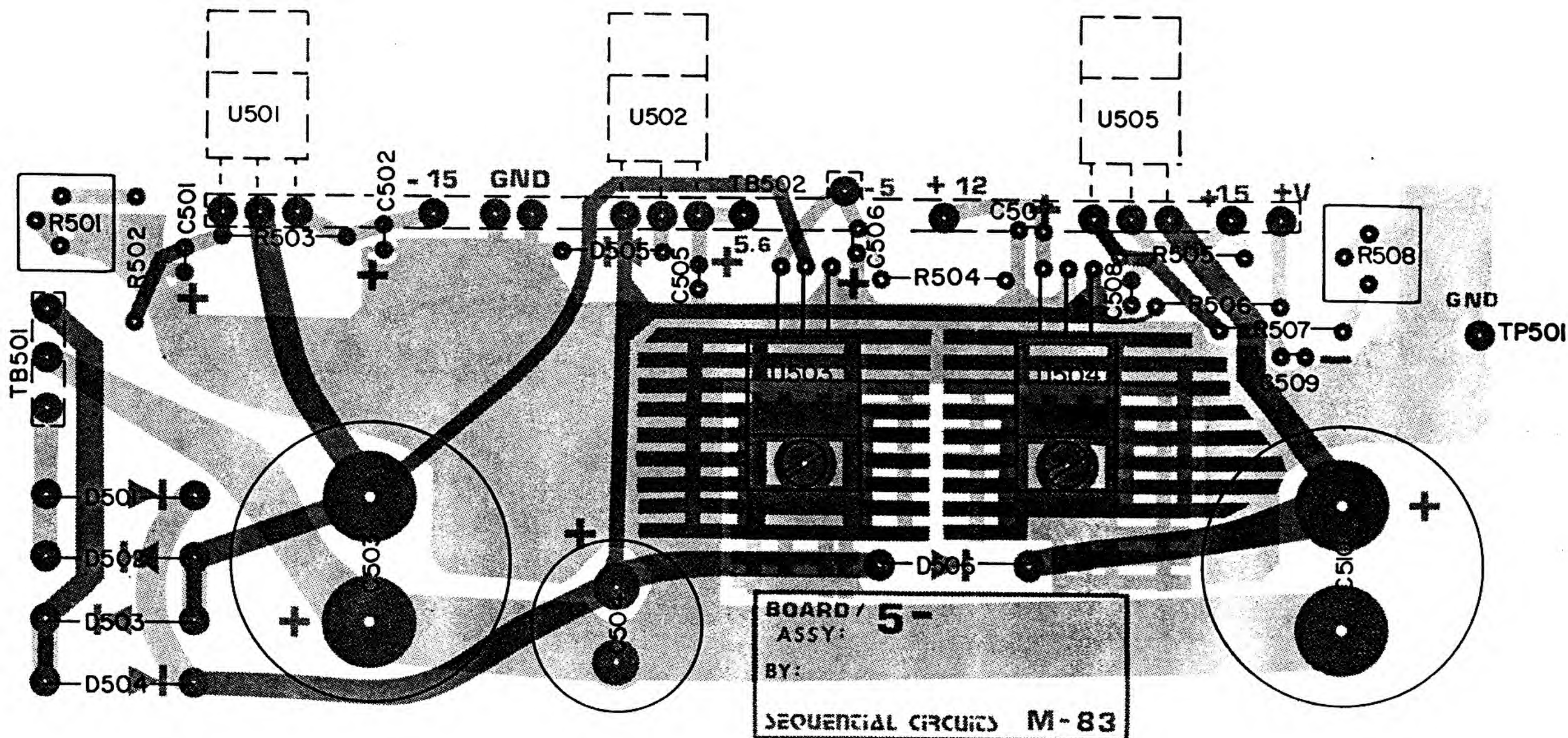

3-22

				J	SEQUENTIAL CIRCUITS INC				
				H					
				G	TITLE				
				F	PCB 5 PARTS ID				
				E	DSN		DATE	SIZE B	MODEL No 1000.3
				D	DWG D. SIMARD		DOCUMENT No		
				C	APP		PP53I		
				B	ISS S. Langlieb		SHEET 1 OF 1		
FIRST/LAST S/N		DATE	ECR No	REVISION	LTR	9/12/60			
		10/21/80	36	Remove +12 & -5 circuits					

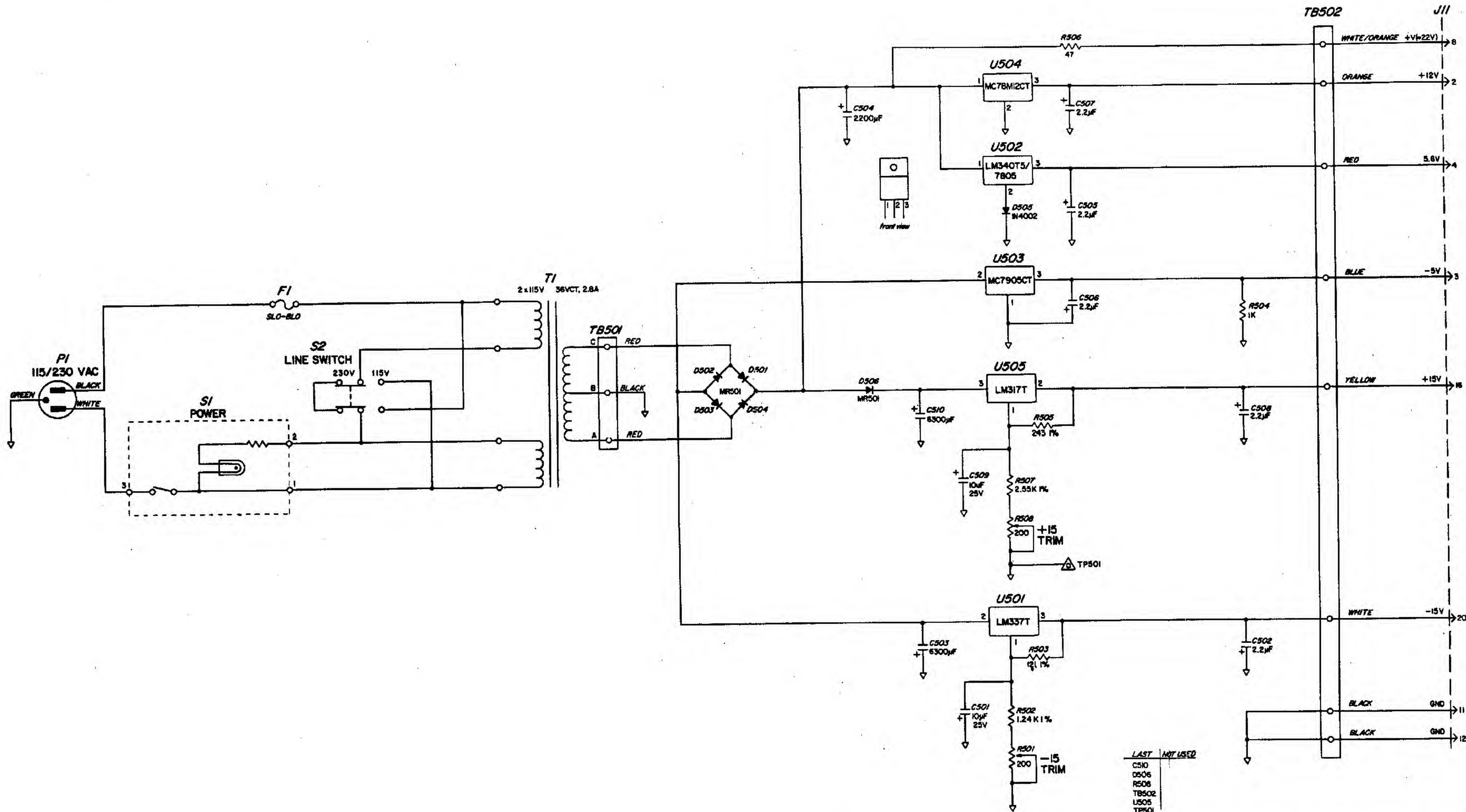

LAST	NOT USED
C510	
D506	
R508	
TB502	
U502	
U505	
TP501	

3-23/3-24

SEQUENTIAL CIRCUITS INC			
PCB 5 POWER SUPPLY			
DESIGNER	DATE	REV	0003
APP	DATE	REV	S0531
DESIGN	DATE	REV	SHEET 1 OF 1

SECTION 4 SERVICE

4-0 GENERAL

This section contains detailed service instructions for complete functional testing and for all adjustments. Instruments to be serviced should be thoroughly tested beforehand. This will verify a malfunction has indeed occurred, perhaps reveal related or unrelated malfunctions, and provide a basis for troubleshooting. The tests suggest trims which may restore normal functions. If the problem(s) persist, you will have to rely on Sections 2 and 3 and your troubleshooting skills to locate the defective component(s).

Throughout the functional tests you must play five different keys to test the five individual voices. All tests are performed by ear; the object generally being consistency between the voices. There will always be slight variations between the voices. If not excessive these differences help to "warm" the Prophet's sound.

Note that while all tests can be performed with the cabinet unopened you will have to open the cabinet to identify the individual voices since there is no reliable way of identifying them by merely listening. To check a single voice, its GATE or Final VCA output can be probed, or its relative volume manipulated (see paragraph 4-22). You may also be able to use the fact that the first voice assigned after the TUNE routine is Voice 1.

Prophet trimming is a sensitive procedure which as a rule should not be done more than necessary. Prophets are carefully adjusted at the factory, where many trimmers are sealed to prevent misadjustment by vibration or accident. You will rarely be able to make an audible improvement upon these trims—unless a malfunction has occurred or a part has been replaced. If you do try to ideally set all 54 trimmers when no repairs have been involved, you may succeed only in correcting for the difference between our DVMs or room temperature and yours.

Most trims require a 4-1/2 digit DVM. An oscilloscope (preferably, dual-trace) is required for filter tuning and for serious troubleshooting.

These procedures are presented in the order recommended for a Prophet assumed to be 100% electrically functional but untrimmed. Real-world problems may require you change the order of some tests and adjustments. Therefore each procedure is written to be performed independently of the others.

In preparation for service, set up the Prophet as follows:

1. Connect mono phone-plug between back panel AUDIO OUT jack and power amplifier.
2. Check back panel 115/230 line voltage selector.
3. Check that back panel power switch is off.
4. Connect power cord to properly-grounded outlet.
5. Switch power on. The power switch should light. TUNE switch on control panel will initially light. After ten seconds, PRESET mode and BANK-PROGRAM 1-1 "comes up." If not, check fuse: 115V—3/4A SLO BLO; 230V—1/2A SLO BLO.
6. Center PITCH wheel and set MOD wheel to minimum.
7. To be safe, SAVE the current program file through the CASSETTE interface. (Better yet, insist owners "back-up" before delivering the machine for service.)
8. Set back panel RECORD ENABLE/DISABLE switch to DISABLE to protect NV RAM.
9. Adjust VOLUME as required.

See Section 1 for mechanical procedures required for service. Sealent can be easily pulled off of trimmers with needle-nose pliers. Be sure to reseal any trim setting you change. It is customary to install sockets when replacing soldered ICs. Also note that the Prophet presets to 1-1 whenever power is switched on. This means you may have to check the controls whenever you power up—after swinging out PCB 4, for example.

IMPORTANT! WHENEVER THE AUDIO CABLE IS DISCONNECTED, PCB 3 MUST BE GROUNDED TO THE BACK PANEL.

4-1 OSCILLATOR A TEST

STEP	MODULE	CONTROL	SETTING	NORMAL INDICATIONS/COMMENTS
1	PRGMR	PRST	OFF	SET CONTROLS ACCORDING TO FIGURE 4-1.
2	—	TUNE	ON	WHEN DONE, PLAY HIGHEST KEY (C5) AND REMEMBER PITCH.
3	OSC A	FREQ	10	HOLD SECOND C (C1) FROM BOTTOM (C0). SAME PITCH AS STEP 2.
4	OSC A	FREQ	0-10	PITCH ADJUSTS IN SEMITONES OVER 4-OCTAVE RANGE. CHECK THAT EACH OSC PLAYS IN TUNE OVER FULL 9-OCTAVE RANGE.
5	OSC A	SYNC	ON	
6	OSC B	KBD	ON	
7	OSC A	FREQ	0-10	SYNC FUNCTION
8	OSC A	FREQ	4	NORMAL KEYBOARD RANGE
9	OSC B	KBD	OFF	
10	OSC A	SYNC	OFF	
11	OSC A	SAW	OFF	
12	OSC A	PULSE	ON	
13	OSC A	PW	0-10	PULSE DEGENERATES NEAR SAME EXTREME KNOB SETTINGS FOR ALL VOICES.

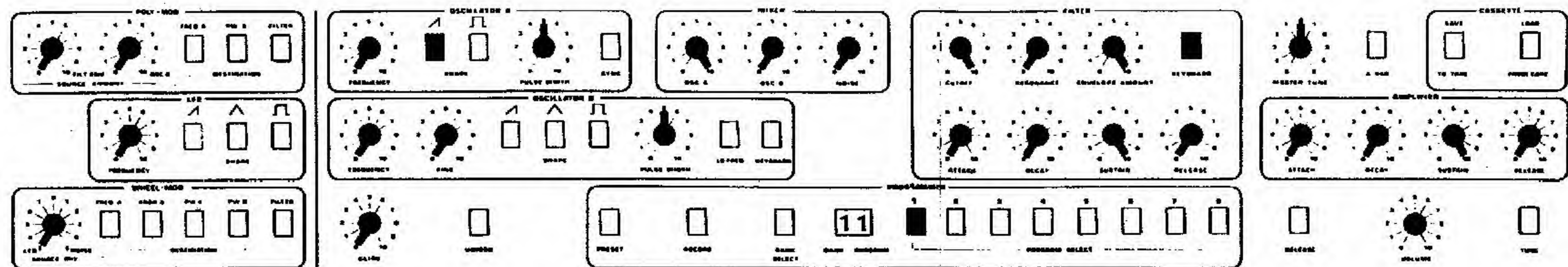

Figure 4-1
OSC A TEST PATCH

RELATED TRIMS: 4-14 DAC GAIN, ADC GAIN, SEQ INTERFACE
4-16 VCO SCALE

4-2 OSCILLATOR B TEST

STEP	MODULE	CONTROL	SETTING	NORMAL INDICATIONS/COMMENTS
1	PRGMR	PRST	OFF	SET CONTROLS ACCORDING TO FIGURE 4-2.
2	—	TUNE	ON	WHEN DONE, PLAY HIGHEST KEY (C5) AND REMEMBER PITCH
3	OSC B	FREQ	10	HOLD SECOND C (C1) FROM BOTTOM (C0). SAME PITCH AS STEP 2.
4	OSC B	FREQ	0-10	PITCH ADJUSTS IN SEMITONES OVER 4-OCTAVE RANGE
5	OSC B	FREQ	4	
6	OSC B	FINE	0-10	PITCH ADJUSTS CONTINUOUSLY OVER 1-SEMITONE RANGE.
7	OSC B	FINE	0	
8	OSC B	SAW	OFF	
9	OSC B	TRI	ON	DULLER TIMBRE, FREE OF HARMONICS.
10	OSC B	TRI	OFF	
11	OSC B	PULSE	ON	
12	OSC B	PW	0-10	PULSE DEGENERATES NEAR SAME EXTREME KNOB SETTINGS FOR ALL VOICES.
13	OSC B	PW	5	
14	OSC B	PULSE	OFF	
15	OSC B	SAW	ON	
16	OSC B	LO FREQ	ON	
17	OSC B	FREQ	0-5	2-40 HZ, CONTROLLED BY HIGHEST KEYS (C3-C5)
18	OSC B	KBD	OFF	
19	OSC B	FREQ	0-10	.1-40 HZ, FIXED FREQ. SLIGHT VARIATION BETWEEN VOICES.

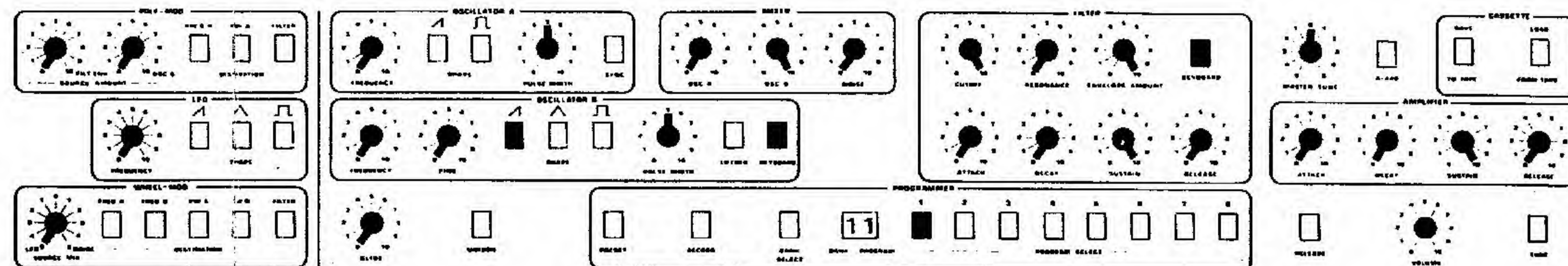

Figure 4-2
OSC B TEST PATCH

4-3 MIXER AND NOISE TEST

STEP	MODULE	CONTROL	SETTING	NORMAL INDICATIONS/COMMENTS
1	PRGMR	PRST	OFF	SET CONTROLS ACCORDING TO FIGURE 4-3.
2	MIX	OSC A	0-10	SMOOTH LEVEL CONTROL THROUGHOUT RANGE. VOICES STAY IN BALANCE.
3	MIX	OSC A	0	
4	MIX	OSC B	0-10	SAME AS STEP 2
5	MIX	OSC B	0	
6	MIX	NOISE	0-10	SAME AS STEP 2

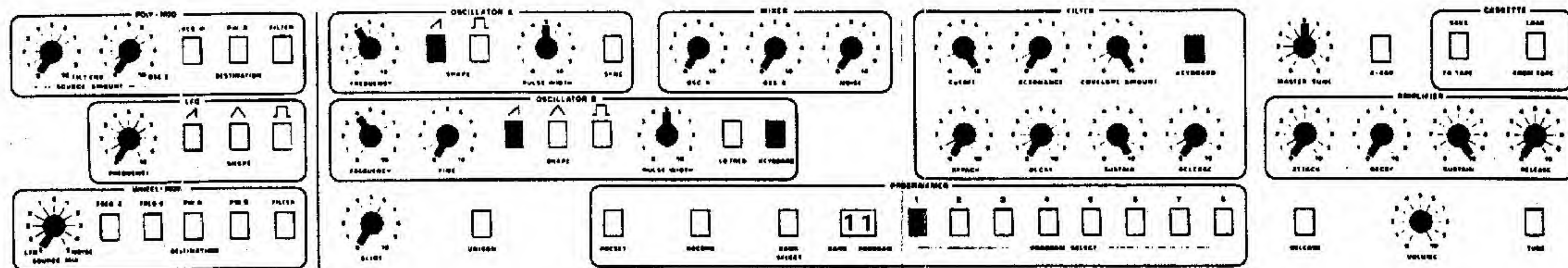

Figure 4-3
MIXER AND NOISE TEST PATCH

4-4 UNISON AND GLIDE TEST

STEP	MODULE	CONTROL	SETTING	NORMAL INDICATIONS/COMMENTS
1	PRGMR	PRST	OFF	SET CONTROLS ACCORDING TO FIGURE 4-4.
2	—	TUNE	ON	WHEN DONE, CHECK THAT OSC A AND OSC B FREQ ARE BOTH SET UP TWO OCTAVES (FROM 0).
3	OSC A	FREQ	4	
	OSC B	FREQ	4	
4	—	A-440	ON	440 REFERENCE ON
5	—	MTUN	+/-1	FINE-TUNE FOR ZERO-BEAT. RESET OSC A AND OSC B FREQ IF REQUIRED.
6	—	A-440	OFF	
7	WHEEL	PITCH	U/D	RAISES AND LOWERS PITCH BY AT LEAST A FIFTH. OSC A AND OSC B MUST TRACK.
8	—	UNI	ON	
9	WHEEL	PITCH	U/D	SAME AS STEP 7
10	WHEEL	PITCH	CENTER	HOLD C5 AND PLAY C0. NO GLIDE.
11	—	GLIDE	6	MEDIUM GLIDE.
12	—	GLIDE	10	MINIMUM: 5 SECS TO SLEW 5 OCTAVES.
13	—	UNI	OFF	
14	—	GLIDE	0-10	NO DETUNING OF OSC A OR OSC B.

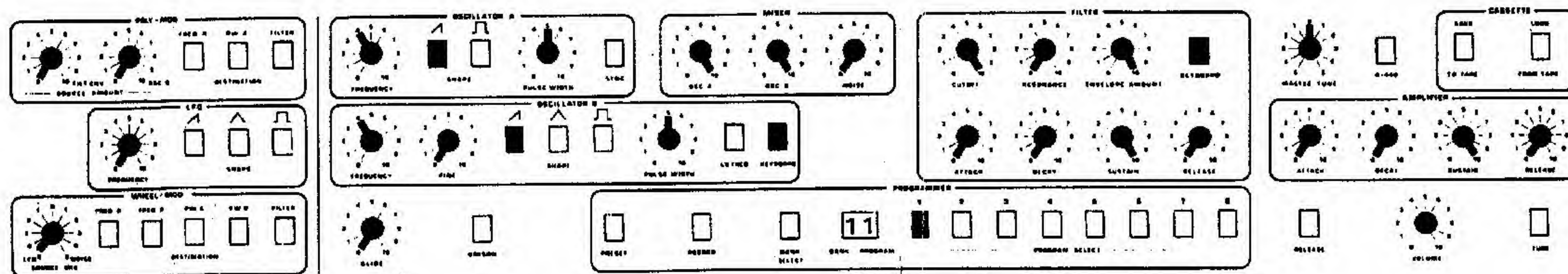

Figure 4-4
UNISON AND GLIDE TEST PATCH

RELATED TRIMS: 4-11 PITCH WHEEL
4-16 VCO SCALE

4-5 FILTER TEST

STEP	MODULE	CONTROL	SETTING	NORMAL INDICATIONS/COMMENTS
1	PRGMR	PRST	OFF	SET CONTROLS ACCORDING TO FIGURE 4-5.
2	FILT	CTF	0-10	SINE-WAVE OSCILLATION THROUGH RANGE.
3	FILT	CTF	4	NORMAL KEYBOARD RANGE.
4	FILT	ENV AMT	0-10	DOESN'T DETUNE ANY VOICE.
5	FILT	KBD	ON/OFF	KEYBOARD TRACKING.
6	FILT	ENV AMT	4	
7	FILT	KBD	ON	
8	FILT	RES	0-10	ALL FILTERS OSCILLATE BETWEEN 7 AND 9-1/2 ON DIAL AND WITHIN 1-1/2 MARKS OF EACH OTHER.
9	FILT	RES	10	
10	FILT	ATK	6	APPROX 1-SEC ATTACK
11	FILT	ATK	0	
12	FILT	DEC	6	APPROX 1-SEC DECAY
13	FILT	DEC	0	
14	FILT	SUS	0-10	RAISES FREQS EVENLY
15	FILT	SUS	10	
16	FILT	REL	6	SWITCH RELEASE ON AND BACK OFF TO KILL DRONING AMP.
18	FILT	REL	10	GREATER THAN 20-SEC RELEASE

RELATED TRIMS: 4-19 FILTER ENVELOPE AMOUNT VCA
4-20. FILTER TUNING

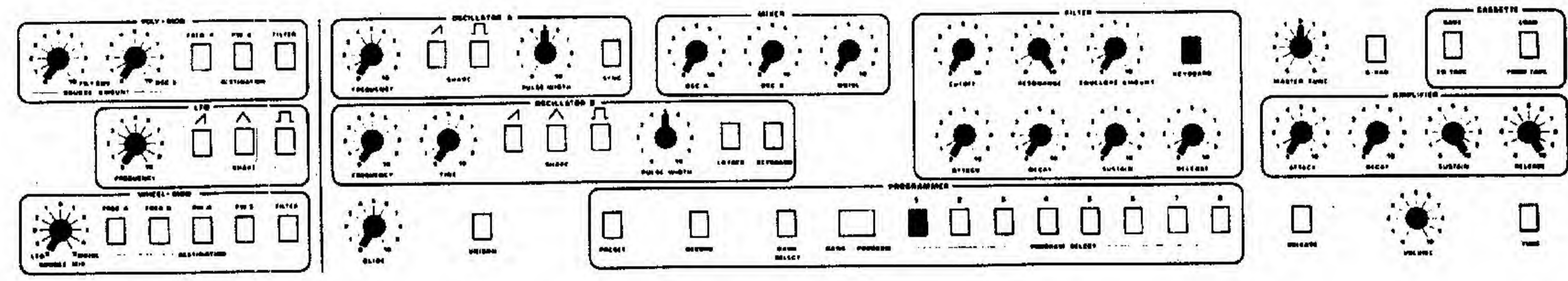

Figure 4-5
FILTER TEST PATCH

4-6 AMPLIFIER TEST

STEP	MODULE	CONTROL	SETTING	NORMAL INDICATIONS/COMMENTS
1	PRGMR	PRST	OFF	SET CONTROLS ACCORDING TO FIGURE 4-6.
2				1-SEC ATTACK
3	AMP	ATK	0	
4	AMP	DEC	6	1-SEC DELAY
5	AMP	DEC	0	
6	AMP	SUS	0-10	SMOOTH VOL INCREASE
7	AMP	SUS	10	
8	AMP	REL	6	1-SEC RELEASE
9	AMP	REL	10	GREATER THAN 20-SEC RELEASE.

RELATED TRIMS: 4-21 FINAL VCA BALANCE
NOTE. THIS TRIM IS INDICATED IF A THUMPING IS HEARD DURING THE TEST.

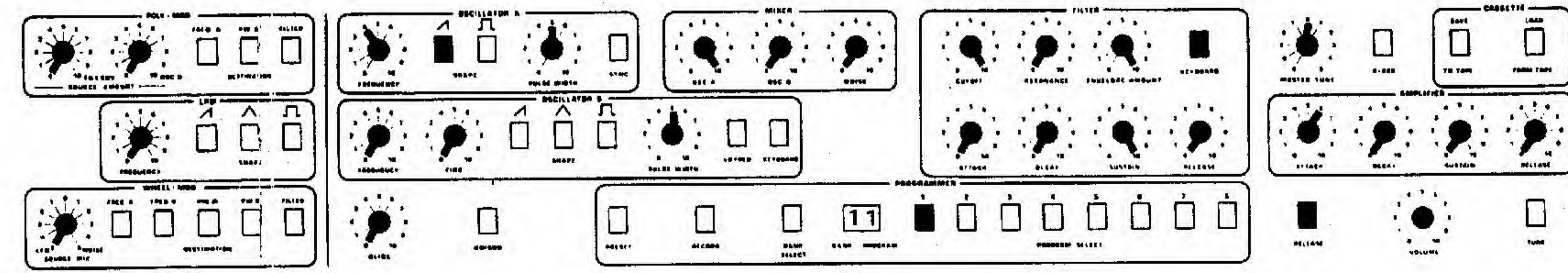

Figure 4-6
AMPLIFIER TEST PATCH

4-7 LFO AND WHEEL-MOD TEST

STEP	MODULE	CONTROL	SETTING	NORMAL INDICATIONS/COMMENTS
1	PRGMR	PRST	OFF	SET CONTROLS ACCORDING TO FIGURE 4-7.
2	W-MOD	FREQ B	ON/OFF	NO OFFSET (LEAVE OFF)
3	W-MOD	FREQ A	ON/OFF	NO OFFSET
4	W-MOD	FREQ A	ON	
5	WHEEL	MOD	UP	NO OFFSET. MOVE MOD WHEEL UP AND DOWN THROUGHOUT REST OF TEST.
6	LFO	TRI	ON	SMOOTH CONTROL
7	LFO	FREQ	0-10	
8	LFO	FREQ	6	
9	LFO	TRI	OFF	
10	LFO	SQUARE	ON	50% DUTY CYCLE, INCREASING INTERVAL WITH INCREASED MOD-WHEEL SETTING.
11	LFO	SQUARE	OFF	
12	LFO	SAW	ON	SMOOTH RAMP
13	LFO	FREQ	3	SLOW, SMOOTH RAMP
14	LFO	FREQ	7	FASTER RAMP
15	LFO	SAW	OFF	
16	LFO	TRI	ON	
17	W-MOD	FREQ A	OFF	
18	W-MOD	PW A	ON	PW-MOD
19	W-MOD	PW A	OFF	
20	W-MOD	FILT	ON	FILT- MOD
21	W-MOD	FILT	OFF	
22	OSC A	PULSE	OFF	
23	OSC B	PULSE	ON	
24	W-MOD	PW B	ON	
25	W-MOD	PW B	OFF	
26	W-MOD	FREQ B	ON	
27	LFO	TRI	OFF	
28	W-MOD	SRC MIX	NOISE	NO OFFSET

RELATED TRIMS: 4-12 MASTER SUMMER OFFSET
 4-13 WHEEL—MOD LFO VCA BALANCE
 4-15 WHEEL-MOD NOISE VCA BALANCE

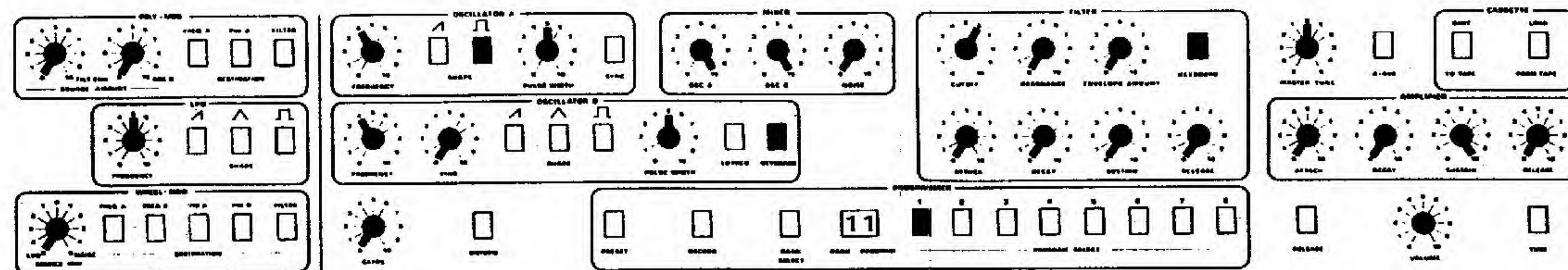

Figure 4-7
 LFO AND WHEEL-MOD TEST PATCH

STEP	MODULE	CONTROL	SETTING	NORMAL INDICATIONS/COMMENTS
1	PRGMR	PRST	OFF	SET CONTROLS ACCORDING TO FIGURE 4-8.
2	P-MOD	FREQ A	ON/OFF	NO OFFSET (LEAVE OFF)
3	P-MOD	PW A	ON/OFF	NO OFFSET (LEAVE OFF)
4	P-MOD	FILT	ON/OFF	NO OFFSET (LEAVE OFF)
5	P-MOD	FREQ A	ON	
6	P-MOD	FIL ENV	0-10	NO OFFSET
7	P-MOD	ENV	0	
8	P-MOD	OSC B	0-10	NO OFFSET
9	P-MOD	OSC B	0	
10	FILT	DEC	5	
11	OSC B	TRI	ON	
12	P-MOD	FIL ENV	2	DESCENDING FREQ
13	P-MOD	FIL ENV	4	DESCENDING FREQ
14	P-MOD	FIL ENV	10	SIMILAR
15	P-MOD	FIL ENV	0	
16	P-MOD	OSC B	4	MOD
17	P-MOD	OSC B	10	SIMILAR
18	P-MOD	OSC B	0	
19	P-MOD	FREQ A	OFF	
20	P-MOD	PW A	ON	
21	OSC A	PW	2	
22	P-MOD	FIL ENV	4	PW-SWEEP
23	P-MOD	FIL ENV	10	
24	P-MOD	FIL ENV	0	
25	P-MOD	OSC B	4	MOD
26	P-MOD	OSC B	10	
27	P-MOD	OSC B	0	
28	P-MOD	PW A	OFF	
29	P-MOD	FILT	ON	
30	OSC A	PULSE	OFF	
31	FILT	CTF	4	
32	FILT	RES	10	
33	P-MOD	FIL ENV	4	DESCENDING RES FILT SWEEP
34	P-MOD	FIL ENV	10	SIMILAR

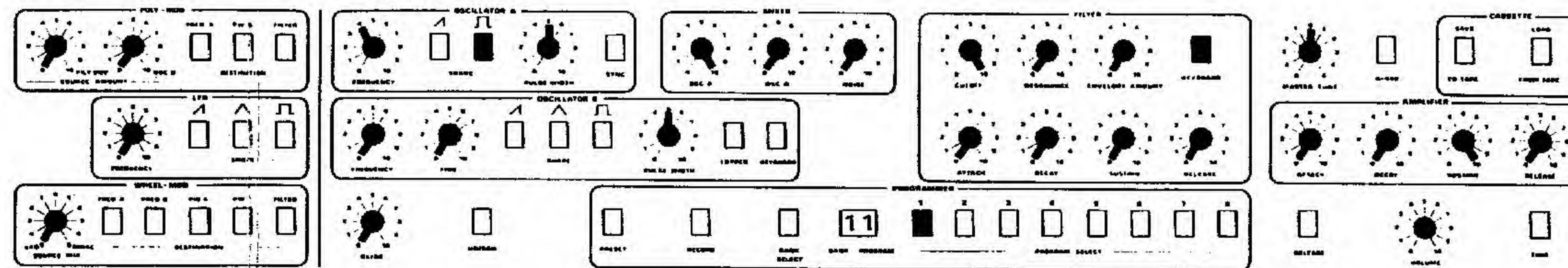

Figure 4-8
POLY-MOD TEST PATCH

- 35 P-MOD FIL ENV 0
- 36 P-MOD OSC B 4 MOD
- 37 P-MOD OSC B 10
- 38 P-MOD OSC B 0

RELATED TRIMS: 4-17 POLY-MOD FILTER ENVELOPE VCA BALANCE
4-18 POLY-MOD OSCILLATOR B VCA BALANCE

4-9 FINAL TEST

1. Check that the back panel RECORD switch is DISABLED.
2. Press RECORD. It should not light.
3. If necessary, load custom or factory programs through the Cassette Interface.
4. Select a program.
5. Patch SEQUENCER VOLTAGE OUT jack to FILTER CONTROL VOLTAGE IN and check for increased brightness across entire keyboard.
6. Move connector from FILTER CONTROL VOLTAGE IN to AMPLIFIER CONTROL VOLTAGE IN. Volume should increase as you play up from the bottom of the keyboard.
7. Move connector from AMPLIFIER CONTROL VOLTAGE IN to SEQUENCER VOLTAGE IN.
8. Patch SEQUENCER TRIGGER OUT to SEQUENCER GATE IN. Check for function and offset.
9. Remove both SEQUENCER INTERFACE cords.
10. Connect footswitch to RELEASE FOOTSWITCH jack.
11. With factory program 1-4 or similar selected, play and check for footswitch function. (Switch RELEASE off.)

RELATED TRIMS: 4-14 DAC GAIN, ADC GAIN, AND SEQ INTERFACE
4-21 FINAL VCA BALANCE
4-22 VOICE VOLUME

4-10 POWER SUPPLY TRIM

GENERALLY, THE POWER SUPPLY SHOULD NOT BE ADJUSTED UNLESS IT HAS BEEN REPAIRED, READJUSTMENT WILL OFFSET ALL OTA BALANCES, WHICH WILL THEN HAVE TO BE RE-TRIMMED.

1. With power off, unscrew the box and slide the top panel assembly forward as discussed in paragraph 1-2, but do not raise to service position.
2. For component location see PP531. For schematic, see SD531.
3. Switch power on.
4. Probe +15V where marked on PCB 5 and adjust R508 to read +15.000V.
5. Probe -15 where marked on PCB 5 and adjust R501 to read -15.000V.
6. Repeat steps 4 and 5 as required. (It is probably not possible to make these settings perfect.)

TO TRIM, THE SUPPLY MUST BE FULLY LOADED.

AFTER REPAIR, CHECK POWER SUPPLY OUTPUT BEFORE INSTALLING, BUT DO NOT OPERATE THE UNLOADED SUPPLY FOR LONG PERIODS WITHOUT HEAT-SINKING THE REGULATORS. NEVER OPERATE THE SUPPLY UNDER LOAD WITHOUT HEATSINKING.

WHEN INSTALLING, BE SURE REGULATOR TABS ARE FLAT AGAINST THE HEATSINK AND THE MICA INSULATOR IS WELL-COATED ON BOTH SIDES WITH THERMAL COMPOUND. BEFORE APPLYING POWER, CHECK REGULATOR INSULATION FROM BACK PANEL WITH OHMMETER. ALL OUTPUTS SHOULD READ "INFINITE" RESISTANCE.

4-11 PITCH WHEEL TRIM

This trim removes offset from the pitch wheel, so that when centered, R1 adds .0000V to the master summers. Trimming R3129 may only be required. For complete pitch-wheel alignment:

1. Switch power off and swingout PCB 4. (Be sure to ground PCB 3.)
2. Switch power on.
3. For component locations, see PP331. For schematic see SD334.
4. Probe P301-7 with DVM.
5. Center R3129 P-WH trimmer.
6. Loosen pitch wheel set screw. For location, see Figure 1-4.
7. With your left hand, hold the pitch wheel tight by pressing the detent with your thumb while pushing against the exposed center notch with your second finger.
8. While holding the wheel steady, adjust R1 to read +/- .05V by turning the shaft slot—rather than the wheel.
9. Being certain the wheel is center-detented, tighten set screw.
10. Move wheel up and down and check center-detent position reads +/- .05V.
11. Trim-out residual offset with R3129.
12. Repeat steps 10 and 11 for best repeatability of .000-V reading.

4-12 MASTER SUMMER OFFSET TRIM

The A and B OFFSET trimmers remove residual wheel-mod offsets in the Master Summers.

1. Switch power off and swing-out PCB 4.
2. Switch power on.
3. For component locations see PP331. For schematic, see SD334.
4. Check that R2 MOD wheel is set to minimum.
5. Probe U368-7 by clipping to the left end of R363.
6. Toggle W-MOD FREQ A switch and adjust R339 A OFFSET for same reading (e.g. +/- mV) with W-MOD FREQ A on and off.
7. Probe U368-1 by clipping on to the left end of R360.
8. Toggle W-MOD FREQ B and adjust R338 B OFFSET as in step 6.

4-13 WHEEL-MOD LFO VCA BALANCE

1. Switch power off and unmount PCB 4.
2. For component locations see PP331. For schematic, see SD334.
3. Check that W-MOD SRC MIX is set to LFO and all W-MOD DESTINATIONS and LFO SHAPES are off.
4. Probe U378-13 by clipping on to left end of R3113.
5. Trim R3141 LFO BAL to read 0.000V.

4-14 DAC GAIN, ADC GAIN, SEQ INTERFACE TRIM

This procedure actually contains four trims which need always be performed together and in the order given.

1. Switch power off and unmount PCB 4.
2. For component locations see PP331. For schematic, see SD332 and SD333.
3. Hit C0 (lowest key).
4. Probe U348-6 at TP302 CV OUT hole and note reading (e.g., +0.093V).
5. Hit C5 (highest key).
6. Trim R333 DAC GAIN for reading in step 4 plus exactly 5.000V (e.g., +5.093V).
7. Repeat steps 3 - 6 until exact.
8. Check other Cs. Each should be exact (e.g., 1.093, 2.093...).
9. Set FILT CUTOFF knob to 10.
10. Probe U360-7 at TP303 FILT CV hole just above U350.
11. Trim R334 ADC GAIN to read as close to 10.000V as the 83-mV quantized voltage steps will allow.
12. Patch SEQ VOLTAGE OUT to SEQUENCER VOLTAGE IN and SEQUENCER TRIGGER OUT to SEQ GATE IN.
13. Probe U374-1, by clipping to right end of R389.
14. Hit C0.
15. Trim R385 SEQ OFFSET reading to exactly half that read in step 4 (e.g. $0.093/2 = 0.046$).
16. Select a non-UNISON program. While playing monophonically, trim R386 SEQ SCALE so Voice 5 plays the same note as the other voice over the entire keyboard. (Hit key repeatedly while trimming.).
17. Disconnect sequencer interface cables.

4-15 WHEEL-MOD NOISE VCA BALANCE

PCB 4 need not be removed for this trim.

1. Switch PRESET off and set up controls according to Figure 4-4.
2. Turn W-MOD SRC MIX to NOISE.
3. Switch W-MOD FREQ B on.
4. Press TUNE. When done tuning, zero-beat oscillators (Leave OSC B FINE at 0).
5. With your left hand, play a key while advancing the MOD wheel until beating is heard.
6. R3142 NOISE BALANCE is accessible through a hole on PCB 4 near U418. Trim out beats.

BE SURE RECORD IS DISABLED

THE RANGE OF THE TUNE SYSTEM IS LARGE ENOUGH SO IT WILL RARELY BE NECESSARY TO TRIM VCO SCALE. IN FACT VCOS CAN USUALLY BE SUBSTITUTED WITHOUT ANY READJUSTMENT. THEREFORE IF THE PROPHET IS BADLY OUT OF TUNE THERE IS PROBABLY A COMPONENT FAILURE.

A SCALE TRIM IS INDICATED FOR OSCILLATORS WHICH DO NOT TRACK THE PITCH WHEEL, OR WHICH ARE DETUNED IN UNISON, ESPECIALLY WITH LONG GLIDE TIMES.

This trim uses a special microcomputer subroutine which sets up the VCOs to be scaled in the order OSC 1A, 1B, 2A, 2B, 3A, etc. The lowest key, C0, is used to tell the microcomputer to recompute the VCO SCALE bias. One starts with OSC 1A by trimming for zero-beat with a C-reference which the computer also provides (through the A-440 circuit), hitting C0, retrimming, hitting C0, and retrimming and so on until no further improvement can be made. Then key D0 is pressed to bring up the next oscillator, 1B, and the process repeated (trim, C0, trim, C0, etc.).

1. Locate TP301 at U324-6 (schematic SD332). Tie this to +5V (Most PCB 3s have a wire loop at the +5V rail, left of U301 - U308).
2. Press TUNE. You will now hear OSC 1A's sawtooth with a reference tone in the background.
3. Trim R4294 OSC 1A SCALE for zero-beat. Hit key C0 and retrim, using a good amount of "overshoot." Repeat until the tones are in zero-beat.
4. When OSC 1A is done, hit key D0 and TRIM OSC 1B. Table 4-0 lists OSC SCALE trim designators.
5. Repeat step 4 for OSC 2A - 5B. If you lose track of which VCO you are supposed to be trimming, simply run your hand along the two rows of VCOs (see Figure 1-0). You will know when you touch a pin of the currently-tuning VCO—they are very sensitive to detuning in this way.
6. When done untie TP301 from +5V. The Prophet will enter TUNE mode, then come up to program 1-1.

Table 4-0
OSCILLATOR SCALE TRIMMERS

VCO	TRIMMER
1A	R4294
1B	R4186
2A	R4300
2B	R4190
3A	R4306
3B	R4194
4A	R4312
4B	R4198
5A	R4318
5B	R4203

4-17 POLY-MOD FILTER ENVELOPE VCA BALANCE

1. Switch PRESET off and set controls according to Figure 4-8.
2. To trim Voice 1, first turn P-MOD FILT ENV to 10.
3. Probe U422-13 by clipping to right end of R4108.
4. With no keys hit, trim R494 for .000V.
5. Trim Voices 2 - 5 in the same way, referring to Table 4-1.

Table 4-1
POLY-MOD FILTER ENVELOPE VCA BALANCE

VOICE	OTA	PROBE (RIGHT END)	TRIMMER
1	U422-13	R4108	R494
2	U423-13	R4109	R496
3	U424-13	R4118	R498
4	U425-13	R4119	R4100
5	U426-13	R4128	R4102

4-18 POLY-MOD OSCILLATOR B VCA BALANCE

1. Switch PRESET off and set controls according to Figure 4-8.
2. Turn P-MOD OSC B to 10.
3. Probe U428-13 by clipping to right end of R4108.
4. With no keys hit, trim R4138 for .000V.
5. Trim Voices 2 - 5 in the same way, referring to Table 4-2.

Table 4-2
POLY MOD OSC B VCA BALANCE

VOICE	OTA	PROBE (RIGHT END)	TRIMMER
1	U428-13	R4108	R4138
2	U428-12	R4109	R4139
3	U429-13	R4118	R4140
4	U429-12	R4119	R4141
5	U430-13	R4128	R4142

4-19 FILTER ENVELOPE AMOUNT VCA BALANCE

1. Switch PRESET off and set controls according to Figure 4-8.
2. Switch FILTER KEYBOARD off.
3. Probe TP303 FILT CV at hole just above U350 and adjust FILT CTF knob to read approximately 5.75V.
4. Probe U433-7 VOICE 1 FILT FREQ SMR by clipping to the right end of R4145.
5. Note reading (e.g., .063V), then turn FILT ENV AMT to 10. Trim R495 for same reading as with FILT ENV AMT knob set to 0.
6. Trim Voices 2 - 5 in the same way, referring to Table 4-3.

Table 4-3
FILTER ENVELOPE AMOUNT VCA BALANCE

VOICE	OTA	PROBE	TRIMMER
1	U433-7	R4145	R495
2	U434-14	R4146	R497
3	U434-1	R4149	R499
4	U434-7	R4154	R4101
5	U434-8	R4157	R4103

4-20 FILTER TUNING

NOTE: If Rev 3.0 Software level is V.8.1, (original) and VCO SCALE TRIM has been performed, switch power off then back on to reset the A-440 port (otherwise the reference will be left tuned to "C"). If V.8.2 is installed, power-reset will not be necessary because the tuning port is automatically reset when exiting SCALE TRIM routine.

A scope is required for this trim.

Note that there is no computer-correction of filter tuning as there is for the oscillators, so the filters will never track as well as the oscillators. There is also no temperature compensation, so the filters will always drift a certain amount. For this reason, filter tuning can degrade as soon as five minutes after tuning. The filters are gain-matched, with the set code written on PCB 4 just above U469 (e.g. 3.60 - 3.64). Include this set code when ordering replacement filters.

1. Switch PRESET off and set controls according to Figure 4-5.
2. Switch UNISON on.
3. Probe TP303 FILT CV at hole just above U350 and adjust FILT CTF knob to read as close to 2.000V as the quantized voltage steps will allow.
4. Switch A-440 on.
5. Sync scope from TP401, A-440, located above and to the left of U464. It may be easier to clip to the left end of R4498.
6. Probe U474-7 FILT output buffer by clipping on to left end of R4500.
7. Alternately play A3 and A4 (highest A) while tuning R4501 INIT FREQ (OFFSET) and R4133 FILT SCALE for 440- and 880-Hz. The two trimmers interact, so repeat until no improvement is possible. See Waveform 4-0.
8. Trim Voices 2 - 5 in the same way, referring to Table 4-4.

440-HZ
REFERENCE

FILTER IN
RESONANCE
(A3 HELD)

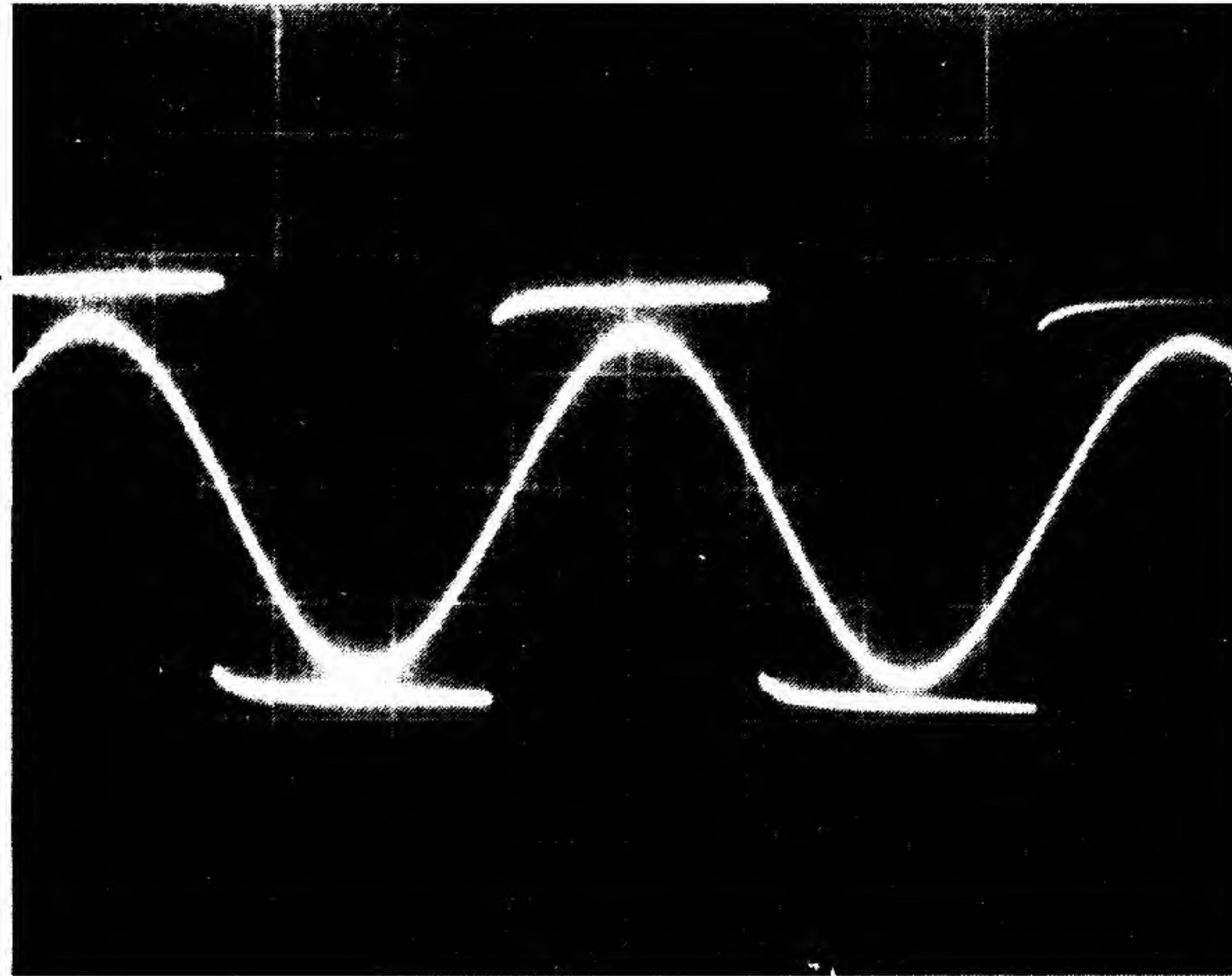

V = .1V/div
H = 5 ms/div

Waveform 4-0
FILTER TUNING

Table 4-4
FILTER TUNING TRIMMERS

VOICE	FILT BUFFER	PROBE	INIT FREQ	SCALE
1	U474-1	R4500-RIGHT END	R4501	R4133
2	U475-1	R4506-LEFT END	R4504	R4134
3	U475-7	R4508-RIGHT END	R4509	R4135
4	U476-1	R4514-LEFT END	R4512	R4136
5	U476-7	R4516-RIGHT END	R4517	R4137

4-21 FINAL VCA BAL

1. Switch PRESET off and set controls according to Figure 4-8.
2. Turn MIX OSC A to 0.
3. Switch FILT KBD off.
4. Switch UNISON on.
5. Tie any key on by clipping J-wire to bus bar.
6. Referring to Table 4-5, turn down Voice 2 - 5 volumes with trimmers listed.
7. Check that R4529 is set for maximum Voice 1 volume.
8. Probe U480-5 at left end of R4565-569.
9. Trim R4520 for .000-V reading.
10. Turn Voice 1 volume all the way down.
11. Turn Voice 2 Volume up fully, and trim in the same way.
12. Repeat for Voices 3 - 5.
13. Untie key.

Table 4-5
FINAL VCA BAL

VOICE	VOLUME	FINAL VCA BAL
1	R4529	R4520
2	R4528	R4521
3	R4527	R4522
4	R4526	R4523
5	R4525	R4524

4-22 VOICE VOLUME

1. Switch PRESET off and set controls according to Figure 4-1 or factory program 1-8.
2. Adjust OSC A FREQ to 5.
3. With scope, probe U480-7 at right end of R4564.
4. Check that all Voice Volume trimmers are set for maximum volume (see Table 4-5).
5. Play polyphonically and measure each voice level on scope. (To identify the voices, touch the OSC As.).
6. Turn down louder voices to volume of the softest voice.

SECTION 5 PARTS

5-0 CHASSIS

NOTE. FOR ITEM DESCRIPTIONS
SEE PARAGRAPH 5-6,
BILL OF MATERIALS

DESIGNATOR	ITEM NO.
F1	E-051
J1/2	J-001
J3	J-014
J4-10	J-001
J11	J-029/P-028
J12	J-043/P-022
J13	J-007 (SEE SA1)
J14	J-044/P-022
P1	E-037
R1/2	R-207
S1	S-025
S2	S-032
S3	S-038
SA1	S-027
T1	E-048
W1	E-080
W2	E-078

5-2 PCB 2

C201-04	C-045
C205	C-031
D201-23	D-005
DS201-22	SEE S201-22
DS224	L-005
J201	J-007
P201	P-025, P-032
P202	P-040
Q201	T-002
QA201	T-011
R201/02	R-221
R203	R-008
R204/05	R-221
R206	R-008
R207/08	R-221
R209	R-008
R210/11	R-221
R212	R-010
R213-17	R-221
R218-20	R-010
RA201	R-300
RA202	R-301
S201-20	S-028
S221	S-029
S222	S-030
S223	S-031
U201-03	I-211
U204/05	I-227
U206	I-235
U207/08	I-227
U209/10	I-216
U211	I-228
U212	I-218
W201	E-071

5-1 PCB 1

C101	C-045
D101-14	D-005
DS101-14	SEE S101-14
R101-13	R-221
S101	S-028
S102-12	S-029
S113	S-028
S114	S-029

5-3 PCB 3

BT301	E-040	R301	R-025
C301	C-045	R302	R-014
C302	C-031	R303	R-022
C303	C-021	R304	R-010
C304-15	C-045	R305/06	R-011
C316	C-014	R307	R-025
C317	C-031	R308	R-011
C318-20	C-045	R309	R-010
C321	C-036	R310	R-004
C322/23	C-045	R311-13	R-025
C324	C-040	R314	R-011
C325/26	C-045	R315	R-025
C327-48	C-012	R316	R-010
C349/50	C-045	R317	R-011
C351	C-046	R318	R-025
C352	C-045	R319	R-047
C353/54	C-036	R320	R-062
C355/56	C-021	R321	R-064
C357	C-045	R322	R-054
C358	C-047	R323	R-040
C359	C-012	R324	R-025
C360	C-021	R325	R-010
C361	C-014	R326	R-031
C362-64	C-012	R327	R-022
C365-69	C-045	R328	R-054
C370	C-031	R329	R-110
C371	C-045	R330	R-162
C372	C-012	R331	R-008
C373/74	C-045	R332	R-067
C375	C-012	R333	R-212
C376	C-041	R334	R-211
C377-81	C-045	R335	R-163
C382	C-041	R336	R-144
C383	C-045	R337	R-107
C384/85	C-012	R338	R-217
C386	C-045	R339	R-218
D301-3	D-005	R340	R-107
D304	D-001	R341	R-108
D305-19	D-005	R342/43	R-115
J301	J-031, J-042, P-031	R344	R-144
J302	J-042	R345	R-068
P301	P-027	R346	R-045
P302	P-029	R347-49	R-025
P303	P-030	R350	R-167
P304	P-013	R351	R-025
Q301-08	T-003	R352	R-110
Q309	T-008	R353	R-012
		R354/55	R-110N
		R356	R-165
		R357	R-110N
		R358-60	R-110A
		R361/62	R-045
		R363-5	R-110B
		R366	R-142
		R367	R-014

R368/69	R-162	R3133	R-065
R370	R-014	R3134	R-006
R371	R-142	R3135	R-123
R372	R-110N	R3136	R-159
R373	R-025	R3137	R-139
R374	R-110	R3138	R-116
R375	R-008	R3139	R-006
R376	R-116	R3140	R-004
R377	R-121	R3141/142	R-217
R378	R-110	R3143	R-004
R379	R-110A	R3144	R-026
R380/81	R-012	R3145	R-064
R382/3	R-110B	R3146	R-012
R384	R-008	R3147/148	R-025
R385	R-217	R3149/150	R-029
R386	R-218	R3151	R-030
R387	R-110 A	R3152	R-004
R388/89	R-008	R3153	R-011
R390	R-029		
R391	R-113	U301-8	I-226
R392	R-161	U309	I-230
R393	R-025	U310	I-101
R394	R-066	U311	I-025
R395	R-018	U312	Z-985 0.V.8.2
R396	R-006	U313	Z-986 1.V.8.2
R397/98	R-014	U314	Z-987 2.V.8.2
R399	R-119	U315	I-414
R3100	R-110	U316/17	I-033
R3101	R-025	U318/19	I-117
R3102	R-110	U320	I-101
R3103/104	R-128	U321	I-102
R3105	R-122	U322	I-109
R3106	R-011	U323/24	I-216
R3107	R-113	U325	I-008
R3108	R-142	U326	I-503
R3109	R-063	U327/28	I-237
R3110	R-012	U329	I-229
R3111	R-010	U330	I-205
R3112	R-028	U331	I-209
R3113	R-012	U332-40	I-228
R3114/115	R-036	U341/42	I-205
R3116	R-038	U343-45	I-209
R3117/118	R-029	U346	I-502
R3119	R-015	U347	I-323
R3120	R-004	U348	I-305
R3121/122	R-011	U349-54	I-312
R3123/124	R-025	U355-57	I-211
R3125	R-035	U358-64	I-312
R3126	R-016	U365	I-302
R3127/8	R-012	U366-68	I-313
R3129	R-218	U369-71	I-206
R3130	R-015	U372	I-404
R3131	R-065	U373	I-312
R3132	R-026		

Z-984
(SFT)

Z-985 0.V.8.2
Z-986 1.V.8.2
Z-987 2.V.8.2

U374	I-313	C468	C-008
U375	I-315	C469	C-045
U376	I-321	C470	C-008
U377	I-206	C471-80	C-045
U378	I-322	C481	C-039
U379	I-233	C482	C-045
U380	I-312	C483	C-039
U381	I-322	C484	C-045
		C485	C-039
W301	E-079	C486	C-045
		C487	C-039
		C488	C-045
5-4 PCB 4		C489	C-039
		C490	C-045
C401-02	C-045	C491-100	C-012
C403-09	C-040	C4101-104	C-045
C410	C-045	C4105	C-021
C411-18	C-040	C4106-110	C-005
C419/20	C-045	C4111-118	C-045
C421/22	C-036	C4119	C-039
C423	C-031	C4120	C-045
C424	C-043	C4121	C-039
C425	C-012	C4122	C-045
C426	C-014	C4123	C-039
C427	C-043	C4124	C-045
C428	C-012	C4125	C-039
C429	C-014	C4126	C-045
C430	C-043	C4127	C-039
C431	C-012	C4128	C-045
C432	C-014	C4129-138	C-012
C433	C-043	C4139-144	C-045
C434	C-012	C4145-149	C-044
C435	C-014	C4150-159	C-038
C436	C-043	C4160-163	C-045
C437	C-012	C4164-168	C-021
C438	C-014	C4169-178	C-038
C439/40	C-045	C4179-183	C-045
C441	C-043	C4184	C-018
C442	C-014	C4185-188	C-045
C443	C-043	C4189	C-042
C444	C-014		
C445	C-043	D401-18	D-005
C446	C-045		
C447	C-014	P401	P-013
C448	C-043	P402	P-044
C449	C-014		
C450	C-043	Q401-11	T-003
C451	C-045		
C452	C-014	R402-04	R-168
C453-57	C-045	R405-06	R-141
C458	C-045	R407-09	R-169
C459-63	C-045	R410-15	R-145
C464-66	C-008	R418/19	R-145
C467	C-045	R423-25	R-145

R426	R-141	R4108/09	R-016
R427-29	R-169	R4110	R-140
R430-32	R-168	R4111/12	R-004
R433	R-141	R4113/14	R-030
R439-43	R-145	R4115/116	R-004
R444	R-028	R4117	R-140
R445	R-040	R4118/119	R-016
R446	R-057	R4120	R-140
R447	R-040	R4121/122	R-004
R448/49	R-141	R4123/124	R-030
R450	R-147	R4125/126	R-004
R451	R-149	R4127	R-140
R452	R-147	R4128	R-016
R453	R-171	R4129	R-012
R454	R-028	R4130	R-011
R455	R-040	R4131	R-026
R456	R-057	R4132	R-012
R457	R-040	R4133-137	R-222
R458/59	R-041	R4138-142	R-217
R460	R-147	R4143/144	R-110
R461	R-149	R4145/146	R-151
R462	R-147	R4147/148	R-110
R463	R-171	R4149	R-151
R464	R-028	R4150-153	R-110
R465	R-040	R4154	R-151
R466	R-057	R4155/156	R-110
R467	R-040	R4157	R-151
R468/69	R-141	R4158	R-029
R470	R-147	R4159	R-025
R471	R-149	R4160	R-110
R472	R-147	R4161/162	R-167
R473	R-171	R4163-166	R-110
R474	R-028	R4167	R-167
R475	R-040	R4168	R-012
R476	R-057	R4169	R-030
R477	R-040	R4170/171	R-167
R478/79	R-141	R4172-176	R-113
R480	R-147	R4177-181	R-114
R481	R-149	R4182	R-008
R482	R-147	R4183	R-029
R483	R-171	R4184	R-146
R484	R-028	R4185	R-142
R485	R-040	R4186	R-211
R486	R-057	R4187	R-012
R487	R-040	R4188	R-146
R488/89	R-141	R4189	R-142
R490	R-147	R4190	R-211
R491	R-149	R4191	R-012
R492	R-147	R4192	R-146
R493	R-171	R4193	R-142
R494-103	R-217	R4194	R-211
R4104	R-030	R4195	R-012
R4105/06	R-004	R4196	R-146
R4107	R-140	R4197	R-142

R4198	R-211	R4279	R-108
R4199	R-012	R4280-289	R-041
R4200	R-146	R4290	R-107
R4201	R-142	R4291	R-012
R4202	R-012	R4292	R-146
R4203	R-211	R4293	R-142
R4204	R-170	R4294	R-211
R4205/206	R-110	R4295	R-012
R4207	R-006	R4296	R-018
R4208	R-139	R4297	R-012
R4209	R-116	R4298	R-146
R4210	R-006	R4299	R-142
R4211	R-170	R4300	R-211
R4212/213	R-110	R4301	R-012
R4214	R-006	R4302	R-018
R4215	R-139	R4303	R-012
R4216	R-116	R4304	R-146
R4217	R-006	R4305	R-142
R4218	R-170	R4306	R-211
R4219/220	R-110	R4307	R-012
R4221	R-006	R4308	R-018
R4222	R-139	R4309	R-012
R4223	R-116	R4310	R-146
R4224	R-006	R4311	R-142
R4225	R-170	R4312	R-211
R4226/227	R-110	R4313	R-012
R4228	R-006	R4314	R-018
R4229	R-139	R4315	R-012
R4230	R-116	R4316	R-146
R4231	R-006	R4317	R-142
R4232	R-170	R4318	R-211
R4233/234	R-110	R4319	R-012
R4235	R-006	R4320	R-018
R4236	R-139	R4321/322	R-110
R4237	R-116	R4323	R-006
R4238	R-006	R4324	R-170
R4239/240	R-026	R4325	R-139
R4241-245	R-041	R4326	R-116
R4246/247	R-026	R4327	R-006
R4248	R-041	R4328/329	R-110
R4249-251	R-026	R4330	R-006
R4252/253	R-029	R4331	R-170
R4254/255	R-025	R4332	R-139
R4256/257	R-029	R4333	R-116
R4258-261	R-025	R4334	R-006
R4262/263	R-029	R4335/336	R-110
R4264	R-026	R4337	R-006
R4265/266	R-041	R4338	R-170
R4267	R-026	R4339	R-139
R4268	R-041	R4340	R-116
R4269/270	R-029	R4341	R-006
R4271-274	R-025	R4342/343	R-110
R4275/276	R-029	R4344	R-006
R4277	R-026	R4345	R-170
R4278	R-041	R4346	R-139
		R4347	R-116

R4348	R-006	R4424	R-031
R4349/350	R-110	R4425	R-056
R4351	R-006	R4426	R-058
R4352	R-170	R4427	R-024
R4353	R-139	R4428/429	R-025
R4354	R-116	R4430	R-058
R4355	R-006	R4431	R-024
R4356	R-008	R4432	R-026
R4357-361	R-115	R4433	R-031
R4362	R-025	R4434	R-056
R4363	R-004	R4435	R-058
R4364	R-041	R4436	R-024
R4365	R-004	R4437/438	R-025
R4366	R-026	R4439	R-058
R4367	R-025	R4440	R-024
R4368/369	R-036	R4441	R-026
R4370-372	R-004	R4442	R-031
R4373	R-041	R4443	R-056
R4374	R-004	R4444	R-058
R4375	R-026	R4445	R-024
R4376	R-025	R4446/447	R-025
R4377/378	R-036	R4448	R-058
R4379-381	R-004	R4449	R-024
R4382	R-041	R4450	R-026
R4383	R-004	R4451	R-031
R4384	R-026	R4452	R-056
R4385	R-025	R4453	R-024
R4386/387	R-036	R4454	R-058
R4388-390	R-004	R4455/456	R-025
R4391	R-041	R4457	R-009
R4392	R-004	R4458	R-152
R4393	R-026	R4459	R-139
R4394	R-025	R4460	R-021
R4395/396	R-036	R4461	R-024
R4397-399	R-004	R4462	R-058
R4400	R-041	R4463/464	R-025
R4401	R-004	R4465	R-009
R4402	R-026	R4466	R-152
R4403	R-025	R4467	R-139
R4404/405	R-036	R4468	R-021
R4406/407	R-004	R4469	R-024
R4408	R-058	R4470	R-058
R4409	R-024	R4471/472	R-025
R4410/411	R-025	R4473	R-009
R4412	R-058	R4474	R-152
R4413	R-024	R4475	R-139
R4414	R-026	R4476	R-021
R4415	R-031	R4477	R-024
R4416	R-056	R4478	R-058
R4417	R-058	R4479/480	R-025
R4418	R-024	R4481	R-009
R4419/420	R-025	R4482	R-152
R4421	R-058	R4483	R-139
R4422	R-024	R4484	R-021
R4423	R-026	R4485	R-024
		R4486	R-058

R4487/488	R-025	U412-21	I-319
R4489	R-009	U422-26	I-322A
R4490	R-152	U427	I-315
R4491	R-139	U428-30	I-233B
R4492	R-021	U431-34	I-313
R4493-497	R-036	U435	I-301
R4498	R-012	U436-38	I-206
R4499	R-025	U439/40	I-211
R4500	R-058	U441-45	I-312
R4501	R-212	U446-50	I-206
R4502/503	R-130	U451-53	I-312
R4504	R-212	U454-58	I-321
R4505	R-025	U459-63	I-206
R4506	R-058	U464-68	I-322B
R4507	R-025	U469-73	I-320
R4508	R-058	U474-76	I-312
R4509	R-212	U477	I-321
R4510/511	R-130	U478-79	I-322C
R4512	R-212	U480	I-312
R4513	R-025	U481	I-317
R4514	R-058		
R4515	R-025		
R4516	R-058	W401	E-079
R4517	R-212	W402	E-079
R4518	R-130		
R4519	R-015		
R4520-524	R-217		
R4525-529	R-225		
R4530-534	R-036	5-5 PCB 5	
R4535	R-025	C501	C-036
R4536-540	R-026	C502	C-021
R4541/542	R-011	C503	C-028
R4543	R-025	C504	C-025
R4544	R-008	C505-08	C-021
R4545	R-042	C509	C-036
R4546	R-021	C510	C-028
R4547/548	R-015		
R4549	R-021	D501-04	D-004
R4550/551	R-015	D505	D-001
R4552	R-021	D506	D-004
R4553/554	R-015		
R4555	R-021	R501	R-219
R4556/557	R-015	R502	R-158
R4558	R-021	R503	R-125
R4559/560	R-015	R504	R-008
R4561	R-021	R505	R-156
R4562	R-015	R506	R-043
R4563/564	R-014	R507	R-157
R4565-569	R-017	R508	R-219
U401-04	I-312	U501	I-420
U405/06	I-211	U502	I-410
U407-10	I-312	U503	I-411
U411	I-411	U504	I-409
		U505	I-412

5-6 BILL OF MATERIALS (TOTAL ITEMS)

LINE	ITEM	DESCRIPTION	QTY
000	C-005	200P 50V DISC CAP	5
002	C-008	.001 50V MYLAR 10% CAP	5
004	C-012	.01UF MYLAR 50V	54
006	C-014	.02 50V MYLAR	12
007	C-018	.22 35V TANTALUM	1
008	C-021	2.2 TANTALUM 25V 20% CAP	16
010	C-025	2200 25V ELECTROLYTIC CAP	1
012	C-028	6300 25V CAP	2
014	C-031	10 10V TANTALUM CAP	5
016	C-036	10U 25V TANT	7
018	C-038	150PF POLY 5%	20
020	C-039	1000PF, POLY	10
022	C-040	10,000PF(.01) POLY 50V 5%	16
024	C-041	.1UF MYLAR 50V 5%	2
026	C-042	2.2UF NON-POLAR 25V	1
028	C-043	.039UF MYLAR 5% 50V	10
030	C-044	10UF TANT 3V	5
032	C-045	.1UF 50V DECOUPLER	116
034	C-046	.0056 MYLAR 100V	1
036	C-047	120 PF 10% DISC (WAS 75PF	1
038			
040	D-001	1N4002 100V 1 AMP DIODE	2
042	D-004	MR501(1N5401) 100V 3AMP	5
044	D-005	1N914	73
046			
048	E-001	18 AWG RED	2
050	E-002	18 AWG BLUE	4
052	E-003	BLACK WIRE	5
054	E-017	SQUARE FUSE HOLDER BLACK	1
056	E-018	SQUARE FUSE HOLDER CAP RD	1
058	E-037	PWRCORD BELDEN17238 3C 8'	1
060	E-040	2.9V BATTERY LITHIUM	1
062	E-044	AWG 22 ORANGE--BELDN 8524	4
064	E-045	BLACK COAX 8216-BELDEN	3
066	E-048	CT TRANSFORMER 5V3	1
068	E-051	3/4 AMP SLO-BLO FUSE	1
070	E-053	22 AWG STRANDED YELLOW	2
072	E-054	22 AWG STRANDED BLACK	2
074	E-055	22 AWG STRANDED GREY	2
076	E-056	22 AWG STRANDED WHITE	2
078	E-057	22 AWG STRANDED BROWN	2
080	E-058	22 AWG STRANDED VIOLET	2
082	E-059	22 AWG STRANDED RED	4
084	E-060	22 AWG STRANDED TAN	2
086	E-061	22 AWG STRANDED LGHT BLUE	4
088	E-062	22 AWG STRANDED GREEN	4
090	E-063	18 AWG WHITE	2
092	E-064	18 AWG ORANGE	1
094	E-065	18 AWG YELLOW	2

096	E-066	18 AWG WHITE W\ORANGE STR	1
098	E-071	40 PIN RIBBON CABLE	1
100	E-078	RIB CBL 60COND MLX 2.75"	1
102	E-079	BUS BAR	3
104	E-080	RIBBON CABLE, 16-PIN	1
106			
108	I-008	7474 IC TTL DUAL FLIPFLT	1
110	I-025	Z-80 CPU	1
112	I-027	2708 1024X8 EPROM	3
114	I-033	2114 1024X4 STATIC RAM	2
116	I-101	74LS00 IC LSTTL QUAD NAND	2
118	I-102	74LS02 IC LSTTL QUAD NOR	1
120	I-109	74LS74 LSTTL DUALFLIPFLOP	1
122	I-117	74LS138 3-8 DECODER	2
124	I-205	4013 CMOS DUAL FLIPFLOP	3
126	I-206	4016 CMOS QD ANALOG SWTCH	17
128	I-209	4049 CMOS HEX INVTR\DRIVR	4
130	I-211	4051 CMOS 8-IN AN MULTPLX	10
132	I-216	4503 CMOS HEX 3STATE BUFF	4
134	I-218	4514 CMOS 4-16 DE-MULTPLX	1
136	I-226	6508 CMOS 1K X1 L PWR RAM	8
138	I-227	4042 QUAD LATCH	4
140	I-228	4174 HEX LATCH	10
142	I-229	4556 DUAL 2-4 DEMUX	1
144	I-230	74C02 QUAD NOR	1
146	I-233	14066B QUAD ANALOG SWITCH	1
148	I-235	MC1413(2003)	1
150	I-237	14504 HEX LEVEL SHIFTER	2
152	I-301	311 PRECISION COMPARATOR	1
154	I-302	339 QUAD COMPARATOR	1
156	I-305	LM741CN OP AMP	1
158	I-312	TL082 DUAL BIFET OP AMP	30
160	I-313	LM348 QUAD-741 OP AMP	8
162	I-315	MM5837N NOISE SOURCE	2
164	I-317	NE5534, SIGNETICS	1
166	I-319	3310 ENV GEN	10
168	I-320	3320 VCF	5
170	I-321	3340 VCO	11
172	I-322	3280 DUAL OP TRNSCND AMP	18
174	I-323	LF356 FET OP AMP	1
176	I-404	78M05CT	1
178	I-409	MA78M12UC +12 1\2 AMP REG	1
180	I-410	MA7805VC +5V1AMP(LM340T-5	1
182	I-411	LM7905/79M05 -5V 1A REG	2
184	I-412	LM317T +15V 1AMP REG	1
186	I-414	8253 TIMER	1
188	I-420	LM337T NEG ADJ REG 1-27V	1
190	I-502	16 BIT DAC 71-CSB-I	1
192	I-503	XO-12C, 5-MHZ, DALE	1
194			
196	J-001	1/4" PHONE, SHORTING	9
198	J-007	16-PIN DIP SOCKET	48
200	J-014	SWITCHCRAFT 113 MONOJACK	1
202	J-016	40 PIN DIP SOCKET	1

204	J-017	24 PIN DIP SOCKET	5
206	J-028	3 PIN JACK	1
208	J-029	20 PIN JACK	1
210	J-031	10 PIN MOLEX JACK GOLD	1
212	J-041	18-PIN DIP SOCKET (BURNDY)	7
214	J-042	6-PIN MOLEX JACK GOLD	2
215	J-043	7-PIN MOLEX HOUSING	1
216	J-044	2-PIN MOLEX HOUSING	1
218			
220	L-005	DIS 6740 DL DIG .56 MAN	1
222			
224	M-002	RED PLEXIGLASS 11\2"X2"	1
226	M-005	PLASTIC TIES	2
228	M-009	LARGE STRAIN RELIEF	1
230	M-016	LARGE RUBBER FEET	4
232	M-020	TERM RING LUGS 12GAUGE#10	1
234	M-025	5\16"BLK FLATHEAD PHILLIP	4
236	M-027	SHEETMETAL SCREWS	36
238	M-031	6-32 LOCKWASHERS EX TOOTH	7
240	M-035	6-32 NUTS SMALL	11
242	M-039	700/SCI LABEL, LONG	1
244	M-054	SYNTHESIZER WOOD BOX	1
246	M-056	SYNTH FRONT COSMETIC STRIP	1
248	M-068	STICKER SMALL "PROPHET-5"	1
250	M-069	STICKER SMALL SCI	1
252	M-070	1\2 6-32 SET SCREWS	2
254	M-071	1\4"6-32 PANSLTSCREW MS2P	9
256	M-073	30-1 TENSION CLIP-PW DET	1
258	M-079	KNOB BLCK TOP SPRING CLIP	24
260	M-080	KNOB SILVR TOP SPRNG CLIP	2
262	M-081	THERMALLOY 43-66-2AP	3
264	M-082	CAP HOLDER TH25 MALLORY	2
266	M-085	CLAMP FOR RIB CBLE CFCC-4	1
268	M-088	DBL CBLE CLMP RICHCO UC-2	2
270	M-089	8-32 3\8" PANSLT MS SCREW	4
272	M-090	XLUTS 6-32 LARGE	2
274	M-091	NUTS 8-32 HEX	6
276	M-092	#8 LOCKWSHR INTRNL TOOTH	6
278	M-093	SCREW 1\2" 8-32 PANHD SLT	6
280	M-095	TERMINL RING RED PV18-10R	1
282	M-097	1000 SERIAL # LABELS	1
284	M-107	NYLN SHLDRWSHR - REG #411	3
286	M-111	1 1\4STANDOFF 1\4OD 6-32	4
288	M-112	3\4 STANDOFF 1\4OD 6-32	2
290	M-117	FOAM RBBR1"W 1\16T W\PSA1	5
292	M-119	6\32X5\8BLK PHLLPS M\S	4
294	M-124	HEATSINK	1
296	M-182	3\8" STARWASHER	10
298	M-140	TIE	2
300	M-150	SHRINK TUBING 3\16"	1
302	M-151	SHRINK TUBING 1\4"	1
304	M-152	POT NUT	26
306	M-154	#8 FIBER WASHERS	4
308	M-155	1\2" STANDOFF SMITH8343	6

310	M-156	3/8" X 6-32 PHLP CNTRSNK	25
312	M-157	4-40 X 1/4" BLCK PNHDSL	3
314	M-158	8-32 X 1/2" BLK PANHDSL	4
316	M-159	3/16" WIDE FOAM TAPE	1
318	M-160	MEDIUM "PROPHET-5" STCKR	1
320	M-161	8-32 X 3/4" PNHDSL	2
322	M-200	SYNTH WHEEL, 5V3	2
324	M-201	CONTROL PANEL, 5V3	1
326	M-202	WHEEL BOX, 5V3	1
328	M-203	BOTTOM PANEL, 5V3	1
330	M-204	WHEEL BRACKET, 5V3	2
332	M-205	KEYBOARD BKT, 5V3	1
334	M-206	HEATSINK, BACK PNL	1
336	M-211	PCB1, 5V3	1
338	M-212	PCB2, 5V3	1
340	M-213	PCB3, 5V3	1
342	M-214	PCB4, 5V3	1
344	M-215	PCB5, 5V3	1
346			
348	P-013	60 PIN HEADER AP	2
349	P-022	PINS GOLD	8
350	P-025	10PIN PLUG GOLD	1
352	P-027	7-PIN POLAR. RT-ANGLE	1
353	P-028	GOLD SOCKETS CONTACT	23
354	P-029	20 PIN PLUG GOLD	1
356	P-030	3 PIN PLUG GOLD	1
358	P-031	POLARIZING PINS	2
360	P-032	5 PIN PLUG	1
362	P-040	6 PIN MOLEX ST	2
364	P-044	2-PIN MOLEX GOLD PLUG	1
366			
368	Q-001	PACKING TAPE	1
370	Q-005	1" GLASS TAPE	1
372	Q-009	28X50X.002 BAGS M 1000	1
374	Q-014	WARRANTY CARD	1
376	Q-036	1000.3 OP MAN (CM1000C)	1
378	Q-017	1000 PACKING BOX	1
380			
382	R-004	330 OHM 1/4W 5%	35
384	R-006	470 OHM 1/4W 5% RESISTOR	23
386	R-008	1K 1/4W 5% RESISTOR	12
388	R-009	1.5K 1/4W 5% RESISTOR	5
390	R-010	2K 1/4W 5% RESISTOR	9
392	R-011	4.7K 1/4W 5%	12
394	R-012	10K 1/4W 5% RESISTOR	27
396	R-014	15K 1/4W 5% CARBON FILM	7
398	R-015	20K 1/4W 5% RESISTOR	14
400	R-016	30K 1/4W 5% RESISTOR	6
402	R-017	39K 1/4W 5% RESISTOR	5
404	R-018	47K 1/4W 5% RESISTOR	6
406	R-021	68K 1/4W 5% RESISTOR	11
408	R-022	75K 1/4W 5% RESISTOR	2
410	R-024	91K 1/4W 5% RESISTOR	15
412	R-025	100K 1/4W 5% RESISTOR	63

414	R-026	200K 1\4W 5% RESISTOR	28
416	R-028	470K 1\4W 5% RESISTOR	6
418	R-029	1M 1\4W 5% RESISTOR	17
420	R-030	2.2M 1\4W 5% RESISTOR	7
422	R-031	3K 5% RESISTOR	6
424	R-035	2.7K RESISTOR	1
426	R-036	3.3K RESISTOR	22
428	R-038	8.2K RESISTOR	1
430	R-040	22K, 5%	11
432	R-041	150K RESISTOR	25
434	R-042	560 OHM RESISTOR	1
436	R-043	47 OHM 5% RESISTOR	1
438	R-045	10M 5% RESISTOR	3
440	R-047	10 OHM 5% 1\4W RESISTOR	1
444	R-054	33K, 5%	2
446	R-056	51K,5%	5
447	R-057	120K,5%	5
448	R-058	240K,5%	20
452	R-062	5.6K, 5%	1
454	R-063	910, 5%	1
456	R-064	5.1K, 5%	2
458	R-065	160K, 5%	2
460	R-066	300K, 5%	1
462	R-067	3.9K, 5%	1
464	R-068	100, 5%	1
466	R-107	4.99K 1% RESISTOR	3
468	R-108	10K 1% RESISTOR	2
470	R-110	100K 1% 1/4W	55
472	R-113	30.1K 1% RESISTOR	7
473	R-114	54.9K 1% RESISTOR	5
474	R-115	301K RESISTOR 1%	7
475	R-116	2.21M 1% 1\4W RESISTOR	12
476	R-119	13.3K 1% RESISTOR	1
478	R-121	1M, 1%	1
479	R-122	200K 1% RESISTOR	1
480	R-123	487K 1% RESISTOR	1
482	R-125	121, 1% RN55D1210F	1
484	R-128	182K 1% RESISTOR	2
486	R-130	249K 1% RESISTOR	5
487	R-139	1.82K, 1%	16
488	R-140	3.32K, 1%	5
490	R-141	4.75K, 1%	14
492	R-142	5.62K, 1%	13
494	R-144	20.0K, 1%	2
495	R-145	24.3K, 1%	16
496	R-146	26.7K, 1%	10
498	R-147	47.5K, 1%	10
502	R-149	121K, 1%	5
504	R-151	162K,1%	5
506	R-152	187K, 1%	5
510	R-156	243, 1%	1
512	R-157	2.55K, 1%	1
513	R-158	1.24K, 1%	1
516	R-159	110K, 1%	1

518	R-161	24.9K, 1%	1
520	R-162	332, 1%	3
522	R-163	18.2K, 1%	1
524	R-165	261K, 1%	1
528	R-167	52.3K, 1%	6
530	R-168	806, 1%	6
532	R-169	13.0K, 1%	6
534	R-170	357K, 1%	10
536	R-171	475K, 1%	5
544	R-207	JA1G0405104UA 100K POT	2
546	R-211	5K TRIMMER 1TURN TOP ADJ	11
548	R-212	100K TRIMMER 1TURN TP ADJ	6
550	R-217	100K TRIM, 1TURN TOP PIHER	25
552	R-218	10K TRIM, 1TURN TOP PIHER	2
554	R-219	200 OHM TOP ADJ TRIMMER	2
556	R-221	SPECIAL 10K LIN POT	26
558	R-222	50K CERMET BOUR3386P1503	5
564	R-225	25K 1-TURN TOP ADJ PIHER	5
572	R-300	39-OHM X 8 NTWK, BOURNS	1
574	R-301	22K-OHM X 15 NTWK, BOURNS	1
576			
578	S-025	AC POWER SWITCH LIGHT RED	1
580	S-027	S-OCT KYBD 10-0-0218-1	1
582	S-031	SWITCH GREY SR	1
584	S-032	115/230 SLIDE SW 46206LFR	1
586	S-034	FOOTSWITCH	1
588	S-038	REC ENABLE\DIS SLIDE SW	1
590	S-028	BLACK LED SWITCH SRL	22
592	S-029	GREY LED SWITCH SRL	13
594	S-030	ORANGE LED SWITCH SRL	1
598			
600	T-002	2N3904 PNP TRANSISTOR	1
602	T-003	2N4250 PNP TRANSISTOR	19
604	T-008	AD820 MATCHED PNP PAIR	1
606	T-011	3082 RCA	1

SECTION 6 GLOSSARY

This list covers abbreviations appearing on SCI documentation except that integrated circuits are generally shown with the manufacturer's abbreviations. Refer to the device data sheet as required.

A	address bus	CNT	count
A	VCO A	CNTR	counter
A	Ampere	COAX	coaxial
(a), (A)	analog (for power or common)	COMM	common
AC	alternating current	COMP	computer
ACC	accumulator	CONT	control
ACK	acknowledge	CONV	conversion, converter
A/D	analog/digital (hybrid)	CPR	comparator
ADC	analog-to-digital converter	CPU	central processor unit
ADJ	adjust	CR	rectifier module (designator)
ADPT	adapter	CS	chip select
ADSR	attack/decay/sustain/release (ENV GEN)	CTF	cutoff
AH	address bus, high-voltage	CTR	center
ALU	arithmetic-logic unit	CV	control voltage
AM	ammeter	CW	clockwise
AMP	amplifier (FIN VCA)	CY	carry
AMT	amount		
APPROX	approximate	D	data
ASSY	assembly	D	diode (designator)
ATK	attack	(D)	digital (for power or common)
ATT	attenuation, attenuator	DA	diode array (designator)
AUX	auxiliary	DAC	digital-to-analog converter
AVG	average	dB	decibel
		DB, DBUS	data bus
B	VCO B	DBH	data bus, high-voltage
B	bit number (LSB, MSB)	dc	direct current
BAL	balance	DCOD	decoding, decoder
BANK	bank	DET	detection, detector
BCD	binary-coded-decimal	DI	data in
BFR	buffer	DIP	dual in-line plastic (package)
BLK	black	DIS	disable
BLU	blue	DISCHG	discharge
BRN	brown	DMUX	demultiplexing, demultiplexer
BT	battery (designator)	DO	data out
		DN	data, non-volatile
C	capacitor (designator)	DRVR	driver
C	control (solid-state switch)	DS	indicator (designator)
°C	Centigrade	DSP	display
CAL	calibration, calibrator	DVM	digital voltmeter
CASS	cassette	DX	switch matrix row
CB	circuit breaker (designator)	DY	switch matrix column
CC	control current for OTAs		
CCW	counter-clockwise	EDIT	edit
CHG	charge	EN	enable
CKT	circuit	ENV	envelope
CLK	clock	EOC	end-of-conversion
CLR	clear	EOT	end-of-tape
cm	centimeter	EPROM	erasable-programmable read-only memory
CM	current mirror	EQ	equalization, equalizer
CMOS	complementary metal-oxide semiconductor	EXT	external
CMP	compensation		

F	Farad	n	nano-
F	fuse (designator)	N	non-inverting input
F	Fahrenheit	NC	no connection
FDBK	feedback	NC	normally closed contact
FET	field-effect transistor	NEUT	neutral
FF	flip-flop	NO	normally open contact
FILT	filter (VCF)	NOM	nominal
FIN	final	NORM	normal
FINE	fine	NSE	noise
FOA	(for FACTORY USE ONLY)	NVM	non-volatile memory
FREQ	frequency	O	output (solid-state switch)
FSK	frequency-shift keying	OBS	obsolete
FT	foot	OFST	offset
FTSW	footswitch	ORG	orange
G, GATE	gate	OSC	oscillator (VCO)
GEN	generator	OTA	operational transconductance amplifier
GLD	glide	OUT	output
GND	ground	OV	overflow
GRN	green		
H, HEX	hexadecimal (base 16)	p	pico-
Hz	Hertz	P	plug (designator)
I	inhibit	P-	polyphonic (modulation)
I	input (solid state switch)	PBND	pitch bend
labc	amplifier bias current (3280 control)	PC	program counter (in CPU)
IC	integrated circuit	PCB	printed circuit board
IN	input	PED	pedal
INIT	initial	PNK	pink
INT	interrupt	PNL	panel
INV	inversion, inverter	POS	positive
I/O	input/output	POT	potentiometer
IRQ	interrupt request	PR	pair
J	jack (female pins)	PRGM	program
JSTK	joystick	PRGMR	programmer
K	kilo-	PROM	programmable read-only memory
KBD	keyboard	PRST	preset
L,	lower	PS	program select
LD	load	PSB	power supply board
LED	light-emitting diode	PW	pulse width
LFO	low frequency oscillator	PWM	pulse-width modulation
LFT	left	PWR	power
LIM	limit, limiter	Q	transistor (designator)
LIN	linear	QA	transistor array (designator)
LOG	logarithmic	QTY	quantity
LSB	least significant bit	R	resistor (designator)
LSI	large-scale integration	RA	resistor array (designator)
LVL	level	RAM	random-access memory
m	mili-	REC	record
M	mega-	REF	reference
MAX	maximum	REG	regulation, regulator
MEM	memory	REL	release
MIN	minimum	RES	resonance
MIX	mixer	REV	revision
MOD	modulation	RGT	right
MOS	metal-oxide semiconductor	RIP	ripple clock
MSB	most significant bit	ROM	read-only memory
MSI	medium-scale integration	RS	reset
MSUM	master summer	RST	restart
MTUN	master tune	S	switch
MUX	multiplexing, multiplexer	S	analog switch signal
		SA	switch array (designator)
		SAR	successive approximation register
		SEC	second

SEL select
 SEQ sequencer
 SER serial
 S/H sample and hold
 SHT sheet
 SIG signal
 S/N signal-to-noise ratio
 S/N serial number
 SPAD scratchpad (RAM)
 SPK spare parts kit
 SPKR speaker
 SRC source
 ST start
 STRB strobe
 SUM summation, summer
 SUS sustain
 SYM symmetry
 SYNC synchronization, synchronizer
 SYNTH synthesizer
 SYS system

 T transformer (designator)
 TB terminal board (designator)
 TC time constant
 THRS threshold
 TP test point (designator)
 TRI triangle-wave
 TRIG trigger
 TRIM trimming, trimmer
 TTL transistor-transistor logic
 TUN tune

u micro-
 U integrated circuit (designator)
 U, upper
 UART universal asynchronous receiver-transmitter
 UNI unison
 USART universal synchronous-asynchronous receiver-transmitter

 V Volts
 V(A) V supply, analog circuit
 V(D) V supply, digital circuit
 V-C voltage-to-current converter
 VCA voltage-controlled amplifier (AMP)
 VCF voltage-controlled filter (FILT)
 VCO voltage-controlled oscillator (OSC)
 VDAC DAC output voltage
 VIOL violet
 VMUX POT MUX output voltage
 V/OCT volts-per-octave
 VOL volume
 VPED pedal voltage (or, voltage pedal)
 VR voltage regulator (designator)
 VREC voltage record

 W wiring or cable
 W- wheel (MOD)
 WHT white

 XOR exclusive-OR

 Y crystal
 YEL yellow

8-0 INTRODUCTION

This is the first section of supplementary material appended to the Rev 3.0 Technical Manual which covers the series referred to as Rev 3.1 and 3.2.

The updates and expansion of the microcomputer's memory configuration which became Rev 3.1 are transparent, so, of no interest to the player. But once the Polyphonic Sequencer for the Prophet-10 was designed, we couldn't resist developing one for the Prophet-5. Thus, shortly after Rev 3.1 went into production, we again redesigned the Prophet-5 computer (and a few other circuits) to allow it to interface with the Model 1005 Polyphonic Sequencer and Model 1001 Remote Keyboard/Controller. Therefore if they desire to use these products, owners of Rev 3.0 and 3.1 Prophets will need to have their instruments upgraded to Rev 3.2.

Rev 3.0 started with serial number 1300. Specific tables of 3.1 and 3.2 serial numbers and software versions are in Section 11. If you are in doubt about a Prophet's Rev, just look at the silk-screening on PCB 3. Both revisions 3.0 and 3.2 have the numbers silk-screened at the center top edge of the board. (Note that revision 3.0 is simply called revision 3.) Revision 3.1 has the number screened at the top left corner of the board.

8-1 REVISION 3.1 COMPUTER and POWER SUPPLY

Please refer to SD341 in Section 10. Revision 3.1 incorporates changes to the computer operating system PROM and the Non-Volatile program RAM. For PROM, U312/13 2716 2-K units were put in place of the three 2708 1-K units in Rev 3.0. This allowed the use of a higher-reliability part, elimination of the +12V and -5V power supplies, and created program space for the diagnostic memory test. (The tests are covered in Section 11.)

To use the higher-density 2716s, the CPU address lines to U318 Memory Address Decoder are shifted up to A12-A14. A11 was provided for later updating this board with a 2732 4-K. As shown, it is normally disconnected from the CPU. Instead, the A11 lines to U312-U314 sockets are tied high. (On the 2716, pin 21 is for the Vpp programming pulse.)

The eight 6508 (1K x 1) NV RAM was changed to U383/84, two 4334 or 6514 (1K x 4). These parts have a higher reliability than the parts previously used. To achieve the correct timing, the 3.1 (and 3.2) -NV WRITE signal is generated very differently from the way it is in Rev 3.0. NAND-Gate U382-8 is wired as an inverter. Thus when U311-19 CPU -MREQ goes low, and A15 goes high, U382-11 goes low. U382-6, also an inverter, goes high, raising U320-13. If S3 RECORD is set to ENABLE, U320-12 will also be high, causing U320-11 to go low, enabling the NV RAM -WR inputs.

The Power Distribution area of the schematic shows the spare pins (2 and 3) on P302 created by removing the +12V and -5V lines from PCB 3. The back-panel cable wires to these pins may or may not exist in a specific 3.1 unit. But on all 3.1 units, the regulators and associated components were removed from PCB 5. (See SD541.)

An additional, simple change was made to the CPU which has absolutely no effect on operation. U311-25 -BUSRQ is a CPU output which in REV 3.0 was tied high. In Rev 3.1 this pin is pulled high through R3154 for optional use with factory test instruments.

SD342 shows how TP304 was added to U324-10 ADC BUS DRIVER, pulled low through R3155. Tying this point high starts the memory test routine, as discussed in Section 11.

8-2 REVISION 3.2 COMPUTER and USART

Rev 3.2 was created to interface with the Model 1005 Polyphonic Sequencer and Model 1001 Remote Keyboard/Controller. In order to arrange the interface, the operating system was again expanded and communication circuitry added. Changes were also made to the Common Analog circuitry to accommodate PITCH and MOD CV inputs (see para. 8-3).

See BD051 Rev 3.2 Interconnect Diagram. J17 DIGITAL INTERFACE jack on the back panel is a 4-pin Switchcraft SL-17-4F, SCI #J-053. To mate, use SL-40-4M, SCI #P-053. This jack is cabled along with ANALOG inputs from J16 (see below) through J15, to added connector P305. SD351 shows the DIGITAL CABLE destination, U386 SIGNETICS 2661 Programmable Communications Interface. This USART exchanges data with a compatible transceiver over three lines as specified below. System interface programming is discussed in Section 9 (as well as in the current Prophet-5 Operation Manual, CM1000C.1).

WARNING! This is not an RS-232 interface. It uses 5-V TTL levels. RS-232 voltage levels (+/- 12 or +/-15V) will most likely blow the two input gates. Furthermore, most RS-232 interfaces lack the speed required for transparent sequencer-Prophet communications.

Pin 1, GROUND

Pin 2, CLOCK TO SYNTH

This input sees pin 2 of a 74LS08 (U385-3), with a 10K pull-up to +5V. Note that the transmit and receive clocks (TxC, RxC) are tied together. Maximum frequency: 625 kHz. Minimum clock frequency for "transparent" real-time sequencer operation depends on exact operations involved. Slower speeds will generally degrade performance by causing the Prophet to wait too long for the sequencer to complete multi-byte data transfers. 50 kHz is probably as slow as anyone is likely to find useful.

Pin 3, DATA TO SYNTH

This input sees pin 4 of a 74LS08 (U385-6), with a 10K pull-up to +5V. Data format is discussed in Section 9.

Pin 4, DATA FROM SYNTH

This is a MOS output direct from pin 19 of the Signetics 2661 USART. The driver Low output voltage (V_{OL}) is specified at 0.4V max. with a 2.2 mA output current (I_{OL}). The driver High output voltage (V_{OH}) is 2.4V min., specified at -400 μ A (I_{OH}).

Digital Cable Specifications

The cabling used depends on the distance desired between units, and upon the noise present in the system environment. Using individual coaxial cables for the two data and clock lines will work best. It is likely you could have trouble-free operation at 20-ft or longer. Three-conductor coax will probably work up to 10 ft. Single wires may be used

for the 2 to 5-foot range. The clock speed influences cable performance, since data transferred at higher speeds encounters more reactance (hence, degradation) in the cable.

USART OPERATION

Normally U386 USART stands unused. But it is initialized to interrupt the CPU when serial data is received. When the CPU is interrupted, it stops whatever it is doing and reads the USART data as if it were reading a memory device. The CPU can also output a byte to the USART. As discussed in the section on programming, this data exchange enables sequencing and remote keyboard control.

In more detail, pin 21 RESET connects to the CPU -RESET through inverter-wired U382-3. When power comes on, RESET clears the USART's internal registers and sets it to Idle. To operate, it must be initialized with the appropriate bytes sent to its control registers.

The USART connects to the Address Bus. A0 and A1 select, while A15 actually programs the reading and writing to or from the USART's receive, transmit, or control registers.

While the Address Bus is used to program the USART, its data lines remain tri-stated until pin 11 -CS goes low. The CPU sends commands and output data to the USART over the Data Bus. The USART sends input data and its own status bytes (as opposed to status bytes sent by the external sequencer) to the CPU.

After resetting and initializing the USART, it is set-up to respond to data input as follows. Through the Low-Voltage Output Port Decoder U319, the CPU sets pin 10 -CSOL5 low. On Rev 3.0 this signal cleared the monophonic sequencer interface to GATE 5. On Rev 3.2 this signal clears the Interrupt Flip-Flop U330-2 (see SD352), while GATE 5 is controlled separately. (GATE 5 is now memory-mapped. It is enabled by U318-10, through inverter U343-6 and Flip-Flop U330-13.)

Once the Flip-Flop is reset, U330-2 -INT is high. Notice U385-8, the AND gate (converted to negative logic by DeMorgan) connected to USART pin 14 RxRDY. -INT connects to U385-9. Pin 10 is pulled high by R3153. Thus, with both inputs high, U385-8--which actually connects to the CPU--is high and the CPU runs normally.

The CPU is interrupted either by the USART signalling that it has received a byte, or by a GATE occurring through the monophonic sequencer interface. In the first case, the USART RxRDY pin goes low when the USART has received a serial data byte. Whenever the -INT occurs, the CPU first examines the USART to see if its receiving register is holding data. If not, then the -INT must have arisen from the monophonic sequencer interface.

In this second case, the high SEQ GATE IN (J3) is inverted by U331-4, delayed slightly, and re-inverted by U331-2 to clock the Interrupt Flip-Flop U330-2. Since pin 5 D is tied high, pin 1 Q goes high, and pin 2 -Q goes low, generating the -INT.

8-2 REVISION 3.2 ANALOG and POWER SUPPLY

J16 ANALOG INTERFACE connector is SCI #J-054. To mate, use SL-40-5M, SCI #P-054. The pin specifications are:

WARNING! Since we have no idea what you will be connecting to these inputs, we cannot guarantee this interface will work with any custom device. You are completely responsible for any damage to the Prophet which may result from connecting non-SCI accessories.

Pin 1, GROUND

Pin 3, +22V, unregulated, 50 mA

Pin 5, -22V, unregulated, 50 mA

These two supplies have 5.1-ohm current-limiting resistors (see SD551). But accessories should be fully tested with another power source before connecting to these supplies. WARNING! The Prophet can be damaged if these supplies are tampered with. For best protection of the Prophet, it is best to avoid using these supplies.

Pin 4, PITCH WHEEL CONTROL VOLTAGE INPUT (P-WH CV IN)

This input raises or lowers the pitch of all five voices. The voltage applied should be nominally zero for the instrument to be tuned to A-440. Both positive and negative voltages can be applied. The Prophet disables this input during its TUNE routine to prevent accidental detuning.

Pin 2, MODULATION WHEEL CONTROL VOLTAGE INPUT (M-WH CV IN)

This input ranges 0 - +10V, with maximum modulation being applied at +10V. Do not apply a negative voltage to this input.

Rev 3.2 changes to the Common Analog section are shown on SD354. The MOD Wheel circuitry has gained a Summer U374-8 to add the Mod Wheel CV and an external Mod CV together. VCA U381-12 allows the remote voltage control, and introduces WHEEL BAL trimmer R3168. Trim procedure is in Section 11.

Remote PITCH CV input required switch U377-10 to disable this input during the TUNE routine.

9-0 INTRODUCTION

This section is the software guide to the system interface distinguishing Rev 3.2 Prophet-5s. The interface was specifically designed to accommodate the Model 1005 Polyphonic Sequencer, Model 1001 Remote Keyboard/Controller, and other accessories. But to encourage experimentation with remote programming of the Prophet we publish this specification for enthusiasts who would design their own sequencer/controller. Many of the popular microcomputers can now be interfaced to the Prophet-5.

All the information you need to use the interface is below. The programs required to transmit keyboard status and to process external keyboard and program commands are contained within the Prophet's own software. This considerably simplifies your sequencer software design into the data exchange of "bit maps" of the keyboard as it is recorded or played. The sequencer never enters into the Prophet's operating system itself, so your experiments can not "hurt" the Prophet by faulty programming. (Although you can of course cause damage with faulty hardware.) The Prophet's operating system is in PROM and remains unaltered, no matter what you do. At worst you will erase the Non Volatile (NV) RAM which stores the "sound" programs. But the programs are easily re-loaded through the standard CASSETTE interface. (The Model 1005 stores and loads programs through this system interface.)

This is a high-speed serial interface, with the clock supplied by the external sequencer or keyboard. We can recommend the SIGNETICS 2651 or 2661 Programmable Communications Interface, which is essentially a microcomputer-oriented USART (Universal Synchronous/Asynchronous Receiver-Transmitter), because it is what the Prophet uses. The 2661 can be clocked to 1 MHz. The Model 1005 clocks the Prophet at 625 kHz. Not all USARTs will operate at the speeds required, so choose carefully. USARTs are probably the easiest to use, but other techniques are possible. A cleverly-programmed microprocessor could drive the interface directly, as could discrete logic.

9-1 Data Format

Both the DATA TO and DATA FROM SYNTH signals use the standard asynchronous serial format; start bit, eight data bits, parity (odd), stop bit. Start bit is low, data is positive, stop is high.

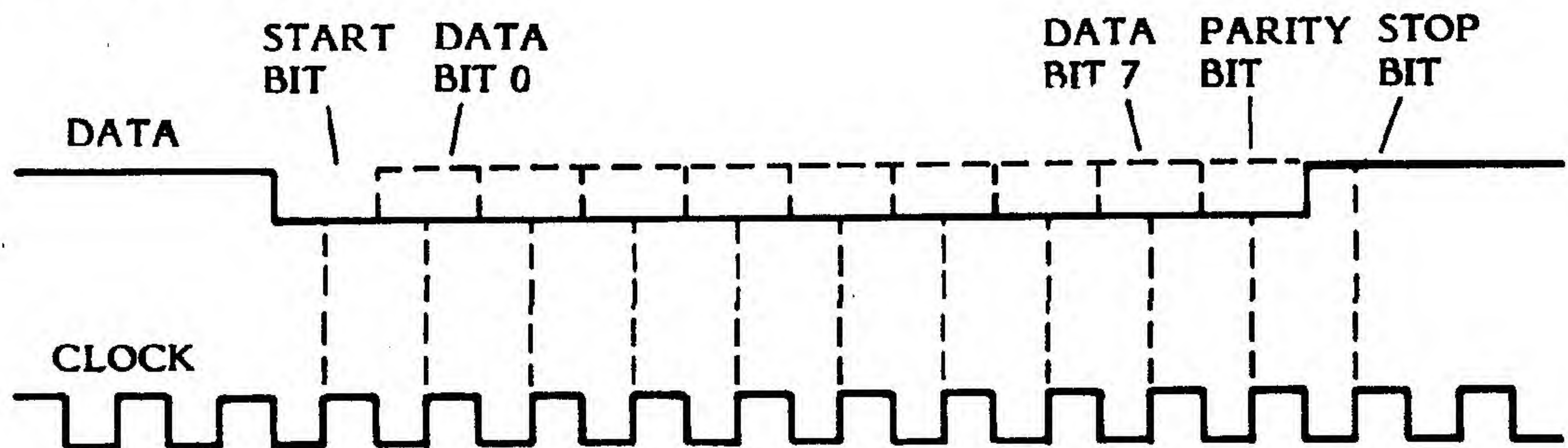

Figure 9-0
DATA FORMAT

At the speed this system normally operates, completely asynchronous operation was not possible. Therefore the external circuitry provides its own normally-high clock. Clock division is not used, so during data transmission a clock pulse must accompany each data bit. As shown, the Prophet receiver samples DATA TO on the rising edge of the clock. The clock should be free running, but the system will work if the clock toggles only during data transmission.

9-2 Error Checking

When it receives data, the Prophet receiver interrupts its CPU which examines a status register in the receiver. The status register indicates if there are any errors. If there is an error, the Prophet transmits code 3F on DATA FROM SYNTH.

There are three possible types of errors: parity, framing, and overrun.

Odd parity works by counting the total number of the data bits and the parity bit (9 total) which are set. If one, three, five, or seven data bits are set (1), parity is already odd, therefore the parity bit is left reset (0). If zero, two, four, six, or eight data bits are set, the parity bit is set to make the total set bit count odd. The Prophet checks DATA TO for parity. The Prophet sends the parity bit with DATA FROM. However, you may choose to ignore parity at your sequencer receiver.

A framing error results when the receiver doesn't find a stop bit at the end of the byte. In a standard asynchronous system this could be caused by a gross difference in transmit and receive clock frequencies. On this system there is a single clock, so a framing error may only result from actual data loss or noise.

An overrun error results when data is being sent too fast for the Prophet receiver to process it (or, by not allowing enough time between bytes). So, this error results from transmit timing problems with your interface.

9-3 Status Bytes

The Prophet-5 never volunteers DATA FROM, it only transmits when prompted by the sequencer. Communication is initiated by the sequencer transmitting "status" bytes which may or may not signify that data follows. For example, to change programs the sequencer first sends a byte to the Prophet saying that the next byte is the new program number. The Prophet will then wait for this second byte, and change its program accordingly when it is received.

There are 12 unique status bytes. A status byte is simply a unique hexadecimal (H) number. It is distinguished from other bytes merely by being the first which the sequencer transmits to the Prophet as part of any data transfer. The Prophet requires 0 - 1-1/2 milliseconds (worst case) to respond to the status byte interrupt. It will then be ready to receive or transmit data which is formatted and timed as specified below. Generally, while data can be transmitted with spaces of between 1 to 4 ms between bytes without causing errors, you will probably want to operate faster for the most transparent operation. Most of the Prophet's receiving operations are accompanied by a "time-out" which declares an error if data is not received within 4 ms. When such an error is detected, the Prophet simply ignores the received data and resets to wait for another status byte. So if your data arrives too late, or you accidentally send more data than needed, the Prophet may interpret the data as a status byte.

The Prophet will not accept status bytes during its TUNE routine. During TUNE, DATA FROM transmits a BREAK signal to tell the sequencer the Prophet isn't listening. The BREAK is simply a continuous low on DATA FROM. In other words, your receiver will see a start bit followed by no stop bit. The break can therefore be detected by counting at least two framing errors with zero as data received. The BREAK can therefore be used to inhibit the sequencer.

9-4 STATUS 0: SEND KEYBOARD and BANK/PROGRAM BYTES

This status byte is used for the sequencer to record the Prophet's keyboard and "sound" program status. Code 01(H) on DATA TO interrupts the Prophet to read its keyboard. After a 0 - 2-ms (worst-case) delay to respond to the interrupt, the Prophet transmits eight bytes of keyboard information over DATA FROM. As mapped below, 61 of the 64 bits represent key status (three aren't used). 0 means the key is off ("up"), 1 means the key is on ("down"). As shown, the least-significant bit (LSB) of the first byte is the lowest C (CO).

	<u>LSB</u>							<u>MSB</u>
Byte 0	C0	C#0	D0	D#0	E0	F0	F#0	G0
Byte 1	G#0	A0	A#0	B0	C1	C#1	D1	D#1
Byte 2	E1	F1	F#1	G1	G#1	A1	A#1	B1
Byte 3	C2	C#2	D2	D#2	E2	F2	F#2	G2
Byte 4	G#2	A2	A#2	B2	C3	C#3	D3	D#3
Byte 5	E3	F3	F#3	G3	G#3	A3	A#3	B3
Byte 6	C4	C#4	D4	D#4	E4	F4	F#4	G4
Byte 7	G#4	A4	A#4	B4	C5	X	X	X

After sending the eight keyboard bytes the Prophet sends a byte which contains the bank and program number. This byte's format is that the least significant three bits are the PROGRAM number; 0 corresponds to program number 1, 7 corresponds to program number 8. The next three bits are the BANK number; 0 is bank 1, 4 is bank 5. (The two most significant bits aren't used.)

These nine bytes follow close on one another. The delay between keyboard bytes 0 and 1 is 150 us. The time between the remaining eight bytes is a uniform 36.4 us. The sequencer receiver must be ready to receive this data with the required speed, or an overrun error will occur in the sequencer. Note that it is also a good idea to insert "time-outs" in your receiver software so your system is not hung-up waiting for bytes which it somehow may have missed.

You will have to format this data in RAM for your particular requirements. For example, since these bytes only tell the sequencer what keys are being held when it asks, in order to create timing information the sequencer will have to continually sample the Prophet's keyboard and compare to find out when keys go on or off.

9-5 STATUS 1: SEND ACK and RECEIVE KEYBOARD and BANK/PROGRAM BYTES

This status is used for the sequencer to play the Prophet's keyboard and select programs. When code 02(H) is received, the Prophet processes the interrupt (again, for up to 2-ms, worst-case). When it is ready to receive eight keyboard bytes and a program byte, it acknowledges the sequencer's request by sending the "ACK" code 36(H). The sequencer then transmits the keyboard and program bytes in the format discussed under STATUS 0.

For the most transparent operation, you will want a minimum of time between bytes transmitted to the Prophet. The faster the transfer, the truer the timing will be. Some specific timing figures may be of use. For example, the Prophet's scan time (for each program loop) is 6 ms, or 11 ms if controls are being used. This means there is a worst-case delay of 11 ms between a key being pressed and its being heard or recorded. This is not normally detectable in the Prophet. However, sequencing adds new timing concerns, since the Prophet waits for the transfer to be completed before continuing its loop. With a 625 kHz clock, 9 serially-formatted bytes will take only 158.4 us (1.6 us X 99 bits). But if they are spaced 1 ms apart, the whole transfer will about double the worst-case loop time. It is more reasonable to use the fastest clock possible, and allow up to 100 us between bytes. This will have a negligible effect on the Prophet's loop.

The Prophet is protected from being "hung-up" by extremely slow or nonexistent data. Its time-out software declares an error and ignores the whole message if more than about 4 milliseconds elapses between bytes.

When the message is complete, the Prophet places this data into its "Scratchpad" RAM table, playing the notes as if they came from its own keyboard. Even while receiving from the external sequencer the Prophet's keyboard remains active and can be used normally (unless the sequencer TRANSPOSE function is enabled, see STATUS 2). Of course you still have a five-voice maximum. So if you, for example, play on the keyboard while the sequencer is playing, you will "steal" voices from the sequence.

If no program change is desired, you can either transmit the last program number, or the code FF(H) which the Prophet simply ignores. Except for the FF code, the Prophet will sense an error if either of the two MSBs of the program byte are set.

NOTE. Be sure the Prophet is switched to PRESET mode when you want to change programs.

(Status B can be used for changing the program only. Status E can be used for receiving "short" keyboard data. See below.)

9-6 STATUS 2: TRANSPOSE ON

This status byte is used to enable the sequencer transpose function. Once the Prophet receives code 04(H), you can transpose the entire playback sequence over a four-octave range by just hitting a key between C0 and C4 on the Prophet. The transposition is equal to the interval between C2 and the key played. For example, to transpose down a fifth, hit F1. To transpose up a major seventh from the original key, hit B2. To transpose back to the original key, hit C2.

9-7 STATUS 3: SAVE TO TAPE

This status byte is used to extract the contents of the Non-Volatile program RAM from the Prophet, without using the independent CASSETTE interface. Organized as 40 24-byte programs, NV RAM uses 960 of its 1024 (1K) bytes. The least-significant seven bits of each byte represent a programmable pot setting of 0 -127 steps, while the MSB represents a switch setting (1=on, 0=off). The Prophet has another area of RAM called "Scratchpad" in which the current status of the machine is registered. When selecting a program in PRESET mode, a set of 24 bytes is transferred from NV RAM to the Scratchpad, with the "pot" bits filling the pot table and the switch bits being regrouped into the switch status table. Here is how the pot and switch bits are grouped in each NV program:

	<u>Switch Bit (7)</u>	<u>Pot Bits (0-6)</u>
Byte 0	OSC A PULSE	FILT ATK
	OSC A SAW	FILT DEC
	OSC A SYNC	FILT SUS
	OSC B SAW	FILT REL
	OSC B TRI	AMP ATK
	OSC B PULSE	AMP DEC
	OSC B KBD	AMP SUS
	UNISON	AMP REL
	POLY-MOD FREQ A	FILTER CUTOFF
	POLY-MOD PW A	FILT ENV AMT
	POLY-MOD FILT	MIX OSC B
	LFO SAW	OSC B PW
	LFO TRI	MIX OSC A
	LFO SQUARE	OSC A PW
	FILT KBD	MIX NOISE
	RELEASE	FILT RESONANCE
	W-MOD FREQ A	GLIDE
	W-MOD FREQ B	LFO FREQ
	W-MOD PW A	W-MOD SOURCE MIX
	W-MOD PW B	P-MOD OSC B
	W-MOD FILT	P-MOD FILT ENV
	OSC B LO FREQ	OSC A FREQ
	X	OSC B FREQ
Byte 23	X	OSC B FINE

For use with this interface, the Prophet maintains a pointer to NV RAM addresses which allows implied addressing. The pointer initially indicates the first NV RAM address. Whenever the Prophet receives a code 08(H), it outputs the NV RAM byte currently being pointed to, then increments the pointer. Therefore to read all of the NV RAM, the sequencer will have to supply exactly 1024 STATUS 3 requests. (This will leave the pointer reset at the NV RAM beginning address again.) To access specific programs, you can send the number of STATUS 3's required to increment the pointer to the desired starting address, and simply ignore the data the Prophet returns.

Any detected error resets the NV RAM pointer to the first address.

9-8 STATUS 4: LOAD FROM TAPE

This status byte is used to initiate a loading of NV RAM. When the Prophet receives code 10(H), it sets itself to TAPE READ mode, in which it expects to receive exactly 2048 bytes. This will be the entire 40-program data block sent twice (without interruption). The first byte received will be placed in the NV location indicated by the pointer. The Prophet will not recognize status bytes again until all 2048 bytes have been received, or an error occurs. The error clears TAPE READ mode and resets the NV pointer to the first NV address.

To load NV RAM, the Prophet's back panel RECORD switch must be ENABLED.

9-9 STATUS 5: CLEAR TRANSPOSE

Code 20(H) turns off the TRANSPOSE function enabled by Status 2. It also returns the sequence to its original key.

9-10 STATUS 6: INITIALIZE SEQ LOWER PROGRAM

This status byte 40(H) was inherited from the Prophet-10 but should not be sent to the Prophet-5.

9-11 STATUS 9: DISABLE TUNE

Code 09(H) is used to disable the Prophet's TUNE switch. An ideal application would be for the sequencer to disable TUNE before executing a LOAD FROM TAPE operation (STATUS 4).

9-12 STATUS A: ENABLE TUNE

Code 0A(H) reverses STATUS 9, to allow the Prophet to be tuned. This code doesn't start the TUNE routine, it just enables you to hit the switch.

9-13 STATUS B: RECEIVE PROGRAM CHANGE

Code 0B(H) prepares the Prophet to change programs, without the Prophet sending an ACK as with STATUS 1. The program byte has the format described under STATUS 0, and should follow STATUS B after 2 milliseconds. If it arrives before 2 ms, an overrun error may occur. If it doesn't arrive within 4 ms, the Prophet will then expect to be receiving status bytes again.

9-14 STATUS C: SYSTEM CONNECT

This status byte is best used for initial testing of your system hardware. The Prophet responds to code 0C(H) by sending an AA(H). The sequencer thus learns that the Prophet is connected and listening.

9-15 STATUS E: RECEIVE SHORT KEYBOARD DATA

This status byte is similar to STATUS 1, except that the keyboard data is limited to seven bytes (56 notes), and there is no program byte. There is also no ACK. In short, the sequencer ideally sends code 0E(H), waits 2 ms, then sends seven bytes at 100-us intervals. There is a 4-ms timeout.

10-0 DOCUMENT LIST

D	SD341C	Rev 3.1 PCB 3 CPU, MEMORY (1/4)
E	SD342B	Rev 3.1 PCB 3 DAC, ADC, TUNE, SEQ, CASS BUS DRIVERS (2/4)
N	SD541A	REV 3.1 PCB 5 POWER SUPPLY
	BD051A	REV 3.2 INTERCONNECT DIAGRAM
	PP351	Rev 3.2 PCB 3 PARTS ID
D	SD351D	Rev 3.2 PCB 3 CPU, MEMORY, USART (1/4)
E	SD352C	Rev 3.2 PCB 3 DAC, ADC, TUNE, SEQ, CASS, BUS DRIVERS (2/4)
G	SD354A	Rev 3.2 PCB 3 WMOD, MASTER SUMMERS (4/4)
	PP551A	Rev 3.2 PCB 5 PARTS ID
N	SD551A	REV 3.2 PCB 5 POWER SUPPLY

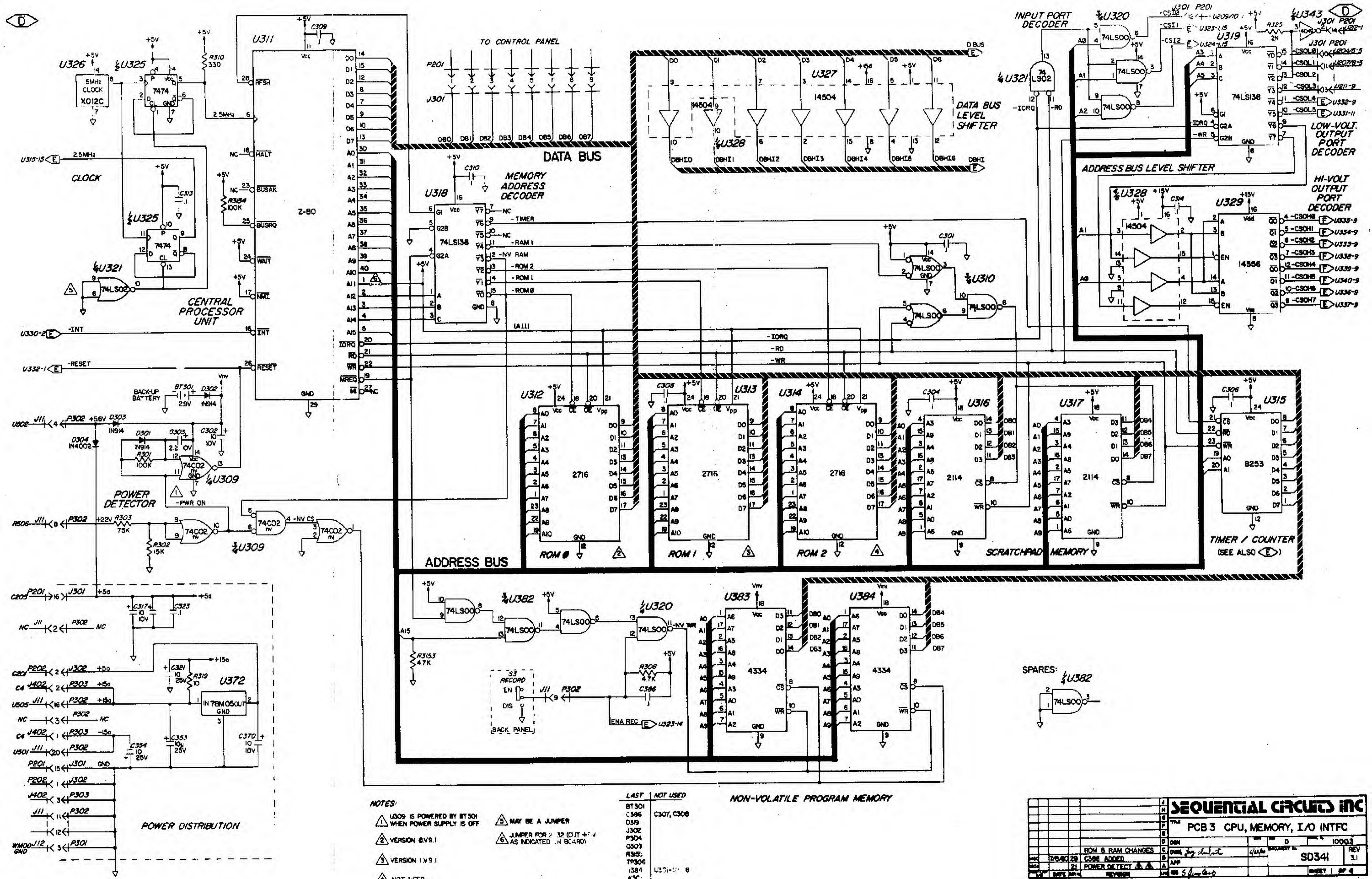

CENTRAL PROCESSOR UNIT

DATA BUS

MEMORY ADDRESS DECODER

DATA BUS LEVEL SHIFTER

ADDRESS BUS LEVEL SHIFTER

LOW-VOLT OUTPUT PORT DECODER

HI-VOLT OUTPUT PORT DECODER

POWER DETECTOR

ADDRESS BUS

ROM 0

ROM 1

ROM 2

SCRATCHPAD MEMORY

TIMER / COUNTER

NON-VOLATILE PROGRAM MEMORY

- NOTES:**
- ⚠ U309 IS POWERED BY BT501 WHEN POWER SUPPLY IS OFF
 - ⚠ MAY BE A JUMPER
 - ② VERSION 0V9.1
 - ⚠ JUMPER FOR 2 32 (OUT +7V AS INDICATED .N BC-ARD)
 - ③ VERSION 1V9.1
 - ⚠ NOT USED

LAST	NOT USED
BT501	C307, C308
C306	
D308	
J302	
P304	
Q309	
R309	
TP306	
J384	U321-11 8
K3C	

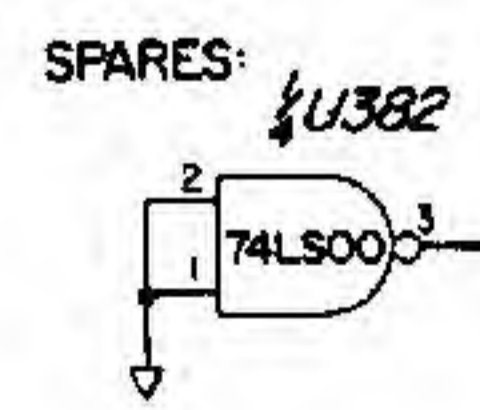

SEQUENTIAL CIRCUITS INC			
PCB 3 CPU, MEMORY, I/O INTFC			
REV	DATE	BY	APP
1000.3			
ROM & RAM CHANGES			
C306 ADDED			
POWER DETECT			
REVISED			
S0341	REV 3.1		

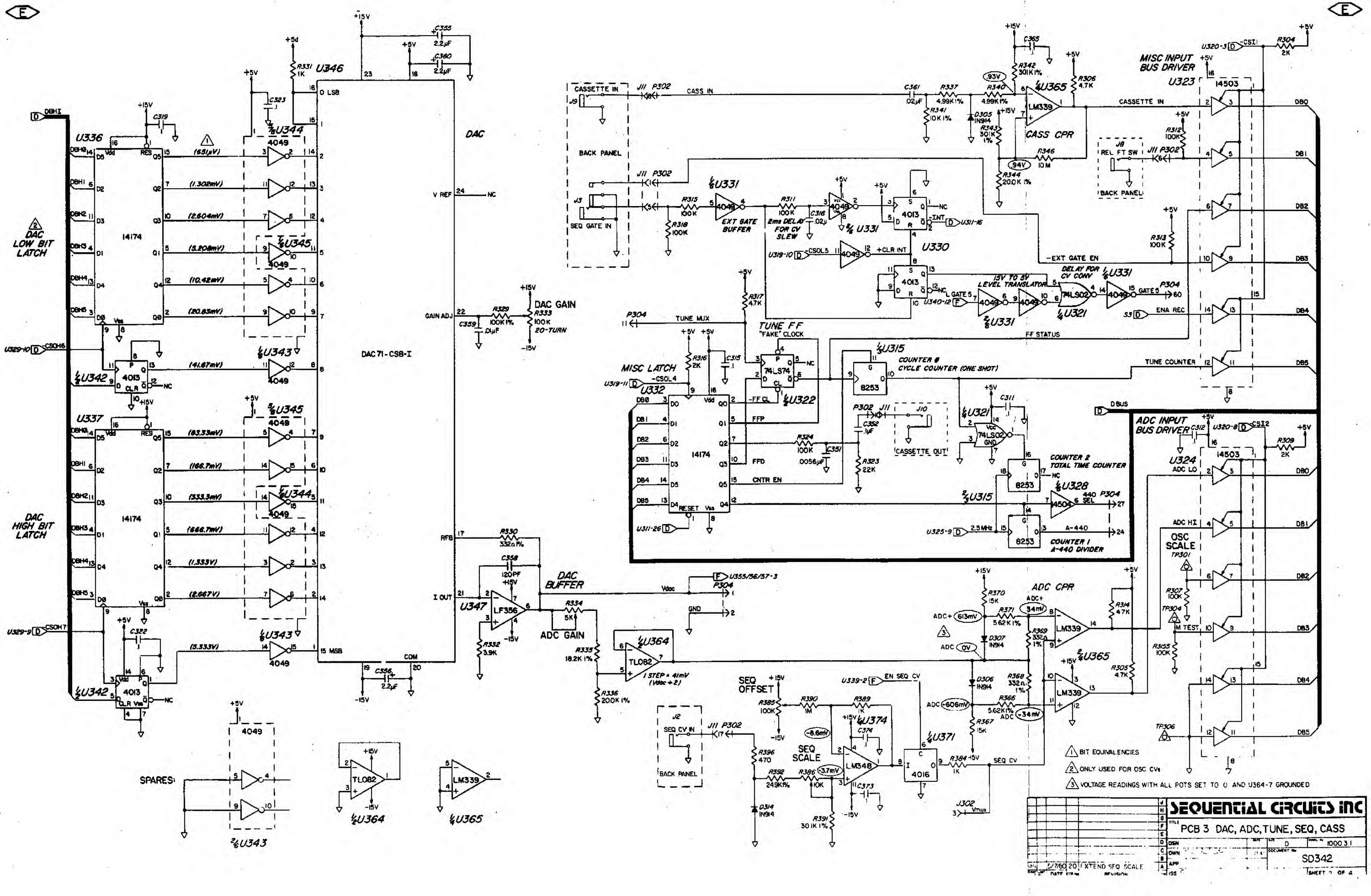

▲ DAC LOW BIT LATCH

▲ DAC HIGH BIT LATCH

SPARES:

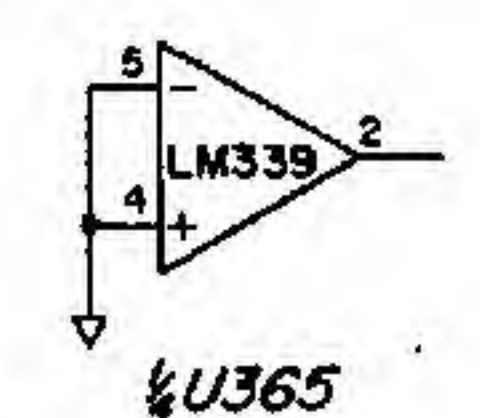
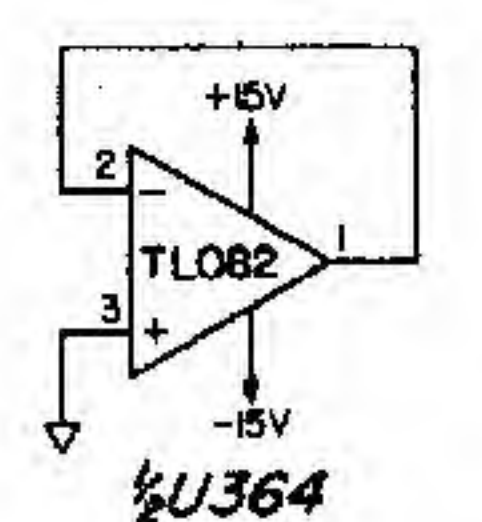
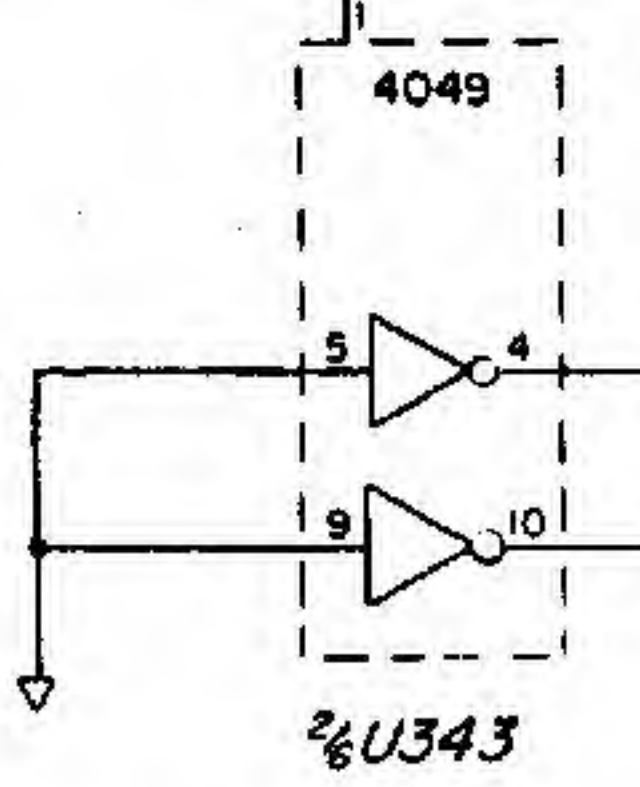

- ▲ BIT EQUIVALENCIES
- ▲ ONLY USED FOR OSC CV4
- ▲ VOLTAGE READINGS WITH ALL POTS SET TO 0 AND U364-7 GROUNDED

SEQUENTIAL CIRCUITS INC PCB 3 DAC, ADC, TUNE, SEQ, CASS		DATE	REV	ISS	FORM
		2/78020		0	1000 3.1
TITLE PCB 3 DAC, ADC, TUNE, SEQ, CASS		DATE	REV	ISS	FORM
DSN OWN APP		DATE	REV	ISS	FORM
2/78020 EXTEND SEQ SCALE		DATE	REV	ISS	FORM
SD342		DATE	REV	ISS	FORM
SHEET 2 OF 4		DATE	REV	ISS	FORM

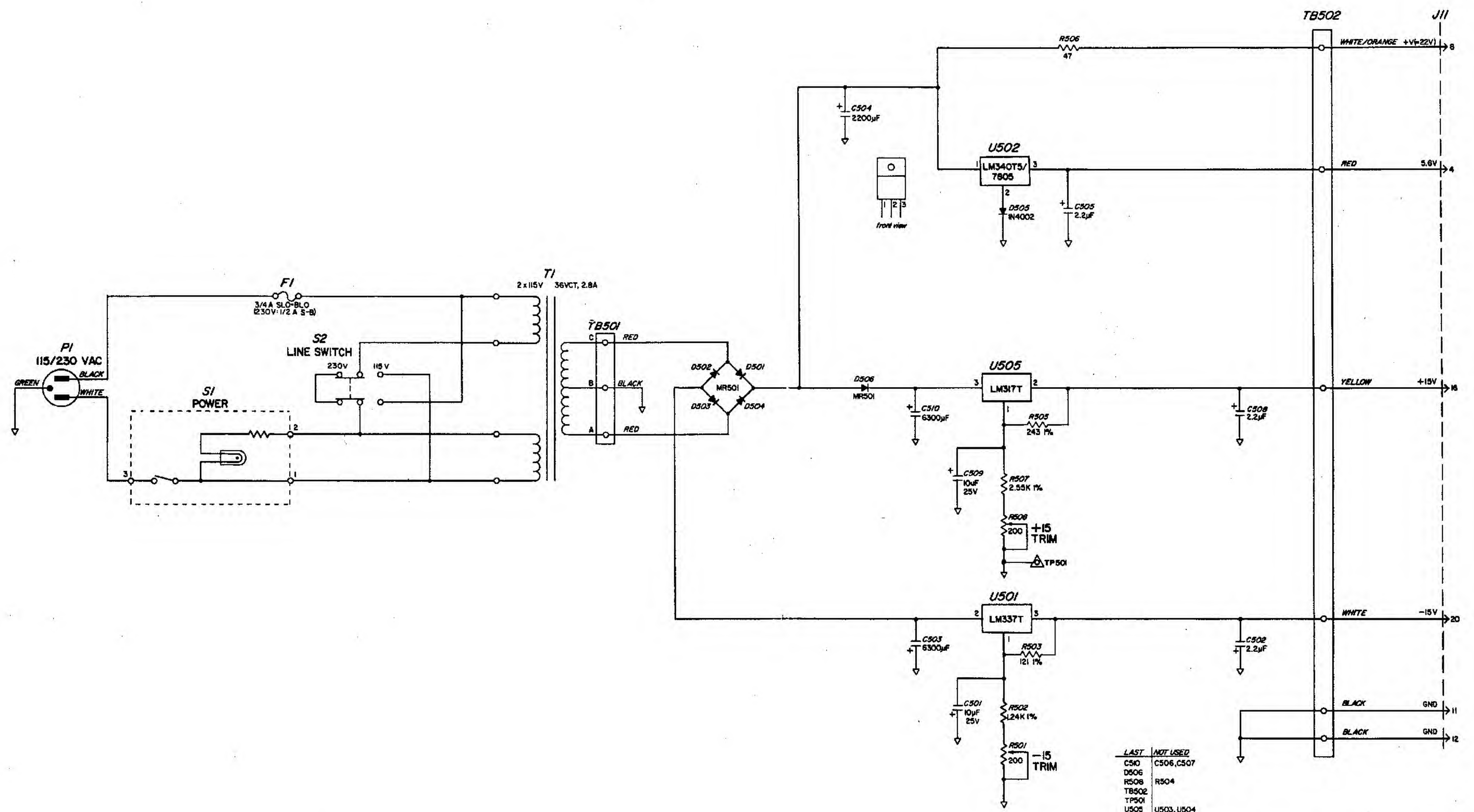

LAST	NOT USED
C510	C506, C507
D506	
R508	R504
TB502	
TP501	
U505	U503, U504

SEQUENTIAL CIRCUITS INC	
PCB 5 POWER SUPPLY	
DATE	REV
4/9	3.1
DATE	REVISION
4/9	REV 5/Amplid
SD54I 3.1	
SHEET 1 OF 1	

TOP PANEL ASSEMBLY

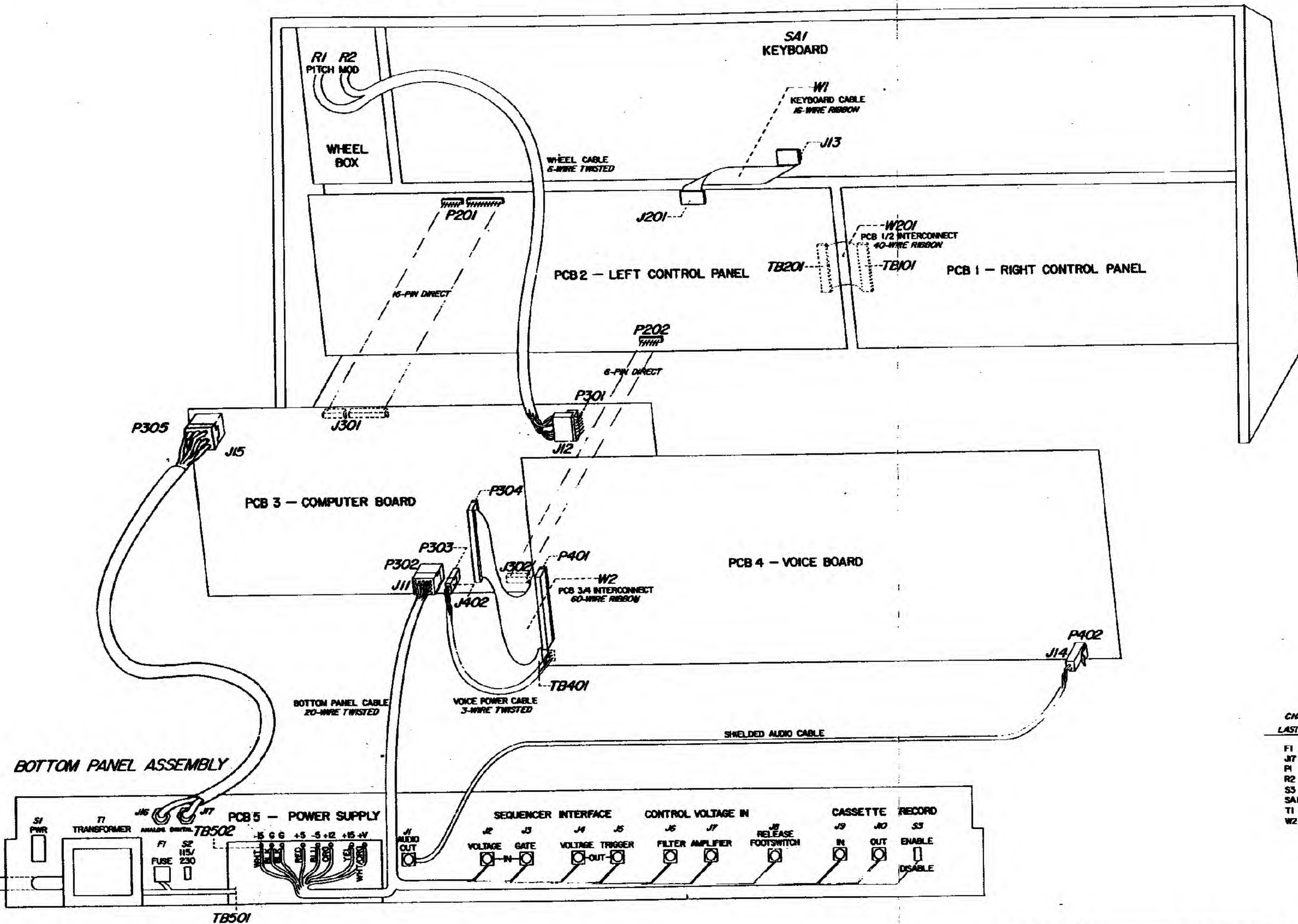

CHASSIS	
LAST	NOT USED
F1	
J7	
F1	
R2	
S3	
SA1	
T1	
W2	

SEQUENTIAL CIRCUITS INC	
TITLE INTERCONNECTION	
DATE	REV D 1000.3.2
DESIGNER <i>galt</i>	PROJECT NO. BD051
APP <i>S. H. ...</i>	SHEET 1 OF 1

(D)

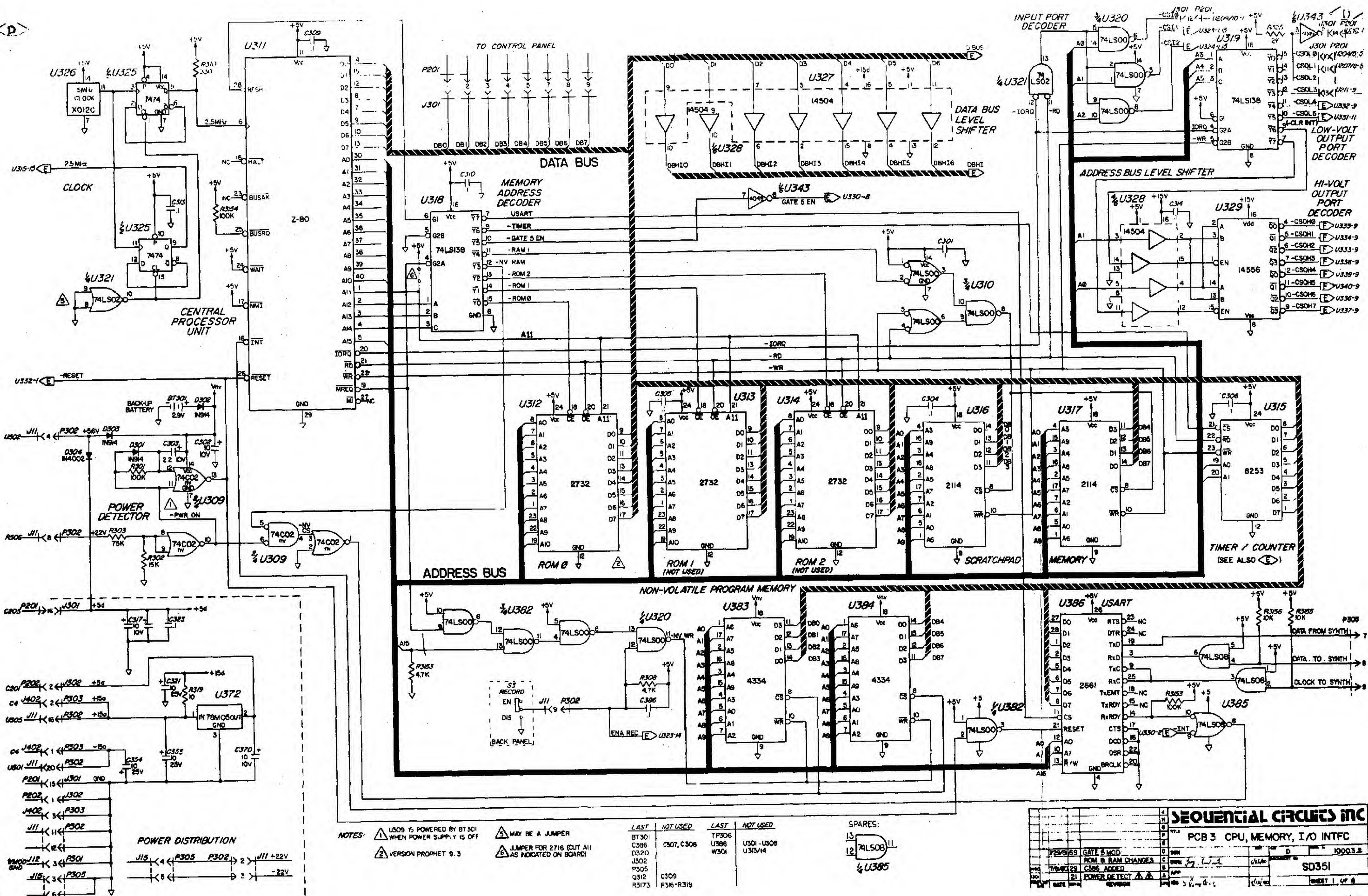

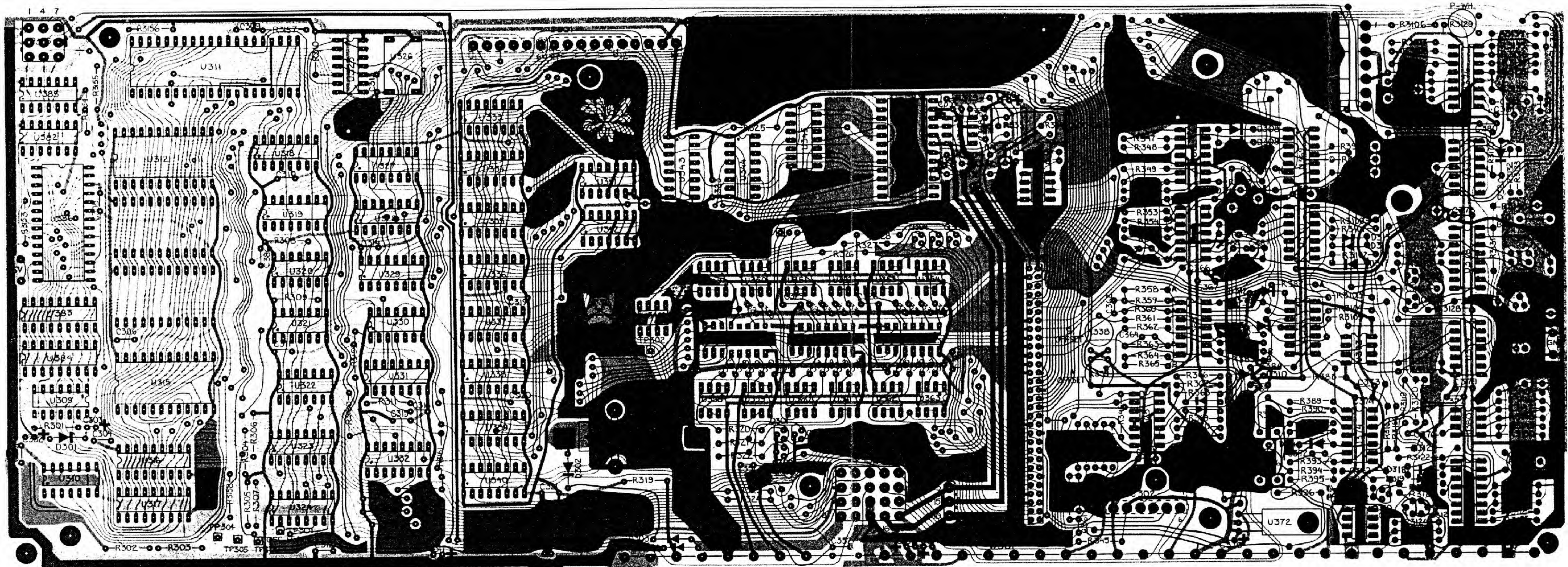

		SEQUENTIAL CIRCUITS INC	
		TITLE PCB 3 DESIGNATOR MAP	
		DATE	REV D 1000.3.2
		DOCUMENT NO	
		PP351	
DATE	REV	REVISION	SHEET 1 OF 1

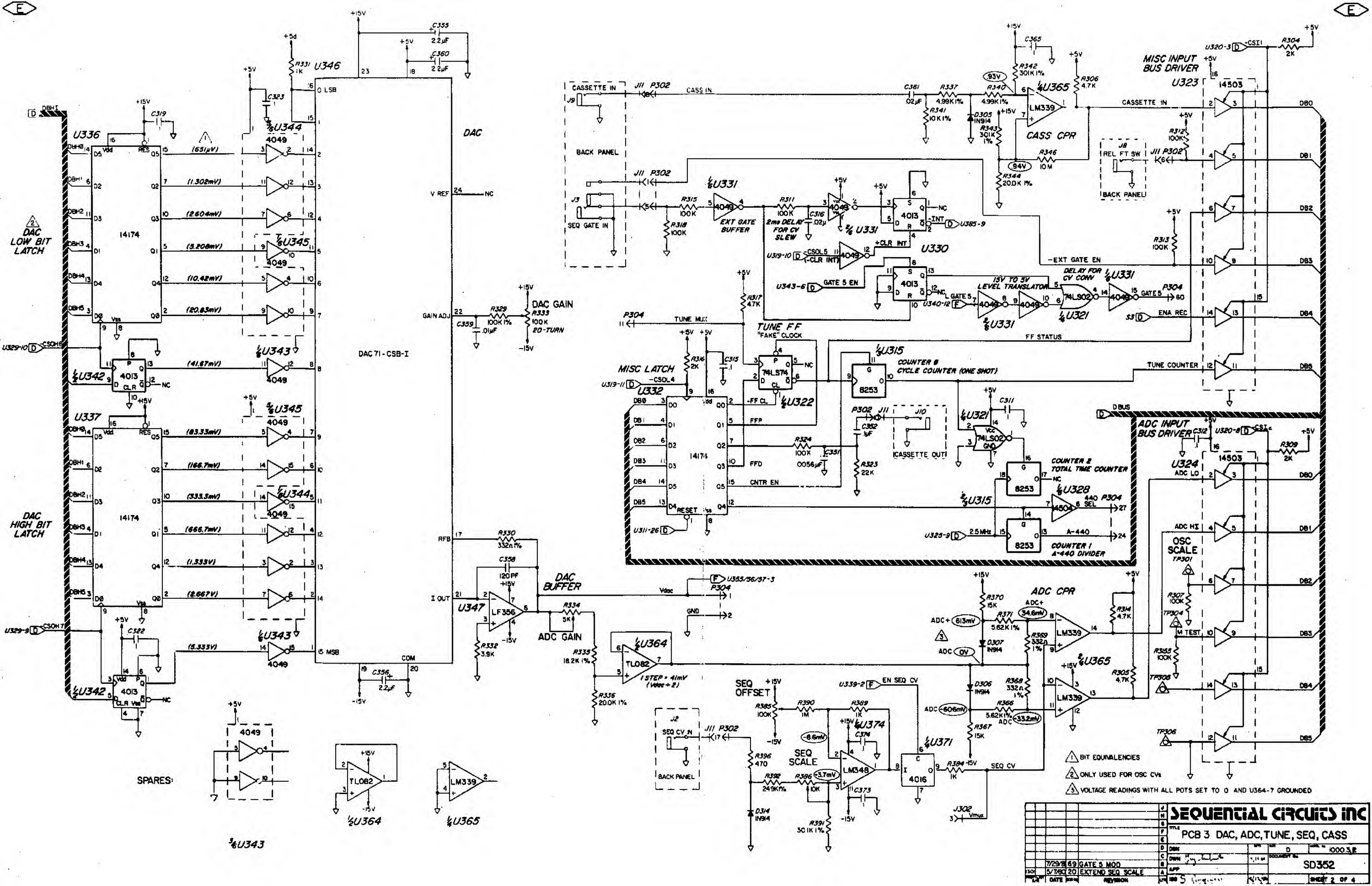

DAC LOW BIT LATCH

DAC HIGH BIT LATCH

SPARES:

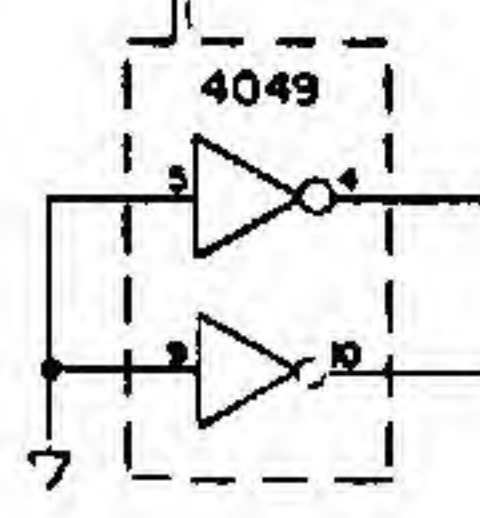

3/4 U343

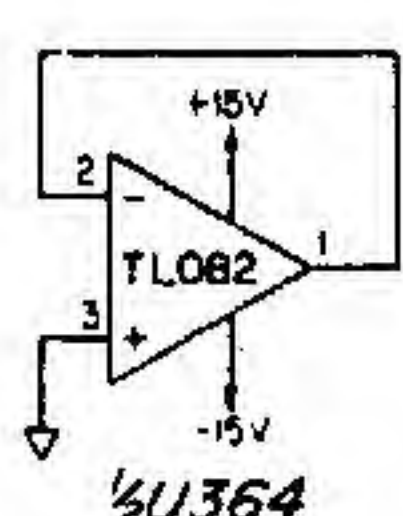

1/4 U364

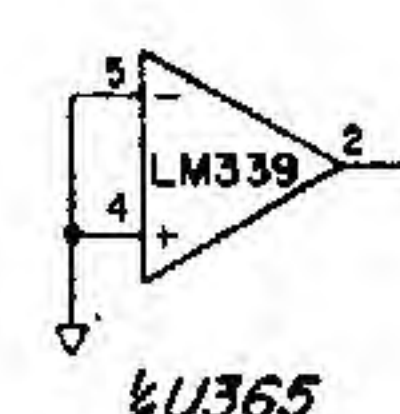

1/4 U365

- 1 BIT EQUIVALENCIES
- 2 ONLY USED FOR OSC CV
- 3 VOLTAGE READINGS WITH ALL POTS SET TO 0 AND U364-7 GROUNDED

SEQUENTIAL CIRCUITS INC			
PCB 3 DAC, ADC, TUNE, SEQ, CASS			
REV	DATE	BY	CHKD
1	7/29/69	69	GATE 5 MOD
2	5/7/69	20	EXTEND SEQ SCALE
3			
4			
5			

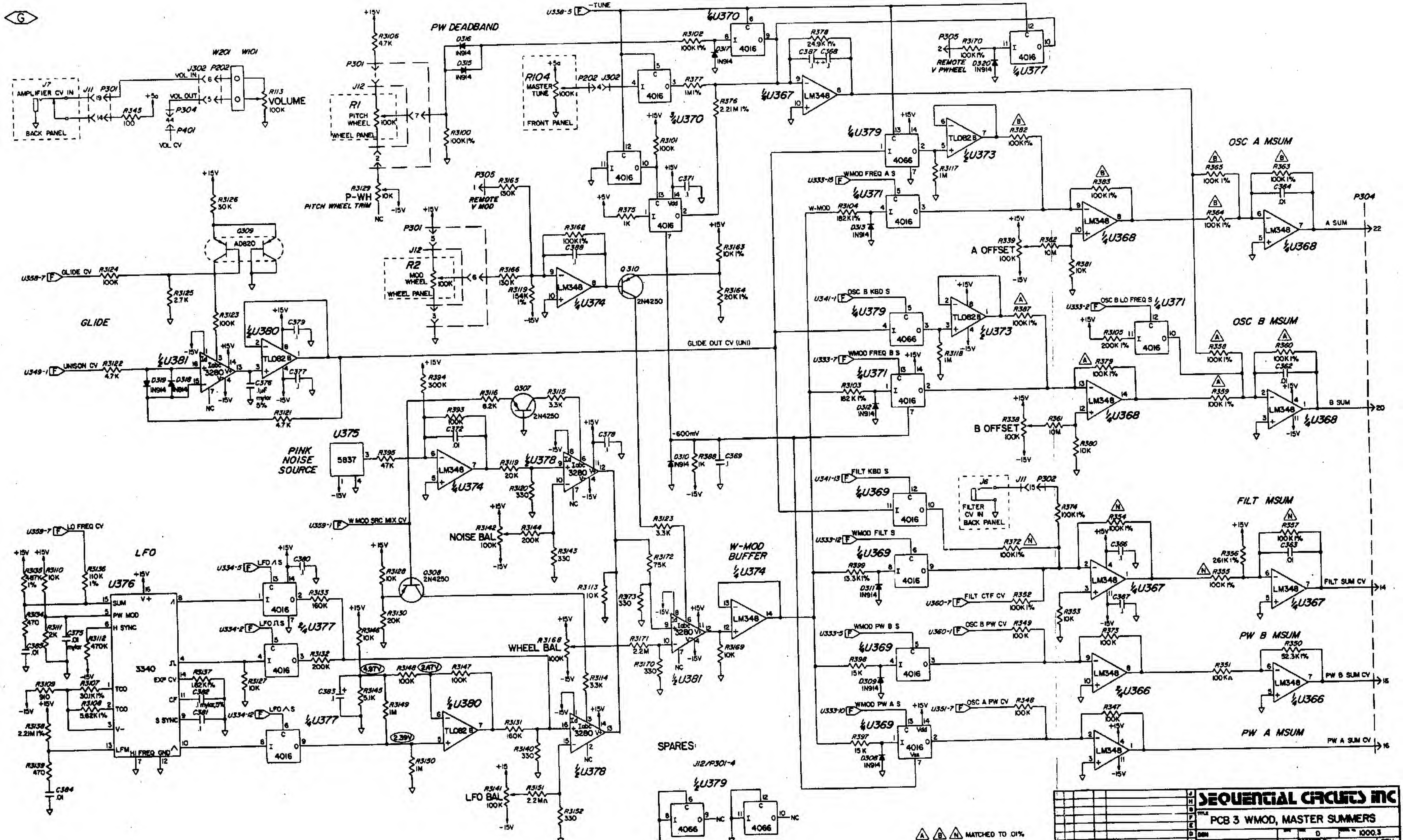

SEQUENTIAL CIRCUITS INC				
PCB 3 WMOD, MASTER SUMMERS				
REV	DATE	BY	CHKD	APP
1				
2				
3				
4				
5				
6				
7				
8				
9				
10				
11				
12				
13				
14				
15				
16				
17				
18				
19				
20				
21				
22				
23				
24				
25				
26				
27				
28				
29				
30				
31				
32				
33				
34				
35				
36				
37				
38				
39				
40				
41				
42				
43				
44				
45				
46				
47				
48				
49				
50				

△ △ △ MATCHED TO 0.1%

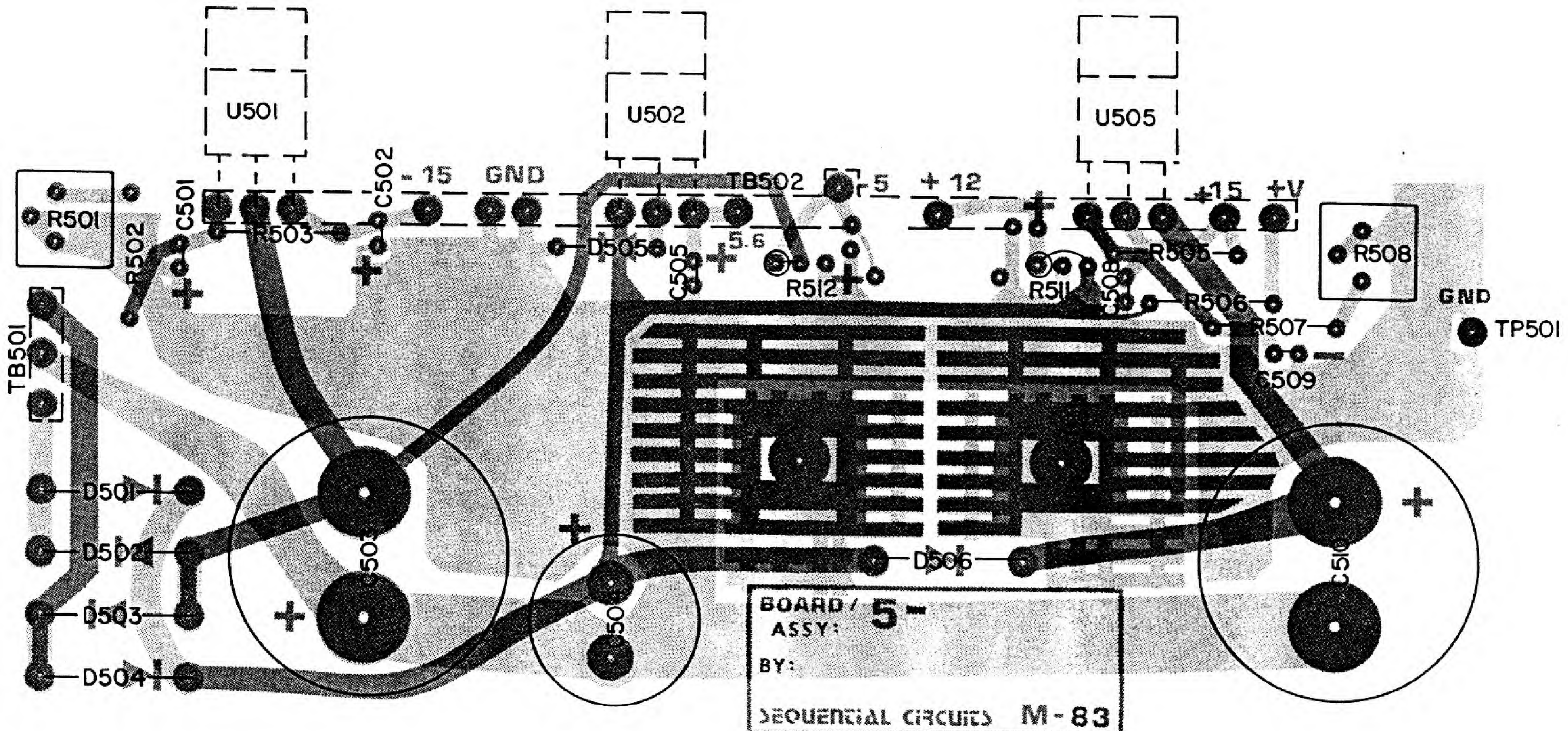

				J	SEQUENTIAL CIRCUITS INC				
				H	TITLE				
				G	PCB 5 PARTS ID				
				F	DSN		DATE	SIZE B	MODEL No 1000.3.2
				E	DWG D. SIMARD		DOCUMENT No.		
				D	APP		PP55I		
				C	ISS S. HUNGLEIB		9/12/60		
				B	REVISION		SHEET 1 OF 1		
				A	ADD 2X5.1Ω				
					Remove +12E-5 circuits				
FIRST S/N	DATE	ECR No		LTR					
	10/21/60	36							

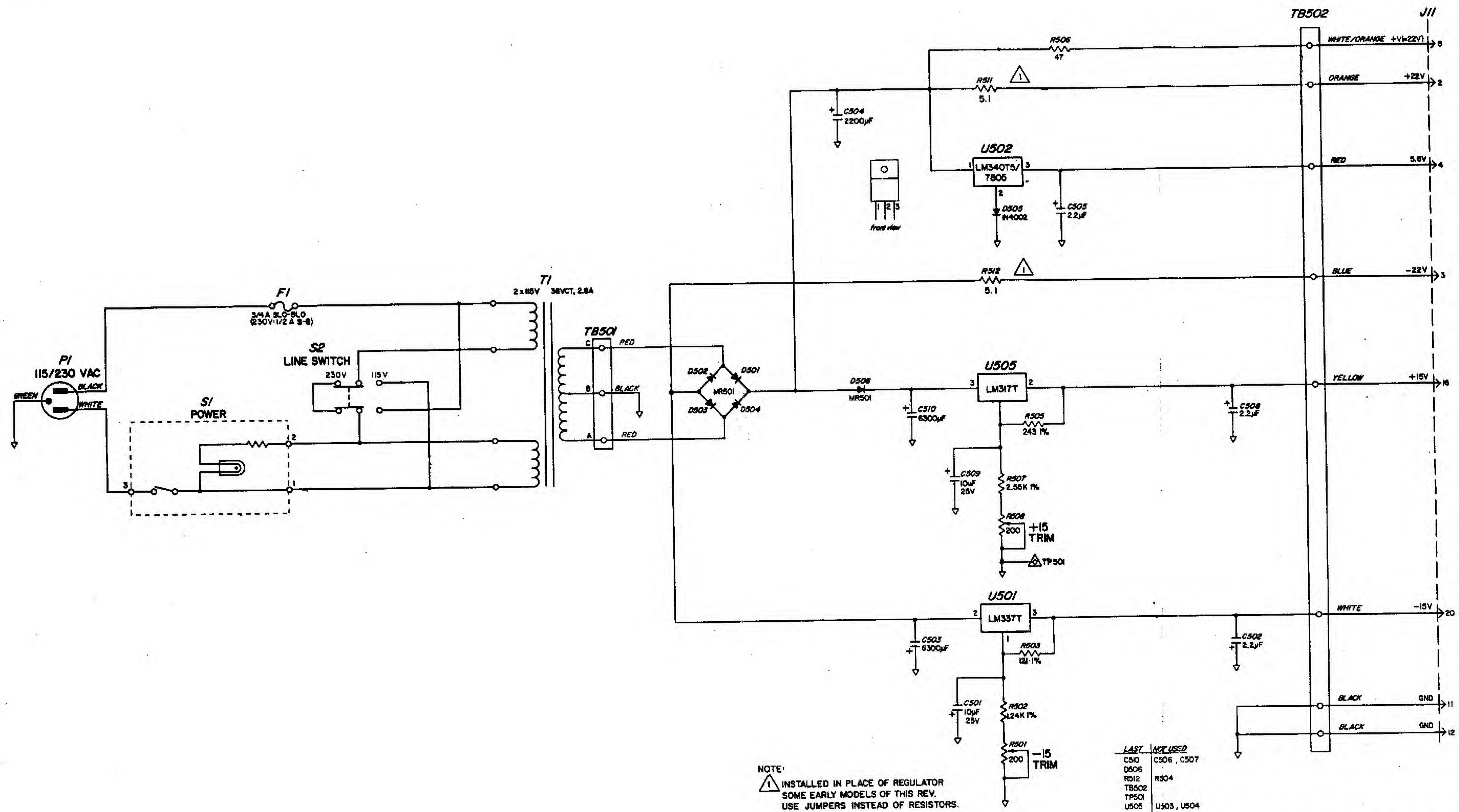

NOTE:
 INSTALLED IN PLACE OF REGULATOR
 SOME EARLY MODELS OF THIS REV.
 USE JUMPERS INSTEAD OF RESISTORS.

LAST	NOT USED
C510	C506, C507
D508	
R512	R504
TB502	
TP501	
U505	U503, U504

J		SEQUENTIAL CIRCUITS INC	
M		TITLE	
T		PCB 5 POWER SUPPLY	
E		D	
C		DATE	REV
B		DATE	REV
A		DATE	REV
DATE	REV	DATE	REV
DATE	REV	DATE	REV

11-0 INTRODUCTION

This section contains instructions for converting Rev 3.0 or 3.1 Prophets to Rev 3.2. It also presents procedure for Rev 3.0, 3.1, and 3.2 diagnostic computer tests. Finally, there is a trim procedure for the added WHEEL-MOD VCA in Rev 3.2.

11-1 REVISION 3.2 RETROFIT KIT INSTRUCTIONS

Revision 3.2 Retrofit kits can be ordered through the Service Dept. as Model 863. The kit includes:

<u>QUANTITY</u>	<u>SCI P/N</u>	<u>DESCRIPTION</u>
3	M-031	lockwasher
1	M-362	DIGITAL/ANALOG Label
2	R-046	5.1 ohm
1	Z-803	Assembled and Tested PCB 3
1	Z-804	Assembled and Tested Wire Harness

Back Panel Modification

1. Open the Rev 3.0 or 3.1 Prophet as shown in Section 1. Disconnect Power Supply connector P302 and the Audio Cable P402. Set the entire top section aside.
2. Remove PCB 5 Power Supply Board and regulators from back panel. PCB 5 will later be modified.
3. Mark and centerpunch the back panel according to Fig. 11-0.
4. Drill (2) 1/4-inch pilot holes.
5. Enlarge the holes to 5/8" using a chassis punch according to the instructions provided by the manufacturer. (Order SCI #Q-064, GREENLEE Chassis Punch #799-3214.)
6. Mount the jacks according to Fig. 11-1. Make sure that the jacks are mounted in the correct locations, which are the 5-pin jack on the right (toward edge) and 4-pin jack on the left. **Note:** To prevent twisting which could damage the wiring, hold the back of the jack with a wrench when tightening the front nut.
7. Install label (M-362) below jacks as shown in Fig. 11-0.

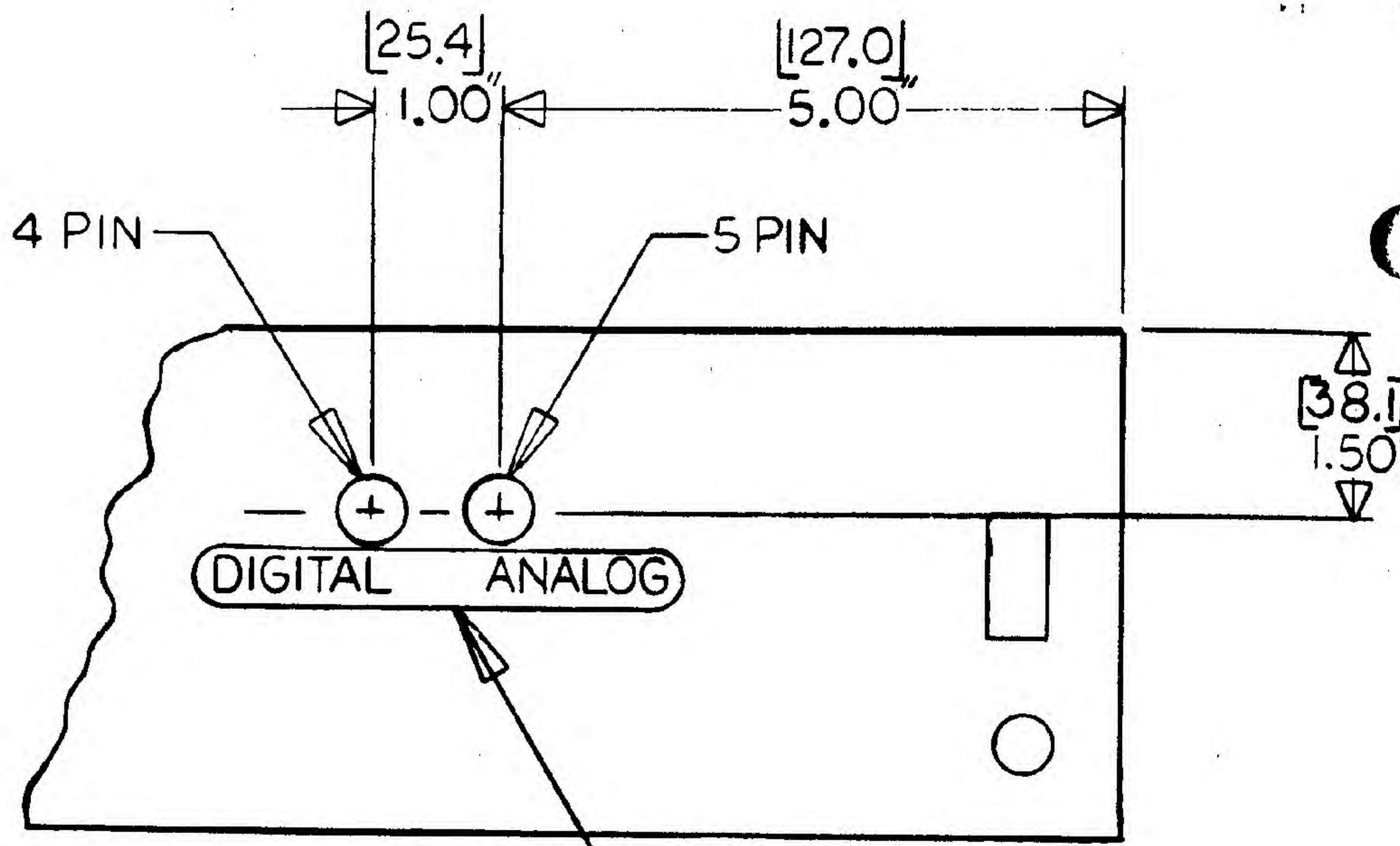

Figure 11-0

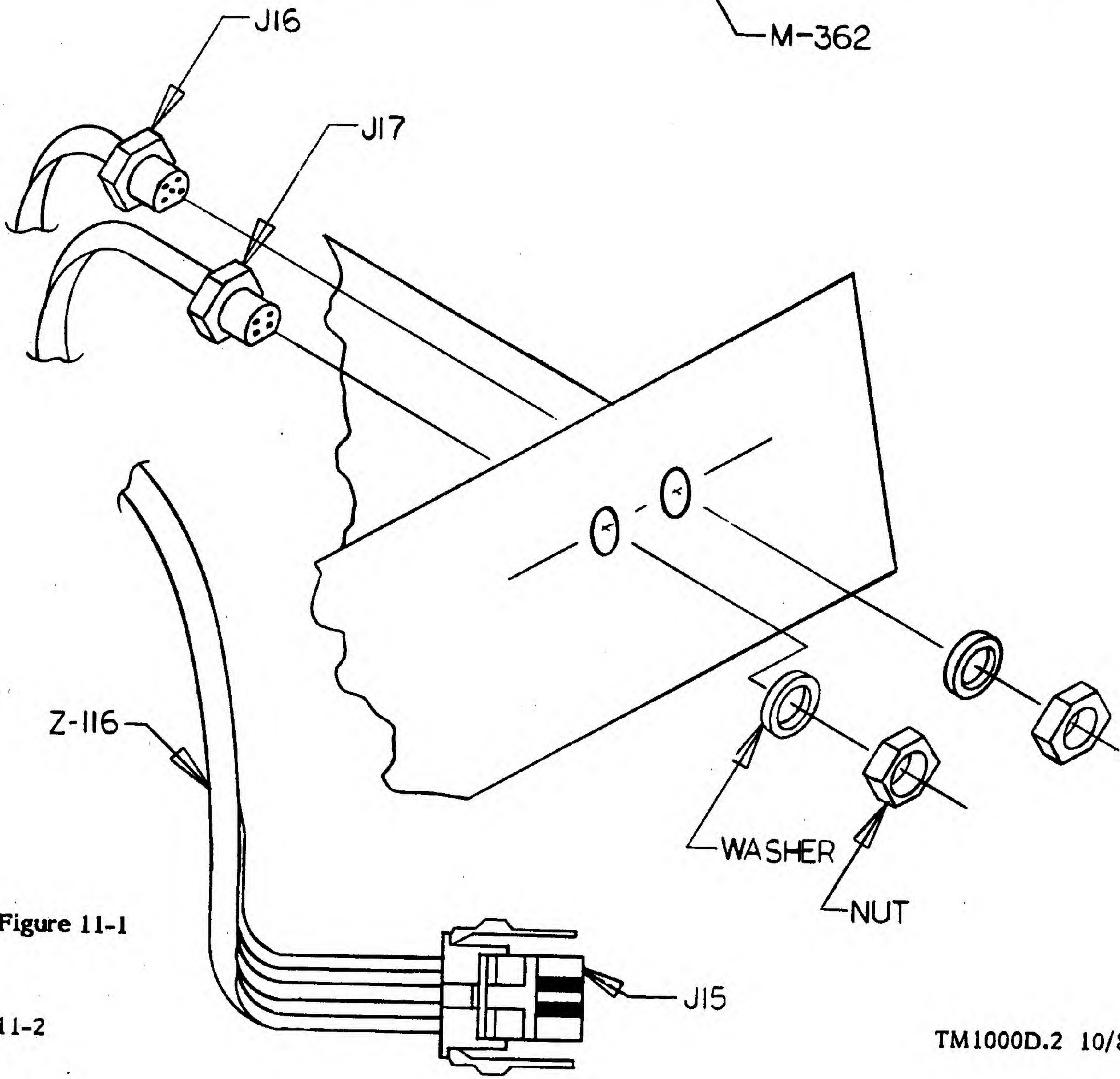

Figure 11-1

11-2

PCB 5 Modifications

8. If the Prophet is Rev 3.1, go to step 10.
9. If the Prophet is Rev 3.0, refer to pages 3-22 and 3-23 above, and remove these parts from PCB5: C507 (2.2 uF), U504 (78M12), R504 (1K), C506 (2.2 uF), U503 (7905).
10. Install a 5.1-ohm resistor between holes 1 and 3 of U504. As can be seen on the schematic, this ties +22V to the (formerly) +12V line. (The Rev 3.2 PROM doesn't need +12 or -5V.)
11. Install a 5.1-ohm resistor between holes 2 and 3 of U503. This ties -22V to the (formerly) -5V line.
12. Reinstall PCB5. There have been a few instances of loose regulators producing intermittent problems, usually with tuning. To prevent this, drill out the mounting holes with a #33 bit. Re-install the three remaining regulators, using nylon shoulder washers and adding the provided lockwasher under the #4 nut. Use loctite on threads. Hold nut with wrench and tighten screw with screwdriver tightly (until nylon shoulder washer begins to deform). Check for electrical isolation with ohmmeter.

PCB 3 Replacement

13. Remove the Rev 3.0 or 3.1 PCB 3 referring to pages 1-1 through 1-4.
14. Install the Rev 3.2 PCB 3.
15. Connect J15 9 pin connector to P305 on PCB 3. (For reference, see Rev 3.2 Interconnect diagram in Section 10.)
16. Reconnect remaining cables and check that all connections are tight.
17. Follow the Functional Test Procedures detailed above in pages 4-2 through 4-9.
18. Trim as required (see pages 4-11 to 4-16).

11-2 REVISION 3.0 MEMORY TEST

Rev 3.0 Serial Numbers: 1300-2285, 2424-2451, 2456, 2466, 2477

Software: V.8.0 (1300-1309, 1311, 1312, 1314-1321, 1324, 1328)
V.8.1 (1310, 1313, 1321-1323, 1325-1327, 1329-2285,
2424-2451, 2456, 2466, 2477)

NOTE: Following the appearance of a few Rev 3.0 Prophets which spontaneously put themselves into Edit Mode, the Rev 3.0 has been updated to (post-production) V.8.2, available as a 3-PROM set, SCI #Z-984.

Rev 3.0 Prophet-5s are tested with a special 2708 EPROM which can be ordered as SCI #Z-953.

NOTE. Check that the RECORD switch is ENABLED, and that user's programs are stored on cassette since the memory tests erase the NV RAM contents.

1. Switch power off and insert PROM in PROM 0 location (U312). (If available, insert factory program PROM PROGS.5 into PROM 1 (U313) location. The test will load NV RAM with programs during section 3).

2. Switch power on. The test will start, indicating the memory section in the PROGRAM display:

- 1 = Scratchpad RAM
- 2 = NV RAM
- 3 = NV RAM load
- 4 = 8253 Timer
- 0 = End of test. No failures.

3. If a test fails, the program halts and displays the section number for the problem area. Further tests are not executed until the problem is fixed.

11-3 REVISION 3.1 MEMORY TEST

Rev 3.1 Serial Numbers 2286-2423
Software: V.9.1

Rev 3.1 has the memory test built-in but a simple hardware modification may be required before it can be enabled.

NOTE. Check that the RECORD switch is ENABLED, and that user's programs are stored on cassette since the memory tests erase the NV RAM contents.

1. First, switch power off. The RAM test program is contained in the standard 2716 software, V.9.1. (NV load similar to Rev 3.0 is provided.)

2. If necessary, on foil-side (or, bottom) of PCB 3, cut trace between U324-10 and ground.

3. See SD342 in Section 10. If not installed, connect R3155 100K pull-down resistor from U324-10 to ground at U324-8.

4. To vector to the internal test program, jumper TP305 (U324-10) to +5V then switch power on. (The test point location is shown on PP351, Section 10). The test will start, indicating the memory section in the PROGRAM display:

- 1 = Scratchpad RAM
- 2 = NV RAM
- 3 = NV RAM load
- 4 = 8253 Timer
- 0 = End of test. No failures.

5. If a test fails, the program halts and displays the section number for the problem area. Further tests are not executed until the problem is fixed.

11-4 REVISION 3.2 MEMORY TEST

All Rev 3.2 Prophet-5s have the memory test built-in.

Rev 3.2 2452-2455, 2457-2465, 2467-2476, 2478 and up
Software: V.9.2

Software level V.9.2 has the memory test only. Later-production instruments have software version V.9.3 which prefaces the memory test with a basic CPU test. This routine doesn't use RAM so is useful for seeing if the CPU itself is working and accessing PROM.

NOTE. Check that the RECORD switch is ENABLED, and that user's programs are stored on cassette or via the Model 1005 Polyphonic Sequencer since the memory tests erase the NV RAM contents.

1. First, switch power off.

2. To vector to the internal test program, jumper TP304 MEM TEST to +5V then switch power on.

3. If software is V.9.3, the Prophet will sequentially flash its LEDs (in the order in which they are wired in the matrix). To exit this mode and start the regular RAM test, press TUNE.

4. The memory test will start, indicating the memory section in the PROGRAM display:

- 1 = Scratchpad RAM
- 2 = NV RAM
- 3 = PROM
- 4 = 8253 Timer
- 0 = End of test. No failures.

3. If a test fails, the program halts and displays the section number for the problem area. Further tests are not executed until the problem is fixed.

11-5 WHEEL BALANCE TRIM

1. See para. 4-13 and trim WHEEL-MOD LFO VCA BALANCE, and see para. 4-15 and trim WHEEL-MOD NOISE VCA BALANCE.
2. Switch off all LFO waveshapes.
3. Set WHEEL-MOD SOURCE MIX knob to 0.
4. Advance MOD wheel fully.
5. Probe U374-14, W-MOD Buffer output. (For parts locations, see PP351 in Section 10.)
6. Adjust R3168 WHEEL BAL trimmer to read as close to 0.000V as possible.

SECTION 12

PARTS

REVISION 3.2 COMPONENTS

Changed from Rev 3.0

R339	R-217
R378	R-110A
R3119	R-175
R3120	R-015
R3153	R-025

Added

D320	D-005
------	-------

Q310-12	T-003
---------	-------

R3154	R-011
R3155/6	R-012
R3157/8	R-025
R3159	R-011
R3160	R-010
R3161	R-025
R3162	R-110
R3163	R-108
R3164	R-144
R3165/6	R-077
R3167	R-036
R3168	R-217
R3169	R-012
R3170	R-004
R3171	R-030
R3172	R-022
R3173	R-004

R511/2	R-046
--------	-------

PROPHET-5 REV 3.3 UPDATE

This modification increases the Prophet-5's program storage capacity from 40 to 120. The update involves adding a jumper to the back of PCB 2 Left Control Panel, adding RAM and some logic to the Rev 3.2 PCB 3 Computer Board, and changing the software. The Update Kit (#Z-205) includes the following parts:

PARTS

CM1000C.2	Prophet-5 Rev 3.3 Op Manual Addendum
I-043	6116 RAM
I-240	74C00 Quad NAND gate
J-017	24-pin DIP socket
Z-994	Prophet-5 software
Z-068	Prophet-5 120-Factory Program Cassette

PROCEDURE

1. Switch power off and disconnect the Prophet from the AC line.
2. Open the box. (For instructions, see Section 1 of Technical Manual TM1000D.)
3. Disconnect and remove PCB 4.
4. Disconnect and remove PCB 3.
5. See Fig. 1 and add the jumpers shown to the back of PCB 2. This ties together the display decimal points (pins 4 and 9) to LD7, pin 33 of TB201, as shown on the Rev 3.3 PCB 2 schematic (attached).
6. The remaining modifications to PCB 3 are illustrated in Figs. 2 and 3, and the Rev 3.3 PCB 3 schematic (attached). First bend out all the pins of the enclosed 74C00 Quad NAND gate, except pins 4, 7, and 14. Solder this device "piggyback" to U309 (74C02) at pins 4, 7, and 14 (Note that U309 is oriented with pin 1 at the upper right).
7. The added 74C00 is designated U387. Jumper U387 pins 2, 1, 14, and 13 in a loop around the end of the IC.
8. Jumper U387-10 and U387-11.
9. Jumper U387-4 to U387-9.
10. Jumper from the feed-through for U311-1 (A11), to U387-5 and -12. It should be possible to do this with one piece of wire.

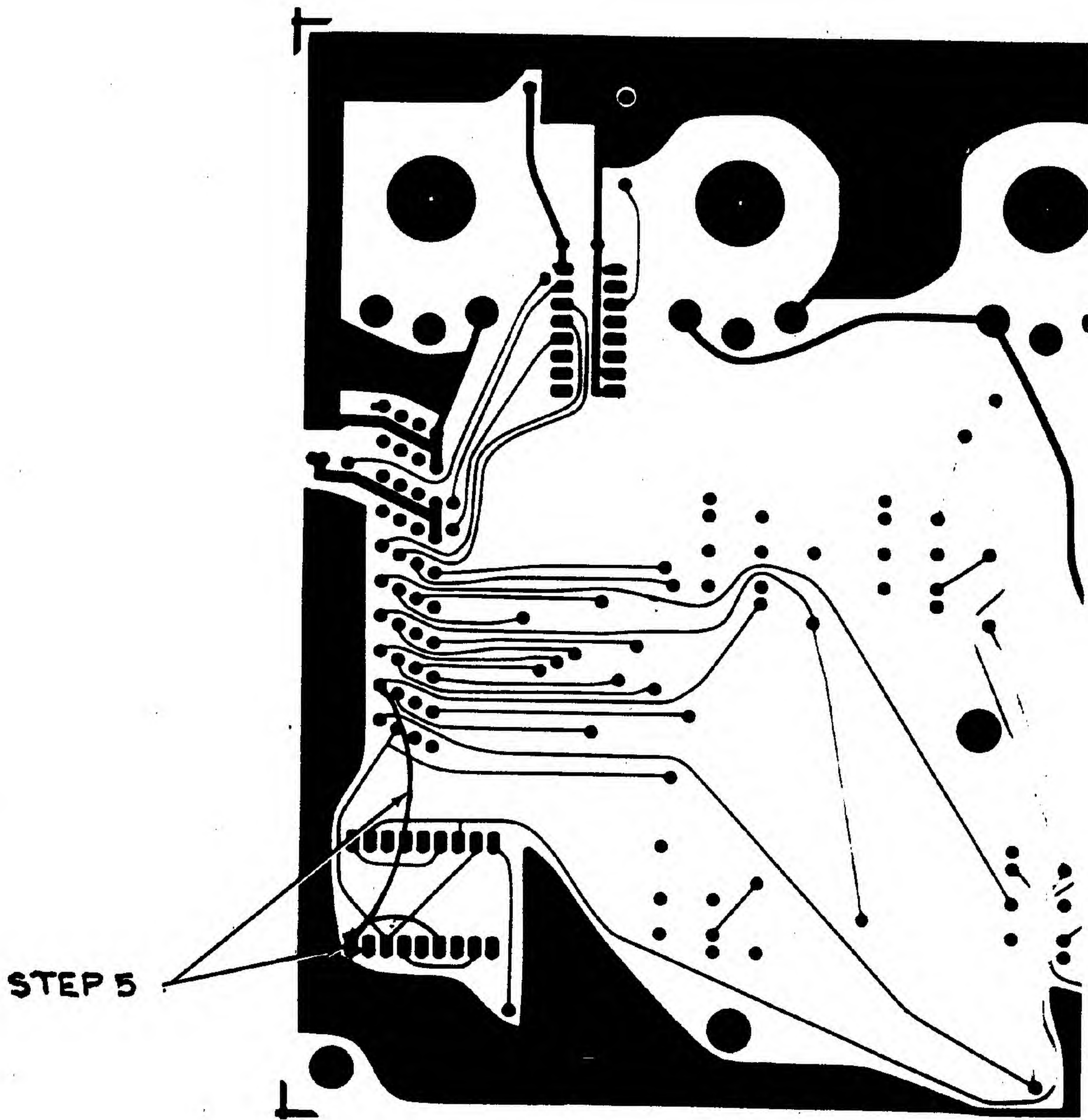

STEP 5

Figure 13-0
PCB 2 BOTTOM MODIFICATION

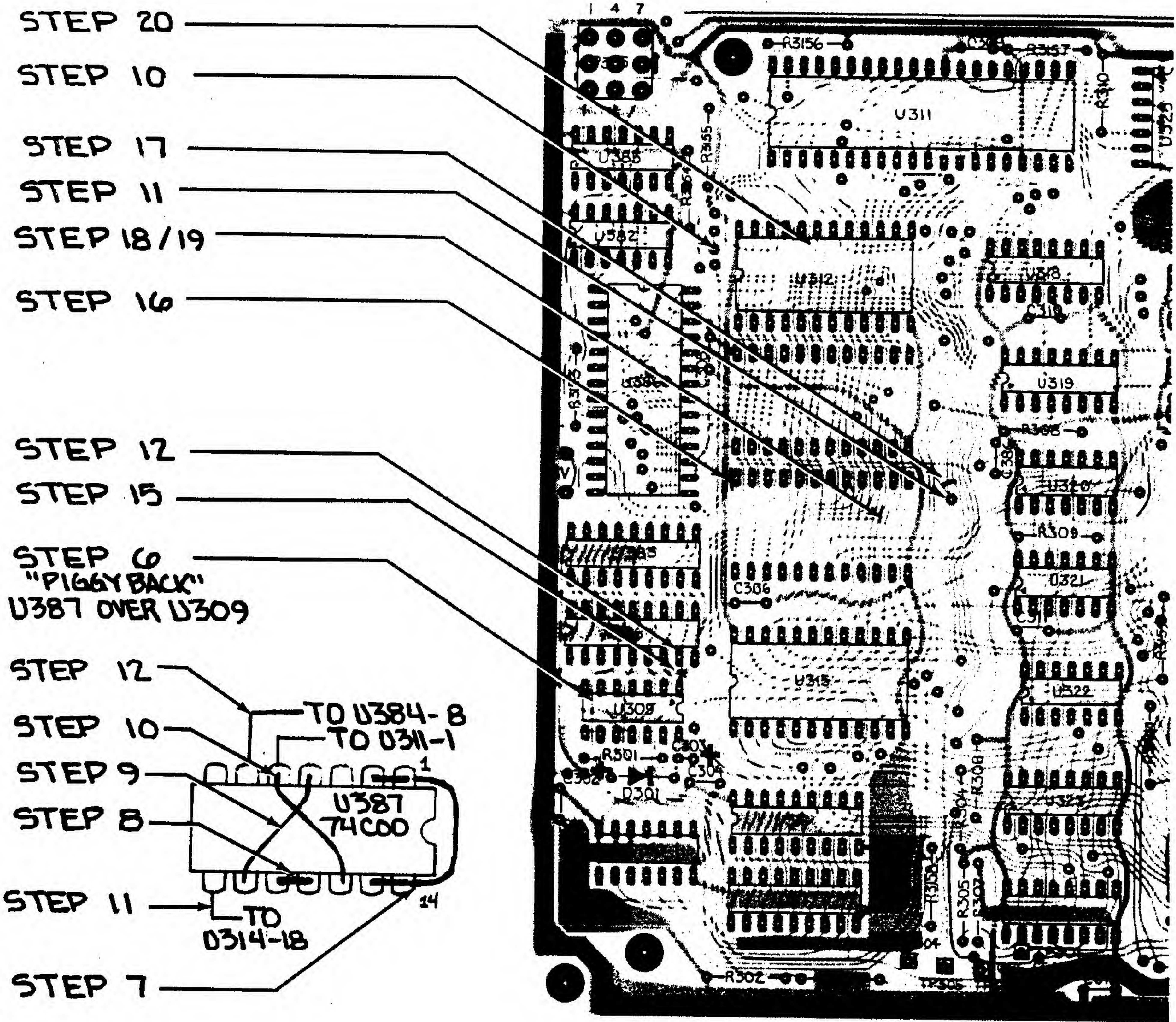

Figure 13-1
PCB 3 TOP MODIFICATION

TM1016A 4/82

11. Jumper from the feed-through for U314-18 (-CE), to U387-8.
12. Jumper from U384-8 (-CS), to U387-6.
13. See Fig. 3 (bottom). Jumper U314-24 to U383-18 (Vnv).
14. Jumper U314-21 to U383-10 (-WR).
15. See Fig 2. Cut trace between U384-8 and U309-1.
16. Cut the trace between U314-24 and +5V.
17. Cut the trace from U318-13 (-ROM 2) to U314-18.
18. Install the 24-pin socket in the space reserved for U314.
19. Insert 6116 RAM into U314 socket.
20. Replace software at U312 with version enclosed.
21. Assemble unit and run a functional test.
22. Verify NV operation by recording, and loading (and re-saving) included factory programs to Program Files 2 and 3 with the Cassette Interface. (The Addendum enclosed with the kit explains how to access the new Program Files.)

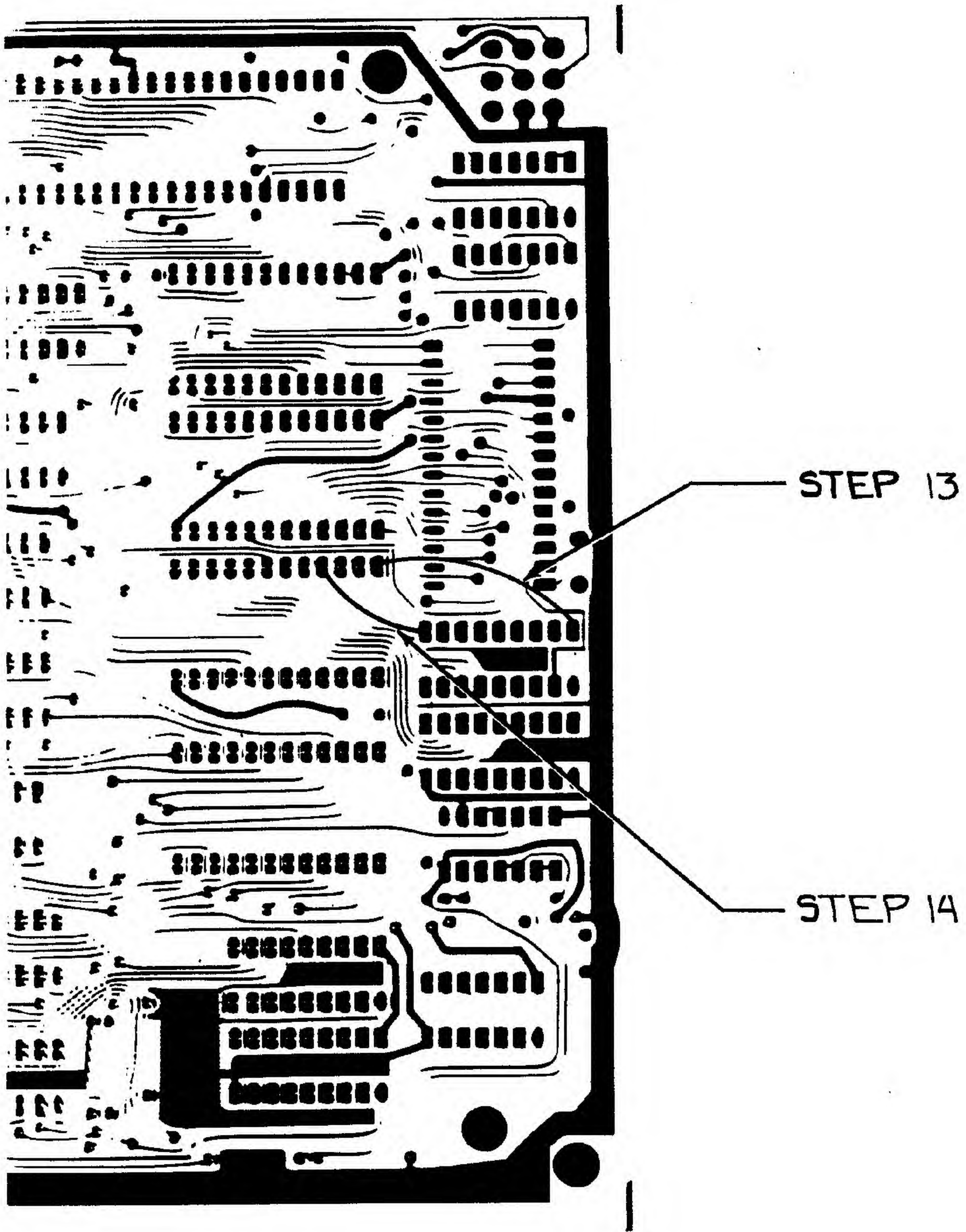
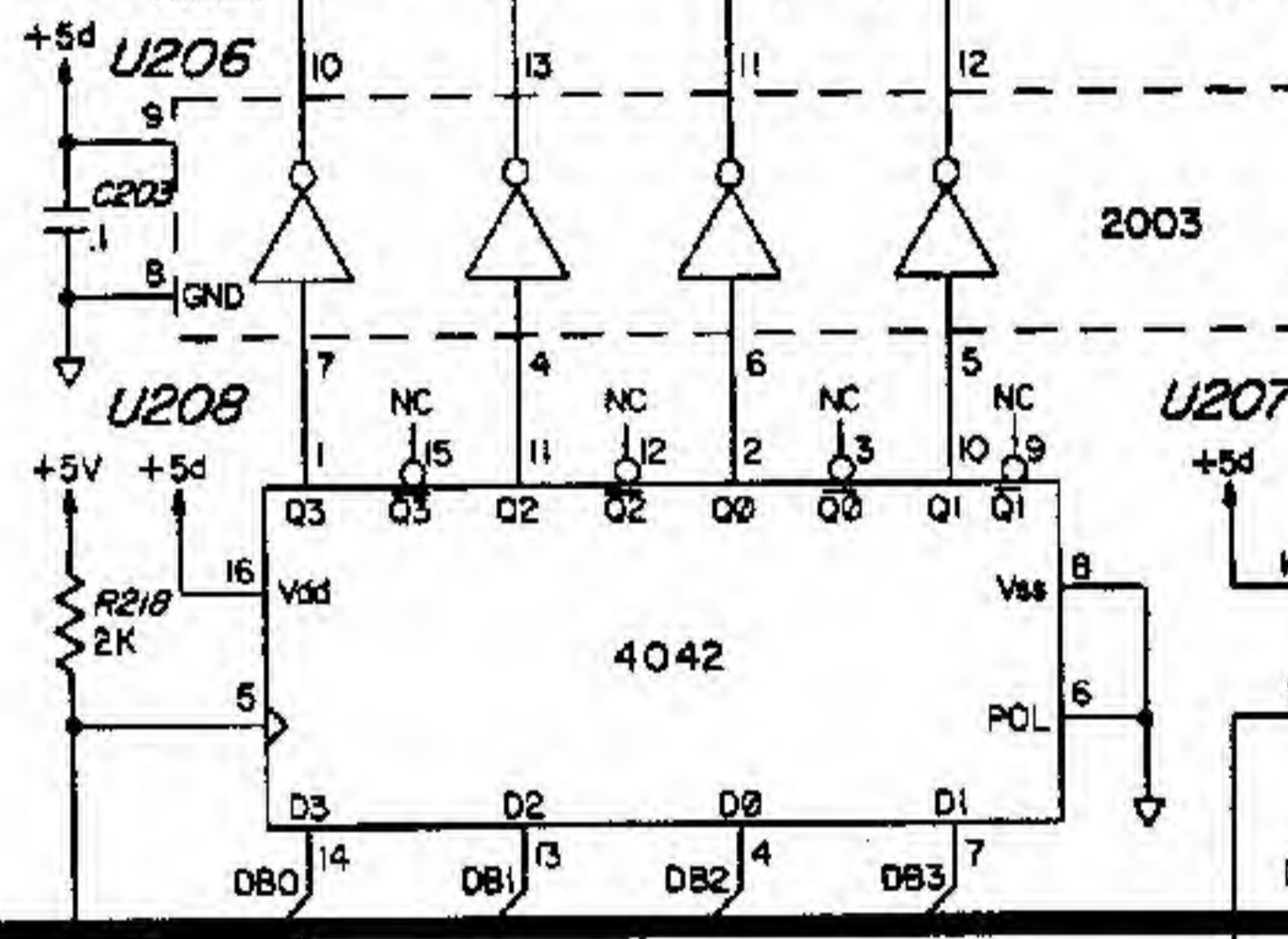
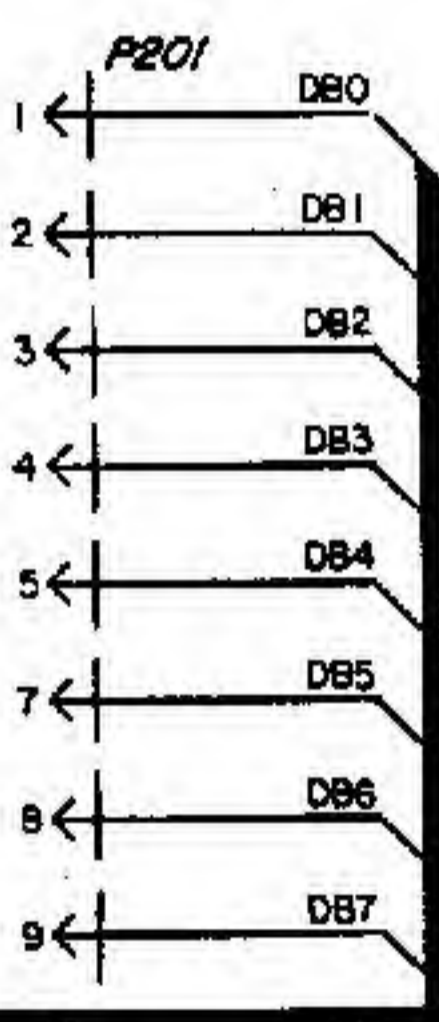
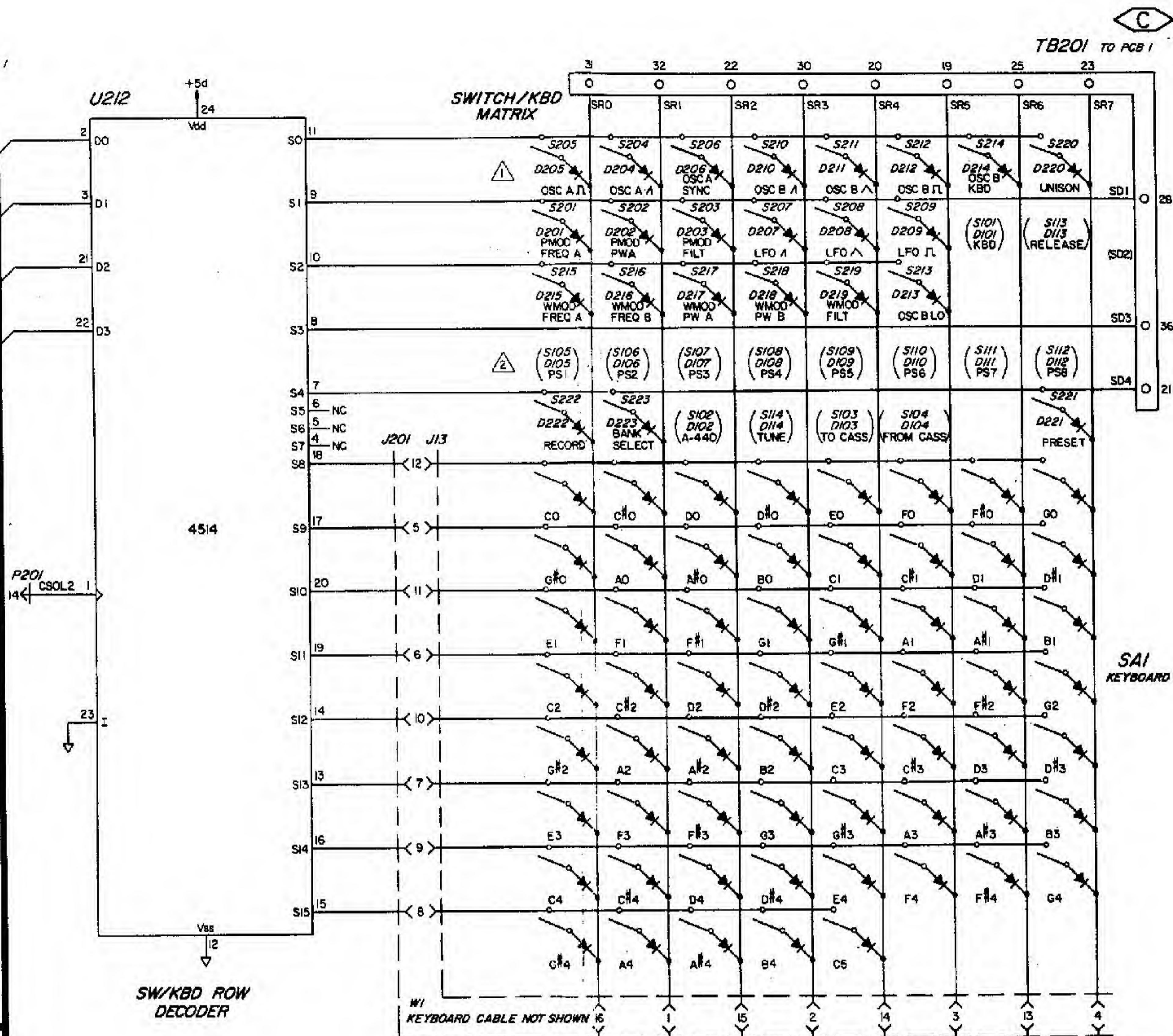
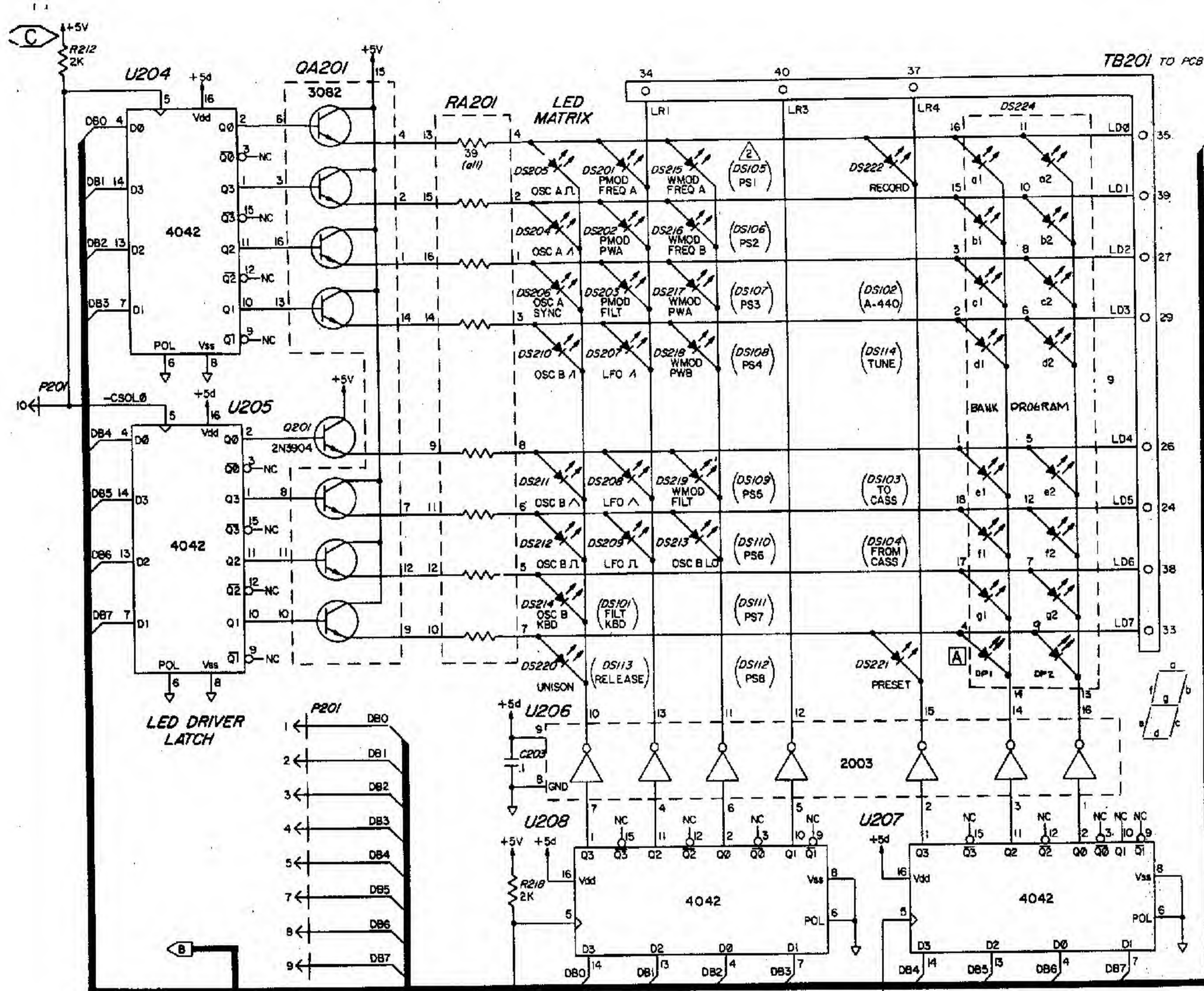
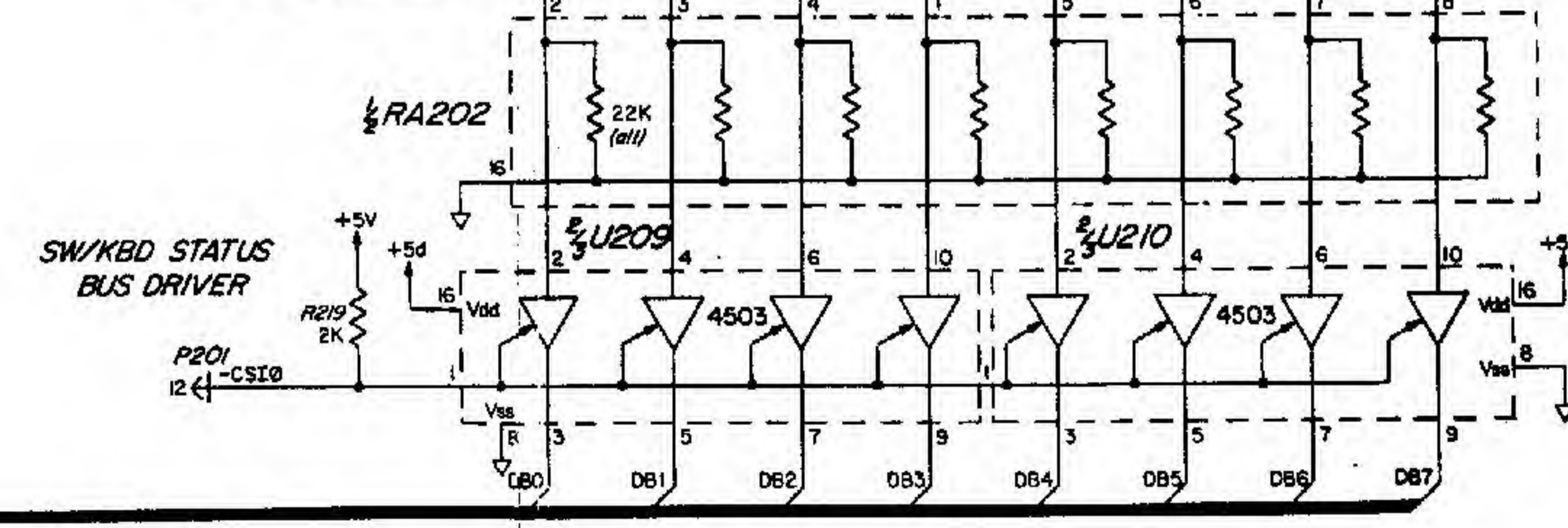

Figure 13-2
PCB 3 BOTTOM MODIFICATION

TM1016A 4/82



SW/KBD ROW DECODER



SPARES:

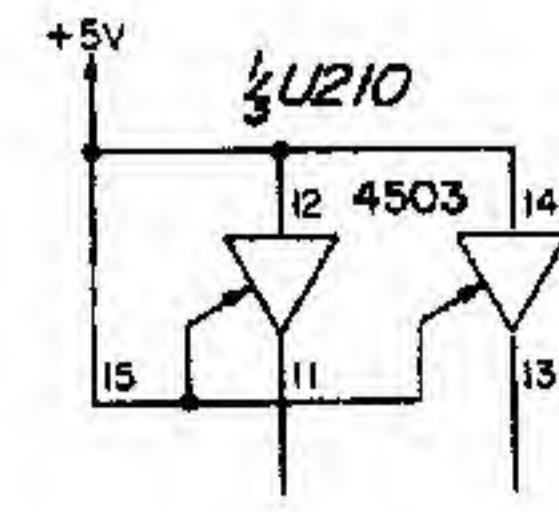
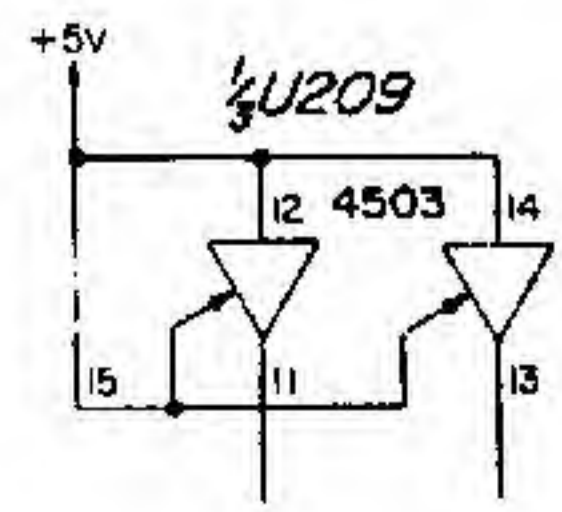
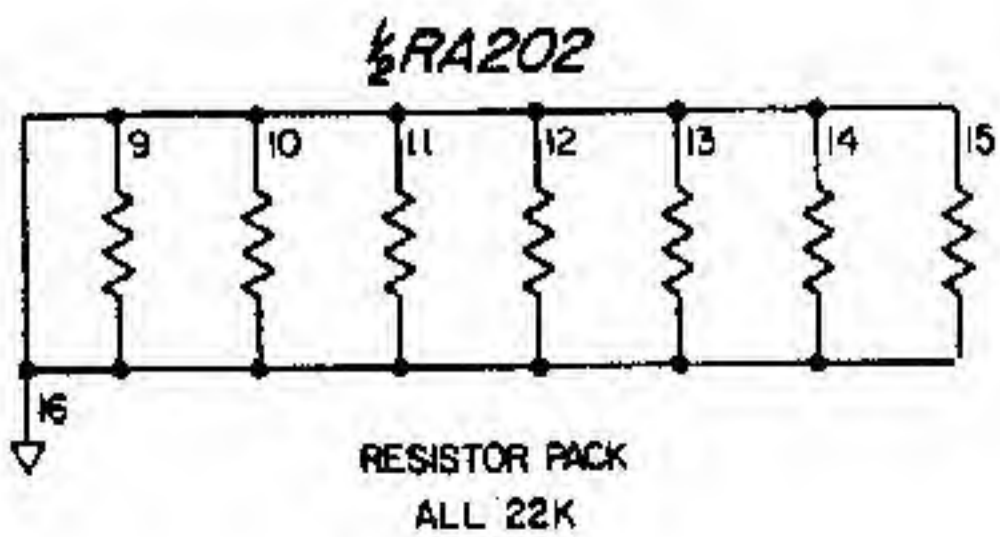

△ S201-21 ARE BLACK
 S222/24 ARE GREY
 S223 IS ORANGE
 △ CONTROLS IN PARENTHESIS
 ARE ON PCB1

SEQUENTIAL CIRCUITS INC			
PCB 2 CONTROL MATRICES			
D	DSN	REV	D
C	DWN	DATE	1000.3
B	APP	DATE	SD232
A	REV	DATE	SD232
DATE		REVISION	SHEET 2 OF 2

INDEX TO TM1016B

Index Date: 6 Dec, 1982

Index also covers TM1000D.4 (Sections 1-13, 23) and TM1016A (Sections 1-22)

Instrument Codes

Instrument series are coded by model number, followed by a period and the rev level.

1000.1	Prophet-5 Synthesizer, Rev 1 (S/N 1-182)
1000.2	Prophet-5 Synthesizer, Rev 2 (184-1299)
1000.3.0	Prophet-5 Synthesizer, Rev 3 (1300-)
1000.3.1	Prophet-5 Synthesizer, Rev 3.1 (RAM changes)
1000.3.2	Prophet-5 Synthesizer, Rev 3.2 (USART, Analog)
1000.3.3	Prophet-5 Synthesizer, Rev 3.3 (120-program)
1001	Prophet-5 Remote Keyboard
1005	Prophet-5 Polyphonic Sequencer
1010.0	Prophet-10 Synthesizer, Rev 0 (1-329)
1010.1	Prophet-10 Synthesizer, Rev 1
1015.0	Prophet-10 Polyphonic Sequencer, Rev 0 (1-329)
1015.1	Prophet-10 Polyphonic Sequencer, Rev 1 (330-)
1016.0	Prophet-10 with Rev 0 Sequencer
1016.1	Prophet-10 with Rev 1 Sequencer

<u>TOPIC</u>	<u>PAGE(S)</u>
ADC	
1000.3.0	2-16, 2-17, 2-19, 2-20, 3-12, 4-11
1010	14-8, 15-13, 16-14
additive synthesis	2-2
address	see "memory address" or "I/O interface"
address bus	
1000.3.0	2-10, 2-12, 3-11
1000.3.1	8-1
1000.3.2	8-3
1005	18-2
1010	14-6, 14-7
1015.1	18-2
amplifier (final VCA)	2-1, 2-4, 2-9, 3-17 thru 3-21, 4-1, 4-6, 4-16
amplifier envelope generator	2-1, 2-4, 2-7, 2-9, 3-17 thru 3-21
analog interface	
1000.3.2	8-2, 8-4
assembly procedures	1-1 thru 1-7
audio output (volume)	
1000.3.0	2-4 thru 2-6, 2-9, 2-10, 3-5, 3-14, 3-15, 4-1
1010	14-10, 15-5, 15-23, 16-15

A-440	
1000.3.0	2-20, 3-15
1010	14-5
back panel	4-9
balance (VCA)	2-9
battery	
1000.3.0	2-12, 3-11
1010	14-6, 15-11
bias (tuning)	2-7, 2-19, 2-20
BIFET	2-18
BOM	5-9
bottom panel assembly	1-1,
bus bar	1-6
cable,	
1000.3	
audio output	1-1 thru 1-3
back panel	1-4
interconnect	1-3
keyboard	1-5
voice power	1-3
wheel	1-4
1005 interface	20-7
cassette interface	
1000.3.0	2-12, 2-21, 3-12
1010	15-13
chassis parts	
1000.3.0	5-1
chip select (-CS)	
1000.3.0	2-10
1010	14-5
clock, system	
1000.3.0	2-4, 2-12, 3-11
1000.3.1	10-2
1005	18-1, 19-11
1010	14-5, 15-11
1015.0	20-1
1015.1	18-1
common analog	
1000.3.0	1-3, 2-4, 2-7, 2-8, 3-14
1000.3.2	8-2
1010	14-8
computer	
1000.3.0	2-4, 2-5, 2-10, 2-14, 3-11 thru 3-13
1000.3.1	8-1, 10-2
1000.3.2	8-2, 10-7
1005	18-1
1010	14-2, 15-11 thru 15-14
1015.1	18-1
control bus	
1000.3.0	2-10, 2-12
controls	see "knobs" or "switches"

control panel	
1000.3.0	1-5, 2-15, 3-2 thru 3-9
1010	15-4 thru 15-9
CPU	
1000.3.0	2-4 thru 2-7, 2-10, 2-12, 2-15, 2-17, 2-19, 3-11
1000.3.1	10-2
1000.3.2	8-3, 10-7
1005	18-1
1005	18-1, 19-4
1010	14-5, 14-6, 15-11, 16-1
1015.0	19-4
1015.1	18-1, 19-10
CV outputs	see "demultiplexer"
DAC	
1000.3.0	2-8, 2-15 thru 2-18, 3-12, 4-11
1010	14-8, 15-13, 16-14
deck, mini cassette	18-6 thru 18-8, 19-12, 19-13, 20-1
deck, wafer	14-2, 14-9, 18-1, 18-4, 18-5, 19-8, 20-1
demultiplexer (CV DMUX)	
1000.3.0	2-16, 2-18, 3-13, 3-15
1010	14-8, 15-14
diagnostics	
1000.3.0	11-4
1000.3.1	11-4
1000.3.2	11-5
1005	20-5
1010	16-16
1015.0	20-1
1015.1	20-5
digital interface	
1000.3.2	8-2, 9-1 thru 9-6, 11-1
1001	22-1
diodes, matrix	2-15
disassembly procedures	1-1 thru 1-7
documents	see "parts identification" or "schematics"
document lists	
1000.3.0	3-1
1000.3.1	10-1
1000.3.2	10-1
1005	19-1
1010	15-1
1015.0	19-1
1015.1	19-1
document notes	3-1
drivers (bus)	2-10
edit mode	2-7, 2-10, 2-16
envelope	see "filter envelope" or "amplifier envelope"
equalization	14-10, 15-24

EPROM	
1000.3.0	2-7, 2-10, 2-12, 2-14, 3-11
V.8.0	11-4
V.8.1	11-4
V.8.2	11-4
1000.3.1	8-1
V.9.1	11-4
1000.3.2	9-1
V.9.2	11-5
1000.3.3	
V.9.5	23-3
1001	22-1
1005	18-1, 19-10, 19-11, 20-5
1010.0	14-6, 15-11
V.4	16-1
1010.1	
V.5	16-1
1015.0	19-4
SEQ9.1	20-1
1015.1	18-1, 19-11, 20-5
SEQB.1 (16K)	20-4
SEQC.1 (64K)	20-4
fake clock	2-19
filter (VCF)	
1000.3.0	2-1, 2-4 thru 2-7, 2-9, 3-17 thru 3-21, 4-6, 4-14, 7-9
filter envelope amount VCA	4-14
filter envelope generator	2-1, 2-4, 2-6 thru 2-9, 3-17 thru 3-21, 7-5
filter keyboard	2-7
final VCA	see "amplifier"
frequency CV	2-4, 2-7
gate	
1000.3.0	2-2, 2-4, 2-7, 2-14, 2-15, 4-1
1010	14-7
glide	
1000.3.0	2-9, 2-17, 3-14, 4-5
1010	14-8, 14-10, 15-16
gate output	
1010	14-7
ground loop	1-3
input/output (I/O) interface	
1000.3.0	2-7, 2-10, 2-12, 2-13, 3-11
1000.3.2	8-3, 10-7
1005	18-1, 18-2
1010	14-5, 15-12
1015.0	19-4
1015.1	18-2, 19-10
interconnection	
1000.3.0	3-3
1000.3.2	10-5
1016	15-3

interrupt (-INT or -NMI)	
1000.3.0	2-12, 2-20
1000.3.2	8-3
1001	22-2
1010	14-5, 14-6, 15-3
J-wires	1-6
1000.3.0	2-15
1010	14-2
keyboard CV	2-1, 2-7, 2-8, 2-15, 2-17
keyboard	see also "switch/keyboard matrix"
1000.3.0	1-6, 1-7, 2-1, 2-4, 2-7, 2-8, 2-17, 3-9
1010	14-2, 14-7, 15-8
knobs	2-7
LED matrix	
1000.3.0	2-15, 3-5, 3-9
1000.3.3	13-7
1001	22-1
1010	14-5 thru 14-7, 15-5, 15-9
level shifters	
address bus	2-13, 3-11
CS/data bus	2-13, 3-11
envelope generator CV	2-9, 3-15
oscillator B triangle	2-8
LFO	
1000.3.0	2-7, 2-8, 3-14, 4-7
1010	14-8, 15-15, 16-13
line voltage select switch	1-1
loop (scan time)	
1000.3.0	2-10, 2-15, 2-16, 2-18
1000.3.2	9-2, 9-4
1010	14-2, 14-5
manual mode	2-7, 2-16
master summers	
1000.3.0	3-14, 4-10
1010	14-7, 15-16, 15-17, 16-14
master tune	
1000.3.0	2-4, 2-7, 3-5, 3-14
1001	22-6
1010	14-10
master volume	16-15
memory	see also "EPROM" and "RAM"
1000.3.0	2-7, 2-10, 2-12, 3-11
1005	18-1
1010	14-5, 14-6

memory interface	
1000.3.0	2-10, 2-13, 3-11
1000.3.1	8-1, 10-2
1000.3.2	10-7
1000.3.3	13-8
1005	18-1
1010	14-6, 14-7, 15-11
1015.0	19-4
1015.1	18-1, 19-10
microcomputer	see "computer"
microprocessor	see "CPU"
mixer	2-4 thru 2-7, 2-9, 4-5
models	see "revisions"
modification policy	v (D.2)
modifications (authorized)	
1000.3.0 to 1000.3.2	11-1
1000.3.0 to 1000.3.3	23-1
1000.3.1 to 1000.3.2	11-1
1000.3.1 to 1000.3.3	23-1
1000.3.2 to 1000.3.3	13-1
1005	20-4
1010.0	14-1, 16-1, 16-12
1015.0 to 1015.1	14-2, 20-1
1015.1	20-4
modulation wheel	see "wheel-mod"
mono-mod	16-13
multiplexer (POT MUX)	
1000.3.0	2-12, 2-16 thru 2-19, 3-5, 3-8
1010	14-8, 15-5, 15-7
multiplexer (TUNE MUX)	see "TUNE"
n-key rollover	2-15
noise (modulation)	3-14
noise (white-mixer)	3-15, 4-5
organ	2-1
oscillator (VCO)	2-1, 2-4, 2-19
oscillator (OSC) A	2-4 thru 2-8, 3-17 thru 3-21, 4-3, 4-12, 7-15
oscillator (OSC) B	2-4 thru 2-8, 3-17 thru 3-21, 4-4, 4-12, 7-15
OTA (VCA)	2-9, 7-2
patch CV	2-7, 2-8
pedal	14-10, 15-15
PCB 1	
1000.3.0	1-5, 3-3, 3-4, 5-1
1001	22-3, 22-8
1005	18-1, 19-9, 20-4, 21-2
1010	15-4, 17-2
PCB 2	
1000.3.0	1-5, 3-7, 5-1
1010	15-6, 16-12, 17-3
1015.1	21-2

PCB 3	
1000.3.0	1-1 thru 1-6, 2-8, 2-10, 3-10, 5-2
1000.3.2	10-6
1010	15-10, 16-1, 17-4
PCB 4	
1000.3.0	1-1 thru 1-6, 3-16, 5-4
1010	17-10
PCB 5	
1000.3.0	3-23, 4-9, 4-10, 5-8
1000.3.1	8-1, 10-4
1000.3.2	8-4, 10-10, 10-11
1010	see "PCB 4"
PCB 6	
1010	14-11, 15-18, 15-19, 16-6, 16-13, 17-11
PCB 7	15-20, 15-21, 17-12
PCB 8	15-22, 16-12, 17-12
PCB 9	
1015.0	19-3, 21-1
1015.1	19-9, 20-4
PCB 10	
1015.0	18-1, 19-6, 19-7, 21-2
PITCH wheel (PBNB)	
1000.3.0	1-6, 2-4 thru 2-7, 2-19, 3-14, 4-10
1000.3.2	8-2, 8-4, 10-9
1001	22-1, 22-5, 22-4
1010	14-10, 15-16, 16-13
poly-mod	2-8, 2-9, 3-17 thru 3-21, 4-8
poly-mod filter envelope VCA	4-13
poly-mod oscillator B VCA	4-13
ports	see "I/O interface"
power detect	
1000.3.0	2-12, 3-11
1010	14-6, 14-11, 15-11, 16-1
power supply	
1000	see "PCB 5"
1010	see "PCB 6"
precautions	1-1
preset mode	
1000.3.0	2-2, 2-7, 2-10, 2-21
PROM	see "EPROM" or "software"
programmability	2-3
programmer	2-5
programming	see "digital interface"
Prophet description	2-4
quantize	2-8
RAM, dynamic (DRAM)	
1005	18-1, 18-2, 19-11
1015.0	19-5
1015.1	18-1, 18-2, 19-11

RAM, non-volatile (NV)	
1000.3.0	2-7, 2-10, 2-12, 2-13, 2-21, 3-11
1000.3.1	8-1, 10-2
1000.3.2	11-4
1000.3.3	13-8
1010	14-7, 15-11, 16-1
RAM, scratchpad (SPAD)	
1000.3.0	2-7, 2-10, 2-13 thru 2-17, 2-19, 3-11
1010	14-5 thru 14-7, 15-11
real time clock (RTC)	
1005	18-1, 18-2
1010	14-5, 14-6, 15-11
record enable	
1000.3.0	2-12, 4-1, 3-11
1000.3.1	8-1
1010	14-8, 15-11
reset	
1000.3.0	2-12
1000.3.2	8-2
revision description(s)	
1000.1	v (D.2)
1000.2	v (D.2)
1000.3.0	v (D.2)
1000.3.1	v (D.2), 8-1
1000.3.2	v (D.2), 8-1, 8-2
1000.3.3	13-1, 23-1
1005	iii, 18-1
1010	iii, 14-1
1015.0	iii, 18-1
1015.1	iii
1016	iii, 18-1
revision procedures	see "modifications (authorized)"
ROM	see "EPROM"
sample/hold	2-8, 2-14, 2-18
scale mode	2-8
scaling (V/OCT)	2-8, 2-9, 2-19, 4-12
scan time	see "loop"
schematics	
1000.3.0	3-5 thru 3-23
1000.3.1	10-2 thru 10-4
1000.3.2	10-5 thru 10-11
1001	22-1
1005	19-7, 19-10 thru 19-13
1010	15-3 thru 15-24
1015.0	19-4 thru 19-7
1015.1	19-7, 19-10 thru 19-13
sequencer interface (mono or poly)	
1000.3.0	2-20, 3-12, 3-13, 4-11
1000.3.2	8-3, 10-8
1010	14-6 thru 14-8, 15-13, 15-14, 16-14

serial numbers	
1000.1	v (D.2)
1000.2	v (D.2)
1000.3.0	v (D.2), 8-1, 11-4, 14-1
1000.3.1	11-4, 14-1
1000.3.2	11-5, 12-1, 13-1
1000.3.3	13-1
1001	22-1
1005	18-1, 20-4
1010	14-1, 18-1
1015.0	18-1, 20-4
1015.1	18-1
1016.0	20-4
service position	1-1 thru 1-3
service, general	
1000.3.0	4-1, 4-2
software	see "EPROM"
subtractive synthesis	2-2
switch, bipolar	14-10
switch/keyboard matrix	
1000.3.0	2-7, 2-15, 3-5, 3-9, 3-13
1001	22-1
1010	14-7, 15-5, 15-8
synthesizer	2-1
tape transfer (1015.0 to 1015.1)	20-6, 20-7
test points	
1000.3	
TP301 OSC SCALE	3-10, 3-12
TP302 CV OUT	3-10, 3-13
TP303 FILT CV	3-10, 3-13
timer (tune, A-440)	
1000.3.0	2-13, 2-19, 3-11
1010	14-5, 14-6, 15-11
timbre	2-2
top panel assembly	
1000.3.0	1-1 thru 1-3, 1-6
TUNE	see also "timer"
1000.3.0	2-19, 3-12, 3-14, 3-15
1000.3.2	14-10
1010	14-10, 15-12
tuning	see "oscillator A," "oscillator B," or "filter"
UART/USART	
1000.3.2	8-2, 8-3, 10-7
1000.3.3	13-8
1005	18-1
1010	14-5, 14-6, 15-11
1015.0	19-4
1015.1	18-1, 19-11
ugly mod	14-1, 16-1
unison	see also "glide"
1000.3.0	2-9, 2-17, 2-19, 2-20, 3-14, 4-5
updates	see "modifications"

voltage-current converter	2-9
voice assignment	2-4
voice volume	4-16
volume	see "audio output"
voltage control (VC)	2-1
wheels	see "wheel-mod" or "pitch wheel"
wheel modulation	
1000.3.0	1-6, 2-4 thru 2-7, 2-9, 2-15, 2-19, 3-14, 4-7, 4-10, 4-11
1000.3.2	8-2, 8-4, 10-9, 11-6
1001	22-1, 22-4, 22-5
1010	14-8, 15-15, 16-3, 16-14