

# Albira PET/SPECT/CT

## USER GUIDE

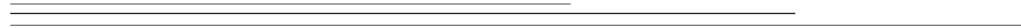

**Carestream**  
Molecular Imaging

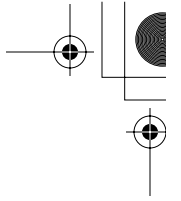

# Carestream Albira User's Guide

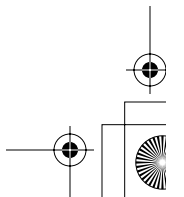
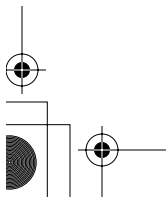

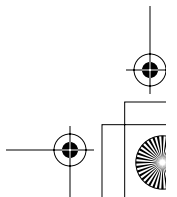
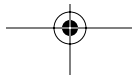
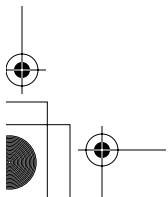
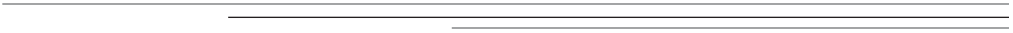
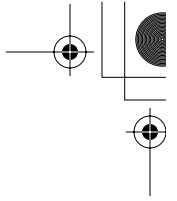

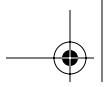

# Table of Contents

<b>Introduction</b>	<b>1-1</b>
About the User's Guide	1-2
Safety and Regulatory Information	1-3
Carestream Albira Configuration Options	1-8
Registering the Carestream Albira	1-9
Obtaining Technical Support	1-10
<b>System Requirements</b>	<b>2-1</b>
Environmental Requirements	2-2
Electrical Requirements	2-2
Space Requirements	2-3
Networking	2-4
Networking Imaging Modalities	2-5
Moving the Albira System	2-6
<b>System Overview</b>	<b>3-1</b>
Albira Core Acquisition System	3-2
Imaging Modalities Overview	3-4
System Interface—Back Panel	3-9
System Interface—Front Panel	3-10
Animal Chamber/Stretcher	3-12
Animal Chamber Interface Panel	3-13
Albira Software Interface	3-14

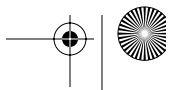



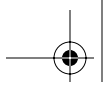

---



---



---

<b>System Safety</b> .....	<b>4-1</b>
Electrical Safety .....	4-3
Fire Safety .....	4-4
Radiation Safety .....	4-4
Shielding .....	4-5
Radioisotope Laboratory Management .....	4-9
<b>Capturing Images</b> .....	<b>5-1</b>
Powering the System .....	5-2
Preparing your Animal for Imaging .....	5-3
Acquiring Images using the Albira Suite .....	5-5
<b>Maintaining the System</b> .....	<b>6-1</b>
Regular End-User Maintenance .....	6-2
PET Validation .....	6-4
SPECT Validation .....	6-8
CT Validation .....	6-11
<b>Warranty Information</b> .....	<b>7-1</b>
The Carestream Albira Limited Warranty .....	7-2
How to Obtain Service .....	7-4
<b>Imaging Concepts</b> .....	<b>8-1</b>
PET and SPECT Concepts .....	8-2
X-ray Concepts .....	8-4
<b>Glossary</b> .....	<b>G-1</b>

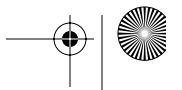

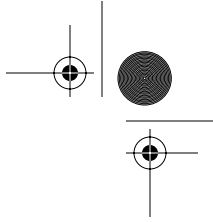

---

---

# Introduction

Thank you for purchasing the Carestream Albira Imaging System. Albira combines Positron Emission Tomography (PET), a Single Photon Emission Computerized Tomography (SPECT) and a Computerized Tomography (CT) imaging for use with small animals across a wide variety of research fields. The system modular design enables you to choose one or a combination of these modalities. Once you purchase a system, you can add additional modalities- the footprint remains the same.

The PET and SPECT subsystems are made of several cameras each having a scintillation crystal and a position sensitive photomultiplier (PSPMT) which converts the emitted light by the crystal into signal pulses. The CT is basically formed by an X-ray emitter and by a bi-dimensional detector. These three devices are mounted on an aluminum frame and covered by a radiation shielded shell.

Excerpts in this user guide are courtesy of Oncovision, Inc.

© Carestream Health, Inc., 2011. All rights are reserved. No section of this manual may be photocopied, reproduced, translated to another language, stored in a retrieval system, or transmitted in any form without the prior written consent of Carestream Health, Inc.

The information contained in this manual is subject to change without notice. Carestream Health, Inc. makes no warranty of any kind with regard to this written material. Carestream Health, Inc. assumes no responsibility for any errors that may appear in this document.

Disclaimer: While the Carestream Albira can be used for in vivo molecular imaging of materials, a purchaser should be aware that the methods of preparing and viewing the materials for molecular imaging may be subject to various patent rights.

Should you have any questions concerning this product, contact Technical Support, Carestream Molecular Imaging, Carestream Health, Incorporated, 4 Research Drive, Woodbridge, CT 06525 USA.

For laboratory research use only. Not suitable for human or animal diagnostic or therapeutic use.

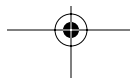

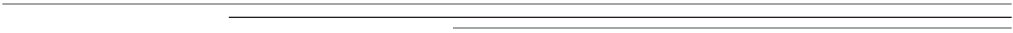
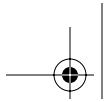

## About the User's Guide

The Carestream Albira System User's Guide provides you with all of the information you need to capture images.

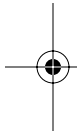

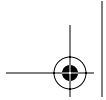

## Safety and Regulatory Information

### User Guide Conventions & Special Messages

The following special messages emphasize information or indicate potential risks to personnel or equipment.

**NOTE:** Notes provide additional information, such as expanded explanations, hints, or reminders.

**IMPORTANT:** Important notes highlight critical policy information that affects how you use this guide and this product.

**CAUTION:** Cautions point out procedures that you must follow precisely to avoid injury to the user, damage to the system or any of its components, loss of data, or corruption of files in software applications.

### General Requirements



**WARNING:** It is the responsibility of the purchaser to register this device with their State, local or country specific Radiation Safety Agency. This should be coordinated with the Radiation Safety Officer (RSO) at your facility.



**WARNING:** The Carestream Albira should only be installed by Carestream Health, Inc. trained personnel.



**WARNING:** The Carestream Albira should only be operated by personnel who have been instructed in radiation safety by the radiation safety officer at your facility and in the operating instructions outlined throughout this User's Guide.

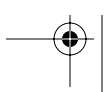
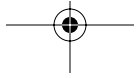
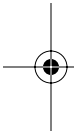

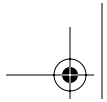

## Conventions



WARNING: Important safety warnings appear in the text as follows: This symbol is used in the User's Guide to designate a warning or caution statement.



WARNING: This symbol is used in the User's Guide to designate where electrical shock is possible.



WARNING: This symbol is used on the instrument to indicate protective earth.



WARNING: This symbol is used in the User's Guide to designate when there is a potential exposure to X-rays.



WARNING: This symbol is used in the User's Guide to designate when there is a potential exposure to X-rays for Canada.

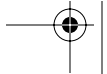
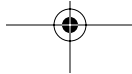
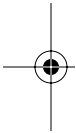

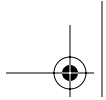

---

---

## Declaration of Conformity (European Union)

This device is declared as compliant to European Economic Community Low Voltage Directive (2006/95/EC) as well as the EMC Directive (2004/108/EC).

European Authorized Representative: Carestream Health UK Ltd.  
1 Park Lane  
Hemel Hempstead  
Hertfordshire  
HP2 4YJ  
UNITED KINGDOM

## Health and Safety Compliance

The following Standards apply to the Albira Imaging System:

### *Safety*

- o United States: UL 61010-1
- o Canada: CAN/CSA C22.2 No. 61010-1
- o International: IEC 61010-1

### *EMC*

- o United States: FCC Part 15, Sub B, Class A
- o Canada: ICES-003 Issue 4, Class A
- o Europe:  
EN 55011:2007 +A2:2007  
EN 61326-1:2006  
EN 61000-3-2:2006  
EN 61000-3-3:1995 +A2:2005:

1

Introduction

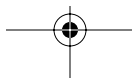

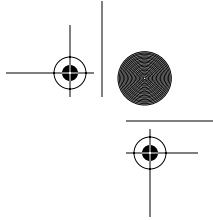

## General

### *United States and Canada*

This equipment has been tested and found to comply with the limits for a Class A digital device pursuant to Part 15 of the FCC rules. These limits are designed to provide reasonable protection against harmful interference when the equipment is operated in a commercial environment. This equipment generates, uses, and can radiate radio frequency energy and, if not installed and used in accordance with the instruction manual, may cause harmful interference to radio communications. Operation of this equipment in a residential area is likely to cause harmful interference in which case the user will be required to correct the interference at his own expense. Any changes or modifications not expressly approved by the party responsible for compliance could void the user's authority to operate the equipment. Where shielded interface cables have been provided with the product or specified additional components or accessories elsewhere defined to be used with the installation of the product, they must be used in order to ensure compliance with FCC regulations.

Any changes or modifications not expressed by the party responsible for compliance could void the user's authority to operate the equipment. Where shielded interface cables have been provided with the product or specified additional components or accessories elsewhere defined to be used with the installation of the product, they must be used in order to ensure compliance with FCC regulation.

Disposal of these materials may be regulated due to environmental considerations. For disposal or recycling information, please contact your local authorities, or in the U.S.A., contact the Electronics Industry Alliance web site at [www.eiae.org](http://www.eiae.org).

The sound pressure level (LA) is less than 70 dB.

This Class A digital apparatus meets all requirement of the Canadian Interference-Causing Equipment Regulations.

Cet appareil numérique de la classe A respecte toutes les exigences du Règlement sur le matériel brouilleur du Canada.”

The Albira system contains small amounts of lead in the lens and circuit boards. Disposal of these materials may be regulated due to environmental considerations. For disposal or recycling information, please contact your local authorities, or in the U.S.A., contact the Electronics Industry Alliance website at [www.eiae.org](http://www.eiae.org)

Carestream Health certifies that this equipment was designed and manufactured pursuant to the requirements of 21 CFR 1020.40, entitled “Cabinet X-Ray Systems” in effect at time of manufacture.

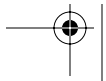
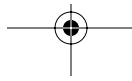

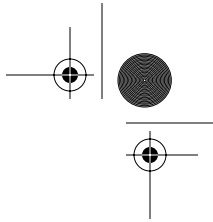

It is often the responsibility of the purchaser to register this device with their local Radiation Safety Agency. This should be coordinated with the Radiation Safety Officer (RSO) at your facility if applicable.

*European Union*

**WARNING**

This is a class A product. In a domestic environment this product may cause radio interference in which case the user may be required to take adequate measures.

*End of Life Information*

This equipment is subject to the Waste Electronic and Electrical Equipment Directives and the Battery and Acumulator Directives for requirements of the treatment and recycling at the end of the equipment life.



In the European Union, this symbol indicates that when the last user wishes to discard this product, it must be sent to appropriate facilities for recovery and recycling. Contact your local sales representative or refer to [www.carestreamhealth.com/go/recycle](http://www.carestreamhealth.com/go/recycle) for additional information on the collection and recovery programs available for this product.

*For Use in Japan*

この装置は、情報処理装置等電波障害自主規制協議会（VCCI）の基準に基づくクラスA情報技術装置です。この装置を家庭環境で使用すると電波障害を引き起こすことがあります。この場合には使用者が適切な対策を講ずるよう要求されることがあります。

*For Use in Taiwan*

**警告使用者:**

這是甲類的資訊產品，在居住的環境中使用時，可能會造成射頻干擾，在這種情況下，使用者會被要求採取某些適當的對策。

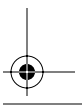
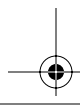



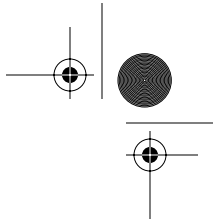

## Carestream Albira Configuration Options

The Albira system is available in different configurations. Configurations vary with respect to the modalities included as well as variations in sensor configurations. The three modality options available for variable configuration are the Positron Emission Tomography (PET) modality, the Single Photon Emission Computerized Tomography (SPECT) modality, and the Computerized Tomography (CT) modality. The table below provides a list of the available Albira system configurations

**Table 1: Albira II Models**

Catalog Number	Description
8005233	Carestream Albira CT Imaging System
8005258	Carestream Albira PET Imaging System, 1 Ring
8005266	Carestream Albira PET Imaging System, 2 Ring
8005274	Carestream Albira PET Imaging System, 3 Ring
8005282	Carestream Albira PET-CT Imaging System, 1 Ring
8005290	Carestream Albira PET-CT Imaging System, 2 Ring
8005316	Carestream Albira PET-CT Imaging System, 3 Ring
8005399	Carestream Albira SPECT Imaging System, S102
8005423	Carestream Albira SPECT Imaging System, S108
8005449	Carestream Albira SPECT/CT Imaging System, S102
8005456	Carestream Albira SPECT/CT Imaging System, S108
8005464	Carestream Albira PET-SPECT-CT Imaging System, 1 Ring S102
8005480	Carestream Albira PET-SPECT-CT Imaging System, 2 Ring S102
8005530	Carestream Albira PET-SPECT-CT Imaging System, 3 Ring S102
8005597	Carestream Albira PET-SPECT-CT Imaging System, 1 Ring S108
8005605	Carestream Albira PET-SPECT-CT Imaging System, 2 Ring S108
8005613	Carestream Albira PET-SPECT-CT Imaging System, 3 Ring S108



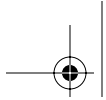

---

---

## Registering the Carestream Albira Imaging System

To be eligible for maintenance releases, upgrade programs, and to receive new product information, you must register your system by completing and returning the enclosed registration cards. For best product support, please take the time to complete and return the enclosed cards.

### Regulatory Requirements for the Carestream Albira CT Module



**WARNING:** It is normally the responsibility of the purchaser to register this device with their state, local or country specific Radiation Safety Agency. If there is a Radiation Safety Officer (RSO) at your facility, registration should be coordinated with them..



**WARNING:** X-rays Produced When Energized.

The CT Module installed with the Albira System meets or exceeds compliance to FDA Department of Health and Human Services regulation 21 CFR 1020.40 for radiation safety.

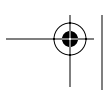

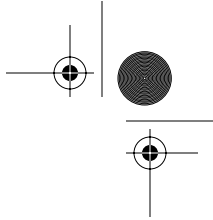

## Obtaining Technical Support

For technical support, contact Technical Support or your CarestreamMolecular Imaging Systems dealer. For up to date dealer information, visit our WEB site at [mi.carestream.com](http://mi.carestream.com). When contacting technical support, please have the following information available:

- ✓ The serial number of your system.
- ✓ The type of image you are capturing or analyzing.
- ✓ The problem you are having and what you were doing when the problem occurred. Please note the exact wording of any error messages, including any error numbers displayed.

Contact Carestream Molecular Imaging Technical Support by:

- ✓ By contacting your local account manager.
- ✓ Utilizing our World Wide Web support pages at:  
[mi.carestream.com](http://mi.carestream.com)
- ✓ Calling Carestream Molecular Imaging Technical Support at:  
877-747-HELP or 203-786-5657, between the hours of 8:00 a.m. and 6:00 p.m.  
(Eastern Standard Time) Monday through Friday
- ✓ E-mailing Carestream Molecular Imaging Technical Support at:  
[molecular-support@carestream.com](mailto:molecular-support@carestream.com)
- ✓ Faxing Carestream Molecular Imaging Technical Support at:  
203-786-5656

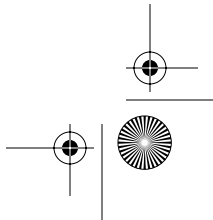
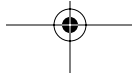

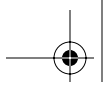

# System Requirements

This section details the installation requirements for the Carestream Albira.

 **NOTE:** It is the responsibility of the purchaser to register this device with their State, local or country specific Radiation Safety Agency. This should be coordinated with the Radiation Safety Officer (RSO) at your facility.



**WARNING:**The Carestream Albira should only be installed by Carestream Health, Inc. trained personnel.



**WARNING:**The Carestream Albira CT Imaging Module should only be operated by personnel who have been instructed in radiation safety by the radiation safety officer at your facility and in the operating instructions outlined throughout this User's Guide.

The Albira system is a complex laboratory instrument that must be used with caution and must be protected from vibrations and shocks.

Depending on the system configuration, the Albira system may include CT (includes an X-ray tube that emits X-ray energy), SPECT and/or PET.



**WARNING:**It is normally the responsibility of the purchaser to register this device with their State, local or country specific Radiation Safety Agency. If there is a Radiation Safety Officer (RSO) at your facility, registration should be coordinated with them.

The Albira complies with the 21 CFR 1020.40: Performance standard for ionizing radiation emitting products – Cabinet X-Ray systems and IEC 61010-1: Safety requirements for electrical equipment for measurement, control and laboratory use. Part 1: General requirements.

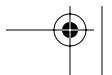

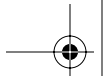

## Environmental Requirements

The Carestream Albira Imaging System is designed to operate effectively within the temperature and humidity ranges typically found in laboratories. For effective operation, the temperature and relative humidity should be:

- ✓ Temperature: 15° to 22° C, never expose equipment to temperatures under 10°C.
- ✓ Relative Humidity: 30- 70%, non-condensing
- ✓ Altitude: This product is designed for use at altitudes up to 2000 meters.

This product is designed for indoor use only. This product meets Pollution Degree 2 standards in accordance with IEC 664.

## Electrical Requirements

United States and Canada

- ✓ 100-125V~ 50/60Hz, 10A for customers located in the United States and Canada. A 220 to 110V transformer will be included with Albira system for customers located outside the US and Canada.
- ✓ Maximum operating consumption: 1.25 kW
- ✓ A minimum of one electrical power socket, NEMA5-15P plug, is required in the equipment room and a minimum of 5 electrical power sockets, NEMA5-15P plug, are required in the operator's room.
- ✓ Albira consoles may be also powered by an UPS system, 2 kVA.

This product is designed to withstand transient overvoltage according to Installation Category.

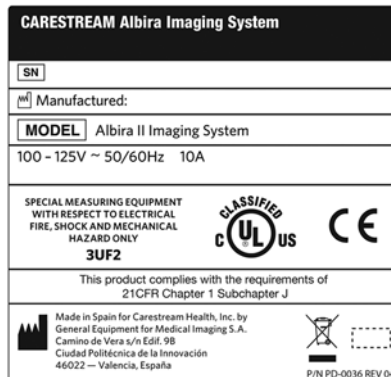

Refer to your computer operator's manual for its electrical requirements.

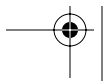
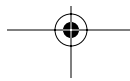

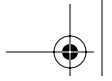

## Space Requirements

The Albira can be installed in a single room, but a dedicated room for the Core Acquisition System is recommended.

- ✓ Minimum Floor Space: acquisition system of 3.5 x 2.5 m<sup>2</sup> in order to allow users and maintenance service to properly perform their work.

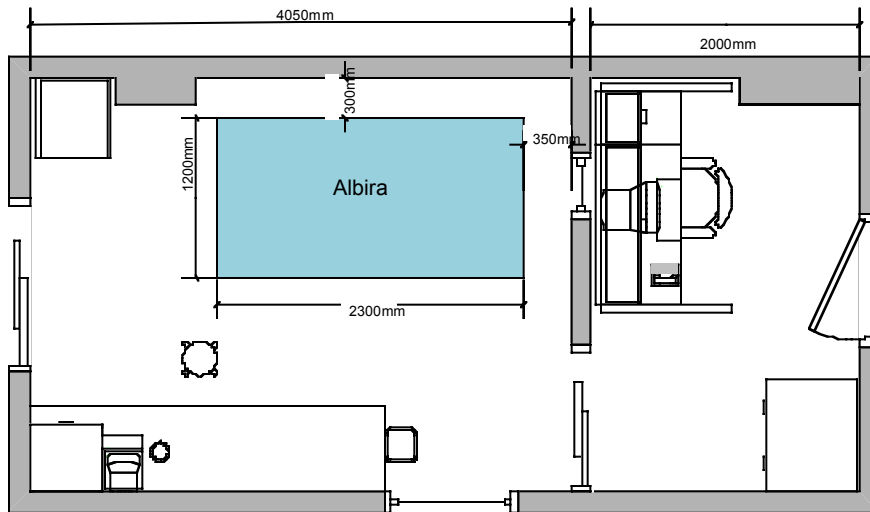

- ✓ Albira is a precision aligned system that requires a rigid, level concrete floor for proper support. It weighs approximately 800 Kg.
- ✓ Floor levelness with a vertical adjustment of 5mm/M is recommended.



**WARNING:** We strongly recommend that a structural engineer inspect the floor to verify that it can support the Albira system.

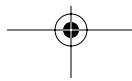

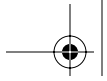

---

---

## Networking

Internal cabling between points must comply with category 5e or 6 UDP TIA/EIA-568-B (ISO-11801) standards.

- ✓ Equipment Room—a minimum of one Ethernet network point, for RJ-45(8P8C) plug, connected with the operator's room, is required.
- ✓ Operator's Room—a minimum of two Ethernet network points, for RJ-45(8P8C) plug, are required. One of them should be connected to the equipment room. The second one should be connected to an external network.

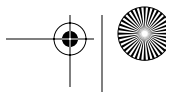
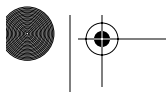

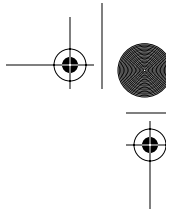

## Imaging Modalities

PET SPECIFICATIONS	
Detector Type	LYSO single crystal with associated position sensitive photomultiplier tube
Number of Detectors	8 per ring up to 3 rings
Depth of Interaction Correction	State-of-the-art DOI correction based upon the distribution of the light detected
Sensitivity	3 ring: 9% 2 ring: 5% 1 ring: 3%
Resolution (mm)	3 ring: <1.1 2 ring: 1.2 1 ring: < 1.3
FOV (transaxial mm)	80
FOV (axial mm)	3 ring: 148 2 ring: 94 1 ring: 40

SPECT SPECIFICATIONS	
Detector Type	CsI(Na) single crystals associated PSPMT and dedicated SPECT electronics, 2 detectors per instrument
Maximum Sensitivity (cps/MBq)	S108: 1000 S102: 650
Energy Range (keV)	S108: 30 - 400 S102: 40 -250
Energy Discrimination	14% at 140 keV
Collimators Provided	1 pinhole, 5 pinhole
FOV (mm)	S108: 30 - 140 S102: 20, 40, 60, or 80
Reconstruction Time	<= 5 min
Acquisition Time (60 projections)	<= 30 min
Minimum resolution	S108: <= 0.6 S102: <= 0.8

CT SPECIFICATIONS	
Minimum Resolution ( $\mu\text{m}$ )	90
X-ray Focal Spot Size (Nominal $\mu\text{m}$ )	35
Energy Range (kVp)	10 - 50
Max Current (mA)	1
FOV (transaxial x axial mm)	70 x 70
Detector Pixels	2400 x 2400

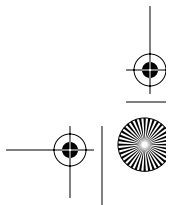



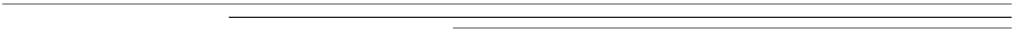
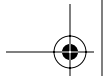

## Moving the Albira System

The Albira is installed by a technician trained by Carestream Health personnel. Once installed, the unit should not be moved. To move the instrument, contact Carestream Molecular Imaging to arrange for a authorized Service Technician.



**WARNING:DO NOT** move the Albira System once it is installed and performance verified to ensure that the shielding has not been compromised.

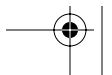
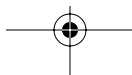

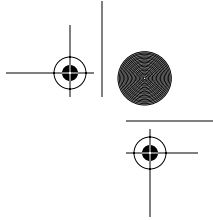

---

---

# *System Overview*

This section provides an overview of the Albira Imaging System. In this section you will review the principles of operation and get a better understanding of the critical components-the System Unit, the Animal Preparation Unit and the Sensor Unit. You will also be introduced to important safety information related to the use of the instrument.

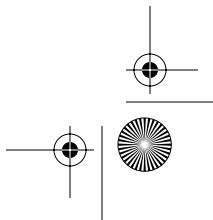
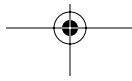

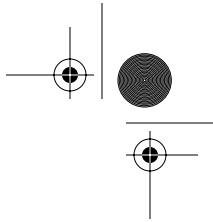

## Albira Core Acquisition System

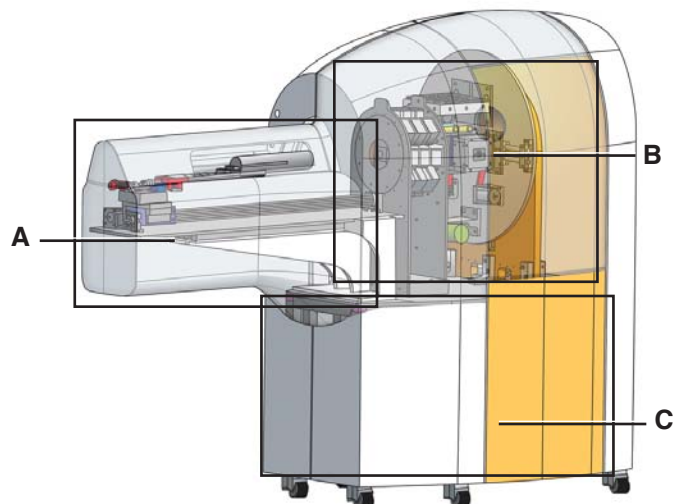

The Core Acquisition System of the Albira has 4 well differentiated units (A, B, C and D):

- A The *Animal Preparation Unit* (stretcher access zone) contains the translation motion system enabling easy access to the animal to perform routine procedures, i.e. providing anaesthesia or an in-situ tracer injection.
- B The *Sensor Unit* contains the PET, SPECT, CT modules (depending on the model you purchased). This portion of the unit is locked and redundant alarms to restrict access to authorized service personnel.

A high precision and strong torque rotatory stage is installed within a robust frame. Albira PET is located in a front disc, closer to the aperture bore. The SPECT and CT subsystems are mounted on a larger disc that moves synchronized with the PET, creating a unique rotational axis for the three devices. The moveable wiring has been protected by means of mechanisms which adapt to the motion, avoiding cable wear or strong pulls.

### The Albira CT Module Only:



CAUTION: X-rays Produced When Energized.

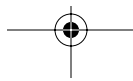

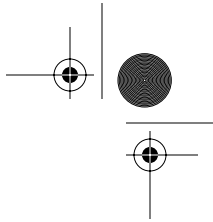

CAUTION: The Albira System should only be operated by personnel who have been instructed in radiation safety by the radiation safety officer at your facility.



CAUTION: There are no user serviceable parts in the Sensor Unit. At no time should the door locks be opened, which could cause a radiation safety hazard.



CAUTION: Unauthorized use prohibited. Redundant emergency alarms have been installed in order to prevent user access.



CAUTION: Do Not Insert Any Part of the Body When System is Energized— X-Ray Hazard.

C The *System Unit* contains the sensor subsystems and associated electronics.



D The *Control or Acquisition Unit* (above) is composed of a computer console that controls the X-ray source and the others system devices, including motors and sensors. Keep the control unit in a radiation protected place to eliminate radiation exposure from PET isotopes.

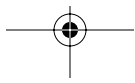

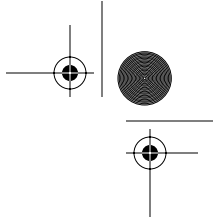

## Imaging Modalities Overview

The Albira system includes up to three subsystems. These subsystems are the Positron Emission Tomography (PET) subsystem, the Single Photon Emission Computerized Tomography (SPECT) subsystem, and the Computerized Tomography (CT) subsystem.

- ✓ The *PET* and *SPECT* subsystems consist of PET and SPECT specific scintillation crystals and interfacing position sensitive photomultiplier tubes (PSMTs). These subsystems are designed for functional 3D imaging.
- ✓ The *CT* subsystem consists of an X-ray emitter and a bi-dimensional detector for anatomical 3D imaging.

Albira subsystems are mounted within the Albira shell. The Albira PET, SPECT, and CT subsystems are detailed further below.

### Positron Emission Tomography (PET)

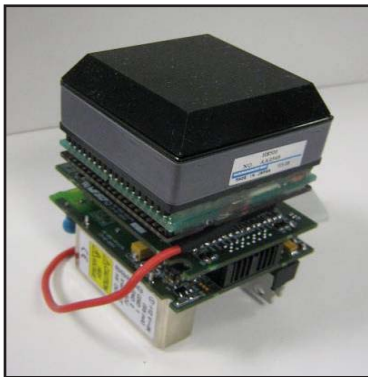

PET module: Single crystal, PMT and electronics

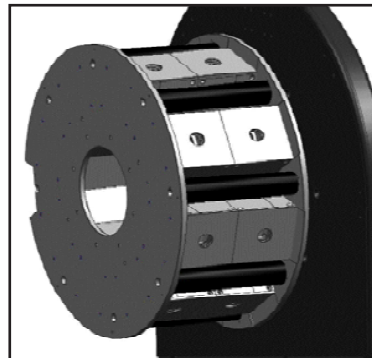

PET system in dual ring configuration

The Albira PET subsystem is housed in the Sensor Unit region (see figure “Albira Core Acquisition System”) of the Albira system. The Albira PET subsystem is a modular device that can be configured with 1, 2 or 3 rings (8 PET detectors per ring). System performance (i.e. resolution, sensitivity, and field of view (FOV)) improve with the addition of each ring. Each PET head consists of a continuous crystal, a PSMT, and a proprietary resistor network.

The use of a continuous crystal for PET detection represents a significant innovation in PET detection. Traditional PET systems employ a non-continuous (or pixilated) crystal design. Using this traditional approach, detectors are constructed from thousands of small crystals. In an effort to maximize resolution, manufacturers of traditional PET systems have employed smaller and smaller crystals. Furthermore, the potential for additional

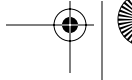
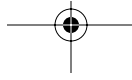

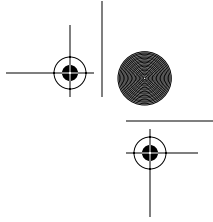

gains in system performance using this approach are limited. This is because the potential of producing a detector with even higher crystals densities is unlikely. The Albira PET technology design overcomes limitations of pixilated technology, in part through the use of a continuous crystal. Also important to the Albira design are those components (largely achieved through patented resistor network) that allow for accurate measurements of the depth of interaction (DOI) of the gamma rays within the continuous crystals. This is important because inaccurate DOI measurements result in images with a large degree of parallax error. Images with a large degree of parallax error exhibit poor spatial resolution. Accurate DOI measurements are particularly critical when the detectors are positioned close to the sample, as is the case in a pre-clinical PET system.

Again, each PET ring is comprised of 8 individual detectors. Each detector includes a scintillation crystal, a photo-detection system and a single specific electronic board. The Albira PET crystal is a 50 X 50 mm<sup>2</sup> Lutetium Yttrium Orthosilicate (LYSO) crystal that is 10 mm thick and cut into a pyramidal shape. The impinging coordinates of the gamma-ray are not determined by the localization of the pixel containing all the emitted light, but by the determination of the gravity center of the detected light. Such detection is performed by photodetector anodes.

The system employs position sensitive photomultipliers for light detection. Every photodetector has 64 reading anodes with a total sensible detection area defined by the photocathode of 49 X 49 mm<sup>2</sup>. Digitalizing all 64 corresponding signals could incur significant economical and computational costs using traditional means. A novel resistor network was designed for the Albira PET system as a both economical and computational solution. Based on the Anger logic, the X and Y coordinates of a photon impact are obtained analogically, thus reducing the number of required digitalization channels required to estimate the transversal position to 4. The Albira PET measures the DOI of the gamma-rays inside the crystal, using the information of the light spread distribution. This has been achieved by a modification of the resistor network with the digitalization of an additional channel.

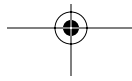

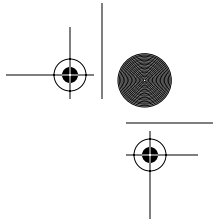

## Single Photon Emission Computerized Tomography (SPECT)

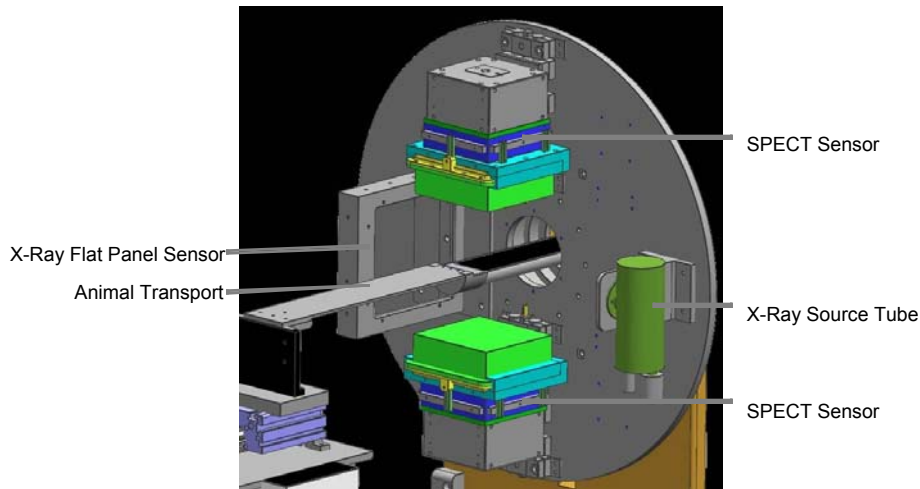

The Albira SPECT subsystem is housed in the Sensor Unit (see figure “Albira Core Acquisition System” section B) of the Albira system. The SPECT sensors are installed in plane with CT components when the Albira system is configured for both modalities (see figure above for location of SPECT sensors). The central components of the gamma camera are the collimators (single pinhole or multi-pinhole), a continuous scintillation crystal, and a PSMT. The system also incorporates the proprietary technology related to the resistor network mentioned above. The SPECT boards are designed for high portability and low electronic noise. The Albira SPECT subsystem as a whole has a low electronic noise required for high spatial resolution and energy resolutions.

The Albira SPECT (and PET) subsystem provides for functional (or metabolic) imaging capability. The Albira SPECT subsystem includes two gamma cameras that rotate at 180°. This configuration allows for complete 360° detection of tracer. The use of two gamma cameras offers faster (2X) capture speeds than a single camera configuration. The cameras positioning may be adjusted inward and outward to the axial axis via a computer control. This control permits users to optimize according to sample size, and desired sensitivity and special resolution. A system user may program a series of acquisitions for the sample at various FOVs to obtain whole body (lower sensitivity) imaging and partial body (higher sensitivity) imaging.

The functional SPECT images can be combined with the PET and CT images allowing for powerful studies in pre-clinical imaging.

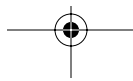

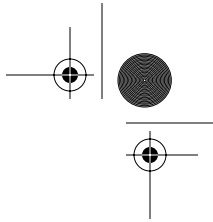

## Computerized Tomography (CT) Subsystem

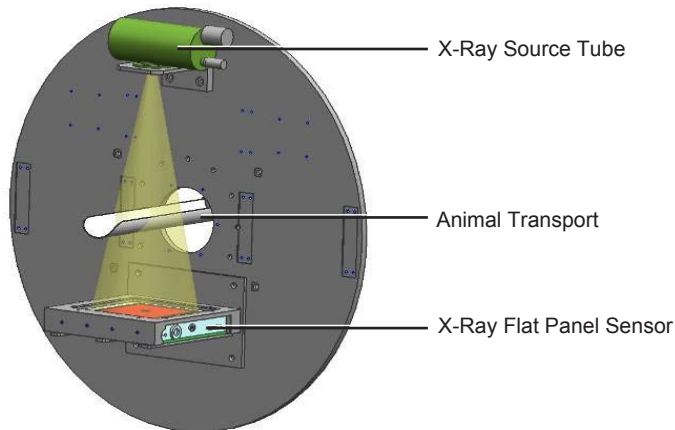

The Albira can be configured for standalone CT or combinations of PET/CT, SPECT/ CT, or PET/SPECT/CT. As mentioned above, the PET and SPECT subsystems provide for functional imaging. The CT subsystems provides for anatomical imaging that acts as a useful reference for functional images.

The Albira CT subsystem is housed in the Sensor Unit region (see figure “Albira Core Acquisition System” section B) of the Albira system. As mentioned above, the CT components are installed in plane with SPECT sensors when the Albira system is configured for both modalities (see above figure for location of CT components). The Albira CT employs an X-ray tube which is currently used for industrial applications. The CT subsystem consists of the X-ray source and corresponding detector which will be described further below.

The X-ray tube used generates X-ray beams with a nominal focal spot size of  $35 \mu\text{m}$  that is suitable for small animal imaging. The X-ray tube operates according to standard X-ray tubes sources. Briefly, electrons within the tube are thermally extracted from the cathode and accelerated through the vacuum pipe towards the tungsten anode where X-rays are generated. (The tungsten material of the anode has an ideal melting point and thermal capability relative to the 50 W X-ray tube allowing for a simple forced convection air cooling system.) The X-ray beam energy depends on the electron acceleration within the vacuum tube. This is controlled by the voltage difference between the anode and the cathode. The voltage for the Albira CT may be adjusted to between 4 kV and 50 kV. The

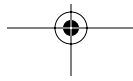



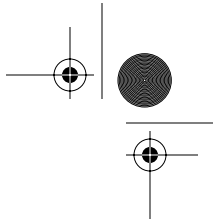

applied current to the cathode may be adjusted to between 0 mA and 1 mA. Adjustments to X-ray energy can be made to minimize X-ray dose or maximize image quality when needed.

The transfer and detection of X-ray energy to a final digital product can be considered relative to the detector components. The X-ray sensor consists of a Cesium Iodide (CsI) crystal and photodiodes. Photons emitted by the crystal are captured by a matrix of coupled photodiodes. Captured photons are converted into an electric charge. The electric charge is stored in a photodiode union until it is read and amplified by the acquisition electronics. The output is transferred to the computer via a frame grabber card.

The crystal is constructed of a matrix of needle shaped subunits allowing for high resolutions ( $50\mu\text{ m}$ ) over large areas. The flat panel is comprised of a 2400 x 2400 pixels. This translates into a 2D detection area of 120 mm<sup>2</sup> X 120 mm<sup>2</sup> allowing for whole body imaging of a mouse in a single rotation. Furthermore, the system detects X-rays energies ranging from 20 kV to 80 kV, covering energy levels applicable to small animal imaging.

Both the Albira CT X-ray tube and camera are mounted on a 360° rotation device that allows for precision positioning down to as low as 0.01°. The X-ray tube and camera have been positioned (425 mm gap and at a 22° angle) such that the X-ray beam aperture completely fits the detector sensor. The X-ray tube and detector are positioned at 290 mm and 135 mm (respectively) from the rotational axis. The two devices position in combination to provide a 70 mm axial by 70 mm transaxial FOV. The minimum achievable resolution for this system is  $90\mu\text{ m}$ .



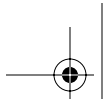

## System Interface — Back Panel

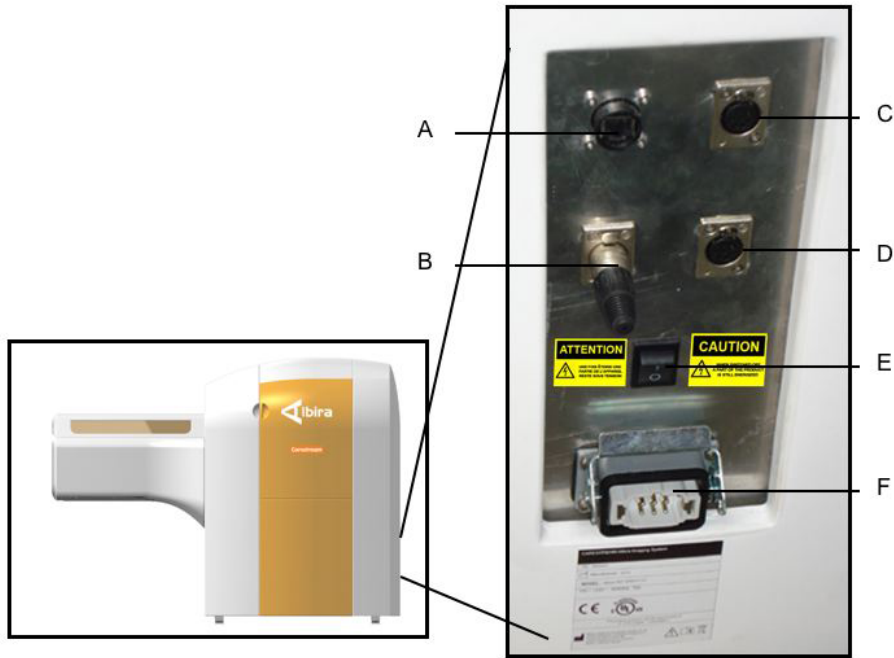

- A *Ethernet Plug RJ45 connector* for networking internal acquisition computer with operator's control computer.
- B *Security Key*, when removed from the back panel, all the systems are shut down and unable to be restarted.
- C *X-ray External Warning Light Plug* Provided external warning light must be plugged in this port and placed at a location visible from every side of the Albira system. Manufacturer recommends to place it in the ceiling, right over the Albira main system.
- D *External Emergency Stop Plug* Allows connection of the provided external emergency stop to the Albira main system. It is recommended that you place this emergency stop close to the operator's control console.
- E *Main Power Control Switch* Turns the supply of electricity from the MAINS to the Albira on and off. When this button is switched off from the main power control, all the critical components of the equipment are switched off but current is still delivered to the switch. The Albira CT unit will not energize when Main Power Control Switch is off.
- F *Main Power Plug* Connects the system to the network power supply.





## System Interface – Front Panel

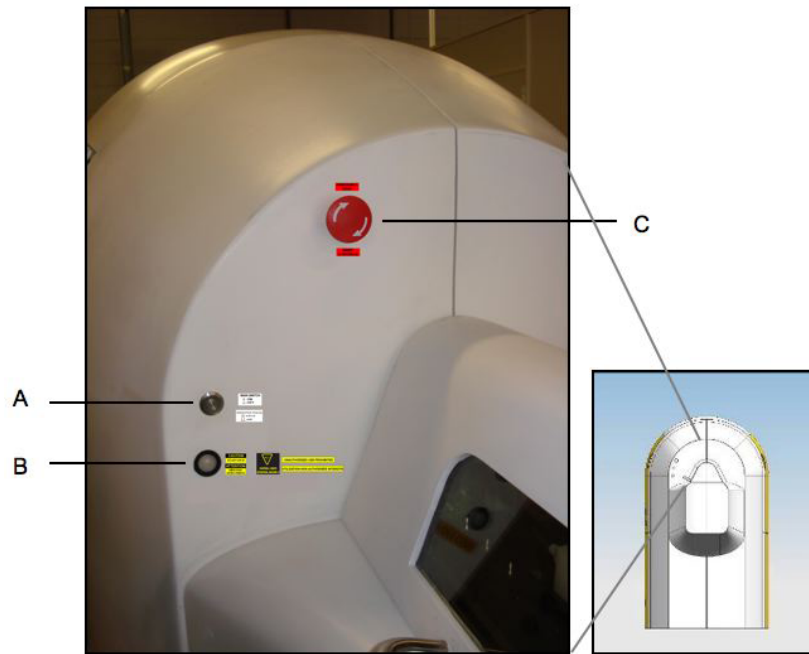

A Main Switch—turns on the system. When the system is ON a Blue indicator light is illuminated.



NOTE: The front panel ON/OFF button does not turn off this system and is only a partial acquisition systems power disconnection.

B System Status Indicator—shows the system current status. It has three states:

- OFF: System is ready and no X-Rays are produced.
- Yellow: An emergency stop is pressed or a door is open.
- Red: The X-ray source is emitting X-ray radiation.

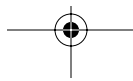

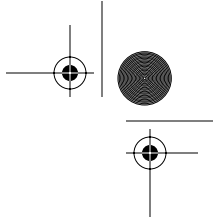

**WARNING:** Label next to the System Status Indicator warns the user that the X-Ray tube is emitting when the light is red.

**C Emergency Stop:** When pressed, the X-Ray production is stopped. To reset, turn the button clockwise. You must restart X-ray using Albira software. This is one of two Emergency Stops.

The X-Ray emission could be also be stopped in an emergency using:

- ✓ Albira software (described later in this chapter ).
- ✓ Pressing the other Emergency Stop located near the Control unit.

 **NOTE:** Manufacturer requires that the Emergency Stop be secured near (see example below) the Control Unit.



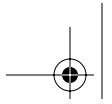

## Animal Chamber/Stretcher

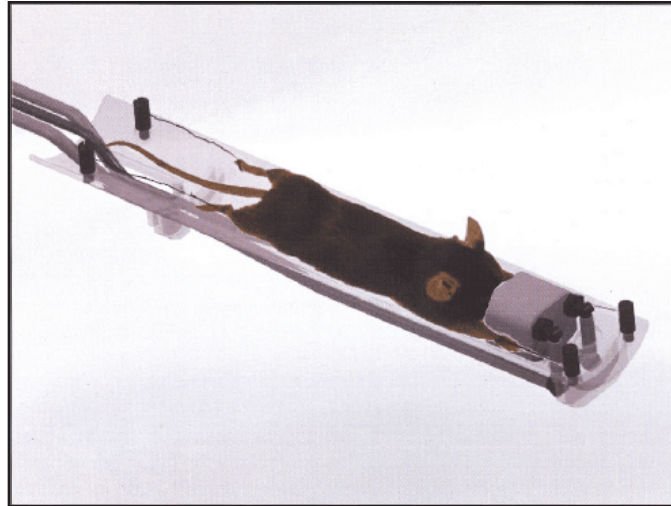

The Albira system comes standard with three animal stretchers:

- Stretcher for rats
- Stretcher for mice
- Stretcher for mice for high resolution SPECT



## Animal Chamber Interface Panel

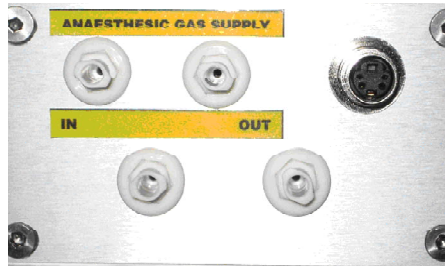

The animal chamber interface panel offers an interface with the animal chamber for the purpose of administering gas anesthetics. The Gas Supply inlets/outlets consist of standard female luer connectors.

Anesthetic Gas Supply inlet to animal chamber is ported with two standard luer connectors..



**WARNING:** Isoflurane is the only gas anesthetic recommended for use with the Albira system.



**WARNING:** Do not exceed a gas anesthetic pressure of 2 kg/cm<sup>2</sup>.

The animal chamber interface is also compatible with optional thermal control hardware. The heater control interfaces with a female 4-pin MINI-DIN (S-Video) connector.

The interface panel includes additional connectors for possible future applications.

## Albira Software Interface



Albira system functions are controlled and supervised through a complete software interface called the Albira Suite.

The Albira Suite is composed of a group of user-friendly and very specific applications. The applications that are available for the suite are following:

- ✓ Albira Manager—user interface for subject manager, studies, acquisition templates and protocols.
- ✓ Albira Acquirer—user interface for acquisitions following a predefined protocol, or independent acquisitions.
- ✓ Albira Reconstructor—user interface to generate images from acquired data.
- ✓ Albira Supervisor—user interface to know the system status and quality controls. It will also inform you when a new quality control is required.

Main Suite features are the following:

- ✓ Database driven. All subjects, protocols, and studies are stored in a database.
- ✓ Dynamic, bed, multimodal and other complex acquisitions supported.
- ✓ Multimodal reconstruction.

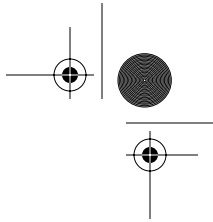

# System Safety

The Albira system should be operated with care and protected from shock and vibration in order to avoid a system hazard(s).



**WARNING:**Do not remove any parts of the shielding or open the lateral maintenance door. Albira must be serviced by an Authorized Service Technician.



**WARNING:**Turn off the Main Switch located at the front panel before accessing the back panel wires. Note that the Main Switch only provides a partial power cut to the Albira system. For a complete power cut the Main Power Control located at the back panel must also be powered off.



**WARNING:**If a system failure is suspected, turn off the system by powering the system down at the Main Power Control on the back panel.



**WARNING:**Do not expose the Albira system to magnetic fields, external electrical influences, electrostatic discharges, pressures or pressure variations, acceleration and thermal ignition sources. Some system components are sensitive to high electrical and magnetic fields generated by Nuclear Magnetic Resonance systems. The system should not be used in proximity to powerful magnets.



**WARNING:**Do not install the system where exposure to liquids is possible to minimize the risk of electrical discharges.



**WARNING:**Do not unsettle, modify or repair the system. Numerous internal system components are under high voltages capable of hazardous electrical discharge.



**WARNING:**Do not cover the system ventilation slits of the system. Ventilation slits prevent system overheating. Covering system ventilation slits may result in overheating, system damage, and represents a possible fire hazard.



**WARNING:**Do not install the equipment near corrosive liquids or gasses. This may result in smoke or even fire.

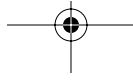



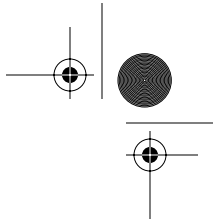

WARNING: Albira has been designed for safe operation. If in spite of apparently normal operation of the system, you feel a continuous discharge or ticklish sensation when touching any connector, do not use the equipment and contact the authorized Technical Service immediately.



WARNING: Albira has been designed for safe operation for the subject and user. In case you notice any kind of electrical discharge under normal running of the system, disconnect it and contact the official Technical Service immediately.

Furthermore, if the equipment is used in a manner not specified by the manufacturer, user safety may be compromised.

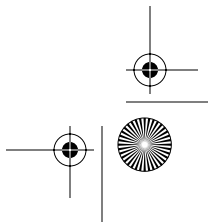
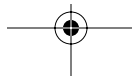

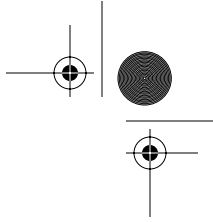

---

---

## Electrical Safety

Electrical installation requires an isolated dedicated ground connection according to the electrical safety standards.

The Albira does not have a general fuse replaceable by the user. The system should be powered by a source that employs a circuit breaker.

The internal fuses should only be replaced by Authorized Technical Service.

The internal button battery (for time and hour of the internal PC) a CR 2032 lithium ion battery of the manufacturer PANASONIC or equivalent, shall only be replaced by the Authorized Technical Service.

To ensure a stable current supply, the whole equipment should be supplied through an uninterruptible power supply (UPS), preferably a double conversion UPS.

When the Main Power Control is switched off, all critical components of the instrument are switched off but current is still flowing to the switch. As a consequence, a warning label has been placed close to this button to remind the user.

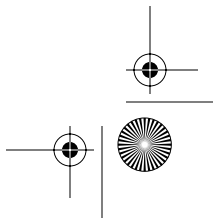
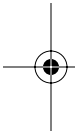

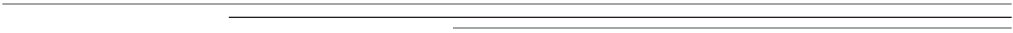
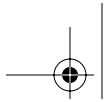

## Fire Safety

Albira is commonly used in facilities where flammable compounds and gases are stored or used. Follow the local guidelines and observe the required precautions.

Verify that fire extinguishers are accessible and ready to use. Periodic inspections must be performed.

Observe all fire and safety standards in each designated area where the Albira is used or serviced.

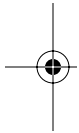

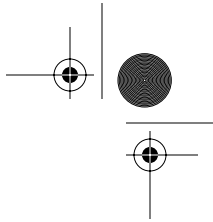

## Radiation Safety

The Albira System, depending on the model, may incorporate a X-Ray tube which emits X-Ray, and/or a SPECT and/or PET detector, both requiring the use of radioisotopes. In this case the user and/or the installation must have the suitable licenses required by the Competent National Authorities to use such equipment.



**WARNING:**It is the normally the responsibility of the purchaser to register this device with their State, local or country specific Radiation Safety Agency. If there is a Radiation Safety Officer (RSO) at your facility, registration should be coordinated with him or her.

The Albira complies with the 21 CFR 1020.40: Performance standard for ionizing radiation emitting products – Cabinet X-Ray systems and IEC 61010-1: Safety requirements for electrical equipment for measurement, control and laboratory use. Part 1: General requirements.

X-ray exposures from cabinet-type units are normally very controlled and well shielded to prevent x-ray exposure beyond the surface of this device (Albira) and are therefore not normally a significant health risk. Although the risk of exposure is low, it is prudent for the owners and operators of cabinet x-ray equipment to be aware of the health risks of X-rays in general.

Direct exposure to X-rays can cause:

Example Prompt Effects:

- ✓ Reddening of the skin (in high doses > 1,000 mSv)

Example Delayed Effects:

- ✓ Increased Risk of cancer (leukemia)
- ✓ Cataracts (if exposed to the eye))

Operators and owners should note that through the use of engineering controls, occupational X-ray exposure from this device as installed by a qualified service provider is minimal less than 0.2 mRem (=2  $\mu$ Sv) per hour and are essentially at background radiation levels. It is important to note that X-rays are created from electrical current and can be turned off promptly by cutting power to this device. X-rays are created by electrons in electrical current crashing into a target within an x-ray tube to create heat and x-rays. Essentially by cutting electrical power/current to the x-ray tube, there can be no radiation.

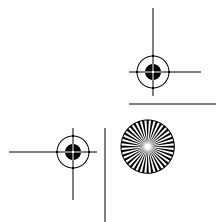
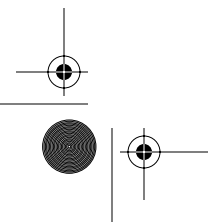

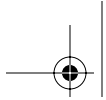

---

---

As was designed and shipped from the factory and installed, your unit contains no radioactive materials. (Note that handling and use of radioisotopes for PET and SPECT imaging has special considerations. See the section below "Special safety considerations with PET Isotopes"). Exposure to X-rays does not make samples or persons "radioactive" in anyway and any exposed samples are as radiologically safe after exposure as they were prior to exposure.

When working with or near cabinet x-ray equipment, exposures are taken with radiation barriers in place. Radiation barriers can include, steel, lead, concrete, and other dense materials to minimize x-ray leakage/scatter beyond the surface of the device enclosure.

End users should obtain detailed X-ray and radioisotope safety training from their radiation safety officer or qualified individual(s).

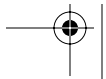
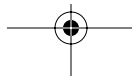

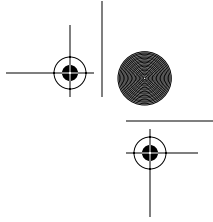

## Shielding

The shielding of the Albira is reinforced by a lead sheet of 1,01mm of thickness at minimum which prevents from the emission of X-Rays outside of the shielding. In the part of the Animal Preparation unit, the sheet of lead is substitute by a leaded glass of 7mm of thickness, equivalent to 2.2 mm of lead.

This shielding reinforcement limits the X-ray emission of the Albira to an exposure of 0.5 mR ( $= 5 \mu\text{Sv}$ ) in any 1 hour at a point 5 cm outside the external surface.

The user is advised of the presence of the X-Ray tube in the Sensor Unit by the warning labels placed on each of the maintenance doors.

It is important to note that the Albira system as shipped and installed contains no radioisotope (radioactive) materials.

When and if a customer decides to use radioactive materials, the customer must employ appropriate safety measures for their use.

The safe use of Radioactive Materials is typically stipulated both in regulation and in accordance with radioactive materials license conditions. Because there are literally thousands of combinations isotopes in various physical forms and hazards, the licensee of the materials must determine how to engage the use of radioactive materials to this (or any other device).

The customer should be well versed in the use of radioactive material safety, employing the common radiation exposures rules of time, distance and shielding. Keeping Operator Doses as low as Reasonably Achievable (ALARA), minimizing radioisotope contamination and managing proper waste disposition. IF questions arise regarding the safe use of radioisotopes, please refer to:

- ✓ Your facility's Radiation Safety Officer if applicable.
- ✓ Regulatory Authorities (i.e. NRC or agreement State or applicable agency) and associated regulations.
- ✓ Your Radioactive Material License.

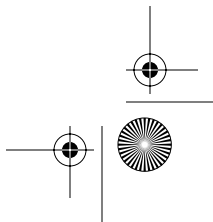
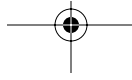

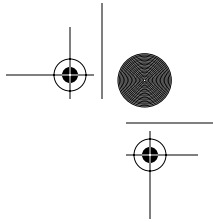

Any time the device is suspected of being contaminated with radioactive materials, this could compromise imaging quality and/or personnel (especially service personnel) safety. In the event contamination is suspected, the customer/licensee shall make every reasonable effort to remove such contamination in accordance with release limits specified in the radioactive materials licensing or corresponding regulations.

### Safety Interlocks

The presence of a pair of interlocks in each door of the Albira guarantees that the X-Ray emission stops in the case that doors are opened accidentally during operation of the CT. The maintenance doors (one of each side of the Albira) are locked with a key and are only accessible to the Authorized Technical Service.



**WARNING:** Do not remove any parts of the shielding or open the lateral maintenance door. Albira must be serviced by an Authorized Service Technician.

Each time the door is unlocked, the two interlocks are activated and the X-Rays tube stops. The Animal Preparation unit door is protected in the area of its aperture by a sheet of lead which overlaps with the shielding avoiding X-ray emission from the beginning of the opening of the door to the activation of the interlock..

The lock has two positions:

- ✓ Position 1: when you turn to the middle, then the interlocks are activated but the door cannot be opened.

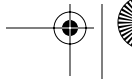
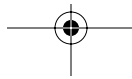

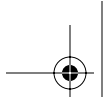

✓ Position 2: when you make a complete turn, the door can be opened.



To restart image capture, ensure that the access door is closed and then restart the capture using the Albira Software.

The access doors are interlocked. If opened during capture, the X-ray imaging is stopped.



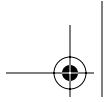

In case of emergency, the user could stop the equipment with one of the two emergency stops connected to the equipment:

- ✓ The emergency stop on the System Front Panel (described earlier in this chapter).
- ✓ The external emergency stop that is associated with the Control Unit. (described earlier in this chapter).

When this button is pressed, the power supply to the motors and to the X-Ray tube stops.

To restart image capture, turn the button clockwise to release and then restart the capture using the Albira Software.

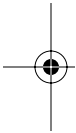

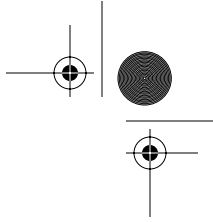

---

---

## Radioisotope Laboratory Management

Carestream Health does not sell, distribute, or offer the use of radioactive materials or prescribe specific site safety practices used in PET or SPECT imaging. Radioisotopes used in PET & SPECT imaging techniques must only be issued and utilized in accordance with a Radioactive Materials Licensing Agency. Carestream Health offers the below information for a review of the basic skills to utilize such materials, and this information should not be relied upon as a replacement of a qualified Radiation Safety Officer / Health Physicist and proper use.

Anyone who wishes to acquire radioactive materials must be specifically authorized to do so. Specific Licensing from regulatory agencies must be obtained prior to any unsealed radioisotope use. Authorization means that the licensing agency has prior knowledge of the laboratory and has approved its location, facilities, equipment, and personnel for use with radioactive materials

All acquisitions for radioactive material must be in accordance your respective licensing agency & license conditions. If procedures or equipment warrant obtaining radioisotopes that are not on your respective license, contact you licensing agency for guidance to amend your radioactive materials license.

### Receipt of Radioactive Materials

Upon receipt of any radioactive materials, it is prudent to verify package for integrity and wipe test. Specifically, the external surface of the package is monitored for radiation levels and for radioactive contamination. This monitoring must be performed as soon as practical after receipt of the package. If unacceptable contamination or radiation levels are found, the delivery carrier and appropriate regulators must be informed. The recipient should also reconcile the material description on the packing slip with the description on the purchase requisition.

If the package is acceptable, the radioactive material must be stored in a secure (locked) and posted area. Two important steps remain for the proper management of the empty package:

- ✓ 1. The empty package must be surveyed and/or visually inspected to ensure that it is in fact empty.
- ✓ 2. If an empty package or container bears a "radioactive" label or marking, the label must be removed or defaced before discarding into normal trash.

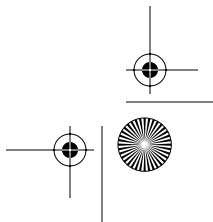
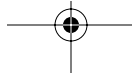

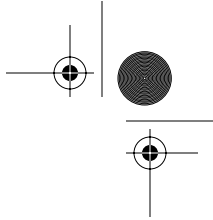

## Contamination Control

The safe use of radionuclides in a laboratory relies heavily on a combination of training, pre-planning, organization, and common sense. A primary concern is radioactive contamination - loosely defined as "radioactivity where you don't want it." There are three types of contamination:

- ✓ Fixed contamination - becomes integral with its host; is resistant to transfer
- ✓ Removable contamination - loose, easily transferred
- ✓ Airborne contamination - activity released into a closed atmosphere (e.g., lab space)

Containing, confining, or eliminating contamination altogether should be a radiation safety goal in each lab. Removable contamination is the most common type in radioisotope labs. Because it is easily transferred, there is increased opportunity for cross contamination. The contamination on an instrument control panel transfers to the gloved hand, which transfers to a phone, and then transfers to an ungloved hand, which then handles food. Protective clothing and frequent hand washing are very important in laboratory hygiene and hence, radiation safety.

Protective clothing consists of gloves, safety glasses, and a long-sleeved lab coat. Lab coats should be removed when outside the lab, in order to reduce the potential spread of contamination. When working with isotopes that can "creep" through materials or that are carried in strong solvents, it is often recommended to wear two pair of gloves and change the outer pair about once every 20 to 30 minutes.

It is also important to note that eating, drinking, smoking, and application of make-up are must not be permitted in isotope labs, and that labeled refrigerators/freezers used for storage of radioisotopes shall not hold food.

### *Work Area*

The area in which radionuclides are used should be well defined and, if possible, restricted. It should also be easily decontaminated. Use of spill trays and/or absorbent paper should be considered. Good housekeeping ultimately helps to reduce the spread of contamination.

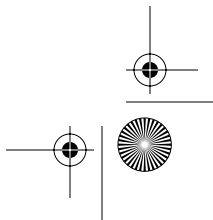
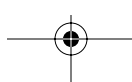

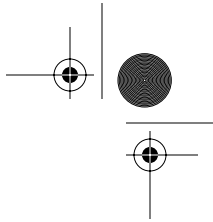

## Posting and labeling

Laboratories that contain radioisotopes shall be posted with proper signs, including entrance doors, storage cabinets, refrigerators, equipment which may come in contact with radioisotopes, etc. as required by licensee requirements.

Typically any primary storage container of radioactive material bears a clearly visible label bearing:

- ✓ The universal radiation symbol
- ✓ The words "Caution, Radioactive Material"
- ✓ Radionuclides present
- ✓ Estimated activity
- ✓ Date for which activity is estimated
- ✓ Radiation levels (if applicable)

## Storage

Radioisotope storage areas must be labeled and locked. Liquids should be stored in secondary containers to prevent accidental leakage/spills. Contact your facility Radiation Safety Officer for specific guidance.

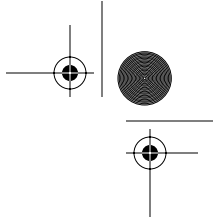

## Basic Contamination Surveys

In order to assess the levels of cleanliness or contamination in a lab, it is prudent to perform surveys on a regular and ongoing basis. Results of the survey are then compared to action levels for remediation, and areas are decontaminated, if needed.

Surveys for removable contamination (also called swipes, smears, or wipes) must be conducted in each lab on a regular basis. The surveyor may use a wet or dry filter paper disk or swab and wipe within an 100 cm<sup>2</sup> area (approximately 4 inches by 4 inches). Perform wipe samples in different areas where radioactive materials are being used/stored. (Do not survey identical areas each month.) The disks/swabs are then analyzed by an appropriate method (liquid scintillation, gamma counter, proportional counter).

Wipe tests should be completed directly after significant activities of radionuclides have been used, to ensure potential contamination is detected in a timely manner.

Wipe tests will not detect fixed contamination. A survey meter is generally used to make this assessment. An example of fixed contamination is absorption of radioisotopes into a porous surface.

## Inventory / Disposal Records

A complete inventory of radioactive materials typically must be kept on hand at all times. Inventory and disposal of unsealed material should be recorded. This record tracks radioactive material from "cradle to grave," and may include other information, including package wipe tests and survey information.

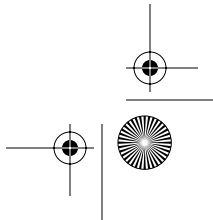
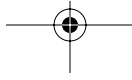

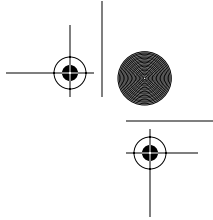

---

---

## Basic Radioactive Waste Management

The disposal of low level radioactive waste (LLRW) is highly regulated by both state and federal agencies. Levels released to our environment must be As Low As Reasonably Achievable. Adherence to the ALARA principle begins in the adhering to license conditions and good laboratory practices. Identification of the type of LLRW to be generated and determination of collection and disposal (or hold for decay) should be done in advance of conducting an experiment.

### *Avoid Mixed Waste (Hazardous and Radioactive)*

Mixed Waste is classified as being both Hazardous Waste, as defined by the EPA, and radioactive waste. Hazardous waste can be either listed specifically (e.g., lead, PCBs, arsenic, etc.) or listed by a hazardous characteristic property, including ignitability (flash point of  $< 140^{\circ}$  F) corrosivity, reactivity, or toxicity. Contact your respective Radiation Safety Officer for guidance.

Mixed waste can be difficult to dispose of properly. The best solution is to minimize its production. The RSO should be notified of any potential mixed waste before it is generated, in order to determine the appropriate disposal option and method. If necessary, the RSO may elect to prevent the generation of the mixed waste by recommending the experiment be modified or not be undertaken.

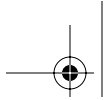

### *Waste Minimization Practices*

Disposal of radioactive waste is expensive, and waste generators must make reasonable efforts to reduce its volume, from both budgetary and environmental standpoints. The following practices should be followed by waste generators to minimize the amount of radioactive waste generated.

- ✓ Inventory Control - order only the minimum amount needed to complete the job satisfactorily.
- ✓ Substitution - consider substituting short-lived radionuclides for longer-lived ones, or using non-radioactive methods
- ✓ Waste Segregation - Do not mix non-radioactive waste with radioactive waste. In addition, radioisotopes with half-lives of greater than 90 days should be segregated from those with less than 90 day half-lives for easier storage for decay procedures.
- ✓ Biodegradable Liquid Scintillation Cocktails - use biodegradable liquid scintillation cocktails rather than organically-based flammable cocktails. This practice reduces the potential for creating mixed wastes, which are expensive and difficult to dispose of.
- ✓ Contamination Control/Common Sense - Avoid unnecessary contamination by careful planning and handling.
- ✓ Storage for Decay - Some short-lived isotopes (half-life less than 90 days) may be stored until the residual activity has decayed to background levels.

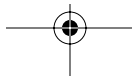

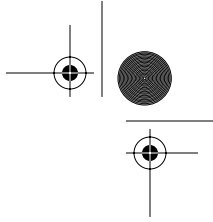

---

---

## Emergency Procedures

### *Spills*

Spills of radioactive material within a lab are not uncommon. Common sense and preplanning will help contain the spills and allow their proper cleanup. Gloves, lab coat, shoe covers, paper toweling, wipe test supplies, and survey meter should be readily available. If a minor liquid spill occurs, contain the liquid to the extent possible. Wearing appropriate protective clothing and notify applicable safety personnel.

### *Fire*

Firefighters are trained to respond to emergencies involving HAZMAT materials. The activities of a facility utilizing radioisotopes should be previously shared with local emergency responders and may be a license requirement. Typically the more direct hazard, is the fire itself rather than the radioisotopes. In the event of fire, follow the procedures for your facility and alert supervision/emergency responders that radioactive materials may be involved. Do not re-enter the area until it has been surveyed by a radiation safety officer.

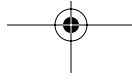



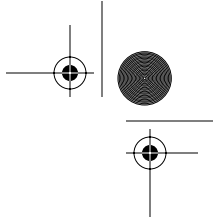

## Special safety considerations with PET Isotopes

PET Isotopes create 511 keV gamma photons, which becomes difficult to effectively shield and contain the radiation exposure. Facilities and operators that use PET isotopes must adopt and utilize good radiation safety practices for both the unsealed isotope containment and radiation emission (exposure) control.

The goal of radiation safety is to keep all radiation exposures As Low As Reasonably Achievable (ALARA). This means that even if exposures are acceptable, if there is a reasonable way to reduce the exposure even further, those controls should be utilized. While there are many components to an effective radiation safety program, there are consistently three basic principals to minimize radiation exposure:

- ✓ Time - minimize time duration working with radiation sources. PET isotope users should use practices that minimize time when using materials in close contact.
- ✓ Distance - increase distance between the source of radiation and yourself. Radiation exposure rates drop off exponentially with distance and operators that use PET isotopes, may consider adopting the use of increasing distance or using long handled tools, etc. to minimize intimate contact.
- ✓ Shielding - Shielding (lead, concrete, barriers, etc.). Since PET presents a potential radiation exposure with 511 keV photons, It is prudent to take advantage of any existing building materials to minimize exposure to the general public or coworkers. Labs that are located in the exterior, exterior corner, basement, etc. corner may reduce the need to acquire additional shielding materials. Typically lead sheeting is used and specified by the radiation safety officer to limit area exposure when needed.

☞ NOTE: radiation safety is best accomplished through the use of engineering and administrative controls. Some administrative controls include the following:

- ✓ Warning signs & postings - Typically radiation areas labeled with various “caution signs” and possibly “radiation area” labels - Utilize and adhere to any warning signs / labels.
- ✓ Radioisotope Laboratory Management - It is important to verify and follow any radiation safety policies & procedures for the licensed facility. Radioisotope laboratory safety is discussed in the next section.
- ✓ Radiation Dosimeters.- A radiation dosimeter monitors personal radiation exposure; it doesn't prevent exposure to the wearer. Monitoring exposure is useful to ensure that radiation exposures are being kept ALARA while performing job duties. Please refer to section 4 of this manual for specific information regarding

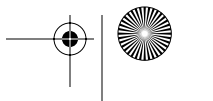

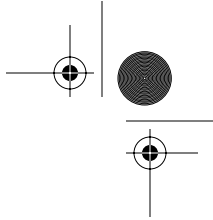

dosimetry.

 Note: Wearing a dosimeter is often a regulatory requirement for individuals who use PET isotopes.

For proper approved dosimeters, contact a NVLAP approved vendor of dosimetry:

Mirion Technologies (GDS) Inc.

2652 McGaw Ave

Irvine, CA 92614

USA

Toll Free: (800) 251-3331.

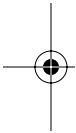

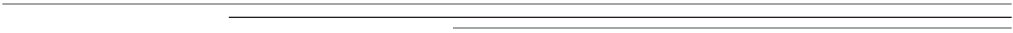
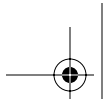

This page intentionally left blank.

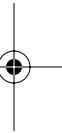

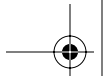

---

---

# *Capturing Images*

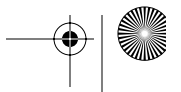
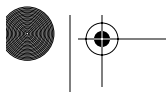

The following section describes the process for acquiring images.

 NOTE: The acquisition workflow may vary depending on end user needs.

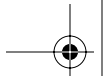



## Powering the System

- 1** Verify that the main power supply cable is connected. If it is not, ensure that the Main Power Control Switch is set in off position, to ensure safety to system and end user, and connect the main supply cable. (See figure “System Interface-Back Panel” on page 3-9 for diagram of Main Power Plug and Main Power Control Switch ).
- 2** Turn ON the Main Power Control in the back panel.
  -  **NOTE:** This configuration is intended for regular equipment utilization. If system is not planned to be used for a long period, user must turn off the main power control. It is not necessary to remove the power cable.
- 3** Press the Main Switch in the front panel. A blue light indicates that system is ON. (See figure “System Interface-Front Panel” on page 3-10 for location of Main Switch with blue indicator).
- 4** Verify the System Status light in the front panel. If the yellow status light appears, release the emergency stops and close the stretcher doors. Light OFF indicates system is ready.
- 5** To turn the system off, press the ON/OFF Main Switch. Blue light off indicates system is OFF. If Albira will not be used for extended periods of time, the Main Power Control at the back panel may also be turned off.
  -  **NOTE:** In the event of an emergency, use one of the Emergency Stop buttons (see below) located both at the Front Panel and near the Control unit.

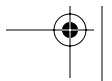
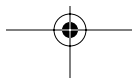

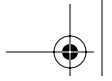

## Preparing your Animal for Imaging

After powering the system on according to the instructions provided above the user is prepared to load a sample animal for imaging. The Albira is equipped with three types of stretcher-Rat Stretcher, Mouse Stretcher and High Resolution SPECT Mouse Stretcher.

- 1 To access the stretcher, open the Animal Preparation Unit cover pushing from the handle.



-  **NOTE** Opening the Animal Preparation unit door will stop motors and X-ray source because of the interlocks systems placed in the closure system of the Animal Preparation unit (see figure “Albira Core Acquisition System”). System activity will be resumed only after the cover is closed and command is executed again from the control console.

- 2 To remove the stretcher, hold the stretcher base at the point indicated by an arrow in the next figure, and pull up from the red handler.

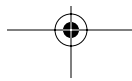
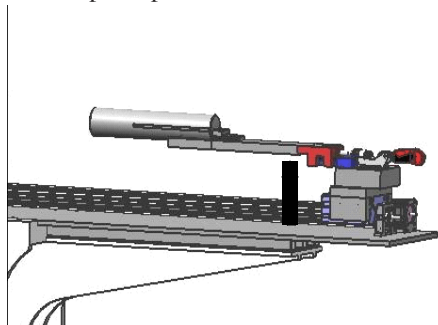

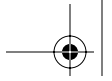

### *Rat and Mouse Stretcher*

- 1** Remove the chamber top from the stretcher.
- 2** Prepare 4 lengths of suture thread (approx. 80mm long) with loops tied in one end to attach the subject's limbs to the limb tie posts.
- 3** Place the head of the subject in to the nose cone as shown below.
- 4** The limb tie threads can be tightened suitably around the limbs and then wrapped around one of the grooves in the corresponding limb tie post and pulled into the slot on top of the limb tie post to secure the end.

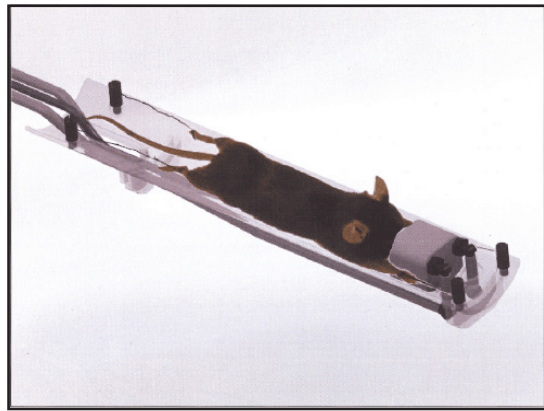

- 5** Place the sled in the stretcher and replace the chamber top.
- 6** Replace the stretcher by pulling up the red handle.

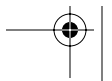
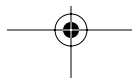

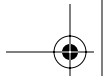

## Acquiring Images using the Albira Suite

The Albira Suite is composed by a group of user-friendly and very specific applications.



The applications that are available include:

- ✓ Albira Manager-allows user to configure the Suite, manage subjects, studies, acquisition templates and protocols; and manage system users.
- ✓ Albira Acquirer-allows user to perform acquisitions following a predefined protocol, or independent acquisitions.
- ✓ Albira Reconstructor-allows user to generate images from acquired data.
- ✓ Albira Supervisor-allows user to check system status and perform periodic maintenance. It will also inform you when maintenance is required.

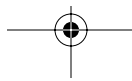



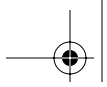

## Configure Capture Parameters using Albira Manager

Albira Manager is the Suite's application providing system management and configuration functionality. Albira Manager allows the user to:

- ✓ Create, edit and delete subjects, studies and experiments
- ✓ Create, edit and delete protocols
- ✓ Create, edit and delete acquisition templates
- ✓ Manage users
- ✓ Perform backups or restore system

The Albira Manager window contains five tabs:

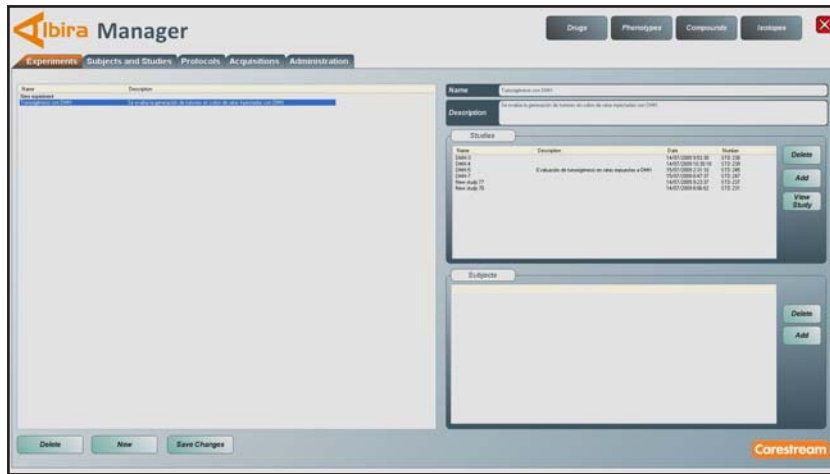

- ✓ Experiments—for experiments management
- ✓ Subject and Studies—for subjects and studies management
- ✓ Protocols—for protocol management
- ✓ Acquisition—for templates management
- ✓ Administration—for system administration.

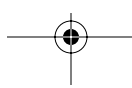

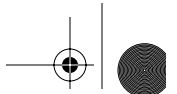

## Experiments Tab

The Experiments tab shows the experiments list on the left hand and the subjects and studies that are part of each experiment on the right side. The available actions buttons are placed on the right of the subjects and studies lists.

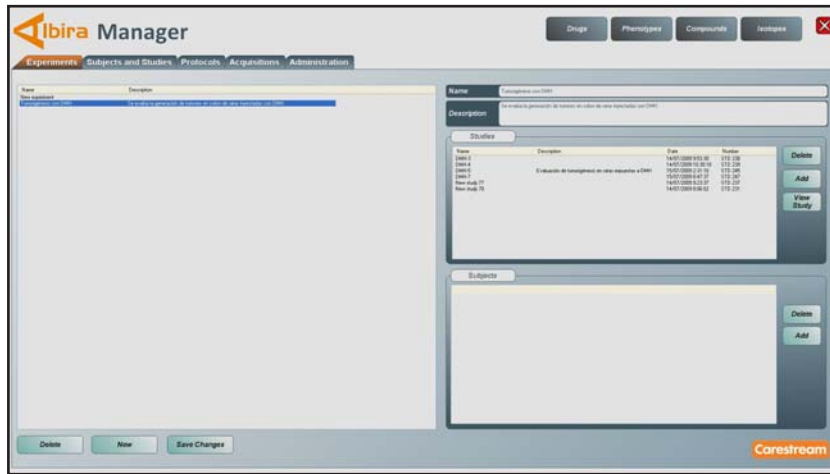

When selecting an experiment in the experiments list, the details are shown (name and description) as well as any related studies and subjects' data. Studies can be added to an experiment one by one or by subject, in that case all studies from that subject will be also added. A subject or study can be part of one or more experiments..

### Creating a New Experiment

To create a new experiment:

- 1 Click New. A new experiment is created with a unique name. It will be added to the database and it will be selected in the list to add subjects or studies.

### Editing an Experiment

To edit an experiment:

- 1 Select the desired experiment from the list.
- 2 Edit the desired fields, including the associated subjects and studies list.
- 3 Click Save to store the new data.

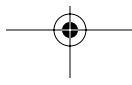

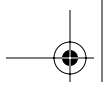

### Deleting an Experiment

To delete an experiment:

- 1 Select the desired experiment from the list.
- 2 Click Delete. A warning message appears asking you to confirm the deletion of the experiment.
- 3 Click OK to delete.

### Managing Subjects and Studies associated with an Experiment

To add a subject or a study:

- 1 Click Add (the right side of the corresponding list). The dialog appears.

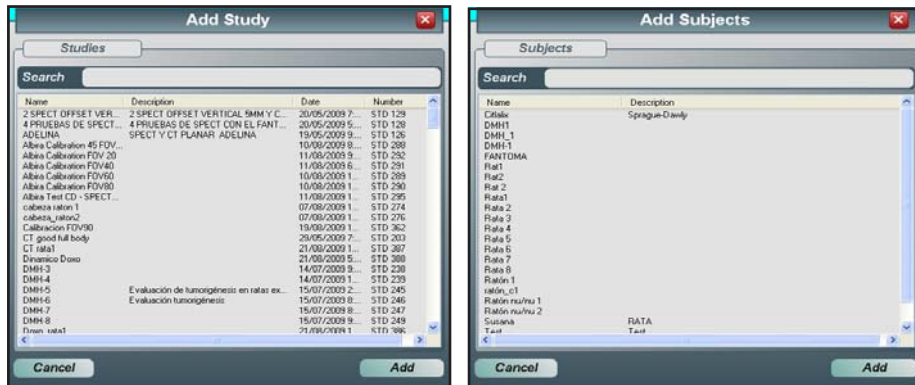

- 2 Select the desired Study or Subject and click the Add button.
  - NOTE: Use the Search bar to locate a specific study or subject.
  - NOTE: To delete a subject or study from the experiment, select the desired subject or study from the corresponding list and click the Delete button. The study or subject will not be deleted until you click Save.

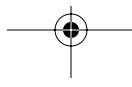

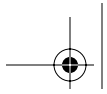

### Viewing Study Images

To view study images within an Experiment:

- 1 Click on View study located to the right of the study list. A new dialog appears prompting you to select the images you want to visualize.

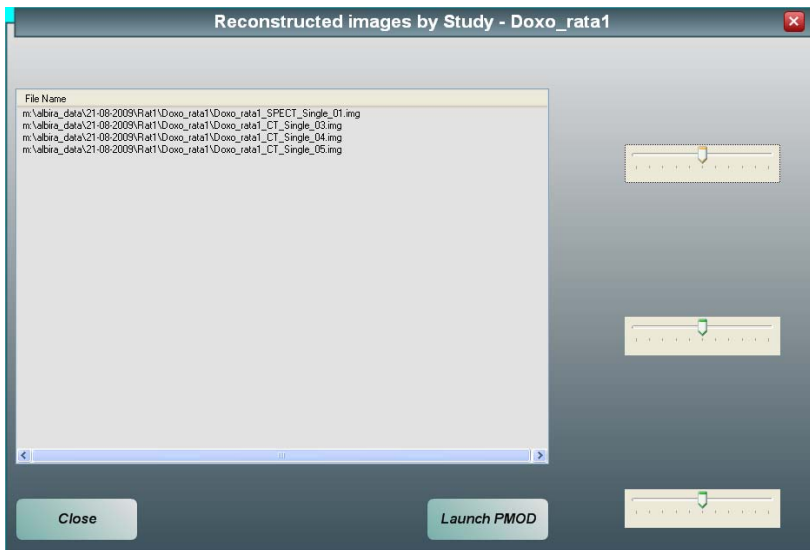

- 2 Select an image, click Launch PMOD. The PMOD application launches and opens the selected image file.

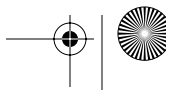
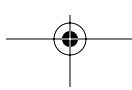
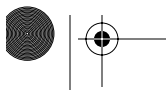

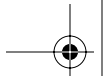

## The Subjects and Studies Tab

Subjects and Studies tab manages the list of subjects and the list of studies.

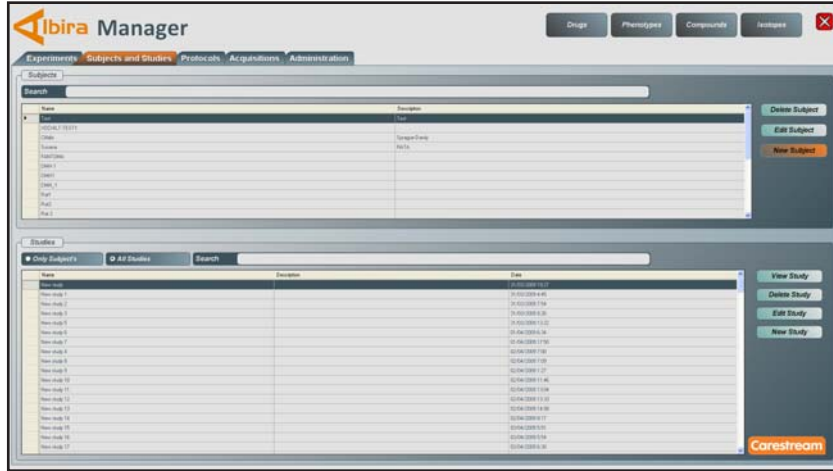

### Creating a New Subject

To create a new subject:

- 1 Click New Subject. The create a subject form appears.

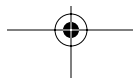

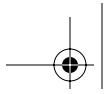

- ✓ *Name*—enter the subject name or identifier. This field is searchable by using the Search bar.
- ✓ *Description*—enter comments that enable to better identification of the subject. This field is also searchable using the Search bar.
- ✓ *Genus*— enter subject sex (Male or Female)
- ✓ *Phenotype*—predefined phenotypes are Mouse or Rat. To add a new phenotype, click the Edit button to access the dialog for editing phenotypes

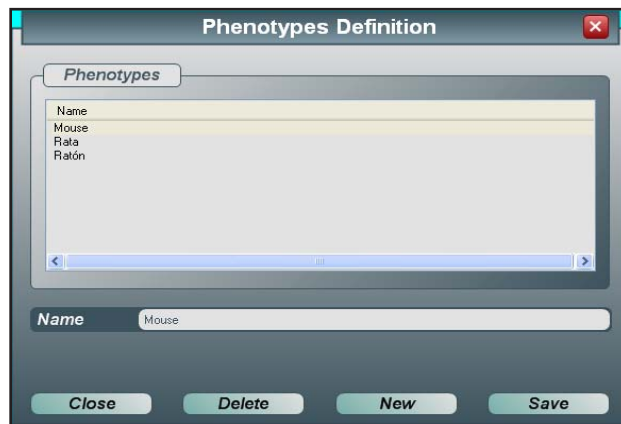

- To edit current phenotype, change name and click Save.
- To add a new phenotype, click New, enter a name and click Save.

- ✓ *Age*—displays the calculated age in weeks based on the birth date.
  - ✓ *Weight (g)*—enter the subject's weight
  - ✓ *Birth Date*—enter the subject's date of birth. This date is used to calculate the subject's age in weeks.
  - ✓ *Length (cm)*—enter the subject's length in centimeters.
- 2 Click Save. The new data is updated in the Subjects list.



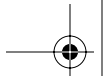

### *Editing a Subject*

To edit an existing Subject:

- 1** Select the desired subject from in the Subjects list and click Edit Subject.
- 2** Edit the fields you want to modify.
- 3** Click Save. The new data is updated in the Subjects list.

### *Deleting a Subject*

- 1** Select desired subject from in the Subjects list and click Delete Subject.
- 2** Click Delete. A warning message appears asking you to confirm the deletion of the experiment.
- 3** Click OK to delete.

 **NOTE:** You can restore a deleted subject from the Administration tab.

### *Searching for Subjects*

You can find a specific subject using the Search bar. The search utilizes the Subject Name and Description fields.

- 1** Enter the subject you are looking for in the Subjects Search bar.

 **NOTE:** Separate search terms using spaces or commas. The software filters the list of subjects and displays those matching the search terms in subject name or description.

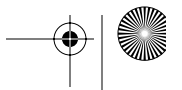
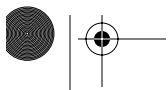

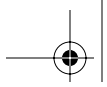

### Searching Studies

You can customize the studies displayed on screen using the Filter buttons located next to the Search bar. The options include:

- ✓ *Only Subject's.*— displays all studies for the subject selected in Subjects list.
- ✓ *All Studies*—displays all studies stored in system database. When selecting all studies, the associated subject is selected in the Subjects list. Use this option when you want to sort studies by date.

☞ NOTE: Separate search terms using spaces or commas. The software filters the list of subjects and displays those matching the search terms in any of the Studies fields, e.g. Name, Description, Subject Name.

☞ NOTE: You can start a new study by clicking New Study which launches Albira Acquirer. Refer to *Albira Acquirer* section described later in this chapter.

### Editing a Study

For editing an existing study or viewing study details

- 1 Select the desired study from the Studies list.
- 2 Click Edit Study or View Study. The Study dialog box is displayed.

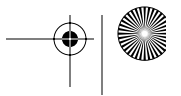
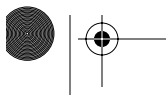
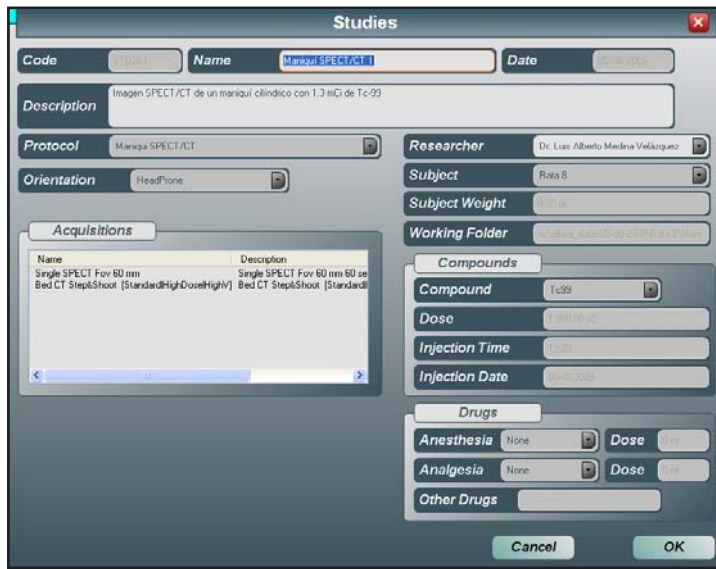



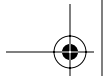

**3** Edit the fields you want to modify, if appropriate. You can only edit the Subjects Name, Researcher, Study Name and Description fields. All other fields are not modifiable. Study details include:

- ✓ Study Code—provides an internal study code. This field is not editable.
- ✓ Study Name—enter a descriptive name for the study. This field is editable.
- ✓ Study Date—provides the date of the study. This field is not editable.
- ✓ Study Description—enter an extended description or comment. This field is editable.
- ✓ Used Protocol—defines the protocols used. *None* protocol indicates that the study used free acquisitions options. This field is not editable.
- ✓ Researcher— indicates the user that executed the study. This field is not editable.
- ✓ Study Subject—indicates the subject. This field is not editable.
- ✓ Orientation—defines the bed orientation. This field is not editable.
- ✓ Subject's weight—indicates subject's weight
- ✓ Working Folder—indicates the folder where acquired files and reconstructed images are stored. This field is not editable.
- ✓ Acquisition—contains the list of acquisitions performed in the study, displaying name, number of frames and acquisition start time for each of them .
- ✓ Reconstructions—contains the list of reconstructions performed in the study, displaying the name.
- ✓ Compounds—details of the compound used, including Compound (name), Dose, injection time and injection date.
- ✓ Drugs—details of the drugs used, including Anesthesia with dose, Analgesia with dose and any other drugs

**4** Click OK.

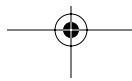

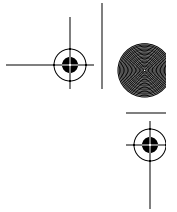

## Protocols Tab

Protocols automate acquisition and reconstruction sequences that are frequently used.

Protocols are based in acquisition templates, highly flexible and allowing to define all acquisition and reconstruction parameters. A protocol can include PET, SPECT or CT acquisitions, or even combine them in multimodal PET/CT and SPECT/CT protocols. The only limitation is that a protocol cannot include both PET and SPECT.

The protocols tab is divided in three sections—the list of defined protocols (left side) and the protocol parameters (right side) and the button section for performing the available actions (bottom).

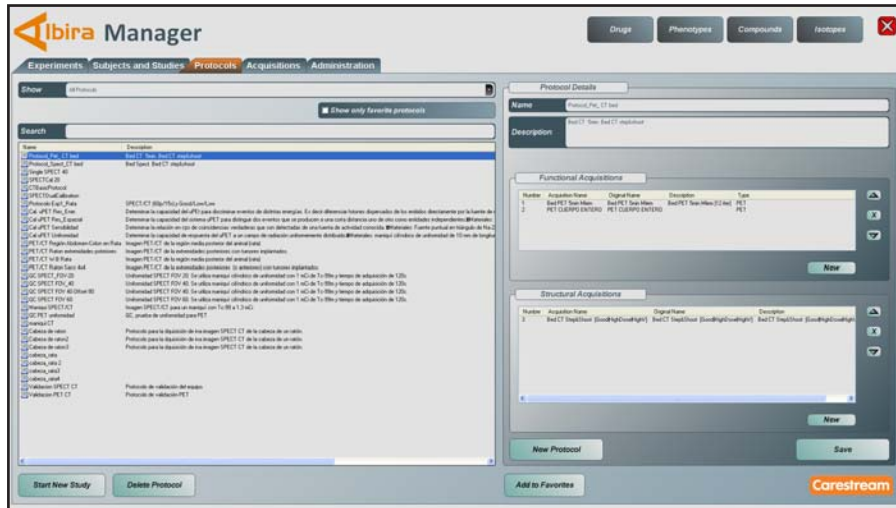

A protocol is defined by the following parameters:

- ✓ Protocol Name—identifies the protocol and must have a unique name.
- ✓ Protocol Type—indicates whether protocols is an acquisition protocol, reconstruction protocol or complete protocol.
- ✓ Protocol Description—provides an extended description of the protocol. The information provided is especially important if the protocol is going to shared by several users.
- ✓ Functional Acquisitions—lists all PET or SPECT acquisitions to perform in the protocol.
- ✓ Structural Acquisitions—list all PET or SPECT acquisitions to perform in the

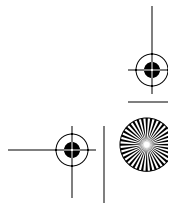
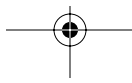
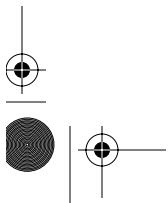

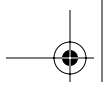

protocol.

NOTE: It is mandatory for a protocol to have at least one acquisition defined.

### Adding a new acquisition

For adding a new functional or structural acquisition to the protocol:

- 1 Click the New button below the appropriate list. The Add Acquisition dialog box appears.

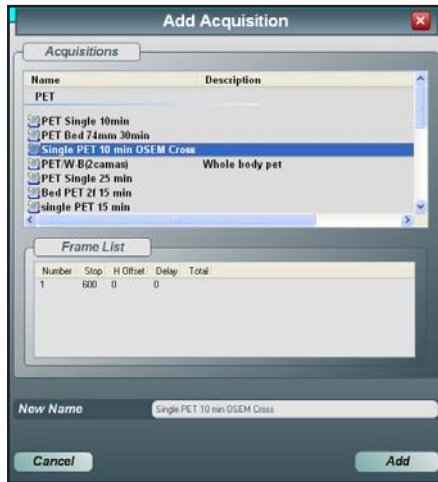

The dialog box contains the following fields:

- ✓ Acquisitions—lists the defined acquisition templates, grouped by acquisition type.
- ✓ When adding the first functional acquisition, both PET and SPECT acquisition templates are listed. Once the first acquisition is added, only the templates for the same modality are listed. When adding an structural acquisition, CT acquisition templates are listed.
- ✓ Frame List—lists defined frames for selected acquisition template.
- ✓ New Name provides the acquisition name in protocol.



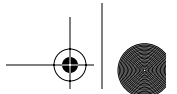

### Organizing Acquisitions List

Acquisitions lists provide the order in which acquisitions are executed, always starting with the functional ones.

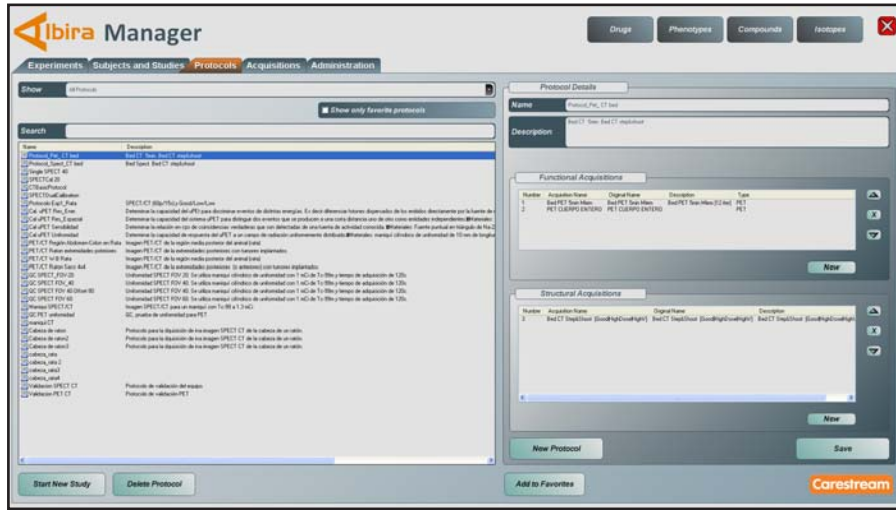

The controls for changing the element order are located to the right of each list. Pressing the top button the selected element moves one position upwards, and pressing the bottom button moves one position downwards. The Middle button deletes the selected element from the list.

### Creating a new protocol

For creating a new protocol, click New Protocol (lower right). When selected, all protocol parameters controls are cleared. Once all the parameters for the new protocol have been defined, and the acquisition and/or reconstruction lists have been created, press Save to store it in the database.



**NOTE:** The protocol name must be unique. An acquisition protocol must have at least one defined acquisition, either functional or structural.

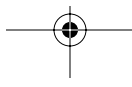

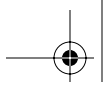

### *Editing a Protocol*

For editing an existing protocol:

- 1 Select the protocol in the protocols list.
- 2 Edit the fields you want to modify.
- 3 Click Save when finished. New data is updated in the protocols list.

 **NOTE:** You can not edit a protocol that has been used in any study. If the protocol has been used, a message warning is displayed with a dialog prompting for a new name for the edited protocol.

### *Deleting a Protocol*

For deleting an existing protocol:

- 1 Select the protocol from the protocols list.
- 2 Click Delete Protocol. It is not possible to delete protocols that have been used in any study. The button will be disabled if no protocol is selected. When clicked, a warning message prompting for confirmation will be displayed. If a protocol is deleted, the protocols list will be updated.

 **NOTE:** You can not delete a protocol that has been used in any study. If the protocol has been used, a message warning will alert you.

### *Listing Protocols*

All protocols are listed by default. You can change the display using the Show selector above the protocols list.

The options are:

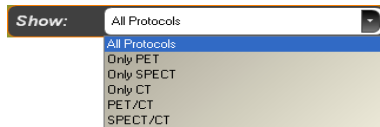

- ✓ All Protocols— displays all protocols stored in the database grouped by protocol type. This is the default view.
- ✓ Only PET— displays only PET protocols.
- ✓ Only SPECT— displays only SPECT protocols.
- ✓ Only CT— displays only CT protocols.



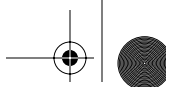

- ✓ PET/CT—displays only multimodal PET/CT protocols
  - ✓ SPECT/CT—displays only multimodal SPECT/CT protocols
- ☞ NOTE: If the “Show only favorite protocols checkbox is checked, only the protocols added to favorites list are displayed, grouped by protocol type. To add or remove protocols from the favorites list, select the protocol and click Add to Favorites/Remove from Favorites.

### Acquisition Tab

Albira Suite defines acquisition as a group of general acquisition configuration and modality dependent parameters.

Acquisition templates allow the user to define acquisition sequences or unique acquisitions to use the protocols. Acquisition definition avoids defining acquisitions every time you want to use that acquisition in a protocol.



The parameters in the Acquisition template are divided into four categories—general (used in all imaging modalities), PET, SPECT and CT. Let’s review the parameters.

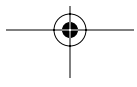

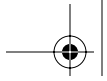

### General Parameters

General parameters for all acquisitions are:

- ✓ Acquisition Template Name—use to identify acquisition template. The template name must be unique.
- ✓ Acquisition Template Description—use to describe template contents. It is especially important if the template is shared by users.
- ✓ Acquisition Template Modality—defines PET, SPECT, CT modalities employed in the template.
- ✓ Acquisition Template Type—indicates whether acquisition is Single, Dynamic or Bed.

 NOTE: Dynamic acquisitions are only available for PET modality.

- ✓ Capture mode—defines how acquisition is done. Even though it is a general parameter it depends on modality
  - PET. It has the only option of specifying the acquiring time.
  - SPECT. There are 4 possibilities available:
    - ✓ Time (average)—calculates each projection time taking into account the decay.
    - ✓ Time (constant)—acquires each projection for the specified time.
    - ✓ Gammagraphy 2D (“Static/2D”)— performs a 2D image in the specified position.
    - ✓ Calibration— performs a Calibration acquisition.
      - CT. There are two possibilities:
        - ✓ Static/2D performs a 2D image in the specified position.
        - ✓ Step&Shoot performs several acquisitions for a 3D reconstruction.
  - ✓ Bed length.—available only when bed acquisition is selected. It defines the axial length of the complete acquisition, automatically calculating the number of frames the system must perform.
  - ✓ Offset H—available only when bed acquisition is selected. This parameter defines the bed offset before starting the acquisition.

 NOTE: This displacement refers to the starting acquisition position and not to the idle bed state.

- ✓ The following additional parameters must also be defined, according to the selected modality and the selected capture mode.



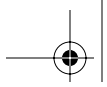

## PET Specific Parameters

The PET acquisition specific parameters are following:

- ✓ Bed Acquisition. In addition to bed length, Capture Time parameter is added. The Capture Time defines each frame acquisition time in seconds.
- ✓ Single acquisition. In addition to bed starting offsets, Capture Time (the frame acquisition time in seconds) and Delay (the time, in seconds, to wait before starting the next acquisition in the protocol) are available.
- ✓ Dynamic acquisition. This configuration is composed by a frame list. Each of those frames must be defined as a single acquisition.

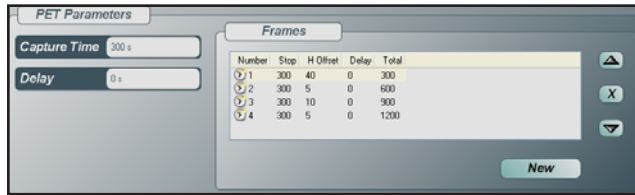

- Capture Time defines the frame acquisition time in seconds
- Offset H defines the bed offset before starting the acquisition.

NOTE: This displacement refers to the starting acquisition position and not to the idle bed state.

- Delay defines the time, in seconds, to wait before starting the next frame in the acquisition.

NOTE: To add a new frame, click New under the desired list. To edit the frame parameters, select the frame in the list and edit it through the controls located to the left of the list. To the right of the list, there is a control that allows the user to modify the list's frames order.

The PET reconstruction specific parameters are as follows:

- ✓ Reconstruction Name—name that appears in the reconstruction list.
- ✓ Reconstruction Description—describes reconstruction.
- ✓ Reconstruction Algorithm.—allows you to chose between all reconstruction algorithms that are available. This version has two algorithms (OSEM and MLEM) with two different implementations. One of the implementations takes into account the crossed coincidences of the system and the other one only takes care of the

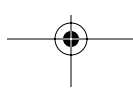



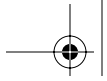

direct coincidences. With crossed coincidences the Field of View grows but increases reconstruction time. Therefore it is only suggested for over 40x40mm FOV sizes. This drives to the following possibilities:

- MLEM (FOV 40 mm x40 mm)
- MLEM Cross (FOV 80 mm x 80 mm)
- OSEM (FOV 40 mm x 40 mm)
- OSEM Cross (FOV 80 mm x 80 mm)
- ✓ Iteration Number— specifies the number of iterations used for iterative algorithms.
- ✓ Data correction. The following corrections are available in the Albira system:
  - Scatter
  - Decay
  - Randoms

#### *SPECT Specific Parameters*

The SPECT acquisition specific parameters are as follows:

- ✓ Acquisition Time. Defines each projection acquisition time.
  - Time (average) Takes into account the isotope decay to make each projection time different to have the same count number.
  - Time (constant) Will force every projection to acquire the same amount of time regardless of the defined isotope.
- ✓ FOV— specifies the field of view. It has 4 options 20, 40, 60 and 80 mm. The bigger the FOV the worse the resolution. Small FOVs have better resolution.
- ✓ Angle— defines the angle of the acquisition. It is only available for Static/2D acquisition. The angle is specified in degrees from the vertical position as 0.

The SPECT reconstruction specific parameters are as follows:

- ✓ Reconstruction Name— name that appears in the reconstruction list.
- ✓ Reconstruction Description— describes reconstruction.
- ✓ Reconstruction Algorithm— defines the reconstruction algorithms that are available in the system
- ✓ Iteration Number— specifies the iteration number for those algorithms that need it. It is recommended to leave the default values.

#### *CT specific parameters*





The CT acquisition specific parameters are as follows:

- ✓ Acquisition Quality— defines the CT acquisition quality option. There are three options: Standard, Good and Best. The higher the quality, the larger the data file will be. Files sizes can be up to 1 GB per frame.
- ✓ Radiation Dose— two options, High Dose or Low Dose.
- ✓ X-ray Source Voltage—two options, Low Voltage or High Voltage.
- ✓ Angle— defines the angle of the acquisition. It is only available for Static/2D acquisition. The angle is specified in degrees from the vertical position as 0.

The CT reconstruction specific parameters are as follows:

- ✓ Reconstruction Name—name that appears in the reconstruction list.
- ✓ Reconstruction Description—describes reconstruction.
- ✓ Reconstruction Algorithm—defines the reconstruction algorithms that are available in the system.

### *Creating a New Acquisition Template*

To create a new Acquisition Template:

- 1 Click New Acquisition at the bottom of the Acquisitions tab. A new acquisition template appears.
- 2 Enter the parameters that have been defined for the new acquisition template, and create the frame list with at least one frame defined.
- 3 Click Save to store template in the database.

 NOTE: The acquisition template name must be unique.

### *Editing an Acquisition Template*

For editing an existing Acquisition Template:

- 1 Select the desired acquisition template from the acquisition templates list.
- 2 Edit the fields you want to modify.
- 3 Click Save when finished. New data will be updated in the acquisition templates list.

 NOTE: You can not edit an Acquisition Template that has been used in any study. If the template has been used, a message warning will appear with a dialog box prompting for a new name for the edited template.

### *Deleting an Acquisition Template*

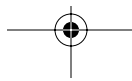

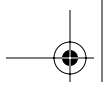

For deleting an Acquisition Template:

- 1 Select the acquisition template in the corresponding list.
- 2 Click Delete Acquisition.

 NOTE: You can not delete acquisition templates that have been used in a study.

- 3 A warning message appears prompting confirmation that you want to delete. Click OK. The list is updated.

### *Displaying Acquisition Template List*

All Acquisition Templates are listed by default. You can change the display using the Filter selector.



The options include:

- ✓ PET — only PET Acquisition Templates are displayed.
- ✓ SPECT — only SPECT Acquisition Templates are displayed.
- ✓ CT — only CT Acquisition Templates are displayed.
- ✓ All Acquisitions — all Acquisition Templates are displayed, grouped by their acquisition modality.



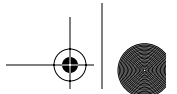

## Administration Tab

The system administration is performed using the Administration tab. This tab is divided in two sections: the Users section, where the user list is available for management, and the System section, where management tasks can be performed.



### Creating a New User

- 1 Click New User from the Administration Tab. The Researcher Details window appears.

**Researcher Details** [X]

Name:

Information:

Male  Female

Occupation:

Birth Date: 26/05/2010

Cancel Save

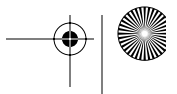
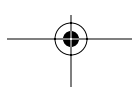
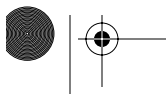

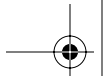

**2** Enter the user information. Information required includes:

- ✓ User Name.
- ✓ User Information.
- ✓ Sex.
- ✓ Occupation.
- ✓ Birth date.

**3** Click Save.

*Editing an Existing User*

**1** Select the user in the corresponding list and click Edit User. The Researcher Details appears.

**2** Enter any changes.

**3** Click Save. The user data is updated.

*Deleting an Existing User*

**1** Select the user in the corresponding list.

**2** Click Delete User.

 **NOTE:** You can not delete a User that has been used in any study. If the protocol has been used, a warning message will appear.

**3** Click OK.

*Searching User*

If you want to locate a user, enter the search terms in the Search bar. The software will filter the list of users and will display results.

*Studies Organization*

Due to the great size of acquisition data and some reconstructed images, Albira Suite stores data directly to HDD. It is possible to select the folder layout to manage the studies through its selector.

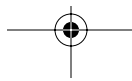

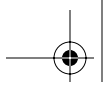

There are available several options:

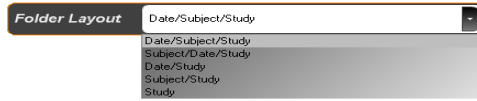

- ✓ Date/Subject/Study.—folders are organized by dates and inside the date folder, studies are grouped by subject. Example: 2007-03-21\Subject 31\Study 312.
- ✓ Subject/Date/Study—folders are organized by subjects and inside the subject folder, studies are grouped by date. Example: Subject 31\2007-03-21\Study 312.
- ✓ Date/Study—folders are organized by dates and inside the date folder are all studies. Example: 2007-03-21\Study 312.
- ✓ Subject/Study—folders are organized by subjects and inside the subject folder are all studies. Example: Subject 31\Study 312.
- ✓ Study— All studies are stored in the same folder with no specific order.

### Restore Deleted Data

To restore deleted data, click Manage Deleted Objects from the Administration tab. A dialog with the list of deleted objects is displayed.

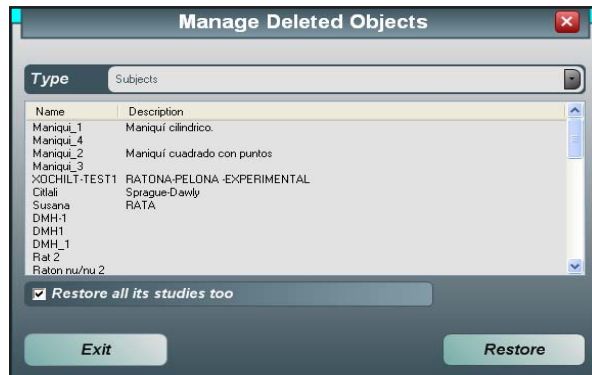

The list displays object name and description.

By default, the list displays the deleted subjects. You can change this option with the selector located above the list. Options are:

- ✓ Subjects—lists all deleted subjects, default selection.



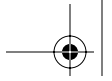

- ✓ Protocol—displays the deleted protocols.
- ✓ Studies—displays the deleted studies.
- ✓ Acquisitions— displays the deleted acquisitions.
- ✓ Reconstructions—displays the deleted reconstructions.
- ✓ Experiments—displays the deleted experiments.

To recover the deleted objects, select the objects to restore in the list and click Restore.

### Data Backups

If you want to perform a data backup, you can carry out this from the Albira Manager by clicking Backup Data in the Administration tab. The Backup Database dialog box appears.

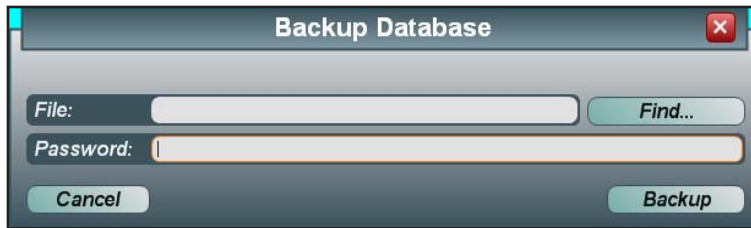

The dialog prompts for a name and password of the file where the backup will be stored. A password is required. Once entered, the data backup is performed.

To restore data from a previous backup, press Restore Data. The Restore Database dialog box is displayed prompting for the name of file containing the backup data and the password.



Before restoring data, a backup of existing data is automatically created.



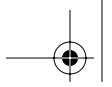

## Compounds, isotopes, drugs and phenotypes definition

At the top of the Albira Manager, the user can find several buttons that manage the compounds, isotopes, drugs and phenotypes.



### Drugs

The Drugs button accesses the Drug Management dialog box.

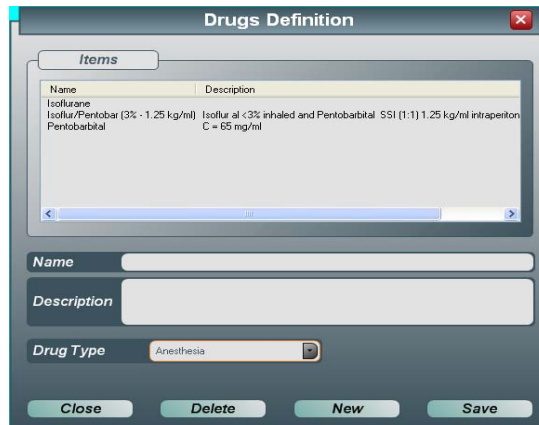

Drugs are defined by following parameters:

- ✓ Name—drug name.
- ✓ Description—drug description, its indication and its effects.
- ✓ Drug Type—anesthesia or analgesia.

For a new drug definition, click New, enter all the parameters and click Save. The new drug will be added to list.

**NOTE:** You can not edit a drug that has been used in any study. If the protocol has been used, a message warning will alert you.

To edit an existing drug, select the drug, edit its parameters and click Save.

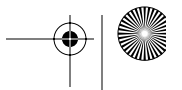
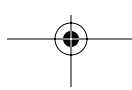
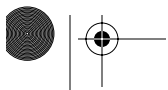



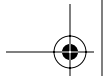

 NOTE: You can not edit a drug that has been used in any study.

To delete an existing drug, select it from the list and press the “Delete” button. A Confirmation dialog will be shown before the drug is deleted.

### *Phenotype Management*

The Phenotype button accesses the phenotype management dialog box.

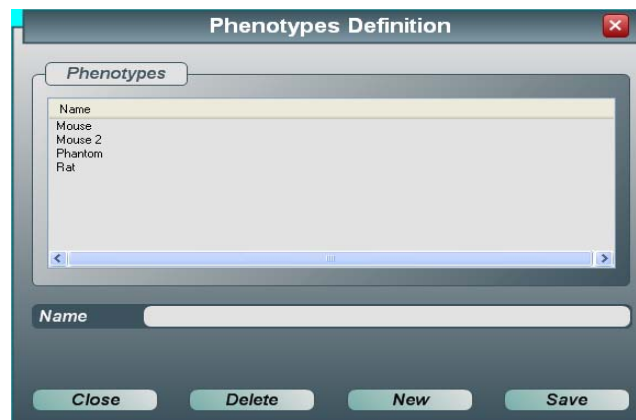

Phenotypes are defined by name only, there are no additional parameters.

For a new Phenotype definition click New, enter all parameters and click Save. The new phenotype is added to list.

To edit an existing Phenotype, select it from the list, edit its parameters and click Save. Changes are updated in the list.

To delete an existing Phenotype, select it from the list and click Delete. A Confirmation dialog will be shown before the phenotype is deleted.

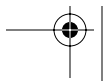
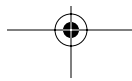

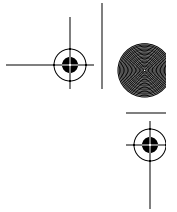

## Compound Management

The Compounds button displays the compound management dialog when clicked.

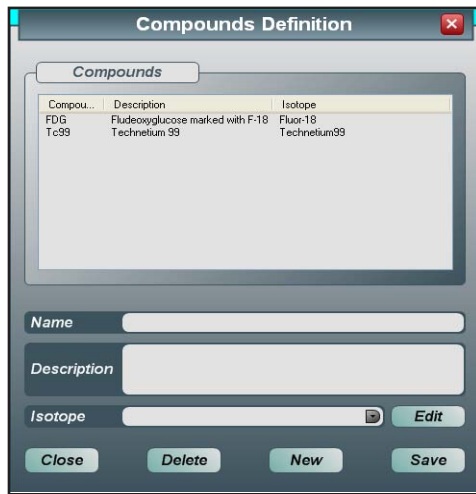

Compounds are defined by following parameters:

- ✓ Name—enter compound name.
- ✓ Description—enter compound description. We recommend that you specify the recommended application, including dose.
- ✓ Isotope—enter the compound isotope. The user can select one from an isotopes list, and modify or create a new one if needed by clicking the edit button.

For a new compound definition, click New, enter all parameters and click Save. The new compound is added to the list.

To edit an existing compound, select the compound from the list, edit its parameters and click Save

 **NOTE:** You can not edit a compound that has been used in a study, except for its name and description.

To delete an existing compound, select the compound from the list and click Delete. A Confirmation dialog box will be shown before the compound is deleted.

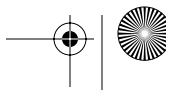
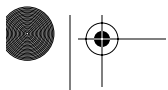

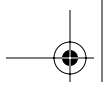

## Isotope Management

The Isotopes button displays the isotope management dialog when clicked.

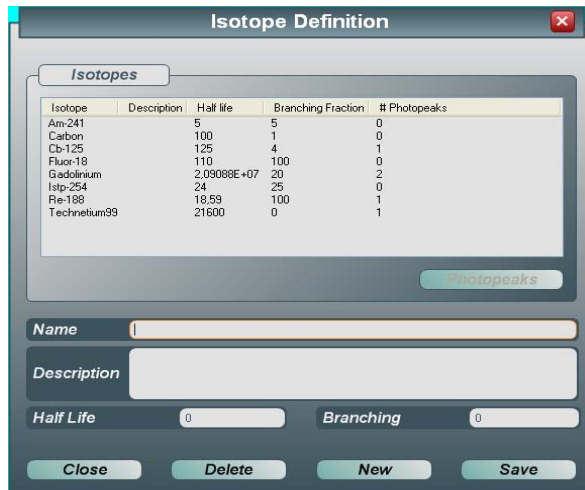

Isotopes are defined by following parameters:

- ✓ Isotope Name.
- ✓ Isotope description.
- ✓ Half-life. Time the isotope takes to reduce its activity to half.
- ✓ Branching.
- ✓ Isotope photopeaks list.

For a new Isotope definition, click new, enter parameters and click Save. The new isotope is added to list.

To edit an Isotope, select isotope from the list, edit its parameters and click Save. Changes will be updated in list.

- 👉 **NOTE:** You can not edit an Isotope that has been used in a study, except for its name and description.

To delete an existing Isotope, select it from the list and click Delete. A Confirmation dialog will be shown before the isotope is deleted.

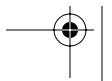
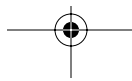

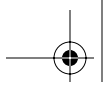

### Isotope's Photopeaks List Management

To view or manage the isotope's photopeaks, select the isotope in the isotope list and click the Photopeaks button. The photopeak definition dialog box appears.

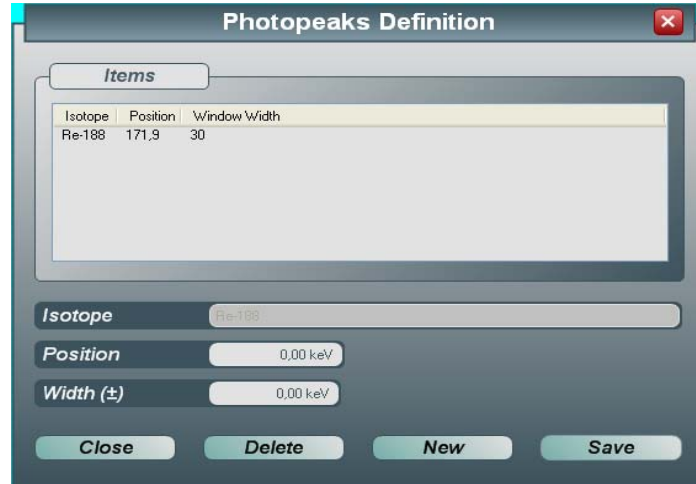

Photopeaks are defined by following parameters:

- ✓ Photopeaks position in keVs. There cannot be more than one photopeak in each position.
- ✓ Windows width to consider the photopeak, in keVs.

For a new Photopeak definition, click New, enter parameters and click Save. The new photopeak definition is added to list.

To edit an existing Photopeak, select the photopeak from the list, edit its parameters and click Save. The list is updated.

To delete an existing Photopeak, select the photopeak from the list and click the Delete button. A warning message appears asking you to confirm the deletion of the photopeak. When you close the dialog box, the number of selected isotope photopeaks is updated.

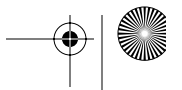
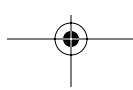

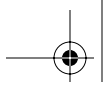

## Generating Images using Albira Acquirer

Albira Acquirer is the Suite's application that provides data acquisition functionality. Albira Acquirer features are the following:

- ✓ Configure acquisitions and studies from templates.
- ✓ Execute acquisition protocols.
- ✓ Acquire data.
- ✓ Move bed.

### Configuration Screen

When Albira Acquirer is launched, the screen shows the study configuration section. The application automatically assigns a new study code and, if it has been launched from manager, it will also load the specified subject and/or protocol.

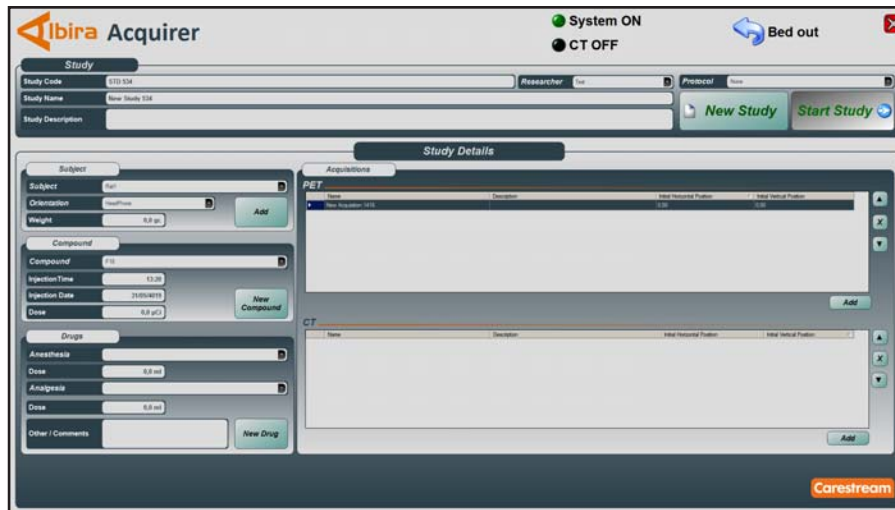

This screen is divided in three main sections-the Study, Study Details and the Indicator section. The Study section contains the main study parameters while the Study Details section contains the parameters that have not been shown in the upper panel. The Indicator section contains the CT state indicator (Black for OFF and Blue for Activated), the Systems State button that allows user to turn the system on (Green) and off (Red) and the “Bed Out” button which returns the bed to its home position, so that the user can place the subject on the bed.

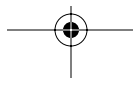

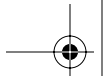

- ☞ NOTE: The X-ray tube will activate when “Start Study” is selected and the CT modality is acquiring.
- ☞ NOTE: The Acquisitions parameters for modalities are defined at the Albira Manager Acquisition tab.

### *Study Parameters*

The study parameters are:

- ✓ Study code is automatically generated and is not editable.
- ✓ Study Name is automatically generated. We recommended you edit the field to provide a more descriptive study name.
- ✓ Study Description—enter an extended description or comment.
- ✓ Researcher—enter the User. Refer to Albira Manager in this section for further details.
- ✓ Protocol— select the Protocol selection.

### *Study Details*

The study details include:

The Subject parameters are mandatory and include

- ✓ Subject—choose between all subjects that are defined in the system, or create a new one using the Add button. Refer to Albira Manager section for creating a new subject.
- ✓ Subject orientation —select the subject's orientation in the bed.
- ✓ Weight—enter the subject's weight.

### *Compound*

The selectable parameters are:

- ✓ Compound used—select from the compound list. You can define a New Compound using the New compound button. Refer to Albira Manager section for Creating a New Compound.
- ✓ Injection date and time—enter data to document date and time
- ✓ Dose—enter injection dose in micro Curies.

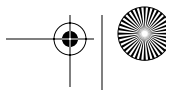
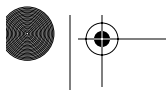

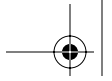

### *Drugs*

The drug definition parameters are not mandatory but they are relevant for study documentation. These parameters are explained as follows:

- ✓ Name of the drug used for anesthesia and dose (ml.)
  - ☞ NOTE: To add a New Drug, refer previous section, Albira Manager in this Chapter.
- ✓ Name of the drug used for analgesia and dose (ml).
- ✓ Other drugs or any other information that you want to associate with the drugs used in this study.

### *Acquisition List*

On the right side of the study details section are the functional and structural acquisition lists that are going to be performed. If a protocol is selected, these lists are filled automatically.

If any of these lists is manually modified, the protocol's name changes automatically to "None".

- ☞ NOTE: The Acquisition Lists work as described in the protocols tab in the Albira Manager. Click Add to add a new acquisition at the end of the ones already defined. The dialog appears allowing you to select from all the acquisition templates defined for the chosen modality.

User can reorder the acquisitions using the controls on the right of each list.

### *Starting a Study*

- 1** To switch system on, click the System On button located in the upper left corner of the screen.
  - ☞ NOTE: When the system is switched on, the button changes color and the "System Off" text is displayed. Clicking the button again switches the system off.
  - ☞ NOTE: To start a new study, you must have defined all parameters required for the study (including the acquisition list if there is no protocol).
- 2** Click Start Study. The Acquisition Details screen appears. This window varies based on the modality.

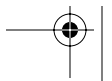
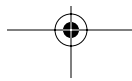

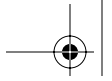

The common controls are those that are available no matter the modality selected. These controls are as follows:

- ✓ Camera Image—The Albira system has an animal monitoring camera inside to monitor the subject and stop acquisition as needed. The image is displayed in the left upper corner of the acquisition information section.
- ✓ Bed Status—There is a window at the bottom of the screen indicating the motion of the bed during an acquisition. The X-axis represents the horizontal movement of the bed. The acquisition's FOV is represented by a colored region.
- ✓ Ring Status—in the lower right corner of the acquisition information section there is a control that represents the ring status. It indicates the position in degrees. The ring is only needed for SPECT and CT acquisitions, so during PET acquisitions it will not move.
- ✓ Progress—displayed in the upper right corner of the acquisition information section, representing the study progress you can monitor:
  - Overall progress. Progress of the complete study as % of completion.
  - Acquisition progress—current acquisition progress as % of completion.
  - Total Elapsed time—elapsed time of the complete study.
  - Acquisition Elapsed time—elapsed time of current acquisition.
  - Estimated remaining time—time required to complete remaining acquisitions.

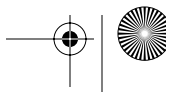
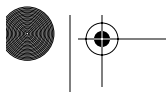





The PET window:

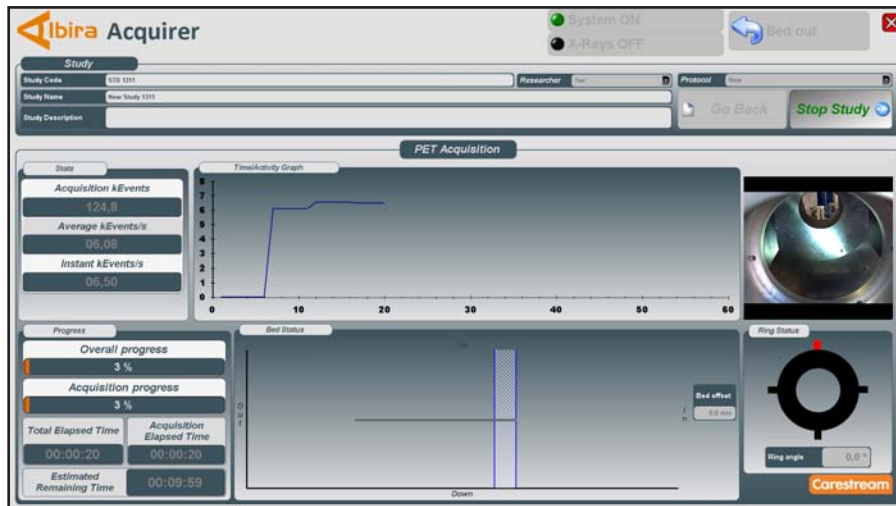

The SPECT window:



The PET data acquisition screen and the SPECT data acquisition screen are almost identical and present following specific controls:



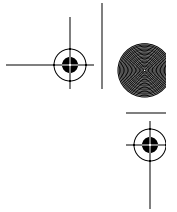

- ✓ PET/SPECT acquisition statistics. The PET or SPECT statistics shown during acquisition are as follows:
  - Number of events for current acquisition, in kEvents.
  - Instant activity, in kEvents/s.
  - Average activity for current acquisition, in kEvents/s.
  - Activity/time graph. It represents the activity behavior during time. The X-axis represents the time in seconds while the Y-axis represents the instant activity in kEvents/s.
- ✓ The SPECT acquisition screen also displays an image on the right of the activity VS time graph with the representation of the current projection.

### CT Data Acquisition



The CT acquisition screen has the following specific controls.

- ✓ X-Ray ON indicator—red indicator when system is generating an X-Ray.



CAUTION: X-rays Produced When Energized.

The CT Module installed with the Albira System meets or exceeds compliance to FDA Department of Health and Human Services regulation 21 CFR 1020.40 for radiation safety.



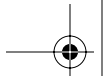

 **NOTE:** It is the responsibility of the purchaser to register this device with their State, local or country specific Radiation Safety Agency. This should be coordinated with the Radiation Safety Officer (RSO) at your facility.



**CAUTION:** The Albira System should only be operated by personnel who have been instructed in radiation safety by the radiation safety officer at your facility and in the operating instructions outlined throughout this User's Guide.



**CAUTION:** Do Not Insert Any Part of the Body When System is Energized— X-Ray Hazard.

- ✓ CT acquisition Statistics including:
    - Current projection—number and total number of projections.
    - X-ray source status—displays Voltage and Current
    - Elapsed time for the study and for the current acquisition.
  - ✓ CT Projections—images of last projections. This window shows last 2 acquired images.
- 3** When every acquisition from the study is completed, a dialog box appears asking if you'd like to launch the Albira Reconstructor to reconstruct the study that has just been completed. Click OK to proceed.

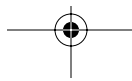

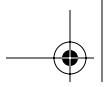

## Albira Reconstructor

The Albira Reconstructor application offers the PET, CT and SPECT reconstruction functionality by reconstructing several studies in a row or manually one by one specifying the desired reconstruction parameter.

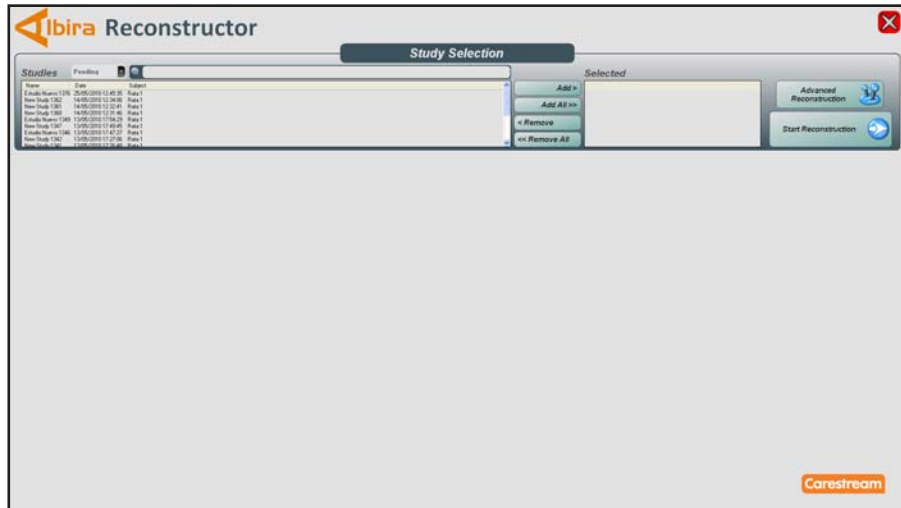

### Available studies list

The available studies list (Studies) is located on the left side of the panel. The default display shows the last 10 studies. You can modify using the Study Selector to the following options:

- ✓ Last 10—list displays the last 10 studies generated.
- ✓ Pending— lists all studies that have not been reconstructed.
- ✓ All— shows all studies.

☞ NOTE: You can filter using the Search bar to find a selected study based on the name or partial name.

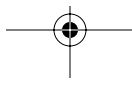

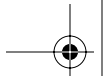

### *Selected Study List*

The selected study list (“Selected”) is located on the right side of the panel and shows the selected studies for reconstruction.

- ✓ To add studies to this list, select the studies from the available study list and click Add. The Study appears in the Selected Study list.
- ✓ To add all studies to the selected list, click Add all. All studies appear in the Selected Study list.
- ✓ If you want to delete a study from the selected studies list, select the desired studies, and click Remove. The study is moved to the available list.
- ✓ To clean the selected study list, click the “Remove All” button. This will clean the selected list passing all studies back to the available list.

☞ NOTE: Studies will be reconstructed in the same order they are shown in the list. As the reconstructions are finishing the selected list will change a study’s colors to Green if the study was successfully reconstructed or to Red if any error was found. The current study will be selected. Once all studies are reconstructed, the selected list will be cleaned up in order to allow user to add new studies to be reconstructed.

☞ NOTE: You can remove studies from the selected list even if the reconstruction has already started. Only the studies that have not been completed or started can be removed using the Remove option.

☞ You can add studies to an on-going reconstruction and using Add. The studies are added to the end of the list.

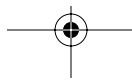



### Starting Reconstruction

To start reconstruction, one or more studies must be in the selected list. Click the Reconstruction button.

**NOTE:** When working with multimodal studies, automatic fusion will be performed to create a new structural image ready to be viewed with the provided Pmod application.

### Reconstruction Screen

Once reconstruction is launched, the Reconstruction Information panel is displayed.

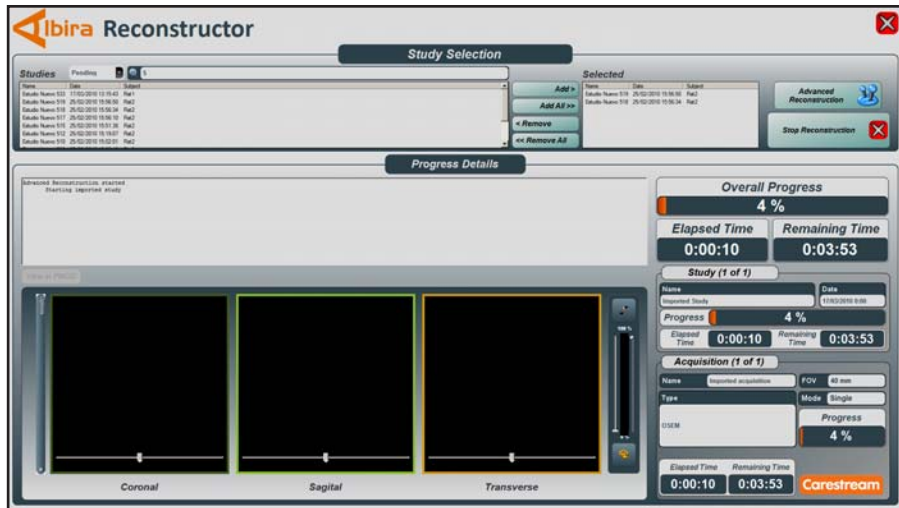

In this panel the last reconstructed Image Preview (lower left corner), progress information (right side of the panel) and the operation log (upper left corner) are displayed.

- ✓ Progress Information
  - The total progress in %, elapsed time and estimated remaining time is displayed. The specific acquisition and study progress are shown in the acquisition and study panels respectively.
- ✓ Study Information
  - The Study date and study time when its acquisitions were performed.

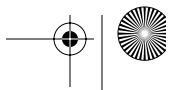
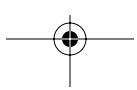

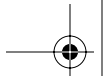

- Study Name.
- Study Description.
- Study reconstruction progress in %.
- Reconstruction elapsed time for current study.
- Estimated remaining time for study reconstruction completion.
- ✓ Acquisition Information
  - Acquisition Name.
  - Image's Field of View (FOV).
  - Acquisition Details. Indicates modality, reconstruction algorithm, number of iterations and reconstruction options (Decay, Scatter, Randoms)
  - Acquisition reconstruction progress in %.
  - Reconstruction elapsed Time for current acquisition.
  - Estimated remaining time for acquisition reconstruction completion.
- ✓ Image preview — the latest image reconstructed is displayed on the image preview panel. It displays Coronal, Sagittal and Transverse cuts of the reconstructed image. You can change the cut position with the trackbar associated with each view. The preview is updated every time an acquisition finishes, to show the last reconstructed acquisition.

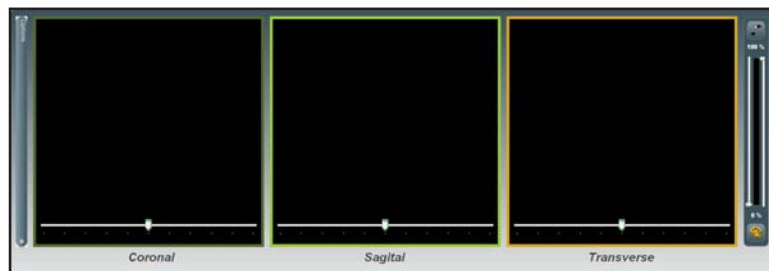

Clicking on any of the cuts centers the other cuts around the coordinates of the clicked point.

- ✓ The View in PMOD button located above the image preview panel launches PMOD with the image displayed in the panel.

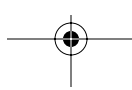

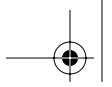

### Palette and Levels

The control located on the right side of the image preview panel allows the user to change the color palette and set the saturation and noise levels for the image. The bar represents the image's color palette, and allows the user to control the saturation and noise thresholds using the sliders on each side of the bar (the right slider controls saturation threshold, and the left slider controls the noise threshold).

Current saturation and noise thresholds are indicated in % above and below the bar, respectively. Above the number indicating current saturation threshold there is a button to reset thresholds to default values (saturation 100%, noise 0%).



Below the number indicating current noise threshold there is a button for modifying the active palette. When it is clicked, a dialog for selecting the Palette pop-ups appears.





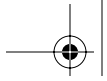

### Additional visualization options

The bar located on the left side of the image shows or hides the available options for the image preview panel.



- ✓ Gauss filter—when checked, image is smoothed using a gaussian filter of the specified sigma.
- ✓ Show coordinates—when checked, the image coordinates will be displayed when the user moves the cursor over the image. Cursor and text color for coordinates can be selected on the control at the right of the checkbox.
- ✓ SUV—when checked, Standard Uptake Value correction will be applied to the image.
- ✓ Screen Shot button—when clicked, a screen shot of the displayed image cuts will be saved to a file in the desired format.
- ✓ Export button—when clicked, image will be exported to the desired file with all active modifications such as gaussian filter and SUV correction.

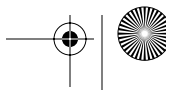

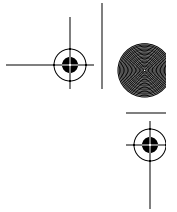

### Reconstruction Log

The reconstruction log is located at the top of the reconstruction information panel. It contains a log of all operation performed since the Application was launched. When an error is found during reconstruction, it is highlighted in Red, indicating error description. Each time a frame, acquisition or study is successfully reconstructed, it is indicated in the log, highlighted in Green. Log entries are separated by study, acquisition, image, and frame.

You can export the log to a file by clicking the Save Log button. A Save file dialog is shown and by default the log will be saved as RTF which can be read by most text readers. To clean the on screen log, click Clean Log.

### Advanced Reconstruction

Advanced reconstruction allows the user to reconstruct from files. It also provides a means to reconstruct the images with different reconstruction options that can lead to more accurate studies.

To perform an advanced reconstruction, click Advanced Reconstruction from the Study Selection panel. The advanced reconstruction dialog box appears.



To use the Advanced Reconstruction, indicate the files to be reconstructed and the reconstruction parameters.

- ✓ Files to be reconstructed—The file list contains the files that are to be reconstructed. If there were any studies on the selected studies list when “Advanced Reconstruction” was executed, the Advanced Reconstruction dialog box will import all files and show them as the content of the file list.



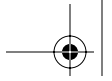

- ✓ You can add files to the list manually. To do that, select the desired reconstruction modality through the mode control (PET, SPECT, CT) and then click Add. It will open a windows file selection dialog filtered by the previously selected modality (“`.lm`” for PET, “`.spect`” for SPECT and “`.raw`” for CT). Once the selection is made, it will be added to the end of the list.
- ☞ NOTE: The reconstruction parameters will be the same for all files, they can not be changed between files.
- ✓ The files must match the selected modality and parameters must be configured accordingly. If the match criteria are not met, a dialog box appears indicating the mismatch.
- ✓ To remove any file from the file list, select the file and then click Remove. To remove all files, click Remove All.
- ✓ For Single reconstructions, a reconstructed image will be written for every file in the list, to the same folder as the source file. All files will have same reconstruction parameters.
- ✓ For a Dynamic reconstruction, one single file will be created with multiple frames (one for each source file). All files will have same reconstruction parameters.
- ✓ For a Bed reconstruction, one single file will be created merging all reconstructed images in the bed horizontal movement direction.

Files will be reconstructed in the order they are added to the list. The user can reorder files by using the “^” button to move the file upwards and the “v” to move the file downwards.

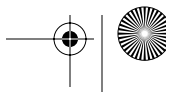
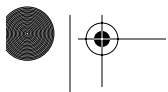

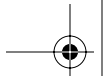

### Reconstruction Configuration

The reconstruction parameters can vary between modalities (PET, SPECT, CT) or between reconstruction types (Single, Dynamic, Bed). The parameters are the same that the user must define in Albira Manager to configure studies reconstruction:

For PET:

- ✓ Reconstruction Algorithm— allows the user to chose from any of the reconstruction algorithms that are available (OSEM and MLEM with two different implementations). One of the implementations takes into account the crossed coincidences of the system and the other only takes care of the direct coincidences. With crossed coincidences the Field of View grows but reconstruction time increases, so it is only suggested for FOV sizes over 40x40mm. Options are:
  - MLEM (FOV 40x40mm).
  - MLEM Cross (FOV 80x80mm).
  - OSEM (FOV 40x40mm).
  - OSEM Cross (FOV 80x80mm).
- ✓ Iteration Number. Specifies the number of iterations for those algorithms that need it.
- ✓ Data correction options include:
  - Scatter
  - Decay
  - Randoms

For SPECT:

- ✓ Reconstruction Algorithm— defines the reconstruction algorithms that are available in the system.
- ✓ Iteration Number— specifies the number of iterations. We recommend using the default values.

For CT:

- ✓ Reconstruction Algorithm— defines the reconstruction algorithms that are available in the system.
- ✓ Include fusion option is checked (only available for SPECT and PET). When Start

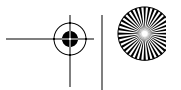
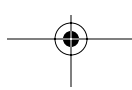

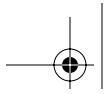

is initiated, the Select CT Header File dialog box appears.

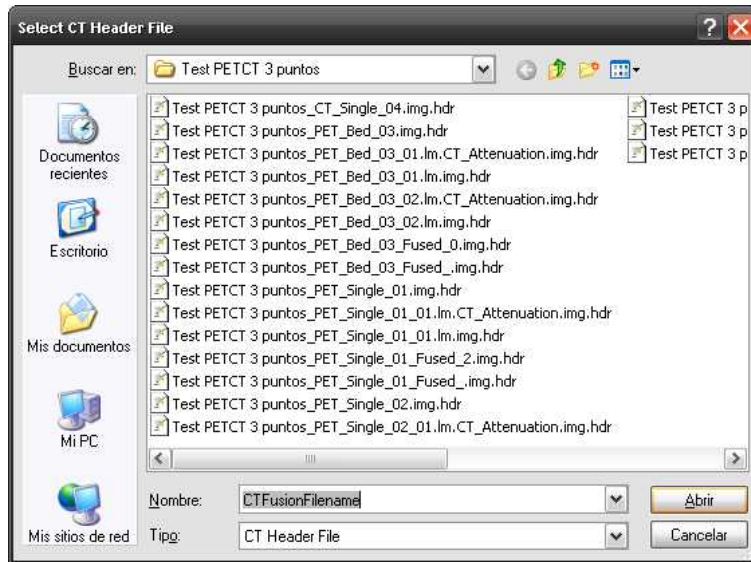

Select the image you want to use for the fusion. All selected images are going to be fused ASSUMING the same origin. You may need to configure to view them correctly with PMOD.

- 4 After all files are added and configured, click Start to begin the reconstruction. If the reconstruction has only one file, it will ask for the output file name. If there is more than one file, the files will be created in the same path where the source files are with an “.img” extension

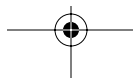

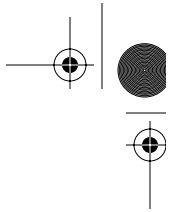

## Albira Supervisor

the Albira Supervisor is the Albira Suite's application that provides the user with quality control functions. These quality controls will verify that the obtained data is correct and that the equipment is completely functional. The Albira Supervisor is overviewed here. The protocols and instructions for performing the quality control procedures are detailed further below in the section “Maintaining the System” found on page 6-1. To validate the system, Albira Supervisor will perform following tests for the correspondent systems:

### PET

- ✓ Energy resolution for every available module.
- ✓ Decompression.
- ✓ Uniformity.

### SPECT

- ✓ Energy resolution for every available gamma camera.
- ✓ Sensitivity and differential sensitivity of SPECT system.
- ✓ Image Decompression.
- ✓ Image Uniformity.

### CT

- ✓ Water Hounsfield Number Validation.
- ✓ Air Hounsfield Number Validation.
- ✓ Hounsfield numbers uniformity.
- ✓ Hounsfield numbers transaxial uniformity.

If the System does not have all available modalities, Albira Supervisor will only perform the installed subsystems modalities.

Albira Supervisor’s main screen has four tabs. The first tab is Systems Overview and shows the systems summary of the last performed validation. The second tab shows the PET validation results while the third and fourth one show the SPECT and CT results respectively.

The main screen also features the “New Quality Control” button that will launch the New Validation Wizard to guide the user through creating a new quality control. It is located on the upper right corner of the screen below the Exit button.

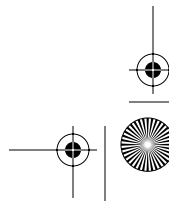
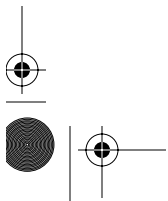

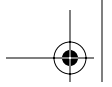

When Albira Supervisor is launched, the main screen is displayed with systems summary and last validation results.



- ✓ The Summary tab provides data from the last quality control results, indicating passed validations and failed validations and in Red. To pass or fail the validation tests depends on the results and criteria for each test which are shown in the detailed test section.
- ✓ The PET Overview panel shows the PET's Decompression, Uniformity and Energy Resolution,
- ✓ The SPECT Overview panel shows SPECT's Energy Resolution, Decompression, Uniformity, and Sensitivity test results.
- ✓ The last tab, the "CT Validation" tab shows the Hounsfield Number and Uniformity validation tests results for the CT subsystem.

The Equipment Information:

- ✓ Current quality control date and result (PASSED/FAILED).
  - ✓ Last Calibration Date.
  - ✓ Last Validation Date and expected next validation date for each modality (PET, CT and SPECT).
  - ✓ System's serial number, registered user and model.
- ☞ NOTE: When new complete or partial validation is done, the window is updated. To check PET, SPECT or CT detailed validation you must select the corresponding tab to go to the desired window.

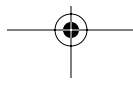

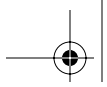

### Results Report

Clicking Print Report in the Summary tab generates the report window with the validation results report displayed. This report contains every measured value, acceptance criteria, measure deviation, and result for each modality .

Test Name	Value	Criteria	Deviation	Result
Energy Resolution (Module 0)	16.3019045686627	< 20.00	0	PASSED
Energy Resolution (Module 1)	15.016549747265	< 20.00	0	PASSED
Energy Resolution (Module 2)	14.8590637870099	< 20.00	0	PASSED
Energy Resolution (Module 3)	16.8463279774224	< 20.00	0	PASSED
Energy Resolution (Module 4)	15.2922491605321	< 20.00	0	PASSED
Energy Resolution (Module 5)	15.4547260590959	< 20.00	0	PASSED
Energy Resolution (Module 6)	16.6815230725789	< 20.00	0	PASSED
Energy Resolution (Module 7)	16.1808436239267	< 20.00	0	PASSED
Energy Resolution (Mean)	15.6157938101105	< 20.00	0	PASSED
Decompression Y Axis	30.5	30.00 ±10.00%	10	PASSED
Decompression X Axis	31	30.00 ±10.00%	10	PASSED
Integral 100%	6.32484872007248	< 16.00	0	PASSED
Integral 75%	5.83865029432035	< 16.00	0	PASSED
Differential 100%	4.0769939569525	< 16.00	0	PASSED

Print the report by clicking Print or store the report by clicking Save.

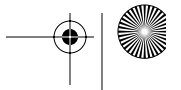
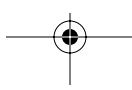



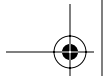

## *PET Validation Results*

### *PET Validation Summary*

The PET validation results tab is also divided into 4 tabs. The first (PET Overview) shows the PET result summary. In this tab the PET results are more detailed than in the summary tab, showing the measured value, acceptance criteria, measure deviation, and result (in Green if test has passed and in Red if test has failed.) for each of the performed tests .

Each test has its own measures:

- ✓ Energy Resolution—the mean Energy resolution validation for all module in %. Even though the mean measure can pass the criteria, if any of the modules do not pass the test, it will be shown as failed. There is also a Gaussian graph that shows the mean measured energy resolution in Blue and the acceptance criteria energy resolution graph in Red. The Blue graph (measured) must always be underneath the control graph (Red).
- ✓ Decompression—the decompression is calculated for X and Y-axis. It is shown in mm and it is also represented the fitting graph for the phantoms section. The graph shows a Blue line that represents the line samples and two Red lines that show the position of the found phantom size. This representation is presented for both the X and Y-axis.
- ✓ Uniformity
  - Integral Uniformity considers the complete phantom area for the 100% representation and only the center for the 75% representations. It measures the values fluctuations in %.
  - Differential uniformity considers the complete phantom area for the 100% representation and only the center for the 75% representations. It also measures the values fluctuations in% but it differs from integral that it only takes into

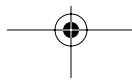



account the neighbor values.



This tab also shows last quality control date and state (PASSED/FAILED) and expected next quality control. (It only represents PET next quality control. Other validations can expire earlier).

If more detailed information is needed, the user can select the specific tab. Within these tabs, the user will find each of the test values and graphs. Alternatively, the user may click the Details button for more information.



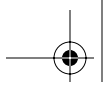

### PET results report

Clicking Print report in the PET tab makes the report window appear with the PET validation results report shown. This report contains every measured value, acceptance criteria, measure deviation, and result for each modality. The report appears on screen.

Test Name	Value	Criteria	Deviation	Result
Energy Resolution (Module 0)	16.3019045686627	< 20.00	0	PASSED
Energy Resolution (Module 1)	15.016549747265	< 20.00	0	PASSED
Energy Resolution (Module 2)	14.8590637870099	< 20.00	0	PASSED
Energy Resolution (Module 3)	16.8463279774224	< 20.00	0	PASSED
Energy Resolution (Module 4)	15.2922491605321	< 20.00	0	PASSED
Energy Resolution (Module 5)	15.4547260590959	< 20.00	0	PASSED
Energy Resolution (Module 6)	16.6815230725789	< 20.00	0	PASSED
Energy Resolution (Module 7)	16.1808436239267	< 20.00	0	PASSED
Energy Resolution (Mean)	15.8157938101105	< 20.00	0	PASSED
Decompression Y Axis	30.5	30.00 ±10.00%	10	PASSED
Decompression X Axis	31	30.00 ±10.00%	10	PASSED
Integral 100%	6.32484872007248	< 16.00	0	PASSED
Integral 75%	5.83865029432035	< 16.00	0	PASSED
Differential 100%	4.0769939569525	< 16.00	0	PASSED

You can print the report by clicking Print or store the report by clicking Save.

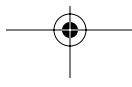

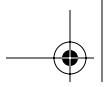

### Energy resolution validation test details

The Energy Validation details tab shows every detail of the energy validation tests performed to each module.

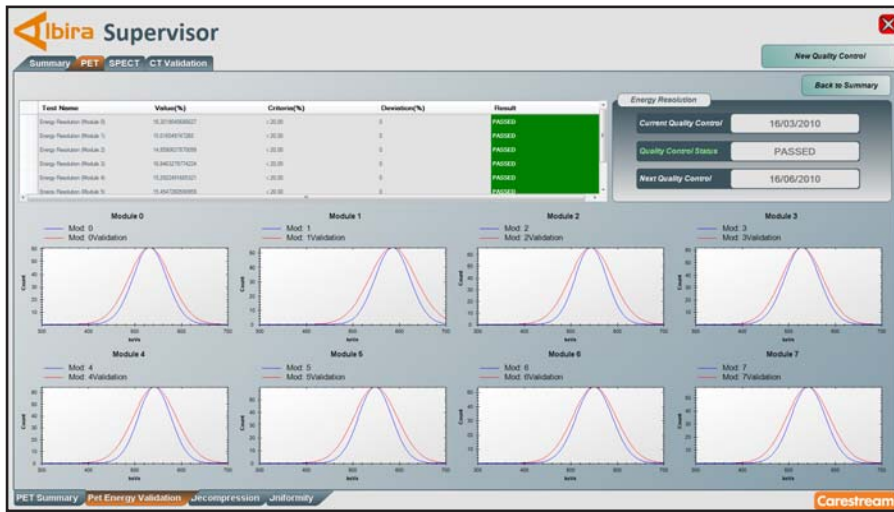

- ✓ Each module's energy resolution validation in %. Every module has the same passing criteria and it will be shown in Green if it is passed or Red in case it does not meet the criteria requirements.
- ✓ A Gaussian graph is displayed that shows each module's measured energy resolution in Blue and the acceptance criteria energy resolution graph in Red. The Blue graph (measured) must always be underneath the control graph (Red). The narrower the Blue graph the better the energy resolution is.

This tab also shows last energy resolution quality control date and state (PASSED/ FAILED) and expected next quality control (It only represents PET's energy resolution next quality control. Other validations can expire earlier).

The return to overview button takes the user to the PET Overview tab.

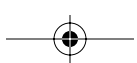

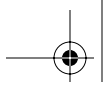

### PET Decompression details tab

The Decompression details tab details the decompression tests performed to PET system.

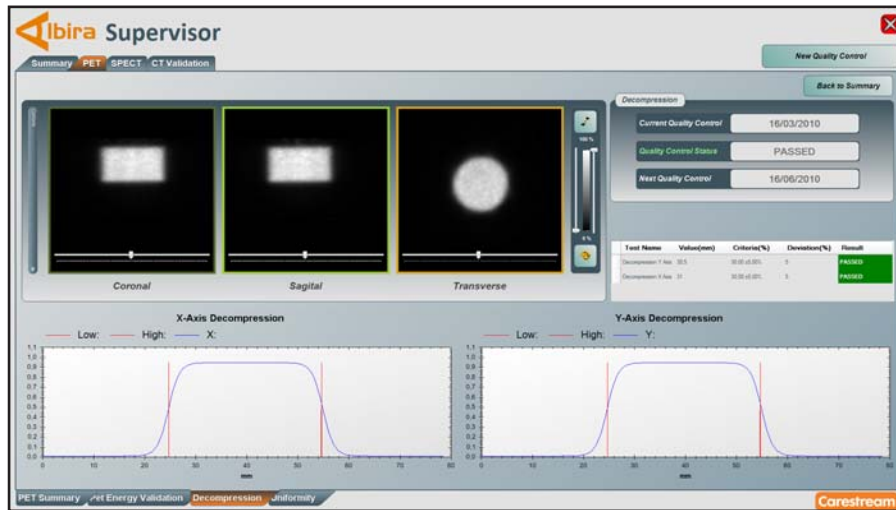

- ✓ The decompression calculated for X and Y-axis in mm. It also shows the validation result in Green if criteria passed and in Red for non-passed criteria validations.
- ✓ The fitting graph for the phantoms section. The graph shows a Blue line that represents the line samples and two Red lines that show the position of the found phantoms size. This representation is presented for both the X and Y-axis
- ✓ The validation image preview.

This tab also shows the last decompression quality control date and state (PASSED/ FAILED) and expected next quality control (It only represents PET's decompression next quality control. Other validations can expire earlier)

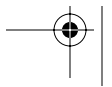
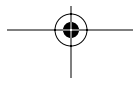

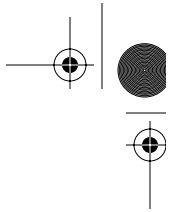

### PET Uniformity details tab

The Uniformity details tab shows every detail of the uniformity tests performed to PET system.



The PET uniformity detail tab presents the following data:

- ✓ Integral Uniformity considers the complete phantom area for the 100% representation and only the center for the 75% representations. It measures the values fluctuations in %.
- ✓ Differential uniformity considers the complete phantom area for the 100% representation and only the center for the 75% representations. It also measures the values fluctuations in % but it differs from integral in that it only takes into account the neighbor values.
- ✓ The validation image preview. It uses the decompression image.

This tab also shows last uniformity quality control date and state (PASSED/FAILED) and expected next quality control (It only represents PET's uniformity next quality control. Other validations can expire earlier)

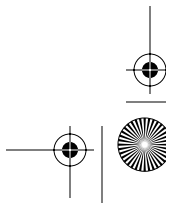
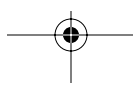

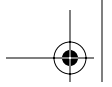

### SPECT Validation Results

SPECT validations are very similar to PET validations adding one for sensitivity. All SPECT validations are presented in one tab because it has only two cameras instead of the eight modules that PET uses.



In this tab you can find the detailed tests values, last quality control date and state (PASSED/FAILED) and expected next quality control. Each test has its own measures:

- ✓ Energy Resolution. The mean Energy resolution validation for all module in %. Even though the mean measure can pass the criteria, if any of the modules does not pass the test, it will be shown as failed. There is also a Gaussian graph that shows the mean measured energy resolution in Blue and the acceptance criteria energy resolution graph in Red. The Blue graph (measured) must always be underneath the control graph (Red).
- ✓ Decompression. The decompression is calculated for X and Y-axis. It is shown in mm and it is also represented the fitting graph for the phantoms section. The graph shows a Blue line that represents the line samples and two Red lines that show the position of the found phantoms size. This representation is presented for both the X and Y-axis.
- ✓ Uniformity:
  - Integral Uniformity considers the complete phantom area for the 100% representation and only the center for the 75% representations. It measures the values fluctuations in %.

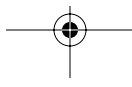

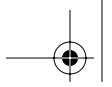

—Differential uniformity considers the complete phantom area for the 100% representation and only the center for the 75% representations. It also measures the values fluctuations in % but it differs from integral that it only takes into account the neighbor values.

- ✓ Sensitivity, the measured values are SPECT sensitivity in cps/MBq and differential sensitivity in %.

This tab also shows last quality control date and state (PASSED/FAILED) and expected next quality control. (It only represents SPECT next quality control. Other validations can expire earlier.)

### SPECT Results Report

Click Print report in the SPECT tab to generate the SPECT validation results report on-screen. This report contains every measured value, acceptance criteria, measure deviation, and result for each modality.

The screenshot shows a 'Print Report' window with a 'Print' button on the left and a 'Save' button on the right. The main content is a table titled 'Validation Status Summary' for 'SPECT'. Below the table is a 'System Status' section.

Test Name	Value	Criteria	Deviation	Result
Spect Energy Resolution Camera 0	16.7451154678235	< 20.00	0	PASSED
Spect Energy Resolution Camera 1	17.4700611141766	< 20.00	0	PASSED
Spect Sensitivity	58.5227817102817	> 10.00	0	PASSED
Spect Sensitivity DDS	22.1071988909998	< 25.00	0	PASSED
SPECT Decompression Y	39.8	30.00 ±10.00%	10	PASSED
SPECT Decompression X	30.4	30.00 ±10.00%	10	PASSED
SPECT Uniformity I75	5.77653643096325	< 15.00	0	PASSED
SPECT Uniformity I100	6.44583287420008	< 15.00	0	PASSED
SPECT Uniformity D75	3.39162830964439	< 15.00	0	PASSED
SPECT Uniformity D100	3.90708284307504	< 15.00	0	PASSED

**System Status**

Last Calibration Date: viernes, 02 de noviembre de 2007  
 Last Quality Control Date: 10/03/2010  
 PASSED

You can print the report by clicking Print or store the report by clicking Save.

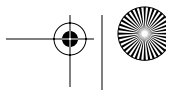
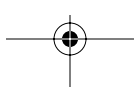
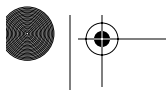



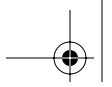

### CT Validation Results

In this tab user can find the detailed tests values, last quality control date and state (PASSED/FAILED) and expected next quality control.

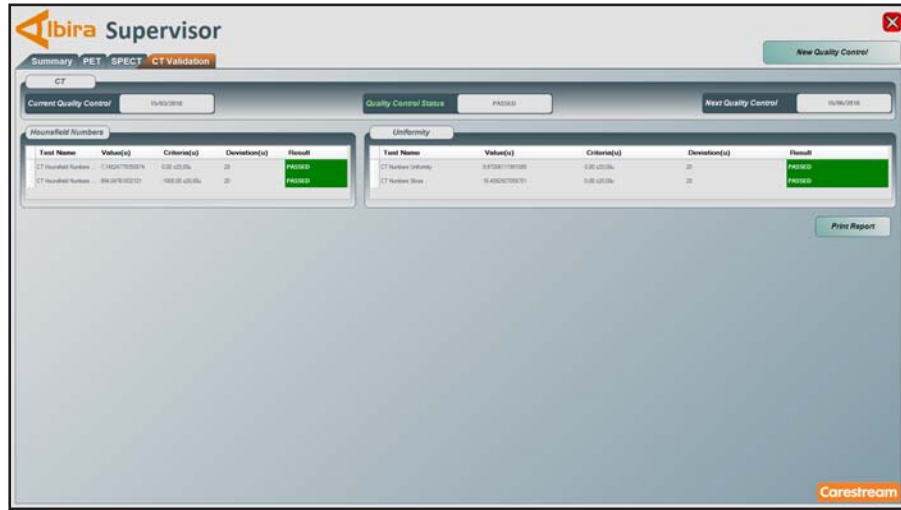

Each test has its own measures:

- ✓ Hounsfield Numbers Validation. The air and water measured and the deviation calculation from the expected resultant value.
- ✓ Uniformity. The uniformity is calculated on the XY plane and then it is also calculated the Z dependence uniformity of the 3D image.

This tab also shows last quality control date and state (PASSED/FAILED) and expected next quality control. (It only represents CT next quality control. Other validations can expire earlier.)

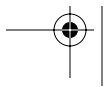
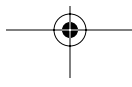

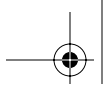

### CT Results Report

Click Print report in the CT tab to generate the CT validation results report on-screen. This report contains every measured value, acceptance criteria, measure deviation, and result for each modality .

Validation Status Summary				
CT				
Test Name	Value	Criteria	Deviation	Result
CT Hounsfield Numbers Water	-1.86157003093106	0.00 ±20.00u	20	PASSED
CT Hounsfield Numbers Air	-997.021049766077	-1000.00 ±20.00u	20	PASSED
CT Numbers Uniformity	15.5706680269378	0.00 ±25.00u	25	PASSED
CT Numbers Slices	20.8946911357069	0.00 ±25.00u	25	PASSED

**System Status**

Last Calibration Date: viernes, 02 de noviembre de 2007  
 Last Quality Control Date: 10/03/2010  
**PASSED**

SND1001. Report generated by Carestream on: jueves, 27 de mayo de 2010  
 Report generated with: Kibra by: Divoision

You can print the report by clicking Print or store the report by clicking Save.



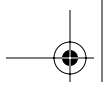

### Quality Control Wizard

To perform a new system validation, click New Quality Control from the Albira Supervisor window. Once the button is clicked the Quality Control Wizard main (start) screen appears.

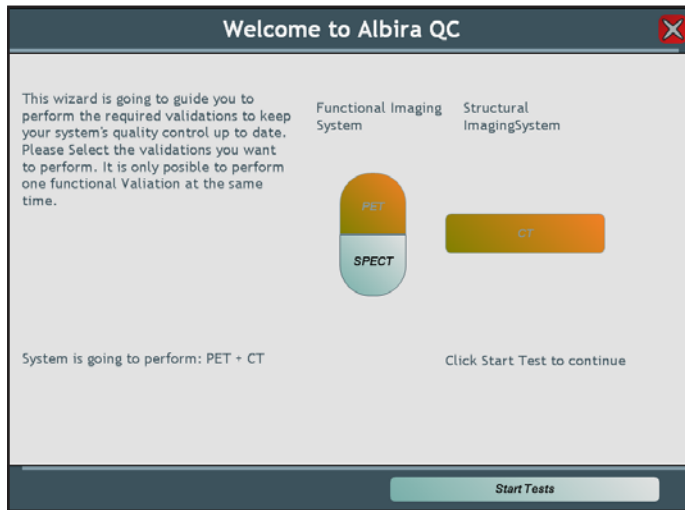

The start or main screen of the Validation Wizard guides you through the validation configuration process. To assist you, only the modality options you want to validate are displayed. Once you have chosen the validation you want to perform, (please note that PET and SPECT validations can not be validated at the same time) click the Continue button and the study dialog will be shown.



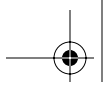

Once the validation modalities are selected, the Quality Control Wizard Study Selection screen will be shown for study selection.

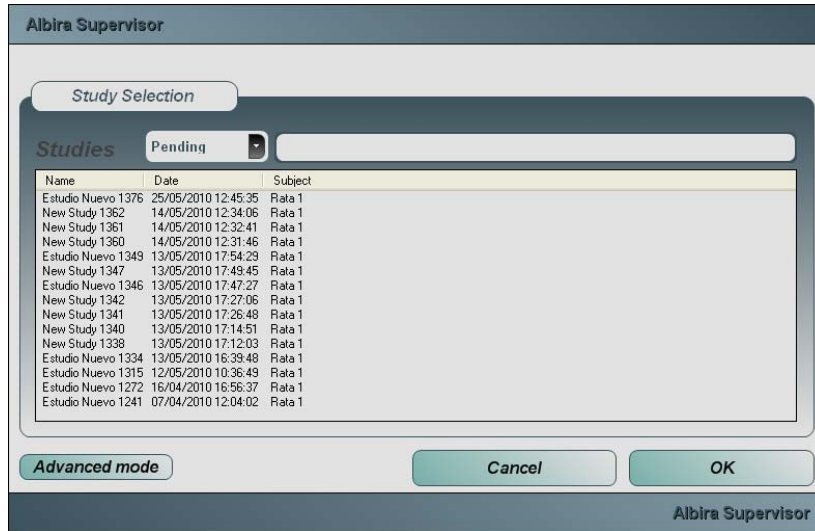

This study must contain the data files from the previously selected modality in order to function properly. Validation requires the acquired data but also the reconstruction files.

Click OK and the validation will start. This process can take several minutes. A progress bar allows the user to monitor progress of the validation.

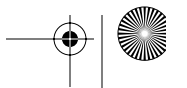
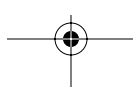
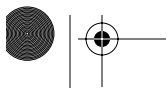

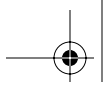

### Advanced Mode

It is also possible to manually select the data that is needed to perform validations instead of working from studies. To do so, you must click the Advanced mode button. From the advanced mode dialog, you can select the specific files for each validation. To return to standard mode, click Standard Mode.

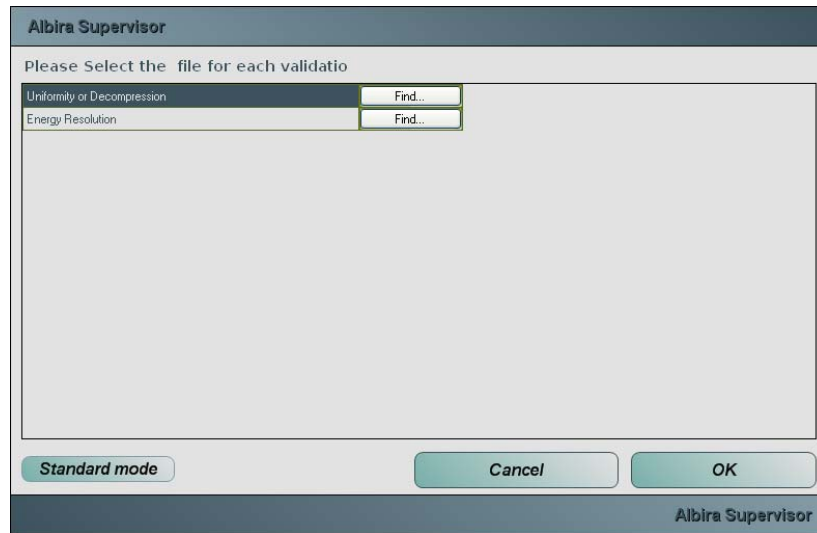

When the Find button is clicked, the corresponding files are reviewed through a windows file dialogue. The file the calibration needs are pre-filtered to each file dialog to meet the requirements set in the quality control wizard main screen.



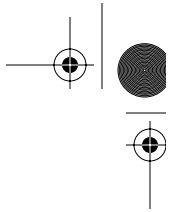

# Maintaining the System

To ensure safety, image quality, and quantitative data collection basic system maintenance procedures are required. This chapter reviews maintenance procedures.

We recommend that quarterly tests be performed by the operator. The protocols and instructions for completing these quarterly quality control tests are detailed further below. The following test are recommended:

**Table 6.1: Quarterly End User Inspection**

Procedure	Description	Frequency
General Cleaning	Routine Cleaning	As needed
	Decontaminating Radioisotopic Contamination	
PET Validation	PET Spatial Resolution	Quarterly
	PET Uniformity	
	PET Sensitivity	
	PET Energy Resolution	
	DOI Resolution	
SPECT Validation	SPECT Spatial Resolution	Quarterly
	SPECT Uniformity	
	SPECT Sensitivity	
	SPECT Energy Resolution	
CT Validation	Hounsfield Units accuracy	Quarterly
	Geometric Accuracy	



**WARNING:**The Albira CT System should be routinely surveyed by Carestream Health, Inc. trained personnel or your site's radiation safety officer if applicable. Leakage monitoring and recording at indicated positions at the surface are defined in the Albira Installation Guide.



**WARNING:**There are no user serviceable parts for the Albira. At no time should any cover be removed which could cause a radiation safety hazard. Contact Molecular Imaging Technical Support or an authorized dealer for repair.

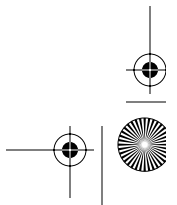

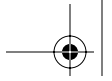

---

---

## Regular End User Maintenance

The Albira requires little maintenance. After each use, the Work Area should be wiped down.

### Routine Cleaning

- 1 Turn off the system at the Main Power Switch. Unplug the unit from the AC wall receptacle (MAINS).
- 2 Using a lint-free cloth, moistened (but not soaked) with a neutral pH antiseptic soak solution (concentrations of 20%), wipe the unit.
- 3 **NOTE:** In the presence of organic residuals, affected parts should be disinfected with surface disinfectants suitable for the disinfection of electromedical equipment.



**WARNING:** Some ammonia based spray cleaners may cause skin or eye irritation. Consult the manufacturer's material safety data sheet for additional information prior to use.



**WARNING:** Do not use strong cleaners or chemical solvents such as ketones, hexanes, acids and alkalis that may permanently damage the finish. This type of damage is not covered by the warranty.



**WARNING:** Care should be taken to avoid leaking solutions when cleaning buttons and the inside of the housing openings.



**WARNING:** Consult manufacturer for instructions on safe disposal of cleaning materials used for removing radioisotopic or other harmful materials.

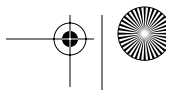
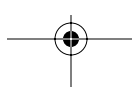

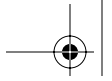

---

---

## Decontaminating Radioisotopic Contamination

- 1** Wearing latex gloves, use a GM-type radioactivity meter calibrated in counts per minute (CPM) to determine the background readings.
- 2** If any part of the Albira system shows readings higher than background, wipe the area using Count Off (PerkinElmer Life Sciences) or another similar commercially available detergent and paper towels. If none are available, use a Formula 409-like solution or a mild detergent.



**WARNING:** When using detergents, consult the manufacturer's material safety data sheet for additional information prior to use.



**WARNING:** If the Radioisotopic Phosphor Screen has unremovable contamination after continued washing and the  $\text{dpm}/\text{cm}^2$  remains constant above 100 of a short half-life isotope such as  $^{99\text{m}}\text{Tc}$ , the unit may be stored for 10 half-lives of isotopic decay and the decontamination procedure repeated.

- 3** As you clean, discard liquid and solid waste (gloves and paper towels) according to your local and institutional regulations for radioactive material disposal. Continue washing until the GM meter reading for the contaminated area(s) is equal to or below background.

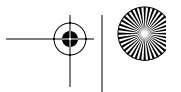
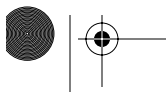



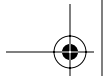

## PET Validation

### *Material*

#### 1 Validation Phantom

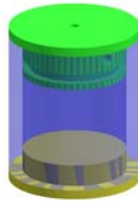

#### 2 Supervisor software.

#### 3 FDG dose.

### *Procedure*

#### 1 Validation Acquisition:

- ✓ Fill the phantom with 2.7 MB of FDG in 19 mL.
- ✓ Place the phantom on the phantom stretcher.
- ✓ Select “PET Acquisition Supervisor” from the Acquirer.
- ✓ Enter the study name “Validation”.
- ✓ Select the isotope FDG if it is not already selected.
- ✓ Select the button “Start Survey”.

#### 2 Validation Reconstruction:

- ✓ Once the acquisition is complete launch the Reconstructor.
- ✓ Select the study “Validation”.
- ✓ Select automatic reconstruction.

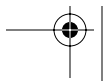

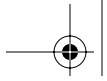

### 3 Supervisor:

- ✓ Launch the Supervisor. Select the PET button as shown below. Select Start Tests.

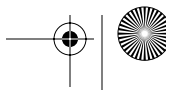
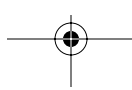
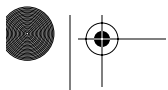

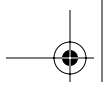

- ✓ Select the Uniformity or Decompression and Energy Resolution files Validation.hdr and Validation.IM res respectively using the interface provided and select OK.

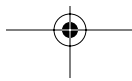
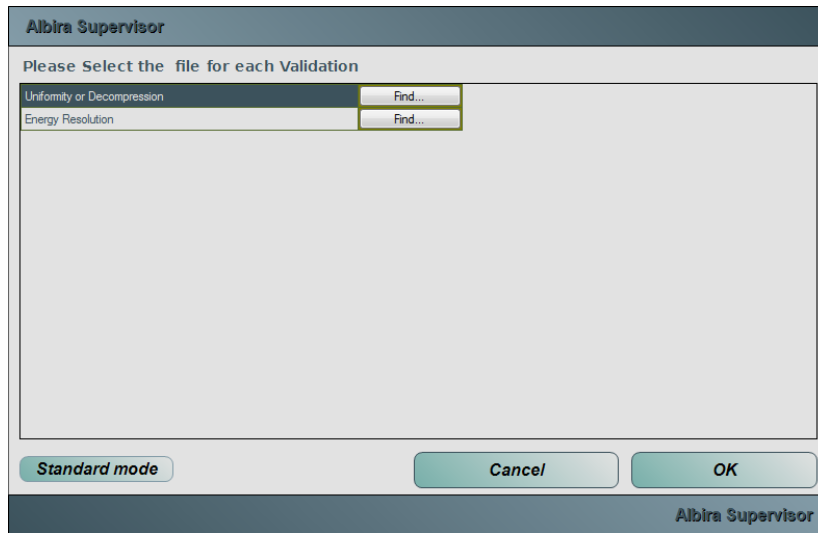



✓ \_ Validation results will appear as below.

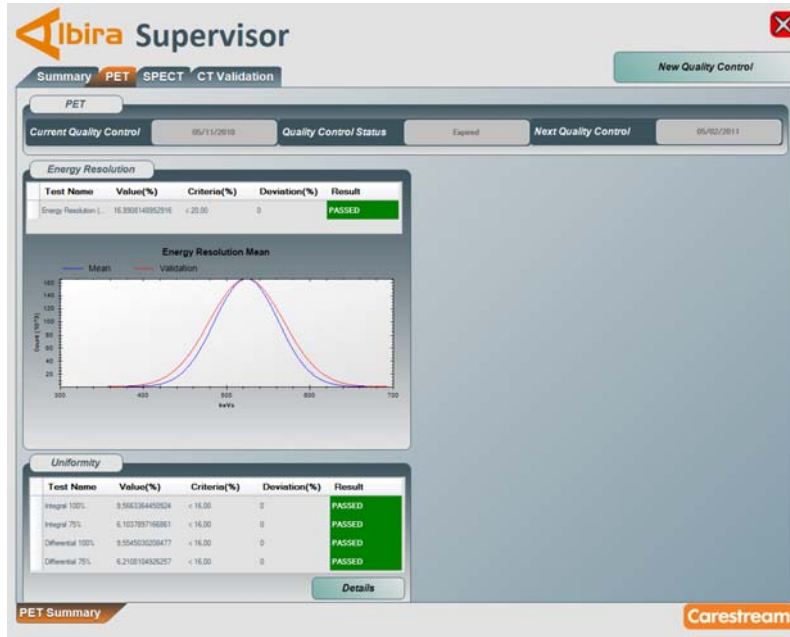

# 6

## Maintaining



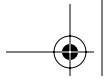

## SPECT Validation

### *Material*

#### 1 Validation Phantom

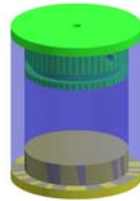

#### 2 Supervisor software

#### 3 $^{99m}\text{Tc}$ dose.

### *Procedure*

#### 1 Validation Acquisition:

- ✓ Fill the phantom with 80 MBq of  $^{99m}\text{Tc}$  in 19 mL.
- ✓ Place the phantom on the phantom stretcher.
- ✓ Select “SPECT Acquisition Supervisor” from the Acquirer.
- ✓ Enter the study name “Validation SPECT”.
- ✓ Select the isotope Tec-99m if it is not already selected.
- ✓ Select the button “Start Survey”.

#### 2 Validation Reconstruction:

- ✓ Once the acquisition is complete launch the Reconstructor.
- ✓ Select the study “Validation SPECT”.
- ✓ Select automatic reconstruction.

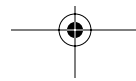

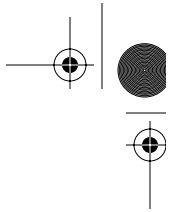

### 3 Supervisor:

- ✓ Launch the Supervisor. Select the SPECT button as shown below.
- ✓ Select Start Tests.



- ✓ Select the data file and image header files Validation SPECT using the interface provided and select OK.

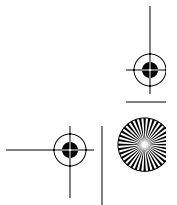
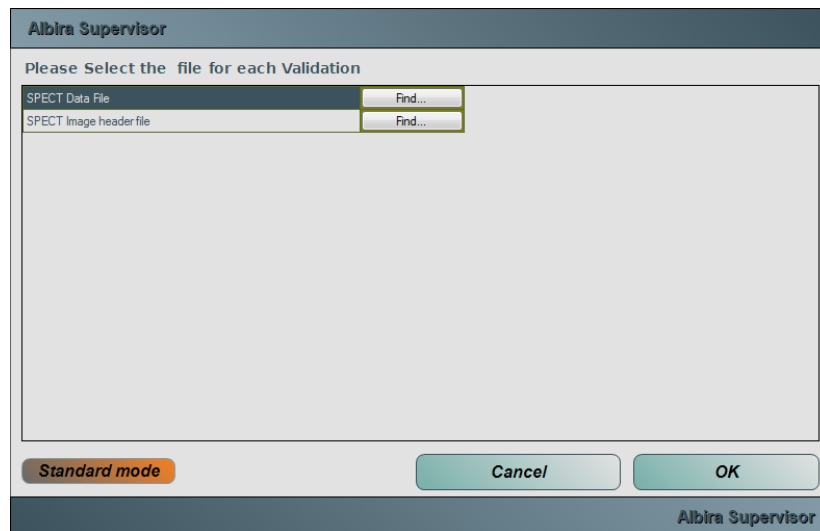

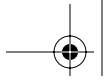

✓ Validation results will appear as below.

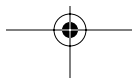

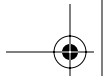

---

---

## CT Validation

### *Material*

#### 1 Validation Phantom

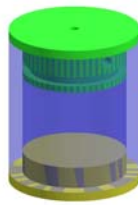

#### 2 Supervisor software

### *Procedure*

#### 1 Validation Acquisition:

- ✓ Place the phantom on the phantom stretcher.
- ✓ Select “CT Acquisition Supervisor” from the Acquirer.
- ✓ Enter the study name “Validation CT”.
- ✓ Select the button “Start Survey”.

#### 2 Validation Reconstruction:

- ✓ Once the acquisition is complete launch the Reconstructor.
- ✓ Select the study “Validation CT”.
- ✓ Select automatic reconstruction.

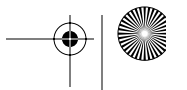
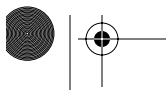



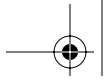

### 3 Supervisor:

- ✓ Launch the Supervisor. Select the CT button as shown below.
- ✓ Select Start Tests.

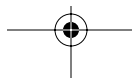
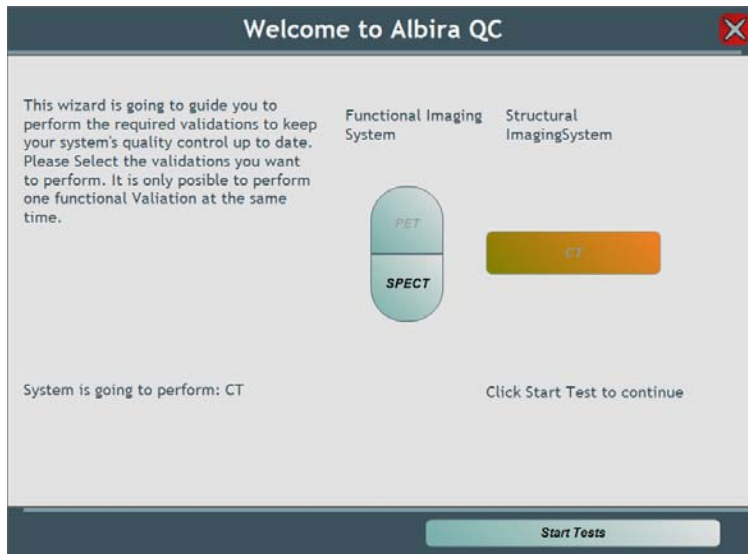

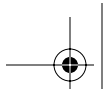

- ✓ Select the data file and image header files Validation CT using the interface provided and select OK.

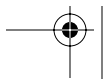
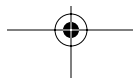
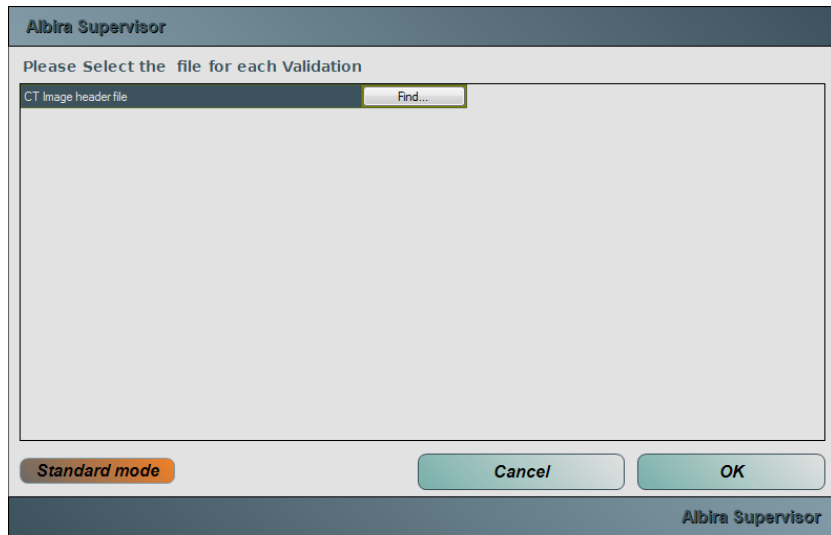

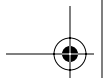

✓ Validation results will appear as below.

The screenshot displays the Ibra Supervisor software interface. At the top, there is a navigation bar with tabs for 'Summary', 'PET', 'SPECT', and 'CT Validation'. The 'CT Validation' tab is active. Below the navigation bar, there are buttons for 'Current Quality Control' (with value 10/20/2010), 'Quality Control Status' (with value PASSED), and 'Next Quality Control' (with value 10/20/2010). A 'New Quality Control' button is also visible in the top right corner. The main area contains two tables: 'Histogram Numbers' and 'Uniformity'. Both tables show test results with columns for Test Name, Value(s), Criteria(s), Deviation(s), and Result. The results for both tables are 'PASSED'. A 'Print Report' button is located at the bottom right of the main area. The 'Carestream' logo is visible in the bottom right corner of the software window.

Test Name	Value(s)	Criteria(s)	Deviation(s)	Result
CT Histogram Numbers	1.138227763205	0.00-10.00	0	PASSED
CT Histogram Numbers	98.0270102717	000.00-100.00	0	PASSED

Test Name	Value(s)	Criteria(s)	Deviation(s)	Result
CT Uniformity Uniformity	9.812811189100	0.00-10.00	0	PASSED
CT Uniformity Uniformity	9.80522788191	0.00-10.00	0	PASSED

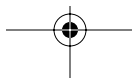

---

---

# *Warranty Information*

This section contains the Albira warranty and information on how to obtain service.

---

---

## **The Carestream Albira Limited Warranty**

### **Warranty Time Period**

Carestream Health, Inc. warrants the Carestream Albira to function properly for one year from date of acceptance. Acceptance date is determined by the date the User signs the completed Installation/Acceptance Form. Specific system components warranted by Carestream Health, Inc. are the Albira hardware components installed within the chamber, SPECT, PET and CT modules. Other components included with the system, including the computer, monitor and storage system are under separate warranty provided by their respective manufacturers.

### **Days and Hours of Coverage**

Arrangements for service through Technical Support can be made Monday through Friday 8:00 a.m. to 6:00 p.m. EST in the United States, except for locally observed holidays. Hours of coverage outside the United States may vary. Contact your local Molecular Imaging Systems dealer for hours of coverage.

### **Warranty Repair Coverage**

If the equipment does not function properly during the warranty period due to defects in either materials or workmanship, Carestream Health will, at its option, either repair or replace the equipment without charge, subject to the conditions and limitations stated herein. Such repair service will include all labor as well as any necessary adjustments and/or replacement parts.

If replacement parts are used in making repairs, these parts may be remanufactured, or may contain remanufactured materials. If it is necessary to replace the entire system, it may be replaced with a remanufactured system.

Carestream Health will also provide telephone assistance during the warranty period.

---

---

## Limitations

WARRANTY SERVICE WILL NOT BE PROVIDED WITHOUT DATED PROOF OF PURCHASE. PLEASE RETURN THE WARRANTY REGISTRATION CARD WITHIN 30 DAYS OF PURCHASE.

THIS WARRANTY BECOMES NULL AND VOID IF YOU FAIL TO PACK YOUR INSTRUMENT IN A MANNER CONSISTENT WITH THE ORIGINAL PRODUCT PACKAGING AND DAMAGE OCCURS DURING PRODUCT SHIPMENT.

THIS WARRANTY DOES NOT COVER: CIRCUMSTANCES BEYOND CARESTREAM HEALTH, INC.'S CONTROL; SERVICE OR PARTS TO CORRECT PROBLEMS RESULTING FROM THE USE OF ATTACHMENTS, ACCESSORIES OR ALTERATIONS NOT MARKETED BY CARESTREAM HEALTH, INC.; SERVICE REQUIRED AS THE RESULT OF UNAUTHORIZED MODIFICATIONS OR SERVICE; MISUSE, ABUSE; FAILURE TO FOLLOW CARESTREAM HEALTH, INC.'S OPERATING, MAINTENANCE OR REPACKAGING INSTRUCTIONS; OR FAILURE TO USE ITEMS SUPPLIED BY CARESTREAM HEALTH, INC. (SUCH AS ADAPTERS AND CABLES).

CARESTREAM HEALTH, INC. MAKES NO OTHER WARRANTIES, EXPRESS, IMPLIED, OR OF MERCHANTABILITY OR FITNESS FOR A PARTICULAR PURPOSE FOR THIS EQUIPMENT OR SOFTWARE.

REPAIR OR REPLACEMENT WITHOUT CHARGE ARE CARESTREAM HEALTH, INC.'S ONLY OBLIGATION UNDER THIS WARRANTY. CARESTREAM HEALTH, INC. WILL NOT BE RESPONSIBLE FOR ANY SPECIAL, CONSEQUENTIAL OR INCIDENTAL DAMAGES RESULTING FROM THE PURCHASE, USE, OR IMPROPER FUNCTIONING OF THIS EQUIPMENT REGARDLESS OF THE CAUSE. SUCH DAMAGES FOR WHICH CARESTREAM HEALTH, INC. WILL NOT BE RESPONSIBLE INCLUDE, BUT ARE NOT LIMITED TO, LOSS OF REVENUE OR PROFIT, DOWNTIME COSTS, LOSS OF USE OF THE EQUIPMENT, COST OF ANY SUBSTITUTE EQUIPMENT, FACILITIES OR SERVICES, OR CLAIMS OF YOUR CUSTOMERS FOR SUCH DAMAGES.

Depending on your geographical location, some limitations and exclusions may not apply.

---

---

## How to Obtain Service

If the instrument does not function properly during the warranty period, contact Technical Support or your local dealer to arrange for service. If your unit needs to be returned for any reason, please contact your local dealer to obtain a return authorization. All returned units must be decontaminated prior to their return. No returns will be accepted without a return authorization and proper decontamination documentation.

When contacting technical support, please have the following information available:

- ✓ The serial number of your system located on the back of the unit.
- ✓ The problem you are having and what you were doing when the problem occurred. Please note the exact wording of any error messages

When contacting technical support by telephone, you will be assisted best if you are seated in front of your computer with the system running.

Contact Carestream Molecular Imaging Technical Support by:

- ✓ Utilizing our World Wide Web support pages at:  
[mi.carestream.com](http://mi.carestream.com)
- ✓ Calling Carestream Molecular Imaging Technical Support toll free at:  
877-747-4357, between the hours of 8:00 a.m. and 6:00 p.m. (Eastern Standard Time) Monday through Friday
- ✓ E-mailing Carestream Molecular Imaging Technical Support at:  
[molecular-support@Carestream.com](mailto:molecular-support@Carestream.com)
- ✓ Faxing Carestream Molecular Imaging Technical Support at:  
203-786-5656

For up-to-date dealer information, visit our WEB site at [mi.carestream.com](http://mi.carestream.com).

---

---

## General Instructions for Cleaning and Decontamination for Return of the Carestream Albira

All returned material must be cleaned and decontaminated prior to shipping. To meet Federal and State Regulatory and Safety standards, please follow the decontamination procedure given here if radioactive materials are used with this product or are used in the vicinity of where this apparatus has been used or stored. You will be required to sign a certificate of decontamination prior to sending any component for repair. Anything received with contamination will be subject to a charge for decontamination.

### *General Cleaning Procedure*

For materials not contaminated with biological or radiological substances, components may be gently washed using water or an ammonia based spray cleaner using soft lint-free cloth or lens paper.



**WARNING:**Ammonia based spray cleaners may cause eye irritation. Consult the manufacturer's material safety data sheet for additional information prior to use.

### *Radiological Decontamination Procedure*



**WARNING:**Carestream Health, Inc. cannot accept return of products which are contaminated with any radioactivity.

For isotopes such as  $^{99m}\text{Tc}$ , use a GM-type survey meter with a thin-end window detector, calibrated in counts per minute (CPM) to determine the background readings for your work area. Wearing latex gloves, survey the unit to be returned with the GM meter. If any part of the unit is found to show readings higher than background, wash the area using Count Off (PerkinElmer Life Sciences) or another similar commercially available detergent and paper towels. If none are available, a Formula 409™-like solution or a mild detergent will do. As you clean, discard liquid and solid waste (gloves and paper towels) according to your local and institutional regulations for radioactive material disposal. Continue washing until the GM meter reading for the contaminated area(s) is equal to or below background.

Once the unit has been determined to be radiation free ( $< 100 \text{ dpm/cm}^2$ ), remove all the hazardous and radioactive labels from the unit. If the labels cannot be removed, deface them. Failure to do so may result in significant delay or a refusal of repair.



---

---

If your unit has unremovable contamination (detectable with a GM-meter and not with paper swipes, or detectable with paper swipes but after continued washing the  $\text{dpm/cm}^2$  remains constant above 100) of a short half-life isotope such as  $^{99\text{m}}\text{Tc}$ , the unit may be stored for 10 half-lives of isotopic decay and the decontamination procedure repeated.

Contact your Radiation Safety Officer for further assistance.

 NOTE: Units contaminated with unremovable, long half-life isotopes may not be returned.

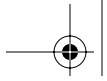

---

---

# *Imaging Concepts*

8

*Imaging Concepts*

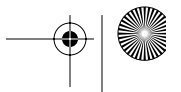
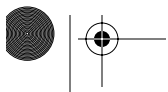

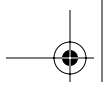

## PET and SPECT Concepts

Positron emission tomography (PET) and single photon emission computed tomography (SPECT) are imaging techniques that produce quantitative three-dimensional images of functional or metabolic processes. The most common biologically active molecule chosen for PET imaging is FDG (Fludeoxyglucose), a glucose analogue (see figure below). (FDG detection is indicative of regional glucose uptake and metabolic activity). Other PET isotopes are employed for PET imaging. The various PET isotopes exhibit common decay properties. PET isotopes emit two 511 keV gamma photons at 180 degrees.

### FDG and PET (Positron Emission Tomography)

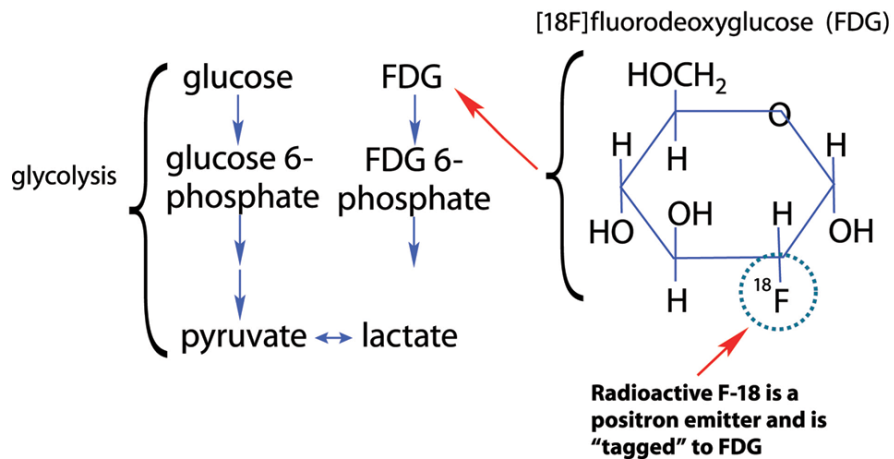

A PET system consists of a ring of fixed detectors (see figure below) that detects opposite pairs of gamma rays emitted indirectly by a positron-emitting radionuclide. By detecting coincidence detections for the relative photons emitted at 180 degrees and through the application of algorithms the system allows for tomographic reconstruction of FDG that provides both spatial and quantitative information.



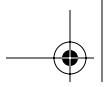

## Acquiring Images using the Albira Suite

### PET: Timing coincidence

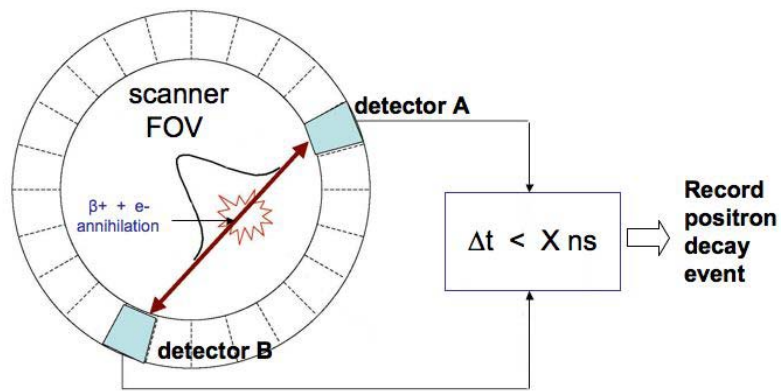

The most common isotope employed for SPECT imaging is  $^{99m}\text{Tc}$ .  $^{99m}\text{Tc}$  is commonly conjugated to a molecule of interest and provides information regarding biodistribution, targeting, and/or specificity of the molecule. Other SPECT isotopes are employed for SPECT imaging. The various SPECT isotopes exhibit common properties. As the name implies, SPECT isotopes emit Single photons not coordinated with a paired photon at a 180 degree angle as in PET. The energy emitted by SPECT agents is lower than PET agents and varies among the various SPECT agents. A SPECT detector consists of SPECT sensors mounted on a precision rotating disc. A computed tomography image can be created when images are collected at multiple rotational projections.

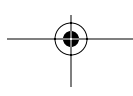
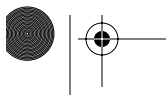

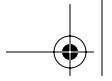

## X-ray Concepts

X-ray CT (computed tomography) is frequently generated in concert with PET and SPECT imaging to provide an anatomical reference for functional imaging. A typical CT system consists of an X-ray source tube and X-ray flat panel detector mounted at opposite ends of a precision rotating ring. An X-ray computed tomography (CT) image can be created when X-ray images are collected at multiple rotational projections.

X-rays are very high-energy photons that penetrate materials and are absorbed according to the mass and electron density of material constituents within a sample. This behavior contrasts with optical photons, whose absorption is due to molecular resonance of the sample constituents. A relevant demonstration of X-ray density is shown in the graph to the below, in which the inherent X-ray attenuation properties of water, bone and fat are distinguished. The X-ray densities of water, bone and fat are quite different and vary with X-ray energy. The extent to which these substances differ or contrast in an X-ray image are governed by the equation shown in the graph. For a given material, X-ray density is a product of the X-ray absorption coefficient, the mass density, and the thickness. Since the mass density (simply called density in the above) of bone is greater than water, and water is greater than adipose, the final X-ray densities differ more than is apparent in the graph. In practice, bone/water/fat contrast varies according to the extent they attenuate X-rays ( $\text{Log}[I/I_0]$ ), and is related to the product of X-ray density and the material thickness.

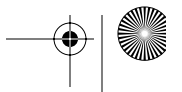
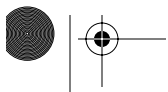

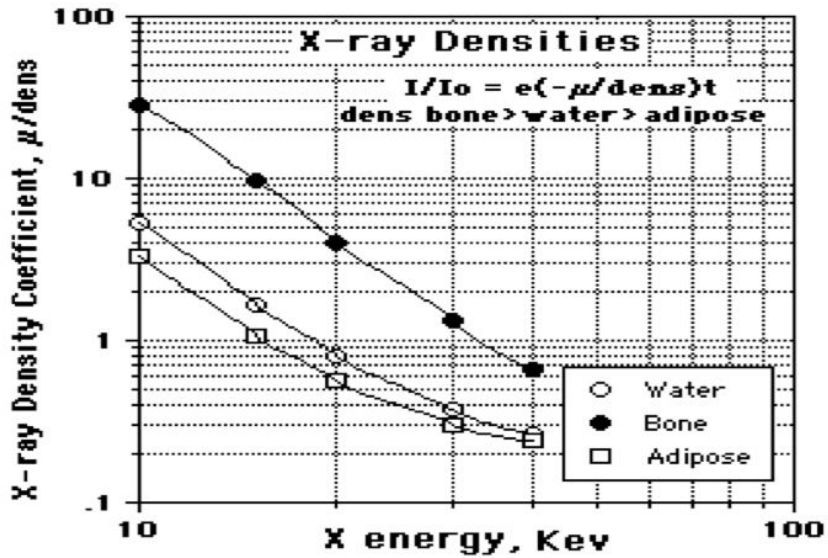
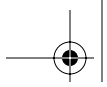

In theory, the above is a concise summary of how X-rays penetrate objects and are subsequently imaged by the Albira. In practice, more understanding of X-rays is needed. While object contrast varies with X-ray energy, the figure above applies to particular X-ray energies. An X-ray Source does not produce defined energies (so-called “monochromatic” X-rays). X-rays are a product of an electron collision with a metal, resulting in an entire spectrum of X-ray energy. The maximum X-ray energy that can be produced in the collision is the upper bound of the energy spectrum, and few X-rays are produced at that energy. The upper bound of X-ray energies produced is called the X-ray kVP, or the kilovolt potential energy of the electrons in the collision. The X-ray kVP is adjustable in the Albira, so the user may control the energy spectrum delivered to the sample object.

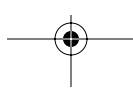

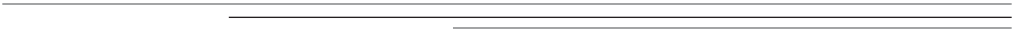
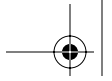

This page intentionally left blank.

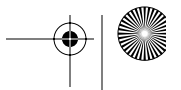
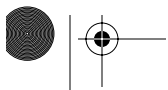

---

---

# Glossary

**Analog Signal**—A signal that is continuous and uninterrupted. Variations in voltage correspond to variations in brightness. This differs from digital, where a signal is represented in discrete steps of digital value (1's, 0's).

**Analog to Digital (A/D) Converter**—An integrated circuit that transforms an analog (voltage level) to a binary (or digital) value. The Albira camera converts the analog signal into a digital signal using an A/D converter.

**Aperture**—The opening within a lens that limits light passage, usually adjustable and referred to as the  $f$ -stop.

**Bit (Binary Digit)**—The smallest amount (unit) of information, measured on a binary scale (integer exponents of 2), where combinations of 0's and 1's are used to code information. See *Bit Depth*. Eight bits of information is called one byte.

**Bit Depth (Bits-Per-Pixel or Pixel Depth)**—The number of intensity values that can be assigned to each pixel. Images usually fall between 8 and 24 bits. A 16-bit image has 65,536 gray levels.

**Brightness**—A relative measure of light associated with a pixel representing its gray level from black and white, through intermediate levels of gray. Perceived brightness increases from dark to bright, or black to white through intermediate levels of gray. However, the convention of quantitative imaging is quite the opposite, wherein the gray scale is increased from white to black.

**Contrast**—The contrast of an image represents the perceived differences in intensity between dark and light areas within the image. A low contrast image contains gray levels that are similar in visual intensity, whereas a high contrast image contains extreme differences in visual intensity.

**Floating Point**—A means of representing a signal as real numbers (fractions or decimals). Floating point calculations are important in maintaining the accuracy of analysis data.

**Gamma**—A mathematical transformation function that can be used to improve image appearance by decreasing or increasing the contrast of an element of interest in an image. Adjusting the gamma of an image disproportionately skews the gray level distribution, higher gamma values lighten the image and lower gamma values darken the image. Adjusting the gamma does not alter the image data file and is only used to enhance the viewing of the image.



---

---

**Gray Level**—The digital signal assigned to a pixel associated with a level of light (from black to white). For example, an 8-bit and a 16-bit system includes gray level values between 0–255 and 0–65,535, respectively.

**Half-life**—The time taken for half the quantity of a radioisotope to decay.

**Histogram**—The frequency of the distribution of pixels over the range of signals within an image. The horizontal axis represents the gray level and the vertical axis represents the number of pixels.

**Image Compression**—A computational operation upon image data that results in a reduction of data storage volume. Usually results in some loss of image data.

**Interpolation**—A numerical estimate of a value within a range of empirical data, based on the mathematical trend of data. Contrasts with extrapolation, in which a value outside the range of data is estimated.

**Kilovoltage (kV)** = 1000 volts. In the Albira CT Module kilovoltage controls the speed of electrons flowing from the cathode to anode. The higher the kV the faster the electrons move and the more energetic and penetrating is the x-ray beam they produce.

**Microamps**—In the Albira CT Module the number of electrons is controlled by the temperature of the cathode filament. The control is accomplished by adjusting the current. The hotter the filament, the more electrons available to form the stream. The intensity of x-rays produced at a particular kV depends on this number

**Photon**—The smallest unit of light, or any electromagnetic radiation. Characterized by wavelength.

**Pixel**—The fundamental element in a digital image.

**Read Noise**—Electronic distortions in signal introduced when converting the analog signal to a digital signal.

**Resolution**—The capability to distinguish between objects of interest. It is customary, when describing the characteristics of a digital imaging device or image, to describe the resolution by specifying the number of pixels it captures in the horizontal by vertical direction.

**TIFF**—(Tagged Image File Format) is an industry standard file format for storing images. Images from Carestream Molecular Imaging Software can be saved in TIFF format for use with other computer programs.



## Carestream Albira PET/SPECT/CT

**Carestream** Molecular Imaging

**one source**  
*for all your molecular imaging needs*

Carestream Molecular Imaging  
4 Research Drive • Woodbridge, Connecticut 06525 • [mi.carestream.com](http://mi.carestream.com)

© Carestream Health, Inc. 2011  
Pub. No. IB5438511 Rev. B 9/11