

SERIES ABR • Air Actuated Ball Valves 3" & 4"

Rack & Pinion Pneumatic Actuator engineered for corrosion resistance Double-Acting or Spring Return

The ABR rack and pinion pneumatic actuator produces linear torque output in a compact design utilizing the same body and end caps for double-acting and spring return units.

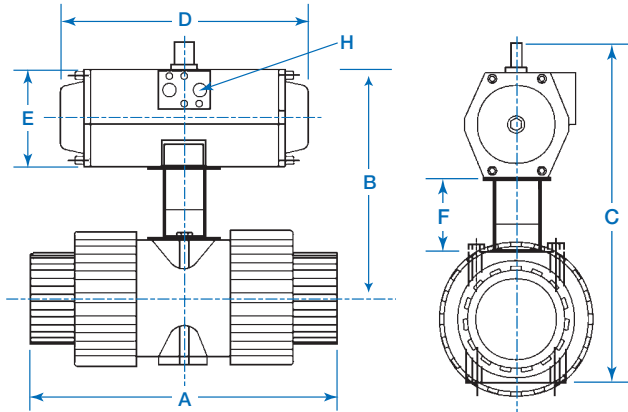

Each activated valve is 100% individually inspected and tested prior to shipment.

Features:

- Million cycle design
- Polished bore & low friction bearings
- Visual indication
- Blowout-proof shaft
- Meets ASTM B117-73 (500 hrs. salt spray)

Actuator Materials of Construction

Actuator body is aluminum alloy (ASTM 6063T6 and ASTM B179) with additional components constructed of nickel plated steel, stainless steel, spring steel, high alloy spring steel, aluminum, nylon, nitril, nitrile, and acetal resin.

Air x Air (Top View)

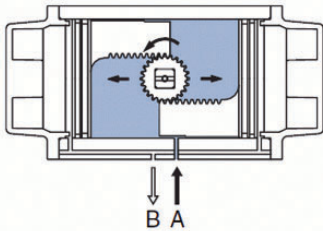

Air supplied to Port A forces pistons apart and toward end positions with exhaust air exiting at Port B. (A counter-clockwise rotation is obtained)

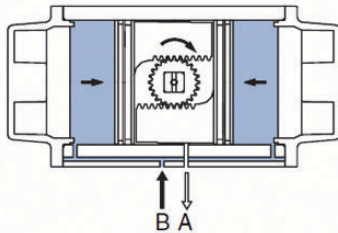

Air supplied to Port B forces pistons toward center with exhaust air exiting at Port A. (A clockwise rotation is obtained)

Air x Spring (Top View)

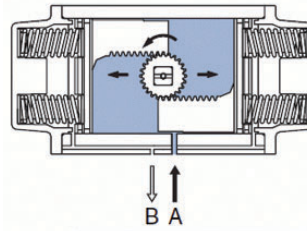

Air supplied to Port A forces pistons apart and toward end position, compressing springs. Exhaust air exits at Port B. (A counter-clockwise rotation is obtained)

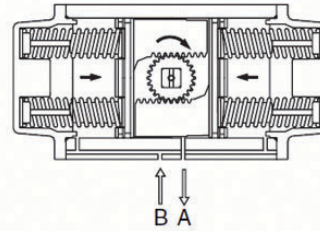

Air or electric failure allows springs to force pistons toward center position with exhaust air exiting at Port A. (A clockwise rotation is obtained)

DIMENSIONS

Pipe Size	Activator with Valve Model No.	A		B		C		D		E		F		H
		IN	MM	IN	MM	IN	MM	IN	MM	IN	MM	IN	MM	
3"	ABRA 300 -	10.6	270					6.12	156	3.27	83			1/4" NPT
4"	ABRA 400-	12.76	324					6.12	156	3.27	83			1/4" NPT

* To complete the Model Numbers refer to the ordering chart below.

Ordering Information

Order by part number and specify exact chemicals, temperatures and pressures. To arrive at the proper part number, please consult diagram below. The letters and numbers used in this part number are for example only!

ABRA*	300	V	T	-PV
AIR ACTUATED BALL VALVE	VALVE PIPE SIZE	SEAL MATERIAL	CONNECTIONS	BODY MATERIAL
	300 3"	V FKM	S Socket Ends	-PV Polyvinyl Chloride (PVC)
	400 4"	EP EPDM	T Threaded Ends	-CP Chlorinated Polyvinyl Chloride (CPVC)
			F Flanges*	-PP Virgin Polypro
			<small>*Flanges are not usually needed with true-union ball valves.</small>	-PF PVDF

*For Air x Spring, change ABRA to ABRS.