

RESTRICTED

T. O. No. 01-90CC-4

SECTION II—GROUP ASSEMBLY PARTS LISTS

FIG. NO.	INDEX NO.	STOCKED	GROUP Body						UNITS PER ASSY	PROPERTY CLASSIFICATION				
			MAJOR ASSEMBLY		Installation - Rudder Pedals Toe Brake - Parking Brake					U.S. NAVY	U.S. ARMY	BRITISH		
			PART NUMBER	1	2	3	4	5					6	NOMENCLATURE
13	9	S	D17792-5							4		01-H		
		S	D17792-6							1		01-H		
		S	105976							1		01-H		
		S	AC995-C40-4							1		04-A		
		S	107486							1		01-H		
		S	AN913-3							1		04-A		
		S	AC365-C32							4		04-A		
		S	AN520-8-7							4		29		
		S	100951-L-040-005-024							4		01-H		
	13	10	S	D177934							1		01-H	
			S	D177934-2							1		01-H	
			S	5B-D	(P)						2		04-A	
	13	11	S	5C-D	(P)						1		04-A	
	13	12	S	AC311JT5-D							1		04-A	
	13	13	S	D177935							2		01-H	
			S	D177935-2							1		01-H	
			S	5B-D	(P)						2		04-A	
13	14	S	D177936							1		01-H		
		S	D177936-2							1		01-H		
		S	5B-D	(P)						2		04-A		
13	15	S	D177937							1		01-H		
		S	D177937-2							1		01-H		
		S	5B-D	(P)						2		04-A		
13	16	S	D177933							2		01-H		
		S	D177933-2							1		01-H		
		S	5B-D	(P)						2		04-A		
13	17	S	D177939							2		01-H		
		S	D177939-2							1		01-H		
		S	5B-D	(P)						2		04-A		
		S	D177941							2		01-H		
		S	D177941-1							1		01-H		
		S	D177941-2							1		01-H		
		S	D177941-3							2		01-H		
		S	AN535-2-2							2		29		
		S	AN3-12							2		04-A		
		S	AN310-3							2		04-A		
		S	AN380-2-2							2		29		
		S	D177942							2		01-H		
		S	D177942-1							1		01-H		
13	18	S	D177942-2							1		01-H		
		S	D177942-3							1		01-H		
		S	D177942-4							1		01-H		
13	19	S	D177942-5							2		01-H		
		S	D17799-1							1		01-H		
		S	D17799-2							1		01-H		
		S	AN430AD5-12							2		01-H		
		S	AN3-12							1		04-A		
		S	AN310-3							1		04-A		
		S	AN380-2-2							1		29		
13	20	S	D177943-1							1		01-H		
		S	D177943-5							1		01-H		
		S	D177943-6							1		01-H		
13	21	S	D177943-7							2		01-H		
		S	D177943-2							1		01-H		

RESTRICTED

T. O. No. 01-90CC-4

SECTION II—GROUP ASSEMBLY PARTS LISTS

FIG. NO.	INDEX NO.	STOCKED	GROUP Body						UNITS PER ASSY	PROPERTY CLASSIFICATION						
			MAJOR ASSEMBLY		Installation - Rudder Pedal Toe Brake - Parking Brake					U.S. NAVY	U.S. ARMY	BRITISH				
			PART NUMBER	1	2	3	4	5					6	NOMENCLATURE		
		S	AN960-10									1			04-A	
		S	D177950									4			01-H	
		S	AN3-12									1			04-A	
		S	AN310-3									1			04-A	
		S	AN380-2-2									1			29	
		S	AN960-10									1			04-A	
		S	D177951									1			01-H	
			D177952-1									1			01-H	
			D177952-2									1			01-H	
			D177953									1			01-H	
			562-D-9	(P)								2			01-C	
		S	D177954									2			01-H	
		S	AN3-13									1			04-A	
		S	AN310-3									1			04-A	
		S	AN380-2-2									1			29	
		S	D177955									1			01-H	
			D177955-2									1			01-H	
			AN100-4									2			29	
			AN115-8									1			04-A	
			AN130-16S									1			04-A	
		S	AN3-5									2			04-A	
		S	AN310-3									2			04-A	
		S	AN380-2-2									2			29	
		S	AN960-10									2			04-A	
		S	D177956									1			01-H	
		S	D177957									1			01-H	
		S	AC530-6-6									13			29	
13	34	S	D177971									1			01-H	
		S	95-004	(P)								2			03-B	
		S	95-005	(P)								4			03-B	
13	35	S	95-008	(P)								2			03-B	
13	36	S	95-010	(P)								4			03-B	
		S	95-011	(P)								2			03-B	
		S	95-013	(P)								2			03-B	
13	37	S	95-018	(P)								2			03-B	
13	38	S	95-0582	(P)								2			03-B	
			218074	(P)								1			03-B	
			218075	(P)								1			03-B	
			214180	(P)								1			03-B	
			213788	(P)								1			03-B	
			217750-1	(P)								1			03-B	
			217957-1	(P)								1			03-B	
			214238	(P)								1			03-B	
			216347-5	(P)								1			03-B	
			214181	(P)								1			03-B	
			213078	(P)								1			03-B	
			218076	(P)								1			03-B	
			214183	(P)								1			03-B	
			214182	(P)								1			03-B	
			214184	(P)								1			03-B	
			AC.-335-D5									1			29	
			218077	(P)								1			03-B	
			511113	(P)								1			03-B	
			218079	(P)								1			03-B	

RESTRICTED
T. O. No. 01-90CC-4
SECTION II—GROUP ASSEMBLY PARTS LISTS

FIG. NO.	INDEX NO.	STOCKED	GROUP Body						UNITS PER ASSY	PROPERTY CLASSIFICATION						
			MAJOR ASSEMBLY		Installation - Rudder Pedals Top Brake - Parking Brake Gear Assembly - Landing					U.S. NAVY	U.S. ARMY	BRITISH				
			PART NUMBER	1	2	3	4	5					6	NOMENCLATURE		
13	39		1604-41	(P)							2		29			
		S	S-132									4		01-H		
		S	AN380-4-4 3/16 x .063									4		29		
		S	AN210-3A									4		01-H		
		S	AN4-20									1		04-A		
		S	AN310-4									1		04-A		
		S	AN320-4									1		04-A		
		S	AN380-2-2									3		04-A		
		S	AN380-4-4									1		29		
		S	AN380-4-4									2		29		
		S	AN520-6-6									4		29		
		S	702-H-5D	(P)								2		03-I		
		S	AC811JT5-D									1		04-A		
		S	AN960-10									3		04-A		
		S	AN960-416									8		04-A		
		S	D17800									1		01-H		
		S	D170101									1		01-H		
		S	AN545-B2-3									2		29		
		S	D173242									1		01-H		
		S	D173500									1		01-H		
		S	AN340-6									2		29		
		S	AN505-6-8									2		29		
		S	AN935-6									2		29		
		S	AN960-6									2		04-A		
		S	D17576									2		01-H		
		14	2		D17576-1								1		01-H	
					D17576-2								1		01-H	
					D17576-3								1		01-H	
				S	AN455AD3-4								4		29	
				S	D17576-4								1		01-H	
				S	No number	(P)							1		01-H	
				S	8-32								5		29	
				S	D178009 LH								1		01-H	
				S	AC365-624								1		04-A	
				S	D178010								1		01-II	
				S	D178010-1								1		01-H	
				S	AN100-4								1		29	
				S	D178011								1		01-H	
				S	D17854								2		01-H	
S	S-34-2								1		01-H					
S	867	(P)							3		29					
S	1887	(P)							3		29					
S	G-12867	(P)							1		29					
S	C-42867	(P)							3		29					
S	D178011 RH								1		01-H					
S	D17854								2		01-H					
S	S-34-2								3		01-H					
S	867	(P)							1		29					
S	1887	(P)							3		29					
S	G-12867	(P)							1		29					

RESTRICTED

RESTRICTED

T. O. No. 01-90CC-4

SECTION II—GROUP ASSEMBLY PARTS LISTS

FIG. NO.	INDEX NO.	STOCKED	GROUP Body						UNITS PER ASSY	PROPERTY CLASSIFICATION			
			MAJOR ASSEMBLY Gear Assembly - Landing							U.S. NAVY	U.S. ARMY	BRITISH	
			PART NUMBER	1	2	3	4	5					6
14	5	S	G-42067 (P)						Link - Straight (Diamond)	3		29	
		S	D178012						Cable Assembly - Tail wheel re-tracting	1		01-H	
14	6	S	D178012-2						Cable - Tail wheel retracting	1		01-H	
		S	AN100-4						Thimble - Wire cable	2		29	
14	7	S	D178013						Cord - Tail wheel retracting cable	1		01-H	
		S	3/8						Cord - Shock	1		01-H	
14	8	S	D178014						Cord Assembly - Tail wheel extending shock	1		01-H	
		S	D178014-2						Cord - Tail wheel extending shock	1		01-H	
14	9	S	D178015						Cable Assembly - Tail wheel extending	1		01-H	
		S	D178015-1						Cable - Tail wheel extending	1		01-H	
14	10	S	AN100-4						Thimble - Wire cable	2		29	
		S	AN140-16S						Turnbuckle Assembly - Cable eyes	1		04-A	
14	11	S	AN155-16S						Barrel - Turnbuckle	1		04-A	
		S	AN170-16LS						Eye - Turnbuckle cable	1		04-A	
14	12	S	AN170-16RS						Eye - Turnbuckle cable	1		04-A	
		S	D178016						Chain Assembly - Landing gear retracting cross shaft	1		01-H	
14	13	S	D178016-1						Chain - Landing gear retracting cross shaft	1		01-H	
		S	35 (P)						Chain (American Standard)	1		29	
14	14	S	S-34-2 (P)						Clip - Safety	1		01-H	
		S	35 (P)						Clip - Connecting link spring (American Standard)	1		29	
14	15	S	35 (P)						Link - Combination offset (American Standard)	2		29	
		S	D178017						Chain Assembly - Landing gear retracting motor	1		01-H	
14	16	S	D178017-1						Chain - Landing gear retracting motor	1		01-H	
		S	35 (P)						Chain (American Standard)	1		29	
14	17	S	S-34-2 (P)						Clip - Safety	2		01-H	
		S	35 (P)						Link - Spring clip connecting (American Standard)	2		29	
14	18	S	35 (P)						Link - Combination offset (American Standard)	1		29	
		S	D17810-1						Leg Assembly - Landing gear diagonal	2		01-H	
14	19	S	D17810-2						End Assembly - Diagonal leg attaching	1		01-H	
		S	D17810-3						Tube - Diagonal leg end	1		01-H	
14	20	S	D17810-4						Bracket - Diagonal leg end	1		01-H	
		S	D17810-5						Plate - Diagonal leg end	2		01-H	
14	21	S	D17810-6						Reinforcement - Landing gear diagonal leg	1		01-H	
		S	D17810-7						Fitting - Diagonal leg end attaching	1		01-H	
14	22	S	D17810-8						Tube - Landing gear diagonal leg	1		01-H	
		S	D17810-11						Bushing - Landing gear diagonal leg	1		01-H	
14	23	S	D17810-9						Bolt - Landing gear diagonal leg	2		01-H	
		S	AN6-17						Bolt - Aircraft	1		04-A	
14	24	S	AN320-6						Nut - Aircraft shear	2		04-A	
		S	D17810-10						Bushing - Landing gear diagonal leg	2		01-H	
14	25	S	AN6-21						Bolt - Aircraft	2		04-A	
		S	AN310-6						Nut - Aircraft castle	2		04-A	
14	26	S	D17815-1						Universal - Landing gear	2		01-H	
		S	AN6-17						Bolt - Aircraft	1		04-A	
14	27	S	AN6-20						Bolt - Aircraft	1		04-A	

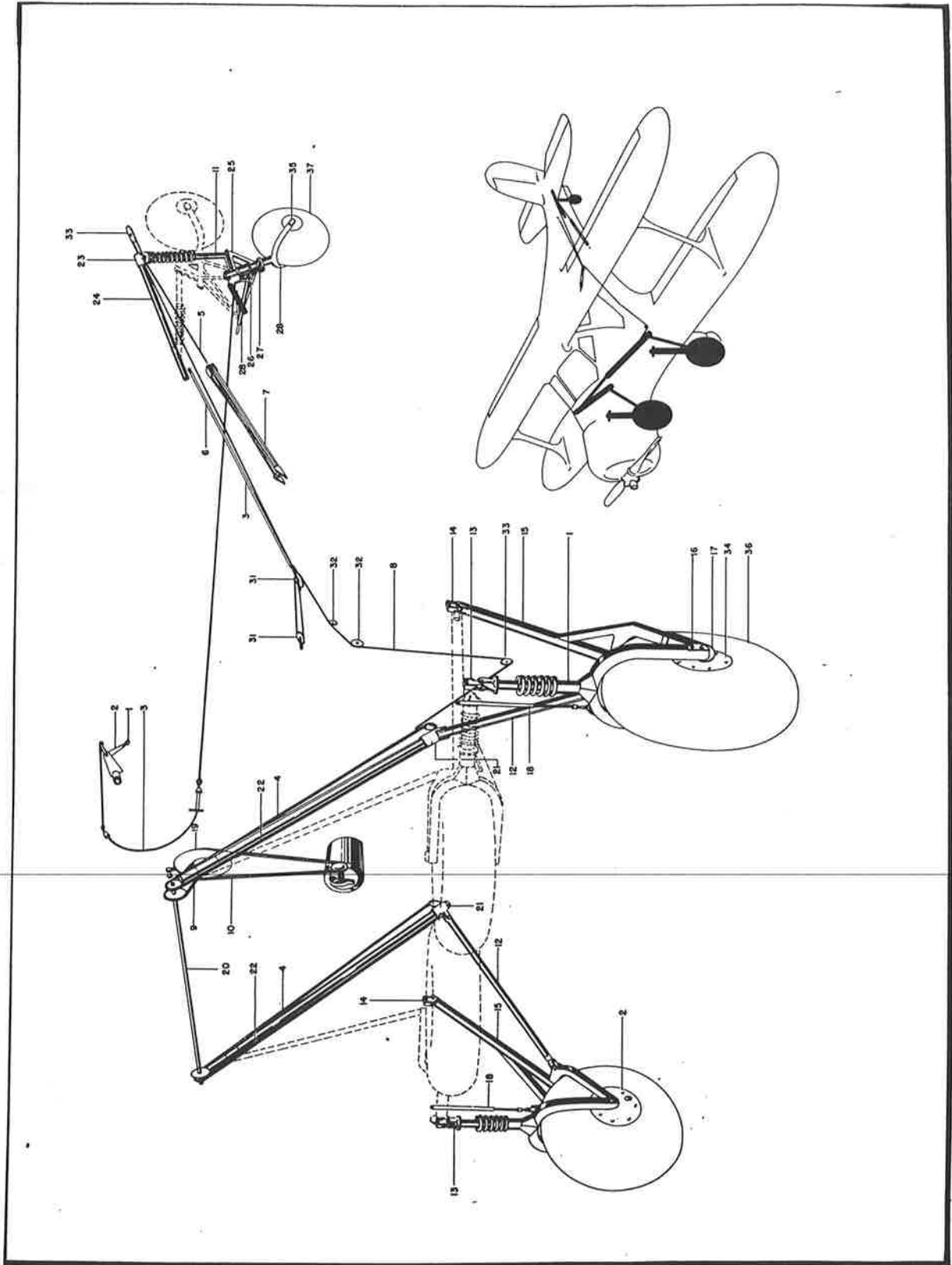

Figure 14 - Landing Gear and Tail Wheel Lock Assembly

RESTRICTED

T. O. No. 01-90CC-4

SECTION II—GROUP ASSEMBLY PARTS LISTS

FIG. NO.	INDEX NO.	STOCKED	GROUP Body						UNITS PER ASSY	PROPERTY CLASSIFICATION						
			MAJOR ASSEMBLY Gear Assembly - Landing							U.S. NAVY	U.S. ARMY	BRITISH				
			PART NUMBER	1	2	3	4	5					6	NOMENCLATURE		
14	14	S	AN310-6								2		04-A			
		S	D17815-2 LH								1		01-H			
		S	AN6-20								1		04-A			
		S	AN6-25								1		04-A			
		S	AN310-6								2		04-A			
		S	AN960-616								2		04-A			
		S	D17815-2 RH								1		01-H			
	14	15	S	AN6-20								1		04-A		
			S	AN6-25								1		04-A		
			S	AN310-6								2		04-A		
			S	AN960-616								2		04-A		
			S	D17815-3								4		01-H		
			S	D17815-4								2		01-H		
			S	D17815-6								6		01-H		
S			D17815-7								4		01-H			
S			D17815-8								2		01-H			
S			AN6-20								2		04-A			
S			AN310-6								2		04-A			
S			AN960-616								2		04-A			
S			D17820 LH								1		01-H			
14			15	S	D17820-1								1		01-H	
	S	D17820-2									1		01-H			
	S	D17820-3									1		01-H			
	S	D17820-4									2		01-H			
	S	D17820-5									2		01-H			
	S	D17820-6									1		01-H			
	S	D17820-7									1		01-H			
	S	D17820-9									1		01-H			
	S	D17820-10									1		01-H			
	S	D17821-1 LH									1		01-H			
	S	D17821-2 LH									1		01-H			
	S	D17821-3									2		01-H			
	S	D17821-4 LH									1		01-H			
	S	D17821-5									1		01-H			
	S	D17821-6									4		01-H			
	S	D17821-7									2		01-H			
	S	D17821-8									1		01-H			
	S	D17821-9									2		01-H			
	S	D17822									1		01-H			
	S	D178240									1		01-H			
	S	AN535-2-2									5		29			
	S	D17820 RH									1		01-H			
	14	15		S	D17820-1								1		01-H	
				S	D17820-2								1		01-H	
				S	D17820-3								1		01-H	
				S	D17820-4								2		01-H	
				S	D17820-5								2		01-H	
				S	D17820-6								1		01-H	
S			D17820-7								1		01-H			
S			D17820-9								1		01-H			
S			D17820-10								1		01-H			
S			D17821-1 RH								1		01-H			
S			D17821-2 RH								1		01-H			
S			D17821-3 RH								1		01-H			
S			D17821-4 RH								1		01-H			
S			D17821-5 RH								2		01-H			

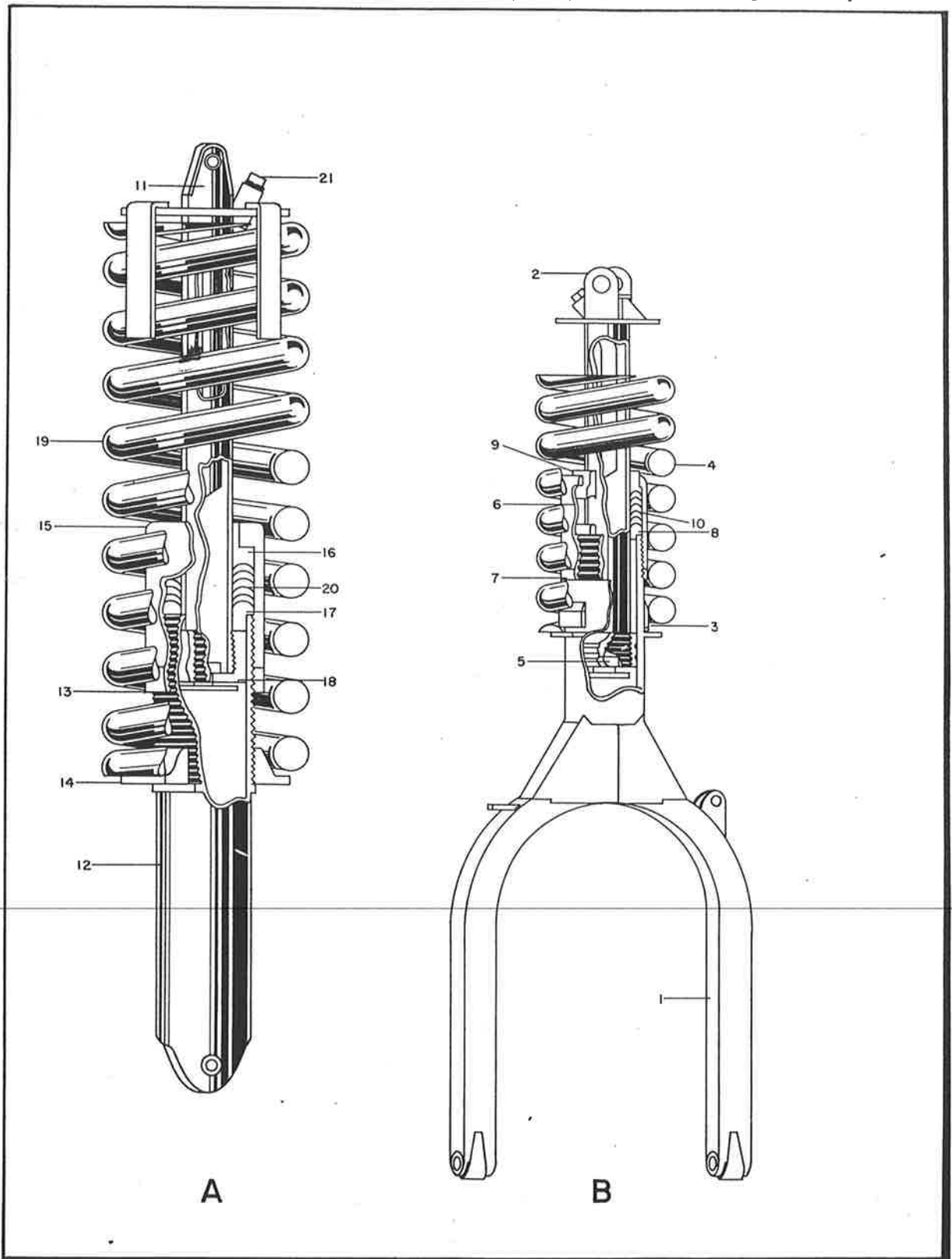

Figure 15 - Main Landing Gear and Tail Wheel Shock Struts

RESTRICTED
T. O. No. 01-90CC-4
SECTION II—GROUP ASSEMBLY PARTS LISTS

FIG. NO.	INDEX NO.	STOCKED	GROUP Body						UNITS PER ASSY	PROPERTY CLASSIFICATION			
			MAJOR ASSEMBLY Gear Assembly - Landing							U.S. NAVY	U.S. ARMY	BRITISH	
			PART NUMBER	1	2	3	4	5					6
14	16	S	D17821-2 RH						Support - Rear leg fairing RH	1		01-H	
			D17821-3						Tube - Rear leg fairing support	2		01-H	
			D17821-4 LH						Plate - Landing gear rear leg reinforcing LH	1		01-H	
			D17821-5						Plate - Landing gear rear leg end attaching	1		01-H	
			D17821-6						Plate - Landing gear rear leg fairing attaching	4		01-H	
			D17821-7						Plate - Landing gear rear leg end reinforcing	2		01-H	
			D17821-8						Gusset - Landing gear rear leg	1		01-H	
			D17821-9						Lug - Landing gear rear leg	2		01-H	
			D17822						Pad - Jack pad	1		01-H	
			D178240						Lug - Towing	1		01-H	
			AN535-2-2						Screw - Drive	5		29	
			D17830-1 LH						Axle and Torque Arm Assembly - Landing gear LH	1		01-H	
			D17830-2						Arm - Landing gear torque	1		01-H	
			D17830-3						Axle - Landing gear	1		01-H	
			D17830-5						Plate - Torque landing gear	1		01-H	
D17830-6						Plug - Axle	2		01-H				
D17830-9						Spacer - Torque plate	1		01-H				
AN5-20						Bolt - Aircraft	1		04-A				
AN310-5						Nut - Aircraft	1		04-A				
D17830-1 RH						Axle and Torque Arm Assembly - Landing gear RH	1		01-H				
D17830-2						Arm - Landing gear torque	1		01-H				
D17830-3						Axle - Landing gear	1		01-H				
D17830-5						Plate - Torque landing gear	1		01-H				
D17830-6						Plug - Axle	2		01-H				
D17830-9						Spacer - Torque plate	1		01-H				
AN5-20						Bolt - Aircraft	1		04-A				
AN310-5						Nut - Aircraft	1		04-A				
D17830-4						Bushing - Axle	2		01-H				
D17830-7						Bolt - Axle	2		01-H				
AN310-8						Nut - Aircraft	4		04-A				
D17830-8						Nut - Axle	2		04-A				
D17830-10						Washer - Axle	2		04-A				
D17830-11						Lock - Axle bolt	2		04-A				
D17840						Absorber Assembly - Shock	2		01-H				
D17840-1 LH						Fork Assembly - Shock absorber LH	1		01-H				
D17840-2						Fork - Shock absorber	1		01-H				
D17840-3						Bushing - Shock absorber fork	2		01-H				
D17840-4						Barrel Assembly - Shock absorber fork	1		01-H				
D17840-5						Barrel - Shock absorber fork	1		01-H				
D17840-6						Plug - Barrel end	1		01-H				
D17840-7						Washer - Shock absorber spring retaining	1		01-H				
D17847-1						Plate - Shock absorber fork reinforcing	2		01-H				
D17847-3						Strap - Shock absorber fork end reinforcing	2		01-H				
D17847-6						Lug - Shock absorber fork	2		01-H				
D17847-7						Lug - Shock absorber fork	1		01-H				
D17840-1 RH						Fork Assembly - Shock absorber RH	1		01-H				
D17840-2						Fork - Shock absorber	1		01-H				

RESTRICTED

T. O. No. 01-90CC-4

SECTION II—GROUP ASSEMBLY PARTS LISTS

FIG. NO.	INDEX NO.	STOCKED	GROUP Body						UNITS PER ASSY	PROPERTY CLASSIFICATION				
			MAJOR ASSEMBLY Gear Assembly - Landing							U.S. NAVY	U.S. ARMY	BRITISH		
			PART NUMBER	1	2	3	4	5					6	NOMENCLATURE
15	2	S	D17840-3							1		01-H		
			D17840-4								1		01-H	
			D17840-5								1		01-H	
			D17840-6								1		01-H	
			D17840-7								1		01-H	
			D17847-1								2		01-H	
			D17847-3								2		01-H	
			D17847-6								2		01-H	
			D17847-7								1		01-H	
			D17840-8 LH								1		01-H	
			D17840-9								1		01-M	
			D17840-10								1		01-H	
			D17840-11								1		01-H	
			D17840-12								1		01-H	
			D17840-13								1		01-H	
D17847-2								1		01-H				
D17847-4								2		01-H				
15	2	S	D17847-5							3		01-H		
			D17840-8 RH							1		01-H		
			D17840-9								1		01-H	
			D17840-10								1		01-H	
			D17840-11								1		01-H	
			D17840-12								1		01-H	
			D17840-13								1		01-H	
			D17847-2								1		01-H	
			D17847-4								2		01-H	
			D17847-5								3		01-H	
			D17840-11								1		01-H	
			D17840-12								1		01-H	
			D17840-13								1		01-H	
			D17847-2								1		01-H	
			D17847-4								2		01-H	
15	3	S	D17847-5							3		01-H		
			D17840-11							1		01-H		
			D17841							1		01-H		
15	4	S	D17841							1		01-H		
			D17841							1		01-H		
			D17841							1		01-H		
15	5	S	D17843							1		01-H		
			D17843-1							1		01-H		
			D17843-2							1		01-H		
			D17843-3							1		01-H		
15	6	S	D17844-1							1		01-H		
			D17844-2							1		01-H		
			D17845							1		01-H		
			D17846							1		01-H		
			D17848							5		01-H		
14	18	S	S.A.E. 50									06		
			S-113-17							2		01-H		
			AN310-5							2		04-A		
			D17842-1							2		01-H		
			D17842-2							1		01-H		
			D17842-3							1		01-H		

RESTRICTED

T. O. No. 01-90CC-4

SECTION II—GROUP ASSEMBLY PARTS LISTS

FIG. NO.	INDEX NO.	STOCKED	GROUP Body						UNITS PER ASSY	PROPERTY CLASSIFICATION		
			MAJOR ASSEMBLY Gear Assembly - Landing							U.S. NAVY	U.S. ARMY	BRITISH
			PART NUMBER	1	2	3	4	5				
			D17842-4						3		01-H	
			D17842-5						1		01-H	
			D17842-6						1		01-H	
		S	AN315-4						1		04-A	
		S	D17842-7					Universal - Shock absorber extending tube	4		01-H	
		S	AN3-5					Bolt - Aircraft	4		04-A	
		S	AN3-13					Bolt - Aircraft	4		04-A	
		S	AN310-3					Nut - Aircraft castle	8		04-A	
14	19	S	D17850-1					Crank Assembly - Landing gear retracting	1		01-H	
16	1	S	D17850-2					Crank Assembly - Landing gear hand welded	1		01-H	
			D17850-3					Rod - Hand crank	1		01-H	
			D17850-4					Tube - Hand crank handle	1		01-H	
			D17850-5					End - Hand crank tube	1		01-H	
			D17850-6					Washer - Hand crank	1		01-H	
			D17850-7					Tube - Hand crank	1		01-H	
			D17850-8					Tube - Hand crank	1		01-H	
16	2	D	D17850-17					Bracket - Hand crank	1		01-H	
16	3	S	AN3-14					Bolt - Aircraft	1		04-A	
16	4	S	AN320-3					Nut - Aircraft shear	1		04-A	
16	5	S	AN380-2-2					Pin - Cotter	1		29	
16	6	S	D17850-9					Spring - Hand crank	1		01-H	
16	7	S	D17850-11					Bearing Assembly - Hand crank	1		01-H	
			D17850-12					Tube - Bearing hand crank	1		01-H	
			D17856-1					Sprocket - Hand crank	1		01-H	
			D17856-3					Sprocket - Hand crank	1		01-H	
			KAL0 (P)					Bearing (Fafnir)	2		29	
16	8	S	D17857					Knob - Hand crank	1		01-H	
16	9	S	AN526-832-8					Screw - Buttonhead	1		29	
16	10	S	AC940-8					Washer - Burr	1		29	
16	20	S	D17850-14					Shaft Assembly - Landing gear cross	1		01-H	
			D17850-13					Gear - Cross shaft	1		01-H	
			D17850-41					Tube - Cross shaft	1		01-H	
			D17850-42					Tube - Cross shaft inner reinforcing	2		01-H	
			D17850-51					Spacer - Cross shaft gear	1		01-H	
			D17850-52					Spacer - Cross shaft sprocket	1		01-H	
			D17856-2					Sprocket - Cross shaft	1		01-H	
			D17856-5					Sprocket - Cross shaft	2		01-H	
			2195DP (P)					Bearing (Schatz)	2		29	
		S	AN4-20					Bolt - Aircraft	2		04-A	
		S	AN4-22					Bolt - Aircraft	2		04-A	
		S	10-32					Nut - Hexagon	2		29	
		S	AN310-4					Nut - Aircraft castle	4		04-A	
		S	AN520-10-16					Screw - RH	2		29	
		S	AN935-10					Washer - Medium spring lock	2		29	
			D17850-19					Sprocket Assembly - Landing gear rear truss	2		01-H	
			D17850-18					Bushing - Landing gear rear truss sprocket	1		01-H	
			D17850-6					Sprocket - Landing gear rear truss	1		01-H	
		S	D17850-20					Tube	2		01-H	
		S	AN3-43					Bolt - Aircraft	1		04-A	
		S	AN4-30					Bolt - Aircraft	1		04-A	
		S	S198-4-128					Bushing	1		01-H	
		S	AN310-3					Nut - Aircraft castle	1		04-A	

RESTRICTED

T. O. No. 01-9000-4

SECTION II—GROUP ASSEMBLY PARTS LISTS

FIG. NO.	INDEX NO.	STOCKED	GROUP Body						UNITS PER ASSY	PROPERTY CLASSIFICATION			
			MAJOR ASSEMBLY Gear Assembly - Landing							U.S. NAVY	U.S. ARMY	BRITISH	
			PART NUMBER	1	2	3	4	5					6
16	11	S	D17850-121							1		01-H	
			D17850-123							1		01-H	
16	12		D17850-124							1		01-H	
			D17850-125							1		01-H	
			D17850-126							1		01-H	
			D17850-141							1		01-H	
			D17850-127							1		01-H	
			D17850-122							1		01-H	
			D17850-128							1		01-H	
16	13	S	D17850-129							1		01-H	
			D17850-130							2		01-H	
16	14	S	AN310-3							2		01-H	
16	59	S	D17850-134							1		01-H	
		No number (P)											
		S	D17850-137							1		01-H	
			D17850-138							2		01-H	
			D17850-139							2		01-H	
			D17850-146							1		01-H	
16	15		D17850-106							1		01-H	
			D17850-107							1		01-H	
			D17850-108							1		01-H	
16	16	S	D17850-109							1		01-H	
			D17850-110							1		01-H	
16	17		D17850-111							1		01-H	
			D17850-112							1		01-H	
16	18		D17850-113							1		01-H	
			D17850-114							1		01-H	
			D17850-115							1		01-H	
			D17850-136							1		01-H	
			D17850-133							1		01-H	
			D17850-140							1		01-H	
			D17850-147							1		01-H	
16	19	S	AN3-7							2		01-H	
16	14	S	AN310-3							2		01-H	
16	5	S	AN380-2-2							2		29	
16	21		D17850-153							1		01-H	
16	22	S	D17850-142							1		01-H	
			D17850-145							1		01-H	
			D17850-154							1		01-H	
			D17850-140							1		01-H	
			D17850-147							1		01-H	

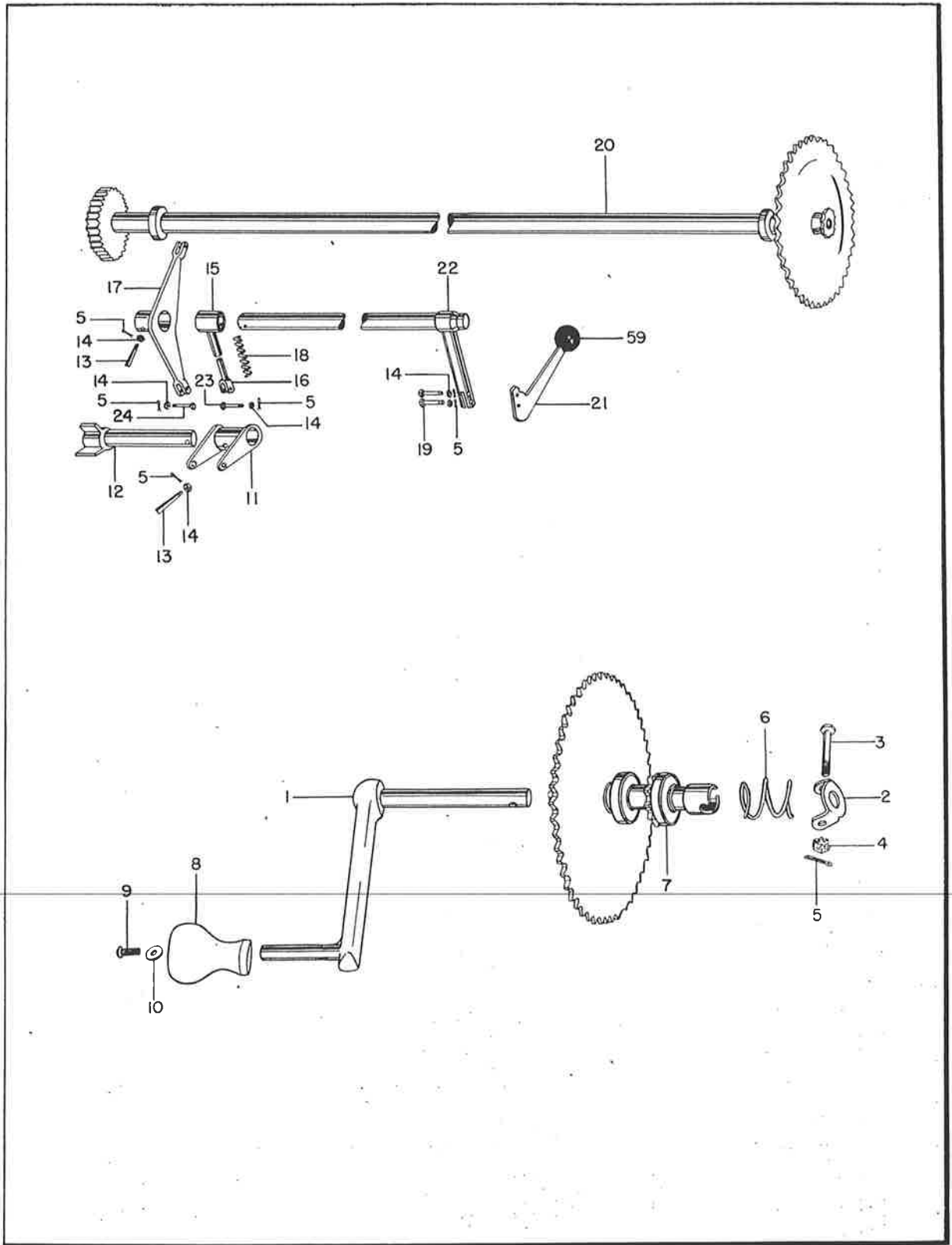

Figure 16 - Landing Gear Handcrank and Cross Shaft Assembly

RESTRICTED

T. O. No. 01-9000-4

SECTION II—GROUP ASSEMBLY PARTS LISTS

FIG. NO.	INDEX NO.	STOCKED	GROUP Body						UNITS PER ASSY	PROPERTY CLASSIFICATION			
			MAJOR ASSEMBLY Gear Assembly - Landing							U.S. NAVY	U.S. ARMY	BRITISH	
			PART NUMBER	1	2	3	4	5					6
16	23	S	D17850-152							1		01-H	
		S	D17850-152							1		01-H	
		S	D17850-143							1		01-H	
		S	D17850-144							1		01-H	
		S	AN3-4							1		04-A	
		S	AN3-5							2		04-A	
		S	AN310-3							3		04-A	
		S	105739-X0191-0249-0156							1		01-H	
		S	105739-X0191-0249-0344							1		01-H	
		S	D17850-148							1		01-H	
		S	AN3-7							1		04-A	
		S	AN310-3							1		04-A	
		S	AN380-2-2							1		29	
		S	AN960-10							1		04-A	
		S	D17850-150							4		01-H	
		S	AN3-13							2		04-A	
S	AN310-3							2		04-A			
S	D17850-151							1		01-H			
S	AN316-5B							8		04-A			
34	23	S	D178550						1		01-H		
		S	D178551						1		01-H		
		S	D178552						1		01-H		
		S	D178553-1						1		01-H		
		S	D178553-2						1		01-H		
		S	D178553-3						1		01-H		
		S	D178553-4						1		01-H		
		S	S-137						1		01-H		
		S	AN960-6						1		04-A		
		S	D178553-5						2		01-H		
		S	AN315-3R						2		04-A		
		S	AN936-B10						2		29		
		S	D178554						1		01-H		
		S	S-136						1		01-H		
		S	AN960-6						1		04-A		
		S	8909K51 (P)						1		03-C		
S	AN3-20						2		04-A				
S	S-108-4-31						2		01-4				
S	AN310-3						2		04-A				
34	24	S	D178550-1						1		01-H		
		S	D178551						1		01-H		
		S	D178553-1						1		01-H		
		S	D178553-2						2		01-H		
		S	D178553-3						2		01-H		
		S	D178553-4						2		01-H		
		S	S-137						1		01-H		
		S	AN960-6						1		04-A		
		S	D178553-5						2		01-H		
		S	AN315-3R						2		04-A		
		S	AN936-B10						2		29		
		S	D178554						1		01-H		

RESTRICTED
T. O. No. 01-90CC-4
SECTION II—GROUP ASSEMBLY PARTS LIST

FIG. NO.	INDEX NO.	STOCKED	GROUP Body						UNITS PER ASSY	PROPERTY CLASSIFICATION				
			MAJOR ASSEMBLY Gear Assembly - Landing							U.S. NAVY	U.S. ARMY	BRITISH		
			PART NUMBER	1	2	3	4	5					6	NOMENCLATURE
34	25	S	D178590							1		01-H		
		S	D178552-1							1		01-H		
		S	D178557							1		01-H		
		S	8909K51	(P)							1		03-C	
		S	S136								1		01-H	
		S	AN960-6								1		04-A	
		S	AN3-16								1		04-A	
		S	AN4-6A								1		04-A	
		S	S-108-4-4								1		01-H	
		S	AN310-3								1		04-A	
		S	42E048	(P)							1		04-A	
		S	D178555								2		01-H	
		S	D17858								1		01-H	
		S	890K560	(P)							1		03-C	
		S	B-9A	(P)							2		03-C	
		S	M64161W2	(P)							2		03-C	
		S	M64161W3	(P)							1		03-C	
		S	AN515-3-4								2		29	
		S	10-32	(P)							4		04-A	
		S	AN520-10-6								4		29	
		14	11	S	D17860						1		01-H	
		15	1	S	D17860-1						1		01-H	
		15	12	S	D17860-2						1		01-H	
					D17860-3						1		01-H	
					D17860-4						1		01-H	
					D17860-5						1		01-H	
					D17860-6						1		01-H	
					D17860-8						1		01-H	
					D17860-7						1		01-H	
					D17860-10						1		01-H	
					D17860-9						1		01-H	
					D17860-11						1		01-H	
					D17860-12						3		01-H	
					D17860-13						1		01-H	
			D17860-14						1		01-H			
15	13	S	D17860-15						1		01-H			
			D17862-1						1		01-H			
15	14	S	D17862-2						1		01-H			
15	15	S	D17862-3						1		01-H			
15	16	S	D17863-1						1		01-H			
15	17	S	D17863-2						1		01-H			
15	18	S	D17864A						1		01-H			
		S	D17864A-1						1		01-H			
		S	D17864A-2						1		01-H			
15	19	S	D17864A-3						1		01-H			
		S	D17866						1		01-H			

RESTRICTED

RESTRICTED

T. O. No. 01-90CC-4

SECTION II—GROUP ASSEMBLY PARTS LISTS

FIG. NO.	INDEX NO.	STOCKED	GROUP Body						UNITS PER ASSY	PROPERTY CLASSIFICATION		
			MAJOR ASSEMBLY Gear Assembly - Landing							U.S. NAVY	U.S. ARMY	BRITISH
			PART NUMBER	1	2	3	4	5				
15	20	S	D17868						5		01-H	
			78150 (P)					Washer - Shock absorber packing	1		04-B	
15	21	S	AC895-B70					Washer (Garlock)	1		04-A	
14	23	S	D17869-1					Fitting - Pipe	1		01-H	
			D17869-2					Slide Assembly - Tail wheel	1		01-H	
								Bracket Assembly - Tail wheel slide	1		01-H	
			D17869-3					Bracket - Tail wheel slide	1		01-H	
			100951-X063-010-020					Washer	1		01-H	
			D17869-5					Bracket Assembly - Tail wheel slide	1		01-H	
			D17869-6					Bracket - Tail wheel slide	1		01-H	
			100951-X063-010-020					Washer	1		01-H	
			D17869-7					Tube - Tail wheel slide	1		01-H	
			D17869-8					Bushing - Tail wheel slide	2		01-H	
			125 (P)					Bushing (Bunting)	1		29	
			D17869-9					Spacer - Tail wheel slide	1		01-H	
14	24	S	D17869-10					Tube Assembly - Tail wheel slide	1		01-H	
			D17869-15					Tube - Tail wheel slide	1		01-H	
			D17869-16					Tube - Tail wheel slide inner	1		01-H	
		S	D17869-11					Bracket Assembly - Tail wheel cable	2		01-H	
			D17869-12					Bracket - Tail wheel cable	2		01-H	
			D17869-13					Tube - Tail wheel cable bracket	1		01-H	
		S	AN3-5					Bolt - Aircraft	2		04-A	
		S	AN310-3					Nut - Aircraft castle	2		04-A	
		S	D17869-14					Link - Tail wheel slide	1		01-H	
		S	AN3-5					Bolt - Aircraft	2		04-A	
		S	AN3-14					Bolt - Aircraft	1		04-A	
		S	AN100-4					Thimble - Wire cable	2		29	
		S	AN310-3					Nut - Aircraft castle	3		04-A	
		S	D178700					Housing and Fork Assembly - Tail wheel	1		01-H	
14	25		D17865					Housing Assembly - Tail wheel fork	1		01-H	
			D17865-1					Shaft - Tail wheel fork housing	1		01-H	
			D17865-6					Anchor - Fork housing	2		01-H	
			D17865-24					Plate - Tail wheel fork housing	1		01-H	
			D17865-31					Housing Assembly - Tail wheel fork welded	1		01-H	
			D17865-2					Tube - Tail wheel fork housing center upper	1		01-H	
			D17865-3					Housing - Tail wheel fork	1		01-H	
			D17865-4					Brace - Tail wheel fork housing	2		01-H	
			D17865-5					Brace - Tail wheel fork housing	2		01-H	
			D17865-7 LH					Support - Tail wheel housing LH	1		01-H	
			D17865-7 RH					Support - Tail wheel housing RH	1		01-H	
			D17865-8					Tube - Tail wheel fork housing	1		01-H	
			D17865-9					Spacer - Tail wheel fork housing	1		01-H	
			D17865-21					Guide - Tail wheel fork housing	2		01-H	
			D17865-25					Plate - Tail wheel fork housing	1		01-H	
			D17865-26					Bracket - Tail wheel locking support	2		01-H	

RESTRICTED

T. O. No. 01-90CC-4

SECTION II—GROUP ASSEMBLY PARTS LISTS

FIG. NO.	INDEX NO.	STOCKED	GROUP Body						UNITS PER ASSY	PROPERTY CLASSIFICATION			
			MAJOR ASSEMBLY Gear Assembly - Landing							U.S. NAVY	U.S. ARMY	BRITISH	
			PART NUMBER	1	2	3	4	5					6
14	26	S	100951-X063-010-024						Washer	2		01-H	
		S	AN135-8S						Turnbuckle Assembly	2		04-A	
		S	AN155-8S						Barrel - Turnbuckle	1		04-A	
		S	AN165-8S						Eye - Turnbuckle pin	1		04-A	
		S	AN170-8LS						Eye - Turnbuckle cable	1		04-A	
		S	D17865-29						Arm Assembly - Tail wheel locking	1		01-H	
			D17865-27						Arm - Tail wheel locking	1		01-H	
			D17865-28						Tube - Tail wheel locking arm	1		01-H	
			304196-4-5						Rivet - Stainless	1		01-H	
			D17865-30						Rod - Tail wheel locking stop	1		01-H	
			AN380-2-2						Pin - Cotter	1		29	
			AN393-17						Pin - Flathead	1		04-A	
			100943-.062-016-108-4						Spring - Compression	1		01-H	
		14	28	S	100951-X.062-016-070						Washer	1	
S	D178701								Fork Assembly - Tail wheel	1		01-H	
	D178701-1								Fork - Tail wheel	1		01-H	
	D178701-2								Tube - Tail wheel fork	1		01-H	
	D178701-3								Gusset - Tail wheel fork	2		01-H	
	D178702								Plate - Tail wheel fork bearing	1		01-H	
	D178703								Device Assembly - Tail wheel fork aligning	1		01-H	
S	D178704								Collar Assembly - Tail wheel fork aligning	1		01-H	
	D178705								Lug - Aligning collar tail wheel fork	1		01-H	
	D178708								Collar - Aligning device tail wheel fork	1		01-H	
	D178706								Link - Tail wheel fork aligning collar	1		01-H	
S	AN4-4								Bolt - Aircraft	1		04-A	
S	AN320-4								Nut - Aircraft shear	1		04-A	
S	AN380-2-2								Pin - Cotter	1		29	
S	D178707-1						Washer - Aligning device	1		01-H			
S	D178707-2						Bushing - Aligning device	1		01-H			
S	AN3-5						Bolt - Aircraft	1		04-A			
S	AN320-3						Nut - Aircraft shear	1		04-A			
S	AN380-2-2						Pin - Cotter	1		29			
S	D178709						Pin - Tail wheel locking	1		01-H			
S	AN286-1						Fitting - Lubricator	1		29			
S	B17871						Spring - Tail wheel swivel	1		01-H			
S	D178900						Motor Assembly - Landing gear retracting	1		01-H			
S	D178556						Block - Landing gear motor junction	1		01-H			
S	AC500-A10-8						Screw - Fillister-head	2		29			
S	AC940-316						Washer - Burr	2		29			
S	AC995-32-4						Wire - Locking	1		04-A			
S	D17856-4						Sprocket - Motor	1		01-H			
S	102809-125-028						Pin - Drilled	1		01-H			
S	S-38						Motor Assembly - Landing gear	1		01-H			
S	3843 (P)						Motor Assembly (Dumore)	1		03-C			
S	1528 (P)						Anchor - Field (Dumore)	2		03-C			
S	3843 (P)						Armature - 12 volt (Dumore)	1		03-C			
S	R9433 (P)						Bearing (Dumore)	2		03-C			
S	2274 (P)						Holder - Brush (Dumore)	2		03-C			
S	5835 (P)						Plug - Brush (Dumore)	2		03-C			

RESTRICTED

RESTRICTED

T. O. No. 01-90CC-4

SECTION II—GROUP ASSEMBLY PARTS LISTS

FIG. NO.	INDEX NO.	STOCKED	GROUP Body						UNITS PER ASSY	PROPERTY CLASSIFICATION			
			MAJOR ASSEMBLY Gear Assembly-- Landing							U.S. NAVY	U.S. ARMY	BRITISH	
			PART NUMBER	1	2	3	4	5					6
	S	R4119	(P)							4		03-C	
	S	2813	(P)							1		03-C	
	S	R3836	(P)							2		03-C	
	S	3843	(P)							1		03-C	
	S	8121	(P)							1		03-C	
	S	608	(P)							1		03-C	
	S	3843	(P)							1		03-C	
	S	3843	(P)							2		03-C	
	S	3843	(P)							1		03-C	
	S	R9436	(P)							1		03-C	
	S	R1986	(P)							8		03-C	
	S	KL82	(P)							1		03-C	
	S	KL60	(P)							2		03-C	
	S	R1541	(P)							1		03-C	
	S	R1542	(P)							1		03-C	
	S	7400	(P)							1		03-C	
	S	3843B	(P)							1		03-C	
	S	R1580	(P)							2		03-C	
	S	R3654	(P)							2		03-C	
	S	R1387	(P)							1		03-C	
	S	6377	(P)							1		03-C	
	S	KL-61	(P)							1		03-C	
	S	4379	(P)							1		03-C	
	S	3392	(P)							4		03-C	
	S	6649	(P)							1		03-C	
	S	KL-85	(P)							1		03-C	
	S	5624	(P)							1		03-C	
	S	1559	(P)							1		03-C	
	S	4501	(P)							2		03-C	
	S	7401	(P)							1		03-C	
	S	3843	(P)							2		03-C	
	S	1545	(P)							2		03-C	
	S	4025	(P)							1		03-C	
	S	1513	(P)							1		03-C	
	S	6357	(P)							1		03-C	
	S	2811	(P)							1		03-C	
	S	1548	(P)							1		03-C	
	S	1549	(P)							4		03-C	
	S	1551	(P)							1		03-C	
	S	1552	(P)							4		03-C	
	S	R19	(P)							2		03-C	
	S	R48	(P)							3		03-C	
	S	R1575	(P)							2		03-C	
	S	R3366	(P)							1		03-C	
	S	R4328	(P)							1		03-C	
	S	6444	(P)							2		03-C	
	S	1557	(P)							4		03-C	
	S	1584	(P)							1		03-C	
	S	1589	(P)							2		03-C	

RESTRICTED

T. O. No. 01-90CC-4

SECTION II—GROUP ASSEMBLY PARTS LISTS

FIG. NO.	INDEX NO.	STOCKED	GROUP Body						UNITS PER ASSY	PROPERTY CLASSIFICATION		
			MAJOR ASSEMBLY Gear Assembly - Landing							U.S. NAVY	U.S. ARMY	BRITISH
			PART NUMBER	1	2	3	4	5				
		S	1558 (P)						2		03-C	
		S	1560 (P)					Stud - Field anchor (Dumore)	1		03-C	
		S	1585 (P)					Washer (Dumore)	1		03-C	
		S	4168 (P)					Washer (Dumore)	1		03-C	
		S	3843B (P)					Washer (Dumore)	1		03-C	
		S	R3673 (P)					Washer - Thrust screw (Dumore)	1		03-C	
		S	FT.R8716 (P)					Wick (Dumore)	1		03-C	
		S	AN503-10-8					Wire - Safety (Dumore)	2		03-C	
		S	AN3-4					Screw - Aircraft fillister-head	2			
		S	AN3-5					Bolt - Aircraft	1		04-A	
		S	AN3-6					Bolt - Aircraft	2		04-A	
		S	AN3-10					Bolt - Aircraft	4		04-A	
		S	AN3-11					Bolt - Aircraft	1		04-A	
		S	AN3-15					Bolt - Aircraft	1		04-A	
		S	AN3-16					Bolt - Aircraft	1		04-A	
		S	AN3-26					Bolt - Aircraft	1		04-A	
		S	AN4-7					Bolt - Aircraft	12		04-A	
		S	AN4-23					Bolt - Aircraft	1		04-A	
		S	AN5-14					Bolt - Aircraft	1		04-A	
		S	AN5-21					Bolt - Aircraft	1		04-A	
		S	6-2-6 (P)					Lock Nut (Breeze)	1		04-A	
		S	S-8-1					Bushing	5		01-H	
		S	28-12-6 (P)					Connector (Breeze)	1		04-A	
		S	AN100-4					Thimble - Wire cable	1		29	
		S	101-0375 (P)					Shielding (Breeze)	1		04-A	
		S	111-0375 (P)					Ferrule (Breeze)	2		04-A	
		S	118-0375 (P)					Nut (Breeze)	2		04-A	
14	31	S	A-124					Pulley (Formica)	4		04-A	
14	32	S	A-138					Pulley (Formica)	1		04-A	
14	33	S	AN210-4A					Pulley - Control	1		04-A	
		S	AN310-3					Nut - Aircraft castle	10		04-A	
		S	AN310-5					Nut - Aircraft castle	2		04-A	
		S	AN340-8					Nut - Machine screw hexagonal	2		29	
		S	AN380-2-2					Pin - Cotter	7		29	
		S	AN505-8-12					Screw - Flathead	2		29	
		S	AN935-8					Washer - Medium spring lock	2		29	
		S	AN960-10					Washer - Plain	4		04-A	
		S	100696-D16-07-014					Spacer	1		01-H	
		S	E50021-45 (P)					Retainer - Hub felt (Hayes)	2		03-B	
		S	218262-M (P)					Brake Assembly - Landing gear (Goodyear)	2		03-B	
		S	218654-M (P)					Brake - Subassembly (Goodyear)	1		03-B	
		S	273378-M (P)					Bracket - Anchor detail (Goodyear)	1		03-B	
		S	218261 (P)					Key - Anchor (Goodyear)	6		03-B	
		S	AN505-516-12					Screw - 5/16-18 x 3/4 long	6		29	
		S	511298 (P)					Felt - Piston groove (Goodyear)	1		03-B	
		S	218065 (P)					Expander - Piston gasket (Goodyear)	1		03-B	
		S	217076-2 (P)					Gasket - Piston (Goodyear)	1		03-B	
		S	216205-M (P)					Piston (Goodyear)	1		03-B	
		S	217435 (P)					Spring - Piston return (Goodyear)	3		03-B	
		S	AC501A10-7					Screw - Fillister-head	3		29	
		S	AC995C40-3					Lock Wire - .040 x 3 long	3		04-A	
		S	272295 (P)					Disc - Insulating (Goodyear)	1		03-B	
		S	216005 (P)					Disc - Stationary (Goodyear)	7		03-B	
		S	216004 (P)					Disc - Rotating (Goodyear)	6		03-B	
		S	218263 (P)					Nut - Adjusting (Goodyear)	1		03-B	
		S	AN510-10-8					Screw - Flathead	1		29	
		S	1510 (P)					Washer - "Snakeproof" (Goodyear)	1		04-A	
		S	213933 (P)					Plug - Bleeder (Goodyear)	1		03-B	
		S	216929 (P)					Washer - Bleeder (Goodyear)	1		03-B	
		S	216950 (P)					Screw - Bleeder cap (Goodyear)	1		03-B	
		S	218376 (P)					Washer - Inlet (Goodyear)	2		03-B	

RESTRICTED

T. O. No. 01-90CC-4

SECTION II—GROUP ASSEMBLY PARTS LISTS

FIG. NO.	INDEX NO.	STOCKED	GROUP Body						UNITS PER ASSY	PROPERTY CLASSIFICATION			
			MAJOR ASSEMBLY Gear Assembly - Landing							U.S. NAVY	U.S. ARMY	BRITISH	
			PART NUMBER	1	2	3	4	5					6
14	34	S	218375 (P)							2		03-B	
		S	218264-M (P)						Wheel Assembly - Landing gear (Goodyear)	2		03-B	
		S	218601-M (P)						Wheel - Subassembly (Goodyear)	1		03-B	
		S	273093-M (P)						Wheel - Detail (Goodyear)	1		03-B	
		S	216017-4 (P)						Key - Tabular drive (Goodyear)	10		03-B	
		S	216023 (P)						Stop (Goodyear)	1		03-B	
		S	AN430-D3-5						Rivet - Round head	2		29	
		S	07196 (P)						Cup - Outboard bearing (Timken)	1		29	
		S	19268 (P)						Cup - Inboard bearing (Timken)	1		29	
		S	07100 (P)						Cone - Outboard bearing (Timken)	1		29	
		S	19150 (P)						Cone - Inboard bearing (Timken)	1		29	
		S	216008 (P)						Ring - Seal inboard assembly (Goodyear)	1		03-B	
		S	216008-1 (P)						Ring - Seal inboard (Goodyear)	1		03-B	
		S	216009 (P)						Ring - Felt retainer (Goodyear)	1		03-B	
		S	510525-6 (P)						Felt - Inboard bearing seal (Goodyear)	1		03-B	
		S	510525-8 (P)						Felt - Outboard bearing seal (Goodyear)	1		03-B	
		S	214595 (P)						Ring - Felt retaining inboard (Goodyear)	1		03-B	
		S	510590 (P)						Ring - Felt retaining inboard (Goodyear)	1		03-B	
		S	216024 (P)						Ring - Felt retaining outboard (Goodyear)	1		03-B	
		S	510589 (P)						Ring - Felt retaining outboard (Goodyear)	1		03-B	
		S	AN935-8						Washer - Lock	5		29	
		S	AN515-8-4						Screw - Round head	5		29	
		S	510525-7 (P)						Ring - Felt (Goodyear)	1		03-B	
		S	216012 (P)						Cover - Outboard (Concave) (Goodyear)	1		03-B	
		S	217004 (P)						Grommet - Rubber (Goodyear)	1		03-B	
		S	AN505-8-5						Screw - Flat head	5		29	
		S	510671 (P)						Ring - Key retaining (Goodyear)	1		03-B	
		S	216019 (P)						Spacer - Axle (Goodyear)	1		03-B	
		S	272775 (P)						Cover - Assembly - (Convex) (Goodyear)	1		03-B	
		S	272775-1 (P)						Plate - Cover detail (Goodyear)	1		03-B	
		S	214692 (P)						Cover - Valve hole (Goodyear)	1		03-B	
		S	214693 (P)						Plate - Screw (Goodyear)	1		03-B	
		S	216965 (P)						Screw (Goodyear)	1		03-B	
		S	AN380-2-2						Pin - Cotter	1		29	
S	AN430-D2-4						Rivet - Round head	3		29			
S	E-50024-45 (P)						Retainer - Hub felt (Hayes)	2		03-B			
S	510646-M (P)						Wheel Assembly - 10 inch (Goodyear)	1		03-B			
S	510655-M (P)						Wheel Subassembly (Goodyear)	1		03-B			
S	530167-M (P)						Detail - Wheel (Goodyear)	1		03-B			
S	03162 (P)						Cup - Bearing (Timken)	2		29			
S	03062 (P)						Cone - Bearing (Timken)	2		29			
S	510661 (P)						Cover - Bearing (Goodyear)	2		03-B			
S	AN515-6-4						Screw - Round head	6		29			
S	510639-1M (P)						Flange - Demountable (Goodyear)	1		03-B			
S	213896 (P)						Lock Ring - Flange (Goodyear)	1		03-B			
S	214015 (P)						Fairing Assembly - Solid (Goodyear)	1		03-B			

RESTRICTED

RESTRICTED

T. O. No. 01-90CC-4

SECTION II—GROUP ASSEMBLY PARTS LISTS

FIG. NO.	INDEX NO.	STOCKED	GROUP Body Flight Controls						UNITS PER ASSY	PROPERTY CLASSIFICATION		
			MAJOR ASSEMBLY Gear Assembly - Landing Installation - Tail Wheel Lock Control							U.S. NAVY	U.S. ARMY	BRITISH
			PART NUMBER	1	2	3	4	5				
		S	214015-1 (P)						1		03-B	
		S	214019 (P)						1		03-B	
		S	510524-3 (P)						1		03-B	
		S	AN430AD2-3						3		29	
		S	214016						1		03-B	
		S	214016-1						1		03-3	
		S	214019						1		03-B	
		S	510524-3						1		03-B	
		S	AN430AD2-3						3		29	
		S	214016-2						1		03-B	
		S	AN505-6-4						3		29	
		S	214018 (P)						2		03-B	
		S	No number (P)						1			
		S	214429 (P)						1		03-B	
		S	AN320-10						1		04-A	
		S	AN380-4-5						1		29	
14	36	S	No number (P)						2			
14	27	S	No number (P)						1			
		S	D178711						1		01-H	
14	1	S	D178711-2						1		01-H	
		S	201717-4						1			
		S	AN425-4-10						2		29	
14	2	S	D178712						1		01-H	
		S	D178712-1						1		01-H	
		S	S-195-4-10						1		01-H	
		S	S-17-12-10-.032						2		01-H	
		S	S-73-10						1		01-H	
		S	AN310-3						1		04-A	
		S	A1380-2-2						1		29	
14	3	S	D178716						1		01-H	
		S	D178716-1						1		01-H	
		S	D178716-2						1		01-H	
		S	D178716-3						1		01-H	
		S	S-167						1		01-H	
		S	D178717						1		01-H	
		S	D178717-1						1		01-H	
		S	D178718						1		01-H	
		S	S-17-20-11-.050						1		01-H	
		S	AN430AD4-5						4		29	
		S	D178719						1		01-H	
		S	S-123						2		01-H	
		S	AC365-624						2		04-A	
		S	AN100-3						2		29	
		S	AN140-8S						1		04-A	
		S	AN3-6						1		04-A	
		S	AN310-3						1		04-A	
		S	AN380-2-2						1		29	
		S	AN960-10						1		04-A	
		S	AN960-416L						1		04-A	
		S	AN3-4						1		04-A	
		S	AN310-3						1		04-A	
		S	AN380-2-2						1		29	
		S	AN960-10						1		04-A	

RESTRICTED

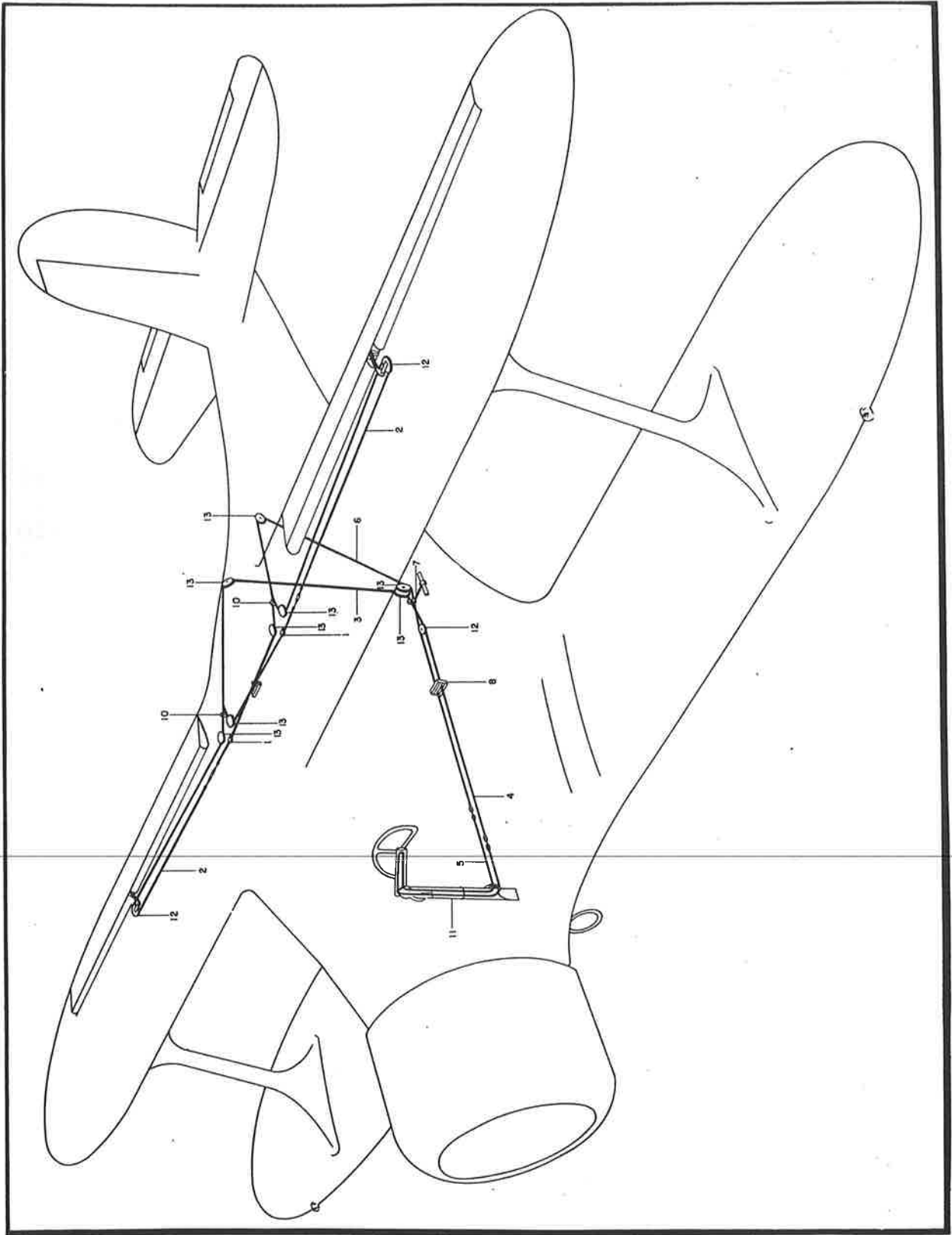

Figure 17 - Aileron Control Assembly

RESTRICTED

T. O. No. 01-90CC-4

SECTION II—GROUP ASSEMBLY PARTS LISTS

FIG. NO.	INDEX NO.	STOCKED	GROUP Flight Controls						UNITS PER ASSY	PROPERTY CLASSIFICATION					
			MAJOR ASSEMBLY Installation - Flight Controls							U.S. NAVY	U.S. ARMY	BRITISH			
			PART NUMBER	1	2	3	4	5					6	NOMENCLATURE	
18	5	S	100696-F16-06-100							2		01-H			
			AN100-4								2		29		
			AN115-32									1		04-A	
			AN155-21L									1		04-A	
			AN170-21RL									1		04-A	
			D177009									1		01-H	
			D177009-2									1		01-H	
			AN100-4									2		29	
			AN115-32									1		04-A	
			AN170-21LL									1		04-A	
			D177010									2		01-H	
			D177010-2									1		01-H	
			D177010-3									1		01-H	
100696-F16-06-100									1		01-H				
17	6	S	AN100-4								3		29		
			AN130-21L								1		04-A		
			AN155-21L									1		04-A	
			AN170-21L									1		04-A	
			AN3-5									4		04-A	
			AN31-3									4		04-A	
			AN380-2-2									4		29	
			D177011									1		01-H	
			D177011-2									1		01-H	
			D177011-3									1		01-H	
			100696-F16-06-100									1		01-H	
			AN100-4									3		29	
			AN115-21									1		04-A	
19	4	S	AN155-16S								2		04-A		
			AN170-16-RS								2		04-A		
			D177012								2		01-H		
			D177012-2								2		01-H		
			AN100-4								2		29		
			AN115-21								1		04-A		
			AN170-21LL								1		04-A		
			D177013								1		01-H		
			D177013-2								1		01-H		
			562-D-9									1		01-C	
			AN380-4-6									1		29	
			D177105									1		01-H	
			19	5	S	D177111							1		01-H
D177111-1											1		01-H		
AN100-3											2		29		
AN115-32											1		04-A		
AN140-8S											1		04-A		
AN380-3-3											1		29		
AC995C40-14											1		04-A		
AN3-7											2		04-A		
AN310-3											2		04-A		
AN380-2-2											2		29		
AN960-416											4		04-A		
105739-X0190-0250-0437											2		01-H		
S-67											2		29		
AN-115-8								2		04-A					
AN3-6								2		04-A					
AN310-3								2		04-A					
AN380-2-2								2		29					
AC995C40-10								2		04-A					
D17716								1		01-H					

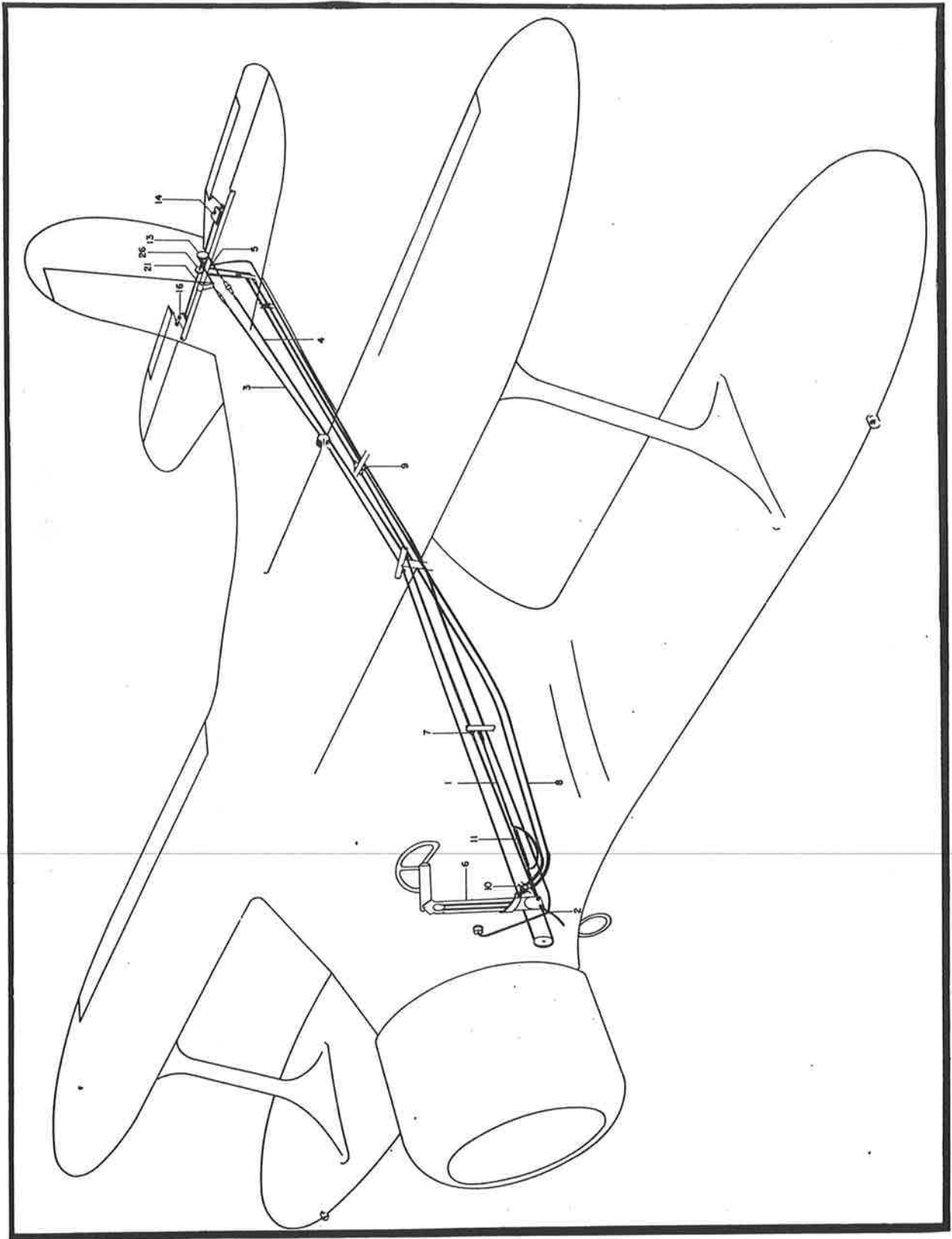

Figure 16 - Elevator and Tab Control Assembly

RESTRICTED
T. O. No. 01-90CC-4
SECTION II—GROUP ASSEMBLY PARTS LISTS

FIG. NO.	INDEX NO.	STOCKED	GROUP Flight Controls						UNITS PER ASSY	PROPERTY CLASSIFICATION		
			MAJOR ASSEMBLY Installation - Flight Controls							U.S. NAVY	U.S. ARMY	BRITISH
			PART NUMBER	1	2	3	4	5				
17	7	S	561-D-4							1		01-C
			562-D-8							1		01-C
			D17717							1		01-H
			D17717-1							1		01-H
17	8	S	D17717-2							1		01-H
			D17717-3							2		01-H
			561-D-4							2		01-C
			D17721							2		01-H
			D17721-1							4		01-H
			D17721-2							2		01-H
			D17721-3							2		01-H
			D17721-4							4		01-H
			AC365-852							2		04-A
			AN505-8-48							2		29
17	10	S	AN960B8							2		04-A
			D17722-1							1		01-H
			D17722-2							1		01-H
			D17722-3							1		01-H
			AN430AD4-4							2		29
			D17722-4							2		01-H
			D17722-5							1		01-H
			D17722-6							1		01-H
			AN430AD4-3							2		29
			D17750A							1		01-H
17	11	S	D17750A-5							1		01-H
			82 (P)							1		29
			No number (P)							2		
			D177501							1		01-H
			D17750A-1							1		01-H
			D17751-1							1		01-H
			D17751-3							1		01-H
			D17751-5							2		01-H
			D17751-2							1		01-H
			D17751-3							1		01-H
20	2	S	D17751-5							1		01-H
			D17751-6							2		01-H
			D17751-29							2		01-H
			D17751-45							2		01-H
			D17751-47							2		01-H
			D17751-49							2		01-H
			D177602-1							1		01-H
			D177602-2							1		01-H
			D177602-3							1		01-H
			D177602-4							2		01-H

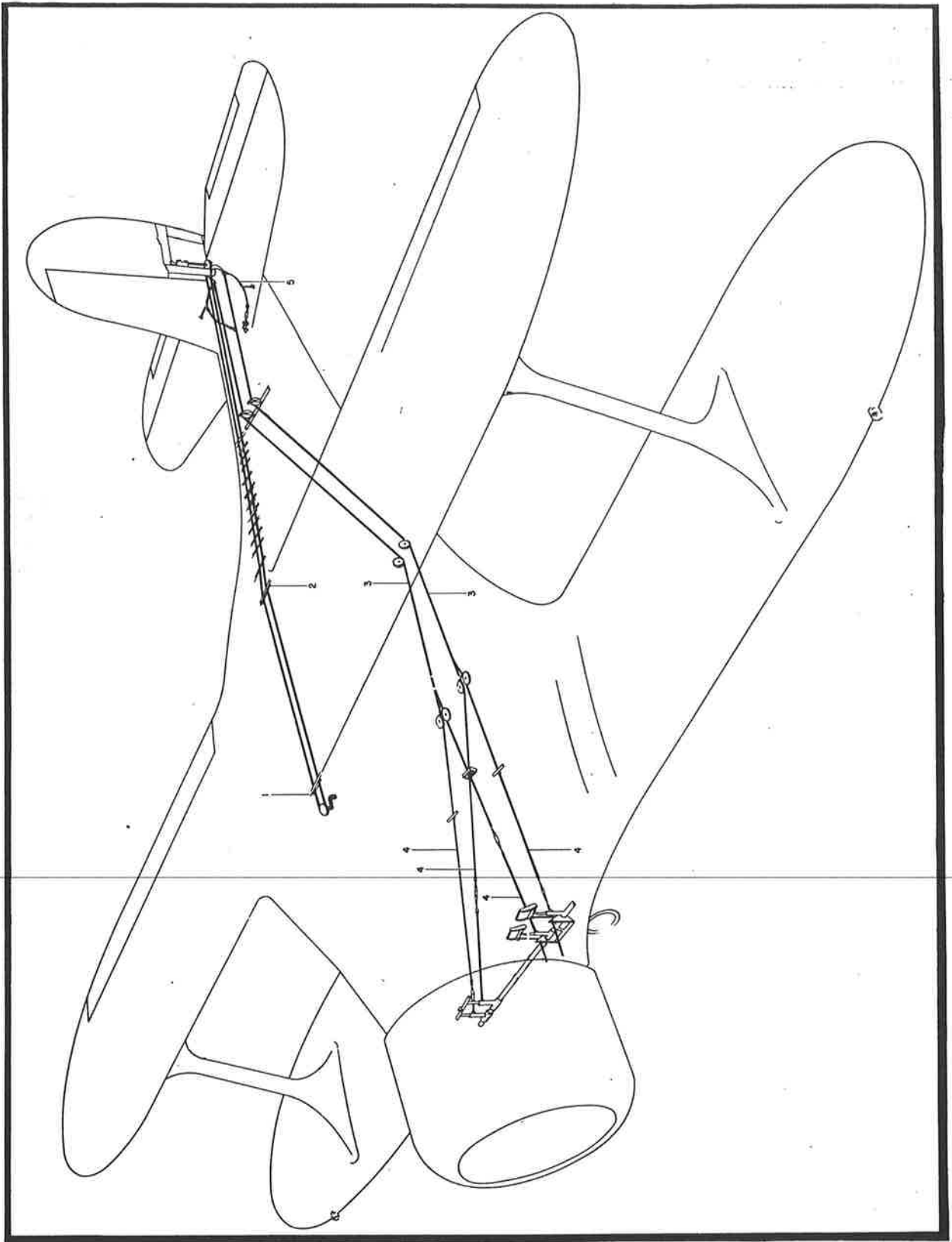

Figure 19 - Rudder and Tab Control Assembly

RESTRICTED
T. O. No. 01-90CC-4
SECTION II—GROUP ASSEMBLY PARTS LISTS

FIG. NO.	INDEX NO.	STOCKED	GROUP Flight Controls						UNITS PER ASSY	PROPERTY CLASSIFICATION			
			MAJOR ASSEMBLY Installation - Flight Controls							U.S. NAVY	U.S. ARMY	BRITISH	
			PART NUMBER	1	2	3	4	5					6
			D177611						Attachment - Bowden housing control column	1		01-H	
			100696-X12-06-400						Spacer - Control column bottom	1		01-H	
20	3	S	D177502						Arm Assembly - Control column throw-over	1		01-H	
			D17750A-2						Arm - Control column throw-over	1		01-H	
			D17751-7						Plate Assembly - Control column throw-over shaft	2		01-H	
			D17751-8						Plate - Control column throw-over shaft	1		01-H	
			D17751-12						Insert - Control column throw-over shaft	2		01-H	
			D17751-50						Reinforcement	2		01-H	
20	6	S	D17262-2						Pulley - Aileron control	2		01-H	
			A114						Pulley	1		29	
20	7	S	AN4-14						Bolt	1		04-A	
20	8	S	AN320-4						Nut	1		04-A	
20	9	S	AN380-2-2						Pin	1		29	
20	10	S	AN960-416						Washer	1		04-A	
			D17751-9						Spacer	1		01-H	
20	11	S	D17751-10						Bearing Assembly - Throw-over control column	2		01-H	
			D17751-11						Collar - Bearing	1		01-H	
			SIK-6 (P)						Bearing (Fafnir)	1		29	
20	12	S	S-74-14						Bolt	2		01-H	
20	13	S	AN310-4						Nut	2		04-A	
			AN380-2-2						Pin	2		29	
			AN960-416						Washer	2		04-A	
20	14	S	D17751-12						Spacer - Throw-over control column	2		01-H	
20	15	S	D17751-14						Spring - Throw-over latch pin	1		01-H	
20	16	S	D17751-15						Pin - Throw-over latch	1		01-H	
20	17	S	D17751-20						Spacer - Throw-over control column outer	2		01-H	
20	18	S	D17751-21						Spacer - Throw-over control column inner	1		01-H	
			D17751-23						Axle - Throw-over control column	1		01-H	
20	19	S	D17751-27						Knob - Throw-over control column latch pin	1		01-H	
20	20	S	D17751-31						Cover - Throw-over control column outer end	1		01-H	
20	21	S	D17751-35						Bearing Assembly - Control column center	1		01-H	
			D17751-48						Collar - Bearing	1		01-H	
			SIK-6 (P)						Bearing (Fafnir)	1		29	
			S-74-15						Bolt	1		01-H	
			AN310-4						Nut	1		04-A	
			AN380-2-2						Pin	1		29	
			AN960-416						Washer	1		04-A	
			D177600						Control Assembly - Elevator tab	1		01-H	
20	22	S	D170104						Placard - Elevator tab control	1		01-H	
20	23	S	D177601						Disc - Elevator tab control	1		01-H	
20	24	S	6-32 x 3/8						Screw - Round head machine	1			
			D177602-1						Housing Assembly - Elevator tab control	1		01-H	
			D177602-2						Side - Tab control housing	1		01-H	
			D177602-3						Base - Tab control housing	1		01-H	
			D177602-4						Spacer - Tab control housing	1		01-H	

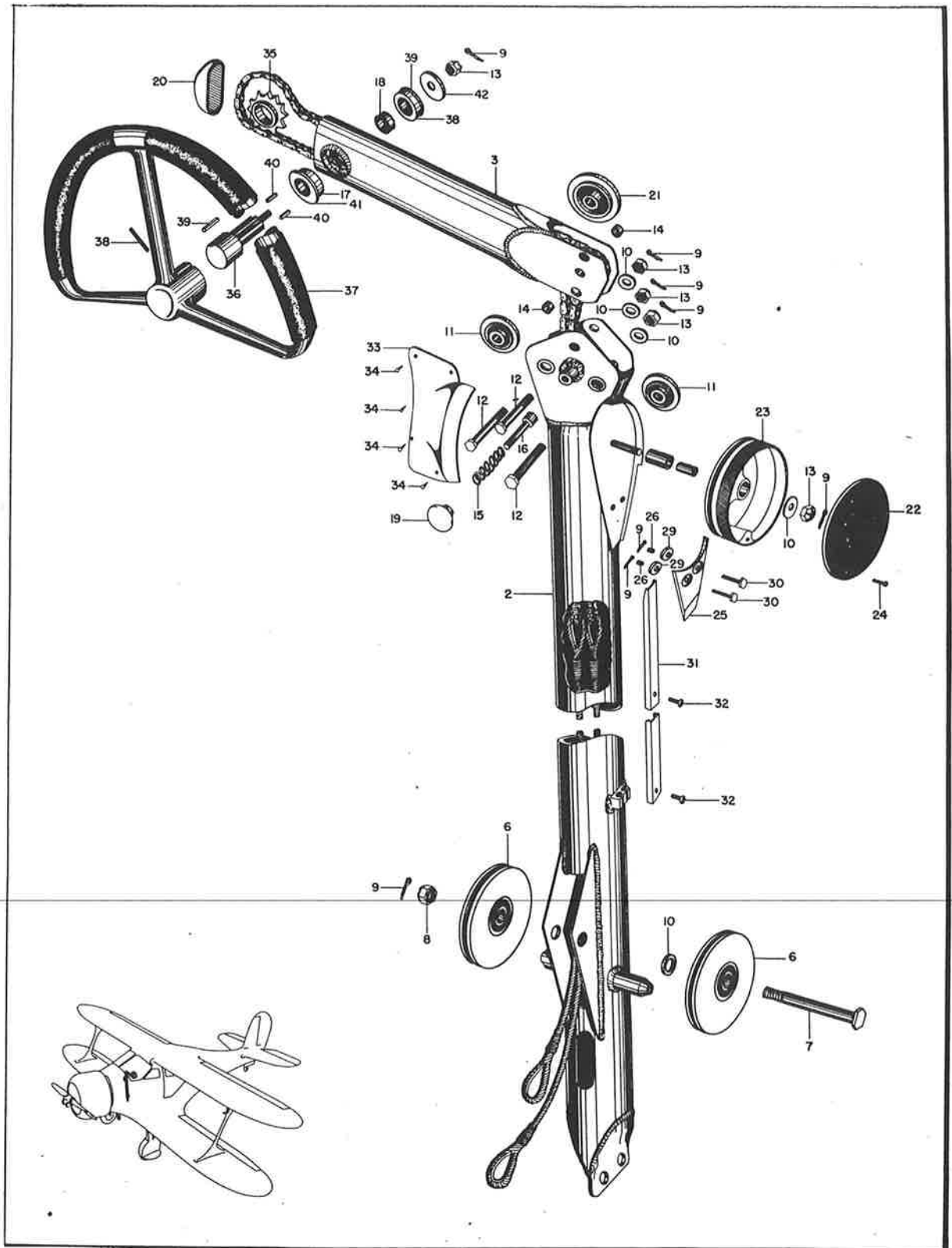

Figure 20 - Control Column Assembly

RESTRICTED
T. O. No. 01-90CC-4
SECTION II—GROUP ASSEMBLY PARTS LISTS

FIG. NO.	INDEX NO.	STOCKED	GROUP Flight Controls						UNITS PER ASSY	PROPERTY CLASSIFICATION				
			MAJOR ASSEMBLY Installation - Flight Controls							U.S. NAVY	U.S. ARMY	BRITISH		
			PART NUMBER	1	2	3	4	5					6	NOMENCLATURE
20	25	S	D177603								1		01-H	
		S	D177602-5								1		01-H	
		S	D177604								1		01-H	
		S	D177605								1		01-H	
20	26	S	D177606								1		01-H	
		S	AN310-4								1		04-A	
		S	AN380-2-2								1		29	
		S	AC940-416								1		29	
20	29	S	D177607								1		01-H	
20	30	S	AN3-5								2		04-A	
		S	AN380-2-2								2		29	
20	31	S	D177608								1		01-H	
20	32	S	AN505-8-6								2		29	
20	33	S	D177612								1		01-H	
20	34	S	AN535-0-3								4		29	
20	35	S	D17856-7								1		01-H	
		S	187519								1		01-H	
20	36	S	187518								1		01-H	
20	37	S	302515								1		01-H	
20	38	S	102809-125-112								1		01-H	
20	39	S	105693-01250								2		01-H	
		S	AN310-4								1		04-A	
		S	AN380-2-2								1		29	
20	40	S	S-21-3								2		01-H	
		S	S-34-2								2		01-H	
20	41	S	4110 (P)								2		29	
20	42	S	100951-S-008-012								1		01-H	
18	7	S	D17751-44								1		01-H	
		S	D17751-40								2		01-H	
		S	561-D-4								1		01-C	
		S	561-D-8								1		01-C	
18	8	S	D177613								1		01-H	
		S	D177613-1								1		01-H	
		S	S-123								6		01-H	
		S	AC365-624								6		04-A	
		S	S-167								4		01-H	
		S	100696-F10-03-100								2		01-H	
18	9	S	D17763-2								1		01-H	
		S	S-59								2		01-H	
		S	562-D-6								1		01-C	
18	10	S	D17763-3								1		01-H	
		S	D177631								1		01-H	
		S	562-D-9								1		01-C	
		S	D177710								1		01-H	
		S	D177710-2								1		01-H	
		S	S-123								4		01-H	
		S	AC365-624								4		04-A	
		S	S-167								2		01-H	
		S	D17774								1		01-H	
		S	D1774-1								1		01-H	

RESTRICTED

T. O. No. 01-90CC-4

SECTION II—GROUP ASSEMBLY PARTS LISTS

FIG. NO.	INDEX NO.	STOCKED	GROUP Flight Controls						UNITS PER ASSY	PROPERTY CLASSIFICATION				
			MAJOR ASSEMBLY	Installation - Flight Controls						U.S. NAVY	U.S. ARMY	BRITISH		
				Installation - Flap Operating Mechanism										
			PART NUMBER	1	2	3	4	5	6	NOMENCLATURE				
19	26	S	D17774-2							Arm - Rudder tab crank bracket	1		01-H	
			D17774-3							Bearing - Rudder tab crank bracket	1		01-H	
			D17774-4							Guard - Rudder tab cable	1		01-H	
			562-D-12							Clamp Curtis	1		01-C	
			AN4-10							Bolt	1		04-A	
			AN310-4							Nut	1		04-A	
			AN380B-2-2							Pin	1		29	
			D17774-5							Bushing - Rudder tab crank	1		01-H	
			D17774-6							Shaft - Rudder tab crank	1		01-H	
			D170103							Placard - Rudder tab control	1		01-H	
			D17776-2							Pulley - Rudder tab control	1		01-H	
			No number							Pin	1			
			121842 (P)							Plate - Escutcheon (Hudson Motor Company)	1		29	
			142017 (P)							Handle (Hudson Motor Co.)	1		29	
			B48248 (P)							Pin - Escutcheon (Hudson Motor Co.)	1		29	
			D177911							Guard Assembly - Rudder cable pulley	2		01-H	
			D177911-1							Guard - Pulley	1		01-H	
			D177911-2							Reinforcement - Pulley guard	1		01-H	
AN425AD-3-4							Rivet	2		29				
AN430AD-4-5							Rivet	1		29				
SIK-6 (P)							Bearing (Fafnir)	2		29				
S-71							Spring	1		01-H				
S-108-4-4							Spacer	3		01-H				
S-108-4-7							Spacer	3		01-H				
100951-S-031-008-028							Washer	1						
17	12	S	AN210-3A						Pulley	11		04-A		
			AN4-10						Bolt	4		04-A		
			AN4-14						Bolt	2		04-A		
			AN4-15						Bolt	1		04-A		
			AN4-16						Bolt	4		04-A		
			AN310-4						Nut	11		04-A		
			AN380-2-2						Pin	11		29		
			AN210-4A						Pulley	10		04-A		
			AN4-10						Bolt	7		04-A		
			AN4-13						Bolt	1		04-A		
17	13	S	AN4-20						Bolt	2		04-A		
			AN310-4						Nut	10		04-A		
			AN380-2-2						Pin	10		29		
			AN755-4						Clip - Tube, loop type	2		04-A		
			100696-D8-06-008						Spacer	1		01-H		
			AF775-12						Bolt - Universal fitting	1		04-A		
			AC365-832						Nut	1		04-A		
			AN515-832-14						Screw	1		29		
			D177750						Installation - Flap operating mechanism	1		01-H		
			D177751-1						Housing Assembly - Flexible shaft in fuselage	1		01-H		
21	2	S	D177751-2					Housing - Flexible shaft in fuselage	1		01-H			
			D177751-5					End - Flexible shaft housing	1		01-H			
21	3	S	D177751-3					Housing Assembly - Flexible shaft in fuselage	1		01-H			
			D177751-4					Housing - Flexible shaft in fuselage	1		01-H			
			D177751-5					End - Flexible, shaft housing	1		01-H			
			D177751-6					Bracket Assembly - Flexible shaft housing attaching	2		01-H			
			D177751-7					Tube - Flexible shaft housing attaching	1		01-H			

RESTRICTED

T. O. No. 01-9000-4

SECTION II—GROUP ASSEMBLY PARTS LISTS

FIG. NO.	INDEX NO.	STOCKED	GROUP Flight Controls						UNITS PER ASSY	PROPERTY CLASSIFICATION		
			MAJOR ASSEMBLY Installation - Flap Operating Mechanism							U.S. NAVY	U.S. ARMY	BRITISH
			PART NUMBER	1	2	3	4	5				
21	4	S	D177754						1		01-H	
		S	AC501-10-4						2		29	
		S	D177752-1						1		01-H	
		S	No number						1			
21	5	S	No number						1			
		S	No number						1			
		S	D177752-2						1		01-H	
		S	No number						1			
21	6	S	No number						1			
		S	D177755						1		01-H	
		S	D177755-1						1		01-H	
		S	562-D-11 (P)						2		01-C	
		S	AN4-10						2		04-A	
		S	AN310-4						2		04-A	
		S	AN380-2-2						2		29	
		S	AC500-10-7						4		29	
		S	D177756						2		01-H	
		S	AN805-6						1		04-A	
		S	D177757-2 LH						1		01-H	
		S	D177757-3						1		01-H	
		S	D177757-4						1		01-H	
		S	561-D-7 (P)						1		01-C	
		S	AN3-7						1		04-A	
		21	7	S	AN310-3						1	
S	AN380-2-2								1		29	
S	D177757-2 RH								1		01-H	
S	D177757-3								1		01-H	
S	D177757-4								1		01-H	
S	561-D-7 (P)								1		01-C	
S	AN3-7								1		04-A	
S	AN310-3								1		04-A	
S	AN380-2-2								1		29	
S	4253 (P)								1		03-C	
S	4253								1		03-C	
S	9429								2		03-C	
S	1057								2		03-C	
S	5835								2		03-C	
S	8582								2		03-C	
S	R4119								4		03-C	
S	R8640						2		03-C			
S	4253A						1		03-C			
S	4253						1		03-C			
S	8109						1		03-C			
S	4253						1		03-C			
S	4253						1		03-C			
S	4253						1		03-C			
S	4253						1		03-C			
S	4253						1		03-C			

RESTRICTED

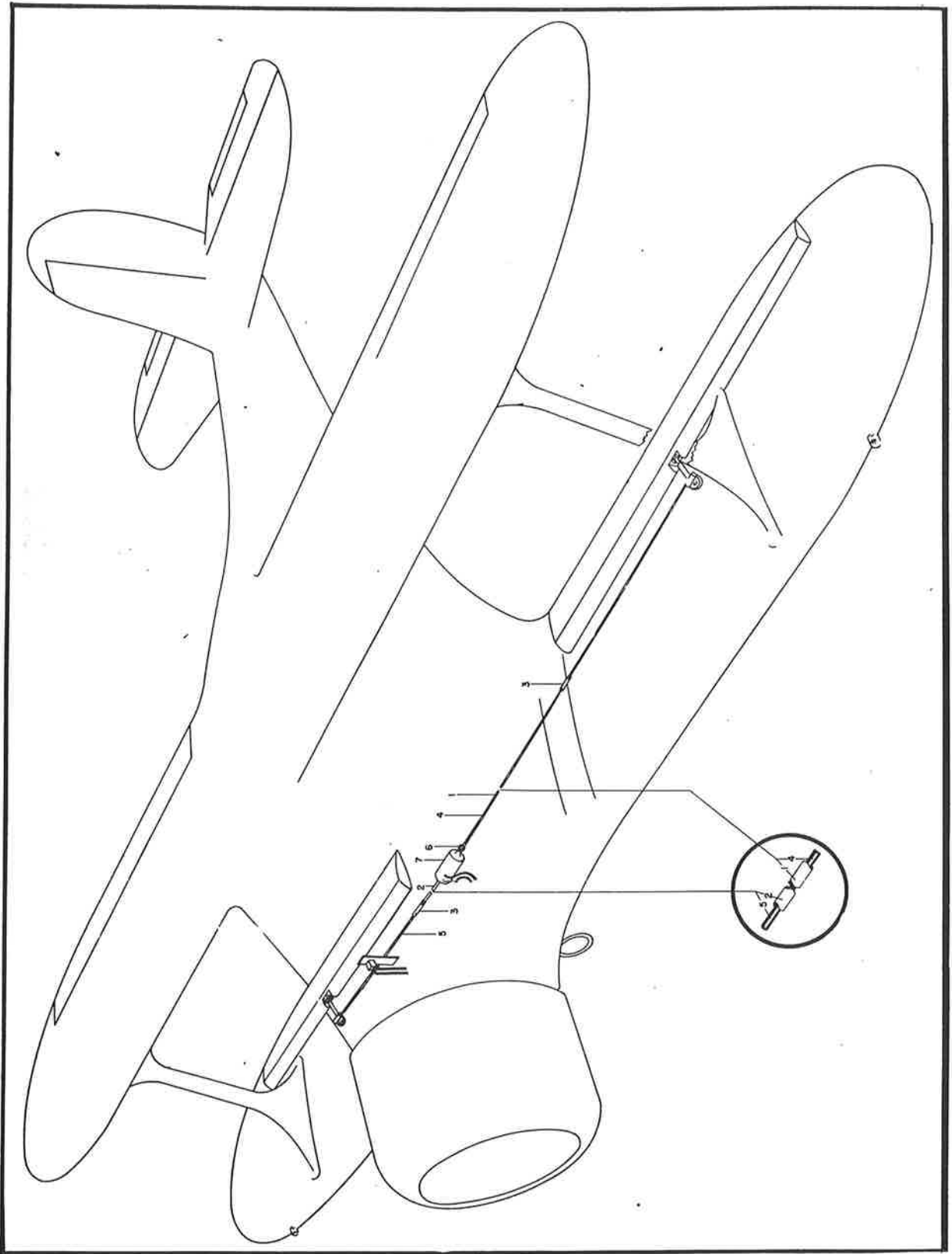

Figure 21 - Flap Operating Mechanism

RESTRICTED

T. O. No. 01-90CC-4

SECTION II—GROUP ASSEMBLY PARTS LISTS

FIG. NO.	INDEX NO.	STOCKED	GROUP Flight Controls Power Plant						UNITS PER ASSY	PROPERTY CLASSIFICATION		
			MAJOR ASSEMBLY Installation - Flap Operating Mechanism Installation - Power Plant							U.S. NAVY	U.S. ARMY	BRITISH
			PART NUMBER	1	2	3	4	5				
		S	4253						1		03-C	
		S	5335						2		03-C	
		S	R3352						2		03-C	
		S	R4243						2		03-C	
		S	R4297						2		03-C	
		S	J-18						5		03-C	
		S	R-3676						2		03-C	
			D17S9005					Installation - Power plant	1		01-H	
			D175902					Installation - Engine cowling			01-H	
			D175950					Cowling Assembly			01-H	
			D179007					Installation - Fuel system			01-H	
			D17S9100					Mount Assembly - Engine			01-H	
28	15	S	AN7-50					Bolt - Aircraft 7/16-20	9		04-A	
28	17	S	AN310-7					Nut - Aircraft castle	9		04-A	
28	1	S	AN380-3-3					Pin - Cotter	9		29	
28	14	S	AN945-7					Washer - Plain commercial standard	16		29	
28	16	S	AN960-716					Washer - Plain	11		04-A	
			D179807					Installation - Oil system			01-H	
			D170190					Installation - Fuel analyzer cell	1		01-H	
		S	D170190-2					Tube - Fuel analyzer cell	1		01-H	
		S	FB-6A (P)					Clamp (Wittek)	4		04-A	
		S	AC884-6-9					Hose - Aromatic resistant synthetic	2		04-B	
		S	D170190-3					Tube - Fuel analyzer cell	1		01-H	
		S	D170190-6					Hose - Fuel analyzer cell	4		01-H	
		S	AC884-6					Hose - Aromatic resistant synthetic			04-B	
		S	105792					Clamp - Adjustable low pressure hose	4		01-H	
		S	D170190-7					Tube - Fuel analyzer cell	1		01-H	
		S	AC365-632					Nut - Self-locking	3		04-A	
		S	AN526-632-8					Screw - Button head	3		29	
		S	AC811-HT-6					Fitting - Solderless union	1		04-A	
		S	AC811-T-6CS					Fitting - Solderless sleeve	2		04-A	
		S	AC811-BT-6D					Fitting - Solderless nut	2		04-A	
		S	AN960-6					Washer - Plain	3		04-A	
		S	100951-F125-012-200					Washer	1		01-H	
		S	D170190-8					Tube - Fuel analyzer cell	1		01-B	
		S	FB-6A (P)					Clamp (Wittek)	4		04-A	
		S	AC884-6-9					Hose - Aromatic resistant synthetic	1		04-B	
		S	D170190-9					Tube - Fuel analyzer cell	1		01-H	
34	20	S	AN931-6-10					Grommet - Elastic	1		04-B	
		S	No number (P)					Indicator - Mixture type A (Cambridge)	1			
		S	10554					Plate and Filter Assembly	1		05-E	
		S	8853					Baffle Plate	1		05-E	
		S	6762					Meter Block Assembly	1		05-E	
		S	6492					Moisture Vapor Plug	1		05-E	
		S	8291					Moisture Wick	1		05-E	
		S	8852					Filter Screen	1		05-E	
		S	8695					Filter Cover	1		05-E	
		S	8696A					Filter Cover Gasket	1		05-E	
		S	8698					Snap Lock	1		05-E	
		S	10286					Terminal Panel Posts	2		05-E	
		S	SK-2652					Terminal Strip Assembly	1		05-E	
		S	7081F5					Coil - 90 ohms	1		05-E	
		S	7081F6					Coil - 100 ohms	1		05-E	
		S	10285					Meter Cover	1		05-E	
		S	8289					Grommet	16		05-E	
		S	6774					Meter Block Gasket	1		05-E	
		S	8290					Resistor - 15 ohms variable	1		05-E	

RESTRICTED

T. O. No. 01-9000-4

SECTION II—GROUP ASSEMBLY PARTS LISTS

FIG. NO.	INDEX NO.	STOCKED	GROUP Power Plant						UNITS PER ASSY	PROPERTY CLASSIFICATION		
			MAJOR ASSEMBLY Installation - Power Plant							U.S. NAVY	U.S. ARMY	BRITISH
			PART NUMBER	1	2	3	4	5				
		S	S-16-4-4						5		01-H	
		S	84-185883					Rivet - Thomson 1/8 inch	1		01-H	
		S	84-185878					Segment Assembly - Left engine inner cowling ring left	1		01-H	
		S	84-185889					Segment - Left engine inner cowling ring left	1		01-H	
		S	84-185889					Seal - Inner cowling ring	1		01-H	
		S	S-16-4-4					Rivet - Thomson 1/8 inch	5		01-H	
		S	84-185894					Seal - Inner cowling ring	1		01-H	
		S	S-16-4-4					Rivet - Thomson 1/8 inch	5		01-H	
		S	84-185885					Segment Assembly - RH engine inner cowling ring RH	1		01-H	
		S	84-185875					Segment - Right engine inner cowling ring right	1		01-H	
		S	84-185887					Seal - Inner cowling ring	1		01-H	
		S	S-16-4-4					Rivet - Thomson 1/8 inch	5		01-H	
		S	84-185893					Seal - Inner cowling ring	1		01-H	
		S	S-16-4-4					Rivet - Thomson 1/8 inch	5		01-H	
		S	84-185895					Seal - Inner cowling ring	2		01-H	
		S	S-16-4-4					Rivet - Thomson 1/3 inch	6		01-H	
		S	84-185899					Seal - Scavenger pump line inner cowl	1		01-H	
		S	D175909					Support Assembly - Former ring upper	1		01-H	
		S	D175909-1					Tube - Former ring upper support	1		01-H	
		S	D175909-2					Plate - Former ring upper support	1		01-H	
		S	18S5918					Bracket - Fore and after support M.A.C.A. cowl	9		01-H	
		S	AN4-11					Bolt - Aircraft 1/4-28	18		04-A	
		S	AN310-4					Nut - Aircraft castle	18		04-A	
		S	AN380-2-2					Pin - Cotter	18		29	
		S	AN960-416					Washer - Plain	36		04-A	
		S	D175945					Ring Assembly - Cowling former	1		01-H	
		S	D175945-1					Block - Former ring reinforcement	4		01-H	
		S	D175945-2					Strip - Former ring	1		01-H	
		S	AN425AD4-5					Rivet - 78° countersunk head	1		29	
		S	AN425AD4-7					Rivet - 78° countersunk head	15		29	
		S	D175945-3					Strip - Former ring	1		01-H	
		S	AN425AD4-7					Rivet - 78° countersunk head	23		29	
		S	D175945-4					Segment - Cowling former ring	1		01-H	
		S	102718-S04800					Extrusion - 1/2 channel	1		01-H	
		S	AN456AD4-12					Rivet - Brazier head	2		29	
		S	D175945-5					Segment - Cowling former ring	1		01-H	
		S	102718-08016					Extrusion - 1/2 channel	1		01-H	
		S	D175945-6					Segment - Cowling former ring	1		01-H	
		S	102718-S01600					Extrusion - 1/2 channel	1		01-H	
		S	AN3-7A					Bolt - Aircraft 10-32	2		04-A	
		S	AC365-1032					Nut - Self-locking	2		04-A	
		S	AN960-10L					Washer - Plain	2		04-A	
		S	D175945-7					Strip - Former ring	1		01-H	
		S	AN425AD4-5					Rivet - 78° countersunk head	1		29	
		S	AN425AD4-7					Rivet - 78° countersunk head	4		29	
		S	D175945-8					Bar - Cowling former ring splice	1		01-H	
		S	E17B5904					Plate - Cowl former ring offset	4		01-H	
		S	AN430AD4-12					Rivet - Round head	14		29	
		S	F17D5907					Spacer - Cowl former ring	2		01-H	
		S	AN425AD4-18					Rivet - 78° countersunk head	4		29	
		S	AN3-7					Bolt - Aircraft 10-32	5		04-A	
		S	AN310-3					Nut - Aircraft castle	5		04-A	
		S	AN380-2-2					Pin - Cotter	5		29	
		S	D175954					Tube Assembly - Manifold pressure front	1		01-H	
		S	D175954-2					Tube - Manifold pressure front	1		01-H	
		S	AC811T-4CS					Fitting - Solderless sleeve	1		04-A	

RESTRICTED

T. O. No. 01-9000-4

SECTION II—GROUP ASSEMBLY PARTS LISTS

FIG. NO.	INDEX NO.	STOCK E	GROUP Power Plant						UNITS PER ASSY	PROPERTY CLASSIFICATION		
			MAJOR ASSEMBLY Installation - Power Plant							U.S. NAVY	U.S. ARMY	BRITISH
			PART NUMBER	1	2	3	4	5				
		S	A-513-10						1		03-I	
		S	A-513-11					Body	1		03-I	
		S	A-513-4					Cover	1		03-I	
		S	A-513-5					Sleeve	1		03-I	
		S	A-513-8					Rotor	1		03-I	
		S	A-513-12					Blade	2		03-I	
		S	A-513-13					Pin - Anchor	1		03-I	
		S	A-513-13A					Gasket - .001 thick	4		03-I	
		S	A-513-16					Gasket - .002 thick	4		03-I	
		S	A-510-14					Dowel	1		03-I	
		S	A-510-15					Spring	1		03-I	
		S	A-501-16					Plunger	1		03-I	
		S	A-513-17					Retainer	1		03-I	
		S	A-513-18					Gasket	1		03-I	
		S	A-513-15					Cap	1		03-I	
		S	AN-535-00-2					Name Plate	1		03-I	
		S	No number					Drive Screw	4			
		S	No number					Bearing - Fafnir (202 KPP)	1		29	
		S	AN-500-A8-7					Bearing - Fafnir (202K)	1		29	
		S	AN-73-5					Screw - No. 8-32 x 7/16 long, fillister head	3		29	
		S	AN-960-10L					Screw - No. 10-32 x 9/16 long, hexagonal head	6		29	
		S	A-514-A					Washer No. 10	6		04-A	
		S	A-502-6					Coupling Asserby	1		03-I	
		S	A-513-19					Snap Ring	1		03-I	
		S	AN895-70					Plug - Shipping 3/8 pipe	2		03-I	
		S	A-513-14					Plug - 1/8 pipe, square head	1		04-A	
		S	A-513-20					Gasket	1		03-I	
		S	AN-515-8-16					Shipping Block	1		03-I	
		S	AN-340-8					Screw - Round head No. 8-32 x 1 long	2		29	
		S	218-K (P)					Nut - No. 8-32 hexagonal	2		29	
		S	AC835-8					Separator - Oil (Pump Engineering Service Co.)	1		03-I	
		S	AC850-8					Nipple - Hose, fuel and oil	1		04-A	
		S	AC851-8					Elbow - Hose, fuel and oil	1		04-A	
		S	AN884-8-9					Elbow - Hose, fuel and oil 45°	1		04-A	
		S	FB8A (P)					Hose - Aromatic resistant synthetic	9		04-B	
		S	D179016					Clamp (Wittek)	18		04-A	
		S	D179017					Installation + Crankcase vent	1		01-H	
		S	FB12A (P)					Tube + Crankcase vent upper	1		01-H	
		S	AC365-1032					Clamp (Wittek)	2		04-A	
		S	AN520-10-10					Nut - Self-locking	1		04-A	
		S	AC755-16					Screw - Round head	1		29	
		S	AC882-12-11					Clip - Tube, loop type	1		04-A	
		S	AN960-10					Hose - Aircraft	1		04-B	
		S	105933-12					Washer - Plain	1		04-A	
		S	D179018					Clip + Bonded cushion Adel 755-12-2-8	1		04-A	
		S	FB12A (P)					Tube + Crankcase vent center	1			
		S	AC882-12-11					Clamp (Wittek)	4		04-A	
		S	D179019					Hose - Aircraft	2		04-B	
		S	AC365-1032					Tube + Crankcase vent lower	1		01-H	
		S	AN520-10-10					Nut - Self-locking	1		04-A	
		S	AC755-16					Screw - Round head	1		29	
		S	AN931-12-17					Clip + Tube, loop type	1		04-A	
		S	AN960-10					Grommet - Elastic	2		04-B	
		S	105933-12					Washer - Plain	1		04-A	
24	40	S	D179025					Clip + Bonded cushion Adel 755-12-2	1		04-A	
		S	D179025-1					Duct Assembly - Carburetor hot air left hand	1		01-H	
		S						Shell - Upper	1		01-H	

RESTRICTED

T. O. No. 01-90CC-4

SECTION II—GROUP ASSEMBLY PARTS LISTS

FIG. NO.	INDEX NO.	STOCKED	GROUP Power Plant						UNITS PER ASSY	PROPERTY CLASSIFICATION				
			MAJOR ASSEMBLY Installation - Power Plant							U.S. NAVY	U.S. ARMY	BRITISH		
			PART NUMBER	1	2	3	4	5					6	NOMENCLATURE
24	41	S	D179025-2							Shell - Lower	1		01-H	
			D179026							Duct Assembly - Carburetor hot air right hand	1		01-H	
			D179026-1							Shell - Upper	1		01-H	
			D179026-2							Shell - Lower	1		01-H	
			D179027							Clamp - Carburetor Hot air duct	2		01-H	
			96-B-9010 (P)							Nut (Boots)	4		04-A	
			AN515-8-10							Screw - Round head	4		29	
			AN960-8							Washer - Plain	8		04-A	
			D17S9034							Clamp Assembly - Cabin heater tube	1		01-H	
			D17S9034-2							Tube - Clamp	1		01-H	
			AN741-8							Clamp - Tube	1		04-A	
			AN741-14							Clamp - Tube	1		04-A	
			AN4-7A							Bolt - Aircraft 1/4-28	2		04-A	
			AC365-428							Nut - Self-locking	2		04-A	
			D17S9066							Installation - Engine baffles	1		01-H	
			D17S9066-6							Baffle - Engine	1		01-H	
			No number (P)							Baffle (Pratt and Whitney)	1			
			D17S9066-7							Baffle - Engine	1		01-H	
			No number (P)							Baffle (Pratt and Whitney)	1			
			AN456-AD4-5							Rivet - Brazier head	8		29	
			D17S9066-8							Baffle - Engine	1		01-H	
			No number (P)							Baffle (Pratt and Whitney)	1			
			AN456-AD4-5							Rivet - Brazier head	8		29	
			D17S9066-9							Baffle - Engine	1		01-H	
			No number (P)							Baffle (Pratt and Whitney)	1			
			D17S9066-11							Retainer - Engine baffle	1		01-H	
			No number (P)							Retainer (Pratt and Whitney)	1			
			D17S9066-12							Baffle - Engine	1		01-H	
			No number (P)							Baffle (Pratt and Whitney)	1			
			AN456-AD4-5							Rivet - Brazier head	6		29	
			D17S9066-13							Baffle - Engine	1		01-H	
			No number (P)							Baffle (Pratt and Whitney)	1			
			D17S9066-14							Retainer - Engine baffle	2		01-H	
			No number (P)							Retainer (Pratt and Whitney)	2			
			D17S9066-15							Baffle - Engine	1		01-H	
			No number (P)							Baffle (Pratt and Whitney)	1			
			84-189114							Plate - Baffle small patch	1		01-H	
			AC-365-832							Nut - Self-locking	4		04-A	
			AN515-8-7							Screw - Round head	4		29	
			D17S9121							Inlet Assembly - LH heater muff	1		01-H	
			D17S9121-2							Flange - LH heater muff inlet	1		01-H	
			D17S9121-4							Tube - LH heater muff inlet	1		01-H	
			D17S9121-6							Tube - LH heater muff inlet	1		01-H	
			AC365-832							Nut - Self-locking	3		04-A	
			AN515-8-8							Screw - Round head	3		29	
AC940-8							Washer - Burr	6		29				
D17S9122							Inlet Assembly - RH heater muff	2		01-H				
D17S9122-2							Flange - RH heater muff inlet	1		01-H				
D17S9122-4							Tube - RH heater muff inlet	1		01-H				
D17S9122-6							Tube - RH heater muff inlet	1		01-H				
AC365-832							Nut - Self-locking	6		04-A				
AN515-8-8							Screw - Round head	6		29				
AC940-8							Washer - Burr	12		29				
M33705 (P)							Plug - Rubber (Goodrich)	1		04-B				
D17074							Installation - Constant speed propeller piping	1		01-H				
D17S9072A							Bracket Assembly - Constant speed control, engine control	1		01-H				
D17S9072A-1							Bracket Assembly - Engine control	1		01-H				

RESTRICTED

RESTRICTED
T. O. No. 01-9000-4
SECTION II—GROUP ASSEMBLY PARTS LISTS

FIG. NO.	INDEX NO.	STOCKED	GROUP Power Plant						UNITS PER ASSY	PROPERTY CLASSIFICATION		
			MAJOR ASSEMBLY Installation - Power Plant							U.S. NAVY	U.S. ARMY	BRITISH
			PART NUMBER	1	2	3	4	5				
			D17S9072A-2						1		01-H	
			D17S9072A-3						1		01-H	
			D17S9072A-4						1		01-H	
			D17S9072A-5						1		01-H	
			D17S9072A-6						1		01-H	
			D17S9072A-7						1		01-H	
			561-D-4 (P)						1		01-C	
		S	AN3-5					Bolt - Aircraft 10-32	1		04-A	
		S	AN3-7					Bolt - Aircraft 10-32	1		04-A	
		S	S-241					Bushing - Engine control bracket	1		01-H	
		S	AN310-3					Nut - Aircraft castle	2		04-A	
		S	AN500-2-2					Pin - Cotter	2		29	
		S	D179073					Arm Assembly - Constant speed control	1		01-H	
		S	D17S9079					Block - Stop, arm, constant speed control, engine	1		01-H	
		S	AN425-AD4-3					Rivet - 70° countersunk head	1		29	
		S	D17S9060					Bracket - Stop, arm, constant speed control, engine	1		01-H	
		S	AN425-AD4-5					Rivet - 78° countersunk head	2		29	
		S	D179062					Arm - Constant speed control	1		01-H	
		S	105740-X0195-0250-0135					Bushing - Special press fit	1		01-H	
		S	64-189074					Tube Assembly - LH engine constant speed front	1		01-H	
		S	64-189069					Tube - LH engine constant speed unit to crankcase front	1		01-H	
		S	AC995-032-51					Wire - Locking	1		04-A	
		S	104036-1-0100-4800					Pad - Felt	1		01-H	
		S	AC365-832					Nut - Self-locking	1		04-A	
		S	AN515-8-10					Screw - Round head	1		29	
		S	8100-6 (P)					Nut (Weatherhead)	1		04-A	
		S	8150-6 (P)					Sleeve (Weatherhead)	1		04-A	
		S	8400-6 (P)					Elbow - 90° (Weatherhead)	1		04-A	
		S	AN931-6-16					Grommet - Elastic	1		04-B	
		S	AN960-8					Washer - Plain	1		04-A	
		S	105933-6					Clip - Bonded cushion Adel 755-6-2-6	1		04-A	
		S	105933-16					Clip - Bonded cushion Adel 755-16-2-4	1		04-A	
		S	D17S9078					Washer - Arm, constant speed control, engine	2		01-H	
		S	AN380-2-2					Pin - Cotter	1		29	
		S	AN392-9					Pin - Flat head 1/8	1		29	
		S	D179085					Tube - Constant speed governor upper pressure	1		01-H	
		S	AC365-832					Nut - Self-locking	1		04-A	
		S	AN515-8-14					Screw - Round head	1		29	
		S	8100-6 (P)					Nut (Weatherhead)	3		04-A	
		S	8150-6 (P)					Sleeve (Weatherhead)	3		04-A	
		S	8300-6 (P)					Union (Weatherhead)	1		04-A	
		S	8355-6 (P)					Elbow - 45° (Weatherhead)	1		04-A	
		S	AN931-8-13					Grommet - Elastic	1		04-B	
		S	AN960-8					Washer - Plain	1		04-A	
		S	100696-D12-06-016					Spacer	1		01-H	
		S	105933-6					Clip - Bonded cushion Adel 755-6-2-6	2		04-A	
		S	64-189090					Tube - LH engine oil pressure to constant speed unit	1		01-H	
		S	8100-6 (P)					Nut (Weatherhead)	2		04-A	

RESTRICTED
T. O. No. 01-9000-4
SECTION II—GROUP ASSEMBLY PARTS LISTS

FIG. NO.	INDEX NO.	STOCKED	GROUP Power Plant						UNITS PER ASSY	PROPERTY CLASSIFICATION				
			MAJOR ASSEMBLY Installation - Power Plant							U.S. NAVY	U.S. ARMY	BRITISH		
			PART NUMBER	1	2	3	4	5					6	NOMENCLATURE
		S	8150-6 (P)								2		04-A	
		S	8355-6 (P)								1		04-A	
		S	8400-6 (P)								1		04-A	
		S	84-189092								1		01-H	
		S	8100-6 (P)								2		04-A	
		S	8150-6 (P)								2		04-A	
		S	8200-6 (P)								2		04-A	
		S	ACS95-D82								1		04-A	
		S	1A2-A5								1		03-A	
		S	562 (P)								1		04-A	
		S	AI3-6								1		04-A	
		S	AI310-3								1		04-A	
		S	AI380-2-2								1		29	
		S	D179077								1		01-H	
		S	D170108								1		01-H	
		S	D170109								1		01-H	
		S	AI930-16								1		04-A	
		S	D170110								1		01-H	
		S	D172856								2		01-H	
		S	100E01-X10-0500								2		01-H	
		S	D173837								1		01-H	
		S	100696-D32-24-100								1		01-H	
		S	D173966-1								1		01-H	
		S	FC-125 (P)								1		03-F	
		S	O-1 (P)								1		03-F	
		S	C-1A (P)								1		03-F	
		S	C-2A (P)								1		03-F	
		S	PL121-5 (P)								1		03-F	
		S	SL169-5-1/2P (P)								1		03-F	
		S	HT330-4R (P)								2		03-F	
		S	LF-250 (P)								1		03-F	
		S	FP-100 (P)								1		03-F	
		S	KH-100-1 (P)								1		03-F	
		S	BT-101 (P)								1		03-F	
		S	PL-130A-5P (P)								1		03-F	
		S	SL-154-5-1/2P (P)								1		03-F	
		S	BA-300-2 (P)								1		03-F	
		S	WD-301-4 (P)								1		03-F	
		S	SP-306 (P)								1		03-F	
		S	WA-320-616 (P)								1		03-F	
		S	NT-330-6R (P)								1		03-F	
		S	AC365-832								1		04-A	
		S	AN515-8-7								1		29	
		S	AC755-5								1		04-A	
		S	AN931-5-9								2		04-B	
		S	AN960-8								1		04-A	
		S	D178009								1		01-H	
		S	AC364-624								1		04-A	
		S	D179064								1		01-H	
		S	D179064-2								1		01-H	

RESTRICTED

RESTRICTED

T. O. No. 01-9000-4

SECTION II—GROUP ASSEMBLY PARTS LISTS

FIG. NO.	INDEX NO.	STOCKED	GROUP Power Plant						UNITS PER ASSY	PROPERTY CLASSIFICATION			
			MAJOR ASSEMBLY Installation - Power Plant							U.S. NAVY	U.S. ARMY	BRITISH	
			PART NUMBER	1	2	3	4	5					6
			561-D-4 (P)						1		01-C		
			562-D-8 (P)						1		01-C		
		S	AN3-7					Bolt - Aircraft 10-32	1		04-A		
		S	AN4-10					Bolt - Aircraft 1/4-28	1		04-A		
		S	S-241					Bushing - Engine control bracket	1		01-H		
		S	AN310-3					Nut - Aircraft castle	1		04-A		
		S	AN310-4					Nut - Aircraft castle	1		04-A		
		S	AN380-2-2					Pin - Cotter	2		29		
		S	D179078					Support Assembly - Throttle control	1		01-H		
			D179078-2					Support - Throttle control	1		01-H		
		S	561-D-4					Clamp (Curtis)	1		01-C		
		S	AN3-7					Bolt - Aircraft 10-32	1		04-A		
		S	S-241					Bushing - Engine control bracket	1		01-H		
		S	AN310-3					Nut - Aircraft castle	1		04-A		
		S	AN380-2-2					Pin - Cotter	1		29		
		S	D179079					Support Assembly - Throttle stop	1		01-H		
			D179079-2					Bracket - Throttle stop support	1		01-H		
		S	D179079-4					Tube - Throttle stop support	1		01-H		
			D179083					Support Assembly - Constant speed propeller control	2		01-H		
			D179083-2					Tube - Support	1		01-H		
		S	D179083-3					Tube - Support	1		01-H		
		S	AN3-7					Bolt - Aircraft 10-32	2		04-A		
		S	AN4-10					Bolt - Aircraft 1/4-28	2		04-A		
		S	AN310-3					Nut - Aircraft castle	2		04-A		
		S	AN310-4					Nut - Aircraft castle	2		04-A		
		S	AN380-2-2					Pin - Cotter	4		29		
		S	561-D-4 (P)					Clamp (Curtis)	2		01-C		
		S	562-D-5 (P)					Clamp (Curtis)	2		01-H		
		S	18S9185					Arm Assembly - Carburetor throttle and mixture control	1		01-H		
			18S9185-1					Bracket - Arm	1		01-H		
			18S9185-2					Arm - Carburetor throttle and mixture control	1		01-H		
		S	P22186 (P)					Arm (Bendix)			03-C		
		S	AN3-11					Bolt - Aircraft 10-32	1		04-A		
		S	AN310-3					Nut - Aircraft castle	1		04-A		
		S	AN380-2-2					Pin - Cotter	1		29		
		S	18S9187					* Bushing - Carburetor throttle arm	1		01-H		
39	49	S	D179347					Control Assembly - Throttle	1		01-H		
		S	3-A-42 (P)					Control Assembly (Shakespeare)	1		03-F		
		S	REB-3N (P)					End - Rod (Fafnir)	1		04-A		
39	50	S	AN931-5-9					Grommet - Elastic	1		04-B		
		S	D179348-1					Control Assembly - Engine carburetor heat	1		01-H		
		S	FC-125 (P)					Control Assembly (Arens)	1		03-F		
		S	O-1 (P)					Housing (Arens)	1		03-F		
		S	I-1A (P)					Wire (Arens)	1		03-F		
		S	C-2A (P)					Cable (Arens)	1		03-F		
		S	PL-121-5 (P)					Plunger Rod (Arens)	1		03-F		
			1/2										
		S	SL169-6P (P)					Sleeve (Arens)	1		03-F		
		S	NF-330-4R (P)					Nut - Aircraft check (Arens)	2		03-F		
		S	LF-250 (P)					Unit - Locking (Arens)	1		03-F		
		S	FP-100 (P)					Face Plate Acorn Nut (Arens)	1		03-F		
		S	KN-100-1 (P)					Knob (Arens)	1		03-F		
			* Used on airplanes, Navy, 12330 to 1244, 12353 and 01644; Army, 12345 to 12352.										

RESTRICTED
T. O. No. 01-90CC-4
SECTION II—GROUP ASSEMBLY PARTS LISTS

FIG. NO.	INDEX NO.	STOCKED	GROUP Power Plant						UNITS PER ASSY	PROPERTY CLASSIFICATION			
			MAJOR ASSEMBLY Installation - Power Plant							U.S. NAVY	U.S. ARMY	BRITISH	
			PART NUMBER	1	2	3	4	5					6
39	51	S	BT-101 (P)							1		03-F	
		S	PL-130A-5 (P) 1/2P							1		03-F	
		S	SL154-6P (P)							1		03-F	
		S	BA-300-2 (P)							1		03-F	
		S	WD301-4 (P) 25/32							1		03-F	
		S	SP-306 (P)							1		03-F	
		S	WA320-616 (P)							1		03-F	
		S	NT330-6R (P)							1		03-F	
		S	REB-3N (P)							1		04-A	
		S	AN3-12							1		04-A	
		S	73-2909 (P)							1		01-F	
		S	AN310-3							1		04-A	
		S	AN380-2-2							1		29	
		S	AN931-5-9							1		04-B	
		S	D179348-2							1		01-H	
		S	FC-125 (P)							1		03-F	
		S	O-1 (P)							1		03-F	
		S	I-1A (P)							1		03-F	
		S	C-2A (P)							1		03-F	
		S	PL-128-5 (P)							1		03-F	
		S	SL-151-5 (P) 1/2P							1		03-F	
		S	NT330-4R (P)							2		03-F	
		S	LF-250 (P)							1		03-F	
		S	FP-100 (P)							1		03-F	
		S	KN-100-1 (P)							1		03-F	
		S	BT-101 (P)							1		03-F	
		S	PL-130A-5P (P)							1		03-F	
		S	SL-154-5 (P) 1/2P							1		03-F	
		S	BA-300-2 (P)							1		03-F	
		S	WD-301-4 (P) 9/32							1		03-F	
		S	SP-306 (P)							1		03-F	
		S	WA320-616 (P)							1		03-F	
		S	NT330-6R (P)							1		03-F	
S	AN3-6							1		04-A			
S	AN310-3							1		04-A			
S	AN380-2-2							1		29			
S	562 (P)							1		04-A			
S	AN931-5-9							2		04-B			
S	AN931-12-17							1		04-B			
S	D179349-1							1		01-H			
S	FC-125 (P)							1		03-F			
S	O-1 (P)							1		03-F			
S	I-1A (P)							1		03-F			
S	C-2A (P)							1		03-F			
S	PL121-5 (P) 1/2P							1		03-F			
S	SL-169-5 (P) 1/2P							1		03-F			
S	NT330-4R (P)							2		03-F			

RESTRICTED

RESTRICTED

T. O. No. 01-9000-4

SECTION II—GROUP ASSEMBLY PARTS LISTS

FIG. NO.	INDEX NO.	STOCKED	GROUP Power Plant						UNITS PER ASSY	PROPERTY CLASSIFICATION			
			MAJOR ASSEMBLY Installation - Power Plant							U.S. NAVY	U.S. ARMY	BRITISH	
			PART NUMBER	1	2	3	4	5					6
		S	V-375 (P)							1		03-F	
		S	BU-101-1 (P)							1		03-F	
		S	FP-103 (P)							1		03-F	
		S	SL-136A-6P (P)							1		03-F	
		S	HT-101 (P)							1		03-F	
		S	SL-141-L (P)							1		03-F	
		S	BU-153-2 (P)							1		03-F	
		S	BO-300-10A (P)							1		03-F	
		S	WA-300-10 (P)							1		03-F	
		S	WA-320-10 (P)							1		03-F	
		S	WA-320-816 (P)							1		03-F	
		S	NT-330-8R (P)							1		03-F	
		S	NT-351-1032 (P)							1		03-F	
		S	PL-355-5 (P)							1		03-F	
		S	1/2 KI-528 (P)							1		03-F	
		S	GR-750 (P)							1		03-F	
		S	WA-750 (P)							4		03-F	
		S	WA-750-1 (P)							2		03-F	
		S	WA-600 (P)							10		03-F	
		S	REB-31 (P)							1		04-A	
		S	A-931-5-9 (P)							1		04-B	
39	53	S	D179349-2 (P)							1		01-H	
		S	FC-125 (P)							1		03-F	
		S	O-1 (P)							1		03-F	
		S	C-1A (P)							1		03-F	
		S	C-2A (P)							1		03-F	
		S	PL-120-6 (P)							1		03-F	
		S	1/2 SL-151-6 (P)							1		03-F	
		S	1/2P NT-330-3R (P)							2		03-F	
		S	V-375 (P)							1		03-F	
		S	BU-101-1 (P)							1		03-F	
		S	FP-103 (P)							1		03-F	
		S	SL-136A-7P (P)							1		03-F	
		S	HT-101 (P)							1		03-F	
		S	SL-141-L (P)							1		03-F	
		S	BU-153-2 (P)							1		03-F	
		S	BO-300-10A (P)							1		03-F	
		S	WA-300-10 (P)							1		03-F	
		S	WA-320-10 (P)							1		03-F	
		S	WA-320-816 (P)							1		03-F	
		S	NT-330-8R (P)							1		03-F	
		S	NT-351-1032 (P)							1		03-F	
		S	1/2P PL-355-6 (P)							1		03-F	
		S	KI-528 (P)							1		03-F	
		S	GR-750 (P)							1		03-F	

RESTRICTED

RESTRICTED
T. O. No. 01-9000-4
SECTION II—GROUP ASSEMBLY PARTS LISTS

FIG. NO.	INDEX NO.	STOCKED	GROUP Power Plant						UNITS PER ASSY	PROPERTY CLASSIFICATION			
			MAJOR ASSEMBLY Installation - Power Plant							U.S. NAVY	U.S. ARMY	BRITISH	
			PART NUMBER	1	2	3	4	5					6
		S	WA-750 (P)						4		03-F		
		S	WA-750-1 (P)						2		03-F		
		S	WA-800 (P)						10		03-F		
		S	AN931-5-9						1		04-B		
		S	D17S9357						1		01-H		
			D17S9357-1						1		01-H		
			D17S9357-2						1		01-H		
			No number (P)						1				
		S	AN3-11						1		04-A		
		S	AN310-5						1		04-A		
		S	AN380-2-2						1		29		
		S	D17S9358						1		01-H		
			D17S9358-1						1		01-H		
			561-D-4 (P)						1		01-C		
			562-D-8 (P)						2		01-C		
			AN3-7						1		04-A		
		S	AN4-10						1		04-A		
			S-241						1		01-H		
		S	AN310-3						1		01-H		
		S	AN310-4						1		04-A		
		S	AI380-2-2						1		29		
		S	PS611-51 (P)						1		03-F		
		S	S-7-3						5		01-H		
		S	AN316-6R						3		04-A		
		S	AN365-1032						5		04-A		
		S	AI515-10-10						2		29		
		S	AN526-1032-9						3		29		
		S	AC755-16						2		04-A		
		S	AN931-3-5						1		04-A		
			106043-06-03-150						1		04-B		
		S	D179110						1		01-H		
			D179110-1						1		01-H		
			D179110-2						1		01-H		
		S	D179110-3						1		01-H		
			D179110-5						3		01-H		
		S	D179115						1		01-H		
			D179113						1		01-H		
		S	SK-694 (P)						1		04-B		
		S	D179114						1		01-H		
28	8	S	AN6-50						1		04-A		
28	2	S	AN310-5						6		04-A		
28	3	S	AN310-6						1		04-A		
28	1	S	AN380-3-3						1		29		
28	4	S	AN960-516						5		04-A		
28	5	S	AN960-616						1		04-A		
28	11	S	AC995-C40-10						1		04-A		
28	6	S	D179111						2		01-H		
			D179111-1						1		01-H		
			D179111-2						1		01-H		
		S	D179111-3						1		01-H		
			D179111-6						1		01-H		
			* Used on airplanes 42-38665 to 42-38673 incl., and 43-10613 to 43-10829 incl.										

RESTRICTED

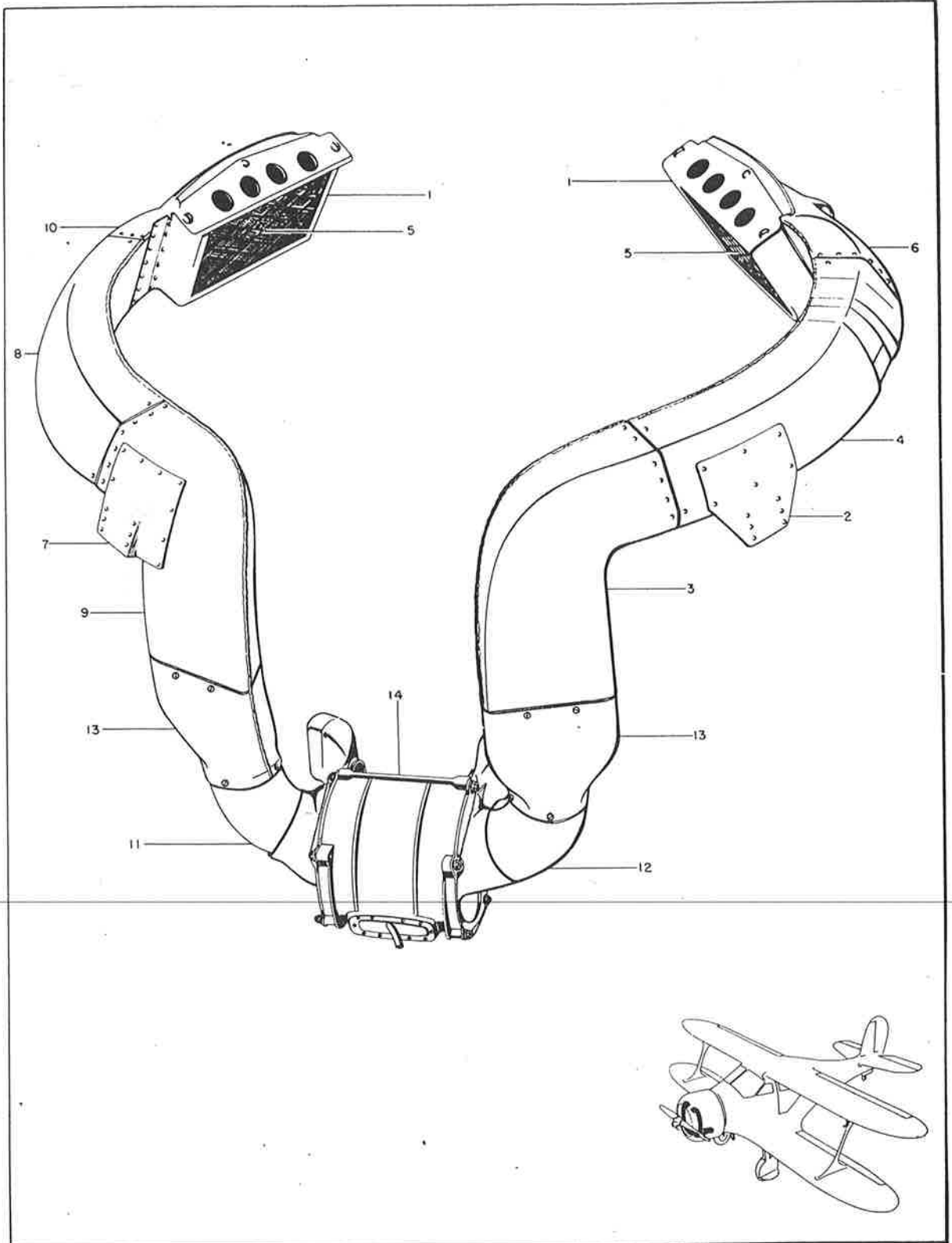

Figure 22 - Carburetor Air Duct Assembly

RESTRICTED

T. O. No. 01-90CC-4

SECTION II—GROUP ASSEMBLY PARTS LISTS

FIG. NO.	INDEX NO.	STOCKED	GROUP Power Plant						UNITS PER ASSY	PROPERTY CLASSIFICATION			
			MAJOR ASSEMBLY Installation - Power Plant							U.S. NAVY	U.S. ARMY	BRITISH	
			PART NUMBER	1	2	3	4	5					6
22	4	S	189134-2						Shell - Duct	1		01-H	
		S	189134-4						Shell - Duct	1		01-H	
		S	AN430AD4-5						Rivet - Round head	14		01-H	
		S	189135						Duct Assembly - Carburetor air middle	1		01-H	
		S	189135-2						Plate - Duct	1		01-H	
		S	189135-4						Shell - Duct	1		01-H	
		S	189135-6						Splice - Duct	2		01-H	
		S	AN430AD4-5						Rivet - Round head	12		29	
		S	189187						Filter - Carburetor air	1		01-H	
		S	UM-130 (P)						Filter - Carburetor air (American Air Filter Co.)	1		03-I	
22	5	S	189190						Channel Assembly - Carburetor upper air duct	1		01-H	
		S	189190-2						Seal - Carburetor upper air duct channel	1		01-H	
		S	S-16-4-8						Rivet - Thomson 1/8 inch	2		01-H	
		S	S-16-4-9						Rivet - Thomson 1/8 inch	4		01-H	
		S	189197						Channel - Carburetor upper air duct LH	1		01-H	
		S	189242						Bracket - Carburetor upper air duct	1		01-H	
		S	AN425AD4-5						Rivet - 78° countersunk head	10		29	
		S	S5-2251 (P)						Spring (Dzus)	1		04-A	
		S	AN425AD4-5						Rivet - 78° countersunk head	2		29	
		S	AC366F532						Nut - Plate	2		04-A	
		S	AN425AD3-4						Rivet - 78° countersunk head	4		29	
		S	AC365-632						Nut - Self-locking	2		04-A	
		S	AN430AD4-5						Rivet - Round head	5		29	
		S	AN430AD4-6						Rivet - Round head	4		29	
		S	AH505-6-6						Screw - Flat head	4		29	
		S	AH960-6						Washer - Plain	2		04-A	
		S	189192						Angle - Carburetor upper left air duct support	1		01-H	
		S	AN430AD4-5						Rivet - Round head	4		29	
		S	189193						Bracket - Carburetor center air duct support LH	1		01-H	
		S	AN430AD4-5						Rivet - Round head	3		29	
		S	189193-1						Bracket - Carburetor center air duct support RH	1		01-H	
		S	AN430AD4-5						Rivet - Round head	3		29	
		S	189195						Bracket - Carburetor left upper air duct top	1		01-H	
		S	189196						Bracket - Carburetor left upper air duct lower	1		01-H	
		S	189198						Duct Assembly - Carburetor air upper LH	1		01-H	
		S	189198-2						Shell - Duct	1		01-H	
		S	189198-4						Cover - Duct	1		01-H	
		S	AN430AD4-5						Rivet - Round head	4		29	
		S	AN430AD4-5						Rivet - Round head	14		29	
		S	189225						Plate Assembly - Air cleaner cover	1		01-H	
S	189225-2						Plate - Air cleaner cover	1		01-H			
S	A5-30 (P)						Fastener (Dzus)	1		04-A			
S	GA5-312 (P)						Grommet (Dzus)	1		04-A			
S	A6 1/2-40						Fastener (Dzus)	2		04-A			
S	GA6 1/2-375 (P)						Grommet (Dzus)	2		04-A			
S	AN430AD4-5						Rivet	12		29			

RESTRICTED

T. O. No. 01-90CC-4

SECTION II—GROUP ASSEMBLY PARTS LISTS

FIG. NO.	INDEX NO.	STOCKED	GROUP Power Plant						UNITS PER ASSY	PROPERTY CLASSIFICATION			
			MAJOR ASSEMBLY Installation - Power Plant							U.S. NAVY	U.S. ARMY	BRITISH	
			PART NUMBER	1	2	3	4	5					6
1	69	S	AN4-12A						Bolt - Aircraft 1/4-28	5		04-A	
		S	AC365-428						Nut - Self-locking	5		04-A	
		S	AN960-416L						Washer - Plain	10		04-A	
		S	189124						Duct Assembly - Carburetor air filter RH	1		01-H	
			189124-2					Reinforcement - Carburetor air filter duct	1		01-H		
22	1	S	AN430AD4-5						Rivet - Round head	4		29	
		S	189113						Box Assembly - Carburetor air filter support	1		01-H	
		S	189114					Angle Assembly - Carburetor air filter support box	2		01-H		
		S	189114-2					Angle - Support box	1		01-H		
		S	S6-275 (P)					Spring (Dzus)	1		04-A		
		S	AN425-4-7					Rivet - 78° countersunk head	2		29		
		S	AN425AD4-5					Rivet - 78° countersunk head	10		29		
			189115					Box - Carburetor air filter support	1		01-H		
22	7	S	AN430AD4-5						Rivet - Round head	16		29	
		S	189116						Gusset - Carburetor air RH lower duct	1		01-H	
		S	AN430AD4-5					Rivet - Round head	8		29		
		S	AN430AD4-5					Rivet - Round head	6		29		
		S	189117					Gusset - Carburetor air center duct	1		01-H		
		S	AN430AD4-5					Rivet - Round head	8		29		
		S	AN430AD4-6					Rivet - Round head	2		29		
		S	189118					Gusset - Carburetor air RH upper duct	1		01-H		
		S	AN430AD4-5					Rivet - Round head	8		29		
		S	189126-1					Bracket - Carburetor air duct center support RH	1		01-H		
		S	AN430AD4-5					Rivet - Round head	3		29		
		S	189128					Link - Carburetor air duct	5		01-H		
		S	AN4-13A					Bolt - Aircraft 1/4-28	5		04-A		
		S	AN365-428					Nut - Self-locking	5		04-A		
		S	AN960-416					Washer - Plain	10		04-A		
22	8	S	100801-S6-0836					Bushing - Clearance fit	5		01-H		
		S	189135-1					Duct Assembly - Carburetor air middle	1		01-H		
22	5	S	189135-2					Plate - Duct	1		01-H		
		S	189135-5					Shell - Duct	1		01-H		
		S	189135-6					Splice - Duct	1		01-H		
		S	AN430AD4-5					Rivet - Round head	12		29		
		S	189187					Filter - Carburetor air	1		01-H		
		S	UM-180 (P)					Filter (American Air Filter Co.)	1		03-I		
22	9	S	189188					Duct Assembly - Carburetor air lower right	1		01-H		
		S	189188-2					Shell - Duct	1		01-H		
		S	189188-4					Shell - Duct	1		01-H		
		S	AN430AD4-5					Rivet - Round head	14		29		
		S	189193					Bracket - Carburetor center air duct support LH	1		01-H		
		S	AN430AD4-5					Rivet - Round head	3		29		
		S	189193-1					Bracket - Carburetor center air duct support RH	1		01-H		
		S	AN430AD4-5					Rivet - Round head	3		29		
		S	189194					Bracket - Carburetor upper right air duct lower	1		01-H		
		S	AN425AD4-5					Rivet - 78° countersunk head	2		29		

RESTRICTED

RESTRICTED

T. O. No. 01-3000-4

SECTION II—GROUP ASSEMBLY PARTS LISTS

FIG. NO.	INDEX NO.	STOCKED	GROUP Power Plant						UNITS PER ASSY	PROPERTY CLASSIFICATION				
			MAJOR ASSEMBLY Installation - Power Plant							U.S. NAVY	U.S. ARMY	BRITISH		
			PART NUMBER	1	2	3	4	5					6	NOMENCLATURE
22	10	S	AN420AD4-5						Rivet - Round head	4		29		
		S	189198-1						Duct Assembly - Carburetor air upper	1		01-H		
			189198-3						Shell - Duct RH	1		01-H		
			189198-5						Cover - Duct RH	1		01-H		
			AN430AD4-5						Rivet - Round head	4		29		
		S	AN430AD4-5						Rivet - Round head	16		01-H		
		S	189199						Bracket - Carburetor upper right air duct top	1		01-H		
		S	AN425AD4-5						Rivet - 78° countersunk head	2		29		
		S	AN430AD4-5						Rivet - Round head	4		29		
		S	189201						Channel Assembly - Carburetor upper air duct	1		01-H		
		S	189201-2						Seal - Channel	1		01-H		
		S	S-16-4-8						Rivet - Thomson 1/8 inch	2		01-H		
		S	S-16-4-9						Rivet - Thomson 1/8 inch	4		01-H		
		S	189197						Channel - Carburetor upper air duct	1		01-H		
			189241						Bracket - Carburetor upper air duct RH	1		01-H		
		S	AN425AD4-5						Rivet - 78° countersunk head	10		29		
		S	S5-225 (P)						Spring (Dzus)	1		04-A		
		S	AN425AD4-5						Rivet - 78° countersunk head	2		29		
		S	AC366F632						Nut - Plate	2		04-A		
		S	AN425AD3-4						Rivet - 78° countersunk head	4		29		
		S	AC365-632						Nut - Self-locking	2		04-A		
		S	AN505-6-6						Screw - Flat head	4		29		
S	AN430AD4-5						Rivet - Round head	9		29				
S	AN960-6						Washer - Plain	2		04-A				
S	189209						Bracket - Carburetor air RH lower duct	1		01-H				
S	189225						Plate Assembly - Air cleaner cover	1		01-H				
S	189225-2						Plate - Air cleaner cover	1		01-H				
S	A5-30 (P)						Fastener (Dzus)	1		04-A				
S	GA5-312 (P)						Grommet (Dzus)	1		04-A				
S	A6 1/2-40 (P)						Fastener (Dzus)	2		04-A				
S	GA6 1/2 375 (P)						Grommet (Dzus)	2		04-A				
S	AN4-12A						Bolt - Aircraft 1/4-28	5		04-A				
S	AC365-428						Nut - Self-locking	5		04-A				
S	AN960-416L						Washer - Plain	10		04-A				
22	11	S	189132-1					Elbow Assembly - Carburetor air duct RH	1		01-H			
			189132-3					Elbow - Carburetor air duct half	1		01-H			
			189132-4					Elbow - Carburetor air duct half	1		01-H			
		S	AC366-F832					Nut - Plate	2		04-A			
		S	AN425AD3-4					Rivet - 78° countersunk head	4		29			
		S	AN526-832-8					Screw - Button head	2		29			
		S	AN960-8					Washer - Plain	2		04-A			
		22	12	S	189132-2					Elbow Assembly - Carburetor air duct LH	1		01-H	
					189132-5					Elbow - Carburetor air duct half	1		01-H	
					189132-6					Elbow - Carburetor air duct half	1		01-H	
S	AC366-F832							Nut - Plate	2		04-A			
S	AN425AD3-4							Rivet - 78° countersunk head	4		29			
S	AN526-832-8							Screw - Button head	2		29			
S	AN960-8					Washer - Plain	2		04-A					

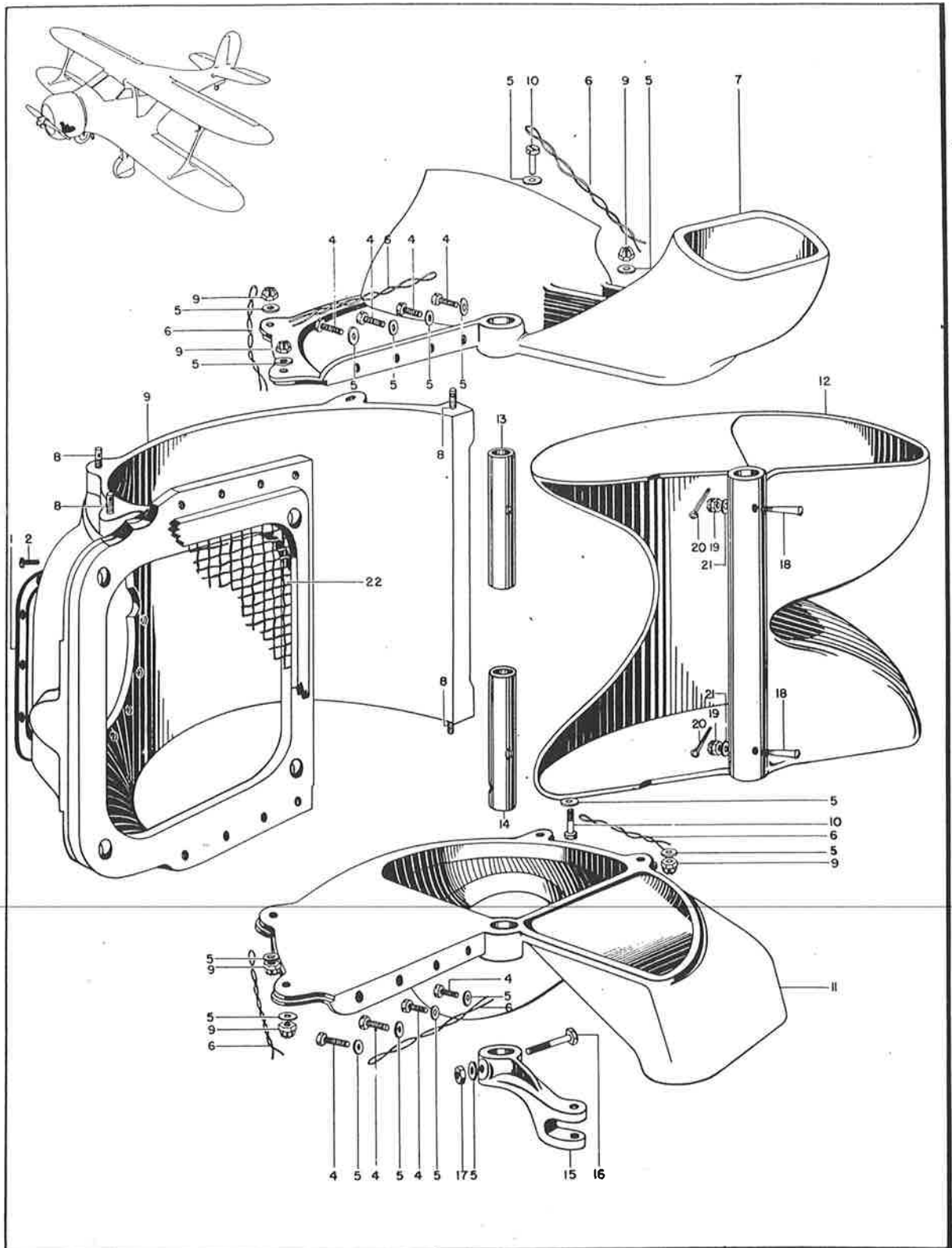

Figure 23 - Carburetor Air Scoop Assembly

RESTRICTED

T. O. No. 01-90CC-4

SECTION II—GROUP ASSEMBLY PARTS LISTS

FIG. NO.	INDEX NO.	STOCKED	GROUP Power Plant						UNITS PER ASSY	PROPERTY CLASSIFICATION											
			MAJOR ASSEMBLY Installation - Power Plant							U.S. NAVY	U.S. ARMY	BRITISH									
			PART NUMBER	1	2	3	4	5					6	NOMENCLATURE							
22	13	S	804-189140														Duct Assembly - Carburetor air intake	2		01-H	
		S	804-189061														Bracket Assembly - Carburetor air duct right	1		01-H	
		S	804-189061-1														Baffle - Carburetor air duct right bracket	1		01-H	
		S	AN430AD4-5														Rivet - Round head	2		29	
		S	D17S9052														Lug - Retaining P and W baffle	1		01-H	
		S	AN3-4A														Bolt - Aircraft 10-32	2		04-A	
		S	AC365-1032														Nut - Self-locking	2		04-A	
		S	AN960-10														Washer - Plain	4		04-A	
		S	804-189062														Bracket Assembly - Carburetor air duct left	1		01-H	
		S	804-189062-1														Baffle - Carburetor air duct right bracket	1		01-H	
		S	AN430AD4-5														Rivet - Round head	2		29	
		S	D17S9052														Lug - Retaining P and W baffle	1		01-H	
		S	AN3-4A														Bolt - Aircraft 10-32	2		04-A	
		S	AC365-1032														Nut - Self-locking	2		04-A	
		S	AN960-10														Washer - Plain	4		04-A	
		S	804-189139														Duct Assembly - Carburetor air intake welded	1		01-H	
		S	804-189139-1														Duct - Carburetor air intake lower	1		01-H	
		S	804-189139-2														Duct - Carburetor air intake upper	1		01-H	
		S	AC366-F832														Nut - Plate	6		04-A	
		S	AN425AD3-4														Rivet - 78° countersunk head	12		29	
		S	AN526-832-8														Screw - Button head	6		29	
		S	AN960-8														Washer - Plain	4		04-A	
		S	189228														Bushing - Carburetor air filter link	20		01-H	
22	14	S	D17S9150														Scoop Assembly - Carburetor air	1		01-H	
23	1	S	D179152														Plate Assembly - Carburetor air scoop cover	1		01-H	
			D179152-1														Tube - Carburetor air scoop drain	1		01-H	
			D179152-2														Brace - Carburetor air scoop plate	1		01-H	
			D179153														Plate - Carburetor air scoop cover	1		01-H	
23	2	S	AN520-10-5														Screw - Round head	10		29	
		S	AN935-10														Washer - Medium spring lock	10		29	
		S	18S9151														Body Assembly - Carburetor air scoop	1		01-H	
		S	18S9151-1														Strip - Carburetor air scoop seal	1		01-H	
		S	AN425AD3-8														Rivet - 78° countersunk head	6		29	
		S	AN940-13														Washer - Burr	6		29	
		S	18S9153														Body - Carburetor air scoop	1		01-H	
		S	18S9158														Plate - Carburetor air scoop attaching	1		01-H	
		S	AN425AD4-9														Rivet - 78° countersunk head	10		29	
23	4	S	AC500A-10-6														Screw - Fillister head	8		29	
23	5	S	AN960-10														Washer - Plain	8		04-A	
23	6	S	AC995-040-14														Wire - For locking	2		04-A	
23	7	S	18S9152LH														Side - Carburetor air scoop LH	1		01-H	
23	8	S	S-190-30G-028														Stud	3		01-H	
23	9	S	AN310-3														Nut - Aircraft castle	3		04-A	
23	10	S	AC500A-10-18														Screw - Fillister head	1		29	
23	5	S	AN960-10														Washer - Plain	4		04-A	

RESTRICTED
T. O. No. 01-90CC-4
SECTION II—GROUP ASSEMBLY PARTS LISTS

FIG. NO.	INDEX NO.	STOCKED	GROUP Power Plant						UNITS PER ASSY	PROPERTY CLASSIFICATION			
			MAJOR ASSEMBLY Installation - Power Plant							U.S. NAVY	U.S. ARMY	BRITISH	
			PART NUMBER	1	2	3	4	5					6
1	65	S	18S9184							1		01-H	
		S	18S9186							1		01-H	
24	1	S	D17S920							1		01-H	
		S	D17S920-35							1		01-H	
			D17S920-20							1		01-H	
			D17S920-12							1		01-H	
			S-228 LH							1		01-H	
			S-228 RH							1		01-H	
			D17S920-21							4		01-H	
24	2		D17S920-11							4		01-H	
24	3		D17S920-18							4		01-H	
24	4		S-224							4		01-H	
24	5		S-227 LH							4		01-H	
24	5		S-227 RH							4		01-H	
24	35	S	AN3-4							4		04-A	
24	36	S	AN310-3							4		04-A	
24	37	S	AN380-2-2							4		29	
24	6		S-228 LH							4		01-H	
24	6		S-228 RH							4		01-H	
24	7		D17S920-26							1		01-H	
			108403							1		01-H	
24	8		D17S920-28							1		01-H	
			108402							1		01-H	
			D17S920-30							1		01-H	
			S-182							1		01-H	
24	9		D17S920-31							1		01-H	
			108402							1		01-H	
			D17S920-32							1		01-H	
			S-182							1		01-H	
24	10		D17S920-33							1		01-H	
			108402							1		01-H	
			D17S920-34							1		01-H	
			S-227 LH							1		01-H	
			S-227 RH							1		01-H	
		S	AN3-4							1		04-A	
		S	AN310-3							1		04-A	
		S	AN380-2-2							1		29	
24	11		No number (P)							1			
24	12	S	D17S920-36							1		01-H	
24	13		D17S920-19							1		01-H	
			108402							1		01-H	
			D17S920-20							1		01-H	
			D17S920-17							1		01-H	
			S-228 LH							1		01-H	
			S-228 RH							1		01-H	
			D17S920-21							8		01-H	
			D17S920-11							1		01-H	
			D17S920-18							1		01-H	
			S-224							1		01-H	
			S-227 LH							1		01-H	
			S-227 RH							1		01-H	
24	35	S	AN3-4							1		04-A	

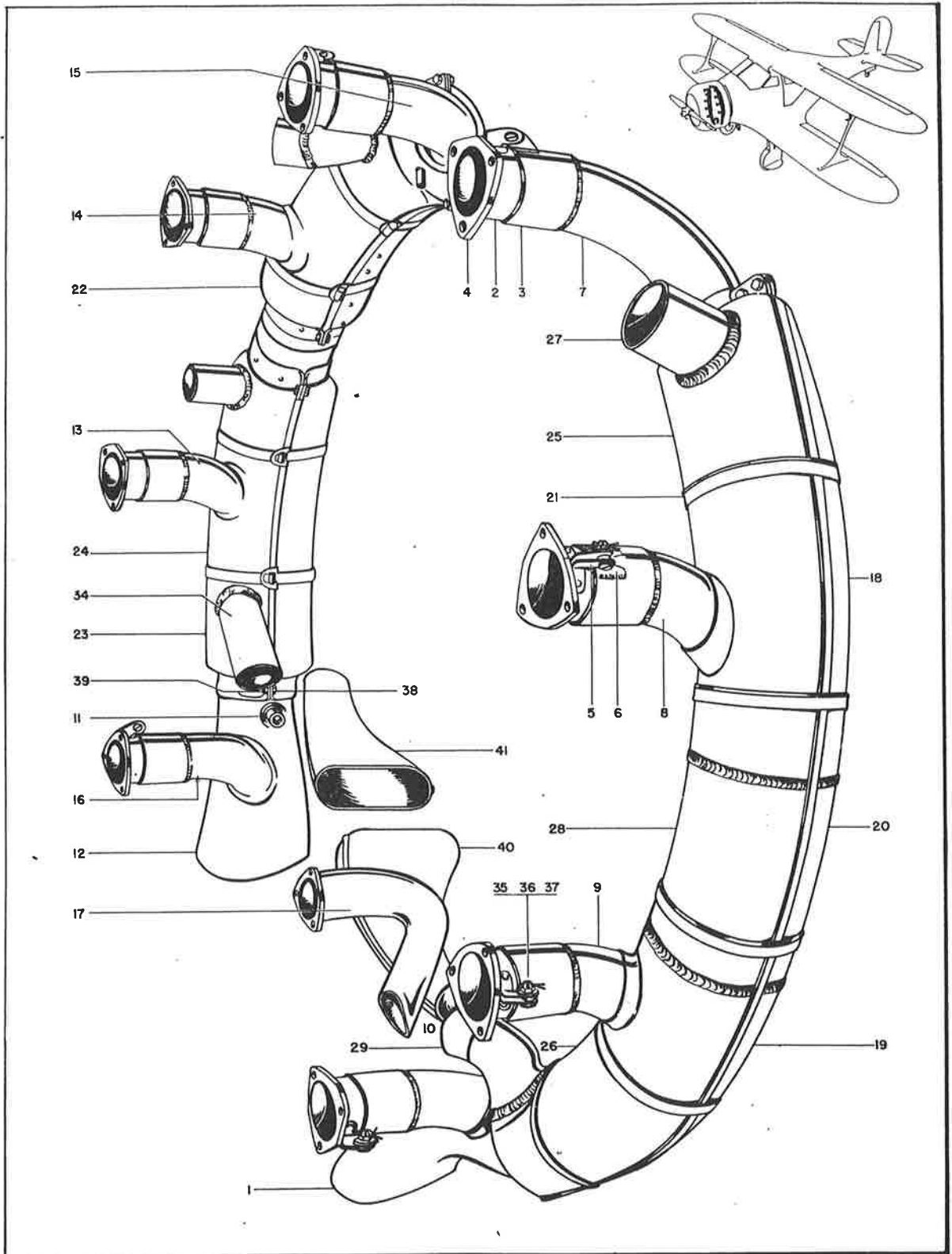

Figure 24 - Exhaust Stack and Heater Muff Assembly

RESTRICTED
T. O. No. 01-90CC-4
SECTION II—GROUP ASSEMBLY PARTS LISTS

FIG. NO.	INDEX NO.	SYMBOL	GROUP Power Plant						UNITS PER ASSY	PROPERTY CLASSIFICATION					
			MAJOR ASSEMBLY Installation - Power Plant							U.S. NAVY	U.S. ARMY	BRITISH			
			PART NUMBER	1	2	3	4	5					6	NOMENCLATURE	
39	54	S	AC811T4CS								1		04-A		
		S	AC811BT4D									1		04-A	
		S	AN931-4-16									1		04-B	
		S	17274 (P)									1		03-F	
		S	20863 (P)									1		03-F	
		S	100951-S03E-006-024									1		01-H	
		S	105933-4									1		04-A	
		S	D179535-9									1		01-H	
		S	9559 (P)									1		03-F	
		S	AC365-1032									1		04-A	
		S	AN520-10-12									2		29	
		S	AC755-20									4		04-A	
		S	AC811T8CS									1		04-A	
		S	AC811BT8D									1		04-A	
		S	AN960-10									1		04-A	
		S	105933-8									4		04-A	
		S	D179535-10									1		01-H	
		S	9559 (P)									1		03-F	
		S	D179535-11									1		01-H	
		S	9559 (P)									1		03-F	
		S	AC811TSCS									1		04-A	
		S	AC811BT8D									1		04-A	
		S	AC811HT8D									1		04-A	
		S	189461									2		01-H	
		S	103636-3-020									2		01-H	
		S	D179536									1		01-H	
		S	D179536-1									1		01-H	
		S	D179536-2									2		01-H	
		S	D179536-3									1		01-H	
		S	D179536-4									1		01-H	
		S	D179536-5									1		01-H	
		S	D179536-9									1		01-H	
		S	D179536-10									1		01-H	
		S	D179536-11									1		01-H	
		S	D179536-6									1		01-H	
		S	D179536-7									1		01-H	
		S	D179536-8									1		01-H	
		S	AN3-4A									4		04-A	
		S	AN4-20A									1		04-A	
		S	AC365-428									1		04-A	
S	AC365-1032									4		04-A			
S	D179537									1		01-H			
S	AC365-1032									7		04-A			
S	AN430AD4-4									6		29			
S	AN520-10-8									7		29			
S	D179538									1		01-H			
S	AN3-4A									1		04-A			
S	AC365-1032									1		04-A			
S	AN430AD4-4									5		29			
S	20612 (P)									1		03-F			
S	4 (P)									1		04-A			
S	7324 (P)									1		03-F			
S	8810 (P)									1		03-F			
S	20611 (P)									1		03-F			
S	No number									1					
S	AN535-0-3									4		29			
S	20613 (P)									1		03-F			
S	1791-0800 (P)									1		03-F			

RESTRICTED
T. O. No. 01-90CC-4
SECTION II—GROUP ASSEMBLY PARTS LISTS

FIG. NO.	INDEX NO.	STOCKED	GROUP Power Plant						UNITS PER ASSY	PROPERTY CLASSIFICATION						
			MAJOR ASSEMBLY Installation - Power Plant							U.S. NAVY	U.S. ARMY	BRITISH				
			PART NUMBER	1	2	3	4	5					6	NOMENCLATURE		
36	2	S	1791-9876	(P)							1		03-F			
		S	20449	(P)								1		03-F		
		S	20771 (73470G)	(P)								1		03-F		
			17671	(P)								1		03-F		
		S	19289	(P)								1		03-F		
		S	19290	(P)								1		03-F		
		S	20863	(P)								1		03-F		
		S	61603	(P)								1		03-F		
		S	73069-H	(P)								1		03-F		
			1236-0306	(P)											03-F	
			1246-0300	(P)											03-F	
			1527-0308	(P)											03-F	
			1555-0504	(P)											03-F	
			1605	(P)											03-F	
			1644	(P)											03-F	
			2444	(P)											03-F	
			3681	(P)											03-F	
			3682	(P)											03-F	
			6660	(P)											03-F	
			15975	(P)											03-F	
			15976	(P)											03-F	
			15977	(P)											03-F	
			15981	(P)											03-F	
			15982	(P)											03-F	
			16487	(P)											03-F	
			16488	(P)											03-F	
			16489	(P)											03-F	
			16937	(P)											03-F	
			16938	(P)											03-F	
			16939	(P)											03-F	
			16940	(P)											03-F	
			16941	(P)											03-F	
			16943	(P)											03-F	
			16945	(P)											03-F	
			16946	(P)											03-F	
			16976	(P)											03-F	
	16977	(P)											03-F			
	17033	(P)											03-F			
	17671	(P)											03-F			
	17672	(P)											03-F			
	17689	(P)											03-F			
	18043	(P)											03-F			
	18087	(P)											03-F			
	19000	(P)											03-F			
	20860	(P)											03-F			
	20877	(P)											03-F			
	62738	(P)											03-F			
	77591	(P)											03-F			

RESTRICTED

T. O. No. 01-90CC-4

SECTION II—GROUP ASSEMBLY PARTS LISTS

FIG. NO.	INDEX NO.	STOCKED	GROUP Power Plant						UNITS PER ASSY	PROPERTY CLASSIFICATION										
			MAJOR ASSEMBLY Installation - Power Plant							U.S. NAVY	U.S. ARMY	BRITISH								
			PART NUMBER	1	2	3	4	5					6	NOMENCLATURE						
			12308	(P)												Bushing - Insulator (Eclipse)	3		03-C	
			12312	(P)												Strip Assembly - Window (Eclipse)	1		03-C	
			12323	(P)												Cover - Bearing (Eclipse)	1		03-C	
			12665	(P)												Brush Assembly (Eclipse)	2		03-C	
			12913	(P)												Shoe - Pole (Eclipse)	4		03-C	
			12958	(P)												Screw - Pole shoe (Eclipse)	3		03-C	
			13123	(P)												Coil Assembly - Field (Eclipse)	1		03-C	
			13535	(P)												Nut (Eclipse)	3		03-C	
			14015	(P)												Retainer - Rear packing (Eclipse)	1		03-C	
			14022	(P)												Screw (Eclipse)	3		03-C	
			14105	(P)												Nut - Lock (Eclipse)	1		03-C	
			14364	(P)												Nut (Eclipse)	1		03-C	
			16203	(P)												Washer - Felt (Eclipse)	1		03-C	
			16437	(P)												Washer - Felt (Eclipse)	1		03-C	
			16795	(P)												Bushing (Eclipse)	1		03-C	
			17219	(P)												Armature Assembly (Eclipse)	1		03-C	
			17374	(P)												Retainer - Felt (Eclipse)	1		03-C	
			17348	(P)												Spacer - Front (Eclipse)	1		03-C	
			17418	(P)												Post - Terminal (Eclipse)	3		03-C	
			17423	(P)												Rest Assembly - Brush (Eclipse)	2		03-C	
			17425	(P)												Spacer (Eclipse)	3		03-C	
			17430	(P)												Board Assembly - Brush (Eclipse)	1		03-C	
			17959	(P)												Screw - (Eclipse)	6		03-C	
			17961	(P)												Washer - (Eclipse)	6		03-C	
			13357	(P)												Washer - (Eclipse)	6		03-C	
			13359	(P)												Yoke - (Eclipse)	1		03-C	
			18361	(P)												Yoke - Assembly (Eclipse)	1		03-C	
			19686	(P)												Screw - (Eclipse)	6		03-C	
			20500-1	(P)												Washer - Lock (Eclipse)	6		03-C	
			20500-2	(P)												Washer - Lock (Eclipse)	4		03-C	
			20500-3	(P)												Washer - Lock (Eclipse)	3		03-C	
			20500-20	(P)												Washer - Lock (Eclipse)	6		03-C	
			20500-22	(P)												Washer - Lock (Eclipse)	5		03-C	
			20501-12	(P)												Nut	6		03-C	
			20502-2	(P)												Screw - (Eclipse)	3		03-C	
			20503-1	(P)												Pin - Cotter (Eclipse)	3		03-C	
			20503-2	(P)												Pin - Cotter (Eclipse)	1		03-C	
			20503-10	(P)												Pin - Cotter (Eclipse)	2		03-C	
			20504-9	(P)												Bearing - Ball (Eclipse)	1		03-C	
			20504-15	(P)												Bearing - Ball (Eclipse)	1		03-C	
			21031	(P)												Sleeve - Adjusting (Eclipse)	2		03-C	
			21032	(P)												Spring - Brush (Eclipse)	2		03-C	
			21053	(P)												Jump Wire No. 1 - Assembly (Eclipse)	1		03-C	
			21055	(P)												Jump Wire No. 2 - Assembly (Eclipse)	1		03-C	
			22506-2	(P)												Head Assembly - Front (Eclipse)	1		03-C	
			22507-1	(P)												Head - Front (Eclipse)	1		03-C	
			22548	(P)												Head Assembly - Back (Eclipse)	1		03-C	
			22549	(P)												Head - Back (Eclipse)	1		03-C	
			22916-1	(P)												Head - Intermediate (Eclipse)	1		03-C	
			25103	(P)												Washer (Eclipse)	5		03-C	
			25238	(P)												Terminal (Eclipse)	1		03-C	
			26806	(P)												Terminal (Eclipse)	3		03-C	
			27611	(P)												Washer - Thrust (Eclipse)	1		03-C	
			27669	(P)												Rubber - Driving (Eclipse)	8		03-C	
			27689	(P)												Insulator - Terminal	3		03-C	
			27773	(P)												Cover - Terminal guard (Eclipse)	1		03-C	
			27774	(P)												Terminal - Guard (Eclipse)	1		03-C	
			43367	(P)												Housing and Drive Shaft Assembly (Eclipse)	1		03-C	
			43520	(P)												Retainer - Rubber (Eclipse)	1		03-C	

RESTRICTED

RESTRICTED

T. O. No. 01-90CC-4

SECTION II—GROUP ASSEMBLY PARTS LISTS

FIG. NO.	INDEX NO.	STOCKED	GROUP Power Plant						UNITS PER ASSY	PROPERTY CLASSIFICATION							
			MAJOR ASSEMBLY Installation - Power Plant							U.S. NAVY	U.S. ARMY	BRITISH					
			PART NUMBER	1	2	3	4	5					6	NOMENCLATURE			
34	22		43579	(P)							1		03-C				
			51359	(P)								6		03-C			
			61515	(P)									3		03-C		
			63176	(P)									1		03-C		
			77115	(P)									1		03-C		
			106492	(P)									1		03-C		
			13	(P)									1		03-C		
			(F-90328)														
			2126	(P)										2		03-C	
			4072	(P)										1		03-C	
			4192	(P)										3		03-C	
			6069	(P)										2		03-C	
			7318	(P)										2		03-C	
			11133	(P)										1		03-C	
			11450	(P)										11		03-C	
			11451	(P)										11		03-C	
			11486	(P)										1		03-C	
			11558	(P)										4		03-C	
			11573	(P)										1		03-C	
			12059	(P)										1		03-C	
			12582	(P)										2		03-C	
			13207	(P)										1		03-C	
			13210	(P)										1		03-C	
			13235	(P)										1		03-C	
			14942	(P)										1		03-C	
			14967	(P)										2		03-C	
			15130	(P)										3		03-C	
			15132	(P)										1		03-C	
			15142	(P)										1		03-C	
			15191	(P)										1		03-C	
			15457	(P)										1		03-C	
			17349	(P)										4		03-C	
			18357	(P)										6		03-C	
			18917-1	(P)										4		03-C	
			19715	(P)										1		03-C	
			20439-7	(P)										7		03-C	
			20500-9	(P)										2		03-C	
			20500-21	(P)										2		03-C	
			20500-22	(P)										4		03-C	
			20501-7	(P)										3		03-C	
			20503-8	(P)										1		03-C	
			20503-9	(P)										6		03-C	
			20503-11	(P)										1		03-C	
			20503-18	(P)										1		03-C	
			20504-12	(P)										1		03-C	
20504-13	(P)										1		03-C				
20504-14	(P)										2		03-C				
20504-23	(P)										6		03-C				
20506-2	(P)										3		03-C				
20506-7	(P)										4		03-C				
20506-12	(P)										3		03-C				
20507-7	(P)										4		03-C				
20521-7	(P)										1		03-C				
20978	(P)										1		03-C				
21007	(P)										4		03-C				
21010	(P)										4		03-C				
21012-2	(P)										1		03-C				
21014	(P)										4		03-C				

RESTRICTED

RESTRICTED
T. O. No. 01-90CC-4
SECTION II—GROUP ASSEMBLY PARTS LISTS

FIG. NO.	INDEX NO.	STOCKED	GROUP Power Plant						UNITS PER ASSY	PROPERTY CLASSIFICATION			
			MAJOR ASSEMBLY Installation - Power Plant							U.S. NAVY	U.S. ARMY	BRITISH	
			PART NUMBER	1	2	3	4	5					6
			21015	(P)						4		03-C	
			21023	(P)						1		03-C	
			21182	(P)						1			
			21524	(P)						1		03-C	
			21529	(P)						3		03-C	
			21530	(P)						1		03-C	
			21531	(P)						1		03-C	
			21532	(P)						1		03-C	
			21533	(P)						6		03-C	
			21536	(P)						1		03-C	
			21537	(P)						1		03-C	
			21585	(P)						1		03-C	
			21590	(P)						6		03-C	
			21593	(P)						1		03-C	
			21594	(P)						1		03-C	
			21595	(P)						1		03-C	
			21596	(P)						1		03-C	
			29589	(P)						2		03-C	
			41784	(P)						9		03-C	
			42088	(P)						1		03-C	
			42096	(P)						1		03-C	
			42425	(P)						1		03-C	
			46913	(P)						3		03-C	
			46914	(P)						3		03-C	
			46915	(P)						3		03-C	
			46916	(P)						3		03-C	
			46917	(P)						1		03-C	
			46918	(P)						1		03-C	
			46943	(P)						1		03-C	
			46995	(P)						1		03-C	
			47093	(P)						1		03-C	
			50511	(P)						1		03-C	
			50512	(P)						1		03-C	
			60344	(P)						1		03-C	
			76288	(P)						1		03-C	
			81086	(P)						1		03-C	
			81087	(P)						1		03-C	
			81092	(P)						1		03-C	
			82280	(P)						2		03-C	
			89633	(P)						1		03-C	
			90192	(P)						1		03-C	
			90193	(P)						1		03-C	
			S OK38-6							1		05-E	
			S 106200-8-4							1			
			S AC39B3481-4A							1		04-B	
			S AC811BT4D							1		04-A	
			S AC811FT-4D							1		04-A	
1	3		S R-985-AN-1 (Oran-3)							1		02-H	
			S AN4100 (Type G-6)							1		03-I	
			S D-75378	(P)						1		05-D	
			S D-75418	(P)						1		05-D	
			S 105947							3		01-H	
			S 105947-2							1		01-H	
			S B-71	(P)						1		08-B	
			S 75	(P)						1		08-B	
			S AN936-B6							1		29	
			S B-77	(P)						1		08-B	

RESTRICTED

RESTRICTED
T. O. No. 01-9000-4
SECTION II—GROUP ASSEMBLY PARTS LISTS

FIG. NO.	INDEX NO.	STOCKED	GROUP Power Plant						UNITS PER ASSY	PROPERTY CLASSIFICATION			
			MAJOR ASSEMBLY	Installation - Power Plant						U.S. NAVY	U.S. ARMY	BRITISH	
				Installation - Engine Cowling									
PART NUMBER	1	2	3	4	5	6	NOMENCLATURE						
		S	GA6 1/2-375 (P)						Grommet - (Dzus)	1		04-A	
		S	S-36-4						Hinge - Cowl fastener	1		01-H	
		S	AN3-12						Bolt	1		04-A	
		S	AN310-3						Nut	1		04-A	
		S	AN330-2-2						Pin - Cotter	1		29	
		S	AN960-10						Washer	1		04-A	
		S	S-36-6						Bracket - Cowl fastener	1		01-H	
		S	200 (P)						Spring (Dzus)	1		04-A	
		S	107464						Turnbuckle Assembly	1		01-H	
		S	107462						Barrel - Turnbuckle	1		01-H	
		S	107463-2						Eye - Turnbuckle LH	1		01-H	
		S	107463-4						Eye - Turnbuckle RH	1		01-H	
		S	AN3-6						Bolt	1		04-A	
		S	AN320-3						Nut	1		04-A	
		S	AN330-2-2						Pin - Cotter	2		29	
		S	AN393-11						Pin - Flathead 3/16	1		04-A	
		S	AN960-10						Washer	1		04-A	
		S	AC995-C40-7						Wire - For locking	1		04-A	
		S	AN430-AD4-5						Rivet - Round-head	2		29	
		S	AN455-AD4-5						Rivet - Brazier head	2		29	
		S	AN455-AD4-6						Rivet - Brazier head	2		29	
		S	D175911-3						Plate and Fastener Assembly - Upper cowling rear right	1		01-H	
			185907-1						Plate - Cowling fastener bearing lower RH	1		01-H	
		S	AN456AD4-5						Rivet	3		29	
25	5	S	S-36-7						Fastener Assembly - Cowl	1		01-H	
		S	S-36-3						Fastener - Cowl	1		01-H	
		S	A6 1/2-50 (P)						Fastener (Dzus)	1		04-A	
		S	GA6 1/2-375 (P)						Grommet (Dzus)	1		04-A	
		S	S-36-4						Hinge - Cowl fastener	1		01-H	
		S	AN3-12						Bolt	1		04-A	
		S	AN310-3						Nut	1		04-A	
		S	AN330-2-2						Pin - Cotter	1		29	
		S	AN960-10						Washer	1		04-A	
		S	S-36-6						Bracket - Cowl fastener	1		01-H	
		S	200 (P)						Spring (Dzus)	1		04-A	
		S	107464						Turnbuckle Assembly	1		01-H	
		S	107462						Barrel - Turnbuckle	1		01-H	
		S	107463-2						Eye - Turnbuckle LH	1		01-H	
		S	107463-4						Eye - Turnbuckle RH	1		01-H	
		S	AN3-6						Bolt	1		04-A	
		S	AN320-3						Nut	1		04-A	
		S	AN330-2-2						Pin - Cotter	2		29	
		S	AN393-11						Pin - Flathead	1		04-A	
		S	AN960-10						Washer	1		04-A	
		S	AC995-C40-7						Wire - For locking	1		04-A	
		S	AN430-AD4-5						Rivet - Round-head	2		29	
		S	AN455AD4-5						Rivet - Brazier head	2		29	
		S	AN455AD4-6						Rivet - Brazier head	2		29	
		S	D175911-4						Strip - Upper cowl rear edge reinforcing	1		01-H	
		S	AN456AD4-6						Rivet - Brazier head	7		29	
		S	D175911-5						Stiffener - Upper cowl baffle seal	3		01-H	
			D175911-6						Angle - Upper cowl center reinforcing	3		01-H	
		S	AN456AD4-4						Rivet - Brazier head	12		29	
		S	D175911-7						Strip - Upper cowl center reinforcing	1		01-H	
		S	AN456AD4-5						Rivet - Brazier head	22		29	
		S	D175911-8						Ring - Upper cowl nose reinforcement	1		01-H	

RESTRICTED

RESTRICTED

T. O. No. 01-90CC-4

'SECTION II—GROUP ASSEMBLY PARTS LISTS

FIG. NO.	INDEX NO.	STOCKED	GROUP Power Plant						UNITS PER ASSY	PROPERTY CLASSIFICATION					
			MAJOR ASSEMBLY Installation - Engine Cowling							U.S. NAVY	U.S. ARMY	BRITISH			
			PART NUMBER	1	2	3	4	5					6	NOMENCLATURE	
25	5	S	F17D5902								1		01-H		
			D175911-9									1		01-H	
			185906									1		01-H	
			AN456AD4-5									3		29	
			S-36-7									1		01-H	
			S-36-3									1		01-H	
			A6 1/2-50 (P)									1		04-A	
			GA6 1/2-375 (P)									1		04-A	
			S-36-4									1		01-H	
			AN3-12									1		04-A	
			AN310-3									1		04-A	
			AN330-2-2									1		29	
			AN960-10									1		04-A	
			S-36-6									1		01-H	
			200 (P)									1		04-A	
			107464									1		01-H	
			107462									1		01-H	
			107463-2									1		01-H	
			107463-4									1		01-H	
			AN3-6									1		04-A	
			AN320-3									1		04-A	
			AN330-2-2									2		29	
			AN393-11									1		04-A	
			AN960-10									1		04-A	
			AC995-040-7									1		04-A	
			AN430AD4-5									2		29	
			AN455AD4-5									2		29	
			AN455AD4-6									2		29	
			D175911-10									1		01-H	
			AN456AD4-5									3		29	
			AN456AD4-6									1		29	
			D175911-11									1		01-H	
	AN456AD4-5									4		29			
	AN456AD4-6									3		29			
	AN456AD4-7									1		29			
	D175911-12									2		01-H			
	AN456AD4-5									2		29			
	AN456AD4-6									2		29			
	D175911-13									1		01-H			
	AN456AD4-5									3		29			
	AN456AD4-6									2		29			
	D175911-14									1		01-H			
	D175911-15									1		01-H			
	205399-1									1		01-H			
	205402									1		01-H			
	AN430AD5-6									15		29			
	185915									1		01-H			
	105350									2		01-H			
	AN4-14									1		04-A			
	AN310-4									1		04-A			

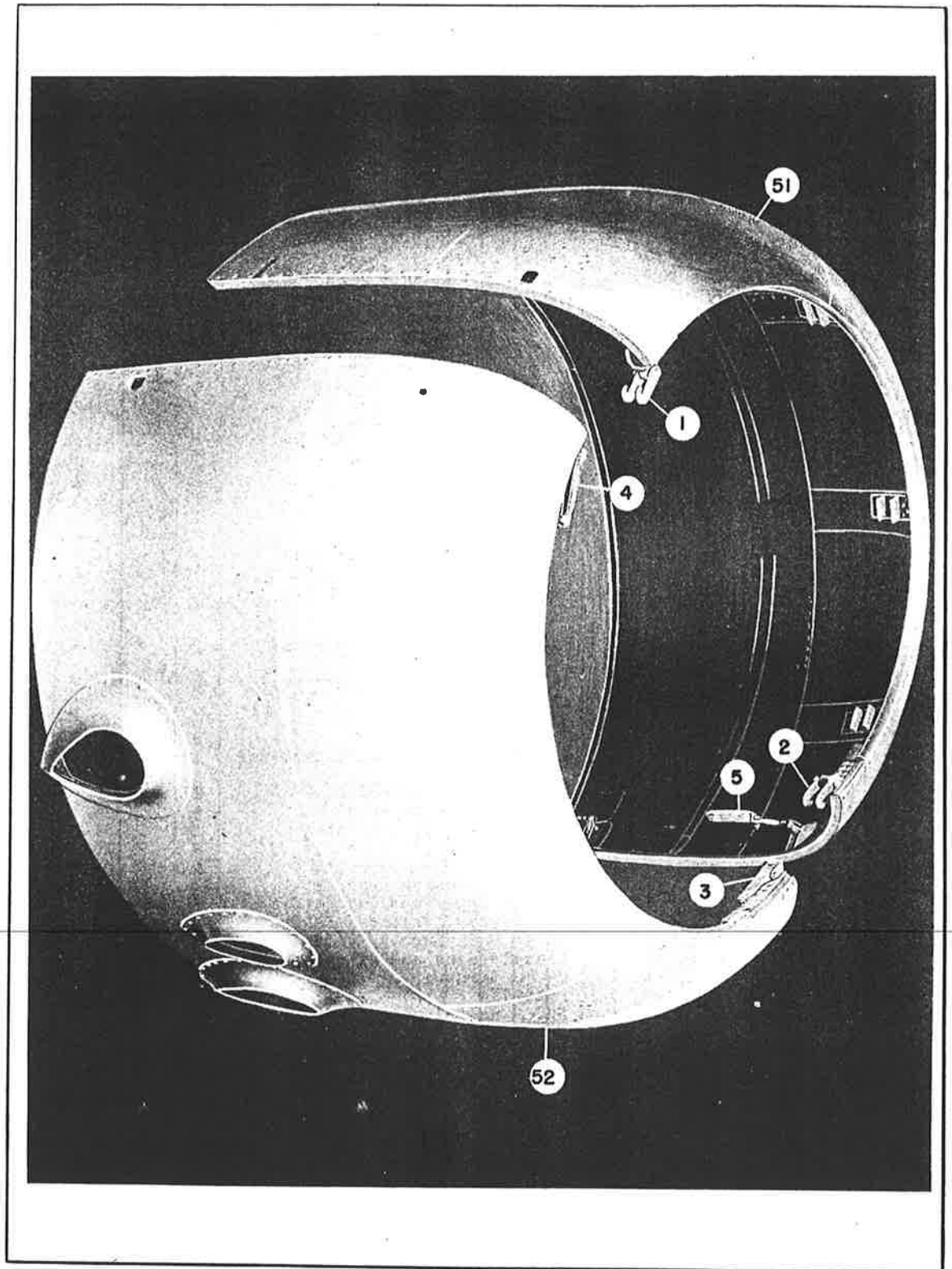

Figure 25 - Engine Cowling Assembly

RESTRICTED

T. O. No. 01-9000-4

SECTION II—GROUP ASSEMBLY PARTS LISTS

FIG. NO.	INDEX NO.	STOCKED	GROUP Power Plant						UNITS PER ASSY	PROPERTY CLASSIFICATION			
			MAJOR ASSEMBLY Installation - Engine Cowling							U.S. NAVY	U.S. ARMY	BRITISH	
			PART NUMBER	1	2	3	4	5					6
25	2	S	AN380-2-2							1		29	
		S	AN960-416							2		04-A	
		S	100801-X5-0785							1		01-H	
		S	185916							1		01-H	
		S	AN430AD5-7							8		29	
		S	AN455AD5-7							8		29	
		S	D175911-16							1		01-H	
		S	205399-1							1		01-H	
		S	205402							1		01-H	
		S	AN430AD5-6							15		29	
		S	185915							1		01-H	
		S	105350							2		01-H	
		S	AN4-14							1		04-A	
		S	AN310-4							1		04-A	
		S	AN380-2-2							1		29	
		S	AN960-416							2		04-A	
		S	100801-X5-0785							1		01-H	
		S	185916							1		01-H	
		S	AN430AD5-7							8		29	
		S	AN455AD5-7							8		29	
		S	D175911-17							2		01-H	
		S	18S5902A-1							4		01-H	
		S	AN456AD4-5							11		29	
		S	AN456AD4-6							12		29	
		S	18S5903A							1		01-H	
		S	AN456AD4-5							2		29	
		S	AN456AD4-6							3		29	
		S	18S5921-1							1		01-H	
		S	AN456AD4-6							8		29	
		S	18S5921-2							4		01-H	
		S	AN456AD4-6							32		29	
		S	185928							3		01-H	
S	5910B	(P)						3		29			
S	S-16-10-4							78		01-H			
S	18S5937							2		01-H			
S	AN3-22A							2		04-A			
S	AN365-1032							2		04-A			
S	AN960-10							2		04-A			
S	18S5938							5		01-H			
S	AN455AD3-6							15		29			
S	D175951							1		01-H			
S	AN456AD4-5							27		29			
S	D175951-1							1		01-H			
S	AN456AD4-5							27		29			
S	74	(P)						2		08-B			
S	AN935-416							2		29			
S	D175912							1		01-H			
S	D175912-1							1		01-H			

RESTRICTED

T. O. No. 01-9000-4

SECTION II—GROUP ASSEMBLY PARTS LISTS

FIG. NO.	INDEX NO.	STOCKED	GROUP Power Plant						UNITS PER ASSY	PROPERTY CLASSIFICATION				
			MAJOR ASSEMBLY Installation - Engine Cowling							U.S. NAVY	U.S. ARMY	BRITISH		
			PART NUMBER	1	2	3	4	5					6	NOMENCLATURE
25	3	S	AN456AD4-6							Rivet - Brazier head	7		29	
		S	D175912-2							Splice - Lower cowl corner reinforcing	2		01-H	
		S	AN456AD4-6							Rivet - Brazier head	2		29	
		S	AN456AD4-7							Rivet - Brazier head	2		29	
		S	D175912-3							Skin - Engine lower cowling rear	1		01-H	
		S	D175912-4							Skin - Lower cowling left forward	1		01-H	
		S	AN456AD4-5							Rivet - Brazier head	2		29	
		S	AN456AD4-6							Rivet - Brazier head	2		29	
		S	D175912-5							Skin - Lower cowling right forward	1		01-H	
		S	AN456AD4-5							Rivet - Brazier head	2		29	
		S	AN456AD4-6							Rivet - Brazier head	2		29	
		S	D175912-6							Skin - Lower cowling center forward	1		01-H	
		S	AN456AD4-5							Rivet - Brazier head	2		29	
		S	AN456AD4-6							Rivet - Brazier head	4		29	
		S	D175912-7							Stiffener - Lower cowl baffle seal side	2		01-H	
		S	D175912-8							Angle - Lower cowl side reinforcing	2		01-H	
		S	AN456AD4-5							Rivet - Brazier head	4		29	
		S	D175912-9							Angle - Lower cowl center reinforcing	1		01-H	
		S	AN456AD4-5							Rivet - Brazier head	2		29	
		S	D175912-10							Stiffener - Lower cowl baffle seal center	1		01-H	
		S	D175912-12							Fastener Assembly - Lower cowl left nose	1		01-H	
		S	205401							Plate - Front cowling fastener lower	1		01-H	
		S	AN430AD5-6							Rivet - Round-head	10		29	
		S	D175915							Channel Assembly - Front cowling fastener lower LH	1		01-H	
		S	205400-2							Channel - Front cowling fastener lower	1		01-H	
		S	S5-200	(P)						Spring - (Dzus)	1		04-A	
		S	AN425AD4-5							Rivet - 78° countersunk head	2		29	
		S	185920							Fastener Assembly - Front cowling lower	1		01-H	
		S	105349							Arm - Front cowling fastener	1		01-H	
		S	105351							Pin - Front cowling fastener	1		01-H	
		S	105352							Bushing - Front cowling fastener	1		01-H	
		S	185917							Hinge - Front cowling fastener lower	1		01-H	
S	A5-40	(P)						Fastener (Dzus)	1		04-A			
S	GA5-312	(P)						Grommet (Dzus)	1		04-A			
S	AN425AD4-7							Rivet - 78° countersunk head	2		29			
S	AN425AD5-7							Rivet - 78° countersunk head	3		29			
S	AN430AD5-7							Rivet - Round-head	4		29			
S	AN430AD5-6							Rivet - Round-head	4		29			
S	AN430AD5-7							Rivet - Round-head	9		29			
S	D175912-13							Fastener Assembly - Lower cowl right nose	1		01-H			
S	205401							Plate - Front cowling fastener lower	1		01-H			

RESTRICTED

RESTRICTED
T. O. No. 01-90CC-4
SECTION II—GROUP ASSEMBLY PARTS LISTS

FIG. NO.	INDEX NO.	STOCKED	GROUP Power Plant						UNITS PER ASSY	PROPERTY CLASSIFICATION					
			MAJOR ASSEMBLY		Installation - Engine Cowling					U.S. NAVY	U.S. ARMY	BRITISH			
			PART NUMBER		1	2	3	4					5	6	NOMENCLATURE
1	53	S	D175912-18								3		01-H		
		S	18S5902A-1									3		01-H	
		S	AN456AD4-5									9		29	
		S	AN456AD4-6									9		29	
		S	D175912-19									1		01-H	
		S	18S5903A									1		01-H	
		S	AN456AD4-5									3		29	
		S	AN456AD4-6									3		29	
		S	D175912-20									2		01-H	
		S	D175901									1		01-H	
		S	AN455AD3-4									18		29	
		S	D1785903 LH									1		01-H	
		S	AN455AD3-4									22		29	
		S	D1785903 RH									1		01-H	
		S	AN455AD3-4									22		29	
		S	18S5921-1									1		01-H	
		S	AN456AD4-6									8		29	
		S	18S5921-2									3		01-H	
		S	AN456AD4-6									24		29	
		S	185929									1		01-H	
		S	AN456AD4-5									3		29	
		S	185929-1									1		01-H	
		S	AN456AD4-5									3		29	
		S	18S5937									2		01-H	
		S	AN3-22A									2		04-A	
		S	AC365-1032									2		04-A	
		S	AN960-10									2		04-A	
		S	18S5938									4		01-H	
		S	AN455AD3-6									12		29	
		S	D175951									1		01-H	
		S	AN456AD4-5									21		29	
		S	AN456AD4-6									6		29	
		S	D175951-1									1		01-H	
		S	AN456AD4-5									21		29	
		S	AN456AD4-6									6		29	
		S	185987									1		01-H	
		S	5910B	(P)								1		29	
		S	S-16-4-10									10		01-H	
		S	185989									2		01-H	
		S	5910B	(P)								2		29	
S	S-16-4-10									38		01-H			
S	74	(P)								1		08-B			
S	AN935-416									1		29			
S	185918									2		01-H			
S	105090-CR016-3-014									2		01-H			
S	D175950									1		01-H			
S	D175950-1									1		01-H			
S	102718-02111									1		01-H			
S	AC366-F832									3		04-A			
S	AN425AD3-5									6		29			
S	AN425AD4-5									4		29			

RESTRICTED

RESTRICTED

T. O. No. 01-90CC-4

SECTION II—GROUP ASSEMBLY PARTS LISTS

FIG. NO.	INDEX NO.	STOCK #	GROUP Power Plant						UNITS PER ASSY	PROPERTY CLASSIFICATION		
			MAJOR ASSEMBLY Cowling Assembly - Engine Inner							U.S. NAVY	U.S. ARMY	BRITISH
			PART NUMBER	1	2	3	4	5				
26	1	S	D175950-4							1		01-H
		S	AN425-AD4-6							2		29
		S	D175950-6							1		01-H
		S	AN450A8C12							8		29
		S	D175950-7							1		01-H
		S	102718-05416							1		01-H
		S	AN425-AD4-5							9		29
		S	D175950-8							2		01-H
		S	D175950-9							1		01-H
		S	D17951							1		01-H
		S	D175950-10							1		01-H
		S	AN425AD3-4							2		29
		S	AN425AD3-5							1		29
		S	D175950-11							1		01-H
		S	D175950-12 LH							1		01-H
		S	AN425AD4-5							2		29
		S	AN456AD4-6							2		29
		S	D175950-12 RH							1		01-H
		S	AN425AD4-5							2		29
		S	AN456AD4-6							2		29
		S	D175950-14							1		01-H
		S	D175950-15							1		01-H
		S	D175950-17							1		01-H
		S	AN450A8C12							3		29
		S	D175950-18							1		01-H
		S	D175950-2							1		01-H
		S	102718-03022							1		01-H
		S	AN425AD4-5							5		29
		S	D175950-5							1		01-H
		S	D17951							1		01-H
		S	D175950-16							1		01-H
		S	AN450A8C12							4		29
		S	D1789266							1		01-H
		S	D1789266-4							1		01-H
S	D1789266-5							1		01-H		
S	D1789266-6							1		01-H		
S	AN425AD3-4							3		29		
S	AN455AD3-4							5		29		
S	A5-30 (P)							7		04-A		
S	GA5-312 (P)							7		04-A		
S	AN425AD4-5							4		29		
S	AN455AD3-4							5		29		
S	S5-200 (P)							7		04-A		
S	D175950-19							1		01-H		
S	D175950-2							1		01-H		
S	102718-03022							1		01-H		
S	AN425AD4-5							5		29		
S	D175950-3							1		01-H		
S	D17951							1		01-H		
S	D175950-16							1		01-H		
S	AN450A8C12							4		29		
S	A5-30 (P)							8		04-A		
S	GA5-312 (P)							8		04-A		
S	AN425AD4-5							16		29		
S	S5-200 (P)							8		04-A		
S	D175913							2		01-H		
S	D175914							1		01-H		

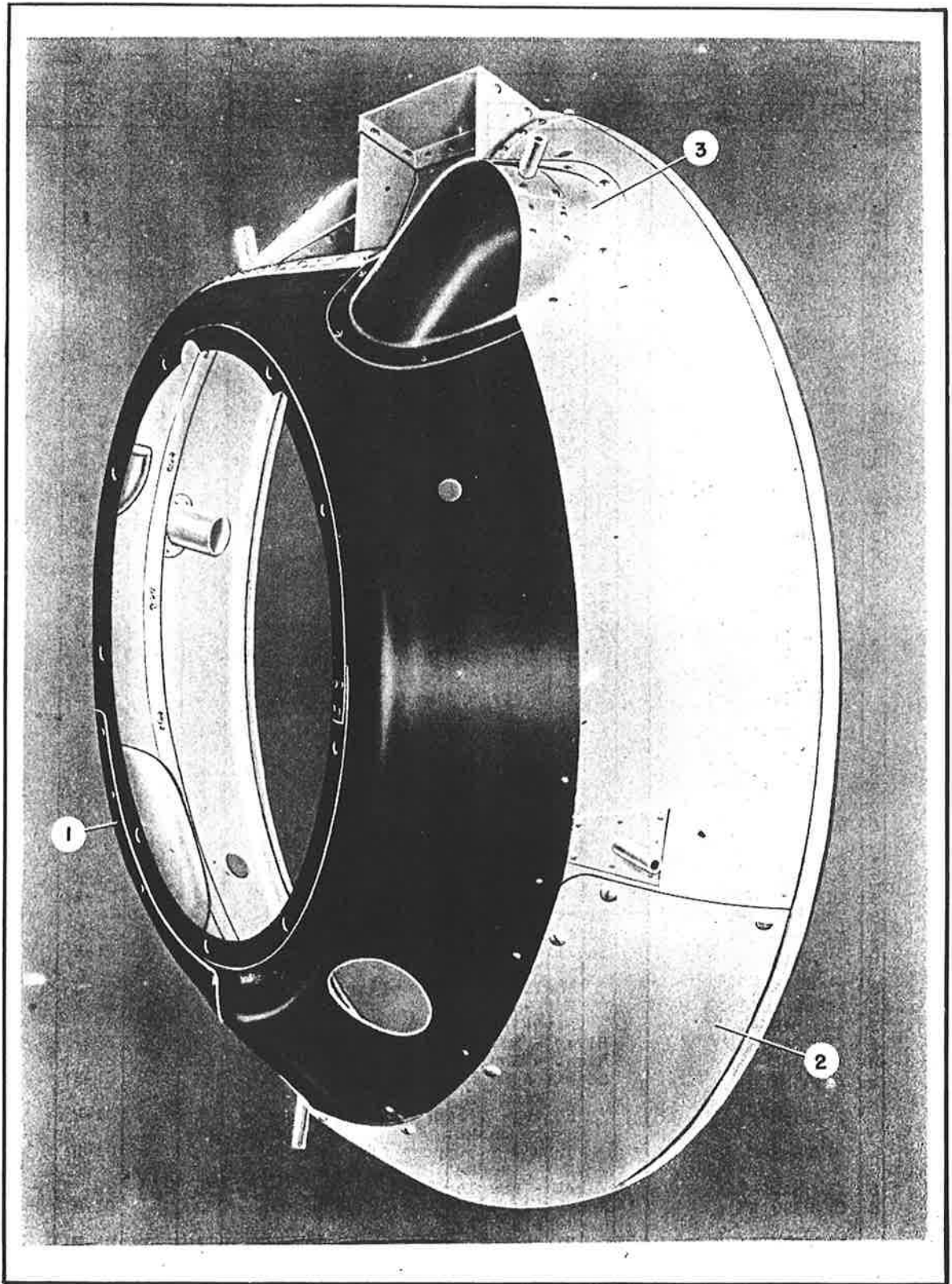

Figure 26 - Inner Cowling Assembly

RESTRICTED
T. O. No. 01-9000-4
SECTION II—GROUP ASSEMBLY PARTS LISTS

FIG. NO.	INDEX NO.	STOCKED	GROUP Power Plant						UNITS PER ASSY	PROPERTY CLASSIFICATION				
			MAJOR ASSEMBLY Cowling Assembly - Engine Inner							U.S. NAVY	U.S. ARMY	BRITISH		
			PART NUMBER	1	2	3	4	5					6	NOMENCLATURE
26	3	S	D175917							1		01-H		
		S	D175918							2		01-H		
		S	AN430-4-10							10		29		
		S	D175919							1		01-H		
		S	D175921							1		01-H		
		S	AN430-3-4							8		29		
		S	D175921-1							1		01-H		
		S	AN430-3-4							8		29		
		S	D17922							1		01-H		
		S	AN430-4-5							8		29		
		S	AN430-4-6							4		29		
		S	D17922-1							1		01-H		
		S	AN430-4-5							8		29		
		S	AN430-4-6							4		29		
		S	D175923							1		01-H		
		S	AC365-832							4		04-A		
		S	AN515-8-6							4		29		
		S	AN960-8							4		04-A		
		S	AC366-F832							3		04-A		
		S	AN425-3-5							6		29		
		S	AN430AD4-5							13		29		
		S	AN430AD4-6							10		29		
		S	D175924							1		01-H		
		S	D175937							1		01-H		
		S	D175928							1		01-H		
					D175928-1						1		01-H	
					D175928-2						1		01-H	
		S	AC365-832							4		04-A		
		S	AN526-832-8							4		29		
		S	AN960-8							4		04-A		
		S	D175935							1		01-H		
		S	AN430AD4-4							8		29		
		S	D175936							1		01-H		
		S	AC366-F1032							8		04-A		
		S	AN425-AD3-4							16		29		
		S	AN520-10-8							8		29		
		S	D175965							1		01-H		
		S	D175965-1							1		01-H		
		S	AC366-F832							3		04-A		
		S	AN425AD3-4							6		29		
		S	AN430AD4-5							3		29		
		S	AN430AD4-6							11		29		
		S	D17S598 LH							2		01-H		
					D17S598-1						1		01-H	
					D17S598-2						1		01-H	
S	AN455AD3-5							14		29				
S	D17S598 RH							2		01-H				
			D17S598-1						1		01-H			
			D17S598-2						1		01-H			

RESTRICTED

T. O. No. 01-90CC-4

SECTION II—GROUP ASSEMBLY PARTS LISTS

FIG. NO.	INDEX NO.	STOCKED	GROUP Power Plant						UNITS PER ASSY	PROPERTY CLASSIFICATION			
			Cowling Assembly - Engine Inner Installation - Fuel System							U.S. NAVY	U.S. ARMY	BRITISH	
			MAJOR ASSEMBLY	1	2	3	4	5					6
27	1	S	AN455AD3-5							14		29	
		S	D17S9503							4		01-H	
		S	AN3-7A							4		04-A	
		S	AC365-1032							4		04-A	
		S	AN430AD4-12							12		29	
		S	AN960-10							4		04-A	
		S	AN455AD3-5							8		29	
		S	AN931-8-13							1		04-B	
		S	AN931-16-22							1		04-B	
		S	D179007							1		01-H	
		S	D179013							1		01-H	
		S	D179013-1							1		01-H	
		S	561-D-4	(P)						1		01-C	
		S	105933-8							3		04-A	
		S	AN3-7							1		04-A	
		S	AN310-3							1		04-A	
		S	AC365-1032							2		04-A	
		S	AN380-2-2							1		29	
		S	AN520-10-10							2		29	
		S	AN960-10							3		04-A	
		S	D179190							1		01-H	
		S	AC365-1032							6		04-A	
		S	AN520-10-8							2		29	
		S	AN520-10-40							4		29	
		S	AN960-10							6		04-A	
		S	D179262							1		01-H	
		S	AC884-8-9							1		04-B	
		S	FB8A	(P)						2		04-A	
		S	D179271							1		01-H	
		S	AC884-6-9							2		04-B	
		S	FB6A	(P)						4		04-A	
		S	D179272							1		01-H	
		S	106043-12-04-030							1		01-H	
		S	FB6A	(P)						1		04-A	
		S	AN931-6-10							1		04-B	
S	D179274							1		01-H			
S	AC850-4							1		04-A			
S	AC884-4-9							2		04-B			
S	FB1A	(P)						4		04-A			
S	D179275							1		01-H			
27	3	S	D179275-2							1		01-H	
		S	AC811BT4D							1		04-A	
		S	AC811T4CS							1		01-H	
		S	D179276							1		01-H	
		S	D179276-2							1		01-H	
		S	AC811BT4D							1		04-A	
		S	AC811T4CS							1		04-A	
		S	AN931-4-7							2		04-B	
		S	D179277							1		01-H	
		S	D179277-2							1		01-H	
		S	AC811BT4D							2		04-A	
		S	AC811T4CS							2		04-A	
		S	D179278							1		01-H	
		S	FB8A	(P)						4		04-A	
		27	4	S	AC850-8							1	
S	AN884-8-9									2		04-B	
S	AC895-85									1		04-A	
S	D179279									1		01-H	
27	5	S	D179275-2							1		01-H	
		S	AC811BT4D							1		04-A	
		S	AC811T4CS							1		01-H	
		S	D179276							1		01-H	
		S	D179276-2							1		01-H	
		S	AC811BT4D							1		04-A	
		S	AC811T4CS							1		04-A	
		S	AN931-4-7							2		04-B	
		S	D179277							1		01-H	
		S	D179277-2							1		01-H	
		S	AC811BT4D							2		04-A	
		S	AC811T4CS							2		04-A	
		S	D179278							1		01-H	
		S	FB8A	(P)						4		04-A	
		S	AC850-8							1		04-A	
S	AN884-8-9							2		04-B			
S	AC895-85							1		04-A			
S	D179279							1		01-H			

RESTRICTED

RESTRICTED

T. O. No. 01-90CC-4

SECTION II—GROUP ASSEMBLY PARTS LISTS

FIG. NO.	INDEX NO.	STOCKED	GROUP Power Plant						UNITS PER ASSY	PROPERTY CLASSIFICATION			
			MAJOR ASSEMBLY Installation - Fuel System							U.S. NAVY	U.S. ARMY	BRITISH	
			PART NUMBER	1	2	3	4	5					6
27	6	S	FB8A (P)							4		04-A	
		S	AC850-8							1		04-A	
		S	AC851-8							1		04-A	
		S	AC884-8-9							2		04-B	
		S	AC895-85							1		04-A	
		S	D179280							1		01-H	
		S	D179280-2							1		01-H	
		S	AC811BT4D							1		04-A	
		S	AC811T4CS							1		04-A	
		S	D179281							1		01-H	
27	7	S	FB4A (P)							2		04-A	
		S	AC884-4-9							1		04-B	
		S	AN931-4-16							1		04-B	
		S	D179283							1		01-H	
		S	D179283-2							1		01-H	
		S	AC811BT4D							1		04-A	
		S	AC811T4CS							1		04-A	
		S	FB4A (P)							2		04-A	
		S	AC811CT4							1		04-A	
		S	AC884-4-9							1		04-B	
27	8	S	AN931-4-16							1		04-B	
		S	D179284							1		01-H	
		S	D179284-2							1		01-H	
		S	AC811BT4D							2		04-A	
		S	AC811T4CS							2		04-A	
		S	AC811CT4D							1		04-A	
		S	AN931-4-16							1		04-B	
		S	D179285							1		01-H	
		S	FB8A (P)							2		04-A	
		S	AC884-8-9							1		04-B	
27	9	S	D179286							1		01-H	
		S	FB8A (P)							4		04-A	
		S	AC884-8-9							2		04-B	
		S	AN931-12-20							1		04-B	
		S	D179287							1		01-H	
		S	D179287-2							1		01-H	
		S	AN800-4							1		04-A	
		S	AN805-4							1		04-A	
		S	AC811BT4D							1		04-A	
		S	AC811T4CS							1		04-A	
27	10	S	100951-L040-005-024							3		01-H	
		S	105933-4							3		04-A	
		S	AC365-832							3		04-A	
		S	AN515-8-10							3		29	
		S	AN931-4-16							1		04-B	
		S	D179288							1		01-H	
		S	D179288-2							1		01-H	
		S	AC811BT4D							1		04-A	
		S	AC811T4CS							1		04-A	
		S	105933-4							1		04-A	
27		S	AC365-832							1		04-A	
		S	AN515-8-10							1		29	
		S	D179289							1		01-H	
		S	D179289							1		01-H	

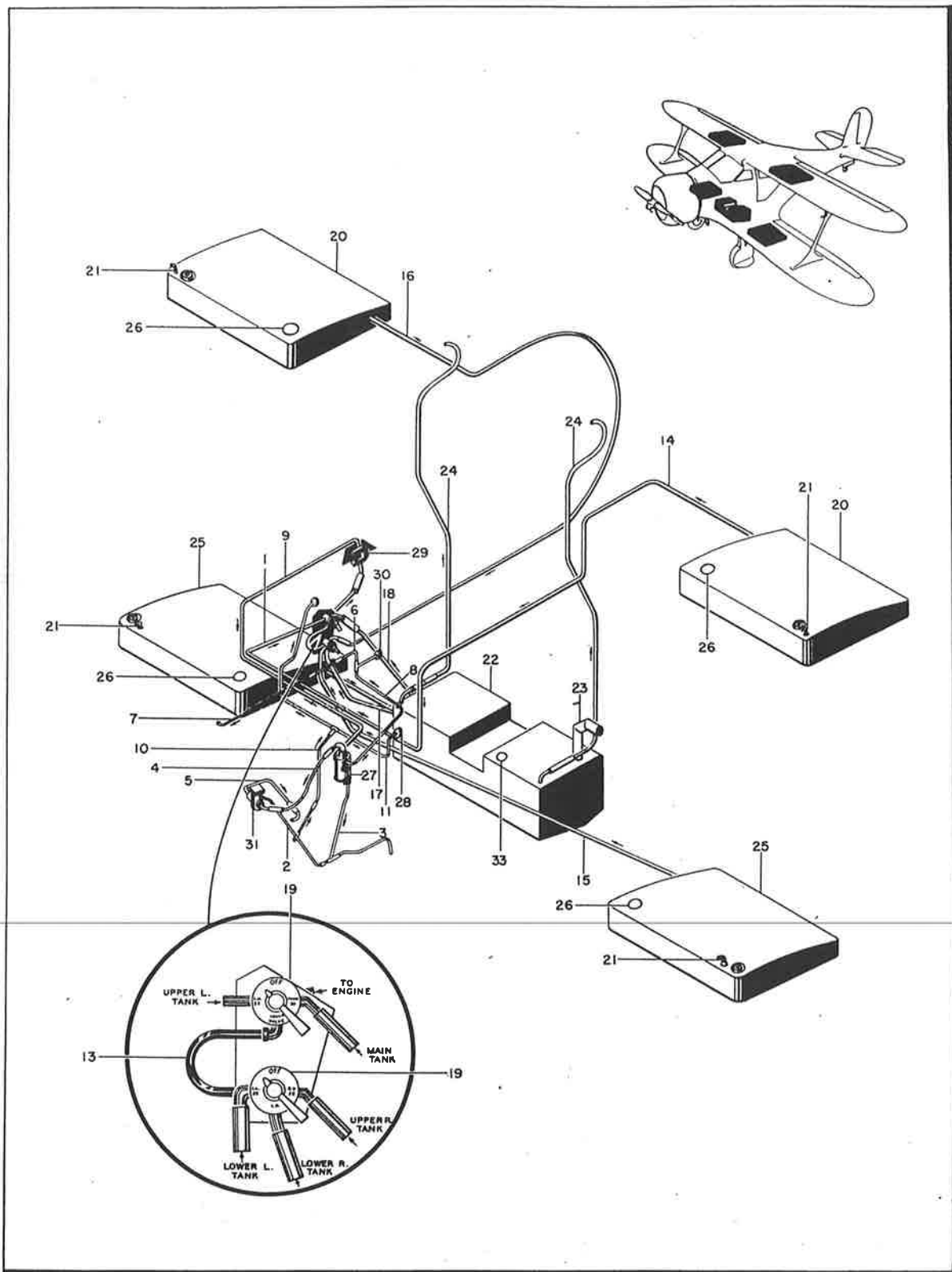

Figure 27 - Installation - Fuel System