

RCS2-A4R

Robo Cylinder, Arm Type, Actuator Width 40mm, 200V Servo Motor, Side-mounted Motor

Model Specification Items	RCS2 — A4R — <input type="checkbox"/> — 20 — <input type="checkbox"/> — <input type="checkbox"/> — <input type="checkbox"/> — <input type="checkbox"/> — <input type="checkbox"/>	Series	Type	Encoder type	Motor type	Lead	Stroke	Applicable controller	Cable length	Options
	I: Incremental A: Absolute	20: 20W Servo motor	10: 10mm 5: 5mm	50: 50mm 200: 200mm (50mm pitch increments)	T1: XSEL-J/K T2: SCON MSCON SSEL XSEL-P/Q XSEL-R/S	N: None P: 1m S: 3m M: 5m X <input type="checkbox"/> : Custom length R <input type="checkbox"/> : Robot cable	See options below. * Be sure to specify which side the motor is to be mounted (MB/MR/ML)			
	* See page Pre-47 for details on the model descriptions.									



*CE compliance is optional.



Technical References Appendix P.5

- POINT**
Notes on selection
- (1) When the stroke increases, the maximum speed will drop to prevent the ball screw from reaching the critical rotational speed. Use the actuator specification table below to check the maximum speed at the stroke you desire.
 - (2) The load capacity is based on operation at an acceleration of 0.2G. This is the upper limit of the acceleration.
 - (3) See page A-71 for details on push motion.

Actuator Specifications

Leads and Payloads

Model number	Motor output (W)	Lead (mm)	Max. Load Capacity		Rated thrust (N)	Stroke (mm)
			Horizontal (kg)	Vertical (kg)		
RCS2-A4R-①-20-10-②-③-④-B-⑤	20	10	—	2.5	39.2	50~200 (every 50mm)
RCS2-A4R-①-20-5-②-③-④-B-⑤		5	—	4.5	78.4	

Stroke and Maximum Speed

Stroke Lead	50~200 (every 50mm)
	10
5	165

Code explanation ① Encoder ② Stroke ③ Applicable Controller ④ Cable Length ⑤ Options *See page A-71 for details on push motion. (Unit: mm/s)

① Encoder Type/② Stroke

② Stroke (mm)	Standard price	
	① Encoder Type	
	Incremental	Absolute
	I	A
50	—	—
100	—	—
150	—	—
200	—	—

④ Cable Length

Type	Cable symbol	Standard Price
Standard	P (1m)	—
	S (3m)	—
	M (5m)	—
Special length	X06 (6m) ~ X10 (10m)	—
	X11 (11m) ~ X15 (15m)	—
	X16 (16m) ~ X20 (20m)	—
Robot Cable	R01 (1m) ~ R03 (3m)	—
	R04 (4m) ~ R05 (5m)	—
	R06 (6m) ~ R10 (10m)	—
	R11 (11m) ~ R15 (15m)	—
	R16 (16m) ~ R20 (20m)	—

* See page A-59 for cables for maintenance.

⑤ Options

Name	Option code	See page	Standard price
Brake	B	→ A-42	—
CE compliance	CE	→ A-42	—
Bottom-mounted motor	MB	→ A-52	—
Right-mounted motor	MR	→ A-52	—
Left-mounted motor	ML	→ A-52	—
Non-motor end specification	NM	→ A-52	—

Actuator Specifications

Item	Description
Drive System	Ball screw, ø8mm, rolled C10 (ball screw speed reduced by 1/2 by timing belt)
Positioning repeatability	±0.02mm
Lost Motion	0.1mm or less
Base	Material: Aluminum, white alumite treated
Allowable dynamic moment	Ma: 2.7 N·m, Mb: 3.1 N·m, Mc: 2.9 N·m
Ambient operating temperature, humidity	0 to 40°C, 85% RH or less (Non-condensing)

Directions of allowable load moments

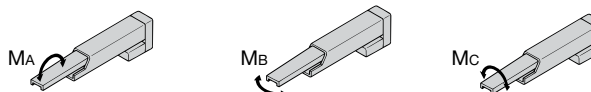

Dimensional Drawings

CAD drawings can be downloaded from the website. www.intelligentactuator.com

For Special Orders Appendix P.15



- (*1) Connect the motor and encoder cables here. See page A-59 for details on cables.
 - (*2) After homing, the slider moves to the ME, therefore, please watch for any interference with surrounding objects.
- ME : Mechanical end SE : Stroke end

Bottom-mounted motor (option code: MB)

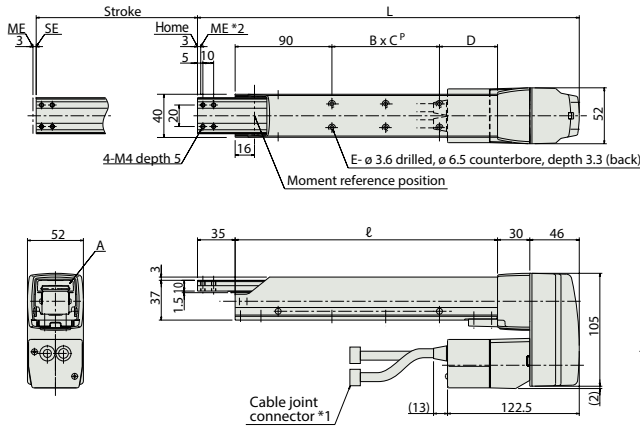

Right-mounted motor (option code: MR)

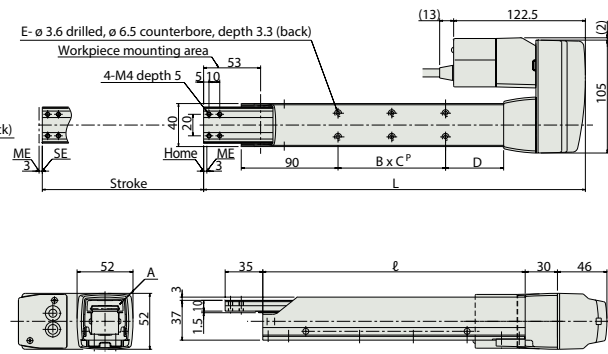

Left-mounted motor (option code: ML)

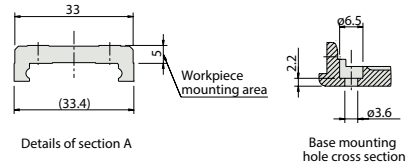
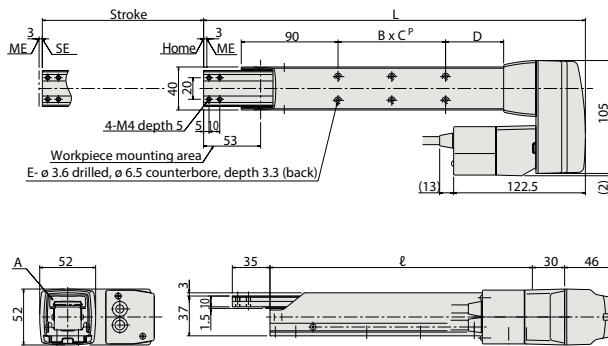

Dimensions and Weight by Stroke

Stroke	50	100	150	200
L	255	305	355	405
ℓ	144	194	244	294
B x C ^P	1x19	1x50	2x50	2x50
D	35	54	54	104
E	4	4	6	6
Weight (kg)	1.7	1.8	2.0	2.1

Applicable Controllers

RCS2-series actuators can be operated with the following controllers. Select an appropriate controller type according to your application.

Name	External view	Model number	Features	Maximum number of positioning points	Input power	Power supply capacity	Standard price	Reference page		
Positioner mode		SCON-CA-20①-NP-2-②	Up to 512 positioning points are supported.	512 points	Single-phase 100VAC Single-phase 200VAC 3-phase 200VAC (XSEL-P/Q/R/S ONLY)	106 VA max. *Power supply capacity will vary depending on the controller, so please refer to the instruction manual for details.	—	→ P643		
Solenoid valve mode			Actuators can be operated through the same control used for solenoid valves.	7 points						
Field network type			Movement by numerical specification is supported.	768 points						
Pulse-train input control type			Dedicated pulse-train input type	(-)						
Positioner multi-axis, network type		MCON-C-1-20①-④-0-②	Up to 6 axes can be operated. Movement by numerical specification is supported.	256 points	3-phase 200VAC (XSEL-P/Q/R/S ONLY)	106 VA max. *Power supply capacity will vary depending on the controller, so please refer to the instruction manual for details.	—	→ P655		
Program control type, 1 to 2 axes		SSEL-CS-1-20①-NP-2-②	Program operation is supported. Up to 2 axes can be operated.	20000 points					—	→ P685
Program control type, 1 to 8 axes		XSEL③-1-20①-N1-EEE-2-④	Program operation is supported. Up to 8 axes can be operated.	Varies depending on the number of axis connected						

* This is for the single-axis MCON, SSEL, and XSEL.
 * ① indicates the power-supply voltage type (1: 100V / 2: Single-phase 200V).
 * ② indicates the power-supply voltage type (1: 100V / 2: Single-phase 200V / 3: Three-phase 200V).
 * ③ indicates the encoder type (I: Incremental / A: Absolute).
 * ④ indicates the XSEL type (J / K / P / Q / R / S).
 * ⑤ indicates field network specification symbol.

Slider Type

Mini

Standard

Controllers Integrated

Rod Type

Mini

Standard

Controllers Integrated

Table/ Arm/ Flat Type

Mini

Standard

Gripper/ Rotary Type

Linear Servo Type

Clean-room Type

Splash-Proof Type

Pulse Motor

Servo Motor (24V)

Servo Motor (200V)

Linear Servo Motor