

ED 033 037

SE 007 475

Space Science K-6; Elementary Science Unit No. 1.

Bethlehem Area Schools, Pa.

Pub Date 66

Note-172p.

EDRS Price MF-\$0.75 HC Not Available from EDRS.

Descriptors-\*Aerospace Technology, Astronomy, Concept Formation, \*Curriculum Guides, \*Discovery Learning, Educational Objectives, \*Elementary School Science, Instructional Materials, Problem Solving, \*Science Activities, Science Equipment, Teaching Procedures

This curriculum guide, part of a series of science units, provides for differentiation of emphasis of subject areas at different grade levels. It is intended that the unit will be studied in depth by grades 1, 4, and 6. Kindergarten, grades 2 and 3 will study the unit in less detail. "Our Wonderful Sun" is studied in Kindergarten, "Earth in Space" in grade 1, "Men and Machines in Space" in grade 2, "Movements of the Earth and Moon" in grade 3, "Our Great Universe" in grade 4, and "From Atmosphere to Space" in grade 6. The unit for each grade contains (1) understandings to be discovered, (2) activities, and (3) activities to assign for homework or individual research. Each activity is introduced by a "leading question," followed by a list of materials and a description of the procedure to be followed. Children are taught to observe, infer, discuss problems and use reference and audiovisual aid materials. There is an index of science textbooks for reference for the teacher. The appendix contains (1) instructions for the construction and use of a star projector, (2) a guide for locating stars and constellations, (3) planetary data, and (4) dates of solar, annular and lunar eclipses. [Not available in hard copy due to marginal legibility of original document]. (LC)

EDO 33037

U.S. DEPARTMENT OF HEALTH, EDUCATION & WELFARE  
OFFICE OF EDUCATION

THIS DOCUMENT HAS BEEN REPRODUCED EXACTLY AS RECEIVED FROM THE  
PERSON OR ORGANIZATION ORIGINATING IT. POINTS OF VIEW OR OPINIONS  
STATED DO NOT NECESSARILY REPRESENT OFFICIAL OFFICE OF EDUCATION  
POSITION OR POLICY.

# SPACE SCIENCE

K-6

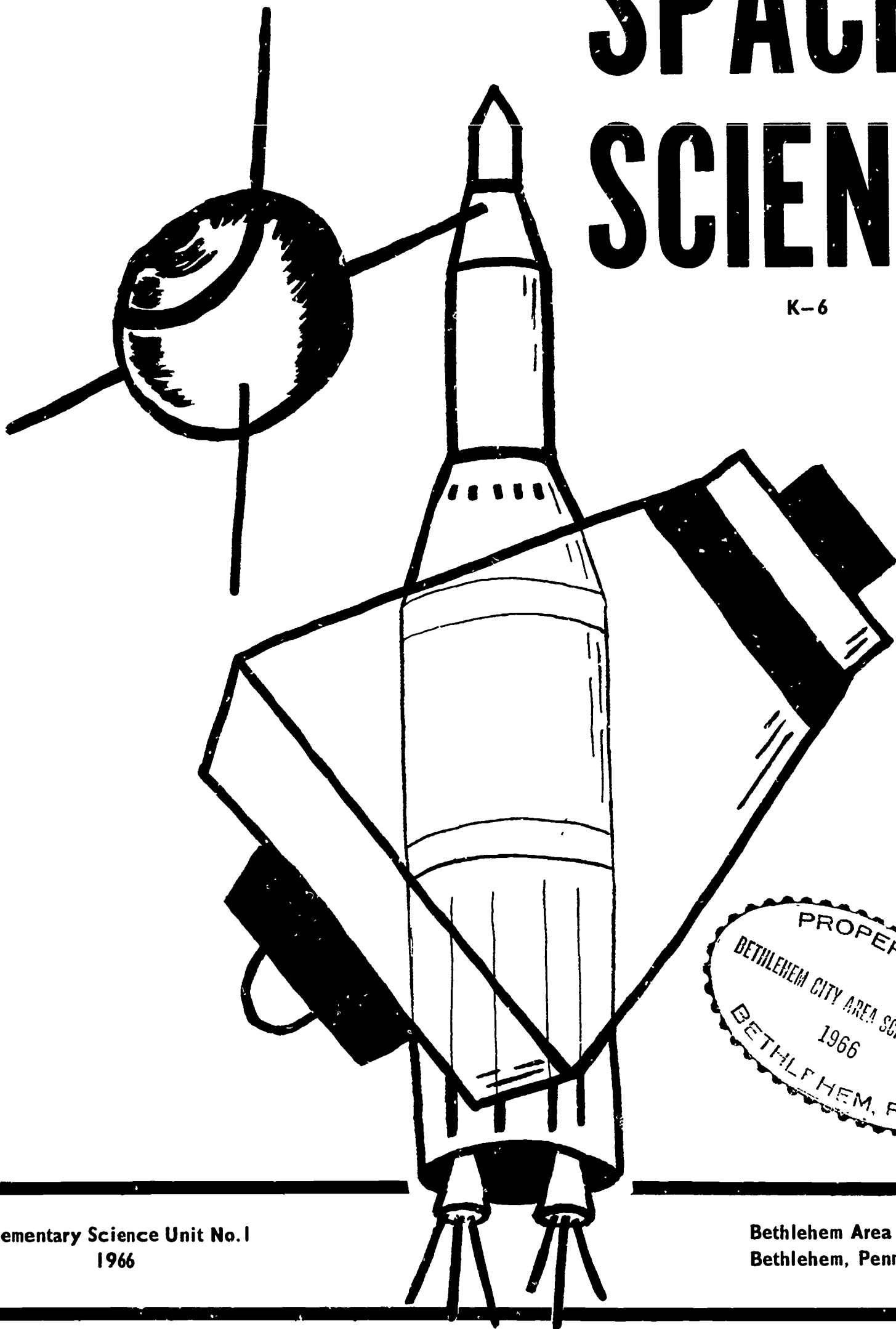

SE 007 475

PROPERTY OF  
BETHLEHEM CITY AREA SCHOOL DISTRICT  
1966  
BETHLEHEM, PA.

Elementary Science Unit No. 1  
1966

Bethlehem Area School District  
Bethlehem, Pennsylvania

SPACE SCIENCE

BETHLEHEM AREA ELEMENTARY SCHOOLS



BETHLEHEM AREA SCHOOL DISTRICT  
Bethlehem, Pennsylvania

CHARLES E. CHAFFEE Ed.D.  
Superintendent of Schools

REBECCA W. STEWART Ed.D.  
Director of Elementary Education

1966

TABLE OF CONTENTS

	Page
SCIENCE EDITING COMMITTEE.....	3
GOALS OF SCIENCE EDUCATION.....	4
FOREWORD .....	6
Kindergarten      OUR WONDERFUL SUN	
Understandings to be Discovered.....	7
Activities.....	8
* Grade 1            EARTH IN SPACE	
THE EARTH	
Understandings to be Discovered.....	13
THE MOON	
Understandings to be Discovered.....	14
THE SUN AND OTHER STARS	
Understandings to be Discovered.....	15
Activities .....	16
Grade 2             MEN AND MACHINES IN SPACE	
Understandings to be Discovered.....	30
Activities.....	32
Activities to Assign for Homework or	
Individual Research.....	41
Grade 3             MOVEMENTS OF THE EARTH AND MOON	
SEASONS	
Understandings to be Discovered.....	43
GRAVITY	
Understandings to be Discovered.....	44
Activities .....	45
Activities to Assign for Homework or	
Individual Research.....	57
* Grade 4            OUR GREAT UNIVERSE	
THE EARTH	
Understandings to be Discovered.....	61
THE MOON	
Understandings to be Discovered.....	62
THE SUN'S FAMILY	
Understandings to be Discovered.....	63
CELESTIAL BODIES	
Understandings to be Discovered.....	64
THE UNIVERSE	
Understandings to be Discovered .....	65
EARLY ASTRONOMERS	
Understandings to be Discovered .....	66
Activities .....	67
Activities to Assign for Homework or	
Individual Research .....	89

Table of Contents (continued)

	Page
* Grade 6	
FROM ATMOSPHERE TO SPACE	
FORCE, ENERGY, AND POWER	
Understandings to be Discovered.....	97
DISTANCES IN SPACE	
Understandings to be Discovered.....	98
FLIGHT AND SPACE TRAVEL	
Understandings to be Discovered.....	99
Activities.....	102
Activities to Assign for Homework or	
Individual Research.....	126
SCIENCE TEXTBOOK INDICES.....	130
APPENDIX.....	
LVAAS Star Projector.....	156
LVAAS Stellar Sign Posts.....	158
Planetary Data.....	163
Satellites of the Solar System.....	164
Total Solar Eclipses.....	165
Annular Eclipses.....	167
Total Lunar Eclipses.....	168

\* Major Emphasis Study

## SCIENCE EDITING COMMITTEE

*Loretta B. Minnich	Kindergarten
Kathryn W. Rau	Kindergarten
Irene J. Kasapyr	Grade 1
*Joanne P. McLernon	Grade 1
Vasilias B. Pappas	Grade 1
Kay O. Comly	Grade 2
Patricia G. Doane	Grade 2
Lucille W. Stewart	Grade 2
*Eileen C. Fielding	Grade 3
*Carol M. Hahn	Grade 3
John J. Hippensteal	Grade 4
*Janet E. Leeb	Grade 4
Suzanne C. Hulsizer	Grade 5
*Phyllis M. Peters	Grade 5
Doris M. Freudenberger	Grade 6
*Richard J. Pappas	Grade 6
William L. Kadoich	Assistant Supervisor, Audio-Visual Education
*A. Thomas Kartsotis	Science Helping Teacher
Paul E. Kuklantz	Supervisor, Health and Physical Education
Rebecca W. Stewart, Ed.D.	Director of Elementary Education

\*Members of the Summer Writing Conference

The committee wishes to thank the Lehigh Valley Amateur Astronomical Society for permission to use various materials included in this unit.

Cover Design - Phyllis Peters

Illustrations - Carol Hahn, Phyllis Peters, Thomas Kartsotis



## THE GOALS OF SCIENCE EDUCATION IN THE BETHLEHEM AREA ELEMENTARY SCHOOLS

In the past five decades science and technology have made a tremendous impact on our lives. As a result educators have had to re-examine the purposes and scope of the science curriculum in the public school. It is no longer a question whether or not science will be taught in the elementary school. Science education must be a definite, planned part of the elementary school program, providing science experiences which prepare boys and girls to live in an ever-expanding universe. The curriculum must explore every facet of science, physical, biological, astronomical, and natural. In redesigning the elementary school science curriculum, the curriculum questions of why, when, how, and what have to be answered if educational goals are to be achieved.

**WHY DO WE TEACH SCIENCE IN THE ELEMENTARY SCHOOL?** We provide curriculum opportunities to develop the knowledge, skills and attitudes needed to:

1. Appreciate intelligently the natural and physical environment and the discoveries and work of scientists.
2. Recognize the scientific method and apply it in solving problems.
3. Understand and interpret scientific happenings (phenomena) and relate this knowledge to other areas of the curriculum.
4. Recognize scientists and technicians as community helpers.
5. Become acquainted with the terminology and tools which will provide opportunities to explore beyond the limits of the curriculum in areas of interest.
6. Eliminate superstition and fear of science so that the individual benefits socially, morally and spiritually.

**WHEN DO WE TEACH SCIENCE IN THE ELEMENTARY SCHOOL?** The developmental characteristics, maturity and interests of the children in the classroom determine the timing of the sequence and scope of the science curriculum. In any classroom program there must be:

1. Time allotted for science in the daily program.
2. A planned but flexible program of exploration.
3. A developmental sequence which leads children from their present levels of understanding by relating new experiences to previous ones and by challenging them to explore and question.

**HOW DO WE TEACH SCIENCE IN THE ELEMENTARY SCHOOL?** In providing science experiences the teacher must:

1. Organize experiences so that children's understandings both expand and deepen.
2. Establish a purpose or a reason for activity.
3. Select science materials and experiences that are adapted to the maturity level of pupils.

4. Establish a favorable environment for teaching and learning.
5. Motivate through teacher-pupil planning so that children's interests may be recognized.
6. Encourage active participation of all children so that they may acquire necessary experiences.
7. Help children to gather facts through observation, reading, experimentation, and discussion.
8. Evaluate failure not as defeat but as a step toward knowledge.
9. Use community facilities, field trips, visual aids, and resource people.
10. Encourage ingenuity and creativity in the construction and use of materials.
11. Encourage the use of problem solving techniques.
12. Help children achieve a sense of the dynamics of change.
13. Take advantage of opportunities for incidental learning that arise from current situations, while recognizing that an adequate science program can not be built on incidental experiences alone.

WHAT DO WE TEACH IN THE SCIENCE CURRICULUM IN THE ELEMENTARY SCHOOL: This Space Unit represents the first of a series of units to answer this question in detail.



## FOREWORD

The SPACE SCIENCE UNIT is the first of a series of units to be written for the Bethlehem Area Elementary Schools. It is a major revision in both structure and content of the second edition of the Science Curriculum Guide.

In the first two editions of the Science Curriculum Guide all areas of science were part of the curriculum at succeeding grade levels with ever-increasing detail. This third edition will provide for differentiation of emphasis. Certain units will receive major emphasis at prescribed grade levels and minor emphasis at other grade levels. Designated grade-levels will not study particular units at all except as current events. The result will be that each grade level will study fewer areas but in greater detail.

For example, grades one, four and six will study space science in depth. Kindergarten and grades two and three will study space science in less detail or with minor emphasis. Grade five will not have a unit on space except incidentally as space technology and exploration makes news.

Examination of the table of contents will disclose that there is very little repetition of areas studied in the various grades. However, understandings at one grade level build upon the understandings gained at the previous grade level and it may often be necessary to reteach understandings from a previous grade level. For instance, a child in third grade cannot understand seasons if he has not mastered the concepts concerned with the movements of the earth introduced in grade one.

The unit for each grade in this book will usually contain:

1. UNDERSTANDINGS TO BE DISCOVERED with a cross-reference
2. ACTIVITIES
3. ACTIVITIES TO ASSIGN FOR HOMEWORK OR INDIVIDUAL RESEARCH

The UNDERSTANDINGS TO BE DISCOVERED are listed for teacher reference and are to be developed through child-centered activities. A teacher should choose activities that best suit the need of the students. Obviously it would be impractical to use every activity listed.

Do not begin a lesson by stating a concept and proceeding to "prove" it with one or more experiments. Allow children to discover a concept in a learning situation. Children themselves should find solutions when confronted with a problem.

Teach children to observe, draw conclusions from observations, discuss problems with fellow students and other people, and to use a variety of references and audio-visual aid materials. Classroom textbooks should be used as reference materials in addition to the encyclopedias and books found in the library.

The science textbooks have been indexed for quick reference for the teacher in the SPACE SCIENCE UNIT. This index is not to be used by students. Children should practice basic reading skills by using the table of contents and index in their textbooks to discover pertinent references.

SPACE SCIENCE

Our Wonderful Sun

Kindergarten

UNDERSTANDINGS TO BE DISCOVERED

RELATED ACTIVITIES

The sun is a star.

The sun is big and round.

The sun is shining all the time even though we can not always see it.

1, 2

The sun helps plants and animals to grow.

6, 7

The sun gives us heat.

3, 4, 5

The sun gives us light.

3

Shadows are made when an object is in the path of light.

9, 10, 11, 12

Shadows change in size as the source of light changes.

8, 14, 16

Shadows are longest in the morning and in the evening.

14

Shadows are shortest at noon when the sun is directly overhead.

14

Night shadows are not as clear as day shadows because the light from the moon is not as bright as the light from the sun.

13

## Our Wonderful Sun

### ACTIVITIES

1. **Leading Question:** Why can't we see the sun every day?  
**Materials:** Light, ball, oaktag, a piece of light fabric.  
**Procedure:** Shine the light on the ball. Put the cardboard oaktag between the ball and the light. Can you see the light on the ball? Replace the cardboard with the light fabric. Can you see the light on the ball? What can you see?
  
2. **Leading Question:** What makes day and night?  
**Materials:** Light, ball, colored pin.  
**Procedure:** Put a colored pin in the ball to represent your school. Shine the light on the pin. Is it day or night? Turn the ball so that the pin is on the opposite side. Is it day or night? Have the children turn the ball to show day and night.
  
3. **Leading Question:** Does sun give us heat?  
**Materials:** Two thermometers.  
**Procedure:** Put two thermometers outdoors - one in the sun, the other in the shaded area. Have some children mark the differences in temperature on paper thermometers. Is there a difference in the temperatures? Why? Use this activity at various times of the year.
  
4. **Leading Question:** Is it cold or hot outdoors?
  - A. **Materials:** Thermometer  
**Procedure:** Have the children put a thermometer outdoors at the beginning of the session. Check the temperature before dismissal. Keep a record for two weeks. Was the thermometer "up" or was it "down"? When the thermometer is up, is it hot or cold? Were the past two weeks generally hot or cold?
  
  - B. **Materials:** Pan, water  
**Procedure:** Have the children put a pan of water outdoors at the beginning of the session. Before school closes, bring the pan into the room. What has happened? Why?

5. Leading Question: Which color holds the heat from the sun longer - black or white?

Materials: Construction paper - one sheet of black and one sheet of white

Procedure: Place the two sheets of construction paper, black and white, in a sunny area. Can the children make any observations as to which piece of paper feels warmer when it is touched? Help them to realize the relationship between wearing dark-colored clothing in winter and light-colored clothing in summer. During the winter time the two pieces of paper can be placed on snow in direct sunlight. What happens to the snow under the white paper? Under the black paper? Why?

6. Leading Question: Do animals need sunlight?

Procedure: Through discussion, let the children speculate as to what would happen if there were no sun. Someone may make the statement that it would be too cold for animals to live without the sun. Plants could not grow, so there would be no food. A discussion will point out the necessity of using plants in aquariums. Encourage the children to relate their own feelings when the sun shines after a week of rainy or snowy weather.

7. Leading Question: Do plants need sunlight?

A. Materials: Soil, seeds, containers

Procedure: Plant seeds in containers of soil. Water them daily and allow them to grow for about a week. Cover one container completely so that all light is excluded. Continue to water both containers. Compare the growth of the plants daily for about two weeks. Are plants able to grow in the dark? What has happened to the plants which were covered? Now leave both containers uncovered. What observations can the children make about the two containers?

B. Materials: A small grass strip, a board

Procedure: Get permission from your principal to use a part of the grassy area around the school. Place the board on a strip of grass. Leave it there for a few days. Uncover the grass. Does it look the same as the grass which was not covered? Next leave it uncovered. Now what happens? Why?

8. **Leading Question:** Are shadow sticks fun to make and use?
- Materials:** Straws, clay, piece of chalk
- Procedure:** Have each child make a shadow stick using a small ball of clay and a straw. Place them on the window sill or in a sunny place. Encourage each child to mark the size of their own stick at different times of the day.
9. **Leading Question:** Can shadows be made indoors?
- Materials:** Movable hand-light
- Procedure:** Hold the light directly over a child. How tall is the shadow? Lower the light so it shines on the child's side. As the height of the light is changed, measure the size of the shadow. Is it always the same size? Shorter? Longer?
10. **Leading Question:** Can we play with shadows?
- Procedure:** Play Shadow Tag. Each child tries to avoid being tagged by the person who is "it". Instead of tagging with his hand, the person who is "it" tries to step on the other children's shadows. This game is more challenging to the children when the shadows are shorter.
11. **Leading Question:** Can you make shadow pictures?
- Materials:** Filmstrip projector or any other bright light.
- A. Procedure:** Use the bright light to cast a light on the wall. Have a child sit between the light and the paper. Trace around the shadow of his head and cut it out of the paper. Mount it on colored construction paper. The child will have his profile.
- B. Procedure:** Use the projector to cast a light on white paper. Children can make shadow animals using their fingers and hands. Another child can draw around the shadow. These can be cut out and mounted by the children to make a shadow booklet.



12. Leading Question: Can we make shadows using any type of object?
- Materials: Projector, various materials from room, i.e. small blocks, can, large beads, crayon, crumpled tissue, small toys.
- Procedure: Allow each child to choose an object for his "surprise" for the class. Have class sit in front of projector. One by one, let each child have a turn to project his surprise on the wall. Choose a child to name the object which made the shadow.
13. Leading Question: Can we see shadows at night?
- Materials: Moonlight
- Procedure: Ask the children to go outdoors on a moonlight night—properly dressed, of course. Can you see your shadow? Are you able to see the shadows of other objects? What other shadows can you see? Are the shadows light or dark? Why? Do you suppose the shadows are lighter or darker than on a sunny day? Why?
- NOTE TO TEACHERS: This difference may be very difficult for young children to observe.
14. Leading Question: Do shadows change at different times of the day?
- Materials: Stick, plaster of Paris, flower pot, chalk or yarn
- Procedure: Place a stick in a flower pot filled with plaster of Paris when school begins. Measure the length of the shadow. Where is the sun? What time of day is it? Mark it with the chalk or with the yarn. Measure again before class is dismissed. Now where is the sun? Is the shadow the same size, longer, or shorter? What observations can the children make concerning the length of the shadows? Suggest that the children can make the same observations at home after school until bedtime.
15. Leading Question: Can shadows tell us the time of day?
- Materials: Flag pole, trees, service poles
- Procedure: Look at the object's shadow. Where is it? Where is the sun? Is it morning, afternoon, or evening? Return later the same day or the following day at a later time. Is the shadow the same or is it different?



16. Leading Question:

Can you make a circle look larger?

Materials:

Various sized oaktag circles on notched sticks, projector, popsicle sticks.

Procedure:

Have children cut circles and insert them in split popsicle sticks or tongue depressors. Two children using the same size circles will make shadow circles. How can the circles be made to look larger? Why? Use other children's circles to discover that the position of the child holding the circle and the size of the circle makes a difference in the size of the shadow picture. Encourage the children to predict what will happen when the children move about with their circles. Will the circle always appear as a shadow circle? (The children will probably turn the stick around so the circle will not appear.) Let the children tell you what the shadow looks like to them.

## Space Science

### Earth In Space

Grade 1

#### The Earth

#### UNDERSTANDINGS TO BE DISCOVERED

#### RELATED ACTIVITIES

The earth is almost round.	1, 2
The earth consists of land, water, and air.	3
The earth is a planet.	4
There are nine planets.	4
Each planet is different.	4
Rotation is a spinning motion.	5, 6, 7
The earth rotates once every twenty-four hours.	
The earth rotates from west to east.	6, 7
The earth is always rotating.	7, 8
The rotation of the earth makes night and day.	7, 8, 9, 10
Only half the earth faces the sun at a given time - this is daytime.	7, 10
The other half of the earth does not face the sun - then it is nighttime.	7, 10
As the earth rotates toward the sun, we see the sunrise.	9
As the earth turns away from the sun, we see the sunset.	9
Circular movement around an object is called revolution.	11, 13
As the earth rotates, it revolves around the sun.	11, 12, 13
The path the earth takes in traveling around the sun is called an orbit.	12, 13
The earth moves in its orbit about the sun once a year.	12, 13

Space Science

Earth In Space

Grade 1

The Moon

UNDERSTANDINGS TO BE DISCOVERED

RELATED ACTIVITIES

The earth is larger than the moon.	20
The sun is many times larger than either the earth or moon.	19, 20
The moon looks as big as the sun because it is much closer to us.	
The moon has no light of its own. Moonlight is reflected sunlight.	4, 21
Our sun and other stars shine by their own light.	21
The sun lights only half of the moon.	22
The only part of the moon you can see is the part that is in sunlight.	
The moon does not always look the same to us.	16, 17, 18, 24
The moon rotates and revolves around the earth.	15
It takes the same amount of time for the moon to rotate as it does to revolve; this period of time is approximately one month.	15
Scientists are studying the moon with telescopes and spacecraft.	
Scientists believe there are no living things on the moon because of the absence of air, water, and temperature extremes.	

Earth In SpaceThe Sun and Other StarsUNDERSTANDINGS TO BE DISCOVEREDRELATED ACTIVITIES

The sun is round like a big ball.	1
The sun looks small but it is very large.	19, 20
The sun is very far away.	
The sun gives us heat and light which makes life on earth possible.	21
The sun is always shining.	10
Sometimes clouds hide the sun.	22
The sun is made of very hot gases.	23, 24
No one can live on the sun.	24
There are many stars in the sky.	25, 26
Stars look little but they are big round balls.	19, 25
Stars are very far away.	26
The stars are always shining.	27
The sun is the star which is nearest to the earth.	27
You can see many stars at night.	27
Stars form patterns in the sky. Two of these are shaped like dippers. They are called the Big Dipper and the Little Dipper.	25, 26
The brightest star in the Little Dipper is called the North Star.	25

## Earth In Space

### ACTIVITIES

1. Leading Question:

Why is it difficult to determine the shapes of large objects?

Materials:

Small ball, triangle, square, large ball, square, triangle, beach ball or large flat circle, handkerchief

Procedure:

Teach various shapes of objects so that the children can identify them.

Later, blindfold a child and see if he can identify both smaller and larger objects. He should have some difficulty getting the feel of the larger objects. Have class draw some conclusions as to determining shapes in relation to size.

Blindfold a different child. Have another child hold a small rubber ball or circle directly in front of the blindfolded child. Remove the blindfold and ask the child to identify the object without moving his head or eye level.

Repeat this activity, only this time use a very large beach ball or paper circle. Can the child identify the shape of this object?

2. Leading Question:

How do we know that the earth is round?

A. Materials:

Small paper model of ship, paper sail, map of earth, toothpick, clay

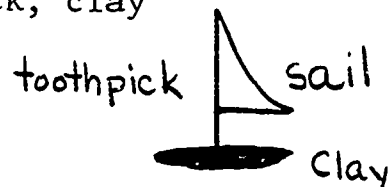

Procedure:

Collect a classroom library of stories of early navigation. In the beginning man thought the earth was flat. Lay a map of the earth on a table. "Sail" a ship across the map. What would eventually happen to the ship?

Columbus watched ships sailing away and observed that the masts remained visible long after the ship's hull disappeared. Did this happen in the previous activity? Now put the ship on the globe. Observe how the ship appears to us as it goes around the earth.

B. Materials:

Pictures taken from space craft.

Procedure:

Look at pictures of earth taken from a space craft.  
How does the earth look?

3. Leading Question:

What is the earth's surface made of?

A. Materials:

Globe

Procedure:

Place a globe before the class. Why are there different colors? Is there more land or water? The teacher must bring in the concept of air through discussion.

B. Materials:

Pictures of physical features of earth, flat picture of globe.

Procedure:

Arrange a bulletin board. Get pictures representing the different physical features of the earth. Use these pictures to show where they belong on the globe.

The geographical terms chart can be used to reinforce understandings.

4. Leading Question:

What kind of a heavenly body is the earth?

Materials:

Charts, Verson Planetarium

Note to teacher:

Since this concept will be developed later it is only necessary at this point to tell them that earth is a planet and there are more planets in our solar system.

The Verson Planetarium which is available through the Central Science Material Library will illustrate this concept. Charts of our solar system can also be used.

5. Leading Question:

What is rotation?

Materials:

Spinning Top, Trippensee Planetarium

Procedure:

Use a toy top to demonstrate the spinning motion called rotation. Ask a child to stand in front of the class and turn around but not move from a certain spot. Then have the whole class rotate at one time. Ask them to name other things that rotate and perhaps bring them to school.

Use the Trippensee Planetarium. Orient the planetarium for your location. Move the arm of the planetarium over December 21. Now turn the whole planetarium by its base so that as the compass needle points to the north, it points down the red arm toward the earth globe. When this is done, the north pole of the earth points toward the North Star. Hold the base still and move the arm



Procedure: (cont'd.)

of the planetarium partly through the earth's orbit. What is happening to the earth as it moves in its orbit? This spinning is called rotation.

6. Leading Question:

In which direction does the earth rotate?

Materials:

Trippensee Planetarium, globe, directional signs (east, west)

Procedure:

Set up the globe and directional signs as shown below.

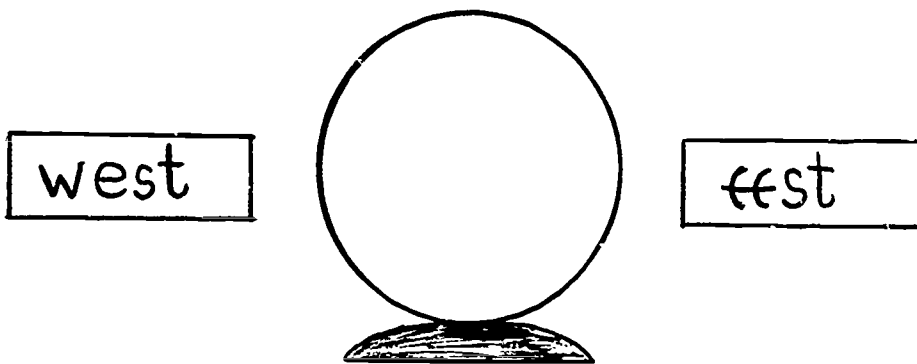

Observe the movements of the Trippensee Planetarium. Which way is it rotating? Have the children move the globe in the same way. The children will be able to discover the earth's rotation from west to east by looking at both the movement and reading the directional signs.

Now if we want to pretend we are the earth, in which direction will we rotate? Practice this to develop a sense of direction.

7. Leading Question:

What causes day and night?

A. Materials:

Labels to pin on (sun, earth), flashlight, globe, filmstrip projector, Trippensee Planetarium with flood light.

Procedure:

Pin the label sun on one child and label another child earth. Be sure the child who represents the earth understands rotation before you begin. Give the "sun" a flashlight. Darken the room.

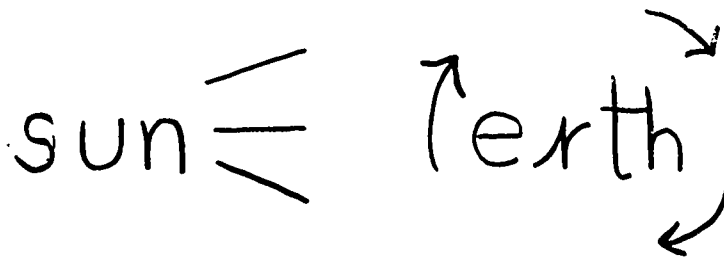

Procedure: (cont'd)

Have the class discover that the sun is only shining on one side of the earth at a time.

Now use a globe and the filmstrip projector as the source of light. Mark the globe with a wad of clay to show where the children live. Have the children turn the globe to differentiate between night and day. The side facing the sun is brightly lighted. This side has daylight. The other side is having nighttime. When will it have daytime?

Now use the Trippensee Planetarium with the floodlight as the sun. Review the rotation to differentiate night and day. Now point out that it takes twenty-four hours or one day (combination of daytime and nighttime) for a complete rotation. This rotation never stops. An example of this would be Sunday for first rotation, Monday, etc.

8. Leading Question:

Where is the sun at different times during the day?

Materials:

Chart paper, shadow stick, chalk

Note to teacher:

Caution the children that we never look directly at the sun.

Procedure:

Chart the position of the sun during the day with a shadow stick on the playground.

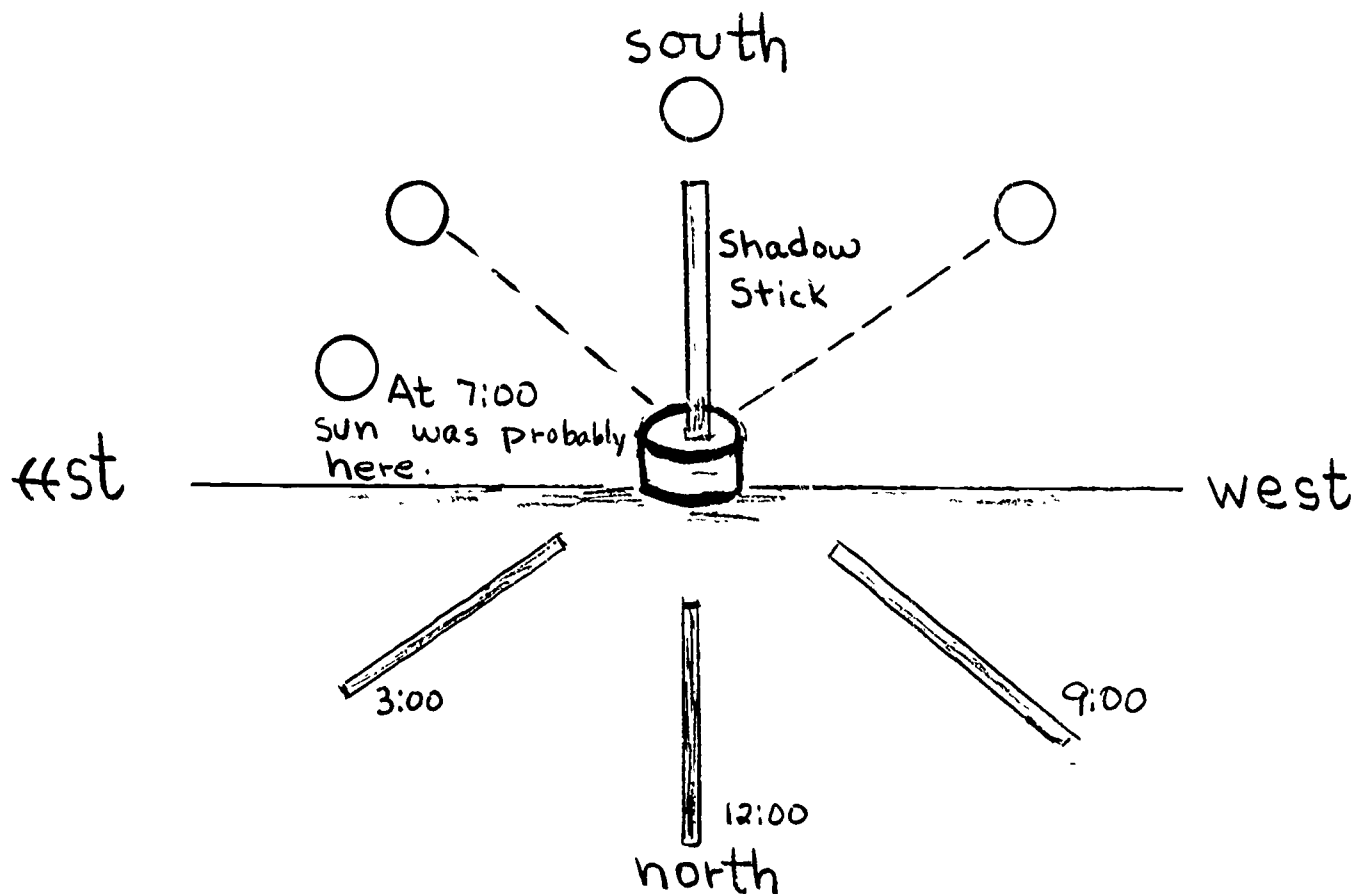

Place a rod or stick in a pot of sand. Color the shadow with chalk at various times during the day and label time when activity was done. Before dismissal discuss where the sun must have been for each shadow. Then draw the sun at those positions. If the sun was in this position at this time (use specific

Procedure: (cont'd.)

examples) where do you think the sun was before we came to school?

In the classroom, follow up with an illustration as shown below. We learned that the earth's rotation determines day and night. The sun appears to be moving but it is the earth which moves.

Note to teacher:

The angles indicated on the illustration are approximations. They will change with the seasons.

When we move in a car or bus, why do we think that the houses and trees are moving?

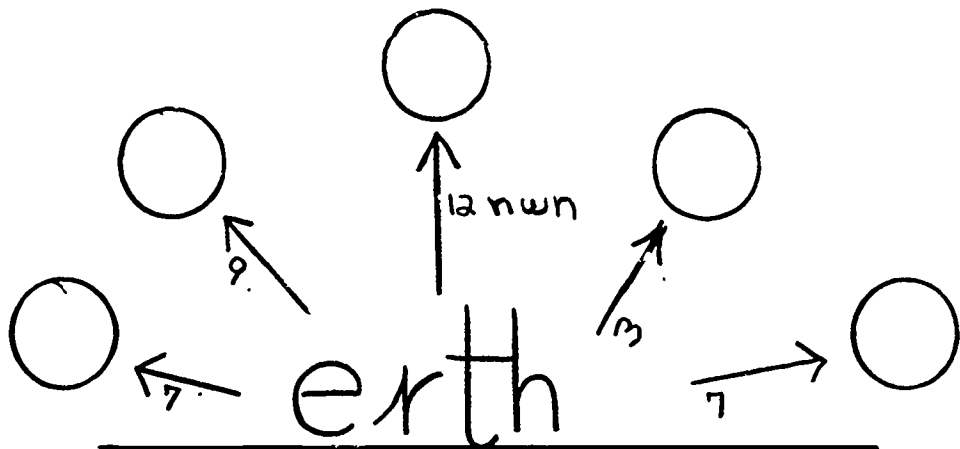

9. Leading Question:

Why does the sun rise in the east and set in the west?

Materials:

Clay, Trippensee Planetarium with floodlight

Procedure:

Place the wad of clay on that side of the earth which is dark. This will be the observer. Rotate the earth until the sun (floodlight) appears in the east. This is sunrise. Stop and give each child an opportunity to sight this from the position of the observer. (wad of clay) Continue this motion until the sun seems to disappear to the observer. This is the sunset.

If some children need clarification on this concept have them rotate from east to west and sight the sun.

Note to teacher:

Keep the planetarium on the science table until all the children have an opportunity to view the sun from different positions.

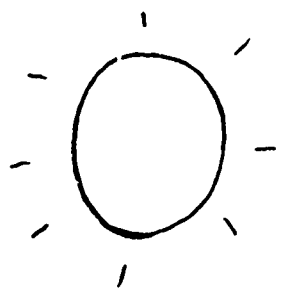

east

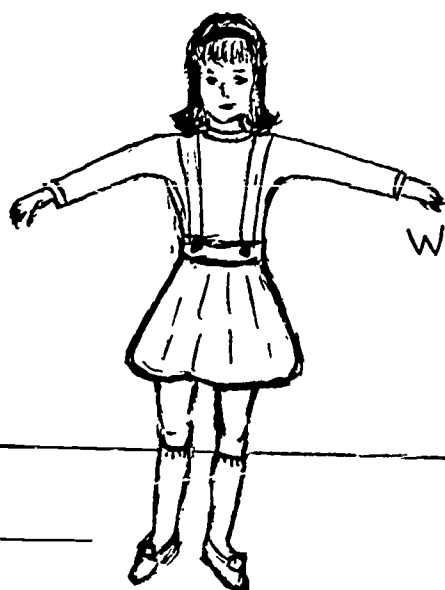

west

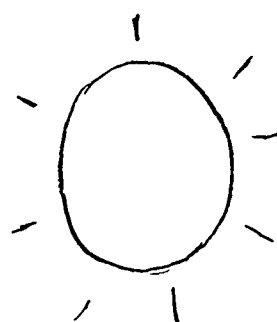

west

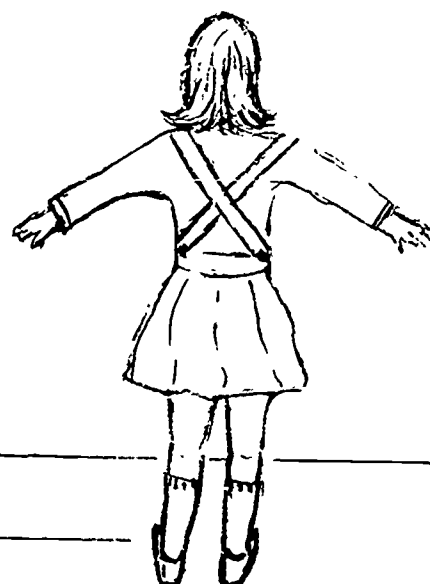

east

10. Leading Question:

Where is the sun during the night?

Materials:

Masking tape, filmstrip projector, globe

Procedure:

Mark your location on the earth. Place globe so that half the earth is lighted by the sun. Ask a child to show you where the sun is during the night. He should rotate the globe so that the tape is located on the dark side.

Note to teacher:

Stress that the sun itself does not move but the apparent motion of the sun is due to the rotation of the earth.

11. Leading Question:

What is a revolution?

Procedure:

Divide the children in pairs. Ask one child to represent a fixed object and have the other walk around the child (fixed object) in a circular path.

Note to teacher:

At this time you may tell them this circular path is called an orbit.

12. Leading Question:

How does the earth revolve around the sun?

Materials:

Labels: sun, earth

Procedure

Two children will participate in this activity. Use labels, one child will be the sun and the other the earth. Now the earth revolves around the sun. "Show me how." The child should walk around the sun in a

12. Procedure: (cont'd.)

circular path. "Who remembers what this path is called?" Be sure the child walks around the "sun" and does not face the "sun" as he moves. It takes the earth one year to complete this orbit.

What other way does the earth move? (review rotation) This time the child will rotate and revolve around the sun.

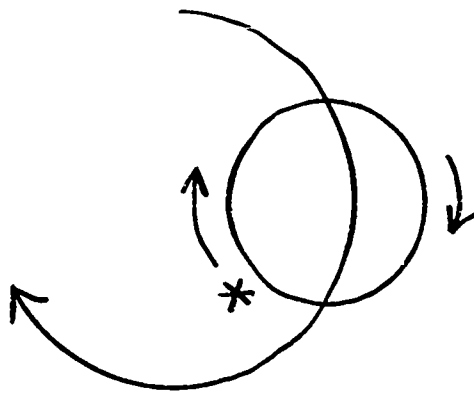

13. Leading Question:

What is a year?

Materials:

Trippensee Planetarium

Procedure:

Orient the planetarium so that the compass is pointing north. Move the arm slowly to review the concept of rotation. Notice that the earth moves forward around the sun as it rotates. Continue to move the arm until the earth is back in its original position (wherever you started). What kind of motion does the earth make around the sun? It seems to be constantly going around it in circles. Move the earth through its orbit again and point out that this takes 365 days for a complete trip. We call this period of time one year.

14. Leading Question:

Why does the moon shine?

Materials:

Filmstrip projector, ball, mirror, masking tape

Procedure:

With masking tape, attach a mirror to a ball. Label this ball as the moon. The moon has no light of its own. Where will the light come from? Turn the filmstrip projector on so that the light is reflected back to us on earth.

Have children find other things that will reflect light. (bicycle reflector is a good example)



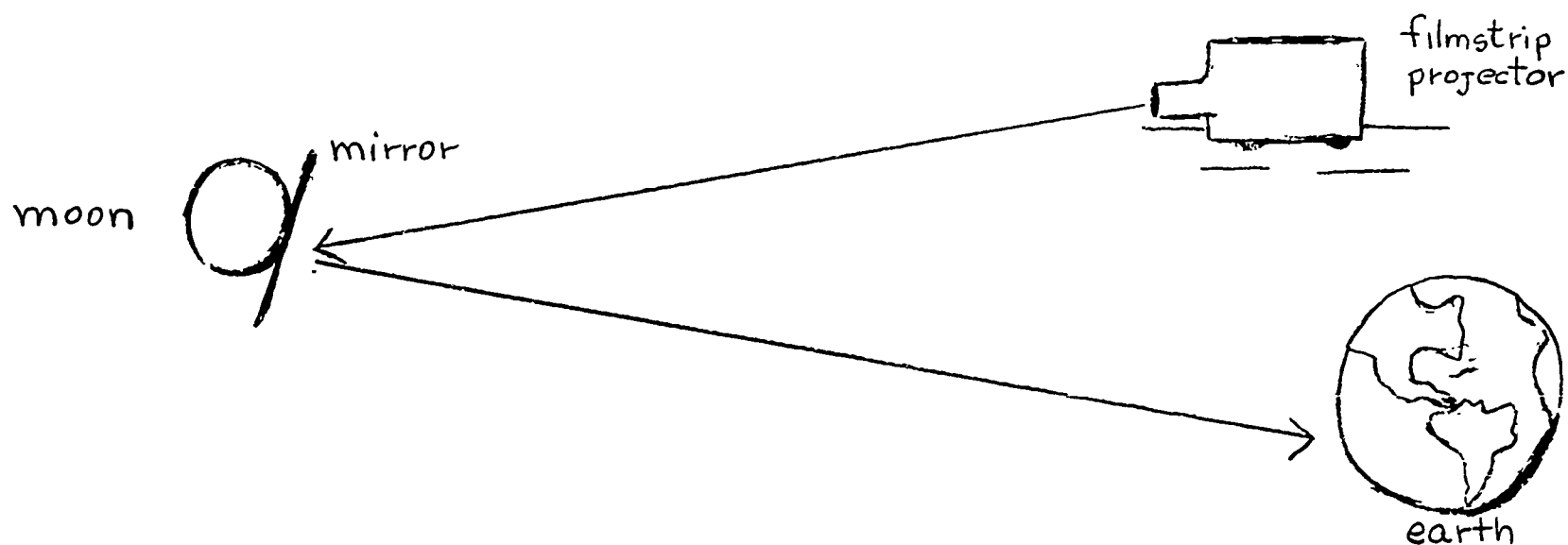

15. Leading Question:

How does the moon travel around the earth?

Materials:

Globe, wagon, labels (moon, earth)

Procedure:

Make a large circle on the floor of the classroom. Place the globe in the center of the circle and label. The globe is the earth. Now have someone (label-moon) sit in the wagon sideways (facing away from the globe) as another child pulls the wagon around the circle. The moon has two different movements around the earth. Who can identify them?

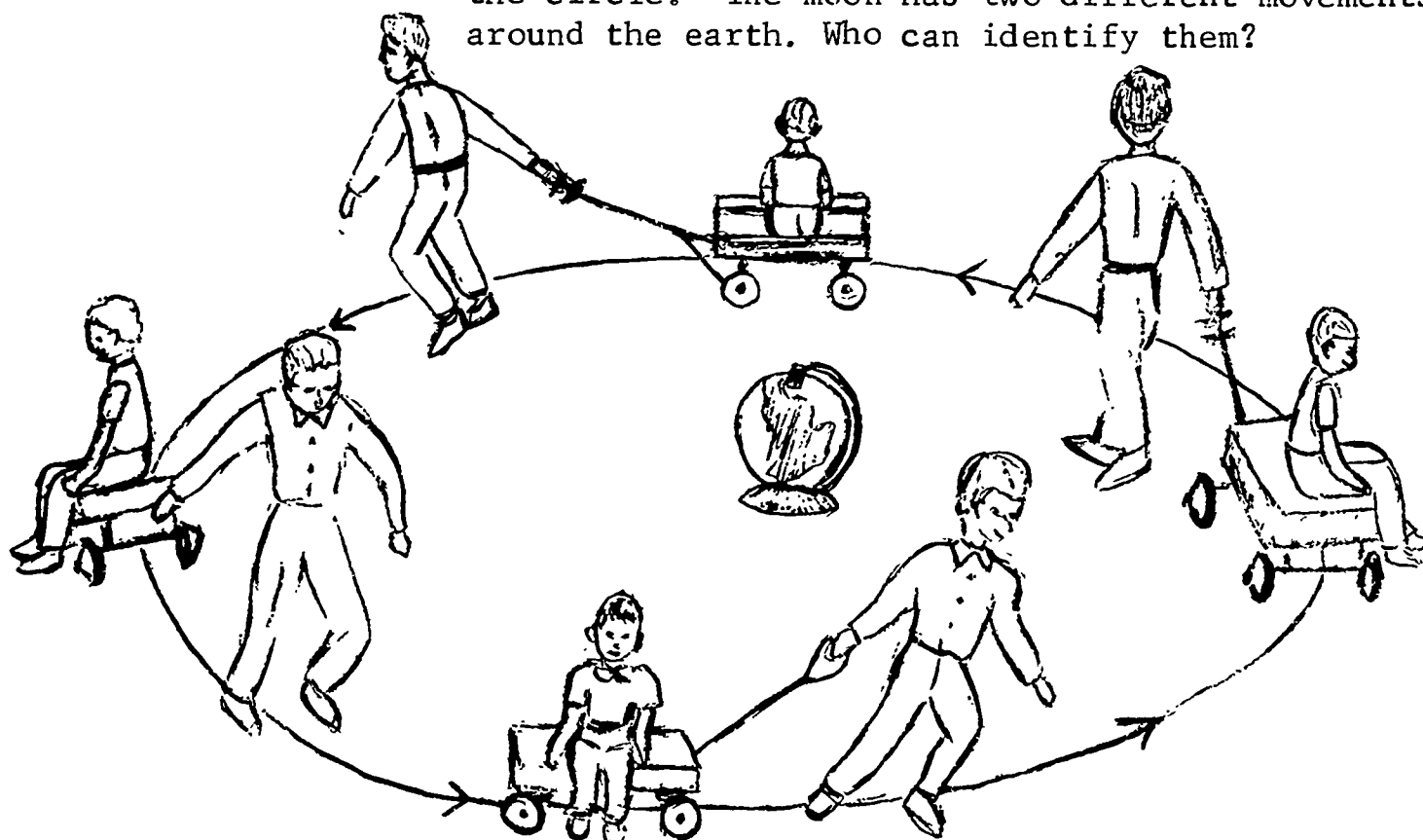

How many times did the moon rotate? How many times did the moon revolve around the earth?

If children have difficulty with the rotation of the moon, ask them to rotate. How many walls did they see in the classroom? Now ride once again around the earth in the wagon, how many walls did you see?

Note to teacher:

From previous learnings about the earth's rotation around the sun, the children should recognize revolution and rotation.



16. Leading Question: Do we see the moon every night?  
Materials: Trippensee Planetarium with floodlight, sheet of white paper  
Procedure: Place a wad of clay on earth in approximately the same location in which we live. Everytime we experience nighttime (that is: the wad of clay is on the dark side of earth) decide whether or not we would see the moon. Stop during one of the nights when the moon is visible and hold a piece of white paper close to the earth (clouds). Can we see the moon if its cloudy?

17. Leading Question: How does the moon change in its appearance?  
Materials: Filmstrip projector, white volley ball  
Procedure: Place the filmstrip projector (sun) on a table in a dark room. Stand approximately 20 ft. from the sun. Hold the ball (moon) a little higher than your head (earth) in line between you and the light. When the ball is exactly between you and the light, you will not be able to see any part of the half on which the light is shining. Now make a quarter turn from right to left keeping the ball in front of you and above your head. Observe the shape of the lighted area. Continue around the circle.

18. Leading Question: Does the moon always look the same to us?  
Materials: Paper, paste, calendar  
Procedure: Cut different shapes of moon out of white paper. On a calendar, paste that phase of the moon as the children report seeing it through the month. Soon children will see the relation between dates and the phase of the moon.

19. Leading Question: How does distance affect the size of objects?  
Materials: 3 balls of same size, 1 large ball  
Procedure: Go out on the playground. Have all the children stand together at one end of the playground and tell them to close their eyes. Now pick 3 children and hand each the same size ball.

X

X

X

( clas

19. Procedure: (cont'd.)

Next hand a large ball to one child and a medium size ball to another. Have the child with larger ball farther away so that both balls will look the same size to the class.



Note to teacher:

This game should be played in many ways until most of the children reach the conclusion that it is the distance which affects the size.

For those children who cannot understand this theory start at that spot on the playground where the children are standing and have them observe the size as one child walks away with a ball. Do this activity in various ways.

20. Leading Question:

Which is largest, the earth, the moon, or the sun?

Materials:

Beach ball, volley ball, basketball, softball, ping-pong ball, tennis ball, marble, pea, bead or B-B pellet, trundle wheel or 72ft. string (Central Science Materials library) and chalk

Procedure:

Arrange all the round objects on a table. Ask the class which two objects could represent the earth and the moon. If no one can make the right comparison show them.

Which object could represent the sun? If no one comes to the conclusion that none of the objects are large enough, tell them. Go out on the playground. Using the trundle wheel mark off a 36 feet or 12 yard radius.

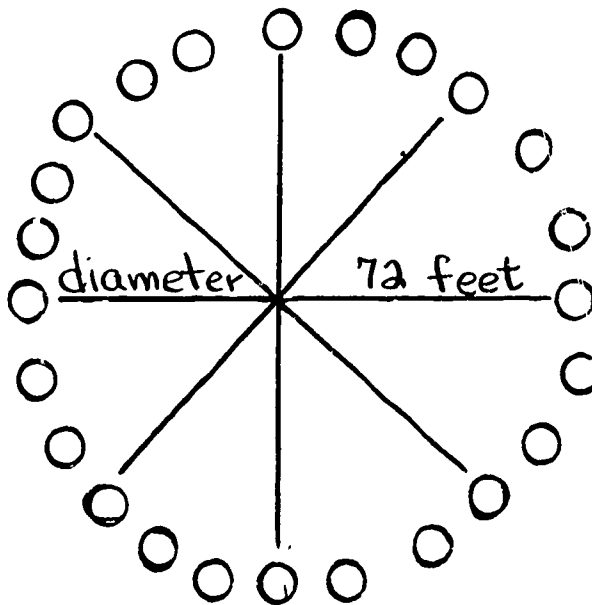

20. Procedure: (cont'd.)

Starting at the center, continue marking radii. Place the children around the circle. Now we have the scaled size of the sun with a diameter of 72 feet. Compare this to the size of the earth and the moon by placing two circles, one with a diameter of two inches, the other with a diameter of eight inches, in the center of the circle.

Note to teacher:

	diameter	ratio
moon	2160 miles	2 in.
earth	7927 miles	8 in.
sun	864,000 miles	72 ft.

21. Leading Question:

What do we get from the sun?

A. Procedure:

On a hot afternoon go outside and feel the surface of the black top, a sliding board, grass, a see-saw, a side of the building. How do they feel? What causes this? Why are some things hotter than others? Then feel objects that are in the shade. Talk about the differences in how the surfaces in the sun and the shade feel.

B. Materials:

Two jars of water

Procedure:

Now take two jars of cold water and place one in the shade and one in very strong sunlight. After a few hours feel the water in both jars.

C. Materials:

Two tin cans (paint one black)

Procedure:

Put both cans in the strong sunlight for a few hours. What happens? Why?

D. Materials:

Two shallow dishes, measuring stick, ice cubes, black material

Procedure:

Place a strip of black material in a glass dish and place an ice cube on it. Set up another dish the same way. Place one dish in the shade and the other in strong sunlight. Every 5 minutes measure the two ice cubes.

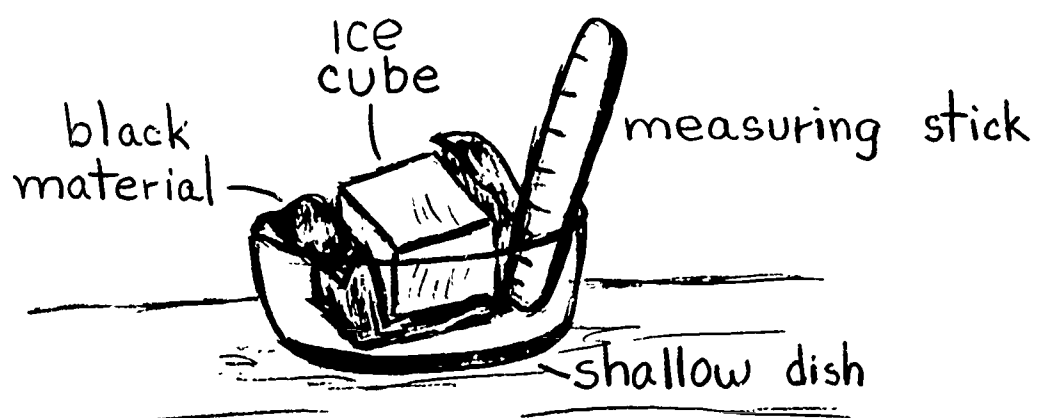

21. E. Procedure:

Have a child stand directly in front of a radiator. How does it feel? Now move away. Does it still feel the same way?

F. Procedure:

Make a temperature chart. Use an indoor-outdoor thermometer. Cut strips of red construction paper so that the children can measure the length of mercury on thermometer and then paste the red strip on the chart. Record the time when the temperature was taken and weather conditions. (Sunshine, clouds, rain, snow, wind). Construct a chart everyday for a week.

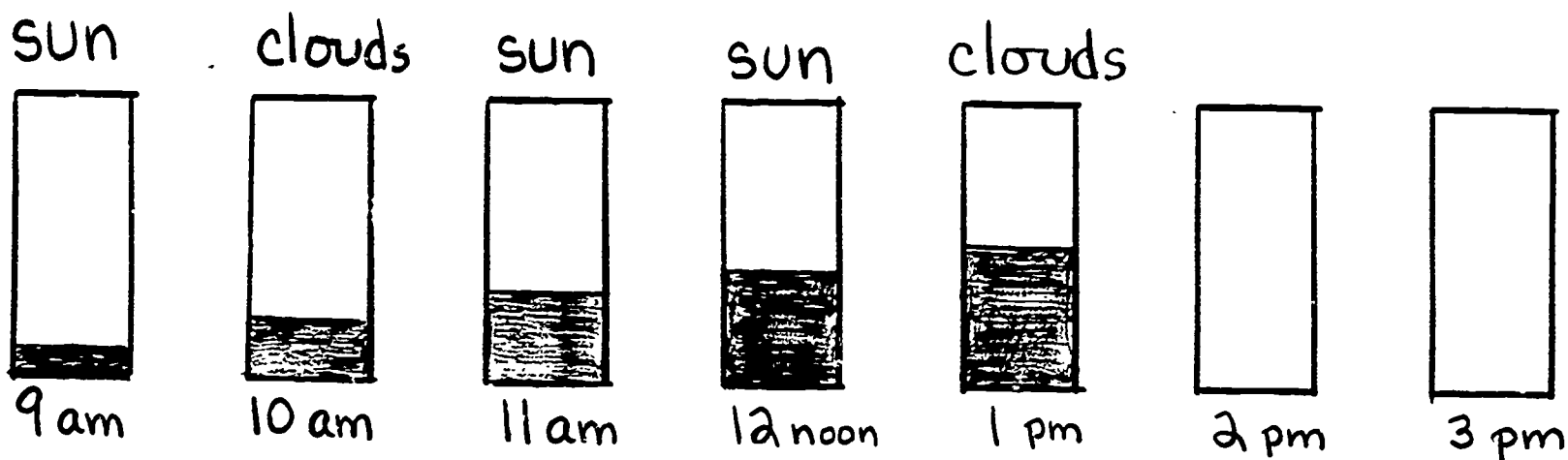

mundæ

22. Leading Question:

Where is the sun on a cloudy day?

Materials:

Trippensee Planetarium with floodlight, sheet of white paper.

Procedure:

If the earth faces the sun during the daytime, why can't we always see the sun? Place a sheet of white paper (clouds) between sun and earth. Can we see the sun? Do the clouds block off all the light? Be sure children see that enough light shines through the paper to give us daylight even though we do not see the sun.

23. Leading Question:

What is the sun made of?

Materials:

Eight glasses, jello, sand, cracker, clay, milk, water, liquid soap, balloon, Bunsen burner.

Procedure:

Set up glasses on a table. All the glasses but one will contain either a liquid or solid. Include the Bunsen burner and balloon. Ask the children which containers hold something which is like that in another one. Arrange those containers side by side in categories of solids, liquids, and gases. Turn it so that they hear the gas escaping. (Turn on and off immediately).

The sun is made of very hot gases. A discussion of this could follow now that the children have identified gases. Compare the surface of the sun to that of the earth and the moon.

24. Leading Question: How would the sun feel if we were closer to it?
- Materials: Electric hot plate
- Procedure: Darken the room. Turn on the hot plate. Hold the child's hand so that he can feel the heat produced. Watch the coils begin to glow. Feel how the surrounding air is effected by the glowing hot plate. Explain that when an object is hot enough it will glow or burn. Could we live on the sun?
- Note to Teacher: Caution - Teacher should be aware of the dangers which could result if not closely supervised.
25. Leading Question: What do star patterns look like?
- A. Materials: Filmstrip projector, 35 mm slides (exposed)
- Procedure: Use exposed 35 mm slides. With a needle prick out constellations on the exposed slide. Project these slides on screen. It is not necessary to identify the constellations.
- B. Materials: Oatmeal boxes, light bulb
- Procedure: Make star boxes with oatmeal boxes. Make holes in bottom of the box to represent a constellation. Place the boxes over a light bulb.
- Note to teacher: When making star patterns use a dot or circle to indicate a star, not an \*.
26. Leading Question: Do the constellations look the same from anywhere in space?
- Materials: Seven ping-pong balls, thread
- Procedure: Hang some ping-pong balls on threads about the room. Arrange them so that they look like the Big Dipper when seen from one spot but like something else when viewed from another area. The constellations are not in one flat plane. If we were traveling in space we would not see the Big Dipper as it appears on earth.
27. Leading Question: Why can't we see the stars during the day?
- A. Materials: White chalk, white paper, black paper
- Procedure: Print the word stars on white paper with the chalk. Can you see the word? Print the word stars on dark paper. Be sure the children associate daylight with white paper and nighttime with the black paper.



27. B. Materials:

Flashlight

Procedure:

Pretend the flashlight is a star. Can you see it during the day? Can you see it at nighttime? Which would be a better place to observe the stars, in the city or in the country? Why?



## Space Science

### Men and Machines in Space

Grade 2

#### UNDERSTANDINGS TO BE DISCOVERED

#### RELATED ACTIVITIES

Space is dark.	1, 22
There is no air in space.	
Conditions in space are not favorable for man to live unless he takes certain precautions against the known hazards of radiation, weightlessness, extreme temperatures, and meteoroids.	2, 3, 4, 5, 6, 7, 10, 11, 23, 25
Spacesuits and spacecraft are needed to protect man in space.	7, 9, 10, 11
In order to travel in space, man needs a supply of oxygen, food, water, and equipment to maintain normal temperature and pressure.	7, 8, 10, 11, 24, 25
Space stations are necessary to aid in explorations of outer space.	18, 29
For every action there is an equal and opposite reaction.	12, 13, 26
A rocket must carry its own supply of fuel and oxygen.	13, 27
The burning of the fuel and oxygen give off gases which make the rocket move.	13, 27
Most rockets have several stages which fire one after another, each stage dropping off when the fuel in it is burned.	13, 14, 27
When a rocket leaves the ground it moves straight up.	13, 27
The last stage of the rocket places the spacecraft in orbit.	13, 27
Gravity is force which pulls all bodies toward the center of the earth.	12, 13, 16, 26
Rockets must travel at great speeds to overcome the force of the earth's gravity.	12, 13, 15, 16, 26
A satellite is a small object which revolves around a larger object.	19, 30
There are two kinds of satellites: natural and man-made.	19, 30
The moon is earth's only natural satellite.	19, 30
We can make satellites (spacecraft) and send them out into space with rockets.	13, 19, 27, 30

UNDERSTANDINGS TO BE DISCOVERED (cont'd.)

RELATED ACTIVITIES

The speed of the rocket determines whether a spacecraft will orbit our planet or continue in its travel away from the earth.	13, 15, 27
Objects are weightless in space because they are in free fall. (A misconception is that the absence of gravity is the cause of weightlessness,)	6, 7, 23
To orbit the earth, a satellite must keep falling around the earth.	20
A satellite obeys Newton's Law that a body in motion tends to remain in motion.	20
Satellites are being used for communications, weather research, military purposes, and other space probes.	19, 30
The landing speed of spacecraft can be controlled by retro-rockets, wings, drag brakes, parachutes, and flaps.	17, 28
Thousands of people must work together in order to accomplish a safe, successful spaceflight.	
As man learns more about his universe, he learns how to improve his life on earth.	19, 30
As a result of space exploration many new job opportunities are and will be available.	

ACTIVITIES

1. Leading Question: Why is space dark?
  - A. Materials: A large picture of our universe
  - Procedure: Children can identify various objects in space which they see on the picture. Start a discussion with children about what they believe space is.
  - B. Materials: A dark room, a strong beam of light
  - Procedure: In a darkened classroom have children discover that they cannot see the beam of light as it travels through the air. The beam of light can only be seen when it reaches its destination. Show that one cannot see light radiation until it hits an object.
  - Note to Teacher: Have the children reach the conclusion that since space is almost empty, it is dark.
  
2. Leading Question: Why is radiation dangerous to spacemen?
  - Procedure: Most children have had sunburns during the summer. This topic can serve as an introduction to radiation. Have children compare the effects of radiation of man on earth with man in outer space.
  
3. Leading Question: What are some kinds of radiation?
  - Materials: Hot Plate
  - Procedure: Turn on a hot plate so that children can see the coils. They can feel the heat it gives off before they can see the light.
  - Note to Teacher: Radiation is in the form of heat and light from the sun and other stars.
  
4. Leading Question: Is the intensity of radiation the same in various locations?
  - Materials: Thermometer
  - Procedure: Let children put a thermometer in the sunny part of a classroom and another in a shady part of the room. Have the children read the thermometers and reach the conclusion that the sun gives off radiation, but not every place receives the same amount at the same time.

5. **Leading Question:** How are spacemen protected from harmful radiation?
- Note to Teacher:** The atmosphere acts as a shield to protect living things from the dangers of radiation. In space, there is no atmosphere to protect the astronauts.
- A. Materials:** Black frying pan, piece of aluminum foil, butter
- Procedure:** Heat a piece of aluminum foil and a black frying pan. Place a piece of butter in each. The butter melts and sputters in the frying pan but is hardly affected in the aluminum foil.
- Note to Teacher:** Have children compare the frying pan with black clothing which absorbs a lot of radiation. Compare the aluminum foil with the highly reflective astronaut's space suit (most of the radiation which hits it bounces off).
- B. Materials:** Two milk cartons, white and black paint
- Procedure:** Let children discover that color as well as materials is an important factor in the amount of heat that is absorbed by a spaceman's suit. Paint one carton black, the other white. Place them in strong sunlight or close to a bright light bulb. Put thermometers inside both containers. After five minutes read the temperatures in both cartons.
6. **Leading Question:** What is weightlessness?
- A. Materials:** Spring scale, small object
- Procedure:** Have a child hold a spring scale with a small object attached to it. Measure the weight of the object. Next measure the weight if both the spring scale and object are dropped.
- Note to Teacher:** Since both the object and spring scale are falling at the same rate of speed, the spring scale would not show any weight.
- B. Materials:** Books
- Procedure:** Have each child in the classroom hold a book in one hand. Note how heavy the book feels. Next quickly drop your hand with the book on top. Does the book seem to weigh the same while it is falling? What has happened?
- Have children read to discover how weightlessness affects earth satellites and spacecraft in orbit. Discuss the results of their research.

6. Procedure (cont'd.) Have a group of children make a list of places where "weightlessness" can be felt. This list can be charted for a bulletin board. (Example, weightlessness can be felt for a short time when you dive off a diving board).
7. Leading Question: How can a spacecraft be protected in space?
- A. Materials: Part of a puncture-proof tire
- Procedure: Ask children to bring in advertisements for puncture-proof tires. Have a cut piece (cross-section) of a tire and let a garageman explain the purpose of the double tube for blow out protection. Let the children compare the tire with the double walls of the spacecraft.
- Note to Teacher: Demonstrate what it would be like if the pressurized spacecraft was punctured by a meteor. A spacecraft has double walls for protection against meteroids.
- B. Materials: 4 feet wax paper, rock
- Procedure: Tear off two sheets of wax paper (2 feet) and have two children hold the corners tightly. Take two more sheets of wax paper and place them two to three inches below the first two sheets. Find a rock that will break through the paper when dropped on it. Now have a child drop the rock on the paper. What happened? Did the rock penetrate the first layer of wax paper? The second? What does this tell us about the double wall structure of the spacecraft?
8. Leading Question: How can food be provided in outer space?
- A. Procedure: Discuss why the food and liquids must be packaged in a special way (packets and tubes).
- Note to Teacher: Have the children recall the idea of no gravity in space.
- B. Materials: Tube of icing or food coloring
- Procedure: To illustrate the ease with which food in a tube can be eaten, have children demonstrate for the class. Next squeeze out three inches of icing. What happens? Discuss what would happen to it in space.
9. Leading Question: How do space suits protect man in space?
- A. Materials: Pictures, drawings, models
- Procedure: Have class look at pictures of astronauts and discuss



the purposes of the spacesuit and helmet. Ask the children to bring in pictures and make drawings of these special suits. Let a child bring in a model of a spaceman and explain the parts of the spacesuit.

B. Materials: Blown-up balloon

Procedure: Ask what would happen to the astronaut if there was a leak in his suit. Perhaps a blown-up balloon allowed to deflate gradually will suggest the answer to the children. Let the children investigate to find the answer.

10. Leading Question: How will spacemen get their supply of oxygen?

Note to Teacher: Astronauts need oxygen all the time they are in space. A great deal of oxygen can be carried in pressure cans or in liquid form.

Materials: Pressure can, inner-tube

Procedure: You can show pupils how much oxygen can fill a small pressure can. Get a pressure can used for repairing flat tires and connect the nozzle to the inner tube. Inflate the inner tube. Investigate the use of oxygen tanks and oxygen masks and how they work. Have children find out how scientists are planning to use green plants in spacecraft to supply oxygen and to provide food.

11. Leading Question: How are temperatures controlled in a spacecraft?

Note to Teacher: Demonstrate how the temperature of a spacecraft can be controlled by controlling the color of paint.

Materials: Hot water, paint, cans

Procedure: Pour some very hot water into two cans, one painted white and the other painted black. Have children measure the temperature change every five minutes.

12. Leading Question: What are the "G" forces? How do they affect space flight?

Note to Teacher: The force which acts on the body is called the "G" force. G is equal to the force of gravity acting upon an object at the surface of the earth.

A. Procedure: Ask the children to describe how they feel when a car stops or starts suddenly. They should agree that they get a sinking sensation in the stomach or that they are pressed back in the opposite direction to that which they are going.

Compare this to a spacecraft rising from earth with the astronaut being thrust downward in the same manner.

B. Materials: Pyrex bottle, wire, stopper, water, burner

Procedure: Suspend a pyrex bottle in a horizontal position with a few pieces of bare wire. Put a small amount of water in the bottle and stopper the bottle. Heat the bottle carefully with a burner. What happens to the stopper? What does the bottle do?

Note to Teacher: The pressure of the steam will make the stopper pop out. When the stopper is fired in one direction the bottle will start swinging in the opposite direction. Compare the bottle moving in one direction and the water and cork in the opposite direction to the spacecraft moving in one direction and the astronaut thrust in the other direction.

13. Leading Question: What is a rocket? How does it work?

A. Procedure: Introduce principles of a rocket by showing a filmstrip or movie. (Can be ordered from NASA or local film library).

B. Materials: Balloon

Procedure: Blow air into a round balloon. Close the open end of the balloon with your fingers. Place the balloon on the edge of a table. Remove your fingers. The balloon moves off the table through the air in a zig-zag path. What made the balloon move? In what direction did the balloon move? In what direction did the air from the balloon go?

Note to Teacher: The jet of air makes the balloon move. The jet of air moves out of the end of the balloon. The balloon moves in one direction.

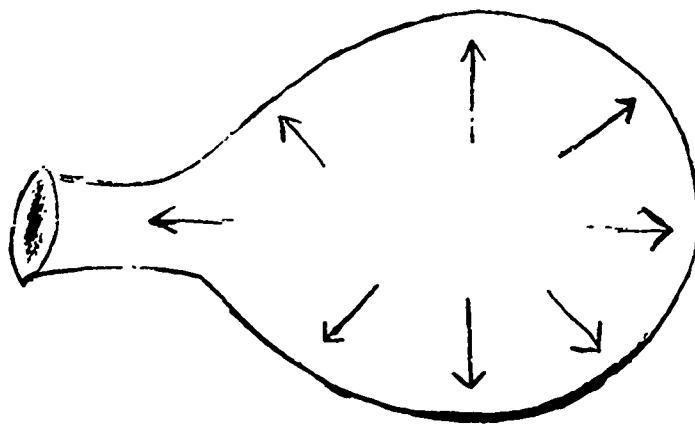

14. **Leading Question:** Why do rockets have several firing stages?
- A. **Procedure:** Show film or filmstrip that shows and explains the several stages of a rocket.
- B. **Procedure:** Have children make diagrams for the bulletin board of the rocket's stages. Let the children explain the various stages. Refer to illustrations in science texts and materials from NASA.
- C. **Procedure:** Use model rockets to show several stages involved, or have children build models.
15. **Leading Question:** Why does a spacecraft keep on moving after the rocket has stopped?
- Materials:** Paper
- Procedure:** Make airplanes out of paper. Fly the paper planes outdoors or in the classroom. Allow children to discover that their hand is acting like an engine by pushing the airplane forward just as the rocket pushes the spacecraft forward. Investigate: (1) Why does the paper airplane eventually fall to the ground? (2) Why don't spaceships eventually fall to the ground after the rocket stops going?
16. **Leading Question:** What is gravity? How does gravity affect a space flight?
- Procedure:** Investigate the meaning of gravity. Have them find and perform experiments involving gravity.
- A. **Materials:** Ball, string
- Procedure:** Hold a ball as shown in the diagram below. What makes it hang straight down toward the center of the earth? Make the ball go in a circle. Observe what happens to the ball. Now make the ball go very fast in a circle. Why does the ball keep moving fast? Next let it go slower and slower. What does the earth's gravity do to the ball?
- Note to Teacher:** Compare this demonstration with a spacecraft or a satellite escaping earth's gravity. The force of gravitation holds satellites in their orbits. If it were not for gravitation, the satellites would travel out into space, instead of orbiting around the earth.



17. Leading Question:

How does a spacecraft come back to earth?

A. Procedure:

Bring in pictures of spacecrafts that are in the process of landing.

B. Materials:

Parachute, rocket model

Procedure:

If any children have parachute toys, have them bring them in and demonstrate to the class how a parachute works. Find out what causes the parachute to come out. Be ready to ask if a parachute will work where there is no air.

As children are demonstrating the workings of a parachute the following question can be discussed. Why does the spacecraft come back to earth? (gravity) This activity can be performed to illustrate gravity. Have the children jump up. Ask them why they keep coming down instead of going up.

C. Procedure:

Have children investigate retro-rockets and their purpose in spacecraft. Find out how wings, drag brakes and flaps are used in the landing of a spacecraft.

D. Materials:

Boards or children's hands

Procedure:

Demonstrate friction by having the children rub their hands or some boards together until they are warm.

Note to Teacher:

Help pupils reach the conclusion that the more the spacecraft rubs against the air, the hotter it gets from friction.

E. Materials:

Old dishes, container, water

Procedure:

Find out if it is better to land a spacecraft on water or on the ground. Get some old dishes. Drop one dish into a container of water so that it hits on the flat surface and not the side. Drop the same dish from the same height onto the classroom floor. What does this tell us about a spacecraft's landing.

18. Leading Question:

How can space stations help man? How can a space station be built?

A. Procedure:

Dramatize ways of living and working at a space station.

B. Procedure:

The following drawing will show how a space station can be constructed. The station can be suspended from the ceiling.

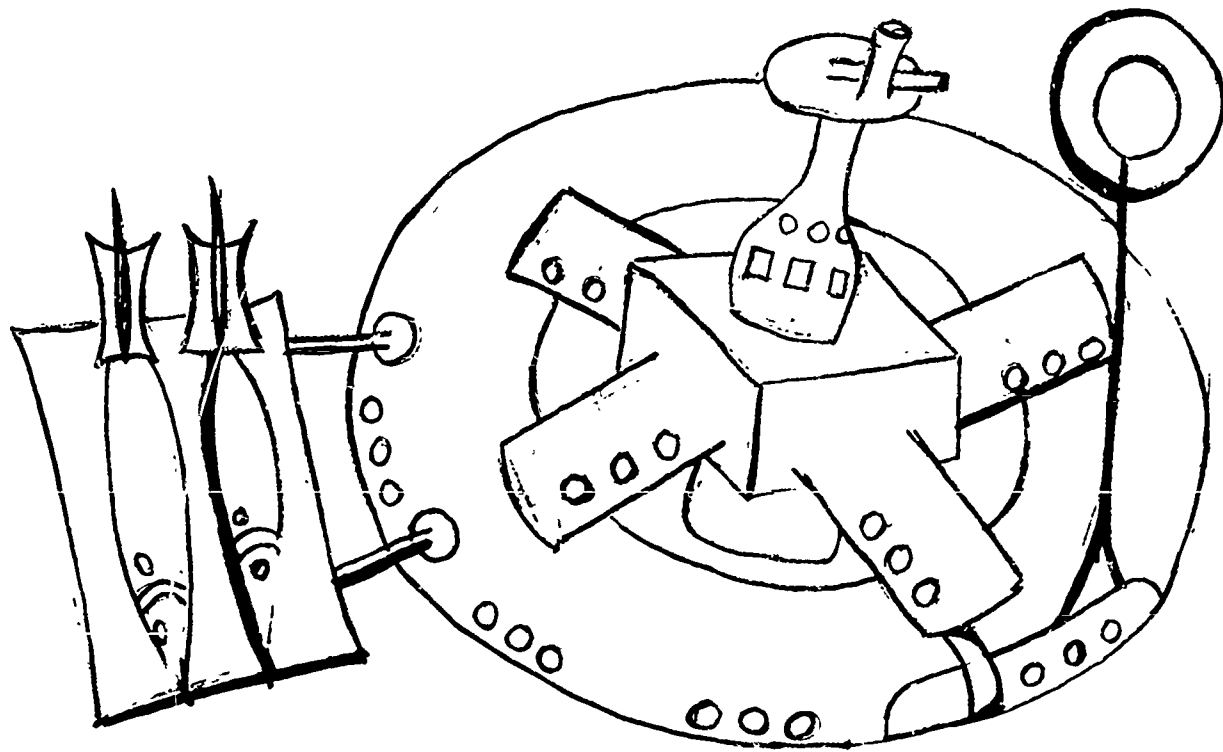

19. Leading Question:

What are satellites?

A. Procedure:

Let the children define satellites and give some examples of natural and man-made satellites.

B. Procedure:

Explain and how how man-made satellites are sent into space and how they remain in orbit.

C. Procedure:

Compare the movement of a natural satellite (moon) with a man-made satellite.

20. Leading Question:

When does a satellite move slowly? When does a satellite move faster?

Materials:

Small ball, rubber string

Procedure.

Hold the end of the rubber string in one hand and whirl it around your head. Try to whirl the ball in a circular orbit? Can this be done?

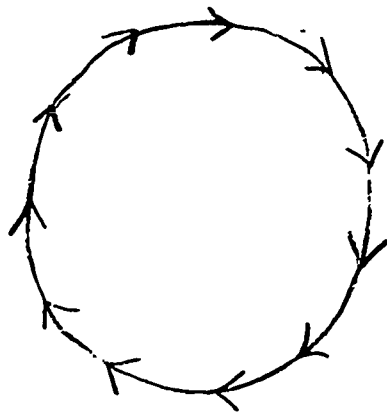



Now whirl the ball much harder in one direction than in the other. What shape orbit do you get?

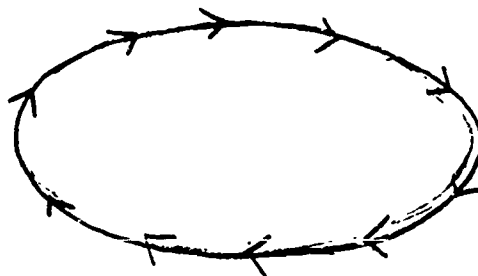

Watch the ball carefully. In what part of the orbit is it traveling slowest? In what part of the orbit is it traveling fastest?

Note to Teacher: Satellites travel in oval (elliptical) orbits.

21. Possible Culminating Activity for Probing into Space

Let children plan a space trip. One group might design the rocket and spacecraft. Another group could make a list of things they would take along. One group could be the scientists who would try to figure out what space is like and what problems the space traveler might have. Some children could design and make the spacesuits. Another group could figure out how the spaceship would get back to earth. Children could draw a large mural showing the entire spaceflight from take-off to return.

Another interesting activity might be a "home-made" movie of a space flight.

A visitor from a missile or a space installation might be available to speak to your class.

ACTIVITIES TO ASSIGN FOR HOMEWORK OR INDIVIDUAL RESEARCH

22. Leading Question: Why is space dark?  
Materials: Science texts, library books, children's encyclopedias
23. Leading Question: What is weightlessness?  
Materials: Science textbooks, NASA booklets
24. Leading Question: How can food be provided in outer space?  
A. Procedure: Have children make up menus for space flights ranging from a few hours to a few days. The problem will be to provide food energy, taste, ease of handling, storage, and spoilage.  
B. Procedure: Let children look for and bring in pictures of food packaged for space travel.  
C. Procedure: Allow children to try to package food that they could take along on a space flight.
25. Leading Question: How are temperatures controlled in a spacecraft?  
Materials: Science textbooks, NASA material, library books.  
Procedure: Have children find out other ways the temperature is controlled in various spacecrafts. Let them report their finding to the class.
26. Leading Question: What are the "G" forces? How do they affect space flight?  
Procedure: Have the children read to discover why it is better for the astronaut to be lying down during lift-off.
27. Leading Question: What is a rocket? How does it work?  
A. Procedure: Ask pupils to search through newspapers and magazines for pictures of spacecraft for the classroom bulletin board. You can get pictures from NASA too.  
B. Procedure: Have the children make models of rockets and spacecrafts. Some children may have toy rockets which they can bring from home to demonstrate the "workings" of the rocket.
28. Leading Question: How does a spacecraft come back to earth?  
A. Procedure: Find out why the spacecraft gets hot when it hits the air. Tell how and why the astronaut is

protected during re-entry.

**B. Procedure:** Investigate how the shape of the spacecraft and the materials used in the cone (blunt end) protect the spacecraft and the astronauts.

**C. Procedure:** Investigate how the spacecraft is found once it lands in the water.

**Note to Teacher:** Make use of films, filmstrips, and pictures showing the landing and recovery of the spacecraft.

**29. Leading Question:** How can space stations help man? How can a space station be built?

**A. Procedure:** Let children read about space stations in science books, library books, recent science digests, and newspapers articles.

**B. Procedure:** Allow some children to construct a space station. Others can show cross-sections of the space station on a mural.

**30. Leading Question:** What are satellites?

**A. Procedure:** Have children find pictures of man-made satellites such as Telstar, Tiros VI, Pioneer V.

**B. Procedure:** List on a chart the uses for satellites and space probes. (For example, study of outer space, weather research, communications, etc.)

Movements of the Earth and MoonGrade 3SeasonsUNDERSTANDINGS TO BE DISCOVEREDRELATED ACTIVITIES

The imaginary line the earth spins around is called its axis.	1,3,4
The earth is tilted as it rotates on its axis.	1,3
The earth's axis points toward Polaris or the North Star.	3
Seasons are the result of the tilt of the earth's axis as it revolves around the sun.	1,3,6
The amount of energy received by a hemisphere on the earth depends upon the angle at which the sun's rays strike the earth.	1,3,5,6
The sun's rays fall more nearly vertically upon the equator in all seasons of the year than upon other parts of the earth.	1,3,5,6
When the Northern Hemisphere is tilted toward the sun, we have summer because the sun's rays are most direct.	1,3,5,6
When the Northern Hemisphere is tilted away from the sun, we have winter because the sun's rays are least direct.	1,3,5,6
When the Northern Hemisphere is having summer the Southern Hemisphere is having winter.	1,2,3,4,5,6,7,8
The Northern Hemisphere of the earth is closest to the sun in winter.	1,2,3,4,5,6,7,8,
The duration of sunlight is longer in summer than winter.	1,2,3,4,5,6,8
One end of the imaginary axis is the North Pole. The other end is the South Pole.	2,3,5
When you are facing north, east is on your right and west is on your left.	1,3
The earth rotates from west to east causing day and night.	1,3
As the earth turns toward the sun, the sun seems to come up in the east.	1,2,3,5
As the earth turns away from the sun, the sun seems to go down in the west.	1,2,3,5
"Up" is away from the earth, "down" is toward the center of the earth.	15

## SPACE SCIENCE

### Movements of the Earth and Moon

Grade 3

#### Gravity

#### UNDERSTANDINGS TO BE DISCOVERED

#### RELATED ACTIVITIES

Everything in the world is attracted to every other thing by a force called gravity.

9,10,11,12,13,14,15,16

The earth's gravity is a force which pulls all bodies toward the center of the earth.

15,16

Gravity helps to keep the earth and other planets in orbit about the sun.

19

The earth's gravity helps to keep the moon revolving about the earth.

19

All heavenly bodies possess gravitational force which varies according to their size and weight.

19

The moon's gravity causes tides on earth.

26



## SPACE SCIENCE

### Movements of the Earth and Moon

Grade 3

#### ACTIVITIES

1. Leading Question: What causes seasons?  
Materials: Seasons Lab Kit (Central Science Library Center)  
Procedure: Request Seasons Lab Kit from Central Science Library Center. The Lab Kit provides enough materials for 10 groups of children to work on the problems simultaneously.
  
2. Leading Question: Why do the seasons change?  
Materials: Trippensee Planetarium with floodlight, tape measure  
Procedure: After orienting the Trippensee Planetarium toward the north, move the earth through its yearly orbit. Observe closely how the tilt of the earth changes with respect to the sun. Notice how light from the sun strikes the earth differently during the year. What changes in weather might result from more direct rays? From longer periods of sunlight? Does any part of the earth get the same amount of sunlight all year? Measure the distance from earth to sun for various months. Does the distance from the sun correspond to the seasonal changes?
  
3. Leading Question: How does the earth move around the sun?  
Materials: Bright lamp, globe  
Procedure: Place a bright lamp in the center of a dark room. Carry a globe around the lamp, moving from left to right. Keep the North Pole tilted toward the north.  
  
Stop at the places indicated for the four seasons. Notice how the light shines on different parts of the globe.  
  
Each time you stop for a season; answer these questions. What is the season in the northern half of the earth? What is the season in the southern half of the earth? Where is the sun shining day and night? Where is the sun not shining at all? What places on earth do not have four different seasons? Why?

If the earth's axis were not tilted, would there be seasons? Why? On what day of the year do the sun's rays shine most directly on the place where you live?

4. Leading Question:

Why is it cold in winter and warm in summer?

A. Materials:

Piece of string, bright flashlight, piece of chalk, chalkboard

Procedure:

Tie a string around a flashlight. Hold the end of the string on the chalkboard. Hold the flashlight at a set distance from the chalkboard. Shine the flashlight straight at the board. Have someone draw a ring around the spot of light on the board. From the same distance, shine the flashlight on the board at a slant. Have someone draw a ring around the spot of light on the board. Which ring of light is larger? Within which ring was the light brighter? Was the light brighter because the flashlight gave off more light? What happens when the rays of the sun strike the earth at a slant?

B. Materials:

Large beach ball, bright flashlight, piece of chalk.

Procedure:

Let the beach ball represent the earth. The flashlight will be the sun. Make the room as dark as possible. Shine the flashlight directly on the ball. Draw a chalk line around the spot, on the ball, lighted by the flashlight beam. Now slant the flashlight so the beam strikes the ball at an angle. With the chalk, draw a line around the lighted spot. Which spot is larger? How does this help explain why it is warmer in summer and colder in winter?

5. Leading Question:

What determines the amount of heat the earth receives during the seasons of the year?

A. Materials:

2 straight pins, flashlight or filmstrip projector, tennis ball, Trippensee Planetarium with floodlight

Procedure:

Push one pin partway into a tennis ball. Push the other pin into the ball opposite the first pin. These represent the axis of the earth. Draw a line around the ball halfway between the pins. This line will represent the equator. The tennis ball represents the earth. The flashlight represents the sun. Prop the flashlight on the books. Let the light shine on the ball with the axis extending straight up and down. Darken the room. Place the ball so the light spreads out equally above and below the equator. Next, tilt the ball. What happens to the amount of light seen above and below the equator when the ball is

tilted? Which part of the ball gets the most amount of light?

Imagine the part of the ball above the equator to be the Northern Hemisphere and the part below the equator as the Southern Hemisphere. In which season are the sun's rays more direct on the Northern Hemisphere? In which season are the sun's rays less direct in the Northern Hemisphere?

Repeat experiment with Trippensee Planetarium and floodlight.

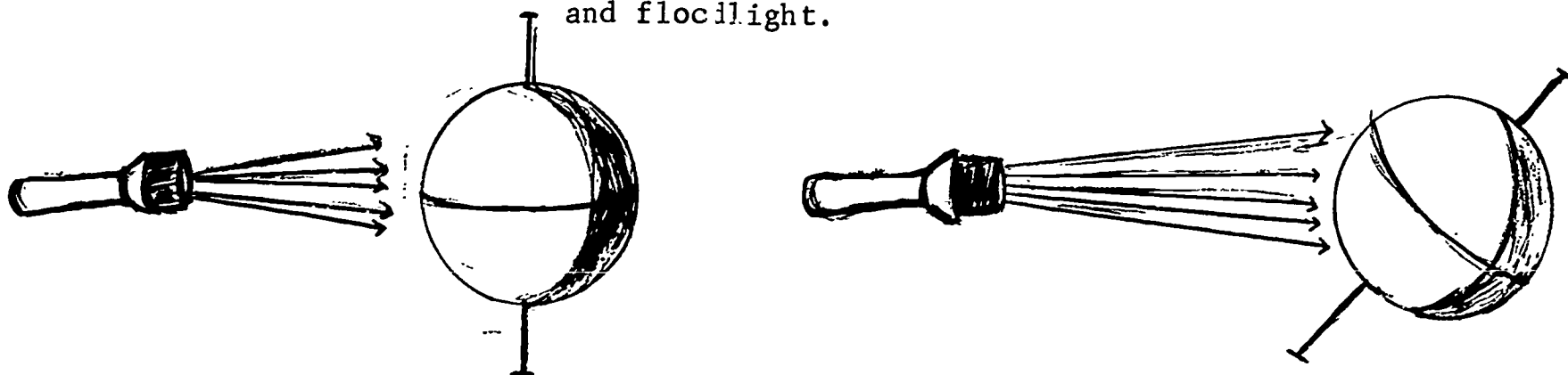

Note to Teacher:

It is the slant of the rays - not the closeness to the sun that determines the amount of heat the earth receives.

B. Materials:

Ball of clay, pencil, bright lamp

(1) Procedure:

Push a pencil through a ball of clay. Mark the top part of the pencil for the North Pole and the bottom of the pencil for the South Pole. Tilt the pencil which represents the axis. Twist the pencil from left to right to show rotation.



(2) Procedure:

Place a bright lamp in the center of a dark room. Walk around the light and turn the tilted axis as you move. Keep the pencil pointed in the direction of the North Pole. Do the rays of light strike all places in the same way? How much of the earth is tilted toward the sun? How much of the earth is tilted away from the sun? Which half gets more energy? Is the same half tilted toward the sun all the

time? During which season do the sun's rays strike the earth more directly?

6. Leading Question:

Why is March 21 called the vernal equinox?

Materials:

Trippensee Planetarium

Procedure:

After orienting the planetarium toward north, rotate the earth so that the arm is over the marking on the base of March 21. Notice that the North Pole is not pointing either toward or away from the sun, but in a position between these two. Rotate the earth one time and observe carefully the duration of day and night. Notice that the sun's rays shine directly on the equator. Before March 21, where have the direct rays been? After March 21, where will they be? Are days getting longer or shorter in the Northern Hemisphere after the vernal equinox is past? Repeat for other seasons.

7. Leading Question:

What determines the length of days?

Materials:

Globe, flashlight or filmstrip projector, piece of masking tape

Procedure:

Shine the flashlight or filmstrip projector on the Northern Hemisphere of the globe. Be sure the flashlight beam covers the Arctic Circle. Rotate the globe. Does the Arctic Circle remain in the light through a complete rotation? Find Bethlehem on the globe. Put a piece of masking tape where you live. Rotate the globe. Be sure to keep the North Pole in the light through the complete rotation. Does Bethlehem remain in the light through a complete rotation?

Locate Miami, Florida on the globe. Put a piece of masking tape on Miami. Rotate the globe. Is the day longer in Bethlehem than in Miami? What season is it?

8. Leading Question:

When is the longest (and shortest) day of the year?

Materials:

Trippensee Planetarium, globe, filmstrip projector

Procedure:

Orient planetarium and turn the arm counter clockwise until the arm is over June 21 on the base. Observe the tilt of the axis toward the sun. How much of the Northern Hemisphere is having daylight? Rotate the earth once. Is the period of day or night longer (summer solstice) Continue to revolve the earth around the sun. Note how the period of light decreases. When



is it shortest? (December 21 - winter solstice)

Place a filmstrip projector in the light of a filmstrip projector so that the daylight area can be more easily estimated.

9. Leading Question:

What effect does size and weight have on the time it takes two bodies to fall the same distance?

Materials:

2 marbles of different size, wooden block, hammer

Procedure:

Place a block of wood near the edge of a table and place the marbles against the side of the block nearer the table's edge. Tap the center of the block lightly with a hammer. Be sure to hit the block in the center to get the best results. Which marble will hit the floor first? Was it the largest or the smallest? Did both hit the floor at the same time? What does this show about the fall of objects?

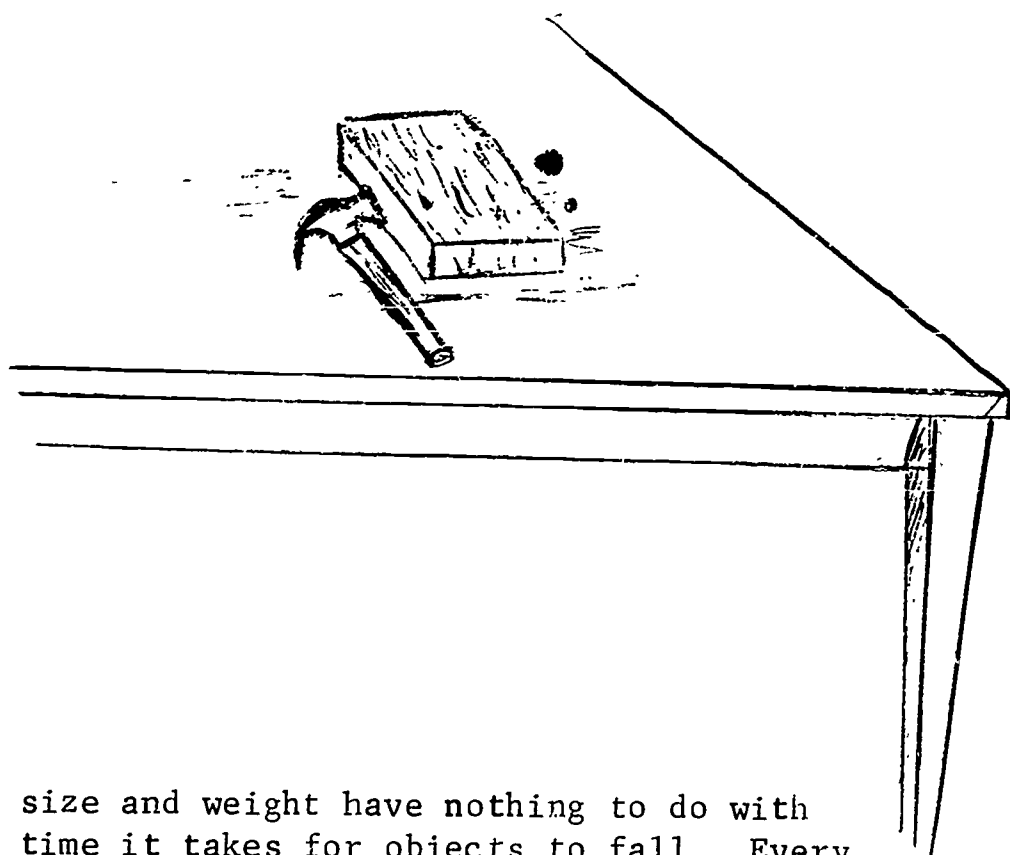

Note to Teacher:

The size and weight have nothing to do with the time it takes for objects to fall. Every ounce of matter is pulled with an equal force of one ounce. When gravity pulls on a body, the pull is the same, ounce for ounce or pound for pound.

10 Leading Question:

Does air affect the rate of speed of falling object?

Materials:

1 marble, flat piece of aluminum foil, 2 sheets of paper



Procedure:

Hold a marble in one hand and a flat piece of aluminum foil in the other. Extend the arms at the same height and let the articles drop. Will the marble and the foil take the same amount of time to drop? Why?

Now fold the foil into a tight compact lump. Hold the marble and the foil at arm's length again and let them fall. Will the marble and the foil hit the ground at the same time? Explain why. Compare the results of both experiments and state the reason for the difference in time.

Now try the same experiment with two sheets of paper the same size. Drop one flat piece of paper and the other rolled into a ball. Which took longer to fall? Why?

Note to Teacher:

When the foil was dropped the first time, the air resisted the movement of the foil. The second time the air resistance was cut down by reducing the amount of foil surface exposed to the air.

11. Leading Question:

When we measure the weight of an object, what are we really measuring?

A. Materials:

Pan balance scale (Central Science Materials Library), various objects to be weighted.

Procedure:

Place an object on one plate of a pan balance scale. Place another object in the pan attached to the opposite arm of the balance. Are the pans balanced? Is one pan pulled down farther than the other? If so, why is the one pan pulled down farther? What really pulls one pan down farther? Can we see the force which pulls one pan down farther? Does the larger size of the object in one pan mean that it will be heavier? Repeat with different sized objects.

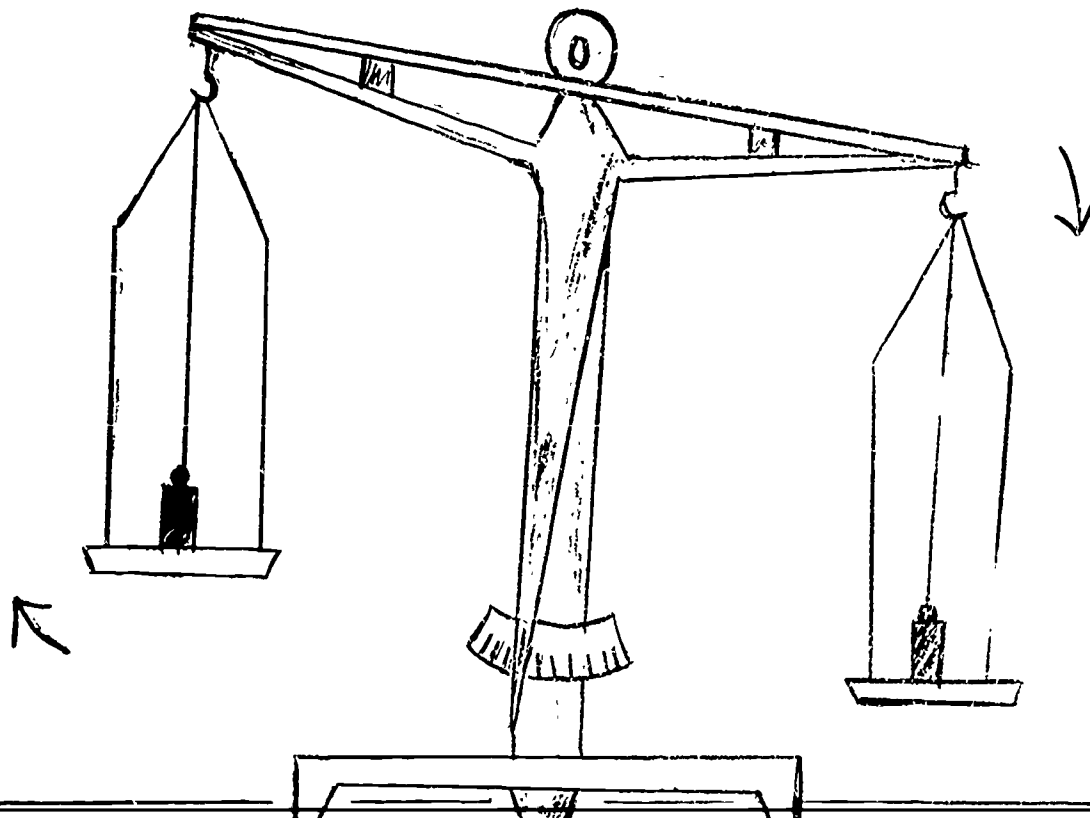

B. Materials:

Spring Balance Scale, various objects to be weighed

Procedure:

Use a spring balance scale. Hang an object on the hook. What weight does the indicator point to? Try using several objects. Keep an account of the pull for each object. What causes a pull on the spring balance scale each time? Compare the pull for the different objects.

12. Leading Question:

Does gravity have an effect on air?

A. Materials:

Yardstick (or Welch Machine Kit with lever), string, 2 balloons.

Procedure:

Tie a string to the center of a yardstick. Blow up two balloons until they are rather large. Tie strings around the necks of the balloons so that the air cannot escape. Tie each balloon to a string and fasten it about an inch from the ends of the yardstick or on the lever of the Welch Machine Kit. Let a classmate hold the string that is tied to the middle of the stick. Do you think each balloon has the same amount of air?

Does air have weight? Burst one of the balloons with a pin. What happens to each balloon? Why? Why does the balloon filled with the air pull the balance lower?

Note to Teacher:

Air has weight. Gravity pulls all objects toward the earth.

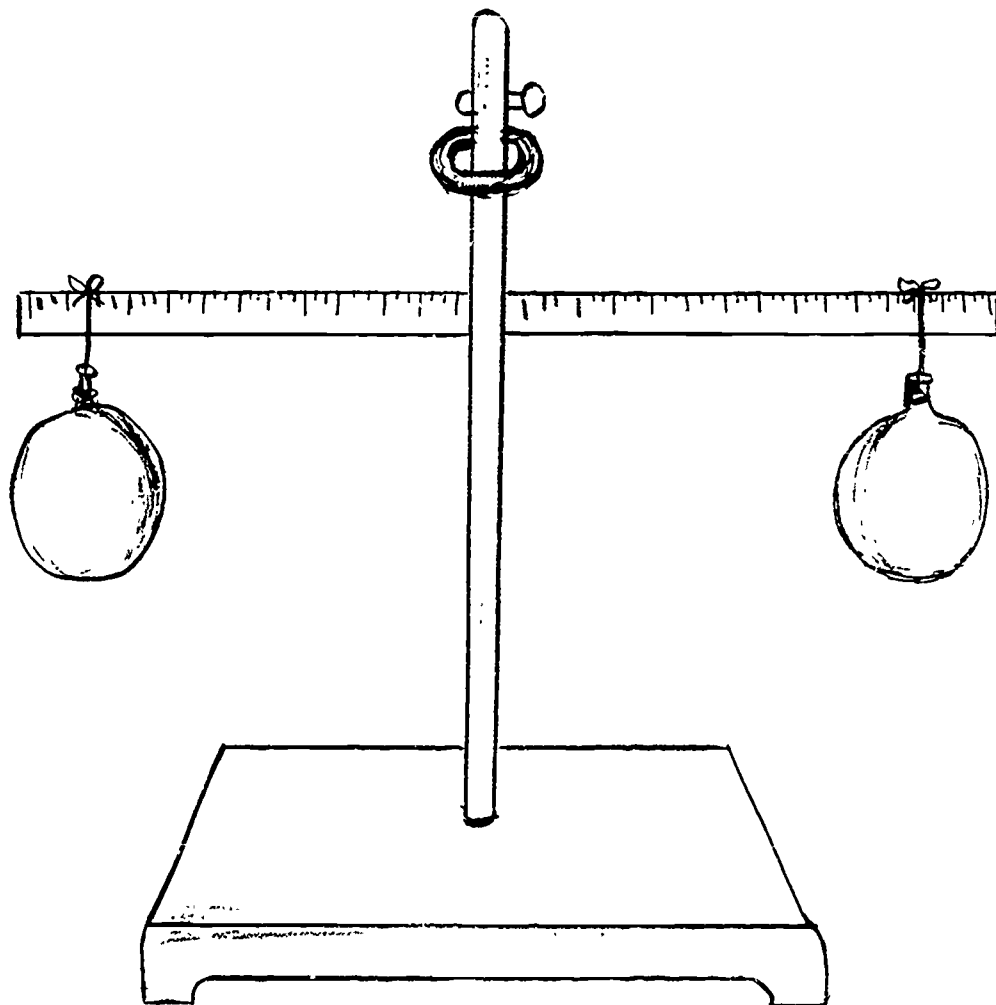

B. Materials:

Balance beam scale, basketball, air pump

Procedure:

Weigh a deflated basketball and record its weight. Inflate the ball by means of an air pump. Weigh the basketball. Compare the weights of the deflated ball and the ball with air. Which one is heavier? Why? What does the weight of the inflated ball have to do with gravity?

13. Leading Question:

How far can you push a book off the side of a desk before it falls to the floor?

Materials:

Book, white chalk

Procedure:

Lay a book close to the edge of a desk. Very slowly, begin to push the book out over the edge. Push it until it falls. Try this several times. At the point when it is ready to fall, draw a chalk line on the book. Then turn the book in another direction. Push until it falls. Try it again and mark the point where it begins to fall. Move the book at all angles as you experiment until you have a number of chalk lines. What do you notice about the lines? Do they all cross at one point? What do you think this might mean?

Note to Teacher:

At the moment that the center of gravity passes the edge of the table the object begins to topple. This is the center of gravity.

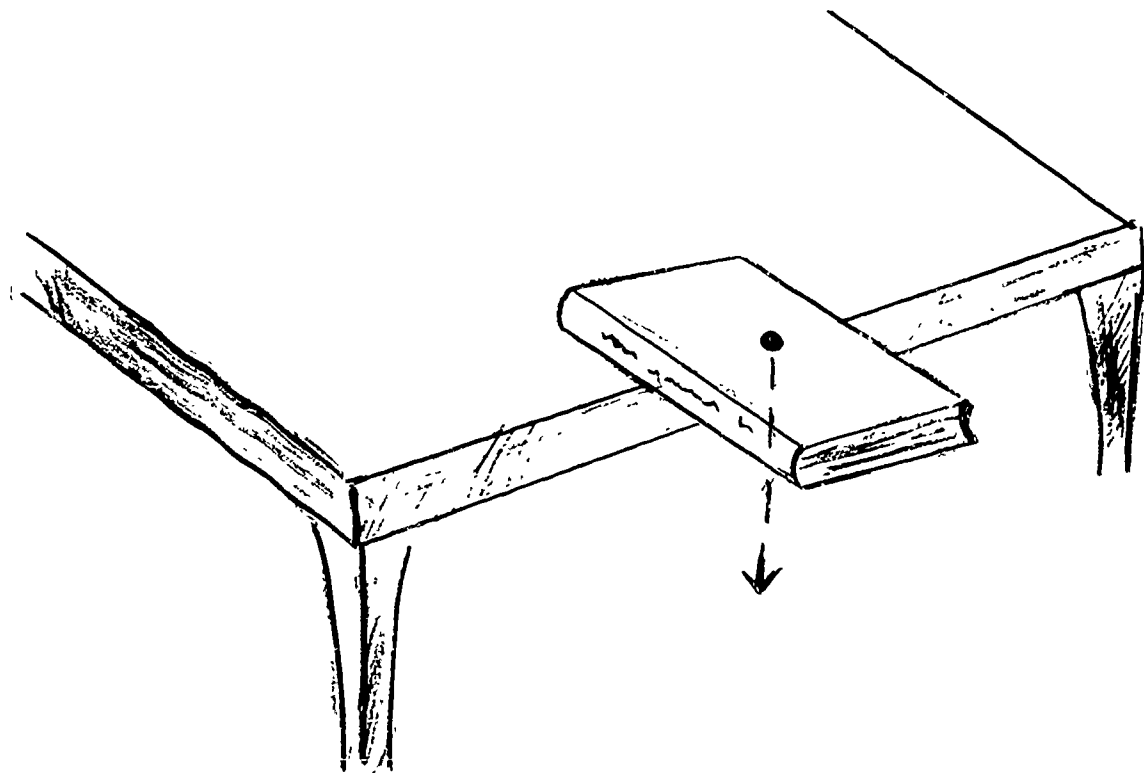

14. Leading Question:

Where is the center of gravity of a wire coat hanger?

Materials:

Wire coat hanger, nail, sheet of paper, 2 clips, small weight, piece of string, fork

Procedure:

Let a wire coat hanger extend freely from a nail as shown in figure A. Repeat from several different places on the coat hanger. Fasten a string with a weight on the end and observe the position of the string through the center of the hanger. Where does the center of gravity seem to be?

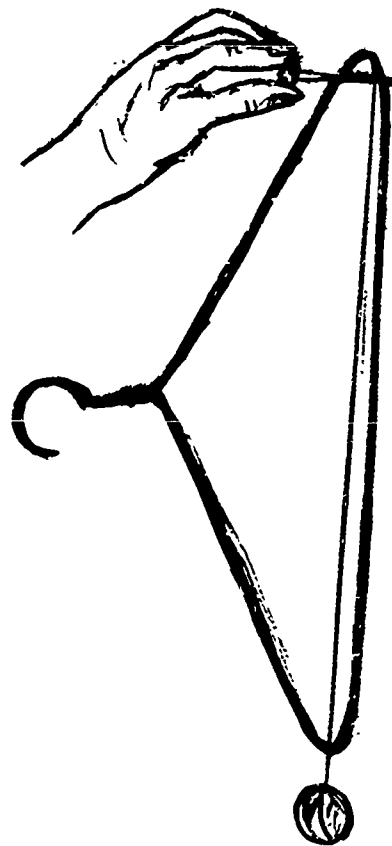

You can find the location of the center of gravity by clipping a sheet of paper to the triangle of the hanger and marking off the vertical lines as you hang the coat hanger in different positions. What happens to the position of the center of gravity if you fasten a weight (fork) to one side of the coat hanger? Try it. Attach a fork to the coat hanger and locate the new center of gravity. At what point does the extra weight shift the center of gravity? Will it be near the center or nearer the fork? On what does the center of gravity depend?

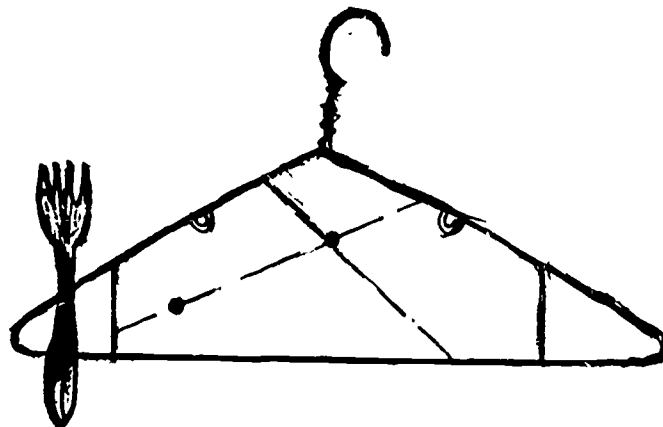

15. Leading Question: Why do things fall?
- A. Materials: Ruler, string, ball or other small objects
- Procedure: Suspend a ball on a string from a ruler. Ask a child to cut the string. What happens? Repeat it a few times with different objects. Why did the object fall down? What other things always fall down?
- Note to Teacher: The children may mention rain, snow, leaves, and other familiar things.
- B. Materials: Ball
- Procedure: Throw a ball up into the air. Throw it up as far as you can. What happens to the ball? Why? Will the same thing happen to other articles thrown into the air? Why?
16. Leading Question: Can you prove that gravity pulls all bodies toward the center of the earth?
- A. Materials: Large plastic ball, glue, a number of small magnets, cellophane tape, strips of tin from a tin can, tin shears
- Procedure: Cut the plastic ball in half. Glue some small magnets inside the ball's surface. The greater number of magnets you use, the better the experiment will work. Reassemble the ball and seal the seam with cellophane tape. Using tin snips, cut out some pieces of tin 1" long to represent some people. Include a section of tin to act as a stand. Place each figure on the ball near a magnet where it will be held in place. Which direction do all the stands holding the men point? In which direction do all of the heads point? What force pulls all bodies towards the center of the earth?
- B. Materials: Grapefruit, toothpicks
- Procedure: Insert the toothpicks into different points of the grapefruit so that they all stick out straight. Then fasten tiny paper figures to the protruding ends of each toothpick.
17. Leading Question: Was Galileo right about the force of gravity?
- Materials: 3 x 5 index card (or library index card), stapler, scissors, 2 paper clips, small piece of cardboard or oaktag
- Note to Teacher: It is generally difficult to prove that a ball thrown horizontally over level ground, will reach the ground simultaneously with one dropped



at the same time and from the same height as the one thrown because it is hard to release the two objects at exactly the same time. This is a simple attempt to overcome this limitation.

**Procedure:**

Fold the piece of oaktag in half and staple one half near the edge of the card (forms the shape of a seat). Set the paper clips on the card as in the diagram. Hold the card horizontally with the thumb and third finger of one hand, and "flick" the side where the oaktag is stapled with a finger of the other hand.

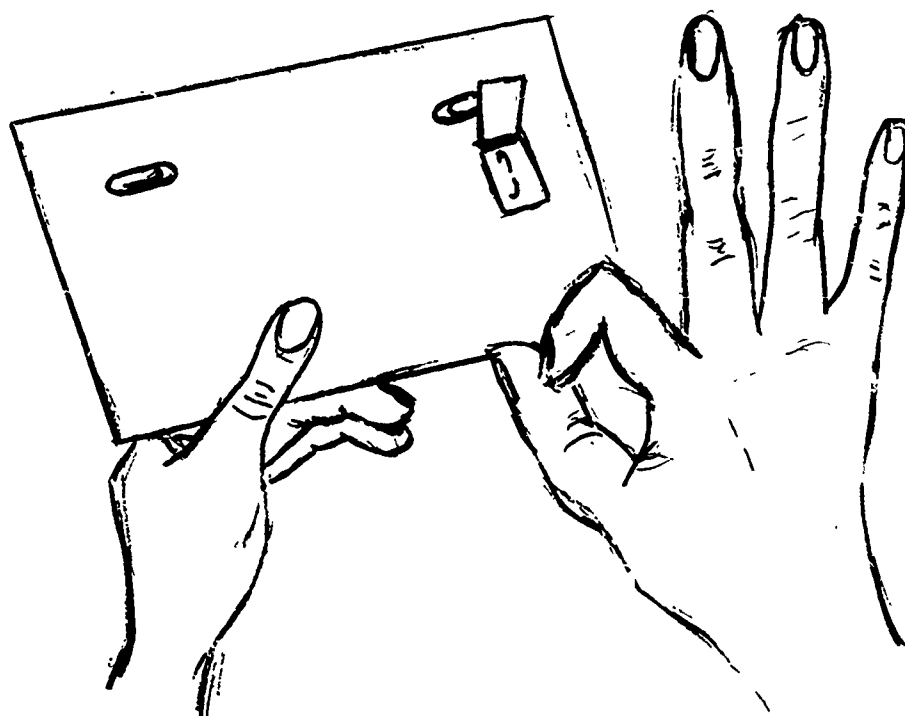

The clip in front of the oaktag will be pushed forward with the force of the flick, and will also be affected by gravity. The other clip will drop because of gravity. Listen carefully for the clips to land. Which one lands first? Was Galileo right?

**18. Leading Question:**

Does food go down by gravity?

**Materials:**

Pillow, bananas, drinking glass, straws, clean water

**Procedure:**

Ask for children to serve as volunteers for the experiment. Place a pillow on the floor. Each volunteer will take his turn standing on his

head. While he is in this position feed him a banana and also let him sip water through a straw. Keep a chart of the results of each experiment. How many children were not able to swallow the food or water? How many children were able to swallow the food and water? How did the food get into the stomach? Did gravity cause the food to reach the stomach?

Note to Teacher:

Muscles push food and water into the stomach and not gravity.

19. Leading Question:

What do you think would happen if the earth suddenly stopped revolving about the sun?

Materials:

Ball, long rubber string

Procedure:

Fasten a ball to the end of a long rubber string. Have one child swing this ball around his head. This child represents the sun. The ball on the end of the string represents the earth which is revolving around the sun.

Ask another child to catch the ball as it swings around. Then let go of the ball. What happens? If this were the earth, what would happen? What would happen if this was the moon instead of the earth? What would happen if this was another planet instead of the earth? What keeps the earth revolving around the sun? What keeps the moon revolving around the earth?

✓

ACTIVITIES TO ASSIGN FOR HOMEWORK OR INDIVIDUAL RESEARCH

20. Leading Question: Is it the earth or the sun that is moving?
- A. Procedure: When you are riding on a merry-go-round, what do the stationary objects appear to be doing as you are turning around? Pretend that the merry-go-round is the earth and that a set object is the sun. What does the object seem to be doing as you move toward it?
- B. Procedure: Drive with your father past a line of train cars which are standing still. Will the train alongside appear to be moving? Compare your car to the earth and observe what seems to be moving.
21. Leading Question: When is the earth closest to the sun?
- Materials: Library
- Procedure: Read to find out if the sun is closer to the earth at any time of the year. Report to the class. What conclusions did you make? Is the earth closer to the sun in winter or in summer?
- Note to Teacher: The earth hurtles along in its orbit at the rate of 66,000 miles an hour to complete its yearly tour of 600 million miles. This path is not a perfect circle, it is slightly elliptical, with the sun not quite in the center. As a result the earth is closest to the sun on January 1, being  $91\frac{1}{2}$  million miles away, and furthest away on July 1, when it is  $94\frac{1}{2}$  million miles away. On April 1 and October 1 the distance is between these extremes, being 93 million miles.
22. Leading Question: Does the sun rise and set at the same time every day?
- Materials: Newspaper record of sunrise and sunset.
- Procedure: Form a committee to record the times the sun rises and sets each day for a period of 60 days. Check the local newspaper for the proposed record of sunrise and sunset. Take turns in getting up early enough to record the time the sun rises each day. Take turns in recording your observation of the sunset. Compare your record with that of the newspaper schedule. What have you found out about the amount of daylight for each day? Does the sun rise at the same time each day? Does it set at the same time each day. Keep a record of another period of time later on in the year and compare the two records.

23. Leading Question:

How could you tell time without a clock?

Materials:

Pencil, piece of cardboard, thumbtack, chalk

Procedure:

Research how people kept an account of time in the past. List a variety of "timepieces" used before clocks and watches were used. Bring in pictures or examples of early devices used in telling time. Keep a record from a very simple sundial. Outline a child's feet as he stands in the sun on the school sidewalk or playground. At hourly intervals mark the direction of his shadow with lines radiating from the center where he stands.

Make a simple sundial with a pencil and a piece of cardboard about 1 by 2 feet in size. Push a thumbtack through the cardboard near the edge and at the center of one of the long sides. Push the eraser end of a four inch pencil over the point of the tack so that the pencil stands straight up. The pencil is used to cast a shadow. This is called the gnomon of the sundial. Place the sundial on a flat surface where the sun will fall on it throughout the day. Turn it so that the gnomon is on the south side of the cardboard. Fasten the cardboard down with masking tape. A number of times during the day, make a dot where the tip of the gnomon's shadow falls on the cardboard. From noon make such dots every 15 minutes for an hour. Try this without a watch. At the end of the day draw a line connecting all the dots. What kind of pattern do you see? What device was used to tell time at night?

24. Leading Question:

What would happen if the earth slowed down?

Materials:

Library

A. Procedure:

Search for information about the rotation of the earth. Keep in mind that from this time on, the earth would keep the same face pointing toward the sun all the time just as the moon keeps the same face pointing toward us as it circles the earth.

B. Procedure:

Use a chair for the sun. Walk in a circle around the chair, keeping your face pointed directly at the chair all the time. As you circle the chair with your face toward it, notice that your head and body make one complete revolution. If the earth slowed down so that it rotated just once in a year, what would the world be like?

How would our lives be changed? Would there be sunrises and sunsets? Would all parts of the earth have day and night? Would there be seasons? Would we have to change our methods of keeping time? Would there still be days, weeks, months, and years according to our present day calendars? Where would it be hottest of all? Where would it be the coldest of all? What would happen to the oceans on the side of the earth facing the sun all the time? Would there be tides? What would happen to plants and animals on the land and in the sea? Could you live where you live today? With which other body in space would you compare the earth?

25. Leading Question:

How do we find the center of an object's weight?

Materials:

Cardboard, paper punch, nail, string, small stone for a weight

Procedure:

Cut a piece of cardboard into an irregular shape. Punch five or six holes anywhere in the cardboard. Now push a small nail through one of the holes. Let the cardboard swing freely on the nail. Finally it will come to rest. Hang a weight (a small stone) on a string fastened to the pencil, Figure A. Locate the vertical line from the pivot. Let the cardboard, weight and string swing freely until they come to a stop. Draw a line along the position of the string against the cardboard. This is the vertical direction from the pivot. Place the nail in another hole and repeat the process until you have marked the vertical line from each hole. What happens to all of the lines? Next, balance the cardboard on the point of a pencil at the point where all of the lines cross as in Figure B. What are you able to discover? Try holding the cardboard on the tip of the pencil at other points on the cardboard. What happens? What would we call the point where all the lines cross on the cardboard?

Note to Teacher:

The point of balance is called the center of gravity or the "center of weight".



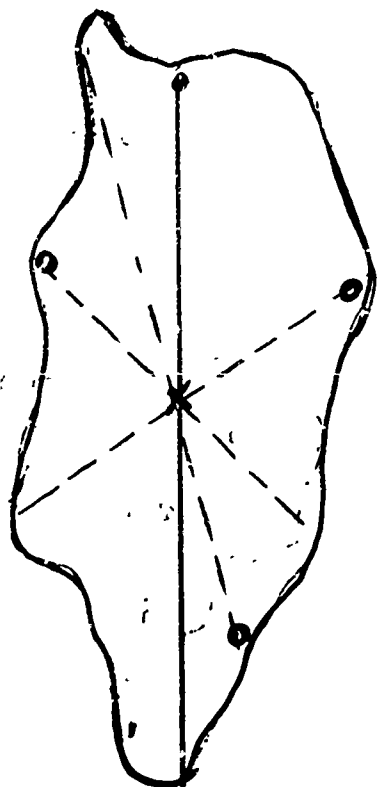

A.

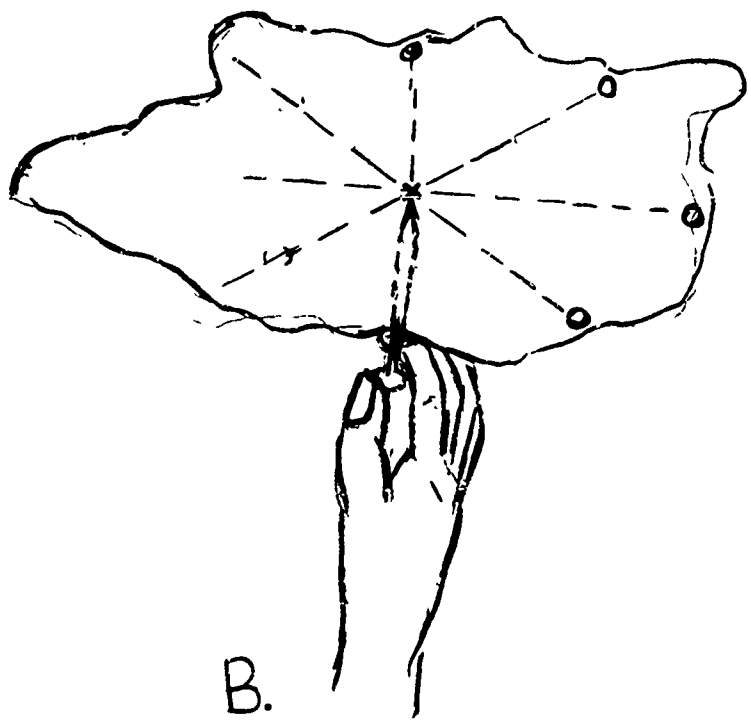

B.

26. Leading Question:

What causes tides?

Materials:

Library

Procedure:

Look up the topic "tides" in the encyclopedia or Library books. Have the librarian help select simple information. Report to the class. What main topic led you to your information? What do we mean by high and low tides? How many high tides and low tides does any one spot on earth have every 24 hours? Compare neap tides and spring tides.

## SPACE SCIENCE

### Our Great Universe

Grade 4

#### The Earth

##### UNDERSTANDINGS TO BE DISCOVERED

##### RELATED ACTIVITIES

The shape of the earth is an oblate spheroid (pear-shaped or flattened at the poles).	17
The earth wobbles (precession) as it rotates on its imaginary axis and revolves around the sun.	21,22,24
The earth's rotation causes the apparent motion of the sun, moon, and stars across the sky.	4,6,7,11,23,27,28,33,36,37
The earth travels around the sun in almost 365½ days. Every fourth year is leap year.	25
The equator is an imaginary line half-way between the North and South Poles.	5
Latitude is the distance in degrees north and south of the equator.	5,30
A sextant is an instrument for finding latitude.	5,17,30
Longitude is the distance east or west on the earth's surface from Greenwich, England.	5,25,30
To find the longitude, a navigator needs to know the time in Greenwich and the place where he is.	5,30
A magnetic compass is a useful navigation instrument because it always points toward the north magnetic pole (Northern Hemisphere).	5,30

Our Great Universe

Grade 4

The MoonUNDERSTANDINGS TO BE DISCOVEREDRELATED ACTIVITIES

Earth's natural satellite, the moon, is our closest neighbor in space.

There is no atmosphere or water on this lifeless ball of rock.

The moon has extreme temperatures (210°F to -250°F).

The moon's surface is covered with mountains, valleys and craters which appear as shadows to the naked eye.

Some scientists believe the moon is covered with a thick layer of dust.

Craters on the moon may have been caused by meteorites or volcanic eruptions.

The moon keeps the same side turned toward the earth; therefore, it rotates once during its 27½ day orbit. 18

The half of the moon facing the sun is always brightly lighted, but we do not always see this entire area. 18

The moon goes through various phases, showing parts of the lighted area as it revolves around the earth. 18

A lunar eclipse occurs when the earth, sun, and moon are in a straight line in space and the earth's shadow falls on the moon. 19

Our Great Universe

Grade 4

The Sun's FamilyUNDERSTANDINGS TO BE DISCOVEREDRELATED ACTIVITIES

The solar system includes nine planets, planetoids, meteors, comets, and the moons that travel around some of the planets.

3,16,26

The inner planets are Mercury, Venus, and the Earth.

26

The outer planets are Mars, (Asteroids), Jupiter, Saturn, Uranus, Neptune, Pluto.

26

The solar system belongs to another and greater system called the Milky Way Galaxy.

3,8,35

Planets and moons shine by reflected light.

20

All nine planets rotate on their axes.

The planets revolve around the sun in paths or orbits.

15,17

The time taken for a revolution depends on the distance of the planet from the sun.

15

Tiny fragments of stony materials, called meteoroids, from outer space are sometimes pulled into the earth's atmosphere by the earth's gravitational field.

Asteroids are bodies smaller than planets that revolve around the sun.

Comets are hot heavenly bodies that travel in long elliptical orbits around the sun.

The aurora borealis is a phenomenon that occurs at times when there are disturbances in the sun.

Interplanetary space lies beyond the earth's atmosphere.

Our Great Universe

Grade 4

Celestial BodiesUNDERSTANDINGS TO BE DISCOVEREDRELATED ACTIVITIES

The sun, our nearest star, is only an average star in size, temperature and brilliance.

1,13,14,37

The outer layers of the sun include 3 main parts: photosphere, chromosphere, and corona.

The photosphere is the visible surface of the sun.

2

The gases above the surface of the sun are its atmosphere and beyond this is the chromosphere.

2

Solar prominences (red) and the corona (white) are bright gases thousands of miles above the sun's surface and are studied carefully during an eclipse.

We know that the sun rotates because the dark sun spots appear in different places on its surface.

An eclipse of the sun occurs when the moon is between the earth and the sun so that the sun's disk is partially or totally screened.

2,34

Stars are spherical in shape, even though they sometimes appear to have points.

Stars shine all the time, but we cannot see them in the daytime because our sun shines so brightly.

Stars appear to twinkle as their light is dimmed or intensified in traveling through earth's turbulent atmosphere.

Stars vary in size, color, and brightness according to their temperature and composition.

9,11,34

Constellations are sky patterns of stars that happen to lie approximately in the same direction of the earth. The movements of the earth causes the positions of the constellations to change in the sky.

10,11,33

Stars exist in large groups (billions of stars) called galaxies.

4,6,8

Our solar system is a minute part of the Milky Way Galaxy which is believed to look like a giant pin wheel of stars.

8,35

Our Milky Way is part of a much larger system called a supergalaxy.

There are thousands of galaxies like the Milky Way in the universe.

The size of the universe is not known, but it appears to be ever expanding at tremendous speed.

Nebulae are clouds of cosmic gas and dust.



Our Great UniverseGrade 4UniverseUNDERSTANDINGS TO BE DISCOVEREDRELATED ACTIVITIES

Telescopes receive light from a heavenly body and focus this light to form an image of the object.

29

Refracting telescopes bend the rays of light with a series of lenses to bring objects closer.

29

Reflecting telescopes gather the light in concave mirrors and reflect the light from stars as an inverted real image.

Radio telescopes study the heavens by receiving cosmic radiation at radio wave length and enable astronomers to "hear" signals from twice the distance refracting telescopes can "see" heavenly bodies.

Spectroscopes are often attached to telescopes to help determine the following:

- a. what the temperature of a star is
- b. whether the star is a solid or gas
- c. whether the star is coming toward the earth or going away
- d. if the body is rotating

Man-made satellites collect data and transmit it back to earth.

Photography plays an important role in astronomy.

Project Ozma has an 85 foot radio telescope pointed at two stars hoping to receive signals from possible inhabitants of other worlds in space.

Our universe is so vast that astronomers use light years to measure distance.

## SPACE SCIENCE

### Our Great Universe

Grade 4

#### Early Astronomers

##### UNDERSTANDINGS TO BE DISCOVERED

Astronomy, one of the first sciences studied by man, is the scientific study of the planets, stars, and other celestial bodies, while astrology is the superstitious attempt to tell fortunes by the positions of the stars.

In 1543 Copernicus put forth his theory that the earth rotates and revolves around the sun.

Tycho Brahe improved the instruments and methods of observing heavenly bodies and kept accurate records of his own observations.

Galileo, an Italian scientist, made the first telescope in 1610 and was able to see Saturn's rings and Jupiter's moons.

Kepler discovered that the orbits of planets are ellipses and the nearer the planets are to the sun, the faster they move.

In 1781 William Herschel accidentally discovered Uranus while he was studying the stars.

##### RELATED ACTIVITIES

31,32

ACTIVITIES

## 1. Leading Question:

Why does the sun feel warmer at noon than in the early morning?

## Materials:

Flashlight, blackboard, thermometer

## Procedure:

Darken the room. Shine the flashlight directly on the blackboard. Observe that the light makes a perfect circle on the board. Move the flashlight to various positions and angles. The circles become bulgy or eccentric. Discuss this change in the circle. Why does it change its shape? Which circle is the brightest? What happens to the intensity and heat of the light as it is spread out over a wider area? Place a thermometer on the window sill in the early morning when the sun's rays are more slanted. Repeat at noon when the rays are most direct. When is the temperature highest? Draw the parallel between the flashlight and the circles it makes, and the result of the change of direction. Would this same principle apply in the case of summer and winter temperatures?

## 2. Leading Question:

How does a solar eclipse occur?

## Materials:

Trippensee Planetarium with floodlight

## Procedure:

Move the moon by hand in its orbit around the earth. Notice the shadow cast by the moon when our natural satellite is in the new moon position. Does the moon block out the sun's light for the whole earth? (No, it cannot, because it is much smaller than the earth.) When the moon's shadow falls on the earth, what is happening at that particular place? What appears to be happening to the sun? What portion of the earth does the eclipse cover at a given time?

## 3. Leading Question:

What is our position in our universe?

## Materials:

Chalkboard

## Procedure:

Ask a child to give you his address. Discuss the meaning of his address:

John Smith  
210 Main Street  
Bethlehem, Pennsylvania

Discuss what would be added if we mailed a letter out of the country? Discuss what would be

needed if we sent a letter from the planet earth? Out of our solar system? Out of our galaxy? A complete address might look like this:

John Smith  
210 Main Street  
Bethlehem, Pennsylvania  
United States of America  
Planet Earth  
Solar System  
Milky Way Galaxy  
Universe

4. Leading Question:

Can we see circumpolar stars throughout the year?

A. Materials:

Revolving Chair (piano stool)

Procedure:

Have a child sit in a chair representing the earth. Have him rotate. Hold an object over his head to represent the North Star. As he revolves looking up at the object, it will always remain within his vision.

B. Materials:

Cardboard

Procedure:

Draw a picture of the circumpolar stars on a cardboard. Tack it into the top center portion of a doorway. Have the children stand in the doorway and rotate looking up.

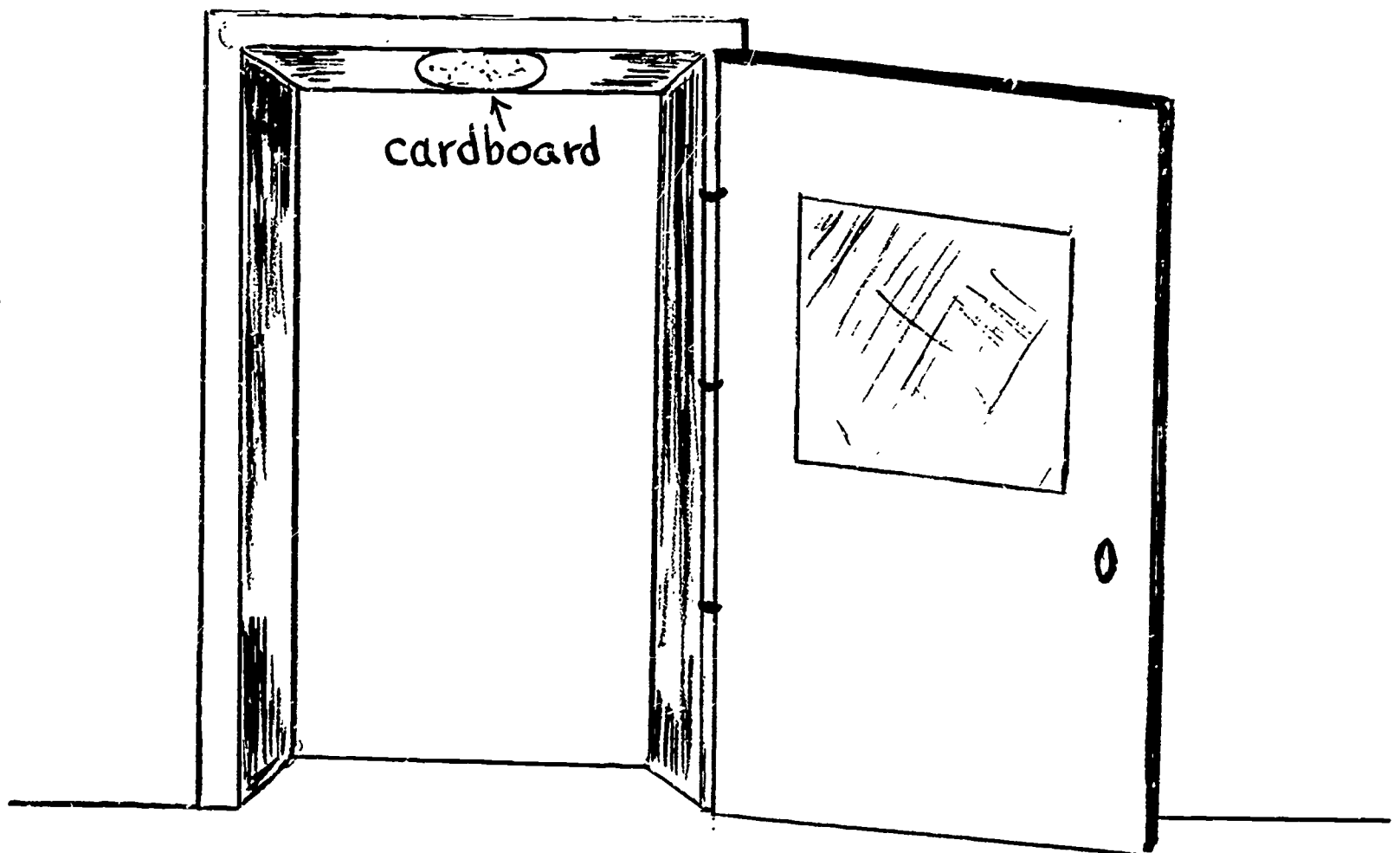

5. Leading Question: How can we locate places on our earth?
- Materials: Geography Learning Laboratory# 172- The Earth: Shape and Magnetism (Central Science Materials Library)
- Note to Teacher: The lessons in the guide are excellent background for teaching about latitude and longitude.
6. Leading Question: Does everyone around the world see the same stars in the sky at night?
- Materials: Farquhar "Earth in Space" Globe (Central Science Materials Center)
- Procedure: Examine the globe. Point out to children that the stars have all been brought in to the same plane of sphere outside the earth. This is for simplification because this is the way they seem to appear as one looks at the dark sky at night. Notice that there are stars in all directions from the earth. Rotate the earth through a 24 hour period keeping the sun in the summer months by turning the screw on the top until the small white ball rests over July - August. What are some of the stars we would see (be sure to check night sky - opposite sun)? Can we see the same stars that people in South America see? Move the sun to its place for the winter months. What different stars can be seen now. Notice how the constellation Orion gets into the winter skies. Are there some stars we never see? Are there some stars that are always in our sky? Do you think the astronauts can see all of the stars as they travel around the earth?
7. Leading Question: Why do stars appear to be moving in a counter-clockwise direction if you are in the Northern Hemisphere?
- Materials: Rotating chair (piano stool)
- Procedure: Have a pupil representing the earth rotate while sitting on a rotating chair. Put other pupils around the room to represent the stars. They will not move. As the stool turns, what does the pupil see when he looks at the stars? Draw conclusions.
8. Leading Question: Where is our sun located in relation to the rest of the Milky Way Galaxy?
- Materials: Galaxy Model (Central Science Materials Library)
- Procedure: Examine the model. Discuss the scale (1 inch equals 6,750 light years).



Measure the diameter of the galaxy (15 inches). The diameter of the galaxy is approximately 100,000 light years. The model is  $1\frac{1}{4}$  inches thick at the center. This represents approximately 10,000 light years.

Notice that the galaxy is spiral in shape. Locate the sun in its position out from the center where the thickness of the galaxy is approximately 5,000 light years.

Rotate the galaxy in a clockwise direction to show the motion of the sun within the galaxy.

Notice that the sun lies along the central plane of the galaxy. In what way does this make the night sky appear as it does? When we look out into space, we are looking through our galaxy. What large band of stars does this form in the sky (Milky Way)?

9. Leading Question:

Why are stars different colors?

Materials:

Nail or steel knitting needle, portable bunsen burner, pliers

Procedure:

Have the children look at stars on clear nights to observe a reddish star, a yellow star, and a bluish-white star.

Heat a nail or steel knitting needle. Use a gas flame (Bunsen burner) since a candle or alcohol burner flame will not give the proper effect. Ask the children to carefully observe the color that will appear on the knitting needle or nail as it becomes hotter. They should be able to see the object become red - then yellow gold - then blue as it remains in the heat. From this the children should draw conclusions that red stars are "coolest", yellowish stars are "hotter" than the red stars, and bluish-white stars are the "hottest".

10. Leading Question:

How can we display some star groups in our classroom?

A. Materials:

Tinker toy set

Procedure:

Fit the tinker toy parts together to represent a star group. The fixed holes in the tinker-toy parts will not always allow for accurate positioning, but should serve a practical

purpose of learning some star groups.

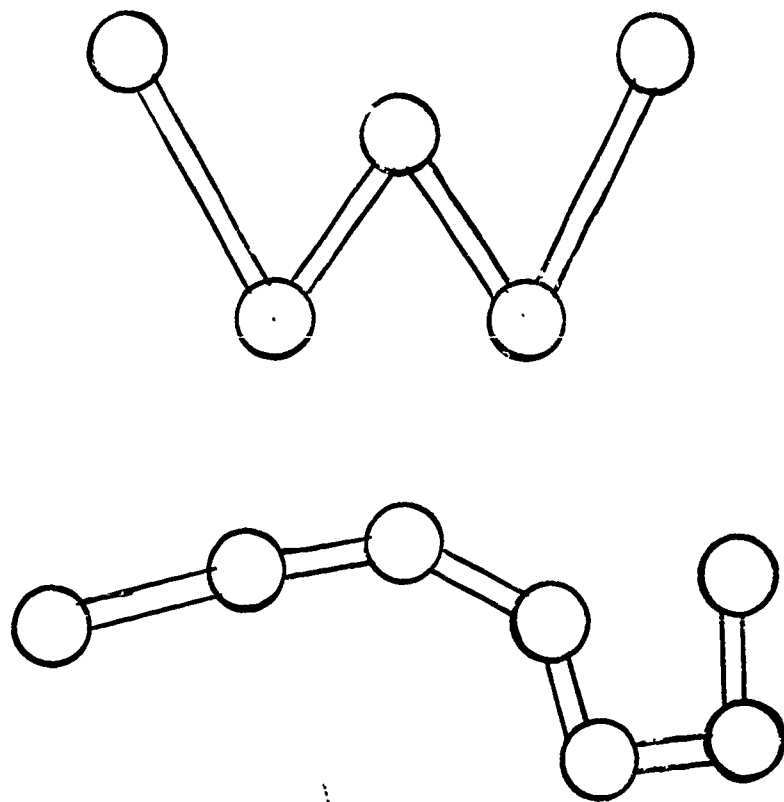

**B. Materials:**

Blue crepe paper, silver circles\*, tissue paper

**Procedure:**

Make a bulletin board display of constellations. Cover the whole board with blue crepe paper. Have the children arrange silver circles that they have cut out in the shapes of star patterns. With transparent tissue paper cover the star pattern with a picture.

\* Do not use stars since children get the misconception that stars have five points.

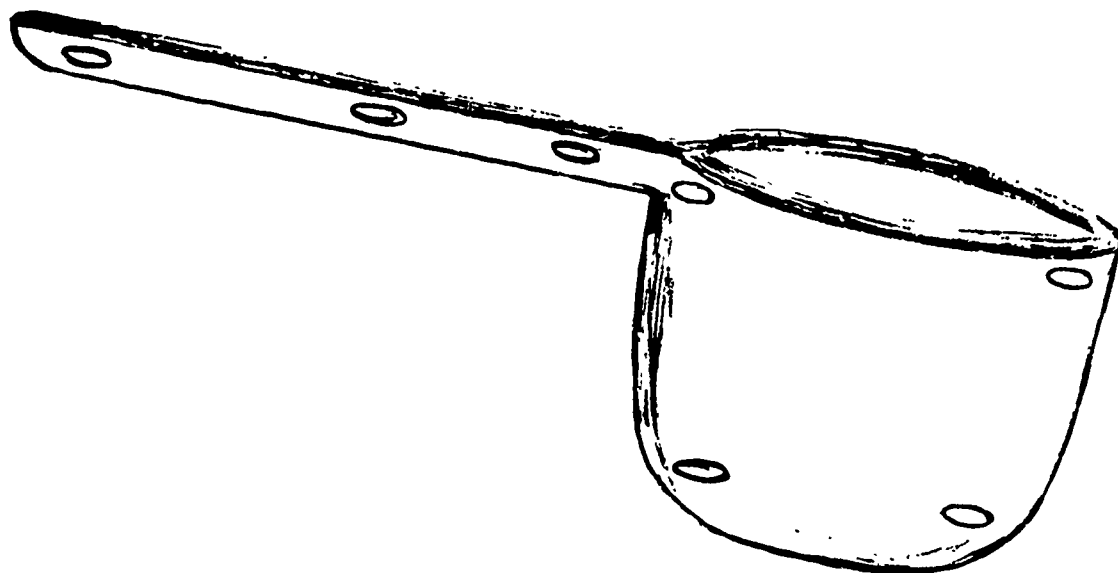

11. Leading Question:

Why do the stars seem to change their positions during the night?

Materials:

Globe, miniature figure, ping-pong balls

Procedure:

Place the miniature figure representing a person in the northern hemisphere on the globe (attach with clay or stick-tack)

Arrange some star constellations in the "sky". Use the ceiling, or an umbrella canopy over the globe. Place a ping-pong ball directly over the North Pole to represent Polaris. Suspend seven more balls to represent the Big Dipper. Be sure to have the pointer stars of the ladle part in line with Polaris.

Rotate the globe. Imagine yourself in the position of the figure on the globe. Note the way the Big Dipper seems to assume successive positions around the North Star. Have the pupils observe the Big Dipper several times in the evening. Note especially the direction in which it seems to move. (The stars appear to move clockwise around Polaris.)

12. Leading Question:

Why don't we see stars during the day?

Materials:

Flashlight

Procedure:

Darken the room and have a child shine a flashlight. Tell the children to look directly at the light. Take the flashlight out of doors in the bright sunlight. While the flashlight is lit, have the sunlight shine directly on it. What happens to the light from the flashlight? Draw conclusions. Suggest the children look out the window of a lighted room at night and observe the stars. They should put the lights out and look again. Follow with discussion and conclusions.

13. Leading Question:

How can we capture the sun's energy?

Materials:

Automobile headlight reflector, test tube, silvered reflector spotlight bulb, stand with clamp.

Procedure:

Fill the test tube half full with water. Attach it to the stand with the clamp. Set up the headlight reflector underneath the test tube. Shine the spotlight bulb down on the test tube so that the light is reflected back to the test tube.

How long does the water take to boil when the light is on? (Probably less than five minutes) Can you devise ways of getting the water to boil faster. Do you think the sun could boil water in this manner.

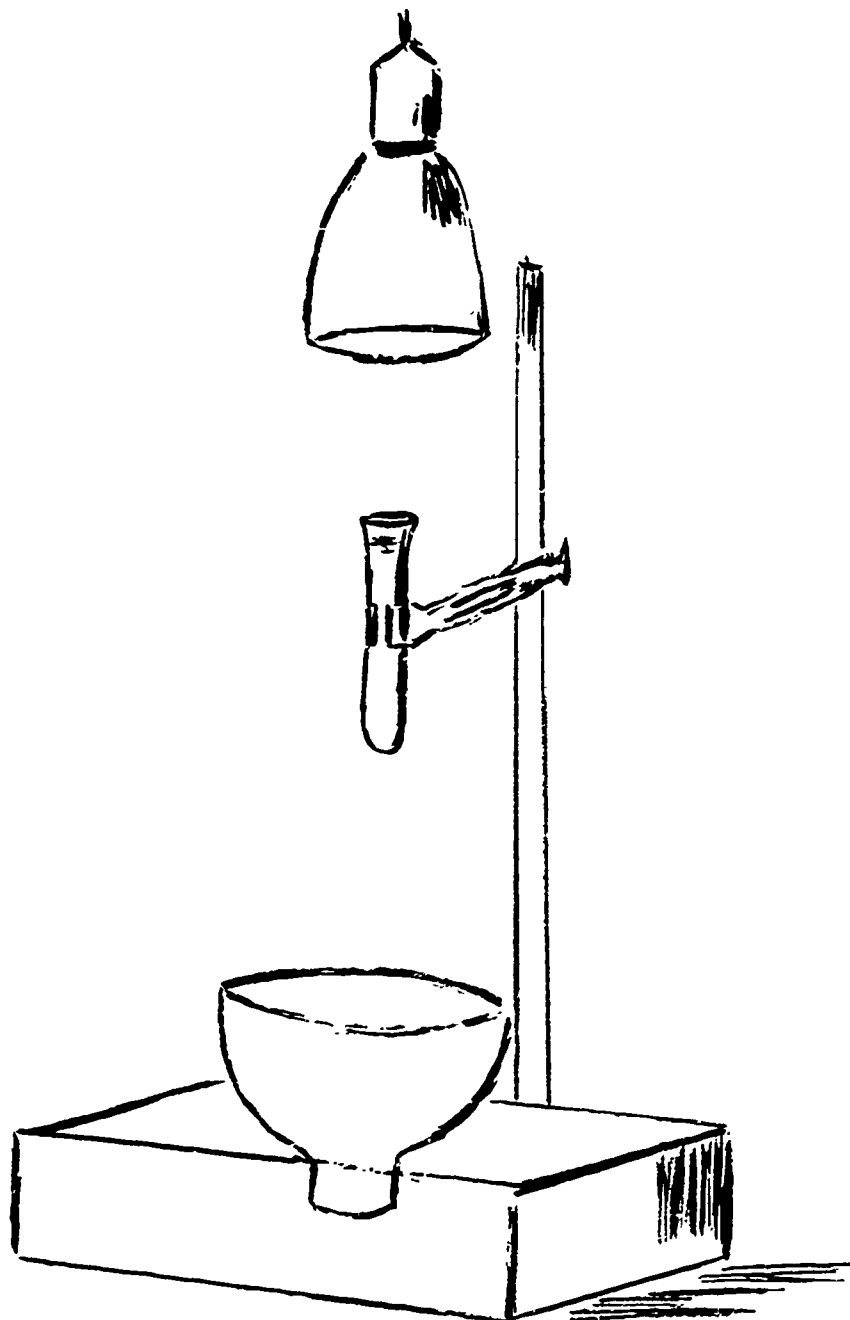

14. Leading Question:

Why is the sky blue? Why does the sun change color?

Materials:

Clear plastic dish, water, soap (not detergent) filmstrip projector, large sheet of black paper

Procedure:

1. Fill the plastic dish with water and place the sheet of paper behind it. Darken the room and shine flashlight through one end of the dish.
2. Look at the beam of light from the side as it passes through the water. Do you see the light? Why? or why not? Do you see any colors?
3. Swish the soap around in the water. Now look at the beam of light. Do you see any colors? Add more soap to see if the colors change.

Like the sun, a projector gives off light which is a mixture of a rainbow of colors (red, orange, yellow, green, blue, indigo, violet). The specks of soap mixed with the water and scattered the light so that some of these colors became visible.

When we view the sky from the earth we see colors that are scattered from sunlight by tiny particles of dust, water, smoke in our atmosphere. Why does the sky appear black to the astronauts?

Repeat steps 1 and 3, but this time observe the beam by looking directly toward the flashlight. Notice the color change as more soap is added. The increased amounts of soap are similar to increased particles in the atmosphere. When the sun is rising or setting it may appear bright yellow or red. Why is this so? (What is the difference in the amount of atmosphere through which we see the sun at noon and in the morning and evening?)

15. **Leading Question:**

Why do the planets have years of varying lengths?

**Materials:**

Spool (or 1-hole rubber stopper), piece of string, about 4 feet long, and a rubber eraser

**Procedure:**

Tie one end of the string onto the eraser.

Pass the opposite end of the string through the hole in the spool. Hold the spool in one hand with the free end of the string coming out of the bottom of the spool. Hold this free end in your hand.

Begin whirling the eraser in a circular motion by shaking the spool. This eraser represents a planet revolving the sun.

Observe how long one turn takes. Pull the free end of the string to make the orbit shorter. How long does it take to make one turn?

Place a marker on the end of the string 20 inches from the rubber eraser. Place the eraser in orbit. Observe how long it takes. Continue placing marks at other lengths and repeat above experiment.



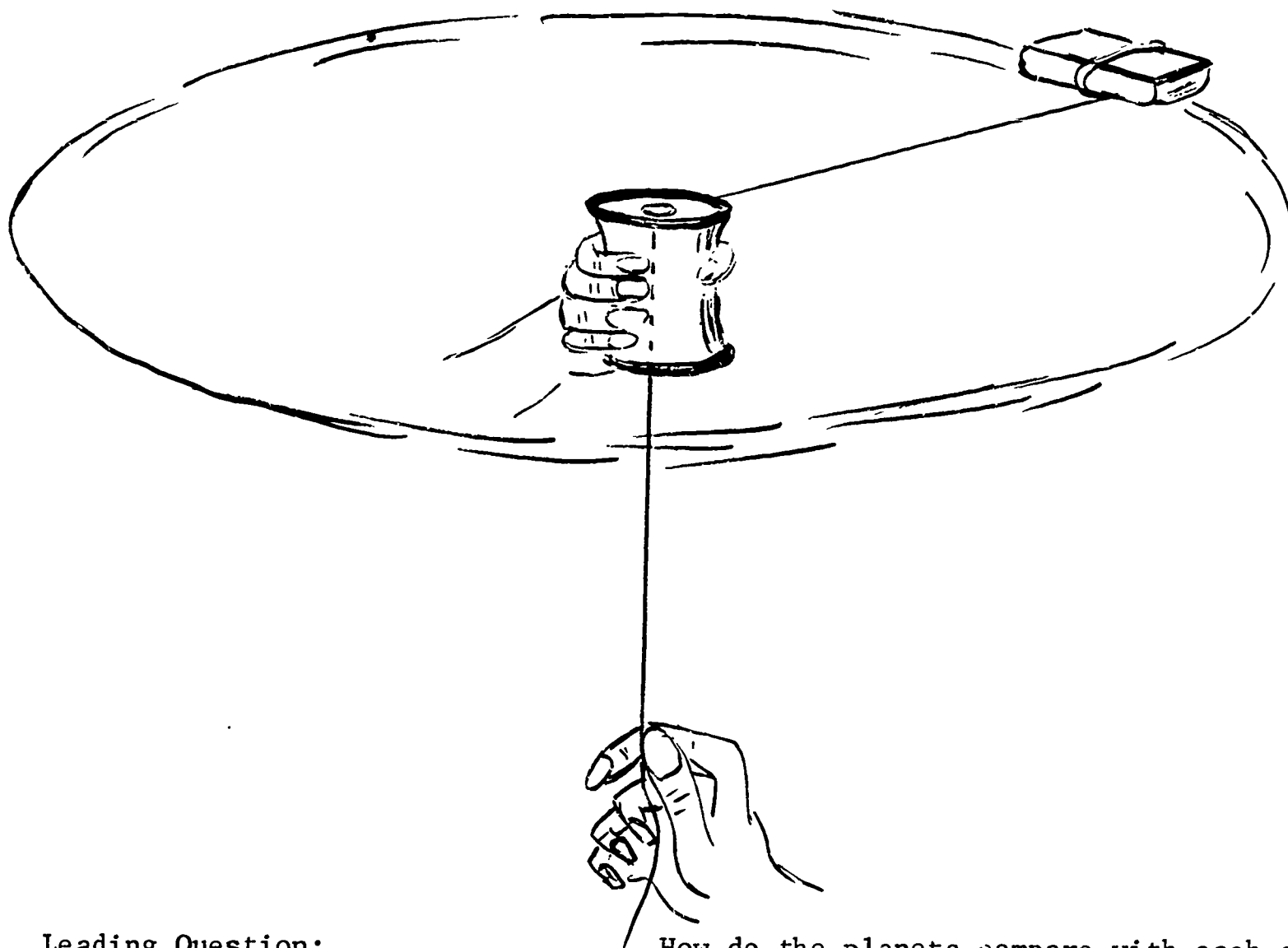

16. Leading Question:

How do the planets compare with each other?

Materials:

Large mural paper or blackboard, reference books

Procedure:

This planet chart will be set up in such a way so that one planet can be compared to another one in various categories. Suggested categories are given below. However, this may be deviated from depending upon classroom suggestions. The children should do all the research and investigation needed and when the chart is completed comparisons and contrasts should be discussed.

PLANET	SIZE	DISTANCE FROM SUN	YEAR	CLIMATE	HISTORY OF NAME	MOONS	CHARACTERISTICS
Mercury							
Venus							
Earth							
Mars							
Jupiter							
Saturn							
Uranus							
Neptune							
Pluto							

Many sources, both old and new, should be checked to compile the data. The children will see how the answer to a question in one book will differ in another book. This is a good way to show children how we are still learning more and more about space and that the book with the later copyright is more reliable.

#### LANGUAGE ARTS

Have the children write poems about the planets or solar system after the data has been compiled. Example

I am a star, my name's the sun  
 On summer days I give you lots of fun.  
 I give you heat and help you grow  
 I'm in the sky and I glow, glow, glow

**B. Materials:**

Chalk and blackboard or construction paper, tape and hallway, reference books

**Procedure:**

How can we find the relative distances of all the planets from the sun? Have the children make suggestions guiding them to making a large blackboard diagram or a hallway diagram. This will have to be done on a scale which should be determined by the children depending on the area and space they have to work with. Planet committees can find and compute data in order to begin the project. The planets should be arranged in the proper order of their orbits and the number of moons can also be added. The belt of asteroids should not be omitted. When the children complete their diagram make sure they include a legend explaining the scale.

A similar model can also be made to compare the sizes of the individual planets.

**Note to Teacher:**

Using the scale  $3/16'' = 1$  million miles a fairly good representation can be put on a long roll of paper (eg. adding machine paper). On this scale the sun is almost  $3/16''$  in diameter and all of the planets are merely pin points. The following scale is orbital distance. (When this is unrolled it conveys vividly the minute specks of matter that the planets make in this huge area of the solar system.

**Solar System Distance Scale**

	Distance from the sun
Mercury	6.750''
Venus	12.55''
Earth	17.4''
Mars	26.6
Jupiter	7 ft. 6.7''
Saturn	13 ft. 10.2''
Uranus	27 ft. 10''
Neptune	43 ft. 8''
Pluto	57 ft. 4''

**17. Leading Question:**

Do planets travel around the sun in a circle?

**Materials:**

2 pins, board, paper, string, pencil

**Procedure:**

Stick 2 pins into a piece of paper that is resting on a board or wooden surface. Put a loop of string over the 2 pins. Be sure to keep the string stretched with the point of a pencil. Have a child draw a line with the pencil

going around the 2 pins. Ask them if the orbit shown is a circle? What is it? (Ellipse) Compare this to a circle.

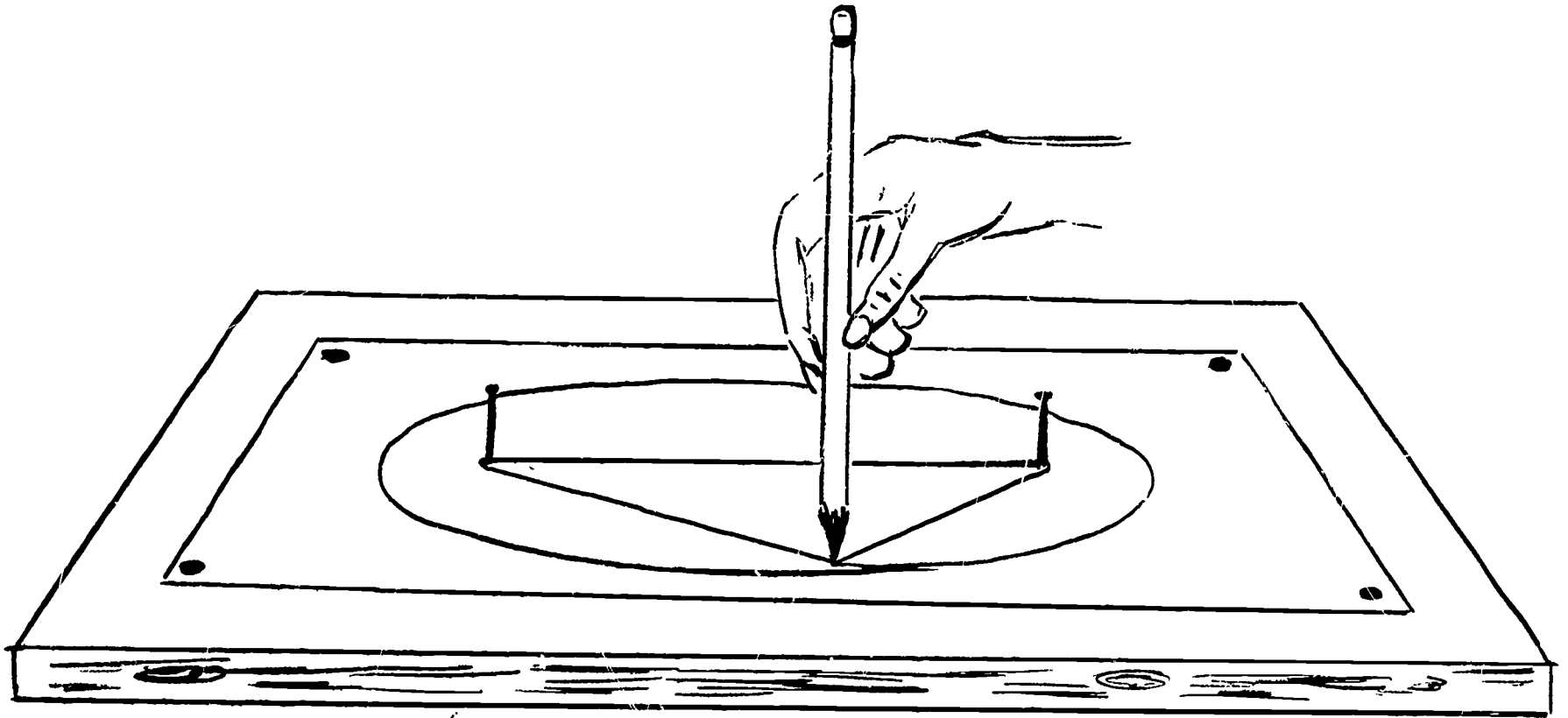

18. Leading Question:

Why is the moon constantly changing? Why do we see different phases of the moon?

A. Materials:

Trippensee Planetarium

Procedure:

Move the earth in its orbit so that the moon make one revolution around the earth.

Move the moon around the earth very slowly, observing it in various positions by looking over the top of the globe from the opposite side from the moon. Notice that as the moon travels, we on earth cannot always see the entire lighted portion of the moon, as the black (unlighted portion) is not visible.

Note to Teacher:

For simplification the Trippensee has one side of the moon colored white while the other is black. This might lead one to believe that the moon always keeps one side toward the sun. This is not true.

The moon makes one rotation during each revolution. Therefore, all sides of the moon face the sun in turn. However, the moon does keep the same side toward the earth - we do not see the "back side" of the moon. The coloring on the planetarium does help to clarify the phases.

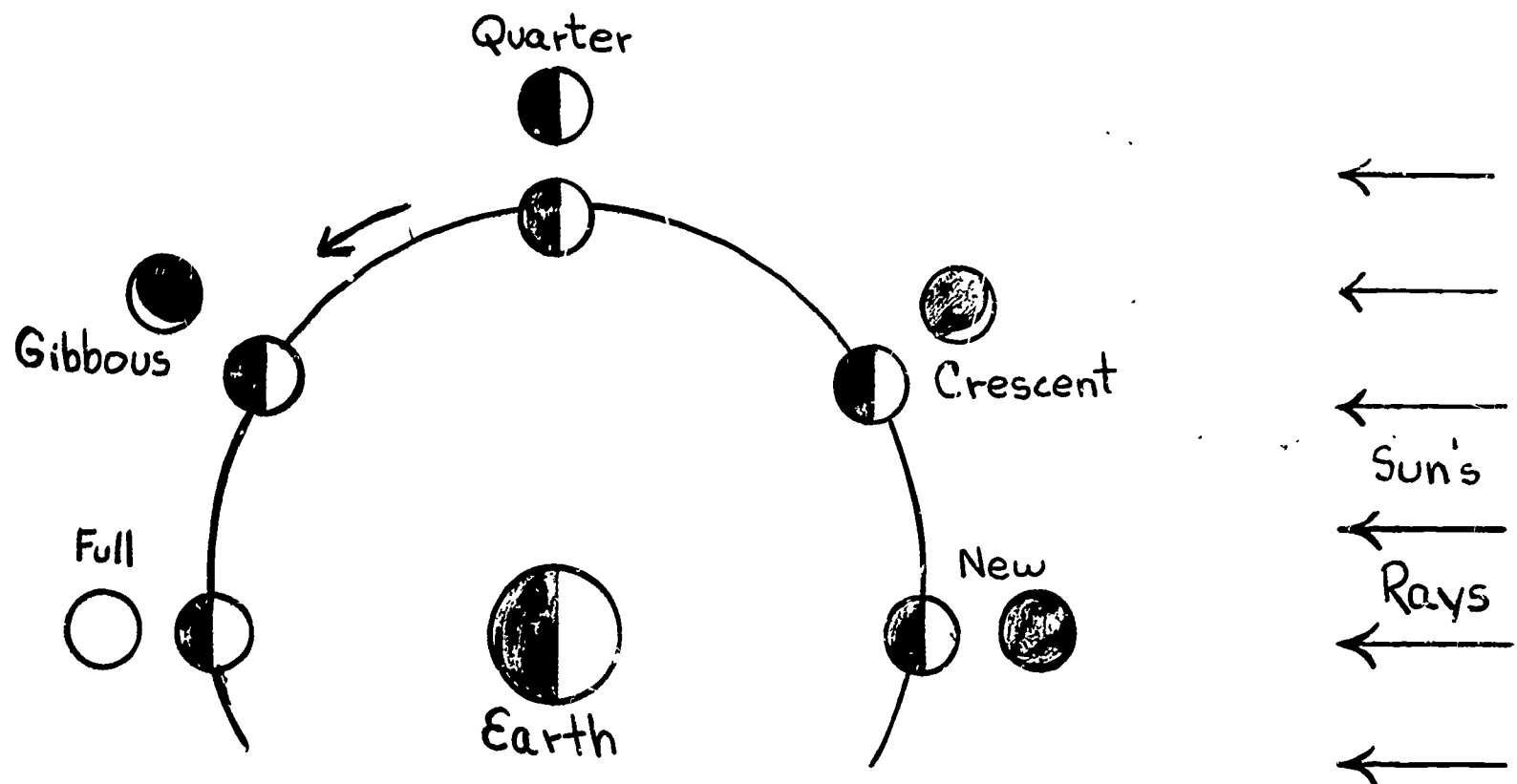

The Phases of the Moon

The outer figures show the phases as seen from the earth.

**B. Materials:**

Piece of wood (5" square), cleat socket that can be attached to base, 15-25 watt bulb, electric cord, globe of frosted glass (porch light type)

**Procedure:**

With wood screws, attach the socket to the base. Paint half of the globe black (Tempera water paint works well). Place the globe over the bulb and light the lamp. The side which is illuminated represents the side of the moon which is facing toward the sun. Keeping the moon in a stationary place in a darkened room, turn the base so that the different phases appear. Begin with the new moon and turn it clockwise so that the phases of the



moon appear in order. Remind the children that the moon does not have light of its own like this globe does.

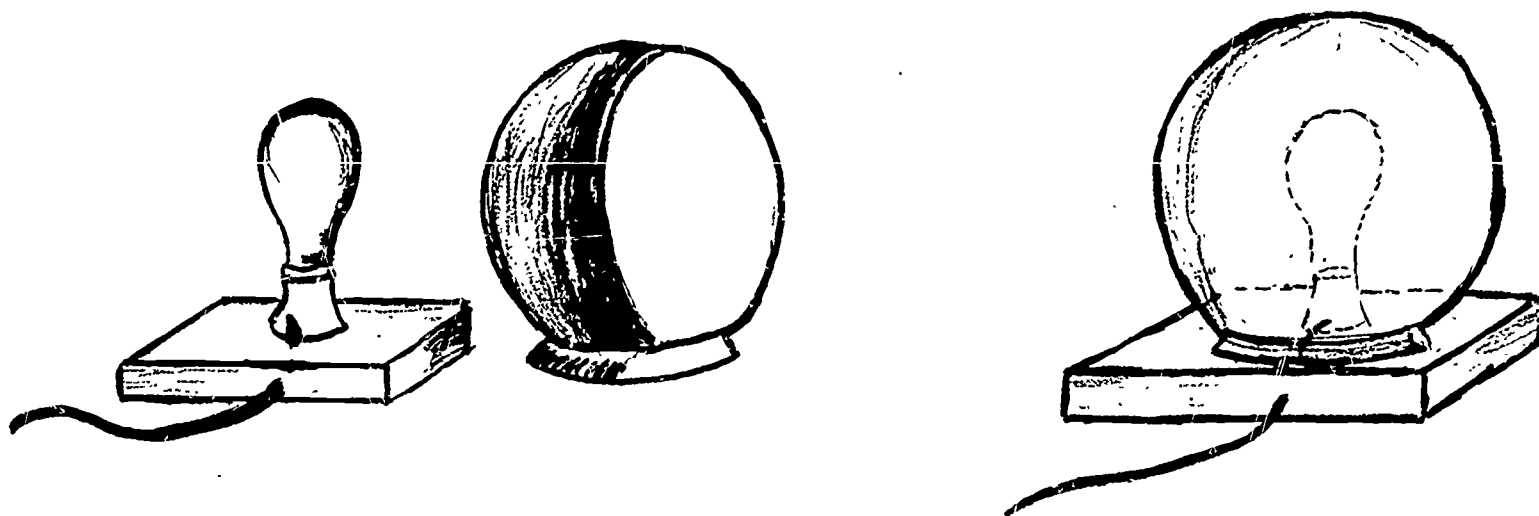

**C. Materials:**

30 pieces of 7 x 4 inch cardboard, 3 pieces of orange construction paper, 3 pieces of black construction paper

**Procedure:**

Cut 29 circles (3 inches in diameter) from the orange construction paper. Cut 30 circles (3" in diameter) from the black construction paper. Overlapping the circles as necessary, pattern the progressive phases of the moon and mount them on the pieces of cardboard. Punch two holes in the top of each card so that they may be bound together. Number each card beginning with one (black new moon) to 30. The first 15 will be waxing phases - the moon is getting larger. Numbers 16 - 30 will be the waning phases - the moon appears to be shrinking. Also write the name for each phase on the card. Tie the cards together and hang up at a conspicuous place. Have the pupils observe the moon each night and turn up the proper card in the morning. The children can draw a small picture of the moon each day. They will become more aware of the changes in the moon's appearance.

**Note to Teacher:**

After new moon phase is called crescent until the eighth day when the first quarter appears. The moon is then in gibbous until the fifteenth day, when it is full. Another gibbous phase (reversed to previous one) appears until the twenty-third day when the moon is in the last quarter. Crescent moons again appear and become smaller until finally there is no moon visible.

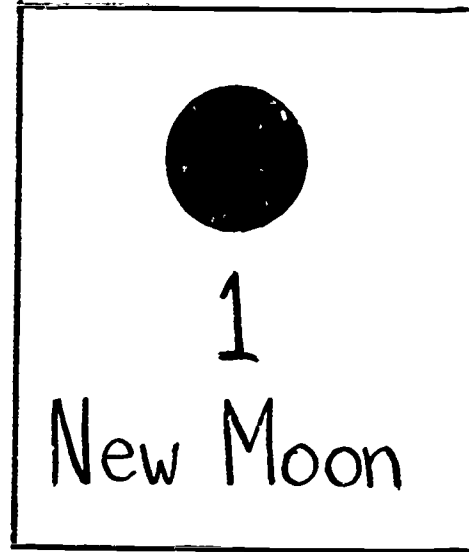

**19. Leading Question:**

What causes an eclipse of the moon?

**Materials:**

Trippensee Planetarium with floodlight

**Procedure:**

Orient the planetarium. Move the earth through several seasons. Notice the location of the moon with respect to the earth and sun. What does the earth do to the sun's light? Notice the shadow area behind the earth. What happens to the moon as it passes through the earth's shadow?

Does an eclipse occur each time the moon revolves around the earth? Why or why not?

(Planetarium may be slightly misleading here. Have the pupils do some research.)

**20. Leading Question:**

Why can we see planets (or moons) in the sky?

**Materials:**

Filmstrip projector, ball

**Procedure:**

Darken the room. Use a filmstrip projector to represent sunlight. Shine the light on any object in the room. Now we can see this object because of reflected light. Compare this to the moon.

Place a ball, which represents a planet in space in a dark closet. Close the door partly so that the ball cannot be seen. Using the projector to represent sunlight, shine it on the ball through the partially opened door. Can you see the ball? (Like the ball, the planets reflect the sun's light to us.)

21. **Leading Question:**

What happens to the North Pole as the earth wobbles?

**Materials:**

Farquhar "Earth in Space" (Central Science Materials Library)

**Procedure:**

Observe how Polaris seems to be directly over the North Pole. How does this help establish directions in the sky. (Polaris is near the celestial North Pole. The celestial equator is an extension of the earth's equator.)

Examine the black circle continuing around from Polaris. As the earth goes through its wobbling cycle (precession) the axis will be pointed toward places along this circumference.

Will Polaris be our North Star in 8500 A.D.? (No) If the north celestial pole is shifted will what will happen to the celestial equator? (Will it shift).

What does the imaginary line for the equator of earth help us determine? (Location, distance) How might we use latitude and longitude in space? (again for location).

22. **Leading Question:**

How do we know the earth wobbles?

**Materials:**

Toy tops

**Procedure:**

Set several tops spinning. Notice the motion of the tops as they begin to slow down. Watch the axis shift as friction causes the top to spin more slowly. What force pulls the top down on one side? What nearby heavenly body might exert a force on the earth as it rotates?

**Note to Teacher:**

The axis of rotation of the earth moves slowly in a circle in a manner similar to the top. This motion, precession, is so slow that it takes 25,800 years for one complete rotation. As it moves, the orientation of the earth's axis, with respect to the stars is changed, so that Vega will become the north star in 14,860 A.D. (See Trippensee Manual p. 43).

23. Leading Question:

How long is a day?

Materials:

Clock with second hand, sun dial or gnomon

Note to Teacher:

We say that a "day" is the time it takes the earth to rotate one time on its axis. The Babylonian and Egyptian astronomers worked out a method for dividing the day into time units of hours, minutes and seconds. But, does it actually take the earth 24 hours to make each rotation? The length of time depends on how and when you measure a day.

Procedure:

Use a sun dial or gnomon to determine when the sun is at its zenith or 12:00 noon. Start the clock making a record of the setting. Record the time that the sun reaches its zenith the following day. Determine the exact number of hours, minutes and seconds in this day and repeat for several days.

The length of the solar day is 24 hours, more or less. Some days will be shorter and some longer. Why is this true? (Remember that the earth is moving forward in its orbit by 170,000 miles per day. Thus it must make more than the complete rotation in order to bring the observer back to the same angle with the sun. Also, when the earth, is closest to the sun, it travels faster than when it is farther away. Then the amount of extra rotation is increased.)

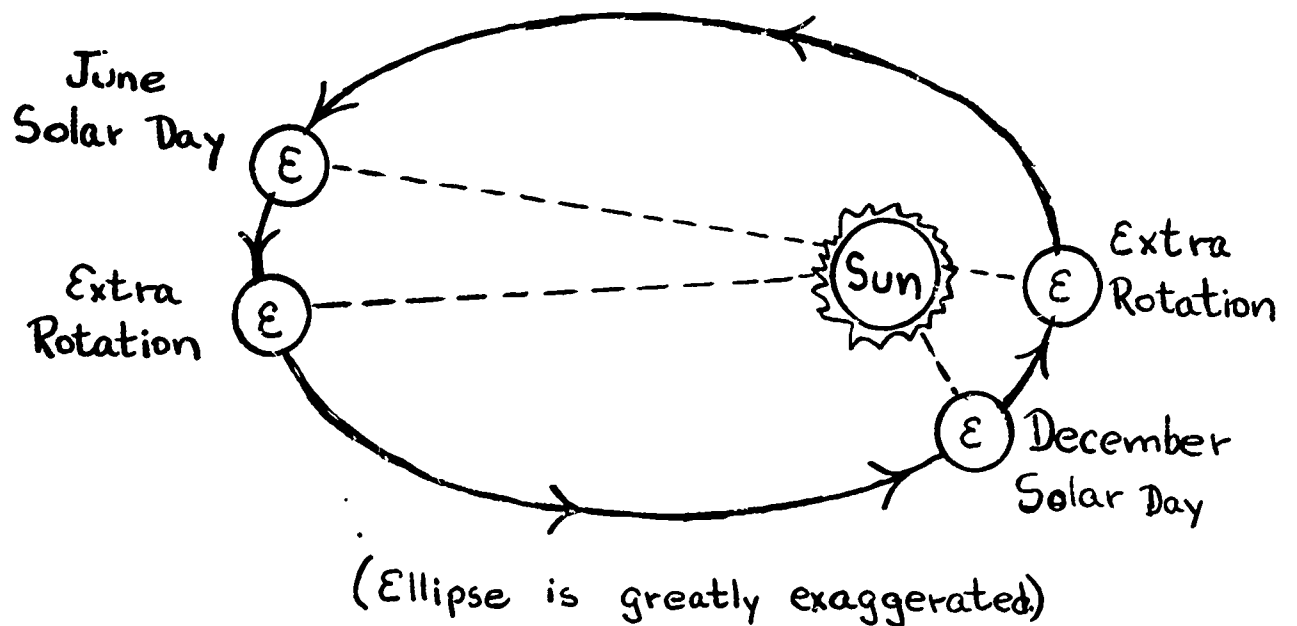

The length of the solar day is longer in our winter because the earth is then moving faster in its orbit. If the earth moved at exactly the same speed all the time would all solar days be the same length?

Obviously, we do not adjust our clocks each day. How do you think astronomers have figured this out? We use a mean solar day or average day that always has the same length. (Actually astronomers use their instruments with the stars to find out the correct time. The pupils might try to find out why star measurement is more accurate, and even try this.)

24. Leading Question:

Why is Polaris called the North Star?

Materials:

Trippensee Planetarium

Note to Teacher:

This model is designed to show that the earth's axis always points toward the north star.

Procedure:

Establish directions (N) in the classroom. Move the whole planetarium on its base so that the compass needle points to the north. Note the direction in which the North Pole of the earth is pointed. Discuss the fact that Polaris is located in the region above the North Pole. Move the red arm so that the earth revolves about the sun. Observe the direction in which the pole points during the earth's revolution.

25. Leading Question:

How do we know what time it is?

Materials:

Trippensee Planetarium, world map (showing longitude, time zones if possible)

Procedure:

Rotate the earth so that pupils are conscious of the way in which the earth's rotation produces night and day.

Notice that in each rotation there is a place where the sun is most directly overhead a given area (eg. Pennsylvania).

Observe that a given area circumscribes a full circle (360 degrees) from one noon or zenith to the next. We know that the period of time for one rotation has been divided into 24 hour periods. Since there are 360 degrees through which the earth turns in 24 hours through how many degrees does it turn in one hour? Standard meridians are marked off around the world for each 15 degrees. The local times on these meridians differ by whole hours. Is the time the same between these lines? What would happen if each place would go by its actual time?



Time zones have been set up where local areas adjust their time to the standard meridian. Greenwich meridian was chosen as the beginning place. What time would it be in the first time zone west of Greenwich when it is 3:00 P.M. at 0 degrees? What is the time in the first time zone to the east.

Move westward on the map from Greenwich. Subtract one hour in each time zone. What would happen if you would continue around the world and continue counting back? Can we turn the clock back? Locate International Date Line and determine its significance.

26. Leading Question:

How does our earth move in relation to the other planets?

Materials:

Verson Solar System (Central Science Materials Library)

Procedure:

Attach all planets, lining them up in a straight line before turning the machine on. The planets will move at their own relative speeds. (Speed scale is accurate, but size and distance are not.) Which planets are traveling the fastest? The slowest? Which planet has the shortest year? Notice which planets have moons similar to the earth. These can be moved by hand. Why are we able to see Mercury and Venus as morning and evening "stars". Would we ever be able to see Venus at midnight?

Why have Mars and Venus been chosen for space probes? In what way does the movement of these planets affect the launching of rockets to reach them?

27. Leading Question:

How does a pendulum work?

Materials:

String, weight, stand (upright with a crossbar) or hook from which pendulum can swing freely.

Procedure:

Tie weight on string and fasten string to stand. Allow pendulum to swing freely and observe. Decide on set distance to begin swing and keep a record of the number of swings per minute. Let everyone participate in many trials. Find the average number of swings per minute. Notice that as the pendulum slows down it makes a smaller arc, but each swing, regardless of size, takes the same amount of time. Repeat process with a shorter string. Does this pendulum take more or less time for a complete swing? Do all of its swings require the same amount of time, regardless of the distance covered?

Length of String	Number of Swings Per Minute		
	Trial #1	Trial #2	Trial #3

28. Leading Question:

How can a pendulum help us to know that the earth turns?

A. Materials:

Heavy metal ball (such as a 16 lb. shot), long wire (15 to 20 feet), steel hook, suspension bracket, room with high ceiling, hook mounted on the wall.

Procedure:

Hang the heavy ball at the end of the long wire, from a suspension bracket in the ceiling. The steel hook must be sharpened and rest in a depression ground in the bracket.

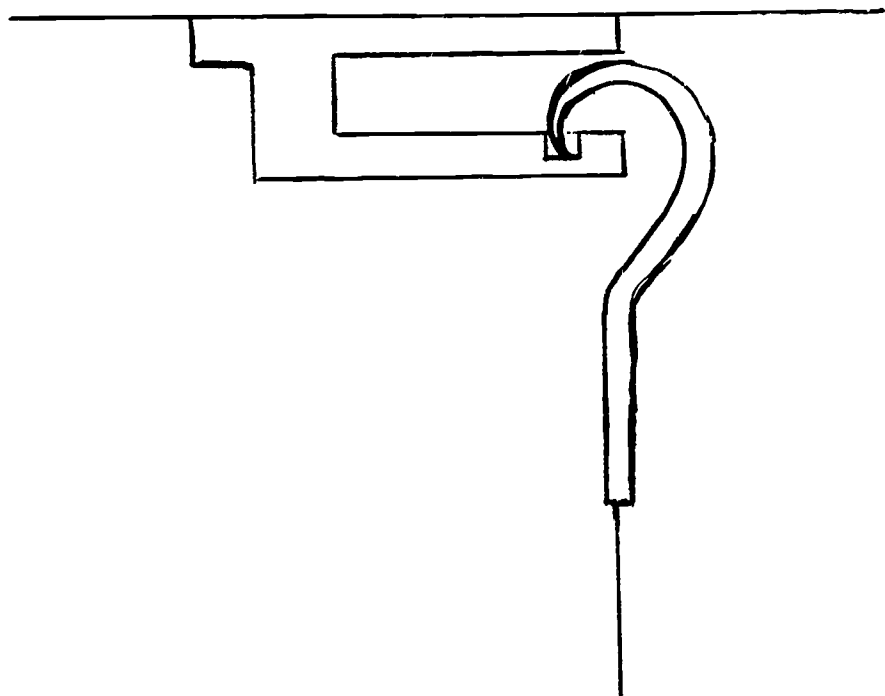

Pull the pendulum aside and tie it by a string to the wall. When it is perfectly still, burn the thread, so that the pendulum is released without any disturbance. The pendulum will continue to swing freely because the support is

practically frictionless. Make a mark on the floor parallel to the direction of the pendulum's swing. Every half hour make another mark parallel to the swing of the pendulum. What appears to be happening to the pendulum? (It seems to be shifting clockwise) Is the pendulum changing? Was there anything to change it? Obviously the earth is turning under the pendulum. Because the support is almost frictionless, the rotation of the room is not communicated to the pendulum.

**B. Materials:**

Large iron staple, bent nail, long wire, can of sand (or other heavy weight), wire basket, small pendulum, rotating stool.

**Procedure:**

Suspend the weight from the highest possible point. Try to have it as free from friction as you can.

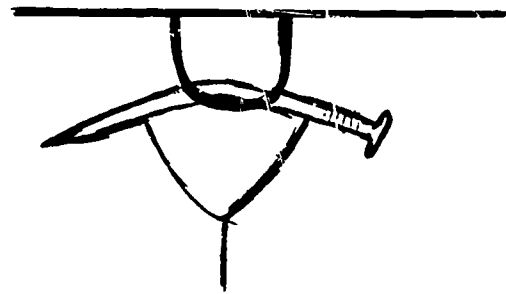

The pendulum should just clear the floor as it swings. Place a circle of upright chalk or small plastic medicine bottles in a circle around the midpoint of the pendulum's swing. Place the circle markers quite close together (diameter should be about two feet). Bring the pendulum about 3 feet back to one side and tie it with thread. When it is perfectly still, burn the thread with a match. Arrange the pendulum so that it will swing back and forth over a north-south path. Allow the pendulum to swing freely and check every half hour. Have more of the bottles been knocked over? In what way has the original path of the pendulum's swing changed? Is the pendulum changing its direction or is it the earth under the pendulum? The force of inertia keeps the pendulum swinging in the same place. In the northern hemisphere the pendulum seems to turn to the right, i.e. the path it makes will move toward a N.E. and S.W. direction. In which direction would the pendulum appear to turn in the southern hemisphere (to the left, i.e., from the north-south swing to a northwest-southeast swing). Would the pendulum turn at the equator? (No) What would happen at the poles? (The pendulum would circumscribe a full circle once each day).

C. Materials:

Yardstick, string, stone, rotating stool (piano).

Procedure:

Place a wire basket on a rotating stool. Hold a swinging pendulum over the basket. Notice the direction of the swing. Rotate the stool. Does the pendulum change direction? (No) Would it appear to change direction from a point of view at the bottom of the wastebasket?

ACTIVITIES TO ASSIGN FOR HOMEWORK OR INDIVIDUAL RESEARCH

29. Leading Question:

How could we make a telescope with which to study the stars?

Materials:

Two mailing tubes, one slightly smaller in diameter so that it fits inside the larger tube, four cardboard discs, four cardboard rings, two lenses (convex)

Procedure:

There are two lenses necessary to make a simple telescope. The one lens (objective lens) must have a fairly long focal length (about 8" - this can be measured by standing next to a wall that is 30 feet or more from a window opposite it. Move the lens so that it produces a sharp image on the wall. The distance from the lens to the wall is the focal length.) A stamp magnifier (focal length about 1") makes a good eye-piece lens. Cut two discs of cardboard exactly the inside diameter of the mailing tube. Glue to either side of the objective lens and place just inside of the larger tube. Hold it in position with cardboard rings on either side of it. The eye-piece lens is mounted in the same way and placed in the front end of the smaller mailing tube. This smaller tube is inserted into the larger one on the opposite end from the objective lens. Slide the eyepiece back and forth within the larger tube in order to focus on distant objects.

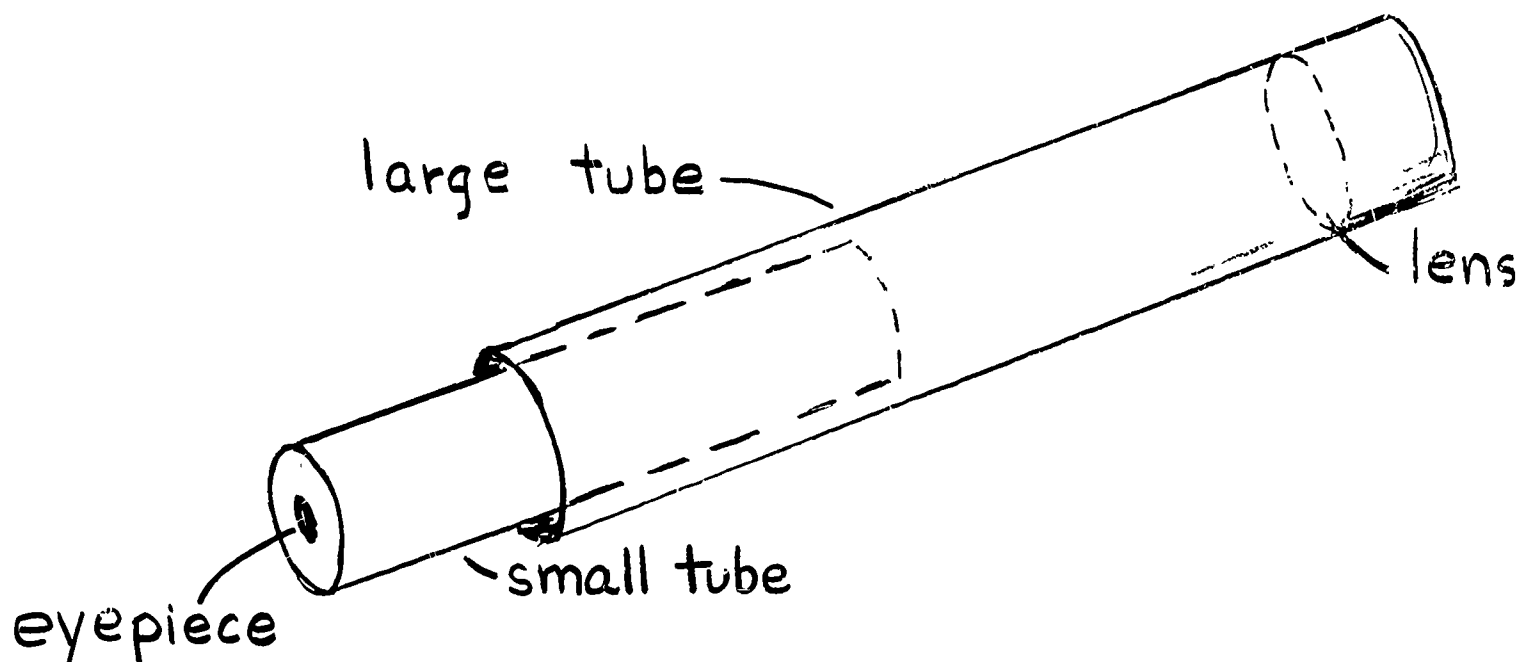



0. Leading Question:

How can we determine our latitude?

Materials:

Protractor, straw, string, paper clip, globe

Note to Teacher:

Latitude is used to determine distance north or south of the equator. The equator is an imaginary line drawn around the earth, midway between the poles. It is important to remember that at the North Pole, Polaris is directly (for our calculations) overhead.

Procedure:

Look at the globe and imagine yourself at the north pole. Point toward the North Star. Here the North Star is directly overhead, so your arm would point straight up. Imagine you are standing at the equator. Again point to the North Star. Your arm should be straight out in front of you.

Make a simple astrolabe to determine the direction of the North Star. Tape a straw to the straight bottom of a protractor. Tie the paper clip to the string and attach this swinging weight to the bottom central point of the protractor.

Sight the astrolabe by looking through the straw toward the North Star. The string will mark an angle on the protractor which is equal to the latitude of the observer.

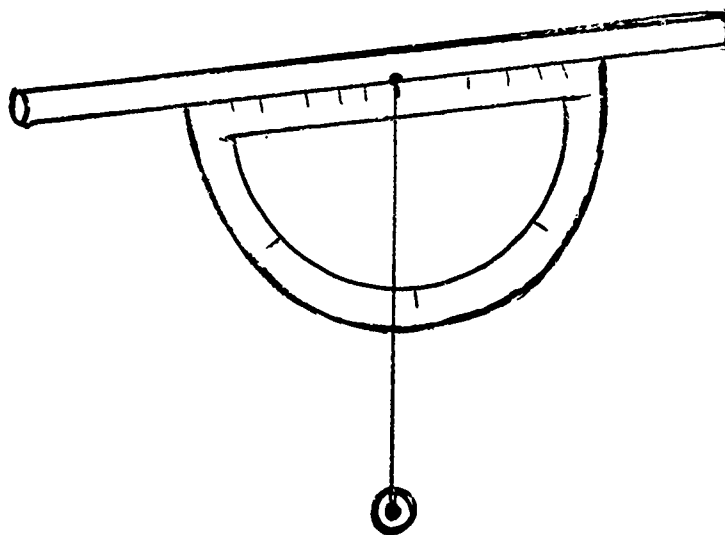

31. Leading Question:

Who are some modern day astronomers?

Materials:

Library

Procedure:

By committees or individual reports obtain information about:

1. Sir James H. Jeans
2. Sir Arthur S. Eddington
3. V.M. Slipher
4. George Ellery Hale
5. Forest Ray Moulton
6. Edwin P. Hubble

32. Leading Question:

What is astrology? Can we rely on astrology and horoscopes as a true science?

Materials:

Encyclopedias or other books to do research on the Zodiac, newspaper and magazine clippings on horoscopes, construction paper, crayons

Procedure:

Before science class ask a pupil to find out what astrology is and to be able to explain the definition to the class. Ask the class how they think you can find out whether astrology is a true science? Guide them to make the following suggestions:

A. Find out what ancient peoples believed in this science and if it worked (Include the signs of the Zodiac)

B. Bring in horoscopes from newspapers and magazines. If there is a variety of sources the children will be able to check how consistent their horoscopes will be for the same period of time. Have them make a chart of their own for a period of a week. Each day have a horoscope in the classroom for each child to read his daily fortune. He can see if this fortune is true and record it on his chart. Possible suggestion for the chart is as follows:

Name Mary Jones  
 Date Week of March 6

Day	Yes	No
Sunday		x
Monday		x
Tuesday	x	
Wednesday		x
Thursday		x
Friday		x
Saturday		x

At the end of the week\*, collect the data and make comparisons for the entire class. From this you can draw your conclusions.

\* The suggested period of a week is merely a suggestion. The class may wish to work on this further.

33. Leading Question:

Are the stars in the same place all night long?

Materials:

Camera, tripod (or homemade stand using a table and books for support), film ("fastest" possible)

Procedure:

Assemble the camera on the tripod and set it to time exposure. Allow the shutter to remain open at least an hour. Notice on the film that each star leaves a trail of light as it seems to move across the sky. Remember, the earth is rotating. The stars appear to move. Try again aiming the camera toward Polaris. What kind of trail will the stars leave in relation to the North Star? (The earth's axis is tilted toward Polaris so this star seems to remain stationary while the others make arcs around it.)

34. Leading Question:

How do we know what the stars are made of?

A. Materials:

Light source, mailing tube, diffraction grating (Central Science Materials Library) mirror

Note to Teacher:

Astronomers can learn about the elements in the stars by using a spectroscope. When certain elements are heated they produce wave lengths of energy which are in the visible light section of the spectrum. The varying temperatures also produce differences in the lines on the spectrum. A simple spectroscope can be made so that children can see the colors in light.

Procedure:

Make a fine scratch one-half inch long on the silvered side of a small mirror. Fasten the mirror to one end of a mailing tube. Cut a hole in the tube so the diffraction grating may be inserted. Hold the mirror in front of a light source (sun or light bulb) so that light shines through the slit. Look through the other end of the tube and adjust the diffraction grating so that a clear spectrum is seen. (Various angles may have to be tried and then the prism can be taped into place).

Try again using a propane burner. In what way does the spectrum change?

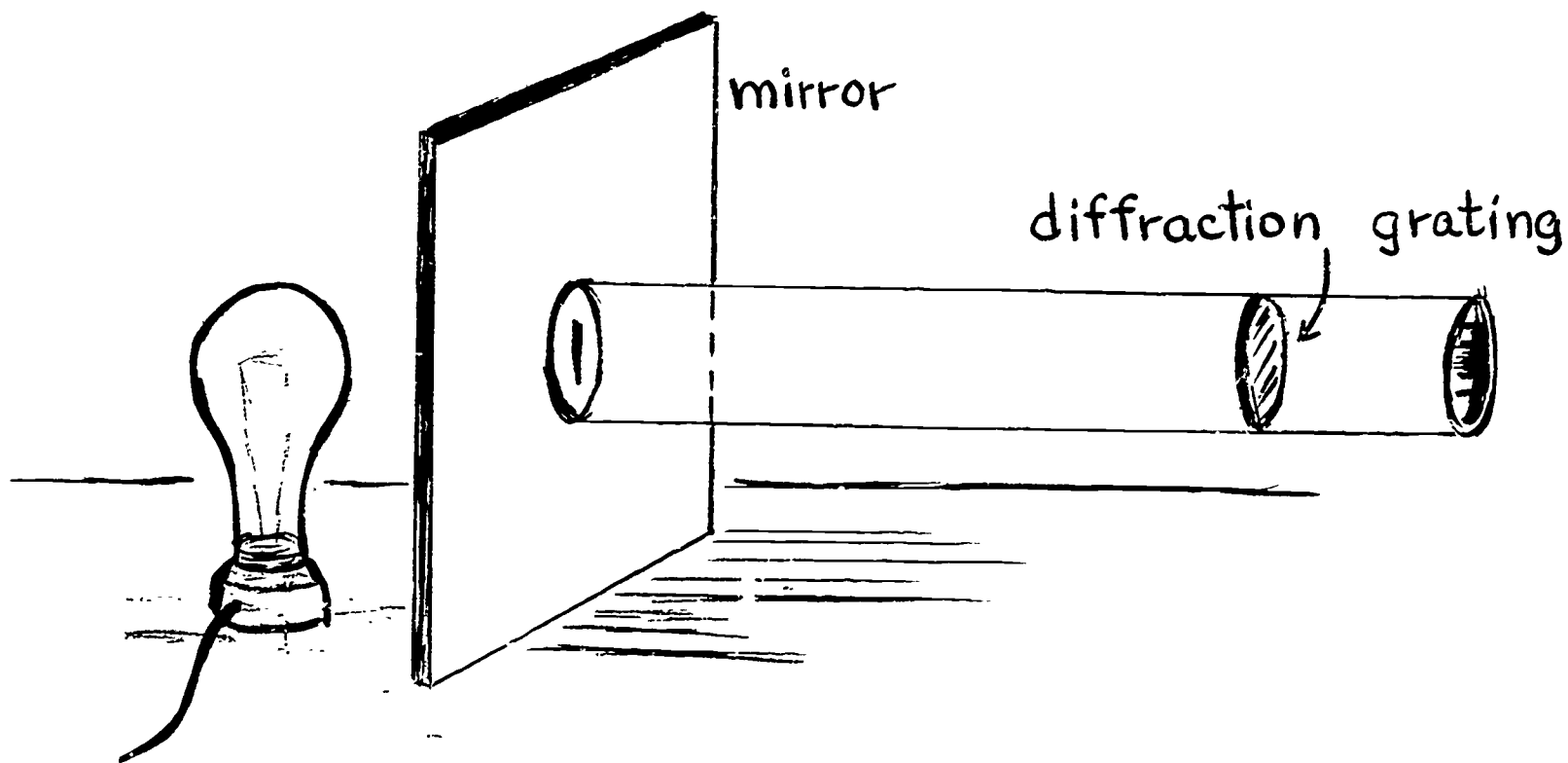

B. Materials:

Shoebox, diffraction grating, razor blade, tape.

Procedure:

The spectroscope can also be made with a shoebox. The diffraction grating is taped behind a  $3/4$ " square hole in the front of the box. A very narrow slit in the back of the box can be achieved by mounting two halves of a razor blade with their sharp edges almost meeting in front of an opening cut in the box. (The diffraction pattern may have to be adjusted to get a good, clear spectrum).

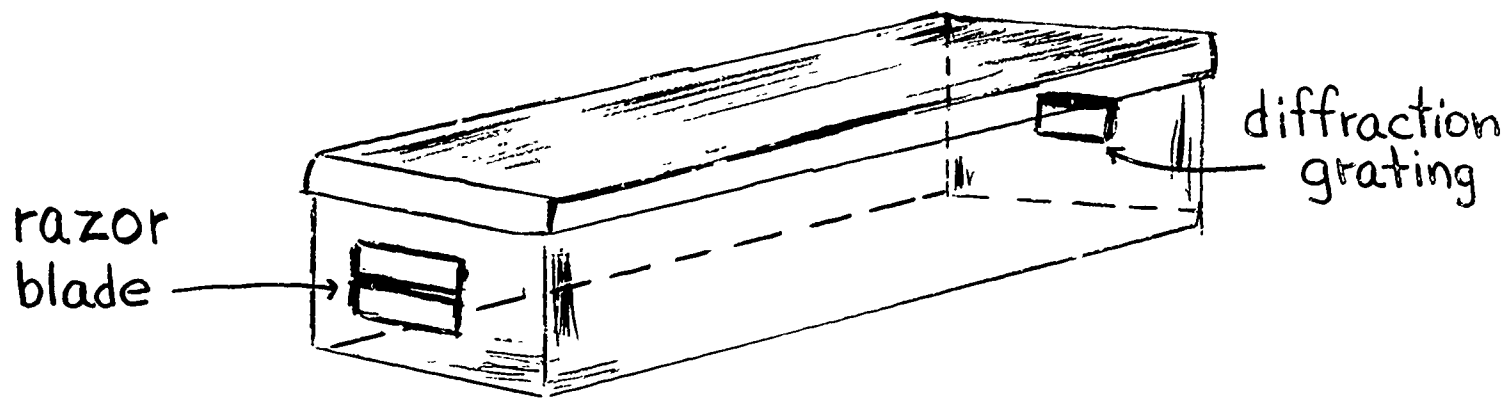

35. Leading Question:

How can you make a spiral by drawing a straight line?

Materials:

Phonograph turntable, oaktag paper, pencil

Procedure:

Ask the children to give their suggestions for solving the question. Perhaps they might like to try to prove their solutions. In order to show them how it could be done, attach a piece of oaktag to the turntable. Turn on the phonograph so that the turntable spins rapidly. With the pencil placed at the center of the paper, draw a straight line toward the edge. Turn off the phonograph and check the "straight line."

Compare this to the spiral motion of the Milky Way Galaxy. If the phonograph is equipped to regulate different speeds, you may experiment with what happens here and compare. See what would happen if you drew a line from the edge of the paper to the center.

36. Leading Question:

We see the sun rise in the east and set in the west. Does it really move across the sky?

Materials:

Playground merry-go-round



Procedure:

Have a few children at a time stand on the merry-go-round. Be sure to have them face forward as they rotate in a way similar to the earth's turning. Notice several objects on the playground. Can you see objects in all directions at once? Move around very slowly so that objects seem to rise and set. Which objects can be seen longer? Which ones seem to travel by faster?

37. Leading Question:

How can we tell when the sun is at its zenith?

Materials:

Straight stick, nail, square board, string, weight, compass

Procedure:

A shadow stick or gnomon can be used to determine when the sun is most directly overhead. Nail the straight stick to the square piece of board. Set the board on a flat piece of ground so that the stick points straight upwards.

Use the weight on the string to assure accuracy in making the stick vertical. Hold the string with the weight near the stick. When the weight stops swinging, adjust the stick so that it is parallel with the string.

Use the compass to orient the gnomon. Mark the directions on the base of the gnomon so that a shift in direction of shadow may be observed. Note when the stick's shadow falls directly on the line pointing north. The sun is then at its zenith.

The gnomon can also be used to determine how high the sun is in the sky. Use a protractor to measure the angle made by the tip of the shadow line. Will this angle become smaller or larger in the winter? after December 21?

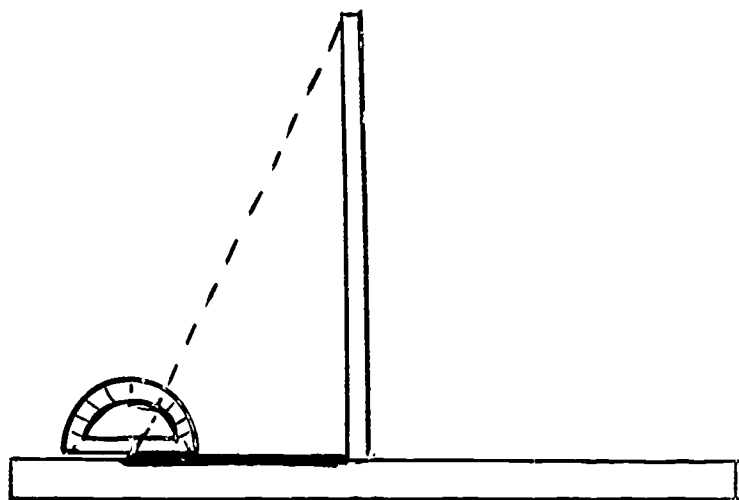

38. Leading Question:

How can we visualize the planets suspended in space?

Materials:

Tall slender bottle (olive jar), medicine dropper, alcohol, water, motor oil (no. 30 weight)

Procedure:

Fill the jar half full of water. Tip the bottle and carefully pour 2 or 3 inches of alcohol in, so that it is on top of the water. Carefully straighten out the tipped bottle and set it on a flat surface. With a medicine dropper add some motor oil (several drops) to the bottle. Here with a little imagination, we see a model of planets suspended in space.

Note to Teacher:

The oil is heavier than the alcohol and lighter than water. Therefore, the droplets will rest where the alcohol and water meet. The motor oil should assume a spheroid shape when dropped in the bottle. Gentle circulation of the bottle can make the planets orbit.

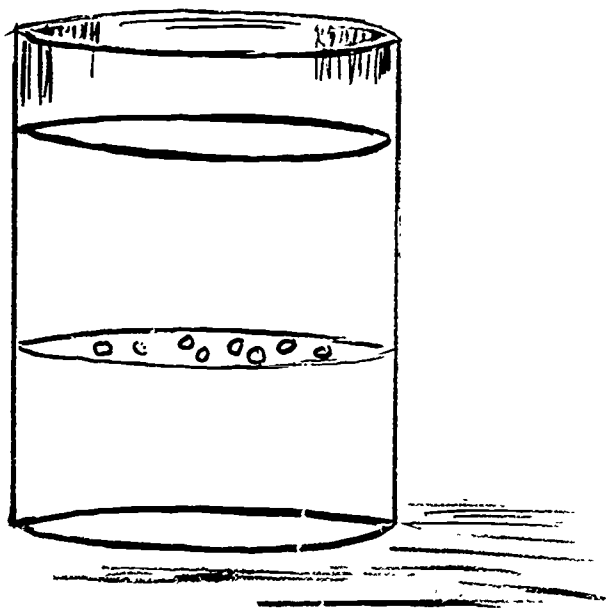

39. Leading Question:

What are constellations?

Materials:

Research books

Procedure:

Have the children research constellations. What are some of the famous constellations? What are their names? How did they get their names? There are interesting stories and legends behind each star group which the children will enjoy. Have a discussion to compile data.

From Atmosphere to SpaceGrade 6Force, Energy and PowerUNDERSTANDINGS TO BE DISCOVEREDRELATED ACTIVITIES

The tendency of objects to remain in place or in motion, is called inertia (Newton's First Law of Motion).	1,2,3,4,5
Inertia is a basic property of matter.	1,2,3,5
A scientist's measure of inertia is mass.	
Mass does not change, but weight does, depending where you are in the universe.	
Weight is a measurement of force exerted by gravity on an object.	5
A force is a push or pull.	6
Centrifugal force is the outward force by an object moving in a circle.	4,7,8,34,35
Centripetal force is the force at the center acting on a rotating object tending to pull toward the center of the circle.	4,7,8,34,35
Forces are in equilibrium if two equal and opposite forces are acting on an object.	9
Velocity is the rate of motion in a particular direction.	5
Acceleration is the rate of change in velocity (speed and/or direction) in a given time period.	10
Falling bodies on earth accelerate at 32 feet per second (or 22 miles/hr.).	10
Force required to produce acceleration is equal to mass times acceleration ( $F=MA$ , Newton's Law of Motion).	10
Work is the result when a force moves an object through a distance.	
The amount of work done depends on how far something is moved and the push or pull needed to move it.	
Energy is the ability to do work.	
Kinetic energy is the energy an object has because it is in motion.	35
Potential energy is the capacity or stored-up ability to do work.	35
Power is the rate of doing work or using energy.	

## SPACE SCIENCE

From Atmosphere to Space

Grade 6

### Distances in Space

#### UNDERSTANDINGS TO BE DISCOVERED

#### RELATED ACTIVITIES

One light year is the distance light travels in one year (365 $\frac{1}{4}$  days).

36

The apparent change in the position of objects when viewed from different places is called parallax.

11,12

The distance of a star is measured by parallax.

11,12

Distances in space can be measured by sighting on an object from each end of a base line.

13,14,37

The longest base line for measuring distances to stars is the distance across the orbit of the earth.

13,14,37

An instrument like a light meter is used to measure the brightness of the light that reaches the earth from a star.

The difference between true brightness and apparent brightness helps astronomers measure distances of stars.

15,16

## SPACE SCIENCE

### From Atmosphere to Space

Grade 6

#### Flight and Space Travel

##### UNDERSTANDINGS TO BE DISCOVERED

##### RELATED ACTIVITIES

Balloons and dirigibles rise because they contain a gas lighter (less dense) than air.

Four forces act on a plane in flight: lift, gravity, thrust and drag.

18

The wings of an airplane provide its lift. This force helps overcome gravity.

17,18,19

The lifting force (lift) of an airplane is provided by the velocity of air over the surface of its wings.

17,18,19

The impact of air across the lower surface of the wing is accompanied by a reduction in pressure on the upper surface

17,18,19

Thrust is the force which drives an airplane forward. This is provided by a propeller or jet.

18,21

Thrust and lift must be stronger than the forces of gravity and drag if a plane is to fly.

18

Drag is the force which tends to hold an airplane back. It is due to friction between the air and the parts of the airplane.

18

Gravity is a force which pulls everything toward the earth.

18

Ailerons control the banking (roll) of an airplane.

18

At take-off the flaps extend the surface of the wing and increase lift. When landing the flaps serve as brakes.

18

Elevators cause an airplane either to climb or descend (pitch).

18

The rudder causes an airplane to turn right or left (yaw).

18

The pilot depends on many instruments to navigate the aircraft.

A helicopter can hover in air.

The propeller on a helicopter is called the rotor. The rotor on a helicopter provides lift.

Helicopters are guided mainly by tipping the rotor. The rotor produces thrust in the direction in which it is tipped. The amount of lift is controlled by changing the pitch of rotor blades.



The small control rotor at the rear of the helicopter controls the direction in which the helicopter will point. It also is used in turning the helicopter.

The internal-combustion engine is the power-unit used for airplanes flying at low speeds and altitudes up to 20,000 feet.

The jet engine is the power unit for airplanes flying at high speeds and high altitudes. 42

Aircraft that fly faster than the speed of sound are called supersonic planes.

The sound barrier is reached as the greatest turbulence of air arises as an airplane begins to fly at the speed of sound. 20

Speed of sound varies with temperature. At sea level sound travels 760 mph at normal temperatures.

The sonic boom is the result of pressure waves which build up around an aircraft flying faster than sound.

The shock wave is a strong pressure wave of compressed air. As a supersonic aircraft rams into the wall of crowded gas molecules, this shock wave is produced.

Aerodynamics is an important factor in airplane design. 19,25,41

Supersonic aircraft are designed to reduce air friction to overcome the heat barrier. 19

A rocket is the only vehicle that is able to function in space.

A rocket, unlike a jet engine, carries its own oxygen and therefore is independent of the atmosphere.

The jet or rocket principle is based on Newton's third law of motion (action and reaction).

Jet and rocket vehicles are moved by the force of high pressure gases generated in their engines.

Thrust (horsepower) is used to express a capability to move weight. 21

The liquid propellant rocket and the solid propellant rocket are the two basic kinds of rockets today.

The forward velocity of a rocket is determined greatly by its exhaust velocity.

A propellant consists of a fuel and oxidizer.

A rocket must reach the speed of 25,000 miles per hour or 7 miles per second to escape the earth. 26

An object must reach the speed of approximately 18,000 miles per hour or 5 miles per second in order to orbit the earth at an altitude of several hundred miles.

26

Multi-stage rockets are used for orbital or space flight.

Each stage of a multi-stage rocket increases the speed of the vehicle and then separates from it.

The moon is a natural satellite of the earth.

Gravity is the force which pulls an earth satellite toward the earth.

The farther away something is from the earth's center, the weaker the pull of the earth's gravity upon it.

To stay in orbit a satellite must move fast enough to counteract the gravitational pull of the earth.

The orbit of a satellite is usually elliptical.

Perigee is a satellite's closest approach to the earth.

Apogee is the most distant point of a satellite's orbit.

Satellites are used for communication, earth measurement, weather observation, navigation, planet exploration and other space investigations.

Telemetry makes it possible for spacecraft and satellites to gather information and relay this information to receiving stations on earth.

Man in space must contend with many psychological factors and physical problems: oxygen, air pressure, water, food, disposal of wastes, acceleration, radiation, weightlessness, meteors and extreme temperature.

22,23,23,27,28,  
29,30,32,33

Developments in the space program have resulted in many new benefits for man on earth: microminiaturization, pyroceram (nosecones-kitchenware), drugs, solar cells and batteries.

38,39

ACTIVITIES

Leading Question:

What is inertia?

A. Materials:

Inertia apparatus, ball, card

Procedure:

Place the ball on the cardboard. Release the spring to knock the card out from under the ball. The ball should settle in the cupped top or the vertical rod.

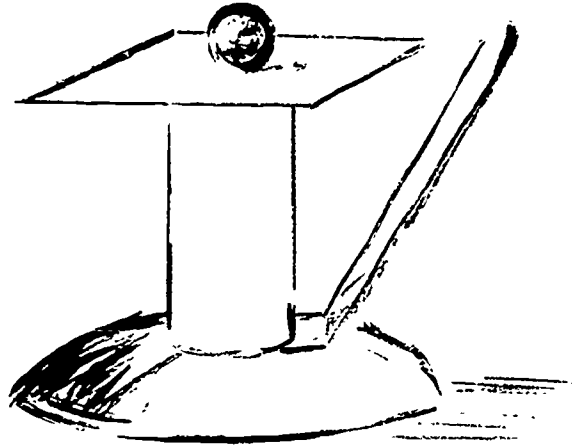

B. Materials:

Coin, glass, card to cover top of glass

Procedure:

Place the card on the top of the glass and put the coin in the center of the card. With your finger, shoot the card off the glass. The coin, instead of going off with the card, will fall into the glass.

Reference:

Refer to Gravity section of Grade 3

C. Materials:

Glass, typewriter paper

Procedure:

Place a sheet of paper on a table with a glass almost full of water and set it about 2" from the top of the sheet of paper. Take hold of the bottom of the sheet of paper and push the lower edge toward the glass until there is a big bend in the paper between your hands and the glass. Jerk the paper toward you quickly. The paper will come out from under the glass, leaving the glass standing where it was.

D. Materials:

6 books

Procedure:

Stack a pile of books. Grasp hold of the one book at the bottom of the pile and give it a quick jerk. Can you get it out without upsetting the whole pile on top?

E. Materials:

8" stick or lead pencil

Procedure:

Fold a newspaper and place it near the edge of a table. Place the stick under the newspaper on the table. Let about half the stick extend over the edge. Strike the stick a sharp blow with another stick. Inertia should cause the one on the table to break in 2 parts.

2. Leading Question:

What happens to an object in motion when outside forces act on it? (Newton's first law of motion)

A. Materials:

Ball or marble, plastic drinking glass

Procedure:

Place the ball or marble in a plastic drinking glass. Push the glass along a large table top in the direction of its open end. Stop the glass suddenly. Why does the ball keep on moving?

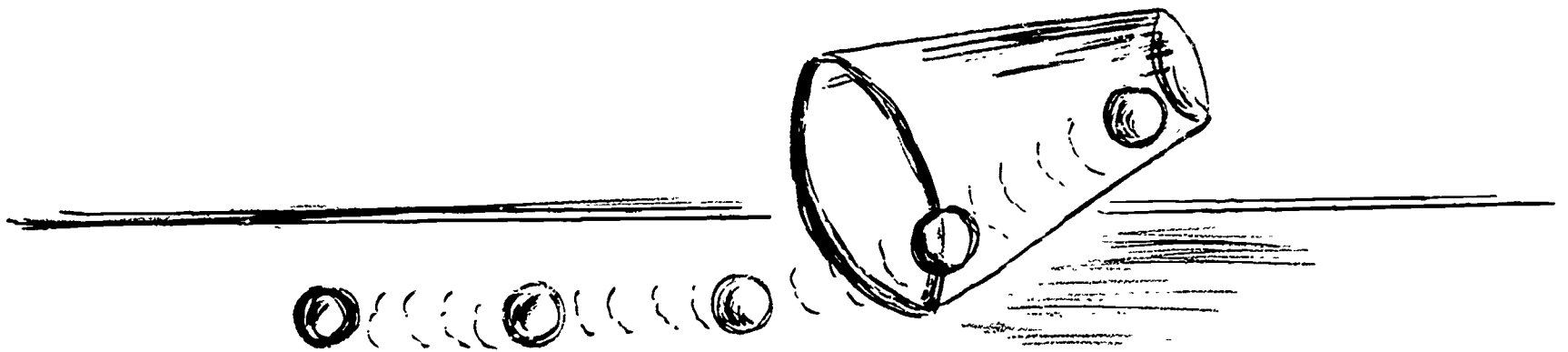

B. Materials:

Can (2 holes punched near top of can), string, cut paper

Procedure:

Put cut-up paper in can. Swing in a full circle alongside your body. If you swing can fast enough, paper will stay in it.



Note to teacher:

Water could be used instead of the cut-up paper, although if experiment fails, the consequences are greater.

3. Problem:

Compute the time and distance it takes a roller skate to come to rest when moving.

Materials:

Roller skate, stop watch

Procedure:

Draw a line on the floor and measure the time and distance it takes a roller skate to come to rest after crossing the line. Preliminary practice with a stop watch should assist students in making more accurate measurements. An underlying assumption is that a constant force due to friction is being exerted on the skate. Observations should be tabulated and graphed to derive some conclusions from the information.

Trial	Distance	Time
1.		
2.		
3.		

Is the acceleration constant? If you double the weight of the skate, what results do you get? What force is required to overcome friction with the empty skate? It is desirable to make 40 or 50 measurements in order to find if any uniformity exists. Is there a relationship between mass and acceleration? Compute the product of mass and acceleration ( $ma$ ). (Newton's Second Law of Motion)

4. Leading Question:

Why does a satellite stay in orbit.

Materials:

Soft rubber ball, piece of string

Procedure:

Tie a soft rubber ball on the end of a piece of string. Swing the ball around in a circle in a horizontal plane. Increase the speed of the ball in its orbit. Is more force required to hold it in place? Release the ball at various points in its orbit and see what happens.

As the child is twirling the ball ask if he can feel the ball pulling away from him.



Many children may try the experiment to see who can throw the ball the farthest. Mention can be made that the hammer throw in the Olympics is of the same principle, also circular rides in amusement parks in which you are thrown to the side of the car, or sliding across the seat of an automobile when you go around a curve.

5. Leading Question:

Does the force exerted on an earth satellite remain the same if the satellite is moved farther away from the earth or if it is brought closer?

Materials:

String, 2 rubber stoppers, weight (small rock), stop watch

A. Procedure:

Place a marker on a string about 20 inches from the end where a stopper is tied. A piece of masking tape will work. Now place the ball in orbit and keep the radius at 20 inches. Use a stop watch to find the time it takes for 25 revolutions of the ball. Divide this time by 25 to get the time for one revolution.

B. Procedure:

Remove the marker and slide another rubber stopper on the string. Tie a weight on the end to represent gravity. Repeat the procedure of swinging the stopper that is attached, so that it orbits your hand which is holding the free-moving stopper. What happens when the satellite moves faster? As it slows down what happens to the rock? As a satellite slows down, which force is stronger, gravity or centrifugal force?

6. Leading Question:

How many forces act on a baseball from the time it is thrown until it is caught?

Materials:

Baseball, 2 gloves

Procedure:

Have a child throw a baseball to another child. The person throwing the ball should see that there is an initial force applied when he throws the ball. The person catching the ball should feel the force applied by the catcher's mitt. Other forces that should be observed are: normal air resistance, force of gravity and possible moving air currents and forces produced by the spin of the ball.

7. Leading Question:

What position will sand take in a bottle of water after it is stirred vigorously?

Materials:

Wide mouth gallon jar, sand, ruler

Procedure:

Drop 2 or 3 tablespoons of sand into a gallon jar half-full of water. Sand will sink since it is considerably heavier than water. When the water is stirred, will the sand move to the outside of the jar or will it collect in the center? Stir the water vigorously with a ruler and let the class observe what happens.

Repeat this activity using various material in place of sand, eg. BB shot, marbles.

Try same experiment using a record player and placing a jar of water with sand in it on the turntable. Do not stir. Will the same thing happen as when you stir it?

Note to Teacher:

Scientists use an apparatus called a centrifuge, a machine that spins material at high speeds to separate things of different weights.

8. Leading Question:

What path does a ball take when released after spinning it over your head?

A. Materials:

Rubber balls (small, large, light, heavy), 3 foot string

Procedure:

In a large room where the floor is smooth, let the class stand around the wall while someone stands in the center and whirls a ball around his head on the end of a 3 foot string. Let the ball go and see if the ball keeps going in a circle. Perhaps the children can observe carefully the path of the ball and can mark it with pieces of masking tape. Try this with the other balls and see what path each ball takes as it is released from its whirling circle.

Note to Teacher:

If possible observe a grinding wheel to see how sparks come off the wheel when sharpening an object.

B. Materials:

2 rubber band chains, tennis ball, ping-pong ball

Procedure:

Ask a child to whirl one ball around his head at a constant speed (the class can count as the ball revolves). Then ask the child to whirl the other ball at the same speed, with the class counting to make sure the speed is the same. How does the stretch of the rubber band chain on the tennis ball compare with the stretch of the rubber chain on the ping-pong ball? Can you see that heavy objects exert more pull away from the center than light objects? What direction will the tennis ball take if it is released?

9. Leading Question:

What is an unbalanced force? (Newton's Third Law)

Materials:

Wagon

Procedure:

Have a child push a wagon across the playground area. Gravity pulls downward and the ground pushes upward and counterbalances the pull of gravity. (equilibrium) The boy pushing the wagon, should be exerting enough force to overcome friction; this creates an unbalanced force and the wagon moves in the direction of the strongest force.

If another boy were pushing with equal force in the opposite direction, we would have a balanced force, and the wagon would not move.

10. Leading Question:

Why does an object fall?

Materials:

Glass marble, steel ball bearing, wood block, golf ball, styrofoam ball, ping-pong ball

Procedure:

Take 2 of the objects such as a glass marble and steel ball. Hold the objects several feet from the floor and allow them to fall at precisely the same instant. Do they appear to strike the floor at the same time? Repeat the experiment using steel or other relatively dense material in combination with a material of low density such as a styrofoam ball or a ping-pong ball. Repeat the experiment using 2 objects made of the same material, but different in size and weight. After many trials have the pupils make a generalization about the way things fall.

11. Leading Question:

How do astronomers determine the distance to the stars? (parallax)

Materials:

Foot rule

Procedure:

Ask a pupil to stand some distance away from the chalkboard with a ruler held horizontally with one end against his forehead and the other end supported by his index finger held vertically. Have him close one eye and sight across the finger toward the end of a horizontal line which is already drawn on the chalkboard. Without moving, he then closes the eye first used and opens the other. A second pupil then makes a mark, according to instructions on the horizontal line at the point that lines up with the other eye. He then erases the remainder of the line. Now measure the distance between the eyes, which is usually about  $2\frac{1}{2}$ ". Measure also the length of the line on the chalkboard in inches and divide this by  $2\frac{1}{2}$ ". The result should be the approximate distance in feet between the observer and the chalkboard.

It will readily be seen that if observations are made at opposite sides of the earth's orbit, sighting across a relatively near star, there will be a similar displacement of distant stars. The

greater the distance the greater the displacement.

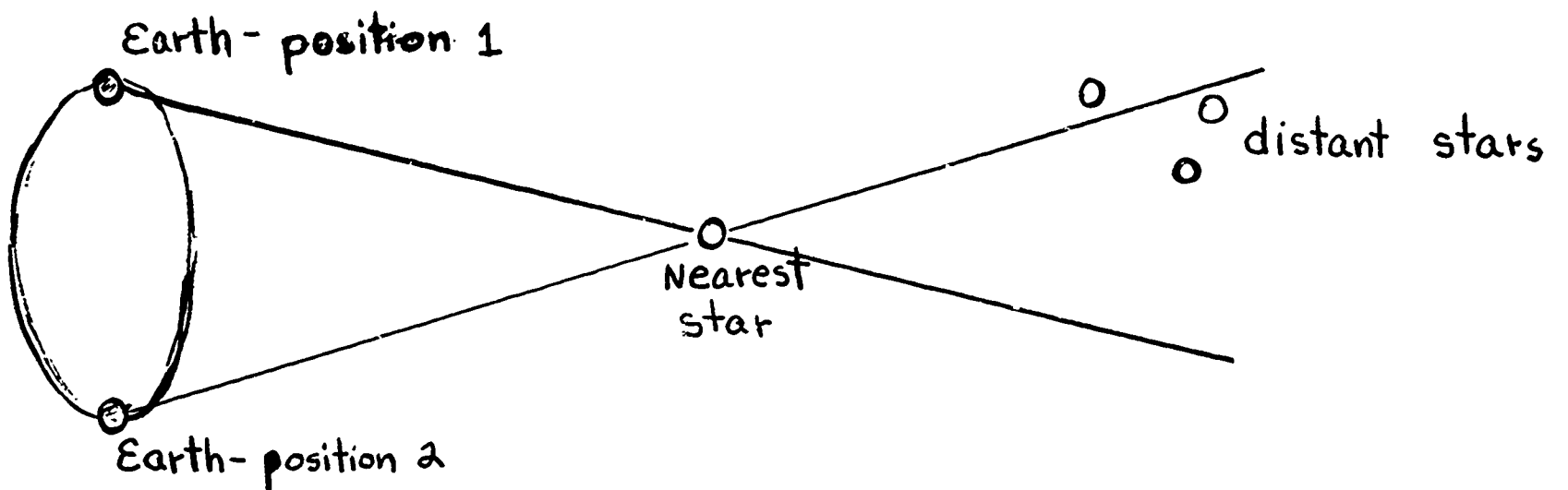
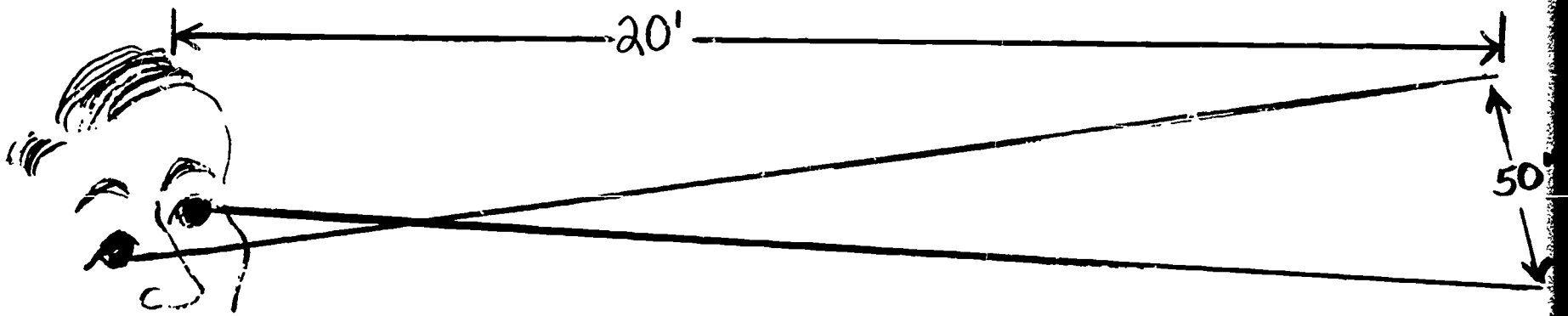

12. Leading Question:

What is the parallax effect?

A. Materials:

Ruler or stick

Procedure:

Hold a small stick in one hand about 12" in front of your eyes. With your other hand, first cover one eye and then the other. What happens? Does the stick seem to move? You may wish to line up the stick with some straight line on the wall to find out how much the stick seems to move against the background. Try holding the stick 2 feet away from your eyes, what difference will you notice? You should notice that putting the stick farther away the parallax effect will be less, putting it closer the parallax effect should be more.

B. Materials:

Chalkboard, pencil

Procedure:

Mark 2 stars on the chalkboard about 4 feet apart. Ask a pupil to hold a pencil at arm's length, close one eye and plot the position on the board. Then have the pupil view the pencil with the other eye and plot the position. This

will provide a record of positions much like an astronomer's photograph.

Note to Teacher:

An astronomer will observe the degrees of the angle at the star section of the triangle. Knowing this angle and the length of the base line, the other 2 sides can be calculated.

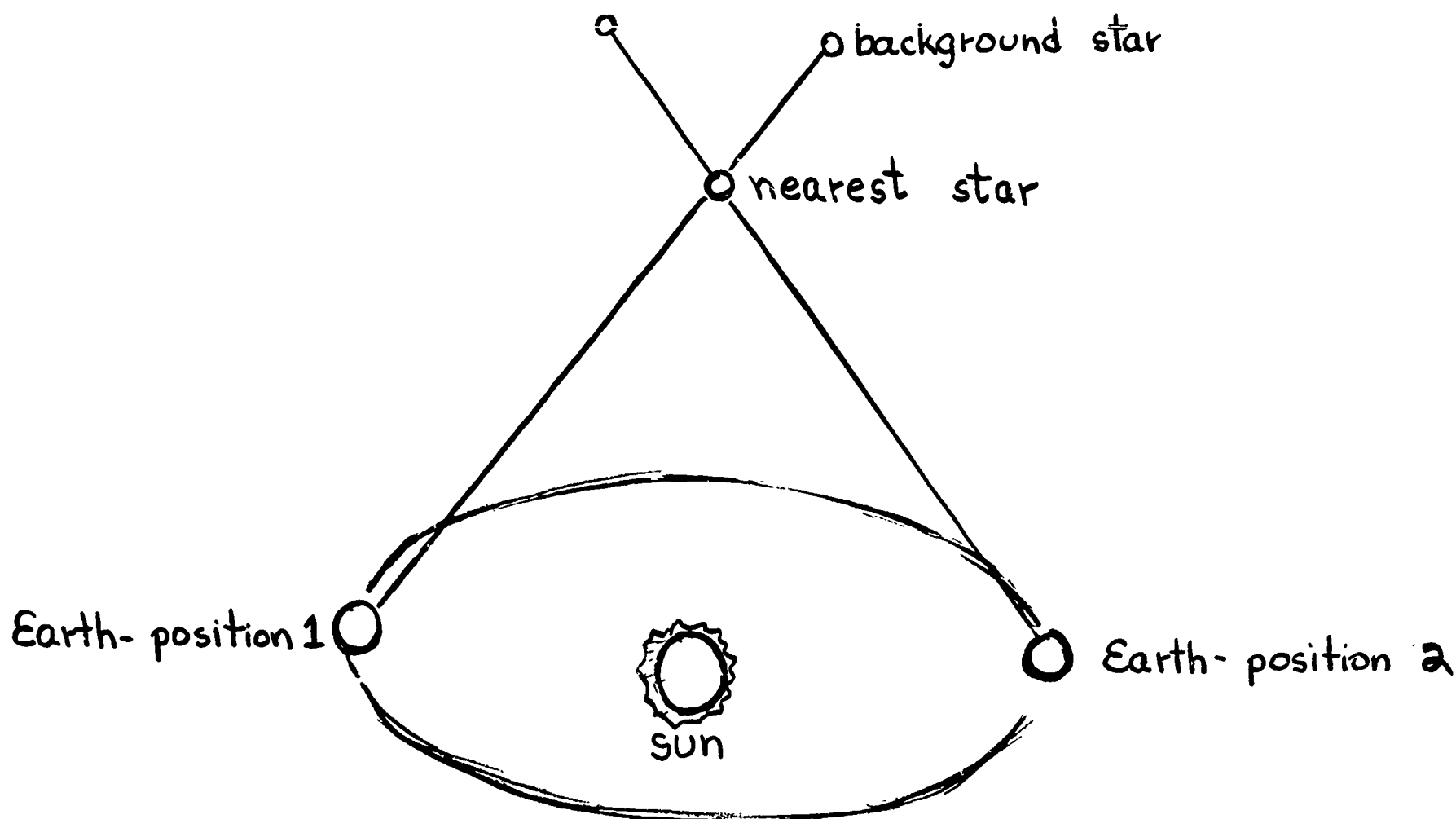

### 13. Leading Question:

How can we compare the distance between the earth and the moon, and other celestial bodies.

Materials:

Globe, 2 strings, tennis ball (moon)

Procedure:

If the globe in your room is 1 foot in diameter, it is on a scale where 1 foot represents nearly 8,000 miles. The moon's distance of 238,000 miles is represented by nearly 30 feet. Fasten 2 strings to a tennis ball as shown in the diagram. Ask the child to take the tennis ball (the moon) out to its proper distance while you hold a string at either side of the earth as shown. The string represents the lines of sight of observers on the opposite sides of the earth. It is then possible to compute the



distance to the moon, knowing the angles for the lines of sight, and the distance between the observers.

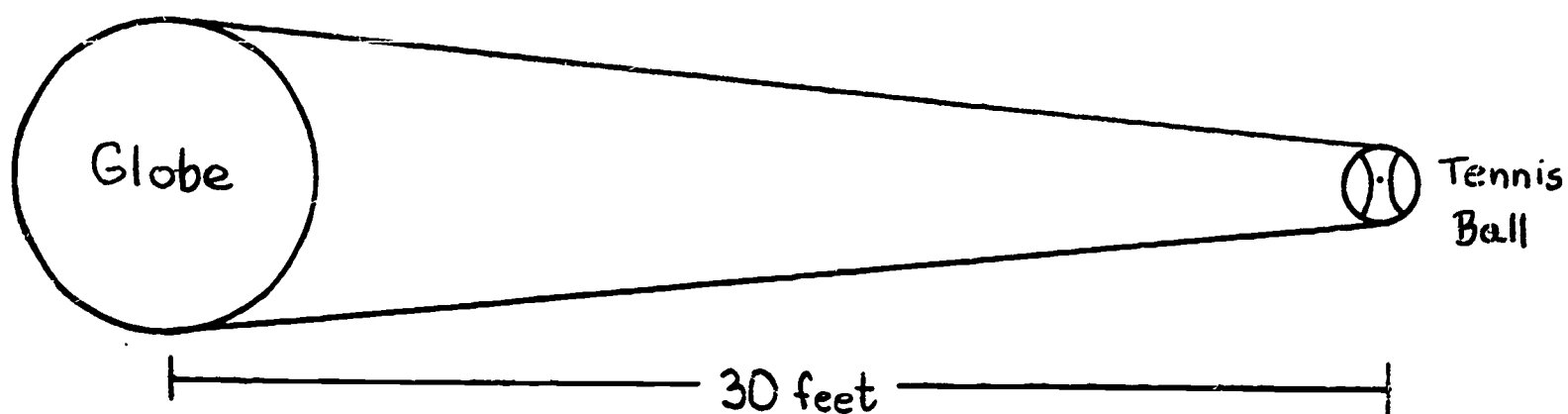

14. **Leading Question:**

How can you measure across a field? (Triangulation)

**Materials:**

Yardstick, 12" ruler, protractor, a pin, straw, large sheets of paper, pencil

**Procedure:**

On the playground measure a line ten yards long. This line will be used as your base line. Repeat this base line along one edge of a piece of paper by drawing a line one inch long. You will be making a scale drawing in which one inch will represent 10 yards.

Fasten the protractor to one end of the yardstick, as shown in the illustration. Pin the straw through the hole in the center of the protractor. Place the yardstick so that the center of the yardstick is even with one end of the line on the ground. Aim the straw at same object, such as a tree, at the other side of the field.

Measure the angle that the straw makes with the yardstick. Draw a line at this same angle from one end of the line on your paper.

Place the protractor and yardstick at the other

end of the line on the ground. Aim the straw at the same object from this end of the line. Measure the angle and draw a line at the same angle from one end of the line on your paper.

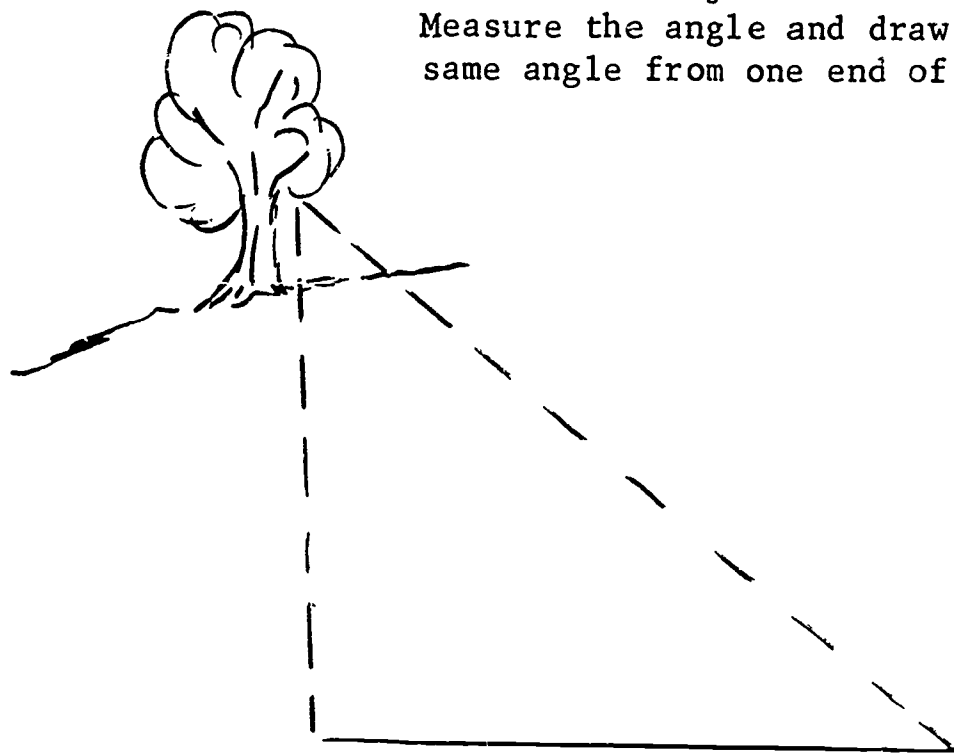

base line

Note to Teacher:

Activities related to triangulation should be planned at several times during the year to re-inforce the students understanding of this principle

15. Leading Question:

How does brightness help to find distance?

A. Materials:

Flashlights

Procedure:

In a dark room, have pupils view the light of several flashlights of varying power through a roll of black paper. Arrange the flashlights so that they are the same distance from the viewer. See if each pupil can tell that one flashlight is not farther away from him than any of the others.

B. Materials:

2 candles, black paper

Procedure:

In a dark room, light 2 similar candles. Place one about 2 yards in front of the other. Let pupils view the light through a tube of black paper. Which candle seems brighter?

The class can observe automobile lights at night to compare the brightness at various distances. The lights appear to become brighter as they get closer to the observer.

16. Leading Question:

How do astronomers measure the light output (luminosity) of stars the same distance from the earth?

Materials:

Light bulbs (10 watt, 100 watt, 150 watt)

**Procedure:**

Use 3 light bulbs of different wattages at the same distance to designate how brightly they shine. The 150 watt bulb shines more brightly than a 100 watt bulb and the 10 watt bulb. Different stars at the same distance would be brighter and some would be fainter. Why? Different stars emit different amounts of light. We say that stars have different luminosities. The apparent brightness changes if the light bulbs are moved to different distances. But the luminosity remains the same no matter where the bulbs are.

**17. Leading Question:**

How is air pressure related to speed?

**A. Materials:**

2 ping-pong balls, 1 straw, thread

**Procedure:**

Suspend 2 ping-pong balls so that they come to rest about one-half inch apart. Using a straw blow a stream of air between the balls. What happens to the balls?

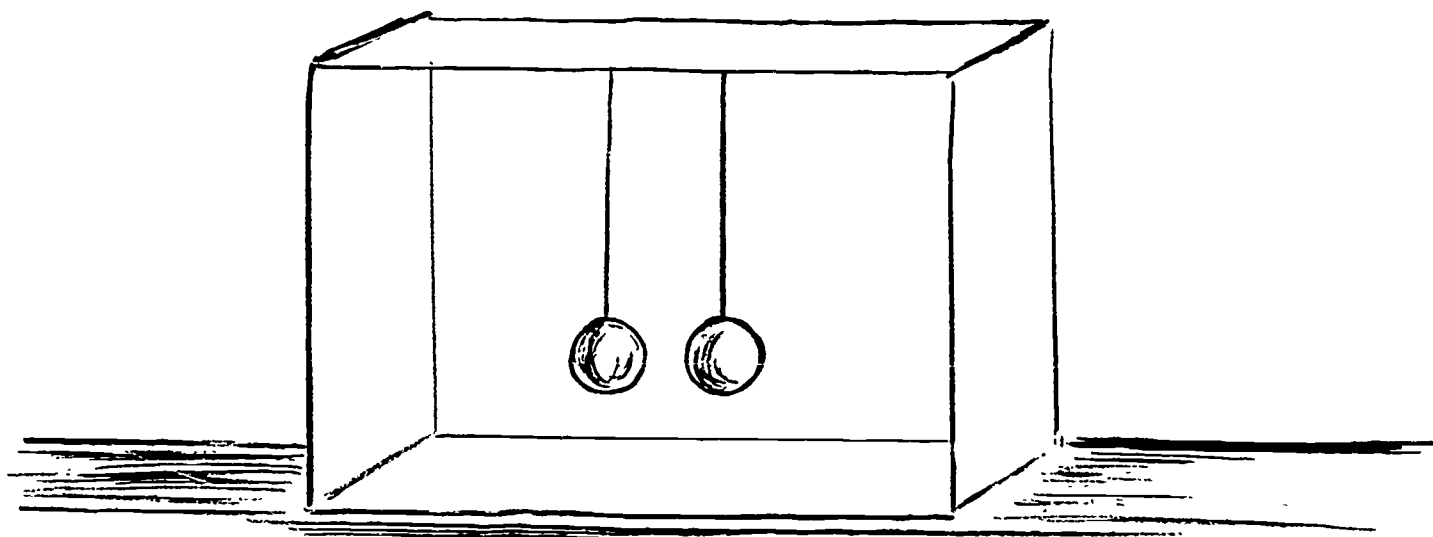

**B. Materials:**

2 pencils, 2 pieces of 6" square construction paper, 1 straw

**Procedure:**

Roll each piece of construction paper into the shape of a tube. Lay the two pencils on a table about three inches apart and parallel to each other. Place the tubes on the pencils about one inch apart. Blow through the straw directing the air between the tubes. What happens to the tubes.

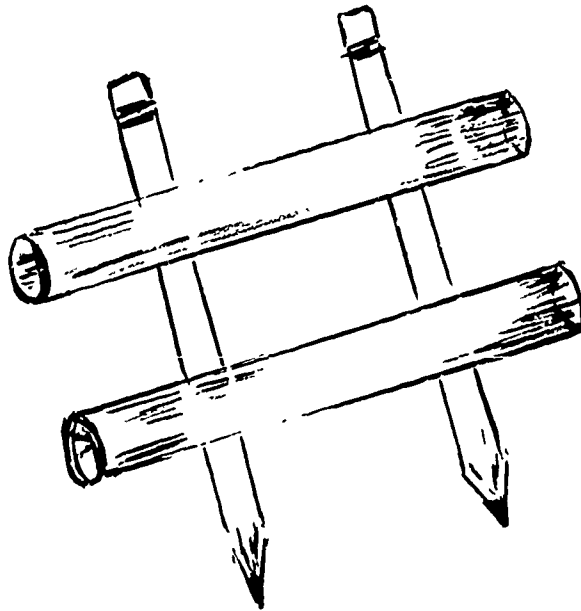

**C. Materials:**

1 tin can (approximately 1 qt. capacity), 1 candle

**Procedure:**

Cut an oblong or square opening in a tin can (a one pound coffee can works well). Place the can over a lighted candle. Have a child blow hard against the opposite side of the can. Observe what happens to the flame. As the air is blown around the can, a low pressure area is created leaving a high pressure within the can. As a result the flame is forced out of the can.

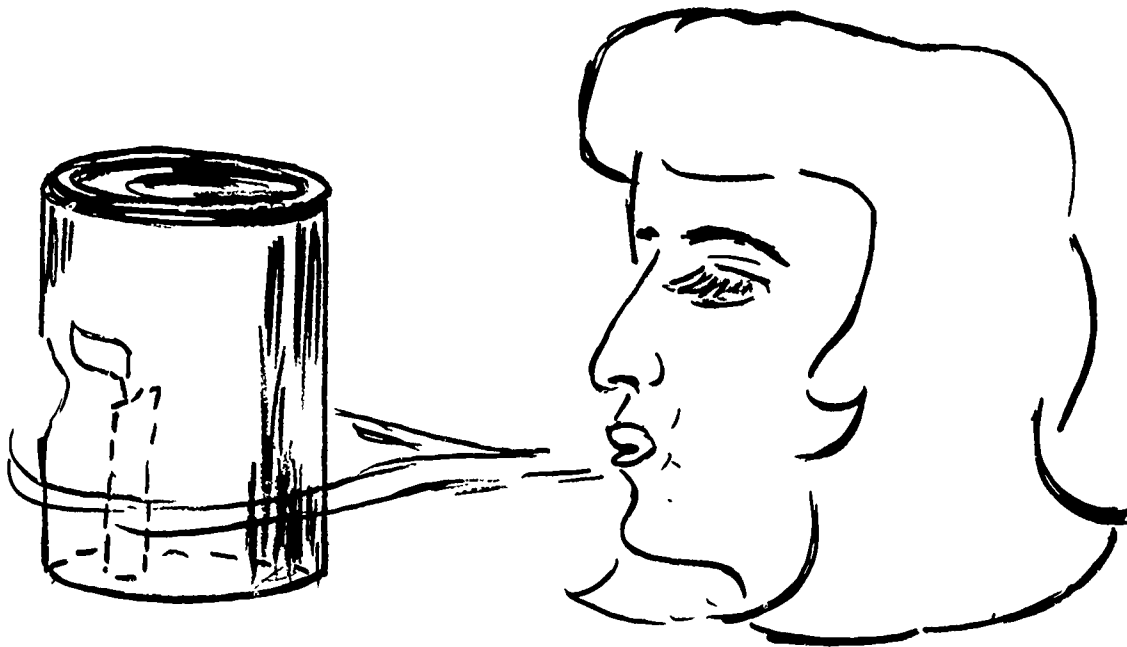

**D. Materials:**

1 empty thread spool, 1 3" x 5" index card,  
1 straight pin

**Procedure:**

Place a pin through center of the 3" x 5" card and insert the pin in the hole of the spool. Blow through the opposite end of the spool. The card will stick to the spool because of the low air pressure caused by the fast-moving air rushing between the card and the spool.

**E. Materials:**

Glass of water, drinking straw

**Procedure:**

Cut a drinking straw almost in half, so that it can be bent at right angles. Place one end of the straw in a glass of water. Blow through the other end of the straw. What happens? How does this relate to an airplane wing?



**Leading Question:**

How is an airplane controlled?

**Materials:**

Airplane model and wind tunnel (Central Science Library Center)

**Procedure:**

Follow instructions included with model.

**Leading Question:**

Why do supersonic aircraft have small wings?

**Materials:**

3 x 5 index card, aquarium or similar basin of water

**Procedure:**

Have a child move a 3 x 5 card against water in an aquarium. First move the card broadside and then with the thin edge against the water. Feel the resistance to motion when holding the card in each of the positions. Compare this to the resistance of air against small thin wings on a supersonic aircraft and larger wings on a slower flying aircraft.



20. **Leading Question:**

How are shock waves created when the sound barrier is broken?

**Materials:**

Round oatmeal or salt box, large balloon, candle, touch paper (available in your science closet)

**Procedures:**

Cut one end of the box off and stretch a piece of rubber balloon over the open end and secure it with a rubber band. Cut a half-inch hole in the center of the other end of the box.

Have a child pluck the end of the balloon and feel the compressed air coming out of the half-inch hole opening.

Light a candle and place it several feet away. Point the open end of the box toward the balloon and pluck the balloon. Observe the effect on the candle.

Using touch paper fill the box with smoke. Repeat the previous experiment, but observe the changing shape of the smoke wave as it emerges from the can.

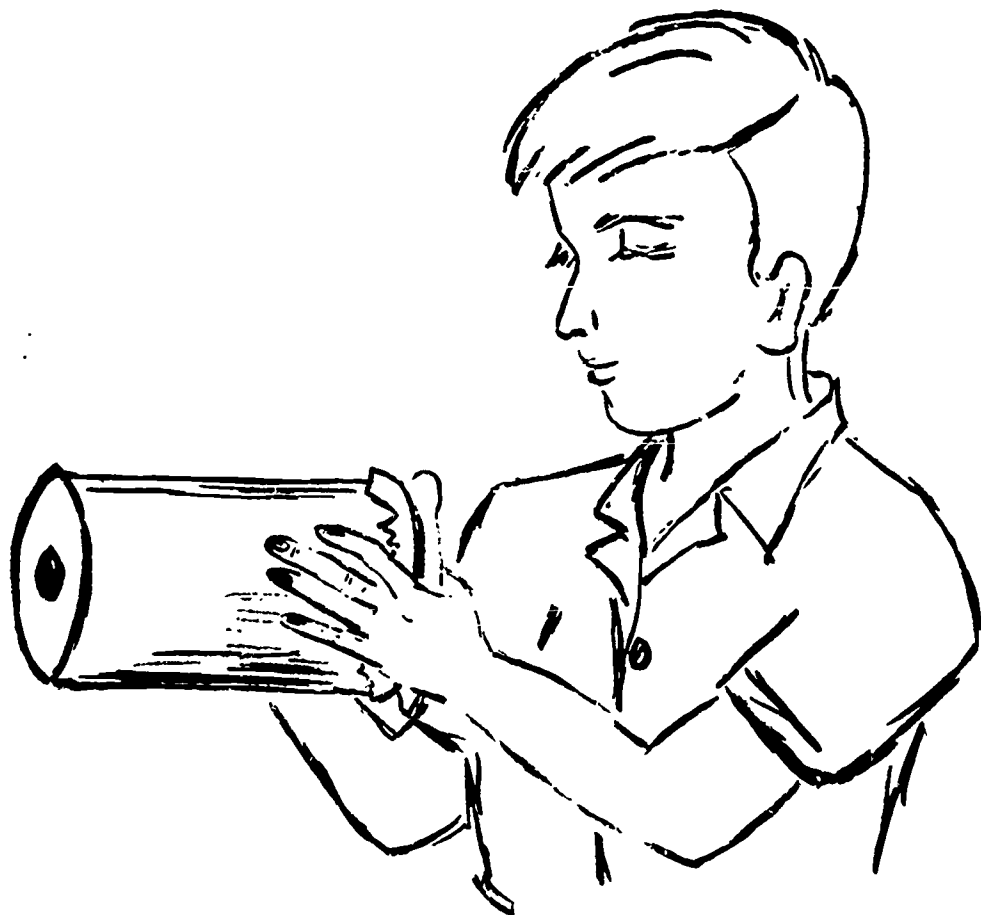
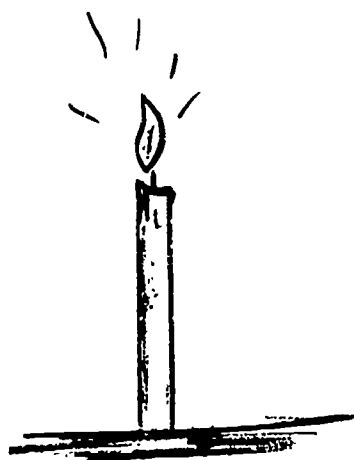

21. **Leading Question:**

How can we determine thrust (horsepower)?

**Materials:**

Table, chair, yard stick, stop watch, nurse's scale (or bathroom scale)

**Procedure:**

Place a chair next to a table. Working in groups of two, have one child count the number of times his partner can step from the floor to the table top in  $\frac{1}{4}$  minute. Multiply the height of the table in feet by the weight of the child. Multiply the product by the number of

trips which could be made in a minute. Divide the second product by 33,000.

Note to Teacher:

One pound of thrust is equivalent to 20 horsepower. The Saturn I rocket with 1,500,000 thrust theoretically produces about 30,000,000 horsepower

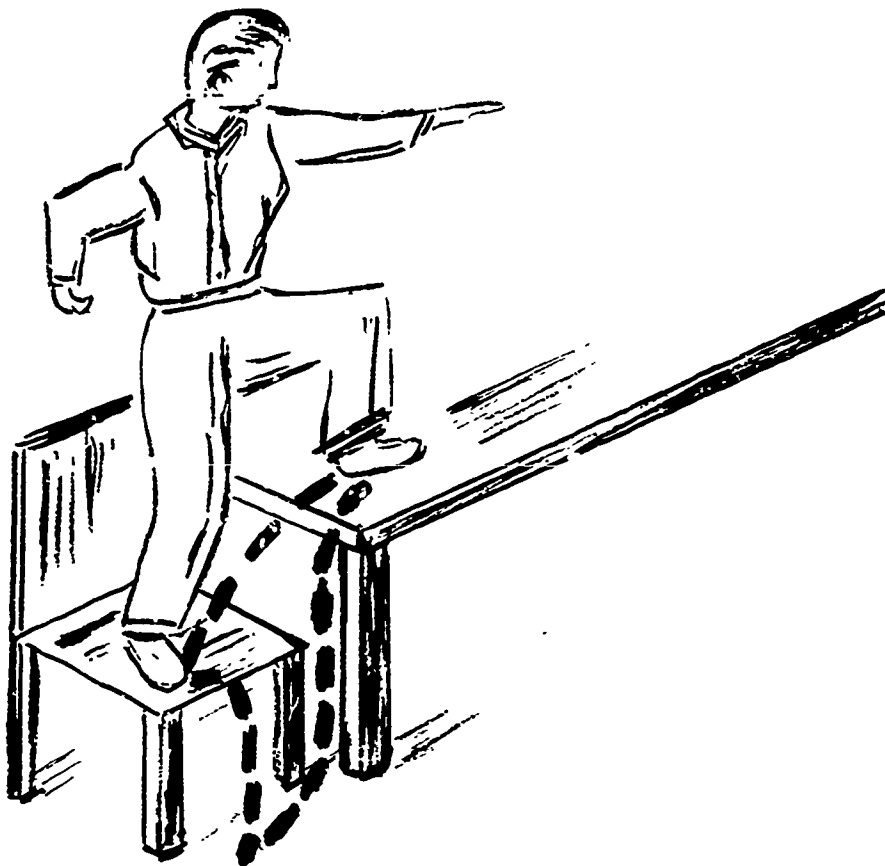

22. Leading Question:

Why must an earth atmosphere be created for man in space?

A. Materials:

3 small candles, 2 beakers or jars (different sizes), glass of water

Procedure:

Place three candles next to each other. At a given moment have two children each cover a candle with a beaker or jar. Observe what happens. Which candle went out first? Which candle continued to burn? Why? What do the candles need in order to burn? What does man need in order to breathe?

B. Materials:

Round bottom pyrex flask (floreence), chemical thermometer, rubber stopper, electric hot plate

Procedure:

Fill the flask half full of water. Place a Thermometer in the flask and heat on an electric hot plate. Observe at which temperature water boils. Allow the water to boil for several minutes and tightly seal the flask.

Place the sealed flask under a cold stream of water. Observe what happens. Why did this happen? How can this be related to the fluids in an astronaut's body if he suddenly lost the air pressure around him?

23. Leading Question:

How can man provide himself with food in prolonged spaceflight?

Materials:

3 baby food jars, 2 snails, 2 pieces of aquarium plant

Procedures:

Man in prolonged space flight may have to take with him ecological communities to supply him with a constant source of food.

Set up the following miniature ecological communities in baby food jars:

Jar #1 - water and a plant

Jar #2 - water and 1 snail

Jar #3 - water, plant, snail

Observe the 3 jars over a period of time and make note in which environment life can continue for the longest period of time.

24. Leading Question:

How can the g-force affect an astronaut?

A. Materials:

Modeling clay, 2 or 3 pound book

Procedure:

Model a man out of modeling clay. Drop a heavy book on him. What happens? Relate this to a man in spacecraft if the g-force was more than his body could withstand.

Note to Teacher:

G-force is defined as a unit of stress measurement for bodies undergoing accelerations. One g-force is an acceleration equal to the acceleration of gravity, approximately 32.2 feet per second at sea level.

Man in spacecraft may be subjected to an acceleration of 10 g's meaning that an astronaut would be pushed against his seat with a force of ten times his normal weight.

B. Materials:

8-penny nail, board, hammer

Procedure:

Have a child push an eight-penny nail in a board just using his hands. Next let him take the wood and place it on top of the nail and attempt to push the nail into the board.

The child may be able to exert a force of 30, 40 pounds or more and not be able to push the nail into the board. Now take the hammer and hit the nail. What happens? The hammer probably weighs less than one pound. Why could the hammer exert a large force to drive the nail?

**C. Materials:**

2 ft. glass tube, small balloon, string

**Procedure:**

Seal one end of the glass tubing using the portable bunsen burner. (See "lab procedures" in Elementary School Science Handbook). Fill the balloon with a few ounces of water and place it on the open end of the glass tube. Move the water from the balloon into the glass tubing. Securely tie the balloon to the tubing. Move the tubing and balloon forward quickly and then suddenly stop it. Did the water stay in the glass tubing? Would the water leave the tube if the balloon was encased in a pressure suit? Which would not allow the balloon to expand?

Assume this apparatus represents an astronaut being rapidly slowed down. Let the sealed end tube represent his head and the water represent blood in the astronaut's body. What would the blood tend to do? Remember parts of the body are somewhat flexible. How can a pressure suit retard the effects of the blood being forced out of the brain? Would the effects be less if the astronaut traveled crosswise to the direction of acceleration?

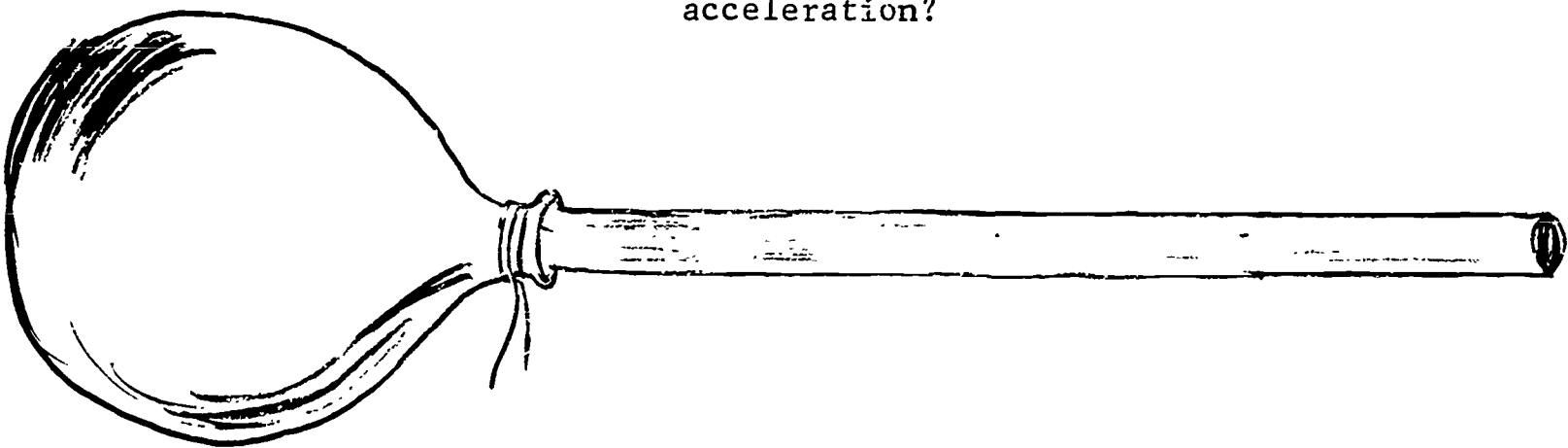

25. Leading Question:

How is a gyroscope used in helping to stabilize airplanes and spacecraft?

Materials:

Gyroscope, homemade wooden stand, rubber bands

Procedure:

Construct a wooden stand for the gyroscope. Tie small rubber bands to the crossframe of the gyroscope and mount it on the stand so that it will swing freely. While the gyroscope is spinning rapidly, turn the wooden stand. Have the children observe and feel how the gyro tilts.

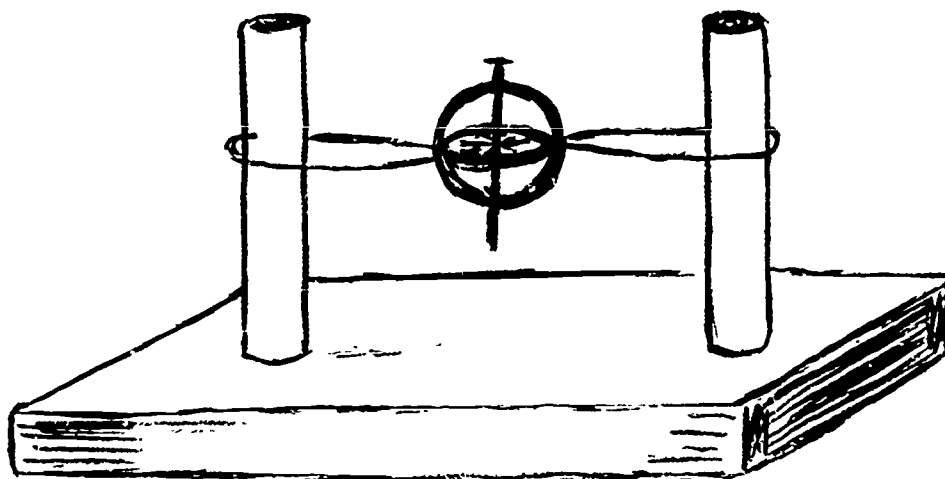

Note to Teacher:

Many spacecraft use a three-gyro inertial system with each of the three gyro axes mounted perpendicular to each other. With this type of system it is possible to detect all of the spacecraft's movements such as yaw, pitch, and roll.

26. Leading Question:

What is the shape of a rocket's trajectory?

Materials:

Balsa wood "rocket", 1 board 4" x 30" or inclined plane from Welch Machine Kit, heavy rubber band

Procedure:

Construct a rocket out of balsa wood or similar material.



Set up the inclined plane as shown below.

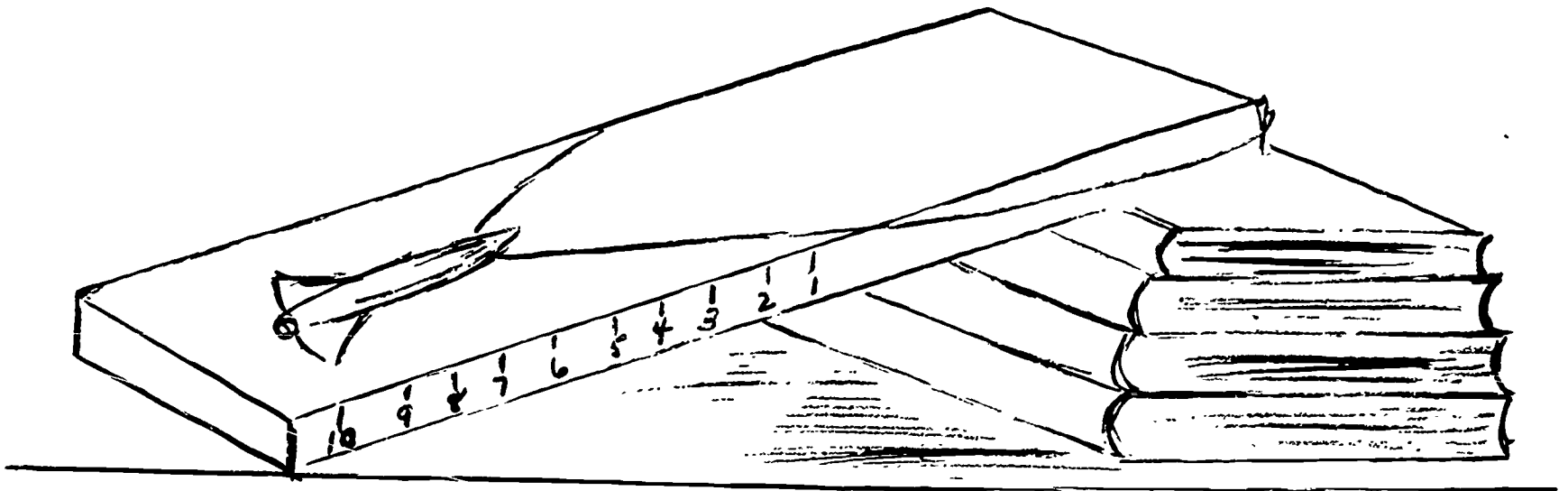

Observe the arching shape of a rocket's trajectory using the rocket model and catapult. Take proper safety precautions as to direction in which rocket is launched. Vary the amount of initial energy of the model by varying the amount of pull on the rubber band. Measure and record distances the rocket travels and compare with the varying amounts of pull on the rubber band. Lead children to relate previous learnings of potential and kinetic energy with catapult.

Vary the angle of the catapult launch. Note the typical parabolic shape of the trajectories.

27. Leading Question:

What devices can spacecraft use in re-entry for successful soft landings on the earth?

A. Materials:

Handkerchief, 4 pieces of string 12" long, weight (rubber stopper or thumb tack box, etc.)

Procedure:

Tie strings to each corner of a handkerchief and fasten the opposite ends to a small weight. Roll

the handkerchief strings and weight in a ball and throw it in the air. Observe the rate of fall.

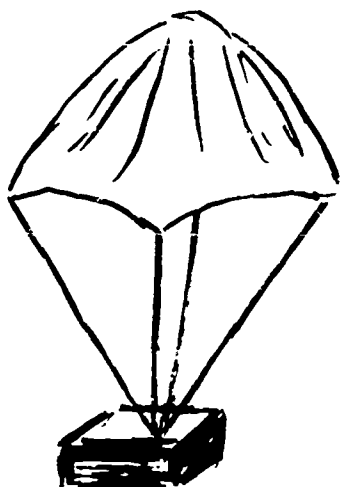

**B. Materials:**

Stiff typewriter paper

**Procedure:**

Fold a sheet of typewriter paper as shown below. Experiment in making adjustments to make it glide slowly to the ground. Investigate the flex wing (Ragallo) and its possibilities for future spacecraft.

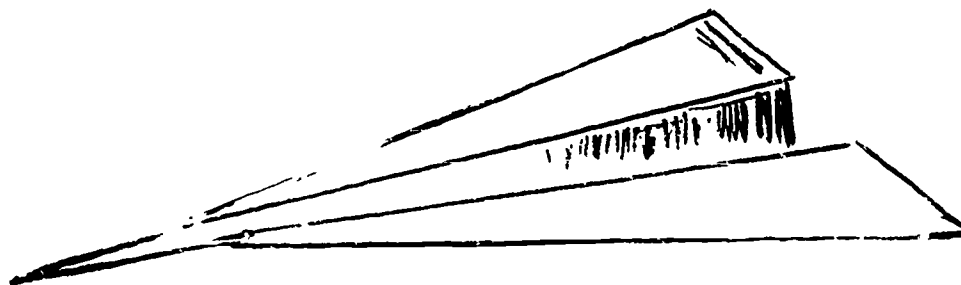
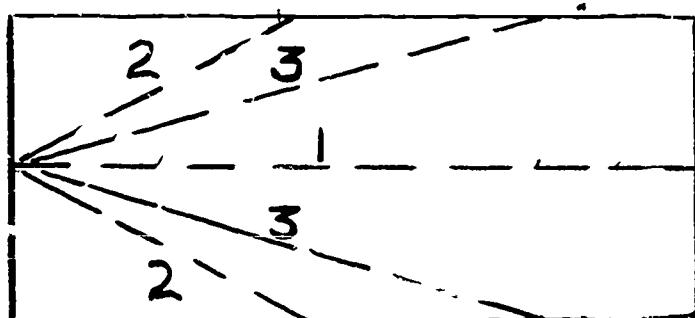

C. Materials:

3" x 5" file card, 1 paper clip

Procedure:

Cut a file card as shown in the drawing below. Fold the lower section and fasten it with a paper clip. Keep adjusting the vanes until the "helicopter" falls slowly through the air. Compare the speed of this falling object with a falling ball of paper.

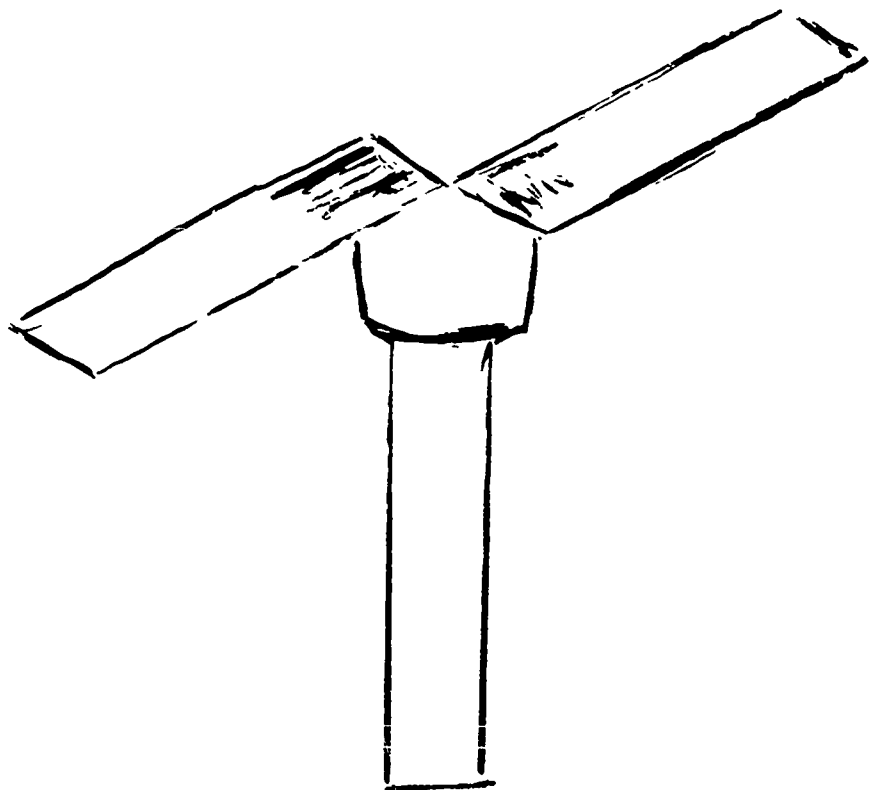
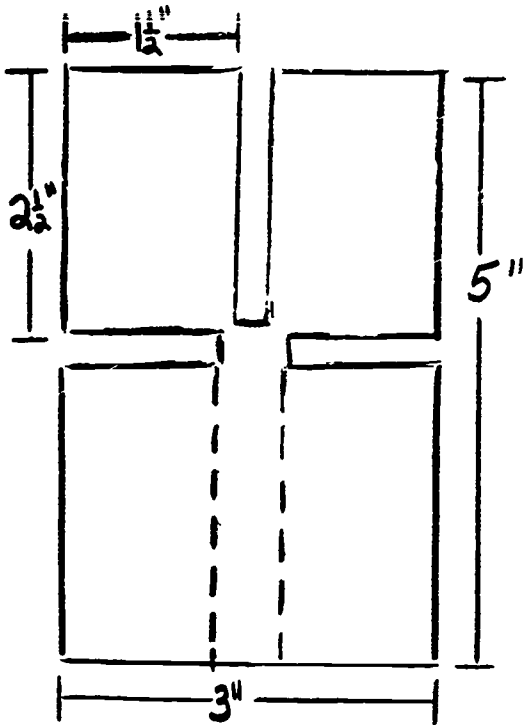

28. Leading Question:

Why does an astronaut face backward in re-entry to our atmosphere?

Materials:

Hall's carriage or roller skate, shoe box, doll, large book

Procedure:

Attach a shoe box to a Hall's carriage or roller skate. Seat a doll at the back end of the shoe box. Give the box a strong push across the floor into an obstacle such as a book. Repeat the experiment with the doll sitting with its back against the front end of the box. Observe the difference in what happens to the doll in the two collisions. Relate this to an astronaut in deceleration.

29. Leading Question:

How can gravity be created in a space station?

Materials:

Bicycle wheel (Central Science Materials Library),  
6" length of mailing tube

Procedure:

Slit a 6" length of mailing tube down one side and place it around a spoke on the bicycle wheel. Rotate the bicycle wheel and observe that the force resulting from the rotating wheel is greater than the pull of gravity. The mailing tube will stay at rim of the wheel. Compare this demonstration to donut-shaped station in space. Where would men inside the space station experience gravitational force?

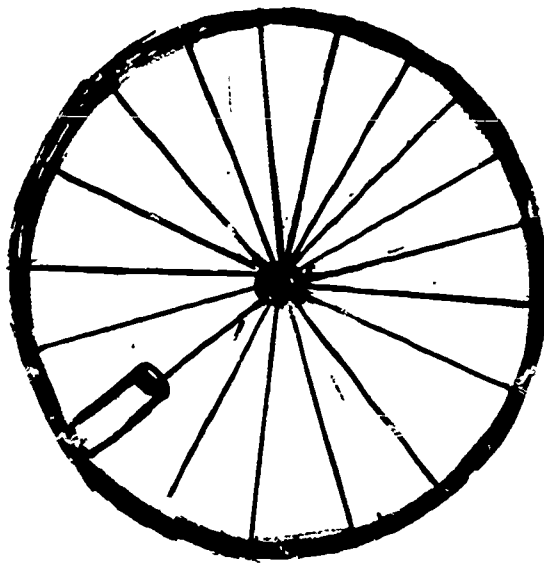

30. Leading Question:

What effect does weightlessness have on liquid rocket fuels?

Note to Teacher:

Scientists have found that when spacecraft are in orbit, fuel cannot be transferred from storage tanks with pumps and pressurized gases to the rocket engine. It was found that when liquids are freed from the earth's gravity and velocity changes, the molecular cohesion on the liquid's outside surface pulls it into globules the shape of a sphere. The floating globules of fuel float around the storage tank making the pumps ineffective. New ways of moving the fuel had to be devised.

Materials:

Rubbing alcohol, olive oil, water, glass jar or beaker

Procedure:

Fill a beaker or jar with about two inches of water. Place a drop of olive oil in the water. Slowly add rubbing alcohol. The oil will sink until it floats beneath the surface of the liquid in a state of weightlessness. Have the

children observe the shape of the olive oil. Using a spoon or glass rod break the oil drops and observe the shape of each of the small globules.

31. **Leading Question:**

How can a magnetic field be used for controlling satellites?

**Materials:**

Electromagnet (iron nail with copper wire), battery, permanent bar magnet, string

**Note to Teacher:**

Many of the man-made satellites are using the magnetic field of the earth for stabilization. The spacecraft are equipped with extremely sensitive electromagnet coils which detect the earth's magnetic field. This equipment can control the spacecraft by changing altitude or direction.

**Procedure:**

Construct an electromagnet and connect it to a flashlight battery. Suspend the electromagnet on a string so that it will swing freely. Stand a permanent bar magnet in a vertical position and support with two books.

Holding the electromagnet by the string, move the electromagnet around the mounted permanent magnet. Compare the vertical permanent bar magnet with the earth. The electromagnet can be compared to a satellite.

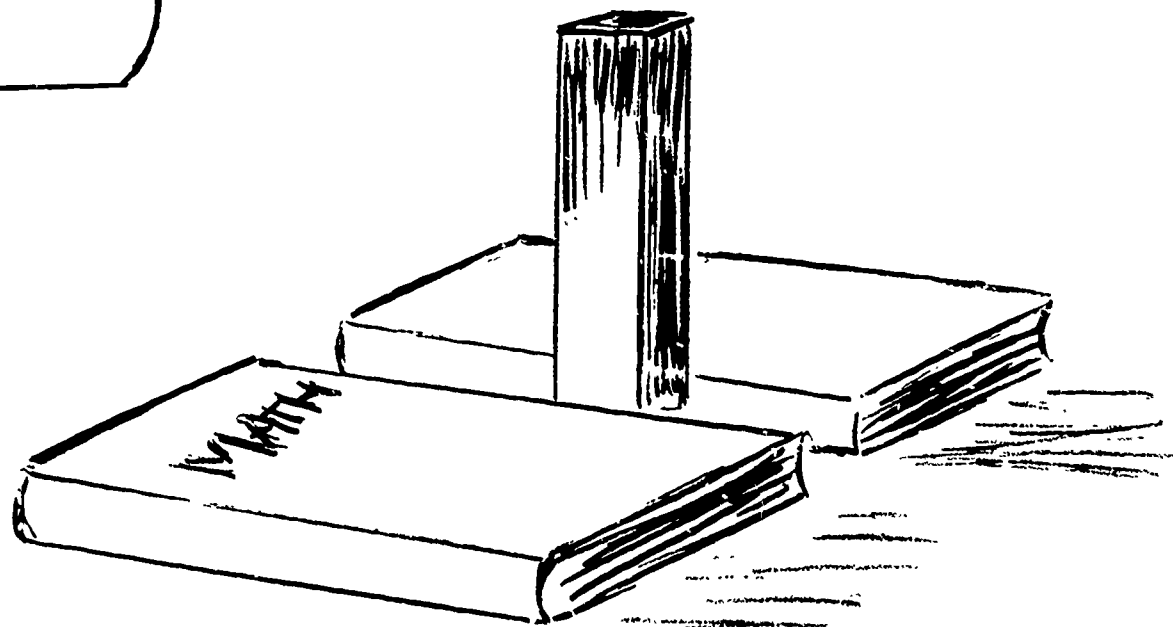
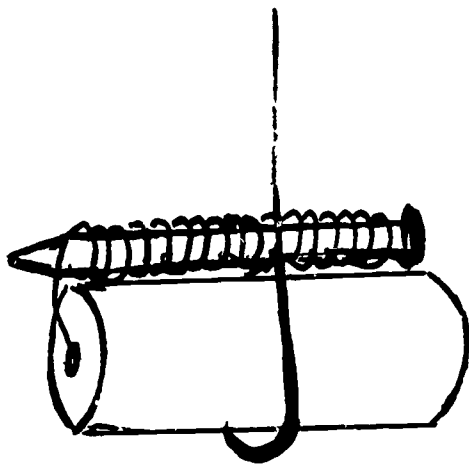



32. Leading Question:

How can we regulate the temperature on a spacecraft?

Note to Teacher:

In space, particles of matter are spread very far apart. These particles contribute very little to making any changes in temperature in a spacecraft. Spacecraft gain or lose heat by radiation.

A. Materials:

Paint one can black, and cover the other can with aluminum foil. Put a thermometer in each can. Place the two cans next to each other and heat them with a heat lamp for a few minutes. Observe which can absorb heat more rapidly?

Now pour very hot water in each can. Observe what happens to the temperatures inside both cans. Which loses heat more rapidly? How can the temperature be regulated (to some extent) on a spacecraft?

B. Materials:

Large can, black construction paper, shiny aluminum foil

Procedure:

Cover one quarter of the can with aluminum foil. Cover the second quarter of the can with black construction paper. Cover the third quarter with aluminum foil and the fourth quarter with black construction paper.

Place a thermometer in the can. Shine a heat lamp on the can. See if you can regulate the temperature inside the can by turning the can allowing the light to shine at intervals on different portions of the can.

ACTIVITIES TO ASSIGN FOR HOMEWORK OR INDIVIDUAL RESEARCH

33. Leading Question: How can we package an instrument to soft-land on the moon?
- Materials: Raw egg, various materials to be selected by students
- Procedure: Scientists are faced with the problem of soft-landing instruments on the moon. Because the moon lacks an atmosphere, landings as used by our astronauts (parachutes) on earth would not be possible on the moon.
- Present the problem of packaging a raw egg (represents scientific instrument) that can be dropped from the top floor of your school. Children can use any kind of material but are not permitted to use any kind of parachute.
- Note to Teacher: In the past, children have come up with ingenious ideas in successful moon "drops".

34. Leading Question: What is centrifugal force?
- Materials: Wire coat hanger, small coin
- Procedure: Flatten a small space on the bar of the hanger with a file or a hammer. Carefully balance a small coin on the straight wire at the bottom of the hanger. Gently start to swing the hanger and coin on your finger. When it has gained a little motion, and with practice, you can swing the hanger around in a circle, the coin will be held to the wire by centrifugal force.

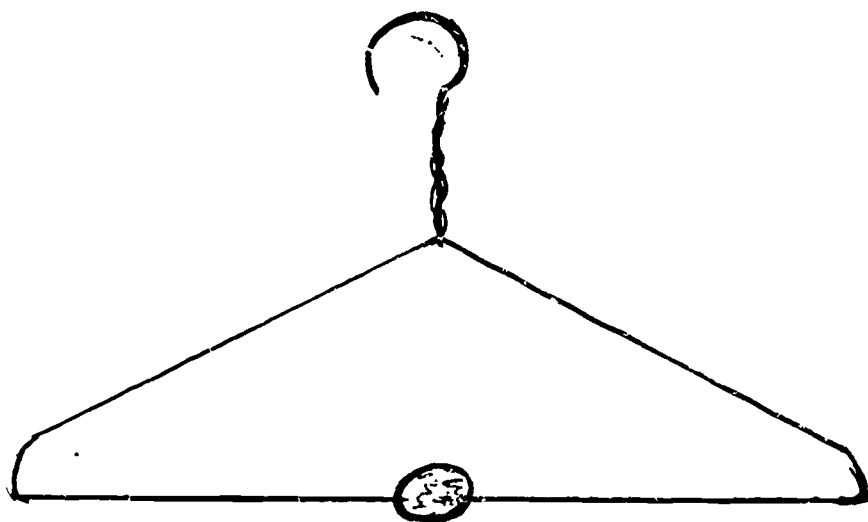

35. Leading Question:

What kinds of energy does an airplane propeller have?

Materials:

Model airplane powered by a rubber band

Procedure:

Wind the rubber band by turning the propeller. When you let go, the twisted rubber band begins to unwind, turning the propeller. Your muscles supplied kinetic energy. How was that kinetic energy stored as potential energy? How was the potential energy changed back into kinetic energy?

36. Leading Question:

How many miles are in a light year?

Procedure:

Using arithmetic, find out how many miles light travels in a year. (Answer - 5,870,000,000,000)

How far will light travel in one hour? (Answer 669,600,000 miles)

How far will light travel in one 24-hour day? (Answer 16,070,400,000 miles)

How far will light travel in a 31-day month? (Answer 498,937,708,800)

With the help of a watch, find out how long it takes you to read a page in a book. Why would you not expect your friends to get the same answer that you did?

37. Leading Question:

How can we measure the height of a flagpole without climbing the pole?

Materials:

Yardstick

Procedure:

Hold the yardstick straight up so that it casts a shadow. The triangle formed by the yardstick with its shadow is similar to triangle formed by the flagpole and its shadow. Measure the shadow of the yardstick and of the flagpole. If the flagpole shadow is seven times as long as the stick shadow, then the flagpole must be seven times as long as your yardstick. It must be 21 ft. Measure the height of your school's flagpole or a building, a tree or a telephone pole using this method.

38. Leading Question:

Who are famous scientists in aerospace and how did their accomplishments help our space program today?

Materials:

Library

Procedure:

Research famous scientists and their accomplishments in science.

Jean Pilatre de Rozier and Marquis d' Arlandes  
Leonardo da Vinci  
Johannes Kepler  
Konstantin Edvardovich Tsiolkovsky  
Robert Hutchings Goddard  
Hermann Oberth  
Willy Ley  
Wernher Von Braun  
James Van Allen

39. Leading Question:

What country was the first to use rockets?

Materials:

Library

Procedure:

Research and discuss the role of rockets as used by the Chinese in the 13th Century. How were they used in the battle of Fort Henry in 1814? What famous song immortalized this battle?

40. Leading Question:

What are some of the famous stories about flight and space written by man?

Materials:

Library

Procedure:

Research famous stories about man in flight and in space. Some authors are:

Lucian  
Johannes Kepler  
Cyrano de Bergerac  
Jules Verne  
H. G. Welles  
Edward Everett Hale

41. Leading Question:

How does design affect the flight of an airplane?

Materials:

Stiff paper

Procedure:

Experimental models can be cut from folded stiff paper. Several aircraft designs can be designed and tested for flight. Weight the nose with a paperclip or clay.

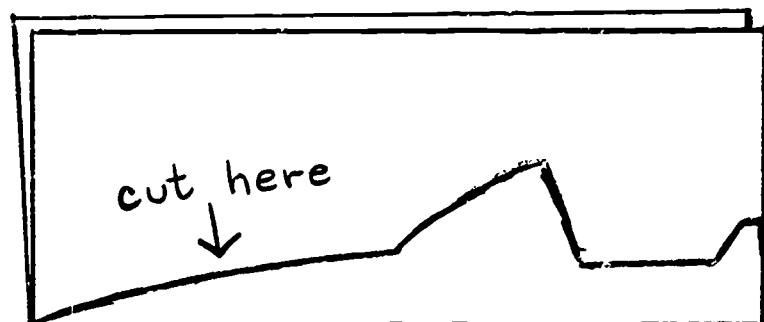

42. Leading Question:

How does a jet engine work?

Materials:

Library

Procedure:

Research the various types of jet engines. Draw diagrams and build models. (Children may have models purchased from hobby shops).

43. Leading Problem:

Investigate the findings for Unidentified Flying Objects (UFO)

Material:

Library

Procedure:

What are UFO's? Where are they claimed to have been seen? What evidence is there of their landings? What kind of beings are reported to be in these UFO's? What does the U.S. government and Russia say about these objects? What are "flying saucers"?

44. Subjects That Could Be Used For Individual Reports

Types of Radiation

The Nova Rocket

Effects of Radiation on the Human Body

The Atlas Rocket

Instruments for Measuring Radiation

Telemetry

Cosmic Rays

The Solar Cell

Production of X-rays

The Atomic Battery

Value of Space Stations

The Space Suit

The Saturn Rocket

The Density of Meteorites in Space



**SPACE SCIENCE**

**TEXTBOOK INDICES**

Related Pages in Textbooks								
	K	1	2	3	4	5	6	7
Space Science Unit								
K OUR WONDERFUL SUN		58-78						
1 EARTH IN SPACE								
The Earth								
The Moon				174-182				
Sun and Other Stars				46-59 150-151 158			170-216	
2 MEN AND MACHINES								
MOVEMENTS OF THE EARTH AND MOON				183				
3 SEASONS								
Seasons		58-78	152-153	100-148				
Gravity			2-17	182	181			
4 OUR GREAT UNIVERSE								
The Earth								
The Moon				174-182				
The Sun's Family				152 162-173	22-38	273, 277	182-183 188-189	

	K	1	2	3	4	5	6	7
Space Science Unit								
Celestial Bodies				150-161				
The Universe								
Early Astronomers								
6. FROM ATMOSPHERE TO SPACE								
Force Energy and Power			6-9		176-214		123-125 164-165	
Distances in Space					2-38	276-277	211-213	
Flight and Space Travel								
Special Notes:								

	Related Pages in Textbooks							
	K	1	2	3	4	5	6	7
Space Science Unit								
'K OUR WONDERFUL SUN								
1 EARTH IN SPACE								
The Earth								
The Moon								
Sun and Other Stars		49-72		66-75		291-300		
2 MEN AND MACHINES		122-144	162-192	98-128	227-284			
MOVEMENTS OF THE								
3 EARTH AND MOON								
Seasons				76-96				
Gravity			98-117	103-104	226		186 210-211	
4 OUR GREAT UNIVERSE								
The Earth								
The Moon			2-32					
The Sun's Family				195-216			66-110	



	K	1	2	3	4	5	6	7
Space Science Unit								
Celestial Bodies								
The Universe				217-224	301-336	243-261		
Early Astronomers				194	290	242		
6 FROM ATMOSPHERE TO SPACE								
Force Energy and Power							275-282	
Distances in Space						243-288		
Flight and Space Travel								
Special Notes:								



Related Pages in Textbooks

	K	1	2	3	4	5	6	7
Space Science Unit								
K OUR WONDERFUL SUN								
1 EARTH IN SPACE								
The Earth		49-59	126-129					
The Moon		57-58	132-135					
Sun and Other Stars		54-59	64-66 130-131 136-148					
2 MEN AND MACHINES				22-26				
MOVEMENTS OF THE EARTH AND MOON								
Seasons				7-12				
Gravity								
4 OUR GREAT UNIVERSE								
The Earth								
The Moon				97-105	255-260			
The Sun's Family				73-96				

	K	1	2	3	4	5	6	7
Space Science Unit								
Celestial Bodies					260-278			
The Universe					261			
Early Astronomers								
6 FROM ATMOSPHERE TO SPACE								
Force Energy and Power						92-143		
Distances in Space						271-303	365-407	
Flight and Space Travel							195-229	
Special Notes:								

		Related Pages in Textbooks						
		1	2	3	4	5	6	7
Space Science Unit	K							
K OUR WONDERFUL SUN	Chart 4							
1 EARTH IN SPACE								
The Earth								
The Moon								
Sun and Other Stars		32-35	78-83					
2 MEN AND MACHINES				2-21	31-46	31-35		
MOVEMENTS OF THE 3 EARTH AND MOON								
Seasons					51-54 84-89			
Gravity					32, 38, 40- 43 - 245- 250, 258, 262			
4 OUR GREAT UNIVERSE								
The Earth						16-20	240-243	
The Moon				9-13	251-261		240-248 270	
The Sun's Family				14	31-47		248-276	



	K	1	2	3	4	5	6	7
Space Science Unit								
Celestial Bodies				18-19		8-9	246-248	
The Universe					244-245		253-276	
Early Astronomers							239-276	

ATMOSPHERE TO SPACE

Force Energy and Power								
Distances in Space					37-38 248-250		253-276	
Flight and Space Travel					144-158 257		317-322	
Special Notes:						Unit on Latitude, Longitude 16-20 Problems of Space Travel 31-35	Finding Answers in Astronomy 239-276	

		Related Pages in Textbooks						
		1	2	3	4	5	6	7
Space Science Unit	K							
K OUR WONDERFUL SUN	Chart 14	1-13						
1 EARTH IN SPACE								
The Earth		137-150						
The Moon								
Sun and Other Stars		1-13						
2 MEN AND MACHINES			119-133	189-209				
MOVEMENTS OF THE								
3 EARTH AND MOON								
Seasons			1-17 92-103					
Gravity			135-143					
4 OUR GREAT UNIVERSE								
The Earth					271-272 277-279			
The Moon				190-192 195-201	273 280-286			
The Sun's Family				202-205	274 286-290			





Space Science Unit	K	1	2	3	4	5	6	7
Celestial Bodies				207-209	275-277			
The Universe								
Early Astronomers							301-304	
6 FROM ATMOSPHERE TO SPACE								
Force Energy and Power					207-269	69-72 75-91	308-317	
Distances in Space							267-325	
Flight and Space Travel					229-241	37-73	313-317	
Special Notes					Tides P. 291- 297			

Related Pages in Textbooks

	K	1	2	3	4	5	6	7
Space Science Unit								
K OUR WONDERFUL SUN		3-10	81-87					
1 EARTH IN SPACE								
The Earth			94-97	82-86				
The Moon			95-96	95-107				
Sun and Other Stars			88-91 94-97	87-94				
2 MEN AND MACHINES								
MOVEMENTS OF THE EARTH AND MOON								
Seasons				102-104	7, 100			
Gravity				109-114				
4 OUR GREAT UNIVERSE								
The Earth				89-94	99-125			
The Moon					96-116	99 206		
The Sun's Family				95-115	99-125	94-119		



	K	1	2	3	4	5	6	7
Space Science Unit								
Celestial Bodies						106-109		
The Universe								
Early Astronomers				86				

6 FROM ATMOSPHERE TO SPACE

Force Energy and Power							199-200	
Distances in Space							117-118	
Flight and Space Travel							183-207	
Special Notes:								

Space Science Unit	Related Pages in Textbooks							
	K	1	2	3	4	5	6	7
K OUR WONDERFUL SUN								
1 EARTH IN SPACE								
The Earth								
The Moon								
Sun and Other Stars								
2 MEN AND MACHINES			33-47					
3 MOVEMENTS OF THE EARTH AND MOON								
Seasons								
Gravity								
4 OUR GREAT UNIVERSE								
The Earth								
The Moon				36-43				
The Sun's Family								

Space Science Unit

K

1

2

3

4

5

6

7

Celestial Bodies

The Universe

29-59

Early Astronomers

52-53

6 FROM ATMOSPHERE TO SPACE

Force Energy and Power

271-295

181-202

Distances in Space

143-191

219-257

Flight and Space Travel

263-309

Special Notes:



Related Pages in Textbooks

	K	1	2	3	4	5	6	7
Space Science Unit								
K OUR WONDERFUL SUN								
1 EARTH IN SPACE								
The Earth		6-9 38-41	53-67	12-21 138-143				
The Moon		80-81						
Sun and Other Stars		76-83		7-11				
2 MEN AND MACHINES			129					
MOVEMENTS OF THE EARTH AND MOON								
Seasons			118 132	144-152	170-211			
Gravity		54-55	64			136-137		
4 OUR GREAT UNIVERSE								
The Earth						142-143	48-49	
The Moon								
The Sun's Family						140-141 150-151		



	K	1	2	3	4	5	6	7
Space Science Unit								
Celestial Bodies				22-27		134-135 144-147 152-155		
The Universe					166-167	148-149 156-157		
Early Astronomers						125 128-129 132		
6 FROM ATMOSPHERE TO SPACE								
Force Energy and Power		126-127						
Distances in Space								
Flight and Space Travel						160-169 206-207		
Special Notes.								

	Related Pages in Textbooks							
	K	1	2	3	4	5	6	7
Space Science Unit								
K OUR WONDERFUL SUN		9-15						
1 EARTH IN SPACE								
The Earth		16-27	16	7-34 86-97	25-39			
The Moon		10-13	21-26	102-109	20-24			
Sun and Other Stars		8-12 84-89 110-112	17-20 27-34	91 116-117	272-277		291-304	
2 MEN AND MACHINES			6-15	110-115				
MOVEMENTS OF THE EARTH AND MOON								
Seasons				98-101	25-39	34-40	298	
Gravity					7, 9-14, 42	15 20-22	331	
4 OUR GREAT UNIVERSE								
The Earth					25-39		308-309	
The Moon					40-45	20-25	309-313	
The Sun's Family				118	7-33		3-14-316 305-307	



	K	1	2	3	4	5	6	7
Space Science Unit								
Celestial Bodies					272-277		291-295	
The Universe					110-112	176	316-320	
Early Astronomers							316	
<b>6 FROM ATMOSPHERE TO SPACE</b>								
Force Energy and Power							24-24 231 245	
Distances in Space							294-295 321-339	
Flight and Space Travel					160-164	118-130	23-29 321-339	
Special Notes:								

Related Pages in Textbooks

	K	1	2	3	4	5	6	7
Space Science Unit								
K OUR WONDERFUL SUN								
1 EARTH IN SPACE								
The Earth								
The Moon								
Sun and Other Stars								
2 MEN AND MACHINES			62 - 64					
3 MOVEMENTS OF THE EARTH AND MOON								
Seasons								
Gravity								
4 OUR GREAT UNIVERSE								
The Earth					204-220			
The Moon								
The Sun's Family					236-263	221-227		



	K	I	2	3	4	5	6	7
Space Science Unit								
Celestial Bodies					230-235 263-266	130-140		
The Universe								
Early Astronomers					262-63	142-163.		

6 FROM ATMOSPHERE TO SPACE

Force Energy and Power						105-109		
Distances in Space						157-174		
Flight and Space Travel						174-184		

Special Notes:

--	--	--	--	--	--	--	--	--

Related Pages in Textbooks							
K	1	2	3	4	5	6	7
Space Science Unit							
K OUR WONDERFUL SUN							
1 EARTH IN SPACE							
The Earth	32 - 35						
The Moon							
Sun and Other Stars							
2 MEN AND MACHINES							
3 MOVEMENTS OF THE EARTH AND MOON							
Seasons	68 - 75	29 - 42		230-241			
Gravity				275-279			
4 OUR GREAT UNIVERSE							
The Earth					5 - 9		
The Moon			232-235	280-285	8 - 9		
The Sun's Family	32 - 35			270-302			



	K	1	2	3	4	5	6	7
Space Science Unit								
Celestial Bodies				236-242				
The Universe						18 - 23	247-284	
Early Astronomers						1 - 15		

6 FROM ATMOSPHERE TO SPACE

Force Energy and Power								
Distances in Space							271-276	
Flight and Space Travel						26 - 33		
Special Notes:								

PUBLISHER: Allyn and Bacon

SERIES: Exploring Science Series

EDITION: 1955 - 1964

		Related Pages in Textbooks						
		1	2	3	4	5	6	7
Space Science Unit		K						
K OUR WONDERFUL SUN			19 - 20					
1 EARTH IN SPACE								
The Earth			49 - 64					
The Moon			30 - 31					
Sun and Other Stars			19 - 20					
2 MEN AND MACHINES			62 - 63					
3 MOVEMENTS OF THE EARTH AND MOON								
Seasons							76 - 80	
Gravity			49 - 64					
4 OUR GREAT UNIVERSE								
The Earth					5 - 19			
The Moon				20		152 - 153		
The Sun's Family								

	K	1	2	3	4	5	6	7
Space Science Unit								
Celestial Bodies						138-151 154		
The Universe								
Early Astronomers								

6 FROM ATMOSPHERE TO SPACE

Force Energy and Power								
Distances in Space							53 - 80	
Flight and Space Travel							226 - 250	
Special Notes:								



PUBLISHER:

SERIES:

EDITION:

Related Pages in Textbooks

	K	1	2	3	4	5	6	7
Space Science Unit								
OUR WONDERFUL SUN								
EARTH IN SPACE								
The Earth								
The Moon								
Sun and Other Stars								
2 MEN AND MACHINES								
3 MOVEMENTS OF THE EARTH AND MOON								
Seasons								
Gravity								
4 OUR GREAT UNIVERSE								
The Earth								
The Moon								
The Sun's Family								

	K	1	2	3	4	5	6	7
Space Science Unit								
Celestial Bodies								
The Universe								
Early Astronomers								
6 FROM ATMOSPHERE TO SPACE								
Force Energy and Power								
Distances in Space								
Flight and Space Travel								
Special Notes:								

SPACE SCIENCE

APPENDIX

# THE LEHIGH VALLEY AMATEUR ASTRONOMICAL SOCIETY

## THE PIE PLATE PLANETARIUM

This simple to make star projector provides a means of projecting the fifty principal circumpolar star groups. By careful construction the builder will be rewarded with a device that will perform with sufficient accuracy and lifelike appearance to make it a useful teaching aid.

### USING THE STAR PROJECTOR

A completely dark room preferably having light colored walls and ceiling is the most important requirement. With the pie plate assembly on edge and light operating, project the stars on a side wall and gain a familiarity with the star groups and relation to each other. Once you have done this, form a plate holder from a wire coat holder to hold the pie plate assembly at an angle of about 40 degrees. This will then project the star groups in the approximate positions that they appear in this latitude.

### THE SKY CALENDAR: SEASONS AND RELATIVE TIME

An easy way to tell the seasons from the stars is to note the positions of the Big Dipper right after sunset. The diagram shows its position for the four seasons as it appears right after sunset. The rotation of the earth will cause its position to shift in a counter-clockwise direction until it completes about 180 degrees by sunrise. By comparing the position at sunset with other positions during the night, relative hourly time may be reckoned. Note the last two stars in the bowl of the Big Dipper are the pointer stars, that is they are in a line that goes through the North Star. Rotate your pie plate projector through the seasonal positions and note how all the star groups change their position except the North Star. The North Star will always appear stationary with the other star groups rotating around it. Look for the twin star in the handle of the Big Dipper. This is rather difficult to see. Try to find it the next time you are out on a clear dark night. Try to remember the star groups by the outlines they describe. In this way you will be able to recognize them more easily when looking for them in the sky.

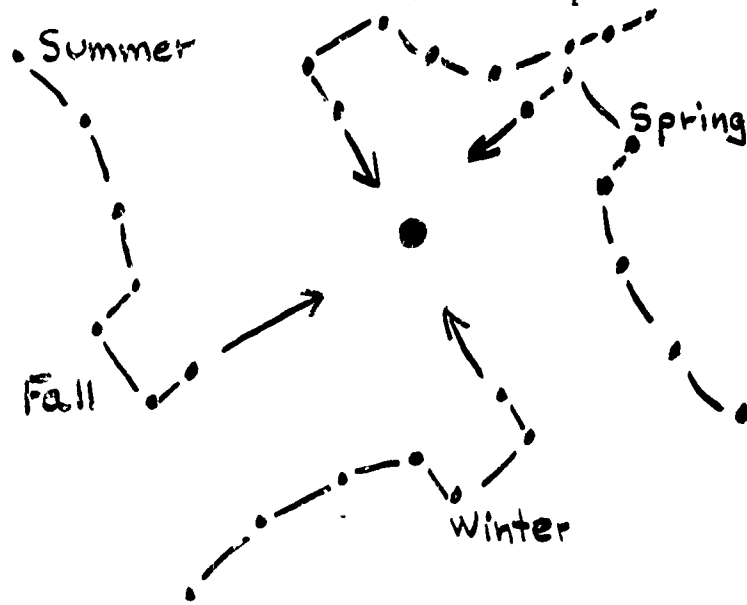

**MATERIALS NEEDED:** Two 8 inch aluminum foil pie plates without holes  
One #14 flashlight bulb and small screw socket  
Two flashlight batteries with some kind of holder  
About three feet of black vinyl electrical tape

The small screw socket may be salvaged from an old Christmas tree light set.

There are many inexpensive books available on Astronomy that are excellent sources of further information in easily readable text with many illustrations. The following two are recommended:

ASTRONOMY MADE SIMPLE - The made Simple Series  
HANDBOOK OF THE HEAVENS - Signet Pocket Books

### HOW TO CONSTRUCT A PIE PLATE STAR PROJECTOR

**PROCEDURE:** In the center of the pie plate to be used for the bottom half, pierce a small hole in the center of the bottom. Carefully enlarge this hole with a sharp pencil until the bulb just fits; remove bulb. Now blacken the inside surfaces of both plates by smoking lightly in a candle flame. Next push the bulb through the bottom of the plate in the hole provided and screw the socket on the bulb from the back. Place both plates rim to rim and bind together with the black vinyl tape. Light the lamp and check that the assembly is light tight. If not cover any holes with a little black tape.

**Making the Stars:** Cut out the circular pattern below and lightly glue it to the bottom of the top pie plate. Remember you will remove this pattern later. With a thimble on your forefinger and using a small thin needle, pierce all the holes indicated by dots on the pattern. Use care and make the holes as small as possible. Next, with a standard straight pin, enlarge the following holes, carefully! The North Star, the five stars in both Cassiopeia and Cepheus, the Stars of Lynx and Camelopardalis AND all the stars of the Big Dipper EXCEPT THE SMALL STAR NEAR THE SECOND STAR IN THE HANDLE. When you are sure you have completed the above, remove the pattern from the plate.

This completes the Pie Plate Star Projector.

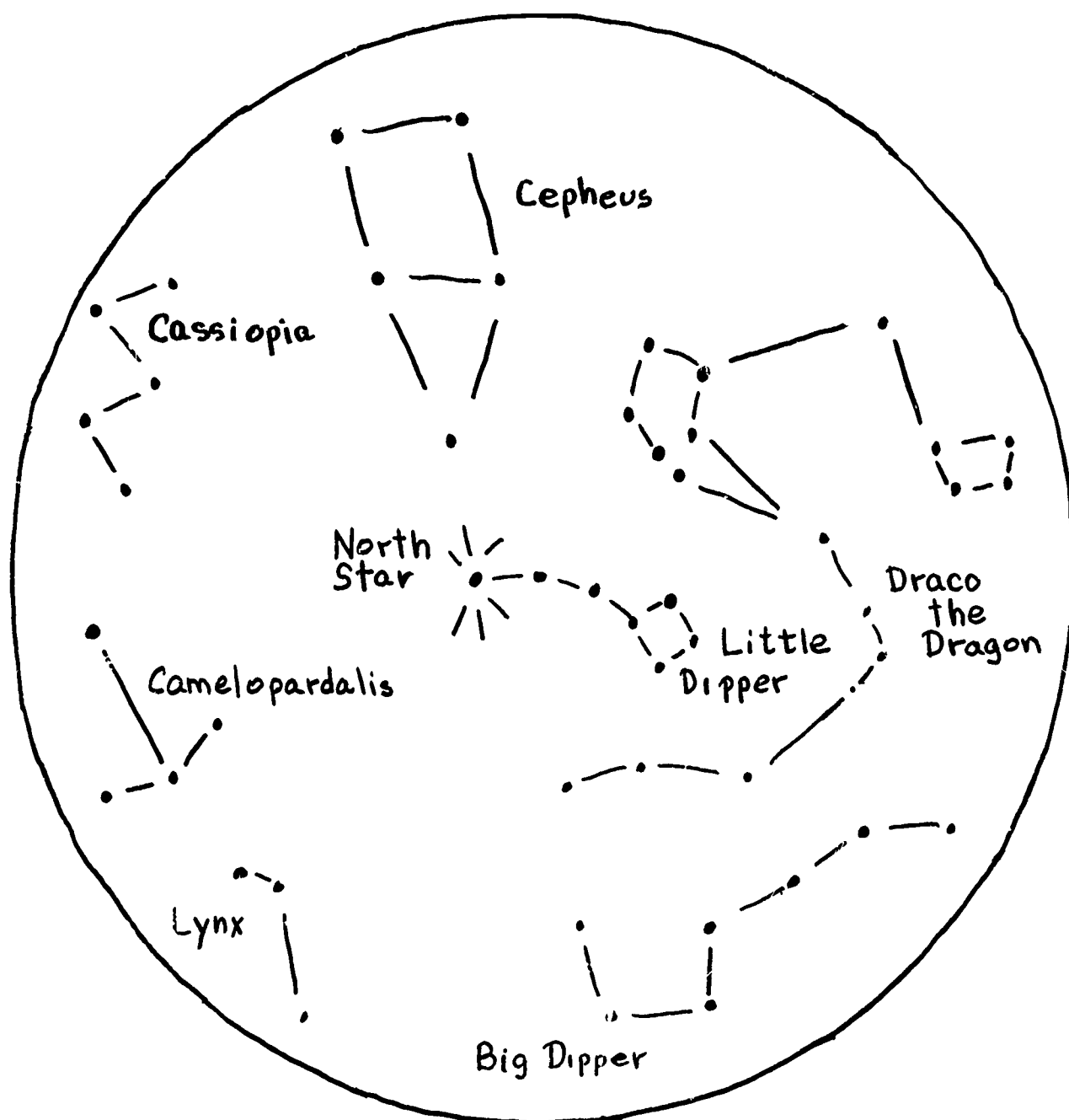



STELLAR SIGNPOSTS

STELLAR SIGNPOSTS is a system of aiding an observer to locate and identify some of the principal stars and constellations. Once this is done, the observer will find it easier to locate other groups, objects, and less prominent stars.

In its simplest form, only the prominent and more easily recognized stars and constellations are used. From these, imaginary single lines are extended which direct the observer to another star or constellation. Since in all cases only single lines are used, the system can be easily committed to memory as a useful observing aid.

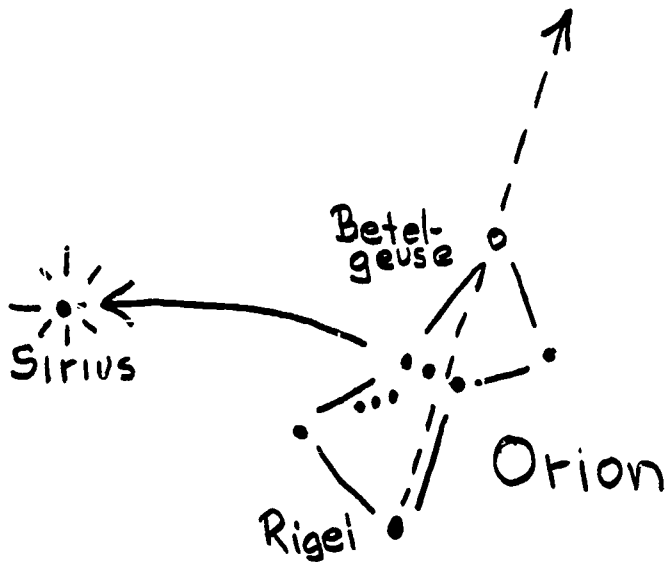

ORION is one of the most prominent Constellations in the winter sky. The three stars that form the belt of Orion will lead the observer to the brilliant star SIRIUM by extending the belt in a very slight curve toward the South.

By extending a line Northward through the bright stars, Rigel and Betelgeuse, the observer will be directed to the two first magnitude stars Castor and Pollux in the constellation of Gemini.

In late spring and early summer, the Big Dipper will be high overhead in the early evening. By allowing your eye to travel along the arc described by the handle of the Dipper and continuing beyond the end of the handle, the observer will be directed to the brilliant Arcturus in the constellation of Boötes. By looking carefully the fainter stars of this constellation may be seen.

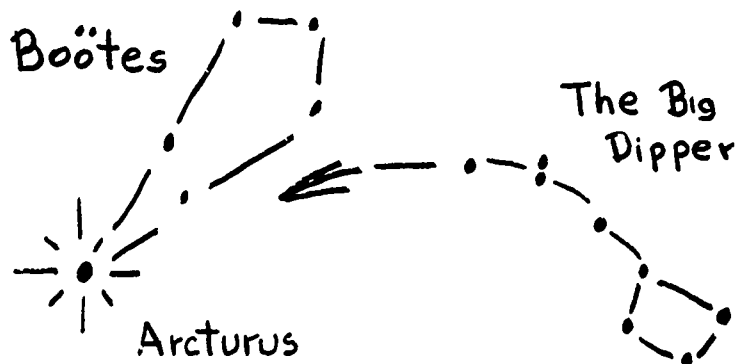

By looking Southward during the early evening hours of late Spring and early Summer, the inverted keystone shape of Corvus is easily seen. By allowing the eye to travel in a line along the top two stars, the observer will be directed to the first magnitude star, Spica in Virgo.

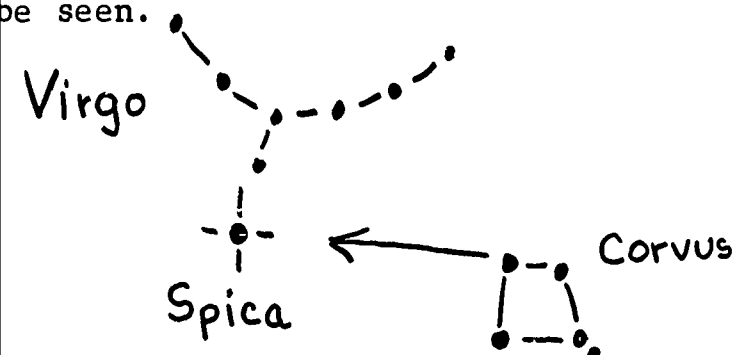

In the evenings of early summer, the head of the dragon, Draco will be high in the northern sky. The three brightest stars form a "V" which points to the brilliant star Vega in Lyra while the two stars that designate the top of the "V" are in a line that will direct the observer to the keystone in the constellation of Hercules. Hercules is composed of mostly third magnitude stars that are sometimes hard to find.

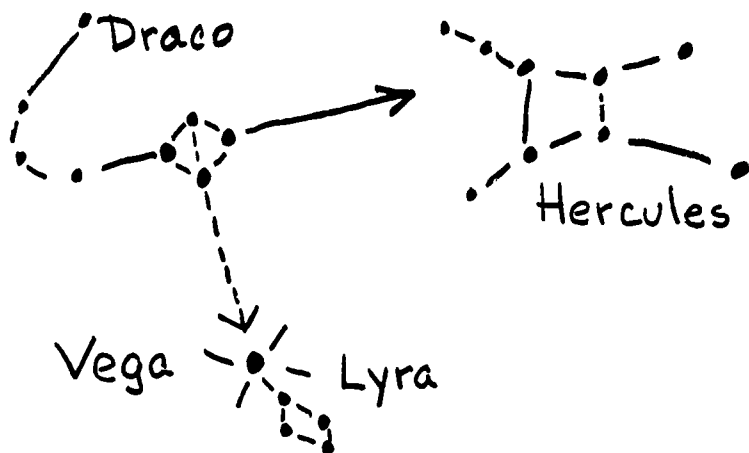

Stars for March  
9-10 PM

NORTH

SOUTH

EAST

WEST

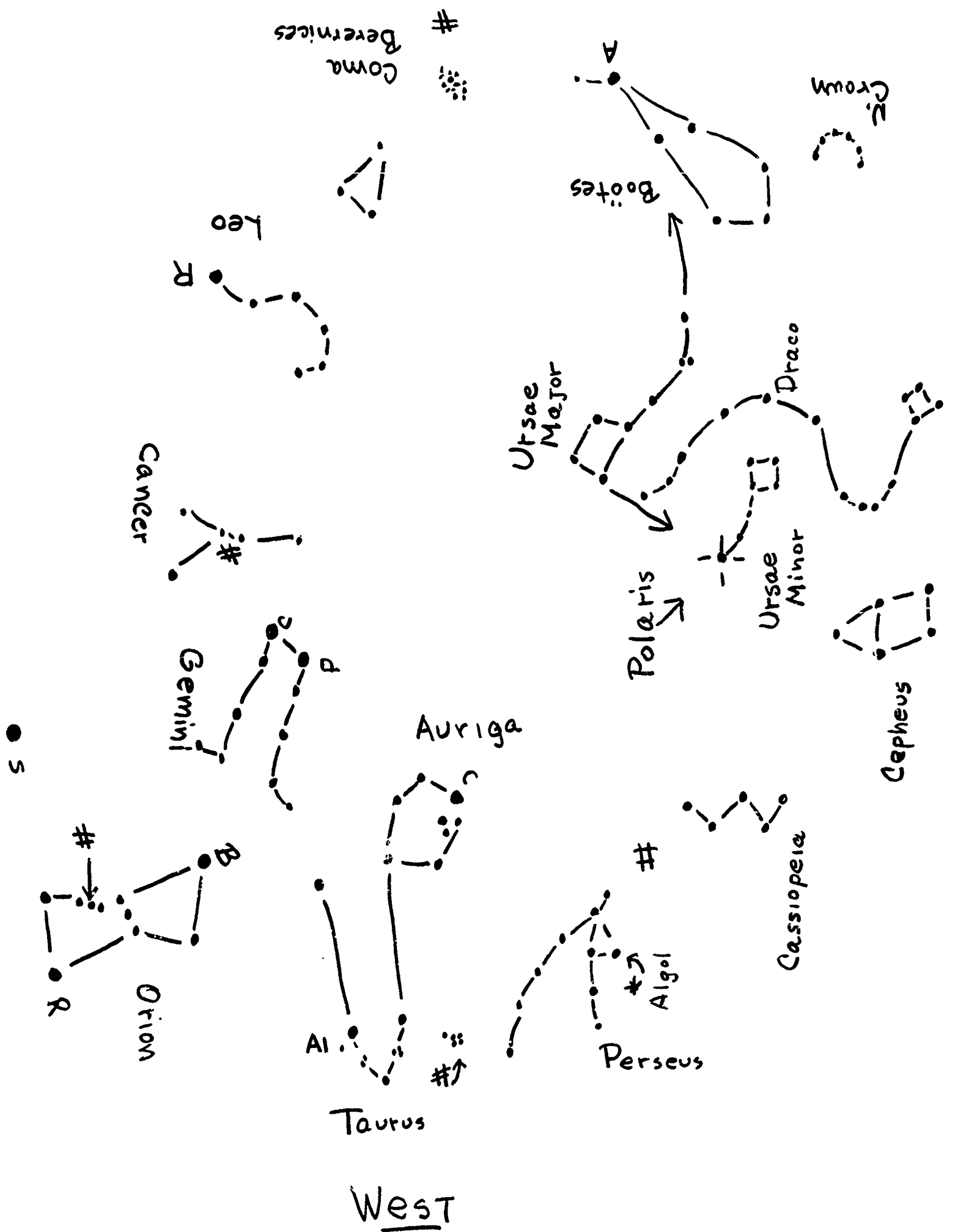

SOUTH

Cornus

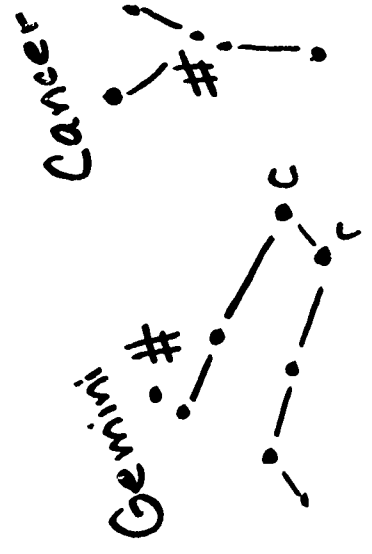

Cancer

Geminus

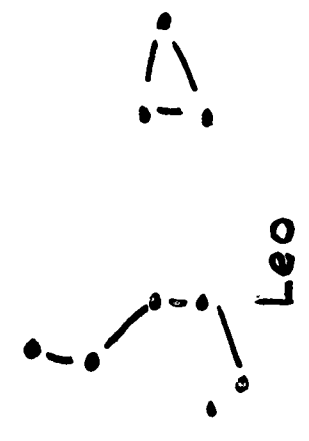

Leo

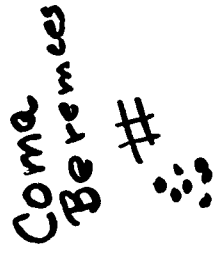

Coma Berenices

WEST



Capella

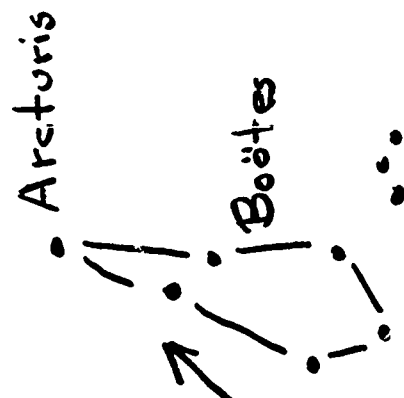

Arcturus

Boötes

EAST



N. Crown

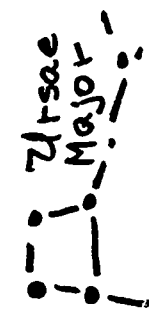

Ursae Major

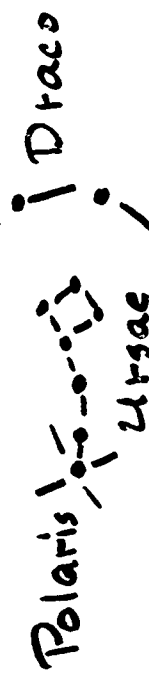

Polaris

Ursae Minor

Draco



Double Cluster



Cassiopeia

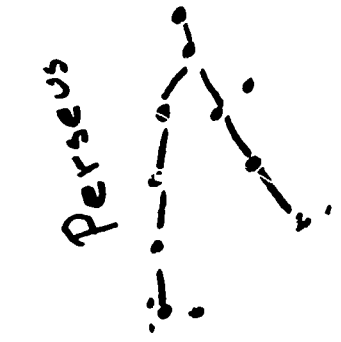

Perseus



Cepheus

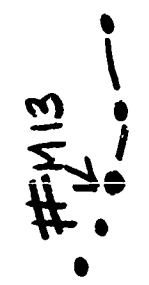

#M13

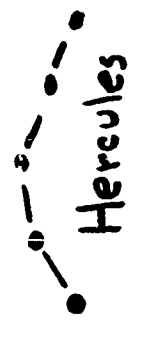

Hercules

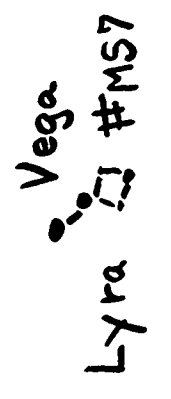

Vega

Lyra #M57

NORTH

Stars for May-June  
9:00-9:30 PM

NORTH

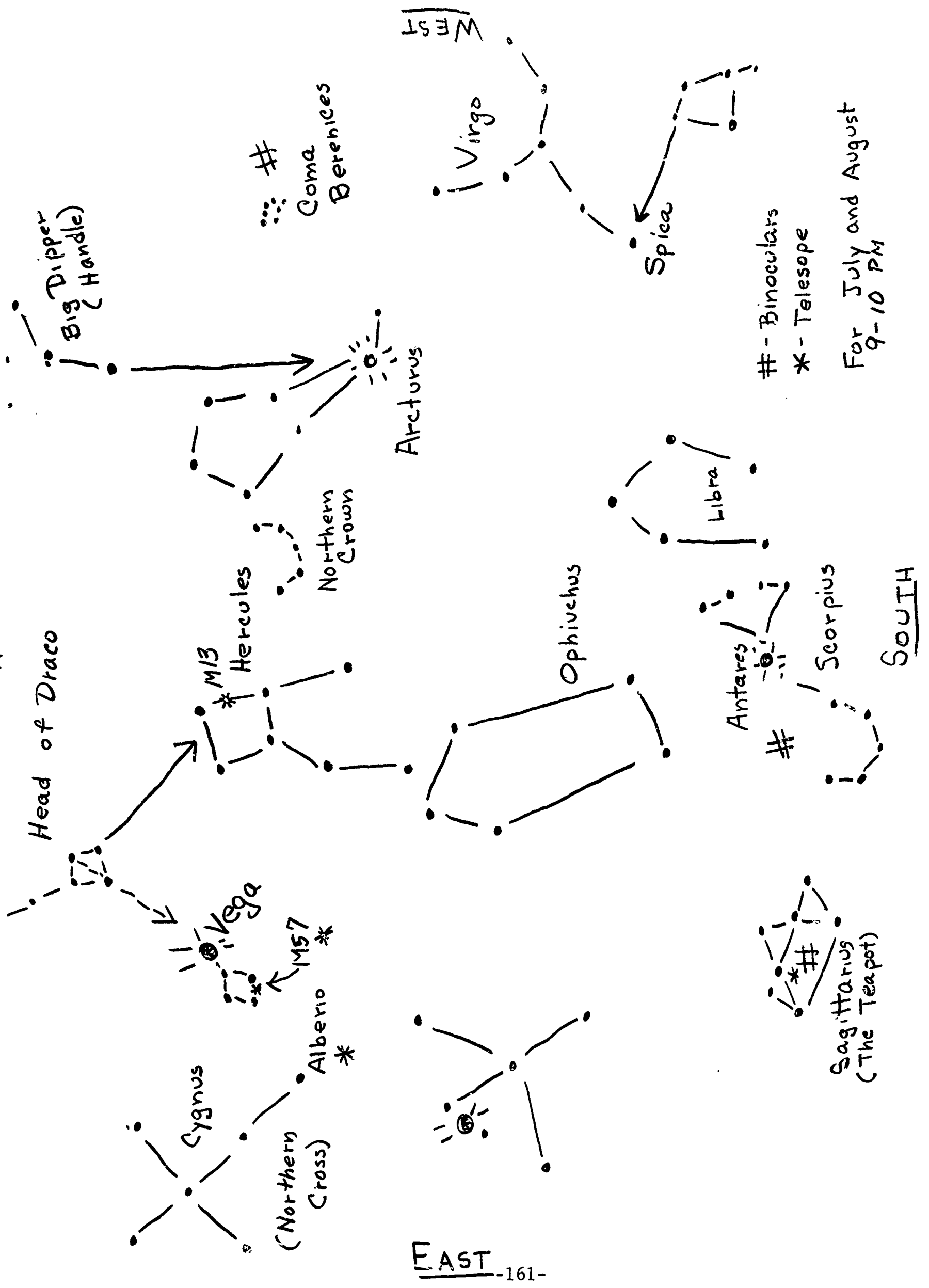

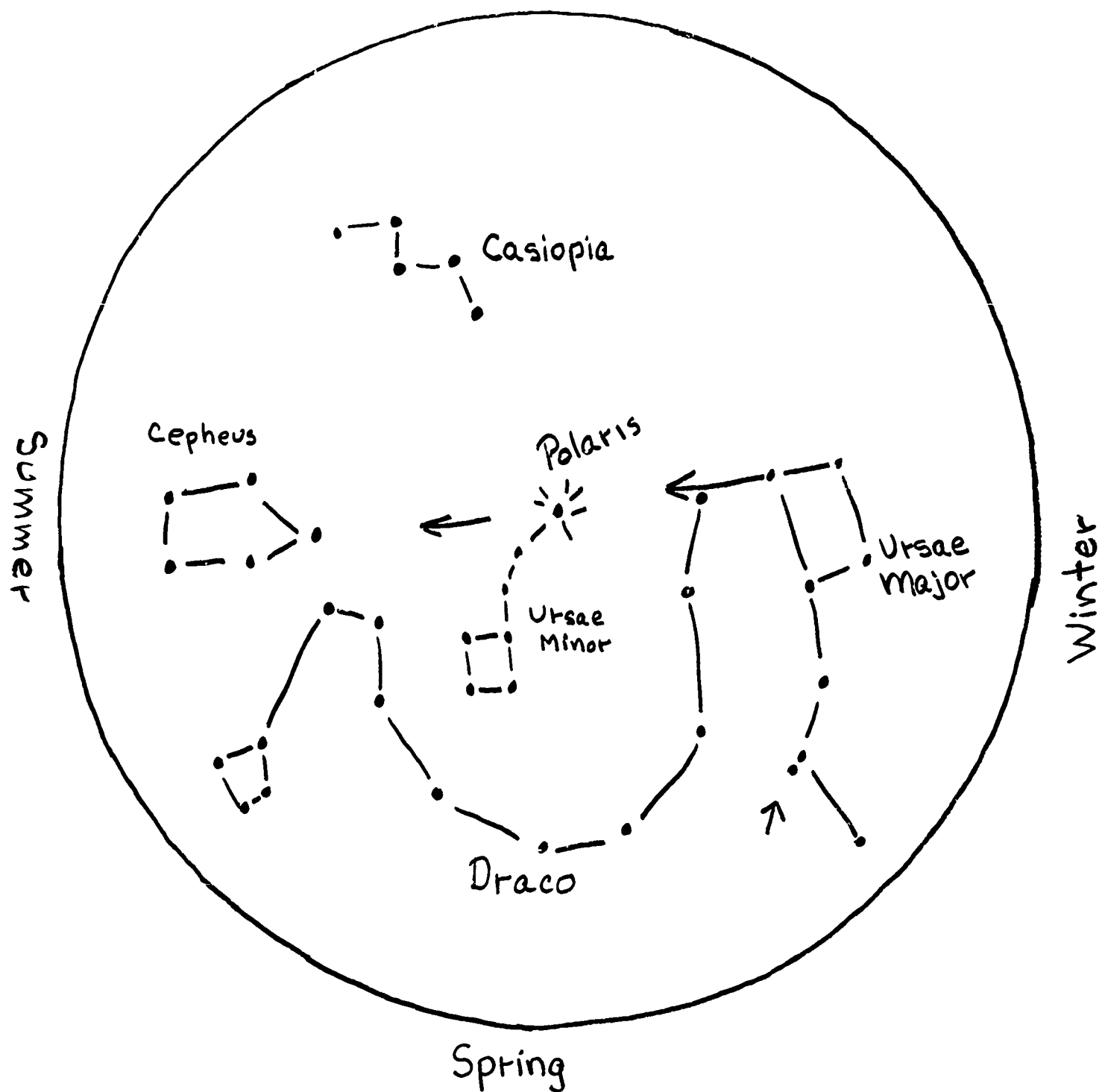

There are FIVE easily identified constellations that are located near the NORTH STAR (polaris). Since they seem to circle the pole they are called the CIRCUMPOLAR constellations. The positions and relationships can be learned within a short time. These constellations are visible on any clear evening.

To use the above chart, turn it so that your present season is at the bottom of the chart. Looking northward the chart should be approximately correct between the hours 7 - 8 PM.

A knowledge and familiarity of this group of constellations will be a great help in locating many other constellations during the year. Using this group as a starting point we can extend lines and form angles that will be a great help in becoming better acquainted with our celestial neighbors.



PLANETARY DATA

	Mean Distance From Sun		Period of Revolution Around the Sun	Period of Rotation on Axis
	Miles	Astronomical Units		
Sun				25 <sup>d</sup>
Mercury	36,000,000	0.387	87 <sup>d</sup> .969	88 <sup>d</sup>
Venus	67,270,000	0.723	224 <sup>d</sup> .701	few wk.
Earth	93,000,000	1.000	365 <sup>d</sup> .256	23 <sup>h</sup> 56 <sup>m</sup>
Mars	141,700,000	1.524	1 <sup>y</sup> .881	24 <sup>h</sup> 37 <sup>m</sup>
Jupiter	483,900,000	5.203	11 <sup>y</sup> .862	9 <sup>h</sup> 50 <sup>m</sup>
Saturn	887,100,000	9.539	29 <sup>y</sup> .458	10 <sup>h</sup> 14 <sup>m</sup>
Uranus	1,783,900,000	19.182	84 <sup>y</sup> .013	10 <sup>h</sup> .8*
Neptune	2,795,400,000	30.058	164 <sup>y</sup> .794	15 <sup>h</sup> .8*
Pluto	3,675,000,000	39.518	248 <sup>y</sup> .430	?

\* Approximately

	Diameter	Surface gravity (earth=1)	Density (earth=1)	Known Moons
Sun	865,400	28.	1.4	
Mercury	3,000	0.27	3.8	0
Venus	7,848	0.85	5.1	0
Earth	7,927	1.00	5.5	1
Mars	4,268	0.38	4.0	2
Jupiter	89,329	2.64	1.3	12
Saturn	75,021	1.17	0.7	9
Uranus	33,219	1.07	1.3	5
Neptune	27,700	1.4	2.2	2
Pluto	3,600	?	?	0

Note: The information above was taken from recent and reliable sources. However, the sources did not agree on a few of the above figures.

SATELLITES OF THE SOLAR SYSTEM

Name	Distance From Planet (Miles)	Period (Days)	Dia- meter (Miles)	Discoverer	Date
<u>Earth</u>					
Moon	239,100	27.32	2,162		
<u>Mars</u>					
I Phobos	5,830	0.32	7	Hall	1877
II Deimos	14,600	1.26	5	Hall	1877
<u>Jupiter</u>					
V	113,000	0.50	150	Barnard	1892
I Io	262,000	1.77	2,090	Galileo	1610
II Europa	417,000	3.55	1,870	Galileo	1610
III Ganymede	666,000	7.16	3,100	Galileo	1610
IV Callisto	1,170,000	16.69	2,850	Galileo	1610
VI	7,120,000	251	100	Perrine	1904
VII	7,290,000	260	35	Perrine	1905
X	7,300,000	260	15	Nicholson	1938
XII	13,000,000	625	14	Nicholson	1951
XI	14,000,000	700	19	Nicholson	1938
VIII	14,600,000	739	35	Melotte	1908
IX	14,700,000	758	17	Nicholson	1914
<u>Saturn</u>					
I Mimas	186,000	0.94	370	Herschel	1789
II Enceladus	238,000	1.37	460	Herschel	1789
III Tetys	295,000	1.89	750	Cassini	1684
IV Dione	338,000	2.74	900	Cassini	1684
V Rhea	527,000	4.52	1,150	Cassini	1672
VI Titan	1,200,000	15.9	2,950	Huyghens	1655
VII Hyperion	1,500,000	21.3	300	Bond	1848
VIII Iapetus	3,600,000	79	1,100	Cassini	1671
IX Phoebe	13,000,000	550	150	Pickering	1898
<u>Uranus</u>					
I Miranda	81,000	1.41	200?	Kuiper	1948
II Ariel	119,000	2.52	600?	Lassell	1851
III Umbriel	166,000	4.14	400?	Lassell	1851
IV Titania	273,000	8.71	1,000?	Herschel	1787
V Oberon	365,000	13.46	900?	Herschel	1787
<u>Neptune</u>					
I Triton	220,000	5.88	2,800?	Lassell	1846
II Nereid	5,800,000	785	200?	Kuiper	1948

TOTAL SOLAR ECLIPSES, 1963 to 2000 A.D.

Date	Path of Total Phase
1963, July 20	Japan, Bering Sea, Alaska, northern Canada, mid-north Atlantic Ocean
1965, May 30	South Pacific: New Zealand - Marquesas Islands - Peru
1966, May 20	Atlantic Ocean, NW Africa, Mediterranean Sea, across Asia
1966, Nov. 12	Pacific, west of Galapagos Islands, across southern South America across the south Atlantic to the Indiana Ocean
1967, Nov. 2	Antarctic Ocean, Antarctica
1968, Sept.22	Arctic Ocean, northern Russia, to central Asia
1970, Mar. 7	Central Pacific Ocean, Mexico, Florida, to mid-north Atlantic Ocean
1972, July 10	Northeastern Asia, Alaska, northern Canada, to mid-Atlantic Ocean
1973, June 30	Northern South America, Atlantic Ocean, across northern Africa to mid-Indian Ocean
1974, June 20	Southern Indian Ocean and Antarctic Ocean, south of Australia
1976, Oct. 23	East Africa, across the Indian Ocean and Australia to a point near New Zealand
1977, Oct. 12	Mid-north Pacific Ocean, southeastward, extending into northern South America
1979, Feb. 26	North Pacific Ocean, northwest tip of United States, across Canada Hudson Bay, into central Greenland
1980, Feb. 16	Atlantic Ocean, across central Africa, Indian Ocean, India, southern China
1981, July 31	Southeastern Europe, across Siberia, to mid-north Pacific Ocean
1983, June 11	South Indian Ocean, across the East Indies, to western Pacific Ocean
1984, May 30	Pacific Ocean, across Mexico, southern United States, across the Atlantic to northern Africa
1984, Nov. 22	East Indies, across the south Pacific Ocean to a point off the coast of Chile
1985, Nov. 12	Antarctic Ocean
1986, Oct. 3	(A short eclipse.) In the Atlantic just off the southeast of Greenland
1987, Mar. 29	Patagonia, across the south Atlantic Ocean, across Africa

- 1988, Mar. 18 ..... Eastern Indian Ocean, across Sumatra, the Malay Peninsula, into the north Pacific, across the Philippine Islands to a point south of Alaska
- 1990, July 22 ..... Finland, the Arctic Ocean, northeastern Asia, across the north Pacific
- 1991, July 11 ..... Mid-Pacific Ocean, across Mexico, central America, northern South America, into Brazil
- 1992, June 30 ..... Southeastern South America, across mid-south Atlantic to the Indian Antarctic Ocean
- 1994, Nov. 3 ..... Pacific Ocean south of the Galapagos Island across South America and the south Atlantic Ocean to the western Indian Ocean
- 1995, Oct. 24 ..... Southwestern Asia, across northern India, the Malay Peninsula, into mid-Pacific Ocean
- 1997, Mar. 9 ..... Central Asia, across N.E. Asia, into the Arctic Ocean
- 1998, Feb. 26 ..... Mid-Pacific Ocean, across the northern tip of South America, across the Atlantic Ocean to the Canary Islands
- 1999, Aug. 11 ..... Atlantic Ocean south of Nova Scotia, across the north Atlantic, across central Europe, southern Asia, and northern India
- 2000..... No total solar eclipse

Note: The next total solar eclipse over our area occurs on April 8, 2024.

ANNULAR ECLIPSES, 1963 to 1990 A.D.\*

Date	Path of Annular Phase
1963, Jan. 25	South Pacific west of Chile, across southern South America, into the Antarctic O. and to Indian O. east of Madagascar
1965, Nov. 23	Northwestern India to coast near Calcutta, across Malay Peninsula, Borneo, and New Guinea, into mid-north Pacific
1969, Mar. 18	Across the Indian Ocean and the East Indies Islands
1969, Sept. 11	Northern and eastern Pacific Ocean into Brazil
1970, Aug. 31	The East Indies and into the south Pacific Ocean
1972, Jan. 16	Marie Byrd Land and eastern Antarctica
1973, Jan. 4	South Pacific, South America, into the south Atlantic
1973, Dec. 24	Across northern S. America, Atlantic O., ending in N. Africa
1976, Apr. 29	Atlantic, North Africa, Med. Sea, south central Asia
1977, Apr. 18	South Atlantic, across South Africa to the Indian Ocean
1979, Aug. 22	Across Amundseen Sea into western Antarctica
1980, Aug. 10	Mid-Pacific Ocean into Brazil
1981, Feb. 4	Pacific O., from South of Australia to near S. American coast
1983, Dec. 4	North Atlantic Ocean, across central Africa
1987, Sept. 22	Central Asia to mid-Pacific Ocean
1988, Sept. 11	West Indian Ocean to south Pacific south of New Zealand
1990, Jan. 26	South Indian Ocean and south Atlantic Ocean

\* Annular Eclipse is an eclipse in which a thin ring of sunlight is visible encircling the dark moon.



TOTAL LUNAR ECLIPSES, 1963 to 1984

Date	Time		Dur.		Region of visibility
	h	m	h	m	
1963, Dec. 30...	6	7	1	24	Mid-Pacific, and partly in North America
1964, June 24...	20	7	1	38	Africa, Europe, South America, eastern North America
1964, Dec. 18...	21	35	1	4	South America, most of North America, western Africa, Europe
1967, Apr. 24...	7	7	1	22	Pacific Ocean and Australia
1967, Oct. 18...	5	16	0	56	Pacific Ocean, western North America
1968, Apr. 12...	23	49	0	56	Most of United States, Mexico, South America
1968, Oct. 6...	6	41	1	2	Pacific Ocean and Australia
1971, Feb. 10...	2	42	1	18	S. Canada, United States, part of South America
1971, Aug. 6...	14	44	1	42	Part of Africa, India, west Indian Ocean
1972, Jan. 30...	5	53	0	42	Pacific Ocean, western North America
1974, Nov. 29...	10	16	1	16	Eastern Asia and Australia
1975, May 25...	0	46	1	30	Southern United States, Mexico, South America
1975, Nov. 18...	17	24	0	46	Europe and Africa
1978, Mar. 24...	11	25	1	30	Southern Asia and Australia
1978, Sept. 16...	14	3	1	22	Most of Africa, southern Asia
1979, Sept. 6...	5	54	0	52	Pacific Ocean, eastern Australia
1982, Jan. 9...	14	56	1	24	Part of Africa, eastern Europe, southern Asia
1982, July 6...	2	30	1	42	South Pacific Ocean, Mexico, western South America
1982, Dec. 30...	6	26	1	6	Central Pacific Ocean
1983.....	.....	.....	.....	.....	No total lunars in 1983-1984