

**PUBLIC MEETING
BOARD OF COUNTY COMMISSIONERS
DESOTO COUNTY, FLORIDA
JUNE 11, 2013**

CALL TO ORDER

9:00 AM

PRAYER/PLEDGE OF ALLEGIANCE

INTRODUCTION OF ELECTED OFFICIALS

SET/AMEND

PUBLIC FORUM FOR NON-AGENDA ITEMS

CONSENT AGENDA-MOTION TO APPROVE

1. Accounts and Warrants drawn according to schedule of bills payable.
2. Minutes of May 28, 2013 Public Meeting and May 28, 2013 Workshop.
3. Declaration of Surplus Property.
4. Employment contract agreement with the Code Compliance Director, Environmental Services Director, Human Resources Director, Library Director, Purchasing Director, Social Services Director, Turner Center Director and Utilities Director.
5. Sufficiency of Surety Bonds for DeSoto County Officials.
6. Approval to apply for and accept the Edward Byrne Memorial Justice Assistance Grant in the amount of \$10,941.00.
7. Approval to serve as the coordinating unit of Government in the FDLE's Edward Byrne Memorial Justice Assistance Grant Program in the amount of \$61,316.00.

PRESENTATION

8. Presentation/DeSoto Mining Update

Request to present an update of the DeSoto Mining.

REGULAR BUSINESS

9. Resolution/Budget Amendment

Request to adopt the Resolution amending the 2012/13 budget including attachments 2013-75, 2013-76, 2013-77, 2013-78 and 2013-79.

10. Proposed M.S.B.U. Rates/Fire Rescue

Request approval of the proposed rates for publication and for notification.

11. Purchase/Tanker Truck

Request to approve the purchase of a Tanker Truck and authorize the County Administrator to execute a purchase order.

12. Memorandum of Understanding/Boca Grande

Request to approve the MOU between Boca Grande Fire Control District and DeSoto County.

13. Approval/Insurance Bid Recommendations

Request to approve the bid recommendations to Agent of Record Brown & Brown/PRIA for Health, Dental, Vision and Life Insurance benefits.

14. Prioritization of Projects/FDOT Work Program for FY 2014/15 through FY 2018/19

Request to approve prioritization of projects and authorize the Chairman to sign the letter to FDOT to consider projects for funding.

15. Pepper Ave. Bridge

Request to pursue FDOT funds for bridge replacement or remove the bridge.

16. Release of Lien/Rainbow Avenue

Request to approve the release of lien and all associated fines levied by DeSoto County for the County owned property located at 1106 Rainbow Avenue.

17. Bid Award/Karle Enviro-Organic Recycling Inc

Request to award bid to Karle Enviro-Organic Recycling Inc. for Sludge Management Services of Lake Suzy WW Treatment Plant and authorize Chairman to execute the Contract.

18. Bid Award/Synagro South, LLC

Request to award bid to Synagro South, LLC for Sludge Management Services for DeSoto County Wastewater Facilities and authorize Chairman to execute the Contract.

19. Administrative Assistant Position/Desoto County Utilities

Request the approval of a Utilities Department Administrative Assistant position.

20. Position Changes/Facilities

Request to approve two position changes and allow posting of one vacant position.

21. Discussion-Taxing Unit/DeSoto County Hospital

Request to discuss a DeSoto County Hospital Taxing Unit Ordinance.

ADMINISTRATOR'S REPORT

COUNTY ATTORNEY'S REPORT

BOARD MEMBER COMMENTS

EXECUTIVE SESSION-ASTALDI CONSTRUCTION CORPORATION V. DESOTO COUNTY

ADJOURNMENT

NOTE: For quasi-judicial matters, any party desiring a verbatim record of the proceeding of this hearing for the purpose of an appeal is advised to make private arrangements for the production of a record. If special accommodations are required in accordance with the Americans with Disabilities Act, individuals should contact the County Administrator's Office by calling 863-993-4800 at least forty-eight hours prior to the hearing.

**BOARD OF COUNTY COMMISSIONERS
DESOTO COUNTY, FLORIDA
DATE: April 9, 2013**

Consent Agenda
 Regular Business
 Public Hearing

Quasi-Judicial Public Hearing
 Time

DEPARTMENT: Administrative Services
SUBMITTED BY: Linda Nipper
PRESENTED BY: N/A

TITLE & DESCRIPTION: Accounts and Warrants Drawn Per Schedule of Bills Payable

REQUESTED MOTION: Motion to approve accounts and warrants drawn according to Schedule(s) of Bills Payable May 15, 2013 – May 29, 2013

SUMMARY:

BACKGROUND: Check Warrants as follows: Seacoast National Bank Consolidated Fund, Wire Transfers, Bank Drafts, Payroll Fund, and Check #210096 – 210368; Payroll Clearing Fund wire drafts; Local Housing-SHIP Fund Check #701 - 704; Utilities Capital Fund Check #N/A; Turner Center Manual Check #N/A

FUNDS:

| | |
|--------------------|-----|
| Budget Amount | N/A |
| Actual Agenda Item | N/A |
| Cost: | |
| Account Number: | N/A |
| Explanation: | N/A |

ATTACHMENTS: 1.

REVIEW APPROVAL:

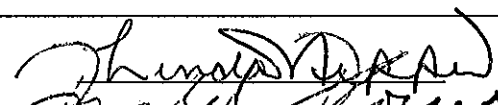
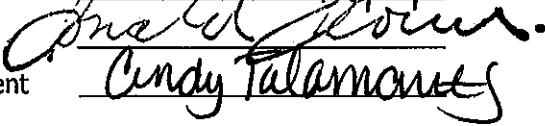
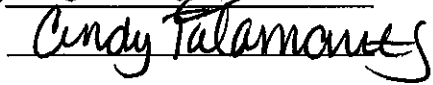
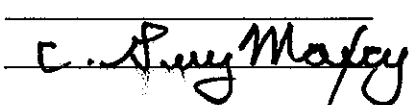
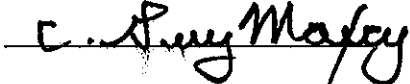
| | |
|-----------------------|--|
| Department Director |  |
| Finance Director |  |
| Purchasing Department |  |
| County Attorney |  |
| County Administrator |  |

5/30/2013 8:29 AM
 VENDOR SET: 01 Desoto County
 BANK: * ALL BANKS
 DATE RANGE: 5/15/2013 THRU 5/29/2013

A/P HISTORY CHECK REPORT

| VENDOR I.D. | NAME | STATUS | CHECK DATE | AMOUNT | DISCOUNT | CHECK NO | CHECK STATUS | CHECK AMOUNT |
|-------------|------------|--------|------------|--------|----------|----------|--------------|--------------|
| C-CHECK | VOID CHECK | V | 5/17/2013 | | | 210097 | | |
| C-CHECK | VOID CHECK | V | 5/17/2013 | | | 210158 | | |

| * * T O T A L S * * | NO | INVOICE AMOUNT | DISCOUNTS | CHECK AMOUNT |
|---------------------|---------------|----------------|-----------|--------------|
| REGULAR CHECKS: | 0 | 0.00 | 0.00 | 0.00 |
| HAND CHECKS: | 0 | 0.00 | 0.00 | 0.00 |
| DRAFTS: | 0 | 0.00 | 0.00 | 0.00 |
| EFT: | 0 | 0.00 | 0.00 | 0.00 |
| NON CHECKS: | 0 | 0.00 | 0.00 | 0.00 |
| VOID CHECKS: | 2 VOID DEBITS | 0.00 | | |
| | VOID CREDITS | 0.00 | 0.00 | 0.00 |

TOTAL ERRORS: 0

| | | | | | |
|------------------------|---------|---|------|------|------|
| VENDOR SET: 01 BANK: * | TOTALS: | 2 | 0.00 | 0.00 | 0.00 |
| BANK: * | TOTALS: | 2 | 0.00 | 0.00 | 0.00 |

VENDOR SET: 01 Desoto County
 BANK: APBK POOLED CASH ACCOUNT
 DATE RANGE: 5/15/2013 THRU 5/29/2013

| VENDOR I.D. | NAME | STATUS | CHECK DATE | AMOUNT | DISCOUNT | CHECK NO | CHECK STATUS | CHECK AMOUNT |
|--------------------|--------------------------------|--------------------|---------------|--------|----------|-------------|-----------------|-----------------|
| 2024 | FL DEPT OF ENVIRONMENTAL PROTE | | | | | | | |
| I-201301292053 | PERMIT- LANDFILL | V | 1/29/2013 | | | 208423 | | 400.00 |
| 2024 | FL DEPT OF ENVIRONMENTAL PROTE | | | | | | | |
| M-CHECK | FL DEPT OF ENVIRONMENTALUNPOST | V | 5/21/2013 | | | 208423 | | 400.00 |
| 1811 | BROADCAST MUSIC INC. | | | | | | | |
| I-23194777 | 1145838 | V | 2/22/2013 | | | 208724 | | 294.00 |
| 1811 | BROADCAST MUSIC INC. | | | | | | | |
| M-CHECK | BROADCAST MUSIC INC. UNPOST | V | 5/21/2013 | | | 208724 | | 294.00 |
| 3293 | JACOBSON, SOBO & MOSELLE | | | | | | | |
| M-CHECK | JACOBSON, SOBO & MOSELLEUNPOST | V | 5/23/2013 | | | 208813 | | 37.52 |
| 4110 | STORAGECRAFT | | | | | | | |
| I-247845 | DES350 | V | 3/08/2013 | | | 209006 | | 600.00 |
| 4110 | STORAGECRAFT | | | | | | | |
| M-CHECK | STORAGECRAFT UNPOST | V | 5/21/2013 | | | 209006 | | 600.00 |
| 3175 | TOSHIBA AMERICA | | | | | | | |
| I-2317270 | BLANKET | V | 4/05/2013 | | | 209458 | | 120.00 |
| 3175 | TOSHIBA AMERICA | | | | | | | |
| M-CHECK | TOSHIBA AMERICA UNPOST | V | 5/21/2013 | | | 209458 | | 120.00 |
| 2024 | FL DEPT OF ENVIRONMENTAL PROTE | | | | | | | |
| I-39 | APP REVIEW FEE-LAKE SUZY FMAIN | V | 4/08/2013 | | | 209469 | | 100.00 |
| 2024 | FL DEPT OF ENVIRONMENTAL PROTE | | | | | | | |
| M-CHECK | FL DEPT OF ENVIRONMENTALUNPOST | V | 5/21/2013 | | | 209469 | | 100.00 |
| 2667 | WASTE MANAGEMENT INC.OF FL. | | | | | | | |
| I-15627 | HAULING | V | 4/26/2013 | | | 209786 | | 331.29 |
| 2667 | WASTE MANAGEMENT INC.OF FL. | | | | | | | |
| M-CHECK | WASTE MANAGEMENT INC.OF UNPOST | V | 5/21/2013 | | | 209786 | | 331.29 |
| 0251 | KATHRYN J HILL | | | | | | | |
| I-201305152519 | TAG AND TITLE WORK | R | 5/15/2013 | | | 210096 | | |
| 001 00001150000000 | ACCOUNTS RECEIVABLE | TAG AND TITLE WORK | | 88.10 | | | | 88.10 |

VENDOR SET: 01 Desoto County
 BANK: APBK POOLED CASH ACCOUNT
 DATE RANGE: 5/15/2013 THRU 5/29/2013

| VENDOR I.D. | NAME | STATUS | CHECK DATE | AMOUNT | DISCOUNT | CHECK NO | CHECK STATUS | CHECK AMOUNT |
|--------------------|---------------------|-------------------|---------------|--------|----------|-------------|-----------------|-----------------|
| 3688 | BV OIL COMPANY, INC | | | | | | | |
| I-000577620 | DCTURN | R | 5/17/2013 | | | 210099 | | |
| 001 70815754010000 | GAS & OIL | FUEL | | 33.17 | | | | 33.17 |
| 3692 | BV OIL COMPANY, INC | | | | | | | |
| I-000575925 | DCPUBL | R | 5/17/2013 | | | 210100 | | |
| 106 70725225201000 | GASOLINE & OIL | BV BLANKET FIRE | | 38.48 | | | | |
| I-000576322 | DCPUBL | R | 5/17/2013 | | | 210100 | | |
| 106 70725225201000 | GASOLINE & OIL | BV BLANKET FIRE | | 106.75 | | | | |
| I-000577013 | DCPUBL | R | 5/17/2013 | | | 210100 | | |
| 106 70725225201000 | GASOLINE & OIL | BV BLANKET FIRE | | 158.30 | | | | |
| I-000577248 | DCPUBL | R | 5/17/2013 | | | 210100 | | |
| 106 70725225201000 | GASOLINE & OIL | BV BLANKET FIRE | | 55.05 | | | | 358.58 |
| 3698 | BV OIL COMPANY, INC | | | | | | | |
| I-000575922 | DCFACIL | R | 5/17/2013 | | | 210101 | | |
| 001 26085195201000 | GASOLINE & OIL | GAS | | 67.97 | | | | |
| I-000576317 | DCFACIL | R | 5/17/2013 | | | 210101 | | |
| 001 26085195201000 | GASOLINE & OIL | GAS | | 6.43 | | | | |
| I-000576751 | DCFACIL | R | 5/17/2013 | | | 210101 | | |
| 001 26085195201000 | GASOLINE & OIL | GAS | | 81.46 | | | | |
| I-000577244 | DCFACIL | R | 5/17/2013 | | | 210101 | | |
| 001 26085195201000 | GASOLINE & OIL | GAS | | 136.05 | | | | |
| I-000577614 | DCFACIL | R | 5/17/2013 | | | 210101 | | |
| 001 26085195201000 | GASOLINE & OIL | GAS | | 68.33 | | | | |
| I-000577843 | DCFACIL | R | 5/17/2013 | | | 210101 | | |
| 001 26085195201000 | GASOLINE & OIL | GAS | | 60.30 | | | | 420.54 |
| 3702 | BV OIL COMPANY, INC | | | | | | | |
| I-000575637 | DCUTIL | R | 5/17/2013 | | | 210102 | | |
| 410 70945365201000 | GASOLINE & OIL | UT. ADMIN. FUEL | | 41.74 | | | | |
| 410 70965335201000 | GASOLINE & OIL | WATER FAC FUEL | | 49.43 | | | | |
| 410 70975355201000 | GASOLINE & OIL | | | 67.88 | | | | |
| I-000575928 | DCUTIL | R | 5/17/2013 | | | 210102 | | |
| 410 70965335201000 | GASOLINE & OIL | WATER FAC FUEL | | 41.92 | | | | |
| I-000576119 | DCUTIL | R | 5/17/2013 | | | 210102 | | |
| 410 70965335201000 | GASOLINE & OIL | WATER FAC FUEL | | 41.20 | | | | |
| I-000576325 | DCUTIL | R | 5/17/2013 | | | 210102 | | |
| 410 70975355201000 | GASOLINE & OIL | | | 73.61 | | | | |
| I-000576575 | DCUTIL | R | 5/17/2013 | | | 210102 | | |
| 410 70945365201000 | GASOLINE & OIL | UT. ADMIN. FUEL | | 28.76 | | | | |
| 410 70955365201000 | GASOLINE & OIL | SYST. MAINT. FUEL | | 95.84 | | | | |
| 410 70975355201000 | GASOLINE & OIL | | | 119.98 | | | | |
| I-000576756 | DCUTIL | R | 5/17/2013 | | | 210102 | | |
| 410 70955365201000 | GASOLINE & OIL | SYST. MAINT. FUEL | | 125.97 | | | | |
| 410 70965335201000 | GASOLINE & OIL | WATER FAC FUEL | | 102.47 | | | | |
| 410 70975355201000 | GASOLINE & OIL | | | 78.51 | | | | |
| I-000577016 | DCUTIL | R | 5/17/2013 | | | 210102 | | |

VENDOR SET: 01 Desoto County
 BANK: APBK POOLED CASH ACCOUNT
 DATE RANGE: 5/15/2013 THRU 5/29/2013

| VENDOR I.D. | NAME | STATUS | CHECK DATE | AMOUNT | DISCOUNT | CHECK NO | CHECK STATUS | CHECK AMOUNT |
|--------------------|-----------------------------|---------|---------------|----------|----------|-------------|-----------------|-----------------|
| 3702 | BV OIL COMPANY, INC | CONT | | | | | | |
| I-000577016 | DCUTIL | R | 5/17/2013 | | | 210102 | | |
| 410 70965335201000 | GASOLINE & OIL | WATER | FAC FUEL | 37.87 | | | | |
| 410 70975355201000 | GASOLINE & OIL | | | 65.91 | | | | |
| I-000577251 | DCUTIL | R | 5/17/2013 | | | 210102 | | |
| 410 70965335201000 | GASOLINE & OIL | WATER | FAC FUEL | 45.90 | | | | |
| I-000577440 | DCUTIL | R | 5/17/2013 | | | 210102 | | |
| 410 70955365201000 | GASOLINE & OIL | SYST. | MAINT. FUEL | 79.64 | | | | |
| 410 70975355201000 | GASOLINE & OIL | | | 67.04 | | | | |
| I-000577621 | DCUTIL | R | 5/17/2013 | | | 210102 | | |
| 410 70965335201000 | GASOLINE & OIL | WATER | FAC FUEL | 68.12 | | | | |
| I-000577849 | DCUTIL | R | 5/17/2013 | | | 210102 | | |
| 410 70955365201000 | GASOLINE & OIL | SYST. | MAINT. FUEL | 87.75 | | | | |
| 410 70965335201000 | GASOLINE & OIL | WATER | FAC FUEL | 39.39 | | | | |
| 410 70975355201000 | GASOLINE & OIL | | | 126.27 | | | | 1,485.20 |
| 3686 | BV OIL COMPANY, INC. | | | | | | | |
| I-000577250 | DCTRAN | R | 5/17/2013 | | | 210103 | | |
| 102 60505415201000 | GASOLINE & OIL-DEPARTMENTAL | FUEL | FOR MAY 2013 | 559.96 | | | | |
| I-000577439 | DCTRAN | R | 5/17/2013 | | | 210103 | | |
| 102 60505415201000 | GASOLINE & OIL-DEPARTMENTAL | FUEL | FOR MAY 2013 | 1,426.55 | | | | |
| I-000577619 | DCTRAN | R | 5/17/2013 | | | 210103 | | |
| 102 60505415201000 | GASOLINE & OIL-DEPARTMENTAL | FUEL | FOR MAY 2013 | 494.68 | | | | 2,481.19 |
| 3687 | BV OIL COMPANY, INC. | | | | | | | |
| I-000573787 | DCENVIR | R | 5/17/2013 | | | 210104 | | |
| 400 42305345201000 | GASOLINE & OIL | GAS | ON ROAD | 48.72 | | | | |
| I-000574742 | DCENVIR | R | 5/17/2013 | | | 210104 | | |
| 400 42305345201000 | GASOLINE & OIL | GAS | ON ROAD | 47.82 | | | | |
| I-000574861 | DCENVIR | R | 5/17/2013 | | | 210104 | | |
| 400 42305345201000 | GASOLINE & OIL | GAS | ON ROAD | 100.40 | | | | |
| I-000575243 | DCENVIR | R | 5/17/2013 | | | 210104 | | |
| 400 42305345201000 | GASOLINE & OIL | GAS | ON ROAD | 188.47 | | | | |
| I-000575921 | DCENVIR | R | 5/17/2013 | | | 210104 | | |
| 400 42305345201000 | GASOLINE & OIL | GAS | ON ROAD | 126.86 | | | | |
| I-000577613 | DCENVIR | R | 5/17/2013 | | | 210104 | | |
| 400 42305345201000 | GASOLINE & OIL | GAS | ON ROAD | 77.61 | | | | 589.88 |
| 3689 | BV OIL COMPANY, INC. | | | | | | | |
| I-000577842 | DCCODE | R | 5/17/2013 | | | 210105 | | |
| 001 30185245201000 | GASOLINE & OIL | BV OIL | | 58.41 | | | | 58.41 |
| 3693 | BV OIL COMPANY, INC. | | | | | | | |
| I-000578292 | DCADMIN | R | 5/17/2013 | | | 210106 | | |
| 001 26015125201000 | GAS AND OIL | BLANKET | | 41.94 | | | | 41.94 |

VENDOR SET: 01 Desoto County
 BANK: APBK POOLED CASH ACCOUNT
 DATE RANGE: 5/15/2013 THRU 5/29/2013

| VENDOR I.D. | NAME | STATUS | CHECK DATE | AMOUNT | DISCOUNT | CHECK NO | CHECK STATUS | CHECK AMOUNT |
|---------------------|--------------------------------|-------------------|---------------|----------|----------|-------------|-----------------|-----------------|
| 3694 | BV OIL COMPANY, INC. | | | | | | | |
| I-000578613 | DCCOMSV | R | 5/17/2013 | | | 210107 | | |
| 001 31165644000000 | TRAVEL | BLANKET | PO FUEL | 42.83 | | | | 42.83 |
| 3697 | BV OIL COMPANY, INC. | | | | | | | |
| I-000578454 | DCENGIN | R | 5/17/2013 | | | 210108 | | |
| 104 30205415201000 | GAS AND OIL | | | 78.76 | | | | 78.76 |
| 3713 | BV OIL COMPANY, INC. | | | | | | | |
| I-000576116 | DCPUBE | R | 5/17/2013 | | | 210109 | | |
| 106 70735265201000 | GASOLINE & OIL | BV FUEL- | EMS | 122.52 | | | | |
| I-000576754 | DCPUBE | R | 5/17/2013 | | | 210109 | | |
| 106 70735265201000 | GASOLINE & OIL | BV FUEL- | EMS | 78.17 | | | | |
| I-000577247 | DCPUBE | R | 5/17/2013 | | | 210109 | | |
| 106 70735265201000 | GASOLINE & OIL | BV FUEL- | EMS | 20.08 | | | | |
| I-000577437 | DCPUBE | R | 5/17/2013 | | | 210109 | | |
| 106 70735265201000 | GASOLINE & OIL | BV FUEL- | EMS | 50.38 | | | | |
| I-000577617 | DCPUBE | R | 5/17/2013 | | | 210109 | | |
| 106 70735265201000 | GASOLINE & OIL | BV FUEL- | EMS | 47.19 | | | | 318.34 |
| 3714 | BV OIL COMPANY, INC. | | | | | | | |
| I-000576572 | DCPUBAD | R | 5/17/2013 | | | 210110 | | |
| 106 70715295201000 | GAS & OIL-GENERAL USE | BV ADMIN | | 82.47 | | | | |
| I-000576753 | DCPUBAD | R | 5/17/2013 | | | 210110 | | |
| 106 70715295201000 | GAS & OIL-GENERAL USE | BV ADMIN | | 167.28 | | | | |
| I-000577011 | DCPUBAD | R | 5/17/2013 | | | 210110 | | |
| 106 70715295201000 | GAS & OIL-GENERAL USE | BV ADMIN | | 46.11 | | | | |
| I-000577436 | DCPUBAD | R | 5/17/2013 | | | 210110 | | |
| 106 70715295201000 | GAS & OIL-GENERAL USE | BV ADMIN | | 36.72 | | | | 332.58 |
| 3758 | CATERPILLAR FINANCIAL SERV COR | | | | | | | |
| I-05/15/13-826H | MAY INVOICE | R | 5/17/2013 | | | 210111 | | |
| 400 42305344400000 | LEASE EQUIPMENT | 826H-AWF00699 | | 6,179.79 | | | | 6,179.79 |
| 3283 | TOSHIBA AMERICA BUSINESS SOLUT | | | | | | | |
| I-05/15/13-57989700 | SCXB022205 | R | 5/17/2013 | | | 210112 | | |
| 106 71315254400000 | RENTALS AND LEASES | SCXB022205 | | 41.88 | | | | 41.88 |
| 3961 | AIR MECHANICAL & SERVICE CORP | | | | | | | |
| I-60227 | DESOTURN | R | 5/17/2013 | | | 210113 | | |
| 001 70815754601000 | MAINTENANCE CONTRACTS | QUARTERLY MEETING | | 1,700.00 | | | | 1,700.00 |
| 4538 | AKCA, INC | | | | | | | |
| I-1707 | DC13-12-00 | R | 5/17/2013 | | | 210114 | | |
| 104 605454163000RR | RR XING REPAIR | | | 717.50 | | | | |
| I-1708 | DC13-12-00 | R | 5/17/2013 | | | 210114 | | |
| 104 605454163000RR | RR XING REPAIR | | | 713.75 | | | | 1,431.25 |

VENDOR SET: 01 Desoto County
 BANK: APBK POOLED CASH ACCOUNT
 DATE RANGE: 5/15/2013 THRU 5/29/2013

| VENDOR I.D. | NAME | STATUS | CHECK DATE | AMOUNT | DISCOUNT | CHECK NO | CHECK STATUS | CHECK AMOUNT |
|--------------------|---|--------|--------------------|------------|----------|-------------|-----------------|-----------------|
| 2690 | ARCADIA DO IT BEST HARDWARE | | | | | | | |
| I-A350068 | 2000100 | R | 5/17/2013 | | | 210115 | | |
| 410 70975354600000 | GENERAL REPAIR & MAINTENANCE CO. WW SYST. REPAIRS | | | 20.05 | | | | 20.05 |
| 4490 | AT & T MOBILITY | | | | | | | |
| I-X05022013 | 287250041307 | R | 5/17/2013 | | | 210116 | | |
| 001 26015124100000 | TELEPHONE | | APRIL CELL CHARGES | 153.21 | | | | |
| 001 26035154100000 | TELEPHONE | | APRIL CELL CHARGES | 40.25 | | | | |
| 001 30185244100000 | TELEPHONE | | APRIL CELL CHARGES | 40.25 | | | | |
| 106 70715294100000 | TELEPHONE | | APRIL CELL CHARGES | 79.98 | | | | 313.69 |
| 1950 | BENCHMARK ENVIRO | | | | | | | |
| I-13050107 | DCI WWTP | R | 5/17/2013 | | | 210117 | | |
| 410 70975353400000 | CONTRACTED SERVICES | | DCI WWTP | 56.80 | | | | |
| I-13050108 | DCR WWTP | R | 5/17/2013 | | | 210117 | | |
| 410 70975353400000 | CONTRACTED SERVICES | | DCR WWTP | 56.80 | | | | |
| I-13050109 | DCR WWTP | R | 5/17/2013 | | | 210117 | | |
| 410 70975353400000 | CONTRACTED SERVICES | | DCR WWTP | 26.48 | | | | 140.08 |
| 2309 | BIG T TIREMAN | | | | | | | |
| I-1-GS381901 | RB200128 | R | 5/17/2013 | | | 210118 | | |
| 102 60505414600000 | REPAIR & MAINTENANCE | | GS381901 | 499.90 | | | | |
| I-1-GS382009 | RB200455, RB200829, STOCK | R | 5/17/2013 | | | 210118 | | |
| 102 60505414600000 | REPAIR & MAINTENANCE | | GS382009 | 1,317.50 | | | | 1,817.40 |
| 0098 | BOWLING GREEN SMALL ENGINE | | | | | | | |
| I-29482 | STOCK | R | 5/17/2013 | | | 210119 | | |
| 102 60505414600000 | REPAIR & MAINTENANCE | | 29482 | 611.60 | | | | 611.60 |
| 3701 | BV OIL COMPANY, INC | | | | | | | |
| I-000579086 | DCEMERG | R | 5/17/2013 | | | 210120 | | |
| 106 71315255201000 | GASOLINE & OIL | | | 68.29 | | | | 68.29 |
| 3702 | BV OIL COMPANY, INC | | | | | | | |
| C-000577772 | DCUTIL | R | 5/17/2013 | | | 210121 | | |
| 410 70965335201000 | GASOLINE & OIL | | WATER FAC FUEL | 4,497.81CR | | | | |
| I-000578086 | DCUTIL | R | 5/17/2013 | | | 210121 | | |
| 410 70945365201000 | GASOLINE & OIL | | UT. ADMIN. FUEL | 46.98 | | | | |
| 410 70955365201000 | GASOLINE & OIL | | SYST. MAINT. FUEL | 109.97 | | | | |
| 410 70965335201000 | GASOLINE & OIL | | WATER FAC FUEL | 45.93 | | | | |
| I-000578225 | DCUTIL | R | 5/17/2013 | | | 210121 | | |
| 410 70965335201000 | GASOLINE & OIL | | WATER FAC FUEL | 4,497.81 | | | | |
| I-000578460 | DCUTIL | R | 5/17/2013 | | | 210121 | | |
| 410 70965335201000 | GASOLINE & OIL | | WATER FAC FUEL | 112.30 | | | | |
| 410 70975355201000 | GASOLINE & OIL | | | 159.96 | | | | |
| I-000578501 | DCUTIL | R | 5/17/2013 | | | 210121 | | |
| 410 70965335201000 | GASOLINE & OIL | | WATER FAC FUEL | 2,113.09 | | | | |
| 410 70975355201000 | GASOLINE & OIL | | | 1,914.56 | | | | |
| I-000578502 | DCUTIL | R | 5/17/2013 | | | 210121 | | |

VENDOR SET: 01 Desoto County
 BANK: APBK POOLED CASH ACCOUNT
 DATE RANGE: 5/15/2013 THRU 5/29/2013

| VENDOR I.D. | NAME | STATUS | CHECK DATE | AMOUNT | DISCOUNT | CHECK NO | CHECK STATUS | CHECK AMOUNT |
|--------------------|-----------------------------|--------------------|---------------|----------|----------|-------------|-----------------|-----------------|
| 3702 | BV OIL COMPANY, INC | CONT | | | | | | |
| I-000578502 | DCUTIL | R | 5/17/2013 | | | 210121 | | |
| 409 70875365201000 | GAS AND OIL | DIESEL | FOR GENERATOR | 470.15 | | | | 4,972.94 |
| 3686 | BV OIL COMPANY, INC. | | | | | | | |
| I-000577848 | DCTRAN | R | 5/17/2013 | | | 210122 | | |
| 102 60505415201000 | GASOLINE & OIL-DEPARTMENTAL | FUEL | FOR MAY 2013 | 75.63 | | | | |
| I-000578085 | DCTRAN | R | 5/17/2013 | | | 210122 | | |
| 102 60505415201000 | GASOLINE & OIL-DEPARTMENTAL | FUEL | FOR MAY 2013 | 1,444.04 | | | | |
| I-000578298 | DCTRAN | R | 5/17/2013 | | | 210122 | | |
| 102 60505415201000 | GASOLINE & OIL-DEPARTMENTAL | FUEL | FOR MAY 2013 | 520.69 | | | | |
| I-000578459 | DCTRAN | R | 5/17/2013 | | | 210122 | | |
| 102 60505415201000 | GASOLINE & OIL-DEPARTMENTAL | FUEL | FOR MAY 2013 | 1,588.10 | | | | |
| I-000578620 | DCTRAN | R | 5/17/2013 | | | 210122 | | |
| 102 60505415201000 | GASOLINE & OIL-DEPARTMENTAL | FUEL | FOR MAY 2013 | 296.02 | | | | |
| I-000579092 | DCTRAN | R | 5/17/2013 | | | 210122 | | |
| 102 60505415201000 | GASOLINE & OIL-DEPARTMENTAL | FUEL | FOR MAY 2013 | 1,273.26 | | | | 5,197.74 |
| 3689 | BV OIL COMPANY, INC. | | | | | | | |
| I-000579297 | DCCODE | R | 5/17/2013 | | | 210123 | | |
| 001 30185245201000 | GASOLINE & OIL | BV OIL | | 61.55 | | | | 61.55 |
| 3693 | BV OIL COMPANY, INC. | | | | | | | |
| I-000578807 | DCADMIN | R | 5/17/2013 | | | 210124 | | |
| 001 26015125201000 | GAS AND OIL | BLANKET | | 42.85 | | | | 42.85 |
| 1 | Century Manufacturing | | | | | | | |
| I-DC522412 | 164731 | R | 5/17/2013 | | | 210125 | | |
| 001 70745725200000 | OPERATING SUPPLIES | WEED DESTROYER | | 99.80 | | | | 99.80 |
| 3848 | CENTURYLINK | | | | | | | |
| I-201305172535 | 312204069 | R | 5/17/2013 | | | 210126 | | |
| 106 70715294100000 | TELEPHONE | TELEPHONE | | 36.18 | | | | 36.18 |
| 0084 | CITY OF ARCADIA, | | | | | | | |
| I-108344 | 2110839200 | R | 5/17/2013 | | | 210127 | | |
| 106 70715294300000 | UTILITIES | WATER SEWER OFFICE | | 88.86 | | | | 88.86 |
| 2724 | CULLIGAN WATER | | | | | | | |
| I-201305152525 | 1111962 | R | 5/17/2013 | | | 210128 | | |
| 102 60505414601000 | MAINT. AGREEMENTS | WATER TREATMENT | | 89.00 | | | | |
| I-800257442 | 1013721 | R | 5/17/2013 | | | 210128 | | |
| 102 60505415205000 | DEPARTMENT SUPPLIES | WATER | | 86.15 | | | | 175.15 |

VENDOR SET: 01 Desoto County
 BANK: APBK POOLED CASH ACCOUNT
 DATE RANGE: 5/15/2013 THRU 5/29/2013

| VENDOR I.D. | NAME | STATUS | CHECK DATE | AMOUNT | DISCOUNT | CHECK NO | CHECK STATUS | CHECK AMOUNT |
|--------------------|-------------------------------|----------------------|---------------|-----------|----------|-------------|-----------------|-----------------|
| 4485 | DADE PAPER & BAG COMPANY | | | | | | | |
| I-365195 | 156400 | R | 5/17/2013 | | | 210129 | | |
| 001 26085195200000 | OPERATING SUPPLIES | MAINT. | | 549.00 | | | | |
| I-365197 | 856402 | R | 5/17/2013 | | | 210129 | | |
| 001 26085195200000 | OPERATING SUPPLIES | MAINT. | | 232.00 | | | | 781.00 |
| 0688 | DESOTO INSURANCE AGENCY | | | | | | | |
| I-201305162527 | LSM0019465 | R | 5/17/2013 | | | 210130 | | |
| 001 70835145100000 | OFFICE SUPPLIES | | | 99.52 | | | | 99.52 |
| 0704 | DESOTO COUNTY COMMUNITY | | | | | | | |
| I-201305162526 | 01-170 | R | 5/17/2013 | | | 210131 | | |
| 102 60505415301000 | ROAD & BRIDGE MATERIALS | 243255 | | 64.26 | | | | |
| 102 60505415301000 | ROAD & BRIDGE MATERIALS | 243266 | | 33.18 | | | | |
| 102 60505415301000 | ROAD & BRIDGE MATERIALS | 243347 | | 80.22 | | | | |
| 102 60505415301000 | ROAD & BRIDGE MATERIALS | 243366 | | 74.34 | | | | |
| 102 60505415301000 | ROAD & BRIDGE MATERIALS | 243375 | | 56.70 | | | | |
| 102 60505415301000 | ROAD & BRIDGE MATERIALS | 243386 | | 64.68 | | | | |
| 102 60505415301000 | ROAD & BRIDGE MATERIALS | 243402 | | 70.14 | | | | |
| 102 60505415301000 | ROAD & BRIDGE MATERIALS | 243405 | | 56.28 | | | | |
| 102 60505415301000 | ROAD & BRIDGE MATERIALS | 243432 | | 82.32 | | | | |
| 102 60505415301000 | ROAD & BRIDGE MATERIALS | 243462 | | 41.58 | | | | |
| 102 60505415301000 | ROAD & BRIDGE MATERIALS | 243866 | | 112.98 | | | | |
| 102 60505415301000 | ROAD & BRIDGE MATERIALS | 243900 | | 52.92 | | | | |
| 102 60505415301000 | ROAD & BRIDGE MATERIALS | 243904 | | 47.46 | | | | |
| 102 60505415301000 | ROAD & BRIDGE MATERIALS | 243909 | | 34.44 | | | | 871.50 |
| 0702 | DESOTO MEMORIAL HOSPITAL | | | | | | | |
| I-201305172531 | INDIGENT CARE FUNDS/RACETRACK | R | 5/17/2013 | | | 210132 | | |
| 001 31165648200000 | DMH PARA-MUTUAL | INDIGENT CARE FUNDS | | 50,000.00 | | | | 50,000.00 |
| 0229 | DESOTO FORD AUTOMALL INC | | | | | | | |
| I-18694 | 2764 | R | 5/17/2013 | | | 210133 | | |
| 102 60505414600000 | REPAIR & MAINTENANCE | 18694 | | 14.67 | | | | 14.67 |
| 1010 | DESOTO COUNTY CHAMBER OF | | | | | | | |
| I-54 | 2013/2014 CHAMBER DUES | R | 5/17/2013 | | | 210134 | | |
| 001 26015125400000 | SUBSCRIPTIONS AND DUES | 2013/2014 CHAMBER DU | | 80.00 | | | | 80.00 |
| 1 | DESOTO COUNTY SUPERINTEND | | | | | | | |
| I-201305152523 | DEPO | R | 5/17/2013 | | | 210135 | | |
| 001 00002202000000 | DEPOSIT REFUNDS RENTALS -- TC | DEPOSIT REFUND | | 500.00 | | | | 500.00 |

VENDOR SET: 01 Desoto County
 BANK: APBK POOLED CASH ACCOUNT
 DATE RANGE: 5/15/2013 THRU 5/29/2013

| VENDOR I.D. | NAME | STATUS | CHECK DATE | AMOUNT | DISCOUNT | CHECK NO | CHECK STATUS | CHECK AMOUNT |
|--------------------|-----------------------------|--------|---------------------|-----------|----------|-------------|-----------------|-----------------|
| 4528 | DESOTO COUNTY TEEN COURT | | | | | | | |
| I-201305152521 | TEEN COURT FEES/APRIL | R | 5/17/2013 | | | 210136 | | |
| 190 24106894900415 | TEEN COURT EXPENSE | | TEEN COURT FEES | 910.75 | | | | 910.75 |
| 1187 | DOWNTOWN SIGNS | | | | | | | |
| I-8293 | BLANKET | R | 5/17/2013 | | | 210137 | | |
| 001 26015125101000 | BOARD ROOM OFFICE EXPENSE | | BLANKET | 25.10 | | | | 25.10 |
| 2735 | DUMONT COMPANY, INC. | | | | | | | |
| I-277807 | DESU-LAKE SUZY | R | 5/17/2013 | | | 210138 | | |
| 409 70875365203000 | CHEMICALS & SUPPLIES | | CHEMICALS - LS WWTP | 357.50 | | | | |
| I-277820 | DESU-PHASE 1 WRF | R | 5/17/2013 | | | 210138 | | |
| 410 70975355203000 | CHEMICALS & SUPPLIES | | DCR WWTP CHEMICALS | 272.00 | | | | 629.50 |
| 4187 | EXCAVATION POINT, INC | | | | | | | |
| I-00015781 | 13c014-2 | R | 5/17/2013 | | | 210139 | | |
| 104 60555416300113 | SCOP-JPA NOTTS DAIRY | | | 1,200.00 | | | | 1,200.00 |
| 1311 | FLASH EQUIPMENT INC | | | | | | | |
| I-98554 | DESO3 | R | 5/17/2013 | | | 210140 | | |
| 102 60505414600000 | REPAIR & MAINTENANCE | | 98554 | 125.95 | | | | 125.95 |
| 3206 | FLORIDA POWER & LIGHT CO | | | | | | | |
| I-201305152520 | 22593-44469 | R | 5/17/2013 | | | 210141 | | |
| 001 52425234300000 | UTILITIES | | 22593-44469 | 197.88 | | | | |
| I-201305172534 | 53586-70064 | R | 5/17/2013 | | | 210141 | | |
| 106 70715294300000 | UTILITIES | | UTILITIES STATION 1 | 369.34 | | | | 567.22 |
| 1918 | FPL-ASSIST | | | | | | | |
| I-201305172532 | LIHEAP BLANKET PO | R | 5/17/2013 | | | 210142 | | |
| 101 39005644300000 | HOME ENERGY ASSISTANCE | | LIHEAP BLANKET PO | 11,050.00 | | | | |
| 101 39005644310000 | CRISES BENEFIT PAYMENTS | | LIHEAP BLANKET PO | 7,189.46 | | | | 18,239.46 |
| 3877 | FRED'S HYDRAULIC HOSE | | | | | | | |
| I-872 | RB200445 | R | 5/17/2013 | | | 210143 | | |
| 102 60505414600000 | REPAIR & MAINTENANCE | | 872 | 180.00 | | | | 180.00 |
| 3145 | GAMETIME, INC | | | | | | | |
| I-819262 | 60488 | R | 5/17/2013 | | | 210144 | | |
| 001 70735725200000 | OPERATING SUPPLIES | | KINGS PARK SPRING | 148.00 | | | | 148.00 |
| 3107 | GLADE AND GROVE SUPPLY, INC | | | | | | | |
| I-P15211 | 9934821 | R | 5/17/2013 | | | 210145 | | |
| 102 60505414600000 | REPAIR & MAINTENANCE | | P15211 | 273.16 | | | | |
| I-P15429 | 9934821 | R | 5/17/2013 | | | 210145 | | |
| 102 60505414600000 | REPAIR & MAINTENANCE | | RB201021 & RB201022 | 39.20 | | | | 312.36 |

VENDOR SET: 01 Desoto County
 BANK: APBK POOLED CASH ACCOUNT
 DATE RANGE: 5/15/2013 THRU 5/29/2013

| VENDOR I.D. | NAME | STATUS | CHECK DATE | AMOUNT | DISCOUNT | CHECK NO | CHECK STATUS | CHECK AMOUNT |
|--------------------|-------------------------------|--------------------|---------------|-----------|----------|-------------|-----------------|-----------------|
| 1391 | GRAINGER INC | | | | | | | |
| I-9129834330 | 851295683 | R | 5/17/2013 | | | 210146 | | |
| 001 26085194602000 | BUILDING MAINTENANCE | MAINT. | | 33.04 | | | | |
| I-9132991416 | 866230576 | R | 5/17/2013 | | | 210146 | | |
| 410 70955365202000 | TOOLS | MINOR TOOLS | | 77.53 | | | | |
| I-9133110735 | 866230576 | R | 5/17/2013 | | | 210146 | | |
| 410 70955365202000 | TOOLS | MINOR TOOLS | | 1,138.26 | | | | |
| I-9134021683 | 866230576 | R | 5/17/2013 | | | 210146 | | |
| 410 70975355202000 | MINOR EQUIPMENT | BLANK SQUARE STOCK | | 13.79 | | | | 1,262.62 |
| 2652 | HOME OWNERS SUPPLY | | | | | | | |
| I-237143 | 142919 | R | 5/17/2013 | | | 210147 | | |
| 410 70975354600000 | GENERAL REPAIR & MAINTENANCE | MINOR REPAIRS - WW | | 28.36 | | | | |
| I-237172 | 142919 | R | 5/17/2013 | | | 210147 | | |
| 410 70975354600000 | GENERAL REPAIR & MAINTENANCE | MINOR REPAIRS - WW | | 11.00 | | | | 39.36 |
| 1482 | J.M. TODD, INC | | | | | | | |
| I-409964 | 5472 | R | 5/17/2013 | | | 210148 | | |
| 001 52425234400000 | RENTALS AND LEASES | COPIER LEASE | | 30.00 | | | | 30.00 |
| 4451 | JERRY ULM DODGE CHRYSLER JEEP | | | | | | | |
| I-447909 | 179602 | R | 5/17/2013 | | | 210149 | | |
| 001 70745724600000 | REPAIR AND MAINTENANCE | OIL | | 28.20 | | | | 28.20 |
| 1 | JUSTIN SMITH | | | | | | | |
| I-201305162529 | DEPOSIT REFUND | R | 5/17/2013 | | | 210150 | | |
| 001 00002202000000 | DEPOSIT REFUNDS RENTALS - TC | DEPOSIT REFUND | | 500.00 | | | | 500.00 |
| 3854 | KEY GOVERNMENT FINANCE, INC. | | | | | | | |
| I-1897571305 | 189757 | R | 5/17/2013 | | | 210151 | | |
| 102 60505414400000 | LEASE EQUIPMENT | LEASE AGREEMENT | | 13,442.01 | | | | 13,442.01 |
| 2094 | KINARD'S TREE SERVICE | | | | | | | |
| I-431 | MAINT. | R | 5/17/2013 | | | 210152 | | |
| 001 26085194600000 | REPAIRS & MAINTENANCE | MAINT. | | 250.00 | | | | 250.00 |
| 4374 | KONICA MINOLTA | | | | | | | |
| I-224543249 | 1187510 | R | 5/17/2013 | | | 210153 | | |
| 001 30155154601000 | MAINTENANCE AGREEMENTS | | | 84.09 | | | | |
| 001 30185244601000 | MAINTENANCE AGREEMENTS | | | 84.09 | | | | |
| 104 30205414601000 | MAINTENANCE AGREEMENTS | | | 84.09 | | | | 252.27 |
| 4508 | MADER ELECTRIC, INC | | | | | | | |
| I-0005408 | DESBDC | R | 5/17/2013 | | | 210154 | | |
| 410 70975354600000 | GENERAL REPAIR & MAINTENANCE | REBALANCE PUMP | | 400.00 | | | | 400.00 |

VENDOR SET: 01 Desoto County
 BANK: APBK POOLED CASH ACCOUNT
 DATE RANGE: 5/15/2013 THRU 5/29/2013

| VENDOR I.D. | NAME | STATUS | CHECK DATE | AMOUNT | DISCOUNT | CHECK NO | CHECK STATUS | CHECK AMOUNT |
|--------------------|------------------------------|----------------------|------------|----------|----------|----------|--------------|--------------|
| 2533 | MARGARET WATERS | | | | | | | |
| I-201305162530 | TRAVEL | R | 5/17/2013 | | | 210155 | | |
| 001 31165644000000 | TRAVEL | TRAVEL | | 42.00 | | | | 42.00 |
| 2932 | MED-VET INT'L | | | | | | | |
| I-423975-1-1 | 28366 | R | 5/17/2013 | | | 210156 | | |
| 001 30195625206000 | VETERINARY SUPPLIES/SERVICES | SUPPLIES | | 301.14 | | | | 301.14 |
| 2051 | NAPA-GENIUNE PARTS CO. | | | | | | | |
| C-204716 | 2136 | R | 5/17/2013 | | | 210157 | | |
| 001 26085194600000 | REPAIRS & MAINTENANCE | MAINT. | | 148.46CR | | | | |
| C-204865 | 2136 | R | 5/17/2013 | | | 210157 | | |
| 102 60505414600000 | REPAIR & MAINTENANCE | 204865 | | 442.31CR | | | | |
| C-205085 | 2136 | R | 5/17/2013 | | | 210157 | | |
| 102 60505414600000 | REPAIR & MAINTENANCE | 205085 | | 6.50CR | | | | |
| I-204431 | 2136 | R | 5/17/2013 | | | 210157 | | |
| 001 26085194600000 | REPAIRS & MAINTENANCE | MAINT. | | 230.66 | | | | |
| I-204600 | 2136 | R | 5/17/2013 | | | 210157 | | |
| 001 26085194600000 | REPAIRS & MAINTENANCE | MAINT. | | 6.99 | | | | |
| I-204683 | 2136 | R | 5/17/2013 | | | 210157 | | |
| 410 70965334601000 | VEHICLE REPAIR & MAINTENANCE | WATER VEH REPAIRS | | 234.22 | | | | |
| I-204766 | 2136 | R | 5/17/2013 | | | 210157 | | |
| 410 70975354601000 | VEHICLE REPAIR & MAINTENANCE | WW VEH REPAIRS | | 177.26 | | | | |
| I-204785 | 2136 | R | 5/17/2013 | | | 210157 | | |
| 001 26085194600000 | REPAIRS & MAINTENANCE | MAINT. | | 44.48 | | | | |
| I-204864 | 2136 | R | 5/17/2013 | | | 210157 | | |
| 102 60505414600000 | REPAIR & MAINTENANCE | 204864 | | 442.31 | | | | |
| I-204867 | 2136 | R | 5/17/2013 | | | 210157 | | |
| 001 26085194600000 | REPAIRS & MAINTENANCE | MAINT. | | 15.39 | | | | |
| I-205155 | 2136 | R | 5/17/2013 | | | 210157 | | |
| 001 70745724600000 | REPAIR AND MAINTENANCE | Parts for Parks equi | | 17.44 | | | | |
| I-205164 | 2136 | R | 5/17/2013 | | | 210157 | | |
| 102 60505414600000 | REPAIR & MAINTENANCE | 205164 | | 58.76 | | | | |
| I-205165 | 2136 | R | 5/17/2013 | | | 210157 | | |
| 102 60505414600000 | REPAIR & MAINTENANCE | 205165 | | 59.87 | | | | |
| I-205199 | 2136 | R | 5/17/2013 | | | 210157 | | |
| 001 70745724600000 | REPAIR AND MAINTENANCE | Parts for Parks equi | | 62.55 | | | | 752.66 |
| 1421 | NEXTEL COMMUNICATIONS | | | | | | | |
| I-644985413-134 | 644985413 | R | 5/17/2013 | | | 210159 | | |
| 001 30175164100000 | TELEPHONE | SPRINT CHARGES | | 39.99 | | | | |
| 001 31165644100000 | TELEPHONE | SPRINT CHARGES | | 39.99 | | | | |
| 001 70815754100000 | COMMUNICATIONS | SPRINT CHARGES | | 39.99 | | | | |
| 102 60505414100000 | COMMUNICATIONS | SPRINT CHARGES | | 39.99 | | | | |
| 106 70715294100000 | TELEPHONE | SPRINT CHARGES | | 52.99 | | | | 212.95 |

VENDOR SET: 01 Desoto County
 BANK: APBK POOLED CASH ACCOUNT
 DATE RANGE: 5/15/2013 THRU 5/29/2013

| VENDOR I.D. | NAME | STATUS | CHECK DATE | AMOUNT | DISCOUNT | CHECK NO | CHECK STATUS | CHECK AMOUNT |
|--------------------|------------------------------|----------------------|---------------|-----------|----------|-------------|-----------------|-----------------|
| 0432 | OFFICE DEPOT | | | | | | | |
| I-654078320001 | 27272349 | R | 5/17/2013 | | | 210160 | | |
| 001 31165645100000 | OFFICE SUPPLIES | BLANKET PO OFFICE SU | | 18.74 | | | | |
| I-656290816001 | 27272349 | R | 5/17/2013 | | | 210160 | | |
| 001 26015125100000 | OFFICE SUPPLIES | | | 30.51 | | | | 49.25 |
| 0333 | PEACE RIVER/MANASOTA | | | | | | | |
| I-1881 | UTILITY | R | 5/17/2013 | | | 210161 | | |
| 410 70965334301000 | PRMRWSA VARIABLE USAGE | VARIABLE WATER USAGE | | 13,418.00 | | | | |
| 410 70965334302000 | PRMRWSA BASE USAGE | BASE WATER USAGE | | 41,256.00 | | | | 54,674.00 |
| 2744 | PENNINGTON, MOORE, WILKINSON | | | | | | | |
| I-130140 | 21137 21925 CONN (UTIL) | R | 5/17/2013 | | | 210162 | | |
| 410 70945363100000 | PROFESSIONAL SERVICES | LEGAL SERVICES | | 10,223.94 | | | | |
| I-130142 | 21137 26161 CONN (UTIL) | R | 5/17/2013 | | | 210162 | | |
| 410 70945363100000 | PROFESSIONAL SERVICES | LEGAL SERVICES | | 2,624.29 | | | | |
| I-130145 | 21137 26476 CONN (UTIL) | R | 5/17/2013 | | | 210162 | | |
| 410 70945363100000 | PROFESSIONAL SERVICES | LEGAL SERVICES | | 64.77 | | | | |
| I-130148 | 21137 28490 CONN (UTIL) | R | 5/17/2013 | | | 210162 | | |
| 410 70945363100000 | PROFESSIONAL SERVICES | LEGAL SERVICES | | 67.50 | | | | |
| I-130408 | 21137 21925 CONN (UTIL) | R | 5/17/2013 | | | 210162 | | |
| 410 70945363100000 | PROFESSIONAL SERVICES | LEGAL SERVICES | | 3,387.50 | | | | |
| I-130410 | 21137 26161 CONN (UTIL) | R | 5/17/2013 | | | 210162 | | |
| 410 70945363100000 | PROFESSIONAL SERVICES | LEGAL SERVICES | | 963.00 | | | | |
| I-130411 | 21137 26476 CONN (UTIL) | R | 5/17/2013 | | | 210162 | | |
| 410 70945363100000 | PROFESSIONAL SERVICES | LEGAL SERVICES | | 720.00 | | | | 18,051.00 |
| 1483 | PRAXAIR DISTRIBUTION SE, LLC | | | | | | | |
| I-PJ02322611 | 21760 | R | 5/17/2013 | | | 210163 | | |
| 102 60505414600000 | REPAIR & MAINTENANCE | TANK RENTAL | | 98.34 | | | | 98.34 |
| 2727 | GLENN PRESCOTT, PETTY CASH | | | | | | | |
| I-201305172533 | PETTY CASH | R | 5/17/2013 | | | 210164 | | |
| 106 70715295100000 | OFFICE SUPPLIES | Reimburshment | | 6.11 | | | | |
| 106 70715295100000 | OFFICE SUPPLIES | Reimburshment | | 19.95 | | | | |
| 106 70725224901000 | MISCELLANEOUS CHGS | Reimburshment | | 15.93 | | | | |
| 106 70735264600000 | REPAIRS & MAINTENANCE | Reimburshment | | 6.23 | | | | |
| 106 70735264600000 | REPAIRS & MAINTENANCE | Reimburshment | | 17.97 | | | | 66.19 |
| 4061 | RAPID SYSTEMS, INC. | | | | | | | |
| I-243326 | EOC | R | 5/17/2013 | | | 210165 | | |
| 106 71315254100000 | TELEPHONE | | | 118.00 | | | | |
| I-243327 | STATION 1 | R | 5/17/2013 | | | 210165 | | |
| 106 70715294100000 | TELEPHONE | RAPID SYSTEMS STATIO | | 98.00 | | | | |
| I-243328 | STATION 3 | R | 5/17/2013 | | | 210165 | | |
| 106 70715294100000 | TELEPHONE | RAPID SYSTEM STATION | | 98.00 | | | | |
| I-243329 | STATION 4 | R | 5/17/2013 | | | 210165 | | |
| 106 70715294100000 | TELEPHONE | RAPID SYSTEM-STATION | | 98.00 | | | | |
| I-243330 | TURNER CENTER | R | 5/17/2013 | | | 210165 | | |

VENDOR SET: 01 Desoto County
 BANK: APBK POOLED CASH ACCOUNT
 DATE RANGE: 5/15/2013 THRU 5/29/2013

| VENDOR I.D. | NAME | STATUS | CHECK DATE | AMOUNT | DISCOUNT | CHECK NO | CHECK STATUS | CHECK AMOUNT |
|--------------------|------------------------------|----------------------|------------|----------|----------|----------|--------------|--------------|
| 4061 | RAPID SYSTEMS, INC. CONT | | | | | | | |
| I-243330 | TURNER CENTER | R | 5/17/2013 | | | 210165 | | |
| 001 70815754100000 | COMMUNICATIONS | INTERNET SERVICE | | 118.00 | | | | 530.00 |
| 3389 | RING POWER CORPORATION | | | | | | | |
| I-15PX7880945 | 001610 | R | 5/17/2013 | | | 210166 | | |
| 102 60505414600000 | REPAIR & MAINTENANCE | 15PX7880945 | | 142.95 | | | | |
| I-15PX7883571 | 001610 | R | 5/17/2013 | | | 210166 | | |
| 102 60505414600000 | REPAIR & MAINTENANCE | 15PX7883571 | | 223.91 | | | | |
| I-15PX7885951 | 001610 | R | 5/17/2013 | | | 210166 | | |
| 102 60505414600000 | REPAIR & MAINTENANCE | 15PX7885951 | | 34.20 | | | | 401.06 |
| 1803 | SAFETY PRODUCTS INC | | | | | | | |
| I-074555 | DES36 | R | 5/17/2013 | | | 210167 | | |
| 102 60505415302000 | TRAFFIC CONTROL DEVICES | 74555 | | 22.77 | | | | 22.77 |
| 4426 | SERVICE PRINTERS, INC. | | | | | | | |
| I-103867 | 00000000006297 | R | 5/17/2013 | | | 210168 | | |
| 150 20105524700000 | PRINTING AND BINDING | PRINTING | | 3,492.00 | | | | |
| 150 20105524700000 | PRINTING AND BINDING | SHIPPING | | 462.50 | | | | 3,954.50 |
| 2809 | SHERWIN-WILLIAMS CO. | | | | | | | |
| I-2842-1 | 4202-4789-2 | R | 5/17/2013 | | | 210169 | | |
| 001 26085194600000 | REPAIRS & MAINTENANCE | MAINT. | | 62.59 | | | | |
| I-3261-3 | 4202-4789-2 | R | 5/17/2013 | | | 210169 | | |
| 001 26085194600000 | REPAIRS & MAINTENANCE | MAINT. | | 155.00 | | | | |
| I-3273-8 | 4202-4789-2 | R | 5/17/2013 | | | 210169 | | |
| 001 26085194600000 | REPAIRS & MAINTENANCE | MAINT. | | 4.49 | | | | 222.08 |
| 0259 | SMITH'S RANCH & GARDEN | | | | | | | |
| I-101055346 | 142224 | R | 5/17/2013 | | | 210170 | | |
| 102 60505415205000 | DEPARTMENT SUPPLIES | 101055346 | | 4.08 | | | | |
| I-102070335 | 142224 | R | 5/17/2013 | | | 210170 | | |
| 102 60505415205000 | DEPARTMENT SUPPLIES | 102070335 | | 132.96 | | | | |
| I-102071425 | 142224 | R | 5/17/2013 | | | 210170 | | |
| 410 70955365207000 | SAFETY | SIZE 12 RUBBER BOOTS | | 29.99 | | | | 167.03 |
| 1 | ST PAUL MISSIONARY BAPTIS | | | | | | | |
| I-201305152524 | DEPO | R | 5/17/2013 | | | 210171 | | |
| 001 00002202000000 | DEPOSIT REFUNDS RENTALS - TC | DEPOSIT REFUND | | 100.00 | | | | 100.00 |
| 2283 | STREAMLINE TECHNOLOGIES, LLC | | | | | | | |
| I-3662 | TICKETING-WEBSITE | R | 5/17/2013 | | | 210172 | | |
| 001 70815754601000 | MAINTENANCE CONTRACTS | TICKETING-WEBSITE | | 62.50 | | | | 62.50 |

VENDOR SET: 01 Desoto County
 BANK: APBK POOLED CASH ACCOUNT
 DATE RANGE: 5/15/2013 THRU 5/29/2013

| VENDOR I.D. | NAME | STATUS | CHECK DATE | AMOUNT | DISCOUNT | CHECK NO | CHECK STATUS | CHECK AMOUNT |
|--------------------|--------------------------------|--------|----------------------|--------|----------|-------------|-----------------|-----------------|
| 2709 | SUNSHINE STATE ONE CALL OF FLO | | | | | | | |
| I-00000095099 | AP1472 | R | 5/17/2013 | | | 210173 | | |
| 410 70955363404000 | SUNSHINE ONE CALL | | LOCATE TICKETS | 59.79 | | | | 59.79 |
| 0697 | THE SUN | | | | | | | |
| I-2875177 | 101305 | R | 5/17/2013 | | | 210174 | | |
| 400 42305346304000 | COVER MAT/SITE IMPROVEMENT | | LEGAL LINE AD | 30.79 | | | | 30.79 |
| 1513 | WEST PAYMENT CENTER | | | | | | | |
| I-827172609 | 1004047295 | R | 5/17/2013 | | | 210175 | | |
| 190 24107146600415 | LAW LIBRARY EXPENSES | | LAW LIBRARY | 506.93 | | | | 506.93 |
| 2059 | TRACTOR SUPPLY CO | | | | | | | |
| I-179603 | 5840/MAINT. | R | 5/17/2013 | | | 210176 | | |
| 001 26085194600000 | REPAIRS & MAINTENANCE | | MAINT. | 81.84 | | | | 81.84 |
| 2471 | TRACTOR SUPPLY CO | | | | | | | |
| I-180163 | 5923/TRANS | R | 5/17/2013 | | | 210177 | | |
| 102 60505415205000 | DEPARTMENT SUPPLIES | | 180163 | 314.97 | | | | 314.97 |
| 4094 | UNIFIRST CORPORATION | | | | | | | |
| I-0927161 | 921553 | R | 5/17/2013 | | | 210178 | | |
| 102 60505415203000 | UNIFORMS | | UNIFORMS | 152.34 | | | | |
| I-0927383 | 921589 | R | 5/17/2013 | | | 210178 | | |
| 410 70955365200000 | UNIFORMS | | SYST. MAINT.UNIFORMS | 3.85 | | | | |
| 410 70965335200000 | UNIFORMS | | WATER - UNIFORMS | 7.70 | | | | |
| 410 70975355200000 | UNIFORMS | | WW - UNIFORMS | 19.25 | | | | 183.14 |
| 0356 | UNITED PARCEL SERVICE | | | | | | | |
| I-201305162528 | F49V11 | R | 5/17/2013 | | | 210179 | | |
| 001 26015124201000 | POSTAGE | | BLANKET | 15.01 | | | | 15.01 |
| 3895 | USA BLUEBOOK | | | | | | | |
| I-944535 | 959717 | R | 5/17/2013 | | | 210180 | | |
| 410 70975354600000 | GENERAL REPAIR & MAINTENANCE | | DCI WWTP-PH ELECTROD | 85.95 | | | | |
| 410 70975354600000 | GENERAL REPAIR & MAINTENANCE | | DCR WWTP-PH ELECTROD | 85.95 | | | | |
| 410 70975354600000 | GENERAL REPAIR & MAINTENANCE | | FREIGHT | 14.29 | | | | 186.19 |
| 3708 | VERIZON WIRELESS | | | | | | | |
| I-9703776191 | 322824883-00001 | R | 5/17/2013 | | | 210181 | | |
| 001 26015124100000 | TELEPHONE | | APRIL CELL CHARGES | 167.51 | | | | |
| 001 26035154100000 | TELEPHONE | | APRIL CELL CHARGES | 75.36 | | | | |
| 001 26085194100000 | TELEPHONE | | APRIL CELL CHARGES | 61.55 | | | | |
| 001 30155154100000 | TELEPHONE | | APRIL CELL CHARGES | 73.70 | | | | |
| 001 30175164100000 | TELEPHONE | | APRIL CELL CHARGES | 44.74 | | | | |
| 001 36245374100000 | TELEPHONE | | APRIL CELL CHARGES | 86.15 | | | | |
| 001 70745724100000 | COMMUNICATIONS | | APRIL CELL CHARGES | 40.01 | | | | |
| 001 70815754100000 | COMMUNICATIONS | | APRIL CELL CHARGES | 88.54 | | | | |

VENDOR SET: 01 Desoto County
 BANK: APBK POOLED CASH ACCOUNT
 DATE RANGE: 5/15/2013 THRU 5/29/2013

| VENDOR I.D. | NAME | STATUS | CHECK DATE | AMOUNT | DISCOUNT | CHECK NO | CHECK STATUS | CHECK AMOUNT |
|--------------------|-----------------------------|--------|--------------------|----------|----------|----------|--------------|--------------|
| 3708 | VERIZON WIRELESS | CONT | | | | | | |
| I-9703776191 | 322824883-00001 | R | 5/17/2013 | | | 210181 | | |
| 001 71375134100000 | TELEPHONE | | APRIL CELL CHARGES | 142.80 | | | | |
| 102 60505414100000 | COMMUNICATIONS | | APRIL CELL CHARGES | 274.63 | | | | |
| 104 30205414100000 | TELEPHONE | | APRIL CELL CHARGES | 47.66 | | | | |
| 106 70715294100000 | TELEPHONE | | APRIL CELL CHARGES | 1,249.77 | | | | |
| 190 23066044100000 | TELEPHONE/COMMUNICATIONS | | APRIL CELL CHARGES | 40.01 | | | | |
| 400 42305344100000 | TELEPHONE | | APRIL CELL CHARGES | 69.01 | | | | |
| 410 70945364100000 | TELEPHONE | | APRIL CELL CHARGES | 483.64 | | | | |
| 410 70965334100000 | TELEPHONE | | APRIL CELL CHARGES | 170.82 | | | | |
| 410 70975354100000 | TELEPHONE | | APRIL CELL CHARGES | 88.39 | | | | |
| I-9704366364 | 542007243-00001 | R | 5/17/2013 | | | 210181 | | |
| 001 26015124100000 | TELEPHONE | | APRIL CHARGES | 62.97 | | | | |
| 001 26085194100000 | TELEPHONE | | APRIL CHARGES | 83.24 | | | | |
| 001 30155154100000 | TELEPHONE | | APRIL CHARGES | 2.45 | | | | |
| 001 30175164100000 | TELEPHONE | | APRIL CHARGES | 51.04 | | | | |
| 001 30185244100000 | TELEPHONE | | APRIL CHARGES | 17.04 | | | | |
| 001 30195624100000 | TELEPHONE | | APRIL CHARGES | 193.29 | | | | |
| 001 52425234100000 | COMMUNICATIONS | | APRIL CHARGES | 28.81 | | | | |
| 001 70745724100000 | COMMUNICATIONS | | APRIL CHARGES | 23.62 | | | | |
| 001 71375134100000 | TELEPHONE | | APRIL CHARGES | 5.72 | | | | |
| 001 71395134100000 | TELEPHONE | | APRIL CHARGES | 2.79 | | | | |
| 102 60505414100000 | COMMUNICATIONS | | APRIL CHARGES | 75.40 | | | | |
| 104 30205414100000 | TELEPHONE | | APRIL CHARGES | 5.54 | | | | |
| 106 70715294100000 | TELEPHONE | | APRIL CHARGES | 53.17 | | | | |
| 190 24086034100000 | TELEPHONE/COMMUNICATIONS | | APRIL CHARGES | 47.34 | | | | |
| 400 42305344100000 | TELEPHONE | | APRIL CHARGES | 133.04 | | | | |
| 410 70955364100000 | TELEPHONE | | APRIL CHARGES | 52.83 | | | | |
| 410 70965334100000 | TELEPHONE | | APRIL CHARGES | 248.55 | | | | |
| 410 70975354100000 | TELEPHONE | | APRIL CHARGES | 60.14 | | | | |
| 415 30255244100000 | TELEPHONE | | APRIL CHARGES | 104.50 | | | | 4,455.77 |
| 1439 | WALMART COMMUNITY/GEMB | | | | | | | |
| I-06624 | 5505 | R | 5/17/2013 | | | 210182 | | |
| 001 26085195200000 | OPERATING SUPPLIES | | MAINT. | 251.29 | | | | |
| I-08200 | 5504 | R | 5/17/2013 | | | 210182 | | |
| 001 26085195200000 | OPERATING SUPPLIES | | MAINT. | 40.74 | | | | |
| I-09139 | 5504 | R | 5/17/2013 | | | 210182 | | |
| 001 26085195200000 | OPERATING SUPPLIES | | MAINT. | 17.54 | | | | 309.57 |
| 0367 | WEST FLORIDA SUPPLY CO, INC | | | | | | | |
| I-015846 | 0102325 | R | 5/17/2013 | | | 210183 | | |
| 001 70815755200000 | OPERATING SUPPLIES | | Toilet Paper | 699.05 | | | | |
| I-016621 | 0102325 | R | 5/17/2013 | | | 210183 | | |
| 001 26085195200000 | OPERATING SUPPLIES | | OPERATING | 547.57 | | | | 1,246.62 |

VENDOR SET: 01 Desoto County
 BANK: APBK POOLED CASH ACCOUNT
 DATE RANGE: 5/15/2013 THRU 5/29/2013

| VENDOR I.D. | NAME | STATUS | CHECK DATE | AMOUNT | DISCOUNT | CHECK NO | CHECK STATUS | CHECK AMOUNT |
|--------------------|--------------------------------|----------------------|------------------|--------|----------|----------|--------------|--------------|
| 0378 | WOMACK SANITATION, INC. | | | | | | | |
| I-27796 | 1124 | R | 5/17/2013 | | | 210184 | | |
| 001 36245374300000 | UTILITIES | BLANKET | GARBAGE PO | 92.50 | | | | |
| 410 70945364300000 | UTILITIES | BLANKET | GARBAGE PO | 92.50 | | | | |
| I-27938 | 1721-001 | R | 5/17/2013 | | | 210184 | | |
| 102 60505414601000 | MAINT. AGREEMENTS | | GARBAGE DUMPSTER | 185.00 | | | | |
| I-27982 | 1721-002 | R | 5/17/2013 | | | 210184 | | |
| 102 60505415301000 | ROAD & BRIDGE MATERIALS | 20 YD | DUMPSTER | 420.00 | | | | 790.00 |
| 1 | ENGLEWOOD AREA FIRE DISTR | | | | | | | |
| I-2657 | GOVD | R | 5/20/2013 | | | 210185 | | |
| 106 70725225206000 | FIRE SUPPLIES | GOVDEALS | -FAN | 155.00 | | | | 155.00 |
| 2870 | ADVANCE AUTO PARTS | | | | | | | |
| I-9127312675925 | 9999015935 | R | 5/21/2013 | | | 210186 | | |
| 102 60505414600000 | REPAIR & MAINTENANCE | 9127312675925 | | 222.17 | | | | 222.17 |
| 4210 | AFFORDABLE PARTS & SUPPLY, LLC | | | | | | | |
| I-3668 | STOCK | R | 5/21/2013 | | | 210187 | | |
| 102 60505414600000 | REPAIR & MAINTENANCE | 3668 | | 173.93 | | | | 173.93 |
| 3961 | AIR MECHANICAL & SERVICE CORP | | | | | | | |
| I-60320 | DESOTURN | R | 5/21/2013 | | | 210188 | | |
| 001 70815754600000 | REPAIR & MAINTENANCE | Maintenance | | 722.50 | | | | 722.50 |
| 0091 | ARCADIA ELECTRIC CO. | | | | | | | |
| I-18581 | REPAIR & MAINTENANCE | R | 5/21/2013 | | | 210189 | | |
| 102 60505414600000 | REPAIR & MAINTENANCE | 18581 | | 24.00 | | | | 24.00 |
| 4114 | BAKER & TAYLOR, INC. | | | | | | | |
| I-5012567381 | 517753 L494401 5 B00000 | R | 5/21/2013 | | | 210190 | | |
| 001 38265716600000 | BOOKS & LIBRARY MATERIALS | May books | | 966.63 | | | | 966.63 |
| 3457 | BASKERVILLE-DONOVAN, INC. | | | | | | | |
| I-89326 | 011303.02 | R | 5/21/2013 | | | 210191 | | |
| 410 70965333104000 | PROFESSIONAL SERVICES HWY 17 | ENG. SVCS - WATER | | 177.50 | | | | |
| I-89327 | 011303.02 | R | 5/21/2013 | | | 210191 | | |
| 410 70975353104000 | PROFESSIONAL SERVICES HWY 17 | ENG. SVCS - WASTEWAT | | 177.50 | | | | 355.00 |
| 0098 | BOWLING GREEN SMALL ENGINE | | | | | | | |
| I-29788 | ROAD & BRIDGE | R | 5/21/2013 | | | 210192 | | |
| 102 60505414600000 | REPAIR & MAINTENANCE | 29788 | | 45.68 | | | | 45.68 |

VENDOR SET: 01 Desoto County
 BANK: APBK POOLED CASH ACCOUNT
 DATE RANGE: 5/15/2013 THRU 5/29/2013

| VENDOR I.D. | NAME | STATUS | CHECK DATE | AMOUNT | DISCOUNT | CHECK NO | CHECK STATUS | CHECK AMOUNT |
|--------------------|---------------------------|-------------|-------------------|-----------|----------|-------------|-----------------|-----------------|
| 1811 | BROADCAST MUSIC INC. | | | | | | | |
| I-23194777 | 1145838 | R | 5/21/2013 | | | 210193 | | |
| 001 70815754904000 | LICENSING | Contact | | 294.00 | | | | 294.00 |
| 3762 | C B LOCKSMITH | | | | | | | |
| I-2341 | UTILITIES | R | 5/21/2013 | | | 210194 | | |
| 409 70875364600000 | REPAIRS AND MAINTENANCE | SS | LOCKS FOR LS | 920.00 | | | | |
| I-2342 | UTILITIES | R | 5/21/2013 | | | 210194 | | |
| 410 70945364901000 | MISC EXPENSES | UT. | ADMIN.OFFICE KEYS | 7.50 | | | | |
| 410 70965334901000 | OTHER CHARGES | NST | KEYS | 7.50 | | | | |
| 410 70975354901000 | OTHER CHARGES | LIFT | STATION KEYS | 15.00 | | | | |
| 410 70975354901000 | OTHER CHARGES | DCI | WWTP KEYS | 7.50 | | | | 957.50 |
| 0974 | CARDINAL HEALTH 110, INC | | | | | | | |
| I-2534615 | 487029 | R | 5/21/2013 | | | 210195 | | |
| 106 70735265205000 | DRUGS & MEDICAL SUPPLIES | BLANKET | FOR DRUG ORD | 511.48 | | | | |
| I-2606484 | 487029 | R | 5/21/2013 | | | 210195 | | |
| 106 70735265205000 | DRUGS & MEDICAL SUPPLIES | BLANKET | FOR DRUG ORD | 405.53 | | | | 917.01 |
| 4111 | CENTER POINT LARGE PRINT | | | | | | | |
| I-1096413 | LP books | R | 5/21/2013 | | | 210196 | | |
| 001 38265716600000 | BOOKS & LIBRARY MATERIALS | LP | books | 102.00 | | | | 102.00 |
| 0229 | DESOTO FORD AUTOMALL INC | | | | | | | |
| I-18663 | 2764 | R | 5/21/2013 | | | 210197 | | |
| 106 70735264600000 | REPAIRS & MAINTENANCE | VALVE | R40 | 199.56 | | | | |
| I-67426 | 1246 | R | 5/21/2013 | | | 210197 | | |
| 106 70735264600000 | REPAIRS & MAINTENANCE | AIR | FILTER | 39.95 | | | | 239.51 |
| 4184 | DIGITECH COMPUTER, INC | | | | | | | |
| I-15386 | BILLING SERVICE AGREEMENT | R | 5/21/2013 | | | 210198 | | |
| 106 70735264601000 | MAINTENANCE AGREEMENTS | BILLING | SERVICE AGRE | 4,212.58 | | | | 4,212.58 |
| 0291 | ELECTRONIC MAINTENANCE | | | | | | | |
| I-SEB01IN6094 | RADIO REPAIR | R | 5/21/2013 | | | 210199 | | |
| 106 70715294603000 | COMMUNICATION MAINT. | RADIO | REPAIR | 20.00 | | | | 20.00 |
| 4518 | ESI ACQUISITION, INC | | | | | | | |
| I-INV10098 | WEB EOC | R | 5/21/2013 | | | 210200 | | |
| 106 71315256800000 | SOFTWARE | | | 14,019.00 | | | | |
| 106 71335256800000 | SOFTWARE | | | 9,978.90 | | | | 23,997.90 |
| 0314 | FLORIDA POWER & LIGHT | | | | | | | |
| I-201305202539 | 64163-47026 | R | 5/21/2013 | | | 210201 | | |
| 001 70815754300000 | UTILITIES | 24899-12424 | | 20.19 | | | | 20.19 |

VENDOR SET: 01 Desoto County
 BANK: APBK POOLED CASH ACCOUNT
 DATE RANGE: 5/15/2013 THRU 5/29/2013

| VENDOR I.D. | NAME | STATUS | CHECK DATE | AMOUNT | DISCOUNT | CHECK NO | CHECK STATUS | CHECK AMOUNT |
|--------------------|------------------------------|---------|----------------------|-----------|----------|-------------|-----------------|-----------------|
| 0207 | GAYLORD BROTHERS INC | | | | | | | |
| I-2165410 | 728010 | R | 5/21/2013 | | | 210202 | | |
| 001 38265716600000 | BOOKS & LIBRARY MATERIALS | 1 | blue bookshelf | 292.00 | | | | 292.00 |
| 1416 | DESOTO CO PUBLIC HEALTH | | | | | | | |
| I-201305202537 | SEWAGE PERMIT | R | 5/21/2013 | | | 210203 | | |
| 106 70715294602000 | BUILDING MAINTENANCE | | SEWAGE PERMIT | 190.00 | | | | 190.00 |
| 0251 | KATHRYN J HILL | | | | | | | |
| I-201305212542 | DISTRIBUTION 2012-14 | R | 5/21/2013 | | | 210204 | | |
| 001 71495139100000 | TAX COLLECTOR FEES | | DISTRIBUTION 2012-14 | 11,248.54 | | | | |
| 106 70735139109000 | TAX COLLECTOR FEES | | DISTRIBUTION 2012-14 | 292.48 | | | | 11,541.02 |
| 2124 | HOME OWNERS SUPPLY INC | | | | | | | |
| C-237368 | 142307 | R | 5/21/2013 | | | 210205 | | |
| 102 60505415301000 | ROAD & BRIDGE MATERIALS | 237368 | | 19.99 | CR | | | |
| I-237223 | 142307 | R | 5/21/2013 | | | 210205 | | |
| 102 60505415205000 | DEPARTMENT SUPPLIES | 237223 | | 13.52 | | | | |
| I-237224 | 142307 | R | 5/21/2013 | | | 210205 | | |
| 102 60505414600000 | REPAIR & MAINTENANCE | 237224 | | 7.99 | | | | |
| I-237365 | 142307 | R | 5/21/2013 | | | 210205 | | |
| 102 60505415301000 | ROAD & BRIDGE MATERIALS | 237365 | | 39.98 | | | | 41.50 |
| 1482 | J.M. TODD, INC | | | | | | | |
| I-410460 | 8917 | R | 5/21/2013 | | | 210206 | | |
| 001 38265714400000 | LEASE EQUIPMENT | | Copy machine lease | 38.44 | | | | |
| I-410461 | 8917 | R | 5/21/2013 | | | 210206 | | |
| 001 38265715100000 | OFFICE SUPPLIES | | | 3.66 | | | | 42.10 |
| 4371 | JUST JACK'S LAWNMOWER REPAIR | | | | | | | |
| I-1369 | MOWER BLADES | R | 5/21/2013 | | | 210207 | | |
| 001 70745724600000 | REPAIR AND MAINTENANCE | | MOWER REPAIR | 239.88 | | | | 239.88 |
| 4427 | LIBBY BROWN | | | | | | | |
| I-201305202536 | REFUND INSURE OVERPAYMENT | R | 5/21/2013 | | | 210208 | | |
| 001 71495132300000 | HEALTH AND LIFE SUPPL BOCC | | REFUND INSURE OVERPA | 1,360.86 | | | | 1,360.86 |
| 1484 | LOU'S PAINT SPOT & CARPET | | | | | | | |
| I-5734A | PARTS | R | 5/21/2013 | | | 210209 | | |
| 102 60505414600000 | REPAIR & MAINTENANCE | 5734A | | 3.28 | | | | 3.28 |
| 3526 | LOWES HOME CENTER, INC. | | | | | | | |
| I-09940 | 6700647 | R | 5/21/2013 | | | 210210 | | |
| 102 60505415205000 | DEPARTMENT SUPPLIES | 9948803 | | 102.49 | | | | 102.49 |

VENDOR SET: 01 Desoto County
 BANK: APBK POOLED CASH ACCOUNT
 DATE RANGE: 5/15/2013 THRU 5/29/2013

| VENDOR I.D. | NAME | STATUS | CHECK DATE | AMOUNT | DISCOUNT | CHECK NO | CHECK STATUS | CHECK AMOUNT |
|--------------------|--------------------------------|----------------------|------------|----------|----------|----------|--------------|--------------|
| 4060 | MID-STATE FIRE EQUIPMENT, INC. | | | | | | | |
| I-52240 | MAINT. | R | 5/21/2013 | | | 210211 | | |
| 001 26085194600000 | REPAIRS & MAINTENANCE | MAINT. | | 108.00 | | | | |
| I-52324 | MAINT. | R | 5/21/2013 | | | 210211 | | |
| 001 26085194600000 | REPAIRS & MAINTENANCE | MAINT. | | 63.00 | | | | 171.00 |
| 3547 | MYAKKA HEATING & COOLING | | | | | | | |
| I-8463 | UTILITIES | R | 5/21/2013 | | | 210212 | | |
| 001 26085194600000 | REPAIRS & MAINTENANCE | MAINT. | | 1,776.51 | | | | |
| 410 70945364600000 | REPAIR AND MAINTENANCE | A/C REPLACEMENT | | 1,776.50 | | | | 3,553.01 |
| 2051 | NAPA-GENIUNE PARTS CO. | | | | | | | |
| I-205290 | 2146 | R | 5/21/2013 | | | 210213 | | |
| 106 70725224600000 | REPAIRS & MAINTENANCE | ANTI SEIZE | | 8.49 | | | | |
| I-205505 | 2146 | R | 5/21/2013 | | | 210213 | | |
| 106 70715294601000 | REPAIR AND MAINTENANCE | HOSE CONNECTORS | | 16.67 | | | | |
| I-205536 | 2146 | R | 5/21/2013 | | | 210213 | | |
| 106 70725224600000 | REPAIRS & MAINTENANCE | OIL DRY ABSORBANT | | 34.95 | | | | 60.11 |
| 0432 | OFFICE DEPOT | | | | | | | |
| I-649393586002 | 27272349 | R | 5/21/2013 | | | 210214 | | |
| 106 70715295100000 | OFFICE SUPPLIES | BLANKET OFFICE SUPPL | | 1.85 | | | | |
| I-654726873001 | 27272349 | R | 5/21/2013 | | | 210214 | | |
| 102 60505415100000 | OFFICE SUPPLIES | 654726873001 | | 51.48 | | | | |
| I-654727096001 | 27272349 | R | 5/21/2013 | | | 210214 | | |
| 102 60505415100000 | OFFICE SUPPLIES | 654727096001 | | 32.20 | | | | |
| I-655960561001 | 27272349 | R | 5/21/2013 | | | 210214 | | |
| 001 31165645100000 | OFFICE SUPPLIES | BLANKET PO OFFICE SU | | 28.43 | | | | |
| I-656071301001 | 27272349 | R | 5/21/2013 | | | 210214 | | |
| 001 38265715100000 | OFFICE SUPPLIES | Labels, sharpener | | 19.23 | | | | |
| I-656083452001 | 27272349 | R | 5/21/2013 | | | 210214 | | |
| 106 70715295100000 | OFFICE SUPPLIES | BLANKET OFFICE SUPPL | | 17.90 | | | | |
| I-656083518001 | 27272349 | R | 5/21/2013 | | | 210214 | | |
| 106 70715295100000 | OFFICE SUPPLIES | BLANKET OFFICE SUPPL | | 28.50 | | | | |
| I-656575242001 | 27272349 | R | 5/21/2013 | | | 210214 | | |
| 001 71375135100000 | OFFICE SUPPLIES | OFFICE SUPPLIES | | 75.76 | | | | |
| I-656827885001 | 27272349 | R | 5/21/2013 | | | 210214 | | |
| 001 26015125100000 | OFFICE SUPPLIES | | | 54.87 | | | | |
| I-656828504001 | 27272349 | R | 5/21/2013 | | | 210214 | | |
| 001 26015125100000 | OFFICE SUPPLIES | | | 205.95 | | | | |
| I-657032412001 | 27272349 | R | 5/21/2013 | | | 210214 | | |
| 001 71375135100000 | OFFICE SUPPLIES | OFFICE SUPPLIES | | 195.83 | | | | |
| I-657458024001 | 27272349 | R | 5/21/2013 | | | 210214 | | |
| 001 71375135100000 | OFFICE SUPPLIES | OFFICE SUPPLIES | | 23.16 | | | | 735.16 |

VENDOR SET: 01 Desoto County
 BANK: APBK POOLED CASH ACCOUNT
 DATE RANGE: 5/15/2013 THRU 5/29/2013

| VENDOR I.D. | NAME | STATUS | CHECK DATE | AMOUNT | DISCOUNT | CHECK NO | CHECK STATUS | CHECK AMOUNT |
|--------------------|--------------------------------|----------------------|---------------|--------|----------|-------------|-----------------|-----------------|
| 1483 | PRAXAIR DISTRIBUTION SE, LLC | | | | | | | |
| I-PJ02328480 | B3527 | R | 5/21/2013 | | | 210215 | | |
| 410 70975354400000 | RENTALS & LEASES | TANK LEASE | | 163.00 | | | | 163.00 |
| 4292 | PROFESSIONAL MANAGEMENT COACHI | | | | | | | |
| I-12021 | LEADERSHIP WEBINARS | R | 5/21/2013 | | | 210216 | | |
| 106 70715295500000 | TRAINING | LEADERSHIP WEBINARS | | 900.00 | | | | 900.00 |
| 2195 | QUADMED, INC. | | | | | | | |
| I-75525 | DESOTO | R | 5/21/2013 | | | 210217 | | |
| 106 70735265205000 | DRUGS & MEDICAL SUPPLIES | EMS SUPPLIES | | 415.55 | | | | |
| I-75590 | DESOTO | R | 5/21/2013 | | | 210217 | | |
| 106 70735265205000 | DRUGS & MEDICAL SUPPLIES | EMS SUPPLIES | | 11.50 | | | | |
| I-75712 | DESOTO | R | 5/21/2013 | | | 210217 | | |
| 106 70735265205000 | DRUGS & MEDICAL SUPPLIES | EMS SUPPLIES | | 82.45 | | | | 509.50 |
| 4061 | RAPID SYSTEMS, INC. | | | | | | | |
| I-243325 | BREWER PARK | R | 5/21/2013 | | | 210218 | | |
| 001 70745724100000 | COMMUNICATIONS | monthly computer ser | | 118.00 | | | | 118.00 |
| 4563 | RICKY MERCER | | | | | | | |
| I-201305212543 | TRAVEL/MEALS 5/12 - 5/17 | R | 5/21/2013 | | | 210219 | | |
| 106 70725225500000 | TRAINING | TRAVEL/MEALS 5/12 - | | 120.00 | | | | 120.00 |
| 1803 | SAFETY PRODUCTS INC | | | | | | | |
| I-074968 | DES36 | R | 5/21/2013 | | | 210220 | | |
| 102 60505415205000 | DEPARTMENT SUPPLIES | 074968 | | 35.13 | | | | 35.13 |
| 0240 | SHORT ENVIRONMENTAL | | | | | | | |
| I-13-1369 | quarter/annual water test | R | 5/21/2013 | | | 210221 | | |
| 001 70745723400000 | CONTRACTED SERVICES | quarter/annual water | | 42.00 | | | | |
| I-13-1370 | quarter/annual water test | R | 5/21/2013 | | | 210221 | | |
| 001 70735723400000 | CONTRACTED SERVICES | quarter/annual water | | 67.00 | | | | 109.00 |
| 1445 | STAPLES ADVANTAGE | | | | | | | |
| I-115814921 | 16307405 | R | 5/21/2013 | | | 210222 | | |
| 001 71375135100000 | OFFICE SUPPLIES | OFFICE SUPPLIES | | 63.00 | | | | |
| I-3198807958 | 70109845 | R | 5/21/2013 | | | 210222 | | |
| 106 71315255100000 | OFFICE/OPERATING SUPPLIES | | | 16.63 | | | | |
| I-3198807959 | 70109845 | R | 5/21/2013 | | | 210222 | | |
| 106 71315255100000 | OFFICE/OPERATING SUPPLIES | | | 21.85 | | | | |
| I-3199543564 | 70109845 | R | 5/21/2013 | | | 210222 | | |
| 001 71375135100000 | OFFICE SUPPLIES | OFFICE SUPPLIES | | 301.18 | | | | 402.66 |

VENDOR SET: 01 Desoto County
 BANK: APBK POOLED CASH ACCOUNT
 DATE RANGE: 5/15/2013 THRU 5/29/2013

| VENDOR I.D. | NAME | STATUS | CHECK DATE | AMOUNT | DISCOUNT | CHECK NO | CHECK STATUS | CHECK AMOUNT |
|--------------------|--------------------------------|----------------------|---------------|----------|----------|-------------|-----------------|-----------------|
| 4110 | STORAGECRAFT | | | | | | | |
| I-247845 | DES350 | R | 5/21/2013 | | | 210223 | | |
| 102 60505415205000 | DEPARTMENT SUPPLIES | LOCKERS | | 600.00 | | | | 600.00 |
| 3946 | SUN COAST MEDIA GROUP INC | | | | | | | |
| I-201305202540 | 2000081 | R | 5/21/2013 | | | 210224 | | |
| 001 38265716601000 | PUBLICATIONS & SUBSCRIPTIONS | Charlotte Sun - annu | | 183.82 | | | | 183.82 |
| 1464 | SUN STATE INT'L TRUCKS,LLC | | | | | | | |
| I-X400023206:01 | 10602 | R | 5/21/2013 | | | 210225 | | |
| 102 60505414600000 | REPAIR & MAINTENANCE | X400023206:01 | | 81.99 | | | | |
| I-X400023637:01 | 10602 | R | 5/21/2013 | | | 210225 | | |
| 102 60505414600000 | REPAIR & MAINTENANCE | X400023637:01 | | 33.76 | | | | 115.75 |
| 1823 | SUNCOAST FORMS & SYSTEMS,INC | | | | | | | |
| I-337159 | 10541 | R | 5/21/2013 | | | 210226 | | |
| 001 26085195203000 | UNIFORMS | FACILITIES SHIRTS | | 209.64 | | | | 209.64 |
| 3283 | TOSHIBA AMERICA BUSINESS SOLUT | | | | | | | |
| I-2317270 | 57792000 | R | 5/21/2013 | | | 210227 | | |
| 001 26015124601000 | MAINTENANCE AGREEMENTS | 57792000 | | 100.20 | | | | 100.20 |
| 3628 | TOSHIBA FINANCIAL SERVICES | | | | | | | |
| I-228027231 | 810962 | R | 5/21/2013 | | | 210228 | | |
| 410 70945364400000 | RENTALS AND LEASES | COPIER LEASE & COPIE | | 184.48 | | | | 184.48 |
| 2471 | TRACTOR SUPPLY CO | | | | | | | |
| I-152451 | 5923/TRANS | R | 5/21/2013 | | | 210229 | | |
| 102 60505415205000 | DEPARTMENT SUPPLIES | 152451 | | 67.96 | | | | 67.96 |
| 4094 | UNIFIRST CORPORATION | | | | | | | |
| I-0928267 | 921553 | R | 5/21/2013 | | | 210230 | | |
| 102 60505415203000 | UNIFORMS | UNIFORMS | | 155.98 | | | | 155.98 |
| 0356 | UNITED PARCEL SERVICE | | | | | | | |
| I-0000FE9095183 | FE9095 | R | 5/21/2013 | | | 210231 | | |
| 001 71375134201000 | POSTAGE | UPS BLANKET PO | | 14.66 | | | | 14.66 |
| 3963 | VERIZON BUSINESS NETWORK SERVI | | | | | | | |
| I-68542054 | Y2616890 | R | 5/21/2013 | | | 210232 | | |
| 190 24086034100000 | TELEPHONE/COMMUNICATIONS | VERIZON BILLINGS | | 1,858.98 | | | | 1,858.98 |
| 1439 | WALMART COMMUNITY/GEMB | | | | | | | |
| I-01876 | 5519 | R | 5/21/2013 | | | 210233 | | |
| 102 60505415205000 | DEPARTMENT SUPPLIES | 01876 | | 8.14 | | | | 8.14 |

VENDOR SET: 01 Desoto County
 BANK: APBK POOLED CASH ACCOUNT
 DATE RANGE: 5/15/2013 THRU 5/29/2013

| VENDOR I.D. | NAME | STATUS | CHECK DATE | AMOUNT | DISCOUNT | CHECK NO | CHECK STATUS | CHECK AMOUNT |
|--------------------|---------------------------------|---------------------|------------|----------|----------|----------|--------------|--------------|
| 4236 | WEILER ENGINEERING CORPORATIO | | | | | | | |
| I-43792 | 13052.002 | R | 5/21/2013 | | | 210234 | | |
| 410 70975353100000 | PROFESSIONAL SERVICES | WA #39 LAKE SUZY FM | | 1,498.20 | | | | 1,498.20 |
| 4561 | WELLNESSTEK LLC | | | | | | | |
| I-201305202538 | REFRIGERATORS | R | 5/21/2013 | | | 210235 | | |
| 106 70735265207000 | EMS SUPPLIES | REFRIGERATORS | | 521.09 | | | | 521.09 |
| 2666 | WEST COAST SOUTHERN MEDICAL, IN | | | | | | | |
| I-13-3030 | MORGUE TRANSPORTS | R | 5/21/2013 | | | 210236 | | |
| 106 70735263403000 | MORGUE TRANSPORT | MORGUE TRANSPORTS | | 150.00 | | | | |
| I-13-3177 | MORGUE TRANSPORTS | R | 5/21/2013 | | | 210236 | | |
| 106 70735263403000 | MORGUE TRANSPORT | MORGUE TRANSPORTS | | 150.00 | | | | 300.00 |
| 3875 | WILLIAMS SCOTSMAN, INC. | | | | | | | |
| I-97017734 | 14173535 | R | 5/21/2013 | | | 210237 | | |
| 106 70715294400000 | RENTALS AND LEASES | STATION 1 RENTAL | | 505.00 | | | | 505.00 |
| 2074 | ZEP MANUFACTURING | | | | | | | |
| I-9000268971 | 31037122 | R | 5/21/2013 | | | 210238 | | |
| 001 26085195200000 | OPERATING SUPPLIES | STOCK | | 384.15 | | | | 384.15 |
| 3775 | ZOLL MEDICAL CORP | | | | | | | |
| I-2011212 | 137492 | R | 5/21/2013 | | | 210239 | | |
| 106 70735265205000 | DRUGS & MEDICAL SUPPLIES | LIFE PAC BANDS | | 712.50 | | | | 712.50 |
| 2870 | ADVANCE AUTO PARTS | | | | | | | |
| I-9127312988592 | 9999015935 | R | 5/24/2013 | | | 210242 | | |
| 102 60505414600000 | REPAIR & MAINTENANCE | 9127312988592 | | 49.59 | | | | 49.59 |
| 4210 | AFFORDABLE PARTS & SUPPLY, LLC | | | | | | | |
| I-3667 | ROAD & BRIDGE | R | 5/24/2013 | | | 210243 | | |
| 102 60505414600000 | REPAIR & MAINTENANCE | 3667 | | 49.12 | | | | |
| I-3704 | ROAD & BRIDGE | R | 5/24/2013 | | | 210243 | | |
| 102 60505414600000 | REPAIR & MAINTENANCE | 3704 | | 157.70 | | | | |
| I-3706 | ROAD & BRIDGE | R | 5/24/2013 | | | 210243 | | |
| 102 60505414600000 | REPAIR & MAINTENANCE | 3706 | | 330.24 | | | | 537.06 |
| 0611 | ARCADIA ANIMAL HOSPITAL | | | | | | | |
| I-4.044 | VET CERTS | R | 5/24/2013 | | | 210244 | | |
| 001 30195625206000 | VETERINARY SUPPLIES/SERVICES | VET CERTS | | 37.00 | | | | |
| I-4.128 | VET CERTS | R | 5/24/2013 | | | 210244 | | |
| 001 30195625206000 | VETERINARY SUPPLIES/SERVICES | VET CERTS | | 12.00 | | | | 49.00 |

VENDOR SET: 01 Desoto County
 BANK: APBK POOLED CASH ACCOUNT
 DATE RANGE: 5/15/2013 THRU 5/29/2013

| VENDOR I.D. | NAME | STATUS | CHECK DATE | AMOUNT | DISCOUNT | CHECK NO | CHECK STATUS | CHECK AMOUNT |
|--------------------|--------------------------------|-----------------|---------------|-----------|----------|-------------|-----------------|-----------------|
| 1 | B & D BIOMEDICAL WASTE | | | | | | | |
| I-11572 | SHARPS | R | 5/24/2013 | | | 210245 | | |
| 001 30195625200000 | OPERATING SUPPLIES | SHARPS DISPOSAL | | 40.00 | | | | 40.00 |
| 4482 | BECERRA CONSTRUCTION OF CENTRA | | | | | | | |
| I-201305242546 | JESSIE DURHAM | R | 5/24/2013 | | | 210246 | | |
| 170 30165544600000 | HOUSING/REHAB | JESSIE DURHAM | | 24,000.00 | | | | |
| I-201305242548 | EVA RODRIGUEZ | R | 5/24/2013 | | | 210246 | | |
| 170 30165544600000 | HOUSING/REHAB | EVA RODRIGUEZ | | 24,000.00 | | | | 48,000.00 |
| 1950 | BENCHMARK ENVIRO | | | | | | | |
| I-13041136 | DCI WWTF | R | 5/24/2013 | | | 210247 | | |
| 410 70975353400000 | CONTRACTED SERVICES | DCI WWTF | | 817.20 | | | | 817.20 |
| 2309 | BIG T TIREMAN | | | | | | | |
| I-1-382830 | RB200274 | R | 5/24/2013 | | | 210248 | | |
| 102 60505414600000 | REPAIR & MAINTENANCE | 382830 | | 582.76 | | | | 582.76 |
| 3692 | BV OIL COMPANY, INC | | | | | | | |
| I-000577892 | DCPUBL | R | 5/24/2013 | | | 210249 | | |
| 106 70725225201000 | GASOLINE & OIL | BV BLANKET FIRE | | 39.02 | | | | |
| I-000578047 | DCSFIR | R | 5/24/2013 | | | 210249 | | |
| 106 70725225201000 | GASOLINE & OIL | BULK FUEL | | 890.75 | | | | |
| I-000578296 | DCPUBL | R | 5/24/2013 | | | 210249 | | |
| 106 70725225201000 | GASOLINE & OIL | BV BLANKET FIRE | | 59.55 | | | | |
| I-000578618 | DCPUBL | R | 5/24/2013 | | | 210249 | | |
| 106 70725225201000 | GASOLINE & OIL | BV BLANKET FIRE | | 36.85 | | | | |
| I-000579059 | DCPUBL | R | 5/24/2013 | | | 210249 | | |
| 106 70725225201000 | GASOLINE & OIL | BV BLANKET FIRE | | 105.36 | | | | |
| I-000579090 | DCPUBL | R | 5/24/2013 | | | 210249 | | |
| 106 70725225201000 | GASOLINE & OIL | BV BLANKET FIRE | | 108.72 | | | | |
| I-000579502 | DCPUBL | R | 5/24/2013 | | | 210249 | | |
| 106 70725225201000 | GASOLINE & OIL | BV BLANKET FIRE | | 44.51 | | | | 1,284.76 |
| 3703 | BV OIL COMPANY, INC | | | | | | | |
| I-000578081 | DCPARK | R | 5/24/2013 | | | 210250 | | |
| 001 70745725201000 | GAS AND OIL | | | 48.14 | | | | |
| I-000578457 | DCPARK | R | 5/24/2013 | | | 210250 | | |
| 001 70745725201000 | GAS AND OIL | | | 273.34 | | | | |
| I-000579300 | DCPARK | R | 5/24/2013 | | | 210250 | | |
| 001 70745725201000 | GAS AND OIL | | | 71.49 | | | | |
| I-000579499 | DCPARK | R | 5/24/2013 | | | 210250 | | |
| 001 70745725201000 | GAS AND OIL | | | 240.60 | | | | 633.57 |

VENDOR SET: 01 Desoto County
 BANK: APBK POOLED CASH ACCOUNT
 DATE RANGE: 5/15/2013 THRU 5/29/2013

| VENDOR I.D. | NAME | STATUS | CHECK DATE | AMOUNT | DISCOUNT | CHECK NO | CHECK STATUS | CHECK AMOUNT |
|--------------------|-------------------------------|-------------------|---------------|----------|----------|-------------|-----------------|-----------------|
| 3686 | BV OIL COMPANY, INC. | | | | | | | |
| I-000579304 | DCTRAN | R | 5/24/2013 | | | 210251 | | |
| 102 60505415201000 | GASOLINE & OIL-DEPARTMENTAL | FUEL FOR MAY 2013 | | 525.29 | | | | |
| I-000579504 | DCTRAN | R | 5/24/2013 | | | 210251 | | |
| 102 60505415201000 | GASOLINE & OIL-DEPARTMENTAL | FUEL FOR MAY 2013 | | 312.96 | | | | 838.25 |
| 3687 | BV OIL COMPANY, INC. | | | | | | | |
| I-000578079 | DCENVIR | R | 5/24/2013 | | | 210252 | | |
| 400 42305345201000 | GASOLINE & OIL | GAS ON ROAD | | 58.38 | | | | |
| I-000578809 | DCENVIR | R | 5/24/2013 | | | 210252 | | |
| 400 42305345201000 | GASOLINE & OIL | GAS ON ROAD | | 126.50 | | | | 184.88 |
| 3694 | BV OIL COMPANY, INC. | | | | | | | |
| I-000580458 | DCCOMSV | R | 5/24/2013 | | | 210253 | | |
| 001 31165644000000 | TRAVEL | BLANKET PO FUEL | | 27.88 | | | | 27.88 |
| 3697 | BV OIL COMPANY, INC. | | | | | | | |
| I-000579645 | DCENGIN | R | 5/24/2013 | | | 210254 | | |
| 104 30205415201000 | GAS AND OIL | | | 62.91 | | | | 62.91 |
| 3714 | BV OIL COMPANY, INC. | | | | | | | |
| I-000577890 | DCPUBAD | R | 5/24/2013 | | | 210255 | | |
| 106 70715295201000 | GAS & OIL-GENERAL USE | BV ADMIN | | 26.03 | | | | |
| I-000578082 | DCPUBAD | R | 5/24/2013 | | | 210255 | | |
| 106 70715295201000 | GAS & OIL-GENERAL USE | BV ADMIN | | 98.02 | | | | |
| I-000578294 | DCPUBAD | R | 5/24/2013 | | | 210255 | | |
| 106 70715295201000 | GAS & OIL-GENERAL USE | BV ADMIN | | 27.89 | | | | |
| I-000578616 | DCPUBAD | R | 5/24/2013 | | | 210255 | | |
| 106 70715295201000 | GAS & OIL-GENERAL USE | BV ADMIN | | 74.56 | | | | |
| I-000578811 | DCPUBAD | R | 5/24/2013 | | | 210255 | | |
| 106 70715295201000 | GAS & OIL-GENERAL USE | BV ADMIN | | 85.54 | | | | |
| I-000579088 | DCPUBAD | R | 5/24/2013 | | | 210255 | | |
| 106 70715295201000 | GAS & OIL-GENERAL USE | BV ADMIN | | 100.72 | | | | |
| I-000579302 | DCPUBAD | R | 5/24/2013 | | | 210255 | | |
| 106 70715295201000 | GAS & OIL-GENERAL USE | BV ADMIN | | 26.03 | | | | |
| I-000579500 | DCPUBAD | R | 5/24/2013 | | | 210255 | | |
| 106 70715295201000 | GAS & OIL-GENERAL USE | BV ADMIN | | 75.68 | | | | |
| I-000579648 | DCPUBAD | R | 5/24/2013 | | | 210255 | | |
| 106 70715295201000 | GAS & OIL-GENERAL USE | BV ADMIN | | 42.13 | | | | 556.60 |
| 3873 | C.FULLERTON SOD & LANDSCAPING | | | | | | | |
| I-07460 | SOD FOR SLOPES | R | 5/24/2013 | | | 210256 | | |
| 400 42305345300000 | LANDFILL MATERIALS/MISC IMPR | SOD FOR SLOPES | | 1,080.00 | | | | 1,080.00 |

VENDOR SET: 01 Desoto County
 BANK: APBK POOLED CASH ACCOUNT
 DATE RANGE: 5/15/2013 THRU 5/29/2013

| VENDOR I.D. | NAME | STATUS | CHECK DATE | AMOUNT | DISCOUNT | CHECK NO | CHECK STATUS | CHECK AMOUNT |
|--------------------|-----------------------------------|----------------------|---------------|-----------|----------|-------------|-----------------|-----------------|
| 3177 | CENTRAL FIRE | | | | | | | |
| I-50122 | LANDFILL | R | 5/24/2013 | | | 210257 | | |
| 400 42305343400931 | CONTRACTED SERVICES - HAZ WASTHHW | | | 299.10 | | | | 299.10 |
| 3848 | CENTURYLINK | | | | | | | |
| I-201305232544 | 311573058 | R | 5/24/2013 | | | 210258 | | |
| 133 71425264100000 | UTILITIES/TELEPHONE | BLANKET | P.O. E-911 | 219.38 | | | | 219.38 |
| 3685 | CLEAN CUTS, LLC. | | | | | | | |
| I-201305242552 | LETTY HARRIS -- REPLACE | R | 5/24/2013 | | | 210259 | | |
| 170 30165544600000 | HOUSING/REHAB | LETTY HARRIS - REPLA | | 12,000.00 | | | | 12,000.00 |
| 3685 | CLEAN CUTS, LLC. | | | | | | | |
| I-201305242554 | LETTY HARRIS - REPLACE | R | 5/24/2013 | | | 210260 | | |
| 170 30165544600000 | HOUSING/REHAB | LETTY HARRIS - REPLA | | 12,000.00 | | | | 12,000.00 |
| 1108 | CRANKSHAW VETERINARY SERVICES | | | | | | | |
| I-03.095 | VET CERT | R | 5/24/2013 | | | 210261 | | |
| 001 30195625206000 | VETERINARY SUPPLIES/SERVICES | VET CERT | | 37.00 | | | | |
| I-04.037 | VET CERT | R | 5/24/2013 | | | 210261 | | |
| 001 30195625206000 | VETERINARY SUPPLIES/SERVICES | VET CERT | | 12.00 | | | | |
| I-4.013 | VET CERT | R | 5/24/2013 | | | 210261 | | |
| 001 30195625206000 | VETERINARY SUPPLIES/SERVICES | VET CERT | | 37.00 | | | | |
| I-4.148 | VET CERT | R | 5/24/2013 | | | 210261 | | |
| 001 30195625206000 | VETERINARY SUPPLIES/SERVICES | VET CERT | | 12.00 | | | | |
| I-4.149 | VET CERT | R | 5/24/2013 | | | 210261 | | |
| 001 30195625206000 | VETERINARY SUPPLIES/SERVICES | VET CERT | | 12.00 | | | | |
| I-4.150 | VET CERT | R | 5/24/2013 | | | 210261 | | |
| 001 30195625206000 | VETERINARY SUPPLIES/SERVICES | VET CERT | | 12.00 | | | | |
| I-4.151 | VET CERT | R | 5/24/2013 | | | 210261 | | |
| 001 30195625206000 | VETERINARY SUPPLIES/SERVICES | VET CERT | | 12.00 | | | | |
| I-4.158 | VET CERT | R | 5/24/2013 | | | 210261 | | |
| 001 30195625206000 | VETERINARY SUPPLIES/SERVICES | VET CERT | | 12.00 | | | | 146.00 |
| 0675 | CREEL FORD TRACTOR INC | | | | | | | |
| C-C902188 | 23370 | R | 5/24/2013 | | | 210262 | | |
| 102 60505414600000 | REPAIR & MAINTENANCE | C902188 | | 16.71CR | | | | |
| I-3943460 | 23370 | R | 5/24/2013 | | | 210262 | | |
| 102 60505414600000 | REPAIR & MAINTENANCE | 3943627 | | 16.71 | | | | |
| I-3943627 | 23370 | R | 5/24/2013 | | | 210262 | | |
| 102 60505414600000 | REPAIR & MAINTENANCE | 3943460 | | 16.71 | | | | 16.71 |
| 0693 | DESOTO SOD, INC | | | | | | | |
| C-128660 | 231864 | R | 5/24/2013 | | | 210263 | | |
| 102 60505415301000 | ROAD & BRIDGE MATERIALS | SOD BLANKET | | 260.00CR | | | | |
| I-128711 | 231894 | R | 5/24/2013 | | | 210263 | | |
| 102 60505415301000 | ROAD & BRIDGE MATERIALS | SOD BLANKET | | 58.00 | | | | |
| I-129835 | 232523 | R | 5/24/2013 | | | 210263 | | |

VENDOR SET: 01 Desoto County
BANK: APBK POOLED CASH ACCOUNT
DATE RANGE: 5/15/2013 THRU 5/29/2013

| VENDOR I.D. | NAME | STATUS | CHECK DATE | AMOUNT | DISCOUNT | CHECK NO | CHECK STATUS | CHECK AMOUNT |
|--------------------|--------------------------------|----------------------|------------|----------|----------|----------|--------------|--------------|
| 0693 | DESOTO SOD, INC | CONT | | | | | | |
| I-129835 | 232523 | R | 5/24/2013 | | | 210263 | | |
| 102 60505415301000 | ROAD & BRIDGE MATERIALS | SOD BLANKET | | 232.00 | | | | |
| I-129843 | 232531 | R | 5/24/2013 | | | 210263 | | |
| 102 60505415301000 | ROAD & BRIDGE MATERIALS | SOD BLANKET | | 192.00 | | | | |
| I-129862 | 232550 | R | 5/24/2013 | | | 210263 | | |
| 102 60505415301000 | ROAD & BRIDGE MATERIALS | SOD BLANKET | | 174.00 | | | | |
| I-129878 | 232566 | R | 5/24/2013 | | | 210263 | | |
| 102 60505415301000 | ROAD & BRIDGE MATERIALS | SOD BLANKET | | 124.00 | | | | 520.00 |
| 1160 | DESOTO VETERINARY SERVICE | | | | | | | |
| I-4.100 | VET CERTS | R | 5/24/2013 | | | 210264 | | |
| 001 30195625206000 | VETERINARY SUPPLIES/SERVICES | VET CERTS | | 12.00 | | | | |
| I-4.106 | VET CERTS | R | 5/24/2013 | | | 210264 | | |
| 001 30195625206000 | VETERINARY SUPPLIES/SERVICES | VET CERTS | | 37.00 | | | | |
| I-65.018 | VET CERTS | R | 5/24/2013 | | | 210264 | | |
| 001 30195625206000 | VETERINARY SUPPLIES/SERVICES | VET CERTS | | 12.00 | | | | 61.00 |
| 3887 | DOUGLASS SCREEN PRINTERS, INC. | | | | | | | |
| I-072628 | 09167 | R | 5/24/2013 | | | 210265 | | |
| 102 60505415302000 | TRAFFIC CONTROL DEVICES | 072628 | | 47.47 | | | | 47.47 |
| 1 | DR PAMELA WRIGHT | | | | | | | |
| I-4 | VET FEE | R | 5/24/2013 | | | 210266 | | |
| 001 30195624901000 | DONATION EXPENSES | VET FEE | | 300.00 | | | | 300.00 |
| 1234 | EQUIPMENT CARE SYSTEM | | | | | | | |
| I-2703 | 8615 | R | 5/24/2013 | | | 210267 | | |
| 102 60505414601000 | MAINT. AGREEMENTS | WASH BAY MAINT | | 43.50 | | | | |
| 102 60505414601000 | MAINT. AGREEMENTS | WASH BAY SVC 2012-20 | | 152.00 | | | | 195.50 |
| 1774 | EVERGLADES FARM EQUIPMENT | | | | | | | |
| I-P41577 | DESOT007 | R | 5/24/2013 | | | 210268 | | |
| 102 60505414600000 | REPAIR & MAINTENANCE | P41577 | | 281.89 | | | | 281.89 |
| 0306 | FENDER AUTO PARTS INC | | | | | | | |
| I-1029 | 166 | R | 5/24/2013 | | | 210269 | | |
| 400 42305344600000 | REPAIR & MAINTENANCE | repair parts | | 76.40 | | | | |
| I-30129 | 168 | R | 5/24/2013 | | | 210269 | | |
| 102 60505414600000 | REPAIR & MAINTENANCE | BLANKET PO FOR PURCH | | 18.59 | | | | 94.99 |
| 4422 | FORTILINE, INC. | | | | | | | |
| I-3066892 | 212541 | R | 5/24/2013 | | | 210270 | | |
| 001 70815754602000 | STORM WATER MODIFICATION EXP | PER CONTRACT | | 5,259.20 | | | | 5,259.20 |

VENDOR SET: 01 Desoto County
 BANK: APBK POOLED CASH ACCOUNT
 DATE RANGE: 5/15/2013 THRU 5/29/2013

| VENDOR I.D. | NAME | STATUS | CHECK DATE | AMOUNT | DISCOUNT | CHECK NO | CHECK STATUS | CHECK AMOUNT |
|--------------------|-------------------------------|----------------------|---------------|-----------|----------|-------------|-----------------|-----------------|
| 3107 | GLADE AND GROVE SUPPLY, INC | | | | | | | |
| I-P15943 | 9934821 | R | 5/24/2013 | | | 210271 | | |
| 102 60505414600000 | REPAIR & MAINTENANCE | P15943 | | 45.14 | | | | 45.14 |
| 1391 | GRAINGER INC | | | | | | | |
| I-9135076843 | 86623576 | R | 5/24/2013 | | | 210272 | | |
| 410 70965334600000 | GENERAL REPAIR & MAINTENANCE | LAMPS FOR SST | | 57.00 | | | | |
| I-9135342146 | 866230576 | R | 5/24/2013 | | | 210272 | | |
| 410 70975355202000 | MINOR EQUIPMENT | PIPE WRENCHES | | 64.42 | | | | 121.42 |
| 4285 | HERITAGE SPECIALTIES | | | | | | | |
| I-528309 | PLAQUE ENGRAVING | R | 5/24/2013 | | | 210273 | | |
| 001 30195624900000 | MISCELLANEOUS | PLAQUE ENGRAVING | | 16.00 | | | | 16.00 |
| 3000 | HILLS PET NUTRITION , INC | | | | | | | |
| I-220184531 | 726022 | R | 5/24/2013 | | | 210274 | | |
| 001 30195625200000 | OPERATING SUPPLIES | SHIPPING ON PET FOOD | | 56.23 | | | | |
| I-220236593 | 726022 | R | 5/24/2013 | | | 210274 | | |
| 001 30195625200000 | OPERATING SUPPLIES | SHIPPING ON PET FOOD | | 49.17 | | | | 105.40 |
| 0456 | HOME DEPOT CREDIT SVCS | | | | | | | |
| I-5230222 | 4522 | R | 5/24/2013 | | | 210275 | | |
| 102 60505414602000 | BLDG/COMPOUND MAINT. | 5230222 | | 48.87 | | | | 48.87 |
| 4457 | J & C RADIATOR SERVICE | | | | | | | |
| I-415237 | RBF500 | R | 5/24/2013 | | | 210276 | | |
| 102 60505414600000 | REPAIR & MAINTENANCE | 415237 | | 959.00 | | | | 959.00 |
| 1482 | J.M. TODD, INC | | | | | | | |
| I-410663 | 8697 | R | 5/24/2013 | | | 210277 | | |
| 001 30195624601000 | MAINTENANCE AGREEMENTS | COPIER FEES | | 125.47 | | | | 125.47 |
| 1 | JACK L SIKES | | | | | | | |
| I-201305232545 | TRAP DEPOSIT REFU | R | 5/24/2013 | | | 210278 | | |
| 001 00002200000000 | DEPOSITS PAYABLE (CAT TRAPS) | TRAP DEPOSIT REFUND | | 20.00 | | | | 20.00 |
| 4451 | JERRY ULM DODGE CHRYSLER JEEP | | | | | | | |
| I-450744 | 179602 | R | 5/24/2013 | | | 210279 | | |
| 102 60505414600000 | REPAIR & MAINTENANCE | 450744 | | 54.49 | | | | 54.49 |
| 3652 | JEWEL CONTRACTING, INC. | | | | | | | |
| I-201305242550 | RAMON MANCERA | R | 5/24/2013 | | | 210280 | | |
| 170 30165544600000 | HOUSING/REHAB | RAMON MANCERA | | 24,000.00 | | | | 24,000.00 |

VENDOR SET: 01 Desoto County
 BANK: APBK POOLED CASH ACCOUNT
 DATE RANGE: 5/15/2013 THRU 5/29/2013

| VENDOR I.D. | NAME | STATUS | CHECK DATE | AMOUNT | DISCOUNT | CHECK NO | CHECK STATUS | CHECK AMOUNT |
|--------------------|------------------------------|----------------------|---------------|---------|----------|-------------|-----------------|-----------------|
| 1484 | LOU'S PAINT SPOT & CARPET | | | | | | | |
| I-143194 | 1360 | R | 5/24/2013 | | | 210281 | | |
| 001 30195624600000 | REPAIR AND MAINTENANCE | 2012-61 | | 215.99 | | | | 215.99 |
| 1729 | MID-STATE SCALE COMPANY | | | | | | | |
| I-6465 | LANDFILL | R | 5/24/2013 | | | 210282 | | |
| 400 42305344600000 | REPAIR & MAINTENANCE | REPAIRS | | 604.80 | | | | 604.80 |
| 4211 | MITZIE MCGAVIC | | | | | | | |
| I-AC-01406 | FILING FEES | R | 5/24/2013 | | | 210283 | | |
| 001 30195624900000 | MISCELLANEOUS | FILING FEES | | 10.00 | | | | |
| I-AC-01407 | FILING FEES | R | 5/24/2013 | | | 210283 | | |
| 001 30195624900000 | MISCELLANEOUS | FILING FEES | | 10.00 | | | | |
| I-AC-01408 | FILING FEES | R | 5/24/2013 | | | 210283 | | |
| 001 30195624900000 | MISCELLANEOUS | FILING FEES | | 10.00 | | | | |
| I-AC-01464 | FILING FEES | R | 5/24/2013 | | | 210283 | | |
| 001 30195624900000 | MISCELLANEOUS | FILING FEES | | 10.00 | | | | |
| I-AC-01465 | FILING FEES | R | 5/24/2013 | | | 210283 | | |
| 001 30195624900000 | MISCELLANEOUS | FILING FEES | | 10.00 | | | | |
| I-AC-01466 | FILING FEES | R | 5/24/2013 | | | 210283 | | |
| 001 30195624900000 | MISCELLANEOUS | FILING FEES | | 10.00 | | | | |
| I-AC-01467 | FILING FEES | R | 5/24/2013 | | | 210283 | | |
| 001 30195624900000 | MISCELLANEOUS | FILING FEES | | 10.00 | | | | |
| I-AC-01468 | FILING FEES | R | 5/24/2013 | | | 210283 | | |
| 001 30195624900000 | MISCELLANEOUS | FILING FEES | | 10.00 | | | | 80.00 |
| 3547 | MYAKKA HEATING & COOLING | | | | | | | |
| I-8471 | DJJ | R | 5/24/2013 | | | 210284 | | |
| 410 70965334600000 | GENERAL REPAIR & MAINTENANCE | REPAIRS TO ICE MAKER | | 444.88 | | | | |
| 410 70965334600000 | GENERAL REPAIR & MAINTENANCE | ICE MAKER PARTS | | 101.46 | | | | 546.34 |
| 3604 | NAFECO, INC. | | | | | | | |
| I-690593 | DES095 | R | 5/24/2013 | | | 210285 | | |
| 106 70725225203000 | UNIFORMS-BUNKER GEAR | BUNKER GEAR | | 246.00 | | | | |
| I-691323 | DES095 | R | 5/24/2013 | | | 210285 | | |
| 106 70715295203000 | UNIFORMS | | | 23.95 | | | | |
| I-691578 | DES095 | R | 5/24/2013 | | | 210285 | | |
| 106 70725225203000 | UNIFORMS-BUNKER GEAR | BUNKER GEAR | | 612.00 | | | | 881.95 |
| 2051 | NAPA-GENIUNE PARTS CO. | | | | | | | |
| C-204247 | 2136 | R | 5/24/2013 | | | 210286 | | |
| 106 70725224600000 | REPAIRS & MAINTENANCE | air and oil filters | | 37.60CR | | | | |
| I-205082 | 2136 | R | 5/24/2013 | | | 210286 | | |
| 106 70725224600000 | REPAIRS & MAINTENANCE | air and oil filters | | 12.10 | | | | |
| I-205427 | 2136 | R | 5/24/2013 | | | 210286 | | |
| 106 70725224600000 | REPAIRS & MAINTENANCE | air and oil filters | | 9.00 | | | | |
| I-205488 | 2136 | R | 5/24/2013 | | | 210286 | | |
| 102 60505414600000 | REPAIR & MAINTENANCE | 205488 | | 77.14 | | | | |
| I-205877 | 2123 | R | 5/24/2013 | | | 210286 | | |

VENDOR SET: 01 Desoto County
BANK: APBK POOLED CASH ACCOUNT
DATE RANGE: 5/15/2013 THRU 5/29/2013

| VENDOR I.D. | NAME | STATUS | CHECK DATE | AMOUNT | DISCOUNT | CHECK NO | CHECK STATUS | CHECK AMOUNT |
|--------------------|--------------------------------|----------------------|------------|----------|----------|----------|--------------|--------------|
| 2051 | NAPA-GENIUNE PARTS CO.CONT | | | | | | | |
| I-205877 | 2123 | R | 5/24/2013 | | | 210286 | | |
| 410 70975354600000 | GENERAL REPAIR & MAINTENANCE | WW - REPAIRS | | 320.08 | | | | |
| I-25409 | 2136 | R | 5/24/2013 | | | 210286 | | |
| 106 70725224600000 | REPAIRS & MAINTENANCE | air and oil filters | | 339.26 | | | | 719.98 |
| 0432 | OFFICE DEPOT | | | | | | | |
| I-656216289001 | 27272349 | R | 5/24/2013 | | | 210287 | | |
| 410 70945365100000 | OFFICE SUPPLIES | OT ADMIN OFFICE SUPP | | 97.12 | | | | 97.12 |
| 4492 | OPTIMAL PHONE INTERPRETERS, IN | | | | | | | |
| I-P248729 | ID 6708 | R | 5/24/2013 | | | 210288 | | |
| 133 71425264901000 | MISCELLANEOUS CHARGES | 911 LANGUAGE SERVICE | | 21.41 | | | | 21.41 |
| 3324 | PEACE RIVER SHOPPER | | | | | | | |
| I-14509 | CAT CLINIC AD | R | 5/24/2013 | | | 210289 | | |
| 001 30195625200000 | OPERATING SUPPLIES | CAT CLINIC AD | | 90.00 | | | | 90.00 |
| 4061 | RAPID SYSTEMS, INC. | | | | | | | |
| I-243331 | UTILITIES | R | 5/24/2013 | | | 210290 | | |
| 410 70945364100000 | TELEPHONE | INTERNET SERVICES | | 168.00 | | | | 168.00 |
| 2026 | RING POWER CORPORATION | | | | | | | |
| I-15PX7907067 | 001610 | R | 5/24/2013 | | | 210291 | | |
| 102 60505414600000 | REPAIR & MAINTENANCE | 15PX7907067 | | 241.08 | | | | 241.08 |
| 3389 | RING POWER CORPORATION | | | | | | | |
| I-15CX07898254 | 011803 | R | 5/24/2013 | | | 210292 | | |
| 400 42305344400000 | LEASE EQUIPMENT | T & m | | 786.81 | | | | 786.81 |
| 1445 | STAPLES ADVANTAGE | | | | | | | |
| I-115814920 | 16307405 | R | 5/24/2013 | | | 210293 | | |
| 001 30155155100000 | OFFICE SUPPLIES | STAPLES | | 185.03 | | | | |
| I-3197771914 | 70109845 | R | 5/24/2013 | | | 210293 | | |
| 001 30195625100000 | OFFICE SUPPLIES | CARTRIDGES | | 13.62 | | | | 198.65 |
| 1298 | FLORIDA DEPARTMENT OF | | | | | | | |
| I-3G-7277 | AJ7 | R | 5/24/2013 | | | 210294 | | |
| 001 00001334100000 | ACCTS REC - TELEPHONE | AJ7AR10 | | 87.91 | | | | |
| 001 00001334100000 | ACCTS REC - TELEPHONE | AJ7AR12 | | 75.14 | | | | |
| 001 00001334100000 | ACCTS REC - TELEPHONE | AJ7AR19 | | 34.14 | | | | |
| 001 26015124100000 | TELEPHONE | AJ7AR13 ADMIN | | 37.16 | | | | |
| 001 26035154100000 | TELEPHONE | AJ7AR34 DIRECTORY | | 0.17 | | | | |
| 001 26085194100000 | TELEPHONE | AJ7AR04 | | 137.29 | | | | |
| 001 26097124605031 | REPAIRS AND MAINTENANCE | AJ7AR04 COURTHOUSE | | 112.55 | | | | |
| 001 30155154100000 | TELEPHONE | AJ7AR31 | | 5.51 | | | | |
| 001 30175164101000 | COMMUNICATION ENHANCEMENTS | AJ7AR13 INFO SYSTEM | | 1,670.50 | | | | |
| 001 30185244100000 | TELEPHONE | AJ7AR32 | | 26.37 | | | | |

VENDOR SET: 01 Desoto County
BANK: APBK POOLED CASH ACCOUNT
DATE RANGE: 5/15/2013 THRU 5/29/2013

| VENDOR I.D. | NAME | STATUS | CHECK DATE | AMOUNT | DISCOUNT | CHECK NO | CHECK STATUS | CHECK AMOUNT |
|--------------------|----------------------------|----------------------|------------|--------|----------|----------|--------------|--------------|
| 1298 | FLORIDA DEPARTMENT OF CONT | | | | | | | |
| I-3G-7277 | AJ7 | R | 5/24/2013 | | | 210294 | | |
| 001 30195624100000 | TELEPHONE | AJ7AR06 | | 92.47 | | | | |
| 001 31165644100000 | TELEPHONE | AJ7AR07 | | 25.00 | | | | |
| 001 36245374100000 | TELEPHONE | AJ7AR21 | | 93.21 | | | | |
| 001 38265714100000 | TELEPHONE | AJ7AR05 | | 47.32 | | | | |
| 001 52425234100000 | COMMUNICATIONS | AJ7AR17 | | 92.07 | | | | |
| 001 70735724100000 | TELEPHONE | AJ7AR26 PARKS ADMIN | | 30.16 | | | | |
| 001 70745724100000 | COMMUNICATIONS | AJ7AR26 PARKS MAINT | | 155.08 | | | | |
| 001 70815754100000 | COMMUNICATIONS | AJ7AR01 | | 299.86 | | | | |
| 001 71375134100000 | TELEPHONE | AJ7AR18 | | 55.80 | | | | |
| 001 71395134100000 | TELEPHONE | AJ7AR23 | | 4.37 | | | | |
| 001 71405534100000 | TELEPHONE | AJ7AR35 | | 29.34 | | | | |
| 102 60505414100000 | COMMUNICATIONS | AJ7AR02 | | 94.75 | | | | |
| 104 30205414100000 | TELEPHONE | AJ7AR00 | | 12.07 | | | | |
| 106 70715294100000 | TELEPHONE | AJ7AR20 | | 286.95 | | | | |
| 106 71315254100000 | TELEPHONE | AJ7AR08 | | 227.73 | | | | |
| 190 23066044100000 | TELEPHONE/COMMUNICATIONS | AJ7AR11 | | 57.31 | | | | |
| 190 24076024100000 | TELEPHONE/COMMUNICATIONS | AJ7AR15 | | 42.11 | | | | |
| 190 24086034100000 | TELEPHONE/COMMUNICATIONS | AJ7AR14 | | 74.79 | | | | |
| 190 24096014100000 | TELEPHONE/COMMUNICATIONS | AH2AR01 | | 223.84 | | | | |
| 400 42305344100000 | TELEPHONE | AJ7AR16 | | 117.40 | | | | |
| 410 70945364100000 | TELEPHONE | AJ7AR27 UTIL ADMIN | | 192.05 | | | | |
| 410 70965334100000 | TELEPHONE | AJ7AR27 (491-7576) | | 22.51 | | | | |
| 410 70965334100000 | TELEPHONE | AJ7AR28 (993-4584) | | 22.51 | | | | |
| 410 70965334100000 | TELEPHONE | AJ7AR28 (491-7603) | | 22.51 | | | | |
| 410 70975354100000 | TELEPHONE | AJ7AR27 (491-7578) | | 45.48 | | | | |
| 410 70975354100000 | TELEPHONE | AJ7AR27 (993-4553) | | 22.51 | | | | |
| 410 70975354100000 | TELEPHONE | AJ7AR27 (993-4523) | | 22.75 | | | | |
| 410 70975354100000 | TELEPHONE | AJ7AR27 (993-4522) | | 22.51 | | | | |
| 410 70975354100000 | TELEPHONE | AJ7AR27 (993-4537) | | 22.51 | | | | |
| 410 70975354100000 | TELEPHONE | AJ7AR (993-4642) | | 22.51 | | | | |
| 410 70975354100000 | TELEPHONE | AJ7AR27 (491-7503) | | 22.51 | | | | |
| 410 70975354100000 | TELEPHONE | AJ7AR27 941-255-7424 | | 22.62 | | | | |
| 410 70975354100000 | TELEPHONE | AJ7AR27 941-255-7434 | | 22.51 | | | | |
| 415 30255244100000 | TELEPHONE | AJ7AR03 | | 96.60 | | | | 4,830.46 |
| 2471 | TRACTOR SUPPLY CO | | | | | | | |
| I-153736 | 5923/TRANS | R | 5/24/2013 | | | 210295 | | |
| 102 60505414600000 | REPAIR & MAINTENANCE | 153736 | | 71.95 | | | | 71.95 |
| 4094 | UNIFIRST CORPORATION | | | | | | | |
| I-0927382 | 921575 | R | 5/24/2013 | | | 210296 | | |
| 400 42305345203000 | UNIFORMS | UNIFORMS | | 38.40 | | | | |
| I-0928499 | 921575 | R | 5/24/2013 | | | 210296 | | |
| 400 42305345203000 | UNIFORMS | UNIFORMS | | 38.40 | | | | |
| I-0928500 | 921589 | R | 5/24/2013 | | | 210296 | | |
| 410 70955365200000 | UNIFORMS | SYST. MAINT.UNIFORMS | | 3.85 | | | | |

VENDOR SET: 01 Desoto County
 BANK: APBK POOLED CASH ACCOUNT
 DATE RANGE: 5/15/2013 THRU 5/29/2013

| VENDOR I.D. | NAME | STATUS | CHECK DATE | AMOUNT | DISCOUNT | CHECK NO | CHECK STATUS | CHECK AMOUNT |
|--------------------|------------------------------|--------|------------|----------|----------|----------|--------------|--------------|
| 4094 | UNIFIRST CORPORATION CONT | | | | | | | |
| I-0928500 | 921589 | R | 5/24/2013 | | | 210296 | | |
| 410 70965335200000 | UNIFORMS | | | 7.70 | | | | |
| 410 70975355200000 | UNIFORMS | | | 19.25 | | | | |
| I-0929384 | 921553 | R | 5/24/2013 | | | 210296 | | |
| 102 60505415203000 | UNIFORMS | | | 148.38 | | | | 255.98 |
| 4315 | UNITED HEALTHCARE | | | | | | | |
| I-JUNE 2013 | 23502 | R | 5/24/2013 | | | 210297 | | |
| 001 71495132301000 | RETIREE HEALTH SUPPLEMENT | | | 1,227.00 | | | | 1,227.00 |
| 3931 | CAW DBA VTech | | | | | | | |
| I-21826 | IT SUPPORT SERVICE | R | 5/24/2013 | | | 210298 | | |
| 001 30175163100000 | PROFESSIONAL SERVICES | | | 2,431.00 | | | | |
| I-21827 | DATA REPLICATION | R | 5/24/2013 | | | 210298 | | |
| 001 30175165205000 | SOFTWARE LICENSE FEES | | | 510.00 | | | | 2,941.00 |
| 1439 | WALMART COMMUNITY/GEMB | | | | | | | |
| I-00263 | 5503 | R | 5/24/2013 | | | 210299 | | |
| 001 70815755203000 | CONCESSION SUPPLIES | | | 28.13 | | | | |
| I-08313 | 5501 | R | 5/24/2013 | | | 210299 | | |
| 400 42305345202000 | OPERATING SUPPLIES/MATERIALS | | | 3.88 | | | | 32.01 |
| 0378 | WOMACK SANITATION, INC. | | | | | | | |
| I-27757 | 1054-001 | R | 5/24/2013 | | | 210300 | | |
| 001 30195625200000 | OPERATING SUPPLIES | | | 185.00 | | | | 185.00 |
| 4489 | ARCADIA SHOPPES, LLC | | | | | | | |
| I-05/28/13-LEASE | JUNE RENT | R | 5/29/2013 | | | 210301 | | |
| 001 71515628101000 | HEALTH DEPT RENTAL UNIT | | | 3,333.33 | | | | 3,333.33 |
| 3023 | BRENDA M. HARP | | | | | | | |
| I-05/28/13-3023 | PROPERTY PYMNT- 06/01/2013 | R | 5/29/2013 | | | 210302 | | |
| 106 70715297100000 | PROPERTY PRINCIPAL PMT | | | 106.02 | | | | 106.02 |
| 4125 | CANON FINANCIAL SERVICES | | | | | | | |
| I-05/23/13-601378 | MAY | R | 5/29/2013 | | | 210303 | | |
| 190 24086033400000 | CONTRACTED SERVICES | | | 229.15 | | | | |
| I-05/24/13-601378 | MAY | R | 5/29/2013 | | | 210303 | | |
| 190 24086033400000 | CONTRACTED SERVICES | | | 229.15 | | | | 458.30 |
| 4243 | BARBARA JEAN DRILL | | | | | | | |
| I-05/28/13-RENTAL | JUNE RENT 06/01/2013 | R | 5/29/2013 | | | 210304 | | |
| 001 52425234400000 | RENTALS AND LEASES | | | 1,200.00 | | | | 1,200.00 |

VENDOR SET: 01 Desoto County
 BANK: APBK POOLED CASH ACCOUNT
 DATE RANGE: 5/15/2013 THRU 5/29/2013

| VENDOR I.D. | NAME | STATUS | CHECK DATE | AMOUNT | DISCOUNT | CHECK NO | CHECK STATUS | CHECK AMOUNT |
|----------------------|------------------------------|----------------------|------------------|--------|----------|-------------|-----------------|-----------------|
| 4427 | LIBBY BROWN | | | | | | | |
| I-05/28/13-INSURANCE | INSURANCE REIMBURSEMENT | R | 5/29/2013 | | | 210305 | | |
| 001 71495132301000 | RETIREE HEALTH SUPPLEMENT | MAY | INSURANCE REIMBU | 42.00 | | | | 42.00 |
| 3025 | MARY ANN ROE | | | | | | | |
| I-05/28/13-3025 | PROPERTY PYMNT- 06/01/2013 | R | 5/29/2013 | | | 210306 | | |
| 106 70715297100000 | PROPERTY PRINCIPAL PMT | PROPERTY | PYMNT-06/01 | 106.02 | | | | |
| 106 70715297100000 | PROPERTY PRINCIPAL PMT | PROPERTY | PYMNT-06/01 | 563.83 | | | | 669.85 |
| 4428 | RACHEL GRIFFIN | | | | | | | |
| I-05/28/13-INSURANCE | INSURANCE REIMBURSEMENT | R | 5/29/2013 | | | 210307 | | |
| 001 71495132301000 | RETIREE HEALTH SUPPLEMENT | MAY | INSURANCE REIMBU | 146.90 | | | | 146.90 |
| 4053 | SARAH A. ROE | | | | | | | |
| I-05/28/13-LEASE | PROPERTY PYMNT 06/01/2013 | R | 5/29/2013 | | | 210308 | | |
| 106 70715297100000 | PROPERTY PRINCIPAL PMT | PROPERTY | PYMNT 06/01 | 106.02 | | | | |
| 106 70715297100000 | PROPERTY PRINCIPAL PMT | PROPERTY | PYMNT 06/01 | 563.82 | | | | 669.84 |
| 2775 | SHARON COLLINS | | | | | | | |
| I-05/28/13-2775 | JUNE RENT 06/01/13 | R | 5/29/2013 | | | 210309 | | |
| 190 24116854400000 | RENTALS AND LEASES | LEASE-GUARDIAN AD LI | | 850.00 | | | | 850.00 |
| 4429 | SHARRON REINHOLD | | | | | | | |
| I-05/28/13-INSURANCE | INSURANCE REIMBURSEMENT | R | 5/29/2013 | | | 210310 | | |
| 001 71495132301000 | RETIREE HEALTH SUPPLEMENT | MAY | INSURANCE REIMB | 52.50 | | | | 52.50 |
| 1850 | TERRY WELLES | | | | | | | |
| I-05/28/13-INS REIMB | INSURANCE REIMBURSEMENT | R | 5/29/2013 | | | 210311 | | |
| 001 71495132301000 | RETIREE HEALTH SUPPLEMENT | MAY | INSURANCE REIMBU | 35.00 | | | | 35.00 |
| 2870 | ADVANCE AUTO PARTS | | | | | | | |
| I-9127312824302 | 9999015935 | R | 5/29/2013 | | | 210312 | | |
| 001 70745724600000 | REPAIR AND MAINTENANCE | Parts for Parks Equi | | 12.99 | | | | |
| I-9127314088803 | 9999015935 | R | 5/29/2013 | | | 210312 | | |
| 410 70975354601000 | VEHICLE REPAIR & MAINTENANCE | WW VEH - PARTS | | 14.70 | | | | 27.69 |
| 1 | AGRICULTURAL WATER SOLUTI | | | | | | | |
| I-201305242558 | DEPO | R | 5/29/2013 | | | 210313 | | |
| 001 00002202000000 | DEPOSIT REFUNDS RENTALS - TC | DEPOSIT REFUND | | 500.00 | | | | 500.00 |
| 0408 | ALERT PLUMBING SERVICE | | | | | | | |
| I-059097 | TURNER CENTER | R | 5/29/2013 | | | 210314 | | |
| 001 70815754600000 | REPAIR & MAINTENANCE | Restroom repairs | | 492.00 | | | | 492.00 |

VENDOR SET: 01 Desoto County
 BANK: APBK POOLED CASH ACCOUNT
 DATE RANGE: 5/15/2013 THRU 5/29/2013

| VENDOR I.D. | NAME | STATUS | CHECK DATE | AMOUNT | DISCOUNT | CHECK NO | CHECK STATUS | CHECK AMOUNT |
|--------------------|--------------------------------|--------|---------------|----------|----------|-------------|-----------------|-----------------|
| 0781 | ALLEN, NORTON & BLUE, P.A | | | | | | | |
| I-99213 | 2096 00000 BK | R | 5/29/2013 | | | 210315 | | |
| 001 71395133100000 | LABOR ATTORNEY FEES | | | 67.50 | | | | 67.50 |
| 2690 | ARCADIA DO IT BEST HARDWARE | | | | | | | |
| I-A350423 | 12345 | R | 5/29/2013 | | | 210316 | | |
| 106 70715294601000 | REPAIR AND MAINTENANCE | | | 6.08 | | | | 6.08 |
| | MURICATIC ACID | | | | | | | |
| 3637 | BATTERIES PLUS | | | | | | | |
| I-451-312631 | 8639905640 | R | 5/29/2013 | | | 210317 | | |
| 001 26085195200000 | OPERATING SUPPLIES | | | 43.90 | | | | 43.90 |
| | MAINT. | | | | | | | |
| 2309 | BIG T TIREMAN | | | | | | | |
| I-1-GS382343 | R&B | R | 5/29/2013 | | | 210318 | | |
| 410 70975354601000 | VEHICLE REPAIR & MAINTENANCE | | | 591.64 | | | | 591.64 |
| | TIRES - 2006-02 | | | | | | | |
| 4553 | BLUFFS GOLF COURSE, INC. | | | | | | | |
| I-201305292571 | Ballfield Demand Maint. | R | 5/29/2013 | | | 210319 | | |
| 001 70745724600000 | REPAIR AND MAINTENANCE | | | 3,500.00 | | | | 3,500.00 |
| | Ballfield Demand Mai | | | | | | | |
| 1784 | BRYAN'S FARM SUPPLY | | | | | | | |
| I-0183969 | DCFR | R | 5/29/2013 | | | 210320 | | |
| 106 70715294601000 | REPAIR AND MAINTENANCE | | | 17.00 | | | | 17.00 |
| | SALT FOR WATER SOFTN | | | | | | | |
| 3848 | CENTURYLINK | | | | | | | |
| I-201305282562 | 311620332 | R | 5/29/2013 | | | 210321 | | |
| 001 26097124605031 | REPAIRS AND MAINTENANCE | | | 37.37 | | | | 37.37 |
| | COURTHOUSE MAINT. | | | | | | | |
| 3848 | CENTURYLINK | | | | | | | |
| I-201305292570 | 311620039 | R | 5/29/2013 | | | 210322 | | |
| 001 36245374100000 | TELEPHONE | | | 136.66 | | | | 136.66 |
| 3419 | CHANCEY BOHANNAN SEPTIC&PORTA- | | | | | | | |
| I-1315 | PARKS | R | 5/29/2013 | | | 210323 | | |
| 001 70745725200000 | OPERATING SUPPLIES | | | 750.00 | | | | 750.00 |
| | SEPTIC/FORT-A-LET SE | | | | | | | |
| 0681 | CHANNEL INNOVATIONS CORP | | | | | | | |
| I-3624 | NFPA QUARTERLY RENEWAL | R | 5/29/2013 | | | 210324 | | |
| 106 70725224600000 | REPAIRS & MAINTENANCE | | | 1,568.50 | | | | 1,568.50 |
| | NFPA QUARTERLY RENEW | | | | | | | |
| 0084 | CITY OF ARCADIA, | | | | | | | |
| I-108345 | 2110840400 | R | 5/29/2013 | | | 210325 | | |
| 415 30255244300000 | UTILITIES | | | 63.86 | | | | 63.86 |
| | UTILITIES | | | | | | | |

VENDOR SET: 01 Desoto County
 BANK: APBK POOLED CASH ACCOUNT
 DATE RANGE: 5/15/2013 THRU 5/29/2013

| VENDOR I.D. | NAME | STATUS | CHECK DATE | AMOUNT | DISCOUNT | CHECK NO | CHECK STATUS | CHECK AMOUNT |
|--------------------|------------------------------|----------------------|------------|----------|----------|----------|--------------|--------------|
| 0304 | CONSOLIDATED PRODUCTIONS | | | | | | | |
| I-201305242556 | DCBCC | R | 5/29/2013 | | | 210326 | | |
| 410 7097535460000 | GENERAL REPAIR & MAINTENANCE | FM REPAIRS | | 2,035.50 | | | | 2,035.50 |
| 1153 | DESOTO AUTOMOTIVE INC | | | | | | | |
| I-333614B | 2813 | R | 5/29/2013 | | | 210327 | | |
| 106 7072522460000 | REPAIRS & MAINTENANCE | PRESSURE GAUGE | | 27.04 | | | | 27.04 |
| 1774 | EVERGLADES FARM EQUIPMENT | | | | | | | |
| I-P41576 | DESOT007 | R | 5/29/2013 | | | 210328 | | |
| 001 7074572460000 | REPAIR AND MAINTENANCE | General equipment re | | 37.30 | | | | 37.30 |
| 0306 | FENDER AUTO PARTS INC | | | | | | | |
| I-490. | 168 | R | 5/29/2013 | | | 210329 | | |
| 001 7081575460000 | REPAIR & MAINTENANCE | Forklift Repairs | | 53.45 | | | | 53.45 |
| 3107 | GLADE AND GROVE SUPPLY, INC | | | | | | | |
| C-R05037 | 9934821 | R | 5/29/2013 | | | 210330 | | |
| 102 60505415301000 | ROAD & BRIDGE MATERIALS | R05037 | | 587.40CR | | | | |
| I-R05000 | 9934821 | R | 5/29/2013 | | | 210330 | | |
| 102 60505415301000 | ROAD & BRIDGE MATERIALS | R05000 | | 880.00 | | | | 292.60 |
| 2462 | GOLF VENTURES WEST | | | | | | | |
| I-54730 | BALLFIELD SUPPLIES | R | 5/29/2013 | | | 210331 | | |
| 001 7074572460000 | REPAIR AND MAINTENANCE | BUNKER RAKE REPAIR | | 110.52 | | | | 110.52 |
| 0421 | HELENA CHEMICAL COMPANY | | | | | | | |
| I-23744581 | 206559 | R | 5/29/2013 | | | 210332 | | |
| 001 70745725200000 | OPERATING SUPPLIES | fertilizers/weed con | | 1,013.00 | | | | |
| I-23744695 | 206559 | R | 5/29/2013 | | | 210332 | | |
| 001 70745725200000 | OPERATING SUPPLIES | fertilizers/weed con | | 1,465.47 | | | | |
| I-23744746 | 206559 | R | 5/29/2013 | | | 210332 | | |
| 001 70745725200000 | OPERATING SUPPLIES | fertilizers/weed con | | 171.00 | | | | 2,649.47 |
| 0397 | HICKSON FUNERAL HOME | | | | | | | |
| I-201305282561 | JAMIE JACKSON | R | 5/29/2013 | | | 210333 | | |
| 001 31165643104000 | PAUPER BURIAL | JAMIE JACKSON | | 785.00 | | | | 785.00 |
| 2658 | HOME OWNERS SUPPLY | | | | | | | |
| I-237621 | 142943 | R | 5/29/2013 | | | 210334 | | |
| 001 70745724600000 | REPAIR AND MAINTENANCE | Parks repairs/operat | | 124.25 | | | | |
| I-237840 | 142943 | R | 5/29/2013 | | | 210334 | | |
| 001 70745725200000 | OPERATING SUPPLIES | Parks repairs/operat | | 77.95 | | | | 202.20 |

VENDOR SET: 01 Desoto County
 BANK: APBK POOLED CASH ACCOUNT
 DATE RANGE: 5/15/2013 THRU 5/29/2013

| VENDOR I.D. | NAME | STATUS | CHECK DATE | AMOUNT | DISCOUNT | CHECK NO | CHECK STATUS | CHECK AMOUNT |
|--------------------|-------------------------------|----------------------|---------------|----------|----------|-------------|-----------------|-----------------|
| 4126 | IMAGE TREND, INC. | | | | | | | |
| I-25350 | RESCUE BRIDGE | R | 5/29/2013 | | | 210335 | | |
| 106 70715294600000 | MAINTENANCE AGREEMENTS | RESCUE BRIDGE | | 500.00 | | | | |
| I-25406 | RESCUE BRIDGE SAAS | R | 5/29/2013 | | | 210335 | | |
| 106 70715294600000 | MAINTENANCE AGREEMENTS | RESCUE BRIDGE SAAS | | 6,250.00 | | | | 6,750.00 |
| 1482 | J.M. TODD, INC | | | | | | | |
| I-411638 | 7087 | R | 5/29/2013 | | | 210336 | | |
| 001 70745724601000 | MAINTENANCE CONTRACTS | monthly service cont | | 25.75 | | | | 25.75 |
| 4451 | JERRY ULM DODGE CHRYSLER JEEP | | | | | | | |
| I-454563 | 179602 | R | 5/29/2013 | | | 210337 | | |
| 410 70975354601000 | VEHICLE REPAIR & MAINTENANCE | PM ON 2003-46 | | 28.20 | | | | 28.20 |
| 1 | LA'SHONIQUE LATTIMORE | | | | | | | |
| I-201305242559 | DD REFUN | R | 5/29/2013 | | | 210338 | | |
| 001 00002201000000 | DEPOSITS PAYABLE - RENTALS | DD REFUND | | 75.00 | | | | 75.00 |
| 1446 | LIBERTY FLAGS INC | | | | | | | |
| I-65660 | SUPPLIES | R | 5/29/2013 | | | 210339 | | |
| 001 26085195200000 | OPERATING SUPPLIES | SUPPLIES | | 917.50 | | | | 917.50 |
| 2821 | MADER ELECTRIC MOTORS, INC. | | | | | | | |
| I-34590 | LAKE SUZY #2 | R | 5/29/2013 | | | 210340 | | |
| 409 70875364600000 | REPAIRS AND MAINTENANCE | LAKE SUZY LS 2 PUMP | | 8,794.80 | | | | 8,794.80 |
| 4342 | MARKETING ALLIANCE, INC | | | | | | | |
| I-18098 | TOURISM MAP | R | 5/29/2013 | | | 210341 | | |
| 150 20105524800000 | PROMOTIONAL ACTIVITIES | INVOICE 18098 | | 242.00 | | | | 242.00 |
| 3604 | NAFECO, INC. | | | | | | | |
| I-691864 | DES095 | R | 5/29/2013 | | | 210342 | | |
| 106 70715295203000 | UNIFORMS | | | 59.50 | | | | 59.50 |
| 2051 | NAPA-GENIUNE PARTS CO. | | | | | | | |
| I-205889 | 2136 | R | 5/29/2013 | | | 210343 | | |
| 410 70965334601000 | VEHICLE REPAIR & MAINTENANCE | WATER VEH REPAIRS | | 29.38 | | | | |
| I-205934 | 2136 | R | 5/29/2013 | | | 210343 | | |
| 410 70975354600000 | GENERAL REPAIR & MAINTENANCE | WW - REPAIRS | | 29.98 | | | | |
| I-205957 | 2123 | R | 5/29/2013 | | | 210343 | | |
| 410 70965334601000 | VEHICLE REPAIR & MAINTENANCE | WATER VEH REPAIRS | | 105.50 | | | | |
| I-206017 | 2136 | R | 5/29/2013 | | | 210343 | | |
| 001 70745724600000 | REPAIR AND MAINTENANCE | Parts for Parks equi | | 190.47 | | | | |
| I-206032 | 2136 | R | 5/29/2013 | | | 210343 | | |
| 001 70745724600000 | REPAIR AND MAINTENANCE | Parts for Parks equi | | 8.11 | | | | 363.44 |

VENDOR SET: 01 Desoto County
 BANK: APBK POOLED CASH ACCOUNT
 DATE RANGE: 5/15/2013 THRU 5/29/2013

| VENDOR I.D. | NAME | STATUS | CHECK DATE | AMOUNT | DISCOUNT | CHECK NO | CHECK STATUS | CHECK AMOUNT |
|--------------------|-------------------------------|--------|----------------------|--------|----------|-------------|-----------------|-----------------|
| 0432 | OFFICE DEPOT | | | | | | | |
| I-656751141001 | 27272349 | R | 5/29/2013 | | | 210344 | | |
| 001 36245375100000 | OFFICE SUPPLIES | | | 48.99 | | | | |
| I-656751455001 | 27272349 | R | 5/29/2013 | | | 210344 | | |
| 001 36245375100000 | OFFICE SUPPLIES | | | 33.66 | | | | |
| I-657311076001 | 27272349 | R | 5/29/2013 | | | 210344 | | |
| 001 70745725100000 | OFFICE SUPPLIES | | Office Supplies | 43.31 | | | | |
| I-657441328001 | 27272349 | R | 5/29/2013 | | | 210344 | | |
| 106 70715295100000 | OFFICE SUPPLIES | | BLANKET OFFICE SUPPL | 20.15 | | | | |
| I-657446398001 | 27272349 | R | 5/29/2013 | | | 210344 | | |
| 106 70715295100000 | OFFICE SUPPLIES | | BLANKET OFFICE SUPPL | 2.09 | | | | 148.20 |
| 4305 | PHIL'S AUTOMOTIVE | | | | | | | |
| I-24712 | UTILITIES | R | 5/29/2013 | | | 210345 | | |
| 410 70975354601000 | VEHICLE REPAIR & MAINTENANCE | | ALIGNMENT - 2006-02 | 49.95 | | | | 49.95 |
| 4564 | PR AUDIO, LLC | | | | | | | |
| I-201305292569 | STAGE FOR AG FEST | R | 5/29/2013 | | | 210346 | | |
| 001 70815754804000 | AG-FEST EXPENSES | | STAGE FOR AG FEST | 825.00 | | | | 825.00 |
| 2195 | QUADMED, INC. | | | | | | | |
| I-75939 | DESOTO | R | 5/29/2013 | | | 210347 | | |
| 106 70735265205000 | DRUGS & MEDICAL SUPPLIES | | MEDICAL SUPPLIES | 897.17 | | | | 897.17 |
| 4289 | RINALDI'S SMALL ENGINE REPAIR | | | | | | | |
| I-26 | HURSE UNIT E 30 | R | 5/29/2013 | | | 210348 | | |
| 106 70725224600000 | REPAIRS & MAINTENANCE | | HURSE UNIT E 30 | 41.10 | | | | |
| I-27 | CARB REBUILD HURST E40 | R | 5/29/2013 | | | 210348 | | |
| 106 70725224600000 | REPAIRS & MAINTENANCE | | CARB REBUILD HURST E | 56.86 | | | | 97.96 |
| 1 | ROSA MARTINEZ | | | | | | | |
| I-201305292567 | DD REFUND | R | 5/29/2013 | | | 210349 | | |
| 001 00002201000000 | DEPOSITS PAYABLE - RENTALS | | DD REFUND | 75.00 | | | | 75.00 |
| 2950 | SAFEGUARD SECURITY, INC | | | | | | | |
| I-047080 | 2128 | R | 5/29/2013 | | | 210350 | | |
| 001 26085194600000 | REPAIRS & MAINTENANCE | | MAINT. | 80.00 | | | | 80.00 |
| 1 | SHARON BRYANT | | | | | | | |
| I-201305242557 | DEPOSIT REFUND | R | 5/29/2013 | | | 210351 | | |
| 001 00002202000000 | DEPOSIT REFUNDS RENTALS - TC | | DEPOSIT REFUND | 100.00 | | | | 100.00 |
| 0240 | SHORT ENVIRONMENTAL | | | | | | | |
| I-13-1444 | quarter/annual water test | R | 5/29/2013 | | | 210352 | | |
| 001 70735723400000 | CONTRACTED SERVICES | | quarter/annual water | 39.00 | | | | |
| I-13-1446 | quarter/annual water test | R | 5/29/2013 | | | 210352 | | |
| 001 70745723400000 | CONTRACTED SERVICES | | quarter/annual water | 14.00 | | | | 53.00 |

| VENDOR I.D. | NAME | STATUS | CHECK DATE | AMOUNT | DISCOUNT | CHECK NO | CHECK STATUS | CHECK AMOUNT |
|--------------------|---------------------------------|----------------------|------------|----------|----------|----------|--------------|--------------|
| 2940 | SOUTHERN OXYGEN & WELDING SUPP | | | | | | | |
| I-357493 | DC4842 | R | 5/29/2013 | | | 210353 | | |
| 106 70735265205000 | DRUGS & MEDICAL SUPPLIES | EMS SUPPLIES | | 35.25 | | | | |
| I-357631 | DC4842 | R | 5/29/2013 | | | 210353 | | |
| 106 70735265205000 | DRUGS & MEDICAL SUPPLIES | EMS SUPPLIES | | 24.25 | | | | |
| I-357780 | DC4842 | R | 5/29/2013 | | | 210353 | | |
| 106 70735265205000 | DRUGS & MEDICAL SUPPLIES | EMS SUPPLIES | | 66.75 | | | | |
| I-357781 | DC4842 | R | 5/29/2013 | | | 210353 | | |
| 106 70735265205000 | DRUGS & MEDICAL SUPPLIES | EMS SUPPLIES | | 18.75 | | | | 145.00 |
| 1445 | STAPLES ADVANTAGE | | | | | | | |
| I-3199993990 | 70109845 | R | 5/29/2013 | | | 210354 | | |
| 001 71375135100000 | OFFICE SUPPLIES | OFFICE SUPPLIES | | 448.13 | | | | |
| 001 71375135100000 | OFFICE SUPPLIES | OFFICE SUPPLIES | | 283.90 | | | | 732.03 |
| 4565 | THE MARKET PLACE | | | | | | | |
| I-201305292568 | VIDEO FOR AG FEST | R | 5/29/2013 | | | 210355 | | |
| 001 70815754804000 | AG-FEST EXPENSES | VIDEO FOR AG FEST | | 1,600.00 | | | | 1,600.00 |
| 0697 | THE SUN | | | | | | | |
| I-2893746 | 101305 | R | 5/29/2013 | | | 210356 | | |
| 001 70745726308000 | BOAT RAMP IMPROVEMENTS | LIVERPOOL LEGAL LINE | | 31.97 | | | | 31.97 |
| 3283 | TOSHIBA AMERICA BUSINESS SOLUT | | | | | | | |
| I-2373879 | 57792000 | R | 5/29/2013 | | | 210357 | | |
| 001 70815754601000 | MAINTENANCE CONTRACTS | COPIER | | 72.84 | | | | 72.84 |
| 4094 | UNIFIRST CORPORATION | | | | | | | |
| I-0929606 | 921589 | R | 5/29/2013 | | | 210358 | | |
| 410 70955365200000 | UNIFORMS | SYST. MAINT.UNIFORMS | | 3.85 | | | | |
| 410 70965335200000 | UNIFORMS | WATER - UNIFORMS | | 7.70 | | | | |
| 410 70975355200000 | UNIFORMS | WW - UNIFORMS | | 19.25 | | | | 30.80 |
| 0359 | UNIVERSITY OF CENTRAL FLORIDA | | | | | | | |
| I-013-0101-1 | DEBRA MERKIN | R | 5/29/2013 | | | 210359 | | |
| 001 30185245400000 | PUBLICATIONS & DUES | FACE RENEWAL MEMBERS | | 55.00 | | | | 55.00 |
| 0356 | UNITED PARCEL SERVICE | | | | | | | |
| I-201305242560 | F49V11 | R | 5/29/2013 | | | 210360 | | |
| 001 26015124201000 | POSTAGE | BLANKET | | 64.42 | | | | 64.42 |
| 3666 | VEOLIA TRANSPORTATION SRVS, INC | | | | | | | |
| I-10 4/13 | TD BILL | R | 5/29/2013 | | | 210361 | | |
| 001 31165648207000 | TRANSPORT | TD LOCAL MATCH | | 1,989.50 | | | | |
| I-10- 4/13 | 5317 | R | 5/29/2013 | | | 210361 | | |
| 001 31165443402000 | FTA SECT 5317 CONTRACT | 5317 | | 8,578.62 | | | | |
| I-57 4/13 | 5311 | R | 5/29/2013 | | | 210361 | | |
| 001 31165443400000 | FTA SECT 5311 CONTRACT SER | 5311 | | 4,261.40 | | | | 14,829.52 |

VENDOR SET: 01 Desoto County
 BANK: APBK POOLED CASH ACCOUNT
 DATE RANGE: 5/15/2013 THRU 5/29/2013

| VENDOR I.D. | NAME | STATUS | CHECK DATE | AMOUNT | DISCOUNT | CHECK NO | CHECK STATUS | CHECK AMOUNT |
|--------------------|-------------------------------|-----------|----------------|----------|----------|----------|--------------|--------------|
| 4236 | WEILER ENGINEERING CORPORATIO | | | | | | | |
| I-43793 | 13052.003 | R | 5/29/2013 | | | 210362 | | |
| 410 70945363100000 | PROFESSIONAL SERVICES | WA #40 | GEN. ENG. SVC | 2,516.25 | | | | |
| I-43795 | 12052.013 | R | 5/29/2013 | | | 210362 | | |
| 104 30205413100000 | PROFESSIONAL SERVICES | GENERAL | PROJECTS | 525.45 | | | | |
| I-43796 | 12052.017 | R | 5/29/2013 | | | 210362 | | |
| 104 60555416300951 | SCOP 40004 GUARDRAIL DESIGN | GUARDRAIL | PROJECT | 707.10 | | | | |
| I-43797 | 12052.018 | R | 5/29/2013 | | | 210362 | | |
| 104 60555416310099 | SCOP 40025 GR DESIGN | GUARDRAIL | PROJECT | 1,215.20 | | | | |
| I-43798 | 12052.019 | R | 5/29/2013 | | | 210362 | | |
| 104 60555416310100 | SCOP 400005 BRIDGE GR DESIGN | GUARDRAIL | BROWNVILLE | 3,532.55 | | | | |
| I-43799 | 12052.025 | R | 5/29/2013 | | | 210362 | | |
| 104 60555413190602 | SCOP BRIDGE 40010 CEI | BLANKET | PO | 1,019.75 | | | | |
| I-43800 | 12052.026 | R | 5/29/2013 | | | 210362 | | |
| 104 60555413190605 | SCOP BRIDGE 40026 CEI | BLANKET | PO | 4,889.12 | | | | |
| I-43801 | 12052.027 | R | 5/29/2013 | | | 210362 | | |
| 104 60555413190608 | SCOP BRIDGE 400005 CEI | BLANKET | PO | 3,572.75 | | | | |
| I-43802 | 12052.015 | R | 5/29/2013 | | | 210362 | | |
| 104 30205413100000 | PROFESSIONAL SERVICES | GENERAL | PROJECTS | 2,641.25 | | | | 20,619.42 |
| 0367 | WEST FLORIDA SUPPLY CO, INC | | | | | | | |
| I-016621A | 0102325 | R | 5/29/2013 | | | 210363 | | |
| 001 26085195200000 | OPERATING SUPPLIES | OPERATING | | 9.64 | | | | 9.64 |
| 3649 | WILLIAM P. WISE, SHERIFF | | | | | | | |
| I-201305292577 | ARTICLE V TRANSFER #6 | R | 5/29/2013 | | | 210364 | | |
| 001 25095214900000 | ARTICLE V EXPENSE | ARTICLE V | TRANSFER # | 1,500.00 | | | | 1,500.00 |
| 2282 | XEROX CORPORATION | | | | | | | |
| I-701636257 | 718123342 | R | 5/29/2013 | | | 210365 | | |
| 190 24096014600000 | REPAIRS AND MAINTENANCE | XEROX | COPIER MAINTEN | 105.00 | | | | 105.00 |

| * * T O T A L S * * | NO | INVOICE AMOUNT | DISCOUNTS | CHECK AMOUNT |
|---------------------|---------------|----------------|-----------|--------------|
| REGULAR CHECKS: | 265 | 0.00 | 0.00 | 476,456.20 |
| HAND CHECKS: | 0 | 0.00 | 0.00 | 0.00 |
| DRAFTS: | 0 | 0.00 | 0.00 | 0.00 |
| EFT: | 0 | 0.00 | 0.00 | 0.00 |
| NON CHECKS: | 0 | 0.00 | 0.00 | 0.00 |
| VOID CHECKS: | 7 VOID DEBITS | 0.00 | | |
| | VOID CREDITS | 1,882.81 | 1,882.81 | 0.00 |

TOTAL ERRORS: 0

VENDOR SET: 01 Desoto County
 BANK: APBK POOLED CASH ACCOUNT
 DATE RANGE: 5/15/2013 THRU 5/29/2013

** G/L ACCOUNT TOTALS **

| G/L ACCOUNT | NAME | AMOUNT |
|--------------------|------------------------------|----------|
| 001 00001150000000 | ACCOUNTS RECEIVABLE | 88.10 |
| 001 00001334100000 | ACCTS REC - TELEPHONE | 197.19 |
| 001 00002200000000 | DEPOSITS PAYABLE (CAT TRAPS) | 20.00 |
| 001 00002201000000 | DEPOSITS PAYABLE - RENTALS | 150.00 |
| 001 00002202000000 | DEPOSIT REFUNDS RENTALS - TC | 1,700.00 |
| 001 25095214900000 | ARTICLE V EXPENSE | 1,500.00 |
| 001 26015124100000 | TELEPHONE | 420.85 |
| 001 26015124201000 | POSTAGE | 79.43 |
| 001 26015124601000 | MAINTENANCE AGREEMENTS | 100.20 |
| 001 26015125100000 | OFFICE SUPPLIES | 291.33 |
| 001 26015125101000 | BOARD ROOM OFFICE EXPENSE | 25.10 |
| 001 26015125201000 | GAS AND OIL | 84.79 |
| 001 26015125400000 | SUBSCRIPTIONS AND DUES | 80.00 |
| 001 26035154100000 | TELEPHONE | 115.78 |
| 001 26085194100000 | TELEPHONE | 282.08 |
| 001 26085194600000 | REPAIRS & MAINTENANCE | 2,730.49 |
| 001 26085194602000 | BUILDING MAINTENANCE | 33.04 |
| 001 26085195200000 | OPERATING SUPPLIES | 2,993.33 |
| 001 26085195201000 | GASOLINE & OIL | 420.54 |
| 001 26085195203000 | UNIFORMS | 209.64 |
| 001 26097124605031 | REPAIRS AND MAINTENANCE | 149.92 |
| 001 30155154100000 | TELEPHONE | 81.66 |
| 001 30155154601000 | MAINTENANCE AGREEMENTS | 84.09 |
| 001 30155155100000 | OFFICE SUPPLIES | 185.03 |
| 001 30175163100000 | PROFESSIONAL SERVICES | 2,431.00 |
| 001 30175164100000 | TELEPHONE | 135.77 |
| 001 30175164101000 | COMMUNICATION ENHANCEMENTS | 1,670.50 |
| 001 30175165205000 | SOFTWARE LICENSE FEES | 510.00 |
| 001 30185244100000 | TELEPHONE | 83.66 |
| 001 30185244601000 | MAINTENANCE AGREEMENTS | 84.09 |
| 001 30185245201000 | GASOLINE & OIL | 119.96 |
| 001 30185245400000 | PUBLICATIONS & DUES | 55.00 |
| 001 30195624100000 | TELEPHONE | 285.76 |
| 001 30195624600000 | REPAIR AND MAINTENANCE | 215.99 |
| 001 30195624601000 | MAINTENANCE AGREEMENTS | 125.47 |
| 001 30195624900000 | MISCELLANEOUS | 96.00 |
| 001 30195624901000 | DONATION EXPENSES | 300.00 |
| 001 30195625100000 | OFFICE SUPPLIES | 13.62 |
| 001 30195625200000 | OPERATING SUPPLIES | 420.40 |
| 001 30195625206000 | VETERINARY SUPPLIES/SERVICES | 557.14 |
| 001 31165443400000 | FTA SECT 5311 CONTRACT SER | 4,261.40 |
| 001 31165443402000 | FTA SECT 5317 CONTRACT | 8,578.62 |
| 001 31165643104000 | PAUPER BURIAL | 785.00 |
| 001 31165644000000 | TRAVEL | 112.71 |
| 001 31165644100000 | TELEPHONE | 64.99 |
| 001 31165645100000 | OFFICE SUPPLIES | 47.17 |

VENDOR SET: 01 Desoto County
 BANK: APBK POOLED CASH ACCOUNT
 DATE RANGE: 5/15/2013 THRU 5/29/2013

** G/L ACCOUNT TOTALS **

| G/L ACCOUNT | NAME | AMOUNT |
|--------------------|------------------------------|------------|
| 001 31165648200000 | DMH PARA-MUTUAL | 50,000.00 |
| 001 31165648207000 | TRANSPORT | 1,989.50 |
| 001 36245374100000 | TELEPHONE | 316.02 |
| 001 36245374300000 | UTILITIES | 92.50 |
| 001 36245375100000 | OFFICE SUPPLIES | 82.65 |
| 001 38265714100000 | TELEPHONE | 47.32 |
| 001 38265714400000 | LEASE EQUIPMENT | 38.44 |
| 001 38265715100000 | OFFICE SUPPLIES | 22.89 |
| 001 38265716600000 | BOOKS & LIBRARY MATERIALS | 1,360.63 |
| 001 38265716601000 | PUBLICATIONS & SUBSCRIPTIONS | 183.82 |
| 001 52425234100000 | COMMUNICATIONS | 120.88 |
| 001 52425234300000 | UTILITIES | 197.88 |
| 001 52425234400000 | RENTALS AND LEASES | 1,230.00 |
| 001 70735723400000 | CONTRACTED SERVICES | 106.00 |
| 001 70735724100000 | TELEPHONE | 30.16 |
| 001 70735725200000 | OPERATING SUPPLIES | 148.00 |
| 001 70745723400000 | CONTRACTED SERVICES | 56.00 |
| 001 70745724100000 | COMMUNICATIONS | 336.71 |
| 001 70745724600000 | REPAIR AND MAINTENANCE | 4,331.71 |
| 001 70745724601000 | MAINTENANCE CONTRACTS | 25.75 |
| 001 70745725100000 | OFFICE SUPPLIES | 43.31 |
| 001 70745725200000 | OPERATING SUPPLIES | 3,577.22 |
| 001 70745725201000 | GAS AND OIL | 633.57 |
| 001 70745726308000 | BOAT RAMP IMPROVEMENTS | 31.97 |
| 001 70815754010000 | GAS & OIL | 33.17 |
| 001 70815754100000 | COMMUNICATIONS | 546.39 |
| 001 70815754300000 | UTILITIES | 20.19 |
| 001 70815754600000 | REPAIR & MAINTENANCE | 1,267.95 |
| 001 70815754601000 | MAINTENANCE CONTRACTS | 1,835.34 |
| 001 70815754602000 | STORM WATER MODIFICATION EXP | 5,259.20 |
| 001 70815754804000 | AG-FEST EXPENSES | 2,425.00 |
| 001 70815754904000 | LICENSING | 294.00 |
| 001 70815755200000 | OPERATING SUPPLIES | 699.05 |
| 001 70815755203000 | CONCESSION SUPPLIES | 28.13 |
| 001 70835145100000 | OFFICE SUPPLIES | 99.52 |
| 001 71375134100000 | TELEPHONE | 204.32 |
| 001 71375134201000 | POSTAGE | 14.66 |
| 001 71375135100000 | OFFICE SUPPLIES | 1,390.96 |
| 001 71395133100000 | LABOR ATTORNEY FEES | 67.50 |
| 001 71395134100000 | TELEPHONE | 7.16 |
| 001 71405534100000 | TELEPHONE | 29.34 |
| 001 71495132300000 | HEALTH AND LIFE SUPPL BOCC | 1,360.86 |
| 001 71495132301000 | RETIREE HEALTH SUPPLEMENT | 1,503.40 |
| 001 71495139100000 | TAX COLLECTOR FEES | 11,248.54 |
| 001 71515628101000 | HEALTH DEPT RENTAL UNIT | 3,333.33 |
| | *** FUND TOTAL *** | 129,647.78 |

VENDOR SET: 01 Desoto County
 BANK: APBK POOLED CASH ACCOUNT
 DATE RANGE: 5/15/2013 THRU 5/29/2013

** G/L ACCOUNT TOTALS **

| G/L ACCOUNT | NAME | AMOUNT |
|--------------------|------------------------------|-----------|
| 101 39005644300000 | HOME ENERGY ASSISTANCE | 11,050.00 |
| 101 39005644310000 | CRISES BENEFIT PAYMENTS | 7,189.46 |
| | *** FUND TOTAL *** | 18,239.46 |
| 102 60505414100000 | COMMUNICATIONS | 484.77 |
| 102 60505414400000 | LEASE EQUIPMENT | 13,442.01 |
| 102 60505414600000 | REPAIR & MAINTENANCE | 7,201.71 |
| 102 60505414601000 | MAINT. AGREEMENTS | 469.50 |
| 102 60505414602000 | BLDG/COMPOUND MAINT. | 48.87 |
| 102 60505415100000 | OFFICE SUPPLIES | 83.68 |
| 102 60505415201000 | GASOLINE & OIL-DEPARTMENTAL | 8,517.18 |
| 102 60505415203000 | UNIFORMS | 456.70 |
| 102 60505415205000 | DEPARTMENT SUPPLIES | 1,365.40 |
| 102 60505415301000 | ROAD & BRIDGE MATERIALS | 2,124.09 |
| 102 60505415302000 | TRAFFIC CONTROL DEVICES | 70.24 |
| | *** FUND TOTAL *** | 34,264.15 |
| 104 30205413100000 | PROFESSIONAL SERVICES | 3,166.70 |
| 104 30205414100000 | TELEPHONE | 65.27 |
| 104 30205414601000 | MAINTENANCE AGREEMENTS | 84.09 |
| 104 30205415201000 | GAS AND OIL | 141.67 |
| 104 605454163000RR | RR XING REPAIR | 1,431.25 |
| 104 60555413190602 | SCOP BRIDGE 40010 CEI | 1,019.75 |
| 104 60555413190605 | SCOP BRIDGE 40026 CEI | 4,889.12 |
| 104 60555413190608 | SCOP BRIDGE 400005 CEI | 3,572.75 |
| 104 60555416300113 | SCOP-JPA NOTTS DAIRY | 1,200.00 |
| 104 60555416300951 | SCOP 40004 GUARDRAIL DESIGN | 707.10 |
| 104 60555416310099 | SCOP 40025 GR DESIGN | 1,215.20 |
| 104 60555416310100 | SCOP 400005 BRIDGE GR DESIGN | 3,532.55 |
| | *** FUND TOTAL *** | 21,025.45 |
| 106 70715294100000 | TELEPHONE | 2,053.04 |
| 106 70715294300000 | UTILITIES | 458.20 |
| 106 70715294400000 | RENTALS AND LEASES | 505.00 |
| 106 70715294600000 | MAINTENANCE AGREEMENTS | 6,750.00 |
| 106 70715294601000 | REPAIR AND MAINTENANCE | 39.75 |
| 106 70715294602000 | BUILDING MAINTENANCE | 190.00 |
| 106 70715294603000 | COMMUNICATION MAINT. | 20.00 |
| 106 70715295100000 | OFFICE SUPPLIES | 96.55 |
| 106 70715295201000 | GAS & OIL-GENERAL USE | 889.18 |
| 106 70715295203000 | UNIFORMS | 83.45 |
| 106 70715295500000 | TRAINING | 900.00 |
| 106 70715297100000 | PROPERTY PRINCIPAL PMT | 1,445.71 |
| 106 70725224600000 | REPAIRS & MAINTENANCE | 2,059.70 |
| 106 70725224901000 | MISCELLANEOUS CHGS | 15.93 |
| 106 70725225201000 | GASOLINE & OIL | 1,643.34 |

VENDOR SET: 01 Desoto County

BANK: APBK POOLED CASH ACCOUNT

DATE RANGE: 5/15/2013 THRU 5/29/2013

** G/L ACCOUNT TOTALS **

| G/L ACCOUNT | NAME | AMOUNT |
|--------------------|--------------------------------|-----------|
| 106 70725225203000 | UNIFORMS--BUNKER GEAR | 858.00 |
| 106 70725225206000 | FIRE SUPPLIES | 155.00 |
| 106 70725225500000 | TRAINING | 120.00 |
| 106 70735139109000 | TAX COLLECTOR FEES | 292.48 |
| 106 70735263403000 | MORGUE TRANSPORT | 300.00 |
| 106 70735264600000 | REPAIRS & MAINTENANCE | 263.71 |
| 106 70735264601000 | MAINTENANCE AGREEMENTS | 4,212.58 |
| 106 70735265201000 | GASOLINE & OIL | 318.34 |
| 106 70735265205000 | DRUGS & MEDICAL SUPPLIES | 3,181.18 |
| 106 70735265207000 | EMS SUPPLIES | 521.09 |
| 106 71315254100000 | TELEPHONE | 345.73 |
| 106 71315254400000 | RENTALS AND LEASES | 41.88 |
| 106 71315255100000 | OFFICE/OPERATING SUPPLIES | 38.48 |
| 106 71315255201000 | GASOLINE & OIL | 68.29 |
| 106 71315256800000 | SOFTWARE | 14,019.00 |
| 106 71335256800000 | SOFTWARE | 9,978.90 |
| | *** FUND TOTAL *** | 51,864.51 |
| 133 71425264100000 | UTILITIES/TELEPHONE | 219.38 |
| 133 71425264901000 | MISCELLANEOUS CHARGES | 21.41 |
| | *** FUND TOTAL *** | 240.79 |
| 150 20105524700000 | PRINTING AND BINDING | 3,954.50 |
| 150 20105524800000 | PROMOTIONAL ACTIVITIES | 242.00 |
| | *** FUND TOTAL *** | 4,196.50 |
| 170 30165544600000 | HOUSING/REHAB | 96,000.00 |
| | *** FUND TOTAL *** | 96,000.00 |
| 190 23066044100000 | TELEPHONE/COMMUNICATIONS | 97.32 |
| 190 24076024100000 | TELEPHONE/COMMUNICATIONS | 42.11 |
| 190 24086033400000 | CONTRACTED SERVICES | 458.30 |
| 190 24086034100000 | TELEPHONE/COMMUNICATIONS | 1,981.11 |
| 190 24096014100000 | TELEPHONE/COMMUNICATIONS | 223.84 |
| 190 24096014600000 | REPAIRS AND MAINTENANCE | 105.00 |
| 190 24106894900415 | TEEN COURT EXPENSE | 910.75 |
| 190 24107146600415 | LAW LIBRARY EXPENSES | 506.93 |
| 190 24116854400000 | RENTALS AND LEASES | 850.00 |
| | *** FUND TOTAL *** | 5,175.36 |
| 400 42305343400931 | CONTRACTED SERVICES - HAZ WAST | 299.10 |
| 400 42305344100000 | TELEPHONE | 319.45 |
| 400 42305344400000 | LEASE EQUIPMENT | 6,966.60 |
| 400 42305344600000 | REPAIR & MAINTENANCE | 681.20 |
| 400 42305345201000 | GASOLINE & OIL | 774.76 |
| 400 42305345202000 | OPERATING SUPPLIES/MATERIALS | 3.88 |

VENDOR SET: 01 Desoto County

BANK: APBK POOLED CASH ACCOUNT

DATE RANGE: 5/15/2013 THRU 5/29/2013

** G/L ACCOUNT TOTALS **

| G/L ACCOUNT | NAME | AMOUNT |
|--------------------|------------------------------|-----------|
| 400 42305345203000 | UNIFORMS | 76.80 |
| 400 42305345300000 | LANDFILL MATERIALS/MISC IMPR | 1,080.00 |
| 400 42305346304000 | COVER MAT/SITE IMPROVEMENT | 30.79 |
| | *** FUND TOTAL *** | 10,232.58 |
| 409 70875364600000 | REPAIRS AND MAINTENANCE | 9,714.80 |
| 409 70875365201000 | GAS AND OIL | 470.15 |
| 409 70875365203000 | CHEMICALS & SUPPLIES | 357.50 |
| | *** FUND TOTAL *** | 10,542.45 |
| 410 70945363100000 | PROFESSIONAL SERVICES | 20,567.25 |
| 410 70945364100000 | TELEPHONE | 843.69 |
| 410 70945364300000 | UTILITIES | 92.50 |
| 410 70945364400000 | RENTALS AND LEASES | 184.48 |
| 410 70945364600000 | REPAIR AND MAINTENANCE | 1,776.50 |
| 410 70945364901000 | MISC EXPENSES | 7.50 |
| 410 70945365100000 | OFFICE SUPPLIES | 97.12 |
| 410 70945365201000 | GASOLINE & OIL | 117.48 |
| 410 70955363404000 | SUNSHINE ONE CALL | 59.79 |
| 410 70955364100000 | TELEPHONE | 52.83 |
| 410 70955365200000 | UNIFORMS | 11.55 |
| 410 70955365201000 | GASOLINE & OIL | 499.17 |
| 410 70955365202000 | TOOLS | 1,215.79 |
| 410 70955365207000 | SAFETY | 29.99 |
| 410 70965333104000 | PROFESSIONAL SERVICES HWY 17 | 177.50 |
| 410 70965334100000 | TELEPHONE | 486.90 |
| 410 70965334301000 | PRMRWSA VARIABLE USAGE | 13,418.00 |
| 410 70965334302000 | PRMRWSA BASE USAGE | 41,256.00 |
| 410 70965334600000 | GENERAL REPAIR & MAINTENANCE | 603.34 |
| 410 70965334601000 | VEHICLE REPAIR & MAINTENANCE | 369.10 |
| 410 70965334901000 | OTHER CHARGES | 7.50 |
| 410 70965335200000 | UNIFORMS | 23.10 |
| 410 70965335201000 | GASOLINE & OIL | 2,697.62 |
| 410 70975353100000 | PROFESSIONAL SERVICES | 1,498.20 |
| 410 70975353104000 | PROFESSIONAL SERVICES HWY 17 | 177.50 |
| 410 70975353400000 | CONTRACTED SERVICES | 957.28 |
| 410 70975354100000 | TELEPHONE | 374.44 |
| 410 70975354400000 | RENTALS & LEASES | 163.00 |
| 410 70975354600000 | GENERAL REPAIR & MAINTENANCE | 3,031.16 |
| 410 70975354601000 | VEHICLE REPAIR & MAINTENANCE | 861.75 |
| 410 70975354901000 | OTHER CHARGES | 22.50 |
| 410 70975355200000 | UNIFORMS | 57.75 |
| 410 70975355201000 | GASOLINE & OIL | 2,673.72 |
| 410 70975355202000 | MINOR EQUIPMENT | 78.21 |
| 410 70975355203000 | CHEMICALS & SUPPLIES | 272.00 |
| | *** FUND TOTAL *** | 94,762.21 |

VENDOR SET: 01 Desoto County

BANK: APBK POOLED CASH ACCOUNT

DATE RANGE: 5/15/2013 THRU 5/29/2013

** G/L ACCOUNT TOTALS **

| G/L ACCOUNT | NAME | AMOUNT |
|--------------------|-----------|--------|
| 415 30255244100000 | TELEPHONE | 201.10 |
| 415 30255244300000 | UTILITIES | 63.86 |
| *** FUND TOTAL *** | | 264.96 |

| | | | | | | |
|----------------|------------|---------|-----|--------------|------|------------|
| VENDOR SET: 01 | BANK: APBK | TOTALS: | 272 | 480,440.78CR | 0.00 | 476,456.20 |
|----------------|------------|---------|-----|--------------|------|------------|

| | | | | | |
|------------|---------|-----|--------------|------|------------|
| BANK: APBK | TOTALS: | 272 | 480,440.78CR | 0.00 | 476,456.20 |
|------------|---------|-----|--------------|------|------------|

VENDOR SET: 01 Desoto County
 BANK: PYBK CONSOLIDATED ACCOUNT
 DATE RANGE: 5/15/2013 THRU 5/29/2013

| VENDOR I.D. | NAME | STATUS | CHECK DATE | AMOUNT | DISCOUNT | CHECK NO | CHECK STATUS | CHECK AMOUNT |
|--------------------|-------------------------------|----------|-------------|----------|----------|----------|--------------|--------------|
| 4215 | UNITED HEALTH CARE | | | | | | | |
| I-201305152522 | MAY 2013 HEALTH&LIFE BILL ADJ | D | 5/15/2013 | | | 051513 | | |
| 001 00002183000000 | DEPENDENT HEALTH | MAY 2013 | HEALTH&LIFE | 0.37CR | | | | |
| 001 26015122300000 | EMPLOYEE INSURANCE | MAY 2013 | HEALTH&LIFE | 0.13 | | | | |
| 001 26015122310000 | SUBSIDIZED DEP HEALTH INS | MAY 2013 | HEALTH&LIFE | 0.04CR | | | | |
| 001 26015122320000 | SUBSIDIZED RETIREE INSURANCE | MAY 2013 | HEALTH&LIFE | 3,167.96 | | | | |
| 001 26035152300000 | EMPLOYEE INSURANCE | MAY 2013 | HEALTH&LIFE | 0.02 | | | | |
| 001 26035152310000 | SUBSIDIZED DEP HEALTH INS | MAY 2013 | HEALTH&LIFE | 0.02CR | | | | |
| 001 26085192300000 | EMPLOYEE INSURANCE | MAY 2013 | HEALTH&LIFE | 0.12 | | | | |
| 001 26085192310000 | SUBSIDIZED DEP HEALTH INS | MAY 2013 | HEALTH&LIFE | 0.02CR | | | | |
| 001 26097122300000 | EMPLOYEE INSURANCE | MAY 2013 | HEALTH&LIFE | 0.02 | | | | |
| 001 30155152300000 | EMPLOYEE INSURANCE | MAY 2013 | HEALTH&LIFE | 0.04 | | | | |
| 001 30155152310000 | DEPENDENT HEALTH SUBSIDY | MAY 2013 | HEALTH&LIFE | 0.01CR | | | | |
| 001 30175162300000 | EMPLOYEE INSURANCE | MAY 2013 | HEALTH&LIFE | 0.02 | | | | |
| 001 30175162310000 | DEPENDENT HEALTH SUBSIDY | MAY 2013 | HEALTH&LIFE | 0.02CR | | | | |
| 001 30185242300000 | EMPLOYEE INSURANCE | MAY 2013 | HEALTH&LIFE | 0.04 | | | | |
| 001 30185242310000 | SUBSIDIZED DEP HEALTH INS | MAY 2013 | HEALTH&LIFE | 0.01CR | | | | |
| 001 30195622300000 | EMPLOYEE INSURANCE | MAY 2013 | HEALTH&LIFE | 0.08 | | | | |
| 001 31165642300000 | EMPLOYEE INSURANCE | MAY 2013 | HEALTH&LIFE | 166.95CR | | | | |
| 001 31165642310000 | SUBSIDIZED DEP HEALTH INS | MAY 2013 | HEALTH&LIFE | 0.01CR | | | | |
| 001 36245372300000 | EMPLOYEE INSURANCE | MAY 2013 | HEALTH&LIFE | 500.89CR | | | | |
| 001 36245372310000 | SUBSIDIZED DEP HEALTH INS | MAY 2013 | HEALTH&LIFE | 0.01CR | | | | |
| 001 38265712300000 | EMPLOYEE INSURANCE | MAY 2013 | HEALTH&LIFE | 0.10 | | | | |
| 001 38265712310000 | SUBSIDIZED DEP HEALTH INS | MAY 2013 | HEALTH&LIFE | 0.02CR | | | | |
| 001 52425232300000 | EMPLOYEE INSURANCE | MAY 2013 | HEALTH&LIFE | 0.06 | | | | |
| 001 52425232310000 | SUBSIDIZED DEP HEALTH INS | MAY 2013 | HEALTH&LIFE | 0.02CR | | | | |
| 001 52425232320000 | SUBSIDIZED RETIREE HEALTH | MAY 2013 | HEALTH&LIFE | 1,164.26 | | | | |
| 001 70735722300000 | HEALTH AND LIFE INS | MAY 2013 | HEALTH&LIFE | 0.04 | | | | |
| 001 70735722310000 | SUBSIDIZED DEP. HEALTH | MAY 2013 | HEALTH&LIFE | 0.02CR | | | | |
| 001 70745722300000 | EMPLOYEE INSURANCE | MAY 2013 | HEALTH&LIFE | 8.23CR | | | | |
| 001 70745722310000 | SUBSIDIZED DEP HEALTH INS | MAY 2013 | HEALTH&LIFE | 3.24CR | | | | |
| 001 70815752300000 | HEALTH & LIFE INSURANCE | MAY 2013 | HEALTH&LIFE | 0.06 | | | | |
| 001 70815752310000 | DEPENDENT HEALTH INS SUBSIDY | MAY 2013 | HEALTH&LIFE | 0.01CR | | | | |
| 001 71375132300000 | EMPLOYEE INSURANCE | MAY 2013 | HEALTH&LIFE | 175.48 | | | | |
| 001 71375132310000 | SUBSIDIZED DEP HEALTH INS | MAY 2013 | HEALTH&LIFE | 3.18 | | | | |
| 001 71395132300000 | EMPLOYEE INSURANCE | MAY 2013 | HEALTH&LIFE | 0.02 | | | | |
| 001 71405532300000 | HEALTH & LIFE INSURANCE | MAY 2013 | HEALTH&LIFE | 0.02 | | | | |
| 001 71405532310000 | SUBSIDIZED DEP HEALTH INS | MAY 2013 | HEALTH&LIFE | 0.01CR | | | | |
| 102 60505412300000 | EMPLOYEE INSURANCE | MAY 2013 | HEALTH&LIFE | 0.68 | | | | |
| 102 60505412310000 | SUBSIDIZED DEP HEALTH INS | MAY 2013 | HEALTH&LIFE | 0.08CR | | | | |
| 102 60505412320000 | SUBSIDIZED RETIREE INSURANCE | MAY 2013 | HEALTH&LIFE | 1,832.16 | | | | |
| 102 00002183000000 | DEPENDENT HEALTH | MAY 2013 | HEALTH&LIFE | 0.11CR | | | | |
| 104 30205412300000 | EMPLOYEE INSURANCE | MAY 2013 | HEALTH&LIFE | 0.06 | | | | |
| 104 30205412310000 | DEPENDENT HEALTH SUBSIDY | MAY 2013 | HEALTH&LIFE | 0.04CR | | | | |
| 104 00002183000000 | DEPENDENT HEALTH | MAY 2013 | HEALTH&LIFE | 0.06CR | | | | |
| 106 70715292300000 | HEALTH INSURANCE | MAY 2013 | HEALTH&LIFE | 6.46CR | | | | |
| 106 70715292310000 | DEPENDENT HEALTH SUBSIDY | MAY 2013 | HEALTH&LIFE | 3.47CR | | | | |
| 106 71315252300000 | EMPLOYEE INSURANCE | MAY 2013 | HEALTH&LIFE | 7.64 | | | | |

VENDOR SET: 01 Desoto County
 BANK: PYBK CONSOLIDATED ACCOUNT
 DATE RANGE: 5/15/2013 THRU 5/29/2013

| VENDOR I.D. | NAME | STATUS | CHECK DATE | AMOUNT | DISCOUNT | CHECK NO | CHECK STATUS | CHECK AMOUNT |
|--------------------|--------------------------------|----------------------|---------------|------------|----------|-------------|-----------------|-----------------|
| 4215 | UNITED HEALTH CARE CONT | | | | | | | |
| I-201305152522 | MAY 2013 HEALTH&LIFE BILL ADJ | D | 5/15/2013 | | | 051513 | | |
| 106 71315252310000 | SUBSIDIZED DEP HEALTH INS | MAY 2013 | HEALTH&LIFE | 3.26 | | | | |
| 106 71335252300000 | EMPLOYEE INSURANCE | MAY 2013 | HEALTH&LIFE | 0.04 | | | | |
| 106 71315252320000 | SUBSIDIZED RETIREE INSURANCE | MAY 2013 | HEALTH&LIFE | 667.90 | | | | |
| 106 00002183000000 | DEPENDENT HEALTH | MAY 2013 | HEALTH&LIFE | 0.29CR | | | | |
| 190 24096012300000 | HEALTH & LIFE INSURANCE | MAY 2013 | HEALTH&LIFE | 0.02 | | | | |
| 190 24096012310000 | DEPENDENT HEALTH SUBSIDY | MAY 2013 | HEALTH&LIFE | 0.01CR | | | | |
| 190 00002183000000 | DEPENDENT HEALTH | MAY 2013 | HEALTH&LIFE | 0.01CR | | | | |
| 400 00002183000000 | DEPENDENT HEALTH | MAY 2013 | HEALTH&LIFE | 0.02CR | | | | |
| 400 42305342300000 | EMPLOYEE INSURANCE | MAY 2013 | HEALTH&LIFE | 0.16 | | | | |
| 400 42305342310000 | SUBSIDIZED DEP HEALTH INS | MAY 2013 | HEALTH&LIFE | 0.02CR | | | | |
| 410 00002183000000 | DEPENDENT HEALTH | MAY 2013 | HEALTH&LIFE | 0.05CR | | | | |
| 410 70945362300000 | EMPLOYEE INSURANCE | MAY 2013 | HEALTH&LIFE | 0.06 | | | | |
| 410 70955362300000 | EMPLOYEE INSURANCE | MAY 2013 | HEALTH&LIFE | 667.92 | | | | |
| 410 70955362310000 | SUBSIDIZED DEP HEALTH INS | MAY 2013 | HEALTH&LIFE | 0.01CR | | | | |
| 410 70965332300000 | EMPLOYEE INSURANCE | MAY 2013 | HEALTH&LIFE | 0.06 | | | | |
| 410 70965332310000 | SUBSIDIZED DEP HEALTH INS | MAY 2013 | HEALTH&LIFE | 0.02CR | | | | |
| 410 70975352300000 | EMPLOYEE INSURANCE | MAY 2013 | HEALTH&LIFE | 0.10 | | | | |
| 410 70975352310000 | SUBSIDIZED DEP HEALTH INS | MAY 2013 | HEALTH&LIFE | 0.03CR | | | | |
| 415 00002183000000 | DEPENDENT HEALTH | MAY 2013 | HEALTH&LIFE | 0.01CR | | | | |
| 415 30255242300000 | EMPLOYEE INSURANCE | MAY 2013 | HEALTH&LIFE | 0.06 | | | | |
| 415 30255242310000 | SUBSIDIZED DEP HEALTH INS | MAY 2013 | HEALTH&LIF | 0.01CR | | | | |
| 001 00001332300000 | ACCTS REC - HEALTH INSURANCE | MAY 2013 | HEALTH&LIF | 129,792.59 | | | | |
| 001 71495132301000 | RETIREE HEALTH SUPPLEMENT | MAY 2013 | HEALTH&LIFE | 9,927.20 | | | | |
| I-UCA201304012312 | DEPENDENT CHILD HEALTH AF TAX | D | 5/15/2013 | | | 051513 | | |
| 410 00002183000000 | DEPENDENT HEALTH | DEPENDENT CHILD HEAL | | 64.54 | | | | |
| I-UCA201304092367 | DEPENDENT CHILD HEALTH AF TAX | D | 5/15/2013 | | | 051513 | | |
| 410 00002183000000 | DEPENDENT HEALTH | DEPENDENT CHILD HEAL | | 64.54 | | | | |
| I-UCA201304152400 | DEPENDENT CHILD HEALTH AF TAX | D | 5/15/2013 | | | 051513 | | |
| 410 00002183000000 | DEPENDENT HEALTH | DEPENDENT CHILD HEAL | | 64.54 | | | | |
| I-UCA201304232435 | DEPENDENT CHILD HEALTH AF TAX | D | 5/15/2013 | | | 051513 | | |
| 410 00002183000000 | DEPENDENT HEALTH | DEPENDENT CHILD HEAL | | 64.54 | | | | |
| I-UCB201304012312 | DEPENDENT CHILD HEALTH PRE TAX | D | 5/15/2013 | | | 051513 | | |
| 001 00002183000000 | DEPENDENT HEALTH | DEPENDENT CHILD HEAL | | 387.24 | | | | |
| 102 00002183000000 | DEPENDENT HEALTH | DEPENDENT CHILD HEAL | | 129.08 | | | | |
| 104 00002183000000 | DEPENDENT HEALTH | DEPENDENT CHILD HEAL | | 64.54 | | | | |
| 106 00002183000000 | DEPENDENT HEALTH | DEPENDENT CHILD HEAL | | 129.08 | | | | |
| I-UCB201304092367 | DEPENDENT CHILD HEALTH PRE TAX | D | 5/15/2013 | | | 051513 | | |
| 001 00002183000000 | DEPENDENT HEALTH | DEPENDENT CHILD HEAL | | 387.24 | | | | |
| 102 00002183000000 | DEPENDENT HEALTH | DEPENDENT CHILD HEAL | | 129.08 | | | | |
| 104 00002183000000 | DEPENDENT HEALTH | DEPENDENT CHILD HEAL | | 64.54 | | | | |
| 106 00002183000000 | DEPENDENT HEALTH | DEPENDENT CHILD HEAL | | 129.08 | | | | |
| I-UCB201304152400 | DEPENDENT CHILD HEALTH PRE TAX | D | 5/15/2013 | | | 051513 | | |
| 001 00002183000000 | DEPENDENT HEALTH | DEPENDENT CHILD HEAL | | 387.24 | | | | |
| 102 00002183000000 | DEPENDENT HEALTH | DEPENDENT CHILD HEAL | | 129.08 | | | | |
| 104 00002183000000 | DEPENDENT HEALTH | DEPENDENT CHILD HEAL | | 64.54 | | | | |
| 106 00002183000000 | DEPENDENT HEALTH | DEPENDENT CHILD HEAL | | 129.08 | | | | |
| I-UCB201304232435 | DEPENDENT CHILD HEALTH PRE TAX | D | 5/15/2013 | | | 051513 | | |

| VENDOR I.D. | NAME | STATUS | CHECK DATE | AMOUNT | DISCOUNT | CHECK NO | CHECK STATUS | CHECK AMOUNT |
|--------------------|--------------------------------|--------|----------------------|----------|----------|----------|--------------|--------------|
| 4215 | UNITED HEALTH CARE CONT | | | | | | | |
| I-UCB201304232435 | DEPENDENT CHILD HEALTH PRE TAX | D | 5/15/2013 | | | 051513 | | |
| 001 00002183000000 | DEPENDENT HEALTH | | DEPENDENT CHILD HEAL | 387.24 | | | | |
| 102 00002183000000 | DEPENDENT HEALTH | | DEPENDENT CHILD HEAL | 129.08 | | | | |
| 104 00002183000000 | DEPENDENT HEALTH | | DEPENDENT CHILD HEAL | 64.54 | | | | |
| 106 00002183000000 | DEPENDENT HEALTH | | DEPENDENT CHILD HEAL | 129.08 | | | | |
| I-UDC201304012312 | SUBSIDIZED DEP HEALTH INS | D | 5/15/2013 | | | 051513 | | |
| 001 26015122310000 | SUBSIDIZED DEP HEALTH INS | | SUBSIDIZED DEP HEALT | 182.22 | | | | |
| 001 26035152310000 | SUBSIDIZED DEP HEALTH INS | | SUBSIDIZED DEP HEALT | 104.87 | | | | |
| 001 26085192310000 | SUBSIDIZED DEP HEALTH INS | | SUBSIDIZED DEP HEALT | 170.82 | | | | |
| 001 30155152310000 | DEPENDENT HEALTH SUBSIDY | | SUBSIDIZED DEP HEALT | 85.41 | | | | |
| 001 30175162310000 | DEPENDENT HEALTH SUBSIDY | | SUBSIDIZED DEP HEALT | 64.54 | | | | |
| 001 30185242310000 | SUBSIDIZED DEP HEALTH INS | | SUBSIDIZED DEP HEALT | 85.41 | | | | |
| 001 31165642310000 | SUBSIDIZED DEP HEALTH INS | | SUBSIDIZED DEP HEALT | 71.30 | | | | |
| 001 36245372310000 | SUBSIDIZED DEP HEALTH INS | | SUBSIDIZED DEP HEALT | 85.41 | | | | |
| 001 38265712310000 | SUBSIDIZED DEP HEALTH INS | | SUBSIDIZED DEP HEALT | 156.71 | | | | |
| 001 52425232310000 | SUBSIDIZED DEP HEALTH INS | | SUBSIDIZED DEP HEALT | 64.54 | | | | |
| 001 70735722310000 | SUBSIDIZED DEP. HEALTH | | SUBSIDIZED DEP HEALT | 64.54 | | | | |
| 001 70745722310000 | SUBSIDIZED DEP HEALTH INS | | SUBSIDIZED DEP HEALT | 71.30 | | | | |
| 001 70815752310000 | DEPENDENT HEALTH INS SUBSIDY | | SUBSIDIZED DEP HEALT | 71.30 | | | | |
| 001 71375132310000 | SUBSIDIZED DEP HEALTH INS | | SUBSIDIZED DEP HEALT | 292.55 | | | | |
| 001 71405532310000 | SUBSIDIZED DEP HEALTH INS | | SUBSIDIZED DEP HEALT | 71.30 | | | | |
| 102 60505412310000 | SUBSIDIZED DEP HEALTH INS | | SUBSIDIZED DEP HEALT | 456.61 | | | | |
| 104 30205412310000 | DEPENDENT HEALTH SUBSIDY | | SUBSIDIZED DEP HEALT | 235.36 | | | | |
| 106 70715292310000 | DEPENDENT HEALTH SUBSIDY | | SUBSIDIZED DEP HEALT | 1,561.12 | | | | |
| 106 71315252310000 | SUBSIDIZED DEP HEALTH INS | | SUBSIDIZED DEP HEALT | 34.79 | | | | |
| 150 20105522310000 | DEPENDENT HEALTH SUBSIDY | | SUBSIDIZED DEP HEALT | 12.81 | | | | |
| 400 42305342310000 | SUBSIDIZED DEP HEALTH INS | | SUBSIDIZED DEP HEALT | 71.30 | | | | |
| 410 70955362310000 | SUBSIDIZED DEP HEALTH INS | | SUBSIDIZED DEP HEALT | 71.30 | | | | |
| 410 70965332310000 | SUBSIDIZED DEP HEALTH INS | | SUBSIDIZED DEP HEALT | 170.82 | | | | |
| 410 70975352310000 | SUBSIDIZED DEP HEALTH INS | | SUBSIDIZED DEP HEALT | 135.84 | | | | |
| 415 30255242310000 | SUBSIDIZED DEP HEALTH INS | | SUBSIDIZED DEP HEALT | 71.30 | | | | |
| I-UDC201304092367 | SUBSIDIZED DEP HEALTH INS | D | 5/15/2013 | | | 051513 | | |
| 001 26015122310000 | SUBSIDIZED DEP HEALTH INS | | SUBSIDIZED DEP HEALT | 182.22 | | | | |
| 001 26035152310000 | SUBSIDIZED DEP HEALTH INS | | SUBSIDIZED DEP HEALT | 104.87 | | | | |
| 001 26085192310000 | SUBSIDIZED DEP HEALTH INS | | SUBSIDIZED DEP HEALT | 170.82 | | | | |
| 001 30155152310000 | DEPENDENT HEALTH SUBSIDY | | SUBSIDIZED DEP HEALT | 85.41 | | | | |
| 001 30175162310000 | DEPENDENT HEALTH SUBSIDY | | SUBSIDIZED DEP HEALT | 64.54 | | | | |
| 001 30185242310000 | SUBSIDIZED DEP HEALTH INS | | SUBSIDIZED DEP HEALT | 85.41 | | | | |
| 001 31165642310000 | SUBSIDIZED DEP HEALTH INS | | SUBSIDIZED DEP HEALT | 71.30 | | | | |
| 001 36245372310000 | SUBSIDIZED DEP HEALTH INS | | SUBSIDIZED DEP HEALT | 85.41 | | | | |
| 001 38265712310000 | SUBSIDIZED DEP HEALTH INS | | SUBSIDIZED DEP HEALT | 156.71 | | | | |
| 001 52425232310000 | SUBSIDIZED DEP HEALTH INS | | SUBSIDIZED DEP HEALT | 64.54 | | | | |
| 001 70735722310000 | SUBSIDIZED DEP. HEALTH | | SUBSIDIZED DEP HEALT | 64.54 | | | | |
| 001 70745722310000 | SUBSIDIZED DEP HEALTH INS | | SUBSIDIZED DEP HEALT | 71.30 | | | | |
| 001 70815752310000 | DEPENDENT HEALTH INS SUBSIDY | | SUBSIDIZED DEP HEALT | 71.30 | | | | |
| 001 71375132310000 | SUBSIDIZED DEP HEALTH INS | | SUBSIDIZED DEP HEALT | 292.55 | | | | |
| 001 71405532310000 | SUBSIDIZED DEP HEALTH INS | | SUBSIDIZED DEP HEALT | 71.30 | | | | |

VENDOR SET: 01 Desoto County
 BANK: PYBK CONSOLIDATED ACCOUNT
 DATE RANGE: 5/15/2013 THRU 5/29/2013

| VENDOR I.D. | NAME | STATUS | CHECK DATE | AMOUNT | DISCOUNT | CHECK NO | CHECK STATUS | CHECK AMOUNT |
|--------------------|------------------------------|------------|------------|----------|----------|----------|--------------|--------------|
| 4215 | UNITED HEALTH CARE CONT | | | | | | | |
| I-UDC201304092367 | SUBSIDIZED DEP HEALTH INS | D | 5/15/2013 | | | 051513 | | |
| 102 60505412310000 | SUBSIDIZED DEP HEALTH INS | SUBSIDIZED | DEP HEALT | 456.61 | | | | |
| 104 30205412310000 | DEPENDENT HEALTH SUBSIDY | SUBSIDIZED | DEP HEALT | 235.36 | | | | |
| 106 70715292310000 | DEPENDENT HEALTH SUBSIDY | SUBSIDIZED | DEP HEALT | 1,561.06 | | | | |
| 106 71315252310000 | SUBSIDIZED DEP HEALTH INS | SUBSIDIZED | DEP HEALT | 34.85 | | | | |
| 150 20105522310000 | DEPENDENT HEALTH SUBSIDY | SUBSIDIZED | DEP HEALT | 12.81 | | | | |
| 400 42305342310000 | SUBSIDIZED DEP HEALTH INS | SUBSIDIZED | DEP HEALT | 213.90 | | | | |
| 410 70955362310000 | SUBSIDIZED DEP HEALTH INS | SUBSIDIZED | DEP HEALT | 71.30 | | | | |
| 410 70965332310000 | SUBSIDIZED DEP HEALTH INS | SUBSIDIZED | DEP HEALT | 170.82 | | | | |
| 410 70975352310000 | SUBSIDIZED DEP HEALTH INS | SUBSIDIZED | DEP HEALT | 135.84 | | | | |
| 415 30255242310000 | SUBSIDIZED DEP HEALTH INS | SUBSIDIZED | DEP HEALT | 71.30 | | | | |
| I-UDC201304152400 | SUBSIDIZED DEP HEALTH INS | D | 5/15/2013 | | | 051513 | | |
| 001 26015122310000 | SUBSIDIZED DEP HEALTH INS | SUBSIDIZED | DEP HEALT | 182.22 | | | | |
| 001 26035152310000 | SUBSIDIZED DEP HEALTH INS | SUBSIDIZED | DEP HEALT | 104.87 | | | | |
| 001 26085192310000 | SUBSIDIZED DEP HEALTH INS | SUBSIDIZED | DEP HEALT | 170.82 | | | | |
| 001 30155152310000 | DEPENDENT HEALTH SUBSIDY | SUBSIDIZED | DEP HEALT | 85.41 | | | | |
| 001 30175162310000 | DEPENDENT HEALTH SUBSIDY | SUBSIDIZED | DEP HEALT | 64.54 | | | | |
| 001 30185242310000 | SUBSIDIZED DEP HEALTH INS | SUBSIDIZED | DEP HEALT | 85.41 | | | | |
| 001 31165642310000 | SUBSIDIZED DEP HEALTH INS | SUBSIDIZED | DEP HEALT | 71.30 | | | | |
| 001 36245372310000 | SUBSIDIZED DEP HEALTH INS | SUBSIDIZED | DEP HEALT | 85.41 | | | | |
| 001 38265712310000 | SUBSIDIZED DEP HEALTH INS | SUBSIDIZED | DEP HEALT | 156.71 | | | | |
| 001 52425232310000 | SUBSIDIZED DEP HEALTH INS | SUBSIDIZED | DEP HEALT | 64.54 | | | | |
| 001 70735722310000 | SUBSIDIZED DEP. HEALTH | SUBSIDIZED | DEP HEALT | 64.54 | | | | |
| 001 70745722310000 | SUBSIDIZED DEP HEALTH INS | SUBSIDIZED | DEP HEALT | 71.30 | | | | |
| 001 70815752310000 | DEPENDENT HEALTH INS SUBSIDY | SUBSIDIZED | DEP HEALT | 71.30 | | | | |
| 001 71375132310000 | SUBSIDIZED DEP HEALTH INS | SUBSIDIZED | DEP HEALT | 292.55 | | | | |
| 001 71405532310000 | SUBSIDIZED DEP HEALTH INS | SUBSIDIZED | DEP HEALT | 71.30 | | | | |
| 102 60505412310000 | SUBSIDIZED DEP HEALTH INS | SUBSIDIZED | DEP HEALT | 456.61 | | | | |
| 104 30205412310000 | DEPENDENT HEALTH SUBSIDY | SUBSIDIZED | DEP HEALT | 235.36 | | | | |
| 106 70715292310000 | DEPENDENT HEALTH SUBSIDY | SUBSIDIZED | DEP HEALT | 1,561.06 | | | | |
| 106 71315252310000 | SUBSIDIZED DEP HEALTH INS | SUBSIDIZED | DEP HEALT | 34.85 | | | | |
| 150 20105522310000 | DEPENDENT HEALTH SUBSIDY | SUBSIDIZED | DEP HEALT | 12.81 | | | | |
| 400 42305342310000 | SUBSIDIZED DEP HEALTH INS | SUBSIDIZED | DEP HEALT | 142.60 | | | | |
| 410 70955362310000 | SUBSIDIZED DEP HEALTH INS | SUBSIDIZED | DEP HEALT | 71.30 | | | | |
| 410 70965332310000 | SUBSIDIZED DEP HEALTH INS | SUBSIDIZED | DEP HEALT | 170.82 | | | | |
| 410 70975352310000 | SUBSIDIZED DEP HEALTH INS | SUBSIDIZED | DEP HEALT | 135.84 | | | | |
| 415 30255242310000 | SUBSIDIZED DEP HEALTH INS | SUBSIDIZED | DEP HEALT | 71.30 | | | | |
| I-UDC201304232435 | SUBSIDIZED DEP HEALTH INS | D | 5/15/2013 | | | 051513 | | |
| 001 26015122310000 | SUBSIDIZED DEP HEALTH INS | SUBSIDIZED | DEP HEALT | 182.22 | | | | |
| 001 26035152310000 | SUBSIDIZED DEP HEALTH INS | SUBSIDIZED | DEP HEALT | 104.87 | | | | |
| 001 26085192310000 | SUBSIDIZED DEP HEALTH INS | SUBSIDIZED | DEP HEALT | 170.82 | | | | |
| 001 30155152310000 | DEPENDENT HEALTH SUBSIDY | SUBSIDIZED | DEP HEALT | 85.41 | | | | |
| 001 30175162310000 | DEPENDENT HEALTH SUBSIDY | SUBSIDIZED | DEP HEALT | 64.54 | | | | |
| 001 30185242310000 | SUBSIDIZED DEP HEALTH INS | SUBSIDIZED | DEP HEALT | 85.41 | | | | |
| 001 31165642310000 | SUBSIDIZED DEP HEALTH INS | SUBSIDIZED | DEP HEALT | 71.30 | | | | |
| 001 36245372310000 | SUBSIDIZED DEP HEALTH INS | SUBSIDIZED | DEP HEALT | 85.41 | | | | |
| 001 38265712310000 | SUBSIDIZED DEP HEALTH INS | SUBSIDIZED | DEP HEALT | 156.71 | | | | |

VENDOR SET: 01 Desoto County
 BANK: PYBK CONSOLIDATED ACCOUNT
 DATE RANGE: 5/15/2013 THRU 5/29/2013

| VENDOR I.D. | NAME | STATUS | CHECK DATE | AMOUNT | DISCOUNT | CHECK NO | CHECK STATUS | CHECK AMOUNT |
|--------------------|------------------------------|--------|------------|-----------|----------|----------|--------------|--------------|
| 4215 | UNITED HEALTH CARE CONT | | | | | | | |
| I-UDC201304232435 | SUBSIDIZED DEP HEALTH INS | D | 5/15/2013 | | | 051513 | | |
| 001 52425232310000 | SUBSIDIZED DEP HEALTH INS | | | 64.54 | | | | |
| 001 70735722310000 | SUBSIDIZED DEP. HEALTH | | | 64.54 | | | | |
| 001 70745722310000 | SUBSIDIZED DEP HEALTH INS | | | 74.53 | | | | |
| 001 70815752310000 | DEPENDENT HEALTH INS SUBSIDY | | | 71.30 | | | | |
| 001 71375132310000 | SUBSIDIZED DEP HEALTH INS | | | 289.32 | | | | |
| 001 71405532310000 | SUBSIDIZED DEP HEALTH INS | | | 71.30 | | | | |
| 102 60505412310000 | SUBSIDIZED DEP HEALTH INS | | | 456.61 | | | | |
| 104 30205412310000 | DEPENDENT HEALTH SUBSIDY | | | 235.36 | | | | |
| 106 70715292310000 | DEPENDENT HEALTH SUBSIDY | | | 1,561.06 | | | | |
| 106 71315252310000 | SUBSIDIZED DEP HEALTH INS | | | 34.85 | | | | |
| 150 20105522310000 | DEPENDENT HEALTH SUBSIDY | | | 12.81 | | | | |
| 400 42305342310000 | SUBSIDIZED DEP HEALTH INS | | | 142.60 | | | | |
| 410 70955362310000 | SUBSIDIZED DEP HEALTH INS | | | 71.30 | | | | |
| 410 70965332310000 | SUBSIDIZED DEP HEALTH INS | | | 170.82 | | | | |
| 410 70975352310000 | SUBSIDIZED DEP HEALTH INS | | | 135.84 | | | | |
| 415 30255242310000 | SUBSIDIZED DEP HEALTH INS | | | 71.30 | | | | |
| I-UDD201304012312 | SUBSIDIZED DEP HEALTH INS | D | 5/15/2013 | | | 051513 | | |
| 190 24096012310000 | DEPENDENT HEALTH SUBSIDY | | | 71.30 | | | | |
| I-UDD201304092367 | SUBSIDIZED DEP HEALTH INS | D | 5/15/2013 | | | 051513 | | |
| 190 24096012310000 | DEPENDENT HEALTH SUBSIDY | | | 71.30 | | | | |
| I-UDD201304152400 | SUBSIDIZED DEP HEALTH INS | D | 5/15/2013 | | | 051513 | | |
| 190 24096012310000 | DEPENDENT HEALTH SUBSIDY | | | 71.30 | | | | |
| I-UDD201304232435 | SUBSIDIZED DEP HEALTH INS | D | 5/15/2013 | | | 051513 | | |
| 190 24096012310000 | DEPENDENT HEALTH SUBSIDY | | | 71.30 | | | | |
| I-UEE201304012312 | COUNTY PAID HEALTH INSURANCE | D | 5/15/2013 | | | 051513 | | |
| 001 26015122300000 | EMPLOYEE INSURANCE | | | 1,085.30 | | | | |
| 001 26035152300000 | EMPLOYEE INSURANCE | | | 225.41 | | | | |
| 001 26085192300000 | EMPLOYEE INSURANCE | | | 960.07 | | | | |
| 001 26097122300000 | EMPLOYEE INSURANCE | | | 208.72 | | | | |
| 001 30155152300000 | EMPLOYEE INSURANCE | | | 333.94 | | | | |
| 001 30175162300000 | EMPLOYEE INSURANCE | | | 166.97 | | | | |
| 001 30185242300000 | EMPLOYEE INSURANCE | | | 333.94 | | | | |
| 001 30195622300000 | EMPLOYEE INSURANCE | | | 667.88 | | | | |
| 001 31165642300000 | EMPLOYEE INSURANCE | | | 333.94 | | | | |
| 001 36245372300000 | EMPLOYEE INSURANCE | | | 500.91 | | | | |
| 001 38265712300000 | EMPLOYEE INSURANCE | | | 834.85 | | | | |
| 001 52425232300000 | EMPLOYEE INSURANCE | | | 500.91 | | | | |
| 001 70735722300000 | HEALTH AND LIFE INS | | | 333.94 | | | | |
| 001 70745722300000 | EMPLOYEE INSURANCE | | | 1,001.82 | | | | |
| 001 70815752300000 | HEALTH & LIFE INSURANCE | | | 500.91 | | | | |
| 001 71375132300000 | EMPLOYEE INSURANCE | | | 1,335.76 | | | | |
| 001 71395132300000 | EMPLOYEE INSURANCE | | | 166.97 | | | | |
| 001 71405532300000 | HEALTH & LIFE INSURANCE | | | 166.97 | | | | |
| 102 60505412300000 | EMPLOYEE INSURANCE | | | 5,676.98 | | | | |
| 104 30205412300000 | EMPLOYEE INSURANCE | | | 500.91 | | | | |
| 106 70715292300000 | HEALTH INSURANCE | | | 10,270.69 | | | | |

VENDOR SET: 01 Desoto County
 BANK: PYBK CONSOLIDATED ACCOUNT
 DATE RANGE: 5/15/2013 THRU 5/29/2013

| VENDOR I.D. | NAME | STATUS | CHECK DATE | AMOUNT | DISCOUNT | CHECK NO | CHECK STATUS | CHECK AMOUNT |
|--------------------|------------------------------|----------------------|---------------|----------|----------|-------------|-----------------|-----------------|
| 4215 | UNITED HEALTH CARE CONT | | | | | | | |
| I-UEE201304012312 | COUNTY PAID HEALTH INSURANCE | D | 5/15/2013 | | | 051513 | | |
| 106 71315252300000 | EMPLOYEE INSURANCE | COUNTY PAID HEALTH I | | 248.44 | | | | |
| 106 71335252300000 | EMPLOYEE INSURANCE | COUNTY PAID HEALTH I | | 333.94 | | | | |
| 150 20105522300000 | EMPLOYEE INSURANCE | COUNTY PAID HEALTH I | | 25.05 | | | | |
| 190 24096012300000 | HEALTH & LIFE INSURANCE | COUNTY PAID HEALTH I | | 166.97 | | | | |
| 400 42305342300000 | EMPLOYEE INSURANCE | COUNTY PAID HEALTH I | | 1,168.79 | | | | |
| 410 70945362300000 | EMPLOYEE INSURANCE | COUNTY PAID HEALTH I | | 333.94 | | | | |
| 410 70955362300000 | EMPLOYEE INSURANCE | COUNTY PAID HEALTH I | | 166.97 | | | | |
| 410 70965332300000 | EMPLOYEE INSURANCE | COUNTY PAID HEALTH I | | 500.91 | | | | |
| 410 70975352300000 | EMPLOYEE INSURANCE | COUNTY PAID HEALTH I | | 834.85 | | | | |
| 415 30255242300000 | EMPLOYEE INSURANCE | COUNTY PAID HEALTH I | | 500.91 | | | | |
| I-UEE201304092367 | COUNTY PAID HEALTH INSURANCE | D | 5/15/2013 | | | 051513 | | |
| 001 26015122300000 | EMPLOYEE INSURANCE | COUNTY PAID HEALTH I | | 1,085.31 | | | | |
| 001 26035152300000 | EMPLOYEE INSURANCE | COUNTY PAID HEALTH I | | 225.41 | | | | |
| 001 26085192300000 | EMPLOYEE INSURANCE | COUNTY PAID HEALTH I | | 960.08 | | | | |
| 001 26097122300000 | EMPLOYEE INSURANCE | COUNTY PAID HEALTH I | | 208.71 | | | | |
| 001 30155152300000 | EMPLOYEE INSURANCE | COUNTY PAID HEALTH I | | 333.94 | | | | |
| 001 30175162300000 | EMPLOYEE INSURANCE | COUNTY PAID HEALTH I | | 166.97 | | | | |
| 001 30185242300000 | EMPLOYEE INSURANCE | COUNTY PAID HEALTH I | | 333.94 | | | | |
| 001 30195622300000 | EMPLOYEE INSURANCE | COUNTY PAID HEALTH I | | 667.88 | | | | |
| 001 31165642300000 | EMPLOYEE INSURANCE | COUNTY PAID HEALTH I | | 166.97 | | | | |
| 001 36245372300000 | EMPLOYEE INSURANCE | COUNTY PAID HEALTH I | | 333.94 | | | | |
| 001 38265712300000 | EMPLOYEE INSURANCE | COUNTY PAID HEALTH I | | 834.85 | | | | |
| 001 52425232300000 | EMPLOYEE INSURANCE | COUNTY PAID HEALTH I | | 500.91 | | | | |
| 001 70735722300000 | HEALTH AND LIFE INS | COUNTY PAID HEALTH I | | 333.94 | | | | |
| 001 70745722300000 | EMPLOYEE INSURANCE | COUNTY PAID HEALTH I | | 1,001.82 | | | | |
| 001 70815752300000 | HEALTH & LIFE INSURANCE | COUNTY PAID HEALTH I | | 500.91 | | | | |
| 001 71375132300000 | EMPLOYEE INSURANCE | COUNTY PAID HEALTH I | | 1,502.73 | | | | |
| 001 71395132300000 | EMPLOYEE INSURANCE | COUNTY PAID HEALTH I | | 166.97 | | | | |
| 001 71405532300000 | HEALTH & LIFE INSURANCE | COUNTY PAID HEALTH I | | 166.97 | | | | |
| 102 60505412300000 | EMPLOYEE INSURANCE | COUNTY PAID HEALTH I | | 5,676.98 | | | | |
| 104 30205412300000 | EMPLOYEE INSURANCE | COUNTY PAID HEALTH I | | 500.91 | | | | |
| 106 70715292300000 | HEALTH INSURANCE | COUNTY PAID HEALTH I | | 9,602.64 | | | | |
| 106 71315252300000 | EMPLOYEE INSURANCE | COUNTY PAID HEALTH I | | 248.59 | | | | |
| 106 71335252300000 | EMPLOYEE INSURANCE | COUNTY PAID HEALTH I | | 333.94 | | | | |
| 150 20105522300000 | EMPLOYEE INSURANCE | COUNTY PAID HEALTH I | | 25.04 | | | | |
| 190 24096012300000 | HEALTH & LIFE INSURANCE | COUNTY PAID HEALTH I | | 166.97 | | | | |
| 400 42305342300000 | EMPLOYEE INSURANCE | COUNTY PAID HEALTH I | | 1,502.73 | | | | |
| 410 70945362300000 | EMPLOYEE INSURANCE | COUNTY PAID HEALTH I | | 667.88 | | | | |
| 410 70955362300000 | EMPLOYEE INSURANCE | COUNTY PAID HEALTH I | | 166.97 | | | | |
| 410 70965332300000 | EMPLOYEE INSURANCE | COUNTY PAID HEALTH I | | 500.91 | | | | |
| 410 70975352300000 | EMPLOYEE INSURANCE | COUNTY PAID HEALTH I | | 834.85 | | | | |
| 415 30255242300000 | EMPLOYEE INSURANCE | COUNTY PAID HEALTH I | | 500.91 | | | | |
| I-UEE201304152400 | COUNTY PAID HEALTH INSURANCE | D | 5/15/2013 | | | 051513 | | |
| 001 26015122300000 | EMPLOYEE INSURANCE | COUNTY PAID HEALTH I | | 1,085.31 | | | | |
| 001 26035152300000 | EMPLOYEE INSURANCE | COUNTY PAID HEALTH I | | 225.40 | | | | |
| 001 26085192300000 | EMPLOYEE INSURANCE | COUNTY PAID HEALTH I | | 960.08 | | | | |

VENDOR SET: 01 Desoto County
 BANK: PYBK CONSOLIDATED ACCOUNT
 DATE RANGE: 5/15/2013 THRU 5/29/2013

| VENDOR I.D. | NAME | STATUS | CHECK DATE | AMOUNT | DISCOUNT | CHECK NO | CHECK STATUS | CHECK AMOUNT |
|--------------------|------------------------------|----------------------|------------|----------|----------|----------|--------------|--------------|
| 4215 | UNITED HEALTH CARE | CONT | | | | | | |
| I-UEE201304152400 | COUNTY PAID HEALTH INSURANCE | D | 5/15/2013 | | | 051513 | | |
| 001 26097122300000 | EMPLOYEE INSURANCE | COUNTY PAID HEALTH I | | 208.71 | | | | |
| 001 30155152300000 | EMPLOYEE INSURANCE | COUNTY PAID HEALTH I | | 333.94 | | | | |
| 001 30175162300000 | EMPLOYEE INSURANCE | COUNTY PAID HEALTH I | | 166.97 | | | | |
| 001 30185242300000 | EMPLOYEE INSURANCE | COUNTY PAID HEALTH I | | 333.94 | | | | |
| 001 30195622300000 | EMPLOYEE INSURANCE | COUNTY PAID HEALTH I | | 667.88 | | | | |
| 001 31165642300000 | EMPLOYEE INSURANCE | COUNTY PAID HEALTH I | | 166.97 | | | | |
| 001 36245372300000 | EMPLOYEE INSURANCE | COUNTY PAID HEALTH I | | 166.97 | | | | |
| 001 38265712300000 | EMPLOYEE INSURANCE | COUNTY PAID HEALTH I | | 834.85 | | | | |
| 001 52425232300000 | EMPLOYEE INSURANCE | COUNTY PAID HEALTH I | | 500.91 | | | | |
| 001 70735722300000 | HEALTH AND LIFE INS | COUNTY PAID HEALTH I | | 333.94 | | | | |
| 001 70745722300000 | EMPLOYEE INSURANCE | COUNTY PAID HEALTH I | | 1,001.82 | | | | |
| 001 70815752300000 | HEALTH & LIFE INSURANCE | COUNTY PAID HEALTH I | | 500.91 | | | | |
| 001 71375132300000 | EMPLOYEE INSURANCE | COUNTY PAID HEALTH I | | 1,502.73 | | | | |
| 001 71395132300000 | EMPLOYEE INSURANCE | COUNTY PAID HEALTH I | | 166.97 | | | | |
| 001 71405532300000 | HEALTH & LIFE INSURANCE | COUNTY PAID HEALTH I | | 166.97 | | | | |
| 102 60505412300000 | EMPLOYEE INSURANCE | COUNTY PAID HEALTH I | | 5,676.98 | | | | |
| 104 30205412300000 | EMPLOYEE INSURANCE | COUNTY PAID HEALTH I | | 500.91 | | | | |
| 106 70715292300000 | HEALTH INSURANCE | COUNTY PAID HEALTH I | | 9,602.64 | | | | |
| 106 71315252300000 | EMPLOYEE INSURANCE | COUNTY PAID HEALTH I | | 248.59 | | | | |
| 106 71335252300000 | EMPLOYEE INSURANCE | COUNTY PAID HEALTH I | | 333.94 | | | | |
| 150 20105522300000 | EMPLOYEE INSURANCE | COUNTY PAID HEALTH I | | 25.05 | | | | |
| 190 24096012300000 | HEALTH & LIFE INSURANCE | COUNTY PAID HEALTH I | | 166.97 | | | | |
| 400 42305342300000 | EMPLOYEE INSURANCE | COUNTY PAID HEALTH I | | 1,335.76 | | | | |
| 410 70945362300000 | EMPLOYEE INSURANCE | COUNTY PAID HEALTH I | | 500.91 | | | | |
| 410 70955362300000 | EMPLOYEE INSURANCE | COUNTY PAID HEALTH I | | 166.97 | | | | |
| 410 70965332300000 | EMPLOYEE INSURANCE | COUNTY PAID HEALTH I | | 500.91 | | | | |
| 410 70975352300000 | EMPLOYEE INSURANCE | COUNTY PAID HEALTH I | | 834.85 | | | | |
| 415 30255242300000 | EMPLOYEE INSURANCE | COUNTY PAID HEALTH I | | 500.91 | | | | |
| I-UEE201304232435 | COUNTY PAID HEALTH INSURANCE | D | 5/15/2013 | | | 051513 | | |
| 001 26015122300000 | EMPLOYEE INSURANCE | COUNTY PAID HEALTH I | | 1,085.30 | | | | |
| 001 26035152300000 | EMPLOYEE INSURANCE | COUNTY PAID HEALTH I | | 225.42 | | | | |
| 001 26085192300000 | EMPLOYEE INSURANCE | COUNTY PAID HEALTH I | | 960.08 | | | | |
| 001 26097122300000 | EMPLOYEE INSURANCE | COUNTY PAID HEALTH I | | 208.71 | | | | |
| 001 30155152300000 | EMPLOYEE INSURANCE | COUNTY PAID HEALTH I | | 333.94 | | | | |
| 001 30175162300000 | EMPLOYEE INSURANCE | COUNTY PAID HEALTH I | | 166.97 | | | | |
| 001 30185242300000 | EMPLOYEE INSURANCE | COUNTY PAID HEALTH I | | 333.94 | | | | |
| 001 30195622300000 | EMPLOYEE INSURANCE | COUNTY PAID HEALTH I | | 667.88 | | | | |
| 001 31165642300000 | EMPLOYEE INSURANCE | COUNTY PAID HEALTH I | | 166.97 | | | | |
| 001 36245372300000 | EMPLOYEE INSURANCE | COUNTY PAID HEALTH I | | 166.97 | | | | |
| 001 38265712300000 | EMPLOYEE INSURANCE | COUNTY PAID HEALTH I | | 834.85 | | | | |
| 001 52425232300000 | EMPLOYEE INSURANCE | COUNTY PAID HEALTH I | | 500.91 | | | | |
| 001 70735722300000 | HEALTH AND LIFE INS | COUNTY PAID HEALTH I | | 333.94 | | | | |
| 001 70745722300000 | EMPLOYEE INSURANCE | COUNTY PAID HEALTH I | | 1,010.17 | | | | |
| 001 70815752300000 | HEALTH & LIFE INSURANCE | COUNTY PAID HEALTH I | | 500.91 | | | | |
| 001 71375132300000 | EMPLOYEE INSURANCE | COUNTY PAID HEALTH I | | 1,494.38 | | | | |
| 001 71395132300000 | EMPLOYEE INSURANCE | COUNTY PAID HEALTH I | | 166.97 | | | | |

VENDOR SET: 01 Desoto County
 BANK: PYBK CONSOLIDATED ACCOUNT
 DATE RANGE: 5/15/2013 THRU 5/29/2013

| VENDOR I.D. | NAME | STATUS | CHECK DATE | AMOUNT | DISCOUNT | CHECK NO | CHECK STATUS | CHECK AMOUNT |
|--------------------|-------------------------------|----------------------|---------------|----------|----------|-------------|-----------------|-----------------|
| 4215 | UNITED HEALTH CARE CONT | | | | | | | |
| I-UEE201304232435 | COUNTY PAID HEALTH INSURANCE | D | 5/15/2013 | | | 051513 | | |
| 001 71405532300000 | HEALTH & LIFE INSURANCE | COUNTY PAID HEALTH I | | 166.97 | | | | |
| 102 60505412300000 | EMPLOYEE INSURANCE | COUNTY PAID HEALTH I | | 5,676.98 | | | | |
| 104 30205412300000 | EMPLOYEE INSURANCE | COUNTY PAID HEALTH I | | 500.91 | | | | |
| 106 70715292300000 | HEALTH INSURANCE | COUNTY PAID HEALTH I | | 9,602.64 | | | | |
| 106 71315252300000 | EMPLOYEE INSURANCE | COUNTY PAID HEALTH I | | 248.59 | | | | |
| 106 71335252300000 | EMPLOYEE INSURANCE | COUNTY PAID HEALTH I | | 333.94 | | | | |
| 150 20105522300000 | EMPLOYEE INSURANCE | COUNTY PAID HEALTH I | | 25.04 | | | | |
| 190 24096012300000 | HEALTH & LIFE INSURANCE | COUNTY PAID HEALTH I | | 166.97 | | | | |
| 400 42305342300000 | EMPLOYEE INSURANCE | COUNTY PAID HEALTH I | | 1,335.76 | | | | |
| 410 70945362300000 | EMPLOYEE INSURANCE | COUNTY PAID HEALTH I | | 500.91 | | | | |
| 410 70955362300000 | EMPLOYEE INSURANCE | COUNTY PAID HEALTH I | | 166.97 | | | | |
| 410 70965332300000 | EMPLOYEE INSURANCE | COUNTY PAID HEALTH I | | 500.91 | | | | |
| 410 70975352300000 | EMPLOYEE INSURANCE | COUNTY PAID HEALTH I | | 834.85 | | | | |
| 415 30255242300000 | EMPLOYEE INSURANCE | COUNTY PAID HEALTH I | | 500.91 | | | | |
| I-UFA201304012312 | FAMILY HEALTH AFTER TAX | D | 5/15/2013 | | | 051513 | | |
| 106 00002183000000 | DEPENDENT HEALTH | FAMILY HEALTH AFTER | | 85.41 | | | | |
| I-UFA201304092367 | FAMILY HEALTH AFTER TAX | D | 5/15/2013 | | | 051513 | | |
| 106 00002183000000 | DEPENDENT HEALTH | FAMILY HEALTH AFTER | | 85.41 | | | | |
| I-UFA201304152400 | FAMILY HEALTH AFTER TAX | D | 5/15/2013 | | | 051513 | | |
| 106 00002183000000 | DEPENDENT HEALTH | FAMILY HEALTH AFTER | | 85.41 | | | | |
| I-UFA201304232435 | FAMILY HEALTH AFTER TAX | D | 5/15/2013 | | | 051513 | | |
| 106 00002183000000 | DEPENDENT HEALTH | FAMILY HEALTH AFTER | | 85.41 | | | | |
| I-UFB201304012312 | DEPENDENT FAMILY HLTH PRE TAX | D | 5/15/2013 | | | 051513 | | |
| 001 00002183000000 | DEPENDENT HEALTH | DEPENDENT FAMILY HLT | | 755.88 | | | | |
| 102 00002183000000 | DEPENDENT HEALTH | DEPENDENT FAMILY HLT | | 256.23 | | | | |
| 104 00002183000000 | DEPENDENT HEALTH | DEPENDENT FAMILY HLT | | 170.82 | | | | |
| 106 00002183000000 | DEPENDENT HEALTH | DEPENDENT FAMILY HLT | | 1,024.92 | | | | |
| 150 00002183000000 | DEPENDENT HEALTH | DEPENDENT FAMILY HLT | | 12.81 | | | | |
| 410 00002183000000 | DEPENDENT HEALTH | DEPENDENT FAMILY HLT | | 170.82 | | | | |
| I-UFB201304092367 | DEPENDENT FAMILY HLTH PRE TAX | D | 5/15/2013 | | | 051513 | | |
| 001 00002183000000 | DEPENDENT HEALTH | DEPENDENT FAMILY HLT | | 755.88 | | | | |
| 102 00002183000000 | DEPENDENT HEALTH | DEPENDENT FAMILY HLT | | 256.23 | | | | |
| 104 00002183000000 | DEPENDENT HEALTH | DEPENDENT FAMILY HLT | | 170.82 | | | | |
| 106 00002183000000 | DEPENDENT HEALTH | DEPENDENT FAMILY HLT | | 1,024.92 | | | | |
| 150 00002183000000 | DEPENDENT HEALTH | DEPENDENT FAMILY HLT | | 12.81 | | | | |
| 410 00002183000000 | DEPENDENT HEALTH | DEPENDENT FAMILY HLT | | 170.82 | | | | |
| I-UFB201304152400 | DEPENDENT FAMILY HLTH PRE TAX | D | 5/15/2013 | | | 051513 | | |
| 001 00002183000000 | DEPENDENT HEALTH | DEPENDENT FAMILY HLT | | 755.88 | | | | |
| 102 00002183000000 | DEPENDENT HEALTH | DEPENDENT FAMILY HLT | | 256.23 | | | | |
| 104 00002183000000 | DEPENDENT HEALTH | DEPENDENT FAMILY HLT | | 170.82 | | | | |
| 106 00002183000000 | DEPENDENT HEALTH | DEPENDENT FAMILY HLT | | 1,024.92 | | | | |
| 150 00002183000000 | DEPENDENT HEALTH | DEPENDENT FAMILY HLT | | 12.81 | | | | |
| 410 00002183000000 | DEPENDENT HEALTH | DEPENDENT FAMILY HLT | | 170.82 | | | | |
| I-UFB201304232435 | DEPENDENT FAMILY HLTH PRE TAX | D | 5/15/2013 | | | 051513 | | |
| 001 00002183000000 | DEPENDENT HEALTH | DEPENDENT FAMILY HLT | | 755.88 | | | | |
| 102 00002183000000 | DEPENDENT HEALTH | DEPENDENT FAMILY HLT | | 256.23 | | | | |

VENDOR SET: 01 Desoto County
BANK: PYBK CONSOLIDATED ACCOUNT
DATE RANGE: 5/15/2013 THRU 5/29/2013

| VENDOR I.D. | NAME | STATUS | CHECK DATE | AMOUNT | DISCOUNT | CHECK NO | CHECK STATUS | CHECK AMOUNT |
|--------------------|-------------------------------|--------|------------|----------|----------|----------|--------------|--------------|
| 4215 | UNITED HEALTH CARE | CONT | | | | | | |
| I-UFB201304232435 | DEPENDENT FAMILY HLTH PRE TAX | D | 5/15/2013 | | | 051513 | | |
| 104 00002183000000 | DEPENDENT HEALTH | | | 170.82 | | | | |
| 106 00002183000000 | DEPENDENT HEALTH | | | 1,024.92 | | | | |
| 150 00002183000000 | DEPENDENT HEALTH | | | 12.81 | | | | |
| 410 00002183000000 | DEPENDENT HEALTH | | | 170.82 | | | | |
| I-USA201304012312 | DEPENDENT SPOUSE HLTH AFT TAX | D | 5/15/2013 | | | 051513 | | |
| 001 00002183000000 | DEPENDENT HEALTH | | | 71.30 | | | | |
| I-USA201304092367 | DEPENDENT SPOUSE HLTH AFT TAX | D | 5/15/2013 | | | 051513 | | |
| 001 00002183000000 | DEPENDENT HEALTH | | | 71.30 | | | | |
| I-USA201304152400 | DEPENDENT SPOUSE HLTH AFT TAX | D | 5/15/2013 | | | 051513 | | |
| 001 00002183000000 | DEPENDENT HEALTH | | | 71.30 | | | | |
| I-USA201304232435 | DEPENDENT SPOUSE HLTH AFT TAX | D | 5/15/2013 | | | 051513 | | |
| 001 00002183000000 | DEPENDENT HEALTH | | | 71.30 | | | | |
| I-USB201304012312 | DEPENDENT SPOUSE HLTH PRE TAX | D | 5/15/2013 | | | 051513 | | |
| 001 00002183000000 | DEPENDENT HEALTH | | | 427.80 | | | | |
| 102 00002183000000 | DEPENDENT HEALTH | | | 71.30 | | | | |
| 106 00002183000000 | DEPENDENT HEALTH | | | 356.50 | | | | |
| 190 00002183000000 | DEPENDENT HEALTH | | | 71.30 | | | | |
| 400 00002183000000 | DEPENDENT HEALTH | | | 71.30 | | | | |
| 410 00002183000000 | DEPENDENT HEALTH | | | 142.60 | | | | |
| 415 00002183000000 | DEPENDENT HEALTH | | | 71.30 | | | | |
| I-USB201304092367 | DEPENDENT SPOUSE HLTH PRE TAX | D | 5/15/2013 | | | 051513 | | |
| 001 00002183000000 | DEPENDENT HEALTH | | | 427.80 | | | | |
| 102 00002183000000 | DEPENDENT HEALTH | | | 71.30 | | | | |
| 106 00002183000000 | DEPENDENT HEALTH | | | 356.50 | | | | |
| 190 00002183000000 | DEPENDENT HEALTH | | | 71.30 | | | | |
| 400 00002183000000 | DEPENDENT HEALTH | | | 213.90 | | | | |
| 410 00002183000000 | DEPENDENT HEALTH | | | 142.60 | | | | |
| 415 00002183000000 | DEPENDENT HEALTH | | | 71.30 | | | | |
| I-USB201304152400 | DEPENDENT SPOUSE HLTH PRE TAX | D | 5/15/2013 | | | 051513 | | |
| 001 00002183000000 | DEPENDENT HEALTH | | | 427.80 | | | | |
| 102 00002183000000 | DEPENDENT HEALTH | | | 71.30 | | | | |
| 106 00002183000000 | DEPENDENT HEALTH | | | 356.50 | | | | |
| 190 00002183000000 | DEPENDENT HEALTH | | | 71.30 | | | | |
| 400 00002183000000 | DEPENDENT HEALTH | | | 142.60 | | | | |
| 410 00002183000000 | DEPENDENT HEALTH | | | 142.60 | | | | |
| 415 00002183000000 | DEPENDENT HEALTH | | | 71.30 | | | | |
| I-USB201304232435 | DEPENDENT SPOUSE HLTH PRE TAX | D | 5/15/2013 | | | 051513 | | |
| 001 00002183000000 | DEPENDENT HEALTH | | | 427.80 | | | | |
| 102 00002183000000 | DEPENDENT HEALTH | | | 71.30 | | | | |
| 106 00002183000000 | DEPENDENT HEALTH | | | 356.50 | | | | |
| 190 00002183000000 | DEPENDENT HEALTH | | | 71.30 | | | | |
| 400 00002183000000 | DEPENDENT HEALTH | | | 142.60 | | | | |
| 410 00002183000000 | DEPENDENT HEALTH | | | 142.60 | | | | |
| 415 00002183000000 | DEPENDENT HEALTH | | | 71.30 | | | | |
| I-UTB201304012312 | EMP TWO FAMILY HLTH PRE TAX | D | 5/15/2013 | | | 051513 | | |
| 106 00002183000000 | DEPENDENT HEALTH | | | 7.66 | | | | |

VENDOR SET: 01 Desoto County
 BANK: PYBK CONSOLIDATED ACCOUNT
 DATE RANGE: 5/15/2013 THRU 5/29/2013

| VENDOR I.D. | NAME | STATUS | CHECK DATE | AMOUNT | DISCOUNT | CHECK NO | CHECK STATUS | CHECK AMOUNT |
|--------------------|--------------------------------|----------------------|------------|--------|----------|----------|--------------|--------------|
| 4215 | UNITED HEALTH CARE CONT | | | | | | | |
| I-UTB201304012312 | EMP TWO FAMILY HLTH PRE TAX | D | 5/15/2013 | | | 051513 | | |
| 410 00002183000000 | DEPENDENT HEALTH | EMP TWO FAMILY HLTH | | 3.83 | | | | |
| I-UTB201304092367 | EMP TWO FAMILY HLTH PRE TAX | D | 5/15/2013 | | | 051513 | | |
| 106 00002183000000 | DEPENDENT HEALTH | EMP TWO FAMILY HLTH | | 7.66 | | | | |
| 410 00002183000000 | DEPENDENT HEALTH | EMP TWO FAMILY HLTH | | 3.83 | | | | |
| I-UTB201304152400 | EMP TWO FAMILY HLTH PRE TAX | D | 5/15/2013 | | | 051513 | | |
| 106 00002183000000 | DEPENDENT HEALTH | EMP TWO FAMILY HLTH | | 7.66 | | | | |
| 410 00002183000000 | DEPENDENT HEALTH | EMP TWO FAMILY HLTH | | 3.83 | | | | |
| I-UTB201304232435 | EMP TWO FAMILY HLTH PRE TAX | D | 5/15/2013 | | | 051513 | | |
| 106 00002183000000 | DEPENDENT HEALTH | EMP TWO FAMILY HLTH | | 7.66 | | | | |
| 410 00002183000000 | DEPENDENT HEALTH | EMP TWO FAMILY HLTH | | 3.83 | | | | 303,666.93 |
| 0006 | VALIC RETIREMENT SERVICES | | | | | | | |
| I-DC3201305132512 | DEFERRED COMP/VALIC | D | 5/17/2013 | | | 051713 | | |
| 001 00002185000000 | DEFERRED COMP | DEFERRED COMP/VALIC | | 135.00 | | | | |
| 102 00002185000000 | DEFERRED COMP | DEFERRED COMP/VALIC | | 10.00 | | | | |
| 106 00002185000000 | DEFERRED COMP | DEFERRED COMP/VALIC | | 422.50 | | | | |
| 410 00002185000000 | DEFERRED COMP | DEFERRED COMP/VALIC | | 75.00 | | | | 642.50 |
| 0004 | HARTFORD LIFE INSUR CO | | | | | | | |
| I-DC1201305132512 | DEFERRED COMP/HARTFORD | D | 5/17/2013 | | | 051714 | | |
| 106 00002185000000 | DEFERRED COMP | DEFERRED COMP/HARTFO | | 50.00 | | | | 50.00 |
| 3004 | ICMA-RC | | | | | | | |
| I-DC4201305132512 | ICMA-RC FLAT AMOUNT | D | 5/17/2013 | | | 051715 | | |
| 001 00002185000000 | DEFERRED COMP | ICMA-RC FLAT AMOUNT | | 25.00 | | | | |
| 106 00002185000000 | DEFERRED COMP | ICMA-RC FLAT AMOUNT | | 80.00 | | | | 105.00 |
| 3756 | NATIONWIDE RETIREMENT SOLUTION | | | | | | | |
| I-DC2201305132512 | DEFERRED COMP/NACO | D | 5/17/2013 | | | 051716 | | |
| 001 00002185000000 | DEFERRED COMP | DEFERRED COMP/NACO | | 707.30 | | | | |
| 102 00002185000000 | DEFERRED COMP | DEFERRED COMP/NACO | | 40.00 | | | | |
| 106 00002185000000 | DEFERRED COMP | DEFERRED COMP/NACO | | 940.00 | | | | |
| 400 00002185000000 | DEFERRED COMP | DEFERRED COMP/NACO | | 75.00 | | | | |
| 410 00002185000000 | DEFERRED COMP | DEFERRED COMP/NACO | | 406.53 | | | | 2,168.83 |
| 3125 | EXPERTPAY | | | | | | | |
| I-C01201305132512 | CASE #149900000158CA | D | 5/17/2013 | | | 051717 | | |
| 001 00002188000000 | CHILD SUPPORT | CASE #149900000158CA | | 118.00 | | | | |
| I-C02201305132512 | CASE #1149963212 | D | 5/17/2013 | | | 051717 | | |
| 106 00002188000000 | CHILD SUPPORT | CASE #1149963212 | | 102.00 | | | | |
| I-C38201305132512 | CASE #25-2007-DR-000615 | D | 5/17/2013 | | | 051717 | | |
| 102 00002188000000 | CHILD SUPPORT | CASE #25-2007-DR-000 | | 104.00 | | | | |
| I-C40201305132512 | CASE #140800000648DR | D | 5/17/2013 | | | 051717 | | |
| 102 00002188000000 | CHILD SUPPORT | CASE #140800000648DR | | 15.00 | | | | |
| I-C42201305132512 | CASE #80000995DR14 | D | 5/17/2013 | | | 051717 | | |
| 102 00002188000000 | CHILD SUPPORT | CASE #80000995DR14 | | 71.45 | | | | |
| I-C43201305132512 | CASE #070000238DR14 | D | 5/17/2013 | | | 051717 | | |

VENDOR SET: 01 Desoto County
 BANK: PYBK CONSOLIDATED ACCOUNT
 DATE RANGE: 5/15/2013 THRU 5/29/2013

| VENDOR I.D. | NAME | STATUS | CHECK DATE | AMOUNT | DISCOUNT | CHECK NO | CHECK STATUS | CHECK AMOUNT |
|--------------------|---------------------------|--------|------------|-----------|----------|----------|--------------|--------------|
| 3125 | EXPERTPAY | CONT | | | | | | |
| I-C43201305132512 | CASE #070000238DR14 | D | 5/17/2013 | | | 051717 | | |
| 102 00002188000000 | CHILD SUPPORT | | | 85.00 | | | | |
| I-C49201305132512 | CASE# 1279347830 | D | 5/17/2013 | | | 051717 | | |
| 102 00002188000000 | CHILD SUPPORT | | | 175.00 | | | | |
| I-C50201305132512 | CASE # PT06DM000037 | D | 5/17/2013 | | | 051717 | | |
| 102 00002188000000 | CHILD SUPPORT | | | 70.48 | | | | |
| I-C51201305132512 | CASE # 1103386883 | D | 5/17/2013 | | | 051717 | | |
| 102 00002188000000 | CHILD SUPPORT | | | 115.38 | | | | |
| I-C52201305132512 | CASE # 1328062562 | D | 5/17/2013 | | | 051717 | | |
| 102 00002188000000 | CHILD SUPPORT | | | 93.00 | | | | |
| I-C53201305132512 | CASE # 1291358340 | D | 5/17/2013 | | | 051717 | | |
| 106 00002188000000 | CHILD SUPPORT | | | 260.54 | | | | |
| I-C54201305132512 | CASE# 2000079204 | D | 5/17/2013 | | | 051717 | | |
| 106 00002188000000 | CHILD SUPPORT | | | 125.00 | | | | 1,334.85 |
| 1288 | DESOTO CO COMM PAYROLL AC | | | | | | | |
| I-001201305132512 | PAYROLL REIMBURSEMENT | D | 5/17/2013 | | | 051719 | | |
| 001 00001310000802 | DUE TO/FROM PAYROLL | | | 31,953.92 | | | | |
| I-102201305132512 | PAYROLL REIMBURSEMENT | D | 5/17/2013 | | | 051719 | | |
| 102 00001310000802 | DUE TO/FROM PAYROLL | | | 14,382.64 | | | | |
| I-104201305132512 | PAYROLL REIMBURSEMENT | D | 5/17/2013 | | | 051719 | | |
| 104 00001310000802 | DUE TO/FROM PAYROLL | | | 1,864.89 | | | | |
| I-106201305132512 | PAYROLL REIMBURSEMENT | D | 5/17/2013 | | | 051719 | | |
| 106 00001310000802 | DUE TO/FROM PAYROLL | | | 35,937.46 | | | | |
| I-150201305132512 | PAYROLL REIMBURSEMENT | D | 5/17/2013 | | | 051719 | | |
| 150 00001310000802 | DUE TO/FROM PAYROLL | | | 89.65 | | | | |
| I-190201305132512 | PAYROLL REIMBURSEMENT | D | 5/17/2013 | | | 051719 | | |
| 190 00001310000802 | DUE TO/FROM PAYROLL | | | 258.42 | | | | |
| I-400201305132512 | PAYROLL REIMBURSEMENT | D | 5/17/2013 | | | 051719 | | |
| 400 00001310000802 | DUE TO/FROM PAYROLL | | | 3,485.01 | | | | |
| I-410201305132512 | PAYROLL REIMBURSEMENT | D | 5/17/2013 | | | 051719 | | |
| 410 00001310000802 | DUE TO/FROM PAYROLL | | | 8,847.44 | | | | |
| I-415201305132512 | PAYROLL REIMBURSEMENT | D | 5/17/2013 | | | 051719 | | |
| 415 00001310000802 | DUE TO/FROM PAYROLL | | | 2,018.28 | | | | 98,837.71 |
| 0006 | VALIC RETIREMENT SERVICES | | | | | | | |
| I-DC3201305202541 | DEFERRED COMP/VALIC | D | 5/24/2013 | | | 052413 | | |
| 001 00002185000000 | DEFERRED COMP | | | 135.00 | | | | |
| 102 00002185000000 | DEFERRED COMP | | | 10.00 | | | | |
| 106 00002185000000 | DEFERRED COMP | | | 372.50 | | | | |
| 410 00002185000000 | DEFERRED COMP | | | 75.00 | | | | 592.50 |

VENDOR SET: 01 Desoto County
 BANK: PYBK CONSOLIDATED ACCOUNT
 DATE RANGE: 5/15/2013 THRU 5/29/2013

| VENDOR I.D. | NAME | STATUS | CHECK DATE | AMOUNT | DISCOUNT | CHECK NO | CHECK STATUS | CHECK AMOUNT |
|--------------------|--------------------------------|--------|----------------------|--------|----------|----------|--------------|--------------|
| 0004 | HARTFORD LIFE INSUR CO | | | | | | | |
| I-DC1201305202541 | DEFERRED COMP/HARTFORD | D | 5/24/2013 | | | 052414 | | |
| 106 00002185000000 | DEFERRED COMP | | DEFERRED COMP/HARTFO | 50.00 | | | | 50.00 |
| 3756 | NATIONWIDE RETIREMENT SOLUTION | | | | | | | |
| I-DC2201305202541 | DEFERRED COMP/NACO | D | 5/24/2013 | | | 052415 | | |
| 001 00002185000000 | DEFERRED COMP | | DEFERRED COMP/NACO | 707.30 | | | | |
| 102 00002185000000 | DEFERRED COMP | | DEFERRED COMP/NACO | 40.00 | | | | |
| 106 00002185000000 | DEFERRED COMP | | DEFERRED COMP/NACO | 940.00 | | | | |
| 400 00002185000000 | DEFERRED COMP | | DEFERRED COMP/NACO | 75.00 | | | | |
| 410 00002185000000 | DEFERRED COMP | | DEFERRED COMP/NACO | 406.53 | | | | 2,168.83 |
| 3004 | ICMA-RC | | | | | | | |
| I-DC4201305202541 | ICMA-RC FLAT AMOUNT | D | 5/24/2013 | | | 052416 | | |
| 001 00002185000000 | DEFERRED COMP | | ICMA-RC FLAT AMOUNT | 25.00 | | | | |
| 106 00002185000000 | DEFERRED COMP | | ICMA-RC FLAT AMOUNT | 80.00 | | | | 105.00 |
| 3125 | EXPERTPAY | | | | | | | |
| I-C01201305202541 | CASE #149900000158CA | D | 5/24/2013 | | | 052417 | | |
| 001 00002188000000 | CHILD SUPPORT | | CASE #149900000158CA | 118.00 | | | | |
| I-C02201305202541 | CASE #1149963212 | D | 5/24/2013 | | | 052417 | | |
| 106 00002188000000 | CHILD SUPPORT | | CASE #1149963212 | 102.00 | | | | |
| I-C38201305202541 | CASE #25-2007-DR-000615 | D | 5/24/2013 | | | 052417 | | |
| 102 00002188000000 | CHILD SUPPORT | | CASE #25-2007-DR-000 | 104.00 | | | | |
| I-C40201305202541 | CASE #140800000648DR | D | 5/24/2013 | | | 052417 | | |
| 102 00002188000000 | CHILD SUPPORT | | CASE #140800000648DR | 15.00 | | | | |
| I-C42201305202541 | CASE #80000995DR14 | D | 5/24/2013 | | | 052417 | | |
| 102 00002188000000 | CHILD SUPPORT | | CASE #80000995DR14 | 71.45 | | | | |
| I-C43201305202541 | CASE #070000238DR14 | D | 5/24/2013 | | | 052417 | | |
| 102 00002188000000 | CHILD SUPPORT | | CASE #070000238DR14 | 85.00 | | | | |
| I-C49201305202541 | CASE# 1279347830 | D | 5/24/2013 | | | 052417 | | |
| 102 00002188000000 | CHILD SUPPORT | | CASE# 1279347830 | 175.00 | | | | |
| I-C50201305202541 | CASE # PT06DM000037 | D | 5/24/2013 | | | 052417 | | |
| 102 00002188000000 | CHILD SUPPORT | | CASE # PT06DM000037 | 70.48 | | | | |
| I-C51201305202541 | CASE # 1103386883 | D | 5/24/2013 | | | 052417 | | |
| 102 00002188000000 | CHILD SUPPORT | | CASE # 1103386883 | 115.38 | | | | |
| I-C52201305202541 | CASE # 1328062562 | D | 5/24/2013 | | | 052417 | | |
| 102 00002188000000 | CHILD SUPPORT | | CASE # 1328062562 | 93.00 | | | | |
| I-C53201305202541 | CASE # 1291358340 | D | 5/24/2013 | | | 052417 | | |
| 106 00002188000000 | CHILD SUPPORT | | CASE # 1291358340 | 260.54 | | | | |
| I-C54201305202541 | CASE# 2000079204 | D | 5/24/2013 | | | 052417 | | |
| 106 00002188000000 | CHILD SUPPORT | | CASE# 2000079204 | 125.00 | | | | 1,334.85 |

VENDOR SET: 01 Desoto County
 BANK: PYBK CONSOLIDATED ACCOUNT
 DATE RANGE: 5/15/2013 THRU 5/29/2013

| VENDOR I.D. | NAME | STATUS | CHECK DATE | AMOUNT | DISCOUNT | CHECK NO | CHECK STATUS | CHECK AMOUNT |
|--------------------|--------------------------------|----------------------|---------------|-----------|----------|-------------|-----------------|-----------------|
| 1288 | DESOTO CO COMM PAYROLL AC | | | | | | | |
| I-001201305202541 | PAYROLL REIMBURSEMENT | D | 5/24/2013 | | | 052419 | | |
| 001 00001310000802 | DUE TO/FROM PAYROLL | PAYROLL | REIMBURSEMEN | 31,781.34 | | | | |
| I-102201305202541 | PAYROLL REIMBURSEMENT | D | 5/24/2013 | | | 052419 | | |
| 102 00001310000802 | DUE TO/FROM PAYROLL | PAYROLL | REIMBURSEMEN | 14,351.75 | | | | |
| I-104201305202541 | PAYROLL REIMBURSEMENT | D | 5/24/2013 | | | 052419 | | |
| 104 00001310000802 | DUE TO/FROM PAYROLL | PAYROLL | REIMBURSEMEN | 1,864.89 | | | | |
| I-106201305202541 | PAYROLL REIMBURSEMENT | D | 5/24/2013 | | | 052419 | | |
| 106 00001310000802 | DUE TO/FROM PAYROLL | PAYROLL | REIMBURSEMEN | 34,680.73 | | | | |
| I-150201305202541 | PAYROLL REIMBURSEMENT | D | 5/24/2013 | | | 052419 | | |
| 150 00001310000802 | DUE TO/FROM PAYROLL | PAYROLL | REIMBURSEMEN | 89.65 | | | | |
| I-190201305202541 | PAYROLL REIMBURSEMENT | D | 5/24/2013 | | | 052419 | | |
| 190 00001310000802 | DUE TO/FROM PAYROLL | PAYROLL | REIMBURSEMEN | 428.59 | | | | |
| I-400201305202541 | PAYROLL REIMBURSEMENT | D | 5/24/2013 | | | 052419 | | |
| 400 00001310000802 | DUE TO/FROM PAYROLL | PAYROLL | REIMBURSEMEN | 3,467.64 | | | | |
| I-410201305202541 | PAYROLL REIMBURSEMENT | D | 5/24/2013 | | | 052419 | | |
| 410 00001310000802 | DUE TO/FROM PAYROLL | PAYROLL | REIMBURSEMEN | 9,093.03 | | | | |
| I-415201305202541 | PAYROLL REIMBURSEMENT | D | 5/24/2013 | | | 052419 | | |
| 415 00001310000802 | DUE TO/FROM PAYROLL | PAYROLL | REIMBURSEMEN | 2,018.28 | | | | 97,775.90 |
| 3293 | JACOBSON, SOBO & MOSELLE | | | | | | | |
| I-G04201302192112 | CASE #2004-SC-000474 | V | 2/22/2013 | | | 208813 | | 37.52 |
| 3293 | JACOBSON, SOBO & MOSELLE | | | | | | | |
| M-CHECK | JACOBSON, SOBO & MOSELLEUNPOST | V | 5/23/2013 | | | 208813 | | 37.52 |
| 3293 | JACOBSON, SOBO & MOSELLE | | | | | | | |
| I-G04201305132512 | CASE #2004-SC-000474 | R | 5/17/2013 | | | 210098 | | |
| 001 00002187000000 | MISC DEDUCTIONS | CASE #2004-SC-000474 | | 37.52 | | | | 37.52 |
| 3293 | JACOBSON, SOBO & MOSELLE | | | | | | | |
| I-G04201305202541 | CASE #2004-SC-000474 | R | 5/24/2013 | | | 210240 | | |
| 001 00002187000000 | MISC DEDUCTIONS | CASE #2004-SC-000474 | | 37.52 | | | | 37.52 |
| 3293 | JACOBSON, SOBO & MOSELLE | | | | | | | |
| I-G04201302192112 | CASE #2004-SC-000474 | R | 5/24/2013 | | | 210241 | | |
| 001 00002187000000 | MISC DEDUCTIONS | CASE #2004-SC-000474 | | 37.52 | | | | 37.52 |
| 0010 | AFLAC | | | | | | | |
| C-201305282565 | 5/2013 INS BILLING ADJ | R | 5/29/2013 | | | 210366 | | |
| 001 00002184200000 | AFLAC | 5/2013 | INS BILLING A | 0.10CR | | | | |
| 102 00002184200000 | AFLAC | 5/2013 | INS BILLING A | 0.08CR | | | | |
| 106 00002184200000 | AFLAC | 5/2013 | INS BILLING A | 0.04CR | | | | |
| 400 00002184200000 | AFLAC | 5/2013 | INS BILLING A | 0.02CR | | | | |
| 410 00002184200000 | AFLAC | 5/2013 | INS BILLING A | 0.04CR | | | | |
| I-LF1201304292449 | AFLAC PRETAX | R | 5/29/2013 | | | 210366 | | |
| 001 00002184200000 | AFLAC | AFLAC | PRETAX | 61.33 | | | | |
| 102 00002184200000 | AFLAC | AFLAC | PRETAX | 56.72 | | | | |

VENDOR SET: 01 Desoto County
 BANK: PYBK CONSOLIDATED ACCOUNT
 DATE RANGE: 5/15/2013 THRU 5/29/2013

| VENDOR I.D. | NAME | STATUS | CHECK DATE | AMOUNT | DISCOUNT | CHECK NO | CHECK STATUS | CHECK AMOUNT |
|--------------------|-----------------|--------|-----------------|--------|----------|-------------|-----------------|-----------------|
| 0010 | AFLAC | CONT | | | | | | |
| I-LF1201304292449 | AFLAC PRETAX | R | 5/29/2013 | | | 210366 | | |
| 106 00002184200000 | AFLAC | | AFLAC PRETAX | 42.77 | | | | |
| 150 00002184200000 | AFLAC | | AFLAC PRETAX | 0.39 | | | | |
| 400 00002184200000 | AFLAC | | AFLAC PRETAX | 5.33 | | | | |
| 410 00002184200000 | AFLAC | | AFLAC PRETAX | 34.89 | | | | |
| I-LF1201305062480 | AFLAC PRETAX | R | 5/29/2013 | | | 210366 | | |
| 001 00002184200000 | AFLAC | | AFLAC PRETAX | 61.33 | | | | |
| 102 00002184200000 | AFLAC | | AFLAC PRETAX | 56.72 | | | | |
| 106 00002184200000 | AFLAC | | AFLAC PRETAX | 42.77 | | | | |
| 150 00002184200000 | AFLAC | | AFLAC PRETAX | 0.39 | | | | |
| 400 00002184200000 | AFLAC | | AFLAC PRETAX | 5.33 | | | | |
| 410 00002184200000 | AFLAC | | AFLAC PRETAX | 34.89 | | | | |
| I-LF1201305132512 | AFLAC PRETAX | R | 5/29/2013 | | | 210366 | | |
| 001 00002184200000 | AFLAC | | AFLAC PRETAX | 61.33 | | | | |
| 102 00002184200000 | AFLAC | | AFLAC PRETAX | 56.72 | | | | |
| 106 00002184200000 | AFLAC | | AFLAC PRETAX | 42.77 | | | | |
| 150 00002184200000 | AFLAC | | AFLAC PRETAX | 0.39 | | | | |
| 400 00002184200000 | AFLAC | | AFLAC PRETAX | 5.33 | | | | |
| 410 00002184200000 | AFLAC | | AFLAC PRETAX | 34.89 | | | | |
| I-LF1201305202541 | AFLAC PRETAX | R | 5/29/2013 | | | 210366 | | |
| 001 00002184200000 | AFLAC | | AFLAC PRETAX | 61.33 | | | | |
| 102 00002184200000 | AFLAC | | AFLAC PRETAX | 56.72 | | | | |
| 106 00002184200000 | AFLAC | | AFLAC PRETAX | 42.77 | | | | |
| 150 00002184200000 | AFLAC | | AFLAC PRETAX | 0.39 | | | | |
| 400 00002184200000 | AFLAC | | AFLAC PRETAX | 5.33 | | | | |
| 410 00002184200000 | AFLAC | | AFLAC PRETAX | 34.89 | | | | |
| I-LF2201304292449 | AFLAC AFTER TAX | R | 5/29/2013 | | | 210366 | | |
| 001 00002184200000 | AFLAC | | AFLAC AFTER TAX | 40.24 | | | | |
| 102 00002184200000 | AFLAC | | AFLAC AFTER TAX | 17.03 | | | | |
| 106 00002184200000 | AFLAC | | AFLAC AFTER TAX | 6.24 | | | | |
| 150 00002184200000 | AFLAC | | AFLAC AFTER TAX | 1.07 | | | | |
| 410 00002184200000 | AFLAC | | AFLAC AFTER TAX | 9.40 | | | | |
| I-LF2201305062480 | AFLAC AFTER TAX | R | 5/29/2013 | | | 210366 | | |
| 001 00002184200000 | AFLAC | | AFLAC AFTER TAX | 40.24 | | | | |
| 102 00002184200000 | AFLAC | | AFLAC AFTER TAX | 17.03 | | | | |
| 106 00002184200000 | AFLAC | | AFLAC AFTER TAX | 6.24 | | | | |
| 150 00002184200000 | AFLAC | | AFLAC AFTER TAX | 1.07 | | | | |
| 410 00002184200000 | AFLAC | | AFLAC AFTER TAX | 9.40 | | | | |
| I-LF2201305132512 | AFLAC AFTER TAX | R | 5/29/2013 | | | 210366 | | |
| 001 00002184200000 | AFLAC | | AFLAC AFTER TAX | 40.24 | | | | |
| 102 00002184200000 | AFLAC | | AFLAC AFTER TAX | 17.03 | | | | |
| 106 00002184200000 | AFLAC | | AFLAC AFTER TAX | 6.24 | | | | |
| 150 00002184200000 | AFLAC | | AFLAC AFTER TAX | 1.07 | | | | |
| 410 00002184200000 | AFLAC | | AFLAC AFTER TAX | 9.40 | | | | |
| I-LF2201305202541 | AFLAC AFTER TAX | R | 5/29/2013 | | | 210366 | | |
| 001 00002184200000 | AFLAC | | AFLAC AFTER TAX | 40.24 | | | | |
| 102 00002184200000 | AFLAC | | AFLAC AFTER TAX | 17.03 | | | | |

VENDOR SET: 01 Desoto County
 BANK: PYBK CONSOLIDATED ACCOUNT
 DATE RANGE: 5/15/2013 THRU 5/29/2013

| VENDOR I.D. | NAME | STATUS | CHECK DATE | AMOUNT | DISCOUNT | CHECK NO | CHECK STATUS | CHECK AMOUNT |
|--------------------|-----------------------------|--------|----------------------|--------|----------|----------|--------------|--------------|
| 0010 | AFLAC | CONT | | | | | | |
| I-LF2201305202541 | AFLAC AFTER TAX | R | 5/29/2013 | | | 210366 | | |
| 106 00002184200000 | AFLAC | | AFLAC AFTER TAX | 6.24 | | | | |
| 150 00002184200000 | AFLAC | | AFLAC AFTER TAX | 1.07 | | | | |
| 410 00002184200000 | AFLAC | | AFLAC AFTER TAX | 9.40 | | | | 1,101.36 |
| 0012 | LIBERTY NATIONAL | | | | | | | |
| C-201305282566 | 5/2013 LIFE INSBILL ADJ | R | 5/29/2013 | | | 210367 | | |
| 001 00002184000000 | LIBERTY NATIONAL/BEFORE TAX | | 5/2013 LIFE INSBILL | 0.03CR | | | | |
| 102 00002184000000 | LIBERTY INSURANCE | | 5/2013 LIFE INSBILL | 0.01CR | | | | |
| 106 00002184000000 | LIBERTY INSURANCE | | 5/2013 LIFE INSBILL | 0.03CR | | | | |
| I-LF5201304292449 | LIBERTY NATIONAL/BEFORE TAX | R | 5/29/2013 | | | 210367 | | |
| 001 00002184000000 | LIBERTY NATIONAL/BEFORE TAX | | LIBERTY NATIONAL/BEF | 14.87 | | | | |
| 102 00002184000000 | LIBERTY INSURANCE | | LIBERTY NATIONAL/BEF | 13.32 | | | | |
| 104 00002184000000 | LIBERTY NATIONAL/BEF TAX | | LIBERTY NATIONAL/BEF | 9.25 | | | | |
| 106 00002184000000 | LIBERTY INSURANCE | | LIBERTY NATIONAL/BEF | 30.55 | | | | |
| I-LF5201305062480 | LIBERTY NATIONAL/BEFORE TAX | R | 5/29/2013 | | | 210367 | | |
| 001 00002184000000 | LIBERTY NATIONAL/BEFORE TAX | | LIBERTY NATIONAL/BEF | 14.87 | | | | |
| 102 00002184000000 | LIBERTY INSURANCE | | LIBERTY NATIONAL/BEF | 13.32 | | | | |
| 104 00002184000000 | LIBERTY NATIONAL/BEF TAX | | LIBERTY NATIONAL/BEF | 9.25 | | | | |
| 106 00002184000000 | LIBERTY INSURANCE | | LIBERTY NATIONAL/BEF | 30.55 | | | | |
| I-LF5201305132512 | LIBERTY NATIONAL/BEFORE TAX | R | 5/29/2013 | | | 210367 | | |
| 001 00002184000000 | LIBERTY NATIONAL/BEFORE TAX | | LIBERTY NATIONAL/BEF | 14.87 | | | | |
| 102 00002184000000 | LIBERTY INSURANCE | | LIBERTY NATIONAL/BEF | 13.32 | | | | |
| 104 00002184000000 | LIBERTY NATIONAL/BEF TAX | | LIBERTY NATIONAL/BEF | 9.25 | | | | |
| 106 00002184000000 | LIBERTY INSURANCE | | LIBERTY NATIONAL/BEF | 30.55 | | | | |
| I-LF5201305202541 | LIBERTY NATIONAL/BEFORE TAX | R | 5/29/2013 | | | 210367 | | |
| 001 00002184000000 | LIBERTY NATIONAL/BEFORE TAX | | LIBERTY NATIONAL/BEF | 14.87 | | | | |
| 102 00002184000000 | LIBERTY INSURANCE | | LIBERTY NATIONAL/BEF | 13.32 | | | | |
| 104 00002184000000 | LIBERTY NATIONAL/BEF TAX | | LIBERTY NATIONAL/BEF | 9.25 | | | | |
| 106 00002184000000 | LIBERTY INSURANCE | | LIBERTY NATIONAL/BEF | 30.55 | | | | |
| I-LF6201304292449 | LIBERTY NATIONAL/AFTER TAX | R | 5/29/2013 | | | 210367 | | |
| 001 00002184000000 | LIBERTY NATIONAL/BEFORE TAX | | LIBERTY NATIONAL/AFT | 38.29 | | | | |
| 102 00002184000000 | LIBERTY INSURANCE | | LIBERTY NATIONAL/AFT | 4.21 | | | | |
| 106 00002184000000 | LIBERTY INSURANCE | | LIBERTY NATIONAL/AFT | 33.65 | | | | |
| I-LF6201305062480 | LIBERTY NATIONAL/AFTER TAX | R | 5/29/2013 | | | 210367 | | |
| 001 00002184000000 | LIBERTY NATIONAL/BEFORE TAX | | LIBERTY NATIONAL/AFT | 38.29 | | | | |
| 102 00002184000000 | LIBERTY INSURANCE | | LIBERTY NATIONAL/AFT | 4.21 | | | | |
| 106 00002184000000 | LIBERTY INSURANCE | | LIBERTY NATIONAL/AFT | 33.65 | | | | |
| I-LF6201305132512 | LIBERTY NATIONAL/AFTER TAX | R | 5/29/2013 | | | 210367 | | |
| 001 00002184000000 | LIBERTY NATIONAL/BEFORE TAX | | LIBERTY NATIONAL/AFT | 38.29 | | | | |
| 102 00002184000000 | LIBERTY INSURANCE | | LIBERTY NATIONAL/AFT | 4.21 | | | | |
| 106 00002184000000 | LIBERTY INSURANCE | | LIBERTY NATIONAL/AFT | 33.65 | | | | |
| I-LF6201305202541 | LIBERTY NATIONAL/AFTER TAX | R | 5/29/2013 | | | 210367 | | |
| 001 00002184000000 | LIBERTY NATIONAL/BEFORE TAX | | LIBERTY NATIONAL/AFT | 38.29 | | | | |
| 102 00002184000000 | LIBERTY INSURANCE | | LIBERTY NATIONAL/AFT | 4.21 | | | | |
| 106 00002184000000 | LIBERTY INSURANCE | | LIBERTY NATIONAL/AFT | 33.65 | | | | 576.49 |

VENDOR SET: 01 Desoto County
 BANK: PYBK CONSOLIDATED ACCOUNT
 DATE RANGE: 5/15/2013 THRU 5/29/2013

| VENDOR I.D. | NAME | STATUS | CHECK DATE | AMOUNT | DISCOUNT | CHECK NO | CHECK STATUS | CHECK AMOUNT |
|--------------------|----------------------------|--------|------------|--------|----------|----------|--------------|--------------|
| 2727 | GLENN PRESCOTT, PETTY CASH | | | | | | | |
| I-COK201304012312 | COKE FUND DEDUCTIONS | R | 5/29/2013 | | | 210368 | | |
| 106 00001020000000 | CASH ON HAND | | | 109.00 | | | | |
| I-COK201304092367 | COKE FUND DEDUCTIONS | R | 5/29/2013 | | | 210368 | | |
| 106 00001020000000 | CASH ON HAND | | | 109.00 | | | | |
| I-COK201304152400 | COKE FUND DEDUCTIONS | R | 5/29/2013 | | | 210368 | | |
| 106 00001020000000 | CASH ON HAND | | | 109.00 | | | | |
| I-COK201304232435 | COKE FUND DEDUCTIONS | R | 5/29/2013 | | | 210368 | | |
| 106 00001020000000 | CASH ON HAND | | | 109.00 | | | | 436.00 |

| * * T O T A L S * * | NO | INVOICE AMOUNT | DISCOUNTS | CHECK AMOUNT |
|---------------------|---------------|----------------|-----------|--------------|
| REGULAR CHECKS: | 6 | 0.00 | 0.00 | 2,226.41 |
| HAND CHECKS: | 0 | 0.00 | 0.00 | 0.00 |
| DRAFTS: | 13 | 0.00 | 0.00 | 508,832.90 |
| EFT: | 0 | 0.00 | 0.00 | 0.00 |
| NON CHECKS: | 0 | 0.00 | 0.00 | 0.00 |
| VOID CHECKS: | 1 VOID DEBITS | 0.00 | | |
| | VOID CREDITS | 37.52 | 37.52 | 0.00 |

TOTAL ERRORS: 0

** G/L ACCOUNT TOTALS **

| G/L ACCOUNT | NAME | AMOUNT |
|--------------------|------------------------------|------------|
| 001 00001310000802 | DUE TO/FROM PAYROLL | 63,735.26 |
| 001 00001332300000 | ACCTS REC - HEALTH INSURANCE | 129,792.59 |
| 001 00002183000000 | DEPENDENT HEALTH | 6,568.51 |
| 001 00002184000000 | LIBERTY NATIONAL/BEFORE TAX | 212.61 |
| 001 00002184200000 | AFLAC | 406.18 |
| 001 00002185000000 | DEFERRED COMP | 1,734.60 |
| 001 00002187000000 | MISC DEDUCTIONS | 112.56 |
| 001 00002188000000 | CHILD SUPPORT | 236.00 |
| 001 26015122300000 | EMPLOYEE INSURANCE | 4,341.35 |
| 001 26015122310000 | SUBSIDIZED DEP HEALTH INS | 728.84 |
| 001 26015122320000 | SUBSIDIZED RETIREE INSURANCE | 3,167.96 |
| 001 26035152300000 | EMPLOYEE INSURANCE | 901.66 |
| 001 26035152310000 | SUBSIDIZED DEP HEALTH INS | 419.46 |
| 001 26085192300000 | EMPLOYEE INSURANCE | 3,840.43 |
| 001 26085192310000 | SUBSIDIZED DEP HEALTH INS | 683.26 |
| 001 26097122300000 | EMPLOYEE INSURANCE | 834.87 |
| 001 30155152300000 | EMPLOYEE INSURANCE | 1,335.80 |
| 001 30155152310000 | DEPENDENT HEALTH SUBSIDY | 341.63 |
| 001 30175162300000 | EMPLOYEE INSURANCE | 667.90 |

VENDOR SET: 01 Desoto County
 BANK: PYBK CONSOLIDATED ACCOUNT
 DATE RANGE: 5/15/2013 THRU 5/29/2013

** G/L ACCOUNT TOTALS **

| G/L ACCOUNT | NAME | AMOUNT |
|--------------------|------------------------------|------------|
| 001 30175162310000 | DEPENDENT HEALTH SUBSIDY | 258.14 |
| 001 30185242300000 | EMPLOYEE INSURANCE | 1,335.80 |
| 001 30185242310000 | SUBSIDIZED DEP HEALTH INS | 341.63 |
| 001 30195622300000 | EMPLOYEE INSURANCE | 2,671.60 |
| 001 31165642300000 | EMPLOYEE INSURANCE | 667.90 |
| 001 31165642310000 | SUBSIDIZED DEP HEALTH INS | 285.19 |
| 001 36245372300000 | EMPLOYEE INSURANCE | 667.90 |
| 001 36245372310000 | SUBSIDIZED DEP HEALTH INS | 341.63 |
| 001 38265712300000 | EMPLOYEE INSURANCE | 3,339.50 |
| 001 38265712310000 | SUBSIDIZED DEP HEALTH INS | 626.82 |
| 001 52425232300000 | EMPLOYEE INSURANCE | 2,003.70 |
| 001 52425232310000 | SUBSIDIZED DEP HEALTH INS | 258.14 |
| 001 52425232320000 | SUBSIDIZED RETIREE HEALTH | 1,164.26 |
| 001 70735722300000 | HEALTH AND LIFE INS | 1,335.80 |
| 001 70735722310000 | SUBSIDIZED DEP. HEALTH | 258.14 |
| 001 70745722300000 | EMPLOYEE INSURANCE | 4,007.40 |
| 001 70745722310000 | SUBSIDIZED DEP HEALTH INS | 285.19 |
| 001 70815752300000 | HEALTH & LIFE INSURANCE | 2,003.70 |
| 001 70815752310000 | DEPENDENT HEALTH INS SUBSIDY | 285.19 |
| 001 71375132300000 | EMPLOYEE INSURANCE | 6,011.08 |
| 001 71375132310000 | SUBSIDIZED DEP HEALTH INS | 1,170.15 |
| 001 71395132300000 | EMPLOYEE INSURANCE | 667.90 |
| 001 71405532300000 | HEALTH & LIFE INSURANCE | 667.90 |
| 001 71405532310000 | SUBSIDIZED DEP HEALTH INS | 285.19 |
| 001 71495132301000 | RETIREE HEALTH SUPPLEMENT | 9,927.20 |
| | *** FUND TOTAL *** | 260,928.52 |
| 102 00001310000802 | DUE TO/FROM PAYROLL | 28,734.39 |
| 102 00002183000000 | DEPENDENT HEALTH | 1,826.33 |
| 102 00002184000000 | LIBERTY INSURANCE | 70.11 |
| 102 00002184200000 | AFLAC | 294.92 |
| 102 00002185000000 | DEFERRED COMP | 100.00 |
| 102 00002188000000 | CHILD SUPPORT | 1,458.62 |
| 102 60505412300000 | EMPLOYEE INSURANCE | 22,708.60 |
| 102 60505412310000 | SUBSIDIZED DEP HEALTH INS | 1,826.36 |
| 102 60505412320000 | SUBSIDIZED RETIREE INSURANCE | 1,832.16 |
| | *** FUND TOTAL *** | 58,851.49 |
| 104 00001310000802 | DUE TO/FROM PAYROLL | 3,729.78 |
| 104 00002183000000 | DEPENDENT HEALTH | 941.38 |
| 104 00002184000000 | LIBERTY NATIONAL/BEF TAX | 37.00 |
| 104 30205412300000 | EMPLOYEE INSURANCE | 2,003.70 |
| 104 30205412310000 | DEPENDENT HEALTH SUBSIDY | 941.40 |
| | *** FUND TOTAL *** | 7,653.26 |
| 106 00001020000000 | CASH ON HAND | 436.00 |

VENDOR SET: 01 Desoto County
 BANK: PYBK CONSOLIDATED ACCOUNT
 DATE RANGE: 5/15/2013 THRU 5/29/2013

** G/L ACCOUNT TOTALS **

| G/L ACCOUNT | NAME | AMOUNT |
|--------------------|------------------------------|------------|
| 106 00001310000802 | DUE TO/FROM PAYROLL | 70,618.19 |
| 106 00002183000000 | DEPENDENT HEALTH | 6,413.99 |
| 106 00002184000000 | LIBERTY INSURANCE | 256.77 |
| 106 00002184200000 | AFLAC | 196.00 |
| 106 00002185000000 | DEFERRED COMP | 2,935.00 |
| 106 00002188000000 | CHILD SUPPORT | 975.08 |
| 106 70715292300000 | HEALTH INSURANCE | 39,072.15 |
| 106 70715292310000 | DEPENDENT HEALTH SUBSIDY | 6,240.83 |
| 106 71315252300000 | EMPLOYEE INSURANCE | 1,001.85 |
| 106 71315252310000 | SUBSIDIZED DEP HEALTH INS | 142.60 |
| 106 71315252320000 | SUBSIDIZED RETIREE INSURANCE | 667.90 |
| 106 71335252300000 | EMPLOYEE INSURANCE | 1,335.80 |
| | *** FUND TOTAL *** | 130,292.16 |
| 150 00001310000802 | DUE TO/FROM PAYROLL | 179.30 |
| 150 00002183000000 | DEPENDENT HEALTH | 51.24 |
| 150 00002184200000 | AFLAC | 5.84 |
| 150 20105522300000 | EMPLOYEE INSURANCE | 100.18 |
| 150 20105522310000 | DEPENDENT HEALTH SUBSIDY | 51.24 |
| | *** FUND TOTAL *** | 387.80 |
| 190 00001310000802 | DUE TO/FROM PAYROLL | 687.01 |
| 190 00002183000000 | DEPENDENT HEALTH | 285.19 |
| 190 24096012300000 | HEALTH & LIFE INSURANCE | 667.90 |
| 190 24096012310000 | DEPENDENT HEALTH SUBSIDY | 285.19 |
| | *** FUND TOTAL *** | 1,925.29 |
| 400 00001310000802 | DUE TO/FROM PAYROLL | 6,952.65 |
| 400 00002183000000 | DEPENDENT HEALTH | 570.38 |
| 400 00002184200000 | AFLAC | 21.30 |
| 400 00002185000000 | DEFERRED COMP | 150.00 |
| 400 42305342300000 | EMPLOYEE INSURANCE | 5,343.20 |
| 400 42305342310000 | SUBSIDIZED DEP HEALTH INS | 570.38 |
| | *** FUND TOTAL *** | 13,607.91 |
| 410 00001310000802 | DUE TO/FROM PAYROLL | 17,940.47 |
| 410 00002183000000 | DEPENDENT HEALTH | 1,527.11 |
| 410 00002184200000 | AFLAC | 177.12 |
| 410 00002185000000 | DEFERRED COMP | 963.06 |
| 410 70945362300000 | EMPLOYEE INSURANCE | 2,003.70 |
| 410 70955362300000 | EMPLOYEE INSURANCE | 1,335.80 |
| 410 70955362310000 | SUBSIDIZED DEP HEALTH INS | 285.19 |
| 410 70965332300000 | EMPLOYEE INSURANCE | 2,003.70 |
| 410 70965332310000 | SUBSIDIZED DEP HEALTH INS | 683.26 |
| 410 70975352300000 | EMPLOYEE INSURANCE | 3,339.50 |
| 410 70975352310000 | SUBSIDIZED DEP HEALTH INS | 543.33 |
| | *** FUND TOTAL *** | 30,802.24 |

VENDOR SET: 01 Desoto County
 BANK: PYBK CONSOLIDATED ACCOUNT
 DATE RANGE: 5/15/2013 THRU 5/29/2013

** G/L ACCOUNT TOTALS **

| G/L ACCOUNT | NAME | AMOUNT |
|--------------------|---------------------------|----------|
| 415 00001310000802 | DUE TO/FROM PAYROLL | 4,036.56 |
| 415 00002183000000 | DEPENDENT HEALTH | 285.19 |
| 415 30255242300000 | EMPLOYEE INSURANCE | 2,003.70 |
| 415 30255242310000 | SUBSIDIZED DEP HEALTH INS | 285.19 |
| | *** FUND TOTAL *** | 6,610.64 |

| | | | | | |
|----------------|--------------------|----|--------------|------|------------|
| VENDOR SET: 01 | BANK: PYBK TOTALS: | 20 | 511,134.35CR | 0.00 | 511,059.31 |
| BANK: PYBK | TOTALS: | 20 | 511,134.35CR | 0.00 | 511,059.31 |

VENDOR SET: 01 Desoto County
 BANK: PYCL PAYROLL CLEARING
 DATE RANGE: 5/15/2013 THRU 5/29/2013

| VENDOR I.D. | NAME | STATUS | CHECK DATE | AMOUNT | DISCOUNT | CHECK NO | CHECK STATUS | CHECK AMOUNT |
|-------------|------------------------|---------------------|---------------------|----------|----------|----------|--------------|--------------|
| 0017 | DEPARTMENT OF TREASURY | | | | | | | |
| I-T1 | 201305132512 | FEDERAL WITHHOLDING | D 5/17/2013 | | | 051718 | | |
| 001 | 00002172100000 | FEDERAL WITHHOLDING | FEDERAL WITHHOLDING | 4,457.38 | | | | |
| 102 | 00002172100000 | FEDERAL WITHHOLDING | FEDERAL WITHHOLDING | 1,667.84 | | | | |
| 104 | 00002172100000 | FEDERAL WITHHOLDING | FEDERAL WITHHOLDING | 255.96 | | | | |
| 106 | 00002172100000 | FEDERAL WITHHOLDING | FEDERAL WITHHOLDING | 5,598.12 | | | | |
| 150 | 00002172100000 | FEDERAL WITHHOLDING | FEDERAL WITHHOLDING | 4.64 | | | | |
| 400 | 00002172100000 | FEDERAL WITHHOLDING | FEDERAL WITHHOLDING | 420.43 | | | | |
| 410 | 00002172100000 | FEDERAL WITHHOLDING | FEDERAL WITHHOLDING | 1,311.41 | | | | |
| 415 | 00002172100000 | FEDERAL WITHHOLDING | FEDERAL WITHHOLDING | 359.93 | | | | |
| I-T3 | 201305132512 | FICA WITHHOLDING | D 5/17/2013 | | | 051718 | | |
| 001 | 00002172000000 | FICA | FICA WITHHOLDING | 2,627.33 | | | | |
| 001 | 26015122100000 | FICA | FICA WITHHOLDING | 448.39 | | | | |
| 001 | 26035152100000 | FICA | FICA WITHHOLDING | 77.96 | | | | |
| 001 | 26085192100000 | FICA | FICA WITHHOLDING | 235.56 | | | | |
| 001 | 26097122100000 | FICA | FICA WITHHOLDING | 34.93 | | | | |
| 001 | 30155152100000 | FICA | FICA WITHHOLDING | 95.28 | | | | |
| 001 | 30175162100000 | FICA | FICA WITHHOLDING | 60.67 | | | | |
| 001 | 30185242100000 | FICA | FICA WITHHOLDING | 89.39 | | | | |
| 001 | 30195622100000 | FICA | FICA WITHHOLDING | 168.56 | | | | |
| 001 | 31165642100000 | FICA | FICA WITHHOLDING | 90.56 | | | | |
| 001 | 36245372100000 | FICA | FICA WITHHOLDING | 65.64 | | | | |
| 001 | 38265712100000 | FICA | FICA WITHHOLDING | 154.30 | | | | |
| 001 | 52425232100000 | FICA | FICA WITHHOLDING | 132.27 | | | | |
| 001 | 70735722100000 | FICA | FICA WITHHOLDING | 97.80 | | | | |
| 001 | 70745722100000 | FICA | FICA WITHHOLDING | 168.96 | | | | |
| 001 | 70815752100000 | FICA | FICA WITHHOLDING | 110.94 | | | | |
| 001 | 70835142100000 | FICA | FICA WITHHOLDING | 40.46 | | | | |
| 001 | 71375132100000 | FICA | FICA WITHHOLDING | 425.93 | | | | |
| 001 | 71395132100000 | FICA | FICA WITHHOLDING | 93.16 | | | | |
| 001 | 71405532100000 | FICA | FICA WITHHOLDING | 36.57 | | | | |
| 102 | 00002172000000 | FICA | FICA WITHHOLDING | 1,173.62 | | | | |
| 102 | 60505412100000 | FICA | FICA WITHHOLDING | 1,173.62 | | | | |
| 104 | 00002172000000 | FICA | FICA WITHHOLDING | 149.52 | | | | |
| 104 | 30205412100000 | FICA | FICA WITHHOLDING | 149.52 | | | | |
| 106 | 00002172000000 | FICA | FICA WITHHOLDING | 3,045.53 | | | | |
| 106 | 70715292100000 | FICA | FICA WITHHOLDING | 2,890.57 | | | | |
| 106 | 71315252100000 | FICA | FICA WITHHOLDING | 92.84 | | | | |
| 106 | 71335252100000 | FICA | FICA WITHHOLDING | 62.12 | | | | |
| 150 | 00002172000000 | FICA | FICA WITHHOLDING | 6.69 | | | | |
| 150 | 20105522100000 | FICA | FICA WITHHOLDING | 6.69 | | | | |
| 190 | 00002172000000 | FICA | FICA WITHHOLDING | 18.15 | | | | |
| 190 | 24096012100000 | FICA | FICA WITHHOLDING | 18.15 | | | | |
| 400 | 00002172000000 | FICA | FICA WITHHOLDING | 277.51 | | | | |
| 400 | 42305342100000 | FICA | FICA WITHHOLDING | 277.51 | | | | |
| 410 | 00002172000000 | FICA | FICA WITHHOLDING | 745.35 | | | | |
| 410 | 70945362100000 | FICA | FICA WITHHOLDING | 205.36 | | | | |
| 410 | 70955362100000 | FICA | FICA WITHHOLDING | 95.96 | | | | |

VENDOR SET: 01 Desoto County
 BANK: PYCL PAYROLL CLEARING
 DATE RANGE: 5/15/2013 THRU 5/29/2013

| VENDOR I.D. | NAME | STATUS | CHECK DATE | AMOUNT | DISCOUNT | CHECK NO | CHECK STATUS | CHECK AMOUNT |
|-------------|----------------------------|----------------------|----------------------|--------|----------|----------|--------------|--------------|
| 0017 | DEPARTMENT OF TREASURYCONT | | | | | | | |
| I-T3 | 201305132512 | FICA WITHHOLDING | D 5/17/2013 | | | 051718 | | |
| 410 | 70965332100000 | F.I.C.A. | FICA WITHHOLDING | 186.85 | | | | |
| 410 | 70975352100000 | FICA | FICA WITHHOLDING | 257.18 | | | | |
| 415 | 00002172000000 | FICA | FICA WITHHOLDING | 166.12 | | | | |
| 415 | 30255242100000 | FICA | FICA WITHHOLDING | 166.12 | | | | |
| I-T4 | 201305132512 | MEDICARE WITHHOLDING | D 5/17/2013 | | | 051718 | | |
| 001 | 00002172000000 | FICA | MEDICARE WITHHOLDING | 614.43 | | | | |
| 001 | 26015122100000 | FICA | MEDICARE WITHHOLDING | 104.85 | | | | |
| 001 | 26035152100000 | FICA | MEDICARE WITHHOLDING | 18.24 | | | | |
| 001 | 26085192100000 | FICA | MEDICARE WITHHOLDING | 55.08 | | | | |
| 001 | 26097122100000 | FICA | MEDICARE WITHHOLDING | 8.17 | | | | |
| 001 | 30155152100000 | FICA | MEDICARE WITHHOLDING | 22.28 | | | | |
| 001 | 30175162100000 | FICA | MEDICARE WITHHOLDING | 14.19 | | | | |
| 001 | 30185242100000 | FICA | MEDICARE WITHHOLDING | 20.91 | | | | |
| 001 | 30195622100000 | FICA | MEDICARE WITHHOLDING | 39.42 | | | | |
| 001 | 31165642100000 | FICA | MEDICARE WITHHOLDING | 21.18 | | | | |
| 001 | 36245372100000 | FICA | MEDICARE WITHHOLDING | 15.35 | | | | |
| 001 | 38265712100000 | FICA | MEDICARE WITHHOLDING | 36.09 | | | | |
| 001 | 52425232100000 | FICA | MEDICARE WITHHOLDING | 30.93 | | | | |
| 001 | 70735722100000 | FICA | MEDICARE WITHHOLDING | 22.87 | | | | |
| 001 | 70745722100000 | FICA | MEDICARE WITHHOLDING | 39.52 | | | | |
| 001 | 70815752100000 | FICA | MEDICARE WITHHOLDING | 25.94 | | | | |
| 001 | 70835142100000 | FICA | MEDICARE WITHHOLDING | 9.46 | | | | |
| 001 | 71375132100000 | FICA | MEDICARE WITHHOLDING | 99.61 | | | | |
| 001 | 71395132100000 | FICA | MEDICARE WITHHOLDING | 21.79 | | | | |
| 001 | 71405532100000 | FICA | MEDICARE WITHHOLDING | 8.55 | | | | |
| 102 | 00002172000000 | FICA | MEDICARE WITHHOLDING | 274.48 | | | | |
| 102 | 60505412100000 | FICA | MEDICARE WITHHOLDING | 274.48 | | | | |
| 104 | 00002172000000 | FICA | MEDICARE WITHHOLDING | 34.96 | | | | |
| 104 | 30205412100000 | FICA | MEDICARE WITHHOLDING | 34.96 | | | | |
| 106 | 00002172000000 | FICA | MEDICARE WITHHOLDING | 712.28 | | | | |
| 106 | 70715292100000 | FICA | MEDICARE WITHHOLDING | 676.03 | | | | |
| 106 | 71315252100000 | FICA | MEDICARE WITHHOLDING | 21.72 | | | | |
| 106 | 71335252100000 | FICA | MEDICARE WITHHOLDING | 14.53 | | | | |
| 150 | 00002172000000 | FICA | MEDICARE WITHHOLDING | 1.56 | | | | |
| 150 | 20105522100000 | FICA | MEDICARE WITHHOLDING | 1.56 | | | | |
| 190 | 00002172000000 | FICA | MEDICARE WITHHOLDING | 4.24 | | | | |
| 190 | 24096012100000 | FICA | MEDICARE WITHHOLDING | 4.24 | | | | |
| 400 | 00002172000000 | FICA | MEDICARE WITHHOLDING | 64.91 | | | | |
| 400 | 42305342100000 | FICA | MEDICARE WITHHOLDING | 64.91 | | | | |
| 410 | 00002172000000 | FICA | MEDICARE WITHHOLDING | 174.32 | | | | |
| 410 | 70945362100000 | FICA | MEDICARE WITHHOLDING | 48.03 | | | | |
| 410 | 70955362100000 | FICA | MEDICARE WITHHOLDING | 22.44 | | | | |
| 410 | 70965332100000 | F.I.C.A. | MEDICARE WITHHOLDING | 43.70 | | | | |
| 410 | 70975352100000 | FICA | MEDICARE WITHHOLDING | 60.15 | | | | |
| 415 | 00002172000000 | FICA | MEDICARE WITHHOLDING | 38.85 | | | | |
| 415 | 30255242100000 | FICA | MEDICARE WITHHOLDING | 38.85 | | | | |

VENDOR SET: 01 Desoto County
 BANK: PYCL PAYROLL CLEARING
 DATE RANGE: 5/15/2013 THRU 5/29/2013

| VENDOR I.D. | NAME | STATUS | CHECK DATE | AMOUNT | DISCOUNT | CHECK NO | CHECK STATUS | CHECK AMOUNT |
|-------------|------------------------|---------------------|---------------------|----------|----------|-------------|-----------------|-----------------|
| 0017 | DEPARTMENT OF TREASURY | | | | | | | |
| I-T1 | 201305202541 | FEDERAL WITHHOLDING | D 5/24/2013 | | | 052418 | | |
| 001 | 00002172100000 | FEDERAL WITHHOLDING | FEDERAL WITHHOLDING | 4,391.78 | | | | |
| 102 | 00002172100000 | FEDERAL WITHHOLDING | FEDERAL WITHHOLDING | 1,661.82 | | | | |
| 104 | 00002172100000 | FEDERAL WITHHOLDING | FEDERAL WITHHOLDING | 255.96 | | | | |
| 106 | 00002172100000 | FEDERAL WITHHOLDING | FEDERAL WITHHOLDING | 5,524.83 | | | | |
| 150 | 00002172100000 | FEDERAL WITHHOLDING | FEDERAL WITHHOLDING | 4.64 | | | | |
| 190 | 00002172100000 | FEDERAL WITHHOLDING | FEDERAL WITHHOLDING | 0.67 | | | | |
| 400 | 00002172100000 | FEDERAL WITHHOLDING | FEDERAL WITHHOLDING | 417.05 | | | | |
| 410 | 00002172100000 | FEDERAL WITHHOLDING | FEDERAL WITHHOLDING | 1,316.51 | | | | |
| 415 | 00002172100000 | FEDERAL WITHHOLDING | FEDERAL WITHHOLDING | 359.93 | | | | |
| I-T3 | 201305202541 | FICA WITHHOLDING | D 5/24/2013 | | | 052418 | | |
| 001 | 00002172000000 | FICA | FICA WITHHOLDING | 2,610.79 | | | | |
| 001 | 26015122100000 | FICA | FICA WITHHOLDING | 448.40 | | | | |
| 001 | 26035152100000 | FICA | FICA WITHHOLDING | 77.95 | | | | |
| 001 | 26085192100000 | FICA | FICA WITHHOLDING | 230.42 | | | | |
| 001 | 26097122100000 | FICA | FICA WITHHOLDING | 32.50 | | | | |
| 001 | 30155152100000 | FICA | FICA WITHHOLDING | 95.28 | | | | |
| 001 | 30175162100000 | FICA | FICA WITHHOLDING | 62.40 | | | | |
| 001 | 30185242100000 | FICA | FICA WITHHOLDING | 89.39 | | | | |
| 001 | 30195622100000 | FICA | FICA WITHHOLDING | 152.44 | | | | |
| 001 | 31165642100000 | FICA | FICA WITHHOLDING | 90.56 | | | | |
| 001 | 36245372100000 | FICA | FICA WITHHOLDING | 71.13 | | | | |
| 001 | 38265712100000 | FICA | FICA WITHHOLDING | 154.30 | | | | |
| 001 | 52425232100000 | FICA | FICA WITHHOLDING | 132.27 | | | | |
| 001 | 70735722100000 | FICA | FICA WITHHOLDING | 93.27 | | | | |
| 001 | 70745722100000 | FICA | FICA WITHHOLDING | 168.96 | | | | |
| 001 | 70815752100000 | FICA | FICA WITHHOLDING | 115.40 | | | | |
| 001 | 70835142100000 | FICA | FICA WITHHOLDING | 40.46 | | | | |
| 001 | 71375132100000 | FICA | FICA WITHHOLDING | 425.93 | | | | |
| 001 | 71395132100000 | FICA | FICA WITHHOLDING | 93.16 | | | | |
| 001 | 71405532100000 | FICA | FICA WITHHOLDING | 36.57 | | | | |
| 102 | 00002172000000 | FICA | FICA WITHHOLDING | 1,171.06 | | | | |
| 102 | 60505412100000 | FICA | FICA WITHHOLDING | 1,171.06 | | | | |
| 104 | 00002172000000 | FICA | FICA WITHHOLDING | 149.52 | | | | |
| 104 | 30205412100000 | FICA | FICA WITHHOLDING | 149.52 | | | | |
| 106 | 00002172000000 | FICA | FICA WITHHOLDING | 2,949.86 | | | | |
| 106 | 70715292100000 | FICA | FICA WITHHOLDING | 2,794.90 | | | | |
| 106 | 71315252100000 | FICA | FICA WITHHOLDING | 92.84 | | | | |
| 106 | 71335252100000 | FICA | FICA WITHHOLDING | 62.12 | | | | |
| 150 | 00002172000000 | FICA | FICA WITHHOLDING | 6.69 | | | | |
| 150 | 20105522100000 | FICA | FICA WITHHOLDING | 6.69 | | | | |
| 190 | 00002172000000 | FICA | FICA WITHHOLDING | 30.00 | | | | |
| 190 | 24096012100000 | FICA | FICA WITHHOLDING | 30.00 | | | | |
| 400 | 00002172000000 | FICA | FICA WITHHOLDING | 276.07 | | | | |
| 400 | 42305342100000 | FICA | FICA WITHHOLDING | 276.07 | | | | |
| 410 | 00002172000000 | FICA | FICA WITHHOLDING | 762.59 | | | | |
| 410 | 70945362100000 | FICA | FICA WITHHOLDING | 203.76 | | | | |

VENDOR SET: 01 Desoto County
 BANK: PYCL PAYROLL CLEARING
 DATE RANGE: 5/15/2013 THRU 5/29/2013

| VENDOR I.D. | NAME | STATUS | CHECK DATE | AMOUNT | DISCOUNT | CHECK NO | CHECK STATUS | CHECK AMOUNT |
|--------------------|----------------------------|--------|----------------------|--------|----------|----------|--------------|--------------|
| 0017 | DEPARTMENT OF TREASURYCONT | | | | | | | |
| I-T3 201305202541 | FICA WITHHOLDING | D | 5/24/2013 | | | 052418 | | |
| 410 70955362100000 | FICA | | FICA WITHHOLDING | 87.71 | | | | |
| 410 70965332100000 | F.I.C.A. | | FICA WITHHOLDING | 209.48 | | | | |
| 410 70975352100000 | FICA | | FICA WITHHOLDING | 261.64 | | | | |
| 415 00002172000000 | FICA | | FICA WITHHOLDING | 166.12 | | | | |
| 415 30255242100000 | FICA | | FICA WITHHOLDING | 166.12 | | | | |
| I-T4 201305202541 | MEDICARE WITHHOLDING | D | 5/24/2013 | | | 052418 | | |
| 001 00002172000000 | FICA | | MEDICARE WITHHOLDING | 610.56 | | | | |
| 001 26015122100000 | FICA | | MEDICARE WITHHOLDING | 104.86 | | | | |
| 001 26035152100000 | FICA | | MEDICARE WITHHOLDING | 18.23 | | | | |
| 001 26085192100000 | FICA | | MEDICARE WITHHOLDING | 53.88 | | | | |
| 001 26097122100000 | FICA | | MEDICARE WITHHOLDING | 7.60 | | | | |
| 001 30155152100000 | FICA | | MEDICARE WITHHOLDING | 22.28 | | | | |
| 001 30175162100000 | FICA | | MEDICARE WITHHOLDING | 14.60 | | | | |
| 001 30185242100000 | FICA | | MEDICARE WITHHOLDING | 20.91 | | | | |
| 001 30195622100000 | FICA | | MEDICARE WITHHOLDING | 35.65 | | | | |
| 001 31165642100000 | FICA | | MEDICARE WITHHOLDING | 21.18 | | | | |
| 001 36245372100000 | FICA | | MEDICARE WITHHOLDING | 16.63 | | | | |
| 001 38265712100000 | FICA | | MEDICARE WITHHOLDING | 36.09 | | | | |
| 001 52425232100000 | FICA | | MEDICARE WITHHOLDING | 30.93 | | | | |
| 001 70735722100000 | FICA | | MEDICARE WITHHOLDING | 21.81 | | | | |
| 001 70745722100000 | FICA | | MEDICARE WITHHOLDING | 39.52 | | | | |
| 001 70815752100000 | FICA | | MEDICARE WITHHOLDING | 26.98 | | | | |
| 001 70835142100000 | FICA | | MEDICARE WITHHOLDING | 9.46 | | | | |
| 001 71375132100000 | FICA | | MEDICARE WITHHOLDING | 99.61 | | | | |
| 001 71395132100000 | FICA | | MEDICARE WITHHOLDING | 21.79 | | | | |
| 001 71405532100000 | FICA | | MEDICARE WITHHOLDING | 8.55 | | | | |
| 102 00002172000000 | FICA | | MEDICARE WITHHOLDING | 273.88 | | | | |
| 102 60505412100000 | FICA | | MEDICARE WITHHOLDING | 273.88 | | | | |
| 104 00002172000000 | FICA | | MEDICARE WITHHOLDING | 34.96 | | | | |
| 104 30205412100000 | FICA | | MEDICARE WITHHOLDING | 34.96 | | | | |
| 106 00002172000000 | FICA | | MEDICARE WITHHOLDING | 689.92 | | | | |
| 106 70715292100000 | FICA | | MEDICARE WITHHOLDING | 653.67 | | | | |
| 106 71315252100000 | FICA | | MEDICARE WITHHOLDING | 21.72 | | | | |
| 106 71335252100000 | FICA | | MEDICARE WITHHOLDING | 14.53 | | | | |
| 150 00002172000000 | FICA | | MEDICARE WITHHOLDING | 1.56 | | | | |
| 150 20105522100000 | FICA | | MEDICARE WITHHOLDING | 1.56 | | | | |
| 190 00002172000000 | FICA | | MEDICARE WITHHOLDING | 7.02 | | | | |
| 190 24096012100000 | FICA | | MEDICARE WITHHOLDING | 7.02 | | | | |
| 400 00002172000000 | FICA | | MEDICARE WITHHOLDING | 64.57 | | | | |
| 400 42305342100000 | FICA | | MEDICARE WITHHOLDING | 64.57 | | | | |
| 410 00002172000000 | FICA | | MEDICARE WITHHOLDING | 178.36 | | | | |
| 410 70945362100000 | FICA | | MEDICARE WITHHOLDING | 47.66 | | | | |
| 410 70955362100000 | FICA | | MEDICARE WITHHOLDING | 20.51 | | | | |
| 410 70965332100000 | F.I.C.A. | | MEDICARE WITHHOLDING | 48.99 | | | | |
| 410 70975352100000 | FICA | | MEDICARE WITHHOLDING | 61.20 | | | | |
| 415 00002172000000 | FICA | | MEDICARE WITHHOLDING | 38.85 | | | | |

VENDOR SET: 01 Desoto County
 BANK: PYCL PAYROLL CLEARING
 DATE RANGE: 5/15/2013 THRU 5/29/2013

| VENDOR I.D. | NAME | STATUS | CHECK DATE | AMOUNT | DISCOUNT | CHECK NO | CHECK STATUS | CHECK AMOUNT |
|--------------------|----------------------------|--------|------------|--------|----------|----------|--------------|--------------|
| 0017 | DEPARTMENT OF TREASURYCONT | | | | | | | |
| I-T4 201305202541 | MEDICARE WITHHOLDING | D | 5/24/2013 | | | 052418 | | |
| 415 30255242100000 | FICA | | | 38.85 | | | | 33,977.95 |

| * * T O T A L S * * | NO | INVOICE AMOUNT | DISCOUNTS | CHECK AMOUNT |
|---------------------|---------------|----------------|-----------|--------------|
| REGULAR CHECKS: | 0 | 0.00 | 0.00 | 0.00 |
| HAND CHECKS: | 0 | 0.00 | 0.00 | 0.00 |
| DRAFTS: | 2 | 0.00 | 0.00 | 68,313.36 |
| EFT: | 0 | 0.00 | 0.00 | 0.00 |
| NON CHECKS: | 0 | 0.00 | 0.00 | 0.00 |
| VOID CHECKS: | 0 VOID DEBITS | 0.00 | | |
| | VOID CREDITS | 0.00 | 0.00 | 0.00 |

TOTAL ERRORS: 0

** G/L ACCOUNT TOTALS **

| G/L ACCOUNT | NAME | AMOUNT |
|--------------------|---------------------|-----------|
| 001 00002172000000 | FICA | 6,463.11 |
| 001 00002172100000 | FEDERAL WITHHOLDING | 8,849.16 |
| 001 26015122100000 | FICA | 1,106.50 |
| 001 26035152100000 | FICA | 192.38 |
| 001 26085192100000 | FICA | 574.94 |
| 001 26097122100000 | FICA | 83.20 |
| 001 30155152100000 | FICA | 235.12 |
| 001 30175162100000 | FICA | 151.86 |
| 001 30185242100000 | FICA | 220.60 |
| 001 30195622100000 | FICA | 396.07 |
| 001 31165642100000 | FICA | 223.48 |
| 001 36245372100000 | FICA | 168.75 |
| 001 38265712100000 | FICA | 380.78 |
| 001 52425232100000 | FICA | 326.40 |
| 001 70735722100000 | FICA | 235.75 |
| 001 70745722100000 | FICA | 416.96 |
| 001 70815752100000 | FICA | 279.26 |
| 001 70835142100000 | FICA | 99.84 |
| 001 71375132100000 | FICA | 1,051.08 |
| 001 71395132100000 | FICA | 229.90 |
| 001 71405532100000 | FICA | 90.24 |
| | *** FUND TOTAL *** | 21,775.38 |
| 102 00002172000000 | FICA | 2,893.04 |
| 102 00002172100000 | FEDERAL WITHHOLDING | 3,329.66 |

VENDOR SET: 01 Desoto County
 BANK: PYCL PAYROLL CLEARING
 DATE RANGE: 5/15/2013 THRU 5/29/2013

** G/L ACCOUNT TOTALS **

| G/L ACCOUNT | NAME | AMOUNT |
|--------------------|---------------------|-----------|
| 102 60505412100000 | FICA | 2,893.04 |
| | *** FUND TOTAL *** | 9,115.74 |
| 104 00002172000000 | FICA | 368.96 |
| 104 00002172100000 | FEDERAL WITHHOLDING | 511.92 |
| 104 30205412100000 | FICA | 368.96 |
| | *** FUND TOTAL *** | 1,249.84 |
| 106 00002172000000 | FICA | 7,397.59 |
| 106 00002172100000 | FEDERAL WITHHOLDING | 11,122.95 |
| 106 70715292100000 | FICA | 7,015.17 |
| 106 71315252100000 | FICA | 229.12 |
| 106 71335252100000 | FICA | 153.30 |
| | *** FUND TOTAL *** | 25,918.13 |
| 150 00002172000000 | FICA | 16.50 |
| 150 00002172100000 | FEDERAL WITHHOLDING | 9.28 |
| 150 20105522100000 | FICA | 16.50 |
| | *** FUND TOTAL *** | 42.28 |
| 190 00002172000000 | FICA | 59.41 |
| 190 00002172100000 | FEDERAL WITHHOLDING | 0.67 |
| 190 24096012100000 | FICA | 59.41 |
| | *** FUND TOTAL *** | 119.49 |
| 400 00002172000000 | FICA | 683.06 |
| 400 00002172100000 | FEDERAL WITHHOLDING | 837.48 |
| 400 42305342100000 | FICA | 683.06 |
| | *** FUND TOTAL *** | 2,203.60 |
| 410 00002172000000 | FICA | 1,860.62 |
| 410 00002172100000 | FEDERAL WITHHOLDING | 2,627.92 |
| 410 70945362100000 | FICA | 504.81 |
| 410 70955362100000 | FICA | 226.62 |
| 410 70965332100000 | F.I.C.A. | 489.02 |
| 410 70975352100000 | FICA | 640.17 |
| | *** FUND TOTAL *** | 6,349.16 |
| 415 00002172000000 | FICA | 409.94 |
| 415 00002172100000 | FEDERAL WITHHOLDING | 719.86 |
| 415 30255242100000 | FICA | 409.94 |
| | *** FUND TOTAL *** | 1,539.74 |

| | | | | | | |
|----------------|------------|---------|---|-------------|------|-----------|
| VENDOR SET: 01 | BANK: PYCL | TOTALS: | 2 | 68,313.36CR | 0.00 | 68,313.36 |
| BANK: PYCL | TOTALS: | | 2 | 68,313.36CR | 0.00 | 68,313.36 |

VENDOR SET: 01 Desoto County
BANK: SHIP LOCAL HOUSING/ SHIP ACCT
DATE RANGE: 5/15/2013 THRU 5/29/2013

| VENDOR I.D. | NAME | STATUS | CHECK DATE | AMOUNT | DISCOUNT | CHECK NO | CHECK STATUS | CHECK AMOUNT |
|--------------------|--------------------------------|----------------------|------------|----------|----------|----------|--------------|--------------|
| 4482 | BECERRA CONSTRUCTION OF CENTRA | | | | | | | |
| I-201305242547 | JESSIE DURHAM | R | 5/24/2013 | | | 000701 | | |
| 141 71295543400000 | CONTRACTED SERVICES-SHIP | JESSIE DURHAM | | 1,800.00 | | | | |
| I-201305242549 | EVA RODRIGUEZ | R | 5/24/2013 | | | 000701 | | |
| 141 71295543400000 | CONTRACTED SERVICES-SHIP | EVA RODRIGUEZ | | 2,400.00 | | | | 4,200.00 |
| 3685 | CLEAN CUTS, LLC. | | | | | | | |
| I-201305242553 | LETTY HARRIS - REPLACE | R | 5/24/2013 | | | 000702 | | |
| 141 71295543400000 | CONTRACTED SERVICES-SHIP | LETTY HARRIS - REPLA | | 2,680.00 | | | | 2,680.00 |
| 3685 | CLEAN CUTS, LLC. | | | | | | | |
| I-201305242555 | LETTY HARRIS - REPLACE | R | 5/24/2013 | | | 000703 | | |
| 141 71295543400000 | CONTRACTED SERVICES-SHIP | LETTY HARRIS - REPLA | | 2,680.00 | | | | 2,680.00 |
| 3652 | JEWEL CONTRACTING, INC. | | | | | | | |
| I-201305242551 | RAMON MANCERA | R | 5/24/2013 | | | 000704 | | |
| 141 71295543400000 | CONTRACTED SERVICES-SHIP | RAMON MANCERA | | 3,115.60 | | | | 3,115.60 |

| * * T O T A L S * * | NO | INVOICE AMOUNT | DISCOUNTS | CHECK AMOUNT |
|---------------------|----|-------------------|-----------|--------------|
| REGULAR CHECKS: | 4 | 0.00 | 0.00 | 12,675.60 |
| HAND CHECKS: | 0 | 0.00 | 0.00 | 0.00 |
| DRAFTS: | 0 | 0.00 | 0.00 | 0.00 |
| EFT: | 0 | 0.00 | 0.00 | 0.00 |
| NON CHECKS: | 0 | 0.00 | 0.00 | 0.00 |
| VOID CHECKS: | 0 | VOID DEBITS 0.00 | | |
| | | VOID CREDITS 0.00 | 0.00 | 0.00 |

TOTAL ERRORS: 0

** G/L ACCOUNT TOTALS **

| G/L ACCOUNT | NAME | AMOUNT |
|--------------------|--------------------------|-----------|
| 141 71295543400000 | CONTRACTED SERVICES-SHIP | 12,675.60 |
| | *** FUND TOTAL *** | 12,675.60 |

| | | | | | | |
|----------------|------------|---------|-----|----------------|------|--------------|
| VENDOR SET: 01 | BANK: SHIP | TOTALS: | 4 | 12,675.60CR | 0.00 | 12,675.60 |
| BANK: SHIP | TOTALS: | | 4 | 12,675.60CR | 0.00 | 12,675.60 |
| REPORT TOTALS: | | | 300 | 1,072,564.09CR | 0.00 | 1,068,504.47 |

SELECTION CRITERIA

VENDOR SET: 01-DESOTO COUNTY
VENDOR: ALL
BANK CODES: All
FUNDS: All

CHECK SELECTION

CHECK RANGE: 000000 THRU 999999
DATE RANGE: 5/15/2013 THRU 5/29/2013
CHECK AMOUNT RANGE: 0.00 THRU 999,999,999.99
INCLUDE ALL VOIDS: YES

PRINT OPTIONS

SEQUENCE: CHECK NUMBER

PRINT TRANSACTIONS: YES
PRINT G/L: YES
UNPOSTED ONLY: NO
EXCLUDE UNPOSTED: NO
MANUAL ONLY: NO
STUB COMMENTS: NO
REPORT FOOTER: NO
CHECK STATUS: NO
PRINT STATUS: * - All

BOARD OF COUNTY COMMISSIONERS

AGENDA ITEM #2

DESOTO COUNTY, FLORIDA

DATE: June 11, 2013

Consent Agenda
 Regular Business
 Public Hearing

Quasi-Judicial Public Hearing
 Time

DEPARTMENT: Administration

SUBMITTED BY:

PRESENTED BY:

TITLE & Minutes

DESCRIPTION:

REQUESTED MOTION: Approve the Minutes of May 28, 2013 Public Meeting and May 28, 2013 Workshop

SUMMARY:

BACKGROUND:

FUNDS:

| | |
|--------------------------|-----|
| Budget Amount | N/A |
| Actual Agenda Item Cost: | N/A |
| Account Number: | N/A |
| Explanation: | N/A |

ATTACHMENTS:

REVIEW APPROVAL:

County Administrator

C. Amy Mafey

County Attorney

Department Director

Other

Jill Thompson

**PUBLIC MEETING OF THE BOARD OF COUNTY COMMISSIONERS
HELD ON MAY 28, 2013 AT 3:00 PM
IN THE COUNTY COMMISSIONERS' MEETING ROOM
ROOM 103, ADMINISTRATION BUILDING
ARCADIA, FLORIDA**

The Board of County Commissioners held a Public Meeting on May 28, 2013 with the following persons present:

| | |
|--|--|
| Commissioner, Buddy Mansfield, Dist#1 | Code Compliance Director, Jorge Hernandez |
| Chairman, James Selph, Dist#2 | Utilities Director, Eddie Miller |
| Commissioner, Gabriel Quave, Dist#3 | Social Services Director, Peggy Waters |
| Commissioner, Elton Langford, Dist#4 | Fire Chief, Glenn Prescott |
| Commissioner, Bob Miller, Dist#5 | Building Official, Lester Hornbake |
| County Administrator, C. Guy Maxcy | HR Director, Don Kesterson |
| County Attorney, Don Conn | Purchasing Director, Cindy Talamantez |
| Office Manager, Lauri Jones | Facilities Director, Richard Metzger |
| County Coordinator, Mandy Hines | DeSoto County Sheriff, Will Wise |
| Transcribing Secretary, Jill Thompson | County Engineer, Mike Giardullo |
| Turner Center Director, Jody Sullivan | Administrative Services Director, Linda Nipper |
| Road & Bridge Director, Shawn Edwards | Dep. Fire Chief, Larry Taylor |
| Planning Manager, Tom Cookingham | County Extension Director, Ken Johnson |
| Environmental Svcs. Director, Henry Grimes | Parks & Recreation Director, Tara Anderson |
| Emergency Mgmt. Director, Doug Christ | Compliance Specialist, Cathy Miller |

CALL TO ORDER 3:00 PM

PRAYER- Commissioner Langford

PLEDGE OF ALLEGIANCE

INTRODUCTION OF ELECTED OFFICIALS

Sheriff Will Wise, Kathy Hill

SET/AMEND-A motion was made by Commissioner Mansfield to set the agenda. Seconded by Commissioner Quave. Motion carried unanimously.

CONSENT AGENDA-MOTION TO APPROVE

A motion was made by Commissioner Langford to approve the Accounts and Warrants drawn according to schedule of bills payable; Minutes of May 14, 2013 Public Meeting and Minutes of May 14, 2013 I. Seconded by Commissioner Mansfield. Motion carried unanimously.

PUBLIC FORUM FOR NON-AGENDA ITEMS

None

PRESENTATION

3. Presentation/District 12, Chief Medical Examiner

Dr. Russell Vega, Chief Medical Examiner District 12 presented information on how he and his staff operate and how his budget is developed. Mr. Vega reviewed different topics such as The Medical Examiner Act, districts, staff, death investigations, cremations, investigative authority, public health, mass fatality events, budget, expenses, the current ME budget, facility expenses and body transport expense. Chairman Selph thanked Dr. Vega for his presentation and requested an annual report.

4. Presentation/Pepper Ave. Bridge #044036

Mike Giardullo gave a presentation regarding the poor condition of Pepper Ave. Bridge. Mr. Giardullo commented the bridge was constructed in 1927. The bridge has cracking, exposed steel, decaying foundation and undermining of abutment. Mr. Giardullo reviewed different options to solve the problem of the declining bridge. Two options included replacing or removing the bridge.

Ken Pepper commented that both he and Steve Sorrels are ok with any solution the County decides upon. Shawn Edwards commented that if the Board decides to close the road, the County will continue to maintain the drainage. Mike Giardullo will bring back to the Board as an agenda item. He also suggested closing the road immediately until a final decision is made. A motion was made by Commissioner Quave to close Pepper Ave. Rd and bridge as soon as possible with the correct barrier and signage. Seconded by Commissioner Langford. Motion carried unanimously.

PROCLAMATION

5. Proclamation/Civility Month

Guy Maxcy read into record the Proclamation declaring May 2013 as Civility Month. A motion was made by Commissioner Miller to proclaim the month of May as Civility Month. Seconded by Commissioner Quave. Motion carried unanimously.

REGULAR BUSINESS

6. Resolution/Budget Amendments

Linda Nipper requested the Board to approve Amendments #2013-67,# 2013-70, #2013-71 and #2013-72. A motion was made by Commissioner Langford to adopt the Resolution amending the 2012/2013 Budget including attachments. Seconded by Commissioner Mansfield. Motion carried unanimously.

7. Resolution/Economic Development Advisory Committee Appointment

Mandy Hines commented there are three sectors that are mandated by the Board as participants in EDAC and those are the Chamber, Education and the City. The new members are Dr. Karen Gary, Penny Kurtz and Tom Slaughter. Ms. Hines also requested the Board to appoint a member to serve on the EDAC. Staff recommends to incorporate Planning into this process and appoint Tom Cookingham. A motion was made by Commissioner Langford to adopt the Resolution appointing members to serve on the Economic Development Advisory Committee as presented and to appoint Mr. Tom Cookingham, Planning Manager as the County Commission appointee. Seconded by Commissioner Miller. Motion carried unanimously.

8. Letter of Commitment/Community Development Block Grant

Mandy Hines stated this is an amended Letter of Commitment that's relative to the CDBG Block Grant application on behalf of Allied Recycling. A motion was made by Commissioner Mansfield to approve the revised Letter of Commitment as presented. Seconded by Commissioner Quave. Motion carried unanimously.

9. Short Sale/SHIP Mortgage forgiveness

Peggy Waters stated the County holds a second mortgage on said property. Due to the economic situation of the homeowner, the property is in foreclosure. The first mortgage holder has agreed to the short sale and is allowing DeSoto County \$6,000.00 satisfaction to the second mortgage. A motion was made by Commissioner Quave to approve the short sale offer of \$6,000.00 as payment for the SHIP second mortgage on a home located at 235 Colombia St. Seconded by Commissioner Mansfield. Motion carried unanimously.

10. Bid Award-Agreement/BOCC and Emergency Response Educators & Consultants

Doug Christ requested execution of a contract to conduct a learning exercise. A motion was made by Commissioner Quave to approve, award the bid and accept the agreement with EREC and

authorize the Chairman to execute the agreement. Seconded by Commissioner Mansfield. Motion carried unanimously.

11. Agreement/Venice Island Development, Inc

Eddie Miller stated Mr. Patterson has 16 homes he has started in the Lake Suzy area and has paid his reservation fees. A motion was made by Commissioner Langford to approve the Utility Service and Conveyance Agreement with Venice Island Development, Inc. Seconded by Commissioner Mansfield. Motion carried unanimously.

ADMINISTRATOR'S REPORT

Mr. Maxcy requested the addition of discussion on the Highway 17 utility project for the June 11, 2013 Workshop. There was consensus from the Board. Mr. Maxcy then requested Linda Nipper to present the MSBU rate revision review. Ms. Nipper stated there were concerns with the flat rate for commercial. The tiered method was decreased according to size. Further discussion was had. Mr. Maxcy suggested dividing the total square footage in the County and divide into the budget needed to see what that rate would be. Chairman Selph requested no more than 8.5 cent per acre regarding the Ag properties. Commissioner Quave feels to tax by square footage without regard to how that parcel is zoned, may affect the Property Appraiser. David Williams commented non-ad valorem assessments would have no affect on what he does. Commissioner Miller feels there is no way to offset the individuals due to the fact that the MSBU cannot fluctuate. Further discussion was had. The Board feels it is better to start higher and can always decrease if needed. Commissioner Mansfield requested that Ms. Nipper figure 8.5 cent per acre as well as 10 cent per acre to be brought back to the Board at the June 11th Board Meeting.

Mr. Maxcy called on Shawn Edwards and Robert Hamrick to discuss mitered ends. Mr. Edwards stated the mitered ends takes longer to install. Further discussion followed. Robert Hamrick will contact Road & Bridge along with Engineering and bring results back to the Board at the June 25th Board Meeting. Mr. Maxcy stated the LDR will need to be amended asked that Robert Hamrick work with Engineering as well as Road & Bridge for solutions on this issue.

Mr. Maxcy called on Peggy Waters to give a report regarding the withdrawal of commodity distribution by County employees. Ms Waters stated DeSoto County is the only local government left that is doing this program. The State will find another person or entity to continue with the program. Ms. Waters commented there is a wealth of different ways to help feed residents of the County. There will be a 30 day notice given due to the contract.

COUNTY ATTORNEY'S REPORT

Mr. Conn suggested setting an Executive Session regarding the status of the Astaldi Construction case. He suggested June 11, 2013 following the regular Board meeting.

BOARD MEMBER COMMENTS

Commissioner Quave commented on his trip to Orlando for Emergency Management training. He spoke at the British Memorial on Memorial Day. Commissioner Quave commended Lee Gallagher on a job well done regarding the Memorial Day Ceremony at the Courthouse.

Commissioner Langford had no comments.

Commissioner Mansfield had no comments.

Commissioner Miller thanked all for civility.

Chairman Selph announced that at 5:30 pm on June 5, 2013 at the Turner Center they will hold the Hurricane Seminar. He also commented about the Memorial Service for Sgt. Chris Ward. Chairman Selph commended Rotary for commemorating the loss of life of the British soldiers in WWII. He also commented the Governor had signed the State Budget.

Commissioner Mansfield asked that everyone remember the people in Moore, Oklahoma.

Dr. Louis Kirschner, Chairman of the Republican Executive Committee in DeSoto County, read to the Board a Resolution in opposition of the increase of taxes.

RECESSED AT 5:17 PM UNTIL 6:30 PM PUBLIC HEARING

PUBLIC HEARING 6:30 PM

12. Ordinance/County Comprehensive Plan Text Changes

Tom Cookingham presented a request for an amendment to the Comprehensive Plan. The text amendment is a result of the 10 year Water Facility Supply Plan. Mr. Cookingham stated that Chapter 163 requires local jurisdiction prepare a Water Supply Facility Plan based on the adopted Regional Water Supply Plan. The goals, objectives and policies of the Potable Water, Conservation and Intergovernmental Coordination Elements of the Comprehensive Plan were updated. A Public Hearing was held on November 12, 2013 and transmitted the changes to the Department of Economic Opportunity as required by state law. A response of no comment was received from The Department of Economic Opportunity and SWFWMD. Chairman Selph questioned why such a large reduction from 118 gallons to 95 gallons. Mr. Cookingham replied it is usually due to water or energy efficiency and other conservation methods that are part of the goals, objectives and policies in the Water Supply Plan as well as the other policies being adopted. A motion was made by Commissioner Mansfield to adopt the Ordinance implementing text changes to the Potable Water, Conservation and Intergovernmental Coordination Elements of the Comprehensive Plan. Seconded by Commissioner Miller. Motion carried unanimously.

ADJOURNMENT

There being no further business, Chairman Selph adjourned the meeting 6:37 PM.

ATTEST:

**BOARD OF COUNTY COMMISSION
DESOTO COUNTY, FLORIDA**

**C. GUY MAXCY
COUNTY ADMINISTRATOR**

**JAMES F. SELPH
CHAIRMAN**

**WORKSHOP OF THE BOARD OF COUNTY COMMISSIONERS
HELD ON MAY 28, 2013
IN THE COUNTY COMMISSIONERS' MEETING ROOM
ROOM 103, ADMINISTRATION BUILDING
ARCADIA, FLORIDA**

The Board of County Commissioners held a Workshop on May 28, 2013 with the following persons present:

Commissioner, Buddy Mansfield, Dist#1
Chairman, Jim Selph, Dist#2
Commissioner, Gabriel Quave, Dist#3
Commissioner, Elton Langford, Dist#4
Commissioner Bob Miller, Dist#5
County Administrator, Guy Maxcy
County Attorney, Don Conn
County Coordinator, Mandy Hines
Transcribing Secretary, Jill Thompson
Administrative Services Director, Linda Nipper
Purchasing Director, Cindy Talamantez

Office Manager, Lauri Jones
Facilities Director, Richard Metzger
Sheriff Will Wise
Code Compl. Director, Jorge Hernandez
Fire Chief, Glen Prescott
Utilities Director, Eddie Miller
Deputy Fire Chief, Larry Taylor
Turner Center Director, Jody Sullivan
Transportation Director, Shawn Edwards
County Engineer, Mike Giardullo
Building Official, Lester Hornbake

**CALL TO ORDER
PRESENTATION**

1. Review of Current Fire Standards/State Fire Marshall

Julius Halas, Director of Division of State Fire Marshall gave a brief background on how he reached his current position. Mr. Halas reviewed the requirements and criteria of fire inspections in local jurisdiction. Mr. Halas reviewed the following:

- Responsibilities of the Authority Having Jurisdiction (AHJ)
- Appeals process
- Amendments- Mr. Maxcy verified that is mandated that fire inspections must be performed.
- Responsibilities of the AHJ pursuant to NFPA1- Chairman Selph commented regarding flammable material/hazardous conditions.
- The Florida Building Code
- Scope of Building Code
- Costs & areas for revenue
- Comparing fire & building codes

Mr. Halas also spoke regarding the benefits of an effective fire prevention program. Some of the benefits are identifying and correcting hazards, reducing fire risks, maintaining ISO ratings and consistency of enforcement and safety.

There was discussion by the Board regarding fire standards.

Mr. Halas commented that there are alternatives to sprinkler systems such as separation/wall rating, door closures and HVAC systems. Mr. Halas also stated that even if the AHJ makes a decision; the local authority has the final decision and state will not overrule unless there is a complaint by a citizen.

Recess at 10:15am

Called to Order at 10:28am

2. Review and Submission of BCC Five Year Capital Improvement Program

Linda Nipper stated the 2013-2014 will appear in the Budget and anything beyond 2014 will fluctuate from year to year. There will be corrections and changes to the plan. The Program is usually adopted along with the Budget. Ms. Nipper stated she would like to be more formal with the Five Year Plan for good planning purposes. A decision is not necessary at this time and an electronic copy will be forwarded to the Board. It was consensus of the Board that more time is needed to review the Program.

Mr. Maxcy stated he will comment on the MSBU revision rate during the 3pm meeting.

ADJOURNMENT

There being no further business, Chairman Selph adjourned the workshop at 10:35am.

ATTEST:

**BOARD OF COUNTY COMMISSION
DESOTO COUNTY, FLORIDA**

**C. GUY MAXCY
COUNTY ADMINISTRATOR**

**JAMES F. SELPH
CHAIRMAN**

BOARD OF COUNTY COMMISSIONERS
DESOTO COUNTY, FLORIDA
DATE: June 11, 2013

Consent Agenda
 Regular Business
 Public Hearing

Quasi-Judicial Public Hearing

9:00 Time

DEPARTMENT: Administrative Services
SUBMITTED BY: Cindy Talamantez
PRESENTED BY: Cindy Talamantez

TITLE & DESCRIPTION: Declaration of Surplus Property

REQUESTED MOTION: To declare all property listed in attached Action Surplus Report as surplus and authorize staff to remove from inventory.

SUMMARY: Declaration of Surplus property

BACKGROUND: The listed items have been deemed unused or unwanted by all County departments. All items will be advertised and sold to the highest bidder either by utilizing the GovDeals online Auction or by sealed bidding.

FUNDS: Budget Amount: N/A
Actual Agenda Item Cost:
Account Number:
Explanation:

ATTACHMENTS: 1.

REVIEW APPROVAL: Department Director
Finance Director *Lynne Ruppe*
Purchasing Department *Cindy Talamantez*
County Attorney *C. J. Maxey*
County Administrator

SURPLUS ACTION REPORT

Attachment 1

| <u>ITEM #</u> | <u>DESCRIPTION</u> | <u>FUND</u> | <u>DEPARTMENT</u> | <u>SERIAL NUMBER</u> | <u>REASON</u> |
|---------------|-------------------------------|-------------|-------------------|----------------------|--|
| 200746 | HP Pavillion Desktop Computer | 001-2601 | Administration | MXF6510310 | Worn out cost more to replace then repair |
| 200836 | Canon Image Runner Copler | 001-3019 | Animal Control | 2000130752 | Maintenance Issues - Costs - Down Time Etc |
| 200652 | Gateway Desktop Computer | 415-3025 | Building | 36370090 | Worn out cost more to replace then repair |
| 200801 | Gateway Desktop Computer | 001-3116 | Social Services | 40483792 | Worn out cost more to replace then repair |

DATE APPROVED: JUNE 11, 2013

ATTEST:

C. Guy Maxcy
County Administrator

BOARD OF COUNTY COMMISSIONERS
OF DESOTO COUNTY, FLORIDA

By: _____
James F. Selph, Chairman

BOARD OF COUNTY COMMISSIONERS

DESOTO COUNTY, FLORIDA

DATE: June 11, 2013

| | |
|--|--|
| <input checked="" type="checkbox"/> Consent Agenda <input type="checkbox"/> Regular Business <input type="checkbox"/> Public Hearing | Quasi-Judicial Public Hearing <hr style="width: 50px; margin-left: auto; margin-right: auto;"/> 9am Time |
|--|--|

| | | |
|---------------------------------|--|---|
| DEPARTMENT: | Human Resources | |
| SUBMITTED BY: | Don Kesterson | |
| PRESENTED BY: | Don Kesterson | |
| TITLE & DESCRIPTION: | Agreement /Employment Contracts – Code Compliance, Environmental Services, Human Resources, Library, Purchasing, Social Services, Turner Center, and Utilities. | |
| REQUESTED MOTION: | To approve the contracts between DeSoto County BOCC and each Director indicated. | |
| SUMMARY: | The Board approved the new Director policy on May 14, 2013 this is to complete the process for the Directors. This is a housekeeping measure. | |
| BACKGROUND: | The new policy was passed on May 14, 2013. There are currently 7 active contracts other than the County Administrator. In the FY 12-13 Budget the Board approved the title changes to Director for the Code Compliance, Human Resources, Library, Purchasing, Social Services and Turner Center positions. At the March 26, 2013 meeting the Board confirmed the two new Directors for Environmental Services and Utilities Dept. | |
| FUNDS: | Budget Amount | N/A |
| | Actual Agenda Item Cost: | N/A |
| | Account Number: | N/A |
| | Explanation: | Housekeeping item to provide contracts for the Directors with no changes in current salary. |
| ATTACHMENTS: | <ol style="list-style-type: none"> 1. Employment Contract for Jorge Hernandez. – Code Compliance Director 2. Employment Contract for Henry Grimes – Environmental Services Director 3. Employment Contract for Donald L. Kesterson Jr. – Human Resources Director 4. Employment Contract for Lorel Reinstrom – Library Director 5. Employment Contract for Cindy Talamantez – Purchasing Director 6. Employment Contract for Margaret Waters – Social Services Director 7. Employment Contract for Jody Sullivan – Turner Center Director 8. Employment Contract for Clarence E .Miller Jr. – Utilities Director | |

REVIEW

APPROVAL:

Department Director

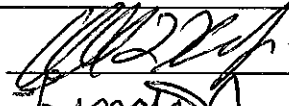

Finance Director



Purchasing Department

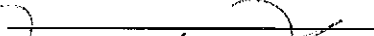

County Attorney

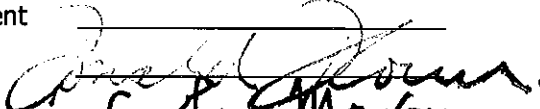

County Administrator

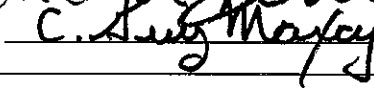

EMPLOYMENT AGREEMENT

THIS AGREEMENT made and entered into this 11 day of June, 2013, by and between DESOTO COUNTY, a political subdivision of the State of Florida, acting by and through the DeSoto County Board of County Commissioners, 201 E. Oak Street, Arcadia, Florida 34266, hereinafter referred to as (Employer), and Jorge L. Hernandez, hereinafter referred to as (Employee).

1. EMPLOYMENT

The Employer hereby employs, engages and hires the Employee as Code Compliance Director. Employee is an "at will" employee and as such works at the pleasure of the County Administrator.

2. BEST EFFORTS OF EMPLOYEE

Employee agrees that he/she will at all times faithfully, industriously, and to the best of his or her ability, experience and talents, perform all of the duties that may be required of and from him/her pursuant to the express and implicit terms of the Agreement to the reasonable satisfaction of Employer.

3. TERM OF EMPLOYMENT

a. The term of this Agreement commences on June 11, 2013. Employee agrees to remain in the exclusive employ of DeSoto County, and to neither accept nor to become employed by any other employer while serving DeSoto County, except as may otherwise be approved by the County Administrator.

b. Employee's service shall be reviewed by the County Administrator in accordance with the Personnel Policies of DeSoto County.

c. Nothing in this Agreement shall prevent or otherwise interfere with the right of the Employer to evaluate the performance of the Employee at any time, and to continue or terminate the service of the Employee at any time.

4. COMPENSATION AND BENEFITS

a. Employer agrees to pay Employee for his/her services rendered pursuant hereto an annual salary of \$ 53,156.48, payable weekly at the same time other employees of Employer are paid.

b. Employee is entitled to the following benefits as part of his/her employment with DeSoto County.

1. Health Care: "Employees only" coverage paid by the County, effective per current Health Plan wait period.
2. Vacation:
 - Seven (7) days the first year;
 - Ten (10) days beginning the second year through the fifth year;
 - Fifteen (15) days beginning the sixth year through the tenth year; and
 - Twenty (20) days the beginning of the eleventh year.
3. Sick Leave: Two (2) hours per week.
4. Retirement – Membership in the Florida Retirement System in the Senior Management Service Class (SMSC) if position is designated; otherwise in the Regular Class.
5. Pay Increases:
 - Cost of living increases or any other pay increases that are approved by the Board and apply to all County employees;
 - Merit increases at the discretion of the Administrator within budgeted amounts, not to exceed 10% per year.

6. Workers Compensation, FICA (Employer Matching), Unemployment Compensation and Florida Retirement Plan (Employer Contribution) will all be paid by the County.

5. PROFESSIONAL DEVELOPMENT

- a. The County may pay for Employee's annual membership cost for up to two (2) professional organizations.

- b. The County will pay for the cost of out of County travel when traveling on County business which includes attendance at conferences, seminars, etc., which are for professional development.

6. SEVERANCE

- a. In the event Employee voluntarily resigns his/her position, Employee shall not be entitled to severance pay. However, Employee shall receive accumulated annual leave and fifty percent (50%) of his/her accumulated sick leave up to a maximum of two hundred (200) hours.

- b. If Employee is asked to resign or is terminated, he/she will receive thirty (30) working days of severance pay in addition to all accumulated annual leave and fifty percent (50%) of unused sick leave up to a maximum of two hundred (200) hours.

- c. If Employee retires, he/she will receive all accumulated annual leave and fifty percent (50%) of accumulated sick leave up to a maximum of two hundred (200) hours.

- d. If employee is convicted of a crime, he/she will be terminated, no severance benefits will be paid and all accumulated annual and sick leave will be forfeited.

7. NOTICE OF RESIGNATION

Employee is required to provide the County Administrator with sixty (60) days written notice of resignation. The County Administrator may accept less notice time if it is determined that less notice would not adversely affect the County. However, if Employee fails to provide the required sixty days notice and the Administrator does not accept less than the sixty days notice, the Employee will not be entitled to receive any severance or accumulated leave benefits, but shall receive a final pay check.

8. BENEFITS IN CASE OF EXTENDED ILLNESS

In addition to being eligible for the County Sick Leave Sharing, the County Administrator may propose to the Board extension of benefits for Employee for a specified period of time. The recommendation will list the specific benefits requested and the time frame for the request.

9. EMPLOYMENT STATUS

In addition to the fact that the Employee works at the pleasure of the County Administrator and is an "at will" employee, the Administrator may elect to place Employee on a leave with pay or without pay for a specified period of time. If Employee is placed on leave with pay status, he/she will continue to receive all benefits and pay as they were prior to being placed on the leave with pay status. If Employee is placed on a leave without pay status, he/she will continue to receive all benefits he/she received prior to his/her status change with the exception of being paid.

10. MODIFICATION OF POLICY

If the Board modifies the Employment Policy Affecting Director Positions, Employee agrees that this contract is subject to and shall be amended to conform to such modifications.

11. INDEMNIFICATION

The Employer shall defend, save harmless and indemnify the Employee against any actions, in tort or if he/she is named in his/her capacity as Code Compliance Director as a party defendant in any action for any injury or damage suffered as a result of any act, event or omission of action in the scope of his/her duties or function, unless he/she acted in bad faith or with malicious purpose or in a manner exhibiting wanton and willful disregard of human rights, safety, or property. The Employer shall not be liable in tort for the acts or omissions of the Employee committed while acting outside the course and scope of his/her agreed duties or committed in bad faith or with malicious purpose or in a manner exhibiting wanton and willful disregard of human rights, safety or property. Employer shall have the right to settle and compromise claims brought against Employee in his/her official capacity.

12. CONTROLLING LAW

This Agreement is to be governed by the laws of the State of Florida. The venue for any litigation resulting out of this Agreement shall be in DeSoto County, Florida.

13. EXTENT OF AGREEMENT

This Agreement represents the entire integrated agreement between the Employer and Employee and supersedes all prior negotiations, representations or agreements, either written or oral. This Agreement may only be amended, supplemented, modified, changed or cancelled by a duly executed written instrument.

[Remainder of page intentionally left blank]

IN WITNESS WHEREOF, the parties hereto have executed this Agreement as of the day and year written above.

ATTEST:

DESOTO COUNTY BOARD OF COUNTY COMMISSIONERS

By: _____
County Administrator

By: _____
Chairman

WITNESSES:

EMPLOYEE

Print Name: _____

Print Name: _____

EMPLOYMENT AGREEMENT

THIS AGREEMENT made and entered into this 11 day of June, 2013, by and between DESOTO COUNTY, a political subdivision of the State of Florida, acting by and through the DeSoto County Board of County Commissioners, 201 E. Oak Street, Arcadia, Florida 34266, hereinafter referred to as (Employer), and Henry W. Grimes, hereinafter referred to as (Employee).

1. EMPLOYMENT

The Employer hereby employs, engages and hires the Employee as Environmental Services Director. Employee is an "at will" employee and as such works at the pleasure of the County Administrator.

2. BEST EFFORTS OF EMPLOYEE

Employee agrees that he/she will at all times faithfully, industriously, and to the best of his or her ability, experience and talents, perform all of the duties that may be required of and from him/her pursuant to the express and implicit terms of the Agreement to the reasonable satisfaction of Employer.

3. TERM OF EMPLOYMENT

a. The term of this Agreement commences on March 26, 2013. Employee agrees to remain in the exclusive employ of DeSoto County, and to neither accept nor to become employed by any other employer while serving DeSoto County, except as may otherwise be approved by the County Administrator.

b. Employee's service shall be reviewed by the County Administrator in accordance with the Personnel Policies of DeSoto County.

c. Nothing in this Agreement shall prevent or otherwise interfere with the right of the Employer to evaluate the performance of the Employee at any time, and to continue or terminate the service of the Employee at any time.

4. COMPENSATION AND BENEFITS

a. Employer agrees to pay Employee for his/her services rendered pursuant hereto an annual salary of \$ 52,291.20, payable weekly at the same time other employees of Employer are paid.

b. Employee is entitled to the following benefits as part of his/her employment with DeSoto County.

1. Health Care: "Employees only" coverage paid by the County, effective per current Health Plan wait period.
2. Vacation:
 - Seven (7) days the first year;
 - Ten (10) days beginning the second year through the fifth year;
 - Fifteen (15) days beginning the sixth year through the tenth year; and
 - Twenty (20) days the beginning of the eleventh year.
3. Sick Leave: Two (2) hours per week.
4. Retirement – Membership in the Florida Retirement System in the Senior Management Service Class (SMSC) if position is designated; otherwise in the Regular Class.
5. Pay Increases:
 - Cost of living increases or any other pay increases that are approved by the Board and apply to all County employees;
 - Merit increases at the discretion of the Administrator within budgeted amounts, not to exceed 10% per year.

6. Workers Compensation, FICA (Employer Matching), Unemployment Compensation and Florida Retirement Plan (Employer Contribution) will all be paid by the County.

5. PROFESSIONAL DEVELOPMENT

- a. The County may pay for Employee's annual membership cost for up to two (2) professional organizations.

- b. The County will pay for the cost of out of County travel when traveling on County business which includes attendance at conferences, seminars, etc., which are for professional development.

6. SEVERANCE

- a. In the event Employee voluntarily resigns his/her position, Employee shall not be entitled to severance pay. However, Employee shall receive accumulated annual leave and fifty percent (50%) of his/her accumulated sick leave up to a maximum of two hundred (200) hours.

- b. If Employee is asked to resign or is terminated, he/she will receive thirty (30) working days of severance pay in addition to all accumulated annual leave and fifty percent (50%) of unused sick leave up to a maximum of two hundred (200) hours.

- c. If Employee retires, he/she will receive all accumulated annual leave and fifty percent (50%) of accumulated sick leave up to a maximum of two hundred (200) hours.

- d. If employee is convicted of a crime, he/she will be terminated, no severance benefits will be paid and all accumulated annual and sick leave will be forfeited.

7. NOTICE OF RESIGNATION

Employee is required to provide the County Administrator with sixty (60) days written notice of resignation. The County Administrator may accept less notice time if it is determined that less notice would not adversely affect the County. However, if Employee fails to provide the required sixty days notice and the Administrator does not accept less than the sixty days notice, the Employee will not be entitled to receive any severance or accumulated leave benefits, but shall receive a final pay check.

8. BENEFITS IN CASE OF EXTENDED ILLNESS

In addition to being eligible for the County Sick Leave Sharing, the County Administrator may propose to the Board extension of benefits for Employee for a specified period of time. The recommendation will list the specific benefits requested and the time frame for the request.

9. EMPLOYMENT STATUS

In addition to the fact that the Employee works at the pleasure of the County Administrator and is an "at will" employee, the Administrator may elect to place Employee on a leave with pay or without pay for a specified period of time. If Employee is placed on leave with pay status, he/she will continue to receive all benefits and pay as they were prior to being placed on the leave with pay status. If Employee is placed on a leave without pay status, he/she will continue to receive all benefits he/she received prior to his/her status change with the exception of being paid.

10. MODIFICATION OF POLICY

If the Board modifies the Employment Policy Affecting Director Positions, Employee agrees that this contract is subject to and shall be amended to conform to such modifications.

11. INDEMNIFICATION

The Employer shall defend, save harmless and indemnify the Employee against any actions, in tort or if he/she is named in his/her capacity as Environmental Services Director as a party defendant in any action for any injury or damage suffered as a result of any act, event or omission of action in the scope of his/her duties or function, unless he/she acted in bad faith or with malicious purpose or in a manner exhibiting wanton and willful disregard of human rights, safety, or property. The Employer shall not be liable in tort for the acts or omissions of the Employee committed while acting outside the course and scope of his/her agreed duties or committed in bad faith or with malicious purpose or in a manner exhibiting wanton and willful disregard of human rights, safety or property. Employer shall have the right to settle and compromise claims brought against Employee in his/her official capacity.

12. CONTROLLING LAW

This Agreement is to be governed by the laws of the State of Florida. The venue for any litigation resulting out of this Agreement shall be in DeSoto County, Florida.

13. EXTENT OF AGREEMENT

This Agreement represents the entire integrated agreement between the Employer and Employee and supersedes all prior negotiations, representations or agreements, either written or oral. This Agreement may only be amended, supplemented, modified, changed or cancelled by a duly executed written instrument.

[Remainder of page intentionally left blank]

IN WITNESS WHEREOF, the parties hereto have executed this Agreement as of the day and year written above.

ATTEST:

DESOTO COUNTY BOARD OF COUNTY COMMISSIONERS

By: _____
County Administrator

By: _____
Chairman

WITNESSES:

EMPLOYEE

Print Name: _____

Print Name: _____

EMPLOYMENT AGREEMENT

THIS AGREEMENT made and entered into this 11 day of June, 2013, by and between DESOTO COUNTY, a political subdivision of the State of Florida, acting by and through the DeSoto County Board of County Commissioners, 201 E. Oak Street, Arcadia, Florida 34266, hereinafter referred to as (Employer), and Donald L. Kesterson Jr., hereinafter referred to as (Employee).

1. EMPLOYMENT

The Employer hereby employs, engages and hires the Employee as Human Resources Director. Employee is an "at will" employee and as such works at the pleasure of the County Administrator.

2. BEST EFFORTS OF EMPLOYEE

Employee agrees that he/she will at all times faithfully, industriously, and to the best of his or her ability, experience and talents, perform all of the duties that may be required of and from him/her pursuant to the express and implicit terms of the Agreement to the reasonable satisfaction of Employer.

3. TERM OF EMPLOYMENT

a. The term of this Agreement commences on June 11, 2013. Employee agrees to remain in the exclusive employ of DeSoto County, and to neither accept nor to become employed by any other employer while serving DeSoto County, except as may otherwise be approved by the County Administrator.

b. Employee's service shall be reviewed by the County Administrator in accordance with the Personnel Policies of DeSoto County.

c. Nothing in this Agreement shall prevent or otherwise interfere with the right of the Employer to evaluate the performance of the Employee at any time, and to continue or terminate the service of the Employee at any time.

4. COMPENSATION AND BENEFITS

a. Employer agrees to pay Employee for his/her services rendered pursuant hereto an annual salary of \$ 48,672.00, payable weekly at the same time other employees of Employer are paid.

b. Employee is entitled to the following benefits as part of his/her employment with DeSoto County.

1. Health Care: "Employees only" coverage paid by the County, effective per current Health Plan wait period.
2. Vacation:
 - Seven (7) days the first year;
 - Ten (10) days beginning the second year through the fifth year;
 - Fifteen (15) days beginning the sixth year through the tenth year; and
 - Twenty (20) days the beginning of the eleventh year.
3. Sick Leave: Two (2) hours per week.
4. Retirement – Membership in the Florida Retirement System in the Senior Management Service Class (SMSC) if position is designated; otherwise in the Regular Class.
5. Pay Increases:
 - Cost of living increases or any other pay increases that are approved by the Board and apply to all County employees;
 - Merit increases at the discretion of the Administrator within budgeted amounts, not to exceed 10% per year.

6. Workers Compensation, FICA (Employer Matching), Unemployment Compensation and Florida Retirement Plan (Employer Contribution) will all be paid by the County.

5. PROFESSIONAL DEVELOPMENT

- a. The County may pay for Employee's annual membership cost for up to two (2) professional organizations.

- b. The County will pay for the cost of out of County travel when traveling on County business which includes attendance at conferences, seminars, etc., which are for professional development.

6. SEVERANCE

- a. In the event Employee voluntarily resigns his/her position, Employee shall not be entitled to severance pay. However, Employee shall receive accumulated annual leave and fifty percent (50%) of his/her accumulated sick leave up to a maximum of two hundred (200) hours.

- b. If Employee is asked to resign or is terminated, he/she will receive thirty (30) working days of severance pay in addition to all accumulated annual leave and fifty percent (50%) of unused sick leave up to a maximum of two hundred (200) hours.

- c. If Employee retires, he/she will receive all accumulated annual leave and fifty percent (50%) of accumulated sick leave up to a maximum of two hundred (200) hours.

- d. If employee is convicted of a crime, he/she will be terminated, no severance benefits will be paid and all accumulated annual and sick leave will be forfeited.

7. NOTICE OF RESIGNATION

Employee is required to provide the County Administrator with sixty (60) days written notice of resignation. The County Administrator may accept less notice time if it is determined that less notice would not adversely affect the County. However, if Employee fails to provide the required sixty days notice and the Administrator does not accept less than the sixty days notice, the Employee will not be entitled to receive any severance or accumulated leave benefits, but shall receive a final pay check.

8. BENEFITS IN CASE OF EXTENDED ILLNESS

In addition to being eligible for the County Sick Leave Sharing, the County Administrator may propose to the Board extension of benefits for Employee for a specified period of time. The recommendation will list the specific benefits requested and the time frame for the request.

9. EMPLOYMENT STATUS

In addition to the fact that the Employee works at the pleasure of the County Administrator and is an "at will" employee, the Administrator may elect to place Employee on a leave with pay or without pay for a specified period of time. If Employee is placed on leave with pay status, he/she will continue to receive all benefits and pay as they were prior to being placed on the leave with pay status. If Employee is placed on a leave without pay status, he/she will continue to receive all benefits he/she received prior to his/her status change with the exception of being paid.

10. MODIFICATION OF POLICY

If the Board modifies the Employment Policy Affecting Director Positions, Employee agrees that this contract is subject to and shall be amended to conform to such modifications.

11. INDEMNIFICATION

The Employer shall defend, save harmless and indemnify the Employee against any actions, in tort or if he/she is named in his/her capacity as Human Resources Director as a party defendant in any action for any injury or damage suffered as a result of any act, event or omission of action in the scope of his/her duties or function, unless he/she acted in bad faith or with malicious purpose or in a manner exhibiting wanton and willful disregard of human rights, safety, or property. The Employer shall not be liable in tort for the acts or omissions of the Employee committed while acting outside the course and scope of his/her agreed duties or committed in bad faith or with malicious purpose or in a manner exhibiting wanton and willful disregard of human rights, safety or property. Employer shall have the right to settle and compromise claims brought against Employee in his/her official capacity.

12. CONTROLLING LAW

This Agreement is to be governed by the laws of the State of Florida. The venue for any litigation resulting out of this Agreement shall be in DeSoto County, Florida.

13. EXTENT OF AGREEMENT

This Agreement represents the entire integrated agreement between the Employer and Employee and supersedes all prior negotiations, representations or agreements, either written or oral. This Agreement may only be amended, supplemented, modified, changed or cancelled by a duly executed written instrument.

[Remainder of page intentionally left blank]

IN WITNESS WHEREOF, the parties hereto have executed this Agreement as of the day and year written above.

ATTEST:

DESOTO COUNTY BOARD OF COUNTY COMMISSIONERS

By: _____
County Administrator

By: _____
Chairman

WITNESSES:

EMPLOYEE

Print Name: _____

Print Name: _____

EMPLOYMENT AGREEMENT

THIS AGREEMENT made and entered into this 11 day of June, 2013, by and between DESOTO COUNTY, a political subdivision of the State of Florida, acting by and through the DeSoto County Board of County Commissioners, 201 E. Oak Street, Arcadia, Florida 34266, hereinafter referred to as (Employer), and Lorel K. Reinstrom, hereinafter referred to as (Employee).

1. EMPLOYMENT

The Employer hereby employs, engages and hires the Employee as Library Director. Employee is an "at will" employee and as such works at the pleasure of the County Administrator.

2. BEST EFFORTS OF EMPLOYEE

Employee agrees that he/she will at all times faithfully, industriously, and to the best of his or her ability, experience and talents, perform all of the duties that may be required of and from him/her pursuant to the express and implicit terms of the Agreement to the reasonable satisfaction of Employer.

3. TERM OF EMPLOYMENT

a. The term of this Agreement commences on June 11, 2013. Employee agrees to remain in the exclusive employ of DeSoto County, and to neither accept nor to become employed by any other employer while serving DeSoto County, except as may otherwise be approved by the County Administrator.

b. Employee's service shall be reviewed by the County Administrator in accordance with the Personnel Policies of DeSoto County.

c. Nothing in this Agreement shall prevent or otherwise interfere with the right of the Employer to evaluate the performance of the Employee at any time, and to continue or terminate the service of the Employee at any time.

4. COMPENSATION AND BENEFITS

a. Employer agrees to pay Employee for his/her services rendered pursuant hereto an annual salary of \$ 41,200.64, payable weekly at the same time other employees of Employer are paid.

b. Employee is entitled to the following benefits as part of his/her employment with DeSoto County.

1. Health Care: "Employees only" coverage paid by the County, effective per current Health Plan wait period.
2. Vacation:
 - Seven (7) days the first year;
 - Ten (10) days beginning the second year through the fifth year;
 - Fifteen (15) days beginning the sixth year through the tenth year; and
 - Twenty (20) days the beginning of the eleventh year.
3. Sick Leave: Two (2) hours per week.
4. Retirement – Membership in the Florida Retirement System in the Senior Management Service Class (SMSC) if position is designated; otherwise in the Regular Class.
5. Pay Increases:
 - Cost of living increases or any other pay increases that are approved by the Board and apply to all County employees;
 - Merit increases at the discretion of the Administrator within budgeted amounts, not to exceed 10% per year.

6. Workers Compensation, FICA (Employer Matching), Unemployment Compensation and Florida Retirement Plan (Employer Contribution) will all be paid by the County.

5. PROFESSIONAL DEVELOPMENT

- a. The County may pay for Employee's annual membership cost for up to two (2) professional organizations.

- b. The County will pay for the cost of out of County travel when traveling on County business which includes attendance at conferences, seminars, etc., which are for professional development.

6. SEVERANCE

- a. In the event Employee voluntarily resigns his/her position, Employee shall not be entitled to severance pay. However, Employee shall receive accumulated annual leave and fifty percent (50%) of his/her accumulated sick leave up to a maximum of two hundred (200) hours.

- b. If Employee is asked to resign or is terminated, he/she will receive thirty (30) working days of severance pay in addition to all accumulated annual leave and fifty percent (50%) of unused sick leave up to a maximum of two hundred (200) hours.

- c. If Employee retires, he/she will receive all accumulated annual leave and fifty percent (50%) of accumulated sick leave up to a maximum of two hundred (200) hours.

- d. If employee is convicted of a crime, he/she will be terminated, no severance benefits will be paid and all accumulated annual and sick leave will be forfeited.

7. NOTICE OF RESIGNATION

Employee is required to provide the County Administrator with sixty (60) days written notice of resignation. The County Administrator may accept less notice time if it is determined that less notice would not adversely affect the County. However, if Employee fails to provide the required sixty days notice and the Administrator does not accept less than the sixty days notice, the Employee will not be entitled to receive any severance or accumulated leave benefits, but shall receive a final pay check.

8. BENEFITS IN CASE OF EXTENDED ILLNESS

In addition to being eligible for the County Sick Leave Sharing, the County Administrator may propose to the Board extension of benefits for Employee for a specified period of time. The recommendation will list the specific benefits requested and the time frame for the request.

9. EMPLOYMENT STATUS

In addition to the fact that the Employee works at the pleasure of the County Administrator and is an "at will" employee, the Administrator may elect to place Employee on a leave with pay or without pay for a specified period of time. If Employee is placed on leave with pay status, he/she will continue to receive all benefits and pay as they were prior to being placed on the leave with pay status. If Employee is placed on a leave without pay status, he/she will continue to receive all benefits he/she received prior to his/her status change with the exception of being paid.

10. MODIFICATION OF POLICY

If the Board modifies the Employment Policy Affecting Director Positions, Employee agrees that this contract is subject to and shall be amended to conform to such modifications.

11. INDEMNIFICATION

The Employer shall defend, save harmless and indemnify the Employee against any actions, in tort or if he/she is named in his/her capacity as Library Director as a party defendant in any action for any injury or damage suffered as a result of any act, event or omission of action in the scope of his/her duties or function, unless he/she acted in bad faith or with malicious purpose or in a manner exhibiting wanton and willful disregard of human rights, safety, or property. The Employer shall not be liable in tort for the acts or omissions of the Employee committed while acting outside the course and scope of his/her agreed duties or committed in bad faith or with malicious purpose or in a manner exhibiting wanton and willful disregard of human rights, safety or property. Employer shall have the right to settle and compromise claims brought against Employee in his/her official capacity.

12. CONTROLLING LAW

This Agreement is to be governed by the laws of the State of Florida. The venue for any litigation resulting out of this Agreement shall be in DeSoto County, Florida.

13. EXTENT OF AGREEMENT

This Agreement represents the entire integrated agreement between the Employer and Employee and supersedes all prior negotiations, representations or agreements, either written or oral. This Agreement may only be amended, supplemented, modified, changed or cancelled by a duly executed written instrument.

[Remainder of page intentionally left blank]

IN WITNESS WHEREOF, the parties hereto have executed this Agreement as of the day and year written above.

ATTEST:

DESOTO COUNTY BOARD OF COUNTY COMMISSIONERS

By: _____
County Administrator

By: _____
Chairman

WITNESSES:

EMPLOYEE

Print Name: _____

Print Name: _____

EMPLOYMENT AGREEMENT

THIS AGREEMENT made and entered into this 11 day of June, 2013, by and between DESOTO COUNTY, a political subdivision of the State of Florida, acting by and through the DeSoto County Board of County Commissioners, 201 E. Oak Street, Arcadia, Florida 34266, hereinafter referred to as (Employer), and Cindy S. Talamantez, hereinafter referred to as (Employee).

1. EMPLOYMENT

The Employer hereby employs, engages and hires the Employee as Purchasing Director. Employee is an "at will" employee and as such works at the pleasure of the County Administrator.

2. BEST EFFORTS OF EMPLOYEE

Employee agrees that he/she will at all times faithfully, industriously, and to the best of his or her ability, experience and talents, perform all of the duties that may be required of and from him/her pursuant to the express and implicit terms of the Agreement to the reasonable satisfaction of Employer.

3. TERM OF EMPLOYMENT

a. The term of this Agreement commences on June 11, 2013. Employee agrees to remain in the exclusive employ of DeSoto County, and to neither accept nor to become employed by any other employer while serving DeSoto County, except as may otherwise be approved by the County Administrator.

b. Employee's service shall be reviewed by the County Administrator in accordance with the Personnel Policies of DeSoto County.

c. Nothing in this Agreement shall prevent or otherwise interfere with the right of the Employer to evaluate the performance of the Employee at any time, and to continue or terminate the service of the Employee at any time.

4. COMPENSATION AND BENEFITS

a. Employer agrees to pay Employee for his/her services rendered pursuant hereto an annual salary of \$ 55,001.44, payable weekly at the same time other employees of Employer are paid.

b. Employee is entitled to the following benefits as part of his/her employment with DeSoto County.

1. Health Care: "Employees only" coverage paid by the County, effective per current Health Plan wait period.
2. Vacation:
 - Seven (7) days the first year;
 - Ten (10) days beginning the second year through the fifth year;
 - Fifteen (15) days beginning the sixth year through the tenth year; and
 - Twenty (20) days the beginning of the eleventh year.
3. Sick Leave: Two (2) hours per week.
4. Retirement – Membership in the Florida Retirement System in the Senior Management Service Class (SMSC) if position is designated; otherwise in the Regular Class.
5. Pay Increases:
 - Cost of living increases or any other pay increases that are approved by the Board and apply to all County employees;
 - Merit increases at the discretion of the Administrator within budgeted amounts, not to exceed 10% per year.

6. Workers Compensation, FICA (Employer Matching), Unemployment Compensation and Florida Retirement Plan (Employer Contribution) will all be paid by the County.

5. PROFESSIONAL DEVELOPMENT

- a. The County may pay for Employee's annual membership cost for up to two (2) professional organizations.

- b. The County will pay for the cost of out of County travel when traveling on County business which includes attendance at conferences, seminars, etc., which are for professional development.

6. SEVERANCE

- a. In the event Employee voluntarily resigns his/her position, Employee shall not be entitled to severance pay. However, Employee shall receive accumulated annual leave and fifty percent (50%) of his/her accumulated sick leave up to a maximum of two hundred (200) hours.

- b. If Employee is asked to resign or is terminated, he/she will receive thirty (30) working days of severance pay in addition to all accumulated annual leave and fifty percent (50%) of unused sick leave up to a maximum of two hundred (200) hours.

- c. If Employee retires, he/she will receive all accumulated annual leave and fifty percent (50%) of accumulated sick leave up to a maximum of two hundred (200) hours.

- d. If employee is convicted of a crime, he/she will be terminated, no severance benefits will be paid and all accumulated annual and sick leave will be forfeited.

7. NOTICE OF RESIGNATION

Employee is required to provide the County Administrator with sixty (60) days written notice of resignation. The County Administrator may accept less notice time if it is determined that less notice would not adversely affect the County. However, if Employee fails to provide the required sixty days notice and the Administrator does not accept less than the sixty days notice, the Employee will not be entitled to receive any severance or accumulated leave benefits, but shall receive a final pay check.

8. BENEFITS IN CASE OF EXTENDED ILLNESS

In addition to being eligible for the County Sick Leave Sharing, the County Administrator may propose to the Board extension of benefits for Employee for a specified period of time. The recommendation will list the specific benefits requested and the time frame for the request.

9. EMPLOYMENT STATUS

In addition to the fact that the Employee works at the pleasure of the County Administrator and is an "at will" employee, the Administrator may elect to place Employee on a leave with pay or without pay for a specified period of time. If Employee is placed on leave with pay status, he/she will continue to receive all benefits and pay as they were prior to being placed on the leave with pay status. If Employee is placed on a leave without pay status, he/she will continue to receive all benefits he/she received prior to his/her status change with the exception of being paid.

10. MODIFICATION OF POLICY

If the Board modifies the Employment Policy Affecting Director Positions, Employee agrees that this contract is subject to and shall be amended to conform to such modifications.

11. INDEMNIFICATION

The Employer shall defend, save harmless and indemnify the Employee against any actions, in tort or if he/she is named in his/her capacity as Purchasing Director as a party defendant in any action for any injury or damage suffered as a result of any act, event or omission of action in the scope of his/her duties or function, unless he/she acted in bad faith or with malicious purpose or in a manner exhibiting wanton and willful disregard of human rights, safety, or property. The Employer shall not be liable in tort for the acts or omissions of the Employee committed while acting outside the course and scope of his/her agreed duties or committed in bad faith or with malicious purpose or in a manner exhibiting wanton and willful disregard of human rights, safety or property. Employer shall have the right to settle and compromise claims brought against Employee in his/her official capacity.

12. CONTROLLING LAW

This Agreement is to be governed by the laws of the State of Florida. The venue for any litigation resulting out of this Agreement shall be in DeSoto County, Florida.

13. EXTENT OF AGREEMENT

This Agreement represents the entire integrated agreement between the Employer and Employee and supersedes all prior negotiations, representations or agreements, either written or oral. This Agreement may only be amended, supplemented, modified, changed or cancelled by a duly executed written instrument.

[Remainder of page intentionally left blank]

IN WITNESS WHEREOF, the parties hereto have executed this Agreement as of the day and year written above.

ATTEST:

DESOTO COUNTY BOARD OF COUNTY COMMISSIONERS

By: _____
County Administrator

By: _____
Chairman

WITNESSES:

EMPLOYEE

Print Name: _____

Print Name: _____

EMPLOYMENT AGREEMENT

THIS AGREEMENT made and entered into this 11 day of June, 2013, by and between DESOTO COUNTY, a political subdivision of the State of Florida, acting by and through the DeSoto County Board of County Commissioners, 201 E. Oak Street, Arcadia, Florida 34266, hereinafter referred to as (Employer), and Margaret A. Waters, hereinafter referred to as (Employee).

1. EMPLOYMENT

The Employer hereby employs, engages and hires the Employee as Social Services Director. Employee is an "at will" employee and as such works at the pleasure of the County Administrator.

2. BEST EFFORTS OF EMPLOYEE

Employee agrees that he/she will at all times faithfully, industriously, and to the best of his or her ability, experience and talents, perform all of the duties that may be required of and from him/her pursuant to the express and implicit terms of the Agreement to the reasonable satisfaction of Employer.

3. TERM OF EMPLOYMENT

a. The term of this Agreement commences on June 11, 2013. Employee agrees to remain in the exclusive employ of DeSoto County, and to neither accept nor to become employed by any other employer while serving DeSoto County, except as may otherwise be approved by the County Administrator.

b. Employee's service shall be reviewed by the County Administrator in accordance with the Personnel Policies of DeSoto County.

c. Nothing in this Agreement shall prevent or otherwise interfere with the right of the Employer to evaluate the performance of the Employee at any time, and to continue or terminate the service of the Employee at any time.

4. COMPENSATION AND BENEFITS

a. Employer agrees to pay Employee for his/her services rendered pursuant hereto an annual salary of \$ 51,502.88, payable weekly at the same time other employees of Employer are paid.

b. Employee is entitled to the following benefits as part of his/her employment with DeSoto County.

1. Health Care: "Employees only" coverage paid by the County, effective per current Health Plan wait period.
2. Vacation:
 - Seven (7) days the first year;
 - Ten (10) days beginning the second year through the fifth year;
 - Fifteen (15) days beginning the sixth year through the tenth year; and
 - Twenty (20) days the beginning of the eleventh year.
3. Sick Leave: Two (2) hours per week.
4. Retirement – Membership in the Florida Retirement System in the Senior Management Service Class (SMSC) if position is designated; otherwise in the Regular Class.
5. Pay Increases:
 - Cost of living increases or any other pay increases that are approved by the Board and apply to all County employees;
 - Merit increases at the discretion of the Administrator within budgeted amounts, not to exceed 10% per year.

6. Workers Compensation, FICA (Employer Matching), Unemployment Compensation and Florida Retirement Plan (Employer Contribution) will all be paid by the County.

5. PROFESSIONAL DEVELOPMENT

- a. The County may pay for Employee's annual membership cost for up to two (2) professional organizations.

- b. The County will pay for the cost of out of County travel when traveling on County business which includes attendance at conferences, seminars, etc., which are for professional development.

6. SEVERANCE

- a. In the event Employee voluntarily resigns his/her position, Employee shall not be entitled to severance pay. However, Employee shall receive accumulated annual leave and fifty percent (50%) of his/her accumulated sick leave up to a maximum of two hundred (200) hours.

- b. If Employee is asked to resign or is terminated, he/she will receive thirty (30) working days of severance pay in addition to all accumulated annual leave and fifty percent (50%) of unused sick leave up to a maximum of two hundred (200) hours.

- c. If Employee retires, he/she will receive all accumulated annual leave and fifty percent (50%) of accumulated sick leave up to a maximum of two hundred (200) hours.

- d. If employee is convicted of a crime, he/she will be terminated, no severance benefits will be paid and all accumulated annual and sick leave will be forfeited.

7. NOTICE OF RESIGNATION

Employee is required to provide the County Administrator with sixty (60) days written notice of resignation. The County Administrator may accept less notice time if it is determined that less notice would not adversely affect the County. However, if Employee fails to provide the required sixty days notice and the Administrator does not accept less than the sixty days notice, the Employee will not be entitled to receive any severance or accumulated leave benefits, but shall receive a final pay check.

8. BENEFITS IN CASE OF EXTENDED ILLNESS

In addition to being eligible for the County Sick Leave Sharing, the County Administrator may propose to the Board extension of benefits for Employee for a specified period of time. The recommendation will list the specific benefits requested and the time frame for the request.

9. EMPLOYMENT STATUS

In addition to the fact that the Employee works at the pleasure of the County Administrator and is an "at will" employee, the Administrator may elect to place Employee on a leave with pay or without pay for a specified period of time. If Employee is placed on leave with pay status, he/she will continue to receive all benefits and pay as they were prior to being placed on the leave with pay status. If Employee is placed on a leave without pay status, he/she will continue to receive all benefits he/she received prior to his/her status change with the exception of being paid.

10. MODIFICATION OF POLICY

If the Board modifies the Employment Policy Affecting Director Positions, Employee agrees that this contract is subject to and shall be amended to conform to such modifications.

11. INDEMNIFICATION

The Employer shall defend, save harmless and indemnify the Employee against any actions, in tort or if he/she is named in his/her capacity as Social Services Director as a party defendant in any action for any injury or damage suffered as a result of any act, event or omission of action in the scope of his/her duties or function, unless he/she acted in bad faith or with malicious purpose or in a manner exhibiting wanton and willful disregard of human rights, safety, or property. The Employer shall not be liable in tort for the acts or omissions of the Employee committed while acting outside the course and scope of his/her agreed duties or committed in bad faith or with malicious purpose or in a manner exhibiting wanton and willful disregard of human rights, safety or property. Employer shall have the right to settle and compromise claims brought against Employee in his/her official capacity.

12. CONTROLLING LAW

This Agreement is to be governed by the laws of the State of Florida. The venue for any litigation resulting out of this Agreement shall be in DeSoto County, Florida.

13. EXTENT OF AGREEMENT

This Agreement represents the entire integrated agreement between the Employer and Employee and supersedes all prior negotiations, representations or agreements, either written or oral. This Agreement may only be amended, supplemented, modified, changed or cancelled by a duly executed written instrument.

[Remainder of page intentionally left blank]

IN WITNESS WHEREOF, the parties hereto have executed this Agreement as of the day and year written above.

ATTEST:

DESOTO COUNTY BOARD OF COUNTY COMMISSIONERS

By: _____
County Administrator

By: _____
Chairman

WITNESSES:

EMPLOYEE

Print Name: _____

Print Name: _____

EMPLOYMENT AGREEMENT

THIS AGREEMENT made and entered into this 11 day of June, 2013, by and between DESOTO COUNTY, a political subdivision of the State of Florida, acting by and through the DeSoto County Board of County Commissioners, 201 E. Oak Street, Arcadia, Florida 34266, hereinafter referred to as (Employer), and Jody B. Sullivan, hereinafter referred to as (Employee).

1. EMPLOYMENT

The Employer hereby employs, engages and hires the Employee as Turner Center Director. Employee is an "at will" employee and as such works at the pleasure of the County Administrator.

2. BEST EFFORTS OF EMPLOYEE

Employee agrees that he/she will at all times faithfully, industriously, and to the best of his or her ability, experience and talents, perform all of the duties that may be required of and from him/her pursuant to the express and implicit terms of the Agreement to the reasonable satisfaction of Employer.

3. TERM OF EMPLOYMENT

a. The term of this Agreement commences on June 11, 2013. Employee agrees to remain in the exclusive employ of DeSoto County, and to neither accept nor to become employed by any other employer while serving DeSoto County, except as may otherwise be approved by the County Administrator.

b. Employee's service shall be reviewed by the County Administrator in accordance with the Personnel Policies of DeSoto County.

c. Nothing in this Agreement shall prevent or otherwise interfere with the right of the Employer to evaluate the performance of the Employee at any time, and to continue or terminate the service of the Employee at any time.

4. COMPENSATION AND BENEFITS

a. Employer agrees to pay Employee for his/her services rendered pursuant hereto an annual salary of \$ 44,990.40, payable weekly at the same time other employees of Employer are paid.

b. Employee is entitled to the following benefits as part of his/her employment with DeSoto County.

1. Health Care: "Employees only" coverage paid by the County, effective per current Health Plan wait period.
2. Vacation:
 - Seven (7) days the first year;
 - Ten (10) days beginning the second year through the fifth year;
 - Fifteen (15) days beginning the sixth year through the tenth year; and
 - Twenty (20) days the beginning of the eleventh year.
3. Sick Leave: Two (2) hours per week.
4. Retirement – Membership in the Florida Retirement System in the Senior Management Service Class (SMSC) if position is designated; otherwise in the Regular Class.
5. Pay Increases:
 - Cost of living increases or any other pay increases that are approved by the Board and apply to all County employees;
 - Merit increases at the discretion of the Administrator within budgeted amounts, not to exceed 10% per year.

6. Workers Compensation, FICA (Employer Matching), Unemployment Compensation and Florida Retirement Plan (Employer Contribution) will all be paid by the County.

5. PROFESSIONAL DEVELOPMENT

- a. The County may pay for Employee's annual membership cost for up to two (2) professional organizations.

- b. The County will pay for the cost of out of County travel when traveling on County business which includes attendance at conferences, seminars, etc., which are for professional development.

6. SEVERANCE

- a. In the event Employee voluntarily resigns his/her position, Employee shall not be entitled to severance pay. However, Employee shall receive accumulated annual leave and fifty percent (50%) of his/her accumulated sick leave up to a maximum of two hundred (200) hours.

- b. If Employee is asked to resign or is terminated, he/she will receive thirty (30) working days of severance pay in addition to all accumulated annual leave and fifty percent (50%) of unused sick leave up to a maximum of two hundred (200) hours.

- c. If Employee retires, he/she will receive all accumulated annual leave and fifty percent (50%) of accumulated sick leave up to a maximum of two hundred (200) hours.

- d. If employee is convicted of a crime, he/she will be terminated, no severance benefits will be paid and all accumulated annual and sick leave will be forfeited.

7. NOTICE OF RESIGNATION

Employee is required to provide the County Administrator with sixty (60) days written notice of resignation. The County Administrator may accept less notice time if it is determined that less notice would not adversely affect the County. However, if Employee fails to provide the required sixty days notice and the Administrator does not accept less than the sixty days notice, the Employee will not be entitled to receive any severance or accumulated leave benefits, but shall receive a final pay check.

8. BENEFITS IN CASE OF EXTENDED ILLNESS

In addition to being eligible for the County Sick Leave Sharing, the County Administrator may propose to the Board extension of benefits for Employee for a specified period of time. The recommendation will list the specific benefits requested and the time frame for the request.

9. EMPLOYMENT STATUS

In addition to the fact that the Employee works at the pleasure of the County Administrator and is an "at will" employee, the Administrator may elect to place Employee on a leave with pay or without pay for a specified period of time. If Employee is placed on leave with pay status, he/she will continue to receive all benefits and pay as they were prior to being placed on the leave with pay status. If Employee is placed on a leave without pay status, he/she will continue to receive all benefits he/she received prior to his/her status change with the exception of being paid.

10. MODIFICATION OF POLICY

If the Board modifies the Employment Policy Affecting Director Positions, Employee agrees that this contract is subject to and shall be amended to conform to such modifications.

11. INDEMNIFICATION

The Employer shall defend, save harmless and indemnify the Employee against any actions, in tort or if he/she is named in his/her capacity as Turner Center Director as a party defendant in any action for any injury or damage suffered as a result of any act, event or omission of action in the scope of his/her duties or function, unless he/she acted in bad faith or with malicious purpose or in a manner exhibiting wanton and willful disregard of human rights, safety, or property. The Employer shall not be liable in tort for the acts or omissions of the Employee committed while acting outside the course and scope of his/her agreed duties or committed in bad faith or with malicious purpose or in a manner exhibiting wanton and willful disregard of human rights, safety or property. Employer shall have the right to settle and compromise claims brought against Employee in his/her official capacity.

12. CONTROLLING LAW

This Agreement is to be governed by the laws of the State of Florida. The venue for any litigation resulting out of this Agreement shall be in DeSoto County, Florida.

13. EXTENT OF AGREEMENT

This Agreement represents the entire integrated agreement between the Employer and Employee and supersedes all prior negotiations, representations or agreements, either written or oral. This Agreement may only be amended, supplemented, modified, changed or cancelled by a duly executed written instrument.

[Remainder of page intentionally left blank]

IN WITNESS WHEREOF, the parties hereto have executed this Agreement as of the day and year written above.

ATTEST:

DESOTO COUNTY BOARD OF COUNTY COMMISSIONERS

By: _____
County Administrator

By: _____
Chairman

WITNESSES:

EMPLOYEE

Print Name: _____

Print Name: _____

EMPLOYMENT AGREEMENT

THIS AGREEMENT made and entered into this 11 day of June, 2013, by and between DESOTO COUNTY, a political subdivision of the State of Florida, acting by and through the DeSoto County Board of County Commissioners, 201 E. Oak Street, Arcadia, Florida 34266, hereinafter referred to as (Employer), and Clarence E. Miller Jr., hereinafter referred to as (Employee).

1. EMPLOYMENT

The Employer hereby employs, engages and hires the Employee as Utilities Director. Employee is an "at will" employee and as such works at the pleasure of the County Administrator.

2. BEST EFFORTS OF EMPLOYEE

Employee agrees that he/she will at all times faithfully, industriously, and to the best of his or her ability, experience and talents, perform all of the duties that may be required of and from him/her pursuant to the express and implicit terms of the Agreement to the reasonable satisfaction of Employer.

3. TERM OF EMPLOYMENT

a. The term of this Agreement commences on March 26, 2013. Employee agrees to remain in the exclusive employ of DeSoto County, and to neither accept nor to become employed by any other employer while serving DeSoto County, except as may otherwise be approved by the County Administrator.

b. Employee's service shall be reviewed by the County Administrator in accordance with the Personnel Policies of DeSoto County.

c. Nothing in this Agreement shall prevent or otherwise interfere with the right of the Employer to evaluate the performance of the Employee at any time, and to continue or terminate the service of the Employee at any time.

4. COMPENSATION AND BENEFITS

a. Employer agrees to pay Employee for his/her services rendered pursuant hereto an annual salary of \$ 65,000.00, payable weekly at the same time other employees of Employer are paid.

b. Employee is entitled to the following benefits as part of his/her employment with DeSoto County.

1. Health Care: "Employees only" coverage paid by the County, effective per current Health Plan wait period.
2. Vacation:
 - Seven (7) days the first year;
 - Ten (10) days beginning the second year through the fifth year;
 - Fifteen (15) days beginning the sixth year through the tenth year; and
 - Twenty (20) days the beginning of the eleventh year.
3. Sick Leave: Two (2) hours per week.
4. Retirement – Membership in the Florida Retirement System in the Senior Management Service Class (SMSC) if position is designated; otherwise in the Regular Class.
5. Pay Increases:
 - Cost of living increases or any other pay increases that are approved by the Board and apply to all County employees;
 - Merit increases at the discretion of the Administrator within budgeted amounts, not to exceed 10% per year.

6. Workers Compensation, FICA (Employer Matching), Unemployment Compensation and Florida Retirement Plan (Employer Contribution) will all be paid by the County.

5. PROFESSIONAL DEVELOPMENT

- a. The County may pay for Employee's annual membership cost for up to two (2) professional organizations.

- b. The County will pay for the cost of out of County travel when traveling on County business which includes attendance at conferences, seminars, etc., which are for professional development.

6. SEVERANCE

- a. In the event Employee voluntarily resigns his/her position, Employee shall not be entitled to severance pay. However, Employee shall receive accumulated annual leave and fifty percent (50%) of his/her accumulated sick leave up to a maximum of two hundred (200) hours.

- b. If Employee is asked to resign or is terminated, he/she will receive thirty (30) working days of severance pay in addition to all accumulated annual leave and fifty percent (50%) of unused sick leave up to a maximum of two hundred (200) hours.

- c. If Employee retires, he/she will receive all accumulated annual leave and fifty percent (50%) of accumulated sick leave up to a maximum of two hundred (200) hours.

- d. If employee is convicted of a crime, he/she will be terminated, no severance benefits will be paid and all accumulated annual and sick leave will be forfeited.

7. NOTICE OF RESIGNATION

Employee is required to provide the County Administrator with sixty (60) days written notice of resignation. The County Administrator may accept less notice time if it is determined that less notice would not adversely affect the County. However, if Employee fails to provide the required sixty days notice and the Administrator does not accept less than the sixty days notice, the Employee will not be entitled to receive any severance or accumulated leave benefits, but shall receive a final pay check.

8. BENEFITS IN CASE OF EXTENDED ILLNESS

In addition to being eligible for the County Sick Leave Sharing, the County Administrator may propose to the Board extension of benefits for Employee for a specified period of time. The recommendation will list the specific benefits requested and the time frame for the request.

9. EMPLOYMENT STATUS

In addition to the fact that the Employee works at the pleasure of the County Administrator and is an "at will" employee, the Administrator may elect to place Employee on a leave with pay or without pay for a specified period of time. If Employee is placed on leave with pay status, he/she will continue to receive all benefits and pay as they were prior to being placed on the leave with pay status. If Employee is placed on a leave without pay status, he/she will continue to receive all benefits he/she received prior to his/her status change with the exception of being paid.

10. MODIFICATION OF POLICY

If the Board modifies the Employment Policy Affecting Director Positions, Employee agrees that this contract is subject to and shall be amended to conform to such modifications.

11. INDEMNIFICATION

The Employer shall defend, save harmless and indemnify the Employee against any actions, in tort or if he/she is named in his/her capacity as Utilities Director as a party defendant in any action for any injury or damage suffered as a result of any act, event or omission of action in the scope of his/her duties or function, unless he/she acted in bad faith or with malicious purpose or in a manner exhibiting wanton and willful disregard of human rights, safety, or property. The Employer shall not be liable in tort for the acts or omissions of the Employee committed while acting outside the course and scope of his/her agreed duties or committed in bad faith or with malicious purpose or in a manner exhibiting wanton and willful disregard of human rights, safety or property. Employer shall have the right to settle and compromise claims brought against Employee in his/her official capacity.

12. CONTROLLING LAW

This Agreement is to be governed by the laws of the State of Florida. The venue for any litigation resulting out of this Agreement shall be in DeSoto County, Florida.

13. EXTENT OF AGREEMENT

This Agreement represents the entire integrated agreement between the Employer and Employee and supersedes all prior negotiations, representations or agreements, either written or oral. This Agreement may only be amended, supplemented, modified, changed or cancelled by a duly executed written instrument.

[Remainder of page intentionally left blank]

IN WITNESS WHEREOF, the parties hereto have executed this Agreement as of the day and year written above.

ATTEST:

DESOTO COUNTY BOARD OF COUNTY COMMISSIONERS

By: _____
County Administrator

By: _____
Chairman

WITNESSES:

EMPLOYEE

Print Name: _____

Print Name: _____

BOARD OF COUNTY COMMISSIONERS
DESOTO COUNTY, FLORIDA
DATE: June 11, 2013

| | |
|--|---|
| <input checked="" type="checkbox"/> Consent Agenda <input type="checkbox"/> Regular Business <input type="checkbox"/> Public Hearing | <input type="checkbox"/> Quasi-Judicial Public Hearing <input type="checkbox"/> Time |
|--|---|

DEPARTMENT: Human Resources
SUBMITTED BY: Don Kesterson
PRESENTED BY: Don Kesterson

TITLE & DESCRIPTION: Sufficiency of Surety Bonds. Determine that County Official's Surety Bond coverage is adequate.

REQUESTED MOTION: Request a motion for the Board to conclude that, after careful examination, the sufficiency of bonds for the county officials are adequate.

SUMMARY: Semi-annual FL stature requirement to review the sufficiency of the elected and appointed officials surety bonds.

BACKGROUND: Florida Statute 137.05 requires the County Commissioners, at their regular meeting in January and June of each year, to examine carefully as to the sufficiency of bonds for the county officers, and if it has reason to believe that the sufficiency of any bond has become impaired, it must at once require the officer to execute and file with the proper officer a new bond for the same amount and under the same conditions as his or her former bond.
 All bonds are secured with Hartford Insurance Company through DeSoto Insurance Agency, Inc.

FUNDS:

| | |
|--------------------------|--------|
| Budget Amount | \$0.00 |
| Actual Agenda Item Cost: | N/A |
| Account Number: | N/A |
| Explanation: | N/A |

ATTACHMENTS:

REVIEW APPROVAL:

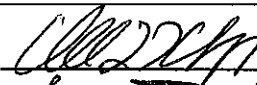
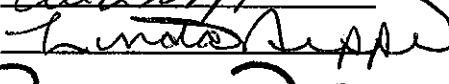
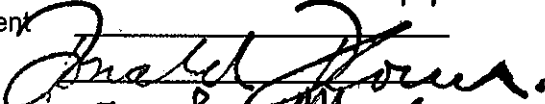
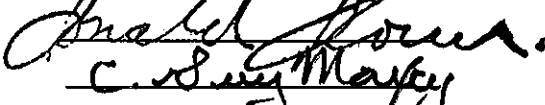
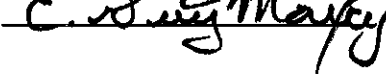
| | |
|-----------------------|--|
| Department Director |  |
| Finance Director |  |
| Purchasing Department |  |
| County Attorney |  |
| County Administrator |  |

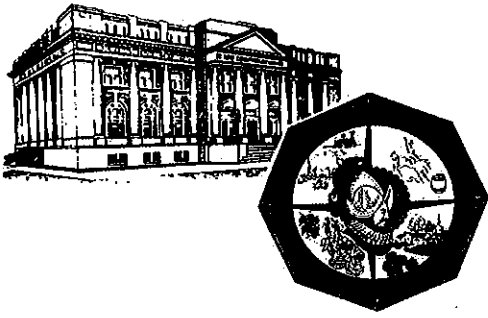

DeSoto County

Board of County Commissioners
Human Resources/Risk Management
201 East Oak Street, Suite 201
Arcadia, Florida 34266
(863) 993-4800 / (863) 993-4809 fax
www.desotobocc.com
Equal Opportunity Employer / Drug-Free Workplace

Current County Officials Bond Coverage as of June 11, 2013

| <u>Position</u> | <u>Amount</u> | <u>Expires on</u> |
|-------------------------|---------------|-------------------|
| County Administrator | \$2,000 | October 11, 2013 |
| Commissioner Dist 1 | \$2,000 | November 19, 2016 |
| Commissioner Dist 2 | \$2,000 | November 15, 2014 |
| Commissioner Dist 3 | \$2,000 | November 21, 2016 |
| Commissioner Dist 4 | \$2,000 | November 21, 2014 |
| Commissioner Dist 5 | \$2,000 | November 20, 2016 |
| Clerk of Circuit Court | \$5,000 | January 2, 2017 |
| County Sheriff | \$2,000 | January 1, 2017 |
| Property Appraiser | \$2,000 | January 2, 2017 |
| Tax Collector | \$10,000 | January 2, 2017 |
| Supervisor of Elections | \$5,000 | January 2, 2017 |

BOARD OF COUNTY COMMISSIONERS
DESOTO COUNTY, FLORIDA
DATE: June 11, 2013

| | |
|--|---|
| <input type="checkbox"/> Consent Agenda <input checked="" type="checkbox"/> Regular Business <input type="checkbox"/> Public Hearing | <input type="checkbox"/> Quasi-Judicial Public Hearing <input type="checkbox"/> Time |
|--|---|



| | |
|---------------------------------|--|
| DEPARTMENT: | Administration |
| SUBMITTED BY: | C. Guy Maxcy |
| PRESENTED BY: | Sheriff, Will Wise |
| TITLE & DESCRIPTION: | Grant Application/Edward Byrne Memorial Justice Assistance (JAG) Program |
| REQUESTED MOTION: | To apply for the Edward Byrne Memorial Justice Assistance (JAG) Program FY 2013 Local Solicitation Grant in the amount of \$10,941.00 and to allow the Chairman to sign and execute any paperwork pertaining to this grant when and if the Grant is awarded. |
| SUMMARY: | The Sheriff's office will apply for the Edward Byrne Memorial Justice Assistance (JAG) Program FY 2013 Local Solicitation Grant in the amount of \$10,941.00 dollars for the purpose of purchasing firearms for our Detectives and Deputies. |

BACKGROUND: The Sheriff's office applies for this grant every year.

| | | |
|---------------|--------------------|-----|
| FUNDS: | Budget Amount | N/A |
| | Actual Agenda Item | N/A |
| | Cost: | |
| | Account Number: | N/A |
| | Explanation: | N/A |

ATTACHMENTS: 1.

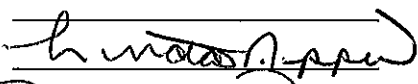
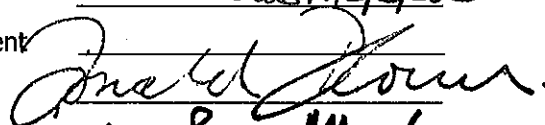
REVIEW APPROVAL:

| | |
|-----------------------|--|
| Department Director | |
| Finance Director |  |
| Purchasing Department |  |
| County Attorney | |
| County Administrator |  |



Office Of
SHERIFF
DESOTO COUNTY

208 East Cypress Street
Arcadia, Florida 34266-4410
863-993-4700 or 941-743-6777 Ex 863-993-4712

William P. "Will" Wise
Sheriff



June 3, 2013

Lori Jones
Board of County Commissioners
201 East Oak St.
Arcadia, FL 34266

Ref: Information added to the June Agenda

Dear Lori:

Desoto County Sheriff's Office requests the following information to be added to the June Agenda:

Desoto County Sheriff Office will be applying for the Edward Byrne Memorial Justice Assistance (JAG) Program FY 2013 Local Solicitation Grant in the amount of \$ 10, 941.00 dollars for the purpose of purchasing firearms for our Detectives and Deputies.

As per Grant requirements, it states:

1. No fewer than 30 days prior to application submission, the applicant agency (fiscal agent in disparate situations) must make the grant application available for review by the governing body (or to the organization designed by the governing body).
2. At the time of application submission, the applicant agency (fiscal agent in disparate situations) must provide an assurance that the application was made public and an opportunity to comment was provided to citizens and neighborhood or community organizations to the extent the application law or established procedure makes such an opportunity available.

The Grant application will be made available as soon as the application has been completed and submitted.

Sincerely,

A handwritten signature in black ink that reads "William P. Wise".

William P. Wise
Sheriff of Desoto County

BOARD OF COUNTY COMMISSIONERS
DESOTO COUNTY, FLORIDA
DATE: June 11, 2013

- Consent Agenda
- Regular Business
- Public Hearing

Quasi-Judicial Public Hearing

9am Time

DEPARTMENT: Administration
SUBMITTED BY: Mandy Hines, County Coordinator
PRESENTED BY: Mandy Hines
TITLE & DESCRIPTION: Certificate of Participation/Edward Byrne Memorial Justice Assistance Grant Program
REQUESTED MOTION: Motion to accept the invitation to serve as the coordinating unit of Government in the FDLE's Edward Byrne Memorial Justice Assistance Grant Program, Federal Fiscal Year 2013 State Solicitation
SUMMARY: This action will allow the County to serve as the Coordinating Agency for the referenced grant in the amount of \$61,316, set aside for all jurisdictions within DeSoto County and designated the Sheriff's Office as the agency to coordinate the preparation of applications. Submission of this form to FDLE will result in the issuance of access to the SIMON system whereby the Sheriff's Office will have access to prepare and submit an application. A grant agreement will come before the board for acceptance.

BACKGROUND:

FUNDS:

| | |
|--------------------|-----|
| Budget Amount | N/A |
| Actual Agenda Item | N/A |
| Cost: | |
| Account Number: | N/A |
| Explanation: | N/A |

ATTACHMENTS: 1.

REVIEW APPROVAL:

| | |
|-----------------------|---------------------|
| Department Director | <u>Mandy Hines</u> |
| Finance Director | _____ |
| Purchasing Department | _____ |
| County Attorney | _____ |
| County Administrator | <u>C. Amy Mayoy</u> |

CERTIFICATE OF PARTICIPATION

Edward Byrne Memorial Justice Assistance Grant (JAG) Program

Date: June 11, 2013

Mr. Clayton H. Wilder
Administrator
Office of Criminal Justice Grants
Florida Department of Law Enforcement
2331 Phillips Road
Tallahassee, Florida 32308

Dear Mr. Wilder:

This is to inform you that the Board of County Commissioners Accepts x
Declines the invitation to serve as the coordinating unit of government in the Florida
Department of Law Enforcement's Edward Byrne Memorial Justice Assistance Grant
(JAG) Program.

For purposes of coordinating the preparation of our application(s) for grant funds with
the Office of Criminal Justice Grants, we have designated the following person:

Name: Kay Hill

Title: Finance Director

E-mail address: khill@desotosheriff.org

Agency: DeSoto County Sheriff's Office

Address: 208 East Cypress Street, Arcadia, Florida 34266

Telephone: 863-993-4700 County: DeSoto

Date: June 11, 2013

Sincerely,

Chair, Board of County Commissioners

Rule Reference 11D-9.006 OCJG-024 (Rev. June 2012)



Office Of
SHERIFF
DESOTO COUNTY
208 East Cypress Street
Arcadia, Florida 34266-4410
863-993-4700 or 941-743-6777 Ex 863-993-4712
William P. "Will" Wise
Sheriff



June 4, 2013

Mr. Clayton H. Wilder
Administrator
Office of Criminal Justice Grants
Department of Law Enforcement
2331 Phillips Road
Tallahassee, Fl 32308

Dear Mr. Wilder:

In compliance with the State of Florida *Rule 11 D-9*, F.A.C., the County of DeSoto approves the distribution of \$61,316 (total collection available) of Federal Fiscal Year 2013 Edward Byrne Memorial JAG Program funds for the following projects within DeSoto County:

Subgrantee: DeSoto County Board of Commissioners

Title of Project: DeSoto County Narcotics Enforcement Project

Dollar Amount (Federal Funds): \$49,053.00

Title of Project: Arcadia Police Department Anti-Drug Program

Dollar Amount (Federal Funds): \$12,263.00

TOTAL COLLECTION AVAILABLE: \$61,316.00

Sincerely,

JAMES SELPH
CHAIRMAN OF THE BOARD



Florida Department of
Law Enforcement

Gerald M. Bailey
Commissioner

Business Support
Office of Criminal Justice Grants
Post Office Box 1489
Tallahassee, FL 32302-1489
(850) 617-1250
www.fdle.state.fl.us

Rick Scott, *Governor*
Pam Bondi, *Attorney General*
Jeff Atwater, *Chief Financial Officer*
Adam Putnam, *Commissioner of Agriculture*

May 24, 2013

The Honorable James Selph
Chairman, Desoto County
Board of Commissioners
201 East Oak Street, Suite 201
Arcadia, FL 34266

Re: Federal Fiscal Year (FFY) 2013 Edward Byrne Memorial Justice Assistance
Grant (JAG) Program – JAG Countywide – State Solicitation

Dear Chairman Selph:

The Florida Department of Law Enforcement (FDLE) anticipates an award from the United States Department of Justice for FFY 2013 JAG funds. FDLE will distribute these funds in accordance with the JAG Countywide distribution provisions of Chapter 11D-9, Florida Administrative Code.

FDLE has set aside \$61,316 funds for use by all units of government within Desoto County. The enclosed Program Announcement provides an overview of these funds which can be used by local units of government to support a broad range of activities to prevent and control crime and to improve the criminal justice system. Please note that the Program Announcement includes information from the U.S. Department of Justice relating several areas of national focus and its priorities to help maximize the effectiveness of the Byrne/JAG funding.

As a condition of participation in this program, the units of government in each county must reach a consensus concerning the expenditure of these funds. This consensus must include the projects to be implemented as well as the agency responsible for such implementation.

Developing such consensus will require someone to exercise leadership and assume a coordinating role in the development of applications for these funds. FDLE recommends that the Board of County Commissioners assume this responsibility. In the event the county declines to serve in this capacity, the Department will request the governing body of each municipality in the county, in descending order of population, to serve as the coordinating unit of government.

The Honorable James Selph
May 24, 2013
Page Two

The enclosed Certificate of Participation form requests the identification of an individual coordinator. We will send this individual further information regarding the application process in FDLE's on-line grant management system. Please complete the enclosed Certificate of Participation and return it as soon as possible to:

Florida Department of Law Enforcement
Office of Criminal Justice Grants
2331 Phillips Road
Tallahassee, Florida 32308
Attention: Clayton H. Wilder, Administrator

FDLE does not discriminate, and prohibits subgrant recipients from discriminating, on the basis of race, color, religion, national origin, sex, disability, or age in the delivery of services or benefits or in employment.

We look forward to working with you. If you have any questions or if we can provide you with any assistance regarding the JAG Program, please contact me at (850) 617-1250.

Sincerely,

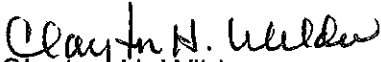
Clayton H. Wilder
Administrator

CHW/JP/al

Enclosures

cc: Mayors in Desoto County
Law Enforcement Agencies in Desoto County
Project Directors in Desoto County

**BOARD OF COUNTY COMMISSIONERS
DESOTO COUNTY, FLORIDA
DATE: June 11, 2013**

| | | | |
|-------------------------------------|------------------|--------------------------|-------------------------------|
| <input type="checkbox"/> | Consent Agenda | <input type="checkbox"/> | Quasi-Judicial Public Hearing |
| <input checked="" type="checkbox"/> | Regular Business | <input type="checkbox"/> | Time |
| <input type="checkbox"/> | Public Hearing | | |

DEPARTMENT: Administration
SUBMITTED BY: C. Guy Maxcy
PRESENTED BY: C. Guy Maxcy

TITLE & DESCRIPTION: Presentation/ DeSoto Mining update

REQUESTED MOTION: No motion required

SUMMARY: This is an brief update on the DeSoto Mining

BACKGROUND:

FUNDS:

| | |
|--------------------|-----|
| Budget Amount | N/A |
| Actual Agenda Item | N/A |
| Cost: | |
| Account Number: | N/A |
| Explanation: | N/A |

ATTACHMENTS: 1. N/A

REVIEW APPROVAL:

| | |
|-----------------------|-------|
| Department Director | _____ |
| Finance Director | _____ |
| Purchasing Department | _____ |
| County Attorney | _____ |
| County Administrator | _____ |

BOARD OF COUNTY COMMISSIONERS
DESOTO COUNTY, FLORIDA
DATE: JUNE 11, 2013

| | | | |
|-------------------------------------|------------------|--------------------------|-------------------------------|
| <input type="checkbox"/> | Consent Agenda | <input type="checkbox"/> | Quasi-Judicial Public Hearing |
| <input checked="" type="checkbox"/> | Regular Business | <input type="checkbox"/> | 9:00 a.m. Time |
| <input type="checkbox"/> | Public Hearing | | |

DEPARTMENT: Administrative Services
SUBMITTED BY: Linda Nipper
PRESENTED BY: Linda Nipper
TITLE & DESCRIPTION: Resolution/Budget Amendments

REQUESTED MOTION: To adopt a resolution amending the 2012/13 Budget including attachments.

SUMMARY: Resolution will approve the 2012-13 additions, corrections and redistributions of funds to meet current budget needs and requirements.

BACKGROUND: Budget amendments are an ongoing process throughout the fiscal year that more clearly define the actual costs of doing business.

FUNDS: Budget Amount
 Actual Agenda Item Total:
 Account Number:
 Explanation: Amendments affect various areas throughout the budget.

- ATTACHMENTS:**
1. Summary
 2. Amendment 2013-75
 3. Amendment 2013-76
 4. Amendment 2013-77
 5. Amendment 2013-78
 6. Amendment 2013-79

REVIEW APPROVAL:

County Administrator C. Bruce Mackey
 County Attorney Angela R. Rook
 Department Director Linda Nipper
 Finance Director _____
 Purchasing Director Cindy Talamante

DESOTO COUNTY, FLORIDA

RESOLUTION NO. 2013- _____

A RESOLUTION OF THE BOARD OF COUNTY COMMISSIONERS OF DESOTO COUNTY, FLORIDA, AMENDING AND SUPPLEMENTING THE BUDGET FOR FISCAL YEAR 2012-2013; AND PROVIDING FOR AN EFFECTIVE DATE.

WHEREAS, the Board of County Commissioners of Desoto County, Florida ("the Board") adopted an annual budget for Fiscal Year 2012-2013 as required by Florida law; and

WHEREAS, since its adoption, the Board has examined the adopted budget for Fiscal Year 2012-2013 and finds that amendments and supplements to the budget are necessary; and

NOW, THEREFORE, BE IT RESOLVED BY THE BOARD OF COUNTY COMMISSIONERS OF DESOTO COUNTY, FLORIDA, AS FOLLOWS:

Section 1. That the foregoing "WHEREAS" clauses are ratified and confirmed as being true and correct and are hereby incorporated by reference as part of this Resolution.

Section 2. That the adopted budget for Fiscal Year 2012-2013 is hereby amended and supplemented as provided in Attachments 1 and subsequent attachments.

Section 3. That this Resolution shall take effect immediately upon its adoption.

PASSED AND ADOPTED this 11th day of June, 2013.

ATTEST:

C. Guy Maxcy
County Administrator

BOARD OF COUNTY COMMISSIONERS
OF DESOTO COUNTY, FLORIDA

By: _____
James F. Selph
Chairman

Approved as to form and legal sufficiency:

Donald D. Conn
County Attorney

**2012/13 Budget Amendments Packet 13
June 11, 2013**

Revenue Sources

Expenses Account Description

Attachment

| General Fund | | Funds From: | Fund | B.A. | Funds Disbursed For: |
|---------------------|----------|--------------------|------|------|-----------------------------------|
| 4 | 500.00 | DCYB | 001 | 77 | 500.00 Parks Operating Supplies |
| 5 | 6,600.00 | Geocare | 001 | 78 | 6,600.00 Sheriff's Inmate Housing |
| 6 | 1,500.00 | Court 's Article V | 001 | 79 | 1,500.00 |
| <hr/> | | | | | |
| | 8,600.00 | | | | <hr/> 8,600.00 |

Attachment

| Special Revenue | | Funds From: | Fund | B.A. | Funds Disbursed For: |
|------------------------|-------------|----------------------|------|------|--|
| 3 | 3,150.00 | Engineering Reserves | 104 | 76 | 3,150.00 Engineering Contracted Services |
| <hr/> | | | | | |
| | \$ 3,150.00 | | | | <hr/> \$ 3,150.00 |

Attachment

| Construction Funds | | Funds From: | Fund | B.A. | Funds Disbursed For: |
|---------------------------|---|-------------|------|------|----------------------|
| <hr/> | | | | | |
| | - | | | | <hr/> \$ - |

Attachment

| Enterprise Funds | | Funds From: | Fund | B.A. | Funds Disbursed For: |
|-------------------------|----------|--------------------|------|------|-------------------------|
| 2 | 1,500.00 | Utility Operations | 410 | 75 | 1,500.00 Lake Suzy Fund |
| <hr/> | | | | | |
| | 1,500.00 | | | | <hr/> 1,500.00 |

Attachment

| Agency Funds | | Funds From: | Fund | B.A. | Funds Disbursed For: |
|---------------------|---|-------------|------|------|----------------------|
| <hr/> | | | | | |
| | - | | | | <hr/> - |

| | | | | | |
|-------------|--------------|--------------|--|--------------|---------------|
| <hr/> <hr/> | \$ 13,250.00 | Total Debits | | \$ 13,250.00 | Total Credits |
|-------------|--------------|--------------|--|--------------|---------------|

BUDGET AMENDMENT REQUEST/CORRECTION

Department **Utilities** 05/16/2013 2013-075

| Account # | Account Description | CURRENT Budget | DEBIT | CREDIT | REVISED Budget Amt | Explanation for Request |
|----------------------|----------------------------|-------------------|-------------|-------------|-----------------------|-------------------------|
| 40970875363400000 | Contracted Services | - | 1,500.00 | - | 1,500.00 | |
| 40900003810000410 | Transfer from Operations | 7,000.00 | | 1,500.00 | 8,500.00 | |
| 41070975356301000 | R & R Capital Projects | 509,000.00 | - | 1,500.00 | 507,500.00 | |
| 41070975359100002 | Transfer to Lake Suzy Fund | 7,000.00 | 1,500.00 | | 8,500.00 | |
| | | | | | | |
| | | | | | | |
| | | | | | | |
| | | | | | | |
| | | | | | | |
| | | | | | | |
| | | | | | | |
| | | | | | | |
| | | | | | | |
| | | | | | | |
| | | | | | | |
| | | | | | | |
| | | | | | | |
| | | | | | | |
| | | | | | | |
| | | | | | | |
| | | | | | | |
| | | | | | | |
| | | | | | | |
| | | | | | | |
| | | | | | | |
| | | | | | | |
| Column TOTALS | | | \$ 3,000.00 | \$ 3,000.00 | | \$ - |

APPROVALS

Board Chairman _____

Date: _____

County Administrator _____

Date: _____

Administrative Services Director *Kenneth Hopper* _____

Date: 05/16/2013

System Updated by: _____

Date: _____

ATTACHMENT 2

BUDGET AMENDMENT REQUEST/CORRECTION

Department **Engineering** 05/16/2013 2013-076

| Account # | Account Description | CURRENT Budget | DEBIT | CREDIT | REVISED Budget Amt | Explanation for Request |
|----------------------|----------------------|-------------------|-------------|-------------|-----------------------|-------------------------|
| 10430205413400000 | Contracted Services | - | 3,150.00 | - | 3,150.00 | |
| 10430205419900000 | Engineering Reserves | 132,332.00 | | 3,150.00 | 129,182.00 | |
| | | | | | | |
| | | | | | | |
| | | | | | | |
| | | | | | | |
| | | | | | | |
| | | | | | | |
| | | | | | | |
| | | | | | | |
| | | | | | | |
| | | | | | | |
| | | | | | | |
| | | | | | | |
| | | | | | | |
| | | | | | | |
| | | | | | | |
| | | | | | | |
| | | | | | | |
| | | | | | | |
| | | | | | | |
| | | | | | | |
| | | | | | | |
| | | | | | | |
| | | | | | | |
| | | | | | | |
| | | | | | | |
| | | | | | | |
| | | | | | | |
| Column TOTALS | | | \$ 3,150.00 | \$ 3,150.00 | | \$ |

APPROVALS

Board Chairman _____

County Administrator _____

Administrative Services Director *Linda Appel* _____

System Updated by: _____

Date: _____

Date: _____

Date: 05/16/2013 _____

Date: _____

ATTACHMENT 3

BUDGET AMENDMENT REQUEST/CORRECTION

Department **Sheriff** 05/17/2013 2013-078

| Account # | Account Description | CURRENT Budget | DEBIT | CREDIT | REVISED Budget Amt | Explanation for Request |
|----------------------|----------------------------|---------------------------|--------------|---------------|-------------------------------|--------------------------------|
| 00125095215200006 | Geocare | 55,440.00 | 6,600.00 | - | 62,040.00 | |
| 00100003420300001 | Inmate Housing Revenue | 55,440.00 | | 6,600.00 | 62,040.00 | |
| | | | | | | |
| | | | | | | |
| | | | | | | |
| | | | | | | |
| | | | | | | |
| | | | | | | |
| | | | | | | |
| | | | | | | |
| | | | | | | |
| | | | | | | |
| | | | | | | |
| | | | | | | |
| | | | | | | |
| | | | | | | |
| | | | | | | |
| | | | | | | |
| | | | | | | |
| | | | | | | |
| | | | | | | |
| Column TOTALS | | | \$ 6,600.00 | \$ 6,600.00 | | - |
| APPROVALS | | | | | | |

Board Chairman _____

County Administrator _____

Administrative Services Director *[Signature]* _____

System Updated by: _____

Date: _____

Date: _____

Date: 05/16/2013

Date: _____

ATTACHMENT 5

June 11, 2013 BCC Meeting

BUDGET AMENDMENT REQUEST/CORRECTION

Department **Sheriff** 05/21/2013 2013-079

| Account # | Account Description | CURRENT Budget | DEBIT | CREDIT | REVISED Budget Amt | Explanation for Request |
|----------------------|--------------------------------|----------------|-------------|-------------|--------------------|-------------------------|
| 00125095214900000 | Article V Expense | 21,692.41 | 1,500.00 | - | 23,192.41 | |
| 00100003810200190 | Transfer in from Courts Fund | 21,692.41 | | 1,500.00 | 23,192.41 | |
| 19024105219100000 | Transfer to Sheriff's Gen Fund | 21,692.41 | 1,500.00 | | 23,192.41 | |
| 19024106019900000 | Courts Reserve | 23,529.03 | | 1,500.00 | 22,029.03 | |
| | | | | | | |
| | | | | | | |
| | | | | | | |
| | | | | | | |
| | | | | | | |
| | | | | | | |
| | | | | | | |
| | | | | | | |
| | | | | | | |
| | | | | | | |
| | | | | | | |
| | | | | | | |
| | | | | | | |
| | | | | | | |
| | | | | | | |
| | | | | | | |
| | | | | | | |
| | | | | | | |
| | | | | | | |
| Column TOTALS | | | \$ 3,000.00 | \$ 3,000.00 | | \$ - |

APPROVALS

Board Chairman _____

Date: _____

County Administrator _____

Date: _____

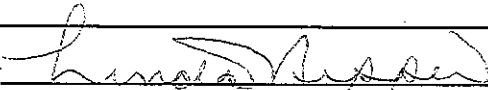
Administrative Services Director 

Date: 05/21/2013

System Updated by: _____

Date: _____

June 11, 2013 BCC Meeting

ATTACHMENT 6

AGENDA ITEM 10

BOARD OF COUNTY COMMISSIONERS

DESOTO COUNTY, FLORIDA

DATE: JUNE 11, 2013

| | | | |
|-------------------------------------|------------------|--------------------------|-------------------------------|
| <input type="checkbox"/> | Consent Agenda | <input type="checkbox"/> | Quasi-Judicial Public Hearing |
| <input checked="" type="checkbox"/> | Regular Business | <input type="checkbox"/> | 9:00 Time |
| <input type="checkbox"/> | Public Hearing | <input type="checkbox"/> | a.m. |

DEPARTMENT: Administrative Services
SUBMITTED BY: Linda Nipper
PRESENTED BY: Linda Nipper

TITLE & DESCRIPTION: 2013/14 Proposed Fire Rescue M.S.B.U. Rates

REQUESTED MOTION: Approval of the proposed rates for publication and for notification.

SUMMARY: In order to reflect potential increases, staff wishes to have a consensus from the Board that the rates included in today's summary may be advertised, however, by agreeing that staff may advertise, the Board is not approving or disapproving the proposed rates until the Public Hearing.

BACKGROUND: Proposed M.S.B.U. rates must be publicized and notifications submitted four weeks prior the Public Hearing in which the final rates will be decided.

FUNDS: Budget Amount N.A.
Actual Agenda Item
Cost:
Account Number:
Explanation:

ATTACHMENTS: 1. Final summary of proposed Fire/Rescue M.S.B.U. Rates

REVIEW APPROVAL:

| | |
|-----------------------|-----------------------|
| Department Director | <u>Linda Nipper</u> |
| Finance Director | |
| Purchasing Department | <u>Andy Talan</u> |
| County Attorney | <u>Frank Brown</u> |
| County Administrator | <u>C. Sunny Mayes</u> |

| Category | Amount |
|---------------------|--------------|
| Residential | \$ 1,900,109 |
| R.V., Hotels, Camps | \$ 87,835 |
| Commercial | \$ 233,779 |
| Vacant Lots/Acres | \$ 112,535 |

Revenue Percentages as related to Fire and E.M.S. Calls

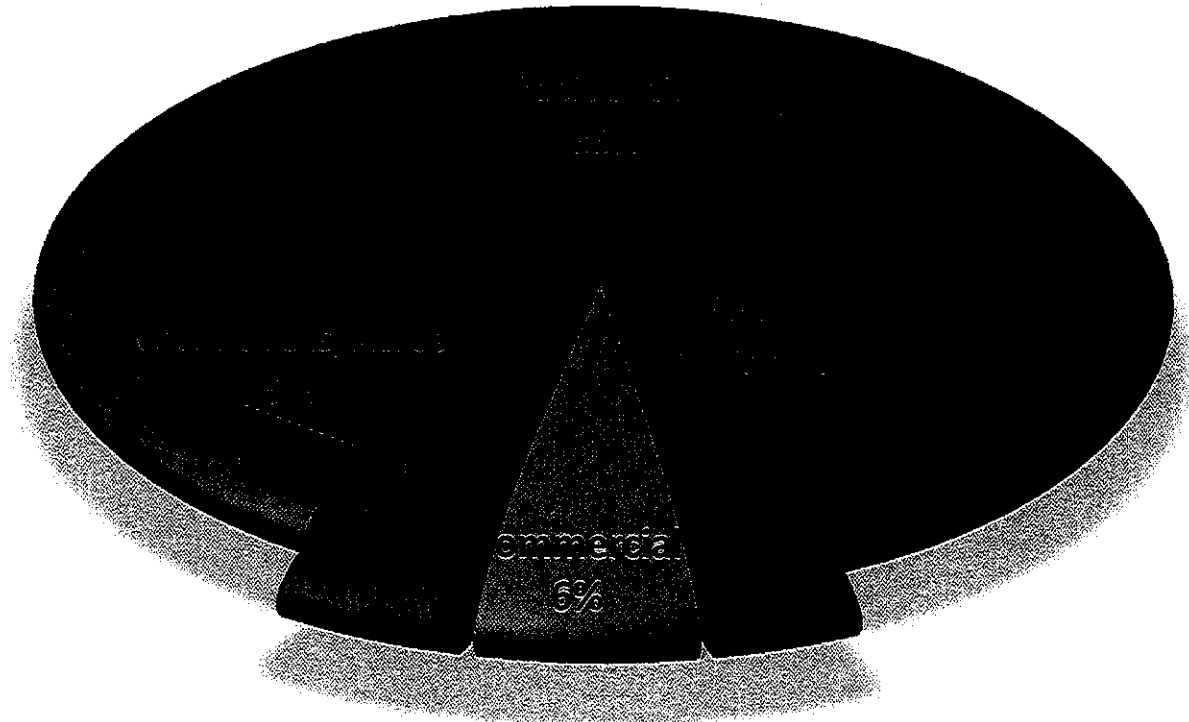

| Residential | Units | Rate | Total |
|---|--|----------------------|-----------------------|
| City | 2,672 | 152.35 | \$ 407,079.20 |
| County | 9,800 | 152.35 | <u>\$1,493,030.00</u> |
| | | | \$1,900,109.20 |
| R.V.'s, Hotel Motel, Campsites | | | |
| City | 106 | \$25.00 | \$ 2,650.00 |
| County | 3,407 | \$25.00 | <u>\$85,175.00</u> |
| | | | \$87,825.00 |
| Commercial | | | |
| City | 1,638,294 | .04 | \$ 65,531.76 |
| County | 1,708,303 | .04 | <u>\$ 68,332.12</u> |
| | | | \$133,863.88 |
| Vacant Lots | | | |
| City | 682 | 13.00 per lot | \$ 8,866.00 |
| County | 3,064 | 13.00 per lot | <u>\$ 39,832.00</u> |
| | | | \$ 48,698.00 |
| Vacant Acreage | | | |
| City | \$.13 per acre w/ \$8.50 minimum | | \$ 68.00 |
| County | \$.13 per acre w/ \$8.50 minimum | | <u>\$ 63,768.63</u> |
| | | | \$ 63,836.63 |
| Total Fire Rescue M.S.B.U.s | | | \$2,234,332.71 |

Alternative Vacant Acreage pricing

Vacant Acreage

| | | |
|---------------|--|----------------------------|
| City | \$.08 per acre w/ \$8.50 minimum | \$ 68.00 |
| County | \$.08 per acre w/ \$8.50 minimum | <u>\$ 51,082.76</u> |
| | | \$ 51,150.76 |

Total Fire Rescue M.S.B.U.s **\$2,221, 646.84**

| | |
|---|----------------------|
| Additional revenue required to eliminate General Fund Transfers | \$1,101,439.00 |
| Additional revenue from M.S.B.U. revisions | <u>\$ 784,515.71</u> |
| Balance Required from M.S.T.U. | \$ 316,923.29 |
| | |
| Additional Funds from proposed M.S.T U. rate of .7125 | \$ 419,879.00 |
| \$102,955 Over the minimum required. | |

BOARD OF COUNTY COMMISSIONERS
DESOTO COUNTY, FLORIDA
DATE: June 11, 2013

| | | | |
|-------------------------------------|------------------|--------------------------|-------------------------------|
| <input type="checkbox"/> | Consent Agenda | <input type="checkbox"/> | Quasi-Judicial Public Hearing |
| <input checked="" type="checkbox"/> | Regular Business | <input type="checkbox"/> | Time |
| <input type="checkbox"/> | Public Hearing | | |

DEPARTMENT: Public Safety
SUBMITTED BY: Glenn H. Prescott, Sr.
PRESENTED BY: Glenn H. Prescott, Sr.

TITLE & DESCRIPTION: Purchase/Tanker Truck

REQUESTED MOTION: To approve the purchase of a Tanker Truck and authorize the County Administrator to execute a purchase order.

SUMMARY: DeSoto County Fire Rescue is in imminent need of a Tanker Truck due to our deteriorating fleet. We are requesting authorization from the Board to proceed with the purchase of an available Tanker Truck from Pierce Manufacturing Inc.

BACKGROUND: DeSoto County Fire Rescue is in dire need of replacing one of three aging Tanker Trucks. We have one truck which is 23 years old and has recently been red-tagged by DOT. The estimated repair costs are \$138,543. Pierce Manufacturing Inc. currently has a new truck that meets our needs and is priced at \$210,500. They are an authorized dealer under the Florida Sheriff's Purchasing Contract. Research has been conducted on used trucks but we have not found any as of yet to meet our specifications. The problem has been locating one with sufficient water capacity and that includes a fire rated pump. Tanker truck manufacturing times are generally 6-8 months. It is imperative that we have the capability to carry large quantities of water to help achieve our fire flow requirements and to maintain our ISO rating.

FUNDS:

| | |
|--------------------------|------------------------------------|
| Budget Amount | \$ 0.00 |
| Actual Agenda Item Cost: | \$ 210,500.00 |
| Account Number: | 10670725226400000 |
| Explanation: | Cost of requested vehicle purchase |

ATTACHMENTS:

1. Pierce proposal, financing options, spec sheets.
2. Truck and price comparisons
3. Repair estimates of existing trucks

REVIEW APPROVAL:

| | |
|-----------------------|--------------------------|
| Department Director | <u>Glenn H. Prescott</u> |
| Finance Director | <u>Christina Lippert</u> |
| Purchasing Department | <u>[Signature]</u> |
| County Attorney | <u>[Signature]</u> |
| County Administrator | <u>C. Sunny Mayes</u> |

PROPOSAL FOR FURNISHING FIRE APPARATUS

June 3, 2013

DeSoto County Fire and Rescue
1985 SE Carlstrom Field RD
Arcadia, FL 34266

The undersigned is prepared to manufacture for you, upon an order being placed by you, for final acceptance by Pierce Manufacturing, Inc., at its home office in Appleton, Wisconsin, the apparatus and equipment herein named and for the following prices:

| | |
|--|---------------|
| One Pierce Heavy Duty Freightliner DX 3000 Tanker ¹ | \$ 210,500.00 |
|--|---------------|

| | |
|---|--|
| Price includes the following: rear camera, rear tailboard with ladder and hosebed sides, one air bottle compartment each side of truck, front chevron on bumper, and striping of truck. | |
|---|--|

| | |
|---|--|
| Unit can be delivered in less than 30 days. | |
|---|--|

| | |
|--|--|
| Financing options from Oshkosh Capital are attached for 3, 5, 7, and 10 year | |
|--|--|

| | |
|--|---------------------|
| | Total \$ 210,500.00 |
|--|---------------------|

Said apparatus and equipment are to be built and shipped in accordance with the specifications hereto attached, delays due to strikes, war, or intentional conflict, failures to obtain chassis, materials, or other causes beyond our control not preventing, within about 30 calendar days after receipt of this order and the acceptance thereof at our office at Appleton, Wisconsin, and to be delivered to you at Arcadia, FL.

The specifications herein contained shall form a part of the final contract, and are subject to changes desired by the purchaser, provided such alterations are interlined prior to the acceptance by the company of the order to purchase, and provided such alterations do not materially affect the cost of the construction of the apparatus.

The proposal for fire apparatus conforms with all Federal Department of Transportation (DOT) rules and regulations in effect at the time of bid, and with all National Fire Protection Association (NFPA) Guidelines for Automotive Fire Apparatus as published at the time of bid, except as modified by customer specifications. Any increased costs incurred by first party because of future changes in or additions to said DOT or NFPA standards will be passed along to the customers as an addition to the price set forth above.

Unless accepted within 30 days from date, the right is reserved to withdraw this proposition.

Pierce Manufacturing, Inc.

By: _____

AUTHORIZED SALES REPRESENTATIVE

John Thompson



PERFORM. LIKE NO OTHER



June 3, 2013

SALES ORGANIZATION: Ten- 8 – John
 LESSEE: Desoto County
 TYPE OF EQUIPMENT: Pierce 3000 DX tanker
 EQUIPMENT COST: \$ 210,500.00
 CUSTOMER DOWNPAYMENT: \$0.00
 TRADE-IN: \$0.00
 DELIVERY TIME: std
 PAYMENT MODE: Annual In Arrears
 FIRST PAYMENT DUE DATE: 1 Year After delivery
 LEASE COMMENCEMENT DATE: At delivery

| Term | Number of Payments | Payment Amount - Interest rate |
|----------|--------------------|--------------------------------|
| 3 years | 3 annual | \$73,475.78 – 2.34% |
| 5 years | 5 annual | \$45,296.42 – 2.49% |
| 7 years | 7 annual | \$33,621.25 – 2.87% |
| 10 years | 10 annual | \$25,579.43 – 3.71% |

The above listed payment(s) reflect all program discounts available exclusively through Oshkosh Capital. There are no closing costs or documentation fees associated with the completion of this financing.

NOTE: All lease documents must be fully executed within 14 days of the date of this proposal. Failure to receive completed documents may alter the final payment schedule due to changes in rates and/or discounts.

PERFORMANCE BOND: To utilize the prepay program, a performance bond is required. Said performance bond shall be paid for directly to Pierce manufacturing or financed by Oshkosh Capital as part of the transaction

TYPE OF FINANCING: Tax-exempt Lease Purchase Agreement with a \$1.00 buy out option at end of lease term. Said agreement shall be a net lease arrangement whereby lessee is responsible for all costs of operation, maintenance, insurance, and taxes.

BANK QUALIFICATION: This proposal assumes that the lessee will not be issuing more than \$10 million in tax-exempt debt this calendar year. Furthermore, it is assumed that the lessee will designate this issue as a qualified tax-exempt obligation per the tax act of 1986.

LEGAL TITLE: Legal title to the equipment during the lease term shall vest in the lessee, with Oshkosh Capital perfecting a first security interest

AUTHORIZED SIGNORS: The lessee's governing board shall provide Oshkosh Capital with its resolution or ordinance authorizing this agreement and shall designate the individual(s) to execute all necessary documents used therein.

LEGAL OPINION: The lessee's counsel shall furnish Oshkosh Capital with an opinion covering this transaction and the documents used herein. This opinion shall be in a form and substance satisfactory to Oshkosh Capital.

VOLUNTEER FIRE DEPARTMENTS: If Lessee is a Volunteer Fire Department, a public hearing under the requirements of Section 147(f) of the Internal Revenue Code of 1986 shall be conducted to authorize this transaction. It is recommended that a notice of the public hearing be published 10 to 14 days in advance of the public hearing.

This proposal will be valid for fourteen (14) days from the above date and is subject to final credit approval by Oshkosh Capital and approval of the lease documents in Oshkosh Capital's sole discretion. To render a credit decision, lessee shall provide Oshkosh Capital with their most recent two years' audited financial statements, copy of their most recent interim financial statement, and current budget.

Accepted by:

Proposal submitted by:

 Lessee Date

Kim Simon

 Kim Simon
 Kim.Simon@oshkoshcapital.com





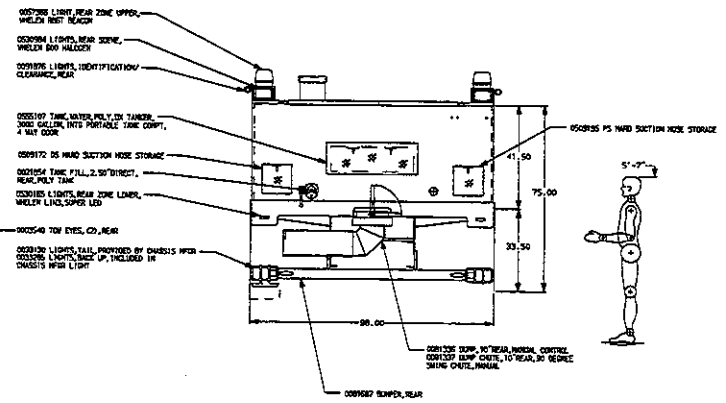
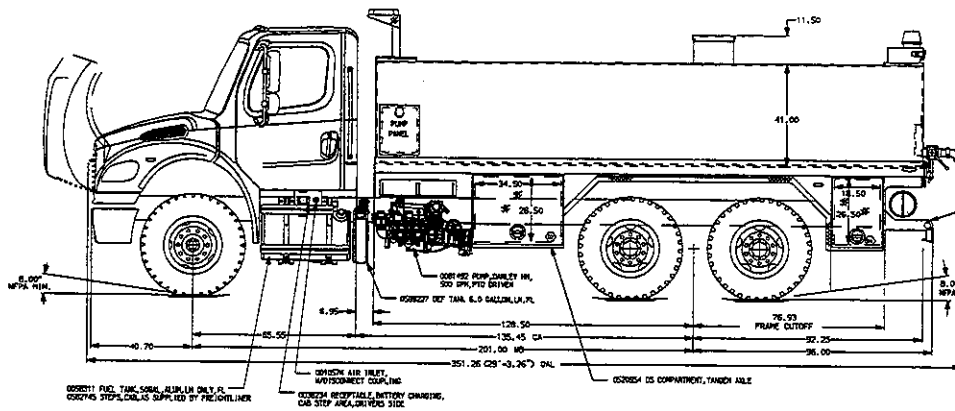
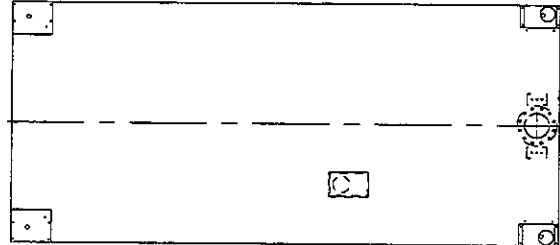
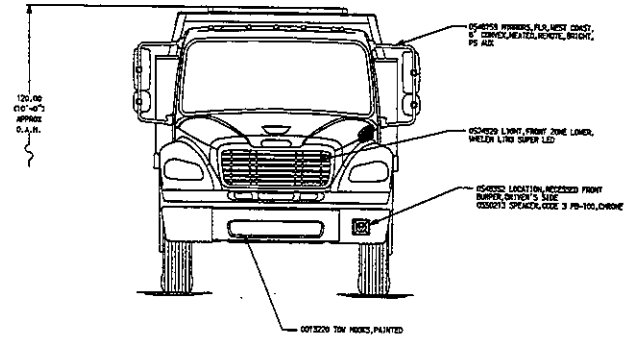
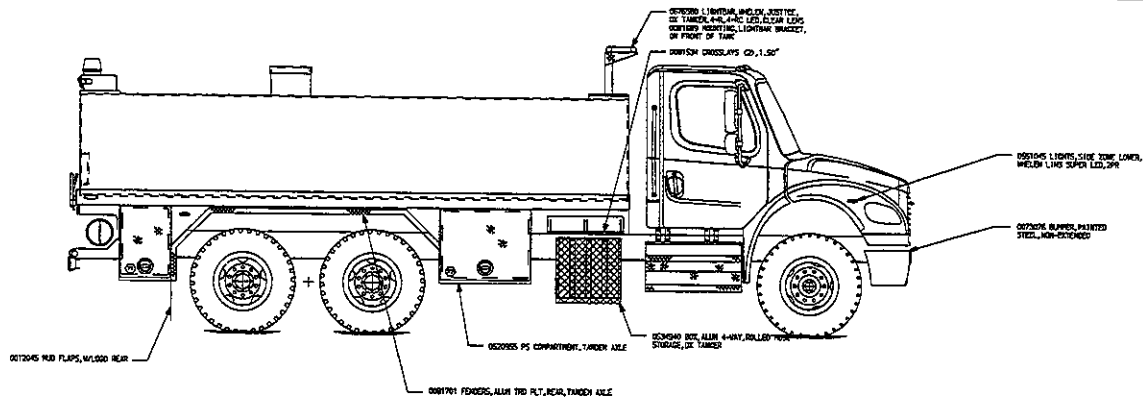

NOTE
DIMENSIONS SHOWN ARE APPROXIMATE
AND ARE SUBJECT TO MINOR DEVIATIONS
AS MAY OCCUR OR BE NECESSARY IN
CONSTRUCTION.
MINOR DETAILS NOT SHOWN.

REF 3000 GALLON 15725B1

| | | | |
|---|--------------------------------------|------------|-----------|
| PIERCE MANUFACTURING INC. BRADENTON, FLORIDA | | JOB NO. | 26203 |
| | | DATE | 1.24.12 |
| | | DRAWN BY | JAF |
| | | CHK'D BY | AIV |
| | | SHEET NO. | 1 of 1 |
| | | DRAWN DATE | 31 JUN 12 |
| | | DRG. NO. | 26203AD |
| | | NO. | D |
| TITLE: 500-D-3000 GALLON POLY WETSIDE TANKER, 154 BODY DARLEY 500 GPM PUMP FOR: PIERCE FIELD UNIT BRADENTON, FLORIDA | | | |
| CHASSIS DATA CHASSIS FL MODEL P2-10S DRG. NO. | DATE 11/08/12 BY JAF CHK'D AIV | | |



Proposal Option List

6/3/2013

| | | | |
|------------------------------|---|----------------------|-----------------|
| Customer: | Pierce Field Unit (original) | Bid Number: | 565 |
| Representative | Mori, Christina | Job Number: | 26200 |
| Organization: | Pierce Manufacturing Inc | Bid Date: | |
| Requirements Manager: | Mori, Christina | Stock Number: | 26200 |
| Description: | Freightliner M2 106 3000 Gallon DX Tanker - FY13 - 8 | DBVersion: | 02.00.0387.0000 |
| Body: | Tanker, DX Style, Alum, Tandem Rear Axle, PMFD | | |
| Chassis: | Freightliner M2-106, 6x4 Tandem Rear Axle, WITH PRICING | | |

| Line | Option | Type | Option Description | Qty |
|------|---------|------|--|-----|
| 1 | 0551024 | | DX Tanker, BTO, Tandem Axle | 1 |
| 2 | 0584455 | | Manufacture Location: Bradenton, Florida | 1 |
| 3 | 0584453 | | RFP Location: Bradenton, Florida | 1 |
| 4 | 0588609 | | Vehicle Destination, US | 1 |
| 5 | 0581843 | | Boiler Plate, Elliptical, Dry Side, DX Tanker, PMFD | 1 |
| 6 | 0018257 | | Commercial chassis & Snorkel products | 1 |
| 7 | 0542373 | | Comply NFPA 1901 Changes Effect Jan 1, 2009, With Exceptions, Commercial Chassis | 1 |
| 8 | 0545738 | | Mobile Water Supply Fire Apparatus, PMFD | 1 |
| 9 | 0588617 | | Vehicle Certification, Tanker | 1 |
| 10 | 0568412 | | Agency, Apparatus Certification, Pumper/Tanker, Third Party, PMFD | 1 |
| 11 | 0008051 | | No Fire Department Defined | 1 |
| 12 | 0536644 | | Customer Service Website | 1 |
| 13 | 0537375 | | Unit of Measure, US Gallons | 1 |
| 14 | 0000005 | | Bid Bond, 10% | 1 |
| 15 | 0540326 | | Performance Bond, Not Requested | 1 |
| 16 | 0010007 | | No Approval Drawing Req'd. | 1 |
| 17 | 0589819 | | Electrical Diagrams, Commercial | 1 |
| 18 | 0583766 | | Freightliner M2-106, 6x4 Tandem Rear Axle, WITH PRICING | 1 |
| 19 | 0672490 | | Base Spec, Freightliner M2-106, 6x4, Pricing Level 3/1/2012, EXPIRED | 1 |
| 20 | 0684965 | | Price Override Not Required - Domestic USA or Canada Destination | 1 |
| 21 | 0582822 | | Wheelbase, 187" to 202", FL M2-106/112 Wheelbase - 201" | 1 |
| 22 | 0584367 | | GVW Rating, Commercial Chassis GVW rating - 54,600# | 1 |
| 23 | 0579898 | | Frame, Chassis, Freightliner, 120 KSI | 1 |
| 24 | 0584366 | | Frame Liner not Req'd, Commercial Chassis | 1 |
| 25 | 0669872 | | Axle, Front, Detroit, 14.7K,(w/14.6K Rating) with Rear Tandem Axle, Freightliner | 1 |
| 26 | 0098703 | | Suspension, Front Spring, 14,600 lb FL | 1 |
| 27 | 0073051 | | Shock Absorbers, Front | 1 |
| 28 | 0585779 | | Goodyear Tires (Default Brand) | 1 |
| 29 | 0693862 | | Tires, Goodyear, 12R22.50 | 1 |
| 30 | 0582452 | | Wheel, Steel, 22.50" x 8.25", Commercial Chassis | 1 |
| 31 | 0582405 | | Axle, Tandem Rear, 40K, Freightliner | 1 |
| 32 | 0544651 | | Top Speed of Vehicle, 60 MPH, Commercial Chassis | 1 |
| 33 | 0006589 | | Suspen, Rear, Freightliner Flat Spring, 40,000 lb (spring) FLR | 1 |
| 34 | 0582603 | | Dust Shields, Front and Rear Brakes, Tandem Axle, Freightliner | 1 |
| 35 | 0693879 | | Tires, Goodyear, 11R22.50 | 1 |
| 36 | 0582450 | | Wheel, Steel, 22.50" x 8.25", Commercial Chassis | 1 |
| 37 | 0545391 | | Tire Pressure Monitoring Valve Cap Qty, Tire Pressure Ind - 10 | 1 |
| 38 | 0057936 | | Covers, Lug Nut, Chrome | 1 |
| 39 | 0002045 | | Mud Flaps, w/logo front & rear | 1 |
| 40 | 0526810 | | Wheel cover, S/S, 8.25" & 9.00", Tandem, PMFD | 1 |
| 41 | 0533329 | | Chocks, Wheel, Mobile Water Supply, Provided by Fire Department | 1 |
| 42 | 0544690 | | Mounting Brackets, Chocks, Provided by Fire Department | 1 |
| 43 | 0582634 | | ABS, Wabco Anti-Lock Braking Sys w/Electronic Stability Pgm w/ATC, Tandem, FLR | 1 |
| 44 | 0082993 | | Brakes, Cam Front, 16.50"x 5.00" Freightliner | 1 |
| 45 | 0009547 | | Air Compressor, Brake, Wabco Cummins 18.7 CFM, ISL/ISC/ISB, FLR | 1 |
| 46 | 0687210 | | Air Dryer, Brake, AD-IP w/Heater, FLR | 1 |

| Line | Option | Type | Option Description | Qty |
|------|---------|------|--|-----|
| 102 | 0072785 | | Cab Lighting, Commercial Chassis | 1 |
| 103 | 0091876 | | Lights, Identification/Clearance, Rear | 1 |
| 104 | 0033130 | | Lights, Tail, Supplied by Chassis Mfgr | 1 |
| 105 | 0033285 | | Lights, Backup, Included in Chassis Mfgr Light Cluster, USFS, MTRV, DX | 1 |
| 106 | 0589905 | | Alarm, Back-up Warning, PRECO 1040 | 1 |
| 107 | 0057865 | | Lights, Perimeter Scene Cab Exits, Truck-Lite, Model 60 Cab, Perimeter Scene - Cab, 2dr Commercial | 1 |
| 108 | 0551175 | | Lights, No Lights Req'd, Perm Scene, Body, DX Tanker | 1 |
| 109 | 0048225 | | Lights, Step, No Lights Required | 1 |
| 110 | 0530984 | | Lights, Rear Scene, Whelen 600 Halogen, DX Tanker/ICAO Value ARFF | 1 |
| 111 | 0056087 | | Not Required, Lights, Rear Deck | 1 |
| 112 | 0518784 | | Tanker, DX Style, Alum, Tandem Rear Axle, PMFD | 1 |
| 113 | 0555107 | | Tank, Water, Poly, DX Tanker, 3000 Gallon, Intg Portable Tank Compt, 4way Door | 1 |
| 114 | 0028107 | | Not Required, Foam Cell Modification | 1 |
| 115 | 0556517 | | Restraint, Water Tank, Dry Side or DX Tanker | 1 |
| 116 | 0059109 | | No Tank Access Ladder Required, DX Tanker/ICAO Value ARFF | 1 |
| 117 | 0027805 | | Overflow, 6" Poly, Dry Sides/DX Tanker/ICAO Value ARFF | 1 |
| 118 | 0021854 | | Tank Fill, 2.50" Direct, Rear, Poly Tank Location, driver's/passenger's/center - driver's Adapter, Elbow - 2.5"NST | 1 |
| 119 | 0048710 | | Jet Assist Not Req'd | 1 |
| 120 | 0081336 | | Dump, 10" Rear, Manual Control, DX Tanker | 1 |
| 121 | 0081337 | | Dump Chute, Rear, 90 Degree Swing Chute, Manual | 1 |
| 122 | 0028740 | | No Drivers Side Dump Req'd | 1 |
| 123 | 0028767 | | No Dump Chute Req'd, DS | 1 |
| 124 | 0028741 | | No Pass Side Tank Dump Req'd | 1 |
| 125 | 0028759 | | No Dump Chute Req'd, PS | 1 |
| 126 | 0081354 | | No Hose Bed, DX Tanker/Hawk EX | 1 |
| 127 | 0073494 | | Not Required, Divider, Hose Bed | 1 |
| 128 | 0000728 | | No Runningboards, Body | 1 |
| 129 | 0081687 | | Bumper, DX Tanker | 1 |
| 130 | 0681298 | | Wall, Rear, Material, Smooth Poly, DX Tanker | 1 |
| 131 | 0003540 | | Tow Eyes (2) (Tanker/Rescue) | 1 |
| 132 | 0081356 | | Construction, DX Tanker | 1 |
| 133 | 0520954 | | DS Compartment, Tandem Axle, DX Tanker, PMFD | 1 |
| 134 | 0509172 | | DS Hard Suction Hose Storage, 5" Hose or Less, DX Tanker, Alum Treadplate Door | 1 |
| 135 | 0520955 | | PS Compartment, Tandem Axle, DX Tanker, PMFD | 1 |
| 136 | 0509195 | | PS Hard Suction Hose Storage, 5" Hose or Less, DX Tanker, Alum Treadplate Door | 1 |
| 137 | 0081399 | | Doors, Treadplate, Double Pan w/D" Handle, Side Cmpt, | 1 |
| 138 | 0048732 | | No Rear Compt Req'd - Elliptical/Dry Side/Tanker | 1 |
| 139 | 0005920 | | Lights, Compt, Truck-Lite, Model 79384 Incandescent | 1 |
| 140 | 0687139 | | No Shelf Tracks Required | 1 |
| 141 | 0014015 | | Rubrail, Not Req'd | 1 |
| 142 | 0081701 | | Fenders, Aluminum Treadplate, Rear, Tandem Axle, DX Tanker | 1 |
| 143 | 0519849 | | Not Required, Hose, Hard Suction | 1 |
| 144 | 0022041 | | No Handrails Req'd @ Side Pump Panel, No Pump Module | 1 |
| 145 | 0044229 | | No Extension Ladder Req'd | 1 |
| 146 | 0074231 | | No Roof Ladder Req'd | 1 |
| 147 | 0557331 | | Not Required, Ladder Storage | 1 |
| 148 | 0074248 | | Not Required, Folding Ladder | 1 |
| 149 | 0543349 | | Pike Pole, 6', Mobile Water Supply, Provided by Fire Department | 1 |
| 150 | 0064388 | | No Steps Front of Body | 1 |
| 151 | 0014381 | | Not Required, Rear Step (No rear door) | 1 |
| 152 | 0081492 | | Pump, Darley HM, 500 GPM, PTO Driven, DX Tanker Program | 1 |
| 153 | 0551160 | | Mechanical Seals, Darley HM/PSP, DX Tanker | 1 |
| 154 | 0091446 | | Pump Setup Charges N/A | 1 |
| 155 | 0021437 | | Transmission, PTO, 2 Gear, Darley Pump | 1 |
| 156 | 0017177 | | Pumping Mode Pumping Mode - Pump in Motion | 1 |
| 157 | 0535276 | | Shift, Pump PTO | 1 |

| Line | Option | Type | Option Description | Qty |
|------|---------|------|---|-----|
| 215 | 0091110 | | Not Required, Foam Tank Drain | 1 |
| 216 | 0091079 | | Not Required, Foam Tank #2 | 1 |
| 217 | 0091112 | | Not Required, Foam Tank Drain | 1 |
| 218 | 0081491 | | Not Required, Pump House, DX Tanker Program | 1 |
| 219 | 0000261 | | Not Required, Pump Panel Layout | 1 |
| 220 | 0514020 | | Panel, Pump and Gauge, Stainless Steel DX Tanker | 1 |
| 221 | 0081545 | | Pump Access, DX Tanker Program | 1 |
| 222 | 0050398 | | Pump House Structure, N/A | 1 |
| 223 | 0001836 | | No Light, No Pump Compartment | 1 |
| 224 | 0528996 | SP | Engine Indicators, Included With Pierce Pressure Controller | 1 |
| 225 | 0005601 | | Throttle Included w/ Pressure Controller | 1 |
| 226 | 0549333 | | Indicators, Engine, Included with Pressure Controller | 1 |
| 227 | 0084207 | | Not Required, Gauges, Vac/Pressure, FRC Auto Control | 1 |
| 228 | 0511100 | | Gauge, 2.0" Pressure, Class 1, 30"-0-400psi | 1 |
| 229 | 0062847 | | Gauge, Water Level, Class 1, Pierce Std. | 1 |
| 230 | 0006774 | | Not Required, Foam Level Gauge | 1 |
| 231 | 0081546 | | Lighting for Pump Controls, DX Tanker Program | 1 |
| 232 | 0006133 | | Siren, Code 3 3692 100W or 200W | 1 |
| 233 | 0065403 | | Location, Elect Siren, Overhead, Freightliner M2 -106/112 | 1 |
| 234 | 0006145 | | Control, Elec Siren, Horn Ring, PS Foot Sw | 1 |
| 235 | 0550213 | | Speaker, Code-3 PB100C, Chrome | 1 |
| | | | Qty, Speakers - 1 | |
| | | | Connection, Speaker - siren head | |
| 236 | 0548352 | | Location, Recessed in the Front Bumper, Driver Side | 1 |
| 237 | 0676580 | | Lightbar, Whelen, Justice, LED, 4-R, 4-RC, Clear Lens, DX Tanker | 1 |
| 238 | 0081689 | | Mounting, Lightbar Bracket, On Front of Tank, DX Tanker | 1 |
| 239 | 0524929 | | Lights, Front Zone, Whelen LIN3 Super LED, Comm | 1 |
| 240 | 0551045 | | Lights, Side Zone Lower, Whelen LIN3 Super LED, 2pr | 1 |
| | | | Location, lights rear - one each side behind the rear axles | |
| | | | Location, lights frt side - a)each side engine hood | |
| | | | Color, Lt, Rear Fender - r)red | |
| 241 | 0530165 | | Lights, Rear Zone Lower, Whelen LIN3 Super LED | 1 |
| 242 | 0057366 | | Light, Rear Zone Upper, Whelen RB6T Beacon | 1 |
| | | | Color, Dome, Rear Warning - e)DS red & PS amber | |
| 243 | 0006551 | | Not Required, Lights, Rear Upper Zone Blocking | 1 |
| 244 | 0081666 | | Rear Warning Brackets, DX Tanker | 1 |
| 245 | 0519934 | | Not Required, Brand, Hydraulic Tool System | 1 |
| 246 | 0007150 | | Bag of Nuts and Bolts | 1 |
| | | | Qty, Bag Nuts and Bolts - 1 | |
| 247 | 0532869 | | NFPA Required Loose Equipment, Mobile Water Supply, Provided by Fire Department | 1 |
| 248 | 0544716 | | Soft Suction Hose, Provided by Fire Department, Mobile Water Supply | 1 |
| 249 | 0027023 | | No Strainer Required | 1 |
| 250 | 0533271 | | Extinguisher, Dry Chemical, Mobile Water Supply, Provided by Fire Department | 1 |
| 251 | 0533281 | | Extinguisher, 2.5 Gal. Press. Water, Mobile Water, Provided by Fire Department | 1 |
| 252 | 0533265 | | Axe, Flathead, Mobile Water Supply, Provided by Fire Department | 1 |
| 253 | 0007492 | | Not Required, Axes, Pickhead | 1 |
| 254 | 0586561 | | Chassis Cab Paint, #90 Red, Standard | 1 |
| | | | Paint Color, Commercial, Std - #90 Candy Apple Red | |
| 255 | 0583915 | | No Two-Tone Paint Req'd | 1 |
| 256 | 0583882 | | Paint, 90 Red, Commercial Grade Chassis Finish, PMFD Comm Chassis w/Pricing | 1 |
| | | | Paint Color, Commercial, Std - #90 Candy Apple Red | |
| 257 | 0582663 | | Paint, Chassis Frame Assy, Black, by Commerical Chassis Mfgr | 1 |
| 258 | 0081667 | | Compartment, Unpainted, PMFD | 1 |
| 259 | 0544129 | | Reflective Band, 1"-6"-1" | 1 |
| | | | Color, Reflect Band - A - a) white | |
| | | | Color, Reflect Band - B - l) white | |
| | | | Color, Reflect Band - C - w) white | |
| 260 | 0007357 | | Reflective on Front Bumper | 1 |
| 261 | 0551061 | | Stripe, Chevron, Rear, Diamond Grade, DX Tanker | 1 |
| | | | Color, Rear Chevron DG - fluorescent yellow green | |

FLORIDA DX TANKER USER LIST

| Job # | Customer | Chassis | Body | RFP/Delivery |
|--------------|-----------------|----------------|-------------|---------------------|
| 7564501 | Clay County | KW | DX Tanker | 6/5/07 |
| 7564498 | Golden Gate | KW | DX Tanker | 6/21/07 |
| 9113091 | North Naples | KW | DX Tanker | 9/30/08 |
| 20974 | Volusia | KW | DX Tanker | 10/23/08 |
| 22304 | Walton County | IHC | DX Tanker | 3/31/10 |
| 24248 | Brevard County | FL-M2 | DX Tanker | 9/9/11 |
| 24309 | Brevard County | FL-M2 | DX Tanker | 1/30/12 |
| 24999 | Parrish | IHC | DX Tanker | 7/2/12 |
| 24999 | Parrish | IHC | DX Tanker | 7/15/12 |
| 25457 | Liberty County | IHC | DX Tanker | 7/25/12 |
| 25809 | Hardee County | FL-M2 | DX Tanker | 11/20/12 |
| 25712 | Big Corkscrew | FL-M2 | DX Tanker | 12/6/2012 |



E-ONE, INC
PO BOX 2710
OCALA, FL 34478-2710

Quote No: 54019

8/2/2012

Quote Rev:2 Drawing Rev:1

3500 GALLON TANK

500 GPM PUMP

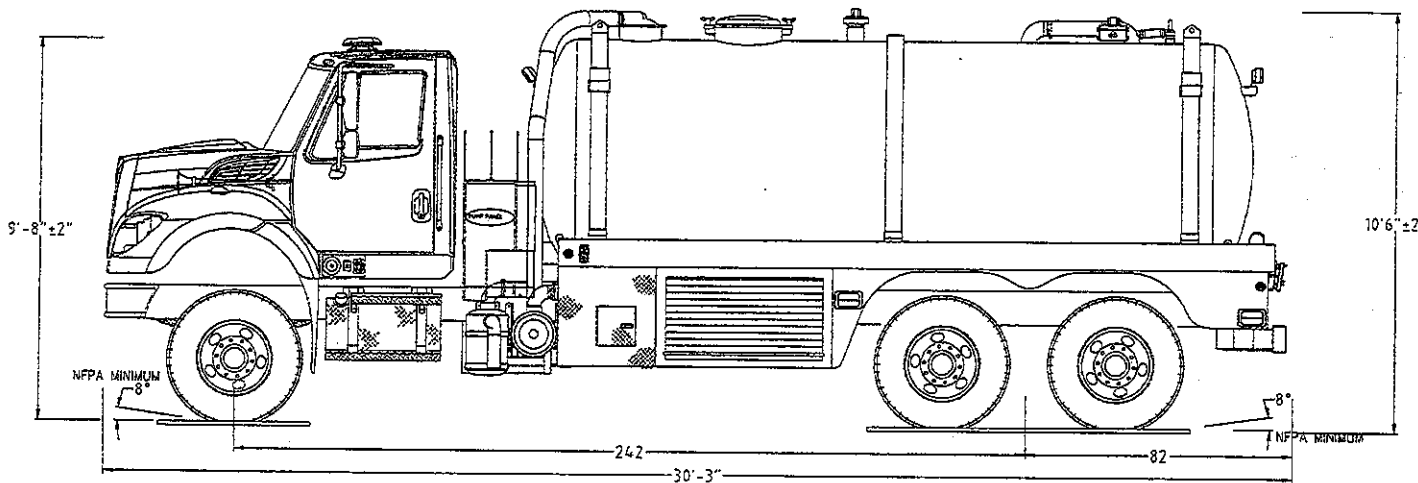
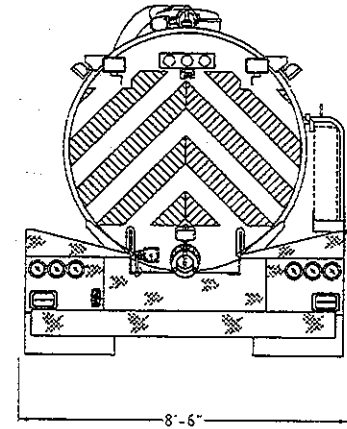

POWERED BY



This drawing provides a GENERAL REPRESENTATION of the vehicle configuration and should be used for evaluation purposes. The respective dimensions shown, including overall height and length, are estimates and may vary due to manufacturing processes. All other items such as lighting and fixtures, plumbing, compartmentation, and other generally assembled details are shown for REFERENCE ONLY and may not be a direct reflection of the final truck configuration. In ALL situations where this drawing may conflict with the applications, THE SPECIFICATIONS, AS REFLECTED IN THE APPROVED SHOP ORDER, SHALL PREVAIL. Unless otherwise specified, the proposed apparatus will be manufactured to the latest NFPA recommendations as well as other applicable federally regulated safety conditions. E-One reserves the right to engineer and incorporate design improvements and changes without notice, while adhering to the intent of the specification.

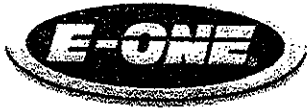

Fire Apparatus Quotation for: E-ONE, INC



Quotation Number: 54019 Rev: 2

Unit Description: WMST-COMM

Quote Description: Water Master Tanker Commercial Chassis

Salesperson: TWELFEL

| Salescode | Extended Description | Qty |
|--------------------------------------|---|-----|
| Watermaster Tanker Base Model | | |
| 0502-0001 | A Water Master apparatus being compliant to NFPA 2009 (plumbing as applicable) or ULC (as applicable) to be provided. | 1 |
| BUMPERS | | |
| 1160-0056 | OEM chrome front bumper. | 1 |
| CHASSIS MODEL | | |
| 1005-0161 | International 7400 (2) door, 242" WB, front tow hooks, 18K & 40K tandem axle with ESC, Officer side vertical exhaust with pipe guard, ABS brakes, 50 gal driver side fuel tank, (3) 2100 CCA batteries, 320 alternator, ember separator and AC. | 1 |
| 1005-0166 | Chassis Prep International with Maxx Force engine and tandem rear axle. Includes rear bumper/tow eyes, high idle, master light switch and master battery switch. | 1 |
| 1200-0117 | International Maxx Force 330 HP engine with EVS3000 transmission. Includes Diamond Logix Exhaust Brake. | 1 |
| 1200-0123 | Engine block heater. Locate receptacle below the driver side cab door. | 1 |
| WHEEL OPTIONS | | |
| 1050-0052 | International chassis rims painted job color. For use with tandem rear axle. | 1 |
| TIRE OPTIONS | | |
| 1060-0057 | Tire pressure monitoring valve stem caps. For use with a chassis with 18K front and 40K tandem rear axle. | 1 |
| ENGINES & TRANSMISSIONS | | |
| 1200-0122 | Electronically limited speed to 60 MPH. | 1 |
| CHASSIS OPTIONS | | |
| 1680-0142 | Two (2) hood-mounted air horns with driver and officer mounted foot switches. International. | 1 |

| Salescode | Extended Description | Qty | |
|-------------------------------|---|-----|--|
| LADDER STORAGE / RACKS | | | |
| 3365-0151 | Zico electric drop down rack on officer body. Secures portable folding tank with capacity of main tank on body. | 1 | |
| 3365-0158 | Diamond plate portable folding tank cover. For use with 3500 tank and Zico drop down rack. | 1 | |
| MISC BODY OPTIONS | | | |
| 3340-0504 | E-ONE logo mounted (1) each side on forward body side rearward of water level gauge and (1) rear below the rear tank inlet and offset to driver side. Logos to be sized as applicable to available space. | 1 | |
| PUMPS | | | |
| 4005-0065 | PM100 Vacuum Pump (for use with AP or MBP pumps only). Includes primary and secondary shut offs, (4) water level gauges- (3) body and (1) cab and the (3) inlets/outlets with switching. | 1 | |
| 4005-0073 | PTO for use with PM100 vacuum pump and EVS3000 transmission. | 1 | |
| 4005-0075 | PTO for use with AP50 pump and EVS3000 transmission. | 1 | |
| PLUMBING KITS | | | |
| 4410-0016 | Plumbing kit with Hale AP50 (with officer side steamer) pump (500GPM). Includes (1) 2.5" Driver Side Discharge with droop and cap, (1) 2.5" Officer Side Discharge with droop and cap and (2) 1.5" Crosslay Discharges. The discharges are to be labeled and color coded in compliance with current NFPA. | 1 | |
| PUMP OPTIONS | | | |
| 4015-0093 | The optional pump to be NFPA or ULC (as applicable) compliant. Includes primer, pump shift and indicators, (1) 2.5" driver side aux. intake with swing handle and test ports. | 1 | |
| 4015-0095 | Engine cooler. For use with International 7400 chassis. | 1 | |
| PRESSURE GOVERNORS | | | |
| 4465-0014 | FRC In-Control pressure governor. Includes engine and master pump gauges. For use with International MaxxForce engines. | 1 | |
| GAUGES | | | |
| 4435-0141 | Pump module discharge gauges (4) to be english dominant. For use with AP/MBP pumps. | 1 | |
| ELECTRICAL SYSTEMS | | | |
| 5010-0020 | Body and cab electrical system. | 1 | |
| 5150-0089 | Vehicle data recorder - 2009 NFPA compliant. Includes occupant detection with | 1 | |

| Salescode | Extended Description | Qty |
|---|--|-----|
| CAMERAS / INTERCOM | | |
| | mounted cameras. | |
| MISC ELECTRICAL | | |
| 5110-0056 | NFPA cab siren and speaker (WHLN) package. Includes (1) siren with (1) speaker located center in front bumper (includes mounting bracket). | 1 |
| HOSE / NOZZLES | | |
| 7700-0091 | Floating strainer. For use with vacuum pump system. | 1 |
| 7700-0100 | Adaptor, hose and strainer package. For use with vacuum pump system. For use with 2000 thru 4000 gallon tanks only. | 1 |
| 7700-0101 | Aluminum 6" storz x 5" NH female thread swivel adaptor. For use with AP50 Pump Inlet. | 1 |
| MISC LOOSE EQUIPMENT | | |
| 7900-0140 | 3500 Gallon portable folding tank. Ship with unit stored in storage tank rack. | 1 |
| 7900-0165 | DOT driveway kit. Includes three (3) triangular reflectors with case. | 1 |
| EXTERIOR PAINT | | |
| 8100-0196 | Cab paint FLNA 3225 Red. International NAV2893. | 1 |
| STRIPING | | |
| 8300-0001 | NFPA required reflective striping to be dealer/customer applied. | 1 |
| 8300-0106 | Chevron "A" style 6" Scotchlite striping on rear of tank. Colors to be Yellow/Red. | 1 |
| WARRANTY / STANDARD & EXTENDED | | |
| 9100-0039 | 1 year full warranty. | 1 |
| 9100-0043 | 10 Year stainless steel plumbing warranty. | 1 |
| Dealer Supplied Equipment | | |
| | | |



VISIT OUR WEBSITE:
www.leasing2.com

REQUEST TO PROCEED:

When you are ready to proceed and would like to move towards finalizing this lease, please acknowledge that you have reviewed this entire proposal and understand its contents and that you have awarded this business to Leasing 2, Inc. by completing this section of the proposal and faxing it to Leasing 2. We will immediately fax you "next step" instructions.

In the event Lessee refuses to finalize this transaction once this "Request to Proceed" has been signed and received by Lessor, Lessee agrees to pay Lessor \$1,000.00 in order to cover costs incurred by Lessor as a result of receiving this "Request To Proceed" from Lessee.

We appreciate your confidence and consideration.

Proposal date: June 3, 2013

Option Chosen: _____ (where applicable)

Upcoming Governing Body meeting date for lease approval: _____

DeSoto County, Florida

Name of Lessee

Authorized Signature

Date

Printed Name Of Authorized Signature

Title

Contact Name (if Different Than
Authorized Signature)

Contact Phone

Contact E-Mail Address

Contact Fax

Do you prefer e-mail or fax? _____

*Please complete the above information and fax or email all pages of the proposal to
813-258-9333 / bmeyers@leasing2.com*

**** Important: A Resolution will be required with the lease contract ****
In the event that you require board action to sign this proposal,
please call us so that we may forward the preferred form for the meeting.



3431 NW 27th Avenue • Ocala, Florida 34475
Office: 352-629-6305 • Fax: 352-629-2018
Toll Free: 1-800-524-6072

FIRE APPARATUS PROPOSAL

DATE: May 30, 2013

This Proposal has been prepared for:
**Desoto County Fire Rescue
1985 SE Carlstrom Field Road
Arcadia, FL. 34266**

We propose to furnish to you one (1) E-One TTSAWater Master Tanker on a two door International 7400 chassis, built and equipped per the attached components list.

The base vehicle shall be in accordance with the attached Components List and is priced according to the Bid No. 11-10-1202 with the Florida Sheriff's Association. The purchase price also includes all listed vehicle components and recommended equipment as required by the fire department.

Delivery will be F.O.B. Arcadia, FL. and will be made approximately 30 calendar days after receipt of Purchase Order. This is a new truck that is currently finished in production. And is subject to prior sale. Terms of payment shall be cash on delivery unless otherwise specified by the department.

The current purchase price for the specified rescue vehicle per the Florida Sheriff's Association Bid # 11-10-2012 is as follows:

| | |
|---|----------------------|
| Cost per F.S.A. Bid Spec # 13 with published and unpublished options as required by the Fire Department and by NFPA 1901: | \$ 265,155.00 |
| <u>FSA .5% Contract Fee:</u> | <u>\$ 1,345.00</u> |
| Total Contract Price: | \$ 266,500.00 |

The proposal price shall expire on. 6/30/2013

This proposal is deemed acceptable by the undersigned. In witness whereof, The Company and the Purchaser shall execute an agreement to this proposal with signatures from authorized representatives as of the date set forth by each.

Sales Dealership: Hall-Mark Fire Apparatus

Purchaser:

By: Steve Kern Steve Kern

By: _____

Title: Sales Representative

Title: _____

Date: 5-30-13

Date: _____



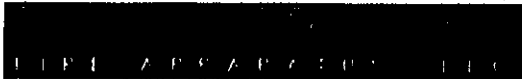

  Toll Free: 866.285.9305

[HOME](#) [FIRE TRUCKS FOR SALE](#) [RECENT DELIVERIES](#) [TESTIMONIALS](#) [SERVICE](#) [ABOUT US](#) [CONTACT](#)

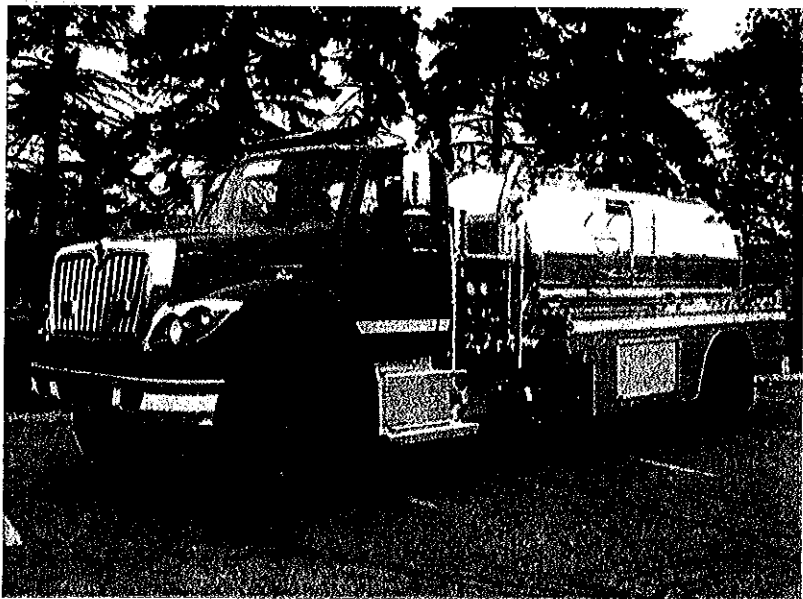

2013 International Vacuum Tanker



2013 International Vacuum Tanker
International 7400 Chassis
International Maxxforce 9 330 HP Diesel Engine
Automatic Transmission
Hale AP500 PM100 Vacuum Pump
2500 Gallon Tank
FRC Telescoping lights

\$262,800
For Additional Information,
Contact Brindlee Mountain at
1-866-285-9305 or [email us](#)
[Print this page](#)



SCOPE OF WORK TANKER

PRE-INSPECTION OF UNIT:

- Upon arrival at ETR's shop, the unit will be powered up so we can identify any possible electrical problems on the unit. We will advise customer of our findings and what action will be taken.

CHASSIS:

- The chassis will have all suspension parts and components removed for sand blasting. The frame rails will be evaluated and the customer will be notified if the frame rails are damaged and require replacement. **PRICE DOES NOT INCLUDE REPLACEMENT OF FRAME RAILS IF RUST AND CORROSION IS EXTENSIVE AND REQUIRES REPLACEMENT.**
- Frame rails will be painted if condition is okay. The removed suspension parts and components will be reinstalled. **PRICE DOES NOT INCLUDE ANY REPLACEMENT OF SUSPENSION PARTS DAMAGED BY RUST AND CORROSION.**
- The lift axle will be removed and a new lift axle and controls will be installed. Lift axle includes new wheels and tires.
- Front cab seats will be recovered with new vinyl. **PRICE DOES NOT INCLUDE REPLACEMENT OF THE SEAT AND BACK CUSHION FOAM.**
- Remove and replace all drive and steering axle seals. The gear oil in all axles will be replaced with new.
- **THE FRONT AND REAR SUSPENSION COMPONENTS WILL BE INSPECTED AND THE CUSTOMER WILL BE NOTIFIED OF FINDING. PRICE DOES NOT INCLUDE AND REPLACEMENT PARTS OR LABOR IF PROBLEMS ARE FOUND.**

TANK:

- Disconnect all wiring, harnesses, plumbing, and mounting bolts from the chassis.
- Remove the tank from the chassis and place on a cart.
- Complete underside to be cleaned and inspected for damage. Customer will be notified if damage to the tank is present. **PRICE DOES NOT INCLUDE REPAIRS TO THE TANK OR MOUNTING BRACKETS.**
- The tank will be prepared and painted black.
- The tank will be installed with new tank to frame isolator material.

PAINT:

- Remove all decals and graphics.
- All components will be removed from the tank and cab for paint.
- All minor body imperfections to be repaired.
- Treat the electrolysis (NOTE: ETR's warranty does not warrant against the return of electrolysis or rust).
- Tank will be sealed and painted with black Essentials.
- Cab will be sealed and painted with red PPG paint.
- Sealer to be sanded and primed.
- Any nibs on cab are to be sanded and buffed.
- All lettering, graphics, and rear Chevrons will be installed at ETR.

NOTE:

- Price includes Landoll pickup of the tanker from Desoto County and delivery to the ETR facility.
- Price does not include replacement of the frame rails. Price is for sand blasting and painting of the frame rails. Price does not include any additional damage caused by rust and/or corrosion. ETR will not repair frame rails if extensive damage is found that requires replacement.
- Price does not include any repairs to the front or rear suspension. Suspensions will require inspection with a separate estimate for repairs if problems are found.
- Price does not include any repairs or replacement to the pump, PTO, valves, or gauges if present and require repair or replacement.

PRICING:

- Total price - \$138,543.00 Price is good for 30 days.
- Final vehicle inspection to be performed at ETR's facility.
- Payment due upon completion and picking up of unit.

SCOPE OF WORK ENGINE 21

PRE-INSPECTION OF UNIT:

- Upon arrival at ETR's shop, the unit will be powered up so we can identify any possible electrical problems on the unit. We will advise customer of our findings and what action will be taken.

CHASSIS:

- Front cab seats will be recovered with new vinyl. **PRICE DOES NOT INCLUDE REPLACEMENT OF THE SEAT AND BACK CUSHION FOAM.**
- **THE FRONT AND REAR SUSPENSION COMPONENTS WILL BE INSPECTED AND THE CUSTOMER WILL BE NOTIFIED OF FINDING. PRICE DOES NOT INCLUDE AND REPLACEMENT PARTS OR LABOR IF PROBLEMS ARE FOUND.**
- Install new Goodyear G661 LR H tires to chassis (6).

TANK:

- Remove the hose bed and components to gain access to the water tank.
- Disconnect all plumbing and components to remove decayed steel water tank. Pricing does not include any damage to the tank supports.
- Install a new rectangular poly tank. Connect plumbing and components.
- Remove and rebuild all valves.
- Provide a pump test and report any finding to the customer. **PRICE DOES NOT INCLUDE ANY PUMP RELATES PROBLEMS THAT WOULD PUMP FROM PASSING PUMP TEST.**

PAINT:

- Remove all decals and graphics.
- All components will be removed from the vehicle for paint. All components will be reinstalled after painting is completed.
- All diamond plate is to be treated with an oxidizer and polished. Diamond plate that is removable will be removed for this process and reinstalled after polishing.
- All minor body imperfections to be repaired.
- Treat the electrolysis (NOTE: ETR's warranty does not warrant against the return of electrolysis or rust).
- Vehicle will be sealed and painted with red and white PPG paint. Layout will match existing layout unless informed of a different layout.

- Any nibs on the cab are to be sanded and buffed.
- All lettering, graphics, and rear Chevrons will be installed at ETR.

NOTE:

- Price does not include any transportation of vehicle.
- Price does not include any repairs or replacement to any unseen damage or worn components.
- Price does not include any repairs to the front or rear suspension. Suspensions will be inspected. A separate estimate for repairs if problems are found.
- Price does not include any repairs or replacement to the pump, PTO, valves, or gauges if present and require repair or replacement.

PRICING:

- Total price - \$106,650.00. Price is good for 30 days.
- Final vehicle inspection to be performed at ETR's facility.
- Payment due upon completion and picking up of unit.

BOARD OF COUNTY COMMISSIONERS
DESOTO COUNTY, FLORIDA
DATE: June 11, 2013

| | | | |
|-------------------------------------|------------------|--------------------------|-------------------------------|
| <input type="checkbox"/> | Consent Agenda | <input type="checkbox"/> | Quasi-Judicial Public Hearing |
| <input checked="" type="checkbox"/> | Regular Business | <input type="checkbox"/> | Time |
| <input type="checkbox"/> | Public Hearing | | |

DEPARTMENT: Public Safety
SUBMITTED BY: Glenn Prescott
PRESENTED BY: Glenn Prescott

TITLE & DESCRIPTION: Agreement/Boca Grande

REQUESTED MOTION: To approve an agreement between Boca Grande Fire Control District and DeSoto County and allow the Chairman to execute.

SUMMARY: Boca Grande Fire Control District (BGFCD) wishes to enter into an agreement with DeSoto County Road and Bridge Department for mechanical repair and maintenance of their vehicle fleet.



BACKGROUND: Maintenance and repair of all DeSoto County Fire Rescue (DCFR) will take precedence over BGFCD vehicles.

FUNDS:

| | |
|--------------------------|-----|
| Budget Amount | N/A |
| Actual Agenda Item Cost: | N/A |
| Account Number: | N/A |
| Explanation: | N/A |

ATTACHMENTS: 1. Memorandum of Understanding

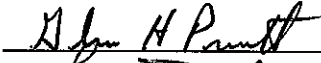
REVIEW APPROVAL:

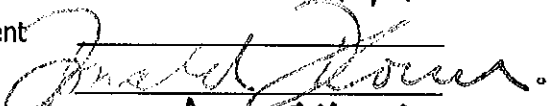
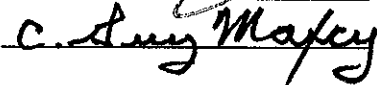
| | |
|-----------------------|--|
| Department Director |  |
| Finance Director |  |
| Purchasing Department |  |
| County Attorney | |
| County Administrator |  |

**Memorandum of Understanding
Desoto County
and
Boca Grande Fire Control District**

The Boca Grande Fire Control District hereafter referred to as "BGFCD" in this document, and Desoto County hereby enter into this agreement in order to coordinate the mechanical repair and maintenance of the vehicle fleet of the "BGFCD" by the Desoto County Road and Bridge Department.

This agreement encompasses all mechanical repair and preventative maintenance needs of the "BGFCD" within the scope, availability and capability of the Desoto County Road and Bridge Department. This agreement also recognizes from time to time that other needs may be requested such as welding and fabrication or other improvements needed to facilitate or upgrade the function of a specific vehicle. The "BGFCD" recognizes that Desoto County Fire Rescue vehicles will take priority of repair and the "BGFCD" will coordinate repairs so that all work will be scheduled and performed most efficiently for both parties. DeSoto County will make every effort to perform requested work in a timely manner but makes not representation or guarantee either that work will be accepted or that work will be completed within the time requested by BGFCD. Nothing in this Memorandum of Understanding prevents or limits BGFCD from using other facilities or vendors to perform repair, maintenance or other work.

The following considerations are also understood:

- The hourly rate for labor will be \$65
- Parts will be supplied and paid for by the "BGFCD" unless other arrangements have been made. Accounts for parts suppliers (suggested by Desoto County) will be established and maintained by the "BGFCD"
- The "BGFCD" is responsible for delivery of vehicles for repair to Desoto County and return to Boca Grande. This includes towing if needed.
- If mobile repair is required the "BGFCD" will be responsible for tolls and will pay the hourly labor rate of \$65 for travel time.
- The "BGFCD" will provide any needed vehicle information or other historical information pertaining to repair needs of the fleet.
- Desoto County Road and Bridge agrees to assist the "BGFCD" in tracking its fleet for preventative maintenance or other needs.
- BGFCD agrees to indemnify and hold DeSoto County harmless for any damage, claims or injuries resulting from or incurred while BGFCD vehicles are in the care and custody of DeSoto County, or as a result of or caused by work performed by DeSoto County on BGFCD vehicles.
- Any deviation from this plan must be agreed upon in writing by both parties.

IN WITNESS WHEREOF, the Parties hereto have caused their respective representatives to execute this instrument on their behalf, on the dates set forth below.

BOCA GRANDE FIRE CONTROL DISTRICT

By: _____
Fire Chief

Dated: _____

DESOTO COUNTY, FLORIDA

By _____
James F. Selph, Chairman

Dated: _____

ATTEST:

C. Guy Maxcy, County Administrator

Approved as to Form and Correctness:

Donald D. Conn, County Attorney

**BOARD OF COUNTY COMMISSIONERS
DESOTO COUNTY, FLORIDA
DATE: June 11, 2013**

| | |
|--|-------------------------------|
| <input type="checkbox"/> Consent Agenda | Quasi-Judicial Public Hearing |
| <input checked="" type="checkbox"/> Regular Business | 9am Time |
| <input type="checkbox"/> Public Hearing | |

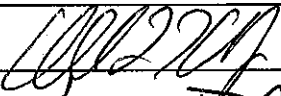
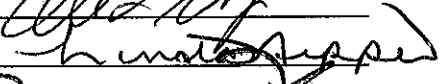
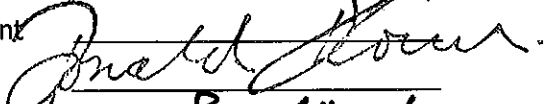
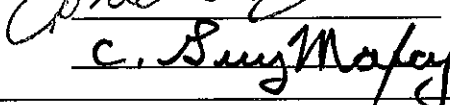
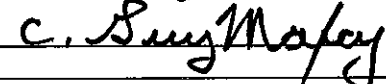
| | | |
|---------------------------------|--|--|
| DEPARTMENT: | Human Resources | |
| SUBMITTED BY: | Don Kesterson | |
| PRESENTED BY: | Don Kesterson | |
| TITLE & DESCRIPTION: | Approval /Insurance Bid Recommendations | |
| REQUESTED MOTION: | To approve the bid recommendations to Agent of Record Brown & Brown/PRIA for Health, Dental, Vision and Life Insurance benefits. | |
| SUMMARY: | The Insurance Committee bid recommendations to the Board: Health Request bids for current or equivalent or better plan 1.) Fully-funded and 2.) Self-funded with a separate Pharmacy benefit. Also recommends a Dependent Eligibility audit be performed by PRIA. Dental 1.) Recommend we stay with The Standard if they agree to re-open enrollment to all employees with no 1st year plan limitation for use and to provide coverage for teeth implants; or if not agreed too then 2.) Take out for bid. Vision Take out for bid. Life Insurance Take out for bid. | |
| BACKGROUND: | The committee is comprised of the 5 Constitutional Officers and a County Commissioner. The Insurance Committee was created to make recommendations to the Board to provide the best quality benefit at the most reasonable cost for all eligible individuals. On May 30, 2013 the committee met and discussed the current Health, Dental, Vision and Life Insurance plans and are making the following recommendations to the Board concerning the renewal of benefits. | |
| FUNDS: | Budget Amount | N/A |
| | Actual Agenda Item Cost: | N/A |
| | Account Number: | N/A |
| | Explanation: | N/A |
| ATTACHMENTS: | 1. Recommendation letter | |
| REVIEW APPROVAL: | Department Director |  |
| | Finance Director |  |
| | Purchasing Department |  |
| | County Attorney |  |
| | County Administrator |  |

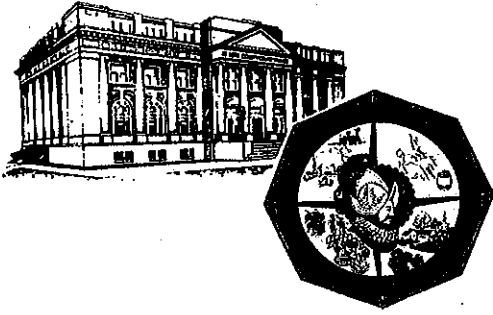

DeSoto County

Board of County Commissioners

201 East Oak Street, Suite 201

Arcadia, Florida 34266

(863) 993-4800 / (863) 993-4809 fax

www.desotobocc.com

Equal Opportunity Employer / Drug-Free Workplace

June 11, 2013

RE: DeSoto County Bid Recommendations

Dear Robin,

This letter confirms that, on June 11, 2013, the Board approved the following recommendations to be used while preparing the County's insurance benefit renewal.

- Health insurance coverage should be placed out to bid with the current carrier and any others for the current Fully-funded plan or an equivalent plan and also placed out to bid for a Self-funded plan with a separate Pharmacy option. Also requests a Dependent Eligibility Audit be performed by PRIA. Request that all billing be broken down by group and then department.
- Dental insurance coverage it is recommended that the County stay with our current carrier The Standard and plans if they agree to re-open enrollment to all employees with no first year plan limitation for use and also to provide coverage for teeth implants no currently offered under the plan. If have do not agree to the requested changes then take it out to bid. Request that all billing be broken down by group and then department.
- Vision insurance is recommended to be taken out to bid and request a bid from the current carrier. Request that all billing be broken down by group and then department.
- Life insurance County provided and Voluntary is recommended to be taken out to bid and request a bid from the current carrier. Request that all billing be broken down by group and then department.





This letter also constitutes the authority of any underwriter to furnish Risk Management Associates, Inc., dba Public Risk Insurance Agency, Inc. representatives with any information or data that may be required in order to respond to our present and future insurance needs. Please waive any grace period as this decision is effective immediately. Thank you for your cooperation.

Sincerely,

James F. Selph
Chairman, DeSoto County BOCC

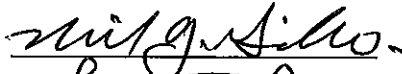
**BOARD OF COUNTY COMMISSIONERS
DESOTO COUNTY, FLORIDA
DATE: June 11, 2013**

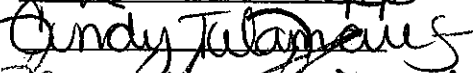
| | |
|--|-------------------------------|
| Consent Agenda | Quasi-Judicial Public Hearing |
| <input checked="" type="checkbox"/> Regular Business | 9:00 Time |
| Public Hearing | |

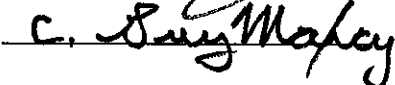
| | | |
|---------------------------------|--|--|
| DEPARTMENT: | Engineering | |
| SUBMITTED BY: | Michael Giardullo | |
| PRESENTED BY: | Michael Giardullo | |
| TITLE & DESCRIPTION: | Prioritization of Projects – FDOT Work Program for FY 2014/15 through FY 2018/19 consideration. | |
| REQUESTED MOTION: | To approve prioritization of projects and authorize the Chairman to sign the letter to FDOT to consider projects for funding. | |
| SUMMARY: | To apply for FDOT grant money for roadway improvements, bicycle and pedestrian improvements, and new roadways to be considered for FDOT Work Program for FY 2014/15 through FY 2018/19. | |
| BACKGROUND: | Board of County Commissioners endorsed grant projects for FDOT consideration are due by July 1, 2013. Staff has created a prioritization list for each grant category of significant projects. | |
| FUNDS: | Budget Amount | N/A |
| | Actual Agenda Item | N/A |
| | Cost: | |
| | Account Number: | N/A |
| | Explanation: | N/A |
| ATTACHMENTS: | Letter to FDOT with prioritization list. | |
| REVIEW | | |
| APPROVAL: | Department Director |  |
| | Finance Director |  |
| | Purchasing Department |  |
| | County Attorney |  |
| | County Administrator |  |

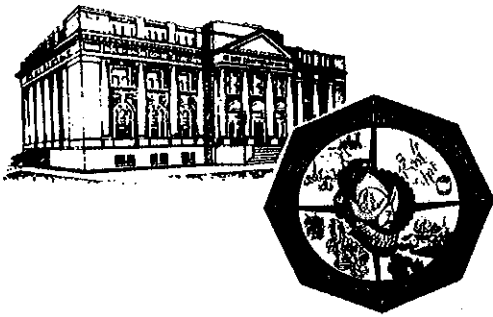

DeSoto County

Board of County Commissioners

Administration

201 East Oak Street, Suite 205

Arcadia, Florida 34266

(863) 993-4587

(863) 993-4643 fax

www.co.desoto.fl.us

June 11, 2013

Mr. Johnny Limbaugh
Florida Department of Transportation
Director, Southwest Area Office
10041 Daniels Parkway
Fort Myers, Florida 33913

Re: DeSoto County Priority Projects FY 2014/15 – 2018/19

Dear Mr. Limbaugh:

Shown below, in order of importance and prioritized by funding program, is a list of projects we would like the Florida Department of Transportation (FDOT) to consider for funding for Fiscal Years 2014/15 through 2018/19

SCOP

1. Resurfacing of NW Florida Ave. (SW Pine Level St. to SR 70).
2. Resurfacing of SW Fletcher St. (SW Hillsborough Ave. to US 17).
3. Resurfacing of SW Shores Ave. (SW CR 760A to SW Beard St.).
4. Resurfacing SW CR 769 (Barnwell Street to SR 72).
5. Resurfacing Oak Street (SR 70E to SR 70W).

SCRAP

1. Resurfacing NE Roan Rd. (Turner Ave. to Arcadia Village).
2. Resurfacing SW Shores Ave. (SW US 17 to CR 760A).
3. Resurfacing SE Durrance St. (SR 31 to Airport Rd.).
4. Resurfacing Hull Avenue (Senate St to US 17).

Local Enhancement

1. Turner/Gibson/Roan Pedestrian Improvements.
2. Restore Historic Bridge on Old SR 70 crossing Peace River.
3. Oak St. Bicycle/Pedestrian Improvements.
4. McSwain Park Improvements.
5. Sidewalks E Maple Drive (Mills Ave to La Solona Ave).
6. Sidewalk N Robert Avenue (Gibson St to Nursing Home Dr).

CIGP

1. Extension of West Farms Road (Terminus to SW Golden Rod Ave).

Capacity/Operational Improvement

1. SR 31 Re-alignment (SR 70 to 0.4 miles S of SR 70).

TRIP

1. Civic Center Boulevard – New Road Construction (US 17 N to SR 70).
2. Extension of West Farms Road (Terminus to SW Golden Rod Ave).
3. Bridge Replacement on CR 769 (Bridge #040022).
4. Extension of La Solona Ave (NE Fiveash to Gibson St).

Thank you for your continued cooperation with DeSoto County. If you need additional information regarding this listing, please contact Michael Giardullo, P.E. County Engineer or Cathy Miller, Compliance Specialist at 863 491-7543.

Sincerely,

James Selph, Chairperson
DeSoto County Board of County Commissioners

**BOARD OF COUNTY COMMISSIONERS
DESOTO COUNTY, FLORIDA
DATE: June 11, 2013**

| | | | | | | | | | | | |
|---|-------------------------------|----------------|-------------------------------------|------------------|--|----------------|--|--|-------------------------------|------|------|
| <table style="width: 100%; border-collapse: collapse;"> <tr> <td style="width: 20px; border-bottom: 1px solid black;"></td> <td>Consent Agenda</td> </tr> <tr> <td style="border-bottom: 1px solid black; text-align: center;"><input checked="" type="checkbox"/></td> <td>Regular Business</td> </tr> <tr> <td style="border-bottom: 1px solid black;"></td> <td>Public Hearing</td> </tr> </table> | | Consent Agenda | <input checked="" type="checkbox"/> | Regular Business | | Public Hearing | <table style="width: 100%; border-collapse: collapse;"> <tr> <td style="width: 20px; border-bottom: 1px solid black;"></td> <td>Quasi-Judicial Public Hearing</td> </tr> <tr> <td style="border-bottom: 1px solid black; text-align: center;">9:00</td> <td>Time</td> </tr> </table> | | Quasi-Judicial Public Hearing | 9:00 | Time |
| | Consent Agenda | | | | | | | | | | |
| <input checked="" type="checkbox"/> | Regular Business | | | | | | | | | | |
| | Public Hearing | | | | | | | | | | |
| | Quasi-Judicial Public Hearing | | | | | | | | | | |
| 9:00 | Time | | | | | | | | | | |

DEPARTMENT: Engineering

SUBMITTED BY: Michael Giardullo

PRESENTED BY: Michael Giardullo

TITLE & DESCRIPTION: Pepper Ave. Bridge #044036

REQUESTED MOTION: Direct Staff to pursue FDOT funds for bridge replacement or remove the bridge.

SUMMARY: FDOT has identified the bridge replacement as qualifying for the FDOT 5 Year Work Program. The County could remove the bridge and close the road on both sides of the canal.



BACKGROUND: Please see attached presentation from May 28, 2103 BOCC meeting.

FUNDS:

| | |
|--------------------|-----|
| Budget Amount | N/A |
| Actual Agenda Item | N/A |
| Cost: | |
| Account Number: | N/A |
| Explanation: | N/A |

ATTACHMENTS: May 28, 2013 Pepper Ave. Bridge Presentation.

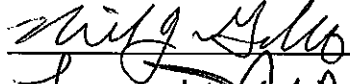
REVIEW APPROVAL:

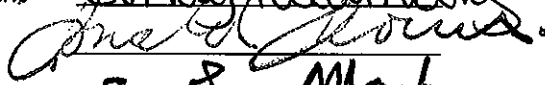
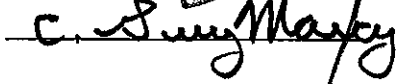
| | |
|-----------------------|--|
| Department Director |  |
| Finance Director |  |
| Purchasing Department |  |
| County Attorney |  |
| County Administrator |  |



DeSoto County

PEPPER BRIDGE

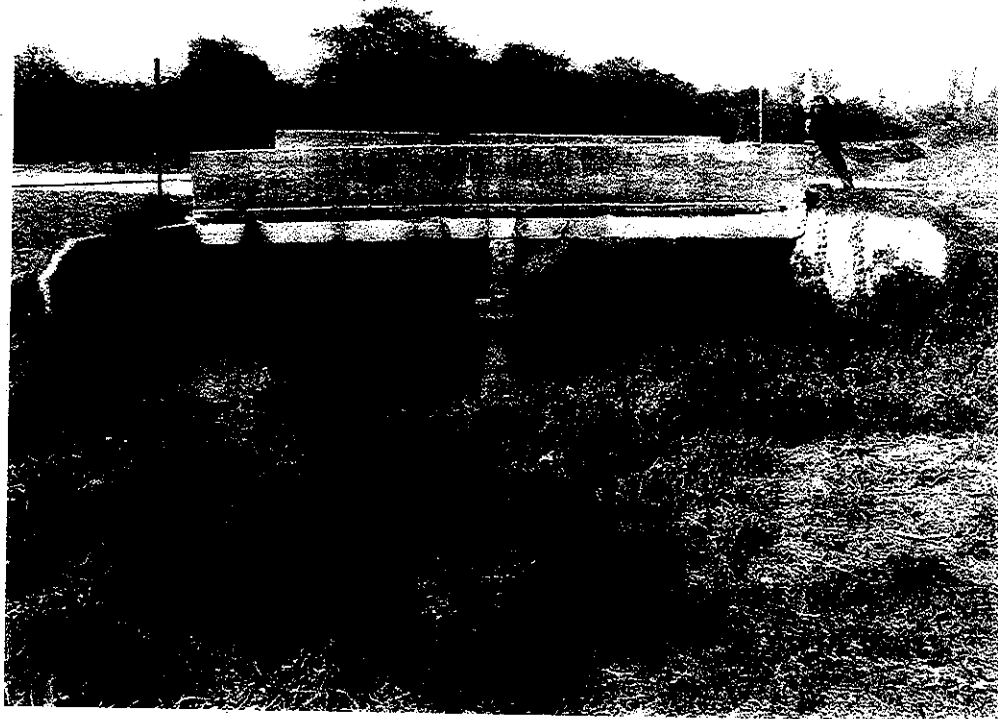

Background

- Located on County maintained ROW of Pepper Avenue (south of Livingston Street, north of Arcadia Avenue)
- Constructed 1927
- Single Lane Width (Pepper Avenue has +/- 10' width)
- Posted Weight Restrictions
- Bridge is in poor condition and action needs to be taken soon

Bridge Location

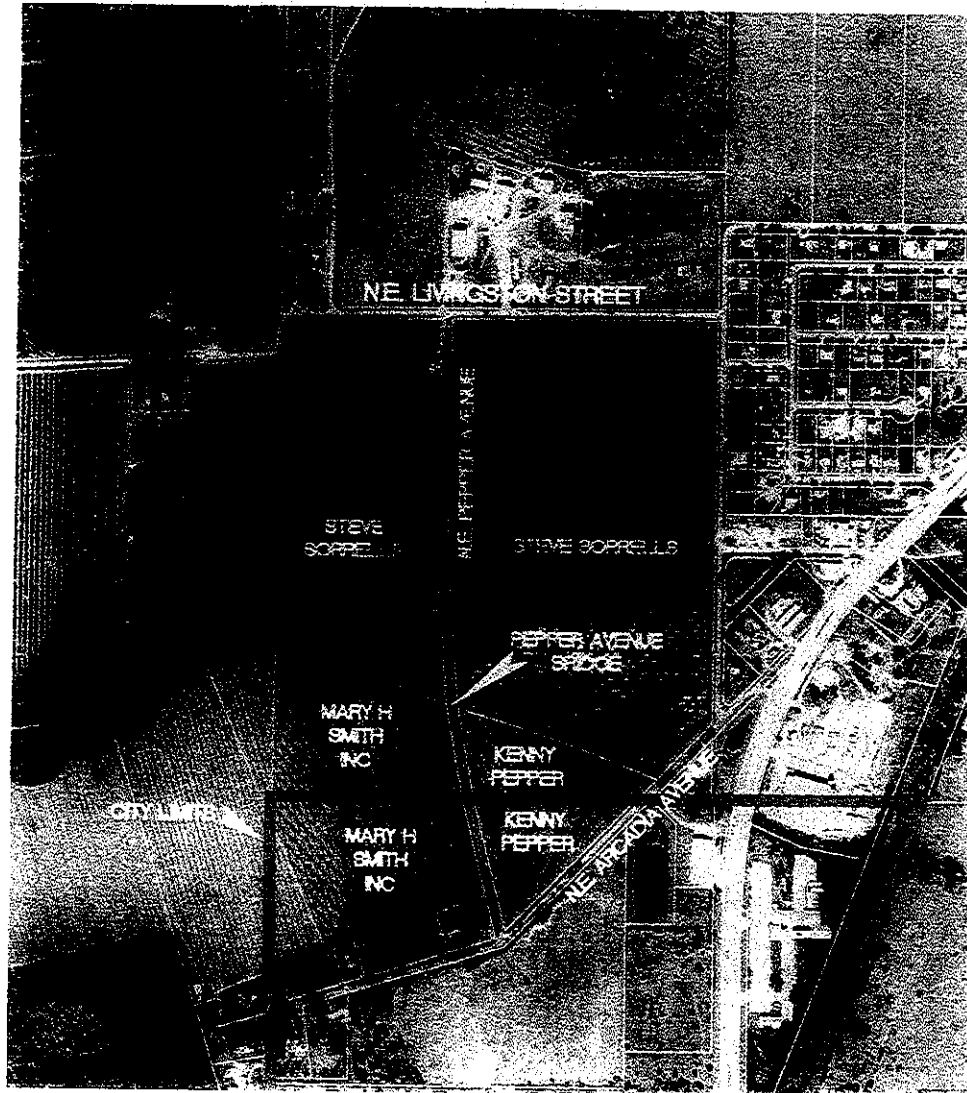

Bridge Location

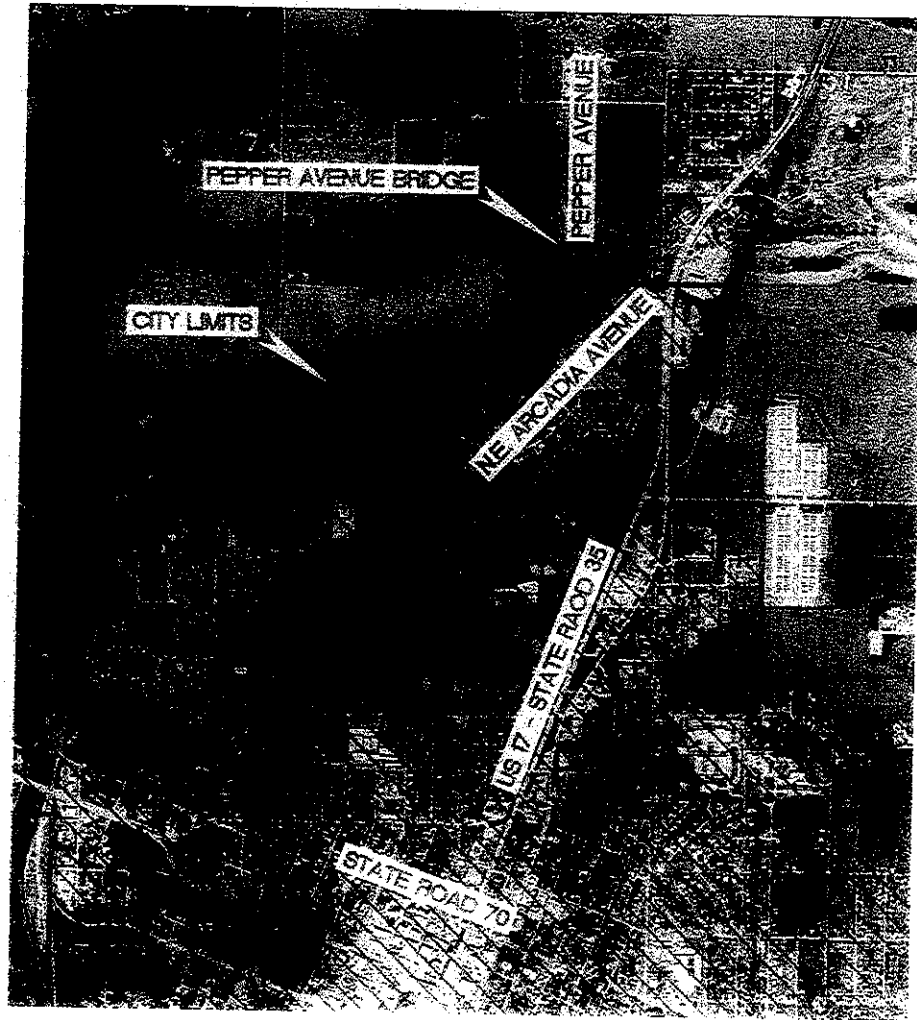

Single Lane Bridge

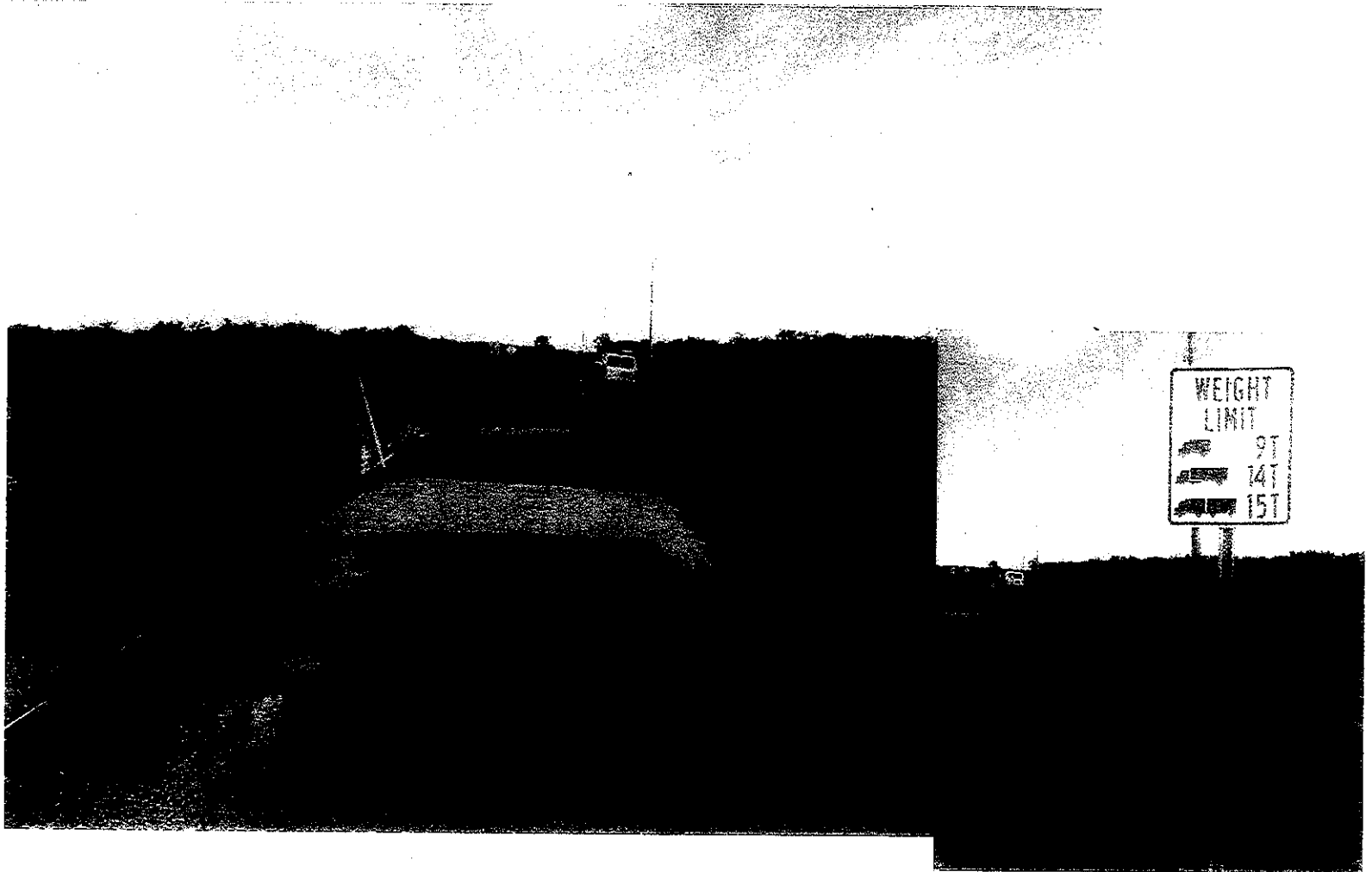

Bridge Deficiencies



Delamination and cracking of western fascia

Delamination and spalling of deck underside



Bridge Deficiencies



Underside deterioration
exposing steel

Cracking of the barrier

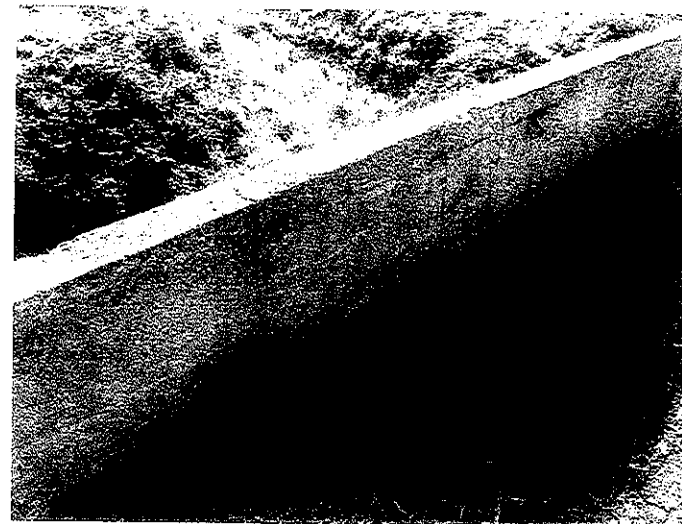

Bridge Deficiencies



Decaying of bridge
foundation – Timber Piles

Undermining of abutment



Sufficiency Rating

- FDOT rates bridges using a sufficiency index between 0 and 100
- Sufficiency rating – “numerical rating of a bridge based on its structural adequacy and safety, essentiality for public use, and its serviceability and functional obsolescence” - FHWA
- Ratings of less than 50 qualify for replacement with Federal Funding
- Pepper Avenue Bridge has a sufficiency rating of 27.7 and has been deemed “Structurally Deficient” by FDOT
- If rehab or replacement work is not going to take place immediately, the bridge should be shut down.

Options

Options



Replace Bridge?

Options



Replace Bridge?

Remove without Replacement?

Options



Replace Bridge?

Remove without Replacement?

- Single or Double Lane Width for Bridge?
- Upgrade Pepper Avenue to County Standards?

Options



Replace Bridge?

- Single or Double Lane Width for Bridge?
- Upgrade Pepper Avenue to County Standards?

Remove without Replacement?

- Continue to maintain Pepper Avenue or Deed to Abandon to Owners?
- Removing Pepper Road?

Coordination with Stakeholders

- FDOT – potential funding source for replacement
- DeSoto County Road and Bridge Dept.
- Local business – Sorrells Citrus and Grove Care
- Private property owners
- School Board
- City of Arcadia

Traffic Count Results

- County conducted a traffic count for a 12-day period in April 2013
- 270 total trips
- 23 trips per day (12 trips each direction)

Alternative Routes



Option 1 – Bridge Replacement

PROS

- High probability of FDOT Funding
- Keep Pepper Avenue Open

CONS

- May not be programmed for 5-years – repairs/closure needed in the mean time
- County costs – design, inspection, grant management, continual maintenance
- If grant funded, potentially at the cost of another County project

Option 1 – Bridge Removal

PROS

- Low Cost Alternative
- Can be done rather quickly by County forces

CONS

- No longer able to drive through Pepper Road
- Impacts to business and residents

Questions?

BOARD OF COUNTY COMMISSIONERS
DESOTO COUNTY, FLORIDA
DATE: June 11, 2013

| | | | |
|-------------------------------------|------------------|-------------------------------------|-------------------------------|
| <input type="checkbox"/> | Consent Agenda | <input type="checkbox"/> | Quasi-Judicial Public Hearing |
| <input checked="" type="checkbox"/> | Regular Business | <input checked="" type="checkbox"/> | 9AM Time |
| <input type="checkbox"/> | Public Hearing | | |

DEPARTMENT: Administrative Services
SUBMITTED BY: Cindy Talamantez
PRESENTED BY: Cindy Talamantez

TITLE & DESCRIPTION: Release of Lien- 1106 Rainbow Avenue

REQUESTED MOTION: To approve the release of lien and all associated fines levied by DeSoto County for the County owned property located at 1106 Rainbow Avenue



SUMMARY: Release of Code Enforcement Lien

BACKGROUND: The County is the legal owner of property located at 1106 Rainbow Avenue. Under the previous owner, the Special Master ordered a Lien on the property as a result of unresolved code enforcement violations. When the County received the property it was cleared and the lot was cleaned resolving the violations. The Board has declared this property as surplus and has authorized staff to sell by sealed bid. Staff feels that it would be less confusing to the public if the lien were removed prior to advertising the sale.

FUNDS: Budget Amount:
 Actual Agenda Item Cost:
 Account Number:
 Explanation: Recorded lien is \$5,800.00 plus \$429.00 in court costs.

ATTACHMENTS: 1.

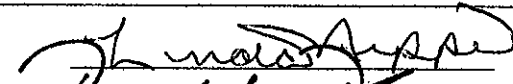
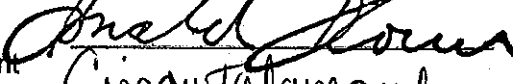
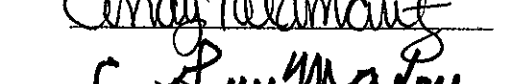
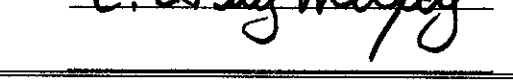
REVIEW APPROVAL:

| | |
|-----------------------|--|
| Department Director |  |
| Finance Director |  |
| Purchasing Department |  |
| County Attorney |  |
| County Administrator |  |

BEFORE THE SPECIAL MASTER OF DESOTO COUNTY, FLORIDA

DESOTO COUNTY, a political subdivision
of the State of Florida, principal address at
201 East Oak Street, Suite 201
Arcadia, Florida 34266,

Inst:201214003539 Date:7/26/2012 Time:11:23 AM
Km DC,Mitzie McGavic,Desoto County Page 1 of 2

Petitioner/Lienholder,

v,

Case Number CE 2010-027

GEORGIA LEE JONES ESTATE,

Inst:201214003539 Date:7/26/2012 Time:11:23 AM
Km DC,Mitzie McGavic,Desoto County Page 1 of 2

Respondent /

LIEN

PENALTY ORDER

THIS CAUSE came on for hearing November 4, 2010, before the DeSoto County Special Master, upon notice and prior Orders in this matter directing that a compliance hearing be set, alleging that the Respondent has failed to comply with the Special Master's order entered August 17, 2010. Pursuant to Section 162.091(1), *Florida Statutes*, and upon consideration of all matters presented and the file and record hereof, the Special Master finds and mitigates that the Respondent has failed to mow and remove overgrown grass and weeds and to regularly maintain the property within the time period set forth in the above order. Respondent has further failed to pay ordered case costs in the amount of \$226.57, and has caused petitioner to incur additional costs in the amount of \$202.43 in bringing this action.

It is, therefore, ORDERED that the fine for non-compliance with prior orders is fixed at \$5,800.00, which represents fines for 58 days in violation at the rate of \$100.00 per day, which Respondent is ordered to pay, together with unpaid case costs and current case costs totaling \$429.00, to Petitioner within ten (10) days of the date hereof.

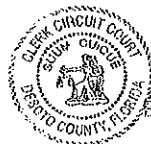

CERTIFIED
TO BE A TRUE COPY
MITZIE W. MCGAVIC, CLERK

BY K.M. Hargis, D.C.

6229.00

The aforementioned fine is for a violation that existed on the real property located at 1106 SW Rainbow Avenue, Arcadia, Florida, as described in the petition and orders filed in this case.

It is the further order of the Special Master that the penalties imposed herein, if unpaid after ten(10) days from the date of this order, shall constitute a lien against all real and personal property owned by the Respondent in DeSoto County, Florida, pursuant to Section 162.093(3), *Florida Statutes*, DeSoto County Land Development Regulations Section 11706 and DeSoto County Resolution 2002-11. The unpaid sums constituting the lien shall further bear interest at the current legal rate until paid in full. The Clerk of Court is directed to record a certified true copy of this order in the Official Records of DeSoto County, Florida.

DONE AND ORDERED in Arcadia, DeSoto County, Florida, this 11th day of January, 2011.

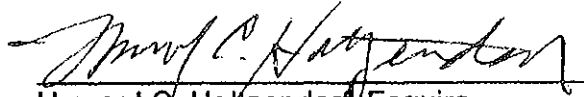
Howard C. Holtzendorf Esquire
Special Master, DeSoto County, Florida

ATTEST:

Betty Phillippe, Transcribing Secretary

I hereby certify that a copy of tshe foregoing order was furnished to Donald D. Conn, Esq., DeSoto County Attorney, and by U.S. Mail to Georgia Lee Jones Estate, % Austin Campbell, Personal Representative or successor and assigns, 1106 SE Rainbow Avenue, Arcadia, Florida 34266, this 11th day of January, 2011.

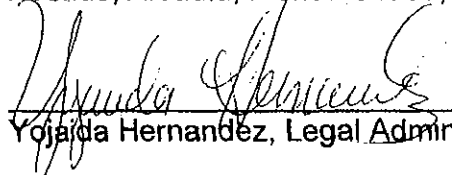
Yajaira Hernandez, Legal Administrative Assistant

**DESOTO COUNTY UTILITIES SLUDGE MANAGEMENT SERVICES
 BID NO. 13-18-00 INVITATION TO BID**

| Company Name | Annual Total | Option 1 Per Load | Option 2 Per Gal. | Option 3 Per Gal. | Overtime | Lake Suzy Per Gal. |
|--------------------------|---------------------|------------------------------|------------------------------|---|-----------------|-------------------------------|
| Synagro | \$ 37,872.50 | \$ 405.00 | \$ 0.04 | \$ 0.04 | \$ 257.00 | No Bid |
| Karle Recycling* | \$ 51,800.50 | \$ 385.00 | No Bid | *DeSoto CI \$0.112 Desoto WRF \$0.101 Lake Suzy \$0.109 | \$ 275.00 | \$ 2,180.00 |
| Merrell Bros. | \$ 68,265.35 | \$ 835.00 | \$ 0.1245 | \$ 0.0475 | \$ 269.00 | \$ 2,970.00 |
| T. Wayne Hill Trucking** | N/A | N/A | N/A | \$ 32,500.00 | \$ - | \$ 2,500.00 |

Annual Total Includes:

1. Provide a Sludge Dump trailer at DCI that is a 24-ton trailer, 38' long with 60" sides.
2. Tractor with driver to haul 24-ton loaded dump trailer from DCI WWTP to Okeechobee Landfill
3. Contractor will dewater digester sludge at the WRF, a minimum of 100,000 gallons per each mobilization including hauling to Okeechobee Landfill

Option 1:

Tractor with driver to haul 24-ton loaded dump trailer from DCI WWTP and/or County Water Reclamation Facility to DeSoto County Landfill.

Option 2:

Contractor will dewater digester sludge at the County Water Reclamation Facility, a minimum of 100,000 gallons per each mobilization including haulint to DeSoto County Landfill.

Option 3:

Hauling of liquid biosolids

Lake Suzy

Hauling of liquid biosolids per month

*** Annual Total Tractor with Driver includes Tipping Fees**

***Hauling of liquid biosolids to Karle Enviro Dewatering Facility. Dewatering and Lanfill Fees Included**

**** Bidder proposes the hauling of liquid biosolids to RMF not Okeechobee Landfill, will require Permit modification**

**DESOTO COUNTY
CONTRACT FOR UTILITIES
SLUDGE MANAGEMENT SERVICES
Bid No. 13-18-00ITB**

THIS CONTRACT is made this _____ day of _____, 2013, between **BOARD OF COUNTY COMMISSIONERS, DESOTO COUNTY, FLORIDA**, a Political subdivision of the State of Florida hereinafter referred to as ("COUNTY"), whose address is 201 East Oak Street, Arcadia, Florida 34266, and **KARLE ENVIRO-ORGANIC RECYCLING INCORPORATED** a Corporation, authorized to do business in the State of Florida, hereinafter referred to as ("CONTRACTOR"), whose address is 2991 South Street, Fort Myers, Florida 33916.

WHEREAS, the COUNTY desires to retain a CONTRACTOR to perform services described as the DeSoto County Utilities Department Sludge Management Services as listed in the Technical Specifications. All specific duties are listed within the Technical Specifications, and;

WHEREAS, CONTRACTOR desires to render services described as DeSoto County Utilities Department Sludge Management Services for the DeSoto County Lake Suzy Facility in accordance with in the Technical Specifications, and has the qualifications, experience, staff and resources to perform those services; and

WHEREAS, the COUNTY, through a competitive selection process conducted in accordance with the requirements of Florida Law and County Policy, has determined that it would be in the best interest of the COUNTY to award a Contract to the CONTRACTOR for the rendering of those services described in the Technical Specifications; and.

NOW, THEREFORE, in consideration of the mutual covenants and agreements hereinafter contained, the parties hereto agree as follows:

SECTION 1. INCORPORATION BY REFERENCE AND ENTIRE CONTRACT.

A. The foregoing "Whereas" clauses are hereby incorporated by reference and affirmed and ratified by the parties as true and correct.

SECTION 2. EMPLOYMENT OF CONTRACTOR.

A. The COUNTY hereby agrees to engage CONTRACTOR to perform the

services as set forth in the Scope of Work for the DeSoto County Lake Suzy Facility, and CONTRACTOR hereby agrees to perform the described services diligently and in a timely and professional manner.

B. All representations, certifications, statements contained in CONTRACTOR'S bid submittal are true and accurate and are incorporated by reference herein.

SECTION 3. THE COUNTY'S RESPONSIBILITY.

Unless otherwise provided in the Scope of Work, the COUNTY'S responsibilities are as follows:

A. To provide, at the request of CONTRACTOR, existing data, plans, reports, and other information in the COUNTY'S possession or under the COUNTY'S control which are necessary for the execution of the duties of the CONTRACTOR in the Technical Specifications; and to provide full information regarding requirements of the Technical Specifications, including objectives, budget constraints, criteria and other requirements that exist at the time of signing of this Contract or which may develop during the execution of this Contract.

B. To give prompt written notice to CONTRACTOR if the COUNTY observes or otherwise becomes aware of any fault or defect in the Technical Specifications or non-conformance with the Contract requirements as stated herein.

C. To furnish required information, services, render approvals, and decisions as expeditiously as necessary for the orderly progress of CONTRACTOR'S services.

D. The COUNTY hereby designates the Utilities Director to act on the COUNTY'S behalf with respect to the Scope of Work. The Director shall have authority to transmit instructions, receive information, interpret and define COUNTY policies and decisions with respect to materials, elements and systems pertinent to CONTRACTOR'S services.

SECTION 4. TIME OF PERFORMANCE.

The CONTRACTOR agrees to commence work in accordance with the Notice to Proceed issued after Contract execution. If not canceled by the COUNTY, this Contract shall be for a period of one (1) year and may be renewed for a period of two (2) additional years, one year at a time, upon mutual consent and approval by the DeSoto County board of County Commissioners. The CONTRACTOR shall make no claims for

additional compensation or damages due to suspensions, delays or hindrances. CONTRACTOR may only be compensated for the extension of time as the COUNTY may decide. However, such extension shall not operate as a waiver of any other rights of the COUNTY.

SECTION 5. COMPENSATION.

Compensation for the Scope of Work performed by CONTRACTOR shall be payable as follows:

A. The COUNTY shall pay an annual amount not to exceed **TWENTY SIX THOUSAND ONE HUNDRED SIXTY DOLLARS (\$26,160.00)**. The CONTRACTOR may submit invoices on a monthly basis for work completed.

B. CONTRACTOR shall prepare and submit to the DeSoto County Finance Department, invoices for the services rendered under this Contract. Invoices for services shall be paid in accordance with the Florida Prompt Payment Act. All invoices shall be accompanied by a report identifying the nature and progress of the work performed. The statement shall show a summary of fees with an accrual of the total fees billed and credits for portions paid previously. The COUNTY reserves the right to withhold payment to CONTRACTOR for failure to perform the work in accordance with the provisions of this Contract and the COUNTY shall promptly notify CONTRACTOR if any invoice or report is found to be unacceptable and will specify the reasons therefore.

C. Compliance with requirements for the release of, or receipt of payment for, any lien or notice to owner relating to this project.

D. All representations, indemnifications, warranties and guarantees made in, required by or given in accordance with this Contract, as well as all continuing obligations indicated in this Contract, will survive final payment and termination or completion of this Contract.

SECTION 6. DOCUMENTS.

The documents which comprise this Contract between the COUNTY and CONTRACTOR are attached hereto and made a part and consist of the following:

1. This Contract;
2. The Technical Specifications attached as Exhibit "A" consisting of 5 pages.

3. Contractor's Bid Form attached as Exhibit "B" consisting of 1 pages. Please note, total reflected is a monthly total not an annual total as listed on Contractor's Bid Form

B. This Contract represents the entire and integrated agreement between the COUNTY and CONTRACTOR and supersedes all prior negotiations, representations or contracts, either written or oral.

C. This Contract may only be amended, supplemented, modified, changed or canceled by a duly executed written instrument in accordance with County Policies.

In the event of a conflict between the terms of the Exhibits and this Contract, this Contract shall prevail.

SECTION 7. GENERAL CONSIDERATIONS.

A. Subcontractors. If CONTRACTOR subcontracts any of the work required under this Contract, CONTRACTOR agrees to include in the subcontract that the Subcontractor is bound by the terms and conditions of this Contract with the COUNTY. CONTRACTOR further agrees to include in the subcontracts, that the Subcontractor shall hold the COUNTY and CONTRACTOR harmless against all claims of whatever nature by Subcontractor's performance of Work under this Contract.

B. Public Records. CONTRACTOR shall allow public access to all documents, reports, papers, letters or other materials, subject to the provision of Chapter 119, Florida Statutes, prepared or received by CONTRACTOR in conjunction with this Contract. It is expressly understood that upon receipt of substantial evidence of CONTRACTOR'S refusal to comply with this provision, the COUNTY will have the right to terminate this Contract for breach.

C. Contract Assurance. The CONTRACTOR or Subcontractor shall not discriminate on the basis of race, color, national origin or sex in the performance of this Contract. Failure of the CONTRACTOR to carry out these requirements is a material breach of this Contract, which may result in the termination of this Contract or such other remedy as the COUNTY deems appropriate.

D. Licenses and Certifications: The CONTRACTOR shall be properly certified and licensed; financially solvent; experienced in and competent to perform the required work.

SECTION 8. PROHIBITION AGAINST CONTINGENCY FEES.

CONTRACTOR warrants that it has not employed or retained any company or person, other than a bona fide employee working solely for CONTRACTOR to solicit or secure this Contract and that CONTRACTOR has not paid or agreed to pay any person, company, corporation, individual or firm, other than a bona fide employee working solely for CONTRACTOR, any fee, commission, percentage, gift or any other consideration contingent upon or resulting from the award or making of this Contract. For the breach or violation of this provision, the COUNTY shall have the right to terminate this Contract without liability, and at its discretion, to deduct from the contract price, or otherwise recover, the full amount of such fee, commission, percentage, gift or consideration.

SECTION 9. TRUTH-IN-NEGOTIATIONS/PUBLIC ENTITY CRIMES AFFIDAVIT.

CONTRACTOR certifies that wage rates and other factual unit costs supporting the compensation are accurate, complete, and current at the time of contracting. The original Contract price and any additions thereto shall be adjusted to exclude any significant sums by which the COUNTY determines the Contract price was increased due to inaccurate, incomplete, or non-current wage rates and other factual unit costs. CONTRACTOR represents that it has furnished a Public Entity Crimes Affidavit pursuant to Section 287.113, Florida Statutes.

SECTION 10. INSURANCE.

A. The CONTRACTOR shall provide and maintain such Commercial (Occurrence Form) or Comprehensive General Liability, Professional Liability, Workers Compensation and other insurance as is appropriate for the services being performed hereunder by CONTRACTOR, its employees or agents. The amounts and types of insurance shall conform to the following minimum requirements:

WORKERS' COMPENSATION:

Coverage is to apply for all employees for statutory limits in compliance with the applicable state and federal laws. The policy must include Employers' Liability with a limit of \$500,000 each accident, \$500,000 each employee, \$500,000 policy limit for disease.

COMMERCIAL GENERAL LIABILITY – OCCURRENCE FORM REQUIRED:

CONTRACTOR shall maintain Commercial General Liability (CGL) Insurance

with a limit of not less than \$500,000 each occurrence. If such CGL insurance contains a general aggregate limit, it shall apply separately to this project in the amount of \$1,000,000. Products and completed operations aggregate shall be \$1,000,000. CGL insurance shall be written on an occurrence form and shall include bodily injury and property damage liability for premises, operations, independent contractors, products and completed operations, contractual liability, broad form property damage and property damage resulting from explosion, collapse or underground (x. c, u) exposures, personal injury and advertising injury. Damage to rented premises shall be included at \$100,000.

COMMERCIAL AUTOMOBILE LIABILITY INSURANCE:

CONTRACTOR shall maintain automobile liability insurance with a limit of not less than \$1,000,000 each accident for bodily injury and property damage liability. Such insurance shall cover liability arising out of any auto (including owned, hired and non-owned autos). The policy shall be endorsed to provide contractual liability coverage.

EVIDENCE OF INSURANCE:

CONTRACTOR shall, at its sole cost and expense, procure and maintain throughout the term of this Contract, Comprehensive General Liability and Worker's Compensation Insurance, including Employer Liability Insurance, with minimum policy limits of \$500,000 Combined Single Limits, or to the extent and in such amounts as required and authorized by Florida Law, and will provide endorsed Certification of Insurance generated and executed by a licensed insurance broker, brokerage or similar licensed insurance professional evidencing such coverage, and naming the COUNTY as a named, additional insured, as well as furnishing the COUNTY with a Certified Copy, or Copies, of said insurance policies. Certificates of Insurance and Certified Copies of these Insurance Policies must accompany this signed Contract. Said insurance coverage(s) procured by the CONTRACTOR as required herein shall be considered, and the CONTRACTOR agrees that said insurance coverage(s) it procures as required herein shall be considered, as primary insurance over and above any other insurance, or self-insurance, available to the COUNTY, and that

any other insurance, or self-insurance available to the COUNTY shall be considered secondary to, or in excess of, the insurance coverage(s) procured by the Contractor as required herein.

Nothing herein shall be construed to extend the COUNTY'S liability beyond that provided in Section 768.28, Florida Statutes.

In the event the insurance coverage expires prior to the completion of the project, a renewal certificate shall be issued 30-days prior to said expiration date. The policy shall provide a 30-day notification clause in the event of cancellation or modification to the policy. All Certificates of Insurance must be on file with and approved by the COUNTY before the commencement of any work activities.

B. The required Certificates of Insurance not only shall name types of policies provided, but also shall refer specifically to this Contract. All the policies of insurance so required of CONTRACTOR, except workers compensation insurance, shall be endorsed to include as additional insured; the COUNTY, its officers, employees and agents

C. Insurance coverage shall be placed with insurers or self-insurance funds, satisfactory to the COUNTY, licensed to do business in the State of Florida and with a resident agent designated for the service of process. All insurers shall have an "A" policyholder's rating and a financial rating of at least Class IX in accordance with the most current Best's rating. CONTRACTOR shall provide the COUNTY with financial information concerning any self-insurance funds insuring CONTRACTOR. At the COUNTY'S option, a Best's rating or Self-Insurance Fund financial information may be waived.

SECTION 11. TERMINATION FOR DEFAULT.

The COUNTY shall be the sole judge of nonperformance, which shall include any failure on the part of the CONTRACTOR to accept the award, to furnish required documents, and/or to fulfill any portion of this Contract within the time stipulated. Upon default by the CONTRACTOR to meet any term of this Contract or related Exhibit, the COUNTY will notify the CONTRACTOR to advise the COUNTY of its plan for corrective action to remedy the default within three (3) days (weekends and holidays excluded). The corrective action plan must be accepted by the Utilities Director. Failure on the

CONTRACTOR's part to correct the default within the approved time period shall result in the Contract being terminated and the COUNTY notifying in writing the CONTRACTOR of the effective date of the termination. The following shall constitute an act of default:

- Failure to perform the Work required under the Contract and/or within the time required or failing to use the sub-consultants, entities, and personnel as identified and set forth, and to the degree specified in the Contract.
- Failure to begin the Work under this Contract within the time specified.
- Failure to perform the Work with sufficient workers to ensure timely completion.
- Neglecting or refusing to correct Work where prior Work has been rejected as nonconforming with the terms of the Contract.
- Becoming insolvent or being declared bankrupt by a US Bankruptcy Court.
- Failure to comply with any of the terms of the Contract.
- Failure to pay sub-consultants or others pursuant to Work done under this Contract.

In the event of default, the CONTRACTOR shall pay any damages sustained by the COUNTY including attorney's fees and court costs incurred in collecting any damages. Title to all materials, work-in-progress, and completed but undelivered goods will pass to the COUNTY after costs are claimed and allowed. All documents prepared by the CONTRACTOR in connection with this Contract will be the property of the COUNTY.

The Utilities Director shall authorize payment to the CONTRACTOR, the costs and expenses for Work performed by the CONTRACTOR prior to receipt of the Notice of Termination; however, the COUNTY may withhold from amounts due the CONTRACTOR such sums as the Administrative Services Director deems to be necessary to protect the COUNTY against loss caused by the CONTRACTOR because of the default.

SECTION 12: TERMINATION FOR CONVENIENCE.

The COUNTY reserves the right to cancel this Contract by written notice to the CONTRACTOR effective the date specified in the Notice, for any of the following

reasons:

- The COUNTY has determined that such cancellation will be in the best interest of the COUNTY.
- Funds are not available to cover the cost of the services. The COUNTY'S obligation is contingent upon the availability of appropriate funds.

The Purchasing Manager shall give written notice of the termination to the CONTRACTOR specifying the reason for the Contract termination and when termination becomes effective.

The CONTRACTOR shall incur no further obligations in connection with the terminated Work and on the date set in the Notice of Termination the CONTRACTOR will stop Work to the extent specified.

The COUNTY shall pay the CONTRACTOR under following conditions:

- All costs and expenses incurred by the CONTRACTOR for work accepted by the COUNTY prior to the CONTRACTOR 'S receipt of the Notice of Termination.

Anticipatory profit for work and services not performed by the CONTRACTOR shall not be allowed.

SECTION 13: DISPUTES.

All controversies between the COUNTY and the CONTRACTOR which arise under, or are by virtue of, this Contract and which are not resolved by mutual agreement, shall be decided by the County Administrator in writing, within 30 days after a written request by the CONTRACTOR for a final decision concerning the controversy.

The COUNTY shall immediately furnish a copy of the decision to the CONTRACTOR by certified mail, return receipt requested, or by any other method that provides evidence of receipt. Any such decision shall be final and conclusive, unless the CONTRACTOR brings an action seeking judicial review of the decision. The CONTRACTOR shall comply with any decision of the County Administrator and proceed diligently with performance of this Contract until final resolution by a Court of Law, if a judicial remedy is pursued.

SECTION 14. CONTROLLING LAW.

This Contract is to be governed by the laws of the State of Florida. The venue for any litigation resulting out of this Contract shall be in DeSoto County, Florida.

SECTION 15. SUCCESSORS AND ASSIGNS.

The COUNTY and CONTRACTOR respectively, bind themselves, their partners, successors, assigns and legal representatives to the other party to this Contract and to the partners, successors, assigns and legal representatives with respect to all covenants of this Contract. Neither the COUNTY nor CONTRACTOR shall assign or transfer any interest in this Contract without the written consent of the other.

SECTION 16. INDEMNIFICATION OF THE COUNTY.

CONTRACTOR shall defend, indemnify and hold harmless DeSoto County, and its agents, employees, and public officials from and against all suits, losses, claims, demands, judgments, liabilities and actions, including attorney's fees and all costs of litigation and judgments of every name and description arising out of or incidental to the performance of this Contract or work performed thereunder, whether or not due to or caused by the negligence of DeSoto County, its agents, employees, and public officials excluding only the sole negligence of DeSoto County, its agents, employees, and public officials.

SECTION 17. INDEPENDENT CONTRACTOR.

Neither the COUNTY nor any of its employees shall have any control over the conduct of CONTRACTOR or any of CONTRACTOR'S employees, except as herein set forth. CONTRACTOR expressly warrants not to represent at any time or in any manner that CONTRACTOR or any of its agents, servants or employees are agents, servants or employees of the COUNTY. It is understood and agreed that CONTRACTOR is, and shall at all times remain as to the COUNTY, a wholly independent Contractor and the CONTRACTOR'S obligations to the COUNTY are solely as prescribed by this Contract.

SECTION 18. NOTICES.

Any notices to be given under this Contract shall be given by the United States mail, addressed to CONTRACTOR at its address stated herein, and to the COUNTY at its address stated herein.

[REMAINDER OF PAGE LEFT INTENTIONALLY BLANK]

IN WITNESS WHEREOF, the parties have executed this Contract as of the _____
OF _____, 2013.

ATTEST:

**BOARD OF COUNTY COMMISSIONERS
DESOTO COUNTY, FLORIDA**

By: _____
C. Guy Maxcy
County Administrator

By: _____
James F. Selph
Chairman

BOCC Approved: _____

Approved as to form and
Legal sufficiency:

Date: _____

Donald D. Conn
County Attorney

WITNESSES:

**KARLE ENVIRO-ORGANIC RECYCLING,
INCORPORATED**

By: _____

Printed Name: _____

Title: _____

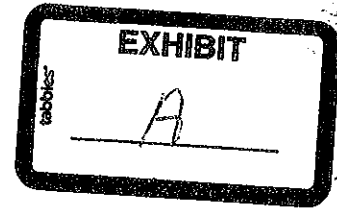

TECHNICAL SPECIFICATIONS

Bide # 13-18-00ITB

PURPOSE:

DeSoto County is soliciting Bids for the purpose of selecting a Vendor to perform Sludge Management Services throughout the term of this Contract for the Utilities Department.

BID AWARD:

Award will go to the Vendor which is more advantageous and in the best interest of the County.

DEFINITIONS AS USED HEREIN:

1. CONTRACTOR shall mean the Vendor awarded the Sludge Management Contract.
2. COUNTY shall mean DeSoto County Government.
3. FACILITY(IES) shall pertain to the Wastewater Treatment Plants.
4. NON-CONFORMING SLUDGE shall mean any County Sludge which fails to conform to FDEP FAC.
5. OKEECHOBEE LANDFILL shall mean the landfill operated by Waste Management on Okeechobee County, 10800 N.E. 128th Ave, Okeechobee, Florida 34972.
6. SEWAGE shall mean any raw wastewater transported from the County operated collection system.
7. PROCESSING or PROCESS shall mean the appropriate dewatering, transportation, and final disposition of County Sludge.
8. SLUDGE shall mean sludge, which substantially conforms to general industry standards for wastewater sludge, non-hazardous.

RESPONSIBILITIES OF THE VENDOR:

1. Contractor shall process County sludge generated at the County -owned facilities. The County will generate approximately two million (2,000,000) gallons per year and the percent of solids are estimated to be 2%. Facilities may be added or deleted during the term of this Contract. Any such additions or deletions shall not affect the per-gallon Contract Price or other services of this Contract. The DeSoto Correctional Facility will generate the majority of digester sludge.

NOTE: Contractor shall assume all responsibility for the proper disposition of all County sludge once accepted by the Contractor.

2. Contractor shall accept all of the County's sludge unless:
 - A. The sludge is not of a type with respect to which Contractor is legally authorized, by regulatory agencies, to process; or
 - B. The sludge in non-conforming sludge.
3. Contractor shall dewater the County sludge and guarantee that the sludge will pass a paint filter test and disposal in a Class I or II solid waste landfill before hauling.

4. Contractor shall haul liquid sludge from DeSoto County Regional Wastewater Treatment Facility to Desoto Correctional Institution Wastewater Treatment Facility if unable at any time to dewater sludge as well as from DeSoto Correctional Institution Wastewater Treatment Facility to DeSoto County Regional Wastewater Treatment Facility.
5. Contractor shall haul liquid sludge to and from either County Wastewater Treatment Facility (DeSoto Correctional Institution or DeSoto County Regional Wastewater Treatment Facilities) in lieu of dewatering, if deemed monetarily advantageous for the County to pursue this alternative.
6. Contractor pricing shall reflect the possibility that the percent of solids could be greater or less than the estimated percent of solids expected.
7. Contractor's dewatering equipment shall be self-contained and self-supporting, including electricity, in operation.
8. Contractor's dewatering equipment shall not exceed 65 decibels at any point of the property line while operational.
9. Contractor shall provide adequate trained personnel to efficiently process the County sludge and perform other services as indicated herein.
10. Contractor shall provide, within 5 days, sufficient replacement dewatering equipment in the event of mechanical failure.
11. Contractor's dewatering equipment shall be portable and capable of dewatering all generated County sludge on a schedule mutually agreeable; however, the County shall have final approval of said schedule.
12. Contractor shall provide the necessary equipment to deliver dewatered sludge to the Okeechobee Landfill and/or the DeSoto County Landfill. Contractor shall coordinate deliveries with the Landfill Manager. All material is currently going to the Okeechobee Landfill, however we are requesting a price to haul to DeSoto County Landfill if the need should arise. Contractor may transport dewatered sludge to the DeSoto County Landfill only at the County's direction. Contractor shall coordinate deliveries with the DeSoto Landfill Manager whose phone number is (863) 993-4826.
13. Contractor shall be responsible for the cleanup of any and all spills, on or off County property and any required notification of and documentation to regulatory agencies. The County shall be immediately notified of any spill with a follow up in writing.
14. Contractor shall maintain all documentation required by regulatory agencies and make such documentation available to the County upon request.

15. Contractor's responsibility for the County's sludge shall cease upon delivery to the landfill(s) or other County authorized locations.
16. Contractor shall have the equipment available to jet out, vacuum clean, and haul sewer collection liquid and debris. The County anticipates this being done annually. This request may include both a "Vactor type snorkel truck" or a "vacuum pumper truck". This is mainly to clean lift station grit and debris.
17. Contractor shall respond to the County's requests for the transport of liquid wastewater or sewage within two (2) hours of an emergency situation and the emergency equipment must be within 60 minutes travel time, non-emergency situations within twenty-four (24) hours. All calls shall be 365 days a year with uninterrupted answering of phones.
18. Contractor shall be responsible for all overage costs in mileage, fuel rate increases and/or dewatering. The awarded Contractor will be responsible for tipping fees and all charges associated with this service. Awarded Contractor must provide copies of Landfill Scale Tickets to the County for payment. The County will only pay tipping fees and no other surcharges or mark-ups will be allowed.
19. Contractor shall be responsible for all manifests.
20. Any modifications to the requirements of this Article must be expressly approved by the County.

RESPONSIBILITIES OF THE COUNTY

1. The County shall provide the Contractor with a minimum of one hundred thousand (100,000) gallons of sludge to dewater per mobilization.
2. The County shall provide all County sludge to the Contractor.
3. The County shall provide adequate space for Contractor's dewatering equipment at the Facilities.
4. The County will provide fifty (50) psi water pressure at each of the Facilities.
5. The County shall provide access to the Facilities eight (8) hours a day, five (5) days a week to carry out the dewatering process. After hour arrangements may be approved with prior notifications.
6. The County is responsible for the testing of sludge analysis performed and analyzed by an accredited independent testing laboratory. Results shall be sent directly to landfill(s), the Contractor, appropriate regulatory agencies and the County.

7. The County will dewater the sludge at the Correctional Facility and load the sludge into a trailer. The DeSoto Correctional Wastewater Treatment Plant should generate approximately one trailer load of sludge every two to three weeks for hauling, depending on flow.

REJECTION OF SLUDGE

1. The Contractor shall have the right to reject any non-conforming sludge, provided that the Contractor notifies the County by telephone and/or in writing of such rejections for non-conformance promptly upon Contractor's discovery thereof, but in no event later than forty-eight (48) hours after the discovery of such non-conforming sludge.
2. Any such Notice of Rejection not given initially in writing shall be promptly confirmed in writing to the County.
3. The County shall within twenty-four (24) hours after receipt of the Notice of Rejection of non-conforming sludge arrange for and pay all costs associated with taking possession of and the transport of such non-conforming sludge for appropriate processing and/or other necessary treatment.

LOCATION FOR DEWATERING AND LOADING SLUDGE

1. DeSoto County Regional Wastewater Treatment Facility
7728 S.E. Highway 31
Arcadia, Florida 34266
2. DeSoto Correctional Institution Wastewater Treatment Facility
13617 S.W. Highway 70
Arcadia, Florida 34266

TERM OF CONTRACT

One year with an option to renew for two additional years one year at a time upon mutual agreement.

CRITERIA FOR AWARD

The award of this Bid may be in total or in part, to the lowest responsive responsible Bidder(s) who possess adequate equipment with operators, labor, and materials necessary to perform the Work in accordance with the requirements of the Contract.

[REMAINDER OF PAGE LEFT INTENTIONALLY BLANK]

**DESOTO COUNTY
UTILITIES SLUDGE MANAGEMENT SERVICES
Project No. 13-18-00ITB
Addendum # 4**

DeSoto County has just acquired a new Utility System located at 12169 SW Egret Circle, Lake Suzy, Florida 34269. Below is information for the new plant.

Type of Plant

Capacity is .087

Extended Air Package Plant

2 – 10,000 gallons Digesters, total 20,000 gallons

Digesters must be emptied one per month.

This plant is currently serviced once per month with four liquid loads of 5,000 gallons per load, taken back to the current Contractor's facility, pressed and taken to Okeechobee Landfill.

This site will be added on the Sludge Management Services as an alternate and may result in two separate Contracts. Please find attached a separate Bid Form for this new site. If Contractor does not wish to service this location, simply check No Bid on this Alternate Bid Form and submit with your Bid.

**ANNUAL CONTRACT FOR SLUDGE MANAGEMENT SERVICES
ALTERNATE BID FORM FOR LAKE SUZY**

| ITEMS | RATE | UNIT PRICE | ANNUAL TOTAL |
|-------|------|------------|-----------------|
|-------|------|------------|-----------------|

OPTIONS

1. Hauling of liquid bio-solids Price per gal. 0.109 x 20,000 gal. 2,180.00

Company Name: Karle Enviro-Organic Recycling Inc.

Address: 2991 South Street Fort Myers FL 33916

Signature: Krish A. Alexander

Email: Krishalexander@embargmail.com

Date: 5-17-2013

NO BID _____



BOARD OF COUNTY COMMISSIONERS

DESOTO COUNTY, FLORIDA

DATE: June 11, 2013

| | | | |
|----|------------------|---------|-------------------------------|
| | Consent Agenda | | Quasi-Judicial Public Hearing |
| XX | Regular Business | 9:00 AM | Time |
| | Public Hearing | | |

DEPARTMENT: Utilities
SUBMITTED BY: Utilities
PRESENTED BY: Eddie Miller, Utilities Director

TITLE & DESCRIPTION: Bid Award – Sludge Management Contract/Synagro South, LLC

REQUESTED MOTION: To award Bid to Synagro South, LLC for Sludge Management Services and authorize Chairman to execute the Contract.

SUMMARY: Staff requests to approve the Sludge Management Contract with Synagro South, LLC of Lake Suzy Wastewater Treatment Facility for sludge dewatering and hauling services for DeSoto County Wastewater Facilities.



BACKGROUND: The County Purchasing Department solicited for bids on April 16, 2013. After the evaluation of the four responding bidders, staff recommends that the bid be awarded to Synagro South, LLC which provided the lowest contract price for the bidding services. This Contract will provide sludge dewatering and hauling from the DeSoto Regional Wastewater Treatment Plant and sludge hauling from the DCI Wastewater Treatment Plant. Sludge removed from both facilities will be hauled to the Okeechobee Landfill located in Okeechobee, Florida. The Contract will provide services for one (1) year with the option to renew for two (2) additional years, one year at a time upon approval by the Board of County Commissioners.

FUNDS:

| | |
|--------------------------|--|
| Budget Amount: | \$4,420.25 for remainder of FY 2012-2013 |
| Actual Agenda Item Cost: | Estimated at \$37,872.50 annually |
| Account Number: | 410-70975353400000 |
| Explanation: | Facilities Contract Services |

ATTACHMENTS:

REVIEW APPROVAL:

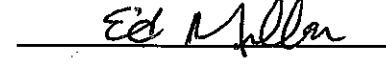
| | |
|----------------------|--|
| County Administrator |  |
| County Attorney |  |
| Department Director |  |
| Department Manager | _____ |

**DESOTO COUNTY UTILITIES SLUDGE MANAGEMENT SERVICES
 BID NO. 13-18-00 INVITATION TO BID**

| Company Name | Annual Total | Option 1 Per Load | Option 2 Per Gal. | Option 3 Per Gal. | Overtime | Lake Suzy Per Gal. |
|--------------------------|---------------------|------------------------------|------------------------------|---|-----------------|-------------------------------|
| Synagro | \$ 37,872.50 | \$ 405.00 | \$ 0.04 | \$ 0.04 | \$ 257.00 | No Bid |
| Karle Recycling* | \$ 51,800.50 | \$ 385.00 | No Bid | *DeSoto CI \$0.112 Desoto WRF \$0.101 Lake Suzy \$0.109 | \$ 275.00 | \$ 2,180.00 |
| Merrell Bros. | \$ 68,265.35 | \$ 835.00 | \$ 0.1245 | \$ 0.0475 | \$ 269.00 | \$ 2,970.00 |
| T. Wayne Hill Trucking** | N/A | N/A | N/A | \$ 32,500.00 | \$ - | \$ 2,500.00 |

Annual Total Includes:

1. Provide a Sludge Dump trailer at DCI that is a 24-ton trailer, 38' long with 60" sides.
2. Tractor with driver to haul 24-ton loaded dump trailer from DCI WWTP to Okeechobee Landfill
3. Contractor will dewater digester sludge at the WRF, a minimum of 100,000 gallons per each mobilization including hauling to Okeechobee Landfill

Option 1:

Tractor with driver to haul 24-ton loaded dump trailer from DCI WWTP and/or County Water Reclamation Facility to DeSoto County Landfill.

Option 2:

Contractor will dewater digester sludge at the County Water Reclamation Facility, a minimum of 100,000 gallons per each mobilization including haulint to DeSoto County Landfill.

Option 3:

Hauling of liquid biosolids

Lake Suzy

Hauling of liquid biosolids per month

*** Annual Total Tractor with Driver includes Tipping Fees**

***Hauling of liquid biosolids to Karle Enviro Dewatering Facility. Dewatering and Lanfill Fees Included**

**** Bidder proposes the hauling of liquid biosolids to RMF not Okeechobee Landfill, will require Permit modification**

**DESOTO COUNTY
CONTRACT FOR UTILITIES
SLUDGE MANAGEMENT SERVICES
Bid No. 13-18-00ITB**

THIS CONTRACT is made this _____ day of _____, 2013, between **BOARD OF COUNTY COMMISSIONERS, DESOTO COUNTY, FLORIDA**, a Political subdivision of the State of Florida hereinafter referred to as ("COUNTY"), whose address is 201 East Oak Street, Arcadia, Florida 34266, and **SYNAGRO SOUTH, LLC**, a Limited Liability Company, authorized to do business in the State of Florida, hereinafter referred to as ("CONTRACTOR"), whose address is 1800 Bering Drive, Suite 1000, Houston, Texas 77057.

WHEREAS, the COUNTY desires to retain a CONTRACTOR to perform services described as the DeSoto County Utilities Department Sludge Management Services as listed in the Technical Specifications. All specific duties are listed within the Technical Specifications, and;

WHEREAS, CONTRACTOR desires to render services described as DeSoto County Utilities Department Sludge Management Services for the DeSoto Correctional Institution and the DeSoto County Regional Wastewater Treatment Facility in accordance with in the Technical Specifications, and has the qualifications, experience, staff and resources to perform those services; and

WHEREAS, the COUNTY, through a competitive selection process conducted in accordance with the requirements of Florida Law and County Policy, has determined that it would be in the best interest of the COUNTY to award a Contract to the CONTRACTOR for the rendering of those services described in the Technical Specifications; and.

NOW, THEREFORE, in consideration of the mutual covenants and agreements hereinafter contained, the parties hereto agree as follows:

SECTION 1. INCOPORATION BY REFERENCE AND ENTIRE CONTRACT.

A. The foregoing "Whereas" clauses are hereby incorporated by reference and affirmed and ratified by the parties as true and correct.

SECTION 2. EMPLOYMENT OF CONTRACTOR.

A. The COUNTY hereby agrees to engage CONTRACTOR to perform the services as set forth in the Scope of Work for the DeSoto Correctional Institution and the DeSoto County Regional Wastewater Treatment Facility, and CONTRACTOR hereby agrees to perform the described services diligently and in a timely and professional manner.

B. All representations, certifications, statements contained in CONTRACTOR'S bid submittal are true and accurate and are incorporated by reference herein.

SECTION 3. THE COUNTY'S RESPONSIBILITY.

Unless otherwise provided in the Scope of Work, the COUNTY'S responsibilities are as follows:

A. To provide, at the request of CONTRACTOR, existing data, plans, reports, and other information in the COUNTY'S possession or under the COUNTY'S control which are necessary for the execution of the duties of the CONTRACTOR in the Technical Specifications; and to provide full information regarding requirements of the Technical Specifications, including objectives, budget constraints, criteria and other requirements that exist at the time of signing of this Contract or which may develop during the execution of this Contract.

B. To give prompt written notice to CONTRACTOR if the COUNTY observes or otherwise becomes aware of any fault or defect in the Technical Specifications or non-conformance with the Contract requirements as stated herein.

C. To furnish required information, services, render approvals, and decisions as expeditiously as necessary for the orderly progress of CONTRACTOR'S services.

D. The COUNTY hereby designates the Utilities Director to act on the COUNTY'S behalf with respect to the Scope of Work. The Director shall have authority to transmit instructions, receive information, interpret and define COUNTY policies and decisions with respect to materials, elements and systems pertinent to CONTRACTOR'S services.

SECTION 4. TIME OF PERFORMANCE.

The CONTRACTOR agrees to commence work in accordance with the Notice to Proceed issued after Contract execution. If not canceled by the COUNTY, this Contract

shall be for a period of one (1) year and may be renewed for a period of two (2) additional years, one year at a time, upon mutual consent and approval by the DeSoto County board of County Commissioners. The CONTRACTOR shall make no claims for additional compensation or damages due to suspensions, delays or hindrances. CONTRACTOR may only be compensated for the extension of time as the COUNTY may decide. However, such extension shall not operate as a waiver of any other rights of the COUNTY.

SECTION 5. COMPENSATION.

Compensation for the Scope of Work performed by CONTRACTOR shall be payable as follows:

A. The COUNTY shall pay an annual amount not to exceed **THIRTY SEVEN THOUSAND EIGHT HUNDRED SEVENTY TWO DOLLARS AND FIFTY CENTS (\$37,872.50)**. The CONTRACTOR may submit invoices on a monthly basis for work completed.

B. CONTRACTOR shall prepare and submit to the DeSoto County Finance Department, invoices for the services rendered under this Contract. Invoices for services shall be paid in accordance with the Florida Prompt Payment Act. All invoices shall be accompanied by a report identifying the nature and progress of the work performed. The statement shall show a summary of fees with an accrual of the total fees billed and credits for portions paid previously. The COUNTY reserves the right to withhold payment to CONTRACTOR for failure to perform the work in accordance with the provisions of this Contract and the COUNTY shall promptly notify CONTRACTOR if any invoice or report is found to be unacceptable and will specify the reasons therefore.

C. Compliance with requirements for the release of, or receipt of payment for, any lien or notice to owner relating to this project.

D. All representations, indemnifications, warranties and guarantees made in, required by or given in accordance with this Contract, as well as all continuing obligations indicated in this Contract, will survive final payment and termination or completion of this Contract.

SECTION 6. DOCUMENTS.

The documents which comprise this Contract between the COUNTY and

CONTRACTOR are attached hereto and made a part and consist of the following:

1. This Contract;
2. The Technical Specifications attached as Exhibit "A" consisting of 4 pages.
3. Contractor's Bid Form attached as Exhibit "B" consisting of 2 pages.

B. This Contract represents the entire and integrated agreement between the COUNTY and CONTRACTOR and supersedes all prior negotiations, representations or contracts, either written or oral.

C. This Contract may only be amended, supplemented, modified, changed or canceled by a duly executed written instrument in accordance with County Policies.

In the event of a conflict between the terms of the Exhibits and this Contract, this Contract shall prevail.

SECTION 7. GENERAL CONSIDERATIONS.

A. Subcontractors. If CONTRACTOR subcontracts any of the work required under this Contract, CONTRACTOR agrees to include in the subcontract that the Subcontractor is bound by the terms and conditions of this Contract with the COUNTY. CONTRACTOR further agrees to include in the subcontracts, that the Subcontractor shall hold the COUNTY and CONTRACTOR harmless against all claims of whatever nature by Subcontractor's performance of Work under this Contract.

B. Public Records. CONTRACTOR shall allow public access to all documents, reports, papers, letters or other materials, subject to the provision of Chapter 119, Florida Statutes, prepared or received by CONTRACTOR in conjunction with this Contract. It is expressly understood that upon receipt of substantial evidence of CONTRACTOR'S refusal to comply with this provision, the COUNTY will have the right to terminate this Contract for breach.

C. Contract Assurance. The CONTRACTOR or Subcontractor shall not discriminate on the basis of race, color, national origin or sex in the performance of this Contract. Failure of the CONTRACTOR to carry out these requirements is a material breach of this Contract, which may result in the termination of this Contract or such other remedy as the COUNTY deems appropriate.

D. Licenses and Certifications: The CONTRACTOR shall be properly certified

and licensed; financially solvent; experienced in and competent to perform the required work.

SECTION 8. PROHIBITION AGAINST CONTINGENCY FEES.

CONTRACTOR warrants that it has not employed or retained any company or person, other than a bona fide employee working solely for CONTRACTOR to solicit or secure this Contract and that CONTRACTOR has not paid or agreed to pay any person, company, corporation, individual or firm, other than a bona fide employee working solely for CONTRACTOR, any fee, commission, percentage, gift or any other consideration contingent upon or resulting from the award or making of this Contract. For the breach or violation of this provision, the COUNTY shall have the right to terminate this Contract without liability, and at its discretion, to deduct from the contract price, or otherwise recover, the full amount of such fee, commission, percentage, gift or consideration.

SECTION 9. TRUTH-IN-NEGOTIATIONS/PUBLIC ENTITY CRIMES AFFIDAVIT.

CONTRACTOR certifies that wage rates and other factual unit costs supporting the compensation are accurate, complete, and current at the time of contracting. The original Contract price and any additions thereto shall be adjusted to exclude any significant sums by which the COUNTY determines the Contract price was increased due to inaccurate, incomplete, or non-current wage rates and other factual unit costs. CONTRACTOR represents that it has furnished a Public Entity Crimes Affidavit pursuant to Section 287.113, Florida Statutes.

SECTION 10. INSURANCE.

A. The CONTRACTOR shall provide and maintain such Commercial (Occurrence Form) or Comprehensive General Liability, Professional Liability, Workers Compensation and other insurance as is appropriate for the services being performed hereunder by CONTRACTOR, its employees or agents. The amounts and types of insurance shall conform to the following minimum requirements:

WORKERS' COMPENSATION:

Coverage is to apply for all employees for statutory limits in compliance with the applicable state and federal laws. The policy must include Employers' Liability with a limit of \$500,000 each accident, \$500,000 each employee, \$500,000 policy limit for disease.

COMMERCIAL GENERAL LIABILITY – OCCURRENCE FORM REQUIRED:

CONTRACTOR shall maintain Commercial General Liability (CGL) Insurance with a limit of not less than \$500,000 each occurrence. If such CGL insurance contains a general aggregate limit, it shall apply separately to this project in the amount of \$1,000,000. Products and completed operations aggregate shall be \$1,000,000. CGL insurance shall be written on an occurrence form and shall include bodily injury and property damage liability for premises, operations, independent contractors, products and completed operations, contractual liability, broad form property damage and property damage resulting from explosion, collapse or underground (x. c, u) exposures, personal injury and advertising injury. Damage to rented premises shall be included at \$100,000.

COMMERCIAL AUTOMOBILE LIABILITY INSURANCE:

CONTRACTOR shall maintain automobile liability insurance with a limit of not less than \$1,000,000 each accident for bodily injury and property damage liability. Such insurance shall cover liability arising out of any auto (including owned, hired and non-owned autos). The policy shall be endorsed to provide contractual liability coverage.

EVIDENCE OF INSURANCE:

CONTRACTOR shall, at its sole cost and expense, procure and maintain throughout the term of this Contract, Comprehensive General Liability and Worker's Compensation Insurance, including Employer Liability Insurance, with minimum policy limits of \$500,000 Combined Single Limits, or to the extent and in such amounts as required and authorized by Florida Law, and will provide endorsed Certification of Insurance generated and executed by a licensed insurance broker, brokerage or similar licensed insurance professional evidencing such coverage, and naming the COUNTY as a named, additional insured, as well as furnishing the COUNTY with a Certified Copy, or Copies, of said insurance policies. Certificates of Insurance and Certified Copies of these Insurance Policies must accompany this signed Contract. Said insurance coverage(s) procured by the CONTRACTOR as required herein shall be

considered, and the CONTRACTOR agrees that said insurance coverage(s) it procures as required herein shall be considered, as primary insurance over and above any other insurance, or self-insurance, available to the COUNTY, and that any other insurance, or self-insurance available to the COUNTY shall be considered secondary to, or in excess of, the insurance coverage(s) procured by the Contractor as required herein.

Nothing herein shall be construed to extend the COUNTY'S liability beyond that provided in Section 768.28, Florida Statutes.

In the event the insurance coverage expires prior to the completion of the project, a renewal certificate shall be issued 30-days prior to said expiration date. The policy shall provide a 30-day notification clause in the event of cancellation or modification to the policy. All Certificates of Insurance must be on file with and approved by the COUNTY before the commencement of any work activities.

B. The required Certificates of Insurance not only shall name types of policies provided, but also shall refer specifically to this Contract. All the policies of insurance so required of CONTRACTOR, except workers compensation insurance, shall be endorsed to include as additional insured; the COUNTY, its officers, employees and agents

C. Insurance coverage shall be placed with insurers or self-insurance funds, satisfactory to the COUNTY, licensed to do business in the State of Florida and with a resident agent designated for the service of process. All insurers shall have an "A" policyholder's rating and a financial rating of at least Class IX in accordance with the most current Best's rating. CONTRACTOR shall provide the COUNTY with financial information concerning any self-insurance funds insuring CONTRACTOR. At the COUNTY'S option, a Best's rating or Self-Insurance Fund financial information may be waived.

SECTION 11. TERMINATION FOR DEFAULT.

The COUNTY shall be the sole judge of nonperformance, which shall include any failure on the part of the CONTRACTOR to accept the award, to furnish required documents, and/or to fulfill any portion of this Contract within the time stipulated. Upon default by the CONTRACTOR to meet any term of this Contract or related Exhibit, the

COUNTY will notify the CONTRACTOR to advise the COUNTY of its plan for corrective action to remedy the default within three (3) days (weekends and holidays excluded). The corrective action plan must be accepted by the Utilities Director. Failure on the CONTRACTOR's part to correct the default within the approved time period shall result in the Contract being terminated and the COUNTY notifying in writing the CONTRACTOR of the effective date of the termination. The following shall constitute an act of default:

- Failure to perform the Work required under the Contract and/or within the time required or failing to use the sub-consultants, entities, and personnel as identified and set forth, and to the degree specified in the Contract.
- Failure to begin the Work under this Contract within the time specified.
- Failure to perform the Work with sufficient workers to ensure timely completion.
- Neglecting or refusing to correct Work where prior Work has been rejected as nonconforming with the terms of the Contract.
- Becoming insolvent or being declared bankrupt by a US Bankruptcy Court.
- Failure to comply with any of the terms of the Contract.
- Failure to pay sub-consultants or others pursuant to Work done under this Contract.

In the event of default, the CONTRACTOR shall pay any damages sustained by the COUNTY including attorney's fees and court costs incurred in collecting any damages. Title to all materials, work-in-progress, and completed but undelivered goods will pass to the COUNTY after costs are claimed and allowed. All documents prepared by the CONTRACTOR in connection with this Contract will be the property of the COUNTY.

The Utilities Director shall authorize payment to the CONTRACTOR, the costs and expenses for Work performed by the CONTRACTOR prior to receipt of the Notice of Termination; however, the COUNTY may withhold from amounts due the CONTRACTOR such sums as the Administrative Services Director deems to be necessary to protect the COUNTY against loss caused by the CONTRACTOR because of the default.

SECTION 12: TERMINATION FOR CONVENIENCE.

The COUNTY reserves the right to cancel this Contract by written notice to the CONTRACTOR effective the date specified in the Notice, for any of the following reasons:

- The COUNTY has determined that such cancellation will be in the best interest of the COUNTY.
- Funds are not available to cover the cost of the services. The COUNTY'S obligation is contingent upon the availability of appropriate funds.

The Purchasing Manager shall give written notice of the termination to the CONTRACTOR specifying the reason for the Contract termination and when termination becomes effective.

The CONTRACTOR shall incur no further obligations in connection with the terminated Work and on the date set in the Notice of Termination the CONTRACTOR will stop Work to the extent specified.

The COUNTY shall pay the CONTRACTOR under following conditions:

- All costs and expenses incurred by the CONTRACTOR for work accepted by the COUNTY prior to the CONTRACTOR 'S receipt of the Notice of Termination.

Anticipatory profit for work and services not performed by the CONTRACTOR shall not be allowed.

SECTION 13: DISPUTES.

All controversies between the COUNTY and the CONTRACTOR which arise under, or are by virtue of, this Contract and which are not resolved by mutual agreement, shall be decided by the County Administrator in writing, within 30 days after a written request by the CONTRACTOR for a final decision concerning the controversy.

The COUNTY shall immediately furnish a copy of the decision to the CONTRACTOR by certified mail, return receipt requested, or by any other method that provides evidence of receipt. Any such decision shall be final and conclusive, unless the CONTRACTOR brings an action seeking judicial review of the decision. The CONTRACTOR shall comply with any decision of the County Administrator and proceed diligently with performance of this Contract until final resolution by a Court of Law, if a judicial remedy is pursued.

SECTION 14. CONTROLLING LAW.

This Contract is to be governed by the laws of the State of Florida. The venue for any litigation resulting out of this Contract shall be in DeSoto County, Florida.

SECTION 15. SUCCESSORS AND ASSIGNS.

The COUNTY and CONTRACTOR respectively, bind themselves, their partners, successors, assigns and legal representatives to the other party to this Contract and to the partners, successors, assigns and legal representatives with respect to all covenants of this Contract. Neither the COUNTY nor CONTRACTOR shall assign or transfer any interest in this Contract without the written consent of the other.

SECTION 16. INDEMNIFICATION OF THE COUNTY.

CONTRACTOR shall defend, indemnify and hold harmless DeSoto County, and its agents, employees, and public officials from and against all suits, losses, claims, demands, judgments, liabilities and actions, including attorney's fees and all costs of litigation and judgments of every name and description arising out of or incidental to the performance of this Contract or work performed thereunder, whether or not due to or caused by the negligence of DeSoto County, its agents, employees, and public officials excluding only the sole negligence of DeSoto County, its agents, employees, and public officials.

SECTION 17. INDEPENDENT CONTRACTOR.

Neither the COUNTY nor any of its employees shall have any control over the conduct of CONTRACTOR or any of CONTRACTOR'S employees, except as herein set forth. CONTRACTOR expressly warrants not to represent at any time or in any manner that CONTRACTOR or any of its agents, servants or employees are agents, servants or employees of the COUNTY. It is understood and agreed that CONTRACTOR is, and shall at all times remain as to the COUNTY, a wholly independent Contractor and the CONTRACTOR'S obligations to the COUNTY are solely as prescribed by this Contract.

SECTION 18. NOTICES.

Any notices to be given under this Contract shall be given by the United States mail, addressed to CONTRACTOR at its address stated herein, and to the COUNTY at its address stated herein.

[REMAINDER OF PAGE LEFT INTENTIONALLY BLANK]

IN WITNESS WHEREOF, the parties have executed this Contract as of the _____
OF _____, 2013.

ATTEST:

**BOARD OF COUNTY COMMISSIONERS
DESOTO COUNTY, FLORIDA**

By: _____
C. Guy Maxcy
County Administrator

By: _____
James F. Selph
Chairman

BOCC Approved: _____

Approved as to form and
Legal sufficiency:

Date: _____

Donald D. Conn
County Attorney

WITNESSES:

SYNAGRO SOUTH LLC

By: _____

Printed Name: _____

Title: _____

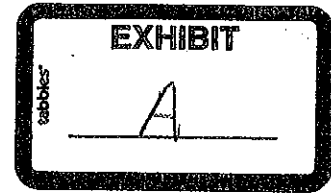

TECHNICAL SPECIFICATIONS

Bide # 13-18-00ITB

PURPOSE:

DeSoto County is soliciting Bids for the purpose of selecting a Vendor to perform Sludge Management Services throughout the term of this Contract for the Utilities Department.

BID AWARD:

Award will go to the Vendor which is more advantageous and in the best interest of the County.

DEFINITIONS AS USED HEREIN:

1. CONTRACTOR shall mean the Vendor awarded the Sludge Management Contract.
2. COUNTY shall mean DeSoto County Government.
3. FACILITY(IES) shall pertain to the Wastewater Treatment Plants.
4. NON-CONFORMING SLUDGE shall mean any County Sludge which fails to conform to FDEP FAC.
5. OKEECHOBEE LANDFILL shall mean the landfill operated by Waste Management on Okeechobee County, 10800 N.E. 128th Ave, Okeechobee, Florida 34972.
6. SEWAGE shall mean any raw wastewater transported from the County operated collection system.
7. PROCESSING or PROCESS shall mean the appropriate dewatering, transportation, and final disposition of County Sludge.
8. SLUDGE shall mean sludge, which substantially conforms to general industry standards for wastewater sludge, non-hazardous.

RESPONSIBILITIES OF THE VENDOR:

1. Contractor shall process County sludge generated at the County -owned facilities. The County will generate approximately two million (2,000,000) gallons per year and the percent of solids are estimated to be 2%. Facilities may be added or deleted during the term of this Contract. Any such additions or deletions shall not affect the per-gallon Contract Price or other services of this Contract. The DeSoto Correctional Facility will generate the majority of digester sludge.

NOTE: Contractor shall assume all responsibility for the proper disposition of all County sludge once accepted by the Contractor.

2. Contractor shall accept all of the County's sludge unless:
 - A. The sludge is not of a type with respect to which Contractor is legally authorized, by regulatory agencies, to process; or
 - B. The sludge is non-conforming sludge.
3. Contractor shall dewater the County sludge and guarantee that the sludge will pass a paint filter test and disposal in a Class I or II solid waste landfill before hauling.

4. Contractor shall haul liquid sludge from DeSoto County Regional Wastewater Treatment Facility to Desoto Correctional Institution Wastewater Treatment Facility if unable at any time to dewater sludge as well as from DeSoto Correctional Institution Wastewater Treatment Facility to DeSoto County Regional Wastewater Treatment Facility.
5. Contractor shall haul liquid sludge to and from either County Wastewater Treatment Facility (DeSoto Correctional Institution or DeSoto County Regional Wastewater Treatment Facilities) in lieu of dewatering, if deemed monetarily advantageous for the County to pursue this alternative.
6. Contractor pricing shall reflect the possibility that the percent of solids could be greater or less than the estimated percent of solids expected.
7. Contractor's dewatering equipment shall be self-contained and self-supporting, including electricity, in operation.
8. Contractor's dewatering equipment shall not exceed 65 decibels at any point of the property line while operational.
9. Contractor shall provide adequate trained personnel to efficiently process the County sludge and perform other services as indicated herein.
10. Contractor shall provide, within 5 days, sufficient replacement dewatering equipment in the event of mechanical failure.
11. Contractor's dewatering equipment shall be portable and capable of dewatering all generated County sludge on a schedule mutually agreeable; however, the County shall have final approval of said schedule.
12. Contractor shall provide the necessary equipment to deliver dewatered sludge to the Okeechobee Landfill and/or the DeSoto County Landfill. Contractor shall coordinate deliveries with the Landfill Manager. All material is currently going to the Okeechobee Landfill, however we are requesting a price to haul to DeSoto County Landfill if the need should arise. Contractor may transport dewatered sludge to the DeSoto County Landfill only at the County's direction. Contractor shall coordinate deliveries with the DeSoto Landfill Manager whose phone number is (863) 993-4826.
13. Contractor shall be responsible for the cleanup of any and all spills, on or off County property and any required notification of and documentation to regulatory agencies. The County shall be immediately notified of any spill with a follow up in writing.
14. Contractor shall maintain all documentation required by regulatory agencies and make such documentation available to the County upon request.

15. Contractor's responsibility for the County's sludge shall cease upon delivery to the landfill(s) or other County authorized locations.
16. Contractor shall have the equipment available to jet out, vacuum clean, and haul sewer collection liquid and debris. The County anticipates this being done annually. This request may include both a "Vactor type snorkel truck" or a "vacuum pumper truck". This is mainly to clean lift station grit and debris.
17. Contractor shall respond to the County's requests for the transport of liquid wastewater or sewage within two (2) hours of an emergency situation and the emergency equipment must be within 60 minutes travel time, non-emergency situations within twenty-four (24) hours. All calls shall be 365 days a year with uninterrupted answering of phones.
18. Contractor shall be responsible for all overage costs in mileage, fuel rate increases and/or dewatering. The awarded Contractor will be responsible for tipping fees and all charges associated with this service. Awarded Contractor must provide copies of Landfill Scale Tickets to the County for payment. The County will only pay tipping fees and no other surcharges or mark-ups will be allowed.
19. Contractor shall be responsible for all manifests.
20. Any modifications to the requirements of this Article must be expressly approved by the County.

RESPONSIBILITIES OF THE COUNTY

1. The County shall provide the Contractor with a minimum of one hundred thousand (100,000) gallons of sludge to dewater per mobilization.
2. The County shall provide all County sludge to the Contractor.
3. The County shall provide adequate space for Contractor's dewatering equipment at the Facilities.
4. The County will provide fifty (50) psi water pressure at each of the Facilities.
5. The County shall provide access to the Facilities eight (8) hours a day, five (5) days a week to carry out the dewatering process. After hour arrangements may be approved with prior notifications.
6. The County is responsible for the testing of sludge analysis performed and analyzed by an accredited independent testing laboratory. Results shall be sent directly to landfill(s), the Contractor, appropriate regulatory agencies and the County.

7. The County will dewater the sludge at the Correctional Facility and load the sludge into a trailer. The DeSoto Correctional Wastewater Treatment Plant should generate approximately one trailer load of sludge every two to three weeks for hauling, depending on flow.

REJECTION OF SLUDGE

1. The Contractor shall have the right to reject any non-conforming sludge, provided that the Contractor notifies the County by telephone and/or in writing of such rejections for non-conformance promptly upon Contractor's discovery thereof, but in no event later than forty-eight (48) hours after the discovery of such non-conforming sludge.
2. Any such Notice of Rejection not given initially in writing shall be promptly confirmed in writing to the County.
3. The County shall within twenty-four (24) hours after receipt of the Notice of Rejection of non-conforming sludge arrange for and pay all costs associated with taking possession of and the transport of such non-conforming sludge for appropriate processing and/or other necessary treatment.

LOCATION FOR DEWATERING AND LOADING SLUDGE

1. DeSoto County Regional Wastewater Treatment Facility
7728 S.E. Highway 31
Arcadia, Florida 34266
2. DeSoto Correctional Institution Wastewater Treatment Facility
13617 S.W. Highway 70
Arcadia, Florida 34266

TERM OF CONTRACT

One year with an option to renew for two additional years one year at a time upon mutual agreement.

CRITERIA FOR AWARD

The award of this Bid may be in total or in part, to the lowest responsive responsible Bidder(s) who possesses adequate equipment with operators, labor, and materials necessary to perform the Work in accordance with the requirements of the Contract.

[REMAINDER OF PAGE LEFT INTENTIONALLY BLANK]

ANNUAL CONTRACT FOR SLUDGE MANAGEMENT SERVICES BID FORM

| ITEMS | RATE | UNIT PRICE | ANNUAL TOTAL |
|--|-----------------------|-----------------------------|---------------------------|
| 1. Provide a Sludge dump trailer at DeSoto Correctional Institution that is a 24-ton trailer, 38' long with 60" sides. | <u>Per Day</u> | <u>\$22.00</u> x 365 | <u>\$8,030.00</u> |
| 2. Tractor with driver to haul 24-ton loaded dump trailer from DCI WWTP to Okeechobee Landfill. | <u>Per Load</u> | <u>\$578.75</u> x 30 | <u>\$17,362.50</u> |
| 3. Contractor will dewater digester sludge at the DeSoto County Water Reclamation Facility, a minimum of 100,000 gallons per each mobilization including hauling to Okeechobee landfill. | <u>Price per gal.</u> | <u>0.048</u> X 260,000 gal. | <u>\$12,480.00</u> |
| ANNUAL TOTAL | | | <u>\$37,872.50</u> |

Write out amount: Thirty Seven Thousand Eight Hundred Seventy Two Dollars and Fifty Cents

OPTIONS

1. Tractor with driver to haul 24-ton loaded dump trailer from DCI WWTP and/or DeSoto County Water Reclamation Facility to DeSoto County Landfill.

| | |
|-----------------|-----------------|
| <u>Per Load</u> | <u>\$405.00</u> |
|-----------------|-----------------|
2. Contractor will dewater digester sludge at the DeSoto County Water Reclamation Facility, a minimum of 100,000 gallons per each mobilization including hauling to DeSoto County landfill.

| | |
|-----------------------|---------------|
| <u>Price per gal.</u> | <u>\$0.04</u> |
|-----------------------|---------------|
3. Hauling of liquid biosolids

| | |
|-----------------------|-----------------|
| <u>Price per gal.</u> | <u>\$0.0375</u> |
|-----------------------|-----------------|
4. Overtime \$ 257.00

Company Name: Synagro South, LLC

Address: 1800 Bering Drive Suite 1000, Houston, TX 77057

Signature: *Anne Lamer*
Anne Lamer- V.P. & President

Email: mwolfe@synagro.com

Date: 5-16-2013

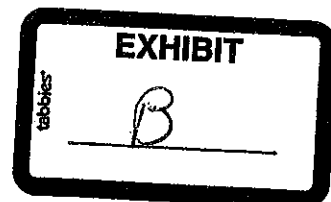

**ANNUAL CONTRACT FOR SLUDGE MANAGEMENT SERVICES
ALTERNATE BID FORM FOR LAKE SUZY**

| ITEMS | RATE | UNIT PRICE | ANNUAL TOTAL |
|---------------------------------|------------------------------|---------------|-----------------|
| OPTIONS | | | |
| 1. Hauling of liquid bio-solids | <u>Price per gal. No Bid</u> | x 20,000 gal. | <u>No Bid</u> |

Company Name: Synagro South, LLC

Address: 1800 Bering Drive Suite 1000

Signature: 
Anne Lamar- V.P. & Treasurer

Email: mwolfe@synagro .com

Date: 5-16-2013

NO BID X

BOARD OF COUNTY COMMISSIONERS
DESOTO COUNTY, FLORIDA
DATE: June 11, 2013

| | |
|--------------------------------|---|
| <u> </u> Consent Agenda | <u> </u> Quasi-Judicial Public Hearing |
| <u> X </u> Regular Business | <u> 9:00 </u> Time |
| <u> </u> Public Hearing | |

DEPARTMENT: Facilities
SUBMITTED BY: Richard Metzger
PRESENTED BY: Richard Metzger

TITLE & DESCRIPTION: Approval Facilities Position changes

REQUESTED MOTION: To approve two position changes and allow posting of one vacated position.

SUMMARY:

- Reclassification of Repair Tech to Warehouse Controller.
- Downgrading vacated position from Supervisor I to Maintenance Specialist and allowing posting of position.

BACKGROUND:





- The Facilities Dept. has become Central Stores for the Counties main supply needs for custodial and maintenance items. The job of inventory and issuance as well as delivery has now consumed more than 70% of the Repair Tech position and is out of classification/description.
- Due to a resignation the Supervisor I position is vacate. It has been determined that two supervisors are not needed and would like to reclass. the position prior to posting.

FUNDS:

| | |
|--------------------|--------------------------------|
| Budget Amount | |
| Actual Agenda Item | |
| Cost: | Savings of \$4,969.00 per year |
| Account Number: | 26085191200000 Reg. Salaries |
| Explanation: | N/A |

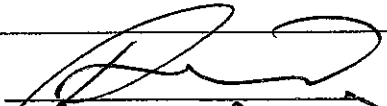
ATTACHMENTS: 1.

REVIEW APPROVAL:

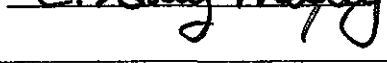
| | |
|-----------------------|--|
| Department Director |  |
| Finance Director |  |
| Purchasing Department |  |
| County Attorney |  |
| County Administrator |  |

DESOTO COUNTY

JOB DESCRIPTION

JOB TITLE: FACILITIES WAREHOUSE CONTROLLER/MAINTENANCE

DEPARTMENT: FACILITIES

PAY RANGE: 17

GENERAL DESCRIPTION:

Receive, store, and issue supplies, and other items from warehouse. Keep records and compile stock reports. Perform maintenance duties as time allows. Works under the general supervision and direction of the Maintenance Supervisor or Department Director.

ESSENTIAL JOB FUNCTIONS:

1. Clean and maintain supplies, tools, equipment and storage areas in order to ensure compliance with safety regulations.
2. Compile, review, and maintain data from contracts, purchase orders, requisitions, and other documents in order to assess supply needs.
3. Determine proper storage methods, identification, and stock location based on turnover, environmental factors, and physical capabilities of facilities.
4. Examine and inspect stock items for wear or defects, reporting any damage to supervisors.
5. Keep records on the use and/or damage of stock or stock handling equipment.
6. Pack and unpack items to be stocked on shelves in warehouse.
7. Prepare and maintain records and reports of inventories, price lists, shortages, shipments, expenditures, and goods used and issued.
8. Issue and distribute supplies to coworkers, based on information from incoming requisitions.
9. Receive and count stock items, and record data using inventory software on the computer.
10. Store items in an orderly and accessible manner in warehouses, tool rooms, supply rooms, or other areas.
11. Verify inventory computations by comparing them to physical counts of stock, and investigate discrepancies or adjust errors.
12. Dispose of damaged or defective items, or return them to vendors.
13. Rejects defective deliveries or materials not ordered.
14. Drive truck in order to deliver supplies to designated locations.
15. Purchase new or additional stock, or prepare documents that provide for such purchases.

FACILITIES WAREHOUSE CONTROLLER
PAGE 2

16. Recommend disposal of excess, defective, or obsolete stock.
17. Performs Maintenance tasks as assigned
18. Performs all other duties as assigned

MINIMUM QUALIFICATIONS:

KNOWLEDGE, SKILLS AND ABILITIES:

- Knowledge of administrative and clerical procedures and systems such as word processing, managing files and records, designing forms, and other office procedures and terminology.
- Ability to use mathematic to solve problems
- Ability to arrange things or actions in a certain order or pattern according to a specific rule or set of rules (e.g., patterns of numbers, letters, words, pictures, mathematical operations).
- Ability to remember information such as words, numbers, pictures, and procedures.
- Ability to quickly and accurately compare similarities and differences among sets of letters, numbers, objects, pictures, or patterns. The things to be compared may be presented at the same time or one after the other. This ability also includes comparing a presented object with a remembered object.
- Ability to interpret manuals and catalogues related to the position.
- Ability to read and understand information and ideas presented in writing.
- Ability to use good judgment and work independently under limited supervision.
- Ability to accept personal responsibility for one's decisions
- Ability to remain clam in stressful situations.
- Ability to establish and maintain effective working relationships with subordinates, supervisors and the general public.
- Ability to understand and follow oral and written instructions.
- Ability to perform physical activities that require considerable use of your arms and legs and moving your whole body, such as climbing, lifting, balancing, walking, stooping, and handling of materials.
- Ability to lift and carry more than 45 pounds for extended periods of time.

DESOTO COUNTY

JOB DESCRIPTION

JOB TITLE: FACILITIES MAINTENANCE SPECIALIST

DEPARTMENT: FACILITIES MAINTENANCE

PAY RANGE: 13

GENERAL DESCRIPTION:

Performs highly skilled specialized work involving mechanical, electrical, plumbing, irrigation, construction and repair, maintenance and landscaping within the County. Buildings, Facilities and Grounds. Employee will be required to perform inspections based on established Facilities Standards, An employee in this class is required to supervise and provide technical assistance using independent judgments in the performance of assigned tasks. Must be able to follow written as well verbal work assignments which are reviewed through observation of results obtained, conferences and periodic reports or evaluations. Work is performed under general direction of the Facilities Director or Maintenance Supervisor II.

ESSENTIAL JOB FUNCTIONS

1. Performs work in the following: construction, renovation, modification, installation and repair of buildings, irrigation and grounds. Inspects work sites to insure work is performed in accordance with public and employee safety guidelines, established criteria of the Facilities Standards, and with adequate regard for proper vehicles, tools and equipment.
2. Use and be familiar with computers applications in construction and cost tracking of materials and labor hour expenditures.
3. Prepares work estimates, schedules time, estimates and procures required materials and services.
4. Read and interpret blueprints and schematics diagrams, design and draw sketches of purposed projects.
5. Establish schedules, tracks project inventories and adjusts priorities on projects using meeting and information from users, staff, and supervisor.
6. Consults with users at the beginning of a project or task to establish the final layout of projects and establish the best method of achieving satisfactory project results.
7. Coordinate and oversee landscaping and grounds keeping maintenance performed by contractor.
8. Performs work in repairing irrigation systems. Repairs and replaces old lines and replaces broken fixtures.
9. Performs painting of buildings, facilities and equipment.
10. Performs related work as required.

These essential of job functions are not to be construed as a complete statement of duties performed. Employees will be required to perform other job-related marginal duties as required.

**FACILITIES MAINTENANCE SPECIALIST
PAGE TWO**

MINIMUM QUALIFICATIONS:

KNOWLEDGE, SKILLS AND ABILITIES:

- Knowledge of materials, methods, codes and techniques commonly used in construction, plumbing, electrical, mechanical, carpentry, and related maintenance and repair work.
- Knowledge of math to prepare cost estimates along with simple budgets, other financial plans and for calibration techniques.
- Knowledge of landscaping and plant care methods and techniques.
- Knowledge of irrigation systems and related components.
- Skilled in using a variety of standard hand tools, machines, and equipment used in building, electrical, plumbing trades, and facility repair work.
- Ability to operate equipment such as mowers, tractors, light and heavy trucks with trailer units.
- Ability to recognize safety hazards in the work involved and takes precautionary methods to protect self and others.
- Ability to make proper field decisions and adjustments to preplanned work in order to complete projects within time and cost constraints.
- Knowledge of cleaning materials, methods, and equipment.
- Knowledge of operation, maintenance, and repair of small power equipment and skill in use and care of hand tools and other related materials and equipment.
- Ability to understand and follow oral and written instructions.
- Ability to read and interpret blueprints, rough sketches and equipment diagrams, draw sketches of proposed projects, plan assignments and order materials.
- Ability to operate a personal computer and other automated systems to monitor, work, enter and retrieve information.
- Ability to perform tasks requiring physical strength and endurance occasionally under adverse weather conditions.
- Ability to establish and maintain effective working relationships with fellow employees and deal tactfully and diplomatically with the general public.

FACILITIES MAINTENANCE SPECIALIST

PAGE THREE

EDUCATION AND EXPERIENCE:

High school diploma or an acceptable equivalency diploma Supplemental formal training and/or coursework in a building construction and/or grounds maintenance trade desired. Three (3) years of experience in building construction and/or grounds maintenance with a demonstrated level of proficiency, at least two (2) years direct work experience in building and/or grounds maintenance required. A comparable amount of training or experience may be substituted for the maximum qualifications.

LICENSES, CERTIFICATIONS OR REGISTRATIONS:

- Must possess a Florida Driver's License

ESSENTIAL PHYSICAL SKILLS:

- Acceptable eyesight (with or without corrections)
- Must be able to distinguish colors
- Acceptable hearing (with or without aid)
- Ability to communicate orally and in writing
- Heavy (45 Pounds and over) lifting and carrying
- Reaching, pulling, pushing, throwing, and balancing.
- Climbing, walking, standing, kneeling, bending, stooping.
- Sufficient physical stamina to perform a variety of tasks in the care and maintenance of building and equipment.
- Driving and operating equipment with controls.

ENVIRONMENTAL CONDITIONS:

- Works inside and outside with chemicals, solvents, and oils.
- Work in and around moving vehicles or equipment.
- Works outside in various weather conditions with noise, dust, fumes, and dirt.
- Uneven surfaces.

(Reasonable accommodation will be made for otherwise qualified individuals with disability.)

APPROVED:

| NAME | TITLE | DATE |
|------|-------|------|
|------|-------|------|

BOARD OF COUNTY COMMISSIONERS
DESOTO COUNTY, FLORIDA
DATE: June 11, 2013

| | |
|--|---|
| <input type="checkbox"/> Consent Agenda <input checked="" type="checkbox"/> Regular Business <input type="checkbox"/> Public Hearing | <input type="checkbox"/> Quasi-Judicial Public Hearing <input type="checkbox"/> Time |
|--|---|

| | | |
|---------------------------------|--|-------|
| DEPARTMENT: | N/A | |
| SUBMITTED BY: | Vince Sica, CEO, DMH | |
| PRESENTED BY: | Vince Sica | |
| TITLE & DESCRIPTION: | Discussion/DeSoto Memorial Hospital Indigent Care | |
| REQUESTED MOTION: | No motion requested today | |
| SUMMARY: | DeSoto Memorial Hospital provides charity care and other unpaid services in excess of \$3.6 million per year to the citizens of DeSoto County. Given the present state of healthcare, the political landscape and the economic climate, it has fallen upon the local government to create a means of providing financial assistance to the Hospital. | |
| BACKGROUND: | The Hospital cannot continue to provide charity care services to DeSoto County residents without the receipt of non-operational funds from the local government. The cost of caring for residents, who are in need of essential healthcare services (both emergent and non-emergent) and have no visible means to pay, exceeds \$3.6 million annually. | |
| FUNDS: | Budget Amount | N/A |
| | Actual Agenda Item | N/A |
| | Cost: | |
| | Account Number: | N/A |
| | Explanation: | N/A |
| ATTACHMENTS: | 1. Fair Market Evaluation | |
| REVIEW APPROVAL: | Department Director | _____ |
| | Finance Director | _____ |
| | Purchasing Department | _____ |
| | County Attorney | _____ |
| | County Administrator | _____ |

**RESPECTFULLY SUBMITTED TO THE BOARD OF COUNTY COMMISSIONERS,
DESOTO COUNTY, ARCADIA, FLORIDA
JUNE 11, 2013**

REQUEST:

THE BOARD OF COUNTY COMMISSIONERS APPROVE THE CREATION OF A COUNTY ORDINANCE WHICH WOULD CREATE A MSTU (MUNICIPAL SERVICE TAXING UNIT) FOR THE PROVISION OF HEALTHCARE SERVICES IN OUR COMMUNITY.

WHY:

BECAUSE THE FEDERAL GOVERNMENT AND OUR STATE GOVERNMENT HAVE **FAILED** TO ADDRESS THE NEEDS OF OUR COMMUNITY.

- Patient Protection and Affordable Care Act (PPACA)
- State Legislature's decision **not** to accept \$52 Billion Dollars from the Federal Government to expand Medicaid

FACTS:

- A. THE COST INCURRED BY THE HOSPITAL TO PROVIDE CHARITY CARE AND OTHER UNPAID SERVICES TO THE CITIZENS OF ARCADIA AND DESOTO COUNTY EXCEEDS \$3.6 MILLION DOLLARS PER YEAR.
(The Hospital receives approximately 30 cents for every dollar billed.)
- B. THE HOSPITAL IS AN ECONOMIC ENGINE:
- EMPLOYS APPROXIMATELY 250 PEOPLE
 - GENERATES APPROXIMATELY \$20 MILLION IN SALARIES PER YEAR
 - RIGHT NOW ARCADIA IS A VIABLE DESTINATION FOR WINTER VISITORS AND INDUSTRY BECAUSE HOSPITAL SERVICES ARE AVAILABLE LOCALLY
(Winter residents consider a local hospital at the top of the "must have" list)
(10,000 winter residents X \$300/wk x 20 weeks = \$60,000,000/Yr)
(5,000 winter residents X \$300/wk x 20 weeks = \$30,000,000/Yr)
- C. 34 SPECIAL HOSPITAL DISTRICTS IN FLORIDA
- 17 have taxing authority and have levied some form of taxes
- | | | |
|-------------------------------------|-------------|--------------|
| Hendry County Hospital District | (2.9 Mils) | \$ 6,315,734 |
| North Lake County Hospital District | (1.0 Mils) | \$ 9,963,399 |
| West Volusia Hospital Authority | (2.08 Mils) | \$15,951,095 |
| Southeast Volusia Hospital District | (3.25 Mils) | \$16,650,096 |

SOLUTION:

THE BOARD OF COUNTY COMMISSIONERS MUST APPROVE A COUNTY ORDINANCE WHICH WOULD CREATE A MSTU (MUNICIPAL SERVICE TAXING UNIT) FOR THE PROVISION OF HEALTHCARE SERVICES IN OUR COMMUNITY.

THE ACTUAL DOLLARS SPENT BY DMH TO DESOTO COUNTY RESIDENTS OVER THE LAST 12 MONTHS

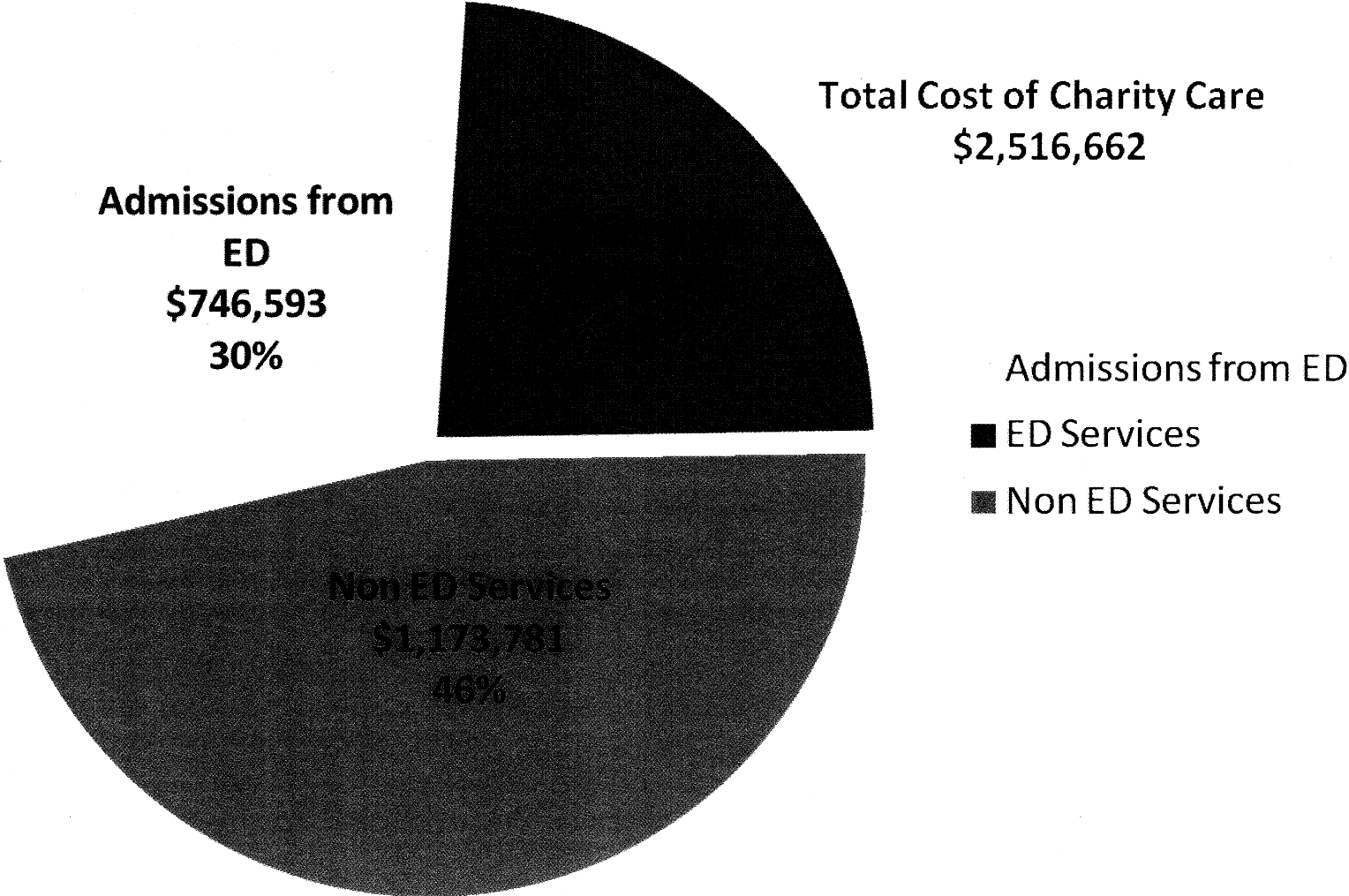

THE ACTUAL DOLLARS SPENT BY DMH TO PROVIDE CHARITY CARE & OTHER UNPAID SERVICES OVER THE LAST 12 MONTHS

\$3,699,999

Total Cost of Other Unpaid Services
\$1,183,337
32%

Total Cost of Charity Care
\$2,516,662
68%

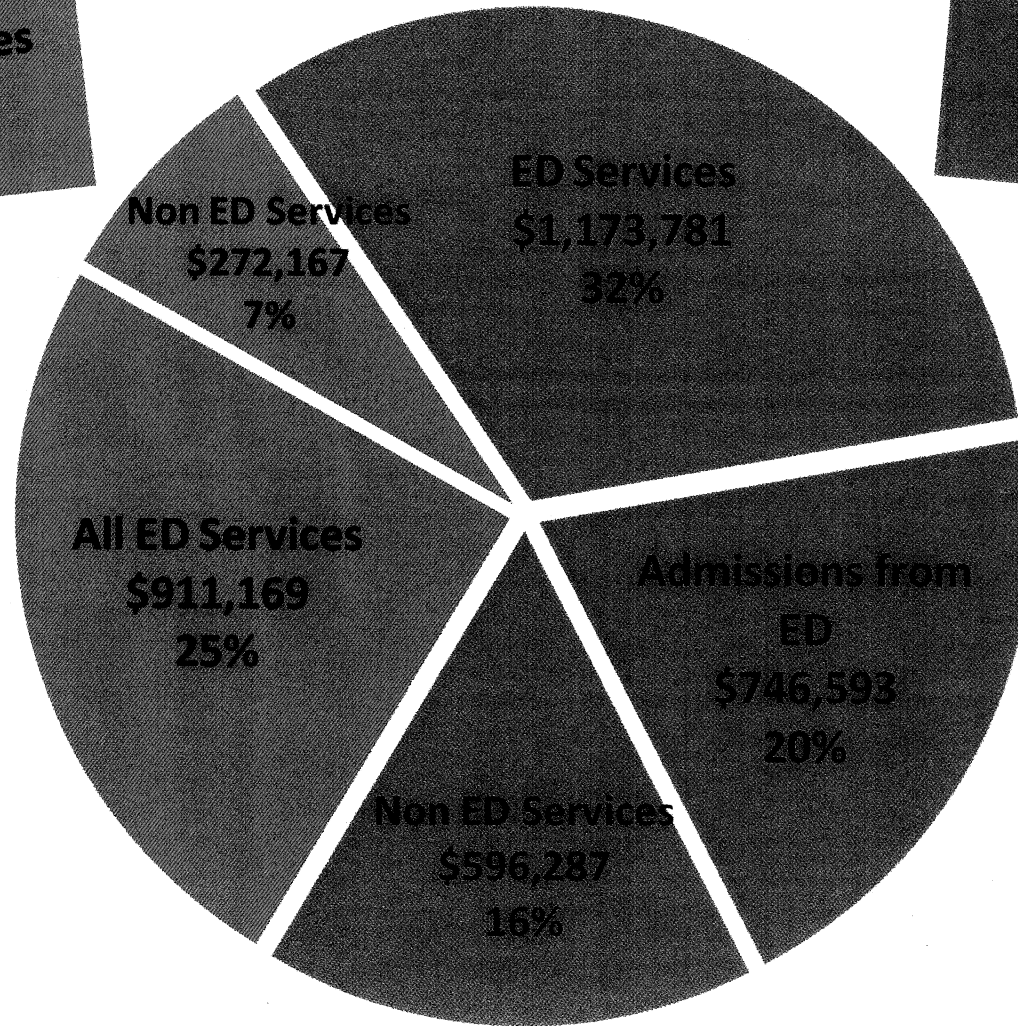

- ED Services
- Admissions from ED
- Non ED Services
- All ED Services
- Non ED Services

DESOTO COUNTY, FLORIDA

ORDINANCE NO. 2013-__

AN ORDINANCE CREATING THE DESOTO COUNTY HEALTH CARE AND HOSPITAL MUNICIPAL SERVICE TAXING UNIT; DESCRIBING THE BOUNDARIES OF THE UNIT; AUTHORIZING SUCH TAXING UNIT TO ANNUALLY LEVY AD VALOREM TAXES WITHIN SUCH UNIT TO PROVIDE HOSPITAL AND HEALTH CARE SERVICES; AND PROVIDING AN EFFECTIVE DATE.

BE IT ORDAINED BY THE BOARD OF COUNTY COMMISSIONERS OF DESOTO COUNTY, FLORIDA:

SECTION 1. FINDINGS. It is hereby ascertained, determined and declared that:

- (A) Pursuant to Article VIII, section 1 of the Florida Constitution, and sections 125.01 and 125.06, Florida Statutes, the Board of County Commissioners (the "Board") of DeSoto County, Florida has local home rule authority and all powers of local self-government authorized pursuant to the Florida Constitution and laws of Florida to perform county and municipal functions and to render municipal services in a manner not inconsistent with general law and such power may be exercised by the enactment of county ordinances and resolutions.
- (B) Pursuant to Article VII, section 9 of the Florida Constitution, the Board has been granted 10 mills of ad valorem taxing authority. Further, Article VII, section 9 grants to all counties the authority to furnish municipal services, and levy additional taxes within the limits fixed for municipal services.
- (C) Section 125.01(1)(q), Florida Statutes provides specific legislative authorization for counties to establish municipal service taxing units for any part or all of the unincorporated areas within its boundaries, or within the municipal boundaries of an incorporated area upon consent of the governing body of such municipality, within which may be provided essential municipal services and facilities.

- (D) The purpose of this ordinance is to create the DeSoto County Health Care and Hospital Municipal Services Taxing Unit (the "Health Care and Hospital MSTU") to fund services and facilities described in Section 4 below.

Section 2. CREATION. The DeSoto County Health Care and Hospital MSTU is hereby created pursuant to section 125.01(1)(q), Florida Statutes. The boundaries of the Health Care and Hospital MSTU shall be coterminous with the unincorporated area of DeSoto County Florida, as described by Exhibit "A" which is attached and incorporated herein.

Section 3. AUTHORIZATION FOR AD VALOREM TAXES. The Board is hereby authorized to levy annual ad valorem taxes for municipal services and facilities upon taxable real and personal property within the Health Care and Hospital MSTU, beginning with the county budget for the fiscal year beginning October 1, 2013. The budget and millage rate for the Health Care and Hospital MSTU shall be approved and levied in the manner provided by general law for the levy of County ad valorem taxes.

Section 5. AUTHORIZATION OF EXPENDITURES. Revenues derived from ad valorem taxes levied within the Health Care and Hospital MSTU shall be used exclusively for the maintenance and operational expenses of the DeSoto Memorial Hospital and for the provision of all health care and hospital services provided by the Hospital.

Section 5. EFFECTIVE DATE. The Clerk shall file a certified copy of the Ordinance with the Department of State within ten days of its adoption. This Ordinance shall take effect immediately upon its filing with the Department of State.

DULY ENACTED this ____ day of _____, 2013.

BOARD OF COUNTY COMMISSIONERS
OF DESOTE COUNTY, FLORIDA

By: _____,
_____, Chairman

ATTEST:

By: _____,
_____, County Administrator

Approved as to form and legal sufficiency:
