

# Thioredoxin and Glutaredoxin Systems under Oxidative and Nitrosative Stress



Thioredoxin and Glutaredoxin Systems under Oxidative and Nitrosative Stress

Xiaoyuan Ren

Xiaoyuan Ren

From the Department of Medical Biochemistry and Biophysics  
Karolinska Institutet, Stockholm, Sweden

# **THIOREDOXIN AND GLUTAREDOXIN SYSTEMS UNDER OXIDATIVE AND NITROSATIVE STRESS**

Xiaoyuan Ren

任晓远



**Karolinska  
Institutet**

Stockholm 2017

**Front Cover Image:** Traditional Chinese painting of “gods of doors” which is used to protect against evils and ghosts. They are like thioredoxin and glutaredoxin systems for cells. A pair of swords they used was modified into cysteines pairs, which are present at the active site of Trx and Grx. The Chinese characters in the middle “驅邪” means “keeping the evils away”. Originally designed by 禾田设计, modified by Xiaoyuan Ren. License for non-commercial use.

All previously published papers were reproduced with permission from the publisher.

Published by Karolinska Institutet.

Printed by E-print AB, 2017

© Xiaoyuan Ren, 2017

ISBN 978-91-7676-615-6

# THIOREDOXIN AND GLUTAREDOXIN SYSTEMS UNDER OXIDATIVE AND NITROSATIVE STRESS

THESIS FOR DOCTORAL DEGREE (Ph.D.)

AKADEMISK AVHANDLING

som för avläggande av medicine doktorsexamen vid Karolinska Institutet  
offentligen försvaras i Samuelssonsalen, Scheelelaboratoriet,  
Tomtebodav ägen 6, Karolinska Institutet, Solna  
Fredagen den 7 april, 2017, kl 9:00

av

**Xiaoyuan Ren**

*Principal Supervisor:*

Professor Arne Holmgren  
Karolinska Institutet  
Department of Medical Biochemistry and  
Biophysics  
Division of Biochemistry

*Co-supervisor(s):*

Professor Jun Lu  
Southwest University  
School of Pharmaceutical Sciences

Dr. Rajib Sengupta  
Adamas University  
Department of Biochemistry

Professor Elias Arnér  
Karolinska Institutet  
Department of Medical Biochemistry and  
Biophysics  
Division of Biochemistry

*Opponent:*

Dr. Anders Hofer  
Umeå University  
Department of Medical Biochemistry and  
Biophysics

*Examination Board:*

Professor Sven Ove Ögren  
Karolinska Institutet  
Department of Neuroscience

Professor Ylva Engström  
Stockholm University  
Department of Molecular Biosciences, The  
Wenner-Gren Institute

Professor Eddie Weitzberg  
Karolinska Institutet  
Department of Physiology and Pharmacology



TO MY FAMILY  
AND  
IN MEMORY OF MY FATHER  
致我的家人，并谨此纪念我的父亲

A tidy laboratory means a lazy chemist.

- *Jöns Jacob Berzelius*

(1779 - 1848)

Good results? Bad results? Nature is always right.

- *Arne Holmgren*

(1940- )

## ABSTRACT

Our knowledge about reactive oxygen species (ROS) and reactive nitrogen species (RNS) has been changed from simple damaging molecules to redox signaling mediators. ROS/RNS mediated signaling is mainly based on the reversible post-translational modifications of cysteine which works as a switch for protein functions. A proper amount of ROS/RNS is necessary to trigger such signaling, while excessive amount will lead to oxidative and nitrosative stress, which was recently defined as the disruption of redox signaling and control. In order to maintain the redox homeostasis, mammalian cells are equipped with two major antioxidant systems: the thioredoxin (Trx) system, which is composed of Trx, thioredoxin reductase (TrxR) and NADPH, and the glutaredoxin (Grx) system, which is grouped by Grx, glutathione (GSH), glutathione reductase (GR) and NADPH. Both systems play important roles in counteracting ROS/RNS and regulating redox signaling.

In **Paper I**, we investigated the toxicity of several arsenic compounds on mammalian cells. We found that arsenical-induced cytotoxicity was related to inhibition of TrxR, suggesting an important role of TrxR for cell survival and potential usage as an anti-cancer target. Among the compounds, As6 and As7 exhibited higher cytotoxicity by directly oxidizing Trx1 and leading to the formation of a structural disulfide between Cys63 and Cys69. The formation of Cys63-Cys69 disulfide blocked the electron transfer from TrxR to peroxiredoxin (Prx) via Trx1, which allowed H<sub>2</sub>O<sub>2</sub> to accumulate and activate the Nrf2 antioxidant pathway. This study highlighted the importance of the structural cysteines in human Trx1 and provided a potential rational design of new anticancer agents.

In **Paper II**, we studied the effect of Apatone, a vitamin C and vitamin K3 combination used for cancer treatment, on antioxidant systems. We found that Apatone induced oxidative stress in various cancer cell lines which is characterized by GSH depletion, protein glutathionylation, and Trx1 oxidation. In addition, it inhibited ribonucleotide reductase (RNR), which is essential for DNA replication and repair, and caused replicative stress. A caspase-independent cell death pathway was also elucidated that Apatone elevated lipid peroxidation which triggered the nuclear translocation of apoptosis-inducing factor (AIF). We conclude that Apatone works by dramatically disturbing the redox balance in cancer cells.

In **Paper III**, the role of nitric oxide (NO) during trypanosome infection was studied by using a *Trypanosoma Brucei* infected inducible nitric oxide synthase knocked (*inos*<sup>-/-</sup>) mice model. NO exhibited a protective role by maintaining the integrity of blood-brain-barrier (BBB). We found that macrophage-derived NO curbed the inflammatory effect of TNF- $\alpha$  by S-nitrosylating the p65 subunit of NF- $\kappa$ B, a transcription factor staying in the center of inflammation. Matrix metalloproteinase 9 (MMP9), one of the targets of NF- $\kappa$ B degrading BBB, was also decreased by NO. Thus we conclude that NO plays a protective role during parasite infection by serving as a negative feedback for neuronal inflammatory signaling.

In **Paper IV**, we characterized Grxs as S-denitrosylases catalyzing the reversible S-nitrosylation. We observed that reduced human dithiol Grx1 and Grx2a denitrosylated S-nitrosothiols (SNOs) directly by the active site dithiol. GSH can denitrosylate part of protein SNOs, while some of them are stable in the presence of high concentration of GSH. Both dithiol and monothiol Grxs exhibited denitrosylation ability to GSH-stable SNOs. We proposed Grxs catalyze S-denitrosylation via both dithiol and monothiol mechanisms.

To summarize, this thesis consolidated the importance of Trx and Grx systems in fighting against ROS/RNS and mediating redox signaling in mammalian cells.



## LIST OF SCIENTIFIC PAPERS

- I. Xu Zhang, Jun Lu, **Xiaoyuan Ren**, Yatao Du, Yujuan Zheng, Panayiotis Ioannou, Arne Holmgren.  
Oxidation of structural cysteine residues in thioredoxin 1 by aromatic arsenicals enhances cancer cell cytotoxicity caused by the inhibition of thioredoxin reductase 1  
*Free Radical Biology and Medicine* 89 (2015) 192–200
- II. **Xiaoyuan Ren**, Sebastin Santhosh, Lucia Coppo, Fernando Ogata, Jun Lu and Arne Holmgren.  
Vitamin C and K3 cause cancer cell death by oxidative stress and effects on ribonucleotide reductase and its electron donors  
*Submitted manuscript*
- III. Gabriela C. Olivera, **Xiaoyuan Ren**, Suman K. Vodnala, Jun Lu, Lucia Coppo, Chaniya Leepiyasakulchai, Arne Holmgren, Krister Kristensson, Martin E. Rottenberg.  
Nitric Oxide Protects against Infection-Induced Neuroinflammation by Preserving the Stability of the Blood-Brain Barrier.  
*PLoS Pathog.* 2016 Feb; 12(2): e1005442.
- IV. **Xiaoyuan Ren**, Rajib Sengupta, Jun Lu, Jon O. Lundberg, Arne Holmgren.  
Characterization of mammalian glutaredoxin isoforms as S-denitrosylases.  
*Submitted manuscript*

Papers not included in this thesis:

- V. **Xiaoyuan Ren**\*, Lili Zou\*, Xu Zhang, Vasco Branco, Jun Wang, Cristina Carvalho, Arne Holmgren, and Jun Lu  
Redox Signaling Mediated by Thioredoxin and Glutathione Systems in the Central Nervous System  
*Submitted manuscript*
- VI. Lili Zou, Jun Lu, Jun Wang, **Xiaoyuan Ren**, Lanlan Zhang, Yu Gao, Martin E. Rottenberg, Arne Holmgren.  
A synergistic antibacterial effect of silver and ebselen against multidrug-resistant Gram-negative bacterial infections  
*Submitted manuscript*

\* Equal contribution

# CONTENTS

1	Introduction .....	1
1.1	The Appearance of Oxygen on Earth .....	1
1.2	Reactive Oxygen Species (ROS) .....	2
1.2.1	Production of ROS .....	3
1.3	Reactive Nitrogen Species (RNS).....	5
1.3.1	Production of NO .....	5
1.3.2	Peroxynitrite (ONOO <sup>-</sup> ).....	6
1.4	Physiological Role of ROS and RNS .....	7
1.4.1	The killing effect of ROS and RNS .....	8
1.4.2	The Signaling Effect of ROS and RNS .....	8
1.5	Oxidative and Nitrosative Stress.....	11
1.5.1	Cellular Damage.....	12
1.5.2	Signaling Dysfunction.....	12
1.6	Antioxidant Systems.....	13
1.6.1	Small Antioxidant Molecules .....	13
1.6.2	Antioxidant Enzymes .....	14
1.7	Thioredoxin system .....	15
1.7.1	Thioredoxin .....	15
1.7.2	Thioredoxin Reductase .....	16
1.7.3	Trx Targeted Proteins.....	17
1.7.4	Trx Binding Proteins .....	19
1.7.5	Trx System-mediated Redox Signaling.....	20
1.7.6	Trx System-mediated Reversible Thiol Modification .....	21
1.8	Glutaredoxin System .....	24
1.8.1	Glutaredoxin (Grx).....	25
1.8.2	Glutathione Reductase (GR).....	26
1.8.3	Glutathione Peroxidases (GPxs).....	26
1.8.4	Grx System-mediated Redox Signaling .....	27
1.9	Targeting Antioxidant System for Cancer Therapy .....	28
2	Present Investigation .....	31
2.1	Aim of This Thesis .....	31
2.2	Methodology.....	32
3	Summary and Discussion.....	36
3.1	Paper I .....	36
3.2	Paper II.....	39
3.3	Paper III .....	41
3.4	Paper IV .....	44
4	Conclusion and Future Perspectives .....	47
5	Acknowledgements .....	50
6	References .....	53

## LIST OF ABBREVIATIONS

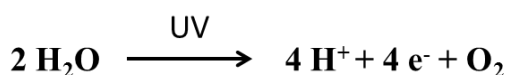
AIF	Apoptosis inducing factor
AP-1	Activator protein – 1
ARE	Antioxidant response elements
ASK1	Apoptosis-regulating kinase 1
BBB	Blood-brain-barrier
CAT	Catalase
BMM	Bone marrow-derived macrophages
EDRF	Endothelium-derived relaxing factor
ER	Endoplasmic reticulum
ETC	Electron transport chain
FAD	Flavin adenine dinucleotide
GCL	Glutamate cysteine ligase
GPx	Glutathione peroxidase
GR	Glutathione reductase
Grx	Glutaredoxin
HIF-1	Hypoxia-inducible factor 1
HO-1	Heme oxygenase 1
Keap1	Kelch-like ECH-associated protein 1
MMP	Matrix metalloprotease
Msr	Methionine sulfoxide reductase
NF- $\kappa$ B	Nuclear factor kappa-light-chain-enhancer of activated B-cells
NOS	Nitric oxide synthase
NOX	NADPH oxidase
Nrf2	Nuclear factor E2-related factor 2
PDI	Protein disulfide isomerase
PICOT	Protein kinase C interacting cousin of thioredoxin
Prx	Peroxiredoxin
PTEN	Phosphatase and tensin homolog
PTP	Protein tyrosine kinase
Ref-1	Redox factor -1
RNR	Ribonucleotide reductase
RNS	Reactive nitrogen species
ROS	Reactive oxygen species
SecTRAPs	<u>S</u> elenium <u>c</u> ompromised <u>t</u> hioredoxin <u>r</u> eductase-derived <u>a</u> poptotic <u>p</u> roteins
SOD	Superoxide dismutase
TRP14	Thioredoxin-related protein of 14-kDa
Trx	Thioredoxin
TrxR	Thioredoxin reductase
TXNIP	Thioredoxin interacting protein
XIAP	X-linked inhibitor of apoptosis protein

# 1 INTRODUCTION

## 1.1 THE APPEARANCE OF OXYGEN ON EARTH

We cannot survive without oxygen (O<sub>2</sub>), which constitutes 21% of the atmosphere we are living in now. However, when the first life-like structure appeared about 3.5 billion years ago [1], the atmosphere surrounding Earth was quite different. The components of atmosphere then were mainly reducing gases, such as hydrogen (H<sub>2</sub>), nitrogen (N<sub>2</sub>), water vapor (H<sub>2</sub>O), ammonia (NH<sub>3</sub>), methane (CH<sub>4</sub>) and H<sub>2</sub>S. Although the abundance of element oxygen was huge, it mainly existed as oxide, such as carbon oxide (CO), carbon dioxide (CO<sub>2</sub>), hydrogen oxide (water, H<sub>2</sub>O), as the reducing environment rapidly reduced the small amount of oxygen produced by ultraviolet photolysis of water vapor [2]. So we can easily speculate that O<sub>2</sub> was dispensable for the first-ever life on our planet.

Evidence showed that it was until 2.5 billion years ago that oxygen level in the atmosphere started rising [3]. During the 1 billion years oxygen-free gap, anaerobic metabolism was the only way of gaining energy for all living organisms to survive, and evolve. The turning point was marked around 2.7 billion years ago by the evolution of oceanic cyanobacteria, which utilizes H<sub>2</sub>O as the electron donor to fix CO<sub>2</sub> for energy production and releases O<sub>2</sub> as a by-product, as the very simplified scheme follows:



At the beginning, the ocean which was fulfilled with metals (mainly iron) in their reduced form trapped most of the oxygen. It took another several hundred millions of years to saturate the metals and finally, the concentration of O<sub>2</sub> in the atmosphere started rising rapidly. The fast increase of O<sub>2</sub> in the atmosphere was termed the Great Oxidation Event (GOE) which happened about 2.3 billion years ago and dramatically changed the ecology [4].

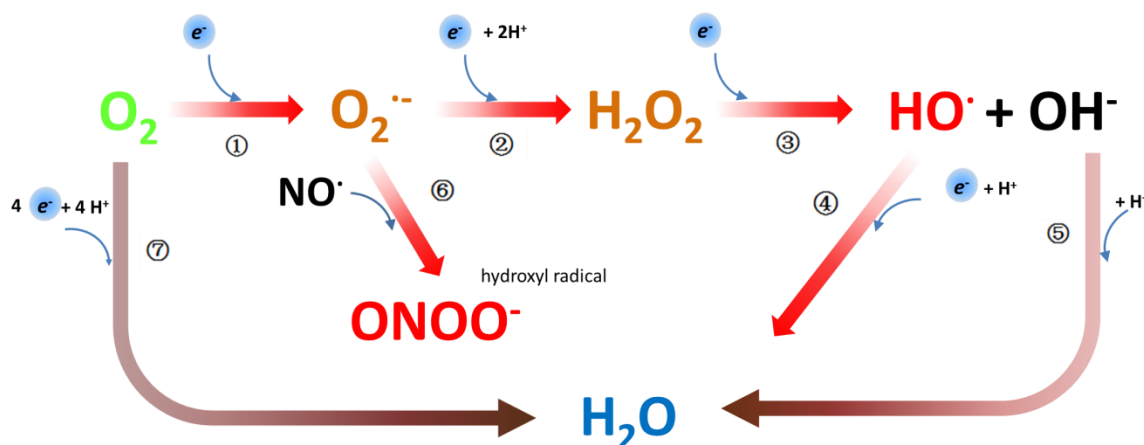
As the Nobel laureate Albert Szent-Györgyi (1893 –1986) said, “Life is nothing but an electron looking for a place to rest”. Indeed, we can divide all living organisms on earth simply by how they manage electron flow: the photosynthetic organisms which use the solar light to pump electrons to a higher energy position; and the rest including us which live on the energy released by electrons jumping from higher energy level to lower energy level [5]. The electron flow is the driven force of evolution.

In general, electrons flow to and rest in the molecule that wants them most. Each molecule of O<sub>2</sub> needs four additional electrons to couple all the unpaired electrons on its spin orbitals. The

chemical structure of  $O_2$  makes it eager for electrons. Other reasons may also explain why  $O_2$  is favored as a biological electron acceptor. First of all, aerobic respiration is a (19 fold!) more efficient way to extract energy than anaerobic metabolism; secondly,  $O_2$  can pass through biological membranes; lastly, the final products of aerobic respiration are  $H_2O$  and  $CO_2$ , which can be recycled by photosynthetic organisms. Being aerobic seems like a perfect style to live with, and indeed evolution has shown us the right choice, only if we do not have to pay the price -- reactive oxygen species [6].

## 1.2 REACTIVE OXYGEN SPECIES (ROS)

From the anaerobic point of view,  $O_2$  is a toxic pollutant and the oxidative crisis expelled anaerobes to the places where oxygen level keeps low, such as deep ocean and lakes. It was until 1954 that Rebeca Gerschman and colleagues first time proposed that oxygen toxicity was related to free radicals and reactive oxygen species (ROS) formation [7]. Free radicals are molecules with one or more unpaired electrons and ROS are those radicals and reactive molecules derived from oxygen. During the successive reduction of  $O_2$  to  $H_2O$ , different ROS are produced stepwise (**Fig. 1**).  $O_2$  receiving one electron results in superoxide anion radical ( $O_2^{\cdot -}$ ) (**Fig. 1, Step 1**), which sequentially takes another electron and two concomitant protons to generate hydrogen peroxide ( $H_2O_2$ ) (**Fig. 1, Step 2**). When one more electron is taken by  $H_2O_2$ , the molecule is split into a hydroxyl anion ( $OH^-$ ) and a hydroxyl radical ( $HO^{\cdot}$ ) (**Fig. 1 Step 3**). Hydroxyl radical is fiercely reactive with an extremely short half-life ( $10^{-9}$  second) [8] and can take another electron and a proton to yield water [9] (**Fig. 1 Step 4**). ROS also include peroxides derived from lipids [10] and proteins[11]. ROS can also interact with other reactive species, for example, superoxide anion with nitric oxide (NO) to form peroxynitrite (**Fig. 1 Step 6**), which will be discussed in a later section.



**Fig. 1 A simplified scheme of biological reduction of O<sub>2</sub> to H<sub>2</sub>O.** Most of the O<sub>2</sub> can be reduced directly into H<sub>2</sub>O by a four-electron mechanism without ROS formation catalyzed by cytochrome oxidase (**Step 7**) [12]. A small part of O<sub>2</sub> will go through successive reduction by receiving four electrons one by one and generate ROS (**Step 1 - 4**). Superoxide anion can react with NO to form peroxynitrite (**Step 6**).

## 1.2.1 Production of ROS

ROS can be produced by exogenous factors in the environment we live. For example, exposure to sunlight, both the low-energy visible light and ultraviolet (UV) light, can directly induce ROS production in cells [13, 14]. Not to mention the ionizing radiation such as X-ray, nuclear weapons with much higher energy [15]. Inhalation of air pollutant and smoking cigarette are also associated with increased ROS production [16, 17]. Some chemical compounds and toxins exert their poisonousness by inducing ROS production [18, 19]. ROS can be generated in our food during the storage and processing [20]. However, it is the endogenous ROS more biologically important because they continuously influence cells at every stage of their lifespan. Several main sources of ROS within cells will be discussed as follows.

### 1.2.1.1 Mitochondria

Mitochondria are considered as the cellular “power station”. The endosymbiotic theory for mitochondrial origin has been widely accepted that mitochondria were once free-living prokaryotes and taken up by the eukaryotic ancestor [21]. Since then, they started their significant roles in leading evolution and contributing every aspect of cellular events, not only boosting energy production but also mediating programmed cell death, forming nuclear capsules and endomembrane system [22]. However, mitochondria came along with a dangerous tool, electron transport chain (ETC) which is composed of a series of compounds, peptides, enzymes and protein complexes (Complex I to V), to burn the fuels.

Electron donors from the tricarboxylic acid (TCA) cycle, such as NADH and FADH<sub>2</sub>, donate electrons to Complex I and Complex II, respectively [23]. As the electrons pass through the ETC, any leakage caught by O<sub>2</sub> will lead to the formation of O<sub>2</sub><sup>•-</sup>. The leakage mainly happens at Complex I and Complex III and makes them the main sources of ROS in mitochondria. It has been estimated that the ROS production at Complex I is about half as at Complex III [24]. Complex II was also reported as an O<sub>2</sub><sup>•-</sup> production site although the contribution is lower than Complex I [25, 26]. O<sub>2</sub><sup>•-</sup> then can be converted into H<sub>2</sub>O<sub>2</sub> spontaneously or catalyzed by the superoxide dismutases (SODs) (**Fig.2**).

### 1.2.1.2 Endoplasmic reticulum (ER)

ER is an important organelle for protein quality control which ensures proteins are synthesized, folded and post-translational-modified correctly. Different from the cytosol, ER is a highly oxidizing environment with a high oxidized glutathione to reduced glutathione (GSSG/GSH) ratio which facilitates disulfide bonds formation during protein maturation. During the process, electrons can be transferred from unfolded proteins to protein disulfide isomerase (PDI), then to endoplasmic reticulum oxidoreductin-1 (ERO-1) and finally to  $O_2$  to produce  $H_2O_2$  [27] (**Fig.2**). Several members of quiescin sulfhydryl oxidase (QSOX) family in ER were also found to generate  $H_2O_2$  [28]. It has been estimated that ER accounts for about 25% of ROS production in growing cells [29].

### 1.2.1.3 Peroxisome

The peroxisome is another membrane-capsuled organelle playing multiple roles in both anabolic and catabolic reactions. Peroxisomes are responsible for oxidative breakdown some metabolites such as fatty acids, purines and amino acid therefore they contain different oxidases, including Acyl-CoA oxidases, urate oxidase, D-amino acid oxidase, D-aspartate oxidase, L-pipecolic acid oxidase, L- $\alpha$ -hydroxyacid oxidase, polyamine oxidase, and xanthine oxidase, which extract electron from substrates and pass it to  $O_2$  to produce  $H_2O_2$  as their normal function [30]. So peroxisome has been considered as another main source of ROS in cells, especially the tissues with high metabolic efficiency and it is estimated that peroxisome accounted for 35% of all  $H_2O_2$  produced in rat liver [31].

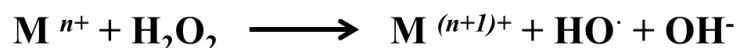
### 1.2.1.4 NADPH Oxidase (NOX)

The sources we discussed above generate ROS as a by-product, but NOXs are “professional” ROS producers [32]. So far, seven members of NOX family have been identified in various mammalian tissues, namely, Nox1-5 and DUOX1-2 (dual oxidase 1 and 2). All NOX family members are membrane-bound proteins which transfer electrons from NADPH to  $O_2$  and yield  $O_2^{\cdot-}$  (**Fig.2**). ROS produced by NOXs were primarily found as a weapon used by host phagocytes to kill microorganisms. Later studies revealed that NOXs produced ROS are also involved in other cellular events such as cellular signaling, gene expression, oxygen sensing and so on [33].

### 1.2.1.5 Metal-induced ROS Production

Transition metal ions are key elements for some proteins which are indispensable for cellular processes. Due to their electron distribution, transition metal ions can easily undergo one-

electron redox reaction and produce reactive species [34]. This property renders them the capacity to generate highly reactive hydroxyl radicals ( $\text{HO}^\cdot$ ) from  $\text{H}_2\text{O}_2$  by Fenton reaction:



where  $\text{M}^{n+}$  is a transition metal ion. Iron was the first metal found by Fenton to catalyze the reaction, later copper, chromium, cobalt and certain other metals were also found as Fenton's reagents *in vivo* [35].

### 1.3 REACTIVE NITROGEN SPECIES (RNS)

RNS refer nitric oxide and those reactive molecules derived from nitric oxide (NO). Similar to ROS, RNS have been found to take part in various biological processes in cells. NO also react with ROS to produce highly reactive radicals, such as peroxyxynitrite, which may cause damage to cellular components and contribute to pathological conditions. The thesis will mainly focus on NO since it is the precursor of all RNS.

#### 1.3.1 Production of NO

Nitric oxide (NO) is a simple diatomic molecule which was considered as an air pollutant first, then surprisingly found to play diverse biological roles in living organisms. In 1977, Murad's group discovered that NO and other NO donors increased the guanylate cyclase's activity, therefore may influence smooth muscle relaxation [36]. In 1980, Furchgott and colleagues found that endothelium can release a substance, endothelium-derived relaxing factor (EDRF), which leads to vasodilation [37]. A further study performed by Ignarro demonstrated the EDRF turned out to be nitric oxide due to their identical properties [38]. Nobel Prize was awarded to these three scientists who contributed a lot to discover the physiological roles of NO in 1998.

##### 1.3.1.1 Nitric oxide synthase (NOS)

NO can be synthesized endogenously by nitric oxide synthases (NOSs) which convert L-arginine and  $\text{O}_2$  into NO and L-citrulline via a complex redox reaction in the presence of the cofactors: NADPH, flavin adenine dinucleotide (FAD), flavin mononucleotide (FMN), and tetrahydrobiopterin ( $\text{BH}_4$ ) [39]. There are three NOS isoforms identified in human bodies and named mainly depending on the tissue distribution, respectively, neuronal NOS (nNOS), endothelial NOS (eNOS) and inducible NOS (iNOS).



nNOS was first found in central and peripheral nervous system. It has been also found in other tissues such as skeletal muscle [40], cardiac myocytes [41], and vascular smooth muscle cells [42]. eNOS is mainly expressed in endothelial cells in blood vessels, but also present in platelets, smooth muscle cells, hepatocytes and certain types of neuronal cells [43]. Both nNOS and eNOS are constitutively expressed and their activity is dependent on  $\text{Ca}^{2+}$  fluxes that enable the binding of calmodulin [43]. Different from the other two isoforms, iNOS is regulated in a  $\text{Ca}^{2+}$ -calmodulin-independent manner and not constitutively expressed in cells. Instead, the expression and activity of iNOS can be induced dramatically by inflammatory stimulations such as cytokines and lipopolysaccharide (LPS). The property of iNOS is used by immune cells like macrophages [44], natural killer (NK) cells [45] and neutrophils [46] to fight against invading microbes and tumor cells [47].

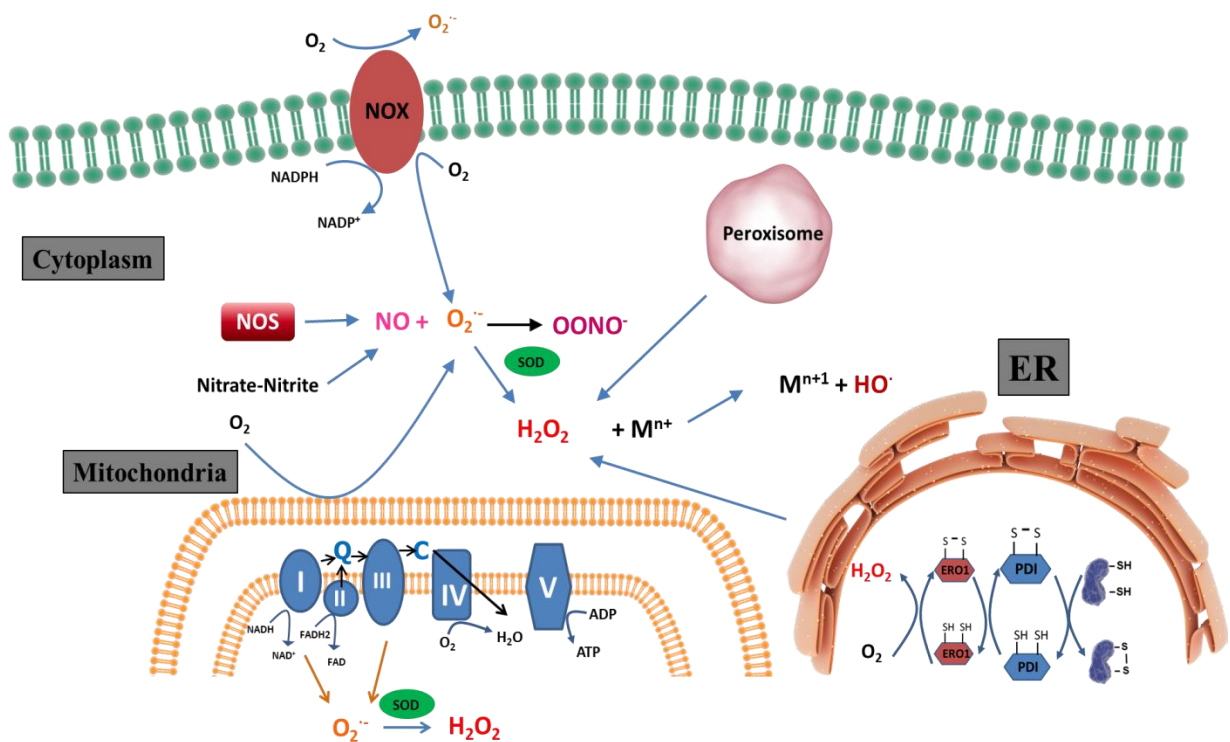
### 1.3.1.2 The nitrate-nitrite-nitric oxide pathway

An alternative source of NO is the nitrate ( $\text{NO}_3^-$ ) – nitrite ( $\text{NO}_2^-$ ) – NO pathway [48]. Dietary uptake of leafy vegetables (e.g. spinach and lettuce) and beetroot is the major source of inorganic nitrate [49]. Nitrite is found at relatively low level in natural products; however it is commonly used as an additive of preserved food [50]. In order to be used as a NO donor, nitrate needs to be reduced to nitrite by digestive track bacteria [51] or mammalian nitrate reductase [52]. The liberation of NO from nitrite is catalyzed by several molecules, including xanthine oxidoreductase [53], ascorbate [54], hemoglobin [55], carbonic anhydrase [56], aldehyde oxidase [57], and enzymes in the mitochondrial respiratory chain [58]. Different from NOSs, NO derived from nitrate and nitrite does not require oxygen so it is believed that nitrate – nitrite – NO pathway can ensure the NO supply under hypoxic conditions [59]. On the other hand, NO can be oxidized into nitrite and nitrate in the presence of oxygen or metals under different conditions [60].

### 1.3.2 Peroxynitrite ( $\text{ONOO}^-$ )

Generally, NO is not too active and can be well-tolerated by cells. For example, NO is used by brain as a neurotransmitter without any toxicity during a healthy person's life span. However, under pathological conditions, such as cerebral ischemia, the same molecule can become highly damaging [61]. The paradox was explained by  $\text{ONOO}^-$ , a strong oxidizing and nitrating agent which is formed by the reaction of NO and  $\text{O}_2^{\cdot-}$  (**Fig.1, step 6**) and capable of causing damage to protein, lipid, and DNA. The reaction between NO and  $\text{O}_2^{\cdot-}$  is fast, with an estimated rate constant of  $6.7 \times 10^9 \text{ M}^{-1} \cdot \text{s}^{-1}$  [62] and NO is one of the only few biological molecules which reacts faster with  $\text{O}_2^{\cdot-}$  than superoxide dismutase (SOD) (estimated rate

constant of  $2 \times 10^9 \text{ M}^{-1} \cdot \text{s}^{-1}$ ) [63]. However, considering the concentration of SOD is much higher than NO and it keeps  $\text{O}_2^{\cdot -}$  at a relatively low level normally, a large amount of peroxynitrite can only be formed when a huge amount of NO and  $\text{O}_2^{\cdot -}$  was produced at the same time, such as inflammation. Surprisingly, as an anion, peroxynitrite is relatively stable in the aqueous solution not only because it can fold into a cis-conformation and distribute the negative charge all over the ring structure [64], but also form hydrogen bonds with water [65]. The stability contributes a lot to the toxicity of peroxynitrite because it can travel to a further spot.



**Fig. 2 Production of ROS and RNS in cells.** ROS are produced via the leaking of electrons from the mitochondrial respiration chain, or through NOX under physiological conditions. ER and peroxisome also contribute to cellular ROS production. NO can be synthesized by NOS or the nitrate-nitrite pathway. NO and  $\text{O}_2^{\cdot -}$  form peroxynitrite. SOD can convert  $\text{O}_2^{\cdot -}$  into  $\text{H}_2\text{O}_2$  which goes through Fenton's reaction to yield  $\text{HO}^{\cdot}$ .

## 1.4 PHYSIOLOGICAL ROLE OF ROS AND RNS

ROS and RNS are important molecules in many physiological processes. The reactivity is the foundation for their functions in that it renders them the possibility to interact with other molecules. The physiological role of ROS and RNS can be divided into two aspects: the killing and the signaling effect.

### 1.4.1 The killing effect of ROS and RNS

Our immune system has developed many strategies to keep us from infections caused by pathogenic microbes. The main weapon used is ROS and RNS, which can cause damage to microbial components, such as lipid, DNA, and proteins. It was firstly reported by Babior et al in 1973 that professional phagocytes, mainly macrophages, and neutrophils, produced a large amount of ROS, known as “respiratory burst” or “oxidative burst” by NOX during bacterial infection [66]. Since then the role of ROS in the immune system has been intensively studied. NO production is also a feature of some immune cells such as macrophages, microglia, neutrophils, dendritic cells (DC), NK cells [67]. Although NO itself is not highly toxic, it forms peroxynitrite with  $O_2^{\cdot -}$  produced by NOX. The anti-microbial effect of ROS and RNS has been demonstrated by various studies showing a broad killing spectrum of microbes ranging from virus to parasites [68]. However, the role of ROS/RNS is far beyond as a weapon, they are also important modulators for immune cell differentiation and activation, cytokine secretion and so on.

### 1.4.2 The Signaling Effect of ROS and RNS

For many years, ROS and RNS were considered as undesired toxic metabolites mainly causing damages. Surprisingly, during last few decades, they were re-recognized as messenger molecules mediating the redox signaling. A large part of ROS/RNS-mediated signal transduction relies on the post-translational modification (PTM) of cysteine thiol (-SH) within proteins. Several properties qualify thiols as signal switches. First of all, thiols are susceptible to ROS/RNS challenge that lays a foundation for its sensitivity. Secondly, due to the different local environment, thiols exhibit different reactivity which renders them selectivity [69]. Lastly, most of the thiol modifications are reversible which provides flexibility for sophisticated signaling regulation.

The major redox signaling molecules in cells are  $H_2O_2$  and NO.  $H_2O_2$  can lead to reversible thiol modifications such as S-sulfenylation (sulfenic acid, -SOH), sulfinic acid (-SO<sub>2</sub>H), disulfide bond (-S-S-), and S-glutathionylation (-SSG) when glutathione (GSH) is around. If sulfinic acid gets further oxidized, sulfonic acid (-SO<sub>3</sub>H), an irreversible thiol modification, will be formed and it has been considered as a hallmark of diseases and usually leads to permanent functional inactivation and protein degradation [70]. NO can manipulate the formation of S-nitrosylation (-SNO), which is also reversible. Peroxynitrite is versatile thiol modifier that has shown the ability to form -SOH, -SO<sub>2</sub>H, -SO<sub>3</sub>H, -SNO, -S-S- [71] and -SSG [72].

#### 1.4.2.1 Sulfenic Acid and Sulfinic Acid

For many thiols, the first step of oxidation by  $H_2O_2$  is sulfenic acid (**Fig.3 step 1**). Sulfenic acid is not stable and rapidly forms intramolecular or intermolecular disulfides with another thiol (**Fig.3 step 7**). Disulfide bonds are relatively inactive thus they can stabilize the structure of proteins and prevent them from further oxidation. Sulfenic acid also reacts with GSH to yield S-glutathionylation (**Fig.3 step 4**) [73]. However, when the microenvironment is suitable, sulfenic acid can be stabilized. The redox regulation of protein tyrosine kinases (PTPs) is a well-studied example of sulfenic acid mediated signaling. During ligand-receptor based signal transduction, the catalytic cysteine in PTPs can be oxidized by  $H_2O_2$  produced by NOX into sulfenic acid, which inhibits PTPs activity and activates protein tyrosine kinases (PTKs) to phosphorylate target proteins [74].

The instability of sulfenic acid, on the other hand, makes it vulnerable to further oxidation that leads to sulfinic (**Fig.3 step 2**) and sulfonic acid (**Fig.3 step 3**). The sulfinic acid modification has been found in several proteins such as peroxiredoxins (Prxs) [75], SOD1 [76] and matrix metalloproteases (MMPs) [77].

#### 1.4.2.2 Disulfide Bonds

Disulfide bonds can be formed by further oxidizing intermedia modifications such as sulfenic acid (**Fig.3 step 7**), S-glutathionylation (**Fig.3 step 8**), and S-nitrosylation. They can also be produced by direct attack of hydroxyl radical from Fenton reaction [78]. Disulfide bonds also participate cellular signaling. For example, cell-surface tissue factor (TF) is important to activate coagulation and signaling relevant to inflammation and angiogenesis [79]. It has been reported that disulfide formation between Cys186 and Cys209 in TF is required for coagulation activation [80]. PTEN (phosphatase and tensin homolog), for instance, an tumor suppressor essential for regulating signaling pathways involved in apoptosis was shown to be inactivated when cells were exposed to  $H_2O_2$  due to the formation of an intramolecular disulfide bond between Cys124 and Cys71 [81].

#### 1.4.2.3 S-glutathionylation

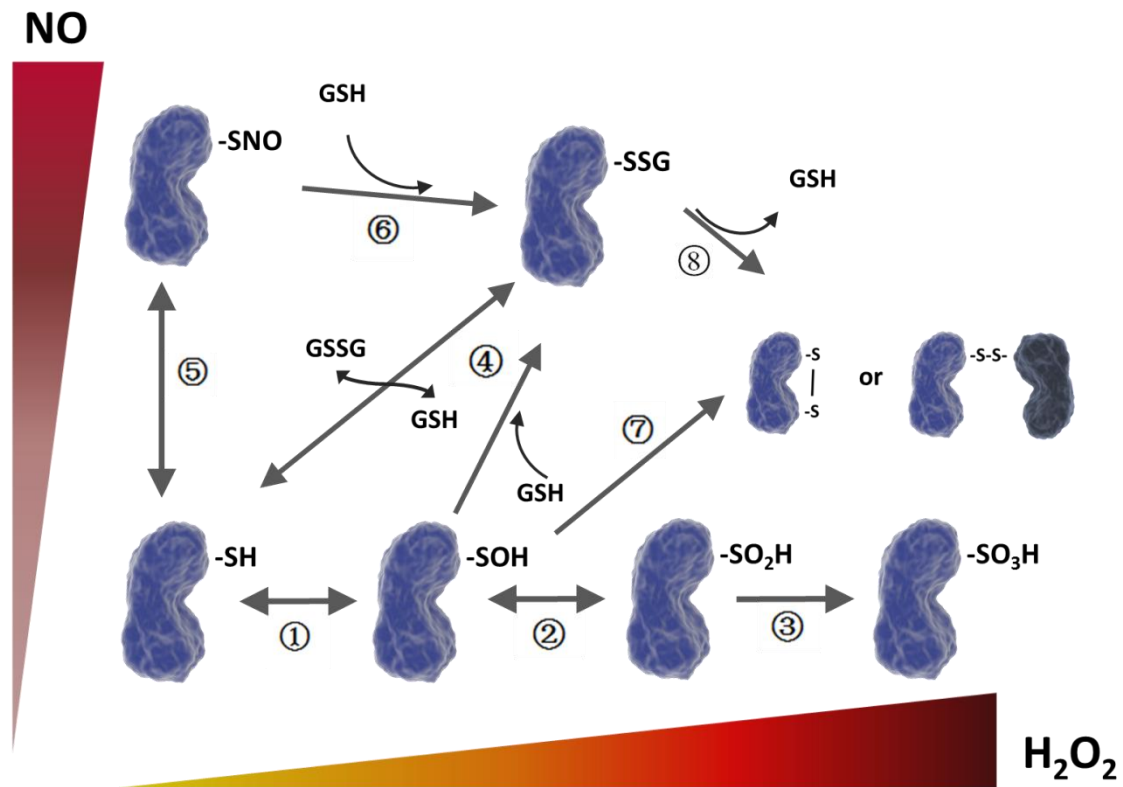
GSH is the dominant low-molecular-weight antioxidant in mammalian cells. The ratio between GSH and GSSG maintains the cellular redox potential and contributes significantly to redox balance. When the balance is disrupted, decreased GSH/GSSG ratio can cause mixed disulfide formation between reactive thiols and GSH, named S-glutathionylation (**Fig.3 step 4**), which is considered as a protection of thiols from irreversible oxidation [82]. Under basal condition, protein S-glutathionylation is a well-controlled, reversible PTM and

plays a role in redox signaling. For example,  $\text{Ca}^{2+}$  dependent phosphorylation of ERK and cAMP/ $\text{Ca}^{2+}$  response element binding protein (CREB) is required for synaptic plasticity. A study found that  $\text{H}_2\text{O}_2$  could cause increased glutathionylation and activation of ryanodine receptors (RyR), which release  $\text{Ca}^{2+}$  and enhance ERK and CREB phosphorylation and helped maintain the long-term potentiation (LTP) in the hippocampus [83]. S-glutathionylation of PTP1B was detected in conditions when GSH/GSSG ratio drops or in the presence of  $\text{H}_2\text{O}_2$ , suggesting it takes part in the regulation of ligand-receptor based signal transduction [84].

#### **1.4.2.4 S-nitrosylation**

The first characterized physiological signaling of NO in mammals is binding to the heme domain of soluble guanylate cyclase (sGC) and activates its activity to convert GTP to cGMP, which triggers downstream cascades involving in vasodilation, smooth muscle relaxation and neurotransmission [85]. In addition to the classical signaling pathway mentioned above, NO is involved in a PTM named S-nitrosylation which is defined as directly adducting the NO moiety to a reactive thiol of cysteine to form S-nitrosothiol (SNO). Similar with other PTMs such as phosphorylation, S-nitrosylation alters proteins activities, interactions pattern and redox status [86]. Growing number of proteins have been reported to be S-nitrosylated in different biological contexts. Interestingly, S-nitrosylation does not occur randomly, it shows certain specificity. Factors like NO donor type, thiol reactivity, and cellular local redox environment contribute to the selectivity of S-nitrosylation [87].

Several transcription factors are regulated by S-nitrosylation. For example, NF- $\kappa$ B plays a central role in immune system. Both p50 [88] and p65 [89] subunits of NF- $\kappa$ B were found to be S-nitrosylated at a cysteine in the DNA-binding region by iNOS-derived NO with a hampered binding ability during immune response. The observation indicated that NF- $\kappa$ B is negatively regulated by NO. Hypoxia-inducible factor 1 (HIF-1) is a master transcriptional factor mediating the hypoxic adaptation which is essential for cellular survival. S-nitrosylating cysteines in HIF-1 $\alpha$  not only promoted its DNA binding [90], but also kept it from proteasomal degradation [91].



**Fig.3 Post-translational modification of cysteines by ROS and RNS.** A free thiol (-SH) can be firstly oxidized by H<sub>2</sub>O<sub>2</sub> to sulfenic acid (-SOH) (Step 1), then to sulfinic acid (-SO<sub>2</sub>H) (Step 2), both are reversible. Further oxidation from -SO<sub>2</sub>H to -SO<sub>3</sub>H makes the modification irreversible (Step 3). Nitric oxide can lead to S-nitrosylation (-SNO) (Step 5), which is not stable and easily converted into S-glutathionylation (-SSG) (Step 6). -SSG can also be formed via GSH/GSSG reacting with thiols (Step 4). Disulfide (-S-S-) is also stable modification derived from -SSG or -SOH (Step 7 and Step 8)

## 1.5 OXIDATIVE AND NITROSATIVE STRESS

If we consider ROS and RNS as the weapons used fighting against invading microbial enemies, we should notice that friendly fire is unavoidable as it happens in every war. In our scenario, the killing effect of ROS and RNS will not only be cast on the alien intruders, but also cells constituting our bodies. Luckily, mammalian cells are equipped with anti-oxidant mechanisms, both enzymatically and non-enzymatically, to counteract the deleterious effects of ROS and RNS. Under physiological condition, the production and disposal of ROS/RNS are maintained in an equilibrium state, so-called redox balance or redox homeostasis. However, when production of ROS/RNS exceeds the ability of disposal by anti-oxidant systems, the balance collapses and oxidative/nitrosative stress is induced [92]. With increased knowledge about redox signaling, the concept of oxidative and nitrosative stress has evolved during last two decades and it is preferably considered as the disruption of a proper redox

signaling and control [93]. Indeed, oxidative and nitrosative stress induced cellular damage and signal dysregulation have been considered as hallmarks of various diseases.

### **1.5.1 Cellular Damage**

Excessive ROS/RNS react directly with biological molecules such as lipid, DNA, and proteins and cause damages to them. For example, biological membranes contain polyunsaturated fatty acid to maintain their functions and fluidity [94]. However, unsaturated lipid is sensitive to ROS/RNS which produces lipid peroxides, disrupts normal membrane structure of cells and organelles, such as mitochondria and ER, and results in loss of function and enveloped contents, finally necrotic cell death [95]. Both nuclear and mitochondrial DNA can be attacked by ROS/RNS and several types of DNA lesion have been observed including oxidation of sugar and base, DNA single strand break [96] and double strand break [97] which will trigger apoptosis [98].

### **1.5.2 Signaling Dysfunction**

The redox signaling is also affected by oxidative and nitrosative stress and the dysfunction is reflected in aberrant protein thiol modifications. For example, chronic inflammation is characterized by persistent activation of macrophages which results in continuous ROS/RNS production. Due to the DNA-damage effect of ROS/RNS, chronic inflammation has been considered as one of the risk factors for tumor initiation [99]. Usually, when DNA damage happens, the genome guardian, p53 gets activated as a transcription factor and triggers multiple downstream effects, such as DNA repair, cell cycle arrest, and apoptosis so cells with damaged DNA will not transform into cancer cells [100]. Due to the high level of ROS/RNS under inflammation, cysteine residues in the DNA binding site of p53 can be abnormally S-nitrosylated [101] or S-glutathionylated [102]. The redox modification of p53 leads to the loss of surveillance function.

In contrast to cancer in which cells stop dying, neurodegenerative diseases suffer from undesired neuron death caused by oxidative/nitrosative stress. Caspase - mediated neuronal cell death contributes to the pathological progress of neurodegenerative diseases. The X-linked inhibitor of apoptosis protein (XIAP), an E3 ligase, binds to several members of caspase family directly and mediates their degradation, therefore plays a protective role in neurodegenerative diseases [103]. In Parkinson's Diseases (PD), XIAP was found to be S-nitrosylated and lose its binding ability to caspases, which was thus stabilized and triggered the apoptosis cascade [104]. S-nitrosylation cysteine 150 of GAPDH promoted its binding to

Siah1 and enhanced the GAPDH-Siah1 complex's nuclear translocation, which initiated the apoptotic pathway contributing to neuronal death [105].

## **1.6 ANTIOXIDANT SYSTEMS**

In order to maintain the redox balance, mammalian cells are equipped with antioxidant systems to neutralize ROS/RNS or repair the caused damages. Moreover, antioxidant systems widely affect redox signaling by reversible cysteine modifications.

### **1.6.1 Small Antioxidant Molecules**

Small antioxidant molecules directly scavenge ROS/RNS via non-enzymatic mechanisms. Some of them are endogenously synthesized while others can be only obtained by dietary uptake.

Glutathione (GSH) is the most abundant low molecular antioxidant in eukaryotes with an estimated concentration at the millimolar level and most of them are in reduced form [106]. The tripeptide Glu-Cys-Gly ( $\gamma$ -glutamyl-cysteinyl-glycine) is synthesized endogenously in a two-step process. The first step is to link a cysteine and a glutamate to form  $\gamma$ -glutamylcysteine which is carried out by the glutamate cysteine ligase (GCL). The second step, catalyzed by GSH synthetase, is to add a glycine to the  $\gamma$ -glutamylcysteine. The first step is considered as the rate-limiting step in GSH synthesis [107]. Although GSH is exclusively synthesized in the cytosol, it is distributed all over the cells and organelles, such as ER (where GSSG is the dominant form [108]), nucleus and mitochondria [109]. The ratio of GSH to its oxidized form, GSSG, (GSH: GSSG) determines the redox status of cells and has been used a biomarker for oxidative stress [110]. GSH not only reacts directly with oxidizing agents to detoxify them, but also serves as electron donors for other efficient antioxidant enzymes, such as glutaredoxins, glutathione transferases, and glutathione peroxidases [111].

Exogenous small antioxidant molecules are mainly vitamins and minerals from daily food. Vitamin C (ascorbic acid), for example, is a water-soluble antioxidant with multiple biological functions. It can not only react readily with ROS/RNS but also regenerate vitamin E ( $\alpha$ -tocopherols), an important lipid-soluble antioxidant protecting polyunsaturated fatty acids in membranes and lipoproteins from oxidative damage [112]. In addition, carotenoids [113], lipoic acid [114], ubiquinol [115], flavonoids [116], uric acid [117] and mineral supplement such as selenium [118], zinc [119] are also small antioxidant molecules participating the scavenging of ROS/RNS.



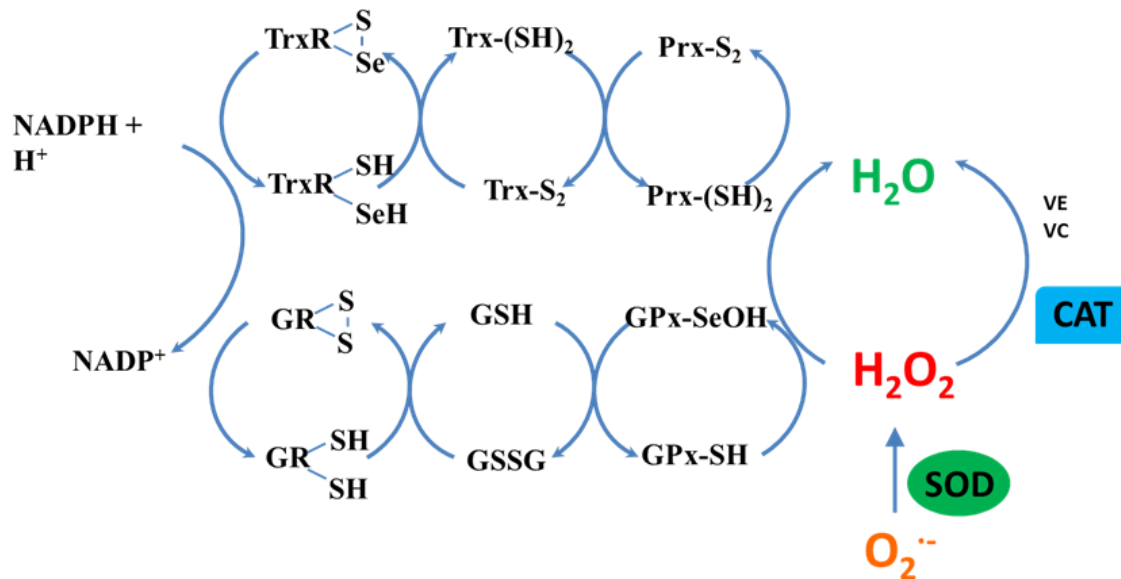
## 1.6.2 Antioxidant Enzymes

The antioxidant enzymes can metabolize ROS/RNS in a more efficient and specific way than small antioxidant molecules. A large part of antioxidant enzymes is transcriptionally controlled by the Keap1/Nrf2 pathway that stays in the center of stress response. The nuclear factor E2-related factor 2 (Nrf2) is a transcription factor targeting genes involved in response to oxidative/nitrosative stress. Nrf2 is mainly regulated by a cytoplasmic protein Kelch-like ECH-associated protein 1 (Keap1) which is an E3 ubiquitin ligase. Under basal conditions, Nrf2 has a relatively short half-life and binds to Keap1 which mediates the ubiquitination and degradation of Nrf2 [120]. Keap1 is rich in cysteines and some of these cysteines serve redox sensors. In the presence of electrophilic or oxidative/nitrosative insult, these cysteines get modified and Nrf2 is released from Keap1 and stabilized [121]. Then, Nrf2 translocates from cytoplasm into nuclei and binds the antioxidant response element (ARE) to activate the transcription of target genes [122], such as superoxide dismutases (SODs), catalase and members in thioredoxin and glutaredoxin systems.

Superoxide dismutases (SODs) are a group of metal-containing enzymes that catalyze the dismutation of superoxide anion to hydrogen peroxide and molecular oxygen (**Fig. 4**). There are three isoforms of SOD in human cells, the copper and zinc-containing cytosolic SOD (Cu/ZnSOD, SOD1), the manganese-containing mitochondrial SOD (MnSOD, SOD2) and extracellular Cu/ZnSOD (SOD3) [123]. SODs are efficient to dismutate superoxide with an estimated rate constant of  $2 \times 10^9 \text{ M}^{-1} \cdot \text{s}^{-1}$  [63]. The importance of SODs has been proven by genetically modified animal models lacking SODs which exhibit various abnormality such as hypersensitivity to ROS/RNS, neonatal or perinatal lethality [124].

Catalase (CAT), a heme-containing enzyme ubiquitously expressed in mammalian cells, catalyzes the decomposition of  $\text{H}_2\text{O}_2$  to water and  $\text{O}_2$  (**Fig. 4**), therefore it plays a critical role in antioxidant defense and redox signaling. The genetic deficiency of CAT in human is called acatalasemia which may be related to high risk of various diseases during aging [125].

Different from SODs and CAT, the thioredoxin and glutaredoxin systems serve not only as antioxidant systems but also important mediators that modulate redox signaling involved in numerous biological events.



**Fig. 4 The antioxidant system in mammalian cells.** SOD catalyzes the dismutation of superoxide to hydrogen peroxide. Small antioxidants like VC, VE can scavenge H<sub>2</sub>O<sub>2</sub> via non-enzymatic mechanisms. Catalase decomposes H<sub>2</sub>O<sub>2</sub> to H<sub>2</sub>O. Both Trx and Grx system use NADPH as the ultimate electron donor. For Trx system, electrons go from NADPH to TrxR to Trx to Prx, respectively. For Grx system, electrons are transferred from NADPH to GR to GSH to GPx, respectively. Prx and GPx are efficiently enzymes to remove H<sub>2</sub>O<sub>2</sub>

## 1.7 THIOREDOXIN SYSTEM

The thioredoxin system, which contains thioredoxin (Trx), thioredoxin reductase (TrxR), and NADPH, is the major disulfide reduction system targeting a broad range of substrates. After reducing its targets, a disulfide is formed in Trx that will be reduced by TrxR using NADPH as the electron donor (**Fig.4**).

### 1.7.1 Thioredoxin

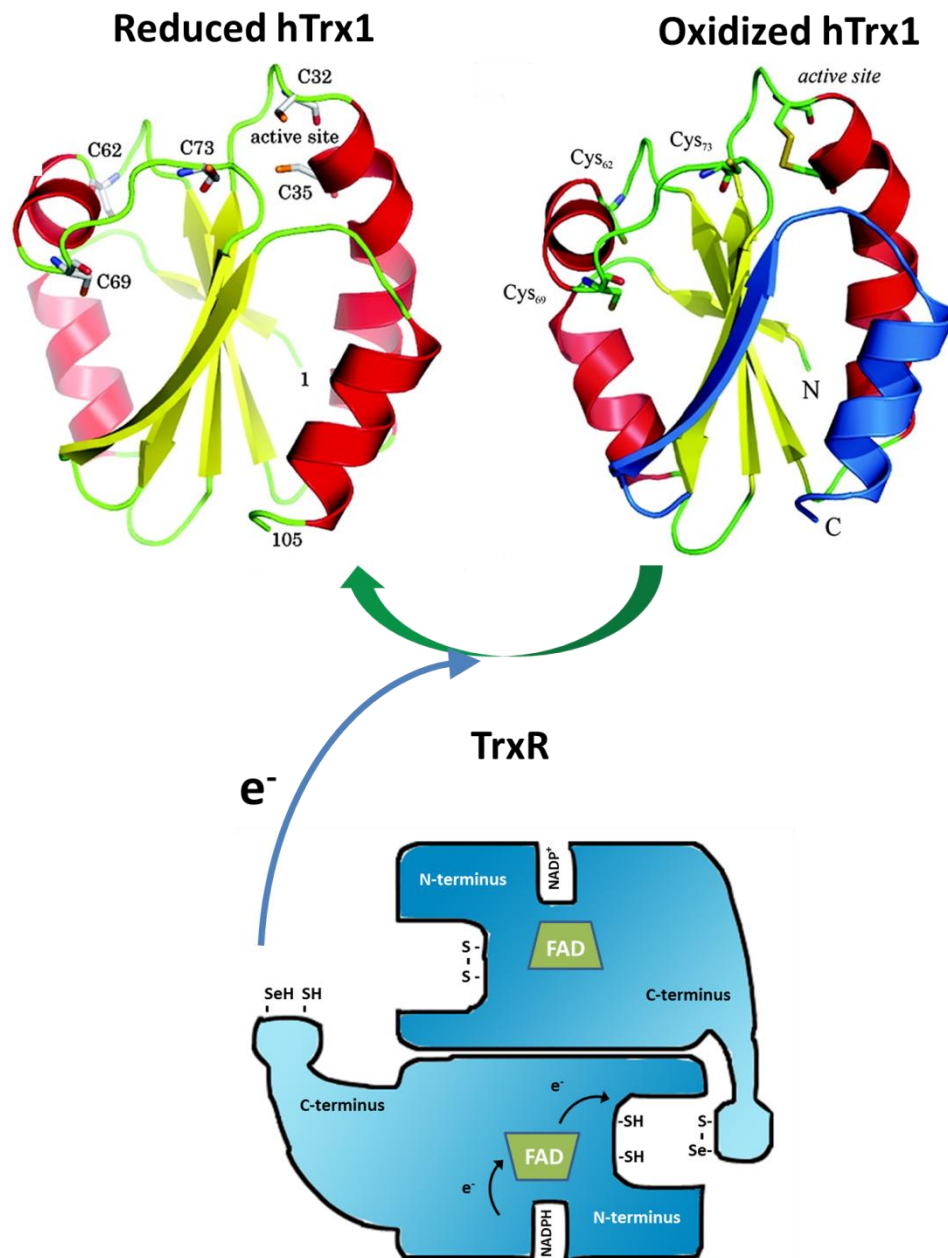
Thioredoxin is a ubiquitous small enzyme around 12-kDa with a -CGPC- motif at the active site, which was originally found in *Escherichia coli* (*E. coli*) to provide electrons for ribonucleotide reductase (RNR) [126, 127]. The 3D structure of bacterial Trx was first described by Prof. Holmgren in 1975 [128] and now many Trxs have been structurally resolved [129]. The structure of Trx is known as the Trx fold, containing four  $\beta$ -strands in the core, and some  $\alpha$ -helices surrounding the central  $\beta$ -sheets [130] (**Fig.5**). In mammalian cells, there are three isoforms of Trxs, Trx1 in the cytosol, Trx2 in mitochondria [131], and a testis-specific Trx [132]. Trxs utilize the two cysteines at the active site to perform substrate reduction. The N-terminal cysteine at the active site first attacks the disulfide in substrate proteins and forms an intermedia disulfide between Trx and substrate, then the C-terminal

cysteine at the active site takes over and leaves reduced protein and an active-site disulfide in Trx which can be sequentially reduced by TrxR [133].

Besides the two active site cysteines (Cys32 and Cys35), human Trx1 (hTrx1) contains three structural cysteines, Cys62, Cys69 and Cys73, issuing hTrx1 unique biological properties. Several studies has shown that the structural cysteines of hTrx1 can be redox-modified and regulated in different redox contexts [134].

### 1.7.2 Thioredoxin Reductase

Thioredoxin reductase (TrxR) is the enzyme recycling oxidized Trx to its reduced form by using NADPH as electron donors. Corresponding to Trxs, there are three forms of mammalian TrxRs, cytosolic TrxR1, mitochondrial TrxR2, and testis-specific TrxR3 (or TGR standing for thioredoxin and GSSG reductase due to its ability to reduce both Trx and GSSG) [135, 136]. Mammalian TrxRs are homodimeric flavoproteins with a molecular weight around 115 kDa. Each subunit contains an active site motif -CVNVGC- in its N-terminus and a 16 amino-acid residue extension with a selenocysteine (Sec, U) in a -GCUC- active site motif in C-terminus [137]. Sec is the analog of cysteine in which the sulfur is substituted by selenium. Due to the chemical property of selenium and the high redox reactivity of Sec, selenoprotein TrxR is efficient in catalyzing redox reactions [138]. During the reduction of Trx, both subunits arranged in a head-to-tail fashion are required. Firstly, NADPH passes electrons to the enzyme-bound FAD in one subunit, then FAD subsequently transfers reducing equivalents to the -CVNVGC- active site motif of the same subunit and reduces the disulfide into a dithiol motif. Secondly, the dithiol-containing active site in TrxR reduces the C-terminal selenenylsulfide motif of the other subunit in the dimer into a selenolthiol motif. In turn, the selenolthiol motif reduces the substrates of TrxR, including not only the active site disulfide in Trx (**Fig.5**), but also glutaredoxin 2, PDI, Trx-like-1, granulysin, and some nonprotein substrates such as selenite, dehydroascorbate, lipoic acid, ubiquinone, cytochrome C, or the cancer drugs motexafin gadolinium and alloxan [139]. Knocking out TrxR1 [140] or TrxR2 [141] in mice led to early embryonic death with improper development, suggesting important roles of TrxRs in neonatal development.



**Fig 5. Catalytic mechanism of mammalian TrxR and 3D structure of hTrx1 [142].** Mammalian TrxR is a homodimer. During the catalysis, NADPH binds to the FAD domain of TrxR and electrons are transferred from NADPH to N-terminal redox center where the reduction of the other subunit's selenium-containing C-terminal active site. Then the reduced seleno-active site reduces the active-site-oxidized hTrx1 to its fully reduced form.

### 1.7.3 Trx Targeted Proteins

Trx interacts with a broad range of proteins not only to maintain the reducing cellular environment by transferring electrons to them, but also to mediate different cellular signaling pathways by regulating cysteine PTMs. With the help of proteomic technology, more and more potential targets for Trx system have been discovered [143].

### 1.7.3.1 Ribonucleotide Reductases (RNR)

Trx was originally discovered as the electron donor to reduce RNR, the rate-limiting enzyme converting ribonucleotides to deoxyribonucleotides for DNA synthesis and repair [144]. Mammalian RNR is a  $\alpha_2\beta_2$  tetramer in which  $\alpha_2$  homodimer forms R1 subunit and  $\beta_2$  homodimer forms R2 subunit. Both R1 and R2 are predominantly expressed during S phase when a large amount of dNTP is needed [145]. R1 remains stable during cell cycle due to its long half-time [146] while R2 is degraded rapidly when cells exit S phase [147]. There is another isoform of R2, p53R2, which is induced by p53 upon DNA damage in resting cells to provide dNTP for DNA repair, in particular mitochondrial DNA replication and repair [148]. In each R2 subunit, there is a Fe-O-Fe center generating and stabilizing a tyrosyl radical, which can be sequentially transferred to the active site cysteine in R1 subunit to generate a thiyl radical which is critical for the conversion of substrates. After each cycle of reaction, a disulfide is formed at the active site in R1 subunit. However, due to the protein conformation, the active site is too narrow to be reduced directly by antioxidant enzymes. Instead, the reduction of the active site disulfide is performed by a pair of shuttle cysteine residues in the C-terminal mobile tail of R1 subunit which can be accessed and reduced by Trx and glutaredoxin [149]. Considering the importance of RNR for proliferating cells, it has been used as a drug target for cancer treatment [150].

### 1.7.3.2 Peroxiredoxins (Prxs)

Prxs are ubiquitous enzymes efficiently catalyzing the decomposition of  $H_2O_2$ , lipid peroxides, and peroxynitrite. To date, 6 mammalian Prx isoforms have been discovered, namely Prx I to Prx VI which can be divided into 3 groups based on their structure and catalytic mechanism: 2-Cys (Prx I - IV), atypical 2-Cys (Prx V), and 1-Cys (Prx VI) Prxs. All isoforms contain the N-terminal cysteine which can be oxidized by their substrates rapidly and selectively during catalysis [151]. Usually, the N-terminal thiolate is oxidized by substrate into a sulfenic acid, then the other cysteine at C-terminus resolves and forms an intermolecular (Prx I-IV) or intramolecular (Prx V) disulfide which can be reduced by Trxs [152]. Prx VI, the 1-Cys Prx, is lack of the resolving cysteine, therefore, it does not form disulfide and cannot be reduced by Trx. Instead, the oxidized cysteine in Prx VI is reduced by GSH catalyzed S-transferase isoform  $\pi$  (GST $\pi$ ) [153]. Prxs are efficient peroxidases with an estimated rate constant of  $10^7 - 10^8 M^{-1} s^{-1}$  [154]. Paradoxically, a study found that human Prx1 can be inactivated by as little as 100  $\mu M$   $H_2O_2$  and this inactivation was shown to be due to the hyperoxidation of the N-terminal cysteine into a sulfinic acid which cannot be regenerated by Trx [155]. This inactivation is called “floodgate model” which is important

for redox signaling since it allows non-stress  $H_2O_2$  produced by NOX get stabilized and exert its function [151]. The sulfinic acid in Prxs can be reduced specifically by sulfiredoxin (Srx) [156]. Other PTMs can also modulate the activity of Prxs, such as phosphorylation [157], S-glutathionylation [158] and S-nitrosylation [159]. Interestingly, Prx takes part in the redox regulation of Trx1, too. When the active site cysteine of Trx1 is oxidized, Prx can promote the formation of another disulfide between Cys62 and Cys69 in the presence of  $H_2O_2$  [160] (**Fig.7**)

### **1.7.3.3 Methionine Sulfoxide Reductase (Msr)**

Another sulfur-containing amino acid, methionine, is also sensitive to oxidation. Both free methionine and methionine in proteins can be oxidized by ROS to methionine sulfoxide. Similar to cysteine modification, methionine oxidation affects protein structure and functions [161]. Msrs are the enzymes catalyzing the reduction of methionine sulfoxide. Although different isoforms of Msrs employ different mechanisms [162], they all receive electrons from Trx system [163].

## **1.7.4 Trx Binding Proteins**

### **1.7.4.1 Apoptosis-regulating Kinase 1 (ASK1)**

Trx1 has been found as a physiological inhibitor of ASK1 by direct protein-protein interaction (**Fig.7**). ASK1 is a MAP3K (Mitogen-activated protein kinase kinase kinases) activating MAP2K-JNK/p38 signaling cascades which are essential for ER stress-induced apoptosis [164]. Trx1 binds ASK1 via disulfide formation between its active site Cys32 or Cys35 and Cys250 in the N-terminal portion of ASK1, and inhibits ASK1 kinase activity. The binding also promotes the degradation of ASK1 by ubiquitin proteasome [165]. When cytosolic Trx1 gets oxidized in response to pro-inflammatory stimuli, ROS, or cellular stress, ASK1 is released from the Trx1-ASK1 complex and subsequent ASK1 dependent apoptotic pathway will be activated. Trx2 associates with mitochondrial located ASK1 via binding Cys30 within ASK1 and activates a JNK-independent apoptosis pathway [166].

### **1.7.4.2 Thioredoxin Interacting Protein (TXNIP)**

The activity of Trx is also regulated by TXNIP, its endogenous inhibitor which binds to reduced Trx but not the oxidized form [167] (**Fig.7**). The interaction between Trx and TXNIP involves the disulfide formation between Cys32 in Trx and Cys247 in TXNIP [168]. The inhibitory effect of TXNIP on Trx can be achieved by two aspects: first, TXNIP competes with other Trx-binding proteins and release them from the Trx binding complex, i.e. ASK1

[169]; second, because one of the active site cysteine of Trx is involved in TXNIP binding, it blocks electron transfer from Trx to target proteins and leads to ROS accumulation in cells [170]. Collectively, TXNIP has been considered as a pro-apoptotic protein and tumor suppressor.

#### **1.7.4.3 Phosphatase and Tensin Homolog (PTEN)**

PTEN, one of the most commonly mutated tumor suppressors in human malignancies, serves as a phosphatase to counteract the phosphoinositide 3-kinase (PI3K)/AKT/ mammalian target of rapamycin (mTOR) pathway [171]. AKT-mediated activation of mTOR is involved in multiple processes to promote cellular proliferation and survival, such as ribosome biogenesis, nutrient import, growth factor response, hypoxia adaptation and so on [172]. Trx1 can bind PTEN directly and inhibit its phosphatase activity by forming a disulfide between Cys32 of Trx1 and Cys212 of PTEN [173]. On the other hand, PTEN can be indirectly regulated by TXNIP which binds to Trx and frees PTEN from Trx-binding for its function [174].

### **1.7.5 Trx System-mediated Redox Signaling**

Trx system mediates redox signaling via different mechanisms. Firstly, it puts out ROS/RNS directly before they reach target proteins. For example, Trx1 coupled Prx I/II and Trx2 coupled Prx III/V in mitochondria can scavenge H<sub>2</sub>O<sub>2</sub>, peroxides and peroxynitrite efficiently [175]. Secondly, it directly binds signaling molecules and regulates their downstream events, such as ASK1, PTEN we discussed above. Thirdly, it modulates the redox properties of signaling molecules to switch on/off signaling pathways. Several important transcription factors are regulated by Trx system.

#### **1.7.5.1 Keap1/Nrf2 Pathway**

Trx system and Keap1/Nrf2 regulate each other putatively. Upon oxidative/nitrosative stress, Nrf2 is released from Keap1, binds to ARE and starts the transcription of antioxidant proteins including Trx and TrxR [122] which at the same time serves as a negative feedback to restore the Keap1/Nrf2 binding. Pharmaceutical inhibition or genetic depletion of TrxR usually leads to activation of Nrf2 [176] [177]. Nrf2 is also redox sensitive and has at least two key cysteines within its nuclear localization signal (NLS) and nuclear export signal (NES) regions. Oxidation of Cys183 in the NES site was proposed to retain Nrf2 in the nucleus [178] and Trx was reported to reduce the oxidation and promote Nrf2 nuclear exportation [179].

### **1.7.5.2 Nuclear Factor- $\kappa$ B (NF- $\kappa$ B)**

Activation of nuclear factor- $\kappa$ B (NF- $\kappa$ B) plays an essential role in immune response. Reduced key cysteines in NF- $\kappa$ B's subunits are required for its DNA binding [180]. It has been reported that under oxidative/nitrosative stress, the activation of NF- $\kappa$ B was hampered in the nucleus [181]. Trx system exerts dual roles in regulating NF- $\kappa$ B. In the cytosol, overexpression Trx stabilizes I $\kappa$ B, the inhibitor of NF- $\kappa$ B, which sequesters NF- $\kappa$ B in the cytosol and promotes its degradation. While in the nucleus, Trx reduces the oxidized cysteine in NF- $\kappa$ B and promote the DNA binding [182].

### **1.7.5.3 Redox Factor -1 (Ref-1) and Activator Protein-1(AP-1)**

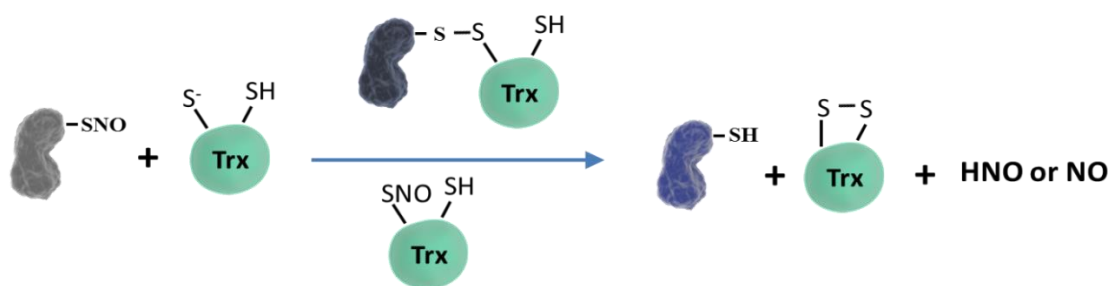
AP-1 is not a single protein, but represents a group of proteins homo- or heterodimers formed between the proteins of the basic region-leucine zipper (bZIP) mainly from Jun, Fos, activating transcription factor (ATF), musculoaponeurotic fibrosarcoma (MAF) protein families [183]. AP-1 regulates a wide range of genes involved in cellular proliferation, transformation, differentiation, survival, and death. Oxidation of cysteine in DNA binding site of AP-1 hampers its transcriptional activity [184]. However, Trx does not directly reduce AP-1, the reduction requires the assistance of another redox protein, redox factor 1 (Ref-1) which transfers reducing power from Trx to AP-1 and restores its activity [185] (**Fig.7**).

## **1.7.6 Trx System-mediated Reversible Thiol Modification**

### **1.7.6.1 S-nitrosylation**

The evolutionarily conserved active site -CXXC- motif in Trxs emphasizes its biological importance. Trx system has been intensively investigated for its thiol reduction activity during last few decades and recent studies reveal that Trx is also an efficient denitrosylase. During S-denitrosylation, one cysteine at active site may form intermolecular disulfide as an intermediate or get transnitrosylated by the substrate as an intermediate. The resulting product is nitroxyl (HNO) or NO and oxidized Trxs which can be reduced by TrxR [186] (**Fig.6**). Using a proteomic approach, a broad spectrum of denitrosylation substrates, including some nitrosylation examples we discussed above, were discovered and Trx has been suggested as the major denitrosylase in mammalian cells [187].

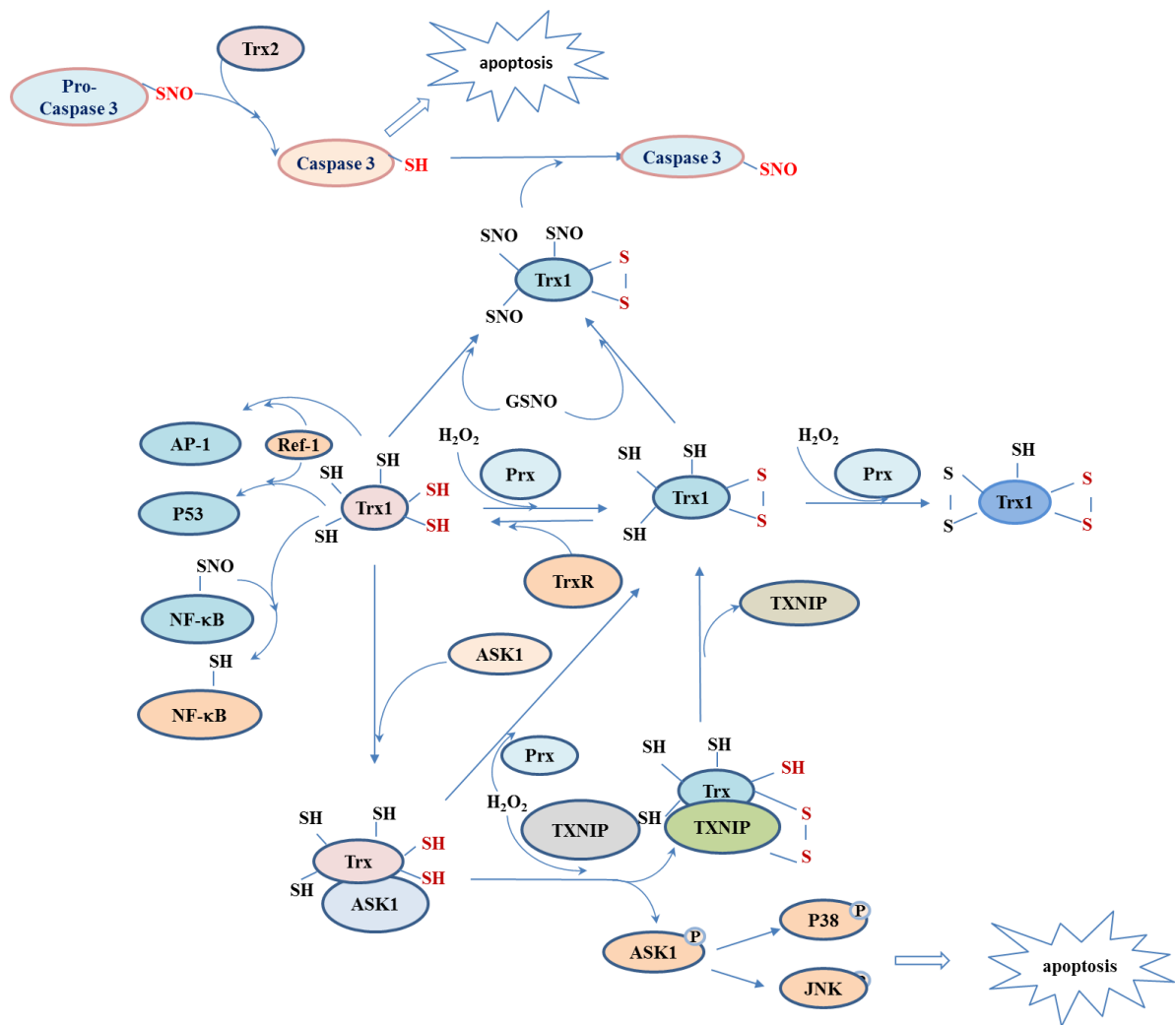




**Fig. 6 Proposed mechanism of Trx-mediated S-denitrosylation.**

It is worth noting that hTrx1 plays different roles upon different redox status in S-nitrosylation regulation. Besides the two cysteines at the active site, hTrx1 contains three structural cysteines, Cys62, Cys69 and Cys73, all of which can be nitrosylated in different contexts [188]. However, so far only Cys69 and Cys73 were reported being nitrosylated physiologically [189, 190]. Nitrosylated Trx1 serves as a transnitrosylase which can transfer the NO group to target proteins including caspases [191], Prx1 and so on [192]. The prerequisite for Trx1's transnitrosylase activity is the formation of active site disulfide or mutated active site cysteines [193]. Therefore under different redox contexts, Trx1 may serve as a denitrosylase or a transnitrosylase.

Trx1 mediated regulation of apoptosis can be an example. Caspases are a family of proteins regulating apoptosis and have a critical cysteine for its function, which can be targeted for S-nitrosylation. Reduced Trx1 and Trx2 can denitrosylate caspase-3 both in the cytosol and mitochondria and facilitate Fas-induced apoptosis which is important for neuronal development but may, on the other hand, contribute to the pathological progress of neurodegenerative diseases [194]. Interestingly, nitrosylated Trx1 is capable of transnitrosylating the catalytic cysteine of caspase-3 specifically and hampering caspase activity thereby protects neurons from stress-induced apoptosis [193] (**Fig.7**). Performing a mass-spectrum-based bioinformatics analysis in neuroblastoma cells, a study surprisingly found more than 40 proteins, which S-nitrosylation was reversibly regulated by Trx1 [192]. Among these targets, GAPDH S-nitrosylation is also highly related to apoptosis, indicating Trx1 is a sophisticated regulator in cell death.



**Fig. 7 Thioredoxin regulated redox signaling.** Trx is a redox regulator for several transcription factors involved in many cellular events, for example, AP-1, NF- $\kappa$ B, p53. Trx1 can direct prevent cell death by binding ASK1. Not surprisingly, TXNIP, the endogenous inhibitor of Trx1, can promote ASK1 mediated apoptosis. Different redox status of Trx1 exerts different effects on caspases. Reduced Trxs can denitrosylate and activate caspase 3 which executes apoptosis while oxidized Trx1 can be nitrosylated and subsequently trans-nitrosylate caspase 3 thereby curb the caspase 3-mediated apoptosis.

### 1.7.6.2 S-sulphydration

Similar to NO, hydrogen sulfide ( $H_2S$ ) also targets reactive protein cysteines and forms persulfide bond (-SSH). This cysteine-based PTM is named S-sulphydration, which has recently drawn a lot of attention for its biological functions. Compared with S-nitrosylation which only occurs in a small fraction of proteins, sulphydration is a more abundant PTM that modifies about 10-25% of total amount of some proteins in the liver lysate, including actin, tubulin and GAPDH [195]. S-nitrosylation usually inhibits proteins' activity while sulphydration typically enhances the reactivity of modified cysteines. For example, parkin is an E3 ligase protecting the brain from accumulation of undesired proteins. S-sulphydration of parkin enhanced its E3 ligase activity and depleted parkin sulphydration was detected in brain samples from PD patients, suggesting a beneficial effect on clearing misfolded proteins in the

brain [196]. H<sub>2</sub>S also boosted GSH production by enhancing the rate-limiting enzyme,  $\gamma$ -glutamyl cysteine synthetase ( $\gamma$ -GCS) activity. Although the mechanism is not clear yet, it is highly possible that it is through sulfhydration [197]. Inflammatory cytokines can cause sulfhydration of GAPDH and enhance its binding to Siah1. The binding promoted Siah1 activity of degrading postsynaptic density 95 (PSD95), which is an important protein for neuron maturation and synaptic plasticity. Exaggerated loss of PSD95 can be seen in several neuronal diseases such as dementia and depression [198].

Several studies have reported that Trx system catalyzed desulfhydration, the reversed reaction of sulfhydration, in different cases [199, 200]. Using different methods, Trx system has been suggested to regulate cellular desulfhydration globally [201, 202]. Grx system and thioredoxin-related protein of 14-kDa (TRP14) also showed the ability to reduce protein sulfhydration [203]. Our understanding about desulfhydration still remains vague and more effort is needed to elucidate the whole picture.

## 1.8 GLUTAREDOXIN SYSTEM

Glutaredoxin system, which is composed of glutaredoxin (Grx), glutathione reductase (GR) and glutathione (GSH), is another cellular disulfide reductase system existing in most of living organisms from prokaryotes, plants, virus, and eukaryotes [204]. It was first discovered by Prof. Arne Holmgren in 1976 as a reductase system for RNR in a mutant *E.coli* unable to replicate phage T7 and shown to lack Trx [205]. Purification of *E.coli* Grx to homogeneity [206, 207] demonstrated that it contained a single disulfide in its oxidized form with the unique sequence Cys-Pro-Tyr-Cys (CPYC) [208]. Grx also showed a strong GSH-disulfide transhydrogenase activity apart from its role as a GSH-dependent hydrogen donor for RNR. Subsequently, Grx was demonstrated in calf thymus [209] and purified to homogeneity [210]. GSH is the most abundant small molecular thiol, which is found as high concentration as millimolar range in cells and important to maintain cellular redox homeostasis [106]. GSH can reduce a wide range of proteins via a non-enzymatic mechanism [211]. The resulting glutathione disulfide (GSSG) can be recycled by GR utilizing NADPH as the electron donor [212] (**Fig.4**). Grxs were firstly considered to be exclusively reduced by GSH, later mammalian mitochondrial Grx was found to be reduced by mitochondrial TrxR, too [213]. Grxs are low-molecular-weight, versatile proteins playing roles in redox regulation, PTM modification, and iron metabolism. What's more, glutathione peroxidases (GPxs) coupled with GSH is also regarded as one of the major antioxidant enzymes to scavenge ROS/RNS.

### 1.8.1 Glutaredoxin (Grx)

So far, four isoforms of human Grx have been discovered. They are divided into two groups based on the cysteine numbers at the active site: the dithiol Grxs including Grx1 and Grx2 with a CXXC active site motif; the monothiol Grxs including Grx3 and Grx5 with a CXXS active site motif [214].

Human Grx1 with a Cys-Pro-Tyr-Cys (CPYC) active site is mainly present in the cytosol and functions as an antioxidant enzyme. Although the gene of Grx1 does not contain subcellular localization sequence, it is also distributed in the nucleus [215] [216], mitochondrial intermembrane space [217], and secreted into plasma [218] (**Fig.8**). To our surprise, knocking out the Grx1 gene in mice does not cause obvious abnormalities [219]. Instead, some studies showed a protective effect against inflammation [220], cardiovascular hypertrophy [221] or airway hyperresponsiveness [222].

Human Grx2 is encoded by one gene but exists in three different splice variants. The N-terminus of Grx2a contains a mitochondrial targeting sequence leading it into mitochondrial matrix [223]. Grx2b and Grx2c are located in the cytosol but these two isoforms are restrictedly expressed in testes, immortalized cell lines, and tumors [224]. Different from Grx1, the active site of Grx2 is Cys-Ser-Tyr-Cys (CSYC) instead of CPYC (**Fig.8**). The subtle substitution renders Grx2 abilities to receive electrons from mitochondrial TrxR and coordinating iron-sulfur cluster [213] [225]. The iron-sulfur cluster is assembled from the cysteine residue in the active site of two Grx2a with GSH as a ligand [226]. Under oxidative/nitrosative stress, the ratio of GSH/GSSG goes down and the cluster gets degraded. Then Grx2 is released to participate in antioxidant processes, thus Grx2 is considered as a redox sensor [225]. Knocking-out Grx2 in mice leads to early-onset of age-dependent cataract [227], enlarged hearts and high blood pressure [228].

Monothiol Grxs, which contain a Cys-Gly-Phe-Ser (CGFS) motif at the active site, can be further categorized into two groups. Grx3 consists of an N-terminal Trx domain that lacks a redox active motif and two monothiol Grx domains that both harbor the CGFS active site motif and it is also named protein kinase C interacting cousin of thioredoxin (PICOT) [229]. Grx3 is located in the cytosol and important for embryonic development because genetic ablation of Grx3 caused embryonic death between E12.5 and E14.5 [230]. Grx3 is also an iron-sulfur cluster protein with a similar redox-sensor function with Grx2 [231]. Another human monothiol Grx, Grx5, is located in mitochondria and contains a single monothiol Grx domain. Grx5 is evolutionarily conserved in eukaryotes [232]. It has been reported that Grx5

is essential for mitochondrial iron-sulfur cluster biogenesis [233]. A clinical case that a patient with Grx5 deficiency suffered from anemia and blood iron overload also highlights the importance of Grx5 in iron metabolism [234] (**Fig.8**).

### 1.8.2 Glutathione Reductase (GR)

Glutathione disulfide (GSSG) is reduced back to two molecules of GSH by NADPH-dependent glutathione reductase (GR), which is highly conserved in nature from *E.coli* to human beings. Similar to TrxR, human GR is also a homodimer arranged in a head-to-tail fashion. Each subunit is grouped by three parts: FAD binding domain, NADPH domain and interface domain and the redox active site, -Cys-Val-Asn-Val-Gly-Cys- (-CVNVGC-) lies in the N-terminus [235]. During the catalysis, electrons are transferred from NADPH to FAD and then to the active site where the reduction of GSSG happens [236]. Although only one gene encodes GR in mammalian cells, GR is distributed in both cytosol and mitochondria [237]. By reducing GSSG, GR takes part in maintaining redox balance in cells. However, genetic deletion of GR gene did not exhibit obvious abnormality and it is reasonable to speculate that other disulfide reduction system and *de novo* GSH synthesis may compensate the loss of GR activity [238].

### 1.8.3 Glutathione Peroxidases (GPxs)

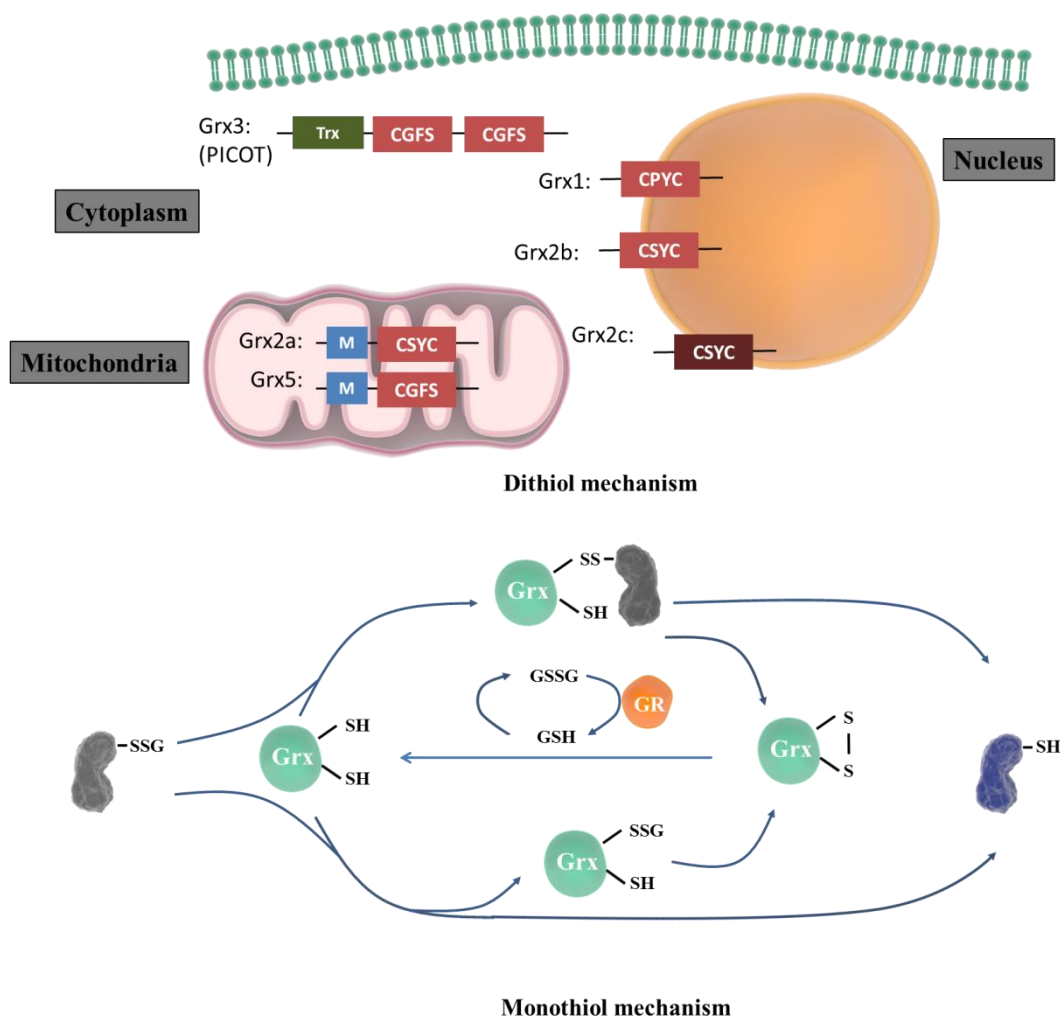
GPxs are GSH-dependent peroxidases which catalyze the reduction of H<sub>2</sub>O<sub>2</sub> or organic hydroperoxides to water or to the corresponding alcohols. Eight isoforms of GPxs have been discovered in human cells. Five of them (human GPx1 to GPx4, and GPx6) are selenoproteins with a selenocysteine at their active sites, the rest three GPxs (GPx5, GPx7 and GPx8) contain cysteine-substituted active site [239]. Selenocysteine is important for GPx activity because substitution of the selenocysteine to a cysteine results in an activity drop by two to three orders of magnitude [240]. The rate of seleno-GPxs reacting with H<sub>2</sub>O<sub>2</sub> is higher than 10<sup>7</sup> M<sup>-1</sup>s<sup>-1</sup> which is similar to Prxs. Thus GPxs and Prxs are considered as the primary scavengers of H<sub>2</sub>O<sub>2</sub> in mammalian cells [241]. Among the isoforms, GPx1 and GPx4 are most well-studied. GPx1 is a homo-tetramer which reacts mainly with H<sub>2</sub>O<sub>2</sub> and soluble low molecular weight hydroperoxides. Knocking out GPx1 in mice does not cause abnormal phenotype but sensitizes mice to acute oxidative stress induced by toxic compounds [242]. GPx4, which acts as a monomer, draws a lot of efforts due to its unique ability to reduce not only H<sub>2</sub>O<sub>2</sub> and hydroperoxides in general, but also a broad range of lipid peroxides such as phospholipid, cholesterol, cholesterol ester hydroperoxides either in free form or in the biological membranes [243]. Systemic knockout of GPx4 gene leads to embryonic death

which suggests GPx4 is not simply an antioxidant enzyme [244]. Indeed, GPx4 was found to play an important role in counteracting lipid peroxide-induced apoptosis [245].

#### **1.8.4 Grx System-mediated Redox Signaling**

Besides the role as the electron donor for RNR and other proteins, Grx system mediates redox signaling mainly by reversibly catalyzing protein S-glutathionylation. The reversed reaction of glutathionylation is named S-deglutathionylation. Although several proteins such as Trxs [246], PDI [247] and sulfiredoxin [248] showed their deglutathionylation activity in different cases, glutaredoxins are considered as the major deglutathionylases due to their high affinity and selectivity to glutathionylated proteins [249]. Two mechanisms have been proposed for Grxs-catalyzed deglutathionylation: (I) the dithiol mechanism requires both cysteines in the active site. At the beginning, N-terminal cysteine forms a disulfide with target protein and releases GSH, and then the other active site cysteine attacks and leaves deglutathionylated protein and an active-site-disulfide Grx which can be later reduced by GSH; (II) the monothiol mechanism suggests that the N-terminal cysteine first takes over the -SG group and leaves the reduced target protein, then the glutathionylated active site cysteine can be reduced by GSH or forms disulfide with the other cysteine [250] (**Fig.8**). Although both mechanisms were reported from different studies, the monothiol mechanism is considered as the prevalent way due to its universal recognition for glutathionylated targets [251].

Grxs exert an important influence on redox signaling by their ability of modulation protein glutathionylation. For example, actin was found constitutively glutathionylated in the human central nervous system (CNS) [252]. Studies showed that Grx1 catalyzed deglutathionylation of actin is crucial for its polymerization, which is a key event for cellular dynamics and protects neurons from accumulating disarranged actin filament [253]. In a MPTP-induced PD model, up-regulation of Grx restored complex I activity most likely via deglutathionylation of its catalytic cysteines [254]. Studies also revealed that human mitochondrial Grx, Grx2a, exhibited higher affinity to glutathionylated substrates and electron donors compared to Grx1, suggesting its important role in regulating mitochondrial redox homeostasis by deglutathionylation target proteins, including complex I [249, 255]. Glutathionylation of active site cysteine of Prx2 was also found in Grx1 knocked-out cells treated with H<sub>2</sub>O<sub>2</sub>, suggesting a protective role of Grx1 in guarding Prx2's activity under oxidative stress [256]. Interestingly, due to the high reactivity of active site cysteine (PK<sub>a</sub> ≈ 3.5), Grxs may form a glutaredoxin-S-S-glutathione-disulfide anion radical (GRx-SSG<sup>-</sup>) which facilitates the transfer of -SG group to other proteins including GAPDH and PTP1B [257].



**Fig.8 Cellular distribution of human Grxs and two proposed mechanisms for Grx catalyzed deglutathionylation.** Grx1, 2b, and 2c can be found both in cytosol and nucleus, Grx3 is present in the cytosol, Grx2a and Grx5 are located in mitochondria. The dithiol mechanism requires both active site cysteines. During the reaction, N-terminal active site cysteine forms a disulfide with targeted proteins. The monothiol mechanism needs only the N-terminal active site cysteine, which takes over the GSH mixed disulfide from targeted proteins.

## 1.9 TARGETING ANTIOXIDANT SYSTEM FOR CANCER THERAPY

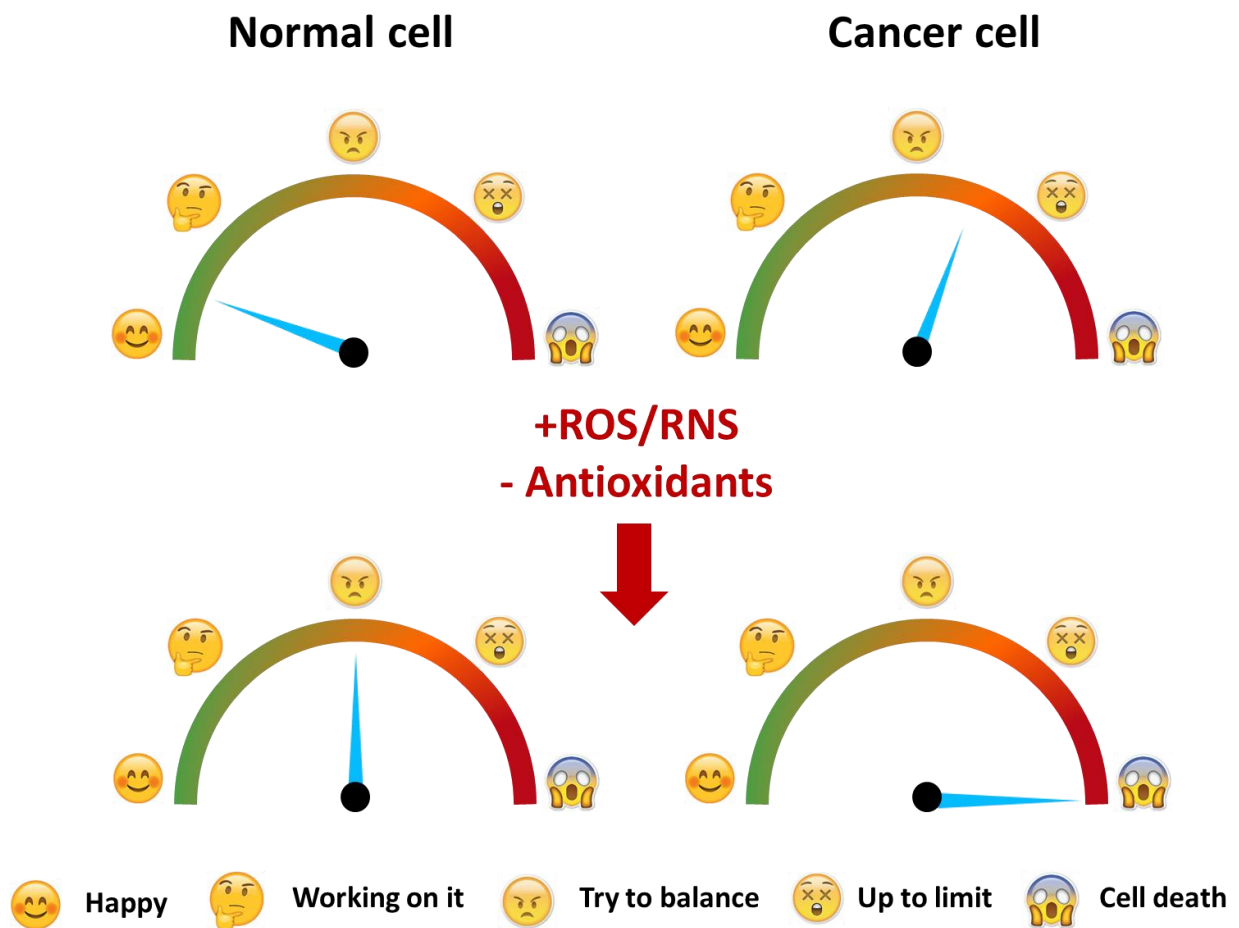
Cancer is a leading cause of mortality worldwide in both developed and developing countries. The initiation and development of cancer are complex progresses involving in alterations in many cellular aspects which characterize cancer cells with uncontrolled proliferation. Hallmarks of cancers were described at the beginning of 21st century [258] and the concept has been evolved recently that oxidative stress is included [259] [260]. Cancer cells usually exhibit a higher level of ROS/RNS compared to normal cells due to several reasons: (1) Elevated energy and material demand for proliferation make cancer cells take up much more glucose than normal cells and switch metabolism from oxidative phosphorylation to glycolysis, which is known as Warburg effect [261]. (2) Alterations in mitochondrial respiratory chain due to mutation lead to increased possibility of electron leakage and ROS formation [262]. (3) Cancer-related chronic inflammation results in excessive production of

nitric oxide and nitrosative stress [263]. (4) Activation of oncogenes and hypoxia-response mechanisms promote ROS/RNS generation [264]. Cancer cells benefit from the relatively high level of ROS/RNS which facilitate cancer initiation, metastasis, hypoxic adaptation, and angiogenesis by mediating redox signaling.

However, playing with ROS/RNS is a tricky game. When ROS/RNS level is high enough, cell death pathways will be activated [264]. In order to cope with the situation, cancer cells have to upregulate the antioxidant systems to counteract the detrimental effect of ROS/RNS. For example, the elevated activity of Nrf2 and Nrf2-targeted proteins, including GPxs and SODs, have been found in various types of cancer [265]. Trx system in cancer cells is also overexpressed not only to lower the oxidative/nitrosative stress, but also to inhibit apoptosis pathways [266]. At the end, the elevated ROS/RNS and the exhausted antioxidant systems reach a vulnerable equilibrium, like an acrobat walking a tightrope, in which ROS/RNS level is closely under the cell death threshold. As a result, cancer cells become more sensitive to additional ROS/RNS challenge which normal cells can well tolerate (**Fig.9**). Therefore, inducing ROS/RNS in cancer cells by promoting oxidant production or inhibiting antioxidant systems gains popularity in cancer therapy [267].

Many chemotherapeutic reagents, as well as radiotherapy, have been suggested to promote cancer cell death by inducing ROS production [268]. Antioxidant systems have been considered as cancer cells' "Achilles' heel" because cancer cells heavily rely on the antioxidant systems to counteract ROS/RNS. Targeting main antioxidant enzymes also showed promising results for cancer treatment. Numerous TrxR inhibitors have been developed and many of them exhibited specific toxicity towards cancer cells [269]. Buthionine-[S, R]-sulfoximine (BSO) is a potent inhibitor of GCL, the rate-limiting enzyme in GSH synthesis. A recent study showed that inhibition of GSH synthesis by BSO and thioredoxin antioxidant pathways by sulfasalazine and auranofin led to a synergistic anti-cancer effect both *in vitro* and *in vivo*, emphasizing the importance of Grx and Trx systems in cancer cells and promising usage as drug targets [270].





**Fig.9 Mechanism of inducing oxidative/nitrosative stress as an anticancer strategy.** Normal cells have a relatively low basal level of ROS and antioxidant systems. In cancer cells, ROS/RNS is elevated due to various reasons. At the same time, antioxidant systems in cancer cells are also upregulated to maintain a vulnerable equilibrium. When additional ROS/RNS is added or antioxidant system is inhibited, normal cells can tolerate it by upregulating antioxidant systems. While cancer cells can no longer enhance its antioxidant systems and go to cell death. (License for non-commercial use from Phantom Open Emoji)

## **2 PRESENT INVESTIGATION**

### **2.1 AIM OF THIS THESIS**

The overall aim of this thesis is, as described in the title, to investigate the role of mammalian thioredoxin and glutaredoxin systems under oxidative and nitrosative stress. The effect must be mutual thus we will study the both sides: how Trx and Grx systems change ROS/RNS and how they are changed by ROS/RNS. By studying the changes, we also tried to interpret our results in a disease-related context in which promising therapy might be derived.

To specify in each paper:

#### **Paper I**

In this study, the toxic effect of several arsenic compounds on cancer cells was investigated. Their effect on human Trx system and the importance of structure cysteine of Trx1 was elucidated.

#### **Paper II**

Apatone (the combination of vitamin C and vitamin K3) can cause cancer cell death by inducing oxidative stress and it is an anti-cancer drug under clinical trial. In this study, the mechanism of ROS production and how Trx and Grx systems get affected were investigated.

#### **Paper III**

Infection is a classical way to induce nitrosative stress due to NO produced by iNOS. In the paper, we studied the role of iNOS and NO during *Trypanosoma brucei* infection.

#### **Paper IV**

In this study, we investigated the role of Grxs in the regulation of NO metabolism and their potential usage as S-denitrosylases.

## 2.2 METHODOLOGY

The methods used in the papers included in this thesis will be briefly described. For more details, please check the sections of materials and methods in each paper.

### Cell culture (Paper I-III)

In Paper I, human neuroblastoma cell line SH-SY5Y was cultured with 1 g/L glucose Dulbecco's modified Eagle's medium (DMEM) containing 100 units/ml penicillin, 100 µg/ml streptomycin, 2 mM l-glutamine, and 10% (v/v) fetal bovine serum (FBS). In Paper II, human prostate cancer cell line LNCaP was cultured in RPMI 1640; human glioblastoma cell line A172, human prostate cancer cell line PC3, human pancreatic cancer cell line PANC-1 and human breast cancer cell line MCF7 were cultured in DMEM; human lung cancer cell line A549 was cultured in F-12 medium. All medium was supplemented with 10% FBS and 2 mM l-glutamine. In Paper III, Bone marrow-derived macrophages from mice were cultured in DMEM containing glucose and supplemented with 2 mM L-glutamine, 10% FBS, 10 mM HEPES, 100 µg/ml streptomycin, 100 U/ml penicillin. All cell lines were kept in a humidified atmosphere of 5% CO<sub>2</sub> at 37 °C.

### Cell viability assay (Paper I & II)

MTT assay is widely used to measure cellular proliferation and viability. The principle is based on the reaction that MTT (3-[4,5-dimethylthiazol-2-yl]-2,5-diphenyltetrazolium bromide) can be reduced into purple formazan by living cells. The exact cellular mechanism of MTT reduction has not been fully understood yet, but likely involves reaction with NADH or similar reducing molecules both in mitochondria and cytosol that transfer electrons to MTT [271].

Cells were seeded into 96-well plates at  $1 \times 10^4$  cells per well and allowed to adhere and get confluent for about 24 h. The following day, cells were treated with different reagents with desired concentration for different time periods after which, media was carefully removed and replaced with 150 µl fresh medium containing 0.5 mg/ml MTT. After incubating for 3 h, the medium was carefully removed and the formazan crystal formed was dissolved in 150 µl of DMSO. Absorbance at 550 nm was recorded.

### TrxR activity assay (Paper I)

For recombinant TrxR activity, a Trx-insulin-coupled assay was employed based on the reaction that TrxR transfers electrons from NADPH to Trx, which then reduces insulin [272].

Briefly, NADPH-reduced TrxR1 (1  $\mu$ M) was incubated with arsenic compounds at room temperature for 60 min. Then, TrxR1 activity was assayed by insulin reduction assay in the solution containing 50 mM Tris-HCl, pH 7.5, 1 mM EDTA, 200  $\mu$ M NADPH, in the presence of 5  $\mu$ M Trx1 and 160  $\mu$ M insulin. The absorbance at 340 nm was followed and TrxR1 activity was calculated by measuring the slope of absorbance change during the initial 10 minutes.

Cellular TrxR activity was measured by a fluorescent assay which is more sensitive and allows determine low level of TrxR in biological materials. In this assay, insulin was replaced by a redox-sensitive fluorescent substrate which increases fluorescence upon reduction by Trx. In general, 30  $\mu$ g of cell lysates were used to determine TrxR activity with a Kit for assay of mammalian TrxR (FkTRXR-03\*) from IMCO ([www.imcocorp.se](http://www.imcocorp.se)), which was optimized from previous method [273]. The cell lysates from untreated cells were used as a control.

#### **Detection redox status of Trx (Paper I & II)**

Thioredoxin redox status was detected using a modified redox western blot method [274]. To prepare mobility standard, cells were lysed in urea lysis buffer (8 M urea in in 50 mM Tris-HCl, 1 mM EDTA, pH 8.0) containing DTT to denature and fully reduce proteins. Then lysate was aliquoted and incubated with different molar ratio of iodoacetic acid (IAA) and iodoacetamide (IAM). If a protein contains “n” cysteines, the reaction will create “n+1” isoforms labeled with different numbers of IAA or IAM. When the sample is separated in urea-PAGE, IAA adducts get ionized and exhibit higher mobility while the IAM adducts stay neutral, therefore, “n+1” bands will be shown on the gel which can be used as a standard (**Fig.10**). For samples, after treatment, cells were lysed in urea lysis buffer containing 30mM IAA and incubated at 37  $^{\circ}$ C for 30min to alkylate free thiols. After centrifugation, the supernatant containing proteins was precipitated by cold acetone: HCl (98:2, v/v). The precipitate was pelleted by centrifugation and washed in cold acetone: HCl for two times and resuspended in urea lysis buffer containing 3.5 mM DTT. After 30min incubation at 37  $^{\circ}$ C, 10 mM IAM was added for another 30 min incubation. Protein concentration was measured. After separation in urea-PAGE, membranes were processed for western blot and probed using goat anti-Trx1 antibody.

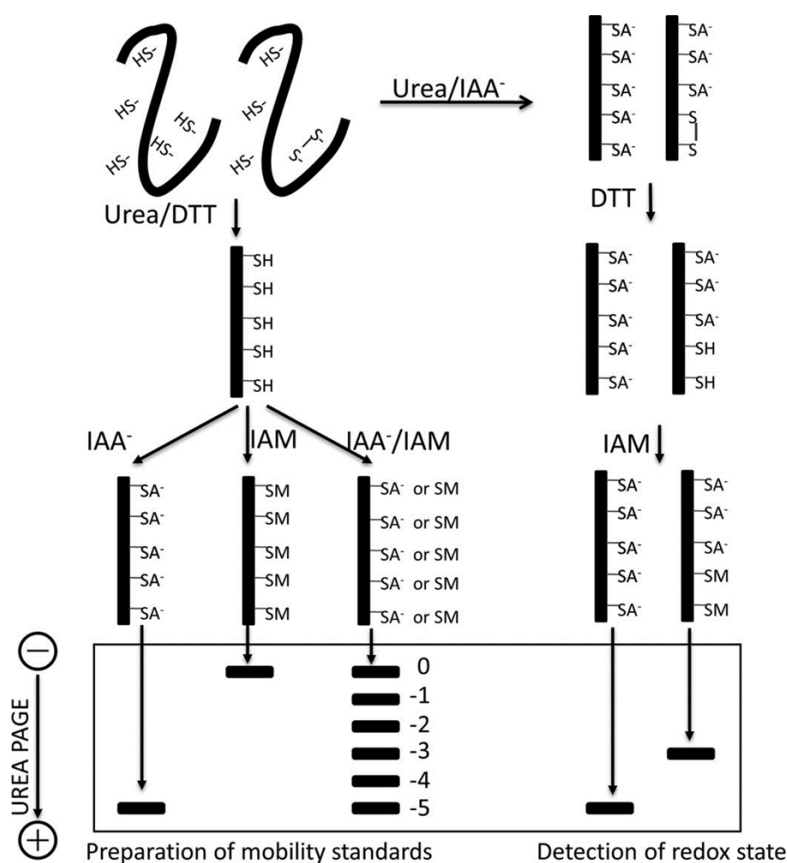


Fig. 10 The principle of redox western blot for hTrx1

### Total cellular glutathionylation detection (Paper II)

Cells were seeded into 6-well plates at  $3 \times 10^5$  cells per well. After treatment, cells were washed and harvested at different time points in cold PBS. Cells were lysed in lysis buffer (25 mM Tris HCl, pH 7.5, 100 mM NaCl, 2.5 mM EDTA, 2.5 mM EGTA, 20 mM NaF, 1 mM  $\text{Na}_3\text{VO}_4$ , 20 mM sodium  $\beta$ -glycerophosphate, 10 mM sodium pyrophosphate, 0.5% Triton X-100) containing protease inhibitor cocktail (Roche) and 50 mM iodoacetamide (IAM). After centrifugation, 25  $\mu\text{g}$  of total proteins from the supernatant were separated by SDS-PAGE and probed with anti-glutathione antibody (VIROGEN Corporation). Anti-GAPDH (Santa Cruz) antibody was used as loading control.

### Biotin-switch assay (Paper III)

Biotin-switch assay is a well-established method to detect protein S-nitrosylation. It can be used for comparing total cellular S-nitrosylation level, as well as fishing out individual proteins. The basic idea is to use ascorbate to specifically switch the unstable S-nitrosothiols into biotin labeled disulfides which are stable and detectable by streptavidin-biotin interaction. Cell lysate was prepared by adding urea lysis buffer (8 M urea, 50 mM Tris pH 8.0, 1 mM EDTA) and 20 mM blocking reagent methyl methanethiosulfonate (MMTS). The

lysates were incubated at 50 °C for 30 min with frequent vortexing and centrifuged at 17,000 g for 10 min. Proteins in the supernatant were precipitated with cold acetone in order to remove free MMTS. The pellet was washed 3 times with cold acetone and resuspended in urea lysis buffer with 20 mM sodium ascorbate and 0.5 mM N-6-(biotinamido) hexyl-3'-(2'-pyridyldithio) propionamide (Biotin-HPDP). The reaction was done at room temperature for 1 hr. Cold acetone was then added to remove excessive biotin-HPDP and the resulting pellet was dissolved into 2 M urea 50 mM Tris-EDTA (pH 8.0). Protein concentration was determined by BCA protein assay. Protein samples (10 µg) were loaded on a SDS-PAGE, blotted and biotinylated proteins were detected by streptavidin-HRP. To detect NF-κB p65 nitrosylation, biotinylated proteins were immunoprecipitated by high capacity neutravidin agarose resin at 4 °C overnight. Proteins were eluted with 20 mM HEPES, pH 7.7, 100 mM NaCl, 1 mM EDTA, 100 mM DTT. Eluted proteins were loaded on a SDS-PAGE for detection of p65 by immunoblotting NF-κB p65 antibody.

#### **DAN fluorescent assay (Paper III & IV)**

The principle of this assay is based on the reaction of DAN (2,3-diaminonaphthalene) with NO<sup>+</sup> liberated from S-nitrosothiols following mercuric chloride addition to yield a primary nitrosamine which is converted rapidly to a fluorescent triazole, 2,3-naphthotriazole (NAT). DAN was dissolved in 0.62 M HCl to a concentration of 5 mM, HgCl<sub>2</sub> 5 mM was prepared in H<sub>2</sub>O. DAN, at a final concentration of 100 µM, and HgCl<sub>2</sub>, at a final concentration of 300 µM were added into S-nitrosothiols samples and kept at room temperature in dark for 30 min. NaOH was added to a final concentration of 0.5 M to terminate the reaction [275]. The fluorescence of the samples was read by Perkin Elmer EnSpire 2300 multilabel reader (excitation at 375 nm, emission at 450 nm).

#### **Nitric oxide analyzer (Paper IV)**

Nitric oxide analyzer (NOA) is the regarded as the gold standard of S-nitrosothiols determination due to its high sensitivity. Cu<sup>+</sup> catalyzed the decomposition of S-nitrosothiols was employed to convert S-nitrosothiols into nitric oxide and the corresponding thiols. The NO released was sent into the detection chamber filled with ozone, which reacts with NO. The reaction emits light and the chemiluminescence can be detected and quantified by the sensor.

## 3 SUMMARY AND DISCUSSION

### 3.1 PAPER I

Oxidation of structural cysteine residues in thioredoxin 1 by aromatic arsenicals enhances cancer cell cytotoxicity caused by the inhibition of thioredoxin reductase 1

Xu Zhang, Jun Lu, **Xiaoyuan Ren**, Yatao Du, Yujuan Zheng, Panayiotis V. Ioannou, Arne Holmgren

*Free Radical Biology and Medicine* 89 (2015) 192–200

#### **Background**

Exposure to arsenic leads to the onset of various diseases including cancer [276]. Paradoxically, arsenic trioxide (ATO) has been successfully used in the treatment of acute promyelocytic leukemia [277] and solid tumors [278]. One of the important mechanisms for arsenical-induced toxicity is to break the redox balance. Arsenicals can inhibit mitochondrial respiratory function, and increase ROS generation. Additionally, arsenicals like ATO can react with sulfhydryl groups, such as in GSH, or selenocysteines such as in TrxR, leading to the inactivation of antioxidant enzymes and cell apoptosis in cancer cells [279]. Another member in Trx system, Trx1, plays an important role in maintaining redox homeostasis by donating electrons to Prx which removes H<sub>2</sub>O<sub>2</sub> efficiently. Although various arsenical compounds have been synthesized, the relationship between arsenical structure and their cytotoxicity is not well-studied yet. In this study, we investigated several arsenicals and their effects on Trx system and elucidated their different toxic mechanisms.

#### **Main findings**

*TrxR inhibition is a mechanism of arsenical-induced cytotoxicity*

In this study, we found that 7 arsenic compounds (As1 to As7) inhibited TrxR activity both on pure protein level and cellular level. Cytotoxicity results revealed that the killing effect was highly related to their inhibitory effect on TrxR. Interestingly, As6 and As7 showed much higher cytotoxicity than the rest, although their ability to inhibit TrxR was not above the other compounds.

*Aromatic arsenical compounds highly oxidized hTrx1*

To further understand why As6 and As7 were more toxic, we studied the effects of arsenicals on hTrx1 itself. After incubating the arsenicals with pre-reduced hTrx1, only compounds with an aromatic group (As5, As6, and As7) led to the formation of hTrx1 dimer or oligomer. Free thiols titration showed that high concentration of As7 can oxidize all 5 cysteines while high

concentration of As6 can maximally cause oxidation of 2 out of 5. ATO did not change the number of free thiol in Trx1 even at as high as 10 fold concentration of Trx1.

Human Trxs has two cysteine residues in its active site (CGPC), which can reduce the disulfide of target proteins by a thiol-disulfide exchange reaction. In addition, hTrx1 contains three structural cysteines, Cys62, Cys69, and Cys73. These additional cysteines attract more and more attentions because studies have shown that the disulfide between Cys62 and Cys69 is important for the regulation of Trx1 activity and Trx-mediated redox signaling [160] [280]. In order to know which 2 cysteines were affected by As6, a C62S/C73S double mutant hTrx1 and human Trx2 were used to incubate with As6. The result indicated that Cys62 and Cys69 were involved in the reaction.

#### *As6 and As7 activated Nrf-2 pathway*

Treating cells with As6 and As7, both protein and mRNA levels of cytosolic TrxR1 and Trx1 got increased. The nuclear factor erythroid 2-related factor 2 (Nrf-2) regulated genes including heme oxygenase 1 (HO-1) and NAD(P)H: quinone oxidoreductase 1 (NQO1) were dramatically increased, indicating the treatment induced ROS production and activated Nrf-2 pathway.

#### *Oxidation of cysteines in hTrx1 impaired its ability to reduce Prx1*

Peroxiredoxin 1 (Prx1) removes H<sub>2</sub>O<sub>2</sub> by receiving electrons from Trx1. Arsenicals-induced Trx1 oxidation may disturb the interaction between Trx1 and Prx1. We found that As7-treated, but not As6-treated, Trx1 lost its activity to reduce Prx1, suggesting the reducing ability depends on the active site cysteines. Using a TrxR and NADPH coupled assay, we found both As6 and As7 pretreated Trx1 failed to reduce Prx1, indicating oxidation of Cys62 and Cys69 affected its ability to transfer electrons from TrxR and NADPH to Prx1.

## **Discussion**

Cancer cells generally have elevated ROS production due to several reasons and benefit from the effect of H<sub>2</sub>O<sub>2</sub> mediated signaling. Trx1 and TrxR1 have been found to be overexpressed in certain cancer cell lines as a strategy of counteracting the harmful effect of ROS. These observations suggest Trx system as an attractive target for cancer treatment. Indeed, the low pKa value of the selenocysteine in TrxR makes it highly reactive, and its location in the open C-terminal active site makes it easy to be accessed by electrophiles, including anticancer drugs such as cisplatin, mitomycin C, doxorubicin and so on [281]. Previous study from our laboratory has shown that ATO inhibited TrxR1, most likely by reacting with the selenium-



containing active site [279]. Here we showed that the inhibition of TrxR1 is necessary for the cell toxicity, implying that TrxR1 is a reliable target for arsenic compounds as anticancer drugs.

However, only inhibiting TrxR1 is not enough to induce cell death. It is the redox status of Trx1 that determines the cell fates [282]. In most cases, inhibition of TrxR1 hampers the reduction of its primary substrate, Trx1. Interestingly, some compounds can not only inhibit TrxR1 activity, but also convert the enzyme into an NADPH oxidase which produces ROS and causes Trx1 oxidation. This phenomenon can be usually found when the selenocysteine of TrxR1 is targeted by electrophiles, or the C-terminus of TrxR1 is truncated that SecTRAPs (selenium compromised thioredoxin reductase-derived apoptotic proteins) are formed [283]. In this study, although we didn't check whether SecTRAPs were formed or not, As6 and As7 inhibited TrxR activity, at the same time led to oxidation of Trx1. Trx1 is an important mediator of cell death in that it directly interacts with key proteins in cell death pathway. As we discussed in the introduction section, ASK1 and PTEN-mediated apoptosis are highly dependent on the redox status of Trx1 that oxidation of Trx1 releases ASK1, PTEN and activates their activity [282].

The importance of the structural cysteines in hTrx1 was highlighted in this study. The three additional cysteines make hTrx1 more susceptible to oxidation. Cys73 is exposed on the surface of the hTrx1 structure and has been suggested to form intermolecular disulfides with Cys73 in another hTrx1 [284]. A second disulfide outside the active site can be formed between Cys62 and Cys69, and the oxidized Trx1 with two disulfides cannot be reduced by TrxR and NADPH [285]. However, the structural disulfide of Trx1 can be reduced by Grx system [286]. Cys62 and Cys69 are both partially buried under  $\alpha$ -helix3 and not easily accessible, however, a recent study showing that thioredoxin can undergo a large conformation change to expose Cys62 and Cys69 [287], which may explain why they can be targeted by As6.

Our data also showed that oxidation of Trx1 blocked electron transfer for Prx1, which is a key enzyme for scavenging  $H_2O_2$ . Prx1 contains four cysteines: active site Cys52, Cys173 for peroxide decomposition, and extra Cys71 and Cys83. The catalytic cycle of Prx1 involves a nucleophilic attack by Cys52 towards peroxide to form a sulfenic acid intermediate, which reacts with the resolving Cys173 in another subunit to form an intermolecular disulfide. This disulfide can be reduced by thioredoxin system and get reactivated [288]. Cys83 has been suggested to contribute to oligomer formation of Prx1 via Cys83-Cys83 bond with other Prx1

[289]. Here we showed that Trx1 reduce not only the intermolecular Cys52-Cys173 disulfides, but also the Cys83-Cys83 disulfides.

## **3.2 PAPER II**

Vitamin C and K3 cause cancer cell death by oxidative stress and effects on ribonucleotide reductase and its electron donors

**Xiaoyuan Ren**, Sebastin Santhosh, Lucia Coppo, Fernando Ogata, Jun Lu and Arne Holmgren

*Submitted manuscript*

### **Background**

Apatone is an investigational drug that has been used in Phase I /II clinical trials for cancer treatment [290]. The drug comprises vitamin C / vitamin K3 ( 100:1) and several types of cancer cells have been reported to be sensitive [291]. The design rationale of the drug is based on the idea that cancer cells take up oxidized VC (dehydroascorbic acid) via glucose transporters, which are highly expressed in cancer cells, and reactive oxygen species (ROS) is produced via a redox cycle formed by VC and VK3[292]. Following increased oxidative stress, stopped cell cycle, apoptosis and autophagy have been reported [293]. However, the exact action mechanism of Apatone has not been fully understood yet.

In this study, we investigated the effect of Apatone on Trx and Grx systems and their important downstream proteins such as RNR and GPx. We also proposed a redox-related mechanism for Apatone induced cell death.

### **Main findings**

*Apatone inhibited RNR and caused replicative stress in cancer cells*

Due to its important function in DNA replication and repair, RNR was found to be highly expressed in cancer cells. We found Apatone showed a synergetic inhibitory effect on recombinant RNR activity which is more efficient than VC or VK3 alone. The inhibitory effect of Apatone was partially rescued by adding catalase, suggesting Apatone acts via the generation of H<sub>2</sub>O<sub>2</sub>. RNR activity in cancer cells was also inhibited by Apatone treatment. Apatone-treated cells also showed less thymidine incorporation, suggesting they are under a replicative stress.

*Apatone induced Trx1 oxidation and total protein glutathionylation*

When different cancer cell lines were treated with Apatone (VC: VK3 = 500: 5  $\mu$ M), A172 cells exhibited higher sensitivity than LNCaP cells. We found that Apatone treatment induced a higher level of total cellular glutathionylation, higher Trx1 oxidation in A172 cells than in LNCaP cells. The results indicated Apatone caused higher oxidative stress in A172 which explained the different sensitivity. The cellular GSH content was also decreased by Apatone treatment.

#### *Apatone enhanced cellular lipid peroxidation and inhibited GPX activity*

Apatone treatment caused a higher level of lipid peroxidation in A172 cells than LNCaP cells in a time-dependent manner, which is consistent with the viability assay. The enhanced lipid peroxidation indicated an elevated ROS production and/or inhibited antioxidant system. In addition, Apatone inhibited GPx activity both on protein and cellular level that may also contributed to the elevated lipid peroxidation.

#### *AIF-mediated Apatone induced cell death*

Since previous studies have suggested that Apatone induced cell death is via a caspase-independent manner [294], we studied another cell death effector that is emerging as a central mediator of this process, apoptosis-inducing factor (AIF). Apatone treatment promoted AIF nuclear translocation, especially in A172 cells which are more sensitive to Apatone. VE supplement hampered the nuclear translocation of AIF in A172, suggesting lipid peroxidation may trigger the cell death pathway.

## **Discussion**

Using vitamin C as an anticancer reagent has been pioneered by Linus Pauling since 1970s [295]. However, the result has been contradicted by studies carried out in Mayo clinic [296, 297]. Later studies revealed that the administration routine matters for the treatment because oral administration of VC can maximally reach about 200  $\mu$ M in blood, while intravenous administration can bypass the limitation and go beyond 10 mM [298] [299]. Low concentration of VC in blood serves as an antioxidant while a high concentration of VC dramatically induces oxidative stress in cells. Apatone is another strategy to use VC at low concentration by redox-cycling VK3. VK3 can be reduced by VC into its semiquinone form that sequentially transfers electrons to O<sub>2</sub> to generate ROS [300].

Increasing ROS has been considered as a specific strategy for cancer treatment due to the reasons we have discussed in the introduction section. Moreover, another grade of specificity for Apatone consists in the uptake. In order to cope with the high energy demand, cancer cells

usually upregulate glucose transporters. Because of the structural resemblance of DHA to glucose, Apatone can be rapidly taken up by glucose transporters that are overexpressed in tumor cells [301].

It is worth noting that the two major antioxidant systems, Trx and GSH systems, were affected by Apatone treatment. The consequence was not only diminished antioxidant capacity, but also dysregulated downstream proteins. RNR, which receives electrons from Trx and Grx, got affected not only by the limited electron supply, but also by Apatone itself. RNR is essential for cancer cells to maintain dNTP homeostasis for DNA replication and repair. The dual inhibitory effect of RNR led to replicative stress in cancer cells. Apatone-induced lipid peroxidation can also be explained by multiple reasons: (1) oxidized Trx can not reduce Prx and led to accumulation of H<sub>2</sub>O<sub>2</sub> which oxidized lipid; (2) GPx activity was directly inhibited by Apatone; (3) decreased GSH content limited GPx activity.

Our study is the first time to link Apatone's killing effects to a caspase-independent cell death pathway, AIF. AIF is a conserved mitochondrial flavoprotein mediating cell death upon the apoptotic stimulus. During the AIF-mediate cell death, it translocates from mitochondria into the nucleus to trigger chromatin condensation and DNA degradation [302]. Studies have shown that lipid peroxide triggered the AIF-induced cell death [303] which is consistent with our results that showed a correlation between elevated lipid peroxidation and increased AIF nuclear translocation. What's more, Trx1 was found to bind AIF in cytosol under physiological condition [304] and oxidation of Trx1 also contributed to cytosolic release and nuclear accumulation of AIF.

### 3.3 PAPER III

Nitric Oxide Protects against Infection-Induced Neuroinflammation by Preserving the Stability of the Blood-Brain Barrier

Gabriela C. Olivera, **Xiaoyuan Ren**, Suman K. Vodnala, Jun Lu, Lucia Coppo, Chaniya Leepiyasakulchai, Arne Holmgren, Krister Kristensson, Martin E. Rottenberg

*PLoS Pathog.* 2016 Feb; 12(2): e1005442.

#### Background

Infection of parasite *Trypanosoma brucei* (*T.b.*) causes human and animal African trypanosomiasis. During the early stage of infection, the parasites overrun the hemolymphatic system, while during the late meningo-encephalitic stage severe signs of nervous system involvement are observed [305]. Infection-induced NO production by iNOS is a host defending mechanism mediated by macrophages. Meanwhile, overexpression of NO has been

considered as a risk factor for neuroinflammation. The paradoxical effects make the function of iNOS and derived NO during infection-induced brain inflammation ambiguous. In this study, we used an iNOS knockout mouse model and infected it with *T.b.* to see the effect of NO during parasite infection and brain inflammation.

## **Main findings**

*iNOS-derived NO impedes trypanosome and T cell brain invasion by maintaining the integrity of blood-brain-barrier (BBB)*

After 15 days of parasitic infection, wild-type (WT) and iNOS knockout (KO) mice showed a similar level of parasitemia. However, more parasites and T cells were found in KO mice brains than those in WT's. The infected KO mice also showed higher BBB permeability than infected WT mice which was proven by IgG and Evans blue and explained the difference in the parasite and immune cell invasion.

*Infection with *T.b. brucei* stimulates the expression of iNOS in macrophages*

Parasites infection significantly increased iNOS mRNA level which led to higher protein nitrosylation level in serum and brain in WT mice than in KO mice. Treating KO mice with S-nitrosoglutathione (GSNO), a NO donor, lowered the number of parasites passing through the BBB, suggesting a beneficial role of NO in keeping BBB stability. Since iNOS is mainly expressed by both macrophages and glial cells, flow cytometry was used to identify which type of cells contributed most to the NO production. CD45<sup>high</sup>CD11b<sup>high</sup> inflammatory cells, which were characterized as inflammatory monocytes and macrophages, were observed in brain cell suspensions from infected mice. Although microglial cells got activated after infection, no increased iNOS expression was detected. These results were also confirmed by immunostaining that macrophages in the brain are the main source of NO during *T.b.* infection.

*iNOS-derived NO mediates the protection by S-nitrosylating p65 subunit of NF-κB*

The mechanism of iNOS-mediated BBB protection was studied. Brains from infected mice had higher *tnf* mRNA level than uninfected controls, especially in infected KO mice which are twice higher than infected WT mice. After GSNO treatment, *tnf* mRNA level was significantly reduced in infected KO mice. We used LPS treated bone marrow-derived macrophages (BMM) as an *in vitro* model and similar results were obtained. NF-κB plays a central role in immune response and mediates the expression of iNOS and various cytokines including TNF-α. LPS treatment increased nuclear translocation of NF-κB and GSNO

treatment impaired the effect. What's more, increased level of nitrosylated p65 subunit of NF- $\kappa$ B was observed in LPS treated WT BMM and WT infected mice brains but not in KO ones. Therefore, NO exerts its neuronal protection via hampering NF- $\kappa$ B's nuclear translocation and activation by S-nitrosylating its p65 subunit.

#### *MMP9 mediates parasite and T cell penetration and BBB leakage*

TNF-mediated activation of matrix metalloproteases (MMPs) is critical for BBB disruption due to their ability to degrade matrix proteins. We found significantly higher mRNA expression of MMP9 in the brains and in the macrophages from infected mice. The expression of MMP9 was TNF-dependent and increased in the absence of iNOS.

#### *T cells are required for iNOS-mediated protection during infection*

Whether T cells also played a role in the iNOS-mediated inhibition of parasite penetration into the brain was then studied. B and T cell deficient *rag1*<sup>-/-</sup> and *rag1*<sup>-/-</sup>/*inos*<sup>-/-</sup> mice showed similar parasitemia levels and very few parasites in the brain parenchyma after infection, indicating that T and/ or B cells are required for the increased parasite penetration into the brain of *inos*<sup>-/-</sup> mice. When infected *rag1*<sup>-/-</sup> mice were transferred with T cells, the parasite density in the brain increased. *Tnf*, *inos* and *ifng* mRNA levels were all elevated in the brains of infected *rag1*<sup>-/-</sup> mice transferred with T cells compared to non-transferred infected controls. High levels of *ifng* mRNA were found in T cell-enriched populations from brains of infected mice but not in macrophages or microglia. Thus, T cells express IFN- $\gamma$  in the brain and contribute to the induction of TNF- $\alpha$  and iNOS expression by brain macrophages. In summary, both TNF- $\alpha$  and activated T cells are necessary to stimulate iNOS expression by brain macrophages, while reciprocally iNOS-derived NO dampens the TNF- $\alpha$  and T cell-mediated brain invasion of parasites and leukocytes.

## **Discussion**

NO production is a commonly used mechanism for the host to defend invading microbes, such as virus, bacteria, and parasites. However, the role of NO during African trypanosomiasis is controversial. One study on a *T. congolense* model indicated that TNF- $\alpha$  and NO had a protective role in controlling parasitemia [306]. While in a *T.b.* model, iNOS-derived NO suppressed bone marrow proliferation and induced anaemia [307]. Others have shown that the NO synthesized in *T.b.*-infected mice lacked trypanocidal activity in vivo [308]. Although there is a consensus that NO generation is stimulated by infection, the role of iNOS-generated NO during the infection and specifically in the brain at the encephalitic stage

is still unclear. In this study, we did not see the obvious killing effect of NO on parasites, but a protective mechanism of NO via maintaining the integrity of BBB and preventing brain from parasites and immune cells invasion was elucidated.

Although several types of neuronal cells including perivascular macrophages, microglia, astrocytes and even neurons can produce NO, we found that in the brain parenchyma, iNOS was prominently expressed in perivascular macrophages during trypanosome infection. The produced NO not only S-nitrosylated proteins intracellularly, but also elevated global protein S-nitrosylation and nitrite/nitrate concentration in serum. T cell also participates in the process by producing INF- $\gamma$  which is indispensable for TNF- $\alpha$  production.

Consistent with our observations, a recent study also showed a beneficial effect of NO donors on reducing neuroinflammation and increasing cerebrovascular flow [309]. By S-nitrosylating NF- $\kappa$ B, NO serves as a negative feedback to curb the inflammation. Both S-nitrosylation of p50 and p65 subunits of NF- $\kappa$ B have been observed previously and S-nitrosylation inhibited DNA binding activity of NF- $\kappa$ B [310, 311]. Our experiments indicated that NO mediates S-nitrosylation and inhibits NF- $\kappa$ B p65 activation in the brain of infected mice. The regulation of NF- $\kappa$ B is complicated. It is sequestered in the cytoplasm by inhibitory I $\kappa$ B (inhibitor of NF- $\kappa$ B) which can be phosphorylated by I $\kappa$ B-kinase complex (IKK $\alpha$ , IKK $\beta$ , and IKK $\gamma$ ) upon stimuli and get degraded by the ubiquitin proteasome. The degradation of I $\kappa$ B releases NF- $\kappa$ B and allows its nuclear translocation [312]. Therefore, our study does not exclude the possibility that NO interacts with other molecules regulating NF- $\kappa$ B activation.

We also identified MMP9 as the executor of degrading BBB integrity. MMP is a family of structurally related zinc-dependent endopeptidases capable of degrading extracellular matrix (ECM) and basement membrane, both in physiological and pathological events. We found here that expression of MMP9 in the brains of infected mice in vivo and in macrophage cultures in vitro was dependent on TNF- $\alpha$  and increased in the absence of iNOS. The effect of NO on MMP9 has been investigated by different studies, but the data still seem complex and sometimes contradictory [313]. In our case, NO indirectly down-regulated MMP9 expression by negatively regulating TNF.

### **3.4 PAPER IV**

Characterization of mammalian glutaredoxin isoforms as S-denitrosylases

**Xiaoyuan Ren**, Rajib Sengupta, Jun Lu, Jon O. Lundberg, Arne Holmgren

## **Background**

Protein S-nitrosylation is a reversible PTM. Under physiological condition, the homeostasis of S-nitrosothiols is kept in a balance between S-nitrosylation and S-denitrosylation. Although several proteins including GSNOR, PDI and Trx, have been identified as S-denitrosylases, there still remains a lot unknown in S-denitrosylation and the role of Grx system in regulating NO metabolism has never been investigated. In this study, we characterized Grxs as S-denitrosylases.

## **Main findings**

### *Reduced human Grx1 & 2 denitrosylates S-nitrosothiols*

Reduced human Grx1 and Grx2a exhibited denitrosylase activity towards L-Cys-SNO, GNSO and HEK cell-derived S-nitrosylated proteins (HEK-PSNOs). The denitrosylase activity is highly related to their redox status. If one cysteine at the active site of Grx1 was mutated (C26S), it lost denitrosylase activity, suggesting the importance of active cysteine for the catalysis. In addition, we found a subgroup of HEK-PSNOs remains in the presence of high concentration of GSH. When Grx1 was added, those GSH-stable HEK-PSNOs were further denitrosylated. We also identified caspase 3 and cathepsin B as two substrates for Grx1-mediated denitrosylation.

### *Monothiol Grxs denitrosylates HEK-PSNOs*

Monothiol Grxs can deglutathionylate protein mixed disulfide via the monothiol mechanism. In this study, we investigated whether monothiol Grxs can mediate S-denitrosylation using an active site C40S mutant human Grx2a and a naturally occurred human Grx5. Monothiol Grxs alone did not show any denitrosylation activity, however, when they were coupled with GSH, those GSH-stable HEK-PSNOs got further denitrosylated. Thus, GSH and Grxs have a cooperative effect on denitrosylating proteins.

### *Crosstalk between Grx and Trx in denitrosylation*

Both Trxs and Grxs contain structural cysteines which can be nitrosylated in different biological conditions. Nitrosylated Trx1 (Trx1-SNO) at Cys73 serves as a transnitrosylase which transfers the NO group to target proteins including caspases [191], peroxiredoxin 1 (Prx1) etc. [192]. Therefore understanding how Trx1-SNO is regulated is of high importance.



We found that denitrosylation of Trx1-SNO by GSH was facilitated by monothiol Grx2a, but not by Grx1. Trx system failed to denitrosylate Grx1-SNO

## **Discussion**

This study is the first time to reveal the role of Grxs in S-denitrosylation. We found that human dithiol Grxs directly denitrosylated L-Cys-SNO and GSNO, which are the two most common cellular low molecular weight SNOs in living organisms and have been used as NO donors in various studies. GSNO can slowly release NO extracellularly. L-Cys-SNO is a more potent trans-nitrosylation reagent which is imported by the amino acid transporter system L into cells and performs protein S-nitrosylation [314].

GSH, as an essential member in Grx system at high biological concentration, has been shown to catalyze protein denitrosylation in different biological events [315, 316]. We also found that HEK cells pretreated with BSO, a compound inhibits GSH production, were more susceptible to NO donor-induced cell death (data not shown). Even though, we found that there are some proteins resistant to the denitrosylation effect of GSH. When Grxs were added, those GSH-stable nitrosylated proteins were further denitrosylated. This result indicated an indispensable role of Grxs in S-denitrosylation.

S-nitrosylated caspase 3 was identified as one of the stable S-nitrosothiols in the presence of GSH and has been reported to be specifically denitrosylated by the Trx system [191]. Here we found that reduced Grx1 can also denitrosylate caspase 3. The denitrosylation of the functional cysteine in cathepsin B could also be mediated by Grx1. Since both caspase 3 and cathepsin B play important roles in apoptosis, our results indicate a possible function of Grx1 in the regulation of apoptosis through its denitrosylase activity.

Grxs are considered as the major deglutathionylases due to their high affinity and selectivity to glutathionylated proteins [249]. Two mechanisms have been proposed: the dithiol and the monothiol mechanisms. In this study, we also noticed that coupled with GSH, both dithiol Grxs and monothiol Grxs can denitrosylate HEK-PSNOs, suggesting that Grxs-mediated denitrosylation can be via both mechanisms similar to Grx-mediated deglutathionylation. In addition, monothiol Grxs exhibited a broader substrate than dithiol Grxs in denitrosylation.

## 4 CONCLUSION AND FUTURE PERSPECTIVES

This thesis further explored the interaction between ROS/RNS and the two major antioxidant systems, Trx and Grx systems, under different conditions. The findings of the thesis added a small piece to the big complex picture of redox regulation and may inspire others for future studies, because it is evident that ROS/RNS play essential roles in both physiological and pathological conditions.

In **Paper I**, arsenicals-induced cytotoxicity was linked to the Trx system. Interestingly, different arsenic compounds exert their toxicity via different mechanisms. Even so, inhibition of TrxR emerges as a universal basis for arsenical-induced cytotoxicity. Arsenic compounds with aromatic groups exhibited higher toxicity due to their ability to oxidize Trx1 besides the inhibitory effect on TrxR. The importance of the structural cysteines of Trx1 was also highlighted that formation of Cys62-Cys69 disulfide hampers electron transfer from TrxR. Structure modeling suggested that Cys62-Cys69 disulfide substantially alters the structure in this region proximal to the active site [285], that might explain the loss of ability to receive electrons from TrxR. However, the crystal structure is needed to confirm the speculation. The arsenicals used in this study provide us a handy toolkit to investigate certain cysteine functions by specifically oxidize desired cysteines into disulfide. What's more, Grx system has been reported by our lab to serve as a backup of TrxR to reduce Trx1 [160, 317], and whether Grx system is also affected by arsenicals should be addressed. Arsenicals treatment has gained some success in treating leukemia, our study may help to elucidate the action mechanism and develop strategy to minimize side effect. Another aspect need to be considered is the physiological role of Cys62-Cys69 disulfide. Although a previous study from our lab has shown that treating A549 cells with high concentration of H<sub>2</sub>O<sub>2</sub> can induce double disulfides formation in Trx1 [160], there is concern that whether it can happen in physiological condition. There might be a possibility that H<sub>2</sub>O<sub>2</sub> generated by NOX during certain processes may reach such a high local concentration which will trigger the redox-dependent signaling pathways. Because Prxs receive reducing power from Trx1 to efficiently remove H<sub>2</sub>O<sub>2</sub>, Cys62-Cys69 disulfide blocks electron flow from TrxR to Prx via Trx1 and allows H<sub>2</sub>O<sub>2</sub> accumulation. Interestingly, using pure protein, the H<sub>2</sub>O<sub>2</sub> mediated Trx1 oxidation was accelerated in the presence of Prx [160], suggesting a dual role of Prx in redox signaling. However, more evidence is needed to confirm our hypothesis.

In **Paper II**, the effect of an anticancer drug, Apatone, on both systems was investigated. The H<sub>2</sub>O<sub>2</sub> produced by Apatone (VC and VK3 redox cycling) dramatically disturbed the redox balance in cancer cells, including GSH depletion, protein hyper-glutathionylation, Trx1

oxidation and lipid peroxidation. RNR was also inhibited by Apatone which sequentially induced replicative stress in cancer cells. The mechanism of RNR inhibition by Apatone is unknown yet. One possible reason is that R2 subunit contains iron metal at the radical generation site, the chemical property of this transition metal makes R2 sensitive to redox turbulence. Apatone induced cell death was named autoschizis, which is characterized by nuclear changes, chromatin disassembly, DNA condensation and fragmentation, and decreased nuclear volume [318]. This phenomenon has only been described morphologically under microscopy, the evidence link between autoschizis and replicative stress and RNR has not been chained yet. We also noticed that different cell lines exhibited different sensitivity towards Apatone treatment. The reason behind this observation needs to be explained. Is that due to different basal ROS and antioxidant level, or due to different GLUTs expression level so cell lines with higher GLUTs can take up more Apatone than others? Understanding these questions will provide us knowledge about the Apatone's mechanism which will definitely help us to select the most suitable patients and minimize side effect for clinical trials. In addition, a biomarker shall also be developed to monitor the patient's response to Apatone.

In **Paper III**, we elucidate a protective mechanism that iNOS-derived NO maintains the integrity of BBB by S-nitrosylation of NF- $\kappa$ B during *T. brucei* infection. NO serves as an indispensable negative feedback to curb the TNF- $\alpha$ -mediated neuroinflammation. The role of NO in neuroinflammation has been contradicted by several studies due to a fact that NO is used as a weapon to fight against invading microbes, therefore, it might cause damage to host cells, too. Our data also showed that *T. brucei* and several mammalian cells exhibited similar IC<sub>50</sub> to NO donors *in vitro*. How to utilize the beneficial effect and avoid the detrimental effect of NO will be an interesting topic to study. Besides the endogenous production by NOSs, NO can be generated by nitrate-nitrite-NO pathway [48] which provides us a possible way to manipulate NO production by oral administration of nitrate-rich diet. Whether such a diet has similar protection is still a question mark. Another concern is that whether the protective effect is commonly found in other brain infection diseases, such as cerebral malaria, viral and bacterial encephalitis, and it will be interesting to use the iNOS knockout mice to check other infections. The role of Trx and Grx systems was not studied in this paper; however, as denitrosylases they might be involved in the process and it has been reported that Trx1 regulates NF- $\kappa$ B by S-denitrosylation [319]. This study inspires us another way to maintain the S-nitrosylation of NF- $\kappa$ B: to inhibit TrxR. TrxR inhibitors have been widely investigated as a potential treatment for cancer [320] and they may also inhibit S-denitrosylation by limiting Trx1 reduction via TrxR. From parasites' point of view, NO produced by macrophages may also nitrosylate some of their proteins and they must be

equipped with mechanisms neutralizing the effect of NO to penetrate BBB anyway because *T.brucei* were also found in the brains of wild-type mice. Indeed, different from mammalian cells, the main antioxidant system in trypanosomes is the trypanothione system, which is similar to the Grx system. Trypanothione is a parasitic special form of GSH, which contains two molecules of GSH linked by a spermidine linker. Trypanothione reduces tryparedoxin, which sequentially supplies electrons to tryparedoxin peroxidase, an enzyme decomposes H<sub>2</sub>O<sub>2</sub> in parasites. After the redox reaction, oxidized trypanothione is reduced by trypanothione reductase [321]. It will be interesting to fish out which transcription factors in *T.brucei* get nitrosylated and to investigate the role of trypanothione in NO metabolism.

In **Paper IV**, we characterized Grxs as S-denitrosylases working via both dithiol and monothiol mechanisms. A major challenge for future study is to identify the specific denitrosylation substrates of Grxs. Within cells, Grxs must compete with other denitrosylases such as Trxs, GSNOR, PDI and so on. A Grx1-deficient model will help a lot to evaluate the importance of Grx1 in cellular denitrosylation. What's more, GSH also denitrosylate many proteins, which makes the whole picture even more complicated. Recently, a trapping method was described to identify specific denitrosylation substrates of Trx1 based on the catalytic mechanism. In general, the C-terminal active site cysteine (Cys35) of Trx1 was mutated to serine. During the denitrosylation, N-terminal active site cysteine attacks the sulfur atom on the SNO moiety of the substrate protein. Due to the lacking of resolving cysteine, the substrates will be trapped by the mutant [322]. A modified method using a Grx mutant may also help discover the specific substrates for Grx. We have discussed that the structural cysteines of Trx1 can be nitrosylated and act as transnitrosylase which transfers the NO moiety to other proteins, for example, caspases [323]. The nitrosylation of Grx1's structural cysteines was also observed [280]. It will be interesting to exam whether nitrosylated structural cysteines in Grx1 can transnitrosylate other proteins.

To summarize, this thesis investigated Trx system and Grx system under oxidative and nitrosative stress. We found both systems are important for ROS/RNS defending, cellular detoxification and redox signaling.

## ACKNOWLEDGEMENTS

This thesis was performed at **the Division of Biochemistry, Department of Medical Biochemistry and Biophysics, Karolinska Institutet**, Sweden. I feel so lucky that I was trained in one of the most prestigious medical universities in the world.

First of all, I would like to give my deepest gratitude to my main supervisor, **Prof. Arne Holmgren**. Thank you so much for your generous support and unconditional trust, so I always feel supportively confident with necessary freedom during my Ph.D. study. Every time we discuss science, I get fascinated by your “old” stories and your boundless knowledge about redox biology. As a pioneer in the field, you do lay a foundation and set a role model for me and other scientists.

My co-supervisor, **Prof. Jun Lu**, the best way to describe our relation is a Chinese saying: “亦师亦友” that you are both a good friend and a good teacher. Every time an immature idea pops into my brain, I immediately go to your office. Most of the time, you are so supportive and let me go ahead and try, sometimes you use your sharp insight to prick the bubble so I can think it through. I appreciate both as good training for a student. Thank you so much for the tremendous help during my Ph.D. study.

**Rajib Sengupta**, my another co-supervisor, thank you for introducing me into the nitric oxide field which I find it amazing. I always get inspired by your way of thinking which is full of Indian wisdom. I feel grateful for your rookie’s training so I can keep good habits in the lab.

I would also like to thank **Prof. Elias Arnér**, as my co-supervisor, although we don’t have too much scientific collaboration, you are always supportive of every step of my Ph.D. study and I get a lot of scientific input from you via seminars and courses. As the head of our division, your fantastic leadership unites us as a strong team and your passion about science infects me a lot. I am also grateful for all the memorable activities you organized in our division and in your house.

My mentor, **Björn Högberg**, thank you for accepting me as a project student in my early life in Karolinska and I really learned a lot from your enthusiasm about science. I am proud that I worked in your DNA-origami lab where fantasy and science meet each other.

**Lena Ringdén**, thank you for a fantastic administrative work. You always help us to maintain a wonderful working environment in the best way. **Åse Mattson**, thank you for taking good care of ordering and being such a good lab manager and officemate. **Jacek Andrzejewski** and **Cecilia Bosdotter** are also highly appreciated.

**Aristi Fernandes**, thank you so much for being willing to serve as the chairperson of my dissertation, and all the good discussions about Grxs and selenium, and the generous gift of Grx5.

Another fantastic gain of my Ph.D. journey is to know a lot of wonderful friends. As an introverted person, science helped me find the common topic and language we talk.

I’d like to thank current and former members in AH group. **Lucia Coppo**, for being super nice and helpful around the lab and sharing fantastic coffee from your magic pot to make affogato. You are so organized that you shattered our stereotype for Italian. **Sebastin Santhosh**, for being a wonderful officemate, teaching me RNR assay and discussing about science and life in Stockholm. **Lili Zou**, for sharing spicy snacks, funny jokes and brilliant scientific ideas. You are always efficient and brave to explore the unknown area with your strong power of execution which encouraged me a lot. **Fernando Ogata**, for being so kind

and supportive in the lab and collaborating for Apatone project. **Xu Zhang**, for helping me so much in my early life of Ph.D. both inside and outside lab like an elder sister. **Lanlan Zhang**, for good discussion about the balance of life. **Tomas Gustafsson**, for good training of protein purification and random Swedish culture input. **Lars Br äutigam**, for setting a good example of handling mice pedigree and organizing files in a German style, also answering me any questions about Grx. **Sergio Montano**, for good discussion in journal club. **Yatao Du and Huihui Zhang**, for handing the tricky redox western blot down to me and solving technical troubles at the beginning of my study.

Special thanks to those who shared the Ph.D. journey with me, **Xiaoxiao Peng**, for a lot of fun time, eating, drinking and good discussion about science and career development. **Irina Pader**, for the wonderful trip in US and guiding me through my half-time control, and inspiring me for career planning. **William Stafford**, for always being fun and warm-hearted like the Californian sunshine. **Marcus Cebula**, for infecting me with your optimism and good appetite.

I'd like to thank my dear colleagues in Biochemistry: **Qing Cheng**, for countless help and support, from protein purification to fish-market navigation, you are the big brother in the lab and the opposite of Jon Snow! **Katarina Johansson**, for being so patient and tolerant about my lame Swedish, talking with you is always joyful, also great scientific input and cheerful time in Chicago. **Alfredo Gimenez-Cassina**, for being such a gentleman with natural willingness to help and good collaborating in lunch seminar committee. **Markus Dagnell**, for good discussion about science, life with children and photography. **Belen Espinosa**, for all the fun moments in our kitchen and Nobel minds program. **Renato Alves**, for bringing us evilly delicious pastry from Portugal. **Yurika Katsu**, for showing me how cool a geeky girl can be. **Deepika Nair**, for a good company in Chicago. **Prajakta Khalkar**, for being one of us, Your Highness! **Michael Bonner**, welcome to the big family! **Carmela V ázquez Calvo**, for great beer time in the kitchen.

Also friends I got to know in Biochemistry, **Teodor Sventelius, Vasco Branco, Cristina Álvarez-Zaldiernas, Vanda Mendes, Fredrik Tholander, Mikael Crona, Sofi Eriksson, Hanna-Stina Martinsson Ahlzén, Olle Rengby, Paula Codó, Nuria D áz Argelich, Hayrie Aptula, Anna Kipp, Mireille Stijhns, Eva D áka and Weng Kee Leong, Aida Rodriguez, Tom Reichenbach**, it is a pleasure doing science with you. Special thanks to **Jianqiang Xu & Weiping Xu**, for great help of all kinds. Very special thanks to **Prof. Ed Schmidt** for being a member of my halftime control committee and having a good discussion about my studies, also for all fun memories when you were here: the picky taste of beer, amazing cookies made by your wife and fantastic mice science.

Many thanks to my collaborators, **Prof. Martin Rottenberg, Dr. Gabriela Olivera** for involving me into the amazing iNOS project; **Prof. Jon Lundberg**, for collaborating for denitrosylation study and being a board member of my halftime control, **Carina Nihlen, Mike Hezel** and **Marcelo Montenegro** for the help with nitric oxide analyzer.

My best buddies in Sweden: **Meng Chen, Tian Li, Chang Liu & Xiao Tang, Yiqiao Wang**, during the last 6.5 years, we “mastered” and “Ph.Ded” our life together. We had so much fun together, the video game nights, the class-skipping travels and the competitive hot-pottings. We also discussed a lot about life, love, career and future collaborations. Without your friendship, I cannot survive so many Nordic winters. Also thanks to **Xiaofei Li, Bojing Liu, Jing Guo, Xintong Jiang, Yixin Wang, Yabin Wei**, for all the fun activities and parties we went together. **Jianren Song & Na Guan**, for your generous help and sincere friendship. **Tiansheng Shi, Zi Ning** for sparing me a space when I was homeless in Stockholm. **Yuan Xu**, for your medical advice as a real doctor, **Yi Wang** for being a good flatmate then a neighbor.

And all the friends I met in Sweden, those of you from MEB are my friends-in-law: **Chen Suo, Ci Song & Zheng Chang, Donghao Lv, Fang Fang, Fei Yang, Haomin Yang, Huan Song & Jianwei Zhu, Jiaqi Huang, Jiayao Lei, Jie Song, Mei Wang, Qi Chen, Qing Shen, Ruoqing Chen & Yiqiang Zhan, Shuyang Yao & Shuoben Hou, Tong Gong, Xu Chen.** And those from KI and outside KI, **Bo Zhang, Bin Zhao, Chao Sun & Ying Lei, Chenfei Ning, Fan Zhang & Fan Yang, Jia Sun, Hongqian Yang, Kai Du, Lidi Xu, Meiqiongzi Zhang, Meng Xu, Min Wan, Ming Liu, Ning Yao, Qiang Zhang, Qiaoli Wang, Qinzi Yan & Shuo Liu, Qun Wang & Hongyu Ren, Shan Jiang, Shuijie Li, Xicong Liu, Xiaonan Zhang, Xinming Wang, Xinsong Chen & Ran Ma, Ting Jia, Yang Xuan, Yi Jin, Ying Qu, Yu Gao & Honglei Zhao, Yu Qian & Rui Wang, Yuanjun Ma, Yuning Zhang, Zhuochun Peng,** it feels great having you around. Special thanks to **Prof. Yongxing Zhao and Cosimo Ducani,** it was a great pleasure working with you in Björn's lab. **Goncalo Castelo-Branco, Katja Petzold, Hassan Foroughi Asl, Lorenzo Baronti** for a good team work in lunch seminar committee. My best friends since high school, **Yu Bai, Anchao Xue, Yaran Zhang,** although we didn't get too much time for reunion, I know you will be there for me, thank you guys for the everlasting friendship.

To my dearest family, thank you all for unconditional love and support. 致我最亲爱的家人: 爸爸, 感谢您从小到大给这个家无私的爱, 让我明白家庭的责任, 教育我认认真真做事, 不卑不亢做人, 您一直是我的榜样。妈妈, 您是最善良开明的母亲, 感谢您给予我生命和追求梦想的自由, 您为这个家付出了太多。岳父, 感谢您的谆谆教导, 从您身上传递出对事业的执着, 对家国的赤诚, 时时触动着我。岳母, 感谢您无条件的支持和帮助, 让我们俩能安心完成学业。感谢我的妹妹和妹夫, 无微不至的照顾父母, 你们辛苦了! 也感谢家族里的各位亲人对我们的帮助。

Last but foremost, to my beloved wife, **Jiangrong Wang,** thank you for standing by me whatever happens. I am so touched that you care about my dream and pursuit more than I do, you calm me down when I am lost, cheer up when I am depressed. All the complimentary words suddenly turn shallow to describe you, you know me so well even I don't say a word. You are my soulmate, I love you and I will always do.

## REFERENCES

1. Rosing, M.T., *<sup>13</sup>C-Depleted carbon microparticles in >3700-Ma sea-floor sedimentary rocks from west greenland*. Science, 1999. **283**(5402): p. 674-6.
2. Decker, H. and K.E. Van Holde, *Oxygen and the evolution of life*. 2011, Heidelberg ; New York: Springer. xi, 172 p.
3. Lyons, T.W., C.T. Reinhard, and N.J. Planavsky, *The rise of oxygen in Earth's early ocean and atmosphere*. Nature, 2014. **506**(7488): p. 307-15.
4. Holland, H.D., *The oxygenation of the atmosphere and oceans*. Philos Trans R Soc Lond B Biol Sci, 2006. **361**(1470): p. 903-15.
5. McCord, J.M., *The evolution of free radicals and oxidative stress*. Am J Med, 2000. **108**(8): p. 652-9.
6. Fridovich, I., *Oxygen toxicity: a radical explanation*. J Exp Biol, 1998. **201**(Pt 8): p. 1203-9.
7. Gerschman, R., et al., *Oxygen poisoning and x-irradiation: a mechanism in common*. Science, 1954. **119**(3097): p. 623-6.
8. Pryor, W.A., *Oxy-radicals and related species: their formation, lifetimes, and reactions*. Annu Rev Physiol, 1986. **48**: p. 657-67.
9. Lushchak, V.I., *Free radicals, reactive oxygen species, oxidative stress and its classification*. Chem Biol Interact, 2014. **224**: p. 164-75.
10. Reed, T.T., *Lipid peroxidation and neurodegenerative disease*. Free Radic Biol Med, 2011. **51**(7): p. 1302-19.
11. Gebicki, S. and J.M. Gebicki, *Formation of peroxides in amino acids and proteins exposed to oxygen free radicals*. Biochem J, 1993. **289** ( Pt 3): p. 743-9.
12. Skulachev, V.P., *Mitochondria-targeted antioxidants as promising drugs for treatment of age-related brain diseases*. J Alzheimers Dis, 2012. **28**(2): p. 283-9.
13. Lavi, R., et al., *Low energy visible light induces reactive oxygen species generation and stimulates an increase of intracellular calcium concentration in cardiac cells*. J Biol Chem, 2003. **278**(42): p. 40917-22.
14. Heck, D.E., et al., *UVB light stimulates production of reactive oxygen species: unexpected role for catalase*. J Biol Chem, 2003. **278**(25): p. 22432-6.
15. Riley, P.A., *Free radicals in biology: oxidative stress and the effects of ionizing radiation*. Int J Radiat Biol, 1994. **65**(1): p. 27-33.
16. Gurgueira, S.A., et al., *Rapid increases in the steady-state concentration of reactive oxygen species in the lungs and heart after particulate air pollution inhalation*. Environ Health Perspect, 2002. **110**(8): p. 749-55.
17. Valavanidis, A., T. Vlachogianni, and K. Fiotakis, *Tobacco smoke: involvement of reactive oxygen species and stable free radicals in mechanisms of oxidative damage, carcinogenesis and synergistic effects with other respirable particles*. Int J Environ Res Public Health, 2009. **6**(2): p. 445-62.
18. Heiser, I., W. Osswald, and E.F. Elstner, *The formation of reactive oxygen species by fungal and bacterial phytotoxins*. Plant Physiology and Biochemistry, 1998. **36**(10): p. 703-713.
19. Winterbourn, C.C., *Reconciling the chemistry and biology of reactive oxygen species*. Nature Chemical Biology, 2008. **4**(5): p. 278-286.
20. Choe, E. and D.B. Min, *Chemistry and reactions of reactive oxygen species in foods*. Crit Rev Food Sci Nutr, 2006. **46**(1): p. 1-22.
21. Zimorski, V., et al., *Endosymbiotic theory for organelle origins*. Curr Opin Microbiol, 2014. **22**: p. 38-48.
22. Martin, W.F., et al., *Energy for two: New archaeal lineages and the origin of mitochondria*. Bioessays, 2016. **38**(9): p. 850-6.
23. Boveris, A., *Determination of the production of superoxide radicals and hydrogen peroxide in mitochondria*. Methods Enzymol, 1984. **105**: p. 429-35.
24. Li, X.Y., et al., *Targeting mitochondrial reactive oxygen species as novel therapy for inflammatory diseases and cancers*. Journal of Hematology & Oncology, 2013. **6**.
25. Siebels, I. and S. Drose, *Q-site inhibitor induced ROS production of mitochondrial complex II is attenuated by TCA cycle dicarboxylates*. Biochimica Et Biophysica Acta-Bioenergetics, 2013. **1827**(10): p. 1156-1164.
26. Brand, M.D., *The sites and topology of mitochondrial superoxide production*. Experimental Gerontology, 2010. **45**(7-8): p. 466-472.
27. Cao, S.S. and R.J. Kaufman, *Endoplasmic Reticulum Stress and Oxidative Stress in Cell Fate Decision and Human Disease*. Antioxidants & Redox Signaling, 2014. **21**(3): p. 396-413.
28. Gross, E., et al., *Generating disulfides enzymatically: Reaction products and electron acceptors of the endoplasmic reticulum thiol oxidase Ero1p*. Proceedings of the National Academy of Sciences of the United States of America, 2006. **103**(2): p. 299-304.
29. Gross, E., et al., *Generating disulfides enzymatically: reaction products and electron acceptors of the endoplasmic reticulum thiol oxidase Ero1p*. Proc Natl Acad Sci U S A, 2006. **103**(2): p. 299-304.



30. Schrader, M. and H.D. Fahimi, *Peroxisomes and oxidative stress*. Biochim Biophys Acta, 2006. **1763**(12): p. 1755-66.
31. Boveris, A., N. Oshino, and B. Chance, *The cellular production of hydrogen peroxide*. Biochem J, 1972. **128**(3): p. 617-30.
32. Lambeth, J.D., *NOX enzymes and the biology of reactive oxygen*. Nat Rev Immunol, 2004. **4**(3): p. 181-9.
33. Bedard, K. and K.H. Krause, *The NOX family of ROS-generating NADPH oxidases: physiology and pathophysiology*. Physiol Rev, 2007. **87**(1): p. 245-313.
34. Hippeli, S. and E.F. Elstner, *Transition metal ion-catalyzed oxygen activation during pathogenic processes*. FEBS Lett, 1999. **443**(1): p. 1-7.
35. Valko, M., et al., *Free radicals, metals and antioxidants in oxidative stress-induced cancer*. Chem Biol Interact, 2006. **160**(1): p. 1-40.
36. Arnold, W.P., et al., *Nitric oxide activates guanylate cyclase and increases guanosine 3':5'-cyclic monophosphate levels in various tissue preparations*. Proc Natl Acad Sci U S A, 1977. **74**(8): p. 3203-7.
37. Furchgott, R.F. and J.V. Zawadzki, *The obligatory role of endothelial cells in the relaxation of arterial smooth muscle by acetylcholine*. Nature, 1980. **288**(5789): p. 373-6.
38. Ignarro, L.J., et al., *Endothelium-derived relaxing factor produced and released from artery and vein is nitric oxide*. Proceedings of the National Academy of Sciences, 1987. **84**(24): p. 9265-9269.
39. Zhang, Y.H. and B. Casadei, *Sub-cellular targeting of constitutive NOS in health and disease*. J Mol Cell Cardiol, 2012. **52**(2): p. 341-50.
40. Nakane, M., et al., *Cloned human brain nitric oxide synthase is highly expressed in skeletal muscle*. FEBS Lett, 1993. **316**(2): p. 175-80.
41. Xu, K.Y., et al., *Nitric oxide synthase in cardiac sarcoplasmic reticulum*. Proc Natl Acad Sci U S A, 1999. **96**(2): p. 657-62.
42. Ward, M.E., et al., *Hypoxia induces a functionally significant and translationally efficient neuronal NO synthase mRNA variant*. J Clin Invest, 2005. **115**(11): p. 3128-39.
43. Forstermann, U., J.P. Boissel, and H. Kleinert, *Expressional control of the 'constitutive' isoforms of nitric oxide synthase (NOS I and NOS III)*. FASEB J, 1998. **12**(10): p. 773-90.
44. Denlinger, L.C., et al., *Regulation of inducible nitric oxide synthase expression by macrophage purinoreceptors and calcium*. J Biol Chem, 1996. **271**(1): p. 337-42.
45. Cifone, M.G., et al., *Interleukin-2-activated rat natural killer cells express inducible nitric oxide synthase that contributes to cytotoxic function and interferon-gamma production*. Blood, 1999. **93**(11): p. 3876-84.
46. Wheeler, M.A., et al., *Bacterial infection induces nitric oxide synthase in human neutrophils*. J Clin Invest, 1997. **99**(1): p. 110-6.
47. Vannini, F., K. Kashfi, and N. Nath, *The dual role of iNOS in cancer*. Redox Biol, 2015. **6**: p. 334-43.
48. Lundberg, J.O., E. Weitzberg, and M.T. Gladwin, *The nitrate-nitrite-nitric oxide pathway in physiology and therapeutics*. Nat Rev Drug Discov, 2008. **7**(2): p. 156-67.
49. Khatri, J., et al., *It is rocket science - why dietary nitrate is hard to 'beet'! Part I: twists and turns in the realization of the nitrate-nitrite-NO pathway*. Br J Clin Pharmacol, 2017. **83**(1): p. 129-139.
50. Dahle, H.K., *Nitrite as a food additive*. NIPH Ann, 1979. **2**(2): p. 17-24.
51. Lundberg, J.O. and M. Govoni, *Inorganic nitrate is a possible source for systemic generation of nitric oxide*. Free Radic Biol Med, 2004. **37**(3): p. 395-400.
52. Jansson, E.A., et al., *A mammalian functional nitrate reductase that regulates nitrite and nitric oxide homeostasis*. Nature Chemical Biology, 2008. **4**(7): p. 411-417.
53. Webb, A., et al., *Reduction of nitrite to nitric oxide during ischemia protects against myocardial ischemia-reperfusion damage*. Proceedings of the National Academy of Sciences of the United States of America, 2004. **101**(37): p. 13683-13688.
54. Carlsson, S., et al., *Effects of pH, nitrite, and ascorbic acid on nonenzymatic nitric oxide generation and bacterial growth in urine*. Nitric Oxide-Biology and Chemistry, 2001. **5**(6): p. 580-586.
55. Gladwin, M.T. and D.B. Kim-Shapiro, *The functional nitrite reductase activity of the heme-globins*. Blood, 2008. **112**(7): p. 2636-47.
56. Aamand, R., et al., *Generation of nitric oxide from nitrite by carbonic anhydrase: a possible link between metabolic activity and vasodilation*. American Journal of Physiology-Heart and Circulatory Physiology, 2009. **297**(6): p. H2068-H2074.
57. Zweier, J.L., et al., *Mechanisms of nitrite reduction to nitric oxide in the heart and vessel wall*. Nitric Oxide, 2010. **22**(2): p. 83-90.
58. Kozlov, A.V., K. Staniek, and H. Nohl, *Nitrite reductase activity is a novel function of mammalian mitochondria*. Febs Letters, 1999. **454**(1-2): p. 127-130.
59. Lundberg, J.O., E. Weitzberg, and M.T. Gladwin, *The nitrate-nitrite-nitric oxide pathway in physiology and therapeutics*. Nature Reviews Drug Discovery, 2008. **7**(2): p. 156-167.
60. Doyle, M.P. and J.W. Hoekstra, *Oxidation of Nitrogen-Oxides by Bound Dioxygen in Hemoproteins*.

- Journal of Inorganic Biochemistry, 1981. **14**(4): p. 351-358.
61. Iadecola, C., et al., *Delayed reduction of ischemic brain injury and neurological deficits in mice lacking the inducible nitric oxide synthase gene*. J Neurosci, 1997. **17**(23): p. 9157-64.
  62. Huie, R.E. and S. Padmaja, *The reaction of NO with superoxide*. Free Radic Res Commun, 1993. **18**(4): p. 195-9.
  63. Beckman, J.S. and W.H. Koppenol, *Nitric oxide, superoxide, and peroxynitrite: the good, the bad, and ugly*. Am J Physiol, 1996. **271**(5 Pt 1): p. C1424-37.
  64. Tsai, J.H.M., et al., *Role of Conformation of Peroxynitrite Anion (Onoo-) in Its Stability and Toxicity*. Journal of the American Chemical Society, 1994. **116**(9): p. 4115-4116.
  65. Tsai, H.H., et al., *Ab-Initio Studies of Peroxynitrite Anion-Water Complexes*. Structural Chemistry, 1995. **6**(4-5): p. 323-332.
  66. Babior, B.M., R.S. Kipnes, and J.T. Curnutte, *Biological defense mechanisms. The production by leukocytes of superoxide, a potential bactericidal agent*. J Clin Invest, 1973. **52**(3): p. 741-4.
  67. Valenti, S., et al., *Nitric oxide modulates Leydig cell function in vitro: is this a way of communication between the immune and endocrine system in the testis?* Ann N Y Acad Sci, 1999. **876**: p. 298-300.
  68. Bogdan, C., M. Rollinghoff, and A. Diefenbach, *Reactive oxygen and reactive nitrogen intermediates in innate and specific immunity*. Curr Opin Immunol, 2000. **12**(1): p. 64-76.
  69. Ferrer-Sueta, G., et al., *Factors affecting protein thiol reactivity and specificity in peroxide reduction*. Chemical Research in Toxicology, 2011. **24**(4): p. 434-50.
  70. Ying, J., et al., *Thiol oxidation in signaling and response to stress: detection and quantification of physiological and pathophysiological thiol modifications*. Free Radic Biol Med, 2007. **43**(8): p. 1099-108.
  71. Alvarez, B. and R. Radi, *Peroxynitrite reactivity with amino acids and proteins*. Amino Acids, 2003. **25**(3-4): p. 295-311.
  72. Adachi, T., et al., *S-Glutathiolation by peroxynitrite activates SERCA during arterial relaxation by nitric oxide*. Nat Med, 2004. **10**(11): p. 1200-7.
  73. Reddie, K.G. and K.S. Carroll, *Expanding the functional diversity of proteins through cysteine oxidation*. Curr Opin Chem Biol, 2008. **12**(6): p. 746-54.
  74. Tanner, J.J., et al., *Redox regulation of protein tyrosine phosphatases: structural and chemical aspects*. Antioxid Redox Signal, 2011. **15**(1): p. 77-97.
  75. Vivancos, A.P., et al., *A cysteine-sulfinic acid in peroxiredoxin regulates H2O2-sensing by the antioxidant Pap1 pathway*. Proc Natl Acad Sci U S A, 2005. **102**(25): p. 8875-80.
  76. Cozzolino, M., et al., *Cysteine 111 affects aggregation and cytotoxicity of mutant Cu,Zn-superoxide dismutase associated with familial amyotrophic lateral sclerosis*. J Biol Chem, 2008. **283**(2): p. 866-74.
  77. Fu, X., et al., *Hypochlorous acid oxygenates the cysteine switch domain of pro-matrix metalloproteinase (MMP-7). A mechanism for matrix metalloproteinase activation and atherosclerotic plaque rupture by myeloperoxidase*. J Biol Chem, 2001. **276**(44): p. 41279-87.
  78. Sutton, H.C. and C.C. Winterbourn, *On the participation of higher oxidation states of iron and copper in Fenton reactions*. Free Radic Biol Med, 1989. **6**(1): p. 53-60.
  79. Mackman, N., *Role of tissue factor in hemostasis, thrombosis, and vascular development*. Arterioscler Thromb Vasc Biol, 2004. **24**(6): p. 1015-22.
  80. Ahamed, J., et al., *Disulfide isomerization switches tissue factor from coagulation to cell signaling*. Proc Natl Acad Sci U S A, 2006. **103**(38): p. 13932-7.
  81. Lee, S.R., et al., *Reversible inactivation of the tumor suppressor PTEN by H2O2*. J Biol Chem, 2002. **277**(23): p. 20336-42.
  82. Klatt, P. and S. Lamas, *Regulation of protein function by S-glutathiolation in response to oxidative and nitrosative stress*. Eur J Biochem, 2000. **267**(16): p. 4928-44.
  83. Kemmerling, U., et al., *Calcium release by ryanodine receptors mediates hydrogen peroxide-induced activation of ERK and CREB phosphorylation in N2a cells and hippocampal neurons*. Cell Calcium, 2007. **41**(5): p. 491-502.
  84. Barrett, W.C., et al., *Regulation of PTP1B via glutathionylation of the active site cysteine 215*. Biochemistry, 1999. **38**(20): p. 6699-6705.
  85. Ignarro, L.J., *Signal transduction mechanisms involving nitric oxide*. Biochem Pharmacol, 1991. **41**(4): p. 485-90.
  86. Mannick, J.B. and C.M. Schonhoff, *Nitrosylation: the next phosphorylation?* Arch Biochem Biophys, 2002. **408**(1): p. 1-6.
  87. Lopez-Sanchez, L.M., C. Lopez-Pedraza, and A. Rodriguez-Ariza, *Proteomics insights into deregulated protein S-nitrosylation and disease*. Expert Review of Proteomics, 2012. **9**(1): p. 59-69.
  88. DelaTorre, A., R.A. Schroeder, and P.C. Kuo, *Alteration of NF-kappa B p50 DNA binding kinetics by S-nitrosylation*. Biochemical and Biophysical Research Communications, 1997. **238**(3): p. 703-6.
  89. Kelleher, Z.T., et al., *NOS2 regulation of NF-kappaB by S-nitrosylation of p65*. The Journal of biological chemistry, 2007. **282**(42): p. 30667-72.

90. Yasinska, I.M. and V.V. Sumbayev, *S-nitrosation of Cys-800 of HIF-1alpha protein activates its interaction with p300 and stimulates its transcriptional activity*. FEBS Letters, 2003. **549**(1-3): p. 105-9.
91. Li, F., et al., *Regulation of HIF-1 alpha stability through S-nitrosylation*. Molecular Cell, 2007. **26**(1): p. 63-74.
92. Sies, H., *Oxidative stress: a concept in redox biology and medicine*. Redox Biol, 2015. **4**: p. 180-3.
93. Jones, D.P., *Redefining oxidative stress*. Antioxid Redox Signal, 2006. **8**(9-10): p. 1865-79.
94. Stubbs, C.D. and A.D. Smith, *The modification of mammalian membrane polyunsaturated fatty acid composition in relation to membrane fluidity and function*. Biochim Biophys Acta, 1984. **779**(1): p. 89-137.
95. Halliwell, B. and S. Chirico, *Lipid peroxidation: its mechanism, measurement, and significance*. Am J Clin Nutr, 1993. **57**(5 Suppl): p. 715S-724S; discussion 724S-725S.
96. Pogozelski, W.K. and T.D. Tullius, *Oxidative Strand Scission of Nucleic Acids: Routes Initiated by Hydrogen Abstraction from the Sugar Moiety*. Chem Rev, 1998. **98**(3): p. 1089-1108.
97. O'Driscoll, M. and P.A. Jeggo, *The role of double-strand break repair - insights from human genetics*. Nat Rev Genet, 2006. **7**(1): p. 45-54.
98. Roos, W.P. and B. Kaina, *DNA damage-induced cell death by apoptosis*. Trends Mol Med, 2006. **12**(9): p. 440-50.
99. Fitzpatrick, B., et al., *iNOS as a therapeutic target for treatment of human tumors*. Nitric Oxide-Biology and Chemistry, 2008. **19**(2): p. 217-224.
100. Sato, Y. and T. Tsurumi, *Genome guardian p53 and viral infections*. Reviews in Medical Virology, 2013. **23**(4): p. 213-220.
101. Calmels, S., P. Hainaut, and H. Ohshima, *Nitric oxide induces conformational and functional modifications of wild-type p53 tumor suppressor protein*. Cancer Research, 1997. **57**(16): p. 3365-3369.
102. Cao, X., et al., *Glutathionylation of two cysteine residues in paired domain regulates DNA binding activity of Pax-8*. J Biol Chem, 2005. **280**(27): p. 25901-6.
103. Holcik, M. and R.G. Korneluk, *XIAP, the guardian angel*. Nature reviews. Molecular cell biology, 2001. **2**(7): p. 550-6.
104. Tsang, A.H., et al., *S-nitrosylation of XIAP compromises neuronal survival in Parkinson's disease*. Proceedings of the National Academy of Sciences of the United States of America, 2009. **106**(12): p. 4900-5.
105. Hara, M.R., et al., *S-nitrosylated GAPDH initiates apoptotic cell death by nuclear translocation following Siah1 binding*. Nature Cell Biology, 2005. **7**(7): p. 665-74.
106. Morgan, B., et al., *Multiple glutathione disulfide removal pathways mediate cytosolic redox homeostasis*. Nat Chem Biol, 2013. **9**(2): p. 119-25.
107. Lu, S.C., *Glutathione synthesis*. Biochim Biophys Acta, 2013. **1830**(5): p. 3143-53.
108. Hwang, C., A.J. Sinskey, and H.F. Lodish, *Oxidized redox state of glutathione in the endoplasmic reticulum*. Science, 1992. **257**(5076): p. 1496-502.
109. Mari, M., et al., *Mitochondrial glutathione, a key survival antioxidant*. Antioxid Redox Signal, 2009. **11**(11): p. 2685-700.
110. Mari, M., et al., *Redox control of liver function in health and disease*. Antioxid Redox Signal, 2010. **12**(11): p. 1295-331.
111. Aoyama, K. and T. Nakaki, *Glutathione in Cellular Redox Homeostasis: Association with the Excitatory Amino Acid Carrier 1 (EAAC1)*. Molecules, 2015. **20**(5): p. 8742-58.
112. Clarke, M.W., J.R. Burnett, and K.D. Croft, *Vitamin E in human health and disease*. Crit Rev Clin Lab Sci, 2008. **45**(5): p. 417-50.
113. Fiedor, J. and K. Burda, *Potential role of carotenoids as antioxidants in human health and disease*. Nutrients, 2014. **6**(2): p. 466-88.
114. Rochette, L., et al., *Direct and indirect antioxidant properties of alpha-lipoic acid and therapeutic potential*. Mol Nutr Food Res, 2013. **57**(1): p. 114-25.
115. Ernster, L. and P. Forsmark-Andree, *Ubiquinol: an endogenous antioxidant in aerobic organisms*. Clin Investig, 1993. **71**(8 Suppl): p. S60-5.
116. Galleano, M., et al., *Antioxidant actions of flavonoids: thermodynamic and kinetic analysis*. Arch Biochem Biophys, 2010. **501**(1): p. 23-30.
117. Nieto, F.J., et al., *Uric acid and serum antioxidant capacity: a reaction to atherosclerosis? Atherosclerosis, 2000. 148(1): p. 131-9.*
118. Rayman, M.P., *The importance of selenium to human health*. Lancet, 2000. **356**(9225): p. 233-41.
119. Powell, S.R., *The antioxidant properties of zinc*. J Nutr, 2000. **130**(5S Suppl): p. 1447S-54S.
120. McMahon, M., et al., *Keap1-dependent proteasomal degradation of transcription factor Nrf2 contributes to the negative regulation of antioxidant response element-driven gene expression*. J Biol Chem, 2003. **278**(24): p. 21592-600.
121. Holland, R. and J.C. Fishbein, *Chemistry of the cysteine sensors in Kelch-like ECH-associated*

- protein I*. Antioxid Redox Signal, 2010. **13**(11): p. 1749-61.
122. Baird, L. and A.T. Dinkova-Kostova, *The cytoprotective role of the Keap1-Nrf2 pathway*. Arch Toxicol, 2011. **85**(4): p. 241-72.
  123. Schreibelt, G., et al., *Therapeutic potential and biological role of endogenous antioxidant enzymes in multiple sclerosis pathology*. Brain Res Rev, 2007. **56**(2): p. 322-30.
  124. Lei, X.G., et al., *Paradoxical Roles of Antioxidant Enzymes: Basic Mechanisms and Health Implications*. Physiol Rev, 2016. **96**(1): p. 307-64.
  125. Goth, L. and T. Nagy, *Inherited catalase deficiency: is it benign or a factor in various age related disorders?* Mutat Res, 2013. **753**(2): p. 147-54.
  126. Laurent, T.C., E.C. Moore, and P. Reichard, *Enzymatic Synthesis of Deoxyribonucleotides. Iv. Isolation and Characterization of Thioredoxin, the Hydrogen Donor from Escherichia Coli B*. J Biol Chem, 1964. **239**: p. 3436-44.
  127. Luthman, M. and A. Holmgren, *Rat liver thioredoxin and thioredoxin reductase: purification and characterization*. Biochemistry, 1982. **21**(26): p. 6628-33.
  128. Holmgren, A., et al., *Three-dimensional structure of Escherichia coli thioredoxin-S2 to 2.8 Å resolution*. Proc Natl Acad Sci U S A, 1975. **72**(6): p. 2305-9.
  129. Collet, J.F. and J. Messens, *Structure, function, and mechanism of thioredoxin proteins*. Antioxid Redox Signal, 2010. **13**(8): p. 1205-16.
  130. Martin, J.L., *Thioredoxin--a fold for all reasons*. Structure, 1995. **3**(3): p. 245-50.
  131. Vlamis-Gardikas, A. and A. Holmgren, *Thioredoxin and glutaredoxin isoforms*. Methods Enzymol, 2002. **347**: p. 286-96.
  132. Miranda-Vizuete, A., et al., *The mammalian testis-specific thioredoxin system*. Antioxid Redox Signal, 2004. **6**(1): p. 25-40.
  133. Lillig, C.H. and A. Holmgren, *Thioredoxin and related molecules--from biology to health and disease*. Antioxid Redox Signal, 2007. **9**(1): p. 25-47.
  134. Haendeler, J., *Thioredoxin-1 and posttranslational modifications*. Antioxid Redox Signal, 2006. **8**(9-10): p. 1723-8.
  135. Lu, J. and A. Holmgren, *Selenoproteins*. J Biol Chem, 2009. **284**(2): p. 723-7.
  136. Papp, L.V., et al., *From selenium to selenoproteins: synthesis, identity, and their role in human health*. Antioxid Redox Signal, 2007. **9**(7): p. 775-806.
  137. Sandalova, T., et al., *Three-dimensional structure of a mammalian thioredoxin reductase: implications for mechanism and evolution of a selenocysteine-dependent enzyme*. Proc Natl Acad Sci U S A, 2001. **98**(17): p. 9533-8.
  138. Zhong, L. and A. Holmgren, *Essential role of selenium in the catalytic activities of mammalian thioredoxin reductase revealed by characterization of recombinant enzymes with selenocysteine mutations*. J Biol Chem, 2000. **275**(24): p. 18121-8.
  139. Arner, E.S., *Focus on mammalian thioredoxin reductases--important selenoproteins with versatile functions*. Biochim Biophys Acta, 2009. **1790**(6): p. 495-526.
  140. Bondareva, A.A., et al., *Effects of thioredoxin reductase-1 deletion on embryogenesis and transcriptome*. Free Radic Biol Med, 2007. **43**(6): p. 911-23.
  141. Conrad, M., et al., *Essential role for mitochondrial thioredoxin reductase in hematopoiesis, heart development, and heart function*. Mol Cell Biol, 2004. **24**(21): p. 9414-23.
  142. Weichsel, A., et al., *Crystal structures of reduced, oxidized, and mutated human thioredoxins: Evidence for a regulatory homodimer*. Structure, 1996. **4**(6): p. 735-751.
  143. Wu, C., et al., *Thioredoxin 1-mediated post-translational modifications: reduction, transnitrosylation, denitrosylation, and related proteomics methodologies*. Antioxid Redox Signal, 2011. **15**(9): p. 2565-604.
  144. Holmgren, A., *Thioredoxin*. Annu Rev Biochem, 1985. **54**: p. 237-71.
  145. Johansson, E., K. Hjortsberg, and L. Thelander, *Two YY-1-binding proximal elements regulate the promoter strength of the TATA-less mouse ribonucleotide reductase R1 gene*. J Biol Chem, 1998. **273**(45): p. 29816-21.
  146. Engstrom, Y., et al., *Cell cycle-dependent expression of mammalian ribonucleotide reductase. Differential regulation of the two subunits*. J Biol Chem, 1985. **260**(16): p. 9114-6.
  147. Aye, Y., et al., *Ribonucleotide reductase and cancer: biological mechanisms and targeted therapies*. Oncogene, 2015. **34**(16): p. 2011-21.
  148. Pontarin, G., et al., *Mammalian ribonucleotide reductase subunit p53R2 is required for mitochondrial DNA replication and DNA repair in quiescent cells*. Proc Natl Acad Sci U S A, 2012. **109**(33): p. 13302-7.
  149. Holmgren, A. and R. Sengupta, *The use of thiols by ribonucleotide reductase*. Free Radic Biol Med, 2010. **49**(11): p. 1617-28.
  150. Shao, J., et al., *Targeting ribonucleotide reductase for cancer therapy*. Expert Opin Ther Targets, 2013. **17**(12): p. 1423-37.
  151. Rhee, S.G. and H.A. Woo, *Multiple functions of peroxiredoxins: peroxidases, sensors and regulators*

- of the intracellular messenger  $H_2O_2$ , and protein chaperones. *Antioxid Redox Signal*, 2011. **15**(3): p. 781-94.
152. Seo, M.S., et al., *Identification of a new type of mammalian peroxiredoxin that forms an intramolecular disulfide as a reaction intermediate*. *J Biol Chem*, 2000. **275**(27): p. 20346-54.
  153. Manevich, Y., S.I. Feinstein, and A.B. Fisher, *Activation of the antioxidant enzyme I-CYS peroxiredoxin requires glutathionylation mediated by heterodimerization with pi GST*. *Proc Natl Acad Sci U S A*, 2004. **101**(11): p. 3780-5.
  154. Perkins, A., et al., *Peroxiredoxins: guardians against oxidative stress and modulators of peroxide signaling*. *Trends Biochem Sci*, 2015. **40**(8): p. 435-45.
  155. Yang, K.S., et al., *Inactivation of human peroxiredoxin I during catalysis as the result of the oxidation of the catalytic site cysteine to cysteine-sulfinic acid*. *J Biol Chem*, 2002. **277**(41): p. 38029-36.
  156. Mishra, M., et al., *The sulfiredoxin-peroxiredoxin (Srx-Prx) axis in cell signal transduction and cancer development*. *Cancer Lett*, 2015. **366**(2): p. 150-9.
  157. Chang, T.S., et al., *Regulation of peroxiredoxin I activity by Cdc2-mediated phosphorylation*. *J Biol Chem*, 2002. **277**(28): p. 25370-6.
  158. Park, J.W., et al., *Glutathionylation of peroxiredoxin I induces decamer to dimers dissociation with concomitant loss of chaperone activity*. *Biochemistry*, 2011. **50**(15): p. 3204-10.
  159. Engelman, R., et al., *Multilevel regulation of 2-Cys peroxiredoxin reaction cycle by S-nitrosylation*. *J Biol Chem*, 2013. **288**(16): p. 11312-24.
  160. Du, Y.T., et al., *Thioredoxin 1 Is Inactivated Due to Oxidation Induced by Peroxiredoxin under Oxidative Stress and Reactivated by the Glutaredoxin System*. *Journal of Biological Chemistry*, 2013. **288**(45): p. 32241-32247.
  161. Kim, H.Y., *The methionine sulfoxide reduction system: selenium utilization and methionine sulfoxide reductase enzymes and their functions*. *Antioxid Redox Signal*, 2013. **19**(9): p. 958-69.
  162. Lee, B.C., et al., *Functions and evolution of selenoprotein methionine sulfoxide reductases*. *Biochim Biophys Acta*, 2009. **1790**(11): p. 1471-7.
  163. Kim, H.Y. and V.N. Gladyshev, *Different catalytic mechanisms in mammalian selenocysteine- and cysteine-containing methionine-R-sulfoxide reductases*. *PLoS Biol*, 2005. **3**(12): p. e375.
  164. Nishitoh, H., et al., *ASK1 is essential for endoplasmic reticulum stress-induced neuronal cell death triggered by expanded polyglutamine repeats*. *Genes Dev*, 2002. **16**(11): p. 1345-55.
  165. Liu, Y. and W. Min, *Thioredoxin promotes ASK1 ubiquitination and degradation to inhibit ASK1-mediated apoptosis in a redox activity-independent manner*. *Circ Res*, 2002. **90**(12): p. 1259-66.
  166. Zhang, R., et al., *Thioredoxin-2 inhibits mitochondria-located ASK1-mediated apoptosis in a JNK-independent manner*. *Circ Res*, 2004. **94**(11): p. 1483-91.
  167. Nishiyama, A., et al., *Identification of thioredoxin-binding protein-2/vitamin D(3) up-regulated protein 1 as a negative regulator of thioredoxin function and expression*. *J Biol Chem*, 1999. **274**(31): p. 21645-50.
  168. Hwang, J., et al., *The structural basis for the negative regulation of thioredoxin by thioredoxin-interacting protein*. *Nat Commun*, 2014. **5**: p. 2958.
  169. Yamawaki, H., et al., *Fluid shear stress inhibits vascular inflammation by decreasing thioredoxin-interacting protein in endothelial cells*. *J Clin Invest*, 2005. **115**(3): p. 733-8.
  170. Spindel, O.N., C. World, and B.C. Berk, *Thioredoxin interacting protein: redox dependent and independent regulatory mechanisms*. *Antioxid Redox Signal*, 2012. **16**(6): p. 587-96.
  171. Song, M.S., L. Salmena, and P.P. Pandolfi, *The functions and regulation of the PTEN tumour suppressor*. *Nat Rev Mol Cell Biol*, 2012. **13**(5): p. 283-96.
  172. Wullschleger, S., R. Loewith, and M.N. Hall, *TOR signaling in growth and metabolism*. *Cell*, 2006. **124**(3): p. 471-84.
  173. Meuillet, E.J., et al., *Thioredoxin-1 binds to the C2 domain of PTEN inhibiting PTEN's lipid phosphatase activity and membrane binding: a mechanism for the functional loss of PTEN's tumor suppressor activity*. *Arch Biochem Biophys*, 2004. **429**(2): p. 123-33.
  174. Hui, S.T., et al., *Txnip balances metabolic and growth signaling via PTEN disulfide reduction*. *Proc Natl Acad Sci U S A*, 2008. **105**(10): p. 3921-6.
  175. Lu, J. and A. Holmgren, *The thioredoxin antioxidant system*. *Free Radic Biol Med*, 2014. **66**: p. 75-87.
  176. Locy, M.L., et al., *Thioredoxin reductase inhibition elicits Nrf2-mediated responses in Clara cells: implications for oxidant-induced lung injury*. *Antioxid Redox Signal*, 2012. **17**(10): p. 1407-16.
  177. Suvorova, E.S., et al., *Cytoprotective Nrf2 pathway is induced in chronically txnrd 1-deficient hepatocytes*. *PLoS One*, 2009. **4**(7): p. e6158.
  178. Li, W. and A.N. Kong, *Molecular mechanisms of Nrf2-mediated antioxidant response*. *Mol Carcinog*, 2009. **48**(2): p. 91-104.
  179. Hansen, J.M., W.H. Watson, and D.P. Jones, *Compartmentation of Nrf-2 redox control: regulation of cytoplasmic activation by glutathione and DNA binding by thioredoxin-1*. *Toxicol Sci*, 2004. **82**(1):

- p. 308-17.
180. Matthews, J.R., et al., *Thioredoxin regulates the DNA binding activity of NF-kappa B by reduction of a disulphide bond involving cysteine 62*. Nucleic Acids Res, 1992. **20**(15): p. 3821-30.
  181. Toledano, M.B. and W.J. Leonard, *Modulation of transcription factor NF-kappa B binding activity by oxidation-reduction in vitro*. Proc Natl Acad Sci U S A, 1991. **88**(10): p. 4328-32.
  182. Hirota, K., et al., *Distinct roles of thioredoxin in the cytoplasm and in the nucleus. A two-step mechanism of redox regulation of transcription factor NF-kappaB*. J Biol Chem, 1999. **274**(39): p. 27891-7.
  183. Eferl, R. and E.F. Wagner, *AP-1: a double-edged sword in tumorigenesis*. Nat Rev Cancer, 2003. **3**(11): p. 859-68.
  184. Abate, C., et al., *Redox regulation of fos and jun DNA-binding activity in vitro*. Science, 1990. **249**(4973): p. 1157-61.
  185. Hirota, K., et al., *AP-1 transcriptional activity is regulated by a direct association between thioredoxin and Ref-1*. Proc Natl Acad Sci U S A, 1997. **94**(8): p. 3633-8.
  186. Benhar, M., M.T. Forrester, and J.S. Stamler, *Protein denitrosylation: enzymatic mechanisms and cellular functions*. Nature reviews. Molecular cell biology, 2009. **10**(10): p. 721-32.
  187. Benhar, M., et al., *Identification of S-Nitrosylated Targets of Thioredoxin Using a Quantitative Proteomic Approach*. Biochemistry, 2010. **49**(32): p. 6963-6969.
  188. Weichsel, A., J.L. Brailey, and W.R. Montfort, *Buried S-nitrosocysteine revealed in crystal structures of human thioredoxin*. Biochemistry, 2007. **46**(5): p. 1219-1227.
  189. Haendeler, J., et al., *Redox regulatory and anti-apoptotic functions of thioredoxin depend on S-nitrosylation at cysteine 69*. Nature cell biology, 2002. **4**(10): p. 743-9.
  190. Hashemy, S.I. and A. Holmgren, *Regulation of the catalytic activity and structure of human thioredoxin 1 via oxidation and S-nitrosylation of cysteine residues*. J Biol Chem, 2008. **283**(32): p. 21890-8.
  191. Mitchell, D.A. and M.A. Marletta, *Thioredoxin catalyzes the S-nitrosation of the caspase-3 active site cysteine*. Nature Chemical Biology, 2005. **1**(3): p. 154-8.
  192. Wu, C., et al., *Distinction of thioredoxin transnitrosylation and denitrosylation target proteins by the ICAT quantitative approach*. Journal of proteomics, 2011. **74**(11): p. 2498-509.
  193. Wu, C., et al., *Redox regulatory mechanism of transnitrosylation by thioredoxin*. Molecular & cellular proteomics : MCP, 2010. **9**(10): p. 2262-75.
  194. Benhar, M., et al., *Regulated protein denitrosylation by cytosolic and mitochondrial thioredoxins*. Science, 2008. **320**(5879): p. 1050-1054.
  195. Mustafa, A.K., et al., *H2S Signals Through Protein S-Sulphydration*. Science signaling, 2009. **2**(96).
  196. Vandiver, M.S., et al., *Sulphydration mediates neuroprotective actions of parkin*. Nature Communications, 2013. **4**.
  197. Kimura, Y., Y. Goto, and H. Kimura, *Hydrogen sulfide increases glutathione production and suppresses oxidative stress in mitochondria*. Antioxidants & Redox Signaling, 2010. **12**(1): p. 1-13.
  198. Mir, S., T. Sen, and N. Sen, *Cytokine-induced GAPDH sulphydration affects PSD95 degradation and memory*. Molecular Cell, 2014. **56**(6): p. 786-95.
  199. Mikami, Y., et al., *Thioredoxin and dihydrolipoic acid are required for 3-mercaptopyruvate sulfurtransferase to produce hydrogen sulfide*. The Biochemical journal, 2011. **439**(3): p. 479-85.
  200. Krishnan, N., et al., *H2S-Induced sulphydration of the phosphatase PTP1B and its role in the endoplasmic reticulum stress response*. Science signaling, 2011. **4**(203): p. ra86.
  201. Wedmann, R., et al., *Improved tag-switch method reveals that thioredoxin acts as depersulfidase and controls the intracellular levels of protein persulfidation*. Chemical Science, 2016.
  202. Ju, Y., L. Wu, and G. Yang, *Thioredoxin 1 regulation of protein S-desulphydration*. Biochemistry and Biophysics Reports, 2016. **5**: p. 27-34.
  203. Doka, E., et al., *A novel persulfide detection method reveals protein persulfide- and polysulfide-reducing functions of thioredoxin and glutathione systems*. Science advances, 2016. **2**(1): p. e1500968.
  204. Fernandes, A.P. and A. Holmgren, *Glutaredoxins: glutathione-dependent redox enzymes with functions far beyond a simple thioredoxin backup system*. Antioxid Redox Signal, 2004. **6**(1): p. 63-74.
  205. Holmgren, A., *Hydrogen donor system for Escherichia coli ribonucleoside-diphosphate reductase dependent upon glutathione*. Proc Natl Acad Sci U S A, 1976. **73**(7): p. 2275-9.
  206. Holmgren, A., *Glutathione-dependent synthesis of deoxyribonucleotides. Purification and characterization of glutaredoxin from Escherichia coli*. J Biol Chem, 1979. **254**(9): p. 3664-71.
  207. Holmgren, A., *Glutathione-dependent synthesis of deoxyribonucleotides. Characterization of the enzymatic mechanism of Escherichia coli glutaredoxin*. J Biol Chem, 1979. **254**(9): p. 3672-8.
  208. Hoog, J.O., et al., *The primary structure of Escherichia coli glutaredoxin. Distant homology with thioredoxins in a superfamily of small proteins with a redox-active cystine disulfide/cysteine dithiol*. Eur J Biochem, 1983. **136**(1): p. 223-32.

209. Luthman, M., et al., *Glutathione-dependent hydrogen donor system for calf thymus ribonucleoside-diphosphate reductase*. Proc Natl Acad Sci U S A, 1979. **76**(5): p. 2158-62.
210. Luthman, M. and A. Holmgren, *Glutaredoxin from calf thymus. Purification to homogeneity*. J Biol Chem, 1982. **257**(12): p. 6686-90.
211. Diaz-Vivancos, P., et al., *Glutathione--linking cell proliferation to oxidative stress*. Free Radic Biol Med, 2015. **89**: p. 1154-64.
212. Lillig, C.H., C. Berndt, and A. Holmgren, *Glutaredoxin systems*. Biochim Biophys Acta, 2008. **1780**(11): p. 1304-17.
213. Johansson, C., C.H. Lillig, and A. Holmgren, *Human mitochondrial glutaredoxin reduces S-glutathionylated proteins with high affinity accepting electrons from either glutathione or thioredoxin reductase*. J Biol Chem, 2004. **279**(9): p. 7537-43.
214. Hanschmann, E.M., et al., *Thioredoxins, glutaredoxins, and peroxiredoxins--molecular mechanisms and health significance: from cofactors to antioxidants to redox signaling*. Antioxid Redox Signal, 2013. **19**(13): p. 1539-605.
215. Padilla, C.A., et al., *Immunolocalization of thioredoxin and glutaredoxin in mammalian hypophysis*. Mol Cell Endocrinol, 1992. **85**(1-2): p. 1-12.
216. Rozell, B., et al., *Immunochemical characterization and tissue distribution of glutaredoxin (thioltransferase) from calf*. Eur J Cell Biol, 1993. **62**(2): p. 314-23.
217. Pai, H.V., et al., *What is the functional significance of the unique location of glutaredoxin 1 (GRx1) in the intermembrane space of mitochondria?* Antioxid Redox Signal, 2007. **9**(11): p. 2027-33.
218. Lundberg, M., et al., *Cellular and plasma levels of human glutaredoxin 1 and 2 detected by sensitive ELISA systems*. Biochem Biophys Res Commun, 2004. **319**(3): p. 801-9.
219. Ho, Y.S., et al., *Targeted disruption of the glutaredoxin 1 gene does not sensitize adult mice to tissue injury induced by ischemia/reperfusion and hyperoxia*. Free Radic Biol Med, 2007. **43**(9): p. 1299-312.
220. Aesif, S.W., et al., *Ablation of glutaredoxin-1 attenuates lipopolysaccharide-induced lung inflammation and alveolar macrophage activation*. Am J Respir Cell Mol Biol, 2011. **44**(4): p. 491-9.
221. Bachschmid, M.M., et al., *Attenuated cardiovascular hypertrophy and oxidant generation in response to angiotensin II infusion in glutaredoxin-1 knockout mice*. Free Radic Biol Med, 2010. **49**(7): p. 1221-9.
222. Hoffman, S.M., et al., *Genetic ablation of glutaredoxin-1 causes enhanced resolution of airways hyperresponsiveness and mucus metaplasia in mice with allergic airways disease*. Am J Physiol Lung Cell Mol Physiol, 2012. **303**(6): p. L528-38.
223. Lundberg, M., et al., *Cloning and expression of a novel human glutaredoxin (Grx2) with mitochondrial and nuclear isoforms*. J Biol Chem, 2001. **276**(28): p. 26269-75.
224. Lonn, M.E., et al., *Expression pattern of human glutaredoxin 2 isoforms: identification and characterization of two testis/cancer cell-specific isoforms*. Antioxid Redox Signal, 2008. **10**(3): p. 547-57.
225. Lillig, C.H., et al., *Characterization of human glutaredoxin 2 as iron-sulfur protein: a possible role as redox sensor*. Proc Natl Acad Sci U S A, 2005. **102**(23): p. 8168-73.
226. Johansson, C., et al., *Reversible sequestration of active site cysteines in a 2Fe-2S-bridged dimer provides a mechanism for glutaredoxin 2 regulation in human mitochondria*. J Biol Chem, 2007. **282**(5): p. 3077-82.
227. Wu, H., et al., *Glutaredoxin 2 knockout increases sensitivity to oxidative stress in mouse lens epithelial cells*. Free Radic Biol Med, 2011. **51**(11): p. 2108-17.
228. Mailloux, R.J., et al., *Glutaredoxin-2 is required to control oxidative phosphorylation in cardiac muscle by mediating deglutathionylation reactions*. J Biol Chem, 2014. **289**(21): p. 14812-28.
229. Isakov, N., S. Witte, and A. Altman, *PICOT-HD: a highly conserved protein domain that is often associated with thioredoxin and glutaredoxin modules*. Trends Biochem Sci, 2000. **25**(11): p. 537-9.
230. Cha, H., et al., *PICOT is a critical regulator of cardiac hypertrophy and cardiomyocyte contractility*. J Mol Cell Cardiol, 2008. **45**(6): p. 796-803.
231. Haunhorst, P., et al., *Characterization of the human monothiol glutaredoxin 3 (PICOT) as iron-sulfur protein*. Biochem Biophys Res Commun, 2010. **394**(2): p. 372-6.
232. Wingert, R.A., et al., *Deficiency of glutaredoxin 5 reveals Fe-S clusters are required for vertebrate haem synthesis*. Nature, 2005. **436**(7053): p. 1035-39.
233. Ye, H., et al., *Glutaredoxin 5 deficiency causes sideroblastic anemia by specifically impairing heme biosynthesis and depleting cytosolic iron in human erythroblasts*. J Clin Invest, 2010. **120**(5): p. 1749-61.
234. Camaschella, C., et al., *The human counterpart of zebrafish shiraz shows sideroblastic-like microcytic anemia and iron overload*. Blood, 2007. **110**(4): p. 1353-8.
235. Karplus, P.A. and G.E. Schulz, *Refined structure of glutathione reductase at 1.54 Å resolution*. J Mol Biol, 1987. **195**(3): p. 701-29.
236. Karplus, P.A. and G.E. Schulz, *Substrate binding and catalysis by glutathione reductase as derived*

- from refined enzyme: substrate crystal structures at 2 Å resolution. *J Mol Biol*, 1989. **210**(1): p. 163-80.
237. Kelner, M.J. and M.A. Montoya, *Structural organization of the human glutathione reductase gene: determination of correct cDNA sequence and identification of a mitochondrial leader sequence*. *Biochem Biophys Res Commun*, 2000. **269**(2): p. 366-8.
238. Rogers, L.K., et al., *Analyses of glutathione reductase hypomorphic mice indicate a genetic knockout*. *Toxicol Sci*, 2004. **82**(2): p. 367-73.
239. Brigelius-Flohe, R. and M. Maiorino, *Glutathione peroxidases*. *Biochim Biophys Acta*, 2013. **1830**(5): p. 3289-303.
240. Rocher, C., J.L. Lalanne, and J. Chaudiere, *Purification and properties of a recombinant sulfur analog of murine selenium-glutathione peroxidase*. *Eur J Biochem*, 1992. **205**(3): p. 955-60.
241. Flohe, L., *The impact of thiol peroxidases on redox regulation*. *Free Radic Res*, 2016. **50**(2): p. 126-42.
242. Cheng, W.H., et al., *Cellular glutathione peroxidase is the mediator of body selenium to protect against paraquat lethality in transgenic mice*. *J Nutr*, 1998. **128**(7): p. 1070-6.
243. Thomas, J.P., et al., *Enzymatic reduction of phospholipid and cholesterol hydroperoxides in artificial bilayers and lipoproteins*. *Biochim Biophys Acta*, 1990. **1045**(3): p. 252-60.
244. Yant, L.J., et al., *The selenoprotein GPX4 is essential for mouse development and protects from radiation and oxidative damage insults*. *Free Radic Biol Med*, 2003. **34**(4): p. 496-502.
245. Seiler, A., et al., *Glutathione peroxidase 4 senses and translates oxidative stress into 12/15-lipoxygenase dependent- and AIF-Mediated cell death*. *Cell Metabolism*, 2008. **8**(3): p. 237-248.
246. Greetham, D., et al., *Thioredoxins function as deglutathionylase enzymes in the yeast *Saccharomyces cerevisiae**. *BMC Biochemistry*, 2010. **11**.
247. Peltoniemi, M.J., et al., *Insights into deglutathionylation reactions - Different intermediates in the glutaredoxin and protein disulfide isomerase catalyzed reactions are defined by the gamma-linkage present in glutathione*. *Journal of Biological Chemistry*, 2006. **281**(44): p. 33107-33114.
248. Findlay, V.J., et al., *A novel role for human sulfiredoxin in the reversal of glutathionylation*. *Cancer Research*, 2006. **66**(13): p. 6800-6806.
249. Johansson, C., C.H. Lillig, and A. Holmgren, *Human mitochondrial glutaredoxin reduces S-glutathionylated proteins with high affinity accepting electrons from either glutathione or thioredoxin reductase*. *Journal of Biological Chemistry*, 2004. **279**(9): p. 7537-7543.
250. Mieval, J.J., et al., *Molecular mechanisms and clinical implications of reversible protein S-glutathionylation*. *Antioxidants & Redox Signaling*, 2008. **10**(11): p. 1941-1988.
251. Fernandes, A.P. and A. Holmgren, *Glutaredoxins: Glutathione-dependent redox enzymes with functions far beyond a simple thioredoxin backup system*. *Antioxidants & Redox Signaling*, 2004. **6**(1): p. 63-74.
252. Sparaco, M., et al., *Protein glutathionylation in human central nervous system: Potential role in redox regulation of neuronal defense against free radicals*. *Journal of Neuroscience Research*, 2006. **83**(2): p. 256-263.
253. Pastore, A., et al., *Actin glutathionylation increases in fibroblasts of patients with Friedreich's ataxia - A potential role in the pathogenesis of the disease*. *Journal of Biological Chemistry*, 2003. **278**(43): p. 42588-42595.
254. Kenchappa, R.S. and R. V., *Glutaredoxin is essential for maintenance of brain mitochondrial complex I: studies with MPTP*. *FASEB Journal*, 2003. **17**(2): p. 717-+.
255. Beer, S.M., et al., *Glutaredoxin 2 catalyzes the reversible oxidation and glutathionylation of mitochondrial membrane thiol proteins - Implications for mitochondrial redox regulation and antioxidant defense*. *Journal of Biological Chemistry*, 2004. **279**(46): p. 47939-47951.
256. Peskin, A.V., et al., *Glutathionylation of the Active Site Cysteines of Peroxiredoxin 2 and Recycling by Glutaredoxin*. *Journal of Biological Chemistry*, 2016. **291**(6): p. 3053-3062.
257. Starke, D.W., P.B. Chock, and J.J. Mieval, *Glutathione-thiyl radical scavenging and transferase properties of human glutaredoxin (thioltransferase) - Potential role in redox signal transduction*. *Journal of Biological Chemistry*, 2003. **278**(17): p. 14607-14613.
258. Hanahan, D. and R.A. Weinberg, *The hallmarks of cancer*. *Cell*, 2000. **100**(1): p. 57-70.
259. Hanahan, D. and R.A. Weinberg, *Hallmarks of cancer: the next generation*. *Cell*, 2011. **144**(5): p. 646-74.
260. Luo, J., N.L. Solimini, and S.J. Elledge, *Principles of cancer therapy: oncogene and non-oncogene addiction*. *Cell*, 2009. **136**(5): p. 823-37.
261. Lu, J., M. Tan, and Q. Cai, *The Warburg effect in tumor progression: mitochondrial oxidative metabolism as an anti-metastasis mechanism*. *Cancer Lett*, 2015. **356**(2 Pt A): p. 156-64.
262. Tan, A.S., J.W. Baty, and M.V. Berridge, *The role of mitochondrial electron transport in tumorigenesis and metastasis*. *Biochim Biophys Acta*, 2014. **1840**(4): p. 1454-63.
263. Fionda, C., et al., *Immunoregulatory and Effector Activities of Nitric Oxide and Reactive Nitrogen Species in Cancer*. *Curr Med Chem*, 2016. **23**(24): p. 2618-2636.



264. Schumacker, P.T., *Reactive oxygen species in cancer cells: live by the sword, die by the sword*. *Cancer Cell*, 2006. **10**(3): p. 175-6.
265. Moon, E.J. and A. Giaccia, *Dual roles of NRF2 in tumor prevention and progression: possible implications in cancer treatment*. *Free Radic Biol Med*, 2015. **79**: p. 292-9.
266. Holmgren, A. and J. Lu, *Thioredoxin and thioredoxin reductase: current research with special reference to human disease*. *Biochem Biophys Res Commun*, 2010. **396**(1): p. 120-4.
267. Trachootham, D., J. Alexandre, and P. Huang, *Targeting cancer cells by ROS-mediated mechanisms: a radical therapeutic approach?* *Nat Rev Drug Discov*, 2009. **8**(7): p. 579-91.
268. Wondrak, G.T., *Redox-directed cancer therapeutics: molecular mechanisms and opportunities*. *Antioxid Redox Signal*, 2009. **11**(12): p. 3013-69.
269. Gandin, V. and A.P. Fernandes, *Metal- and Semimetal-Containing Inhibitors of Thioredoxin Reductase as Anticancer Agents*. *Molecules*, 2015. **20**(7): p. 12732-56.
270. Harris, I.S., et al., *Glutathione and thioredoxin antioxidant pathways synergize to drive cancer initiation and progression*. *Cancer Cell*, 2015. **27**(2): p. 211-22.
271. Jo, H.Y., et al., *The Unreliability of MTT Assay in the Cytotoxic Test of Primary Cultured Glioblastoma Cells*. *Exp Neurobiol*, 2015. **24**(3): p. 235-45.
272. Holmgren, A., *Thioredoxin catalyzes the reduction of insulin disulfides by dithiothreitol and dihydrolipoamide*. *J Biol Chem*, 1979. **254**(19): p. 9627-32.
273. Montano, S.J., et al., *Activity assays of mammalian thioredoxin and thioredoxin reductase: fluorescent disulfide substrates, mechanisms, and use with tissue samples*. *Anal Biochem*, 2014. **449**: p. 139-46.
274. Du, Y., et al., *Glutathione and glutaredoxin act as a backup of human thioredoxin reductase 1 to reduce thioredoxin 1 preventing cell death by aurothioglucose*. *J Biol Chem*, 2012. **287**(45): p. 38210-9.
275. Wink, D.A., et al., *Detection of S-nitrosothiols by fluorometric and colorimetric methods*. *Methods in enzymology*, 1999. **301**: p. 201-11.
276. Abdul, K.S., et al., *Arsenic and human health effects: A review*. *Environ Toxicol Pharmacol*, 2015. **40**(3): p. 828-46.
277. Shen, Z.X., et al., *Use of arsenic trioxide (As<sub>2</sub>O<sub>3</sub>) in the treatment of acute promyelocytic leukemia (APL): II. Clinical efficacy and pharmacokinetics in relapsed patients*. *Blood*, 1997. **89**(9): p. 3354-60.
278. Douer, D. and M.S. Tallman, *Arsenic trioxide: new clinical experience with an old medication in hematologic malignancies*. *J Clin Oncol*, 2005. **23**(10): p. 2396-410.
279. Lu, J., E.H. Chew, and A. Holmgren, *Targeting thioredoxin reductase is a basis for cancer therapy by arsenic trioxide*. *Proceedings of the National Academy of Sciences of the United States of America*, 2007. **104**(30): p. 12288-12293.
280. Hashemy, S.I. and A. Holmgren, *Regulation of the catalytic activity and structure of human thioredoxin 1 via oxidation and S-nitrosylation of cysteine residues*. *Journal of Biological Chemistry*, 2008. **283**(32): p. 21890-21898.
281. Cai, W., et al., *Small molecule inhibitors of mammalian thioredoxin reductase*. *Free Radic Biol Med*, 2012. **52**(2): p. 257-65.
282. Lu, J. and A. Holmgren, *Thioredoxin system in cell death progression*. *Antioxid Redox Signal*, 2012. **17**(12): p. 1738-47.
283. Anestak, K., et al., *Cell death by SecTRAPs: thioredoxin reductase as a prooxidant killer of cells*. *PLoS One*, 2008. **3**(4): p. e1846.
284. Ren, X., et al., *Mutagenesis of structural half-cystine residues in human thioredoxin and effects on the regulation of activity by selenodiglutathione*. *Biochemistry*, 1993. **32**(37): p. 9701-8.
285. Watson, W.H., et al., *Redox potential of human thioredoxin 1 and identification of a second dithiol/disulfide motif*. *J Biol Chem*, 2003. **278**(35): p. 33408-15.
286. Du, Y., et al., *Thioredoxin 1 is inactivated due to oxidation induced by peroxiredoxin under oxidative stress and reactivated by the glutaredoxin system*. *J Biol Chem*, 2013. **288**(45): p. 32241-7.
287. Hall, G. and J. Emsley, *Structure of human thioredoxin exhibits a large conformational change*. *Protein Sci*, 2010. **19**(9): p. 1807-11.
288. Wood, Z.A., et al., *Structure, mechanism and regulation of peroxiredoxins*. *Trends Biochem Sci*, 2003. **28**(1): p. 32-40.
289. Lee, W., et al., *Human peroxiredoxin 1 and 2 are not duplicate proteins: the unique presence of CYS83 in Prx1 underscores the structural and functional differences between Prx1 and Prx2*. *J Biol Chem*, 2007. **282**(30): p. 22011-22.
290. Tareen, B., et al., *A 12 week, open label, phase I/IIa study using apatone for the treatment of prostate cancer patients who have failed standard therapy*. *Int J Med Sci*, 2008. **5**(2): p. 62-67.
291. Taper, H.S., *Altered deoxyribonuclease activity in cancer cells and its role in non toxic adjuvant cancer therapy with mixed vitamins C and K3*. *Anticancer Res*, 2008. **28**(5A): p. 2727-32.
292. Du, J., J.J. Cullen, and G.R. Buettner, *Ascorbic acid: chemistry, biology and the treatment of cancer*.

- Biochim Biophys Acta, 2012. **1826**(2): p. 443-57.
293. Calderon, P.B., et al., *Potential therapeutic application of the association of vitamins C and K3 in cancer treatment*. *Curr Med Chem*, 2002. **9**(24): p. 2271-85.
294. Verrax, J., et al., *Ascorbate potentiates the cytotoxicity of menadione leading to an oxidative stress that kills cancer cells by a non-apoptotic caspase-3 independent form of cell death*. *Apoptosis*, 2004. **9**(2): p. 223-233.
295. Cameron, E. and L. Pauling, *Supplemental ascorbate in the supportive treatment of cancer: Prolongation of survival times in terminal human cancer*. *Proc Natl Acad Sci U S A*, 1976. **73**(10): p. 3685-9.
296. Creagan, E.T., et al., *Failure of high-dose vitamin C (ascorbic acid) therapy to benefit patients with advanced cancer. A controlled trial*. *N Engl J Med*, 1979. **301**(13): p. 687-90.
297. Moertel, C.G., et al., *High-dose vitamin C versus placebo in the treatment of patients with advanced cancer who have had no prior chemotherapy. A randomized double-blind comparison*. *N Engl J Med*, 1985. **312**(3): p. 137-41.
298. Padayatty, S.J., et al., *Intravenously administered vitamin C as cancer therapy: three cases*. *Canadian Medical Association Journal*, 2006. **174**(7): p. 937-942.
299. Yun, J., et al., *Vitamin C selectively kills KRAS and BRAF mutant colorectal cancer cells by targeting GAPDH*. *Science*, 2015. **350**(6266): p. 1391-6.
300. Verrax, J., et al., *The association of vitamins C and K3 kills cancer cells mainly by autophagy, a novel form of cell death. Basis for their potential use as adjuvants in anticancer therapy*. *Eur J Med Chem*, 2003. **38**(5): p. 451-7.
301. Yun, J., et al., *Glucose deprivation contributes to the development of KRAS pathway mutations in tumor cells*. *Science*, 2009. **325**(5947): p. 1555-9.
302. Susin, S.A., et al., *Molecular characterization of mitochondrial apoptosis-inducing factor*. *Nature*, 1999. **397**(6718): p. 441-446.
303. Seiler, A., et al., *Glutathione peroxidase 4 senses and translates oxidative stress into 12/15-lipoxygenase dependent- and AIF-mediated cell death*. *Cell Metab*, 2008. **8**(3): p. 237-48.
304. Shelar, S.B., et al., *Thioredoxin-dependent regulation of AIF-mediated DNA damage*. *Free Radical Biology and Medicine*, 2015. **87**: p. 125-136.
305. Kennedy, P.G., *Human African trypanosomiasis-neurological aspects*. *J Neurol*, 2006. **253**(4): p. 411-6.
306. Wei, G., et al., *Intradermal infections of mice by low numbers of african trypanosomes are controlled by innate resistance but enhance susceptibility to reinfection*. *J Infect Dis*, 2011. **203**(3): p. 418-29.
307. Mabbott, N. and J. Sternberg, *Bone marrow nitric oxide production and development of anemia in Trypanosoma brucei-infected mice*. *Infect Immun*, 1995. **63**(4): p. 1563-6.
308. Hertz, C.J. and J.M. Mansfield, *IFN-gamma-dependent nitric oxide production is not linked to resistance in experimental African trypanosomiasis*. *Cell Immunol*, 1999. **192**(1): p. 24-32.
309. Khan, M., et al., *Cerebrovascular protection by various nitric oxide donors in rats after experimental stroke*. *Nitric Oxide-Biology and Chemistry*, 2006. **15**(2): p. 114-124.
310. Kelleher, Z.T., et al., *NOS2 regulation of NF-kappaB by S-nitrosylation of p65*. *J Biol Chem*, 2007. **282**(42): p. 30667-72.
311. Marshall, H.E. and J.S. Stamler, *Inhibition of NF-kappa B by S-nitrosylation*. *Biochemistry*, 2001. **40**(6): p. 1688-93.
312. Marshall, H.E., D.T. Hess, and J.S. Stamler, *S-nitrosylation: physiological regulation of NF-kappaB*. *Proc Natl Acad Sci U S A*, 2004. **101**(24): p. 8841-2.
313. O'Sullivan, S., et al., *Nitric oxide-matrix metalloproteinase-9 interactions: biological and pharmacological significance--NO and MMP-9 interactions*. *Biochim Biophys Acta*, 2014. **1843**(3): p. 603-17.
314. Broniowska, K.A., A.R. Diers, and N. Hogg, *S-nitrosoglutathione*. *Biochimica et biophysica acta*, 2013. **1830**(5): p. 3173-81.
315. Romero, J.M. and O.A. Bizzozero, *Intracellular glutathione mediates the denitrosylation of protein nitrosothiols in the rat spinal cord*. *Journal of neuroscience research*, 2009. **87**(3): p. 701-9.
316. Zaffagnini, M., et al., *Mechanisms of nitrosylation and denitrosylation of cytoplasmic glyceraldehyde-3-phosphate dehydrogenase from Arabidopsis thaliana*. *The Journal of biological chemistry*, 2013. **288**(31): p. 22777-89.
317. Du, Y.T., et al., *Glutathione and Thioredoxin Act as a Backup of Human Thioredoxin Reductase 1 to Reduce Thioredoxin 1 Preventing Cell Death by Aurothioglucose*. *Journal of Biological Chemistry*, 2012. **287**(45).
318. Gilloteaux, J., et al., *Ultrastructural aspects of autophagy: a new cancer cell death induced by the synergistic action of ascorbate/menadione on human bladder carcinoma cells*. *Ultrastruct Pathol*, 2001. **25**(3): p. 183-92.
319. Kelleher, Z.T., et al., *Thioredoxin-mediated denitrosylation regulates cytokine-induced nuclear factor kappaB (NF-kappaB) activation*. *J Biol Chem*, 2014. **289**(5): p. 3066-72.

320. Zhang, B., et al., *Thioredoxin reductase inhibitors: a patent review*. Expert Opin Ther Pat, 2016: p. 1-10.
321. Flohe, L., *The trypanothione system and its implications in the therapy of trypanosomatid diseases*. Int J Med Microbiol, 2012. **302**(4-5): p. 216-20.
322. Benhar, M., *Application of a Thioredoxin-Trapping Mutant for Analysis of the Cellular Nitrosoproteome*. Methods Enzymol, 2017. **585**: p. 285-294.
323. Wu, C., et al., *Redox regulatory mechanism of transnitrosylation by thioredoxin*. Mol Cell Proteomics, 2010. **9**(10): p. 2262-75.