



PDi LED Televisions

PDI-E24LED-NK

Document Number: PD196-253R7



 <small>Communication Systems, Inc.</small> <i>A Leader in Patient Communication Solutions™</i>	MODEL NUMBER: PDI-E24" LED TV	Document Number: PD196-253R7
	User Manual	Page 1 of 36



Table of Contents



CAUTIONS AND WARNINGS.....	3
IMPORTANT SAFETY INSTRUCTIONS	4
SAFETY INSTRUCTIONS (FRENCH)	5
Mounting	6
Connections.....	6
Across-Room Wiring	6
Pillow Speaker	6
Antenna Connections.....	7
DVD Connection	7
Side-Panel Buttons	7
Remote Controls.....	8
Programming	10
Service Levels.....	10
Picture	11
Brightness, Contrast, Color, Tint, and Sharpness.....	11
Sound.....	12
Balance.....	12
Minimum Volume.....	12
Maximum Volume.....	12
Power on Volume	12
Internal Speaker Enable.....	13
HDMI 1 and 2 Audio Port	13
Composite Sound Mode.....	13
Volume Leveling.....	13
Pillow Speaker Boost	13
Channels.....	14
Signal.....	14
Auto Program	14
Channel Aliasing	15
Clear Service Level	18
Copy Service Level	18
Parental Control.....	19
TV Rating.....	19
MPAA Rating	20
Change Password	20
Block Aux. Sources.....	21
Parental Lock Duration	21
Parental Lock	21
Power on Channel.....	21
Channel Lock.....	21
Channel Memory Override	22
Pro:Idiom	22
Features	23
Power on Caption Mode.....	23
Auto Power On/Lock	23
Inactive Power Off (h:mm).....	23
Bed A/B/C/D	23
Caption Text Modes	23
Digital Captions	24
Digital Mode Time Setup.....	24

 <small>Communication Systems, Inc.</small> <i>A Leader in Patient Communication Solutions™</i>	MODEL NUMBER: PDI-E24" LED TV	Document Number: PD196-253R7
	User Manual	Page 2 of 36

- Channel up Power Off 24
- Channel to Other Sources 25
- Power on ARC Mode 25
- Wireless 25
- Analog Pillow Speaker 25
- UR3-SR3 Remote 25
- Splash Image 25
- OSD Language (On Screen Display) 26
- Sources 27
 - Source Enable 27
 - Source Name 27
 - Power on Source 27
 - FM Radio 28
- System 29
 - Diagnostics 29
 - Reset to Factory Defaults 30
 - Standby Power 30
 - USB Cloning and FW Update 30
 - See cloning section below 30
 - RF Cloning and FW Update 30
 - Support 30
- Cloning 31
 - Restore Setting to TV 31
 - Save Settings to USB Flash Drive 32
 - Upload Firmware to TV 32
 - Upload Boot Code to TV 33
 - Upload Splash Image to TV 33
- Information 33
- Operation 34
 - Accessing External Video Sources 34
 - Wireless Control 34
- Troubleshooting Tips 35
- Product Accessories 35
- Limited Warranty 36

CAUTIONS AND WARNINGS

	This symbol indicates that dangerous voltage constituting a risk of electric shock is present within this unit.
	This symbol indicates that there are important operating and maintenance instructions in the literature accompanying this unit.

	CAUTION	
RISK OF ELECTRIC SHOCK, DO NOT OPEN!		
CAUTION: TO REDUCE THE RISK OF ELECTRIC SHOCK, DO NOT REMOVE COVER. NO USER SERVICEABLE PARTS INSIDE. REFER SERVICING TO QUALIFIED SERVICE PERSONNEL		

 **Overhead Falling Hazard**
TV can pose a striking hazard when mounted at an elevated position. Use only PDI mounting brackets, support arms, and appropriate hardware to assure TV will not fall from the mounted position. Failure to do so may cause injury or death.

 **Rain and Moisture**
WARNING: To avoid the hazards of fire or electrical shock, DO NOT expose this television to rain or moisture.

 **Oxygen Environment**
WARNING: Do not use in any oxygen tent or oxygen chamber. Such use may cause a fire hazard.

 **Wet Location**
Do not use this television near water. Television shall not be exposed to dripping or splashing and no objects filled with liquids, such as vases, shall be placed on the television.

Note to Cable TV Installer

This reminder is provided to call the cable TV systems installer's attention to Article 820-40 of the National

Example of Antenna Grounding as per NEC - National Electrical Code

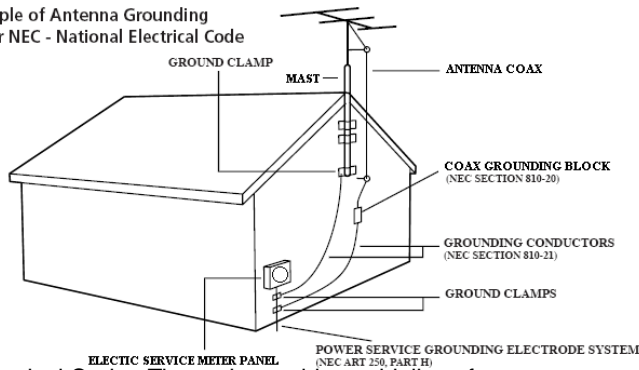

Electrical Code. The code provides guidelines for proper grounding and, in particular, specifies that the cable ground shall be connected to the grounding system of the building, as close to the point of the cable entry as practical. Canadian installations shall be properly grounded in accordance with the Canadian Electrical Code, Part 1.

FCC

This equipment has been tested and found to comply with the limits for a Class A digital device, pursuant to part 15 of the FCC Rules. These limits are designed to provide

reasonable protection against harmful interference when the equipment is operated in residential or commercial installation. If this equipment does cause harmful interference to radio or television reception, which can be determined by turning the equipment off and on, the user is encouraged to try to correct the interference by one or more of the following measures:

- Reorient or relocate the receiving antenna.
- Increase the separation between the equipment and receiver.
- Connect the equipment into an outlet on a circuit different from that to which the receiver is connected.
- Consult the dealer or an experienced radio/TV technician for help.

Cleaning and Disinfection

Clean the exterior of this television by removing dust with a lint-free cloth. Suggested cleaning agent is 5% Bleach and Water solution. CAUTION: To avoid damage to the surface of the television, do not use abrasive or chemical cleaning agents. Spot test a new disinfectant by test cleaning a non-obvious small spot on the TV's back cabinet, keypad, and LED panel. Allow the disinfectant to soak per its instructions and then wipe clean. Do not use the disinfectant if the TV's surfaces show any sign of discoloration or softening. Do not immerse this TV.

Trademarks

Manufactured under license from Dolby Laboratories, All other brand names and product names used in this manual are trademarks, registered trademarks, or trade names of their respective holder. "PDI" is a registered trademark of PDI Communication Systems, Inc. All rights reserved.

Underwriters Laboratories

The model E24LED Hospital Grade TV is a specialized LED TV and should be installed to National Electrical Code specifications. This device is safety tested and listed by the Underwriters Laboratories as a product suitable for use in health-care facilities in both the United States and Canada.



IMPORTANT SAFETY INSTRUCTIONS

THIS INSTALLATION SHOULD BE MADE BY A QUALIFIED SERVICE PERSON AND SHOULD CONFORM TO ALL LOCAL CODES. READ AND FOLLOW THE SAFETY INSTRUCTIONS BEFORE ATTEMPTING THIS INSTALLATION.

1. Read these Instructions – All the safety and operating instructions should be read before the product is operated.
2. Keep these Instructions – The safety and operating instructions should be retained for future reference.
3. Heed all warnings – All warnings on the product and in the operating instructions should be adhered to.
4. Follow all instructions – All warnings on the product and in the operating instructions should be followed.
5. Do not use this apparatus near water – for example, near a bath tub, wash bowl, in a wet basement; or near a swimming pool; and the like.
6. Clean only with dry cloth. Do not use liquid cleaners or aerosol cleaners.
7. Do not block any ventilation openings. Install in accordance with the manufacturer's instructions. The openings should never be blocked by placing the product on a bed, sofa, rug, or other similar surface.
8. Do not install near any heat sources such as radiators, heat registers, stoves, or other apparatus (including amplifiers) that produce heat.
9. DO NOT defeat the safety purpose of the polarized or grounding-type plug. This product is equipped with a three-wire grounding-type plug, a plug having a third (grounding) pin. This plug will only fit into a grounding-type power outlet. This is a safety feature. If you are unable to insert the plug into the outlet, contact your electrician to replace your obsolete outlet.
10. Protect the power cord from being walked on or pinched particularly at plugs, convenience receptacles, and the point where they exit from the product.
11. Attachments – Only use attachments/accessories specified by the manufacturer.
12. Use only with the cart, stand, tripod, bracket, or table specified by the manufacturer, or sold with the apparatus. When a cart is used, use caution when moving the cart/apparatus combination to avoid injury from tip-over.
13. Unplug this apparatus during lightning storms or when unused for long periods of time.
14. Refer all servicing to qualified service personnel. Servicing is required when the apparatus has been damaged in any way, such as power-supply cord or plug is damaged, liquid has been spilled or objects have fallen into the apparatus, the apparatus has been exposed to rain or moisture, does not operate normally, or has been dropped.
15. Power Sources – This product should be operated only from the type of power source indicated on the marking label. If you are not sure of the type of power supply to your home, consult your product dealer or local power company. For products intended to operate from battery power, or other sources, refer to the operating instructions.
16. Oxygen Environment – Do not use in an oxygen tent or oxygen chamber. Such use may cause a fire hazard.
17. Lightning – For added protection for this product during a lightning storm, or when it is left unattended and unused for long periods of time, unplug it from the wall outlet and disconnect the antenna or cable system. This will prevent damage to the product due to lightning and power-line surges.
18. Servicing – Do not attempt to service this product yourself as opening or removing covers may expose you to dangerous voltage or other hazards. Refer all servicing to qualified service personnel.



SAFETY INSTRUCTIONS (FRENCH)

	<p>Ce symbole indique qu'une tension dangereuse constituant un risque de choc électrique est présente dans cet appareil.</p>		AVERTISSEMENT	
	<p>Ce symbole indique qu'il existe des instructions d'utilisation et d'entretien importantes dans la documentation accompagnant cet appareil.</p>	<p>AVERTISSEMENT: AFIN DE RÉDUIRE LE RISQUE DE CHOC ÉLECTRIQUE, NE PAS RETIRER LE COUVERCLE. L'APPAREIL NE CONTIENT AUCUN COMPOSANT SUSCEPTIBLE D'ÊTRE RÉPARÉ PAR L'UTILISATEUR. CONFIER L'ENTRETIEN À DU PERSONNEL QUALIFIÉ</p>		

Danger chute d'objets



AVERTISSEMENT: Afin d'éviter toute blessure, cet appareil doit être solidement fixé au sol/mur conformément aux instructions d'installation. Les télévisions peuvent présenter un risque de heurt lorsqu'elles sont montées en position élevée. Utiliser uniquement des supports de montage, des bras de support et le matériel approprié de PDI afin d'assurer que la télévision ne tombe pas de sa position de montage. Le non-respect de ces instructions peut causer des blessures ou la mort.

Pluie et humidité



AVERTISSEMENT: Afin d'éviter les risques d'incendie ou de choc électrique, NE PAS exposer cette télévision à la pluie ou à l'humidité ou l'utiliser dans un endroit humide.

Environnement d'oxygène



AVERTISSEMENT: Ne pas utiliser dans une tente à oxygène ou chambre à oxygène. Une telle utilisation peut causer un risque d'incendie.

CONSIGNES DE SÉCURITÉ IMPORTANTES

CETTE INSTALLATION DOIT ÊTRE EFFECTUÉE PAR UN TECHNICIEN QUALIFIÉ ET DOIT ÊTRE CONFORME À TOUS LES CODES LOCAUX. LIRE ET SUIVRE LES CONSIGNES DE SÉCURITÉ AVANT DE PROCÉDER À L'INSTALLATION.

1. Lire ces instructions. Toutes les consignes de sécurité et d'utilisation doivent être lues avant d'utiliser le produit.
2. Conserver ces instructions. Les consignes de sécurité et d'utilisation doivent être conservées pour référence future.
3. Respecter tous les avertissements. Tous les avertissements sur le produit et dans les consignes d'utilisation doivent être respectés.
4. Suivre toutes les instructions. Tous les avertissements sur le produit et dans les consignes d'utilisation doivent être suivis.
5. Ne pas utiliser cet appareil près de l'eau - par exemple près d'une baignoire, d'un lavabo, dans un sous-sol humide, ou près d'une piscine ou similaire.
6. Nettoyer avec un chiffon sec. Ne pas utiliser de nettoyeurs liquides ou en aérosol.
7. Ne pas obstruer les ouvertures de ventilation. Installer conformément aux instructions du fabricant. Les ouvertures ne doivent jamais être obstruées en plaçant le produit sur un lit, un canapé, un tapis ou toute autre surface similaire.
8. NE PAS installer près de sources de chaleur telles que radiateurs, registres de chaleur, poêles ou tout autre appareil (y compris les amplificateurs) qui produit de la chaleur.
9. NE PAS neutraliser le dispositif de sécurité de la fiche polarisée ou de terre. Ce produit est équipé d'une prise de terre à trois fils, une fiche ayant une troisième broche (mise à la terre). Cette fiche ne peut s'insérer que dans une prise de courant avec mise à la terre. Il s'agit d'une caractéristique de sécurité. Si vous êtes incapable d'insérer la fiche dans la prise, contacter votre électricien pour remplacer votre prise obsolète.
10. Protéger le cordon d'alimentation pour qu'il ne soit pas piétiné ni pincé, en particulier au niveau des fiches, des prises de courant et au point de sortie de l'appareil.
11. Accessoires - Utiliser uniquement les attaches/accessoires recommandés par le fabricant.
12. Utiliser uniquement avec un chariot, stand, trépied, support ou table recommandé par le fabricant ou vendu avec l'appareil. Lorsqu'un chariot est utilisé, faire attention lors du déplacement de l'ensemble chariot/appareil afin d'éviter des blessures en cas de basculement.
13. Débrancher cet appareil en cas d'orages ou lorsqu'il reste inutilisé pendant de longues périodes.
14. Confier toute réparation à un personnel de service qualifié. Des réparations sont nécessaires si l'appareil est endommagé d'une façon quelconque, par exemple : cordon ou prise d'alimentation endommagé, liquide renversé ou des objets sont tombés dans l'appareil, l'appareil a été exposé à la pluie ou à l'humidité, ne fonctionne pas normalement ou s'il est tombé.
15. Sources d'alimentation - Ce produit doit être utilisé uniquement à partir du type de source d'alimentation indiqué sur l'étiquette. Si vous n'êtes pas sûr sur le type d'alimentation de votre domicile, consultez le détaillant de votre produit ou la compagnie d'électricité locale. Pour les produits proposés de fonctionner par piles, ou autres sources d'alimentation, reportez-vous aux consignes d'utilisation.
16. Environnement d'oxygène - Ne pas utiliser sous une tente à oxygène ou chambre à oxygène. Une telle utilisation peut causer un risque d'incendie.
17. Foudre - Pour une protection supplémentaire pour ce produit lors d'un orage, ou lorsqu'il est laissé sans surveillance et inutilisé pendant de longues périodes de temps, le débrancher de la prise murale et déconnecter l'antenne ou le système de câble. Cela permettra d'éviter tout dommage à l'appareil causé par la foudre et par les surtensions des lignes électriques.

Mounting

PDi offers a wide range of wall, floor and ceiling mounting options. Contact PDi for more information.

Connections

Across-Room Wiring

NOTE: A jumper Cable (shown below) is NOT supplied with the TV and must be ordered separately.

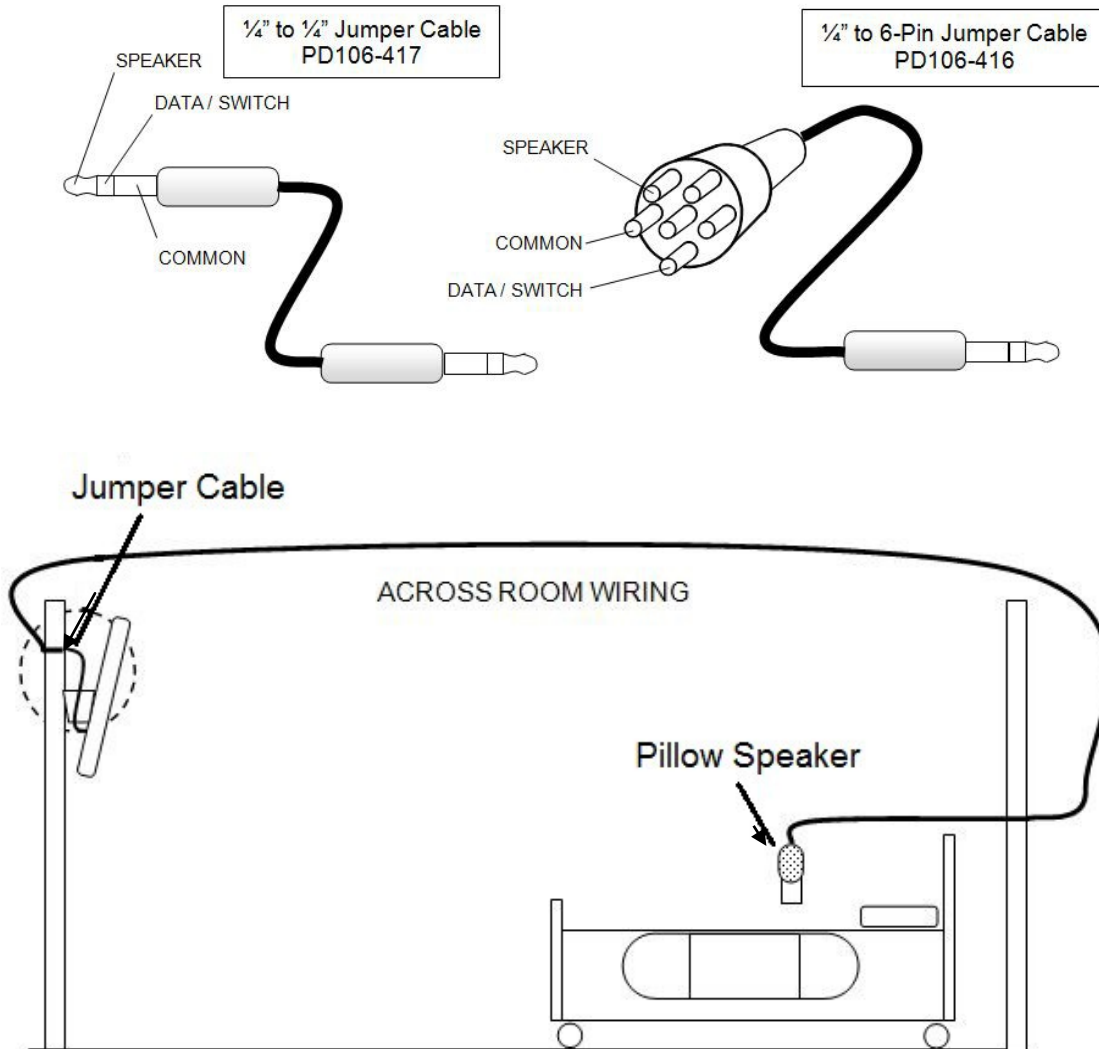

Pillow Speaker

A 1/4" stereo-style pillow speaker (pendant control) jack is located on the TV's connector panel on the left side of the TV. This TV is designed to work with either a digital pillow speaker that generates digital-style control codes or a single-button analog (switch-style) pillow speaker. A side panel mounted switch allows use of different brands of pillow speakers and supports the major brands: Zenith, Philips, and RCA.



CAUTION: Confirm the pillow speaker type and set the slide switch appropriately **BEFORE** connecting the pillow speaker to the TV. Failure to follow this procedure could result in damage to the pillow speaker and/or TV.

Antenna Connections



CAUTION: Some hospital cable systems provide power voltage on the coaxial cable. This TV is NOT designed to be powered via a coaxial cable. **DO NOT** connect to a powered coaxial cable. Damage will result to the TV.

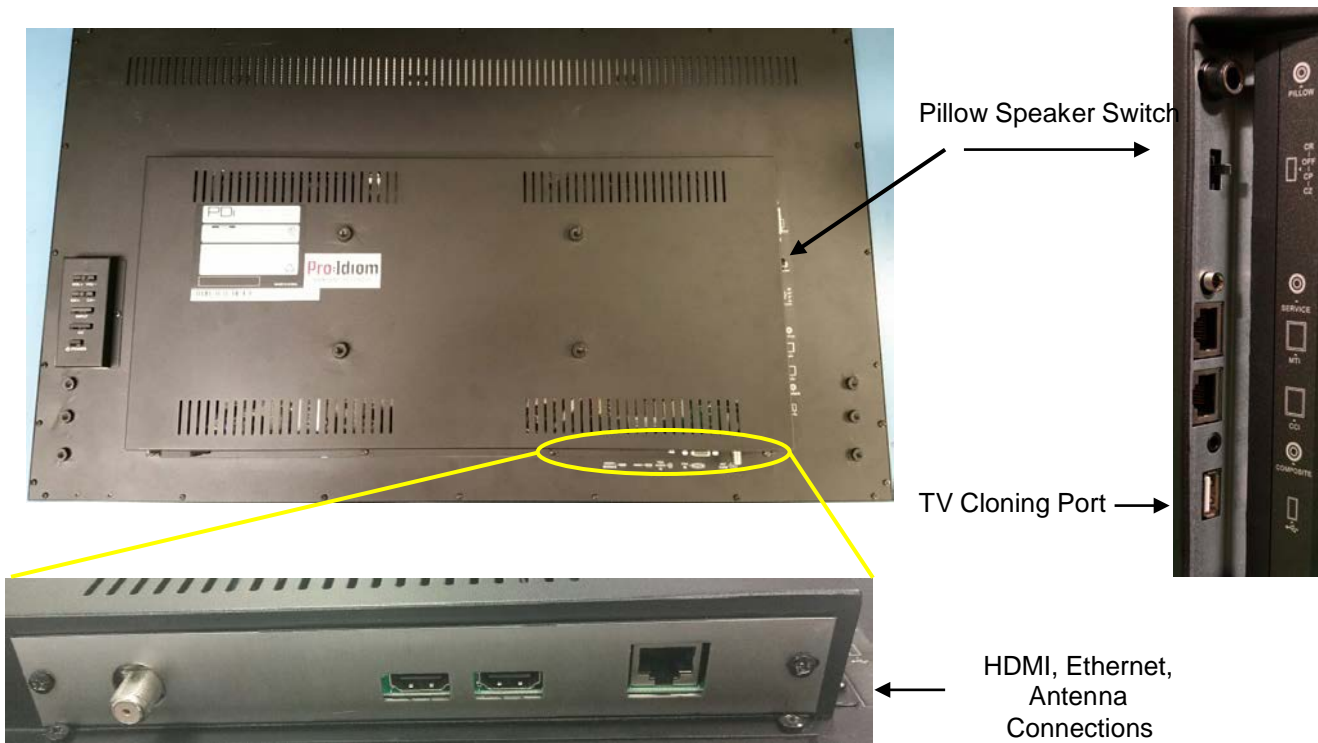

DVD Connection

The ELED series televisions are made to accept optional PDi DVD module. This mounts on the back of the television with side access. Detailed installation instructions are available with the DVD.

Side-Panel Buttons

The buttons on the right side of the TV can be used to control a limited number of the television's basic operating functions.



- **INPUT**
Press this button to cycle through all enabled sources. Press and hold for 5 seconds to configure wireless connections. NOTE: Wifi must be enabled and standby power must be set to normal.
- **CC**
Caption OFF, CC1, CC2, CC3, CC4
- **VOL ▲**
Press this button to increase volume.
- **VOL ▼**
Press this button to decrease volume.
- **CH ▲**
Press this button to go to the next highest channel.
- **CH ▼**
Press this button to go to the next lowest channel.
- **POWER**
Press this button to turn the TV on and off.

Remote Controls

Programming Remote Control

A programming remote control PD108-420 is required to perform all setup operations for the television. The programming remote is NOT packaged with the TV and must be ordered separately. Power, setup, and the directional buttons will be the main buttons used on this remote.

1. POWER button
Turns the TV on or off
2. MUTE button
Turns the sound on or off
3. SETUP button
Access programming menus
4. TV/AV button
Selects enabled external inputs or TV
5. CH LIST button
Display list of channels programmed into TV
6. TV/FM button
Switch between TV and FM Radio sources
7. SLEEP button
Sets the sleep timer
8. LAST button
Return to previously viewed channel
9. VOL ◀▶ buttons
Raises or lowers volume. Also used to navigate programming menus.
10. OK button
Confirms the current channel selection
11. CH ▲▼ buttons
Selects next channel. Also used to navigate programming menus.
12. ARC button
Changes the aspect ratio.
13. CC button
Cycles through Closed caption choices
14. PSM button
Adjust sound setting for content type
15. SAP button
Adjust audio mode
16. SSM button
Adjust sound setting for content type
17. Number buttons
Use to directly enter channels
18. DASH button
Use to enter second part of a digital channel
19. Teletext buttons
Navigates teletext displays.
Teletext is not used in the USA



Patient Remote Controls

The patient remotes, PD108-421 and PD108-210 are used for controlling the TV.

The optional DVD remote PD108-427 (sold with DVD Module) will control the compatible DVD and TV.

Patient remotes offer independent Bed A or Bed B selectable codes and independent control of a single TV in a two TV room.

For remote PD108-421, insert a paperclip to depress the *CODE* button to select Bed A or Bed B.

For patient remote PD108-210, to set bed A, B, C, or D:

Press and hold the function button while simultaneously pressing:

- 1 & 2 for bed A
- 2 & 3 for bed B
- 4 & 5 for bed C
- 5 & 6 for bed D

PD108-421
Basic Patient Remote

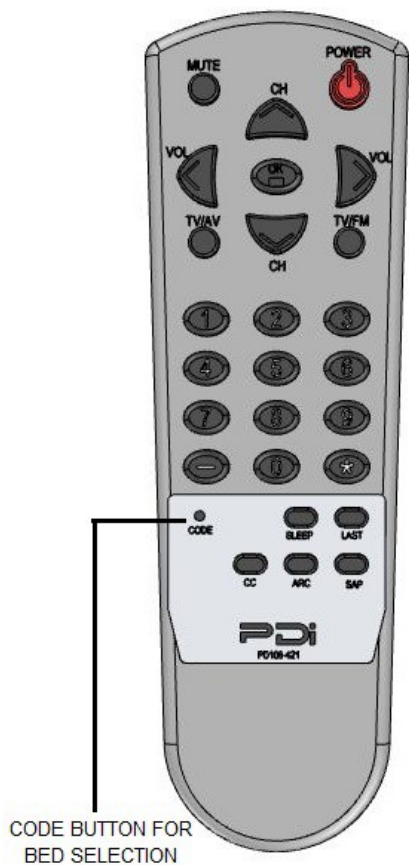

PD108-210
Enhanced Patient Remote

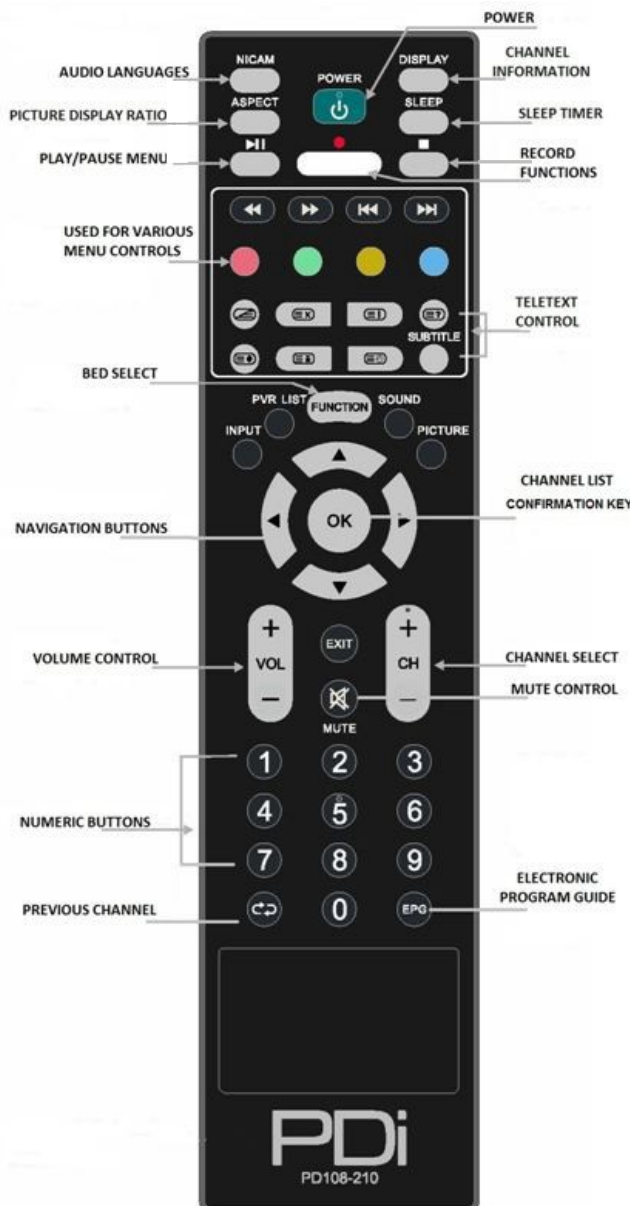

Programming

The following instructions assume you have a programming remote, have correctly mounted the TV, and connected power and RF signal.

Access the menus by pressing *SETUP* on the remote. These menus allow you to add TV channels, adjust the picture and sound, setup external components, and control settings.

The SETUP menu is the first menu that appears. All the other menus and all the settings can be accessed through it. This manual explains and shows how to setup the different features of the PDI-E24 ELED TV.



Service Levels

This TV contains four separate Service Levels, allowing the hospital to offer either basic or enhanced viewing. The current Service Level can be quickly determined by accessing the SETUP menu using the remote control. The Service Level can be changed to any of the 4 levels at any time by entering the SETUP menu and changing the Service Level menu items.

DISABLED – This is like a mechanical key lock – when in *Disabled* Service Level, the TV can be turned off and on, but it cannot be used for viewing. A standard message appears on a black screen.

FREE – This lets patients watch hospital education and information channels without renting the TV. The channels containing programming for no charge are typically programmed into this level of service. This is the factory default setting for Service Level.

BASIC – This service level typically allows additional channels beyond those offered in the FREE level.

PREMIUM – This is the highest service level with typically the most channels available for viewing.



Picture

This menu allows you to make changes to settings that will change the picture's appearance.

1. Press the SETUP button on the remote control.
2. Press ▲ or ▼ to highlight Picture.
3. Press ► to enter the Picture sub-menu.

Brightness, Contrast, Color, Tint, and Sharpness

These settings have a range of 1-100. To change one of them, change the number by following this process.

1. Enter the Picture menu
2. Press ▲ or ▼ to highlight the setting you want to change.
3. Press ◀ or ▶ to the desired number.
4. Press SETUP to return to the previous menu. To exit, press SETUP until the programming menus disappear.



Backlight

This setting allows you to make changes to the backlight from bright, normal and low

1. Enter the Picture menu
2. Press ▲ or ▼ to highlight Backlight.
3. Press ► to change the settings from bright, normal, or low.

Color Temperature

Color Temperature adjusts the color balance of the picture. Standard, Reddish, Greenish, and Bluish are preset adjustments. You can customize the color temperature with the User setting.

1. Enter the Picture menu
2. Press ▲ or ▼ to highlight Color Temperature.
3. Access the menu by pressing ►.
4. Press ▲ or ▼ to highlight and select one of the five settings.
5. For User, press ◀ and ▶ to select R, G, or B or to get out of the customized adjustments.
6. Press ▲ or ▼ to adjust R,G, or B
NOTE: When you select one of the three colors to adjust, the other two turn grey.
7. Press SETUP to return to the previous menu. To exit, press SETUP until the programming menus disappear.

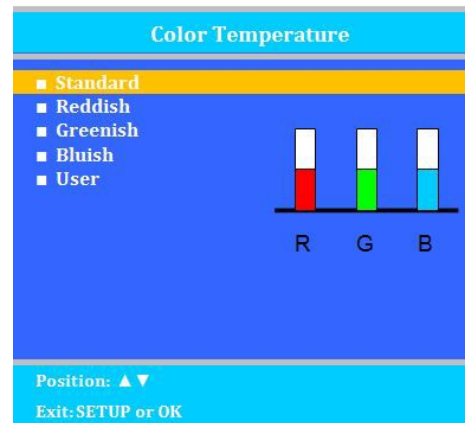

Noise Reduction

This setting enables impulse, spatial, and temporal video noise filtering.

1. Enter the Picture menu
2. Press ▲ or ▼ to highlight Noise Reduction.
3. Press ► to choose Enable or Disable
4. Press SETUP to return to the previous menu.

PC Analog/HDMI Picture

Adjustment of a computer's picture can be made only when the TV is in PC-Analog or HDMI mode.

1. Enter the Picture menu
2. Press ▲ or ▼ to highlight PC Analog/HDMI Picture.
3. Access the menu by pressing ►.
4. Press ▲ or ▼ to highlight and select one of the settings.
5. Press ◀ and ▶ to adjust the setting.
6. Press SETUP to return to the previous menu. To exit, press SETUP until the programming menus disappear.

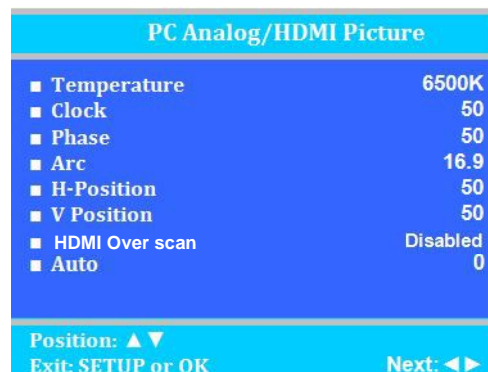

Sound

The sound menu allows precise adjustment of several sound parameters.

1. Press the SETUP button on the remote control.
2. Press ▲ or ▼ on to highlight Sound.
3. Press ► to enter the Sound sub-menu.



Balance

This controls how the sound is distributed between the left and right speakers.

1. Enter the Sound menu.
2. If Balance is not highlighted, press ▲ or ▼ to highlight it.
3. Press ◀ or ▶ to select the desired number (0-100).
4. Press SETUP to return to the previous menu. To exit, press SETUP until the programming menus disappear.

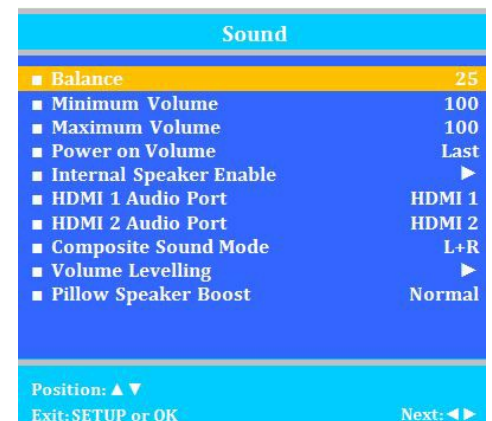

Minimum Volume

Sets the minimum volume level the TV can reach. Setting this to any value other than 0 guarantees that some level of sound will always be heard when the TV is operating.

1. Enter the Sound menu.
2. Press ▲ or ▼ to highlight Minimum Volume.
3. Press ◀ or ▶ to select the desired number (0-100).
4. Press SETUP to return to the previous menu. To exit, press SETUP until the programming menus disappear.

Maximum Volume

Sets the maximum volume level the TV is allowed to reach.

1. Enter the Sound menu
2. Press ▲ or ▼ to highlight Maximum Volume.
3. Press ◀ or ▶ to select the desired number (0-100).
4. Press SETUP to return to the previous menu. To exit, press SETUP until the programming menus disappear.

Power on Volume

Sets the initial volume for when the TV is turned on. Last will cause the TV to be at the same volume setting before it was turned off.

1. Enter the Sound menu
2. Press ▲ or ▼ to highlight Power on Volume.
3. Press ◀ or ▶ to select the desired number (0-100) or Last.
4. Press SETUP to return to the previous menu. To exit, press SETUP until the programming menus disappear.

NOTE: If Power on Volume is set to Last and the physical power is removed, the TV will power on with a volume equal to the minimum volume setting.

Internal Speaker Enable

This allows the TV's speakers for each source to be enabled, disabled, or controlled by the patient. Sound is always routed externally to the attached pillow speaker, regardless of these settings.

1. Enter the Sound menu
2. Press ▲ or ▼ to highlight the component you want to change.
3. Press ◀ or ▶ to select Enabled or Disabled.
4. Press SETUP to return to the previous menu. To exit, press SETUP until the programming menus disappear.

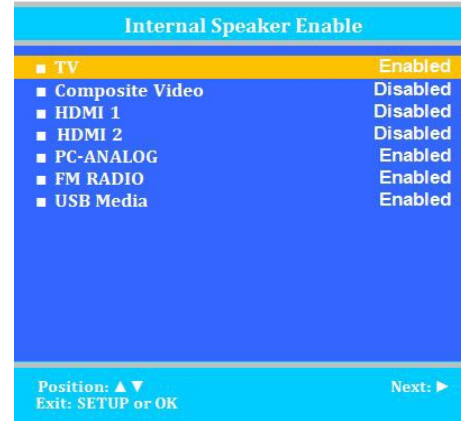

HDMI 1 and 2 Audio Port

Sound can be routed from various inputs when the TV is set to HDMI. The HDMI Audio Ports have two settings: PC and HDMI 1 or 2.

1. Enter the Sound menu
2. Press ▲ or ▼ to highlight HDMI Audio Port.
3. Press ◀ or ▶ to select PC or HDMI 1 or 2.
4. Press SETUP to return to the previous menu. To exit, press SETUP until the programming menus disappear.

Composite Sound Mode

These settings are L+R, L+L, and R+R to allow for stereo or mono audio sources.

1. In the Sound menu, press ▲ or ▼ to highlight Composite Sound Mode.
2. Press ◀ or ▶ to choose between settings.
3. Press SETUP to return to previous menu.

Volume Levelling

Allows source inputs which sound louder to be scaled down to provide a consistent volume when changing inputs.

The settings can be adjusted from 50% to 100%

1. Enter the Sound menu
2. Press ▲ or ▼ to highlight Volume Levelling.
3. Press ◀ or ▶ to select the desired number (50%-100%).
4. Press SETUP to return to the previous menu. To exit, press SETUP until the programming menus disappear.

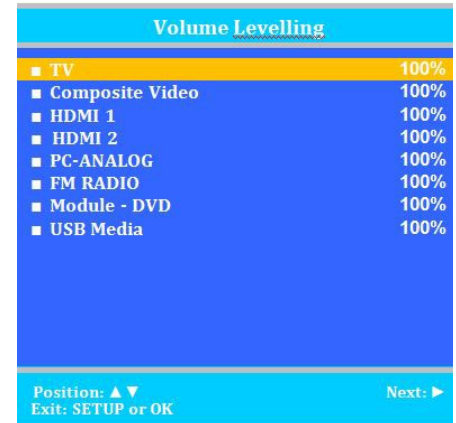

Pillow Speaker Boost

Pillow speaker audio level can be increased to compensate for the speaker's impedance and efficiency. Choices are Normal, Strong, and Disable

NOTE: Too much boost can cause audible distortion.

1. In the Sound menu, press ▲ or ▼ to highlight Pillow Speaker Boost menu.
2. Press ◀ or ▶ to choose between settings.
3. Press SETUP to return to previous menu.

Channels

The Channel Setup menu allows you to program different signal sources into three Service Levels (Free, Basic, and Premium) and to add or delete individual channels. It also allows you to block channels, TV programs, movies, and auxiliary sources that can be input to the TV. Each Service Level contains a different channel map.

1. Press the SETUP button on the remote control.
2. Press ▲ or ▼ to highlight Channel Setup.
3. Press ► to enter the Channels sub-menu.

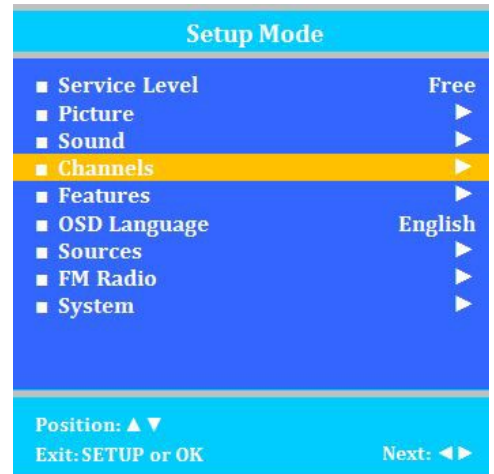

Signal

Four different tuning types are available depending upon the healthcare facility's signal type. Selection of the correct signal type is required for the TV to recognize all possible channels and before any channel programming can begin.

NOTE: Most hospitals use the Cable STD signal style.

1. Enter the Channel Setup menu
2. Press ▲ or ▼ to highlight Signal.
3. Press ◀ or ▶ to select Air, Cable STD, Cable IRC, or Cable HRC.
4. Now perform Auto Program or Add/Delete Channels to adjust the channels.



Auto Program

The TV scans each available channel for activity. Channels that display activity are memorized into the selected Service Level.

NOTE: A programmed service level can also be reprogrammed if desired. Digital channel auto programming may take longer than 10 minutes to complete.

1. After setting Signal, press ▲ or ▼ to highlight Auto Program.
2. Press ► to select it.
3. On Mode, press ◀ or ▶ to select the scope of channel scanning.
 - Analog Only: TV searches for analog channels only.
 - Digital Only: TV searches for digital channels only.
 - Analog and Digital: TV searches for both analog and digital channels.
4. Press ▲ or ▼ to highlight Channel Sequence.
5. Press ◀ or ▶ to select the Channel Sequence in which the channels are displayed.
 - Interleave A+D: Channels are displayed in the order of channel number. (Analog + Digital)
 - All A then D: All digital channels are displayed after all analog channels.
6. Press ▲ or ▼ to highlight Add'l Digital Signal.
7. Press ▲ or ▼ to select a signal type to scan for digital channels in addition to the signal type selected on the previous menu.
 - None: Only the primary signal type will be scanned for digital channels
 - Air or Cable: This signal type will be scanned for digital channels after the primary type is scanned.



8. Press ▲ or ▼ to highlight the Service Level (Free, Basic, or Premium) you wish to program. The menu displays the current programming status of each level as either Programmed or Blank.
9. Press ► to start auto programming.
10. A confirmation menu will appear before proceeding. Press ▲ to start auto programming. Press ▼ to cancel the operation. The TV now will search all available channels. Auto programming requires several minutes to complete.
11. Press the SETUP button to return to normal TV viewing.

Auto Channel Alias

Digital channels contain both a major channel number as well as a minor sub-channel number. Channel Aliasing (Channel Number Remapping) allows a digital channel containing major and minor numbers to be remapped or aliased to a major channel number only. As an example, the following digital channel numbers contain both Major and Minor numberings that are remapped (Aliased) to a Major channel number. 10-7 becomes channel 10

10-8 becomes channel 11 10-22 becomes channel 12

Channel Aliasing creates ready channel tuning, eliminating the requirement to enter a minor channel number. Channel Aliasing also provides flexibility as many local channels may appear with unusual digital channel numbers on a hospital's cable system. For example, a local CBS TV affiliate always appeared on channel 5. Patients may be accustomed to locating their favorite programs and news by tuning to channel 5. However, the cable system now places this local CBS TV affiliate on channel 17-22. Channel aliasing is used to modify the channel numbering in the TV, allowing channel 5 to be tuned directly as channel 5, and also appearing on the TV's screen as channel 5, as would be expected.

Channel Labels

A custom channel label may be created that appears on screen with the displayed channel number. For example, the aliased channel 5 is labeled as "CBS" and appears on the TV's screen as follows: 5 CBS

1. Enter the Channels menu.
2. Press ▲ or ▼ to highlight Auto Channel Alias.
(If the TV's Channels menu lacks this item, the TV does not support Channel Aliasing)
3. Press ► to select it.

NOTE: The remainder of the instructions assumes that the TV has Already been Auto Programmed with channels.



Configure Channels

The Configure Channels item provides a manual technique to channel setup. Once a TV is configured correctly, a clone file can be generated to reproduce the original TV's setup including the aliased channels on additional televisions, greatly reducing the amount of time to program televisions.

1. Enter the Channels menu.
2. Press ▲ or ▼ to highlight Configure Channels.
3. Press ► to select it.
4. The Configure Channels menu display provides a list of active channels found after an auto channel search. NOTE: Your display will appear different, since your channel lineup is likely different.

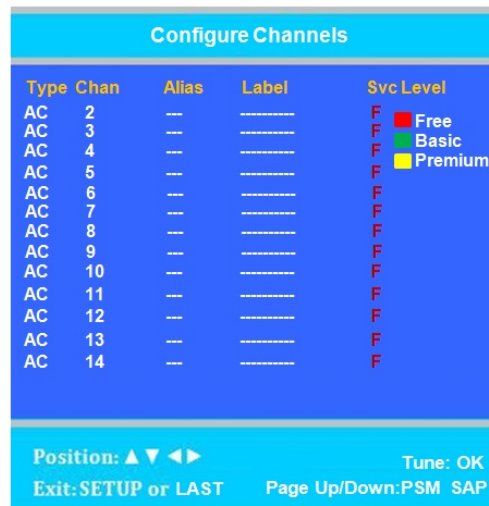

TYPE

The type of channel is listed on the far left with the following abbreviations.

- AC Analog Cable
- DC Digital Cable
- AA Analog Air
- DA Digital Air

CHAN

White channel numbers indicate the channel contains signal and is active in at least one Service Level. Blue channel numbers are either empty without signal following an Auto Search, or were once active, but have been excluded from all Service Levels – turned off for viewing. The example screen shows inactive analog channels 5, 6 and 10 following an Auto Search.

ALIAS

The Alias channel number is manually entered and represents the channel the patient directly enters for desired viewing.

LABEL

Labels are also manually entered to provide a description of the channel. Only the channel number appears if the label field is blank.

SVC LEVEL

Channels may be in no Service Level (Disabled), one or multiple Service Levels. The Channel’s membership in the Free, Basic, or Premium Service Levels is shown in the “SVC Level” column.

5. Use the TV’s remote control and highlight that Channel you wish to Alias.

- a. Press the VOL▶ to highlight the Alias entry field. The field appears red when it is ready for editing.
- b. Press OK. A three digit entry window will appear above the dash placeholder.



Use VOL◀▶ to select the hundredths, tens, or ones place. Use CH▲▼ to index the number to the desired value.

- c. Press OK when complete.

6. Press the VOL▶ button and highlight the Label field. The field appears red when highlighted.

- a. Press the OK button. A label entry window appears above the dash placeholders.

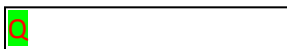

- b. Use CH▲▼ to index to the desired alpha/numeric value. Use the VOL◀▶ to select the position within the label.

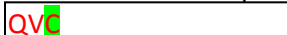

- c. Press OK to complete.

7. The use of Service Levels is optional. Only one active Service Level is required to make the channel available for viewing.

- a. Press the VOL▶ button and highlight the Svc Level field.
- b. Press the OK button to alternately Add or Remove the channel from the Free Service Level.
- c. Press the VOL▶ button again to advance to the next Service Level Basic. Press the OK button to Add or remove the channel from the Service Level. **B**
- d. In link manner, press the VOL▶ button again, advance to the final Service Level Premium. Press the OK button to alternately Add or Remove the channel from the Premium Service Level. **P**

Configure Channels				
Type	Chan	Alias	Label	SvcLevel
AC	2	---	-----	F ■ Free
AC	3	---	-----	F ■ Basic
AC	4	---	-----	F ■ Premium
AC	5	---	-----	F
AC	6	---	-----	F
AC	7	---	-----	F
AC	8	---	-----	F
AC	9	---	-----	F
AC	10	---	-----	F
AC	11	---	-----	F
AC	12	---	-----	F
AC	13	---	-----	F
AC	14	---	-----	F

Position: ▲▼◀▶ Tune: OK
Exit: SETUP or LAST Page Up/Down: PSM SAP

NOTE: A channel number without any indicated Service Level will not be viewable.

EXAMPLE

The example Channel Configuration display on the right represents the enhancements possible.

Channels have been Aliased with several analog channels using the same channel number. However, any channel number may have been used.

Digital numbers with sub-channels have been Aliased to major channel numbers with the following changes:

- 10-73 becomes 10
- 10-74 becomes 11
- 10-75 becomes 13

NOTE: Channel 4 was not Aliased and will not be available for viewing. Only channels that have been Aliased are available for viewing.

Several channels have been included in the Basic service level, namely: 7,8,9,13 and 12.

Configure Channels					
Type	Chan	Alias	Label	Svc Level	
AC	2	2	QVC	F	Free
AC	3	3	HSN	F	Basic
AC	4	---	-----	F	Premium
AC	5	---	-----		
AC	6	---	-----		
AC	7	7	CBS	FB	
AC	8	8	FOX	FB	
AC	9	9	ABC	FB	
AC	10	---	-----		
DC	10-73	10	C-SPAN	F	
DC	10-74	11	C-SPAN2	F	
DC	10-75	13	EWTN	FB	
AC	12	12	WKRC	FB	

Position: ▲ ▼ ◀ ▶ Tune: OK
Exit: SETUP or LAST Page Up/Down: PSM SAP

NAVIGATION

To page through additional channel screens, press the PSM or SAP buttons on the TV's remote control to change to the previous or next channel listing screen.

- PSM = Previous Channel Screen
- SAP = Next Channel Screen

Automatic Channel Aliasing

This enhanced feature provides a means to alias channels automatically with minimal manual intervention.

1. Enter the Channels menu.
2. Press ▲ or ▼ to highlight Auto Channel Alias.
(If the TV's Channels menu lacks this item, the TV does not support Channel Aliasing)
3. Press ▶ to select it.
4. In the Auto Channel Alias menu, three different methods are available to Alias channels. Each method is illustrated below. Select the first menu item, Fill Analog Gaps with Digital Channels.

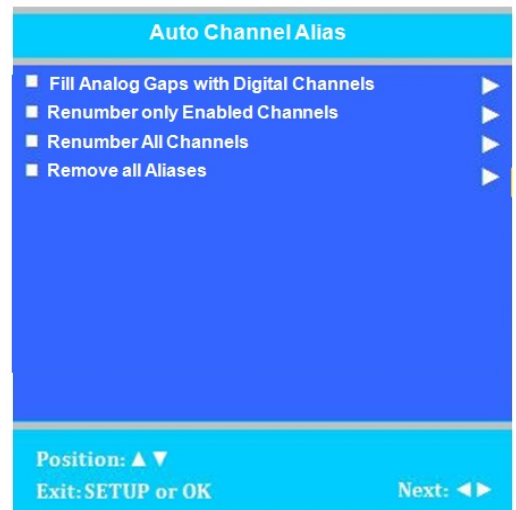

If a previous channel alias exists, a confirmation window appears "Remove existing aliases and renumber channels". Select Yes to continue.

Fill Analog Gaps with Digital Channels

As the menu title states, gaps between Analog Channels are populated with Digital Channels.

Renumber only Enabled Channels

Active channels are renumbered. This Aliasing scheme usually results in each original channel number changed to a different number.

Renumber all Channels

All active Analog channels and all Digital Channels (both Active and Disabled) are renumbered.

Remove All Aliases

Removes all present aliases and restores the channels to their original numbers.

Source Numbering

Finally, the TV's input sources appear on the last Configure Channels screen.

Each of the TV's video input sources is assigned a channel and can be selected by entering the Sources' channel number. Each source can be aliased to a different channel number if desired.

However, unlike regular TV channels, Sources are Enabled, Disabled and Labeled in the Sources menu. Please refer to that section of this manual for additional information.

Configure Channels				
Type	Chan	Alias	Label	Svc Level
S	141	---	Composite	Free
S	146	---	HDMI 1	Basic
S	150	---	HDMI 2	Premium
S	147	---	PC-ANALOG	
S	149	---	FM RADIO	
S	151	---	Module	
S	152	---	USB Media	

Position: ▲ ▼ ◀ ▶ Tune: OK
 Exit: SETUP or LAST Page Up/Down: PSM SAP

Clear Service Level

This empties a service level of all its programmed channels, leaving it blank.

NOTE: After a Service Level is cleared, the TV returns to the Clear Service Level menu. "Blank" will appear to the right of the Service Level.

1. Enter the Channels menu
2. Press ▲ or ▼ to highlight Clear Service Level.
3. Press ► to select it.
4. Press ▲ or ▼ to highlight the Service Level (Free, Basic, or Premium).
5. Press ► to select the highlighted Service Level.
6. A confirmation page will appear. Press ▲ to proceed. Press ▼ or SETUP to return to the previous menu.
7. Press SETUP to return to the previous menu. To exit, press SETUP until the programming menus disappear.

Clear Service Level	
■ Free	Programmed
■ Basic	Blank
■ Premium	Blank

Position: ▲ ▼ Exit: SETUP or OK Next: ◀ ▶

Copy Service Level

This copies one Service Level's channels to another.

NOTE: After a Service Level is copied, the TV returns to the Copy Service Level menu. If the To Service Level has been set to active in the Service Level setting (see Service Levels on page 16), TV programming will appear.

1. Enter the Channels menu.
2. Press ▲ or ▼ to highlight Copy Service Level.
3. Press ► to select it.
4. Press ▲ to set the From Service Level. Press ▼ to set the To Service Level.
5. Press ► to copy the Service Level.
6. A confirmation page will appear. Press ▲ to proceed. Press ▼ or SETUP to return to the previous menu.
7. Press SETUP to return to the previous menu. To exit, press SETUP until the programming menus disappear.

Copy Service Level	
■ Free	Basic ►

Adjust From: ▲ Adjust to: ▼
 Exit: SETUP or OK Next: ◀ ▶

Parental Control

Parental Control allows you to block channels, TV shows, movies, and devices that are connected to the TV.

1. Enter the Channels menu.
2. Press ▲ or ▼ to highlight Parental Control.
3. Press ► to select it.



TV Rating

Most TV programs are now rated. TV Rating allows the TV to selectively present only programming content that is unblocked per its preset level. A program that is blocked, displays a black screen only.

NOTE: The U or B (unblocked or blocked) will turn red when it is highlighted. Categories that are rated for older audiences will be automatically blocked. If you block TV-Y category, then TV-Y7 will be blocked automatically. Similarly, if you block TV-G category, then TV-PG, TV-14 and TV-MA will also be blocked.

1. From the Parental Control menu, enter the TV Rating menu.
2. Press ▲ or ▼ to move to one of the six age-based categories.
3. Press ◀ or ▶ to cycle through the sub-ratings (ALL, FV, V, S, L or D) or exit out of the sub-categories in that category.
4. Press ▲ or ▼ to change the sub-rating.
5. Press the SETUP button to return to the previous menu. Or press ◀ to get out of the sub-category.

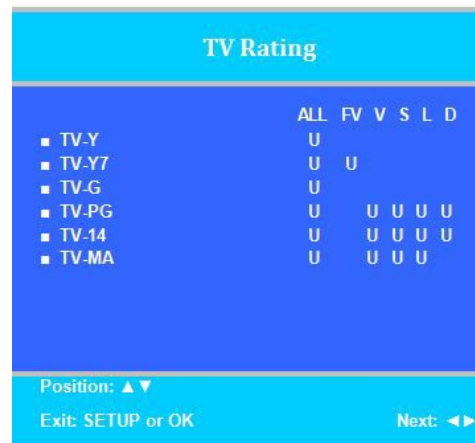

TV Parental Guideline Rating System

Guide		Meaning
TV-Y	Young Children	Content not offensive to most viewers.
TV-Y7	Children 7 and over	Considered suitable for children over 7, may contain Fantasy Violence Scenes.
TV-G	General Audience	Considered suitable for all audiences; children may watch unattended.
TV-PG	Parental Guidance	Suggested Unsuitable for younger children, may contain: Suggestive Dialog, Bad Language, Sex, and Violence Scenes
TV-14	Parents Strongly Cautioned	Unsuitable for children under 14, may contain: Strong Dialog, Bad Language, Sex, and Violence Scenes.
TV-MA	Mature Audience Only	Adults only, may contain: Strong Dialog, Bad Language, Sex, and Violence Scenes.

The sub-rating of TV rating

Grade	Meaning
FV	Fantasy Violence
V	Violence
S	Sexual Situation
L	Adult Language
D	Sexual Suggestive Dialog



MPAA Rating

Most televised movies are now rated. MPAA Rating selectively allows the TV to only present movie content that is unblocked per its preset level.

1. From the Parental Control menu, enter the MPAA Rating menu.
2. Press ▲ or ▼ to highlight a particular MPAA Rating.
3. Press ◀ or ▶ to select Blocked or Unblocked.
4. Press SETUP to return to the previous menu. To exit, press SETUP until the programming menus disappear.

NOTE: Parental Control will automatically block any category that is rated for older audiences. For example, if you block the PG-13 category, then R, NC-17 and X will be automatically blocked also.

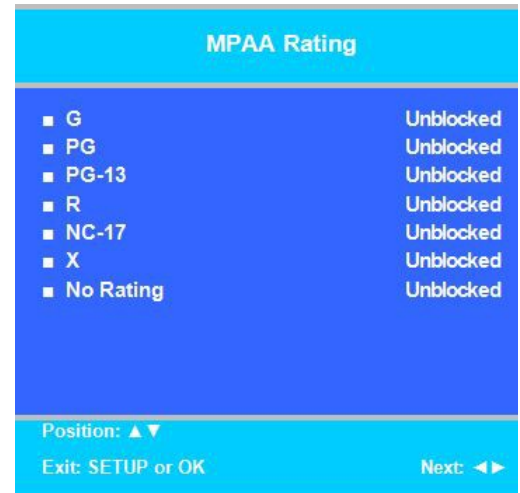

Motion Picture Association of USA (MPAA) Rating System

Guide		Meaning
G	General Audiences	Content not offensive to most viewers.
PG	Parental Guidance Suggested	Content is such that parents may not want their children to view the program.
PG-13	Parents Strongly Cautioned	Program is inappropriate for preteens, with a greater degree of offensive material Suggested than a PG rated program.
R	Restricted Viewing	Not for children under age 17. Strong elements of sex and/or violence.
NC-17	No Children under age 17	Not for children under age 17 under any circumstances. Strong sexual content.
X	Hard Core Films	Same as NC-17 rating.
No Rating	No Rating	MPAA Not Rated

NOTE: Digital Rating and Clear Digital/Download New are available when the current TV channel contains new parental control (Open V-Chip) rating information.

Change Password

The Parental Control access password can be changed using this menu.

NOTE: The factory default password that is programmed into the TV is 0000.

1. From the Parental Control menu, enter the Change Password menu.
2. Enter a new password by using the number buttons on the remote.
3. Confirm the password by entering the same digits. After confirming the password, the TV will return to the Parental Control menu.



Block Aux. Sources

Like TV programs and channels, the auxiliary sources can be blocked too. When the TV encounters an external signal source that is not appropriate per its settings, a black screen appears with muted sound.

NOTE: Parental Lock must be enabled for the sources to be blocked.

1. In the Parental Control menu, press ▲ or ▼ to highlight Aux. Block Source.
2. Press ◀ or ▶ to select Unblocked or Blocked.
3. Press SETUP to return to the previous menu. To exit, press SETUP until the programming menus disappear.

Parental Lock Duration

This sets how long an enabled Parental Lock will be active.

1. In the Parental Control menu, press ▲ or ▼ to highlight Parental Lock Duration.
2. Press ◀ or ▶ to select the desired number of hours (1-99) or Always.
3. Press the SETUP button to return to the previous menu. To exit, press SETUP until the programming menus disappear.

Parental Lock

This enables or disables the settings in the Parental Control menu. Enabling it will require the password to be entered to access the Parental Control menu in the future.

1. In the Parental Control menu, press ▲ or ▼ to highlight Parental Lock.
2. Press ◀ or ▶ to select Enable or Disable.
3. Press the SETUP button to return to the previous menu. To exit, press SETUP until the programming menus disappear.

Power on Channel

Displays a certain channel each time the TV is turned on. This feature is useful for hospitals that have a Welcome Channel and wish to have it displayed upon initial use of the TV. The patient can then tune to any other available channel. Each service level is programmed separately. "Last" will cause the TV to turn on to the last channel before it was turned off.

NOTE: If Power on Channel is set to "Last" and the physical power is removed, the TV will power on with the lowest programmed channel.

1. Enter the Channels menu.
2. Press ▲ or ▼ to highlight Power on Channel.
3. Press ▶ to select it.
4. Press ▲ or ▼ to highlight the desired Service Level (Free, Basic, or Premium).
5. Press ◀ or ▶ to scroll through the channels currently available in the Service Level or Last.
6. Press the SETUP button to return to the previous menu. To exit, press SETUP until the programming menus disappear.



Channel Lock

Locks the currently viewed channel and prevents patients from tuning to any other channel. This feature is useful when the TV is used for information display purposes.

1. Enter the Channels menu.
2. Press ▲ or ▼ to highlight Channel Lock.
3. Press ◀ or ▶ to select Enable or Disable.
4. Press the SETUP button to return to the previous menu. To exit, press SETUP until the programming menus disappear.

CH Mem Override/Auto Update

Allows a channel to be entered with the remote's number buttons that is not memorized in the current Service Level.

1. Enter the Channels menu.
2. Press ▲ or ▼ to highlight Channel Memory Override.
3. Press ◀ or ▶ to select Enabled or Disabled.
 - DISABLED = Service Level Channels only.
 - ENABLED = All possible channels.
4. Press the SETUP button to return to the previous menu. To exit, press SETUP until the programming menus disappear.

Pro:Idiom

This feature controls how Pro:Idiom signals are decoded.

1. Enter the Channels menu.
2. Press ▲ or ▼ to highlight Pro:Idiom.
3. Press ▶ to select Free to Guest, or MTI Port. (Free to Guest enables Pro:Idiom signal reception when no external control system is in place. MTI Port allows Pro:Idiom channels to be selected by an external set top box using the MTI port.)
4. Press the SETUP button to return to the previous menu. To exit, press SETUP until the programming menus disappear.

NOTE: When Free to Guest is selected, data ports including CCI and MTI are disabled.

Features

The Features menu provides adjustable settings that customize the TV to your hospital.

1. Press the SETUP button.
2. Press ▲ or ▼ to highlight Features.
3. Press ► to enter the Features sub-menu.

Power on Caption Mode

Power on Caption Mode memorizes the caption setting upon powering the TV off. With this feature set to off, the TV will always power on with captions disabled. With this feature set to Last, the TV turns on with the last caption's setting.

1. Enter the Features menu.
2. Press ▲ or ▼ to highlight Power on Caption Mode.
3. Press ◀ or ▶ to select Last or Off.
4. Press the SETUP button to return to the previous menu. To exit, press SETUP until the programming menus disappear.

NOTE: If Power on Caption Mode is set to Last and the physical power is removed, the TV will power on with caption off.

Features	
■ Power on Caption Mode	Last
■ Auto Power ON/Lock	Disabled
■ Inactive Power Off (h:mm)	Disabled
■ Bed A/B/C/D	Bed A
■ Caption Text Modes	Disabled
■ Digital Captions	▶
■ Digital Mode Time Setup	▶
■ Channel Up Power Off	Enabled
■ Channel To Other Sources	Disabled
■ Power on ARC Mode	16:9
■ Wireless	Enabled
■ Analog Pillow Speaker	Enabled
■ UR3-SR3 Remote	Support
■ Splash Image	Enabled
Position: ▲ ▼	
Exit: SETUP or OK	
Next: ◀ ▶	

Auto Power On/Lock

The TV will turn on and stay on whenever electrical power is applied to the set. The feature is useful for controlling the TV from a wall switch or preventing the TV from being turned off by the TV power button or the remote control.

1. Enter the Features menu.
2. Press ▲ or ▼ to highlight Auto Power On.
3. Press ◀ or ▶ to select Disabled or Enabled.
4. Press the SETUP button to return to the previous menu. To exit, press SETUP until the programming menus disappear.

Inactive Power Off (h:mm)

The TV will automatically power off after a specific period of viewer inactivity, providing energy savings.

NOTE: Auto Power On/Lock must be set to Disabled for this function to operate.

1. Enter the Features menu.
2. Press ▲ or ▼ to highlight Power Management.
3. Press ◀ or ▶ to select an active time or select Disabled to disable this feature.
4. Press the SETUP button to return to the previous menu. To exit, press SETUP until the programming menus disappear.

Bed A/B/C/D

The TV can be controlled by a patient IR remote without interference from another nearby remote. The TV offers selectable codes for independent control of each television in a 2, 3, or 4 television room. See the Remote Controls section (pg. 8) for instructions to set PD108-210, PD108-421, or PD108-427 patient remote.

1. Enter the Features menu.
2. Press ▲ or ▼ to highlight Bed A/B/C/D.
3. Press ◀ or ▶ to select A, B, C, or D to match the remote's code set.
4. Press the SETUP button to return to the previous menu. To exit, press SETUP until the programming menus disappear.
5. Try the patient remote to make sure it works with the Bed setting.
6. If it does not, change the remote's code setting.
7. Try the remote again.

NOTE: Some patient remotes do not allow Bed C or Bed D codes.

Caption Text Modes

Teletext can be displayed in addition to Captions. Teletext is not normally broadcast in the USA. Caption Text Modes should be set to Disabled for TVs operated in the USA.

1. Enter the Features menu.

2. Press ▲ or ▼ to highlight Caption Text Modes.
3. Press ◀ or ▶ to select Disabled or Enabled.
4. Press SETUP to return to the previous menu. To exit, press SETUP until the programming menus disappear.

Digital Captions

Customization of Closed Captions on digital channels.

1. Enter the Features menu.
2. Press ▲ or ▼ to highlight Digital Captions.
3. Press ▶ to select it.
4. Press ▲ or ▼ to highlight the attribute you wish to change.
5. Press ▶ to change it. (See the table below for the settings of each attribute.)
6. Press SETUP to return to the previous menu. To exit, press SETUP until the programming menus disappear.

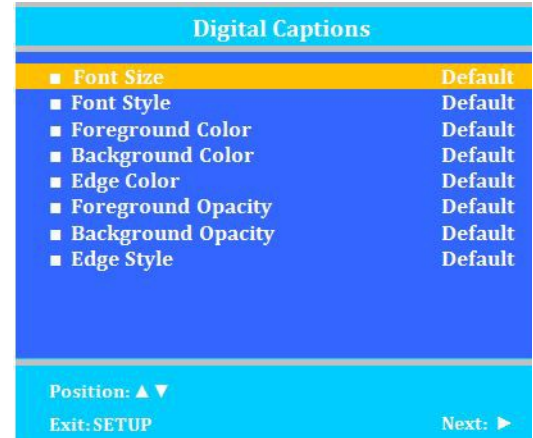

Attribute	Settings
Font Size	default, small, standard, large
Font Style	default, sizes 0 through 7
Foreground Color	default, white, black, red, green, blue, yellow, magenta, cyan
Background Color	default, white, black, red, green, blue, yellow, magenta, cyan
Edge Color	default, white, black, red, green, blue, yellow, magenta, cyan
FG (Foreground Opacity)	default, translucent, transparent, flashing, solid
BG (Background Opacity)	default, translucent, transparent, flashing, solid
Edge Style	Default, none, raised, depressed, uniform, left drop shadow, right drop shadow,

Digital Mode Time Setup

The current time will be set automatically from a digital channel signal provided by a broadcasting TV station.

1. Enter the Features menu.
2. Press ▲ or ▼ to highlight Digital Mode Time Setup.
3. Press ▶ to select it.
4. Press ◀ or ▶ to select your viewing area time zone: Pacific, Alaska, Hawaii, Newfoundland, Atlantic, Eastern, Central or Mountain.
5. Press ▲ or ▼ to highlight Daylight Savings.
6. Press ◀ or ▶ to select Auto, On, or Off depending on whether or not your viewing area observes Daylight Savings Time.
7. Press SETUP to return to the previous menu. To exit, press SETUP until the programming menus disappear.

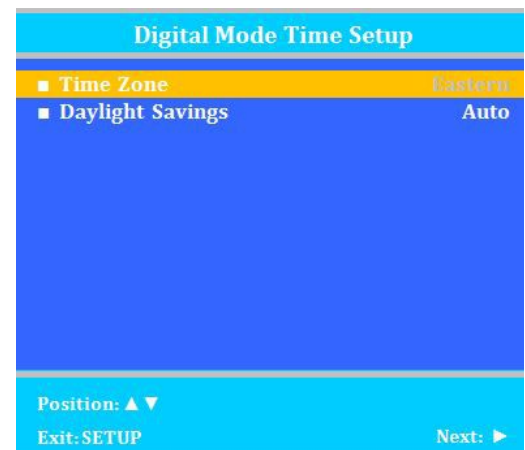

Channel up Power Off

This feature causes the TV to turn off once it reaches the highest numbered (last) channel and is usually used with single button style pillow speakers. When additional sources are enabled, and "channel to other sources" is enabled, the TV will channel up to them and then turn off. When the feature is disabled, the TV will continue on to the lowest channel and not turn off.

1. Enter the Features menu.
2. Press ▲ or ▼ to highlight Channel Up Power Off.

3. Press ◀ or ▶ to select Enabled or Disabled.
4. Press SETUP to return to the previous menu. To exit, press SETUP until the programming menus disappear.

Channel to Other Sources

External signal sources connected to the TV, such as DVD players or video-game systems, are shown in the current channel lineup after the highest channel and then shown on the TV. Set this feature to Disabled to require the activation of the external sources by pressing the remote's or the TV's TV/AV button. Set this feature to Enabled to allow access to external devices by pressing the channel up or down buttons on a remote or most pillow speakers.

1. Enter the Features menu.
2. Press ▲ or ▼ to highlight Channel to Other Source.
3. Press ◀ or ▶ to select Enabled or Disabled.
4. Press SETUP to return to the previous menu. To exit, press SETUP until the programming menus disappear.

Power on ARC Mode

The TV powers on with a set screen size aspect ratio of 4:3, 14:9, 16:9, 16:9 Panorama, or Last.

1. Enter the Features menu.
2. Press ▲ or ▼ to highlight Power On ARC Mode.
3. Press ▶ to select 4:3, 14:9, 16:9, 16:9 Panorama, or Last.
4. Press SETUP to return to the previous menu. To exit, press SETUP until the programming menus disappear.

NOTE: If Power on ARC Mode is set to Last and the physical power is removed, the TV will power on with the default ARC mode for the power on channel type.

Wireless

Wireless Audio provides sound to Headsets, PDI Table Radio, or other similar wireless devices.

1. Enter the Features Menu.
2. Press ▲ or ▼ to select Wireless Audio.
3. Press ◀ or ▶ to select Other or Wireless PDi.
4. Press the SETUP button to return to the previous menu. To exit, press SETUP until the programming menus disappear.

Analog Pillow Speaker

Enables/disables use of an Analog Pillow speaker for controlling TV. An Analog Pillow Speaker is operated by one button located in the center of the speaker. This button controls the Power ON/OFF, as well as the channels.

Note: To turn the TV off, press and hold down the button for 3 seconds.

1. Enter the Features Menu.
2. Press ▲ or ▼ to select Analog Pillow Speaker.
3. Press ◀ or ▶ to select Enable/Disable.
4. Press the SETUP button to return to the previous menu. To exit, press SETUP until the programming menus disappear.

UR3-SR3 Remote

This PDi TV can accept IR codes from the UR3-SR3 universal remote. To take advantage of this feature you must enable by choosing "Support" in this menu. When enabling support, some pillow speakers will no longer operate as expected. Codes for specified beds are listed.

1. Enter the Features Menu.
2. Press ▲ or ▼ to select UR3-SR3 Remote.
3. Press ◀ or ▶ to select Support/No Support
4. Press the SETUP button to return to the previous menu. To exit, press SETUP until the programming menus disappear.

TV	UR3-SR3
Bed A	072
Bed B	073

Splash Image

This PDi TV can have a custom image displayed every time TV is powered on.

1. Enter the Features Menu.
2. Press ▲ or ▼ to select Splash image.
3. Press ◀ or ▶ to select Enabled/Disabled
4. Press the SETUP button to return to the previous menu. To exit, press SETUP until the programming menus disappear.

OSD Language (On Screen Display)

You can adjust the language used in displaying the (OSD) on screen display.

1. Press **SETUP**.
2. Press **▲** or **▼** to select the OSD Language menu.
3. Press **◀** or **▶** to select your desired language.

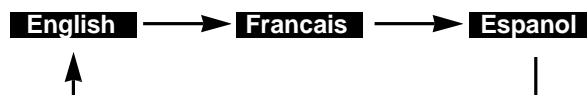

4. Press **SETUP** to return to the previous menu. To exit, press **SETUP** until the programming menus disappear.

Sources

The TV's signal sources can be individually Enabled or Disabled. The available sources in this menu correspond with the components you have connected to the TV's connectors.

NOTE: It is recommended to disable all of the TV's sources that are not being used. A TV that is switched to a non-connected source generates nuisance hospital maintenance calls of TV Not Working, when in fact the TV does work, but has been set to an inactive source.



Source Enable

This menu allows sources to be enabled/disabled.

1. From the SETUP menu, enter Sources.
2. Press ▲ or ▼ to highlight Source Enable.
3. Press ◀ or ▶ to change the source status to either Disabled or Enabled/APO, Enabled/No APO (No Auto Power Off).
4. Press SETUP to return to the previous menu. To exit, press SETUP until the programming menus disappear.

NOTE: Sources that are grayed out are not installed in the TV. For the TV source, Enabled/APO means the TV will turn off if there is no video.



Source Name

Source Name allows each source to be named according to what is connected to the TV. You can choose from None, Cable, Antenna, Satellite, BD/DVD, VCR, Game, MP3 Player, IPTV, PC, or Set Top Box.

1. From the SETUP menu, enter Sources.
2. Press ▲ or ▼ to highlight Source Enable.
3. Press ◀ or ▶ to name the selected source.
4. Press SETUP to return to the previous menu. To exit, press SETUP until the programming menus disappear.

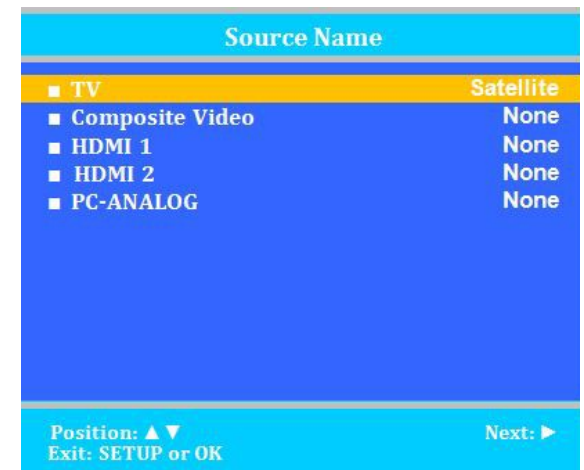

Power on Source

The TV can be preset to power on to a selected source.

NOTE: The source must be enabled before it can be chosen as a power on source. The Last entry causes the TV to power on to the Last source selected.

1. Enter the Sources menu.
2. Press ▲ or ▼ highlight Power On Source.
3. Press ◀ or ▶ to change to the source that you want the TV to power on to.
4. Press SETUP to return to the previous menu. To exit, press SETUP until the programming menus disappear.

NOTE: If Power on Source is set to Last and the physical power is removed, the TV will power on with the first enabled source.

FM Radio

Verify that the FM Radio source is enabled.

1. From the SETUP menu, enter SOURCES.
2. Press ▲ or ▼ to highlight FM Radio.
3. Press ◀ or ▶ to change the source status to either Disabled or Enabled.
4. Press SETUP to return to the previous menu. Once in SETUP menu, press ▲ or ▼ to highlight FM Radio. Press ▶ to get to FM Radio screen.
5. From the FM Radio menu, press ▲ or ▼ to highlight Auto Program, then press ▶ to begin.
6. Press ▲ or ▼ to highlight Frequency, then press to ▲ or ▼ to manually change the channels.
7. Press ▲ or ▼ to highlight Add/Delete, then press to ▶ to add or delete channels.



System

The Setup Menu allows you to set up the TV's internal operations.

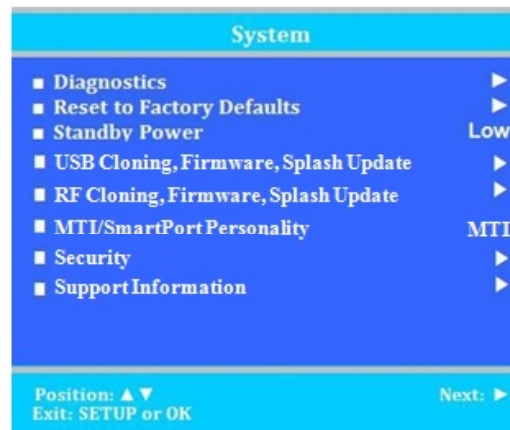

Diagnostics

This is a display menu that provides readout of the TV's internal operations and version numbers.

Description of the diagnostics parameters:

Model: Model of television (EX. PDI-E24LEDA)

Firmware version: The version that is running on the television (Example: 2.08)

Boot version: The version that is running on the television (Example: 2.3)

Power On Cause:

- Cold: First time the television is turned on.
- CPU: Restart from firmware update or changes to the "Pro:Idiom" setting.
- WatchDog: Forced restart power on by boot controller.

If Standby Power is set to low, additional power on reasons may be displayed:

- Remote: Power on with the IR remote.
- Front: Button on the right side of the screen.
- Comm: Power on through CCI or MTI.

Pro:Idiom diagnostic codes:

- OK: Pro:Idiom channel is tuned and decoding properly.
- Missing ID: Session ID missing - decryption disabled.
- Invalid key: Invalid or corrupted key set.
- Stream Errors: No encrypted stream present or checksum errors in stream.
- Non Pro:Idiom Ch: TV is tuned to a non-Pro:Idiom channel.
- Disabled: Pro:Idiom chip is disabled because TV is not set to "Free to Guest" and MTI is not connected.
- Not Supported: Pro:Idiom chip is not present on this television.

CCI/MTI/SmartPort diagnostic codes:

- CCI Connected: CCI port is connected to a host.
- MTI Connected: MTI/Smartport is in MTI mode and port is connected to a host.
- SmartPort Connected: MTI/SmartPort is in SmartPort mode and port is connected to a host.
- Disconnected: CCI and MTI/SmartPort are enabled but are not connected to a host.
- Disabled: CCI and MTI/SmartPort ports are disabled because Pro:Idiom is set to "Free to Guest".

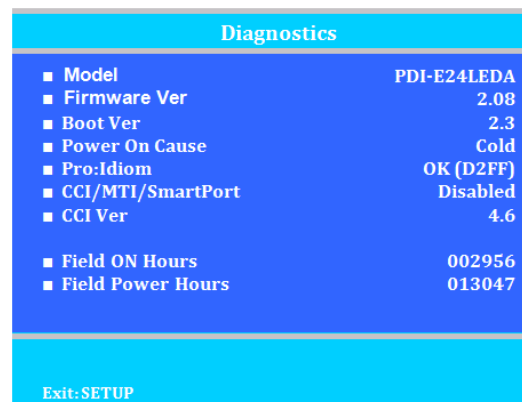

Model, versions and hours shown are for reference only

CCI Version: Displays version of CCI protocol supported by the TV.

Field ON Hours: This will display how many hours that the television has "ON".

Field Powered Hours: This will display how many hours the television had electrical power applied.

Reset to Factory Defaults

This menu will allow you to reset the television to the factory default settings. After choosing this function, you will reach a confirmation screen. Press ► to begin reset process.

Standby Power

Low and Normal. Low will use less power in standby but will require several additional seconds to turn on.

USB Cloning and FW Update

See cloning section below.

RF Cloning and FW Update

Allows programming and firmware updates to be sent to the TV over the coaxial antenna input. This requires special equipment. Contact PDi for more information.

Security

Allows menu password protection and the ability to change the password.

Support

Technical support contact information.

Cloning

Cloning allows quick programming of a TV from a USB Flash Drive. The operation involves first downloading setup information from a programmed host TV to a USB Flash Drive and then uploading the setup information to another TV. Cloning can also be used to re-program a programmed TV.

NOTE: For cloning operation, the "USB Media" source must be *disabled*, otherwise the Media menu appears instead of the desired Clone menu when using a blank USB drive.

NOTE: Firmware files for both firmware upgrade and cloning of TV settings must be placed in folder PDITDF

*To exit cloning menu, you must remove the thumb drive.



Save Settings to USB Flash Drive

1. Turn the TV On.
2. Insert a blank USB thumb Drive (user provided) into the USB Clone Port located adjacent the Cable TV Jack.
3. When the Cloning Main Menu appears, Press ▲ or ▼ to highlight Save Setting to USB Disk.
4. Press ▶ to enter the save settings to USB menu.
5. If you want to rename the file, press the ▲ or ▼ to highlight the file name, otherwise go to step 6.
 - a. Press ◀ or ▶ to highlight each character.
 - b. Press ▲ or ▼ to change each character.
 - c. Repeat this process until you have the desired file name. Up to 8 characters may be used.
 - d. When done, press ◀ until the characters are no longer highlighte
6. Press ▲ or ▼ to highlight Save.
7. Press ▶ to initiate.
8. Wait for the Cloning Main Menu to say "setting saved to USB", then press ◀ to go back to main menu.
9. Remove the USB Disk from the TV.



File name shown is for reference only

Restore Setting to TV

1. Turn the TV On.
2. Insert a Flash Drive with stored clone file (user provided) into the USB Clone Port located adjacent the Cable TV Jack.
3. When the Cloning Main Menu appears, press ▲ or ▼ to highlight Restore Setting to TV.
4. Press ► to initiate.
5. When the Restore Settings to TV menu appears, press ▲ or ▼ to highlight the appropriate settings file.
6. Press ► to initiate.
7. Wait for the Cloning Main Menu to reappear. You will get a confirmation screen. Press ▲ to continue or ◀ to go back.
8. The TV will restart after settings are restored.
9. Remove the USB Disk from the TV.
10. Verify correct setup of the TV.



File name shown is for reference only

Upload Firmware to TV

You are cautioned that changes or modifications not expressly approved by the party responsible for compliance could void the use's authority to operate the equipment.

The firmware for the ELED TV is field upgradeable, but normally does not require this process and should be performed by the hospital technician. A special data file is required from the PDi factory to complete this process. The file is posted on the web site: <http://www.pdiarm.com/support/>

Firmware files are written to a USB Flash Drive, connected to the TV's Cloning port (See page 7), and updated using the TV's menus. Once complete, the TV settings may need to be reprogrammed.

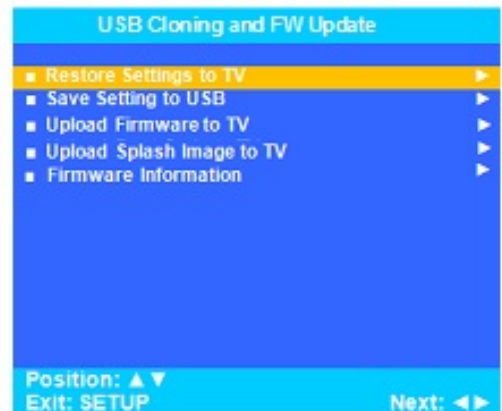

Uploading Automatically:

1. Insert USB into TV. USB Cloning and Firmware Update Menu will appear.
2. Press ▲ or ▼ to highlight Upload Firmware to TV.
3. Press ► to select and Upload Firmware to TV menu will appear.
4. Press ▲ or ▼ to highlight Automatic Upload New Firmware. Press ► to select.
5. A confirmation will ask to verify firmware, Yes ▲ or Back ◀.
6. Press ► to select.
7. Screen will confirm "Firmware upgrade is done".

Uploading Manually:

1. Insert USB into TV. USB Cloning and Firmware Update Menu will appear.
2. Press ▲ or ▼ to highlight Upload Firmware to TV.
3. Press ► to select and Upload Firmware to TV menu will appear.
4. Press ▲ or ▼ to highlight Manual Upload Digital Firmware. Press ► to select.



5. Press ▲ or ▼ to highlight the Digital Firmware version desired.
6. Press ► to select.
7. A confirmation will ask to verify firmware, Yes ▲ or Back ◀.
8. Press ► to select.
9. Screen will confirm “Firmware upgrade is done”.

NOTE: Cloning Main Menu only appears if “USB Media” source is disabled when using a blank USB drive.

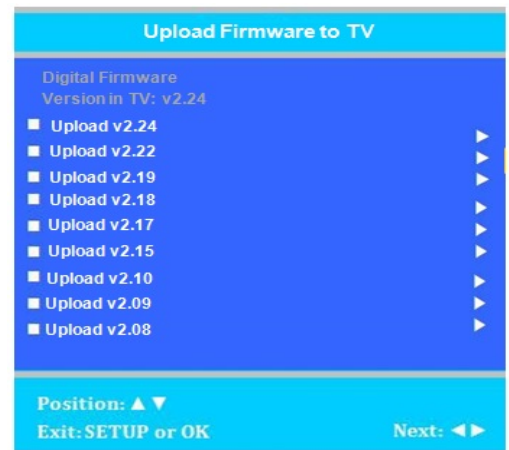

File names shown are for reference only

Upload Boot Code to TV

Bootstrap firmware code is updateable if necessary, but is seldom required. Please contact PDi for additional instructions.

Upload Splash Image to TV

A custom graphic image can be displayed every time the TV is powered on instead of the PDi logo. Graphics such as the hospital’s logo, picture, or other information is displayable and is easily changed once the graphic has been created.

Create a JPEG image of the desired content with an image resolution and color depths not to exceed the model’s limits. NOTE: the JPEG file must not exceed 1 MB in size.

MODEL	MAX RESOLUTION	MAX COLOR DEPTH
E24ELED	1920 x 1080	24 bit

1. Name the file “logo.jpg” and then copy it to root of USB Flash Drive.
2. Insert the USB Flash Drive into the TV. If USB media source is set to disabled, A Cloning Main Menu will appear.
3. Press ▲ or ▼ to highlight Upload Splash Image to TV.
4. Press ► to select and upload the new logo image.
5. A confirmation screen will ask to verify the upload, press Yes ▲ to continue or Back ◀ to exit.
6. A progress screen indicating Splash Image Upload will appear as the image is uploaded to the TV, followed by a completion screen indicating successful uploading.
7. The TV will shut off. Remove the USB drive.
8. Power the TV On and verify the new Logo image is displayed at startup.

Information

Displays the Digital Firmware and Boot Code versions currently resident in the TV.

1. Turn the TV On and insert a USB Flash Drive into the TV. A Cloning Main Menu will appear.
2. Press ▲ or ▼ to highlight Information.
3. Press ► to select and display the TV’s current firmware version.
4. A read-only screen lists the current Digital Firmware and Boot Code versions in the TV.
5. Press Back ◀ to exit and return to the previous menu.

NOTE: If the USB drive contains a “.tdf” file, then the clone menu appears regardless of “USB Media” source status.

*To exit cloning menu, you must remove the thumb drive.

MTI/Smart Port

Allows the TV to connect to alternate sources through MTI or Smart Port.

1. Enter the Setup menu.
2. Press ▲ or ▼ highlight MTI/Smart Port Source.
3. Press ◀ or ▶ to change to the source that you want the TV.
4. Press SETUP to return to the previous menu. To exit, press SETUP until the programming menu disappears.

Operation

Accessing External Video Sources

PDi LED televisions come with all external video sources disabled. Only the TV tuner and USB Media sources are enabled. See the Programming section for instructions on enabling other sources such as HDMI. There are three ways to change the currently active video source.

1. Press the TV/AV key (sometimes labeled SOURCE or INPUT) to cycle through each enabled video source. Some pillow speakers have a TV/FM key (sometimes labeled with a musical note) which only cycles between the FM Radio (if enabled) and the TV tuner.
2. Pressing Channel Up/Down will cycle through each video source after visiting all the programmed TV channels. The setting "Channel to Other Sources" must be enabled.
3. Type the virtual channel number corresponding to the video source.

Channel	Video Source
141	Composite (A/V)
146	HDMI 1
147	PC-Analog (VGA)
149	FM Radio
150	HDMI 2
151	DVD/Android Module
152	USB Media

Wireless Control

PDi LED televisions include wireless connectivity for use with the optional PDI-TR100 Table Radio. Both wireless audio and control of the TV are possible using the Table Radio. Please refer to the Table Radio manual (PD196-191) for setup instructions.

NOTE: TV's Standby power should be set to "Normal" when using the table radio for control.

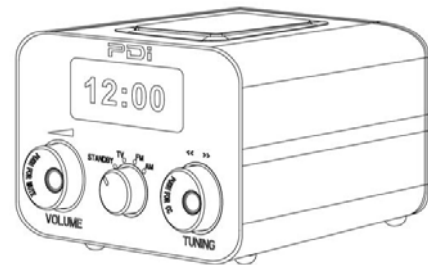

Troubleshooting Tips

Analog pillow speaker problems	<ul style="list-style-type: none"> • Confirm pillow speaker is securely plugged in • Connect the pillow speaker directly to the TV and verify that the across-room or bedside wiring is not faulted • Check fluorescent lighting is not causing interference
TV takes long time to turn on	<ul style="list-style-type: none"> • Check standby power setting
Pro:Idiom digital channels not showing up	<ul style="list-style-type: none"> • Check Setup > Channels > Pro:Idiom
CCI/MTI not working	<ul style="list-style-type: none"> • Check Setup > Channels > Pro:Idiom
PDi Qube will not turn on TV	<ul style="list-style-type: none"> • Check standby power is set to normal
No picture from external source	<ul style="list-style-type: none"> • Make sure external source is connected properly • Confirm source is not being blocked by Parental Control setting
Picture, but no sound	<ul style="list-style-type: none"> • Check internal speaker is enabled • Confirm sound is not muted • Confirm no headphones are plugged in • If using an external source, confirm proper connection
Remote not working	<ul style="list-style-type: none"> • Check batteries in remote • Check Bed A, B, C, D setup is correct
TV channels up or turns off unexpectedly	<ul style="list-style-type: none"> • In rare situations, fluorescent lighting reaching the IR receiver can cause erratic behavior • Disable analog pillow speaker • Relocate the TV away from the light source • Apply opaque tape over the IR sensor
Clone menu does not appear	<ul style="list-style-type: none"> • Verify "USB Media" source is disabled in Sources menu

Product Accessories (Not Included with TV)

Programming Remote Control	PD108-420	Enhanced Patient Remote Control (For TV's with electronic program guide or DVD module)	PD108-210
Patient Remote Control (Remote comes with DVD module)	PD108-427	¼" to 6-Pin Jumper Cable	PD106-416
Basic Patient Remote Control (For TV's without DVD module)	PD108-421	¼" to ¼" Jumper Cable	PD106-417

Limited Warranty

PDi Communication Systems Inc., ("PDi") warrants, to the original purchaser only, that this product will be free from defects in materials and workmanship, under normal use, for 2 years from the date of original purchase. This warranty does not cover any other equipment that may have been included with PDi's shipment of this product.

After receipt of written notice of a defect or malfunction occurring during the warranty period, PDi will repair or replace goods returned to its Springboro, Ohio location, at its discretion, free of charge to the original purchaser, the whole or any component part of any product manufactured by PDi and found by PDi to be defective.

As a condition to obtaining warranty service, written notification must be received by PDi within at least ten (10) days after defect is first observed. Repair of said product requires it to be shipped to the PDi factory in Springboro, Ohio. All shipments shall be F.O.B. Springboro, Ohio, and all shipping and freight charges to PDi's factory shall be paid by the customer.

This warranty shall not apply to any PDi products subjected to improper use, negligence or accident; nor to tampering, alterations, or repairs by others, without PDi's specific prior written authorization. For information regarding authorized servicing and all other information pertaining to this warranty, please contact PDI COMMUNICATION SYSTEMS, Inc. at 40 Greenwood Lane, Springboro, Ohio 45066 or phone 800-628-9870.

This warranty gives specific legal rights and you may also have other rights which vary from state to state.

PDi's liability under this warranty is limited to repair or replacement of defective products and parts as provided above. PDi shall not be liable for incidental or consequential damages.*

The warranty contained herein is in lieu of all other expressed or implied warranties, including any implied warranty of merchantability or fitness for any particular purpose. PDi neither assumes nor authorizes any person to assume, on its behalf, any other obligation or liability.

*Some states DO NOT allow the exclusion of limitation of incidental or consequential damages or a disclaimer of warranties implied by law, so the above limitation or exclusion may not apply.

The information and technical data in this manual is believed accurate, but is not warranted and is subject to change without notice or obligation.

"PDi" and "A Leader in Patient Communication Systems" are registered trademarks of PDi Communication Systems, Inc.

Copyright © 2004-2016 by PDi Communication Systems, Inc.
All rights reserved