

NAVAL POSTGRADUATE SCHOOL
Monterey, California



DTIC QUALITY INSPECTED 1

THESIS

**GLOBAL BROADCAST SERVICE REACH BACK VIA
ULTRA HIGH FREQUENCY DEMAND ASSIGNED
MULTIPLE ACCESS SATELLITE COMMUNICATIONS**

by

Joseph E. Arthur

June 1998

Thesis Advisor:
Co-Advisor:

Paul H. Moose
Roy A. Axford

Approved for public release; distribution is unlimited.

19980915 027

DTIC QUALITY INSPECTED 1

REPORT DOCUMENTATION PAGE			Form Approved OMB No. 0704-0188	
Public reporting burden for this collection of information is estimated to average 1 hour per response, including the time for reviewing instruction, searching existing data sources, gathering and maintaining the data needed, and completing and reviewing the collection of information. Send comments regarding this burden estimate or any other aspect of this collection of information, including suggestions for reducing this burden, to Washington headquarters Services, Directorate for Information Operations and Reports, 1215 Jefferson Davis Highway, Suite 1204, Arlington, VA 22202-4302, and to the Office of Management and Budget, Paperwork Reduction Project (0704-0188) Washington DC 20503.				
1. AGENCY USE ONLY (Leave blank)		2. REPORT DATE June 1998		3. REPORT TYPE AND DATES COVERED Master's Thesis
4. TITLE AND SUBTITLE GLOBAL BROADCAST SERVICE REACH BACK VIA ULTRA HIGH FREQUENCY DEMAND ASSIGNED MULTIPLE ACCESS SATELLITE COMMUNICATIONS			5. FUNDING NUMBERS	
6. AUTHOR(S) Arthur, Joseph E.			8. PERFORMING ORGANIZATION REPORT NUMBER 98-065	
7. PERFORMING ORGANIZATION NAME(S) AND ADDRESS(ES) Naval Postgraduate School Monterey, CA 93943-5000			10. SPONSORING / MONITORING AGENCY REPORT NUMBER	
9. SPONSORING / MONITORING AGENCY NAME(S) AND ADDRESS(ES) THE DEPARTMENT OF THE AIR FORCE AFIT CIA BLDG 125 2950 P STREET WPAFB OH 45433			11. SUPPLEMENTARY NOTES The views expressed in this thesis are those of the author and do not reflect the official policy or position of the Department of Defense or the U.S. Government.	
12a. DISTRIBUTION / AVAILABILITY STATEMENT Approved for public release; distribution is unlimited.			12b. DISTRIBUTION CODE	
13. ABSTRACT (maximum 200 words) The US military requires a reliable, high-speed, multimedia capable system to disseminate information that cannot be efficiently distributed over existing low data rate channels. The Global Broadcast Service (GBS) is being developed to meet this requirement. The cornerstones of the GBS simplex broadcast are the premises of smart push and user pull. An integral part of the user pull is the reach back channel. The reach back channel allows users to specify the information they need broadcast and tailor the information to meet their mission needs. Ultra high frequency (UHF) demand assigned multiple access (DAMA) satellite communications are the most widely available long haul communication systems available to members of the armed services and as such are a prime candidate to provide a reach back path for GBS. In order to fully utilize UHF DAMA as a reach back channel for data communications a number of interface requirements must be met. The problems of using UHF DAMA are discussed and recommendations are made for the GBS Phase Two systems so they might support the use of UHF DAMA as a reach back channel. This thesis shows that UHF DAMA is a viable reach back channel, however there are factors which could improve the efficiency.				
14. SUBJECT TERMS Global Broadcast Service, Reach Back, Ultra High Frequency Demand Assigned Multiple Access			15. NUMBER OF PAGES 76	
			16. PRICE CODE	
17. SECURITY CLASSIFICATION OF REPORT Unclassified	18. SECURITY CLASSIFICATION OF THIS PAGE Unclassified	19. SECURITY CLASSIFICATION OF ABSTRACT Unclassified	20. LIMITATION OF ABSTRACT UL	

**GLOBAL BROADCAST SERVICE REACH BACK VIA ULTRA HIGH
FREQUENCY DEMAND ASSIGNED MULTIPLE ACCESS SATELLITE
COMMUNICATIONS**

**Joseph E. Arthur-Captain, United States Air Force
B.S., Clarkson University, 1992**

Master of Science in Systems Technology-June 1998

**Advisor: Professor Paul Moose, Department of Electrical and Computer
Engineering**

Co-Advisor: Dr. Roy Axford, SPAWAR Systems Center - San Diego

The US military requires a reliable, high-speed, multimedia capable system to disseminate information that cannot be efficiently distributed over existing low data rate channels. The Global Broadcast Service (GBS) is being developed to meet this requirement. The cornerstones of the GBS simplex broadcast are the premises of smart push and user pull. An integral part of the user pull is the reach back channel. The reach back channel allows users to specify the information they need broadcast and tailor the information to meet their mission needs. Ultra high frequency (UHF) demand assigned multiple access (DAMA) satellite communications are the most widely available long haul communication systems available to members of the armed services and as such are a prime candidate to provide a reach back path for GBS. In order to fully utilize UHF DAMA as a reach back channel for data communications a number of interface requirements must be met. The problems of using UHF DAMA are discussed and recommendations are made for the GBS Phase Two systems so they might support the use of UHF DAMA as a reach back channel. This thesis shows that UHF DAMA is a viable reach back channel, however there are factors which could improve the efficiency.

KEYWORDS: Global Broadcast Service, Reach Back, Ultra High Frequency Demand Assigned Multiple Access

DOD KEY TECHNOLOGY AREA: Command, Control, and Communications

19980915 027

Approved for public release; distribution is unlimited

**GLOBAL BROADCAST SERVICE REACH BACK VIA ULTRA HIGH
FREQUENCY DEMAND ASSIGNED MULTIPLE ACCESS SATELLITE
COMMUNICATIONS**

Joseph E. Arthur
Captain, United States Air Force
B.S., Clarkson University, 1992

Submitted in partial fulfillment of the
requirements for the degree of

MASTER OF SCIENCE IN SYSTEMS TECHNOLOGY

from the

**NAVAL POSTGRADUATE SCHOOL
June 1998**

Author:

Joseph E. Arthur

Approved by:

Paul H. Moose, Thesis Advisor

Roy A. Axford, Co-Advisor

Dan Boger, Chairman
C4I Academic Group

ABSTRACT

The US military requires a reliable, high-speed, multimedia capable system to disseminate information that cannot be efficiently distributed over existing low data rate channels. The Global Broadcast Service (GBS) is being developed to meet this requirement. The cornerstones of the GBS simplex broadcast are the premises of smart push and user pull. An integral part of the user pull is the reach back channel. The reach back channel allows users to specify the information they need broadcast and tailor the information to meet their mission needs. Ultra high frequency (UHF) demand assigned multiple access (DAMA) satellite communications are the most widely available long haul communication systems available to members of the armed services and as such are a prime candidate to provide a reach back path for GBS. In order to fully utilize UHF DAMA as a reach back channel for data communications a number of interface requirements must be met. The problems of using UHF DAMA are discussed and recommendations are made for the GBS Phase Two systems so they might support the use of UHF DAMA as a reach back channel. This thesis shows that UHF DAMA is a viable reach back channel, however there are factors which could improve the efficiency.

TABLE OF CONTENTS

I. THE GLOBAL BROADCAST SERVICE	1
A. HISTORY	1
B. THE GBS PROGRAM.....	1
1. <i>Overview</i>	1
2. <i>Phase One GBS System</i>	4
3. <i>Phase Two GBS System</i>	8
C. GBS REACH BACK EXPERIMENTS	13
1. <i>JWID 1996</i>	14
2. <i>JWID 1997</i>	14
3. <i>Naval Research Laboratory Experiments</i>	15
4. <i>JWID 1998</i>	16
II. ULTRA HIGH FREQUENCY DEMAND ASSIGNED MULTIPLE ACCESS SATELLITE COMMUNICATIONS	17
A. DAMA BACKGROUND	17
B. 25-KHZ DAMA	18
C. 5-KHZ DAMA	20
D. TCP/IP OVER UHF DAMA.....	21
E. IMPLEMENTATIONS OF TCP/IP OVER DAMA	23
F. TCP/IP OVER DAMA SUMMARY	27
III. EXPERIMENT SETUP	29
A. BACKGROUND	29
B. TEST CONFIGURATION.....	30
1. <i>Tunnel Connection</i>	32
C. DATA COLLECTION.....	35
D. ADNS CAP LOADING	37
E. EXPERIMENT SETUP SUMMARY	38
IV. TEST RESULTS	39
A. DISCUSSION	39
B. OBSERVATIONS	40
C. SUCCESSFUL REACH BACK SESSION.....	42
D. TOTAL TIME TO COMPLETE REACH BACK SESSION	44
E. TIME TO FIRST ACK.....	45
F. TEST RESULTS SUMMARY	46
V. CONCLUSION	47
A. APPLICATION TO GBS PHASE TWO	47
B. GBS PHASE TWO SYSTEMS.....	47
C. 25 KHZ UHF DAMA VERSUS 5 KHZ UHF DAMA	48
D. RECOMMENDATIONS FOR FUTURE RESEARCH	50
E. SUMMARY	51
APPENDIX A GBS PRODUCTS	53

LIST OF REFERENCES.....57
INITIAL DISTRIBUTION LIST59

LIST OF FIGURES AND TABLES

Figure 1 GBS Phase One Receive Suite	6
Figure 2 GBS Phase Two Coverage	9
Figure 3 GBS Phase Two Space Segment	11
Figure 4 PPTP Connection	13
Figure 5 25-kHz DAMA Frame.....	19
Figure 6 5-kHz DAMA Frame.....	20
Figure 7 JMCOMS Build "1"	25
Figure 8 Notional ADNS Frame	26
Figure 9 NPS GBS Test Bed.....	29
Figure 10 GBS Reach Back Test Configuration.....	31
Figure 11 Tunneling Setup.....	33
Figure 12 Tunnel Interface.....	34
Figure 13 Four User ADNS Frame	37
Figure 14 Failed Reach back Session	39
Figure 15 Successful Reach back Session	43
Figure 16 PPTP Tunnel.....	50
Table 1 GBS Reach Back Modes.....	3
Table 2 GBS Transponder Center Frequencies.....	10
Table 3 Sample Snoop Line.....	36
Table 4 Total Time to Complete Reach Back.....	44
Table 5 Average Time to First ACK.....	45

EXECUTIVE SUMMARY

The US military requires a reliable, high-speed, multimedia capable system to disseminate information that cannot be efficiently distributed over existing low data rate channels. The Global Broadcast Service (GBS) is being developed to meet this requirement. The GBS program is capitalizing on the huge civilian investment in direct broadcast satellite (DBS) technology and adapting it to meet warfighter needs. DBS technology offers small end-user antennas, increased mobility, and an aggregate data rate of up to 23 million bits per second.

The GBS program is being developed in three phases. Phase one involves the lease of commercial Ku-band transponders and the use of commercial off the shelf (COTS) components. Although Phase One has been used primarily for testing and exercises, it has also supported the delivery of information to North Atlantic Treaty Organization (NATO) peacekeeping forces in Bosnia. Phase two is an initial military capability with GBS Ka-band transponders hosted on the Ultra High Frequency (UHF) Follow On (UFO) Satellites 8, 9, and 10. UFO 8 was launched in Spring 1998 and the first receive suites will be delivered in late summer 1998. Phase three, scheduled to begin in 2009, is the complete integration of GBS into the Defense Information Infrastructure. This thesis concentrates on the GBS Phase One and Phase Two systems.

The cornerstones of the GBS program are the concepts of smart push and user pull. The information content of the smart push is determined at the theater level without real-time input from end-users at the unit level. User pull allows unit level end-users to

define specific information to be broadcast on demand in response to operational circumstances. User pull also enables end-users to request that certain smart push products be rebroadcast in the event that they were not received at their unit during the regularly scheduled smart push. Both these capabilities are enabled by the reach back channel. The reach back channel can be implemented with any suitable means of communication available to the unit level force in question.

UHF demand assigned multiple access (DAMA) satellite communications is the most widely available long haul system to members of the armed services. As such, it is a prime candidate to provide a reach back path for GBS. In order to fully utilize UHF DAMA as a reach back channel for user pull communications, a number of interface requirements must be met. One of the problems encountered when using UHF DAMA as a GBS reach back channel is the substantial time delay associated with the DAMA protocol itself. In fact, UHF DAMA may represent a worst case scenario for timing delays. Modern day computer communication protocols such as the ubiquitous Transmission Control Protocol / Internet Protocol (TCP/IP) do not tolerate long communications delays well. A number of systems have been developed to interface protocols such as TCP/IP with UHF DAMA. An example is the Automated Digital Network System (ADNS), a major portion of the Navy's Joint Maritime Communications Strategy (JMCOMS). ADNS has developed protocols to interface computer communications with a large number of transmission media, including UHF DAMA. It

is the performance of just such an interface, the UHF DAMA channel access protocol (CAP), which is investigated in this thesis.

The Naval Postgraduate School (NPS) has developed a GBS Phase One test bed with some unique testing capabilities. In addition, the ADNS program office has established a lab for testing of the ADNS CAPs at the Space and Naval Warfare Systems Center in San Diego (SSC-SD). The NPS test bed and the ADNS lab were connected using an IP tunnel through the Secure Internet Protocol Routed Network (SIPRNET). The tunnel established a virtual connection between the two labs and allowed testing using UHF DAMA SATCOM assets at SSC-SD as the reach back channel for the GBS receiver suite at NPS. The tests were conducted using the manual retransmit request on the GBS Phase One software and varying the loading on the UHF DAMA back channel. The manual retransmit request consists of a short (~ 200 bytes) TCP/IP connection between the NPS test bed and the Phase One GBS satellite uplink facility. If the requested files were available at the GBS uplink facility, then they were queued up and delivered over the Phase One GBS CONUS broadcast. If the files were not available, then the request failed. Parameters such as the number of users and the traffic load were varied on the UHF DAMA back channel until the computer communications failed.

The results of this testing have identified some areas of concern for GBS Phase Two. However, it is early enough that if these concerns are addressed in a timely manner, then the GBS Phase Two system will support the use of UHF DAMA as a reach back

channel. This thesis has shown that UHF DAMA can be a viable GBS reach back channel if certain steps are taken to improve efficiency.

I. THE GLOBAL BROADCAST SERVICE

A. HISTORY

The Global Broadcast Service is a military adaptation of the civilian direct broadcast satellite (DBS) technology. DBS systems use high-power geostationary satellites to deliver over one hundred channels of digital audio and video directly to consumers. The high power satellite transponders (~53 dBW) allow the use of relatively small (18" – 24") consumer antennas. The fact that industry has borne the majority of the research and development costs makes this technology attractive to the military. The GBS Concept of Operations (CONOPS) envisions using similar commercial technology to support the warfighter. The types of information and products delivered over GBS will include mission data updates (MDUs), air tasking orders (ATOs), Global Command and Control System (GCCS) and Joint Maritime Command Information System (JMCIS) data, meteorological and oceanographic (METOC) data and multiple video services. A representative list of data products identified for broadcast over GBS by United States Pacific Command (PACOM) is provided in Appendix A. [Ref. 1]

B. THE GBS PROGRAM

1. Overview

The GBS program is being implemented in three overlapping phases. Phase one (FY96 – FY98+) consists of the utilization of a leased Ku-Band (14 gigahertz (GHz) uplink, 12 GHz downlink) commercial transponder on Hughes' SBS-6 satellite located at

74° West longitude. Phase two (FY-98 – FY09+) of the GBS program consists of an interim military satellite capability. The GBS Phase Two Ka-Band (30 GHz uplink, 20 GHz downlink) transponders are hosted on the Ultra High Frequency (UHF) Follow-On (UFO) satellites 8, 9, and 10. UFO 8 was successfully launched on March 16, 1998, UFO 9 is scheduled for launch in August 1998, and UFO 10 is scheduled to be launched in March 1999. GBS Phase Two will not provide coverage of the majority of the continental United States. GBS phase three (FY09+) goals include worldwide coverage and the complete integration of GBS into the Defense Information Infrastructure. GBS will support the Unclassified through Top Secret Sensitive Compartmented Information classification levels. [Ref. 1]

The GBS program incorporates the concepts of smart push and user pull. The information content of the smart push is determined at the theater level without real-time input from end-users at the unit level. User pull allows unit level end-users to define specific information to be broadcast on demand in response to operational circumstances. User pull also enables end-users to request that certain smart push products be rebroadcast in the event that they were not received, or received in a corrupted form at their unit during the regularly scheduled smart push broadcast. Both these capabilities are enabled by a reach back channel. The reach back channel(s) can be implemented with any suitable means of communication available that provides connectivity from the unit level force in question to the GBS Satellite Broadcast Manager (SBM). [Ref. 1]

The actual method used to make a user pull request will depend on the user's existing communications capabilities. The GBS Phase Two CONOPS specifies four methods of user pull connectivity shown in Table 1.

Mode	Retransmission Requests	User Pull Requests	Back Channel (Example)
Receive Only	N/A	N/A	N/A
Manually Connected	Human-in-the-Loop	Human-in-the-Loop	Telephone
Partially Connected	Human-in-the-Loop	Human-in-the-Loop	SIPRNET
Fully Connected	Automatic (Virtual Full Duplex)	Human-in-the-Loop	SIPRNET

Table 1 GBS Reach Back Modes

Regardless of the connectivity mode, the need for retransmission requests is detected automatically by the GBS receiver suite's Receive Broadcast Manager (RBM), and user pull requests are, by definition, generated manually. In Receive Only (RO) Mode, the unit level end-user has no available means of communication except a GBS receiver. It is therefore not possible for the RO user to submit retransmission or user pull requests. The Manually Connected (MC) user may have voice or dial-up data communications capabilities, but no other external data network connectivity. The voice-only MC user will be alerted to the need to submit a retransmission request by an indication on the screen of the RBM or an end-user terminal connected to the RBM. The MC user with dial-up data communications will make use of an RBM utility that stores automatically generated retransmission requests in properly formatted e-mail text files. Depending on the internal connectivity at the unit level, the MC connected GBS user will get the retransmission request message file(s) to the equipment (typically another

computer) that has the dial-up data communications connectivity via file transfer protocol (FTP), internal e-mail, or simply copy it to a disc and “sneaker net” it. Both the Partially Connected (PC) and Fully Connected (FC) modes require that the unit level end-user have some form of external data network connectivity and that the GBS RBM is somehow wired to this connectivity (e.g., via a ship’s onboard Local Area Network - LAN). The PC user does not have full-time external data network connectivity while the FC user does. The PC user’s external network connection schedule may be tied to reach back satellite access periods. The PC user does not achieve “virtual full duplex” connectivity because a human-in-the-loop (or an automated process external to the RBM) is required to ensure that GBS retransmission request e-mail queue is launched when external data network connectivity is available (via the reach back channel). Since the FC user has a full-time external data network connection, the RBM-generated retransmission requests are launched automatically without a human-in-the-loop nor the need for any other external automated process. Therefore, the FC GBS user achieves “virtual full duplex” connectivity. To focus on the performance of UHF Demand Assigned Multiple Access (DAMA) Satellite Communications (SATCOM) as a GBS reach back channel, the research conducted for this thesis was performed with the NPS GBS receive suite in the Fully Connected (FC) mode. [Ref. 1 Appendix B]

2. Phase One GBS System

The primary purpose of the Phase One system is the refinement of the CONOPS and the investigation of emergent technologies that may support GBS in the future. In

addition, Phase One supports the Joint Broadcast Service (JBS). The JBS is a direct broadcast capability used in support of North Atlantic Treaty Organization operations in Bosnia. The JBS utilizes the Orion-1 satellite located over the Atlantic Ocean at 37.5° West longitude. The JBS and GBS Phase One systems share a satellite uplink facility the JBS Information Management Center (JIMC) which is currently located in the Pentagon.

[Ref. 1]

The Phase One GBS broadcast is approximately 23 megabits per second (Mbps) and is subdivided into channels. The broadcast uses the proprietary Hughes Corporation Direct Satellite System (DSS) waveform for data transmission [Ref. 5]. Typical channels include secret Internet protocol (IP) data, unclassified IP data, secret asynchronous transfer mode (ATM) data, and a video broadcast.

Figure 1 shows the components of a Phase One receive suite involved in the reception of an IP data channel. The broadcast is received by a 1 meter satellite dish, downconverted to an L-Band intermediate frequency, and sent to the integrated receiver decoder (IRD). The IRD is the "set top box" that allows one to select the desired channel. The data output of the IRD is a 15 pin parallel data port. The data bridge converts the parallel output of the IRD into a serial data stream for decryption by the KG-194A. The IP channel is typically operated at a data rate of 4 Mbps. The KG-194A decrypts the signal and provides an input to the one of the serial ports on the Cisco router. The Cisco router converts the serial data into the Ethernet protocol which allows a simple interface with the Sun workstation. For a more detailed discussion including directions

on how to develop a GBS Phase One receive suite from commercial components see Schaffler [Ref. 4]. The Phase One GBS broadcast uses the User Datagram Protocol (UDP) at the transport layer. UDP is a connectionless IP based protocol. Connectionless means that each data packet is not acknowledged. Multiple transmissions are used to make a best-effort at delivery, but there is no way to ensure the data has been received correctly on a packet-by-packet basis.

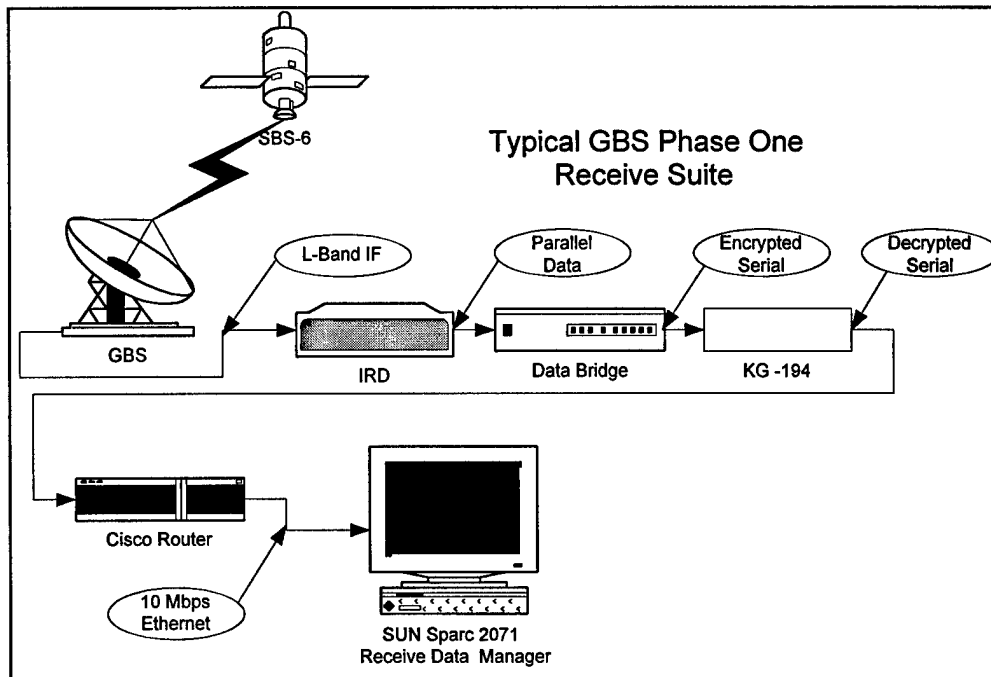

Figure 1 GBS Phase One Receive Suite

a) GBS Reach Back via Phase One Systems

Since GBS is a simplex link there are numerous methods used to ensure reception. For example, transmissions are typically repeated 3 times and may be repeated up to 30 times to help ensure reception. Forward error correction allows the link to operate at a bit error rate of less than 1×10^{-10} , reducing corrupted files and therefore

reducing the need to retransmit. The only reach back communication methods available in the GBS Phase One software are the automatic and manual retransmit requests. The uplink site periodically transmits a list of all files that have been broadcast. The receive data manager (RDM) compares that list of files with the files that have been received. (The GBS Phase One RDM is referred to as the receive broadcast manager (RBM) in the Phase Two systems.) If there are files which have not been received there are two methods to request retransmission. In the automatic retransmit mode the RDM establishes a Transmission Control Protocol / Internet Protocol (TCP/IP) session between the GBS gateway computer and the RDM. The RDM then requests the files that are missing. In the manual retransmit mode the RDM operator selects a file or multiple files in the RDM X-Windows file manager and clicks on the retransmit icon. This method uses the same procedure as the automatic retransmit request with only the selected files being requested for retransmission. The full TCP/IP retransmit request for a single file typically consists of approximately 200 bytes in the forward direction (from the RDM to the GBS gateway computer) and 100 bytes in the return path. The retransmit request executes a common gateway interface (CGI) script at the GBS gateway. The CGI script queues up the file(s) for retransmission. These files are then rebroadcast via the GBS link provided they are still available at the gateway computer. If they are not available the operator is notified by the gateway computer that the retransmit request has failed before the TCP connection is closed. [Ref. 2]

In the experiment discussed in Chapter III the manual retransmit request will be utilized. This is the most likely configuration for a GBS user for whom UHF DAMA is the primary means of long haul communications. The fact that the retransmit request consists of a TCP/IP session allows us to extrapolate the results to other scenarios. For example, the request could be the acknowledgment of a high priority message. In addition, the PACOM CONOPS [Ref. 3] describes a scenario that has similarities to the manual reach back request. According to the PACOM CONOPS the GBS satellite broadcast manager will develop and broadcast a catalog of information products. Users may then subscribe or request these information products via alternate communications systems, for example, UHF DAMA.

3. Phase Two GBS System

The GBS Phase Two system is composed of three major segments, the satellite broadcast manager (SBM), receive broadcast manager (RBM), and the space segment. I will concentrate on the RBM and the space segment. Currently it is planned that the RBM will use the Microsoft NT Version 4.0 operating system and Internet Explorer 4.0 as the web browser to access the information. There are numerous configuration options for the Phase Two receive suite. The main differences between the receive suite configurations are the number and types of video and data feeds. The broadcast uses the European Digital Video Broadcast Standard (DVB). DVB was chosen for a number of reasons including its ability to support variable data rates. For a more detailed comparison of DVB and the Hughes' DSS standard see Wellborn [Ref. 5].

When fully implemented the GBS Phase Two system will provide coverage as shown in Figure 2. The majority of the receive suites for the Phase Two system will include dual band capability. Dual band receivers allow the augmentation of the military Ka-band systems with commercial Ku-band capability. This will be especially important since there will not be any GBS coverage in the central portion of the Continental United States.

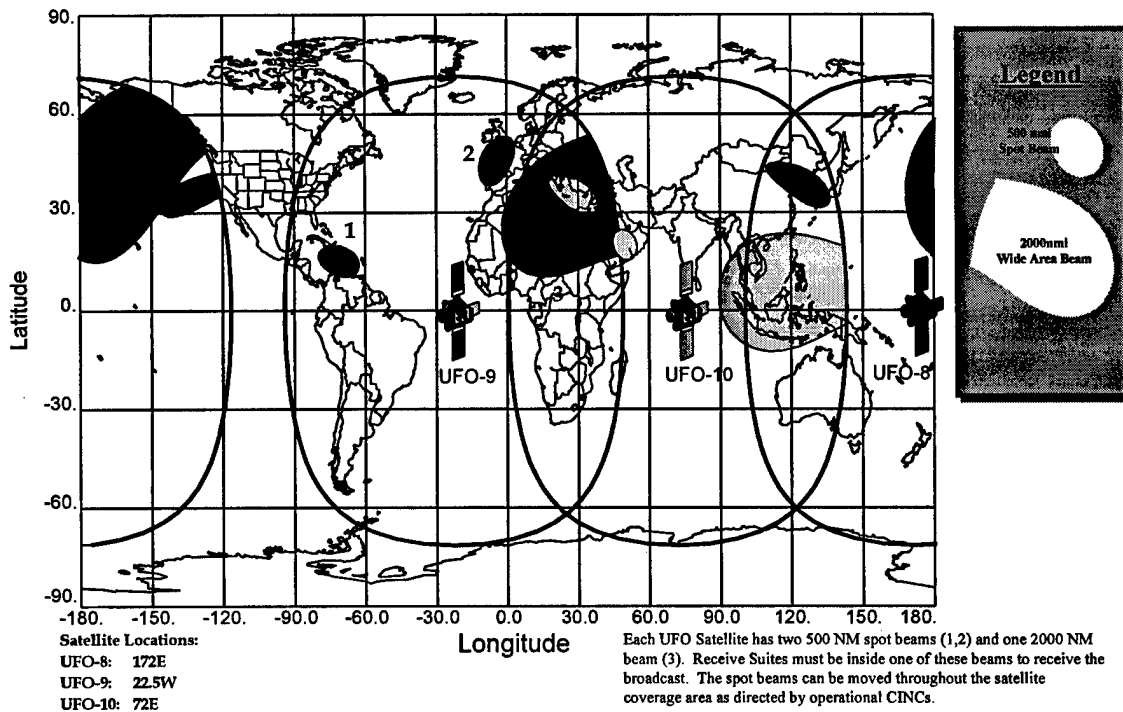

Figure 2 GBS Phase Two Coverage

[Ref. 3]

The Phase Two space segment consists of four transponders, two uplink antennas, one of which is steerable, and three steerable downlink antennas on each satellite. (Refer to Figure 3.) Each transponder is rated for 130 watts of transmit power and has a 3 dB

uplink bandwidth of 33 Megahertz. The transponder center frequencies are shown in Table 2. [Ref. 6]

The fixed uplink antenna for each satellite will be pointed at a primary injection point (PIP). The PIPs will be located in Wahiawa, HI; Norfolk, VA; and Sigonella, Italy. The steerable uplink antenna may be pointed to receive information from up to three theater injection points (TIP). If multiple TIPs are used each would be assigned to a separate transponder and they must all be within a single 350 NM diameter as determined by the footprint of the steerable uplink antenna. [Ref. 1]

Transponder Channel	Uplink Center Frequency (GHz)	Downlink Center Frequency (GHz)
1	30.095	20.295
2	30.215	20.415
3	30.275	20.475
4	30.395	20.595

Table 2 GBS Transponder Center Frequencies

[Ref. 6]

The GBS Phase Two space segment is shown in Figure 3. The downlink antennas offer two distinctive broadcast patterns, one 2000 nautical mile (NM) wide area coverage beam (at nadir) and two 500 NM spot beams (at nadir). The wide area coverage beam provides a 1.544 Mbps data rate while the spot beams offer a 24 Mbps data rate. The downlink antennas may be configured to provide up to four simultaneous 24 Mbps data streams distributed between the two spot beams, or three 24 Mbps data streams distributed between the two spot beams and one 1.544 Mbps wide area beam. [Ref. 1]

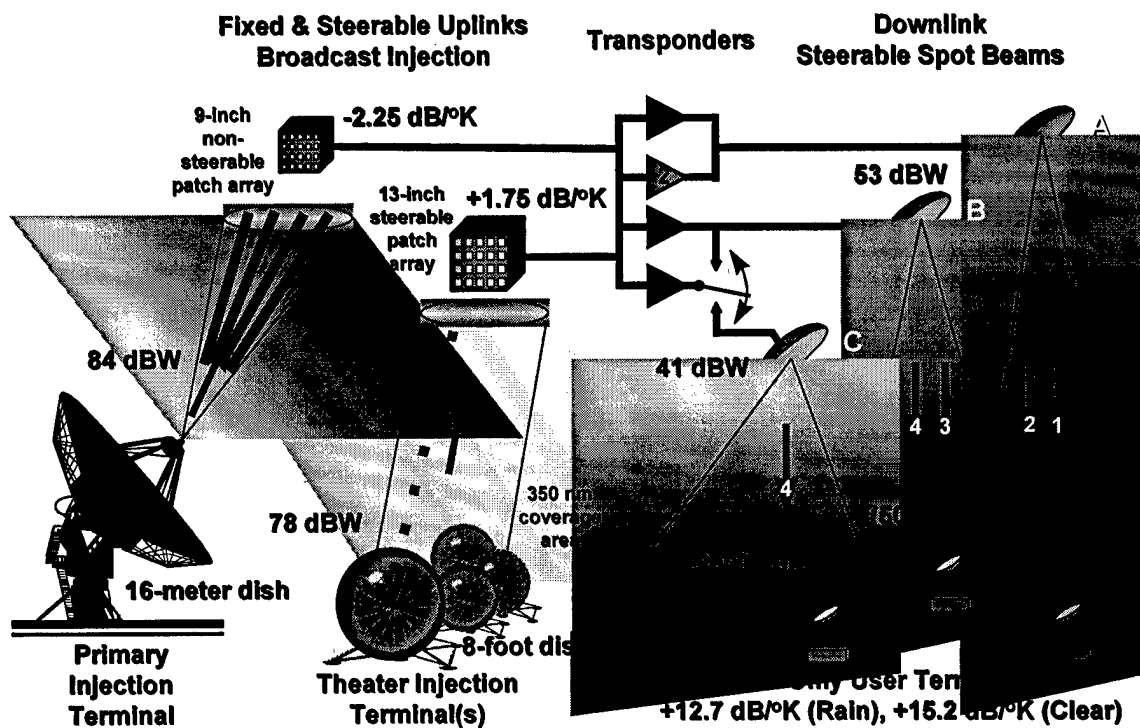

Figure 3 GBS Phase Two Space Segment

[Ref. 3]

a) *GBS Reach back via Phase Two Systems*

The GBS Phase Two broadcast will also consist of smart push and user pull components. The SBM will maintain smart push interest profiles for individual units, battle groups, etc. These will be set up as “channels” to information source web sites defined by “.cdf” files using the Microsoft FrontPage software product. (Note: Information providers who desire their products to be distributed via GBS will have to make them available at web sites on the SIPRNET or the NIPRNET.) The .cdf files then direct the operation of an automated search engine, i.e., a “web crawler.” The web crawler copies updates of desired information from the sites contained in the .cdf files to

a cache at the SBM. These are then smartly pushed to the unit level receive terminals according to the broadcast access schedule (i.e., the pointing schedules of the downlink beams) where they reside on the unit level users' RBMs. The RBMs become, in effect, proxy web servers for the individual end-users whose workstations will be connected to the RBM via a LAN or other means. The content of the smart push portion of each broadcast is catalogued in the electronic program guide (EPG) which is also transmitted with the broadcast.

In addition to the smart push products, the Phase Two GBS SBM will maintain a menu (in hypertext format) of products available for user pull. The SBM will download the current version of the user pull menu to the unit level users with each broadcast along with the EPG. Users will click on hypertext links to make requests from the available list of user pull information products. In response, the RBM generates an email message addressed to the SBM which will be sent via the reach back channel. The email message will be acknowledged as soon as possible by the SBM via the reach back channel, but the scheduling of the actual user pull data delivery via the broadcast will depend on CINC priorities and bandwidth availability. [Ref. 9]

The Microsoft Point-to-Point Tunneling Protocol (PPTP) is responsible for routing reach back email messages from the RBM to the SBM. PPTP is a built-in option in Microsoft NT Version 4.0, and is planned for NT Version 5.0. In addition, Windows 95 users can download an add-on which will allow them to establish a PPTP tunnel between a Windows 95 client computer and an NT Server. A sample PPTP connection is

shown in Figure 4. The purpose of PPTP is to securely connect a private network to a remote access client. PPTP relieves the planners of some of the Internet Protocol (IP) addressing requirements. As can be seen in Figure 4, the actual addresses of the computers are not used through the Internet, only the PPTP tunnel addresses. [Refs. 9, 21]

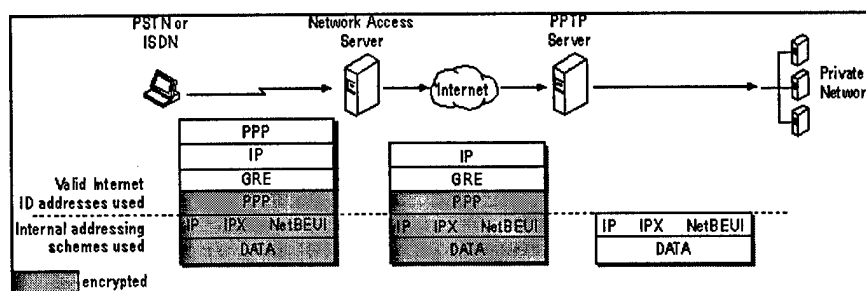

Figure 4 PPTP Connection

[Ref. 21]

C. GBS REACH BACK EXPERIMENTS

Since the first days of the GBS experiments there has been interest in how to deliver requests for information from users. The Joint Staff sponsors an exercise every year called the Joint Warrior Interoperability Demonstration (JWID). The purpose of the JWID exercise is to examine emerging technology and investigate how that technology may support the warfighter. The subject of GBS reach back has been a topic in at least two previous JWID exercises and is planned for a third.

1. JWID 1996

The Army sponsored a demonstration using the Extremely High Frequency (EHF) MILSTAR SATCOM system as a reach back channel for GBS. The MILSTAR System provided a dedicated 2400 bps point-to-point link between remote users and the Joint Task Force Headquarters. The demonstration was hosted onboard the USS Kearsarge, and at Fort Bragg, NC. The operators used INTELINK-X menu based software written by the Air Intelligence Agency and an All Source Analysis System - Remote Workstation to communicate directly with information providers via the Secure Internet Protocol Routed Network (SIPRNET). The requested information was wrapped and delivered via the SIPRNET to the GBS uplink facility. The request-to-receipt cycle time was typically three to five minutes, with some exceptions taking up to 15 minutes. The exceptionally long delivery times were attributable to the GBS broadcast queue length and poor weather conditions at the uplink facility which disrupted the uplink signal. [Ref. 10]

2. JWID 1997

The National Reconnaissance Office (NRO) Operational Support Office (OSO) sponsored a GBS reach back demonstration during JWID 1997. The reach back channel actually utilized available unused bandwidth on the SBS-6 transponder used for the GBS Phase One broadcast. Specifically they used a 100 watt transmitter, spread spectrum modulation, and a 1.2 meter antenna. The reach back channel operated at 40 kilobits per second (kbps). Spread spectrum modulation was used to reduce the signal power density and avoid adjacent satellite interference which is problematic when using a small uplink

antenna. The demonstration typically received the requested data within five minutes, with some exceptions taking up to 30 - 40 minutes. The longer transfer times were again attributable to queuing delays at the uplink facility. There did not seem to be any correlation between file size and delivery time. The demonstration was hosted at Fort Gordon, GA and was a proof of concept and did not allow for other units to utilize the reach back channel. The technique will actually not work in GBS Phase Two because all in-theater uplinking capability in Phase Two is intended for the TIPs, not end users. If end users were to use the Phase Two uplink for reach back, they would need powerful transmitters at 30 GHz (see Table 2). Also, the footprint of the Phase Two steerable uplink spot beam would have to be pointed to include their location. [Ref. 11]

3. Naval Research Laboratory Experiments

In December 1997 the Naval Research Laboratory (NRL) began a set of experiments that took the concept of GBS reach back one step further. The NRL has demonstrated the capability to access a world wide web server via multiple reach back channels such as a dial up telephone line, cellular phone, dedicated 25-kHz UHF SATCOM, and the Planet One Data Phone. The Phase One GBS was used to deliver the web pages. The Planet One Data Phone is 2.4 kbps data service provided by the International Maritime Satellite Organization (INMARSAT). The goal of the experiment was to demonstrate smart "user pull" of data over the GBS system using standard protocols. [Ref. 13]

4. JWID 1998

The NRO/OSO and NRL have submitted a proposal that builds upon the NRL experiment. The proposed JWID 1998 demonstration includes web browsing via all of the reach back channels in the NRL demonstration in addition to a very small aperture terminal (VSAT) code division multiple access (CDMA) SATCOM system. There will also be additional users: the proposal includes two shore-based users and one afloat user.

[Ref. 12]

II. ULTRA HIGH FREQUENCY DEMAND ASSIGNED MULTIPLE ACCESS SATELLITE COMMUNICATIONS

A. DAMA BACKGROUND

The ever-increasing demand for UHF satellite communications has led to the saturation of the existing UHF SATCOM assets. In the 1970s Demand Assigned Multiple Access (DAMA) was developed as a method for multiple users to share a single communications channel. DAMA is basically a form of time division multiple access (TDMA) where the channel is partitioned into time slots which can then be assigned on a dynamic basis. There are several methods to access a time slot on a DAMA channel.

In 1986 the Navy implemented DAMA in the distributed control (DC) mode. The DC mode involved centralized assignment of time slots within the SATCOM channel. The control site determined how the DAMA slots would be allocated and distributed a message with the assignments. For example, if there was a net operating on time slot 10158 that a ship needed to participate in, then the radiomen aboard ship would enter this time slot number into the DAMA terminal. This would allow that ship to participate in that DAMA net. In the DC mode there was no dynamic reallocation of bandwidth. [Ref. 7]

In the automatic control (AC) mode a time slot is requested from a central controller via a satellite orderwire, assigned to a terminal, and released back to the controller once the terminal has completed using it. In the AC mode DAMA terminals are identified by a unique address. The ability to identify the terminals allows a DAMA

controller to verify that the requesting terminal is authorized to initiate or join a net, in addition to determining its priority. An additional capability when operating in the AC mode of operation is called demand assigned single access (DASA). The DASA mode allows a single user access to an entire channel without having to share the bandwidth. The request for a DASA channel is made via the user's UHF DAMA channel. In the DASA mode of operation once the channel has been assigned to a user it is operated in the dedicated UHF SATCOM mode (MIL-STD-188-181). The DASA channel is allocated for a fixed time period. The user retains use of the DASA channel until he voluntarily gives the channel up and logs back onto his home channel or the timer expires. DASA channels cannot be preempted. [Ref. 7]

There are currently two different UHF DAMA SATCOM waveforms, one for operation over 5-kilohertz (kHz) channels, and one for operation over 25-kHz channels. The Navy has focused on the development of the 25-kHz DAMA controllers and terminals (MIL-STD-188-183) for both ships and aircraft, while the Air Force has concentrated on the 5-kHz DAMA controllers and terminals (MIL-STD-188-182).

B. 25-KHZ DAMA

The 25-kHz DAMA waveform has a relatively short frame length of approximately 1.3866 seconds (Figure 5). The user segments are capable of being subdivided into over 1500 different frame format combinations, allowing users to select setups that would best fit their needs. A CINC communications planner typically specifies the frame formats. For example, the Navy often uses Frame Format 259 which

provides five 2400 bit per second (bps) voice or data slots in addition to twelve 75 bps slots and one 300 bps slot.

When operated in the AC mode, the 25-kHz waveform supports point-to-point, conference, and network calls. The baseband data rates supported range from 75 bps – 16 kilobits per second (kbps). If the 16 kbps data rate is selected it occupies all of segments B and C, leaving only segment A for other users. The minimum time to request and access a time slot is three frames, one frame to request the slot, one for the controller to process the request, and the third for the controller’s reply. The terminal is allowed to start transmitting during the same frame that the reply is received. A typical time would then be 3 frames plus two satellite hop delays, approximately 4.6 seconds total. [Ref. 7]

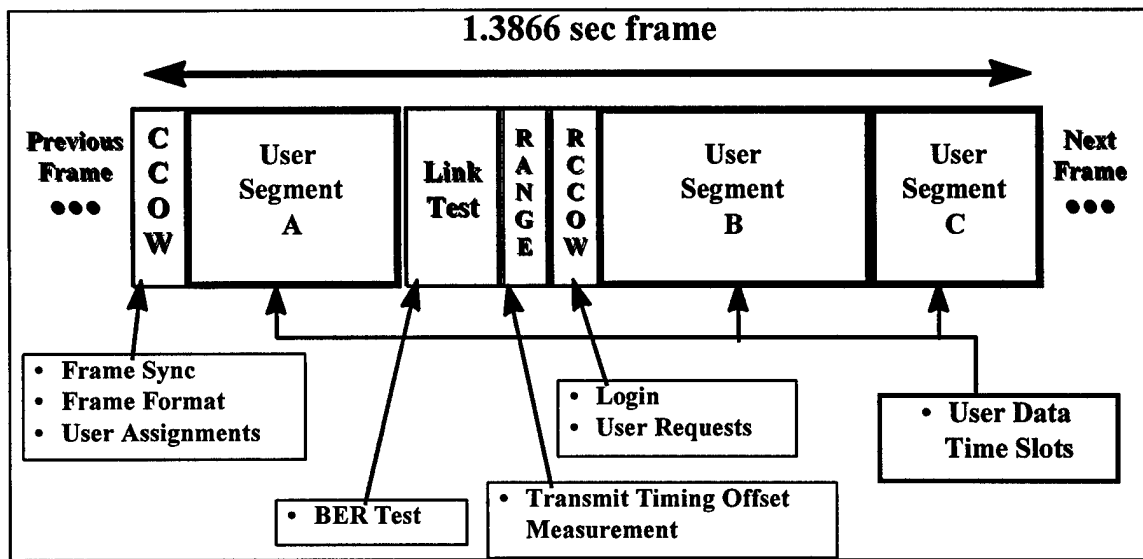

Figure 5 25-kHz DAMA Frame

[Ref. 7]

C. 5-KHZ DAMA

The 5-kHz DAMA frame is shown in Figure 6. 5-kHz DAMA was designed for short data messages, low speed data circuits, and limited secure voice capability for the Air Force's Military Airlift Command (now Air Mobility Command). The capabilities of 5-kHz DAMA include packetized message service, voice, and data circuit service. The entire 5-kHz frame is 8.96 seconds in duration, but the lengths of the time slots assigned for circuit use within the frame vary with the type of data, modulation, and code rate. The length of the time slots used for messaging can vary depending on the amount of unused space in each frame. The packetized message service allows up to 900 messages per hour with an average message size of 200 characters. The messages are typically generated on a laptop computer and stored until the terminal is granted access to the

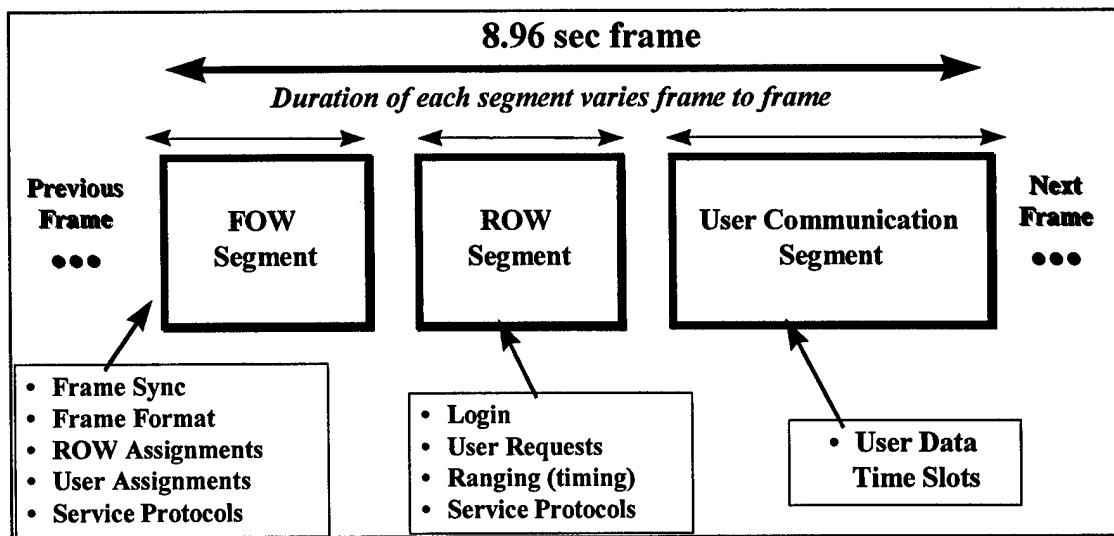

Figure 6 5-kHz DAMA Frame

[Ref. 7]

channel. The frame length of almost 9 seconds may cause problems with voice and data circuits. The minimum time to set up a channel is also 3 frame cycles or almost 27 seconds and could be longer if more, higher priority users are competing for the channel. Once the circuit is established the worst case delay would be at most two frames which makes full duplex data communications difficult, and voice communications even more difficult. Because of these delays, 25-kHz DAMA with its quicker cycle time or 5-kHz DASA are preferred for voice communications. A 5-kHz DASA circuit may be set up using a 25-kHz channel or a 5-kHz channel to request the circuit. The use of a 25-kHz channel greatly decreases the setup time. In the DASA mode of operation once the channel has been assigned there are no framing delays, only the satellite delay. [Ref. 7]

D. TCP/IP OVER UHF DAMA

DAMA is not an efficient transmission protocol for many computer communications. Protocols like TCP/IP have been optimized to operate over terrestrial links such as phone lines, fiber optic systems, etc. As mentioned earlier the frame delay for a 25-kHz signal is approximately 1.4 seconds, and for a 5-kHz signal is on the order of 9 seconds after the connection has been established. Depending on their location in the frames, two users who are communicating may experience up to two frames of delay. Geosynchronous satellites add to this problem with a round trip delay of approximately 0.5 seconds to transmit a signal and receive a reply. These delays can wreak havoc on computer protocols.

For example, if a system wanted to establish a TCP session with another computer it must complete what is known as a three-way handshake. The originating computer sends a TCP packet with the synchronize (SYN) flag set. If the destination computer is available, it will reply with an acknowledgment packet. The originating computer will then acknowledge this packet, thereby completing the three-way handshake. Once the three-way handshake is completed the data communications may begin. If the SYN is not acknowledged within a certain period of time the originating computer resets the connection. The actual amount of time each a computer will wait to establish a connection varies with the operating system. Once the three-way handshake has been completed data can begin to be transferred. [Ref. 8]

There are two timing problems that computers face with using DAMA. The first is the setup of the DAMA connection. As mentioned earlier it takes up to three frames to setup the connection. The second is the framing delays in between communications once the connection has been established, the worst case scenario is approximately two frames. After completing the three-way handshake the computer may begin communications. Each computer maintains a retransmission timer that is typically set at three seconds. If the destination computer does not respond within three seconds then the last packet is resent. If there was no reply to the second packet the TCP protocol begins an exponential back off where the time it waits to resend the packet doubles. It should be obvious that even with the relatively short 25-kHz frames there may be two frame delays and two satellite delays in between communications. These delays would be approximately 3.3

seconds, long enough to trigger the retransmission timer. In order to efficiently utilize DAMA for TCP/IP an additional layer of complexity must be added.

E. IMPLEMENTATIONS OF TCP/IP OVER DAMA

There are many different ways to approach the problem of using UHF DAMA as a transmission channel for TCP/IP. One such solution is the Automatic Data Controller/Internet Protocol (ADC/IP) Data Controller developed by ViaSat. The ADC/IP has integrated a proxy server within the controller which acknowledges the packets as they are sent from the originating computer, buffers them, and sends them out. The ADC/IP uses carrier sense multiple access (CSMA) without collision detect to access a DASA channel. The advantage of the ADC/IP approach is that for the sending computer the use of DAMA as the transmission channel is transparent. The disadvantage is if the connection is lost there is no way to gracefully degrade the connection. This is because the packets have already been acknowledged and the whole TCP session is just dropped and must be restarted. When compared with the ADNS channel access methods the use of CSMA minimizes the channel access delay at the cost of reduced efficiency at higher traffic loads. In addition, the use of a DASA channel somewhat defeats the purpose of DAMA (because it can not be preempted) although the channel would be available for reassignment if it was released. [Ref. 14]

The Joint Maritime Communications Strategy (JMCOMS) is a Navy program developed to implement the Navy's Copernicus vision. A major portion of JMCOMS is the Automated Digital Network System (ADNS). The goal of ADNS is to provide

seamless, secure multimedia connectivity. A significant portion of the ADNS program is the automated network routing and switching function, which will allow the multiplexing of all traffic types over available Radio Frequency (RF) assets. For example, on an aircraft carrier (refer to Figure 7) ADNS would multiplex signals through systems such as Super High Frequency (SHF) SATCOM, EHF SATCOM, and UHF DAMA SATCOM.

[Ref. 15]

To enable the systems to function seamlessly over such diverse RF links, ADNS has developed channel access protocols (CAPs). One of these is the UHF DAMA CAP. A goal of this thesis is to examine the performance of GBS reach back over UHF DAMA when this ADNS CAP is employed. The typical mode of operation for ADNS and UHF DAMA for the Navy is the assignment of a 2.4 kbps slot on a 25-kHz DAMA channel. The TD-1271 B/U is the DAMA satellite modem/multiplexer used by ADNS and is capable of supporting four baseband channels.

The ADNS UHF DAMA CAP functions slightly differently from the ADC/IP described above. The key to TCP/IP over DAMA for ADNS is the CAP Router Interface Unit (CRIU), see Figure 7. Consider the example mentioned earlier - the three-way handshake to establish a TCP session. Since the channel has a relatively high latency it is probable that the sending computer will have generated duplicate packets due to the retransmission timer. The ADNS CRIU deletes these duplicate packets generated by the originating computer rather than send them over an already bandwidth limited link. If the buffer begins to fill up, the CRIU will send an Internet Control Message Protocol source

quench message to the originating computer. The purpose of the source quench message is to stop the extra packets from cluttering up the local area network until the destination computer has had a chance to respond. The CRIU is responsible for monitoring the link and in effect developing its own retransmission timer based on channel latency to determine when a packet may have been lost. The channel access method used by ADNS is variable slot TDMA with reservation. It has guaranteed minimum access, allowing users to reserve a time slot and expand their access by request. The typical maximum number of simultaneous TCP/IP users that the ADNS UHF DAMA CAP is four. [Ref.

16]

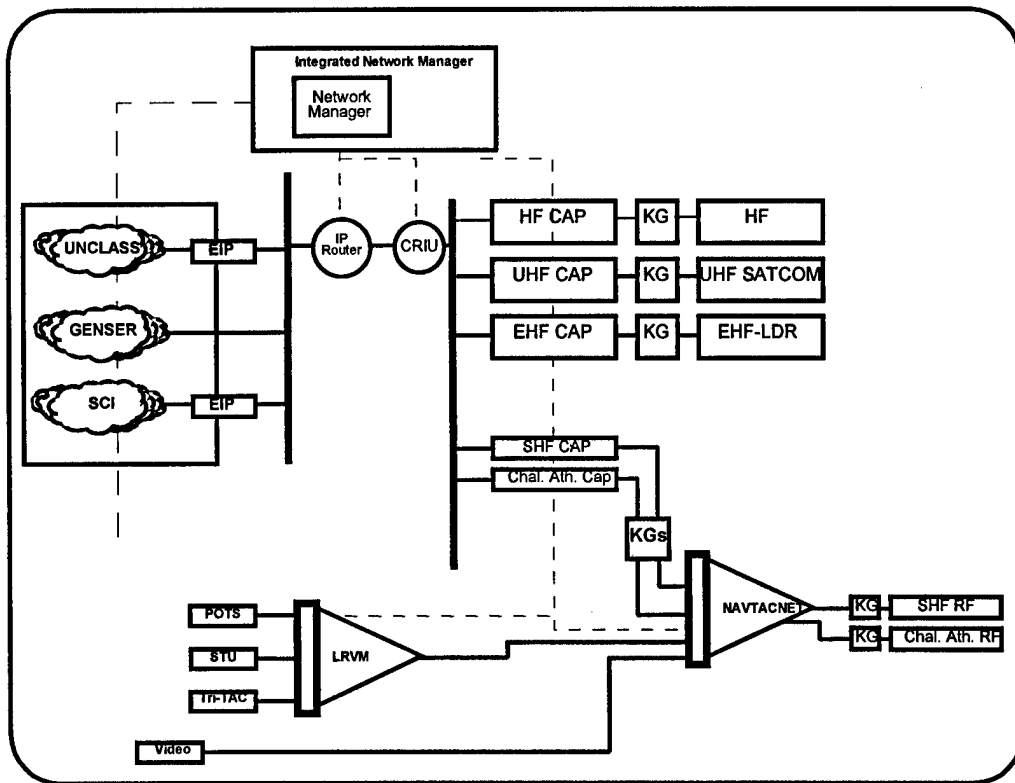

Figure 7 JMCOMS Build "1"

[Ref. 15]

Figure 8 shows a notional ADNS UHF CAP configuration with two users, each with one frame of data. The DAMA channel that is assigned to ADNS is 2.4 kbps; therefore the number of bits available each frame is $2400\text{bits} / \text{sec} * 1.3866\text{sec} = 33327\text{bits}$ or approximately 416 bytes. Within the UHF DAMA CAP each user can be assigned up to 8 time slots, there can be up to four users, and since each user is half-duplex there must be one blank frame in between users so other users can be sure that the previous user is finished. In addition, there is a network join frame which allows a node to request entry into an existing network and the associated blank DAMA frame at the end of the ADNS frame. The total cycle time with four users, each with the maximum amount of data is $((4\text{users} * 9\text{frames}) + (1\text{add} + 1\text{blank})) * 1.3866\text{sec} / \text{frame} = 52.69\text{sec}$. This was designed to limit the total cycle time to under one minute to support TCP applications such as the file transfer protocol (FTP). When compared with the ADC/IP, the ADNS channel access method is less efficient at lower loads (e.g. one user with one data frame would result in at least a 75% overhead), but more efficient as the net becomes congested. [Refs. 15, 16]

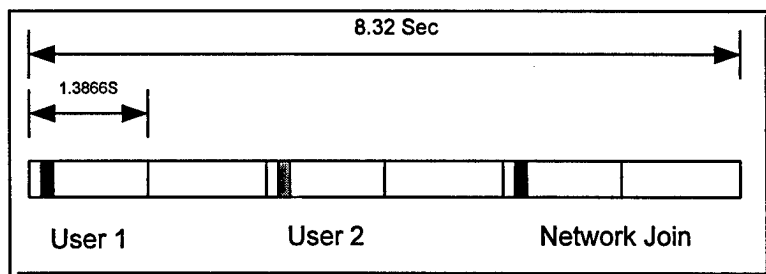

Figure 8 Notional ADNS Frame

F. TCP/IP OVER DAMA SUMMARY

There are quite a few problems inherent with attempting a TCP/IP data connection using UHF DAMA. TCP/IP has not been optimized to operate over high latency links. The UHF DAMA 5-kHz and 25-kHz frame structures incur relatively high latencies. Because of DAMA's framing delays, it cannot support a direct connection between two computers without a third party system which governs data access to the channel or time slot. It is the performance of just such a third party system, the ADNS UHF DAMA CAP, that will be investigated in the following chapters.

III. EXPERIMENT SETUP

A. BACKGROUND

The Naval Postgraduate School (NPS) established a GBS receive suite in the Spring of 1997. [Refs. 4, 18] The lab is used primarily for thesis research and GBS experimentation. [Refs. 5, 17] The lab configuration is shown in Figure 9. The GBS Receive Data Manager (RDM) was initially installed in a receive-only configuration. Therefore the initial step in preparation for this experiment was to configure the RDM to

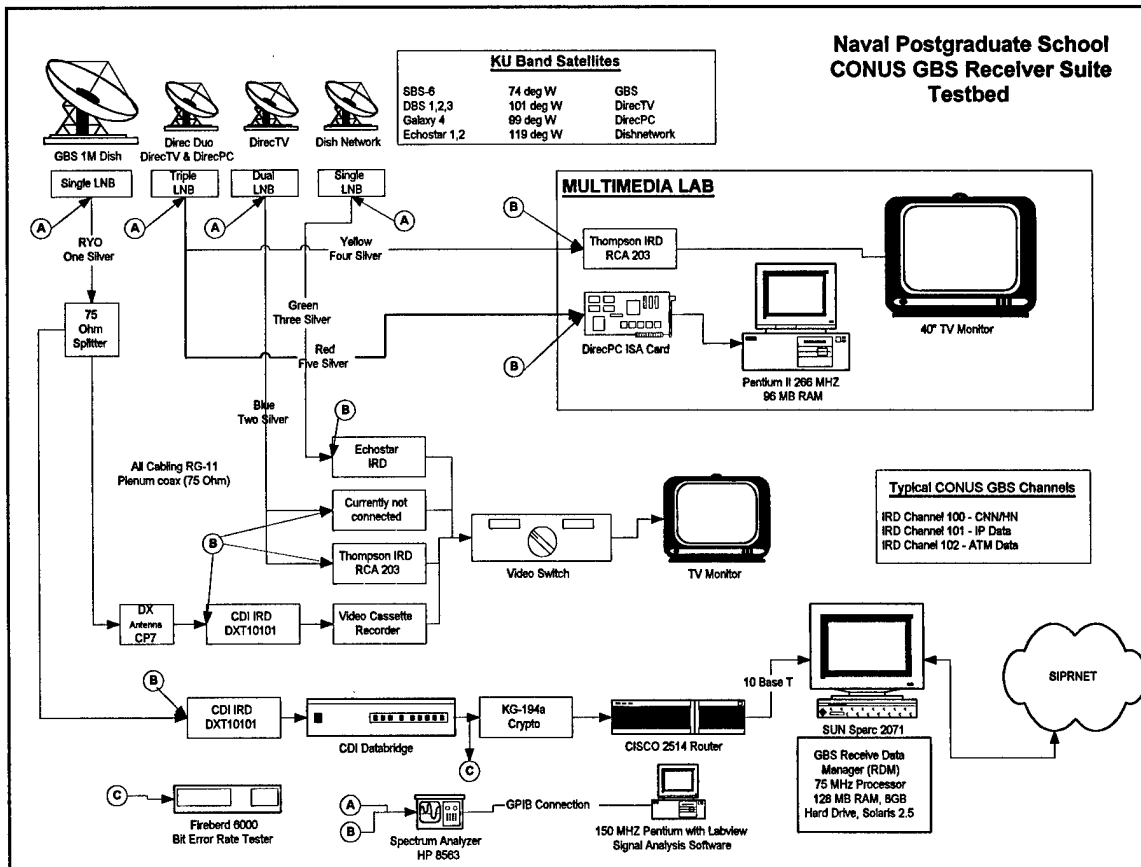

Figure 9 NPS GBS Test Bed

allow reach back communications with the GBS gateway at the JIMC in the Pentagon. The NPS GBS Test Bed already had Secure Internet Protocol Routed Network (SIPRNET) connectivity when this work started. A SIPRNET connection was added to the RDM (as shown in Figure 9) and it was confirmed that files could be requested from the GBS gateway directly through the SIPRNET with the GBS Phase One software. Once this was completed, the various segments of the UHF DAMA SIPRNET connection were added in one at a time. Troubleshooting was performed on each segment as it was added.

B. TEST CONFIGURATION

The GBS reach back test configuration is show in Figure 10. The ADNS program office has established a lab located in building 660 at the Space and Naval Warfare Systems Command (SPAWAR) Systems Center - San Diego (SSC-SD). The lab has been designed mainly for testing and validation of the CAPs. To avoid the added expense and labor of duplicating these facilities at NPS, the SSC-SD ADNS lab was used to provide access to UHF DAMA SATCOM. The ADNS lab also has the capability to access SHF and EHF satellites via the appropriate CAPs. The normal configuration for a UHF DAMA SATCOM data connection is from the ship to a regional Naval Computer and Telecommunications Master Station (NCTAMS) where the information can be sent forward via a terrestrial SIPRNET connection. This is the type of configuration used for our test, with the ADNS lab simulating a NCTAMS. This was accomplished by setting up both ends of the UHF DAMA SATCOM link (one which would typically be aboard a

ship, and the other at the NCTAMS) and routing data to the SIPRNET as shown in Figure 11.

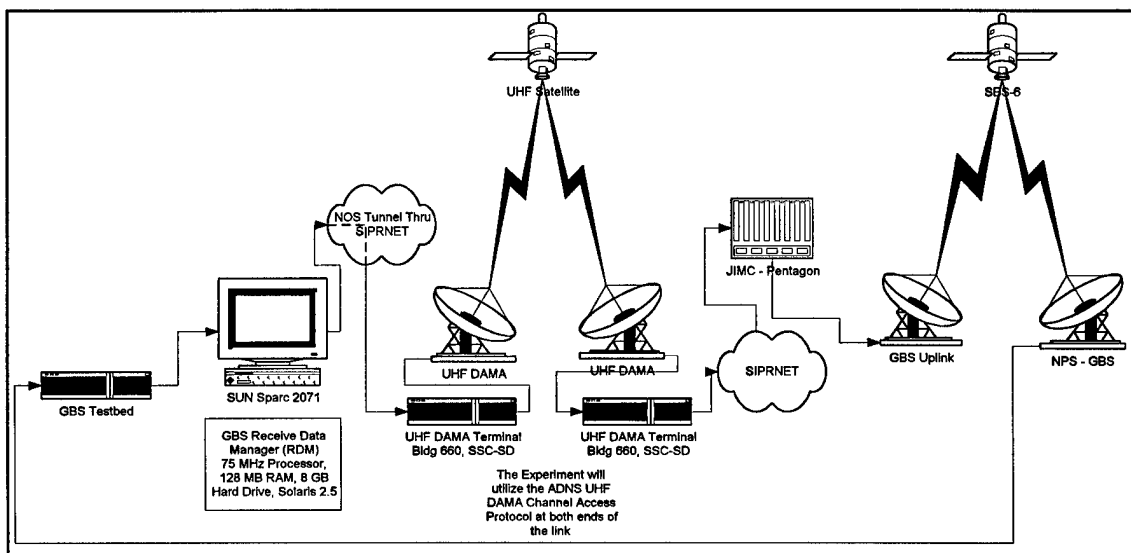

Figure 10 GBS Reach Back Test Configuration

One of the main challenges faced in setting up this test concerned the routing of the reach back requests through the SIPRNET. Specifically, it was necessary to force the reach back request to go through the UHF DAMA CAP located at the ADNS lab and ensure the retransmit request acknowledgments from the gateway computer (at the JIMC) came back along the same path (i.e., through the ADNS lab and the UHF DAMA SATCOM circuit) rather than some other SIPRNET path to the NPS RDM. If no special action were taken, when the GBS operator at NPS made a reach back request, the IP packet would show the NPS IP address as the source and the GBS gateway IP address as the destination. Assuming we could statically route the request through the UHF DAMA channel (which would be a challenge in itself with all of the intermediate routers in the path), the problem remains as how to ensure the reply from the GBS gateway does not

come directly back through the SIPRNET to NPS and skip the UHF DAMA channel entirely.

1. Tunnel Connection

The solution involved setting up a KAQ9 Network Operating System (NOS) tunnel between two Cisco routers, one located at NPS and one located at SSC. (See Figure 11.) In addition to the tunnel, an IP address from the ADNS lab subnet was assigned to the GBS RDM. As far as the computers were concerned, the use of an ADNS IP address allowed the NPS RDM in Monterey to "look like" it was physically located at SSC in San Diego.

The KAQ9 NOS tunnel is a selectable mode of operation on the Cisco routers which allows discontinuous sections of a Local Area Network (LAN) to be connected. The protocol is based on the KAQ9 NOS packet radio protocol for TCP/IP. Each end of the tunnel has a specific IP address as shown in Figure 11. The tunnel encapsulates the IP datagram with a destination address of the other end of the tunnel. Once the datagram reaches the other end of the tunnel it is unwrapped and sent out in the normal manner. To the computers connected at each end of the tunnel it looks as if the other section of the LAN is only one router hop away, while in fact it may be many hops away. (In our case there were approximately six hops from NPS to the SSC ADNS lab without the tunnel.) The tunnel interface display is shown in Figure 12. The important fields are described below the figure.

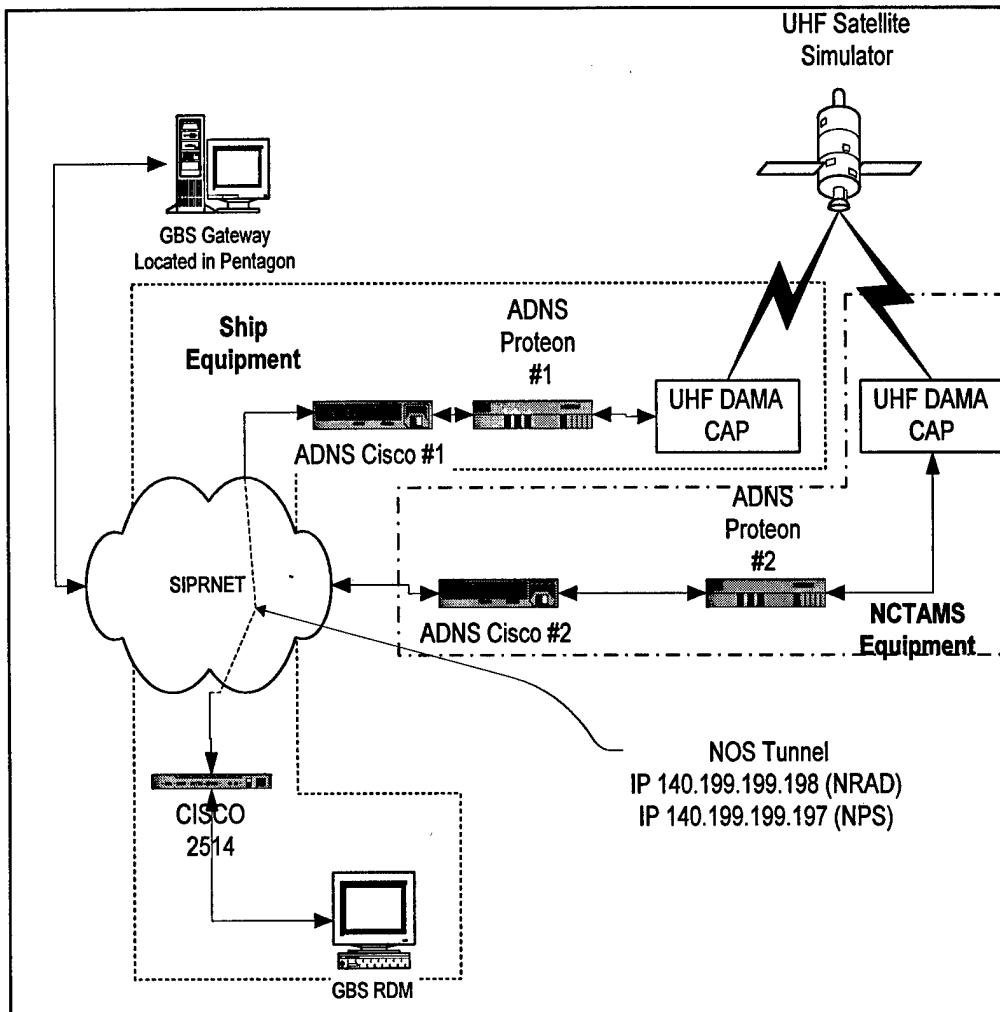

Figure 11 Tunneling Setup

Referring to Figure 11, the signal flow is as follows:

- The GBS RDM operator makes a request
- The packet is sent through the tunnel to the ADNS Cisco router #1
- The ADNS Cisco router #1 static routes anything destined to the GBS Gateway via UHF DAMA

- The GBS Gateway acknowledges the packet and replies to the GBS RDM (whose address is a part of the SSC subnet)
- The reply is static routed back through the UHF DAMA channel by the ADNS Cisco Router #2
- After the reply is received it is sent by the ADNS Cisco router #1 via the NOS tunnel to the NPS RDM

```

1. nps#show interface tunnel 0
2. Tunnel0 is up, line protocol is up
3. Hardware is Routing Tunnel
4. Internet address is 140.199.199.97, subnet mask is 255.255.255.248
5. MTU 1500 bytes, BW 9 Kbit, DLY 500000 usec, rely 255/255, load 1/255
6. Encapsulation TUNNEL, loopback not set, keepalive set (10 sec)
7. Tunnel source 207.85.236.1, destination 192.84.124.36
8. Tunnel protocol/transport KA9Q-NOS/IP, key disabled, sequencing disabled
9. Checksumming of packets disabled
10. Last input 2w6d, output 0:00:04, output hang never
11. Last clearing of "show interface" counters 4w5d
12. Output queue 0/0, 0 drops; input queue 0/75, 0 drops
13. 5 minute input rate 0 bits/sec, 0 packets/sec
14. 5 minute output rate 0 bits/sec, 0 packets/sec
15. 82700 packets input, 5287830 bytes, 0 no buffer
16. Received 0 broadcasts, 0 runts, 0 giants
17. 0 input errors, 0 CRC, 0 frame, 0 overrun, 0 ignored, 0 abort
18. 380322 packets output, 26048407 bytes, 0 underruns
19. output errors, 0 collisions, 0 interface resets, 0 restarts

```

Figure 12 Tunnel Interface

Referring to Figure 12, the tunnel statistics of particular interest are:

- Line 1 is the command on the Cisco to view the tunnel statistics.
- Line 4 shows the IP address of the NPS end of the tunnel (this is the address that the static route from the RDM is set to).

- Line 7 shows the IP addresses of the NPS and SSC-SD routers at each end of the tunnel.
- Line 8 shows the tunneling protocol.
- Lines 15 and 18 show the number of packets input to the tunnel and number of packets output from the tunnel respectively. Clearing the counters and using the ping utility allowed us to determine if the packets were being routed properly. Ping would send a fixed number of packets to a destination IP address and then we could look at the counter and determine if they had actually been routed through the tunnel.

C. DATA COLLECTION

The purpose of the data collection was to evaluate the effectiveness of the ADNS CAP and UHF DAMA SATCOM as a reach back channel for the GBS Phase One system, and then interpret the data as they apply to GBS Phase Two. As discussed in Chapter I, this experiment would be impossible without a CAP or some other protocol which handles the timing and interface requirements to transmit TCP/IP over UHF DAMA. The majority of the data collection involves the use of the UNIX command *snoop* which allows us to monitor and time tag all activity taking place on a specific network device. A sample session and labels for the columns are shown in Table 3. To save space, some of the additional information normally found in the snoop output has been deleted. The column headings are explained below the table.

The NPS RDM has two network devices; le0 which is connected directly to the GBS Cisco router, and le1 which is connected to the SIPRNET (as shown in Figure 9). Snoop must be run while logged in with root privileges. The command line entry is `%snoop -d le1 -tr hostname`. The `-d le1` option allows us to filter packets only on the le1 network device. The `-tr` option time stamps all packets received relative to the first packet with an accuracy of +/- 4 microseconds. The `hostname` option allows some additional filtering so that only packets addressed to or from the specified hostname will be displayed. [Ref. 19]

<u>Time</u>	<u>Orig</u>	<u>Dest</u>	<u>Type</u>	<u>Dest Port</u>	<u>Source Port</u>	<u>Special</u>	<u>Sequence Number</u>	<u>Data</u>
0.000	daffey >	GBS_GATEWAY	TCP	D=80	S=32966	Syn	Seq=3178448483	Len=0

Table 3 Sample Snoop Line

- Time - relative time since last event
- Orig - originating computer (daffey is an alias for the RDM)
- Dest - destination computer
- Type - type of connection e.g. FTP, TCP...
- Dest Port - Destination port
- Source port
- Special - in this case SYN is used when establishing a TCP session, usually blank

- Sequence Number of packet
- Data - Number of bytes of data contained in packet

Snoop was the primary tool used to collect data during all of the reach back trials.

The data collection and results are described in the following chapter.

D. ADNS CAP LOADING

The test was conducted with the RDM directly connected to the SIPRNET and under varying loads on the GBS reach back UHF DAMA SATCOM channel. The loads on the back channel were:

- Two users (each is $\frac{1}{2}$ of a full duplex link)
- Four users no load
- Four users 25% load
- Four users 50% load

The loads were defined as follows. A four user frame with a 25% load is shown in Figure 13. Each user is allowed up to eight frames of data, therefore a 25% load would

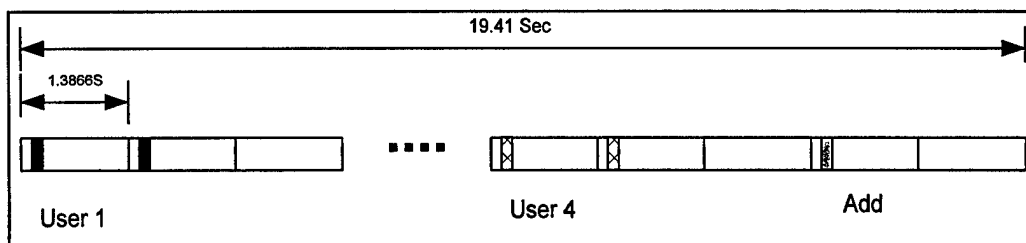

Figure 13 Four User ADNS Frame

utilize two of the eight frames. The load determines the minimum response time of the link. If there is only one user with one data frame (not a very efficient use of the link) ADNS would use four DAMA frames and the total ADNS frame length could be as short as 5.5 seconds. As mentioned in Chapter II, when fully loaded (four users each with 8 frames of data) the link cycle time is 52.69 seconds.

E. EXPERIMENT SETUP SUMMARY

With all of the equipment properly configured, the routing problems solved, and the data collection plan in place, all that remained was to run the tests. The tests were conducted 6 - 17 April 1998 utilizing the Phase One GBS secret IP channel. The specific results are discussed in the next chapter. The tunnel remains active although the default route has been removed to facilitate future testing.

IV. TEST RESULTS

A. DISCUSSION

Tests were conducted varying the UHF DAMA channel loading and number of users parameters discussed in the previous chapter. Each configuration was tested until there were ten successful reach back sessions or until it became obvious that the link was not going to work. One of the key points that became obvious early on as we began to add additional users and traffic was that the TCP session would be closed by the RDM if it had not received an acknowledgment to its SYN packet (the beginning of the three-way handshake) from the GBS gateway within 30 seconds. An example of a failed session is shown in Figure 14. This particular example is from a test with four users and a 25% load. The only differences between Figure 14 and the explanation of the snoop display in the previous chapter are the RST in line 4 which indicates the connection has been closed out since there was no response within 30 seconds and the ACK field in line 5 (which is the acknowledgment of a packet from the destination computer). Once a session had been established (the three-way handshake completed), it was satisfactory if the subsequent acknowledgments took longer than 30 seconds, and several did. Timely acknowledgment of the initial SYN packet was the critical factor.

1	0.00000 daffey -> GBS_GATEWAY TCP D=80 S=32966 Syn Seq=3178448483 Len=0
2	4.73776 daffey -> GBS_GATEWAY TCP D=80 S=32966 Syn Seq=3178448483 Len=0
3	14.20794 daffey -> GBS_GATEWAY TCP D=80 S=32966 Syn Seq=3178448483 Len=0
4	29.99909 daffey -> GBS_GATEWAY TCP D=80 S=32966 Rst Seq=3178448484 Len=0
5	31.34264 GBS_GATEWAY -> daffey TCP D=32966 S=80 Syn Ack=3178448484 Seq=1548124364 len=0
6	31.34279 daffey -> GBS_GATEWAY TCP D=80 S=32966 Rst Seq=3178448484 Len=0

Figure 14 Failed Reach back Session

The GBS RDM operating system - Sun Solaris 2.5.1 has a utility called 'nnd' which allows manipulation of the TCP/IP driver configuration parameters. These configurable parameters can be viewed by typing the command `%nnd /dev/tcp \?`. The names of the parameters are somewhat self explanatory, e.g. TCP_CONN_ABORT_THRESHOLD. I was able to vary how long the RDM waits to retransmit a packet. Unfortunately, I was unable to have any impact on the problem of the driver resetting the connection if it had not received the SYN ACK within 30 seconds.

B. OBSERVATIONS

During the initial test setup we were unable to establish the tunnel connection between NPS and SSC. The difficulty turned out to be the SSC firewall which was blocking our connection. After discussing our test with the appropriate security personnel, we were able to get access through the firewall and complete the tunnel.

When we first switched from a direct SIPRNET connection to using the UHF DAMA back channel, there were a large number of Internet Control Message Protocol (ICMP) messages being sent over the link. The GBS RDM would send an ICMP message every few seconds until it got a response; this occurred approximately every thirty seconds. The RDM would send about ten packets until the first response was received. After some investigation it was determined that the xferit script (running on the RDM) was the culprit. Xferit is the process that transfers wrapped information product files to the GBS gateway for broadcast. If a RDM was setup to allow users to wrap files, the process would check the link to the GBS gateway every 30 seconds and then check

the outgoing wrapped directory to see if there were any files to upload. A quick fix from Welkin & Associates changed the script so it checked the outgoing wrapped directory first, and then checked to see if the GBS gateway was reachable. Therefore the ICMP messages would only be sent when there were files to upload. This eliminated the extra traffic on our high latency, bandwidth restricted reach back channel.

When directly connected to the SIPRNET (i.e., not via the UHF satellite) the reach back session took approximately 1.35 seconds to complete. The requested file consistently showed up on the broadcast 1 to 2 minutes after the request. When using UHF DAMA as the reach back channel, the requested file would often arrive before the user pull TCP/IP session had actually completed. This was due to the fact the TCP/IP session took so long to complete (see Table 4). The GBS gateway would have all of the information it needed to queue up the file before all of the handshaking was completed to close out the TCP/IP reach back session. As discussed in Chapter I, some of the previous reach back experiments have experienced wide ranges in file delivery time. This has been attributed to the queuing at the JIMC GBS Gateway. This effect was not observed during the experiments conducted for this thesis. The amount of traffic at the uplink facility did not seem to have an appreciable impact on file delivery times. The testing was conducted over a two-week period and traffic on the Phase One GBS IP data channel ranged from none up to 2 Mbps (the channel allocation is 4 Mbps). Different files were requested each time, and their sizes ranged from approximately 100 kilobytes up to 5 megabytes.

C. SUCCESSFUL REACH BACK SESSION

An example of a successful reach back session is shown in Figure 15. The line numbers have been added to facilitate discussion of what is actually occurring in the session.

- Lines 1-3 are the initial SYN packet and the retransmission due to time-outs. Three SYNs were sent before a response was received from the GBS Gateway.
- Line 4 is the acknowledgment from the GBS gateway. (this one made it with less than 0.2 seconds to spare before the session would have timed out)
- Line 5 is the ACK from the GBS RDM that completes the three-way handshake to establish a TCP/IP connection.
- Lines 6-11 are the initial transmission and time-out retransmissions of the first data packet. Notice the packet contains 164 bytes of data, this was consistent for all of the reach back sessions. The time between successive transmissions is approximately 0.5, 1, 2, 4, and 8 seconds. This is the TCP/IP exponential back-off algorithm where if an ACK is not received the time to retransmit is doubled up to a maximum 64 seconds typically. [Ref. 8]
- Line 12 is the acknowledgment of the first data packet. It can be seen the acknowledgment takes over 30 seconds yet the connection is not reset. This is because once the TCP connection is established, a (different) timer is used that takes into account the round trip time of a connection. [Ref. 8]

1	0.00000	daffey -> GBS_GATEWAY	TCP D=80 S=33291	Syn Seq=1503463643	Len=0
2	4.73658	daffey -> GBS_GATEWAY	TCP D=80 S=33291	Syn Seq=1503463643	Len=0
3	14.20666	daffey -> GBS_GATEWAY	TCP D=80 S=33291	Syn Seq=1503463643	Len=0
4	29.83600	GBS_GATEWAY -> daffey	TCP D=33291 S=80	Syn Ack=1503463644	Seq=154141740 Len=0
5	29.83619	daffey -> GBS_GATEWAY	TCP D=80 S=33291	Ack=154141741	Seq=1503463644 Len=0
6	29.88020	daffey -> GBS_GATEWAY	TCP D=80 S=33291	Ack=154141741	Seq=1503463644 Len=164
7	30.35641	daffey -> GBS_GATEWAY	TCP D=80 S=33291	Ack=154141741	Seq=1503463644 Len=164
8	31.32370	daffey -> GBS_GATEWAY	TCP D=80 S=33291	Ack=154141741	Seq=1503463644 Len=164
9	33.23655	daffey -> GBS_GATEWAY	TCP D=80 S=33291	Ack=154141741	Seq=1503463644 Len=164
10	37.07651	daffey -> GBS_GATEWAY	TCP D=80 S=33291	Ack=154141741	Seq=1503463644 Len=164
11	44.75648	daffey -> GBS_GATEWAY	TCP D=80 S=33291	Ack=154141741	Seq=1503463644 Len=164
12	59.04906	GBS_GATEWAY -> daffey	TCP D=33291 S=80	Ack=1503463808	Seq=154141741 Len=0
13	59.04924	daffey -> GBS_GATEWAY	TCP D=80 S=33291	Ack=154141741	Seq=1503463808 Len=33
14	59.52643	daffey -> GBS_GATEWAY	TCP D=80 S=33291	Ack=154141741	Seq=1503463808 Len=33
15	60.48656	daffey -> GBS_GATEWAY	TCP D=80 S=33291	Ack=154141741	Seq=1503463808 Len=33
16	62.40657	daffey -> GBS_GATEWAY	TCP D=80 S=33291	Ack=154141741	Seq=1503463808 Len=33
17	66.24642	daffey -> GBS_GATEWAY	TCP D=80 S=33291	Ack=154141741	Seq=1503463808 Len=33
18	73.92655	daffey -> GBS_GATEWAY	TCP D=80 S=33291	Ack=154141741	Seq=1503463808 Len=33
19	85.37959	GBS_GATEWAY -> daffey	TCP D=33291 S=80	Ack=1503463841	Seq=154141741 Len=0
20	85.39577	GBS_GATEWAY -> daffey	TCP D=33291 S=80	Ack=1503463841	Seq=154141741 Len=31
21	85.40890	GBS_GATEWAY -> daffey	TCP D=33291 S=80	Ack=1503463841	Seq=154141772 Len=37
22	85.40902	daffey -> GBS_GATEWAY	TCP D=80 S=33291	Ack=154141809	Seq=1503463841 Len=0
23	102.49492	GBS_GATEWAY -> daffey	TCP D=33291 S=80	Ack=1503463841	Seq=154141809 Len=20
24	102.50556	GBS_GATEWAY -> daffey	TCP D=33291 S=80	Ack=1503463841	Seq=154141829 Len=25
25	102.50567	daffey -> GBS_GATEWAY	TCP D=80 S=33291	Ack=154141854	Seq=1503463841 Len=0
26	102.51222	GBS_GATEWAY -> daffey	TCP D=33291 S=80	Ack=1503463841	Seq=154141854 Len=2
27	102.53765	GBS_GATEWAY -> daffey	TCP D=33291 S=80	Ack=1503463841	Seq=154141856 Len=77
28	102.53777	daffey -> GBS_GATEWAY	TCP D=80 S=33291	Ack=154141933	Seq=1503463841 Len=0
29	102.56203	GBS_GATEWAY -> daffey	TCP D=33291 S=80	Fin Ack=1503463841	Seq=154141933 Len=0
30	102.56215	daffey -> GBS_GATEWAY	TCP D=80 S=33291	Ack=154141934	Seq=1503463841 Len=0
31	102.56273	daffey -> GBS_GATEWAY	TCP D=80 S=33291	Fin Ack=154141934	Seq=1503463841 Len=0
32	102.62790	GBS_GATEWAY -> daffey	TCP D=33291 S=80	Fin Ack=1503463841	Seq=154141741 Len=192
33	102.62804	daffey -> GBS_GATEWAY	TCP D=80 S=33291	Ack=154141934	Seq=1503463842 Len=0
34	103.03647	daffey -> GBS_GATEWAY	TCP D=80 S=33291	Fin Ack=154141934	Seq=1503463841 Len=0
35	103.99670	daffey -> GBS_GATEWAY	TCP D=80 S=33291	Fin Ack=154141934	Seq=1503463841 Len=0
36	105.91640	daffey -> GBS_GATEWAY	TCP D=80 S=33291	Fin Ack=154141934	Seq=1503463841 Len=0
37	109.75649	daffey -> GBS_GATEWAY	TCP D=80 S=33291	Fin Ack=154141934	Seq=1503463841 Len=0
38	117.43644	daffey -> GBS_GATEWAY	TCP D=80 S=33291	Fin Ack=154141934	Seq=1503463841 Len=0
39	118.43854	GBS_GATEWAY -> daffey	TCP D=33291 S=80	Fin Ack=1503463841	Seq=154141809 Len=124
40	118.43866	daffey -> GBS_GATEWAY	TCP D=80 S=33291	Ack=154141934	Seq=1503463842 Len=0
41	132.79644	daffey -> GBS_GATEWAY	TCP D=80 S=33291	Fin Ack=154141934	Seq=1503463841 Len=0
42	134.75847	GBS_GATEWAY -> daffey	TCP D=33291 S=80	Fin Ack=1503463841	Seq=154141854 Len=79
43	134.75862	daffey -> GBS_GATEWAY	TCP D=80 S=33291	Ack=154141934	Seq=1503463842 Len=0
44	134.76293	GBS_GATEWAY -> daffey	TCP D=33291 S=80	Ack=1503463842	Seq=154141934 Len=0

Figure 15 Successful Reach back Session

- A similar pattern continues until the GBS Gateway begins to send data back to the GBS RDM. (Note: These data are not the requested file, but rather status information from the GBS gateway. e.g., file availability)
- Once all of the data has finished being transmitted from the GBS gateway it sends a FIN packet on line 29.

- The GBS RDM acknowledges the FIN (line 30) and sends its own FIN on line 31.
- The session is closed out once the GBS RDM receives an ACK for its FIN packet on line 44.
- The additional FIN packets being exchanged are due to the fact that they were not filtered in the ADNS queue.

D. TOTAL TIME TO COMPLETE REACH BACK SESSION

Total time, defined as the time from the first SYN sent from the RDM until the final ACK was received closing out the TCP session, was chosen since it represents the entire time that the UHF DAMA channel was occupied and not available to other users. The total time for the session to complete turned out to be directly related to the amount of traffic and the number of users. This makes sense since more users and more data expand the total time for an ADNS frame. The summary results are shown in Table 4. The reason none of the 50% load attempts were successful is explained in Section E.

	Direct Connect	Two Users	Four Users No Load	Four Users 25% Load	Four Users 50% Load
Attempts / Successful	10/10	10/10	10/10	10/13	0/14
Percent Successful	100%	100%	100%	76.9%	0%
Mean Time	1.356	78.76	79.31	112.01	NA
Std Dev	0.079	2.95	3.21	5.58	NA

Table 4 Total Time to Complete Reach Back

There is not a large difference between the two user configuration and the four user no load configuration. This is because the version of ADNS software that was used removes members from the net if they have not sent data recently. Therefore the two users who were not active participants in the four user net were removed after a period of inactivity. If there was no activity within ten cycles the user was dropped.

E. TIME TO FIRST ACK

The critical factor influencing the number of successful attempts in Table 4 was the time elapsed before acknowledgment of the SYN sent by the RDM. The actual response time for the SYN ACK is shown in Table 5. None of the four user 50% load tests were successful since the average response time did not come close to the required 30 seconds. The four user 25% load result really depended on where the ADNS frame was at in its cycle when the request hit it. For example, if the GBS user was ADNS user one and if user one's time slot had just passed when the request hit the CAP queue, it would have to wait one whole cycle until it went out. The ACK would then take up to almost two cycles to get back.

	Direct Connect	One User	Four User No Load	Four User 25% Load	Four User 50% Load
Mean Time	.260	16.62	17.24	26.77	41.32
Std Dev	.023	2.51	0.92	5.07	4.87

Table 5 Average Time to First ACK

F. TEST RESULTS SUMMARY

The results of the testing identified limitations of the ADNS CAP interface for the use of UHF DAMA SATCOM as a reach back channel for GBS. If the CAP has a round trip cycle time of greater than thirty seconds, then GBS reach back with this set of TCP/IP parameters will not work. The testing reported here actually has application to TCP/IP data connections in general. As shown here, the choice of computer operating system has a direct impact because the TCP/IP parameters vary with operating system. The implications of this testing for the GBS Phase Two systems, and recommendations for further research are discussed in the following chapter.

V. CONCLUSION

A. APPLICATION TO GBS PHASE TWO

This experiment was performed using the GBS Phase One Testbed and the GBS Phase One Receive Suite. The GBS Phase One receive suite is based on the UNIX operating system, while the GBS Phase Two systems will be based on Microsoft Windows NT. What is the relevance of this experiment to the GBS Phase Two system? This chapter will address that question, discuss the application of this testing to 5-kHz UHF DAMA SATCOM, and recommend future areas for thesis research.

B. GBS PHASE TWO SYSTEMS

If one of the goals of the GBS program is to integrate their system into existing communications architectures in a seamless manner, then design configurations must take into account legacy military system specifications. The goal of GBS to use commercial off the shelf (COTS) solutions is admirable, but there are existing military systems which may hamper the use of COTS solutions.

UHF DAMA SATCOM was developed to add flexibility to the existing UHF SATCOM infrastructure. The decision to adopt DAMA as the "protocol of the future" for UHF SATCOM was made before the explosion of TCP/IP based Internet digital communications such as the World Wide Web, Email, Telnet and File Transfer Protocol (FTP). With hindsight, the UHF SATCOM DAMA protocols might have been developed differently to enhance support of data communications. The result of a long acquisition

process and slow fielding of UHF DAMA has resulted in commercial technology eclipsing military capabilities again. COTS - based programs such as GBS must ensure that the drive to adopt COTS solutions takes into account legacy military system requirements.

The GBS Phase Two RBM must have the capability and flexibility to interface with systems ranging from

- Hardwired SIPRNET Connection - variable bandwidth, low latency
- Dial Up Connection - (STU-III, 1200-9600 bps)
- SHF SATCOM - high bandwidth, relatively low latency
- EHF SATCOM - limited bandwidth, relatively low latency
- UHF DAMA SATCOM - limited bandwidth, high latency
- And other systems such as the Army's Mobile Subscriber Equipment...

What will provide this flexible capability? At a minimum, the systems should have the capability to adjust the TCP/IP connection parameters, or at least have different "standard" configurations which allow the system to take into account variable reach back communications methods. This capability would eliminate the problems identified in Chapter IV. It will not solve the high latency problems because they are an artifact of the channel being utilized, but at least the connection would work.

C. 25 KHZ UHF DAMA VERSUS 5 KHZ UHF DAMA

The equipment used for this test limited us to the use of 25-kHz UHF DAMA SATCOM. The TD-1271 multiplexer and the AN/WSC-3 UHF transmitter are designed

to work only with 25-kHz DAMA. This test would be practically impossible to repeat using a protocol like the ADNS CAP and 5-kHz DAMA because of its longer frame length (8.96 seconds versus 1.3866 seconds). In addition, the ADNS approach of time sharing a small portion of the channel would only increase the framing delays by overlaying its own set of delays. This is where an interface such as the ADC/IP discussed previously might help. As mentioned, the ADC/IP is operated in the DASA mode and access to the channel is governed by the CSMA protocol. This is a logical approach for this type of channel and it minimizes the channel access times (which is important with the large framing delays).

Nonetheless, there are two drawbacks to the ADC/IP approach. First, the efficiency of a CSMA system is dependent on the size of the data frames and the total propagation time of the link. [Ref. 20, Chapter 13] For UHF DAMA SATCOM the protocol framing delays and satellite round trip delay combine to increase the propagation time, therefore decreasing the maximum utilization of the link. The second problem is implementation-related and that is the paucity of UHF DAMA channels to provide dedicated data service. Recall that DASA channels cannot be preempted.

In my opinion, the best solution is to try to piggyback any GBS reach back onto existing communications channels. The probability of having a UHF DAMA SATCOM channel dedicated for such a low duty cycle connection is extremely small. This is the mode of operation I would expect for a system using ADNS and in particular the ADNS UHF DAMA CAP.

D. RECOMMENDATIONS FOR FUTURE RESEARCH

As discussed in Chapter II, the GBS Phase Two receive suite RBM will use email and PPTP as the initial reach back communications method. The NPS GBS Test Bed has a Windows NT machine on the same local area network (LAN) as the GBS RDM. The SSC-SD ADNS lab has an NT server on the same LAN as the ADNS CAPs. We are in the process of establishing a PPTP tunnel between the two computers and will perform a similar test, only with the routing being handled by the PPTP connection rather than the NOS tunnel. Of particular interest will be the additional overhead added by PPTP. The test setup is shown in Figure 16. The plan is to present the results of the PPTP testing in

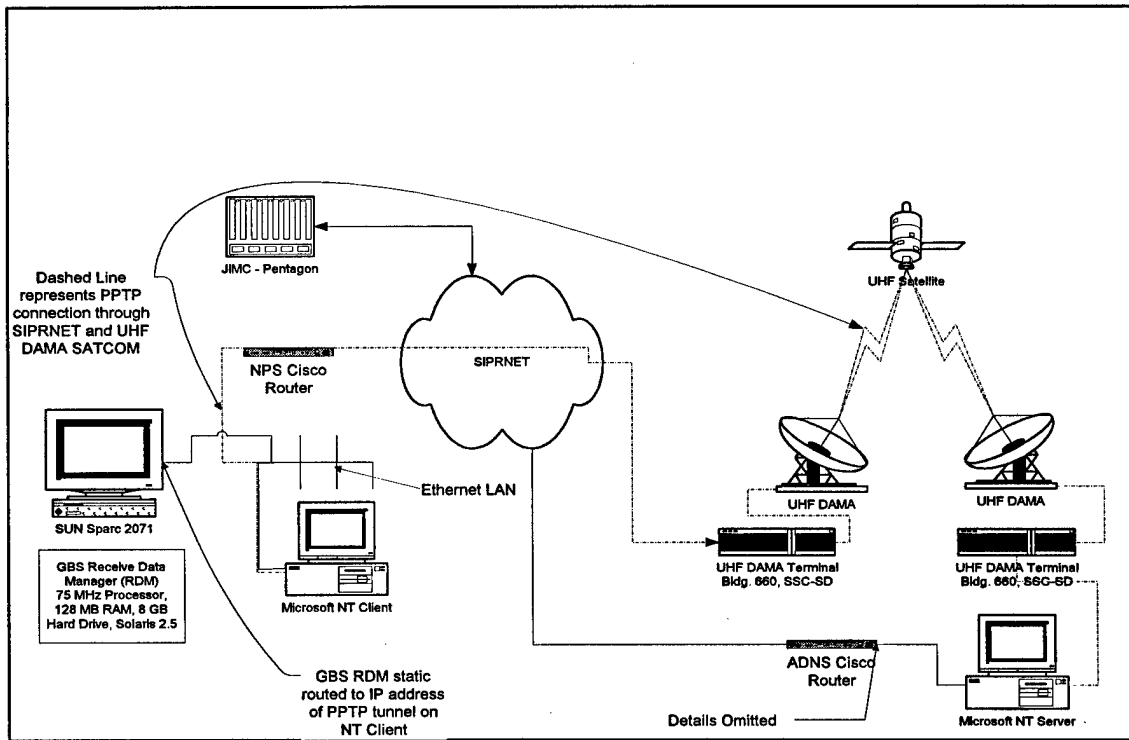

Figure 16 PPTP Tunnel

a paper at MILCOM 1998.

Additionally, experiments involving other protocol/systems which interface computer communications with UHF DAMA would be useful. For example, the ADC/IP and AN/PSC-5 UHF DAMA System.

E. SUMMARY

This thesis has demonstrated that GBS reach back via UHF DAMA SATCOM is indeed a viable option. The actual implementation of such a capability relies on factors such as the GBS Phase Two receive suites, access to a UHF DAMA channel, and for non-ADNS users, a protocol to access the channel that allows it to support TCP/IP communications.

APPENDIX A GBS PRODUCTS

[Ref. 1]

	Information Product	Data		Class	Pt. Of Origin	SBM	End User HW/SW Rqmts
		Data	AV			Source	
1	MAPPING, CHARTING AND GEODESY ((GGIS))	X		S	NIMA -St. Louis	SIPRNET	Browser Applications
2	METEOROLOGICAL AND OCEANOGRAPHIC (METOC)	X		S	NPMOC	SIPRNET	Browser, MPEG viewer
3	ARMY NOTICES OF AMMUNITION RECLASSIFICATION (NARS)	X		U	HQ, JOC	AUTODIN	AMHS
4	MISSILE NOTICE OF AMMUNITION RECLASSIFICATION (NARS)	X		U	HQ, MICOM	AUTODIN	AMHS
5	OVERHEAD FIRE SUPPLEMENTAL NOTICES	X		U	HQ, JOC	AUTODIN	AMHS
6	TPFDL	X		S	CINCPAC J3/4/5	GCCS	GCCS RDA
7	COMMON TACTICAL PICTURE	X		S	J3 (GCCS/JMCIS)	GCCS	GCCS 3.0
8	TOMAHAWK LND CRUISE MISSILE ATK MSN SUPPORT	X		TS	CMSA (CRUISE MISSILE SUPPORT, USPACOM AND USACOM)	CP SMITH B/20	7AF=MDS , Ships=Fire Control Sys
9	ATO	X		S	7 AF	OSAN	CTAPS
10	SOFTWARE UPDATES/PATCHES	X		TSC	MULTIPLE SOURCES	JICPAC et al	?
11	MEDICAL INTELLIGENCE	X	X	U	AFMIC, WHO, JTF	ArMedSurvA cty	WALTER REED
12	GTN (ITV, JTAV/JTAD)	X	X	U,S	USTRANSCOM	?	BROWSER
13	SARSS-O/RF/	X		?	?	?	?
14	INTEGRATED BROADCAST SERVICE (IBS)	X		S	NSA/NRO/AIA (JICPAC)	UHF via landline	CTT/MATT=>JTT
15	USE/LOCATION OF WMD	X		S	JTF, JICPAC	SIPRNET	Browser Applications
16	INTEL IMAGERY	X		S	JICPAC	SIPRNET	HTML, 5D, IPL client
17	DAILY INTELLIGENCE BULLETIN (DIB)	X		TSC	JICPAC	TSC Feed	HTML, FrameReader, Adobe Acrobat
18	DAILY INTEL SUMMARY (DISUM)	X		S	JICPAC	SIPRNET	Browser Applications
19	COUNTRY FACT SHEETS	X		S	JICPAC	SIPRNET	HTML, FrameReader, Adobe Acrobat
20	DEFENSE INTELLIGENCE WARNING SYSTEM	X		S	JICPAC	SIPRNET	Browser Applications
21	HULTEC DATABASE MESSAGE	X		S	JICPAC	SIPRNET	Browser Applications
22	POL-MIL AND TACTICAL ADVISORIES	X		S	JICPAC	SIPRNET	Browser Applications
23	TACMILINTSUM AND SI-TACMILINTSUM	X		TSC	JICPAC	TSC Feed	Browser Applications
24	EXPEDITIONARY SUPPORT PACKAGE	X		S	JICPAC	SIPRNET	Browser Applications
25	FEASIBILITY ASSESSMENT SUPPORT	X		S	JICPAC	SIPRNET	Browser Applications
26	MILITARY CAPABILITIES STUDY (MCS)	X		S	JICPAC	SIPRNET	HTML, FrameReader, Adobe Acrobat

27	JICPAC SPECIAL REPORT	X		S	JICPAC	SIPRNET	HTML, FrameReader, Adobe Acrobat
28	TARGET SYSTEM ANALYSIS	X		S	JICPAC	SIPRNET	HTML, FrameReader, Adobe Acrobat
29	LINES OF COMMUNICATIONS ROUTE STUDY	X		S	JICPAC	SIPRNET	Browser Applications
30	OPERATIONAL TARGET GRAPHIC (OTG)	X		S	JICPAC	SIPRNET	Browser Applications
31	BASIC TARGET GRAPHIC (BTG)	X		S	JICPAC	SIPRNET	Browser Applications
32	QUICK RESPONSE GRAPHICS (QRG)	X		S	JICPAC	SIPRNET	Browser Applications
33	TARGET INTELLIGENCE PACKAGE (TIP)	X		S	JICPAC	SIPRNET	Browser Applications
34	IMAGERY INTERPRETATION REPORT	X		S	JICPAC	SIPRNET	Browser Applications
35	MODERNIZED INTEGRATED DATABASE (MIDB)	X		S	JICPAC	SIPRNET	Browser Applications
36	CONTINGENCY EXPEDITIONARY/SOF PRODUCT (CESP)	X		S	JICPAC	SIPRNET	Browser Applications
37	*NEO DATABASE *Not listed in message	X		S	JICPAC	SIPRNET	Browser Applications
38	CURRENT INTELLIGENCE BRIEF		X	TSC	JICPAC	JWICS	Monitor
39	J2 CHALLENGES BRIEF		X	TSC	JICPAC	JWICS	Monitor
40	CNN		X	U	CABLE TV (BROADCAST STATION)	OCEANIC CABLE	Television
41	AFRTS		X	U	MARCH AFB, CA (BROADCAST STATION)	INTELSAT 177W	Television
42	UAV/HUD VIDEO DOWNLINK		X		PLATFORM BASE STATION	BASE STATION	Monitor
43	COMMAND INFORMATION		X	TSC	JTF	JTF	Monitor
44	BDA	X	X	S	JICPAC	Browser, JWICS	HTML, Monitor
45	PSYCHOLOGICAL OPERATIONS PRODUCTS	X	X		JPOTF		Television
46	PREVENTIVE MEDICINE ORIENTATION AND TRAINING	X	X	U	SVCS, COMPONENTS (NAVY EPMU'S)	NAVY EPMU'S	Monitor
47	MEDICAL SIGNIFICANT TRAINING	X	X	U	SERVICES (ECHELON III UNITS, MEDICAL TEACHING FACILITIES)	CONUS	Monitor+H63
48	*NEO SUPPORT *Not listed in message	X	X	?	PACOM, NEO CENTERS	?	
49	EMERGENCY ACTION MESSAGES (EAM)	X		S	COMUSKOREA	SIPRNET	
50	CINC FORCE DIRECTION MESSAGES (FDM)	X		S	USFK (CINCUNC/CFC & USFK)	SIPRNET	
51	SITUATION REPORTS (SITREPS)	X		S	USFK (CINCUNC/CFC & USFK)	SIPRNET	
52	FRIENDLY ORDER OF BATTLE (FOB) DATA	X		S	USFK (CFC FIELD UNITS & SUPPORTING ORGS/ELEMENTS)	SIPRNET	

53	ENEMY ORDER OF BATTLE (EOB) DATA	X		S	USFK (CFC FIELD UNITS & SUPPORTING ORGS/ELEMENTS)	SIPRNET	
54	INTEGRATED TARGETING ORDER (ITO)	X		S	USFK COMPONENTS (COMPONENT COMMANDS)	SIPRNET	
55	TARGET NOMINATION DATA	X		S	USFK (CINCCFC, JICPAC, TARGET NOMINATION BOARDS, COMPONENT COMMANDS)	SIPRNET	
56	COLLECTION MANAGEMENT (RFIS)	X		S	USFK (CP TANGO, OSAN AND CAMP HUMPHREYS, JICPAC)	SIPRNET	
57	HUMINT	X		S	USFK (YONGSAN, CP TANGO, OSAN, HUMPHREYS)	SIPRNET	
58	GRAPHIC INTSUMS (Intel Summaries)	X			USFK (YONGSAN IN ARMISTICE, CP TANGO, CAMP HUMPHREYS, OSAN)	SIPRNET	ASAS/WARLORD
59	INTELLIGENCE ESTIMATE PRODUCTS	X		S	USFK C2 (CFC C2)	SIPRNET	
60	KOREA TACTICS, TECHNIQUES AND PROCEDURES (KTP)	X		S	USFK C2 (CFC C2)	SIPRNET	
61	SIMULATIONS	X		S	USFK, USCP (YONGSAN, OSAN, TAEGU, CP TANGO, SUWON, PACOM)	SIPRNET	
62	THEATER MISSILE DEFENSE INTEL PREPARATION OF THE BATTLEFIELD (TMD IPB)	X		S	USFK (YONGSAN, OSAN, CP TANGO, HUMPHREYS)	SIPRNET	
63	SIGNALS INTELLIGENCE (SIGINT)	X		S	USFK (YONGSAN, OSAN, CP TANGO, K-50, HUMPHREYS)	SIPRNET	
64	JSTARS	X		?	JSTARS MGSM (WARTIME MGSM LOCATIONS)		2D Imagery
65	VIDEO TELECONFERENCE (VTC) BROADCASTS		X	?	USFK (CINCCFC/USFK AND VARIOUS PENINSULA COMMAND CENTERS)	PAC VTC?	VTC
66	DISTANCE LEARNING	X	X	U	USFK (ALL U.S. MILITARY POSTS AND CAMPS IN ARMISTICE. YONGSAN, OSAN, HUMPHREYS, TAEGU, J12 CHINHAE, POHANG, AS A MIN.)	?	VTC, PASS-K
67	NONCOMBATANT EVACUATION OPERATION (NEO) SUPPORT	X	X	S	USCP, NEP CTRS (PACOM, NEO CENTERS)	?	

LIST OF REFERENCES

1. Global Broadcast Service Joint Concept of Operations Version 2.0, 31 Dec 1997
2. GBS Software Architecture Version 2.1, 10 Mar 97
3. United States Pacific Command Global Broadcast Service Concept of Operations - Draft, 7 Jan 98
4. Schaffler, Keith E., "The Design and Installation of a Global Broadcast Service Demonstration Project at the Naval Postgraduate School", NPS Thesis, Mar 1997
5. Wellborn, Robert M., "Analysis of the Digital Video Broadcast Standard for Use in the Global Broadcast Service Architecture", NPS Thesis, Mar 1998
6. Space Segment Specification for Interim Global Broadcast Service, PMW 146-S-003, 27 Feb 96
7. UHF DAMA CD-ROM, Joint DAMA Implementation Working Group September 1996, V 2.0, Mar 1997
8. Stevens, W. Richard, TCP/IP Illustrated, Volume 1, Addison Wesley Longman, 1994
9. Stewart, Alan, conversations with Capt Joe Arthur, 16 Apr 98
10. Roper, CDR Ben, Global Broadcast Service (GBS) Joint Warrior Interoperability Demonstration (JWID) 1996 Final Report, undated
11. Fay, Maj. Matthew; Goldstein, Joseph, GBS Reach back - Integrated Solution NRO/OSO Brief, MILCOM 97, Nov 97
12. JWID 98 Demonstration Plan (JW-112B), 10 Dec 97
13. Krout, Timothy, WWW Browsing Using GBS and SIPRNET, Naval Research Lab, undated
14. VDC-500 IP Data Controller, Product Brochure, ViaSat Inc., 1997
15. PMW 176 JMCOMS Master Plan Appendix A-1, 17 Mar 97
16. Hom, Yau Keung, conversations with Capt Joe Arthur, 16 Apr 98
17. Scotty, Stephen D., Expected Performance of the Global Broadcast Service (GBS), Phase II, With Emphasis on Environmental Limitations to Supportable Data Rates, NPS Thesis, Jun 1997
18. Watkins, John A., Instrumenting the Naval Postgraduate School Global Broadcast Service Testbed Facility, NPS Thesis, Jun 1997
19. UNIX online MAN page, Solaris V 2.5.1

20. Stallings, William, Data and Computer Communications, Prentice-Hall, 1996
21. Understanding the Point to Point Tunneling Protocol, White Paper, Microsoft, 1997

INITIAL DISTRIBUTION LIST

	No. Copies
1. Defense Technical Information Center2 8725 John J. Kingman Rd., Ste 0944 Ft. Belvoir, VA 22060-6218	
2. Dudley Knox Library2 Naval Postgraduate School 411 Dyer Road Monterey, CA 93943-5101	
3. Chairman C4I Academic Group1 Naval Postgraduate School Code CC Monterey, CA 93943	
4. Professor Paul H. Moose.....1 Naval Postgraduate School Code EC/ME Monterey, CA 93943	
5. CAPT Joseph Delpino.....1 GBS/JPO care of DISA D216 C4&I Programs Directorate Skyline 5 5111 Leesburg Pike Falls Church, VA 22041-3205	
6. Commanding Officer1 Dr Roy A Axford Jr. D841 (PL-TS) SPAWARSYSCEN 53560 Hull Street San Diego, CA 92152-5001	
7. Capt Joseph E. Arthur1 527 Aladar Dr. O'Fallon, IL 62269	

8. AFIT/CIGK.....1
 Attn: Capt Kathryn B. Smith
 2950 P Street
 Wright-Patterson AFB OH 45433-7765

9. Mr Timothy Krout.....1
 Code 5550 NRL
 4555 Overlook Ave. SW
 Washington, DC 20375

10. Commanding Officer1
 SPAWAR Systems Center San Diego
 Code 824 Attn: Yau Keung Hom
 53560 Hull St.
 San Diego, CA 92152-5001

11. Commanding Officer1
 SPAWAR Systems Center San Diego
 Code D621 Attn: Mr. Allan Stewart
 53560 Hull St.
 San Diego, CA 92152-5001

12. Commanding Officer1
 SPAWAR Systems Center San Diego
 Code D844 Attn: Mr. James Parsons
 53560 Hull St.
 San Diego, CA 92152-5001

13. Commanding Officer1
 Space and Naval Warfare Systems Command
 PMW 176 Attn: CAPT Gary Graupmann
 4301 Pacific Highway
 San Diego, CA 92110-3127

14. Commanding Officer1
 Space and Naval Warfare Systems Command
 PMW 176-4C Attn: Ms. Audrey Ramirez
 4301 Pacific Highway
 San Diego, CA 92110-3127

- 15. Commanding Officer1
 Space and Naval Warfare Systems Command
 PMW 176-4 Attn: LCDR David Sendek
 4301 Pacific Highway
 San Diego, CA 92110-3127

- 16. Commanding Officer1
 D842 Attn: Mr. Lee Skeen
 SPAWARSYSCEN
 53560 Hull Street
 San Diego, CA 92152-5001

- 17. Chief of Naval Operations1
 Satellite Communications Branch
 N631C Attn: CDR Trinora E. Pinto-Sassman
 2000 Navy Pentagon
 Washington, DC 20350-2000

- 18. Commanding Officer1
 SPAWAR Systems Center San Diego
 Code D80 Attn: Mr. Robert Kochanski
 53560 Hull St.
 San Diego, CA 92152-5001

- 19. Commanding Officer1
 SPAWAR Systems Center San Diego
 Code D84 Attn: Mr. Don Milstead
 53560 Hull St.
 San Diego, CA 92152-5001

- 20. Chief of Naval Research1
 Office of Naval Research
 Code 313 Attn: Dr. Neil Gerr
 800 North Quincy Street
 Arlington, VA 22217-5660

- 21. Chief of Naval Research1
 Office of Naval Research
 Code 313 Attn: Dr. Sherman Gee
 800 North Quincy Street
 Arlington, VA 22217-5660