

NATIONAL BUREAU OF S
MICROCOPY RESOLUT TEST

2

U. S. ARMY MATERIEL COMMAND

AD-A168 382

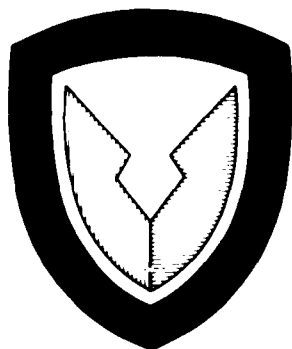

MANUFACTURING METHODS & TECHNOLOGY

This document has been approved for public release and sale; its distribution is unlimited.

PROJECT EXECUTION REPORT

DTIC
ELECTE
JUN 05 1986
S D

DTIC FILE COPY

SECOND CY85

APRIL 1986

PREPARED BY
USA INDUSTRIAL BASE ENGINEERING ACTIVITY

PRODUCTION ENGINEERING DIVISION
ROCK ISLAND, ILLINOIS 61299-7260

012

UNCLASSIFIED

SECURITY CLASSIFICATION OF THIS PAGE (When Data Entered)

REPORT DOCUMENTATION PAGE		READ INSTRUCTIONS BEFORE COMPLETING FORM
1. REPORT NUMBER SECOND CY85	2. GOVT ACCESSION NO. AD-A168382	3. RECIPIENT'S CATALOG NUMBER
4. TITLE (and Subtitle) MANUFACTURING METHODS & TECHNOLOGY PROJECT EXECUTION REPORT	5. TYPE OF REPORT & PERIOD COVERED Semiannual 1 Jul 85 - 31 Dec 85	
7. AUTHOR(s) Debbie O'Connor	6. PERFORMING ORG. REPORT NUMBER	
9. PERFORMING ORGANIZATION NAME AND ADDRESS US Army Industrial Base Engineering Activity ATTN: AMXIB-PS Rock Island, IL 61299-7260	8. CONTRACT OR GRANT NUMBER(s) N/A	
11. CONTROLLING OFFICE NAME AND ADDRESS US Army Industrial Base Engineering Activity ATTN: AMXIB-PS Rock Island, IL 61299-7260	10. PROGRAM ELEMENT, PROJECT, TASK AREA & WORK UNIT NUMBERS N/A	
14. MONITORING AGENCY NAME & ADDRESS (if different from Controlling Office) US Army Materiel Command ATTN: AMCPD 5001 Eisenhower Avenue Alexandria, VA 22333	12. REPORT DATE April 1986	
16. DISTRIBUTION STATEMENT (of this Report) DISTRIBUTION UNLIMITED OPERATIONS SECURITY (OPSEC) REVIEW PERFORMED	13. NUMBER OF PAGES 126	
	15. SECURITY CLASS. (of this report) UNCLASSIFIED	
17. DISTRIBUTION STATEMENT (of the abstract entered in Block 20, if different from Report) DISTRIBUTION UNLIMITED	15a. DECLASSIFICATION/DOWNGRADING SCHEDULE N/A	
18. SUPPLEMENTARY NOTES N/A		
19. KEY WORDS (Continue on reverse side if necessary and identify by block number) Manufacturing Methods & Technology MMT		
20. ABSTRACT (Continue on reverse side if necessary and identify by block number) This document is a summary compilation of the Manufacturing Methods and Technology Program Project Status Reports (RCS DRCMT-301) submitted to IBFA from AMC major Army subcommands and project managers. Each page of the computerized section lists project number, title, funding, and projected completion date. Summary pages give information relating to the overall AMC program. Status reports listed in this document include:		

DD FORM 1 JAN 73 1473

EDITION OF 1 NOV 65 IS OBSOLETE

UNCLASSIFIED

SECURITY CLASSIFICATION OF THIS PAGE (When Data Entered)



DEPARTMENT OF THE ARMY
US ARMY INDUSTRIAL BASE ENGINEERING ACTIVITY
ROCK ISLAND, ILLINOIS 61299-7260

REPLY TO
ATTENTION OF

AMXIB-PS

SUBJECT: Manufacturing Methods and Technology (MMT) Program Project
Execution Report, Second Half CY85

SEE DISTRIBUTION

1. Reference DODI 4200.15, 24 May 1985, subject: Manufacturing Technology Program.
2. The Project Execution Report is a summary compilation of the MMT Project Status Reports (RCS DRCMT-301) submitted to IBEA from AMC Major Army Subcommands (SUBMACOM) and project managers. This document is used as a management tool for monitoring trends of the MMT Program and includes a discussion of the overall AMC Program. There are separate sections in the report showing projects that are new, active, and completed.
3. Due to a reorganization at HQ AMC and the publication of reference 1, the MMT Program and the administration of the program are in the process of change. New reporting forms are being identified and output documents are being revised to reflect the changes. In the interim, this edition of the Execution Report is similar in format to the previous editions; however, the narrative work status summary has been excluded. It is expected that the next Execution Report will be consolidated into the Manufacturing Technology Program Report which is a requirement of the DODI.
4. Persons who are interested in the details of an individual project should contact the Manufacturing Technology representative at the SUBMACOM. A list of those representatives is included in Appendix I to this report. The Project Officer for this task is Ms. Debbie O'Connor, AUTOVON 793-3682.

FOR THE DIRECTOR:

JAMES W. CARSTENS
Chief, Production Engineering Division

	Page
DISCUSSION	1
PROJECTS ADDED 2nd HALF, CY85	7
FINAL STATUS REPORTS RECEIVED DURING 2nd HALF, CY85	29
SUMMARY PROJECT STATUS REPORTS	37
User's Guide	41
Management Engineering Training Activity and Depot Systems Command'	43
Laboratory Command'	47
Materials Technology Laboratory'	51
Test and Evaluation Command'	61
Aviation Systems Command'	65
Communications & Electronics Command'	71
Missile Command'	75
Tank-Automotive Command'	79
Armament, Munitions & Chemical Command (Ammunition)	87
Armament, Munitions & Chemical Command (Weapons)	99
Troop Support Command	109
APPENDICES	
I - Army MMT Program Representatives	115
DISTRIBUTION	121

Accession For	
NTIS CRA&I	<input checked="" type="checkbox"/>
DTIC TAB	<input type="checkbox"/>
Unannounced	<input type="checkbox"/>
Justification	
By	
Distribution/	
Availability Codes	
Dist	Avail and/or Special
A-1	



DISCUSSION

Background

The Army Manufacturing Methods and Technology (MMT) Program was established in 1964 as a part of the Army Production Base Support (PBS) Program. The MMT Program has goals of improving existing manufacturing technology, translating new technology into production line processes, and supporting the modernization and expansion of the military hardware production base. The program is governed by the provisions of AR 700-90, Chapter 3.

In May 1985, DODI 4200.15, Manufacturing Technology Program, was signed into effect. In August 1985, a reorganization at HQ AMC eliminated the office of the Deputy Chief of Staff for Manufacturing Technology as a separate organization. Both of these events are causing changes to be felt in the administration of the MMT Program. Input reports and procedures, as well as output reports, are being redefined. In the interim, this report represents the MMT execution status of projects during the transaction period. In this transaction report, the narrative work status and the project slippage have been deleted. It is expected that both will be reinstated in the future but will be based on the total MMT work effort rather than each fiscal year task.

Composition of the Report

This MMT Project Execution Report provides the status of 516 active projects which have a total authorized cost of \$272.1 million. Total MMT program statistics of all the active projects are also included. The report is compiled, edited, and published for HQ AMC by the Production Engineering Division of the Army Industrial Base Engineering Activity (IBEA) in accordance with AR 700-90, paragraph 3-4j(1).

Distribution of this report is extended to Army materiel developers and users and to counterparts in the Navy and the Air Force. Inquiries on the detailed technical aspects of any individual project may be answered by the MMT Program representative of the action Command under which the project was completed or is being executed. Inquiries or suggestions concerning this report or other facets of the MMT Program may also be directed to the Production Engineering Division of IBEA.

The report is composed of three major sections:

- a. Projects Added 2nd Half, CY85 - A list divided by organization of all projects funded during the second half of CY85. Included is a narrative of the problem for each project.
- b. Final Status Reports Received During 2nd Half, CY85 - A list divided by organization of all projects for which final status reports were received during the second half of CY85.
- c. Summary Project Status Report - These reports are divided by organization and include a summary of funding by fiscal year for each active project.

Status Report Submissions

Figure 1 below summarizes the situation concerning delinquent status reports and final status reports without technical reports.

STATUS REPORT (RCS DRCMT 301) SUBMISSIONS

COMMAND	*301 REPORTS REQUIRED	*301 REPORTS SUBMITTED	NUMBER AND (%) OF DELINQUENT 301 REPORT	NUMBER OF FINAL 301 REPORTS	NUMBER OF TECH RPTS SUBMITTED W/FINAL STATUS REPORTS	NUMBER AND (%) OF DELINQUENT TECHNICAL REPORTS
AMETA	9	9	0 0%	1	N/A	N/A
DESCOM	14	10	4 24%	1	0	1 100%
LABCOM	33	19	14 35%	4	0	4 100%
TMDE	5	5	0 0%	5	0	5 100%
MTL	9	6	3 23%	0	N/A	N/A
TECOM	5	5	0 0%	0	N/A	N/A
AVSCOM	54	40	14 22%	9	0	9 100%
CECOM	40	40	0 0%	1	1	0 0%
MICOM	25	24	1 4%	2	0	2 100%
TACOM	54	38	16 28%	6	4	2 33%
AMCCOM (AMMO)	153	123	30 18%	19	6	13 68%
AMCCOM (WPNS)	112	109	3 2%	15	8	7 47%
TROSCOM	5	5	0 0%	0	0	0
TOTAL	518	433	85 16%**	63	19	43 68%

Figure 1

*Does not include FY86 projects which were recently funded and which did not require a status report.

**Delinquency rate reflects a one week extension of the cutoff date. Actual delinquency as of the regular cutoff date was 181 reports or 31%.

According to this figure, there was a 16% delinquency in receipt of status reports, or 35 reports not submitted by the cutoff date.

Accuracy of MMT summary information for management depends on a complete submission of all the project status reports for each Command. Any delinquency creates a void in the information presented in the compiled report. Therefore, steps are taken to remind the Commands of the regulatory requirements for the submission of these reports. In December 1985, a call letter was mailed out to each SUBMACOM. Enclosed with this letter was a computerized listing of the specific projects for which a status report was required for this reporting period. Also, phone call follow-up was made in March to remind the MSCs of the due date of March 14. When the additional steps were first taken in 1981, the delinquency rate dropped. However, since that time there has been no evidence of any additional, consistent improvement. During this period a delinquency rate of 16% was experienced. The significant changes that the program has undergone, as well as the 60% cut which has recently been experienced in the FY87 program, are felt to be the main factors for the increase in the delinquency rate. Delinquency and timeliness are areas that must be improved in order to insure a useful review of the progression of the MMT Program.

There has always been a requirement that a technical report be prepared for each project (i.e., each fiscal year of funding). The technical report is an accepted vehicle, and in some cases the only vehicle, for technology transfer. For this period, as noted in Figure 1, 63 final status reports were received. Sixty-eight percent, or 43 of these reports, did not have a technical report. This delinquency rate of 68% is even higher than the previous period's delinquency rate of 55%. This continued high rate, to a certain extent, is a reflection of the fact that 55% of the projects which were closed out were funded with R&D funds (FY83 and later). The significance of R&D is that each fiscal year of funding does not necessarily result in a deliverable for which a technical report is easily developed. In many cases, it is viewed and executed as a level of effort with technical report documentation developed at whatever point it is technically reasonable to do so, rather than automatically at the end of the expenditure of each FY of funding. With the redefinition of MMT procedures, attempts are being made to formulate a technical report policy which is sensitive to fiscal year level of effort, yet responsive to the need for tech transfer documentation prior to the overall completion of extended work efforts. In addition, future issues of this document which address delinquent technical reports will likewise use a different basis for calculation in order to reflect the change in the "normal" way of doing MMT business resulting from the R&D funding. The 63 projects for which final status reports were received during this period can be found in a separate section on page 29.

Program Summary

Manufacturing Methods and Technology (MMT) projects and efforts are major elements of the Army's Manufacturing Technology (MANTECH) Program. AR 700-90 succinctly describes the MANTECH objective as the improvement of the industrial readiness and efficiency of the production base for Army materiel. Further defined objectives are stated in the Statement of Principles for the DOD Manufacturing Technology Program. This Statement, originating at the Deputy Under Secretary of Defense level, not only establishes ground rules for the Program but highlights the level of emphasis that the Program receives.

To attain the objectives described in the Statement of Principles, the Army, prior to FY83, funded discrete work units called "Projects" on a yearly basis. These projects, identified by a seven-digit number, contained work requests, which upon completion would result in an end product whose technical transfer could be effected. At times, in order to have a total work package which was implementable, (i.e., which could achieve the payback for which the work was funded) the scope was of such a magnitude that total funding in one fiscal year could be an inefficient use of resources.

In this event, the total work was multi-year funded, (i.e., be more than one project, each having a technically transferrable end product). These total implementable work units were called "Efforts". These efforts could consist of many projects or just be one project, depending on the amount of work required to achieve the implementable technical goal. Efforts are identified by a four-digit number which is the same as the last four digits of a project or projects which make up the effort.

For FY83 through FY85 the conversion from the Procurement Account to the R&D account will result in some administrative changes. An MMT "project" will, under R&D parlance, be considered a "task". Also, to accommodate the R&D obligational goals, these yearly funded tasks will likely become level of effort work rather than discrete, stand alone work units which result in end products whose technical transfer could be effected. Multi-year funding will probably become more prevalent in leading to the completion of an implementable work "effort".

A breakout of the active projects is shown in Figure 2. On a fiscal year basis, this chart shows there are 516 active "projects". However these 516 active projects constitute only 306 active technical work "efforts". Future reports will eliminate the misconceptions that each project (i.e. FY of funding) is a separate technical entity.

ACTIVE PROJECTS BY FISCAL YEAR

ORGANIZATION	76	77	77	78	79	80	81	82	83	84	85	86	TOTAL
AMETA/DESCOM				1	1	1	2	4	0	3	5	7	24
LABCOM					1		3	3	0	3	14	12	36
MTL							1	1	1	2	3	5	13
TECOM							1	1	1	1	1	1	6
AVSCOM							2	6	4	17	16	10	55
CECOM					1	2	4	2	2	6	12	10	39
MICOM								1	0	2	10	10	23
TACOM							2	8	11	7	14	9	51
AMCCOM (AMMO)	1			1	1	2	7	18	9	35	45	30	149
AMCCOM (WEAPONS)	1				2	6	8	21	10	23	23	20	114
TROSCOM										1	2	3	6
TOTAL	2	0	0	2	6	11	30	65	38	100	145	117	516

2nd CY84													
TOTAL	2	1	2	2	10	18	50	93	59	130	149	0	516

Figure 2

MMT PROGRAM

PROJECTS ADDED 2ND HALF, CY85

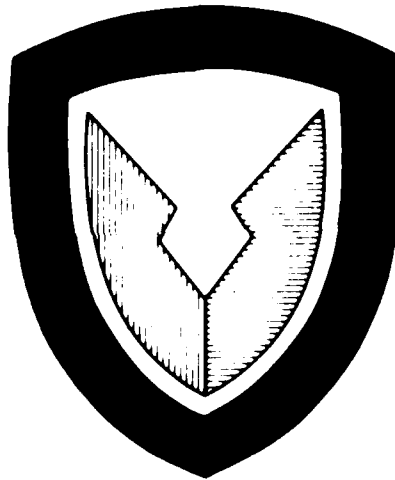

PROJECTS ADDED IN 2ND HALF, CY85

AMETA

C 86 5052

ARMY ENCRG DESIGN HANDBOOKS F/PRODUCTION SUPPORT

TECHNICAL SCIENTIFIC AND ENGINEERING DATA IS CONTINALLY BEING GENERATED WITHIN THE ARMY AND NEEDS TO BE COLLECTED IN APPROPRIATE DOCUMENTS.

DESCOM

C 86 2002

LETTERKENNY EVAL ANALYSIS + PLANNING (LEAP) PROGRAM

THE LACK OF UP-TO-DATE MANUFACTURING AND PROCESSING TECHNOLOGY HAS RESULTED IN HIGHER OVERHAUL/REBUILD COSTS AND ALSO IN LIMITATIONS TO BOTH PRESENT AND FUTURE MISSION NEEDS THROUGHOUT THE DEPOT.

C 86 3001

POWER + INERTIA SIMULATOR (PAISI) COMBAT VEHICLE TESTING

THE TEST TRACK AT THE MAINZ ARMY DEPOT IS A PRIMARY BOTTLENECK IN THE REBUILD MISSION. ALTHOUGH THE TEST TRACK IS OVERLOADED AN INCREASE IN THE WORKLOAD IS PROJECTED.

C 86 6003

CORPUS CHRISTI ARMY DEPOT INTEGRATED MODERNIZATION PROGRAM

THE LACK OF STATE-OF-THE-ART MANUFACTURING AND PROCESSING TECHNOLOGY HAS RESULTED IN HIGHER OVERHAUL REBUILD COSTS AND IN LIMITATIONS TO BOTH PRESENT AND FUTURE MISSION NEEDS.

F 86 6100

ROBOTIC REPAIR OF PRINTED CIRCUIT BOARDS - PHASE III

MANUAL METHODS FOR REPAIRING MULTILAYER PRINTED CIRCUIT BOARDS ARE INEFFICIENT AND COSTLY. A RAPIDLY INCREASING REPAIR AND TEST WORKLOAD OF HIGH TECHNOLOGY PRINTED CIRCUIT BOARDS IS SCHEDULED FOR FUTURE SYSTEMS.

C 86 7004

AUTOMATED ENGINE BLOCK MACHINING

THE CURRENT METHOD OF MACHINING AND INSPECTING ENGINE BLOCKS IS SLOW AND LABOR INTENSIVE. BORING LARS ARE SET UP FOR EACH HOLE TO BE MACHINED AND ALL INSPECTION IS DONE BY HAND.

PROJECTS ADDED IN 2ND HALF, CY85
(CONTINUED)

C 86 7007

ENGINE CONTAINER SEALING-CAM

CURRENTLY ENGINE CONTAINERS ARE CLOSED AND TIGHTENED MANUALLY. IN ONE CASE THIS REQUIRES HAND TIGHTENING 32 BOLTS THREE TIMES EACH IN A SPECIFIC SEQUENCE.

LABOR

F 86 5119

PRECISION HIGH QUALITY X-RAY MASKS

VHSIC R AND D PROGRAMS WILL DEVELOP PROCESS FOR SUBMICRON HIGH SPEED SIGNAL PROCESSORS. POOR YIELD AND LACK OF PRODUCTION TYPE EQUIPMENT RESULTS IN VERY HIGH COST AND LOW RELIABILITY.

F 86 5102

EXJAM BATTERY MANUFACTURING TECHNOLOGY-PHASE III

PRESENT R AND D MODELS OF UNATTENDED EXPENDABLE JAMMER RESERVE POWER SUPPLY (UEJPS) ARE HAND MADE 1 OR 2 AT A TIME. UNLESS FABRICATION/ASSEMBLY ARE PRODUCTION ENGINEERED, LABOR COSTS WILL MAKE THE BATTERY PROHIBITIVELY EXPENSIVE.

F 86 5174

AUTO SPUTTERING PROCESS CONTROL FOR ZNE

GAS MIXTURE, ZNE PURITY + SPUTTERING PARAMETERS ARE MANUALLY MONITORED USING A MASS ANALYZER. CORRECTIONS IN FLOW + DEPOSITION PROCESSES ARE SLOW AND PERFORMED AFTER OCCURRENCE.

F 86 5107

TUNABLE MILLIMETER WAVE INP GUNN SOURCES

TUNABLE MILLIMETER WAVE INP GUNN SOURCES ARE CURRENTLY HAND MADE IN THE LABORATORY BECAUSE THERE ARE NO PROCESSES FOR FABRICATION AND TESTING IN VOLUME.

F 86 5193

PROCESS ADJUSTMENTS FOR VIBRN STRESS ON ELECT CIRCUIT METALS

METALS USED IN ELECTRIC CIRCUITS ARE CORRUDED BY THE ENVIRONMENT + SOME SUBSTITUTE MATERIALS ARE EXPENSIVE.

PROJECTS ADDED IN 2ND HALF, CY85
(CONTINUED)

F 86 5209

HIGH SPEED DIGITAL TO ANALOG CONVERTER (VHSIC)

THE RANGE OF RADARS AND THE SPEED OF DIRECT WRITE ELECTRON BEAM LITHOGRAPH ARE LIMITED BY THE AVAILABILITY OF HIGH SPEED, HIGH RESOLUTION DIGITAL TO ANALOG CIRCUITS.

F 86 5248

ADVANCED WAFER IMAGING SYSTEM (VHSIC)

VHSIC REQUIREMENTS FOR RESOLUTION AND INTER-LEVEL ALIGNMENT ACCURACY CANNOT BE MET WITH CURRENT WAFER PATTERNING SYSTEMS. RESOLUTION OF 1.0 MICROMETERS AND OVERLAY ALIGNMENT OF 0.1 MICROMETER ARE NEEDED.

H 86 5251

AUTO SEM WAFER INSPECTION AND METROLOGY SYS (VHSIC)

HUMAN INTERPRETATION OF SCANNING ELECTRON MICROSCOPE IMAGES OF INTEGRATED CIRCUIT PATTERNS IS LABORIOUS AND PRONE TO ERROR.

F 86 5272

TAPE AUTOMATED BONDING (VHSIC)

PRESENT TAB PROCESSES ARE NOT COMPATIBLE WITH VHSIC CHIP I/O COUNTS, SMALL PAD SIZES AND COMPLEXITY.

H 86 5273

FIRST LEVEL PACKAGING AND INTERCONNECTIONS (VHSIC)

NEITHER THE GRID ARRAY CHIP CARRIER NOR THE PERIMETER CHIP CARRIER IS CURRENTLY VHSIC COMPATIBLE. THERE IS NO ADVANCED TECHNIQUES FOR THEIR MANUFACTURE.

F 86 5274

MULTICHIP PACKAGES (VHSIC)

MANUFACTURING FACILITIES ARE EXTREMELY LIMITED FOR THE PRODUCTION OF VHSIC COMPATIBLE MULTICHIP CERAMIC PACKAGES.

F 86 5281

E-BEAM AND X-RAY RESISTS (VHSIC)

THERE IS NO PRODUCTION SOURCE FOR E-BEAM OR X-RAY RESISTS FOR USE IN THE VHSIC INSERTION PROGRAM. USE OF E-BEAM LITHOGRAPHY MACHINES BUILT UNDER VHSIC SPONSORSHIP WILL BE SEVERELY LIMITED IF THESE RESISTS ARE NOT COMMERCIALY AVAILABLE.

PROJECTS ADDED IN 2ND HALF, CY85
(CONTINUED)

MTL

M 86 5001

DIAPHRAGM TEST MACHINE FOR MLRS FLUIDIC GENERATOR

M445 FUZE FABRICATION IS EXPERIENCING 50 PERCENT REWORK. THIS REWORK IS A DIRECT RESULT OF BEING UNABLE TO ASSURE THE VIABILITY OF THE DIAPHRAGM OF THE GENERATOR OTHER THAN BY ACTUALLY ASSEMBLING IT INTO A COMPLETE GENERATOR.

M 86 5002

PATRIOT FUZE FLEX FIXTURE/ACCEPTANCE TEST LEVELS

OVERTESTING OF PATRIOT FUZE EAS DURING MANUFACTURING ACCEPTANCE TESTING IS CREATING THE POTENTIAL FOR FATIGUE FAILURES IN STOCKPILED PATRIOT MISSILES.

M 85 5013

M732A FUZE POWER SUPPLY LEAK TEST SET

ONE MILLION M732 FUZES IN STOCKPILE HAVE TENDENCIES FOR BATTERY AMPULES TO CORRODE. ELECTROLYTE LEAKAGE ULTIMATE DESTROYS THE FUZE PROX CAPABILITY. A COST EFFECTIVE RELIABLE MEAN OF SORTING FUZES WORLD-WIDE IS REQUIRED.

M 86 5013

M732A FUZE POWER SUPPLY LEAK TEST SET

ONE MILLION M732 FUZES IN STOCKPILE HAVE TENDENCIES FOR BATTERY AMPULES TO CORRODE. ELECTROLYTE LEAKAGE ULTIMATE DESTROYS THE FUZE PROX CAPABILITY. A COST EFFECTIVE RELIABLE MEAN OF SORTING FUZES WORLD-WIDE IS REQUIRED.

M 86 6350

MANUFACTURING TESTING TECHNOLOGY

DESTRUCTIVE AND CERTAIN CONVENTIONAL NON-DESTRUCTIVE TESTING TECHNIQUES ARE RESPECTIVELY UNSUITED AND INADEQUATE OR HARD TO BE ADAPTED TO ON-LINE PRODUCTION TESTING USAGE.

M 86 6390

PROGRAM IMPLEMENTATION AND INFORMATION TRANSFER

THE SUCCESS OF THE MMT PROGRAM IS VERY DEPENDENT ON WHETHER THE RESULTS OF MMT WORK GET IMPLEMENTED. THIS IN TURN IS DEPENDENT ON WHETHER INFORMATION CONCERNING THE MMT TECHNOLOGY IS MADE AVAILABLE AND USED BY CONCERNED PARTIES.

PROJECTS ADDED IN 2ND HALF, CY85
(CONTINUED)

TECOM

C 86 5071

TECOM PRODUCTION METHODOLOGY ENGINEERING MEASURES

ARTILLERY, VEHICLE AND ELECTRONIC CONVENTIONAL TEST CAPABILITIES NEED TO BE UPGRADED TO PROVIDE MORE TIMELY ACCURATE TEST DATA FOR THE TEST AND EVALUATION PROCESS.

AVSCOM

I 86 7384

COMPOSITE ENGINE GEARBOX HOUSING

CONVENTIONAL GEAR HOUSINGS CONSISTING OF MAGNESIUM EXHIBIT LOW MODULUS, LOW FATIGUE STRENGTH, AND SUSCEPTIBILITY TO CORROSION.

I 86 7416

ADVANCED TURBINE AIRFOIL CASTINGS FOR LONG LIFE

TURBINE AIRFOILS ARE DESIGNED TO A STRESS RUPTURE LIMIT WHETHER COOLED OR UNCOOLED. THIS LIMIT IS LOW DUE TO EQUIAXED CAST SUPERALLOY MATERIALS CURRENTLY USED AND THEIR INHERENT GRAIN BOUNDARY LIMITATIONS.

I 86 7417

LOW COST DISKS BY CAP

POWDER METAL DISKS FORM A SIGNIFICANT PART OF THE ENGINE COST DUE TO EXPENSIVE TOOLING/DIE REQUIREMENTS AND HIGH PRESSURE CONSOLIDATION EXPENSE.

I 86 7456

LOW COST TOOLING FOR AIRFRAME COMPONENTS

HIGH COST METAL TOOLING CONCEPTS OR EXPENSIVE AUTOCLAVE CURING APPROACHES HAVE BEEN USED WHICH RESULT IN EXTENDED CURE CYCLES AND POOR ENERGY CONSERVATION.

I 86 7472

SURFACE HARDENING GEARS BY LASER

HELICOPTER TYPE GEARS HAVE BEEN SUCCESSFULLY SURFACE HARDENED BY LASER. THE PROCESS NEEDS TO BE PRODUCTIIONIZED AND EXPANDED FOR USE ON GEARS SUSCEPTIBLE TO HEAVY LOADS IN ORDER TO OBTAIN HIGHEST COST BENEFITS.

PROJECTS ADDED IN 2ND HALF, CY85
(CONTINUED)

1 86 7473

FIBER REINFORCED THERMOPLASTIC STRUCTURES

CURRENT AIRFRAME SECONDARY STRUCTURES ARE CONSTRUCTED FROM SHEET METAL OR THERMOSETTING COMPOSITES. SHEET METAL CONSTRUCTION REQUIRES MANY DETAIL PARTS AND LABOR, AND THERMOSETTING COMPOSITES REQUIRES EXPENSIVE STORAGE, FORMING AND CURING STEPS.

1 86 7474

SINGLE CURE TAIL ROTOR

THE CURRENT METHOD OF CURING COMPOSITE TAIL ROTOR BLADES IS TO PRECURE EACH MAJOR DETAIL SEPARATELY AND THEN BOND THEM TOGETHER AS A FINAL ASSEMBLY. THIS APPROACH IS NECESSARY IN ORDER TO PROVIDE A STABLE ELEMENT FOR FORMING AND HOLDING NUMEX CURE.

1 86 7487

ADVANCED CORROSION RESISTANT BEARINGS

CORROSION PRONE BEARINGS IN HELICOPTER ENGINE AND DRIVE TRAINS IS THE MAIN REASON FOR REPLACEMENT OF BEARINGS AT OVERHAUL.

1 86 7548

EROSION PROTECTION FOR COMPRESSOR AIRFOILS

HARDFACE COATINGS APPLIED TO COMPRESSOR AIRFOILS SEVERELY DEGRADE FATIGUE PROPERTIES.

1 86 7549

ECM OF T700 COMPRESSOR BLISKS

BLISK AIRFOILS ARE CURRENTLY ROUGH + FINISHED MACHINED WITH CONSIDERABLE PRODUCTION TIME SPENT IN ADDITION FOLLOWED BY HAND-BENCHING.

CECLM

2 86 3090

GAINASP LIGHT EMITTING DIODE PACKAGING

THE PRESENT METHOD OF FABRICATION IS LOW VOLUME AND LABOR INTENSIVE. LEOS ADAPTABLE TO MILITARY SYSTEMS ARE AVAILABLE BUT INDUSTRY WILL NOT DEVELOP WITH ITS OWN FUNDS BECAUSE OF LIMITED PRODUCTION PROCUREMENT.

PROJECTS ADDED IN 2ND HALF, CY65
(CONTINUED)

Z 86 3094

COMMUNICATIONS TECHNOLOGY TECHMOD FOR JTIDS

COMMUNICATIONS EQUIPMENT IS MANUFACTURED USING LABOR INTENSIVE, LOW VOLUME PROCESSES. MACHINES ARE OLD AND UNAUTOMATED. NEW METHODS, PROCESSES AND EQUIPMENT ARE NEEDED.

Z 86 3108

CONTROL OF GAAS BUULE DIAMETER

THE MANUAL CONTROL OF LEC GAAS SINGLE CRYSTAL BUULE GROWTH RESULTS IN WIDE BUULE DIAMETER VARIATIONS, WASTED MATERIAL, WASTED UNIFORMITY GRINDING LABOR AND IS A SOURCE OF DEFECTS.

Z 86 3111

AUTOMATIC ADJUSTMENT OF MICROWAVE CIRCUITS

PRESENT METHODS FOR IMPEDANCE MATCHING ARE LABOR INTENSIVE. TECHNIQUES FOR AUTOMATIC ADJUSTMENT AND MATCHING INTERFACE CIRCUIT IMPEDANCES WILL BE ESTABLISHED.

Z 86 3139

AUTOMATED INTERVEN TRANSFER OF GLASS PREFORMS

DEWAR FABRICATION REQUIRES MUCH HAND LABOR AND MOVING MATERIALS FROM PROCESS TO PROCESS CAN INTRODUCE CONTAMINATION AND PRODUCT NONUNIFORMITIES.

F 86 5059

LINEAR RESONANCE COOLERS - PHASE I (NVEUL)

SECOND GENERATION FLIR'S WILL EMPLOY MAGNETIC SUSPENSIONS IN THE CRYOGENIC COOLERS. MAINTAINING CRITICAL SUSPENSION TOLERANCES IN PRODUCTION WILL REQUIRE DEVELOPING EXTENSIVE QUALITY CONTROL PROCEDURES.

F 86 5180

MMT FOR METAL DEWAR AND UNBUNDED LEADS (NVEUL)

THE GOLD WIRE BUNDED CONNECTIONS ARE MADE BY HAND WHICH IS A TEDIOUS AND EXPENSIVE PROCESS. THE GLASS STEM IS HAND FASHIONED AND IS PRONE TO DAMAGE.

F 86 7000

LASER POLARIZERS (NVELL)

US SOURCES HAVE NOT BEEN ABLE TO CONTROL IMPORTANT PARAMETERS IN MANUFACTURING HIGH POWER DENSITY LASER POLARIZERS. THESE POLARIZERS MAKE THE EMITTED ENERGY FROM A LASER TARGET DESIGNATOR UNIDIRECTIONAL.

PROJECTS ADDED IN 2ND HALF, CY85
(CONTINUED)

2 86 9289

AUTOTEST OF MICROWAVE DEVICE WAFERS (CAM)

THE NEED TO WAIT UNTIL PACKAGING IS COMPLETE BEFORE TESTING MICROWAVE DEVICES (DIODES, TRANSISTORS) RUNS UP THE COST BECAUSE PACKAGING COST IS APPRECIABLE. BUT TESTING OF DEVICE CHIPS CANNOT NOW BE DONE.

2 86 9290

AUTOMATIC MICROWAVE SEMICONDUCTOR DEVICE TESTING

PRESENT PRODUCTION TESTING METHODS FOR HIGH FREQUENCY DEVICES ARE INADEQUATE. DEVICE CHARACTERIZATION IS SLOW AND EXPENSIVE, AND IS MOSTLY DONE BY HAND. SMALL SIGNAL READINGS CAN BE TAKEN BUT NOT LARGE SIGNAL READINGS.

MICLM

3 86 1066

SEMIADDITIVE SINGLE + MULTILAYER CIRCUITRY

THICK FILM CIRCUITRY USES THE SCREEN AND FIRE PROCESS ON CERAMIC SUBSTRATES. A SEMIADDITIVE FINE-LINE PROCESS, ELECTROLESS COPPER PLATING, USED ON FIBERGLASS AND CERAMIC SUBSTRATES WILL PROVIDE BETTER FINE-LINE AND A COST REDUCTION.

3 86 1095

AUTOMATIC SEALING OF HYBRID PACKAGES

HYBRID CIRCUIT ASSEMBLIES FOR MILITARY USE REQUIRE HERMETIC SEALING WHICH IS ACCOMPLISHED BY SOLDERING OR WELDING. BOTH TECHNIQUES REQUIRE AN OPERATOR, INVOLVING LABOR INTENSIVE HANDLING AND SET UP ERRORS.

3 86 1120

DETECTOR GRADE CADMIUM SULFIDE

CURRENTLY AVAILABLE PROCESSES FOR PRODUCING CADMIUM SULFIDE CRYSTALS OFTEN RESULT IN SMALL BOULE SIZES THAT LOSE CRYSTALLINITY, LARGE RESISTIVITY VARIATIONS, AND HIGH DENSITY OF CRYSTALLINE FLAWS.

3 86 1134

RF/LASER HARDENING OF DUMES FOR DUAL MODE SYSTEMS

CURRENT MISSILE DUMES ARE NOT HARDENED TO RFI AND LASER THREATS WHILE RETAINING THE ABILITY TO OPERATE IN SPECIFIC SPECTRAL BANDS.

PROJECTS ADDED IN 2ND HALF, CY85
(CONTINUED)

3 86 1144

ELECTROFORMED ASPHERIC METAL MIRROR

A NEW R+D PROCESS IS AVAILABLE TO FABRICATE PRECISION METALLIC MIRRORS. THIS PROCESS INCORPORATES THE USE OF PRECISION MANDRELS WHICH ARE DIFFICULT TO MANUFACTURE. MANY MANDRELS ARE REQUIRED FOR HIGH RATE PRODUCTION.

3 86 1147

OPTICAL FIBER WINDING

THE WINDING OF A FIBER ON A PAY-OUT BUBBIN IS A COSTLY, PRECISION TASK. THIS IS CURRENTLY NOT AVAILABLE AS A HIGH-SPEED PRODUCTION PROCESS FOR THE DELICATE FIBER OPTIC CABLE.

3 86 1148

MILLIMETER WAVE MONOLITHIC/INTEGRATED RECEIVER

NO PRODUCTION CAPABILITY CURRENTLY EXISTS FOR GAAS MILLIMETER WAVE MONOLITHIC/INTEGRATED RECEIVERS.

3 86 1150

LITHIUM NIOBATE LASER Q-SWITCHES

LITHIUM NIOBATE CRYSTALS + CRYSTAL ANTIREFLECTIVE COATINGS CURRENTLY AVAILABLE ARE INADEQUATE FOR OPTICAL Q SWITCH APPLICATION IN Nd/YAG LASER DESIGNATORS + RANGEFINDERS.

3 86 2018

AUTOMATIC TEST OF PRINTED WIRE BOARDS

MANUAL INSPECTION IS A MAJOR COST DRIVER IN PRINTED WIRING BOARD (PWB) MANUFACTURING. INCREASING BOARD COMPLEXITY, FINE LINE RESOLUTION, AND MINIATURIZATION HAS ACCELERATED THE TREND TOWARD HIGHER INSPECTION COSTS.

3 86 2021

CIM TECHNIQUES FOR MISSILE HYBRID ASSEMBLIES

MILITARY HYBRID CIRCUITS ARE COSTLY AND HAVE LOW YIELD BECAUSE THEY ARE MADE BY LOW VOLUME METHODS. THEY ALSO HAVE HIGH PERFORMANCE REQUIREMENTS.

TACLM

4 86 4001

MFG FOR CORROSION PREVENTION IN TACTICAL VEHICLES

CURRENTLY THE ARMY HAS SEVERE CORROSION PROBLEMS WITH ITS TACTICAL TRUCK FLEET. ACHIEVING CORROSION RESISTANCE THROUGH THE APPLICATION OF RUSTPROOFING COMPOUNDS CONTRADICTS THE NDC REQUIREMENT FOR VEHICLES WITH CHEMICAL AGENT RESISTANT COATINGS.

PROJECTS ADDED IN 2ND HALF, CY65
(CONTINUED)

4 86 4008

COMPOSITE DRIVE SHAFTS

A LARGE TRUCK DRIVE SHAFT NEEDS A CENTER BEARING FOR SUPPORT. THE BEARING IS EXPENSIVE AND MUCH MACHINING ON THE SHAFT IS PERFORMED TO INSURE PROPER FIT AND FUNCTION. A COMPOSITE SHAFT WOULD END THESE PROBLEMS BUT NO RELIABLE MASS PDN PROCESS EXISTS.

4 85 4086

ADVANCED CAST ARMOR

SOME ADVANCED ARMOR SYSTEMS ARE EXPENSIVE BECAUSE THEY REQUIRE COSTLY MACHINING AND FABRICATION METHODS.

4 85 4087

EXPLOSIVE COMPACTION OF CERAMICS

THE COSTLY HOT PRESSING COMPACTION PROCESSES AND FINISH MACHINING PROHIBITS THE USE OF HIGH PERFORMANCE CERAMICS IN MANY APPLICATIONS.

4 86 5068

NEW ANTI-CORROSIVE MATERIALS

METALLIC COMPONENTS ARE DETERIORATED BY THE ENVIRONMENT.

4 86 6057

ABRAMS (M1) COMBAT VEHICLE

MATERIALS AND MANUFACTURING PROCESSES EMPLOYED IN THE MFG OF THE M1 CAN BE IMPROVED BY INCORPORATING NEW TECHNOLOGIES TO THE CURRENT SYSTEM. THIS WILL ENABLE THE M1 TO BE PRODUCED MORE ECONOMICALLY.

4 86 6079

AGT-1500 ENGINE

THE NEED TO REDUCE COST AND IMPROVE PERFORMANCE OF THE AGT-1500 TURBINE ENGINE REQUIRES NEWER AND MORE INNOVATIVE MANUFACTURING TECHNOLOGY.

4 86 6090

TEAC DEPT ANALYSIS OF RESOURCES AND TECHNOLOGY (DART)

THE AGING FACILITY AND OUTDATED TECHNIQUES HAVE RESULTED IN AN INEFFICIENT OPERATION AND SLOW DELIVERIES.

PROJECTS ADDED IN 2ND HALF, CY85
(CONTINUED)

4 86 6107
IMPROVED MBT TRACK

INCREASED VEHICLE PERFORMANCE REQUIREMENTS NECESSITATE HIGHER PERFORMANCE TRACKS THAN THOSE AVAILABLE TODAY. TO IMPLEMENT NEW METAL COMPOSITE, HIGHER STRENGTH FERROUS ALLYS, AND TITANIUM NEW MANUFACTURING PROCESSES MUST BE ESTABLISHED.

4 86 6123
CERAMIC TURBOCHARGER ROTOR

SMALL SILICON CARBIDE TURBOCHARGER ROTORS HAVE BEEN FABRICATED WITH A PROPRIETARY PROCESS IN INDUSTRY AND WERE SUCCESSFUL; HOWEVER, THE PROCESS CAN NOT BE APPLIED DIRECTLY TO ARMY COMPONENTS BECAUSE OF THE PROPRIETARY LIMITATION AND SCALE PROBLEMS.

4 86 6125
WELD PROCESS PLANNING AND CONTROL

PLANNING, MONITORING, AND INSPECTION OF THE WELDING PROCESS ARE EXPENSIVE, TIME CONSUMING, AND CAUSE PRODUCTION DELAYS WHEN A QUALITY PROBLEM IS SUSPECTED.

AMCCOM (AMMU)

5 86 0905
MFG OF IMPREGNATED CHARCOAL (WHETLERITE)

ONLY ONE COMPANY (CALGON, INC) SUPPLIES WHETLERIZED CHARCOAL AND CONSIDERS ITS PROCESS PROPRIETARY. THIS MATERIAL IS VITAL FOR NEW PROTECTIVE MASKS. A PROCESS MUST BE DEVELOPED TO DIVERSIFY PRODUCTION BASE AND REDUCE COST THROUGH COMPETITION.

5 86 0918
MODERNIZATION OF FILTER PENETRATION EQUIPMENT

CURRENTLY, ALL PROTECTIVE PARTICULATE FILTERS ARE TESTED WITH THREE TYPES OF EQUIPMENT. THIS EQUIPMENT IS OBSOLETE, INEFFICIENT, AND UNRELIABLE.

5 86 0923
VELOCITY TRAVERSE MAPPER FOR CHARCOAL FILTERS

GAS FILTERS MUST BE MONITORED DURING THE MANUFACTURING PROCESS TO ASSURE THE INTEGRITY OF THE CHARCOAL BED BEFORE ASSEMBLY.

PROJECTS ADDED IN 2ND HALF, CY85
(CONTINUED)

- 5 86 0925
PROTECTIVE MASK LEAKAGE TESTING
- CURRENT GAS MASK TESTER DOES NOT SIMULATE THE ACTUAL FIELD USE AND IS NOT SENSITIVE ENOUGH TO DETECT SMALL LEAKS
- 5 86 0926
MFG METHODS + TECH FOR XM22 CHEMICAL AGENT ALARM SYSTEM
- A CHEMICAL AGENT ALARM SYSTEM, XM22 IS CURRENTLY UNDER DEVELOPMENT TO PROVIDE CAPABILITY OF CHEMICAL DEFENSE. COMPLEX COMPONENTS IN THE ALARM ARE DIFFICULT TO PRODUCE AND LACK AVAILABLE HIGH PRODUCTION TECHNIQUES.
- 5 86 1295
MODERNIZATION OF CHARCOAL FILTER TEST EQUIPMENT
- CHARCOAL FILTER TESTING EQUIPMENT NEEDED TO PROVIDE TESTING CAPABILITY FOR VARIOUS CHEMICAL AGENTS DOES NOT EXIST.
- 5 86 1402
120MM COMBUSTIBLE CASE BODY REMOVAL SYSTEM
- A POTENTIAL SAFETY PROBLEM CURRENTLY EXISTS IN THE COMBUSTIBLE CASE MOLDING AREA ON THE 120MM LINE. THE REMOVAL OF THE CASE BODY FROM THE MALE PRESSING MANDREL IN THIS AREA IS A HAZARDOUS STEP IN THE PRODUCTION OF THE 120MM CASE BODIES.
- 5 85 1725
ELECTRICAL SENSITIVITY OF INITIATING EXPLOSIVES
- FROM THE VERY BEGINNING OF ORDNANCE WORK, THE INDUSTRY HAS BEEN PLAGUED BY MANY COSTLY AND DANGEROUS PROCESS AND STORAGE EXPLOSIVE ACCIDENTS WITH INITIATING EXPLOSIVES. MANY OF THESE INCIDENTS HAVE NEVER BEEN PROPERLY EXPLAINED.
- 5 86 1805
IMPROVED PROD VIBRATION TESTS - H732 PIP FUZE + COMPONENT
- PROJECT WILL EXPAND THE CAPABILITY OF A 3-D VIBRATION SYSTEM BUILT UNDER MMT PROJECTS 5 79, 80, 81 3961. TEST DEFICIENCIES WILL BE ELIMINATED BY EXACT DUPLICATION OF FUZE TRI-AXIAL WAVEFORMS.
- 5 86 4273
AUTOMATED PRODUCTION OF STICK PROPELLANT
- PRESENT BATCH TECHNIQUES FOR STICK PROPELLANT MFG INVOLVE MUCH HAND LABOR THEREBY RESULTING IN LIMITED PRODUCTION CAPACITY, HIGH COST, AND HAZARD EXPOSURE.

PROJECTS ADDED IN 2ND HALF, CY85
(CONTINUED)

- 5 86 4358
AUTO LINE PROCESS INSPECT OF NEW EEDS (ALPONE)
INSPECTION OF BRIDGE WIRE ON ELECTRIC DETONATORS.
- 5 86 4406
IMPROVING THE YIELD OF HMX DURING RDX NITROLYSIS
THE CURRENT MANUFACTURING PROCESS FOR HMX IS INEFFICIENT IN THAT YIELDS OBTAINED ARE STILL LESS THAN THEORETICAL.
- 5 86 4427
EVALUATE ON-LINE CHEMICAL ANALYZERS FOR NQ PLANT
A NITROGUANIDINE MFG FACILITY IS BEING CONSTRUCTED AT SUNFLOWER AAP. MMT 5 78 4447 INDICATED THE FEASIBILITY OF AUTOMATED ON-LINE INSTRUMENTATION FOR PROCESS STREAM CHEMICAL ANALYSIS. HOWEVER THE RELIABILITY HAS NOT BEEN DEMONSTRATED.
- 5 86 4449
PROCESS IMPROVEMENT FOR COMP C-4 EXPLOSIVES
THE EXISTING FACILITIES WHICH ARE COMMON TO THE MANUFACTURE OF COMP C-4 AND THE OTHER RDX COMPOSITION WOULD LIMIT THE AVAILABILITY OF THESE ITEMS BELOW THEIR MOB REQUIREMENTS.
- 5 86 4473
AUTOMATED LEAK DETECTION OF WP MUNITIONS
THE CURRENT METHOD OF HEATING THE WHITE PHOSPHOROUS MUNITIONS TO CHECK FOR LEAKS IS LABOR INTENSIVE AND IS NOT UNIFORM FOR ALL ROUNDS.
- 5 86 4531
AUTOMATED PRODUCTION OF STICK PROPELLANT ON CAMBL
VARIOUS HIGH ENERGY AND LOVA GRANULAR AND STICK MULTI-BASE PROPELLANTS ARE BEING DEVELOPED. BATCH FACILITIES FOR MULTI-BASE HAVE A CONSTRAINED CAPACITY. A NEW CAMBL IS BEING BUILT BUT HAS NOT PROVEN CAPABLE OF MANUFACTURING STICK PROPELLANTS.
- 5 86 4570
IMPK MFG PRO TES PROC FOR ARTY ELEC TIME FUZES
CRYSTAL DEFECTS CAN CAUSE CRYSTAL OSCILLATORS TO FAIL AT HIGH SETBACK FORCES. ALSO, VARIATIONS IN MAGNETIC PROPERTIES OF PARTS IN THE SETBACK GENERATOR CAN CAUSE LOW OUTPUT, AND EACH FUZE MODULE SHOULD BE TESTED AS IT IS BEING ASSEMBLED.

PROJECTS ADDED IN 2ND HALF, CY85
(CONTINUED)

5 86 4578

MCD + IMPROVEMENT OF DMSO PILDT PROCESS FOR RDX/HMX

PILDT SCALE PROCESS FOR RECRYSTALLIZATION OF RDX/HMX FROM DMSO WAS DESIGNED, PROCURED AND INSTALLED AT HAAP, INSUFFICIENT DATA OBTAINED TO YIELD OPTIMIZED OPERATING CONDITIONS.

5 86 4597

MFG PROCESSES FOR CANNON CALIBER DU PENETRATOR

CURRENT FABRICATION TECHNIQUES FOR SMALL CALIBER DEPLETED URANIUM PENETRATORS RESULT IN EXCESSIVE SCRAP OF RADIOACTIVE CONTAMINANTS AND ARE HIGHLY LABOR INTENSIVE.

5 86 4612

NITRAMINE (LOVA) PROPELLANT WASTEWATER ABATEMENT

THE INGREDIENTS (RDX-TAGN) IN NITRAMINE PROPELLANTS WERE NOT CONSIDERED IN DEVELOPING CRITERIA FOR POLLUTION ABATEMENT AT GOC FACILITIES. NOW NITRAMINE PROPELLANTS ARE SCHEDULED FOR PRODUCTION. EFFECT OF NITRAMINE ON POLLUTION ABATEMENT UNKNOWN.

5 86 4615

IMPROVED SOLVENTLESS PASTE BLENDING

PASTE BLENDING AND FINAL BLENDING OF STICK PROPELLANT IS NOW REQUIRED. A MORE INTENSIVE PASTE BLEND MAY ALLOW ELIMINATION OR REDUCTION OF THE FINAL BLENDING STEP.

5 86 4625

AUTO MANUFACTURE OF SILICON IF AMPLIFIER IC (CAM)

COMMERCIAL MONOLITHIC IF AMPLIFIER ICs ARE DEFICIENT IN BAND PASS (1-50 MHZ), NOISE FIGURE (1.5 DB) AND POWER GAIN (60 DB). R+D DEVELOPED A SILICON MONOLITHIC IF AMPLIFIER BUT VOLUME MFG PROCESSES WERE NOT ESTABLISHED.

5 86 4626

AUTOMATED ASSEMBLY OF MMW TRANSDUCER

PLACEMENT AND BONDING OF SMALL SEMICONDUCTOR CHIPS ONTO MICROSTRIP REQUIRES ACCURACY NOT FOUND IN TODAY'S PICK-AND-PLACE EQUIPMENT.

PROJECTS ADDED IN 2ND HALF, CY85
(CONTINUED)

5 86 4627

AUTOMATED TEST OF MMW TRANSDUCER

THE HAND LABOR INVOLVED IN TUNING MILLIMETER WAVE TRANSDUCERS IS EXTREMELY COSTLY.

5 86 4633

AUTO SENSOR SYSTEMS TEST FOR MMW AND IR SENSORS

AT PRESENT THE MILLIMETER/IR SENSOR SYSTEM IS MANUALLY SYNCHRONIZED. THIS METHOD IS SLOW AND NOT CAPABLE OF MEETING COST REQUIREMENTS, THROUGHPUT, AND SCHEDULE GOALS.

5 86 4637

AUTOMATED MANUFACTURE + INSPECTION OF SFF WARHEAD LINERS

CONVENTIONAL SFF LINER MACHINING AND INSPECTION TECHNIQUES REQUIRED TO ACHIEVE DESIGN TOLERANCES ARE COSTLY AND TIME CONSUMING.

5 86 4656

NITRAMINE PROPELLANT PROCESSING

NITRAMINE CONTAINING GUN PROPELLANTS SUCH AS LOVA AND GAU-8 PROP ARE PRESENTLY PRODUCED BY A DISCONTINUOUS, MANPOWER INTENSIVE, INEFFICIENT BATCH PROCESS. PRODUCT UNIFORMITY IS DIFFICULT TO OBTAIN DUE TO IMPRECISE CONTROLS.

5 86 4660

AUTOMATED BLENDING OF STICK PROPELLANT

MANUAL BLENDING OF STICK PROPELLANT IS LABOR AND SPACE INTENSIVE AND CANNOT SUPPORT PRODUCTION OF LARGE QUANTITIES OF STICK PROPELLANT.

5 86 4666

PRO SPIRAL WRAP TOOL F/155M XM203E2 COMB CASE BODIES

AT PRESENT, THESE COMBUSTIBLE CASE COMPONENTS, END CAPS, IGNITER CAPS AND CASE BODIES ARE MADE USING PULP MOLDING TECHNOLOGY. COSTS ARE QUITE HIGH BECAUSE IT IS BOTH CAPITAL AND LABOR INTENSIVE.

5 86 4668

ELECTROSTATIC PRECIP IMPROVEMENTS (SMUG HUG)

THE SMUG HUGS AT MSAAP AND SAAP HAVE BOTH HAD FIRES WITH EXTENSIVE DAMAGE. IMPROVEMENTS WERE MADE TO THEIR FIRE SUPPRESSION SYSTEM. HOWEVER, DETERMINING AND ELIMINATING THE CAUSE OF THE FIRES HAS NOT BEEN STUDIED.

PROJECTS ADDED IN 2ND HALF, CY85
(CONTINUED)

5 86 4763

MANUFACTURING PROCESS FOR AMMO

THIS PROJECT IS CLASSIFIED AS SECRET. NO FURTHER
INFORMATION IS AVAILABLE.

AMCCGM (WPNS)

6 86 7985

SMALL ARMS WEAPONS NEW PROCESS PRODUCTION TECHNOLOGY

CUN BARREL MFG PROCEDURES REFLECT ANTIQUATED TECHNOLOGY AND
RELY ON MASS REMOVAL OF MATERIAL BY CONVENTIONAL MACHINING
METHODS. CURRENT EQUIP REPRESENTS 1940-50 TECHNOLOGY. NEW
MATERIALS COMPOUND THE PROBLEM.

6 86 8305

INTEGRATED MANUFACTURING SYSTEM (IMS)-(CAM)

41 SYSTEMS ARE APPLIED LOCALLY BUT THERE IS NO DATA
MANAGEMENT SYSTEM FOR THE ENTIRE MFG ACTIVITY. THIS
INCREASES COST DUE TO LONG LEAD TIMES, SCHEDULE
INTERRUPTIONS AND SHORTAGES OF MACHINE AVAILABILITY, LABOR
AND MATERIAL.

6 86 8324

PROCESS CONTROLS FOR P/M WEAPON COMPONENTS

PRESENT METHODS OF PRODUCING WEAPON COMPONENTS IS MAINLY BY
MACHINING FROM BROUGHT STOCK. THIS IS A HIGH COST METHOD
WHICH PRODUCES MUCH ALLEY STEEL SCRAP.

6 86 8329

FIRE CONTROL OPTICAL DEVICES NEW PROCESS PROD TECH

PRODUCTION DELAYS AND COST OF REWORKS HAVE BEEN A GREAT
LOGISTICS PROBLEM. THERE HAS BEEN A SIGNIFICANT SHORTFALL
IN PRODUCTION CAPABILITY.

6 86 8352

SKIVING (METAL SHAVING) OF GUN TUBE BORES

INTERMEDIATE TUBE BORE HONING OPERATIONS FOR SURFACE FINISH
AND SIZE CONTROL ARE A TIME CONSUMING, COSTLY METAL REMOVAL
PROCESS. COUNTERBORING OPERATIONS PRIOR TO DWAGE
ACCEPTANCE ARE ALSO SLOW, TIME CONSUMING, AND HIGH IN
TECHNICAL COSTS.

PROJECTS ADDED IN 2ND HALF, CY85
(CONTINUED)

6 86 8370

AUTO INSPECTION + PROC CONT OF WEAPONS PARTS MFG

FOR BARREL MFG, CURRENT HAND GAGED INSPECTION IS A MAJOR TIME FACTOR. BARREL STRAIGHTENING IS ALSO DONE MANUALLY AS MANY AS 13 TIMES DURING THE MFG CYCLE. NEW DNC EQUIP BEING PROCURED VIA PIF 68X7986 REQUIRES CENTRAL CONTROL.

6 86 8403

DESIGN CRITERIA FOR HARDENING

SELECTION OF THE BEST HARDENING PROCESS. INCOMPLETE HARDENING THROUGHOUT THE COMPONENT AND COMPLICATIONS CAUSED DURING THE HEAT TREATMENT OF WELDMENTS ARE RECURRING PROBLEMS CURRENTLY ADDRESSED BY EMPIRICAL METHODS.

6 86 8416

FLEXIBLE MFG SYSTEM WITH SPECIAL TOOLING - KIA

FLEXIBLE MACHINING SYSTEM (FMS) TECHNOLOGY OFFERS MANY ADVANTAGES TO PLANTS THAT MANUFACTURE PARTS ON LOW TO MID VOLUME QUANTITIES. HOWEVER, ESTABLISHING FEASIBILITY, PURCHASING, AND IMPLEMENTING FMS IS WIDE IN SCOPE AND VERY COMPLEX.

6 86 8437

DENSIFICATION OF WEAPON CASTINGS (HIP)

CASTINGS FOR WEAPONS COMPONENTS OFTEN CONTAIN EXCESSIVE SHRINKAGE CAVITIES AND VOIDS, RESULTING IN REJECTION OR COSTLY WELD REPAIR.

6 86 8510

AUTOMATED INSPECTION OF RECOIL COMPONENTS (CAM)

MANY COMPONENTS ARE UNSALVAGEABLE BECAUSE CYLINDRICITY IS LOST AFTER A MANUFACTURING PROCESS OR UNACCEPTABLE SURFACE INTEGRITY. THESE COMPONENTS ARE USUALLY UNDETECTED UNTIL NEEDLESS STEPS IN THE PROCESS ROUTINGS HAVE BEEN PERFORMED.

6 86 8511

DIE CASTING OF ANTIFRICTION METAL COMPONENTS

ANTIFRICTION METAL FOR PACKING GLANDS IN RECOIL MECHANISMS IS PRESENTLY HAND CAST. OVER 70-80 PERCENT OF THE METAL IS EXCESS + HAS TO BE MACHINED OFF AT ADDED COST.

PROJECTS ADDED IN 2ND HALF, CY85
(CONTINUED)

6 86 8518

THIN FILM COATINGS FOR LASER EYE PROTECTION

A RECENT REQUIREMENT FOR IMPLEMENTATION OF HIGH-G OPTICAL NOTCH FILTERS FOR LASER THREAT DEFENSE HAS BEEN ESTABLISHED. THE FILTER DESIGN HAS BEEN ESTABLISHED BUT MANUFACTURERS USE THEIR OWN SELECTION OF PROCESS STEPS TO FABRICATE THE FILTER.

6 86 8546

MACHINERY CONDITIONS SURVEILLANCE SYSTEM

PROVISION DOES NOT PRESENTLY EXIST FOR CONTINUOUS LARGE-SCALE MONITORING OF MACHINE TOOL DYNAMICS IN ORDER TO DETECT CONDITIONS WHICH ARE LIKELY TO RESULT IN MECHANICAL MALFUNCTION.

6 86 8553

APPLICATION OF REFRACTORY + OTHER COAT BY THE SPUTT TECH

COATING LINERS WITH TANTALUM ELECTRODEPOSITION FROM MOLTEN SALTS INVOLVES HEATING THE SUBSTRATE TO ABOUT 800 DEGREE C. AT THIS TEMPERATURE GUN STEEL UNDERGOES UNDESIRABLE CHANGES IN MECHANICAL PROPERTIES.

6 86 8559

CIM FOR CANNON, CAE/CAM/CMM

THE EXCHANGE OF MANUFACTURING DATA AT WATERVIET ARSENAL IS LARGELY MANUAL, ERROR PRONE AND TIME CONSUMING. CURRENT PROCESS PLANNING, SCHEDULING, AND PRODUCTION CONTROL SYSTEMS EXCHANGE DATA MANUALLY.

6 86 8603

ROBOTIC WELDING

PRODUCTIVITY IN THE WELD SHOP IS LIMITED BECAUSE THE MAJORITY OF THE WELDING IS DONE MANUALLY.

6 86 8625

MANUFACTURING OF MULTI-LOG BREECH MECHANISMS

THE MANUFACTURE OF MULTI-LOG COMPONENTS INVOLVES THE USE OF FIRM CUTTERS WHICH ARE USED TO MILL THE REQUIRED CONFIGURATION. ALTHOUGH THIS METHOD HAS BEEN SUCCESSFUL ON A PROTOTYPE BASIS, IT DOES NOT APPEAR TO BE FEASIBLE FOR PRODUCTION QUANTITIES.

PROJECTS ADDED IN 2ND HALF, CY85
(CONTINUED)

6 86 8638

CONTROL OF SEQUENTIAL MACHINING OPERATIONS (CAM)

PRESENTLY, IN ALMOST ALL AUTOMATED MACHINING OPERATIONS, CUTTING RATES ARE LOWERED TO AVOID TOOL BREAKAGE AND REJECTION OF COMPONENTS. MACHINING PARAMETERS ARE SET BY ALLOWING FOR WORST POSSIBLE CONDITIONS.

6 86 8641

MFG OF TITANIUM ALLOY METAL MATRIX CANNON COMPONENTS

THE INTRODUCTION OF TITANIUM ALLOY + VARIOUS METAL MATRIX FORMS FOR LIGHT WEIGHT REINFORCING JACKETS ON GUN TUBES WILL PRESENT MANUFACTURING PROBLEMS. THE PROBLEMS INCLUDE THE DETERMINATION OF PROPER TOOLING AND METHOD OF MANUFACTURING.

6 86 8642

APPLICATION OF ADVANCED MATERIALS TO CANNON PROD

EXISTING MANUFACTURING GUIDELINES ARE NOT YET ESTABLISHED FOR MANUFACTURING TITANIUM ALLOY GUN TUBE JACKETS. THE USE OF TITANIUM WILL REQUIRE MATERIAL CHARACTERIZATION. THIN-WALL DESIGN PRESENTS PROBLEMS WITH WELDING, SHRINK FITTING, FORGING.

TRESCUM

6 86 8796

COMBAT VEHICLE DEPERMING PRODUCTION FACILITY

PRESENT DESIGN AND FABRICATION TECHNIQUES FOR VEHICLES RESULT IN A SIGNIFICANT MAGNETIC SIGNATURE. THIS MAGNETIC SIGNATURE CAN BE USED TO FUZE LAND MINES TO ATTACK THE VEHICLE UNDERCARRIAGE.

6 86 8802

HIGH STABILITY TRUSS CHORD

USE OF BRAIDED GRAPHITE TO MAKE POSSIBLE STRONG BRIDGE SECTIONS HAS BEEN DEMONSTRATED. BUT, BARRIER TO USING BRAIDING IN PRODUCTION IS THAT A RELIABLE METHOD OF IMPREGNATING FIBERS WITH RESIN DOES NOT EXIST.

6 86 8074

ADVANCED HARDENED SHELTER COST OPTIMIZATION

FIRST GENERATION HARDENED SHELTERS, NOW IN DEVELOPMENT, EMPLOY THE SAME MATERIALS AND FABRICATION TECHNIQUES USED IN THE PAST BY THE SHELTER INDUSTRY FOR THE PRODUCTION OF UNHARDENED DESIGNS. OLD METHODS MAKE THE NEW SHELTERS FIVE TIMES AS COSTLY.

TOTAL PROJECTS ADDED IN 2ND HALF, CY85 121

MMT PROGRAM
FINAL STATUS REPORTS RECEIVED
DURING 2ND HALF, CY85

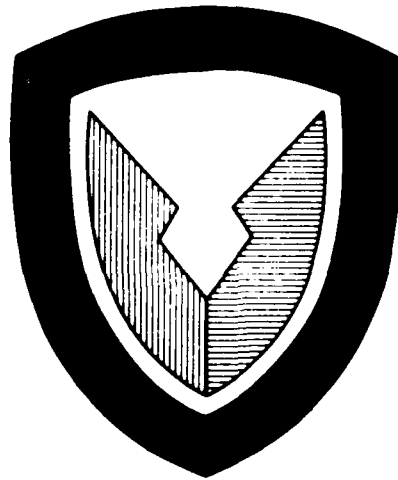

FINAL STATUS REPORTS RECEIVED DURING 2ND HALF, CY85

AMETA

4 71 5052
ARMY ENGINEERING DESIGN HANDBOOK FOR PRODUCTION SUPPORT

DLSCOM

6 85 6003
TEAL PRODUCTION EFFICIENCY REVIEW

LABCOM

H 80 5023
TUBULAR PLASMA PANEL

H 83 5019
LASER-CUT SUBSTRATES FOR MICROWAVE TUBES

H 84 5162
EXJAM BATTERY MANUFACTURING TECHNOLOGY, PHASE II

H 85 5174
AUTO SPUTTERING PROCESS CONTROL F/PRODUCING ZND - PHASE II

TMDA

3 82 3115
ENGINEERING FOR METROLOGY AND CALIBRATION

3 82 3115 17
DYNAMIC ELECTRICAL MEASUREMENT STANDARDS

3 82 3115 25
BASIC METROLOGY STD FOR USE IN WIDE-RANGING ENVIRONMENTS

3 82 3115 34
IMPROVED ON-SITE SERVICE

3 82 3115 35
VISCOSITY AND DENSITY MEASUREMENTS

3 82 3115 37
DATA ANALYSIS TECHNIQUES

FINAL STATUS REPORTS RECEIVED DURING 2ND HALF, CY85
(CONTINUED)

- 3 '83 3115
ENGINEERING FOR METROLOGY AND CALIBRATION
- 3 '83 3115 01
JOSEPHSON EFFECT VOLTAGE STANDARD
- 3 '83 3115 25
BASIC METROLOGY STD FOR USE IN WIDE-RANGING ENVIRONMENTS
- 3 '83 3115 34
IMPROVED ON-SITE SERVICE
- 3 '83 3115 35
VISCOSITY AND DENSITY MEASUREMENTS
- 3 '84 3115
ENGINEERING FOR METROLOGY AND CALIBRATION
- 3 '84 3115 25
BASIC METROLOGY STD FOR USE IN WIDE-RANGING ENVIRONMENTS
- M '85 3115
ENGINEERING FOR METROLOGY AND CALIBRATION
- M '85 3115 01
JOSEPHSON EFFECT VOLTAGE STANDARD
- M '85 3115 17
DYNAMIC ELECTRICAL MEASUREMENT STANDARDS
- M '85 3115 34
IMPROVED ON-SITE CALIBRATION
- M '85 3115 37
DATA COLLECTION/REDUCTION IMPROVEMENT
- M '85 3115 39
IMPROVE ANNEALING PROC, MOUNTING STRUCT PKG + TERM CONFIG
- M '86 3115
ENGINEERING FOR METROLOGY + CALIBRATION
- M '86 3115 42
AUTOMATED INTERCOMPARISON OF STANDARD RESISTORS
- AVSCOM
- I 82 7286
HIGH QUALITY SUPERALLOY POWDER PROD F/TURBINE COMPONENTS

FINAL STATUS REPORTS RECEIVED DURING 2ND HALF, CY85
(CONTINUED)

- I '84 7300
IMPROVED LOW CYCLE FATIGUE (LCF) CAST ROTORS
- I '84 7302
PRODUCTION OF BURIDE COATED LONG LIFE TOOLS
- I '84 7378
STAINLESS STEEL GEARBOX HOUSING
- I '85 7378
STAINLESS STEEL GEARBOX HOUSING
- I '82 7415
MMT T700 BLISK REPAIR
- I '82 7426
MMT-IPI PROGRAM-MARTIN MARIETTA TADS/PNVS
- I '85 7473
FIBER REINFORCED THERMOPLASTIC STRUCTURES
- I '84 8198
T-700 TURBINE ENGINE MFG PRODUCTIVITY IMPROVEMENT
- CECOM
- F '81 9568
THIRD GENERATION LOW COST IMAGE INTENSIFIER TUBES
- MICLM
- I '84 1060
ELECTRICAL TEST AND SCREENING OF CHIPS
- I '85 1095
AUTOMATIC SEALING OF HYBRID PACKAGES (CAM)
- TACCM
- E '77 3749
HYDRAULIC ROTARY ACTUATORS
- E '80 3749
HYDRAULIC ROTARY ACTUATORS

FINAL STATUS REPORTS RECEIVED DURING 2ND HALF, CY85
(CONTINUED)

- E 81 3749
HYDRAULIC ROTARY ACTUATORS FOR M9
- T 82 5024
GEAR DIE DESIGN + MFG UTILIZING COMPUTER TECHNOLOGY (CAM)
- T 82 6038
HIGH DEPOSITION WELDING
- T 81 6098
PRODUCTION OF SPECIAL ARMOR STEEL
- AMCCOM (AMML)
- 5 82 1701
BULK TRANSFER OF CHEMICAL MATERIALS
- 5 82 1711
RED PHOSPHORUS POLLUTION ABATEMENT EVALUATIONS
- 5 81 3961
IMPRVD VIBR ACCEPTANCE TESTING F/M732, XM587/724 FUZES ? S2A
- 5 79 4000
AUTOMATED M55 DETONATOR PRODUCTION EQUIPMENT
- 5 79 4024
DSN DEV BLD PROT COMP AND AUTO ASSY MACH M223 FUZE
- 5 82 4267
CONTINUOUS PROCESS FOR GRANULAR CUMP B
- 5 84 4273
AUTOMATED PRODUCTION OF STICK PROPELLANT
- 5 84 4406
IMPROVING THE YIELD OF HMX DURING RLX NITRILYSIS
- 5 83 4511
DISPOSAL OF FINAL SLUDGE FROM ACID RECOVERY OPERATIONS
- 5 84 4511
DISPOSAL OF FINAL SLUDGE FROM ACID RECOVERY OPERATIONS
- 5 83 4534
SAWS BULLET CONVERSION OF SCAMP EQUIPMENT

FINAL STATUS REPORTS RECEIVED DURING 2ND HALF, CY85
(CONTINUED)

- 5 '85 4534
M855 BULLET CONVERSION OF SCAMP EQUIPMENT
- 5 '84 4540
CaCl₂ COATING OF 7.62MM BALL PROPELLANT
- 5 '82 4557
ARBAT
- 5 '84 4574
IMPROVED PROCESS FOR RDX/HMX FINES MANUFACTURE
- 5 '84 4578
MODIFICATION + IMPROVEMENT OF DMSJ PILOT PROCESS FOR RDX/HMX
- 5 '84 4579
WHITE WATER RECOVERY SYS F/COMBUSTIBLE CASE MANUFACTURING
- 5 '84 4597
MFG PROC F/CANNON CALIBER DU PENETRATOR (20MM, 25MM, 30MM)
- 5 '84 4657
BINARY FACILITY MONITORING AND DETECTION

AMCCDM (WPNS)

- 6 '81 7724
GROUP TECHNOLOGY OF WEAPON SYSTEMS (CAM)
- 6 '85 7724
GROUP TECHNOLOGY OF WEAPON SYSTEMS (CAM)
- 6 '82 7926
HET ISOSTATIC PRESSING (HIP) OF LARGE ORDNANCE COMPONENTS
- 6 '80 7949
APPLICATION OF GROUP TECHNOLOGY TO RIA MFG (CAM)
- 6 '82 7985
SMALL ARMS WEAPONS NEW PROCESS PRODUCTION TECHNOLOGY
- 6 '82 7985 05
RECYCLE OF GUN STEEL
- 6 '81 8135
IN-PROCESS CONTROL OF MACHINING

FINAL STATUS REPORTS RECEIVED DURING 2ND HALF, CY85
(CONTINUED)

- 6 '83 8154
COMPUTER INTEGRATED MANUFACTURING (CIM) FOR CANNON
- 6 '82 8244
OPTIMIZE THE HEAT TREATMENT OF ROTARY FURGE TUBES
- 6 '82 8306
ON-LINE PRODUCTION INFORMATION SYSTEM (CAM)
- 6 '84 8324
PROCESS CONTROLS FOR P/M WEAPON COMPONENTS
- 6 '84 8326
APPLICATION OF CORROSION RESISTANT COATINGS
- 6 '84 8329
FIRE CONTROL OPTICAL DEVICES NEW PROCESS PRODUCTION TECH
- 6 '83 8352
SKIVING (METAL SHAVING) GUN TUBE BORES
- 6 '82 8416
FLEXIBLE MACHINING SYSTEM - RIA (CAM)
- 6 '85 8560
APPLICATION OF COUNTER HOLDER EQUIPMENT TO ROTARY FORGING

TOTAL PROJECTS COMPLETED IN 2ND HALF, CY85 65

MMT PROGRAM

SUMMARY PROJECT STATUS REPORT

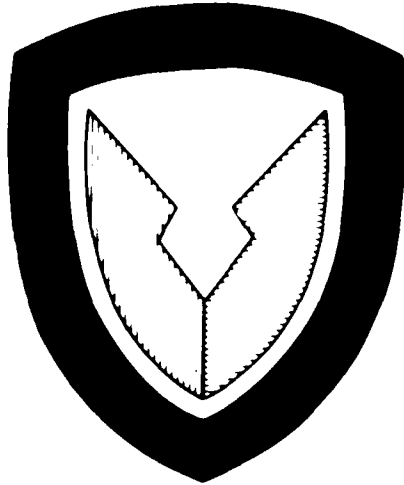

MANUFACTURING METHODS AND TECHNOLOGY PROGRAM

SUMMARY PROJECT STATUS REPORT

The Summary Project Status Report for each major Army subcommand (SUBMACOM) is preceded by the tabulated SUBMACOM MMT project funding status. The accuracy of funding amounts is based on the individual project status reports. If a status report was not provided, a pertinent comment was added to show those projects that were delinquent.

The sample form on the reverse side of this page is an example of the format for the individual project reports that follow. The User's Guide on the next page explains the content of the print out and Table 1 on the following page identifies the commodity commands responsible for the execution of the projects.

MANUFACTURING METHODS AND TECHNOLOGY PROGRAM
 S U B M I T T E D P R O J E C T S T A T U S R E P O R T
 2ND SEMIANNUAL SUBMISSION CY 85 ACS DRAMT-301

PROJ NO.	TITLE + STATUS	AUTHORIZED (\$000)	CONTRACT VALUES (\$000)	EXPENDED LABOR AND MATERIAL (\$000)	ORIGINAL PROJECTED COMPLETE DATE	PRESENT PROJECTED COMPLETE DATE
4 85 6095 05	SKIVE HOBBIING OF GEARMS -----DELINQUENT STATUS REPORT-----				JAN 86	JAN 86
4 85 6099	MANUFACTURING METHODS FOR SPECIALIZED ARMOR MATERIALS	6,500.0		6,515.0	JUL 84	MAR 86
4 83 6107	IMPROVED MBT TRACK	842.0	705.0	100.0	AUG 84	MAY 86
4 83 6107 01	COMP MFG FRM HI STK/LTWEIGHT FERROUS, NON-FERR + MTL MATRIX	842.0	339.0		JUN 84	MAY 86
4 83 6107 03	ORGANIC COMPOSITE ROAD WHEEL	842.0	366.0		AUG 84	MAY 86
4 85 6107	IMPROVED MBT TRACK	623.0	528.0	95.0	SEP 85	DEC 86
4 85 6107 01	TRACK PINS + SHES MFG FRM ALUMINUM MATRIX COMPOSITE MAIL	450.0	160.0			APR 86
4 85 6107 02	LOW COST ADAPTIVE FLUIDIC DAMPER MATERIALS	400.0	368.0			DEC 86
4 86 6107	IMPROVED MBT TRACK -----JUST FUNDED. NO 301 REQUIRED.-----					
4 84 6121	CAU/CAM FOR THE BRADLEY FIGHTING VEHICLE	606.0	580.0	25.0	JAN 86	SEP 86
4 84 6121 01	ROBOTIC WELDING	606.0	580.0	25.0	JAN 86	SEP 86
4 85 6121	CAU/CAM FOR THE BRADLEY FIGHTING VEHICLE -----DELINQUENT STATUS REPORT-----					
4 85 6123	CERAMIC TURBOCHARGER ROTOR	240.0	205.0	35.0	SEP 86	FEB 87
4 86 6123	CERAMIC TURBOCHARGER ROTOR	240.0	234.0	5.0	FEB 87	FEB 87
4 85 6125	WELD PROCESSING PLANNING AND CONTROL -----DELINQUENT STATUS REPORT-----	275.0		275.0	JCT 85	JUN 86
4 86 6125	WELD PROCESS PLANNING AND CONTROL -----JUST FUNDED. NO 301 REQUIRED.-----					

(2) (3)

(4)

(5)

(6)

(7)

(8)

THIS FORM IS USED FOR SUMMARIZING THE MMT PROGRAM PROJECTS' STATUS. USER'S GUIDE BELOW EXPLAINS THE SIGNIFICANCE OF EACH COLUMN HEREIN.

USER'S GUIDE
to
SUMMARY PROJECT STATUS REPORT

COLUMN 1. PROJECT NUMBER

A project identified by the first and last four digits which corresponds to the project title for the life of its execution. However, for accounting and reporting purposes, a project is recognized by the totality of its seven-digit numeric or alphanumeric number. Example:

3 75 6241

Project identifying number, which corresponds to the project title and is designated by action command.

Fiscal year of funding - the only two digits that may vary according to funding frequency (7T for FY transition).

Action command (see list on Table 1).

COLUMN 2. Subtask identifier, if any.

COLUMN 3. PROJECT TITLE

The title descriptive of project effort.

COLUMN 4. AUTHORIZED

The total amount of funds authorized in dollars, to complete the project.

COLUMN 5. CONTRACT VALUES

The portion of authorized funds actually expended or obligated for work performed by private industry.

COLUMN 6. EXPENDED LABOR AND MATERIAL

The portion of authorized funds actually expended in-house, namely within the Government.

COLUMN 7. ORIGINAL PROJECTED COMPLETION DATE

Calendar date clearly given in, or the nearest calendar month and year as could be read from the Milestone Chart of, the very first Project Status Report, RCS DRCMT-301.

COLUMN 8. PRESENT PROJECTED COMPLETION DATE

Calendar date clearly given in, or the nearest calendar month and year as could be read from Milestone Chart of, the latest Project Status Report, RCS DRCMT-301.

ARMY ACTION COMMAND/ACTIVITY IDENTIFICATION

<u>Action Command Identifier</u>	<u>Acronym</u>	<u>Command</u>
Management Engineering Training Activity	AMETA	D
Depot Systems Command	DESCOM	G
Laboratory Command	LABCOM	H
Test Measurement Diagnostic Equipment Support Group	TMDE	K
Materials Technology Laboratory	MTL	M
Test & Evaluation Command	TECOM	O
Aviation Systems Command	AVSCOM	1
Communications & Electronics Command	CECOM	2
Missile Command	MICOM	3
Tank-Automotive Command	TACOM	4
Armament, Munitions, & Chemical Command (Munitions)	AMCCOM (Ammo)	5
Armament, Munitions, & Chemical Command (Weapons)	AMCCOM (Wpns)	6
Troop Support Command	TROSCOM	7

Table 1

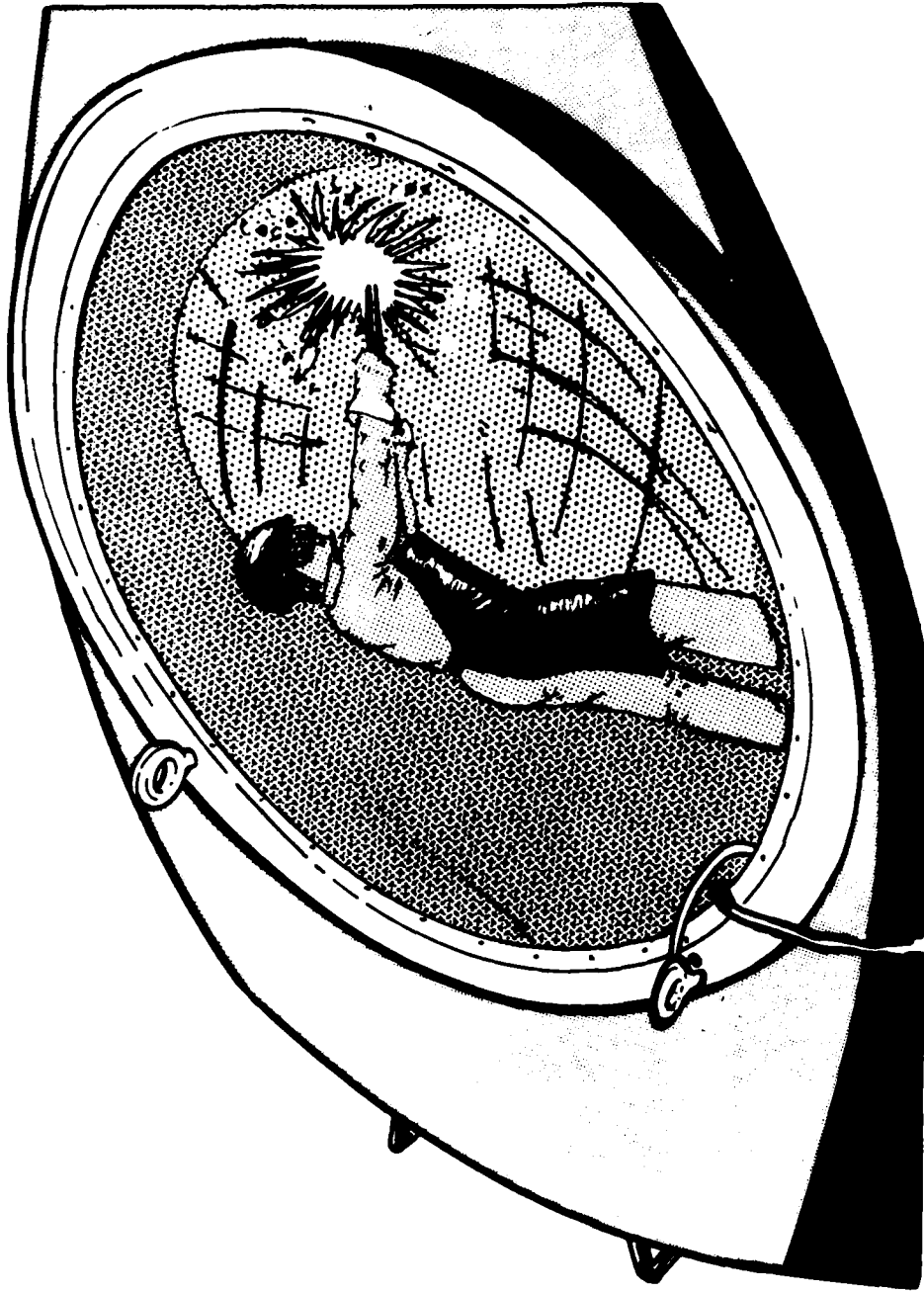

**DEPOT SYSTEMS COMMAND
(DESCOM)
AND
MANAGEMENT ENGINEERING TRAINING ACTIVITY
(AMETA)**

A M E T A A N D D E P U T S Y S T E M S C O M M A N D

CURRENT FUNDING STATUS, 2ND CY85

FISCAL YEAR	NO. OF PROJECTS	AUTHORIZED FUNDS (\$)	CONTRACT FUNDS ALLOCATED (\$)	CONTRACT FUNDS EXPENDED (\$)	PERCENT (%)	IN-HOUSE FUNDS REMAINING (\$)	IN-HOUSE FUNDS EXPENDED (\$)	PERCENT (%)
78	1	870,000	743,000	634,500	(85%)	127,000	127,000	(100%)
79	1	495,000	387,800	365,900	(94%)	107,200	107,200	(100%)
80	1	400,000	432,000	204,200	(61%)	28,000	28,000	(100%)
81	2	1,026,000	797,000	728,800	(91%)	229,000	74,900	(32%)
82	4	3,953,000	1,942,000	1,740,500	(89%)	2,011,000	443,700	(22%)
83	0	0	0	0	(0%)	0	0	(0%)
84	3	1,067,600	1,047,600	424,600	(40%)	20,000	20,000	(100%)
85	5	1,684,000	1,360,000	30,000	(2%)	124,000	31,000	(25%)
86	7	2,441,000	87,400	0	(0%)	3,353,600	0	(0%)
TOTAL	24	12,796,600	6,796,800	4,168,500	(61%)	5,999,800	631,600	(13%)

AUTHORIZED FUNDING CONTRACT ALLOCATED 53%

IN-HOUSE REMAINING 46%

MANUFACTURING METHODS AND TECHNOLOGY PROGRAM
 SUMMARY PROJECT STATUS REPORT
 2ND. SEMIANNUAL SUBMISSION CY-85 RCS DRCHT-301

PROJ NO.	TITLE + STATUS	AUTHO- RIZED (\$000)	CONTRACT VALUES (\$000)	EXPENDED LABOR AND MATERIAL (\$000)	ORIGINAL	PRESENT
					PROJECTED COMPLETE DATE	PROJECTED COMPLETE DATE
D 78 5052	ARMY ENGINEERING DESIGN HANDBOOK FOR PRODUCTION SUPPORT	870.0	743.0	127.0	NOV 79	SEP 86
D 79 5052	ARMY ENGINEERING DESIGN HANDBOOKS FOR PRODUCTION SUPPORT	495.0	387.8	107.2	MAY 83	AUG 86
D 80 5052	ARMY ENGINEERING DESIGN HANDBOOKS FOR PRODUCTION SUPPORT	460.0	432.0	28.0	JAN 83	JAN 87
D 81 5052	ARMY ENGINEERING DESIGN HANDBOOKS FOR PRODUCTION SUPPORT	531.0	392.0	39.0	JAN 84	FEB 87
D 82 5052	ARMY ENGINEERING DESIGN HANDBOOKS FOR PRODUCTION SUPPORT	580.0	542.0	37.0	SEP 83	JUL 86
D 84 5052	ARMY ENGINEERING DESIGN HANDBOOKS	546.0	526.0	20.0	MAR 85	DEC 86
D 85 5052	ARMY ENGRG DESIGN HANDBOOKS F/PRODUCTION SUPPORT	424.0	375.0	6.0	SEP 86	DEC 86
D 86 5052	ARMY ENGRG DESIGN HANDBOOKS F/PRODUCTION SUPPORT	91.0	87.4		JUL 87	JUL 87

MANUFACTURING METHODS AND TECHNOLOGY PROGRAM
 SUMMARY PROJECT STATUS REPORT
 2ND SEMIANNUAL SUBMISSION CY-85 RCS-DRCNT-801

PROJ NO.	TITLE + STATUS	AUTHORIZED (\$000)	CONTRACT VALUES (\$000)	EXPENDED LABOUR AND MATERIAL (\$000)	ORIGINAL	PRESENT
					PROJECTED COMPLETE DATE	PROJECTED COMPLETE DATE
G 84 0002	HMT CAM APPLICATION OF RUBUTICS TO SHELTER REFINISHING	370.0	370.0		OCT 86	MAR 86
G 82 2002	LETTERKENNY EVAL ANALYSIS + PLANNING (LEAP) PROGRAM	2,700.0	1,400.0	307.9	JUN 84	JUN 88
G 85 2002	LETTERKENNY EVAL ANALYSIS + PLANNING (LEAP) PROGRAM	20.0			JUN 88	JUN 88
G 84 2002	LETTERKENNY EVAL ANALYSIS + PLANNING (LEAP) PROGRAM	1,900.0			JUN 88	JUN 88
G 85 3001	POWER AND INERTIA SIMULATOR (PAISI) COMBAT VEHICLE TESTING	985.0	985.0		JUL 87	MAY 88
G 86 3001	POWER + INERTIA SIMULATOR (PAISI) COMBAT VEHICLE TESTING	1,000.0			MAY 88	MAY 88
G 81 4002	ROBOTIZED WELDING OF M113A2 SUSPENSION	495.0	405.0	35.9	SEP 81	DEC 86
G 82 4002	ROBOTIZED WELDING OF M113A2 SUSPENSION -----DELINQUENT STATUS REPORT-----	374.0			AUG 84	JUN 86
G 82 4004	AUTOMATED DISASSEMBLY OF DOUBLE PIN TRACK	299.0		98.8	SEP 83	MAR 86
G 85 6003	CCAD INTEGRATED MODERNIZATION PROGRAM -----DELINQUENT STATUS REPORT-----	25.0		25.0	JUN 87	JUN 87
G 86 6003	CORPUS CHRISTI ARMY DEPOT INTEGRATED MODERNIZATION PROGRAM -----JUST FUNDED. NO 301 REQUIRED.-----					
H 85 6100	ROBOTIC REPAIR OF PRINTED CIRCUIT BOARDS - PHASE I -----DELINQUENT STATUS REPORT-----					
H 86 6100	ROBOTIC REPAIR OF PRINTED CIRCUIT BOARDS - PHASE III -----JUST FUNDED. NO 301 REQUIRED.-----					
G 86 7004	AUTOMATED ENGINE BLOCK MACHINING	450.0			SEP 88	SEP 88
G 86 7007	ENGINE CONTAINER SEALING-CAM -----JUST FUNDED. NO 301 REQUIRED.-----					
G 84 8002	AMAD SUBASSEMBLY MODERNIZATION -----DELINQUENT STATUS REPORT-----	151.6	151.6		JUN 85	JUN 86

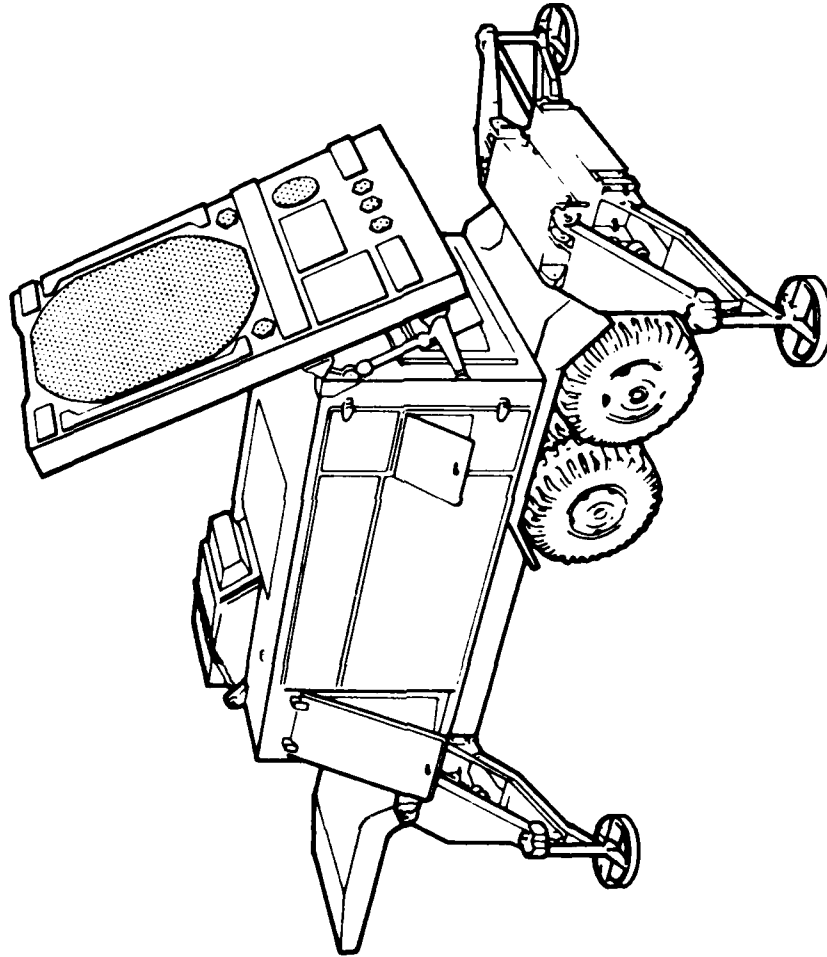

**LABORATORY COMMAND
(LABCOM)**

LABORATORY CUMMANS
CURRENT FUNDING STATUS, 2ND CY85

FISCAL YEAR	NO. OF PROJECTS	AUTHORIZED FUNDS (\$)	CUMULATIVE CONTRACT FUNDS ALLOCATED (\$)	CUMULATIVE CONTRACT FUNDS EXPENDED (\$)	PERCENTAGE (%)	INHOUSE REMAINING (\$)	CUMULATIVE INHOUSE FUNDS EXPENDED (\$)	PERCENTAGE (%)
79	1	1,272,100	1,114,100	1,036,900	(85%)	58,000	58,000	(100%)
80	0	0	0	0	(0%)	0	0	(0%)
81	3	2,199,900	2,028,900	1,872,900	(92%)	171,000	170,900	(99%)
82	3	3,211,600	2,896,600	2,822,100	(97%)	314,800	239,800	(76%)
83	0	0	0	0	(0%)	0	0	(0%)
84	3	935,000	526,000	526,000	(100%)	409,000	160,000	(39%)
85	14	5,049,000	2,241,000	1,803,600	(80%)	2,808,000	348,000	(12%)
86	12	2,915,000	690,000	0	(0%)	2,025,000	5,000	(0%)
TOTAL	36	15,552,600	9,796,600	8,061,500	(82%)	5,785,800	981,700	(16%)

AUTHORIZED FUNDING CONTRACT ALLOCATED 63% INHOUSE REMAINING 37%

MANUFACTURING METHODS AND TECHNOLOGY PROGRAM
 SUMMARY PROJECT STATUS REPORT
 2ND SEMI-ANNUAL SUBMISSION CY 85 RCS DRMT-301

PROJ NO.	TITLE + STATUS	AUTHORIZED (\$000)	CONTRACT VALUES (\$000)	EXPENDED LABOR AND MATERIAL (\$000)	ORIGINAL PROJECTED COMPLETE DATE	PRESENT PROJECTED COMPLETE DATE
H 84 5010	MILLIMETER-WAVE SOURCES FOR 60 AND 94 GHZ -----DELINQUENT STATUS REPORT-----	209.0				
H 85 5010	HYBRID MODULATOR F/PULSED IMPATT MILLIMETER WAVES SOURCE	650.0	500.0	150.0	MAY 86	MAY 86
H 82 5011	INDIUM-PHOSPHIDE GUNN DEVICES -----DELINQUENT STATUS REPORT-----	1,227.1	1,118.1	109.0	AUG 84	JUN 86
H 82 5010	BONDED GRID ELECTRON GUN	997.5	883.7	113.8	MAR 84	MAY 86
H 85 5010	IMPROVED TUBE -----DELINQUENT STATUS REPORT-----					
H 81 5041	MILLIMETER WAVE MIXERS AND ARRAYS -----DELINQUENT STATUS REPORT-----	576.0	495.0	80.9	JUL 83	JUN 86
H 84 5107	HMT EHF SOLID STATE AMPLIFIER -----DELINQUENT STATUS REPORT-----	526.0	526.0		AUG 86	JUN 86
H 85 5107	EHF SOLID STATE AMPLIFIER	407.0	407.0		JUL 86	JUL 86
H 85 5109	PRECISION LU-CUST SURF ACOUSTIC WAVE DELAY LINES F/UHF APPL -----DELINQUENT STATUS REPORT-----					
H 80 5119	PRECISION HIGH QUALITY X-RAY MASKS	800.0	800.0		JAN 87	JAN 87
H 82 5162	CXJAM BATTERY MANUFACTURING TECHNOLOGY - PHASE III	485.0	450.0	34.0	DEC 85	FEB 86
H 80 5162	CXJAM BATTERY MANUFACTURING TECHNOLOGY-PHASE III	95.0	90.0	0.5	MAR 86	MAR 86
H 80 5164	AUTOMATIC RETICLE INSPECTION SYSTEM, PHASE III	700.0	656.0		SEP 85	MAR 86
H 84 5174	AUTO SPUT PROC GUNT F/PRD ZINC OXIDE ACOUSTIC DEVICES - CAM	200.0		160.0	DEC 84	JUN 86
H 80 5174	AUTO SPUTTERING PROCESS CONTROL FOR ZNG	20.0		4.7	JUN 86	JUN 86
H 81 5176	PROGRAM FOR A GRAPHITE/EPOXY ANTENNA REFLECTOR -----DELINQUENT STATUS REPORT-----	681.0	681.0		APR 82	JUN 86
H 80 5167	TUNABLE MILLIMETER WAVE INP GUNN SOURCES	299.0	220.0	60.0	DEC 87	MAY 86
H 80 5167	TUNABLE MILLIMETER WAVE INP GUNN SOURCES -----JUST FUNDED, NO 301 REQUIRED-----					
H 80 5167	PROCESS ADJUSTMENTS F/ENVIRON STRESS ON ELECT CIRCUIT METALS	8.0	9.0		DEC 85	JUN 86

MANUFACTURING METHODS AND TECHNOLOGY PROGRAM
 S U M M A R Y P R O J E C T S T A T U S R E P O R T
 2ND SEMI-ANNUAL SUBMISSION CY 85 RCS DRMT-301

PROJ NO.	TITLE + STATUS	AUTHORIZED (\$000)	CONTRACT VALUES (\$000)	EXPENDED LABOR AND MATERIAL (\$000)	ORIGINAL PROJECTED COMPLETE DATE	PRESENT PROJECTED COMPLETE DATE
H 86 5193	PROCESS ADJUSTMENTS F/ENVIKDN STRESS DN ELECT CIRCUIT METALS -----JUST FUNDED. NO 301 REQUIRED.-----					
H 85 5209	HIGH SPEED DIGITAL TO ANALOG CONVERTER -----DELINQUENT STATUS REPORT-----	1,500.0			FEB 02	
H 86 5209	HIGH SPEED DIGITAL TO ANALOG CONVERTER (VHSIC)					MAR 88
H 85 5248	ADVANCED WAFER IMAGING SYSTEM (AWIS) -----DELINQUENT STATUS REPORT-----	1,900.0				
H 86 5248	ADVANCED WAFER IMAGING SYSTEM (VHSIC) -----JUST FUNDED. NO 301 REQUIRED.-----					
H 85 5251	AUTOMATIC SEM WAFER INSPECTION AND METROLOGY SYSTEM	600.0		60.0	JAN 87	MAR 87
H 86 5251	AUTO SEM WAFER INSPECTION AND METROLOGY SYS (VHSIC) -----JUST FUNDED. NO 301 REQUIRED.-----					
H 85 5272	TAPE AUTOMATED BONDING (TAB) -----DELINQUENT STATUS REPORT-----					
H 86 5272	TAPE AUTOMATED BONDING (VHSIC) -----JUST FUNDED. NO 301 REQUIRED.-----					
H 85 5273	FIRST LEVEL PACKAGING AND INTERCONNECTIONS (VHSIC) -----DELINQUENT STATUS REPORT-----					
H 86 5273	FIRST LEVEL PACKAGING AND INTERCONNECTIONS (VHSIC) -----JUST FUNDED. NO 301 REQUIRED.-----					
H 85 5274	MULTICHIP PACKAGES (VHSIC) -----DELINQUENT STATUS REPORT-----					
H 86 5274	MULTICHIP PACKAGES (VHSIC) -----JUST FUNDED. NO 301 REQUIRED.-----					
H 86 5261	E-BEAM AND X-RAY RESISTS (VHSIC)	500.0			JUN 88	JUN 88
H 79 9807	PROCESSING HIGH STABILITY QUARTZ CRYSTAL UNIT	1,272.1	1,214.1	58.0	MAR 81	MAY 86
H 82 9905	LOW-COST MONOLITHIC GALLIUM ARSENIDE MICROPAVLE INTEG CIRCUITS -----DELINQUENT STATUS REPORT-----	967.0	895.0	17.0	SEP 84	MAY 86
H 81 9909	PRODUCTION TECHNIQUES FOR SILICON MW POWER TRANSISTORS -----DELINQUENT STATUS REPORT-----	942.9	852.9	90.0	SEP 83	JAN 86

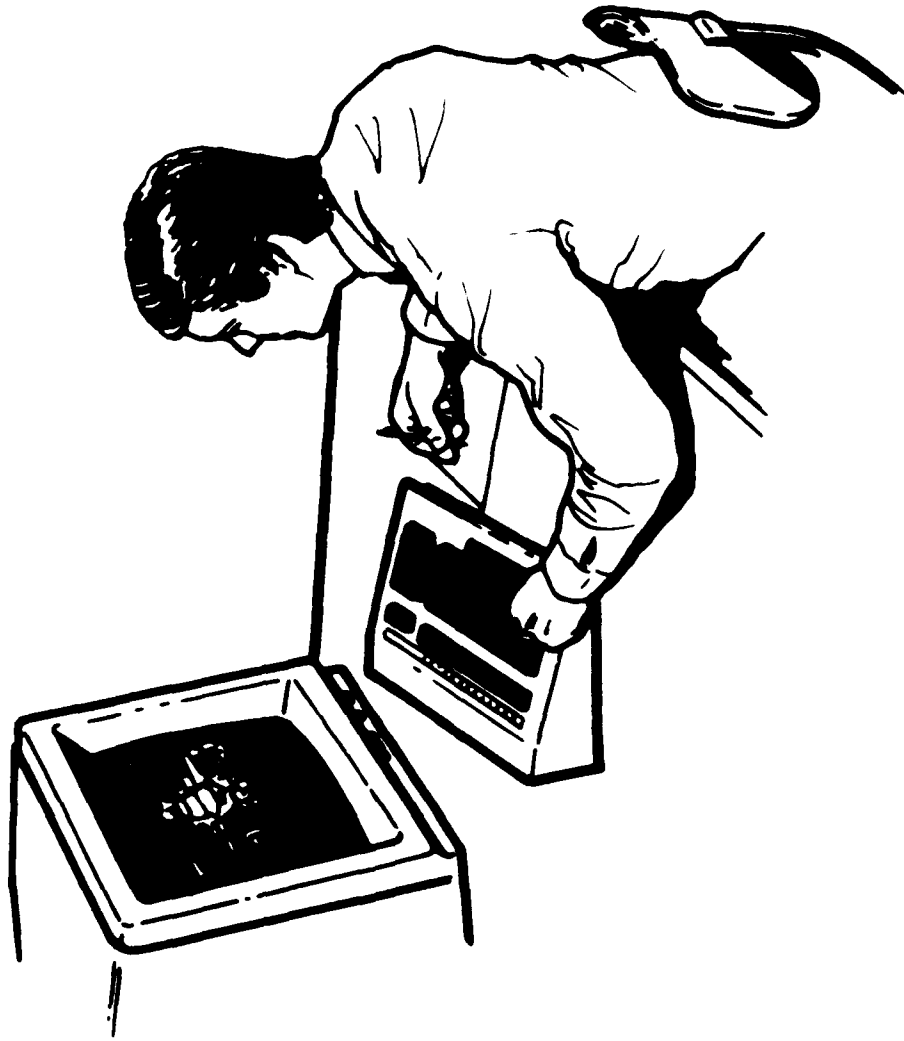

**MATERIALS TECHNOLOGY LABORATORY
(MTL)**

MATERIALS TECHNOLOGY LABORATORY

CURRENT FUNDING STATUS, 2ND CY85

FISCAL YEAR	NO. OF PROJECTS	AUTHORIZED FUNDS (\$)	CUNTRACT ALLOCATED (\$)	FUNDING EXPENDED (\$)	PERCENTAGE (%)	INHOUSE REMAINING (\$)	FUNDING EXPENDED (\$)	PERCENTAGE (%)
81	1	4,349,000	1,509,000	1,509,000	(100%)	2,840,000	2,840,000	(100%)
82	1	4,573,000	1,920,000	1,920,000	(100%)	2,653,000	2,653,000	(100%)
83	1	2,149,000	656,600	656,600	(100%)	1,492,400	1,243,400	(83%)
84	2	4,312,000	1,790,900	128,700	(7%)	2,521,100	2,399,800	(95%)
85	3	4,275,000	1,866,900	49,800	(2%)	2,408,100	2,387,900	(99%)
86	5	2,596,000	1,584,900	0	(0%)	1,011,100	1,011,000	(99%)
TOTAL	13	22,254,000	9,328,300	4,264,100	(45%)	12,925,700	12,535,100	(96%)

AUTHORIZED FUNDING CONTRACT ALLOCATED 42%

INHOUSE REMAINING 58%

MANUFACTURING METHODS AND TECHNOLOGY PROGRAM
 SUMMARY PROJECT STATUS REPORT
 2ND SEMIANNUAL SUBMISSION CY 85 RCS DRMT-301

PROJ NO.	TITLE + STATUS	AUTHORIZED (\$000)	CONTRACT VALUES (\$000)	EXPENDED LABOUR AND MATERIAL (\$000)	ORIGINAL PROJECTED COMPLETE DATE	PRESENT PROJECTED COMPLETE DATE
M 86 5001	DIAPHRAGM TEST MACHINE FOR MLRS FLUIDIC GENERATOR -----JUST FUNDED. NO 301 REQUIRED.-----					
M 86 5002	PATRIOT FUZE FLEX FIXTURE/ACCEPTANCE TEST LEVELS -----JUST FUNDED. NO 301 REQUIRED.-----					
M 85 5013	M732A FUZE PUMPER SUPPLY LEAK TEST SET -----DELINQUENT STATUS REPORT-----					
M 86 5013	M732A FUZE PUMPER SUPPLY LEAK TEST SET -----JUST FUNDED. NO 301 REQUIRED.-----					
M 81 6350	MATERIALS TESTING TECHNOLOGY (MTT)					
M 81 6350 2224	AUTOMATED ANTENNA PATTERN MEASUREMENT -----DELINQUENT STATUS REPORT-----					
M 81 6350 2401	CANNON TUBE AUTOMATIC MAGNETIC BURESCOPE INSPECTION	362.0	294.0	68.0	UCT 83	UCT 86
M 91 6350 2815	CANNON TUBE AUTOMATED CHROME PLATE THICKNESS MEASUREMENT	70.0		70.0	UCT 82	FEB 86
M 81 6350 2977	IMAGE INTENSIFIER SYSTEM VEILING GLARE TESTER	103.0		103.0	SEP 84	DEC 85
M 84 6350	MATERIALS TESTING TECHNOLOGY (MTT)					
M 84 6350 0001	QUALITY ENGINEERING ACTIVITIES -----DELINQUENT STATUS REPORT-----					
M 82 6350 0002	AUTOMATED CUSTOMER SUPPORT SYSTEM -----DELINQUENT STATUS REPORT-----					
M 82 6350 2640	TRACK TEST MACHINE	65.0				JUN 85
M 84 6350 2811	M42/M46 MAGNETIC FLUX LEAKAGE INSPECTION	125.0		100.0	FEB 84	MAR 86
M 82 6350 2878	PROTOTYPE INFRARED SEEKER AND AUTO PILOT TESTING	90.0		90.0		SEP 85
M 82 6350 2878	STRAIGHTENING OF GUN TUBE FORGINGS BY MEANS OF EMAT	63.0			JUN 86	MAR 87
M 84 6350 2889	PROCEDURES FOR INSPECTING + MONITORING THERMOPLASTIC RESINS	80.0			JUN 85	SEP 86
M 82 6350 2891	PC CUT MATERIAL SCREENING TEST	175.0			DEC 84	MAR 86
M 82 6350 2892	REMOTE IMAGING OF PREFORM DEFECTS BY COMPUTER CONTROL	85.0			DEC 83	JUL 86

MANUFACTURING METHODS AND TECHNOLOGY PROGRAM
 S U M M A R Y P R O J E C T S T A T U S R E P O R T
 2ND SEMIANNUAL SUBMISSION CY 85 RCS DRCHT-301

PRJ# WC.	TITLE + STATUS	AUTHO- RIZED (\$000)	CONTRACT VALUES (\$000)	EXPENDED LABOR AND MATERIAL (\$000)	ORIGINAL	PRESENT
					PROJECTED COMPLETE DATE	PROJECTED COMPLETE DATE
M 82 6350 2901	LASER AIMING DEVICE	233.0			AUG 84	APR 86
M 82 6350 2916	AUTOMATING DEPOT REBUILD COMPONENT DIMENSIONAL INSPECTION	290.0			JUL 85	APR 87
M 82 6350 2919	AUTO RESIDUAL STRESS INSP UF GUN TUBES + OTHER RELATED COMP	120.0			NOV 83	JAN 86
M 82 6350	MATERIALS TESTING TECHNOLOGY (MTT)	2,1149.0	656.6	1,243.4	OCT 84	OCT 86
M 83 6350 0001	QUALITY ENGINEERING ACTIVITIES -----DELINQUENT STATUS REPORT-----					
M 83 6350 0002	AUTOMATED CUSTOMER SUPPORT SYSTEM -----DELINQUENT STATUS REPORT-----					
M 83 6350 2876	PROTOTYPE INFRARED SLEEKER AND AUTOPILOT TESTING	310.0		310.0		SEP 85
M 83 6350 2889	PROCEDURES FOR INSPECTING + MONITORING THERMOPLASTIC RESINS	42.0			SEP 83	SEP 86
M 83 6350 2896	STANDARDIZED SOFTWARE TEST FACILITIES	191.0			SEP 85	APR 86
M 83 6350 2962	AUTOMATION OF 65 DEGREE-C PROPELLANT SURVEILLANCE TEST -----DELINQUENT STATUS REPORT-----				SEP 85	SEP 85
M 83 6350 2972	CAPILLARY GAS CHROMATOGRAPHIC TEST OF ARMY SOLID PROPELLANTS -----DELINQUENT STATUS REPORT-----				SEP 83	FEB 85
M 83 6350 2977	VEILING GLARL TESTER FOR IMAGE INTENSIFIER SYS	83.0		83.0		JUL 85
M 83 6350 2980	PORTABILITY OF TEST SOFTWARE FOR VESIC CHIPS	90.0			OCT 83	JUN 86
M 83 6350 2981	FLUIDIC POWER SUPPLY ACCEPTANCE TESTER -----DELINQUENT STATUS REPORT-----				JUL 85	JUL 85
M 84 6350	MATERIALS TESTING TECHNOLOGY (MTT)	4,062.0	1,662.2	2,399.8	OCT 85	OCT 86
M 84 6350 0001	QUALITY ENGINEERING ACTIVITIES -----DELINQUENT STATUS REPORT-----					
M 84 6350 0002	AUTOMATED CUSTOMER SUPPORT SYSTEM -----DELINQUENT STATUS REPORT-----					
M 84 6350 2642	ADV PENETRATING RADIATION TECH FOR PRODUCT EVALUATION	160.0		160.0	SEP 84	SEP 85
M 84 6350 2676	PROTOTYPE INFRARED SLEEKER AND AUTO PILOT TESTING	150.0		150.0	SEP 84	SEP 85

MANUFACTURING METHODS AND TECHNOLOGY PROGRAM
 S U M M A R Y P R O J E C T S T A T U S R E P O R T
 2ND SEMI-ANNUAL SUBMISSION CY 85 ACS DRCHT-301

PROJ NO.	TITLE + STATUS	AUTHOR- KIZED (\$000)	CONTRACT VALUES (\$000)	EXPENDED LABOR AND MATERIAL (\$000)	ORIGINAL PROJECTED COMPLETE DATE	PRESENT PROJECTED COMPLETE DATE
M 84 6350 2867	SIMULANT PERMEATION TESTING OF PROTECTIVE MATLS -----DELINQUENT STATUS REPORT-----					JUN 84
M 84 6350 2889	PROCEDURES FOR INSPECTING + MONITORING THERMOPLASTIC RESINS	50.0				SEP 86
M 84 6350 2891	PGCOTE MATERIAL SCREENING TEST	155.0			MAR 86	MAR 86
M 84 6350 2895	NOT OF ADVANCED COMPOSITES FOR BRIDGING -----DELINQUENT STATUS REPORT-----				MAR 85	AUG 85
M 84 6350 2896	STANDARDIZED SOFTWARE TEST FACILITIES	318.0			SEP 85	APR 86
M 84 6350 2914	AUTO ANALYTICAL + CONTROL SYSTEM FOR GAS LIFE TESTER	78.0			FEB 85	MAR 86
M 84 6350 2916	AUTOMATING DEPOT REBUILD COMPONENT DIMENSIONAL INSPECTION	308.0			JUL 86	APR 87
M 84 6350 2926	TESTING OF M55 DETONATOR STAB SENSITIVITY AND OUTPUT -----DELINQUENT STATUS REPORT-----				FEB 85	DEC 85
M 84 6350 2928	IN-PROCESS THREAD FORM INSPECTION	135.0			APR 86	APR 87
M 84 6350 2929	EVAL OF CPMCIUM ADHESION IN LARGE CALIBER GUNS	78.0	78.0			MAR 86
M 84 6350 2930	IDENTATION TEST FOR YIELD STRENGTH MEASUREMENT -----DELINQUENT STATUS REPORT-----				MAY 85	JUN 86
M 84 6350 2933	STABLE LIGHT SOURCE FOR LOW LEVEL PHOTOLUMTRIC MEAS RADLUM	79.0			APR 85	FEB 86
M 84 6350 2934	APPL OF AN X-RAY TV SYSTEM FOR RECORD + PROC OF DIFFRAT PAT	62.0			DEC 84	FEB 86
M 84 6350 2940	PROGRAMMABLE HIGH RESPONSE FUNCTIONAL ACCELERATION TESTER	109.0			JUL 86	AUG 87
M 84 6350 2945	BALLISTIC SIMULATION - SHUCK TESTING OF ARMAMENT COMPONENTS	160.0	160.0		MAR 86	NOV 85
M 84 6350 2974	SELECTIVE DETECTION OF GUN-BASE STABILIZERS + DECUMP PRG	83.0	83.0			JUN 85
M 84 6350 2978	TESTING AND EVALUATION OF QUARTZ CRYSTAL RESONATORS	100.0			JCT 85	MAR 86
M 84 6350 2979	PHOTOLUMINANCE TESTING OF GAAS PHOTOCATHODES	230.0			AUG 85	JUN 86
M 84 6350 2980	PORTABILITY OF TEST SOFTWARE FOR VHSIC CHIPS	105.0			APR 85	JUN 86
M 84 6350 2981	FLUIDIC PUMPER SUPPLY ACCEPTANCE TESTER -----DELINQUENT STATUS REPORT-----				MAR 85	DEC 85

MANUFACTURING METHODS AND TECHNOLOGY PROGRAM
 SUMMARY PROJECT STATUS REPORT
 2ND SEMIANNUAL SUBMISSION CY 85 RCS DREMT-301

PROJ NO.	TITLE + STATUS	AUTHORIZED (\$000)	CONTRACT VALUES (\$000)	EXPENDED LABOR AND MATERIAL (\$000)	ORIGINAL PROJECTED COMPLETE DATE	PRESENT PROJECTED COMPLETE DATE
M 84 6350 2989	DEPT INSP OF TRANSMISSION VALVE BODY -----DELINQUENT STATUS REPORT-----					DEC 84
M 84 6350 3006	ACOUSTIC EMISSION MONITORING/CONTROL OF GUN TUBE STRAIGHTEN	15.0		15.0	SEP 84	DEC 85
M 84 6350 3010	DIGITAL IMAGE AMPLIFICATION X-RAY SYSTEM (DIAX)	110.0			JAN 85	APR 86
M 84 6350 3015	METHODOLOGY FOR VERIFYING EDDY CURRENT + ULTRASONIC INSP	84.0			JAN 86	JAN 86
M 84 6350 3017	AUTOMATED ACCURACY TARGET SCURING SYSTEM -----DELINQUENT STATUS REPORT-----				JUN 85	JUN 85
M 84 6350 3021	MECH ACCEPT TEST METHODS FOR PENETRATOR COMP AND MATERIALS	50.0			JUN 86	JUN 86
M 84 6350 3027	120 MM GUN TUBE CHROME PLATE EVALUATION SYSTEM	27.0			JUL 86	UCT 86
M 84 6350 3045	FLUIDIC GENERATOR HIGH ALTITUDE SIMULATOR	100.0			MAR 85	SEP 85
M 84 6350 3093	MAGNETIC FLUX LEAKAGE INSPECTION OF THE 60MM M72J MORTAR	67.0				FEB 86
M 85 6350	MATERIALS TESTING TECHNOLOGY (MTT)	4,025.0	1,637.6	2,387.5	UCT 85	UCT 86
M 85 6350 2225	TRI-AXIAL VIBRATION TEST PROC FOR MISSILE + ARTILLERY FUZ	60.0		1.5	MAR 86	JUL 85
M 85 6350 2445	ULTRASONIC TIRE INSPECTION	94.0				SEP 86
M 85 6350 2642	ADV PENETRATING RADIATION TECH FOR PRODUCT EVALUATION	260.0		260.0	SEP 87	SEP 85
M 85 6350 2676	PROTOTYPE INFRARED SEEKER + AUTOPILOT TESTING	51.0		51.0	SEP 85	SEP 85
M 85 6350 2679	STRAIGHTENING OF GUN TUBE FORGINGS BY MEANS OF EMAT	166.0			JUL 86	MAR 87
M 85 6350 2689	PROCEDURES FOR INSPECTING + MONITORING THERMOPLASTIC RESINS	50.0			SEP 86	JFP 86
M 85 6350 2691	MOULTE MATERIAL SCREENING TEST	20.0				MAR 86
M 85 6350 2919	AUTO RESIDUAL STRESS INSP OF GUN TUBES + OTHER RELATED CUMP	70.0			AUG 86	AUG 85
M 85 6350 2929	EVAL OF CHROMIUM ADHESION IN LARGE CALIBER GUNS	42.0		42.0	FEB 86	MAR 86
M 85 6350 2930	INDENTATION TEST FOR YIELD STRENGTH MEASUREMENTS -----DELINQUENT STATUS REPORT-----				JUN 86	JUN 86
M 85 6350 2946	PROGRAMMABLE HIGH RESPONSE FUNCTIONAL ACCELERATION TESTER	93.0			AUG 87	AUG 87

MANUFACTURING METHODS AND TECHNOLOGY PROGRAM
 S O U T H E A S T S T A T E S R E P O R T
 2ND SEMIANNUAL SUBMISSION CY 85 RCS DRCHT-301

PKJ NO.	TITLE + STATUS	AUTHORIZED (\$000)	CONTRACT VALUES (\$000)	EXPANDED LABOR AND MATERIAL (\$000)	ORIGINAL PROJECTED COMPLETE DATE	PRESENT PROJECTED COMPLETE DATE
M 85 6350 2965	BALLISTIC SIMULATOR - SHOCK TESTING OF ARMAMENT COMPONENTS	80.0			MAY 86	MAY 86
M 85 6350 2971	PARTICLE SIZE TESTING OF BALLISTICS MODIFIERS + LIXIDIZERS	88.0			MAY 86	MAY 86
M 85 6350 2973	DIFFUSION PERMEABILITY+SOLUBILITY OF GASES IN MIN SIGNATURE PRGP	80.0		80.0	JAN 86	SEP 86
M 85 6350 2978	TESTING AND EVALUATION OF QUARTZ CRYSTAL RESONATORS	100.0			DEC 85	MAR 86
M 85 6350 2979	PHOTOLUMINANCE TESTING OF GAAS PHOTOCATHODES	14.0				JUN 86
M 85 6350 2980	PORTABILITY OF TEST SOFTWARE FOR VHSIC CHIPS	50.0				JUN 86
M 85 6350 2994	ALUMINUM WELD AE MONITOR	121.0			DEC 86	JCT 86
M 85 6350 3015	METHODOLOGY FOR MONITORING ULTRASONIC INSPECTION	42.0			JAN 86	JAN 86
M 85 6350 3021	MECHANICAL ACCEPTANCE TEST METHODS FOR PENETRATOR COMPONENTS	65.0			JUN 86	JUN 86
M 85 6350 3022	PRIMER IGNITION TEST SYSTEM -----DELINQUENT STATUS REPORT-----					
M 85 6350 3023	AUTOMATED PROPELLANT GRAIN IMAGE ANALYZER	160.0				AUG 86
M 85 6350 3024	STANDARD SOFTWARE REQUIREMENTS ENGINEERING LANGUAGE	40.0		40.0	JCT 86	DEC 85
M 85 6350 3027	120MM GUN TUBE CHROME PLATE EVALUATION SYSTEM	175.0			JCT 86	FEB 87
M 85 6350 3045	FLUIDIC GENERATOR HIGH ALTITUDE SIMULATOR	125.0			JUL 85	DEC 87
M 85 6350 3047	FIBER OPTIC COUPLED ISOTROPIC 'E' FIELD MEASUREMENT SYSTEM	225.0			AUG 87	AUG 87
M 85 6350 3055	ULTRASONIC TRANSDUCER CHARACTERIZATION	120.0		120.0	JCT 85	SEP 85
M 85 6350 3058	ESTABLISH HI-SENS GC/MS + GC/LD METHODS-ANAL F/CHEMICAL AGNT	75.0			JCT 85	FEB 86
M 85 6350 3063	CHEMICAL AGENT MONITOR TEST SYSTEM	115.0			DEC 87	JUL 87
M 85 6350 3075	NONDESTRUCTIVE TEST DEVICE FOR CDS DETECTOR -----DELINQUENT STATUS REPORT-----					SEP 86
M 85 6350 3080	TURNABLE EYESAFE LASER EVALUATION SYSTEM (TELES)	150.0			SEP 86	SEP 86
M 85 6350 3081	DIAPHRAGM TESTING MACHINE FOR MLRS FLUIDIC GENERATOR	150.0			APR 87	JCT 87
M 85 6350 3082	FLEX FIXTURE/ACCEPTANCE LEVELS FOR PATRIOT FUZE ELECTRONICS	80.0			JAN 86	JUN 86

MANUFACTURING METHODS AND TECHNOLOGY PROGRAM
 SUMMARY PROJECT STATUS REPORT
 2ND SEMIANNUAL SUBMISSION CY 85 RCS DRCMT-301

PROJ NO.	TITLE + STATUS	AUTHO- RIZED (\$000)	CONTRACT VALUES (\$000)	EXPENDED LABOR AND MATERIAL (\$000)	ORIGINAL	PRESENT
					PROJECTED COMPLETE DATE	PROJECTED COMPLETE DATE
M 85 6350 3083	EFFICIENT TEST SOFTWARE FOR EVALUATING MUI MICROCHIPS	160.0			SEP 86	SEP 86
M 85 6350 3084	NONDESTRUCTIVE TESTING OF COMBUSTIBLE CARTRIDGE CASES	232.0			JUL 86	DEC 86
M 85 6350 3085	TOMOGRAPHIC AUTOMATIC INSPECTION OF MUNITIONS (TAIM)	182.0			MAY 87	MAY 87
M 85 6350 3091	DETERMINATION OF SILVER IN IMPREGNATED CHARCOAL	38.0			MAY 86	MAY 86
M 85 6350 3094	SOFTWARE TEST DRIVERS	110.0			OCT 86	OCT 86
M 85 6350 3095	INFRARED NONDESTRUCTIVE INSP (IRNDI) OF PRINTER CIRCUIT BOARD	130.0			FEB 86	MAR 86
M 86 6350	MANUFACTURING TESTING TECHNOLOGY	2,596.0	1,584.9	1,011.0	OCT 86	OCT 86
M 86 6350 1001	STICK PRIP AUTO INSPECT BY RADIOLOGY -----JUST FUNDED. NO 301 REQUIRED.-----					
M 86 6350 1026	AUTOMATIC ARTILLERY ROCKET GRAIN INSPECTION SYS -----JUST FUNDED. NO 301 REQUIRED.-----					
M 86 6350 1006	GAS PHASE LEAK TESTER F/PROTECTIVE MASKS -----JUST FUNDED. NO 301 REQUIRED.-----					
M 86 6350 1901	ADVANCED MEASURE OF HOT ROTARY FURGED TUBE WALL VARIATION -----JUST FUNDED. NO 301 REQUIRED.-----					
M 86 6350 2225	TRI-AXIAL VIBRATION TEST PROCS F/MISSILE + ARTILLERY FUZE -----JUST FUNDED. NO 301 REQUIRED.-----					
M 86 6350 2889	PROCEDURES FOR INSPECTING + MONITORING THERMOPLASTIC RESINS	60.0			SEP 86	SEP 86
M 86 6350 2916	AUTOMATED DEPOT REBUILD COMPONENT DIMENSIONAL INSPECTION -----JUST FUNDED. NO 301 REQUIRED.-----					
M 86 6350 2933	STABLE LIGHT SOURCE F/LOW-LEVEL MEAS. OF RADIOLUMINOUS LAMPS -----JUST FUNDED. NO 301 REQUIRED.-----					
M 86 6350 2947	MOBILITY MONITORING SYSTEM -----JUST FUNDED. NO 301 REQUIRED.-----					
M 86 6350 3023	AUTOMATED PROPELLANT GRAIN IMAGE ANALYZER	25.0			AUG 86	AUG 86
M 86 6350 3047	FIBER OPTIC COUPLED ISOTROPIC -E- FIELD MEASUREMENT SYSTEM	225.0			AUG 87	AUG 87
M 86 6350 3063	TEST SYSTEM FOR THE CHEMICAL AGENT MONITOR	95.0			DEC 87	DEC 87

MANUFACTURING METHODS AND TECHNOLOGY PROGRAM
 S U M M A R Y P R O J E C T S T A T U S R E P O R T
 2ND SEMI ANNUAL SUBMISSION CY 85 RCS URCHT-301

PROJ NO.	TITLE + STATUS	AUTHORIZED (\$000)	CONTRACT VALUES (\$000)	EXPENDED LABOR AND MATERIAL (\$000)	ORIGINAL PROJECTED COMPLETE DATE	PRESENT PROJECTED COMPLETE DATE
M 86 6350 3075	NDT CHARACTER OF MISSILE DETECTOR MATERIALS -----JUST FUNDED. NO 301 REQUIRED.-----	125.0			SEP 86	SEP 86
M 86 6350 3080	TUNABLE EYESAFE LASER EVALUATION SYSTEM (TELES)	229.0			MAY 87	MAY 87
M 86 6350 3085	TOPOGRAPHIC AUTOMATIC INSPECTION OF MUNITIONS		128.7		MAR 85	JUN 86
M 86 6350 5017	EX-JAM BALLISTIC TEST EVAL EQUIPMENT -----JUST FUNDED. NO 301 REQUIRED.-----	250.0			MAR 85	JUN 86
M 84 6390	PROGRAM IMPLEMENTATION AND INFORMATION TRANSFER -----DELINQUENT STATUS REPORT-----	250.0	229.3	0.4	MAR 86	MAY 86
M 85 6390	PROGRAM IMPLEMENTATION + INFORMATION TRANSFER -----DELINQUENT STATUS REPORT-----					
M 86 6390	PROGRAM IMPLEMENTATION AND INFORMATION TRANSFER -----JUST FUNDED. NO 301 REQUIRED.-----					

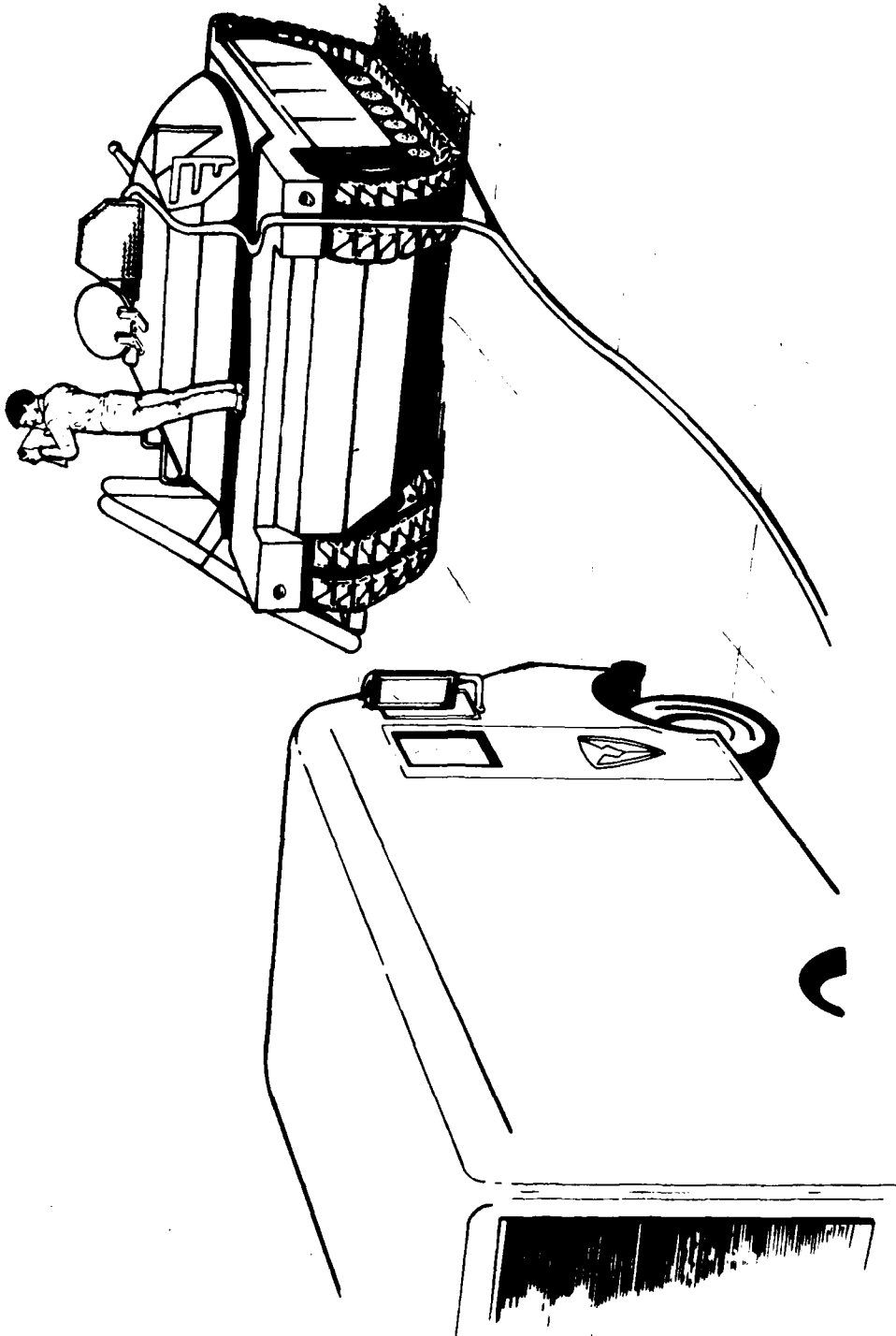

**TEST AND EVALUATION COMMAND
(TECOM)**

TEST AND EVALUATION COMMAND

CURRENT FUNDING STATUS, 2ND CY85

FISCAL YEAR	NU. OF PROJECTS	AUTHORIZED FUNDS (\$)	CONTRACT FUNDS ALLOCATED (\$)	CONTRACT FUNDS EXPENDED (\$)	INHOUSE FUNDS REMAINING (\$)	INHOUSE FUNDS EXPENDED (\$)
81	1	770,000	0	0 (0%)	770,000	769,000 (99%)
82	1	726,000	0	0 (0%)	726,000	725,400 (99%)
83	1	1,038,000	0	0 (0%)	1,038,000	436,000 (42%)
84	1	1,018,000	0	0 (0%)	1,018,000	940,000 (92%)
85	1	1,098,000	0	0 (0%)	1,098,000	950,000 (86%)
86	1	0	0	0 (0%)	0	0 (0%)
TOTAL	6	4,650,000	0	0 (0%)	4,650,000	3,820,400 (82%)

AUTHORIZED FUNDING CONTRACT ALLOCATED 0% INHOUSE REMAINING 100%

MANUFACTURING METHODS AND TECHNOLOGY PROGRAM
 SUMMARY PROJECT STATUS REPORT
 2ND SEMI-ANNUAL SUBMISSION CY 85 RCS DRCHT-301

PROJ NO.	TITLE + STATUS	AUTHORIZED (\$000)	CONTRACT VALUES (\$000)	EXPENDED LABOR AND MATERIAL (\$000)	ORIGINAL PROJECTED COMPLETE DATE	PRESENT PROJECTED COMPLETE DATE
0 81 5071	TECOM PRODUCTION TEST METHODOLOGY ENGINEERING MEASURES	770.0		769.0	DEC 83	DEC 87
0 81 5071 37	ROLLOVER TEST OF MILITARY VEHICLES				DEC 83	MAR 86
0 81 5071 59	SOLAR POWERED INSTRUMENTATION VAN				DEC 83	DEC 85
0 81 5071 67	INTEROPERABILITY TEST METHODOLOGY				DEC 83	DEC 85
0 81 5071 71	COPPER CRUSHER PRESSURE GAGES				DEC 83	DEC 87
0 81 5071 76	GAMMA DOSIMETRY IMPROVEMENT + MODERNIZATION PROGRAM				DEC 83	DEC 86
0 81 5071 77	ELECTROMAGNETIC RADIATION EFFECTS/SUSCEPTIBILITY OF ARMY MAT				DEC 83	DEC 87
0 82 5071	TECOM PRODUCTION TEST METHODOLOGY ENGINEERING MEASURES	726.0		725.4	DEC 84	DEC 87
0 82 5071 37	ROLLOVER TEST OF MILITARY VEHICLES					MAR 86
0 82 5071 59	SOLAR POWERED INSTRUMENTATION VAN					DEC 85
0 82 5071 67	INTEROPERABILITY TEST METHODOLOGY					DEC 85
0 82 5071 71	COPPER CRUSHER PRESSURE GAGES					DEC 87
0 82 5071 76	GAMMA DOSIMETRY IMPROVEMENT + MODERNIZATION PROGRAM					DEC 86
0 82 5071 77	ELECTROMAGNETIC RADIATION EFFECTS + SUSCEPTIBILITY OF ARMY MAT					DEC 87
0 82 5071 81	BINARY MUNITIONS PRODUCTION TEST METHODOLOGY					MAR 86
0 82 5071 90	TOXIC GAS ANAL BY GAS CHROMATOGRAPHY				DEC 84	JUL 85
0 82 5071 95	RAPID EVALUATION OF ENVIRONMENTAL HAZARDS					MAR 86
0 83 5071	TECOM PRODUCTION TEST METHODOLOGY ENGINEERING MEASURES	1,038.0		436.0	DEC 85	JUL 87
0 83 5071 59	SOLAR POWERED INSTRUMENTATION VAN					DEC 85
0 83 5071 67	INTEROPERABILITY TEST METHODOLOGY				JUN 83	JUL 85
0 83 5071 71	IMPROVED COPPER CRUSHER PRESSURE GAGES					DEC 87
0 83 5071 76	GAMMA DOSIMETRY IMPROVEMENT + MODERNIZATION PROGRAM					DEC 86
0 84 5071	TECOM PRODUCTION TEST METHODOLOGY ENGINEERING MEASURES	1,018.0		940.0	DEC 86	JUL 86

MANUFACTURING METHODS AND TECHNOLOGY PROGRAM
 S U M M A R Y P R O J E C T S T A T U S R E P O R T
 2ND SEMIANNUAL SUBMISSION CY 85 RCS DRCHT-301

PROJ NO.	TITLE + STATUS	AUTHORIZED (\$000)	CONTRACT VALUES (\$000)	EXPENDED LABOR AND MATERIAL (\$000)	ORIGINAL PROJECTED COMPLETE DATE	PRESENT PROJECTED COMPLETE DATE
0 84 5071 121	REAL TIME MEASUREMENT OF TOTAL HCL IN ROCKET MOTOR EXHAUST				DEC 86	DEC 86
0 84 5071 130	SOFTWARE INFO RETRIEVAL SYSTEM + REPOSITORY				DEC 86	MAR 86
0 84 5071 142	COMPILATION OF PROJECTILE DRAG COEFFICIENTS				DEC 86	MAR 86
0 84 5071 37	ROLL-OVER TESTS OF MILITARY VEHICLES				SEP 84	MAR 86
0 84 5071 59	SOLAR POWERED INSTRUMENTATION VAN				DEC 86	DEC 85
0 84 5071 67	INTEROPERABILITY TEST METHODOLOGY				DEC 86	DEC 85
0 84 5071 76	UPGRADING OF THE GAMMA POSITRON PROGRAM				DEC 86	DEC 86
0 84 5071 95	KAPPA DETERM OF ENVIRON HAZARDS-BINARY AGENT PERSIST + DECAY				DEC 86	MAR 86
0 85 5071	TECOM PRODUCTION TEST METHODOLOGY ENGRS METHODS	1,098.0		950.0	DEC 87	DEC 87
0 85 5071 01	ACCEPTANCE TEST PROCEDURES				SEP 85	DEC 87
0 85 5071 10	TEST OPERATIONS PROCEDURES - TUPS				SEP 85	DEC 87
0 85 5071 113	PRUG FLOW ANALYZER TOOLS F/CUMP SOFTWARE SYS SPEC ENCODERS				DEC 87	DEC 85
0 85 5071 115	ADAPTATION OF COMPUTER AID TOMOGRAPHY TO MISSILE RADIOGRAPHY				DEC 87	DEC 87
0 85 5071 121	REAL TIME MEASUREMENT OF TOTAL HCL IN ROCKET MOTOR EXHAUST				DEC 87	DEC 87
0 85 5071 130	SOFTWARE CONFIGURATION MANAGEMENT/REPOSITORY				DEC 87	DEC 87
0 85 5071 140	HUMAN FACTORS ENGINEERING FIELD INSTRUMENTATION PACKAGE				DEC 87	DEC 87
0 85 5071 143	VEHICLE PERFORMANCE RECORDER				DEC 87	DEC 87
0 85 5071 74	IMPROVE OF SMCKE MUNIT/GENERATOR PRODUCTION TEST PROCEDURES				DEC 87	DEC 87
0 85 5071 76	UPGRADING OF GAMMA DUSIMETRY PROGRAM				DEC 87	DEC 87
0 85 5071 90	TOXIC GAS ANAL BY GAS CHROMATOGRAPHY				DEC 87	DEC 87
0 86 5071	TECOM PRODUCTION METHODOLOGY ENGINEERING MEASURES -----JUST FUNDED. NO 301 REQUIRED.-----				DEC 87	DEC 85

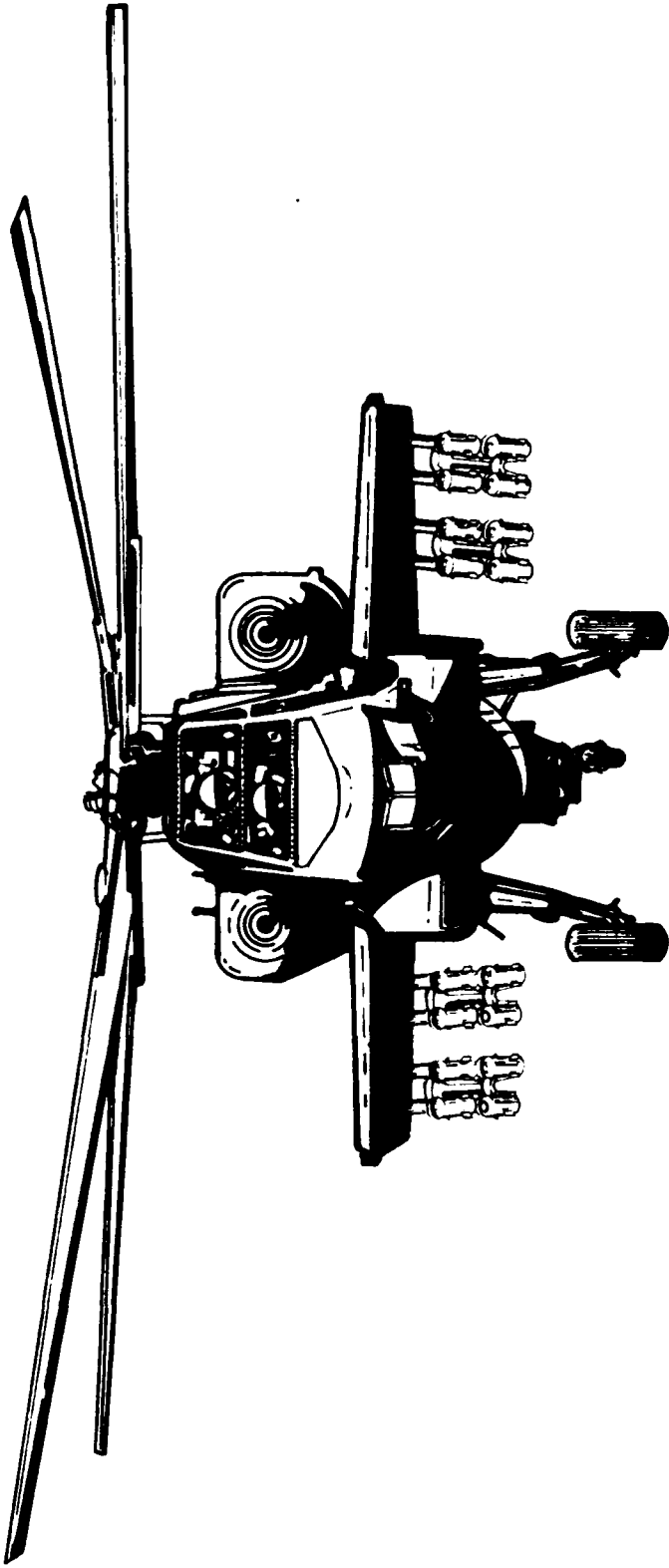

**AVIATION SYSTEMS COMMAND
(AVSCOM)**

AVIATION SYSTEMS COMMAND

CURRENT FUNDING STATUS, 2ND CYRS

FISCAL YEAR	NO. OF PROJECTS	AUTHORIZED FUNDS (\$)	CUNTRACT FUNDED ALLOCATED (\$)	EXPENDED (\$)	PERCENTAGE (%)	FUND BALANCE REMAINING (\$)	PERCENTAGE (%)
61	2	645,000	581,300	543,500	(91%)	63,700	(100%)
62	6	5,105,000	4,854,600	4,067,700	(83%)	350,400	(98%)
63	4	4,437,200	3,441,500	2,700,200	(76%)	895,700	(39%)
64	11	7,078,500	3,377,200	1,555,600	(46%)	3,700,800	(44%)
65	10	3,826,800	2,577,100	152,000	(5%)	1,249,700	(54%)
66	10	0	0	0	(0%)	0	(0%)
TOTAL	55	21,172,000	14,931,700	9,009,000	(60%)	6,240,300	(49%)

ACTORIZED FUNDING CONTRACT ALLOCATED 71% INHOUSE REMAINING 29%

MANUFACTURING METHODS AND TECHNOLOGY PROGRAM
 S U M M A R Y P R O J E C T S T A T U S R E P O R T
 2ND SEMIANNUAL SUBMISSION CY 85 RCS DRGMT-301

PROJ NO.	TITLE + STATUS	AUTHO- RIZED (\$000)	CONTRACT VALUES (\$000)	EXPENDED LABOR AND MATERIAL (\$000)	ORIGINAL PROJECTED COMPLETE DATE	PRESENT PROJECTED COMPLETE DATE
1 81 7143	CERAMIC GAS PATH SEAL-HIGH PRESSURE TURBINE -----DELINQUENT STATUS REPORT-----	430.0	396.8	33.2	FEB 83	JUN 86
1 82 7143	CERAMIC HIGH-PRESSURE GAS PATH SEAL -----DELINQUENT STATUS REPORT-----	405.0	357.2	45.0	FEB 83	JUN 86
1 82 7291	TITANIUM POWDER METAL COMPRESSOR IMPELLER	275.0	210.0	65.0	MAR 84	SEP 86
1 83 7298	HIGH TEMPERATURE VACUUM CARBURIZING	375.0	340.0	35.0	SEP 84	JCT 86
1 84 7298	HIGH TEMPERATURE VACUUM CARBURIZING	400.0	252.4	92.0	SEP 85	JEC 86
1 85 7300	IMPROVED LOW CYCLE FATIGUE CAST ROTORS	85.0	29.8	23.2	SEP 85	SEP 86
1 85 7302	PROD OF DEBRIDE COATED LONG LIFE TOOLS	400.0	248.0	140.0	FEB 82	APR 87
1 82 7322	LOW-COST TRANSPIRATION-COOLED COMBUSTOR LINER	530.0	460.0	70.0	MAR 85	MAR 86
1 84 7344	RIM MOLDING OF HELICOPTER COMPONENTS	175.0	124.0	50.0	AUG 85	FEB 86
1 85 7344	RIM MOLDING OF HELICOPTER COMPONENTS	205.0	114.9	12.4	FEB 87	JAN 87
1 82 7351	COMPOSITE SHAFTING FOR TURBINE ENGINES	404.0	328.9	75.0	SEP 83	APR 86
1 84 7371	INTEGRATED BLADE INSPECTION SYSTEM (IBIS) -----DELINQUENT STATUS REPORT-----	470.0		468.0	DEC 84	JUN 86
1 84 7376	AUTO INSPECT AND PRECISION GRINDING OF SB GEARS -----DELINQUENT STATUS REPORT-----	245.0	164.5	30.0	DEC 84	JUN 86
1 82 7376	AUTO INSPECT AND PRECISION GRINDING OF SB GEARS -----DELINQUENT STATUS REPORT-----	1,012.0	939.5	70.0	JUN 85	JUN 86
1 84 7382	LOW-COST COMPOSITE MAIN BLADE FOR THE UH-60A	555.0	477.0	157.9	SEP 84	FEL 86
1 84 7383	MOLDED HARDWARE FOR TWO AXIS DRY GYRUS	303.0	218.8	83.0	JUN 85	APR 86
1 85 7383	MOLDED HARDWARE FOR TWO AXIS DRY GYRUS	150.0	135.6	54.3	FEB 87	FEB 87
1 84 7384	COMPOSITE ENGINE GEARBOX HOUSING	670.0		120.0	DEC 85	MAY 88
1 85 7384	COMPOSITE ENGINE GEARBOX HOUSING	740.0	610.0	15.0	SEP 87	MAY 88
1 85 7384	COMPOSITE ENGINE GEARBOX HOUSING -----JUST FUNDED, NO 301 REQUIRED.-----					

SUMMARY PROJECT STATUS REPORT
2ND SEMIANNUAL SUBMISSION CY 85 RCS DRGMT-301

PROJ NO.	TITLE + STATUS	AUTHORIZED (\$000)	CONTRACT VALUES (\$000)	EXPENDED LABOR AND MATERIAL (\$000)	ORIGINAL PROJECTED COMPLETE DATE	PRESENT PROJECTED COMPLETE DATE
1 84 7389	PRODUCTION OF ALUMINUM AIRFRAME COMPONENTS	417.0	332.0	85.0	JUN 85	MAK 86
1 84 7389	PROD OF ALUMINUM AIRFRAME COMPONENTS (SUPERPLASTIC FURNING)	225.0	139.8	85.2	JUN 85	MAK 86
1 84 7416	ADVANCED TURBINE AIRFOIL CASTINGS FOR LONG LIFE	365.0	300.0	65.0	DEC 86	JUL 86
1 85 7416	ADVANCED TURBINE AIRFOIL CASTINGS FOR LONG LIFE	316.8	22.0	158.2	JUL 86	JUL 86
1 86 7416	ADVANCED TURBINE AIRFOIL CASTINGS FOR LONG LIFE -----JUST FUNDED, NO 301 REQUIRED.-----					
1 84 7417	LOW-COST DISKS BY CAP -CONSOLIDATION BY ATMOSPHERIC PRESSURE	275.0	250.0	25.0	JUN 87	JUN 87
1 85 7417	LOW COST DISKS BY CONSOLIDATED ATMOSPHERIC PRESSURE	475.0	400.0	70.0	JUN 87	JUN 87
1 86 7417	LOW COST DISKS BY CAP -----JUST FUNDED, NO 301 REQUIRED.-----					
1 83 7427	ATTACK HELICOPTER PRODUCTIVITY IMPROVEMENT (API) PROGRAM -----DELINQUENT STATUS REPORT-----	1,585.0	1,265.4	129.6	MAR 84	JUN 86
1 83 7423	MMT - IPI PGM - BELL HELICOPTER, INC. - AHIP -----DELINQUENT STATUS REPORT-----	1,034.2	1,024.1	10.1	MAY 84	JUN 85
1 84 7456	ADVANCED FUSELAGE TOOLING -----DELINQUENT STATUS REPORT-----	522.0		62.0	NOV 87	JUL 88
1 85 7456	LOW COST TOOLING FOR AIRFRAME COMPONENTS	419.0	409.0	10.0	NOV 87	JCT 87
1 86 7456	LOW COST TOOLING FOR AIRFRAME COMPONENTS -----JUST FUNDED, NO 301 REQUIRED.-----					
1 83 7465	ADVANCED COMPOSITE SENSOR SUPPORT STRUCTURE (ALS-3)	1,443.0	892.0	174.7	APR 84	MAY 86
1 84 7465	FABRICATION TECH F/ADVANCED COMPOSITE SENSOR SUPPORT STRUCT -----DELINQUENT STATUS REPORT-----	515.0				
1 85 7465	FABRICATION TECHNIQUES FOR ADVANCED COMPOSITE SENSOR -----DELINQUENT STATUS REPORT-----					
1 84 7468	INTEGRATION OF ADVANCED REPAIR BONDING	500.0		241.2	JUN 86	JAN 87
1 84 7470	FRANGIBLE HELIX AUTOMATIC POWER CRIMPER	218.0	150.0	68.0	FEB 86	AUG 86
1 84 7471	PROCESS CONTROL SYSTEM FOR N/C AND CNC MACHINES	200.0	155.0	43.4	JUL 86	MAK 87

MANUFACTURING METHODS AND TECHNOLOGY PROGRAM
 S U M M E R P R O J E C T S T A T U S R E P O R T
 2ND SEMIANNUAL SUBMISSION CY 85 RCS URCHT-301

PROJ NO.	TITLE * STATUS	AUTHO- RIZED (\$000)	CONTRACT VALUES (\$000)	EXPENDED		ORIGINAL PROJECTED COMPLETE DATE	PRESENT PROJECTED COMPLETE DATE
				LABOR AND MATERIAL (\$000)	LABOR AND MATERIAL (\$000)		
1 85 7471	PROCESS CONTROL SYSTEM FOR N/C AND CNC MACHINES	485.0	227.0	66.0	66.0	JUL 86	MAR 87
1 84 7472	SURFACE HARDENING GEARS BY LASER	455.0	425.0	30.0	30.0	DEC 85	JUN 88
1 85 7472	SURFACE HARDENING GEARS BY LASER	60.0		25.0	25.0	SEP 85	JUN 86
1 85 7472	SURFACE HARDENING GEARS BY LASER ----JUST FUNDED, NO 301 REQUIRED.----						
1 85 7473	MMC - FIBER REINFORCED THERMOPLASTIC STRUCTURES	610.0	575.0	35.0	35.0	MAY 87	MAY 87
1 85 7473	FIBER REINFORCED THERMOPLASTIC STRUCTURES ----JUST FUNDED, NO 301 REQUIRED.----						
1 84 7474	SINGLE CORE TAIL ROTOR	148.0	118.0	30.0	30.0	NOV 85	SEP 86
1 85 7474	SINGLE CORE TAIL ROTOR	256.0	241.0	15.0	15.0	MAR 86	SEP 86
1 85 7474	SINGLE COPE TAIL ROTOR ----JUST FUNDED, NO 301 REQUIRED.----						
1 86 7487	ADVANCED CORROSION RESISTANT BEARINGS ----JUST FUNDED, NO 301 REQUIRED.----						
1 85 7535	AUTOMATED PRECISION GRINDING OF SPUR GEARS BY CNC ----DELINQUENT STATUS REPORT----						
1 85 7548	EROSION PROTECTION FOR COMPRESSOR AIRFUELS ----JUST FUNDED, NO 301 REQUIRED.----						
1 85 7549	ECM OF 1700 COMPRESSOR BLISKS ----DELINQUENT STATUS REPORT----						
1 86 7549	ECM OF 1700 COMPRESSOR BLISKS ----JUST FUNDED, NO 301 REQUIRED.----						
1 85 7558	AH-64 AUTOMATED WIRE HARNESS FABRICATION ----DELINQUENT STATUS REPORT----						
1 82 8192	TURBINE SHAFT PRODUCTIVITY IMPROVEMENT ----DELINQUENT STATUS REPORT----	2,559.0	2,559.0			MAR 84	JUN 86

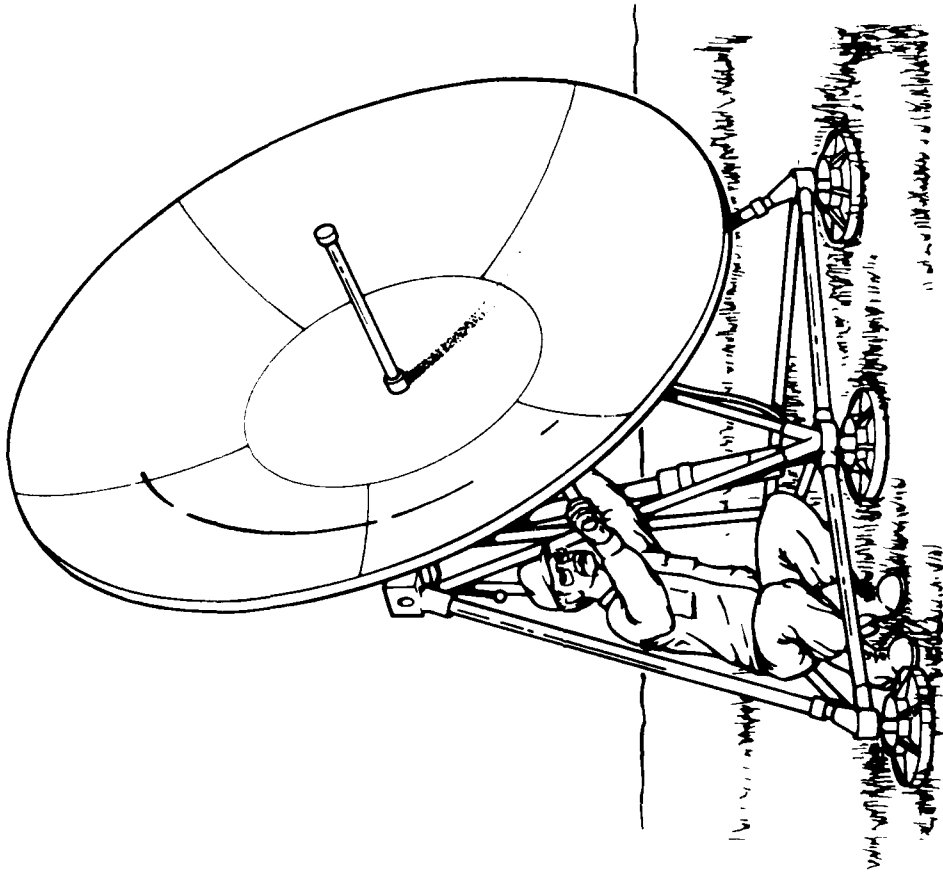

COMMUNICATIONS AND ELECTRONICS COMMAND (CECOM)

COMMUNICATIONS * ELECTRONICS COMMAND

CURRENT FUNDING STATUS, 2ND CY85

FISCAL YEAR	NO. OF PROJECTS	AUTHORIZED FUNDS (\$)	C U N T R A C T A L L O C A T E D (\$)	F U N D I N G E X P E N D E D (\$)	I N H O U S E R E M A I N I N G (\$)	F U N D I N G E X P E N D E D (\$)
75	1	369,200	278,700	0 (0%)	90,500	90,500 (100%)
80	2	1,360,000	1,198,500	996,500 (83%)	161,500	161,100 (99%)
81	4	5,015,300	4,716,500	4,080,800 (86%)	299,000	253,700 (84%)
82	2	2,040,000	1,855,500	1,772,000 (95%)	164,500	184,400 (99%)
83	2	1,282,500	1,253,700	1,253,700 (100%)	28,800	20,700 (71%)
84	6	7,516,800	7,189,300	6,911,300 (96%)	327,500	298,800 (91%)
85	12	3,992,400	3,788,800	2,109,000 (55%)	203,600	122,300 (60%)
86	10	3,348,100	2,442,800	0 (0%)	905,300	1,500 (0%)
TOTAL	39	24,924,300	22,723,600	17,123,300 (75%)	2,200,700	1,133,000 (51%)

AUTHORIZED FUNDING CONTRACT ALLOCATED 91%

IN-HOUSE REMAINING 6%

MANUFACTURING METHODS AND TECHNOLOGY PROGRAM
 SUMMARY PROJECT STATUS REPORT
 2ND SEMIANNUAL SUBMISSION CY 85 RCS DRCMT-301

PROJ NO.	TITLE + STATUS	AUTHORIZED (\$000)	CONTRACT VALUES (\$000)	EXPENDED LABOUR AND MATERIAL (\$000)	ORIGINAL PROJECTED COMPLETE DATE	PRESENT PROJECTED COMPLETE DATE
F 81 3050	EPITAXY OF III-V SEMICONDUCTOR PHOTODETECTORS	892.0	810.0	37.0	DEC 83	JAN 87
F 80 3094	PRODUCTION METHODS FOR MULTI-LAYER FOLDED CIRCUITS	780.0	706.1	73.5	SEP 82	APR 86
F 81 3056	ELECTROLUMINESCENT NUMERIC MODULES	1,271.0	1,131.7	139.0	DEC 82	JUN 86
F 81 3057	HIGH STABILITY VIBRATION RESISTANT QUARTZ CRYSTALS	1,785.3	1,717.6	67.7	JUL 83	JAN 87
F 83 3068	INCREASE PRODUCEABILITY OF VARACTORS AND PIN DIODES	217.0	210.0		JUL 85	MAR 86
F 84 3069	INCREASE PRODUCEABILITY OF VARACTORS AND PIN DIODES	250.0	220.5	0.0	JUL 85	MAR 86
F 85 3068	INCREASE PRODUCEABILITY OF VARACTORS + PIN DIODES (CAM)	29.0	23.6		AUG 85	MAR 86
F 82 3075	TACTICAL GRAPHICS DISPLAY PANEL	950.0	881.5	68.4	UCT 84	JUL 86
F 82 3063	RM WAVE COMMUNICATIONS FRONT END MODULE (CFEM)	1,090.0	974.0	116.0	JUN 84	FEB 87
F 85 3090	GAINASP LIGHT EMITTING DIODE PACKAGING	30.0		30.0	SEP 86	JAN 87
F 85 3090	GAINASP LIGHT EMITTING DIODE PACKAGING	40.0			JAN 87	JAN 87
F 85 3094	COMMUNICATIONS TECHNOLOGY TECHMOD FOR JTIDS	1,065.5	1,043.7	20.7	SEP 84	JAN 87
F 84 3094	COMMUNICATIONS TECHNOLOGY TECHMOD FOR JTIDS (CAM)	1,352.0	1,352.0		UCT 85	JAN 87
F 85 3094	COMMUNICATIONS TECHNOLOGY TECHMOD FOR JTIDS	765.0	766.9	15.0	UCT 86	JAN 87
F 86 3094	COMMUNICATIONS TECHNOLOGY TECHMOD FOR JTIDS	988.0	809.0	1.0	JAN 87	JAN 87
F 85 3105	CONTROL OF GAAS BOULE DIAMETER	413.0	410.0	0.7	APR 87	APR 87
F 86 3108	CONTROL OF GAAS BOULE DIAMETER	211.1	209.1		APR 87	APR 87
F 85 3111	PMT AUTOMATIC MATCHING OF IMPEDANCE	248.0	245.0	0.5	AUG 87	AUG 87
F 86 3111	AUTOMATIC ADJUSTMENT OF MICROWAVE CIRCUITS	215.0	210.0		AUG 87	AUG 87
F 85 3119	AUTOMATED INTERGREN TRANSFER OF GLASS PREFORMS	100.0	100.0		MAY 86	FEB 87
F 86 3119	AUTOMATED INTERGREN TRANSFER OF GLASS PREFORMS	129.0	124.0		FEB 87	FEB 87
F 86 3501	THIRD GENERATION PHOTOLITHOGRAPHY ON FIBER OPTIC FACEPLATE	500.0	492.4	87.6	MAR 82	MAR 86
F 85 3059	LINEAR RESONANCE COOLERS	485.0	465.0		APR 85	JUL 86

MANUFACTURING METHODS AND TECHNOLOGY PROGRAM
 SUMMARY PROJECT STATUS REPORT
 2ND SEMIANNUAL SUBMISSION CY 85 RCS DRCHT-301

PROJ NO.	TITLE + STATUS	AUTHORIZED (\$000)	CONTRACT VALUES (\$000)	EXPENDED LABOR AND MATERIAL (\$000)	ORIGINAL PROJECTED COMPLETE DATE	PRESENT PROJECTED COMPLETE DATE
H 86 5059	LINEAR RESONANCE COOLERS - PHASE I (NVEOL)	533.0			NOV 86	NOV 86
H 84 5111	VAPOR GROWTH FOR THIRD GENERATION PHOTOCATHODE	321.0	321.0		SEP 85	SEP 86
F 85 5111	VAPOR GROWTH FOR THIRD GENERATION PHOTOCATHODE	61.1			SEP 86	SEP 86
H 84 5151	LIQUID PHASE EPITAXY OF HCCDTE F/CUMHBN MOD UET ARRAYS-PH II	3,238.9	3,065.9	173.0	MAR 85	MAY 86
H 84 5180	LOW COST DEWAR + INTERCONNECT ASSEMBLY - PHASE II	2,104.9	1,979.9	125.0	JUN 85	DEC 86
F 85 5180	LOW COST DEWAR + INTERCONNECT ASSEMBLY - PHASE II	857.3	782.3	75.0	JUL 86	JEC 86
H 86 5180	HMT FOR METAL DEWAR AND UNBONDED LEADS (NVEOL)	548.0	548.0		DEC 86	DEC 86
H 84 7000	LASER POLARIZERS	250.0	250.0		AUG 85	JCT 86
H 85 7000	LASER POLARIZERS	173.0	173.0		JUL 86	JCT 86
H 86 7000	LASER POLARIZERS (NVEOL)	157.0	157.0		JCT 86	JCT 86
2 85 9239	AUTOTEST OF MICROWAVE DEVICE WAFERS (CAM)	608.0	603.0	0.5	DEC 86	DEC 86
2 86 9289	AUTOTEST OF MICROWAVE DEVICE WAFERS (CAM)	352.0	326.7		DEC 86	DEC 86
2 85 9290	HMT AUTOMATIC MICROWAVE SEMICONDUCTOR DEVICE TESTING	203.0	200.0		JUL 87	JAN 87
2 86 9290	AUTOMATIC MICROWAVE SEMICONDUCTOR DEVICE TESTING	315.0			JAN 87	JAN 87
H 79 9238	MINIATURE CATHODE RAY TUBES	309.2	278.7	90.5	AUG 81	AUG 86
F 81 9851	TACTICAL MINIATURE CRYSTAL OSCILLATORS	1,007.0	1,057.0		MAR 84	MAR 86

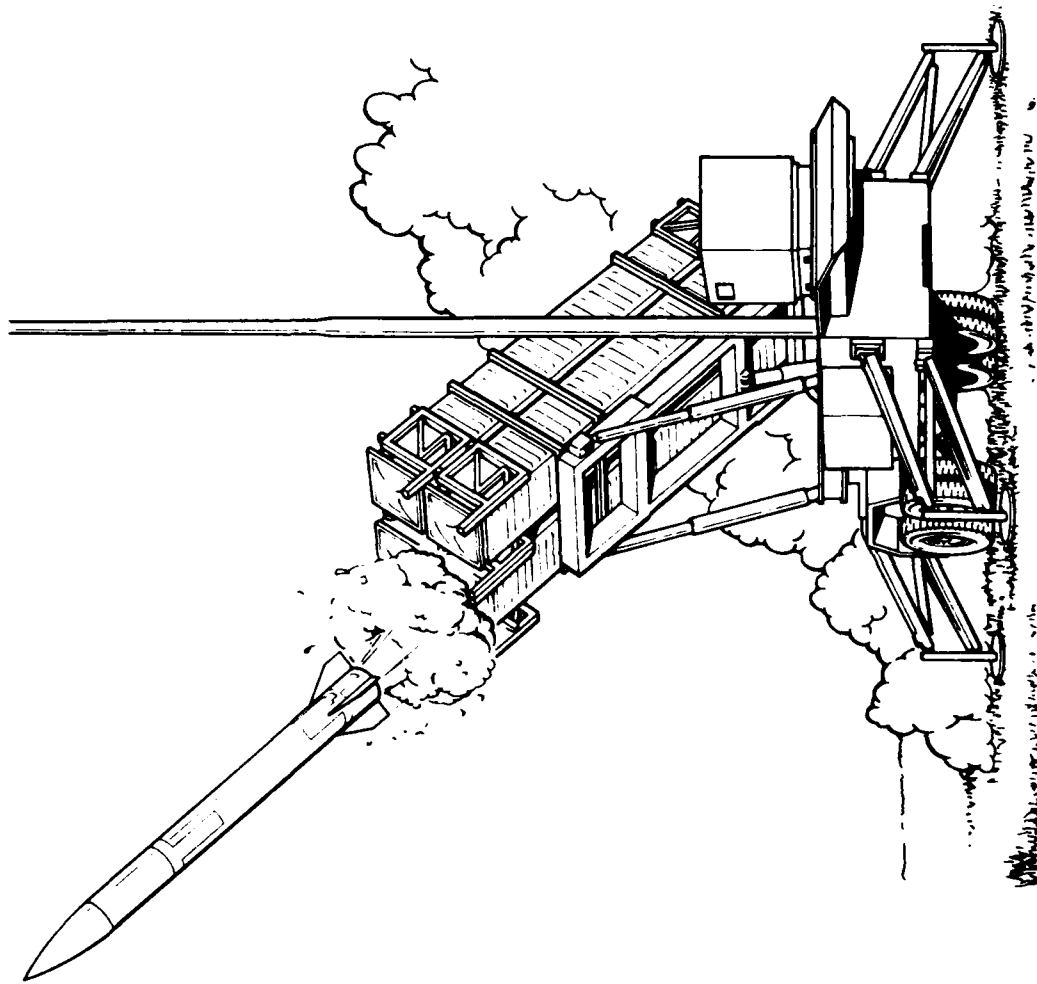

**MISSILE COMMAND
(MICOM)**

M I S S I L E C O M M A N D

CURRENT FUNDING STATUS, 2ND CY85

FISCAL YEAR	NO. OF PROJECTS	AUTHORIZED FUNDS (\$)	* C O N T R A C T A L L O C A T E D (\$)	* F U N D I N G E X P E N D E D (\$)	* I N H O U S E R E M A I N I N G (\$)	* F U N D I N G E X P E N D E D (\$)
82	1	808,000	603,500	603,500 (100%)	204,500	204,200 (99%)
83	0	0	0	0 (0%)	0	0 (0%)
84	2	2,000,000	1,920,900	1,920,900 (100%)	79,100	79,000 (99%)
85	10	5,650,500	4,063,300	2,518,200 (61%)	1,587,200	1,041,300 (65%)
86	10	7,820,500	5,084,200	271,000 (5%)	2,736,300	110,800 (4%)
TOTAL	23	16,279,000	11,671,900	5,313,600 (45%)	4,607,100	1,435,300 (31%)

AUTHORIZED FUNDING CONTRACT ALLOCATED 72% INHOUSE REMAINING 26%

MANUFACTURING METHODS AND TECHNOLOGY PROGRAM
 SUMMARY REPORT STATUS REPORT
 2ND SEMIANNUAL SUBMISSION CY 85 RCS DRGMT-301

PROJ. NO.	TITLE + STATUS	AUTHO- RIZED	CONTRACT VALUES	EXPENDED LABOR AND MATERIAL (\$000)	ORIGINAL PROJECTED COMPLETE DATE	PRESENT PROJECTED COMPLETE DATE
3 85 1066	SEMIADDITIONAL SINGLE AND MULTILAYER CIRCUITRY	425.0	397.9	27.1	MAR 86	SEP 87
3 85 1066	SEMIADDITIONAL SINGLE + MULTILAYER CIRCUITRY	450.0	445.0	4.0	SEP 87	SEP 87
3 85 1076	AUTOMATIC RECOGNITION OF CHIPS	808.0	603.5	204.2	FEB 84	MAR 86
3 85 1089	INTEGRAL RACKET MOTOR COMPOSITE ATTACHMENTS	550.0	480.7	69.3	APR 86	APR 86
3 85 1095	AUTOMATIC SEALING OF HYBRID PACKAGES	1,628.0	1,501.0	2.9	APR 87	APR 87
3 85 1109	ROBOTIZED WIRE HARNESS ASSEMBLY SYSTEM	1,200.0	1,170.9	29.0	AUG 85	MAR 86
3 85 1120	DETECTOR GRADE CADMIUM SULFIDE (CDS)	525.0	379.4	75.0	UCT 85	JAN 87
3 85 1120	DETECTOR GRADE CADMIUM SULFIDE	325.0	269.0		JAN 87	JAN 87
3 85 1124	SCANNING TDI FOCAL PLANE ARRAY DETECTORS	800.0	750.0	50.0	UCT 86	MAR 86
3 85 1124	IMPROVED MFG PROCESSES FOR SCANNING FOCAL PLANE SENSOR ASSY	575.0	450.0	100.0	SEP 85	MAR 86
3 85 1131	MNT FOR INTEGRATED 94 GHZ SUBMUNITION TRANSCIVER -----DELINQUENT STATUS REPORT-----	300.0			SEP 87	SEP 87
3 85 1134	KF/LASER HARDENING OF DOME FOR DUAL MODE SYSTEMS	1,000.0	875.0	125.0	NOV 85	UCT 87
3 85 1134	KF/LASER HARDENING OF DOME FOR DUAL MODE SYSTEMS	1,287.0	1,150.0	6.7		UCT 87
3 85 1144	ELECTROFORMED ASPHERIC METAL MIRROR	400.0	200.0	200.0	AUG 87	AUG 87
3 85 1144	ELECTROFORMED ASPHERIC METAL MIRROR	450.0	337.1	8.0	AUG 87	AUG 87
3 85 1147	OPTICAL FIBER WIND	408.5	430.2	56.0	SEP 85	SEP 87
3 85 1147	OPTICAL FIBER WINDING	540.0		10.0	SEP 87	SEP 87
3 85 1148	MILLIMETER WAVE MONOLITHIC/INTEGRATED RECEIVER	589.0	476.6	12.4	JUN 87	MAR 86
3 85 1148	MILLIMETER WAVE MONOLITHIC/INTEGRATED RECEIVER	851.0	772.0	14.0	SEP 87	SEP 87
3 85 1150	LITHIUM NIOBATE LASER W-SWITCHES	700.0	373.5	326.5	DEC 86	DEC 86
3 85 1150	LITHIUM NIOBATE LASER W-SWITCHES	450.0	310.1	4.5	MAR 87	MAR 87
3 85 2018	AUTOMATIC TEST OF PRINTED WIRE BOARDS	1,068.5		2.7	FEB 88	FEB 88

MANUFACTURING METHODS AND TECHNOLOGY PROGRAM
 S U M M A R Y P R O J E C T S T A T U S R E P O R T
 2ND SEMI ANNUAL SUBMISSION CY 85 RCS DRCNT-301

PROJ NO.	TITLE + STATUS	AUTHORIZED (\$000)	CONTRACT VALUES (\$000)	EXPENDED LABUR AND MATERIAL (\$000)	ORIGINAL PROJECTED COMPLETE DATE	PRESENT PROJECTED COMPLETE DATE
3 86 2021	CIM TECHNIQUES FOR MISSILE HYBRID ASSEMBLIES	771.0	300.0	60.0	AUG 87	AUG 87

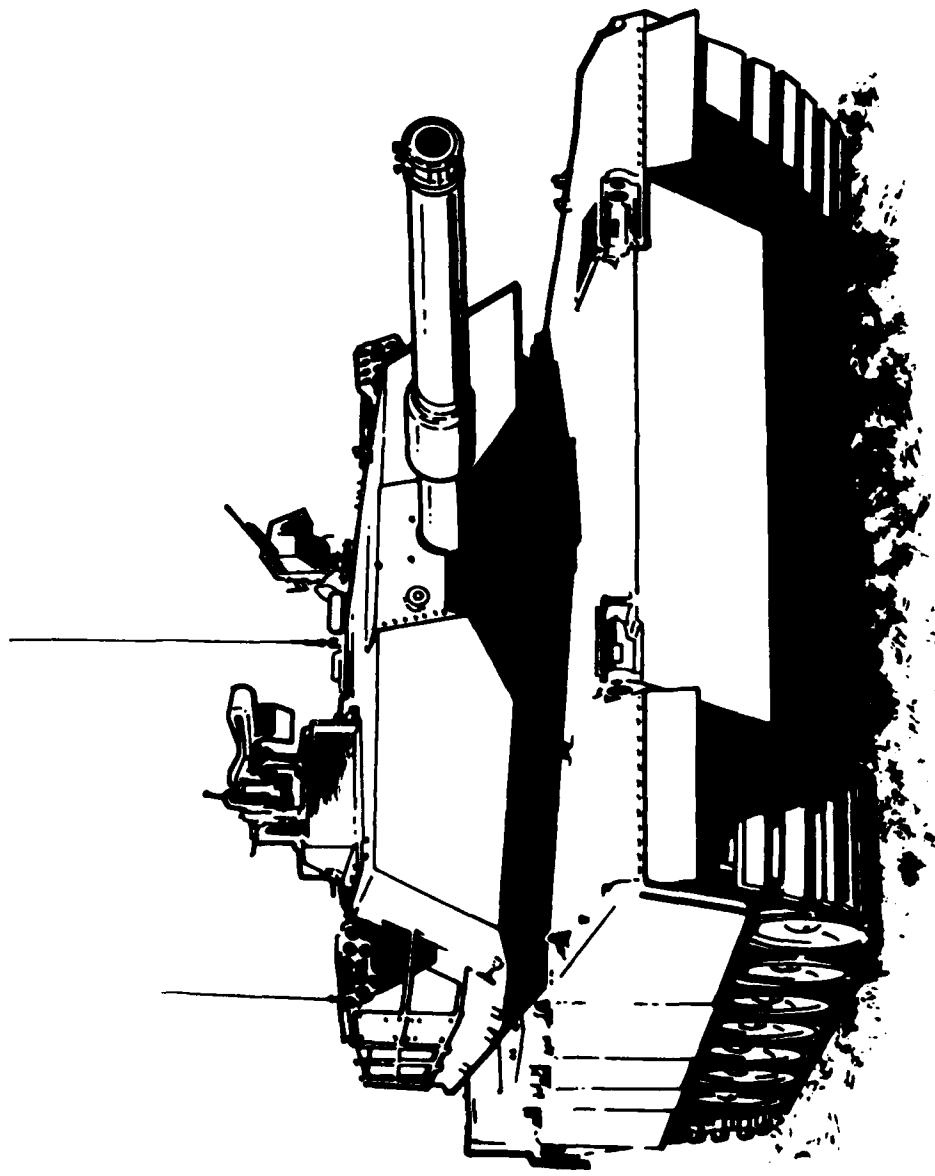

**TANK-AUTOMOTIVE COMMAND
(TACOM)**

MANUFACTURING METHODS AND TECHNOLOGY PROGRAM
 SUMMARY PROJECT STATUS REPORT
 2ND SEMIANNUAL SUBMISSION CY 85 ACS DRCHT-301

PROJ NO.	TITLE + STATUS	AUTHORIZED (\$000)	CONTRACT VALUES (\$000)	EXPENDED LABOR AND MATERIAL (\$000)	ORIGINAL PROJECTED COMPLETE DATE	PRESENT PROJECTED COMPLETE DATE
4 84 4001	MANUFACTURING FOR CORROSION PREVENTION IN TACTICAL VEHICLES -----DELINQUENT STATUS REPORT-----					
4 86 4001	MFG FOR CORROSION PREVENTION IN TACTICAL VEHICLES	500.0		80.0	JAN 88	JAN 88
4 85 4008	COMPOSITE DRIVE SHAFTS	220.0	98.0	121.0	SEP 86	NOV 86
4 86 4008	COMPOSITE DRIVE SHAFTS	25.0		20.0	NOV 86	NOV 86
4 84 4042	FLEXIBLE MANUFACTURING TECHNOLOGY INTEGRATION -----DELINQUENT STATUS REPORT-----	419.0		250.0		JUN 86
4 85 4086	ADVANCED CAST ARMOUR -----DELINQUENT STATUS REPORT-----					
4 85 4087	EXPLOSIVE COMPACTION OF CERAMICS -----DELINQUENT STATUS REPORT-----					
T 82 4575	LASER WELDING TECHNIQUES FOR MILITARY VEHICLES -----DELINQUENT STATUS REPORT-----	308.0	277.0	9.0	JCT 84	DEC 86
T 82 5014	FOUNDRY CASTING PROCESSES USING FLUID FLOW + THERM ANALYS	100.0	60.0	19.0	MAR 84	JUN 86
4 83 5053	ADIABATIC DIESEL ENGINE COMPONENTS (PHASE II)	778.0	633.0	145.0	FEB 85	JAN 87
4 83 5053 01	ADIABATIC DIESEL ENGINE COMPONENTS	563.0	443.0	120.0	SEP 85	JAN 87
4 83 5053 02	BISQUE FIRED CERAMICS	107.0	94.0	13.0	SEP 85	JAN 86
4 83 5053 03	LASER BEAM MACHINING	108.0	95.9	12.0	SEP 85	JAN 86
4 84 5053	ADIABATIC DIESEL ENGINE COMPONENTS (PHASE III)	645.0	545.0	100.0	JAN 86	JAN 87
4 84 5053 01	ADIABATIC DIESEL ENGINE COMPONENTS	645.0	545.0	100.0	JUN 86	JAN 87
4 85 5053	ADIABATIC DIESEL ENGINE COMPONENTS (PHASE IV)	156.0		156.0	JAN 87	JAN 87
4 85 5053 01	ADIABATIC DIESEL ENGINE COMPONENTS	156.0		156.0	JAN 87	JAN 87
T 82 5054	LASER SURFACE HARDENED CUMBAT VEHICLE COMPONENTS -----DELINQUENT STATUS REPORT-----	290.0	243.0	47.0	JAN 84	JUN 86
4 83 5068	NEW ANTI-CORROSSIVE MATERIALS AND TECHNIQUES (PHASE III)	184.0	134.0	50.0	SEP 85	NOV 86
4 86 5068	NEW ANTI-CORROSSIVE MATERIALS	100.0		5.0	FEB 87	FEB 87

MANUFACTURING METHODS AND TECHNOLOGY PROGRAM
 SUMMARY PROJECT STATUS REPORT
 2ND SEMIANNUAL SUBMISSION CY 85 RCS DRCHT-301

PROJ NO.	TITLE + STATUS	AUTHORIZED (\$000)	CONTRACT VALUES (\$000)	EXPENDED LABOR AND MATERIAL (\$000)	ORIGINAL PROJECTED COMPLETE DATE	PRESENT PROJECTED COMPLETE DATE
T 81 5075	MILITARY ELASTOMERS FOR TRACK VEHICLES (PHASE II) -----DELINQUENT STATUS REPORT-----	200.0	55.3	93.7	SEP 82	JAN 86
T 82 5075	MILITARY ELASTOMERS FOR TRACK VEHICLES (PHASE III) -----DELINQUENT STATUS REPORT-----	200.0	52.0	136.6	SEP 83	JAN 86
4 83 5075	MILITARY ELASTOMERS FOR TRACK VEHICLES -----DELINQUENT STATUS REPORT-----	145.0		114.9	JAN 86	JAN 86
4 83 5082	FLEX MACHINING SYS (FMS) PILOT LINE F/TLV COMPS (CAM) (PH V) -----DELINQUENT STATUS REPORT-----	350.0	349.9		UCT 84	JUN 86
4 83 5090	IMPROVED AND COST EFFECTIVE MACHINING TECHNOLOGY (PHASE V)	190.0	165.0	25.0	SEP 84	APK 86
4 83 5091	HEAVY ALUMINUM PLATE FABRICATION (PHASE I)	74.0		74.0	DEC 84	JAN 87
4 85 5091	HEAVY ALUMINUM PLATE FABRICATION	33.0		21.0	JAN 87	JAN 87
4 85 6000	LIGHTWEIGHT TILT-UP HOOD/FENDER ASSEMBLY -----DELINQUENT STATUS REPORT-----					
T 82 6057	M1 COMBAT VEHICLE	2,312.0	1,477.0	767.0	SEP 83	MAY 86
T 82 6057 05	MACHINE DIAGNOSTICS	1,408.0	1,105.0	303.0	SEP 83	MAY 86
T 82 6057 13	LASER CUTTING	471.0	186.0	285.0	MAY 83	MAR 86
T 82 6057 17	MANUFACTURING METHODS FOR SPECIAL ARMORS	3,000.0		2,601.0	JAN 85	MAR 86
4 83 6057	ABRAMS M1 COMBAT VEHICLE	92.0		92.0	FEB 84	MAY 86
4 83 6057 05	MACHINE DIAGNOSTICS	25.0		55.0	FEB 84	MAY 86
4 83 6057 13	LASER CUTTING OF TRACKED COMBAT VEHICLE PARTS	32.0		32.0	FEB 84	MAR 86
4 84 6057	ABRAMS (M1) COMBAT VEHICLE	450.0	450.0		SEP 85	APR 86
4 84 6057 04	THERMAL AND MECHANICAL CUTTING AND BEVELING ARMOR PLATE	450.0	450.0		SEP 85	APR 86
4 85 6057	ABRAMS M1 COMBAT VEHICLE	142.0		142.0	MAY 85	MAR 86
4 85 6057 13	LASER CUTTING	71.0		71.0	MAY 85	MAR 86
4 86 6057	ABRAMS (M1) COMBAT VEHICLE -----JUST FUNDED, NO 301 REQUIRED.-----					

MANUFACTURING METHODS AND TECHNOLOGY PROGRAM
 S U M M A R Y P R O J E C T S T A T U S R E P O R T
 2ND SEMIANNUAL SUBMISSION CY 85 RCS DRCHT-301

PROJ NO.	TITLE + STATUS	AUTHORIZED (\$000)	CONTRACT VALUES (\$000)	EXPENDED LABOR AND MATERIAL (\$000)	ORIGINAL PROJECTED COMPLETE DATE	PRESENT PROJECTED COMPLETE DATE
4 86 6057 04	THERMAL + MECHANICAL CUTTING + BEVELING -----JUST FUNDED. NO 301 REQUIRED.-----					
4 86 6057 13	LASER CUTTING -----JUST FUNDED. NO 301 REQUIRED.-----					
T 82 6059	M2 AND M3 FIGHTING VEHICLE SYSTEM	1,585.0	1,404.0	175.0	DEC 84	MAY 86
T 82 6059 01	M2 AND M3 CAST ALUMINUM COMPONENTS	490.0	445.0	45.0	DEC 83	JAN 86
T 82 6059 02	SELF-THREADING FASTENERS	130.0	106.0	24.0	FEB 83	DEC 85
T 82 6059 03	ADHESIVE BONDING	130.0	105.0	25.0		DEC 85
T 82 6059 06	LASER HEAT TREATING	130.0	107.0	20.0	SEP 84	SEP 85
T 82 6059 08	PRODUCTION METHODS FOR COMPOSITE TURRET BASKET	131.0	107.0	24.0	JUN 83	DEC 85
T 82 6059 20	CARC APPLICATION PROCESSING TECH	574.0	534.0	37.0	DEC 84	MAY 86
4 83 6059	M2 AND M3 FIGHTING VEHICLE SYSTEM	805.0	689.0	114.0	APR 85	MAR 86
4 83 6059 13	METAL ARC SPRAYING	310.0	260.0	48.0	OCT 84	MAR 86
4 83 6059 17	PRE-PAINT CLEANING SYSTEM	325.0	275.0	50.0	OCT 84	MAR 86
4 83 6059 19	SQUEEZE CAST GUNNERS HATCH	170.0	154.0	16.0	APR 85	AUG 85
4 84 6059	M2 AND M3 FIGHTING VEHICLE SYSTEM	263.0	213.0	6.0	JAN 86	JUL 87
4 84 6059 06	PRODUCTION METHODS FOR COMPOSITE TURRET BASKET	263.0	213.0	6.0	JAN 86	JUL 87
T 82 6079	ACT-150C ENGINE -----DELINQUENT STATUS REPORT-----	1,660.0	1,324.0	294.0	MAR 85	JUN 86
T 82 6079 12	LASER WELDER FOR RECUPERATOR ID/DD -----DELINQUENT STATUS REPORT-----					
4 83 6079	ACT-1500 ENGINE	1,534.0	1,342.0	92.0	OCT 85	MAY 86
4 83 6079 01	MONOCRYSTAL ALLOY FOR HIGH PRESSURE TURBINE BLADES	231.0	208.0	23.0		APR 86
4 83 6079 02	RAPIDLY SOLIDIFIED RATE (RSR) NICKEL-BASE SUPERALLOY	363.0	340.0	23.0		MAY 86
4 83 6079 03	BI-CAST HIGH PRESSURE TURBINE NOZZLE	498.0	475.0	23.0		MAR 86

MANUFACTURING METHODS AND TECHNOLOGY PROGRAM
 S U M M A R Y P R O J E C T S T A T U S R E P O R T
 2ND SEMI-ANNUAL SUBMISSION CY 85 RCS DRGNT-301

PROJ NO.	TITLE + STATUS	AUTHORIZED (\$000)	CONTRACT VALUES (\$000)	EXPENDED LABOR AND MATERIAL (\$000)	ORIGINAL PROJECTED COMPLETE DATE	PRESENT PROJECTED COMPLETE DATE
4 83 6079 05	AUTOMATIC DEBURRING OF ENGINE COMPONENTS	442.0	419.0	23.0	MAR 86	MAR 86
4 85 6079	AGT-1500 ENGINE	1,273.0	1,223.0	50.0	MAR 86	JUL 87
4 85 6079 02	RAPID SOLIDIFICATION TECH (RST) NICKEL-BASE SUPERALLOY	33.0	30.0	3.0	DEC 86	APR 86
4 85 6079 05	AUTOMATED DEBURRING OF ENGINE COMPONENTS	335.0	310.0	25.0	JUL 86	JUL 86
4 85 6079 06	ADVANCED BALANCING MACHINING	626.0	615.0	11.0	MAR 86	JUL 87
4 85 6079 11	EROSION RESISTANT COATINGS FOR COMPRESSOR BLADES/VANES	271.0	260.0	11.0	SEP 85	FEB 87
4 86 6079	AGT-1500 ENGINE	875.0	850.0	12.0	JUL 88	JUL 88
4 86 6079 05	AUTOMATED DEBURRING OF ENGINE COMPONENTS- PHASE II	143.0	136.0	4.0	OCT 86	JUL 86
4 86 6079 06	ADVANCING BALANCING MACHINING -----JUST FUNDED. NO 301 REQUIRED.-----					
4 86 6079 11	EROSION RES COATINGS F/COMPRESSOR BLADES/VANES	311.0	303.0	4.0	JAN 88	JAN 88
4 86 6079 12	LASER WELDING FOR RECUPERATOR ID/DU -----JUST FUNDED. NO 301 REQUIRED.-----					
4 86 6079 22	NET-SHAPE CAST COMBUSTOR LINERS FOR AGT-1500 ENGINE	385.0		4.0	JUL 88	JUL 88
T 82 6090	TEAD DEPUT ANALYSIS OF RESOURCES AND TECHNOLOGY (DART)	100.0		27.7	MAY 83	SEP 86
4 84 6090	TEAD DEPUT ANALYSIS OF RESOURCES AND TECHNOLOGY (DART)	2,061.0	1,461.1	487.3	SEP 85	MAR 86
4 85 6090	TEAD DEPUT ANALYSIS OF RESOURCES AND TECHNOLOGY (DART)	250.0			MAY 86	MAR 86
4 86 6090	TEAD DEPUT ANALYSIS OF RESOURCES AND TECHNOLOGY (DART)	1,500.0			JAN 88	JAN 88
4 87 6095	ABRAMS TRANSMISSION PRODUCTIVITY IMPROVEMENTS (PHASE I) -----DELINQUENT STATUS REPORT-----	304.0	286.0		DEC 84	JAN 86
4 83 6095 03	SURFACE TREATMENT AND CAST HARDENING OF STEEL COMPONENTS -----DELINQUENT STATUS REPORT-----				SEP 84	JAN 86
4 83 6095 05	SKIVE HOBBIING -----DELINQUENT STATUS REPORT-----					JAN 86
4 85 6095	ABRAMS TRANSMISSION PRODUCTIVITY IMPROVEMENTS PHASE III -----DELINQUENT STATUS REPORT-----	95.0	70.0	13.0	JAN 86	JAN 86

MANUFACTURING METHODS AND TECHNOLOGY PROGRAM
 SUMMARY PROJECT STATUS REPORT
 2ND SEMIANNUAL SUBMISSION CY 85 RCS DRCMT-301

PROJ NO.	TITLE + STATUS	AUTHO- RIZED (\$000)	CONTRACT VALUES (\$000)	EXPENDED LABOR AND MATERIAL (\$000)	ORIGINAL	PRESENT
					PROJECTED COMPLETE DATE	PROJECTED COMPLETE DATE
4 85 6095 05	SKIVE HOBBIING OF GEARS -----DELINQUENT STATUS REPORT-----				JAN 86	JAN 86
4 85 6094	MANUFACTURING METHODS FOR SPECIALIZED ARMOR MATERIALS	6,550.0		6,515.0	JUL 84	MAR 86
4 85 6107	IMPROVED MBT TRACK	842.0	705.0	100.0	AUG 84	MAY 86
4 85 6107 01	CLAMP MFG FRM HI STR/LTWEIGHT FERROUS, NON-FERR + MTL MATRIX	842.0	339.0		JUN 84	MAY 86
4 85 6107 02	ORGANIC COMPOSITE ROAD WHEEL	842.0	366.0		AUG 84	MAY 86
4 85 6107	IMPROVED MBT TRACK	623.0	528.0	95.0	SEP 85	DEC 86
4 85 6107 01	TRACK PINS + SHOES MFG FROM ALUMINUM MATRIX COMPOSITE MATL	450.0	160.0		APR 86	
4 85 6107 02	LOW COST ADAPTIVE FLUIDIC DAMPER MATERIALS	400.0	368.0		DEC 86	
4 86 6107	IMPROVED MBT TRACK -----JUST FUNDED. NO 301 REQUIRED.-----					
4 84 6121	CAV/CAM FOR THE BRADLEY FIGHTING VEHICLE	606.0	580.0	25.0	JAN 86	SEP 86
4 84 6121 01	ROBOTIC WELDING	606.0	580.0	25.0	JAN 86	SEP 86
4 85 6121	CAV/CAM FOR THE BRADLEY FIGHTING VEHICLE -----DELINQUENT STATUS REPORT-----					
4 85 6125	CERAMIC TUBRECHARGER RJTOR	240.0	205.0	35.0	SEP 86	FEB 87
4 85 6125	CERAMIC TUBRECHARGER RJTOR	260.0	234.0	5.0	FEB 87	FEB 87
4 85 6125	WELD PROCESSING PLANNING AND CONTROL -----DELINQUENT STATUS REPORT-----	275.0		275.0	JCT 85	JUN 86
4 86 6125	WELD PROCESS PLANNING AND CONTROL -----JUST FUNDED. NO 301 REQUIRED.-----					

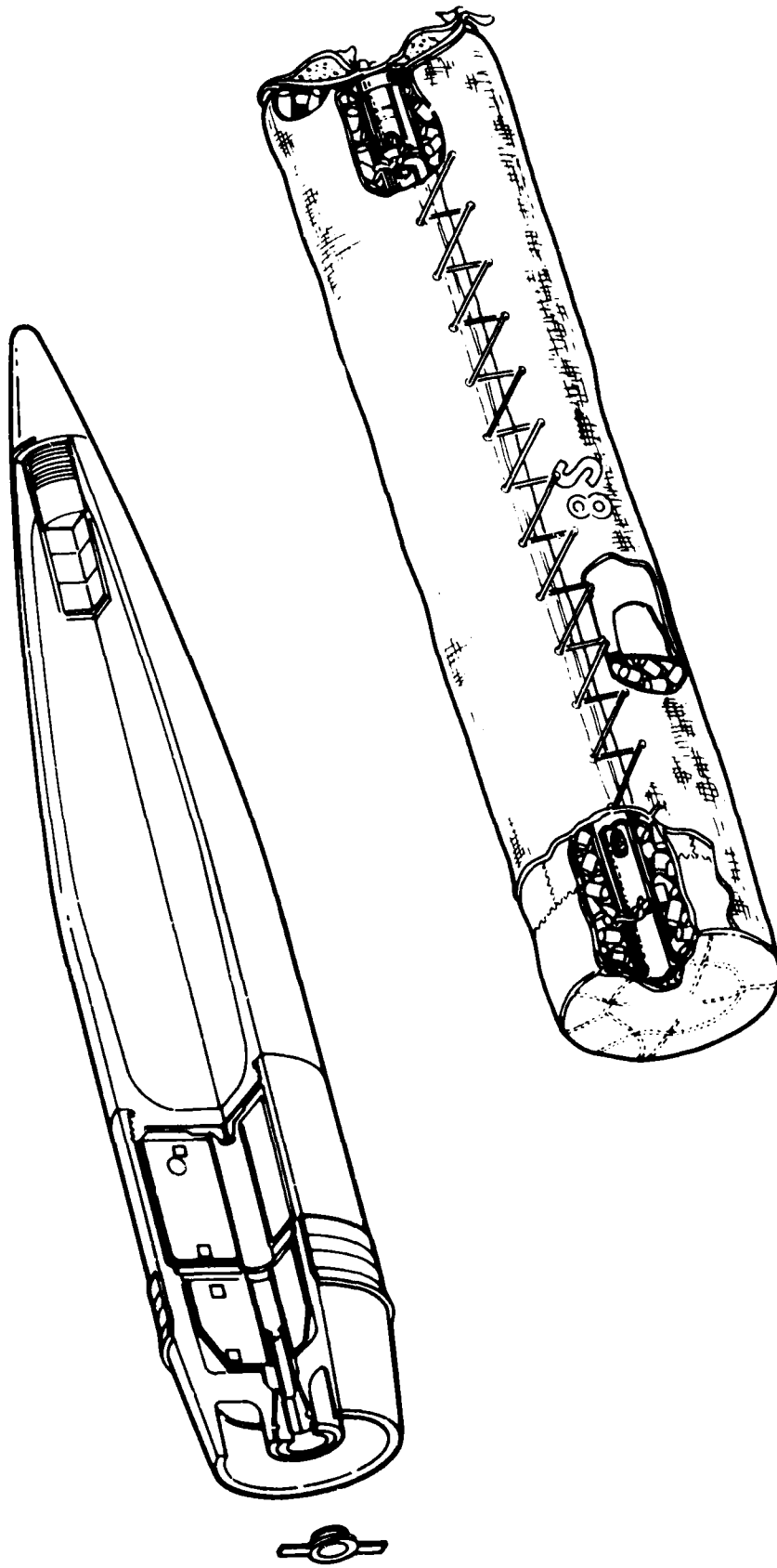

**ARMAMENT, MUNITIONS AND CHEMICAL COMMAND
(AMCCOM)
(AMMUNITION)**

A M C C O M (A M M U N I T I U N)

CURRENT FUNDING STATUS, 2ND CY85

FISCAL YEAR	NO. OF PROJECTS	AUTHORIZED FUNDS (\$)	CONTRACT ALLOCATED (\$)	CONTRACT EXPENDED (\$)	INHOUSE REMAINING (\$)	INHOUSE EXPENDED (\$)
76	1	93,000	14,000	6,000 (42%)	79,000	77,000 (97%)
77	0	0	0	0 (0%)	0	0 (0%)
77	0	0	0	0 (0%)	0	0 (0%)
78	1	322,500	0	0 (0%)	322,500	281,000 (87%)
79	1	878,000	0	0 (0%)	878,000	0 (0%)
80	2	1,852,000	450,000	450,000 (100%)	1,402,000	104,000 (7%)
81	7	5,693,400	2,165,300	1,939,600 (89%)	3,528,100	1,609,600 (45%)
82	18	21,975,600	14,942,900	14,484,000 (96%)	7,032,700	5,909,300 (84%)
83	9	5,710,000	3,729,300	3,599,200 (96%)	1,980,700	1,054,700 (85%)
84	35	20,907,000	14,700,200	11,654,400 (79%)	6,206,800	4,886,000 (78%)
85	45	26,074,000	23,190,000	4,945,300 (21%)	2,884,000	2,409,500 (83%)
86	30	7,557,000	2,253,100	6,000 (0%)	5,303,900	15,000 (0%)
TOTAL	149	91,062,500	61,444,800	37,064,500 (60%)	29,617,700	16,946,100 (57%)

AUTHORIZED FUNDING CONTRACT ALLOCATED 67%

INHOUSE REMAINING 32%

SUMMARY PROJECT STATUS REPORT
 MANUFACTURING METHODS AND TECHNOLOGY PROGRAM
 2ND SEMIANNUAL SUBMISSION CY 85 RCS DRCMT-301

PROJ NO.	TITLE + STATUS	AUTHORIZED (\$000)	CONTRACT VALUES (\$000)	EXPENDED LABOR AND MATERIAL (\$000)	ORIGINAL PROJECTED COMPLETE DATE	PRESENTLY PROJECTED COMPLETE DATE
5 84 0904	CHEMICAL REMOTE SENSING SYSTEMS	2,112.0	1,977.0	135.0	NOV 86	NOV 86
5 85 0904	MFG TECH FOR CHEMICAL REMOTE SENSING SYSTEMS	1,441.0	1,350.0	56.2	JUL 86	APR 87
5 82 0905	MANUFACTURE OF IMPREGNATED CHARCOAL-WHETLERITE	282.0	103.0	179.0	DEC 84	MAR 86
5 84 0905	MANUFACTURE OF IMPREGNATED CHARCOAL (WHETLERITE)	456.0	400.0	56.0	MAR 86	MAR 86
5 85 0905	MANUFACTURE OF IMPREGNATED CHARCOAL	100.0	50.0	50.0	MAR 86	MAR 86
5 86 0905	MFG OF IMPREGNATED CHARCOAL (WHETLERITE)	186.0		15.0	MAR 86	MAR 86
5 84 0913	POVERNIZATION OF FILTER PENETRATION EQUIPMENT	300.0	200.0	80.0	SEP 85	DEC 86
5 85 0918	MODERNIZATION OF FILTER PENETRATION EQUIPMENT	50.0	41.0	9.0	DEC 86	DEC 86
5 86 0918	MODERNIZATION OF FILTER PENETRATION EQUIPMENT	157.0			DEC 87	DEC 87
5 85 0923	VELOCITY TRAVERSE MAPPER F/CHARCOAL FILTERS	200.0		74.0	JUN 87	JUN 88
5 86 0923	VELOCITY TRAVERSE MAPPER FOR CHARCOAL FILTERS	100.0			JUN 89	JUN 89
5 83 0924	MANUFACTURING PROCESS FOR GAS MASK CANISTERS	283.0	228.0	55.0	SEP 85	NOV 86
5 84 0924	MANUFACTURING PROCESS FOR GAS MASK CANISTERS	800.0	512.0	235.0	MAR 86	NOV 86
5 85 0925	PROTECTIVE MASK LEAKAGE TESTING	199.0		49.0	JUN 84	AUG 86
5 84 0925	PROTECTIVE MASK LEAKAGE TESTING	680.0	530.0	150.0	OCT 85	AUG 86
5 85 0925	PROTECTIVE MASK LEAKAGE TESTING	230.0	150.0	15.0	AUG 86	AUG 87
5 86 0925	PROTECTIVE MASK LEAKAGE TESTING	68.0			AUG 87	AUG 87
5 84 0926	MFG TECH F/CHEMICAL AGENT ALARM SYSTEM	700.0	456.0	194.0	OCT 87	FEB 88
5 85 0926	MFG TECH F/CHEMICAL AGENT ALARM, XM22	1,398.0	1,170.0	23.0	SEP 87	FEB 88
5 86 0926	MFG METHODS + TECH FOR XM22 CHEMICAL AGENT ALARM SYSTEM	2,112.0			FEB 88	FEB 88
5 85 0927	COMPUTER AIDED PROCESS PLANNING FOR CB FILTERS (CAM)	105.0		105.0	AUG 88	NOV 90
5 83 1295	MODERNIZATION OF CHARCOAL FILTER TEST EQUIPMENT	219.0	148.0	53.0	JUL 84	MAR 86
5 84 1295	MODERNIZATION OF CHARCOAL FILTER TEST EQUIPMENT	600.0		100.0	SEP 85	MAR 86

MANUFACTURING METHODS AND TECHNOLOGY PROGRAM
 SUMMARY PROJECT STATUS REPORT
 2ND SEMIANNUAL SUBMISSION CY. 85 RCS DRCHT-301

PROJ NO.	TITLE + STATUS	AUTHOR- RIZED (\$000)	CONTRACT VALUES (\$000)	EXPENDED LABOR AND MATERIAL (\$000)	ORIGINAL	PRESENT
					PROJECTED COMPLETE DATE	PROJECTED COMPLETE DATE
5 85 1295	MODERNIZATION OF CHARCOAL FILTER TEST EQUIPMENT	1,285.0	3,450.0	100.0	MAR 86	SEP 86
5 86 1295	MODERNIZATION OF CHARCOAL FILTER TEST EQUIPMENT	845.0			SEP 86	SEP 86
5 84 1402	120MM COMBUSTIBLE CASE BODY REMOVAL SYSTEM	200.0	131.0	59.2	JUN 86	JUN 86
5 86 1402	120MM COMBUSTIBLE CASE BODY REMOVAL SYSTEM	235.0	190.1		MAR 87	MAR 87
5 81 1500	EVAL INDUST CAPABILITY F/LOAD COMMERCIAL EXPL-HIGH USE MUNIT -----DELINQUENT STATUS REPORT-----	543.0	294.0	248.0	SEP 82	JUN 86
5 82 1500	EVAL INDUST CAPABILITY F/LOAD COMMERCIAL EXPL-HIGH USE MUNIT -----DELINQUENT STATUS REPORT-----	450.0		302.0	OCT 83	JUN 86
5 82 1600	THREE PIECE SHAFT FOR THE SUU-65/8 TAILCONE -----DELINQUENT STATUS REPORT-----	250.0				JUN 86
5 83 1701	BULK TRANSFER OF CHEMICAL MATERIALS -----DELINQUENT STATUS REPORT-----	207.0	73.2	87.6	SEP 85	JUN 86
5 82 1709	IMPROVED PROCESSING OF PYROTECHNIC MIXTURES -----DELINQUENT STATUS REPORT-----	500.0	93.1	370.8	JUL 84	JUN 86
5 83 1709	IMPROVED PROCESSING OF PYROTECHNIC MIXTURES -----DELINQUENT STATUS REPORT-----	446.0	274.7	100.9	JUL 84	JUN 86
5 85 1725	ELECTRICAL SENSITIVITY OF INITIATING EXPLOSIVES -----DELINQUENT STATUS REPORT-----					
5 84 1802	AUTOMATED OPTICAL MICROELECTRONICS INSPECTION	496.0	425.0	71.0	JUN 87	AUG 86
5 85 1802	AUTOMATED OPTICAL MICROELECTRONICS INSPECTION	556.0	74.2	1.0	MAR 87	MAR 87
5 84 1803	IMPROVED LEAD DIOXIDE ELECTROPLATING TECHNOLOGY	346.0	271.0	13.0	MAR 86	MAR 86
5 85 1805	IMPROVED PRODUCTION VIBRATION TESTS-M732 (PIP) FUZE	200.0	157.8	30.0	DEC 86	DEC 86
5 86 1805	IMPROVED PROD VIBRATION TESTS - M732 PIP FUZE + COMPONENT	300.0			DEC 87	DEC 87
5 84 1914	PROCESS ENGINEERING FOR EAK EXPLOSIVES -----DELINQUENT STATUS REPORT-----	450.0		369.9	SEP 85	JUN 86
5 81 4000	AUTOMATED M55 DETONATOR PRODUCTION EQUIPMENT	404.0	11.3	378.5	SEP 81	DEC 86
5 82 4062	AUTO MANUFACTURE SYSTEM FOR MORTAR INCREMENT CONTAINERS	4,744.0	4,007.9	724.8	SEP 84	MAR 86

MANUFACTURING METHODS AND TECHNOLOGY PROGRAM
 S U M M A R Y P R O J E C T S T A T U S R E P O R T
 2ND SEMIANNUAL SUBMISSION CY 85 RCS DRGMT-301

PROJ NO.	TITLE + STATUS	AUTHO- RIZED	CONTRACT VALUES	EXPENDED LABOR AND MATERIAL (\$000)	ORIGINAL PROJECTED COMPLETE DATE	PRESENT PROJECTED COMPLETE DATE
5 82 4062 01	SLURRY VACUUM FORMING MFG SYS				SEP 83	DEC 85
5 82 4062 02	PAPER MOLDING MANUFACTURING SYSTEM				JUL 84	MAR 86
5 82 4062 03	ASSEMBLY SYSTEM				SEP 83	MAR 86
5 84 4078	UPGRADE SAFETY, READINESS + PROD OF EXISTING MELT POUR LINES	621.0	488.0	131.0	SEP 85	JUN 86
5 82 4145	CONTROL DRYING AUTO SB + BALL PROPELLANT MANUFACTURING	479.2	260.1	202.0	SEP 83	MAR 87
5 82 4145 01	CONTROL DRYING AUTO SB PROP MFG	336.0	218.7	100.0	SEP 83	MAR 87
5 82 4161	PRODUCTION TECHNIQUES FOR IMPROVED SHOTGUN MUNITION (81 MM) ----DELINQUENT STATUS REPORT----	516.0	97.5	380.0	JUL 83	JUN 86
5 84 4200	TNT CRYSTALLIZER FOR LARGE CALIBER MUNITIONS	570.0	339.7	230.3	JUN 85	JUN 86
5 85 4200	TNT CRYSTALLIZER F/LARGE CALIBER MUNITIONS	235.0		79.9	DEC 85	DEC 86
5 85 4273	AUTOMATED PRODUCTION OF STICK PROPELLANT	698.0	558.2	107.0	MAR 87	MAY 87
5 86 4273	AUTOMATED PRODUCTION OF STICK PROPELLANT	300.0			MAY 87	MAY 87
5 81 4281	CONSERVATION OF ENERGY AT ARMY AMMUNITION PLANTS	1,325.4	632.7	675.3	SEP 84	FEB 87
5 81 4281 A04	ENERGY RECOVERY FROM WASTE HEAT	410.0	194.1	211.0		JUN 86
5 81 4281 A08	CAVITATIONAL REMOVAL OF EXPLOSIVES	376.0	269.6	91.9	JUN 83	MAR 86
5 82 4281	CONSERVATION OF ENERGY AT ARMY AMMUNITION PLANTS	1,362.0	773.2	581.0	SEP 84	FEB 87
5 82 4281 A01	PROCESS ENERGY INVENTORY	193.0	136.3	55.6	JUN 84	DEC 85
5 82 4281 A04	ENERGY RECOVERY FROM WASTE HEAT	419.0	282.0	134.1	SEP 84	MAY 86
5 82 4281 A12	POWER PRODUCTION FROM WASTE HEAT	427.0	355.0	70.0	JUN 84	MAR 86
5 84 4281	CONSERVATION OF ENERGY AT ARMY AMMUNITION PLANTS	180.0	120.0	40.9	MAR 85	FEB 87
5 84 4281 A02	OPTIMIZED INSULATION	180.0	120.0	40.9	MAR 85	DEC 86
5 85 4281	CONSERVATION OF ENERGY AT ARMY AMMUNITION PLANTS	95.0	62.0	16.2	SEP 85	FEB 87
5 85 4281 A02	OPTIMIZED INSULATION	95.0	62.0	16.2	DEC 86	DEC 86

MANUFACTURING METHODS AND TECHNOLOGY PROGRAM
 S U M M A R Y P R O J E C T S T A T U S R E P O R T
 2ND SEMIANNUAL SUBMISSION CY 85 RCS DRGMT-301

PROJ NO.	TITLE → STATUS	AUTHO- RIZED (\$000)	CONTRACT VALUES (\$000)	EXPENDED LABOR AND MATERIAL (\$000)	ORIGINAL PROJECTED COMPLETE DATE	PRESENT PROJECTED COMPLETE DATE
5 76 4303	ACCEPTANCE OF CONTINUOUSLY PRODUCED BLACK POWDER -----DELINQUENT STATUS REPORT-----	93.0	14.0	77.0	APR 77	JUN 86
5 82 4309	AMMUNITION FOR THE 120MM TANK MAIN ARMAMENT	3,942.4	3,271.7	665.8	SEP 84	SEP 86
5 82 4309 04	COMBUSTIBLE CARTRIDGE CASE, 120MM	2,946.0	2,488.7	454.0		SEP 86
5 82 4309 23	AUTOMATIC DEFLASHING EQUIPMENT FOR 120MM REAR SEAL	262.0	247.0	11.6	OCT 86	SEP 86
5 81 4311	DEVELOP AUTOMATED PRODUCTION EQUIPMENT FOR XM 692	465.0	428.9	35.2	SEP 82	SEP 86
5 82 4312	ANTI-ARMOR CLUSTER MUNITION PRODUCTION EXPLOSIVE INVECTION	546.0	351.4	194.7	JUN 83	DEC 86
5 82 4344	ESTABLISH WASTE DISPOSAL TECHNIQUE FOR M687 BINARY PROJECT	580.0	180.0	252.0	NOV 83	SEP 86
5 78 4349	MODERNIZATION OF PRESS LOADING FOR HEP PROJECTILES -----DELINQUENT STATUS REPORT-----	322.5		281.0	JUN 80	JUN 86
5 80 4357	NONDESTRUCTIVE TEST EQUIP F/LARGE CALIBER MUNITIONS F/M483A1 -----DELINQUENT STATUS REPORT-----	554.0	450.0	104.0	JUN 83	FEB 86
5 82 4357	NONDESTRUCTIVE TEST EQUIP F/LARGE CALIBER MUNITIONS F/M483A1 -----DELINQUENT STATUS REPORT-----	199.0	69.0	121.0	UCT 83	FEB 86
5 84 4358	AUTO LINE PROCESS INSPECT OF NEW EEDS (ALPINE) -----DELINQUENT STATUS REPORT-----	356.0	250.0	25.0	JAN 87	JAN 87
5 85 4358	AUTO LINE PROCESS INSPECT OF NEW EED (ALPINE) -----DELINQUENT STATUS REPORT-----	503.0	473.0		JAN 87	JAN 87
5 86 4358	AUTO LINE PROCESS INSPECT OF NEW EEDS (ALPONE) -----JUST FUNDED. NO 301 REQUIRED.-----		261.0	63.0	SEP 83	JUN 86
5 82 4364	CN-LINE PID SENSORS TO MONITOR MIXED WASTE STREAMS -----DELINQUENT STATUS REPORT-----	324.0				
5 85 4406	IMPROVING THE YIELD OF HMX DURING RDX NITROLYSIS	1,393.0	1,281.0	45.0	MAR 86	DEC 86
5 86 4406	IMPROVING THE YIELD OF HMX DURING RDX NITROLYSIS -----JUST FUNDED. NO 301 REQUIRED.-----	504.0	269.0		JUN 87	JUN 87
5 86 4427	EVALUATE CN-LINE CHEMICAL ANALYZERS FOR NO PLANT	563.0	365.5	197.7	MAR 85	AUG 86
5 83 4449	PROCESS IMPROVEMENT FOR COMP C-4					

MANUFACTURING METHODS AND TECHNOLOGY PROGRAM
 S U M M A R Y P R O J E C T S T A T U S R E P O R T
 2ND SEMIANNUAL SUBMISSION CY 85 RCS DRGNT-301

PROJ NO.	TITLE + STATUS	AUTHO- RIZED	CONTRACT VALUES	EXPENDED LABOR AND MATERIAL (\$000)	ORIGINAL		PRESENT	
					PROJECTED COMPLETE DATE	PROJECTED COMPLETE DATE	PROJECTED COMPLETE DATE	PROJECTED COMPLETE DATE
5 85 4449	PROCESS IMPROVEMENT FOR COMP C-4 + PBX EXPLOSIVES	327.0	238.7	23.0	MAR 86	MAR 86	DEC 86	
5 86 4449	PROCESS IMPROVEMENT FOR COMP C-4 EXPLOSIVES ----JUST FUNDED. NO 301 REQUIRED.-----							
5 79 4454	AUTO INSPECTION DEVICE EXPLOS CHARGE SHELL (AIDECS) CAM ----DELINQUENT STATUS REPORT-----	878.0			DEC 81		JUN 86	
5 80 4454	AUTO INSPECTION DEVICE EXPLOS CHARGE SHELL (AIDECS) CAM ----DELINQUENT STATUS REPORT-----	1,298.0			APR 82		JUN 86	
5 80 4454 01	AUTOMATIC INSPECTION DEVICE FOR EXPLOSIVE CHARGE IN SHELL (A ----DELINQUENT STATUS REPORT-----				APR 82		DEC 85	
5 80 4454 02	AUTOMATIC X-RAY INSPECTION SYSTEM (AXIS) ----DELINQUENT STATUS REPORT-----				AUG 80		DEC 85	
5 81 4454	AUTO INSPECTION DEVICE EXPLOS CHARGE SHELL (AIDECS) CAM ----DELINQUENT STATUS REPORT-----	1,885.0			OCT 82		JUN 86	
5 81 4454 01	AUTOMATIC INSPECTION DEVICE FOR EXPLOSIVE CHARGE IN SHELL ----DELINQUENT STATUS REPORT-----				MAY 82		DEC 85	
5 81 4454 02	AUTOMATIC X-RAY INSPECTION SYSTEM (AXIS) ----DELINQUENT STATUS REPORT-----				OCT 82		DEC 85	
5 82 4454	AUTO INSPECTION DEVICE EXPLOS CHARGE SHELL (AIDECS) CAM ----DELINQUENT STATUS REPORT-----	5,883.0	4,915.0	941.0	JUL 83		JUN 86	
5 82 4454 01	AUTO INSP DEVICE FOR EXPLOSIVE CHARGE IN SHELL (AIDECS) ----DELINQUENT STATUS REPORT-----				JUL 83		DEC 85	
5 82 4454 02	AUTO X-RAY INSPECTION SYSTEM (AXIS) ----DELINQUENT STATUS REPORT-----				JUL 83		DEC 85	
5 84 4473	AUTOMATED LEAK DETECTION OF WP MUNITIONS	410.0	330.0	79.0	JUN 85		MAR 86	
5 86 4473	AUTOMATED LEAK DETECTION OF WP MUNITIONS ----JUST FUNDED. NO 301 REQUIRED.-----							
5 84 4489	ADVANCED POLLUTION ABATEMENT TECHNOLOGY F/DARCOM FACILITIES	906.0	612.0	294.0	JUN 85		JUN 86	
5 84 4489 01	DISPOSAL OF WASTEWATER TREATMENT SLUDGES	461.0	329.5	131.0	JUN 85		MAY 86	
5 84 4489 02	ADVANCED PINK WATER TREATMENT (TNT/RDX/HMX IN WATER)	445.0	282.0	163.0	JUN 85		MAY 86	

MANUFACTURING METHODS AND TECHNOLOGY PROGRAM
 SUMMARY PROJECT STATUS REPORT
 2ND SEMIANNUAL SUBMISSION CY 85 RCS DRCMT-301

PROJ NO.	TITLE + STATUS	AUTHO- RIZED (\$000)	CONTRACT VALUES (\$000)	EXPENDED LABOR AND MATERIAL (\$000)	ORIGINAL	PRESENT
					PROJECTED COMPLETE DATE	PROJECTED COMPLETE DATE
5 81 4503	NEW PROCESS FOR SAMS TRACER AMMUNITION	500.0	402.4	97.6	AUG 82	APR 86
5 82 4503	NEW PROCESS FOR SAMS TRACER AMMUNITION	199.0		199.0	SEP 83	APR 86
5 81 4506	5.56 MM CARTRIDGE LINKING SYSTEM	571.0	396.0	175.0	JAN 83	DEC 86
5 82 4506	5.56MM CARTRIDGE LINKING SYSTEM	567.0	321.0	246.0	JAN 84	DEC 86
5 84 4510	AUTO ASSY OF ADDITIVE LINER TO TANK CTG	295.0	225.0	62.8	SEP 85	SEP 86
5 85 4510	AUTO ASSEMBLY OF ADDITIVE LINER TO TANK CARTRIDGE CASE	177.0	91.4	32.1	MAR 86	SEP 86
5 85 4511	DISPOSAL OF FINAL SLUDGE FROM ACID RECOVERY OPERATIONS	375.0	275.0	13.5	DEC 85	SEP 86
5 84 4523	RAPID MOISTURE ANALYSIS OF EXPLOSIVE MIXES	200.0	38.8	157.0	SEP 85	SEP 86
5 84 4524	AUTOMATED MELT POUR EQUIPMENT FOR SMALL AP MINES	385.0	239.9	144.9	SEP 85	DEC 86
5 82 4529	MANUFACTURE OF PRECISION CONES FOR HEAT PROJECTILES	533.0	156.0	151.0	SEP 82	FEB 87
5 85 4531	AUTO PROD OF MULTI-BASE STICK PROPELLANT ON CABML	604.0	492.6	70.2	SEP 86	JUN 86
5 86 4531	AUTOMATED PRODUCTION OF STICK PROPELLANT ON CABML -----JUST FUNDED, NO 301 REQUIRED.-----					
5 84 4534	M855 BULLET CONVERSION OF SCAMP EQUIPMENT	1,859.0	1,655.0	204.0	MAY 86	JUN 86
5 83 4538	5.56 SAMS LINK ORIENTER AND FEED SYSTEM	495.0	390.0	105.0	MAR 85	JUN 86
5 85 4539	AUTOMATED CARTRIDGE CASE HARDNESS MEAS + CONTRL	387.0	247.0	97.0	UCT 85	MAR 86
5 84 4541	HIGH SPEED INSPECTION OF SAA PRIMED CASES	499.0	388.0	92.0	JUN 86	MAY 86
5 84 4544	THIRD GENERATION DYNAGUN (GAMMA) TO SIMULATE TANK GUNS -----DELINQUENT STATUS REPORT-----	496.0	362.0	52.0	JUL 85	JUN 86
5 85 4544	THIRD GENERATION DYNAGUN (GAMMA) TO SIMULATE TANK -----DELINQUENT STATUS REPORT-----	317.0	51.0	21.0	SEP 85	JUN 86
5 85 4545	DIGITAL IMAGE AMPLIFICATION X-RAY SYSTEM (DIAX) -----DELINQUENT STATUS REPJRT-----	180.0	141.0	34.0	SEP 85	AUG 86
5 84 4547	PROCESS TECHNOLOGY FOR XM76 IR SCREENING GRENADE -----DELINQUENT STATUS REPJRT-----	301.0	200.0	101.0	FEB 85	JUN 86

SUMMARY PROJECT STATUS REPORT
 MANUFACTURING METHODS AND TECHNOLOGY PROGRAM
 2ND SEMIANNUAL SUBMISSION CY 85 RCS DRCMT-301

PROJ NO.	TITLE + STATUS	AUTHO- RIZED (\$000)	CONTRACT VALUES (\$000)	EXPENDED LABOR AND MATERIAL (\$000)	ORIGINAL	PRESENT
					PROJECTED COMPLETE DATE	PROJECTED COMPLETE DATE
5 84 4548	PYRO SAFETY ENHANCEMENT	472.0	315.0	128.0	MAR 86	JUN 86
5 84 4548 02	TRANSPORT AND CONVEYING SAFETY ENHANCEMENT	245.0			MAR 86	MAR 86
5 84 4548 04	RAY DESIGN SAFETY ENHANCEMENT	103.0			MAR 86	SEP 86
5 84 4548 05	OPERATORS CLOTHING SAFETY	125.0			MAR 86	SEP 86
5 85 4548	PYRO SAFETY ENHANCEMENT	334.0	164.0	109.0	JUN 86	SEP 86
5 84 4550	AUTOMATED ASSEMBLY OF M22 FLASH SIMULATOR	523.0	394.8	94.9	DEC 85	SEP 86
5 82 4551	MANUFACTURING PROCESS PARAMETER FOR XM855/856 AMMO -----DELINQUENT STATUS REPORT-----	619.0	83.0	335.0	MAR 83	MAY 87
5 84 4556	GN-LINE MONITORS F/WATER POLLUTANTS GENERATED BY MFR OF EXPL	330.0	233.0	97.0	SEP 85	DEC 86
5 83 4563	PROCESS IMPROVEMENT FOR TANK DU PENETRATORS	2,728.0	1,798.0	897.0	JUN 85	DEC 86
5 83 4563 06	RECYCLING OF STABALLOY MACHINING CHIPS	785.0	696.8	82.7	JUL 85	SEP 86
5 83 4563 07	FORMING TO NEAR NET SHAPE	369.9	323.4	41.3	JUN 85	DEL 86
5 83 4563 08	NON-DESTRUCTIVE TESTING OF A PREFORMED SHAPE	228.0		204.5	SEP 85	SEP 86
5 83 4563 11	PROCESS IMPROVE FOR DU PENETRATORS-MG F2 LINERS	317.6	276.1	41.5	JUL 85	DEC 85
5 84 4563	PROCESS IMPROVEMENT FOR TANK DU PENETRATORS	2,350.0	1,394.0	888.0	MAR 86	DEC 86
5 84 4563 05	REDUCTION OF CHIP OXIDATION	656.3	548.7	87.5	MAR 86	SEP 86
5 84 4563 13	ELIMINATE/REDUCE NITRIC ACID PICKLING	283.0	240.5	26.3	SEP 85	SEP 86
5 84 4563 14	EVALUATE MOLD COATINGS	295.2	252.9	42.3	SEP 85	DEC 85
5 84 4563 17	NEUTRON MEASUREMENT OF RESIDUAL STRESSES	125.0		68.5	NOV 85	SEP 86
5 84 4563 18	FILTRATION OF MOLTEN URANIUM	433.0	351.6	65.3	DEC 85	DEC 86
5 84 4563 22	MACHINING LONG ROD DU PENETRATORS	558.3		558.3	DEC 85	JAN 86
5 84 4570	IMPR MFS PRO TES PRODC F/AM762 ARTY ELECT TIME FUZE -----DELINQUENT STATUS REPORT-----	387.0	304.0	71.1	SEP 85	JUL 86
5 85 4570	IMPRUVE MFG PROCESSES + TEST PRODC F/ARTIL ELECT TIME FUZES -----DELINQUENT STATUS REPORT-----	976.0	699.9	15.7	SEP 86	DEC 86

SUMMARY PROJECT STATUS REPORT
 MANUFACTURING METHODS AND TECHNOLOGY PROGRAM
 2ND SEMIANNUAL SUBMISSION, CY 85 RCS-DRCMT-301

PROJ NO.	TITLE + STATUS	AUTHO- RIZED	CONTRACT VALUES	EXPENDED LABOR AND MATERIAL (\$000)	ORIGINAL PROJECTED COMPLETE DATE	PRESENT PROJECTED COMPLETE DATE
5 86 4570	IMPR MFG PROC FOR ARTY ELEC TIME FUZES -----JUST FUNDED. NO 301 REQUIRED.-----					
5 85 4574	IMPROVED PROCESS FOR RDX/HMX FINES MANUFACTURE -----DELINQUENT STATUS REPORT-----					
5 85 4578	MOD + IMP OF THE DMSU PILOT PRUCSS FOR RDX/HMX	159.0	110.9	11.0	MAR 86	FEB 86
5 86 4578	MOD + IMPROVEMENT OF DMSU PILOT PRUCSS FOR RDX/HMX -----JUST FUNDED. NO 301 REQUIRED.-----					
5 85 4584	LOADING EQUIPMENT FOR CAL .50 AMMUNITION	650.0	482.0	99.0	DEC 85	APR 86
5 86 4597	MFG PRUCSSSES FOR CANNON CALIBER DU PENETRATUR -----JUST FUNDED. NO 301 REQUIRED.-----					
5 83 4605	PROPELLANT BED DEPTH CONTROL IN CASBL AT& DRY	570.0	451.9	109.5	JUL 84	SEP 86
5 84 4606	AUTOMATED ASSEMBLY OF BLU 97/B COMBINED EFFECTS MUNITION	1,556.0	1,409.0	80.0	DEC 85	MAR 87
5 95 4612	NITRAMINE (LUVA) PROPELLANT WASTEWATERS ABATEMENT	250.0	175.0	39.9	DEC 86	JUN 87
5 86 4612	NITRAMINE (LUVA) PROPELLANT WASTEWATER ABATEMENT -----JUST FUNDED. NO 301 REQUIRED.-----					
5 85 4613	METHOD F/PROCESS ANALYSIS OF RDX/HMX SLURRY	319.0	212.0	15.0	MAR 86	JUN 86
5 85 4615	IMPRVED SOLVENTLESS PASTE BLENDING	380.0	282.0	61.5	SEP 86	JUN 86
5 86 4615	IMPRVED SOLVENTLESS PASTE BLENDING -----JUST FUNDED. NO 301 REQUIRED.-----					
5 85 4623	CALCIUM CYANAMIDE PRUCSS CONTROL	263.0	209.6	30.0	DEC 85	SEP 86
5 85 4624	AUTOMATED MFG OF MILLIMETER WAVE DIODES (CAM)	2,843.0	2,585.0	214.0	SEP 86	DEC 86
5 85 4625	AUTO MFG OF SILICON IF AMPLIFIER IC (CAM)	284.0	259.0	23.0	JUN 86	DEC 86
5 86 4625	AUTO MANUFACTURE OF SILICON IF AMPLIFIER IC (CAM)	500.0	455.0		SEP 87	SEP 87
5 84 4626	AUTOMATED ASSEMBLY OF MILLIMETER WAVE TRANSDUCERS	180.0	162.0	18.0	DEC 84	SEP 86
5 85 4626	AUTO ASSEMBLY OF MILLIMETER WAVE TRANSDUCER	3,171.0	2,894.0	199.0	JUN 86	DEC 86
5 86 4626	AUTOMATED ASSEMBLY OF MMW TRANSDUCER	500.0			DEC 87	DEC 87

MANUFACTURING METHODS AND TECHNOLOGY PROGRAM
 S U M M A R Y P R O J E C T S T A T U S R E P O R T
 2ND SEMIANNUAL SUBMISSION CY 85 RCS DRCHT-301

PROJ NO.	TITLE + STATUS	AUTHO- RIZED (\$000)	CONTRACT VALUES (\$000)	EXPENDED LABOR AND MATERIAL (\$000)	ORIGINAL	PRESENT
					PROJECTED COMPLETE DATE	PROJECTED COMPLETE DATE
5 85 4627	AUTO TESTING OF MILLIMETER WAVE TRANSDUCER	1,943.0	1,767.0	129.0	SEP 86	DEC 86
5 86 4627	AUTOMATED TEST OF MMW TRANSDUCER	400.0	364.0		DEC 87	DEC 87
5 85 4633	AUTO SENSOR SYSTEMS TEST F/MMW + IR SNEOSR	554.0	554.0		SEP 86	DEC 86
5 86 4633	AUTO SENSOR SYSTEMS TEST FOR MMW AND IR SENSORS	300.0	272.0		SEP 87	SEP 87
5 85 4637	AUTO MFG OF SFF WARHEAD LINERS	785.0	710.0	24.9	DEC 86	DEC 86
5 86 4637	AUTOMATED MANUFACTURE + INSPECTIUN OF SFF WARHEAD LINERS	800.0	703.0		SEP 87	SEP 87
5 85 4642	CAL .50 CARTRIDGE FEEDING	160.0	89.0	71.0	MAR 86	DEC 86
5 85 4643	AUTO LINKING CF CAL .50 AMMUNITION	514.0	513.0		DEC 86	DEC 86
5 85 4656	NITRAMINE PROPELLANT PROCESSING	435.0	184.0	203.0	JUN 86	JUN 86
5 86 4656	NITRAMINE PROPELLANT PROCESSING -----JUST FUNDED. NO 301 REQUIRED.-----					
5 85 4660	AUTOMATED BLENDING OF STICK PROPELLANT	573.0	465.7	80.9	SEP 86	SEP 86
5 86 4660	AUTOMATED BLENDING OF STICK PROPELLANT -----JUST FUNDED. NO 301 REQUIRED.-----					
5 84 4663	REMOVAL OF BARIUM FROM CUMP A-3, TYPE II WASTEWATER	50.0		50.0	SEP 85	JUN 86
5 84 4664	RADIOLOGICAL INSPECTION OF AMMUNITION FOR THE SGT YORK -----DELINQUENT STATUS REPORT-----	91.0			APR 85	JUN 86
5 84 4665	COMPUTER SIMULATION JF DU UENCHING	400.0		375.0	SEP 86	DEC 86
5 86 4666	PRO SPIRAL WRAP TOOL F/155M XM203E2 COMB CASE BODIES -----JUST FUNDED. NO 301 REQUIRED.-----					
5 84 4668	ELECTROSTATIC PRECIP IMPROVEMENTS (SMOG HOG)	350.0	338.0	7.0	SEP 85	DEC 86
5 86 4668	ELECTROSTATIC PRECIP IMPROVEMENTS (SMOG HOG)	250.0			DEC 88	DEC 88
5 85 4698	MULTI-FELTING + PRESSING OF COMBUSTIBLE CART CASE COMPONENTS	625.0	480.0	81.0	MAR 87	SEP 86
5 85 4763	MANUFACTURING PROCESS FOR AMMD ----- SECRET. NO 301 REQUIRED. -----					

MANUFACTURING METHODS AND TECHNOLOGY PROGRAM
 SUMMARY PROJECT STATUS REPORT
 2ND SEMIANNUAL SUBMISSION CY 85 RCS DRMT-301

PROJ NO.	TITLE * STATUS	AUTHO- RIZED	CONTRACT VALUES	EXPENDED LABOR AND MATERIAL (\$000)	ORIGINAL PROJECTED COMPLETE DATE	PRESENT PROJECTED COMPLETE DATE
5 86 4763	MANUFACTURING PROCESS FOR AMMO ----JUST FUNDED. NO 301 REQUIRED.-----					
5 85 4781	AUTOMATIC GAGE FOR THREAD INSPECTION ----DELINQUENT STATUS REPORT-----					

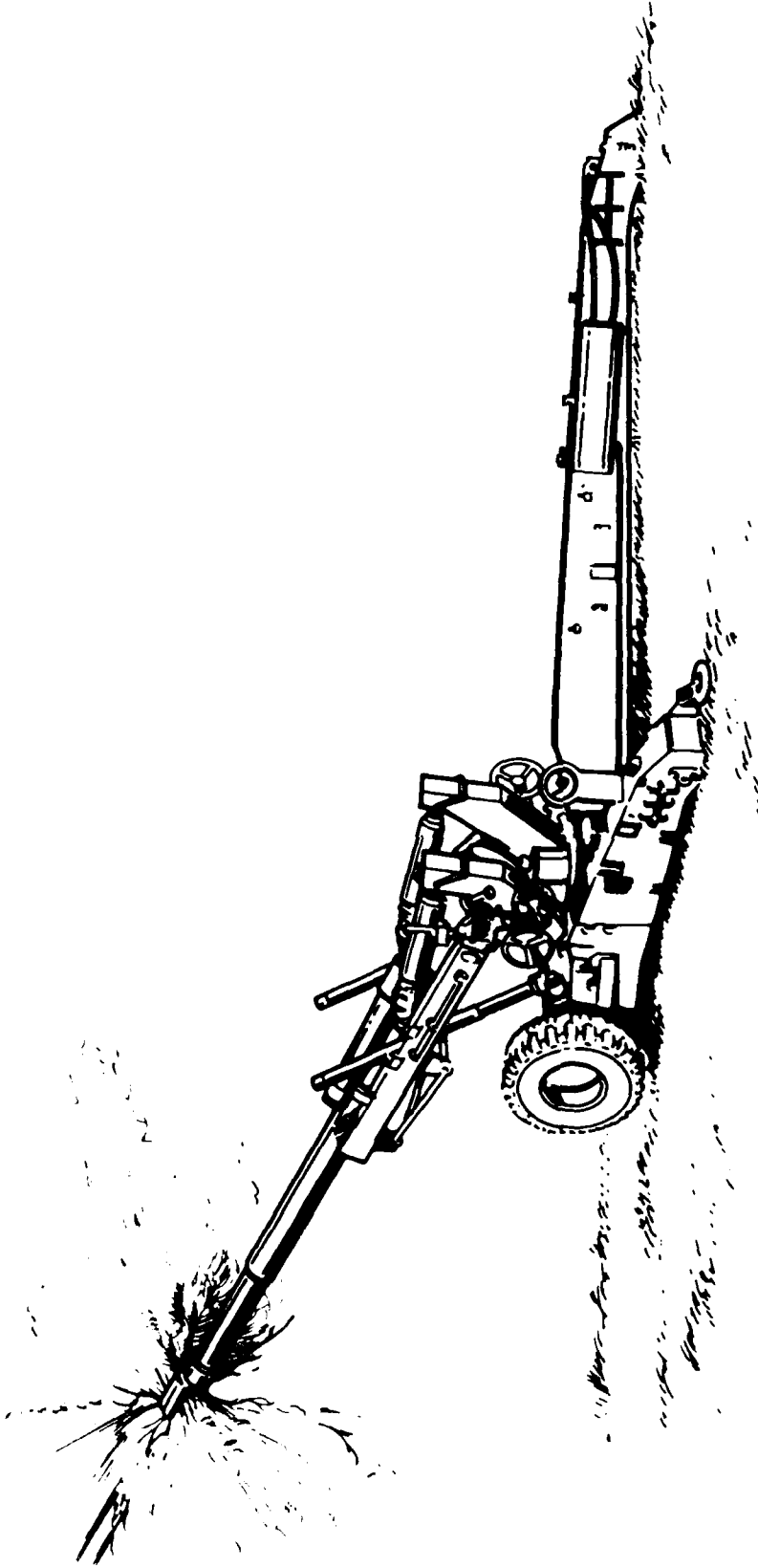

**ARMAMENT, MUNITIONS AND CHEMICAL COMMAND
(AMCCOM)
(WEAPONS)**

A M C U M (W E A P U N S)
CURRENT FUNDING STATUS, 2ND CYR

FISCAL YEAR	NL. OF PROJECTS	AUTHORIZED FUNDS (\$)	C U N T R A C T A L L O C A T E D (\$)	F U N D I N G E X P E N D E D (\$)	I N H O U S E R E M A I N I N G (\$)	F U N D I N G E X P E N D E D (\$)
76	1	331,100	285,200	205,200 (100%)	45,900	45,900 (100%)
77	0	0	0	0 (0%)	0	0 (0%)
77	0	0	0	0 (0%)	0	0 (0%)
78	0	0	0	0 (0%)	0	0 (0%)
79	2	415,000	289,500	209,500 (100%)	125,500	124,600 (99%)
80	6	1,555,000	280,000	286,100 (99%)	1,268,700	1,220,900 (96%)
81	9	1,915,000	1,149,000	734,100 (63%)	765,200	616,600 (80%)
82	21	6,620,000	3,052,700	1,671,400 (54%)	3,567,300	2,230,900 (62%)
83	10	2,802,000	839,900	727,900 (86%)	1,962,100	931,000 (47%)
84	23	8,021,000	1,201,100	561,900 (46%)	6,819,000	1,487,900 (21%)
85	25	6,726,000	1,020,000	421,900 (41%)	5,706,000	1,041,400 (17%)
86	20	1,302,000	197,000	100,000 (50%)	1,185,000	0 (0%)
TOTAL	114	29,767,100	8,521,000	5,078,000 (61%)	21,445,600	6,200,000 (28%)

AUTHORIZED FUNDING CONTRACT ALLOCATED 26% IN-HOUSE REMAINING 72%

AD-A168 382

MANUFACTURING METHODS AND TECHNOLOGY PROJECT
EXECUTIVE REPORT(U) ARMY INDUSTRIAL BASE ENGINEERING
ACTIVITY ROCK ISLAND IL PRODUCTION ENGINEERING DIV
D O'CONNOR APR 86

2/2

UNCLASSIFIED

F/G 13/8

NL

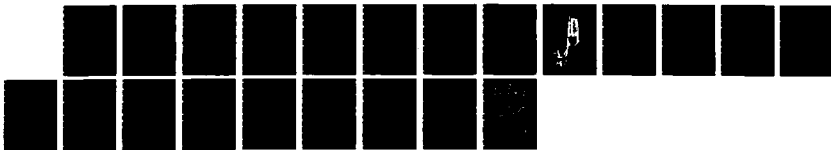

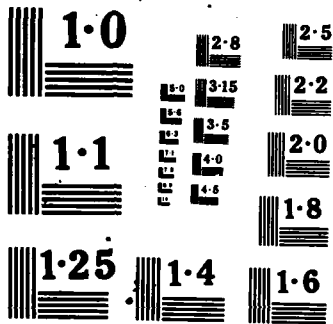

NATIONAL BUREAU OF STANDARDS
MICROCOPY RESOLUTION TEST

MANUFACTURING METHODS AND TECHNOLOGY PROGRAM
 S U M M A R Y P R O J E C T S T A T U S R E P O R T
 2ND SEMIANNUAL SUBMISSION CY 85 BCS DRCHT-301

PROJ NO.	TITLE + STATUS	AUTHO- RIZED	CONTRACT VALUES	EXPENDED LABOR AND MATERIAL (\$000)	ORIGINAL PROJECTED COMPLETE DATE	PRESENT PROJECTED COMPLETE DATE
6 76 7580	PILOT AUTOMATED SHOP LOADING AND CONTROL SYSTEM- CAM -----DELINQUENT STATUS REPORT-----	331.1	285.2	45.9	SEP 78	JUN 86
6 79 7605	CHEMICALLY BONDED SAND FOR CLOSE TOLERANCE CASTING	127.0	22.0	104.9	MAR 80	JUN 86
6 80 7605	CHEMICALLY BONDED SAND FOR CLOSE TOLERANCE CASTING	253.0		252.7	FEB 82	JUN 86
6 82 7707	AUTOMATED PROCESS CONTROL FOR MACHINING	135.0	63.2	71.8	SEP 83	APR 86
6 80 7730	MANUFACTURE OF SPLIT RING BREECH SEALS	363.0	94.2	260.8	DEC 82	SEP 86
6 82 7730	MANUFACTURE OF SPLIT RING BREECH SEALS	108.0		86.5	SEP 84	SEP 86
6 79 7802	ESTABLISH MACHINE TOOL PERFORMANCE SPECIFICATIONS	288.0	267.5	19.7	JUN 81	JUN 86
6 81 7807	PROGRAMMED OPTICAL SURFACING EQUIPMENT AND METHODOLOGY (CAM)	374.0	341.0	26.0	JUL 83	SEP 87
6 81 7928	ROBOTIZED BENCHING OPERATIONS (CAM)	287.0	251.2	35.8	SEP 83	JUL 86
6 80 7963	GROUP TECHNOLOGY FOR FIRE CONTROL PARTS AND ASSEMBLIES	429.0	21.8	396.1	DEC 81	SEP 86
6 83 7985	SMALL ARMS WEAPONS NEW PROCESS PRODUCTION TECHNOLOGY	530.0	348.0	160.0	OCT 84	JUN 86
6 83 7985 01	SMALL ARMS WEAPONS NEW PROCESS TECH-ROTARY FURGING				OCT 86	JUN 86
6 83 7985 05	RECYCLE OF GUN STEEL				JAN 85	JUN 86
6 83 7985 06	TRAVELING ELECTRODE ECM RIFLING					JUN 86
6 84 7985	SMALL ARMS WEAPONS NEW PROCESS PRODUCTION TECHNOLOGY	718.0	348.0	128.0	OCT 85	JCT 87
6 84 7985 01	SMALL ARMS WEAPONS NEW PROCESS TECH-ROTARY FURGING					JCT 87
6 84 7985 04	RAPID FLOW PLATING OF GUN TUBES				OCT 86	JCT 87
6 84 7985 06	TRAVELING ELECTRODE ECM RIFLING					OCT 87
6 84 7985 07	STRAIGHTENING				JAN 85	JCT 87
6 84 7985 08	TRIBOLOGY				JAN 85	OCT 87
6 85 7985	SMALL ARMS WEAPONS NEW PROCESS PRODUCTION TECHNOLOGY	890.0	514.0	14.0	OCT 87	JCT 87
6 85 7985 01	SMALL ARMS WEAPONS NEW PROCESS TECH-ROTARY FURGING				JCT 87	JCT 87

MANUFACTURING METHODS AND TECHNOLOGY PROGRAM
 S U M M A R Y P R O J E C T S T A T U S R E P O R T
 2ND SEMI-ANNUAL SUBMISSION CY 85 RCS DRCHT-301

PROJ NO.	TITLE + STATUS	AUTHO- RIZED	CONTRACT VALUES	EXPENDED LABOR AND MATERIAL (\$000)	ORIGINAL PROJECTED COMPLETE DATE	PRESENT PROJECTED COMPLETE DATE
6 85 7985 04	SMALL ARMS WEAPONS NEW TECH-RAPID FLOW PLATING				OCT 87	OCT 87
6 85 7985 06	TRAVELING ELECTRODE ECM RIFLING				OCT 87	OCT 87
6 85 7985 07	STRAIGHTENING				UCT 87	UCT 87
6 85 7985 08	TRIBULLOLOGY				OCT 87	UCT 87
6 86 7985	SMALL ARMS WEAPONS NEW PROCESS PRODUCTION TECHNOLOGY	632.0	197.0		UCT 87	UCT 87
6 86 7985 01	SMALL ARMS WEAPONS NEW PROCESS TECH-ROTARY FORGING				UCT 87	UCT 87
6 86 7985 04	SMALL ARMS WEAPONS NEW TECH-RAPID FLOW PLATING				UCT 87	UCT 87
6 86 7985 06	TRAVELING ELECTRODE ECM RIFLING				UCT 87	UCT 87
6 86 7985 07	STRAIGHTENING				UCT 87	UCT 87
6 86 7985 08	TRIBULLOLOGY				UCT 87	UCT 87
6 80 8017	POLLUTION ABATEMENT PROGRAM	86.0		86.0	JAN 81	JUN 86
6 82 8024	HIGH SPEED ABRASIVE BELT GRINDING	142.0		104.1	SEP 84	JUN 86
6 82 8030	MANUFACTURING GUIDE FOR ELASTOMERIC SEALS	123.0	16.9	105.3	MAY 83	JUN 86
6 81 8035	COATING TUBE SUPPORT SLEEVES WITH BEARING MATERIALS	200.0	18.7	181.3	JUN 82	JUN 86
6 80 8051	APPLICATION AND CONTROL OF MACHINE TOOLS (CAM)	209.0	148.8	59.7	AUG 81	JUN 86
6 80 8057	DUAL RIFLING BRACH REMOVAL SYSTEM	215.0	21.5	165.6	SEP 82	FEB 86
6 82 8102	POWDER METALLURGY FORGINGS WEAPONS COMPONENTS	110.0	74.3	28.7	SEP 84	MAR 86
6 83 8102	APPL OF POWDER METALLURGY FORGING TO WEAPON COMPONENTS	142.0		41.7	SEP 85	SEP 86
6 81 8105	ESTABLISH ROUGH THREAD BLANKS, 8 IN M201 BUSHING	292.0	204.9	80.0	SEP 83	JUN 86
6 81 8107	CREEP FEED CRUSH FURN GRINDING	73.0		53.7	JUL 84	SEP 86
6 82 8108	PRODUCTION/IN-PROCESS INSPECTION OF OPTICAL BONDS	275.0		213.7	DEC 83	JAN 87
6 83 8120	ADAPTIVE CONTROL TECHNOLOGY (CAM)	532.0		101.6	SEP 85	SEP 87
6 82 8135	IN-PROCESS CONTRLL OF MACHINING	841.0	595.7	137.7	FEB 84	DEC 86

MANUFACTURING METHODS AND TECHNOLOGY PROGRAM
 SUMMARY PROJECT STATUS REPORT
 2ND SEMIANNUAL SUBMISSION CY 85 RCS DRCHT-301

PROJ NO.	TITLE + STATUS	AUTHO- RIZED	CONTRACT VALUES	EXPENDED LABOR AND MATERIAL (\$000)	ORIGINAL PROJECTED COMPLETE DATE	PRESENT PROJECTED COMPLETE DATE
6 81 8136	IMPROVED IMPULSE PROGRAMMERS FOR HYDRAULIC SIMULATORS	80.0	80.0	80.0	SEP 83	JUN 86
6 82 8151	PORTABLE ENGRAVING SYSTEM	171.0	93.0	62.2	JAN 84	JUL 86
6 84 8153	INCREASING GUN TUBE HEAT TREATMENT CAPACITY	250.0	59.0	81.5	OCT 86	OCT 87
6 84 8154	COMPUTER INTEGRATED MANUFACTURING (CIM) FOR CANNONS	500.0	322.3	101.6	SEP 86	SEP 86
6 82 8165	STANDARDS FOR DIAMOND TURNED OPTICAL PARTS -----DELINQUENT STATUS REPORT-----	258.0	125.0	125.0	OCT 83	JUN 86
6 81 8209	PILOT PRODUCTION OF GRADIENT INDEX OPTICS	374.0	334.0	40.0	MAY 83	SEP 86
6 82 8231	IMPROVED CASTING TECHNOLOGY (CAD/CAM)	250.0		163.8	MAR 84	DEC 87
6 83 8231	IMPROVED CASTING TECHNOLOGY (CAD/CAM)	136.0		14.8	FEB 85	DEC 87
6 84 8231	IMPROVED CASTING TECHNOLOGY	122.0		7.7	MAR 86	DEC 87
6 82 8238	BORING BREECH RING LUGS	303.0	159.0	132.4	AUG 84	SEP 86
6 82 8241	COMPUTER DIAGNOSTICS AND CONTROL FOR BORE GUIDANCE	458.0	380.0	46.0	JUN 85	JUN 86
6 84 8241	COMPUTER DIAGNOSTICS + CONTROL APPL TO BORE GUIDANCE (CAM)	85.0		60.6	MAR 86	JUN 87
6 83 8243	COMPUTER CONTROL FOR ELECTRODEPOSITION SYSTEMS	260.0		258.0	SEP 84	AUG 86
6 83 8245	APPLICATION OF EROSION RESIS LOW CONTRACTION CHROMIUM PLATE	195.0		146.0	SEP 84	SEP 86
6 82 8248	APPLICATION OF HIGH-RATE CUTTING TOOLS	102.0		101.9	JUN 83	JUL 86
6 84 8249	SHORT-CYCLE HEAT TREATMENT OF WEAPON COMPONENTS	132.0		59.0	JUN 85	AUG 86
6 85 8249	SHORT-CYCLE HEAT TREATMENT OF WEAPON COMPONENTS	165.0		24.0	MAR 86	DEC 86
6 84 8250	IMPROVED FABRICATION OF RECOIL WEAR SURFACES	28.0	4.5	22.9	DEC 84	MAR 86
6 85 8250	IMPROVED FABRICATION OF RECOIL WEAR SURFACES	109.0		15.7	JUN 86	FEB 87
6 82 8251	IMPROVED MELTING PRACTICES	193.0	49.0	120.3	JUN 83	SEP 86
6 83 8251	IMPROVED MELTING PRACTICES	104.0		74.7	FEB 85	SEP 86
6 82 8252	INDUCTION HEATING OF A VARYING DIAMETER PREFORM	301.0	170.0	123.7	MAR 84	DEC 86

MANUFACTURING METHODS AND TECHNOLOGY PROGRAM
 SUMMARY PROJECT STATUS REPORT
 2ND SEMIANNUAL SUBMISSION CY 85 RCS DRCHT-301

PROJ NO.	TITLE + STATUS	AUTHO- RIZED	CONTRACT VALUES	EXPENDED LABOR AND MATERIAL (\$000)	ORIGINAL PROJECTED COMPLETE DATE	PRESENT PROJECTED COMPLETE DATE
6 82 8253	MACHINE TOOL DYNAMIC MEASUREMENTS AND DIAGNOSTICS	310.0	190.0	93.6	APR 84	MAY 86
6 82 8259	IMPROVED MANUFACTURING PROCESS FOR FIRE CONTROL REGISTERS	261.0		173.5	SEP 84	DEC 86
6 82 8262	PRODUCTION METHODS FOR OPTICAL WAVEGUIDES	480.0	336.0	144.0	JAN 83	JUL 86
6 84 8262	PRODUCTION METHODS FOR OPTICAL WAVEGUIDES	155.0		155.0	APR 85	JUL 86
6 85 8262	PRODUCTION METHODS FOR OPTICAL WAVEGUIDES	597.0		8.0	DEC 85	DEC 86
6 81 8305	INTEGRATED MANUFACTURING SYSTEM (IMS) - (CAM)	235.0		120.0	JUL 82	DEC 86
6 82 8305	INTEGRATED MANUFACTURING SYSTEM (IMS) - (CAM)	204.0		30.8	SEP 86	DEC 86
6 83 2305	INTEGRATED MANUFACTURING SYSTEM (IMS) - (CAM)	75.0		75.0	UCT 34	DEL 86
6 84 8305	INTEGRATED MANUFACTURING SYSTEM (IMS) (CAM)	2,488.0		22.2	SEP 85	DEC 86
6 85 8305	INTEGRATED MANUFACTURING SYSTEM - IMS	950.0			JUN 86	DEC 86
6 86 8305	INTEGRATED MANUFACTURING SYSTEM (IMS)-(CAM) ----JUST FUNDED. NO 301 REQUIRED.-----					
6 83 8306	CN-LINE PRODUCTION INFORMATION SYSTEM - RIA (CAM)	200.0	158.3	2.7	SEP 84	JUL 86
6 84 8306	UN-LINE PRODUCTION INFORMATION SYSTEM - RIA (CAM)	571.0		25.0	UCT 85	MAR 87
6 84 8323	SPRAY-AND-FUZE PROCESSING OF ARMAMENT COMPONENTS	200.0	103.3	96.5	APR 85	MAR 86
6 85 8323	SPRAY-AND-FUZE PROCESSING OF ARMAMENT COMPONENTS	48.0		40.0	DEC 85	JUL 86
6 85 8324	PROCESS CONTROLS FOR P/M WEAPON COMPONENTS	300.0		82.5	SEP 85	SEP 86
6 86 8324	PROCESS CONTROLS FOR P/M WEAPON COMPONENTS ----JUST FUNDED. NO 301 REQUIRED.-----					
6 85 8329	IP1 - FIRE CONTROL OPTICAL DEVICES NEW PROCESS PROD TECH	275.0	200.0	20.0	DEC 85	MAY 86
6 86 8329	FIRE CONTROL OPTICAL DEVICES NEW PRULESS PROD TECH	500.0			UCT 86	UCT 86
6 92 8341	HOLLOW CYLINDER CUT OFF MACHINE	1,335.0	689.1	23.9	SEP 84	APR 87
6 86 8352	SKIVING (METAL SHAVING) OF GUN TUBE BORES ----JUST FUNDED. NO 301 REQUIRED.-----					

MANUFACTURING METHODS AND TECHNOLOGY PROGRAM
 SUMMARY PROJECT STATUS REPORT
 2ND SEMIANNUAL SUBMISSION CY 85 RCS DRCT-301

PROJ NO.	TITLE + STATUS	AUTHO- RIZED	CONTRACT VALUES	EXPENDED LABOR AND MATERIAL (\$000)	ORIGINAL		PRESENT	
					PROJECTED COMPLETE DATE	PROJECTED COMPLETE DATE	PROJECTED COMPLETE DATE	PROJECTED COMPLETE DATE
6 83 8354	CUTTING OF HOT ROTARY FORCE TUBES	568.0	333.6	57.1	SEP 85	SEP 85	APR 87	
6 84 8370	AUTO INSP AND PROC CONTROL OF WPNS PARTS MFG	300.0	221.0	79.0	SEP 86	SEP 86	MAR 86	
6 85 8370	AUTO INSP + PROCESS CONTROL OF WPNS PARTS MFG (CAM)	225.0	145.0	42.0	SEP 86	SEP 86	JUN 86	
6 86 8370	AUTO INSPECTION + PROC CNT OF WEAPONS PARTS MFG	250.0			DEC 86	DEC 86	DEC 86	
6 86 8403	DESIGN CRITERIA FOR HARDENING -----JUST FUNDED. NO 301 REQUIRED.-----							
6 84 8416	FLEXIBLE MFG SYSTEMS W/SPECIAL TOOLING	288.0		51.1	UCT 85	UCT 85	OCT 86	
6 84 8416 01	FLEXIBLE MACHINING SYSTEM	260.0		23.2	OCT 85	OCT 85	OCT 86	
6 85 8416	FLEXIBLE MFG SYSTEM W/SPECIAL TOOLING - RIA	178.0	65.0	63.7	MAR 86	MAR 86	JUN 87	
6 85 8416 02	FLEXIBLE MFG SYS W/SPECIAL TOOLING - RIA (CAM)	178.0	65.0	63.7	MAR 86	MAR 86	JUN 87	
6 86 8416	FLEXIBLE MFG SYSTEM WITH SPECIAL TOOLING - RIA -----JUST FUNDED. NO 301 REQUIRED.-----							
6 84 8426	APPLICATION OF LASERS TO CANNON MANUFACTURE	622.0	83.0	82.3	SEP 86	SEP 86	SEP 86	
6 84 8430	AUTOMATED WELDING OF ROTARY FORCE HAMMERS	137.0	33.9	46.3	SEP 86	SEP 86	JUL 86	
6 84 8431	AUTOMATED WELDING OF BORE EVACUATORS	215.0		48.7	SEP 86	SEP 86	SEP 86	
6 84 8433	IN PROCESS CONTROL OF SELAS HEAT TREAT SYSTEM (CAM)	125.0	1.8	37.5	JUN 86	JUN 86	MAR 87	
6 84 8434	EDDY CURRENT INSPECTION OF GUN TUBES	118.0	9.2	29.1	JUL 85	JUL 85	DEC 86	
6 84 8436	QUENCH CYCLE PROFILE MEASUREMENT SYSTEM	148.0		31.1	SEP 85	SEP 85	SEP 86	
6 85 8436	QUENCH CYCLE PROFILE MEASUREMENT SYSTEM	147.0		64.1	JUL 86	JUL 86	JUL 87	
6 84 8437	DENSIFICATION OF WEAPON CASTINGS (HIP)	108.0	15.1	20.8	SEP 86	SEP 86	DEC 86	
6 86 8437	DENSIFICATION OF WEAPON CASTINGS (HIP) -----JUST FUNDED. NO 301 REQUIRED.-----							
6 84 8439	IMPROVED RIFLING PROCEDURES	80.0		56.8	SEP 85	SEP 85	SEP 86	
6 82 8448	GRAIDED PROCESS FOR BORE EVACUATOR	260.0	111.5	148.0	SEP 84	SEP 84	JUN 86	

MANUFACTURING METHODS AND TECHNOLOGY PROGRAM
 S U M M A R Y P R O J E C T S T A T U S R E P O R T
 2ND SEMIANNUAL SUBMISSION CY 85 ACS DRGMT-301

PROJ NO.	TITLE + STATUS	AUTHO- RIZED	CONTRACT VALUES	EXPENDED LABOR AND MATERIAL	ORIGINAL PROJECTED COMPLETE DATE	PRESENT PROJECTED COMPLETE DATE
6 85 8449	OPTIMAL RIFLING CONFIGURATION FOR CR PLATING	140.0		17.3	SEP 86	SEP 86
6 84 8473	APPL FUSED SALT PROCESS TO COAT TANTALUM ON L CAL LINERS	242.0		97.6	SEP 85	OCT 87
6 85 8473	APPL FUSED SALT PROCESS	250.0		104.4	SEP 86	OCT 87
6 84 8474	APPL OF PARTIAL REFRACTORY LINERS TO CANNON TUBES	389.0		147.0	SEP 86	SEP 87
6 85 8474	APPL OF REFRACTORY LINERS TO CANNON TUBES	290.0		70.2	SEP 86	SEP 87
6 86 8510	AUTOMATED INSPECTION OF RECOIL COMPONENTS (CAM) -----JUST FUNDED. NO 301 REQUIRED.-----					
6 85 8511	CASTING OF ANTIFRICTION METAL COMPONENTS	200.0		12.1	SEP 86	FEB 87
6 86 8511	DIE CASTING OF ANTIFRICTION METAL COMPONENTS -----JUST FUNDED. NO 301 REQUIRED.-----					
6 86 8518	THIN FILM COATINGS FOR LASER EYE PROTECTION -----JUST FUNDED. NO 301 REQUIRED.-----					
6 85 8544	WIRE E.D.H. MACHINING OF RIFLING BROACHES	70.0	1.8	57.1	JAN 86	APR 86
6 85 8546	MACHINERY CONDITIONS SURVEILLANCE SYSTEM	253.0		29.5	SEP 87	MAR 89
6 86 8546	MACHINERY CONDITIONS SURVEILLANCE SYSTEM -----JUST FUNDED. NO 301 REQUIRED.-----					
6 86 8553	APPLICATION OF REFRACTORY + OTHER COAT BY THE SPUTT TECH -----JUST FUNDED. NO 301 REQUIRED.-----					
6 85 8559	CIM FOR CANNON CAD/CAM/COMM	1,010.0	42.2	690.2	JAN 86	SEP 89
6 86 8559	CIM FOR CANNON, CAE/CAM/COMM -----JUST FUNDED. NO 301 REQUIRED.-----					
6 85 8573	GENERIC GUN GYMNASTICATOR -----DELINQUENT STATUS REPORT-----					
6 85 8603	ROBOTIC WELDING - RIA	105.0		42.5	SEP 88	SEP 88
6 86 8603	ROBOTIC WELDING -----JUST FUNDED. NO 301 REQUIRED.-----					
6 85 3606	APPLICATION OF FLUIDIZED BED HEAT TREATMENT	74.0		35.9	JUN 86	JEC 86

MANUFACTURING METHODS AND TECHNOLOGY PROGRAM
 SUMMARY PROJECT STATUS REPORT
 2ND SEMI-ANNUAL SUBMISSION CY 85 RCS DRCHT-301

PROJ NO.	TITLE + STATUS	AUTHO- RIZED	CONTRACT VALUES	EXPENDED LABOR AND MATERIAL (\$000)	ORIGINAL PROJECTED COMPLETE DATE		PRESENT PROJECTED COMPLETE DATE	
					(\$000)	(\$000)		
6 85 8625	MANUFACTURE OF MULTI-LUG BREECH MECHANISMS	80-0		58.7	JAN 86	APR 86		
6 86 8625	MANUFACTURING OF MULTI-LUG BREECH MECHANISMS -----JUST FUNDED. NO 301 REQUIRED.-----							
6 85 8633	A THREE DIMENSIONAL NON-CONTACT MEASURING SYSTEM	125-0	52.0	23.6	DEC 86	DEC 86		
6 86 8638	CONTROL OF SEQUENTIAL MACHINING OPERATIONS (CAM) -----JUST FUNDED. NO 301 REQUIRED.-----							
6 86 8641	MFG OF TITANIUM ALLOY METAL MATRIX CANNON COMPONENTS -----JUST FUNDED. NO 301 REQUIRED.-----							
6 86 8642	APPLICATION OF ADVANCED MATERIALS TO CANNON PROD -----JUST FUNDED. NO 301 REQUIRED.-----							

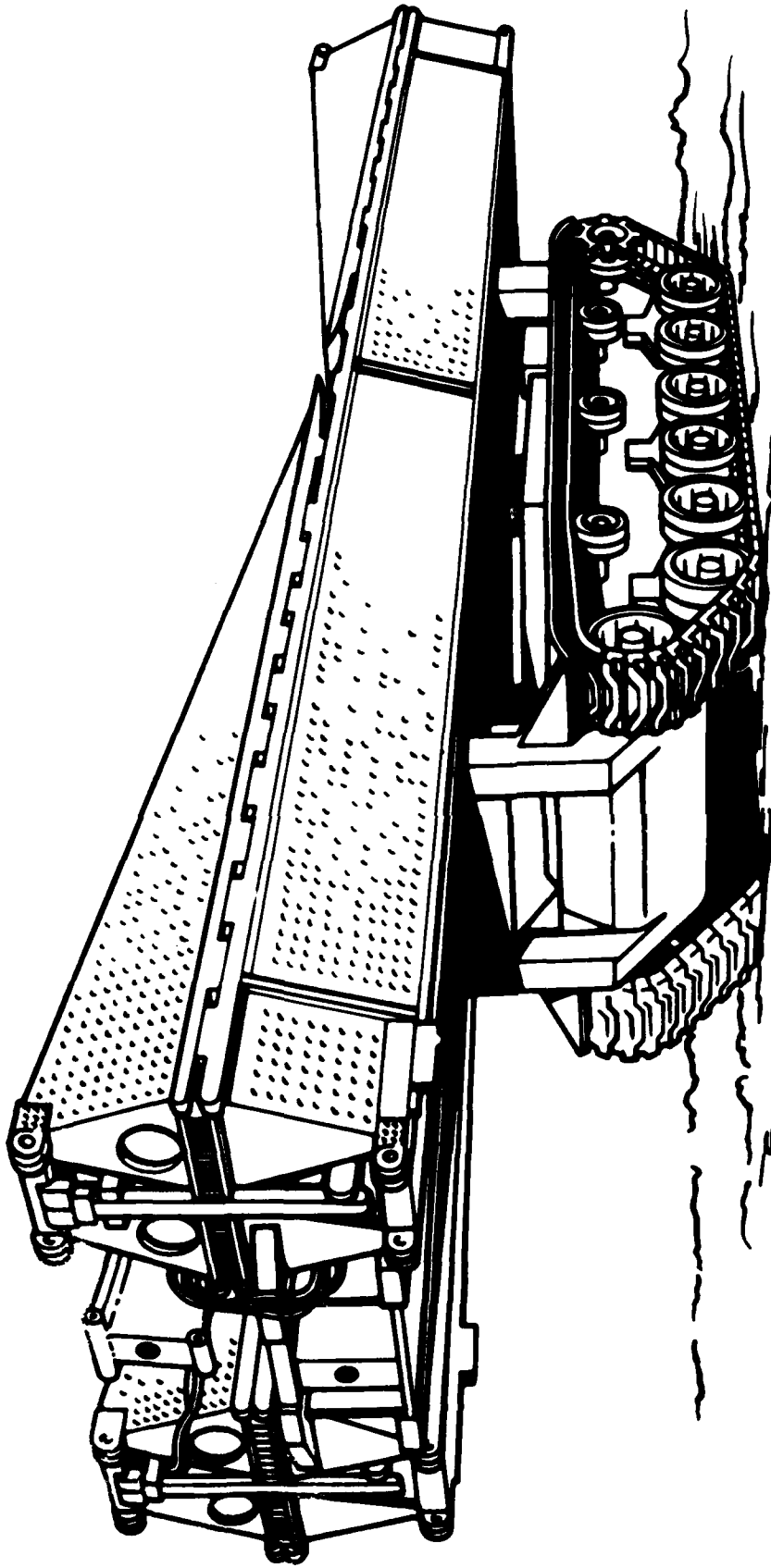

**TROOP SUPPORT COMMAND
(TROSCOM)**

T R O O P S U P P O R T C O M M A N D

CURRENT FUNDING STATUS, 2ND CY85

FISCAL YEAR	NO. OF PROJECTS	AUTHORIZED FUNDS (\$)	C O N T R A C T A L L O C A T E D (\$)	F U N D I N G E X P E N D E D (\$)	I N H O U S E R E M A I N I N G (\$)	F U N D I N G E X P E N D E D (\$)
84	1	1,628,000	1,624,000	1,254,000 (77%)	4,000	4,000 (100%)
85	2	1,837,000	1,200,000	847,000 (70%)	637,000	94,500 (14%)
86	3	580,600	277,600	0 (0%)	303,000	21,300 (7%)
TOTAL	6	4,045,600	3,101,600	2,101,000 (67%)	944,000	119,800 (12%)

AUTHORIZED FUNDING CONTRACT ALLOCATED 77% INHOUSE REMAINING 23%

MANUFACTURING METHODS AND TECHNOLOGY PROGRAM
 SUMMARY PROJECT STATUS REPORT
 2ND SEMI-ANNUAL SUBMISSION CY 85 RCS DRGNT-301

PRCJ NO.	TITLE + STATUS	AUTHORIZED (\$000)	CONTRACT VALUES (\$000)	EXPENDED LABOR AND MATERIAL (\$000)	ORIGINAL	PRESENT
					PROJECTED COMPLETE DATE	PROJECTED COMPLETE DATE
E 84 3796	COMBAT VEHICLE DEPERMING PRODUCTION FACILITY	1,628.0	1,624.0	4.0	DEC 85	FEB 86
E 85 3796	COMBAT VEHICLE DEPERMING PRODUCTION FACILITY	1,167.0	1,050.0	94.5	DEC 85	FEB 86
E 86 3796	COMBAT VEHICLE DEPERMING PRODUCTION FACILITY	252.6	277.6	21.3	SEP 86	SEP 86
E 85 3802	HIGH STABILITY TRUSS CHORD	328.0			APR 86	APR 88
E 85 3074	ADVANCED HARDENED SHELTER COST OPTIMIZATION	670.0	150.0		NOV 87	NOV 87
E 85 6074	ADVANCED HARDENED SHELTER COST OPTIMIZATION -----JUST FUNDED. NO 301 REQUIRED.-----					

APPENDICES

APPENDIX I

ARMY MMT PROGRAM REPRESENTATIVES

ARMY MMT PROGRAM REPRESENTATIVES

Department of the Army

ODCSRDA

ATTN: DAMA-PPM-P (LTC S. Marsh)
Room 3C364, The Pentagon
Washington, DC 20310-0651

C: (202) 695-0507
AV: 225-0506

HQ, AMC

U.S. Army Materiel Command
ATTN: AMCPD-SE (Mr. John Holvoet)
5001 Eisenhower Avenue
Alexandria, VA 22333-0001

C: (202) 274-6748
AV: 284-6748

AMCCOM

U.S. Army Armament, Munitions & Chemical Command
ATTN: AMSMC-PBS-A (R) (Mr. Carrol Schumacher)
Rock Island, IL 61299-6000

C: (309) 782-3517/3665
AV: 793-3517/3665

U.S. Army Armament, Munitions & Chemical Command
Armament Research and Development Center
ATTN: SMCAR-PMP-P (Ms. Loretta Settles)
Dover, NJ 07801

C: (201) 724-7957
AV: 880-7957

U.S. Army Armament, Munitions & Chemical Command
Chemical Research and Development Center
ATTN: SMCCR-PMI (Mr. John Kurtz)
Building E5101
Aberdeen Proving Grounds, MD 21010-5423

C: (301) 724-3418/3586
AV: 584-3418/3586/3010

U.S. Army Armament, Munitions & Chemical Command
Production Base Modernization Agency
ATTN: AMSMC-PB (D) (Mr. Albert Siklosi)
Dover, NJ 07801

C: (201) 724-3560/3563
AV: 880-3560/3563

AMC School of Engineering and Logistics

ATTN: AMXMC-SEL-E (Mr. Mickey Carter)
Red River Army Depot
Texarkana, TX 75501

C: (214) 838-2001
AV: 829-2001

AMETA

U.S. Army Management Engineering Training Activity
ATTN: AMXOM-SE (Mr. Paul Wagner)
Rock Island, IL 61299

C: (309) 782-4041
AV: 793-4041

AMRDL

U.S. Army Applied Technology Laboratory
Army Research Technology Lab (AVSCOM)
ATTN: SAVRT-TY-ATS (Mr. J. Waller)
Fort Eustis, VA 23604-5577

C: (804) 878-5921/2401
AV: 927-5921/2401

AVSCOM

U.S. Army Aviation Systems Command
ATTN: AMSAV-PEC (Mr. Joe Pratcher)
4300 Goodfellow Blvd.
St. Louis, MO 63120

C: (314) 263-3079/3080
AV: 693-3079/3080

CECOM

U.S. Army Communications & Electronics Command
ATTN: AMSEL-POD-P-G (Mr. Al Feddeler)
AMSEL-PC-SI-I (Mr. Sada Barik)
Fort Monmouth, NJ 07703

C: (201) 535-4926
AV: 995-4926
C: (201) 532-4035
AV: 992-4995

DESCOM

U.S. Army Depot Systems Command
ATTN: AMSDS-RM-EM (Mr. Mike Ahearn)
Chambersburg, PA 17201

C: (717) 263-6591
AV: 238-6591

HDL

Harry Diamond Laboratories
ATTN: SLCHD-PO-P (Mr. Julius Hoke) (Ms. Mary Binseel)
2800 Powder Mill Road
Adelphi, MD 20783

C: (202) 394-1551
AV: 290-1551

LABCOM

U.S. Army Laboratory Command
ATTN: AMSLC-AS-SE (Mr. Harold Garson)
2800 Powder Mill Road
Adelphi, MD 20783-1145

C: (202) 394-3448
AV: 290-3448

MICOM

U.S. Army Missile Command
ATTN: AMSMI-RD-SE-MT (Mr. Bobby Park)
Redstone Arsenal, AL 35898

C: (205) 876-2147
AV: 746-2147

MTL

U.S. Army Materials Technology Laboratory
ATTN: SLCMT-TPP (Mr. John Gassner)
Watertown, MA 02172-0001

C: (617) 923-5521
AV: 955-5521

RIA

Rock Island Arsenal
ATTN: SMCRI-ENM (Mr. J. W. McGarvey)
Rock Island, IL 61299-5000

C: (309) 782-4142
AV: 793-4142

TACOM

U.S. Army Tank-Automotive Command
ATTN: AMSTA-TMM (Mr. Jamie Florence)
Warren, MI 48397-5000

C: (313) 574-6065
AV: 786-6065

TECOM

U.S. Army Test & Evaluation Command
ATTN: AMSTE-TC-M (Mr. Robert Brazzon)
Aberdeen Proving Ground, MD 21005

C: (301) 278-3677/2170
AV: 298-3677/2170/2375

TMDE

U.S. Army Test Measurement Diagnostic Equipment Support Group

ATTN: AMXTM-S (Mr. Ken Magnant)

Redstone Arsenal, AL 35898

C: (205) 876-1850/2575

AV: 746-1850/2575

TROSCOM

U.S. Army Troop Support Command

ATTN: AMSTR-PT (Mr. Richard Green)

4300 Goodfellow Blvd.

St. Louis, MO 63120

C: (314) 263-2818

AV: 693-2818

U.S. Army Troop Support Command

Belvoir R&D Center

ATTN: STRBE-CB (Ms. Betz)

Fort Belvoir, VA 22060

C: (703) 664-5174

AV: 354-5174

U.S. Army Troop Support Command

Natick R&D Center

ATTN: STRNC-EML (Mr. Bob Kelly)

Natick, Ma 01760

C: (617) 651-4899

AV: 256-4899

WVA

Watervliet Arsenal

ATTN: SMCWV-PPI (Mr. William Garber)

Watervliet, NY 12189

C: (518) 266-5319

AV: 974-5319

DISTRIBUTION

PROJECT EXECUTION REPORT

AMXIB-PS
DISTRIBUTION:

Department of the Army:

HQDA, OASARDA, ATTN: MT Representative
HQDA, DCSRDA, ATTN: DAMA-PPM-P (LTC S. Marsh)
HQDA, DCSRDA, ATTN: DAMA-WSW (Mr. Jack Lynn)

Department of Defense:

OASD (A&L) PSIR, ATTN: Dr. Lloyd L. Lehn (2 cys)
Department of Defense, ATTN: DTIC-BOS (Mr. R. W. Bergmann)

U.S. Army Materiel Command:

Cdr, ATTN: AMCCG
Cdr, ATTN: AMCDE
Cdr, ATTN: AMCDMD
Cdr, ATTN: AMCDMR
Cdr, ATTN: AMCPD-I
Cdr, ATTN: AMCPD-IP
Cdr, ATTN: AMCPD-IP (Mary Brittain)
Cdr, ATTN: AMCPD-PM (Mr. Jim Sullivan)
Cdr, ATTN: AMCPD-PT (Mr. Al Elkins)
Cdr, ATTN: AMCPD-SE (Mr. John Kicak) (20 cys)
Cdr, ATTN: AMXAM-TL (Technical Library)
Deputy Exec Dir for Conventional Ammo, ATTN: AMXED-AL (Mr. Jim Lutterback)

U.S. Army Armament, Munitions and Chemical Command:

Cdr, ATTN: AMSMC (D)
Cdr, ATTN: AMSMC-ASP (R) (Mr. Rice)
Cdr, ATTN: AMSMC-ASA (R)
Cdr, ATTN: AMSMC-CG (R)
Cdr, ATTN: AMSMC-IRB-C (R) (Mr. Stephen Mapley)
Cdr, ATTN: AMSMC-PB (D) (Mr. Albert Siklosi)
Cdr, ATTN: AMSMC-PBM-PC (D) (Mr. W. Donnelly) (5 cys)
Cdr, ATTN: AMSMC-PBM-TI (D) (Mr. Richard Koppenaal)
Cdr, ATTN: AMSMC-PBS-A (R) (Mr. Carrol Schumacher) (3 cys)
Cdr, ATTN: AMSMC-QAK (R) (Mr. Richard Fer)
Cdr, ATTN: AMSMC-QAH (D) (Mr. George DeMassi)
Cdr, ATTN: AMSMC-QAH-T (D) (Mr. George Drucker)
Cdr, ATTN: AMSMC-QAS-T (D) (Mr. Jaime Vega)
Cdr, ATTN: SMCAR-ESP (R) (5 cys)
Cdr, ATTN: SMCAR-EST-L (R) (Technical Library) (3 cys), [Defense Technical Information Center, ATTN: DDR-1 (2 cys)]

Armament Research & Development Center:

Cdr, ATTN: SMCAR-PMP-P (Ms. Loretta Settles) (8 cys)
PM, Cannon Artillery Weapons Systems, ATTN: AMCPM-CAWS

Chemical Research & Development Center:

Cdr, ATTN: SMCCR-PMI (Mr. John Kurtz)
Cdr, ATTN: SMCCR-SPS-IL (Technical Library)

AMXIB-PS
DISTRIBUTION (Cont'd):

U.S. Army Aviation Systems Command:

Cdr, ATTN: AMSAV-PEC (Mr. Joseph Pratcher)
Cdr, ATTN: AMSAV-QE (Mr. A. Spratt)
Cdr, ATTN: Technical Library

U.S. Army Belvoir R&D Center:

Cdr, ATTN: STRBE
Cdr, ATTN: STRBE-CB (Ms. Betz)
Cdr, ATTN: Technical Library

U.S. Army Communications & Electronics Command:

Cdr, ATTN: AMSEL
Cdr, ATTN: AMSEL-PA-M (Mr. C. Faulkner)
Cdr, ATTN: AMSEL-PC-SI-I (Mr. Leon Field)
Cdr, ATTN: AMSEL-POD-P-G (Messrs. Feddeler, Esposito, Resnic)
Cdr, ATTN: RD&E Technical Documents Center

U.S. Army Depot Systems Command:

Cdr, ATTN: AMSDS-QM (Mr. T. Wolf)
Cdr, ATTN: AMSDS-RM-EM (Mr. Mike Ahearn)

U.S. Army Laboratory Command:

Cdr, ATTN: AMSLC
Cdr, ATTN: AMSLC-PA (Mr. J. Goon)
Cdr, ATTN: AMSLC-AS-SE (Mr. Harold Garson)
Cdr, ATTN: DELET-R (Mr. Joseph Key)

U.S. Army Materials Technology Laboratory:

Dir, ATTN: SLCMT
Dir, ATTN: SLCMT-M
Dir, ATTN: SLCMT-MC (Dr. Morton Kliman)
Dir, ATTN: SLCMT-PL
Dir, ATTN: SLCMT-STQ (Mr. H. Campbell) (Mr. Paul Rolston) (5 cys)
Dir, ATTN: SLCMT-TPP (Mr. John Gassner) (2 cys)
Dir, ATTN: Technical Library

U.S. Army Missile Command:

Cdr, ATTN: AMSMI-CG
Cdr, ATTN: AMSMI-RD-SE-MT (Mr. Bobby Park) (Mr. Bob Austin)
Cdr, ATTN: AMSMI-QA (Mr. Gil Hutchens)
Cdr, ATTN: AMSMI-RST (Mr. Lloyd Chapman)
Cdr, ATTN: RSIC/Magazine Room
Cdr, ATTN: AMCPM-HA

U.S. Army Natick R&D Center:

Cdr, ATTN: STRNC
Cdr, ATTN: STRNC-EML (Mr. Bob Kelly)

U.S. Army Tank-Automotive Command:

Cdr, ATTN: AMSTA-QAT (Mr. F. Braun)
Cdr, ATTN: AMSTA-TMM (Mr. Jamie Florence)
Cdr, ATTN: AMSTA-RP
Cdr, ATTN: Technical Library

AMXIB-PS
DISTRIBUTION (Cont'd):

U.S. Army Test and Evaluation Command:

Cdr, ATTN: AMSTE
Cdr, ATTN: AMSTE-TC-M (Mr. William Deaver) (Mr. Robert Brazzon)

U.S. Army TMDE Support Group:

Cdr, ATTN: AMXTM
Cdr, ATTN: AMXTM-S (Mr. Ken Magnant)

U.S. Army Troop Support Command:

Cdr, ATTN: AMSTR
Cdr, ATTN: AMSTR-PT (Mr. Richard Green) (Mr. G. P. McMichael)
Cdr, ATTN: AMSTR-Q (Mr. W. Creel)

Pine Bluff Arsenal:

Cdr, ATTN: SMCPB-CO

Rock Island Arsenal:

Cdr, ATTN: SMCRI-CO
Cdr, ATTN: SMCRI-ENM (Mr. J. W. McGarvey)
Cdr, ATTN: SMCRI-ENM-T (Mr. Richard Kalkan)

Watervliet Arsenal:

Cdr, ATTN: SMCV-PPI (Mr. R. MaCabe) (Mr. William Garber)
Cdr, Benet Wpns Lab, ATTN: AMSMC-LCB-S (Dr. F. Heiser)
Cdr, Benet Wpns Lab, ATTN: AMSMC-LCB-TL (Tech Library)

Army Ammunition Plants:

Cdr, Crane AAA, ATTN: SMCCN-EDP (Mr. Bill Gates), SMCCN-QAM-C
(Mr. S. R. Caswell)
Cdr, Hawthorne AAP, ATTN: SMCHW-ADF
Cdr, Holston AAP, ATTN: SMCHO-CO
Cdr, Iowa AAP, ATTN: SMCIO-EN
Cdr, Lone Star AAP, ATTN: SMCLS-EN
Cdr, Milan AAP, ATTN: SMCMI-EN
Cdr, Mississippi AAP, ATTN: SMCMS

Depots:

Cdr, Anniston Army Depot, ATTN: SDSAN-RM-PPM (Mr. B. H. Haynes)
(Mr. P. B. Hamilton) (Mr. Mike Trowse)
Cdr, Corpus Christi Army Depot, ATTN: SDSCC-MPI (Mr. Mike Adhern), SDSCC-CME
(Ms. Brenda Lake), SDSCC-MPI (Mr. Don Wells)
Cdr, Letterkenny Army Depot, ATTN: SDSLE-MME (Mr. David Kaufman), SDSLE-MMS
(Mr. Gerald Cline)
Cdr, Mainz Army Depot, ATTN: SDSMZ-FMD (Mr. Karl-Heinz Theuerkauf)
Cdr, New Cumberland Army Depot, ATTN: SDSNC-ME, SDSNC-F (Mr. Joseph Bush)
Cdr, Red River Army Depot, ATTN: SDSRR-MO, SDSRR-ME (Mr. Gary Fuller)
Cdr, Sacramento Army Depot, ATTN: SDSSA-QSM-2 (Mr. Mike Sheehan), SDSSA-RPM-1
(Mr. Pat Coghlan), SDSSA-R (Mr. B. Grindle)
Cdr, Seneca Army Depot, ATTN: SDSSE-FX (Mr. Scott Woodworth)
Cdr, Sierra Army Depot, ATTN: SDSSI-DED (Mr. Donald Smedes)

AMXIB-PS

DISTRIBUTION (Cont'd):

Depots (Cont'd):

Cdr, Tobyhanna Army Depot, ATTN: SDSTO-ME, SDSTO-ME-E (Mr. Frank Estock)
Cdr, Tooele Army Depot, ATTN: SDSTE-MAE, SDSTE-FM (Mr. Stan Perkes),
SDSTE-MAE-E (Mr. Douglas Deem)

Miscellaneous Army Organizations:

Dir, AMC School of Engineering & Logistics, ATTN: AMXMC-SEL-E (Mr. Carter)
(Mr. Achord)
Cdr, Army Combat Systems Test Activity, ATTN: SPECS-DA-M
Cdr, Army Installations & Services Activity, ATTN: AMXEN-RI
Cdr, Army Logistics Management Center (ALMC), ATTN: AMXMC-ACM-MA (Mr. East)
Dir, Army Management Engineering Training Activity (AMETA), ATTN: AMXOM-SE
(Dr. Shallman) (3 cys)
Cdr, Army Signals Warfare Lab, ATTN: DELSW-MP
Cdr, Army Foreign Science and Technology Ctr (FSTC), ATTN: AIAST-RA-ST3
(Mr. David Barlow)
Cdr, Detroit Arsenal Tank Plant, ATTN: AMCPM-M60-TP (Mr. Tom Zemke) (2 cys)
Cdr, Dugway Proving Ground, ATTN: STEDP-PO-M (Mr. E. D. Soliven)
Cdr, Harry Diamond Labs, ATTN: SLCHD-PO-P (Mr. Julius Hoke) (Ms. Mary Binseel)
Cdr, Night Vision & Electro-Optics Lab, ATTN: DELNV-SE
PM, Mobile Electric Power, ATTN: AMCPM-MEP
PM, Stand-off Target Acquisition System, ATTN: AMCPM-STA

Air Force:

Cdr, Air Force Logistics Command, ATTN: AFLC-MAX
Cdr, Air Force Systems Command, ATTN: SD/PD (Mr. Henry Black)
Cdr, Air Force Wright Aeronautical Lab, ATTN: AFWAL/LT, AFWAL/MLS, AFWAL/MLTE,
AFWAL/MLTN
Cdr, San Antonio Air Logistics Ctr, ATTN: B. Boisvert-MMEI, Kelly AFB

Navy Organizations:

Cdr, Naval Material Command, ATTN: Code 064 (Mr. J. W. McInnis)
Dir, Naval Mat Comd Ind Resources Detachment, Bldg. 75-2
Cdr, Naval Ocean Systems Ctr, ATTN: Code 926 (Dr. Wil Watson)
Cdr, Naval Ordnance Station, ATTN: Code 5253 (Mr. Craig Smith)
Cdr, Naval Sea Systems Command, ATTN: Code SEA-05R23 (Mr. T. E. Draschil)
Cdr, Naval Weapons Ctr, ATTN: Code 36404

Mr. Del Spalsbury, Battelle Labs, 705 King Avenue, Bldg 13, Ofc 2044,
Columbus, OH 43201

END

Dtjic

7-86