



LI-ION
TECHNOLOGY

INNOVATIVE LITHIUM-ION

A Series 3-Wheel Electric Forklift with Lithium-ion Technology

with capacities of 3,200 to 4,000lbs

The World of Hangcha
SINCE 1956

HANGCHA
 CANADA

LET THE LITHIUM POWER SPEAK



HANGCHA PROVIDES UP TO A
10 YEAR OR 20000 HOUR GUARANTEE
ON THE LITHIUM-ION BATTERY PACKS.



INNOVATIVE SOLUTIONS NEW POWER NOW

Lithium-ion technology (Lithium Iron-Phosphate), was developed jointly by HANGCHA and CATL for use in material handling equipment applications. These innovative and reliable battery cells and modules are manufactured to the highest standard by CATL exclusively for HANGCHA's forklift line.

- / **Battery Technology:** We use square lithium iron phosphate batteries. These are the same type of batteries used in new electric vehicles.
- / **Design:** The module uses a sturdy and lightweight aluminum alloy frame. It is also designed to provide excellent heat dissipation.
- / **Safe and Effective:** Charging efficiency as high as 98% and the thermal runaway temperature is at 600 °C and above.
- / **Adapted to Low Temperatures:** Comes standard with an electrical heating feature, ensuring normal operation in low temperatures.
- / **Quick Charging:** Fully charges in 2 hours.
- / **Efficient:** Can use opportunity charging to allow for continuous use in multi-shift operations.
- / **Long-Lasting:** 4000 charging cycles with a capacity retention greater than 80%.
- / **Maintenance-Free:** Lithium-ion batteries do not require manual maintenance such as watering.
- / **Green and clean:** The batteries are pollution-free, release zero emissions, and are recyclable.

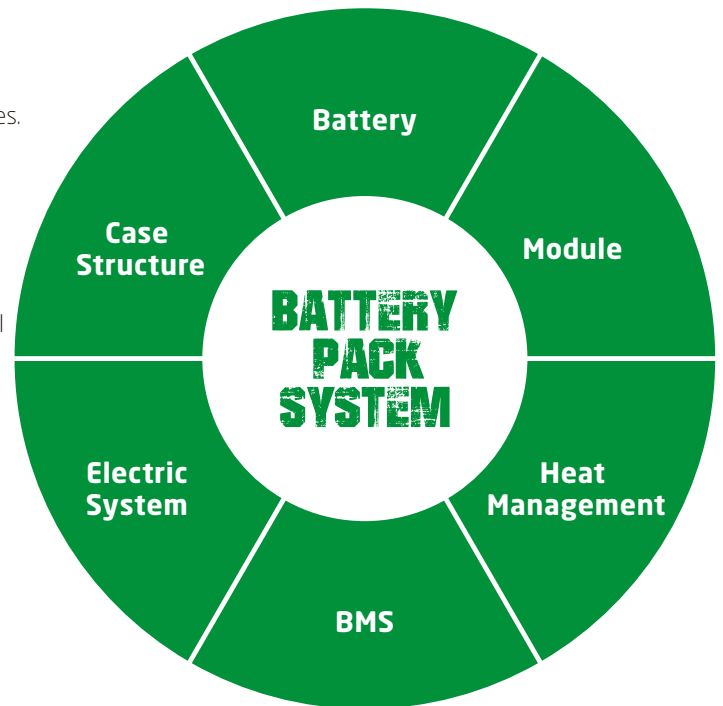

RAPID CHARGING

Li-Ion
2 hours
100%

Lead-acid batteries
8-10 hours **100%**

Rapid and opportunity charging ensure continuous availability of material handling equipment

The chargers allow for fast full charging or boost charging (100 % charge in 2 hours). The lithium-ion batteries are maintenance free and do not require a battery change when used in multi-shift operations. Instead, the batteries can be charged during user breaks and shift changes which allows the forklift to continuously run during multi-shift operations.



TITAN CHARGER
48V/200Ah



Appearance

/ Function meets form with the A Series 3-Wheel Electric Forklift. The exterior of the forklift is powder coated in a durable green finish that designates the forklift is powered by our lithium-ion technology. The robust construction of this forklift is designed with the wear and tear from the multi-shift capabilities of our lithium-ion technology in mind. The eye-catching smooth body lines meet narrow application design with the A Series 3-Wheel Electric Forklift with Lithium-ion Technology.

Maneuverability

/ With dual separate driving motors, this forklift can move the front wheels forward or backwards independently. This combined with the 3-wheel design, allows for the forklift to have a small turning radius suitable for narrow applications. The high-performance AC driving motors deliver reliable power to keep the user moving quickly throughout their facility.

Comfort

/ Operator comfort in mind, the suspension seat, steering column, and the newly designed adjustable levers can be easily adjusted to find the operator's most comfortable driving position. The suspension seat is also designed to minimize vibration and reduce operator fatigue.

Efficiency

/ Thanks to lithium-ion technology, this forklift features opportunity charging. This means that the forklift can work through several shifts, charging during breaks, without needing to stop for hours to recharge. Combined with regenerative braking during deceleration, the powertrain is designed with efficiency in mind. The forklift also comes standard with a high-power pump motor and low noise gear pump. This adds to the efficiency by allowing the hydraulics to work faster. Overall, the A Series 3-Wheel Electric forklift is extremely efficient.

Stability

/ The battery compartment is designed to sit low to the ground. By doing this, the forklift's stability increased and provides more even weight distribution. Standard on this model, the soft landing system provides increased stability by sensing the load and decreasing the lowering speed of the forks.

Safety

- / This forklift was designed to meet both the ANSI and ITSDF safety standards. This means that the following all come standard on this forklift:
- / An emergency cut off switch.
- / An overloading protection system is integrated into the electronics and hydraulic systems.
- / The controller automatically reduces the forklift's speed while cornering.

Maintenance

/ Designed with ease of access in mind, service engineers can remove the front floorboards without the need of tools. The operating levers have also been redesigned so that they can be adjusted forward. This allows the cover to easily open revealing the battery compartment and the power connector.

Control System

/ The MOSFET integrated control system provides accurate control of traveling, fork movement, and adjusting the performance of the motors. The forklift will also not roll back on a ramp thanks to the controller. The controller, connectors, battery plug, and emergency switch are all parts from industry known suppliers to ensure reliability, performance, and ease of service.

CATL Lithium Iron Phosphate Battery Packs

- / Integrated Battery Management System (BMS) continually monitors energy management and ensures reliable operation.
- / HANGCHA provides these Lithium Iron Phosphate (LiFePO4) battery packs with up to a 10 year or 20,000 hour warranty.
- / See warranty certificate for specific warranty information on the Lithium Iron Phosphate battery packs.

Standard Battery Capacity	
Battery Capacity (V/Ah) (kW-h)	51.52V/500Ah 23.04kW-h

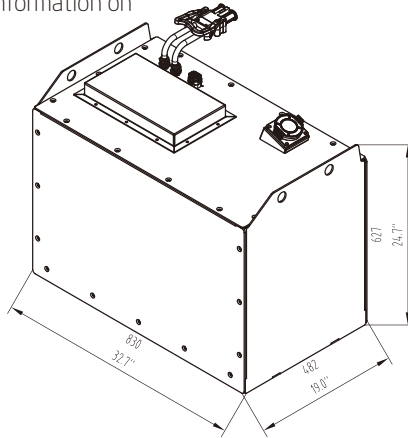

Standard Specification

- / CATL Lithium-ion Battery Pack
- / Dual Front AC Driving Motors
- / Multi-Function Instrument Display
- / Rubber Floor Mat
- / Solid Pneumatic Tires
- / Emergency Disconnect Switch
- / 2 Hydraulic Valves Inside the Chassis
- / LED Headlights
- / Rear Combination LED Light
- / Panoramic Rearview Mirror
- / 118" Limited Free Lift 2 Stage Mast
- / Adjustable Steering Column
- / Horn and Backup Alarm
- / CAN-BUS System
- / Low Noise Gear Pump
- / Full Hydraulic Steering
- / Soft Landing System
- / Non Suspension Seat
- / ZF Reducer
- / SCHABMULLER Traveling Motor

Options

- / 3rd or 4th Hydraulic Function
- / 98.4-177.2" Full Free Lift 2 Stage Mast
- / 169.3-255.9" Full Free Lift 3 Stage Mast
- / Rear Working LED Light
- / Rear Grip with Horn Button
- / Grammer Fingertip Control System
- / Integral Sideshifter
- / OPS System
- / Special Carriage and Backrest
- / Non-Marking Tire
- / Battery Charger
- / Full Suspension Seat
- / Fully Enclosed Cabin
- / Blue Spot Light
- / Other Specialty Attachments
- / Other Dimension Forks



Dual Front AC Driving Motors



Panoramic Rearview Mirror



Adjustable Levers for Easy Battery Access



Tight Turning Radius

A Series 3-Wheel Electric Forklift with Lithium-ion Technology

			HANGCHA GROUP CO.,LTD.				
Distinguishing Marks	1.1	Manufacturer		FBT16Li	FBT18Li	FBT20Li	
		HCFA Model		CPDS16-AD6-I	CPDS18-AD6-I	CPDS20-AD6-I	
	1.2	Manufacturer's Designation		Electric	Electric	Electric	
	1.3	Drive: electric, diesel, petrol, fuel gas		Seated	Seated	Seated	
	1.4	Operator Type: hand, pedestrian, standing, seated, order-picker		Q (lbs)	3200	3500	4000
	1.5	Load Capacity/Rated Load		c (in)	24	24	24
	1.6	Load Centre Distance		x (in)	14.0	14.2	14.2
	1.8	Load Distance, centre of drive axle to fork		y (in)	53.5	53.5	57.7
	1.9	Wheelbase			6884	7149	7657
Weight	2.1	Service Weight	lbs	9047/1368	9598/1522	10481/1589	
	2.2	Axle Loading, laden front/rear	lbs	3177/3707	3177/4148	3376/4281	
	2.3	Axle Loading, unladen front/rear	lbs				
Tires & Chassis	3.1	Tires: solid rubber, superelastic, pneumatic, polyurethane		solid	solid	solid	
	3.2	Tire Size, front		18x7 - 8	18x7 - 8	200/50-10	
	3.3	Tire Size, rear		15x4.5 - 8	15x4.5 - 8	15x4.5 - 8	
	3.5	Wheels, number front rear (x = driven wheels)		2x/2	2x/2	2x/2	
	3.6	Tread, front	b10 (in)	35.8	35.8	36.0	
	3.7	Tread, rear	b11 (in)	6.9	6.9	6.9	
Dimensions	4.1	Tilt of Mast/Fork Carriage Forward/Backward	a/β(°)	6/6	6/6	6/6	
	4.2	Height, mast lowered	h1 (in)	78.5	78.5	78.5	
	4.3	Free Lift	h2 (in)	5.7	5.7	5.7	
	4.4	Lift	h3 (in)	118.1	118.1	118.1	
	4.5	Height, mast extended	h4 (in)	155.3	155.3	155.3	
	4.7	Height of Overhead Guard STD.	h8 (in)	80.3	80.3	80.3	
		Height of Higher Overhead Guard OPT.	h8 (in)	83.9	84.8	84.8	
	4.8	Seat Height	h7 (in)	39.4	39.4	39.4	
	4.1.2	Coupling Height	h10 (in)	19.7	19.7	19.7	
	4.1.9	Overall Length	l1 (in)	110.9	111.1	115.4	
	4.2.0	Length to Face of Forks	l2 (in)	74.7	74.9	79.1	
	4.2.1	Overall Width	b1 (in)	42.8	42.8	44.1	
	4.2.2	Fork Dimensions	s/e/l (in)	1.4/3.9/36.2	1.4/3.9/36.2	1.6/4.8/36.2	
	4.2.3	Fork Carriage DIN 15 173 --- ISO 2328, class/type A,B		ISO2328 2A	ISO2328 2A	ISO2328 2A	
	4.2.4	Fork-Carriage Width	b3 (in)	39.4	39.4	39.4	
4.2.5	Distance between Fork-Arms	b5 (in)	7.9/39.3	9.4/39.3	9.4/39.3		
4.3.1	Ground Clearance, laden, below mast	m1 (in)	3.9	3.9	3.9		
4.3.2	Ground Clearance, centre of wheelbase	m2 (in)	4.3	4.3	4.3		
4.3.4.1	Aisle Width for Pallets 39" x 47" Crossways	Ast (in)	127.4	127.4	131.6		
4.3.4.2	Aisle Width for Pallets 31.5" x 47" Lengthways	Ast (in)	132.3	132.3	136.4		
4.3.5	Turning Radius	Wa (in)	61.2	61.2	65.4		
4.3.6	Internal Turning Radius	b13 (in)	26.8	28.7	28.7		
Performance Data	5.1	Travel Speed, laden/unladen	mph	9.9/9.9	9.9/9.9	9.3/9.3	
	5.2	Lift Speed, laden/unladen	fpm	74.8/92.5	72.8/88.6	68.9/88.6	
	5.3	Lowering Speed, laden/unladen	fpm	90.6/86.6	90.6/82.7	92.5/82.7	
	5.5	Drawbar Pull, laden/unladen	lbf	742/877	719/854	686/832	
	5.6	Max. Drawbar Pull, laden/unladen	lbf	2608/2585	2585/2563	2518/2473	
	5.7	Gradeability, laden/unladen	%	16/18	15/17	13/15	
	5.8	Max. Gradeability, laden/unladen	%	20/20	18/20	15/18	
	5.9	Acceleration Time, laden/unladen (0-10m)	s	4.7/4.3	4.8/4.4	4.9/4.5	
	5.1.0	Service Brake		Hydraulic	Hydraulic	Hydraulic	
	5.1.1	Parking Brake		Mechanical	Mechanical	Mechanical	
	Battery/Electric Motors	6.1	Drive Motor Rating at S2 60 min	kW	4.75x2 AC	4.75x2 AC	4.75x2 AC
6.2		Lift Motor Rating at S3 15%	kW	9.5 AC	9.5 AC	9.5 AC	
6.3		Battery Acc. to DIN 43 531/35/36 A,B,C, no		DIN43531 A	DIN43531 A	DIN43531 A	
6.4		Battery Voltage, capacity	V/Ah	51.52/500	51.52/500	51.52/500	
		Titan Charger		SLC-48200	SLC-48200	SLC-48200	
6.5		Battery Weight	lbs	595	595	595	
		Battery Dimensions	l/b/h(in)	32.7×24.8×24.7	32.7×24.8×24.7	32.7×29×24.7	
6.6		Energy Consumption Acc. to VDI cycle	kWh/h	4.6	5.0	5.5	
		Min. Battery Weight	lbs	1876	1876	1986	
		Max. Battery Weight	lbs	2207	2207	2427	
Additional Data	8.1	Type of Drive Control		MOSFET/AC	MOSFET/AC	MOSFET/AC	
	9.1	Manufacturer		INMOTION	INMOTION	INMOTION	
Additional Data	10.1	Operating Pressure for Attachments	bar	150	150	150	
	10.2	Oil Volume for Attachments	l/min	35	35	35	
	10.3	Hydraulic Tank - capacity (drain & refill)	gal	6.87	6.87	7.66	
	10.7	Sound Level at the Driver's Ear According to EN / DIN 12 053	dB (A)	73	73	74	
	10.8	Towing Coupling, type DIN		φ24 Pin	φ24 Pin	φ24 Pin	

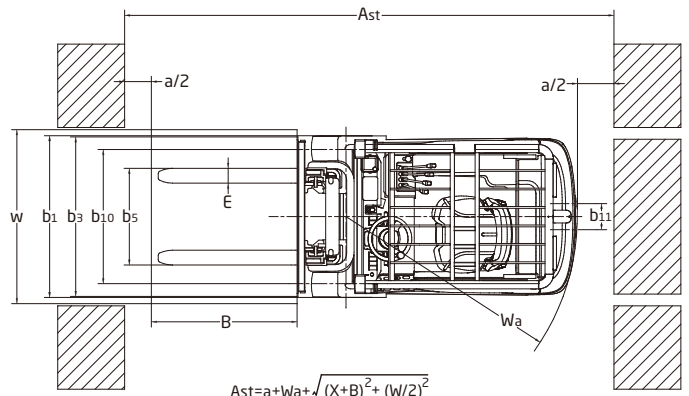
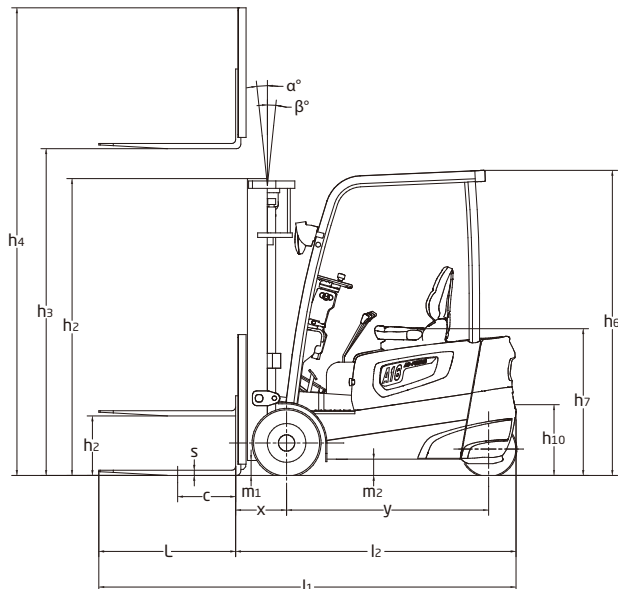

$$Ast = a + Wa + \sqrt{(X+B)^2 + (W/2)^2}$$

X: Load distance

B: Length of load or forks which is longer

3,200-3,500lb Mast

Type	Model	Lifting Height	Overall Height				Free Lifting Height		Front Overhang	Tilting Range		Capacity		
			Lowered	Extended		With Backrest	Without Backrest	With Backrest		Without Backrest	Forward	Backward	Load Capacity at 24" (600mm)	
				With Backrest	Without Backrest								3200lb	3500lb
				in(mm)	in(mm)	in(mm)	in(mm)	in(mm)		deg				
Limited Free-Lift 2 Stage Mast	M250	98.4(2500)	68.7(1745)	135.6(3445)	120.7(3065)	5.7(145)	5.7(145)	14.2(360)	5.5	6	3200(1450)	3500(1630)		
	M270	106.3(2700)	72.6(1845)	143.5(3645)	128.5(3265)	5.7(145)	5.7(145)	14.2(360)	5.5	6	3200(1450)	3500(1630)		
	M300	118.1(3000)	78.5(1995)	155.3(3945)	140.4(3565)	5.7(145)	5.7(145)	14.2(360)	5.5	6	3200(1450)	3500(1630)		
	M330	129.9(3300)	84.4(2145)	167.1(4245)	152.2(3865)	5.7(145)	5.7(145)	14.2(360)	5.5	6	3200(1450)	3500(1630)		
	M350	137.8(3500)	88.4(2245)	175(4445)	160(4065)	5.7(145)	5.7(145)	14.2(360)	5.5	6	3200(1450)	3500(1630)		
	M360	141.7(3600)	90.4(2295)	178.9(4545)	164(4165)	5.7(145)	5.7(145)	14.2(360)	5.5	6	3200(1450)	3500(1630)		
	M400	157.5(4000)	100.2(2545)	194.7(4945)	179.7(4565)	5.7(145)	5.7(145)	14.2(360)	3.5	5	3200(1450)	3500(1630)		
	M430	169.3(4300)	106.7(2710)	206.5(5245)	191.5(4865)	5.7(145)	5.7(145)	14.2(360)	3.5	5	3200(1450)	3400(1540)		
M450	177.2(4500)	111(2820)	214.4(5445)	199.4(5065)	5.7(145)	5.7(145)	14.2(360)	3.5	5	3000(1360)	3400(1540)			
Full Free-Lift 2 Stage Mast	U250	98.4(2500)	68.7(1745)	136(3455)	121.9(3095)	31.5(800)	45.7(1160)	14.9(379)	5.5	6	3200(1450)	3500(1630)		
	U270	106.3(2700)	72.6(1845)	143.9(3655)	129.7(3295)	35.4(900)	49.6(1260)	14.9(379)	5.5	6	3200(1450)	3500(1630)		
	U300	118.1(3000)	78.5(1995)	155.7(3955)	141.5(3595)	41.3(1050)	55.5(1410)	14.9(379)	5.5	6	3200(1450)	3500(1630)		
	U330	129.9(3300)	84.4(2145)	167.5(4255)	153.3(3895)	47.2(1200)	61.4(1560)	14.9(379)	5.5	6	3200(1450)	3500(1630)		
	U350	137.8(3500)	88.4(2245)	175.4(4455)	161.2(4095)	51.2(1300)	65.4(1660)	14.9(379)	5.5	6	3200(1450)	3500(1630)		
	U360	141.7(3600)	90.4(2295)	179.3(4555)	165.2(4195)	53.1(1350)	67.3(1710)	14.9(379)	5.5	6	3200(1450)	3500(1630)		
	U400	157.5(4000)	100.2(2545)	195.1(4955)	180.9(4595)	63(1600)	77.2(1960)	14.9(379)	3.5	5	3200(1450)	3500(1630)		
	U450	177.2(4500)	111(2820)	214.4(5445)	199.4(5065)	5.7(145)	5.7(145)	14.2(360)	3.5	5	3000(1360)	3400(1540)		
Full Free-Lift 3 Stage Mast	N400	157.5(4000)	75.2(1910)	195.1(4955)	180.9(4595)	38(965)	52.2(1325)	15.4(390)	3.5	5	3200(1450)	3500(1630)		
	N430	169.3(4300)	79.1(2010)	206.9(5255)	192.7(4895)	42(1065)	56.1(1425)	15.4(390)	3.5	5	3100(1410)	3400(1540)		
	N450	177.2(4500)	81.7(2075)	214.8(5455)	200.6(5095)	44.5(1130)	58.7(1490)	15.4(390)	3.5	5	3000(1360)	3200(1450)		
	N470	185(4700)	83.7(2125)	222.6(5655)	208.5(5295)	46.5(1180)	60.2(1530)	15.4(390)	3.5	5	2861(1298)	3159(1433)		
	N480	189(4800)	85.6(2175)	226.6(5755)	212.4(5395)	48.4(1230)	62.6(1590)	15.4(390)	3.5	5	2900(1310)	3200(1450)		
	N500	196.9(5000)	88.2(2240)	234.4(5955)	220.3(5595)	51(1295)	65.2(1655)	15.4(390)	3.5	5	2800(1270)	3000(1360)		
	N550	216.5(5500)	94.9(2410)	254.1(6455)	240(6095)	57.7(1465)	71.9(1825)	15.4(390)	3.5	5	2500(1130)	2600(1180)		
	N600	236.2(6000)	103.3(2625)	273.8(6955)	260.8(6625)	66.1(1680)	79.1(2010)	15.4(390)	3.5	5	2200(1000)	2400(1090)		
N650	255.9(6500)	111.8(2840)	293.5(7455)	282.3(7170)	74.6(1895)	85.8(2180)	15.4(390)	3.5	5	1800(810)	2000(910)			

With sidershifter minus 400lb(200kg), with integral sidershifter minus 200lb(100kg).

4,000lb Mast

Type	Model	Lifting Height	Overall Height				Free Lifting Height		Front Overhang	Tilting Range		Capacity		
			Lowered	Extended		With Backrest	Without Backrest	With Backrest		Without Backrest	Forward	Backward	Load Capacity at 24" (600mm)	
				With Backrest	Without Backrest								4000lb	4000lb
				in(mm)	in(mm)	in(mm)	in(mm)	in(mm)		in(mm)				
Limited Free-Lift 2 Stage Mast	M250	98.4(2500)	68.1(1730)	136.0(3455)	119.4(3033)	5.7(145)	5.7(145)	15.0(380)	5.5	6	4000(1810)	4000(1810)		
	M270	106.3(2700)	72.0(1830)	143.9(3655)	127.3(3233)	5.7(145)	5.7(145)	15.0(380)	5.5	6	4000(1810)	4000(1810)		
	M300	118.1(3000)	78.0(1980)	155.7(3955)	139.1(3533)	5.7(145)	5.7(145)	15.0(380)	5.5	6	4000(1810)	4000(1810)		
	M330	129.9(3300)	83.9(2130)	167.5(4255)	150.9(3833)	5.7(145)	5.7(145)	15.0(380)	5.5	6	4000(1810)	4000(1810)		
	M350	137.8(3500)	87.8(2230)	175.4(4455)	158.8(4033)	5.7(145)	5.7(145)	15.0(380)	5.5	6	4000(1810)	4000(1810)		
	M360	141.7(3600)	91.7(2330)	179.3(4555)	162.7(4133)	5.7(145)	5.7(145)	15.0(380)	5.5	6	4000(1810)	4000(1810)		
	M400	157.5(4000)	101.6(2580)	195.1(4955)	178.5(4533)	5.7(145)	5.7(145)	15.0(380)	3.5	5	4000(1810)	4000(1810)		
	M430	169.3(4300)	107.5(2730)	206.9(5255)	190.3(4833)	5.7(145)	5.7(145)	15.0(380)	3.5	5	3900(1770)	3800(1720)		
M450	177.2(4500)	111.4(2830)	214.8(5455)	198.1(5033)	5.7(145)	5.7(145)	15.0(380)	3.5	5	3800(1720)	3800(1720)			
Full Free-Lift 2 Stage Mast	U250	98.4(2500)	68.7(1745)	135.6(3445)	120.4(3059)	31.5(800)	46.7(1186)	15.2(386)	5.5	6	4000(1810)	4000(1810)		
	U270	106.3(2700)	72.6(1845)	143.5(3645)	128.3(3259)	35.4(900)	50.6(1286)	15.2(386)	5.5	6	4000(1810)	4000(1810)		
	U300	118.1(3000)	78.5(1995)	155.3(3945)	140.1(3559)	41.3(1050)	56.5(1436)	15.2(386)	5.5	6	4000(1810)	4000(1810)		
	U330	129.9(3300)	84.4(2145)	167.1(4245)	151.9(3859)	47.2(1200)	62.4(1586)	15.2(386)	5.5	6	4000(1810)	4000(1810)		
	U350	137.8(3500)	88.4(2245)	175.0(4445)	159.8(4059)	51.2(1300)	66.4(1686)	15.2(386)	5.5	6	4000(1810)	4000(1810)		
	U360	141.7(3600)	90.4(2295)	178.9(4545)	163.7(4159)	53.1(1350)	68.3(1736)	15.2(386)	5.5	6	4000(1810)	4000(1810)		
	U400	157.5(4000)	100.2(2545)	194.7(4945)	179.5(4559)	63.0(1600)	78.2(1986)	15.2(386)	3.5	5	4000(1810)	4000(1810)		
	U450	177.2(4500)	111(2820)	214.4(5445)	199.4(5065)	5.7(145)	5.7(145)	14.2(360)	3.5	5	3000(1360)	3400(1540)		
Full Free-Lift 3 Stage Mast	N400	157.5(4000)	74.0(1880)	198.7(5046)	182.0(4622)	32.8(834)	49.5(1258)	15.6(395)	3.5	5	4000(1810)	4000(1810)		
	N430	169.3(4300)	78.0(1980)	210.5(5346)	193.8(4922)	36.8(934)	53.5(1358)	15.6(395)	3.5	5	3800(1720)	3800(1720)		
	N450	177.2(4500)	79.9(2030)	218.7(5556)	202.0(5132)	38.7(984)	55.4(1408)	15.6(395)	3.5	5	3600(1630)	3600(1630)		
	N470	185(4700)	83.7(2125)	222.6(5655)	208.5(5295)	46.5(1180)	60.2(1530)	15.4(390)	3.5	5	3357(1523)	3400(1540)		
	N480	189(4800)	83.9(2130)	230.6(5856)	213.5(5422)	42.7(1084)	59.4(1508)	15.6(395)	3.5	5	3400(1540)	3400(1540)		
	N500	196.9(5000)	86.8(2205)	238.0(6046)	221.3(5622)	45.6(1159)	62.3(1583)	15.6(395)	3.5	5	3200(1450)	3200(1450)		
	N550	216.5(5500)	93.7(2380)	257.7(6546)	241.0(6122)	52.5(1334)	69.2(1758)	15.6(395)	3.5	5	3000(1360)	3000(1360)		
	N600	236.2(6000)	101.6(2580)	277.4(7046)	260.7(6622)	60.4(1534)	77.1(1958)	15.6(395)	3.5	5	2600(1180)	2600(1180)		
N650	255.9(6500)	111.4(2830)	297.1(7546)	280.4(7122)	70.2(1784)	86.9(2208)	15.6(395)	3.5	5	2200(1000)	2200(1000)			

With sidershifter minus 400lb(200kg), with integral sidershifter minus 200lb(100kg).

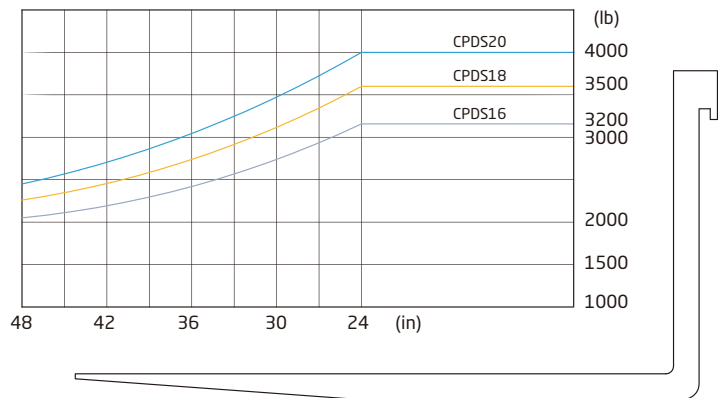



HANGCHA FORKLIFT CANADA INC.

Company address:

6-980 Rue Valois, Vaudreuil-Dorion,
QC, J7V 8P2, Canada

Toll Free: 877-319-HCFC (4232)

Landline: 450-319-HCFC

info@hcforkliftcanada.com

www.hcforkliftcanada.com



ISO14001:2015



ISO9001:2015



Follow us on
Facebook



Follow us on
YouTube



Follow us on
WeChat



Download "Hangcha
Forklift" App

HANGCHA GROUP CO., LTD. reserves the right to make any changes without notice concerning colors, equipment, or specifications detailed in this brochure, or to discontinue individual models. The colors of trucks, delivered may differ slightly from those in brochures.